

RA Roe
Petersfield

THE POST OFFICE ELECTRICAL ENGINEERS' JOURNAL

Vol. 48

OCTOBER 1955

Part 3

CONTENTS

	PAGE
EQUIPMENT FOR MEASUREMENT OF INTER-CHANNEL CROSSTALK AND NOISE ON BROAD-BAND MULTI-CHANNEL TELEPHONE SYSTEMS—R. W. White, B.Sc., F.Inst.P., A.M.I.E.E., and J. S. Whyte, B.Sc.(Eng.), A.M.I.E.E.	127
A TRANSPORTABLE ARTIFICIAL-TRAFFIC EQUIPMENT—D. S. Longmore, A.M.I.E.E., and C. Lawrence	133
“MOSAIC”—AN ELECTRONIC DIGITAL COMPUTER, Part 2—The Control and Input-Output Units—A. W. M. Coombs, Ph.D., B.Sc., A.R.T.C.	137
MEETINGS OF C.C.I.R. STUDY GROUPS I AND XI, BRUSSELS, MARCH/APRIL, 1955..	142
PORTABLE GENERATING SET AND LOW-VOLTAGE ELECTRICAL AIDS FOR EXTERNAL WORK—J. G. Donovan, A.M.I.E.E., and R. Tharby	143
CARRIER FREQUENCY GENERATING EQUIPMENT FOR LARGE COAXIAL AND CARRIER STATIONS, Part 1—General Features, Rack Equipment and Changeover Circuits—E. T. C. Harris, B.Sc.(Eng.), A.M.I.E.E., and S. Munday	148
THE BRITISH POST OFFICE SPEAKING CLOCK, MARK II, Part 1—Design and Performance—A. J. Forty, B.A., A.M.I.E.E., and F. A. Milne, A.M.I.E.E.	154
DEVELOPMENTS IN EXCHANGE RINGING EQUIPMENT—F. C. Gould-Bacon, A.M.I.E.E., and R. F. Purves, A.M.I.E.E.	159
CARTRIDGE-FIRED HAMMER GUNS—E. E. M. Smith, A.M.I.E.E.	164
THE PROVISION OF CIRCUITS FOR TELEVISION OUTSIDE BROADCASTS, Part 1—Video Transmission on Telephone Line Plant—M. B. Williams, B.Sc.(Eng.), A.M.I.E.E., and J. B. Sewter, A.M.I.E.E.	166
OPENING OF NEW RUGBY RADIO STATION.. . . .	170
A MOBILE CALL OFFICE UNIT—F. C. G. Greening, B.Sc.(Eng.), A.M.I.E.E., and E. R. Collings	172
TRANSATLANTIC TELEPHONE CABLE—INAUGURAL CEREMONIES AND THE FIRST LAYING OPERATIONS—R. J. Halsey, B.Sc.(Eng.), M.I.E.E.	174
NOTES AND COMMENTS	177
INSTITUTION OF POST OFFICE ELECTRICAL ENGINEERS	177
REGIONAL NOTES	179
ASSOCIATE SECTION NOTES	186
STAFF CHANGES	187
I.P.O.E.E. PRINTED PAPER NO. 206	136
BOOK REVIEWS	153, 158

Price 2/6 net

THE INSTITUTION OF POST OFFICE ELECTRICAL ENGINEERS

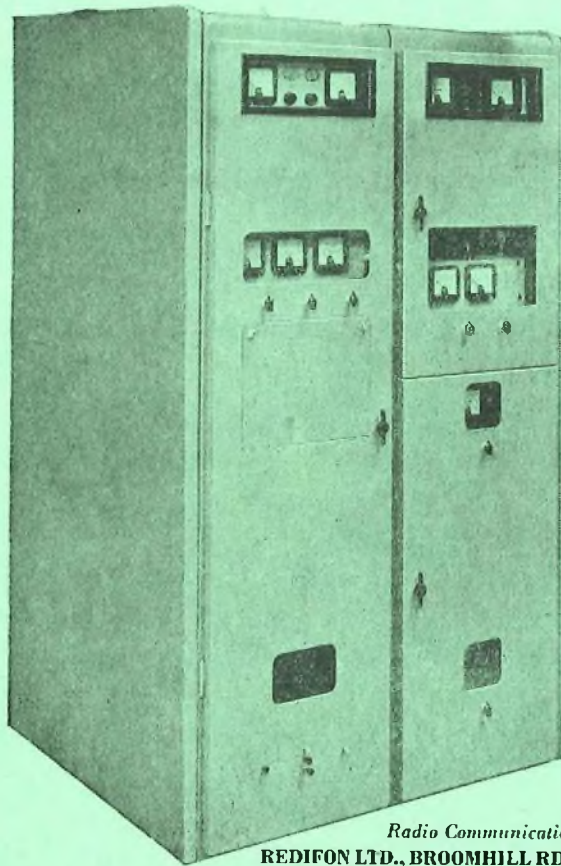

10

SPOT FREQUENCIES

THE ANSWER TO INCREASING
TRAFFIC DENSITIES

The Redifon G.143 TRANSMITTER for medium distance links meets the need for rapid frequency changing where high traffic density conditions prevail at shore stations, and for conserving engineering staffs at all but the largest centres. It provides ten stabilised crystal controlled frequencies for telegraphy or telephony in the 2.26 Mc/s band and has a power output of 1 kW. Only one pair of lines is required for complete remote control up to 25 miles.

Redifon G.143

TRANSMITTER

Radio Communications Division
REDIFON LTD., BROOMHILL RD., LONDON, S.W.18 VAN 7281 A Manufacturing Company in the Rediffusion Group

Electrical Measurements and Measuring Instruments

By E. W. Golding, M.Sc.Tech., M.I.E.E., Mem.A.I.E.E. This well-known title in the Pitman "Engineering Degree Series," has now been revised and brought up to date for a new Fourth Edition. A new chapter has been added on "Electronics and Electronic Measuring Devices." Illustrated. 40/- net.

Radio and Radar Technique

By A. T. Starr, M.A., Ph.D., M.I.E.E. This important book concentrates present-day knowledge of the essential methods and techniques, paying particular attention to noise, microwave techniques, waveforms, pulse circuit techniques, and electronic tubes. Profusely illustrated. It can now be obtained at the reduced price of 60/- net.

"... a notable addition to the literature of the subject."

—WIRELESS ENGINEER.

Telecommunications

Also by A. T. Starr. One of Pitman's "Engineering Degree Series" which covers the B.Sc. (Engineering) syllabus for this subject. 35/- net.

"can be very confidently recommended."—ELECTRICAL REVIEW.

Telephony (2 Vols)

By J. Atkinson, M.I.E.E. A standard textbook for Post Office engineers and students. With over 1,500 illustrations. Vol. I (General Principles and Manual Exchange Systems), 40/- net. Vol. II (Automatic Exchange Systems), 55/- net.

Parker Street • Kingsway •
London • W.C.2

PITMAN

The Pitman Technical List includes many books on aspects of electrical engineering. Write to Sir Isaac Pitman & Sons Ltd. at the address on the right for details of books on the subjects that most interest you.

VALUABLE FREE BOOK

Tells You How to Pass Your C. & G. or Promotion Exam. at First Attempt!



All Post Office Engineering personnel who are anxious to obtain early promotion should at once send for a copy of our handbook "ENGINEERING OPPORTUNITIES," which among other intensely interesting matter describes our unique methods of preparation for TECHNICAL APPOINTMENTS IN THE POST OFFICE (Assistant Engineer—New Style and Assistant Traffic Superintendent), CITY AND GUILDS EXAMINATIONS in Principles of Telecommunications (1-5), Radio (1-4), Telephone Exchange Systems (1-3), Telegraphy (1), Line Transmission (1 and 2), Lines Plant Practice (1 and 2), Mathematics for Telecommunications (1-5), Electrical Engineering Practice (Prelim. Inter. and Final), and outlines a wide range of non-examination courses in all branches of Electrical, Mechanical, Civil, Automobile, Aeronautical and Radio Engineering.

Assistant Engineer and Assistant Traffic Superintendent. Open competitions now resumed. Age extensions for established Civil Servants. Ask us for full details

We definitely guarantee
"NO PASS—NO FEE"

If you intend to make the most of to-day's opportunities, you cannot afford to miss reading "ENGINEERING OPPORTUNITIES." It tells you everything you want to know to secure advancement, and describes many opportunities you may now be missing through lack of information. Send for your copy to-day—FREE and without obligation.

BRITISH INSTITUTE
OF ENGINEERING TECHNOLOGY
369 COLLEGE HOUSE,
29-31 WRIGHT'S LANE, LONDON, W.8

BIET

THE POST OFFICE

ELECTRICAL ENGINEERS' JOURNAL

Vol. 48

October 1955

Part 3

Equipment for Measurement of Inter-Channel Crosstalk and Noise on Broad-Band Multi-Channel Telephone Systems

R. W. WHITE, B.Sc., F.Inst.P., A.M.I.E.E.,
and J. S. WHYTE, B.Sc.(Eng.), A.M.I.E.E.†

U.D.C. 621.317.74:621.395.822.1:621.395.44

A multi-channel telephone signal can be simulated by using a band of random noise extending over the same frequency range, and a technique based upon this has been developed for intermodulation measurements on microwave radio links carrying multi-channel telephone traffic. The method is equally applicable to coaxial-cable systems.

INTRODUCTION

WHEN a large amount of telephone traffic has to be carried by coaxial cables, or by broad-band radio relay links which have to be integrated with a coaxial-cable network, it is now almost universal to employ frequency-division multiplexing with a 4 kc/s spacing, and the number of channels provided is normally an integral multiple of 60. The multiplex telephone signal comprises many rapidly changing components of various frequencies, and non-linear distortion in the transmission system introduces unwanted harmonics and intermodulation products of these components. When distortion is severe, unwanted products are heard by the telephone subscriber as an interference resembling random noise.

Standards of transmission performance for long-distance trunk circuits have been agreed internationally by the C.C.I.F.¹ and, for the topics under discussion in this article, the most important of these standards is the requirement that, for a 2,500-km telephone circuit, the noise measured at a point of zero relative level in any audio channel shall not exceed 10,000 picowatts psophometric for more than 1 per cent. of the busy hour. One-quarter of this figure is normally allotted to the terminal multiplexing equipment and the remainder (i.e., 7,500 pW) is therefore the upper limit for all forms of noise and intermodulation introduced in the transmission path. This is, no doubt, an excellent method of specifying performance from the ultimate users' point of view; but it is quite impracticable for precise specification of equipment performance, for acceptance testing of new systems, or for routine testing and maintenance purposes. For these, the C.C.I.F. noise requirement must be translated into target figures in some form of measurement which can be carried out rapidly under accurately controlled conditions, and which can be repeated readily and consistently whenever and wherever required.

In coaxial-cable practice, it is normal to check the linearity of a multi-channel telephone system by measuring either the harmonics of a single tone or the intermodulation

products between two or three tones transmitted over the system. Such methods can give accurate information on changes of performance and are very useful for routine maintenance; they have the great advantage that they can be applied to working systems, provided that suitably located channels can be freed of traffic. In line systems, second-order and third-order distortion products are generally predominant; but since quite small amounts of high-order harmonic production can give rise to considerable intermodulation on a multi-channel signal,² it is important to search for and to measure very low levels of high-order products when only one or two tones are applied.

The loading of a system with one, two or three tones does not correspond at all closely with normal loading by a large number of telephone channels, and even when all significant harmonics have been measured at various loading levels, interpretation of the results in terms of performance on normal traffic loading is a matter of considerable difficulty. In addition, as the tone techniques are concerned only with non-linear distortion, separate measurements of basic noise are required before any estimate can be made of the anticipated signal-to-noise ratio in an audio channel.

When the situation that arises on broad-band radio relay systems is considered it is soon evident that single-tone or two-tone testing is of little value as an accurate indication of traffic performance, and may at times give distinctly misleading results. Angular modulation* is almost universally employed in these radio systems, and a major source of non-linearity and intermodulation is therefore delay distortion,³ i.e., non-uniformity of the group-delay/frequency characteristic in the R.F. transmission path. The type of delay distortion normally encountered in modulators, filters, amplifiers and demodulators may be expected to give rise to distortion products which are predominantly of low order; but echo signals having appreciable time delay relative to the main signal (e.g., from mismatched aerial feeders, or multi-path propagation) can give rise to sinusoidal variations in group delay within the band of frequencies occupied by the transmitted signal. In the latter case, the relative contributions of various odd-order and even-order components will vary with changes of centre frequency, and the order of distortion which is predominant will increase with increasing deviation. Thus, with single-tone or two-tone tests it is most difficult to

† The authors are, respectively, Senior Executive Engineer and Executive Engineer, Radio Experimental and Development Branch, E.-in-C.'s Office.

¹ For references see end of article.

* The term angular modulation includes not only frequency and phase modulation but also modulation systems intermediate between these two, such as may be produced by the use of pre-emphasis in the modulator.

obtain consistent or accurately repeatable results, and it is virtually impossible to interpret from them what the traffic performance will be. Many products have to be measured at many loading levels if comprehensive data are required, and if only second-order and third-order products are measured an entirely misleading result may be obtained.

It is evident, therefore, that a new approach to the measurement of intermodulation is required for use on multi-channel telephone systems which may at any time be subject to high-order non-linear distortion, and this article is concerned with the technique and equipment now coming into use on broad-band radio links.

NOISE INTERMODULATION TECHNIQUE

In systems carrying a fairly large number of telephone channels, say 60 (one supergroup) or more, the multi-channel signal under busy conditions can be simulated with reasonable accuracy by a band of random noise extending over the same frequency range.⁴ If this band of noise is passed through a very narrow band-stop filter, the resultant signal will be a fair approximation to the traffic on a heavily loaded system with one quiet channel. This type of test signal can be used to load a multi-channel system in a manner closely resembling actual traffic loading, and at the far end of the system measurements of crosstalk and noise can be made in the narrow stop-band.

Outline Description of Equipment.

Two items of equipment are required—a “generator” at the input end of the system under test, and a “receiver” at the output end—the general arrangement being as shown in Fig. 1 (a).

The generator produces a band of random noise having a uniform power/frequency spectrum, and the band edges are then determined by a low-pass and a high-pass filter (Fig. 1 (b)); the latter has a cut-off frequency of 60 kc/s, but alternative low-pass filters are provided so that various numbers of channels may be simulated. Finally, the signal is passed through one or more band-stop filters having an insertion loss of at least 80 db. A diagrammatic representa-

tion of the transmitted signal spectrum, with one band-stop filter in circuit, is shown in Fig. 1 (c).

After transmission over the broad-band system under test, the received signal spectrum (at point B) might appear as in Fig. 1 (d). Due to noise of all kinds introduced by the relay system, including intermodulation between component frequencies of the noise signal, the “hole” in the noise spectrum is now less deep than it was at point A. A special receiver is used to measure the change in noise level as the band-stop filter is switched in and out. This receiver is essentially a device of the insertion-loss measuring type, since it operates always at full gain and measurements are made by means of a calibrated attenuator preceding it. The receiver bandwidth, Δf ,* must be less than the bandwidth of any of the stop filters at their -80 db. points.

The method of making a measurement is very simple. The generator is set to the desired number of channels and a flat band of noise applied at appropriate level to the system under test. The output of the system is applied to the noise-measuring receiver, which is set to the selected stop-band frequency, and the input attenuator of the receiver is adjusted so that mid-scale deflection of the output meter is obtained. The appropriate band-stop filter is then switched into circuit at the sending end, and the input attenuator of the receiver readjusted to restore mid-scale deflection of the meter. The difference between the two attenuator settings on the receiver is the “noise-power ratio” for that particular loading level and stop-band frequency.

Noise and Traffic Loading.

The best-known study of load-rating theory for multi-channel amplifiers is the classic paper by Holbrook and Dixon.⁵ In that paper, curves were derived relating the number of channels in a system and equivalent volume levels exceeded for 1 per cent. of the time, with and without volume limiting in individual channels. These curves were a most valuable contribution to telephone transmission theory, and have been widely accepted; but it must be remembered that they were based on the traffic characteristics of a specific system at a particular stage of development. Modifications are therefore required for differences in speech characteristics and telephone habits of typical subscribers, local line levels, signalling arrangements, carrier leak and pilot levels, amount of V.F. telegraph traffic, etc., before they can be applied to other trunk telephone systems.

The relationship between number of channels and the level exceeded for 1 per cent. of the busy hour, which is given in Fig. 2, is believed to be a reasonable approximation

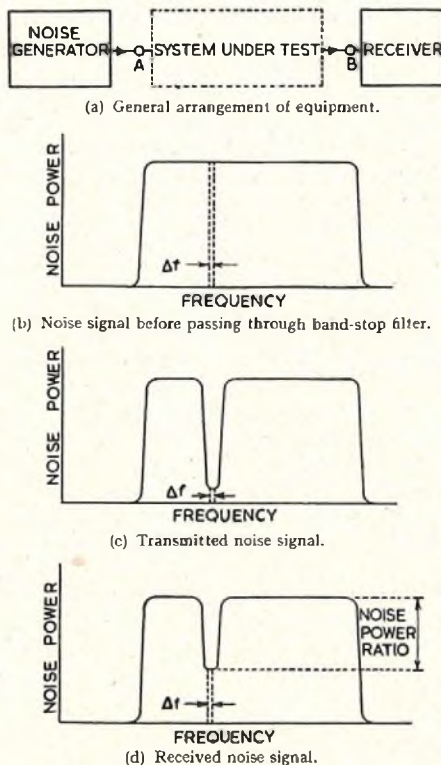

FIG. 1.—PRINCIPLE OF NOISE TESTING METHOD.

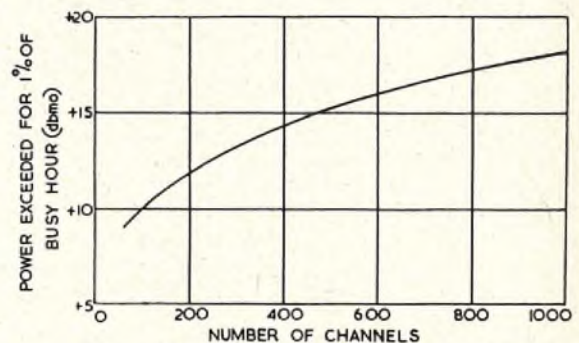

FIG. 2.—TRAFFIC LOADING.

* Strictly speaking, Δf is equal to twice the cut-off frequency of the receiver audio-frequency filter. The noise-power bandwidth of the receiver is slightly less than this, since its audio amplifier does not transmit frequencies much below 200 c/s.

to conditions which would exist in the British trunk network if it employed C.C.I.F. signalling levels. Fig. 2 indicates the basic level at which the noise signal is applied in testing a multi-channel system. Levels are several decibels higher than this on the present British trunk network, due to the high level of tones used in the current 2 V.F. signalling system. As multi-channel loading data are at present under review, the curve shown in Fig. 2 must be regarded as a tentative one, and may therefore be expected to be subject to confirmation or slight amendment from time to time.

Noise-Power Ratio and Signal-to-Noise Ratio.

The noise-power ratio (N.P.R.) of a system loaded with a particular level of noise test signal may be defined as the ratio of the noise power in an arbitrary small bandwidth of the pass-band to the noise power in the same bandwidth within a stop-band. The N.P.R. will vary with loading, and generally with the position of the stop-band in the noise frequency spectrum, so that it cannot be expressed as a single figure. Results are most conveniently given in the form of curves (or tables) of N.P.R. against loading for each measuring frequency, or of N.P.R. against frequency for each loading level. These curves provide fundamental data on system performance in an accurate, simple and readily repeatable form: most important of all, the system is loaded in a realistic manner and account is taken of noise from any source and intermodulation products of any order falling in the measuring channels.

Signal-to-noise ratio is at present a much more familiar term than N.P.R. However, both are normally expressed in decibels, and conversion from N.P.R. to the ratio of channel test tone to noise is simply a matter of adding a "conversion factor" which is given in Fig. 3. It is important

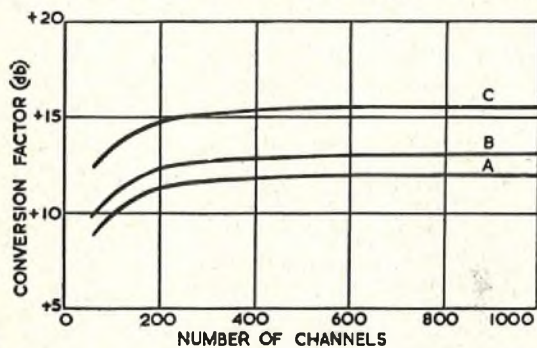

A—4 kc/s bandwidth, unweighted.
B—3.1 kc/s bandwidth, unweighted.
C—3.1 kc/s bandwidth, psophometrically weighted.

FIG. 3.—CONVERSION FACTORS.

to note that, in signal-to-noise measurements on multi-channel systems, the noise may be measured (a) unweighted in a 4 kc/s nominal channel, (b) unweighted in a 3.1 kc/s channel, or (c) with psophometric weighting, and care should be taken to use the conversion factor appropriate to the method of measurement.

The conversion factor may be regarded as an allowance for the difference between channel test-tone level and the proportion of the total noise-power loading which is effectively applied to any one channel. For example, if we wish to obtain 1 per cent. busy-hour performance data on a 600-channel system, noise loading would be applied at a level of +16dbm;* but, when making the upper measurement of a pair for N.P.R. (band-stop filter out), this noise power is spread evenly from 60 kc/s to 2,540 kc/s, a total of 2,480 kc/s. The noise power in, say, 3.1 kc/s is

* The term x dbm is used to mean a power level of x db. relative to 1 milliwatt.

The term x dbmo is used to mean a power level of x db. relative to test level.

3.1/2,480 of the total power (i.e. -29 db. relative to the total power) and so is $+16 - 29 = -13$ db. relative to test-tone level. A conversion factor of 13 db. must therefore be added to the N.P.R. to get the unweighted 3.1 kc/s bandwidth signal-to-noise ratio. Psophometric weighting of uniform noise in a 300-3,400 c/s band introduces a further factor of approximately 2.5 db., and the conversion factor which must be added to N.P.R. to get the weighted signal-to-noise figure is therefore $13 + 2.5 = 15.5$ db.

It has sometimes been suggested that a higher value of conversion factor can be used for the lower-frequency channels of a system in which non-linear distortion is predominantly second order. This hypothesis is based on the facts that (1) speech energy is not distributed uniformly over the 300-3,400 c/s band, but has a maximum at about 1,000 c/s and (2) second-order distortion components in the lower part of the baseband spectrum are predominantly difference products: thus the intermodulation spectrum with speech loading will be non-uniform and will have maxima in the lower part of the baseband around integral multiples of 4 kc/s. Much of the distortion would then be at the top and bottom ends of an audio channel, and the psophometric weighting network would provide additional discrimination. Against this it may be argued that V.F. telemetry on a number of the channels, and various V.F. signalling tones on most of them, invalidate the assumption of a clearly defined energy maximum within each channel. Further, the assumption of predominantly second-order distortion is of doubtful validity in the long-term operation of any actual system, and it is considered, therefore, that the conversion factors of Fig. 3 should be used for all channels quite independently of their position in the baseband spectrum.

Since the conversion factors are based on the traffic-loading data given in Fig. 2, they are subject to the same provisos about applying them to other systems and they may require slight revision with changing practice and new developments. It is partly for this reason that the authors prefer to regard N.P.R. as a more fundamental figure than signal-to-noise ratio for the comparison of multi-channel telephone systems. It is suggested that minimum figures for N.P.R. at particular loading levels might well be used in specifications for, and acceptance testing of, new broad-band systems.

EQUIPMENT DETAILS

Requirements of Level and Sensitivity.

The requirements for the output level available from the noise generator and for the sensitivity of the receiver are as follows:—

- The noise generator must produce sufficient power to supply a baseband signal at the appropriate level to the input of the system under test.
- The receiver sensitivity must be adequate to enable it to measure the anticipated values of noise power in the stop-band at the output of the system.
- The noise generator output and receiver sensitivity must together be such that the receiver can measure the characteristics of the noise generator when receiver and generator are used "back-to-back." Such a test will demonstrate that the equipment is functioning properly before measurements are made.

In present coaxial-cable practice, test-tone level at the traffic input point of the system is -45 dbm. The relation existing between test-tone level and multi-channel signal power for a given number of channels has been given in Fig. 2; thus for 960 channels the noise power required would be $(-45 + 18) = -27$ dbm. Higher levels than this may be required for checking the overload margin or for tests made on a system with the noise injected other than at the traffic input point.

The standard test-tone level at the traffic output point of coaxial cable systems is -15 dbm., and if test-tone-to-noise† ratios of 90 db. are to be measured the noise power which the receiver will have to measure will be -111 dbm per kc/s. Similar traffic levels will probably be encountered on radio systems.

In order to cater for the back-to-back testing of the noise source and receiver the following level requirements must be met:—

Let the receiver sensitivity be $-P$ dbm‡, the maximum loss introduced by the band-stop filter Q db., and the multi-channel signal bandwidth R kc/s. If the receiver is to be just capable of measuring the noise in the stop-band the total noise power must be such that the noise in bandwidth Δf kc/s (the power bandwidth of the receiver) in the absence of the band-stop filter is $(-P + Q)$ dbm. A total noise power of $\{-P + Q + 10 \log (R/\Delta f)\}$ dbm is therefore required.

For the purpose of the present design P has been made 110, Δf is about 1.5 and Q has been assumed to be 80; thus for 960 channels ($R = 3,968$) the total noise power required is approximately $+4$ dbm.

Noise Generator and Filters.

The first stage of the noise generator uses a CV138 valve, and the output is provided by a combination of shot and partition noise plus the thermal noise from the grid resistor. Since the lowest frequency required is 60 kc/s, flicker noise can be ignored. The anode load of this stage is inductance compensated and its gain (and hence the noise output) may be varied by adjusting the screen voltage; a panel control is provided for this purpose. A cathode-follower stage follows the noise generator and makes the output available in an impedance of 75 ohms. The overall noise factor of the first two stages is about 34 db.

A noise diode is not a convenient alternative to the above arrangement. If a diode operating at 10 mA anode current with a 75-ohm anode load were used, the noise power available would be 22 db. less than with the CV138 arrangement. In addition, the diode life is short (the average life of a CV172 is 100 hours at 20 mA) and a stabilised D.C. heater supply is necessary.

This generator is followed by three coaxial line amplifiers in tandem, providing 90 db. of gain, and the resultant noise output is uniform within 1 db. between 60 kc/s and 4,028 kc/s when the band-stop filters are not connected. It is essential that the overload capacity of the amplifiers should be adequate to avoid clipping of the peaks of noise. The low frequency cut-off is fixed at 60 kc/s by a high-pass filter and the high-frequency cut-off can be switched to either 4,028 kc/s, 2,540 kc/s, 1,052 kc/s or 552 kc/s according to whether it is desired to simulate 960, 600, 240 or 120 channels. Five band-stop filters are provided, each of which has an insertion loss of not less than 80 db. in a narrow band centred on 70, 534, 1,002, 2,438 or 3,886 kc/s. These filters may be connected in or out of circuit by means of keys. The frequencies have been chosen so that whatever number of channels is being used, there is always a band-stop filter having a frequency just above the lowest frequency, and just below the highest frequency, of the band. In addition, no filter frequency is a multiple of 4 kc/s or of 60 kc/s, nor is there any known high-power B.B.C. or Post Office transmitter within several kilocycles of each filter centre frequency.

Fig. 4 is a block schematic diagram of the noise generator and Fig. 5 shows a photograph of the experimental noise generator (later models have switched filters instead of the U-link connections shown). For the sake of clarity only one

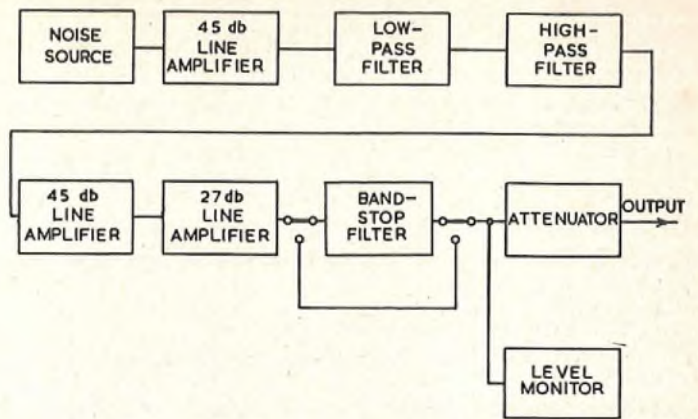

FIG. 4.—BLOCK SCHEMATIC DIAGRAM OF NOISE GENERATOR.

band-stop filter has been shown in Fig. 4. Several factors are involved in the choice of position of the various filters and these are enumerated below:—

- (1) If the band-stop filters are placed after the final amplifier there is no possibility of intermodulation in this amplifier reducing the available noise-power ratio.
- (2) If the band-stop filters were placed before the final amplifier they would be operating at a lower level and there would be reduced possibility of intermodulation occurring in the filters. In the present design it has been found that this is of less importance than factor 1.
- (3) It is convenient to place the high-pass and low-pass filters before the final amplifier, to avoid wasting available overload capacity in this amplifier by loading its input with noise outside the frequency band of interest.
- (4) By separating the band-stop filters from the other filters with an amplifier no isolating pads are necessary.

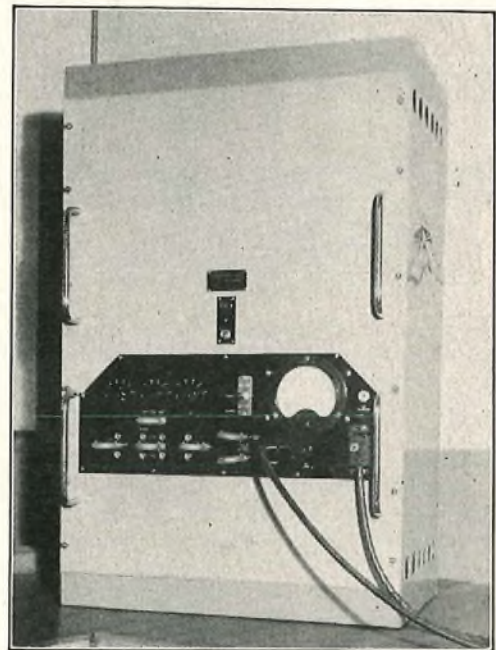

FIG. 5.—EXPERIMENTAL NOISE GENERATOR.

The design of the high-pass and low-pass filters is based on Darlington's method of network synthesis.⁶ In each case a prototype low-pass filter having a variation of loss in the pass-band limited to $\pm \frac{1}{8}$ db. is the basis of the design. The band-stop filters were all designed by the

† Measured in 4 kc/s bandwidth.

‡ This is the input power required to give a standard deflection on the receiver output meter.

method of Cocci⁷ and Fig. 6 shows a circuit diagram of a typical band-stop filter.

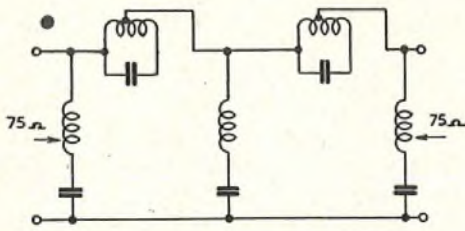

FIG. 6.—TYPICAL BAND-STOP FILTER.

A switched attenuator and level monitor complete the facilities provided on the noise generator.

Noise Receiver.

Fig. 7 is a block schematic diagram of the noise receiver. The receiver is pre-tuned to five different frequencies, corresponding to the frequencies of the various band-stop filters, and the desired frequency is selected by a switch. No intermediate-frequency amplifier as such is used, the local oscillator converting the incoming signals directly to audio frequency. The advantage of this procedure lies mainly in the fact that it solves the image-rejection problem; if a conventional-type receiver with intermediate-frequency gain were used an image ratio of at least 90 db.

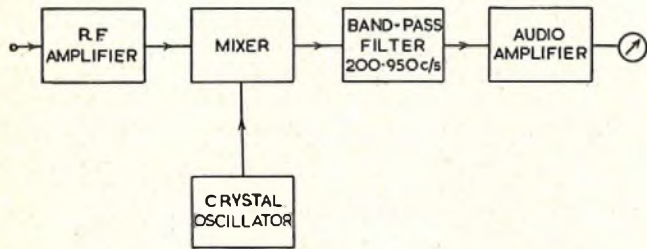

FIG. 7.—BLOCK SCHEMATIC DIAGRAM OF NOISE RECEIVER.

would be required. The intermediate-frequency response ratio would also need to be not worse than 90 db.

By following the mixer valve with a band-pass filter (200-950 c/s) and arranging that the R.F. signal circuit bandwidth is never less than about 3 kc/s the effective receiver bandwidth is 1,500 c/s, irrespective of the signal frequency.

It is necessary that intermodulation produced in the receiver prior to the audio-frequency filter should be small, as such distortion would otherwise lead to erroneous results, due to those intermodulation products which fall inside the audio filter pass-band being recorded on the output meter. With this objective the audio-frequency gain has been made as high as is readily possible, up to the limit imposed by hum and microphony, in order that the signal level at the mixer grid should be as low as possible.

A second feature that is required of the receiver is a very good adjacent-channel selectivity prior to the mixer grid, because when the receiver is used to measure the very small noise power existing in the stop-band, there is present simultaneously a spectrum of energy only a few kilocycles per second away from the tune frequency, which may be at a level 60 to 70 db. higher. Sufficient of this unwanted energy may reach the grid of the R.F. amplifier valve or mixer valve to cause intermodulation (resulting in errors of measurement) if the R.F. selectivity is inadequate.

In addition to providing good R.F. selectivity, negative feedback is used on the R.F. stage to improve its linearity. The mixer stage uses a type CV2209 valve, and an anti-microphonic valve-mounting is employed. The first audio stage uses a low-noise pentode type CV2135 and the coils of the audio filter are wound on ferrite cores and enclosed in mu-metal boxes to reduce induced hum voltages due to

stray fields. A maximum sensitivity of about -120 dbm (for standard deflection of the output meter) can be obtained but this is usually reduced to about -110 dbm for normal use.

Fig. 8 shows a photograph of an experimental model of the receiver, which differed slightly from the production models, and operated on slightly different frequencies.

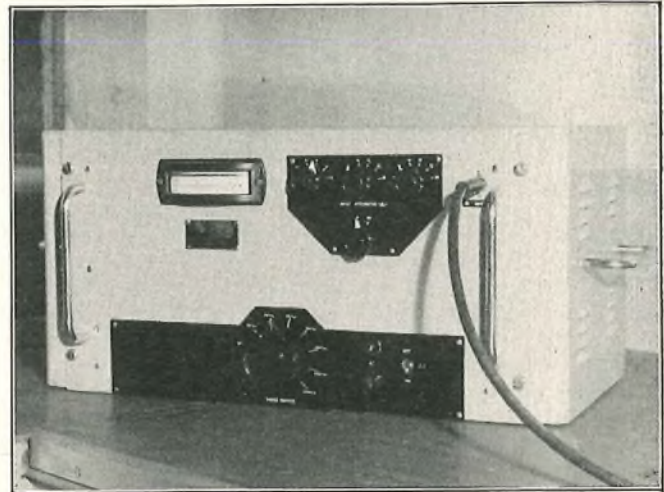

FIG. 8.—EXPERIMENTAL NOISE RECEIVER.

APPLICATIONS OF THE EQUIPMENT

Fig. 9 illustrates some measured results which were obtained on an experimental arrangement comprising a 240-channel modulator and demodulator connected back-to-back at the intermediate frequency of 60 Mc/s. By varying the noise power into the modulator the frequency deviation may be varied, and it is clearly seen that there is an optimum value for the deviation. Reducing the

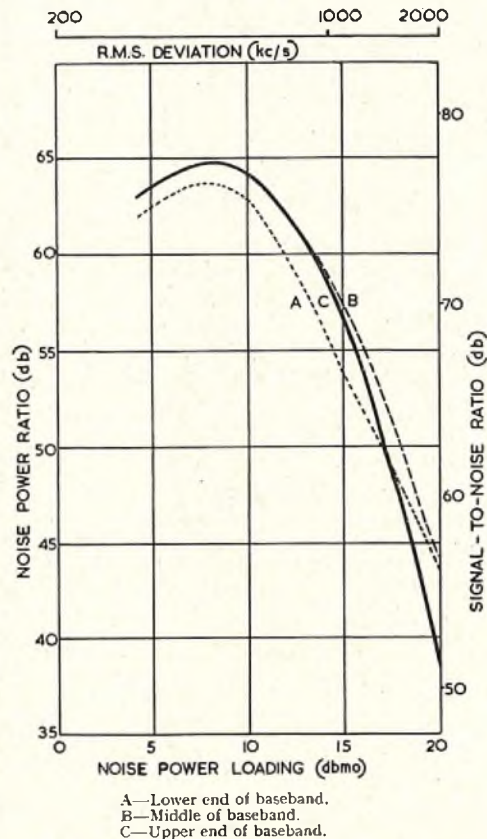

FIG. 9.—PERFORMANCE OF A 240-CHANNEL FREQUENCY MODULATOR AND DEMODULATOR.

deviation reduces intermodulation noise but causes basic noise to rise, whereas increasing the deviation reverses this effect.

The equipment can be used to measure the ratio of test tone to basic noise, and for this purpose no band-stop filters are used. The appropriate level of noise is injected into the modulator and the noise-receiver input attenuator adjusted for mid-scale deflection on the output meter. The noise input to the modulator is then removed and the new setting required on the noise-receiver attenuator noted. The difference in the two settings plus the conversion factor gives the test tone to basic noise figure. Provided the test-tone level at the measuring point is known, it is possible to express the results in terms of the actual noise power existing in a 4 kc/s band if this is preferred.

It would be normal practice to have a generator and receiver at each end of a system under test, so that the system may be tested in both directions. Correct operation of the equipment may be confirmed by connecting the noise generator and noise receiver back-to-back without any intervening equipment and measuring the noise-power ratio at each band-stop filter frequency. The measured N.P.R. should exceed 75-80 db. in all cases.

In general, the distortion encountered on coaxial-cable systems is of comparatively low order and the advantage conferred by the noise-testing method compared with tone methods is not so great, but nevertheless interesting and useful results can be obtained. Fig. 10 shows some

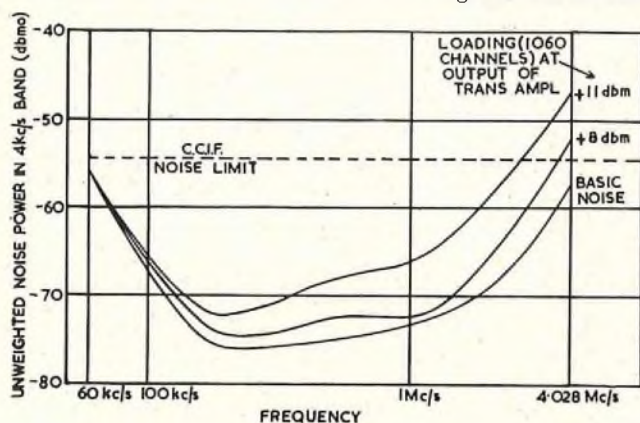

FIG. 10.—PERFORMANCE OF A 335-MILE COAXIAL-CABLE LINK.

measured results taken over 335 miles of route on a C.E.L. 4 television system, when the loading was equivalent to 1,060 telephone channels.* It will be noticed that there is a sharp rise in the basic noise at frequencies below 200 kc/s. Subsequent investigations† have shown that this was due to hitherto unsuspected sources of noise on various neon cable-indicator lamps, and steps have been taken to eliminate this noise on future systems, which will have to carry television or multi-channel telephone traffic.

* At the time that these measurements were made the low-pass filter necessary for the simulation of 960 channels was not available and an existing low-pass filter having a slightly higher cut-off frequency was used. This accounts for the somewhat unusual figure of 1,060 channels.

† By the Post Office Research Station.

Yet another sphere in which the new technique is finding increasing use is that of microwave propagation testing. Under certain conditions multi-path propagation can occur between a microwave transmitter and the distant receiver to which it is working. Under these conditions the delayed signal (or signals) interfere with the main signal and give rise to interchannel crosstalk on the baseband signal. Such experimental evidence as exists at present suggests that, for fades greater than about 10 db., the degradation of signal-to-noise ratio that will occur in a speech channel may be considerably greater than that which would occur due to the fall in received carrier power alone. If this is true, it is obvious that propagation testing which merely records the received carrier power of an unmodulated test signal transmitted at constant power will not give a full picture of the conditions. A recording version of the noise receiver has therefore been developed which enables a continuous record to be made of the received power in a stop-band. Since the microwave receiver A.G.C. will hold the baseband signal level constant, the noise power in the stop-band gives a direct measure of the signal-to-noise ratio, when the system is loaded with the random noise test signal.

CONCLUSIONS

A method of testing broad-band frequency-division multiplex telephone systems has been described which:—

- takes into account intermodulation products of any order which may be present,
- is not affected by dependence of distortion on modulating frequency,
- includes effects of thermal noise, valve noise, and most forms of interference, wherever they may arise on the system,
- uses a test signal which closely simulates actual traffic, and
- gives results which can be converted very simply into normal traffic performance data.

The method has the disadvantage that it cannot be applied to a system which is carrying traffic; but the noise generator and receiver which have been developed enable measurements to be made both rapidly and accurately.

ACKNOWLEDGMENTS

The authors wish to acknowledge the help of colleagues in the development of this equipment, and particularly the work of Messrs. E. R. Broad and E. J. P. May, who were responsible for the filters in the noise generator.

References.

- C.C.I.F. Livre Jaune, Tome III bis, Florence 1951, p. 121.
- Brockbank, R. A., and Wass, C. A. A. Non-Linear Distortion in Transmission Systems. *J.I.E.E.*, Vol. 92, Part III, No. 17, p. 45, 1945.
- Whyte, J. S. An Instrument for the Measurement and Display of V.H.F. Network Characteristics. *P.O.E.E.J.*, Vol. 48, Part II, p. 81, Jul. 1955.
- Peterson, E. Gas Tube Noise Generator for Circuit Testing. *Bell Laboratory Record*, Vol. 18, p. 81, Nov. 1939.
- Holbrook, B. D., and Dixon, J. T. Load Rating Theory for Multichannel Amplifiers. *B.S.T.J.*, Vol. 18, p. 624, Oct. 1939.
- Darlington, S. Synthesis of Reactance 4-poles. *Bell Telephone System*. Monograph No. B1186.
- Cocci, G. Filtri con numero minimo di elementi. *Alta Frequenza*, Vol. XI, Nov.-Dec. 1942.

A Transportable Artificial-Traffic Equipment

D. S. LONGMORE, A.M.I.E.E.,
and C. LAWRENCE †

U.D.C. 621.395.341.8

This article describes a transportable artificial-traffic equipment which has been developed, as a tester, for use in non-director exchanges. The selectors in an exchange and the outgoing junctions are tested by means of artificial traffic which is routed to the local multiple and to test numbers in the surrounding exchanges.

INTRODUCTION

THE use of an automatic tester for originating artificial traffic was suggested in 1931, following an investigation in the London Region to determine the causes of incomplete connections. The investigation was carried out by holding and tracing the failures which occurred when test calls were manually set up from telephones connected to spare subscribers' line circuits. In 1938 a small panel-mounted automatic tester was constructed for this purpose.

No further development took place until 1944, when an experimental rack-mounted equipment, incorporating additional facilities, was designed and tested in a number of provincial exchanges. This equipment, and the method of using it to test an exchange, were described in a previous article in the Journal,¹ which aroused considerable interest in the use of artificial-traffic equipments for testing exchanges and led to a number of requests for further information. Improvements were made to the experimental model, as a result of experience obtained during the following three years, and by 1948 a number of these equipments had been constructed and were in use as maintenance aids in provincial exchanges. The results obtained showed that, in addition to providing a means of locating faulty plant items, an artificial-traffic equipment could be used by exchange maintenance staff for making quality of service measurements, which would be useful supplements to the existing fault statistics.

In exchanges in which the quality of service was initially below standard, it was generally found that considerable improvement could be obtained within a short period of time. The equipments were installed for periods of approximately six months and then moved elsewhere, the object being to achieve a general improvement in the quality of service given by a group of exchanges. Transfers from one exchange to another, as a regular procedure, had not been envisaged previously and rack-mounted equipments were not suitable for the purpose. Subsequent development was therefore concentrated on the production of a transportable equipment, suitable for use in an Area or a group of exchanges.

DEVELOPMENT OF TRANSPORTABLE EQUIPMENT

To reduce installation work to a minimum, use has been made of multi-way plugs and sockets for connecting the tester to the exchange apparatus. This method of connection results in certain advantages in larger exchanges, where the number of line circuits and multiple numbers required is greater than the maximum number of access points on the tester; i.e., 25, using standard P.O.-type uniselectors. The line circuits and multiple numbers can be divided into groups or sections and the tester given access to any section by plugging in as required, the change from one line circuit section to another merely involving a change of position of the access plugs. A change of multiple numbers can also be made in the same way, but, in addition, requires a change in the characteristics which control the routing digits used for setting up the calls. In

the rack-mounted equipments a wired-on cross-connection field was used for this purpose and a complete change of routes required several man-hours to complete. The first experimental transportable model used a digit-control field consisting of double-ended cords plugging on to a panel of test jacks and a change of routes took approximately half an hour. This method has been superseded by the use of multi-way plugs, which enables the change to be made in a few minutes.

A second experimental transportable model, mounted on a test stand No. 22, used a plug-in type of digit-control field and introduced the facility of making test calls to distant exchanges, without using spare junction wires for check of the correct routing. In addition to the standard pulses, 10 p.p.s., 66 per cent. break period, pulses at 12 p.p.s. and 80 per cent. and 50 per cent. break period were used for setting up calls. This model, after a short field trial, formed the basis for production of a standard item known as Tester AT 5261. The facility of testing with pulses at 12 p.p.s. has not been provided on the standard tester but apart from this exception the facilities are substantially the same as those of the model.

GENERAL DESCRIPTION OF THE STANDARD TESTER

The tester, mounted on a test stand No. 26, which is slightly larger than the test stand No. 22, is suitable for use in non-director exchanges and U.A.X.s 14.

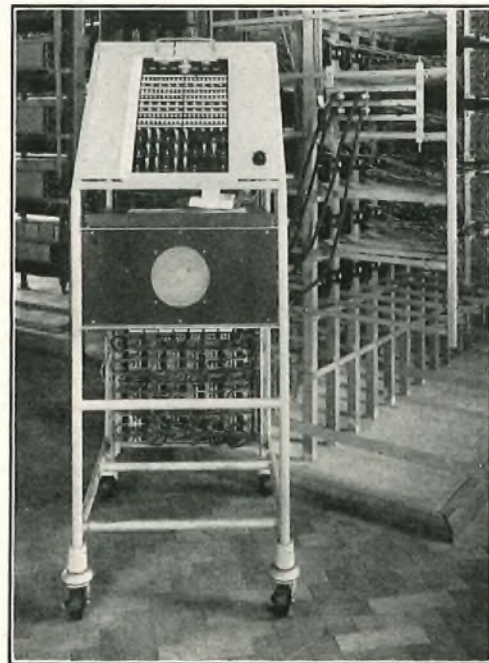

FIG. 1.—FRONT VIEW OF THE TESTER.

Fig. 1 shows the tester in use at Caterham exchange. The general principle of operation is similar to that for earlier designs of artificial-traffic equipment, but considerable changes have been made to the circuit as a result of introducing the additional facilities. As described in the previous article,¹ through tests are made on exchange apparatus by originating artificial traffic from selected

† Assistant Engineers, Telephone Development and Maintenance Branch.

¹ Elstree-Wilson, E. C., and Lawrence, C. The Artificial Traffic Equipment. *P.O.E.E.J.*, Vol. 40, p. 159, Jan. 1948.

spare line circuits. For "local working," traffic is routed to selected spare multiple numbers in the local exchange. Junction routes are tested by "remote working," in which calls are routed to a relay set in the distant exchange. The tester can be used for either fault location or measurement of quality of service. Under fault location conditions the faulty call is held for tracing and the type of failure is indicated. When making quality of service measurements, the equipment does not give an alarm when a call fails to mature, but registers the number of failures encountered and the total number of calls made.

Access Arrangements.

The selected spare-line circuits are arranged in groups of 20 and the spare multiple numbers in groups of 21. These groups are connected, via jumpering on the intermediate distribution frame, to connection strips, from which the circuits are cabled away to access panels. One of these panels, mounted on the end of the I.D.F., is shown in Fig. 2.

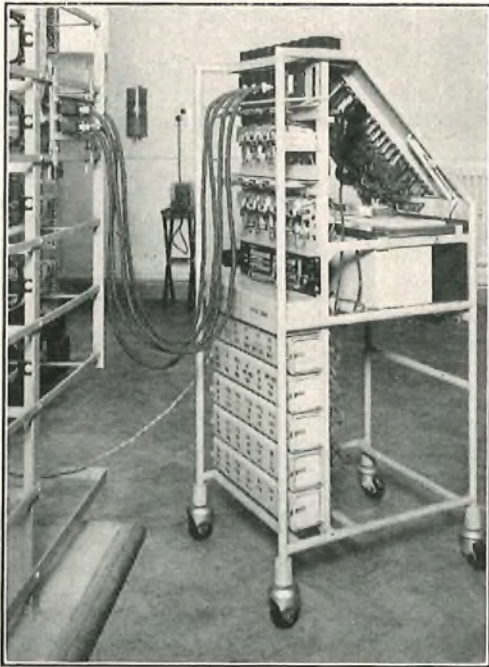

FIG. 2.—REAR VIEW OF THE TESTER, SHOWING ACCESS PLUGS AND SOCKETS.

Each panel consists of a small metal framework on which are mounted five 33-way sockets. The cabling from each group of 20 line circuits is terminated on three of the sockets in the following manner. The negative, positive and private wires of circuits 1-10 are terminated on contacts 1-30 on the first socket and the second caters in a similar manner for circuits 11-20, while the third is available for use in exchanges employing 4th-wire metering. The spare contacts on the first socket are utilised for connections to the exchange alarm system and the N.U. tone supply. The two remaining 33-way sockets are utilised in a similar manner for giving access to the negative, positive and private wires of the 21 multiple numbers. The wiring from the access uniselectors on the tester is terminated on sockets mounted at the rear of the test stand, and connection between the tester and the access panel is effected by means of four cords terminated at each end with a 33-way plug, or five such cords in exchanges using 4th-wire metering.

Number of Access Panels required in Large Exchanges.

To ensure that all final selectors are included in the possible range of testing, one spare outlet is required in each multiple group. In general, these groups consist of

200 multiple numbers; thus one access panel is provided in exchanges with multiples of 4,200 outlets or less. For larger multiples, or for those which are arranged in groups of less than 200 outlets, it is necessary to use more than one access panel. The number of panels required to give access to all first numerical selectors available to the local exchange subscribers depends on the grading arrangements between line circuits and first selectors.

Digit-Control Field.

Control of the trains of pulses required to route the call, for either local or remote working, is effected by means of groups of eight 33-way plugs, which form a digit-control field. These plugs, one of which is shown in Fig. 3, are inserted into sockets mounted on the top of the test stand.

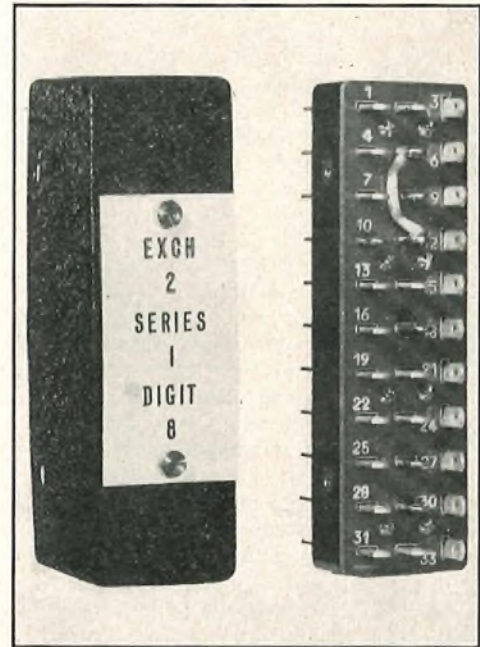

FIG. 3.—PLUGS FORMING THE DIGIT-CONTROL FIELD.

The control field will cater for routes which require up to eight digits and one group of plugs will provide the necessary control for routes to either 21 local multiple numbers, 21 distant exchanges or a combination of 11 local multiple numbers and 10 distant exchanges. Control over the trains of pulses is exercised by the digit-control field in conjunction with a pulse guard element similar to that used for the pulsing-out element in a director. The send switch (25-point unselector) transfers control of the outgoing loop to the pulsing springs of a relay, immediately after starting to step at 10 steps per second. The relay springs break at 10 p.p.s. and the train of breaks on the loop forms the digit being sent to line. The send switch continues stepping until a marking condition is received from the digit-control field, when the required number of pulses have been sent out over the loop. This marking condition operates a relay, which closes the loop, by short circuiting the pulsing springs. The send switch then restores to normal in preparation for sending the next digit. The marking condition is provided through the digit-control field to the send switch by means of internal cross-connections on the tags of the 33-point plugs forming the field. When the plugs are in the sockets, contacts 1-10 are connected to the bank of the send switch and contacts 11-31 are connected to the banks of the route-control switch. The internal cross-connections on the plug are made between these two groups of contacts. Depending on the position of the route-control switch, an earth is extended through the cross-connections to give the required digit marking

condition to the send switch. Each plug provides the marking conditions for one digit of each of the 21 routes served by a group.

Use of Remote Relay Sets.

Junction routes from Non-Director Exchanges to Unit Automatic Exchanges can in some instances be tested by using the remote exchange as a tandem centre, and routing the call back to the local multiple. A call of this nature is treated as a local call as far as the tester is concerned. Where this type of routing is not available, junctions are tested by routing the call to a relay set, teed in to a spare multiple number, in the distant exchange. The relay set trips the ringing current from the final selector and provides called-subscriber-answer conditions, followed by continuous 900 c/s tone. This tone is transmitted over the route and is used by the tester to indicate that the call has been routed correctly. The tone is generated by a 50V oscillator which forms part of the remote relay set and is monitored in the tester by means of a 50V receiver tuned to 900 c/s.

Apparatus Mounting Arrangements.

Fig. 2 shows the layout of the equipment at the rear of the test stand. Five relay mounting plates are bolted to the lower portions of the vertical angle irons, and the tone receiver and a monitoring amplifier are mounted on a common plate immediately above the relays. Tone-receiver components are grouped together on the left-hand side of the plate and monitoring amplifier components on the right-hand side. An alarm buzzer and the fuse panels are mounted just below the two rows of uniselectors. The access sockets, into which are plugged the double-ended cords connecting with the access panel, are mounted above the uniselectors. A group of digit-control plugs is shown inserted in the control-field sockets which are fitted to a horizontal plate, bolted to the top of the test stand.

A front view of the tester is shown in Fig. 1. Two groups of meters for registering on local and remote calls are mounted at the top of the lamp and key panel, together with a battery pilot lamp and fault and fuse alarm lamps. A volume control for the monitoring amplifier is on the right of the panel. The loudspeaker for the monitoring amplifier is mounted on a vertical panel, with the busying jacks for the access-switch outlets immediately below. A box is provided at the rear of the loudspeaker for storing cords and plugs when the tester is being transported. The sliding top of the box forms a writing desk when the tester is in use.

OUTLINE OF OPERATION

Test Cycle on a Local Call.

The sequence of operations by the tester when making a call from a spare line circuit to a spare multiple number is described below. Failure to receive a correct condition is indicated by an alarm after approximately 24 seconds.

- (1) The private wire of the line circuit is tested for absence of earth before the loop is applied.
- (2) The loop is applied and a test is made for earth on the private wire of the line circuit.
- (3) Seizure of a first selector is indicated by the removal of the full earth from the positive wire, its place being taken by a resistance earth from the first selector. The tester waits for this condition before beginning to send the routing digits. If there is congestion on the line circuits and a first selector has not been seized after 24 seconds an alarm is given.
- (4) The routing digits are transmitted and a check is made that the call has been routed to the correct number and that the multiple outlet has been guarded by earth from the final selector.
- (5) The ringing current is tripped by the tester after

two cycles of ringing have been received from the final selector.

- (6) The called subscriber's transmitter supply is checked for polarity.
- (7) A test is made for a metering pulse and the supervisory reversal, from the final selector, when the called subscriber answer condition is applied.
- (8) Called subscriber flash conditions are applied.
- (9) The call is released.

Test Cycle on a Call to a Remote Relay Set.

The sequence of operations is the same as for a local call with the following exceptions:—

- (1) Correct routing of the call is checked by receipt of 900 c/s tone from the remote relay set.
- (2) The tests of ringing current and called subscriber's transmitter supply and flash are omitted.
- (3) The tester checks for receipt of the correct number of metering pulses associated with a multi-fee call.

Test of Disconnection of the Private Wire and the Loop.

The guard earth on the private wire from the group selector, final selector or relay set is continuously monitored for disconnections after the line circuit has been seized. A timing circuit, with lamp indications, is provided to show the approximate duration of any disconnections, as follows:—

Short (1-4 mS), Medium (5-10 mS) and Long (10-40 mS). Disconnections of greater duration than 40 mS are indicated as full disconnections. A key control is provided to enable the tester to be operated under one of three conditions, so that an alarm is given only when the disconnection is either greater than one millisecond, greater than five milliseconds, or greater than ten milliseconds. If an alarm condition arises, the tester suspends the sequence of operations. The forward holding earth, via the private-wire test relay, is applied at all stages of the call, so that the route will not release even if a disconnection of sufficient duration is encountered. This holding earth is replaced by a full earth when an alarm condition is set up.

The test for disconnections of the loop relies on the subsequent disconnection of the private-wire guarding earth under these conditions. The test circuit responds to the disconnection and a test of the continuity of the loop is automatically made in every case. If the test shows that a disconnection of the loop has occurred, a lamp indication is given and this fault takes priority over the private-wire disconnection.

Metering Tests.

The metering test circuit is designed to cater for single or multi-fee metering, up to a maximum of six pulses, and ensures that the correct number of metering pulses are received for the particular route which is being tested. As stated earlier, a group of digit-control plugs caters for 21 routes and the association of the correct fee with any one of the 21 routes is effected by means of a metering plug, which is associated with that particular group of digit-control plugs. This plug is cross-connected internally in a similar manner to the digit control plugs and provides marking conditions for the metering test uniselector. At the beginning of the test cycle, this uniselector drives to one of six positions depending on the number of meter pulses which should be received. The position is marked by the cross-connection associated with the route concerned. The uniselector then takes a single step for each meter pulse received. A lamp indication is given of the total number of pulses. If the metering condition is correct, the uniselector will have stepped to one of six final positions and the tester will then proceed with the testing sequence, provided that no further metering pulses are received within about six seconds. If the number of metering pulses

received is incorrect, the tester will stop with the "metering" test lamp glowing. If more than the correct number of pulses is received, the lamp indication given is restricted to one additional pulse because of circuit design considerations.

Tests made under "Observe Service" Conditions.

If it is required to measure the quality of service provided by the exchange, the tests are made under "observe service" conditions. Calls are originated from each of the 20 line circuits, taken in sequence, and directed over the 21 routes provided by the digit-control field in use, each route also being taken in sequence. A complete cycle of operations comprises 420 calls. An alarm is only given if a fault condition arises on a call before commencing to send the routing digits. Meters are provided for registering the total number of calls made, the number of failures encountered and the number of calls on which busy tone is received. These meters are arranged in two groups, one serving for local calls and the other for calls to remote relay sets. If the digit-control plugs in use are cross-connected to provide a mixture of local and remote routes, the registrations are automatically made on the appropriate group of meters. The tester monitors for busy tone on all calls which fail to reach the objective, by re-tuning the 900 c/s receiver to operate at 400 c/s. If busy tone is not received, the failure is registered in the normal way. If busy tone is received, the tester monitors for two periods of tone and the intermediate period of silence, by means of a timing circuit operated in conjunction with the tone receiver.

Tester Failures.

The circuit has been designed so that an indication is given if certain types of faults occur on the tester, regardless of whether it is being used for fault locating or measuring quality of service. A self-alarm will be given for any of the following conditions:—

- (1) Failure of the multi-metering test circuit to prepare for the reception of meter pulses, due to absence of a marking condition from the metering plug.
- (2) Absence of a marking condition from the digit-control field to the send-switch uniselector.
- (3) Failure of one or more of the uniselectors to restore to normal after completion of the test sequence.

Under these conditions the call and fault registration meters are ineffective and the tester cannot be reset in the normal manner. The start key must be restored and the fault cleared before testing can be continued.

Other Operating Facilities.

The following paragraphs describe some of the facilities provided for the assistance of the exchange staff when the equipment is used for fault location; the required facility being selected on the key panel.

Short test of correct routing.—For local routes the normal rate of testing is approximately 85 calls per hour and on routes to remote relay sets the rate is approximately 100 calls per hour. For local routes only, the rate of testing may be increased to approximately 250 calls per hour by releasing the call as soon as the correct routing conditions have been established.

Hold circuit and tracing tone.—After details of a failure have been recorded by the maintenance officer, the faulty call can be held from the tester, which is then reset in the normal way and will continue testing from the other line circuits. A lamp indication is given of the line circuit from which the faulty call is held, and a distinctive tone can be applied to facilitate tracing the call through the exchange equipment.

Loudspeaker amplifier and telephone circuit.—A 50V amplifier, operating a loudspeaker, is provided to enable the maintenance officer to make an audible check on the progress of the call. A telephone instrument is provided as an alternative for monitoring purposes, and also enables the maintenance officer to speak to subscribers or operators, in case of mis-routed calls or double connections.

Suspension of testing.—The progress of the call can be suspended at any stage in the sequence of testing to facilitate fault finding or listening to noisy connections, faint ringing tone, etc.

Selective testing and spare access positions.—If the maximum capacity of 20 line circuits and 21 multiple numbers is not in use on a particular access group, the spare outlets on the tester are busied out by means of links, and the access switches drive over these positions. This facility also enables the maintenance officer to concentrate the testing on selected line circuits or portions of the multiple, by linking-out the access points not required.

ACKNOWLEDGMENT

It is desired to record acknowledgment to colleagues in the Telephone Development and Maintenance Branch, and in particular the Circuit Laboratory, for co-operation in the development of this transportable artificial-traffic equipment.

I.P.O.E.E. Printed Paper No. 206

"The Influence of Signal Imitation on the design of Voice Frequency Signalling Systems." S. Welch, M.Sc.(Eng.), A.M.I.E.E. This paper was contributed to the proceedings of the Institution during the 1953/54 session, was awarded the Institution Senior Bronze Medal, and printed by the authority of the Council. Copies may be obtained from The Librarian, The Institution of Post Office Electrical Engineers, G.P.O. (Alder House), London, E.C.1. The price per copy is 2s. 6d. net (2s. 8d. post free), but Corporate Members of the Institution and Members of the Associate Section have the privilege of purchasing copies at the reduced price of 1s. 6d. net (1s. 8d. post free).

In this paper the author aims to set down the principles of design of voice frequency signalling systems from the point of view of protection against signal imitation by speech or interference. The fundamental V.F. signalling conditions are detailed, and then the various factors which influence signal imitation are discussed. These factors are—choice of signalling frequency, type of signal (simple, compound, two-pulse, etc.),

sensitivity of receiver signal and guard circuits, type of guard circuit and delayed recognition time of signal, etc.

The paper then discusses the results of tests carried out to determine the relative importance of the various factors stated above. Certain other methods of reducing signal imitation, i.e. locked guard circuits, frequency modulation V.F. signalling, are then examined.

Having determined the relative importance of the various factors, the principles of design of V.F. signalling systems, particularly the receivers, incorporating the various factors as safeguards against signal imitation, are then discussed, the relative complexities in design being pointed out.

The fundamental test work was carried out for the C.C.I.F. and the findings have been incorporated in the international V.F. signalling system, B.P.O. design version, and, where applicable, in the design of the new 2 V.F. receiver for the B.P.O. inland network.

The treatment in the paper is basic principles in simple language rather than involved technical discussion.

"Mosaic"—An Electronic Digital Computer

A. W. M. COOMBS, Ph.D., B.Sc., A.R.T.C.†

Part 2.—The Control and Input-Output Units

U.D.C. 518.5:681.142

In Part 1 it was explained that the principal parts of any digital computer are the Store, the Arithmetic Unit, the Control Unit, and the Input-Output mechanism, and the first two were described in outline. Part 2 deals with the Control Unit and the Input-Output mechanisms and will be followed by a general discussion on programming techniques in Part 3, and discussion of the electronic techniques employed in Part 4, the final part.

THE CONTROL UNIT

"MOSAIC" works on a two-beat cycle. The first beat, which lasts always for exactly one minor cycle, is occupied in examining the next instruction—which has just been extracted from the store—and in setting it up on an array of electronic relays, which will open the necessary "Gating" circuits to allow it to be obeyed. The second beat, which lasts for a variable but integral number of minor cycles, covers the carrying out of the instruction just set up, though the actual transfer of numbers involved to and from the store may take place for anything from a single minor cycle up to the whole of the second beat period. Towards the end of the second beat, the next instruction to be obeyed is extracted from the store ready for the next "Set-up" beat.

The sequence of events just described is governed by the "Control Unit"—sometimes called simply "Control." Before examining the two-beat cycle in detail, it is necessary to consider the make-up of an instruction word.

The standard word, like the standard number, is 40 digits long. It contains the following information relating to the operation it is to control (cf. Table 1, Part 1):—

1. An address in the store (7 digits) for obtaining a number "A."
2. An address in the store (7 digits) for obtaining a number "B."
3. An operation (4 digits) to be performed on the numbers "A" and "B."
4. An address in the store (7 digits) to which the number "C" (the result of the operation) is to be consigned.
5. A "Timing" number (4 digits) and
6. A "Characteristic" (2 digits) which, together with the Timing number, controls the duration of the "Obey Instruction" beat and the beginning and end of the actual operation within that beat.
7. An indication (1 digit) whether the instruction is to be obeyed forthwith, or to await some external authorisation (the "Go" digit).
8. An address in the store (5 digits) for obtaining the next instruction to be obeyed.

This is known in the Computer world as a "4-address" system. Clearly, because of (8) above, once the initial instruction has been inserted by hand, the subsequent operation of the machine is entirely automatic.

A second point requiring preliminary explanation is the nature of a "Staticiser." Words and numbers normally exist in the store in dynamic form—that is to say, the digits comprising them become available singly and in time sequence. It is necessary that a particular word or number should on occasion be made to stand still, in such a way that all its digits are simultaneously and continuously available. It is the function of the Staticiser to provide this facility. We may imagine it as the electronic equivalent of a uniselector with an array of locking relays connected to the contacts on one level, operating signals being sent via the corresponding wiper as the mechanism steps. The inverse unit, called a "Dynamiciser," turns a static array

of digits into a dynamic stream of signals, such as a uniselector wiper would provide were it to be stepped along a row of contacts with differing voltages applied to them.

The Control unit contains such a device, called the "Current Instruction Staticiser," wherein at any given time the instruction being, or about to be, obeyed is held statically, having previously been extracted from the store. The diagram (Fig. 4) shows the arrangement, employing the uniselector analogy given above. The instruction store is a part of the main store (31 long lines and one short) to which access is obtained by the five digits of the instruction word "Next Instruction Source" or N.I.S. These five digits specify only the delay line number; it remains to decide which of the 16 words in the line (if a long one) is to be used. This decision and the operation of the circuit of Fig. 4 will be treated in the next sub-section, since it is now possible to consider in greater detail—though still somewhat sketchily—the operation of the control unit.

The Set-up Beat.

It is always difficult to describe a sequence of events forming a closed ring, where each part of the sequence depends on what has happened immediately before, and there is no beginning. The Control unit involves two such closed rings—the Current Instruction Staticiser with its circuit, and the main Control itself. The description below enters the main loop during the last minor cycle of an Obey Instruction beat, specifies the events occurring at that time, and proceeds from there.

During this minor cycle, the instruction being obeyed is held on the Current Instruction Staticiser. Also, the delay line which will provide the next instruction is connected by virtue of the N.I.S. digits in the current instruction to the special delay line "INST," one minor cycle long (Fig. 4).

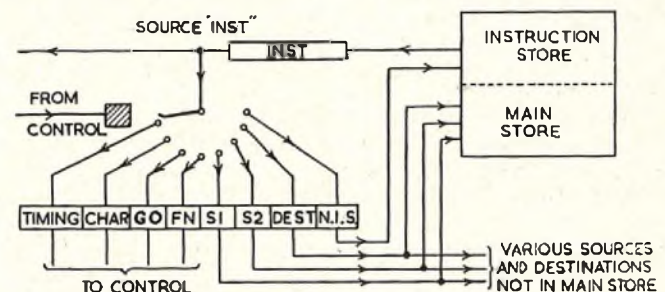

FIG. 4.—BLOCK SCHEMATIC DIAGRAM OF CURRENT INSTRUCTION STATICISER.

The digits in the instruction line are being poured serially into INST, from which they emerge one minor cycle later—and are then in fact available (source INST) as a part of the main store, a facility often useful though not relevant to the present discussion. It is arranged that during the minor cycle now under consideration—the last of the Obey Instruction beat—the correct word which is to be the next instruction, of the 16 available in the specified N.I.S. address, is flowing into INST; at the commencement of the

† Principal Scientific Officer, Post Office Research Station.

next minor cycle, which is also the Set-up beat, it will exactly fill INST.

At this instant, by means as yet unspecified, the "Set-up Control" circuit (Fig. 5) comes into operation, and the Set-up beat commences. During the ensuing minor cycle,

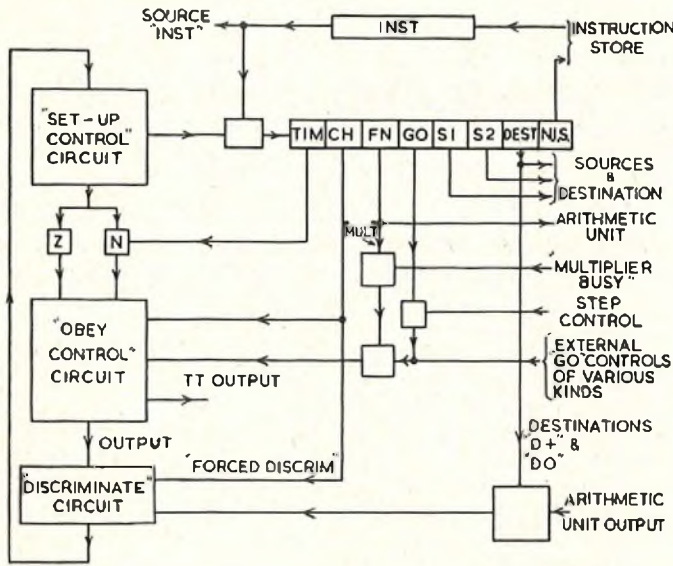

FIG. 5.—BLOCK SCHEMATIC DIAGRAM OF CONTROL CIRCUIT.

the "uniselector wiper" sweeps around the Staticiser input terminals, and causes the array of digits previously held to be replaced by the new ones emerging from INST—that is, by the new instruction. The five digits "N.I.S." will also be changed (if the new "Next Instruction" is to be extracted from a different address in the instruction store) and therefore a different set of words may commence to flow into INST; however, the correct 40 digits of the next instruction being already lodged in INST cannot be changed, and by the time the next group of digits reaches the "uniselector wiper," the set-up beat will be over, and the "wiper" again disconnected from the staticiser contacts.

The next Set-up beat will commence at the end of the following Obey Instruction beat. Therefore, the duration of the Obey Instruction beat must be such that during its last minor cycle the correct word of the 16 in the newly specified instruction address will be flowing into INST. This can be arranged either by the position of the word in the line or by the duration of the Obey Instruction beat, whichever is the more convenient, and in practice both techniques are and must be used.

The Obey Instruction Beat.

Most of the instructions in a computational programme call for a transfer of numbers lasting only a single minor cycle. For instance, two 40-digit numbers may be added, differenced or fed to the multiplier in such a period. However, there are some transfers which last longer; thus the number $A + 3B$ formed from two numbers A and B in short lines a and b may very conveniently be obtained by obeying the single instruction "Add the contents of a to the contents of b and put the answer in a for three successive minor cycles." Again, while most transfers can start simultaneously with the Obey Instruction beat, not all can do so; one of the numbers involved may be in a long line and not available at that instant. The end of the transfer in its turn may, and usually does, coincide with the end of the Obey Instruction beat, but here again there are exceptions, and important ones; thus, it is convenient to use the same basic instruction word at different times to extract different numbers from a long line, and yet retain the same sequence of subsequent instructions, which

implies a fixed duration for the Obey Instruction beat (as mentioned above) yet a variable transfer cycle within that beat. Conversely, the transfer cycle may be fixed, but the duration of the Obey Instruction beat variable—or they may be required to vary independently—in order to provide the essential "Discriminate" facility, whereby an instruction "X" may be followed by either instruction "Y" or instruction "Z," depending on the result of the computation governed by "X." The duration of the Obey Instruction beat must therefore be controllable to some extent from the arithmetic unit.

To satisfy all the requirements of the foregoing paragraph, the instruction word would have to contain three separate Timing numbers, (t_1, t_2, t_3), t_1 indicating the delay before the commencement of transfer, t_2 the duration of transfer, and t_3 the total length of the Obey Instruction beat, this last subject to modification by the arithmetic unit, which could add a further t_4 cycles if required. A timing diagram for the Obey Instruction beat of a machine so equipped is shown in Fig. 6 (a). The arrangement would, however, be extremely wasteful of digits in the instruction word—and far more flexible than strictly necessary, since it is most unlikely that all the special cases given in the previous paragraph will arise together.

The code system used in Mosaic employs only a single Timing number of 4 digits, with a 2-digit "Characteristic" to provide alternative interpretations of the Timing number.

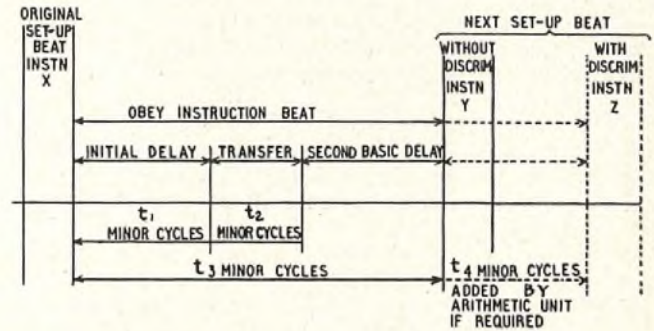

(a) Timing Diagram of Ideal but Wasteful Machine.

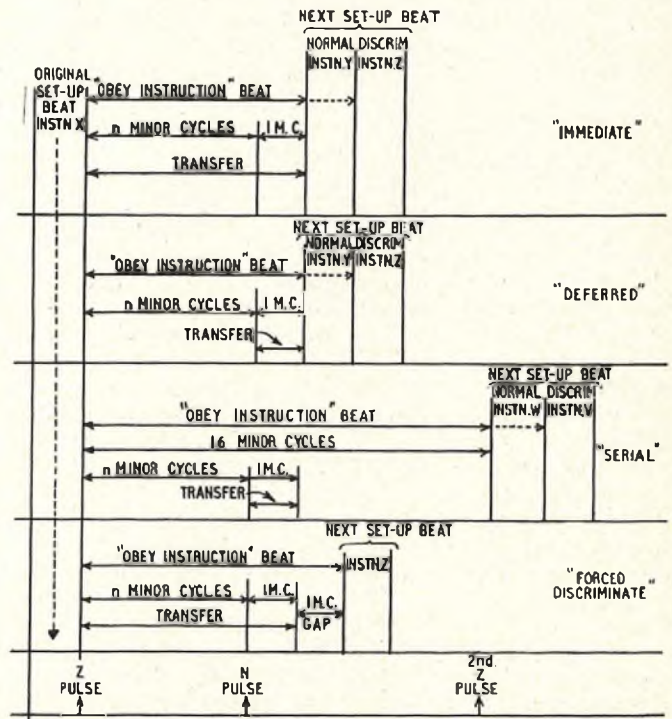

(b) Timing Diagram of Mosaic.

FIG. 6.—TIMING DIAGRAMS.

There are three basic types of characteristic, but since a 2-digit binary number can represent four values, the fourth configuration is used to provide a special type of action which is useful as a time saver. Assuming that the Timing number is n (between 0 and 15 inclusive), then the possible interpretations are as given below, and illustrated in the Timing diagram (Fig. 6 (b)).

Types of Characteristic.

1. "Immediate." The transfer indicated by the Current Instruction X commences immediately (i.e., in the minor cycle following the Set-up minor cycle) and continues to be obeyed for $n + 1$ minor cycles.
In the absence of instructions to the contrary, the next Set-up beat will be the $(n + 2)$ th minor cycle, and will therefore establish instruction Y, which follows X with a gap of $(n + 1)$ minor cycles, as the next instruction to be obeyed. If, however, a Discriminate condition is indicated by the result of operation X, an extra minor cycle is inserted at the end of transfer and before the Set-up beat, which accordingly becomes the $(n + 3)$ th minor cycle, and instruction Z is established.
2. "Deferred." After the Set-up beat, there is a gap of n minor cycles before the transfer, which then takes place for one minor cycle only. In the absence of Discriminate, the next Set-up beat follows immediately (minor cycle $n + 2$); with Discriminate, an idle minor cycle is inserted as before. It will be seen that one of the same two instructions, Y or Z, must follow X, given the Timing number n , whether the current instruction be of Immediate or Deferred type.
3. "Serial." There is a gap of n minor cycles, followed by a transfer for a single minor cycle, as for a Deferred instruction. However, the next Set-up beat does not commence until a further $(16 - n - 1)$ minor cycles have passed—that is to say, the normal duration of the Obey Instruction beat is 16 minor cycles, irrespective of n . Successive instructions may thus be in successive positions of a long line. Discrimination again applies and delays the next Set-up for a further minor cycle if called for. In the diagram, the next instruction to be set up will be W or V.
4. "Forced Discriminate." This is a type of Immediate instruction, and follows the Immediate pattern, except that Discriminate is automatically applied, so that the next instruction is always Z, and no extra discrimination is possible. It is occasionally useful in arranging the order of the programme words, and can save both word-space and time.

Having detailed the forms which the Obey Instruction beat may take, the analysis of the control circuit (Fig. 5) may now be extended from the stage previously reached. A Set-up beat had just finished, so that a new instruction to be obeyed had just been established on the Staticiser, the "uniselector wiper" had returned to normal, and the Set-up Control, having been "On" for a single minor cycle, was just restoring to "Off." Two counters, "Z" and "N," now come into operation. Z produces a pulse immediately (i.e., at the extreme end of Set-up). N is additionally controlled by the staticised Timing number n , and produces a pulse at the extreme end of the n th minor cycle after Set-up. Both Z and N start from their zero position at a Set-up beat, but in the absence of a further such beat, both continue producing pulses at intervals of a major cycle after their first.

The "Obey Control" circuit, by examination of the Z and N pulses, by analysis of the Characteristic in the current instruction word, and under the over-riding control of the Go digit in the instruction word, fixes the exact instants when the specified transfer of numbers must start

and stop, and provides an output pulse to the "Discriminate" circuit to indicate the end of the basic "Obey" period. There is a trigger TT (Transfer Timer) associated with the circuit, which when "On" permits the instructed transfer, and when "Off" inhibits it. For an Immediate or a Forced Discriminate instruction, TT is turned "On" by the first Z pulse and "Off" exactly one minor cycle after the "N" pulse; for a Deferred, TT is switched "On" by the first N pulse and "Off" one minor cycle later. In all three cases, the output pulse to the Discriminate circuit occurs simultaneously with the switching-off of TT. For a Serial instruction, TT is switched "On" and "Off" as for a Deferred instruction, but the output pulse is provided by the second Z pulse, exactly a major cycle after the end of the original Set-up beat. The details given here apply to the normal case where the instruction is obeyed without further authorisation; the modification provided by the Go digit is considered later.

The Discriminate Circuit.

It will be recalled that the Discriminate facility is to be available for Immediate, Deferred or Serial instructions, that it is to operate by inserting an extra minor cycle of delay before the next Set-up beat if the numerical result of the current instruction indicates that this delay is required, and that the delay is to be inserted irrespective of the arithmetic unit if the instruction is of the Forced Discriminate type.

The Discriminate circuit (Fig. 5) provides the desired facilities. The output pulse is accepted from the Obey Control circuit and transmitted either with or without a minor cycle delay back to the Set-up control circuit, where it initiates a new Set-up beat and thereby completes the two-beat cycle.

The Forced Discriminate condition is imparted by control leads straight from the Characteristic digits of the staticised instruction word. The true Discriminate facility giving alternative "Next Instructions" is proper to the other three types of instruction only. If a particular instruction X is to provide the facility, then the destination address number specified in X must be either 97 (known as "D PLUS") or 96 (known as "D NOUGHT"). In either case, the output of the arithmetic unit during the transfer period is fed to the Discriminate circuit and not to any part of the true mercury line store. If D PLUS is called for, the minor cycle delay will be inserted if the output number is negative (by the convention of the machine, this is indicated by a "1" in the 40th digit position), and if D NOUGHT is called for, the delay will be inserted if the output is non-zero; i.e., anything other than all zeros.

The Go Digit.

The output pulse from the Obey Control circuit is dependent on the instructed transfer having taken place, and, as previously stated, is eventually instrumental in starting a new Set-up beat. The transfer itself is controlled by the Z and N pulses. If by some means Z and N are temporarily rendered ineffective, then no transfer can take place and the machine waits with the instruction set up on the staticiser but not yet obeyed, the Z and N pulses continuing to appear at major-cycle intervals. The entire pattern of pulses in the storage lines, both long and short, numerical and instructional, will repeat at the same major-cycle period. If, now, the inhibition on the Z and N pulses be removed, the instructed transfer will take place with the next Z or N pulse, whichever is appropriate, and will operate on the correct stored numbers, because of the common major-cycle period.

This provides a very valuable facility, whereby the machine may be stopped for any purpose whatever, and then at a later time be allowed to proceed, whereupon it will

continue its computational programme as though no gap at all had existed. Normally, any instruction which possesses a Go digit—i.e., a "1" in the 21st position—is obeyed immediately, but if the digit is a "0" (a "Wait" instruction) then the conditions of the previous paragraph apply, and the machine, having set up the instruction, will "Mark Time" pending external authorisation to proceed. The external authorisation may be a push-button signal by the machine operator; thus a programme may be performed in discrete groups of computations by the simple insertion of a Wait instruction at appropriate stages. Possibly the external control is provided from the mechanical input gear; successive instructions to read data from the input are set up much more rapidly than the data can be provided, and it is therefore necessary to make the machine wait until the input mechanism is ready—and the same conditions apply to the output.

Two exceptions exist to the general rule that a Go instruction is obeyed forthwith. There is provided an external "Stop" control, which over-rides the Go digit and in effect turns all instructions into the Wait type. A programme can be carried out a single step at a time by the use of this control. Again, the multiplier requires about six major cycles to complete its operation, and must not be interfered with while it is functioning. Here again, it is arranged that any subsequent instruction calling for the multiplier is forced to become a Wait instruction until the multiplier has finished its computation.

With all its complex functions, the Control unit uses only about 500 valves of the 7,000 in the machine, and conveniently occupies one complete rack, as shown in the photograph (Fig. 7).

INPUT AND OUTPUT

Input numerical data and instruction programmes are fed into the machine using punched cards of standard Hollerith type, and output results are provided on the same type of card. There is an alternative output consisting of an automatic typewriter, but this is seldom used, as it is much too slow and therefore holds up the machine unnecessarily. Only the card technique will be considered and there are three separate conditions to investigate, viz.:

1. Reading-in data when an instructional programme is already stored.
2. Reading-out the result of a computation.
3. Reading-in data at the commencement of a computation, when no instructional programme is as yet in the store.

Although the punched-card mechanism is fast, it is not nearly fast enough to be used for direct control of the operational parts of the machine. Thus the general procedure is to read a batch of cards into the mercury line store and carry out the required programme on the stored numbers with stored instructions. If all the data can be got into the high-speed store at once, that is an advantage; if not, the card reader acts as a slow-speed backing-up

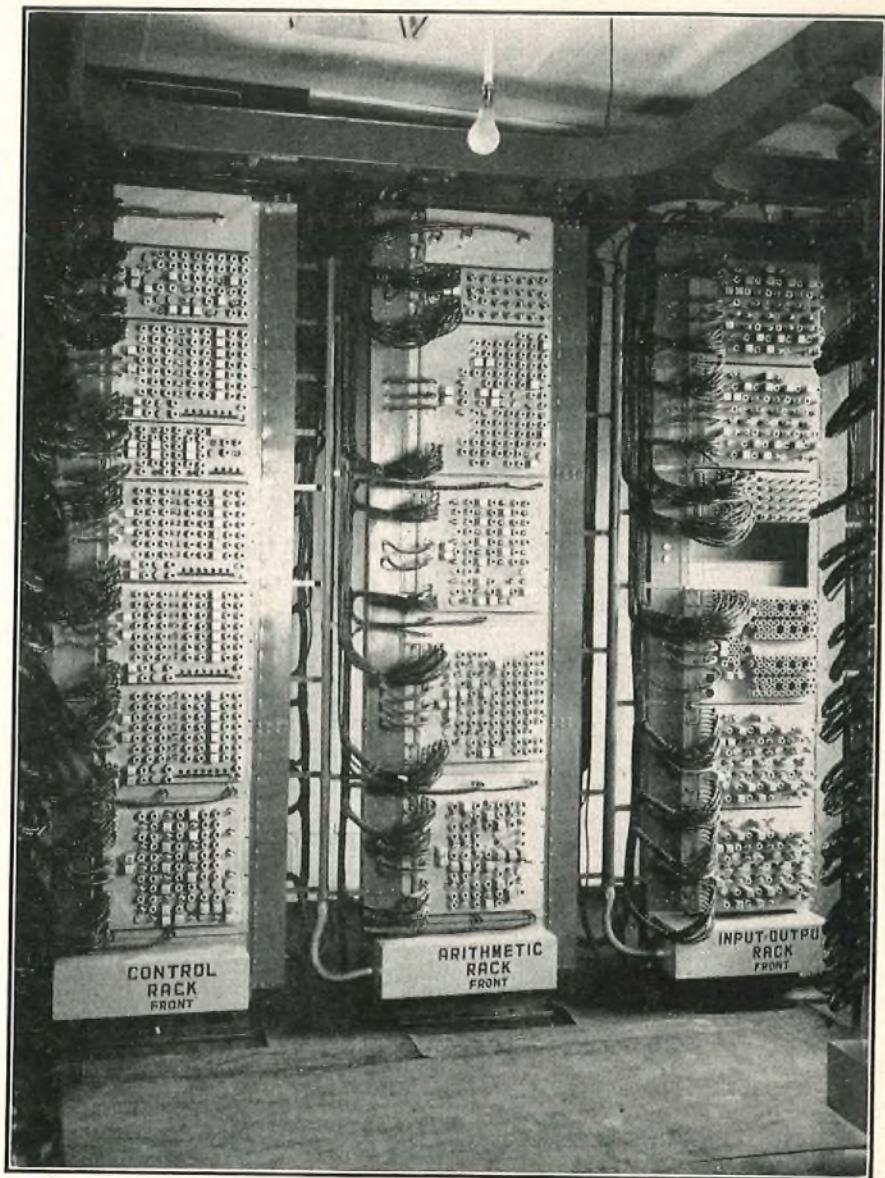

FIG. 7.—CONTROL, ARITHMETIC AND INPUT-OUTPUT RACKS.

store, and is called upon for further data at intervals. Reading-out is a little more complicated, and depends on the kind of problem being solved; there may be a single solution at the end of a run, or there may be a continuous stream of cards—perhaps a tabulated function.

The cards have space for up to 80 punchings per row, with 12 rows per card, the rows being presented to the reading (or punching) mechanism in sequence—but both in reading and punching, once a card has been started through the operating head, it must go through completely. It cannot stop indefinitely on one row. For the moment, cards will be considered used with one 40-digit binary number per row, the remaining 40-digit positions being spare.

Reading-in Data with Stored Programme.

A dynamiciser, such as has been described above, is associated with the Hollerith reader; reverting to the original analogy, one may say that the 40 effective brushes of the reader are connected to the 40 contacts on one level of a dynamiciser uniselector. To transfer a number from a card to the store, two conditions are necessary; the row of holes on the card must be put under the reading brushes

and the "uniselector wiper" must sweep around the 40 contacts while the brushes are so disposed. The card feed is continuous, at the rate of 200 cards/minute, or 20 mS per row, and there is a period of 5 mS at least with any one row under the brushes, a period indicated by a cam-operated contact on the reader.

Suppose, now, at some point in a current computation, a new card is required to be read. The next instruction in the main programme must specify destination address No. 100 (known as "Hollerith Read" or H.R.). The rest of the instruction word is irrelevant; destination 100 is not a normal destination in the store, and does not accept an output from the Arithmetic unit. The group of binary digits representing "100," appearing as a destination in the current instruction word, simply operate the card feed circuit, and start a card moving under the reading head when the instruction is obeyed. The next instruction specifies "Input Dynamiciser" as the first source address—for reasons which will be explained in Part 3, the number of this address is "000000"—and as destination, that point of the store which is to be supplied with the information on the first row of the card. This instruction must be of Wait type; it will be set up but not obeyed until authorised from outside.

As soon as the first row of holes in the card is in position under the reading brushes, the cam-operated contact on the Reader sends a signal to the Control authorising the current instruction to be obeyed, and the transfer of the digits from the card to the store takes place. No matter what the Characteristic of the instruction may be, the transfer is bound to be completed within a major cycle, so the 5 mS period of contact is adequate. The transfer will be followed immediately by the setting-up of a new instruction, in the normal manner. Let this new instruction be one calling for the transfer of the second row of the card to a second destination in the store. It will again specify Input Dynamiciser as first source, and will again be a Wait instruction, for the second row will not be available for a further 20 mS; and so on for the other rows of the card.

Now it will be clear that the rows of the card can be read off much more rapidly than new rows can be provided. It is therefore possible for the machine to carry out several computations *between rows*—a safe maximum time of about 16 mS being available. This is a facility of great value, and it can be used in a variety of ways. For instance, a separate instruction word (with a different destination address) has so far been imagined for each row of the card. But instruction words can be treated as binary numbers and subjected to arithmetical operations in the arithmetic unit, so the addresses and the Timing number can be changed if desired. Therefore, if the transfer instruction to the Input Dynamiciser were made of serial type, the Timing number could be increased by one between each row of the card and the result would be to put the several rows in 12 consecutive positions of the Destination delay line—all with a single basic instruction word. In practice, the Dynamiciser is nearly always fed to the short line T.S.0 (Temporary Storage Line "0") as an intermediate stage, and the ultimate destination sorted out as from that line, but the principle is the same. Then again, the interval between rows can be used for decimal-binary conversion, so that a number punched on the card in conventional Hollerith decimal code can be stored as its equivalent binary number by the time the card has completed its transit. An essential calculation is that of counting the number of rows dealt with; 12 rows constitute one complete card, and if a second card is required, the H.R. instruction (starting a card feed) must be repeated after the 12th row.

Reading-out the Result of a Computation.

The Hollerith punch uses a Staticiser and the cards feed forward with a jerky motion at 100 per minute. Allowing for these differences between input and output, the procedure is the same in the two cases. Thus, when an output is to be recorded, the main programme first calls for Destination 101 ("Hollerith Punch" or H.P.), which starts a card feed to the punch. The next instruction is of Wait type, and calls for the required output to be transferred from its storage location address to "Destination Output Staticiser" (No. 99); it will be obeyed when the moving card is in position under the punches, under the control of cam-operated contacts which simultaneously apply voltage to the punch electromagnets. The facility for carrying out computations between rows again applies, and is used, for instance, for binary-decimal conversion.

There is one extra requirement connected with the use of the Read-out mechanism. The circuit arrangements of the Staticiser are such that incoming pulses can turn the Staticiser units from "Off" to "On," but not from "On" to "Off." Therefore, the Staticiser must be restored to normal (all zeros) between each and every use that is made of it. The "Staticiser Reset" is applied automatically after a punching, but since this does not ensure that all is in order for the very first Read-out of a calculation, the starting programme for all calculations must include a Staticiser Reset instruction (Destination No. 98).

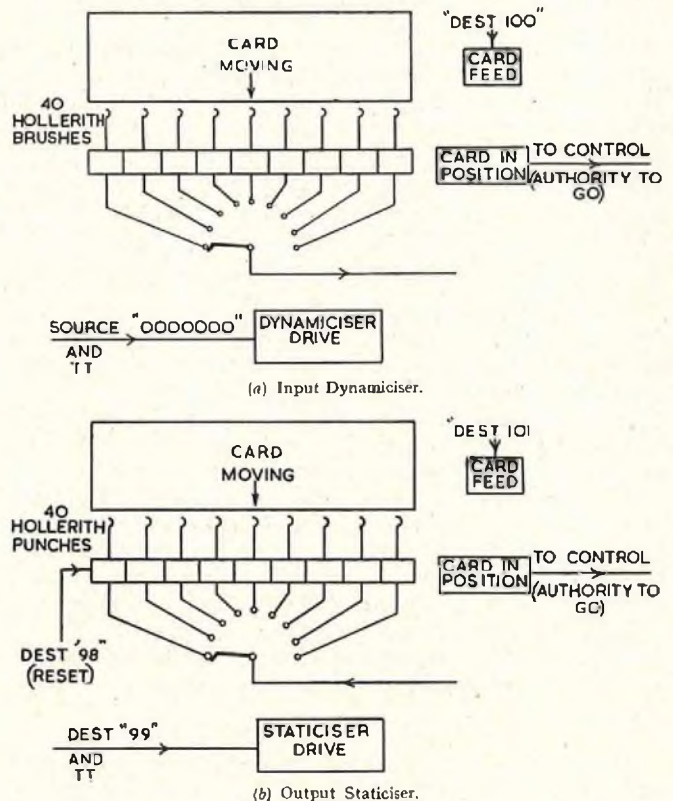

FIG. 8.—INPUT AND OUTPUT CONTROLS.

The diagram (Fig. 8) illustrates the input and output procedures described above. The third form of feed, that of reading-in when no instruction programme is as yet in the machine, is rather more complicated, and is ultimately bound up with the whole programming technique. It will therefore be considered with the general art of programming in the next part of this article.

(To be continued)

Meetings of C.C.I.R. Study Groups I and XI, Brussels, March/April, 1955

U.D.C. 061.3 : 621.396

A note on the recent meetings of C.C.I.R. Study Groups I and XI in Brussels at which the specification and performance of radio transmitters and of television systems were discussed.

INTRODUCTION

INTERIM meetings of C.C.I.R. Study Groups I (Radio Transmitters) and XI (Television) were held in Brussels from the 22nd March to the 6th April, 1955, in preparation for the work of the VIIIth Plenary Assembly which will be held in Warsaw in the Autumn of 1956. Twenty Administrations were represented:

Austria	Italy	P.R. of Rumania
Belgium	Japan	Spain
Czechoslovakia	Monaco	Sweden
Denmark	Netherlands	Switzerland
France	Norway	United Kingdom
F.R. of Germany	P.R. of Poland	United States
P.R. of Hungary		U.S.S.R.

In addition to 100 delegates, 30 representatives of Private Operating Agencies, International Organisations and Industrial and Scientific Organisations attended; approximately two-thirds of the 130 were concerned primarily with Study Group XI and the balance with Study Group I.

The U.K. delegation comprised five members of the Post Office, two from Service establishments, together with two experts nominated by the Radio Industry Council. In addition, eight representatives of the following U.K. Private Operating Agencies were present:

British Broadcasting Corporation; Cable and Wireless, Ltd.; International Marine Radio Co., Ltd.; Marconi International Marine Communication Co., Ltd.; Redifon, Ltd.

Study Group I was concerned with questions relating to the specification of the frequency tolerance, spurious radiations and bandwidth of radio transmitters. In connection with the latter, demonstrations of bandwidth measuring equipment were given.

The main item for discussion by Study Group XI was colour television; a number of other questions, including the relaying of television signals, were also examined.

The Conference was formally opened by Mr. Haemers, Director-General, Telegraph and Telephone Administration, Belgium, and the Director (Dr. van der Pol) and Vice-Director (Mr. L. W. Hayes) were present throughout. The international chairmen of the two Study Groups (Dr. Metzler, Switzerland, Study Group I; Mr. Esping, Sweden, Study Group XI) quickly got down to work and separate meetings of the two Study Groups were held.

WORK OF CONFERENCE

Study Group I.—The more important of the several questions considered were:

- The frequency tolerance limits for radio transmitters.
- The tolerances for harmonic radiation and parasitic emissions from radio transmitters.
- The measurement of the bandwidth of radio transmitters.

It was clear from a discussion of frequency tolerance limits that technical developments in crystal control would make possible the achievement of closer tolerances, and a draft recommendation proposing some tightening of tolerances was accepted, and will be submitted for consideration by the VIIIth Plenary Assembly. (If approved, the recommendation will then be submitted for consideration at the next Radio Conference.)

On harmonic radiation and parasitic emission, some Administrations wished to recommend improvement of the present tolerances, but after discussion this was not accepted.

The demonstration of bandwidth measuring equipments was very successful and clearly demonstrated the problems involved.

Study Group XI.—The three main items examined were:

- The possible standardisation of a colour television system.
- The re-arrangement of the work of the Study Group.
- The relaying of television signals.

In discussing the possibilities of standardising a system of colour television for Europe it was pointed out by several delegations that the present use of different monochrome standards in Bands I (41-68 Mc/s) and III (174-216 Mc/s) would not permit of a common colour standard in those bands. It was agreed, however, that since it was still technically possible to achieve a common standard for Bands IV (470-585 Mc/s) and V (610-960 Mc/s), these bands not having yet been brought into use for television in Europe, the Director of the C.C.I.R. would write to all members of the I.T.U. pointing out the advantages and desirability of achieving a common television standard for these bands, especially for colour television, and asking Administrations to give full consideration to this possibility before taking decisions which might compromise the future adoption of such a standard.

The U.K. proposals for re-arranging the work of the Study Group were adopted with minor modifications, and a programme of colour television studies was approved.

As the result of the U.K. issuing an invitation for members to visit us in late 1955 to see the work being done on colour television, France issued a similar invitation and it is likely that one or two other Administrations will do the same.

The most important other matter considered was the long-distance relaying of television signals and a document on "Circuit Characteristics for the Transmission of Television Signals (Monochrome) over Long Distances" was approved.

During the Conference the Study Group visited Eindhoven as the guests of the Netherlands Administration to see a series of colour television and sound demonstrations.

The opportunity was taken to see television in Brussels. As was expected, the quality of the pictures varied appreciably between the four systems in use in Belgium (the French and Belgian 819-line systems and the Belgian and C.C.I.R. 625-line systems, as detailed in C.C.I.R. VIIth Plenary Assembly, Vol. I, Report No. 35, page 240). Some of the 625-line pictures seen were of particularly good quality; the line structure, even on a 21 in. tube, was not very obvious.

CONCLUSIONS

The work done by the two Study Groups gave a considerable impetus to the work and will facilitate the progress of the VIIIth Plenary Assembly.

C. F. B.

Portable Generating Set and Low-voltage Electrical Aids for External Work

J. G. DONOVAN, A.M.I.E.E.,
and R. THARBY†

U.D.C. 621.313.2-84:621.311.6

This article describes a new design of portable generating set and associated battery which can be used for supplying power for a range of recently developed low-voltage appliances for use on external work.

INTRODUCTION

PORTABLE generating sets and batteries for electric lighting in manholes were first used in 1946, when 1,700 war-surplus American sets were obtained for this purpose. These 24V 300W "Tiny Tim" sets have become less reliable with age and, following difficulty in obtaining spare parts, they are being replaced gradually by British machines. As a first step, 250 sets with Villiers engines were obtained in 1951 and a machine of this type has been described in a previous article.¹ These sets have now been superseded by a type powered by a J.A.P. engine, and it is expected that by the end of 1955 over 1,200 of these will be in use.

The general availability of portable generating equipment in all Regions has permitted the introduction of a range of electrical aids which can be worked in conjunction with the portable generating sets and batteries. The electrical aids described and illustrated are in various stages of development, but it is expected that all of them will be available by the end of 1955.

NEW PORTABLE ENGINE-DRIVEN GENERATING SET

A view of the new set is shown in Fig. 1 and a circuit

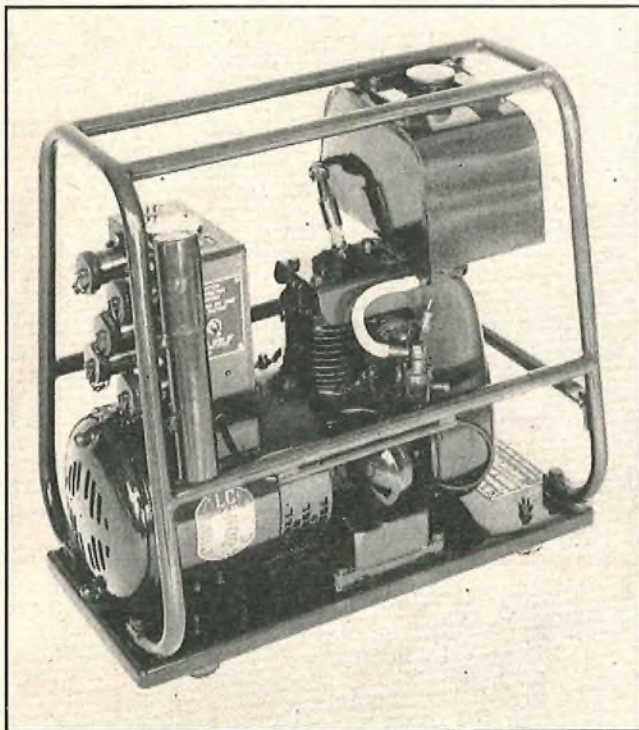

FIG. 1.—NEW PORTABLE ENGINE-DRIVEN GENERATING SET.

diagram of the generator in Fig. 2. The generator is a 24-30V 500W D.C. machine capable of the dual function of battery charging, or supplying a load with, or without, the battery in circuit. The engine and generator are constructed in one unit to reduce the overall size of the set and to avoid

†The authors are, respectively, Executive Engineer and Assistant Engineer, External Plant and Protection Branch, E.-in-C.'s Office. ¹Hill, B. C., and Smith, E. E. M. A New Portable Generating Set for Manhole Lighting. *P.O.E.E.J.*, Vol. 44, p. 7, Apr. 1951.

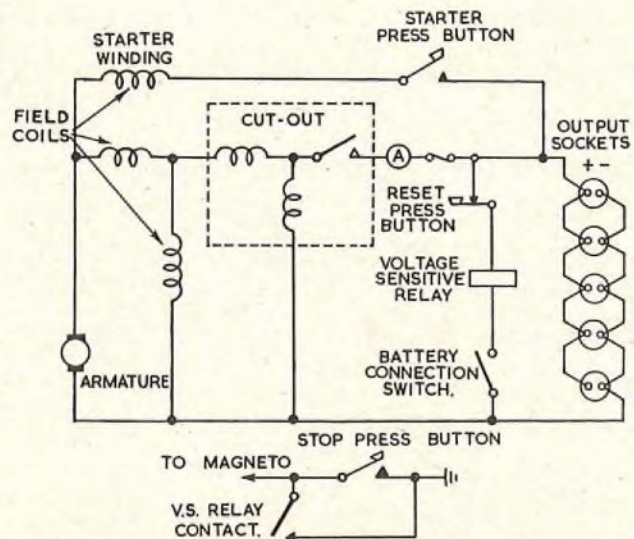

FIG. 2.—DIAGRAM OF GENERATOR CIRCUIT.

shaft alignment troubles. The whole unit is rigidly mounted on a fabricated base plate supported by four anti-vibration mountings to prevent the set "creeping" during use on wet sloping surfaces. The set is enclosed by a tubular steel guard and carrying frame, which is fixed to the base plate by lugs to reduce vibration. Staff using these sets usually work in pairs and the frame is designed to encourage the carriage of the set by two men; its weight is 103 lb. One transverse frame member has been made detachable to facilitate the removal of the engine-fan casing.

Power is supplied by a J.A.P. 4-stroke 98-c.c. air-cooled petrol engine fitted with a flywheel magneto and developing 1.2 b.h.p. at 2,500 R.P.M. The petrol system is gravity fed from a 6-pint petrol tank fitted on the upper members of the carrying frame, the tank being shaped to reduce the possibility of petrol spilling on to the exhaust silencer. The capacity of the tank enables the set to run for five hours at full load without refuelling. The engine can be started manually by a rope round the starting pulley, or automatically, as described later.

To reduce radio and television interference the ignition system is fully suppressed by a screened sparking plug and lead and a 15,000-ohm series resistor located in the sparking plug connector.

A baffle exhaust silencer, superior to the "pepper-pot" type supplied with the standard version of this engine, is fitted and its outlet is designed to permit the connection, whenever necessary, of a large additional silencer with a high efficiency. This additional silencer is connected to the permanent one by a flexible exhaust pipe and an adapter.

The generator is a 4-pole, compound-wound, fan-cooled type generating 30V on no-load and 24V on full-load, voltage regulation within this range being provided automatically by the generator windings. The no-load voltage has been restricted to 30V to ensure that excessive voltage is not supplied to an appliance in use if the set is in operation without a battery in circuit. An additional series field winding is provided in the generator to enable it to be used as a motor for starting the engine from the battery.

The generator armature is mounted on a hollow shaft

fitting on a morse-tapered extension of the engine crankshaft, the complete crankshaft and armature being supported by the two engine ball races and by a self-lubricating bronze bearing at the outer end of the generator frame. The field winding and brush gear are housed in the generator frame, which is secured directly to the engine crankcase. To dismantle the generator, the brushes and end plate of the generator frame are removed first, followed by the armature and the generator frame and field coils.

Fig. 3 shows the output characteristic of the generator when a 24V battery is being charged, and Fig. 4 shows the voltage/load characteristic when no battery is in circuit.

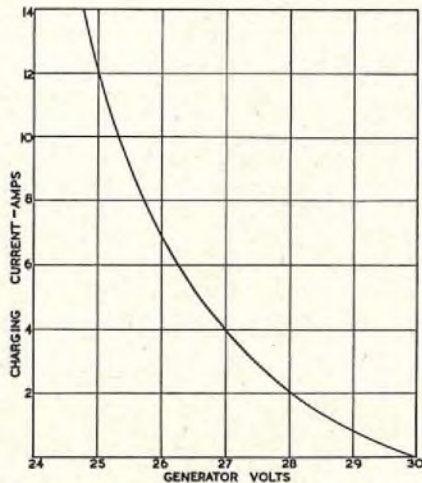

FIG. 3.—CHARGING CHARACTERISTIC OF GENERATOR.

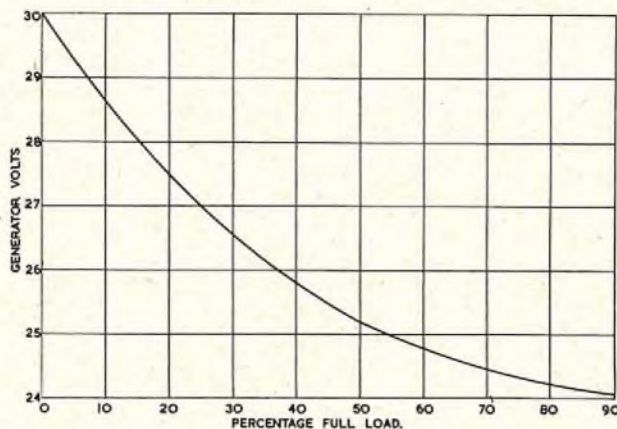

FIG. 4.—VOLTAGE/LOAD CHARACTERISTIC OF GENERATOR.

It will be seen from Fig. 3 that the high initial charging rate decreases to a low figure as the generator voltage approaches the no-load value. This no-load characteristic of the set prevents the 24V battery being fully charged, but this is a desirable feature for reasons explained later.

A control box is mounted on the generator frame and houses the five output sockets, reverse-current cut-out, voltage-sensitive relay and reset switch, stop button, battery connection switch, starter button, fuse and ammeter. The position of the control box reduces the likelihood that vibration of the set will cause damage to the electrical components and wiring. The removable rear panel of the control box is lined with asbestos to protect the components from the hot air surrounding the cylinder of the engine.

The five output sockets are wired in parallel and are of the two-pin, non-reversible, 15-amp weatherproof type. They are mounted on the outer face of the control box and any socket can be used for connecting the set to the battery or to any load appliance in use.

The reverse current cut-out has voltage and current

coils and operates, when the generator output rises to 24.5V, to connect the output to the battery. The cut-out releases when a reverse current of 4 amps flows in the charging circuit.

The voltage-sensitive relay switches off the set to stop charging when the battery being charged attains the state where "gassing" will commence. It has a single coil connected across the output terminals of the generator, and a single "make" contact spring set. The relay is adjusted by varying the pressure exerted on the armature by a coil spring mounted opposite the relay contact springs. The relay operates when the charging voltage rises to 28V. It has been found that a battery removed from charge at this point has a voltage of 26.5V, the limit to which a 24V battery can be charged without "gassing." The contacts of the relay short-circuit the circuit-breaking contacts of the magneto and stop the engine. The relay is held operated by the charged battery, and the set cannot be restarted until the reset press button, which disconnects the relay coil, is pressed. The resistance of the coil of the voltage-sensitive relay is 1,000 ohms so the current drain from the battery is small. The stop button may be used at any time to stop the engine, its contacts being wired in parallel with those of the voltage-sensitive relay.

The battery connection switch (Fig. 2) provides the facility of using the set without a battery by preventing interference from the engine-stopping function of the voltage-sensitive relay, which would otherwise operate and stop the engine.

The starter button and the 25-amp rewirable Sloydlock fuse are mounted on one side of the control box. The 0-30 amp ammeter is located in a conspicuous position in the top of the control box and is protected by toughened glass.

A rainproof cover to fit over the guard frame is provided, so shaped as to enable the set to run when the cover is fitted without appreciably restricting the movement of air to cool the engine.

24V BATTERY FOR USE WITH NEW GENERATING SET

The battery used in conjunction with the new portable generating set has been redesigned and strengthened, in the light of experience with earlier batteries, so that it can supply heavy loads for short periods, e.g. if the generator is stopped when a high-powered appliance is in use.

The new battery is illustrated in Fig. 5 and consists of

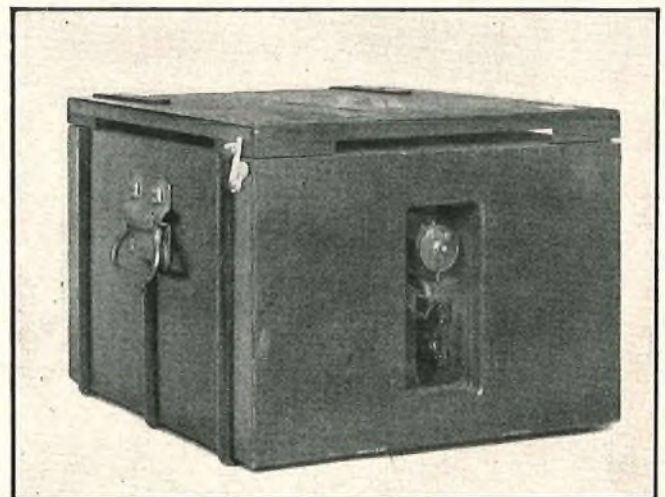

FIG. 5.—24V BATTERY.

two 12V, 45-Ah motor-car type batteries in a hardwood carrying case, connected to a 15-amp outlet socket similar to the type used in the portable generating sets. Car-type batteries are used to withstand the rough handling and rapid

charging and discharging which these batteries encounter in service. Alkaline batteries for this purpose are several times more expensive than the type in use.

A 25-amp fuse, similar to the type used in the generating set, and the output socket are located in a recess in the carrying case to prevent damage occurring during the handling of the battery.

Earlier models of this battery were fully enclosed by a carrying case with a panelled lid which provided an unwanted cavity above the battery with the risk of dangerous accumulation of gases evolved during charging. This danger has been avoided by modifying the battery carrying case to prevent gas accumulation and by the previously mentioned use of a generating set with a low no-load voltage characteristic. The lid of the new battery is not panelled and is supported by four triangular corner pieces which provide ventilating gaps $\frac{1}{2}$ in. high and several inches long on all sides of the carrying case.

LOW-VOLTAGE APPLIANCES

Electric Lighting.

It has been an objective of the Post Office for many years to eliminate naked flames from manholes in an endeavour to reduce the potentially serious accidents which can arise in confined underground structures. To this end electric lighting devices have been preferred to others.

The installation of permanent low-voltage mains lighting in important or frequented manholes has been investigated. All the cables and fittings used in such an installation would need to be flameproof to ensure safety in the event of gas leaking from adjacent mains, and waterproof to render the installation immune from the effects of flood-water. The installation costs would therefore be out of all proportion to the advantages obtained. It is not necessary, however, to use flameproof equipment for portable lamps in manholes as Post Office staff do not work in atmospheres containing explosive quantities of inflammable gas.

The adjustable clip lamps used now for lighting manholes have been described and illustrated in the earlier article already mentioned. To avoid shadows on the work, 25V 40W pearl lamp bulbs are used, and the support enables the lamp to be stood on the floor or clipped to a convenient cable. A universal ball joint allows the lamp to be adjusted to any angle required.

Electric Soldering Irons.

The 25V 110W soldering iron for use with the portable set is illustrated in Fig. 6. It is intended mainly for soldering conductor joints in cables.

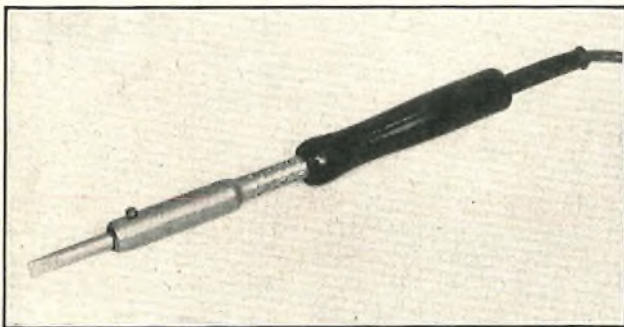

FIG. 6.—25V, 110W SOLDERING IRON.

Electric Floodlights.

An inexpensive electric floodlight, illustrated in Fig. 7, has been developed. The light is obtained from a 25V 150W pearl bulb fitted in an E.S. lampholder and housed in an 8-in. diameter vitreous enamelled reflector with a wire protecting guard. The reflector is fitted on a collapsible stem by means of a universal ball joint and the whole



FIG. 7.—ELECTRIC FLOODLIGHT.

assembly is mounted on a combined clip and stand which gives similar facilities to the lamp used for lighting in manholes. Three of these floodlights can be used simultaneously with one portable generating set if required, to provide reliable floodlighting for emergency breakdowns. The use of more than one floodlight eliminates shadows.

Electric Cable Drier.

All the methods used in the past for drying wet cable joints have required the use of heat from blowlamps, with the attendant risks of fire and of the paper insulation becoming brittle. The electric drier illustrated in Fig. 8

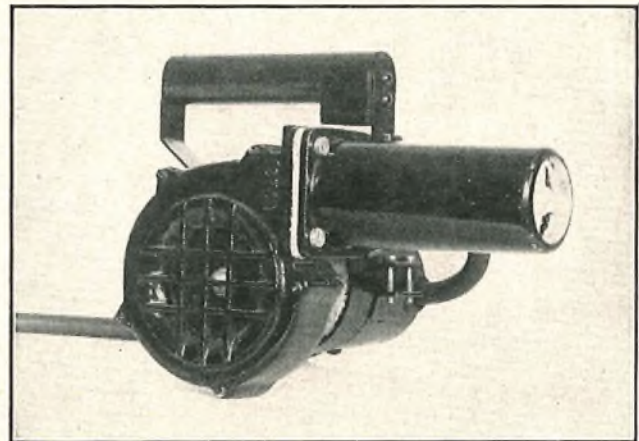

FIG. 8.—CABLE DRIER.

has been designed to deliver hot air to any part of a wet cable joint at a temperature below that at which paper insulation becomes brittle. It operates on the popular hair-drier principle and consists essentially of a centrifugal blower and a cylindrical heater. The series-wound blower motor is rated at 24V 35W and is fully suppressed to prevent radio and television interference. The power consumed by the heater brings the total power consumption to 500W.

Electric Pump.

For some time the need has existed for a method of pumping water from manholes in a manner silent enough to permit its use at night in residential districts, and an

electric pump is therefore being developed for this purpose. It is unfortunately necessary to restrict the power consumption of the pump, and consequently its output, to avoid overloading the battery, and the pumping rate is therefore much below that of the commonly used petrol-engine driven type. The pump will, however, be adequate to deal with most instances of water seeping into a man-hole and so avoid interference with jointing operations.

Tests have been carried out with a $\frac{3}{4}$ -in. bore pump powered by a 250W electric motor; this is illustrated in Fig. 9. A pumping rate of 400 gals./hr. to a height of 10 ft.

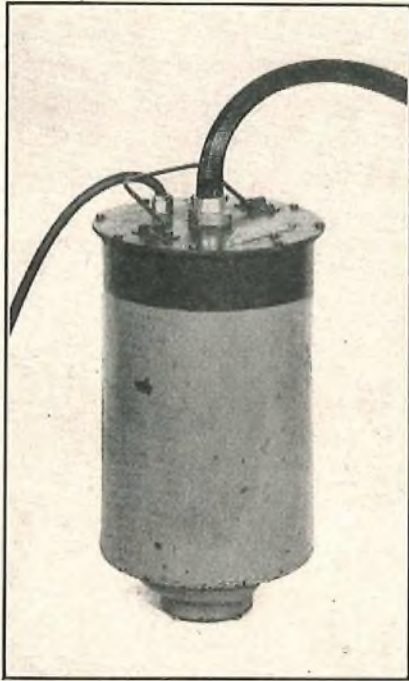

FIG. 9.—ELECTRIC WATER PUMP.

was obtained and pumping at a gradually reduced rate continued to a height of 35 ft. The motor of the pump is enclosed in a buoyant aluminium container which floats on the surface of the water in the manhole. The motor is mounted in the base and drives a centrifugal pump, fitted beneath the container, through a rotating face sealing gland. The water outlet is taken through the centre of the upper part of the container so that the weight of the hose does not affect the upright floating position of the container. As the water level reaches the floor of the manhole the pump can be placed in the sump-hole to complete the pumping and deal with any further ingress of water from the cable ducts.

The pump can be run dry for long periods without adverse effects and it is therefore suitable for being left running in the sump-hole of a manhole in which seepage is being encountered. The pump will remove the water as it accumulates and will not require attention from the jointer.

Some further tests and field trials will be necessary before an appliance of this type is available for general use.

Portable Electric Traffic Signals.

The general tightening of regulations covering road safety and public works has led to the development and use of low-voltage electric traffic signals for controlling traffic where a long obstruction has been caused by such operations as duct-laying or cabling.

The use of these electric signals, which can be automatically controlled, can obviate the need to use two operators of "Stop" and "Go" signs. In view of the high

cost of labour, the initial cost of the electric signals, about £90, can be recovered by their use for six weeks even though the generator is being used solely for working the traffic signals; in many instances, however, the generator may be simultaneously in use for lighting and other purposes.

A typical set of signals is illustrated in Fig. 10. Each

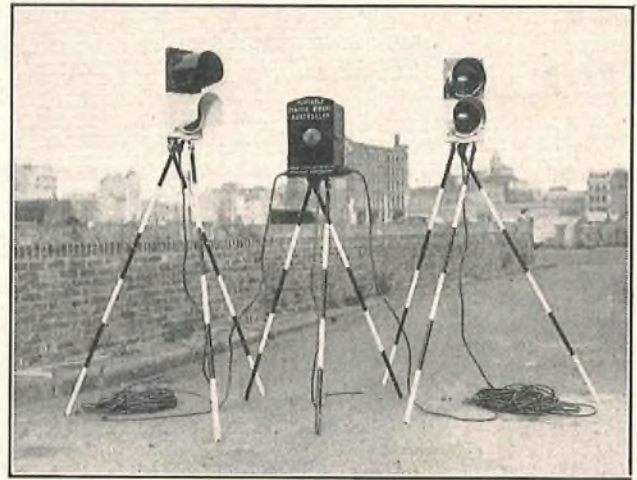

FIG. 10.—TRAFFIC SIGNALS.

set consists of a control unit connected to the generating set and to two similar signal heads. The distance between the signal heads is limited only by the voltage drop along the supply cables. Satisfactory results have been achieved with sets having a distance between the signal heads of 100 yards, and it is not expected that many occasions will be encountered in Post Office work where this length is inadequate.

The signal heads are constructed of cast aluminium and are mounted on collapsible tripods to facilitate their use on uneven surfaces. Each signal head has a red and a green lamp unit consisting of 24V 60W bulbs located in reflectors with coloured "cross-hatch" prismatic lenses and sun visors. Motor-car type bulbs are used for robustness and to increase the lighting efficiency. The light output of these bulbs is greater for a given consumption than that of the general-service types, and the smaller dimensions of their filaments enables a better focus to be obtained from the optical system. Cross-hatch lenses have been used for their superior diffusing properties, an important point if the signals are to be clearly observed from a vehicle stationary alongside them and out of the direct line of the light.

Tests in adverse sunlight showed the signals to be clearly visible for 100 yards, a marked improvement over the performance of the normal commercial mains-voltage signals consuming the same power. The signal-head lamps are changed on a routine basis to anticipate failure since such failures might have serious consequences.

The control unit is usually located near the generating set and the centre of the obstruction. Two types are in use and each will be described, as the methods of obtaining a timed sequence of operations are quite different.

In the first type (see centre of Fig. 10) the electrical parts are housed in a cast aluminium case mounted on a collapsible tripod. The automatic time-switch mechanism is actuated by a series-wound 25W electric motor which, through reduction gears, revolves a disc carrying four adjustable cam levers. As this disc revolves, each of the cams in turn engages an operating lever which turns a shaft on which fixed cams are fitted to actuate the spring sets switching the lamp circuits. The time taken for this

operation may be varied in two ways: the speed of the driving motor can be adjusted by means of an eddy-current disc brake to control the time occupied by the complete cycle of four lamp conditions, i.e., Red 1 Red 2, Red 1 Green 2, Red 1 Red 2, and Green 1 Red 2; or the cams on the revolving disc can be individually adjusted to vary the proportion of the time occupied by any one lamp condition in the complete cycle of operations. The variation of the timing of the signals is essential in order that the duration of the "double red" condition may be related to the length of the obstruction being guarded. In some districts, such as those near the coast, the incidence of traffic may be greater in one direction than the other, and in such cases the signals can be adjusted to give one direction a longer "green" signal than the other. By suitable adjustments of the two timing controls it is possible to vary between 12 and 112 seconds the time occupied by any one of the four lamp conditions.

The control apparatus can be operated manually if desired; the motor is switched off and the disc with the adjustable cams is rotated by a hand lever.

Coloured tell-tale lamps are fitted in the control unit to indicate the conditions at each signal head. These small lamps are controlled by low-resistance relays in series with each lead to a signal-head lamp. The failure of a lamp in the signal head is therefore indicated in the control unit by the release of the low-resistance relay and the extinguishing of the tell-tale lamp associated with the signal-head lamp that has failed.

The second type of control unit is of a simpler design fitted in a wooden "dog-kennel" container. The timing adjustments provide facilities similar to those described above. Four separate rheostat controls, one for each of the four lamp conditions, are used and each can be independently varied to control the duration of its corresponding lamp condition between 12 and 112 seconds. The resistances which are varied by the timing adjustments are located in the circuit of the electric motor used for timing purposes and vary the speed of the motor accordingly. Through reduction gearing the motor drives a camshaft which controls the switching of the signal-head lamps. Coloured tell-tale lamps of very low resistance are fitted to the control unit and wired in series with the signal-head lamps. The low resistance of the tell-tale lamps reduces the voltage drop across them to a minimum. This type of control unit may also be operated manually by switching off the motor and rotating the camshaft by hand.

Both types of control unit and their signal-heads have non-reversible plugs to ensure correct interconnection. The power consumption of each complete set is 170W.

Electric Drill.

The drill likely to prove most useful for P.O. work has a pistol grip, weighs 8 lb. and requires 350W on full load; it is capable of drilling holes up to $\frac{1}{2}$ in. dia. in steel and up to 1 in. dia. in brick. The speed is low, approximately 500 R.P.M. on light load and 300 R.P.M. on full load. This drill, which is now undergoing trials, has been found very useful when attaching cables to walls where mains power is not available, e.g., in houses under construction.

Electric Hammer.

The hammer at present on trial takes 200W and delivers 1,600 blows per minute. Impact on the anvil of the tool-holder occurs only when the hammer is applied to the work. Vibration is further reduced by arranging for the blow to be delivered by a spring which is gradually compressed and suddenly released at each stroke. In addition to drilling

brick, concrete, stone, etc., the hammer can be used for brick-raking and chasing.

Combined Drill-Hammer.

Trials are being made of the drill-hammer shown in Fig. 11. This type of tool operates at a considerably higher

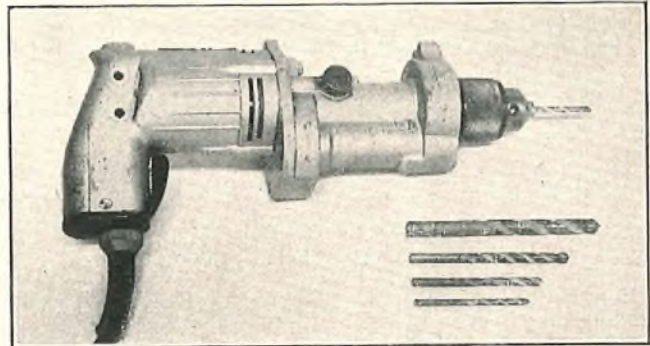

FIG. 11.—ELECTRIC DRILL-HAMMER.

striking-rate than ordinary power-operated hammers, e.g., the tool illustrated delivers 6,500 strokes per minute. The resulting sound, a purring rather than a hammering noise, makes the tool more comfortable to operate.

A hole is started by using the drilling action but after a short time a changeover knob is pressed to bring the hammering mechanism into use.

Special tungsten-carbide tipped bits have been developed for use with this tool, since ordinary bits of this type are inclined to be too brittle for hammering.

The tool illustrated requires only 100W but can drill holes up to 1 in. dia. in brick and at least $\frac{1}{2}$ in. dia. in concrete. A slightly larger version is being developed to drill 1-in. diameter holes in concrete containing large aggregate, and will thus be suitable for fixing cable-bearers to manhole walls.

CONCLUSION

It seems probable that a larger version of the portable generating set will eventually be required in situations where many appliances are being used simultaneously. It is likely that an increase to 750W could be achieved with little increase in the present size and weight.

The development of an electric welding kit for jointing aluminium conductors in cable joints is in progress and a small electric saw for slitting steel ducts is being considered.

The practicability of designing a blower system for ventilating manholes is being examined and an investigation is being made into the design of a sentinel type of inflammable-gas detector to test the atmosphere in a manhole periodically and give an audible or visible alarm if the atmosphere becomes contaminated.

The basis on which the generating sets, batteries and electrical aids will be held in Regions will vary according to local requirements. It is foreseen that, when adequate quantities of the various aids are in service, the high capital outlay incurred by using portable generating sets for manhole lighting will be fully justified and economies in time will be achieved on many types of work which are at present performed with outdated equipment.

ACKNOWLEDGMENTS

Acknowledgments are due to colleagues in the External Plant and Protection, and Power Branches of the Engineer-in-Chief's Office and to the City Area of the London Telecommunications Region for the valuable co-operation they have given in the development of the equipment.

Carrier Frequency Generating Equipment for Large Coaxial and Carrier Stations

E. T. C. HARRIS, B.Sc.(Eng.), A.M.I.E.E.,
and S. MUNDAY†

Part 1.—General Features, Rack Equipment and Changeover Circuits

U.D.C. 621.373.42:621.395.44

A new carrier frequency generating equipment of high stability and accuracy has been developed primarily for use at large coaxial and carrier stations. A complete installation provides carrier frequencies for twenty 10-supergroup route ends. In Part 1 of this article the general features of the system are first explained, followed by an outline of the master oscillator, channel, group and supergroup equipments. The last section describes in some detail the automatic changeover arrangements which are an important feature of the system. Part 2 will cover the 124 kc/s master oscillator and frequency dividing chain and the frequency comparison and alarm apparatus.

INTRODUCTION

THE carrier frequency generating equipment provided for the bulk of the carrier and coaxial equipment in this country at the present time is that widely known as the "No. 7-Type" Carrier Frequency Generating Equipment. Carriers for the channel, group and supergroup modulators are derived from harmonic generators locked to a basic 4 kc/s oscillator. This oscillator was designed to be stable for short periods to a few parts in 10^6 and normally the frequency is maintained to the desired degree of accuracy by a mechanical frequency-control system controlled by an incoming 60 kc/s pilot tone. The mechanical control system and other details of the No. 7-type equipment are described elsewhere.¹ Initially the motor-control oscillator system was used with carrier equipment where the highest frequencies were of the order of 120 kc/s. When coaxial systems with supergroup carrier frequencies up to approximately 3 Mc/s were installed the same carrier generating equipment could still be used and was adopted as the standard. There were, however, certain disadvantages, primarily that the short-term drifts in frequency of the oscillators could be as much as a few parts in 10^5 , and when several terminal stations were routed in tandem a drift of an oscillator early in the chain could give rise to relatively large frequency variations at a distant terminal. Moreover, plans were maturing for the provision of higher-frequency supergroups and, especially with the longer circuit routings envisaged, a higher degree of frequency stability and accuracy in the carrier frequency generating equipment was essential. A maximum frequency error of, say, 2 parts in 10^7 could be tolerated and should be satisfactory for many years.

It was chiefly to meet this need for higher accuracy that the equipment known as the "621-Series" Carrier Frequency Generating Equipment was developed. There were, moreover, other conditions to be met, such as suitability for A.C. operation and provision of new maintenance facilities, formulated as a result of long experience with the No. 7-type carrier equipment. As far as possible the 621-series equipment incorporates all the desired features but this is at the expense of having to provide a comprehensive changeover system, with the corollaries of a relatively inflexible layout and the need for a fairly large initial outlay for equipment. The equipment is, however, suitable for supplying the carrier frequencies for many thousands of circuits and is therefore intended primarily for use at large main coaxial and carrier stations. A smaller, more flexible carrier generating equipment is being developed, using many of the same panels employed in the 621-series equipment, and will be especially suitable for small to medium sized installations where the initial requirements are simple although facilities for growth of the equipment are desired.

One of the basic differences between the 621-series and

No. 7-type carrier frequency generating equipment is that the former is a "Master Oscillator" system as opposed to the "Controlling Pilot" system of the latter. The performance of the master oscillators is such that maintenance frequency checks can only be made against a very high accuracy pilot, and it is part of the general scheme to distribute a 60 kc/s standard frequency to all stations where 621-series equipment will be installed.

GENERAL FEATURES

In this description of the 621-series equipment emphasis will be laid on the facilities provided and the method of provision rather than on details of panels such as the oscillator panels. Where possible, panels of a tried design were used and the novelty of the equipment rests chiefly in the system as a whole.

Fig. 1 shows one master-oscillator equipment driving three sets of dependent equipment, one each of the channel, group and supergroup carrier generating equipments. A maximum of ten of each such equipments can be driven by one master-oscillator equipment.

The master-oscillator equipment provides 20 outlets of each of the "master-frequencies," 4, 12 and 124 kc/s, which drive the harmonic generators of the channel, group and supergroup carrier equipments, respectively. Each of these three groups of 20 outlets is divided into two sets of 10, designated No. 1 and No. 2 supplies.

The dependent equipments each comprise two identical generating rack-sides, designated No. 1 and No. 2, feeding a single changeover and distribution rack-side. The No. 1 sets of all these equipments are connected to the No. 1 supplies of the appropriate master-frequency and the No. 2 sets are similarly connected to the corresponding No. 2 supplies.

The distribution of channel carrier frequencies is effected by means of up to four additional distribution rack-sides per channel-changeover rack-side, whereas the group and supergroup carrier frequencies are distributed directly from their respective changeover rack-sides.

Each dependent equipment provides the carrier frequencies for the appropriate translating equipments sufficient to assemble two 10-supergroup coaxial route ends. Thus one supergroup carrier equipment provides two outlets of each supergroup carrier frequency (S.G.s 3 to 10); one group carrier equipment provides 20 outlets of group carrier frequency and two outlets of the S.G.1 carrier frequency; and one channel carrier equipment, together with the four distribution rack-sides, supplies 104 outlets of each channel carrier frequency. The channel carrier equipment therefore provides channel carriers for four groups over the requirements of two 10-S.G. route ends. The channel equipment can also provide 104 outlets at 120 kc/s for group modulating equipment.

As one master oscillator equipment can drive a maximum of 10 of each type of dependent equipment, the complete installation therefore provides carrier frequencies for twenty 10-supergroup route ends.

†The authors are, respectively, Senior Executive Engineer and Assistant Engineer, Transmission and Main Lines Branch, E.-in-C.'s Office.

¹Taylor, F. J. D. Carrier System No. 7. *P.O.E.E.J.*, Vol. 34, pp. 101 and 161, Oct. 1941 and Jan. 1942.

CHANNEL CARRIER EOMT.
UP TO 104 OUTLETS (IN BLOCKS OF 13) OF EACH CHANNEL CARRIER FREQUENCY AND THE 120 Kc/s GROUP MODULATING FREQUENCY

LEGEND:-
E.F.G. = EQUIPMENT, FREQUENCY-GENERATING
E.F.D. = " " " " - DISTRIBUTION
E.C.D. = " " " " , CHANGE-OVER & " "

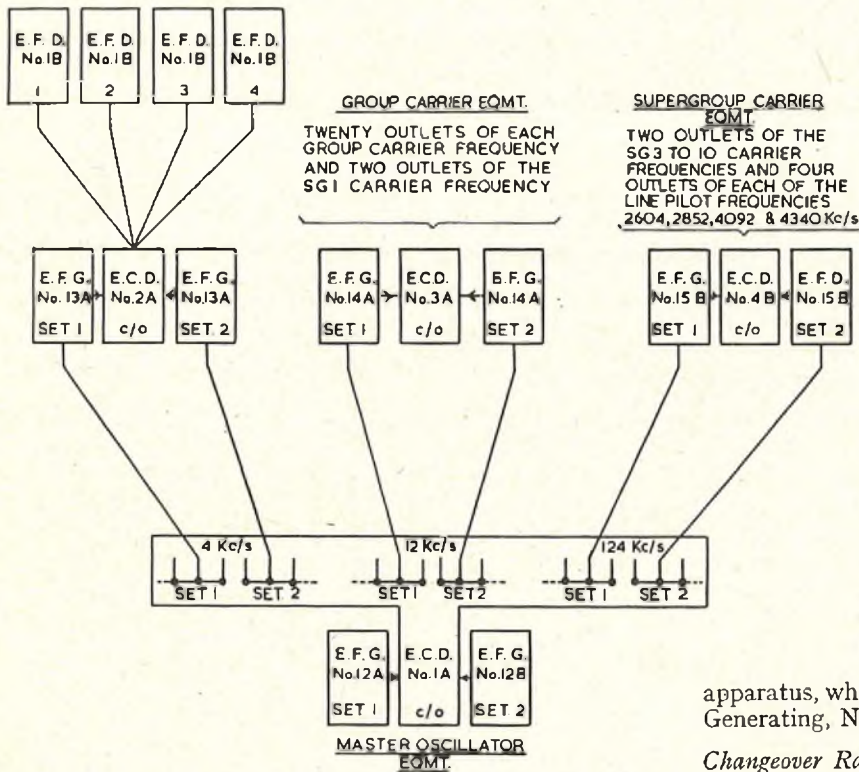

FIG. 1.—GENERAL ARRANGEMENT OF 621-SERIES CARRIER GENERATING EQUIPMENT.

The following line pilot frequencies are also generated from the sources indicated:—

- | | |
|------------|-------------------------------|
| 60 kc/s | Master oscillator equipment |
| 308 kc/s | Channel carrier equipment |
| 2,604 kc/s | Supergroup carrier equipment. |
| 2,852 kc/s | |
| 4,092 kc/s | |
| 4,340 kc/s | |

At some stations through-supergroup working may be used and there may in consequence be no group carrier generating equipment. In this case the S.G.1 carrier frequency, which is a harmonic of the 12 kc/s basic group frequency, may be derived from the supergroup carrier equipment by fitting a group harmonic generator and S.G.1 filter-amplifiers on each generating rack-side and a S.G.1 changeover panel on the changeover rack-side. The group harmonic generators are then supplied with 12 kc/s signals from the master oscillator equipment.

At stations where 16 supergroups are assembled, carrier frequencies derived by some of the supergroup carrier equipments will not be used and the amplifiers and changeover panels concerned may be removed from the equipment.

The generating rack-sides are suitable for operation from regulated A.C. mains (200-250V, 50 c/s) with or without a centralised 220V H.T. supply. The channel carrier distribution rack-sides do not consume power and the changeover rack-sides are designed for full A.C. operation only.

All equipments are mounted on 9-ft. rack-sides of 51-type construction. All panels are demountable except the distribution panels, which are bolted to the rack framework, and the master oscillator U-link panel (dealt with later) which is hinged.

MASTER OSCILLATOR EQUIPMENT

Fig. 2 is a simplified block schematic diagram of the master oscillator equipment and shows the division of equipment into two generating rack-sides and a change-over rack-side.

Generating Rack-sides.

Three 124 kc/s temperature-controlled crystal oscillators, two on the Equipment, Frequency-Generating, No. 12A, and one on the Equipment, Frequency-Generating, No. 12B, are provided, together with a U-link panel that enables any two of the three oscillators to be selected to drive the two sets of "master-frequency apparatus." Each master-frequency apparatus requires two supplies of 124 kc/s, one for the 124/60 kc/s divider and one for the 124 kc/s filter-amplifier; these outputs are derived by hybrid coils in the U-link panel.

The 124/60 kc/s divider, together with the 60/12/4 kc/s divider, derive the master-frequencies which are then amplified by filter-amplifiers. Set 1 and Set 2 master-frequency equipments are entirely independent and continuously operating and their outputs are connected to the changeover panels on the changeover rack-side. In addition, each set provides one supply of 60 kc/s to the frequency-comparison

apparatus, which is mounted on the Equipment, Frequency-Generating, No. 12A.

Changeover Rack-side.

The changeover rack-side selects the outputs of one of the sets to feed the distribution units, the outputs of the other set being terminated in dummy-load resistors. This selection is achieved by the changeover panels, which are provided on a basis of one per pair of inputs. The set that feeds the distribution units is referred to as the working set, the other as the spare set. When both sets are operative the selection of the set to act as "worker" may be made arbitrarily. If any output of the working set fails then all the changeover panels operate simultaneously, the function of the two sets being interchanged and appropriate alarms, audible and visible, given. Failure of an output from a spare set also gives an alarm.

The detailed operation of the changeover equipment and alarms is described later.

CHANNEL, GROUP AND SUPERGROUP CARRIER EQUIPMENTS

Fig. 3 is a block schematic diagram of the channel carrier equipment and one of the four distribution rack-sides. Two Equipments, Frequency-Generating, No. 13A, each comprising a harmonic generator and associated filters and amplifiers, provide duplicate supplies of each channel carrier, and of 120 kc/s and 308 kc/s.

The outputs of both sets are connected to the changeover rack-side, which selects the output of one set, as described previously. The changeover rack-side provides the distribution of the 308 kc/s line pilot frequency and primary distribution of the channel carrier and 120 kc/s frequencies.

The primary distribution provides eight outlets of each frequency which, as indicated in the diagram, will feed up to four distribution rack-sides. Thus 104 outlets in blocks of 13 of each frequency can be provided.

Figs. 4 and 5 are block schematic diagrams of the group and supergroup carrier equipments, respectively, and as seen, they follow the same general pattern as the channel carrier equipment. It will be noted that the group modulators

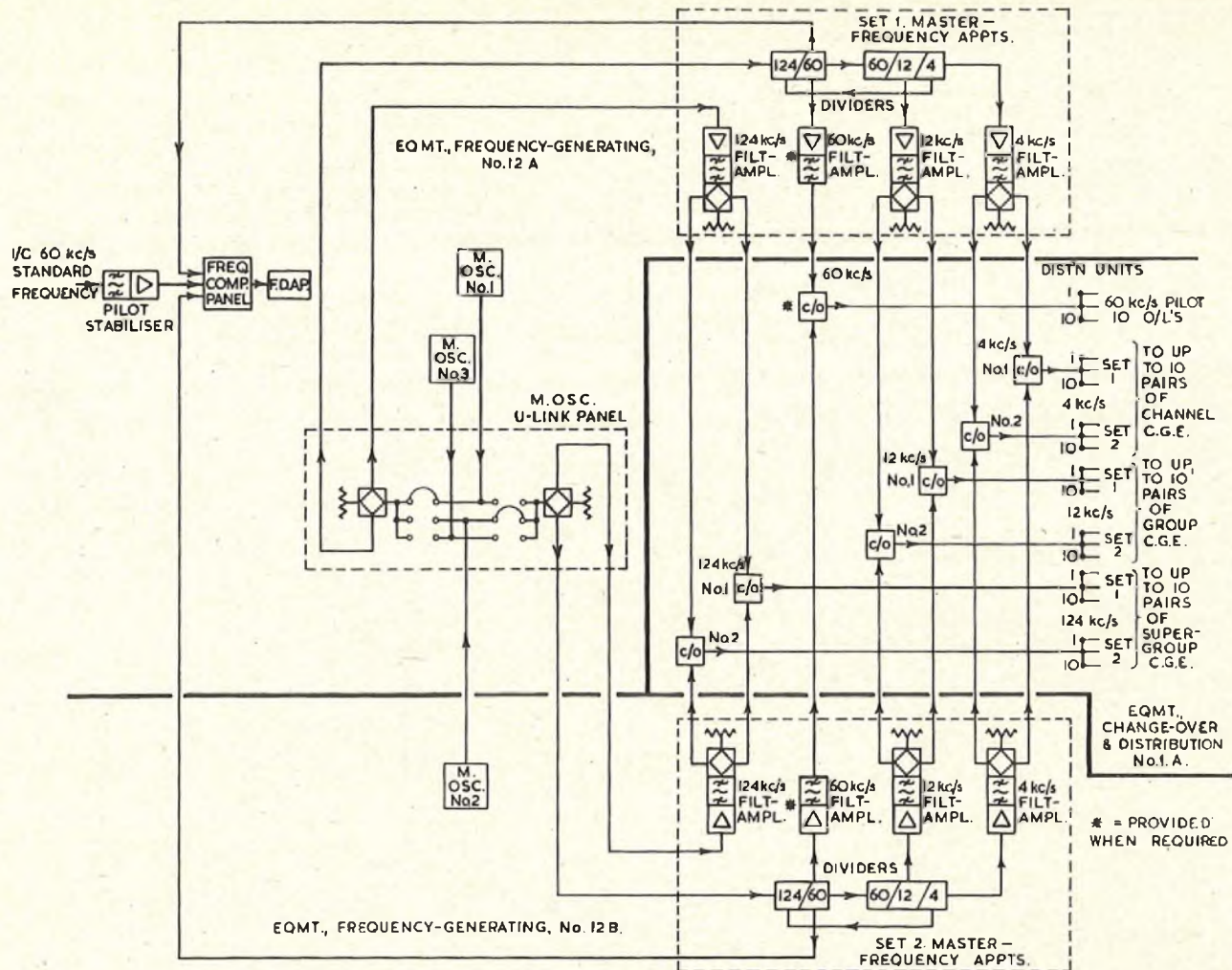

Fig. 2.—MASTER OSCILLATOR EQUIPMENT.

and demodulators are fed separately; all other carrier outlets feed "modems." These are requirements imposed by the translating equipments.

DESCRIPTION OF CHANGEOVER CIRCUITS

Associated with each pair of master and carrier frequency generating rack-sides is a changeover rack-side which continuously monitors the outputs of its connected sets and initiates the appropriate changeover and/or alarm function should any output of either set fail.

The changeover circuits are controlled by D.C. voltages obtained by rectification of the working and spare supplies. In every changeover panel there are two monitor networks, designated "working" and "spare," which electrically precede the associated distribution units and the dummy-load resistor, respectively. The dummy-load resistor is in the changeover panel.

The voltages developed by the monitors are passed to the level monitoring panel (not shown in Figs. 2 to 5) which is common to all the changeover panels on a rack-side. There are two level-detecting valves in the monitoring panel, one for all the working monitor voltages and the other for all the spare monitor voltages; Fig. 6 shows details of this panel together with a changeover panel working monitor.

The full-wave rectifier, W1, rectifies the voltage developed across the secondary winding of the current transformer, the primary of which is in series with the load presented by the distribution unit connected to the "WKG OUT" lead. The rectified voltage, V_m , which is 5V

positive with respect to earth, is passed to the level monitoring panel. At this point the working monitor voltages from all the other changeover panels on the rack-side are applied in parallel, the arrangement of rectifiers preventing back-coupling.

If each monitor voltage is substantially equal to the voltage, V_c , developed across the lower portion of potentiometer P1, there will be little or no current flowing through resistor R1 and the grid-cathode voltage of V1 will be effectively zero. The anode current under these conditions is sufficient to hold the tongue of relay A in the position shown.

Should any monitor voltage fail, current will flow from H.T.+ to the earth presented by the failed monitor via the series rectifier and resistor R2. The potential difference developed across R1 due to this current is of such polarity as to reduce the anode current and the tongue of relay A moves over to the other contact and operates the WF relay in the changeover control panel.

The value to which a monitor voltage must fall in order to operate the anode relay is a function of the standing current in the bias coil; in practice potentiometer P2 is adjusted so that the relay operates when a monitor voltage falls to about 3.5V. This is equivalent to a 3 db. fall in the level of the monitored signal. In a similar manner all the voltages from the spare monitors are supplied to valve V2 with an anode relay B to control the SF relay in the changeover control panel.

The way in which the changeover panels, the level monitoring panel and the changeover control panel are

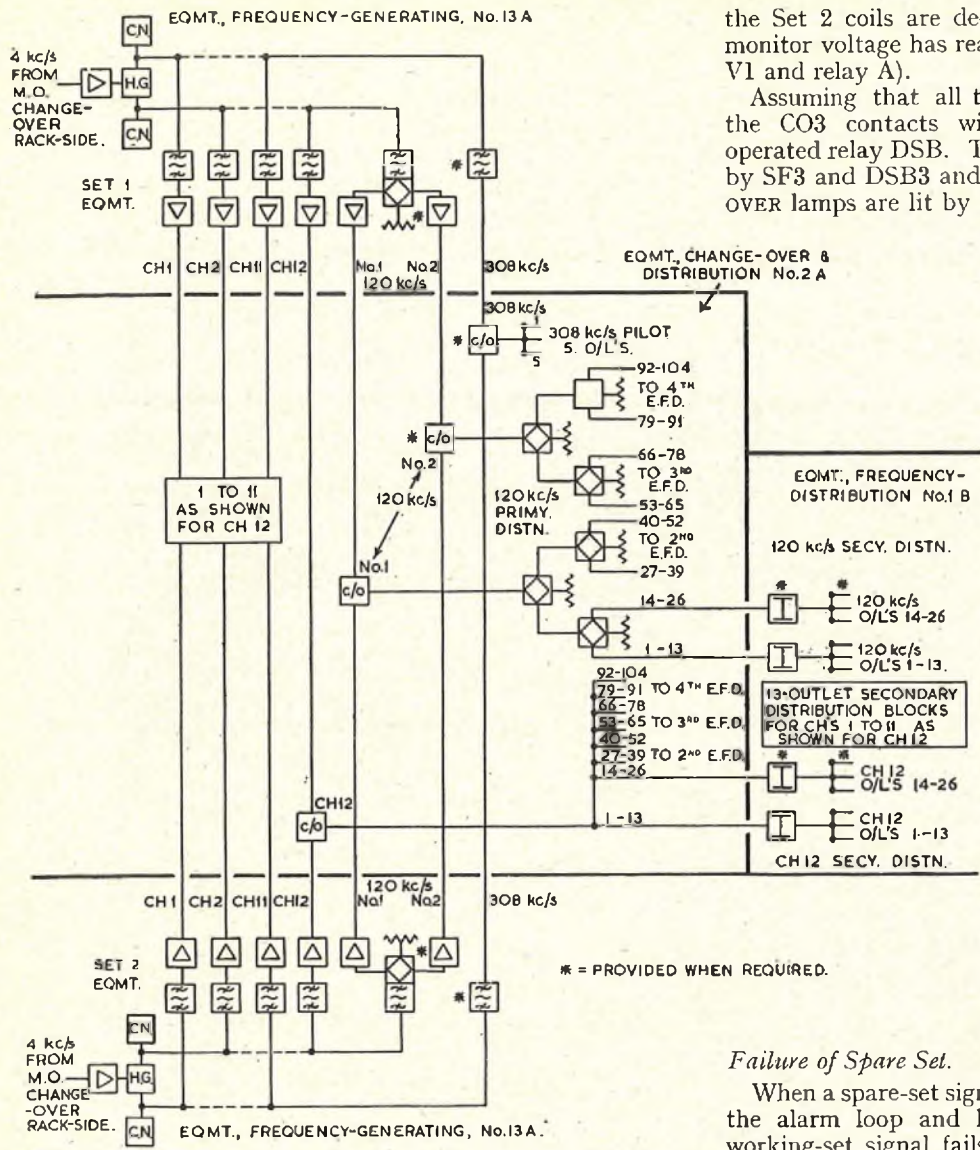

FIG. 3.—CHANNEL CARRIER GENERATING EQUIPMENT.

connected together is shown in Fig. 7, in which it is assumed that conditions are normal and Set 1 is the working set. Under these conditions the DSA relay in the changeover control panel is held operated by the CO3 contacts of the CO relays in the changeover panels.

The CO relays are two 3000-type relays, the armatures of which are mechanically connected with a toggle locking device. When one coil is energised its armature is locked in the operated condition by the toggle and the other armature restored to normal. The coil may now be de-energised but the associated spring-sets will still remain in the operated condition. Assuming, as in the diagram, that the CO relays were last energised over their Set 1 coils, the following changeover arrangements apply.

Failure of Working Set.

When a working-set signal fails a working monitor voltage disappears and relay A in the monitoring panel operates via valve V1 as previously described. A1 operates relay WF in the control panel, which at WF1 operates relay H. H1 energises all the Set 2 coils of the CO relays and the supplies are changed over. The failed supply is now connected to a spare monitor and consequently this monitor voltage will disappear. Relay SF is operated via valve V2 and the anode relay B. SF1 releases relay H and

the Set 2 coils are de-energised. Meanwhile the working monitor voltage has reappeared and WF relay releases (via V1 and relay A).

Assuming that all the CO relays operated successfully, the CO3 contacts will have released relay DSA and operated relay DSB. The ALM EXTN loop is short-circuited by SF3 and DSB3 and the SPARE FAIL and RESET CHANGE-OVER lamps are lit by SF2 and DSB5 respectively.

Operation of the RESET CHANGE-OVER key connects the Set 1 coils in circuit in readiness for the next changeover and also disconnects the RESET CHANGE-OVER lamp, the audible alarm being still maintained by SF3. Relay SF, still operated due to the failed signal, prevents, at SF1, any false operation of relay H, even if a working signal fails or if the manual changeover key is operated. This safeguard persists as long as a spare-set signal failure lasts.

If the REC ATT key is operated, relay ACO operates and locks via ACO1 and 2 and the SF3 contact, the alarm loop being disconnected; ACO3 lights the REC ATT lamp.

When the fault condition is cleared relay SF releases, disconnects the SPARE FAIL lamp and relay ACO, which in turn disconnects the REC ATT lamp. Conditions are now back to normal except that Set 2 is the working set and relay DSB is operated.

Failure of Spare Set.

When a spare-set signal fails, relay SF operates, completes the alarm loop and lights the SPARE FAIL lamp. If a working-set signal fails the WKG FAIL lamp will glow but SF1 operated prevents any changeover on to a failed supply.

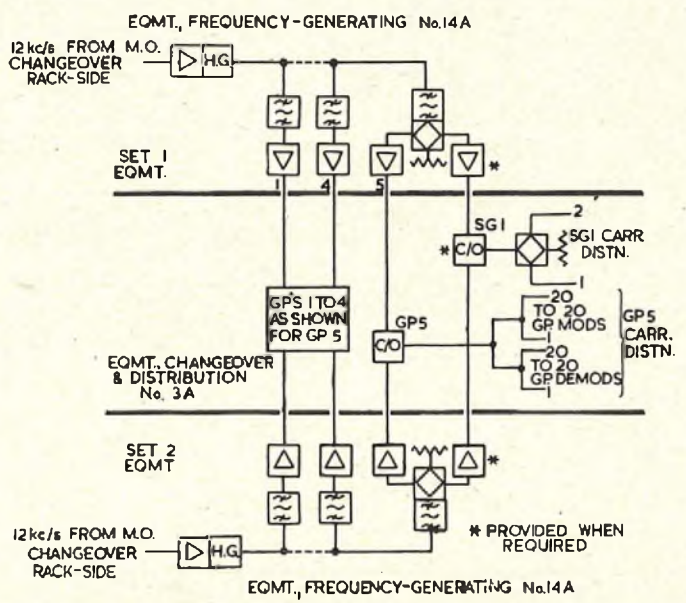

FIG. 4.—GROUP CARRIER GENERATING EQUIPMENT.

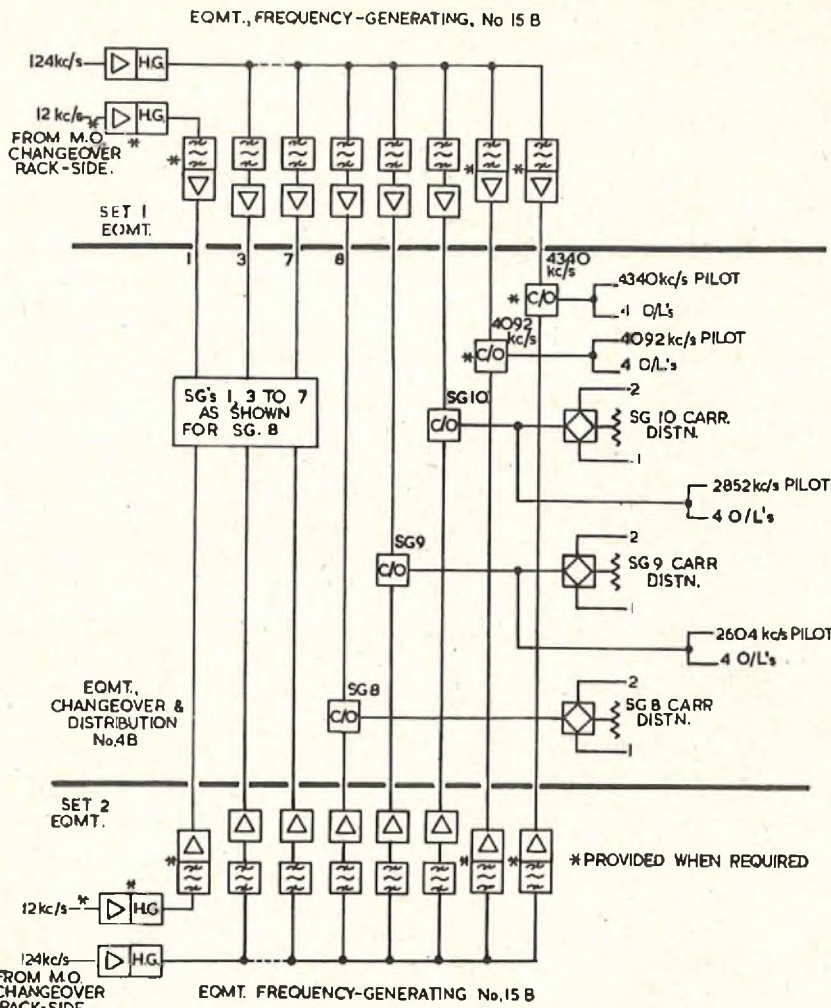

FIG. 5.—SUPERGROUP CARRIER GENERATING EQUIPMENT.

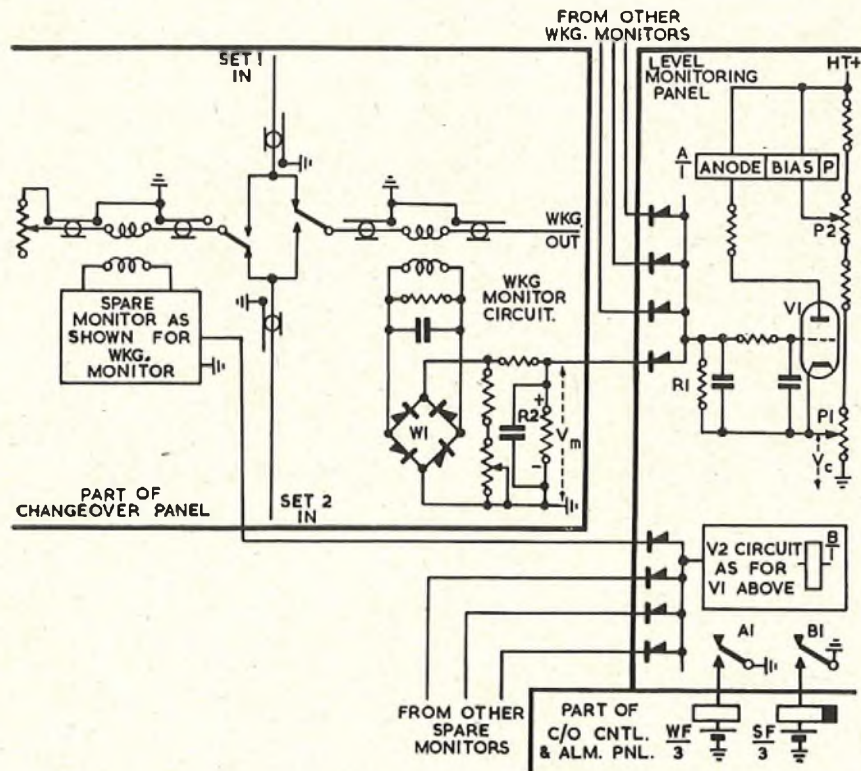

Fig. 6.—MONITOR AND CHANGEOVER CIRCUITS.

Incomplete Changeover.

If, when the CO relays are energised, one or more of them fail to operate then both relays DSA and DSB will be operated by the CO3 contacts. In these circumstances the INCOMP CHANGEOVER lamp glows. Operation of the INDR LAMPS key energises the lamps in the individual changeover panels, thereby identifying the faulty panel(s).

Simultaneous Failure and Restoration of Both Supplies.

This condition occurs on dependent changeover rack-sides when the master oscillator changeover equipment operates. As it is undesirable for any dependent equipment to change over when this occurs, special precautions are taken.

Relay WF is slower to operate than SF, having a much higher coil inductance. Conversely, it is faster to release than SF, the latter being fitted with a heel-end slug. Hence simultaneous failure of both working and spare supplies will not cause a changeover; neither will their simultaneous restoration.

This assumes, of course, that the working and spare monitor voltage decay times are equal, as also must be the grid charge-times of the two valves. The differences between the operate and release times of the WF and SF relays are made sufficiently great to mask any differences in the monitor and grid circuits due to component tolerances.

Changeover Power Panel.

Fig. 8 is a simplified diagram of the power panel fitted on the changeover rack-sides. It derives, from the normal stabilised A.C. mains supply, the H.T., L.T., +50V smoothed and +50V unsmoothed supplies to operate the changeover circuits. A feature worthy of note is the method of deriving the +50V unsmoothed supply from which the CO relays in the changeover panels are energised. The greatest load that can be imposed is on a fully equipped channel carrier changeover rack-side with 15 CO relay coils simultaneously connected in parallel when relay H operates. The combined resistance of all these coils is only 16 ohms, which connected to 50V would draw a current of about 3 amps. The power panel transformer and rectifiers to supply this current from a conventional full-wave rectifier circuit, without damage to the components, would have to be far too large.

In order to overcome this difficulty use is made of the energy stored in a 2,000- μ F capacitor which is kept charged to about 70V, by rectifier MR1, from the unsmoothed output of the W1 rectifier bridge. The resistor bulb limits the current that can be drawn from the rectifier bridge to a safe value even if the 16-ohm load were imposed for a long period, due to a fault condition. The time constant is such that the voltage across the CO relay coils is maintained above 30V

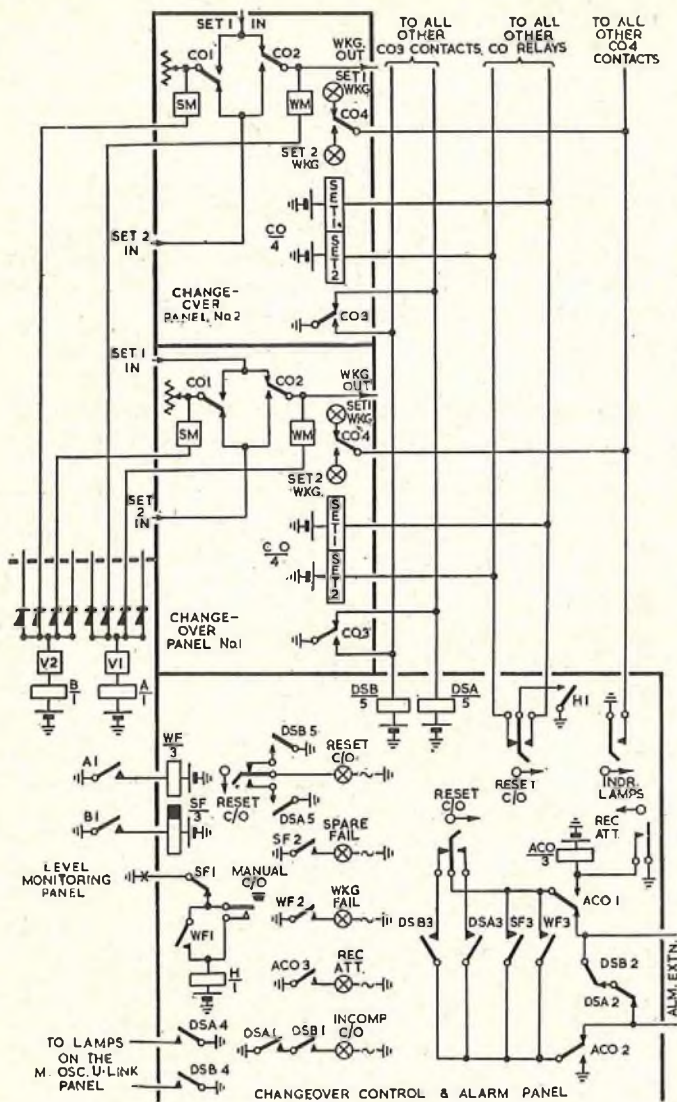

FIG. 7.—CHANGE-OVER CONTROL CIRCUITS.

for at least 20 mS, and the charge time of the capacitor is about 1 second. An alarm relay detects failure of the supply to the CO relays, but since the CO relay armatures are latched as described previously, a failure of the system does not occur.

Failure of the relay power supply to the control panel will cause simultaneous release of relays DSA and DSB,

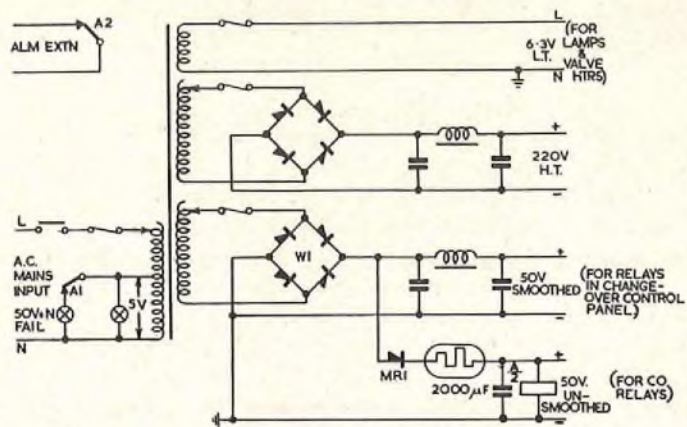

FIG. 8.—POWER PANEL FITTED ON CHANGE-OVER RACK-SIDES.

which complete the alarm loop at DSA2 and DSB2 (Fig. 7).

H.T. failure will not cause changeover because the A and B relays in the monitoring panel are side-stable. The H.T. supply is monitored in the level monitoring panel. L.T. failure may or may not cause a changeover, depending on the relative cooling times of the valve heaters.

Measurement of Signals using Level Monitoring Panel.

The monitoring panel is provided with a meter and two multi-position switches. When these switches are operated the circuit of V2 is rearranged as a high-impedance valve-voltmeter and the individual monitor voltages entering the panel can be measured. The meter is calibrated and marked so that 5V corresponds to 0 db., and when setting up the equipment the individual working monitor potentiometers are adjusted so that the meter indicates the "departure from nominal" of the level at the distribution unit test-jack. The spare monitor potentiometers are adjusted to indicate the "departure from nominal" of the level that would exist at the test-jack of the associated distribution unit if the working and spare sets were interchanged. The switches on the level monitoring panel also set up circuits internally to enable the panel to be calibrated.

The earth for the SF1 contact is supplied via the normal position of the switches so that no false changeover can occur during metering or calibration. The panel is provided with an off-normal lamp.

The interval between failure of a signal and its automatic restoration is about 100 mS. The interruption to the other supplies is less than 10 mS, which is also the time of a manual changeover.

(To be continued)

Book Review

"Fundamentals of Electrical Engineering." E. Hughes, D.Sc.(Eng.), Ph.D., M.I.E.E. Published by Longmans, Green and Co., Ltd. 470 pp. 311 ill. 12s. 6d.

The writing of a school text book is an arduous task that is only justified when the author either approaches an old subject from a new angle or uses new material to modernise an out-of-date syllabus. Dr. Hughes has a wealth of experience in the teaching of electrical engineering and his methods of presenting elementary D.C. and A.C. technology to his students are likely to be of value to many others in the teaching profession. On this occasion, he has in addition set himself the task of introducing to his readers the M.K.S. (metre, kilogram, second) system of units that is now becoming popular in academic engineering circles. With the advantage of this new angle of approach, the author has produced a book on a well-established syllabus that is interesting and worth publishing.

The book covers the electrical engineering syllabuses of the third year course for the Ordinary National Certificate, the first year course for an engineering degree and the intermediate course of the City & Guilds of London "Electrical Engineering Practice" examinations. A treatment of magnetic circuits, the elements of circuit analysis, simple A.C. and D.C. machines and transformers form the main part of the text. A lucid chapter on thermionics describing the operation of simple valve amplifiers and detectors, and a chapter on illumination have also been included. Fundamental units are explained carefully throughout and full comparisons are made between M.K.S. and C.G.S. units. There are many worked examples in the text and sets of examples are included at the end of each chapter.

This book can be recommended to students as a good investment.

C. F. F.

P.O.E.E. Library No. 2246.

The British Post Office Speaking Clock, Mark II*

A. J. FORTY, B.A., A.M.I.E.E., and
F. A. MILNE, A.M.I.E.E.†

Part 1.—Design and Performance

U.D.C. 621.395.91:529.786

The original B.P.O. speaking clock has proved satisfactory during nearly 20 years of operation in this country, but did not meet the requirements of the Australian Post Office in respect of civil and marine time signals. The clocks for Australia were therefore made to a new design which was being undertaken by the P.O. Research Station and which is described in this article. Equipment to the new design, with quartz-crystal drive, has recently been installed in Australia giving signals accurate to ± 5 mS (corrected every 24 hours) which compares with ± 100 mS (corrected every hour) for the B.P.O. installation with pendulum drive. Part 2 of the article will deal with the manufacture of the new speaking clock, its testing and packing for export, and with the layout of the installation on site.

INTRODUCTION

TELEPHONE subscribers in Melbourne and Sydney can now dial a special code and hear time announcements from a speaking clock. The equipment used for these two installations has been designed by the British Post Office Engineering Department and made in England by the Telephone Manufacturing Company. It is an improved version of the original speaking clock apparatus which has provided a similar service in Great Britain since 1936.¹

Each speaking clock consists of an announcing machine (which produces the actual speech and time signals) together with auxiliary rack-mounted apparatus for driving the machine at a constant speed, for amplifying its audio signals, and for correcting the time signals to conform with standard time as determined by an observatory. The original design of speaking clock was controlled by a pendulum, and required hourly correction in order to produce time signals accurate to within ± 0.1 sec. This order of accuracy is insufficient for the requirements of the Australian Post Office because it is necessary to derive, from each clock, civil and marine time signals not deviating more than ± 20 mS from standard time. The requirement has been met by the British Speaking Clock, Mark II, in which a quartz-crystal-controlled oscillator is used for the drive, and which gives signals accurate to within ± 5 mS when corrected only once every 24 hours. The use of a daily rather than hourly correction is attractive, especially when the greater distances (and correspondingly higher charges for the correcting circuit) involved in Australia are considered.

Each installation consists of two complete clocks plus common equipment and auxiliary power supply. Either of the two clocks of an installation may be used to supply announcements of time to the telephone subscribers. The second clock runs continuously as a standby (driven by the auxiliary power equipment) and is put into service automatically if a fault should occur in the first. Facilities are provided to enable the signals from the Melbourne installation to be used to maintain service at Sydney (or vice versa) in the event of a total breakdown of the local system. Intermediate centres can be fed with signals as desired.

After the initial setting-up procedure, the operation of an installation (including the daily time check) is entirely automatic, and skilled attention is required only for routine maintenance and for the clearing of faults if they should arise.

GENERAL PRINCIPLES

Basically each clock consists of a synchronous motor which is driven at a constant speed from the amplified output of a crystal oscillator. Upon the motor shaft are mounted discs carrying sound tracks from which the successive announcements are derived.

Fig. 1 shows the block schematic diagram of an installation. Each clock is driven from a 100 kc/s crystal-controlled

oscillator, the output of which is fed into a frequency divider which produces the 50 c/s supply required by the announcing machine motor. A third oscillator is also provided for reasons which are discussed later. The 50 c/s supply passes first through a timing corrector circuit, which is used during the daily correction interval, and then via amplifiers to the synchronous motor of the announcing machine.

The announcements and time signals produced by the announcing machine pass through a preamplifier, termed "Line Amplifier and Pilot Tone Alarm," and are then fed into two local power amplifiers. One of these is connected to relay sets feeding the local telephone network, while the other acts as a reserve.

Superimposed upon the speech signals from each announcing machine is a pilot tone of 3,200 c/s, which is used to detect the presence or absence of any portion of the announcements. The detection occurs in the "Line Amplifier and Pilot Tone Alarm" panel, and the tone is removed before passing on the signals to the local network. Announcements with the tone included are sent out over lines to a distant centre, if required, to act as a reserve for the distant installation. Similarly, incoming signals from the distant centre pass through "Line Amplifier and Pilot Tone Alarm" panels for the detection and removal of the pilot tone, and act as a reserve for the local installation.

Four sources of signals are thus available for distribution to the local subscribers. If a fault should occur, switching from one source to the next reserve is controlled by the Pilot Tone Alarm circuits and by other alarm circuits of the installation.

The above is a brief outline of the fundamental units of which a clock installation is composed. In the succeeding paragraphs these units are described in greater detail.

THE STABLE 50 c/s SUPPLY

Three 100 kc/s bridge-stabilised crystal-controlled oscillators are provided for each installation. Two of these are normally linked to the clocks via a patching panel; the third is supplied to assist in fault detection, since by inter-comparison the identification of a faulty oscillator can readily be made. An alarm is given whenever the frequency deviation between oscillators becomes excessive. In addition, meters are provided to show the difference in rate of the oscillators, and a log of the readings of these will provide an indication of long-term drift.

The oscillators are connected to individual frequency dividers which give outputs of 50 c/s for driving the clock motors.

* This article was published in the *Telecommunication Journal of Australia* (Vol. 10 No. 1, June 1954) and is reproduced by kind permission of the Editors of that Journal.

† The authors are, respectively, Senior Executive Engineer and Experimental Officer, P.O. Research Station.

¹ "The Speaking Clock." L. E. Magnusson, E. A. Speight and O. W. Gill, *P.O.E.E.J.*, Vol. 29, p. 261.

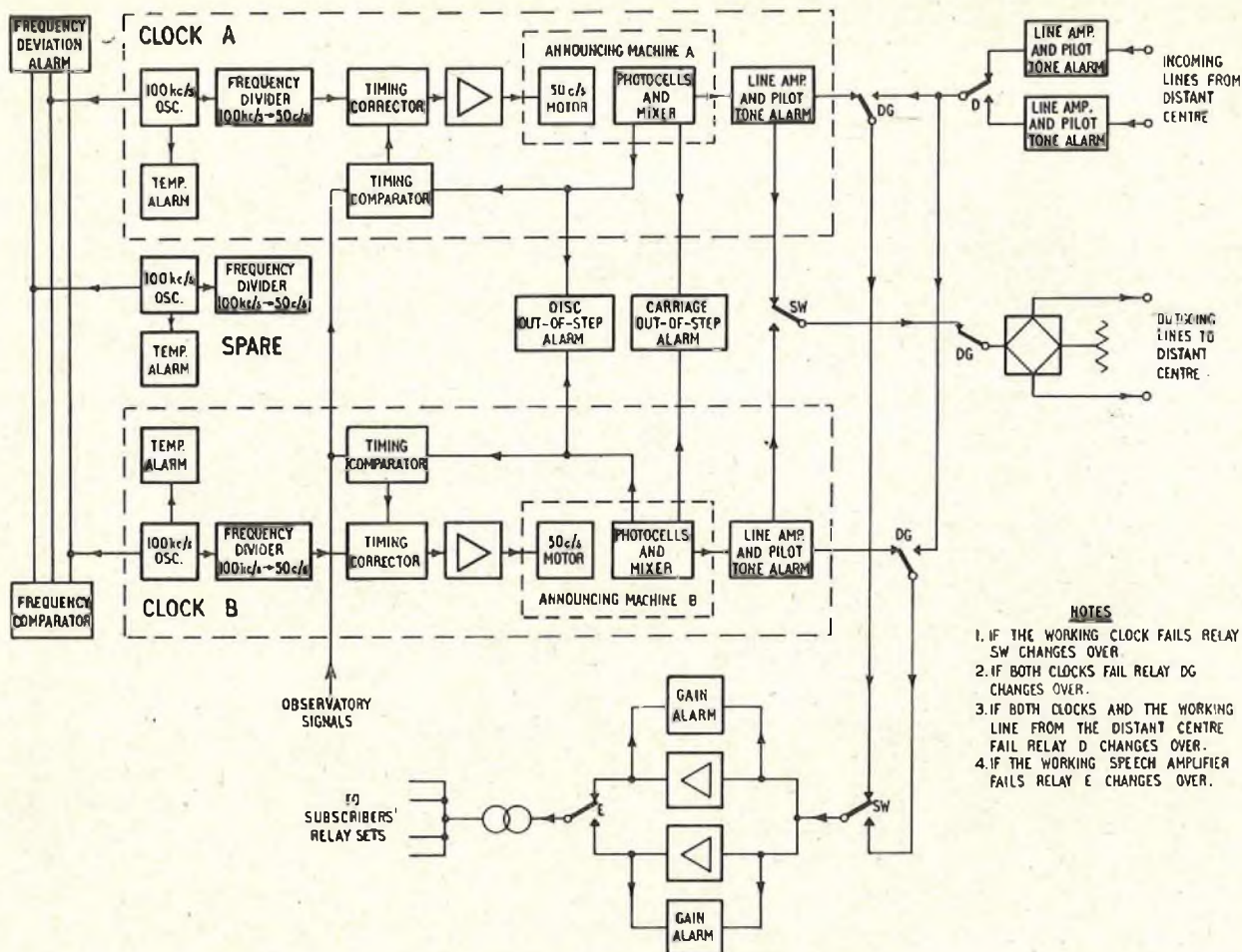

- NOTES**
1. IF THE WORKING CLOCK FAILS RELAY SW CHANGES OVER.
 2. IF BOTH CLOCKS FAIL RELAY DG CHANGES OVER.
 3. IF BOTH CLOCKS AND THE WORKING LINE FROM THE DISTANT CENTRE FAIL RELAY D CHANGES OVER.
 4. IF THE WORKING SPEECH AMPLIFIER FAILS RELAY E CHANGES OVER.

FIG. 1.—BLOCK SCHEMATIC DIAGRAM OF A CLOCK INSTALLATION.

THE ANNOUNCING MACHINE

Fig. 2* shows the Announcing Machine, the fundamental mechanism of a clock. Its main function is to produce, at 10-second intervals, announcements of the type "At the third stroke it will be ten, twenty-four, and forty seconds," followed by three pulses of 1,000 c/s tone (called "pips")

each 100 mS long and spaced at one-second intervals. The commencement of the third pulse of tone marks the time stated in the preceding announcement. Normally the 12-hour system of denoting time is used (e.g. 1 o'clock in the afternoon is called "one" and not "thirteen" hours) but the clock mechanism is so designed that it may easily be adapted for a 24-hour system, if required.

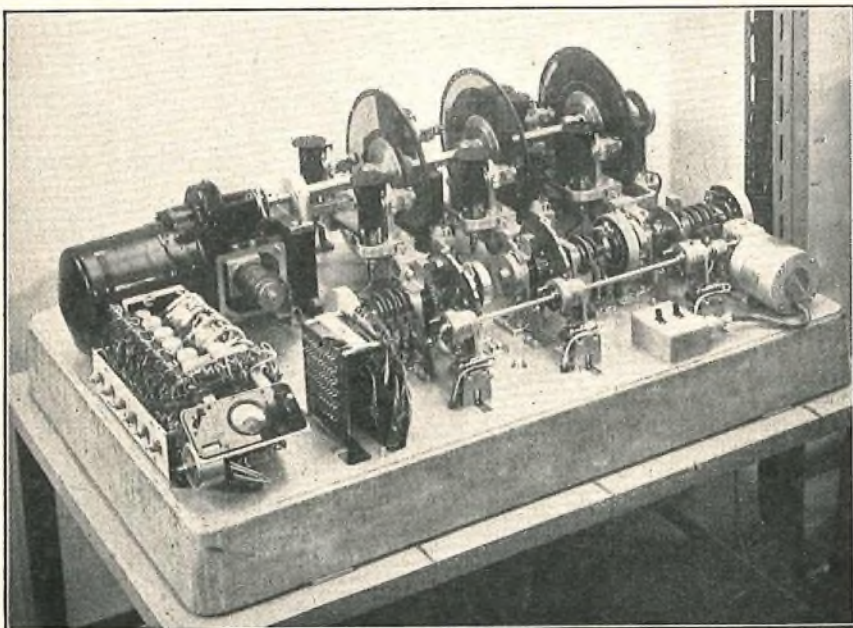

FIG. 2.—THE ANNOUNCING MACHINE.

Referring now to Fig. 3,* the synchronous motor (4) drives at the constant speed of 30 R.P.M. a shaft upon which are mounted three glass discs (1, 2, 3). The announcements and the time signals are derived from variable-area circular sound tracks which have been recorded photographically² upon these discs in the following manner:—

- Disc 1: The minute tracks "one" to "59" and "o'clock."
- Disc 2: The words "At the third stroke . . ." (called the "Phrase") and the hours tracks "(It will be one . . .," "It will be two . . .," etc.).
- Disc 3: A synchronising signal, the seconds tracks (" . . . and ten

² "A Photographic Technique of Sound Recording on Glass Discs." A. J. Forty, P.O.E.E.J., Vol. 47, p. 19.

* Figs. 2 and 3 show the prototype announcing machine with all covers removed. Illustrations of the machines supplied to the Australian Post Office will appear in Part 2.

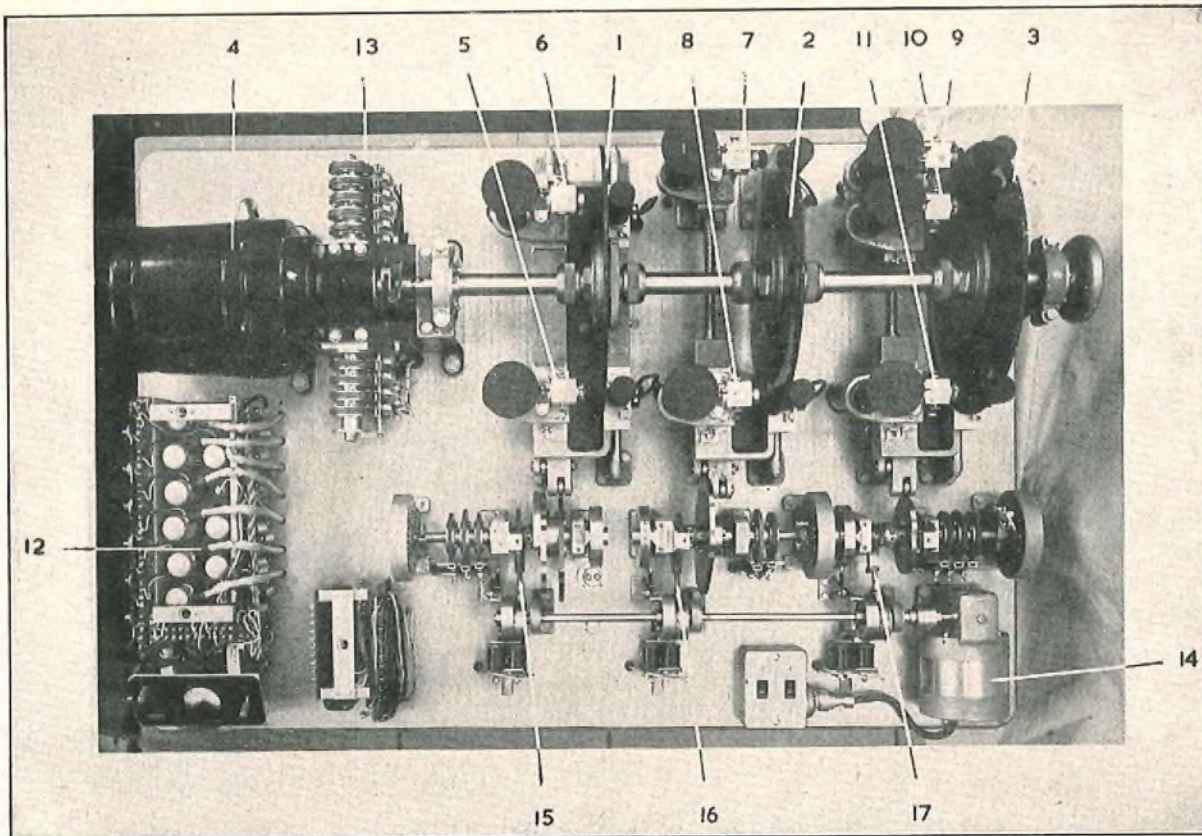

FIG. 3.—PLAN VIEW OF THE ANNOUNCING MACHINE.

seconds," ". . . and twenty seconds," etc., and "precisely"), and a series of 13 "pips" tracks.

Limitations of size restrict the number of complete tracks which can be accommodated on a disc to between 30 and 40. This number is adequate for disc 2 (13 tracks) and disc 3 (20 tracks), but not for disc 1 which requires 60 tracks. Fortunately, however, the "minutes" portion of the announcement is the shortest component (there are no additional words like "and . . . seconds" or "it will be" included) and so each minute track may be recorded on a half-sector of the disc. Disc 1, therefore, has recorded upon it two sets of 30 half-length tracks, one half of the disc bearing the "odd" and the other the "even" minute numerals.

For each set of tracks there is provided a lamp and photocell unit, which is fixed for the phrase, the synchronising signal and the pips, and is moved on a carriage for selection of the hours, minutes and seconds.

Disc 1 therefore has two moving photocell units (5, 6), disc 2 has one fixed and one moving (7, 8) and disc 3 has two fixed and one moving (9, 10, 11). The photocell outputs are connected to cathode followers (12) and thence to springsets (13) which are operated by cams on a 6 R.P.M. shaft of the main motor gearbox. This timing shaft rotates once in 10 seconds (the period of an announcement) and at the appropriate moments the successive parts of the announcement are switched in so that the complete sentence is built up. Thus the switching sequence is in the order

Phrase: Disc 2 (fixed photocell)
 Hours: Disc 2 (moving photocell)
 Minutes: Disc 1 (moving photocell)
 Seconds: Disc 3 (moving photocell)
 Pips: Disc 3 (fixed photocell).

The announcement must be changed every 10 seconds in order to state the correct time. This is achieved by moving the carriages carrying the photocells across the face of each

disc in such a manner that the correct tracks are selected. The motive power for this operation (which obviously must take place between announcements) is derived from an auxiliary motor (14) via a subsidiary shaft which runs past the carriages and carries clutch-operated pawls (15, 16, 17) which engage with ratchet wheels on small camshafts associated with each moving carriage.

Once every 10 seconds, the closing of contacts on the 6 R.P.M. timing shaft of the gearbox causes the clutch (17) of the "seconds" carriage to operate. Its pawl is engaged, the ratchet and cam are moved and the carriage advances one step to select the next track required for this portion of the announcement.

As the carriage moves across the disc, alternate tracks are used for successive announcements until the limit of travel is reached. The carriage then returns in steps to its original position, selecting the remaining tracks as it goes. By using this interlaced system of recording of the tracks it is possible to reproduce the announcements in sequence without the discontinuity of a "carriage return" operation.

The seconds camshaft rotates once every two minutes in 12 discrete steps. Six of the positions correspond to "odd" minute announcements and the other six to "even" minutes. Now the "odd" and "even" minutes photocells must be switched after each "and 50 seconds" announcement, but the minute carriage must be moved only once every two minutes—i.e. once per revolution of the seconds camshaft. This is achieved in the following way.

When the seconds carriage moves to the "odd minute—50 seconds" position, contacts associated with the seconds camshaft are closed and a circuit is thus prepared for the operation of the "minutes" carriage shift. When the next impulse arrives from the timing shaft both the seconds and the minutes carriages move on together. As the seconds carriage thus moves into the "even minute—precisely" position an additional pair of contacts operate a relay which

changes over the input to the announcement combining cams from the odd-minute photocell to the even-minute photocell. The six "even" minute announcements then follow. Then when the seconds carriage moves to the "odd minute—precisely" position the changeover relay releases, and the announcements are again taken from the odd-minute photocell until the "odd minute—50 seconds" position whereupon the cycle recommences. After each announcement ending in "... fifty-nine and fifty seconds" all three carriages move simultaneously and the hour track is also changed. The time taken for the carriage movements is not critical, provided that the operation is completed during the interval between announcements. It is thus permissible to drive the auxiliary motor (14) from the mains supply.

The final part of each announcement, the "pips," is derived from one of a series of 13 tracks recorded on disc 3. These are so disposed on the disc that the pips on successive tracks are displaced by the angular equivalent of 10 mS. By a suitable selection of the pip track, therefore, the timing of the pip signal can be adjusted in steps of 10 mS. This facility is used for compensating for the delay times of the observatory line and the distribution network: the most suitable pip track is chosen when the equipment is installed, and thereafter the pip optical system remains fixed.

Mounted on the announcing machine bedplate is a small chassis (12). This carries cathode followers and a mixer stage for combining the outputs of the various photocells.

TIME CORRECTION

The system so far described would produce announcements of time at 10-second intervals. It is necessary, however, to make these announcements conform with standard time which is determined by the national observatory. The clock oscillator frequency may not be exact or may change with ageing of the crystal. Furthermore, standard time is subject to corrections which are applied by the observatory as a result of astronomical observations. Consequently it is essential to make a periodic comparison of the time declared by the clock with time signals obtained from the observatory, and to apply a correction to the clock if it should be required. A regular check is therefore made for this purpose once per day.

To simplify the error detection and the correcting equipment, the correction is applied in a series of discrete steps. At a prearranged time, therefore, signals derived at one-second intervals from the clock (from the synchronising track on disc 3) are compared with similar signals received over a line from the observatory, and it is determined whether, at the instant of comparison of the first pair of pulses, the clock is fast or slow. If the clock is found to be fast, then it is retarded by an interval of 1 mS, or vice versa. This correction is performed automatically, and is completed before the next pair of pulses arrive for comparison.

The 1 mS corrections continue to be applied in this manner at one-second intervals until it is found that the observatory signal and the clock signal differ by less than ± 1.5 mS, when the examination ceases until the next correction check on the following day.

Referring to Fig. 1, it will be seen that the observatory line is connected to a panel called the Timing Comparator which also receives the signals from the synchronising track of the clock. Associated with this panel are three others called Timing Corrector panels. These collectively form a control circuit in the 50 c/s supply from the oscillator to the clock motor, and contain a phase-shifting device which may introduce a phase shift of either sign and of predetermined magnitude.

The sequence of operations which occurs when time correction is applied may now be described in greater detail.

Shortly before the observatory transmits its time signals, a series of cam-operated contacts associated with the photocell carriages of the announcing machine prepare the time-correction apparatus for the check. When the first pulse arrives from the observatory, it passes through a circuit where its shape is modified and then into the Timing Comparator. At approximately the same time a similar signal is supplied by the clock. The two are compared, and if the clock is fast (or slow) by more than 1.5 mS the "fast" (or "slow") relay of the Timing Comparator is operated and the information is passed to the phase-shifting device of Timing Corrector No. 1. This device then retards or advances the phase of the 50 c/s supply to the clock motor by an amount which corresponds to a change of 1 mS in the clock time. Towards the end of this phase-shifting operation a reset signal is sent to the Timing Comparator to prepare it for the arrival of the next pair of pulses.

The whole of this detecting, correcting and resetting operation takes less than one second to complete. The process is repeated at one-second intervals until the clock time is within ± 1.5 mS of standard time. When this condition occurs both the "fast" and the "slow" relays of the Timing Comparator are operated, no phase shift takes place in Timing Corrector No. 1 and no reset signal is returned. The correction circuit is thus shut down until the next check is initiated. The amount of correction applied to the clock is displayed on the Timing Corrector No. 2 panel, and an alarm is given if a correction of more than 6 mS has been required.

ALARM CIRCUITS AND STANDBY FACILITIES

As described above, there may be four sources of signals available for distribution to local telephone subscribers, i.e., two local clocks and two incoming lines from a distant installation. One of the local clocks is chosen as the working source: the other and the distant clocks are used as reserves. All four sources are linked by changeover contacts which will switch in a reserve source if the working source fails. This operation is controlled by the alarm circuits of the installation, and in particular by the pilot tone alarm system, which will now be described.

During the recording of the announcing machine discs, a constant level tone of 3.2 kc/s has been superimposed on all the speech and "pip" tracks. Consequently if the machine is working correctly this tone should be present continuously in the output signals. A "line amplifier and pilot tone alarm" panel is inserted in the line from each source. On this panel a low-pass filter suppresses the tone and transmits the speech signals to the local distribution amplifiers while a band-pass filter rejects the speech frequencies and passes the tone to a detection alarm circuit. This system gives a complete safeguard against any fault which would cause the omission of part or all of an announcement (such as photocell, lamp, contact, or amplifier faults).

There remains the possibility that a clock may be making announcements which are complete but incorrect. This may happen if, through a fault condition, the motor drive frequency changes, or if a photocell carriage is not stepped forward at the correct moment.

It is unlikely that such faults would occur simultaneously on both the clocks of an installation and so a reliable detection of this type of fault may be made by comparison of the two.

The "disc out of step" alarm compares the timing of the synchronising tracks of disc 3 of the machines and so determines differences of drive frequency, while the "carriage out of step" alarm gives an indication of differences of carriage position. Other alarm circuits are provided to give warning of failure or excessive frequency drift of the oscillators.

DISTRIBUTION OF ANNOUNCEMENTS

The speech and time signals of the working clock are fed into the two power amplifiers, one of which supplies the public network and the other acts as a reserve. An alarm circuit, which detects change of gain, controls the change-over of the amplifiers if a fault should occur on the one connected for service. Since the amplifiers can be interchanged independently of the rest of the system, service can continue provided that any one amplifier and any one clock or distant source are functioning.

It is expected that a clock installation will be accommodated in an exchange building, but its location may be remote from the telephone apparatus room. To avoid loss of level in the junction, therefore, the designed load impedance of the power amplifier is 400 ohms, and a transformer is provided to be installed in the apparatus room to step down to a 4-ohm load resistor across which the subscribers' relay sets are connected in parallel (the low value of 4 ohms for the load being employed to avoid level changes with varying load and to prevent crosstalk).

TIME-SIGNAL GENERATORS

Provided with each installation are two mechanisms (manufactured by Muirhead & Co., Ltd.) for producing civil and marine time signals. Each machine consists of a small synchronous motor which drives a series of cams through suitable gearing. Contacts are closed by the cams at the correct intervals to control the signals transmitted. The machines are mounted on a single table between the clock announcing machines and are driven from the controlled 50 c/s supplies which feed the clocks. Consequently each time-signal generator will continue to function in step with observatory time as long as its parent clock is in operation.

AUXILIARY POWER SUPPLY

An auxiliary 200/250V, 50 c/s power supply is provided to ensure that service is maintained in the event of a mains failure. The equipment comprises two generators, driven by 50 V D.C. motors, and a switchboard. The working clock is normally run from the mains supply and the standby clock from the first generator. The second generator is normally idle. If the mains should fail the standby clock is automatically brought into service and an alarm is given. The second generator may then be started up and used to supply the first clock (which now becomes the standby and which will, of course, require to be synchronised with

the second clock before it can be used). It is important that the supply to the 100 kc/s oscillators should not be interrupted since this would cause a sudden and unpredictable change in the rating of the crystals. Consequently arrangements are made to switch the oscillator supplies automatically from the mains to generator and vice versa if one of these supplies should be interrupted.

ACCURACY

The ultimate accuracy of the time signals received by a telephone subscriber depends upon the following factors:—

- (a) The precision of correction of the clock to conform with observatory time.
- (b) The short-term stability of the synchronous motor.
- (c) The stability of the drive oscillator.
- (d) The time delays in the distribution network and in the observatory line.

Each clock is normally corrected once per day, and immediately after the correction interval the time announced should be within ± 1.5 mS of standard observatory time as received at the clock installation. However, the synchronous motor driving the clock mechanism is subject to random angular variations arising from compliance in both the electrical and the mechanical couplings. These variations give rise to an error which varies from instant to instant but does not exceed ± 1 mS. Furthermore, the drive oscillator frequency is likely to drift by an amount not exceeding 2 mS per day. Consequently the accuracy of the clock signals is within about ± 2.5 mS immediately after correction or ± 4.5 mS just before correction is applied.

Added to these errors is that due to the time delay in the distribution network. This may amount to several milliseconds per 100 miles, and is, of course, always tending to make the signals slow with respect to standard time. Delay in the line from the observatory to the clock has a similar effect. If the distribution network is considered as a whole, it may be desirable to minimise the average error in time signals by sending them from the clock in advance of true time. If, for instance, the delay to the furthest point of the network is 20 mS and the signals are sent 10 mS fast, then the error due to line delay at any point in the system will not exceed ± 10 mS. To make this compromise possible a series of "pip" tracks is provided on the "seconds" disc as previously described.

(To be continued)

Book Review

"Magnetic Materials in the Electrical Industry." P. R. Bardell, B.Sc., M.I.E.E., F.Inst.P. Macdonald. 288 pp. 157 ill. 32s. 6d.

The author, according to his preface, has set out to write a book intended to be helpful to students of physics and electrical engineering and to bridge the gap between an academic study of the properties of magnetic materials and the limited treatment of the subject possible in most textbooks for engineers. In this task he has succeeded. The bias is perhaps more to engineering than to physics and it represents a very common-sense approach.

Following two commendably brief (for this type of book) chapters on Terminology and Theoretical Considerations the book divides naturally into two parts, materials and measurement, and applications. The information is fully up-to-date and presented in a business-like way and we are reminded from time to time that the author has not forgotten his potential readers by sentences such as "A generous safety-factor must be allowed to cover the losses in the magnetising circuit.

Experience shows that three is a reasonable factor" (page 54) and "To express the torque in gram-centimetres the above value must be divided by 981" (page 58).

As usual in this type of book it has been difficult to decide just what of the published data should be passed on, but what is less usual is that Mr. Bardell has made a not unsuccessful attempt to discriminate between data on the attainable properties of materials and those which may be reached in commercial practice. This is a valuable point.

One small point in table 4.3 needs correction; the reviewer believes that both Permalloy C and Mumetal (British made) contain both copper and molybdenum. This explains the resistivity (60) which is higher than that for 4-79 Permalloy (about 55) and for copper-mumetal (about 25).

Among the applications dealt with are magnetic recording, magnetic amplifiers and transducers; the chapters are brief but give an adequate introduction to the subjects.

The book is well produced and well worth the price.

C. E. R.

Developments in Exchange Ringing Equipment

F. C. GOULD-BACON, A.M.I.E.E.,
and R. F. PURVES, A.M.I.E.E.†

U.D.C. 621.395.631.4 + 621.373.1:621.313.332

This article briefly reviews the development of exchange ringing equipment and describes the present standard equipment. It then describes, in some detail, a new type of ringing equipment, constructed as rack-mounted equipment for installation in exchange apparatus rooms, which is undergoing field trials.

INTRODUCTION

IN the very early days of telephony, it was found that a small hand-operated A.C. generator was sufficient to ring the bell of a called subscriber and that, under average conditions of operation, the generator rotated at 1,000 R.P.M., producing approximately 75V at 17 c/s. These figures formed the basis of design of ringing machines from that time onwards, firstly for hand generators belt-driven from small electric motors, and later for power-driven machines of motor-generator or dynamotor type. In addition to supplying ringing current, other facilities were gradually introduced with the increasing complexity of telephony, and ringing machines now supply continuous ringing and three phases of interrupted ringing current; ring, number-unobtainable (N.U.), busy and dial tones and pulses such as flicker earth, interrupted earth and interrupted battery and earth.

For many years the tones and pulses were produced from drum interrupters of commutator type. The tone drums were carried on the main shaft and the interrupter drums were driven by reduction gearing on one end of the machine. Frequent cleaning of the drums was necessary to maintain a reasonable performance and the outputs obtainable were small and resulted in difficulties on heavily-loaded installations. For these reasons, the slow-speed drums producing pulses were replaced by cam-operated springsets of a robust type and, with the introduction of 2,000-type automatic equipment, the high-speed tone drums were replaced by tone-inductor alternators producing approximately sinusoidal wave forms.

THE PRESENT STANDARD EQUIPMENT

With present standard equipment, four sizes of ringing machine are available, 15, 75, 150 and 300W, but they are not readily interchangeable from one size of plant to another. The factor at present determining the size of plant that shall be installed is the forecast number of calls to be rung in the busy hour, and the size is determined as follows:—

Up to 2,600 "rung" calls per busy hour	15W
Exceeding 2,600 but less than 16,000	
"rung" calls per busy hour	75W
Exceeding 16,000	150W
Large multi-exchange buildings	300W

Two machines are provided at each installation, the regular machine being a mains-operated motor generator, and the standby machine a battery-operated dynamotor. The latter is only brought into service during periods of mains failure or when the mains-operated machine requires maintenance attention, and thus the dynamotor receives very little use during the course of its life. Changeover to the standby machine takes place automatically in the event of failure of the mains-operated machine.

The control and distribution equipment is located on a panel of conventional power-board design, usually mounted adjacent to the exchange power switchboard, and appreciable cabling is required between machines and panel, and between the panel and the switching equipment it serves,

† The authors are, respectively, Executive Engineer and Assistant Engineer, Telephone Development and Maintenance Branch, E.-in-C.'s Office.

which is sometimes several floors away.

The machines and panel are normally located in the power room on masonry piers or tubular steel stands. Tubular steel stands, which are a recent development, are less costly than piers, enable access to be gained to the machine from all directions for maintenance purposes, and are easily moved if rearrangements have to be made.

Both machines consist basically of an inductor tone generator and a 17-c/s alternator mounted on the same shaft, and in both types of machine the required interruptions of ringing current and tones are obtained from springsets operated by cams on a camshaft driven from the main shaft by a worm-and-wheel reduction gear. The inductor tone generator is the same for both machines but the 17-c/s alternators differ.

The Inductor Tone Generator.

The facilities provided by the inductor tone generator are:—

- N.U. tone.* 400-c/s continuous sinusoidal waveform at a level of 1-2V is supplied direct, and also via a transformer giving a battery-connected supply.
- Busy tone.* 400-c/s sinusoidal waveform of 2-3V, interrupted via a springset so that tone and earth are sent out alternately at 0.75 sec. intervals.
- Dial tone.* 34 p.p.s. This consists of pulses of approximately 300-c/s tone at 30 millisecond intervals, since 34-c/s tone would be below the range of audibility. It has peak values exceeding 30V, but the R.M.S. value is about 2V. The harmonics are of value in improving audibility.
- Ring tone.* 400-c/s sinusoidal waveform, modulated at 17 c/s, at about 2V R.M.S., which is interrupted, via springsets, at a similar periodicity to ringing current. The 17-c/s modulation is obtained by energising the inductor field with continuous ringing current; the resulting modulated waveform is considered to simulate the sound of a bell ringing.

The inductor tone generator consists of slotted rotors and stators made up of soft iron stampings of high permeability. The rotors, which carry no winding, serve to provide flux paths varying at the required frequency in the magnetic circuit of their stators when the machine is running at its normal speed.

Each stator carries two windings, an energising winding to polarise the stator, and an inductor winding in which alternating current is generated by the flux variations produced by the rotor. For N.U., busy and dial tone, the stator is energised from the exchange battery and adjustment of voltage output is obtained by varying external resistors in the field circuit.

The N.U.-tone and busy-tone inductors are similar, each having 24 slots in the periphery of the rotor and stator; the dial-tone rotor and stator have two slots.

The ring-tone rotor and stator are similar to those for N.U. and busy tone, but the field is energised by current from the 17-c/s alternator. This gives the 17-c/s modulation which characterises ringing tone. Adjustment of output voltage is effected by varying external capacitance in the field circuit.

The Motor Generator.

The 17-c/s alternator is a self-excited generator of the two-pole type rotating at a normal speed of 1,000 R.P.M., and its armature carries two windings, the exciting winding and the alternator winding. The exciting winding is commutator connected and generates direct current which is used to excite the field, the combination constituting a shunt-wound D.C. generator. The alternator winding is slip-ring connected and generates the ringing current at 75V, 17 c/s.

The complete unit (alternator and tone generator) is coupled to a mains-driven electric motor by means of a flexible coupling, the function of which is to take up any small irregularities in alignment between the two units. The overall efficiency of this unit at full load is of the order of 30 per cent.

The Dynamotor.

This is a separately excited battery-driven machine of the two-pole type, running at a normal speed of 1,000 R.P.M.

The armature has two windings and a common field for driving and generation. The field is D.C. excited from the exchange battery, and the armature driving winding is commutator connected to the exchange battery. This arrangement constitutes a shunt-wound D.C. motor. The second armature winding is slip-ring connected and generates the ringing current.

The overall efficiency of this unit at full load is of the order of 40 per cent.

Control Facilities.

The operation of the machines is controlled from the panel which contains the automatic changeover mechanism, automatic starter and associated relays, coils and fuses, and the monitor and alarm circuits. Where 15W machines are used, they are located on the front of the panel, larger machines being mounted on piers or stands, as already described.

The changeover switch consists of 24 mercury tubes mounted on a solenoid-operated tilting platform, to change over each of the outputs and the power supply from the mains-operated to the standby machine. So that the cause of any failure may be investigated, manual operation is necessary to restore the mains-operated machine to service.

Either machine may be run independently for maintenance and testing purposes; the mains-operated machine is provided with a manual starter and the standby (dynamotor) machine with an automatic starter of single- or two-step type according to size. Monitoring relays are connected to the continuous-ring output to the Alarm Equipment Rack and to each of the interrupted-ringing phases so that any failure causes changeover to the standby machine and gives a prompt alarm.

NEW DEVELOPMENTS

It has recently been agreed that the frequency of ringing current can be increased from 17 to 25 c/s. This will enable 50 per cent. more power to be obtained from a given machine-frame size, or, what is more important, enable the frame size for the same power to be reduced.

The present machines are, both mechanically and electrically, rather cumbersome for the amount of work they are called upon to perform. The 75W and larger machines are almost invariably equipped with three in-line bearings, because of their size and shaft length, and the necessity to withdraw the tone-generator rotor from the shaft to enable the centre bearing to be renewed causes difficulty in maintenance.

The efficiencies of the present standard machines are not good, and this has led to consideration being given to the use of a rotary convertor for the generation of ringing current. This type of machine is virtually a shunt-wound

D.C. motor having only one armature winding, commutator connected at the driving end, and tapped at electrically opposite points which are slip-ring connected at the output end. The machine behaves as a commutator switch, effecting (at 25 c/s) 50 reversals per second, the inductance of the magnetic field ensuring a reasonably sinusoidal output.

The output voltage of this machine, unlike that of an alternator, does not vary with machine speed, but only with input voltage and load, and it can consequently be kept within closer limits than that of the present type of machine. The form factor varies slightly with speed but this is not important.

Efficiencies of the order of 80 per cent. at full load are usually obtained with machines of this type, but what is more important, only a comparatively small input is required at no load. It suffers the disadvantage that the R.M.S. value of the output voltage is only $1/\sqrt{2}$ of the input voltage and for an input of 50V the output will be about 37V. Thus a transformer is necessary, but by using a transformer of about 90 per cent. efficiency it becomes economic to use this type of machine and abandon the use of mains-driven machines.

The inductor tone generator of the new machine will be energised by a permanent magnet, thus reducing the size of the stator since exciter windings will not be necessary.

Adjustments of output voltage will be obtained by the use of tapped inductor windings, or adjustable mechanical flux shunts. Modulation of the ring tone will be obtained either through an external non-linear modulator by the use of 25-c/s ringing current, or by the use of split inductors, generating frequencies differing by the required modulation frequency, connected in series.

Finally, the ringing machine can incorporate the functions of the meter-pulse machine, thus dispensing with the present arrangement for the separate generation of meter pulses by separate pulsing machines, two of which, together with a control and changeover panel, are at present provided at each automatic exchange where more than single-fee metering is required.

As the future policy regarding multi-metering is, however, under review, and consideration is being given to other methods of call charging, the present method of metering one to four unit fees will not initially be carried into the new equipment.

The whole conception of the new machine, its reduced size and weight and the fact that it is to be battery operated, lead to the logical conclusion that the machines and control equipment should be rack-mounted in the automatic switch-room and be regarded as an integral part of the signalling system, rather than as part of the power plant.

PROPOSED NEW RINGING RACK

A new rack has been designed to carry any of three sizes of machine, which can be interchanged on the same mounting as the ringing load increases with exchange development. The three sizes of machine that will be standardised are 15, 37.5 and 75W, allowing up to 2,600, 8,000 and 16,000 rung calls per busy hour, respectively.

Where an exchange requires a plant larger than 75W, it is proposed to install two racks, but only multi-exchange installations are likely to come into such a category, and for these it is proposed to install a rack for each exchange.

The first of these new ringing equipments has been installed experimentally at Weymouth Exchange, supplying two 40V installations of CB1 and CB10 type, and equipped with two 37½W inductor machines for 40V D.C. input. During 1955, three more similar equipments are to be installed, two in London automatic exchanges and one in a manual exchange.

The manual-exchange installations are interesting in that

inductor tone machines have been introduced for the first time at a manual exchange owing to virtual cessation of supply of the old drum-interrupter machines and, using a transformer panel described later, they are supplying all the required outputs at levels at least as good as those obtained from the drum.

Figs. 1 and 2 show the rack now installed at Weymouth, and Fig. 3 shows the ringing panel and motor starter slightly

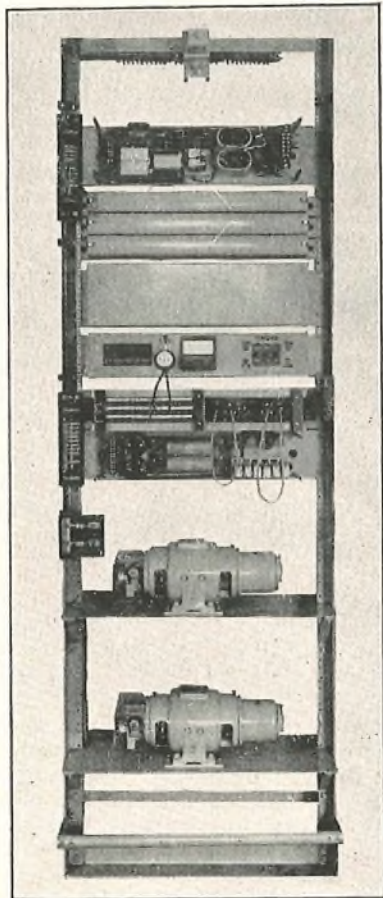

FIG. 1.—THE NEW RINGING EQUIPMENT AT WEYMOUTH C.B. EXCHANGE.

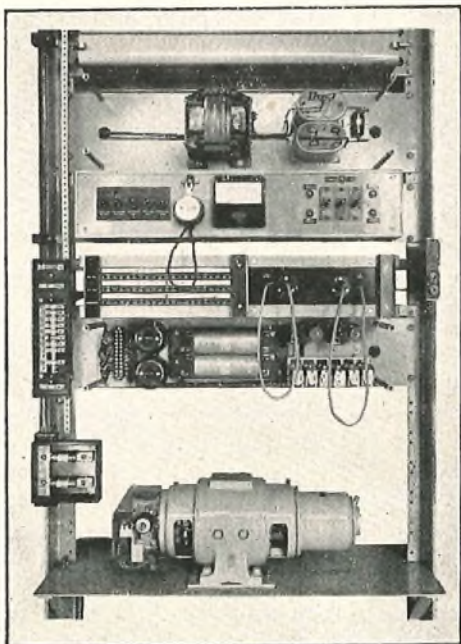

FIG. 2.—RINGING PANEL AND MOTOR-STARTER AT WEYMOUTH C.B. EXCHANGE.

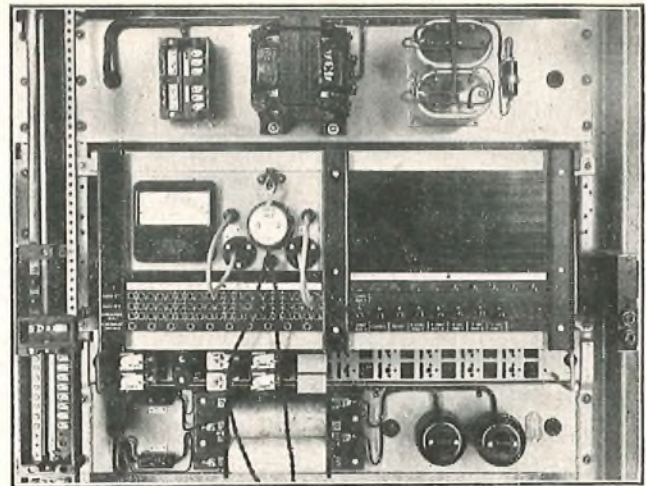

FIG. 3.—MODIFIED VERSIONS OF RINGING PANEL AND MOTOR STARTER.

altered in design to conform more closely with standard 2,000-type rack practice.

The 37½W machines fitted are of Messrs. Dynamo & Motor Repairs Ltd. manufacture, providing 17-c/s ringing and having battery-energised fields for motor and alternator. They are, therefore, only slightly smaller than would be 75W machines having permanent magnet fields and delivering 25 c/s. On the last of the four experimental plants, arrangements have been made to provide 37½W machines of permanent-magnet type delivering 25 c/s, made by Messrs. Walter Jones & Co., as shown in Fig. 4. It is hoped that 75W machines of this type will be available within about 12 months.

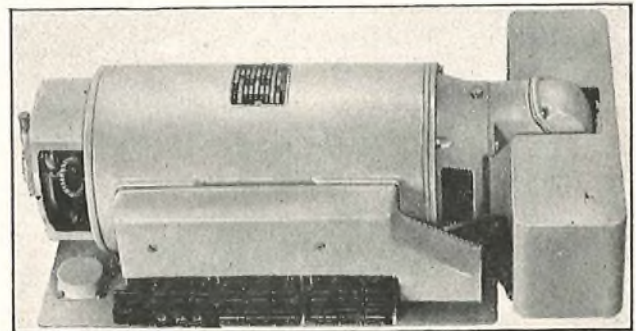

FIG. 4.—ONE OF THE NEW PERMANENT-MAGNET RINGING MACHINES.

Panels, Ringing, No. 10.

The panel incorporates a number of new design features intended to overcome difficulties and shortcomings experienced in the past, but where existing design was considered sound, it has been retained in the new panel. The principal new features are:—

- (a) A symmetrical circuit for two identical battery-driven machines enables No. 1 or No. 2 to be used as the regular supply, with automatic changeover to the other in the event of a failure (see Fig. 5). This permits each machine to take an equal share of wear instead of one doing all the work.
- (b) Changeover is accomplished with 3,000-type relays having heavy-duty or platinum contacts where necessary, instead of a multiplicity of mercury tubes on a tilting platform, as previously used. This effects a worthwhile saving in cost, space and maintenance, and improves circuit flexibility as separate "make" contacts are used for each machine instead of common changeover contacts.
- (c) Simplified circuits for provision of N.U. and busy tone from a single source, and for feeding the

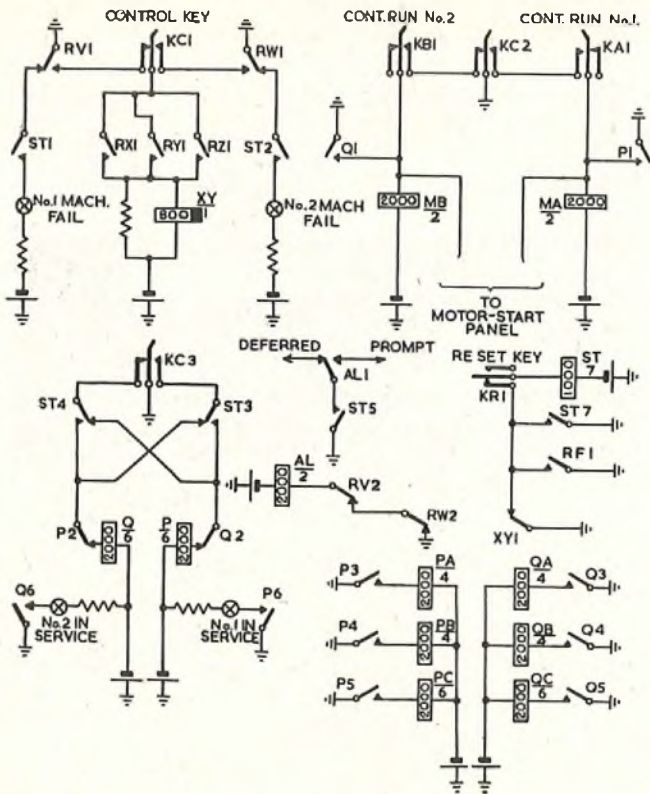

FIG. 5.—CHANGEOVER CIRCUIT ELEMENTS OF PANEL, RINGING, No. 10.

alternator fields (see Fig. 6).

- (d) Operation over the range from 40-50V D.C. (nominal), and connection to auxiliary equipment so that any type of telephone equipment, automatic or manual, can be supplied, within the approximate limits of 400-10,000 connections. The number of installations still working on 22-30V or on 60V does not justify inclusion of these voltage ranges.
- (e) Test-tone and test-meter facilities on all the services provided, both from each machine and to the common feeds on the exchange supply side of the changeover equipment. The meter is of differential

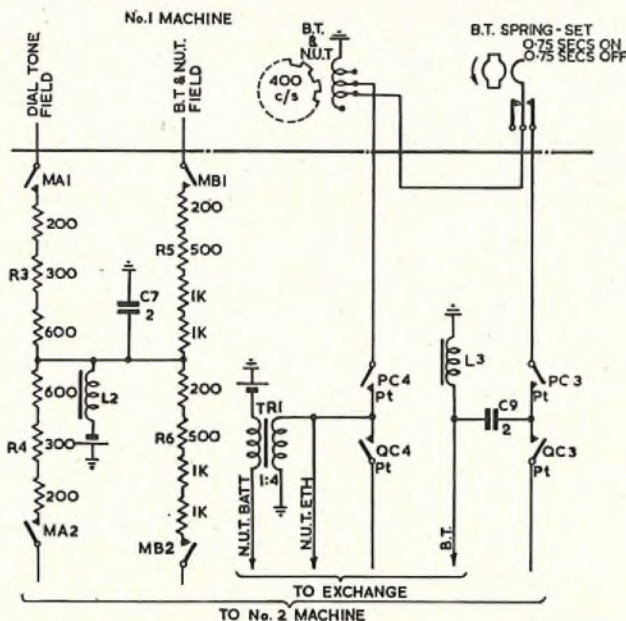

FIG. 6.—MACHINE FIELD CONNECTIONS AND N.U.-TONE AND BUSY-TONE CIRCUITS.

- (f) Provision of a rectified alarm relay winding enabling the A.C. ringing outputs and capacitors to be connected to alarm circuits in the normal manner.

In Fig. 5, No. 1 or No. 2 machine is made the "regular" using the Control key KC. Monitor relays RV and RW (not shown) operate to continuous ringing from No. 1 or No. 2 machine respectively, and monitor relays RX, RY and RZ (not shown) operate sequentially to interrupted ringing, in the manner of existing equipment.

If No. 1 is the regular machine, then relay XY is held operated via RV1 and RX1, RY1 or RZ1 operating in sequence to each of the ringing phases. Release of XY due to a phase or continuous-ringing failure results in operation of relay ST and changeover to No. 2 machine, with prompt alarm during any period of complete failure, changing to deferred alarm when No. 2 is operating.

Relay P or Q operates the chain of relief relays PA, QA, etc., for connecting all facilities provided by No. 1 or No. 2 machine. PI or QI energises the motor-start circuit via relays MA or MB; P2 and Q2 are connected in an interlock circuit which ensures that No. 1 and No. 2 machines are not connected to the load simultaneously.

Relays MA and MB energise the respective alternator field windings and may also be operated by the Continuous-Run keys KA or KB. Separate fusing for the relays associated with each machine ensures that the rupturing of any one fuse does not cause failure of the entire system.

Motor-Start Panels.

An integral part of the new equipment is the motor-start circuit for automatic "direct on" starting of small machines (15W output) or two-stage starting on larger machines. The "direct-on" starter has heavy-duty "Arrow" relays which are energised from the ringer panel. The contacts have wide separation capable of extinguishing any arc formed when breaking the motor circuit under normal or fault conditions.

The two-stage starter (Fig. 7) is for use with 37½W and

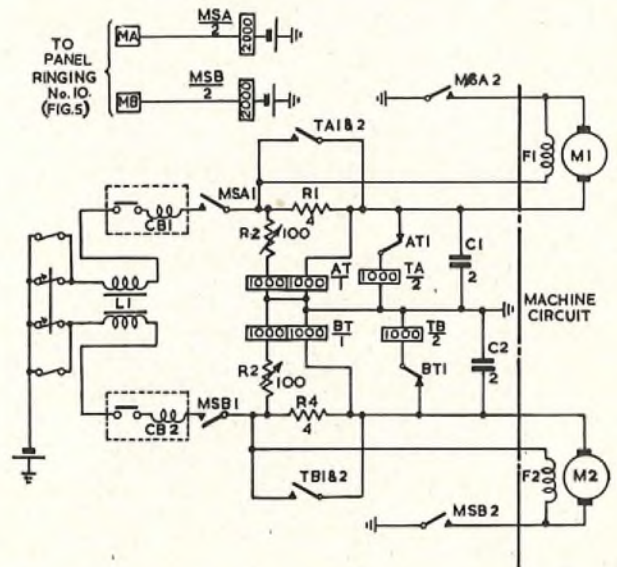

FIG. 7.—TWO-STAGE STARTER (PANEL, MOTOR-START, No. 3A).

larger machines (see Fig. 3). There is an initial start resistance which is cut out when the back E.M.F. in the armature winding has built up to a predetermined value. Good results have been achieved, and with very simple adjustment the maximum start current can be restricted to approximately 2½ times normal for the initial surge when switched on, and for the second surge when the resistor is

cut out. Operation is not affected by exchange voltage variations (46 to 52V).

When No. 1 machine is switched on, relay MSA (Fig. 7) operates to the start earth, and relay AT operates via its left-hand coil. Due to the large voltage drop across R1, the reverse current through the right-hand coil is negligible until armature rotation causes rapid build-up of the back E.M.F. The current through the right-hand coil then increases until it neutralises the left-hand coil and relay AT releases. AT1 then closes to operate relay TA and cut out the start resistance R1. Circuit breakers of common commercial type are provided to deal with gradual overload (thermal release) or sudden heavy overload (magnetic release). The protection thus afforded limits the extent of possible arcing and permits the use of 3,000-type start relays having heavy-duty contacts for MSA, MSB, TA and TB.

When setting up with a particular pair of machines, adjustment of R2 and R3 is made to equalise approximately the first and second current peaks.

Transformer Panels.

Panel, Ringing, No. 10 gives all the standard facilities required by 2,000-type automatic equipment, and where other facilities are required for earlier automatic or manual exchanges, a Panel Transformer No. 5A is used. In this circuit (Fig. 8) some latitude is given in choice of components and circuitry to meet the varying requirements.

Relays operate from the "Int. Earth" from the ringer panel to supply "Busy Tone and Flash," "Busy Hold," "Busy Tone non-balanced" (no flash), or "Busy Back." "Dial Tone non-balanced" is supplied from a step-up

auto-transformer TR3 with tuned output to boost the level and provide an audio bypass to avoid crosstalk due to the common impedance of the transformer winding in circuit with all subscribers connected to the supply at a particular instant. Crosstalk trouble was experienced with the Transformer No. 130A previously used for this purpose.

"NU Tone Earth" and "Inter. Ring Tone" non-balanced supplies are provided from the balanced supplies via transformers TR2 and TR4.

"Feed-back Ring Tone," which is required for manual and early automatic exchanges (double-sided rack equipment) is provided by a step-up transformer from the ring tone balanced supply and superimposed on the ringing current via a $4\mu\text{F}$ capacitor. A choke is introduced into the earthed side of the ringing supply to avoid shunting ring tone to earth via the low impedance alternator winding. Existing designs of transformer for this purpose have too high a step-up ratio for adequate transfer of power, and a new transformer is to be used in future.

The difficulties of equalising tone levels for different types of equipment are sometimes acute, but progress has been made and the new circuits give maximum possible flexibility. The transformer tapplings, field resistors or alternator tapplings, or capacitors in the case of ring tone, enable consistent audio levels to be obtained. It is not possible to lay down specific levels from the machine because of the variations in loss in the user equipment according to the type of feed circuit, and the difference in harmonic content from individual machines, which often results in tones as heard by the subscriber sounding very different from those sent out from the machine. Psophometric weighting factors would be necessary to assess comparable levels of varying frequency and harmonic content and, even then, no account could be taken of line variations.

CONCLUSION

A brief summary of the development of ringing plant from the earliest stages to the present day has been given, and the present lines of development have been explained in some detail. The development constitutes a radical change in conception from power plant design to automatic telephone practice and the initial installations are regarded as experimental, so that any circuit or physical design problems occurring can be remedied before the plant is put into general production. It seems likely, however, that the design can go ahead with little alteration.

The possibility of using electronic equipment wholly or in part has not been overlooked at any stage, but this is a field where well-designed machines compare very favourably with any present-day electronic counterpart from almost every standpoint. Initial cost and annual charges are in themselves decisive, but the difficulty of designing an electronic counter to give the pulse periods required would be considerable, and changeover to standby, which with a machine takes less than one second, could hardly be equalled.

For small manual exchanges and P.B.X.s, where tones and pulses are not required, however, the sub-cycle convertor operated from 50 c/s A.C. mains has found a considerable field of usefulness since the war.

ACKNOWLEDGMENTS

The authors wish to thank the L.T.R. Power Section, Macaulay Workshop, for building the experimental plants and for their assistance in the solution of many of the physical design problems which arose in course of the work, Messrs. Walter Jones, Ltd., for the photograph of the Permanent Magnet Ringing Machine, and Messrs. Dynamo & Motor Repairs, Ltd., for the production of the 40V dynamotors used for the initial installation.

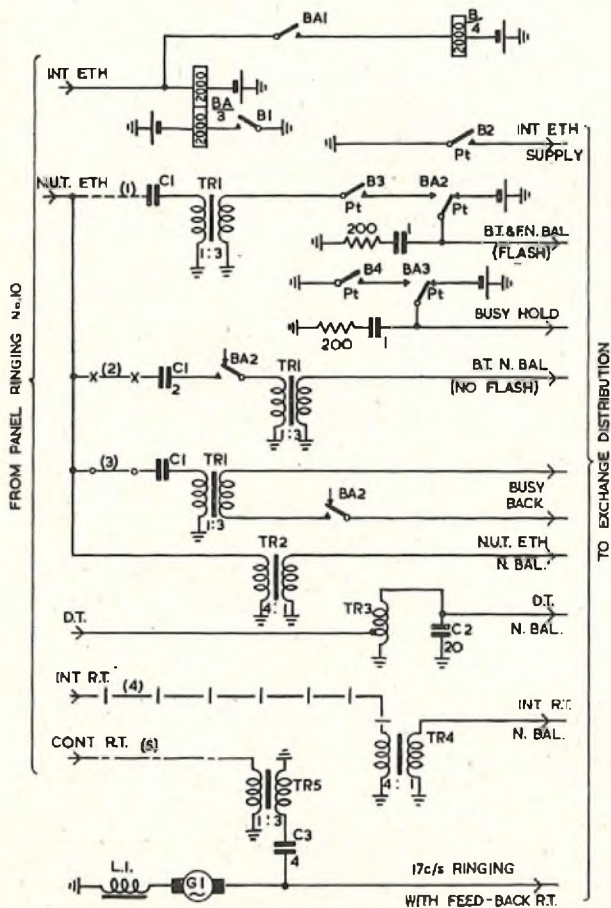

(1), (2) and (3) are alternative "busy" connections.
(4) and (5) are alternative ring-tone connections, but can be used simultaneously.

FIG. 8.—PANEL, TRANSFORMER, NO. 5A.

Cartridge-Fired Hammer Guns

E. E. M. SMITH, A.M.I.E.E.†

U.D.C. 621.974:662.2

A brief description of a tool which, by the use of a cartridge, enables fixing pins and studs to be fired direct into most building materials. The tool is of particular value in repetition work or where congestion of plant makes the use of hammer and jumper, or other tools, undesirable.

OUTLINE OF OPERATION

THE Cartridge-Fired Hammer Gun, a tool for making fixings in structures without previous drilling or plugging, has recently become available in this country, although extensively used for a number of years both in the United States of America and on the Continent.

In the simpler type of hammer gun (see Fig. 1) a stud or pin is push-fitted in the gun barrel and an explosive propellant charge, contained in a cartridge, is placed in direct contact with the head of the stud. The cartridge is fired by a striker-pin hitting a percussion cap, expansion of the gases forcing the stud forward in the barrel and giving it sufficient velocity to penetrate most building materials, including rolled steel joists. The depth of penetration can be varied by using cartridges containing different strengths of propellant charge.

In another type now available a piston is included between the stud and the cartridge, and with accessories supplied with the tool it is possible closely to control the depth of penetration of the stud. Although the piston-drive method is satisfactory, these guns are somewhat complicated due to the large number of parts to be assembled

when loading and it is often as quick, or quicker, to use one of the older and well-tried fixing methods.

The studs and pins are available in various lengths so that in different materials sufficient penetration can be obtained to give satisfactory fixings, e.g., a stud with a short shank is used for fixings in a hard homogeneous material such as steel, whereas a stud with a long shank is required for a material that is inclined to shatter, such as concrete.

DESCRIPTION OF TYPICAL GUN

Fig. 2 shows a sectional view of the simpler type of gun illustrated in Fig. 1, a tool which fires $\frac{1}{4}$ -in. studs. A larger version firing $\frac{1}{2}$ -in. studs is also available, which, by using threaded sleeves screwed on the studs, can be adapted to fire $\frac{5}{16}$ -in. and $\frac{3}{8}$ -in. studs.

Another commercial model uses either the direct or piston-drive method for firing the smaller sizes of studs and, with a conversion kit, can be adapted for firing $\frac{1}{2}$ -in. studs by direct drive.

All makes of tool are fitted with safety devices to prevent them from being accidentally fired. When loaded, a gun cannot be fired unless the muzzle of the barrel is pressed against a solid surface, since pressure is necessary to compress springs within the tool which cock the striker pin

† Assistant Engineer, External Plant and Protection Branch, E.-in-C.'s Office.

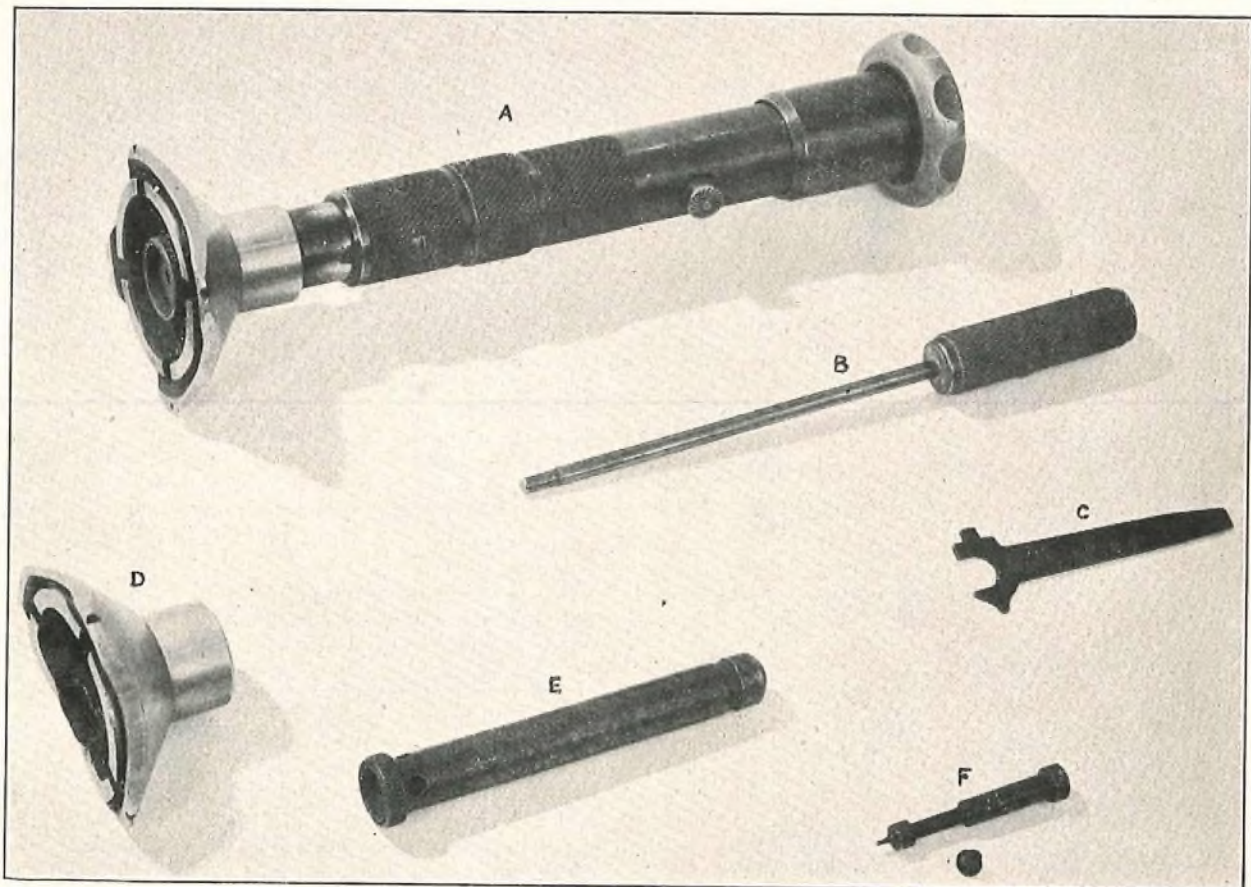

A—The Complete Tool.

B—Cartridge Ejector.

C—Dismantling Tool.

D—Triangular Splinter Guard.

E—Second Barrel (accommodating alternative-sized washer).

F—Spare Striker Pin.

FIG. 1.—TYPICAL SET OF TOOLS FOR THE SIMPLER TYPE OF HAMMER GUN.

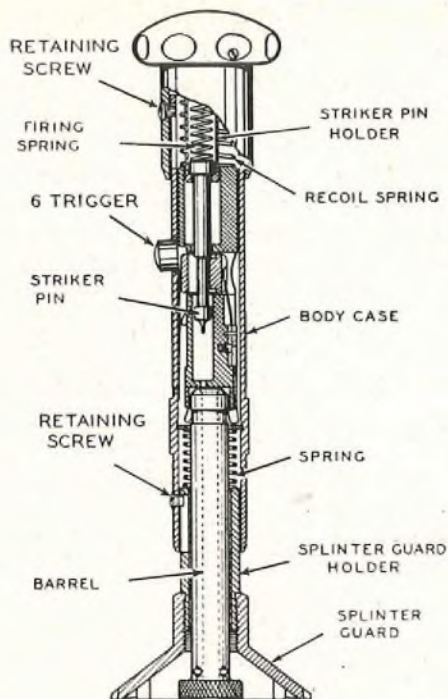

FIG. 2.—SECTIONAL VIEW OF GUN SHOWN AT 'A' IN FIG. 1.

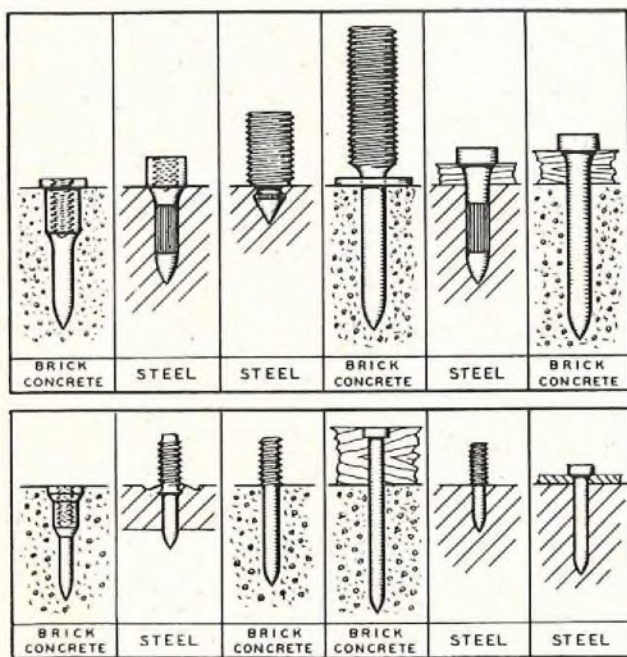

FIG. 3.—SELECTION OF STUDS AND PINS USED WITH HAMMER GUNS.

Book Received

"Die Theorie des Nebensprechens auf Leitungen" (in German). W. Klein. Springer-Verlag, Berlin. 135 pp. 55 ill. DM 18.

Although the theory of crosstalk in high-frequency cables has in recent years reached a conclusive stage of development and the method of calculation can be applied to many practical cases, there are, however, certain important problems in practice which have not been considered. It, therefore, seemed desirable to present the works published in this field in a

and bring the striker-pin release mechanism opposite the trigger button. On most guns a double pressure is necessary before the various components within the tool move into the correct position for the gun to be fired.

A splinter guard is fitted, as shown in Fig. 2, which protects the operator from brick or concrete particles, or steel splinters displaced by the stud entering the material.

The cartridges are of the safety type and would do very little damage if inadvertently fired, except for the possibility of starting a conflagration if they were stored near inflammable materials. The strength of charge in the cartridge is indicated by a colour code.

Fig. 3 shows a selection of studs and pins for use with these guns, ranging from plain pins to externally and internally threaded studs. They are manufactured from high-tensile steel, specially heat-treated so that the points are hard enough not to deform badly when driven into hard materials; at the same time they are sufficiently ductile to allow the shanks to bend without fracturing. All the studs for the guns referred to have standard Whitworth threads.

PRACTICAL EXPERIENCE

A tool firing $\frac{1}{2}$ -in. studs has proved very useful for fixing cable bearers in manholes and cable chambers, especially where, due to congestion of cables, it would be dangerous to use a hammer and jumpe. Further typical uses for a tool of $\frac{1}{2}$ -in. capacity are for fixing ironwork to walls and ceilings in telephone exchanges and repeater stations, and securing hot-water pipes and other hot-water fittings in buildings.

Tools firing $\frac{1}{4}$ -in. fixings provide a very rapid means of cleating large telecommunication cables to walls, and for fixing conduits, wall boards and similar plant.

Experience shows that the gun method of fixing is very reliable, the few failures usually occurring in fixing to concrete, due to the stud or pin hitting a piece of aggregate or reinforcing material. Tests made to determine the holding power of studs in various materials showed, for example, that with a stud fired into a rolled steel joist any attempt to remove it usually resulted in the head breaking off, the shank remaining firmly in the joist. For studs in concrete, a direct pull of more than 300 lb. was required to withdraw a $\frac{1}{4}$ -in. stud, and 1,100 lb. for a $\frac{1}{2}$ -in. stud. In brick, the holding power against a direct pull was more than 200 lb. for the $\frac{1}{4}$ -in. stud and 550 lb. for the $\frac{1}{2}$ -in. stud.

One great advantage in the use of these guns is that the stud or pin may be fired through wooden battens, lead cleats, and even mild steel plates up to $\frac{1}{8}$ in. thick, but still have sufficient velocity to penetrate the masonry behind and make satisfactory fixings.

The guns are not classified as fire-arms and no licence for their use is necessary. Nevertheless they must be handled with the greatest of care and only by men who have received training in their use.

summarised form, together with additional results hitherto unpublished.

The mathematics used are not, in general, very advanced, but the form of writing out the matrices may not be generally familiar and the rules used are, therefore, given in an appendix.

The calculations in this book give formulæ which can be evaluated numerically, but their application to the construction and operation of carrier-frequency cables is only briefly indicated.

The Provision of Circuits for Television Outside Broadcasts

M. B. WILLIAMS, B.Sc.(Eng.), A.M.I.E.E.,
and J. B. SEWTER, A.M.I.E.E.†

Part 1.—Video Transmission on Telephone Line Plant

U.D.C. 621.395.97 : 621.397.24

This article is the first of two articles describing the technique and equipment now used by the Post Office for providing circuits for television outside broadcasts. It deals with video transmission on telephone line plant and includes a description of a new video repeater. Part 2, the second article, will describe the "injecting" of vision signals at intermediate points on main television links.

INTRODUCTION

PREVIOUS articles in the Journal^{1, 2, 3, 4, 5, 7, 10,} and elsewhere^{6, 8, 9,} have described some aspects of the technique of providing line vision circuits for television outside broadcasts. The expansion of the B.B.C. television service and the progress in associated techniques, including those for outside broadcasts, justify a review of recent developments.

With the extension of television broadcasting to give national coverage, outside broadcasts also have extended over most of the country, all the main links having been provided for both-way transmission to make this possible. The B.B.C. now has Regional Outside Broadcast (O.B.) units in operation, and to serve these units with line vision circuits, Post Office mobile teams have been set up at corresponding centres:—

London (for the L.T.R. and Home Counties Region)
Manchester (for the North-Western and North-Eastern Regions)
Birmingham (for the Midland Region)
Cardiff (for Wales and for the South-Western Region)
Edinburgh (for Scotland).

These teams have the necessary repeater, monitor and test equipment for providing video links on telephone plant, and they also operate and maintain cable injection equipment. Fig. 1 shows equipment installed temporarily at

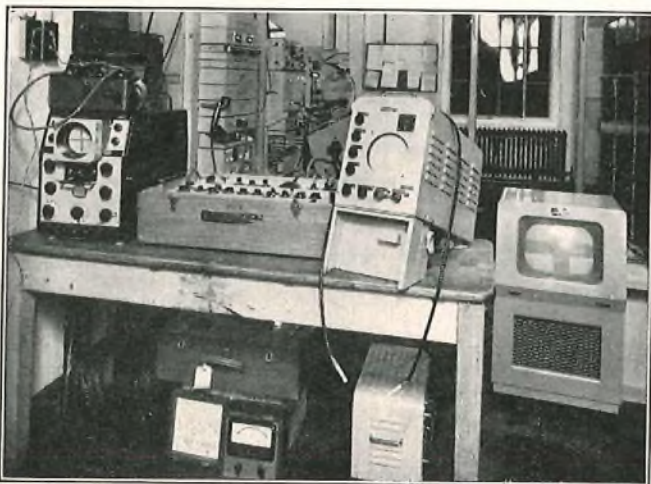

FIG. 1.—VIDEO REPEATER AND O.B. INJECTION EQUIPMENT AT CARDIFF REPEATER STATION.

Cardiff repeater station for an outside broadcast. In the picture can be seen a terminal repeater for a video link connecting the repeater station, via the main telephone exchange, with an O.B. site, and the injection equipment for the Wenvoe-London main circuit.

Table I indicates the growth of circuit-provision works undertaken by the Post Office for B.B.C. television O.B.s.

† The authors are, respectively, Senior Executive Engineer and Executive Engineer, Transmission and Main Lines Branch, E.-in-C.'s Office.

¹ For references see end of article.

TABLE I

Year	London and Home Counties				Wales, Scotland and Provincial Regions (Telephone Pair Circuits)	National Injections	National Total
	Balanced Pair*	Coaxial†	Telephone Pair‡	Total			
1947	17	1	20	38	—	—	38
1948	13	9	17	39	—	—	39
1949	20	18	31	69	1	—	70
1950	22	33	62	117	5	—	122
1951	33	60	76	165	24	—	189
1952	28	21	96	145	76	—	221
1953	19	28	159	206	105	8	319
1954	23	29	181	233	122	52	407

Notes.—* i.e., on the special balanced-pair cable in Central and West London.
† i.e., on the special coaxial-cable network and on spare coaxial cables.
‡ including telephone-pair extensions to balanced pair, etc.

VIDEO TECHNIQUE

The technique of transmitting video signals over spare telephone pairs (or coaxial pairs) is employed in the provision of:—

- Connections within a town or city to a B.B.C. switching centre such as Broadcasting House, London.
- Connections to an injection point along a main vision link.
- Connections between an O.B. site and the transmitter of a temporary radio link, and between the receiver of a temporary radio link and a switching centre or injection point.

The aim when providing this type of circuit is to achieve a performance comparable to that of the main links, but difficulties are sometimes encountered which necessitate slight deterioration below these standards.

The most intransigent problem in using telephone cables for video transmission is that of interference. Telephone pairs are unscreened and subject to inductive interference from other pairs in the same cable. In the local cable network, signalling circuits are often unbalanced and have considerable energy in the video band. Particular trouble is caused by ringing, dialling and unfiltered teleprinter circuits, which carry approximately rectilinear waveforms of peak-to-peak amplitudes which may reach 200V. These are differentiated by the capacitive crosstalk couplings and appear as "spike" signals on an adjacent pair, and if this pair is in use as a vision circuit white flashes will appear on the television picture. Careful selection of cables or particular pairs may be necessary to reduce this trouble; otherwise an increase in the level of the video signal by a send amplifier, as described later, may be necessary.

Radio-frequency interference, particularly from broadcast transmitters, frequently appears in overhead and underground cables. Such signals are apparently introduced into the cables from an open-wire section of overhead line and appear on all wires in the cable, mainly as longitudinal signals which should be discriminated against by the input circuits of the repeaters. Unfortunately, longitudinal to transverse conversion occurs to some extent in any terminal apparatus, such as a repeater or imperfectly balanced circuits, and the magnitude of the longitudinal signals may be so large as to overload the input circuits. The interference caused to the vision signal may appear on the television

picture as a striped pattern, unless the relative level of an unwanted radio-frequency signal is kept below about -50 db. The interference may be minimised by the use of a longitudinal-stop coil ("phantom coil"), and recent development work has produced a phantom coil which gives maximum longitudinal suppression without causing appreciable loss to the desired transverse signal. This coil is fitted to the new equipment described later, but even with this, radio-frequency interference remains one of the major difficulties met with in the field. Although the highest-power broadcast transmitters are placed in areas well removed from Post Office local cable networks, low-power transmitters are often placed in the centres of the smaller towns and cities and give very high field strength in their immediate neighbourhood. Where necessary, an auxiliary high-level send amplifier can be brought into use to raise the working level of the vision signal on an affected cable section by 10-20 db. and thus improve the signal/noise ratio proportionately.

The send amplifiers used at present are of a preliminary design. For use in combating interference from radio-frequency broadcast transmitters at frequencies around 0.5-1 Mc/s, a rising-gain amplifier giving, say, 20 db. of pre-equalisation is satisfactory, but for low-frequency interference, such as from ringing, dialling and teleprinter signals or long-wave radio-telegraph transmissions, the low-frequency level must be raised and a flat-gain amplifier capable of transmitting the whole vision signal at the higher level is required. There is no risk of the vision signals (which are necessarily well balanced) producing interference on telephone circuits because the psophometric weighting is very large, about 30 db. on typical pictures, most of the vision signal energy being centred on the line and frame repetition frequencies, outside the range of telephone frequencies.

When video repeater equipment is installed temporarily in exchanges or other large buildings, a further source of interference is inductive interference from telephone switches or electric lifts. This was a major problem with the older unbalanced type of video repeater⁵ but does not arise with the new design of balanced amplifier having little gain at low frequency.

Mains-frequency interference (50 c/s hum) occasionally appears on O.B. circuits, usually when the B.B.C. mobile control room (M.C.R.) and the Post Office sending equipment operate together from a remote mains connection. Careful

performance in equalising up to, say, 60 db. of cable loss at 3 Mc/s, with sufficient flexibility to permit a fine degree of adjustment, it must be light and reliable and suitable for operating on unstabilised mains supplies in the range 190-260V A.C. It must cater for the various cable conditions met and should be substantially immune to inductive interference and longitudinal signals.

Repeaters Previously Used.

The O.B. video repeaters⁵ previously used by the Post Office incorporated two high-gain compensated flat amplifiers plus two multi-section bridged-T equaliser units, these being unbalanced and connected to the line via balanced/unbalanced convertors. The equipment had been through several stages of development but had retained the use of key-controlled, non-resonant, bridged-T equaliser sections of small basic loss having "half-loss" frequencies distributed over the video band (e.g., 15, 25, 35, 45.....340, 360, 380.....1100, 1200, 1300.....4370, 4520, 4670 kc/s) to build up the desired equalisation characteristic, the process of equalisation being judged by the pulse response of the circuit.

In order to equalise cable lengths having up to 60 db. loss at 3 Mc/s, the amplifiers had a total gain, substantially flat, of over 100 db., the additional gain being required to make good the basic loss in the equaliser sections. The input to each amplifier was thus at a low level for the whole video-frequency band and the repeater was subject to microphony, inductive interference and noise.

The New Repeater.

Experience has shown that the use of unbalanced flat-gain amplifiers and multiple bridged-T equalisers has certain disadvantages and an entirely new approach has been made in the new design. This is a fully-balanced amplifier-equaliser in which variable degenerative cathode networks give an adjustable sloping-gain characteristic.

The amplifier has 11 stages, is balanced throughout (using 22 valves) and its sloping gain/frequency characteristic rises from 0-10 db. at low frequencies up to 60 db. at 3 Mc/s, the slope being controlled in the first nine stages by feedback in the cathode circuits (six non-resonant resistance-capacitance networks and three parallel-resonant circuits). Stage 10 has a uniform gain, adjustable in ten 1 db. steps, and Stage 11 is a simple cathode-follower balanced output stage. A block schematic diagram of the repeater is given in Fig. 2, and a photograph in Fig. 3. It has been coded

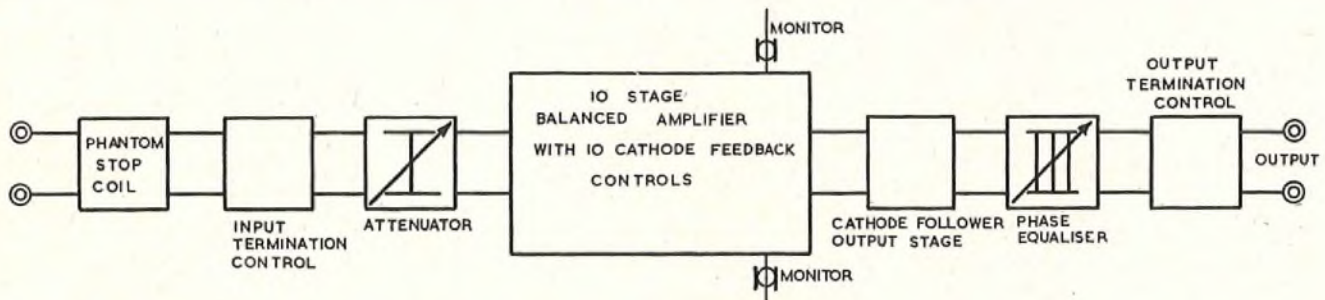

FIG. 2.—BLOCK SCHEMATIC DIAGRAM OF THE NEW VIDEO REPEATER.

attention to earthing is necessary, and in bad cases a transformer capable of handling the video band may be introduced to break the common earth path. All such transformers at present available introduce considerable distortion to the frame waveform (frame tilt) and their use is kept to a minimum. Restoration of the correct frame waveform is effected by a black-level clamp at the switching centre.

THE NEW VIDEO REPEATER

A portable video repeater must satisfy conflicting requirements as far as possible. In addition to its technical

"Amplifier No. 98A with Power Unit No. 26A" and has been adopted for field use.

A switched lattice-section phase equaliser is connected in the output to compensate for phase distortion on multi-repeater circuits. The normal output level is 2V peak-to-peak, balanced, or 1V peak-to-peak, unbalanced, and the output impedance can be adjusted to be 75 ohms unbalanced or 100, 120 or 150 ohms balanced.

The amplifier input circuit includes a phantom coil to ensure a high overall rejection of longitudinal interfering signals, and an input attenuator, adjustable in steps of



FIG. 3.—THE NEW VIDEO REPEATER.

0, 6, 12 and 18 db., is provided to prevent overloading of the amplifier, which could occur if a high-level send amplifier was in use to overcome noise difficulties on the cable. The input impedance of the amplifier is continuously variable from 90 to 180 ohms.

The power supply unit is of the conventional bridge-rectifier choke-input-filter type, but the transformer is of the self-regulating type to cater for any mains voltages between 190 and 260V A.C. The H.T. supply is 220V and the L.T. supply is 6.3V.

Basic Circuit of Equalising Stages.—Fig. 4 shows the basic

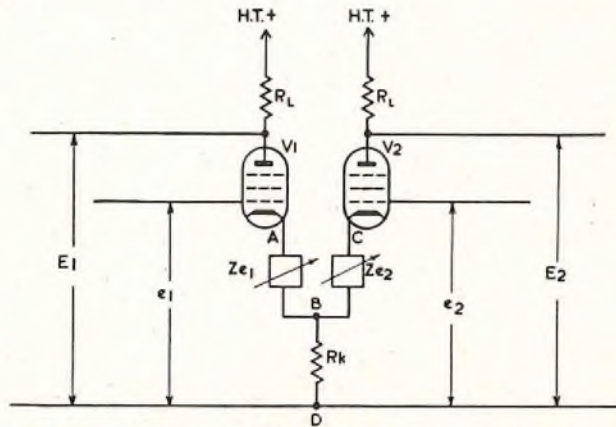

FIG. 4.—BASIC CIRCUIT OF BALANCED AMPLIFIER STAGE.

circuit used on each of the nine balanced equalising stages. For a wanted signal, voltages e_1 and e_2 will be of equal magnitude but opposite sense, i.e., a transverse signal. Equal and opposite voltages will be produced across the common cathode resistor R_k , i.e., no feedback voltage between B and D. Feedback voltages will, however, be produced separately across the similar impedances Z_{e1} and Z_{e2} of V1 and V2. Impedances Z_{e1} and Z_{e2} of V1 and V2 can be made adjustable to control the response of the balanced stage. When unwanted signals are induced into the cable pairs, voltages e_1 and e_2 will usually be of approximately equal magnitude and sense, i.e., a longitudinal signal. Additive voltages will be produced across the cathode resistor R_k and these, being negative feedback voltages, will reduce the gain of the stage. The amplifier is

thus selective to the sense of the input signal, its gain to transverse signals, known as its "differential gain," being much greater than its gain to longitudinal signals, known as its "in-phase gain."

If the electrical components in the two halves of a balanced amplifier stage are not perfectly balanced, a longitudinal input will produce a transverse output component, which will be amplified by subsequent amplifier stages. The rejection of longitudinal signals increases with the number of stages, so a longitudinal signal becomes progressively lower in level than a transverse signal as the number of stages increases. When a balance control is fitted on the first stage, it has been found that by using close tolerance components throughout, adequate balance in the amplifier is achieved. It has not been found essential to select balanced pairs of valves in any stage, though it is desirable to match the pair used in Stage 1.

Stage 1.—The cathode circuit of Stage 1 is of the form shown in Fig. 5; the network of the R_{COARSE} ganged

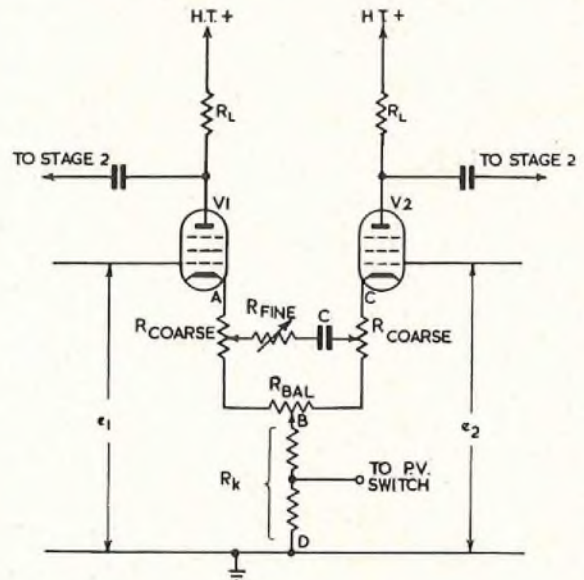

FIG. 5.—OUTLINE DIAGRAM OF STAGE 1 OF THE BALANCED AMPLIFIER.

potentiometers, R_{FINE} , C and R_{BAL} forms a balanced bridge circuit which can be resolved into the impedances Z_{e1} and Z_{e2} shown in Fig. 4. The R_{FINE} control is inserted to give fine control at the low frequencies, where the slope of the cable characteristic is very slight but where the television waveform is very sensitive to small changes in the frequency response.

Stages 2-6.—These stages have values of capacitance in the cathode feedback circuit such that their gain becomes operative at progressively higher frequencies. The R_{FINE} and R_{BAL} controls are omitted, and the two R_{COARSE} potentiometers each become 10 resistors brought out to a switch, the values being chosen to give approximately 10 equal steps in the slope-gain response.

Stages 7-9.—At the upper end of the video spectrum the loss of telephone pair-type cable increases rapidly and the slope of a single RC stage is not sufficient. To obtain the steep positive slope characteristic required, without unnecessary low-frequency gain, the capacitor (C in Fig. 5) is replaced by series resonant circuits in Stages 7-9. To reduce the effect of phase distortion introduced by these stages they are tuned just outside the video band, i.e., approximately 3.1, 3.3 and 3.5 Mc/s respectively.

To extend the control given by the cathode feedback, a fixed resistance-capacitance network is permanently in the

cathode circuit in each amplifying stage. The overall effect of these networks is to give a sloping gain rising to about 12 db. at 3 Mc/s for the complete amplifier. On Stages 3 and 7, variable ganged capacitors ("H.F. reduction" controls) are connected between the grids of the valves and earth; these capacitors can be brought into circuit to counteract the cathode networks and alter the gain/frequency slope to meet the equalisation requirements of short lengths of cable.

Stages 10 and 11.—Stage 10 has a flat gain of 0–10 db. in 1-db. steps, to make good the loss of the cable pairs at low frequencies, and Stage 11 is a simple cathode-follower output stage.

Stages 1–9 employ CV 138 valves and Stage 10 uses CV 455 valves. On Stage 10, a monitoring feed is derived from the anode of one half of the CV 455 (double triode), the other half being used as a buffer amplifier. This monitoring feed is almost independent of the shunting effect of the cable pair connected to the output terminals. CV 2127 valves are employed in Stage 11.

A satisfactory low-frequency response has been achieved (without the use of compensation) by increasing the time constants of the coupling circuits to the maximum extent. A multi-repeater circuit is free from "bumping" (instability in the presence of D.C. transients such as occur when the picture content is abruptly changed by the producer switching from one camera to another) and has an acceptable low-frequency performance (less than 8 per cent. decrement on a 50-c/s square-wave per repeater). With negligible gain in the equalising stages at frequencies of 10 kc/s and below, microphony and hum are avoided, and, due also to the balanced configuration, no decoupling capacitors are required and there is no need for a low-impedance stabilised high-tension supply.

ALIGNMENT AND OVERALL TESTING OF VIDEO CIRCUITS

Following well-established practice, vision O.B. circuits are always lined up and adjusted on the basis of waveform response. Measurements of steady-state gain/frequency characteristics are made only to check the operating conditions, e.g., to prevent overloading. The testing waveform used originally was a step-wave, of 20–40 microseconds duration and 10–20 kc/s repetition rate, sometimes as a composite wave including synchronising pulses. The technique of judging the waveform response from the corner and top of such a wave has been adequately described elsewhere.⁵ Recently, however, the "pulse-and-bar" composite waveform^{11, 12} was introduced for video-to-video testing of main cable links and will be brought into use for O.B. circuit testing. It is highly desirable that uniform testing methods should be used throughout the Post Office network and it is proposed, therefore, to describe the process of alignment of the balanced O.B. repeater solely in terms of the pulse-and-bar response.

The pulse-and-bar waveform generator produces a standard line period (100 microseconds approximately) containing negative-going 10-microsecond synchronising pulses, a positive-going sine-squared pulse and a positive

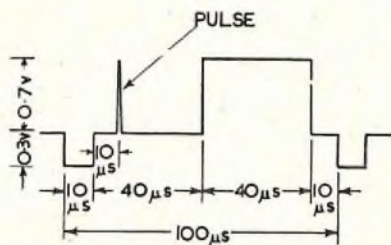

FIG. 6.—PULSE-AND-BAR TEST WAVEFORM.

bar of 40 microseconds duration ("40" bar) (see Fig. 6). The half-amplitude width of the sine-squared pulse and all transitions ("corners") of the synchronising pulses and the bar are shaped by passive networks. Two alternative characteristics are available; either "0.17," when the half-amplitude width of the sine-squared pulse and the 10–90 per cent. rise-time of the bar are 0.17 microsecond; or "0.33," when the width and rise time are 0.33 microsecond.

In general terms, when such a waveform is received on an oscilloscope after transmission through a video repeatered circuit, the flatness of the bar top indicates the uniformity of low-frequency response of the circuit, the relative heights of the sine-squared pulse and the bar indicate the effective bandwidth, and the general form of the sine-squared pulses, particularly the degree of symmetry, and the frequency and amplitude of ringing, indicate the high-frequency and cut-off characteristics. The optimum adjustment of temporary vision circuits is more precisely found and depends less on subjective judgment by the use of this test waveform.

The detailed process of adjustment of a repeatered circuit is as follows. All gain controls and the "H.F. reduction" controls on the amplifier No. 98A are set to minimum, and the phase equalisers are switched out. At the sending end of the circuit, an unbalanced-to-balanced unit will be connected to convert the signal from the normal 75-ohm unbalanced test equipment to a balanced form suitable for application to the cable pair. A preliminary adjustment of flat gain is made by applying a 10-kc/s sinusoidal signal at 1V peak-to-peak amplitude to the input of the convertor and adjusting the flat-gain stage (Stage 10) of the amplifier so that the unbalanced output is also 1V peak-to-peak measured on a wide-band decibelmeter. (This instrument, especially designed for O.B. work but now adopted for main line work in a modified form, may be seen beneath the table in Fig. 1.) The waveform generator is then applied to the sending end of the circuit and an oscilloscope connected to the amplifier output. With the "0.33" setting, the bar waveform is observed as preliminary low-frequency adjustments are made on Stage 1, which have the effect of sharpening the bar corner and producing a flat top portion. Then the sending-end and receiving-end terminating resistors are adjusted to give the optimum terminating condition, as shown by the horizontal portion of the bar waveform being free from tilt. The non-resonant Stages 1 to 6 are then progressively adjusted to sharpen up the bar corner whilst maintaining the bar top flat, and to raise the amplitude of the 0.33 sine-squared pulse until its peak nearly coincides with the bar level.

Adjustment of the resonant Stages 7 to 9, the "H.F. reduction" controls, and the phase sections is made with the "0.17" setting of the waveform generator and the faster sweep speeds of the oscilloscope. As these stages are progressively brought in, the 0.17 sine-squared pulse amplitude rises to 80 per cent. or so of the bar amplitude and ringing and overshoot appear. Careful adjustment ensures that adequate amplitude of the pulse is obtained together with a ringing frequency above 3 Mc/s. The amplitude of the excursion of the ringing from the zero axis must be kept within specified limits.

A return to the "0.33" pulse-and-bar waveform will enable slight readjustment of the low-frequency and middle-frequency response to be made and a final check of the overall performance on all waveforms completes the alignment process.

If there are following repeater sections, the process of adjustment is carried forward to the next repeater point, and each is in turn adjusted to give a satisfactory waveform response with the waveform generator still at the sending end of the circuit.

Final adjustments are made at the receiving terminal

repeater to give the desired overall performance, the net gain of the circuit is adjusted to be correct at 10 kc/s and a gain/frequency measurement is made to check that overload conditions have been avoided. Subjective examination of a test waveform shown on a picture monitor (with its frame sweep generator locked to the mains) is finally necessary to prove the absence of noise or interference in the forms discussed earlier. A simple check is also made of amplitude linearity.

The performance required is in general terms comparable with that of a main line, but the requirements for noise, etc., have to be considered for each case on its merits. The wide-band noise on a video repeated circuit is generally concentrated at the upper end of the video band; measured as wide-band noise, a signal/noise ratio of 27 db. is usually acceptable.

Radio-frequency interference (at a single frequency) in the broadcast band (0.5-1.5 Mc/s) is often troublesome and may appear as a visible pattern, even if at a low level; in this band a signal/noise ratio of 40 to 50 db. is required, the acceptable limit being usually judged subjectively by means of a picture monitor.

Linearity requirements are based on the need to avoid distortion of the synchronising pulses on the one hand, and to avoid compression of the picture high-lights on the other. With the general adoption of efficient black-level stabilisers ("clamps") at switching centres and transmitters, which will overcome much distortion of synchronising pulses, synchronising-pulse distortion ("synch. crushing") is of itself less important. However, measurement of bar/synchronising-pulse ratio is a convenient indication of the linearity of the circuit and a ± 10 per cent. limit on the distortion of the synchronising-pulse amplitude is usually allowed. On portable repeater equipment, considerations of bulk and weight require that the power handling capacity of output valves be kept to the minimum consistent with satisfactory performance.

FUTURE DEVELOPMENTS

Developments in O.B. circuit technique in the immediate future are likely to take the form of expansion rather than any marked advance in technique. This is likely to be dictated by the demands of the new Independent Television Authority and its programme contractors for similar O.B. facilities to those now provided for the B.B.C. The technique for exploiting telephone and other cables for O.B. use is now well established. The new balanced repeater has proved itself in two years' use in the field and, in the near future, only minor modifications to the design are

expected. These could include:

- (1) More elaborate means for suppressing longitudinal interfering signals.
- (2) Revision of the time-constants in the early correcting stages.
- (3) Economy in the number of valves, which may be achieved by combining two or more correcting networks in one cathode circuit.

ACKNOWLEDGMENTS

The original conception of the balanced repeater was due to Messrs. Kilvington & Wray, of the Radio Experimental and Development Branch; the development of the repeater to its present fully engineered form was largely the work of Mr. R. Gardiner, of the Transmission and Main Lines Branch. The authors acknowledge the assistance of colleagues in the Transmission and Main Lines Branch, in RC Division of Research Branch, and of others, particularly Mr. F. Leggett, of the Engineering Branch, North-Western Region, for assistance with the field work.

The work described in this article was undertaken to meet B.B.C. requirements and the close co-operation and assistance afforded by B.B.C. engineering staff at all times is gratefully acknowledged.

References

- ¹ Mitchell, H. T. Provision in London of Television Channels for the B.B.C. *P.O.E.E.J.*, Vol. 40, p. 33, Apr. 1947.
- ² Moore, B. H. Boat Race Television Broadcast. *P.O.E.E.J.*, Vol. 42, p. 99, Jul. 1949.
- ³ Rousell, S. M. E., Beaumont, E. B. M., and Moore, B. H. The Provision of Communications for the Coronation of Her Majesty Queen Elizabeth II. *P.O.E.E.J.*, Vol. 46, p. 71, Jul. 1953.
- ⁴ Collard, J. London's Television Twin Cable Links. *P.O.E.E.J.*, Vol. 30, p. 215, Oct. 1937.
- ⁵ Kilvington, T. A New Television Repeater for Telephone Cable Circuits. *P.O.E.E.J.*, Vol. 42, p. 76, Jul. 1949.
- ⁶ Kilvington, T. Cable Links for Television Outside Broadcasts. *Proceedings I.E.E.*, Vol. 99, Part IIIA, p. 415, 1952.
- ⁷ The Coronation: Telecommunications Arrangements. *P.O.E.E.J.*, Vol. 30, p. 115, Jul. 1937.
- ⁸ Procter, W. S., Pulling, M. J. L., and Williams, F. Technical Arrangements for the Sound and Television Broadcast of the Coronation Ceremonies. *Proceedings I.E.E.*, Vol. 101, Part I, No. 128, p. 57, Mar. 1954.
- ⁹ Rendall, A. R. A., and Anderson, W. N. Temporary Linkages for Outside Broadcasting Purposes. *Proceedings I.E.E.*, Vol. 99, Part IIIA, p. 323, 1952.
- ¹⁰ Slater, G. H. A Vehicle for Television Outside Broadcast Service. *P.O.E.E.J.*, Vol. 46, p. 93, Jul. 1953.
- ¹¹ MacDiarmid, I. F. A Testing Pulse for Television Links. *Proceedings I.E.E.*, Vol. 99, Part IIIA, p. 436, 1952.
- ¹² Lewis, N. W. J. Waveform Response of Television Links. *Proceedings I.E.E.*, Vol. 101, Part III, p. 258, 1954.

Opening of New Rugby Radio Station

U.D.C. 621.396.7

ON 28th July, 1955, the Postmaster-General, Dr. the Rt. Hon. Charles Hill, M.P., opened a large new Post Office radio station adjoining the existing station at Rugby. The ceremony, which was broadcast on sound and later on television by the B.B.C., was attended by leading county and municipal dignitaries, prominent members of the telecommunications world and senior members of the Post Office.

The first photograph shows the Postmaster-General speaking to the assembled guests before starting up several transmitters which sent messages to various parts of the world; and the second shows some of the guests.

The new station is probably the biggest ever to be built as a single project. It is certainly well in advance of any

other in technique, and in the extent to which it economises in man-power. It houses twenty-eight 30-kW H.F. radio transmitters and is capable of transmitting virtually all the types of telephone and telegraph signal used for overseas communication.

In designing the station the Engineering Department have followed a two-fold plan. First, they have segregated the low-power equipment, the high-power equipment and the aerial switches in different parts of the building; and, second, they have introduced a large measure of automatic control and monitoring, which is exercised from a central control position. This has resulted in a station that is very easy to operate and has a pleasing appearance.

One large room houses the drive equipments for telephony

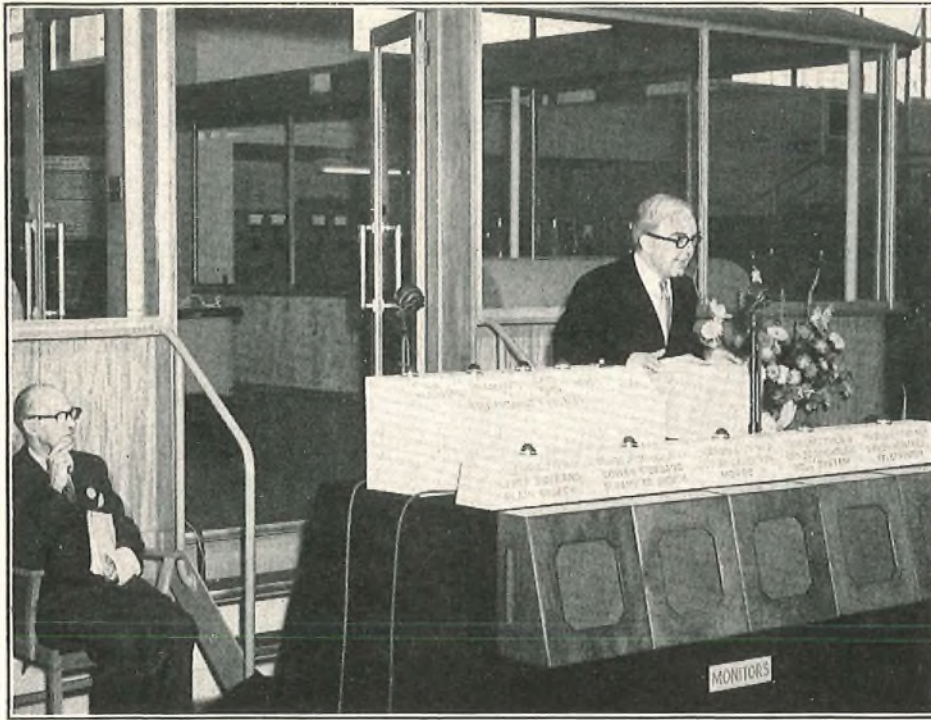

THE POSTMASTER-GENERAL MAKING HIS SPEECH.



SOME OF THE GUESTS ATTENDING THE OPENING CEREMONY.

and telegraphy, the carrier oscillators, the automatic monitors and the land-line equipment. The transmitters proper are air-cooled, and are installed in three halls converging on the Central Control Position, from which any transmitter can, by remote control, be operated on any one of six predetermined frequencies with the appropriate aerial.

Hitherto, in H.F. radio communication, aerial-switching has always been a problem—a problem which has been solved very satisfactorily at the new station. Balanced coaxial feeders carry the power from the transmitters to remotely controlled motor-driven switches in one or the other of two aerial-switch rooms. From this point each transmitter has immediate access to any one of six outgoing aerial feeders. This is quite sufficient for normal operations, but by manually altering connections any aerial feeder can be made available to any transmitter.

From the aerial-switch room the aerial feeders pass, first via balanced coaxial feeders inside the station, then by open-wire feeders outside the station, to the aerials around the periphery of the 700-acre site.

Most of the aerials are triple-wire rhombics. Many are mounted in pairs, one above the other, 150 ft. and 75 ft. above the ground, on light lattice-steel masts; others are mounted singly on spliced wooden poles 75 ft. above the ground. Four Koomans arrays, suspended from 325-ft. masts, are used for the New Zealand service.

Many safeguards are incorporated in the design of the station; the transmitters are fully equipped with interlocks which prevent access when dangerous voltages are present, and with devices which shut a transmitter down if the cooling system should fail or if the aerial-feeder system should become mismatched. All oil-filled power equipment is housed in outside fire-proof enclosures fitted with automatic fire extinguishers. The power supplies are brought in from the old station by twin feeders, and there are diesel sets for supplying locally-generated power in the unlikely event of the mains supply failing.

H. S.

A Mobile Call Office Unit

U.D.C. 621.395.721.2:629.114.7

F. C. G. GREENING, B.Sc.(Eng.), A.M.I.E.E.,
and E. R. COLLINGS†

A description of the mobile call office unit which enables the London Telecommunications Region to provide temporary telephone service quickly on a substantial scale.

INTRODUCTION

THERE are frequent demands for temporary telephone service at race meetings, agricultural shows, etc., and also, happily infrequently, there is the need to provide urgent telephone facilities at the scene of a disaster, of which the Harrow train wreck and the East Coast floods are fairly recent examples.

The normal methods of meeting such demands have been to install call office equipment in cabinets or kiosks, or to provide a rather crude arrangement of a few telephones on tables, often in poor accommodation. A better solution was provided by the Home Counties Region in designing the portable telephone cabinet previously described in this Journal,¹ but this cabinet requires to be crated for transporting and time must be spent in erecting it on site.

The London Telecommunications Region therefore prepared a scheme for a self-contained mobile call office unit, providing ten telephones and an attendant's position. This was considered to be the maximum that could be accommodated in an available type of medium-sized vehicle and so avoid the need for purchasing a special vehicle.

A 28-seat single-deck bus on a Bedford chassis, and of war-time utility construction, was made available to the L.T.R. for conversion to a mobile kiosk unit; the work of converting this vehicle being arranged by the Motor Transport Branch of the Engineer-in-Chief's Office and carried out at Kidbrooke Central Repair Depot (C.R.D.), with exterior decorations and signwriting by Yeading C.R.D.

CONSTRUCTION AND FITTING OF THE UNIT

The vehicle in its original form (Fig. 1) had an entry at the nearside and an emergency exit at the rear. The



FIG. 1.—THE ORIGINAL VEHICLE.

exterior panels, of steel sheet, were in "lobster back" form to avoid panel beating at the roof corners, and the usual flaring of the bonnet to the front of the bodywork was omitted. Interior head-room was a bare 6 ft.; seats had wooden slats instead of cushions and few of the side windows opened.

†The authors are, respectively, Regional Engineer, London Telecommunications Region, and Motor Transport Officer III, Motor Transport Branch, E.-in-C.'s Office.

¹Wells, H. M. A Portable Telephone Cabinet. *P.O.E.E.J.*, Vol. 47, Part 4, p. 230. Jan. 1955.

It became apparent at an early stage that a simple conversion would not be practicable, and it was therefore decided to strip the vehicle body to floor level and rebuild it to suit the new requirements. On this rather old chassis, an elaborately curved bodywork exterior was considered unlikely to be aesthetically satisfactory and it was, therefore, thought best to aim at simplicity. One particularly awkward problem was to decide how best to arrange the side windows which, due to the size of each cubicle and the position of its telephone, had to be narrow and rather high from the floor level. The difficulty of arranging the windows was further aggravated by a decision to raise the internal head-room to 6 ft. 8 in. This abnormality was disguised to some degree, as shown in Fig. 2, by using



FIG. 2.—THE RECONSTRUCTED VEHICLE.

"plant-on" window frames with the frames anodised bronze in colour and by providing a wide waist moulding, similarly anodised, placed well below the window level.

A 2-in. thickness of glass fibre insulating material has been inserted between the inner and outer panels of the vehicle to give both thermal and acoustic insulation. The inner lining is perforated, as shown in Fig. 3, so that the insulation can be effective acoustically. Natural ventilation is obtained by extractor-type roof ventilators, controlled from the inside, and by sliding top windows in all but the end pair of cubicles; ventilation for these is provided by a drop window in the rear door. Two electric fans, extracting air from the vehicle, are fitted above the windscreen, and the expelled air reaches the outside via two venturi louvres fitted with internal waterproof baffles in order that the fans may work regardless of weather conditions.

Bracket-type lamps are provided in each of the cubicles and at the attendant's position (Fig. 3). Flush-type lamps are also fitted along the centre gangway and in the steps of the entry and exit doors. Three 70-A.H. batteries wired in parallel are sufficient to run the electric lights and fans for a long period but provision is made to couple direct to electric light mains, if available, via a transformer. The batteries may be charged by a 500W portable petrol-driven generator, normally stowed under the floor, and a weather-proof cowl is provided for the generator in order that battery charging can be carried out regardless of the weather and with the generator remote from the vehicle. The generator and cowl can be seen in Fig. 4.

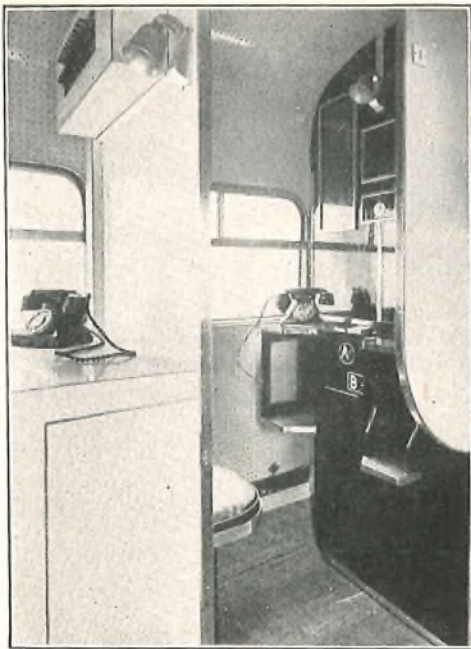

FIG. 3.—ONE OF THE CALL OFFICE CUBICLES AND (LEFT) THE ATTENDANT'S BOOTH.

To avoid disturbance of the coin box mechanism due to movement of the vehicle by people entering and leaving it, steel stabiliser props may be added to each corner of the vehicle when on site. Stowage space for all equipment associated with the vehicle is provided in lockers under the floor (as in Fig. 4) with the exception that two portable wooden platforms, used as steps in front of the doors, are carried in canvas envelopes strapped to the vehicle floor.

The cubicle partitions and seating arrangements were built jointly by Kidbrooke C.R.D. and the L.T.R. Power Section, Cornwallis Road.

TELEPHONE EQUIPMENT IN THE UNIT

For the majority of occasions when the Unit will be used in the L.T.R., connection is required to C.B. manual or automatic exchanges, including U.A.X.s; the standard Jubilee-pattern wall board, including a Bell Set No. 40 (modified) and a Telephone No. 238(L), has therefore been fitted. The two boards in the booths at the rear end of the vehicle were, however, cut and installed without the parcel container because the full width required was not available.

Simple arrangements are necessary to allow the unit to operate to either a C.B. manual or an automatic exchange, and for use at the scene of a disaster it is necessary to cut out quickly the coin box mechanisms. A key switching panel, fitted in the attendant's booth, has therefore been included in the wiring to the individual telephone circuits.

The circuit arrangement (Fig. 5) is based on the standard diagram for conversion from C.B. manual to automatic working but includes an additional key (KB) to cut out the coin box circuit when direct exchange line working is required.

The attendant is given an exchange line over which advance bookings of calls and other service arrangements can be made without interruption to the ten public lines.

P.V.C.-type cable, run in conduit, connects the key panel via fuses and protectors for each line to a simple, robust line terminal board, which is fitted in a locker with external



FIG. 4.—VIEW OF VEHICLE SHOWING EQUIPMENT LOCKERS AND CHARGING SET.

access at the near-side front of the vehicle. From this point a 100-yard length of 15-pair polythene cable, provided with the unit, can be connected by the local staff to the selected distribution pole or box. The spare pairs in this cable are bunched and used to extend the telephone earth from the D.P. to the Unit, where it can be bonded to the earth spikes provided for earthing the chassis of the vehicle.

CONCLUSIONS

The mobile call office unit is garaged in the North West Area of the L.T.R. and is available for use by other Areas. At the time of writing this article, the unit has been in service at the Norfolk Agricultural Show, Norwich, and at a race meeting at Alexandra Park. Experience has shown that adequate provision has been made for securing all portable items and spare equipment in containers or lockers and for clipping the telephone handsets in their normal rest position during travelling. The apparatus has travelled well and no undue maintenance has been required.

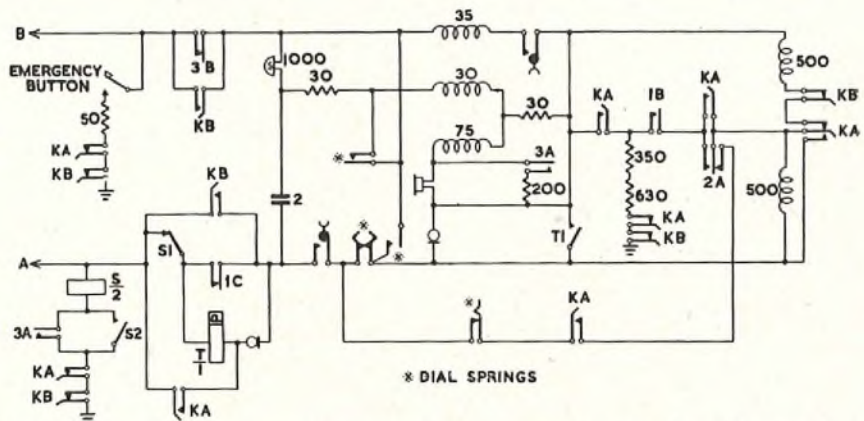

FIG. 5.—TELEPHONE CIRCUIT, INCLUDING KEYS MOUNTED ON THE KEY SWITCHING PANEL.

ACKNOWLEDGMENTS

It is desired to record acknowledgments of the work of the Motor Transport Branch staff at Kidbrook and Yeading C.R.D.s and of the L.T.R. Power Section. The close co-operation of the Motor Transport C.R.D.s, L.T.R. Power Section and L.T.R. North Area's installation staff to ensure that fitting and wiring of the lighting, ventilation and telephone apparatus was carried out in conjunction with the installation of the panelling inside the vehicle contributed greatly to the satisfactory construction of the unit.

Transatlantic Telephone Cable—Inaugural Ceremonies and the First Laying Operations

R. J. HALSEY, B.Sc.(Eng.), M.I.E.E.†

U.D.C. 621.315.285

An account is given of the ceremonies in June, 1955, that formally inaugurated the laying of the Transatlantic Telephone Cable, and the cable-laying operations by H.M.T.S. "Monarch" up to 18th August, 1955, when No. 1 main cable had been laid from Newfoundland to Rockall and the main laying operation was 13 days ahead of schedule.

INAUGURAL CEREMONY AT CLARENVILLE

ON 22nd June, 1955, cable laying associated with the transatlantic telephone (T.A.T.) project was formally inaugurated by Mr. D. F. Bowie, President of the Canadian Overseas Telecommunication Corporation (C.O.T.C.). The occasion was the landing of the shore end of the first of the two main cables at Clarenville, Newfoundland, from H.M.T.S. *Monarch*, which subsequently proceeded down North West Arm, Random Sound and Trinity Bay into the Atlantic, paying out some 200 nautical miles (n.m.) of cable to the edge of the American Continental Shelf.

Clarenville is an important point in the T.A.T. system. To the east, the two 2,000-mile cables, each equipped with 52 American repeaters (flexible and unidirectional), will cross the Atlantic to Oban; to the west, a single cable equipped with 16 British repeaters (rigid and bidirectional) will cross Newfoundland through rock, bog, sea and pond to Terrenceville, at the head of Fortune Bay, and thence to Sydney Mines, Nova Scotia, some 350 n.m. in all (see Fig. 1). Work on the overland cable started in May and,

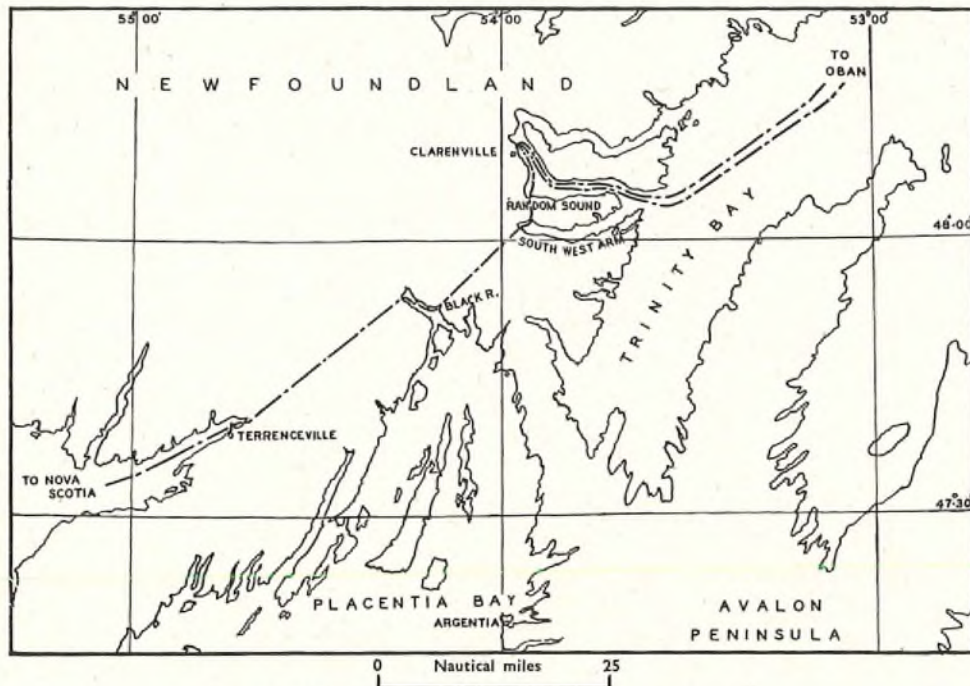

FIG. 1.—ROUTE OF THE CABLE ACROSS NEWFOUNDLAND.

while *Monarch* was in Newfoundland waters, she was able to lay the short submarine sections at and near Clarenville and hand them over to the land cable team.

Monarch had sailed from London River on 21st May for Portsmouth, New Hampshire, U.S.A., where No. 1 Ocean Block of the main West-East cable had been assembled at the Newington works of the Simplex Wire & Cable Co.; this block included 203.8 n.m. of cable with A-type armour wire, having five repeaters spliced in at approximately 37.5

† Assistant Engineer-in-Chief.

n.m. intervals. At the same time *Monarch* loaded 130 n.m. of cable with D-type armour wire and including three repeaters to form part of the next (deep-water) section, which was being mainly manufactured in England. The loading of cable at Portsmouth was the occasion of a visit, on 9th June, by a large number of high-ranking officials of the Bell System and appropriate celebration of the event; Capt. W. H. Leech, Submarine Superintendent, was present on this occasion, as well as Capt. J. P. F. Betson, Commander, H.M.T.S. *Monarch* and ship's officers. The ship sailed from Portsmouth on 14th June, and, after calling at Argentia in Placentia Bay, Newfoundland, to unload cable for the Piper's Hole River crossing into a barge, she anchored off Clarenville on 20th June.

During the early hours of 22nd June, the shore end (0.6 n.m.) of No. 1 main cable, transmitting from Clarenville towards Oban, was floated ashore on drums and the end taken to the enclosure, immediately adjacent to the new gleaming-white repeater station (Fig. 2), where the inaugural ceremony was to be performed. This was essentially a Canadian affair, organised by C.O.T.C. who were represented

by Mr. D. F. Bowie, President, Mr. R. H. Brophy, Chairman of the Board, and other directors. Sir Leonard Outerbridge, Lieutenant-Governor of Newfoundland, was present with the Hon. J. W. Pickersgill, Canadian Minister of Citizenship and Immigration, the Hon. S. J. Hefferton, Minister of Education, Newfoundland, Capt. L. T. Stick, M.P. for the constituency, and Mr. G. A. Myers, Mayor of Clarenville. The American Telephone and Telegraph Company (A. T. & T.) was represented by Mr. W. G. Thompson, Assistant Vice-President, Long Lines Department, who is also President of Eastern Telephone and Telegraph Company, a Canadian subsidiary of A. T. & T., which is providing and operating the Clarenville Station and the microwave link between Sydney Mines and the Canada-United States border. Mr. W. A. Wolverson, Director,

External Telecommunications Executive, was the principal representative of the British Post Office; Mr. R. J. Halsey, Assistant Engineer-in-Chief, Capt. W. H. Leech and Capt. J. P. F. Betson were also present and the ceremony consisted, essentially, of the handing over of the end of the cable by Capt. Betson to Mr. Bowie. The weather was perfect and the scene was a brilliant one, with splashes of colour provided by the representative flags, naval and military uniforms and, far from least, by the bright red jackets of the attendant "Mounties."

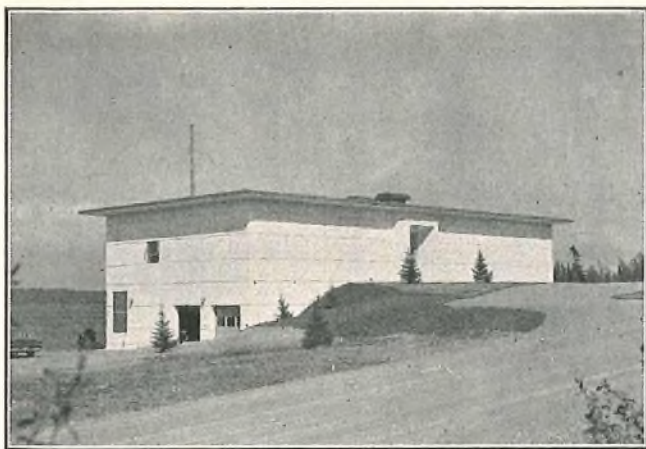

FIG. 2.—CLARENVILLE REPEATER STATION.

The importance and historic interest of the occasion was stressed in speeches by Sir Leonard Outerbridge and by Messrs. Bowie, Thompson and Wolverson. Attention was drawn to the dominant position of Newfoundland in transatlantic communications and to its four famous "firsts"—the first telegraph cable, the first radio communication, the first transatlantic aeroplane flight and now the first telephone cable. The cable was duly handed over by Capt. Betson to Mr. Bowie who formally "christened" it. The original contents of the conventional champagne bottle had been appropriately disposed of beforehand and it was filled for the occasion with water from Heart's Content; this, it will be remembered, was the Newfoundland terminal of the first successful transatlantic telegraph cable (1866), just "round the corner" in Trinity Bay.

After the ceremony, which was filmed, broadcast and recorded, the party inspected the Clarenville Repeater Station and then proceeded to a magnificent lobster lunch prepared by the ladies of Clarenville. After a visit to *Monarch* anchored in the bay, most of the principal guests returned to St. John's, as they had arrived, in chartered seaplanes.

THE FIRST CABLE-LAYING OPERATION

For the next few days *Monarch* proceeded with the routine job of laying short lengths of cable near Clarenville and on 27th June was ready to start laying the main cable. In the early evening a party of distinguished American guests came on board to witness the operation—Mr. C. F. Craig, President, A. T. & T., Mr. F. R. Kappel, President, Western Electric Co., and Mr. H. T. Killingsworth, Head of A. T. & T. Long Lines Department; Mr. Bowie was, unfortunately, unable to be present. Messrs. Wolverson and Halsey and Capt. Leech were on board, also Mr. C. C. Duncan, General Manager, Special Projects, A. T. & T. Long Lines Dept., and a team of Bell System engineers who were primarily responsible for testing the cable. By 06.15 hours, local time (08.45 G.M.T.), on 28th June the main cable had been spliced on to the shore end and *Monarch* moved eastward down North West Arm into Random Sound, paying out the cable steadily over the new 7-ft. diameter forward gear.

To assist in the laying operation, a special Decca Navigator chain had been installed in Newfoundland and this quickly revealed some substantial errors in the geodetic survey of Newfoundland. The master station was found to be (in relation to the survey) some hundreds of yards off shore, while the positions of prominent coastal features in the area were mutually inconsistent.

Communication between *Monarch* and Clarenville was

maintained over the cable (shore-to-ship only) and via a specially erected radio station near the repeater station. Communication via the medium-wave "Albatross" equipment failed within the first hundred miles and it was necessary to use the short-wave single-sideband equipment during most of the operation.

At the entrance to Random Sound a large iceberg appeared right on the planned cable route and a diversion was necessary; this iceberg was the subject of much photography, still and movie, monochrome and colour! After this diversion, paying out proceeded steadily at six and sometimes seven knots, and by 13.05 hours the first repeater section of 41.3 n.m. (plus 0.6 n.m. shore end) had been laid and the first repeater came up from the cable tank. The ship had been slowed to about 2 knots and at this speed the repeater passed easily under the "ironing board" on to the cable drum (Fig. 3) and thence over the bow

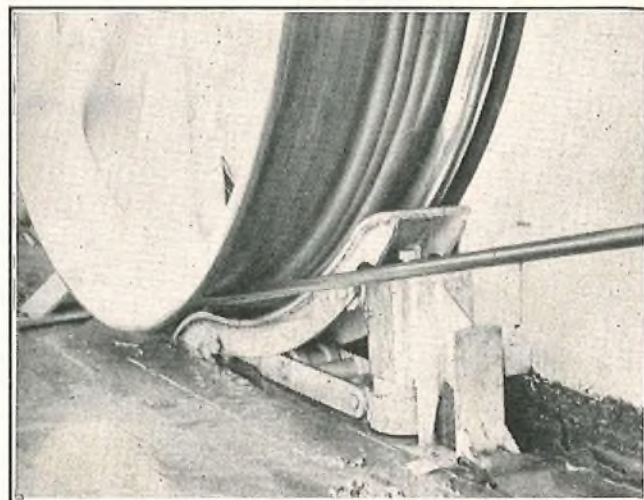

FIG. 3.—A REPEATER (SEEN AT THE EXTREME RIGHT-HAND SIDE OF THE DRUM) PASSING ROUND THE CABLE DRUM.

sheave into the sea; the depth was 118 fathoms. This was the occasion of some excitement and more photography, but the laying routine was quickly resumed.

Icebergs were sighted from time to time but the weather was clear and no further diversions were necessary; the cable lies on its planned route. Repeaters came up at about five-hour intervals and by 10.14 hours on 29th June the last had disappeared into the sea. Throughout the operation precision transmission tests were carried out over the cable between Clarenville Repeater Station, which supplied power to energise the repeaters, and the ship, but nothing untoward was noted, except a slight change in gain (about 0.05 db.) while each repeater was passing through the laying gear. The optimum speed for laying the repeaters was found to be about 3 knots. As the cable was paid out and assumed the temperature and pressure of the sea bottom, the transmission loss decreased; preliminary laying trials had already shown that there would be changes over and above those attributable to the above causes, and length adjustments of repeater sections had been made in expectation of this. The changes proved to be very much as expected and the transmission characteristics of No. 1 Ocean Block are satisfactory.

After the last repeater was overboard and the transmission tests complete, power was disconnected from the cable, the end was sealed and, on completion of the operation at 13.35 hours on 29th June, the cable was bottom-buoyed in 380 fathoms. *Monarch* returned to St. John's early next day, landed most of her passengers and left for home the same day.

LOADING AT ERITH AND SEND-OFF BY THE POSTMASTER-GENERAL

A few days after arriving in the Thames on 8th July, *Monarch* began to load the next section of cable from Ocean Works, the Erith factory of Submarine Cables, Ltd. Including the length brought from America, this involved some 1,287 n.m. of cable, nearly all with D-type armour, and 33 repeaters—Ocean Blocks 2 to 8—reaching as far as Rockall Bank, and 22 n.m. of spare cable.

On 25th July the Postmaster-General, Dr. the Rt. Hon. Charles Hill, visited the ship at Erith and, in a short informal speech, wished Capt. Betson, the officers and ship's company "God-speed" on what he called "the most important assignment in the history of submarine telephony." Guests included Col. W. Shaw Zambra, Secretary General, Commonwealth Telecommunications Board (C.T.B.), Mr. J. H. Tudhope, Canadian Member, C.T.B., Mr. J. N. Dean, Chairman, Submarine Cables, Ltd., with members of his Board and staff, General Sir William Morgan, Chairman, Siemens Bros., Ltd., Mr. H. B. Fischer, Bell System Project Representative in Great Britain, and members of the surveillance and testing teams. Post Office representatives included Sir Gordon Radley, Mr. W. A. Wolverson, Mr. R. J. Halsey and Capt. W. H. Leech.

THE SECOND CABLE-LAYING OPERATION

Monarch sailed for the Clarenville buoyed-end on 30th July, nine days ahead of schedule. The outward passage was uneventful and echo-sounder measurements showed that it would be possible to lay the cable on a route some 7 n.m. shorter than originally planned. The cable buoy was located on 6th August, some $3\frac{1}{2}$ n.m. from its original position; it had broken loose due to parting of the ground chain. Bad visibility and a strong wind hampered grappling operations and the cable was not picked up until 8th August.

At the end of each ocean block it is arranged to make adjustments of cable length and to insert one of the two standard types of equaliser; the first job on recovery of the cable was therefore to re-measure and decide on the length to be cut off (about 1 n.m.) and the equaliser to be inserted. The attenuation of the 203 n.m. of laid cable was found to have decreased by 0.42 db. (in about 330 db.), partly due to a drop in temperature where the iceberg in Random Sound had melted.

Having inserted the equaliser—which is housed in the same way as a repeater—power was reconnected, transmission measurements taken from Clarenville to the end of Ocean Block 2, and the main deep-sea laying operation commenced at 02.52 hours G.M.T. on 10th August. Throughout this operation, the cable was paid out aft, new 7-ft. diameter stern gear having also been provided for the job. The laying speed was 6.5 knots and deep water was soon reached.

Some 18 hours before the end of Ocean Block 2 was reached, it was necessary to predict the cutting length and equalisation from the trend of the transmission measurements, in order that Ocean Block 3 could be joined on in good time; as a precautionary measure speed was dropped to 5 knots for a few hours until the splices were complete. In this way the laying operation progressed uneventfully

until the weather broke, 18 hours before completion. In all, 14 ship joints were made and tested to the highest standards, including X-ray photographs; none required to be remade. Repeater No. 10 lies in the deepest water, 2,250 fathoms, and Repeaters 10-15 are all in more than 2,000 fathoms.

Twenty-four hours before completion an intense depression developed about 300 n.m. S.W. of *Monarch* and moved N.E. From noon on 17th August the barometer fell sharply and by midnight a strong gale was blowing. *Monarch* continued to pay out cable and among other difficulties was the assessment of allowance for leeway due to the gale and the relatively low speed of the ship. The last repeater, No. 38, went out satisfactorily with the gale at Force 9,* in high seas and rain. With 18 n.m. of cable to lay, it became uncertain whether it would be possible to buoy off the end, but this was eventually accomplished, although it was not possible to seal the end of the cable. The buoy was slipped in 700 fathoms at 11.45 hours G.M.T., on 18th August, 1251.4 n.m. of cable, 33 repeaters and five equalisers having been paid out in 8 days 8 hours 13 minutes, at an average speed of 6.24 knots.

It is very unlikely that any other cable ship could have completed the operation in the prevailing weather and great credit is due to Capt. Betson, his officers and all hands. Later in the day the gale increased to Force 11* with very high seas, and it is questionable if the buoy could hold. *Monarch* arrived back at Erith on 22nd August, having gained a further four days on the main laying operation; she was now 13 days ahead of schedule.

Overall transmission measurements between Clarenville and Rockall are in close agreement with expectations, and assure that the design objectives for the system will be met.

THE FINAL SECTION, ROCKALL-OBAN

On 29th August, *Monarch* commenced loading the final 500 n.m. of cable required to complete the connection to Oban—Ocean Blocks 9 to 11, including 13 repeaters. Owing to the shortening of the route and the fact that the repeater sections are somewhat longer than originally planned, due to the lower attenuation of the cable as laid, a total of only 51 repeaters will be included instead of 52. Completion of the cable into Oban was originally scheduled for 2nd October, but it is now likely to be a week or so earlier. Iris will lay both shore-end cables at Oban early in September and the final splice will be made about 2 n.m. from the shore. Hurricanes are traditionally liable to appear in the Atlantic at any time after the end of August; before this date in 1955, we have already had devastation from "Connie" along the eastern United States seaboard and "Diane" and "Edith" have appeared. The ocean east of Rockall is normally clear of the path of such hurricanes but weather conditions in the Atlantic can be expected to deteriorate during September. Apart from the gale at Rockall, the first two operations were carried out mainly in fine weather; by the time this note appears the first cable should be completed into Oban and it is to be hoped that the weather holds good for this, the final operation in the 1955 laying programme.

* Beaufort Scale: Mean wind speed, Force 9, 44 knots; Force 11, 60 knots.

Notes and Comments

Sir W. Gordon Radley, C.B.E., Ph.D.(Eng.), M.I.E.E.

The appointment of Sir Gordon Radley as Director-General has pleased all the engineering staff, as he is the first professional engineer to hold this position.

Sir Gordon joined the Engineering Department in 1920, was Engineer-in-Chief from 1951 to 1954, and has been a Deputy Director-General since that date.

Sir Gordon is also a Vice-President of the Institution of Electrical Engineers.

Col. J. Reading, M.B.E., E.R.D., B.Sc.(Eng.), M.I.E.E.

Members of the Institution and readers of the Journal will be interested to learn that after 30 years' service in the Engineering Department, Col. J. Reading has resigned his appointment as Assistant Engineer-in-Chief.

During his service in the Post Office, he did much to further the activities of the Institution, being Secretary from 1935 to 1951 and Chairman of Council from 1954 onwards. He has also served, at various times, as Managing Editor of the Journal and as a Member and Chairman of the Board of Editors.

Col. Reading has left the Post Office to join industry, where his valuable background of telecommunications experience will continue to serve the national interests. He carries with him the good wishes of his wide circle of friends in the Post Office for a happy and prosperous future.

Awards by the Institution of Electrical Engineers

Congratulations are offered to the following members of the Engineering Department who have received individual or shared awards of Premiums for I.E.E. papers during the 1954-55 Session:—

The John Hopkinson Premium.

M. J. Kelly, Ph.D., D.Eng., D.Sc., LL.D. (Bell Telephone Laboratories); Sir Gordon Radley, C.B.E., Ph.D.(Eng.);

G. W. Gilman, M.S. (Bell Telephone Laboratories); R. J. Halsey, B.Sc.(Eng.). "A Transatlantic Telephone Cable."

The Llewellyn B. Atkinson Premium.

R. W. Palmer. "Maintenance Principles for Automatic Telephone Exchange Plant."

The Blumlein-Browne-Willans Premium.

N. W. J. Lewis, Ph.D.(Eng.). "Waveform Responses of Television Links."

Reprint of Series of Articles on "The Transistor"

Because of the wide interest in the series of articles on transistors, which appeared in the Journal between July 1954 and April 1955, Parts 1 to 6 of "The Transistor" have been reprinted under one cover, and copies of this reprint are available for purchase at 3s. 6d. per copy.

B.B.C. Engineering Monographs

"The Suppressed Frame System of Telerecording" is the first of a series of Engineering Monographs published by the B.B.C. About six will be produced every year, each dealing with a technical subject within the field of television and sound broadcasting. Each Monograph will describe work that has been done by the Engineering Division of the B.B.C. and will include, where appropriate, a survey of earlier work. Subjects to be treated shortly will include:—

The Assessment of Noise in Television.

The Design of the PGS Microphone.

Fine-groove Reproducing Equipment.

This series should be of interest and value to engineers engaged in the fields of broadcasting and of telecommunications generally, both in the United Kingdom and overseas, by giving information that may not otherwise be available to them.

Individual copies will cost 5s. post free, while the annual subscription is £1 post free. Orders can be placed with newsagents and booksellers, or B.B.C. Publications, 35 Marylebone High Street, London, W.1.

Institution of Post Office Electrical Engineers

London Centre

The programme arranged for the first half of the 1955-56 Session is as follows:—

Ordinary Meetings†

4th October, 1955.—"Radio Aids to Marine Navigation."—W. Dolman, M.Eng.

8th November, 1955.—"Economic Principles of Telecommunications Plant Provision."—N. V. Knight, B.Sc.(Eng.), M.I.E.E.

3rd January, 1956.—"Power Plant for Telecommunications."—W. J. Marshall, A.M.I.E.E.

Informal Meetings‡

19th October, 1955.—"What makes an Engineer?"—Discussion to be opened by the Vice-Chairman, J. G. Straw, B.Sc.(Eng.), M.I.E.E.

23rd November, 1955.—"English in the Engineering Department."—L. S. Hughes, A.M.I.E.E.

18th January, 1956.—"Transmission Testing Equipment. Do Current Designs Meet Our Needs?"—S. H. Chisman, B.Sc.(Eng.), A.M.I.E.E. and R. W. Lockton, A.M.I.E.E.

A limited number of advance copies of papers to be presented at ordinary meetings will be available a few days before each meeting.

Applications for copies should be made in writing to the

† To be held at the Institution of Electrical Engineers, Savoy Place, Victoria Embankment, W.C.2, commencing at 5 p.m.

‡ To be held in the Conference Room, Waterloo Bridge House, S.E.1, commencing at 5 p.m.

Local Secretary, W. H. Fox, E.-in-C.'s Office (Tp Branch) Alder House, E.C.1.

Essay Competition 1955-56

To further interest in the performance of engineering duties, and to encourage the expression of thought given to day-to-day departmental activities, the Council of the Institution of Post Office Electrical Engineers offers Five Prizes, a First Prize of Five Guineas and four prizes of Three Guineas, for the five most meritorious Essays submitted by members of the Engineering Department of the Post Office below the rank of *Inspector*. In addition to the five prizes the Council awards five Certificates of Merit. Awards of prizes and certificates made by the I.P.O.E.E. are recorded on the Staff Dockets of the recipients.

An essay submitted for consideration of an award in the Essay Competition and also submitted in connection with the Associate Section I.P.O.E.E. prizes, will not be eligible to receive both awards.

In judging the merits of an essay, consideration will be given to clearness of expression, correct use of words, neatness and arrangement, and although technical accuracy is essential, a high technical standard is not absolutely necessary to qualify for an award. The Council hopes this assurance will encourage a larger number to enter. Marks will be awarded for originality of essays submitted.

Hints on the construction of an Essay can be obtained, if desired, upon application to the Secretary at the address given

below. Copies of previous prize-winning essays have been bound and placed in the Institution Central Library. Members of the Associate Section can borrow these copies from the Librarian, I.P.O.E.E., (G.P.O.), Alder House, London, E.C.1.

Competitors may choose any subject relevant to current telegraph or telephone practice; foolscap or quarto size paper should be used, and the essay should be between 2,000 and 5,000 words. An inch margin is to be left on each page. A certificate is required to be given by each competitor, at the end of the essay, in the following terms:—

*"In forwarding the foregoing essay of..... words
I certify that the work is my own unaided effort both
as regards composition and drawing."*

Name (in Block Capitals).....

Signature

Rank

Departmental Address.....

Date

The Essays must reach
The Secretary,

The Institution of Post Office Electrical Engineers,
G.P.O. (Alder House), London, E.C.1,

by the 31st December, 1955.

The Council reserves the right to refrain from awarding the full number of prizes or certificates if in its opinion the essays submitted do not attain a sufficiently high standard.

Review of Prize-winning Essays— 1954-55 Competition*

The Council of the Institution is indebted to Mr. W. S. Procter, M.I.E.E., F.R.S.E., Chairman of the Judging Panel, for the following review of the five prize-winning essays:—

"Once each of the members of the Panel of Judges had read 'A Diary of Storm-work around Fareham' by Mr. W. T. Webb of that town, there was no doubt about the first prize-winner. His subject, unusual in such a competition as this, deals with one part, though a very important part, of the work falling to engineering staff, the urgent repair work resulting from stormy weather. Mr. Webb tells of his experiences and feelings with a descriptive touch that is delightful to read. In a few words, he takes his reader right into the scene of his experience and one shares with him the dangers, difficulties and disappointments of storm repair work. His comments upon the differences between the front and rear of a street of shops make a perfect little verbal vignette—and how true! So Mr. Webb takes the first prize for his unusual choice of subject and the masterly way in which he dealt with it.

Second in order of merit once again is an essay by Mr. E. H. Piper, of Bournemouth, entitled 'Technology and the Individual.' This is a thoughtful and thought-provoking study of the influence of a technological career on the technician as an individual, with some account of the specialised training of the apprentice or technical student in relation to ethical values in the development of his character.

The essay by Mr. W. Mercer, of Portpatrick, Wigtownshire, entitled 'Earth Currents in Submarine Cables, their Tidal Origin and Character' was awarded third place. The author investigates the parallelism which exists between the variations of the earth current and the variations of the tidal current, with supporting charts and diagrams to assist. He points, also, to the influence that wind direction and strength can exert upon the magnitude of the earth current through its effect on tide level.

Next is the essay by Mr. C. Biddlecombe, of the London Test Section, entitled 'Quality Control by Sampling in the London Test Section.' After dealing with the reasons for making inspections of manufacturers' products handed over for acceptance and subsequent purchase, the author describes the various ways in which inspections may be made. He then

deals in detail with the principles and advantages of sampling as a means of quality control and shows that this method does keep the balance between economic inspection and acceptable quality levels.

Finally, 'A Survey of International Radio Telegraphy,' by Mr. R. A. Lodge of Brentwood Radio Station, reviews briefly the difficulties experienced in maintaining radio communication with all parts of the world and the methods adopted to overcome them. The various communication systems involved are then discussed in more detail, followed by a survey of the keying systems and codes to be encountered. Lastly, the equipment found at radio stations in this country is described, with an emphasis on the ideal types to cope with future trends."

H. E. WILCOCKSON, *Secretary.*

Additions to the Library

2251 *Small Diesel Engines.* D. H. Smith (Brit. 1954).

Gives an understanding of the functions of specialised diesel components in their application and use in cars, light goods vehicles and tractors.

2252 *Diesel Maintenance.* T. H. Parkinson (Brit. 1954).

A practical guide to the servicing of the modern high-speed diesel.

2253 *Atomic Energy and its Applications.* J. M. A. Leniham (Brit. 1954).

Provides a simple account of the physical foundations of nuclear science, a concise description of their applications, and a guide to future progress in the exploitation of atomic energy.

2254 *Electrical Engineering Problems with Solutions.* F. A. Benson (Brit. 1954).

Covers first-year post-intermediate work, for electrical, mechanical and civil engineering students.

2255 *Modern Gas Turbines.* A. W. Judge (Brit. 1950).

Gives an outline of the theory and development of gas turbines to recent times, and forms an introduction to the more advanced considerations of the subject. Special reference is made to stationary, aircraft, locomotive and marine types, and to the supercharging of internal combustion engines.

2256 *Electronic Measuring Instruments.* E. H. W. Banner (Brit. 1954).

A survey of the field of electronic instruments intended for the instrument engineer in general, the instrument user requiring to know more of the scope of electronic measurements, and the student with some knowledge of electronics.

2257 *Electro-plating and Corrosion Prevention.* Ed. E. Molloy (Brit. 1954).

Provides a comprehensive guide for all those engaged in modern plating practice and corrosion inhibiting methods.

2258 *Television Engineering.* D. G. Fink (Amer. 1952).

Designed to enable the technical worker to make the transition from familiarity with radio engineering to familiarity with television engineering. A knowledge of the elementary principles of vacuum-tube circuits and the processes of amplification, modulation, carrier transmission, and demodulation is assumed.

2259 *Development of the Guided Missile.* K. W. Gatland (Brit. 1954).

A survey of the development and future application of guided missiles.

2260 *Electronics.* A. T. Starr (Brit. 1954).

Covers the London University Degree syllabus for electronics, which is roughly that of light-current engineering in which there is a certain emphasis outside telecommunications.

2261 *The Complete Plain Words.* Sir Ernest Gowers (Brit. 1954).

Mainly a reconstruction of the two previous books "Plain Words" and "ABC of Plain Words," and is wholly concerned with the choice and arrangement of words in such a way as to get an idea as exactly as possible out of one mind into another.

W. D. FLORENCE,
Librarian.

* The full list of Awards was published in the *P.O.E.E.J.* Jul. 1955, p. 117.

Regional Notes

Midland Region

ROYAL AGRICULTURAL SHOW, 1955

The 1955 Show of the Royal Agricultural Society of England was held in Wollaton Park in the City of Nottingham; this is some 3½ miles from the City centre and is served telephonically from the satellite exchange, Basford.

Basford Exchange area at the present time is very short of both exchange equipment and line plant, and although schemes are in progress, relief was not available in time for the Show. Very special efforts were therefore entailed to provide the necessary telephone facilities for the Show, which amounted in all to over 200 exchange lines and various other services, including 38 kiosks.

Two Post Offices were set up in the grounds, one by using a mobile office, and five telegraph circuits were installed to these offices. In addition, special arrangements were made for B.B.C. television outside broadcasts. The total area of the Show Ground itself was 165 acres but with the associated car parks, 308 acres were used. This illustrates the sort of difficulties encountered by the organisers of modern shows; almost the same amount of ground was needed for parking cars as for the actual Show.

The plan for Nottingham multi-fee area envisages a new satellite exchange at Wollaton which will eventually serve Wollaton Park area, and it was decided to advance the provision of the junction cable which will eventually serve the new Wollaton exchange. This was done, and a suitable spur cable provided to the centre of the park, where an M.D.F. was installed in a hut. The planning of the work commenced 12 months before the Show was due to open, and the junction cable was requisitioned in August, 1954. The site cable planning was carried out and estimates were prepared by November, 1954. The site cabling involved the provision of some four miles of cable of various sizes and 38 distribution points, of which eight were on power poles; there was quite an amount of joint construction work with the power distribution on site. In total, 450 pairs were terminated on the Show Ground M.D.F.; all the circuits were treated as exchange lines on Nottingham main exchange.

The methods of cabling took various forms and use was made of mole-drainers wherever possible, over a mile of cable

being installed in this way. Nearly two miles of cable was dug into the ground by hand and about ¾-mile was laid in a wide ditch. For the subscribers' distribution, which was mainly overhead, opportunity was taken to use an experimental type of P.V.C. drop wiring. This wiring has a transparent plastic covering and is made up into twin cable, the weight of each conductor being 20 lb. per mile. It was found to be most successful and easy to erect, using normal drop wire clamps, spiral eyes and the usual overhead fixings. The finished appearance of the distribution poles was very good indeed, transparent wire, as indicated by the illustration, being hardly visible to the casual glance. Some 12,000 yards of this experimental P.V.C. wire was used. The bulk of the wire has been recovered intact and it is hoped to re-erect it and use it again on normal subscribers' work. Very close touch was kept with all subscribers, installations were completed as the stands were erected and a considerable saving in man-hours was thereby achieved.

Only 29 faults were reported, of which the majority were due to coin boxes being jammed by misshapen coins. During the building of the Show only three cable faults occurred, two being caused by contractors to the Agricultural Society and one being caused by children. When the cable was laid on the Show Ground precautions were taken to mark exactly the route of each cable with heavy wooden pegs with their tops painted red; this was instrumental in keeping the faults to a low level. The damage caused by children to one cable was rather interesting. This cable was laid in the wide ditch previously mentioned, which contained on an average about one foot of water. At one point a number of children were very busily engaged in trying to spear frogs in the water using a sharp nail on the end of a pole. During their spearing operations they managed to pierce the cable on several occasions. This was remedied at this particular section by burying the cable in the mud and warning the children off.

The whole of the telephone installation was finished well on time and many expressions of appreciation for the service rendered have been received by the Telephone Manager. All Divisions of the Nottingham Area staff were well pleased with the results of their efforts in providing the facilities, which involved so much labour in addition to the current heavy programme of construction work.

LIGHTNING DAMAGE TO COAXIAL CABLE

During a severe thunderstorm on the night of 17/18th July, 1955, at 3.0 a.m., a short circuit on tube 2 of the Leicester-London 4-tube coaxial cable was reported. In view of the cable's fault history and the absence of any working parties it was decided that something unusual had happened and location was put in hand; this showed the fault to be at a pull-through point in the Houghton-Tugby repeater section. Whilst adjacent joints in buried boxes were being opened to prove the fault, a lineman investigating local subscribers' faults arrived with the information that a D.P. fed by a local cable from the same pull-through point had been struck by lightning. The insulators had been damaged and the terminal block completely destroyed. Examination in the jointing chamber showed that the sheath of the local cable had exploded, but the coaxial cable, which was in another barrel of the duct and under water, appeared undamaged. However, the evidence was too strong to be ignored and further tests were made on the tube. A Hilborn test over the length confirmed the location of the fault and a more detailed examination revealed an indentation about the size of a halfpenny on the underside of the coaxial cable where it was supported by a bearer.

Since it is well known that lightning can damage a cable for several yards it was thought that the risk of an *in situ* repair might leave latent faults undetected. Service was therefore restored over the faulty tube by using interruption cable and suspending it as for aerial cable across the carriageway. Although there are some 300 audio pairs in this cable, only one circuit was reported faulty; but further investigation showed that several spare pairs were affected. Further tests were made and in the absence of any new evidence to the contrary it was assumed that the damage was confined to the one point and a permanent repair was made *in situ* by piecing out the audio pairs and tube.

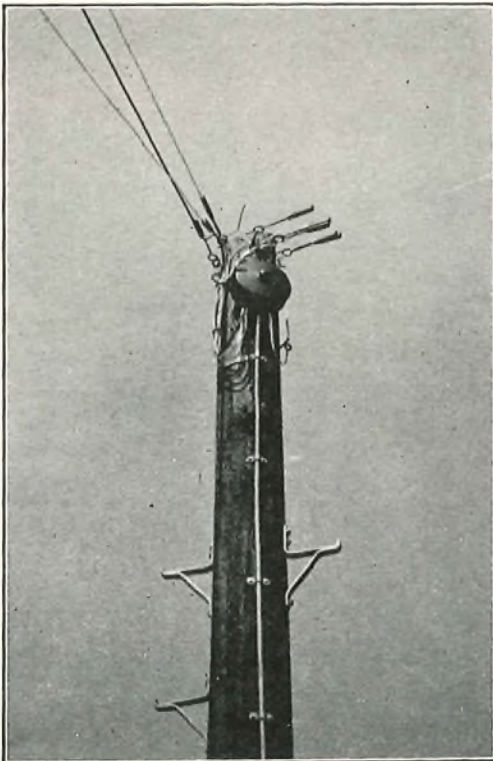

A D.P. WIRED WITH EXPERIMENTAL P.V.C. DROP WIRE AND ONE LEAD OF NORMAL I.R.V., B. AND C. WIRE.

It was interesting to note that neither the audio pairs nor the tubes showed any signs of burning; only tube 2 was flattened on one side as illustrated.

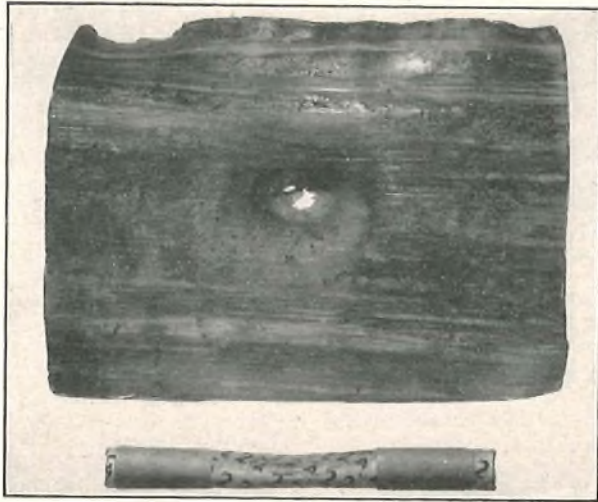

DAMAGED SHEATH REMOVED FROM COAXIAL CABLE, AND COAXIAL TUBE FLATTENED BY LIGHTNING DAMAGE.

The damage was, in fact, similar to that which might have been caused by a pick. Since the cable was under water the indentation to a depth of $\frac{1}{2}$ in. must have been sufficient to seal the perforation in the sheath for the short time till the water was pumped out of the chamber, otherwise more circuits would have been reported faulty. It is believed that the lightning discharge travelled via the local cable and arced across to the coaxial cable and bearer to earth.

E. A.

Scotland

LAYING COAXIAL CABLE ACROSS LOCH AWE

An operation first carried out in 1937 has just been repeated 18 years later, as part of the laying of the coaxial cable, from Glasgow to Oban, that will link the Transatlantic cable to the inland trunk network.

Two 770-yard lengths of 4-tube coaxial cable, including 60 audio pairs, have been laid by a contractor across Loch Awe at a point where the loch is approximately 700 yards wide.

Each length of cable, which, together with its drum, weighed 13 $\frac{1}{2}$ tons, was shipped to Leith, and carried from there by an articulated truck; the last 10 miles of the journey being over a winding and hilly 9-ft. road on which two bridges had to be specially strengthened.

The cable was drawn across the loch with 10-gallon drums attached at 10-ft. intervals. Heavy rain and strong winds hindered and delayed the operation, and the first attempt was unsuccessful. Some drums became detached and the cable



THE CABLE ACROSS LOCH AWE BEFORE STARTING TO PUNCTURE THE DRUMS.

sank prematurely. A number of drums collapsed and were squashed almost flat by the pressure of up to 168 ft. of water. The cable was drawn back, and later laid successfully with the aid of several 40-gallon drums to give additional buoyancy. The second length was laid the following day. After the cable had been pulled across, the 40-gallon drums were detached, and the 10-gallon drums, previously drilled with a small hole to limit the rate of entry of the water, were punctured with a specially shaped hammer to release the air.

The cable sank slowly and evenly, without strain, and as it settled to the bottom of the loch, some 28 fathoms down, about 33 yards were drawn off the shore.

The whole operation entailed a very considerable amount of preparatory work, the actual laying taking only a couple of hours. The need to wait for suitable weather—especially for conditions with little or no wind—was imperative, as it is impracticable to lay the cable on the course required with any appreciable wind.

There are no boats of any size on the loch, and those available were confined to a small launch, and dinghys with outboard motors, normally used for angling.

J. H. R.

South-Western Region

COUNTRY SATELLITE, OXENTON HILL, NEAR CHELTENHAM

The provision of a Country Satellite exchange was required urgently to serve Oxenton, a small village and agricultural area near Cheltenham. The village, which is approached by a "no-through road," is some 200 yards off the Cheltenham-Evesham road, along which the Cheltenham-Stratford MU cable is routed.

All equipment could have been provided at an early date with the exception of Boxes, Country Satellite, No. 2, used for mounting the protectors for the junction and subscribers' lines. As this item was not expected from the Supplies Department for a considerable time, it was decided to adapt a Cabinet, Cross-Connection, No. 1 for the purpose. The opportunity was taken to house all the equipment in the cabinet, thus avoiding the erection of two Boxes, Country Satellite, No. 1, two Boxes, Country Satellite, No. 2, and two terminal blocks on the terminal pole.

The Boxes, Country Satellite, No. 1, containing the relay sets, were bolted to the back of the cabinet. It was necessary to dispense with the lids as the boxes were too deep to allow the cabinet door to close. A wooden backboard was provided on which the junction and subscribers' line protectors were

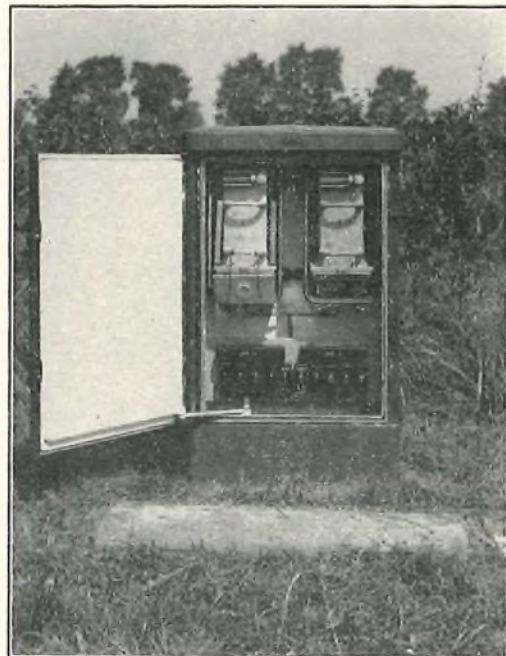

COUNTRY SATELLITE EQUIPMENT FITTED IN CABINET, CROSS-CONNECTION, NO. 1.

mounted. Polythene cable and Cable, Switchboard, P.V.C., S.C. & L., P.V.C., were used for all cable and wiring within the cabinet and additional desiccators were packed in and around the control relay sets to prevent low-insulation troubles.

The general layout of the equipment is shown in the first illustration. For explanatory purposes the additional desiccators were removed from Relay Set No. 2 before the photograph was taken.

The junction was provided by means of a spur from the Cheltenham-Stratford MU cable; a quad was diverted and a spare pair is therefore available if an extension of the scheme is required. The subscribers' lines were served by aerial cable and polythene cable was used to extend the junction and subscribers' cables into the cabinet, the joints being made in a Joint Box JRF 4, provided in front of the cabinet. An earth electrode was placed in the lower part of the grass verge and brought into the corner of the joint box and then via an asbestos bend into the cabinet.

The second illustration shows the general layout of the scheme viewed from the road leading to the village, and the



GENERAL VIEW OF OXENTON HILL COUNTRY SATELLITE.

appearance of this arrangement is preferred to the present method of erecting country satellite equipment on poles. The accessibility for maintenance purposes is also a great advantage. During inclement weather a jointer's tent could be erected over the cabinet if any prolonged operations were necessary.

This Country Satellite exchange opened with one kiosk and seven subscribers, and one additional subscriber's line has been added since. It has been in service for about 12 months and during this period there has been no trouble due to low insulation, and service reports from subscribers have shown complete satisfaction with the system.

T. H. McD.

North-Eastern Region

LIGHTWEIGHT SCAFFOLDING FOR BRIDGE-WORK

Near Middleham in Wensleydale in the Middlesbrough Area a steel pipe had to be fixed to an iron bridge so that a cable could be taken across the River Ure. Plans were made to fasten the pipe with U bolts to iron brackets which were to be welded to the bridge. The County Council Surveyor responsible for maintaining the bridge agreed with the Department's proposals and gave consent for the work to proceed. The brackets had to be fixed to the outside of the bridge 20 ft. or more above a fast-flowing river. Thus, there

was the problem of providing a safe working platform for the welders. This was solved by constructing on site, from "Dexion" Metallic Strip, platforms of ample dimensions and so light that they were lifted over the side of the bridge and hung in position by three men. Later they were moved along the bridge as they hung over the outside by the same three men without undue effort. The illustration shows a welder



WELDER SUPPORTED BY DEXION FRAMEWORK ATTACHED TO BRIDGE ACROSS RIVER URE.

fixing a bracket while sitting comfortably and safely on 1½-in. boards laid across the "Dexion" framework.

This is just one more of the many uses made of "Dexion" in the Middlesbrough Area. As was reported previously in the Journal*, "Dexion" was used to bind several U.A.X. units together into one block so that they could be moved from one building and installed in another without dismantling the wiring and cabling between the units.

E. A. C.

RADIO LINK TO KIOSK ON NORTH YORKSHIRE MOORS

The need for telephone facilities in Bransdale, North Yorkshire, had been apparent for a considerable time but for economic reasons it had not been possible to meet the need by the provision of a physical circuit. The dale contains a number of scattered farms which are regularly isolated by snowdrifts during the winter months.

Service has now been provided to a kiosk situated near one of the farms, Spout House, by means of a radio link to a U.A.X. No. 13, 10 miles away. The radio system used is System 8/3 which has been in use for some time in Scotland

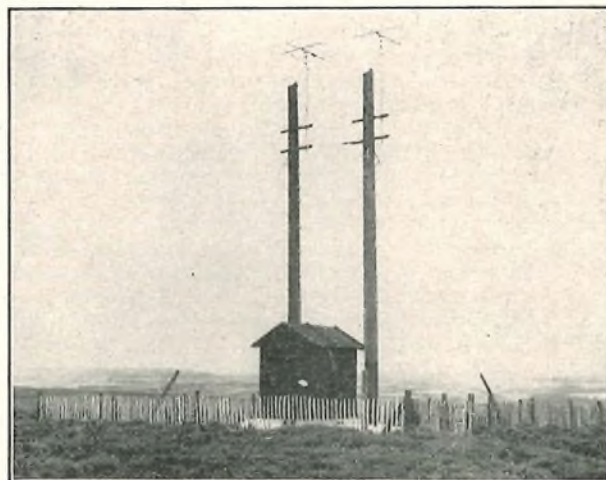

EXCHANGE END TERMINAL AT SPROXTON.

* Vol. 47, Part 3, p. 185, Oct. 1954.

for the provision of links to islands. This is the first application of the system in England.

Selection of the sites for the radio terminals was rendered difficult by the hilly nature of the intervening terrain, and was made possible only by the use of 40-ft. poles for the aerial masts. It was also necessary to position the distant radio terminal in a wood, in order to preserve the appearance of the dale, which possesses much natural beauty.

The two sites are shown in the illustrations. It will be seen that it was thought necessary to anchor each hut to its concrete base and to surround it with a belt of hard-core to serve as a fire-break in the event of moorland fire.



HUT FOR SPOUT HOUSE TERMINAL.

The whole of the work on site was carried out by direct labour, the only assistance being the co-operation of a nearby farmer, who supplied a tractor when required. As the distant terminal is on high ground, approached through trees and a quarter of a mile from the nearest road, it will be appreciated that transport of materials was a major problem.

W. N. P.

SILICONE TREATMENT OF TERMINAL BLOCKS ON UNDERGROUND CABLES TO PREVENT LOW INSULATION

The number of faults attributed to low insulation on terminal blocks in bad weather increased to such an extent in recent years that special action was necessary. As an experiment the faces of two terminal blocks and the associated leads were treated with M.S.4, a silicone compound. The lids were then left off. After nearly two years' exposure to the elements there have been no reports of low insulation faults.

M.S.4 is a grease and for use is diluted with carbon-tetrachloride in the proportion of one ounce to one pint respectively. The mixture is sprayed on the block faces and leads by means of a polythene scent spray of the type sold by most chemists. For efficient spraying the spray should not be more than half full. After application the tetrachloride evaporates, leaving a film of M.S.4. It is essential for the block face to be cleaned and the tapes removed from the wires of lead-covered leads before the mixture is applied.

The initial success of the experiment indicated that an extension of its use was warranted and consequently all Areas in the Region participated in the experiment. As a result of conversations with the External Plant and Protection Branch of the Engineering Department about the terminal block problem, lacquer dipping was tried on a number of other terminal blocks. Reports from Areas on the efficacy of the treatments indicated that low insulation faults on the faces of blocks treated with M.S.4 mixture were non-existent, even though in some cases, as with the initial experiment, the lids had been removed. The general opinion was that M.S.4 was preferred to lacquer dipping for various reasons, the most important of which was that M.S.4 appeared to be more resistant to dampness than the lacquer.

The experience gained and the beneficial results of M.S.4

treatment indicate that there is considerable scope for using the mixture on other types of plant liable to be affected adversely by dampness.

J. A.

London Telecommunications Region

A REPAIR JOB IN VICTORIA EMBANKMENT SUBWAY

There is a side of London, little known to the man in the street, which would both startle and interest him, if he was aware of its existence. This "side" is an underside; an underground network of tunnels or subways immediately beneath the footways and carriageways of London.

These subways were designed and built by the Engineers of the London County Council over a period of 60 years, commencing about 1860, and have a total length of rather more than nine miles.

They were built to house the plant of all the public utility companies, who are usually so industrious in digging up the roads in order to place their plant. The object of constructing the subways was simply to prevent this digging up of roads, and to avoid the attendant dislocation of vehicle and pedestrian traffic, and loss of business to those who have shops and stores in the area.

In 1893 an Act of Parliament was passed which, with certain exceptions, made it compulsory for all undertakers to place new underground plant in the L.C.C. subways. One such subway runs between Westminster and Blackfriars Bridges, under the pavement on the River Thames side of the Victoria Embankment.

The diagram indicates the dimensions of this particular subway, which is about 2 ft. 6 in. below the surface of the

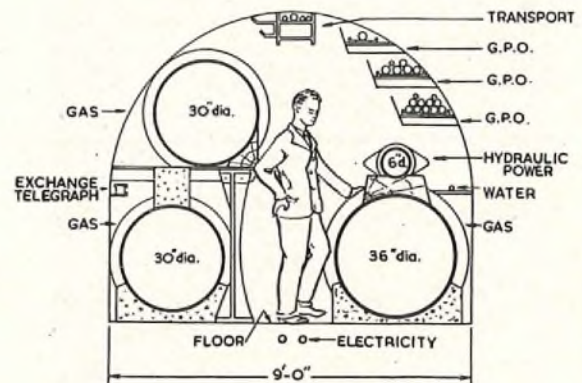

CROSS-SECTION OF L.C.C. SUBWAY BETWEEN WESTMINSTER AND BLACKFRIARS BRIDGES.

footway. In it, it will be observed, there are two 30 in. diameter and one 36 in. diameter gas mains, a 6 in. diameter hydraulic power main, miscellaneous electric power cables and 13 cables of a trunk route which weigh a total of 300 lb. per yard.

Over the passage of years sections of the angle-iron racking supporting this cable route have deteriorated to a dangerous extent. The conditions in the subway have clearly accelerated this deterioration because of the continual presence of moisture from surface water and seepage from the river, some 10 ft. away. At normal high tide most of the subway is below the surface level of the river, and on several occasions during the past 20 years the subway has been flooded. The illustration

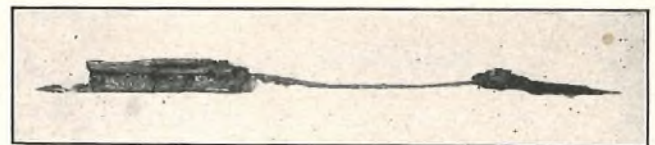

SAMPLE OF CORRODED ANGLE-IRON FROM VICTORIA EMBANKMENT SUBWAY.

of a piece of 1½ in. by 1½ in. by ¼ in. angle iron is an example of the deterioration, showing how in places the iron has almost completely rusted away and in another part rust has

built up the $\frac{1}{4}$ in. thick section to more than 1 in. The potential danger to the cable route had to be removed and the Telephone Manager's staff, Centre Area, and the Power Section of the L.T.R. have co-operated to renew 546 yards of racking running eastwards from a large grating just up river of Waterloo Bridge.

Considerable preliminary work was necessary before the actual task of replacing the ironwork could start. Because of the presence of gas mains, seepage and drainage water in this subway there is always an unpleasant smell and conditions needed improving so that continual work in the subway was tolerable. A wooden hut was erected over the large grating, referred to above, and fitted with electrically-driven fans to blow fresh air into the subway. The floor of the hut was made airtight with roofing felt and the base members sealed to the pavement around the grating with a jointing compound. The air from the fans is ducted downwards into the subway through holes cut into the floor of the hut. Artificial lighting is supplied from a step-down transformer fed from the commercial electrical supply. Power is also available for electrically-driven hand tools.

The deteriorated cable racking consists of cable trays formed by making a "ladder" of two pieces of angle iron with flats where the rungs would be. This cable tray rests on T angle brackets cemented into the brickwork of the subway. Both the brackets and the cable tray have suffered through rusting although it is quite remarkable that some metal is almost unaffected whereas a similar section a few feet away is wasted away.

The new cable racking follows a different technique. A curved member has been designed to suit the curvature of tunnel wall (a radius of approx. 4 ft. 6 in.). This member consists of two pieces of flat mild steel, edge bent to the requisite shape. These parts are welded to two flat spacers, one each end, so that the flat surfaces of the curved pieces are fixed parallel to each other $2\frac{1}{4}$ in. apart. Fixing holes are drilled in each of the spacers; and holes drilled in the sides of the curved parts provide an anchorage for standard cantilever cable brackets. A curved bracket with four cantilever arms is fitted at 2 ft. 6 in. intervals.

The new brackets must be placed on the tunnel wall at the same level as the existing racking to avoid interfering with other services in the subway. Consequently it is necessary to remove the cables from the old racking, support them temporarily, cut away the old ironwork, fix the new brackets and then replace the cables. To provide the temporary supports use was made of 24 Acrow scaffolding jacks. These are erected at 4 ft. intervals, between floor and roof of the subway, along the centre gangway. Each pair of jacks is strapped together with channel iron which carries brackets to form the temporary supports. The gaps between adjacent pairs

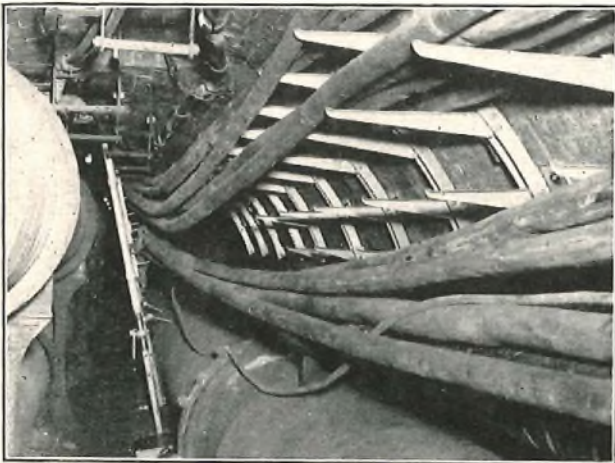

CABLES SUPPORTED PARTLY ON SCAFFOLDING JACKS AND PARTLY ON NEW WALL BRACKETS.

provide a working space. The cabling gangs of the Centre Area swing the cables across on to these racks and the area cleared is available for the Power Section staff to work in.

During the preliminary survey the Power Section were led to think that gas cutting torches would be permitted in the subway but this was eventually found to be incorrect. The cutting away of the old T irons appeared quite a formidable task and since the L.C.C. were averse to cutting out the brickwork it looked like a very long, arduous job with a hacksaw. However, a portable electrically driven circular saw for metal was purchased and it has already saved in labour the equivalent of its own cost. Another mechanical aid in use on this scheme is the plug firing tool. Four $\frac{1}{2}$ in. bolts are being fixed into the brickwork to hold each curved bracket. Should a shot-fired fixing fail, a $\frac{1}{2}$ in. Rawlbolt can be fixed through a spare hole provided for the purpose in each of the spacers of the curved bracket. So far the success of this gun has been about 80 per cent., but the failures, after an initial period, have been due mainly to the sodden brickwork which has not reacted in a normal fashion.

When the new brackets, which are galvanised, are in position the cables are swung back again and the jacks dismantled and then re-erected on the next stretch and the cycle of events is repeated.

The work is still in progress, with about one-third of it finished. Completion is expected late in the autumn of this year.

Home Counties Region

D.P. ERECTION ON NEW ESTATES

It has been necessary to erect a large number of distribution poles in the front gardens of houses on a new estate in the Southend Area. These gardens are surrounded by rendered brick walls some 2 ft. 6 in. high and the roads and footpaths are fully made up and completed over most of the estate, whilst the houses are occupied and the gardens laid out with flower beds.

These factors made the handling and erection of the 30-ft. medium poles a slow and tedious job and a mobile derrick was improvised by the poling gang using materials and tools normally carried by all external gangs. The derrick comprised a stout 18-rung ladder, with suitable top and bottom bracing and strengthening, fixed and stayed on the back of the lorry. Blocks and tackle were rigged between top and bottom of the ladder and the main bench stanchion on the front of the lorry body; the whole assembly could be erected for use in two minutes.

The poles were dressed and prepared at a temporary pole stack on the estate and the pole holes dug each morning ready for the erection of the D.P.s to take place in the afternoons. The pole was lifted by the derrick straight from the stack, taken



ERECTING A POLE WITH THE DERRICK.

through the streets to the prepared site, and, the lorry having been backed at an oblique angle to the kerb, the pole butt was swung over the garden wall and into the hole. The derrick was left in position until the pole had been consolidated, when the ladder was climbed and the guy ropes removed. The whole series of operations from pole stack to final positioning was carried out by a three-man gang, and the assistance afforded by the improvised derrick enabled all safety precautions to be observed.

E. W. M.

North-Western Region

TRAILER MOTOR DESICCATOR EMPLOYING SILICA GEL

These notes give an account of the first practical experience in the Manchester Area of the field use of the Trailer Motor Desiccator employing Silica Gel as the drying agent, which was described in a previous article.*

Soon after receipt of the desiccator a fault developed in a 160-yd. length of the BM-MR No. 2 cable (4 coaxial tubes + 10 interstice pairs); two of the interstice pairs were earthing, and the insulation resistances (I.R.) of the other eight pairs was between 150 and 400 megohms. It was therefore quite clear that the cable must be replaced unless some other means could be adopted to keep it in service. The E.-in-C.'s Office had instructed that a replacing length must be protected antimony-sheathed cable, and there was likely to be some delay in delivery of this cable. Furthermore, because of limited duct space there would be difficulty in accommodating an interruption cable and it was therefore decided to use the new motor desiccator. The following account indicates the method employed and results obtained.

To obtain the maximum drying effect, the coaxial joints at each end of the faulty length were filled with wax. As it was thought that the insertion of the air nozzle in the coaxial cable sheath might damage the tubes it was decided to adopt the following method of connecting the air nozzle. At each end of the section of cable a slit about 4 in. long was made in the cable sheath approximately 14 in. from the joint. The air nozzle was set in a small split sleeve which was placed over the slit and wiped on to the sheath.

The air-delivery tube was connected to the air inlet nozzle, and the motor desiccator set in operation, supplying a pressure of 10 to 12 lb. per sq. in. Desiccating started at 3 p.m. on the 9th June, 1955, and at the end of the first hour the I.R. had risen from 300 megohms to 1,000 megohms and by 5 p.m. it had reached 1,300 megohms. Work was stopped until 8 a.m. the next day, when after a further eight hours desiccating the I.R. went up to 2,200 megohms, but the two pairs which were earthing had only reached a figure of about

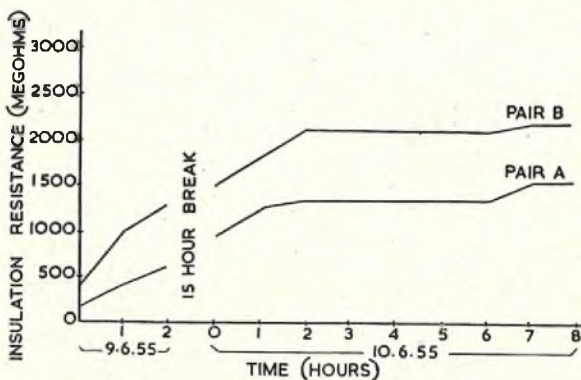

CHANGE IN INSULATION RESISTANCE OF TWO CABLE PAIRS DURING DESICCATION.

100 megohms. The graphs show the results obtained on two pairs, A & B, on which the I.R. of one was down to 150 megohms and the other 300 megohms. Similar results were obtained on the other pairs except the two which were full earth, and for these a more protracted period of desiccating was necessary before a reasonable standard of insulation resistance was obtained.

Further desiccating was carried out over a period of three

* Moffatt, J. J. A Trailer Motor Desiccator using Silica Gel. *P.O.E.E.J.* Vol. 43, p. 165, Jan., 1951.

days, and a check before each day's operations revealed that the I.R. had dropped to about 1,500 megohms, and it was found that a reasonable standard of insulation could be maintained on all pairs by reducing the desiccating operation to approximately five hours a week. At the time of writing it is five weeks since the fault developed, and by using the methods described the cable has been kept in full service.

Although this was the first and limited experience with the Trailer Motor Desiccator in the Manchester Area, it is thought it has provided some useful data for others, and in this particular instance a saving in time and material was achieved; it helped to overcome the difficulties due to limited duct space and saved jointers' time.

When the new protected antimony sheathed cable is available, it is proposed to use the same duct space for the new cable, carry out the changeover in one operation and withdraw the faulty cable.

It is considered that the Trailer Motor Desiccator has the following advantages over the CO₂ method of desiccating:—

- (1) It does not require the precautionary measures needed with CO₂.
- (2) It does not require expert handling, and desiccating can proceed while jointers are working in manholes.
- (3) It can be run continuously and an even pressure maintained.
- (4) Re-activated drying agent is always available.

It seems clear that considerable savings in time and material will be achieved by the use of this desiccator, particularly in dealing with damp which has travelled from cable joints towards the duct mouth. In such cases it is hoped to avoid cutting back the cable sheath by using the desiccator at the same time that joints are being dried out.

In fact, the results of this trial with the desiccator have proved most promising and it seems that in many cases it will be possible to avoid the replacement of section lengths, the need for recessing manholes, elongated or unwieldy joints or the insertion of short pieces of cable in manholes, and sparking faults caused by residual dampness.

Restoration of service should be much quicker and there will be a saving in time and material. S. B. I.

POLE-HOLE BORERS

Although Pole-Hole Borers have been used in some Areas for a number of years, a comparison of their efficiency does not appear to have been undertaken previously. Three different types were recently tried out in Liverpool with a systematic approach to the problems of erection in city and suburban areas. The three types show a progressive efficiency according to their cost. The greater the speed of execution the more intense and exacting is the preliminary organisation necessary, and this must be followed through to the completion of erection, though wiring and cabling can be left to normal routine. Dovetailing such a new procedure into the existing organisation usually brings its own crop of teething troubles which detract from the real advantages. The Liverpool Area were fortunate in having teams of men who were keenly excited at the prospect, and the setbacks were not as serious as they otherwise might have been. It is clear that there is no point in supplying a costly tool unless the programme of work is continuous and most efficiently organised and supervised, a factor which has received much confirmation in other directions.

The three types were (1) the "Danarm" Portable Pole-Hole borer, (2) the Horndraulic, and (3) the Cheshire Highways borer. The first, at a cost of £250, was not an unqualified success. It is supported between handlebars held by two operators and driven by a small petrol engine. The auger is suitable for light and the smaller medium poles. In operation, as it goes progressively deeper, increasing strain is put upon the operators, firstly due to the torque and then in removing the loaded auger from the hole. As a crane is required to set the pole, it can be used during boring to lift the tool and remove the earth after every 12 inches of depth and need not be detached from the borer shackle throughout boring. This need for the 3-ton crane prevents the use of the borer on soft ground and many city and suburban locations inaccessible to the four-wheeled crane. A planned operation for pole erection with this tool consequently suffers from too many restrictions

and, in some comparisons which have been made, a better performance was obtained with the ordinary earth auger aided by the crane.

When using the "Danarm" portable borer in an embankment a site has to be cleared for the operators to take a stand on level ground. In clay, or if a small obstruction is met in boring, the full torque is transferred to the operators with lasting effects. On a suitable site with no setbacks a pole can be erected by a 3- or 4-man party with crane driver in a half to three-quarters of an hour. In an embankment on boulder clay the complete operation might take an hour and a half or more depending on the extent of site preparation, accessibility and the obstructions encountered. In swampy ground the sides of the hole are liable to collapse before the crane can be detached and the pole set for erection. There is, in fact, too high a risk of having to abandon a site after much preparation.

The Horndraulic borer, costing £1,250 complete, is mounted at the rear of a tractor with a jib at the front for lifting poles into position. It has a slow rate of boring and skids over obstructions, which have to be removed by hand. An advantage is that the machine can be used in built-up areas without piloting for gas, water and electric services. Ten widely dispersed poles of sizes up to 40 ft. have been erected in a day with this machine. A vertical hole can be drilled with the tractor resting on ground with an inclination of 20° in any direction. A slight disadvantage is the constant speed of the shaft, so that when the loaded auger is withdrawn the earth has to be shovelled off the blade. It would be better if the speed increased as the boring resistance is decreased on withdrawal, so that the loose earth is flung away from the hole centrifugally.

In a 7-day trial 67 poles were scheduled for erection, 12 of which were 40-ft. poles. 50 poles were erected, including the 12 40-ft. poles; 12 were abandoned due to the obstruction of other services and five due to rock. A total distance of 177 miles was covered. One driver, two gang hands and a survey officer were employed on the work at a cost of 180 man-hours for erection and reinstatement.

The Horndraulic borer can be used in situations inaccessible to the other two types of borer, as difficulties arise with both the 3-ton crane and the six-wheeled truck which can be overcome by a tractor. Bores 18 in. in diameter were made to a depth of 5 or 6 ft. in sand, loam and clay. Two of the bores in sand flooded quickly and the lower half of each hole collapsed before the poles could be set. The holes were rebored to extra depth and the poles then forced down and set firmly. Whilst sand and soil must be shovelled off the auger each time it is withdrawn with a load, clay can be halved and lifted off more readily. The average time for boring 10 holes, with minor obstructions, was 12.8 minutes per hole; the minimum time was six minutes. Some time is saved if the pole is loaded on the jib, with guy lines attached, before boring begins; only a small movement of the tractor is then necessary to set the pole in position. Ten 32-ft. medium poles were erected in an average time of 28.1 minutes per pole, although the total time at each site including some preparation was about 47 minutes. Given reasonable conditions with a properly planned and organised programme of separate jobs, erection of a minimum of eight poles in a normal working day on sites up to 25 miles from headquarters can be expected.

Throughout these trials the shortage of poles was an important delaying factor and considerable distances had to be covered to collect poles from various stacks. In the above figures, the times and distances involved in collection and delivery have been excluded. In the third trial with the Cheshire Highways borer, an average of three hours per pole was spent in this way, and as stores carrying vehicles were used they were loaded up to capacity on each journey when the poles were available.

The Cheshire Highways borer is a fairly well-known American machine which is available in various patterns; the one used is supplied mounted on a six-wheeled truck at a cost of £3,000, although models costing over six times this amount are made. Various types of auger are available, some suitable for rock boring. The auger rack shaft is surmounted by a pulley and can be used as a derrick, in conjunction with the winch on the borer drive, for handling poles. This borer is

speedy and will stop at nothing. It might be considered a danger in the region of other services, but in drilling for 136 poles in town and suburban areas not one failure due to other services was encountered. Three or four were abandoned owing to rock but that was mainly because a Pengo auger for heavy duty was not obtainable at the time. In narrow footways shallow pilot holes were made to ensure safety. At one site the hole was bored, without piloting, and a new pole erected at the side of a dangerous pole within six minutes of arrival.

The machine requires two operators who must have an exceptionally high degree of skill and zeal to achieve the results obtained. One drives the six-wheeled truck and can position the auger, driving in reverse, to within an inch of the required position and without preliminaries or error. The other handles the boring and lifting gear. In rural hedgerows it is possible to erect 50 poles a day and a record of 100 poles has been achieved across country. In built-up areas the erection of 30 poles a day spread over three exchange areas has been completed. The locations were well dispersed and most of them were single pole extensions or renewals on existing routes. The trial, in which 136 poles were erected, lasted six days. The crew of two men handled the borer, and two four-men gangs were employed on the ancillary services which included dressing the poles prior to erection (except renewals) delivery on site, opening up, piloting where necessary, aligning and reinstatement. A Survey Officer pegged the positions in advance as a safeguard against the loss of his services in execution, but he led the delivery vehicles and the erection party and supervised the piloting.

To take full advantage of this borer, particularly its speed of operation, the organisation of the work when it involves only single poles for A.N. and renewal jobs must be carefully planned. Much of this can be done adequately by a detached routing duty collecting all fluid poling jobs in the exchange areas to be covered and, in conjunction with the Survey Officer, scheduling the jobs which can be tackled in the proper order to follow the most economical route. In this connection the Survey Officer took into consideration, as far as his local knowledge permitted, accessibility for the truck and the incidence of rock. A maximum of 200 poles was assumed for a six days' trial and opening-up notices issued for all, wayleaves being checked at the same time. Pole requisitions were issued and poles earmarked as far as possible. An advance party began dressing poles at the stacks, but although a gang dressed nearly 30 poles a day the double handling on a restricted stack reduced the advantage gained in this way. Arrangements were then made for the delivery of the poles at each site. In congested streets this was not always possible and small dumps of four or five poles were made as near as possible to the sites concerned.

In execution, two men worked in advance of the borer, opening up and piloting, and two men followed behind to fill and ram and reinstate the paving. The advance party was not always necessary, and the Survey Officer's knowledge of the sites scheduled for the day was adequate in deciding upon the need for it. Two men were sufficient to set and align a pole and these accompanied the boring crew. The residue of two or four men available were employed on work associated with the jobs scheduled, although their time has been included in the execution time. The total distance travelled by the erection parties was 210 miles; but twice this distance was involved in finding and delivering the necessary poles. Considerable economies are possible in the allocation of staff but in the trial, in order to prevent delay to the boring operations, over 900 man-hours were spent, excluding the Survey Officer's time.

It was necessary to overcome an acute state of nerves engendered in the Electricity Board's representative who was invited to the trials, as there was some doubt about the depth and position of power cables; and piloting did nothing to assuage his fears. There was little cause for alarm as, at the places in question, poles were set against hedges and on garden fences and pilot holes of two to three feet frequently struck virgin ground.

W. K. D.

Associate Section Notes

Edinburgh Centre

The Committee have a hard task during the coming winter session to improve on last year's successful programme, but members are assured of plenty of variety at the meetings and visits in course of preparation. The increase in the Centre membership is most gratifying but Edinburgh can do much better and with this in view the programme is being compiled to encourage non-members to come along and take part in all our activities.

One of the most pleasing aspects of the past session was that most of the papers read during the winter were presented by Associate Section members, and it is hoped that this trend will continue. We are pleased to record also that one of our members obtained an I.P.O.E.E. certificate in the recent essay competition.
J. R. H.

London Centre

Members' activities during the summer months are restricted to the circulation of periodicals and an occasional visit. Not so for the newly elected officers, who hastily prepare lecture programmes, design new membership cards, compile directories of officers and Area/Section chairmen and officers, and carry out the many mundane tasks required to keep the Centre "on its toes" during this period.

The programme of meetings to be held at Waterloo Bridge House during the remainder of this year should satisfy many members as the following examples will show:—

21st September.—"Some Aspects of Automobile Engineering," Post Office M.T. Training School.

25th October.—"Radar and Civil Aviation," Decca Radar, Ltd.

7th December.—"Development of Rocket Propulsion," Mr. W. A. W. Lankshear, B.Sc., A.C.G.I., A.M.I.C.E., A.M.I.Mech.E.

An innovation this session is that Informal Meetings will be arranged in the six border Areas of the L.T.R., and given the status of Centre meetings, to cater for the members who have difficulty in travelling to Waterloo Bridge House meetings. For the first of these meetings, a paper on "Information Theory" will be given in the North Area Telephone Manager's Office on 4th October by Mr. R. W. Whorwood, of the P.O. Research Station.

During the last session it was decided to launch a Youths' Essay Competition. Six essays had been received by the 31st May, the closing date for entries, all from the London Test Section. According to the adjudication committee the standard was very high, and difficulty was experienced in reaching a decision to make the following awards:—

Non-Technical

1st. R. H. Baldwin. "My Path through the London Test Section." (1 guinea.)

2nd. J. M. Shafe. "What Really Started It." (10s. 6d. book token.)

Technical

1st. B. E. Conroy. "The Construction of Lead Acid Secondary Cells." (1 guinea.)

2nd. L. M. Lynch. "The Development of a Triode Valve." (10s. 6d. book token.)

Well done, London Test Section! The closing date for the 1955/56 session Youths' Essay Competition is the 31st May, 1956, and the closing date for the Essay Competition for Associate Section Members organised by the Senior Section is the 31st December, 1955.
P. S.

Carlisle Centre

At the Annual General Meeting, held on Tuesday, 12th April, 1955, the following officials were elected:—

President: Mr. L. A. Triffitt, B.Sc., A.M.I.E.E.; *Vice-President:* Mr. R. D. Thirsk, D.F.C., A.M.I.E.E.; *Chairman:* Mr. A. I. Shirt; *Vice-Chairman:* Mr. R. N. Inniff; *Secretary:* Mr. W. A. Harper; *Deputy Secretary and Librarian:* Mr. R. D. Cleaver; *Committee:* Messrs. R. Brame, J. T. Harrison, J. Hammond, J. Gibson, A. Wilson, S. Shane, P. Hurson,

G. T. Priestley; *Auditors:* G. T. Priestley, P. Hurson.

The following programme has been arranged for the 1955/56 session:—

13th September.—Film Show, "Topical and Technical Films."

11th October.—"The Use of Gas in Telephone Cables," Mr. M. L. E. Grant (Assistant Engineer, Chester Telephone Area).

8th November.—"Mechanical Aids and their Uses," Mr. Rawlinson (Asst. Engr., Lancaster).

10th January.—"Music of the Renaissance Period," Mr. P. Barnfather.

14th February.—"Vehicle Maintenance," by Mechanics Staff, Carlisle.

13th March.—"Tape Recording," Mr. C. F. Murray (T.O., Lancaster).

10th April.—Annual General Meeting.

All the above meetings will be held in the King's Head Hotel, Carlisle.

As the programme indicates, the Centre, which now has 59 members, is quite an active one; it is also fortunate in having, in Mr. Triffitt, a very enthusiastic and helpful president.

W. A. H.

Glasgow and Scotland West Centre

The programme for the 1955/56 session is now almost complete and at the time of writing is as follows:—

30th September.—"Elements of Electronic Switching," Mr. J. J. Loughlin, A.M.I.E.E.

27th October.—"Law and Order," Det.-Supt. G. Maclean, Identification Bureau, City of Glasgow Police.

November.—"P.O. Finance."

8th December.—"Across Canada by Canadian Pacific," A colour film by Canadian Pacific Railways.

3rd January.—Theatre Night.

20th January.—"Hereditry," Dr. A. W. M. Coombs, Research Station, Dollis Hill.

February.—"Radio Links."

16th March.—"TV—Practical Faulting and Testing," R. H. Garner, B.Sc., A.M.I.E.E.

19th April.—"Plastics," a talk by a member of I.C.I., Ltd.

Visits, details of which will be announced later, will take place in the summer and are expected to be as follows: Cable Manufacturing, Carpet Manufacturing, Motor Works, Pitlochry Hydro-Electric Scheme and Kirk O'Shotts.

J. F.

Guildford Centre

The Annual General Meeting of the Guildford Centre was held on Wednesday, 9th March, 1955, and all the retiring officers and committee were re-elected, with the addition of Mr. R. J. Nichols as Honorary Assistant Secretary.

At the meeting the members decided to adopt the scheme whereby subscriptions would be paid by a weekly deduction from pay. The Committee were very pleased to note that, although the introduction of this scheme made it necessary for all members to complete a new membership form, the circulation of these forms aroused such interest among non-members that the total membership of the Centre increased and numbered 116 on 1st April.

Of this total membership exactly 50 per cent. decided to subscribe to the *P.O.E.E. Journal* by weekly deductions from pay.

At the time of writing, the membership has still further increased to 123, 64 of whom are now subscribing to the *Journal*.

During the past months parties of our members have visited the factories of Belling & Co., Ltd., at Enfield; Siemens Bros., Ltd., at Woolwich; and Kodak, Ltd., at Harrow. We should like to express our thanks to the managements of these factories for permitting us to make such interesting visits.

During September a party visited the factory of Vauxhall Motors, Ltd., at Luton, and it is hoped to arrange for further visits to be made during the coming months.

The winter programme will include a monthly programme of sound films, of engineering and general interest, projected from the Centre's own 16-mm. projector. Each programme

(Continued on p. 189.)

Staff Changes

Promotions

Name	Region	Date
<i>Sur. Exec. Engr. to Asst. Staff Engr.</i>		
Birch, S.	E.-in-C.O.	27.5.55
Law, H. B.	E.-in-C.O.	1.6.55
<i>Exec. Engr. to Sur. Exec. Engr.</i>		
Adams, W. R.	E.-in-C.O.	27.4.55
German, A. G.	E.-in-C.O.	25.4.55
Britton, A. D.	H.C. Reg. to E.-in-C.O.	20.6.55
Rymer, N. B.	E.-in-C.O.	27.6.55
<i>Exec. Engr. (Open Competition)</i>		
Dalgleish, D. I.	E.-in-C.O.	1.6.55
<i>Asst. Engr. to Exec. Engr.</i>		
Gresswell, F.	H.C. Reg. to E.-in-C.O.	9.5.55
Stooke, G. H.	E.-in-C.O.	4.5.55
Jones, D. C.	E.-in-C.O.	5.5.55
Hunt, C. S.	E.-in-C.O.	4.5.55
Keep, J. F.	E.-in-C.O.	4.5.55
Reid, H. A.	Mid. Reg. to E.-in-C.O.	23.5.55
Brian, R. H.	Mid. Reg.	12.5.55
Stollard, A. F.	Mid. Reg.	12.5.55
Cheesbrough, J. W. H.	Mid. Reg.	12.5.55
Lewis, W. J.	Mid. Reg.	12.5.55
Rogers, B. H. E.	E.-in-C.O.	12.5.55
Dickinson, R. B.	E.-in-C.O.	18.5.55
Fielding, H.	E.-in-C.O.	23.5.55
Spratt, C. J.	E.-in-C.O.	31.5.55
Cooper, J. H.	W.B.C. to N.W. Reg.	23.5.55
Hunt, A. H.	N.E. Reg. to E.-in-C.O.	6.6.55
Campbell, B. D.	Scot.	29.4.55
Harris, W. E. G.	W.B.C. to Scot.	1.6.55
Naylor, H. C.	N.E. Reg. to E.-in-C.O.	13.6.55
Sharman, H. W.	Mid. Reg.	11.6.55
Mundy, C. F.	S.W. Reg.	2.6.55
Moore, S. J.	S.W. Reg.	2.6.55
Lunt, L. S.	E.-in-C.O.	11.7.55
Housham, F. A.	E.-in-C.O.	12.7.55
Turner, G.	E.-in-C.O.	25.7.55
Taylor, J. E.	Mid. Reg.	12.7.55
<i>Asst. Engr. (Limited Competition)</i>		
Robertson, R. H.	L.T. Reg. to E.-in-C.O.	2.5.55
Massey, A. W.	E.-in-C.O.	2.5.55
Hogben, C. W.	L.T. Reg. to E.-in-C.O.	2.5.55
Loy, A. F.	L.T. Reg.	2.5.55
Collins, R. F.	L.T. Reg. to E.-in-C.O.	2.5.55
Spilsbury, J. R.	E.-in-C.O.	2.5.55
Brown, S.	N.E. Reg.	2.5.55
Rowley, L. G.	Scot.	2.5.55
Evans, T. A.	E.-in-C.O.	2.5.55
Clements, K. F.	E.-in-C.O.	2.5.55
Senior, R. C.	S.W. Reg. to E.-in-C.O.	2.5.55
Wright, R. T.	H.C. Reg.	2.5.55
Wilson, D.	Scot.	2.5.55
Fretten, K. G.	E.-in-C.O.	2.6.55
Howorth, E.	L.T. Reg. to E.-in-C.O.	2.5.55
Sully, D. F.	S.W. Reg.	2.5.55
Lefevre, R. J.	E.-in-C.O.	2.5.55
Medcraft, D. W. F.	E.-in-C.O.	2.5.55
Richmond, V. T. D.	E.-in-C.O.	2.5.55
Appleby, W. J. H.	L.T. Reg. to E.-in-C.O.	2.5.55
Robinson, C. N.	N.E. Reg.	9.5.55
Smith, H. E.	L.T. Reg. to E.-in-C.O.	9.5.55
Moore, P. W.	S.W. Reg. to E.-in-C.O.	9.5.55
Lomas, T.	N.W. Reg. to E.-in-C.O.	9.5.55
Mackrill, P.	E.-in-C.O.	9.5.55
Waldie, L. R.	L.T. Reg. to E.-in-C.O.	9.5.55
Boyd, S. A.	N. Ireland	9.5.55
Davis, K. C.	E.T.E. to E.-in-C.O.	9.5.55
Russell, D.	N. Ireland	9.5.55
Hill, S. J.	L.T. Reg. to E.-in-C.O.	9.5.55
Gerrard, M. H.	S.W. Reg.	9.5.55
Doherty, M.	E.-in-C.O.	9.5.55
Ball, D.	E.-in-C.O.	2.5.55
Booth, F. T.	L.T. Reg.	9.5.55
Bargh, D. W.	Mid. Reg.	9.5.55
Phillips, K. H.	H.C. Reg.	9.5.55
Peters, R. W.	L.T. Reg.	9.5.55
Scott, A. N.	Mid. Reg.	9.5.55
Button, R. W.	E.-in-C.O.	9.5.55
Wadden, E. J.	S.W. Reg. to E.-in-C.O.	9.5.55
Cartwright, A. D.	E.-in-C.O.	9.5.55

Name	Region	Date
<i>Asst. Engr. (Limited Competition)—continued.</i>		
Davies, W. L.	L.T. Reg. to E.-in-C.O.	9.5.55
Penney, B. H.	L.T. Reg. to E.-in-C.O.	9.5.55
Harman, F. H.	L.T. Reg. to E.-in-C.O.	9.5.55
Amery, A. R.	E.-in-C.O.	9.5.55
Browning, A. E.	L.T. Reg.	9.5.55
Finden, R. E.	L.T. Reg. to L.P. Reg.	9.5.55
Bridges, A. R.	Mid. Reg.	9.5.55
Abbott, F. R.	E.-in-C.O.	9.5.55
Allinson, N. V.	N.E. Reg.	9.5.55
Handley, L. B.	Mid. Reg.	9.5.55
Reid, F. P.	E.-in-C.O.	9.5.55
Crowe, M.	H.C. Reg.	9.5.55
Allmark, A. A.	E.-in-C.O.	16.5.55
Young, J. A.	Mid. Reg.	16.5.55
Feldon, B. R.	E.-in-C.O.	16.5.55
Tabraham, R. H.	H.C. Reg.	16.5.55
Lloyd, C. G.	Mid. Reg.	16.5.55
Mackay, E. M.	L.T. Reg.	16.5.55
Collins, A. G.	E.-in-C.O.	16.5.55
Humphreys, S. F.	E.-in-C.O.	16.5.55
Ackerman, P. M.	H.C. Reg.	16.5.55
Daborn, J. F.	L.T. Reg. to E.-in-C.O.	16.5.55
Murdoch, J.	N.W. Reg.	16.5.55
Smith, G.	N.W. Reg.	16.5.55
Parrott, C.	Mid. Reg.	16.5.55
Dowling, R. F.	L.T. Reg.	16.5.55
Byrnam, D. S. J.	E.-in-C.O.	16.5.55
Taylor, K. L.	E.-in-C.O.	16.5.55
Engstrom, W. J.	L.T. Reg.	16.5.55
Ford, T. E.	W.B.C.	16.5.55
Joannou, A.	E.-in-C.O.	2.5.55
South, K. S.	H.C. Reg. to L.T. Reg.	16.5.55
Hobbs, A. J.	L.T. Reg.	16.5.55
Polglase, S. A.	L.T. Reg.	16.5.55
Macfarlane, W.	Scot.	16.5.55
Manuel, W. H.	H.C. Reg.	16.5.55
<i>Inspector to Asst. Engr.</i>		
Largan, T. F.	N. Ireland	17.3.55
Dalton, H.	N.W. Reg.	5.5.55
Durban, F. G.	S.W. Reg.	1.2.55
Cunning, C. K.	S.W. Reg.	6.3.55
Ashley, E.	N.W. Reg.	11.6.55
Baines, W.	N.E. Reg.	9.4.55
Sutchiffe, H.	N.E. Reg.	25.6.55
Moore, F.	N.E. Reg.	26.3.55
<i>Tech. Offr. to Asst. Engr.</i>		
Seago, F. J.	Mid. Reg.	3.5.54
Hitchcock, S. J.	E.-in-C.O.	2.5.55
Evans, W. F.	E.-in-C.O.	2.5.55
Stageman, F. D.	E.-in-C.O.	2.5.55
Horwood, W. D.	E.-in-C.O.	2.5.55
Brooks, M. R.	E.-in-C.O.	2.5.55
Hallam, R. H.	E.-in-C.O.	2.5.55
Dudley, L. W.	E.-in-C.O.	2.5.55
Didcock, F. E.	E.-in-C.O.	2.5.55
Adams, R. C.	E.-in-C.O.	2.5.55
Rowe, J. A. T.	E.-in-C.O.	2.5.55
Power, L. W.	E.-in-C.O.	2.5.55
White, P. E.	E.-in-C.O.	2.5.55
Powell, L. A.	E.-in-C.O.	2.5.55
Worth, G. N.	E.-in-C.O.	2.5.55
McMillan, W. G.	Scot.	18.4.55
Richardson, J. C.	Scot.	16.4.55
Hoare, R. T.	S.W. Reg.	1.1.55
Dodsworth, G. W.	N.E. Reg.	30.4.55
Campbell, A. M.	Scot.	28.5.55
Nidd, R. E. H.	E.-in-C.O.	31.5.55
Smith, G. S.	N.W. Reg.	21.5.55
Schofield, C. E.	N.W. Reg.	5.5.55
Stanton, E.	N.W. Reg.	5.5.55
Rickard, L. C.	L.T. Reg.	25.11.54
Coombes, G. G.	L.T. Reg.	25.11.54
Slight, J. S.	L.T. Reg.	22.11.54
Isherwood, E. R.	L.T. Reg.	19.11.54
Glibbery, S. C.	L.T. Reg.	25.11.54
Willett, G.	L.T. Reg.	25.11.54
Long, C. G.	L.T. Reg.	24.6.54
Oakley, J. H.	L.T. Reg.	25.11.54
Else, S. F. C.	L.T. Reg.	25.11.54

Promotions—continued

Name	Region	Date	Name	Region	Date
<i>Tech. Offr. to Asst. Engr.—continued.</i>			<i>Tech. 1 to Inspector</i>		
Line, J. F.	L.T. Reg.	4.10.54	Price, F. L.	Mid. Reg.	1.3.55
Crandley, W. J.	L.T. Reg.	20.12.54	Payne, C. W. G.	Mid. Reg.	12.4.55
Watkins, F. L.	L.T. Reg.	20.11.54	Byrne, P. J.	N. Ireland	13.12.54
Stanley, E. A.	L.T. Reg.	4.10.54	Black, J.	N. Ireland	17.3.55
Richardson, F. E.	L.T. Reg.	6.12.54	Gray, A.	Scot.	2.5.55
Williamson, H. A.	L.T. Reg.	26.7.54	Brian, J. A.	N.W. Reg.	4.5.55
Proctor, N. A.	L.T. Reg.	3.1.55	Thompson, W.	N.W. Reg.	4.5.55
Malin, L. F.	L.T. Reg.	14.3.55	Thorndyke, T.	N.W. Reg.	4.5.55
Hayes, J. M.	L.T. Reg.	24.1.55	Williams, E.	N.W. Reg.	5.5.55
Childs, G. E.	L.T. Reg.	21.2.55	Medford, E. J.	N.W. Reg.	5.5.55
Alloway, P. G.	L.T. Reg.	20.12.54	Bailey, G. E.	N.W. Reg.	5.5.55
Bass, R. A. A.	L.T. Reg.	24.1.55	Fitzpatrick, A. F.	L.T. Reg.	28.3.55
Anderson, D. H.	L.T. Reg.	21.3.55	Ware, R. H.	L.T. Reg.	7.3.55
Linsley, N. O.	L.T. Reg.	10.1.55	Jewell, H. N.	L.T. Reg.	6.9.54
Evans, W. A. S.	L.T. Reg.	14.2.55	Pearce, H.	L.T. Reg.	1.4.55
Gillan, J. D.	L.T. Reg.	10.1.55	Knight, W.	L.P. Reg.	9.5.55
Herbert, W. C.	L.T. Reg.	7.3.55	Harding, C. W.	L.P. Reg.	23.4.55
Hyatt, T. G.	L.T. Reg.	20.9.54	Partington, H.	N.W. Reg.	25.5.55
Stiles, H. H.	L.T. Reg.	14.3.55	Cawley, W. D.	N.W. Reg.	25.5.55
Jennings, J.	L.T. Reg.	17.5.54	Gleave, J. T.	N.E. Reg.	30.4.55
Pulling, L. E.	L.T. Reg.	14.2.55	Firn, T. H.	N.E. Reg.	5.4.55
Troughton, T. H.	L.T. Reg.	15.2.55	Topham, J.	N.E. Reg.	11.6.55
Dabbs, E.	L.T. Reg.	17.1.55	Gower, E. E.	N.E. Reg.	8.4.55
Ruse, E.	Scot.	17.6.55	Marchant, D. L.	N.E. Reg.	18.6.55
Bains, G. W.	N.W. Reg.	20.5.55	Hudson, H.	N.E. Reg.	20.6.55
Mellor, H.	N.W. Reg.	25.5.55	Brookes, G.	N.E. Reg.	28.5.55
Ireland, A. E.	N.W. Reg.	26.5.55	Biggin, C.	N.E. Reg.	31.3.55
Pople, K.	S.W. Reg.	16.5.55	Bowcock, C.	Mid. Reg.	16.6.55
Bone, T. C.	E.T.E.	17.6.55	Brown, A.	Mid. Reg.	16.6.55
Roads, B. J.	L.P. Reg.	12.4.55	Moore, C. E. S.	S.W. Reg.	11.12.54
Smith, H. D.	Mid. Reg.	14.3.55	Kindleysides, T. W.	N.E. Reg.	11.4.55
Midcalf, H. G.	N.E. Reg.	4.7.55	Lewis, W. K.	W.B.C.	21.12.54
Chapman, J. R.	N.E. Reg.	1.5.55	Grayson, A. E.	Mid. Reg.	30.3.55
McCull, J. L.	Scot.	28.7.55	Wright, E.	Mid. Reg.	9.5.55
Wilsdon, H. F.	Scot.	20.6.55	Martin, H. J.	L.T. Reg.	30.3.55
			Day, C. H.	L.T. Reg.	16.5.55
			Tanswell, H. E.	L.T. Reg.	14.5.55
			Ramsey, E.	N.E. Reg.	10.6.55
			Parfitt, W.	N.E. Reg.	12.15.54
			Balls, A. S.	N.E. Reg.	17.7.55
<i>Tech. Offr. to Inspector</i>			<i>Exptl. Offr. (Open Competition)</i>		
Bell, S.	N. Ireland	9.5.55	Coles, D. A.	E.-in-C.O.	14.7.55
McBride, S. T.	N. Ireland	16.5.55	Clark, G. A.	E.-in-C.O.	1.8.55
McQuaid, J.	N. Ireland	16.5.55	<i>Asst. Exptl. Offr. (Limited Competition)</i>		
Hampton, J. H.	Mid. Reg.	16.5.55	Nye, D. A.	E.-in-C.O.	11.5.55
Larcombe, F. T.	S.W. Reg.	8.11.54	Fiddymont, D. G.	E.-in-C.O.	27.4.55
Parker, O. B.	S.W. Reg.	28.3.55			
Hodgkiss, C. T.	S.W. Reg.	2.7.55			
Seymour, W. H.	S.W. Reg.	29.1.55			
Coles, C. W.	S.W. Reg.	12.2.55			

Retirements and Resignations

Name	Region	Date	Name	Region	Date
<i>Sup. Exec. Engr.</i>			<i>Asst. Engr.—continued.</i>		
Evans, G.	Mid. Reg.	26.5.55	Tandy, A. B.	L.T. Reg.	3.6.55
Meldrum, F.	N.W. Reg.	22.5.55	Foy, A.	L.T. Reg.	8.6.55
Trussler, H.	E.-in-C.O.	5.7.55	Hawes, A. E.	W.B.C.	9.6.55
<i>Exec. Engr.</i>			Davidson, D.	Scot.	16.6.55
Brunel, L. F. J.	E.-in-C.O.	29.5.55	Clarke, W. T.	L.T. Reg.	18.6.55
Dopson, F. W.	E.-in-C.O.	5.6.55	Wagg, H. C.	W.B.C.	24.6.55
Jones, C. E.	Mid. Reg.	10.6.55	Benham, A. D.	L.T. Reg.	30.7.55
Hart, S.	L.T. Reg.	30.6.55	Millar, C. W.	Scot. (Resigned)	31.7.55
Mathewson, J. M.	Scot.	31.5.55	Bradbury, J. J.	Mid. Reg. (Resigned)	31.7.55
Ranner, E. W.	E.T.E.	30.6.55	<i>Inspector</i>		
Read, H.	H.C. Reg.	15.7.55	Phillips, W.	N.E. Reg.	7.4.55
<i>Asst. Engr.</i>			Marshall, E. H.	N.E. Reg.	27.5.55
Hugman, H. L.	E.T.E.	7.5.55	Kennedy, W. B.	L.T. Reg.	16.6.55
Doughty, R. S.	Scot.	24.5.55	Johnston, T. H.	H.C. Reg.	9.5.55
Mawtus, G. T.	N.E. Reg.	27.5.55	Dempsey, J.	W.B.C.	9.7.55
Donaldson, J.	Scot.	31.5.55	Bonnett, P. F.	L.T. Reg.	29.7.55
Fagg, R. L.	H.C. Reg. (Resigned)	14.5.55	Sherriffs, J.	Scot.	31.7.55
			Bradley, S. V.	Mid. Reg.	1.8.55

Transfers

Name	Region	Date	Name	Region	Date
<i>Sup. Exec. Engr.</i>			<i>Exec. Engr.</i>		
Nicholls, C. A. L.	E.-in-C.O. to N.W. Reg.	3.5.55	Brough, R.	E.-in-C.O. to Scot.	2.6.55
Wash, G. H.	E.-in-C.O. to Mid. Reg.	28.5.55	Mackie, G. W.	E.-in-C.O. to H.C. Reg.	6.6.55
Mitchell, M.	E.-in-C.O. to War Office	25.7.55	Mead, A. C.	L.T. Reg. to H.C. Reg.	20.6.55

Transfers—continued.

Name	Region	Date	Name	Region	Date
<i>Exec. Engr.—continued.</i>			<i>Asst. Engr.—continued.</i>		
Hix, K. W.	P.M.G. Dept., Australia to E.-in-C.O.	4.7.55	Marshall, B.	E.-in-C.O. to N.W. Reg.	8.5.55
Burton, R. N.	E.-in-C.O. to P. & T. Dept., Sudan	27.12.51	Newham, K. C.	E.-in-C.O. to P.M.G. Dept., Australia (on loan)	14.6.55
Emery, E. A.	E.-in-C.O. to L.T. Reg.	25.7.55	Lawson, R. N.	E.-in-C.O. to H.C. Reg.	24.7.55
<i>Asst. Engr.</i>			<i>Exptl. Offr.</i>		
Johnson, C. I.	E.-in-C.O. to N. Ireland	1.5.55	Ashton, F. A.	E.-in-C.O. to Min. of Transport & C.A.	8.5.55
Duguid, G. W. A.	E.-in-C.O. to Min. of Transport & C.A.	2.5.55			

Deaths

Name	Region	Date	Name	Region	Date
<i>Sup. Exec. Engr.</i>			<i>Asst. Engr.—continued.</i>		
Tunncliffe, T.	Mid. Reg.	29.5.55	Drake, A.	N.E. Reg.	12.6.55
Wallworth, A. R.	E.-in-C.O.	15.6.55	Haward, R. C.	E.-in-C.O.	27.6.55
<i>Asst. Engr.</i>			<i>Asst. Engr.—continued.</i>		
Shelton, W. T. F.	H.C. Reg.	9.6.55	Law, T.	N.E. Reg.	2.7.55
			Purcell, P.	L.T. Reg.	21.7.55
			Torbet, D. K.	N.E. Reg.	22.7.55
			Ashley, E.	N.W. Reg.	1.8.55

CLERICAL
Promotion

Name	Region	Date
<i>E.O. to H.E.O.</i>		
Sturges, A. F. R.	E.-in-C.O.	1.6.55

Retirements and Resignations

Name	Region	Date	Name	Region	Date
<i>H.E.O.</i>			<i>E.O.</i>		
Evans, H. O.	E.-in-C.O.	31.5.55	Touret, L. J.	E.-in-C.O.	31.5.55
			Logan, G. N. (Miss)	E.-in-C.O. (Resigned)	31.7.55

ASSOCIATE SECTION NOTES—(Continued from p. 186)

will be shown at Guildford and alternately at one of our out-stations, Aldershot and Haslemere.

E. N. H.

Canterbury Centre

At the Annual General Meeting and dinner of the Canterbury Centre, held at Telephone House, Canterbury, the following officers were elected for the 1955/56 session:—

Chairman: V. Dungey; *Vice-Chairman:* L. J. Martin; *Secretary:* R. Pine; *Assistant Secretary:* R. Small; *Treasurer:* A. G. Lee; *Committee:* H. Marsh, C. Cox, P. O'Conner.

The guest speaker was Mr. J. McA. Owen, Regional Director, who spoke on Telephone Development, the present situation and future expectations. An excellent dinner was provided by the Telephone House Canteen, aided by a willing band of helpers from the ladies of the staff.

The first meeting of the 1954-55 session was held on 20th October, 1954, when Mr. G. Chalk gave a talk on "Electric Lift Roping Systems." This was the subject of the paper which won the highest award in the 1952-53 I.P.O.E.E. Essay Competition.

A talk given by Mr. R. Small, at Thanet Exchange, entitled "The Cordless Switchboard," was followed by practical demonstrations on the actual equipment.

Telephone Area Finance was the subject of a talk given by Mr. R. R. Golding, in which he explained the principles and some problems encountered in this difficult subject.

At the last meeting of the session, Mr. W. A. Brown, Associate I.E.E. (District Manager, South-Eastern Electricity

Board), gave a talk on "Some Aspects of Local Power Transmission and Distribution."

R. P.

Birmingham Centre

The second half of the 1954/55 session proved to be quite as interesting and informative as the programme promised and attendance was good. It would be hard to single out any of the papers presented for greater praise than the others, but the paper on the Moon by Mr. E. J. Burden, LL.B., proved most popular with members.

The A.G.M. on 26th April was quite a lively meeting and some drastic alterations were made in our officers. It was with very great regret that we allowed our Secretary, Mr. K. G. S. Adams, to resign, as was made clear in the vote of thanks he received. He had to insist, however, owing to his changed duties and the fact that he is now in the new West Midland Telephone Area. Mr. D. F. Ashmore was elected Secretary in his place, the other officers being:—

Chairman: Mr. E. W. Newnham; *Assistant Secretary:* Mr. C. Hodgetts; *Treasurer:* Mr. B. W. Headley; *Librarian:* Mr. D. W. Rogers. *Committee:* Messrs. Adams, Marland, Edmonds, Gibbs, Carpenter, Hayward, Johnson.

On the advice of the retiring librarian, Mr. Johnson, the Assistant Secretary and Librarian duties have been separated. Mr. Johnson, like Mr. Adams, was warmly thanked for his services to the centre.

At the time of writing, our programme for the 1955/56 session is not quite complete, but it promises to be at least as interesting as last year's.

D. F. A.

BOARD OF EDITORS

Col. J. READING, M.B.E., E.R.D., B.Sc.(Eng.), M.I.E.E., Chairman.
W. WEST, O.B.E., B.A., M.I.E.E.
L. F. SCANTLEBURY, Whit.Sch., A.C.G.I., D.I.C., M.I.E.E.
H. G. BEER, Whit.Sch., A.C.G.I.
C. E. CALVELEY, O.B.E., E.R.D., B.Sc.(Eng.), M.I.E.E.
A. F. STOLLARD.
A. E. BAVIN, A.M.I.E.E.
W. A. HUMPHRIES, T.D., A.M.I.E.E., Managing Editor.
J. H. BROADHURST, A.M.I.E.E.
E. DAVIS, A.M.I.E.E. } Assistant Editors.
A. J. HUTCHISON, Secretary-Treasurer.

Copyright

The entire contents of this JOURNAL are covered by general copyright, and special permission is necessary for reprinting long extracts, but Editors are welcome to use not more than one-third of any article, provided credit is given at the beginning or end thus: "From the *Post Office Electrical Engineers' Journal*."

The Board of Editors is not responsible for the statements made or the opinions expressed in any of the articles in this JOURNAL, unless such statement is made specifically by the Board.

Communications

All communications should be addressed to the Managing Editor, *P.O.E.E. Journal*, Engineer-in-Chief's Office, Alder House, Aldersgate Street, London, E.C.1. Telephone: HEADquarters 1234. Remittances should be made payable to "*The P.O.E.E. Journal*" and should be crossed "& Co."

Binding Cases

Cases for binding are available, and may be obtained from the Local Agents for 3s. Subscribers can have their copies of volumes bound, at a cost of 10s. 6d., by sending the complete set of parts to the Local Agents or to the *P.O.E.E. Journal*, Engineer-in-Chief's Office, Alder House, Aldersgate Street, London, E.C.1. Orders for binding for Vols. 1-19 should indicate whether the original binding case with black lettering, or the later pattern with gold, is required. Cases with gold lettering are the only type stocked from Vol. 20 onwards.

Back Numbers

The price of the JOURNAL, which is published quarterly, is 2s. 6d. (2s. 9d. post free) per copy, or 11s. per annum, post free. Back numbers can be supplied, subject to availability of stocks, at 2s. 6d. each (2s. 9d. post free). Orders for back numbers may be sent to the *P.O.E.E. Journal*, Engineer-in-Chief's Office, Alder House, Aldersgate Street, London, E.C.1, or to the Publishers.

Employees of the British Post Office can obtain the *Journal* through Local Agents at the reduced price of 2s. per copy.

Advertisements

All communications relating to space reservations should be addressed to the Advertisement Editor, *P.O.E.E. Journal*, Alder House, Aldersgate Street, London, E.C.1. Communications regarding advertisement copy, proofs, etc., should be addressed to the Publishers, Messrs. Birch & Whittington (Prop. Dorling & Co. [Epsom] Ltd.), 49 Upper High Street, Epsom, Surrey.

DENSO
INDUSTRY'S PROTECTION
AGAINST CORROSION

DENSO products ensure permanent protection for pipes, mains, cables and all structural steelwork, below and above ground, against atmospheric, industrial and electrolytic corrosion. They are acid-resistant and completely impervious to water.

DENSO REG. **ANTI-CORROSION PRODUCTS**

Full information from
WINN & COALES LTD.
DENSO HOUSE, CHAPEL ROAD, LONDON, S.E.27
Telephone: GIPsy Hill 4247/8
Telegrams: Denselte. Westnor London

PASS YOUR CITY & GUILDS CERTIFICATES AND P.M.G. CERTIFICATE

We offer comprehensive home training in a wide range of subjects, including P.M.G. Certificates, City and Guilds Grouped Certificates in Telecommunications, A.M.Brit.I.R.E. Examination, Radio Amateur's Licence, Radio and Television Servicing Certificates, General Radio and Television Courses, Radar, Sound Recording, etc. Also Courses in all other branches of Engineering.

With the following Courses, Practical Kits are available.

Radio, Television, Mechanics, Electricity, Chemistry, Photography, Carpentry; also Draughtsmanship, Commercial Art, Amateur S.W. Radio, Languages, etc.

Write now

for FREE BROCHURE stating subjects of interest to:

E.M.I. INSTITUTES

Dept. 97, GROVE PARK ROAD, LONDON, W.4
An Educational Organization serving the E.M.I. Group of Companies, including "HIS MASTER'S VOICE", MARCONIPHONE, COLUMBIA, etc.

10.64 10/55

NO EXTERNAL CHANNELLING EQUIPMENT !

Standard
six channel

Very **H**igh **F**requency

radio link

type

FP11

Six Telephone or Teleprinter Channels,
plus Independent Order Wire Circuit.
Full Supervisory and Control Facilities.
Alternative Radio Frequency Bands.

available for
early delivery

Write for leaflet No. 198/46

complete in one cabinet

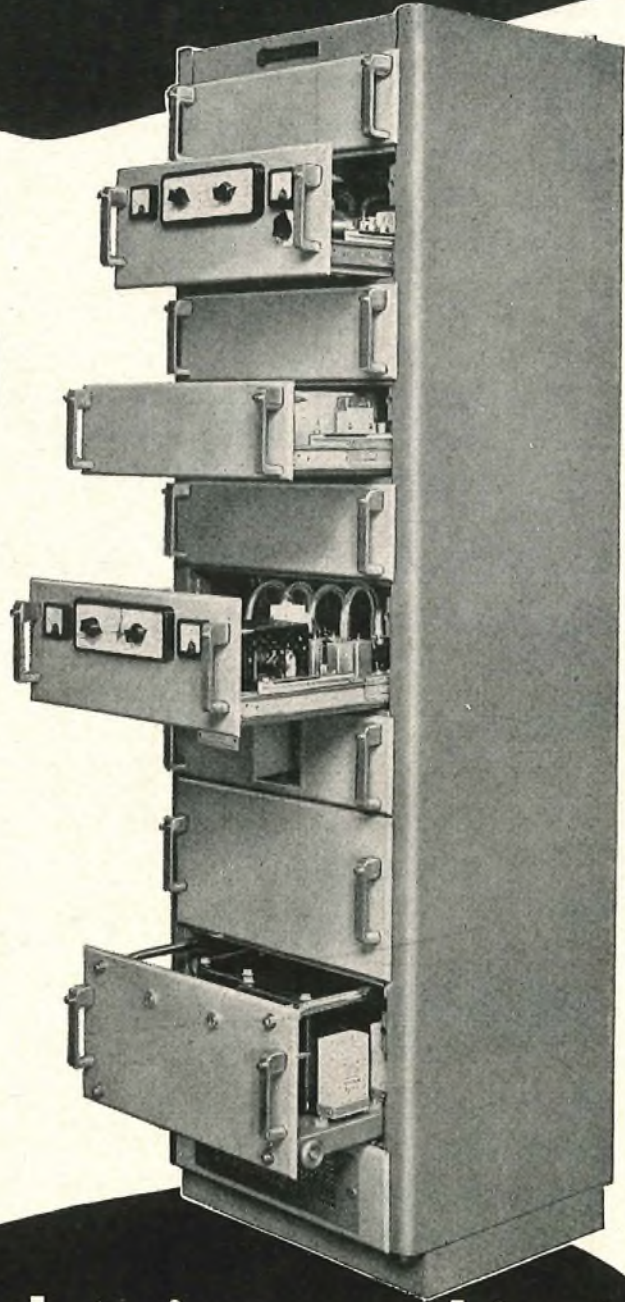

Standard Telephones and Cables Limited

Registered Office : Connaught House, Aldwych, London, W.C.2

RADIO DIVISION, Oakleigh Road, New Southgate, London, N.11

**ELECTRICAL MEASURING
INSTRUMENTS & EQUIPMENT**

designed and built for
specific requirements in
INDUSTRY AND RESEARCH

Contractors to:
Post Office, H.M. Admiralty, Ministry of Supply,
National Coal Board, etc.

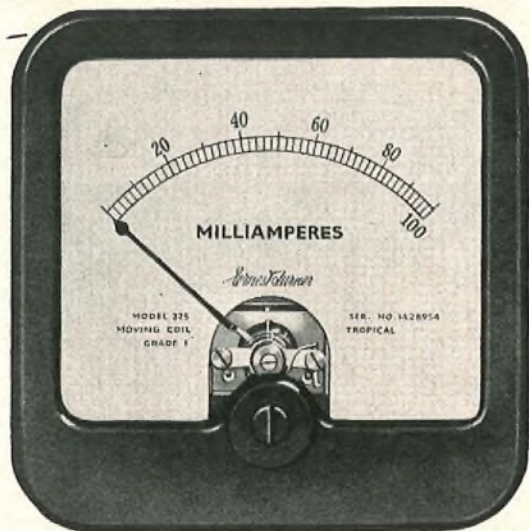

ERNEST TURNER ELECTRICAL INSTRUMENTS LIMITED
CHILTERN WORKS • HIGH WYCOMBE • BUCKS.

Telephone:
HIGH WYCOMBE 1301-2-3

Telegrams:
"GORGEOUS, HIGH WYCOMBE"

**DAMP? HEAT?
COLD? FUMES?
VIBRATION & SHOCK?**



Hermetically sealed potentiometers
are Type Approved to Class H.1. of
RCL 121, 2.5 watt rating for use in
Arctic and Tropical conditions.

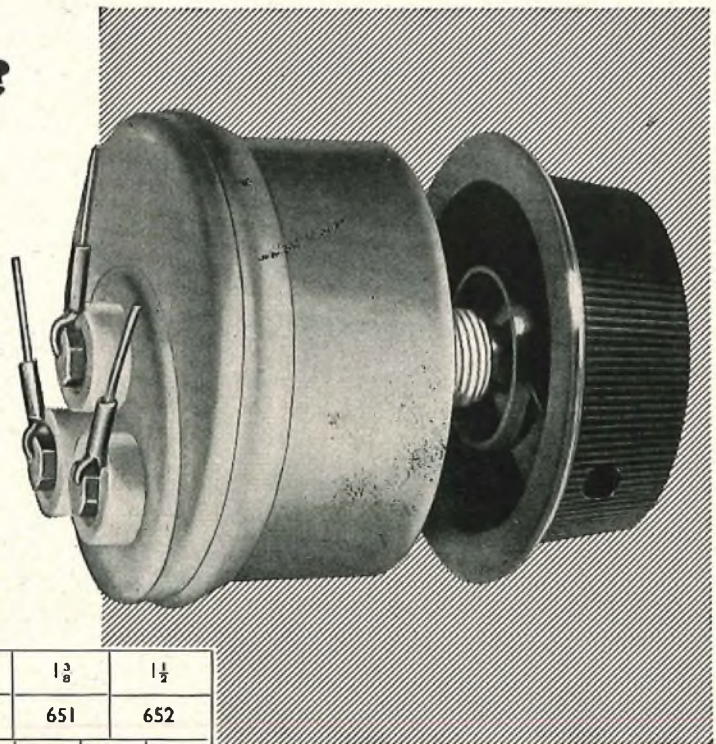

Shaft Length (inches)		$\frac{7}{8}$	1	$1\frac{1}{8}$	$1\frac{1}{4}$	$1\frac{3}{8}$	$1\frac{1}{2}$					
Part No.		647	648	649	650	651	652					
Ohmic value ...	5	10	25	50	100	250	500	1,000	2,500	5,000	10,000	25,000	50,000
Current (amps.)	1	.7	.45	.32	.22	.14	.1	.07	.045	.032	.022	.014	.01

THE BRITISH ELECTRIC RESISTANCE CO. LTD.
Queensway, Ponders End, Middlesex. Telegrams & Cables: VITROHM, ENFIELD. Telephone: HOWARD 1492.



REPERFORATOR

MODEL 451



A truly synchronous reperforator
for Morse code.

Speed range:

40-200 words per minute without
gear changes.

Supplied with A.C. or D.C. motor
as required.

Several of these machines are working daily at 180 words per minute.

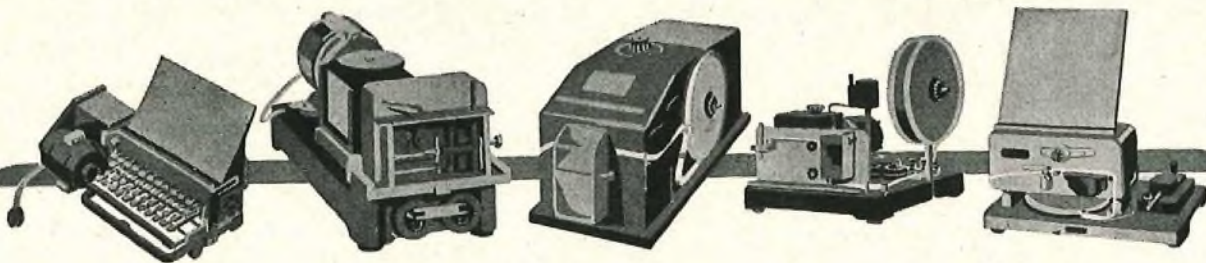

GREAT NORTHERN TELEGRAPH WORKS

DIVISION OF THE GREAT NORTHERN TELEGRAPH CO. LTD.

4, SYDHAVNS PLADS
COPENHAGEN SV, DENMARK

LONDON OFFICE: 5, ST. HELEN'S PLACE
LONDON E. C. 3.

Constant DC Voltage

DC Voltage limits $\pm 1\%$ despite:—

- * AC voltage fluctuations of -10 to $+6\%$.
- * Frequency variations of 48 to 52 cps.
- * Load variations of 5% to 100% and self-protecting on overload.

The above are typical limits of our range of constant DC voltage equipments. Electronic, magnetic or mechanically regulated equipments are available and can also be designed to meet customers' specific requirements. Consult us for the most satisfactory solution to your problems—take full advantage of the WESTINGHOUSE SERVICE.



CONSTANT POTENTIAL RECTIFIERS

Write for details to:—

Dept. P.O.10, WESTINGHOUSE BRAKE & SIGNAL CO. LTD., 82 York Way, King's Cross, London, N.1

Telephone:— TBRminus 6432

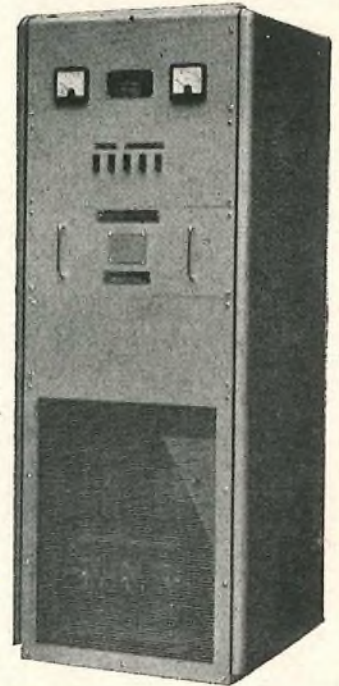

Typical Transbooster

IMPROVEMENT IN THE ACCURACY OF DECADE RESISTANCES

We have pleasure to announce that the well-known and novel

SULLIVAN and GRIFFITHS

DUAL DIAL DECADE RESISTANCE BOXES

FOR ALL FREQUENCIES

Moreover, the windings are now of **Manganin** in order to reduce the temperature coefficient; more important still, to improve the long period of stability and make them as suitable for all direct-current purposes as they are for alternating currents of all frequencies.

Screened Resistances of guaranteed accuracy exactly similar to our well-known Decade Resistances but specially arranged so that one box of a given number of dials gives many different values of maximum resistance. Thus a three-dial box (as illustrated) may be used for instance for

three decades of Thousands, Hundreds and Tens	a total of 10,000 ohms.
or three decades of Hundreds, Tens and Units	a total of 1,000 ohms.
or three decades of Tens, Units and Tenths	a total of 100 ohms.
or three decades of Units, Tenths and Hundredths ,	a total of 10 ohms.

have now been improved in accuracy to

0.05 PER CENT

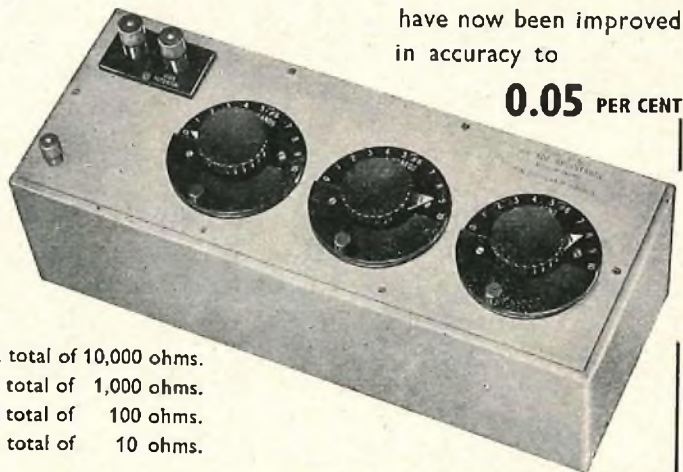

H. W. SULLIVAN LIMITED

LONDON, S.E.15

Telephone: New Cross 3225 (P.B.X.)

The advantages of such a system will be obvious, for in addition to the economy involved much space is saved and the residual resistance and inductance is much reduced.

The resistances are available in 3-dial, 4-dial and 5-dial types with subdivision of 0.001% down to 0.001 ohm if necessary, depending of course on the number of dials incorporated.

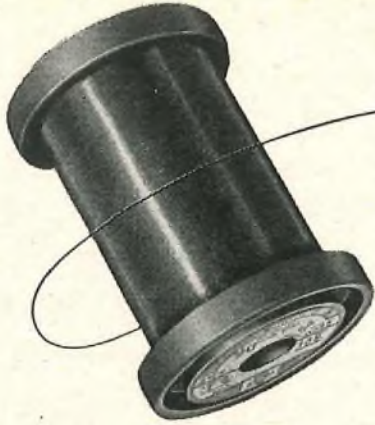

BICC

'BICALEX'

WINDING WIRES

"Bicalex" synthetic-enamel insulated winding wires are ideal for high-speed winding and for applications where abrasion is likely.

They can be stretched, twisted and even flattened without damage to the insulation.

Full details on "Bicalex" Winding Wires are given in Publication No. 322, available on request.



For EVERY type of coil—there's a BICC Winding Wire



BRITISH INSULATED CALLENDER'S CABLES LIMITED
21 BLOOMSBURY STREET, LONDON, W.C.1

Marconi 6kW HF ISB Transmitters

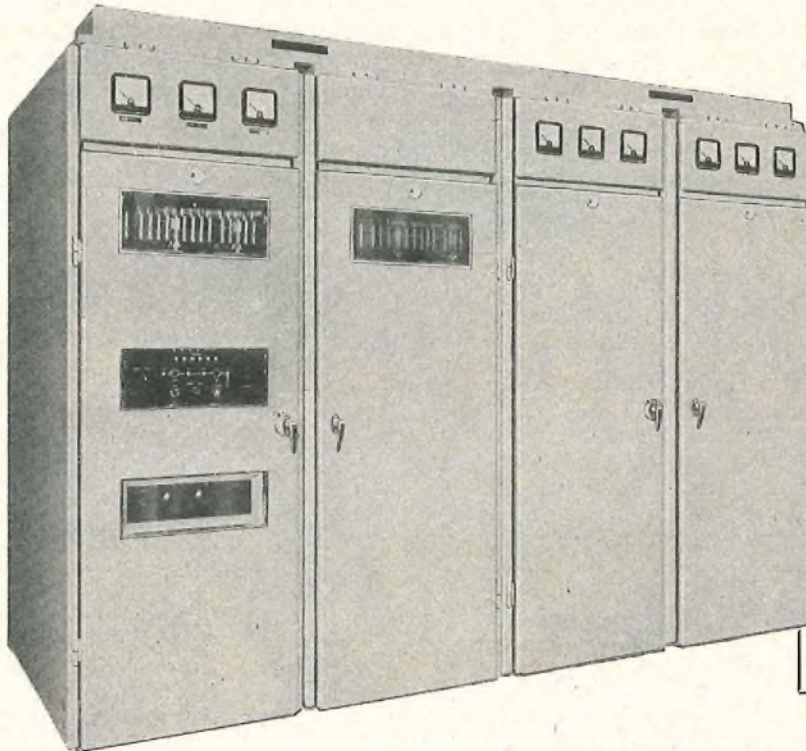

TYPES HS 71 AND HS 72

The assembly is enclosed by unit sections, as shown here, with access through front and rear doors. The two left hand bays house the rectifier and power equipment and the right hand bays the low power and auxiliary transmitting circuits and the main output stage.

These transmitters, designed in accordance with the most advanced practice, provide :—

- (a) Telegraphy on CW and FSK (A1 and F1)
- (b) Independent Sideband Operation (A3b)

The drive equipment is external and provides either ISB modulation or telegraph keying at 3.1 Mc/s and suitable RF oscillator signals for frequency changing in the transmitter. HS 71 is manually operated; HS 72 provides full automatic tuning and selection of any one of six pre-set frequencies.

FEATURES INCLUDE

- Tuning over the whole range without change of components
- Air cooling throughout, with dust filtering.
- Double screening of power stages reduces indirect radiation and cooling air noise.
- Envelope feed back to reduce distortion.
- Compact assembly with good access for servicing and safety interlocking.

More than 80 countries now have Marconi equipped telegraph and communication services, many of which, completed 20 years ago, still give trouble-free operation.



Lifeline of communication

MARCONI

COMPLETE COMMUNICATION SYSTEMS

Surveyed, planned, installed, maintained

Partners in progress with The 'ENGLISH ELECTRIC' Company Limited

MARCONI'S WIRELESS TELEGRAPH CO. LTD., CHELMSFORD, ESSEX

LC12

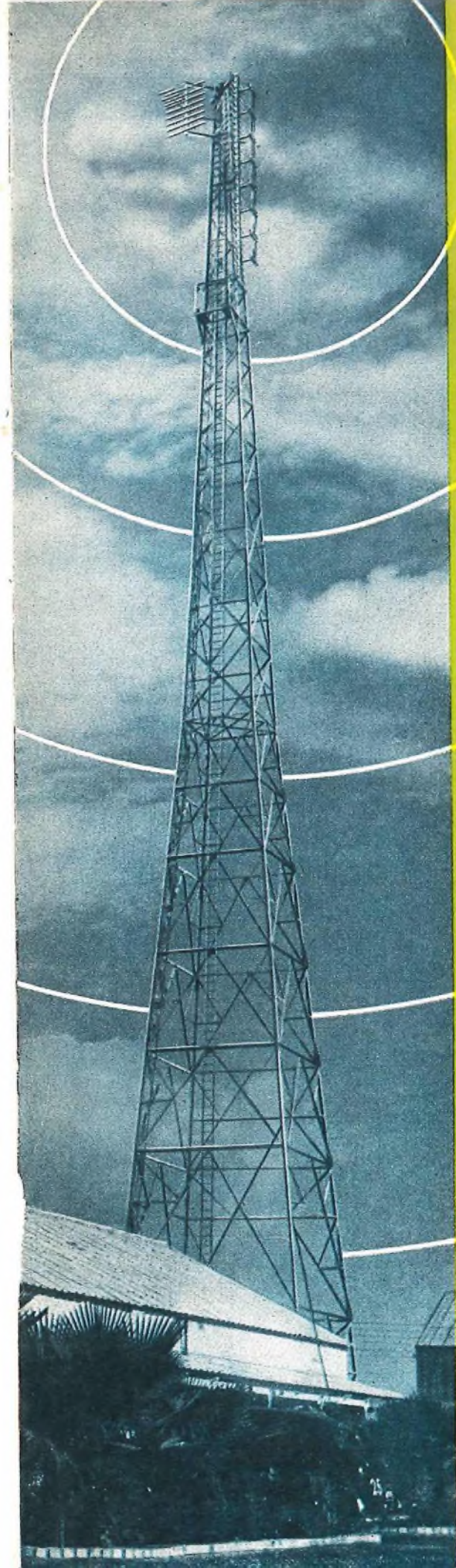

A UNIQUE

AUTO RADIO

INSTALLATION

FOR THE BASRAH PETROLEUM COMPANY

ZUBAIR

MAKINAH

FAO

DESIGNED, ENGINEERED AND MANUFACTURED BY
AUTOMATIC TELEPHONE & ELECTRIC CO. LTD.



TO link the Makinah headquarters of the Basrah Petroleum Co. Ltd., with the Zubair oil fields in one direction and the loading port of Fao in the other, Automatic Telephone & Electric Co. Ltd. have installed a multi-channel v.h.f. radio communication network incorporating inter dialling and teleprinter facilities.

Fully automatic exchanges at Zubair, Makinah and Fao are linked together by three direct and three indirect telephony channels. Duplex telegraph working is also provided, together with through working magneto telephone and teleprinter circuits, to control oil pumping operations over the 74 miles of pipe line connecting Zubair and Fao.

Junction dialling is effected by A.T.E., v.f. dialling equipment pulsing a single audio frequency of 2520 c/s. Special features are automatic change over to stand-by transmitter and receiver bays in the event of failure of working equipment, and an unattended v.h.f. radio repeater station at Seebah which provides remote alarm indications at the Makinah headquarters. Stand-by diesel generators, which automatically start in the event of mains failure, are provided at each location.

The schematic drawing outlines the facilities provided, and the distances covered, by the system.

The decision to use v.h.f. radio, rather than land line routes, was made in view of the natural difficulties presented by the terrain which ranges from hard rocky desert to vast salt marshes inundated for considerable periods each year. The hazards, to a pole and line route, of extremes of heat, humidity and storm, and the risk of accidental or malicious damage to overhead lines were also given due consideration.

The successful installation of this v.h.f. auto-radio system into the Basrah oil field represents a major technical advance directly assisting the production of world oil supplies.

AUTOMATIC TELEPHONE & ELECTRIC CO. LTD.

Radio & Transmission Division,

Strowger House, Arundel Street, London, W.C.2

'Phone: TEMple Bar 9262. 'Grams: Strowgerex London

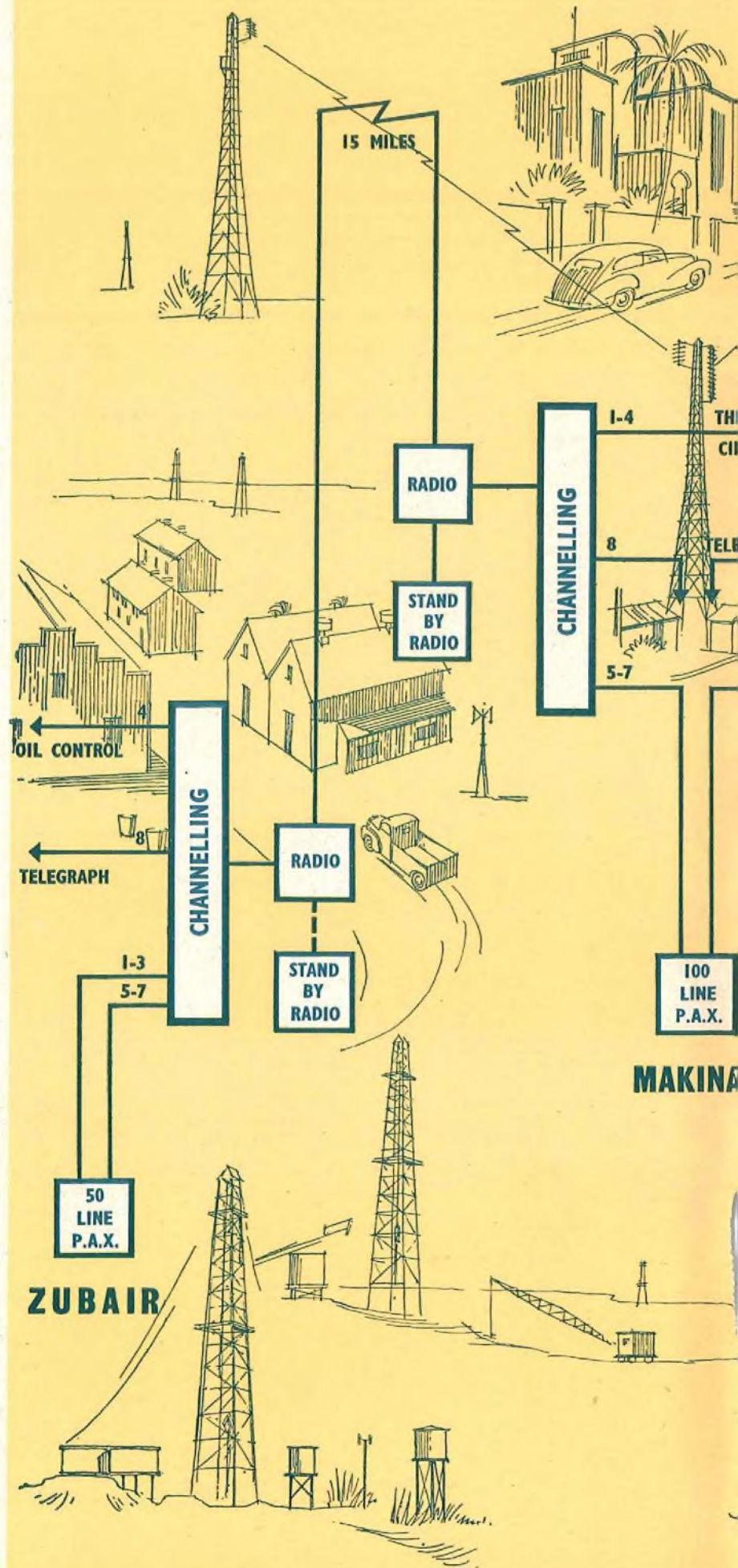

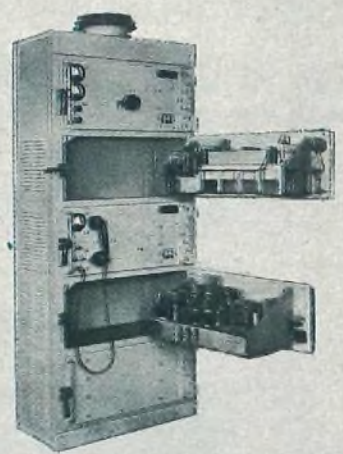
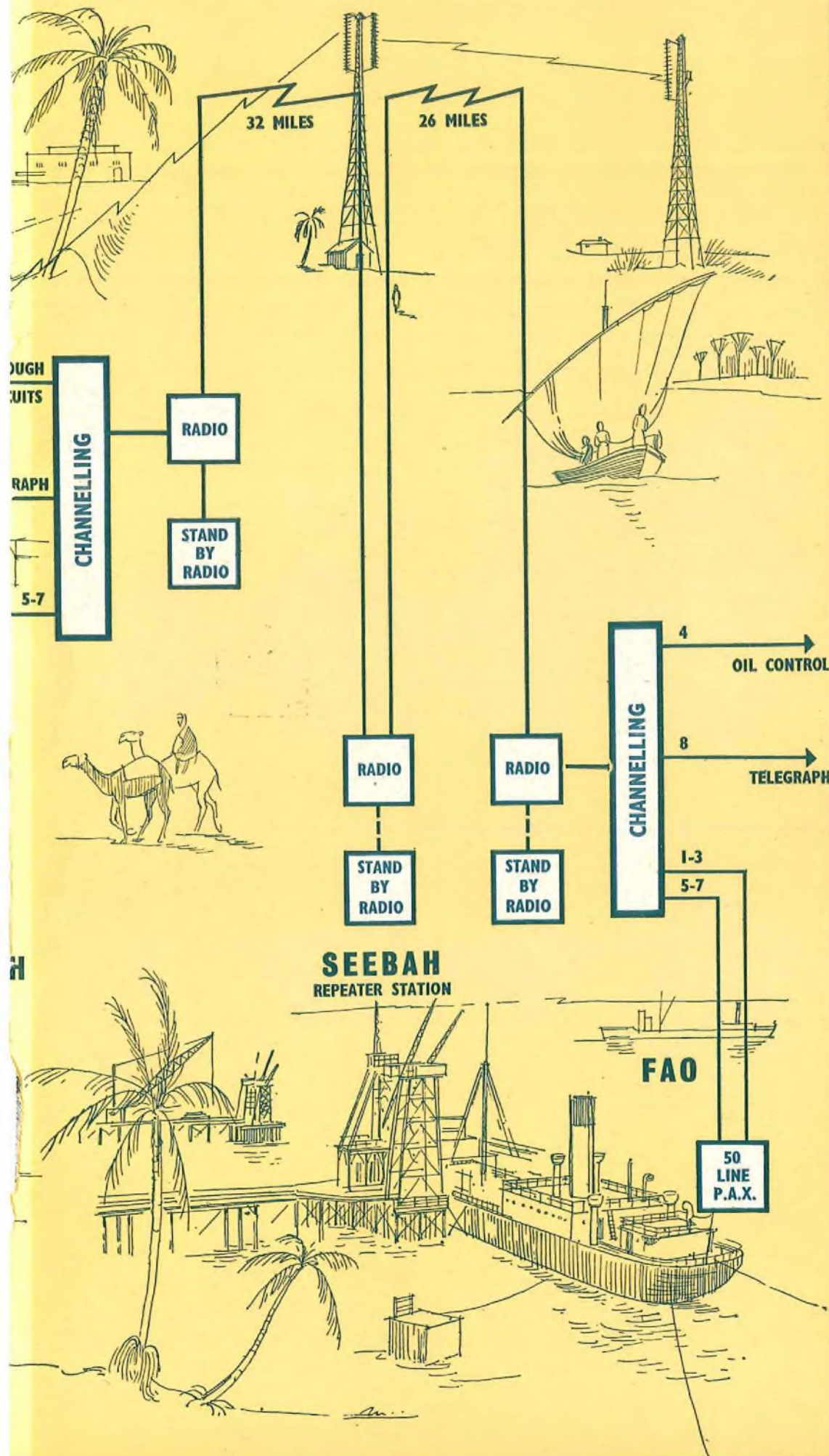

RADIO TRANSMITTER

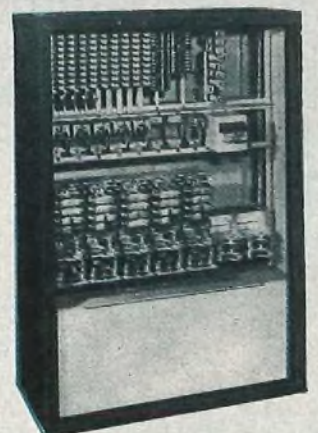

PRIVATE AUTOMATIC EXCHANGE

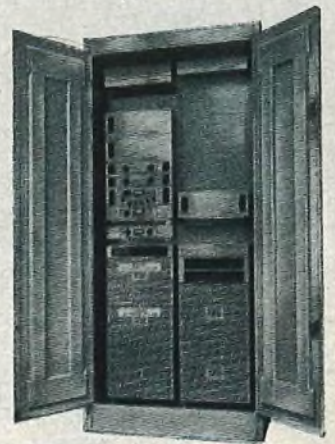

RADIO CHANNELLING EQUIPMENT



OSCILLOSCOPE

Type 830

THE OSCILLOSCOPE TYPE 830 has been designed for general wide-band frequency work, and is particularly suitable for observing pulse waveforms with very fast rise-times. The frequency response of the Y amplifier is flat from 30 c/s to 20 Mc/s and the time-base provides writing speeds up to 20 cms per microsecond.

The mechanical design is the same as that employed in the Airmec Oscilloscope Type 723, the Cathode Ray Tube being mounted vertically and viewed through a surface aluminised mirror. The instrument may therefore be used in conjunction with the Airmec Oscilloscope Camera Type 758.

Y PLATE AMPLIFIER

Frequency Response ± 2.5 db from 30 c/s — 20 Mc/s.
Sensitivity 75 millivolts per cm.
Rise-time 30 millimicroseconds.

TIME-BASE

Range 0.05 second to 1.5 microseconds.
Operation Triggered or repetitive.
Expansion Variable up to 5 times.
Traverse A traverse control enables any portion of the expanded time-base to be viewed.

E.H.T. VOLTAGES 1, 2 or 4 kV.



Full details of this or any other Airmec instrument will be forwarded gladly upon request.

AIRMEC
LIMITED

HIGH WYCOMBE
Telephone: High Wycombe 2060

BUCKINGHAMSHIRE

ENGLAND

Cables: Airmec, High Wycombe

Perfection in Miniature

ARANEUS DIADEMATUS
(the common garden spider)

weaves its web with a thread 0.007 mm in diameter, with a tensile strength of about 2 grams.

The "40 series" valves, one of the Hivac ranges of highly specialised subminiature types, uses a tungsten filament of approximately the same diameter but having a tensile strength more than five times as great.

Hivac Limited

STONEFIELD WAY, VICTORIA ROAD
SOUTH RUISLIP, MIDDLESEX

Subminiature, miniature and midget valves, electrometers, cold-cathode tubes, transistors, indicator and switchboard lamps, neon indicator lamps.



TELEPHONE: Ruislip 3366

Quality, Sir, is a matter of detail.

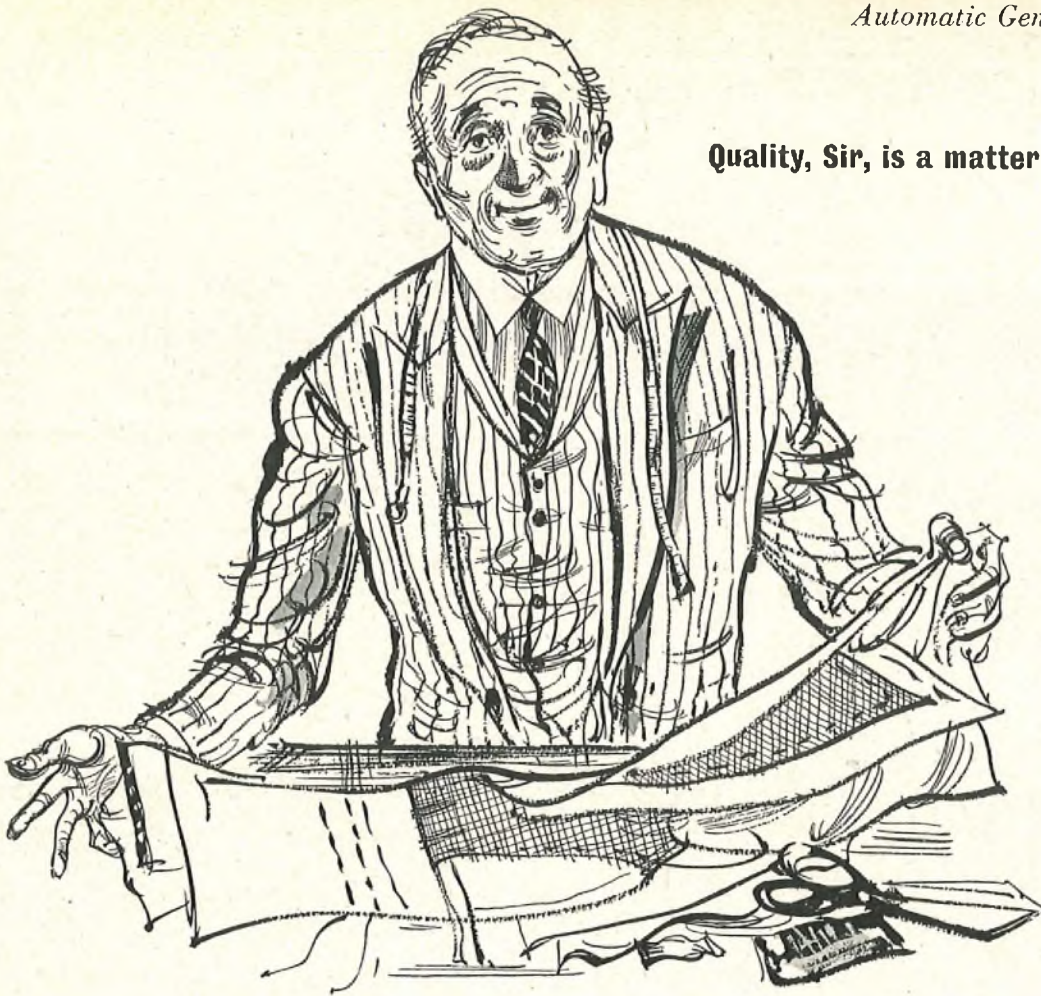

Take a diesel engine and an alternator, bolt them down to a bedplate, couple them together and supply some switchgear. There you have a generating plant. Good enough for some jobs, perhaps, but not for the kind of job Austinlite plant is designed to do.

To see the difference you have to look closely. At the solid steel bearing housings with their special high speed bearings; at the patented bearing wear detection system; at the subsidiary emergency bearings which only come into play in the very unlikely event of main bearing failure; at the electrical equipment specially 'tropicalised' by methods developed as a result of much experience in the supply of plant designed to operate dependably in hot, humid climates.

It is detail of this kind which accounts for the high reputation of Austinlite wherever reliability is an essential. That, and one thing more; Austinlite engineers always enjoy tackling the jobs other people cannot fit. Because, although we make many standard types of generating plant, made-to-measure plant is our forte.

Austinlite **AUTOMATIC GENERATING PLANT**
Tailor-made by STONE-CHANCE LTD.

THE NEW MARCONI SIGNAL GENERATOR TYPE TF 801B

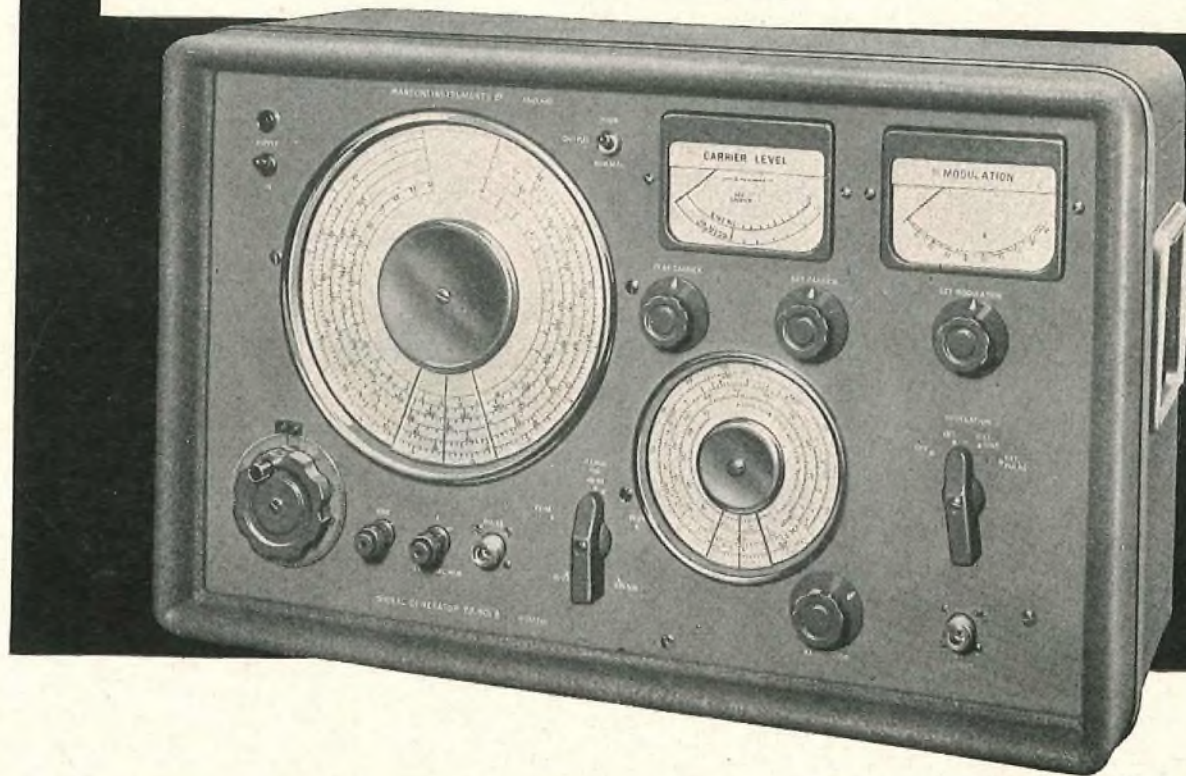

FREQUENCY RANGE 10 to 500 Mc/s

NORMAL OUTPUT: 0.1 μ V to 0.5 volt, c.w. or modulated to 30%, available under all conditions; 90% modulation at most carrier frequencies.

HIGH OUTPUT: up to 2 volts c.w., or 1 volt modulated, at most carrier frequencies. *Sine a.m.*: 1000-c/s internal or 30 c/s to 20 kc/s external. For external pulse modulation, r.f. bandwidth extends to 3 Mc/s. Output impedance: 50 ohms. A.C. mains operated.

MARCONI INSTRUMENTS

SIGNAL GENERATORS · BRIDGES · VALVE VOLTMETERS · Q METERS · WAVEMETERS
FREQUENCY STANDARDS · WAVE ANALYSERS · BEAT FREQUENCY OSCILLATORS

MARCONI INSTRUMENTS LTD · ST. ALBANS · HERTS · TELEPHONE: ST. ALBANS 6160/9

30 Albion St., Kingston-upon-Hull. Phone: Hull Central 16144.

19 The Parade, Leamington Spa. Phone: 1408

Managing Agents in Export:

MARCONI'S WIRELESS TELEGRAPH COMPANY LIMITED · MARCONI HOUSE · STRAND · LONDON · W.C.2

CARPENTER

POLARIZED RELAYS

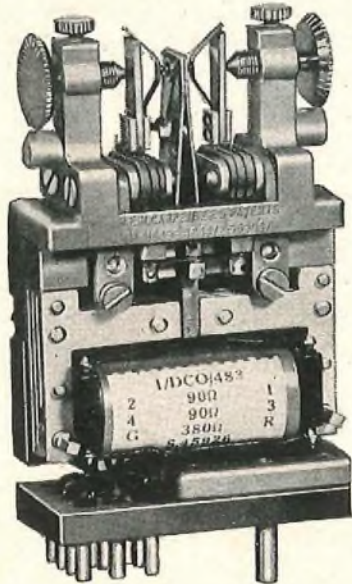

have these outstanding features

- HIGH OPERATIONAL SPEED • HIGH SENSITIVITY
- FREEDOM FROM CONTACT REBOUND
- NO POSITIONAL ERROR • HIGH CONTACT PRESSURES
- ACCURACY OF SIGNAL REPETITION
- EASE OF ADJUSTMENT

The Carpenter Polarized Relay will respond to weak, ill-defined or short-duration impulses of differing polarity, or it will follow weak alternating current inputs of high frequencies and so provide a continuously operating symmetrical changeover switch between two different sources.

Dimensionally the Type 4 relay illustrated is interchangeable with the type "3000" Relay and can be supplied to fit directly to the drilling normally provided for the "3000" Relay.

Manufactured by the sole licensees

TELEPHONE MANUFACTURING CO. LTD

Contractors to Governments of the British Commonwealth and other Nations



HOLLINGSWORTH WORKS, DULWICH, LONDON, SE21

Telephone GIPsy Hill 2211

ZEVA

Electric

SOLDERING TOOLS

*for SPEED, ECONOMY
and BETTER WORK*

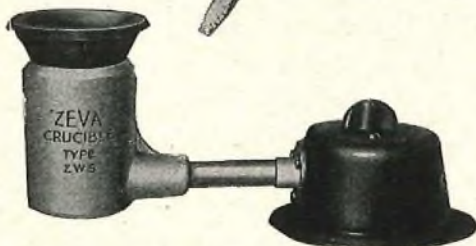

The news that this famous range of Soldering Irons and Crucibles is again available has been welcomed in numerous branches of industry everywhere. Zeva Tools are unquestionably without equal for efficiency, economy and trouble-free long life.

- ZEVA handling elements never need renewal. They last the life of the tool.
- ZEVA Irons can be left switched on all day without detriment to the tool.
- ZEVA current consumption for rated temperature is less than any other make of tool.
- ZEVA initial cost is the only cost.
- ZEVA Irons are guaranteed.

Write for complete
Illustrated Catalogue:—

THE AUTOMATIC COIL WINDER & ELECTRICAL EQUIPMENT CO., LTD
Avocet House, 92/96 Vauxhall Bridge Road, London, S.W.1

VICTORIA 3404 (9 Lines)

Z1.P2.ZWS

Improved filter units

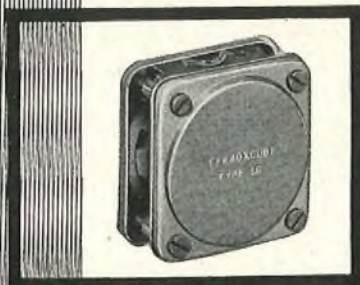
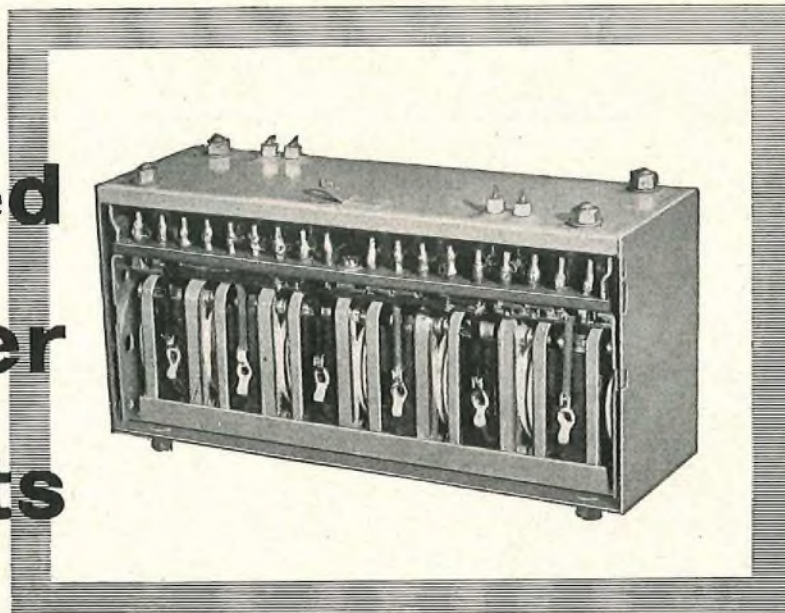

with Ferroxcube pot cores

- 1 *High performance combined with small size and light weight.*
- 2 *Designed and built to customers' individual requirements.*
- 3 *Long term stability, even under conditions of temperature variation.*

High quality electrical filter units built around Ferroxcube cores can now be supplied to communications equipment designers' individual specifications. These filter units have significant advantages over comparable types designed without the use of Ferroxcube, particularly in the frequency range 300 c/s to 500 kc/s. For audio frequencies the use of Ferroxcube cores permits the winding of compact coils with very high inductances. This results in a considerable reduction in the size and cost of the associated condensers and hence of the filter unit as a whole. The high Q values obtained for a given volume, especially above 10 kc/s, enable sharp cut off characteristics and low pass-band losses to be achieved, while negligible stray flux facilitates the production of compact and mechanically robust filters. Electrical filter units are among a number of high quality components now being made available by Mullard. Full details of the complete series of components will be gladly supplied upon request.

Mullard



'Ticonal' alloy permanent magnets
Magnadur permanent ceramic magnets
Ferroxcube ferro-magnetic cores.

MULLARD LTD • COMPONENTS DIVISION • CENTURY HOUSE • SHAFTESBURY AVENUE • WC2

(M1463A)



PRODUCTS

ATTENUATORS AND FADERS · STUD SWITCHES · TOGGLE SWITCHES · PUSH BUTTON SWITCHES
FIXED AND ADJUSTABLE WIREWOUND RESISTORS · HIGH STABILITY CARBON RESISTORS
"METLOHM" STABILITY RESISTORS · WIREWOUND POTENTIOMETERS · MIDGET R.F. CHOKES
KNOBS, DIALS & POINTERS · TERMINALS · PLUGS AND SOCKETS

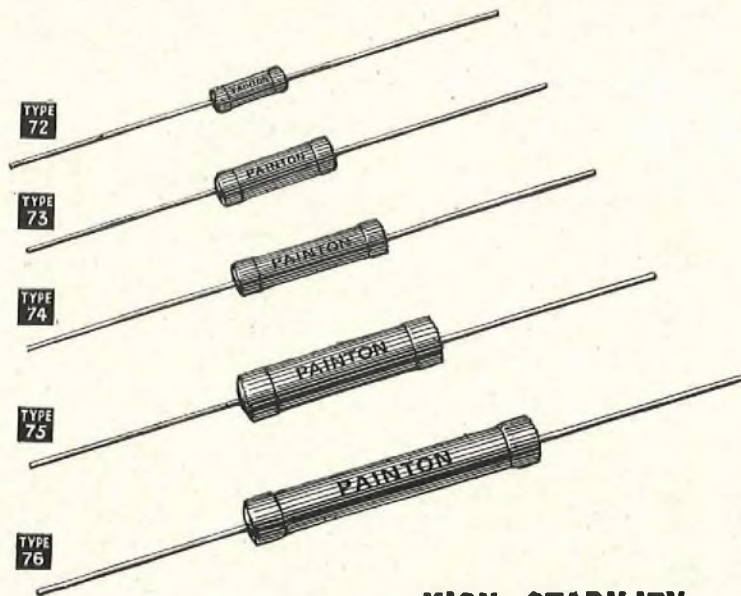

HIGH STABILITY CARBON RESISTORS

$\frac{1}{4}$ w., $\frac{1}{2}$ w., $\frac{3}{4}$ w., 1w. and 2w. types available at 1%, 2%
or 5% Resistance Tolerance.

Complete range fully R.C.S.C. Approved.

For full details please request High Stability Carbon
Resistor Leaflet, HSC1/3.

Painton High Stability Carbon Resistors are now
available with an improved coating protecting the carbon
film, and the smaller sizes (Types 72 and 73) can be
supplied as insulated Resistors.

PAINTON
Northampton England

BY APPOINTMENT TO THE PROFESSIONAL ENGINEER

MARCONI-SIEMENS

Five Band Split Privacy Radio Telephone Equipment

(Type HW 12)

This equipment, which may be switched in or out of use at the radio terminal, provides a very high degree of privacy for speech on a radio-telephone circuit by:-

- (1) splitting the speech band of 250-3000 c/s into five sub-bands of 550 c/s and recombining them in different relative positions,
- (2) inverting the frequency range of any one or more of the sub-bands, and
- (3) rearranging the combination of the sub-bands simultaneously at both ends of the radio-circuit in accordance with a pre-arranged sequence at controlled intervals between 4 and 20 seconds.

The resulting speech band, which modulates the transmitter, is unintelligible and the frequent regrouping of the sub-bands, with or without inversion precludes any simple method of interception. A reversal of the process at the distant terminal restores the original speech. The processes involved are reversible, thus common channel equipment can be used for both transmission and reception. Amplifiers in the privacy path compensate for the losses in band splitting and recombining. The simultaneous switching system, operates by means of relays under the control of a synchronous motor driven by a high precision crystal oscillator, this does away with the need for a transmitter pilot tone.



THE LINK BETWEEN RADIO AND LINE COMMUNICATIONS



Full technical details of this and other Marconi-Siemens equipment, which provides completely integrated radio and line telegraph and telephone systems may be obtained from either

MARCONI'S WIRELESS TELEGRAPH COMPANY LIMITED, CHELMSFORD, ESSEX
OR SIEMENS BROTHERS & CO., LIMITED WOOLWICH, LONDON, S.E. 18

MS2

POWER *behind the lines*

TUNGSTONE PLANTÉ CELLS are being regularly supplied to the British Post Office and Post and Telegraph Departments in many countries overseas. They conform fully to G.P.O. Standard specifications.

OPEN TYPE CELLS

Similar to the illustration here, these are available in glass and/or lead lined wooden boxes in capacities from 100 a.h. to 5000 a.h.

REPLATALS

We are in a position to supply plates for the replating of existing Planté Batteries.

ENCLOSED TYPE CELLS

As illustrated below, these are in moulded glass boxes with sealed-in lid. Capacity range from 10 a.h. to 200 a.h.

PORTABLE TYPE BATTERIES

A range of portable type Batteries is in regular production, made to G.P.O. specifications, for ancillary duties.

Overseas customers are invited to cable or write their enquiries for batteries or parts. Visitors to London are welcome at our offices. (Just off Fleet Street.)

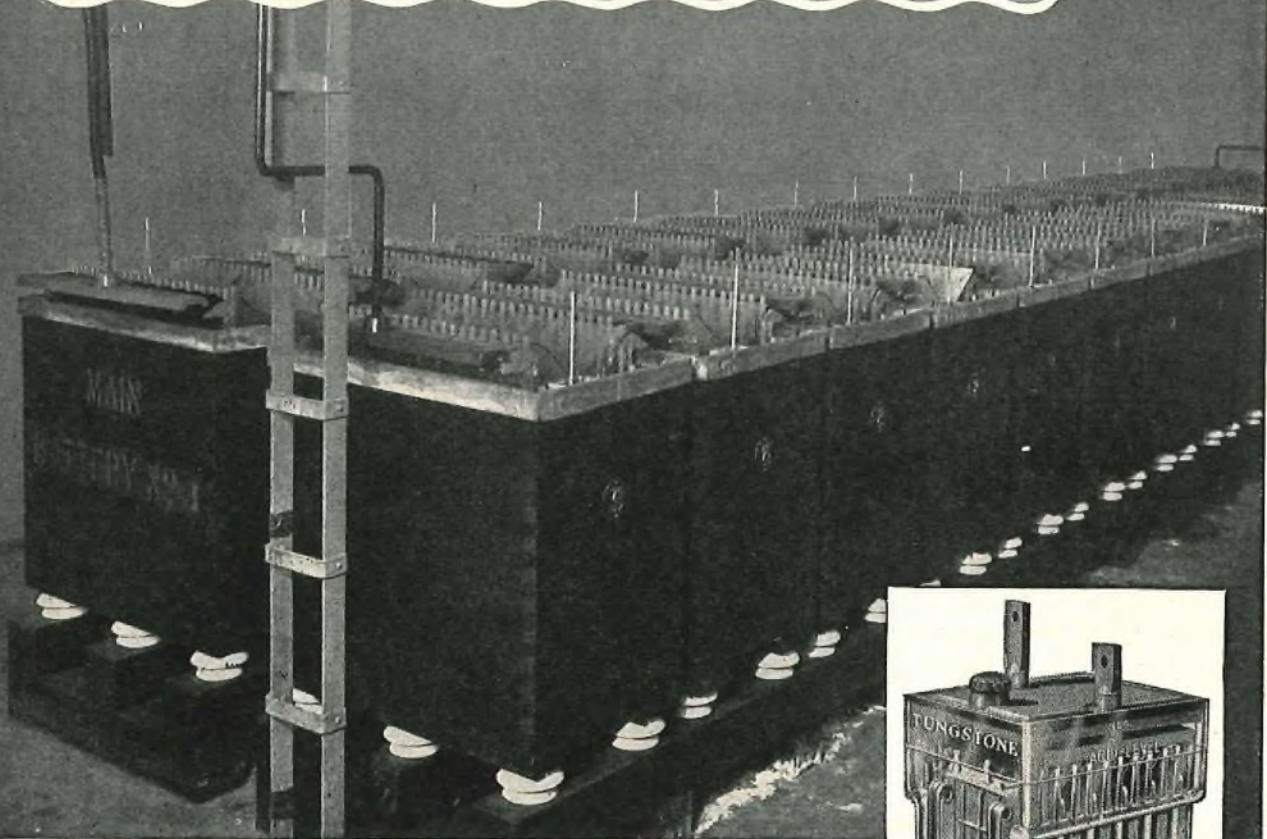

TUNGSTONE *Batteries*

For further particulars write : TUNGSTONE PRODUCTS LIMITED,
10 SALISBURY SQUARE, LONDON, E.C.4, ENGLAND. Cables: "Dilutum" London.

TC 6

Communication

Standard Systems in Service

In the field of television transmission 'Standard' coaxial cable and SHF radio links are the backbone of the G.P.O.'s permanent television transmission network in Great Britain. Illustrated is the tower and antennae system at Blackcastle Hill, Scotland, one of seven repeater stations along the route of the Manchester—Kirk o' Shotts television link.



Standard Telephones

(TELECOMMUNICATION)

Connaught House, Aldwych,

Calro

Dublin

Johannesburg

and Control

One of the largest telecommunication engineering organisations in the British Commonwealth **Standard Telephones and Cables Limited** is engaged in research, and the development, manufacture and installation of all types of communication and control systems.

Concerned with every aspect of telecommunications engineering, the Company is in an unrivalled position to undertake, within its own organisation, the co-ordinated planning of complete communication projects involving interdependent systems of various types.

Standard products include:-

Systems:—

Telecommunications Line Transmission
Radio Broadcasting, Communication and Navigation
Railway Communication and Control
Telephone and Telegraph
Supervisory and Remote Indication and Control
Sound Reproduction
Municipal and Industrial Fire Alarms
Street and Airfield Lighting Control
Signalling (Office and Factory)
Communication Cable
Power Cable

Equipment:—

SenTerSet Selenium rectifier equipment
Power Factor Correction
Heat Treatment
Transmission Testing apparatus
Cable Testing equipment
Loading Coils

Components:—

Quartz Crystals
Transistors
Capacitors and Interference Suppressors
Germanium Rectifiers and Photoelectric Cells
Thermionic Valves

Magnetic Materials
Thermistors
Relays
SenTerCel Selenium Rectifiers
Rubber, Plastic and Textile insulated cables and wires

and Cables Limited
ENGINEERS)

London, W.C.2, England

Karachi • New Delhi • Salisbury

'OPTIMUM SOLUM SUFFICIT'

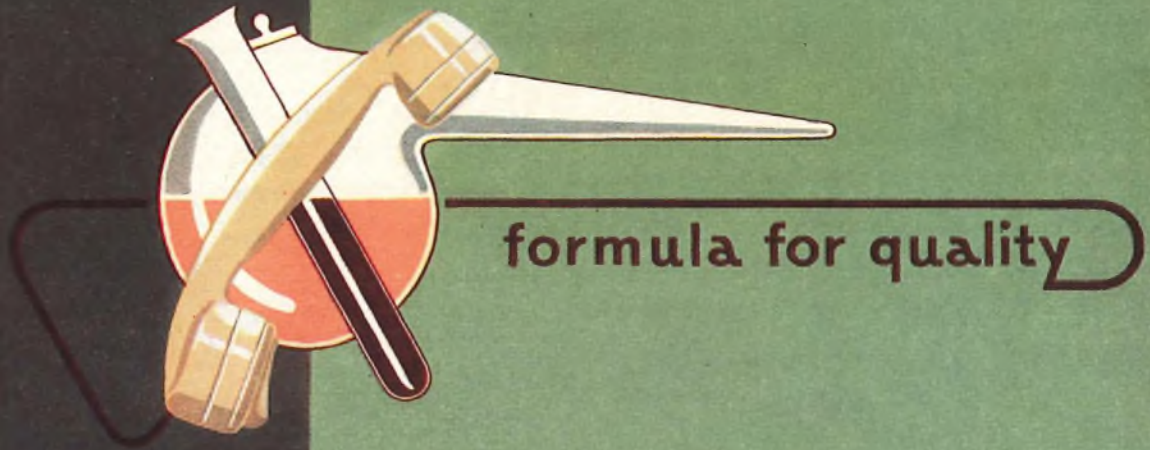

formula for quality

'ONLY THE BEST IS GOOD ENOUGH' is our standard, established as firmly today, as it has been throughout the past. For over half a century, Telecommunication Equipment by ERICSSON has always borne the seal of high quality. Throughout the whole of our Works, appreciation of this has become an endowment that sets a background to every phase of design and production. Modern Plant allied to the highest technical resources is the 'sine qua non' for the exacting standards imposed by modern conditions.

An outstanding example of the unity of these essential ingredients becomes apparent in the finish of all our products. Electro depositions and organic surface coatings are formulated and controlled directly by an extensive PROCESS LABORATORY so that at every stage expert knowledge is applied to ensure the superfine finishes which stand up to the most arduous conditions of service and climate.

What better FORMULA FOR QUALITY ?



HEAD OFFICE: 22, LINCOLNS INN FIELDS, LONDON W.C.2
WORKS: BEESTON, NOTTINGHAM & SUNDERLAND

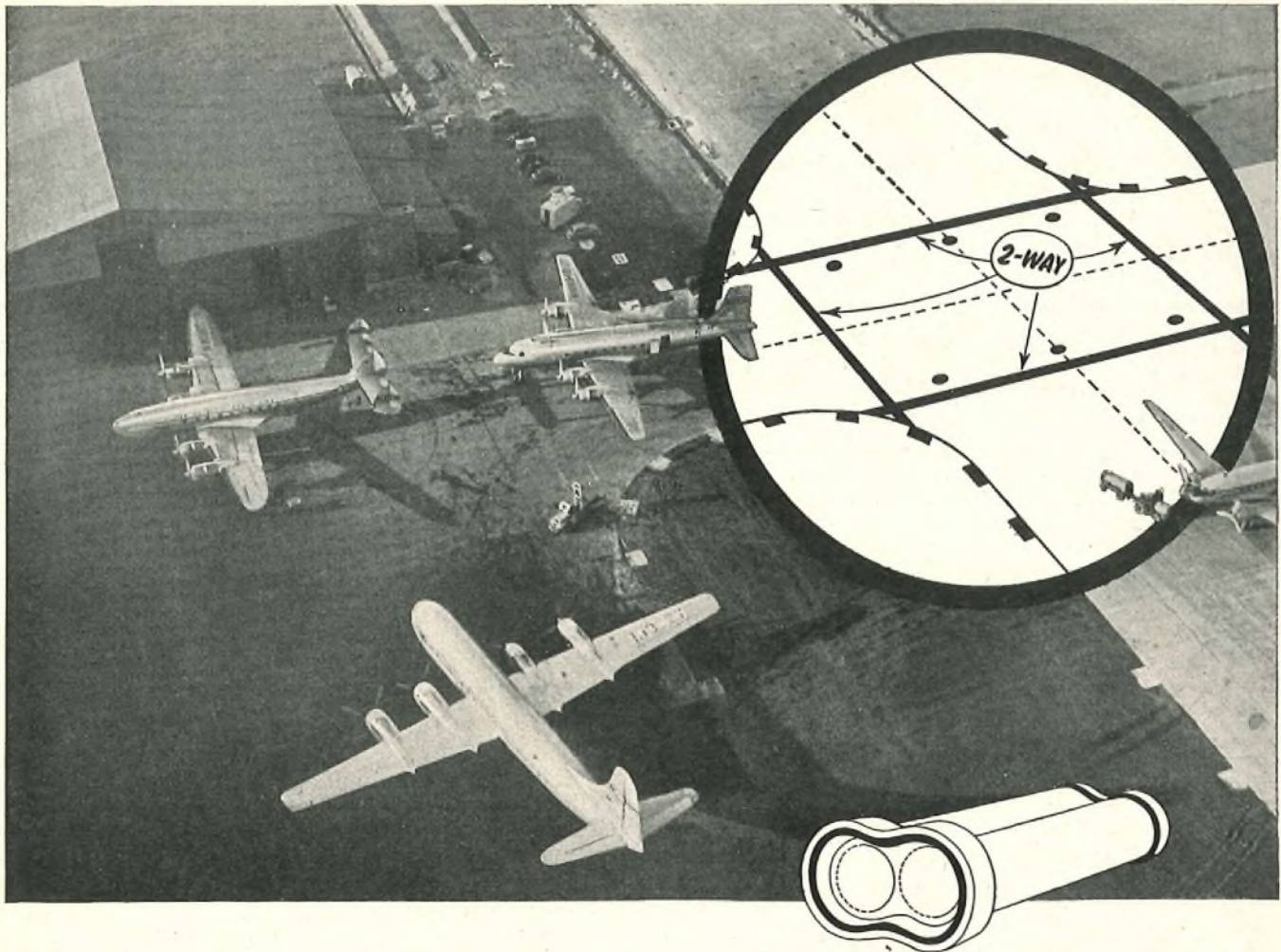

Under an Airport Runway

***If you never
want to have
to dig them
up again
put down***

This is a key point in an airport runway pattern. You lay electric cables under here, to serve the runway lights. Those cables must be easy to get at, easy to service. So you run your cables through conduits — in this case 2-way conduits.

If anything goes wrong with those conduits, if they have to come up again — think of the chaos. Think what would happen at a big airport. Last year *in August alone* London Airport handled nearly 9,500 aircraft and 210,000 passengers. A lot depends on those conduits — you never want to have to dig them up again.

That's why, at London Airport, they put down conduits of salt glazed vitrified clay.

Salt glazed conduits are glassy smooth and hard as nails. They are acid-resisting. Sulphates in the soil cannot corrode them. They go down for good! The same applies to the hundreds of salt glazed *drainpipes* that are out there too. Safe and efficient, salt glazed conduits and pipes can — and do — stay down for centuries.

Salt Glazed



pipes and conduits

NATIONAL SALT GLAZED PIPE MANUFACTURERS' ASSOCIATION



CATHODEON

Quartz Crystals

FOR
RELIABLE
FREQUENCY
CONTROL

Frequency range 2,000 — 20,000 kc/s

*Our range now includes crystals for close tolerance requirements.
Enquiries are invited for overtones up to 60 Mc/s.*

CATHODEON CRYSTALS LIMITED

LINTON · CAMBRIDGESHIRE · Telephone LINTON 223

TELEPHONE DISTRIBUTION

EQUIPMENT

ENGINEERS WHO ARE INTERESTED
IN TELEPHONE DISTRIBUTION EQUIP-
MENT ARE INVITED TO REQUEST
SECTION T.C.13 OF OUR TELECOM-
MUNICATION CABLES CATALOGUE.

TELEPHONE:
SOUTHAMPTON
22141 (5 lines).

IRELLI & GENERAL
CABLE WORKS, Ltd., SOUTHAMPTON

TELEGRAMS
"PIGEKAYBEL
SOUTHAMPTON"

EDISWAN

Telephone Line Protectors

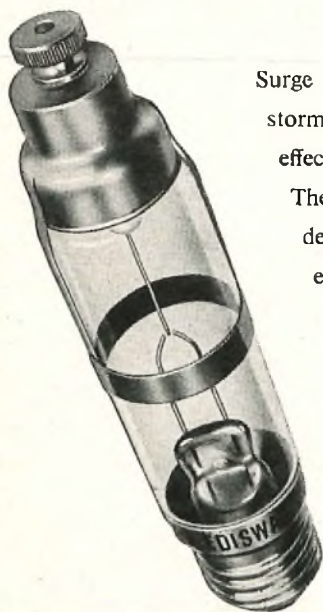

Surge currents induced on telephone lines by electric storms or breakdowns on neighbouring power lines may be effectively controlled by Ediswan telephone line protectors.

These special electrode gas discharge tubes have been developed in collaboration with G.P.O. Engineers to provide economical and effective protection for telephone systems without impairing the service.

Full details of these protectors and their application is given in the Ediswan publication C.1581 which is available on application.

THE EDISON SWAN ELECTRIC CO., LTD.
155 CHARING CROSS ROAD, LONDON, W.C.2

Member of the A.E.I. Group of Companies

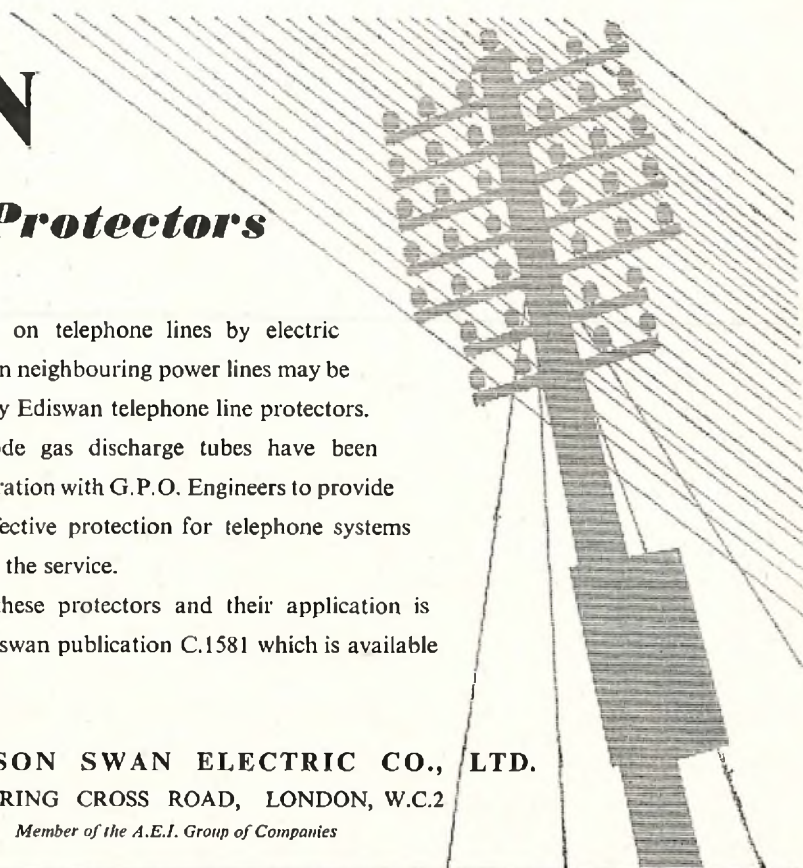

TE107

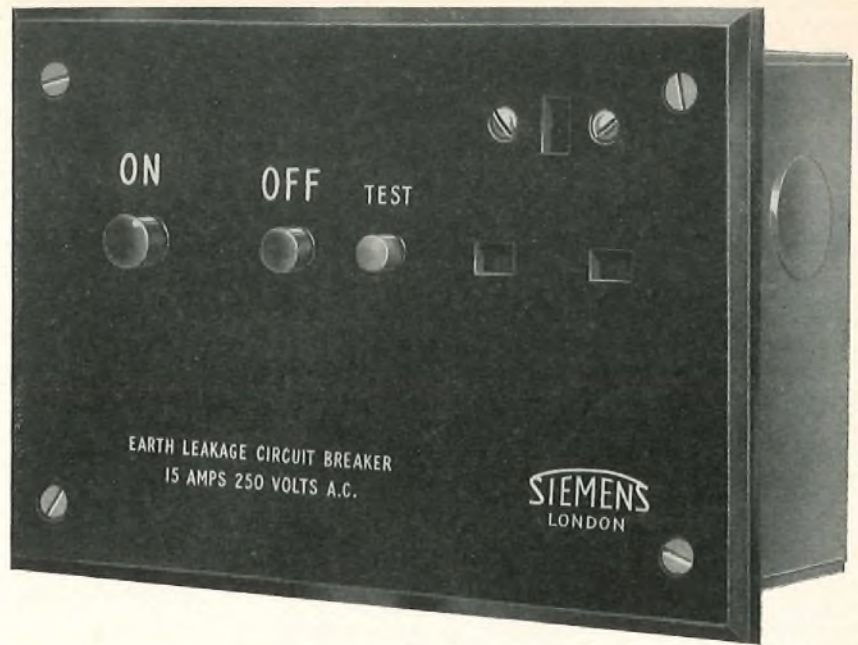

SIEMENS 'SAFETRIP'

There is already a flourishing demand for this robust and inexpensive addition to the Siemens range of Earth Leakage protection devices. The 'Safetrip' is for use on sub-circuits controlling apparatus consuming up to 3 Kw. It is available for flush or surface mounting, with or without socket outlet and conforms to the relevant B.S.S. The many design features of the 'Safetrip' contribute to reliability in service, compactness and ease of maintenance. Complete protection of the switch mechanism is by a single-screw-fixing bakelite cover.

SPECIFICATION : CAT. NO. EL/S (Incorporating 13 amp socket outlet)
 CAT. NO. EL 15 (as above but without socket outlet)



Cat. No.	Description	Cat. No.	Description
EL 15	Excluding box	EL 15/S	Excluding box
EL 15 } BSB }	With bakelite box for surface mounting	EL 15/S } BSB }	With bakelite box for surface mounting
EL 15 } SSB }	With steel box for flush mounting	EL 15/S } SSB }	With steel box for flush mounting

The EL 15 is the smallest Earth Leakage device available today and is the least expensive form of public protection against shock from lighting switches in proximity to earthed metal.

SIEMENS ELECTRIC LAMPS & SUPPLIES LIMITED

38-39 UPPER THAMES STREET, LONDON, E.C.4

Member of the AEI Group of Companies.

SOLDERING
INSTRUMENTS and
ALLIED EQUIPMENT
by **ADCOLA**
PRODUCTS LIMITED
(Regd Trade Mark)

DESIGNED FOR

**Sound Equipment
AND
Bench Line Assembly**

Bit Sizes

$\frac{1}{8}$ " to $\frac{1}{4}$ "

Volt Ranges

6-7v to 230-250v

For CATALOGUES apply

Sole Proprietors & Manufacturers
HEAD OFFICE & SALES

ADCOLA PRODUCTS LTD.

GAUDEN ROAD, CLAPHAM HIGH STREET,
LONDON, S.W.4

Telephone: MACaulay 4272

ACTUAL
SIZE

3/16"
Detachable
Bit
Instrument
List 64



Protective
Shields
List 68

CONTRACTORS TO
BRITISH & OVERSEAS GOVERNMENTS

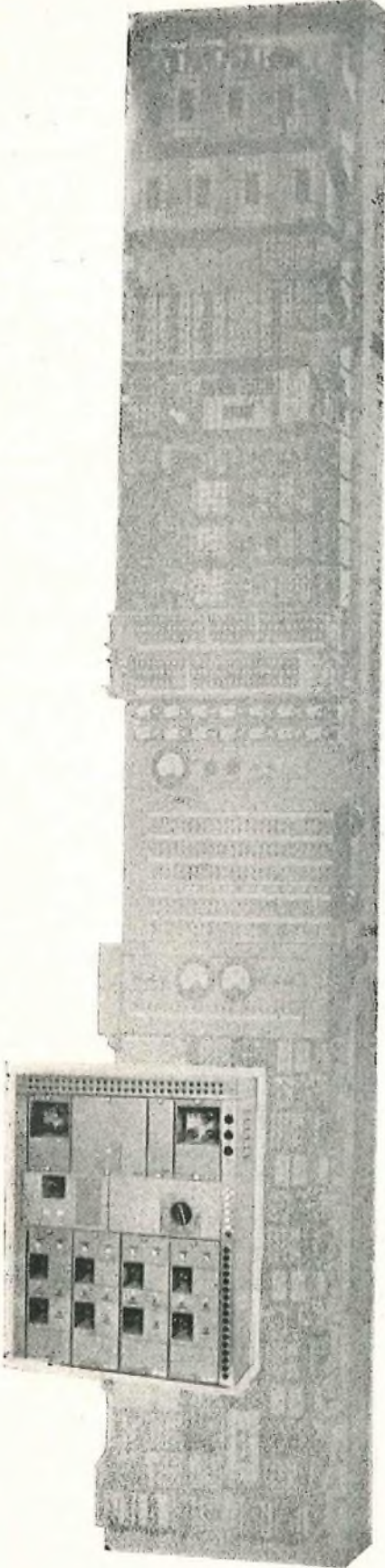

SKILLMAN

a new **1+4 or 5 CHANNEL**
system

for

Open Wires

Single Cables

Double Cables

Radio Links



One **QUARTER THE SIZE** as shown by the small unit at the front



but **IDENTICAL PERFORMANCE** to the old standard system shown behind



at a **PRICE** hitherto unattainable.



REPLACES the conventional 3 Channel System in all respects



and will work on routes already using standard 3 Channel.



Five Star Points *plus* — the most comprehensive range of *SIGNALLING* and other facilities yet offered on such a system.

5 SPEECH CHANNELS with any of the following :

5 DIALLING CHANNELS

5 TELEGRAPH CHANNELS

plus

5 500-1000/20 RINGERS

5 RINGERS convertible to DIALLING later

5 DIALLING CHANNELS

one at the top of each Speech Channel

plus

5 TELEGRAPH CHANNELS

at your choice—by simple “plug-in,” interchangeable units !



T. S. SKILLMAN & CO. LTD., Grove Park, Colindale, London, N.W.9
T. S. SKILLMAN & CO. PTY. LTD., Cammeray, Sydney, N.S.W.

SKILLMAN CARRIER EQUIPMENT HAS BEEN SUPPLIED TO ENGLAND FOR OTHER THAN G.P.O. APPLICATIONS, TO AUSTRALIA, NEW ZEALAND, BELGIUM AND EGYPT, AND ENQUIRIES ARE INVITED FOR REPRESENTATIVES ELSEWHERE



*Design
for*

Continuous

Service

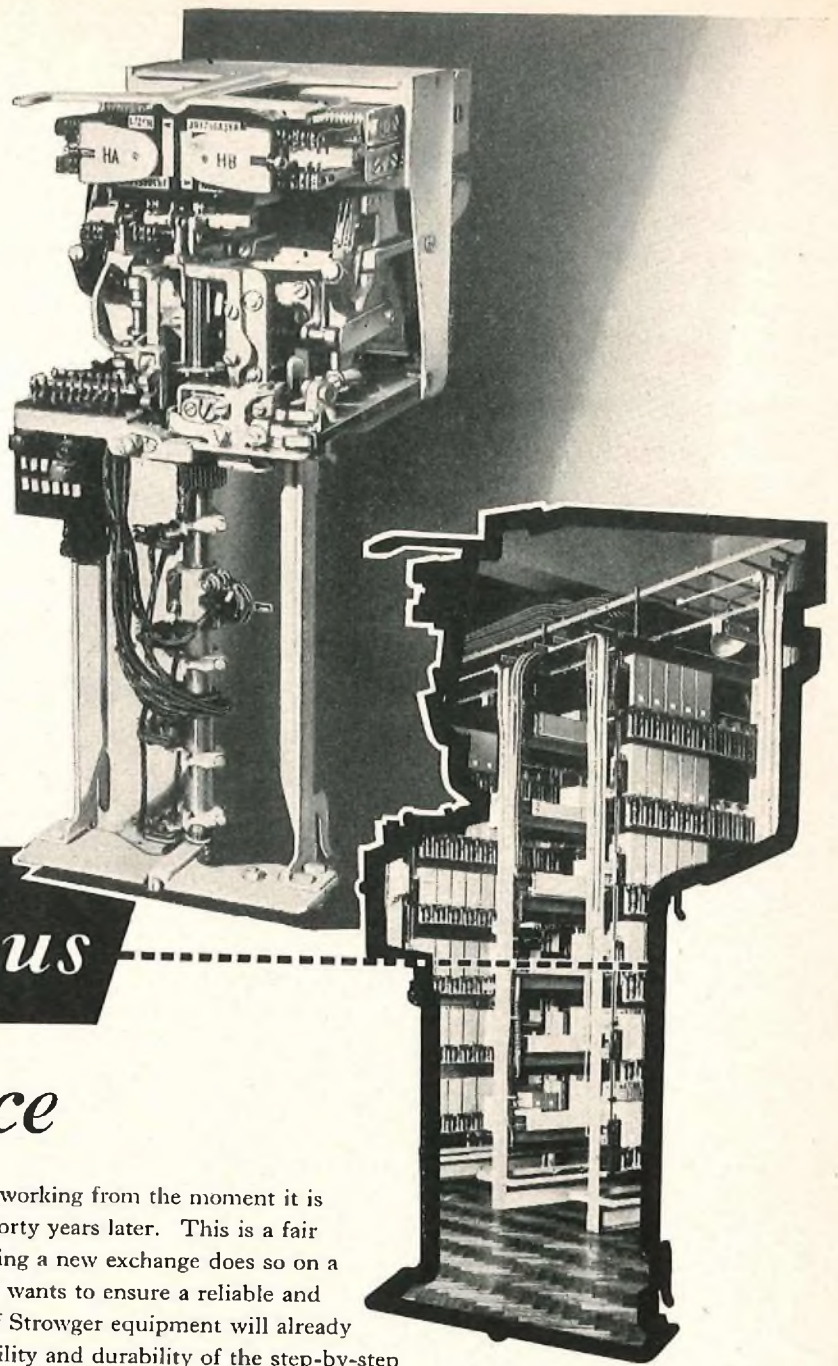

A telephone exchange never stops working from the moment it is cut over until the end of its useful life, perhaps forty years later. This is a fair estimate and any operating Administration planning a new exchange does so on a long-term basis and throughout the whole period wants to ensure a reliable and an economic service to the subscribers. Users of Strowger equipment will already have had long experience of the simplicity, flexibility and durability of the step-by-step system. To them, and to others who may not be so familiar, Automatic Telephone & Electric Co. Ltd. are proud to offer a component and an idea which will set an improved standard in automatic exchange engineering practice. The component is the Type 32A MARK II Selector; the idea is an entirely new conception of maintenance in which the basic principle is to lubricate and clean the mechanism at regular intervals and otherwise leave it completely undisturbed. A long and detailed series of investigations* by the Company's engineers has proved this conclusively. Providing the Mark II Selector is in correct adjustment when installed, and providing this simple basic lubrication and cleaning routine is observed regularly, together with the application of simple operational tests, the equipment will continue to give reliable performance indefinitely.

*These investigations are fully described in a bulletin "The case for a new approach to maintenance." A copy of this will be forwarded on request.



AUTOMATIC TELEPHONE & ELECTRIC CO. LIMITED

AT7911-A



Down Alton way, when a fellow cycles home from work, the woods and fields and streams he sees are those his father knew. The people who lift a hand and exchange a word as he passes are people he knows and knew as a boy. He's a man with a name and a home and a place in his own community: and he feels—who wouldn't?—that life's the better for that. And the batteries men like him are making in Alton? Well, a storage battery is among the most tightly specified, uniform products made. And yet, year after year, come letters telling us our batteries serving overseas have a certain distinguishing overall merit of their own. It could be that what a life that's better than merely worth living puts into a man, comes out in the form of work which is just that vastly important bit better than 'up to specification'.

ALTON *Batteries of Merit*

Alton stationary batteries: 10 to 15,000 ah. Also in regular production, renewal plates for all makes of battery, British and Continental.

THE ALTON BATTERY COMPANY LIMITED, ALTON, HANTS Telephone: ALTON 2267 and 2268 Telegrams: BATTERY ALTON

A.23



G.E.C.

EQUIPMENT

for TELEVISION NETWORKS



G.E.C. continue to lead in the provision of links for Britain's rapidly expanding TV networks. The Post Office is now being supplied with equipment for additional coverage in the Midlands and North-Western Areas against the future requirements of the Independent Television Authority. (G.E.C. equipment already conveys B.B.C. television programmes to these areas). The new coverage being provided, by radio relay or by coaxial cable, is as follows:—

THE MIDLAND LINK

The existing G.E.C. microwave link—the first in Britain, installed in 1946—between London and Birmingham, is the basis of the new network. A spur to Lichfield, using the G.E.C. SPO 5551 radio relay system, is being added.

THE NORTH-WESTERN LINK

The network is being extended to the North-

West by the addition of G.E.C. terminal translating and coaxial line equipment to serve the I.T.A. North-Western Area transmitter, over cable from Birmingham to Manchester and Winter Hill. This route includes 4 terminal and 18 repeater stations, using wideband amplifier equipment with supervision at the Manchester station.

◀ *The SPO 5551 two-channel transmit terminal equipment in Telephone House, Birmingham (London-Lichfield link) during commissioning tests.*

THE GENERAL ELECTRIC CO LTD OF ENGLAND
TELEPHONE WORKS COVENTRY



FREE!

*to YOU!
—if you seek
SUCCESS!*



**"I GUARANTEE TUITION
UNTIL YOU HAVE PASSED"**

**Preliminary Course
Telecommunications
Principles I - V
Radio I - IV
Telegraphy I & II
Line Transmission I & II
Mathematics for Telecommunications
Radio Servicing Certificate**

If you lack qualifications which would get you a better job, more pay and faster progress; if you really want to succeed in your studies for the City & Guilds Certificates . . . send now for this recently published, important book—"Train your Mind to SUCCESS."

HERE is the amazing story of The Famous Bennett College, its awards, scholarships, medals. Read what eminent educationists have to say about Personal Postal Tuition—The Bennett College way!

READ actual cases taken from its half a million success stories—from Bricklayer to Assistant Manager, from Draughtsman to Director—and many others!

SEE how you will learn when you enrol—how your own personal tutor watches over every step of your progress—how your success is guaranteed. **POST THIS COUPON NOW!**

BENNETT COLLEGE
(DEPT. J24), SHEFFIELD

Please send me, without obligation, a free copy of "Train your mind to SUCCESS" and the College Prospectus on:

SUBJECT _____
NAME _____
ADDRESS _____

AGE (if under 21) _____

Please write in Block Letters

THIS DAY
COULD BE THE TURNING-
POINT IN YOUR LIFE.

THIS COUPON

COULD BE YOUR PERSONAL
PASSPORT TO SUCCESS.

Send it NOW!

Hackbridge Cables



for every purpose

Contractors to the G.P.O., National Coal Board, British Railways, C.E.A. and British and Colonial Government Departments.

HACKBRIDGE Cable Company Limited

KELVIN WORKS · HACKBRIDGE · SURREY

In Association with Bryce Electric Construction Company Ltd.

*for the
right
connection*

ANACOS
REGD.

*telephone
line
wire*

FREDERICK SMITH & COMPANY

ANACONDA WORKS, SALFORD, 3, LANCs.

Incorporated in The London Electric Wire Company and Smiths Limited.
Associated with The Liverpool Electric Cable Co. Ltd. and Vactite Wire Co. Ltd.

**THIS INTERESTING QUARTERLY
WILL BE MAILED FREE TO ANY
PART OF THE WORLD**

For almost a century Muirhead & Co. Limited have manufactured precision electrical instruments, and to-day the range of products include measuring instruments for education and industry, synchros and remote control systems and facsimile transmitters and recorders.

Each issue of "Technique" contains details of the newest Muirhead products and of scientific developments in which Muirhead instruments have played an important part. If you think this publication would interest you, we shall be pleased to place your name on our mailing list. Write under your business letterhead to the address given below.



MUIRHEAD

PRECISION ELECTRICAL INSTRUMENTS

136

MUIRHEAD & CO. LIMITED • BECKENHAM • KENT • ENGLAND



FERRANTI

Switchboard Instruments

Illustrated here are several Ferranti Switchboard Instruments from a wide range. Shallow pressed steel cases 3½", 3¾", 4", 6" and 8" round or square dial. Projecting or flush mounting. All types of Ferranti switchboard instruments are also available in hermetically sealed cases.

List IN30 and other catalogues supplied on request.

FERRANTI LTD • MOSTON • MANCHESTER 10

Head Office and Works: HOLLINWOOD, LANC'S London Office: KERN HOUSE, 36 KINGSWAY, W.C.2

F1149

NEW THE SPRING SEAT CLAMP



Photograph reproduced by kind permission of the Postmaster-General of East Africa.

Working quietly and patiently over a period of five years, Telecommunications Engineers in Equatorial Africa have developed and tested with amazing success a new solution to a vexing problem.

2,300 miles of high-grade trunk routes have been constructed with crossarms attached to wooden poles, often of an indifferent quality of timber, without taking recourse to drilling or scarfing the poles. The routes include rural long-span Copperweld and high-grade Carrier routes of the twelve-channel type. Crossarms carry up to eight 300-lbs.-per-mile copper wires.

Not a single nut had to be re-tightened in the five years covered by this experience.

The new Spring Seat Clamp, which has made all this possible, is of very simple construction. It has been tested to withstand a downward thrust of over $2\frac{1}{2}$ tons and is capable of holding a crossarm very firmly to any type of pole. It can be used with concrete or steel poles without any additional preparation of the pole, but its principal advantages are most patently demonstrated when used on wooden poles.

Timber contracts and expands under climatic influences. Without losing its firm grip on the pole, the Spring Seat of the new Clamp is capable of following expansion and contraction so closely that there is hardly anything left of the most vexing maintenance problem set by routes inevitably constructed with wooden poles and exposed not only to changes in temperature, but to the obvious alternating spells of rain and sunshine.



Full particulars from

R. H. COLE (OVERSEAS) LTD., 2 CAXTON STREET, LONDON, S.W.1.

Telephone: Abbey 3061 (10 lines) Cables: Clamping, London