

# THE POST OFFICE ELECTRICAL ENGINEERS' JOURNAL

Vol. 44

JULY 1951

Part 2

## CONTENTS

	PAGE
MULTIPLE TEEING IN LOCAL LINE NETWORKS—T. W. Baker, A.M.I.E.E., and N. B. Rymer, A.M.I.E.E. . . . .	49
A MEASURING SET FOR ELECTRICAL, MECHANICAL OR ACOUSTIC IMPEDANCES . . . . .	54
AN OUTLINE OF THE PRINCIPLES OF DESIGN AND ANALYSIS OF EXPERIMENTS—D. L. Richards, B.Sc.(Eng.), F.S.S., A.M.I.E.E. . . . .	55
AN EXPERIMENTAL POWER-OPERATED PARCEL PLOUGH—E. W. Pettit . . . . .	61
A NEW MOBILE TRACTOR WINCH . . . . .	65
SIGNALLING SYSTEM A.C. NO. 1 (2 V.F.)—Part 1.—Modifications to the Existing 2 V.F. System for Trunk Mechanisation Requirements and Outline of the Operation of the Latest Equipment—D. C. Smith, B.Sc.(Eng.), A.M.I.E.E. . . . .	66
CATHODIC PROTECTION OF UNDERGROUND CABLES—J. Gerrard, A.M.I.E.E. . . . .	71
A SUBSCRIBER'S BATTERY-OPERATED SINGLE-CHANNEL V.H.F. RADIO-TELEPHONE EQUIPMENT—J. H. H. Merriman, M.Sc., A.Inst.P., A.M.I.E.E., R. Hamer, A.M.I.E.E., and B. R. Horsfield, A.M.I.E.E. . . . .	75
COMMUNICATIONS FOR THE FESTIVAL OF BRITAIN, 1951—A. Alexander . . . . .	81
THE NEW STANDARD FOR RINGING TONE . . . . .	85
C.C.I.T. STUDY GROUP MEETINGS; GENEVA, MARCH, 1951 . . . . .	86
NOTES AND COMMENTS . . . . .	87
INSTITUTION OF POST OFFICE ELECTRICAL ENGINEERS . . . . .	87
REGIONAL NOTES . . . . .	88
JUNIOR SECTION NOTES . . . . .	91
STAFF CHANGES . . . . .	93
BOOK REVIEWS . . . . .	74, 80, 84

Price 1/6 net

THE INSTITUTION OF POST OFFICE ELECTRICAL ENGINEERS

STUDY  
AT  
HOME

You Can Have a College Training  
For a Few Shillings Monthly

IN YOUR  
SPARE  
TIME

## CITY and GUILDS (Telecommunication) EXAMINATIONS

To every student we send  
a written Guarantee of  
Tuition until the  
examination is  
actually  
passed

*The most progressive and most successful  
Correspondence College in the world*

Our  
tuition  
is so graded  
that each stage  
is reached without  
difficulty.  
Personal attention is given  
to every student.

FULL PARTICULARS AND  
ADVICE SUPPLIED FREE.

WE TEACH BY POST IN ALL  
PARTS OF THE WORLD.



Dept. 24, THE BENNETT COLLEGE, SHEFFIELD



A.C. Polyphase Wound  
Rotor-Rotor Rheostat.

### FOR EVERY PHASE OF ELECTRICAL WORK

The British Electric Resistance Co. Ltd. can answer the multitude of resistance problems that beset the electrical circuit designer. For twenty years Berco resistances have been giving reliable and steadfast service, and the Berco range is designed to meet every requirement.

Berco engineers are specialists in resistance design and their knowledge is at your disposal.



RESISTANCES

THE BRITISH ELECTRIC RESISTANCE CO. LTD.  
Queensway, Ponders End, Middlesex  
Telephone: Howard 1492      Telegrams: Vitrohm, Enfield

823033-40



FOR THE RIGHT CONNECTION

FREDERICK SMITH & COMPANY

ANACONDA WORKS, SALFORD, 3, LANCs.

*Incorporated in The London Electric Wire Company and Smiths Limited.  
Associated with The Liverpool Electric Cable Co. Ltd. and Yacrite Wire Co. Ltd.*

The tricky ones are fun!



Thanks to 25 years experience in design and manufacture of transformers, we can face most transformer 'headaches' with equanimity. If you want instruments which you can fit and forget, which will give you trouble-free service for years, write or telephone us.



SAVAGE TRANSFORMERS LTD., Nursted Road, Devizes, Wilts.  
Telephone: Devizes 536



# THE POST OFFICE

## ELECTRICAL ENGINEERS' JOURNAL

Vol. 44

July 1951

Part 2

### Multiple Teeing in Local Line Networks

T. W. BAKER, A.M.I.E.E., and  
N. B. RYMER, A.M.I.E.E.†

U.D.C. 621.395.743

This article describes, in simple terms, the principles of multiple teeing now being applied to local line cable networks in this country. The practical considerations which arise are discussed in some detail and a typical multiple-teed layout for a group of cabinets is given by way of illustration, attention being drawn to its economic advantages over the corresponding non-teed arrangement.

#### *Introduction.*

THE local line development engineer has, broadly, a two-fold task. In the first place, he has to plan economically for the provision of local line plant sufficient to meet the demand for telephone service on the basis of development forecasts for various periods up to 20 years; the bulk of this work is, of course, devoted to the provision of cables. Secondly, facilities must be provided to cater for deviations from the anticipated growth in both large and small parcels of territory. These problems have always been present with the telephone engineer, but during the past decade special attention has been directed to the development of a more economic method of plant provision.

Apart from the experience obtained over many years in this country, the planning methods employed in other countries were studied, and in 1945 the Post Office decided to implement the recommendations of the Harvey Smith Report<sup>1</sup>, and adopt a system of full flexibility in local line networks to be provided by means of cabinets and pillars interposed between the exchange and D.P.s<sup>2,3</sup>. It is clear that since the flexibility afforded by a cabinet or pillar is restricted to the territory served by one of these items there is a further need for flexibility between pillars and between cabinets. This need was catered for in the Harvey Smith Report, which recommended that certain main and branch cables feeding cabinets and pillars should be multiple-teed.

Multiple teeing is a method of line plant provision in which a group of pairs is terminated at more than one flexibility unit; a number of such groups may be concerned in the same cable. Thus, a group of main cable pairs from an exchange M.D.F. may appear on the terminal strips of two or more cabinets and individual pairs may be used to provide exchange service at any one of the cabinets. The system is analogous to an exchange multiple where a range of subscribers' circuits makes several appearances at different parts of the switchboard, but each line may only be engaged at one appearance at any one time.

† The authors are respectively, Assistant Staff Engineer and Executive Engineer, Local Lines and Wire Broadcasting Branch, E.-in-C.'s Office.

<sup>1</sup> "Report on the investigations into the need for a change in line plant provision practice."—Harvey Smith, 1945.

<sup>2</sup> *P.O.E.E.J.*, Vol. 39, pp. 100 and 159.

<sup>3</sup> *I.P.O.E.E.* Printed Paper, No. 180.

<sup>4</sup> *I.P.O.E.E.* Printed Paper, No. 170.

#### *Historical.*

Multiple teeing in local line networks is not a new concept. It has been employed for many years in other countries, particularly the U.S.A., where cable pairs are multiple-teed throughout the whole network (including the final distribution cables serving the D.P.s) and one individual M.D.F. pair may make as many as 12 appearances at D.P.s<sup>4</sup>. The conditions which make the use of this form of teeing particularly effective in that country include the widespread use of party line working, a continuing high rate of telephone growth and the relatively low cost of raw material compared with that of labour. The last factor makes it economical to carry a higher proportion of idle copper than could be tolerated in the United Kingdom. Trials of the American system have been carried out in this country and it has been found that although the trial schemes have proved satisfactory as regards construction, maintenance, and utilisation, the system has not proved economical.

The type of multiple teeing recommended in the Harvey Smith Report is based on the American pattern but is limited in application to main and branch cables. It involves the provision of non-tapering cables by means of short-term instalments, the teeing being gradually eliminated by "cutting in" subsequent cable instalments, with consequent cable rearrangements.

As a result of more recent studies, it has been found that a modification of the Harvey Smith proposals could be adopted with advantage. This latest system, described in the following paragraphs, is a partial multiple system which employs a minimum amount of copper and eliminates the costly and complex cable rearrangements which are inherent in the original scheme.

#### *Development Forecasts.*

Before consideration can be given to the various methods of providing flexibility, it is necessary to examine the nature of development forecasts. The forecast for any given area represents the total anticipated demand for service at the appropriate date under conditions of full stimulation. This forecast is based on the assumption that general economic conditions and tariffs will remain unaltered. It is obtained by assessing a classification value for each grade of tenancy according to national trends and statistics, adjusted as necessary to conform to local circumstances. Actual achievement may deviate from the forecast and the deviations can be divided into two main categories which can best be illustrated by a simple example.

Assume that a portion of an exchange area represented by five block areas each consisting of an equal number of the same grades of tenancies, has a forecast of 100 for the year 1960. Deviations from this forecast may fall into one of the following two categories:—

- (a) The forecast of 100 may be achieved either earlier or later than 1960. This may affect all blocks equally and could be due to changing economic circumstances, tariff changes or incorrect assessment of telephone potential.
- (b) When the total forecast of 100 is reached, although the date might be 1960, the achievement in the individual blocks might be above or below the anticipated figure of 20, say, in the range 15-25.

It may prove in practice that deviations in both categories take place simultaneously and are superimposed on one another. It is important to appreciate, however, that it is only the deviations in category (b) which can be taken care of by means of flexibility. The achievement in individual blocks will tend to follow a random or pure chance distribution, the forecast being an average figure for all blocks.

The maximum extent of the deviations from the forecast will vary according to the following main factors:—

- (i) The magnitude of the forecast. The smaller the area the greater will be the percentage deviation, e.g., the percentage deviation in the case of a D.P. area will be greater than for a pillar area, and the percentage for a pillar area will be greater than for a cabinet area.
- (ii) The degree of telephone penetration, i.e. ratio of forecast lines to tenancies. The percentage deviation will decrease as the telephone penetration increases.

In addition, the deviations may be either positive or negative, the two classes being equally probable. They can best be expressed as a percentage of the forecast growth and, until experience provides better figures, the percentages which have been adopted are in the range 15-25 for cabinet-size forecasts, i.e. 600-150, and 25-35 for pillar-size forecasts, i.e. 70-25. Actual choice is governed by local conditions, including telephone penetration and magnitude of forecast. The ranges quoted above should cater for practically all cases, and it would be uneconomical to extend the range in an attempt to cater for every case.

## DESIGN PRINCIPLES

### Non-Multiple-Teed Cable Routes.

When designing a main cable route serving several cabinets, the object is to provide sufficient pairs to each cabinet to cater for the upper limit of the anticipated deviation from forecast, thus ensuring that relief is not required at any one cabinet before the total forecast for all the cabinets is attained. Thus, consider a group of five identical cabinets served by the same main cable route, and suppose there are 80 existing lines in each cabinet and the forecast for 1960 is 200. The forecast growth for each cabinet is therefore 120, and if deviations are assumed to be 25 per cent. of the forecast growth, i.e.  $\pm 30$ , the total number of pairs which might be required at any one cabinet to cater for the achievement in 1960 is 230. If no multiple teeing is incorporated in the main cable route, then a total of  $5 \times 230 = 1,150$  pairs must be provided from the exchange for the total forecast of 1,000. The 150 pairs in excess of the forecast would not be provided as a safeguard against the forecast for the main cable route being exceeded at 1960, but because at the time the total forecast of 1,000 was reached (be it in 1960 or not), the achievement at any one of the cabinets might be as much as 230. As it is impossible to tell in advance which cabinet would be affected, each would be provided with 230 pairs to ensure

that the main cable route would not require relief before the total forecast of 1,000 had been reached. The actual cable-fill achieved would be  $1,000/1,150 \times 100$  per cent. = 87 per cent., which is the planning cable-fill to which the main cable route had been designed.

In practice, a planning cable-fill of 90 per cent. is employed in the design of non-teed main and branch cable routes. It should be appreciated that this figure of 90 per cent. is an average for all sizes of pillars and cabinets. For pillars a lower figure, and for large cabinets a higher figure, would be more appropriate.

### Multiple-Teed Cable Routes.

Provision of additional flexibility by multiple teeing enables a cable-fill of 100 per cent. to be achieved in that portion of the cable route between the exchange and the junction for the first cabinet (also cabinet and junction for first pillar in branch cables). This can conveniently be illustrated by employing the same hypothetical example as used in the previous paragraph. Still assuming a 25 per cent. deviation from forecast, then at the time the total forecast of 1,000 is reached, each cabinet will have attained a *minimum* of  $200 - 30 = 170$  lines; 170 pairs can, therefore, be provided to each cabinet without any multiple teeing and are termed direct pairs. The actual achievement at an individual cabinet may be anything between 170 and 230, and 60 teed pairs are therefore provided to each cabinet to cover the possible range of deviation (see Fig. 1). The teed pairs are shared between

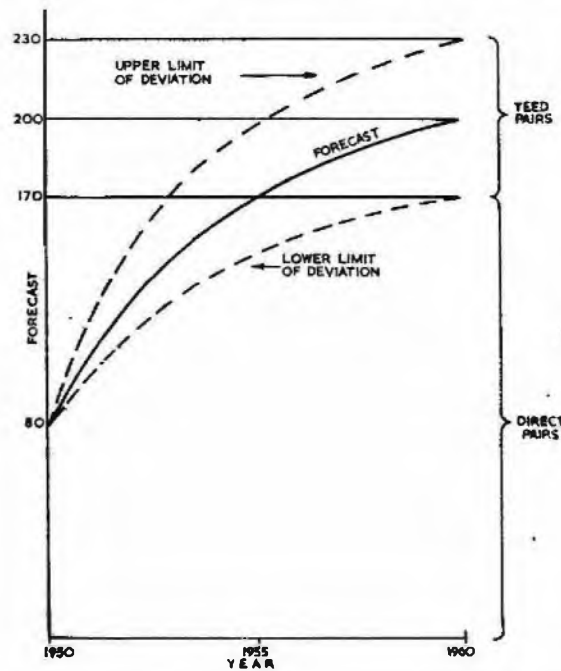

FIG. 1.—CURVE SHOWING FORECAST GROWTH OF NUMBER OF PAIRS REQUIRED AT A CABINET.

the cabinets concerned. At 100 per cent. cable-fill between the exchange and junction for the first cabinet, 1,000 pairs are provided for a forecast of 1,000. Of these,  $5 \times 170 = 850$  are direct, and the remaining 150 are teed.

In practice, the cabinet spurs usually join the main cable route at different points as shown in Fig. 2. The cable route could be designed by totalling both direct and teed pairs from each cabinet along the route towards the exchange as far as point A where all the teeing could be carried out. The resultant duplication of groups of teed pairs over the same section of cable route, however, would be uneconomical and transmission would be unnecessarily degraded. In addition, the teed joint at A would be

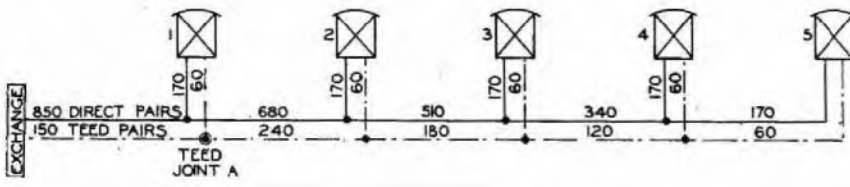

FIG. 2.—TEERING AT ONE JOINT.

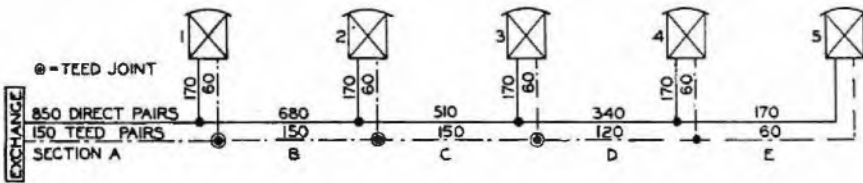

FIG. 3.—TEERING DIVIDED BETWEEN SEVERAL JOINTS.

difficult to construct. It is desirable for both practical and economic reasons to divide the teeing between several joints and reduce to a minimum the number of pairs provided in the intervening cable sections, as indicated in Fig. 3.

The 150 teed pairs from the exchange are extended beyond the junction for cabinet 1 on a non-diminishing basis until a point is reached where the sum of the teed pairs from all the cabinets beyond this point is less than 150. From this point onwards, the number of teed pairs in the cable route is equal to the sum of the teed pairs at the cabinets still to be served. This method enables the 60 teed pairs at cabinets 1 and 2 to be used at other cabinets. When considering section D, however, it can be seen that there is no point in extending the whole 150 teed pairs since there are only 120 teed pairs available at cabinets 4 and 5, where they could be used. This arrangement enables the maximum flexibility to be achieved over the whole group of cabinets. Such provision may be somewhat excessive since it is extremely unlikely that two adjacent cabinets will both deviate simultaneously by the maximum amount above or below forecast, but it is simpler to cater for the extreme condition when designing the cable route.

The teeing arrangements can be illustrated by means of a lapping diagram as shown in Fig. 4. The base of the diagram represents the 150 teed pairs and the cabinets are indicated on the left-hand vertical. Horizontal lines are drawn opposite each cabinet to indicate the groups of pairs terminated at each cabinet. It will be seen that each cabinet has teed connections to two others and each group of 30 teed pairs has two appearances. Furthermore, for

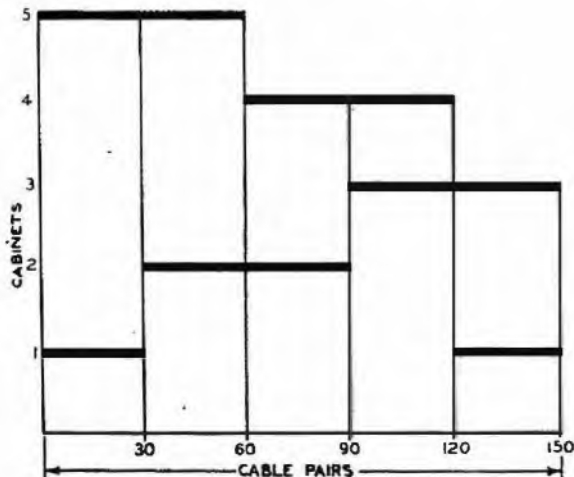

FIG. 4.—LAPPING DIAGRAM, INDICATING DISTRIBUTION OF TEED CABLE PAIRS BETWEEN CABINETS.

any two cabinets there is an overlap to other cabinets, i.e. no pair of cabinets is isolated from the remainder; the overlap gives a measure of flexibility between pairs of cabinets which would not exist if each pair of cabinets were teed to a separate group of pairs and thus isolated. It is possible of course to make other lapping arrangements of the groups of teed pairs, each arrangement giving similar results to the one illustrated in Fig. 4. Although a simple hypothetical case of five similar cabinets has been illustrated, the same principles can be extended to a larger number of cabinets without increasing the complexity; each cabinet would have pairs teed to each of two others and each group of teed pairs would have only

two appearances. Although main cables and cabinets are referred to in this and subsequent paragraphs, the same principles apply to branch cables and pillars.

### PRACTICAL CONSIDERATIONS

When applying the technique of multiple teeing to the design of practical schemes, the following considerations arise.

#### Forecast Growth.

Cabinets generally have different forecast growths and deviations have to be assessed separately for individual cabinets. The cable size to be provided in cabinet spurs is the next stock size above the forecast + deviation.

#### Deviation Allowance.

The number of pairs required in any one section of the main cable route is calculated by adding a deviation allowance to the forecast for the section. Deviation allowance is defined as the lesser of the sums of the cabinet deviations ( $D$ ) on the exchange and remote sides of the section (see Fig. 5). In Section A, there are no cabinets on the exchange side; the deviation allowance is therefore nil, and the number of pairs required equals the total forecast, i.e. the first section is designed at 100 per cent. planning cable-fill. In another section, e.g., section D, the sum of the cabinet deviations on the exchange side is  $D_1 + D_2 + D_3$  and on the remote side  $D_4 + D_5$ . The deviation allowance for the section is the lesser of these two totals. The actual cable size to be provided is the next stock size above the forecast + deviation allowance, due consideration being given to any existing plant.

#### Arrangement of Teed Pairs.

The additional pairs provided above the theoretical requirement due to the use of stock size cables are incorporated in the teeing arrangements, dead pairs being avoided.

Teed pairs are arranged in multiples of 50 (10 in branch cables) for simplification of construction and recording.

The number of teed pairs required at a cabinet, i.e.  $2 \times$  deviation, is rounded up to a multiple of 50, and the number of direct pairs, i.e. forecast - deviation, rounded down to a multiple of 50.

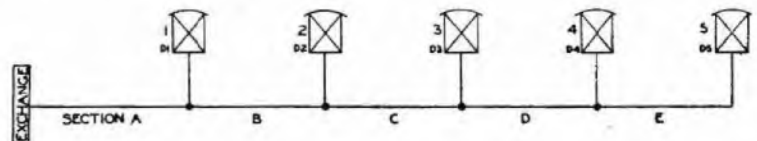

FIG. 5.—DEVIATIONS AND DEVIATION ALLOWANCES.

Teed joints are generally confined to new construction work using unit type cable. When cabinets are cut in on existing cables, the latter provide part or all of the direct pairs required.

Although, in theory, only two appearances of any one group of teed pairs are necessary, it is sometimes found desirable in practice to have three or even four appearances. This is due chiefly to the employment of stock size cables and teeing in multiples of 50. In any case there will only be single teeing in any one cable joint.

Multiple teeing can readily be incorporated in the design of a cable route whether the method of providing for the 20-year forecast is by means of a single or of several cable instalments. The number and dates of provision of instalments are determined on an economic basis in the same way, as for non-teed cable routes. In practice it is found that the incorporation of multiple teeing facilitates the design of economic short-term instalments.

In general, the 20-year forecast does not represent telephone saturation, and there will be a need to retain a measure of flexibility throughout the 20-year period. The teeing provided in the initial cable instalments should therefore be retained when subsequent instalments are provided.

Due to the grouping of teed pairs in multiples of 50 (for main cables) it is frequently found that sufficient flexibility for the full 20-year period is provided in the

smaller size cable required in a teed network can be accommodated in existing duct space, thus deferring the provision of new duct. There are also economies in M.D.F. terminating requirements which may be an important factor in existing exchanges approaching maximum capacity. Due to the use of stock size cables, it is sometimes found that the same size cable has to be provided whether a teed or non-teed method of design is employed. In these cases the exhaustion date of the teed cable will be later, due to the higher cable fill it will attain before relief is required, and rearrangements can be avoided during the last few years of life. As this exhaustion date is later than the 20th year, no allowance can be made in an economic cost comparison based on a 20-year costing period.

There is no limit to the number of cabinets which can be included in a multiple-teeing scheme, provided the cabinets are all served by the same main cable route. The best arrangement is obtained by designing separate schemes for groups of cabinets which are relatively close together and some distance from the exchange. It is emphasised that no standard rule can be given—each case must be treated on its merits.

#### PRACTICAL EXAMPLE

It is very unlikely that all the practical considerations referred to previously will be met with in any one example, but Fig. 6, a straight-line diagram of a typical layout for

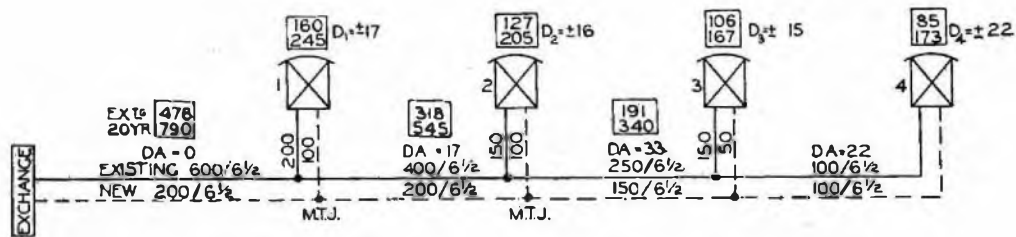

FIG. 6.—STRAIGHT LINE DIAGRAM FOR TYPICAL LAYOUT.

initial cable instalment. Subsequent instalments can then be of direct pairs only, except that some teeing may be necessary to avoid leaving pairs dead in the cables.

Relief of a multiple-teed network should always be by supplementation to spare terminations, thus avoiding cable rearrangements.

#### Transmission Performance.

Due consideration must be given to the effect of teeing on the transmission performance of the network. The T.E.R. of teed cable per mile is less than the T.E.R. per mile of cable pairs in series. Hence, if the furthest cabinet affords satisfactory transmission, so also will all other cabinets *en route* (assuming that the cable mileages within cabinet areas are similar). Cabinets are generally located near the main cable route, and the incorporation of multiple teeing rarely necessitates the provision of heavier gauge conductor than would have been required for non-teed cable routes.

#### Economics.

Theoretically, a multiple-teed network is more economical than a non-teed one since fewer pairs are provided in certain cable sections, particularly the first, and, in no section are more pairs provided than in the corresponding non-teed case. The actual saving in cost will vary according to each individual scheme and 12 per cent. saving in cable costs is about the average. In specific cases, considerable duct economies are realised, particularly when the

a group of four cabinets, illustrates most points. Existing plant and working lines, together with 20-year forecasts, are shown in the diagram. Forecasts for intervening base dates have not been shown, since, in this example, it is economical to provide for the 20-year forecast by a single cable instalment.

The deviations, *D*, from forecast to be catered for are assessed at 25 per cent. of forecast growth for cabinets 3 and 4, since they are small in size, and 20 per cent. of forecast growth for cabinets 1 and 2, which are larger. The deviation allowances (D.A.) for the main cable sections, are shown in addition to the cabinet deviations. The new cable required to meet the 20-year forecast is shown dotted. It will be seen that on the main cable route the cable size is the next stock size above forecast + deviation allowance, and on the cabinet spurs the next stock size above forecast + deviation; due account being taken of existing cables.

The teeing arrangements are illustrated in the lapping diagram (Fig. 7); the existing cable, consisting entirely of direct pairs, is shown on the left-hand side of the diagram.

The teed pairs in the new 200/6½ cable are grouped in multiples of 50 and the lapping arranged so that:—

- The teed pairs at each cabinet are never less than  $2 \times$  deviation.
- The direct pairs at each cabinet are never greater than forecast—deviation.
- The additional flexibility resulting from the teeing covers all four cabinets which are not divided into two separate groups.

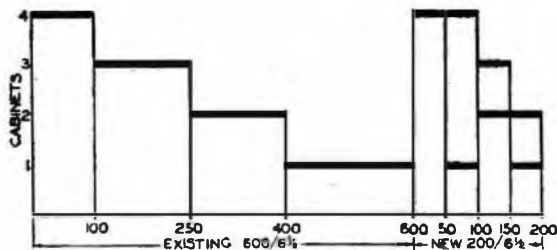

FIG. 7.—LAPPING DIAGRAM FOR LAYOUT SHOWN IN FIG. 6.

*Alternative Arrangement without Multiple Teeing.*

It is of interest to consider the alternative solution to the previous example which would result from employing a wholly direct-pair scheme. The cable sizes required on the cabinet spurs would be the same as for a teed scheme, as they have to cater for the forecast + deviation. Adjustments are sometimes necessary, however, to fit the stock size cables to be provided along the main cable route, e.g., the new provision to cabinet 1 is 150 pairs instead of 100 (Fig. 8). It will be seen that an excessive number of pairs is provided to cabinets 2 and 3, and to a larger extent, cabinet 1. This illustrates one of the difficulties encountered in the design of non-teed cable networks when avoiding dead pairs, viz., the necessity to provide pairs from the exchange to cabinets in disproportion to their requirements, resulting in inflated cable sizes nearer the exchange and a low average cable fill. The additional pairs thus provided are of little value, since they can only be brought into use at the time relief is required, either by diverting them to the cabinet which has exhausted first, or by providing an additional cable instalment to relieve the exhausted cabinet. Both methods involve additional expense, and the rearrangements do not result in an increased number of pairs.

Economies in cable provision could be effected by leaving dead pairs in the cables as shown in Fig. 9. This is unsound engineering practice, however, and unjustified since it is most unlikely that the actual number of pairs required at each cabinet simultaneously will be precisely the number provided. The presence of dead pairs in the network is an added temptation to incur uneconomic cabling rearrangements by diverting spare pairs in times of shortage of plant.

The best non-teed solution to this particular example is probably a compromise between those shown in Figs. 8 and 9 and is indicated in Fig. 10. The 50 pairs provided to cabinet 1 from the 300-pair cable will be insufficient to cater for the 20-year requirement, and an additional 50-pair relief cable should be allowed for at about the 18th year, although it may be found in practice that this relief will not be required.

If, in the foregoing example, it is assumed that all cable sections are of equal length and cabinet spurs are short,

a rough calculation shows that the multiple-teed arrangement effects a saving of 23 per cent. in inclusive capital costs, and 17 per cent. on an annual charge basis as compared with the best non-teed arrangement.

MAINTENANCE AND UTILISATION

The adoption of a multiple-teed cable network should not result in higher maintenance costs. The teed joints themselves, being constructed in new cables and subsequently left undisturbed should, in fact, reduce the fault liability. Such faults as do occur will be due to cable breakdowns caused by corrosion or mechanical damage, and non-teed cables are just as prone to this type of fault. The presence of groups of teed pairs in a cable should not increase the cost of locating and clearing faults. Indeed, a superficial examination of affected terminations on a teed network often indicates the cable section in which the fault exists.

Card records for the utilisation of local line plant incorporating cabinets and pillars have been designed to cater for multiple-teed pairs in the main and branch cables. Once the routing and recording staff are accustomed to thinking of the local line network as three independent cables in tandem and are familiar with the main, branch and distribution cable cards, then little difficulty should be experienced in dealing with multiple-teed pairs. Initially, pre-pinning and pre-jumpering should be carried out under the auspices of the planning group so that the routing and record staff are only concerned with pairs through from the exchange to D.P.s. There is no objection to the pre-pinning of multiple-teed pairs provided they are only pinned or jumpered at one appearance. The direct pairs should, however, be used first for the provision of service and will usually be found sufficient for the first pre-pinning instalment.

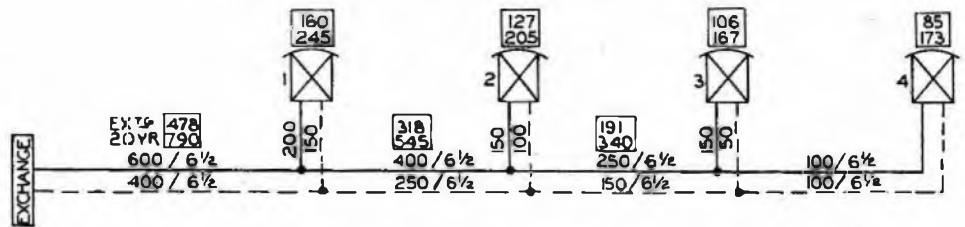

FIG. 8.—STRAIGHT LINE DIAGRAM; NON-TEED.

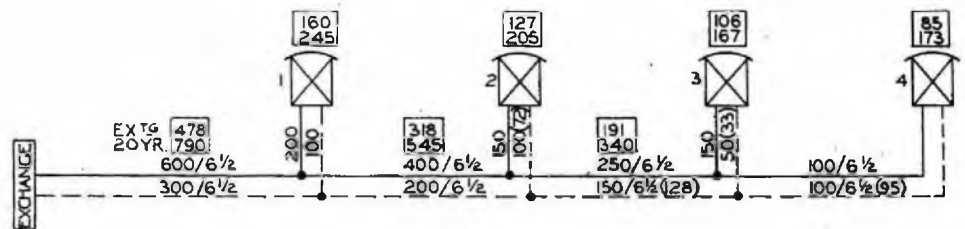

FIG. 9.—STRAIGHT LINE DIAGRAM; NON-TEED WITH DEAD PAIRS.

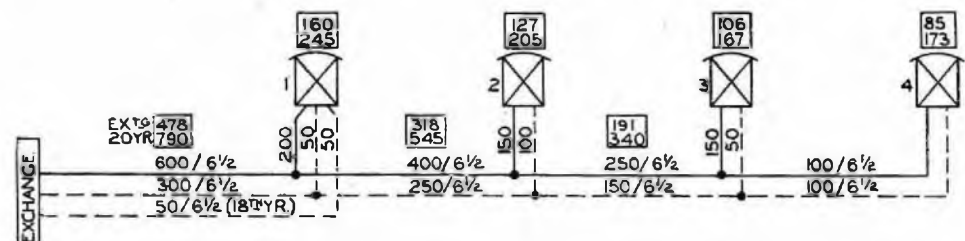

FIG. 10.—STRAIGHT LINE DIAGRAM; PROBABLE BEST NON-TEED ARRANGEMENT FOR EXAMPLE DISCUSSED.



## CONCLUSION

The adoption of the form of multiple teeing described in this article permits the achievement of a higher average cable-fill—as much as 100 per cent. in the first cable section. The main advantages accruing are,

- (a) Economies in the cost of plant provision.
- (b) Individual cabinets will not be exhausted before the main cable route as a whole. Relief measures must necessarily cater for the entire cable route, thus avoiding the necessity for a series of small relief cables to individual cabinets at irregular intervals.
- (c) The avoidance of cable rearrangements by eliminating the possibility of diverting spare pairs from one

cabinet to another, since the cable is full before any one cabinet is exhausted of spares.

- (d) Stock size cables can be incorporated without leaving dead pairs and without excess provision on cabinet spurs.

At first sight, the design of multiple-teeed cable routes may appear more complicated than the design of non-teeed cable routes on the basis of a fixed planning cable-fill. It is anticipated, however, that once the basic principles of the system are clearly understood and some practice in their application has been obtained by planning officers, the design of multiple-teeed cable schemes will present no special difficulties.

---

## A Measuring Set for Electrical, Mechanical or Acoustic Impedances

U.D.C. 621.317.73 + 534.64

**A** MEASURING set for complex electrical, mechanical or acoustic impedances is under development at the Research Station. In principle, the set consists of a generator of constant internal impedance but variable E.M.F., the output terminals of which are first open-circuited, and then connected in turn to a known standard impedance and to the impedance to be measured. In the open-circuit condition the terminal P.D. is, of course, equal to the generator E.M.F. When the standard and unknown impedances are connected to the terminals, the P.D. changes, but may be restored to its original value, in magnitude and phase, by appropriate changes in the generator E.M.F. It may be shown that the vector ratio of the two impedances is then given by the vector ratio of the corresponding *increments* in the generator E.M.F. Somewhat similar relationships hold for the analogous arrangement in which the output current is restored to its short-circuit value after inserting the desired impedances.

To indicate when the terminal P.D. has been restored to its original value, a detector circuit sensitive to changes in phase as well as magnitude is required. This is arranged by connecting to the terminals an auxiliary variable generator in series with a valve voltmeter. The auxiliary generator E.M.F. is adjusted in magnitude and phase so that it exactly opposes the terminal P.D. in the open-circuit condition and a null reading is obtained on the meter. The connection of any impedance to the terminals then alters the terminal P.D. and destroys the balance, which can only be regained by restoring the terminal P.D. to its original value in both magnitude and phase.

For convenience, the restoration of the terminal P.D. after it has been disturbed by the connection of an impedance is effected, not by altering the E.M.F. on the main generator, but by connecting in series with it a further variable generator of very low internal impedance. Two such generators are used in turn, and their outputs are left at the settings required to restore the balance with the standard and unknown impedances, respectively. The vector ratio of the E.M.F.s of the two generators then gives the vector ratio of the two impedances. To measure this ratio the outputs are connected in turn, through separate voltage dividers, to a valve voltmeter. One voltage divider is set to a reading which represents, in convenient units, the numerical value of the standard impedance, and its output is noted on the meter. The other voltage divider is then adjusted so that an equal reading is obtained on the voltmeter, and its setting gives directly the numerical magnitude of the known impedance. To measure the phase difference between the two impedances the sum or difference of the two voltages, now equal in

magnitude, is compared with their separate values. A direct reading of the phase difference from  $0^\circ$  to  $180^\circ$  may be obtained on a calibrated potentiometer dial or on a meter scale, with an ambiguity of sign. The sign of the difference is usually known, but may be determined, if necessary, by a simple check which involves observation of the direction of the change produced when a small capacitor is connected across the circuit.

The set is adapted to measure mechanical and acoustical impedances by replacing the generator and detector by electro-mechanical or electro-acoustic transducers. The internal impedance of the source, including the transducer, if used, does not appear in the final equation for the unknown impedance, and neither transducer needs to be calibrated, though both must remain stable in sensitivity for the duration of a measurement. The detector transducer need not even be linear, provided it does not exhibit hysteresis. A further outstanding advantage of the method is that unknown impedances of any phase angle may be compared with any convenient standard impedance of roughly the same order of magnitude.

Thus, for acoustical measurements, standard pure negative reactances may easily be realised in the form of cavities whose properties may be calculated from their mechanical dimensions. Similarly, for mechanical measurements, the standard impedances may take the form of lumped masses which have easily calculable pure positive reactances.

The set has so far been used in a laboratory form for measurements of acoustical impedances of tubes and silk cloth, and mechanical impedances of various plastic materials and of human flesh, especially over the mastoid process. For this purpose, a mechanical transducer has been devised, which enables the impedance to alternating-forces to be measured in the presence of a much larger static loading. The error of measurement is less than  $\pm 3$  per cent. over the frequency range 200 to 4,000 c/s, using standard impedances between one-fifth and five times the impedances to be measured. The possibility of using the set for electrical impedance measurements is of limited direct use, but is indirectly very valuable, since it affords an easy and reliable means of checking the accuracy of the greater part of the measuring circuits.

An acoustic impedance comparator working on somewhat similar principles was shown by S.R.D.E. at the Physical Society's Exhibition in 1949. The authors are indebted to Mr. E. R. Wigan, formerly with S.R.D.E., for very helpful advice and discussion during the development of the set described above.

E. W. A.  
J. Y. M.



# An Outline of the Principles of Design and Analysis of Experiments

D. L. RICHARDS, B.Sc.(Eng.), F.S.S., A.M.I.E.E.†

U.D.C. 519.2 160

This article gives a brief outline of the background of modern methods of conducting investigations when highly variable material must be used. Descriptions of the detailed statistical techniques are available elsewhere and the discussion is confined to the comparatively simple conceptions on which the statistical techniques are logically based. The experimental methods described are extensively used at the P.O. Research Station for investigations which are concerned with problems of telephone transmission and which involve human subjects. Application of these methods to such problems ensures that unjustified and misleading conclusions are not drawn.

## NECESSITY FOR THE DESIGN OF EXPERIMENTS

"EXPERIMENT" is defined as an "act designed to discover some unknown truth or to test a hypothesis." Whenever an observation or a measurement is made, it may be said that an experiment is being conducted. The simpler kinds of every-day measurements, such as weighing with a chemical balance or measuring resistance with a Wheatstone bridge, are not usually regarded as experiments in themselves. A co-ordinated set of such measurements, however, would constitute an experiment. When the experimental material enables the results to be accurately repeated, one is hardly aware of any necessity to design the experiments (using "design" in a sense to be described later). Difficulty arises when, after the same essential conditions have been set up, the same measured results are not obtained. Sometimes this is due to an error in conducting the experiment but, even when this is not present, "unrepeatability" often remains as a serious difficulty to be contended with. Biological material is, of course, notorious for yielding unrepeatable results, and it is unfortunate for the telephone designer that there is a specimen of biological material at each end of a telephone circuit! When measurements using such material have to be made the lack of repeatability must be accepted; the problem is, then, what is the best course of action in such a situation?

Before considering the design of experiments adapted to such conditions, it is useful to consider just why some experimental materials come to be regarded as yielding repeatable results and others as giving unrepeatable results. The distinction lies in the accuracy with which it is desired to make the measurements. An object may be regarded as being in the "repeatable" class so long as one does not demand such precision in an answer that the results cannot be repeated with the precision demanded. In many cases it is then possible to refine the measuring instrument. If this is done a limit will eventually be reached beyond which the variability of the material itself which is being measured determines the unrepeatability of the result. In experiments with biological material, unrepeatability results even when very low precision is required. It is understandable, therefore, that considerable attention has been given to the design of experiments in the fields of biology and agriculture. This work was originated by Fisher in this country and extended by Yates and others, both here and in America.<sup>1, 2, 3</sup>

It is worth also noting a form of unrepeatability which is present when measurements are made on manufactured articles. In this case, a measurement can be repeated on a given item to the required precision, but selection of another item gives a different result. It is clear, therefore, that "between item" variation can arise as distinct from "within item" variation or "within measuring instrument" variation. In any of these cases the experimenter is faced with unrepeatability.

## TRUE VALUE OF A MEASURED QUANTITY

The meaning which can be attributed to measured results will now be considered. An experiment may well be "designed to discover some unknown truth," but (a) what particular truth is required, and (b) why is it wanted? The second question can, almost always, be answered by saying it is desired to guide a future action by being able to predict some future event. For example, "In a given telephone call, what will be A's talking level?" or "In the next transformer I design, using such and such materials, what should I take to be the initial permeability?" An answer to the first question is that a truth is required that is best adapted to the prediction of future results. These matters may seem rather philosophical, but it is extremely important to be clear at the beginning of an experiment what it is desired to find out. This is by no means always the easy task it sounds, but it is often useful to ask what action would be taken if a certain result were given.

A simple experiment will now be considered. The examples are drawn from the field of speech voltage measurements, but the principles are, of course, of very wide application.

The question asked is:—

"For a given telephone circuit condition, what speech voltage will be produced by talkers?"

In the experiment the telephone circuit is set up, carefully controlling the conditions, such as line attenuation, microphone current, sidetone level, room noise, etc., and two people are caused to talk over it. It will be assumed that the circuit is symmetrical, i.e., the physical conditions presented to each talker are the same. The measured speech voltages are  $-6.1$  and  $-10.7$ , the units being decibels relative to one volt. When, say, twenty people have been persuaded to take part, a set of readings results as follows:—

$-6.1$	$-8.9$	$-13.6$	$-10.9$
$-10.7$	$-4.9$	$-11.1$	$-15.7$
$-13.6$	$-10.2$	$-15.1$	$-13.0$
$-13.1$	$-11.9$	$-8.5$	$-4.2$
$-15.6$	$-6.2$	$-17.6$	$-7.7$

What can be extracted from these readings that will help to predict the speech voltage of, say, the twenty-first person? It may be felt intuitively that the best single value to rely on would be the mean of these readings, namely  $-10.9$  db. One might even go so far as to say the true speech voltage is the mean of an infinite set of such measured values, and that the departures actually experienced are ascribable to "error."

This question of "true value" will now be considered a little further. Suppose the series of speech voltage observations were extended and the cumulative means calculated (i.e., each observation is added to the total of all the previous observations and a new mean taken). If the cumulative mean is plotted against the number of the observations, a graph, as Fig. 1, is obtained. It is important to note that the observations were arranged strictly in order of being made and that the talkers were selected

† Senior Executive Engineer, Research Station.

<sup>1</sup> See references at end of Article.

at random. This graph shows how the cumulative mean converges to a limit which is termed the population mean.

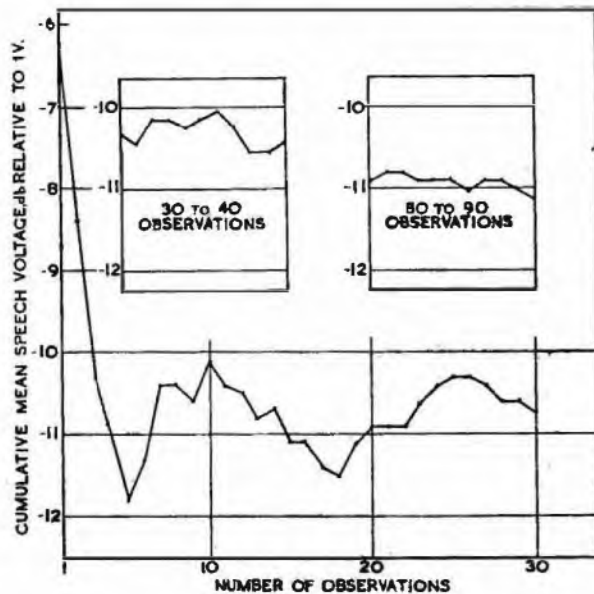

FIG. 1.—VARIATION OF CUMULATIVE MEAN SPEECH VOLTAGE AS NUMBER OF OBSERVATIONS IS INCREASED.

When a large number of observations have been made, they can be classified by magnitude, i.e., by counting how many lie in the range  $-24$  to  $-22$  db., how many in the range  $-22$  to  $-20$  db., etc. If each of these numbers is divided by the total number of observations and by the width of the classifications, the relative frequencies of occurrence are obtained. These have been plotted as a histogram in Fig. 2. If the number of observations is

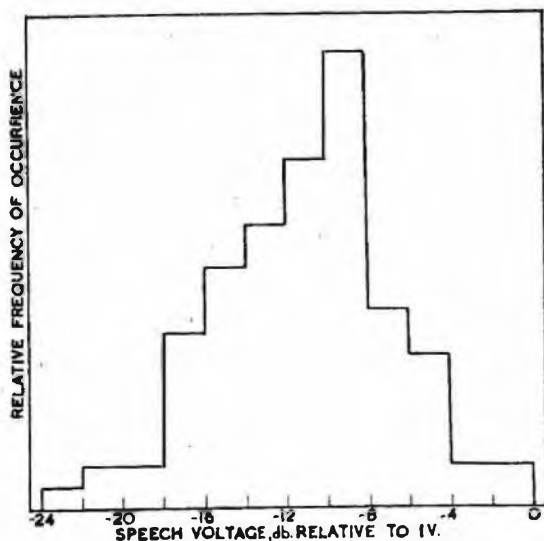

FIG. 2.—HISTOGRAM SHOWING DISTRIBUTION OF SPEECH VOLTAGE OBSERVATIONS.

further increased and the intervals of classification made narrower, it can be assumed that a smooth curve results. This smooth curve is a description of the population of speech levels applying to the particular conditions of the test. From such a curve the "long-term" proportion of speech levels lying between any given limits can be predicted exactly. Such a curve can be defined by a number of parameters of which (1) the arithmetic mean and (2) the variance are the most important. (Variance is the mean squared deviation about the arithmetic mean.)

If the population parameters are known, the "long-term" relative frequencies can be calculated or, what is the same thing, the probability that, in any random "short run," a given proportion of observations lying between given limits will be obtained. It is, therefore, clear that the "true values" really exist as the population parameters since knowledge of them enables accurate predictions to be made about the future. We may take it, therefore, that the "unknown truth" which the experimenter is trying to discover consists of one or more population parameters (especially the population mean).

If departures from the population mean can be regarded as occurring at random in the observations, and if the distribution of the population does not depart much from Gaussian (i.e. normal), one can calculate the accuracy with which the cumulative mean has approached the population mean. Confidence limits give the range within which the population mean may be expected to lie, and the method by which they are calculated is referred to later. In order to achieve 95 per cent. confidence limits of  $\pm 0.5$  db. for the mean of the series of observations of speech level described above, approximately 300 observations would be required. This is a very large number and it will subsequently be shown that, provided care is taken in framing the question to be answered by experiment, the desired result can often be achieved with considerably less work.

#### FRAMING A QUESTION TO BE ANSWERED BY EXPERIMENT

It has been shown above that the observations form a sample from which one or more population parameters are to be inferred. Making observations, therefore, amounts to sampling a population. It follows also that the precision with which a population mean can be inferred depends on the population variance. If a population having a small variance is sampled, higher precision can be achieved than when the population has a large variance. There is usually a choice of population which one might sample and still achieve one's aim. This depends, of course, on the aim, but design of experiments consists very largely in choosing a population of as small a variance as possible consistent with the aim. An example will be given to illustrate this.

The situation is frequently met where there are a number of conditions (keeping to speech voltage problems as examples), and it is desired to determine whether they cause the talkers to give different speech voltages. Suppose there are four circuit conditions differing in the loudness at which side tone is heard. Interest then lies in four values of speech voltage, namely those corresponding to the four circuit conditions. Suppose first that the question is framed in the same form as for the first experiment, i.e. "What is the speech voltage corresponding to each of the four conditions?" In more precise language, "What are the best estimates of the population mean speech voltages corresponding to the four conditions?" In the experiment each condition is set up, pairs of people are caused to talk and the speech voltages for each condition are observed. A set of readings might be obtained as follows:—

TABLE I

Condition 1 (-20)	Condition 2 (-10)	Condition 3 (0)	Condition 4 (+10)
- 2.7	-12.0	- 8.6	-11.7
-14.1	-10.0	- 9.0	-16.0
- 7.5	-12.4	- 8.5	-13.9
- 2.7	-11.4	-13.4	-22.9
- 8.7	-17.0	-12.8	-12.0

The condition means are plotted in Fig. 3 against sidetone level. Conditions 1 to 4 represent different sidetone levels such that a straight line would be expected to fit. It will be seen that the observed condition means are widely dispersed about the true relationship shown also. (This

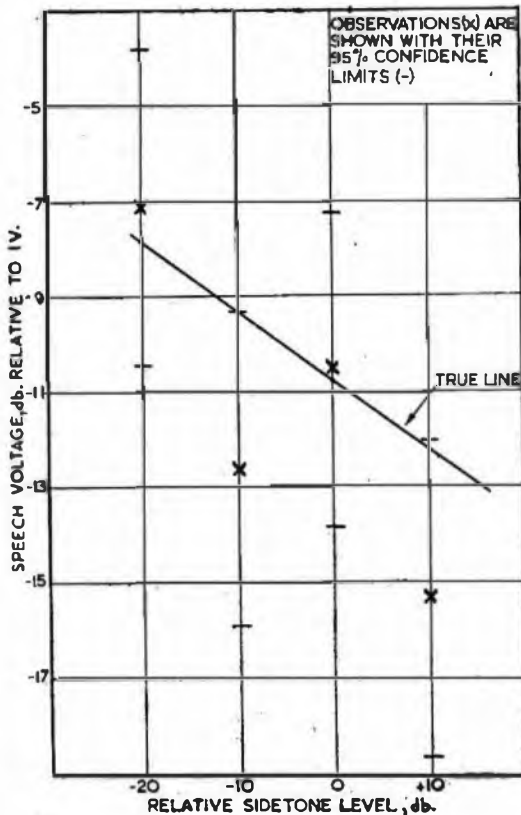

FIG. 3.—OBSERVED SPEECH VOLTAGE AS A FUNCTION OF SIDETONE LEVEL, USING A DIFFERENT SET OF TALKERS FOR EACH CONDITION.

true relationship is what would result from the means of four indefinitely large sets of observations, as explained earlier.) 95 per cent. confidence limits are shown about each observed condition mean, and it will be seen that they are very wide; in consequence, the power of the experiment to answer the question, i.e., to predict the true condition means, is very poor.

In the above experiment it was intended to estimate four separate mean voltages. Are these really necessary, or is it really required to find out whether change of condition is accompanied by change in speech voltage? In other words, would it be satisfactory if the effects of conditions could be estimated? The question might then be reworded, "Are changes in conditions, among the four specified, accompanied by changes in speech voltage and, if so, how much?" Can advantage be taken of this rewording to improve the precision of the information? Whether this can be done or not depends upon the behaviour of the experimental material. At this stage, the experiment will be left and heterogeneity considered.

#### HETEROGENEITY

Consider a set of twenty-four observations by twelve pairs of people all using the same circuit conditions; suppose, furthermore, that they were not actually twelve different pairs, but that there were three different pairs, i.e. six different people, each being used four times. If the name of each talker is written against his observed result, one gets:—

-10.3(C) -10.3(E) -16.3(F) -6.1(A) -3.2(A) -10.3(E)  
 -9.7(F) -5.7(B) -10.3(D) -6.7(B) -9.7(F) -16.3(F)  
 -4.5(A) -11.9(D) -8.5(E) -13.9(D) -7.9(E) -11.9(D)  
 -7.8(C) -6.2(B) -5.0(A) -3.7(B) -3.7(C) -10.3(C)

These data can be classified into talkers, thus:—

TABLE 2

Talker	Talker	Talker	Talker	Talker	Talker
A	B	C	D	E	F
-3.2	-3.7	-10.3	-10.3	-7.9	-9.7
-6.1	-6.2	-10.3	-11.9	-10.3	-9.7
-5.0	-6.7	-7.8	-11.9	-10.3	-16.3
-4.5	-5.7	-3.7	-13.9	-8.5	-16.3
Mean	-4.7	-5.6	-8.0	-12.0	-9.2
					-13.0

The talker means can be calculated, whence there seems to be evidence that the talkers differ. This is confirmed by making a test of significance by the analysis of variance method.<sup>2,3</sup> What this classification really shows is that the variation "between talkers" is significant as compared with the variation "within talkers." "Within talkers" means between the repeated results of each individual talker. In this case, it may be said that heterogeneity is present with respect to classification into talkers. In other words, results are obtained which are more repeatable when a single talker is used many times than when many talkers are used each once only. As a further example, imagine a boxful of numbered tickets of different colours. If heterogeneity with respect to colours is present, there would be less variation between numbers on tickets drawn at random if only those of a single colour were chosen. If the colour does not affect the variation, then there is not that particular form of heterogeneity. There could still be heterogeneity with respect to some other method of classification than colour; for example, shape of ticket, or whether it has holes punched in it, etc.

#### RANDOMISED BLOCKS DESIGN OF EXPERIMENT

##### *The Nature of Blocks.*

The simplest form of experimental design (and perhaps the commonest) is that known as Randomised Blocks. Before describing this design, the term "block" needs to be defined.

Suppose there is a number of treatments, varieties or conditions which it is desired to compare. For this comparison it is evident that observations must be made using some experimental material (i.e., the treatments must be applied to either plots of land, animals, machines, electrical circuits, etc., and the effects observed). If there is reason to believe that a particular classification of the experimental material will result in less variation "within classes" than "between classes," then the experiment should be arranged to use those classes as blocks. This is the same as saying that, if there exists heterogeneity with respect to a particular classification of experimental material, that classification should be used as blocks.

In the experiment described earlier, using several talkers and measuring speech voltages several times with each talker, it would be profitable to use talkers as blocks. In general, the ideal would be for the observations within a block (or the essential operations leading to the observations) to be made simultaneously on a single piece of material. This is clearly impossible, so that at best a choice must be made between (a) simultaneous observations on nearly identical pieces of material and (b) observations separated slightly in time, but made on the same piece of material. Often neither of these is possible, and separation is necessary both in time and between pieces of material. Examples of classifications commonly useful as blocks are

plots of land close to each other ; experimental animals of the same litter (especially identical twins) ; manufactured articles made during the same run of an industrial process ; measurements made within a short interval of time. Such classifications are treated as blocks by applying each treatment the same number of times in each block and randomising the treatments within each block (hence the name Randomised Blocks design).

### The Design of the Experiment.

The experiment described earlier will now be considered again. The question was asked : "Are changes in conditions accompanied by changes in speech voltage ?" There are four different conditions, and let each condition be applied to each of five talkers. The results can be classified as follows : rows representing blocks and columns representing conditions or treatments. This classification does not represent the order in which the tests were made ; the order was randomised within blocks (as shown by the numbers in brackets).

TABLE 3

Block (Talker)	Condition (Sidetone level)				Block mean
	1 (-20)	2 (-10)	3 (0)	4 (+10)	
1	-10.4(2)	-12.7(3)	-16.7(1)	-20.2(4)	-15.0
2	-11.7(4)	-10.8(2)	-10.4(1)	-14.3(3)	-11.8
3	-10.4(4)	-7.8(3)	-13.3(2)	-15.3(1)	-11.7
4	-4.0(3)	-5.0(2)	-5.6(1)	-8.4(4)	-5.7
5	-9.9(3)	-11.9(2)	-14.6(4)	-13.2(1)	-12.4
Condition Mean	-9.3	-9.6	-12.1	-14.3	Grand Mean = -11.3

These condition means have been plotted on Fig. 4 against

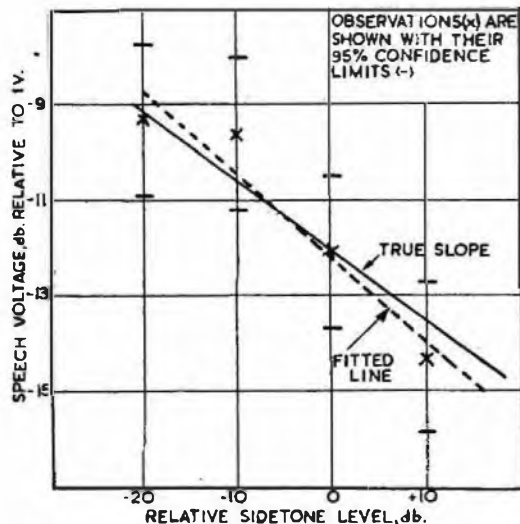

FIG. 4.—OBSERVED SPEECH VOLTAGE AS A FUNCTION OF SIDETONE LEVEL, USING TALKERS AS BLOCKS.

sidetone level, as before, and 95 per cent. confidence limits of the observed condition means are shown together with a straight line fitted to the observed points. The slope of the fitted line is seen to be very close to that of the true slope.

When comparisons are now made between condition means (or between a condition mean and the grand mean), differences between blocks have been eliminated (subject to

an assumption considered in the next section). The 95 per cent. confidence limits of a condition mean can be determined using the estimate of error obtained by the analysis of variance ; these limits are  $\pm 1.6$  db. Similarly, the block means show the variation between talkers with the effects of conditions eliminated ; the 95 per cent. confidence limits of a block mean are  $\pm 1.8$  db.

It is useful to compare these confidence limits for a condition mean with those given earlier for the experiment where the same number of observations were made but blocks were not used (namely  $\pm 3.3$  db.). It must be emphasised that these different limits apply to different populations. The limits without using blocks apply to the population of condition means generated by repeating the experiment, using different talkers every time. Those limits, therefore, express the range within which the mean for the population of talkers (under a particular condition) may be expected to lie. The limits obtained from the Randomised Blocks experiment apply to the population generated by repeating the experiment, using each time the same set of talkers as the blocks. If one is prepared to assume that the effect of conditions is independent of blocks, these confidence limits may be taken as defining the range within which the difference between a condition population mean and the grand population mean may be expected to lie. This assumption of independence means that, if a change from condition 1 to condition 2 causes A's true speech voltage to change by  $x$  db., the same change in condition will cause the same change of  $x$  db. in every other talker's true speech voltage.

### Interaction Effect.

If the assumption of independence of talkers and conditions is not valid, it may be said that a talker-condition interaction exists. Such an interaction expresses the uncertainty with which the true mean for a given talker under a given condition can be predicted, knowing (1) the true condition mean for all talkers, (2) the true talker mean for all relevant conditions, and (3) the true grand mean for all talkers and all (relevant) conditions. A test for the presence of this interaction may be made if one has an estimate of error derived from replications of combinations of talker and condition. A suitable method of making such a test would be to replicate the Randomised Blocks experiment described in the previous section (i.e. repeat using the same sets of talkers and conditions). The interaction can then be tested for significance against the error estimated from the replications. (The methods of testing for significance are described simply by Brownlee.<sup>4</sup>)

### Estimate of Error.

Error may be defined as the variation between replicated observations. Replicated observations means observations repeated under exactly the same controlled conditions ; all other influences operating at random. Error may always be estimated from replications but, under certain conditions, replication may be dispensed with and another criterion for error used. If independence of the effects of talkers and conditions (i.e. no interaction) can be assumed, the criterion of "consistency" may be used to estimate error. In this case, error is given by the lack of consistency as determined by the departure of each observation, given in the table above, from its expected value. The expected value is given by

$$\text{grand mean} + (\text{condition mean} - \text{grand mean}) + (\text{block mean} - \text{grand mean}).$$

This lack of consistency is a measure of the disagreement between the observations and the assumption or hypothesis of no interaction and, if what is assumed is true, the result will be exactly the same as error estimated by replications.



## ANALYSIS OF A RANDOMISED BLOCKS EXPERIMENT

The analysis of the Randomised Blocks experiment described previously will now be considered. Analysing an experiment means choosing a pattern (usually, as in this case, a mathematical model) which fits the observations, by the use of the following set of rules. These rules are chosen so that the resulting pattern is useful for predicting future results.

- (a) The pattern shall be as simple as consistency with the facts will allow.
- (b) One pattern is to be preferred to an equally simple alternative if it fits more facts (e.g., if it fits the facts of more than a single experiment).
- (c) Choice between a simple pattern fitting a restricted set of conditions and a more complicated pattern fitting a more general set of conditions is governed by the purpose for which predictions are required to be made. There is no advantage in adopting a more complicated pattern which will fit a more general set of conditions which are not immediately relevant or which will give greater precision in prediction than is required.

The formal procedure of analysis is as follows :—

- (1) Choice of a mathematical model of a suitable kind.
- (2) Estimation of the most likely values of the parameters of the chosen mathematical model.
- (3) Tests of significance.

A mathematical model is a system of equations which describes a set of observed values, such as those of Table 3 given earlier. Each observation is regarded as comprising a number of components which are directly additive. Thus, if—

- (i) the true grand mean is denoted by  $M$  ;
- (ii) the difference between the true condition mean and  $M$  is  $A$  ;

and (iii) the difference between the true talker mean and  $M$  is  $B$ ,

then the true value of the observation is  $M + A + B$ . The actual observed value ( $y$ ) differs from  $M + A + B$  because of experimental error which is denoted by  $\epsilon$ .

$$\therefore y = M + A + B + \epsilon$$

This equation represents the form of the mathematical model which is used. In the present case there are, of course, 20 observed values, so that there is a set of 20 equations of this form. This set cannot be solved directly in the ordinary way, since there are too many unknowns. Each error term  $\epsilon$  is, in general, different ; there are four different  $A$  terms (one for each condition) ; and there are five different  $B$  terms. Altogether, including  $M$ , there are, therefore, 30 unknowns. If an interaction effect were included, there would be a further 20 terms, but interaction is here assumed not to exist.

The object of the analysis of an experiment is to calculate estimated values of the unknowns, particularly the four  $A$  terms (i.e. the true condition effects). By making certain generally acceptable assumptions,<sup>5,6</sup> the most likely estimates of the  $A$  terms can be very simply calculated. Estimates of the terms  $M$ ,  $A$  and  $B$  are denoted by the corresponding small letters. Thus,

$m$  = grand mean of the observations

$a$  = condition mean of the observations—grand mean

$b$  = block (talker) mean of the observations—grand mean.

In the present experiment, these estimates are as follows :—

$$\begin{array}{ll} m = -11.3 & b_1 = -3.7 \\ a_1 = +2.0 & b_2 = -0.5 \\ a_2 = +1.7 & b_3 = -0.4 \\ a_3 = -0.8 & b_4 = +5.6 \\ a_4 = -3.0 & b_5 = -1.1 \end{array}$$

It is also possible to calculate estimated values of the error terms  $\epsilon$ , but these are not usually required. Only the variance of the  $\epsilon$  terms need be estimated.

So far, (1) a suitable mathematical model has been chosen and (2) the most likely values of its parameters have been determined. It now remains to deal with (3), tests of significance.

### Tests of Significance.

It is the general purpose of the tests of significance made in analysing a set of experimental observations to assess, by a numerical measure, using the mathematical theory of probability, the degree of belief which ought, rationally on the evidence, to be given to any conclusion drawn from the data.<sup>8</sup> The measure which is used is defined in terms of probability : the numerical value for the highest possible degree of credibility (certainty) is unity and the lowest possible (impossibility) is zero. By convention, some level such as 0.05 is regarded as the limit below which it is agreed to act as though the proposition were false.

Making a statistical test of significance consists of calculating a probability. This calculation is considerably simplified by the existence of tables prepared for the purpose. It is not proposed to describe such tests in detail here, but it is important to understand the nature of statistical tests of significance. The purposes are to give rational answers, based on the evidence, to the three following questions.

- (1) Is the particular mathematical model which has been used valid ?
- (2) Would a simpler mathematical model still provide an adequate description ? (See the first rule for choice of a descriptive pattern.)
- (3) What quantitative flexibility in the values of the parameters is possible without violating the adequacy of the mathematical model as a description ?

In the present example (1) means testing whether the  $\epsilon$  terms are independent Gaussian variates. In an experiment of the present dimensions (20 observations), no very sensitive test of this assumption is possible, but, on the other hand, considerable departure will not cause misleading inferences to be drawn. Provided reasonable attention has been given to choosing the units of the dependent variable and to randomising the observations within blocks, no special statistical test of (1) is necessary except in a very large and complicated experiment.

Question (2) is almost always essential in any experiment, unless a considerable body of evidence has already been acquired relating to the magnitude of the error terms. The procedure for the present example can be summarised by the following question. If the condition effects,  $A$ , were all zero, would there still be a reasonable chance of getting the set of estimated values  $a$  which in fact were obtained ? This hypothesis (called a null hypothesis) can be tested by the analysis of variance method,<sup>2,3,4</sup> which consists of calculating a statistic which is a measure of the dispersion of the set of  $a$  terms ; if every  $A$  were zero, the probability of getting this value or a greater value is less than 0.01. This hypothesis, therefore, is not sufficiently credible and must be regarded as false. Therefore the set of  $a$  are "highly significant." The probability is calculated using the estimated value of the error variance (i.e. the variance of the  $\epsilon$  terms). Any terms of a mathematical model which are not significant may be taken as zero, thereby simplifying

the model. In the example under discussion, the  $b$  terms are "very highly significant" (probability  $<0.001$ ), so that no simplification is possible.

The third purpose of the statistical tests of significance is to estimate the interval about the estimated values  $a$  within which each  $A$  may reasonably be expected to lie. The limits of these intervals are termed confidence limits and are calculated from the estimate of error variance and the number of observations which contribute to each condition mean  $a$ . In the present example, the confidence intervals of each condition mean are  $\pm 1.6$  db. for 95 per cent. confidence and  $\pm 2.1$  db. for 99 per cent. confidence. The following four statements may therefore be made with 95 per cent. confidence:

- $A_1$  lies between  $+0.4$  and  $+3.6$  db.
- $A_2$  lies between  $+0.1$  and  $+3.3$  db.
- $A_3$  lies between  $-2.4$  and  $+0.8$  db.
- $A_4$  lies between  $-4.6$  and  $-1.4$  db.

The level of confidence (95 per cent.) means that in the long run 95 per cent. of such statements will be true and 5 per cent. will be false. (There is, of course, no means of distinguishing which are false.)

#### Interpretation of the Results.

The following inferences can be drawn from the data and their analysis:—

- (1) The observed change in mean speech voltage as the circuit conditions are changed is a genuine effect, i.e., has not merely arisen by the chance combination of error terms.
- (2) The observed differences between talker means are genuine, so that the use of talkers as blocks was justified. (No disadvantage would have accrued even if the talker effects had not been significant.)
- (3) The range within which the true values of the condition means lie are as given above.

Each of these inferences is given as an assertion which may reasonably be acted upon as though it were true. Each assertion has, however, a measure of credibility less than complete certainty (as indeed has practically all knowledge). The method of analysis, however, ensures that statements such as the above are not made unless they have a certain minimum measure of credibility determined by the probability levels which are chosen as limits. The choice of what probability levels should be used, depends not on mathematics nor on logic but on the practical consideration of what action will be taken and where the benefit of the doubt should be given. The subject of choice of level of significance is a very broad one and cannot be discussed here. For most work a limiting level of 0.05 is not unreasonable.

#### CONCLUSIONS

The design given as an example (Randomised Blocks) is only one of a vast number which have been developed as requirements arose. All, however, are based on the principles given here. An extensive literature exists on the subject, of which the most general references are given at the end of this article.

The proper application of the methods of design and analysis of experiments depends more than anything upon the attitude of mind of the experimenter. He must be prepared to admit that a simple but adequate mathematical model descriptive of his observations will serve as a means for predicting future observations. This means that a simple but adequate model is assumed to persist in a substantially constant form for all possible sets of observations. The understanding of phenomena merely entails knowing the simplest model which is in accord with the facts.

As knowledge accumulates in any field of science, the

appropriate mathematical models become more and more stabilised until general agreement is reached. In fields where very many facts have accumulated, the mathematical models may require to be very complicated in order that they shall adequately describe all the known facts and not just those of a single experiment. As they adequately describe more facts, the models become proportionately more powerful in predicting further facts. In fields where a large quantity of facts has not been accumulated, or where control of all relevant influences is not feasible, simple mathematical models may be used and it is in such fields that the principles described here have their greatest usefulness. Within the science of telecommunications, both kinds of field exist. The study of new materials, the performance of operations by staff, the behaviour of manufacturing processes, as well as the problems of telephone transmission assessment, immediately suggest themselves as fertile subjects for the application of the principles of experimentation. It must not be supposed that the process, when actually conducted, is always difficult or lengthy; the design of an experiment, such as described here, requires no more effort than the drawing up of blank tables into which the observations can be recorded. For the analysis the calculation of mean values, the analysis of variance, and the estimation of confidence limits can easily be done in less than an hour, using a desk calculating machine, and in little more than two hours without a machine. The making of the observations would probably require at least one whole day's work, so that the proportion of time spent in an analysis which yields sound conclusions is quite small.

Information which must be obtained by experimentation should be regarded as a commodity which must be paid for with observations: just as the prudent man pays no more than he must for an article that he requires, so it is uneconomic to waste observations by poor planning or inefficient analysis. Proper planning and appropriate analysis will ensure not only that every observation contributes its maximum to the information but that unjustified and misleading conclusions are not drawn.

#### ACKNOWLEDGMENTS.

The author wishes to express his indebtedness to those of his colleagues at Dollis Hill with whom he has discussed the matter in this article, and especially to Mr. W. E. Thomson, of the Mathematics Group, and to Dr. J. Swaffield.

#### REFERENCES

- <sup>1</sup> Fisher, R. A. *The Design of Experiments*. Oliver & Boyd. 3rd Edition, 1942.
  - <sup>2</sup> Fisher, R. A. *Statistical Methods for Research Workers*. Oliver & Boyd. 9th Edition, 1944.
  - <sup>3</sup> Snedecor, G. W. *Statistical Methods*. Iowa State College Press, 1946.
  - <sup>4</sup> Brownlee, K. A. *Industrial Experimentation*. H.M.S.O. 4th Edition, 1949.
  - <sup>5</sup> Eisenhart, C. The Assumptions Underlying the Analysis of Variance. *Biometrics* 3, No. 1, p. 1, 1947.
  - <sup>6</sup> Cochran, W. G. Some Consequences when the Assumptions for the Analysis of Variance are not Satisfied. *Biometrics* 3, No. 1, p. 22, 1947.
  - <sup>7</sup> Bartlett, M. S. The Use of Transformations. *Biometrics* 3, No. 1, p. 39, 1947.
  - <sup>8</sup> Russell, Bertrand. *Human Knowledge*. Allen & Unwin, 1948.
- Other references useful as an introduction to the modern philosophical theories of scientific method are:—
- George, W. H. *The Scientist in Action*. Williams & Norgate, 1936.
- Churchman, C. W. *Theory of Experimental Inference*. Macmillan, 1948.
- Farrington, B. *Greek Science, Volumes 1 and 2*. Penguin Books, 1949.
- Caldin, E. F. *The Power and Limits of Science*. Chapman & Hall, 1949.

# An Experimental Power-Operated Parcel Plough

E. W. PETTIT†

U.D.C. 621.867-83 : 656.8

The author describes equipment installed in the Mount Pleasant Sorting Office, London, to distribute parcels to sorting positions by a power-operated, automatically-controlled plough. The function of the plough as an aid to "primary sorting" is first explained and this is followed by an outline of the mechanical and electrical arrangements of the plough and its associated control equipment.

## Introduction.

THE equipment to be described in this article has been designed as a mechanical aid to the transport and sorting of parcels in the Mount Pleasant Sorting Office and it consists of a power-operated plough which traverses the length of a conveyor band to distribute parcels to sorting positions.

The general arrangements covering the so-called "primary sorting" of parcels at this large office are shown in Fig. 1. On arrival at the loading platform the incoming

level of, and discharge them on to, the two sections, F1 and F2, of the glacis conveyor. The parcels moving along the conveyors, F1 and F2, meet the triangular face of a plough operating on each section and are thus directed down the slope of the main glacis, G, to the curved trough, H, at its foot.

The sorting staff stand in the space between the glacis and the groups of baskets, K, and as individual parcels are sorted they are dropped into the trolley baskets for removal to the appropriate division, where a "secondary sorting" process takes place.

## Outline of Scheme.

For more than a decade the method of parcel distribution over a long storage glacis has been to use hand-propelled ploughs but the manpower shortage after the war led to the consideration of mechanically-propelled equipment. Early in 1946, it was decided to install an experimental mechanically-propelled plough on the southern half of the main glacis, operating over section F2, and two methods of propulsion were considered:—

- (a) towing by cable or chain, driven by a stationary motor;
- (b) propulsion by a motor mounted on the plough itself.

In view of the manner in which the two rising conveyors discharge on to the glacis conveyors, method (b) was adopted.

To ensure a positive drive it was decided that the motor should drive a pinion engaging with a horizontal rack, and to provide complete protection from electric shock power was to be brought to the motor through an insulated cable which could be wound on and off a weight-loaded cable drum as required.

It was desired to reproduce as nearly as possible the flexibility of movement of the existing hand-propelled plough and, with this in mind, the glacis conveyor, F2, between the two rising conveyors has been divided into four equal sections or zones. These zones (1-4) form the basis of a remote control which enables the plough to traverse to and fro across any one of ten zones as shown in Fig. 2.

The particular zone to be used and the length of time it remains in use is under the control of the supervising officer. In practice during periods when the load is light, the plough is sometimes left stationary at the northern end of zone 4, or may be left working over zone 4, and the small staff on sorting duties concentrated in front of this zone. During the periods of peak load the plough normally works over zone 10, distributing the parcels evenly on the glacis over the distance covered by this zone, so that the maximum number of sorters may be employed.

The remote control panel is sited well back from the front of the glacis to avoid interference with the free movement of the trolley baskets used for primary sorting and from this position a clear view can be obtained of the whole of the glacis.

## The Mechanised Plough.

The mechanised plough, weighing approximately 2 tons, was designed to deal with a maximum load of 1,000 lb. on

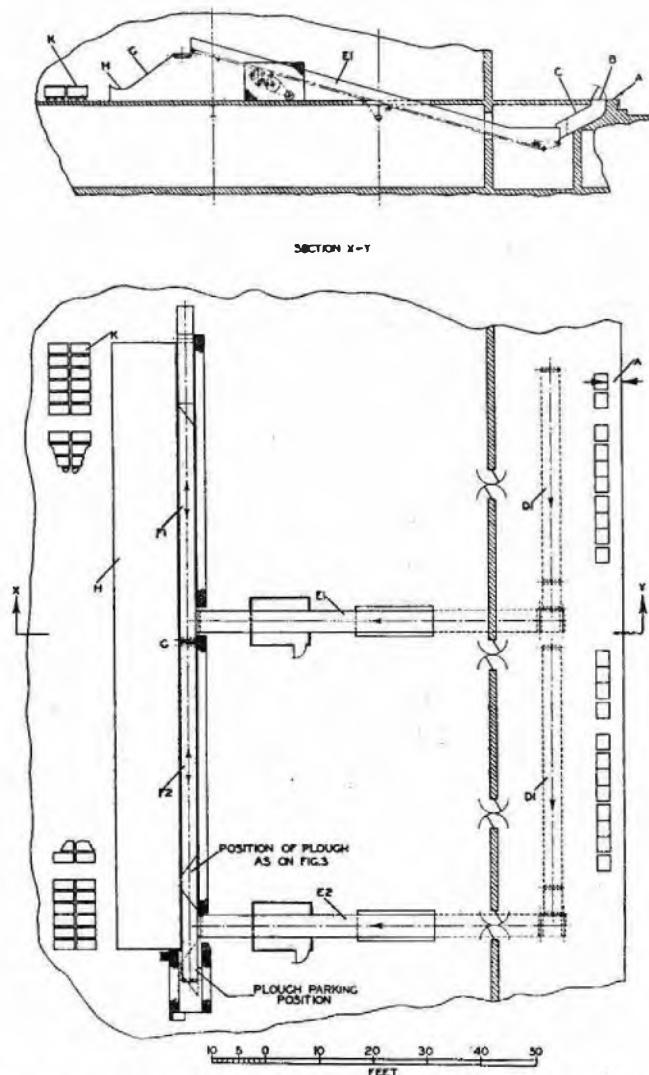

FIG. 1.—THE CONVEYOR SYSTEM FOR "PRIMARY SORTING" AT MOUNT PLEASANT.

mailbags are removed to the platform, A, opened, and their contents poured through balanced trap doors, B, ranged along the front of the platform. Below these doors are a series of minor glaces, C, down which the parcels slide on to two horizontal conveyors, D1. These feed the rising conveyors, E1 and E2, which raise the parcels to the

† Assistant Engineer, Power Branch, E.-in-C.'s Office.

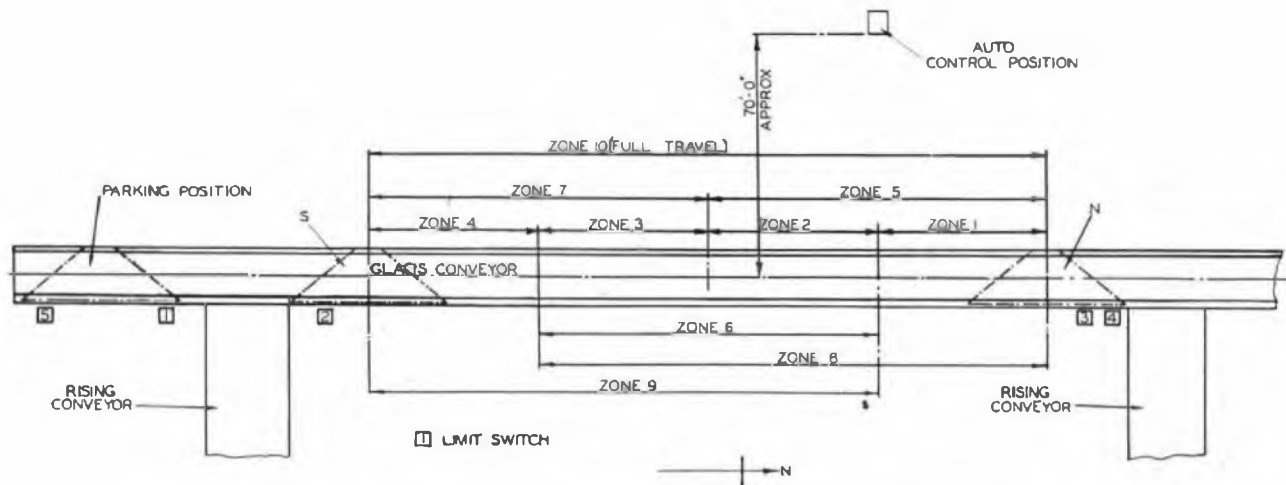

FIG. 2.—PLAN OF GLACIS CONVEYOR SHOWING ZONES OVER WHICH MECHANISED PLOUGH CAN OPERATE.

one angular face. The dimensions of the plough body have been limited, as far as the new conditions permit, to the dimensions of the double hand-propelled plough which operated formerly over section F2. The working base is 10 ft. 6 in. long at the rear, 2 ft. long in the front, 3 ft. 3 in. wide, and 1 ft. 6 in. high, the two angular faces being inclined at 37° to the line of the glacis conveyor. Fig. 3

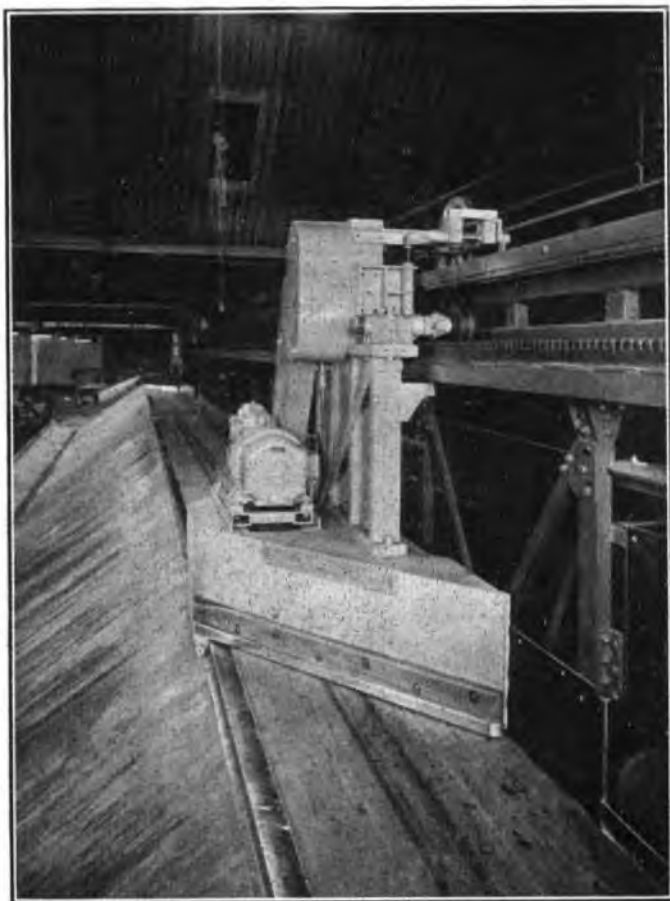

FIG. 3.—THE PLOUGH IN ITS NORMAL WORKING POSITION.

shows the plough in its normal working position. The plough is suspended between two pairs of balanced running wheels on the main track (raised to clear the incoming conveyors), and one pair of spring-suspended balanced bogie wheels running on the front angle of the glacis conveyor. The two pairs of balanced wheels running on

the main track are provided with very long and specially designed bearings in view of the considerable overhang, but are not sprung. The balanced bogiewheels are mounted on a helical compression spring designed to carry a load of 1,220 lb. and the spring absorbs any shock due to unevenness of the front track.

The body of the plough is carefully fabricated to resist distortion when under load, and an elevated platform is provided for the auxiliary gear and brake operating solenoids. This platform is rigidly attached to the body by means of six vertical R.S. channels bolted to the plough body as shown in Fig. 3.

The driving motor, rated at 3 h.p., runs at 720 r.p.m., and is coupled to a 60 to 1 worm speed reduction unit. The driving pinion, driven by a duplex chain, meshes with a special steel rack, made in sections and fixed to the main steelwork. Both rack and pinion are made from carbon steel and the teeth are machine cut.

A double brake is fitted to prevent the plough slipping in any circumstances, and brings the plough from the full speed of 22 ft. per minute to rest in approximately half an inch. Two weighted solenoids are provided, one operating each pair of brake shoes through lever and cam gear. The brakes are held off when current is supplied to the solenoids, but cessation of current allows the weights to fall and hold the brakes on. Each pair of brake shoes provides sufficient power to hold the plough under normal working conditions should either one of the solenoids fail.

The cable supplying power to the motor runs on rollers fixed inside a R.S. channel above the track and running the full length of the track and parking position. The cable is cleated to the arm of the driving bracket and taken into a 7-way connector box from which the motor is wired.

Four check rollers are fitted, working in the inverted R.S. channel supporting the rack, their function being to limit to  $\frac{1}{16}$  in. both side and upward movement of the plough. These limits ensure satisfactory meshing of the driving pinion and rack, and also remove all danger of accidents which might otherwise be caused by derailment of the plough.

The two angular faces of the plough are fitted with facing boards shod with a brass angle, all corners being carefully rounded, and the facing boards slotted to give a small vertical adjustment. The bottom of the body of the plough is approximately 2 in. above the level of the conveyor band to prevent the destruction of any thin parcel which might find its way under the facing boards and into the interior of the plough body. To prevent damage to parcels from the front bogie wheels and to protect the wheels themselves, a hardwood skate is fitted to the lower end of the front



plate. The junctions between the skate and the front ends of the facing boards are protected by specially shaped bronze castings, arranged to deflect small parcels down the slope of the glacis.

In the event of complete electrical breakdown, provision is made for the plough to be removed by hand to its parking position, the hand-operated driving gear being arranged to move the plough at a speed of 11 ft. per minute to keep the required effort within a normal man's strength. The hand gear is provided with a brake and is operated from a chain and chain-wheel from the walk-way at the rear of the glacis conveyor.

During normal power operation the middle pinion of the hand-operated gear is drawn out of gear and locked on its spindle clear of the lower pinion meshing with the rack. This allows the lower pinion to rotate freely on its spindle as the plough moves under power, and entirely disconnects the hand-operated gear. The danger of the electromagnetic brake being left inoperative after the plough has reverted to power operation has been completely overcome by the use of two special driving pins, which hold up the weights of the brake. Until these pins are withdrawn, so bringing the brake into operation, power driving is not possible.

#### *Location of Control Gear.*

The light steel structure supporting the glacis conveyor had to be strengthened to support the weight of the power-driven plough and also extended vertically to give adequate clearance between the main running track and the incoming conveyor. These structural alterations entailed lengthening the vertical members and adding further vertical and horizontal steelwork cross-braced to the existing structure. To accommodate the plough control gear without encroaching on space used for gangways, a reinforced cantilever structure was built round the end of the glacis conveyor as shown in Fig. 4. The horizontal arm of this structure is used as the parking position for the plough and accommodation is provided for the cable drum, drum selector switch and motor starting switch.

The cable drum, which can be seen in Fig. 4, is 3 ft. in diameter and accommodates 60 ft. of 7-core flexible cable 0.95 in. in diameter. The drum is fitted with seven phosphor bronze slip-rings, each with two controller-type fingers. Six of these pairs of fingers are insulated from earth and have a current-carrying capacity of 10 amps., the seventh pair forming an uninsulated earth connection. Tension is applied to the cable by means of a wire rope anchored to the drum and attached to a tension weight



FIG. 4.—THE PLOUGH, GLACIS AND CANTILEVER STRUCTURE ON WHICH THE PLOUGH IS PARKED AND CONTROL GEAR MOUNTED.

which can move freely inside the cantilever tower. The rope is geared to reduce the length of travel of the weight.

The drum selector switch is placed under the drum and is driven from it by a chain. The switch is fitted with ten sets of change-over contacts, each of which is operated by two striker arms, so set that they operate a contact each time the plough reaches one or other of the ends of the zone in which the plough is to travel.

Fitted on the cantilever is a spring-loaded buffer designed to absorb the shock and hold the plough, if, when it is travelling at full speed, the limit switches fail to act.

#### *Electrical Control Equipment.*

The 3-h.p. motor is supplied with direct current at 440V, and the control gear operated by direct current at 220V. Zoning is controlled at the remote control panel (Fig. 5)



FIG. 5.—THE AUTOMATIC CONTROL POSITION, WITH GLACIS IN BACKGROUND.

by a 10-point selector switch which can be set in any one of ten positions, each position corresponding to one of the ten zones of operation. On being set to one of the ten positions it causes the appropriate contact of the drum selector switch to be connected to the main control circuit.

The plough may be controlled in either of two ways:—

(a) By hand control from a motor starting switch fitted on the cantilever structure.

With this form of control the plough can be operated over the whole length of the run, including the parking position. Primarily, hand control is used to move the plough from the parking position to the nearest point of the automatically-operated section and to return it from that point to the parking position.

(b) By automatic control from the remote control position.

Automatic control operates only on the working section of the glacie conveyor between the two incoming conveyors E1 and E2 (Fig. 1).

The controls are divided for the purpose of preventing unauthorised persons from operating the plough. This safeguard can be brought into use by putting the change-over switch on the motor starting switch, to "hand" control and locking the case in which it and the hand control "start" and "stop" push buttons are contained. The control circuit will then be inoperative from the auto control panel and the powerful electro-magnetic brakes will be left on.

Independent limit switches 1 and 2 (Fig. 2) are provided to ensure that the incoming conveyor E2 is shut down while the plough is crossing its discharge position and so obstructing the free flow of parcels; these switches also ensure that the conveyor is re-started as soon as the plough is entirely clear of the rising conveyor, in whichever direction the plough is travelling. These limit switches will only operate when the plough is moving to or from the parking position. Limit switch 3 is so positioned that should the plough overrun its most northerly auto-position, it is stopped before it can protrude across the discharge opening of conveyor E1. Limit switches 4 and 5 are additional ultimate limit switches whose operation breaks the main circuit. As a further precaution, a mechanical stop is fixed in the northern end of the rack to prevent the derailment of the plough should limit switch 4 fail to operate.

#### Operation of Control and Power Circuits.

Fig. 6 shows a simplified diagram of the control and

the motor starting switch will be in the "hand" position. Depression of the "forward start" button allows current to pass from the positive line through the forward contactor coil "a" to the negative line, and at the same time the retaining contact "A" closes. The plough will then move to the nearest point of the automatically-operated section, thus closing limit switch 2 and preparing to connect the automatic control circuit to the positive line. The plough is then stopped by the operator and the change-over switch put to the "auto" control position.

Automatic-control operations are commenced by the operator moving the control selector switch to the number representing the desired zone. The depression of the "auto-start" button energises the "auto-start relay, bringing in the retaining contacts K1/1 and K1/2. Current will pass through the Z1 "auto" contact to the forward relay K2 and to the negative line.

After a short interval, the time delay contact of relay K2 closes and completes the circuit for the forward contactor "a." The plough then moves in the forward direction until the striker arm of the drum control switch changes over its contact. This change over cuts out the forward contactor and completes the circuit of the reverse contactor through the "auto" contact of Z2. The plough then moves in the reverse direction, and this cycle of operations will continue until the "master stop" button is depressed. The procedure applies similarly to each of the ten zones.

The operation of the power circuit is simple. The energising of the forward contactor coil "a" in the control circuit closes the two contacts A1 and A2 in the power circuit. Current then passes through these contacts, the armature, the starting rheostat and series field to the negative line. At the same time current flows through contact B1, one-half of R2, and through the shunt field and

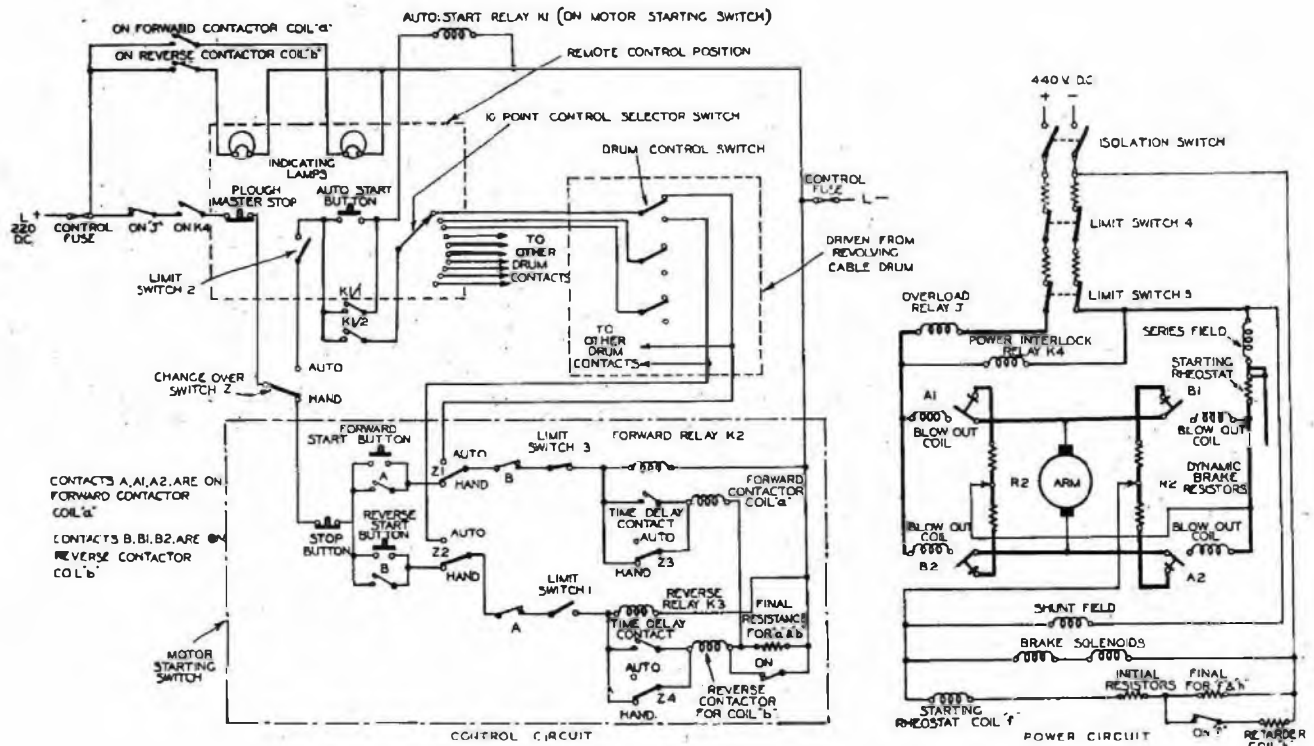

FIG. 6.—SIMPLIFIED DIAGRAM OF CONTROL AND MOTOR CIRCUITS.

motor circuits, and the following description gives the principle of working.

It will be assumed that the plough is in the parking position and therefore the change-over switch (Z to Z4) on

brake solenoids in parallel, to the negative line. The procedure is similar for reverse motion except that the contacts B1 and B2 are closed by the energising of the reverse contactor coil "b"

### Conclusion.

Before erection on site could be commenced, special temporary steelwork had to be fitted to the glacia conveyor, and the existing double hand-operated plough re-equipped, to enable the primary sorting of parcels to be carried on without interruption, except during part of each week-end. The re-equipped hand-operated plough is being retained as a standby should any serious breakdown occur in the mechanised plough.

The mechanised plough was brought into service in November, 1949, after a few hours' trial, which included

an endurance test made during the busiest two hours of the day. The glacia conveyor and the glacia were loaded to their utmost capacity, which provided a test load greatly in excess of the Christmas peak load. Under this test, the plough proved its capacity to spread both large and small parcels over the surface of the glacia, much more evenly than is possible with a hand-operated plough.

Since its introduction, the plough has given almost continuous service for 22 hours each day of the week, and is satisfactorily fulfilling the purpose for which it was designed.

## A New Mobile Tractor Winch

U.D.C. 621.863

Raising or lowering the heavy transmitting aerials suspended on the 800-ft. masts at Rugby Radio Station calls for two mobile winches having a large rope capacity, close control of rope speed, a lift of 3 tons and arrangements for holding the load suspended in any position. These requirements were met in the early days of the station by two tractors, each fitted with a Williams Janney hydraulic, type K, speed gear driving a 4-ft. diameter rope drum. The winches were very satisfactory, having an excellent rope speed range in both directions, but the tractors were not entirely suitable, and after numerous fractures and repairs, it became evident that replacements were essential. Suitable new tractors were unobtainable owing to the war, but one second-hand Fowler "Power" 80 was bought, to which the tractor manufacturer fitted one of the existing winches.

Authority to replace the remaining machine was given in 1946, but search for a suitable Fowler or a similar machine capable of taking the other Williams Janney winch was unsuccessful. The nearest alternative was a Caterpillar D.6, one of which was eventually made available by the Ministry of Supply. The agents thought this tractor's rear casing was too weak to carry the existing Williams Janney gear, so it became necessary to find another winch suited to the tractor. The obvious choice was from the Hyster range, which is made expressly for caterpillars, but none met the specification. The most suitable model available was a Hyster D6N tractor donkey, which has two drums, the largest holding 1,360 ft. of  $\frac{3}{8}$ -in. diameter rope, so one of these was obtained. As supplied, this winch was fitted with a 2-speed gear, foot brake and hand-lever clutch controls, with a full drum rope speed of 200 ft. per minute, which was much too high. Also, the load could only be held suspended by the brake, a risky procedure in very wet weather in case of slip, as the aerial would be wrecked if it fell to the ground. It was therefore decided to modify the winch, and this was done at the Elstree Experimental Department of Jack Olding & Co., Ltd., in consultation with the Engineer-in-Chief's Office.

The rope speed was reduced to one third by removing the smaller and unwanted winch drum, and fitting a counter-shaft with further reduction gears. The high-speed ratio was dispensed with, and instead, a reverse gear fitted, which allows the load to be lowered by engine power with a good control over the speed. The gear-change lever now provides forward or reverse movement for lowering or hoisting as required. In order to hold the load suspended without relying entirely on the brake, a ratchet ring was welded round one rim of the rope drum. In the ratchet teeth drops a pawl which is so arranged that whenever the reverse gear is engaged, the pawl is lifted out. With the pawl

engaged and the brake on it is quite safe to move the tractor. The brake foot control was replaced by a long, ratcheted hand lever to give a smoother and more powerful pull.



REAR VIEW OF TRACTOR WINCH, SHOWING CONTROL LEVERS AFTER MODIFICATION.

The winch was designed to lift 4 tons, and with this loading and the rope at an angle of 25° from the vertical, there is ample power and sufficient brake capacity to raise and lower the load easily and safely. Under these conditions the rear of the tractor starts to lift, unless counter weighted, but as horizontal pulls are always used on the radio station, this does not matter and weights are not used. A 4-ton load can be inched down on the brake, but power lowering is always used in practice. The winch is considered to be satisfactory and the machine should fulfil its primary function and be useful for many other jobs on the station for a long time.

A. B. P.

# Signalling System A.C. No. 1 (2 V.F.)

D. C. SMITH, B.Sc.(Eng.), A.M.I.E.E.†

## Part I.—Modifications to the existing 2 V.F. System for Trunk Mechanisation Requirements and Outline of the operation of the latest equipment.

U.D.C. 621.395.63 : 621.394.441

Signalling System A.C. No. 1 embraces both the existing standard 2 V.F. (600/750 c/s) system of signalling and dialling, and the modernised equipment which is now being introduced to meet the requirements of Trunk Mechanisation. Part 1 of the article includes a brief outline of the existing 2 V.F. system, an account of the steps taken to overcome its limitations, and a general description of the modified system now being introduced. Part 2 will briefly cover the equipment developed for the latest system.

### Introduction.

THE existing 2 V.F. system was first introduced in 1939 and to-day handles the bulk of inter-zone-centre trunk traffic. In the past the 2 V.F. routes outgoing from zone centres have been accessible only from manual boards, and single-link trunk dialling with limited access into the local network surrounding the objective zone centre is all that has been permissible. With the mechanisation of Trunk and Toll traffic, having as its object that controlling operators should be able to complete all calls without assistance from intermediate operators, dialling over several trunk lines in tandem will be required. Any one of these links may employ voice frequency dialling and it is, therefore, necessary,

- (a) to permit access to outgoing 2 V.F. routes from selector levels,
- (b) to ensure that the impulse distortion performance of the 2 V.F. equipment meets the requirements of Trunk and Toll mechanisation, and
- (c) to ensure that 2 V.F. circuits may be connected without restriction to dialling circuits of other types.

### OUTLINE OF THE EXISTING 2 V.F. EQUIPMENT

Although the existing 2 V.F. equipment is fully described elsewhere<sup>1,2,3,4</sup> it is perhaps useful at this stage if a brief outline of it is given.

The system works on the pulse signalling principle and uses tones of the two frequencies "X" (750 c/s) and "Y" (600 c/s). At each 2-wire end of the 2 V.F. dialling trunk circuit there is, in the exchange, one or more relay sets and an associated V.F. signal receiver. When a circuit is seized by the operator inserting a plug into the multiple jack, a short pulse of X tone is sent out to seize the distant end of the circuit and to prepare the incoming equipment to receive impulsing. When the operator dials, pulses of X tone corresponding to the break pulses of the dial are sent out and these are converted at the distant end into loop-disconnect pulses to step the distant selector mechanisms.

When the called subscriber answers, a single short pulse of Y tone is returned and this dims the operator's calling supervisory lamp. When the called party clears, a continuous train of Y pulses (140 mS of Y tone followed by 360 mS of silence) is returned to light the operator's calling supervisory lamp until she clears the circuit by withdrawing her plug at the outgoing end. Should the called party re-answer, the Y pulses are disconnected and the operator's lamp will be dimmed again.

The circuit is cleared from the outgoing end by sending a long (2- or 6-second) pulse of X tone immediately followed by a 300-mS pulse of Y tone. The X tone prepares the incoming end for release and the Y tone following im-

mediately on it causes cleardown to occur. The pulse of X tone is of 2 or 6 seconds' duration, depending upon whether the call is answered or unanswered, respectively.

Any system of V.F. signalling on the speech path must incorporate arrangements to ensure that there is little or no chance of speech causing false signals. On the existing 2 V.F. system the speech path is split in the relay set at the outgoing end and connected through only while the called party is on the line. Before the called party answers, supervisory tones are heard via a one-way repeater (the stopper valve) in the outgoing relay set. Any noise due to the calling party will be prevented from reaching the line by the stopper valve. During conversation the V.F. receivers at both ends of the circuit are exposed to speech, and guard circuits working on the sub-harmonics of the signalling frequencies were incorporated in the receivers to minimise voice operation. In addition, the signals to be sent (backward and forward clear) are of considerable duration and are not recognised until a time-delay guard has been overcome. This combination of frequency guards on the receiver with time-delay guards in the relay set has proved quite satisfactory in practice.

Arrangements are provided in the system to allow its use on circuits equipped with echo suppressors. Until a call is answered, it is arranged that the X pulse of the forward clearing signal shall be of 6 seconds' duration instead of 2 seconds, and also that the speech path shall be split in the incoming relay set for 1 second in every 5 seconds to prevent an echo suppressor being permanently operated by any continuous noise or tone (e.g., NU tone) and blocking the path for forward signals. Thus, the forward clearing signal (6 seconds) persists long enough to switch the echo suppressor during a 1-second period and, holding it over, will allow the signal to become effective at the incoming end.

After a call has been answered, there is still a chance of the called party's speech or noise operating an echo suppressor and preventing the transmission of the forward clearing signal. A "repeat clear" feature is, therefore, provided so that when the called party clears and the forward clearing signal having been lost (due to inopportune speech), the backward clearing signal (pulses of Y tone) is sent back, further forward clearing signals are sent from the outgoing end until the Y pulses are disconnected, indicating that the forward clearing signal has caused the incoming end to cleardown.

### THE LIMITATIONS AND DIFFICULTIES OF THE EXISTING 2 V.F. SYSTEM AND THE STEPS TAKEN TO DEAL WITH THEM

#### *Selector Level Access and the use of Loop-Disconnect Impulsing on Junctions preceding 2 V.F. Links.*

The provision of multi-link trunk dialling by permitting access via selector levels into 2 V.F. signalling routes was originally envisaged, but the facility was not used due to:—

- (i) The time taken to seize equipment at the incoming end of a 2 V.F. trunk circuit (and prepare it to receive impulses) exceeding the time which may be available during the inter-digit pause provided by an operator

† Executive Engineer, Telephone Development and Maintenance Branch, Engineer-in-Chief's Office.

<sup>1</sup> I.P.O.E.E. Printed Paper, No. 162.

<sup>2</sup> P.O.E.E.J., Vol. 29, p. 41.

<sup>3</sup> P.O.E.E.D. Educational Pamphlet (Telephones 1/4).

<sup>4</sup> P.O.E.E.J., Vol. 30, p. 281.



dialling. It will be appreciated that the following sequence of events has to occur:—

- (a) The slow release of the group selector C relay.
  - (b) Rotary search to find a free outlet.
  - (c) Seizure of the outgoing 2 V.F. relay set.
  - (d) Transmission of a V.F. pulse as a seizure signal.
  - (e) Recognition of the V.F. seizure signal.
  - (f) Seizure of the incoming selector and its preparation to receive impulsing.
- (ii) The additional distortion of dialled pulses which occurs if a junction using loop-disconnect impulsing is connected in front of a 2 V.F. link using the existing type of equipment. This distortion very severely restricts the already limited access which may be allowed into the objective local non-director network.

It was originally intended that (i) should be overcome by operators pausing between digits, but later this solution was not favoured.

Both the difficulties have been successfully overcome in certain selected cases (e.g., Bath-Bristol and Bradford-Leeds) by placing impulse repeating equipment of the regenerative type<sup>4</sup> in front of the outgoing 2 V.F. relay set. Difficulty (i) is overcome since the regenerator receives and stores each digit before re-transmitting it, and therefore the time available to seize the 2 V.F. link and prepare it for the reception of impulsing is increased. The regenerator also overcomes difficulty (ii), since it provides the 2 V.F. link with a fresh source of impulsing independent of any distortion incurred on preceding junctions. The use of a regenerator entails the re-transmission of all digits and the relay set concerned automatically inserts between the digits adequate inter-train pauses (of at least 800 mS), so that all subsequent switching stages are allowed sufficient time for unhurried operation.

Unfortunately this expedient of fitting a regenerative auto-auto relay set in front of the outgoing 2 V.F. relay set was not, with the existing equipment, suitable for multi-link dialling, where any preceding link might also use 2 V.F. signalling. The difficulty which arises is that, when an operator dials slowly and allows the regenerator to complete the discharge of its stored digits before she has finished dialling, the surge, which occurs as the relay set changes over to the speech condition, may coincide with subsequent impulsing and, by paralysing the V.F. receiver, cause such impulsing to fail. This difficulty occurs when regenerative auto-auto relay sets are encountered in the local network following a 2 V.F. link. The eventual cure which was found for this and other D.C. surges is discussed later. By including the regenerator in the outgoing 2 V.F. relay set, the surge difficulty could be avoided, as the regenerator output could be made to control directly the application of V.F. tone to line. Further advantages are that one transmission bridge only is needed, and also one stage of impulse repetition, with its attendant relays and impulse distortion, is saved. This solution has, therefore, been adopted for the new equipment.

#### *Tandem Trunk Dialling.*

When the existing system was designed it was envisaged that it would be used for setting up tandem connections on a dialling basis and that when two or more 2 V.F. links became connected together, voice frequency signalling and dialling would be end to end through the voice frequency signalling part of the connection, without the repetition of signals at the intermediate switching points. This is termed end-to-end signalling and has the advantage that impulse distortion is minimised and supervisory signalling is made more rapid.

In order to bring about such end-to-end signalling, discriminating conditions had to be passed in each direction

through the switching stages at the tandem exchange to indicate to the next V.F. link that a 2 V.F. trunk circuit was calling and not another type of circuit. The forward discriminating condition used was to call with an earth on both line wires, battery being returned on both line wires as the backward discriminating condition. When two or more 2 V.F. links became connected together, the discriminating conditions rendered the incoming and outgoing 2 V.F. relay sets at the intermediate centres passive, allowing speech and V.F. signals to pass in both directions until the forward clearing signal was sent and released all the 2 V.F. links in the connection.

Such discriminating conditions are not generally communicated by the other types of signalling systems which may be employed on lines forming part of a multi-link trunk connection, and to arrange for such systems to communicate discriminating signals would involve undesirable complexity and cost. Thus, link-by-link working with impulse repetition at each tandem point is likely to be unavoidable in some cases and the impulsing performance of the 2 V.F. system must be such as to allow for this type of working.

Another aspect of the end-to-end signalling problem is the comparatively large level and frequency variations which are possible under adverse conditions on a multi-link call. There was, it was thought, some risk that these variations might exceed the performance of the early type of 2 V.F. receiver.

The decision to abandon the end-to-end signalling facility and to adopt link-by-link working as a general principle was therefore taken. This decision allowed a difficulty (described in the next paragraph) which had arisen in connection with 2,000-type, 200-outlet final selectors to be avoided.

#### *Use with 2,000-type, 200-outlet Final Selectors.*

The "earthed loop" seizure condition extended by the 2 V.F. equipment to provide a discriminating condition and obtain end-to-end V.F. signalling on 2 V.F. links in tandem, conflicts with the wiper switching arrangements on the 200-outlet final selector. This difficulty was overcome by the interposition of an auto-auto relay set. On the new equipment, however, the end-to-end signalling feature having been abandoned, normal loop seizure is used and the problem no longer arises. Where auto-auto relay sets are in use for this reason alone, the existing 2 V.F. equipment will in due course be modified to provide normal loop seizure and the auto-auto relay sets used for other purposes.

#### *The effects of Surges from the succeeding D.C. Network.*

It was found that surges arising in the D.C. network succeeding a 2 V.F. link can temporarily paralyse the 2 V.F. receiver and prevent it impulsing correctly to V.F. tone signals. In particular, the surges produced by the drop-back of the transmission bridge in a loop dialling auto-auto relay set incorporating a mechanical impulse regenerator cause serious trouble since they may occur at any time with respect to a following impulse train. Fortunately most other surges occur during intertrain pause periods and, therefore, do not cause serious trouble.

Investigations have shown that by connecting a voltage limiter (two copper oxide rectifiers) across the line during the setting up of the call, all surges arising are suitably attenuated and do not adversely affect the V.F. receiver. The rectifiers cause some reduction in the level of supervisory tones if these are loud, but otherwise the slight loss which the presence of the rectifiers causes is made good by the gain of the stopper valve stage in the outgoing relay set.

Surge-suppression rectifiers will be fitted retrospectively on the existing 2 V.F. equipment where it is desirable to use it for working into regenerative auto-auto relay sets.

### *Tone Feed Circuit Faults Leading to Failure to Transmit V.F. Tone Signals.*

Investigations into the performance of the existing 2 V.F. system have shown that a large proportion of the failures is due to faulty contacts in the tone feed circuits. The faults are often of an intermittent character and, therefore, difficult to locate. The contacts concerned connect the V.F. tones to line for dialling and signalling, and it is not feasible to "wet" these contacts because the D.C. surges produced would distort the V.F. signals.

The trouble has been reduced to an appreciable extent by the use of platinum contacts instead of silver. On the new equipment, static relays (rectifier modulators) are being used and are expected to eliminate the trouble.

### *Frequency Variation.*

The motor generators used to supply V.F. tones were driven by synchronous motors from the A.C. mains. War-time variation of the mains frequency led to prolonged running of the stand-by (battery-driven) machines, which themselves were liable to occasional short-term frequency variations. It was, therefore, decided to provide V.F. oscillators to supply tones at all existing and future centres. In addition, the bandwidth of the new V.F. receiver has been made much wider than that provided on the earlier types. This will also allow wider margins for frequency change on the line (e.g., due to abnormal carrier drift).

### *Overloading of Common Amplifiers on Multi-Channel Carrier Systems.*

It was thought that amplifier overloading might be caused by the number and level of V.F. tone signals occurring simultaneously. This is most likely in connection with the backward clearing signal which is a continuous train of Y tone pulses.

On the existing 2 V.F. system it was considered advisable to reduce the Y tone level from + 3 db. to - 3 db. (reference 1 mW in 600 ohms), the X tone level being retained at + 3 db. In addition, the Y tone pulses for backward clearing signals have been "staggered" by having three different pulse supplies to the relay sets.

It is proposed to continue using the existing tone levels on the new equipment since the new equipment at one end of a circuit may be working with the old-type equipment at the other and the performance of the oldest type of signal receiver (TL 1750) leaves little margin for further reduction in signal level. With the new receivers (AT 4931 and AT 5331), however, a further reduction in signal level is possible, should it ever be decided upon, and provision for it is being made on the equipment.

### *Use of Audible Signals at Intermediate Stages.*

In the existing systems, an operator, if instructed to attempt dialling over two 2 V.F. links connected in tandem by a director-type exchange, would receive one "pip" of 900 c/s tone when an A-digit selector is found at the tandem and another when the director has released. If the objective centre is also of the director type the operator would hear another set of "pips"; these might run into a previous set and cause one to be lost. On non-director calls there are no "pips" and the net effect of the varying numbers of "pips" makes the instruction of operators very difficult.

Further, when a bridge control exchange is dialling via a D.C. link into a 2 V.F. link, the operator is unable to hear any "pip" signals unless she restores her dial key, which she is unlikely to do at the correct time.

In the new equipment for auto-auto working, the use of a regenerator at the outgoing end of the 2 V.F. link avoids any necessity for the operator to listen for "pip" signals.

However, Trunk Mechanisation, being on a non-director basis, no application is likely for the feature except possibly in connection with the existing director-type installations.

### *Dependence of Speech on the Return of an Answer Signal.*

The forward direction speech path is established only when the called party answers (it having been appropriated for impulsing during the setting up of the call). Further, when the called party clears a backward clearing signal (consisting of a continuous train of Y pulses) is returned and the speech path is severed in both directions. Thus, speech is impossible unless the correct answering condition is being returned. This leads to complications in the case of non-meter services, such as changed-number interception, which cannot normally return an answer signal for fear of causing metering on local calls. The operators concerned require a special operating procedure to overcome the difficulty.

Speech is also impossible if a line reversal in the local network is encountered, since this will interchange the called party answer and clear conditions. Such a reversal is a definite fault condition, which will cause false supervision on all calls (trunk and local) and premature metering on local calls.

The new equipment is an extension of the existing system, with which it is required to interwork. It uses the same basic signalling code and signalling is carried out to and from the 2-wire ends of the line. It has, therefore, not been possible to avoid continuing to make speech dependent on the receipt of a correct answer signal.

### *Dialling into Small Automatic Exchanges (U.A.X.s 12 and 13) which return Dial Tone on all Calls.*

If dial tone is encountered on a connection being set up over a V.F. dialling route, the dial tone will constitute a "noise" and, if the signal-to-noise performance of the V.F. signalling receiver is not adequate, impulsing will become distorted or may even be completely prevented. A further complication arises if the V.F. signalling link is equipped with echo suppressors. The dial tone operates the echo suppressor and blocks completely the forward direction transmission path so that further impulsing is impossible since the pulses of V.F. tone will never reach the V.F. receiver.

The new V.F. receiver has a very good impulsing performance, even under conditions of severe noise and it will readily impulse in face of dial tone. It is hoped to accommodate the less satisfactory performance of the earlier types of receiver by ensuring that the level of dial tone at U.A.X.s 12 and 13 is not excessive.

Where the 2 V.F. circuits are equipped with echo suppressors, through-dialling cannot be permitted unless arrangements are made to disconnect dial tone or otherwise to prevent it reaching the trunk circuits. Since the linefinders and selectors at U.A.X.s 12 and 13 handle both subscribers' and junction traffic, dial tone cannot be disconnected, but examination of the problem has shown that a possible solution is the temporary disconnection of the transmission path, in the relay set outgoing to the U.A.X. junction, until one digit has been dialled into the U.A.X. The introduction generally of a modification of this type is not at the moment favoured in view of the large number of relay sets involved. Fortunately, the number of circuits which need to be equipped with echo suppressors is comparatively small and is decreasing. It is hoped that it will be possible to mitigate the difficulty by suitable utilisation of the circuits equipped with echo suppressors and by routing the small residual amount of traffic via the manual board.

### Interruption of Supervisory Tones and Verbal Announcements.

As explained previously, the existing 2 V.F. system incorporates a "1 second in every 5 seconds" interruption feature to allow clear-down on circuits equipped with echo suppressors when such circuits become connected to N.U. tone. This periodic interruption chops up all tones and announcements which are heard before an answer signal is received. Whilst only supervisory tones were concerned and only a single 2 V.F. link was involved, the arrangement worked quite well. However, on multi-link calls, chopping occurs at two or more points and may render supervisory tones unrecognisable or even, in extreme cases, prevent them getting through at all. With verbal announcements, any form of chopping is most unwelcome since, for instance, it might easily turn Manchester into Chester.

It has, therefore, been decided to disconnect the chopping feature on all circuits except those equipped with echo suppressors (where it is essential to ensure clear-down). Also it is proposed to synchronise chopping with the silent intervals in verbal announcements where the announcement and the chopping occur at the same centre. In this way the effects of chopping will be minimised, and by the utilisation, where possible, of the circuits equipped with echo suppressors, on routes where verbal announcements are not to be fitted, the difficulty should be effectively overcome.

On circuits without chopping, the X pulse in the forward clearing signal will be of 2 seconds' duration at all times, with consequent saving of circuit clear-down time on unanswered calls.

### OUTLINE OF OPERATION OF LATEST EQUIPMENT

#### General.

The system is a pulse signalling system using pulses of voice frequency tone, the frequencies used being the same as in the existing 2 V.F. system, i.e., 750 c/s (X tone) and 600 c/s (Y tone). Signalling is on a link-by-link basis, each trunk circuit being connected to the next by standard D.C. loop dialling conditions.

The following description details the system of signals for auto-auto circuits and for manual to auto working. In both cases, provision is being made for busying the circuits from the incoming end (test busy facility) when maintenance (routine) testing, etc., may be carried out.

#### Auto-Auto Working.

Considering auto-auto working (Fig. 1), when the outgoing relay set is seized a short pulse of X tone is sent to seize the incoming relay set and extend a loop to the first selector. Each digit received in the outgoing relay set is stored on an impulse regenerator and is retransmitted in the form of pulses of X tone after a delay of 800 mS minimum (corresponding to the preferred inter-train pause). At the incoming end the tone impulsing signals are converted into loop/disconnect impulsing to step the selectors. The use of a regenerator gives the best possible impulsing performance on the 2 V.F. circuit and makes it independent of preceding circuits. Regeneration at the outgoing end of the 2 V.F. circuit is also desirable in order that the less satisfactory impulsing performance of the early types of incoming equipment may be accommodated.

Due to the presence of the regenerator, there is a time delay between the seizure of a circuit and the transmission of digits. This time delay allows the incoming equipment to be fully seized, and in director areas is sufficient for an A-digit switch to be found, before any impulses are received at the incoming end. It is, therefore, not necessary for an operator to listen for a "pip" of 900 c/s tone when tandem dialling into a director system. For non-director working

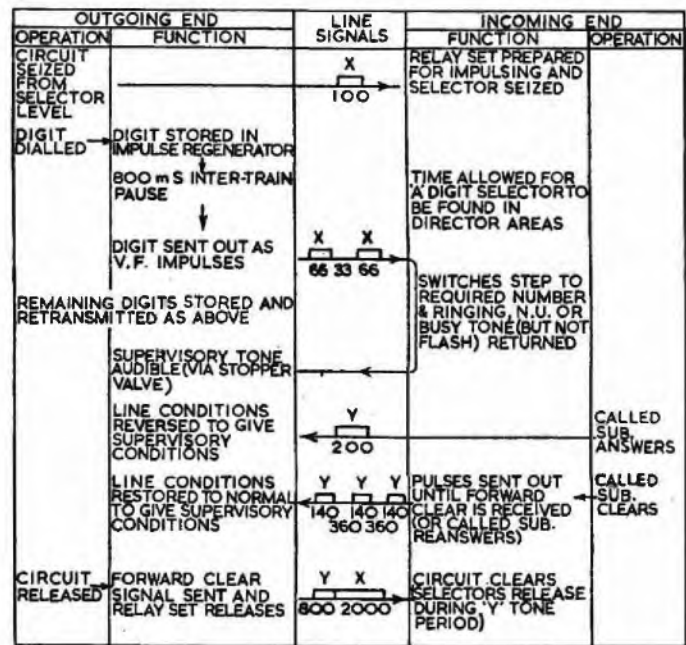

NOTE.—FIGURES GIVE TIMES IN MILLISECONDS.

FIG. 1.—OPERATION AND SIGNALS, AUTO-AUTO WORKING.

the regenerator output with its 800-mS minimum inter-train pause has the advantage of ensuring that at all group selector stages there is adequate time for rotary search for a free outlet and time to seize the succeeding switch (and fully energise its B relay). This is particularly useful on the 2 V.F. link itself, since the loop to seize the selector at the incoming end is not applied until the end of the 100-mS X pulse seizure signal, and seizure, therefore, takes some 100 mS longer than on a loop dialling auto-auto junction.

At the end of dialling, supervisory tones (ringing, busy or N.U.) will be returned, and heard via the stopper valve. When the called subscriber answers, a pulse of Y tone is sent back to the outgoing end where it reverses the battery and earth conditions on line wires to give supervision by dimming the originating operator's calling supervisory lamp.

When the called subscriber clears, a continuous succession of Y pulses is returned over the 2 V.F. link to restore the line wire conditions at the outgoing end to normal so causing the originating operator's calling supervisory lamp to glow. If the called subscriber should re-answer, the Y pulses are cut off, line conditions are again reversed and the originating operator's calling supervisory lamp is dimmed.

The call can be cleared down at any time by the originating operator withdrawing her plug and so disconnecting the loop holding condition to the outgoing 2 V.F. relay set. When the holding loop has been disconnected (and the B relay in the relay set has released) the forward clearing signal is sent out. This comprises a 2-second X pulse, followed immediately by a 800-mS Y pulse. The X pulse prepares the incoming relay set for release, and the Y pulse clears the connection by causing the disconnection of the forward holding loop. The Y pulse, by its 800-mS duration, also provides guarding time for clear-down of subsequent parts of the connection.

The timings of the X pulse and Y pulse, which, together form the clearing signal, are different from those used on the earlier equipment; in particular, the X pulse formerly had a duration of 6 seconds in the unanswered condition and 2 seconds in the answered condition, the 6-second duration being necessary to effect clear-down in the face of N.U. tone on circuits equipped with echo suppressors. It has now been decided to use the 6-second pulse only on circuits

actually equipped with echo suppressors and the outgoing relay set can be strapped to provide this length of pulse when required. A 2-second X pulse is used at all times on circuits not equipped with echo suppressors.

Speech conditions are established on the 2 V.F. circuit as with the existing 2 V.F. equipment.

*Manual to Auto Working.*

Referring to Fig. 2, it is seen that the signalling code

OUTGOING END		LINE SIGNALS	INCOMING END	
OPERATION	FUNCTION		FUNCTION	OPERATION
OPERATOR PLUGS INTO MULTIPLE	SUPERVISORY LAMP FLICKERS	X 100	RELAY SET PREPARED FOR IMPULSING AND SELECTOR SEIZED	
		IN DIRECTOR AREAS A PIP OF 900 c/s IS SENT BACK WHEN AN X-DIGIT SELECTOR HAS BEEN FOUND		
OPERATOR THROWS DIAL KEY	FLICKER CEASES	X X		
OPERATOR DIALS		66 33 66	SWITCHES STEP TO REQUIRED NUMBER. RINGING-NU OR BUSY TONE (NOT FLASH) IS RETURNED	
	SUPERVISORY TONE AUDIBLE (VIA THE STOPPER VALVE)	IN DIRECTOR AREAS A PIP OF 900 c/s TONE IS SENT BACK WHEN THE DIRECTOR CUTS OUT		
OPERATOR RESTORES DIAL KEY	SUPERVISORY LAMP GLOWS	Y		CALLED SUB. ANSWERS
	SUPERVISORY LAMP DIMS	200		
	SUPERVISORY LAMP GLOWS	Y Y Y 140 140 140 360 360	PULSES SENT OUT UNTIL FORWARD CLEAR IS RECEIVED (OR CALLED SUB. REANSWERS)	CALLED SUB. CLEARS
OPERATOR CLEARS		Y X 800 2000	CIRCUIT CLEARS SWITCHES RELEASE DURING Y TONE PERIOD	

NOTE.—FIGURES GIVE TIMES IN MILLISECONDS.

FIG. 2.—OPERATION AND SIGNALS, MANUAL-AUTO WORKING.

of manual to auto working is almost identical to that of the existing 2 V.F. equipment described previously and very similar to that of auto-working described above.

The insertion of a plug into the outgoing jack causes a short pulse of X tone to be sent out to seize the distant end. When dialling directly into a director system a short pip of 900 c/s tone will be returned to indicate when the incoming end is ready to receive dialled impulses. The operator then dials the required number and pulses of X tone are sent out to correspond with the break impulses from the dial. Supervisory tones are heard via the stopper valve until the call is answered or cleared down. In the director case a further pip of 900 c/s tone is heard when the director releases. When the called subscriber answers, a pulse of Y tone is returned to dim the operator's calling supervisory. When the called subscriber clears, a succession of Y pulses is returned and the supervisory glows again. The operator, withdrawing her plug, causes the forward clearing signal comprising 2 seconds of X tone followed by 800 mS of Y tone to be sent out to clear the circuit down.

*Test Busy Facility.*

When it is desired to test the equipment at the incoming end of a circuit it is necessary first to busy the outgoing end so that the circuit is not seized by normal traffic whilst testing is in progress. On the existing 2 V.F. system such busying must be done manually (e.g. by plugging up the circuit) at the outgoing end. On the new equipment it is arranged that the circuit can be busyed from the incoming relay set. When the outgoing end has been made to test

busy in this way the equipment at the incoming end may be removed or tested in situ as required. On the removal of the busying condition from the incoming relay set, signals are sent to remove the busy condition at the outgoing end which then sends a forward clearing signal to release the circuit in the normal way. It will be appreciated that the test busy facility is only available when the new type of equipment is fitted at both ends of the circuit.

In Fig. 3, the arrangement of signals used to provide the

OUTGOING END		LINE SIGNALS	INCOMING END	
RELAY SET FUNCTION			RELAY SET FUNCTION	OPERATION
OUTGOING END IS MADE TO TEST ENGAGED AND A CLEARING SIGNAL IS SENT FORWARD TO THE INCOMING END		Y Y Y 140 140 140 360 360	PULSES ARE SENT OUT UNTIL A FORWARD CLEARING SIGNAL IS RETURNED	MAIN-TENANCE OFFICER PUTS A BUSYING CONDITION ON AN INCOMING LINE
		Y X 800 2000	AT THE END OF THE FORWARD CLEARING SIGNAL A PULSE IS SENT TO THE OUTGOING END TO BUSY IT PERMANENTLY. THEN A START CONDITION IS OFFERED TO THE TESTER	LINE IF NO FREE COMES FREE FOR TEST WHEN CALL IN PROGRESS RELEASES
BUSYING PULSE RECEIVED WITHIN THE RELEASE GUARD PERIOD FOLLOWING THE FORWARD CLEAR LOCKS THE OUTGOING RELAY SET IN AN ENGAGED CONDITION		Y 500		RELAY SET AND V.F. RECEIVER MAY BE REMOVED OR TESTED AS REQUIRED
RELAY SET RELEASES NORMALLY SENDING OUT A FORWARD CLEARING SIGNAL AND THEN TESTING FREE AFTER A FURTHER RELEASE GUARD PERIOD		Y Y Y 140 140 140 360 360	PULSES SENT OUT UNTIL FORWARD CLEAR IS RETURNED	MAIN-TENANCE OFFICER REMOVES THE BUSYING CONDITION
		Y X 800 2000	RELAY SET RESTORES TO NORMAL	

NOTE.—FIGURES GIVE TIMES IN MILLISECONDS.

FIG. 3.—OPERATION AND SIGNALS, "TEST-BUSY" FACILITY (FOR MAINTENANCE TESTING).

test busy facility is indicated. As mentioned earlier, there is a standard "repeat clear" feature on the existing equipment by virtue of which, should the backward clearing signal (pulses of Y tone) be received in an outgoing relay set in an unseized condition, the irregular condition (incoming end seized but outgoing end not seized) will be recognised and repeated forward clearing signals will be sent until the incoming end releases and the backward Y tone pulses cease.

The test busy facility is obtained by the use of the repeat clear feature. When the busying condition (earth on the P wire) is applied at the incoming end, pulses of Y tone (the same as used for the backward clearing signal) are sent to the outgoing end which becomes temporarily engaged and sends out the forward clearing signal (2 seconds of X tone followed immediately by 800 mS of Y tone). This signal causes the incoming end to disconnect the Y tone pulses. However, at the end of the forward clearing signal a single 500-mS Y tone pulse is sent from the incoming end to lock the outgoing relay set in an engaged condition. To be effective this Y pulse must be received within the release period of certain relays in the outgoing relay set which release at the end of the forward clearing signal.

When the busying condition is removed from the incoming end, the routine test relays will release and again call pulses to be sent to the outgoing end. This will again cause the sending of a forward clearing signal which will disconnect the Y tone pulses and clear the circuit down in the normal manner.

(To be continued)



U.D.C. 620.197.5:621.315.23

Small-scale experiments have been conducted by the Post Office during the past few years in the application of cathodic protection to underground cables. This article outlines the principles of this system of protection, gives a brief account of its practical application and mentions the precautions necessary to avoid damage to plant operated by other undertakings.

## Introduction.

A STUDY of the statistics prepared periodically, and relating to cable-sheath faults and their causes, reveals that the largest single cause is corrosion. For main underground cables, over 40 per cent. of all faults which have occurred since 1940 have been due to corrosion. In the year 1949/50 the total number of failures on all types of cables from this cause was 3,616, the cost of renewal amounting to nearly £300,000, as compared, for example, with 2,135 cases in 1938/39, costing approximately £60,000.

Even allowing for increased cable mileage, and for the higher material and labour costs which obtain to-day, it is apparent that measures taken in the past have not succeeded in reducing the extent of failure arising from corrosion and the steadily rising annual cost demands that a greater study of the subject be made to reduce this expense. The costs given above do not include loss of revenue due to lost circuit time, costs incurred in diverting and restoring circuits, or increased operating costs due to routes being thrown into delay, and if these are also totalled it may well be that the true cost would be nearly doubled.

In the past, apparatus faults were the major cause of lost circuit time, but with the present higher standard of equipment maintenance, lost time due to cable faults assumes a greater importance, and it therefore follows that if the methods described later do, in fact, bring a large-scale reduction in the corrosion rate of both main and local cables the telephone service as a whole will be greatly benefited.

## Present Methods of Protection.

The two most common methods of protection in this country at present are the use of insulating gaps and the use of a protective covering over the lead sheath. The former method is generally applied only in areas where it is known that the corrosion is mainly due to leakage currents emanating from a neighbouring D.C. traction system. The gradual changeover from tramways to trolley or motor buses has greatly reduced the number of failures due to corrosion arising directly from this cause, but the development of electrified railways may necessitate an increased use of insulating gaps, possibly augmented by electrical drainage, either direct or forced. This method has been previously referred to in this Journal<sup>1</sup>, and it is not proposed to repeat the details.

The second method of protection, i.e. the use of protective coverings over the lead sheath of the cable, is the one used in areas remote from D.C. traction systems in which the corrosion is normally considered to be due to "natural causes." The use of protected cable has three main disadvantages which can be briefly summarised as follows:—

- (a) Protecting a cable increases the cost by 5 per cent. to 10 per cent. depending on the diameter.
- (b) The increased diameter reduces the available cable capacity of the duct and increases the difficulties of rodding and drawing over.

- (c) The renewal of a length of cable by a protected cable, following a corrosion fault, does not materially reduce the fault liability of the cable as a whole. It will only prevent a further failure in the renewed section, and the remainder of the cable remains exposed to attack. The seriousness of this is apparent when it is realised that the cable network as a whole is valued at something more than £70 million, and of this probably less than 5 per cent. is protected.

If, therefore, a method can be used whereby the existing unprotected cables as well as new cables as they are laid, can be safeguarded against corrosion, a considerable saving in cable maintenance costs can be achieved.

The following method, known generally as Cathodic Protection, has been in use for many years in other countries but has only been used in this country, on a small experimental scale, for about 5 years. The results to date, however, are promising and justify a more extended use.

## Cathodic Protection.

As is well known, electrolytic corrosion occurs when a current from a metallic anode passes to a cathode via an electrolyte. This is the condition which occurs in the vast majority of corrosion faults on Post Office cables. The lead cable sheath constitutes the anode at points where it is at a higher potential than the surrounding earth and the current passes to the earth via the water or moisture in the duct, which forms the electrolyte. The sources of the sheath currents are various but, in general, the magnitude is small, usually of the order of 10-20 milliamps. The importance of these small currents, however, lies in the fact that they flow continuously. It must be realised that a current of 10 milliamps discharging from a cable for one year, will remove 0.75 lb. of lead, and that in practice this loss is not uniformly distributed, but occurs in restricted areas of the sheath where it is anodic to the surrounding earth.

The principle of cathodic protection is to apply a protective negative potential to the cable sheath so that it becomes cathodic to the surrounding earth, by which means the flow of current from the sheath to earth is suppressed or reversed. The two common methods in use for supplying the necessary potential are:—

- (a) Reactive anodes (magnesium alloy).
- (b) Mains-driven rectifiers.

and each has its own characteristics and field of application. The decision as to which method will be employed is taken after a careful study of the exchange area corrosion records. No hard and fast rules can be laid down for the treatment of areas by either method. The limiting condition in each case is the size of area or length of route to be protected with respect to the point of application of the negative potential.

When a potential is applied at a point and measurements are made along a cable route, it will be found that the potential varies according to an exponential law, modified by changes in the environment; that is a very rapid decrease takes place immediately away from the point of application, but the decrease reduces as the distance increases. Mains-driven rectifiers have an advantage over

† Senior Executive Engineer, External Plant and Protection Branch, E.-in-C.'s Office.

<sup>1</sup> "The Leakage of Direct Current and Potential Gradients in the Ground," P. B. Frost. *P.O.E.E.J.*, Vol. 43, p. 126.

reactive anodes because their output can be increased at will, and the distance over which the protective potential is effective is consequently increased, but this feature must be used with care because too high a negative potential may cause cathodic corrosion near the point of application, especially in a saline electrolyte.

*Cathodic Protection Using Reactive Anodes.*

Before proceeding to the application of protection by reactive anodes, it would be as well to explain what is meant by the term reactive anode. All metals when immersed in a "normal" solution, acquire what is known as a normal electrode potential when measured against a constant reference electrode. A "normal" solution is a chemical solution containing one gram equivalent of the solute in each litre of solution.

TABLE I

*Normal Electrode Potentials of the Common Metals Referred to a Standard Hydrogen Electrode\**

Metal	Volts
Magnesium	+2.375
Aluminium	+1.67
Manganese	+1.0
Zinc	+0.7620
Iron	+0.44
Nickel	+0.25
Tin	+0.136
Lead	+0.126
Hydrogen	0
Copper	-0.3448
Silver	-0.7995
Platinum	-1.2 (about)
Gold	-1.42

↓ Current passes through the electrolyte in this direction

Table I shows the normal electrode potentials of the common metals, and it will be seen that they differ considerably from each other and about the datum line, in this case, a hydrogen electrode. For lead, the metal in which we are most interested, the normal potential is +126 millivolts when measured in a normal solution at a temperature of 18°C. In practice, however, the lead cables do not lie in a normal solution, and the above potentials are modified both by the composition of the electrolyte and the temperature. These modified potentials are called the equipotentials, and the object of cathodic protection is to reduce the potential acquired by the metal to a value negative to its equipotential value. These potentials can only be measured accurately, using high-grade apparatus, e.g. non-polarisable electrodes and valve-voltmeters, but in the field, it is generally sufficient to measure the potential between the cable sheath and a lead-earth electrode using a high-resistance voltmeter, e.g., Voltmeter No. 26 or a valve-voltmeter. This value will be termed the "overpotential," and assumes that the equipotential of the lead-earth electrode and the lead sheath are the same. To allow for inaccuracies in tests, it is estimated that if the overpotential can be reduced to -100 millivolts, adequate protection will be afforded to the cable.

To obtain the necessary potential, we select a metal which is anodic to the metal to be protected. Referring back to Table I, lead is the metal we wish to protect and a magnesium alloy, made up into a billet, is selected to form the anode.

The P.D. between pure magnesium and lead in a normal solution is 2.249 V, but in practice, using magnesium alloy, and when natural soils form the electrolyte and oxides are present on the surfaces of the metals, the maximum P.D.

obtained is about 1.1V. The anode is buried in the soil and connected to the cable by an insulated wire. A cell is thus formed and current flows from the anode through the earth to the cable, returning along the cable sheath and the insulated wire to the anode. It will be seen, therefore, that within the effective range of the anode, the direction of current flow is from earth to the cable sheath and under this condition electrolytic corrosion will not occur.

Fig. 1 shows the equivalent circuit of a reactive anode connected to a cable.

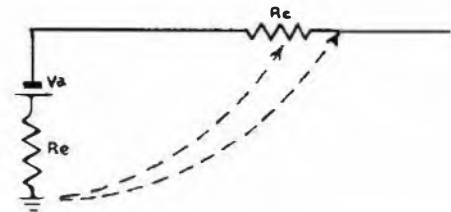

FIG. 1.—EQUIVALENT CIRCUIT OF REACTIVE ANODE CONNECTED TO CABLE.

The reactive anode of magnesium and the lead sheath are shown as being replaced by a cell of voltage  $V_a$ .  $R_c$  is the combined resistance of the lead sheath to earth, and is usually of the order of 1 ohm or less. The resistance  $R_e$  is the total resistance of the anode to the surrounding earth and is, of course, dependent on the volume resistivity of the earth at that point. In soil of fairly low resistivity, e.g. 1,000  $\Omega$  cms, the resistance  $R_e$  will be about 10 ohms, and it will be readily seen, therefore, that most of the available E.M.F. is used for driving the current from the anode into the soil.

The anode itself consists of a cylindrical billet of magnesium alloy, 4 in. diameter and 20 in. long, cast round a steel bar, to which is joined the insulated copper wire tail. The point between the steel rod and the copper tail is sealed in polythene to prevent corrosion at this point due to a local cell action between the steel, copper and magnesium (see Fig. 2).

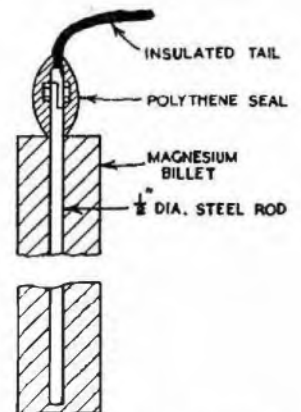

FIG. 2.—CONSTRUCTION OF REACTIVE ANODE.

The resistance of the anode to earth can be reduced by the addition of sodium chloride (common salt) to the soil when burying the anode, and the curves in Fig. 3 show the

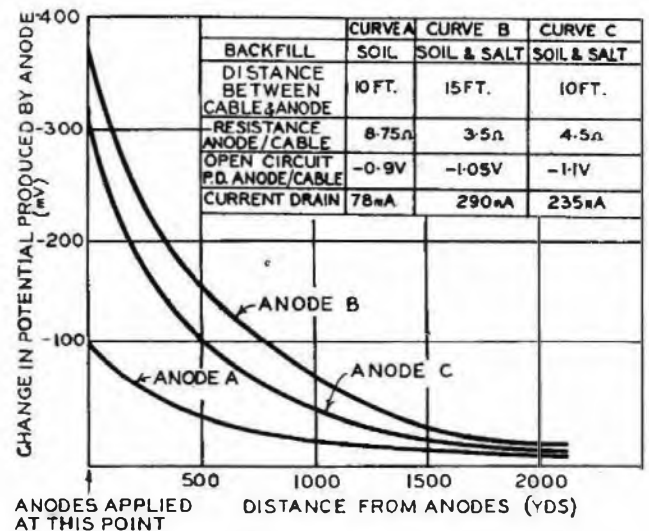

FIG. 3.—RESULTS OF TESTS AT WOOTTON BASSETT.

\* See "An Introduction to Metallic Corrosion" by U. R. Evans.

actual results of tests carried out at Wootton Bassett, near Swindon. The cable was a 60 pr./20 lb. Q.T. cable of 1 in. diameter, laid in a 4-in. earthenware duct, and tests were made to determine the effect of salting the earth round the anode and also the effect of varying the distance between the anode and the point of connection to the cable. The curves show the actual change of potential at points along the cable. Although the salt reduces the resistance of the anode to earth and increases the distance over which it is effective, it does also increase the local action on the surface of the anode and so adds to the corrosion to which it is subjected in its useful function in the electrolytic cell.

The method to date for installing magnesium anodes has been to use a back-fill composed of a slurry of bentonite clay and gypsum. The bentonite clay has good moisture retaining properties and maintains the conductivity of the back-fill. The gypsum (calcium sulphate) provides a sulphate electrolyte which reduces the rate of local action (as distinct from useful corrosion) on the surface of the anode. As most soils in this country are normally moist, consideration is being given to dispensing with the bentonite clay.

It might be asked at this stage why aluminium, a cheaper and more commonly-used metal, which is close to magnesium in the potential scale should not be used instead. The reason is that when acting as an anode it rapidly polarises and an oxide film forms on the surface thus increasing the contact resistance with earth and reducing its efficiency. A depolariser in the form of a magnesium oxy-chloride cement packed round the anode, will prevent the formation of this film, but a large quantity is required for each anode. An aluminium anode of the same dimensions as for magnesium, with depolariser, would measure 12 in. diameter  $\times$  24 in. long, with consequent increases in installation costs.

The typical curves shown in Fig. 3 relate to a single cable in a duct. Assuming that the normal potential of the cable to a lead-earth electrode, i.e. the overpotential, is generally less than +100 millivolts, a potential change of -100 millivolts would theoretically make the cable safe. Under the best condition, shown by the curve for anode B, protection would be given for a distance of about 850 yds. on each side of the point of application. This, however, is an unusual case and very different results are obtained when connecting anodes to more complicated networks. For instance, at Crosshands, near Carmarthen, two magnesium anodes in parallel were connected to 3 moderate size cables. The potential change at the point of connection was -120 millivolts, but at the next jointing point, 176 yds. away, the change was only -40 millivolts. Similarly, at Wootton Bassett, on a route containing 4 cables, the respective potential changes due to one anode were -80 millivolts at the point of application and -10 millivolts 176 yds. away. It is necessary, therefore, in protecting such a route having several cables, to site the anodes at the point where the corrosion is known to occur, or if it is required to protect a long route of this type, the anodes should be connected at each jointing point. This has the added advantage that the depression of the potential at a point due to the adjacent anodes reduces the current drain measured in each anode lead. For instance, at Wootton Bassett, on the route containing 4 cables, two anodes in parallel were connected to the cables at each jointing point. Individually, the current drained by each pair of anodes was about 325 milliamps, but when all the points were connected, the drain in each lead was reduced to 225 milliamps. This is important as the life of the anodes is directly proportional to the current. In practice, therefore, the objects will be to reduce the overpotential of the cable sheath to a negative value and at the same time limit the current output from each anode to about 100 milliamps.

Under these conditions, a magnesium anode of the size given should have a useful life of at least 10 years. In effect, any tendency to corrosion is transferred from the cable sheaths to the anodes which can be renewed at the end of their useful life.

#### Cathodic Protection Using Mains-Driven Rectifiers.

It will be seen from the previous text that because of their limited range reactive anodes can best be used for the treatment of isolated cases or, if installed at fairly close intervals, for the protection of a single route in which there are not more than, say, four cables. It frequently occurs, however, that corrosion failures are grouped in the vicinity of the telephone exchange itself and may be largely due to P.B.X. and junction signalling currents. The aggregate of these currents varies in magnitude as the exchange traffic varies, but it is unidirectional, i.e. it flows out from the exchange on the cable sheaths which are bonded to the exchange earth and to the positive pole of the battery. Because of the density of the cable network near the exchange reactive anodes would not have a useful range. Furthermore, siting the anodes in a built-up area presents difficulty.

To extend the area of protection, the applied potential must be increased, and the simplest method is to use a mains-driven rectifier connected between the exchange earth and the cable sheath network as shown in Fig. 4.

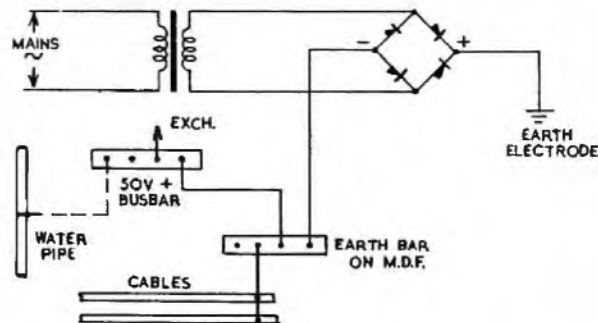

FIG. 4.—CIRCUIT ARRANGEMENT FOR CATHODIC PROTECTION BY MAINS-DRIVEN RECTIFIER.

Unlike the case of reactive anodes, the source of the potential is not sacrificed; but the corrosion is transferred from the cables to the earth electrode system, and the condition of this must be periodically verified. The rating of the rectifier must be sufficiently high to produce the required potential drop at the ends of the system to be protected and also to provide the heavier current resulting from the higher P.D. applied between the cable and the earth electrode.

The equivalent circuit is similar to that shown in Fig. 1, but  $V_a$  is replaced by the rectifier output voltage and  $R_e$  is replaced by the resistance to earth of the earth electrode system. Usually it will be found that the resistance to earth of the cable system will be of the order of 0.5 ohm, and with present methods of construction the resistance of the earth electrode will be between 2 and 8 ohms. Again, therefore, the greater part of the E.M.F. is used to drive the current into the earth, and for maximum efficiency a low earth electrode resistance is necessary. It must also be remembered that the protecting current is discharged into the soil from the electrode which is therefore corroded away at a rate proportional to the value of the current, and a substantial mass of metal is desirable to avoid frequent replacement. The output from the rectifier unit is controllable, and the resistance to earth of the cable network remains reasonably constant, although a small cyclic variation between summer and winter seasons has

been observed. A periodical check of the current in the earth lead will, therefore, indicate the condition of the earth electrode system.

It has been found from experiments in the field that the maximum distance which can be covered, i.e. in which the cables are depressed to a potential of  $-100$  millivolts to earth, by a rectifier installed at the exchange, is about 2 miles. The more dense the cable network in the vicinity of the exchange, the higher the current drain from the cables, and the higher the P.D. which must be applied from the rectifier, but this does not greatly influence the P.D.s at the boundary of the protected area. Too high a negative potential at the point of application may result in cathodic corrosion occurring, and although the conditions which may cause this cannot be defined precisely as they depend to some extent on the nature of the subsoil, it has been decided tentatively that in no case should it exceed 8 volts.

When using mains-driven rectifiers on a large cable network the higher P.D.s involved, especially near to the point of application, introduce a complication which need not be considered when using reactive anodes. The P.O. are not the only users of the ground under the roads and footpaths, and other undertakers' plant—electricity cables, gas and water pipes, etc.—may also be present and in proximity to the cables being protected. The current fed out from the earth electrode may, in its path through the earth, travel along the sheath or pipe of another service, and then leave it at a point where it comes near to the P.O. cables, which will be at a more negative potential. Corrosion may then occur on the other services, and the protection of P.O. plant may result in damage to other

undertakers' plant. It is always necessary, therefore, to ascertain the position of other plant in the ground, and in by tests it is shown that dangerous conditions are set up on such services, then they also must be embraced in the protection scheme. In the first three installations carried out as field trials it was found necessary to include the water pipes in the protection scheme. In each case the water pipe had previously been connected in parallel with the exchange earth electrode system, and had it been left so connected, the current from the rectifier would have been fed out mainly over the water pipes as their resistance to earth was lower than that of the electrode system. Early failure of the water pipes would inevitably have occurred but to prevent this, the bond from the water pipe was transferred to the positive bus bar as shown in Fig. 4, and is now protected with the cables.

#### *Conclusion.*

While the main interest for the P.O. is the use of cathodic protection as a means of preventing corrosion on lead-covered cables, it can be applied to all types of buried metallic installations and many gas, water and oil engineers are now turning their attention towards it for the protection of buried pipes and tanks.

#### *Acknowledgments.*

In writing this article, the author expresses his thanks to Mr. J. R. Walters for his many helpful suggestions and to Mr. J. F. Keep who has carried out much of the investigation work in the field.

## **Book Review**

"Telecommunications Principles." R. N. Renton, A.M.I.E.E.  
Sir Isaac Pitman & Sons, Ltd. 450 pp. 672 ill. 37s. 6d.

The basic theory of magnetism and electricity, with which the young telecommunications engineer must start his training, has been admirably presented by many authors in forms suitable for students. So, also, have the many specialist and advanced sections of electronics and transmission theory. But hitherto there has been no single publication generally available to which a student studying for, say, the Intermediate Certificate in Telecommunications of the City and Guilds of London Institute could be referred for sound practical background allied to theory. This gap in the literature has now been admirably filled by Mr. Renton. In one large volume he has given a systematic and readable account of all the aspects covered by the C. & G. syllabus for Grades 1, 2 and 3 of the Telecommunications (Principles) examinations. In general, his methods of presentation are orthodox and of the type normally taught in the technical colleges dealing with this subject. The great importance of making the student use his newly acquired knowledge by applying it has been stressed, and the text is very liberally interspersed with fully worked examples taken from past City and Guilds examination papers. So many have been included that students may have difficulty in discovering for themselves any fresh examples in the past papers, on which they can try their own skill! There is no doubt, however, that students will benefit from this juxtaposition of descriptive matter and practical illustration.

The author of a book of this nature is faced with the difficulty of deciding on the standard of mathematical analysis he is going to adopt. It is a regrettable fact that many telecommunications students still regard mathematics as an evil to be dodged where possible, rather than an essential tool to be frequently tempered and sharpened. Mr. Renton has decided, from his own experience, that the book will perform a greater service to the student by leaning away from mathematics where possible. He has therefore avoided using any calculus

in the text, even in simple form, except for one or two quotations which are then explained in an appendix. As if to atone for this, he has made a very thorough presentation of vectors applied to A.C. circuitry and has included "graphical," "pythagoras" and "j" types of network solution among his many worked examples from past papers.

A brief survey of the coverage of the book may be of interest to those not acquainted with the City and Guilds syllabus. The book opens with an interesting chapter on modern views of atomic and molecular structure. The next six chapters may be said to cover elementary magnetism and electricity, with a large amount of practical and descriptive matter interspersed with worked examples. D.C. motors and generators are well explained in Chapters 8 and 9, and simple methods of testing the performance of these machines are included. Chapter 10, probably the most important in the book, covers elementary A.C. theory. Chapter 11, entitled "A.C. Transmission," gives a brief analysis of the equivalent circuits of lines, transformers and simple filter networks; the treatment is necessarily sketchy, but it is presented in a manner which makes it interesting and easy to follow. Chapter 12, on Measurements, contains a survey of the electrical measuring instruments in common use and the standard types of A.C. bridge circuits likely to be met in telecommunications practice. Valves, with the common applications to amplifiers, oscillators and modulators, are covered in Chapter 13. Chapter 14, entitled "Sound," contains a curious mixture ranging from telephone ear pieces and the human ear, to quartz crystals and a brief description of a crystal filter.

Six appendices giving various things which engineers often wish to know but can seldom find—such as the relation between equivalent electrical units, standard graphical symbols for telecommunications and the Greek alphabet—are included, together with the syllabus of the City and Guilds of London Institute examinations in telecommunications.

The book is excellently bound and printed on high-quality paper and reflects credit on the author and publishers alike.

C. F. F.



# A Subscriber's Battery-Operated Single-Channel V.H.F. Radio-Telephone Equipment

J. H. H. MERRIMAN, M.Sc., A.Inst.P., A.M.I.E.E.,  
R. HAMER, A.M.I.E.E., and  
B. R. HORSFIELD, A.M.I.E.E.†

U.D.C. 621.396.5

This article describes experimental equipment operating in the 70-90 Mc/s range, using phase modulation and powered by primary batteries, which, together with signalling units, provides a duplex radio channel for connection in a subscriber's line circuit. The characteristics of this equipment which make it suitable for providing telephone service to isolated communities are explained and mention is made of the performance obtained on experimental links using such equipment.

## Introduction.

THE provision and maintenance of telephone service to isolated communities presents a combination of technical and economic problems not usually encountered in those parts of the country where telephone plant density is relatively high. Examples of such isolated communities in the U.K. are islands off the north-west coast of Scotland, remote hill farms in the Yorkshire dales, or groups of crofters separated from the normal flow of mainland life by a loch. Under such circumstances, the provision of telephone service by normal methods presents difficulties, both in construction and maintenance, whether by overhead pole route or by underwater cable. Accordingly, in 1935, a simplex V.H.F. radio system<sup>1,2</sup>, over which telegrams could be dictated at prearranged times, was developed to link such localities to the nearest convenient point on the mainland. A number of these links have been installed, and have given excellent service over a long period; but, in 1946, it was felt desirable to develop equipment which would improve and extend the service, and enable such communities to be linked with the inland trunk network.

There are, however, factors which are peculiar to the problem of maintenance of any form of telephone plant in such localities. Because of the low plant density, the maintenance base must, of necessity, be far distant, and the time spent in travelling is quite disproportionate to the time spent at work. Because of remoteness, there is usually no public power supply in these localities. Therefore, not only must the telecommunication plant be capable of operating independently of any public power supply, but it must also do so for long periods without attention. This combination imposes many restrictions upon the equipment design, and it is the purpose of this article to describe recently-developed equipment in which not only are these restrictions overcome, but the facilities offered by the earlier 1935 equipment are considerably expanded and, in fact, enable the radio link to be integrated with the inland network.

In considering the fundamental design of the system, it was postulated that the equipment would have to satisfy the following two basic requirements:—

1. That it should be suitable for connection as a subscriber's or kiosk line to any type of exchange.
2. That it should be suitable for operation without maintenance attention for not less than three months.

It was appreciated that the provision of a reliable and economical power supply was one of the major design factors, and a large number of possible forms of power

supply, ranging from thermopiles and weight-driven generators to wind-driven generators, were considered. Experiments with a number of possible operating frequencies and forms of modulation were carried out, and eventually it was decided to develop radio equipment operating in the 70-90 Mc/s frequency range, using phase modulation and powered by primary batteries. Economic considerations, together with the need to operate from primary batteries, required the use of a very low-power transmitter and the acceptance of a relatively low value of signal-to-noise ratio. The equipment was therefore designed to yield an output signal-to-noise ratio of not worse than 30 db. over a link of up to about 25 miles on routes with clear and unobstructed radio paths between the terminals, preliminary examination having shown that this would be satisfactory for most of the applications foreseen in the U.K.

For U.K. installations using the type of equipment to be described, it can be shown that the length of route at which line costs are equal to radio costs on an annual charge basis is between 5 and 10 miles for a line route of average construction. The use of radio for spanning a shorter distance would often provide a more economical solution, as, for example, in routes involving submarine or subaqueous cable, the blasting of pole-holes, etc., where construction costs are well above the average. In fact, in certain cases, where the type of conditions render the use of submarine cables impracticable, radio offers the only possible means of providing service, again emphasising the fact, however, that an unobstructed radio path is necessary.

## DESCRIPTION OF EQUIPMENT

### General.

The radio-telephone equipment permits a duplex radio channel with complete signalling facilities to be included in a subscriber's line circuit. Each radio link requires two transmitters, two receivers and two signalling units, with associated power supplies, as shown in the block schematic diagram, Fig. 1.

The equipment has been designed to operate unattended in unheated accommodation, and power economy has been a dominating factor in the design. Although power supply units operating from A.C. mains or exchange secondary batteries have also been developed, the circuit design of the transmitter and receiver has been governed by the need for them to operate for several months from primary batteries of reasonable size. This has been achieved by the use of miniature valves of extremely low total power consumption and by arranging that in the absence of traffic, the receiver is not continuously operated, but is only momentarily energised at half-minute intervals to test for the presence of an incoming calling signal; similarly, the transmitter is energised only when a local calling signal is applied to it. A relay timing circuit contained in each signalling unit performs the function of switching the

†The authors are, respectively: Senior Executive Engineer, Engineer-in-Chief's Office (Radio Planning and Provision Branch); Executive Engineer (Radio Exper. and Dev. Branch); and Executive Engineer (Telephone Dev. and Maint. Branch).

<sup>1</sup>"The Introduction of Ultra-Short-Wave Radio Links into the Telephone Network." A. H. Mumford and D. A. Thorn. *P.O.E.E.J.*, Vol. 31, p. 93.

<sup>2</sup>"Ultra-Short-Wave Radio Telephone Circuits." D. A. Thorn and H. T. Mitchell. *I.P.O.E.E.* Paper No. 158.

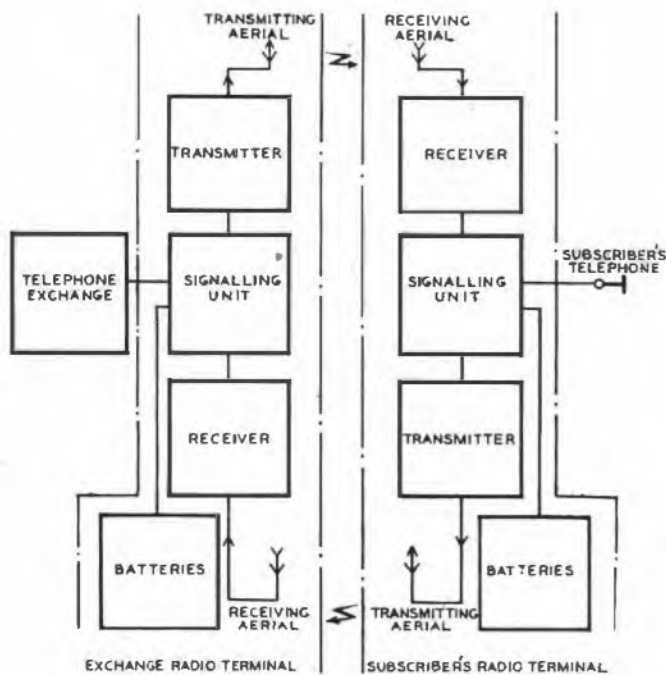

FIG. 1.—BLOCK SCHEMATIC DIAGRAM OF THE RADIO LINK.

L.T. supply to its associated receiver, for approximately two seconds every half-minute, with the H.T. supply permanently connected. Each radio receiver is provided with a high-speed polarised relay, which operates in the presence of a radio carrier signal from the remote terminal. The short switching period is sufficient to cause this relay to operate and hold the receiver permanently energised when a calling radio signal is present. The setting up of a call over the radio link may thus be delayed by up to 30 seconds by the intermittent receiver operation, and the effects of this delay are discussed later.

The internal equipment required for a single terminal is shown in Fig. 2. The transmitter, receiver and signalling units are contained in hermetically sealed cast aluminium cases, each approximately 17 in. × 8 in. × 7 in., fitted with silica-gel desiccators. Fig 3 shows the chassis construction of two typical units. H.T. batteries are contained in a separate hardwood box which also serves as a connecting point for the 1.5-V L.T. and 24-V signalling batteries which are mounted separately.

#### Facilities Provided.

The equipment is suitable for providing a subscriber's connection to any telephone exchange (manual or automatic) utilising loop signalling and standard A.C. ringing—either loop or earth return ringing. It is not suitable, however, for working into automatic exchanges which do not provide dialling tone, neither is it directly workable into magneto exchanges, although this is possible by converting to loop signalling, as, for example, is done when certain house exchange systems are connected to magneto exchanges. Party line working is possible, provided the "X" or "Y" ringing facility is reserved solely for the radio link. It is also possible to use the radio equipment to connect

a public call office, either directly or in conjunction with an extension system; pre-payment working is obtained when connected to an automatic exchange, but post-payment working only is possible on manual exchanges.

Owing to the fact that the radio receivers are energised intermittently to conserve the batteries, a delay of up to

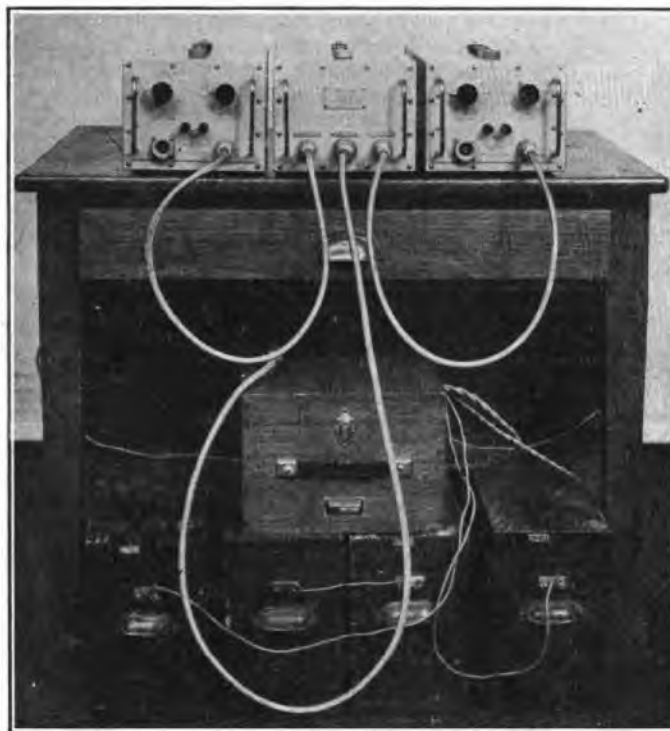
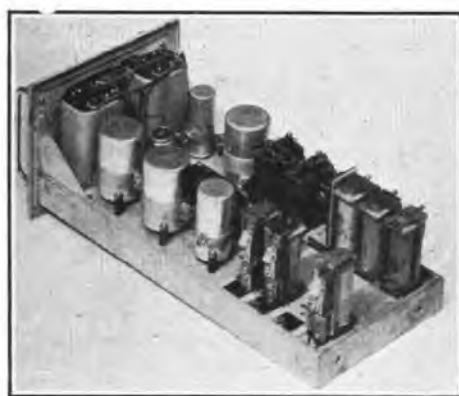

FIG. 2.—EQUIPMENT FOR A COMPLETE RADIO TERMINAL STATION.

half a minute may occur in calling the exchange; similarly, a delay of the same order may occur between the application of exchange ringing and the ringing of the subscriber's bell. The average delay in each case is about a quarter of a minute and has not been found to cause inconvenience.

#### Transmitter.

The transmitter (Fig. 4) is crystal-controlled and phase-



(a)

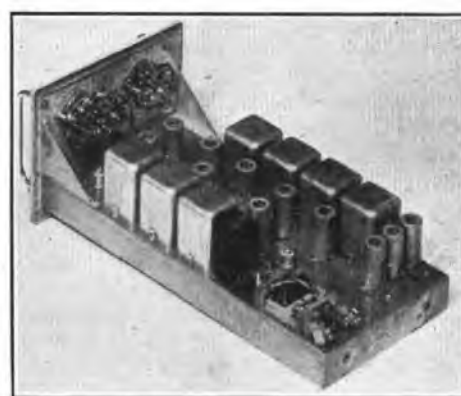

(b)

FIG. 3.—CHASSIS OF TYPICAL UNITS. (a) SIGNALLING UNIT WX2; (b) RECEIVER WX21.

modulated, and preset tuning capacitors enable any carrier frequency in the range 72-87 Mc/s to be used. The output power varies with the H.T. battery voltage, and lies in the range 15-50 mW, with a nominal output impedance of 75 ohms unbalanced. The modulation input level required to produce the full deviation of  $\pm 10$  radians is -24 db., relative to 1 mW. The maximum equivalent

frequency deviation will occur at the highest modulating frequency of 3.0 kc/s and is  $\pm 30$  kc/s.

The use of phase modulation (P.M.), rather than frequency modulation (F.M.), enables direct crystal control of the transmitted frequency to be achieved without the use of an auxiliary automatic frequency control system and thereby enables maximum economy of battery power consumption in the transmitter. Whilst similar economy of power consumption can be achieved by use of direct frequency modulation of a crystal oscillator, the low mutual conductance of the battery type of valves used does not allow sufficient frequency deviation to be generated without at the same time lowering the effective Q-factor of the crystal to such a value that the mean frequency stability suffers.

The transmitter uses valves type CV 1758 (prototype 1L4), in all stages and, apart from the modulator, is orthodox in design. The crystal oscillator operates at one twenty-seventh of the carrier frequency, the large amount of frequency multiplication being necessary to achieve the required deviation. For transmission of signalling intelligence, e.g. calling, clearing, dialling, etc., "on-off" modulation of the carrier signal is used, and this is achieved by earthing the screen grid of the first tripler valve when the carrier is to be suppressed.

#### Receiver.

The receiver (Fig. 4) is of the superheterodyne type, with an intermediate frequency of 3 Mc/s and a crystal-controlled local oscillator. Preset tuning capacitors are used in the oscillator and R.F. stages covering a signal frequency range of 72-87 Mc/s. Valves, type CV 1758, are used in all stages except the detector/audiot amplifier stage, in which a diode-pentode, CV 784 (prototype 1S5), is used. The following features of the receiver are of interest:—

- A germanium crystal diode is placed in the grid circuit of the limiter valve to improve limiting.
- A single de-tuned LC circuit is used as a frequency discriminator, adequate linearity being obtained with simplicity of adjustment.
- An equaliser follows the detector, to convert the frequency discriminator into a phase discriminator. (The equivalent frequency deviation of a phase modulated signal is directly proportional to the modulating frequency.)
- The grid of the limiter valve is connected to the grid of a D.C. amplifier valve, in the anode circuit of which is placed one winding of a polarised relay. (The other winding of the relay is provided with a fixed bias by being included in the anode circuit of the R.F. amplifier valve.) The circuit is arranged so that when a carrier signal is received which is sufficiently strong to produce limiting, the negative voltage developed at the grid of the limiter is sufficient to cut off the anode current of the D.C. amplifier. The relay, therefore, responds to the presence or absence of a carrier signal and two change-over contacts are provided which are extended to the appropriate signalling unit to function as circuit holding and line-impulsing contacts.

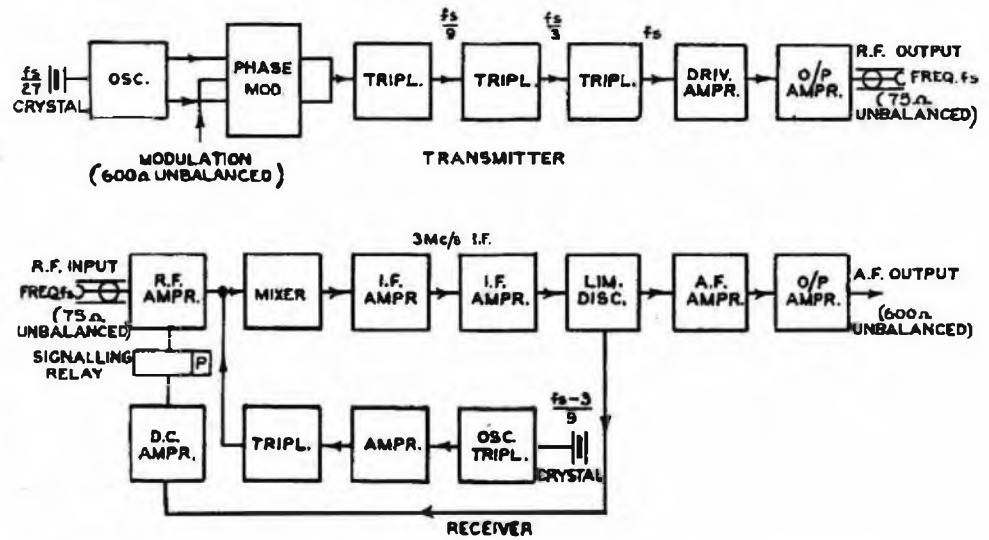

FIG. 4.—BLOCK SCHEMATIC DIAGRAMS OF TRANSMITTER AND RECEIVER.

#### Signalling Units.

The signalling units have been designed to enable a radio link to be connected to either a C.B.S., C.B. or automatic exchange. For lines connected to magneto exchanges, a simple auxiliary unit is required at the main exchange.

The signalling conditions which it is required to transmit over the radio link are indicated by the presence, or absence, of the carrier signal. The signal code used on lines connected to automatic exchanges is shown in Table 1. The code used on lines connected to manual exchanges is similar except that impulsing is not required.

TABLE 1

SIGNAL CODE (AUTOMATIC EXCHANGES)

#### Outgoing calls (from subscriber).

Subscriber's line condition	Subscriber's radio transmitter	Exchange radio transmitter	Exchange line condition
Normal	OFF	OFF	Normal
Loop	ON	ON (within 30 seconds)	Loop
Loop-disconnect impulsing	Carrier signal suppressed during "break" or pulse periods	ON	Loop-disconnect impulsing

#### Incoming calls (to subscriber).

Exchange line condition	Exchange radio transmitter	Subscriber's radio transmitter	Subscriber's line condition
Normal	OFF	OFF	Normal
Ring current transmitted from exchange	ON	OFF	Ring current connected within 30 seconds
Loop (trips ring)	ON	ON	Loop (trips ring)

The signalling units are required to convert the signalling conditions normally encountered on a subscriber's line into the appropriate carrier signal conditions and vice versa. The signalling units also contain the 4-wire/2-wire terminations to give 4-wire transmission over the radio link.

Outline circuit diagrams of the subscriber's and exchange

signalling units are shown in Figs. 5 and 6. The requirement that the units should operate from a low voltage supply, varying between 17 V and 24 V, and should impose the minimum current drain on the primary cells comprising the batteries has necessitated certain departures from normal circuit practice. All the relays have been designed to have the highest practicable value of resistance, bearing in mind the functions which they are required to perform, and the slow-to-release feature required from certain relays has been obtained by the use of low-voltage, high-capacitance, electrolytic capacitors.

*Subscriber's Signalling Unit (Fig. 5).*

When the link is not in use, relays H and TP interact continuously. Relay TP, with its associated capacitor, is arranged to have a release lag of the order of 30 seconds, and relay H, with its capacitor, has a release lag of the order of 2 seconds. During the operate periods of relay H, the receiver is switched on; the receiver is switched on, therefore, for approximately 2 seconds every 30 seconds.

When the subscriber originates a call, relays L, B, H and TP operate. Contacts on relays B and H switch on the associated transmitter and receiver. When the carrier signal is detected by the distant receiver (i.e. within 30 seconds) a carrier signal is returned by the distant transmitter. The receipt of the carrier signal operates relay A, thus providing for relay B a holding circuit which is independent of relay L. At this stage, dial tone is received by the subscriber if connected to an automatic exchange line, or, for a manual subscriber, the calling signal is given at the switchboard. During dialling, relay L impulses, and while contact L1 is released the carrier signal is suppressed by the earth potential connected to the screen grid of the first tripler valve in the transmitter. "Break" impulses are therefore transmitted as disconnections of the carrier signal.

On incoming calls, a carrier signal from the distant exchange unit is detected by the receiver during its energised period and relay A operates. Relay H holds, and maintains the receiver in its energised condition. Contact A2 completes the circuit of the ringing vibrator and operates relay D, which proceeds to interact with relay E. Relay E, with its associated capacitor, has a release lag of the order of 2 seconds, and relay D, with its associated capacitor, has a release lag of the order of 1 second. The ringing vibrator element is connected to line during the operated periods of relay D, and the subscriber's bell is rung for periods of approximately one second at two-second intervals. When the subscriber answers, relay L operates during a release period of relay D, causing the operation of relay B which

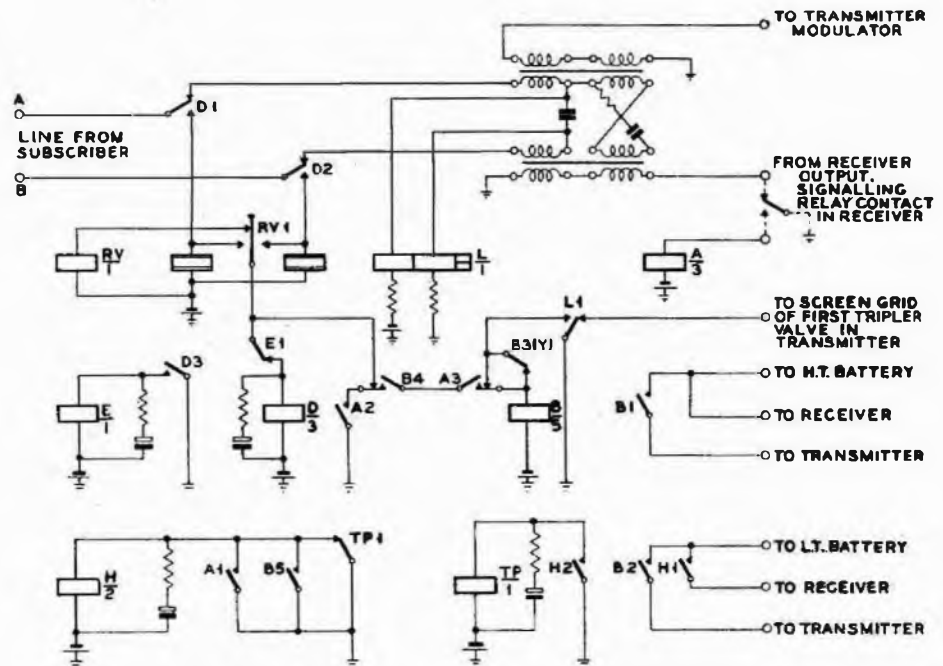
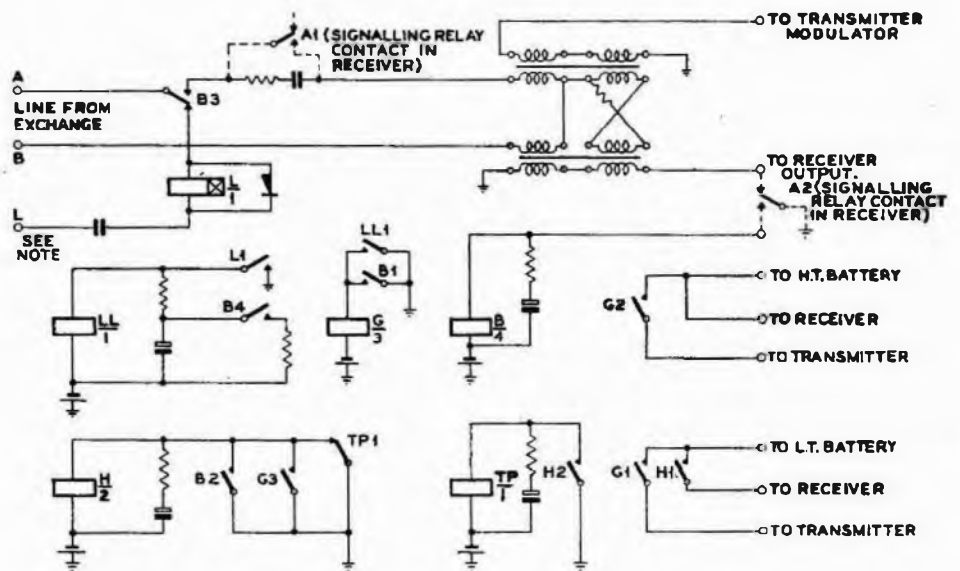

FIG. 5.—SIMPLIFIED CIRCUIT OF SUBSCRIBER'S SIGNALLING UNIT (WX1).



NOTE.—TERMINALS B AND L ARE STRAPPED FOR LOOP RINGING. THE STRAP IS REMOVED AND TERMINAL L IS CONNECTED TO AN EARTH SPIKE FOR EARTH-RETURN RINGING.

FIG. 6.—SIMPLIFIED CIRCUIT OF EXCHANGE SIGNALLING UNIT (WX2).

disconnects the ringing circuit and also energises the transmitter, thus returning a carrier signal. A novel type of ringing vibrator circuit is used in which the ringing vibrator contacts generate an alternating current in the line directly. The use of inductors in the ringing vibrator circuit gives a better performance with reduced current consumption compared with the use of resistors.

*Exchange Signalling Unit (Fig. 6).*

When the circuit is not in use, relays H and TP interact continuously as in the subscriber's signalling unit.

When the subscriber originates a call, the signalling relay in the associated receiver operates (within 30 seconds) and operates relay B, a contact of which completes the signalling loop to the exchange or, for manual exchange lines, gives a calling signal at the switchboard. On automatic exchange lines, when the carrier signal is disconnected during dialling, relay A releases and disconnects the loop to the



exchange. Interruptions of the carrier signal are therefore repeated as "break" impulses to the exchange equipment.

On incoming calls relay L operates on receipt of ringing current from the exchange. Relays LL, G and H then operate. Relays G and H energise the transmitter and receiver. The carrier signal is transmitted to the distant subscriber's unit and when the subscriber answers a carrier signal is received. On receipt of the carrier signal, the receiver relay operates and causes the operation of relay B, which extends the exchange line to the loop via the 4-wire/2-wire termination. The connection of this loop trips the ringing current from the exchange and completes the transmission path.

A contact of the receiver relay is connected directly in the impulsing loop presented to the exchange, to eliminate the distortion which would otherwise be introduced by a relief relay and to obviate the current drain which such a relay would cause. Relay LL, with its associated capacitor, is arranged to have a release lag of not less than 40 seconds to ensure that a single ring from a manual exchange will cause the carrier signal to be transmitted long enough to coincide with an energised period of the distant receiver, and cause the connection of at least one complete cycle of ringing current to the subscriber's line.

Party line working is possible by connecting terminal L to earth and suitably connecting the A and B line terminals. When restricted night service is provided, as at certain C.B.S. exchanges, it is necessary to allocate one ringing code group for the exclusive use of the radio link subscriber since code ringing is not possible with this equipment.

#### Power Supplies.

Each radio terminal station equipment requires the following supplies:—

- (a) H.T., 70-90V ; 25-40 mA ;
- (b) L.T., 1.1-1.5V ; 800-1,000 mA ;
- (c) Signalling, 17-24V ; 35-60 mA in the subscriber's unit and 14-20 mA in the exchange unit.

The battery box is designed to hold six parallel-connected, layer-built 90-V H.T. batteries. Either wet or dry Leclanché batteries may be used for the L.T. and signalling supplies. Power units are available for use when either A.C. mains or an exchange battery is available at a radio terminal station.

### RADIO LINK INSTALLATION

#### External Equipment.

At each terminal station a small hut or, in some cases, a Cabinet, Cross-Connection, No 3,<sup>3</sup> houses the equipment and, in most applications, only one telephone pole is required to carry the aerials. A simple form of directional aerial (e.g. Yagi<sup>4</sup>) providing a gain of about 8 db. relative to a half-wave dipole is likely to be the most suitable for use with the equipment, although on longer or more difficult links rhombic arrays having a gain of 15 db. may be used.

#### Propagation Characteristics.

The suitability of any particular pair of terminals for such a radio link is determined to a major extent by the radio propagation characteristics between them; it is therefore desirable to give some general indication of the limits likely to be imposed by propagation conditions. The signal-to-noise ratio has been calculated for various link lengths and aerial heights assuming the following typical conditions:—

- Mean operating frequency, 80 Mc/s.
- Mean transmitter power, 20 mW.
- Transmit aerial gain, 6 db. (relative half-wave dipole).

Receive aerial gain, 6 db. (relative half-wave dipole).

Receiver noise factor, 20 db.

Receiver audio band-width, 3 kc/s.

Effective gain relative to A.M. system due to phase modulation, 18 db.

The results are shown in Fig. 7. The curves have been evaluated, using the method of Domb and Pryce<sup>5</sup>, and

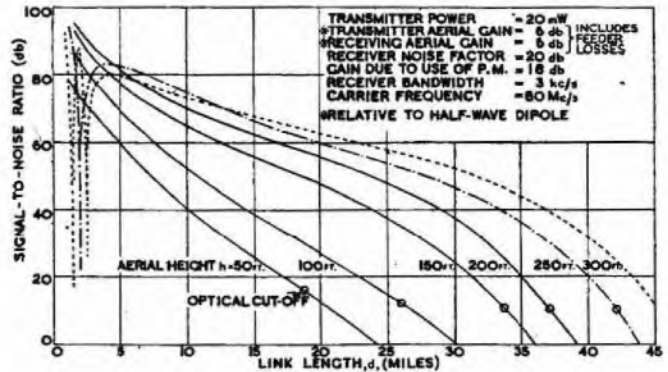

FIG. 7.—VARIATION OF SIGNAL/NOISE RATIO WITH LINK LENGTH AND AERIAL HEIGHT.

assume that there is an unobstructed radio path between transmitter and receiver, and that the aerials are at equal heights above sea-level (or the mean ground level of the intervening terrain); when different heights are involved, the mean height should be used.

It will be appreciated that in equipment such as this there exists little or no reserve of signal level at the receiver input, and therefore every effort has to be made to ensure such unobstructed radio propagation; in examining the suitability of any proposed pair of sites for propagation, the preparation of a path contour can be of considerable assistance. To give protection against locally-generated man-made interference, such as ignition noise, it is desirable to locate the aerial systems away from possible sources of such interference.

#### Transmission and Signalling.

Controls are provided on the radio units to enable the transmitter modulation sensitivity and the receiver output power to be adjusted, and when a link is installed, these controls are preset to provide the greatest usable phase deviation when the circuit is in operation.

When a terminal station is connected to the telephone network, the modulation input level to the transmitter is likely to vary considerably, due to the different voice powers of telephone users and to differences in line levels on local, toll and trunk calls. As has already been stated, the margin of signal-to-noise ratio may be low and since it is uneconomic (and impracticable) to provide constant volume amplifiers, a compromise in the setting of the transmitter modulation attenuator is necessary. If the setting is too high, the effective carrier deviation is small, and the signal-to-noise ratio suffers; if the setting is too low, overloading and excessive distortion occur. Speech intelligibility is therefore liable to suffer either due to low signal-to-noise ratio on toll and trunk calls or due to overload distortion on local calls. The actual modulator setting used in any link is dependent on the carrier signal level available at the receiver, since this determines the fluctuation noise level. In most links the modulator sensitivity may be adjusted

<sup>3</sup>"Flexibility Units for Local Line Networks." J. J. Edwards and J. P. Harding. *P.O.E.E.J.*, Vol. 39, p. 100.

<sup>4</sup>"Theoretical Treatment of Short Yagi Aerials." W. Walkinshaw. *J.I.E.E.*, Vol. 93, Part IIIA, No. 3, p. 598.

<sup>5</sup>*J.I.E.E.*, Vol. 94, Part III, No. 31, p. 325.

so that an adequate signal-to-noise ratio is obtained on toll and trunk calls, and the overload distortion on local calls is small compared with the distortion normally introduced by the carbon transmitters in telephones.

The line balance in the hybrid transformer in each signalling unit consists of a fixed resistor of 600 ohms, and in most applications this enables satisfactory transmission to be obtained over a radio link with an audio-to-audio loss of one decibel in each direction. The receiver output attenuator at each station is therefore set to one decibel below the level of the modulator attenuator setting on the remote transmitter.

Some distortion of dialling impulses is inevitably introduced in transmission over a radio link, and it is therefore desirable to restrict the dialling range to the use of not more than one unamplified junction. The radio equipment introduces a dialling impulse distortion of the order of  $\pm 2$  mS, and the line relay, L, introduces additional distortion as a result of variations in adjustment and battery voltage; the distortion introduced by the line relay also depends on the length and type of land-line connected in the subscriber's circuit. Under average overall conditions, satisfactory through-dialling has been obtained over three unamplified junctions in tandem, but the wide variety of conditions which exists in practice has made it desirable to restrict the dialling range to the use of one unamplified junction.

#### Performance in Trial Links.

Experimental links have been established using experimental models of the equipment, and much valuable information has been obtained on its operation and performances. The results obtained in these experimental links are summarised in Table II.

The link to Shirenewton involved an overland propagation path with poor clearance to local obstructions at one end and was used primarily to investigate dialling performance. The link from Tenby to Caldy Island<sup>6</sup> was the first experimental link to operate as part of the public telephone system and was in operation for over seven months, at an average circuit holding time of 0.85 hours per day, before a change of batteries was required. On both Caldy and N. Ronaldsay links a relatively large number of faults were experienced during the initial stages of the field trials, but the basic causes of these faults have been determined, and with improvements, such as simplification of maintenance procedure and more adequate weather protection, reliable service is now being given.

## Book Review

"Electromagnetic Screening in Telecommunication and High-frequency Engineering" (in German). Dr. H. Kaden. Butterworth-Springer. 274 pp. 133 ill. 66s. 6d.

At relatively low frequencies, screening problems can be solved by treating the metallic screen as a lumped circuit element which has self-impedance and mutual impedance with other components of the circuit of which it forms a part. As the frequency is raised, however, the effect of the magnetic field produced by eddy-currents in the screen becomes increasingly important, thus making the application of simple circuit theory more and more difficult. Dr. Kaden avoids this difficulty by making a fundamental approach to the subject, based on the Maxwell field equations, in which the screen is considered as a medium through which energy is transmitted in the form of electromagnetic waves. The screening effect can then be visualised as due partly to the attenuation which the conducting screen offers to the

TABLE II  
EXPERIMENTAL RADIO LINK PERFORMANCE

Subscriber's Terminal	Exchange Terminal	Type of Exchange	Path Length (miles)	Aerials (gain relative to half-wave dipole)	Average Receiver Input Signal ( $\mu$ V)	Average S/N Ratio (db.)
Castleton Radio Laboratory	Shirenewton	U.A.X.12	16 (a)	Two 8-db. Yagis	20	30
Castleton Radio Laboratory	Backwell Radio Laboratory	CBS No. 2	18 (b)	Two 8 db. Yagis	200	50
Caldy Island	Tenby (Town centre)	CBS No. 2	2½(b)	Two 4-db. Yagis	80	42
Caldy Island	Tenby (North Cliff)	CBS No. 2	4 (b)	Two 8-db. Yagis	300	52
N. Ronaldsay	Sanday	Magneto	13 (b)	12-db. rhombic + 4-db. Yagi	60	40

(a) path entirely over land.  
(b) path mainly over sea.

## CONCLUSIONS

Experimental models of the equipment described above have been subjected to field trials, and apparatus is now being produced which will replace the earlier phonogram type of installations in the Orkneys, Hebrides and Northern Ireland.

Other possible uses for the equipment are being considered. These include the provision of telephone service to inhabited islands which have not yet telephone or telegraph service; the provision of service to kiosks in remote localities; and also the possibility of setting up a central pool of equipment, whereby immediate service could be provided in cases of urgency while the necessary wire connection was being provided.

The experimental equipment has been developed by staff of the Radio Laboratories, Castleton, and the Signalling Group of Telephone Branch, and acknowledgment must be made to the part played by members of the two teams concerned in development and field trials.

<sup>6</sup>P.O.E.E.J., Vol. 43, p. 52.

waves and partly to reflections at its surfaces as a result of the difference between the intrinsic impedance of the screen and that of the space on either side of it.

The first part of the book deals in turn with uniform close screens, built-up screens with non-conducting seams of negligible width and screens with slits of finite width. This leads to a consideration of the problem of the "leakage" of electromagnetic waves through holes and around the edge of open screens, and of the design of wire mesh screens. The second part is concerned mainly with the calculation of the coupling between various types of coaxial, twisted pair and quad cables, with particular reference to the reduction of the coupling by the use of suitable screens. Although most of the work is probably of more interest to the physicist than to the practical designer of electrical equipment, it should nevertheless assist the latter by showing that many screening and coupling problems are capable of exact solution by analytic methods. Dr. Kaden's book undoubtedly forms a useful contribution to the subject.

V. G. W.

# Communications for the Festival of Britain, 1951

A. ALEXANDER†

U.D.C. 06.078 : 621.395.2

This article gives a brief outline of the communication facilities provided for the Festival of Britain on the South Bank and other exhibition sites. Although most of the equipment provided is of standard type, interest arises from the large amount of work involved, the unusual installation conditions and the very short time available for completion.

## *Introduction.*

WHEN the South Bank Exhibition was opened by His Majesty King George VI on the 4th May 1951, to mark the centenary of the Great Exhibition of 1851, the results of two years of intensive labour were revealed to the public. The site extends over some 27 acres, bounded by the River Thames, York Road, County Hall and Waterloo Bridge. Within the 30 principal buildings the Exhibition tells a continuous story of British history and achievements, each pavilion providing a chapter. The site is divided by the Hungerford railway bridge and use is made of this division by basing the Exhibition layout on two sequences of buildings. The sequence lying upstream from Hungerford Bridge tells the story of the land of Britain and what the British have derived from it; while the other, downstream from Hungerford Bridge, concerns itself with the People of Britain in their everyday surroundings.

The main buildings, with the exception of the Royal Festival Hall, are all temporary structures, and are constructed from a wide variety of materials including steel, concrete, brick, wood, asbestos, glass, aluminium, and fabrics of various kinds.

## *General.*

Because of the compact nature of the site and the large number of people to be admitted—up to 60,000 at any time—a system of controls has been evolved to cater for the day-to-day running of the Exhibition and to deal with any emergencies. These controls include the fire alarm system; a crowd counting system coupled to the entrance and exit turnstiles so that the number within the Exhibition is recorded at any moment; a lamp signalling system to attract the attention of key members of the Festival staff; a watchman patrol system which indicates the non-arrival of the night staff at any point on their rounds by a pre-arranged time; a public address system for announcements and rediffusion of music; a master and slave clock system for time keeping; and a number of control cabins situated at vantage points. These control cabins are staffed during the hours the Exhibition is open and are provided with telephonic communication to the Administration authorities.

All these control systems are centred on the main control room, with the exception of an Administration P.B.X., which is situated in accommodation shared with the B.B.C., adjacent to the Royal Festival Hall.

## *Description of Communications.*

Preliminary discussions with the Festival authorities revealed the need for two separate telephone installations, a P.B.X. with approximately 400 extensions to serve as the Administration switchboard for the Festival, and a separate P.B.X. for emergency and control use with a maximum of 30 extensions.

In view of the anticipated traffic, and the need for intercommunication with the other exhibition sites and Festival offices throughout London, it was decided that the

Administration switchboard should be a 10-position P.M.B.X.I.A. With this in mind, a request was made to the Festival authorities to provide the necessary switch-room and staff welfare accommodation in a central position. Eventually, accommodation underneath the Festival Hall terrace on the east side of the Hall was provided for the exchange.

A distinctive telephone number for the Festival was suggested, and as the South Bank site is in the Waterloo exchange area, the number WATERloo 1951 was accepted. A P.B.X. group of 30 lines was reserved and, to ensure that the Festival had the appropriate directory entry in advance of the opening date, the first 10 lines of the group were brought into service in February 1949, at the Festival Office, P.B.X. at 2 Savoy Court.

As there was a shortage of junctions between Waterloo exchange and Temple Bar exchange, which serves Savoy Court, it was necessary to extend an existing 100 pr./10 lb. cable from Waterloo exchange via the Strand into Savoy Court. By this means, it was also possible to give temporary service on the site prior to the opening of the Administration P.B.X., and to provide 30 inter-switchboard extensions when the WATERloo 1951 lines were transferred to the Administration switchboard.

Exchange service was not required on the Emergency switchboard, but subsequently it was found necessary to provide circuits to certain external bodies. A switchboard 10 + 50/65 was provided for these services which are included on the communication diagram (Fig. 1).

Telephone kiosks of an original design were installed by the Festival authorities at convenient points throughout the site but, unfortunately, these have certain defects and they have not proved entirely satisfactory in use. In addition, a number of call office suites situated in restaurants have been included by the architects in the general features of the designs. With a few exceptions these accommodate a standard Jubilee Pattern wallboard, but a number of ingenious ideas have been incorporated; in particular, one for the use of the Press in which the occupant makes his call while seated at a desk, and another with a single sheet of glass for a door, so pivoted that when it is open two-thirds of it is within the call office, while one-third of it remains outside. In all, there are 54 call offices on the site, excluding those in the Post Office suite.

As can well be imagined, the Exhibition provides a fruitful source of material for broadcasting, a fact which was not lost sight of by the B.B.C., and circuits have been provided from the Broadcasting Centre adjacent to the Administration P.B.X. to 13 single and 7 double microphone points throughout the site. Each single point requires 3 pairs of wires and each double point 6 pairs. A number of circuits have also been provided from the Broadcasting Centre to Broadcasting House and Bush House for the transmission of programmes originating from the Exhibition.

The television service was met by the provision of a spur of the London/N.E.—Sth. Wimbledon coaxial cable from a switching point in Waterloo Station to the television

† Assistant Engineer, Engineering Branch, London Telecommunications Region.

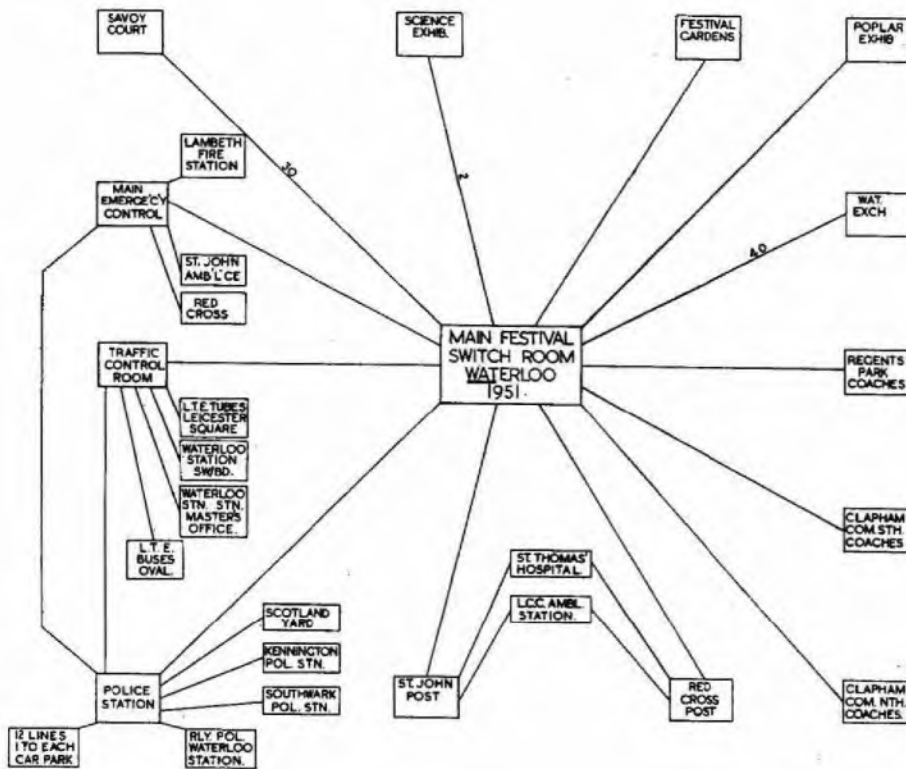

FIG. 1.—COMMUNICATION DIAGRAM.

control room in the Festival Hall, and the laying from there of a coaxial interruption cable of the most recent type, and a 7 pr./20 lb. cable to each of three mobile control room positions from which the camera cables radiate as required. Music and control circuits were also provided between Broadcasting House and the television and sound control rooms in the Festival Hall.

In addition to those mentioned previously, 160 circuits

were provided between the main lighting control room and the numerous electrical switchrooms on the site, over which, by utilising power relays, the electrical contactors controlling the external floodlighting and internal display lighting are operated and released

*Line Plant.*

Fig. 2 shows a general plan of the Festival site and indicates the run of P.O. cable and ducts.

When plans giving the layout of the site were available, a drawing showing the estimated number of telephone required in each building was made. From this plan it was possible to estimate the ducts required to serve the Exhibition. As the Festival authorities wished to limit the number of contractors employed on the site, they arranged for provision of the ducts required for all services. Maximum use was made of a common excavation for all ductwork. As sections of the site became available, asbestos-cement duct of various diameters, jointing chambers and leading-in pipes were provided in advance of the buildings being erected. This method of construction was no ideal as it led to serious delays in cabling

owing to vital sections of the duct being dependent on new roads being opened into certain sections of the site.

To limit the number of joint-box covers in the paving it was agreed that all joint boxes off the main cable route and at the leading-in points to buildings should be buried. Joint Markers No. 3 were used to indicate the positions of the buried boxes.

To secure uniformity and to utilise a type of cover les

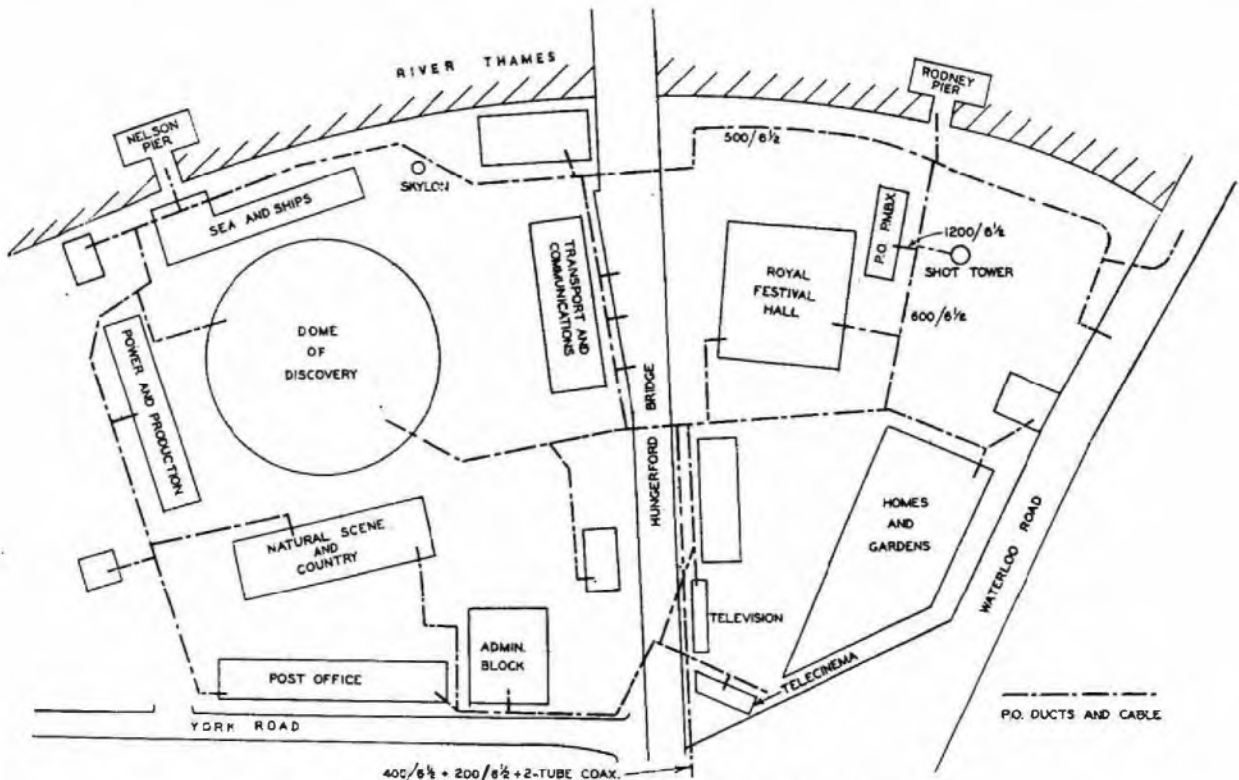

FIG. 2.—MAIN FEATURES OF SITE, SHOWING P.O. DUCT AND CABLE.



conspicuous than that used by the Post Office, special frames and covers were provided by the contractor. These are of a pattern in which the cover is supplied empty and finally filled with the concrete or asphalt finish appropriate to the area pavings. All that remains visible is the thin edge of the frame and cover, as the reinforcing grid of the cover is slightly recessed and thus surfaced over.

The ductwork was directed by a Post Office supervisor, and his advice to the contractor on underground construction matters contributed to the successful completion of this part of the work.

In March 1950, a schedule was provided, giving the locations of individual telephones and consideration was then given to the amount of cable required. Because of the importance placed on the emergency P.B.X. by the Festival authorities, it was served by a separate cable network. Similarly, the B.B.C. microphone points were cabled separately to the Broadcasting Centre, and the television mobile control rooms were connected by cables to the television control room in the Festival Hall. A main cable network was then provided to serve the Administration P.B.X., the kiosks and call offices, the lighting control circuits, and the concessionaires. Owing to the incomplete state of the ductwork on the site only small portions of the cabling could be carried out before December 1950, but any work which could be done outside the site to avoid delay at a later stage was completed. A new 1,100 pr./10 lb. cable, required for the ultimate development of the area, was laid from Waterloo exchange to York Road, and 400 pairs were left ready for extension into the Festival M.D.F.; 200 pairs in an existing cable on an alternative route to the exchange were also made available.

When cabling actually started on the site, there were further delays due to the building contractors having failed to extend the external ducts into the electrical intake rooms. As these omissions were rectified, the M.D.F. was installed, and termination of the main cables involving 1,200 distribution pairs was completed. By the end of February the bulk of the cable was laid. The cabling and jointing was completed during a period of inclement weather, and it must be considered fortunate that faults were found on only two lengths of cable among the 8 miles which had been laid and jointed.

#### *P.B.X. and Subscribers' Apparatus Installation.*

The most notable thing about the installation of the Administration switchboard was the short time which elapsed between the switchroom being fit for work to commence and service being given on 2nd April. At the beginning of December 1950, all that was apparent was a sea of mud, which surrounded the steelwork to support the Festival Hall terrace. As the result of a meeting with the contractor's agent on site, the switchroom was built and plastered, but not decorated, by 21st December, and the M.D.F. was in position before the end of the year. As was to be expected in such a new structure, dampness was evident on the walls and ceiling, but this was dispersed by ventilation and temporary heating and the switch sections and equipment were placed in situ. The installation, as shown in Fig. 3, is completely standard, and consists of a 10-position P.M.B.X.1A. with a 400 subscribers' multiple, 40 exchange line terminations, and 57 inter-switchboard extension and private wire terminations.

The subscribers' installation work was not standard and presented many problems. The site is divided into 20 zones, each designated by a number, e.g. SB1, and for each zone there was a different architect and display designer. It was therefore necessary to obtain from each architect a set of drawings for his particular zone, and then



FIG. 3.—THE ADMINISTRATION SWITCHBOARD.

to mark up the positions of the instruments. After this was done, the display designers were asked if any special decorative treatment was required, e.g. small cabinets or pedestals for the telephones. As no wiring was to be visible in areas open to the public, the electrical contractors provided conduit between the telephone positions and the building distribution cases.

In certain buildings the unusual methods of construction presented some peculiar problems to the fitting staff. In the "Dome of Discovery," for example, the external wall is inclined at an angle of approximately 20° to the vertical interior drum wall. The void thus created circles the building and ascends in step with the various galleries. It provides a useful run for cables, conduits, etc., but as the Dome is 346 ft. in diameter, the length of wiring was in some cases exceptional.

In addition to the Administration and Emergency switchboards, there are others on the site, including a 10 + 50/65 for the Festival Police Station, and two switchboards 10 + 50/65 for the Council of Industrial Design.

#### *Festival Post Office.*

This is situated adjacent to York Road and comprises a Public Office, a teleprinter room, a suite of call offices, accommodation for the Officer-in-Charge, and welfare rooms for the staff. The Public Office (Fig. 4) has a novel



FIG. 4.—THE FESTIVAL POST OFFICE.

counter of sawtooth appearance which, it is claimed, expedites the flow of customers to the counter clerks. The teleprinter room is equipped with 3 circuits to London North Switching Centre, and a pneumatic tube from the public counter.

The suite of call offices is in two sections, the first equipped with 10 Jubilee wall boards, and intended to deal with all normal traffic, while the second consists of four extensions from a switchboard staffed by a "linguist" operator and situated in a small booth in the call office hall. From these four extensions overseas calls may be originated, or assistance may be given to anyone not familiar with the operation of the normal call office. The call office suite is illustrated in Fig. 5.



FIG. 5.—P.O. CALL-OFFICE SUITE.

#### Royal Festival Hall.

This is the only permanent building on the South Bank site and is under the control of the London County Council. The equipment installed in the Hall will remain there after the Festival has closed, and comprises two switchboards 10 + 50/65 and 57 extensions. A number of these, for the use of usherettes and other people employed in the auditorium, are lamp calling circuits.

The B.B.C. broadcast performances from the Hall and they have been provided with control rooms for both sound and television. Music, control, and vision circuits have been provided from them to Broadcasting House.

## Book Review

"GAS DISCHARGE LAMPS." J. Funke and P. J. Oranje. Philips' Technical Library. Distributed in U.K. by Cleaver Hume Press. 273 pp. 171 ill. 30s.

This is the first of a series of books on Light and Lighting, to be published by N. V. Philips' Gloeilampenfabrieken, Eindhoven. The book, which was originally released on the Continent in 1941, has been completely revised and rewritten, and covers technical developments up to the spring of 1950. As electric discharge lamps were only marketed commercially rather less than 20 years ago, one may suppose that to all intents and purposes the present book is new. The first part of the book deals with the fundamentals of gas discharge lamps and auxiliary gear and the relation between auxiliary gear and the performance of the lamps. The second part

#### Kiosks external to the South Bank Site.

In anticipation of the large attendances at the Exhibition, additional kiosks and call office cabinets have been installed in the immediate vicinity and in the West End of London. Wayleaves were obtained for 87, and the kiosks were erected and brought into service during the last week in April and the first week in May; great credit reflects on the London Power Section for this effort. The kiosks were assembled, glazed, and painted in the workshops and then transported to the sites by the aid of a new type of trailer. The concrete bases had already been laid, and the electric light and cable services were provided at short notice.

#### Festival Pleasure Gardens.

These are situated on the bank of the River Thames in Battersea Park and the communication facilities provided there follow very closely those provided on the South Bank. There is an Administration P.B.X. and an Emergency P.B.X. each served by a 10 + 50/65 switchboard and with separate cable networks. The B.B.C. have a sound network and a vision network, but in this instance, as there is no conveniently situated coaxial cable, the vision circuit is provided via Victoria exchange. (Pairs in a Battersea-Victoria junction cable were intercepted and extended into the Park.) Within the Gardens, a 7 pr./20 lb. cable was provided to the positions of the mobile control rooms.

An additional requirement in the Pleasure Gardens is the rediffusion of music, and for this a network of 2 pr./20 lb. P.V.C. cable with aluminium screening has been provided between the Music Pavilion and the various groups of loud speakers.

#### Other Festival Sites.

There are two other exhibitions which should be mentioned; the Live Architecture Exhibition at Lansbury, in the East End of London, and the Science Exhibition in the west wing of the Science Museum, South Kensington. The communications for the former are provided by a 5 + 20/25 switchboard, and for the latter two switchboards 10 + 50/65 suffice. Private wires link these switchboards with the South Bank Exhibition.

#### Conclusion.

A large amount of work has been planned and accomplished in a very short time, and great credit is due to the staff of the Telephone Managers concerned who, by their close co-operation with the Festival authorities and the London County Council, have contributed to the successful installation of plant for the Festival of Britain communications.

deals with the various types of lamp, sodium, mercury vapour and tubular fluorescent, with a brief reference to special lamps such as beacon, stroboscopic and flash tubes. Detailed information is given on the evolution of the gas discharge lamp, and the theory underlying the working of the lamps has been presented in a fairly simple and very readable manner. The lamps described are mainly those in the Philips' range, but many of the details apply to other makes as well. Although a second book in this series dealing solely with fluorescent lamps and fluorescent lighting is in the press, the present book deals in some detail with low pressure tubular fluorescent lamps. The colour of gas discharge and fluorescent lamps and colour rendering properties receives adequate treatment, but no doubt the authors would have much to add after the 1951 meeting of the *Commission Internationale de l'Eclairage*.

This book can be well recommended as authoritative on the subject of electric discharge lamps. W. T. G.

# The New Standard for Ringing Tone

U.D.C. 621.395.664.

THE present standard ringing tone in this country, 133 c/s modulated at 17 c/s, was chosen, *inter alia*, to reduce risk of confusion with "busy" tone (400 c/s). This ringing tone was satisfactory while automatic working was confined to local networks and while drum-interrupter tone generators were used. The introduction of inductor tone machines and the extension of dialling over amplified and carrier circuits has, however, led to increasing complaint by trunk operators of faint or absent ringing tone.

Measurement of the frequency characteristics of ringing-tone from inductor and drum-interrupter machines showed, as was expected, that while the former had a large proportion of energy at the fundamental frequency, the latter had its energy well distributed in the higher harmonics (Fig. 1). When these tones are weighted for

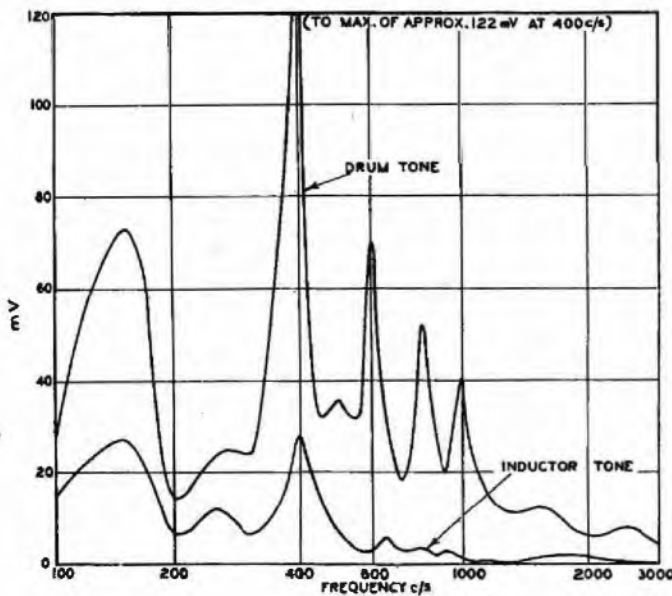

FIG. 1.—FREQUENCY CHARACTERISTICS OF RINGING TONE FROM INDUCTOR AND DRUM-INTERRUPTER MACHINES (UNWEIGHTED).

the variation of sensitivity with frequency of ear and receiver there is a marked difference between the aural effects obtained from the two types of machine (Fig. 2). This difference will be accentuated by the low-frequency attenuation of amplified or carrier circuits. It is apparent that under modern conditions the fundamental frequency of tones to be transmitted over the trunk system should not be less than 300 c/s. Tests have been made with a drum-interrupter machine modified to give 400/17 c/s. Comparison of the weighted outputs of 400/17 and 133/17 c/s shows the improvement about 400 c/s and the proportionate reduction of higher harmonics, which is desirable for reducing cross-talk (Fig. 3). Satisfactory service trials of 400/17 c/s ringing tone have been made at London (Waterloo), Liverpool (Central and Trunks) and Bristol (Central) exchanges and from observation, subscribers have not been confused by the new tone.

It is of interest to compare European with British practice in the frequency of ringing tone. Typical tones are:—

Denmark	450 c/s
France (Provincial)	450 c/s
France (Paris)	400/25 c/s

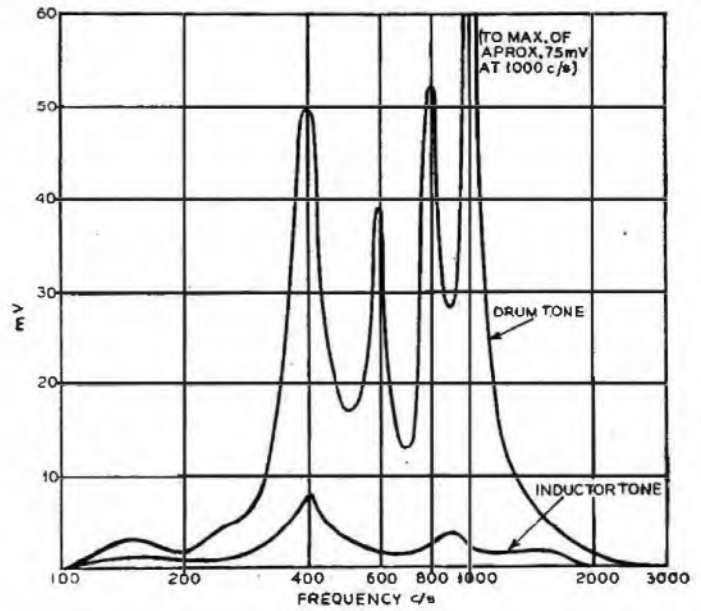

FIG. 2.—AS FOR FIG. 1 BUT WEIGHTED FOR EAR AND RECEIVER SENSITIVITY.

Germany	450 c/s
Holland	400, 400/25 and 450 c/s
Norway	36 and 425 c/s
Sweden	300 and 425 c/s
Switzerland	400 c/s

In future the British Post Office will standardise 400/17 c/s and new specifications for inductor machines have been prepared. No change is necessary to other tone circuit components. Existing installations may be modified by simple changes to drum-interrupter machines, but it is necessary to replace the 133/17 c/s stator and rotor of an inductor machine by 400/17 c/s components. It is not possible to derive ringing tone from existing 400 c/s

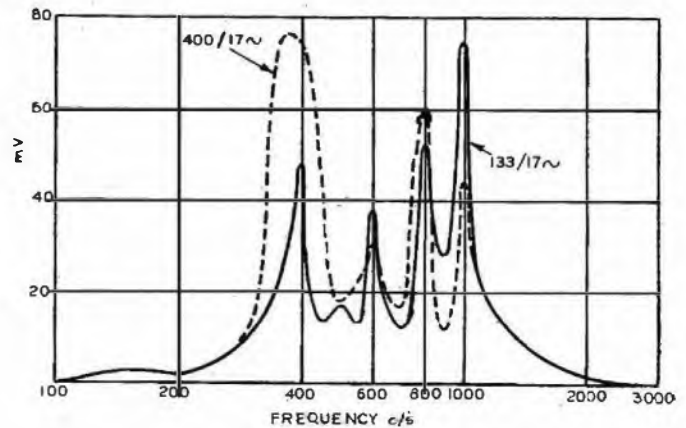

FIG. 3.—FREQUENCY CHARACTERISTICS OF RINGING TONE OF 133/17 c/s AND 400/17 c/s FROM A DRUM-INTERRUPTER MACHINE (WEIGHTED FOR EAR AND RECEIVER SENSITIVITY).

windings without interference between tones. Alternatively, a small belt- or motor-driven ringing-tone generator could be installed.

The cost of full retrospective modification of existing machines would be considerable and the extent of conversion necessary will be determined by further trials.

W. H. M.

# C.C.I.T. Study Group Meetings; Geneva, March, 1951

U.D.C. 061.3: 621.394

THE sixth plenary meeting of the C.C.I.T. was held at Brussels in May 1948, and one of its last acts was to fix the next plenary meeting for the spring of 1951, with its venue in Holland. The administrative affairs of the C.C.I.T., however, seem to be wedded to procrastination, and the Administrative Council of the I.T.U. decreed late in 1950 that the plenary meeting should be postponed until 1953.

To those interested in the technical work of the C.C.I.T. this was a most disappointing decision; however, a meeting of most of the Study Groups of the C.C.I.T. at Geneva during the month of March has largely negated any effect which the decision may have had in retarding the work of the C.C.I.T.

These meetings were the first to be held under the Atlantic City Convention regulations whereby a Study Group, under its Chairman, is responsible for bringing the answers to the questions under its care to the finalised form of Recommendations. It can be stated, without peradventure, that this method of dealing with questions is an unqualified success, and that the useful work of the Geneva meeting was much greater than that achieved at any of the previous plenary meetings of which the writer has experience.

The technical Study Groups most involved were I, dealing with the general technical aspects of Telegraphy, including basic definitions; II, dealing with the technical aspects of the establishment, operation and maintenance of telegraph channels; III, dealing with telegraph apparatus; IV, dealing with facsimile and phototelegraphy; and VII, dealing with the technical aspects of switching.

There was general agreement that the statement of the conclusions reached at the Brussels conference concerning the definitions relating to telegraph transmission required simplification and revision. A great advance was made at Brussels in that more precise meaning was given to distortion as related to start-stop systems, but time did not then allow of more than a compromise statement of the various ideas brought into discussion. Since then, much thought has been given to this important and fundamental matter, and agreement was reached at Geneva on a complete restatement which is generally regarded as a real advance on the work of Brussels.

Study Group II was faced with a very heavy task, and was in continuous session during the first two weeks of the meeting. In the result, it formulated some 21 draft recommendations and 14 new questions. One of the questions of a fundamental nature dealt with by this Study Group concerned the utilisation of regenerative repeaters, particularly on international telex circuits. It is interesting to reflect upon the fact that, whereas the introduction of modern telegraph methods led to the virtual abandonment of the use of repeaters, the growth in the demand for international telex circuits has raised again the need for regenerators—this time electronic. Involved in the use of regenerative repeaters is the question of what is the optimum length of the stop signal in teleprinter working, and Study Group II, whilst issuing a recommendation that regenerative repeaters should be used on the outgoing side of international circuits, has also recommended that a working party from members of Study Groups II and III should be charged to report within a year upon the question of the minimum length of the stop signal. The teleprinters designed for commercial use in this country have a

minimum stop signal of one-and-a-half units, whilst continental practice, pre-war, was more in favour of the use of one unit. Opinion is agreed that, in view of the undoubted future for long-distance commercial usage of teleprinter circuits and the consequent use of regenerative repeaters, a stop signal of a minimum length greater than one unit, is desirable.

The IVth Study Group, concerned with the subject of phototelegraphy, drew up six new provisional recommendations which included the adoption of the recommendation of the C.C.I.R. at its Stockholm meeting of 1948, regarding the measures for working over radio circuits. One of these measures is that sub-carrier frequency modulation should be used over the radio circuit. In view, however, of the indefinite position regarding the signalling system to be recommended for use on international telephone circuits, it was found necessary to recommend that amplitude modulation should be the normal method used in the transmission of pictures over international line telephone circuits, and that the C.C.I.F. be asked to give its opinion as to the conditions under which the transmission of pictures would be possible, using the sub-carrier method of modulation.

Recommendations of a provisional nature were also made, which would allow of the effective use of the wider frequency band-width available in modern telephone circuits, and the existing C.C.I.T. recommendation dealing with the standardisation of phototelegraph apparatus, completely revised to take account of the new recommendations.

Study Group VII drew up provisional recommendations concerning the teleprinter motor control arrangements on private point-to-point circuits; the standardisation of dialling speed and lost-motion period where dials are used for automatic selection of subscribers on a teleprinter switched service; and the conditions governing metering equipment as well as the necessary circuitry, where it is desired to use a system of metering based on transmission time. This latter question was an outcome of the Telegraph and Telephone Conference at Paris in 1949, and had particular reference to the case where a circuit was used by more than one renter.

This Study Group also devoted much time to the discussion of the possibilities of extending the range of signals at present used on the international telex service. This discussion, whilst it did not lead to any actual extension of the limited number of signals at present employed, was most fruitful in that it has given the various experts a clearer picture of the difficulties which exist due to the significant differences between the systems employed in various countries, and has led to the production of an agreed statement which will form the basis of future studies.

The recommendations agreed upon by the various Study Groups were classified as either provisional or draft. The former will be issued by the Bureau of the I.T.U. to all member countries, and will be considered as having provisional force until ratified at the Plenary Meeting due to take place in 1953, whilst the latter will be first issued to those Administrations which have undertaken to pay a share of the extraordinary expenses of the C.C.I.T., for their observations or concurrence before being given the status of provisional recommendations.

F. E. N.



# Notes and Comments

## Recent Awards

The Board of Editors notes with great pleasure that His Majesty the King has approved the award of the British Empire Medal to the undermentioned officers for their brave conduct in extricating a man from underneath a four-ton tractor, at great risk to themselves, after it had overturned during cable-laying operations:—

Mr. W. C. Reed	..	Technician I	..	Cambridge Telephone Area
Mr. E. Curtis	..	Technician IIB	..	Cambridge Telephone Area
Mr. J. J. Peters	..	Technician IIB	..	Cambridge Telephone Area

## The Supplement

It is now 20 years since the Supplement first appeared as a Journal feature and the immediate popularity it achieved has been maintained ever since.

With the needs of our younger readers in mind, a not inconsiderable portion of Journal resources is devoted to the Supplement and no change in this policy is contemplated. Nevertheless, with rising costs it has become a problem to cover the complete range of City and Guilds telecommunications engineering examinations, and, for 1950, it was reluctantly decided to omit altogether publication of answers to certain 4th and 5th year papers.

For the 1951 examinations, on which a start is made in this issue, an alternative means of economising in paper will be adopted. Thus, all subjects will be covered, but one or two questions from each paper will be left unanswered. The selection will be made so as to include those answers

calculated to be of greatest assistance to students and it is considered unlikely that this arrangement will detract noticeably from the value of the Supplement.

## Vacuum Research and Engineering

We have recently received a copy of the first issue of a new technical publication entitled "Vacuum," which is designed to fill a need in scientific literature by reporting only on vacuum matters. "Vacuum" is addressed to the scientist and industrialist using vacuum procedures and to specialists in all fields to whom a knowledge of progress in vacuum matters is of value in their work. This journal, the first in the English language, devoted solely to reporting vacuum developments, is a quarterly publication available on a subscription basis at £1 5s. 0d. per annum (£1 10s. 0d. abroad) and is published by W. Edwards & Co. (London), Ltd.

# Institution of Post Office Electrical Engineers

## Essay Competition, 1950/51, Results

Prizes of £3 3s. each and Institution Certificates have been awarded to the following four competitors:—

J. Methven, Technical Officer, Salford. "An Introduction to Carrier Maintenance."

E. Pratt, Technical Officer, Cardiff. "Difficulties of the Clerk of Works on Contract Installation of Telephone Equipment."

A. V. Huxley, Technician Class I, Birmingham. "Practical Application of Development Schemes using Cabinets and Pillars."

F. R. Lucas, Technical Officer, Bristol. "Youths' Training Schemes and the National Service Acts."

Institution Certificates of Merit have been awarded to:—

A. G. Frame, Technical Officer, Reading. "The Radio Interference Service."

J. Huggett, Technician Class I, Cardiff. "My Idea of a Non-Residential Training School."

R. F. L. White, Technical Officer, Bristol. "Publicity and Public Relation Services."

H. Baines, Technical Officer, London. "An Approach to Managerial Co-ordination."

T. S. Stephenson, Technician Class I, Newcastle-on-Tyne. "External Construction Methods. Underground Conduit Laying by Direct Labour."

The Special Prize of £3 3s. and an Institution Certificate have been awarded to R. C. Medford, Technical Officer, Salford, for his essay "My reactions to the present Essay Competition and my suggestions for improving it."

The Council of the Institution records its appreciation to Colonel C. E. Calveley, O.B.E., Messrs. G. N. Davison and H. Leigh, who kindly undertook to adjudicate upon the essays entered for the competitions.

J. READING, *Secretary.*

N.B.—Particulars of the next competition, entry for which closes on the 31st December, 1951, will be published later.

## Recent Additions to the Library

1972 *Voltage Stabilisers.* F. A. Benson (Brit. 1950).

Reviews methods of stabilising voltage, and collects into one volume such data published previously only in scientific periodicals.

1975 *One Hundred Years of Submarine Cables.* G. R. M. Garratt (Brit. 1950).

A Science Museum publication to coincide with the Centenary Exhibition at the Museum.

1976 *Television Receiving Equipment.* W. T. Cocking (Brit. 1950).

An authentic and comprehensive guide to British practice. The author assumes the reader to be well acquainted with the principles and practice of ordinary broadcast receiver work.

1977 *Permanent Magnets.* F. G. Spreadbury (Brit. 1949).

Gives a comprehensive account of permanent magnets and the apparatus in which they are employed. (Reviewed in *P.O.E.E.J.*, Vol. 43, p. 49.)

1978 *Thermostats and Temperature Regulating Instruments.* R. Griffiths (Brit. 1951).

Deals with every type of instrument, including those which employ servo-systems or electrical mechanisms.

1979 *Sourcebook on Atomic Energy.* S. Glasstone (Amer. 1950).

A comprehensive sourcebook prepared for the Atomic Energy Commission as a balanced guide to all aspects of atomic energy, mainly for the use of textbook authors and editors.

1980 *Mechanisms for Engineers.* A. Fleming (Brit. 1946).

Deals with those branches of mechanics necessary for a Pass Degree in Engineering.

1981 *Waveguide Transmission.* G. C. Southworth (Amer. 1950).

A complete coverage of the fundamentals of waveguide transmission.

1982 *Data and Circuits of Receiver and Amplifier Valves.* Philips Technical Library (Dutch 1949).

Book II of Philips' series of books on electronic valves—covers valves produced in the period 1933-39. (Reviewed in *P.O.E.E.J.*, Vol. 44, p. 34.)

1983 *Data and Circuits of Receiver and Amplifier Valves.* Philips Technical Library (Dutch 1949).

Book III of Philips' series of books on electronic valves—covering valves of the years 1940-41. (Reviewed in *P.O.E.E.J.*, Vol. 44, p. 34.)

W. D. FLORENCE, *Librarian.*

# Regional Notes

## North Western Region

### REMOVAL OF U.A.X.12

Part of the internal construction programme in the Lancaster Telephone Area was to provide a new U.A.X.12 at Langdale, in the Lake District, to meet the telephone development in this widely-scattered district, and serve 33 subscribers then working to the manual exchange at Grasmere, approximately five miles away.

A U.A.X. 12 was thrown spare by the provision of a U.A.X. 13 at Alston, about 70 miles to the north-east of Langdale, and it was decided to attempt the removal of this spare U.A.X.12, *en bloc*, to Langdale. For this purpose a special



By Courtesy of "Cumberland Evening News"

REMOVING THE U.A.X. FROM ALSTON. VIEW SHOWING METHOD OF TRUSSING.

truss was designed to fit the complete U.A.X. (two A units and two B units) from which all doors and switches had been removed to reduce weight. The land outside the path of the U.A.X. building at Alston falls away rather sharply, dropping 3 ft. 6 in. in a distance of 5 ft. It was necessary, therefore, to construct a gantry to receive the trussed units, with the aid of two cable drum jacks and planks, the only possible method

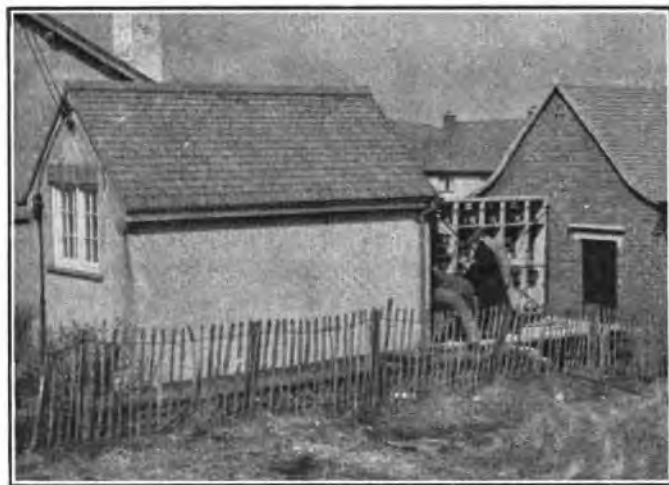

By Courtesy of "Cumberland Evening News"

THE U.A.X. ON THE GANTRY BUILT AT ALSTON.

in the restricted space. The whole U.A.X.12 was then moved as a unit from the building on to the gantry with the aid of rollers and Slingsby bogies, little difficulty being experienced, although a sudden blizzard caused some anxious moments.

When the units arrived at Langdale a three-pole 25-ft. derrick was erected, the lorry backed under this and, with the aid of block and chain, the units were lifted from the lorry,

quickly lowered on to one bogie and then wheeled into the U.A.X. building without difficulty. Examination and test revealed the equipment to be unscratched and in perfect order.

The unit was removed from Alston on 16th April, 1951, and installed at Langdale on the following day, the whole operation employing a total of seven men. A 3-ton Albion was used for transport.

It should be mentioned that an important item not overlooked was that the fitting of the door and jambs at the new U.A.X. had been deferred to allow the necessary clearance for entry of the U.A.X.

Apart from the financial saving resulting from this experiment, there is no doubt that it caused widespread interest and stimulated keen enthusiasm.

## Welsh and Border Counties Region

### ATTENTION TO CABLE FAULT UNDER FLOOD WATER CONDITIONS

Preliminary location of a recent low insulation cable fault affecting, at first, two quads of the Machynlleth-Portmadoc main cable, indicated trouble at a point which had just been described by the Automobile Association and the B.B.C. as "impassable due to heavy flooding." The location of the fault proved to be in a section of the Dovey Bridge Road, which on this occasion was flooded to a depth of between 4 ft. and 8 ft. due to the River Dovey overflowing its banks.

Fortunately a cylinder of CO<sub>2</sub> was available and, under the conditions existing, the only possible remedial course was adopted; gas was inserted at the nearest joint above water and maintained at a low pressure, approximately 2 lb.

There is, of course, nothing original in this procedure, but the results may be of interest to anyone faced with a similar situation. In spite of the fact that the fault subsequently proved to be due to quite a large crater of corrosion, the insulation improved almost immediately and levelled out at 100 megohms. This was maintained for three days, until the water level fell to a degree sufficient to allow the fault to be cleared in the normal way. The Machynlleth-Portmadoc main cable is the only cable serving the west coast between these two points, and had the fault fully developed in this 122/2 cable, much lost trunk time would have ensued, seriously affecting traffic from several exchanges on the route between Machynlleth and Portmadoc.

The actual fault was within a few yards of the joint connecting the cable to the subaqueous length across the River Dovey and, had it been allowed to develop, there is little doubt that the subaqueous portion would have been ruined.

C. B.

### A NEW SATELLITE EXCHANGE IN SWANSEA

The difficulties of obtaining a site and building to accommodate a new main automatic exchange in Swansea have made it necessary to open a new satellite exchange. This will give some much needed relief to the old Siemens No. 16 main exchange and will extend its life by a few more years until its replacement becomes possible.

The new satellite exchange is installed in a large dwelling house in the Uplands suburb of Swansea, which in the pre-war days was the Sectional Engineer's Office. The availability of this accommodation made it possible to avoid any site and building problems, and consequently to give relief somewhat quicker than would otherwise have been possible. The floor had to be strengthened to withstand the weight of the equipment racks, but otherwise the structural alterations were of minor nature. Due to the restricted ceiling height of approximately 10 ft., the apparatus was mounted on 8 ft. 6 in. racks instead of the more usual 10 ft. 6 in. racks used in standard automatic exchange buildings. The apparatus is distributed over seven rooms, but with the help of a concentration of alarm lamps above the main stairway no serious maintenance disadvantage has been noticed.

The exchange was installed by the General Electric Co. and is equipped with 2,000-type non-director satellite equipment with discriminators. It has a multiple capacity of 2,20 and the exchange opened with some 1,300 subscribers and 185 junctions.

The opening of the exchange took place on Sunday, 25th February, 1951, it being necessary to choose a period when traffic was very small because of the complicated nature of the operation. The switching arrangements at transfer were fairly complicated because of the high proportion of subscribers and junctions that used "back end" pairs between the main exchange and the satellite. Also it was necessary to change the numbers of some 550 lines on the main exchange, to prepare the way for the ultimate 5-digit numbering scheme of the area. Thus, there were some 1,200 number changes made at transfer and it was necessary to provide interception facilities on all the old numbers. This was done with level interception and portable changed number interception equipment, specially installed for the purpose.

This transfer is the first stage in the conversion of the Swansea multi-office area from Siemens 16-type equipment (which is believed to have been the first of its kind installed about 1925) to standard 2,000-type equipment. Another satellite will be converted later this year followed by the remaining three satellites and the main exchange, the whole being completed by about 1956. In addition, the bridge control manual board is due to be replaced by a sleeve control board with joint Trunk and Toll working by the end of 1952.

G. W. J.

### North Eastern Region

#### COLLAPSE OF STEEL POLE

The bad weather in February, 1951, caused considerable trouble on the overhead portion of the three circuits existing between Holmfirth telephone exchange and the Television Station at Holme Moss.

Snow and icy winds of extreme gale force continuing for days caused snow and ice to adhere to the wires, which became about 1 in. thick. The 70-lb. C.C. P.V.C. wires forming the three circuits broke, and this caused the steel pole nearest the point of breakage to collapse. The breakage occurred near the summit of the Moss, which is about 1,700 ft. above sea level,

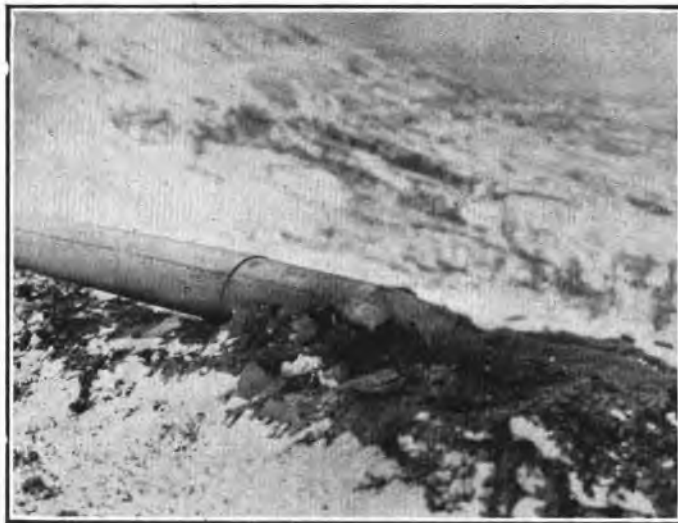

STEEL POLE COLLAPSED AT FOOT.

and the photograph shows that the steel pole "caved in" about a foot above the ground line. The pole was of the 24-ft. L. armed type.

E. S.

### Midland Region

#### AVELING BARFORD TRENCHING MACHINE, TYPE HA 2

A new type of Aveling Barford agricultural drainage machine was recently hired for the purpose of excavating trenching to facilitate the laying of single-way S.A. duct for a junction spur to Whittington U.A.X. from the Lichfield-Tamworth route. This venture proved to be highly successful and progress was very satisfactory. In the absence of a calf-



REAR VIEW OF AVELING BARFORD TRENCHING MACHINE TYPE HA2.

dozer, nine men were employed, plus the machine operator, and the average progress for excavating, duct-laying and filling in (by hand) was found to be easily maintained at 200 yards per day in grass verge.

The claim of the makers that the machine, which works in conjunction with a Fordson Major tractor, can excavate a trench 11 in. wide at the top, 6 in. wide at the bottom, and 2 ft. 6 in. deep at the rate of 5 ft. per minute was substantiated and, since the tractor operates in neutral gear, digging can be carried out on land where it would normally be impossible to use other excavating machinery.

The drive of the machine is from the power-take-off shaft of the tractor to a spring-loaded clutch on the gear-box, through oil-immersed reduction gears, which are housed in a steel case. This spring-loaded clutch is designed to slip, should the cutting rotor plates become overloaded. The forward drive is operated by a ratchet which is part of the "drum assembly." Extended from the drum and anchored ahead of the tractor is a steel rope 65 yards long, and as the ratchet rotates the drum the machine travels along. The ratchet is so adjusted that one, two or three teeth can be operated to propel the machine forward, and should the ground be suitable the engine of the tractor permits an additional speed.

The actual "digging rotor" is fitted at the rear of the tractor. This has six blades of fabricated box section, each fitted with renewable steel cutting-plates and followed by a scraper cleaner. The rotor operating arms are operated by the main driving rods and are fitted with a spring-loaded ratchet plate to allow easy passage over the rotor blades when working. The driving rods are of tubular steel, with a coupling at each end to allow for adjustments when the machine is initially fitted to the tractor. The rotor blades are driven with a lifting cutting action against the undisturbed ground forward, and carry the soil along as they cut through the ground. When they reach the level of the top of the trench, the scraper arm, which is fitted to the rotor operating arms, removes the soil from the plates and, at the same time, prevents them from travelling in the reverse direction until the next cut is made. The soil



THE TRENCHING MACHINE WITH DIGGING ROTOR RAISED CLEAR OF TRENCH.

removed is pushed against a V-shaped plate level with the top of the trench on the ground, and thus deposited on either side of the trench.

The depth of the trench is controlled by the lifting-winch which is operated from the driving seat. The self-sustaining winch raises or lowers the "digging rotor" for working or travelling and there is a safety-catch to prevent over-winding. Power for the winch is taken from the clutch pulley bracket supplied with the tractor. The weight of the excavator at the rear of the tractor is counterbalanced by circular cast-iron weights fitted as discs to the front wheels. The mobility of the unit enables it to be easily moved from site to site.

Acknowledgments are due to Messrs. Aveling Barford and the contractor for details and photographs. E. J. B.

### Home Counties Region

#### RECOVERY OF TS-IH TELEGRAPH CABLE

The recovery of 13 miles of 32/100 + 42/70 cable has recently been completed by Department's labour. At the outset it was anticipated that difficulty would be experienced due to one or more of the following:—

- (a) The cable, which was laid in 1913, was routed through 3½-in. steel pipes for approximately three miles.
- (b) The manholes and surface boxes were, to say the least, not arranged to assist the recovery. (J.R.F.'s existed on the track.)
- (c) Various repairs had been carried out in the past and no record of them was held.

The recovery was commenced using Post Office standard winches but, as was expected, this proved to be an expensive



THE "MORRIS WHEEL," CONSTRUCTED USING A 15-IN. X 9-IN. ARMY TRUCK WHEEL.

method, the recovery rate for a five-man gang being approximately 100 yds. per day. Some lengths had to be passed over as the winch was not powerful enough to move them.

It was then decided to try the "Morris Wheel" and a tractor. A wheel and frame was constructed locally and a Fordson Major tractor, fitted with a winch, hired. The first two lengths were recovered without undue difficulty, but trouble commenced with the third length when the winch rope was broken and the wheel and frame buckled. The winch rope was repaired and another attempt made with the result that the wheel collapsed and the frame (although constructed of 3-in. x ½-in. angle) was completely ruined.

Operations were therefore suspended temporarily while a new wheel was made, a 15-in. x 9-in. Army truck wheel mounted on a 2-in. diameter shaft in a really sturdy frame. The frame dimensions were such as to allow the whole frame to pass through a 2-ft. round manhole entrance, and arrangements were made for the top of the wheel to be level with the roadway surface, the thrust being taken by the concrete structure of the manhole. The Fordson Major was replaced with an International W.9. A snatch block was also constructed with a 5 in. diameter sheave wide enough to pass cable. Operations were then resumed, using either the wheel alone or in conjunction with the 5-in. snatch block and the results surpassed all expectations, the remainder of the cable being recovered with only minor snags.



CUTTING CABLE WITH THE GUILLOTINE.

The wheel is now in as good a condition as at the commencement of the work and is considered a useful addition to the Area mechanical aids pool.

The cutting of the cable into 6-ft. lengths by means of an axe and lead block also seemed inefficient, and a visit to a local agricultural engineering works revealed an obsolete guillotine mounted on a four-wheel bogey. The firm were willing to overhaul and slightly modify it, and when completed this tool was purchased. Using this guillotine, a 176-ft. length can be cut by three men in 25 minutes, thus showing a considerable saving in time and energy.

Using these two mechanical aids a job, which was initially considered to be a "bad debt," has been carried out at less than standard rate. The success, as in all similar jobs, was due to the pooling of ideas of all concerned and the discussion of the problem with the actual workmen who were carrying out the work.

S. W. J.

### London Postal Region

#### POST OFFICE (LONDON) RAILWAY EXHIBIT AT FESTIVAL OF BRITAIN

In May 1949, members of the Council of Industrial Design visited the Post Office Railway and were impressed with the possibilities of a Post Office Railway exhibit at the South Bank site to represent British enterprise in underground railway transport related to Postal Services. Soon afterwards the questions of the form of the exhibit and space required were discussed and agreed, taking into account the space available in the Railway section of the Transport Building.



The final result is a 150 ft. long tunnel, partially underground, the centre area of which is exposed to visitors as a 42 ft. long platform. The viewers stand on a raised platform

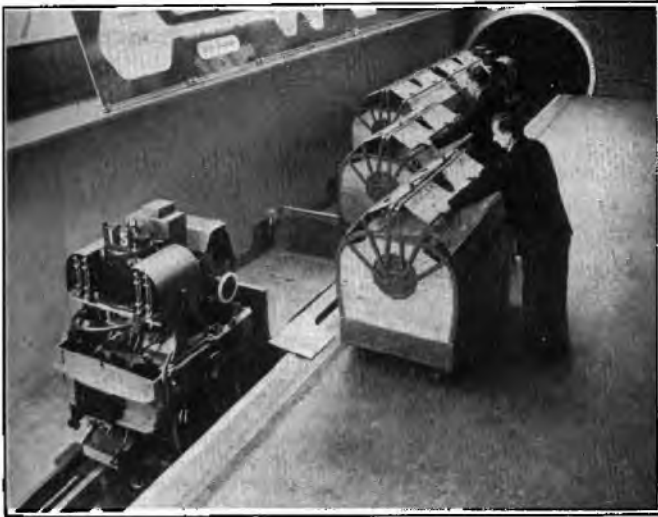

LOADING MAIL CARRIERS AT THE EXHIBITION.

looking down on the train as it moves in and out of the tunnel at each end alternately, with a 10-second stop at each end and in the platform. On this very short track the speed attained is necessarily low. Intermittently a postman switches over to manual control which retains the train in the platform until he has demonstrated to viewers the unloading and reloading of wheeled containers full of dummy mail.

The car used is one withdrawn from normal service, the only modification being the replacement of the manual field reversal switches on each bogie by automatic latching-type contactors. These reversing contactors are energised via auxiliary collector shoes which pick up current from a short portion of permanently energised conductor rail at each end of the tunnel.

A mercury arc rectifier was specially installed to provide the 150-V D.C. supply. A 24-V floating battery supplies the control relays which are of the same type as used on the Post Office Railway and are wired on the same principles. The subdivided conductor rail sections are energised by contactors as is the normal practice on the Post Office Railway.

As with many other South Bank exhibits there were site difficulties up to the last moment, one of the main problems being the bad weather on a very open site when the installation was commenced in February. It is pleasing to be able to report that it was completed and working on the opening day and there is every reason to believe that it is proving of great interest to the visitors.

W. D. McL.

## Junior Section Notes

### Bath Centre

In its first year, the Centre has achieved some measure of success and its Committee have every hope that there will be even better results in the future. Apart from some minor setbacks, resulting in changes in the scheduled programme, the past year has proved our expectations, in enabling members to enjoy lecture matter of interesting quality.

Financially, however, the centre is not particularly stable, and we would express our urgent desire for a membership increase. A sound financial backing can put the Centre's proposed ideas into practice.

The programme now completed was as follows:—"Electrical Engineering in Modern Medicine," by C. Horne, a representative of Stanley Cox, Ltd.; "Cathode Ray Oscillography," by S. A. R. Packer; "Some Differences between British and German Telecommunications Practice," by C. W. Read; "Cornish Tin Mining," by H. W. Jeffries; "The Bath Police Pillar System," by A. L. Mainstone.

During the summer months the emphasis will be on visits instead of lectures.

C. W. R.  
S. A. R. P.

### Bradford Centre

The following notes give a brief review of activities during the 1950-51 session. The annual general meeting was held on 7th June, 1950, when the new committee was elected. Tea was served by members of the Youth Club and afterwards films lent by the British Electricity Authority were shown.

Tuesday, 17th October, 1950, was the occasion of a visit to Players, Ltd., Nottingham; 27 members journeyed by coach and thoroughly enjoyed a most interesting tour of inspection of the factory. Each member was given a packet of 25 cigarettes, many of which were smoked over tea and at a wayside inn on the return journey.

Scarborough Centre still smarting under their defeat of the previous session challenged Bradford to a return Quiz contest, and this was held on Friday, 3rd November, 1950, in the Market Tavern. The questions were of both a humorous and technical nature, and the enjoyment of all 40 members present was further increased by the spontaneous wit of both the question masters and the teams. Needless to say Bradford again won the day, by the narrow margin of a half-mark! For the Quiz contests, amplified lines between the Centres were

"borrowed" and loudspeaker amplifiers No. 6B and carbon microphones were used.

On 4th and 11th November, 1950, visits to the Bradford Town Hall were made for the purpose of inspecting the clock mechanism and the unique carillon, the master clock, the manual tune-playing keyboard, the mechanical tune drum, and the alarm systems. Although a magnificent view of Bradford can be obtained from the top of the tower, few members stayed long enough really to enjoy, it partly because of the great height and partly because of the cold wind.

Mr. Harbottle, the Junior Section President, was kind enough to come to Bradford on Thursday, 14th December, and give his paper, "The Main Phenomena of Hearing and their Effect on the Design of a Communication System." Mr. Harbottle's incomparable method of presentation and illustration of this often overlooked aspect of telecommunication engineering cannot be too highly praised. In spite of very inclement weather, 56 members and guests attended this meeting and once again the Youth Club is to be thanked for providing light refreshments.

Leeds Junior Section, having heard of the success of the Quiz between Bradford and Scarborough, had the temerity to challenge Bradford to such a contest on Wednesday, 7th February, 1951. The meeting was held in the Canteen at Telephone House, and once again the result of a very enjoyable meeting was another victory for Bradford.

Unfortunately, owing to sickness of the speakers, the meetings advertised for January and February, 1951 had to be postponed, but on 12th April Mr. Bauer presented his paper entitled "Ship-to-Shore Radio," and in May Mr. Gleeson read a paper on "Inter-communications Systems." The annual general meeting was held at the end of May. The Hobbies Night, scheduled for February, was not held due to the influenza epidemic, and it is hoped to substitute this with a summer visit to the Bradford Model Engineers' Society's outdoor railway track, when the steam locos. will be seen under "working conditions."

A. E.

### Chiltern Centre

Our 1951 programme opened with a C.O.I. film show on 24th January at the Unity Hall, Aylesbury. Attendance was small, but the show included some very interesting and instructive films. On 14th March, member Mr. K. E. Felton gave a lecture—his third—on "Television, Colour and Cine," at the Electricity Showrooms, Aylesbury, where Mr. Felton had persuaded a local dealer to install, temporarily, two

very fine television sets. Here we must pay tribute to Mr. F. Bent, District Manager, Eastern Electricity Board, who co-operated with us in making the arrangements and attended with his staff. Also present were the Telephone Manager, the Area Engineer and local supervising officers, over 50 in all. The lecturer answered many questions, and these, together with the discussion which followed, indicated the interest with which the lecture had been followed. The rapid passing of time compelled the Chairman to close one of the most successful meetings so far held by this centre.

On 11th April, a further very interesting lecture and demonstration on "Radio and Television Interference" was given by member Mr. T. Leadbitter (High Wycombe). Surrounded by various interference provoking instruments, one television set and one radio set, Mr. Leadbitter produced a variety of devastating noises and picture distortions, followed by practical suggestions for suppressing them. For this meeting we again enjoyed the hospitality of Mr. Bent and his staff at the Electricity Showrooms, Aylesbury, the total number present being about 60.

Arrangements are in hand for a visit to an electrical instrument works, and lectures on (1) "Building a Motor Cycle and Sidecar"; (2) "Constructing a Puppet Theatre"; and (3) "Cycle Racing."  
H. J. T.

### Darlington Centre

An illustrated talk on "Steel" was the feature for our February meeting which attracted a good attendance. Mr. W. French, A.M.I.Mech.E., F.I.W.M. (Darlington and Simpson Rolling Mills, Ltd.), outlined the various aspects of the industry and the specialised work of his own firm. Colour films—from the Sheffield Steel Institute—were shown depicting scenes in various steel works, including works situated in the North-East and they were thoroughly enjoyed. The discussion which followed was obviously enjoyed by Mr. French and the members alike, and an invitation to visit the Darlington Rolling Mills was accepted.

Tuesday, 13th March, marked the fulfilment of a "sporting fixture"—a Quiz—Darlington *v.* Middlesbrough. Prior to the kick-off, a pleasant little ceremony took place at the Darlington end, where the Telephone Manager (Colonel J. R. Sutcliffe) presented his prize to Mr. G. Dale for the best talk given to the Darlington and Middlesbrough Junior Centres. Darlington emerged as the victors in the battle of wits, noteworthy for the good team work, and there were no complaints about the referee (Mr. A. C. Pitcairn, Area Engineer). The success of this Quiz augurs well for any future matches between the two Centres or for inter-Area events.

The last meeting of the session on 10th April, 1951, proved to be a very bright affair and the subject was most appropriate for the season. The speaker was Dr. W. C. Fothergill, M.D., M.B., C.H.B., D.R.M.E., and the subject "Colour Photography." Dr. Fothergill described the development and progress of the art and illustrated several examples of his own work—the collection included photographs of local beauty spots shown in their glorious natural colours. Confirmation of the happy choice of the talk was signified by the enthusiasm shown at the meeting at which the Telephone Manager and the Area Engineer were present.

Written papers read during the session have been submitted, in respect of two members, for the Regional and National Competitions.  
C. N. H.

### Glasgow and West of Scotland Centre

We have now completed our programme for the year. Whilst the membership (59) is good, it could be much better. The attendance at the lectures could be greatly improved upon, but the visits were very well attended. Several of the members made very good use of the Library facilities.

At the annual general meeting on 20th April, it was decided to continue for another session, and the following office-bearers were elected:—

*President*, F. R. B. Bucknall, D.T.M.; *Vice-President*, R. T. Shanks, T.O.; *Secretary and Treasurer*, J. Earls, Y.-in-T.

*Committee*:—W. R. Craig, T.O.; J. J. Brown, T.O.; J. Goldie, T.O.; J. Moore, T.1; W. Livingstone, T.2A; and three Youths to be co-opted.

The programme for 1951-52 was discussed at some length and the following talks and visits were suggested:—

Lectures on Television, Radar, Radio in the P.O., The B.E.A. Grid and Control System; Visits to Cable Ship, Coplaw Road Works, Scottish Iron and Steel Works.

It is hoped to arrange a full programme, and suggestion will be gratefully received by the Secretary. Watch out for further notes, and "Let Glasgow Flourish."  
J. C. E.

### London Centre

The session 1950-51 has seen what may prove to be a notable event in the history of the Junior Section, namely the formation of a Radio Group within the framework of the London Centre. It was to assist members in the practical side of radio communication that the idea of a Radio Group was conceived. With a membership of 278 the Radio Group is now a permanent feature of the London Centre.

The Junior Section Handbook is now complete and is a present in the hands of members of the Institution for verification of accuracy.

The Sub-Committee formed to collect data for the formation of the proposed National Junior Section Council, has made good progress. In this connection it is desired to draw attention to the following:—

#### IMPORTANT NOTICE

Will all I.P.O.E.E. (Junior Section) Centre Secretaries please communicate the name, official address, and telephone number of their Centre Chairman, to:

Mr. P. SAYERS. LD/EE7,  
South East Block,

Faraday Building, London, E.C.4.

Details of the proposed National Junior Section Council will then be forwarded direct.

Youths-in-training are reminded that the London Centre "Youths' Essay Competition" is still in existence, and prize of £2, £1 and 10s. are offered for papers submitted.

The London Centre Librarian has distributed a total of 4,312 periodicals during the year. The aim of the Centre is to complete the circulation of a periodical within six months of the date of issue; it is essential therefore that members co-operate by not retaining an issue more than two days.

The total membership of the London Centre is 2,693, but more members, particularly external personnel, would be very welcome.  
M. J. G.

### Middlesbrough Centre

Our last ordinary meeting for the 1950-51 session was held on the 13th March, and we are now in a position to report steady increase in attendances at our meetings.

On the 22nd February, Mr. R. Dingwall, M.I.E.E., of Messrs. Dorman Long & Co., Ltd., Middlesbrough, gave an interesting and instructive talk on "Electrical Engineering in Iron and Steel Works." During the lively discussion which followed, several questions were put to the speaker, and the talk proved to be most instructive.

To complete the programme, the Inter-Centre Two-Way Quiz between Darlington and Middlesbrough took place on the 13th March. All members who attended voted the venture a great success. At "Close of play" Darlington proved themselves the better team, having defeated Middlesbrough by 10 points, the total scores reading—Darlington 66 points; Middlesbrough 56 points. Our thanks are due to the efficient Quiz-master, Mr. A. C. Pitcairn, Area Engineer, and to Messrs. H. C. Naylor and B. V. Northall, for their services. It is hoped that another Two-Way Quiz will be included in the programme for the next session.

At the time of writing the annual general meeting of the Middlesbrough Centre is planned to take place on the 10th May.  
J. B.

# Staff Changes

## Promotions

Name	Region	Date	Name	Region	Date
<i>Staff Engr. to Asst. E.-in-C.</i>			<i>Tech. Offr. to Asst. Engr.</i>		
Mumford, A. H.	E.-in-C.O.	1.4.51	Weedon, H. F.	L.T. Reg. to E.-in-C.O.	7.4.51
<i>Staff Engr. to Depy. Reg. Dir.</i>			Hawkins, W.	E.-in-C.O.	14.3.51
Jemell, W. T.	E.-in-C.O. to Mid. Reg.	17.5.51	Finch, D. W.	H.C. Reg. to E.-in-C.O.	3.3.51
<i>Area Engr. to Depy. T.M.</i>			Mason, G. A. C.	E.-in-C.O.	14.3.51
Adam, S. A. F.	N.E. Reg. to L.T. Reg.	5.2.51	Adams, H. C.	L.T. Reg. to E.-in-C.O.	7.4.51
<i>Exec. Engr. to Snr. Exec. Engr.</i>			Cooper, E. R.	E.-in-C.O.	14.3.51
Lewis, C. H.	S.W. Reg.	1.3.51	Gill, G. E.	L.T. Reg. to E.-in-C.O.	7.4.51
Funncliffe, T.	Mid. Reg.	5.3.51	Dadd, J. N.	E.-in-C.O.	14.3.51
Barry, C.	W.B.C. Reg.	11.3.51	Teunion, R. J.	Scot. to E.-in-C.O.	3.3.51
Buch, R. C.	H.C. Reg.	5.4.51	Lawrence, J. A.	E.-in-C.O.	14.3.51
Hope, H. G.	N.W. Reg.	5.4.51	<i>M.T.O. III to M.T.O. II</i>		
Hall, G. K.	N.E. Reg. to S.W. Reg.	30.4.51	Bailey, C. S.	E.-in-C.O.	12.4.51
Thwaite, H.	E.-in-C.O.	3.3.51	<i>Tech. Asst. I to M.T.O. III</i>		
Jobbie, A. K.	E.-in-C.O.	5.3.51	Edwards, W. H.	E.-in-C.O.	19.4.51
Hunt, A. H. F.	E.-in-C.O.	5.3.51	<i>Exec. Engr. to Snr. Exptl. Offr.</i>		
Jones, F.	E.-in-C.O.	15.3.51	Seymour, R. A.	E.-in-C.O.	2.5.51
Redshaw, C. C.	E.-in-C.O.	24.5.51	<i>Exptl. Offr. to Snr. Exptl. Offr.</i>		
<i>Regl. Tng. Offr. to Snr. Exec. Engr.</i>			Terrett, L. E.	E.-in-C.O.	24.4.51
Mitchell, M.	L.T. Reg. to E.-in-C.O.	5.3.51	Yemm, H.	E.-in-C.O.	16.3.51
<i>Proby. Exec. Engr. to Exec. Engr.</i>			Taylor, P. E.	E.-in-C.O.	24.4.51
Hale, H. S.	E.-in-C.O.	1.2.51	<i>Asst. Eng. to Exptl. Offr.</i>		
Smith, C.	E.-in-C.O.	1.2.51	Fromberg, C. S.	E.-in-C.O.	7.5.51
Jaxby, F. H.	Mid. Reg.	10.2.51	Smith, J. S.	E.-in-C.O.	7.5.51
Fomlinson, H.	N.E. Reg.	12.2.51	<i>Asst. Exptl. Offr. to Exptl. Offr.</i>		
<i>Asst. Engr. to Exec. Engr.</i>			Harrison, J. I.	E.-in-C.O.	24.4.51
Baxter, W. S.	Scot.	1.3.51	<i>Asst. (Sc.) to Asst. Exptl. Cffr.</i>		
Thomas, A. S.	S.W. Reg.	1.4.51	Rogers, M. W.	E.-in-C.O.	4.4.51
Greaves, D. H.	Mid. Reg.	5.3.51	Dunk, J. O. (Miss)	E.-in-C.O.	4.4.51
Forrester, H.	N.E. Reg. to N. Ire. Reg.	27.3.51	<i>Asst. (Sc.) to Snr. Asst. (Sc.)</i>		
Kelly, F.	N.W. Reg. to E.-in-C.O.	21.4.51	Brown, B. M. (Mrs.)	E.-in-C.O.	4.4.51
Freeman, J. H.	L.T. Reg. to E.-in-C.O.	7.4.51	Holland, L. (Miss)	E.-in-C.O.	4.4.51
Reade, N. I.	H.C. Reg. to E.-in-C.O.	23.4.51			
Roberts, H. E.	N.E. Reg. to E.-in-C.O.	30.4.51			
White, C. F.	H.C. Reg. to E.-in-C.O.	30.4.51			

## Retirements

Name	Region	Date	Name	Region	Date
<i>Asst. E.-in-C.</i>			<i>Asst. Engr.—continued.</i>		
Legg, J.	E.-in-C.O.	31.3.51	Young, T. A. M.	E.-in-C.O. (Resigned)	28.4.51
<i>Regl. Engr.</i>			Montgomery, J. A.	E.-in-C.O. (Resigned)	4.5.51
Stone, A. E.	L.T. Reg.	1.5.51	Harris, G.	L.T. Reg.	24.4.51
<i>Exec. Engr.</i>			Streatfield, F. G.	L.T. Reg.	30.4.51
Price, J. W.	E.-in-C.O.	31.3.51	Fazackerley, H.	N.W. Reg.	12.4.51
Jackson, D.	E.-in-C.O.	30.4.51	Dutton, E. S.	L.T. Reg.	31.5.51
Howe, H. B.	L.T. Reg.	30.4.51	Granby, J. A.	L.T. Reg.	31.5.51
Salt, J. R.	Scot.	5.5.51	Wheeler, W. H.	L.T. Reg.	14.5.51
Willmott, C. J.	H.C. Reg.	31.5.51	Davis, R. E.	L.T. Reg.	30.4.51
Hartley, C. A.	N.E. Reg.	28.5.51	<i>Inspector</i>		
Howard, A. A.	L.T. Reg.	31.3.51	Headen, S. A.*	L.T. Reg.	28.2.51
Thraves, J. J.	L.T. Reg.	12.3.51	Shaddick, W. H. J.	L.T. Reg.	2.3.51
Lowther, S. W.	S.W. Reg.	13.3.51	Morris, S. W.	H.C. Reg.	12.10.50
<i>Asst. Engr.</i>			Brown, J.	N.E. Reg.	31.10.50
Greenwood, E.	Mid. Reg.	10.2.51	Atkinson, J. W.	N.E. Reg.	31.12.50
Connor, C. H.	L.T. Reg.	18.3.51	White, J. B.	M'd. Reg.	2.10.50
Bydwell, L. S.	L.T. Reg.	26.3.51	Cooper, A.	N.W. Reg.	6.8.50
Sparrowe, V. J.	H.C. Reg.	10.9.50	Jefferies, G. T.	S.W. Reg.	31.12.50
Luckham, F. R.	N.E. Reg.	31.12.50	Munro, S. G.	Scot.	31.7.50
Harvey, W. H.	L.T. Reg.	17.3.51	Malcolm, W. A. S.	Scot.	30.11.50
			<i>Asst. (Sc.)</i>		
			Journet, L. F. (Mrs.)	E.-in-C.O. (Resigned)	31.5.51

\*This entry was incorrectly included under Deaths in the April 1951 issue. Apologies are offered for this unfortunate mistake.

### Transfers

Name	Region	Date	Name	Region	Date
<i>Staff Engr.</i>			<i>Exec. Engr.—continued.</i>		
Moffatt, C. E. .. ..	E.-in-C.O. to W.B.C. Reg.	1.4.51	de Wardt, R. H. .. ..	E.-in-C.O. to L.T. Reg. ..	11.2.5
<i>Snr. Exec. Engr.</i>			Rance, J. W. .. ..	E.-in-C.O. to Scot. ..	15.1.5
Mayo, S. J. .. ..	H.C. Reg. to Australian P.O. .. ..	29.3.51	Kitchen, R. G. .. ..	E.-in-C.O. to Australian P.O. .. ..	26.3.5
Burton, J. P. .. ..	N.W. Reg. to Australian P.O. .. ..	7.3.51	Horne, F. A. .. ..	E.-in-C.O. to P. & T. Dept., East Africa .. ..	17.3.5
Barnett, H. E. .. ..	L.T. Reg. to Ministry of Supply .. ..	1.5.51	<i>Asst. Engr.</i>		
Robinson, A. K. .. ..	L.T. Reg. to N.E. Reg. ..	18.2.51	Salter, F. C. .. ..	E.-in-C.O. to Mid. Reg. ..	1.3.5
Wright, C. H. .. ..	E.-in-C.O. to L.T. Reg. ..	5.3.51	Bamford, A. .. ..	E.-in-C.O. to Mid. Reg. ..	25.3.5
Webber, F. W. J. .. ..	E.-in-C.O. to L.T. Reg. ..	1.5.51	Wilson, J. .. ..	L.T. Reg. to E.-in-C.O. ..	12.3.5
Mew, R. J. .. ..	E.-in-C.O. to Ministry of Supply .. ..	15.5.51	Smith, T. E. .. ..	E.-in-C.O. to Mid. Reg. ..	1.4.5
Mew, G. M. .. ..	H.C. Reg. to E.-in-C.● ..	1.5.51	Lynas, T. W. .. ..	E.-in-C.O. to Scot. ..	8.4.5
<i>Exec. Engr.</i>			McHarg, J. .. ..	E.-in-C.O. to Foreign Office	1.1.4
Dafforn, D. G. .. ..	E.-in-C.O. to W.B.C. Reg.	1.4.51	Reardon, J. .. ..	E.-in-C.O. to Foreign Office	1.1.4
Cranston, W. D. .. ..	E.-in-C.O. to S.W. Reg.	11.2.51	Watkins, S. B. .. ..	E.-in-C.O. to N.E. Reg. ..	15.5.5
			<i>M.T.O. III</i>		
			Jamieson, J. A. .. ..	E.-in-C.O. to Public Works Dept., Nyasaland ..	21.3.5

### Deaths

Name	Region	Date	Name	Region	Date
<i>Exec. Engr.</i>			<i>Asst. Engr.—continued.</i>		
McWalter, W. V. .. ..	Scot. .. ..	15.4.51	Crump, A. G. .. ..	L.T. Reg. .. ..	1.5.5
<i>Asst. Engr.</i>			Hawkins, W. .. ..	N.E. Reg. .. ..	24.5.5
Williams, E. .. ..	S.W. Reg. .. ..	4.4.51	<i>Inspector</i>		
Deeks, W. F. .. ..	L.T. Reg. .. ..	9.5.51	Causley, R. W. .. ..	H.C. Reg. .. ..	16.2.5
			Chainey, W. G. .. ..	L.T. Reg. .. ..	11.3.5

### CLERICAL GRADES

#### Promotions

Name	Region	Date	Name	Region	Date
<i>E.O. to H.E.O.</i>			<i>C.O. to E.O.—continued.</i>		
Ledger, F. H. .. ..	E.-in-C.O. .. ..	2.1.51	Bevan, W. R. .. ..	E.-in-C.O. .. ..	5.3.5
Sims, E. K. (Mrs.) .. ..	E.-in-C.O. .. ..	8.2.51	Tolley, D. M. (Miss) .. ..	E.-in-C.O. .. ..	5.3.5
<i>C.O. to E.O.</i>			Embleton, A. .. ..	E.-in-C.O. .. ..	12.3.5
Paxton, W. H. .. ..	E.-in-C.O. .. ..	1.2.51	Howlett, G. V. .. ..	E.-in-C.O. .. ..	21.3.5
Flint, W. D. .. ..	E.-in-C.O. .. ..	1.3.51	Clow, L. E. .. ..	E.-in-C.O. .. ..	23.3.5
			Court, R. .. ..	E.-in-C.O. .. ..	2.2.5

#### Transfers

Name	Region	Date	Name	Region	Date
<i>E.O.</i>			<i>E.O.—continued.</i>		
Newman, W. D. J. .. ..	E.-in-C.O. to Ministry of Supply .. ..	2.4.51	Brimmer, W. L. .. ..	E.-in-C.O. to Min. of T. and C. Planning .. ..	15.1.5
Laidlar, F. E. .. ..	E.-in-C.O. to Ministry of Supply .. ..	23.4.51			

#### Retirement

Name	Region	Date
<i>S.E.O.</i>		
Hamilton, C. J. .. ..	E.-in-C.O. .. ..	31.5.51



## DRAUGHTSMEN

### Promotions

Name	Region	Date	Name	Region	Date
<i>L/D'man to Snr. D'man</i>			<i>D'man Cl. I to L/D'man.—continued.</i>		
Furness, J. . . . .	Scot. . . . .	10.4.51	Pearce, C. C. . . . .	L.T. Reg. . . . .	—
<i>D'man Cl. I to L/D'man</i>			<i>D'man Cl. II to D'man Cl. I</i>		
Bell, W. . . . .	N.W. Reg. . . . .	27.1.51	Gibbs, D. S. . . . .	E.-in-C.O. . . . .	26.2.51
Macklow, C. D. . . . .	Mid. Reg. to H.C. Reg. . . . .	1.5.51	Jones, R. G. . . . .	E.-in-C.O. . . . .	26.2.51
Harding, J. F. . . . .	E.-in-C.O. . . . .	28.5.51	Nettleton, D. J. J. . . . .	E.-in-C.O. . . . .	26.2.51
Alexander, H. C. A. . . . .	E.-in-C.O. . . . .	15.1.51			

### Transfer

Name	Region	Date
<i>L/D'man</i>		
Brasier, C. J. . . . .	N.W. Reg. to H.C. Reg. . . . .	12.3.51

### Retirements

Name	Region	Date	Name	Region	Date
<i>L/Draughtsman</i>			<i>Draughtsman Cl.I.</i>		
Hill, R. . . . .	S.W. Reg. . . . .	26.3.51	Pool, L. B. . . . .	E.-in-C.O. . . . .	17.5.51

### Death

Name	Region	Date
<i>Chief Draughtsman</i>		
Lennon, F. T. . . . .	E.-in-C.O. . . . .	17.3.51

### BOARD OF EDITORS

H. FAULKNER, C.M.G., B.Sc., M.I.E.E., Chairman.  
 F. E. NANCARROW, O.B.E., A.R.C.Sc., M.I.E.E.  
 W. WEST, B.A., M.I.E.E.  
 Capt. C. F. BOOTH, O.B.E., M.I.E.E.  
 L. F. SCANTLEBURY, Whit.Sch., A.C.G.I., D.I.C., A.M.I.E.E.  
 D. A. BARRON, M.Sc., A.M.I.E.E.  
 E. DAVIS, A.M.I.E.E.  
 L. CHANT.  
 G. E. STYLES, A.M.I.E.E., Managing Editor.  
 W. A. HUMPHRIES, A.M.I.E.E.  
 J. P. HARDING, B.Sc.(ENG.),  
 A.M.I.N.S.T.C.E., A.M.I.E.E. } Assistant Editors.  
 A. J. HUTCHISON, Secretary-Treasurer.

### Copyright

The entire contents of this JOURNAL are covered by general copyright, and special permission is necessary for reprinting long extracts, but Editors are welcome to use not more than one-third of any article, provided credit is given at the beginning or end thus: "From the *Post Office Electrical Engineers' Journal*."

The Board of Editors is not responsible for the statements made or the opinions expressed in any of the articles in this JOURNAL, unless such statement is made specifically by the Board.

### Communications

All communications should be addressed to the Managing Editor, *P.O.E.E. Journal*, Engineer-in-Chief's Office, Alder House, Aldersgate Street, London, E.C.1. Telephone: HEAdquarters 1234.

Remittances should be made payable to "*The P.O.E.E. Journal*" and should be crossed "& Co."

### Binding Cases

Cases for binding are available, and may be obtained from the Local Agents for 2s. Subscribers can have their copies of volumes bound, at a cost of 7s. 6d., by sending the complete set of parts to the Local Agents or to the *P.O.E.E. Journal*, Engineer-in-Chief's Office, Alder House, Aldersgate Street, London, E.C.1. Orders for binding for Vols. 1-19 should indicate whether the original binding case with black lettering, or the later pattern with gold, is required. Cases with gold lettering are the only type stocked from Vol. 20 onwards.

### Back Numbers

The price of the JOURNAL, which is published quarterly, is 1s. 6d. (1s. 9d. post free) per copy, or 7s. per annum post free. Back numbers can be supplied, subject to availability of stocks, at 1s. 6d. each (1s. 9d. post free). Orders for back numbers may be sent to the Local Agents or to the Publishers.

### Advertisements

All communications relating to space reservations should be addressed to the Advertisement Editor, *P.O.E.E. Journal*, Alder House, Aldersgate Street, London, E.C.1. Communications regarding advertisement copy, proofs, etc., should be addressed to the Publishers, Messrs. Birch & Whittington (Prop. Dorling & Co. [Epsom], Ltd.), 49 Upper High Street, Epsom, Surrey.

# Ericsson

## TRANSMISSION EQUIPMENT

For use on open wire lines, cables and radio circuits which may form part of a trunk network or provide point to point working.

*The more important products include—*

**P.O. Amplifier No. 32 for 4-wire repeatered circuits.**

**P.O. Amplifier No. 35 for music circuits.**

**Single and 3-channel Carrier System for Open Wires.**

**Radio—Telephone terminating equipment.**

**Single Side Band Transmitter Drive Equipment.**

**Multi Channel V.H.F. Radio Links.**

The performance of the equipment is to C.C.I.F. or customer's specification and carries the same quality and finish as the manual and automatic telephone for which the Company is so well known.

***Performance to C.C.I.F. or  
customer's specification***

**ERICSSON TELEPHONES LTD.**

★ *This illustration shows  
a typical 3-Channel  
Carrier Terminal.*

22 LINCOLN'S INN FIELDS · LONDON · W.C.2 · Telephone: HOLborn 6936 · Works: BEESTON · NOTTS

# AUTOMATIC VOLTAGE REGULATORS by B.P.T

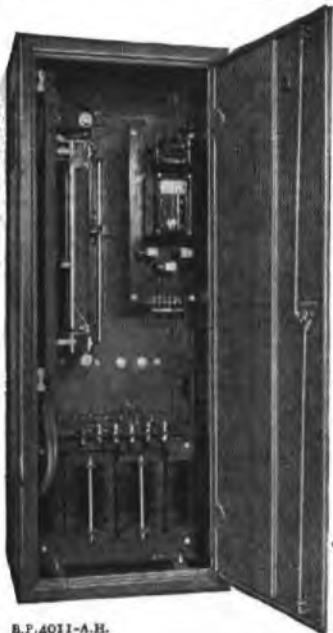

Maintaining a constant voltage unaffected by variation in the supply voltage, frequency, load and load power factor is a problem which can be solved by the aid of our standard range of Automatic Voltage Regulators. For single phase operation there are 11 models from 12½ to 240 amps, for three-phase there are 13 models from 7½ to 150 amps.

Three typical models are illustrated from our standard range of wall or floor mounting types.

- TOP** 3-phase, air cooled, wall mounting model. Input 440V  $\pm$  10%, output 440V  $\pm$  1%. 7½ amps.
- LEFT** 3-phase, air cooled, floor mounting (cubicle) model. Input 440V  $\pm$  10%, output 440V  $\pm$  1%. 40 amps.
- RIGHT** Single-phase, air cooled, wall mounting model. Input 250V  $\pm$  15%, output 250V  $\pm$  1%. 25 amps.

Please write for further information and literature. BP401/9



**BRITISH POWER TRANSFORMER CO. LTD.**

Phone: HOWARD 1492 QUEENSWAY, PONDERS END, MIDDLESEX Grams: "Vitrahm Enfield"

# EDISWAN

## Telephone Line Protectors

FOR THE PROTECTION OF LINES OF COMMUNICATION FROM SURGES INDUCED BY LIGHTNING OR FAULTS ON NEIGHBOURING POWER LINES

Ediswan Telephone Line Protectors have now been in commission for nearly twenty years. They have proved their worth in all parts of the world and are being called for and installed in ever increasing numbers. Many thousands were employed during the war years for the protection of vital lines of communication and were eminently successful. Reports of their outstanding merit and successful operation continue to reach us and in recent years they have proved of particular interest for protection against surges caused by lightning discharges.

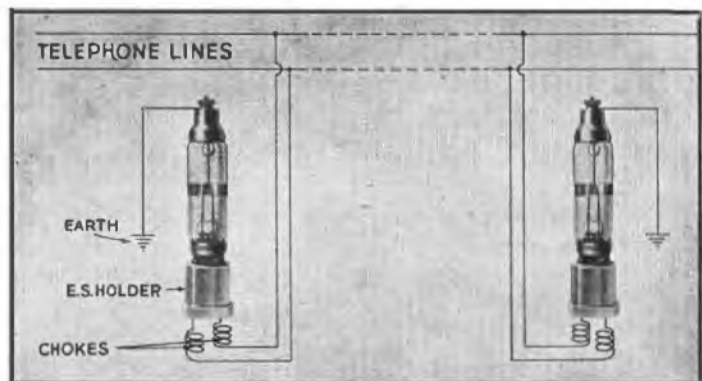

Continued research has enabled us to patent a further improvement which removes any suggestion of delay in operation.

Further information and prices on application.

**THE EDISON SWAN ELECTRIC CO. LTD., 155 CHARING CROSS ROAD, LONDON, W.C.2**

Member of the A.E.I. Group of Companies

T.E.S

## INDEX TO ADVERTISERS

	PAGE
Airmec Laboratories, Ltd. . . . .	xxiii
Alton Battery Co., Ltd., The . . . . .	xv
Automatic Coil Winder & Electrical Equipment Co., Ltd. . . . .	xxii
Automatic Telephone & Electric Co., Ltd. . . . .	viii-ix
Bennett College, The . . . . .	ii
British Electric Resistance Co., Ltd., The . . . . .	ii
British Institute of Engineering Technology . . . . .	iv
British Power Transformer Co., Ltd. . . . .	iii
Creed & Co., Ltd. . . . .	xx
De La Rue & Co., Ltd. . . . .	xxi
Dubilier Condenser Co. [1925], Ltd. . . . .	xi
Edison Swan Electric Co., Ltd., The . . . . .	iii
Ericsson Telephones, Ltd. . . . .	iia
General Electric Co., Ltd., The . . . . .	xviii-xix
Great Northern Telegraph Co., Ltd. . . . .	vii
Hackbridge Cable Co., Ltd. . . . .	vii
International Correspondence Schools, Ltd. . . . .	xxiii
Marconi's Wireless Telegraph Co., Ltd. . . . .	v
Muirhead & Co., Ltd. . . . .	iv
Neill, James, & Co., Ltd. . . . .	xiv
Painton of Northampton . . . . .	xxiv
Pirelli-General Cable Works, Ltd. . . . .	xxiv
Pitman, Sir Isaac, & Sons, Ltd. . . . .	xiv
Savage Transformers . . . . .	ii
Savage, W. Bryan, Ltd. . . . .	xiv
Siemens Brothers & Co., Ltd. . . . .	x
Skillman, T. S. & Co., Ltd. . . . .	vi
Smith, Frederick, & Co. . . . .	ii
Standard Telephones . . . . .	xii-xiii
Sullivan, H. W., Ltd. . . . .	xvii
Telephone Manufacturing Co., Ltd. . . . .	xxii
Tungstone Products, Ltd. . . . .	xviii
Westinghouse Brake & Signal Co., Ltd. . . . .	xvii
Winn & Coales, Ltd. . . . .	xxiii

## VALUABLE FREE BOOK

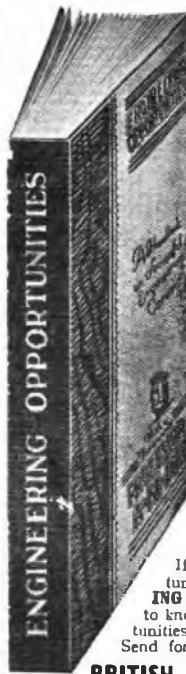

**Tells You How to Pass Your C. & G. or Promotion Exam. at First Attempt!**

All Post Office Engineering personnel who are anxious to obtain early promotion should at once send for a copy of our handbook "ENGINEERING OPPORTUNITIES," which, among other intensely interesting matter, describes our unique methods of preparation for **TECHNICAL APPOINTMENTS IN THE POST OFFICE** (Assistant Engineer—New Style and Assistant Traffic Superintendent), **CITY AND GUILDS EXAMINATIONS** in Principles of Telecommunications (1-5), Radio (1-4), Telephone Exchange Systems (1-3), Telegraphy (1 and 2), Line Transmission (1 and 2), Lines Plant Practice (1 and 2), Mathematics for Telecommunications (1-5), Electrical Engineering Practice (Prelim. Inter. and Final), and outlines a wide range of non-examination courses in all branches of **Electrical, Mechanical, Civil, Automobile, Aeronautical and Radio Engineering.**

**Assistant Engineer and Assistant Traffic Superintendent. Open competitions now resumed. Age extensions for established Civil Servants. Ask us for full details**

**We definitely guarantee  
"NO PASS—NO FEE"**

If you intend to make the most of to-day's opportunities, you cannot afford to miss reading "ENGINEERING OPPORTUNITIES." It tells you everything you want to know to secure advancement, and describes many opportunities you may now be missing through lack of information. Send for your copy to-day—**FREE** and without obligation.

**BRITISH INSTITUTE  
OF ENGINEERING TECHNOLOGY  
369 SHAKESPEARE HOUSE,  
17-19 STRATFORD PLACE, LONDON, W.1**

# BIET

## MUIRHEAD 1951 CATALOGUE

MUIRHEAD & CO., LTD.  
BECKENHAM · KENT · ENGLAND

*Please send me, free of charge,  
your 1951 CATALOGUE advertised in the  
"Post Office Electrical Engineers Journal"*

NAME \_\_\_\_\_

ADDRESS \_\_\_\_\_

46b

**MUIRHEAD**    PRECISION ELECTRICAL INSTRUMENTS

# MUIRHEAD & CO. LTD.

BECKENHAM · KENT · ENGLAND    Telephone: BECKenham 0041  
Telegrams and Cables: MUIRHEADS ELMERS-END



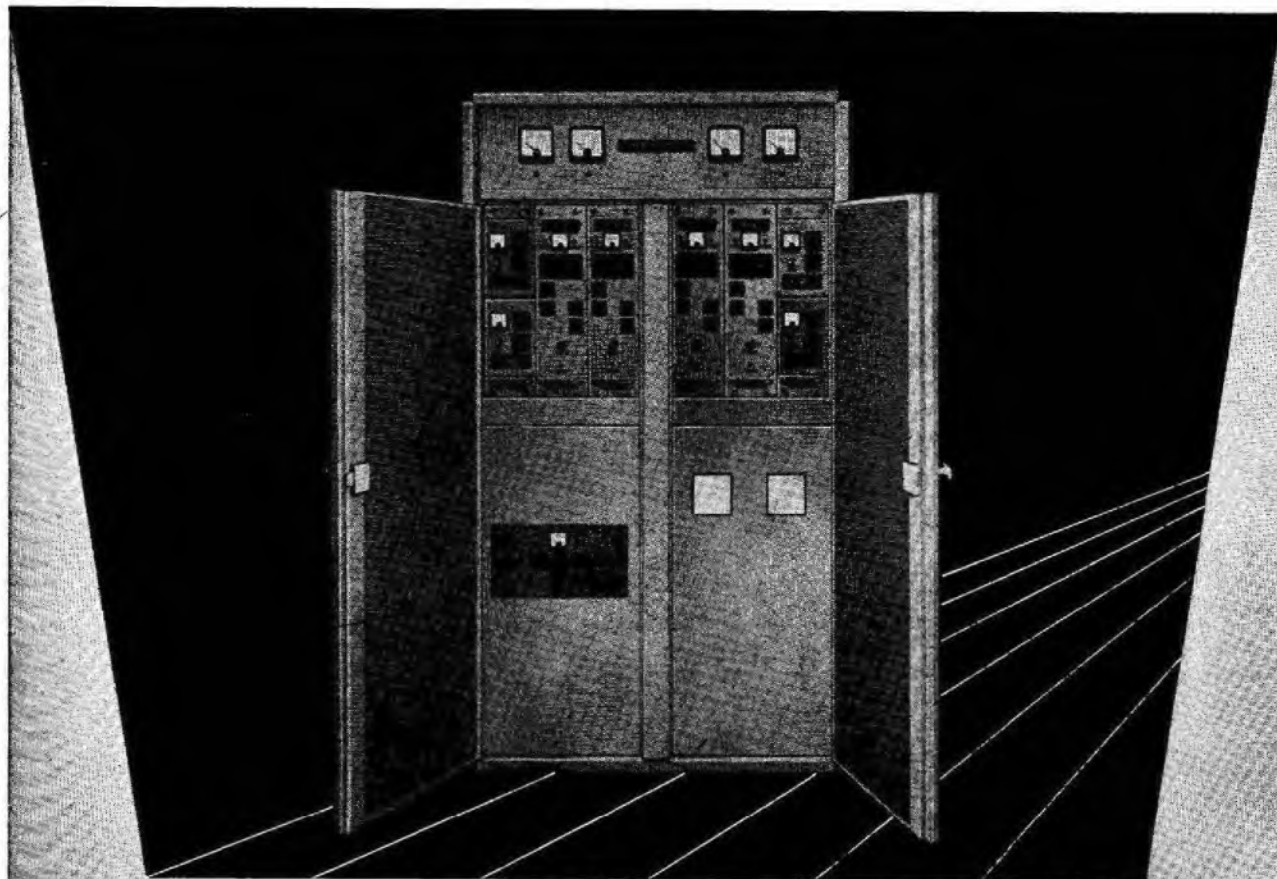

## H.F. CHANNELISED TRANSMITTERS

(H.C. 100 SERIES)

▶ **Output :** 400 watts for all transmissions.

▶ **Frequency Range :** 2 Mc/s to 27.5 Mc/s.

▶ **Transmission :**

Telephony, (high-level modulation).

Telegraphy : C.W. on/off. M.C.W.  
Frequency Shift.

*The Series comprises nine standard editions offering :—*

▶ **Simultaneous Operation** on 2, 3, or 4, pre-selected frequencies, depending on the types of transmission chosen.

▶ **Local or Remote Control** of each channel.

# MARCONI COMMUNICATION SYSTEMS

SURVEYED · PLANNED · INSTALLED · MAINTAINED

# SKILLMAN

## *Telecommunication Equipment*

- \* TELEPHONE SYSTEMS
- \* PRECISION MEASURING APPARATUS
- \* REMOTE CONTROL APPARATUS
- \* SPECIAL COMPONENTS



**T. S. SKILLMAN AND COMPANY LIMITED**

CABLES:  
SKILLCO, LONDON

**6 YORK BUILDINGS,  
ADELPHI,  
LONDON, W.C.2**

PHONE:  
TRAFALGAR 4707

# G.N.T.

## MORSE TRANSMITTERS



MODEL 113  
Speed range:  
5-35 words per  
minute.  
Specially suitable  
for radio  
training schools.

Absolutely constant speed  
at all settings notwithstanding  
large voltage variations.  
Noted for easy maintenance  
and quick adjustment.  
Supplied with A.C. or D.C.  
motors as required.



MODEL 112  
Speed range:  
13-250 words  
per minute  
without gear  
changes.

*Universally adopted*

✧ Write for comprehensive catalogue.

**THE GREAT NORTHERN TELEGRAPH COMPANY'S FACTORY**  
 4, SYDHAVNS PLADS COPENHAGEN SV . DENMARK      ★      LONDON OFFICE: 5, ST. HELENS PLACE LONDON E.C.3.

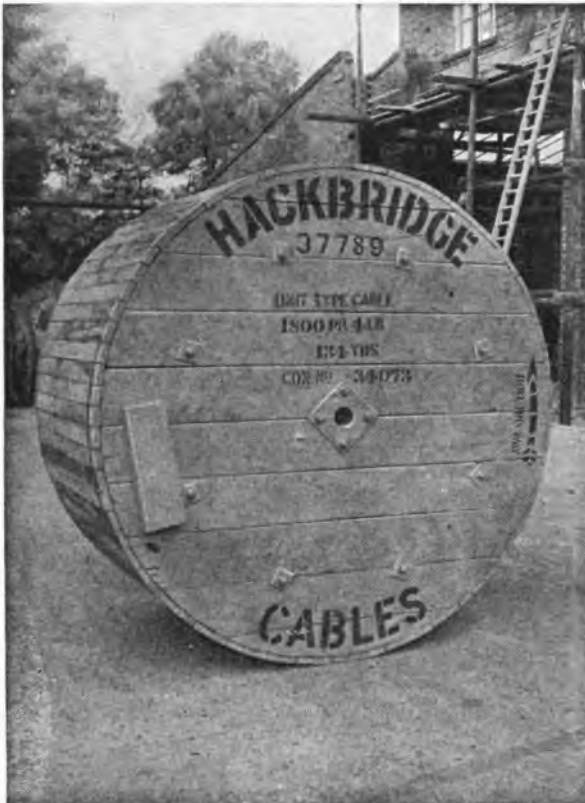

## BEYOND THE BUTTON...

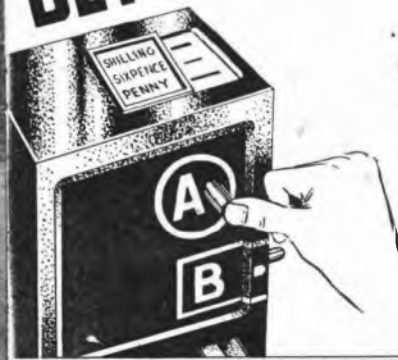

.... Hackbridge under-ground dry-core air-space lead covered and armoured cable.  
 Contractors to G.P.O., British Railways, British and Colonial Government Departments.

**HACKBRIDGE**  
*Cable Company Limited*  
 KELVIN WORKS, HACKBRIDGE, SURREY  
 In Association with Bryce Electric Construction Company Ltd.  
 Branches at:  
 Birmingham, Bristol, Cardiff, Manchester, Newcastle, Sheffield



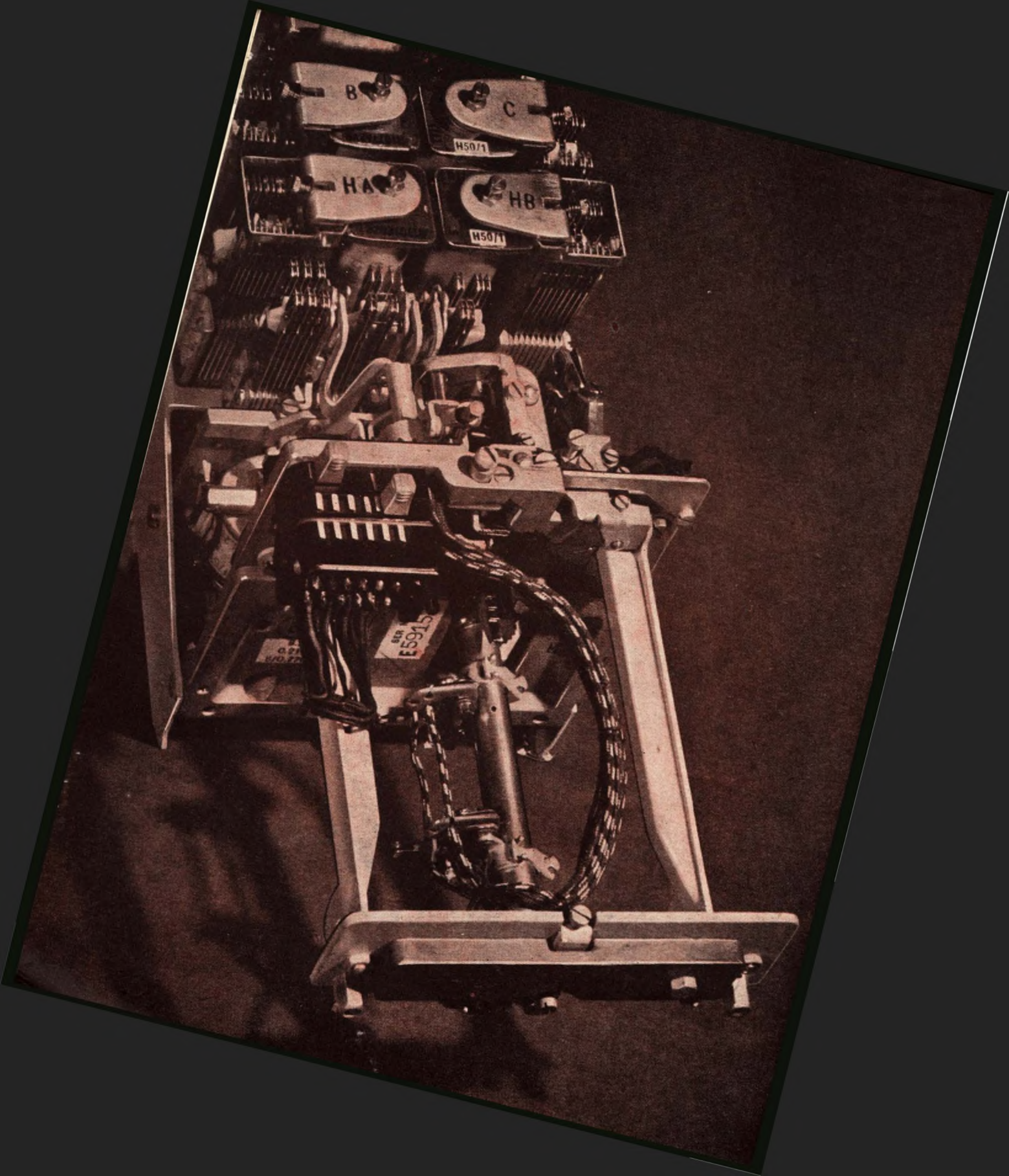



# TYPE 32A MARK II SELECTOR

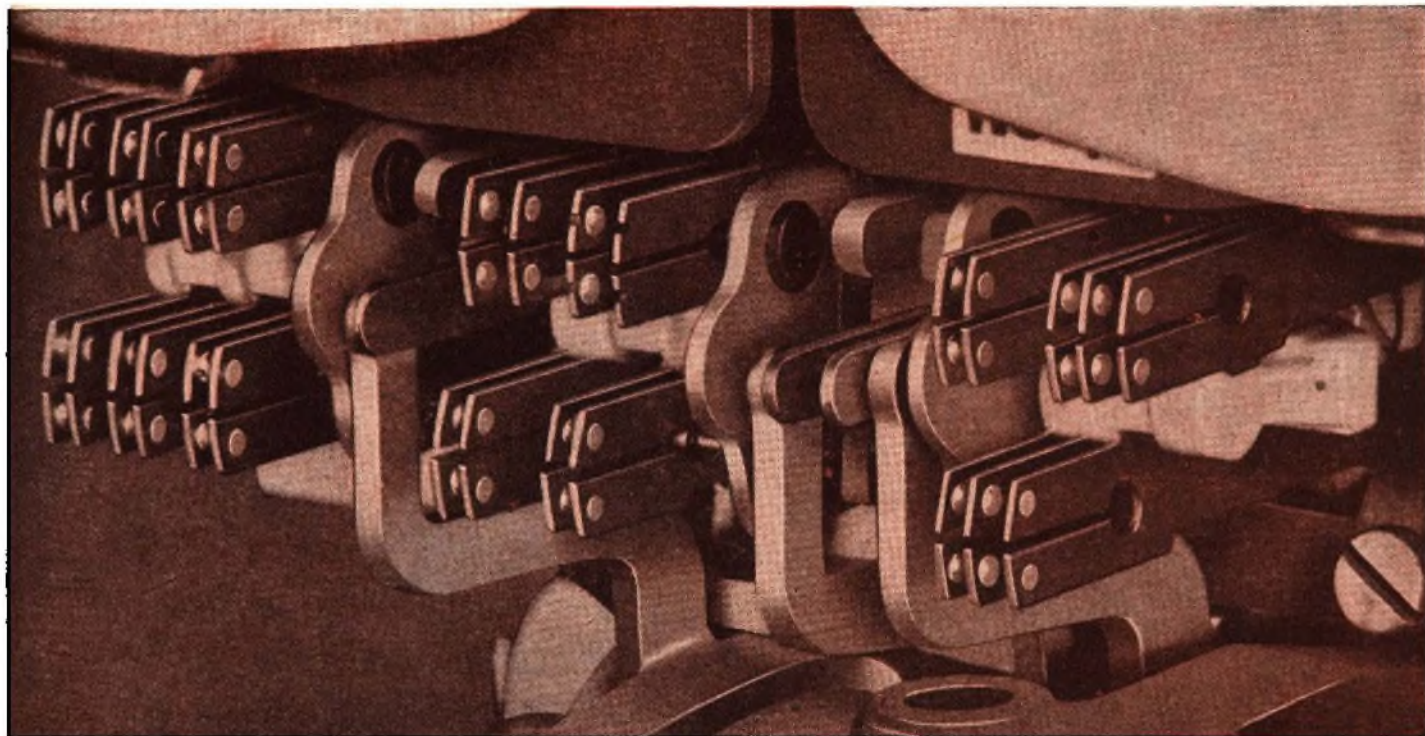

The outstanding features of the Type 32A Mark II Selector are the ease with which adjustments can be made, and the certainty that, once made, such adjustments will remain constant for long periods without attention. The new mechanically operated spring assemblies provide an example. They are similar to the spring sets and buffer blocks fitted on type 600 relays and are adjusted in the same manner.

The Type 32A Mark II Selector is the latest development of the Strowger two-motion mechanism. More than a million lines of type 32A equipment are in operation, are being

installed, or are on order for Aden, Republica Argentina, Australia, Bahama Islands, Bahrein Island, Barbados, Brazil, British East Africa, Ceylon, Curacao Island, Denmark, Egypt, Eire, Finland, Great Britain and N. Ireland, Greece, Hong Kong, India, Iraq, Jamaica, Malta, Netherlands, Newfoundland, New Zealand, Norway, Nova Scotia, Nyasaland, Pakistan, Persia, Poland, Portugal, Portuguese E. Africa, Portuguese W. Africa, S. Africa, N. & S. Rhodesia, Sudan, Trinidad, Turkey, Uruguay, Venezuela, and Yugoslavia.



**AUTOMATIC TELEPHONE & ELECTRIC CO. LTD.**

STROWGER HOUSE, ARUNDEL STREET, LONDON, W.C.2. Telephone: TEMple Bar 4506

Telegrams: Strowger, Estrand, London

STROWGER WORKS, LIVERPOOL, 7.

A7922:AA423



- The Anglo-Dutch No. 5 Cable, which spans the North Sea from Aldeburgh to Domburg, has been provided with four submerged repeaters at intervals of approximately 16 nautical miles. This coaxial cable is 80 nautical miles long and normally carried the equivalent of 10 telephone circuits. The addition of these four repeaters increases the traffic capacity of this cable to 60 circuits.
- This is the first coaxial submarine cable from these shores to be fitted with submerged repeaters connected in tandem, and is the first of a number of such projects.
- The construction of the repeaters was undertaken by the Company to the order of the British Post Office whose Research Branch provided the basic electrical designs to meet the cable requirements. The illustration shows one of the units being lowered into a barge moored alongside the wharf at our Woolwich Works, prior to loading on to the P.O. Cable Ship "Alert" which carried out the laying operations.

**SIEMENS BROTHERS & CO., LIMITED**  
WOOLWICH • LONDON • S. E. 18.

# MODERN CAPACITOR ENGINEERING

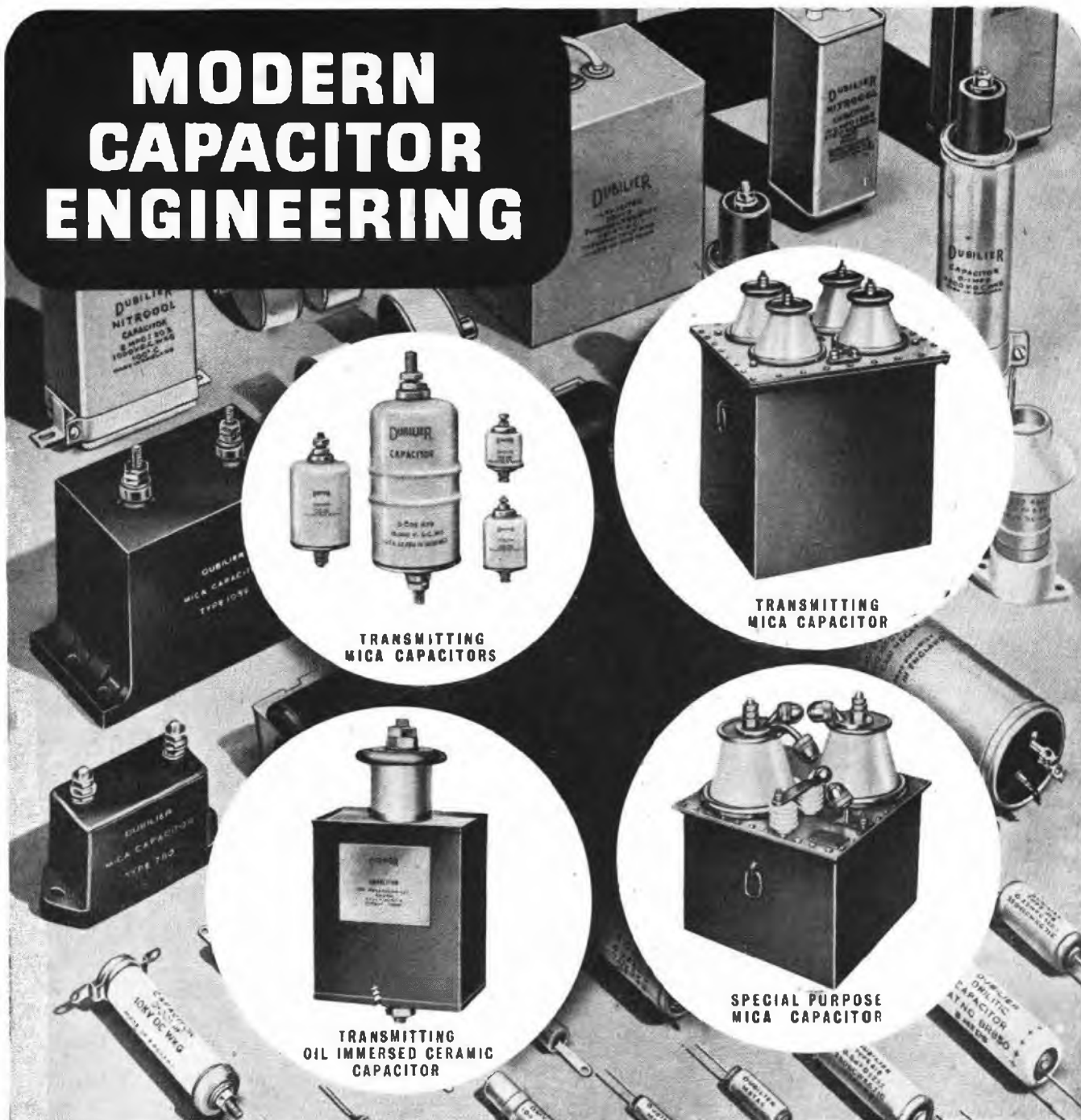

TRANSMITTING  
MICA CAPACITORS

TRANSMITTING  
MICA CAPACITOR

TRANSMITTING  
OIL IMMERSED CERAMIC  
CAPACITOR

SPECIAL PURPOSE  
MICA CAPACITOR

## DUBILIER CAPACITORS

Dubilier provide the most comprehensive range of Capacitors available today for Radio Transmitting and Receiving, in addition to Capacitors for Electronic and Industrial engineering.

Dubilier Capacitors are designed and manufactured to

a high standard of specification, suitability of purpose and meticulous capacitor engineering, and they satisfy the exacting demands of the British Postal Authorities whom we are proud to number amongst our customers.

Full details and technical service upon request.

**DUBILIER CONDENSER CO. (1925) LTD., DUCON WORKS, VICTORIA ROAD, N. ACTON, LONDON, W.3.**

'Phone: Acorn 2241 (5 lines). Cables: Nivoltcon, London. Marconi International Code. 'Grams: Nivoltcon, Wespheon, London.







# Systems for all purposes



TELEGRAPH



TELEPHONE



BROADCAST

## SYSTEM

## APPLICATION

Telegraph Telephone Broadcast Television

SYSTEM	Telegraph	Telephone	Broadcast	Television
Multi-Channel Telephone Carrier-on-Cable Systems	☑	☑		
Axial Cable Carrier Telephone Systems	☑	☑	☑	☑
Optical Sideband Television Transmission Systems				☑
Micro-wave Radio Relay Systems	☑	☑	☑	☑
Portable Micro-wave Television Links				☑
6-Channel Carrier Telephone Systems	☑	☑		
3-Channel Carrier Telephone Systems associated with 6-Channel Carrier Telegraph Systems	☑	☑		
Single Channel Carrier Telephone Systems	☑	☑		
3-Channel A-M Voice Frequency Telegraph Systems	☑	☑		
3-Channel F-M Voice Frequency Telegraph Systems including Radio Diversity Equipment	☑	☑		
Electronic Regenerative Telegraph Repeater	☑	☑		
Diode Rectifier Unit	☑	☑		
Carrier Broadcast Systems			☑	
Radio Repeaters		☑	☑	
Submarine Cable Systems including Repeaters		☑	☑	
Terminating Equipment for H.F. Radio Links	☑	☑	☑	
Wide-Band Speech Scrambler Systems		☑	☑	
High Quality Microphones				
Speech Reinforcement Equipment				
Transmission Testing Apparatus	☑	☑	☑	☑

11 types  
11 types of mains and battery-operated power supplies including stand-by equipment.



TELEVISION

## Cables Limited

London, W.C.2

Box E.16 (Telephone: Albert Dock 1401)

# PITMAN'S

for Technical Books



## Electrical Engineering *Theory and Practice* (3 vols.)

By Philip Kemp, M.Sc.Tech., M.I.E.E.; assisted by over 40 contributors. An up-to-date library of information on all aspects of electrical engineering. Nearly 2,000 quarto pages; over 2,000 illustrations. Per set, £10 net.

## Telephony (2 vols.)

By J. Atkinson, A.M.I.E.E., Area Engineer, Post Office Engineering Dept. A standard textbook for post office engineers and students. Over 1,500 illustrations. Vol. I (General Principles and Manual Exchange Systems), 35/- net. Vol. II (Automatic Exchange Systems), 50/- net.

## Telecommunications Principles

By R. N. Renton, A.M.I.E.E. A new work covering the syllabus for the City and Guilds examinations in Telecommunications Principles, Grades I, II and III. Illustrated. 37/6 net.

## Classified Examples in Electrical Engineering, Vol. I

By S. Gordon Monk, M.Sc., M.I.E.E. Contains a series of questions, with worked answers, covering advanced courses in direct current work. Seventh Edition. 8/6 net.

PITMAN, Parker Street, Kingsway, London, W.C.2

for the best-  
focus on  
**ECLIPSE**

for  
**PERMANENT MAGNETS**  
for television  
radio and  
telecommunications

specify **Eclipse**

EM16  
JAMES NEILL & CO. (Sheffield) Ltd., SHEFFIELD

Exclude 1957 table  
by country of  
origin 1/4

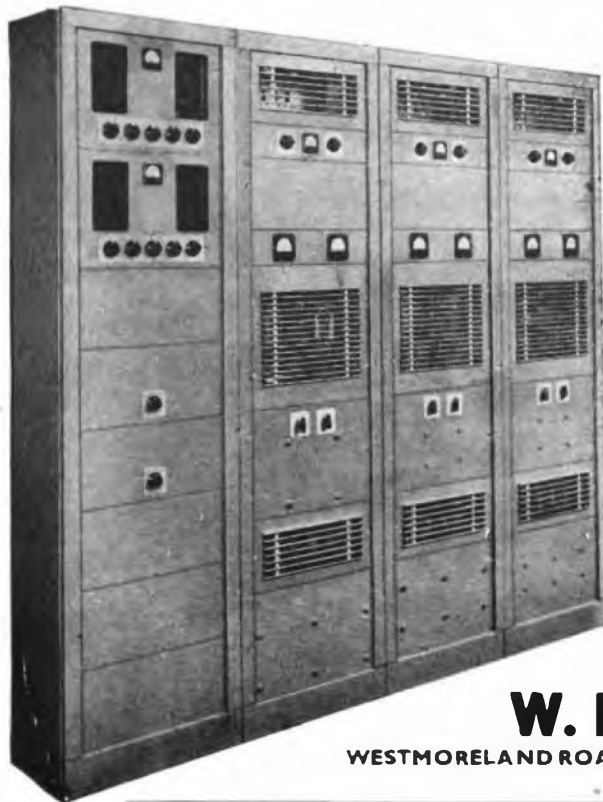

## The Mark II series of **SAVAGE AMPLIFIERS** for Broadcast Relay

● These Amplifiers are examples of what careful design can achieve. A lift-off back panel affords immediate access for maintenance purposes and the removal of six screws releases the side covers of the rack and exposes all the interpanel wiring. Even when the rack is sandwiched between others the side covers can be moved just as easily. All valves are accessible from the front of the rack, and are protected by quick release grilles. The rack is completely flat fronted. The general appearance is further enhanced by the absence of a projecting front foot, and the masking of all panel fixing bolts. Similar racks carrying auxiliary apparatus can be placed side by side with amplifiers so that the whole installation is uniform in appearance. Complete specifications available on request.

### W. BRYAN SAVAGE LIMITED

WESTMORELAND ROAD · LONDON N.W.9 · TELEPHONE: COLINDALE 7131

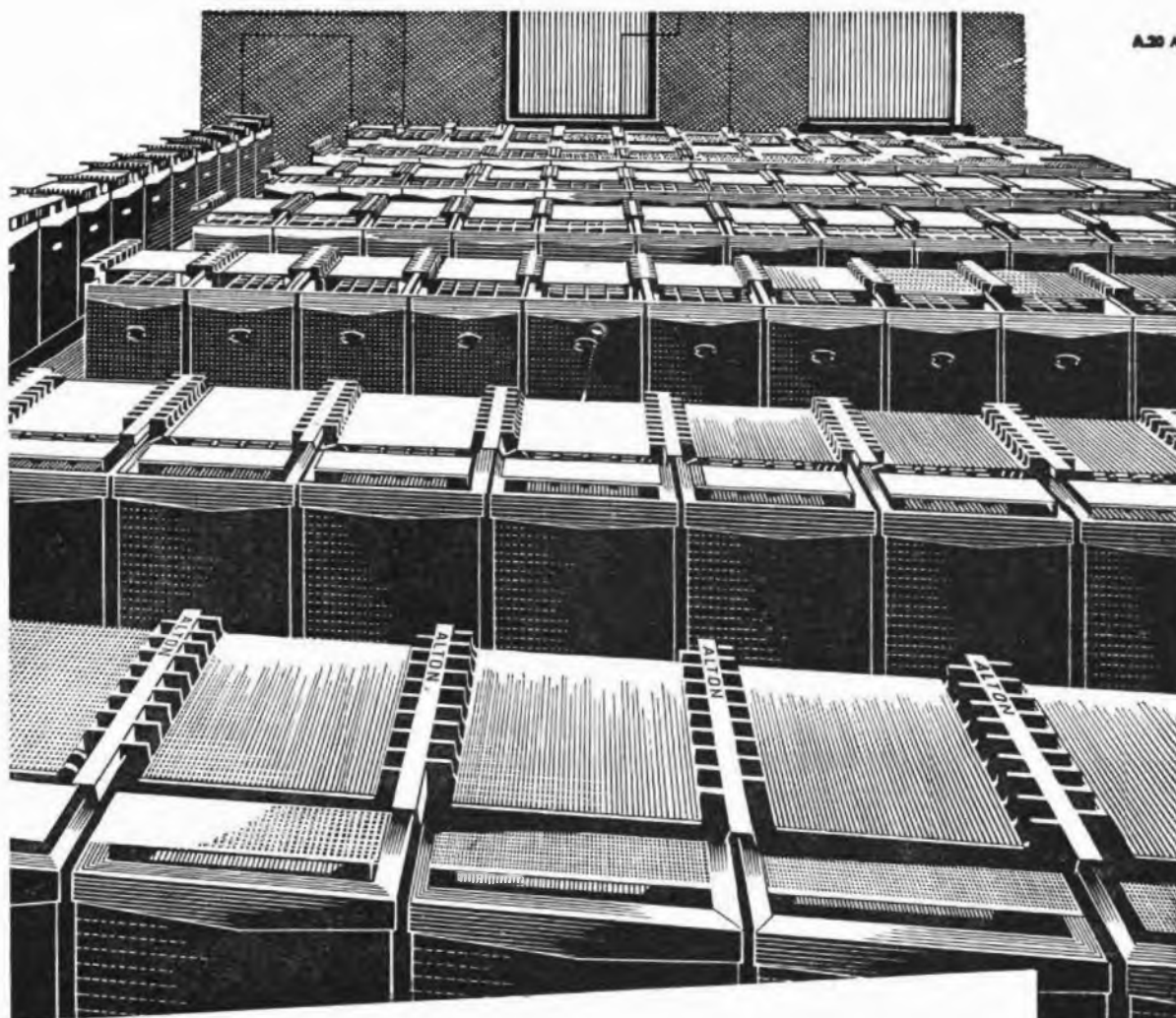

Alton has been exporting batteries for thirty years. In installations in sixty-five countries Alton Batteries, in capacities from 10 to 15,000 ampere-hours, are giving the service only good batteries can give. Alton, in any language, means good batteries and firm delivery dates.

# ALTON

## BATTERIES OF MERIT

THE ALTON BATTERY COMPANY LIMITED  
Alton, Hants. Telephone: Alton 2267 and 2268  
Telegrams: Battery, Alton

*Alton can also supply renewal plates for all makes of battery, British & Continental*





Undoubtedly the most dependable source of D.C. power supply, Westinghouse metal rectifiers are applied extensively in communication engineering, where absolute efficiency and reliability is essential. Employed in telephone and telegraph circuits, they are used either for charging the batteries of the apparatus or operating it direct from A.C. mains. They are installed in transmitting and receiving stations, and numerous other applications include spark quenching, rectifying voice and radio frequency currents and for polarising and slugging standard relays in telephone and telegraph circuits.



## METAL RECTIFIERS

Write for Publication M.R.9 to Dept. P.O. 7.

WESTINGHOUSE BRAKE & SIGNAL CO. LTD. 82, York Way, King's Cross, London, N.1

### DECADE RESISTANCES

in 3 Grades guaranteed

0.01%    0.03%    0.1%

SUPPLIED BOXED OR FOR  
CLIENT'S OWN PANEL

HIGHLY LAMINATED BRUSHES

LOWER DECADES OF ABSOLUTELY  
CONSTANT INDUCTANCE

EQUALLY SUITABLE FOR HIGH FREQUENCY  
LOW FREQUENCY OR DIRECT CURRENT

### Electrical Standards for Research and Industry

Testing and Measuring Apparatus  
for Communication Engineering



**A NOVEL FEATURE.—**Minimising  
the Residual Inductance and High  
Frequency Resistance Error.

A patented method of reactance compensation is employed on the higher decades which compensates automatically for the screen capacitance and so renders the effective residual inductance sensibly independent of the method of screen connection. In addition, the user may, at will by the simple operation of a switch, adjust the reactance or resistance error sensibly to zero at the higher frequencies.

**H. W. SULLIVAN**  
— LIMITED —

LONDON, S.E.15

Telephone : New Cross 3255 (P.B.X.)



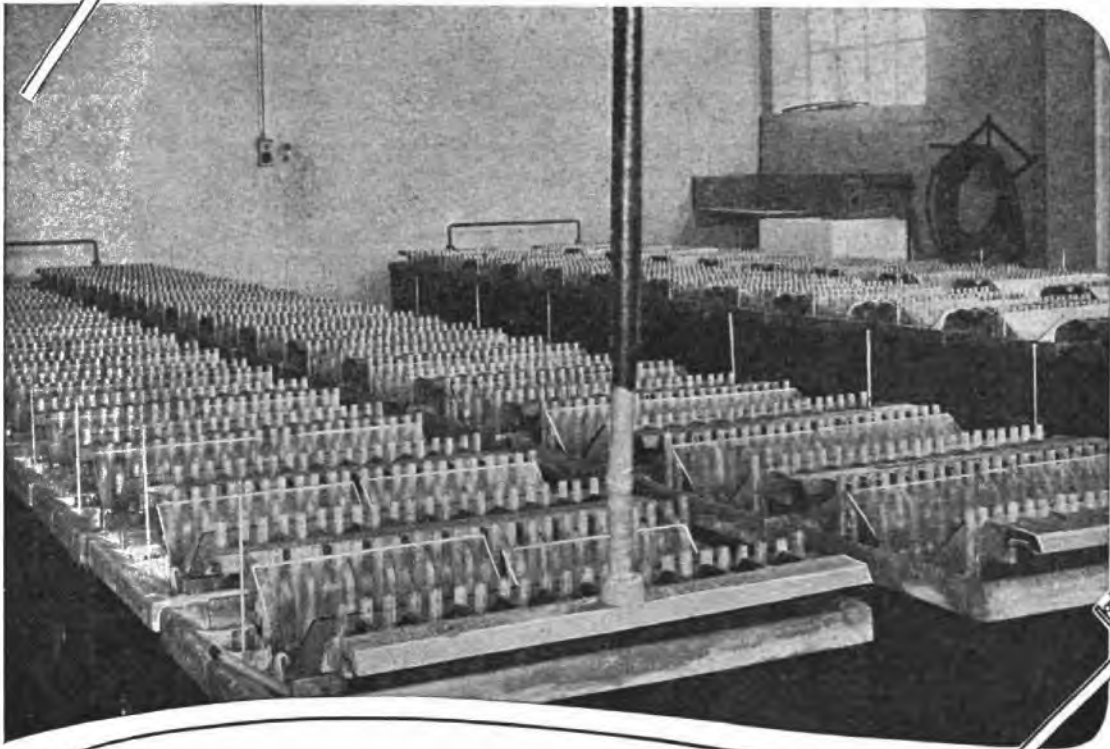

## POWER BEHIND THE LINES

**TUNGSTONE PLANTÉ CELLS** are being supplied to the British Post Office and Post and Telegraph Departments in many countries overseas. They conform fully to G.P.O. and British Standard specifications.

### OPEN TYPE CELLS

Similar to the illustration above, these are available in glass and/or lead lined wooden boxes in capacities from 100 a.h. to 500 a.h.

### REPLATALS

We are in a position to supply plates for the replating of any existing Planté Battery.

### ENCLOSED TYPE CELLS

As illustrated on the right, these are in moulded glass boxes with sealed-in lids. Capacity range from 10 a.h. to 200 a.h.

### HIGH VOLTAGE TELEPHONE BATTERIES

Portable Type. Standard layout for 50 volts, in waxed hard wood crates, exactly to the requirements of the G.P.O.

*Overseas customers are invited to cable or write their enquiries for batteries or parts. Visitors to London are welcome at our offices.*

# TUNGSTONE Batteries

For further particulars write : **TUNGSTONE PRODUCTS LIMITED**  
10 SALISBURY SQUARE · LONDON · E.C.4 · ENGLAND. Cables: "Difurum" London.



T.B.12

# A complete telecommu

## TELEPHONE

### TELEPHONE EXCHANGES OF ANY CAPACITY

*Automatic exchanges, director or non-director for towns and cities. Trunk exchanges, Public manual exchanges. R.A.Xs, P.A.B.Xs, P.M.B.Xs, P.A.Xs. Special systems for ships and railways.*

### TELEPHONES FOR ALL PURPOSES

*Automatic, C.B., magneto and convertible from magneto, Intercommunication, loud-speaking, Iron-cased magneto-type for mines.*

## RADIO

### RADIO AND TELEVISION SYSTEMS

*H.F. and V.H.F. transmitters and receivers. Multi-circuit V.H.F. links. Wideband U.H.F. links. Broadcast receivers for sound and television. Communications receivers. Radio relay and sound reinforcement systems. Four-frequency dialling and signalling for radio links.*

## TRANSMISSION

### TELEPHONE LINE TRANSMISSION SYSTEMS

*Coaxial equipment for hundreds of circuits or a television link over coaxial cable. Single, three, twelve and 24-circuit equipment for underground cables, open-wire lines and radio links. Voice-frequency repeaters. Transmission measuring equipment.*

### TELEGRAPH EQUIPMENT

*Carrier-frequency and voice-frequency telegraph and signalling systems. Picture telegraph and equipment. Teleprinter automatic exchanges.*

## THE GENERAL ELECTRIC COMPANY LIMITED OF ENGLAND

TELEPHONE, RADIO AND TELEVISION WORKS, COVENTRY

Telephone: Coventry 4111 (10 lines). Cablegrams: "Springlock, Coventry." Codes: New Standard, A.B.C. (5th Edition), Bentley, Western Union.

HEAD OFFICE: MAGNET HOUSE, KINGSWAY, LONDON, W.C.2

With an unrivalled experience in the application of modern techniques in line and radio communications, the G.E.C. offers a complete telecommunication service ranging from the supply of a single part to a complete national system.



V.H.F. multi-circuit radio-telephone system—terminal transmitter assembly and control.

### SPECIAL COMMUNICATION AND CONTROL SYSTEMS

*Supervisory remote control, with telemetering and indication. Power line carrier equipment for E.H.T. line communications.*



# Communications service . . .



Bangkok auto exchange.



ALL OVER THE WORLD

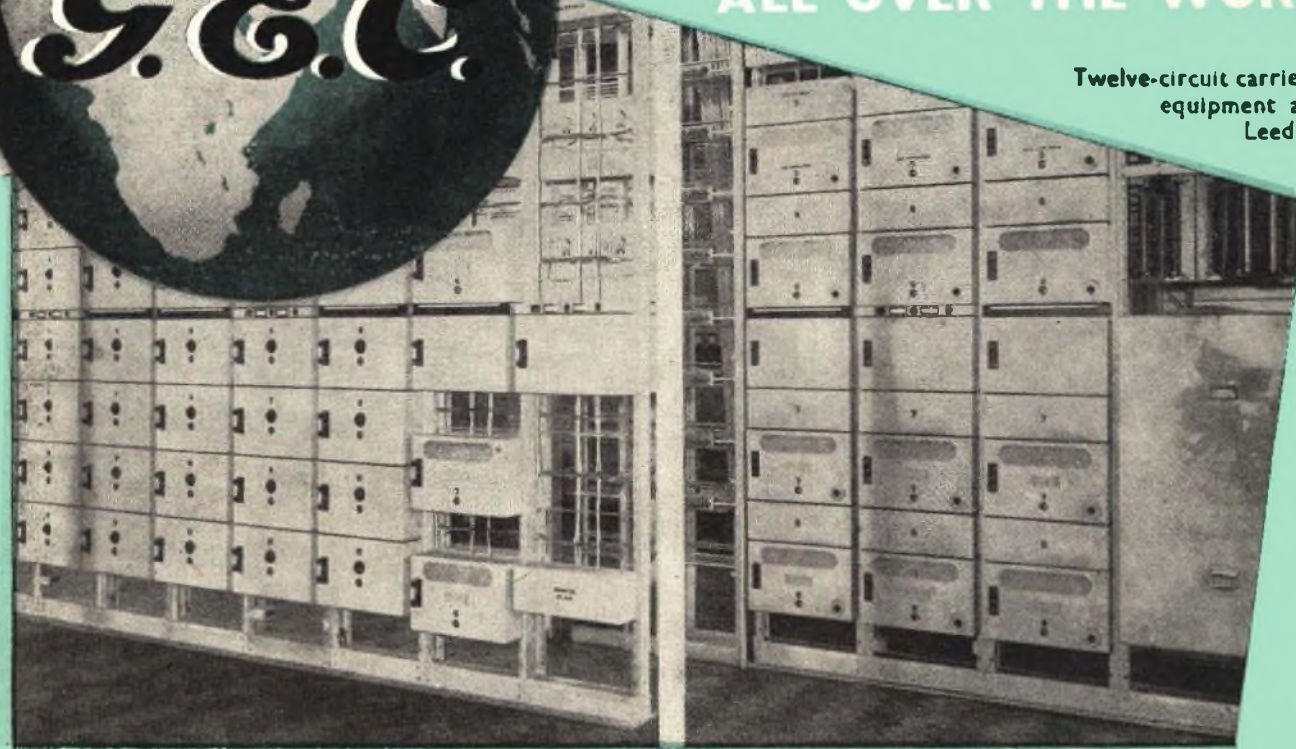

Twelve-circuit carrier equipment at Leeds.

## CABLES AND OPEN-WIRE SUPPLIES

*Manufactured by the associated company, Pirelli-  
General Cable Works, Southampton.*

## PRECISION TESTING EQUIPMENT, LOADING COILS AND METERS

*Manufactured by Salford Electrical Instruments, Ltd.,  
Silk Street, Salford.  
(Proprietors: The General Electric Co., Ltd.)*

MANUFACTURING ORGANISATION.



**Creed**

printing  
telegraph  
systems



No. 47 Tape Model Teleprinter



No. 7 Page Model Teleprinter

**Creed & Company Limited**  
TELEGRAPH HOUSE - CROYDON - ENGLAND



# DELARON

## LAMINATED PLASTIC BOARD

is the perfect material for insulation. It gives constancy of performance within very close limits and can be sawn, drilled, punched and fabricated without difficulty with ordinary equipment. Delaron is supplied in thicknesses from 1/64" to 4", in black or brown, matt or glossy finish, and is available in the widest range of sizes from 38" x 28" to 8' x 4'. There is a grade of Delaron for every British Standard and Ministry Specification. Our Technical Service Department will be pleased to advise you in the correct grade of Delaron for your requirements. Please write for further details and samples.

*Electrical transformer bobbins fabricated from 'Delaron' sheet.*

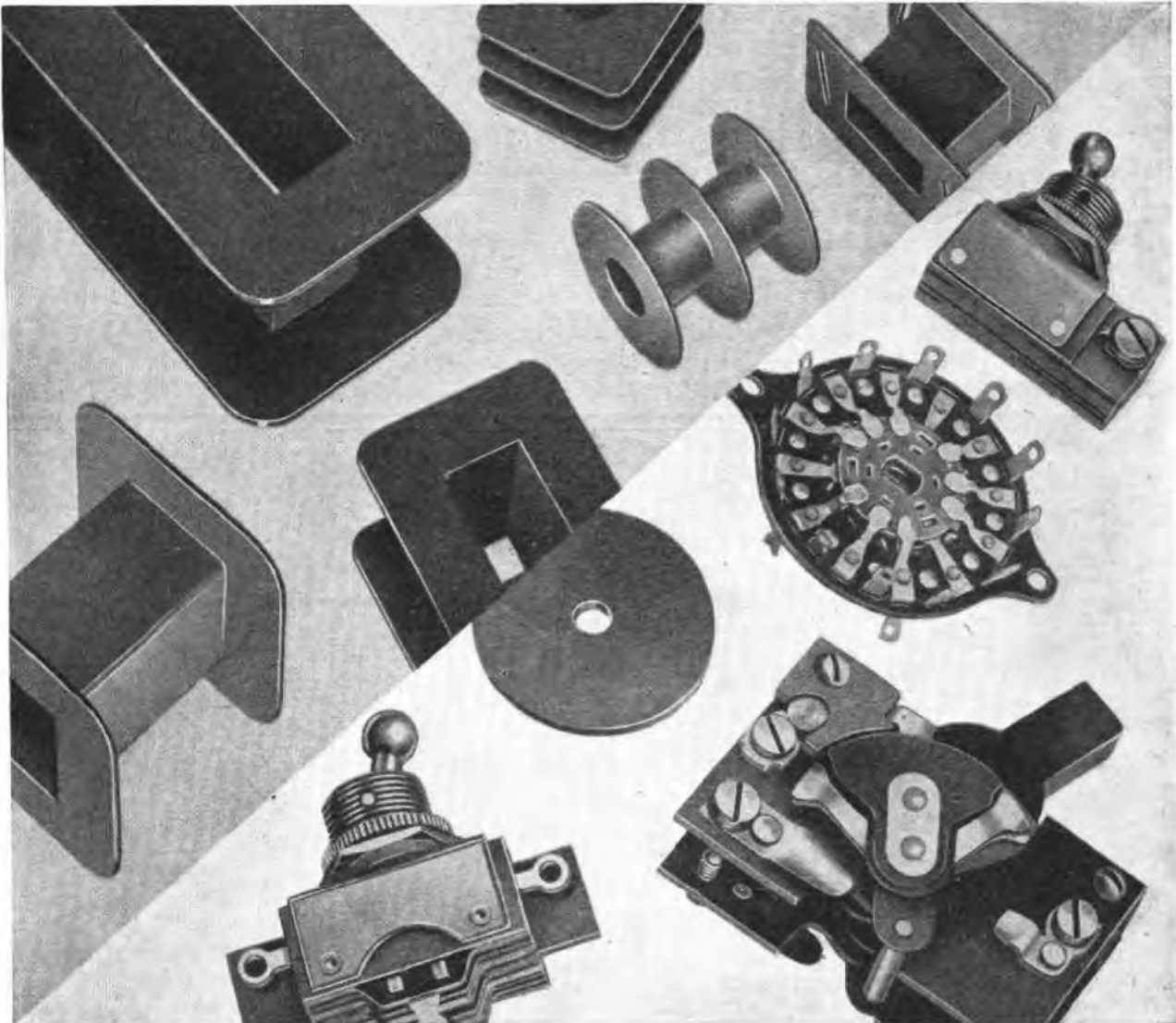

*Switch components manufactured by Messrs. Arrow Electric Switches Ltd. using 'Delaron' as an insulator.*

**THOMAS DE LA RUE & CO. LTD.** (*Plastics Division*), Imperial House, 84/86, Regent Street, London, W.1  
Phone: REGent 2901. Grams: Delinsul, Pickey, London

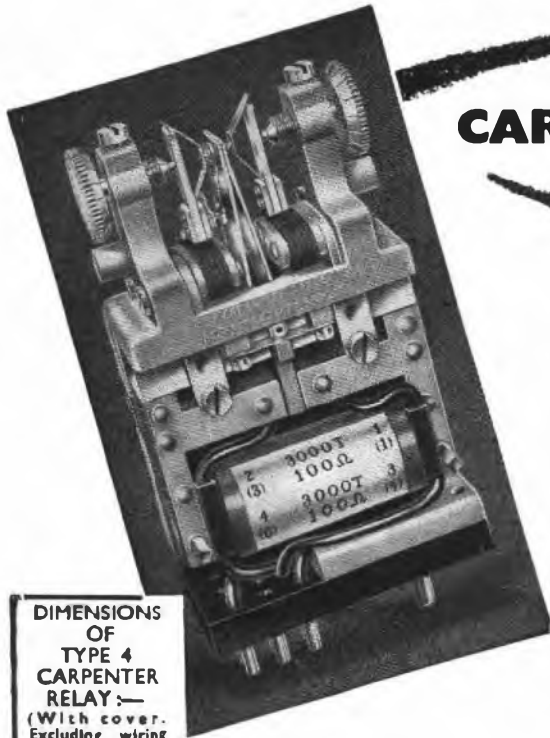

**DIMENSIONS  
OF  
TYPE 4  
CARPENTER  
RELAY:—**  
(With cover.  
Excluding wiring  
tags) 3.5 ins. high x  
2.2 ins. wide x 1 in.  
deep. Weight 13 cws

## CARPENTER POLARIZED RELAY TYPE 4

**T**HIS is a medium speed, sensitive polarized relay designed primarily as a telephone impulsing relay (D.C. dialling up to 100 miles and V.F. dialling on trunk circuits). It has also been successfully adopted for use in Telex systems, but can be used satisfactorily up to speeds of 100 c/s without contact chatter or serious bias disturbances.

Its sensitivity is such that when the gap is adjusted to .004 in. nominal, the relay will just operate at 50 cycles with 3.5 ampere-turns R.M.S. (corresponding to approximately 2 mVA) or on 4.5 D.C. ampere-turns at low speeds. In service, however, the relay is normally operated at currents substantially larger than the minimum operating current quoted.

Contact chatter is absent if the contact gap does not exceed .005 in. The contact gap is adjustable by means of fine pitch screws with knurled heads marked with .001 in. divisions. Contacts on the armature tongue are insulated from it and thereby from the frame.

The relay has a magnetic screening cover with transparent removable top to facilitate contact adjustment.

Dimensionally the relay is interchangeable with the type "3000" relay and can be supplied to fit directly to the drilling normally provided for the "3000" relay.

Termination can either be made by means of a 12 in. plug base as illustrated, or with soldering tags in place of the pins.

Developed & Manufactured by the Sole Licensees:—

Complete details available on request.

## TELEPHONE MANUFACTURING COMPANY LTD.

Contractors to the British Commonwealth and Foreign Governments

HOLLINGSWORTH WORKS • DULWICH • LONDON, S.E.21 GIPsy Hill 2211 (10 lines)



The AvoMeter is one of a useful range of "Avo" electrical testing instruments which are maintaining the "Avo" reputation for an unexcelled standard of accuracy and dependability—in fact, a standard by which other instruments are judged.

### ONE INSTRUMENT measures:—

Current, A.C. and  
D.C. (0 to 10 amps.)  
Volts e. A.C. and  
D.C. (0 to 1,000 v.)  
Resistance (up to 40  
megohms)  
Capacity (.01 to 20  
mfd.)  
Audio-frequency  
Power Output  
(0 to 2 watts)  
Decibels (— 25 Db.  
to + 16 Db.)

Write for fully descriptive pamphlet.

See "Avo" Instruments at the

BRITISH INSTRUMENT INDUSTRIES  
EXHIBITION

Olympia—July 4th to 14th.—Stand 118.

# 'AVO'

## Meters that Matter

**T**HE Model 7 Universal AvoMeter is the world's most widely used combination electrical measuring instrument. It provides 50 ranges of readings on a 5-inch hand-calibrated scale, and is guaranteed accurate to B.S. first grade limits on D.C. and A.C. from 25 c/s to 2 kc/s. It is self-contained, compact and portable, simple to operate and almost impossible to damage electrically. It is protected by an automatic cut-out against damage through severe overload.

Sole Proprietors and Manufacturers:—

THE AUTOMATIC COIL WINDER & ELECTRICAL EQUIPMENT Co. Ltd.  
Winder House, Douglas Street, London, S.W.1. Phone: VICTORIA 3404-9



Denso Tape provides complete protection for pipes, mains, cables and all metalwork against the combined attacks of chemical and electrolytic corrosion. Permanently plastic—Denso forms a perfect gas- and water-tight seal that withstands the heaviest vibration. Ideal for temporary repairs —an aid to frost-proofing.

against **CORROSION**

Write for full details of Denso Anti-corrosive and Sealing Products without obligation, from:—

**WINN & COALES LTD.**  
DENSO WORKS, CHAPEL ROAD, LONDON, S.E.27  
Telephone: GIPSY Hill 4247/8  
Telegrams: Denselte. Westnor, London

**SOUND INSTRUCTION by Postal Method**

The I.C.S., largest school in the world devoted to spare-time training by the postal method, offers you highly specialised Courses for the following examinations:

- P.M.G. Certificates for Wireless Operators.**
- C. & G. Illumination Engineering (Inter.)**
- C. & G. Electrical Engineering Practice, Installation and Telecommunications.**
- Graduateship of the B.I.R.E.**

*I.C.S. Examination students are coached till successful.*

Other Courses meet the requirements of all who desire to qualify for responsible positions in Electric Power, Illumination, Heating and Traction Systems. Equally successful is our instruction for Telegraph and Radio Engineers, Radio Servicemen, and in Elementary Radar and Electronics, Advanced Short-Wave Radio and Television Technology.

Instruction is by correspondence from textbooks specially prepared by many experts.

*WRITE FOR OUR SPECIAL BOOKLET* and state the particular subject or Examination in which you are interested.

Generous Discount granted to members of H.M. Forces.

*—YOU MAY USE THIS COUPON—*

**International Correspondence Schools Ltd.**

Dept. 108, International Buildings, Kingsway, London, W.C.2

Please send me, free of charge, your special booklet on .....

Name ..... Age .....

(BLOCK LETTERS, PLEASE)

Address .....



THE  **STABILISED POWER SUPPLY TYPE 776**  
*provides*

- 1. A Stabilised Positive Output** continuously variable from 200 to 350 volts at maximum currents of 200 to 100 mA.
- 2. A Stabilised Negative Output** suitable for biasing purposes, of 85 volts at a maximum current of 5 mA.
- 3. An Unstabilised Positive Output** of 650 volts minimum at no load falling to 500 volts at a full load of 200 mA.
- 4. An Unstabilised Negative Output** of 600 volts minimum at no load falling to 500 volts at a full load of 5 mA. (Total direct current from all sources must not exceed 220 mA.)
- 5. An Unstabilised Alternating Output** of 6.3 volts at 5 amps for valve heaters.



The unit thus incorporates all the supplies necessary for operating electronic equipment in the laboratory, test room and workshop. Both voltage and current meters are fitted and the H.T. line is provided with a separate switch and fuse. The instrument is enclosed in one of the standard range of Airmec cases and is therefore suitable for bench use or for forward mounting on a 19-inch rack.

*Descriptive Leaflets giving full details of this or any other Airmec instrument will be forwarded upon request.*

**AIRMEC**  
LABORATORIES LIMITED

**HIGH WYCOMBE**  
Telephone: High Wycombe 2060

**BUCKINGHAMSHIRE**

**ENGLAND**  
Cables: Airmec, High Wycombe



# TELEPHONE CABLES

OUR TELECOMMUNICATION CABLES CATALOGUE, GIVING INFORMATION AND SPECIFICATIONS FOR A WIDE RANGE OF TELECOMMUNICATION CABLES MANUFACTURED BY US, IS AVAILABLE UPON REQUEST.

TELEPHONE  
SOUTHAMPTON  
2141 (5 lines)

**PIRELLI-GENERAL**  
CABLE WORKS, Ltd., SOUTHAMPTON.

TELEGRAMS  
- PIGEONBEL  
SOUTHAMPTON

ACTUAL SIZE



## TECHNICAL DATA

CAT. NR 200150

Inductance	17.3 microhenries
Resistance (d.c.)	7.4 ohms.
Self Capacity	11.3 pF
Q at self resonant frequency	64
Self resonant frequency	36 Mc/s
Dynamic Resistance at 36 Mc/s	250 K ohms.

CAT. NR 200151

Inductance	2.3 microhenries
Resistance (d.c.)	0.4 ohms.
Self Capacity	6.5 pF
Q at resonant frequency	290
Self resonant frequency	63 Mc/s
Dynamic resistance at 63 Mc/s	264 K ohms.

THE NEW HIGH 'Q' MINIATURE  
**H·F**  
**CHOKES**  
ANOTHER FINE EXAMPLE  
OF ....

*Control by*

# PAINTON

PAINTON & CO., LTD.,  
PHONE : NORTHAMPTON 1006

KINGSTHORPE NORTHAMPTON  
GRAMS : CEIL NORTHAMPTON