

# THE POST OFFICE ELECTRICAL ENGINEERS' JOURNAL

**VOL. 37**

**JANUARY, 1945**

**PART 4**

## CONTENTS

	PAGE
A MAINS DRIVEN 500/20 cs SIGNALLING EQUIPMENT— H. Williams, A.C.G.I., M.I.E.E. . . . .	97
DISTRIBUTION OF THE SPEAKING CLOCK SERVICE— J. M. Ridd . . . . .	101
PORTABLE TRUNK UNITS—H. S. Waters . . . . .	105
CONSTANT SPEED IMPULSE MOTORS—H. T. Mitchell, A.M.I.E.E., and T. Pilling, B.Sc.(Tech.), A.M.I.E.E. . . . .	109
CRYSTAL FILTERS—Part I.—Introduction to the Lattice Section— R. L. Corke, A.M.I.E.E. . . . .	113
LOCALISATION OF SHEATH PUNCTURES IN ARMoured CABLES BY CO <sub>2</sub> GAS—A. G. Coates, M.I.E.E. . . . .	116
A NEW RECTIFIER UNIT—S. D. Chapman . . . . .	118
NOTES AND COMMENTS . . . . .	120
REGIONAL NOTES . . . . .	121
BOOK REVIEWS . . . . .	123
STAFF CHANGES . . . . .	125
THE INSTITUTION OF POST OFFICE ELECTRICAL ENGINEERS . . . . .	126
INDEX TO VOLUME 37 . . . . .	127

Price 1/- net

**THE INSTITUTION OF POST OFFICE ELECTRICAL ENGINEERS**

# GECALLOY RADIO TUBES

## MAIN ADVANTAGES

- Greater magnification
- Higher selectivity
- Smaller size
- Reduced costs.
- Robust construction
- Simple adjustment.
- Non-rusting

**SALFORD ELECTRICAL INSTRUMENTS LTD.**  
 PEEL WORKS, SALFORD, 3. Telephones : BLackfriars 6688 (6 lines). Telegrams and Cables : "Sparkless, Manchester"  
 PROPRIETORS: THE GENERAL ELECTRIC Co. Ltd., OF ENGLAND

*For large scale  
Electrical  
Purposes*



It is noteworthy where Tudor accumulators are to be found fulfilling the most important duties: over 500 British Power Stations installed Tudor. Many Tudor installations rank among the largest in the land and have an enviable reputation for long-lived reliability. No matter whether they were installed only yesterday, or over thirty

years ago—as many of them were—they are to-day functioning with consistent efficiency.

*SAFETYLYTE (Patent No. 313248) is the Tudor Emergency Lighting System, which is automatic and instantaneous in operation. It is installed in thousands of schools, hospitals, factories and other large buildings.*



**TUDOR ACCUMULATORS**

THE TUDOR ACCUMULATOR CO. LTD  
50 GROSVENOR GARDENS, LONDON, S.W.1

# THE POST OFFICE

## ELECTRICAL ENGINEERS' JOURNAL

Vol. XXXVII

January, 1945

Part 4

### A Mains Driven 500/20 c/s Signalling Equipment

H. WILLIAMS, A.C.G.I., M.I.E.E.

U.D.C. 621.395.342 621.395.631

The need sometimes arises for 500/20 c/s trunk signalling apparatus in buildings where repeater station supplies are not available. For this purpose a bay of apparatus has been developed comprising 20 signalling receivers and all necessary supplies, operated entirely from A.C. mains.

#### *Introduction.*

**D**URING recent years there has been a general trend in transmission equipment towards operation from A.C. mains, following the introduction of indirectly heated valves. Among the reasons for this are the relief from batteries and their attendant maintenance and the possibility of obtaining higher H.T. voltages. In wartime, however, mains-driven equipment has still further attractions, and many officers will be familiar with temporary amplifying and signalling equipment (Equipment Amplifying No. 34 (E.R.B.) and Equipment Signalling No. 8 (V.F.R.B.)) which have been used in emergencies.

The first permanent mains-driven equipment will, however, soon make its appearance in P.O. stations. This is known as Equipment Signalling No. 9, and is a standard 10 ft. 6 in. repeater bay equipped with 500/20 c/s signalling units (Units Signalling No. 9) and all necessary supplies. The units consist of a redesign of the "Unit Signalling No. 3" familiar to many readers, using indirectly heated valves, and the opportunity has been taken to introduce several additional facilities.

At the present time needs arise for signalling facilities at stations where standard repeater station voltages do not exist, and therefore the standard bay of Units Signalling No. 3 cannot be installed. In other cases the repeater station power plant is loaded to capacity. Equipment Signalling No. 9 is therefore designed as a permanent or semi-permanent addition to a repeater station.

The following are the main constructional features and facilities provided:—

- (1) The equipment operates entirely from A.C., 90-250 V, 50-60 c/s. Under mains failure the bay is without standby unless the station has a duplicate supply, but arrangements are made whereby the anode and filament supplies can be taken from batteries, probably the existing 130 V supply in a normal repeater station, and loose 6 V cells.
- (2) Twenty signalling units per bay.
- (3) 500 c/s oscillator.

- (4) 20 c/s machine. This machine, in addition to providing the normal ringing current, is also used to "chop" the 500 c/s supply to produce 500/20 c/s.
- (5) The units may be used either on a 2-wire basis or may be inserted in the line at a 4-wire point.
- (6) Where two bays are supplied, arrangements can be made for 500 c/s and 20 c/s supplies on one bay to be coupled to the other bay.
- (7) All items on the bay are fully alarmed.
- (8) The bay is complete with all supplies and tester (RP398), requiring no additional apparatus for operation.

#### *General Description of the Signalling Panel.*

The conversion unit itself (Unit Signalling No. 9) is a modification of the Unit Signalling No. 3, which has been in use in the Post Office for many years.

Before proceeding to a detailed description of the apparatus, two points regarding signalling frequencies should perhaps be made clear. The C.C.I. recommends<sup>1</sup> that on international circuits a signalling frequency of 500 c/s interrupted at 20 c/s should be transmitted on the trunk line, and this method is standard in the B.P.O. It was standardised when it was considered necessary from speech immunity reasons, and many ringing receivers in this country and on the Continent still require 500/20 c/s for operation. There is no obligation, however, that the receiver must make use of this facility, and, in fact, all the range of No. 3 signalling receivers will operate on receipt of 500 c/s or 500/20 c/s. The new ringer follows the same principle, i.e. it transmits 500/20 c/s to, and operates on receipt of 500 c/s or 500/20 c/s from the trunk line.

The standard low frequency ringing in this country is 17 c/s (strictly 16 $\frac{2}{3}$  c/s). To economise in machines, however, in this apparatus the 20 c/s current utilised for the "chopping" is also used for the actual ringing current, so that although the ringer will accept 17 c/s it actually returns 20 c/s to the exchange. This has no practical difficulties in working, but it is stated to explain some apparent anomalies later.

<sup>1</sup> *Réunions d'Oslo*, Tome 1 ter, p. 83.

The function of the unit is to convert 17 c/s from the exchange to 500/20 c/s for transmission over a repeatered line, and vice versa. Since the ringer has to be tapped across the line to receive signals it must have a low bridging loss and it must not operate on speech. These requirements make the circuit more complicated than would appear at first sight. Certain other false operating conditions have to be guarded against. The schematic circuit diagrams which follow show the insertion of the unit in a 2-wire and a 4-wire line, and the 500/20 conversion circuit itself. To convert the panel to either 2- or 4-wire working necessitates certain straps being inserted on the tag block, and these are shown by broken lines.

### 2-Wire Operation (Fig. 1).

Receipt of a 17 c/s signal from the exchange operates relay F, which operates G. G2 and G5 apply 500/20 c/s to the outgoing line. G3 short-circuits the

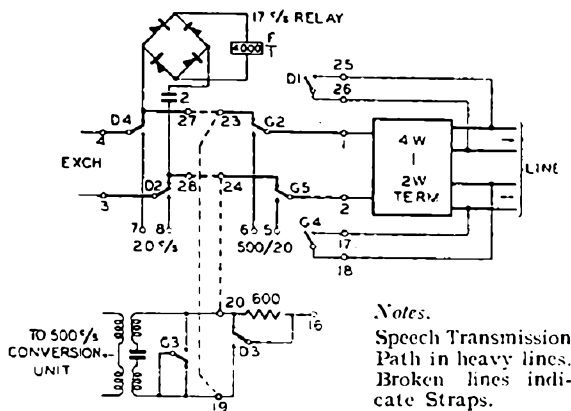

FIG. 1.—OPERATION OF RINGER IN 2-WIRE LINE.

input to the 500 c/s receiver so that the very high voltage of 17 c/s will not cause its operation. If the unit is inserted in a very long 2-wire line, the impedance of the 500/20 c/s generator may not sufficiently match the balance in the termination, and instability may result. G4 is therefore provided so that the "receive" side of the 4-wire line may be short-circuited if necessary.

Receipt of a 500/20 c/s ring operates relay A (Fig. 3. Details will be given later) and eventually relay D. D2 and D4 apply 20 c/s ringing to the exchange line. D3 closes the 2-wire line with 600 Ω. As before, on a long 2-wire line instability may be caused as a result of this, and D1 is provided to short-circuit the "transmit" 4-wire line.

### 4-Wire Operation (Fig. 2).

In this case 20 c/s ringing current will be transmitted and 17 c/s received over the phantom circuit to or from the local exchange. On receipt of 17 c/s, operation is as in the 2-wire case, the contact G3

preventing false operation from the 17 c/s current from the exchange or 500/20 c/s round the remote termination.

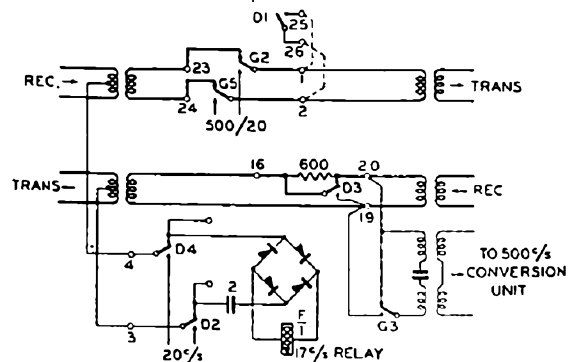

FIG. 2.—OPERATION OF RINGER IN 4-WIRE LINE.

Receiving 500/20 c/s from the distant exchange, D operates as before, D2 and D4 sending 20 c/s current to the local line over the phantom. D3, short-circuiting the receive line, prevents any 20 c/s current or harmonics thereof returning over this pair from mis-operating the receiver and contact D1 prevents any current returning over the other pair also from causing mis-operation.

### 500/20 Conversion Circuit.

The circuit of this portion of the signalling unit is shown in Fig. 3. The first stage is purely amplifying, but the second stage is a limiting amplifier. A signal reaching the grid of this valve if of sufficient level to cause operation, results in grid current flowing. This, by virtue of the small condenser and high resistance in the circuit, increases the bias on the valve and so reduces the signal in the anode circuit. Thus signals over a wide range at the input have a considerable levelling effect applied to them. The output of the second stage is applied to three series-tuned circuits, 500 c/s, 600 c/s and 750 c/s, arranged in parallel. A

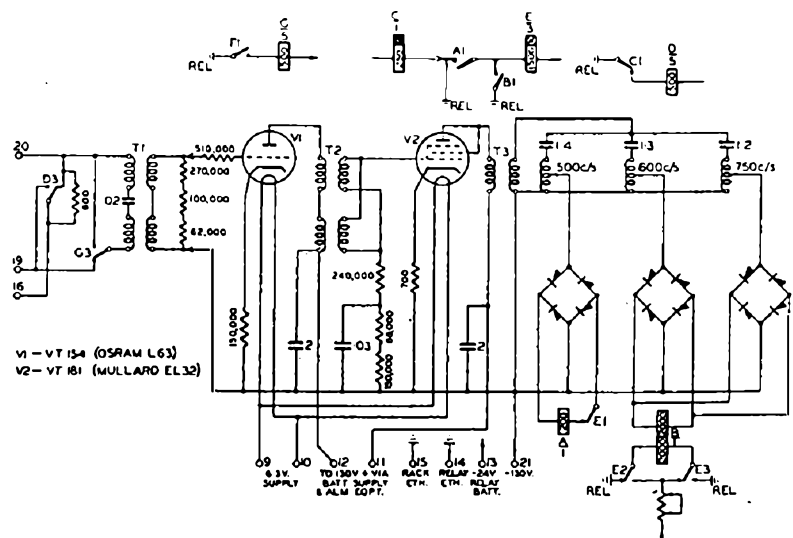

FIG. 3.—500/20 c/s CONVERSION CIRCUIT.

tapping from the inductance of the first supplies power via a full-wave rectifier to operate the signal relay A, while the tappings from the other two are applied in parallel to the guard relay B. Operation of relay A alone releases C, which operates D, causing the 20 c/s to be sent to line, but operation of B in addition to A holds C. Thus operation on speech is prevented (a) by relay C which delays the operation of D over the longest period which speech is likely to contain 500 c/s; (b) by relay B which operates to frequencies other than 500 c/s which speech is liable to contain in addition to 500 c/s. In practice the 500 c/s circuit is broadly tuned to allow for approximately  $\pm 3$  per cent variation of the 500 c/s supply. The 600 c/s circuit is sharply tuned so as to reduce the damping on the 500 c/s circuit, and to be quite certain that 500 c/s is excluded. The 750 c/s circuit, on the other hand, is broadly tuned, and the combined effect of these two simple circuits is to obtain a guarding effect over a very wide band of speech frequencies. Contacts E2 and E3 prevent relay B being held by low level signals such as noise after operation by speech. The unit is specified to be capable of operation with levels of +6 to -15 db. ref. 1 mW, of nominal 500/20 c/s. The 500 c/s may vary  $\pm 3$  per cent, and the 20 c/s interruptions from 15 to 25 c/s. The time of operation 500/20 to 20 c/s must be within the limits 400-800 milliseconds. Severe tests are made to ensure immunity from speech and telex tones, and the bridging loss must not exceed 0.3 db. at 800 c/s.

Referring now to operation on 17 c/s (i.e. operation of relay F, Figs. 1, 2 and 3), the unit is specified to operate under two conditions: (a) when 17 c/s 70 V is applied to the input 20 c/s terminals, tags 3 and 4, and (b) when 17 c/s 70 V is applied through 5,000  $\Omega$  to the 20 c/s input terminals.

#### 500 c/s and 20 c/s Supplies.

The 20 c/s supply is obtained from a small 5 W dynamotor with an associated mains unit (see the bottom of Fig. 6.). The regulation of this equipment in voltage and speed as occasioned by the varying load of the units is well within the limits necessary for ringing.

The 500/20 c/s is supplied by an oscillator, the schematic of which is shown in Fig. 4. This consists of a single valve oscillator coupled by transformers T2 and T3 to a feed-back amplifier. Between these transformers are two rectifier networks

which are used for the modulation of the 500 c/s produced by the oscillator for the production of 500/20 c/s. Assuming a positive half-cycle of 20 c/s is applied to tag 3, rectifier W1 will be closed, i.e. high resistance, whereas W2 will be open. 500 c/s current is therefore free to flow from the lower winding of T2 through the rectifier to the lower half of the winding of T3 and returning via the 0.5 condenser, and a pulse of 500 c/s leaves tags 7 and 8. When the negative half-

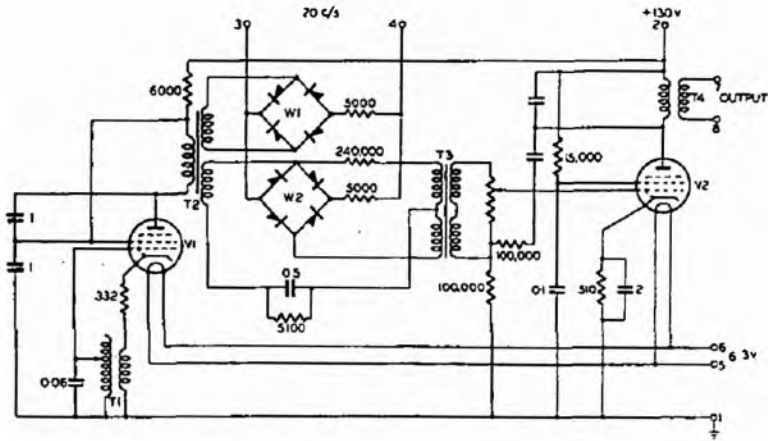

FIG. 4.—500 c/s Oscillator with Static "Chopper."

cycle arrives, however, W1 becomes open and short-circuits one winding of T2, whereas W2 is high resistance. A leak path from T2 via the 240,000  $\Omega$  acts in opposition in transformer T3 to any current resulting via W2, and thus the 500 c/s is reduced to negligible proportions during the "silent" period.

The oscillator is capable of maintaining the 500 c/s frequency  $\pm 1.5$  per cent., with supply mains voltage variation of 10 per cent. By means of a distribution panel the signal voltage to line for each unit can be adjusted within the limits +10 to -20 db. ref. 1 mW.

#### Mains Unit.

The schematic of the rectifier for supplying the various voltages required is shown in Fig. 5 and does not call for comment.

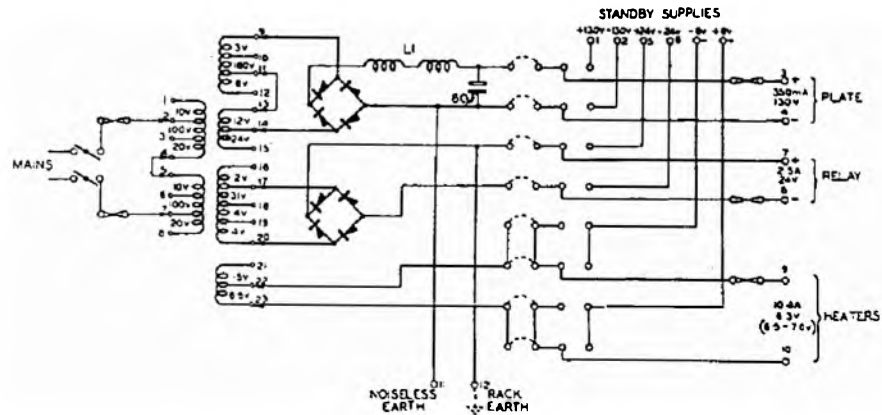

FIG. 5.—Mains Unit.

**Test Facilities.**

The input and other vital points of the ringers are wired out through U links (see Fig. 6) so that tests can be carried out on the panels. A test panel (R.P. 398) is provided for this purpose, and complete functional tests can be made.

**Conclusions.**

It is desired to make grateful acknowledgment to Standard Telephones and Cables, Ltd., with whom the apparatus was developed, for the photographs and assistance given.

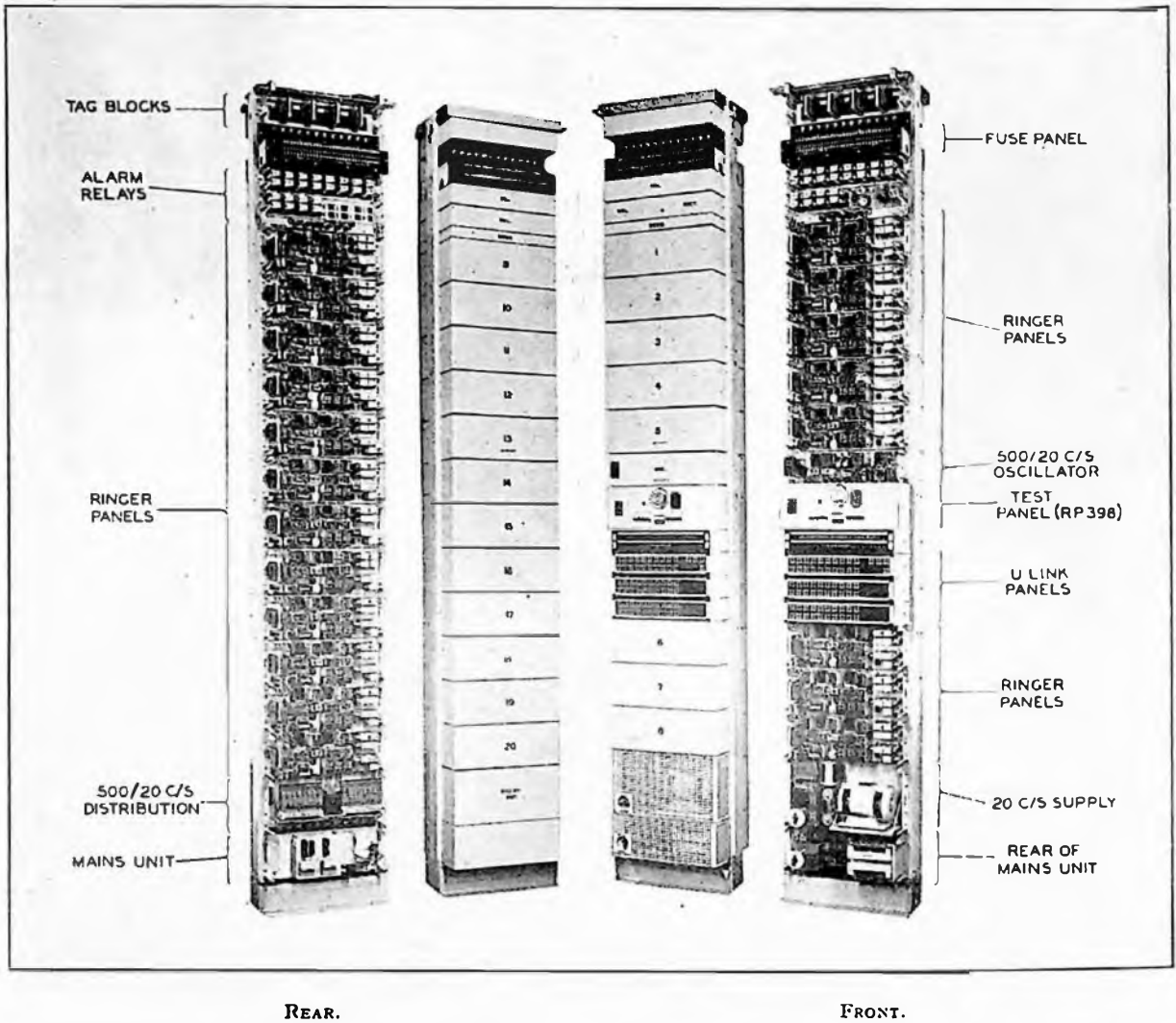

FIG. 6.—REAR AND FRONT VIEWS OF COMPLETE BAY.

# Distribution of the Speaking Clock Service

J. M. RIDD

U.D.C. 621.395.91

This article describes the means adopted to extend the Speaking Clock Service to the principal provincial towns, and the additional safeguards against interruption of service which have been introduced.

## Introduction.

SINCE the introduction of the speaking clock in the London Area in 1936, the service has been extended to certain provincial areas and a second complete clock installation has been provided at Lancaster House, Liverpool.

A description of the clock and the initial installation has been given in an earlier article.<sup>1</sup> Every endeavour was made on the initial equipment to provide an uninterrupted service and, consequently, all the main equipment and circuits used on extensions have been duplicated to maintain an efficient service which now handles over half a million calls per week and also serves some special subscribers. Both the London and Liverpool installations are in continuous service and each supply a selected number of provincial centres; also in the event of a complete breakdown of one installation, or of one of the circuits, the other installation is capable of maintaining the service to all centres.

## Provincial Distribution.

The London and Liverpool clock announcements are connected to two high-grade trunk circuits, which feed the provincial centres on an omnibus basis in the form of a ring passing through a number of Zone Centres. One ring is normally fed by the London installation and the other by the Liverpool installation. The two omnibus Trunk circuits at present feed 13 provincial centres. These are shown in the following list, which also gives the dates when the service was introduced:—

Edinburgh	April, 1938	Newcastle	March, 1939
Manchester	April, 1938	Sheffield	March, 1939
Glasgow	May, 1938	Nottingham	April, 1939
Birmingham	Nov. 1938	Leicester	May, 1939
Leeds	Nov. 1938	Plymouth	June, 1939
Bristol	Nov. 1938	Swansea	June, 1939
		Belfast	Dec. 1940

Fig. 1 is a schematic of the distribution network showing the permanent routes only. It will be seen that centres not on the ring circuit are served by spur connections and that the Swansea-Plymouth-Bristol spur, together with the spurs to Belfast and Nottingham are not provided in duplicate. Normal traffic circuits are earmarked as reserve circuits for use if the regular feeds fail.

Each provincial centre through which the omnibus trunk circuit passes has both the London and Liverpool feeds, and the shortest route, i.e. the route to the nearest clock installation is normally used as the regular feed. The other feed is classified as the

"Reserve" and used only when the regular feed is out of order.

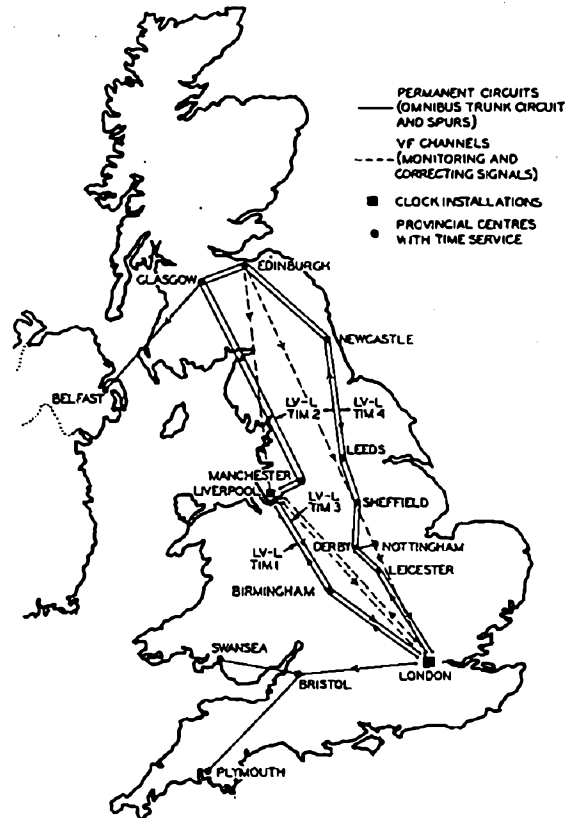

FIG. 1.—DISTRIBUTION CIRCUITS.

## Provincial Exchange Equipment.

The equipment fitted at provincial centres is installed at the central or main exchange in the area and consists of terminating relay sets for terminating automatic calls to the clock, together with two Unit Amplifiers No. 25 or 25A and an amplifier control circuit. One of the amplifiers acts as the working amplifier, while the other acts as the standby and is not normally energised. When a fault occurs on the feed circuit or on the working amplifier, the standby amplifier is automatically brought into service by the amplifier control circuit. During the warming up time of this amplifier, N.U. tone is connected to the terminating relay sets and an "urgent" and "deferred" alarm given. With the energising of the amplifier and the connection of announcement to the output transformer, the N.U. tone and urgent alarm are removed, but the deferred alarm persists, indicating to the maintenance staff that attention is required on the equipment. The

<sup>1</sup> P.O.E.E.J., Vol. 29, p. 261.

amplifiers are designed to provide a low impedance output capable of serving the terminating relay sets at each centre.

Subscribers at the 13 centres requiring the time announcements dial "TIM" in the Director Areas of Birmingham, Manchester and Glasgow, and "952" at all the non-director areas. Generally, the automatic connections to the speaking clock are limited to subscribers within the linked numbering scheme of the area and a unit fee charge is made.

#### Provincial Rack.

Standard racks have been designed to accommodate the equipment required at provincial director and non-director areas and provide for:—

- (a) Mounting space for relay sets.
- (b) Two amplifiers and an amplifier control panel.
- (c) Two time pulse generating circuits.
- (d) Mercury relay switches and iron clad switches in the mains supply to the amplifiers.
- (e) Fuses.
- (f) Wire link strips.

The circuits of the terminating relay sets vary slightly at the different centres on account of differences in the automatic systems. The facilities afforded by the circuits are standardised, however, and are as described in the previous article.

The amplifiers are of the mains energised two-stage type. To the output of the last stage of amplification a valve is connected which monitors the output signals. If signals of a prearranged level persist a relay in the valve anode circuit is held operated. A delay network is employed in the control grid circuit of the valve to maintain an anode current sufficient to hold this relay operated during the silent periods between announcements. On a failure of the signals or of the amplifier itself, this relay is released and causes the amplifier control panel to come into operation. This control panel automatically connects the mains to the reserve amplifier which, if receiving the input signals at the correct level, feeds the announcements to the output transformer.

The "S and Z" pulse generating circuits arrange for the announcements to be disconnected from the relay sets after a period of 60-120 seconds. The leads connecting the announcements, NU tone and "S and Z" pulses to each relay set are fed via wire link strips which provide a means of isolating individual shelves during the tracing and clearing of faults.

Traffic meters are provided on the basis of one per relay set and are located on the meter rack.

#### London and Liverpool Repeater Station Equipment.

The clock announcements are connected to the omnibus trunk circuit at London and Liverpool repeater stations by "U" links, as shown in Fig. 2. These links, if removed from the "supply" position and replaced in the "through" position at London repeater station, disconnect the London input and extend the Liverpool omnibus circuits through to the London circuits. Thus with the U links in

the through position, all omnibus circuits are directly fed from Liverpool.

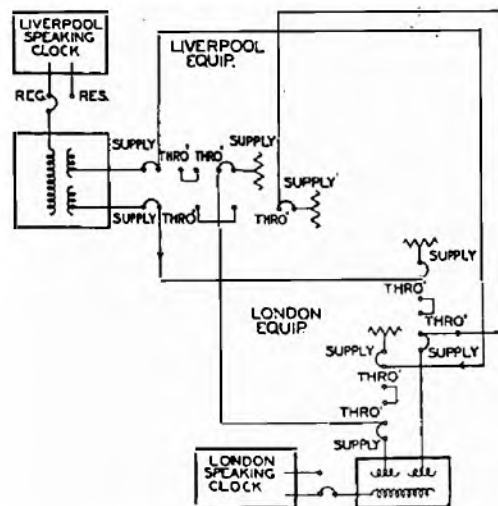

FIG. 2.—OMNIBUS TRUNK CIRCUIT CONNECTIONS AT REPEATER STATIONS.

A similar arrangement is provided at Liverpool, but in this case, when the U links are in the through position the Liverpool input is disconnected and the London omnibus circuits are extended through to the Liverpool circuits.

At the four ends of the omnibus trunk circuits, i.e. the London termination of the circuits feeding the announcements from the Liverpool clock installation and vice versa, an "Announcement Failure Alarm" equipment has been connected. This equipment consists of an amplifier which has been modified to hold a relay operated if the time announcements are continuously received at a prearranged level. Should the input fall below this level or fail completely, the relay releases and an alarm is given in the repeater station.

If an announcement failure alarm is received at London the maintenance officer advises Liverpool of the fault and if the alarm is received at Liverpool, the London maintenance staff are notified.

#### Change-over Arrangement at London Repeater Station.

On all failures of the complete London clock installation with a consequent change-over, the officer-in-charge of the Holborn equipment informs the London Trunk Test that an interruption of the service has occurred. This enables all enquiries from the provincial centres taking the London clock announcement to be informed that a speech failure has occurred, which would account for the change-over of their amplifiers. Further, if it is thought that this condition will persist, the Repeater Room staff will change over the U links to the through position.

The change-over to the "through" position is not imperative on short duration interruptions, as an alternative circuit feeding Liverpool announcements to the London omnibus circuit is automatically connected when the reserve amplifiers at Holborn



Exchange become energised. This alternative feed, however, involves the announcements being supplied through two circuits and the reserve amplifier which are removed from the circuit when the U links are changed over to the "through" position.

#### London Distribution.

By far the greatest traffic to the speaking clock originates in and around London. Originally such calls from subscribers connected to the automatic network terminated on special relay sets at Holborn Tandem. However, with the opening of a duplicate tandem exchange at Museum exchange, approximately half the relay sets were transferred to this exchange and together with the special amplifier equipment were brought into service in December, 1942.

Direct feeds are provided to certain manual exchanges in the unit fee area and also to certain special subscribers. The distribution arrangements for London are shown in Fig. 3.

CFB and the CF relays in all the terminating relay sets to operate, which in turn cause NU tone to be connected to all outlets except the lines to the omnibus trunk circuit. These circuits are left disconnected so that the failure of the announcements causes the provincial amplifiers working to the London clock to change over; otherwise the local subscribers at these centres would be charged a fee for listening to London NU tone instead of the London announcements.

When the reserve amplifier has become energised, announcements are connected to the output transformer. At the same time the operation of a relay in the amplifier causes the release of relays CFA, CFB and CF, which disconnect the NU tone and reconnect the announcements to all the London outlets.

#### Monitoring and Correcting Time Signals.

Facilities are provided for the maintenance staff at each clock installation to be given an indication of

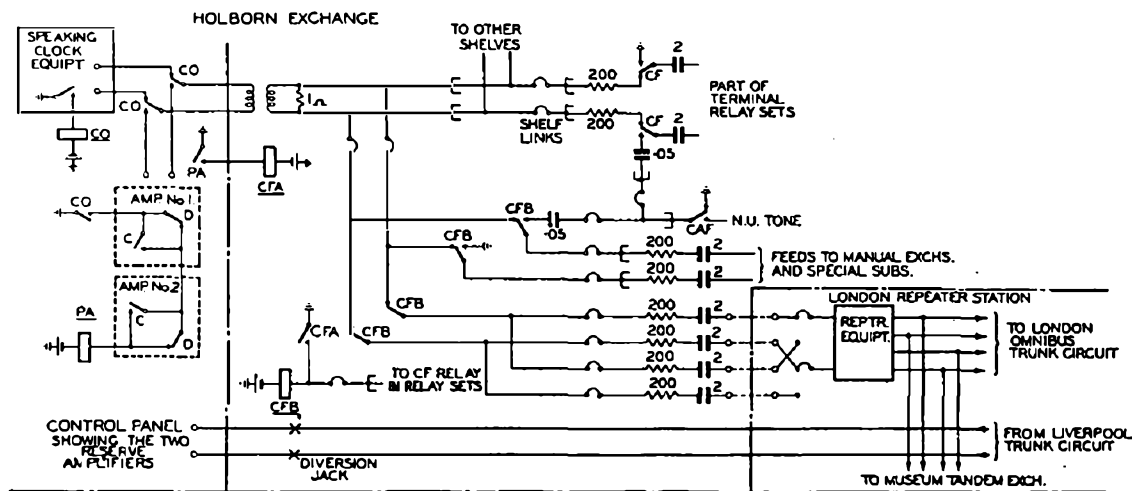

FIG. 3.—TIM DISTRIBUTION (LONDON).

#### Change-over Arrangements at Holborn Exchange.

For the emergency distribution of the Liverpool clock announcements two reserve amplifiers were installed at Holborn Tandem in November, 1943, so that should both the London clocks fail simultaneously the interruption to service is of short duration. Two circuits have been provided connecting the Liverpool omnibus circuit termination at London repeater station to the two reserve amplifiers. Consequently should the clock installation develop a fault or an excess time error an alarm is given and the lines to the output transformer are automatically changed over from the clock amplifiers to the reserve amplifiers. These reserve amplifiers are not normally energised and no Liverpool clock announcements reach the output transformer until the mains supply has been automatically connected and the amplifier warms up.

During the period of warming up, an earth is extended via the two amplifiers to operate relay CFA (Fig. 3). A contact of this relay causes relay

the number of clocks running correctly at the distant installation and also for all the clocks to be checked automatically against hourly time signals originating from either of two sources. These are known as the "Monitoring" and "Correcting" time signals respectively, and Fig. 1 shows the Edinburgh-London, Edinburgh-Liverpool, "go" VF channel and a "go" and "return" London-Liverpool VF channel which have been provided to transmit these signals. Each clock installation is therefore provided with two time signals from observatories in different parts of the country. The Edinburgh-Liverpool and the London-Liverpool circuits provide these signals at the Liverpool clock installation, while the Edinburgh-London (with an alternative route Edinburgh-Liverpool-London), together with the signal received locally, are provided at the London clock installation. To make full use of each VF channel arrangements have been made to connect the channels to the timing equipment from five minutes before until two minutes after each hour to pass the time signals. For the remain-

ing fifty-three minutes of the hour, the Edinburgh-London circuit is switched to give teleprinter service between the two observatories, while the London-Liverpool "go" and "return" channels are used to transmit the monitoring signal between the two clock installations. These monitoring signals arrange to indicate on a lamp at each clock installation whether both clocks at the distant installation are running correctly, or if either or both have failed or been taken out of service, e.g. if both clocks at London are running correctly a steady glow is received at the Liverpool monitoring panel. Should, however, one clock be removed from service for maintenance or due to a failure of the equipment, at London, the steady glow is converted to a flashing signal. Further, if both clocks be removed from service (or in the case of London, the circuits serving the trunk distribution fail) the lamp is extinguished.

It is thus possible for the maintenance staff at each installation to see at a glance whether one or both of the clocks are running correctly at the other

installation before a local clock is removed from service. This facility is of great assistance to the maintenance staff and minimises the risk of simultaneous removal of the clocks from service, which would endanger the continuity of service.

Fig. 4 shows schematically the arrangement adopted at London. With both clocks running correctly, relay GG is held operated, a contact of which causes battery to operate relay TM at the VF Terminal Station, while another lights the "out" lamp locally. The distant VF equipment controls two relays, HH and NN, which are similar to those shown in Fig. 4 and these light the "in" lamp at Liverpool.

The circuits are taken through "U" links at London repeater station, and these are associated with the links carrying the announcements. The change-over of the "U" links releases relay TM if the speech circuits between Holborn and London repeater station become faulty; in addition it prevents the relay being operated when maintenance

work is proceeding on the clock equipment and immediately gives an indication to the Liverpool maintenance staff that their installation is feeding the whole of the country with the time service and that London clocks are out of service.

On this equipment, all junctions connecting apparatus in different buildings are duplicated.

*Conclusion.*

The popularity of the Speaking Clock service is such that consideration has already been given to its extension to group centres. It is probable that this further development will take place at the conclusion of hostilities as plant becomes available.

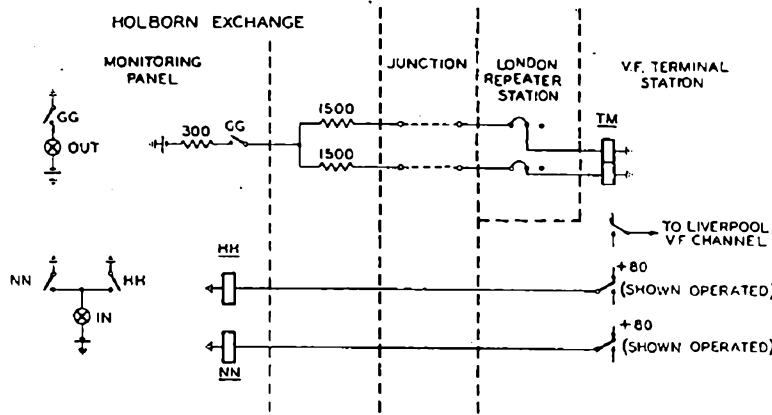

FIG. 4.—MONITORING CIRCUIT

TELEPHONE AND TELEGRAPH STATISTICS—SINGLE WIRE MILEAGES AS AT SEPTEMBER, 1944  
THE PROPERTY OF, AND MAINTAINED BY, THE POST OFFICE

REGION	OVERHEAD			UNDERGROUND		
	Trunks and Telegraphs	Junctions	Subscribers *	Trunks and Telegraphs †	Junction ‡	Subscribers ¶
Home Counties .. ..	16,319	48,366	325,907	1,545,332	344,810	1,373,492
South Western .. ..	7,810	42,213	247,918	778,086	143,092	753,393
Midland .. ..	8,105	37,289	198,922	929,483	298,010	1,034,398
Welsh & Border Counties .. ..	8,762	26,075	141,091	483,775	74,857	314,478
North Eastern .. ..	12,343	24,095	169,384	785,905	233,092	977,698
North Western .. ..	1,315	9,159	108,007	598,449	368,623	1,235,493
Northern Ireland .. ..	9,782	10,667	33,224	107,025	43,929	135,958
Scottish .. ..	24,172	33,694	180,728	703,265	243,041	813,699
Provinces .. ..	88,008	231,558	1,405,181	5,931,320	1,749,454	6,638,609
London .. ..	367	1,640	73,615	868,625	1,700,173	3,760,607
United Kingdom .. ..	88,975	233,198	1,478,796	6,799,945	3,449,627	10,399,216

\* Includes all spare wires.

† All wires (including spares) in wholly M.U. Cables.

‡ All wires (including spares) in wholly Junction Cables

¶ All wires (including spares) in Sub's. and mixed Junction and Sub's. Cables.

# Portable Trunk Units

H. S. WATERS.

U.D.C. 621.395.332

The author gives brief details of the factors leading to the introduction of transportable units for operating trunk circuits on a delay basis and describes their design and operating functions.

## Introduction.

THE dispersal of businesses and population, often into the less densely telephoned areas, and the depletion of public trunk routes to provide circuits for defence and emergency requirements are factors, peculiar to war time, which have resulted in temporary traffic overload conditions unforeseen when the exchanges concerned, particularly Zone and Group Centres, were designed.

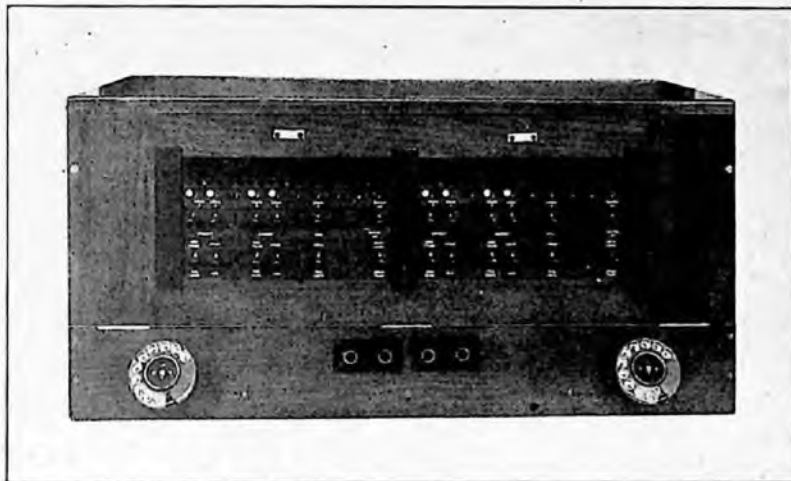

FIG. 1.—PORTABLE TRUNK UNIT.

The desirability of providing some means of affording the necessary relief which could be—

- (a) of small first cost, thus reducing the labour and materials required for construction
- (b) easily installed, to economise in local engineering labour and
- (c) transportable, so that the equipment could be transferred readily for use elsewhere

led to development of the equipment known as portable trunk units, which are described in this article. A typical unit is illustrated in Fig. 1.

## Type of Call Handled.

In order to achieve simplicity, the equipment must of necessity have limited traffic facilities and the type of call handled must be capable of being dealt with away from the main switchboard. This is achieved by handling delayed or suspended calls, which are presented to the delay operator in the form of tickets recorded at other positions so that answering multiple facilities are not required. Moreover, with

this type of call outgoing multiple facilities can be dispensed with, although this tends to reduce the efficiency of the trunk group. These calls have a high operational call value, thus giving a large measure of relief to the main switchboard, and it is found in practice that a delay operator can keep about two trunk circuits fully occupied. Accordingly the portable trunk units have been designed to give facilities for setting up delayed or suspended calls, each operating position controlling two trunk circuits.

Simplicity is also achieved by arranging for all switching operations to be performed by keys and by omitting timing equipment and facilities for controlling 2 V.F. trunk circuits. In other respects portable trunk units provide the usual facilities applicable to the main switchboard positions relevant to the auto-manual, C.B. or C.B.S. exchange in question.

## General Description of Unit.

To give these limited facilities it was found possible to design a self-contained unit comprising two panels or operating positions in a wooden case suitable for placing on an ordinary table. The case is 2 ft. 9 in. long, 1 ft. 4 in. deep and 1 ft. 4½ in. high and has a removable top and hinged back and front to facilitate maintenance access to the relays and other apparatus fitted on standard mounting plates inside the case (Figs. 2 and 3).

Each panel has two connecting circuits, each of

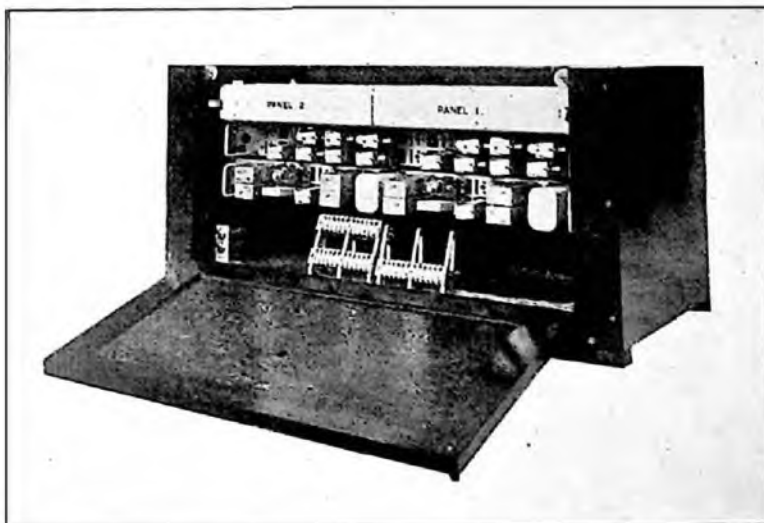

FIG. 2.—REAR VIEW OF UNIT—TOP REMOVED AND BACK OPEN.

which has an outgoing (or bothway used in the outgoing direction) automatic or generator signalling trunk circuit connected to one side and facilities for gaining access to any subscriber in the group on the other.

The connecting circuit is controlled by four keys (Connect Trunk; Connect Local; Speak and Monitor; Ring and Dial) and two supervisory lamps

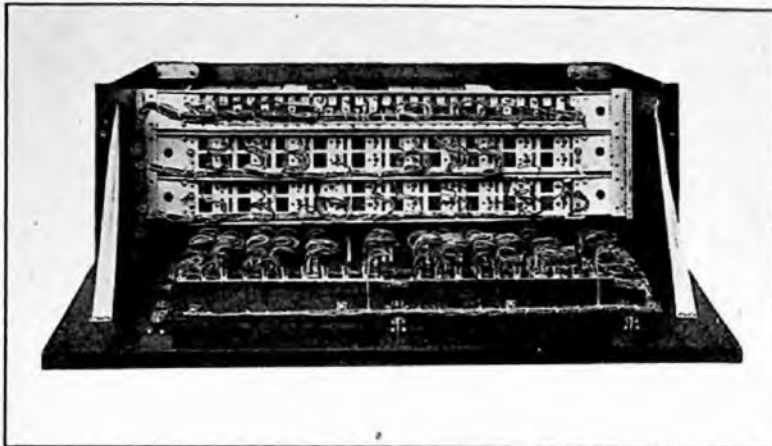

FIG. 3.—FRONT VIEW OF UNIT—TOP REMOVED AND FRONT OPEN.

and is designed to simulate the conditions given by the cord circuits at the exchange concerned. This enables the trunk circuits diverted to the unit to retain the standard terminating equipment already fitted.

A third local circuit is provided and used as a speaker circuit to the main suite. It has only two keys (Speak and Dial; Call) and no supervisory lamp.

A double operator's telephone jack and, at auto-manual exchanges, a dial are fitted for each delay operator.

To provide sufficient "elbow room" for the operators the units are installed in an island suite wherever accommodation permits with alternate units faced in opposite directions (see Fig. 4 (a)). If

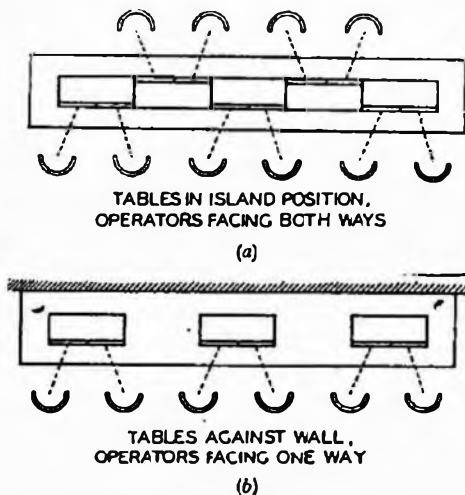

FIG. 4.—ARRANGEMENTS FOR SEATING OF OPERATORS.

accommodation is so limited that operators can sit only at one side of the table the units are spaced out as shown in Fig. 4 (b).

#### *Method of Connecting Trunk Circuits to the Units.*

The trunk side of each connecting circuit is wired to a spare multiple jack into which the traffic staff, when desiring to staff a portable trunk unit, plug one end of a double-ended cord, of which the other end is inserted into the outgoing multiple jack of the selected trunk circuit. Thus the trunk circuit is diverted to the portable trunk unit and at the same time the normal "engaged" conditions are imposed on that circuit throughout the multiple. To avoid having the slack of ordinary double-ended cords trailing over the switchboard and getting into the operators' way, the double-ended cord is formed by removing the wiring from the tags of a spare cord circuit and strapping the T, R and S tags respectively of the pair of cords. The equivalent of a double-ended cord is thus obtained while retaining the pulley-weights to take up slack.

At auto-manual sleeve control exchanges a key is fitted on each panel to condition it for either auto signalling or generator signalling working and for this reason, at sleeve control exchanges, both trunk circuits connected to a panel must have the same method of working.

#### *Operating Procedure at Auto-Manual Exchanges.*

To set up a connection the operator throws a connect trunk key, which sends calling conditions to line if the trunk is automatic signalling. If the trunk is generator signalling, ringing conditions are applied by operation of the "ring trunk" key. The speak key is also operated to enable the demand to be passed to the distant end.

The local subscriber is obtained by operating the connect local key (which gives access to a selector and the dial local key). The operator proceeds to dial the local subscriber, or, if the subscriber cannot be dialled, e.g., because the subscriber is connected to a manual exchange to which dialling access is not provided, dials a code to obtain an operator at the main suite for assistance.

While the two connect keys remain operated the two subscribers are connected for conversation. The operator times the call by reference either to the exchange clock or to a clock fitted adjacent to the suite of portable trunk units.

#### *Operating Procedure at Manual Exchanges.*

The delay operator establishes connection to the distant subscriber over the trunk circuit in the same manner as described above for auto-manual exchanges.

All connections to subscribers in the local area are obtained by enlisting the aid of an operator at the

main suite. Operation of the connect local key causes a calling lamp to light on a main suite position which is equipped with "B" type cord circuits to provide through supervision from the subscriber to the unit. Thus demands are passed from the unit to the main suite over the local circuit to be used for completing the connection.

An alternative method, at C.B. exchanges only, is to terminate the local circuits on plug-ended order wire equipment and to pass demands from the units to the main suite over order wires. Normally in order wire working, the incoming operator allocates the circuit to be used and the originating operator picks up the appropriate circuit in the outgoing multiple. In this case, however, the outgoing circuits are not multiplied over the portable trunk units and it is necessary for the trunk unit operator to advise the incoming order wire operator on which circuit the connection is required.

### Types of Units

To meet the varying circuit conditions applicable to the different types of manual and auto-manual exchanges, it has been found necessary to develop five types of portable trunk units as detailed below :—

#### (c) Bridge control director, non-director and Siemens No. 16 exchange unit.

At bridge control exchanges the trunk terminating equipment may not include a transmission bridge and the bridge is incorporated in the unit. It is also necessary to include a bridge in the unit at bridge control non-director and Siemens No. 16 exchanges as the local side of the connecting circuits is wired to bridgeless 1st selectors.

#### (d) 22 V and 40 V C.B. and C.B.S. No. 2 exchange unit.

This unit incorporates the necessary transmission bridge and includes the alternative methods for obtaining local subscribers already described.

#### (e) C.B.S. No. 1 exchange unit.

This unit includes the necessary transmission bridge, together with special trunk circuit switching keys of which the function is described later.

### Circuit Description of a Sleeve Control Non-Director Exchange Unit.

When a trunk circuit is patched to a connecting

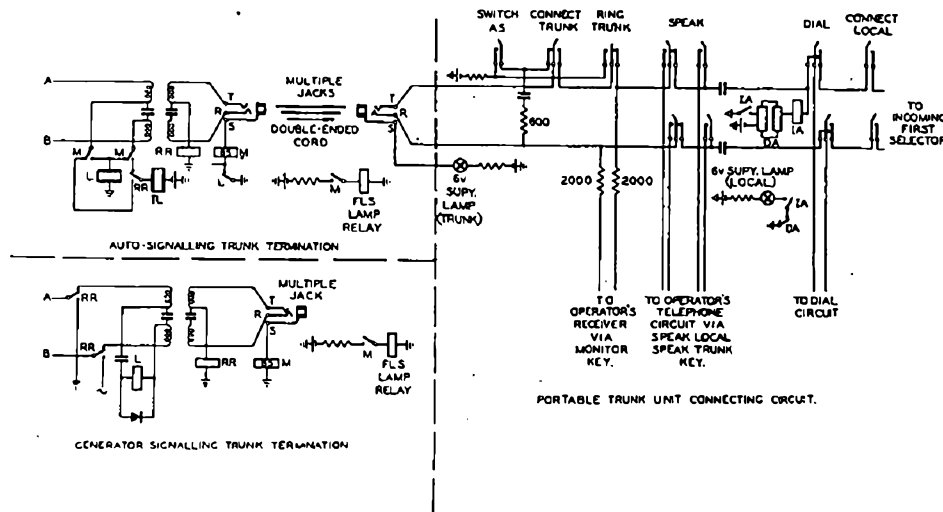

FIG. 5.—CIRCUIT ARRANGEMENTS FOR SLEEVE CONTROL NON-DIRECTOR EXCHANGE UNIT.

#### (a) Sleeve-control director exchange unit.

The local side of each connecting circuit is terminated on a manual 1st code selector. As this selector includes the requisite transmission bridge and returns supervisory conditions over a 3rd wire this type of unit does not need a transmission bridge.

#### (b) Sleeve-control non-director and Siemens No. 16 exchange unit.

At these exchanges the local side of each connecting circuit is terminated on 1st selectors which do not include a transmission bridge and the bridge is incorporated in the unit.

circuit (Fig. 5) the sleeve battery imposes engaged test conditions throughout the multiple and operates relay M in the trunk termination. The operation of relay M operates the free line signal lamp relay which darkens the F.L.S. lamps of that circuit.

When automatic signalling trunks are to be controlled, the portable trunk unit conditioning key will have been operated to "switch AS" and battery will be applied via the connect key to the T wire. This operates relay RR in the trunk termination so that RR contact disconnects battery via M operated from the trunk line. To establish a connection the speak key and the connect trunk key are operated. The latter disconnects the terminating

impedance and connects the trunk circuit, simultaneously disconnecting the battery from the T wire and causing RR relay to release. The RR relay contact, when released, connects battery via M operated to the trunk line which sends a calling signal to the distant end. When the distant operator answers supervisory conditions are returned in the standard manner and the portable trunk unit operator demands the required exchange and/or number. Supervisory conditions are also returned when the required subscriber answers.

When generator signalling trunk circuits are patched to the panel, the conditioning key is not operated and the trunk termination RR relay is normal. To call on the trunk circuit the connect trunk key is operated, followed by the ring trunk key, which causes relay RR to operate and send ringing current to line.

To obtain the originating subscriber, the operator retains operated the connect trunk key and the speak key, operates the connect local key and the dial key and proceeds to dial the subscriber's number, preceded, if necessary, by a code. On completion of dialling, the dial key is restored, but the connect local key is left operated.

When the local subscriber answers, the standard D and I loop conditions cause the local side supervisory lamp to darken. The two subscribers are now connected through for conversation and the operator restores the speak key and times the call. The two connect keys are kept operated for the duration of the call.

The operator's telephone, monitor, dial and speaker circuit is shown in Fig. 6.

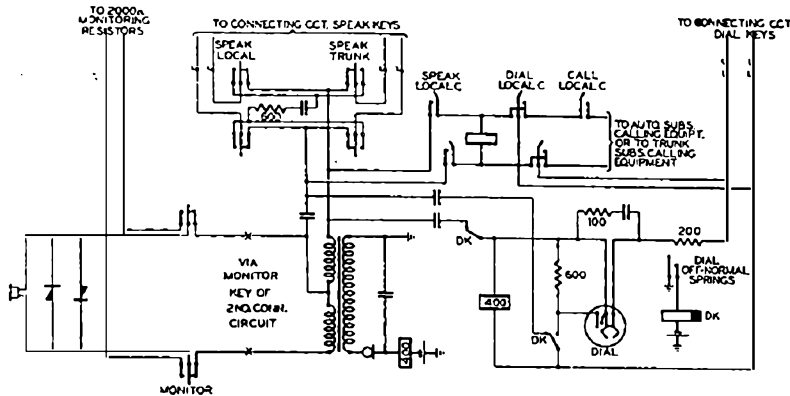

FIG. 6.—OPERATOR'S CIRCUIT.

During the progress of the call the operator can monitor via a low loss circuit by operating the connecting circuit monitor key. By reference to both Figs. 5 and 6 it will be seen that the monitoring circuit is via two 2,000 ohm resistors and the monitor key direct to the operator's receiver, the operator's induction coil being disconnected.

The operator's dial circuit includes the facility, now standard for sleeve control positions, of listening for tone signals while the dial key is operated and

the dial at rest. This is achieved by relay DK, which operates when the dial is moved off normal and completes the dialling circuit. At the end of an impulse train relay DK restores slowly and via its back contacts connects the operator's telephone circuit.

The speaker circuit to the main switchboard has only two keys (call; speak and dial). It is connected either to an automatic subscriber's calling equipment or to a trunk subscriber's calling equipment and loop calling conditions are established when the call key is operated. If wired to an automatic subscriber's calling equipment, the operator dials "0" to obtain access to the main switchboard. Usually, however, this circuit is terminated on trunk subscriber's equipment so that the operator has direct access to the main suite.

#### C.B.S. No. 1 Exchanges.

Special arrangements are required at C.B.S. No. 1 exchanges because the use of 8 point multiple jacks precludes patching trunk circuits to the units by double-ended cords. Instead, two trunk circuits are wired via switching keys to each panel of the portable trunk units. The switching keys are mounted on the units and in their normal position extend the trunk circuits to the main suite outgoing multiple for normal use. When the units are staffed the switching keys are operated and cause the trunk circuits to be diverted to the units and at the same time impose engaged conditions throughout the outgoing multiple. The disadvantage of this scheme is that an alteration in the allocation of trunk circuits to the units involves rejumping, whereas the "patching" scheme used at auto-manual and C.B. exchanges provides full flexibility without jumping alterations.

#### Conclusion.

Although the equipment described in the foregoing paragraphs has been designed primarily to fulfil a need at group and zone centre exchanges, its use need not necessarily be restricted to such exchanges. In many areas severe shortage of circuits exists on toll routes on which delay working is in force, resulting in increased traffic load, and the employment of units at minor exchanges may solve

problems at these congested small exchanges.

It may well be that the future delay or suspended call position will also take a form similar to the portable trunk units as the ordinary switchboard position appears to be unduly expensive to provide the comparatively limited facilities required for delay working. The immediate post-war period may also introduce problems, the solution of which lies in the use of simple transportable equipment.

# Constant Speed Impulse Motors

H. T. MITCHELL, A.M.I.E.E., and  
T. PILLING, B.Sc.(Tech.), A.M.I.E.E.

U.D.C. 621.313.22

The article gives details and performance curves of two constant speed impulse motors. The first of these motors is manufactured in the U.S.A., the second being an experimental model designed and constructed by the authors. The speed of the former is controlled by a centrifugal governor whereas the speed control of the latter is a differential gear in association with a balance wheel and escapement.

## Introduction.

SOME months ago the authors had the problem of designing a small portable radio equipment which would operate unattended for a week from batteries. The radio equipment itself presented little difficulty, but during the course of the week of operation a drum which was associated with the radio equipment had to be rotated at one revolution per minute with an accuracy of  $\pm 10$  revolutions in the 10,080 revolutions it would make in the course of the seven days unattended operation.

The normal type of D.C. motor using a permanent magnet field consumes approximately 8-12 W, which is prohibitive for such work even if an accurate governor could be fitted. The only proprietary motor which could be found which in any way approached the requirements was a motor manufactured in the U.S.A. for controlling over long periods the flashing light of a marine buoy. The energy required to drive this motor for a year was claimed by the manufacturers to be 75 Wh with an efficiency of 25 per cent., that is, a power consumption of 9 mW. This motor is of the impulse type and a centrifugal governor attached to the rotor is arranged to control the speed by adjusting the length of the pulses of current fed to the coils. The accuracy of the speed control by this governor was not sufficient but the idea occurred to the authors that if instead of a centrifugal governor a balance wheel and escapement were used in conjunction with a differential gear to effect the alteration in the length of the pulses of current a motor of similar efficiency and with a much better speed control would be obtained. An experimental motor embodying this idea was made and its performance compared with the governed impulse motor.

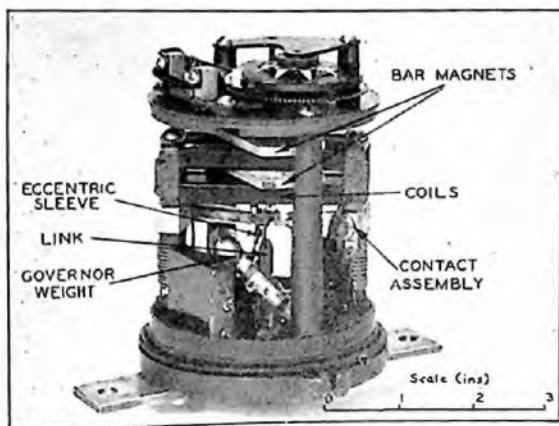

FIG. 1.—WALLACE AND TIERNAN IMPULSE MOTOR.

## Governed Impulse Motor.

This motor is manufactured by Wallace and Tiernan of New Jersey, U.S.A., and has been designed to drive the flasher mechanism of marine lights. It is covered by British Patent Specifications Nos. 409,481 and 498,723. Fig. 1 is a photograph showing the general construction of the motor and Fig. 2 gives additional details to enable the mode

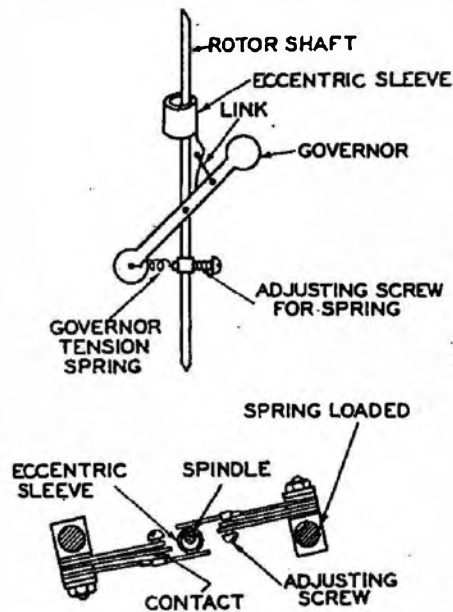

FIG. 2.—GOVERNOR DETAILS. WALLACE AND TIERNAN MOTOR.

of action of the governor to be understood more easily.

The motor consists of a permanent magnet rotor, comprising a pair of similar bar magnets so mounted as to form an astatically balanced system, which revolves in a field created by two coils. Current is supplied to the two field coils through contacts which are opened and closed by the action of an eccentric sleeve fitted to the rotor, one contact being in series with each coil. The use of contacts avoids one of the main losses of power in small low voltage motors, namely the brush gear loss. The contacts are mounted and spring loaded such that they can be easily swung out for inspection and adjustment and yet spring back into their proper position when released. The time during which each contact is closed, that is the duration of the pulse of current through each coil, is determined by the degree of eccentricity of the sleeve which is controlled by a centrifugal governor, as shown in Fig. 2. As the

governor weights fly out the link causes the sleeve, which at rest is in the position of maximum eccentricity (as shown in Fig. 2) to become more nearly concentric with the rotor shaft and hence reduces the degree of eccentricity. The governor is tensioned by a spring, alteration of the tension of which allows the speed of the motor to be varied by some  $\pm 20$  per cent. The motor is made self starting by arranging that the rotor always comes to rest in a position in which the field will be energised when the battery is reconnected. This is done by using two long steel screws to fix the top plate of the motor to the two supporting pillars. Thus in either of these positions the reluctance of the gap between the ends of the magnets is lower than in any other position, and hence the rotor stops in one of these positions.

The action of the motor is as follows. When the motor is running on normal load and on normal supply volts the governor flies out until the centrifugal force just balances that of the retaining spring of the governor. In this position of the governor the eccentricity of the sleeve is at some intermediate value, and the wave shape of the current pulses taken by the motor during one revolution of the rotor is

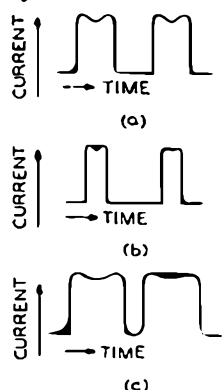

FIG. 3.—WAVE SHAPE OF MOTOR CURRENT IMPULSES.

as shown in Fig. 3 (a). If the battery volts of the motor are increased the speed tends to rise and the governor tends to fly further out. This in turn reduces the eccentricity of the sleeve with the result that the motor takes a current pulse of shorter duration. The overall effect of an increase in battery volts is to cause the motor to settle down to approximately its original speed, but with a reduced length of time over which current is drawn from the battery. This condition is shown in Fig. 3 (b). If, on the other hand, the battery volts are reduced, then the reverse action takes place and the motor settles down to approximately its original speed, but with a current pulse of longer duration. Fig. 3 (c) shows the wave shape of the current pulses when the motor is operating in this condition. Alterations in load have a similar effect on the motor. If the load is increased the motor tends to slow down, and hence the governor weights tend to swing in. This increases the eccentricity of the sleeve, with the result that the motor takes a current pulse of longer duration. The motor settles down to approximately its original speed, but with an increased length of time over which current is drawn from the battery. If instead of increasing the load it is reduced the reverse action takes place and the motor settles down to its original speed, but with a current pulse of shorter duration. It will thus be seen that the amount of power taken from the battery depends on the load on the motor. This is a considerable improvement over the more normal type of governing (e.g., air brake, "fly-out" type of friction governor, etc.) in which, as the load

is removed, the surplus energy is absorbed in the governing mechanism and is thus a loss of useful energy. The type of governing used in this motor therefore results in an improvement in the overall efficiency when compared with a motor employing the normal type of governing. The motor operates at a normal speed of 600 r.p.m. and drives a keying disc through a reduction gearing of 120 to 1.

The performance of the motor, including the reduction gears, was measured by normal methods. The input current and speed were measured for different loads and for different battery voltages. The normal operating voltage of the motor is 6-10 V. The input current was measured by a thermocouple meter and the different loads were applied by a friction brake on the 5 r.p.m. spindle. The speed of this spindle was obtained by counting the number of revolutions in a given time. From the test figures the output and efficiency of the motor down to this spindle were calculated. The input current-output power curves, speed-output power curves and

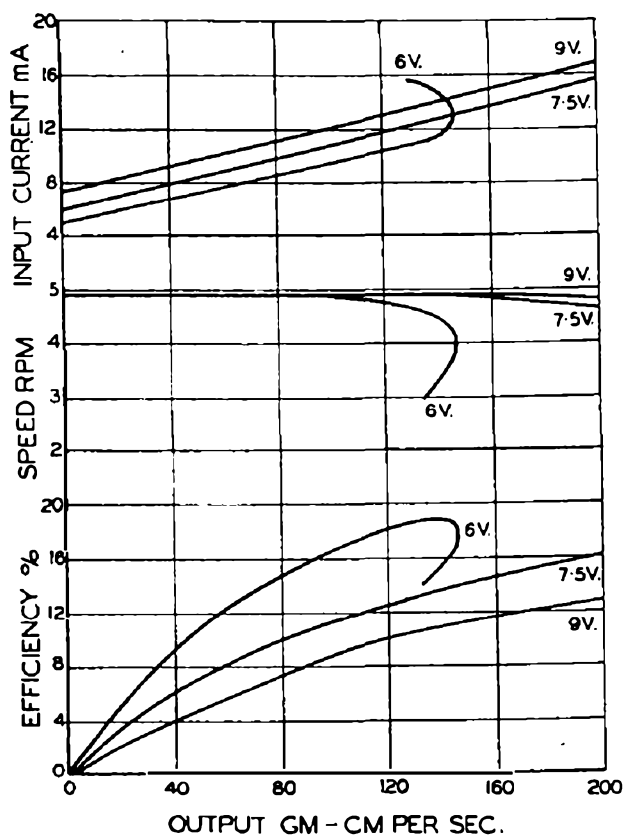

FIG. 4.—PERFORMANCE CURVES OF WALLACE AND TIERNAN MOTOR.

efficiency-output power curves are shown in Fig. 4. It will be seen that with a battery voltage of  $7\frac{1}{2}$  V and with an output of about 100 gm. cm. per second a change in battery voltage of  $\pm 20$  per cent. produces a change in speed of less than  $\pm 1$  per cent. The relatively high efficiency of the motor can also be seen from the curves.



While adjusting the motor it was found to be extremely difficult to make both sets of contacts operate exactly alike. That is, it is very difficult to obtain two equal pulses as shown in Fig. 3. This, however, does not prevent the motor from operating satisfactorily. In fact the motor works quite satisfactorily with only one contact in operation.

*Experimental Impulse Motor.*

Fig. 5 gives two photographs showing the general

construction of the experimental impulse motor and Fig. 6 gives additional details of the eccentric sleeve, differential gear and escapement to enable the mode of action of the motor to be understood more easily. In this motor two disc magnets, magnetised across their diameters, were used for the rotor. Substitution of disc magnets in place of the bar magnets of the Wallace and Tiernan motor was considered an improvement from the point of view of mechanical

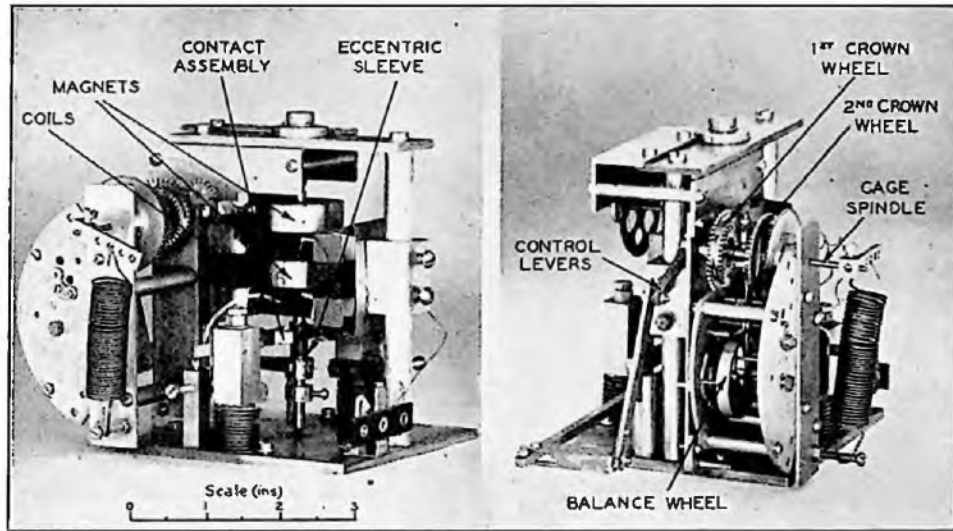

FIG. 5.—EXPERIMENTAL IMPULSE MOTOR.

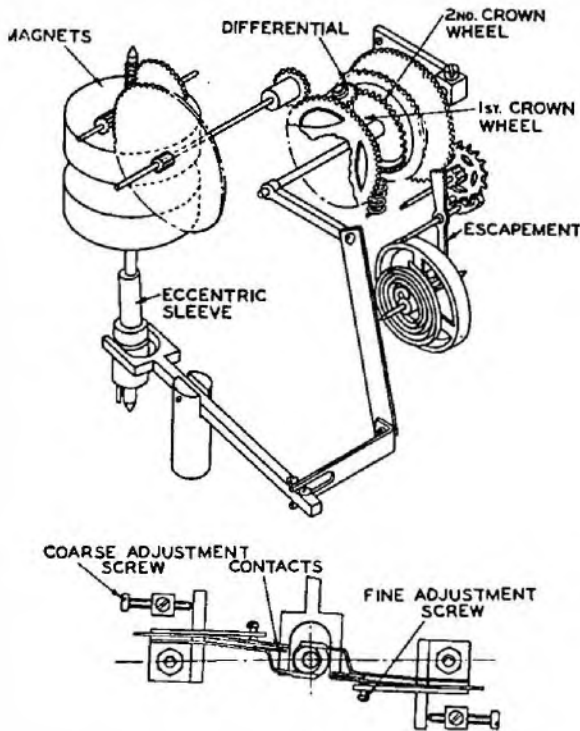

FIG. 6.—CONSTRUCTIONAL DETAILS OF EXPERIMENTAL MOTOR.

balance of the rotor. This rotor, which is also an astatically balanced system, revolves in a field created by two coils. The current is supplied to these field coils through contacts which are opened and closed by the action of an eccentric sleeve which is keyed to but slides up and down the rotor spindle. Coarse and fine adjustment screws were fitted to the contact mounting, to enable the contacts to be adjusted more easily than those of the U.S.A. motor. The position of the sleeve on the rotor spindle, and thus the amount of effective eccentricity of the sleeve, is determined by the position of an arm fixed to the cage wheel of a differential gear (see Fig. 6). The position of this arm in turn depends on the relative action of the crown wheels of the differential. One crown wheel is driven via gearing from the rotor spindle and the other crown wheel is made to rotate in the opposite direction by attaching a light spring to the cage of the differential. The speed of this second crown wheel is controlled at exactly 1 r.p.m. by the escapement mechanism to which it is geared.

The principle of speed control is as follows. When the motor is started up the rotor drives the crown wheel geared to it at a speed slightly greater than 1 r.p.m., as when the motor is at rest the sleeve will be in a position to give the maximum length of current pulse due to the action of the spring attached to the cage of the differential. If now the escapement is started beating, the crown wheel geared to this escapement rotates at exactly 1 r.p.m.

This difference in speed of the two crown wheels causes the cage of the differential to move, and the cage continues to move until, via the levers connecting it to the eccentric sleeve it has adjusted the eccentricity to such a value that the speed of the first crown wheel has been reduced to exactly 1 r.p.m. In this condition both crown wheels are rotating at exactly 1 r.p.m., but in different directions, and hence the cage and the eccentric sleeve remain stationary. If the load or voltage applied to the motor is altered the motor speed tends to alter, and the first crown wheel of the differential will rotate at a speed either greater or less than 1 r.p.m. and thus the cage of the differential will rotate until it has moved far enough to bring the speed of the motor back to normal by changing the amount of eccentricity of the sleeve.

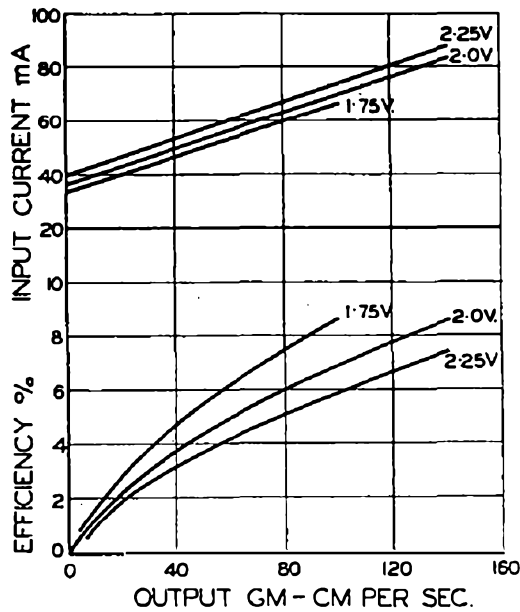

FIG. 7.—PERFORMANCE CURVES OF EXPERIMENTAL MOTOR.

The accuracy of the speed control depends upon the accuracy of the balance wheel and escapement, which can be made quite readily to be of the required order, i.e. 10 minutes in seven days.

The performance of the motor was measured in exactly the same way as the Wallace and Tiernan motor. The normal operating voltage of the motor is 2 V. The friction brake was applied to a spindle which revolves at 2.62 r.p.m. as access to the final 1 r.p.m. spindle was difficult. From the test figures the output and efficiency of the motor down to this spindle were calculated. The input current-output power and efficiency-output power curves are shown in Fig. 7. No speed curve is shown as the speed remained constant at 2.62 r.p.m. Thus a motor with a superior speed performance to the Wallace and Tiernan motor is obtained, but as will be seen from a comparison of Figs. 4 and 7 the efficiency is about one-half of the Wallace and Tiernan motor. A final model could probably be made to have a better efficiency, as the experimental model was built out of oddments which were readily available.

#### Conclusions.

It will be seen that both motors have a much better speed performance than the normal type of small permanent magnet motor, and also that the current consumption is much less. In addition, the experimental motor operates on the low voltage of 2 V with a power consumption of the order of 100 mW. No other motor of this type is known to have been made, but since the motor was built the idea of controlling the speed of a turbine by a differential gear and a source of standard speed has been mentioned in the J.I.E.E.<sup>1</sup>

The authors have pleasure in acknowledging their indebtedness to Messrs Wallace and Tiernan, of London, for the loan of the motor built in the U.S.A., and to Mr. A. D. Hastings, who built the experimental model and fitted the balance wheel and escapement.

<sup>1</sup> J.I.E.E. Vol. 91, Part 1, No. 38, p.77.

## Part I.—Introduction to the Lattice Section

U.D.C. 621.318.7 621.392.52

This series of articles will describe in a simple manner the fundamental properties of crystal filters. The present part introduces the lattice section, the basis of most crystal filter design, and gives some information about reactance circuits.

### Introduction.

THIS series of articles has been written with the object of describing some of the fundamental properties of crystal filters in a way which, it is hoped, will be of general interest and utility especially to those who are concerned with equipment incorporating crystal filters. The treatment in this series is simple and the explanations of the most important fundamentals of quartz crystals and their use have been attempted with only a small employment of elementary mathematics. A knowledge of coil-condenser filters is not an essential preliminary to reading this article, but those who have some knowledge of the usual ladder filter will find that the lattice section is an easy subject for study. In the opinion of the author the lattice section is the best starting point for the study of all types of filters though this is contrary to the usual practice.

### The Symmetrical Lattice Network.

A filter in the form of a lattice network is a more fundamental structure than the ladder network, since, as will be shown, there is more freedom in design with the lattice form. Extensive use of the lattice for crystal filters is due to this greater freedom and justifies devoting the first part of the article to a description of the network. The symmetrical lattice network, to give it its full title, consists of four separate impedances connected together as shown in Fig. 1 in which the series or longitudinal arms  $Z_s$  are

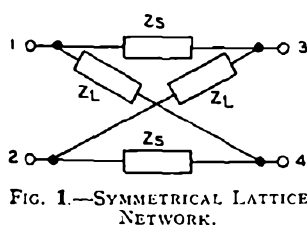

FIG. 1.—SYMMETRICAL LATTICE NETWORK.

identical and in which the lattice or diagonal arms  $Z_L$  are also equal to each other. This network is used between a generator connected to terminals 1 and 2, and a load, equal in impedance to the generator, connected between terminals 3 and 4. Alternatively the load and generator may be interchanged since the network is the same viewed from terminals 1 and 2 as from terminals 3 and 4.

The input impedance of the lattice network in Fig. 1 measured from terminals 1 and 2 depends upon  $Z_s$  and  $Z_L$  as well as upon a terminating impedance  $Z_t$  connected between terminals 3 and 4. If  $Z_t$  is infinite in value the input impedance  $Z_{in}$  is due to two circuits in parallel each comprising  $Z_s$  and  $Z_L$  in series; that is

$$Z_{in} = \frac{1}{2} (Z_s + Z_L).$$

If  $Z_t$  becomes zero the input impedance  $Z_{in}$  is due to twice  $Z_s$  and  $Z_L$  in parallel, that is

$$Z_{in} = \frac{2Z_s Z_L}{Z_s + Z_L}$$

If  $Z_t$  is varied from zero to infinity the input impedance changes from  $Z_{in}$  to  $Z_{oo}$ , and, at a particular value of terminating impedance, the input impedance becomes equal to the terminating impedance. This value is known as the characteristic impedance  $Z_o$ . It corresponds to  $\sqrt{Z_s Z_{oo}}$  and for the network in Fig. 1 is therefore

$$Z_o = \sqrt{Z_s Z_L}.$$

In practical filters the arms of the network always include some resistance. Assuming, however, that all arms have negligible resistance (and in most crystal filters this is a valid assumption) the impedances of the arms become  $\pm jX_s$  and  $\pm jX_L$ ,  $j$  being  $\sqrt{-1}$ . Now if it happens that at certain frequencies  $X_s$  and  $X_L$  have opposite signs then the  $j$ 's disappear from the expression for  $Z_o$ ; that is, for this condition  $Z_o$  is entirely resistive.

If the lattice network is redrawn in the form of a conventional Wheatstone bridge circuit it is at once apparent that no current will be delivered from the network when the input terminals are connected to a source of alternating current if, at that frequency,  $X_s$  is equal to  $X_L$  in magnitude and sign, since a state of balance exists. The frequency  $f_o$  corresponding to this is known as the frequency of infinite loss. If the frequency is altered  $X_s$  is no longer equal to  $X_L$  and some current will enter the output circuit.

To generalise, when  $X_s$  and  $X_L$  are of the same sign the network will restrict or attenuate, the loss increasing as the ratio of  $X_s$  to  $X_L$  approaches unity. At those frequencies, when the reactances of the arms are opposite in sign, the network offers a small loss and those frequencies constitute the pass band of the filter. As a simple example of these rules consider the lattice filter network with the circuit of Fig. 2(a) in which the series arms both consist of an inductor  $L_1$  and the lattice arms each contain an inductor  $L_2$  in series with a condenser  $C_2$ . In this and subsequent circuits of the lattice network only one series arm and one lattice arm are drawn; the others are indicated by broken lines. The reactance curves of the arms are shown in Fig. 2(b). The curve for the series arm indicates the way  $X_s$  changes with frequency  $f$  which it does according to the expression

$$X_s = 2\pi f L_1$$

The dotted curve is that of the lattice reactance which is equal to the algebraic sum of the reactances of the two elements  $L_2$  and  $C_2$ , that is

$$X_s = 2\pi f L_2 - \frac{1}{2\pi f C_2}$$

The reactance of these two together is zero at the frequency  $f_1$  given by

$$f_1 = \frac{1}{2\pi \sqrt{L_2 C_2}}$$

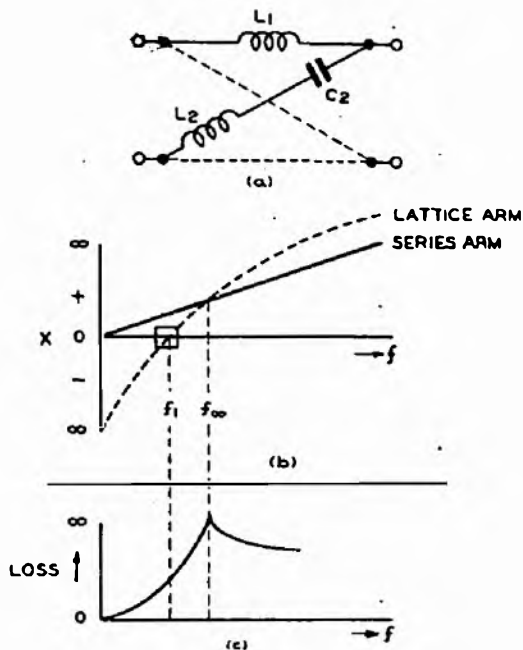

FIG. 2.—REACTANCE AND LOSS CURVES FOR A SIMPLE LOW-PASS LATTICE FILTER NETWORK.

An examination of the reactance curves shows at once that a pass band exists between zero frequency and the frequency  $f_1$  since in this range the reactances are opposite in sign. The network attenuates all frequencies above  $f_1$  so that this is a low-pass network with  $f_1$  the cut-off frequency. The curves as drawn in Fig 2 (b) intersect at the frequency  $f_\infty$ , and as the reactances are equal at this frequency the network will have infinite loss at this frequency. A curve of loss is shown in Fig. 2 (c).

#### Equivalent Ladder Network.

There are two interesting circuit transformations of the lattice network which are frequently used in practice. The first of these is as follows. If the series and lattice arms have a series element common to all, then this element may be withdrawn from all four arms and connected in series with the residue of the lattice on both sides. In Fig. 3 the series arms are  $Z_s$  and  $Z_1$  in series and the lattice arms are  $Z_s$  and  $Z_1$  in series.

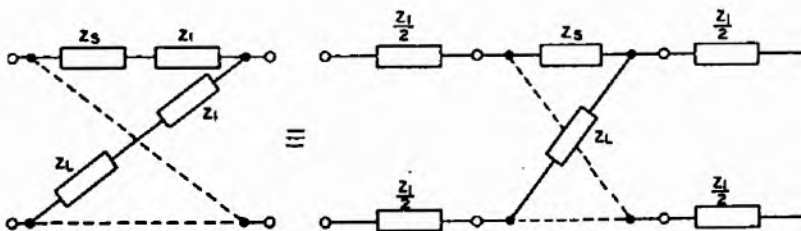

FIG. 3.—LATTICE NETWORK WITH COMMON SERIES ELEMENT AND EQUIVALENT.

$Z_1$  in series. The common element  $Z_1$  is shown withdrawn, leaving the residue  $Z_s$  and  $Z_1$  in the lattice. The elements  $Z_1$  have been divided to preserve the balance. A similar transformation enables a common parallel element to be taken out of the series and lattice arms, and one similar element to be connected across the input terminals and another across the output terminals.

Fig. 4 shows how this method of transformation may be used to convert lattice into ladder networks for the three conditions. (a)  $L_1 = L_2$ , (b)  $L_2 > L_1$ , and (c)  $L_1 > L_2$ . It will be noted that a lattice network cannot always be converted to a ladder network, whereas the reverse transformation can always be made. The lattice is therefore the more general form.

#### Properties of the Lattice Network.

To lead up to the second part of this article, as well as to enquire more closely into the points raised in the previous paragraph, it will be interesting to discover what are the properties of the lattice network shown in Fig. 4. These can be assessed by considering two things, namely, the nature of the characteristic impedance, and the frequency or frequencies of infinite loss. As stated earlier the characteristic impedance is given by  $Z_o = \sqrt{Z_s Z_p}$ . Expressions for  $X_s$  and  $X_p$  have already been given, so that for the resistanceless case being considered

$$Z_s = j2\pi f L_1,$$

$$\text{and } Z_p = j2\pi f L_2 - j \frac{1}{2\pi f C_2}.$$

In the expression for  $Z_p$  it is more convenient to replace  $C_2$  by an expression involving  $L_2$  and  $f_1$ , the resonant frequency of  $L_2$  and  $C_2$  and the cut-off frequency of the filter. Since

$$C_2 = \frac{1}{4\pi^2 f_1^2 L_2}$$

the expression for  $Z_p$  may be written as

$$\begin{aligned} Z_p &= j2\pi f L_2 - \frac{j2\pi^3 f_1^2 L_2}{f} \\ &= j2\pi L_2 \cdot \frac{f^2 - f_1^2}{f}. \end{aligned}$$

Using these expressions for  $Z_s$  and  $Z_p$  the characteristic impedance is

$$Z_o = j2\pi \sqrt{L_1 L_2 (f^2 - f_1^2)}.$$

At zero frequency  $Z_o$  has a particular value called the nominal impedance with the symbol  $R_o$ . By making  $f$  zero

$$\begin{aligned} R_o &= j2\pi \sqrt{L_1 L_2 (-f_1^2)} \\ &= 2\pi f_1 \sqrt{L_1 L_2}. \end{aligned}$$

It is to be noticed that the  $j$  disappears after taking the square root of  $(-f_1^2)$  and making this  $-jf_1$ . At all frequencies between zero and  $f_1$  the  $j$  is absent, so that in the pass band the characteristic impedance

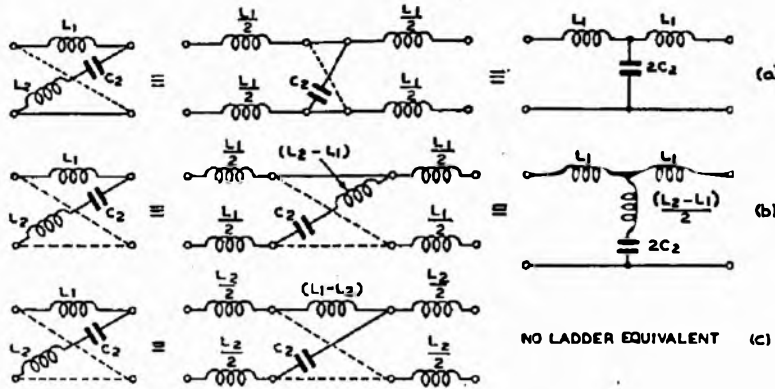

FIG. 4.—EQUIVALENT LATTICE AND LADDER NETWORKS.

is resistive. At the cut-off frequency,  $Z_o$  is zero as can be seen by making  $f$  equal to  $f_1$ . For frequencies greater than  $f_1$  the impedance is reactive.

The condition for frequencies of infinite loss is given by equating  $Z_o$  and  $Z_i$  since they must be equal to give this condition. Thus

$$j2\pi fL_1 = j2\pi fL_2 \left( \frac{f^2 - f_1^2}{f} \right),$$

and from this there is one frequency of infinite loss which is

$$f_\infty = \sqrt{\frac{f_1}{1 - L_1/L_2}}.$$

It is clear from this expression that for a given position of the cut-off frequency the position of  $f_\infty$  is determined by the ratio of  $L_1$  to  $L_2$ . Thus in the lattice section in Fig. 4 (a) and its ladder equivalent, it follows that the frequency  $f_\infty$  is at infinity since the ratio of  $L_1$  to  $L_2$  is unity. When  $L_1$  is less than  $L_2$ , as for the section in Fig. 4 (b),  $f_\infty$  will be between  $f_1$  and infinity. In the condition of Fig. 4 (c) in which no ladder equivalent can be found, it is left to the reader to find where  $f_\infty$  has been placed by making  $L_1$  greater than  $L_2$ .<sup>1</sup> The chief point, however, is that for the network to be realisable as a ladder the frequency of infinite loss can be anywhere in the band above  $f_1$  up to and including infinity.

It follows from the above discussion of the main properties of a simple lattice network that the process can be applied to much more complicated sections, but this means that more complicated filter arms will be encountered and some simple method of dealing with these is necessary. An examination of these reactance circuits will be covered in some detail in the second part of the article but some fundamental properties can be considered now.

#### Reactance Circuits.

Reactance circuits can be composed only of inductance or capacitance or both. If the reactance of an inductor  $L_1$  is plotted against frequency the slope of the expression  $2\pi fL_1$  is positive; that is, when the usual conventions regarding co-ordinates are followed the curve takes the general direction bottom left to top right. Similarly, the reactance of a capacitance  $C_1$

<sup>1</sup>This interesting point has been left because it is outside the scope of this article.

is  $-1/2\pi fC_1$  which, when plotted against frequency also has positive slope. The effect of adding this coil and condenser in series will result, as in a previous example, in a state of zero reactance or "resonance" at the frequency  $f_\infty$  as shown in Fig. 5 (a). Notice that the slope of reactance against frequency is positive. If a coil  $L_2$  is joined in parallel with a condenser  $C_2$  the joint reactance (found by dividing the product of the two by the algebraic sum) when plotted is of the form shown in Fig. 5 (b), with a frequency of infinite impedance or anti-resonance at  $f_\infty$ . Once more the slope is everywhere positive. In fact, whatever type of

reactance circuit is chosen the curve of reactance plotted against frequency will always be found to have a positive slope. If the circuits illustrated in Fig. 5 (a) and (b) are connected in series a four

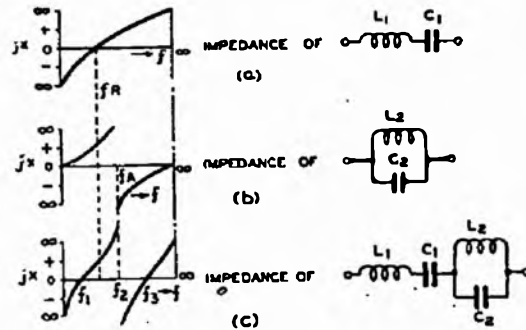

FIG. 5.—IMPEDANCE CURVES OF REACTIVE CIRCUITS.

element circuit is obtained and the joint impedance characteristic (found by addition of the two upper curves) is as shown at (c). There are two frequencies of resonance,  $f_1$  and  $f_2$ , neither of which corresponds to  $f_\infty$ , but the frequency of anti-resonance  $f_3$  corresponds to  $f_\infty$ .

To be consistent in terminology it is proposed to call any frequency of zero impedance a resonance and any frequency of infinite impedance an anti-resonance even if the frequency is zero or infinite. Hence in Fig. 5 (c) there are two further frequencies of anti-resonance, namely, zero and infinity. The term critical frequency will be used to refer to both resonant and anti-resonant frequencies.

From the illustrations of reactance networks in Fig. 5 it is possible to make certain generalisations which will facilitate the sketching of the reactance characteristics of most reactance circuits. Thus:

- (1) The total number of critical frequencies is one more than the total irreducible number of elements.
- (2) A resonance must occur at zero frequency if the circuit will pass direct current.
- (3) An anti-resonance must occur at zero frequency if the circuit will not pass direct current.

Using these rules, and remembering that the reactance slope must be positive, it is possible to sketch the reactance curve of any circuit.

# Localisation of Sheath Punctures in Armoured Cables by CO<sub>2</sub> Gas

A. G. COATES, M.I.E.E.  
(Palestine<sup>1</sup> P. & T. Department).

U.D.C. 621.315.22

A simple method for locating cable sheath punctures by CO<sub>2</sub> gas pressure tests is described in which pressure readings are taken at Schrader tyre valves on ordinary tyre gauges.

## Introduction.

THE localisation of damage to lead cable sheaths by nail holes, fractures, longitudinal splits, or by deliberate or accidental damage in paper core telephone cables laid direct in the ground presents some difficulty, and little appears to have been written on the subject. Punctures may exist for some considerable period before being brought to notice when an electrical fault occurs due to the ingress of moisture. In countries or districts where expensive precision testing equipment is not available circuits may go out of service before the fault can be localised by a megger or similar test set. In countries where there is no rain for months on end, followed by heavy seasonal rainfall, such faults may show up only when the first heavy rains fall, with nightmarish results for the testing staff, if they are faced with the laborious task of sub-localising a number of faults at the same time. Even if sufficient testers and jointers are readily available, a most important trunk cable may be out of service for a period of at least a week if a number of faults develop simultaneously.

Such a predicament should not arise on new cables if the loading sections have been successfully subjected to the usual pressure tests of CO<sub>2</sub> gas, but it is not always possible to ensure that a sufficient number of accurate Bourden-type pressure gauges in good order is available, or that the gauges are identically calibrated; in constant use they tend to become out of order, to sustain broken glasses, etc. This slows up the work and speed is usually essential. To meet such conditions, the author substituted Schrader tyre valves, used in conjunction with an ordinary motor tyre pressure gauge, reading 0-50 lb. In perusing back numbers of the *P.O.E.E. Journal*<sup>2</sup> it was later found that Mr. J. M. Walton had already described the use of such valves in connection with permanently gas-filled cables, but it is thought that the use of the tyre gauge has not been suggested previously. With a number of loading sections condemned for not holding pressure, and about three completely rainless months ahead, a quick method of cleaning up such troubles was devised, tried out, and proved satisfactory. This method avoided digging up considerable lengths of cable for examination and eliminated the need for making many holes in the sheath of the cable. The saving in time, number of men employed, and re-instatement charges was considerable.

## Pressure-Distance Graphs.

The article referred to described a method of localising sheath faults by pressure-distance graphs.

<sup>1</sup> Now with Iraq P. & T. Dept.

<sup>2</sup> *P.O.E.E.J.* Vol. 30, p. 237.

The same general principle was followed by the author. Passing in CO<sub>2</sub> gas in the usual manner by a nozzle in the sleeve of a joint, the pressure was read at this point at a Schrader valve, soldered in a nozzle inserted in a 3-way cock in the delivery tube, and at the other joints in the section and/or the joints to the pots, at Schrader valves plumbed into the ends of short (6") lengths of sheathing, each plumbed in turn over a hole in the sleeve. It was not found necessary to test from the two ends of the section.

The sections consisted of 2,000 yds. of cable divided by three selected joints, numbered 1, 2 and 3, into 4 lengths of about 500 yds. each. The cable was 14pr/40lb. of Trunk and Local types, in some sections armoured, and in others only "protected," i.e., unarmoured laid direct in the ground. A 2,000 yd. section of this cable was found to take about 3 hours to level up to a pressure of 20 lb. if the sheath was intact. If the cable was punctured, the pressure did not level up, but fell evenly from the point where the gas was introduced to the point of damage. The resultant graph was a straight line sloping down to zero at the fault, unless the hole was very small, in which case some gas passed along the cable beyond the fault, and the pressure in this length of cable approximated to the pressure at the fault, usually only a few lb. per sq. in., but sometimes as high as 12 lb. per sq. in. or more.

Faults where the sheath damage is so extensive that no appreciable amount of gas passed the point of damage, may be known as type "A" faults, type "B" being used to describe faults where gas passes the puncture and evens up the pressure in the length beyond.

*Type "A" Fault.*—Conditions relating to a typical type "A" fault are illustrated in Fig. 1. The gas is introduced at the mid-point, Joint 2, of the section.

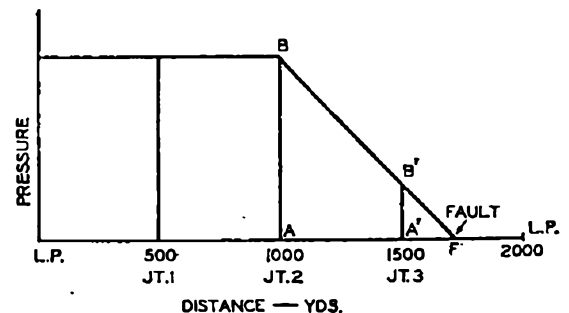

FIG. 1.—TYPE "A" FAULT.

The pressure in one half section remains steady, proving that section to be sound, and in the other half Joint 3 shows a lower figure, and the far end, nil.

By drawing the triangle ABF to scale passing through B' where A'B' is the pressure noted at Joint 3, or by working out length A'F from the similar triangles ABF, A'B'F, the position of F can be found usually to within a few yards. On excavating a short length of trench (generally not more than 25 yds.) the junction can be found by visual and aural superficial examination.

In a typical case the applied pressure AB was 27 lb. and that at JT3 5lb. The distance between JT2 and JT3 was in this instance 530 yds. and calculations indicated the fault to be 120 yds approximately beyond JT3. The fault was actually found to be at this point, due to a hole made by a careless labourer's pick, and was made good. The total working time to locate and repair the fault was 20 hours, including travelling and other ineffective time.

*Type "B" Fault.*—In this case some of the gas passes the puncture and only a part of it is lost due to the hole, so that the pressure is not zero at the fault. The length between the desiccator and the fault will produce a straight line pressure-distance graph sloping down to F, but beyond this, presuming the cable sheath is intact, pressure will tend to level off at the same pressure as at F, as shown in Fig 2, which gives details of an actual fault of this type.

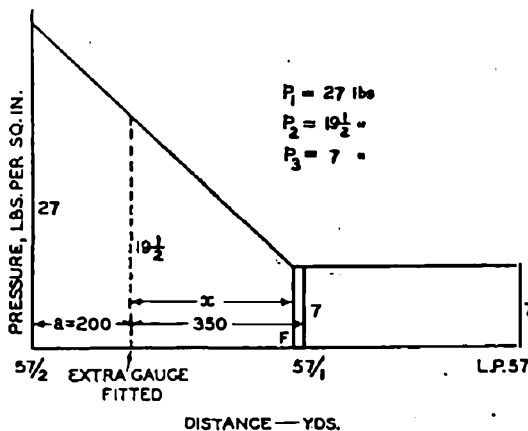

FIG. 2.—TYPE "B" FAULT.

After 3 hours, full pressure was measured at LP 58, and only 6 lb. at LP 57. The fault thus lay between LP 57 and the mid-point, 57/2. A measurement at 57/1 showed 7 lb. From this it was not clear whether the fault lay between 57 and 57/1, or between 57/1 and 57/2, although the latter appeared to be the case. After a further hour, 57/1 and 57 both showed 7 lb.; in other words, equalisa-

tion of pressure in this length had occurred. A further valve was fitted 200 yds. from 57/2, a hole being made in the sheath for the purpose, the valve inner being fitted only after the valve had been connected by a short length of sheathing soldered to the cable over the hole made in the sheath; this precaution was necessary, otherwise the escaping gas would have prevented soldering. The reading at this extra valve proved to be 19½ lb.

Calculation by a simply derived formula gives:—

$$X = \frac{a(p_2 - p_3)}{p_1 - p_2} = \frac{200(19\frac{1}{2} - 7)}{27 - 19\frac{1}{2}} = 333 \text{ yds., i.e., } 17 \text{ yds. from } 57/1.$$

The fault in this case, a small nail hole, was actually found 5 yds. from 57/1 in the direction of 57/2.

The time taken to locate and clear this fault was also 20 hours.

#### Conclusion.

It will be seen that for type "A" or "B" faults a minimum of two valves is needed between the desiccator and the fault, and in type "B" faults, a further two beyond the fault.

The localisations were carried out by jointers, assisted by labourers for digging. The equipment, apart from normal desiccating kit, was extremely cheap and obtainable locally, consisting only of half a dozen valves, some spare inners, and two gauges, one as a spare. The plumbing work is extremely simple and readings can be quickly and accurately taken down to 6 lb., the lowest figure shown on the gauge; the gauge can of course be calibrated for lower pressures, although these are not marked on it when purchased. A more accurate gauge showing 0.30 lb. in ¼ lb. steps could presumably be specially made. Some trouble was found with the gauges in use, apparently due to ingress of dust or sand.

The holes detected were mainly due to nails and had apparently been made at some time during shipment or trans-shipment on the journey overseas. Others were due to fractured sheath—the non-armoured sections being more highly antimonial and consequently brittle—and to somewhat rough handling in very rocky country. Testing instruments capable of localising faults of above 5 megohms were not readily available.

The experience gained while, and subsequent to, laying some 150 sections of cable is now being utilised in normal maintenance work for clearing faults at an incipient stage before circuits become affected, thus avoiding the need for precision apparatus and testing staff.

# A New Rectifier Unit

U.D.C. 621.314.634

S. D. CHAPMAN

The author describes a new selenium type rectifier having a smoothed output and suitable for use with a floating battery at small telephone exchanges. The range of outputs available is greater than that of the superseded type.

## Introduction.

EXPERIENCE gained in the operation of small telephone exchange automatic power plants during recent years indicated the desirability of introducing a range of rectifiers with smoothed output, to replace certain types at present in use with these plants. War-time conditions have necessitated the introduction of various methods of meeting abnormal exchange loads without increase of battery capacity, such as assisted-discharge working, and the conversion of the power plant at certain manual exchanges to a type of automatic working on the lines of the parallel battery automatic scheme. For these purposes, a rectifier having a smoothed output at nominal voltages of 24 and 40, as well as 50 V, was desirable, and opportunity was taken to provide for larger current outputs than the existing range (Rectifier No. 28), and to design all sizes for operation in conjunction with 12, 20 and 25-cell batteries. Some sacrifice in efficiency at the lower voltages was inevitable, but was considered to be justified in view of the unusual circumstances.

## General.

The new rectifier (Rectifier No. 47) consists of a full wave, bridge-connected, dry plate rectifier element of the selenium type, input transformer, mains switch, smoothing inductor, and, in certain types, a ballast resistor, all the components being mounted in a ventilated, pressed steel case suitable for wall mounting. A typical rectifier is shown in

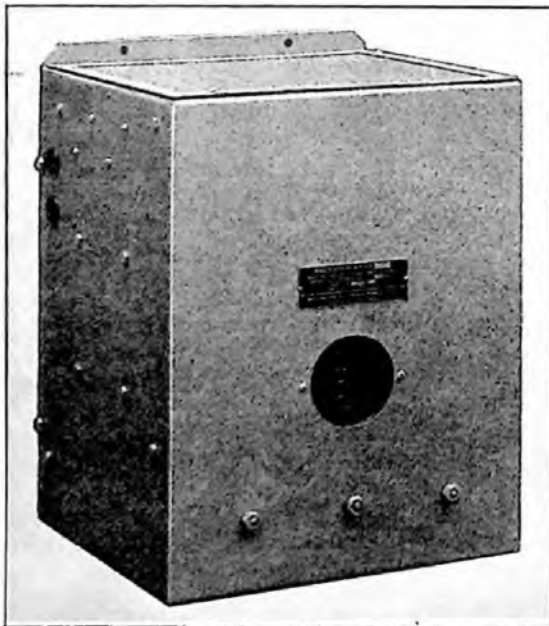

FIG. 1.—RECTIFIER NO. 47A.

Fig. 1. Access to the input and output terminal blocks and current and voltage adjustment tapplings is facilitated by the provision of a removable top cover. The mains switch is recessed below the front surface of the case to prevent damage during storage and transport.

All sizes of rectifier are designed to operate from a 50 c/s, single-phase A.C. supply of any voltage between 200 and 250, the primary winding of the mains transformer being provided with 10-V tapplings terminated on a protected terminal block. Before the mains voltage is applied to the rectifier, the internal leads from the A.C. terminal strip to this block should be adjusted to suit the local supply, i.e. 200 and 0, 220 and 10, etc.

The secondary winding of the transformer is provided with a number of tapplings for adjusting the output of the rectifier. For convenience of installation, these have been segregated into "current" and "voltage" groups. As previously explained, it has been necessary to design the rectifier to be suitable for operation at 24, 40 and 50 V exchanges, and the "voltage" tapping appropriate to each of these is clearly indicated on the transformer terminal panel (see Fig. 2). In addition, a

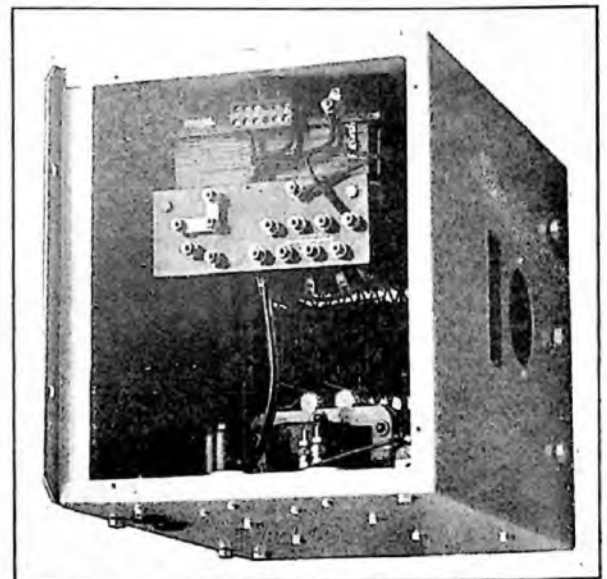

FIG. 2.—RECTIFIER WITH TOP COVER REMOVED.

number of "current" tapplings are provided so that when the rectifier is operating at any of the nominal output voltages mentioned above, the output current may be varied within the limits shown in Table 1. "Fine" and "Coarse" adjustments of output current may be made by the selection of suitable terminal connections, with the assistance of an ammeter connected in the rectifier output



TABLE 1

Rectifier Size	Output Current at 24, 40 or 50 V	
	Minimum A	Maximum A
A	0.5	1.0
B	1.0	3.0
C	2.0	5.0
D	4.0	10.0
E	8.0	20.0

circuit. The output current/voltage characteristic of the rectifier is specified at 50 V and is such that, when this voltage tapping is in use in conjunction with any current tapping, the mean D.C. output current at 60 V is approximately half of the mean D.C. output current at 50V.

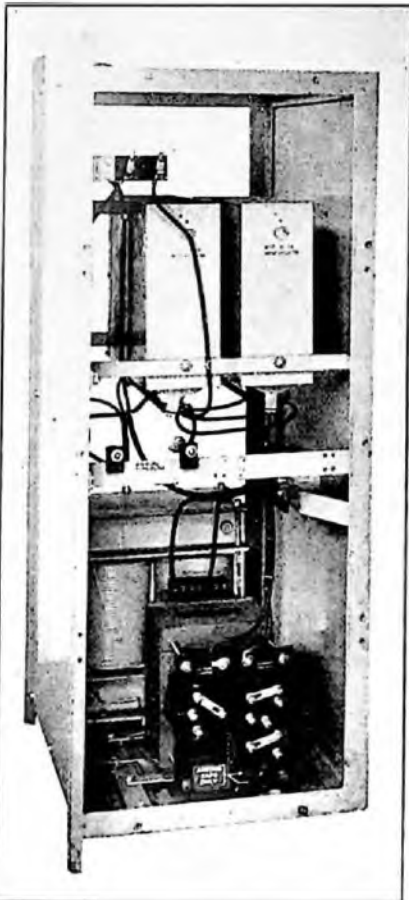

FIG. 3.—RECTIFIER No. 47E.

adjustment of the ballast resistor. Where no ballast resistor is fitted, restoration of output after ageing is effected by the use of additional

The largest size of unit (No. 47 E) is shown in Fig. 3.

*Circuit Arrangement.*

The circuit arrangement of a typical rectifier is shown in Fig. 4. The specified characteristic is obtained in this instance by the use of a ballast resistor connected in the output circuit. After the rectifier has been in service for some time, the rectifier element may "age," i.e. increase its forward resistance, causing a drop in output current. This may be restored by ad-

turns provided on the transformer secondary winding which are connected to terminals marked "Ageing Terminals." In this case, an increased

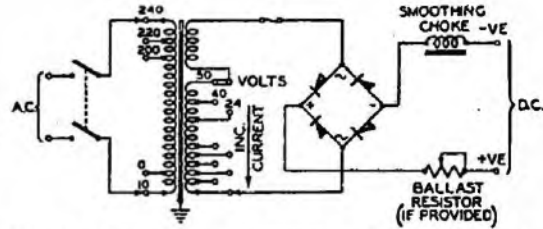

FIG. 4.—CIRCUIT ARRANGEMENT OF RECTIFIER UNIT.

voltage is applied to the rectifier element, to counter the increased forward resistance.

In view of the relatively low current-carrying capacity of the smoothing chokes required and to avoid the necessity for maintenance replacements, electrolytic condensers have not been employed. The smoothing equipment consists of a single choke coil of inductance suitable to ensure that the output noise voltage does not exceed 2 millivolts when the rectifier is operated on a "float" power plant with secondary cells of appropriate capacity. When the new rectifier (No. 47) is used to replace the old pattern rectifier (No. 28) working in conjunction with a standard charging panel (No. 31), the smoothing equipment existing on the power switchboard (i.e. Coil Retardation No. 19A or 20A and Condensers Electrolytic 250  $\mu$ F) is no longer required and may be recovered. The smoothed output of the new rectifier also makes it suitable for use as a trickle charger and for assisted discharge working.

*Superseded Rectifiers.*

In addition to the war-time requirements already mentioned, the new rectifier will gradually replace existing types shown in Table 2.

TABLE 2

Rectifier No. 47	Supersedes Rectifier No. ....
A	28A
B	28B
C	28C and D
D	—
E	4A and 4B

*Conclusion.*

In conclusion, thanks are due to Westinghouse Brake & Signal Co., Ltd., and to Standard Telephones & Cables, Ltd., for information and photographs provided.

# Notes and Comments

## Roll of Honour

The Board of Editors deeply regrets to have to record the deaths of the following members of the Engineering Department :—

### *While serving with the Armed Forces*

Bradford Telephone Area ..	Anthony, H. R.	Skilled Workman, Class II	..	Ordinary Seaman, Royal Navy
Birmingham Telephone Area	Chatwin, F. R.	Skilled Workman, Class II	..	Pilot Officer, Royal Air Force
Bristol Telephone Area ..	Curtis, E. A. V.	Skilled Workman, Class II	..	Signalman, Royal Signals
Bristol Telephone Area ..	Gee, F. H.	Inspector	..	Lieutenant, Airborne Signals
Cambridge Telephone Area ..	Powell, I. L. W.	Skilled Workman, Class II	..	Signalman, Royal Signals
Cambridge Telephone Area ..	Robertson, P. I. N.	Skilled Workman, Class II	..	Signalman, Royal Signals
Cambridge Telephone Area	Saych, R. G.	Labourer..	..	Lance Corporal, Essex Regiment
Cardiff Telephone Area ..	Gale, E. G.	Skilled Workman, Class II	..	Signalman, Royal Signals
Dundee Telephone Area ..	Maxwell, G.	Skilled Workman, Class II	..	Sergeant, Royal Signals
Engineering Department ..	Clark, H. S.	Unestablished Skilled Workman		Private, Argyll and Sutherland Highlanders
Engineering Department ..	Hannah, J. A.	Labourer..	..	Bombardier, Royal Artillery
Engineering Department ..	Harrison, J. H.	Staff Officer	..	Lieutenant. Green Howards
Engineering Department ..	Parker, J. A. T.	Executive Officer	..	Sub-Lieutenant, Royal Navy V.R.
Engineering Department ..	Row, L. N.	Inspector	..	Flight Lieutenant, Royal Air Force
Glasgow Telephone Area ..	Soutar, R. A.	Unestablished Skilled Workman		Sergeant, Royal Air Force
Gloucester Telephone Area..	Emerson, B. F.	Labourer..	..	Private, Gloucestershire Regiment
Liverpool Telephone Area ..	Courtney, W. J.	Skilled Workman, Class II	..	Corporal, Royal Signals
Liverpool Telephone Area ..	Faragher, C. R.	Skilled Workman, Class II	..	Signalman, Royal Signals
Liverpool Telephone Area ..	Oakey, A. F.	Skilled Workman, Class II	..	Sergeant, Royal Engineers
London Telecommunications Region	Atkinson, C. W.	Skilled Workman, Class II	..	Private, Black Watch
London Telecommunications Region	Brennan, M. H.	Skilled Workman, Class II	..	Sergeant, Irish Guards
London Telecommunications Region	Brown, J.	Unestablished Skilled Workman		Signalman, Royal Signals
London Telecommunications Region	Diss, R. W.	Skilled Workman, Class II	..	Flight Sergeant, Royal Air Force
London Telecommunications Region	Hewer, P. S.	Labourer..	..	Private, Royal Army Medical Corps
London Telecommunications Region	Hilder, C. A.	Skilled Workman, Class II	..	Sergeant Pilot, Royal Air Force
London Telecommunications Region	Hobbs, R. H.	Skilled Workman, Class II	..	Electrical Artificer, Royal Navy
London Telecommunications Region	Loveland, A. W.	Skilled Workman, Class II	..	Sergeant, Royal Air Force
London Telecommunications Region	McGarrick, S. E.	Unestablished Skilled Workman		Corporal, Royal Signals
London Telecommunications Region	McGrory, P.	Skilled Workman, Class II	..	Regimental Sergt.-Major, Royal Armoured Corps
London Telecommunications Region	Milburn, D. J.	Skilled Workman, Class II	..	Flight Sergeant, Royal Air Force
London Telecommunications Region	Newell, H. F. J.	Unestablished Skilled Workman		Sergeant, Royal Air Force
London Telecommunications Region	Pemberton, D. S. W.	Labourer..	..	Bombardier, Maritime Royal Artillery
London Telecommunications Region	Preston, G.	Unestablished Skilled Workman		Flight Sergeant, Royal Air Force

London Telecommunications Region	Thorne, F. A. ..	Unestablished Skilled Workman	Cadet, Royal Signals
London Telecommunications Region	Williams, A. R.	Unestablished Skilled Workman	Sergeant, Suffolk Regiment
London Telecommunications Region	Wilson, E. G. ..	Unestablished Skilled Workman	Lance Sergeant, Middlesex Regiment
Newcastle-on-Tyne Telephone Area	Telford, R. ..	Unestablished Skilled Workman	Sergeant, Royal Air Force
Norwich Telephone Area ..	Hogg, B. J. ..	Skilled Workman, Class II ..	Flight Sergeant, Royal Air Force
Taunton Telephone Area ..	Marney, L. T. ..	Unestablished Skilled Workman	Lance Corporal, Durham Light Infantry

### Recent Awards

The Board of Editors has learnt with great pleasure of the honours recently conferred on the following members of the Engineering Department:—

#### *While serving with the Armed Forces*

Belfast Telephone Area ..	Johnston, J. H.	Skilled Workman, Class I	Sergeant, Royal Signals	Mentioned in Despatches
Engineering Department ..	Andrew, P. A.	Skilled Workman, Class I	Flight Lieutenant, R.A.F.	Distinguished Flying Cross
Engineering Department ..	Murphy, D. J.	Unestablished Skilled Workman	Pilot Officer, R.A.F.	Distinguished Flying Cross
Engineering Department ..	Thwaites, H. J.	Assistant Engineer	Squadron Leader, R.A.F.	Mentioned in Despatches
Exeter Telephone Area ..	Thomas, M. G. N.	Skilled Workman, Class II	Warrant Officer, Royal Signals	Mentioned in Despatches
Lancaster Telephone Area ..	Gilpin, F.A. ..	Unestablished Draughtsman	Sub-Lieutenant Royal Navy V.R.	Distinguished Service Cross
London Telecommunications Region	Neilson, D. ..	Unestablished Skilled Workman	Pilot Officer, R.A.F.	Distinguished Flying Cross
London Telecommunications Region	White, R. J. ..	Labourer ..	C.O.M.S., Royal Signals	Military Medal
Reading Telephone Area ..	Bavin, B. E. E.	Skilled Workman, Class II	Sergeant, Royal Signals	Mentioned in Despatches

### New Year Honours

The Board of Editors was particularly pleased to note among the recipients of honours in the New Year's list the name of the Engineer-in-Chief, Sir A. Stanley Angwin, who is made a Knight Commander of the Most Excellent Order of the British Empire for his services to telecommunications during the war years. Other members of the Engineering Department who were honoured included:—

Mr. L. Anderson, Inspector, Welsh and Border Counties Region,

Mr. W. V. Greenwood, Skilled Workman, Class I, North Eastern Region,

Mr. C. J. Reading, Skilled Workman, Class I, London Telecommunications Region, and

Mr. I. H. Wallis, Chief Inspector, Home Counties Region,

who were awarded the British Empire Medal.

Mr. J. Darke, late of the Engineering Department and now Regional Director, North Western Region, was created a Commander of the Order of the British Empire, and Mr. G. Casemere, who is now Telephone Manager, Tunbridge Wells, was appointed a Member of the same Order.

## Regional Notes

### North-Eastern Region

With reference to the notes in the July, 1944, issue of the Journal from the Home Counties Region entitled "Erection of Double-Spliced 113 ft. Poles," which must have been of general interest to engineers, work has recently been carried out in the Leeds area which necessitated the erection of six poles of a similar height.

The method of assembling the poles was very similar to the one used in the Bedford area, but the erection was carried out in a different manner.

Only one 50 ft. derrick pole was used, and this was erected approximately two yards from the back of the

hole which had been excavated ready to receive the pole. Sliding boards were placed in the hole and projected above ground level to enable arms or similar pieces of wood to be placed between the sliding boards and the base of the derrick pole, to take the initial weight at the base of the pole on the commencement of lift.

The main lift of the pole was taken at the first splice by a double and treble set of rope tackle attached to the derrick pole and a chain sling at the splice, luff tackle (i.e. small blocks and tackle to obtain a mechanical advantage) being attached to the pulling rope. At the second splice a 3-in. rope was attached to a sling and

then passed through snatch blocks at the top and bottom of the derrick pole, then on to a hand winch. A 2-in. rope was attached to the top of the pole, then passed through snatch blocks at the top and bottom of the derrick pole. This was a precaution against any possible whipping from the light end of the pole. Below the bottom splice two side guy ropes were fixed to prevent any side movement, one man on each rope being adequate to control a straight lift.

The actual lifting was carried out by man power on the luff tackle and subsidiary lift by the winch and 3 in. rope. The foreman in charge controlled the operation to ensure a consistent lift from both points.

The actual time taken from the commencement of lift to the pole attaining its vertical position was approximately 30 minutes, this time being mostly due to refixing the luff tackle after the blocks had closed to their limit.

The stays were fitted to the pole before lifting, and final adjustments were carried out in a similar manner to that used in the Bedford area.

H. S.

### Home Counties Region

#### M. U. TRACK FAILURE ON A.5 ROAD

The original M.U. track on the A.5 road through part of the Bedford area consisted of three ways laid in 1913. Crossing the canal at Fenny Stratford, the conduits are three C.I. pipes, and during reconstruction of the canal bridge in 1927 the pipes were built into the structure of the bridge. The road over the bridge and the bridge approaches was of reinforced concrete with the usual tar-macadam top surface.

When the bridge was reconstructed, two of the pipes carried the London-Derby No. 1 cable (88/40 + 156/20), and the London-Manchester (160/40), both of which cables were laid in 1924. In 1930 the Liverpool-Birmingham-London cable (4 pr scr/40 + 348 pr/25 Q) was drawn in the third pipe, the left-hand pipe in the photographs.



Recently both the London-Derby and the London-Manchester cables were proved faulty in the section length over the canal bridge, and both cables were interrupted in this section by drawing in suitable cables in new duct, which had been laid in the footway of the bridge. It was found impossible to withdraw the faulty lengths, and after much effort and deliberation it was concluded that the track must have been damaged, and it was decided to open the road. This, in itself, was a large undertaking, involving the consent of the Ministry of Transport, and the employment of a continuous single way traffic control.

After excavation it was found that all three pipes had fractured close to the bridge structure as shown in the photographs. The most interesting point was the way in which the fractures had occurred. All three breaks were practically in line at right angles to the direction of the traffic, and all the fractures were straight round each pipe, almost as though they had been cut with pipe cutters. The sections of conduit running away from the bridge had sunk, over 1 in. in one case, and in consequence the lead sheath of the cables had become damaged.

The photographs clearly show the difference in level of the two sections of the pipe, either side of the break. The material exuding from the centre pipe is lead sheath, which had piled up during the cable withdrawal attempts. It was found that the soil under the conduits



was very loose and waterlogged, and it would appear that the trouble was due to faulty consolidation after the bridge was rebuilt, or entry of water under the road, so causing the road foundation to become loose, or possibly a combination of both. The pipes entering the bridge structure were thus virtually left with no underneath support, and the continual heavy traffic on the main road resulted in the fractures.

It is interesting to note that the road over the bridge and its approaches had been made of reinforced concrete, and there was no evidence of subsidence from the road surface. It would, therefore, appear that the C.I. pipes had fractured because of the road shocks transmitted through the road surface.

After the excavation on the south side of the bridge had been completed, a section of the pipes was cut out and the faulty cables withdrawn, but there was still trouble north of the bridge, and after mandrel tests had been made, it was decided to make a similar opening on the north side of the bridge. It was found that the three pipes had fractured on this side in an exactly similar manner.

Two JRC.9 type jointing chambers were built to restore the track, and the surrounds of both excavations were filled with concrete. The reinforced concrete road was restored by departmental labour as part of the work. Approximately 3 tons of cement, 12 cubic yards of sand and 12 cubic yards of aggregate were used, involving a total expenditure of some 1,600 man-hours, but the finished job resulted in the restoration of the three-way track and prevented a breakdown on the Liverpool-Birmingham-London cable at this point.

E. H. P.

## Book Reviews

"Post-War Building Studies No. 11." — "Electrical Installations." 95 pp. 11 Ill. Published by H.M. Stationery Office. Price 1s. 6d. net.

When it became evident that the present war would seriously restrict the activities of the building industry for some years, the Minister of Works intimated that he would welcome recommendations and suggestions for the improvement of post-war buildings. The various professional institutions interested themselves in the subject and set up a number of committees to make comprehensive studies. The results of the labours of these study groups are now bearing fruit and are being issued in a series of 22 reports entitled "Post-war Building Studies." One report which will be of particular interest to all telecommunication engineers in both their private and official capacities is entitled "Electrical Installations."

This report, which is made by a Committee convened by the Council of the Institution of Electrical Engineers, is probably the most comprehensive study of electrical services in buildings that has yet been made, and so far as telecommunications are concerned it brings up to date a project which was initiated by the G.P.O. in 1931 when the booklet "Facilities for Telephones in New Buildings" was first issued.

The report is divided into six parts. Five of these parts deal with electricity in different types of buildings, i.e., houses and flats, multi-occupier buildings, schools, hospitals and farm buildings, the sixth part being devoted to the problems of ownership and control of distribution in multi-occupier buildings. A comprehensive summary of recommendations and an appendix dealing with a proposed new type of socket outlet and plug are included.

In their introduction the Committee point out that in the past many types of buildings have been "designed" without proper regard to the engineering services required in them and they emphasise that only by the fullest co-operation and collaboration between all interested parties will it be possible to secure for the community at large, both now and in the future, the full advantage and benefit of electrical progress.

Part I of the report commences by the Committee making two basic assumptions, (i) that the standard electrical supply to residential areas will be alternating current only, the negative point being rigidly earthed, and (ii) that supply tariffs will be adjusted to require only one meter. The Committee then proceed very quickly to avoid that awful miscellany of switches, fuses, cut-outs and meters which always seem to adorn domestic residences, by designing a simple but effective Consumers' Supply Control. The design suggested is a pressed steel cabinet, the overall dimensions being 14 in. by 12 in. by 5 in., intended to accommodate the supply company's sealing box fuse and meter in sealed compartments, together with the consumer's fuses, switches and bell transformer in other compartments. Taking advantage of the recent amendments to the wiring regulations, consumers' main fuses are dispensed with and single pole fuses only proposed for sub-distribution circuits. The Committee lay great emphasis on the rapidly increasing number and variety of low power electrical devices and appliances that occurred immediately prior to the war, the acceleration expected after the war and the fact that the only satisfactory means of catering for the use of these appliances is by the provision of a most liberal

and flexible distribution of power points. The Committee propose, therefore, a departure from present practice by suggesting the use of "Ring Main" distribution circuits, each ring being wired with 7/029 (15 A) cable fused to 30A, with only one size of outlet. No alterations are proposed to existing arrangements for lighting and cooking circuits. The proposals appear most attractive to the domestic user, but a disappointing feature is that the Committee seem to have been unable to avoid the introduction of yet another standard plug and socket.

The Committee next give considerable attention to the need for the provision of adequate facilities for telecommunication circuits. They point out that even the smallest house or flat may need to be provided with the following installations:

- A door bell from a mains transformer.
- Telephone, including lead-in and internal wiring.
- Sound broadcasting, i.e., aerial, earth and extension loudspeaker.
- Wire broadcasting, lead-in and internal wiring.
- Television lead-in for special aerial or from "wired television."

The Committee stress that the minimum requirements for the above are: two pipes or conduits for lead-in from underground and/or overhead services, and one pipe or conduit for lead-in from aerial.

The two alternative methods recommended for the accommodation of internal wiring are either deep picture rails with connecting ducts or ways between rooms and floors or hollow walls, ducts or skirtings with inter-connecting ducts under doorways. It is pointed out that in small residences the number of such door crossings would be small.

In a section dealing with larger houses and flats similar arrangements for the control and distribution of power supplies are recommended, the Committee pointing out that the standard cabinet already proposed could be designed to cater for one or more additional distribution circuits as required. It is stressed, however, that the provision of adequate facilities for telecommunication services applies with added force to larger residences, since apart from those facilities already mentioned, additional facilities required may include house telephones, fire alarms, burglar alarms and distribution of low frequency sound broadcasting. A reasonable number of power outlets for the larger self-contained detached type of residence is stated, not unreasonably, to be from 30 to 50.

Sketches showing the overall dimensions of the more bulky type of electrical appliances are included, i.e., cookers, refrigerators, water heaters and washers.

Part II of the report contains a short review of the question of ownership of common cables in multi-occupier buildings.

Part III of the report deals with the requirements of multi-occupier buildings. This part of the report is divided into several subsections, the first being devoted to the common requirements of all electrical services in such buildings. Particular emphasis is given to the need for the architect or builder to plan for and provide in all buildings at an early stage of construction certain fundamental facilities, including:

- (a) Pipes or ducts for lead-in cables.
- (b) Accommodation for control, metering and distribution.
- (c) Vertical ducts for accommodating conductors to the different floors.

- (d) Horizontal ducts for distribution over each floor.
- (e) Liberal provision of flexible outlet positions to allow the efficient utilisation of the different services to be provided.

The second section deals with power and lighting installations in the more common types of buildings; the particular requirements for blocks of flats, office buildings, departmental stores and hotels are each considered separately.

The subject of telecommunication services in these buildings is considered to be so important as to warrant a separate section extending to eight pages. The Committee recognise the importance of the increasing popularity of blocks of flats by treating this type of building separately and in detail. Particular reference is given to the provision of facilities for telephones, sound broadcast, time, bell and fire alarm circuits. It is pointed out that the telephone service within such a building may be provided either by individual exchange lines or by a P.B.X. In the latter case, additional accommodation is required for the equipment, batteries and operating staff. The possible need for public call offices being required as built-in features of the architectural design of the entrance hall or other selected locations is not overlooked.

The telecommunication services in other large buildings are next dealt with, it being pointed out that the type and density of the services required depends to a large extent upon the function for which the building is to be used. The possible facilities required are stated to be most diverse and may include any or all of the following:

- Public telephone service.
- Private telephone service.
- Telegraph service.
- Sound and television service (Music while you work).
- Public address.
- Staff locating system.
- Bells.
- Service call (for hotels).
- Clocks.
- Fire and burglar alarms

Parts IV and V of the report deal with the applications of electricity in schools and hospitals respectively and Part VI of the report is devoted to the question of electricity in farm buildings, a subject which, it is stated, is becoming of increasing importance. The question is dealt with in detail, the many and varied types of appliances and machines available being described. It is of interest to note that the power required to hatch an egg in an incubator is stated to be between  $\frac{1}{4}$  and 1 W. Drawings showing a proposed layout for a typical modern farm are included.

The appendix contains a summary of further investigations made by the Committee on the proposed new fused socket outlet. It is stated that as a result of a questionnaire issued to all supply undertakings, the Committee have reached unanimous agreement on the need for the introduction of a new 3 kW (230 V) socket outlet and fused plug and that they have invited B.E.A.M.E. to prepare suitable designs prior to standardisation by the British Standards Institution. Detailed recommendations to govern the proposed designs are included.

It is obvious that the Committee have taken a very practical and realistic view of electrical installation problems in all types of building and they have gone far to turn suggestions and ideas in which many engineers have been interested, into tangible designs suitable for standardisation and economic bulk production.

F. C. C.

"Telecommunications" by W. T. Perkins, A.M. Brit. I.R.E., A.M. Inst. B.E. 300 pp., 186 ill. Newnes. 12s. 6d.

So long as examinations continue to be the yardstick by which one's educational standard is measured the acquisition of a good examination technique will be of almost equal importance to students as the attainment of real knowledge. A good examination technique includes the ability to:

- (1) state one's facts clearly and concisely,
- (2) draw neat and relevant sketches,
- (3) confine one's answer to the average time allowed (usually 20-30 minutes),

and a knowledge of:

- (4) the type of question likely to be asked,
- (5) the standard of answer required.

It is to help the student with these matters that the author has written this book, which is therefore supplementary to and in no way replaces the standard works on the various branches of telecommunications.

The book is divided into two parts, the first dealing with Transmission and Lines and the second with Telephony. The author claims to have covered Grade I of the City and Guilds examinations in Transmission and Lines and Grades I and II of Telephony. The book commences with a summary of the chief formulæ concerned and follows with a large number of typical examination questions with solutions, and a further selection of questions involving calculations to be worked out by students. For these only the numerical answer is given. Dividing the two sections are the syllabuses of the three examinations covered and to complete the book are 14 tables giving useful data, a set of logarithm tables and an index.

The type of answer is similar to that given in the Supplement to this Journal, but instead of working through any particular examination paper the questions are grouped. Thus, for example, one finds all questions dealing with valves grouped together, followed by questions on equipment employing valves. The usefulness of the book purely as a "crammer" would be increased if a table were included analysing past question papers so that students could gauge the relative importance placed by the examiners on the various sections of the syllabuses. Apart from this, the only criticism is the price, though it may be some consolation to purchasers to know that the author's share of the profits is being donated to the Second Post Office Relief Fund.

The general standard is excellent and the book can be confidently recommended to students wishing to acquire the art of writing brief and lucid reports on technical matters, an art which they will find of greater use than the immediate purpose of answering examination questions.

H. L.

# Staff Changes

## Promotions

Name	Region	Date	Name	Region	Date
<u>Regl. Engr. to Asst. Controller with Allce.</u>			<u>Chief Insp. to Chief Insp. with Allce.</u>		
Boryer, W. F. . . . .	L.T.R. to L.P.R. . . . .	1.11.44	Knott, H. H. R. . . . .	S.W. Reg. . . . .	22.10.44
<u>Exec. Engr. to Regl. Engr.</u>			Birch, F. . . . .	W. & B.C. Reg. . . . .	1.11.44
Penney, A. E. . . . .	L.P.R. to L.T.R. . . . .	8.11.44	<u>Chief Insp. to Tech. Costs Cffr.</u>		
<u>Senior Phys. or Chem. to A.S.E.</u>			Robinson, R. B. . . . .	E.-in-C.O. to Con- tracts Dept.	22.4.44
Richards, C. E. . . . .	E.-in-C.O. . . . .	5.10.44	<u>Insp. to Chief Insp.</u>		
<u>Phys. or Chem. to Senior Phys. or Chem.</u>			Haines, J. P. . . . .	Scot. Reg. . . . .	6.8.44
Taylor, R. . . . .	E.-in-C.O. . . . .	5.10.44	Fairs, A. E. . . . .	L.T.R. . . . .	19.8.44
<u>Asst. Engr. to Exec. Engr.</u>			Fable, F. P. . . . .	H.C. Reg. . . . .	13.8.44
Dudley, J. C. . . . .	E.-in-C.O., on loan to Admiralty	14.11.44	**Thirsk, R. D. . . . .	Mid. Reg. . . . .	15.10.44
Griffiths, G. J. . . . .	Mid. Reg., on loan to Admiralty	2.11.44	Jarvis, H. W. . . . .	H.C. Reg. . . . .	15.10.44
Newley, E. F. . . . .	E.-in-C.O., on loan to Factories Dept.	12.11.44	Polhill, C. T. . . . .	H.C. Reg. . . . .	27.8.44
Loosemore, E. S. . . . .	S.W. Reg., on loan to Admiralty	28.9.44	Smith, S. C. . . . .	H.C. Reg. . . . .	8.10.44
Peddle, H. W. . . . .	Mid. Reg., on loan to Admiralty	25.9.44	**Clark, E. N. . . . .	H.C. Reg. . . . .	8.10.44
<u>Chief Officer to Asst. Sub. Supt.</u>			Came, C. H. . . . .	S.W. Reg. . . . .	10.9.44
Finlayson, J. R. . . . .	H.M.T.S. to E.-in-C.O.	18.9.44	Foskett, G. E. . . . .	Scot. Reg. . . . .	8.10.44
<u>Asst. Engr. to Senior Tech. Costs Cffr.</u>			**Brunton, J. B. . . . .	Scot. Reg. . . . .	1.10.44
Hull, S. D. . . . .	E.-in-C.O. to Con- tracts Dept.	22.4.44	MacCallum, A. . . . .	Scot. Reg. . . . .	1.10.44
<u>Chief Insp. to Asst. Engr.</u>			Little, S. J. . . . .	L.T.R. . . . .	10.9.44
Gibson, J. . . . .	Scot. Reg. to L.T.R.	1.10.44	**Walters, T. L. . . . .	E.-in-C.O. . . . .	1.8.44
**Russel, J. H. . . . .	Scot. Reg. . . . .	25.9.44	Peck, E. J. M. . . . .	E.-in-C.O. . . . .	1.8.44
**Dunkley, L. W. . . . .	Mid. Reg. . . . .	14.11.44	Conolly, E. J. . . . .	N.W. Reg. . . . .	1.11.44
Tinto, J. M. . . . .	S.W. Reg. to Mid. Reg.	25.9.44	Foy . . . . .	L.T.R. . . . .	2.10.44
McWalter, W. V. . . . .	Scot. Reg. to Mid. Reg.	2.11.44	Wood, T. . . . .	N.E. Reg. to E.-in- C.O.	19.11.44
**Trueman, G. F. . . . .	N.W. Reg. . . . .	14.11.44	<u>Insp. to Asst. Tech. Costs Cffr.</u>		
**Waite, D. . . . .	N. Ire. Reg. . . . .	14.11.44	Vickery, F. D. . . . .	E.-in-C.O. to Con- tracts Dept.	22.4.44
McDonald, T. H. . . . .	N. Ire. Reg. to S.W. Reg.	14.11.44	<u>S.IV.1 to Insp.</u>		
			Allchin, M. C. V. . . . .	H.C. Reg. to E.-in- C.O.	10.9.44
			Richardson, J. M. . . . .	Test Section, Ldn.	3.5.44

\*\* Mobilised

## Retirements

Name	Region	Date	Name	Region	Date
<u>Chief Regional Engr.</u>			<u>Chief Insp.—contd.</u>		
Watkins, J. H. . . . .	W. & B.C. Reg. . . . .	30.9.44	Turner, A. E. . . . .	L.P.R. . . . .	31.10.44
<u>Chief Insp. with Allce.</u>			<u>Insp.</u>		
McCann, J. L. . . . .	S.W. Reg. . . . .	1.10.44	Misson, H. G. . . . .	H.C. Reg. . . . .	30.4.44
Halliday, C. W. . . . .	W. & B.C. Reg. . . . .	31.10.44	Rivers, H. G. . . . .	L.T.R. . . . .	8.11.44
<u>Chief Insp.</u>			Tunncliffe, R. T. . . . .	N.I. Reg. . . . .	10.11.44
Hastings, J. W. . . . .	H.C. Reg. . . . .	31.8.44	Mills, A. R. . . . .	S.W. Reg. . . . .	21.11.44
Shaw, A. F. . . . .	L.T. Reg. . . . .	3.9.44	Malley, J. . . . .	Scot. Reg. . . . .	25.11.44
Moss, F. R. . . . .	H.C. Reg. . . . .	25.10.44	Bradley, E. A. . . . .	N.I. Reg. . . . .	27.11.44
			Middleton, K. M. . . . .	E.-in-C.O. . . . .	30.11.44

## Transfers

Name	Region	Date	Name	Region	Date
<u>Exec. Engr.</u>			<u>Asst. Engr.</u>		
Beastall, J. G. . . . .	N.W. Reg. to L.P.R.	19.11.44	Glass, C. G. . . . .	E.-in-C.O. to L.T.R.	16.10.44

**Transfers—continued.**

Name	Region	Date	Name	Region	Date
<b>Chief Inspr.</b>			<b>Insp. (continued)</b>		
Tnompson, S.	.. H.C. Reg. to L.T.R.	3.9.44	Tnompson, R. H.	.. E.-in-C.O. to Mid. Reg.	20.11.44
Herbert, L. J.	.. E.-in-C.O. to L.T.R.	22.10.44	<b>Prov. Inspr.</b>		
<b>Insp.</b>			Si.clair, B. R.	.. E.-in-C.O. to H.C. Reg.	16.10.44
Builey, N.	.. H.C. Reg. to E.-in-C.O.	16.10.44			

**Deaths**

Name	Region	Date	Name	Region	Date
<b>Chief Inspr.</b>			<b>Insp. (continued)</b>		
Tugwell, P. C.	.. H.C. Reg.	9.8.44	Gee, F. H.	.. S.W. Reg., Death on Active Service	17.9.44
Jolliffe, A. P.	.. H.C. Reg.	2.11.44	Spittle, S.	.. S.W. Reg.	22.9.44
<b>Insp.</b>			Knights, A. J. L.	.. Mid. Reg.	29.9.44
Row, L. N.	.. E.-in-C.O., Missing. Death presumed on Military Service	3.12.43	Sleigh, W. R. H.	.. L.T.R.	20.10.44
Rowland, W.	.. N.W. Reg.	25.6.44	Taylor, E.	.. N.E. Reg.	19.11.44
			Townshend, E.	.. N.E. Reg.	21.11.44
			Cameron, J. W.	.. E.-in-C.O.	27.10.44

## Institution of Post Office Electrical Engineers

### Vacancies on Council

Notification is hereby given of the election unopposed of the following members to fill the vacancies indicated :

- (1) *Inspectors and Assistant Chemists and Physicists (Provinces)*.—Mr. V. D. PETTIT, Inspector, Cambridge.
- (2) *Draughtsmen, Class I and II (Provinces)*.—Mr. T. E. WALKER, N. Eastern Region, Leeds.

An election is proceeding in respect of the vacancy for the representative of the Assistant Engineers, M.T.O. Class III, Chemists and Physicists (E.-in-C.O.).

December, 1944. H. L. DUNSTER,  
*Acting Secretary.*

### Junior Section, Aberdeen

A general meeting of the above was held on Friday, November 10, 1944, when it was decided to reopen the local centre. The following office bearers were elected :

Hon President, Mr. C. F. Perryman ; Chairman, Mr. D. S. C. Buchan ; Vice-Chairman, Mr. W. J. Cowie ; Secretary, Mr. S. D. F. Buchan ; Treasurer, Mr. C. L. Bannerman ; Committee, Messrs. W. N. Davidson, G. W. A. Duguid, J. P. McGregor, A. S. Deacon, J. D. Neilson. Auditors, Messrs. C. P. Milne and F. J. Dignan.

The following programme has been arranged :

Date	Subject	Speaker
1.12.44	Police Boxes.	J. W. Mitchell
22.12.44	Carrier Frequency Synchronisation.	G. W. A. Duguid
15.1.45	Diesel Engines.	W. B. Davidson

11.2.45	U.S.W. Radio Links.	J. D. Neilson
10.3.45	Open Night (Any Questions ?).	—
31.3.45	External Construction.	T. I. Miller
21.4.45	Cable Fault Localisation.	D. F. M. Peters S. D. F. B.

### Junior Centre, Edinburgh

The Edinburgh Centre of the Junior Section of the I.P.O.E.E., which ceased functioning at the outbreak of hostilities, has now recommenced activities. A committee of five has been appointed as follows : Chairman, Mr. J. M. Wright ; Vice-Chairman, Mr. G. Alexander ; Secretary and Treasurer, Mr. D. Cunningham ; Librarian, Mr. H. W. Onwin ; with Mr. C. Barrie appointed to the committee in an advisory capacity. This Centre was the first to be established and is registered as No. 1. (*I.P.O.E.E. Journal*, Vol. 25, Part 2 refers.) Its revival is therefore particularly gratifying.

Two interesting meetings have already been held, and membership now numbers fifty. At the October meeting Mr. W. S. Procter, A.M.I.E.E., F.R.S.E., delivered a fine paper on "The Nature of Electricity." This meeting was well attended and was an undoubted success.

The remainder of the programme is as follows :  
November 3.—"Carrier System No. 7," G. Ford.  
December.—"Radio Interference," J. Riva.  
January, 1945.—"Any Questions ?" (a "Brains Trust" composed of five of the Senior Centre).  
February.—"Two V.F. Signalling."  
March.—Annual General Meeting.

D. C.



*So much depends on them*



"AVO" Electrical Testing Instruments are actively engaged on the fighting and factory fronts, sharing a great responsibility with a proud sense of duty and high confidence in the future.

*It will therefore be appreciated by our numerous trade friends that we can now only accept orders which bear a Government Contract Number and Priority Rating.*



*Sole Proprietors and Manufacturers*

THE AUTOMATIC COIL WINDER AND ELECTRICAL EQUIPMENT CO. LTD.  
Winder House, Douglas Street, London, S.W.1  
Phone: VICTORIA 3404-8

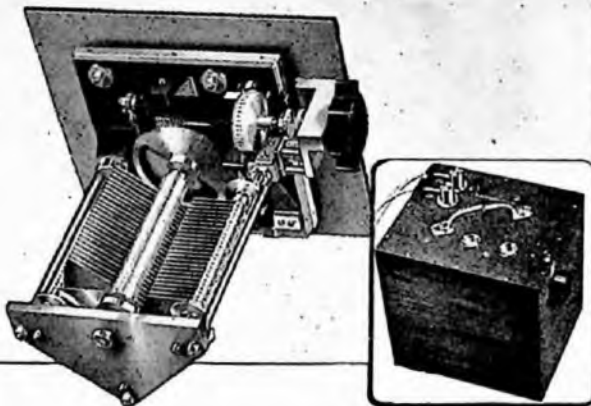

#### BRIEF SPECIFICATION

CAPACITANCE.  $50\mu\text{F}$  min.  $1,250\mu\text{F}$  max.  
LOSS ANGLE. Approximately 1 micro-radian in a dry atmosphere; 7 micro-radians in 75% relative humidity, for the frequency range 50 c.p.s. to 10,000 c.p.s.  
DRIVE. Worm reduction gear, 50 : 1 ratio.  
SCALE READING. To 1 part in 5,000 direct reading; To 1 part in 20,000 by interpolation.  
BACKLASH. Not exceeding 1 part in 20,000.  
DIMENSIONS. 121 x 10 x 131.

Write for Bulletin B-537-A giving further particulars.

MUIRHEAD AND COMPANY LIMITED, ELMERS END,  
BECKENHAM, KENT. TELEPHONE: BECKENHAM 0041-0042

FOR OVER 60 YEARS DESIGNERS AND MAKERS OF PRECISION INSTRUMENTS

## *A Standard of Zero Loss Angle*

### **VARIABLE AIR CONDENSER TYPE D-14-A**

This three-terminal double-screened condenser is provided with a guard circuit which ensures that the dielectric of the plate-to-plate capacitance is composed entirely of air. This, together with the special surface treatment of the plates reduces the plate-to-plate power loss to a quantity which can be disregarded even when measuring the smallest power factors.

**MUIRHEAD**



PRINTING  
TELEGRAPH  
APPARATUS

TELEPRINTERS  
HIGH SPEED MORSE INSTRUMENTS  
RELAYS  
AND REPEATERS

**CREED** AND CO. LTD  
CROYDON

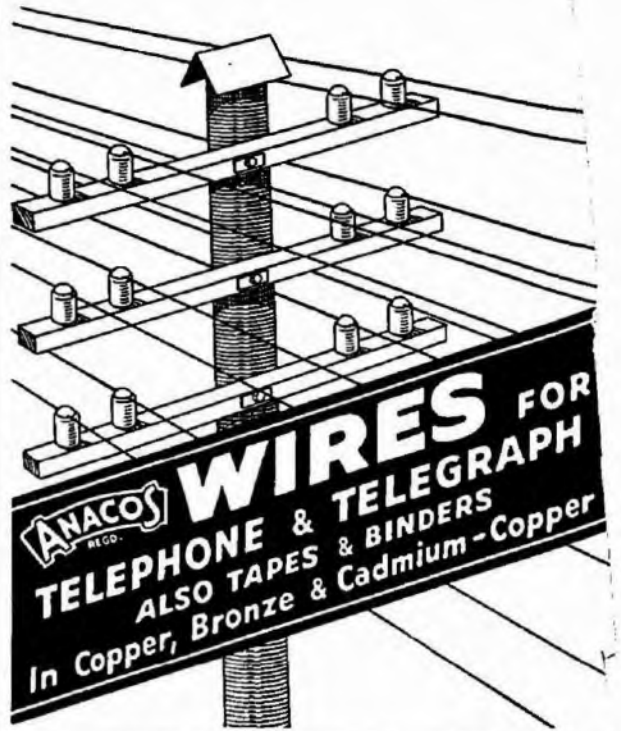

FREDERICK SMITH & CO. LTD. (*Incorporated in The London Electric Wire Company and Smiths, Limited.*)  
ANACONDA WORKS, SALFORD, 3, LANCS.  
Telephone : LACKFRIARS 8701 (8 lines)      Telegrams : "ANACONDA" MANCHESTER

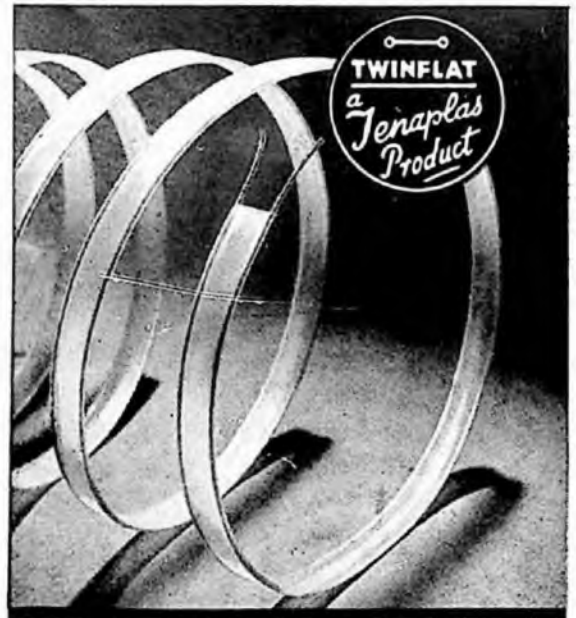

**TENAPLAS**  
*Electrical Insulation*

TENAPLAS LTD., 7 PARK LANE, LONDON, W.1



**AND LIGHT-CURRENT SIGNALLING  
SYSTEMS AND EQUIPMENT...**

including Strowger Automatic Telephone Equipment—standard almost the world over—for networks of all sizes or for isolated exchanges, Manual Telephones and Exchange Equipment, Single and Multi-Channel (Carrier) Transmission Systems and Associated Apparatus, Supervisory Remote Control Equipment, Colliery Telephone and Signalling Equipment, Electro-matic Street Traffic Signals and other products. Fully descriptive literature, catalogues, etc., are available and will be sent upon application, whilst expert technical knowledge and advice are always at the service of those interested.

**UTOMATIC TELEPHONE & ELECTRIC COMPANY LTD**

LONDON AND  LIVERPOOL



## CERAMIC *High Voltage* CONDENSERS

The outstanding characteristics of U.I.C. Ceramic Pot and Plate Condensers are their high break-down strength, low loss factor, and small dimensions.

*Test Voltage* up to 15 KVD.C. or 10 KV R.M.S.  
*Working Voltage* up to 10 KVD.C. or 5 KV R.M.S.  
*Radio Frequency Working Load* from 2.5 to 15 KVA according to type. *Capacity Range* 5 pF to 1250 pF.  
Tested to Specification K.110. Full details on request.

**UNITED INSULATOR CO. LTD. 12-22 LAYSTALL STREET, LONDON, E.C.1**

Tel.: TERminus 7383 (5 lines) Grams.: Calancel, Smith, London

**THE PIONEERS OF LOW LOSS CERAMICS.**

## design for reliability & efficiency

Westinghouse Metal Rectifiers more than meet G.P.O. standards of reliability and efficiency. Every unit, including the latest "Westalte" selenium-compound rectifier, has behind it the experience of eighteen years' rectifier technique and development and is built up to a standard and not down to a price.

Illustrated is a Mobile Power Unit for V.F. Telegraph Equipment, 24 and 130 volts output, incorporating "Westat" Constant Potential System.

Descriptive pamphlet No. 11 H describes the principles of many circuits employed in communication engineering in which Westinghouse Metal Rectifiers play a prominent part. We shall be pleased to send a copy to any Interested Post Office Engineer

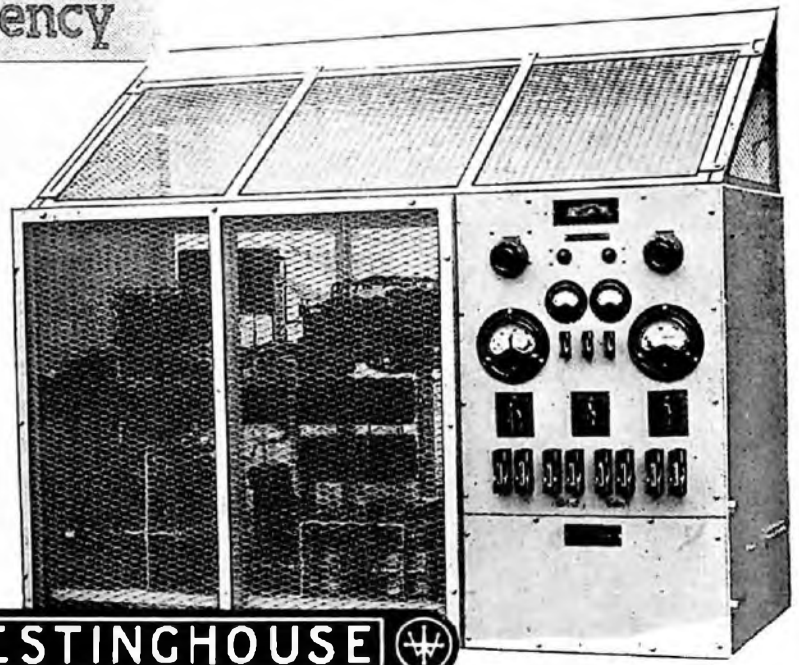

**WESTINGHOUSE**

**METAL RECTIFIERS**

**WESTINGHOUSE BRAKE & SIGNAL CO. LTD.,  
Pew Hill House, Chippenham, Wilts.**

# SIEMENS PRODUCTS

*backed by over 80 years' Electrical Experience*

Contractors for  
the manufacture, laying and main-  
tenance of Submarine and Land  
Cables for Telegraphy, Telephony  
and the Electric Transmission of  
Power, for the erection and main-  
tenance of Overland Telegraph,  
Telephone and Power Transmission  
Lines, Marine Wireless Telegraph  
and Telephone Installations, Public  
and Private Telephone Exchanges  
and Carrier Equipment for  
Telephone Lines.

*Manufacturers of*

Electric Lamps of all types for  
Domestic, Industrial and Street  
Lighting, including "Sieray" Electric  
Discharge Lamps, Fluorescent Tubes,  
Motor Car Lamps, Projectors, etc.



**ELECTRIC  
WIRES & CABLES**

**CABLE  
JOINT BOXES**

**TELEPHONE CABLES**  
*Aerial, Underground, Submarine*

**OVERHEAD  
LINE MATERIAL**

**CELLS & BATTERIES**  
*Dry, Fluid & Inert*

**ELECTRICAL  
MARINE APPARATUS**

**ELECTRIC  
LAMPS**

**PRIVATE  
TELEPHONE SYSTEMS**

**PUBLIC  
TELEPHONE EXCHANGES**

**CARRIER-CURRENT  
EQUIPMENT**

**WIRELESS EQUIPMENT  
FOR SHIPS**

**"ZED" FUSES**  
*L.T. SWITCH & FUSE GEAR*

**SIEMENS BROTHERS & CO., LTD.**

**WOOLWICH, LONDON, S.E. 18**

SIEMENS ELECTRIC LAMPS & SUPPLIES LTD., 38-39 UPPER THAMES STREET, LONDON, E.C. 4

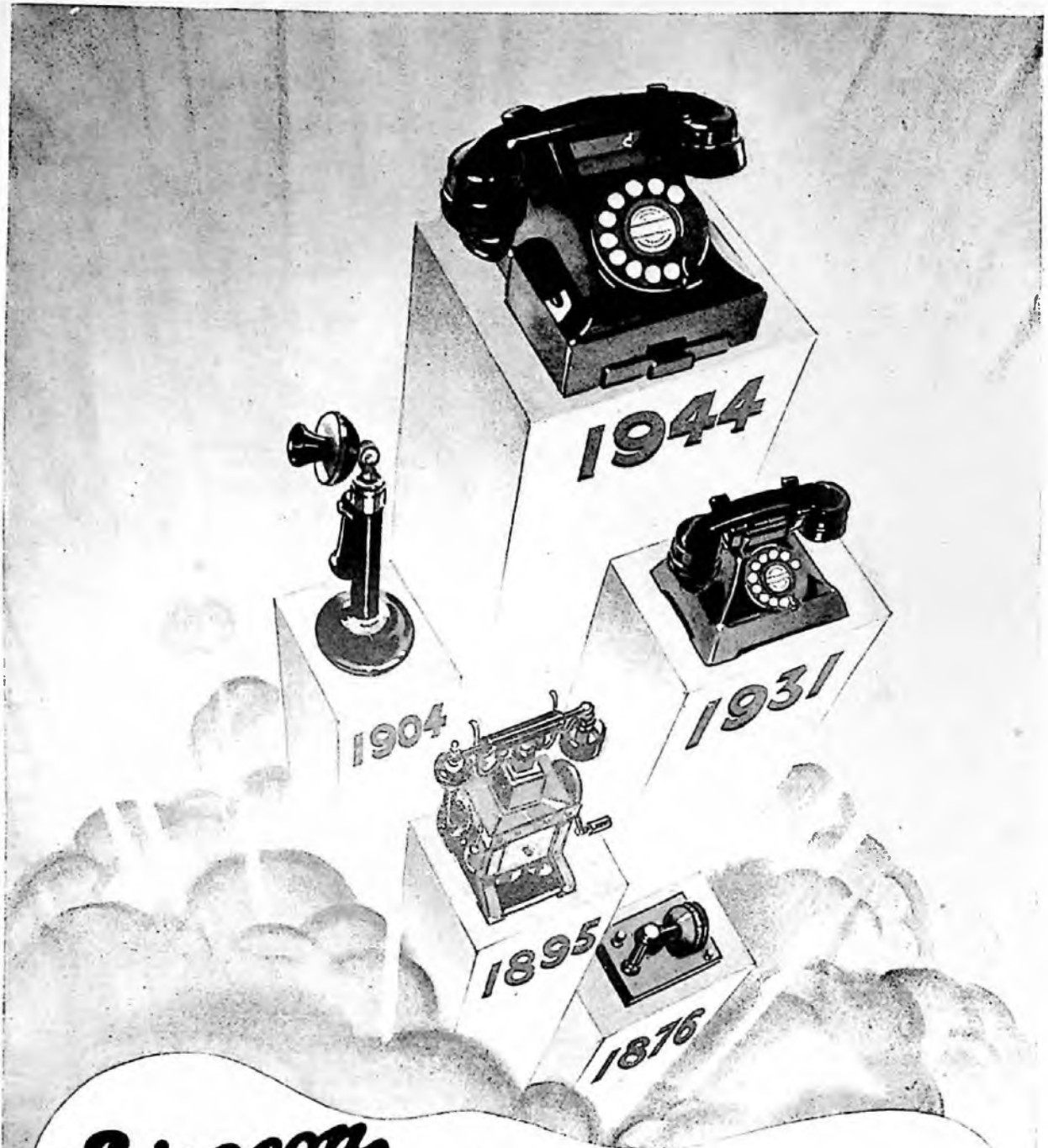

**Ericsson**

66 years of steady progress in telephony and its applications sees Ericssons in their extensive plant to-day utilising Modern Plastics for the improvement of telephone design and efficiency. Ericssons have unrivalled experience in

the production of telephone equipment required to function under tropical and similar extreme conditions—taking full advantage of the application of Plastics in this connection. Enquiries welcomed.

ERICSSON TELEPHONES LTD., Head Office: 56, Kingsway, London, W.C.2. Tel.:—HOL. 6936. Works Beeston, Notts.

---



---



---

**capco**

---



---



---

REGISTERED TRADE MARK

# QUARTZ CUTTING MACHINES

**Q.2.B Machine.** This is the original Q.2, but redesigned, giving full protection to all slides, lead screw, etc. New type gear box enlarged and strengthened.

Cutting can now be carried out in a totally enclosed clear view splash guard enclosing the whole table. There are other new and interesting features too—details on request.

**LIGHT & HEAVY DUTY MACHINES  
HAVE BEEN RE-DESIGNED & IMPROVED  
LATEST DEVELOPMENT, HAND AND  
AUTOMATIC NOTCHING MACHINES  
. . . DETAILS ARE NOW AVAILABLE**

## CAPLIN ENGINEERING CO. LTD.

**25** years of service to the engineering and allied trades.

Well over one thousand "CAPCO" machines in use to-day, including hundreds of special machines and apparatus. "CAPCO" is synonymous with accuracy.

*Designers and manufacturers of Capco Sound-on-Film recorders and equipment. Capco built recorders are in use at Elstree, Pathe News and Universal Talking News, etc. Patentees and manufacturers of Capco Enamelled Wire Cleaning machines.*

**BEACONSFIELD RD WILLESDEN, LONDON, N.W.10**

Sole Agents : CAPCO (Sales) LTD.

Telephone : WILlesden 0067-8

---



---



---

# TRADE MARKS

## A guarantee of Quality

A registered trade mark is the sole property of the trade mark owner and distinguishes his products.

The word "**MEGGER**" is the registered trade mark of  
Evershed & Vignoles Ltd.  
and must only be used to describe their products.

For example, a "**MEGGER**" Insulation Tester means the instrument is made to the designs, standards and inspection of Evershed & Vignoles Ltd.

Thus the registered trade mark "**MEGGER**" which is known all over the world, is your guarantee of a high quality product.







*'The best  
of prophets  
of the future  
is the past'*—BYRON

BEHIND Alton stationary batteries stands a great tradition of painstaking effort and progressive improvement. To-day the result is reflected by the high standard of performance of Alton batteries in Power Houses, Telephone Exchanges and Broadcasting Stations. Because Alton practice is rooted in such fine tradition, to-morrow Alton batteries will be chosen for the maintenance of power supply in vital installations.

# ALTON

## BATTERIES OF MERIT

THE ALTON BATTERY COMPANY LIMITED  
(Sole Suppliers of FULLER Stationary Batteries)  
ALTON, HANTS

Phone: Alton 2267 and 2268 Grams: 'Battery, Alton'

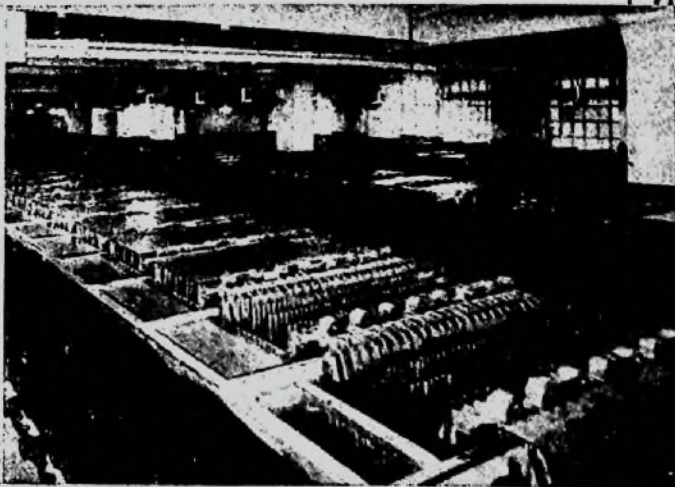

# MAINTAINING EFFICIENCY

THE HIGH STANDARD OF EFFICIENCY  
OF PIRELLI - GENERAL TELEPHONE  
CABLES IS MAINTAINED BY THE  
CONTINUOUS RESEARCH WORK OF  
AN EXPERIENCED TECHNICAL STAFF.

TELEPHONE  
SOUTHAMPTON  
2141 (5 Lines)

**PIRELLI-GENERAL**  
CABLE WORKS, Ltd., SOUTHAMPTON.

TELEGRAMS  
"PIREKAYBEL"  
SOUTHAMPTON

**lbs AND £s**

... 4,416 Good Joints  
TO THE LB. - THEREFORE  
MORE TO THE £.

Of course, Ersin Multicore 3-Core Solder is not as cheap as ordinary solder—but it costs less in the end. The three cores of Ersin flux being continuous, there is no waste of either labour or material, and no dry joints even with the majority of highly oxidised components. One pound of sixteen S.W.G. Ersin Multicore Solder will give as many as 4,416 sound joints which can be trusted to remain sound, both electrically and mechanically. Firms engaged on government contracts are invited to write for reference sheet and samples of Ersin Multicore Solder Wire—approved by the A.I.D. and G.P.O. for all purposes where resin is specified.

**ERSIN MULTICORE**

THE SOLDIER WIRE WITH 3-CORES OF NON-CORROSIVE ERSIN FLUX



MULTICORE SOLDERS LTD. COMMONWEALTH HOUSE, NEW OXFORD ST. LONDON, W.C.1. Tel: CHAncery 5171/2