

Mr. Parker

THE POST OFFICE ELECTRICAL ENGINEERS' JOURNAL

VOL. 35

OCTOBER, 1942

PART 3

CONTENTS

	PAGE
TRUNK DELAY ANNOUNCING—H. Corkett, A.M.I.E.E., and A. C. Lynch, M.A.	73
THE APPLICATION OF CARRIER SYSTEMS TO SUBMARINE CABLES—PART I—R. J. Halsey, B.Sc.(Eng.), A.C.G.I., D.I.C.	79
MODERN MATERIALS IN TELECOMMUNICATIONS—W. G. Radley, Ph.D., M.I.E.E., E. A. Speight, Ph.D., D.I.C., A.R.C.S., C. E. Richards, F.I.C., E. V. Walker, B.Sc., A.R.S.M.	84
CALCULATION OF INSERTION LOSS AND PHASE CHANGE OF 4-TERMINAL REACTANCE NETWORKS—H. Stanesby, A.M.I.E.E., E. R. Broad, B.A., and R. L. Corke, A.M.I.E.E.	88
AIR RAID DAMAGE TO POST OFFICE TELECOMMUNICA- TIONS—PART I—Underground Plant—E. C. Baker	93
IMPROVED MOUNTINGS—F. G. Bird	97
NOTES AND COMMENTS	99
REGIONAL NOTES	100
STAFF CHANGES	102
BOOK REVIEWS	101 & 104

Price 1/- net

THE INSTITUTION OF POST OFFICE ELECTRICAL ENGINEERS

G.E.C.

CRYSTAL CALIBRATOR



A new precision instrument for the rapid and accurate checking and adjustment of radio frequency oscillators, receivers, transmitters and similar apparatus.

It is crystal controlled and A.C. mains operated.

Ask for full information from :

SALFORD ELECTRICAL INSTRUMENTS LTD.

SALFORD. Telephone : Blackfriars 6688 (6 lines). Telegrams and Cables : "SPARKLESS, MANCHESTER"

PROPRIETORS: THE GENERAL ELECTRIC CO., LTD.

EDISWAN

TELEPHONE LINE PROTECTOR PANELS

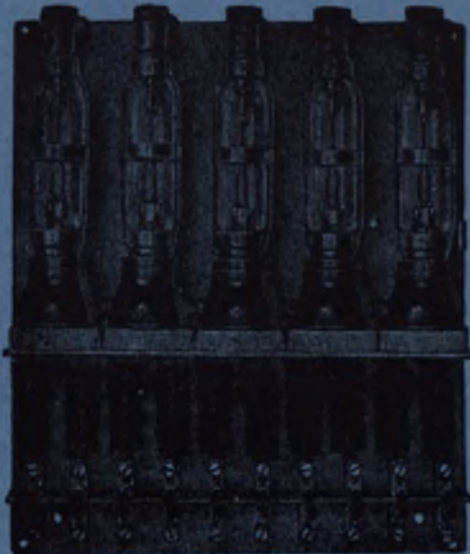

5-circuit panel for overhead lines incorporating choke coils, spark gaps, etc.

EDISWAN-SHOTTER-GREETHAM PATENT

(British Patent No. 353924)

for the protection of telephone systems against surges induced by faults on neighbouring power lines

Of the difficulties attendant upon the employment of overhead systems one of the most serious is to ensure uninterrupted working of the telephone system, by providing adequate protection against induced surges caused by switching or line faults in adjacent power lines or by lightning.

The Ediswan Patent Protectors provide the solution. They are inert at the normal working pressure of the telephone line, they keep the voltage on the line down to a pre-determined figure by providing a path of low resistance to earth whereby the surge is cleared and they again become inert immediately the surge is cleared.

They ensure simultaneous discharge of both lines and are capable of clearing heavy discharges without detriment to the system or the protector.

Ediswan Telephone Line Protectors have now been in use by Supply Companies for many years.

THE EDISON SWAN ELECTRIC CO. LTD.,  155 CHARING CROSS ROAD, LONDON, W.C.2

THE POST OFFICE

ELECTRICAL ENGINEERS' JOURNAL

Vol. XXXV

October, 1942

Part 3

Trunk Delay Announcing

U.D.C. 534.862 : 621.395.63

H. CORKETT, A.M.I.E.E., and
A. C. LYNCH, M.A.

When delay occurs on trunk lines, subscribers are told by operators of its probable duration. This article summarises the methods used for giving the information to the operators, and describes a machine recently introduced for the purpose.

Introduction.

WHEN the trunk demand system was introduced means were provided to enable long-distance telephone calls to be completed while the calling subscriber waits at the telephone. The success achieved by this method of working has been a notable accomplishment in the history of telecommunications. At the same time the extent to which a no-delay service can be maintained at all hours depends on the number of circuits which are available, and although the circuit provision has increased considerably in recent years to meet the increasing volume of trunk traffic, a suspension of demand working is inevitable at times when the carrying capacity of the circuits is inadequate for the immediate disposal of the demands received. Thus a proportion of the calls have to be dealt with on a delay basis and consequently delay working has to be regarded as an integral part of the system; the extent of its actual part may be judged from the fact that prior to the war (June, 1939) about 80 per cent. of the total trunk calls were completed on demand. Of the remaining 20 per cent., some were unsuccessful due to reasons outside Post Office control, e.g. "no reply" or "subscriber engaged." From this it will be concluded that in normal times the average duration of delays incurred is not great. Delay working is of course proportionally less on inland than on overseas services because of the less liberal provision of circuits and of the special operating procedure on the latter circuits; and where a radio link is involved, the unsuitability of the transmission quality of the radio channel for commercial speech at certain times is an additional adverse factor.

When delay working is resorted to, particulars of each call are recorded on a ticket, and the calling subscriber is released after being told that he will probably be connected within (e.g.) one hour. The ticket circulates to an operator controlling the route who eventually completes the connection in its order of booking. Arrangements are made to indicate to the operating staff when demand service is withdrawn from a route and also to enable operators to ascertain the probable period of delay so that the information can be furnished to the subscriber when the call is booked. The arrangements by which this is done are described in the following paragraphs.

Route Delay Indicators

An indication that delay working is being exercised on a route to a particular exchange is given by one of the following methods. At some trunk centres yellow pegs are inserted into the multiple jacks of the first circuit in the trunk group, denoting that no endeavour should be made by the demand operators to complete calls to that exchange either via the primary route or an alternative route. At other centres a lamp signal (red) or switchboard indicator is used. This signal is situated above the jack immediately preceding the first circuit in the group.

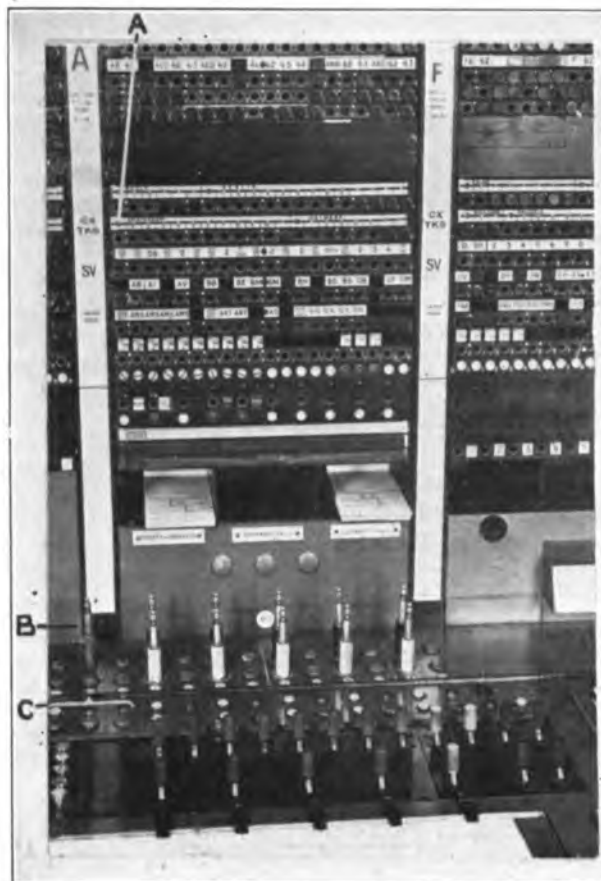

FIG. 1.—SWITCHBOARD FITTED WITH DELAY INDICATOR.

In the larger exchanges with sleeve control switchboards this route-delay lamp is situated in the strip containing the free-line signals. The operation of the route-delay signals is controlled by route-delay keys (1 per route) mounted on the cable turning section of the switchboard.

Delay Period Indicators

A simple device used to supply operators with the duration of delays consists of a delay posting board suspended in a prominent position in the switchroom, on which the codes of the distant exchanges are displayed. When a delay is "posted" a tablet inscribed with the number of minutes delay is affixed to the board at the side of the code to which it refers; as the duration of delay rises or falls, so the tablet is changed accordingly.

A later practice, more appropriate for the larger trunk exchanges where the configuration of the switchroom would necessitate many delay posting boards, takes the form of an electrical indicator provided on each position of the switchboard, shown in Fig. 1.

For this purpose the spare jack associated with the route-delay lamp (A) is brought into use, together with the provision of a delay plug (B) wired to 2 (or 3) delay indicating lamps (C) on the position. The insertion of the delay plug into the delay jack causes one or more of the lights to glow denoting certain periods of delay. For example:

- White lamp to denote 30 mins. delay
- Green lamp to denote 45 mins. delay
- Red lamp to denote 60 mins. delay
- White and red lamps together to denote 90 mins. delay
- White, green, and red lamps together to denote indefinite delay

The discrimination as to which particular lamps (white, green, or red) are required to function is controlled by plunger keys which are accommodated with the route-delay keys on the delay indicator control panel at the end or angle section of the switchboard. One set of keys is fitted for each route. When a key is depressed it connects earth to the respective lamp wire, at the same time switching-on the corresponding lamp on the master control panel. The display on the master control panel thus presents a complete picture of the state of the routes at all times.

When particularly heavy delays occur and information is required concerning the actual delay periods which cannot be indicated directly on the lamps or when supplementary advice is needed as, for example, the treatment of important calls, the particulars are obtained verbally over connections to an enquiry operator's position.

Limitation of Visual Delay-Period Indicator.

The special circumstances which have arisen in the past three years have aggravated the position as far as long-distance communications are concerned and have tended to result in heavier delays on public traffic. The chief reasons for this are the depletion of circuits owing to their appropriation for other services, and occasional unavoidable breakdowns of the routes. In these circumstances it is necessary to exercise a greater measure of control, especially to ensure the prompt treatment of essential calls in emergencies; and with delays of longer duration, the scope of the delay-indicating lamps is insufficient, because of the small range of periods which they indicate. This results in a corresponding increase in the number of references to the delay-enquiry positions, and in a centre with scores of trunk and toll routes, several operators would be required solely for quoting delays and similar advice. With the need for conserving operators and also switchboard equipment for more appropriate uses it was obviously desirable to find a less costly alternative in the form of a mechanical contrivance which would give greater facilities than the "delay-indicators." A scheme was therefore devised whereby electrically recorded announcements can be broadcast over the switchboard multiple wiring from a delay quotation machine and reproduced to the operator when she inserts a plug into the route-delay jack.

Such a machine has been constructed by Post Office engineers to propagate ten different announcements comprising convenient arbitrary periods of delay, e.g. "½ hour," "1 hour," "2 hours," etc., and other appropriate terms of advice such as "Limit" (meaning that connections should be restricted to certain classes of traffic).

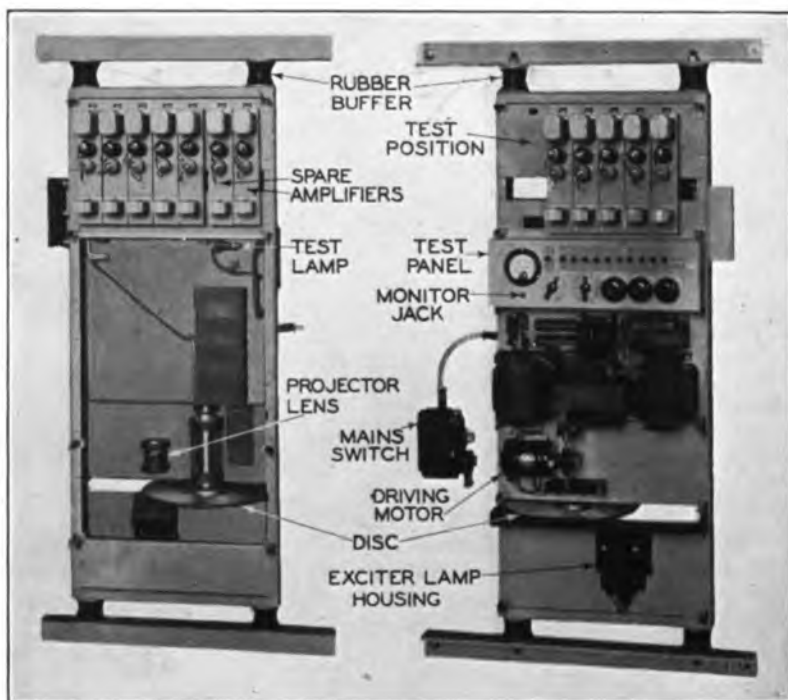

FIG. 2.—ASSEMBLY OF MACHINE (FRONT AND REAR VIEWS)

DESCRIPTION OF MACHINE

The essentials of the machine are a rotating glass disc on which the ten announcements are photographically recorded on ten concentric tracks; an "exciter" lamp; a slit which defines the area of the sound-track being scanned at any moment; and ten photo-electric cells, which produce audio-frequency currents corresponding to the variations in the light received by them, each followed by a two-stage amplifier.

Fig. 2 shows the assembled machine, which is a unit suitable for mounting on exchange-type racks of either 2 ft. 6½ in. or 2 ft. 9 in. width. As the permissible projection in front of and behind the rack varies in the two cases, and the machine requires the maximum permissible front-to-back space (14 in.) but does not fill the width of the rack, it is constructed on a sub-frame 19 in. in width (thereby allowing the use of standard panels and covers) and is fixed to the rack by four bolts. Different fixing brackets have been designed for the two types of rack, and no other alteration in the machine is necessary. Part of the spare space at the side of the rack is used for the main switch and fuse-box and for tag-blocks for distribution wiring where necessary.

The Glass Disc Record.

The glass disc is 12 inches in diameter and about ¼ in. thick. It carries 10 "variable-area" sound-tracks, each of the standard width (0.080 in.), spaced at approximately 0.120 in. centres. The recording on the disc was carried out in a special camera which was originally used for the speaking clock recordings.

If such a record were made directly from speech, there would be difficulty in speaking each phrase during the period for which the camera shutter would be open (1.2 seconds) and there would be a probability that the intonation of the voice in some of the recorded announcements would be slightly faulty. Initial recordings on sound-film were therefore made, and the most pleasant and distinct of the announcements were selected from this film for re-recording on the disc. The re-recording technique used has been developed recently with the object of reducing the background noise.

The disc so made is a negative, having the sound-tracks black on a clear plate. From it contact prints are made, and these are the discs fitted to the machines. Fig. 3 is an enlargement of part of a disc. A thin cover-glass is fitted to protect the emulsion during dusting, although the design of the machine is such that there is little opportunity for dust to reach the disc.

The Optical System.

Ordinary sound-film reproduction practice would require the use of 10 exciter lamps and optical systems for scanning the 10 tracks. This would give an inconvenient mechanical layout, as the lamps and optical systems, which are about 1 in. in diameter, could not be arranged in a single line along the radius of the disc. It would also be uneconomical in running, as each exciter lamp would need 30 watts or

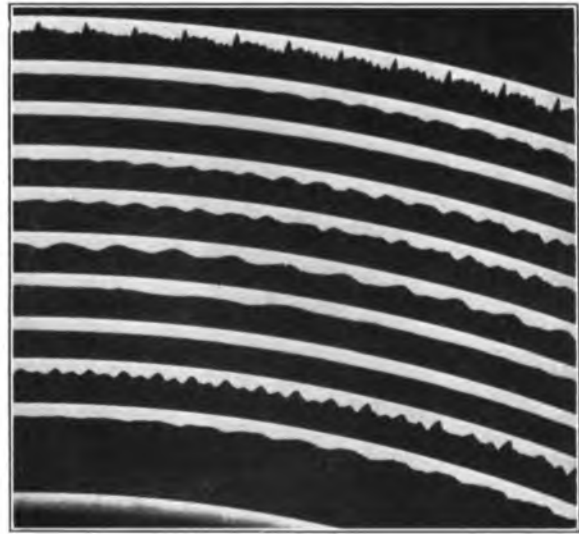

FIG. 3.—PART OF DISC (ENLARGED).

more. These difficulties are overcome by so arranging the optical system that a single lamp illuminates all the ten tracks. An image of the illuminated patch of the disc is then produced on a slit by a projection lens; this image is sufficiently magnified to allow room for the 10 photo-cells side by side behind the slit. The layout is shown diagrammatically in Fig. 4.

So that the slit can be easily accessible, it has been arranged at a distance of 5 in. in front of the photo-cells; and additional lenses are used to prevent spreading of the light from each beam on to adjacent

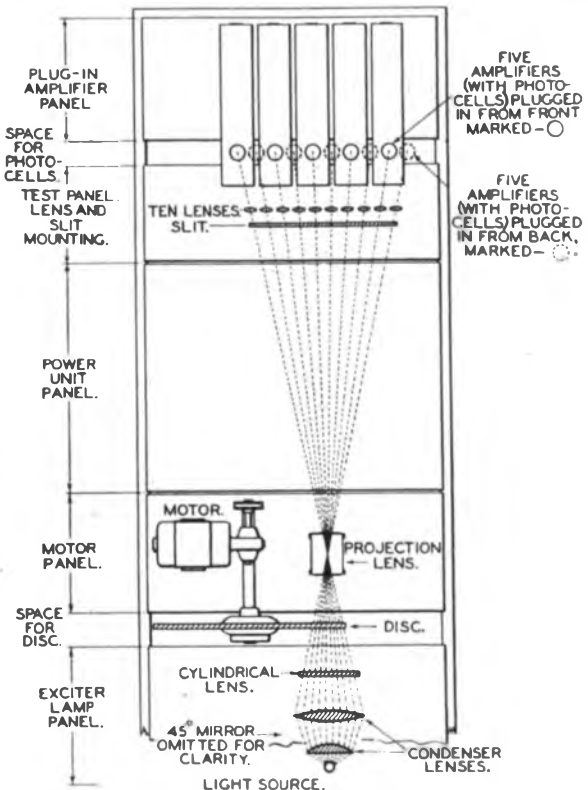

FIG. 4.—DIAGRAMMATIC VIEW OF FRONT OF MACHINE.

cells. The result is to produce on the photo-cell a small patch of light (actually a diminished image of the projection lens), the intensity of which varies according to the modulation on the sound-track but the position and shape of which remain constant. This arrangement has the advantage that no distortion can result from variation of sensitivity from one point to another of the photo-cell.

The efficient production of a brightly illuminated patch on the disc about $1\frac{1}{4}$ in. in length, of which a width of less than 0.002 in. is useful, requires the use of one or more cylindrical lenses. By the use of two cylindrical lenses whose axes are at right angles an image of suitable shape can, however, be produced, which is magnified in one direction and diminished in the other. The improvement in illumination which can thus be obtained is limited chiefly by the imperfections of commercial lenses and the mechanical difficulties of accommodating them. The compromise adopted in this machine consists of two spherical lenses (Fig. 5) which would produce an image of the

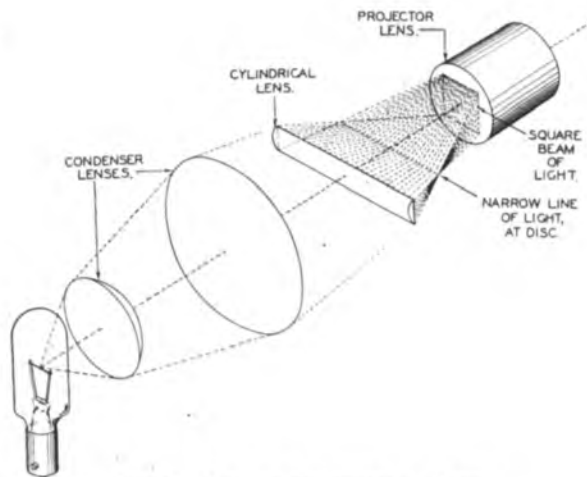

FIG. 5.—USE OF CYLINDRICAL LENS.

lamp slightly beyond the projection lens, together with a short-focus cylindrical lens which brings the light to a focus, in one plane only, at the disc.

The exciter lamp is a 75 W lamp in a cylindrical bulb only 26 mm. in diameter. It is run with its cap downward so that blackening due to evaporation of the filament will occur in the top of the bulb and not on the part of the glass through which the useful light passes. As limitations of space require that the light should be projected vertically, a plane mirror is also included in the system.

The projector lens is of a type intended for 35 mm. film projection, of aperture $f/2.5$. The others are simple uncorrected lenses costing a few shillings each.

The Amplifier Design.

The use of A.C. mains greatly simplifies the amplifier design. Since adequate working voltages for the valves are available, the amplifying stage can be resistance-coupled, and in the output stage a single small valve provides sufficient power (see Fig. 6). The use of a 250 V H.T. supply saves two valves per amplifier—i.e. 24 per machine, including spare

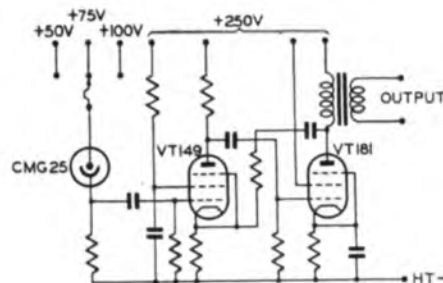

FIG. 6.—SCHEMATIC CIRCUIT OF AMPLIFIER.

amplifiers—compared with the requirements using a 100 V supply such as might be obtained from exchange batteries.

The required output power was estimated by considering the maximum number of operators who may listen simultaneously to one announcement. This has been taken arbitrarily as 100—probably a generous figure in view of the short time for which any one operator is likely to listen. The level required was chosen after representative trunk operators had listened to a sample recording; they selected maximum and minimum levels which were equivalent, at the peaks of the speech, to 0.3 and 0.05 V R.M.S. respectively, measured at the terminals of a single headgear receiver (Receiver Headgear No. 10A).

The level at the receiver of an operator's set is, at most frequencies, 6 db. below the level at the switchboard, which should therefore be between 0.6 and 0.1 V R.M.S. As the impedance of the set is of the order of $400\ \Omega$, the maximum power which the amplifier need deliver to the switchboard is $100 \times (0.6)^2 / 400$, approximately 0.1 W. To allow for losses in transformers and cabling, this figure should be somewhat increased. It suggests the use of a small power valve; the VT 181 was selected. This valve has a heater consumption of only $1\frac{1}{4}$ W, and gives 0.3 W output with an anode current of 15 mA, which is sufficiently below the maximum rating to allow long life of the valve. This economical performance is of some importance since there may be 10 of these amplifiers running simultaneously.

The small pentode valve (VT 149), standardised by the Post Office, is used in the first stage of the amplifier. This valve is anomalous in having a 4 V heater although octal-based, and provision is made in the power unit for changing the L.T. supply to this stage to 6.3 V in the event of the VT 149 becoming unobtainable. The photo-cell is a standard Osram CMG 25, as used in sound-film apparatus.

The large tolerance permitted in the output level makes unnecessary the provision of a normal type of gain control. Instead, arrangements are made for supplying the photo-cell with one of three polarising voltages (approximately 50, 75, and 100 respectively); the higher voltages increase the output level by about 5 and 10 db. respectively. The output of all the amplifiers together can be controlled by adjusting the voltage of the exciter lamp supply, and this is done when the machine is set up initially.

The output impedance of the amplifiers should be very low to maintain constant voltage in spite of load variations and to prevent intercommunication between

operators (or subscribers) who are listening to the same announcement. This could be achieved by placing a permanent load across the amplifier output, but this method is wasteful of power. Instead, negative feed-back has been used to give the effect of a low impedance source. The cathode of the first valve is connected to a potentiometer which supplies to it a constant fraction of the alternating voltage at the anode of the output valve.

The output transformers of the amplifiers are of 3 : 1 ratio, and the full load condition corresponds to a 600 Ω impedance on the secondary side of these transformers. Another set of transformers, of ratio 12 : 1, is provided at the control panel to step down to the 4 Ω load. As the constant-voltage condition is obtained at the primary of the amplifier transformer, the resistance of the wiring and the copper losses of the transformer result in bad regulation and the possibility of intercommunication. This is the reason for the 600 Ω distribution, which keeps the 4 Ω portion of the circuit as short as possible. The transformer windings are of low resistance, a condition easily obtainable by sacrifice of bass response. As the bass response is so severely cut by the operator's set (e.g., 8 db. at 500 c/s) that equalisation is impracticable, transformer losses of the order of 4 db. at 500 c/s can be tolerated. Speech heard under these conditions is perfectly clear and distinct, although the character of the voice is changed to some extent.

The amplifiers are mounted as jacked-in items on the amplifier panel. This method not only enables a rapid change to be made in the event of an amplifier fault, but it also facilitates the testing arrangements. On the other hand, the existence of high tension connections on the contacts required a specially designed plug and socket to ensure safety and reliability. These had to be different from similar items used for 50 V exchange apparatus in order to avoid confusion, and to disconnect all H.T. supplies from the amplifier when it is removed from its position. Flexible cables are obviously undesirable.

The wiring from the sockets is run in two separate cable-forms, one containing the H.T. wiring only. This reduces the chance of accidental contact between the H.T. and the speech circuits. As a further precaution the centre tap on the primary of the 600 Ω to 4 Ω transformer is connected to earth; it is therefore impossible for H.T. voltages to reach the switch-board multiple unless there are more than two simultaneous faults.

Amplifier Testing.

A test position is provided on the amplifier panel into which an amplifier can be placed to check its performance. Test results are indicated on a meter fitted on the test panel; and two 12-point rotary switches apply the appropriate connections for the series of tests which include measurement of anode and screen currents and power output. For the last named purpose a constant input is obtained from the ripple of an under-run 6 W lamp supplied with alternating current.

The meter is also used for checking the voltage of each of the supplies from the power unit, and also the speech output from each of the ten amplifiers in the

working positions. A jack is also provided on the test panel where a receiver may be used to listen to the various announcements.

Power Unit and Switching.

Power supplies are taken from A.C. mains. This is permissible since the machines will be installed only at exchanges where alternative mains supplies already exist; and in any case temporary failure of the machine, although inconvenient, would not disable the exchange. For this reason no stand-by machine is provided; the provision of spare amplifier units for jacking-in is regarded as sufficient.

Since A.C. is available, an induction motor is used for driving the disc. This is very desirable, as with a D.C. motor there would be serious risk of audio-frequency interference from the commutator. The motor has a built-in gearbox giving an output speed of 55 r.p.m. It is rubber-mounted, and drives the disc through a rubber V-belt. The vibration resulting is extremely small, and has no ill-effects on the optical system. The disc itself acts as a flywheel, giving sufficient constancy of speed. It revolves at 50 r.p.m., thus producing 50 announcements per minute.

The power unit is, in most respects, of conventional design. It uses selenium rectifiers and a choke input smoothing filter, in the interests of good regulation. The transformers, chokes, and condensers are all generously designed and unlikely to give trouble. It provides up to 200 mA at 250 V; small currents at each of the three photo-cell polarising voltages; the valve heater supplies; and the exciter lamp supply. All wiring, except that to the motor and to the lamp, is confined to a single panel which carries the power unit, the testing circuits, and the amplifier sockets. It would therefore be easy to dismantle the machine for overhaul, although no necessity for doing so can at present be foreseen.

In addition to the main switch (Box E.L. No. 0) external to the machine, there are switches for controlling the amplifiers in two groups of five, thus



FIG. 7.—MASTER CONTROL PANEL FOR DISTRIBUTION OF ANNOUNCEMENTS.

economising in valve life at times when only a few of the announcements are required.

Distribution of Announcements.

The announcements are distributed to the "route-delay" jacks via rotary type switches situated on the master control panel (Fig. 7), each route having its own switch. Yaxley 3-level switches are employed, with 12 contacts per level—a type already in commercial use and which can accommodate the maximum number of announcements likely to be required.

When the accumulation of waiting calls is sufficient to warrant delay working on a route the approximate duration of the delay is obtained from an Abac calculator, and the switch-arm (Fig. 8) is then moved

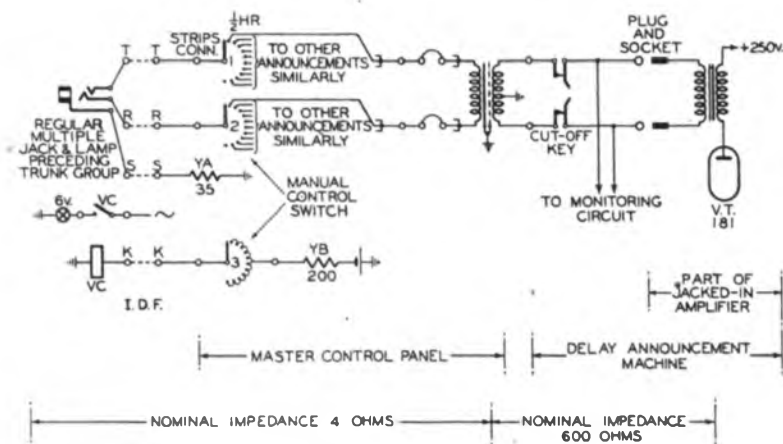

FIG. 8.—CONNECTIONS FOR DELAY ANNOUNCING DISTRIBUTION.

to the corresponding position round the arc. This action lights the route-delay lamps on the switchboard to signify that delay working is in force, and at the same time connects the appropriate announcement to the delay jack so that the operators can hear the announcement by plugging into the route-delay jack with an ordinary connecting cord and operating the listening (speak) key.

It will be noted that lamp signals have not been provided on the control panel because the state of the routes can be readily observed by the position of the control-switch pointers.

Application to Automatic System.

Another useful application of the verbal scheme is at automatic switching centres where access to the outgoing routes is obtained via selector levels. The "route-control" switch is then arranged to disconnect the outgoing line circuits from the selector level and connect the outlets to a delay announcement machine, leaving the trunk-controlling operator with exclusive access to the route. The arrangement is shown schematically in Fig. 9.

Actually only a proportion of the regular outlets need to be extended to the delay-announcement because the holding time of such a connection would be less than a normal call. Those not extended are "busied."

When the originating operator hears the delay announcement the connection is cleared down, and if it is desired to proceed with the call a connection is set up via another level of the selector to a record operator who obtains particulars of the call for later completion by the "trunk-controlling" operator.

Conclusion.

The mechanical announcer is a further addition to the operating aids which have contributed to the success of the long-distance telephone service. Although the present invention is a product of war-time necessity its utility is especially important towards solving one of the problems associated with the automation of the trunk and toll system.

Acknowledgments.

Many of the novel features of the machine were suggested by Dr. E. A. Speight, under whose supervision the experimental work was carried out, and by Mr. R. J. Jury.

Acknowledgments are also due to the S.T. & C. Co., to whom the authors are indebted for the photograph of the control panel.

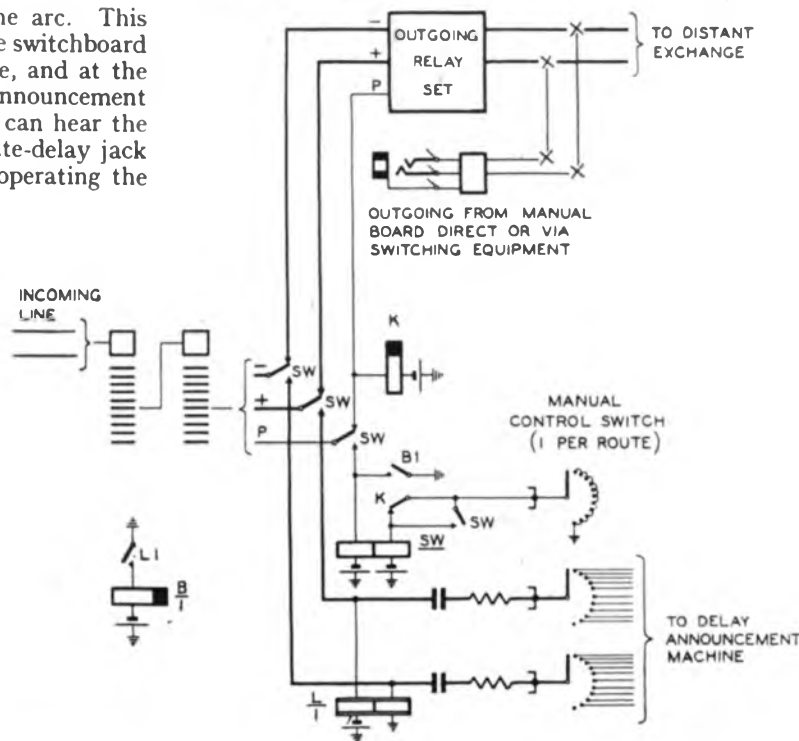

FIG. 9.—DELAY ANNOUNCER FOR AUTOMATIC SYSTEM.

The Application of Carrier Systems to Submarine Cables—Part I

R. J. HALSEY, B.Sc. (Eng.), A.C.G.I., D.I.C.

U.D.C. 621.395.443

In 1938 the problem of providing the maximum number of carrier circuits on the Anglo-Dutch coaxial submarine cables was investigated, and a scheme was prepared for the installation of these circuits using 10-watt transmitting amplifiers and companders. When the installation was partly completed, war broke out, and the scheme was abandoned. Subsequently, schemes have been prepared for other similar submarine cables, sometimes with land cable sections. This article analyses the problem in a general way; it will be completed in the January 1943 issue with some experimental data on cables and equipment

Introduction.

ON long submarine cable links the relative cost of terminal equipment and cable makes it desirable to provide as many circuits as possible on each cable pair. Since the laying of the Anglo-Dutch coaxial cables in June, 1937¹, important submarine cables laid in British waters have been of this type². Being of coaxial construction, with the outer conductor nominally at earth potential, the cables are unsuitable for use over land at low frequencies owing to noise considerations. Two types of low-loss balanced-pair cable have therefore been used for land sections. These are sometimes interposed between the terminal equipment and the submarine sections, owing to the difficulty of selecting landing sites which are also suitable for repeater stations.

The problem of providing the maximum number of circuits on the Anglo-Dutch route was considered during 1938, and a scheme was prepared for the installation of circuits, using 10 W transmitting amplifiers and companders. With this installation only partly completed, the war started, and the scheme was abandoned.

The present article discusses the problem in a general way and visualises conditions which are more stringent than any yet met in practice. Limiting conditions are explored for the frequency range up to 500 kc/s, which is a convenient though somewhat arbitrary limit. Field experience is not always available to cover the problems dealt with since it has not been possible, under wartime conditions, to make exhaustive measurements on the existing cables.

The cable schemes considered fall into two main categories:

- (1) Two-cable schemes in which separate cables are employed for the two directions of transmission.
- (2) Single-cable schemes in which the go and return channels are provided in different frequency bands.

The two-cable schemes are simpler in conception, but since in these schemes it is usual to provide directional filters to enable circuits to be set up on a single cable if the other cable is faulty, the single-cable arrangement must nearly always be considered.

In each of the above arrangements the terminal equipment is usually complicated by the inclusion of a low-frequency duplex carrier system. For example,

on the Belfast-Stranraer route a 1+3 circuit carrier system is worked duplex on each cable.

Cable Types

The coaxial submarine cable, with which the present article is primarily concerned, consists of a central conductor 508 lbs./naut., 0.168 in. diameter, with paragutta insulation 690 lbs./naut. to 0.620 in. diameter. The cable is armoured, and the shore ends are protected with lead sheaths. An attenuation curve for this type of cable is given in Fig. 1 and this is used for all computations made. The characteristic impedance at carrier frequencies is about 50Ω.

The balanced-pair cable most commonly used is manufactured by Messrs. Siemens Bros. It has self-locating conductors and a characteristic impedance of about 195Ω at carrier frequencies. Its attenuation is also given in Fig. 1. An alternative type of cable manufactured by Standard Telephones and Cables, Ltd., has cotopa insulation

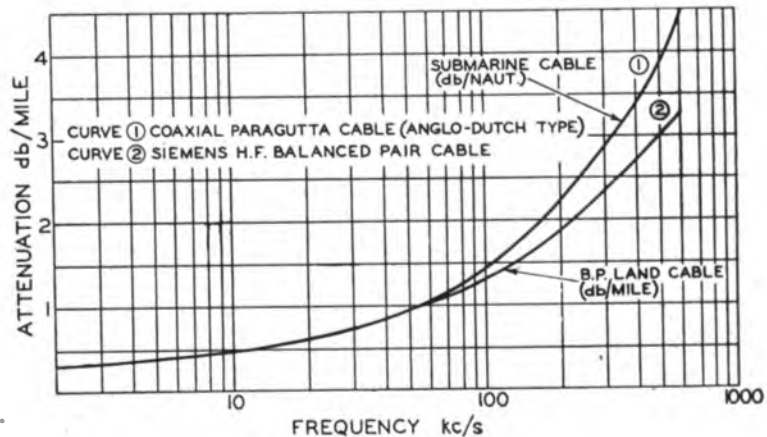

FIG. 1.—CABLE ATTENUATIONS.

which somewhat increases the attenuation and reduces the characteristic impedance to about 160Ω.

Channel and Group Equipment.

The schemes so far installed employ channel equipment of Carrier Systems Nos. 5 and 6, having channels with inverted sidebands in the frequency range 12-60 kc/s, but with Carrier System No. 7 now in production the channel equipment of this system would be used on new schemes, i.e. the primary group would be in the frequency range 60-108 kc/s with inverted sidebands.

Suitable equipment is available for translating either 12-60 kc/s or 60-108 kc/s primary groups, to occupy other frequency bands in the range 12-500 kc/s or higher. It may, however, be noted in this

¹ P.O.E.E.J., Vol. 30, p. 222.

² P.O.E.E.J., Vol. 31, p. 23, and Vol. 32, p. 118.

connection that, owing to the greater separation between group sidebands, the group filters for a 60–108 kc/s primary group are much simpler than for a 12–60 kc/s primary group. Indeed, for groups higher than about 500 kc/s, the use of 12–60 kc/s primary groups may hardly be practicable without the use of super-groups.

When primary groups 60–108 kc/s are to be used, these can readily be assembled into a standard coaxial cable super-group in the range 312–552 kc/s, which may in turn be translated to the frequency band below 312 kc/s. Where the number of groups involved approaches or exceeds five, this is the most economical method; indeed, the group filtration difficulties at the lower frequencies are such that this could be readily accepted as a standard technique for all groups in excess of one or two.

A 3-stage line amplifier developed by the Post Office is suitable for the frequency range 12–500 kc/s and this range therefore forms a convenient basis for the present study.

LIMITING CABLE ATTENUATION

The maximum cable attenuation over which circuits may be operated may be fixed by

- (a) resistance noise, considered in relation to the improvement which can be effected by volume-range compressors and expanders (companders)³ and the maximum practical transmission level;
- (b) crosstalk from other submarine cables which land at the same point;
- (c) in two-cable schemes, the degradation of circuit stability on account of near-end crosstalk between cables. While this can be countered by the use of stabilised repeaters, the fundamental disadvantages of these units are such that their use in this connection has not yet received serious attention;
- (d) extraneous noise, particularly from radio circuits. This is most serious where a balanced-pair land cable is employed between the cable hut and the terminal repeater stations.

Permissible Minimum Level Conditions.

The psophometric value of the noise due to thermal agitation, measured over a frequency band corresponding to speech, is about 139.5 db. below 1 mW. Measurements on a 3-stage line amplifier show that the total (psophometric) noise due to thermal agitation and valve noise corresponds to 139 db. below 1 mW. Valve noise is equal to that caused by a grid resistance of about 1,200 Ω and degrades the total noise by about 0.5 db. For planning purposes it is therefore assumed that the effective noise level at the input of the first receiving amplifier, due to thermal and valve noise, is –139 db. on each speech channel. Measurements on existing submarine cables show that with the exception of crosstalk from other submarine cables terminating at the same station, no interference comparable with resistance noise is detectable across the cable pair. Noise voltages do, however, exist between the outer cable conductor and the station earth; these are considered later.

For international cable circuits the C.C.I.F. has recommended⁴ that the circuit noise should not exceed 2 mV psophometric E.M.F. measured at the end of the cable. With a terminal repeater giving a gain of 1.0 neper, which is envisaged by the C.C.I.F., this is equivalent to 5 mV psophometric E.M.F. measured at the switchboard and has been assumed to be that value of the noise giving rise to 5 per cent. reduction in syllable articulation. The circuit impedance at the switchboard is 600 Ω , and since international circuits have a nominal equivalent of 0.8 neper the equivalent noise is 42.9 db. below 1 mW at a point of zero relative level. If it is assumed that this noise is due to a single contribution of thermal and valve noise, the lowest level to which a signal may fall is 96.1 db. below 1 mW.

The British Post Office has set a higher standard than the above for its carrier links; this is to some extent necessary since several such links may be included in an international circuit, and other sources of noise will be present. Specifications for 12-circuit carrier systems require that the total noise (including intermodulation) shall not exceed 2 mV psophometric E.M.F. at a point of zero relative level. This amounts to 57.8 db. below 1 mW, and the corresponding minimum signal level is –81.2 db. or 14.9 db. higher than the international requirement. Should the limiting transmission level be approached more than once, care must be taken to ensure that the R.M.S. addition of the noise voltages does not exceed the above value.

Thermal noise is readily improved by the use of companders, and the best types of unit available⁵ will give a 2 : 1 expansion law at all levels between 0 and –30 db. (i.e. –60 db. after expansion) referred to 1 mW. If, therefore, the noise is to be –57.8 db. after expansion, the compander will effect an improvement of 28.9 db., and a minimum receiving level of –110.1 db. is permissible. On the other hand, if the C.C.I.F. limit of –42.9 db. is acceptable, the compander will give only 21.5 db. improvement and permit of a minimum level of –117.6 db. These improvements are somewhat offset by the lower transmitting levels necessary if companders are fitted.

Since thermal noise will not be the only contribution to the circuit noise, a margin is necessary, and the optimum planning basis is to assume equal noise contributions from thermal agitation (and valve noise) and intermodulation noise, other sources of noise being negligible. The minimum permissible receiving levels will then be as follows:—

For Post Office noise limits			
(carrier circuits)	–107.1 db.
For C.C.I.F. noise limits	–114.6 db.

Transmitting Levels.

The maximum permissible channel transmitting level will depend upon:

- (a) the power-handling capacity of the transmitting amplifier;
- (b) the quality of this amplifier below overload;
- (c) the number of channels transmitted;

³ P.O.E.E.J., Vol. 32, p. 32.

⁴ Oslo, 1938. Tome 1 ter, p. 48.

⁵ P.O.E.E.J., Vol. 33, p. 120.

- (d) the permissible noise level due to inter-modulation ;
- (e) the degree of voltage limitation employed on the channels ;
- (f) the amount of pre-equalisation employed ;
- (g) the proportion of channels fitted with companders.

Although it is not possible to determine a general economic maximum output for the transmitting amplifier, 1,000 W amplifiers have been considered, and it is doubtful if it is economical to exceed this. Such amplifiers require high-voltage power supplies and cannot be regarded as normal repeater station equipment.

1 W Transmitting Amplifier.—The normal 12-circuit carrier systems (12–60 kc/s) employ amplifiers having a power output of about 1 W, and the P.O. specification test requires that with two talkers at R.T.P.⁶ on any two channels, the psophometric E.M.F. on any other channel (measured at a point of zero relative level) shall not exceed 2 mV. With the normal amplifiers it is possible to meet this specification with a maximum transmission level of +12 db., provided that

- (a) the number of amplifiers in circuit is small ;
- (b) the transmission level is closely controlled ;
- (c) voltage limiters are fitted, restricting the peak channel amplitude to 8 db. above the peak value of a 1 mW sine wave at a point of zero relative level ;
- (d) the quality of the amplifiers below overload is adequate ;
- (e) the amount of pre-equalisation does not exceed about 10 db.

Referring to the specification test it will be seen that at a point of zero relative level, two talkers may together generate a peak voltage 14 db. above that of a 1 mW sine wave, hence the theoretical maximum channel transmission level is 14 db. below the overload point of the amplifier. Since, however, even negative feedback amplifiers are not perfect, some margin is necessary, especially as, for the highest channel at least, half of the permissible noise has been allocated to thermal noise.

Mathematical treatment of the subject of amplifier overload shows that the earlier P.O. specification errs on the side of severity. The subject has been treated in a variety of ways, but the results obtained by Holbrook and Dixon⁷ are typical. Their load capacity curve is deduced on a basis of possible overload for 1 per cent. of the time at the busy hour and assumes a mean talker volume of 16 db. below R.T.P. (standard deviation 5.8 db.) with a voltage limiter on each channel and no pre-equalisation. Interpreted in terms of 12-channel groups, the curve shows that the requisite margin between the relative channel output level and the overload capacity of the amplifier is as shown in Table 1. The corresponding transmission levels for a 1 W amplifier are also given.

⁶ In the specification for Carrier System No. 7 the test level is reduced to 4 db. below R.T.P., but the earlier specification is assumed here since relevant data exist.

⁷ *B.S.T.J.*, Vol. XVIII, p. 624.

This computation is based entirely on considerations of overload and assumes the amplifier quality below overload to be adequate. It will be noted that,

TABLE 1.

No. of 12-chan. groups	Ratio between overload and relative chan. level	Relative chan. level, 1 W amplifier
1	16 db.	+14 db.
2	17	+13
3	17.5	+12.5
6	18	+12
10	19	+11

even without pre-equalisation, the permissible transmission level is reduced by only 3 db. when the number of channels is increased from 12 to 120 ; if pre-equalisation is employed the corresponding reduction is slightly less.

Accurate information relating to talker volumes in this country is restricted to measurements at Radio Terminal and London Trunk Exchange. At the latter station the mean talker volume is 19.6 db. below R.T.P., and the standard deviation is 4.2 db. This corresponds to a mean power level⁸ of 17.6 db. below R.T.P. against 12.1 db. for the American measurements, and the transmission levels in Table 1 may therefore be increased by 5.5 db.

The effect of equipping a channel with a compander is to raise the mean power level halfway to R.T.P. (i.e. on a db. scale) ; this amounts to increases of 6.0 and 8.8 db. for the American and London Trunk Exchange levels respectively. The increase in the effective loading of the amplifier will depend on the proportion of channels equipped with companders and, if all channels are not so equipped, on the amount of pre-equalisation. In the most severe case—that of a single-cable system in which all channels in one direction are equipped with companders—the permissible output levels will be reduced by half the difference between the mean power level and R.T.P. For a single transmitted group the appropriate output level for a 1 W amplifier will therefore be +8 db. for the American data and +10.7 db. for the London Trunk Exchange data.

10 W Transmitting Amplifier.—10 W transmitting amplifiers, operated from repeater station batteries (21 and 130 V) have been designed for submarine cable schemes, and these can be operated satisfactorily at a maximum output level of +22 db. on the same conditions as those stated for the 1 W amplifiers, to meet the P.O. specification test. On the basis of the above data the maximum permissible output level will be as given in Table 2, which refers only to the conditions when all or none of the channels are equipped with companders.

The actual statistics of talker volumes are known to vary considerably with the character of the local

⁸ Mean Power Level = $V_0 + 0.115\sigma^2$ where V_0 = Mean Talker Volume and σ = standard deviation (all in db.).

plant, and individual studies may be necessary if the best use is to be made of a particular system.

TABLE 2.

No. of 12-chan. Groups	Relative Chan. Level (10 W Amplifier)			
	American Data		London Trunk Data	
	No Compandors	Compandors	No Compandors	Compandors
1	+24 db.	+18 db.	+29.5 db.	+20.7 db.
2	+23	+17	+28.5	+19.7
3	+22.5	+16.5	+28	+19.2
6	+22	+16	+27.5	+18.7
10	+21	+15	+26.5	+17.7

LINE EQUALISATION.

On 12-circuit systems with 1 W line amplifiers it is usual to transmit on all channels at the same relative level and to effect the necessary line equalisation at the receiving end of each repeater section. In systems involving a large number of channels and/or limiting attenuation conditions this may not be economical either from the point of view of the transmitting or receiving amplifiers. If both of these amplifiers were completely free from distortion below overload then the most economical arrangement would be to use a large degree of equalisation before or in the transmitting amplifier on those channels which do not require compandors. This would reduce the total amplifier loading and thereby enable rather higher transmitting levels to be used for the higher channels. In practice, however, this would mean that the range of levels at the output of the transmitting amplifier would be considerable, and, unless accompanied by a suitable increase in feedback, this would give rise to excessive intermodulation interference in the low-level channels.⁹ Ideally this arrangement would require that the amplifier should have a uniform gain without feedback and should include a suitable equaliser in the feedback path; such an amplifier is not available at present.

On the other hand, it may not be permissible to include a line equaliser before the first receiving amplifier on account of the minimum loss of such a unit and the general reduction in level which would be entailed.

The various solutions of this problem which have been adopted are all compromises. As amplifier technique has been improved, the methods approach the ideal, but there is still room for further development.

Pre-equalisers.

The theoretical advantages of pre-equalisation (or pre-emphasis) are two-fold. Firstly, it is possible to increase slightly the maximum output level from the transmitting amplifier and, secondly, it reduces the range of levels which must be handled by the first receiving amplifier. The design of transmitting

amplifiers at present limits the amount of pre-equalisation which can be employed with a single group to about 10 db.; for multi-group systems 15 or 20 db. may be a necessary compromise if the receiving conditions are severe. Since transmitting amplifiers are necessarily loaded to their maximum capacity, a wide range of output levels will cause excessive intermodulation interference unless the feedback at low frequencies is increased to an extent which is not yet practicable.

With suitable advances in amplifier design greater pre-equalisation becomes possible; at the same time it tends to become unnecessary since the receiving amplifier can handle the wider range of received levels.

Receiving Equalisers.

Since limiting attenuation conditions are under consideration, it is desirable to avoid the use of an equaliser between the line and the first receiving amplifier, but this is not possible unless special amplifiers, equalised in the feedback circuit, are available. If no equaliser precedes, or is incorporated in, the feedback circuit of the first receiving amplifier, this must handle a very wide range of levels, and acute intermodulation problems arise.

Two-cable Schemes.—Table 3 shows the approximate amount of equalisation necessary for various numbers of transmitted groups, the lowest frequency being 12 kc/s. The cable is assumed to be entirely submarine cable, and the attenuation at the highest frequency is taken as 130 db., i.e. about the highest permissible with a 10 W transmitting amplifier.

TABLE 3.

No. of 12-Ch. Groups	Freq. Range kc/s	Cable Length n.m.	Total Eqn. db.	Assumed Pre-Eqn. db.	Rec. Eqn. db.
1	12-60	122	68	10	58
2	12-108	86.5	86.5	12	74.5
3	12-156	68	95	14	81
4	12-204	58	101.5	16	85.5
5	12-252	50.5	104	17	87
6	12-300	45.5	106	18	88
7	12-348	41.5	108	18	90
8	12-396	38	110	19	91
9	12-444	35.5	112	20	92
10	12-492	33.5	114	20	94

This shows the equalisation problem in its most acute form, since the level difference in the first receiving amplifier may be as much as 94 db., i.e. 12 kc/s will be received at a level of -13 db. and the highest frequency at -107 db. To use a standard 65 db. amplifier without an equaliser is obviously impossible, and there are two alternative arrangements:

- (1) To use an equaliser before the first receiving amplifier. This is undesirable on account of the minimum loss of such a unit; moreover, unless the number of circuits for which compandors are necessary is to be increased, this equaliser must have negligible attenuation over the frequency range where resistance noise is of importance, i.e. it must take the form of a high-

⁹ In an amplifier with uniform loading the modulation products are distributed fairly evenly between the channels. See, for example, *Elect. Comm.*, Vol. XIX, p. 29.

pass filter. Such an arrangement has been carefully investigated, but the insertion loss of the high-pass filter near cut-off is extremely difficult to correct at a later stage. It is not an attractive solution to the problem.

- (2) To use a first receiving amplifier incorporating an equaliser in the feedback path; this is the ideal solution if a suitable amplifier can be made. Although it is quite impossible to obtain all the necessary equalisation in one amplifier it has been found possible to obtain about 35 or 40 db. of equalisation over a wide band such as occurs in the two-cable schemes. This enables the output level of the low-level channels to be raised to a point where further contributions of resistance noise are unimportant, and a second similar amplifier will equalise the levels sufficiently to permit of the use of a normal line equaliser, or even for direct connection to the group equipment.

Where limiting conditions do not obtain, and particularly where compandors are not necessary, the use of a line equaliser before the first receiving amplifier is satisfactory. For the limiting conditions the use of equalised amplifiers as outlined above provides the best solution. To reduce the range of levels somewhat in the wide-band system it is helpful to include a series condenser at either or each end of the line; the levels at various points in a system planned to transmit 10 groups are given in Table 4. In this case the levels at the output of the second amplifier would be sufficiently uniform for connection to the group equipment.

Single-Cable Schemes.—For single-cable schemes the equalisation problem is not so severe, since less than half the total frequency range is occupied by each transmitted band. Table 5 shows the amount of equalisation required in the two directions of transmission on the same assumptions as for the two-cable systems. A frequency gap is allowed between the

two directions of transmission equal to about 20 per cent. of the highest frequency employed in the lower band. This corresponds to the figure commonly used with coil and condenser filters and may be reduced as technique improves. It is not yet certain whether crystal filters are advantageous, owing to the high transmitting levels involved and the increased pass-band losses of resistance-compensated filters.

It will be seen that the maximum level difference in the higher band is less than 30 db., and this can be dealt with by the first receiving amplifier, without previous correction. In the lower band the receiving levels will always be high enough to permit the use of an equaliser before the first amplifier, even if a 1 W transmitting amplifier is used for this band, as is usual.

TABLE 4.

Frequency kc/s	Output Trans. Amp.	Cable Attn.	Rec. from Cable	Input* 1st Ampr.	Output 1st Ampr.	Output 2nd Ampr.
12	+2	18.5	-16.5	-28.5	-18.5	-8.5
60	+4	36.8	-32.8	-34.8	-20.1	-5.4
108	+6	53.5	-47.5	-48.8	-29.1	-9.4
156	+8	63.8	-55.8	-56.1	-34.2	-12.3
204	+10	75.5	-65.5	-65.7	-40.9	-16.1
252	+12	86.5	-74.5	-74.6	-47.3	-20.6
300	+14	97	-83	-82.9	-53.5	-24.1
348	+16	106	-90	-90	-58.3	-26.6
396	+18	114	-96	-96	-61.8	-27.6
444	+20	121	-101	-101	-63.8	-26.4
492	+22	128	-106	-106	-66.3	-26.6

* Through a series condenser 0.035 μ F, giving 12 db. loss at 12 kc/s.

TABLE 5.

No. of 12-ch. Groups	Freq. range kc/s		Cable length n.m.	Total Eqn. (db.)		Assumed Pre-Eqn. db.		Rec. Eqn. db.	
	D-U	U-D		D-U	U-D	D-U	U-D	D-U	U-D
1	12-60	72-120	81	45.5	34	10	10	35.5	24
2	12-108	128-224	54	54	38	12	10	42	28
3	12-156	188-332	43	60	38	14	10	46	28
4	12-204	244-436	36.5	64	39	16	10	48	29

(To be concluded in the January, 1943, issue.)

Modern Materials in Telecommunications

U.D.C. 537.311.3.

W. G. RADLEY, Ph.D., M.I.E.E.

C. E. RICHARDS, F.I.C.

E. A. SPEIGHT, Ph.D., D.I.C., A.R.C.S.

E. V. WALKER, B.Sc., A.R.S.M.

Part VIIa—Non-Conductors ; Insulation Resistance and Electric Strength

The article outlines the present state of knowledge concerning the relationship between the structure of non-conductors and their electrical properties in unidirectional fields. A further part will discuss the properties of non-conductors in alternating fields.

Introduction.

UNTIL about the end of the last century little was demanded of an electrical insulating material other than as low a conductivity as could practically be attained and mechanical properties appropriate to its intended use. In recent years, however, electrical engineers have made ever-increasing demands for the development of various other properties to the maximum extent possible. Meanwhile scientists have made striking progress both in producing new materials and towards discovering the secret of the connection between the fundamental structure of insulating materials and their electrical and mechanical characteristics. The combined result of these and other factors is the bewildering variety of highly specialised insulating materials which now await the choice of the electrical designer.

The chemical nature and the production of insulating materials of organic origin was discussed in Part II¹ of this series. The two parts of the present article will discuss the structure of insulating materials in relation to their properties when subjected respectively to unidirectional and to alternating electric fields. Incidentally it will be shown how work on these lines has shed considerable light on many other problems, some of which, at first sight, appear to have little or no connection with electrical phenomena.

Electrical Conductivity in Insulators.

It has been established beyond all doubt that a flow of current through any substance always involves the movement of discrete electric charges along the direction of the electric field. Sometimes, as in the metals, the moving charges are just electrons and the conductivity is then termed electronic. In other substances, including gases, liquids and many solids the current is carried by ions, i.e. electrically charged atoms or groups of atoms, in motion. This type of conductivity is therefore termed ionic or electrolytic.

Previous articles in this series (Parts V and VIa²) have shown how, for electronic conduction to occur, two main conditions must be satisfied. First there must be a supply of free valency electrons either from the atoms of the material itself, if pure (e.g. in the metals), or from the atoms of some impurity as in the so-called "excess" semi-conductors. Secondly the energies of these particular electrons must lie within, or only slightly below certain "allowed" but incompletely occupied bands of energy levels. Then, when an electric field is applied, the free electrons will be accelerated, i.e. will be able to attain higher

energies, and, in moving along the direction of the field, will constitute a flow of current. (The somewhat more elaborate mechanism of conduction in the "defect" semi-conductors was discussed in Part VIa).

In ionic conduction the mechanism of the transport of electric charge is much the same, and the chief differences between the two modes of conduction lie in the nature of the actual charge-carriers—the ions—and the means by which these are produced. All substances consist of molecules and, with the principal exceptions of the inert gases (helium, argon, etc.) which are mono-molecular, these molecules, at ordinary temperatures, consist of two or more atoms. The interchange or sharing of valency electrons by which this is brought about was explained in Part I³ of this series, and is one of the reasons why, except in the metals, there are no free electrons to take part in electronic conduction.

Since, normally, molecules are electrically neutral, ionic conductivity must be visualised as a two-stage process; first the conversion of molecules into ions and then the movement of the ions. Probably the easiest mode of ionisation to visualise is that which occurs when a stream of electrons, such as those emitted from a heated filament, impinges on a collection of neutral molecules. If the electrons are moving with low velocities the majority on striking a molecule will rebound elastically, i.e. substantially without change of energy or velocity. At somewhat higher initial electron velocities the atom struck may absorb a quantum of energy and the impinging electron will therefore rebound with reduced energy and velocity. (The energy absorbed by the atom will cause one of its electrons to move to a higher energy level, i.e. to a larger orbit. The atom will then be in an unstable—"excited"—condition, and at some subsequent time the electron will return spontaneously to its normal orbit and energy level. In this stage the excess energy will be given up in the form of visible light or some other electromagnetic radiation.) Those few electrons which do not behave in either of these ways may become attached, by electrostatic forces, to the atoms which they strike. These atoms then have negative charges, i.e. have been transformed into negative ions.

Except in special circumstances the degree of ionisation caused in this way is usually small. The most prolific ionisation is usually due to disruption of the atom or molecule. In the atom, unless nuclear disintegration occurs, the only possible form of disruption is loss of one or more electrons leaving the atom as a positively charged ion. This can also occur with molecules, but the more usual course of events

¹ P.O.E.E.J., Vol. 33, p. 127.

² P.O.E.E.J., Vol. 34, p. 72 and 179.

³ P.O.E.E.J., Vol. 33, p. 55.

is for the molecule to split into two (less frequently more) fragments which, most often though not invariably, are single atoms. The products of this process are not, however, neutral atoms. On the contrary, one atom retains not only those electrons to which it is entitled but also a sufficient number of extra electrons to complete its outer electron shell. This, therefore, will be a negatively charged ion. Conversely, the other atom (if there are only two fragments) will be left with less than its normal complement of electrons and will be a positive ion.

Ionisation of this kind can arise from many different causes. In general, any agency which can sufficiently increase the internal molecular energy can cause the molecule to break up into ions. This effect can therefore be produced, for example, by heat or by exposure to ultra-violet light, X-rays, gamma-rays or cosmic rays. Ionisation occurs most readily, however, due to collision with particles having high kinetic energy, e.g. high-speed electrons or β -particles, ions moving rapidly under the influence of high voltage gradients or α -particles.

Breakdown Phenomena.

One of the properties of a perfect insulator would, of course, be no conductivity whatever. This ideal is never attained in practice though, as will be seen later, close approximations to the ideal do exist. Hence, when a small electric field is applied to an insulator, a very small current flows. If the field is increased so also is the current, more or less in the same proportion at first, then less rapidly. With some materials, particularly gases, a period of saturation (i.e. constant current) ensues. As the electric field is steadily increased further the current begins to rise again, with increasing rapidity, and a stage is reached where the resistance of the insulator suddenly falls to a low value and the current increases enormously. The current flows in the form of a spark or arc and, in short, the insulator is punctured or broken down. The critical electric stress—expressed in volts per cm. or volts per mil.—at which this phenomenon occurs is termed the electric strength of the material in question.

An entirely satisfactory explanation of the mechanism of electric breakdown, particularly in solid insulating materials, has not so far been devised. Several important relationships, theoretical and empirical, have, however, been established. In the following sections of this article some of these will be briefly considered in relation to the various classes of insulating material.

Gases as Insulators.

Substances which are gaseous at ordinary temperatures and pressures have molecules which consist of only a small number of atoms, and the mean separation between molecules is very large compared with the molecular diameter. From the energy standpoint molecular interaction is therefore negligible and the electrons occupy widely separate, discrete energy levels. Thus, even if gaseous substances had free electrons, there are no incompletely filled energy bands in which acceleration of electrons could take

place. Electronic conduction, in the sense in which the term is used to describe metallic behaviour, is therefore absent.

For many years, in fact, gases were believed to have no conductivity whatever. With increased refinement of experimental technique, however, it was shown that gases did conduct and that the conduction was ionic. Nevertheless, at ordinary temperatures and pressures, only a very small fraction of the total number of molecules present in a gas is ionised by any combination of the agencies previously mentioned, and even the ionic conductivity is very small indeed. Normally, therefore, of all materials the common gases are the most nearly perfect non-conductors known and approximate very closely to the theoretical ideal. It needs only a moment's reflection to appreciate how, probably largely unconsciously, both power and communications engineers have exploited this very fortunate dispensation of nature.

The most obvious drawback of gaseous insulators is the complete absence of mechanical strength. In consequence the use of some solid insulating material, though electrically inferior, is unavoidable for positioning the conductors. Apart from this it is only at high voltages—as in power transmission lines, X-ray equipment, etc.—or at high voltages combined with high frequencies of alternation—as in radio transmitters—that any other limitation of gaseous insulators becomes seriously apparent. This limitation is the liability to various types of discharge and breakdown. Even so there is the compensating advantage that the discharge ceases if the voltage is sufficiently reduced and the gas is, of course, self-sealing and cannot therefore be permanently damaged.

Though many points of detail regarding the mechanism of breakdown in gases await elucidation, sufficient is known to justify a brief consideration of the subject. At the surface of the earth it is extremely difficult, even under laboratory conditions, to eliminate all ionising agencies entirely. In all gases, therefore, ions are normally being continually produced. At the same time ions disappear chiefly by re-combination of positive and negative ions, and a stage of equilibrium is reached at which the rate of disappearance equals the rate of production. When an electric field is applied to a gas some ions are withdrawn to and discharged on the electrodes (becoming then ordinarily uncharged atoms or molecules). If, starting from a very low value, the field is steadily increased, the ionic current will also increase, at first proportionately to the field, and then less rapidly. Under normal conditions at fields of about 20–30 V per cm. the current ceases to increase with the field, i.e. saturation has been reached and the field withdraws all the ions as fast as they are produced. Over a certain range further increases in the field increase the velocity of the ions without increasing their number. Beyond this range, however, a point is reached where further ions are produced by collision between the original ions, now moving with relatively high velocities, and uncharged atoms or molecules. The current through the gas again increases. If the applied field is great enough the new ions may in turn acquire sufficient velocity to cause ionisation by

collision and the process will be cumulative. Ultimately what has been termed an "avalanche of ions" will be generated, the current will increase rapidly to a high value and breakdown will occur.

From this rough picture of the mechanism of breakdown certain useful conclusions can be drawn. In the first place time is obviously necessary for the cumulative action to take effect. This is confirmed in practice by the fact that the electric strength of gases towards impulses of short duration is higher than towards sustained high voltages. Secondly, to minimise the risk of breakdown, the electric stresses should be as low and uniform as possible. All conductors should have smooth contours and sharp edges or points must be avoided so as to prevent the occurrence of local, excessive electric stresses.

Thirdly, for a given electric stress, any measures which reduce the velocity of the ions will be beneficial. It can easily be shown that the velocity is directly proportional to the mean free path of the ions (i.e. average distance between collisions) which in turn, for a given gas, is inversely proportional to the pressure. Where the design of the equipment permits, therefore, enclosure of the high-potential conductors in an atmosphere, preferably of a chemically inactive gas such as nitrogen or argon, at pressures above atmospheric, allows the safe application of much greater voltages than at atmospheric pressure. This principle has been applied with success to the insulation of equipment such as large circuit breakers and high-voltage cables. Pressures of 10–20 atmospheres have been usefully employed; at higher pressures secondary effects begin to be noticeable and the benefits obtained are less than proportional to the pressure.

Another way of reducing the ionic velocity is to increase the mass of the ions. Partly for this reason it has been found that the electric strength of certain gaseous carbon compounds containing atoms of heavy elements substituted for hydrogen atoms is considerably higher than that of air. An interesting example of this is Dichlorodifluoromethane ($\text{C Cl}_2 \text{F}_2$) or "Freon"—so called because it was originally developed for use as a refrigerant. This substance has an electric strength about three times that of air at the same temperature and pressure and has been quite widely used for preventing flashovers, particularly in the equipment of high-voltage testing laboratories.

Liquid Insulating Materials.

The molecules of the commoner liquids, though more complex than those of the simple gases, do not contain a great number of atoms and the intermolecular distances are still comparatively large. Molecular interaction, though not negligible is still small, hence the energy bands are narrow, usually full and widely separated. The electronic conductivity is therefore very small, except at high temperatures and for high voltage stresses, for all non-metallic liquids. (Metallic liquids, having free electrons and unfilled energy bands, are comparatively good conductors).

The ionic conductivity of liquids, however, varies enormously. The majority of those pure, organic

liquids which are substantially insoluble in water are not appreciably ionised and their conductivity is therefore small. Included in this class of compounds are the hydrocarbons and their halogenated derivatives. Typical of the former are the transformer and switch oils (mainly derived from petroleum), whose good insulating properties are well known. In recent years an increasing amount of attention has been paid to chlorinated hydrocarbons—particularly chlorinated diphenyls—which, from some points of view, are superior to the hydrocarbon oils, being stable up to higher temperatures and much less inflammable.

Organic liquids which are appreciably soluble in water, or in which water is appreciably soluble, include such compounds as the simpler organic acids and bases, alcohols, esters and ketones. All of these, even when as pure as is commercially practicable, are normally ionised to an appreciable extent. Though far from being good conductors, they are nevertheless poor insulators.

Water is, of course, the commonest inorganic liquid. Even when quite pure it is very slightly ionised (into hydrogen and hydroxide ions), though the conductivity due to this cause is very low. Water is of no technical use, however, as an insulator, since it is practically impossible to keep it free from impurities, especially traces of acids, bases or salts, which, being highly ionised in solution enormously increase the conductivity. Similar disadvantages attach to other inorganic liquids with, usually, some further drawback such as toxicity or corrosiveness.

In short, the only practicable liquid insulating materials are organic compounds of the type of hydrocarbons or certain of their simple derivatives. Even these, to be of use, must be carefully purified, and precautions must be taken to avoid contamination, especially with moisture, in service. Provided these steps are taken, hydrocarbon liquids and some of their derivatives are very satisfactory insulators.

In liquids the mean free path of the molecules, though fairly large, is much less than in gases. The electric strength of liquids of low ion content is therefore higher than of gases. As with the conductivity so also is the electric strength very much dependent upon purity. From this point of view the chief sources of weakness are suspended particles and dissolved gases. The former can be kept low by filtration and attention to general cleanliness. Dissolved gases cannot normally be avoided. For this reason the behaviour of liquid insulating materials under conditions of high voltage stress is very complex. There is reason to believe, however, that breakdown in liquids is often initiated by cumulative ionisation of the dissolved gas molecules. The latter process, though considerably modified by the presence of the liquid, is at least qualitatively similar to the process of ionisation in a simple gas. For this reason it is advantageous deliberately to increase the concentration of dissolved gas. This is done, for example, by maintaining a high gas pressure in the oil reservoirs associated with high-voltage oil-filled cables.

Finally mention may be made of the value of oil not only as an insulant but also as a cooling medium for static apparatus such as transformers, condensers and rectifiers.

Solid Insulating Materials.

There are many chemical and physical methods by which the number of atoms in a gaseous molecule can be determined with certainty. Such determinations in liquids present greater difficulties and the results must be accepted with some reserve. Proceeding further, in solids the most that can be stated with certainty is the minimum number of atoms the molecule must contain. For instance, when ordinary sugar is dissolved in water there is no doubt that, as revealed by its chemical formula— $C_{12}H_{22}O_{11}$ —the molecule contains 45 atoms. In solid sugar, however, the nature of the "physical" molecule is not known with certainty. Such evidence as is available suggests that it consists of several "chemical" molecules in close association. Fortunately, the electronic energy situation in solids appears to be determined by the smallest crystals in the body rather than by any smaller unit of the structure, and even the most minute crystal contains very many closely grouped atoms. The energy situation can therefore (see Part V) be represented as a series of relatively wide bands. Leaving the metals out of consideration, in all other pure substances there are no free electrons and the energy bands are either completely full or completely empty. Electronic conduction cannot then occur.

The presence of minute traces of impurities, however, may profoundly modify the state of affairs and may turn an otherwise good insulator into a semiconductor. On the other hand unavoidable impurities or deliberately added constituents are harmless provided that an empty band or energy level of one constituent does not overlap or lie too close to a full band or level of another. (For a more detailed discussion of these principles the reader is referred to Parts V and VIa of this series of articles). Unfortunately there is available far too little quantitative data relating to the energy situations in solids, particularly if these are not pure, to serve as a reliable guide in the development of new insulating materials. Progress has therefore been mainly on empirical lines. Even so, present knowledge of the role of impurities has at least indicated certain compositions that should be avoided.

The above remarks on the conductivity of solids refer only to that part of the whole which is due to electronic conduction. As in gases and liquids, however, ionic conduction can occur and a similar mechanism is involved, i.e. the current is carried by moving charged atoms or molecules. Thus, in general, apart from the actual power loss there would be a change in the composition of any solid insulating material in which appreciable ionic conduction occurs. This is obviously undesirable—the more so because many of the ions on discharge at the interface

between conductor and insulator become substances capable of attacking (corroding) the metal of the conductor. In compounding a solid insulating material it is therefore essential to avoid all ionic conductors, the chief of which are the simple metallic salts and many of the oxides and sulphides. A further disadvantage of such substances is that many are appreciably or even very soluble in water and would tend to pass into solution in any film of moisture deposited on the surface of the insulator. In solution a much higher degree of ionisation would be produced than in the solid state and the conductivity would increase considerably. The unavoidable presence of traces of ionisable impurities is one of the main reasons why many insulating materials, such as ordinary glass, show a big increase in surface leakage when exposed to atmospheres of high humidity.

The general conclusion from the foregoing remarks is that, as with liquids, high purity is one of the outstanding requirements of a solid insulator and, further, that the majority of the objectionable impurities are inorganic. In view of these facts, and having regard to the manufacturing processes involved, it is not difficult to understand why some of the most highly insulating solids are organic substances such as paraffin wax and the newer materials, polythene and polystyrene. Amongst inorganic materials the best are those which, like quartz and mica, occur naturally in a very pure state, and certain of the ceramic insulating materials in the manufacture of which it is possible to attain a high degree of purity. In this connection it should be pointed out that the demands of the electrical industry for insulating materials of greater mechanical strength and resistance to high temperatures have considerably stimulated research into the properties of inorganic insulators. Two out of the many interesting results of this work which may be mentioned are the development of wires insulated with glass fibres for use in machines operating at high temperatures and the production of fireproof cables in which the whole of the insulating material is a compressed refractory material such as magnesium oxide.

Nothing has been said so far on the question of breakdown in solid dielectrics. The subject is obviously one of great technical importance and has attracted a great deal of attention from research workers. Unfortunately, however, the difficulties encountered, both theoretical and experimental, are formidable, and little success has been achieved except for single crystals of a few simple, pure substances. All that can be said with confidence so far is that, as in other types of substance, some process of cumulative ionisation is involved though the precise mechanism of this process still remains obscure.

Calculation of Insertion Loss and Phase Change of 4-Terminal Reactance Networks

U.D.C. 621.391

H. STANESBY, A.M.I.E.E.,
E. R. BROAD, B.A., and
R. L. CORKE, A.M.I.E.E.

The usual method of computing the insertion loss and phase change of wave filters is rather involved and approximate and cannot be applied directly to the less familiar types of wave filter. In this article a simpler and more general method is described which is capable of great accuracy. It may be applied to any four-terminal reactance network operating between constant resistance terminations, provided the ratio of image impedance to terminating resistance is the same at both ends. The method uses the ability to transform any network satisfying these conditions into a lattice structure plus an ideal transformer. The article will be concluded in the January, 1943, issue of the Journal.

Introduction.

THERE is little doubt that in its early stages the development of the electric wave filter was bound up closely with the study of lumped loading on telephone lines. This being so, it is not surprising that the earlier filters usually had a ladder structure, and that their properties were studied by adapting or extending conceptions borrowed from line transmission theory.

It was from this viewpoint that Zobel evolved a method¹ of calculating the transmission characteristics of filters, which, although it was published over seventeen years ago, is still used widely, either in its original or in modified form. The treatment is based primarily on the ladder structure, and therefore regards a filter as consisting of a number of relatively simple sections, a form which is not always possible for modern designs. The insertion loss is considered as being made up of four components, the transfer constant, which has its counterpart in the attenuation constant of a symmetrical network or a length of uniform line, two components of terminal loss, corresponding to direct reflection at the input and output terminals, and the interaction loss, due to multiple reflections from one end of the filter to the other. These loss components are determined by a combination of calculation and reference to charts, their algebraic sum giving the total insertion loss. The insertion phase change is found in a similar way. Unfortunately, the method has several disadvantages. It is complicated and needs a number of charts; nineteen were reproduced in the original article. It is not general and, from its very nature, it fails near the cut-off frequencies, because some of the components tend to infinity in opposite directions. Perhaps this is why it is often assumed that the performance of a filter may be predicted with sufficient accuracy by computing the attenuation constant alone, the wish being father to the thought.

In this article an entirely different method of computing filter performance will be described, which has been developed and used in various forms during the last three years. It makes use of the ability to transform any symmetrical filter, no matter how complicated, into a lattice structure^{2, 3, 4}. When this is done the problem reduces to one of determining the transmission characteristics of a single lattice network, and can best be approached from first principles. Such a procedure allows the rather

artificial separation of insertion loss and phase change into a number of components to be abandoned, and results in great simplification. The total insertion loss is computed directly and the phase change is obtained virtually as a by-product.

Because of its general properties there is an increasing tendency to base preliminary designs on the lattice network, and when this is done transformation from another structure is, of course, unnecessary. But where the line of approach is different the filter may be put in lattice form very easily by using methods^{3, 4, 5}, already well known.

It must be made clear at the outset that the method of computation about to be studied cannot usually be applied to networks that are electrically unsymmetrical, and that, intrinsically, it takes no account of dissipation. Within the range set by these limitations it is, however, perfectly general, and may be used for any reactance network whatsoever.

The first limitation is more apparent than real. A network need not be symmetrical in form to have electrical symmetry. It is only necessary for the impedances presented by the two ends, taken in turn, to be the same when the opposite ends are terminated in equal impedances. This admits any filter designed by combining sections on an image basis in the usual way, if the actual image impedances at the input and output terminals are arranged to be identical. Darlington has in any case pointed out⁶ that symmetrical filters tend to yield efficient characteristics. Where lack of electrical symmetry is due solely to an internal change of impedance level, using the equivalent of an ideal transformer, the characteristics may be found by studying the filter before the impedance change is introduced.

The neglect of dissipation is not often a serious matter. Mason has shown⁷ that frequently resistance compensation is feasible. Where this is not so, and resistance is likely to modify performance materially, its effect may be estimated by using a method described towards the end of the article.

Insertion Loss and Phase Change of Lattice Filter.

It is necessary, therefore, to evolve a simple method of calculating the transmission characteristics of a lattice filter. The first step will be to express the output current of a balanced lattice network⁸ in terms

¹ E. A. Guillemin, *Communication Networks*, Vol. II, p. 439.

² Bell Monograph B-118, p. 8 (footnote).

³ *B.S.T.J.*, Vol. XVI, pp. 423-436, October, 1937.

⁴ A balanced lattice network is one in which the opposite arms are equal, as shown in Fig. 1. Lattice filters are almost invariably balanced networks and are so considered in this article.

¹ *B.S.T.J.*, Vol. III, pp. 567-620, October, 1924.

² *B.S.T.J.*, Vol. I, pp. 1-32, November, 1922.

³ *Phil. Mag.*, Vol. 4, pp. 902-907, November, 1927.

⁴ *Phil. Mag.*, Vol. 14, pp. 806-810, November, 1932.

of an E.M.F., and the terminal and network impedances. In Fig. 1 (a) and (b), a lattice network,

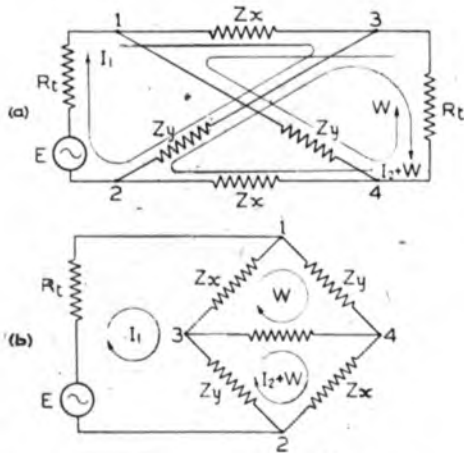

FIG. 1.—BALANCED LATTICE NETWORKS.

comprising generalised series and lattice impedances Z_x and Z_y , is shown in alternative forms. The network is connected between resistive terminations R_t , one of which includes an E.M.F. represented by the vector E .

Writing down the mesh equations, at the same time separating I_2 :

$$\begin{aligned} (R_t + Z_x + Z_y) I_1 - (Z_x + Z_y) W - Z_y I_2 &= E \\ -Z_x I_1 + (Z_x + Z_y) W - R_t I_2 &= 0 \\ -Z_y I_1 + (Z_x + Z_y) W + (R_t + Z_x + Z_y) I_2 &= 0 \end{aligned} \quad \dots \dots \dots (1)$$

Solving for I_2 :

$$I_2 = \frac{E (Z_y - Z_x) (Z_x + Z_y)}{\Delta}$$

$$\text{where } \Delta = \begin{vmatrix} (R_t + Z_x + Z_y) & -(Z_x + Z_y) \\ -Z_x & (Z_x + Z_y) - R_t \end{vmatrix} \begin{vmatrix} (Z_x + Z_y) \\ (R_t + Z_x + Z_y) \end{vmatrix} \begin{vmatrix} (Z_x + Z_y) \\ (R_t + Z_x + Z_y) \end{vmatrix} \\ = \frac{2 (Z_x + Z_y) (R_t + Z_x) (R_t + Z_y)}{E} \frac{Z_y - Z_x}{(R_t + Z_x) (R_t + Z_y)} \quad \dots \dots \dots (2)$$

$$\text{whence } I_2 = \frac{E}{2} \frac{Z_y - Z_x}{(R_t + Z_x) (R_t + Z_y)} \quad \dots \dots \dots (2)$$

The transmission characteristics of the network are determined by the complex ratio of I_0 , the current that would flow if the source and load were connected directly, to I_2 , the load current obtained when the network is interposed. But $I_0 = E/2 R_t$, and dividing this by equation (2):

$$\frac{I_0}{I_2} = \frac{(R_t + Z_x) (R_t + Z_y)}{R_t (Z_y - Z_x)} \quad \dots \dots \dots (3)$$

As this part of the article is concerned only with dissipationless filters the arms of the lattice network are wholly reactive and equation (3) can be rewritten in the form:

$$\frac{I_0}{I_2} = \frac{(R_t + jX_x) (R_t + jX_y)}{jR_t (X_y - X_x)} = \frac{R_t (X_x + X_y) - j (R_t^2 - X_x X_y)}{R_t (X_y - X_x)} \quad \dots \dots \dots (4)$$

The modulus and angle of this expression, which determine the insertion loss and phase change respectively, are given by:

$$\left| \frac{I_0}{I_2} \right| = \frac{\sqrt{(R_t^2 + X_x^2) (R_t^2 + X_y^2)}}{R_t (X_y - X_x)} \quad \dots \dots \dots (5)$$

$$\psi = \tan^{-1} \frac{X_x X_y - R_t^2}{R_t (X_x + X_y)} \quad \dots \dots \dots (6)$$

Bode and Dietzold⁹ have quoted expressions similar

to (5) and (6) except for an unimportant difference of sign in the expression corresponding to (5), but the method of derivation they indicate is very indirect.

By introducing circular functions (5) and (6) may be put in forms much more suitable for computation. From (5):

$$\left| \frac{I_0}{I_2} \right| = \frac{1}{\frac{X_y}{\sqrt{R_t^2 + X_y^2}} \cdot \frac{R_t}{\sqrt{R_t^2 + X_x^2}} - \frac{R_t}{\sqrt{R_t^2 + X_y^2}} \cdot \frac{X_x}{\sqrt{R_t^2 + X_x^2}}} = \frac{1}{\sin \phi \cos \theta - \cos \phi \sin \theta} = \operatorname{cosec} (\phi - \theta) \quad \dots \dots \dots (7)$$

$$\text{Where } \theta = \tan^{-1} \frac{X_y}{R_t} \quad \text{and} \quad \phi = \tan^{-1} \frac{X_x}{R_t} \quad \dots \dots \dots (8)$$

The insertion loss, L , in decibels, is given by:

$$L = 20 \log_{10} \left| \frac{I_0}{I_2} \right| = 20 \log_{10} \operatorname{cosec} (\phi - \theta) \quad \dots \dots \dots (9)$$

From equation (6):

$$\psi = \tan^{-1} \frac{\frac{X_x}{R_t} \cdot \frac{X_y}{R_t} - 1}{\frac{X_x + X_y}{R_t + R_t}} = \tan^{-1} \frac{\tan \theta \tan \phi - 1}{\tan \theta + \tan \phi} = \tan^{-1} \frac{-1}{\tan (\theta + \phi)} = \theta + \phi \pm (1 + 2n) \frac{\pi}{2} \quad \dots \dots \dots (10)$$

(n is an integer)

which gives the insertion phase change. The ambiguity of the last term in (10) depends upon the definition of zero phase change. It can sometimes be resolved by reference to the network itself; for example, it is reasonable to assume that the phase change of a low-pass filter tends to zero with the frequency.

The simplicity of the expressions that have just been derived¹⁰ is surprising, especially when they are compared with those normally used¹¹. This demonstrates one of the advantages of basing computations on the lattice structure. It may also be pointed out that any value of R_t can be used in expressions (8), (9) and (10) with equal facility, whereas the usual method of computation, aided by charts, can be applied directly only to filters terminated in their nominal image impedances, a condition which is often undesirable. In equations (8) R_t can often be written more conveniently as nR_t , where R_t is the nominal image impedance of the filter. The expressions for X_x and X_y , in filters designed on an image basis, will

⁹ The sign \sim means "difference between taken positively."

¹⁰ Since writing this article, U.S. Patent No. 2,070,677 has come to the notice of the authors. In this Patent Norton makes use of a somewhat similar transformation.

¹¹ e.g. T. E. Shea, "Transmission Networks and Wave Filters," Chaps. IV and IX.

⁹ B.S.T.J., Vol. XIV, p. 247, April, 1935.

be found to have a common factor R_i which will then cancel with R_i in the denominators of (8).

Approximations.

Normally the evaluation of expressions (8), (9) and (10) is quite straightforward, but when some of the functions assume extreme values it may be necessary

small angles with accuracy. But when $\phi \sim \theta$ is very small :

$$L \doteq 20 \log_{10} \frac{1}{\phi \sim \theta} \quad (\phi \sim \theta \text{ in radians}) \dots (11)$$

This expression may be used instead of (9) for all values of $\phi \sim \theta$ less than 0.25 radian (13° approx.) without introducing an error of more than 0.1db.

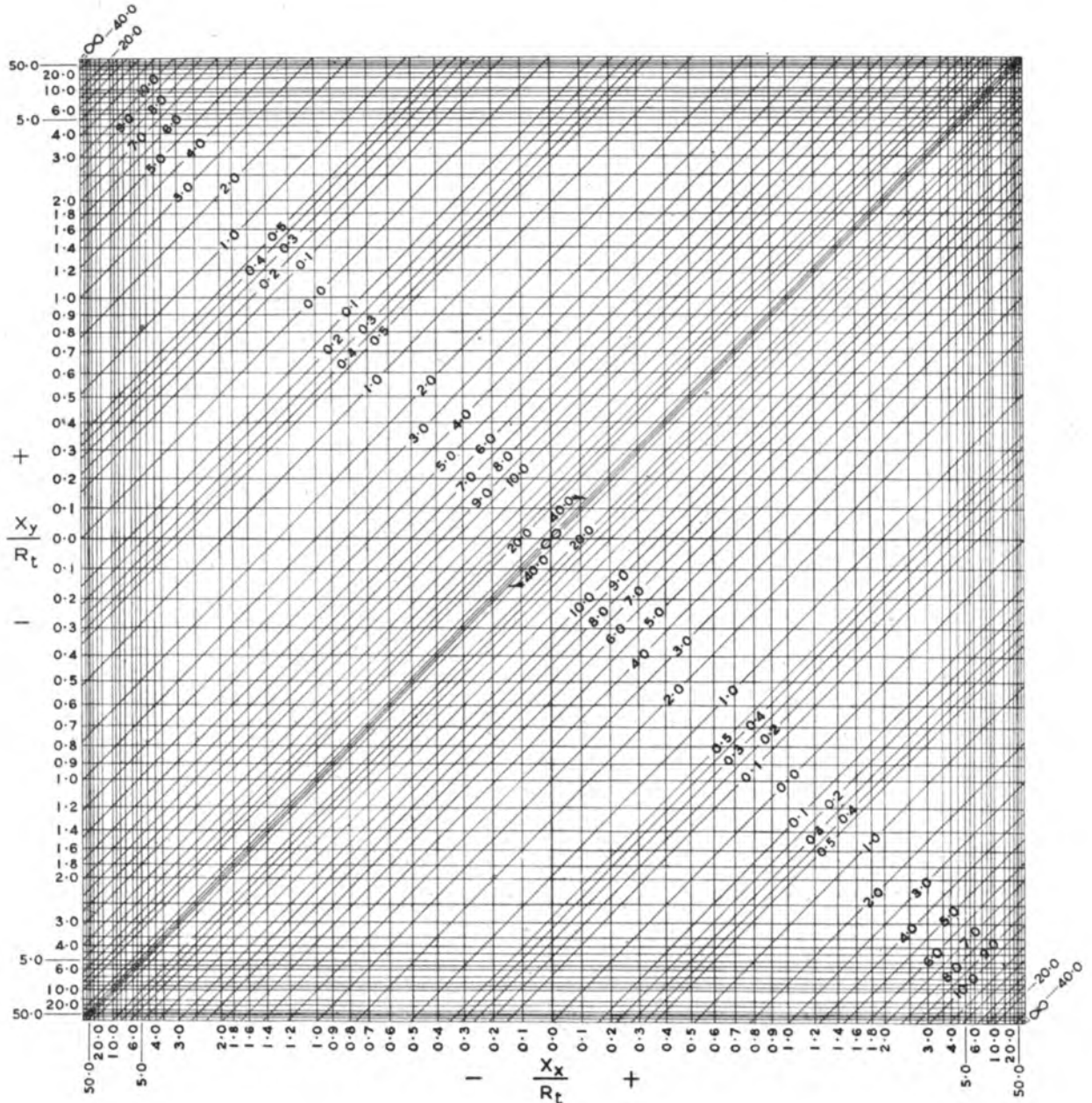

FIG. 2.—CHART FOR INSERTION LOSS CALCULATION.

to make approximations to circumvent the limitations of tables.

Approximation when $\phi \sim \theta$ is small.—High values of loss imply that $\phi \sim \theta$ is a very small angle, in fact when L exceeds 60 db. $\phi \sim \theta$ is less than four minutes of arc, and tables will not give the cosecants of such

Approximation when θ or ϕ approach $\pm \frac{\pi}{2}$. When

$\phi \sim \theta$ is small it is obviously necessary to find θ and ϕ with considerable accuracy. In many cases θ and ϕ approach $\pm \frac{\pi}{2}$ together and in these regions tangent tables are unreliable. But when the absolute

magnitude of X/R is very much greater than unity:

$$\tan^{-1} \frac{X}{R} = \pm \left(\frac{\pi}{2} - \frac{R}{X} \right) \dots \dots \dots (12)$$

the positive and negative signs corresponding to positive and negative values of X/R respectively. This approximation may be used when either or both

Charts

Charts may be used to simplify the computation of insertion loss and insertion phase change still further.

Using equation (11) where small angles are involved and ordinary tables of logarithmic cosecants elsewhere,

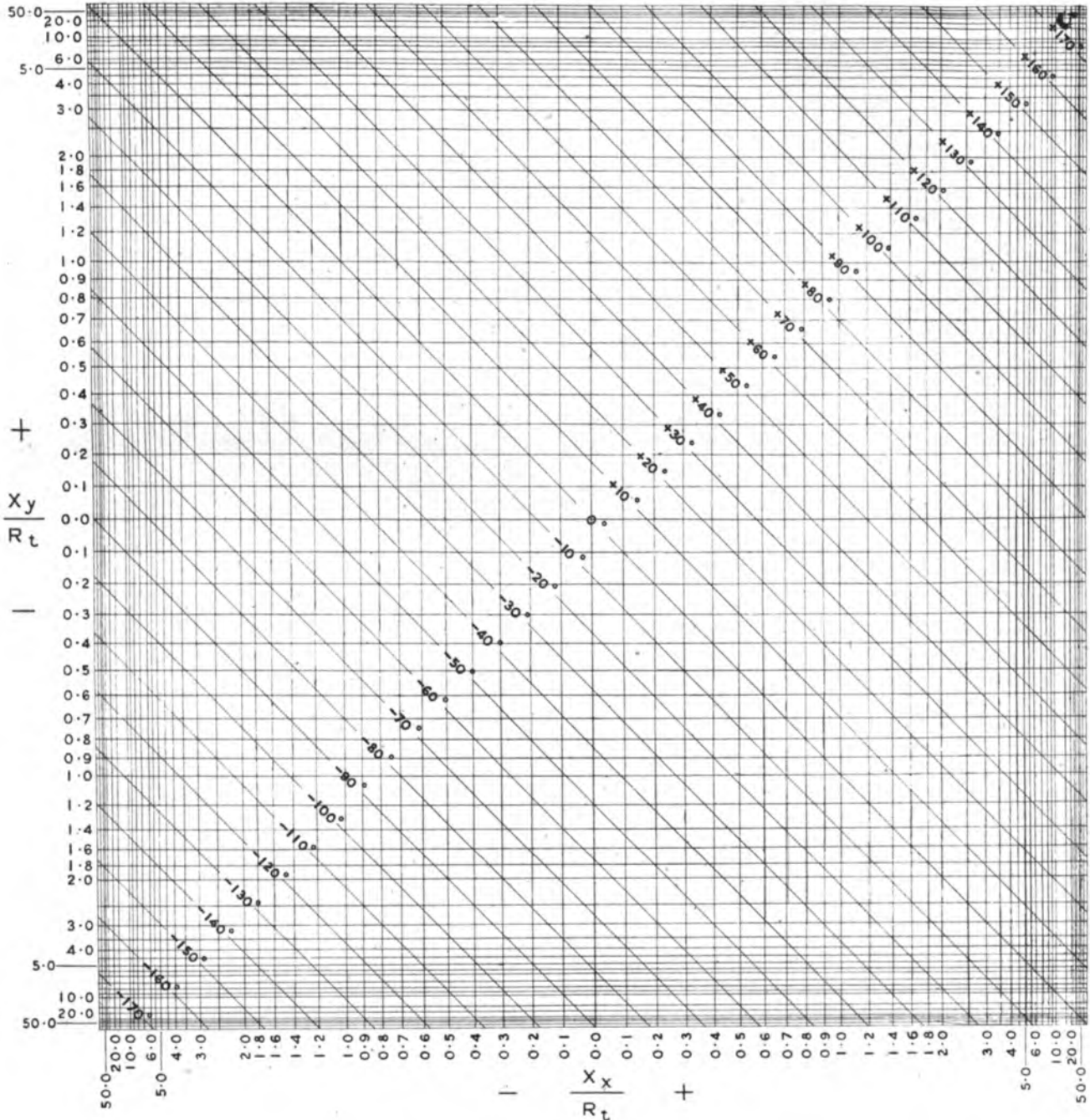

FIG. 3.—CHART FOR PHASE CHANGE CALCULATION.

of the terms X_x/R_t , X_y/R_t exceed 50. The resultant error will then not exceed 0.1 db., provided L itself is not greater than 60 db. A greater error may occur for higher values of loss, but this is not likely to matter in most cases.

a set of curves may be drawn connecting L with $\phi \sim \theta$. These curves save a considerable amount of work and can be made to yield all the accuracy required. They are so easily prepared that copies have not been reproduced in the article.

It is possible to prepare a chart which gives L directly in terms of X_x/R_1 and X_y/R_1 . If these two ratios are taken as the axes on ordinary, uniformly divided, graph paper, and lines of equal loss are plotted, the latter will form a family of quartics. Such a chart has already been published by Feldtkeller¹², although his method of approach is quite different from that employed here. But if X_x/R_1 and X_y/R_1 are plotted on uniform scales the chart can cover only a limited field, as these ratios vary in practice from $-\infty$ to $+\infty$. This difficulty may be overcome in the following way, which offers other advantages as well:

It will be seen from equation (9) that if L is held constant so is $\phi \sim \theta$, and for this condition a change in ϕ gives rise to an equal change in θ . A chart on which the two axes are uniformly scaled to cover values of θ and ϕ from $-\pi/2$ to $+\pi/2$ will therefore yield lines of constant loss, all of which are straight and have unit gradient. It will moreover cover all possible values of θ , ϕ and L . But the axes, instead of being marked off in degrees or radians, can be made to show the tangents of the corresponding angles. The loss can then be determined directly in terms of X_x/R_1 and X_y/R_1 for all values of the latter ranging from $-\infty$ to $+\infty$. As all the loss lines are straight and have the same slope, this chart is easier to construct than one of the type used by Feldtkeller; it is necessary to determine only the co-ordinates of one point on each line and the rest is merely a question of accurate draughtsmanship.

An examination of the chart, reproduced in Fig. 2,¹³

¹² Hirzel, Leipzig, 1939. "Einführung in die Siebschaltungstheorie der Elektrischen Nachrichtentechnik."

¹³ A strictly limited number of copies of this chart, and of the other chart mentioned below, reproduced on a larger scale, are available for distribution. Application should be made to the Managing Editor.

shows that as the loss increases the spacing of the loss lines becomes closer and closer until, for values above, say, 20 db., accurate estimation becomes impossible. This is, of course, natural when all values from zero to infinity are covered. Fortunately, the greatest accuracy is obtained where it is most needed, in and around the pass-band. The curves already referred to, which give L in terms of $\phi \sim \theta$, should be used instead of the loss chart when high losses are involved.

If the phase change, ψ , is held constant it is clear from equation (10) that θ and ϕ will vary equally in opposite directions. Lines of constant phase change could therefore be added to the loss chart in the form of straight lines with a slope of -45° ; the same chart would then serve for loss and phase change calculations. As the result might, however, be rather confusing, a separate chart has been prepared for phase calculations, on the same graticule, and is reproduced in Fig. 3. Values of $\theta + \phi$ are quoted on the phase lines; to obtain the total insertion phase $\pm (1 + 2n)\pi/2$ must be added in accordance with equation (10).

Slide-Rule.

Although the use of a loss chart similar to that reproduced offers great advantages for low and moderate values of loss, the first limit to its usefulness is set by geometrical inaccuracies. The symmetry of the chart allows this to be overcome to some extent by drawing one portion only, on a larger scale, but difficulties in construction, due to distortion of the paper, etc., remain. Using the principle underlying the chart there is, however, another way of increasing the accuracy considerably; a way which offers other advantages. This is by using a slide-rule having special scales and will be described in the second part of this article.

TELEGRAPH AND TELEPHONE STATISTICS—SINGLE WIRE MILEAGES AS AT JUNE, 1942
THE PROPERTY OF, AND MAINTAINED BY, THE POST OFFICE

REGION	OVERHEAD			UNDERGROUND		
	Trunks and Telegraphs	Junctions	Subscribers *	Trunks and Telegraphs †	Junctions ‡	Subscribers ¶
Home Counties	14,181	43,321	297,391	1,106,087	255,526	1,197,810
South Western	8,360	37,506	225,872	511,753	109,510	652,651
Midland	10,419	29,975	187,528	754,271	256,391	934,525
Welsh & Border Counties ..	9,148	24,873	128,068	380,554	66,025	257,400
North Eastern	12,557	24,762	152,418	656,845	204,767	893,257
North Western	1,957	8,263	108,853	527,510	327,948	1,102,704
Northern Ireland	9,182	7,974	28,638	41,991	14,278	107,539
Scottish	23,251	33,898	171,510	540,981	184,147	687,874
Provinces	89,055	210,572	1,300,278	4,519,992	1,418,592	5,833,760
London	677	1,539	69,694	669,209	1,538,217	3,627,701
United Kingdom	89,732	212,111	1,369,972	5,189,201	2,956,809	9,461,461

* Includes all spare wires.

† All wires (including spares) in M.U. Cables.

‡ All wires (including spares) in wholly Junction Cables.

¶ All wires (including spares) in Sub's. and mixed Junction and Sub's. Cables.

Air Raid Damage to Post Office Telecommunications

E. C. BAKER

U.D.C. 623.45 : 621.315.23

Part I.—Underground Plant

The author proposes to give in a short series of articles some examples of the damage caused to Post Office plant by aerial bombardment and of the methods adopted to restore service as early as possible. The first of the series deals with underground plant.

Introduction.

IN 1940 with the approach of Autumn the German Luftwaffe began to bomb our towns and cities. Until mid-December they were rarely absent from our skies for more than a few hours of daylight. (It was during this period that they bombed London for 92 nights in succession.) Thereafter, these attacks became less frequent, but continued to inflict sufficient damage on telecommunications plant to put a heavy strain on Post Office engineering staffs—already depleted by 20 per cent., for more than 8,000 were with the Armed Forces, chiefly in the Royal Corps of Signals—over and above that which they shared with their fellow citizens.

In the main these bombing attacks were quite indiscriminate. The most frequent target was the centre of a town. Under the streets in such an area is run a large number of telephone cables. Inevitably a great deal of damage was done to these cables (Figs. 1 and 2): damage was not confined to the limits of the bomb craters in the streets; faults were found at a considerable distance from the explosion. Sometimes cables were stretched, bent, or flattened in a fantastic manner (Fig. 3) with no effect on the efficiency of the circuits in them. At other times electrical faults had occurred in a cable that on inspection appeared to be undamaged. Earthenware ducts were shattered. Wire joints



FIG. 2. DAMAGED UNDERGROUND CABLES.

were pulled apart and each end drawn two feet into the cable sheath; plumbed joints were destroyed as far as 200 yards from the bomb crater. The centre conductor of a coaxial cable was disconnected three joints away.

Difficulties in Making Repairs.

External repair gangs were not always immediately able to get to work on the damage because of such dangers as floods, insecure masonry, or unexploded bombs.

Jointers worked for hours (Fig. 4) in discomfort and danger, concentrating on their exacting tasks to such good effect that they often completed work in two-thirds of the normal pre-war performance time. During a daylight raid a group of jointers was seen to continue at work although machine-gun bullets from enemy aircraft were striking the ground near them. At another time a jointer and his mate carried out repairs to a cable serving



FIG. 1. TYPICAL BOMB CRATER.



FIG. 3. DAMAGE TO CABLE JOINT AT MANHOLE DUCT ENTRY.

a firm engaged on urgent Air Ministry contracts and worked for over two hours within six yards of an unexploded bomb.

There have been many instances, throughout the country, of engineering staffs courageously carrying out urgent repair work near delayed action bombs when they have been able to obtain permission from the Defence Authorities to do so, or have evaded those Authorities altogether. Sometimes, as the Engineer-in-Chief said when paying a tribute to his staff in a B.B.C. programme early last year, the danger is there when the men do not know it. He told, as an instance, of one job where repairs had been hurriedly pressed on for several days when one of the men did a bit of digging to find out what was the hard object, just under the soil on the floor of the crater, on which he had kept treading. He discovered a large unexploded bomb.

It seems also that quite the opposite can happen. An instance was reported from one town where a gang was not allowed to work on a site because of such a bomb. They by-passed emergency circuits along another cable route, later to learn that the bomb, which had been carefully roped off to await the attention of a Disposal Squad, was a section of sewer pipe half buried in the crater.

More frequently immediate work on damaged cables was held up because of delay in clearing debris from a crater. In those early days Local Authorities were recruiting large numbers of labourers which added to the difficulty of obtaining labourers for the depleted Post Office gangs. A bomb in a main road in the Wood Green district of London damaged the plant of several utility services. Junction cables to four exchanges and two 800-pair subscribers' cables were put out of operation. Large numbers of men employed by these services were soon jostling each other in the restricted space, removing debris and earth from their own damaged plant only to pile it

up where it would interfere with the repair work of the other services. The Post Office representatives, therefore, persuaded the highway authorities to co-ordinate the excavation work.

About this time members of the headquarters staff of the L.C.C. Fire Brigade made representations as to the importance of rapidly repairing their telephone lines. When agreeing to temporary expedients they also considered how to reduce the delays in the repair of water and gas mains, and thereby speed up the restoration of telephone circuits. Later the London Regional Commissioner arranged for his officers to co-ordinate, at bomb damage sites, the activities of the various repair gangs.

To deal with this mass of external telephone repair work the construction staffs were called upon to assist the maintenance staffs, with

consequent delay to new installations, and jointers were exchanged between Regions as required. At the top of the priority list for circuit restoration were the R.A.F. Fighter Commands, and it was necessary to place the Fire Brigades next before the Anti-Aircraft Battery circuits. Many more essential services had then to be attended to before an ordinary subscriber's line could be repaired.

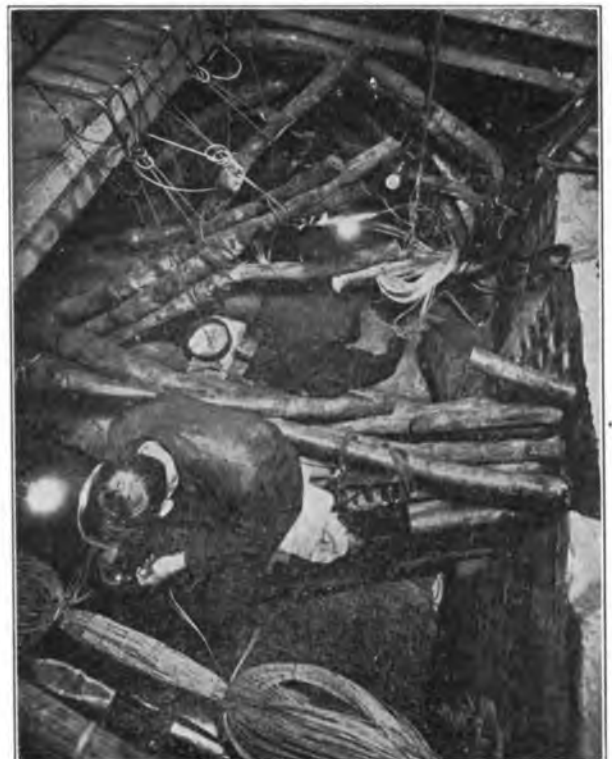

FIG. 4. REPAIRING CABLES AFTER BOMB DAMAGE.



FIG. 5. TEMPORARY CABLE IN TROUGHING.

The engineers' ability to improvise was put to good account in carrying out these repairs. It was often found advisable, in making temporary repairs, to avoid a bomb crater altogether by running interruption cables from the nearest manholes or by sinking a shaft down to the duct track on each side of the route at a suitable distance from the crater. Where convenient these cables were run in surface troughing. Fig. 5 shows such an arrangement around St. Paul's Churchyard, where 10,000 damaged cable pairs had to be put through. When it was impossible to avoid a crater a bridge was constructed over it to carry the interruption cables (Fig. 6). Bridges were formed from two parallel poles with transverse connecting timbers. Steel scaffolding was also used for the same purpose. Sometimes it was necessary to reconstruct a manhole which had been destroyed or to make the crater a site for a manhole and build an additional manhole there.

A Tunnel Repair.

Most of these cables are less than 20 feet below the road surface. Whenever it has been possible to run cables at a much greater depth this has been done, but bombs have penetrated even to these lower levels. Such an occurrence was when a heavy high explosive bomb smashed through an underground railway tunnel in London to sever two telephone cables that had been run

inside the tunnel. While the affected circuits were being temporarily diverted to other routes the damaged tunnel was inspected. It was found to be blocked to the roof with blue clay for approximately 60 feet. To sink shafts from the road down to the tunnel to connect the broken ends of the cable outside the tunnel would have taken more than a week. Other reasons against this course of action were the shortage of timber to make vertical shafts safe and the obstruction this work would have caused to other repair work in the crater above. Experts stated that an attempt to bore through the clay in the tunnel would have slight chance of success. It was, however, agreed that a gang of Post Office engineering workmen should be allowed to make the attempt. The subsequent actions of these men made an impressive exhibition of determination, resourcefulness and courage.

They borrowed a thrust borer from a contiguous telephone area. This machine, normally used only when conditions are much more favourable, is a powerful hand-operated hydraulic ram which forces a strong steel rod through the soil till a steel pipe can be fastened to the distant end to be pulled back, with the rod. Hard objects will deflect the rod, and the clay in the tunnel was full of debris from the road above. A good anchorage is needed to absorb the reaction thrust of the ram, and there was nothing to which to anchor the ram, so stout baulks of timber were fitted to the floor of the tunnel. The men then pierced through the clay at their first attempt. With this surprising success it seemed that the worst part of the job was over: in fact, it had only just begun. The rod had pulled the steel pipe about half-way back when this lodged against a broken segment of the tunnel casing and came adrift from the boring rod.

The men thereupon decided to burrow through the clay to reach the pipe. They were well aware of the



FIG. 6. BRIDGE CARRYING INTERRUPTION CABLE OVER BOMB CRATER.

danger of this action. The clay, through which water was percolating, might fall in on them. It was possible that more of the tunnel itself might collapse. The ventilation was steadily worsening. They made the attempt, but could not reach the pipe because of the piece of casing it had fouled. Thereupon they took their sweeps' rods to the remote end of the obstruction. To reach this they had to walk to the nearest underground station on that side and back along the tunnel for about half a mile. As they went down the slight gradient of the tunnel they saw that the obstruction was damming the rain water and sewage flowing into the tunnel. The tunnel was slowly filling up and their repair work would have to be done in a race against time. They joined up the lengths of rod, probed them through the steel pipe and on through the wet clay to the far side. Where rods could go, so could a small cable. They man-hauled a 100-pair cable through. The jointers worked on a wooden staging with water now two feet deep below them. When one fell into this the other worked away on his own.

The thickness of clay to be penetrated seemed to be much less at the tunnel roof than at the floor, but the thrust borer could be used only at floor level. They decided to try another method for the second—a 254-pair-cable. For this they obtained two 18-foot lengths of steel pipe, fixed a hardwood point on one end, and with sledge-hammer blows drove it into the clay, joined on the second length and continued till the wooden point protruded at the far side. This was removed, rods put through the pipe and the cable drawn in after.

A higher staging had to be erected for the jointers. The water—and sewage—was rising, the air becoming more foul. The plumbing had to be perfect, for within a short time the cable would be immersed. As they put the finishing touches to their work the liquid swirling below the staging reached a depth of seven feet. To retire to safety the men had to clamber laboriously along the side of the tunnel, using cable hangers and other projections as hand-holds.

Fire Damage.

An example of what can happen indirectly as a result of bombing is that of serious fire damage in London in May 1941. Escaping coal-gas from fractured mains exploded in a subway. Eighty-one main trunk, junction, telegraph, and subscribers' cables were burnt and the fire raced along to another manhole 60 yards away. For many hours the intense heat prevented any approach to the subway. It was necessary to wait till the damaged gas mains were sealed and the subway freed from gas. A further difficulty was the large volume of flood water in the manholes, where the cable jointing had to be carried out, so a battery of pumps was kept continuously at work. The damage to this particular telephone and telegraph plant interrupted

communications to all parts of the country. During the work of restoration there developed a serious leakage from a large water main nearby which threatened to damage the new lengths of cable. To prevent this, two of the engineering workmen—stripped to the waist—diverted with their bodies the inflow of water while others fetched steel sheets and sandbags with which to stem it.

Damage at Portsmouth.

In these strenuous times the fine spirit of the engineering staff can be observed throughout the Post Office. At Portsmouth, for example, two 1,000 kilogramme bombs struck the ground 60 yards apart but did not explode. One bomb grazed a cable track before it came to rest more than 20 feet down in the ground. Because of the importance of the circuits in the cables it was agreed to try to remove the bomb rather than explode it where it lay. When the disposal party were excavating the bomb they had to dig round the multiple way cable duct; it was, therefore, necessary for the Post Office men to fit longitudinal supports to the exposed ducts. The men who undertook this work were told beforehand of the attendant danger, but they cheerfully accepted the risk: their attitude was summed up by a foreman who said simply, "There's a job to do, let's get to it."

Portsmouth is one of the large provincial towns that has suffered a considerable amount of bombing. Here, it has been noticed, that apart from damage directly caused—one particular cable has been broken on five occasions—there has been a large increase in cable faults. Especially has this been so in cables of an inch or less in diameter. Of 80 faults during one month only five were in cables exceeding 100 pairs, which by no means represents the proportion of small to large cables in that area. Bombs have exploded near tracks containing large cables without damaging them; even when a duct or pipe has been shattered for several yards the cable has often been only superficially damaged. Bombs have exploded as close as 10 feet to underground tracks at normal depth and have not damaged them. With small cables, however, conductors have been stretched, joints pulled apart, and lead sheaths distorted. Frequently earthborne vibrations from bomb explosions fracture the lead sheath near a joint in a cable.

Conclusion.

The requirements of security have necessitated the omission from this article of anything more than a few brief notes on underground cable damage with which we have had to contend. Though some of the jobs instanced present unusual features there have been others which necessitated a great deal more work before the thousands of circuits damaged could be brought again into service.

Improved Mountings

U.D.C. 621.88

F. G. BIRD

The author describes a method by which satisfactory substitutes for a number of standard mountings and fixings can be cheaply and efficiently made using an ingenious tool sold for model-making purposes.

Introduction.

UNDER present conditions it frequently happens that a miscellaneous assortment of items needs mounting at small stations to meet some urgent requirement. Standard mountings are not always available in time and the following method of constructing substitutes has proved useful and has enabled delays to important work to be avoided. Naturally standard mountings should be used wherever possible, but the number of occasions on which substitutes would prove of value is perhaps large enough to make this article of general interest.

The Juneero Multi-Purpose Tool.

This tool retails (at the time of writing) for the price of 17s. 6d. and is designed for working up mild steel angle, flat strip and rod. These materials are supplied in standard dimensions and of a grade of steel specially suitable for use with the tool. It is important that heavier or harder materials should not be employed or damage to the tool may result.

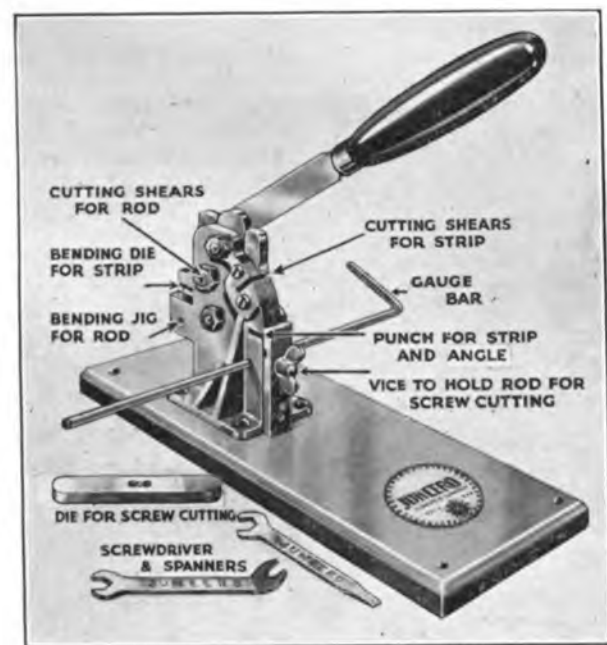

FIG. 1. JUNEERO TOOL.

Fig. 1 shows that five separate tools are incorporated, four of them operated by the single lever. A sixth—the vice—is used only when no bench vice is to hand.

There are shears for cutting $\frac{3}{8}$ in. strip, and at the back are shears for cutting $\frac{1}{8}$ in. rod. Below the shears is a punch for perforating the strips and angle with $\frac{1}{8}$ in. clearance holes. At the back of

the tool is a forming die in which the strip metal can be bent to any angle up to 90° in a very clean and efficient manner. Below this is a hole in which the round bars are held to bend them.

A gauge bar is supplied and gripped by the pinching screw normally used for the vice. This gauge bar is important; with its aid a number of parts can be produced exactly similar and with factory precision and, what is most essential, a finish and general appearance that compares well with the factory produced article.

Use of the Tool.

The use of the tool will best be illustrated by describing the construction of a simple clip (Fig. 2) such as that (Clip Condenser No. 14 lin.) used to mount a condenser (MC No. 102) on a panel.

A strip of metal is inserted in the punch from the left-hand side of the tool, and a hole punched by the depression of the lever; the metal is

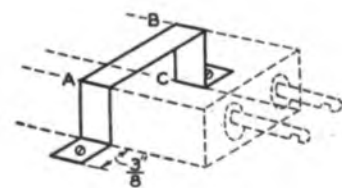

FIG. 2. CLIP CONDENSER NO. 14.

withdrawn and a line drawn square across at a distance of $\frac{3}{8}$ in. from the end. The tool is reversed and a 90° bend made on this line; this is achieved by depressing the lever, inserting the strip in the bending die and raising the lever steadily until the correct angle is obtained—for a right angle the lever is raised to its fullest extent. Next lay the condenser flat and mark for bend A and bend in tool; repeat for bend B and form. Bend C is marked, but before bending $\frac{3}{8}$ in. is allowed for the fixing lug, the hole punched and the bend finally formed. It is obvious that if the correct lengths were cut in the first place and the gauge bar set to each measurement a number such as twelve could be made in, say, fifteen minutes and at a cost for materials of approximately 5d.

For the purpose of enlarging holes a taper broach is very useful. This is made from a length of $\frac{1}{4}$ in. silver steel rod. File or turn a taper to the size shown in Fig. 3 and polish. File the taper to the centre line, taking care to keep the edge clean. Harden and temper to dark straw and sharpen flat on oilstone.

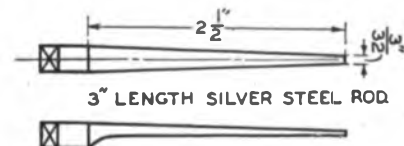

FIG. 3. TAPER BROACH.

Do not attempt to polish or sharpen the rounded portion after flat has been filed.

Key Mounting.

A more elaborate mounting is shown in Fig. 4. This is an improvised box type mounting for a single key (Key Mounting NAA). The construction is straightforward, but care must be taken with detail B2. The two holes for fixing are shown offset from the centre line by $\frac{1}{64}$ in.; this is essential to prevent

but use fibre or ply-wood clamps and a mallet. The bottom can be either soldered into position or a piece of thin wood cut and fixed with panel pins. Two small angle brackets bolted to the sides form a ready means of holding cover in position. In practice it will be found that a tinplate cover will be more serviceable and easier to make than the wood case which is usually attempted. For this and other key mountings used with the key handle in a vertical position a fibre dust cap can be cut and inserted between the key and key plates. The fixing holes are punched with the tool and the slot cut by punching holes at the ends with a belt punch, then cutting along the lines with a sharp wood chisel.

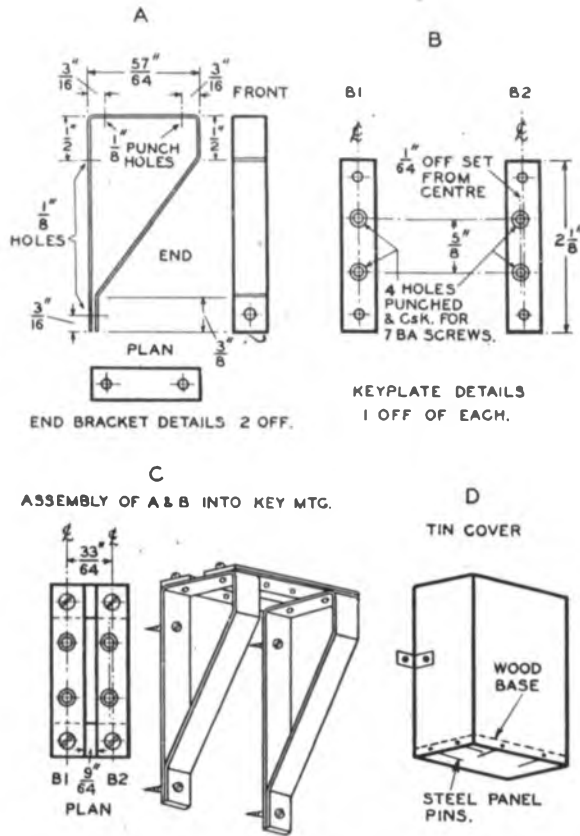

FIG. 4. BOX TYPE MOUNTING FOR SINGLE KEY.

the key binding in the slot and presents no difficulty if a piece of packing $\frac{1}{8}$ in. thick is inserted in the back of the punching slot. The remainder of the Fig. is self-explanatory. A simple cover may be made if required as follows: Shape a block of wood to the outside dimensions, $1\frac{17}{64}$ in. by 2 in. by 3 in., and bend a piece of tinplate, using the block as a former—do not use a hammer and bruise the metal,

Measurements.

Accuracy in measurements is essential. A folding rule and pencil are not the tools for this work. Use an engineer's one foot steel rule (not folding), an engineer's square, dividers and scribe.

Perhaps the correct method of marking out a master copy of detail B for the key mounting will illustrate the point. First select a clean straight piece of flat strip; rub over the face to be marked lightly with 00 emery cloth that is free from grease; get three pennyworth of sulphate of copper from the chemists (ask for large crystals), moisten one of the crystals and gently rub over the face of the strip; a thin face of pure copper is deposited on the metal (do not try to get a thick coat or it will be patchy) the centre line is then drawn down the complete length; obtain centre of length; mark $\frac{1}{16}$ in. each side by means of the dividers and using the square cut a thin, deep line across the face with the scribe.

Conclusion.

The mountings illustrated in this article are but two of a number which the author has constructed. The use of the Juneero angle and strip, and of fibre such as that used for spacing cards at maintenance control centres, offers a wide scope in meeting miscellaneous requirements, the limit being set only by the ingenuity of the operator using the tool. It is safe to say that, with very few exceptions, all the mounting requirements for small, urgent jobs, which would otherwise be delayed because of the shortage of standard mountings, could be met by this method of constructing substitutes on the spot, or preferably in the local mechanic's shop.

Notes and Comments

Roll of Honour

The Board of Editors deeply regrets to have to record the deaths of the following members of the Engineering Department :—

While serving with the Armed Forces, including Home Guard

Belfast Telephone Area	..	Bryson, M. R.	..	Unestablished Skilled Workman	Sergeant, Royal Ulster Rifles	
Birmingham Telephone Area		Gardiner, S. W.	..	Unestablished Skilled Workman	Corporal, Royal Army Service Corps	
Birmingham Telephone Area		Harrison, L. H.	..	Skilled Workman Class II	..	Corporal, Royal Corps of Signals
Canterbury Telephone Area		Sandy, J.	..	Labourer	..	Private, Royal East Kent Regiment
Engineer in Chief's Office	..	Moller, J. D.	..	Unestablished Draughtsman	..	Sergeant Observer, Royal Air Force
Gloucester Telephone Area		Stiff, A. J.	..	Skilled Workman, Class II	..	Leading Telegraphist, Royal Navy
London Telecommunications Region		Allen, G. J.	..	Labourer	..	Private, Wiltshire Regt.
London Telecommunications Region		Chasmar, G. H.	..	Unestablished Skilled Workman		Signalman, Royal Corps of Signals
London Telecommunications Region		Killon, A.	..	Labourer	..	Lance Corporal, Rifle Brigade
London Telecommunications Region		Marchant, G. W.	..	Unestablished Skilled Workman		Able Seaman, Royal Navy
London Telecommunications Region		Russell, A. D.	..	Unestablished Skilled Workman		Acting Leading Airman, Fleet Air Arm
London Telecommunications Region		Walter, R. J.	..	Unestablished Skilled Workman		Signalman, Royal Corps of Signals
Newcastle Telephone Area		Allan, M.	..	Unestablished Skilled Workman		Signalman, Royal Corps of Signals
Oxford Telephone Area	..	Weeks, F. C.	..	Unestablished Skilled Workman		Bandsman, Oxfordshire & Bucks Light Infantry
Scotland West Telephone Area		Anderson, T.	..	Unestablished Skilled Workman		Signalman, Royal Corps of Signals

Recent Awards

The Board of Editors has learnt with great pleasure of the honours recently conferred on the following members of the Engineering Department :—

While serving with the Armed Forces, including Home Guard

Bournemouth Telephone Area		Pettyfer, R. R.	Skilled Workman, Class II	Sergeant, Royal Corps of Signals	Mentioned in Despatches
Liverpool Telephone Area		Hewson, E.	Inspector	Corporal, Royal Corps of Signals	Order of the British Empire

While serving with the Civil Defence Forces or on Post Office Duty

Canterbury Telephone Area		Martin, L. J.	..	Skilled Workman Class II	..	British Empire Medal
York Telephone Area	..	Fox, E. M.	..	Unestablished Skilled Workman		Commended by H.M. the King
York Telephone Area	..	Holder, J. H.	..	Unestablished Skilled Workman		Commended by H.M. the King

Birthday Honours

The Board of Editors offers its congratulations to the following members of the Engineering Staff whom His Majesty the King has been graciously pleased to honour in the Birthday Honours List :—

On loan to Ministry of Home Security		Hembrough, J. R.	Area Engineer	Member of the Order of the British Empire
--------------------------------------	--	------------------	---------------	----	----	---

Birthday Honours—continued.

H.M.C.S.	Pratt, R. O. . .	Chief Officer	Member of the Order of the British Empire
Portsmouth Telephone Area	Willmot, C. J. . .	Chief Inspector	Member of the Order of the British Empire
Norwich Telephone Area . .	England, R. . .	Inspector	Medal of the Order of the British Empire
Swansea Telephone Area . .	Gould, J. S. . .	Inspector	Medal of the Order of the British Empire
Engineer-in-Chief's Office . .	Hobbs, J. G. . .	Inspector	Medal of the Order of the British Empire
Southampton Telephone Area	Lockyer, C. H. . .	Skilled Workman Class I..	Medal of the Order of the British Empire

Regional Notes

Welsh and Border Counties Region

GROUND WATER LOWERING

Recently on commencing to build a few loading coil manholes, it was discovered that the ground to be excavated consisted of running sand, the sand being particularly fine grained. Because of these conditions application was made to Messrs. Blaw Knox for the de-watering plant as described in an article of the P.O.E.E. JOURNAL, Vol. 35, part I, page 1. As a result of this application it was learned that the plant was not available and would not be available in future. Investigation and enquiries with other firms revealed that a similar plant could be hired from Millars Machine Co., Ltd. The plant was hired and tried on work involving the excavation of three manholes and it performed the job of lowering the water level successfully.

Millar's plant differs from that of Blaw Knox principally in that it contains only one valve, the ball valve closing the end of the tube during the pumping operation. During jetting the screen is not cut off. Little difference in the times of jetting was noticed between this plant and that of Blaw Knox, but the jetting operation was carried out in a medium which offered ideal conditions.

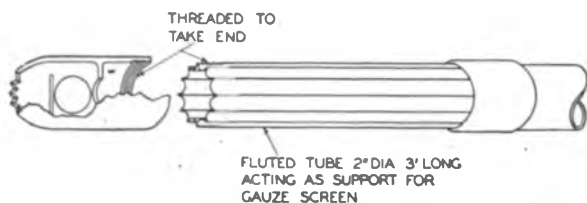

The associated sketch shows roughly the construction of a Millar's well-point, the fluted tube takes the place of the composite tube shown in Fig. 2 of the previously mentioned article, the ring valve at the lower end of the tube being omitted. The upper ends of the flutes are closed. Millar's well-points have the advantage in that they can be entirely dismantled, cleaned and any damaged parts easily replaced.

Another feature of the Millar's plant, which it is considered renders it less useful to the Post Office than that of Blaw Knox, is that the well-points are not coupled to the header-main by flexible hose connections but by lengths of steel pipe having at either end two right-angled elbows in series. The outer unions connect one

with the well-point and the other with the header-main. A stopcock is housed in the steel tube in order that any particular well-point can be shut down.

S. J. M.

London Telecommunications Region

TOTTENHAM AUTO EXCHANGE

The old Tottenham C.B. No. 1 exchange installed in 1922 was replaced by an automatic exchange on May 14th, 1942. The equipment for this exchange was manufactured and installed by the Standard Telephones & Cables, Ltd., and is of the "2000 director type," with subscribers' uniselectors. The latter were used because of the high calling rate, as this exchange serves an important industrial area which in pre-war days was the heart of "furniture land."

The initial capacity is a 6,000 subscribers line multiple with an ultimate capacity of a 10,000 subscribers line multiple. The installation is being carried out in two stages.

Stage I, which included 19 positions erected in a temporary position in the centre of the old manual switch-room, was completed by the opening date.

Stage II consists of the provision of a further 17 automatic positions now being erected for completion by the end of December, 1942.

This will be followed after transfer of the circuits from the positions in the temporary situation by the shifting of these switchboards to the place which they will occupy as part of the permanent suite.

The power plant is of the "divided float" design, and includes two motor generators which have 500 A and 200 A output respectively. The batteries are manufactured by the Hart Accumulator Co., and have a box capacity of 3,000 Ah, with an initial plated capacity of 2,000 Ah.

The circuits transferred to the automatic exchange were:—Subscribers 3,104, incoming junctions 502, and outgoing junctions 464. The line plant terminated on the new main distribution frame comprised 8,300 subscribers' pairs and 3,560 junction pairs.

There were some interesting features in connection with the construction of this exchange: (a) the test room suite comprising five positions is enclosed and separated from the automatic apparatus floor, on which is installed the M.D.F.; (b) it was revealed, as a result of the analysis of the water obtained from the subsoil of the exchange site, that it contained in addition to calcium sulphate, a quantity of nitric nitrogen; these have a deleterious effect upon Portland cement

concrete, iron and lead. It was therefore decided that the usual practice existing at that time of installing a lead electrode earth system should be superseded by the fitting of two sets of four No. 3 G.I. earth plates, not less than 8 ft. apart, with the shafts filled in with soil, not coke. The tails are joined to soft copper stranded wire 19/16, protected by $\frac{3}{4}$ in. lead pipe. The ends and all breaks in the protection are sealed to prevent entry of water. The leading-in manhole had to be made up with "Ciment Fondu."

H. A.

North Eastern Region WATERTIGHT DUCTS

Cable leading-in schemes to points below ground level require that the duct line from the higher to the lower level must be watertight. Normally the requirements could be met by the use of caulked steel in C.I. pipes with a duct seal at each end of the track. Shortage of the above items has made it necessary to find alternative methods of providing a watertight track.

Asbestos cement pressure pipes with a special asbestos cement detachable joint consisting of

- Joint flanges (2), Rubber rings (2), Joint collar (1), Wrought iron bolts treated with non-rust compound (3),

have been used in the N.E. Region and found to achieve the desired result.

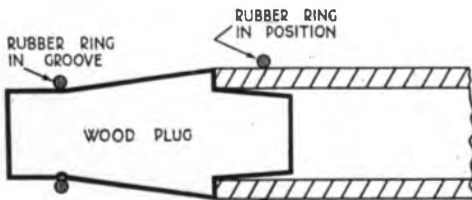

FIG. 1.

Fig. 1 shows the type of jig which is required for slipping the rubber rings into position, and Fig. 2 indi-

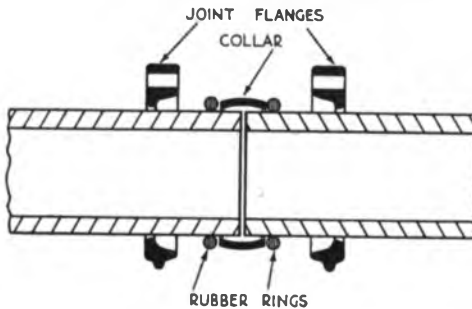

FIG. 2.

Book Review

"Handbook of Technical Instruction for Wireless Telegraphists." By H. M. Dowsett and L. E. Q. Walker. 664 pp. 618 ill. Iliffe. 25s.

In presenting the seventh edition of this well-known handbook Mr. Dowsett decided to share the responsibility of the new production with a second authority possessing the requisite wide experience of modern marine apparatus and its underlying theory. Thus Mr. Walker now joins him as co-author of the seventh edition.

The aim of the book is to provide simple instruction for sea-going operators and others in the general principles and practice of every form of application of marine wireless illustrated by descriptions of apparatus

developed by British wireless companies, and there can be no doubt that it fulfils its object. No one need be deterred by the fact that the examples are all of marine application; there is plenty of well-presented material dealing with the general principles underlying all forms of radio communication.

The chapter on aerials and radiation has been very materially lengthened and this has undoubtedly increased its value to the reader. The original chapters on damped oscillations and commercial types of spark transmitter have now been merged into one chapter, the amount of material being somewhat reduced. This is justified in view of the decreasing importance of spark transmissions. Another sign of the times is the inclusion of a chapter on A.C. power rectification.—A. H. M.

The unit is easily assembled and the prime cost of the whole work is approximately 50 per cent. of that using steel pipes.

H. J. A.

South Western Region TECHNICAL LITERATURE

A novel way of meeting the demand for technical literature has been introduced in the Southampton Telephone Manager's Area with successful results.

A circular letter was despatched to each member of the staff asking for unwanted technical books to be offered for sale to members of the staff at reasonable prices. A request was made that surplus Correspondence Courses, Educational Pamphlets and Technical Pamphlets for Workmen be released, in view of the difficulty in obtaining supplies through the usual channels.

In addition, the members were invited to state what technical literature was required. The response was encouraging. Generous supplies reached the Distribution Centre. The number of Technical Pamphlets for Workmen released was surprising. Several members offered technical books in new condition free of charge. The demand for books was such as to justify the immediate circulation of a "For Sale" and "Wanted" catalogue.

Most of the literature offered was speedily disposed of, and much benefit has been derived by the studiously minded, particularly by the younger members of the staff, including the female members.

Mr. C. F. Middleton, Local Agent *P.O.E.E. Journal*, of the Southampton Telephone Manager's Office, will be happy to give a helping hand to those in other Areas or Regions who desire to benefit from the scheme.

Home Counties Region POST OFFICE RELIEF FUND

On Saturday, July 11th, the Sports and Social Club of the Regional Director's Office organised a Garden Fête, Flower Show and Dance Social in aid of the Second Post Office Relief Fund. The function, the second of its kind held at "The Grange," Finchley, since the Regional Headquarters was set up there, was attended by about 250 people, and proved an unqualified success. The fund benefited to the extent of £19 2s. 6d.

W. R.

Staff Changes

Promotions

Name	Region	Date	Name	Region	Date
<i>Exec. Engr. to Asst. Staff Engr.</i>			<i>Insp. to Chief Insp. —cont.</i>		
Gibson, W. W. M.	E.-in-C.O.	4.6.42	Clayton, W.	E.-in-C.O. to N.E. Reg.	19.7.42
Jarvis, R. F. J.	E.-in-C.O.	4.6.42	Tyler, G. C.	Mid. Reg.	19.7.42
<i>Area Engr. to Telephone Manager.</i>			Duncan, N.	Scot. Reg.	28.6.42
*Hembrough, J. R.	W. & B.C. Reg.	1.7.42	Minns, R. W.	W. & B.C. Reg.	25.8.41
Hudson, A.	N.W. Reg. to Bedford	1.7.42	Lettsome, E. W.	Mid. Reg. to N.W. Reg.	12.7.42
Ramsay, M. W.	Scot. Reg. to Aberdeen	23.8.42	*Armitstead, N. C.	E.-in-C.O.	27.7.42
<i>Area Engr. to Asst. Telephone Manager.</i>			Beak, K. L.	E.-in-C.O.	27.7.42
Cook, A. G.	Mid. Reg. to Birmingham	10.6.42	Graham, A. W.	N.W. Reg.	19.8.42
Brown, A. H.	Scot. Reg. to Glasgow	1.6.42	Wallis, I. H.	H.C. Reg.	27.7.42
<i>Asst. Engr. to Exec. Engr.</i>			Ibbett, R. E.	H.C. Reg.	17.5.42
Critchlow, V. G.	S.W. Reg. to N.E. Reg.	19.7.42	Chipp, S. W.	E.-in-C.O.	10.6.42
Francis, H. E.	Scot. Reg. to E.in-C.O.	5.7.42	Spratley, E. W. F.	E.-in-C.O.	8.4.42
Coleman, W. L. A.	S.W. Reg. to E.in-C.O.	5.7.42	Rapkin, L. W.	L.T. Reg.	7.6.42
Smith, D.	N.E. Reg.	12.7.42	Hargrave, L. R.	S.W. Reg.	19.7.42
Turner, C.	N.W. Reg. to L.T.R.	18.8.42	Maybank, E. W.	L.T. Reg.	3.5.42
Wilcockson, H. E.	E.-in-C.O.	1.7.42	Clark, C. W. A.	L.T. Reg.	26.7.42
<i>Chief Insp. to Asst. Engr.</i>			<i>S.W.I. to Insp.</i>		
*Wilkinson, E. H.	E.-in-C.O.	30.5.42	Wales, H. A.	E.-in-C.O.	23.5.42
Gray, R. E.	H.C. Reg. to E.-in-C.O.	30.5.42	*Harrison, C. J.	E.-in-C.O.	7.2.42
Guy, L.	Scot. Reg.	5.7.42	Poulson, P. R.	E.-in-C.O.	7.2.42
Banks, W. R.	H.C. Reg.	30.5.42	Squire, W. J. S.	E.-in-C.O.	7.2.42
Judson, J. E.	E.-in-C.O.	3.6.42	Dytham, E. T.	E.-in-C.O.	18.4.42
Seymour, R. A.	E.-in-C.O.	30.5.42	Buckland, F. W. V.	E.-in-C.O.	22.3.42
Wilcher, F. B.	E.-in-C.O.	30.5.42	Price, E.	E.-in-C.O.	19.1.42
Palmer, R. N.	Mid. Reg.	12.6.42	Manning, E. H.	L.T. Reg. to E.-in-C.O.	10.5.42
Day, J. V.	N.W. Reg.	12.6.42	Cooke, H. H.	Test Section (Birmingham)	28.12.41
Betts, E. H.	W. & B.C. Reg.	14.6.42	<i>Second Officer to Chief Officer.</i>		
Marchant, P. A.	E.-in-C.O.	12.6.42	Evans, C. M. G.	H.M.C.S.	21.1.42
Bingham, J.	N.E. Reg.	22.6.42	<i>Third Officer to Second Officer.</i>		
Gerry, P. R. C.	E.-in-C.O.	22.6.42	Garnett, F. J.	H.M.C.S.	29.5.40
Devey, G. B.	L.T. Reg. to S.W. Reg.	1.7.42	Ruddock, J. P.	H.M.C.S.	9.6.40
Benzies, A. C.	N.W. Reg.	19.8.42	<i>Fourth Officer to Second Officer.</i>		
Cunningham, J. F.	N.W. Reg.	6.8.42	Bates, O. R.	H.M.C.S.	10.6.40
Nicolson, P.	Scot. Reg.	22.7.42	Dellow, E. G. N.	H.M.C.S.	20.5.40
<i>Chief Insp. to Chief Insp. with Allee.</i>			Nairne, I. U. D.	H.M.C.S.	30.5.40
Read, A.	H.C. Reg.	18.8.42	Marshall, J.	H.M.C.S.	9.2.42
<i>Insp. to Chief Insp.</i>			<i>Fourth Officer to Third Officer.</i>		
Halliday, W. G.	H.C. Reg.	28.4.42	Dixon, J.	H.M.C.S.	1.9.41
Maslin, A. E. W.	H.C. Reg.	31.5.42	<i>Second Engr. to Chief Engr.</i>		
Rice, S. G.	H.C. Reg.	5.7.42	Sloss, J.	H.M.C.S.	3.1.42
Loudwell, A. J.	L.T. Reg.	10.5.42	<i>Fifth Engr. to Second Engr.</i>		
Brooks, C. W.	H.C. Reg.	9.6.42	Soulsby, H. G.	H.M.C.S.	3.1.42
Wall, C. G.	W. & B.C. Reg.	22.4.42	<i>Fourth Engr. to Third Engr.</i>		
Selby, C. H.	W. & B.C. Reg.	10.5.42	Jones, T. L.	H.M.C.S.	18.4.40
Wicks, W. L.	S.W. Reg. to Scot. Reg.	26.5.42	<i>Fifth Engr. to Third Engr.</i>		
Kibby, R. A.	W. & B.C. Reg.	9.6.42	Millar, D. E.	H.M.C.S.	3.1.42
Chapman, S. D.	E.-in-C.O.	1.7.42	<i>Fifth Engr. to Fourth Engr (Unest).</i>		
*Wilson, K. E.	E.-in-C.O.	22.10.41	Sharp, J. F.	H.M.C.S.	2.4.42
Shaw, H.	N.W. Reg. to L.T. Reg.	7.6.42			
Harden, P.	Mid. Reg. to L.T. Reg.	14.6.42			
Murray, J. B.	E.-in-C.O.	22.10.41			
Brown, W. D.	W. & B.C. Reg.	14.6.42			

Appointments

Name	Region	Date	Name	Region	Date
<i>To Prob. Asst. Engr.</i>			<i>To Prob. Asst. Engr.—cont.</i>		
Neal, N. W.	E.-in-C.O.	1.6.42	Bray, P. R.	London Test	1.6.42
Marks, D. J.	E.-in-C.O.	1.6.42	Pearson, H. E.	E.-in-C.O.	1.5.42
Jowett, J. K. S.	E.-in-C.O.	1.6.42	Roberts, F. F.	E.-in-C.O.	1.5.42
Waldram, A. H. T.	E.-in-C.O.	1.6.42	Bampton, J. F.	E.-in-C.O.	1.5.42
Hinchcliff, J. D.	E.-in-C.O.	1.6.42	Walker, D. C.	E.-in-C.O.	1.5.42
Chandler, W. W.	E.-in-C.O.	1.6.42	Holmes, M. F.	London Test	1.5.42
Berry, J.	E.-in-C.O.	1.6.42	Crowther, R. A.	Birmingham Test	1.5.42
Richards, D. L.	E.-in-C.O.	1.6.42	Turner, D.	E.-in-C.O.	1.5.42
Tissington, R. S.	E.-in-C.O.	1.6.42			

Appointments—continued.

Name	Region	Date	Name	Region	Date
<i>To Prob. Insp.</i>			<i>To Prob. Insp.—cont.</i>		
Cooper, H.	E.-in-C.O.	12.7.42	Martin, F. N.	E.-in-C.O.	12.7.42
Driver, E. R.	L.T. Reg.	12.7.42	Allery, G. D.	E.-in-C.O.	12.7.42
Leask, D. R.	E.-in-C.O.	12.7.42	Howells, A. W.	E.-in-C.O.	12.7.42
Low, F. A.	E.-in-C.O.	12.7.42	Faulkner, R. A. R.	E.-in-C.O.	12.7.42
Redman, F. W. G.	E.-in-C.O.	12.7.42	Anderson, J. G.	E.-in-C.O.	12.7.42
Arnold, G. F.	E.-in-C.O.	12.7.42	Fletcher, J. L.	E.-in-C.O.	12.7.42
Milne, F. A.	E.-in-C.O.	12.7.42	Barton, R. W.	E.-in-C.O.	12.7.42
Archbold, R. B.	E.-in-C.O.	12.7.42	Fleming, J. M.	E.-in-C.O.	12.7.42
Brown, W. A.	E.-in-C.O.	12.7.42	Crosby, E.	E.-in-C.O.	12.7.42
Davis, E.	E.-in-C.O.	12.7.42	Foster, F. W.	E.-in-C.O.	12.7.42
Jeffery, N. E.	E.-in-C.O.	12.7.42	Hall, R. R.	E.-in-C.O.	12.7.42
Frost, E. J.	E.-in-C.O.	12.7.42	Graty, H. J.	Mid. Reg.	12.7.42
Garlick, J.	E.-in-C.O.	12.7.42	Deville, C. W. A.	E.-in-C.O.	12.7.42
Hutter, J.	E.-in-C.O.	12.7.42	Edwards, A. J.	E.-in-C.O.	12.7.42
Pember, A. L.	E.-in-C.O.	12.7.42	Brough, R.	E.-in-C.O.	12.7.42
Glanville, J. H.	H.C. Reg.	12.7.42	Nesbitt, W. R.	N.E. Reg.	12.7.42
Varrall, J. E.	E.-in-C.O.	12.7.42	Sinclair, B. R.	E.-in-C.O.	12.7.42
Heesom, S. D.	E.-in-C.O.	12.7.42	Ayling, S. R.	E.-in-C.O.	12.7.42
Mallett, T. H.	E.-in-C.O.	12.7.42	Farmer, W. H.	E.-in-C.O.	12.7.42
Allan, T.	E.-in-C.O.	12.7.42	Cooper, G.	N.W. Reg.	12.7.42
Hince, E. W.	E.-in-C.O.	12.7.42	Thomas, J. F. P.	E.-in-C.O.	12.7.42
Holmes, A. C.	E.-in-C.O.	12.7.42	Glazier, A. W.	E.-in-C.O.	12.7.42
Lilley, M.	E.-in-C.O.	12.7.42	Dickson, J. S.	E.-in-C.O.	12.7.42
Walesby, H. N.	E.-in-C.O.	12.7.42	Parks, F.	N.E. Reg.	22.8.42
Warburton, D.	E.-in-C.O.	12.7.42			

Transfers

Name	Region	Date	Name	Region	Date
<i>Inspr.</i>			<i>Inspr.—cont.</i>		
Smith, L.	E.-in-C.O. to Mid. Reg.	7.6.42	Johnson, E. S.	E.-in-C.O. to Mid. Reg.	29.6.42
Blackie, K. J.	Mid. Reg. to E.-in-C.O.	7.6.42	Wright, H. C.	L.T. Reg. to E.-in-C.O.	1.8.42
Harrison, H. W.	E.-in-C.O. to H.C. Reg.	8.6.42	Newham, A. L.	E.-in-C.O. to N.E. Reg.	1.9.42
Sweeney, L.	N.E. Reg. to W. & B.C. Reg.	6.6.42	<i>Probv. Insp.</i>		
Cullen, W. E.	Test Section to L.T. Reg.	22.6.42	Graty, H. J.	Mid. Reg. to E.-in-C.O.	9.8.42
Carter, G. W.	E.-in-C.O. to H.C. Reg.	29.6.42	Nesbitt, W. R.	N.E. Reg. to E.-in-C.O.	9.8.42

Retirements

Name	Region	Date	Name	Region	Date
<i>Area Engr.</i>			<i>Chief Insp. with allce.</i>		
Skinner, E. J.	L.T. Reg.	17.8.42	Sudell, H.	H.C. Reg.	17.8.42
<i>Drawing Office Supervisor.</i>			<i>Inspr.</i>		
Willmot, A. S.	E.-in-C.O.	10.8.42	Sallnow, C. B.	L.T. Reg.	8.6.42
<i>Asst. Engr.</i>			Deboise, A. S.	L.T. Reg.	16.6.42
Cohen, A. J.	W. & B.C. Reg.	19.5.42	Hooper, W. N.	S.W. Reg.	10.8.42
Hook, A. L.	E.-in-C.O.	1.6.42			

Deaths

Name	Region	Date	Name	Region	Date
<i>Chief Insp.</i>			<i>Inspr.</i>		
Shrubsall, F. W.	E.-in-C.O.	9.6.42	Candish, P.	H.C. Reg.	22.7.42
Halliday, W. G.	H.C. Reg.	30.7.42	<i>Chief Officer.</i>		
			Pratt, R. O.	H.M.C.S.	25.6.42

CLERICAL GRADES

Promotions

Name	Region	Date	Name	Region	Date
<i>From P.C. to Staff Controller.</i>			<i>From S.O. to P.C.—cont.</i>		
Ramsay, J.	E.-in-C.O.	1.7.42	Dunster, H. L.	E.-in-C.O.	1.8.42
<i>From S.O. to P.C.</i>			<i>From E.O. to S.O.</i>		
Baker, A. J.	E.-in-C.O.	1.7.42	*Harrison, J. H.	E.-in-C.O.	1.7.42
*Ford, F. C.	E.-in-C.O.	1.7.42	Hannaford, E. J. G.	E.-in-C.O.	1.7.42

Retirement

Name	Region	Date
<i>Principal Clerk.</i>		
Malkin, J. L.	E.-in-C.O.	30.6.42

* Promoted "in absentia." All promotions "acting."

Book Review

"Wave Guides." By H. R. L. Lamont, M.A., Ph.D.
102 pp. 32 ill. Methuen, 4s.

An electromagnetic wave can be propagated as a free wave in space or as a guided wave. The transmission line wave guided between two conductors is well known to communication engineers. It was known nearly fifty years ago that waves could also be guided in the interior of a single hollow conductor, but the wavelength had to be of the same order of magnitude as the cross-sectional dimensions of the conductor to allow free transmission. For many years the subject remained of only academic interest owing to the difficulty of generating and detecting waves of sufficiently high frequency to be transmitted in reasonably small tubes. The last ten years have seen great developments in the generation of very high radio frequencies. This, together with the increased interest in systems of communication requiring wide frequency bandwidths, such as television, has resulted in an increasing amount of attention being paid to the subject of wave guides, and many papers have appeared in the technical journals. It is believed that the book forming the subject of this review is the first to be published dealing exclusively with the subject of wave guides. It is a valuable and timely summary of the more important theoretical work on the subject published up to the present time.

The writer of a book dealing with this subject must assume that the reader already has some knowledge of electromagnetic theory and the solution of the wave equations. The increasing use of the ultra-high frequencies will call for a wider distribution of such knowledge among communication engineers, who have previously been concerned more with currents in lumped circuits than with wave propagation.

Many different systems of units have been used by workers in electromagnetic theory and wave guides, but the International Electrotechnical Commission meeting at Brussels in June, 1935, adopted the M.K.S. system, and this action became effective in January, 1940. Recent American text-books have used the M.K.S. system, and it seems desirable that writers in this country should now use this system. The book under review, however, uses the Gaussian system.

The book deals with the theoretical aspects of the subject, the experimental side receiving scant attention. The theory of propagation in loss-free rectangular wave guides is first considered using rectangular co-ordinates. A minor criticism might be made of this first chapter in that the expressions derived are for a value of E_z equal to unity at the origin, but this is not stated explicitly.

For the study of wave guides other than of rectangular section the author introduces the use of orthogonal curvilinear co-ordinates. These enable other cross-sections such as circular, elliptical, etc., to be studied in a general manner. As the use of such co-ordinates will not be generally well known, it is unfortunate that somewhat more space could not have been devoted to the explanation of their use. After studying the propagation in loss-free guides the author proceeds to the study of the attenuation due to the conductor and dielectric loss and the stability of the various wave types. The final chapters are devoted to the use of closed wave guides as resonators and to the study of radiation from an open wave guide.

There is a complete and up-to-date bibliography at the end of the book.

R.F.J.J.

BOARD OF EDITORS

A. J. GILL, B.Sc., M.I.E.E., F.I.R.E., Chairman.
F. E. NANCARROW, A.R.C.Sc., M.I.E.E.
P. B. FROST, B.Sc., M.I.E.E.
A. H. MUMFORD, B.Sc.(ENG.), M.I.E.E.
C. W. BROWN, A.M.I.E.E.
G. H. S. COOPER.
H. LEIGH, B.Sc.(ENG.), A.M.I.E.E., Acting Managing Editor.
G. E. STYLES, A.M.I.E.E., Acting Assistant Editor.
A. J. BAKER, Secretary-Treasurer.

Copyright

The entire contents of this JOURNAL are covered by general copyright, and special permission is necessary for reprinting long extracts, but Editors are welcome to use not more than one-third of any article, provided credit is given at the beginning or end thus: "From the *Post Office Electrical Engineers' Journal*."

The Board of Editors is not responsible for the statements made or the opinions expressed in any of the articles in this JOURNAL, unless such statement is made specifically by the Board.

Communications

All Communications should be addressed to the Managing Editor, *P.O.E.E. Journal*, Engineer-in-Chief's Office, Alder House, Aldersgate Street, London, E.C.1. Telephone: HEAdquarters 1234. Remittances should be made payable to "The *P.O.E.E. Journal*" and should be crossed "& Co."

Binding Cases

Cases for binding are available, and may be obtained from the Local Agents for 1s. 9d. Subscribers can have their copies of Volumes bound, at a cost of 3s., by sending the complete set of parts to the Local Agents or to the *P.O.E.E. Journal*, Engineer-in-Chief's Office, Alder House, Aldersgate Street, London, E.C.1. Orders for binding for Vols. 1-19 should indicate whether the original binding case with black lettering, or the later pattern with gold, is required. Cases with gold lettering are the only type stocked from Vol. 20 onwards.

Back Numbers

The price of the JOURNAL, which is published quarterly, is 1s. (1s. 3d. post free) per copy, or 5s. per annum post free. Back numbers can be supplied, subject to availability of stocks, at 1s. each (1s. 3d. post free). Orders for back numbers may be sent to the Local Agents or to the Publishers.

Advertisements

All communications relating to space reservations should be addressed to the Advertisement Editor *P.O.E.E. Journal*, Alder House, Aldersgate Street, London, E.C.1. Communications regarding advertisement copy, proofs, etc., should be addressed to the Publishers, Messrs. Birch & Whittington (Prop. Dorling & Co. [Epsom], Ltd.), 49 Upper High Street, Epsom, Surrey.

NOTE.—The fact that goods made of raw material in short supply owing to war conditions are advertised in this Journal should not be taken as an indication that they are necessarily available for export.

'AVO'

Regd. Trade Mark

46-range Model 7
Universal AvoMeter

40-range Model 40
Universal AvoMeter



Meters that Matter

FROM years of intensive research in the design and manufacture of electrical testing equipment has grown the range of world-famous "AVO" Instruments. To-day, wherever rapid precision testing is demanded, there will be found the meters that matter—"AVO" Meters.

Some delay in delivery of Trade Orders is inevitable, but we shall continue to do our best to fulfil your requirements as promptly as possible.

Sole Proprietors and Manufacturers

THE AUTOMATIC COIL WINDER & ELECTRICAL EQUIPMENT Co. Ltd.
Winder House, Douglas Street, London, S.W.1 Phone: VICtoria 3404-7

FREQUENCY BRIDGE TYPE D - 101 - A

A Bridge for the measurement of audio frequencies—simple to operate—direct reading—outstandingly accurate—reasonably priced.

A complete description of this Bridge is given in Bulletin B-526-A, which will be sent on request.

- ★ Frequency range, 100 c.p.s. to 12,100 c.p.s.
- ★ Direct reading on two decade dials and a third continuously variable dial.
- ★ Measuring accuracy $\pm 0.25\% \pm 1$ c.p.s.
- ★ Reading accuracy—better than 0.05% over the whole range.
- ★ Accuracy unaffected by stray magnetic fields.
- ★ Input impedance 400-1,500 ohms unbalanced.
- ★ Telephones form a suitable detector for most measurements.
- ★ Light and easily portable.

MUIRHEAD & CO. LTD., ELMERS END, BECKENHAM, KENT
TELEPHONE: BECKENHAM 0041-2.

FOR OVER 60 YEARS DESIGNERS AND MAKERS OF PRECISION INSTRUMENTS

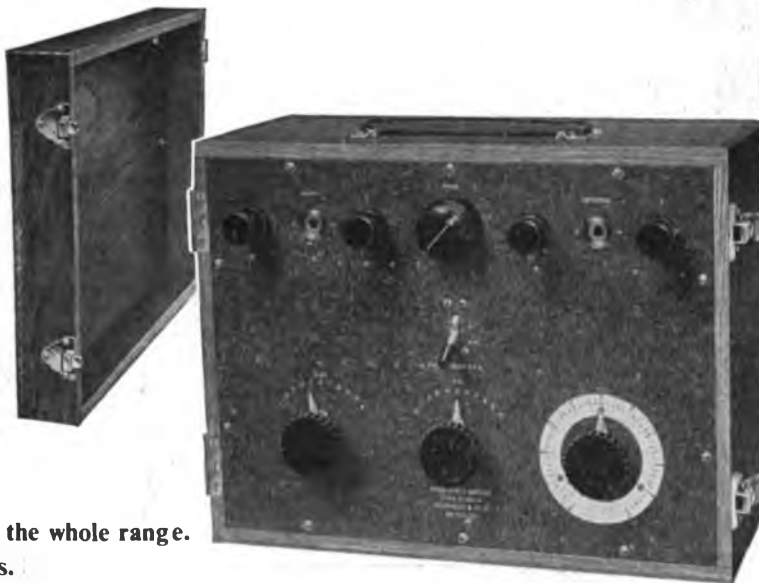

MUIRHEAD

*Clip-on***FOR EASY CURRENT MEASUREMENTS**

in Busbars, Fuses and Cables up to 2½" diam.

- DUAL RANGE WITH SELECTOR SWITCH
- FULLY INSULATED CORE AND HANDLE

FERRANTI
DUAL RANGE
Clip-on **AMMETER**

**QUICK
CHANGE
TO NEW
RANGE**

RANGES

0—10—50 Amps.
0—20—100 Amps.
0—50—250 Amps.
0—100—500 Amps.
0—200—1000 Amps.

P130a

FERRANTI LIMITED, Hollinwood, Lancs.

London Office: Bush House, Aldwych, London, W.C.2

TURNER DIFFERENTIAL MILLIAMMETERS G.P.O. No. 17 & No. 18

Meet the most exacting demands for balancing currents in multiplex telegraph circuits.

— A quality product of outstanding merit —



FULL SIZE

Also manufacturers of G.P.O. Detector No. 4, and a comprehensive line of instruments for precision electrical measurements.

ERNEST TURNER ELECTRICAL INSTRUMENTS, Ltd.

**CHILTERN WORKS,
49-73 TOTTERIDGE AVENUE,
HIGH WYCOMBE,**

BUCKS, ENGLAND

Telephone: High Wycombe 1301, 1302.
Telegrams: Gorgeous. High Wycombe.

Ericsson



MODERN TELEPHONE APPARATUS...

The new automatic telephone No. 1002 has a casework of moulded bakelite. It incorporates a sliding instruction tray and renewable writing pad. Dimensions $5\frac{1}{2} \times 9\frac{1}{4} \times 7$. Weight 6 lbs. Full particulars from makers.

ERICSSON TELEPHONES, LTD., Head Office: 56 Kingsway, London, W.C.2. Phone: HOLborn 6936

Electrical Standards for Research and Industry

Testing and Measuring Apparatus
for Communication Engineering

BRIDGES — Capacitance
Inductance
Resistance

RESISTANCES

INDUCTANCES

CONDENSERS

OSCILLATORS

WAVEMETERS

H. W. SULLIVAN
— LIMITED —

London, S.E.15

ALL TYPES — ALL FREQUENCIES — ALL ACCURACIES

Tel. New Cross 3225 (Private Branch Exchange)

Westinghouse

CONSTANT VOLTAGE RECTIFIERS

The Westinghouse "Westat" constant voltage rectifier for use with batteries, gives complete voltage stabilisation without the use of gas discharge tubes, barretters or D.C. saturated chokes. It is completely automatic in its action and many hundreds, with outputs ranging from 15 watts to 1.2 kW, are already in use.

On the right is shown one of one hundred 1.2 kW equipments, each with an output of 50/54 volts 24 amps. for float-charging a battery. Similar equipments, with an output of 80 + 80 volts 6.75 amps., are in use for power supply to V.F. telegraph systems. Below is one of twenty 50/54 volt 10 amps. equipments used for float charging.

On the left is shown one of one hundred 50/54 volt 5 amps. sets for float-charging signalling batteries. All these "Westat" equipments use the new "Westalite" rectifier.



WESTAT

WESTINGHOUSE BRAKE & SIGNAL CO. LTD.
Pew Hill House, Chippenham, Wilts.



SIEMENS PRODUCTS

MADE IN ENGLAND

Contractors for the manufacture, laying and maintenance of Submarine and Land Cables for Telegraphy and the Electric Transmission of Power, for the erection and maintenance of Overland Telegraph, Telephone and Power Transmission Lines, Public and Private Telephone Exchanges and Carrier Equipment for Telephone Lines.



*Backed by over
80 years experience!*

**ELECTRIC
WIRES & CABLES**

**CABLE
JOINT BOXES**

TELEPHONE CABLES
Aerial, Underground, Submarine

**OVERHEAD
LINE MATERIAL**

CELLS & BATTERIES
Dry, Fluid & Inert

**MARINE
APPARATUS**

**ELECTRIC
LAMPS**

**PRIVATE
TELEPHONE SYSTEMS**

**PUBLIC
TELEPHONE EXCHANGES**

**ELECTRIC
TOTALISATORS**

**MEASURING & RECORDING
INSTRUMENTS**

SIEMENS BROTHERS & CO., LTD

WOOLWICH, LONDON, S. E. 18

ESTABLISHED 1858

Telephone : WOOLWICH 2020

**ELECTRICITY
METERS**

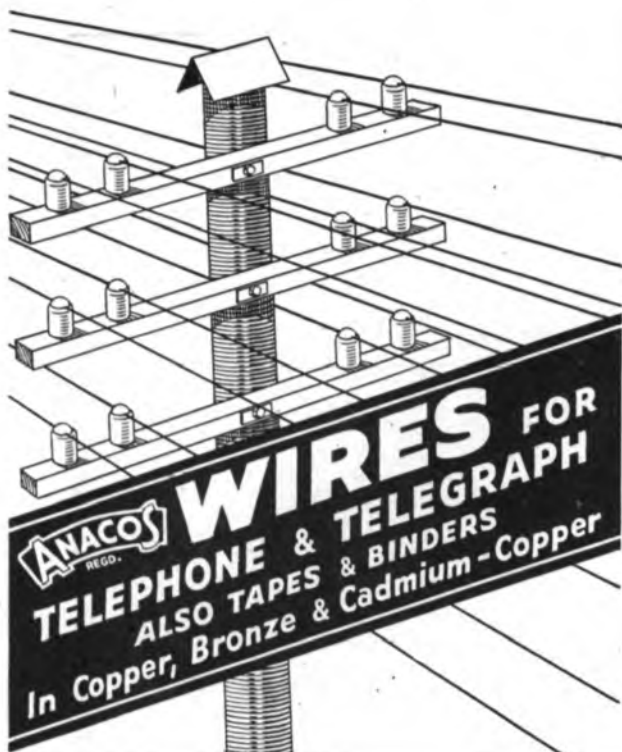

FREDERICK SMITH & CO. LTD. (Incorporated in The London Electric Wire Company and Smiths, Limited.)
ANACONDA WORKS, SALFORD, 3, LANCS.
 Telephone : BLACKFRIARS 8701 (8 lines) Telegrams : "ANACONDA" MANCHESTER

NO WAITING FOR CEMENT TO DRY

if you use

RAWLBOLTS
the speediest method of machine fixing yet devised

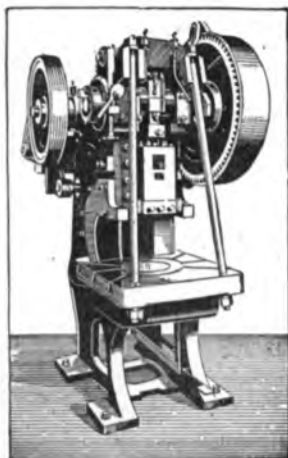

More and more firms are using Rawlbolts for really heavy fixing work. Rawlbolts require no grouting and only a small hole is needed to accommodate them. They can be fixed immediately as there is no waiting for cement to dry. Not only is the Rawlbolt speedy, and therefore very economical, but it is absolutely reliable, too. The two types of Rawlbolts solve every fixing problem with bolts, while the fact that they are available with pipe clips, round and square hooks and eye bolts still further increases their scope and utility. Rawlbolts are sold in stock sizes from $\frac{1}{4}$ " to $\frac{3}{4}$ " diameter.

RAWLBOLTS

Fully illustrated descriptive literature will be supplied on request to:—
 THE RAWLPLUG CO. LTD., CROMWELL ROAD, LONDON, S.W.7

Hall Telephone Accessories (1928) Limited

Suppliers to the British Post Office, Air Ministry, Admiralty, War Office and Foreign Government Departments.

Manufacturers of prepayment telephone multi-coin collectors, gas leak indicators, precision instruments, automatic stamp selling and ticket selling machines, automatic slot machines and fire alarm apparatus.

Registered Office :

70, DUDDEN HILL LANE, WILLESDEN, LONDON, N.W.10

Tel. WILLESDEN 5141/2/3.

Also SOUTH WALES

LONDEX RELAYS



This Relay type LQA is approved by the G.P.O. for use in Telephone Lines

LONDEX BATTERY CUT-OUTS

TYPE L.F.C.

Simple, robust and sensitive. Works in any position. Suitable for ships, vehicles and stationary plants. Heavy silver-to-silver contacts. No mercury



ASK FOR LEAFLETS SPN & 98 PO

LONDEX LTD

Electrical Remote Control Engineers & Manufacturers.

Anerley Wks, 207 Anerley Rd, London S.E.20

Phone: SYDENHAM 6258-9



S.S. "Anglo Saxon," sunk mid-Atlantic, August 21st, 1940.

Seven men left the sinking ship, smashed by a German raider. Most of them were wounded, some gravely. As the mate wrote in the log, they had "British Determination," but their needs were great and their equipment was inadequate—a small boat, little first-aid kit, practically no food and only three gallons of water. Wounds and weather, hunger and thirst claimed five of them. After seventy terrible days—sailing more than 2,000 miles—two were saved. Their adventures live as an epic of the sea.

This announcement is a tribute to the bravery of these and many other gallant souls whose stories of battling against adversity with inadequate equipment will never be told.



The Will alone is not enough—

Need is the measure of the value of equipment . . . The re-organisation which will inevitably have to be undertaken in all countries after the war will be rendered immeasurably more difficult if there is failure to recognise the importance of telecommunications. But the will alone is not enough . . . to enable restoration plans to be promptly co-ordinated. Telephone, Carrier and Radio equipment will have to be brought into service in the shortest possible time. Those State or private concerns which possess Strowger Automatic Telephone equipment will be particularly fortunate, for even though exchanges may have been damaged or denied of parts for military communications, the standardised nature of the apparatus facilitates speedy rehabilitation. This same quality enables the rapid manufacture and installation of new exchanges wherever such may be necessary. For expert advice on every phase of telecommunications, consult



Automatic Telephone & Electric Co. Ltd.

L O N D O N & L I V E R P O O L

Manufacturers of · Strowger Automatic Telephone Equipment · Carrier Current and Transmission Equipment · Street Traffic Signals · Street Fire Alarm Apparatus · Supervisory Remote Control Equipment for Power Networks · Mine Telephones and Signalling Apparatus, etc.



*manufacturers
of High Grade
telephone
communication
equipment...*

G.E.C.

TELEPHONE • WORKS
THE GENERAL ELECTRIC CO., LTD.,
Head Office • MAGNET HOUSE • KINGSWAY • LONDON • W.C.2.

**SILVERED CERAMIC
FIXED CONDENSERS**

PEARL TYPE
0.5 pF to 5 pF.

Max. Dimensions 7 x 9 mm.

Test Voltage 1500V. D.C.

Loss Factor -20×10^{-4}

Mechanical and electrical stability
whatever the climatic conditions
Type approved

MULTUM IN PARVO



UNITED INSULATOR CO. LTD.

12-20 LAYSTALL STREET, LONDON, E.C.1.

Phone: TERMINUS 7383

Grams: CALANET, SMITH, LONDON.

*The Pioneers
of Low-Loss
Ceramics*

★
**TELEGRAPH APPARATUS
MORSE SYSTEMS**

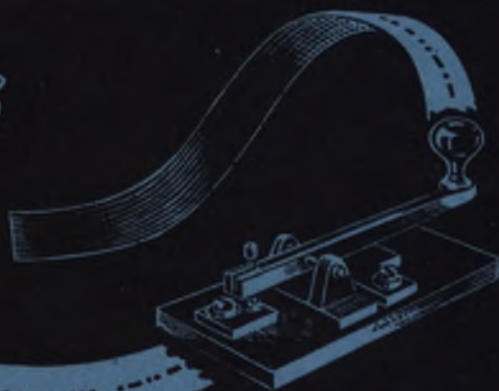

Makers of:

GALVANOSCOPES · INKERS
RESISTANCES · RELAYS
SOUNDERS · DETECTORS
KEYS · MILLIAMMETERS
AUTOMATIC RECEIVERS
& TRANSMITTERS ETC

Write for illustrated catalogue

ELLIOTT BROTHERS (LONDON) LTD. CENTURY WORKS,
LEWISHAM, S.E.13

MAINTAINING EFFICIENCY

THE HIGH STANDARD OF EFFICIENCY
OF PIRELLI - GENERAL TELEPHONE
CABLES IS MAINTAINED BY THE
CONTINUOUS RESEARCH WORK OF
AN EXPERIENCED TECHNICAL STAFF.

TELEPHONE
SOUTHAMPTON
2141 (5 Lines)

PIRELLI-GENERAL
CABLE WORKS, Ltd., SOUTHAMPTON.

TELEGRAMS
"PIRELLI-GENERAL"
SOUTHAMPTON.

Sorry U.S.A.—but

**ERSIN
MULTICORE**

THE SOLDER WIRE WITH 3 CORES
OF NON-CORROSIVE ERSIN FLUX



will not be with you again until after Victory

It sounds like "coals to Newcastle"—but U.S.A., the home of cored solder, found it worth while to import British made Ersin Multicore—the A.I.D. approved solder wire with three cores of non-corrosive Ersin flux, although Ersin Multicore, after paying freight and duty, cost American manufacturers fifty per cent. more than American made solders. Why? With the correct, rapid soldering technique, H.R. or "dry" joints are impossible with Ersin Multicore, and production is speeded up. Present conditions do not permit the export of Multicore to U.S.A., but after Victory U.S.A. manufacturers will, once again, be able to use "the finest cored solder in the world."

MULTICORE SOLDERS LIMITED, BUSH HOUSE, W.C.2. Phone Temp. Bar 5583/4