

THE POST OFFICE ELECTRICAL ENGINEERS' JOURNAL

VOL. 30

JANUARY, 1938

PART 4

CONTENTS

	PAGE
THE MECHANICAL IMPULSE REGENERATOR—A. G. Edwards and J. A. Lawrence	261
THE LONDON-BIRMINGHAM COAXIAL CABLE SYSTEM. Part II.—Description of the Repeaters and Terminal Equipment—A. H. Mumford, B.Sc. (Eng.), A.M.I.E.E.	270
THE LONDON FIRE BRIGADE ALARM SYSTEM—C. H. Wright, A.M.I.E.E.	284
DIAKON: A NEW MATERIAL FOR COLOURED TELEPHONES—C. A. R. Pearce, M.Sc. (Eng.), D.I.C.	292
THE STABILITY AND PERFORMANCE OF THE SINGLE "RECTIFIED-REACTION" STAGE—F. C. Williams, M.Sc., D.Phil., Grad. I.E.E., and Alan Fairweather, M.Sc., Grad. I.E.E.	294
CENTRALISED "ENG" SERVICE, TESTING AND MAINTENANCE CONTROL AT BIRMINGHAM—A. L. Barton	304
READY-RECKONER FOR LOSSES DUE TO MISMATCH—C. E. Palmer Jones	308
NOMENCLATURE AND SYMBOLS FOR TELECOMMUNICATIONS—G. F. O'Dell, B.Sc., M.I.E.E.	310
SIR GEORGE LEE, O.B.E., M.C., B.Sc., M.I.E.E.	312
MICRO WAVE DEMONSTRATION EQUIPMENT—N. Bourdeauz and E. F. S. Clarke	313
THE PROBLEMS ASSOCIATED WITH IMPULSING IN NON-DIRECTOR AREAS—H. Williams A.C.G.I., A.M.I.E.E. and S. Rudeforth	320
GERRARD, OLD AND NEW—A. Miller, A.M.I.E.E.	328
NOTES AND COMMENTS	330
THE INSTITUTION OF POST OFFICE ELECTRICAL ENGINEERS	331
JUNIOR SECTION NOTES	331
LOCAL CENTRE NOTES	333
BOOK REVIEW	334
DISTRICT NOTES	335
STAFF CHANGES	338
INDEX TO VOLUME 30	343

Price 1/6 net

THE INSTITUTION OF POST OFFICE ELECTRICAL ENGINEERS



G.E.C.

MINIATURE

VALVE VOLTMETER

WITH SELF CONTAINED BATTERY

Measures from 0.5 to 100 volts

High Impedance. Light Weight.

A simple and inexpensive valve voltmeter which is operated from a torch battery. Very compact, overall size being $6\frac{1}{2}'' \times 5'' \times 4\frac{1}{2}''$.

No external supply leads are needed as the battery is self-contained.

The meter measures a value approximating to the peak voltage and the scale is calibrated in R.M.S. volts for sinusoidal wave-form.

High Impedance. Measures from 0.5 v. to 100 v. at frequencies from 30 cps. to 10 Mc/s per second.

Made at the SALFORD ELECTRICAL INSTRUMENT WORKS of

THE GENERAL ELECTRIC CO., LTD.

Head Office : MAGNET HOUSE, KINGSWAY, LONDON, W.C.2

Branches throughout Great Britain and in all the principal markets of the World

Write to Salford Electrical Instruments Ltd., Silk Street, Salford for illustrated descriptive leaflet No. S.25.

For situations demanding high mechanical strength, "SILUMINITE" asbestos electrical insulators are ideal. They can be relied upon to withstand the most arduous conditions and give years of trouble-free service. Write for full information & details of searching tests carried out



"Siluminite"

Asbestos Electrical
INSULATING MOULDINGS

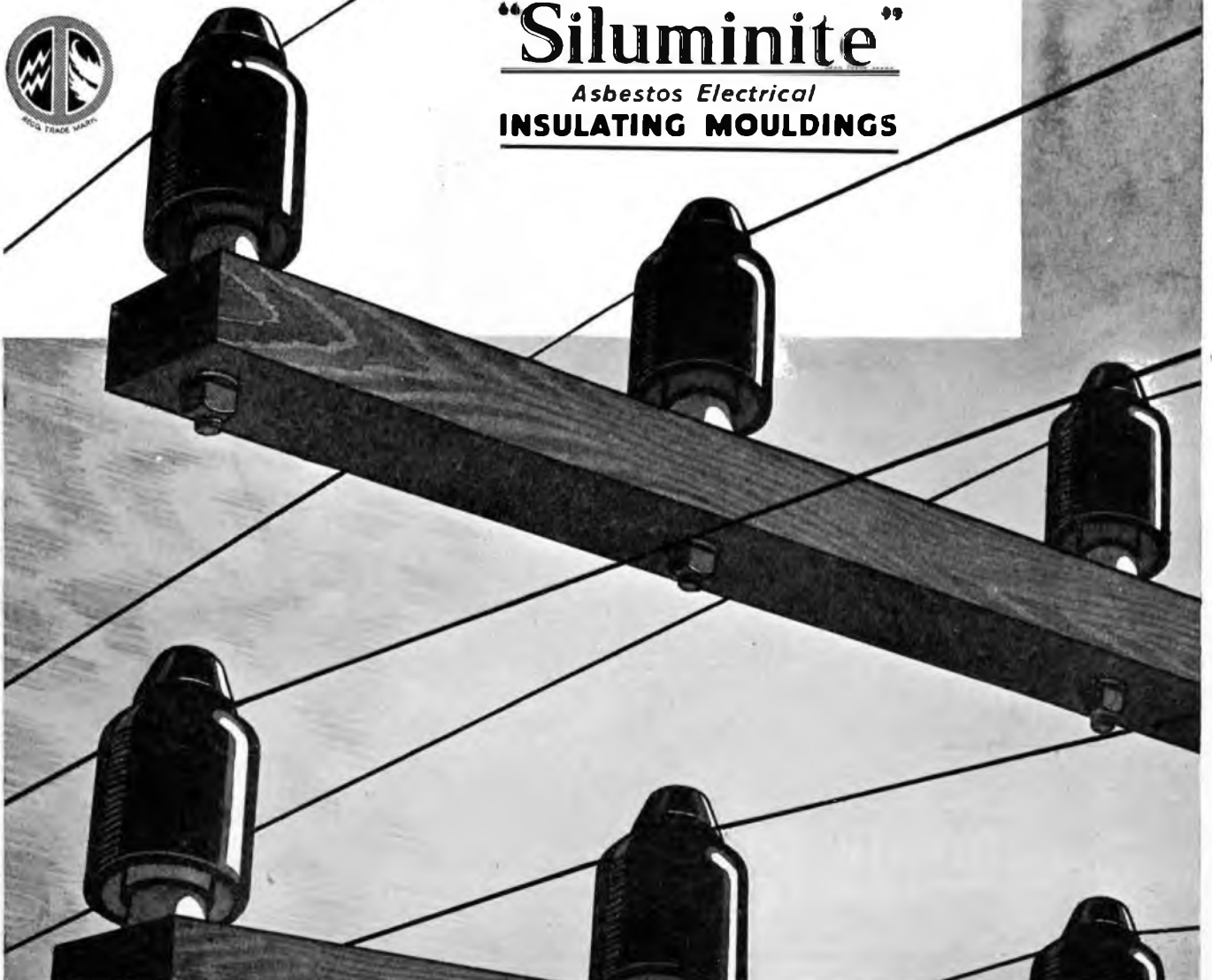



AUTOMATIC TELEPHONE & ELECTRIC Co. Ltd.

MELBOURNE HOUSE, ALDWYCH, LONDON, W.C.2
STROWGER WORKS, LIVERPOOL, 7

Export Sales Office : NORFOLK HOUSE, NORFOLK STREET, LONDON, W.C.2

INTERNATIONAL AGREEMENT STROWGER AUTOMATIC TELEPHONY

★ *The World's Standard*

Three out of every four of the automatic telephones in use throughout the world are Strowger, and there are many millions of them, providing the highest possible standard of service in the diverse and frequently exacting climatic conditions of some seventy different countries. Many of the State or other Administrations responsible for telephone communications in these countries have demonstrated their confidence in the Strowger system by standardising it for all future use.

This universal appreciation of the merits of Strowger automatic telephone equipment has been achieved only with the passing of time; each great communication network, each new exchange supplied to one administration has, from the moment of commencing operation, served as an example to the executives and engineers of other administrations, demonstrating to them that the highest grade of service, ease of extension, and economy in operation are all synonymous with the name "Strowger."



SIEM

Contractors

MANUFACTURE &

of all types

CARRIER

AND

EQUIPMENT

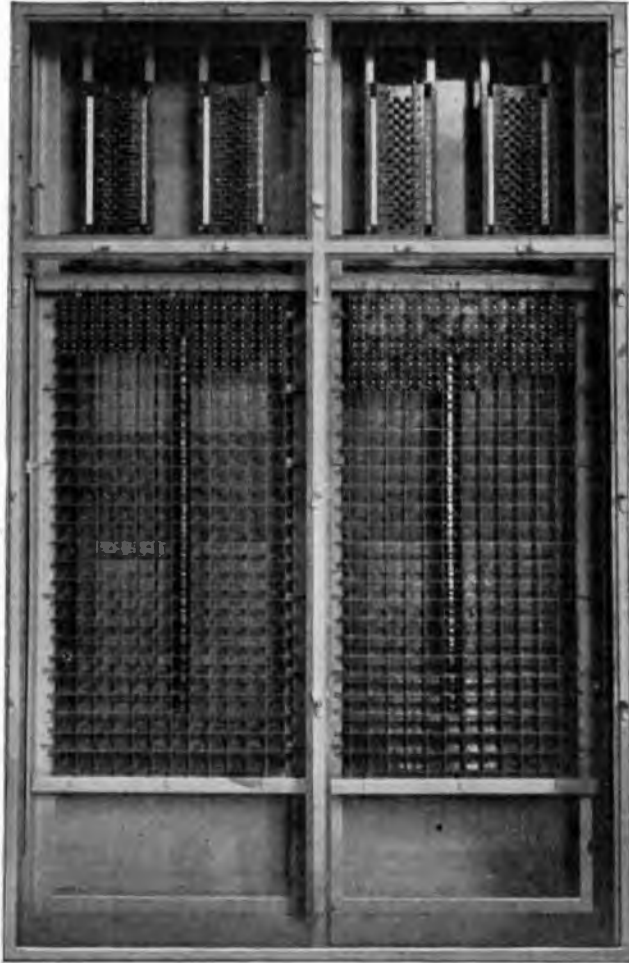

Balancing Network ; cover removed.



SIEMENS BROTHERS

WOOLWICH, LONDON

Established 1858.



MENS

Directors for the
DESIGN & INSTALLATION

of all types of
CARRIER CABLES
AND
EQUIPMENT

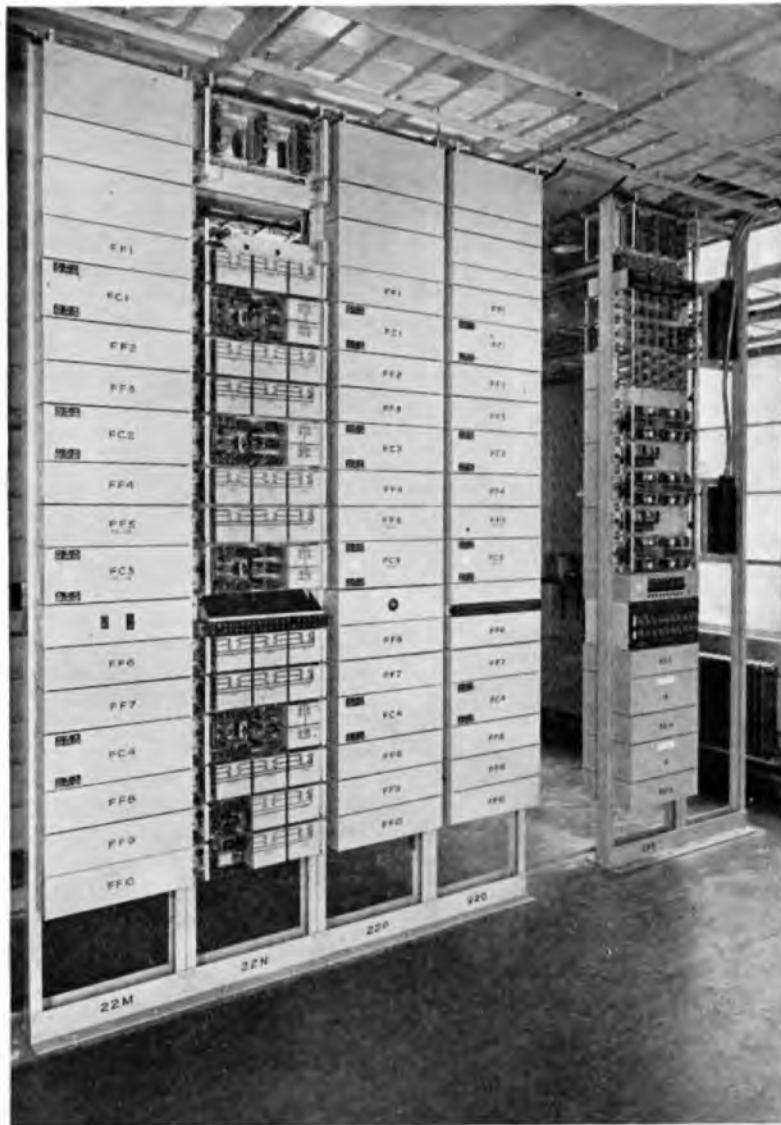

Carrier Equipment.

RS & CO., LIMITED,
LONDON, S.E.18.

Telephone: Woolwich 2020.



G.E.C. TELEPHONES



Robust cradle with strong forks giving marked freedom from breakages.



Positive-action cradle-switch with large insulation area offering extremely high resistance to leakage currents.



Induction coil giving maximum suppression of sidetone and incorporating non-inductive winding for effective spark-quenching at impulse-springs.



Inset transmitter having uniform response over a wide range of frequencies ; independent of position of handset when in use, and unaffected by climatic conditions.



B.P.O. standard dial, incorporating robust impulsing mechanism. Stainless steel finger-plate having lasting finish under all climatic conditions.



Cords capable of withstanding 200,000 reciprocations without fracture of conductors. Heavy rubber insulation renders the cord impervious to moisture, whilst additional mechanical protection is afforded by overall braiding. Ends free from textile covering to prevent current leakage through moisture absorption.



Special terminal strip for tropical use, providing separate channels for line wires and cord conductors. Moulded separators prevent surface leakage between terminals.



Sound outlet holes protected by fine wire-gauze to prevent ingress of insects and foreign matter.



“When better telephones can be made
G.E.C. will make them”

THE GENERAL ELECTRIC COMPANY LIMITED
TELEPHONE WORKS **COVENTRY**
 COVENTRY 4111 (10 LINES) **ENGLAND** “SPRINGJACK,” COVENTRY

Head Office : Magnet House, Kingsway, London, W.C.2

Temple Bar 8000 (75 lines)

“Electricity, Westcent,” London.

“Polyphase,” London (cables)

Branches and Agencies throughout the World

YOU HAVE BEEN WARNED BY RADIO

Professor Hilton on November 19th, 1936, from the B.B.C. broadcast a warning. The warning was to the effect that while there are many really good and reliable Colleges teaching by correspondence, there are many others which are colleges by name only. He said some so-called colleges rented a couple of rooms in a large building in a well-known street. Some made great promises which they did not intend to fulfil. Some claimed successes they could not prove. In some cases the names of prominent men were quoted who were in no way connected with the working of the College.

NOW BE ADVISED BY ME

The big name of a College is no proof of its national standing. The Bennett College has been established over 30 years and our entire building is devoted to Bennett College work. No other business of any kind is either on or attached to The Bennett College. We have seating accommodation for over 10,000. We have a permanent staff of over 180 people on the College premises. Our Professional Staff have all passed their examinations, and our tutors are all experts in their own specialised work. We do not send out any homework to be corrected by tired, spare-time tutors. All students' homework is corrected on the College premises the same day that it arrives, and is returned by evening post. This College is Technical, Scientific, General and Commercial, thus enabling us to cater for all requirements: this is important to Cost and Works Accountants, and all who have to deal with rate-fixing, machining-allowance, and it is also of great importance in many of the Civil Service Examinations. This is an entirely British College. Most of our textbooks are written on the College premises by our professional staff, especially for tutorial purposes. Our tutors specialise in teaching students for the examinations they themselves have already passed.

THERE IS NO OTHER COLLEGE IN THIS KINGDOM THAT CAN CLAIM ALL THE ABOVE ADVANTAGES

It is not necessary for students to attend the College: we can send exactly the same tuition to you by post for a reasonable fee payable monthly. Anyone who reads the journals knows that there are many things advertised that one can study, and any kind of study is good. It is training for the

brain, but the best thing to study, is a course specially prepared to teach your own vocation, or prepare you for the examinations which you have in view. Knowing that you are master of your job gives you self-confidence and personalty, but a Diploma from a College is absolute proof of your efficiency. We have agencies in all English-speaking corners of the world. The nature of our business makes us keep in touch with employment requirements in all parts of the world, therefore we specialise in preparing students for the good positions which we know exist, and for all worth-while examinations.

THE ABOVE VAST ORGANISATION CAN HAVE BEEN CREATED ONLY BY THE SUCCESS OF OUR STUDENTS

There is a tide in the affairs of man which, if taken at the flood, leads on to fortune and success. There are three things which come not back: the sped arrow, the spoken word and the lost opportunity—this is your opportunity. If it is your desire to make progress and establish yourself in a good career, write to us for free particulars on any subject which interests you, or if your career is not decided, write and tell us of your likes and dislikes, and we will give you practical advice as to the possibilities of a vocation and how to succeed in it. You will be under no obligation whatever. It is our pleasure to help. We never take students for courses unless we feel satisfied they are suitable. Do not forget that success is not the prerogative of the brilliant. Our experience of over 30 years proves that the will to succeed achieves more than outstanding brilliancy.

LET ME BE YOUR FATHER

Let me tell you how to make a success of your career. If your future is undecided or appears unsatisfactory, let us talk it over together. I want to help, and it will cost you nothing to get my help; you will be under no obligation whatever.



J. Bennett

We are prepared to produce, on demand, over 10,000 unsolicited testimonials from successful students, or in default we will hand over £100 to charity.



CAN YOU CHANGE MY EXPRESSION?

IF SO, YOU MAY BE THE ARTIST THAT COMMERCE IS WAITING FOR

Just try for yourself, trace or draw the outline and then put in the features.

There are hundreds of openings in connection with Humorous Papers, Advertisement Drawing, Posters, Calendars, Catalogues, Textile Designs, Book Illustrations, etc., etc. 60% of Commercial Work Art is done by "Free Lance Artists" who do their work at home and sell it to the highest bidders. Many Commercial Artists draw retaining fees from various sources; others prefer to work full-time employment or partnership arrangement. We teach you not only how to draw what is wanted, but how to make buyers want what you draw. Many of our students who originally took up Commercial Art as a hobby have since turned it into a full-time paying profession with studio and staff of assistant artists—there is no limit to the possibilities.

Let us send full particulars for a FREE TRIAL and details of our course for your inspection. You will be under no obligation whatever.

John Durr

Art Dept. 24.

YOUNG MEN

Young men physically fit and whose careers are not definitely fixed should join the Police Force. We have special Courses for Entrance and Promotion. Full Particulars Free.

Address
POLICE DEPT. 24.

ENGINEERS

Engineers, now is your chance to dig yourselves into a Key position and make your future solid. It needs Technical Training: we can give you that by post. Full particulars free, Dept. 24.

DO ANY OF THESE SUBJECTS INTEREST YOU?

Accountancy Examinations
Advertising and Sales Management
A.M.I. Fire E. Exam.
Applied Mechanics
Army Certificates
Auctioneers and Estate Agents
Aviation Engineering
Banking. Boilers
Book-keeping, Accountancy and Modern Business Methods
B.Sc. (Eng.)
E.Sc. (Estate Management)
Building, Architecture and Clerk of Works
Cambridge Senior School Certificate Engineering. Civil Service
All Commercial Subjects
Commercial Art
Concrete and Structural Engineering
Draughtsmanship. All branches
Engineering. All branches, subjects and examinations
General Education.
G.P.O. Eng. Dept.
Heating and Ventilating
Industrial Chemistry
Insurance. Mathematics

Matriculation. Metallurgy
Mining, all subjects
Mining, Electrical Engineering
Motor Engineering
Motor Trade
Municipal and County Engineers
Naval Architecture, Pattern Making
Police, Special Course
Preceptors, College of Pumps and Pumping Machinery
Radio Service Engineering
Road Making and Maintenance
Salesmanship, I.S.M.A.
Sanitation
Secretarial Exams.
Sheet Metal Work
Shorthand (Pitman's)
Shipbuilding
Structural Engineering
Surveying
Teachers of Handicrafts
Telephony and Telegraphy
Transport Inst. Exams.
Weights and Measures Inspector
Welding
Wireless Telegraphy and Tele-works Managers

If you do not see your own requirements above, write to us on any subject. Full particulars free.

A FEW POINTS OF INTEREST

CIVIL SERVICE

Thousands of pensionable appointments are made every year; ages 15-24. We guarantee success and our fees are from £4 4s. No extra charge for monthly payments.

MATRICULATION

There are many ways of commencing a career, but Matriculation is the jumping-off board for all the best ones.

TECHNICAL SUBJECTS AND EXAMS.

The size of our staff is sufficient guarantee of our efficiency.

PROFESSIONAL & GENERAL EXAMS.

Seeing that we guarantee success we must be efficient. Our thousands of successes proves that WE ARE.

Why Not Investigate For Yourself?

HOW TO STUDY

In your spare time when it suits YOU. You fix your own time, you do not GO to your studies—the postman brings THEM TO YOU. There is nothing that a class-room teacher can show on a blackboard that we cannot show on a white paper. The lesson on a blackboard will be cleaned off, but our lessons are PERMANENT. A class-room teacher cannot give you a private word of encouragement, but a Correspondence Tutor can do so whenever your work deserves it. On the other hand, he can, where necessary, point out your mistakes PRIVATELY.

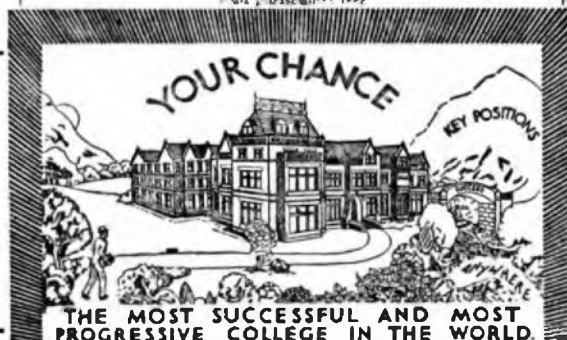

THE MOST SUCCESSFUL AND MOST PROGRESSIVE COLLEGE IN THE WORLD.

NOTE ADDRESS: DEPT. 24 BENNETT COLLEGE, SHEFFIELD

LEVEL & LOSS MEASUREMENTS



INCLUDED in our range of testing apparatus are two portable Transmission Measuring Sets designed primarily for general purpose measurements of levels and losses within their respective ranges. The models available are :

	74105 A	74105 B
LEVELS	-15 db. to +20 db.	-10 db. to +20 db.
LOSSES (600 Ω)	15 db.	10 db.
FREQUENCY RANGE	50~ to 5,000~	50~ to 60,000~
ACCURACY	± 0.5 db.	± 1 db. (± 0.5 db. 50~ to 10,000~)
SIZE	6" \times 6" \times 5"	5 $\frac{1}{2}$ " \times 3 $\frac{3}{4}$ " \times 3 $\frac{3}{8}$ "
WEIGHT	9 lb.	2 lb.

The 74105A TRANSMISSION MEASURING SET has a high degree of stability with temperature change.

Standard Telephones and Cables Limited

NORTH WOOLWICH

LONDON, E.16

TELEPHONE : ALBERT DOCK 1401

BRANCHES AND REPRESENTATIVES THROUGHOUT THE WORLD

THE POST OFFICE ELECTRICAL ENGINEERS' JOURNAL

Vol. XXX

January, 1938

Part 4

The Mechanical Impulse Regenerator

A. G. EDWARDS and
J. A. LAWRENCE.

The first part of this article describes the mechanical details of a mechanism designed to receive trains of impulses in an automatic telephone network and re-transmit them at the correct speed and with the correct "make to break" ratio, thus eliminating the effects of impulse distortion. In the second part the application of the regenerator in a typical circuit is described.

Introduction

ONE of the main problems which has engaged the attention of telephone engineers since the introduction of automatic exchanges is that of impulse distortion. To give a subscriber in a multi-office area access to other exchanges in the area, provision must be made for the repetition of impulses from one exchange to another in the area. This is usually done by an impulsing relay in an outgoing auto-auto relay set associated with the junction between the two exchanges. Owing, however, to the varying performance of the impulsing relay under differing line conditions and battery voltage variations, impulse distortion is inevitable at each point of repetition, and since automatic equipment will not respond satisfactorily to impulses distorted beyond certain limits, the number and type of junctions in tandem over which impulsing may take place is restricted.

After extensive research into impulsing problems, a basis for performance of impulsing relays was agreed between the Post Office and Contractors on the introduction of 3000 type relays as follows:—

Dial Speed Variation 7-12 i.p.s. in non-director areas.

Dial Break Period : 63-72 per cent. of the impulse.

Subscribers' Line Insulation Resistance : A minimum of 50,000 ohms leg to leg.

Multi-Office Junction Insulation Resistance : A minimum of 250,000 ohms leg to leg.

Number of Junctions in Tandem : A maximum of 3.

Voltage Variation : 46-52 volts on the automatic equipment.

Subscribers' Line Resistance : According to the type of the transmission feeding bridge, 0-500 ohms without ballast, 0-600 ohms with ballast.

Subscriber's Instrument : An ordinary Plan 7 or equivalent, e.g., P.B.X. termination.

Auto-Auto Relay Sets and Selectors : Impulsing relays not to be specially adjusted to meet junction conditions.

As a result of investigations with relays designed on this basis, the best limits which could be established are as shown in the following table:—

No. of Jcns.	Junction Line Res. Limit (ohms)			
	●overall		Any individual junction in the chain.	
	DIR.	NON-DIR.	DIR.	NON-DIR.
1	1500	1500	1500	1500
2	1600	1600	800	800
3	1500	1000	800	700

The present maximum number of junctions over which a call may be completed automatically is, therefore, three, and it will be evident that with the progress of automatisations this restriction would seriously handicap area design, and might prevent full economic use of line plant.

Various methods have from time to time been devised with the object of improving impulsing limits by eliminating or correcting impulse distortion, but have been rejected either on the score of cost or because of maintenance difficulties.

One method of impulse correction which may be mentioned consists of a system of condensers and resistances whereby the outgoing impulses are controlled by the time of the discharge of a condenser through a relay, and are practically independent of the incoming impulse ratios, which may vary between wide limits. Where the incoming impulsing speed remains constant, satisfactory correction of ratios by this method is obtained, but for the relatively wide range of impulsing speeds met with in practice the response would not be satisfactory.

A solution to the problem appeared to be a device which regenerated the impulses at standard speed and ratio with a controlled inter-train pause period, and development proceeded on these lines. A circuit was designed by the Post Office which received and stored the incoming impulses on a group of uniselectors and by means of a controlling element similar to that of the Director, arranged to send out similar trains of

impulses as received, but of standard speed and ratio from an impulse machine. Although satisfactory in operation, the scheme was comparatively expensive for general application, and its development was suspended pending investigation of a mechanical regenerator submitted by Messrs. Automatic Telephone and Electric Company.

As a result of exhaustive tests made to date, both in the field and in the laboratory, and after a number of modifications had been made at the request of the Post Office the mechanical regenerator appears to be an economic and satisfactory solution to the problem of D.C. impulse repetition.

MECHANICAL DETAILS

During the preliminary discussions which took place between the Contractors and the

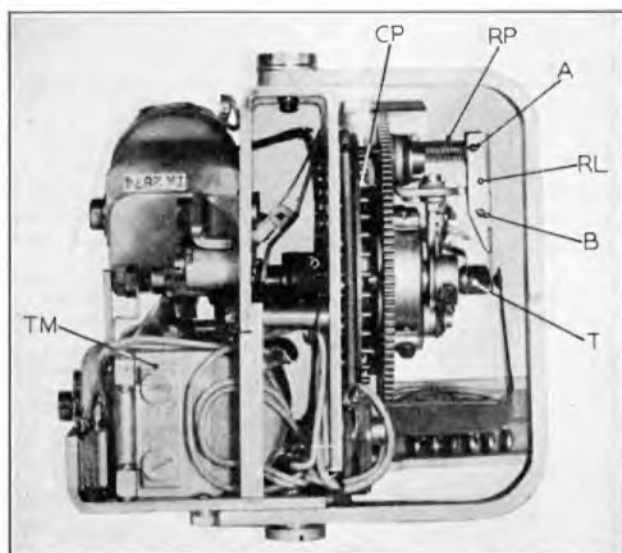

FIG. 1.—FRONT VIEW.

Post Office, it was agreed that it would be desirable to develop one model which should be universal in application, and further, in order to facilitate maintenance, that the mechanism should take the form of an independent "jacked in" unit (Fig. 1). Variations in the method of mounting are catered for by different types of mounting bracket which carry a 12-point 2000 type switch jack. There are at present only two types of mounting bracket under consideration, one for a relay set mounting plate and one for an apparatus rack mounting plate. The cover used with either type of mounting will enclose both relays and mechanism.

Design

The extraordinarily compact design of the mechanism is well illustrated in Figs. 2 and 3, and the appearance of complexity is largely due to this feature. Actually the assembly and adjustment of the unit is, if

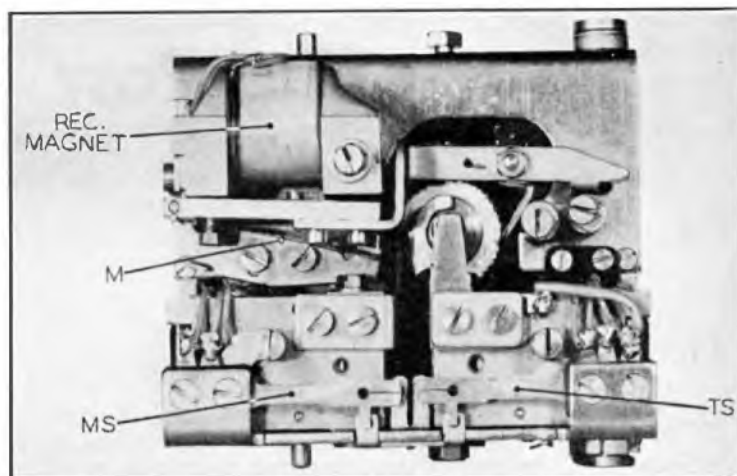

FIG. 2.—RECEIVING AND MARKING ELEMENT.

anything, less complicated than that of the 2000 type selector, the only tools required for such work, apart from those needed for spring adjustments, being two screwdrivers and three spanners.

Except for the magnet cores the entire construction is built up either from sheet metal pressings or from parts machined from the solid. The main frame is a fine example of the type of construction employed and is a pressing from $\frac{3}{32}$ " brass sheet forming a particularly light and rigid foundation for the assembly. The magnet cores are typical 2000 type selector magnets with slightly modified hinge pieces.

The switchplug (SP) can be seen clearly in Fig. 3 together with the handle provided to facilitate jacking movements and subsequent handling. Fig. 4 shows a typical relay set incorporating a regenerator.

In describing the mechanism in detail it is convenient to deal with (1) the receiving and marking element, and (2) the transmitting element; as the two elements can function out-of-phase with and independently of each other.

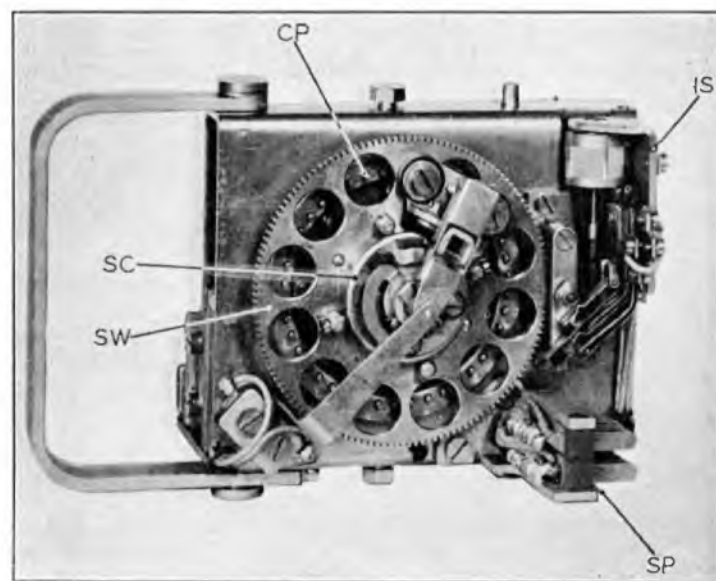

FIG. 3.—TRANSMITTING ELEMENT.

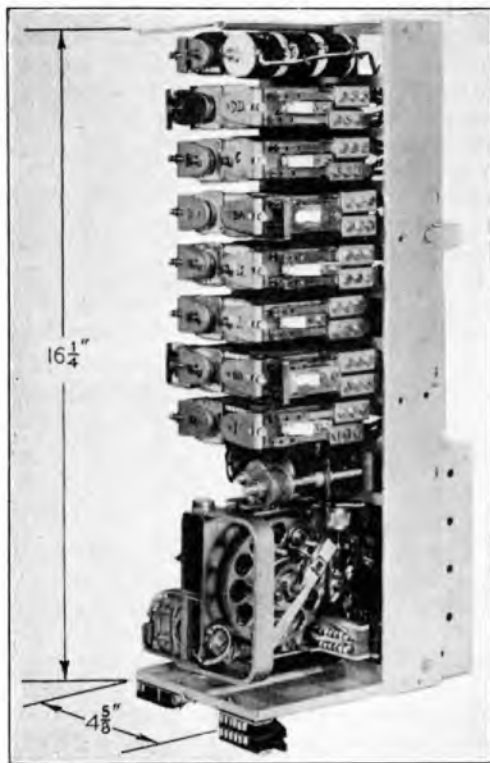

FIG. 4.—TYPICAL RELAY SET WITH A REGENERATOR.

Receiving and Marking Element.

The receiving and marking element is arranged to count the number of impulses in each received train, and to mark off the termination of the train on one of a group of 42 code pins. These pins (CP) are located in a guide ring concentric with the main shaft (see Figs. 1 and 3), and during the marking operation which occurs at the end of each impulse train received, the selected pin is given a sliding motion parallel to the main shaft. The termination of a train is thus

denoted by a code pin which is out of alignment

The pins although free to move as indicated must not be loose since the accuracy and stability of the setting of the pins is of the utmost importance under service conditions. This requirement has been satisfied in a particularly simple and efficient manner (See Fig. 5). Between each alternate pair of code pins a short cylindrical nickel silver roller has been placed,

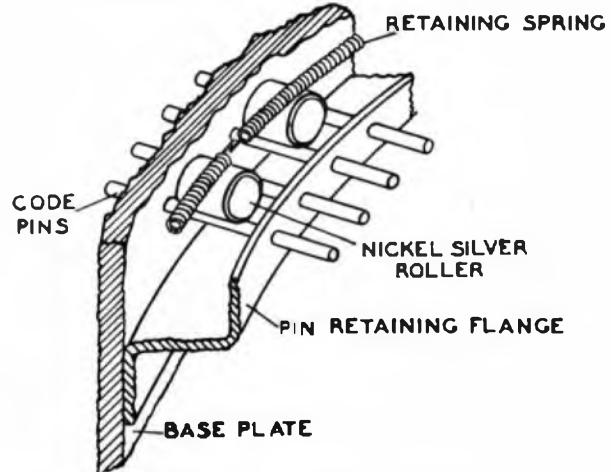

FIG. 5.—METHOD OF RETAINING CODE PINS

the dimensions of the roller being sufficient to prevent it passing through the space between two pins. An endless helical coiled spring is arranged to enclose the rollers, and to hold them in contact with the pins. The spring, which is under tension, applies a sufficient pressure to every pin to prevent any motion, unless an axial load exceeding 60 grams is applied to the pin. The joint in the spring is arranged to coincide with the space between two rollers, so that the usual pressure variation occurring at this point with such arrangements, is completely eliminated. This system also possess additional advantages in that overshooting of pins is avoided, and wear in the pin guide holes is taken up automatically.

The method of counting the received impulses and marking the termination of each impulse train is illustrated in Fig. 6 (a) and (b).

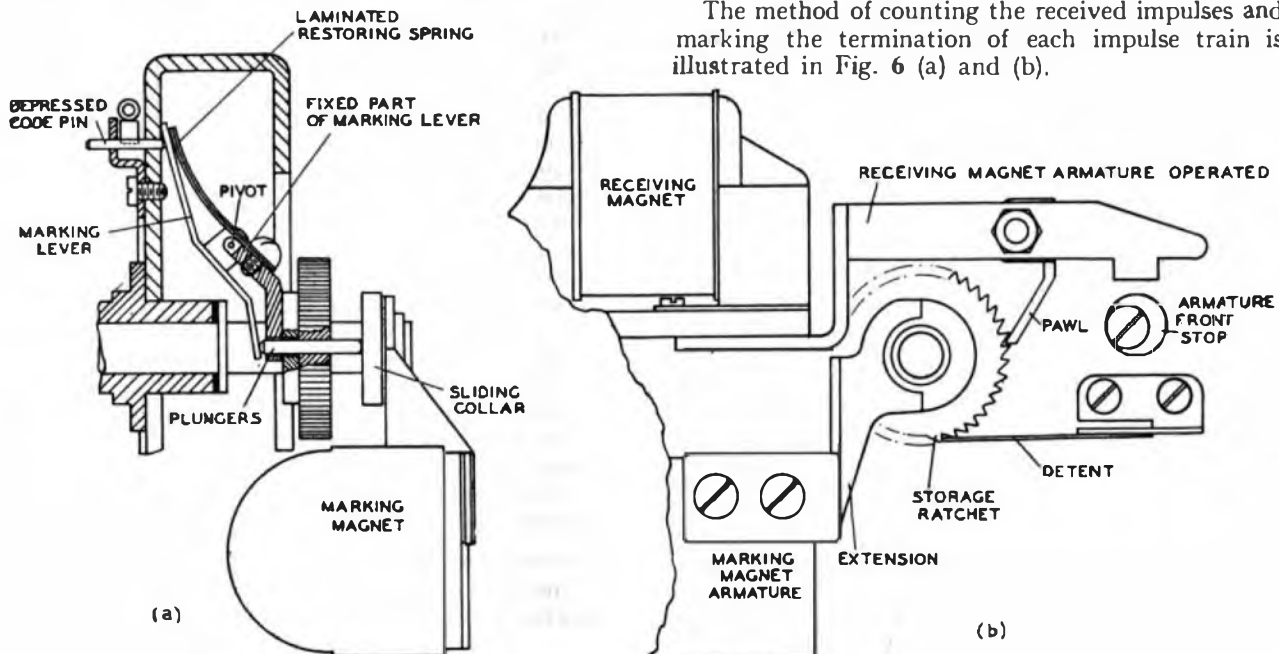

FIG. 6.—GENERAL ARRANGEMENT OF RECEIVING AND MARKING ELEMENT.

Impulse counting is a function of the receiving magnet assembly Fig. 6 (b). The receiving magnet is energised during the break period of each impulse and when released, the armature, which carries a pawl rotates the storage ratchet wheel by one tooth, the action being similar to that employed on the P.O. Standard Uniselect. The armature restoring spring M is shown in Fig. 2.

The marking of the termination of an impulse train occurs almost immediately after the last impulse has been registered and is a function of the marking lever assembly, Fig. 7. The marking lever assembly consists of two parts, one of which is secured to the

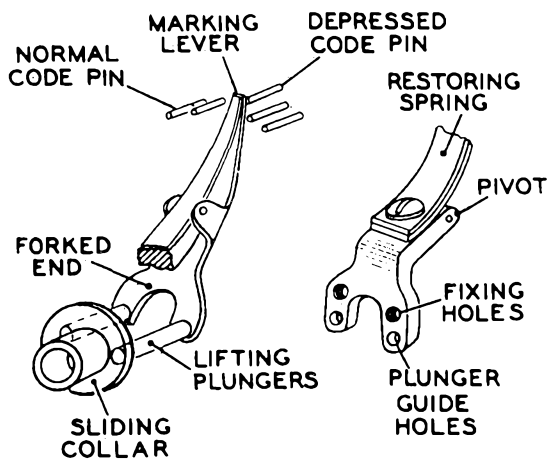

FIG. 7.—MARKING LEVER ASSEMBLY.

ratchet wheel so that both the wheel and marking lever rotate together. The outer end of the marking lever moves over the circle of code pins. It will be seen from Fig. 7 that the part secured to the ratchet wheel carries a pivot bearing, the lever proper being pivoted on this bearing so that when the lower forked end is depressed the upper end is lifted clear of the code pins.

When the marking lever is unoperated, it is adjusted so that the code pin over which it is resting is depressed nearly flush with the base plate. The depressed code pin projects on the opposite side of the plate sufficiently to allow it to engage with a stop mounted on the large gear wheel, shown in Fig. 3.

Before the marking lever can be rotated as indicated above, the outer end of the lever must be lifted clear of any code pins which have not been depressed. This operation is controlled by the marking magnet which when energised transmits the necessary motion to the lower forked end of the marking lever through the forked armature extension piece, sliding collar and plungers as shown in Figs. 6 and 7. The plungers slide in guide holes passing through the ratchet wheel, each plunger bearing on one side of the lower forked end of the marking lever. The collar permits the marking armature extension piece to transmit the necessary motion to the plungers irrespective of their angular position.

Each impulse received, by rotating the storage ratchet wheel through one tooth space, moves the marking lever from a position centrally over one code pin to a similar position over the next so that the

interval between two such pins corresponds to one impulse. The marking lever is released after the termination of each train of impulses registered, the lever in returning to its unoperated position depressing the code pin over which it has been positioned by the rotation of the storage ratchet wheel.

The depression of a code pin thus indicates the termination of an impulse train, the number of normal code pins between two successively depressed pins being equal to one less than the number of impulses stored. This is made clear in Fig. 8.

The registration of successive trains is progressive the interval between successively depressed code pins

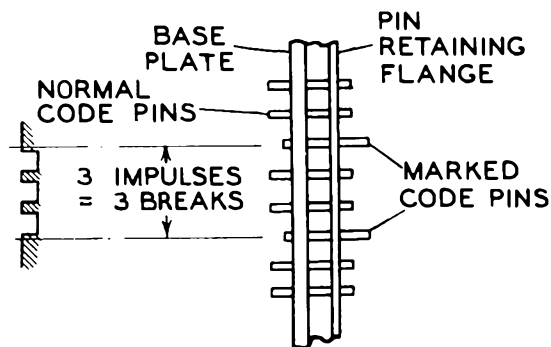

FIG. 8.—METHOD OF MARKING LENGTH OF TRAIN.

indicating the number of impulses in each train stored.

From the above it will be seen that before the counting of a train can proceed, it is necessary to energise the marking magnet. This is essentially a circuit function and is usually dependent upon the operation of a relay connected in parallel with the receiving magnet. Since the receiving magnet has a reverse action there is sufficient time to lift the marking lever clear of the normal code pins before the first impulse is received.

The rotation of the main shaft to which the ratchet wheel is secured, during the reception of a train of impulses also serves another important function. Since the retransmission of the stored impulses is automatic and purely a mechanical operation, the energy expended during retransmission will necessarily have to be derived from the storage operation, since it is only at this stage that the electrical energy can be converted into mechanical energy. The mechanical energy required is stored on a flat spiral spring accommodated in the spring cup (SC) shown in Fig. 3.

One end of the spring is attached to the main shaft, and the other to the impulse selecting wheel which is driven by the spring during retransmission. The amount by which the spring is wound will depend upon the number of impulses received. The increasing pressure does not, however, affect the speed of transmission, owing to the presence of a speed controlling governor, geared to the impulse selecting wheel.

The spring is adjusted during assembly to provide a definite minimum pressure (140 gms.) at the teeth of the selecting wheel, so that quick starting with only one impulse stored, is ensured.

Transmission Element.

The transmission of a stored train of impulses is effected by the rotation of the impulse selecting wheel

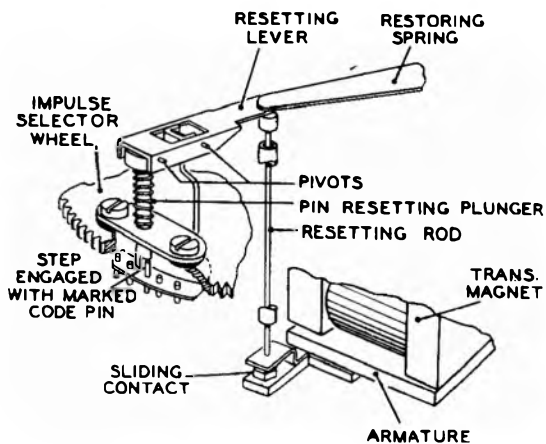

FIG. 9.—TRANSMISSION ELEMENT SHOWING RESETTING ASSEMBLY.

(SW) illustrated in Figs. 3 and 9. This wheel is geared to a speed controlled impulsing spring assembly (IS Fig. 3) carrying two sets of impulsing springs, which are arranged to generate impulses of 63-72 per cent. break ratio and impulses of 37-28 per cent. break ratio respectively at a speed of 9-11 i.p.s.

The two sets of impulsing springs have been provided in accordance with the policy of developing only one universal model. Normally only one set of springs is required, but the other is available for local impulse repetition if required.

The springset is operated by a small 3-lobe cam (Fig. 10) backed by a plain circular collar, the cam assembly being mounted on the shaft carrying

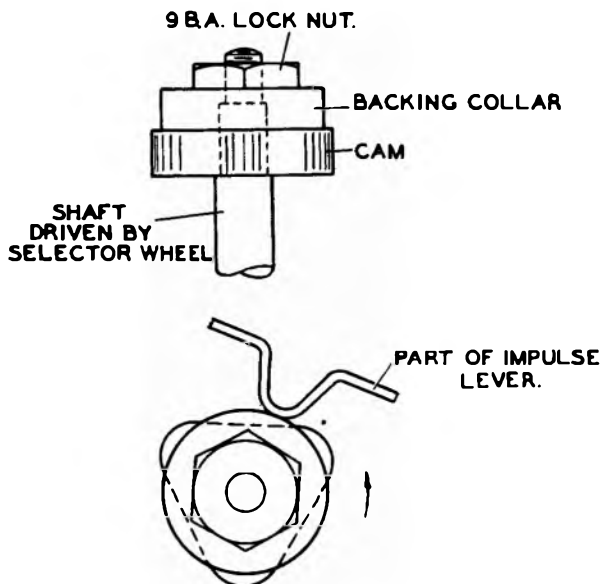

FIG. 10.—IMPULSE GENERATING CAM.

the pinion which meshes with the selecting wheel. Three impulses are generated during each revolution of the cam, one third of a revolution of the cam corresponding to $1/42$ nd of a revolution of the impulse selecting wheel. This fraction of a revolution also corresponds to the angular distance between two code pins so that one impulse is regenerated each

time the resetting plunger¹ passes over the space between two code pins. The selecting wheel carries the code pin resetting plunger (RP Figs 1 and 9) which is placed so that the rectangular step in the lower end of the plunger, when normal, can engage with any projecting code pin (Fig. 9).

Before transmission commences the resetting plunger prevents the selecting wheel from rotating, since it is engaged with a marked pin which represents the termination of the last train dealt with by the mechanism during the previous cycle of operation.

When one of more trains have been stored, certain other code pins will have been depressed, the interval between such pins depending upon the number of impulses in each train. Transmission cannot, however, commence until the code pin engaged with the resetting plunger has been reset, but it is clear that when the selecting wheel is allowed to rotate, the number of impulses regenerated by the impulsing cam before the resetting plunger engages with the next marked code pin will correspond with that previously stored in the train marked off. The resetting of a marked code pin by the resetting plunger is a separate operation controlled by the transmitting magnet (TM Figs. 1 and 9).

The resetting plunger is connected to the resetting lever (RL Fig. 1) at (A), the lever itself being pivoted at (R). The free end of the lever rests on an insulated thimble (T) against which it is held by the restoring spring. This spring holds the resetting plunger in its normal position which is such that the plunger can engage only with a marked pin. The thimble is secured to the end of a thin rod (Fig. 9) passing through, and insulated from the main shaft. This rod is connected at the other end to a transmitting magnet armature extension piece arranged with a sliding contact surface, which permits the rod to rotate without becoming disengaged with the armature extension piece.

When the transmitting magnet is energised the resetting lever is raised against the pressure of the restoring spring, and the resetting plunger depressed. The plunger is thus able to reset the marked code pin with which it is engaged, and when the armature is released the plunger, in returning to normal, becomes disengaged from the pin leaving the selecting wheel free to rotate. This resetting operation is repeated for each train, the transmitting signal being derived from an associated relay group.

A summarised description of a complete cycle of operations is given in the Appendix.

Speed Control.—The speed of retransmission is controlled by a typical dial type governor assembly modified slightly to give an improved performance. The governor wings are of extremely light construction to give quick starting since, in order to avoid first impulse distortion, it is necessary for the governor to become operative before the first break impulse of a train is transmitted. In practice the overall variation in speed including the first impulse does not exceed

¹The resetting plunger assembly, which combines the function of resetting the code pins and tripping the impulse wheel, is known officially as the "tripping arm."

4 per cent. and on the average, ignoring the first impulse, 1.5 per cent.

Owing to the light construction of the governor wings, normal dial methods of adjustment cannot be applied and for this reason, no adjustments of this type are made after the mechanism leaves the factory. For maintenance purposes, adjustments of speed are effected by altering the position of the governor cup which is provided with a tapered internal bore. The taper is a slow one and the adjustment not critical. In order to prevent casual movements of the cup, a locking piece has also been fitted, the existence of this facility limiting the fineness of adjustment to one quarter of a revolution of the cup. An alteration of this order changes the speed by an amount not measurable by normal methods.

Mechanical Springs.

Three mechanically operated springsets apart from the impulsing springs have been provided.

Both the marking and transmitting magnets are equipped with a single break action spring set which opens when the magnets are energised. The springs are of a modified 3000 type design, fitted with twin contacts and properly buffered so that normal methods of adjustment can be applied (see Fig. 2 MS and TS).

The remaining springset is of special design, and is arranged to operate as soon as the marking arm moves off normal. The assembly is clearly illustrated in Fig. 11. The contacts are normally broken, a short insulated operating stud carried on the resetting plunger mounting being provided for this purpose.

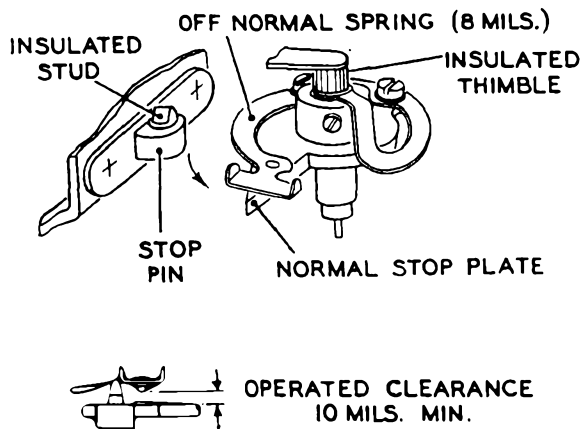

FIG. 11.—OFF-NORMAL SPRING ASSEMBLY.

The moving spring of the assembly is mounted on the normal stop plate which is secured to the main shaft by two set screws, the stop plate itself forming the lower contact mounting. This stop plate also acts as a stop against which the selecting wheel is brought to rest when all stored impulses have been exhausted. The connection to the moving spring is made through the transmitting rod passing through the main shaft, and since this rod is given an axial motion during a pin resetting operation, the spring is constructed from material only 8 mils thick. With a spring thickness of this order, it is difficult to obtain more than 15 grams contact pressure without distortion but so far this has proved sufficient. The moving spring is also provided

with an extension which causes the contact to open on the completion of the 40th stored impulse.

Electrical Connections

The compact design of the mechanism and the necessity for electrically controlled mechanical sequences has led to certain special features in the electrical circuit. In particular the necessity for indicating to the associated relay group the instant at which the transmission of a train of impulses is completed, gives rise to a special circuit path which is completed through the resetting plunger and code pin to frame.

For this reason the resetting lever restoring spring and resetting plunger mounting must be insulated from the frame. As already indicated, the moving off-normal spring connection is passed through the transmitting rod, and thence via the double nut sliding contact surface (Fig. 9) between the transmitting armature extension piece, itself insulated, to the switch plug. These arrangements although representing a departure from present practice so far as mechanisms are concerned, have proved quite satisfactory.

The contact pressure between plunger and pins is not less than 120 grams ensuring good contact in the presence of an oil film, and the design of the rotating contact at the end of the transmitting rod, avoids the necessity for a slip ring and brush assembly.

Good contact at the pivot between the resetting lever and plunger is maintained by the provision of a short contact spring accommodated in a counterbore on the enlarged head of the plunger.

Adjustments.

Adjustments have been kept as simple as possible, but cannot, in the authors' opinion, be carried out efficiently on the exchange premises. The actual adjustment work is not difficult, but some practice is required to obtain the best results and the infrequent attention which the mechanisms would require under maintenance conditions would not give the maintenance staff sufficient experience in this direction. Some form of centralised maintenance procedure would, however, overcome this difficulty and may have to be adopted.

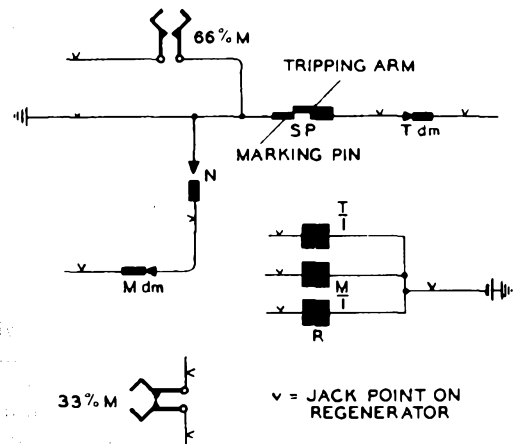

FIG. 12.—REGENERATOR CIRCUIT ELEMENTS AND ACCESS POINTS.

CIRCUIT APPLICATION

Using standardised conventions the circuit elements and access points of the regenerator are shown in Fig. 12 and these may be connected according to the requirements of the particular circuit in which the regenerator is incorporated. A typical circuit of an auto-to-auto relay set incorporating a mechanical regenerator is shown in Fig. 13. The elements shown in Fig. 12 will readily be recognised.

The circuit operation of the regenerator is as follows:—

Relay A is operated to the loop when the relay set is taken into service and at A1 operates relay B. B2 now prepares the circuit for impulsing. Relay A repeats the incoming impulses to the regenerator R magnet and the C relay.

receipt of the first impulse and remain closed until all stored impulses have been sent out).

Relay BY completes the pulsing-out loop at BY4 and 5 and at BY3 operates relay DE via the Tdm springs, and the contact made by the tripping arm resting on a marking pin to the earthed frame of the regenerator. Relay DE disconnects relay IP at DE1. Relay IP releases and releases relay IS. The circuit is then closed for the T magnet to operate at IS1. With the operation of the T magnet the Tdm springs open and release relay DE. At DE1 relay IP is reoperated and reoperates relay IS. The T magnet is now released by the reoperation of IS1 and causes the sending mechanism of the regenerator to pulse out the required number of impulses as marked by the next projecting marking pin. When this pin is reached by

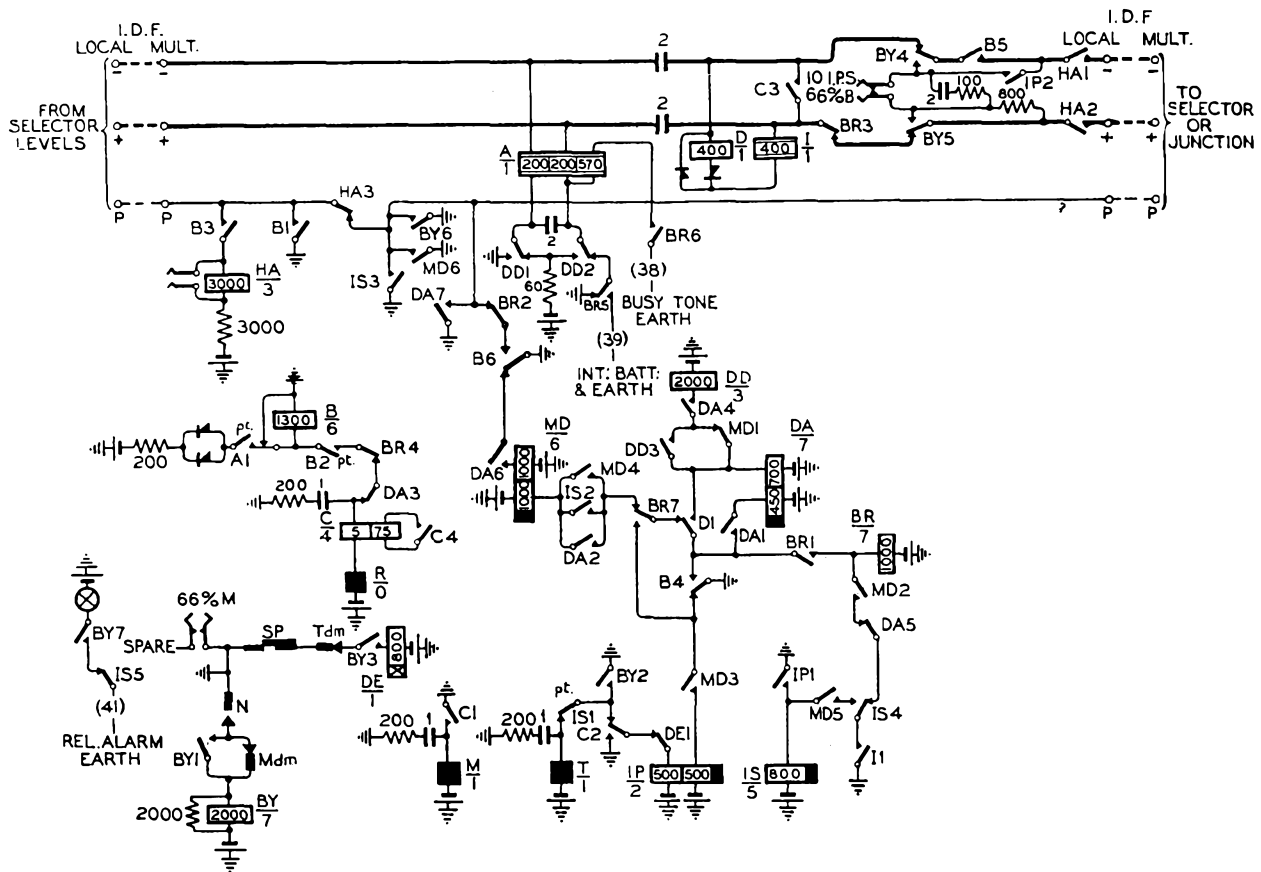

FIG. 13.—TYPICAL AUTO-TO-AUTO RELAY SET WITH REGENERATOR.

Relay C, which holds during impulsing and releases during the intertrain pause period, operates the regenerator M magnet at C1 to enable storage of the incoming train to be effected, and at C2 completes the circuit for relay IP.

Relay IP prepares the pulsing-out loop at IP2 and at IP1 operates relay IS. At the end of the incoming train of impulses relay C releases and releases the M magnet to project a marking pin so marking the digit dialled; on release of the M magnet the Mdm springs close and complete a circuit for relay BY which operates and locks to the N springs (the N springs which are normally open close immediately on

the tripping arm² the circuit is again established for the operation of relay DE and the same cycle of events takes place. This is repeated until the last received train of impulses has been sent out. When the last impulse train has been transmitted, indicated by the tripping arm meeting the last projecting marking pin, the N springs open and release relay BY which changes over from the pulsing-out loop to the transmission bridge.

Design Notes.

It will be noted from the description of the circuit operation that the action of the sending element is

²See note 1

quite independent of the receiving element and that, in addition to correction of impulse ratio and speed, the pulsing-out inter-train pause is controlled by the releasing lags of relays DE, IP and IS. These relays are designed to give a combined minimum releasing lag of 800 milliseconds.

It follows as a corollary to independent control of pulsing-out times, that the regenerator must be able to emet variations, within allowable tolerances, of pulsing-in times. Tests were made in the Post Office Engineering Department's circuit laboratory to establish the ability of the regenerator to meet various conditions of adverse time tolerances and the results are detailed below.

Slow reception of digits with a long pause and fast transmission with a short pause, may result in the transmission catching up the reception to the extent that the N springs open and release relay BY. This condition results in an automatic increase in the outgoing inter-train pause by an amount equal to the release lag of relay C. No mutilation of impulses can occur due to premature sending as transmission is effectively delayed until the next train is completely stored, since relay BY cannot re-operate until relay C has released and released the M magnet to close the Mdm springs.

Another instance of overtaking might be thought to result from the restoring of a marking pin and the commencement of transmission of a train of digits which is not completely stored. It can be shown, however, that mutilation of impulses cannot occur as under the very worst conditions the incoming train may require 1630 mS for completion (i.e., 10 impulses at 7 i.p.s. + release of C relay to project the marking pin) and the outgoing train 800 mS + 910 mS for completion (i.e. release of relays DE, IP and IS + 10 impulses at 11 i.p.s.). There is, therefore, always an excess of transmission time over reception time.

It will be evident, however, from the closing statement of the last paragraph that another similar form of overtaking is possible i.e. fast storage with short pauses and slow sending with long pauses, causing the storage system to become 360° out of phase with the transmission system. This possibility arises because of the maximum storage capacity of the regenerator which is 40 impulses.

It can be shown that overtaking takes place when

$$\frac{40}{N} \left[\frac{1}{1 - \frac{S_o}{S_R} \left[\frac{N + S_R \theta_R}{N + S_o \theta_o} \right]} \right]$$

Where m = No. of trains

S_R = Incoming impulse speed in i.p.s.

S_o = Outgoing impulse speed in i.p.s.

θ_R = Incoming intertrain pause in seconds

θ_o = Outgoing intertrain pause in seconds

and N = No. of digits in the train.

The curve in Fig. 14 shows the calculated values for trains of impulses from 1 to 10, when inter-train times and dialling speeds are most adverse. It will be seen that the worst condition arises when trains of 10 are

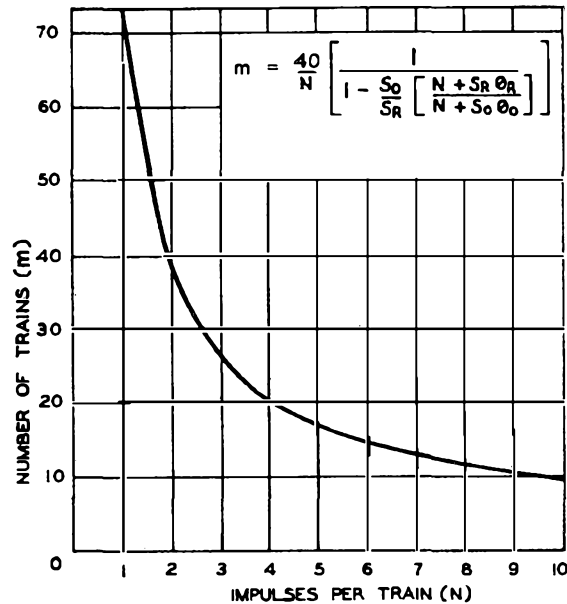

FIG. 14.—CURVE SHOWING NUMBER OF TRAINS RECEIVED BEFORE OVERTAKING OCCURS

stored (i.e. when "0" is dialled), and overtaking would occur on the 9th train i.e. while 9 trains of 10 impulses are received 5 are transmitted leaving four stored. This means that with the 9th train the sending and receiving systems would be 360° out of phase and the N springs would open releasing relay BY. Consequently if each digit dialled was an "0" and timing conditions were most adverse, it is possible for the regenerator to handle only eight digits. A progressive improvement is of course obtained when the digits stored are less than "0" because the difference per train is less and more trains may be stored, e.g. taking the digit 5 as an average figure it will be seen that overtaking does not take place until after the 16th train during which time eight trains will have been transmitted and eight stored. Hence the regenerator could handle sixteen trains of five with adverse speed and pause times.

With the standard practice of dialling "0" for manual board service, it will be appreciated that a dialled sequence of more than eight "0's" will be extremely unlikely and it may safely be said that the regenerator will even with all adverse timings meet all the conditions likely to arise in practice.

Release Guarding.

The normal relationship between the action of the receiving and sending systems of the regenerator is that the sending system is one impulse train behind the receiving system, but it has been shown that the sending system may under certain conditions drop to forty impulses behind the receiving system.

It is clear therefore that with premature release it is necessary to guard the relay set from re-seizure until all the stored impulses have been sent out and the regenerator restored to normal.

Use is made of the relays directly associated with the regenerator to effect the necessary guarding.

Routine Testing.

Design of routine testing equipment for the regenerator has not yet been completed but the facilities provided will include impulse speed and ratio and inter-train pause timing tests.

Conclusion.

Fig. 15 is a sketch showing some of the points at which provision of regenerative relay sets would be advantageous.

It will be seen that without regenerators the tandem dialling limit for two junctions is 800 ohms in the first link followed by 800 ohms in the second link. With the regenerator, however, the limit for each junction is increased to 1500 ohms and since the junctions are not now dependent on the preceding link then any number (from an impulsing standpoint) may be operated in tandem.

The greater flexibility in design of an area and the economy resulting from these advantages justify

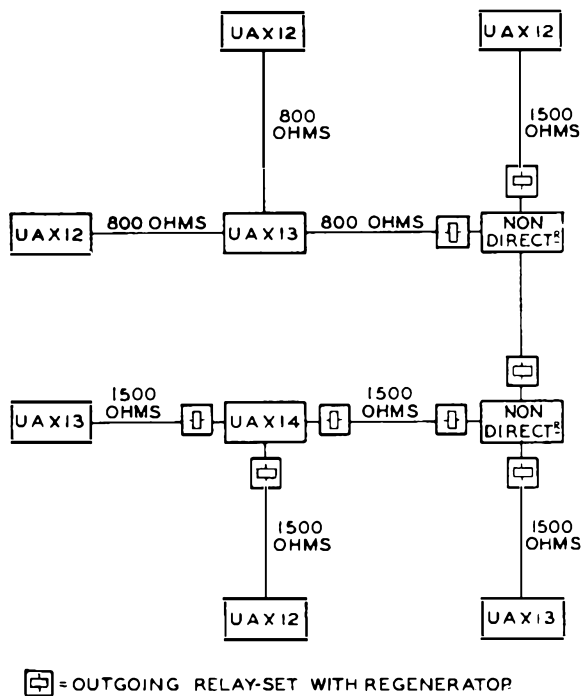

FIG. 15.—TYPICAL APPLICATION OF REGENERATIVE REPEATERS

the provision of regenerators on outgoing auto-to-auto junctions at tandem switching centres.

Apart from its use for impulse repetition the mechanical regenerator may be used for various other purposes and there is little doubt that its sphere of application will widen with the progress of development.

APPENDIX

SUMMARY OF MECHANICAL FUNCTIONS

Assuming that the regenerator is required to receive and transmit the number 370, the mechanical sequences involved would be as follows:

The first release of the impulsing relay energises the

receiving magnet and simultaneously a parallel or series connected relay. The magnet armature pawl is lifted sufficiently to allow it to drop over the adjacent ratchet tooth with a small clearance and at the same time the closure of the relay contact energises the marking magnet. The attraction of the marking armature raises the marking lever clear of the normal code pins. The pin over which the marking lever is resting normally remains depressed, the projection of the pin on the transmitting side engaging with the pin resetting plunger to prevent any rotation of the impulse selecting wheel.

The next reoperation of the impulsing relay releases the receiving magnet armature, which then rotates the storage ratchet by one tooth space, at the same time rotating the marking lever to a position centrally over the adjacent code pin.

For three impulses corresponding to three magnet energisations the marking lever is rotated three steps to come to rest centrally over a code pin four removed from its initial position. The marking magnet does not release until the parallel or series connected relay, mentioned above, releases. During the inter-train pause the marking lever is thus released depressing the code pin over which it has been positioned by the reception of the first train of three impulses. In a similar way two other code pins are depressed to register the termination of the next two trains of seven and ten impulses respectively. The storage operations are not in any way affected by any transmission which may occur simultaneously since the timing sequences in the associated relay group eliminate the possibility of mutilated trains.

In present circuits the transmission of the first train cannot commence until the first train is completely stored. When this operation has been completed a transmitting signal is received from the relay group to energise the transmitting magnet. The energisation of the transmitting magnet opens the magnet normal springs and depresses the pin resetting plunger to restore the code pin with which the plunger is engaged. The signal produced by the opening of the magnet normal springs initiates the release of the transmitting magnet so that the pin resetting plunger may return to normal in order to allow the impulse selecting wheel to rotate.

The selecting wheel continues to rotate until the resetting plunger becomes engaged with the next projecting code pin generating in the process a number of impulses (in this case three) equivalent to that originally stored in the first train. The engagement of the resetting plunger with the code pin initiates a further signal which commences the marking off of an inter-train period in the associated relay group. At the end of this period the transmitting magnet is again energised and released as before, thus commencing the transmission of the next train of seven impulses. In a similar manner the final train of ten impulses is transmitted.

At the end of the last impulse of the third train the normal springs mounted on the main shaft are re-opened to indicate to the relay group that all stored trains have been exhausted.

The London—Birmingham Coaxial Cable System

A. H. MUMFORD, B.Sc. (Eng.), A.M.I.E.E.

Part II.—Description of the Repeaters and Terminal Equipment

In this article, which is continued from the October issue, the author describes the equipment provided at the terminal and intermediate repeater stations. In the concluding article, which will appear in the April issue, particulars of the cable together with the overall test results will be given.

TERMINAL STATION MODULATING EQUIPMENT

THE modulating equipment includes all the apparatus connected directly in the paths between the 2-wire audio frequency circuits and the repeaters terminating the coaxial pairs, together with certain other apparatus it has been found convenient to associate therewith. The functions of the modulating equipment having been outlined already in the general discussion of the system, it is possible to proceed directly to a technical description of the equipment itself.

R.T.P.,¹ the scatter being such that less than 1 per cent. exceeds zero level. The modulating equipment has, therefore, been designed to handle input levels on the 2-wire side up to R.T.P. without introducing appreciable distortion and crosstalk and, unless the contrary is stated, levels at various points in the system will be given in terms of the level due to a single circuit experiencing an input on the 2-wire side of R.T.P. The level at various points in the circuit, and the transmission equivalent of the various units are given in the block schematic shown in

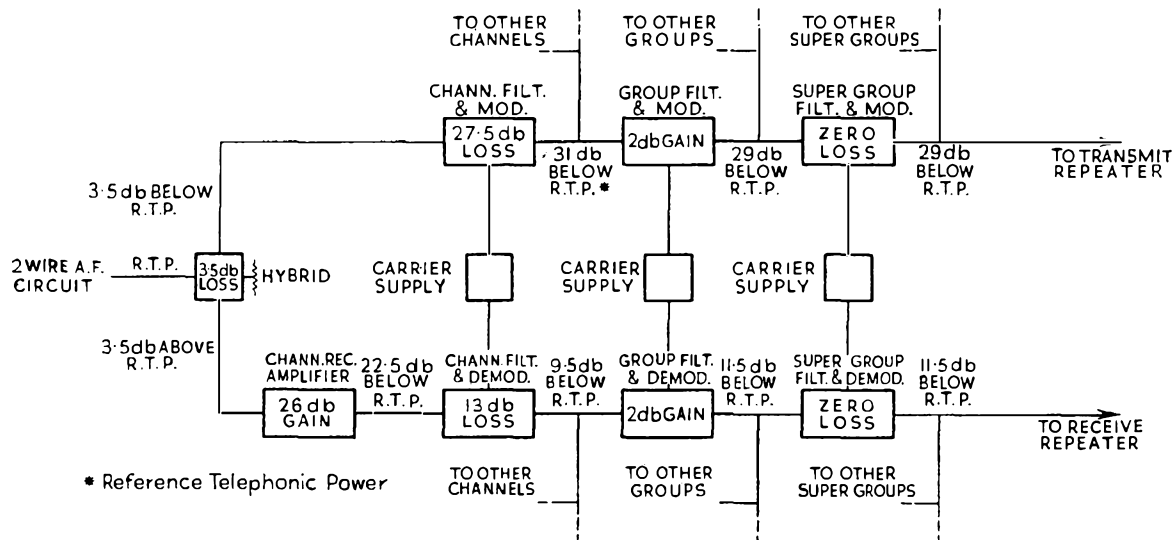

FIG. 11.—BLOCK DIAGRAM OF TERMINAL EQUIPMENT.

The transmission equivalents of the various parts of the circuit are governed by the following factors:—

The coaxial pairs, their repeaters and equalisers together provide transmission paths having 5 db. loss at all frequencies from 500 to 2,100 kc.p.s. The combined gain of the modulating equipment at the two ends must therefore be 5 db. for every circuit in order that the 2-wire to 2-wire loss of the overall circuits provided by the system shall be substantially zero. In practice this is realised by designing the various units in the modulating equipment so that the transmission equivalent for each circuit shall be approximately the same initially, and providing for an individual adjustment of gain in the receive leg of each circuit so that the zero loss condition may be satisfied as closely as possible.

The incoming levels of speech from various subscribers at the terminals of a trunk circuit are distributed about a mean value of 14 db. below

Fig. 11, which indicates the apparatus used at one terminal station in setting up a single circuit.

It will be appreciated that the majority of the equipment involved in the provision of the coaxial carrier telephone system is common to groups of 8, 40 or 320 circuits depending upon the part of the system in which it is located. There is, however, a considerable portion of the modulating equipment which has to be multiplied directly in proportion to the number of circuits provided. The 2-wire terminations, channel receive amplifiers, channel modulators and demodulators and channel filters comprise the latter class. Economic factors, therefore, weigh much more heavily in the design of these particular units than they do for the rest of the equipment.

The various parts of the modulating equipment will now be described in greater detail.

¹Reference Telephonic Power

Two-Wire Terminations.

The 2-wire terminations employed for converting the 2-wire audio frequency circuits into 4-wire circuits are of some interest in that they are considerably smaller than those hitherto employed in trunk working. Two complete terminations are assembled on a $3\frac{1}{2}$ -in. deep mounting plate of the normal width of 19 ins. The terminations employ transformers (type 49) originally developed by the Post Office for use on toll circuits. These have been found to be sufficiently good to warrant their substitution for the more expensive and more bulky type normally used in termination units. A typical insertion loss characteristic when operating between 600 ohm circuits is given in Fig. 12. Under the same conditions, the balance between 4-wire circuits measured at 800 c.p.s. is of the order of 55 db.

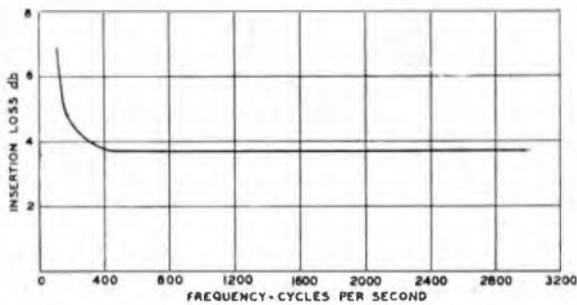

FIG. 12.—INSERTION LOSS CHARACTERISTIC OF 2-WIRE TERMINATION. 2-WIRE TO 4-WIRE.

Channel Receive Amplifiers.

The level at the output terminals of each channel demodulator is increased some 25 db. or so by a channel receive amplifier (Fig. 13) connected between the demodulator and the 2-wire termination. This amplifier serves two other purposes, viz. to compen-

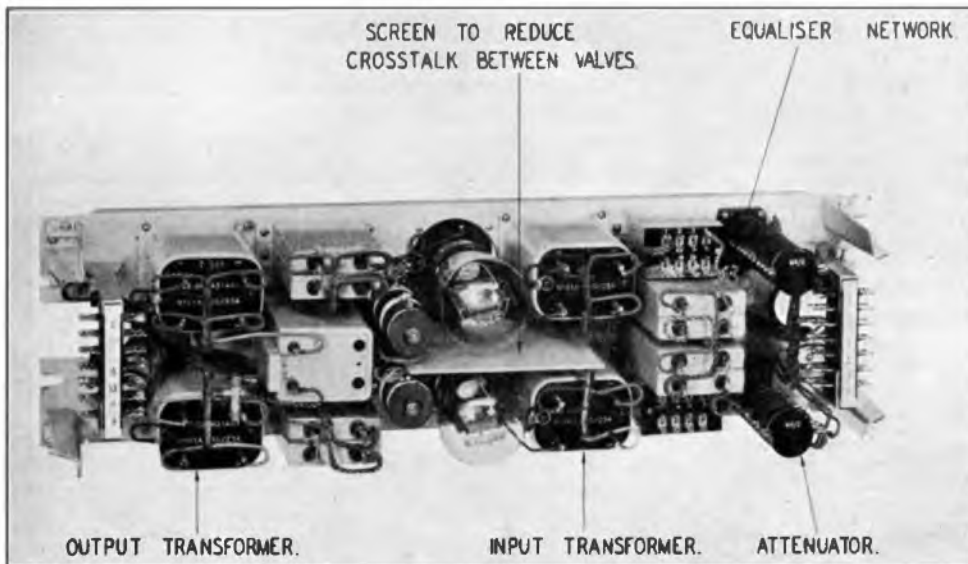

FIG. 13.—CHANNEL RECEIVE AMPLIFIERS.

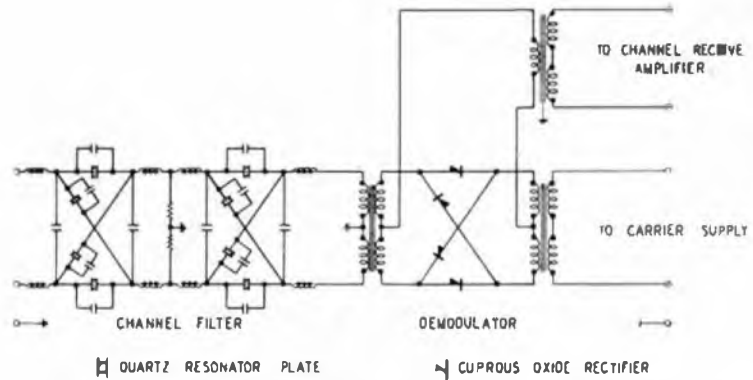

FIG. 14.—CIRCUIT DIAGRAM OF CHANNEL FILTER AND DEMODULATOR.

sate for a certain amount of premature attenuation introduced by the channel filters near the edges of the pass band, and to adjust the overall loss between 2-wire circuits to zero. Each amplifier employs a single stage of amplification using triode valves, P.O. type V.T.82, two amplifiers being accommodated on the same mounting plate. The maximum gain of an amplifier measured at 800 c.p.s. is approximately 30 db., and output levels up to 11 db. relative to one milliwatt can be provided without introducing more than 2 per cent. spurious harmonic content. The cross-talk between two amplifiers mounted on the same unit is not worse than 80 db.

Channel Modulators and Demodulators.

Balanced modulators incorporating cuprous oxide rectifiers are used for the initial stage of modulation. In the type of modulator indicated in Fig. 14 the terminals into which the modulating oscillation is injected and from which the side-band output is obtained, may be interchanged without altering the properties of the modulator; moreover the effective input impedance in one case appears to have the same value as the effective output impedance in the other. These properties enable the same type of circuit to be used for demodulation as well as modulation. Further,

the filter which serves to separate one side-band from the other in the output circuit of the modulator has its counterpart in the filter which is required to restrict and select the band of frequencies applied to a demodulator. In view of the resemblance between the modulator and demodulator circuit arrangements, similar units incorporating the modulator and its associated filter have been used for modulation and demodulation with the sole exception that an

attenuator, used in the modulator to reduce the level of the modulating oscillations, is omitted in the demodulator.

In general, modulators give rise to unwanted modulation products of various orders as well as those it is desired to utilise, particularly when the current-voltage characteristics of the non-linear elements in the circuit depart largely from the parabolic form, as with copper oxide rectifiers. The particular form of modulator shown possesses the advantage that all unwanted products up to and including most of the fourth order products tend to balance out in the output circuit, this cancellation including both the oscillations originally applied to the modulator, i.e. the carrier and modulating oscillations. The absence of these components is of particular interest not only because it is highly desirable to eliminate the carrier at the transmitting end of the circuit, but because the absence of the modulating component as well makes it unnecessary for the circuit connected to the output terminals of the modulator to provide a low impedance path either to the carrier or modulating oscillations. Although no special arrangements have been made to balance out the carrier precisely, apart from matching the rectifier elements, the carrier leak present in the output circuit is normally some 40 db. below the input level. Since the carrier re-introduced in the corresponding channel demodulator at the distant end of the circuit has exactly the same frequency as that originally suppressed, there is no possibility of beats occurring between the re-introduced carrier and the residue. It is only necessary for the magnitude of the carrier residue to be small compared with that re-introduced so that the phase relationship of the two does not affect the magnitude of the resultant appreciably.

With a carrier power of 7 db. relative to 1 milliwatt injected into a modulator the conversion loss of the modulator and its associated filter is of the order of 13 db., of which 7.5 db. is introduced by the filter itself. Input levels of tone up to 9 db. relative to 1 milliwatt may be modulated without introducing appreciable distortion in the overall transmission.

Channel Filters.

The channel filters are called upon to provide high discrimination against frequencies transmitted by adjacent channels combined with uniform response in a relatively narrow pass band. These requirements make it uneconomic, if not impossible, to build satisfactory filters using inductors and capacitors exclusively. The solution is provided by the use of

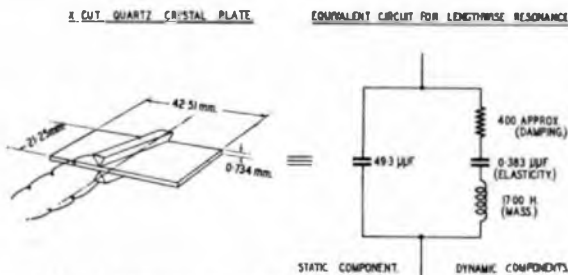

FIG. 15.—EQUIVALENT CIRCUIT OF QUARTZ RESONATOR, 62.39 KC.P.S.

filter sections of such a type that some of the reactive elements may be realised in the normal way, using inductors and capacitors, without impairing the performance of the filter, whereas the remainder may be substituted by quartz crystal resonators which function as substantially ideal reactive elements. The equivalent circuit of a typical crystal is shown in Fig. 15.

The capacitors connected across the resonators (Fig. 14) are adjustable so that due allowance can be made for stray capacitances, and small deviations from the nominal values of the various elements. The crystal resonators are of the normal "X" cut variety utilising the resonance of the "Y" wave: a typical crystal in its associated holder is shown in Fig. 16. Gold electrodes are deposited on the two



FIG. 16.—HOLDER FOR CHANNEL FILTER CRYSTAL RESONATOR

main surfaces of the plate, which is then held between contacts fixed at an angle to coincide with the nodal plane. The inductors are of toroidal form employing iron dust cores. The fixed and adjustable capacitors, which like the inductors require to be of high stability, employ a ceramic dielectric and electrodes which are deposited directly on the surface of the dielectric by a combination of chemical and electrolytic processes. The resistors between the two sections of the filter are used to improve the response of the filter in the pass band. The overall insertion loss characteristic of a complete channel filter operating between 3000 ohm circuits is given in Fig. 17.

In practice, each channel filter and its associated modulator or demodulator is assembled on a common mounting plate. The complete circuit diagram and assembly of such a unit are shown in Figs. 14 and 18 respectively.

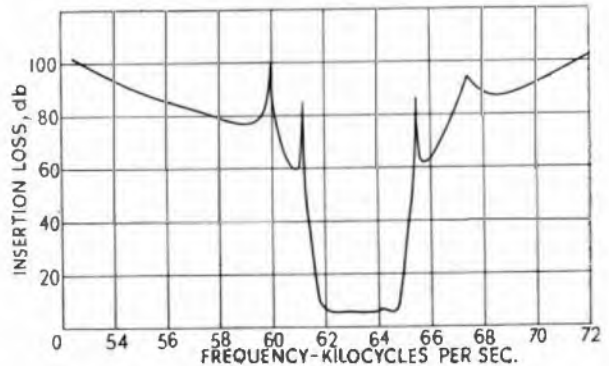

FIG. 17.—INSERTION LOSS CHARACTERISTIC OF CHANNEL FILTER.

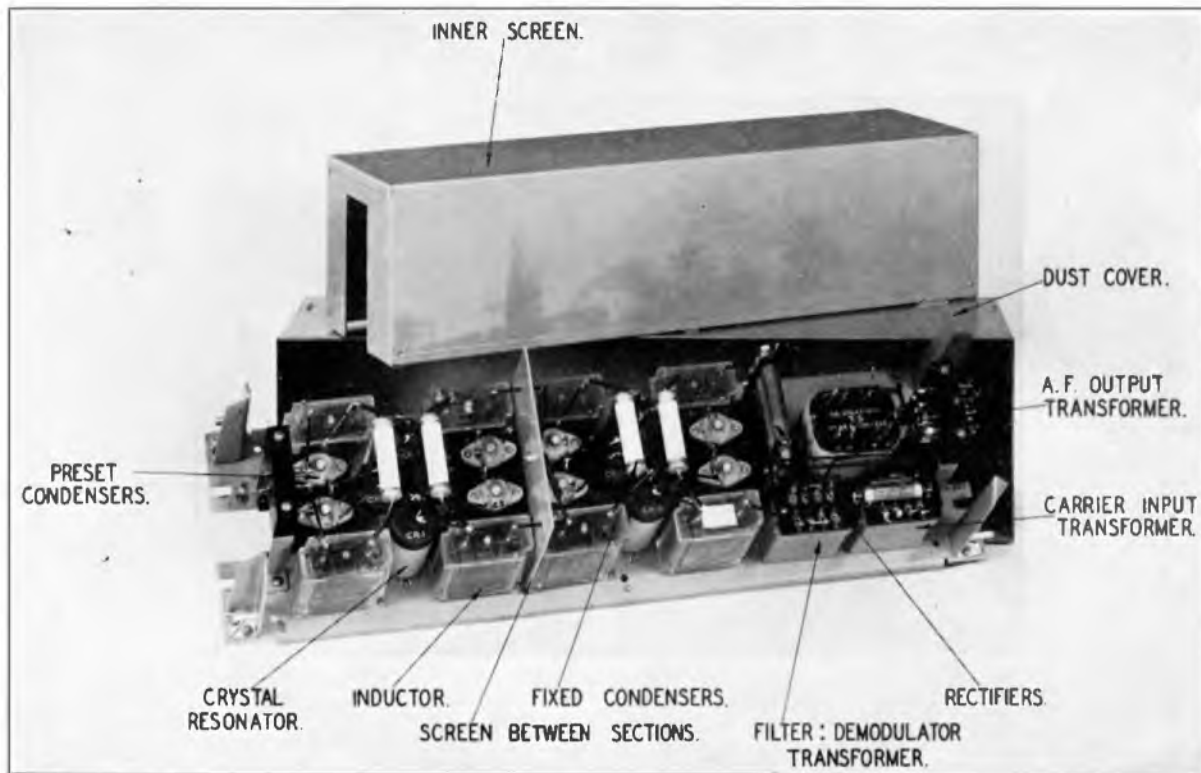

FIG. 18.—CHANNEL FILTER AND DEMODULATOR.

Group Modulators and Demodulators.

The intermediate stage of modulation is carried out by means of Carson type modulators employing P.O. valves type V.T.82. Here again it is unnecessary to take special steps to balance the carrier out exactly apart from using matched valves, because the filter following the modulator introduces considerable attenuation at the carrier frequency. The overall gain of the modulator is adjusted to have the correct value after installation by means of a constant impedance attenuator in the input circuit. The maximum conversion gain of the modulator and filter combined is approximately 10 db., the filter itself introducing a loss of 1.5 db., and side band output levels up to about 1 milliwatt for each of two tones may be handled by the modulator without introducing appreciable distortion or crosstalk in the overall transmission of the system. The group demodulators are similar in type to the group modulators but some circuit details are necessarily different owing to the output frequency bands for the modulators having become the input frequency band for the demodulators and vice versa.

Group Filters.

As the performance requirements of the filters associated with the group modulators and demodulators are not particularly stringent, ladder type filters of the normal type employing inductors and capacitors only, are employed. The high frequencies and relatively narrow band widths involved make it necessary to take special account of stray capacitances, and it has been found advantageous to localise these capacitances by using double screening

so that allowance can be made for them in the adjustment of the filter elements.

The circuit diagram of a complete filter showing the way in which the screens are connected is given in Fig. 19. The series arm of the filter is completely surrounded by a screen joined to one of its terminals; its impedance is, therefore, independent of local conditions and may be adjusted as an independent unit. A second screen completely encloses the screened series arm and the elements of the shunt arm, the latter being adjusted allowing for the

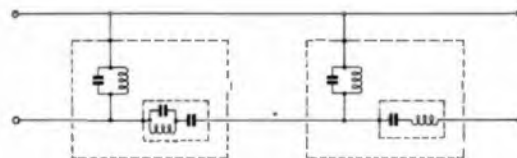

FIG. 19.—SCHEMATIC DIAGRAM OF GROUP FILTER.

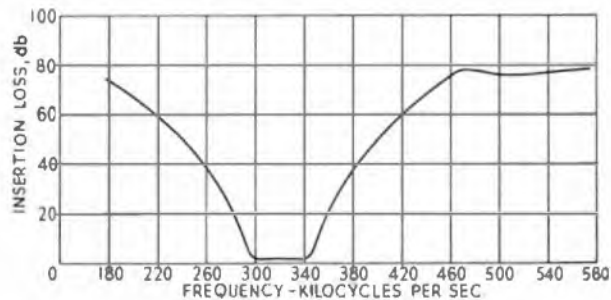

FIG. 20.—INSERTION LOSS CHARACTERISTIC OF GROUP FILTER.

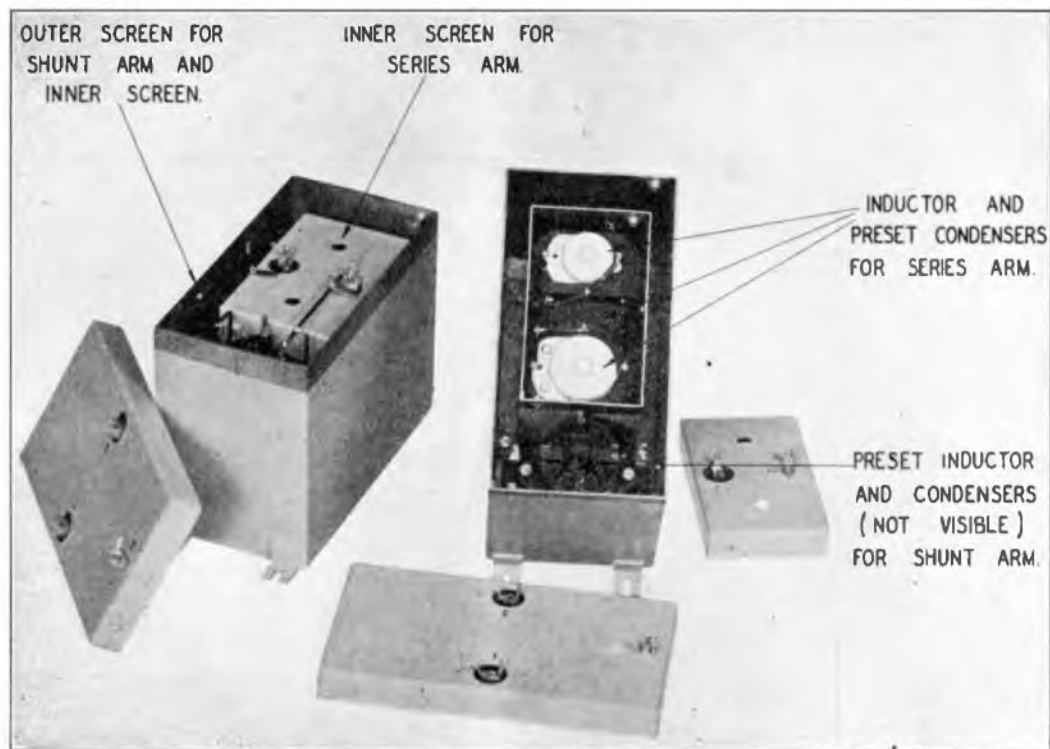

FIG. 21.—DOUBLE SCREENED FILTER SECTIONS.

capacitance between the screens. Adjustable inductors and capacitors are used in the shunt and series arms respectively in order that the various frequencies of resonance and anti-resonance may finally be adjusted to their correct values when the filter elements have been mounted in their screens. The insertion loss characteristic of a typical group filter is given in Fig. 20 and a filter section shown in Fig. 21. The modulators and filters are assembled on the same mounting plate.

Super-Group Modulators, Demodulators and Filters.

The super-group modulators, demodulators and filters are very similar in general design to the corresponding units used for the groups; there is, however, the outstanding difference that the equipment used for the higher frequency super-groups operates at about four times the frequency. This imposes most rigid limitations on the design of transformers and demands greatly increased precision in the construction and adjustment of filters; nevertheless satisfactory equipment has been evolved. The following performance figures for the units designed to operate on the highest super-group frequency band will be of some interest:—

The maximum conversion gain of the modulator and filter is 8 db., the filter itself having a loss of 2 db. Side band output levels up to about 1 milliwatt for each of two tones may be handled without introducing appreciable distortion in the overall transmission. The insertion loss characteristic of one of the filters is given in Fig. 22. The curve is almost identical in shape with that of a group filter given in Fig. 20 but

is included as representing an interesting application of filter technique to high frequencies. The complete

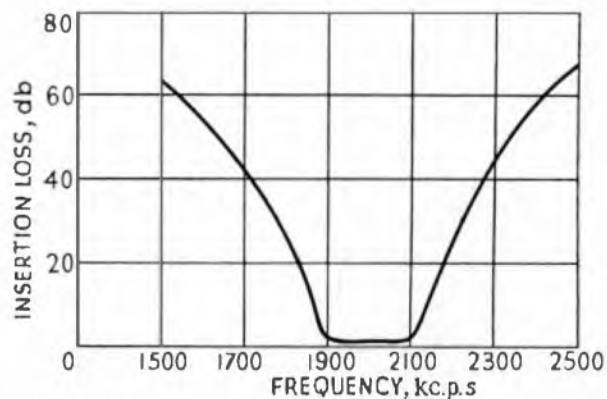

FIG. 22.—INSERTION LOSS CHARACTERISTIC OF SUPER GROUP FILTER.

assembly of a modulator and its associated filter is shown in Fig. 23.

TERMINAL STATION CARRIER GENERATION EQUIPMENT

The order of frequency constancy necessary for the 21 carrier frequencies required at each terminal, in order that corresponding carrier frequencies may not vary mutually by more than a few cycles, is achieved most easily by relating each one harmonically to the frequency generated by a single master oscillator designed to give the required frequency stability. The percentage constancy of the master

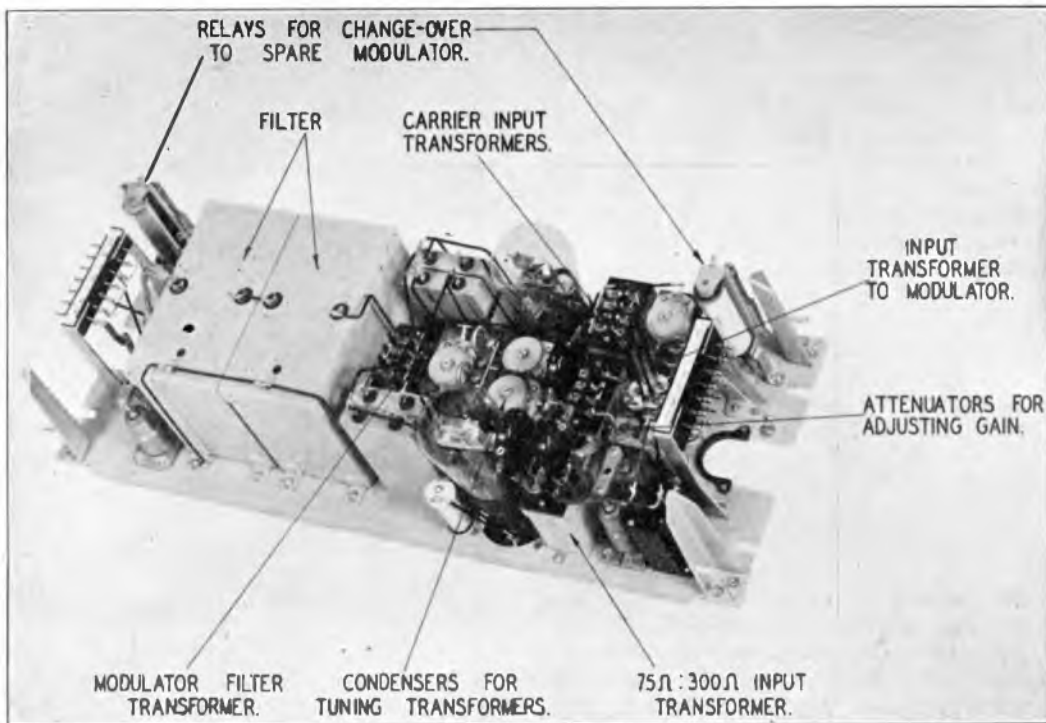

FIG. 23.—SUPER-GROUP MODULATOR AND FILTER.

is translated to each carrier and the relative merits of the system, as compared with one which employs separate oscillators at both terminals for each carrier, are readily appreciated. Thus, the number of precision oscillators is reduced from 42 to 1 and the operation of the speech circuits is unaffected by normal frequency variations of the master. A further advantage which will obtain when the scheme is applied to a cable network extending throughout the country is the supply of standard frequencies available at each terminal for other purposes.

The carriers are generated in synchronised frequency-multiplying equipment at London and Birmingham. The drive for both sets of equipment is a master oscillator located at the London terminal and the carrier frequencies at the two terminals are precise integral multiples or sub-multiples of the master frequency. The values of the 21 carrier frequencies, chosen to facilitate the system of generation, are 1,000 to 2,400 kc.p.s. in 200 kc.p.s. steps for the 8 super-groups, 400 to 560 kc.p.s. in steps of 40 kc.p.s. for the 5 groups and 65 to 100 kc.p.s. in steps of 5 kc.p.s. for the 8 channels. Provision has also been made for extension of the system to provide the 10 channel frequencies, 64 to 100 kc.p.s., in steps of 4 kc.p.s., required for a channel spacing of 4 kc.p.s.

The equipment is divided into four main parts, the master oscillator, production, selection, and power amplification. The carriers are generated in a series of synchronised multi-vibrators which make up the production equipment. The individual carriers are filtered in the selectors and the requisite signal level is obtained in the power amplifiers prior to distribution of the carriers to the modulator and demodulator units. Sufficient power is developed in the selectors on each carrier frequency to energise

four sets of power amplifiers and it will be necessary to repeat only the power amplifiers for each additional pair of cable terminations up to a maximum of four pairs. Failure of any part of the system is so vital that two sets of equipment are installed at each terminal and, on the occurrence of a fault, the faulty apparatus is automatically replaced, without causing interference with the service, and both aural and visual warnings of the fault are given.

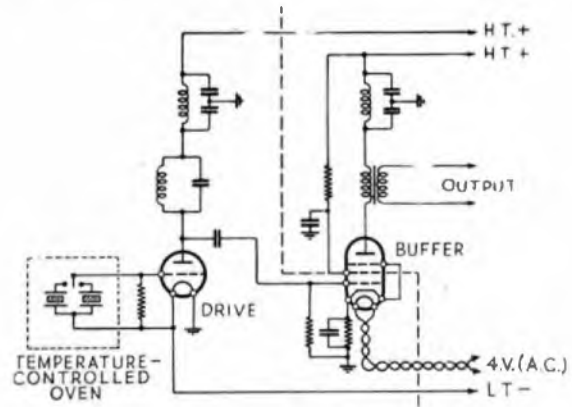

FIG. 24.—CIRCUIT DIAGRAM OF CRYSTAL DRIVE UNIT.

The Master Oscillator.

The drive circuit, Fig. 24, employs a 400 kc.p.s. Y_{ST} quartz plate of sensibly zero frequency-temperature coefficient. Minimum damping of the crystal is ensured by the use of a nodal plane suspension and by a reduction of air pressure in the holder to less than 1 mm. of mercury. The effective frequency-temperature coefficient of the mounted crystal is

within ± 0.5 parts in 10^6 per 1°C temperature change. It is mounted in a thermostatically controlled oven designed to reduce ambient variations at the crystal to less than $\pm 0.05^\circ\text{C}$ and aural and visual warnings of a temperature change of $\pm 0.25^\circ\text{C}$ from the control value are given. Two mounted crystals are included in each oven, either of which may be switched into circuit at will. The load on the drive is stabilised by a pentode buffer stage, from the anode of which the required 400 kc.p.s. outputs are obtained. No special precautions have been taken to stabilise the supply voltages as the normal variations will not appreciably affect the generated frequency. Photographs of the master oscillator crystal with its associated holder and the completed oscillator unit are shown in Figs. 25 and 26 respectively.

Frequency Production.

As pointed out earlier the production equipment at each terminal (see Fig. 27), employs three synchronised multi-vibrators operating on the fundamental frequencies, 200, 40 and 5 kc.p.s. respectively, from which the three harmonic series corresponding to the super-group, group and channel carriers are obtained. The application of the multi-vibrator to the production of a series of frequencies which are harmonically related to a standard frequency is well known. Briefly, the oscillation generated in a multi-vibrator is rich in harmonics and, although the fundamental frequency primarily determined by the circuit constants is unstable, it may be controlled by a signal whose frequency is equal to or is a low order multiple of the fundamental. Thus, if f is the fundamental frequency of the multi-vibrator, it may be controlled by a signal of frequency nf , where n is an integer, and a harmonic series of f is available. The upper practical limit of n is about 10.



FIG. 25.—DRIVE CRYSTAL AND COMPONENTS.

An amplified output from the drive controls the frequency of the 200 kc.p.s. multi-vibrators at London and Birmingham, the control signal for the

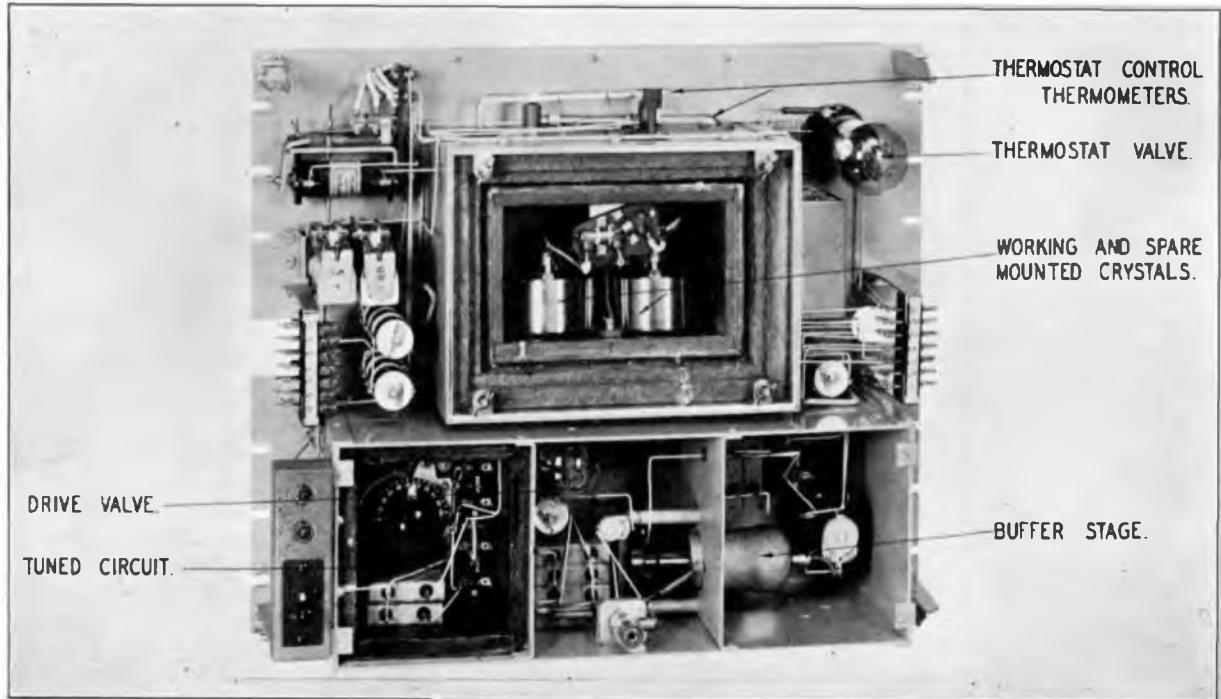

FIG. 26.—DRIVE OSCILLATOR UNIT.

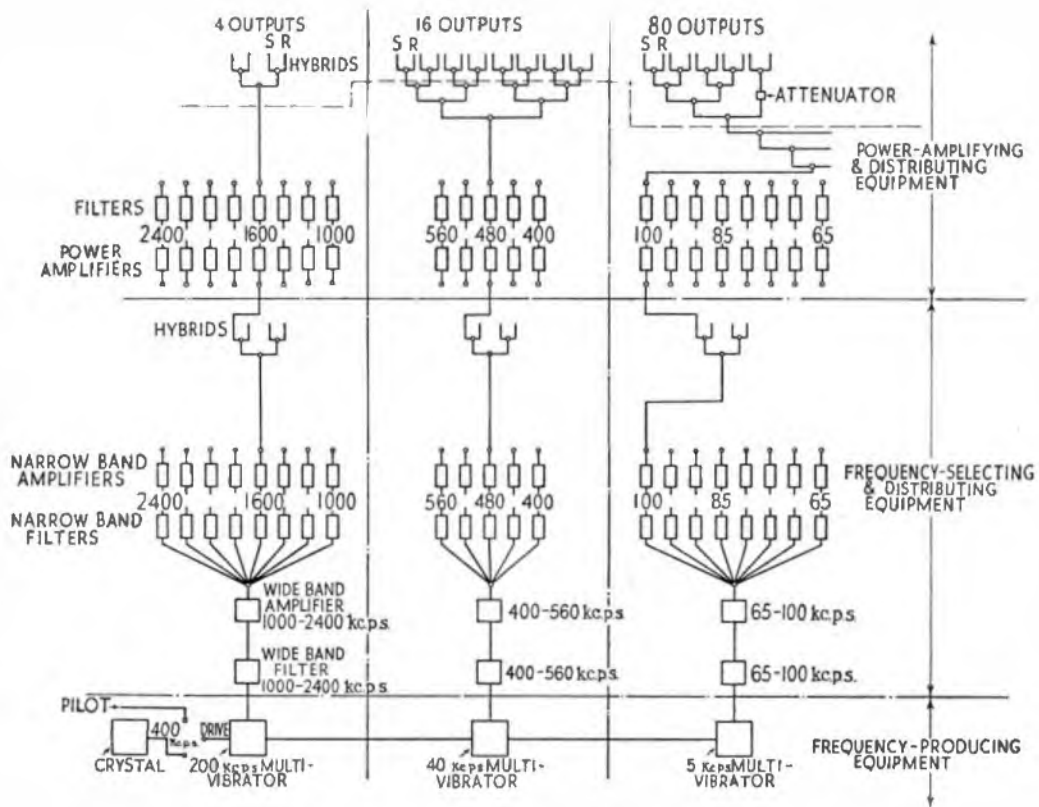

FIG. 27.—CARRIER PRODUCTION EQUIPMENT.

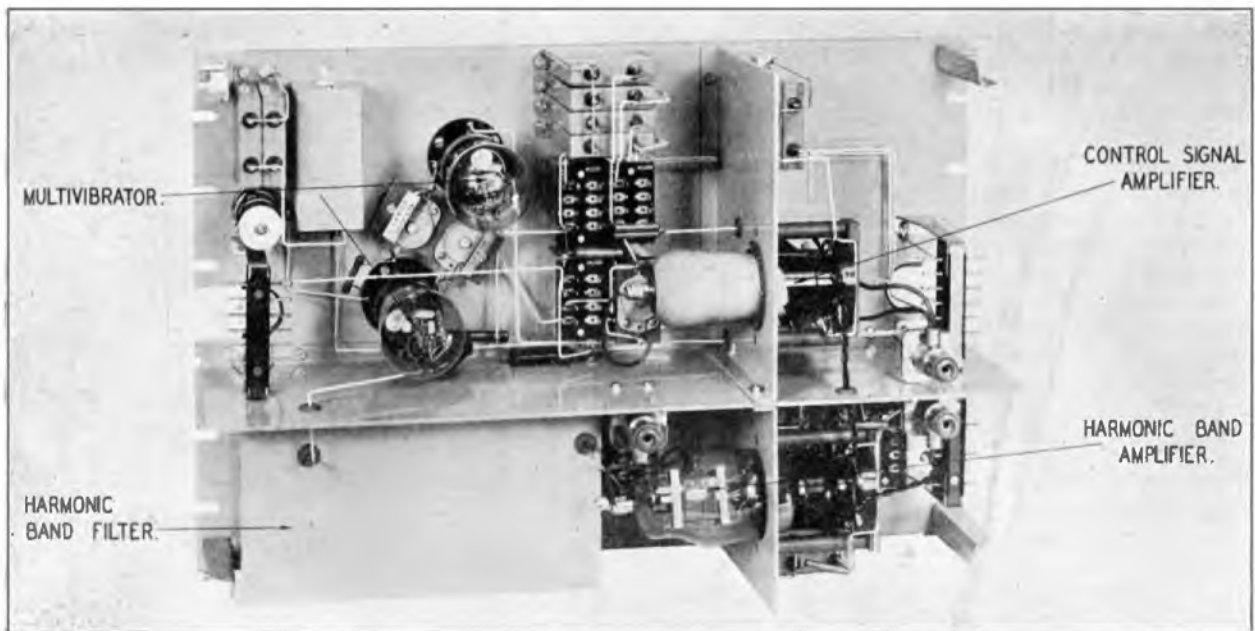

FIG. 28.—MULTI-VIBRATOR UNIT.

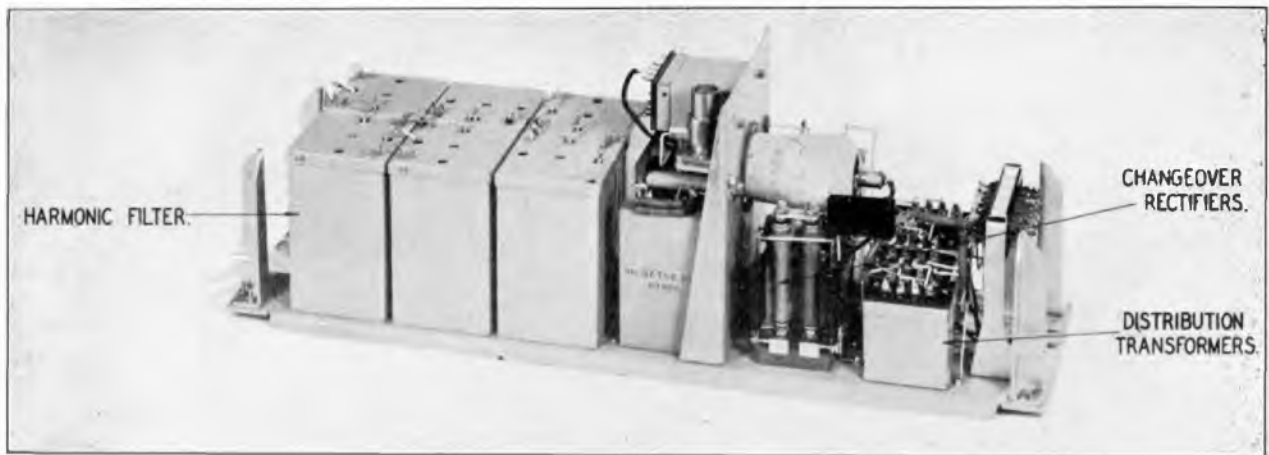

FIG. 29.—FREQUENCY SELECTOR UNIT.

latter terminal being transmitted through the cable. In effect, the control of the 200 kc.p.s. multi-vibrator is accomplished on its 2nd harmonic and the harmonic series of 200 kc.p.s., which includes the super-group frequencies, is produced. In a similar manner each 40 kc.p.s. multi-vibrator is synchronised on its 5th harmonic by a fundamental output from its 200 kc.p.s. multi-vibrator and a further harmonic series of 40 kc.p.s., which includes the group frequencies, is obtained. The process is then repeated for the channel frequencies by locking the 5 kc.p.s. multi-vibrator with an output from the 40 kc.p.s. multi-vibrator. It is not desirable to control the 5 kc.p.s. multi-vibrator direct from the 40 kc.p.s. multi-vibrator and the control is effected indirectly through a 20 kc.p.s. multi-vibrator. The production of the 10 channel frequencies of 64 to 100 kc.p.s. in steps of 4 kc.p.s. will be accomplished with the aid of a 4 kc.p.s. multi-vibrator locked by a second 20 kc.p.s. multi-vibrator. The three harmonic series corresponding to the super-group, group and channel carriers are selected by the respective harmonic band filters and each series is amplified in its harmonic band amplifier. In view of the similarity of the various multi-vibrators, selectors and power amplifiers only one of each type will be discussed.

Each multi-vibrator and associated harmonic band filter and amplifier are mounted as a single unit. The frequency of the uncontrolled multi-vibrator has been approximately adjusted by trimmer condensers to that of the control, which is fed to one anode circuit through a pentode amplifier. The harmonic series is selected from the second anode in a three section band-pass filter designed to pass the required band of carrier frequencies and amplified in a pentode amplifier. A photograph of a typical unit is shown in Fig. 28.

Frequency Selection.

The individual carriers are filtered from their respective harmonic band amplifiers by narrow band filters and each carrier is amplified to a level sufficient to energise four power amplifiers, the four outputs being obtained with a hybrid distribution system. The selector, Fig. 29, comprises a 6-section band-pass filter and a pentode amplifier. The filter

is designed to select one carrier frequency, the pass band loss being less than 10 db. and the loss on adjacent carrier frequencies greater than 60 db. The outputs of corresponding working and standby selectors are connected to the contacts of a relay mounted on the standby unit and the relay tongue is connected to a hybrid system giving four independent outputs. The changeover from working to standby is made by a master relay operated by rectified outputs from both selectors.

Additional outputs are taken from the 100 kc.p.s. and 2,200 kc.p.s. selectors to provide signals for the loss of synchronism unit, and a 2,200 kc.p.s. pilot for the repeater changeover equipment.

Power Amplification.

One of the four carrier outputs from each selector is fed to a power amplifier in which the carrier is amplified to provide the level required at the associated modulator and demodulator units. When the anticipated 320 circuits are in service each super-group, group and channel amplifier respectively

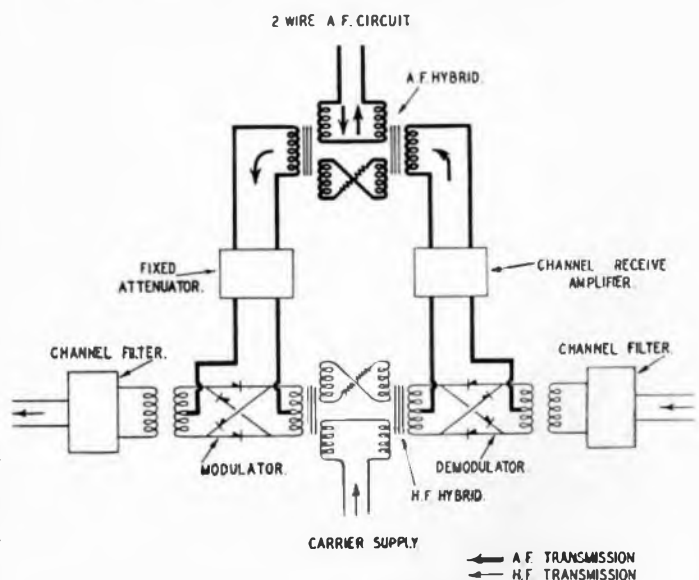

FIG. 30.—SCHEMATIC ILLUSTRATING THE USE OF HYBRIDS IN THE TERMINAL EQUIPMENT.

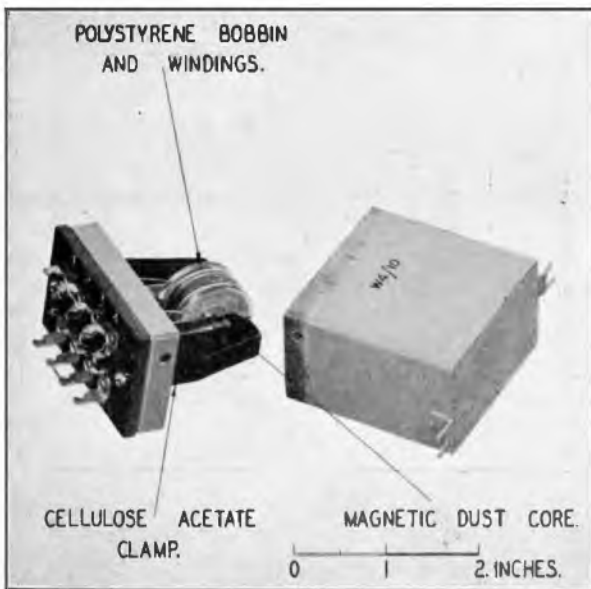

FIG. 31.—TYPICAL CARRIER FREQUENCY TRANSFORMER.

will feed 2, 8 and 40 modulators and a similar number of demodulators. The distribution of the carriers is accomplished in a hybrid distribution system and this is illustrated in Fig. 30. A typical carrier frequency transformer is shown in Fig. 31.

The signal levels of the respective carrier series are obtained with one stage of amplification using a single pentode valve for the super-group and group series, and with two paralleled pentodes for the channel series. The amplifier output is filtered in a 3-section band pass filter designed to introduce a loss of 40 db. on the 2nd harmonic frequency. The output switching system is similar to that for the selectors, the working and standby outputs being connected to relay contacts and the relay tongue to the hybrid distribution system. The relay is switched through a master relay operated by rectified outputs from both amplifiers. Fig. 32 shows a photograph of a typical channel power amplifier unit.

Changeover Equipment.

The operation of the cable is so dependent on the uninterrupted operation of the carrier equipment that it has been thought advisable to duplicate the apparatus at each terminal. The two sets known as the "working" and "standby" equipments are mounted on

opposite sides of a rack assembly, the one being almost a mirror image of the other. On the occasion of a fault on the working set the faulty apparatus is automatically replaced by its standby equivalent without interfering with the service, and visual and aural warning of the fault are given. The "working" apparatus cannot be brought into operation again until the switching system has been reset manually. It has not been found practicable to arrange for a single faulty working unit to be replaced by its standby unit owing to the switching complexity introduced and to the maintenance difficulties which would be experienced on a bay in which part of the apparatus was in service. Consequently, both the working and standby sets are divided into two parts, the first the production and selection equipment, and the second the power amplifiers; each part is switched independently.

Apparatus faults may be considered under four main headings, respectively, failure of drive, loss of synchronism of multi-vibrators, failure of carrier output at selectors and carrier failure at the power amplifier output. These failures are not independent inasmuch as a drive failure will cause the multi-vibrators to lose synchronism and failure of the carrier output at the selectors will be reflected in a corresponding power amplifier failure. A detailed description of the changeover system is not possible here but the design is such as to prevent unnecessary changeovers. For instance should the carrier output of the channel selector on 95 kc.p.s. fail, then the selector unit changeover will take place but the power amplifiers will not be affected.

The London master oscillator unit normally controls the multi-vibrators at both terminals; at the remote terminal by means of a pilot signal transmitted over one of the coaxial pairs. A second drive unit is kept in continuous operation at Birmingham, however, and a pilot signal transmitted to London. In the event of failure of the London drive at either terminal, control of the system is switched automatically to the Birmingham drive. In the remote possibility of a failure of the two pilot signals due to faults outside

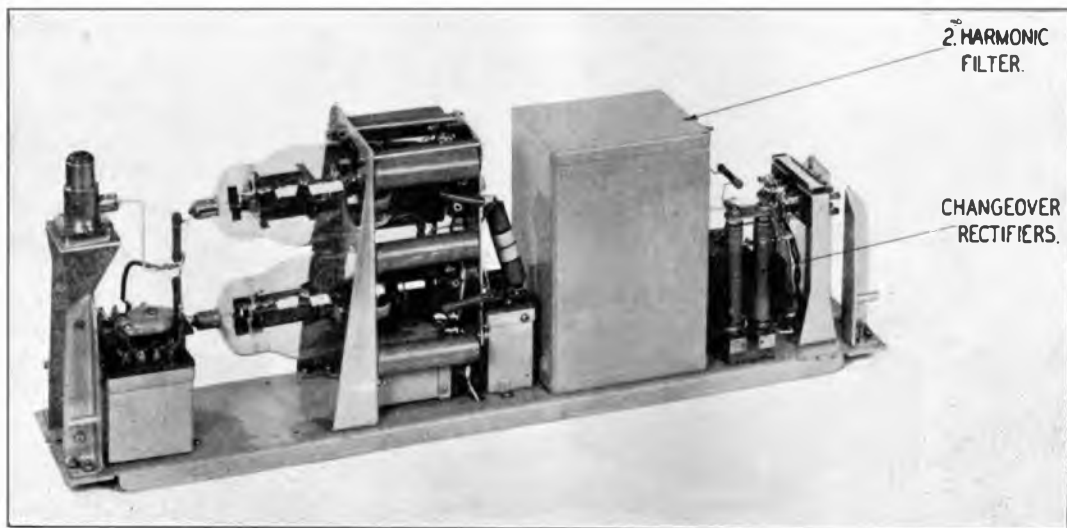

FIG. 32.—CHANNEL POWER AMPLIFIER (WORKING) UNIT.

the respective drives then the drive at each terminal takes control of its own multi-vibrators. In this connection the frequency stabilities and agreements of the two drives are such that the speech circuits are not seriously degraded by the employment of independent drives. Should a multi-vibrator cease to be controlled, due to loss of the control signal or to any other fault, the working multi-vibrators and associated selectors are replaced by the corresponding standby equipment. This changeover is controlled by the loss of synchronism unit. In the event of a failure of the output from the frequency selectors, the working multi-vibrators and associated selectors are replaced by the standby equipment. Standby power amplifiers are switched into service on the failure of the carrier output from the working amplifiers.

Loss of Synchronism Unit.

Should any of the multi-vibrators at one terminal cease to be controlled by the master oscillator, the loss of synchronism is detected by this unit and the necessary changeover made to standby equipment. The design is based on the fact that loss of synchronism in any multi-vibrator is reflected in the 5 kc.p.s. multi-vibrator. An output from the 100 kc.p.s. selector is fed to a tuned circuit connected across the

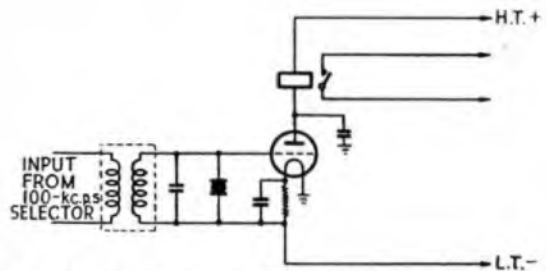

FIG. 33.—CIRCUIT OF LOSS-OF-SYNCHRONISM UNIT.

grid and filament of a triode (Fig. 33) and a crystal resonator, of series resonant frequency 100 kc.p.s., is paralleled with the tuned circuit. The anode current of the triode under static conditions is biased to the cut-off point. When the incoming frequency is precisely 100 kc.p.s. the crystal effectively short-circuits the tuned circuit, the grid input voltage is almost zero and no anode current will flow. Should the carrier frequency differ by even a few cycles from 100 kc.p.s. then, by virtue of the low dissipation constant of the equivalent circuit of the crystal, it ceases to act as a short-circuit, a radio frequency input is applied across the grid circuit, anode current commences to flow and the anode relay is operated. In turn the changeover relay is operated and the

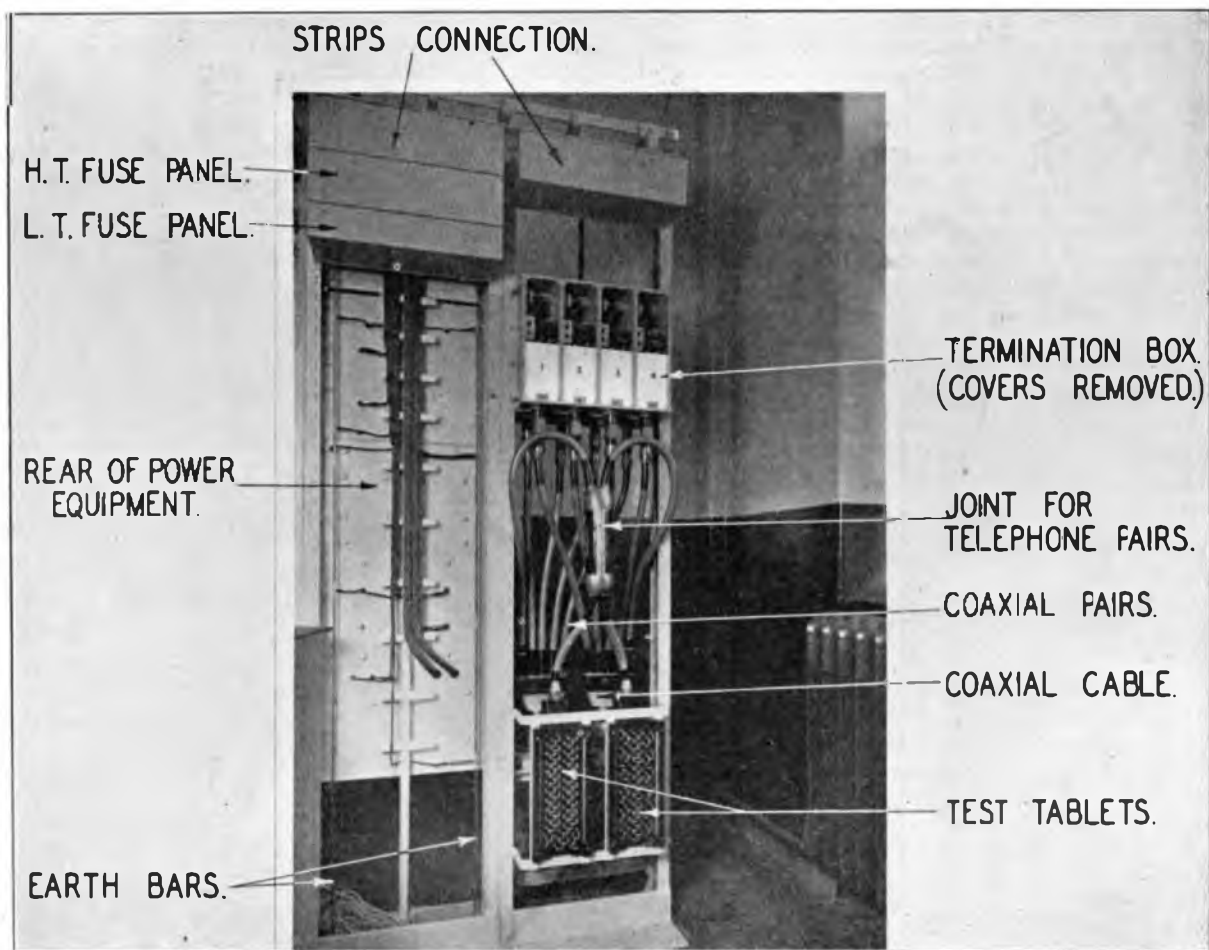

FIG. 34.—CABLE TERMINATION AT REPEATER STATION.

faulty multi-vibrators and associated selectors are replaced. The frequency variation which may be permitted without operation of the relay is adjustable within limits.

REPEATER STATION EQUIPMENT.

The repeater station equipment includes all the apparatus connected directly in the path between the modulating equipment at the two terminal stations. In all, there are 19 repeater stations, two being positioned in the respective terminal stations. Each station contains equipment similar to that at any other, apart from minor differences associated with the provision of a power supply over the coaxial pairs and the supervisory facilities at the terminal repeater stations.

A photograph of a cable termination at a typical repeater station is shown in Fig. 34. The four coaxial pairs from each of the London and Birmingham sides of the main cable and the power supply connections to the repeating equipment are led into a termination box. In the lower half of this box, protected by a sliding partition, are located the various filter networks associated with the transmission of power over the cable; details of the networks have been given in an earlier section. Access to the cable terminations, on which relatively high power supply voltages may be present, can only be obtained by raising the sliding partition. Mechanical interlocks prevent this partition being raised before the power supply connections have been removed and an earth applied to the coaxial pair. The various factors involved in the design of the repeater station equipment having been outlined earlier, the more important parts of this apparatus will now be described in some detail.

The High Frequency Repeater and Equaliser.

The repeater designed for use on the London-Birmingham route comprises an input transformer followed by four stages of amplification with an output transformer (Fig. 35). The first stage is provided with a small degree of feedback from the bias resistor. The coupling between the first and second stages consists of an equaliser network providing the equalisation required for a 6-mile length of cable.

The last three stages have feedback from output to input and also individual feedback on each stage.

The valves employed are high slope indirectly heated pentodes with a maximum anode dissipation of 10 watts at 250 volts. The heaters require 2 amps at 4 volts. The input capacitance is $16 \mu\text{F}$, the output capacitance $16 \mu\text{F}$ and the residual grid to anode capacitance $0.6 \mu\text{F}$, which can be reduced to $0.2 \mu\text{F}$ by means of a screening cap. The working mutual conductance is 10 milliamps per volt ± 10 per cent. Much of the success of the amplifier is due to the excellence of the valve characteristics; a development which has been accelerated by broadcasting requirements. The voltage stability is such that a 5 per cent. change in H.T. or L.T. causes a change not exceeding 0.1 db. The overall maximum gain of the repeater at 2.1 Mc.p.s. is 55 db., sufficient for a repeater section of 8 miles including the loss in the subsidiary equaliser, connected before the amplifier proper, which compensates for the length in excess of 6 miles.

A photograph of the repeater is shown in Fig. 36, which illustrates the type of screen assembly adopted. The components and wiring of the repeater are attached to aluminium screens in such a manner that after unsoldering the input and output coaxial cables, the high and low tension leads and removing a few screws, the whole repeater can be removed from the panel. This method of construction simplifies the wiring and permits of a ready interchange of units. It will be appreciated that the design has been arranged so as to minimise to the utmost interstage wiring. An aluminium cover is fitted over the compartments in addition to the standard dust cover.

The Spare Repeaters.

A spare repeater is automatically switched in if the main repeater fails. This is effected as follows: a control tone having a frequency of 2.2 Mc.p.s. is transmitted on each pair and selected from the output of each main repeater. After amplification and rectification it operates a relay circuit which switches in the spare repeater if the tone ceases to appear at the output of the main repeater. The changeover time is less than 30 milliseconds. A

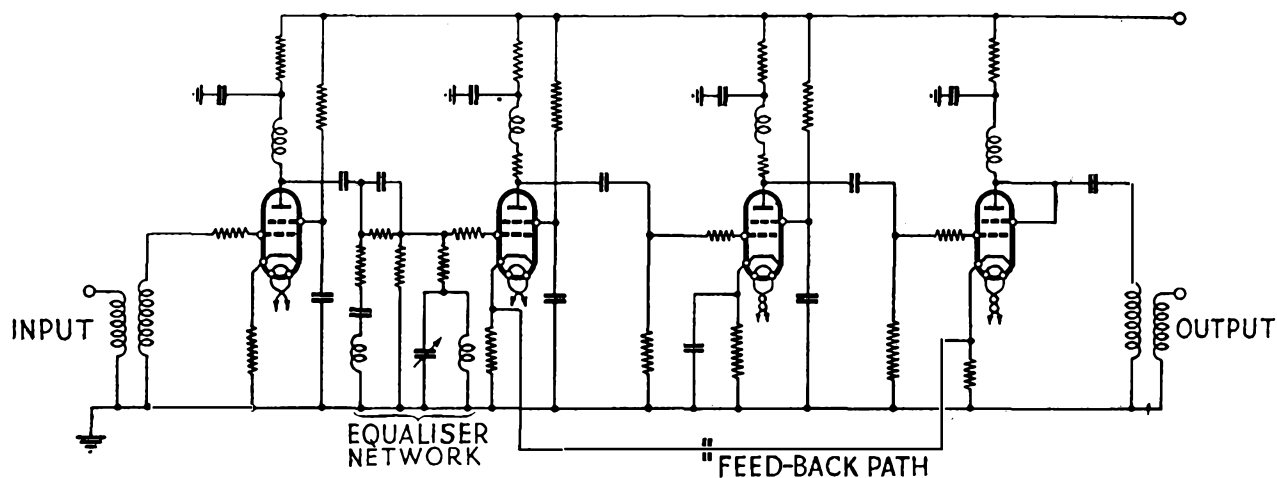

FIG. 35.—HIGH FREQUENCY REPEATER AND EQUALISER.

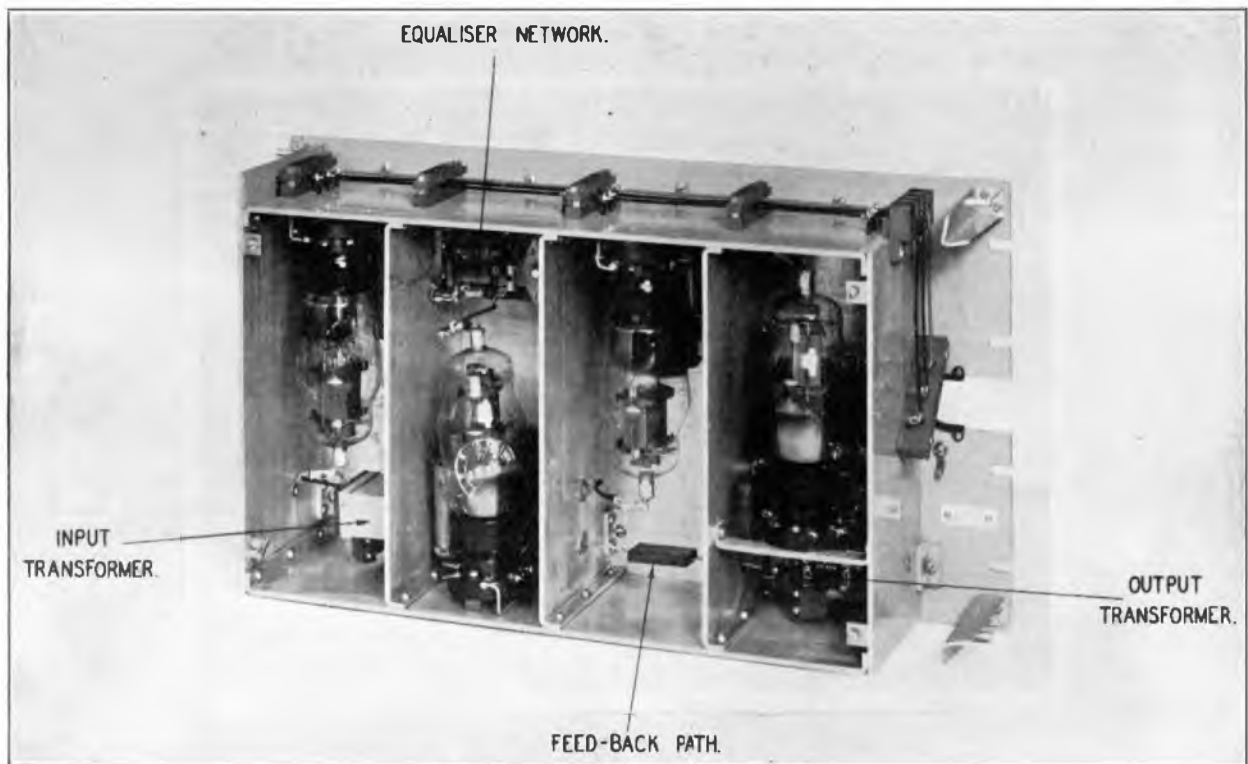

FIG. 36.—FEED-BACK REPEATER.

similar selector panel is also required across the output of the spare repeater.

Features of the scheme are :—

- (a) Only the spare repeater on the appropriate coaxial pairs at the station affected is switched into circuit.
- (b) While the spare repeater is not in circuit it operates under reduced high and low tension voltages. When switched into circuit the voltages are increased to normal and the repeater gives the required gain immediately but does not give the required reduction of inter-modulation products until the cathode has reached the proper operating temperature. By this means valve life in the spare repeater is prolonged and immediate continuity of service, although of a lower standard, ensured with a low power consumption during the inoperative condition.
- (c) In the event of a cessation of the control tone at any point in the system all stations failing to transmit the tone, automatically test to see whether the use of the spare repeater on the particular pair affected will restore the tone. Restoration of the tone, possibly by the automatic replacement of a faulty repeater, automatically causes all the subsequent main repeaters in the system to be tested before allowing any further spare repeaters to come into actual operation at any later station. Thus a spare repeater only remains in circuit if its main repeater is found to be faulty.

- (d) An indicator at London makes it possible to see at a glance which stations are operating on their spare repeaters and thus enables the central control to issue the maintenance instruction and inform them automatically of the restoration of the main repeater to service.

Compensation of Attenuation Changes due to Temperature Variation.

It has been pointed out earlier that the maximum total variation in attenuation from London to Birmingham per year due to temperature will be about 33 db. at 2.2 Mc.p.s. and 12 db. at 0.4 Mc.p.s. From recorded temperature measurements on a section of the cable it appears that any compensation for the most severe temperature changes encountered need not be applied more frequently than once a fortnight and over the greater part of the year the interval will be considerably longer. A much longer period of observation will, however, be necessary before definitely assuming that this will be adequate.

It has been decided to operate the circuit initially with manual control and leave the automatic compensation to be applied later. A small compensating network, forming part of the subsidiary equaliser, is provided on each coaxial pair at each station, and can be switched into or out of circuit. All temperature changes will be taken up as required at the main attended repeater stations, except twice each year when certain of the intermediate station networks will have to be switched; further control for the next six months can then be effected at the main stations.

Speaker and Supervisory Circuits

The provision of adequate and efficient speaker and supervisory circuits forms an integral part of any transmission scheme involving unattended repeater stations. The speaker and supervisory circuits are provided on the unloaded paper insulated pairs contained within the make-up of the complete cable. These are repeated and equalised at main stations by means of single stage feedback repeaters, having a gain of about 40 db. The valves used for the repeaters and for almost all supervisory and test equipment are indirectly heated high slope H.F. pentodes.

In the present system the supervisory and test equipment can be sub-divided into low frequency tone operated and D.C. operated circuits.

(a) L.F. Tone Operated Supervisory Circuits. Each station on the route is associated with a particular frequency which is continuously generated from an L.F. oscillator at that station. The frequencies employed are the same as those used in V.F. telegraphy and consist of odd multiples of 60 c.p.s. commencing at 420 c.p.s. One function of these tones is to provide positive indication at London of the failure of a main repeater at any station. The tones are normally transmitted from each station over a common repeated pair to London where they are selected and used to operate supervisory equipment. Failure of a repeater suppresses the associated tone at the transmitting point thereby giving an indication in London.

The main repeater station oscillators are also used for calling London or Birmingham on the speaker circuit and the two terminal stations can bring in any main station by means of a 6-frequency ringing oscillator.

(b) D.C. Operated Supervisory Circuits. Supervision at London is obtained of other causes of failure, e.g. L.F. repeater, supply failure, cable breakdown, etc. by means of a D.C. bridge circuit operating on two of the telephone pairs.

By these two supervisory systems it is possible to identify and locate most of the important sources of failure that might occur on the coaxial cable system without delay.

The Power Bay

The power required at each station to operate the H.F. repeater and switching equipment for the four coaxial pairs and test, supervisory and L.F. repeater equipment for the telephone pairs is about 800 watts. As explained earlier, power for these purposes is transmitted over the coaxial pairs from the main to the intermediate repeater stations. A local power supply is used for lighting and inspection at all the intermediate stations.

The power supply at every main repeater station is stepped up to 350 volts and all power equipment is designed to operate from 280–350 volts. Power at 350 volts is supplied (a) to the "up" or "down" coaxial pairs as required for transmission to the

intermediate stations, (b) to a 4-volt transformer for filament heating and (c) to a transformer which supplies the Westinghouse rectifier unit yielding a 250 volt D.C. supply; this transformer also carries a

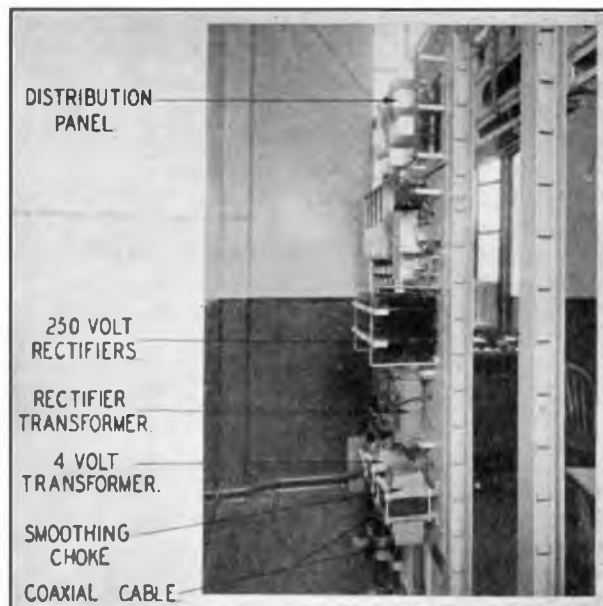

FIG. 37.—POWER BAY AT REPEATER STATION (COVERS REMOVED).

small tertiary winding supplying a small rectifier giving a 40 volt D.C. supply for energising relay circuits.

The power bay equipment is completely enclosed by two expanded metal covers, affording adequate ventilation and ensuring protection against electric shock. The design of the power bays at the intermediate stations is similar to the main stations excepting that the transformer for supplying power to other stations is omitted. A photograph of a typical main repeater station power bay is shown in Fig. 37.

Test Equipment.

Each repeater station is provided with the following panels of test equipment.

(a) Valve Test Panel.

This is used for a rapid test on anode current and mutual conductance of the various valves. Its use necessitates the removal of the valve from its normal working position.

(b) L.F. and D.C. Test Panel.

For measuring H.T. volts and current to every panel, setting up selector detector circuits and measuring L.F. voltages.

(c) H.F. Test Panel.

This comprises an oscillator having a constant output characteristic working over the range 0.35 to 2.3 Mc.p.s. and yielding various fixed output levels of 0 to 40 db. relative to 1 mW in steps of 5 db. It also includes a wide range calibrated receive element for measuring levels.

The London Fire Brigade Alarm System C. H. WRIGHT, A.M.I.E.E.

London Fire Brigade Headquarters have recently been rebuilt and modern equipment installed. The conversion of all stations in the area to the "Gamewell" system, which has been adopted, is proceeding rapidly, and the author gives details of the system and of the equipment.

Introduction.

THE ceremonial opening of the new Fire Brigade Headquarters, Albert Embankment, by His Majesty the King on July 21st 1937, marked the completion of the initial stage in the London County Council's programme to provide London with an up-to-date fire alarm system. For the past 37 years or so London has been protected by the "Brown" fire alarm system which has been rented by the Council from the Postmaster General. This system, which was invented by the late A. C. Brown, is the acme of simplicity and has faithfully fulfilled its purposes.

In the "Brown" system each street post is connected by a direct pair to a common battery at the station via a flap indicator. When a point is "pulled" the line circuit is closed, causing the flap of the indicator to fall, exposing its designation and a line jack, and actuating the station alarm bell. The contact is kept closed by an electromagnet within the head, until released by the watchroom attendant plugging into the line jack and disconnecting the line current. Each street point is also equipped with a buzzer which produces a distinctive signal when the point is pulled enabling the attendant to distinguish between genuine and false calls.

In 1913 as the result of an unfortunate fatality the Brigade intimated that they had ceased to place reliance in the buzzer signal and from that date they have turned out for any and every indication whatsoever.

In 1900 there were 675 posts. They had increased to 1,360 in 1928 and 1,732 in 1936. The number of calls received in 1936 was 9,297. Of these, 5,875 were genuine and 3,422 false. The false calls were divided between 1,304 malicious calls, and 2,118 calls due to electrical defects and other causes. Of the latter figure approximately 1,000 were attributed to electrical faults.

It was with a view to reducing the number of abortive turnouts and the annual costs to the Brigade in rentals that in 1928 the Council approached the Post Office to aid them in providing their own system and the Post Office readily agreed to place its experience at the disposal of the Council.

Following protracted cost studies the Council decided to accept the Gamewell, code signalling, closed circuit, system which was considered to be the most satisfactory, and an experimental system of 26 street boxes arranged on two loops, was provided and installed in 1931 by Messrs. Standard Telephones & Cables, Ltd., at the late Headquarters station in Southwark. The Post Office conducted the negotiations and the placing of the contract, supervised the installation and the acceptance of the equipment, and recovered the cost, which included a nominal percentage service charge, from the Council under

a repayment order. The line wires were of course rented from the Post Office which also undertook the maintenance of the equipment on rental terms. The system functioned satisfactorily and in 1936 the Council decided to proceed with the conversion programme commencing with the new Headquarters Station at Lambeth, to be followed by the "B" District. They expressed a wish, however, for certain later developments which were covered by patents associated with the apparatus manufactured by Messrs. Automatic Telephone & Electric Co., Ltd., to be incorporated in the street boxes. The contractors were approached and by agreement with the Council it was decided to accept street boxes of Messrs. Automatic Telephone & Electric Co.'s design and station equipment designed by Messrs. Standard Telephones & Cables. This has resulted in a division of the work between the two contractors.

Work has been completed in the "B" District and the equipment was brought into use in November. There are ten stations including Clerkenwell, which is the superintendent station, and 299 street boxes. Messrs. Standard Telephones & Cables are installing the equipment at Whitefriars, Cannon Street, Redcross Street, Soho and Holloway, and Messrs. Automatic Telephones and Electric Co. have Clerkenwell, Euston, Islington, Camden Town and Kentish Town in hand.

Instructions have also been received to proceed with the installations for Battersea and Shadwell new fire stations.

Organisation of the London Fire Brigade.

The L.C.C. area is divided into six districts A-F, each in charge of a superintendent station which controls the outstations in the respective districts. The superintendent stations are Manchester Square, Clerkenwell, Whitechapel, New Cross, Southwark and Clapham. The station at the Fire Brigade Headquarters is an outstation on Southwark.

There are 52 outstations and each has a direct telephone line to its superintendent station, each of which has in turn direct communication with the control room at headquarters, Lambeth. Each superintendent station has a direct line numbered 2222 to every telephone exchange in its district. Outstations have no direct exchange line, so that fire calls originated by the public over the telephone exchange network must necessarily be advised to the superintendent station. The alarm is then transmitted to the outstation concerned from the superintendent station by a fire signal over the direct telephone line, which rings the station alarm bells. While the firemen are manning the appliances ready to depart, the watchroom attendant ascertains the particulars of the fire and passes them to the station officer who rides on the first appliance to leave.

An indicator at the superintendent station associated with the fire signal key is operated and remains in view until it is restored manually upon receipt of the advice from the outstation that the appliance has returned.

If a call is received at an outstation from one of its street points the watchroom attendant transmits a fire signal to the superintendent station, which rings a local alarm bell only, and passes over details of the call. The indicator signifying "appliance out" is again operated and remains so until the appliance returns. The superintendent thus knows at any time the disposition of the fire fighting appliances in his area.

The Brigade is organised so that as some stations are deprived of their apparatus in response to calls others are re-distributed to cover those stations. Particulars of all fires and the appliances attending them are notified to headquarters where a mobilisation map is marked to show the seat of the fires and the appliances attending.

Fires which are beyond the capacity of an outstation to deal with become district calls upon which the district appliances are concentrated. If these cannot gain control over the conflagration a brigade call is circulated and appliances are drawn from the stations throughout the London area under the direction of the Mobilisation Officer at headquarters. This may mean as many as 60 pumps, escapes, etc., being employed. The remaining appliances are re-distributed over the area.

The present equipment of the Brigade includes 68 pumps, 55 dual purpose appliances (escape and pumps), 35 escape vans and turntable ladders, 26 other appliances and 3 river floats. There are 31,311 fire hydrants and 52 miles of hose. The personnel comprises 1,980 uniform staff and 163 administrative, technical and other ranks.

" THE ' GAMEWELL ' SYSTEM "

Since its introduction into this country in 1900, the Gamewell System of Fire Alarms has remained basically unchanged. The street fire alarm boxes differ in detail, but the modifications which have been introduced from time to time by the various

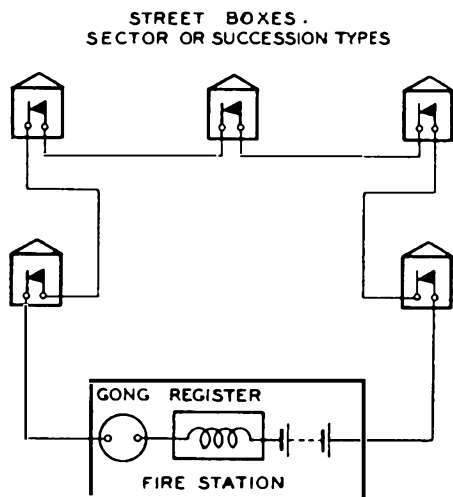

FIG. 1.—PRINCIPLE OF THE GAMEWELL SYSTEM.

manufacturers have all been in the nature of refinements, or added facilities.

The fundamental principles of the system are as follows:—

1. It is a closed circuit system. Fig. 1 shows the electrical circuit in its simplest form.

2. The street fire alarm boxes are arranged in groups. The boxes forming a group, maximum 20, are connected in series by a single wire which passes progressively from one box to the next.

3. A small current of 50 milliamps is maintained around the loop by a battery at the fire station. The maximum permissible voltage of the battery is 50 volts.

4. Each box contains a powerful clockwork mechanism which is employed to drive a code wheel which transmits signals to the fire station.

5. The various electro-magnets in the recording equipment at the station are employed to release the energy of coiled springs.

6. Each box bears a code number of two, three, or four digits. The highest digit is 6.

7. Normally, the mechanism of each box is short-circuited by contacts held closed within the box.

8. When a box is "pulled" it commences to send its code after a short test interval. Impulse contacts in series with the line are intermittently made and broken in accordance with the code number of the box. A box coded 214 would transmit two impulses, followed by one and then by four. Between digits the circuit is disconnected.

9. The code number is sent three times, whereupon the mechanism stops and the short-circuit is restored. The signals are transmitted at a speed of 3 impulses per second.

10. Suitable apparatus is located at the fire station which gives visible and audible indication of the call.

11. A disconnection on the line due to a fault is recorded on the station apparatus and a "patching" switch is operated automatically, which earths the station battery and connects both ends of the fire loop bunched, to the recording apparatus. The system resorts temporarily to earth working.

12. The use of code signalling prevents a fault from being mistaken for a genuine call.

13. Calls can be received without loss of impulses under any one of the following fault conditions:

- Circuit broken.
- Circuit broken and earthed at the same point.
- Box or boxes short-circuited.
- Circuit earthing.

14. Calls incoming from the Gamewell loops can be automatically repeated to a central or superintendent station over a repeat loop.

15. Two types of alarm boxes are used.

- (a) Plain Sector.
- (b) Non-interference Succession.

The plain Sector box is employed on small installations where the possibility is remote of two boxes on the same loop being pulled simultaneously. On large installations this condition is more likely to arise, and from a consideration of Fig. 1, it will be

seen that if a second box is pulled while one is already transmitting, they would interrupt each other's signals and the record at the station would be unintelligible.

To prevent this, the succession box was introduced. With this type more than one box can be pulled simultaneously on the same loop without interference. The succession feature causes each box to await its turn to transmit its code, the order of succession being controlled strictly in accordance with the chronological order in which the boxes were pulled. When a box is once "pulled" further operation of the handle cannot affect the working of the mechanism, until it has transmitted its code and reset itself.

Succession Alarm Box

This box is the one approved for installation in the London County Council Fire Brigade area and incorporates features which were developed by the Post Office. Fig. 2 shows the exterior view of the box mounted on its pedestal, the interior being shown in Fig. 3. The inner box contains the code signalling mechanism and the testing equipment. The hand micro-telephone and the trip lever mechanism T, which is actuated by the pull handle, are mounted behind the outer door. The Gamewell mechanism is further protected by being enclosed in a glazed compartment. Below the Gamewell mechanism is the test panel.

The inner and outer boxes are insulated electrically from each other.

When a box has been operated for a fire call, the projection R prevents the outer door, when opened by the visiting fireman, from being closed until the spring of the code mechanism is fully wound. In conjunction with the door shunt contacts G, it also short-circuits the testing equipment when the outer door is closed. Projection S ensures that the act of closing the outer door will also close the inner door if this should be open.

Electrical Connections.

Fig. 4 shows the connections of the box with all contacts, keys and switches in their normal position, i.e., when the box is closed ready for a call. The path for the line current is line A, door contact, resis. C.O. contacts (C Fig. 3), to line B. When the box is "pulled," the resis. C.O. contacts are opened mechanically and the circuit is then line A, door contact, succession coil A, impulsing springs, succession coil B, to line B. By the same operation, the earth springs are made.



FIG. 2.—THE SUCCESSION ALARM STREET BOX.

There is a short test interval of approximately 3 seconds before coding commences. If the line current is maintained through the succession coils, the impulse springs are actuated by the code wheel and lever, and the code is pulsed to the fire station. After the code has been sent three times the mechanism stops automatically, the shorting springs remake and the earth springs are broken.

Had either line A or B been broken due to a fault, when the box was pulled, the circuit would have previously been switched at the fire station for earth working i.e., with an earthed battery to both lines in parallel. The impulsing circuit would then have been over the good line through one line succession coil, the impulse springs, earth succession coil, earth spring, rectifier, to earth.

With a line current of 50 milliamps, the rectifier offers a resistance of approximately 60 ohms. Its function is to prevent a box in operation being short-circuited if the boxes on either side are pulled at the same time.

Testing Facilities. The testing facilities are accessible only when the inner door is open. The door shunt contacts (G Fig. 3) are then broken, the short-circuit is removed from across the testing equipment, and the tap bell (N) is connected in series with the impulse spring (F).

Telephone Calls. The telephone is provided to enable the firemen to speak to the station over the Gamewell Loop. To call the station, the telephone key (H) is depressed momentarily. The short-circuit is then removed from across the 1,000 ohm resistance which is introduced into the line circuit, and the line current is reduced by 50 per cent. This is insufficient to actuate the fire alarm apparatus at the station,

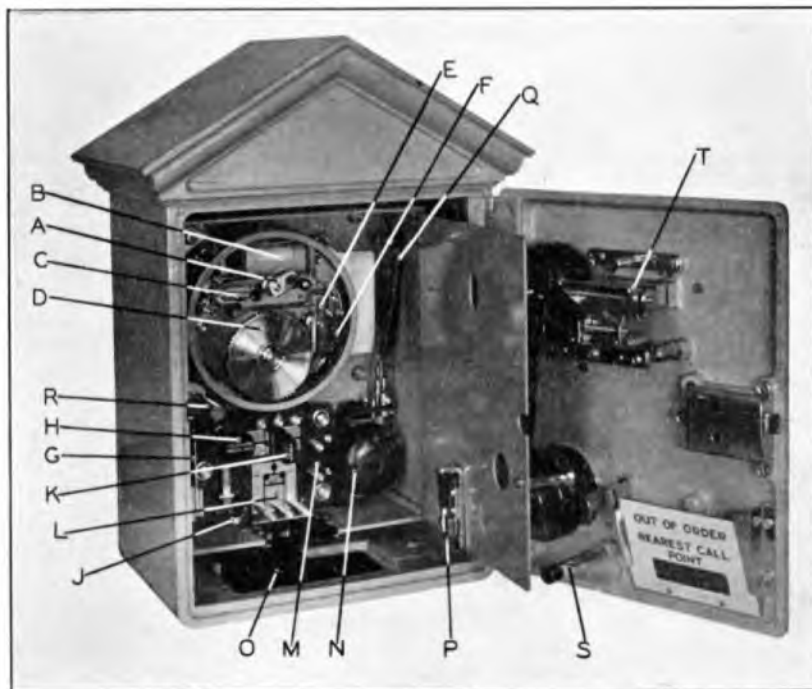

FIG. 3.—INTERIOR OF THE SUCCESSION ALARM BOX.

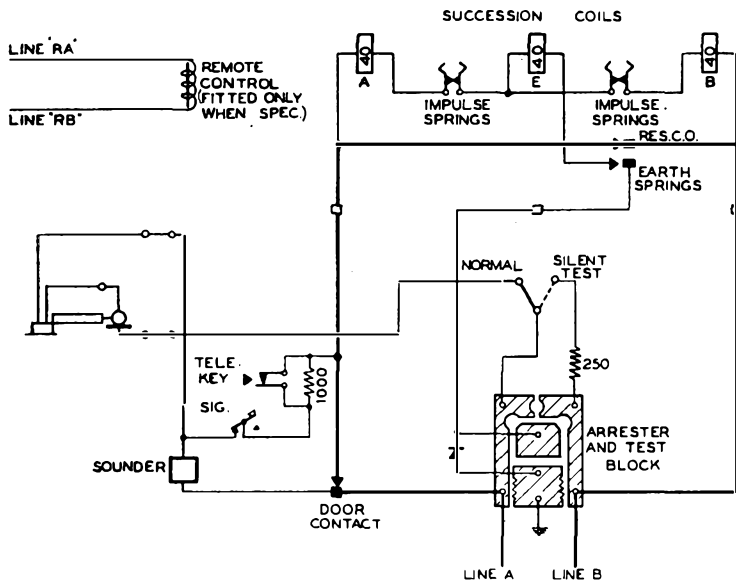

FIG. 4.—CONNECTIONS OF THE SUCCESSION ALARM BOX.

but a marginal relay is released which operates the telephone call apparatus.

The station is able to call the attention of the attending firemen by operating a howler key. The howl being received at the box in the hand microphone receiver.

Signalling Key. The signalling key (J) is used for routine testing and when the necessity arises for signalling to the station. The operation of the key merely breaks the loop.

Silent Test. This facility is provided to enable the operation of the fire alarm mechanism at the box to be checked without actuating the station equipment. When the two position plug switch (K) is pulled out, the connections shown dotted are established. The 250 ohm resistance is connected across the A and B lines, thereby maintaining the loop.

When the alarm mechanism is set in motion, the impulse springs alternately disconnect and reconnect the succession coils (B) with the tap bell (N) in series across the 250 ohm coil. The code of the box is tapped out on the bell but the continuity of the loop circuit is undisturbed.

Arrester and Test Block. This block (L) acts as a lightning arrester and also provides facilities for

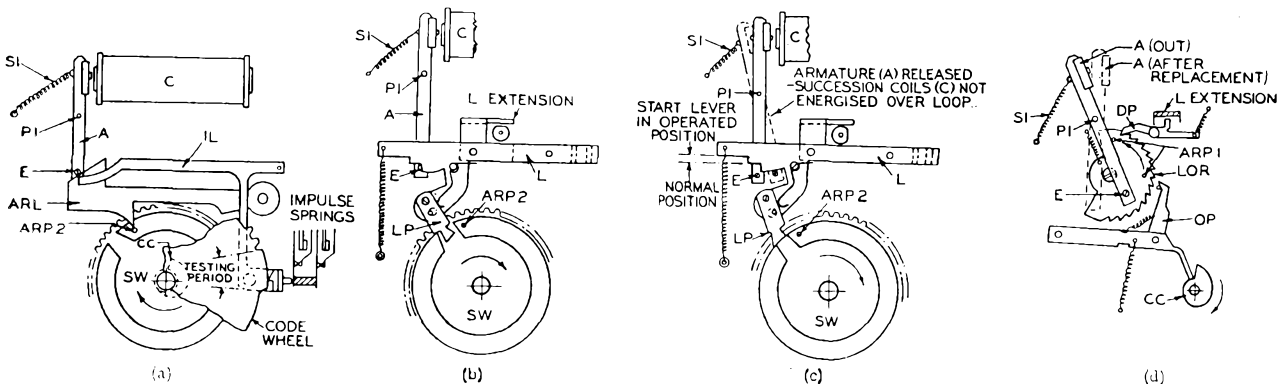

FIG. 5.—DETAILS OF THE CODE MECHANISM.

earthing the line through the rectifier on either side of the box or for short-circuiting the box out altogether.

Mechanism.

The mechanism consists of a spring kept fully wound which, when tripped, drives the code wheel. The speed of impulsing is 3 per second and is controlled by an escapement governor.

Fig. 5 (a) shows the armature A pivoted at P1, the impulsing lever IL resting upon the code wheel, and the impulsing springs, which are kept closed by the insulated pin on IL. Behind the code wheel and mounted on the same shaft is the stop wheel, SW (Fig. 5 (b)) which is held stationary by the pawl LP attached to the start lever L. The armature A is held mechanically, close to the succession coils by the pin E which rests against lever ARL, which in turn rests on pin ARP2.

Operation, Normal Call. When the box is "pulled" the door lever engages with and raises the start lever L (Fig. 5 (c)) and the mechanism commences to revolve. Coincident with this, the short-circuit is removed from across the signalling mechanism, and the box is earthed through the rectifier and earth succession coil. The line current now passes through the line succession coils, and the armature is held in position magnetically.

For the space of approximately 3 seconds the signal lever IL passes over the long test tooth (Fig. 5 (a)) testing the line, and the impulse springs are kept closed. If the line current is maintained, i.e. no other box impulsing, the armature will remain attracted and the signal lever IL will follow the projection of the code wheel, transmitting the code. The normal condition of the line is, during impulsing, a disconnection and the signals consist of a series of "makes" until the signal lever rests again upon the long test tooth, whereupon continuity is reestablished.

The armature is retained in position while the line is disconnected at the impulsing springs by the pin E, resting against the end of the signal lever IL (Fig. 5 (a)). When the code wheel has completed one revolution, the pawl LP drops into the gap in the stop wheel SW and stops the mechanism (Fig. 5 (b)).



FIG. 6.—STATION EQUIPMENT AT HEADQUARTERS, LAMBETH.

Call with line already in use. If a box is "pulled" when another already has possession of the line, the mechanism of the box is started and revolves as before. The armature is, however, released at the first disconnection due to the other box and is pulled away from the coil by the spring S1 (Figs. 5 (c) and (d)). The pin E slips under the start lever L, and over the signal lever IL. The latter is prevented from following the undulations of the code wheel and the former from dropping when pawl LP comes over the slot in the stop wheel (Fig. 5 (c)). The impulse springs are thereby kept closed while the other box is transmitting and the mechanism runs on for an idle revolution.

The line current is insufficient to attract the armature, once released, against the retractive force of the spring S1. At the end of each revolution however, pin ARP2 on the stop wheel (Fig. 5 (a)), engages with the cam face of lever ARL, which thrusts against pin E and presents the armature to the coils. At the moment the armature is presented to the coils the test tooth reaches the impulse lever IL. A further test of the line is made. The armature is either retained by the line current which has been restored, and the box then sends its code as in the normal call, or, it is released again by a disconnection of the line, and the code wheel runs for a further idle revolution.

To prevent the box from running down should a break occur in the line, the mechanism is arranged to stop after 8 revolutions of the code wheel. A full run for one winding is 18 revolutions. A cam CC (Fig. 5 (d)), mounted on the same shaft as the code wheel, actuates the pawl lever OP which advances the ratchet wheel LOR in an anti-clockwise

direction, one tooth per revolution of the code wheel. The ratchet wheel is locked at each stop by the pawl DP. As the code wheel approaches its normal position at the eighth revolution, the pin ARP1 engages with the armature A, advances it to the coils and holds it there. Pin E is carried clear of the start lever allowing pawl LP to drop into the slot in the stop wheel and the mechanism stops.

STATION EQUIPMENT

Each outstation in the London Fire Brigade area is provided with one or more box loop panels mounted above register cabinets and a combined auxiliary and repeat panel mounted above a cabinet to line up with the others. Superintendent stations have similar equipment for their own fire alarms and, in addition, incoming repeat loop panels upon which the repeat loops from the outstations terminate.

At stations where there is an A.C. supply each Gamewell loop is equipped with a single 50 volt, 10Ah battery which is floated across a metal rectifier. A single 24 volt,

30Ah battery, floated, is provided for operating telephones, relays, bells, displays, alarms and miscellaneous station apparatus.

At stations with a D.C. supply the batteries are provided in duplicate and worked on a charge-

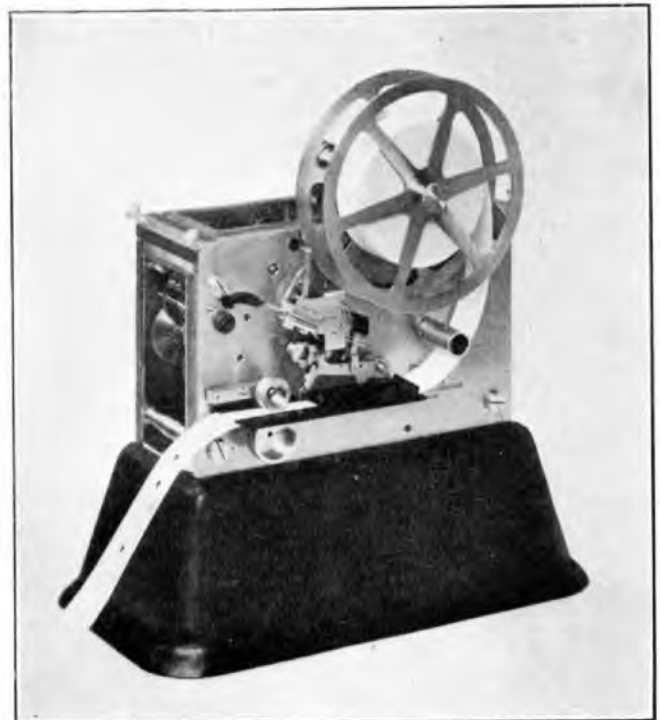

FIG. 7.—SINGLE CIRCUIT REGISTER.

discharge basis, the batteries off-load being charged direct from the mains through rheostats. There is in addition, at the superintendent station, a common 50 volt, 60Ah battery (or batteries) which serves all the incoming repeat loops.

Fig. 6 shows the station equipment installed at Headquarters, Lambeth. The combined auxiliary and repeat panel is in the centre, and the box panels and register cabinets are on either side. Above the panels is the illuminated display, which, in conjunction with a common alarm bell and the panel pilots, gives a positive indication of circuit functions and fault conditions. The displays are fire, fuse, enquiry, short-circuit, telephone, circuit broken, earth, mains failure, fire telephone. The two lamps surmounting the ensemble are emergency lighting.

Box Loop Panel.

The three meters left to right are, a loop battery charging ammeter, 0-0.5 amps, a high resistance voltmeter, 0-70 volts, for measuring the loop battery voltage and for line testing, and a milliammeter, 0-100 mA, for measuring the loop current. Below, are the charging and loop current regulating rheostats.

The five lamps which are coloured red, opal, green, green and red are the panel pilots, and are labelled fire, fuse, short-circuit, earth and circuit broken respectively. The eight keys are test keys for use in conjunction with the meters, testing the lines and cancelling the displays. Within the glazed cabinet is the punch register and take-up reel which are both spring driven. The latter maintains the tape in tension. Fig. 7 shows a single circuit register with a typical tape record of a call. Within the body of the cabinet are located the battery charging equipment and circuit relays, fuses, etc. The loud sounding gong connected in series with the punch register is located in the station appliance room. A 6" dome of bell-metal covers the spring driven mechanism. When the loop current is interrupted an electromagnet releases the hammer which is flung by the spring into violent contact with the dome, and registers one stroke. The electromagnet is re-energised when the current is

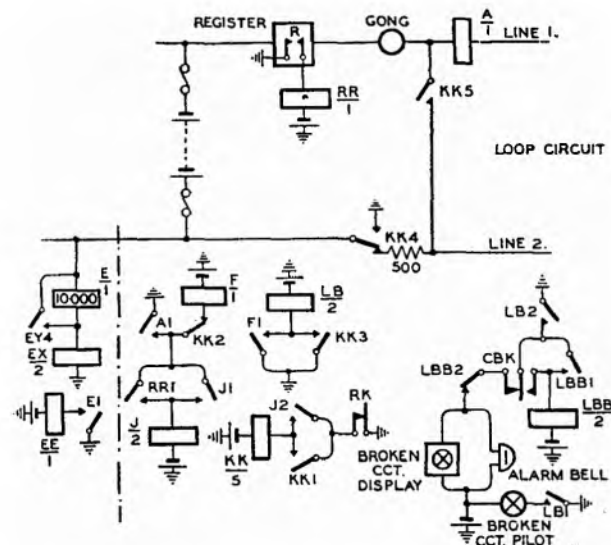

FIG. 8.—"BROKEN LINE" CIRCUIT.

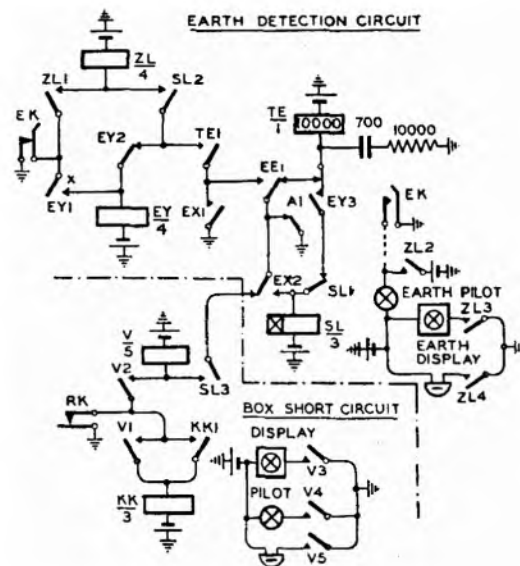

FIG. 9.—CIRCUIT FOR EARTH DETECTION AND BOX SHORT-CIRCUIT.

restored, and re-engages the hammer which remains at rest until released by a further interruption in the line current.

Station Auxiliary and Repeat Panel.

The two meters are a charging ammeter, 0-5 amps, and voltmeter, 0-30 volts, associated with the station 24 volt battery. The four pilot lamps opal, red, red, opal, are labelled, fuse, repeat circuit broken, fire float out and indicator. At a normal out-station the last two pilots would not be required. Their respective functions at headquarters are to indicate that the fire float is away from its moorings on the embankment in front of the station and that the box number and the address of a box actuated for a fire call is being displayed in the appliance room on a special illuminated indicator panel.

The two sets of four keys are for cancelling the various displays in the above panel, measuring battery volts, and controlling the emergency lighting. The battery of toggle switches between the meters operates several special displays about the building which indicate to the crews the appliances to be turned out, and so save the energy of those not required. They also keep the senior brigade officers in touch with the movement of the headquarters appliances. The centre knob is the charging rheostat. The first row of keys on the cabinet controls the house bells which summon the fire fighting personnel. Provision is made for ringing the bells—collectively or individually—automatically on an incoming fire call or signal from a superintendent station, or manually, as required.

The lower keys are the telephone speaking and ringing keys with line lamps above, wired on the cordless board principle. The upper lamp of each of the four lines equipped with two lamps is the fire flash. These lamps are red, and intermittently flash when a fire signal is received. The circuits are connected to Southwark,—which is the superintendent

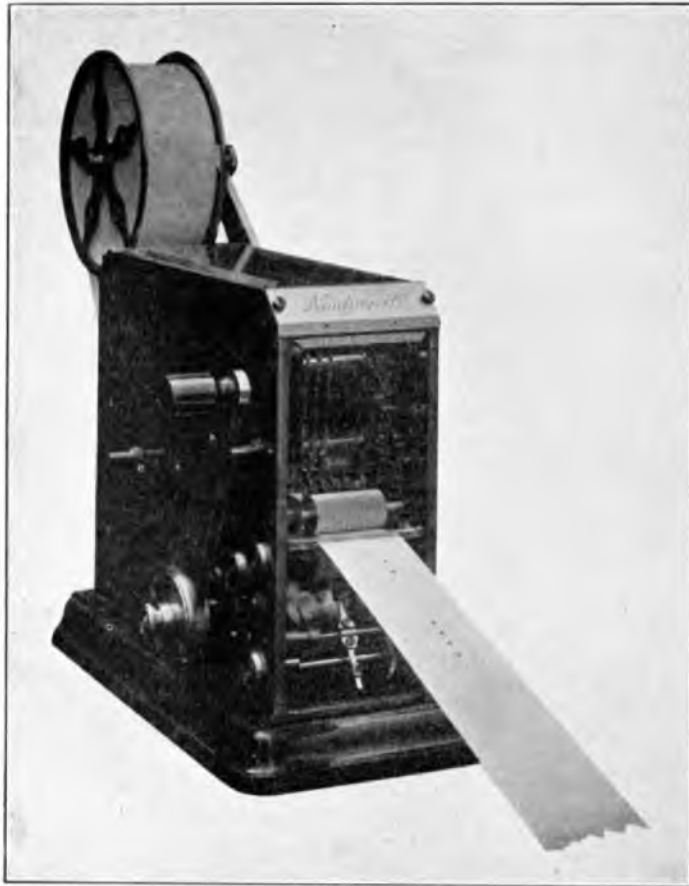

FIG. 10.—4-CIRCUIT PUNCH REGISTER.

station controlling headquarters—Manchester Square, Clapham and the Control Room in the headquarter's building which all have the authority to turn out the appliances.

The remaining four single keys cancel the display associated with enquiry bells at the three entrances to the building and the public fire pull let into the front wall. A hand micro-telephone and a drawleaf writing shelf complete the cabinet.

The circuit relays and battery charging rectifiers are located within the body of the cabinet.

Circuit Facilities.

Normal Working. As will be seen from Fig. 1 the code operation of the impulse springs of a box will actuate the register and gong. The alarm panel displays "Fire," the fire flash lamp on the box loop panel flashes until cancelled, and the alarm and house bells ring.

Telephone Calls incoming from a street box release a marginal relay which lights the line lamp, displays "telephone" and rings the common alarm bell. The attendant answers by throwing the telephone key, which cancels the display and alarm bell.

Broken Line. Fig. 8 shows the principle of

operation of the battery automatic change-over when the loop circuit is broken.

Line relay A releases (shown in the operate position) and operates F which actuates LB. LB lights the "broken circuit" display and pilot, and rings the alarm bell. One stroke is recorded on the gong and tape of the register. The tape runs for approximately 6 inches then stops. The contacts R on the register close momentarily immediately prior to this and operate RR and J which locks via J1 and A1. Relay KK operates and locks via key RK. Lines 1 and 2 of the box loop are connected in parallel at KK5. Relay LB is held by KK3. The display and bell are cancelled by operating key CBK momentarily. Fire alarm calls can now be received over either leg of the loop and earth. Provision is made to prevent calls originated simultaneously on both legs from mutually interfering. When the line break is cleared the battery connections are restored to normal by operating, momentarily, key RK, which releases relays KK and LB and dims the pilot.

Earth Detecting. The principles of the earth detecting circuit are shown in Fig. 9. Contacts A and TE are shown normally operated. An earth on the loop operates relay EE but not EX (See Fig. 8.) The holding circuit of TE is broken by EE and TE releases in 14 secs., whereupon EY operates via TE, EE1 and A1. Relay EY locks and short-circuits E, which releases EE, and changes over relay TE. Relay EX now operates over the low resistance circuit to earth and recloses the operate circuit of

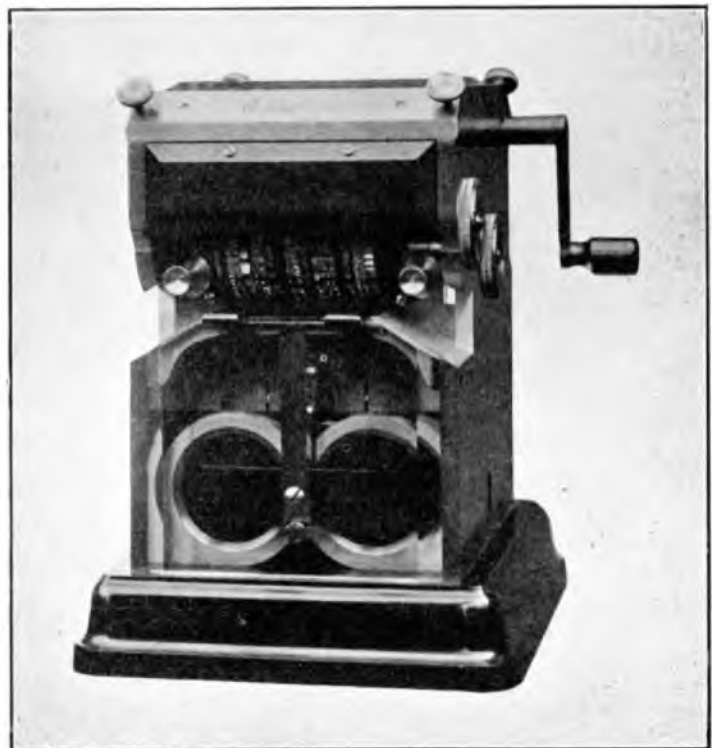

FIG. 11.—DATE AND TIME STAMP.

TE. Relay SL operates slowly, and disconnects TE again. Relay TE releases in 14 seconds, operates ZL which locks and brings in the earth display and alarm bell. The display is cancelled by throwing key EK. The earth pilot remains alight to signify the fault is receiving attention. Location tests are then carried out and the fault cleared in due course, whereupon the circuit is restored by releasing key EK.

The circuit can discriminate between low and high resistance faults up to 2,000 ohms.

Short-Circuited Boxes. Calls from short-circuited boxes are received over the earth detecting circuit, providing there is no extraneous earth on the loop, by virtue of the box impulsing to earth. Relay SL operates after 14 seconds and prepares a circuit for relay V (Fig. 9) which operates on the release of EX, when the latter responds to the earth impulses, and actuates KK. Relay KK locks via key RK and changes the loop over to earth working as with a broken line, and illuminates the short-circuit display and pilot.

Repeat Loop. One repeat loop is provided between each outstation and its superintendent station. This circuit provides a both-way telephone link and also repeats, without loss of impulses, the incoming alarm codes of any street box connected to the outstation, and fire signals. As there may be one to three box loops, the repeat loop is busied to the box loops not transmitting. If calls originate simultaneously on two box loops, the box on one loop runs idly in succession until the repeat loop is available.

A current of 50 mA normally circulates over both legs of the repeat loop to earth from an earthed battery at the superintendent station. A common relay at the out-station which responds to all incoming codes has a contact in each leg of the repeat loop. At the superintendent station the line current (both legs) is fed through one coil of a 4-circuit punch register of which Fig. 10 is an example. All facilities can function over either leg independently in the event of a disconnection on one line.

As its title suggests a 4-circuit register has four independent movements, side by side, which puncture a common tape. One register can therefore serve four separate repeat loops. Associated with the register and its take-up reel is a time and date stamp, Fig. 11. Contacts on the register operate the stamp at the conclusion of an incoming call, so that the tape record is timed and dated. The stamp is impulsed at half minute intervals from a master pendulum and

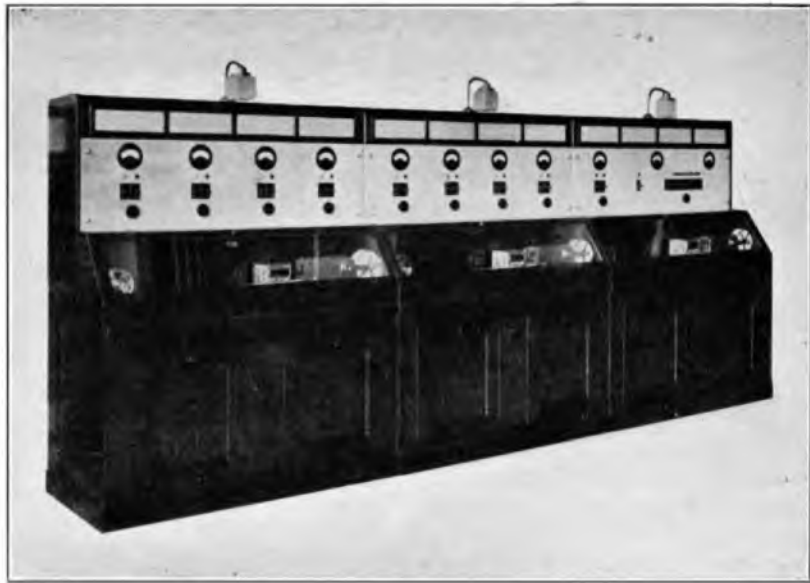

FIG. 12.—REPEAT PANELS AT CLERKENWELL.

will accurately register time and dates for 24 years (including leap years) without changing the character wheels.

Fig. 12 shows the repeat panels and cabinets for 10 loops as supplied to Clerkenwell. Each panel is equipped for 4 repeat loops, except the end panel on the right which carries 2 repeat loops and the repeat battery charging apparatus. The illuminated indicator above the panels displays the name of the station transmitting. The loop circulating current is regulated by the rheostats and recorded on the meters. Broken line faults cause the second pilot to glow and a display of "Broken Circuit" appears on the fault indicator above the end panel on the right. The keys on each panel are for testing and connecting the displays.

The 4-circuit registers with take-up reels are shown behind the glazed drops of the cabinets.

Telephone calls incoming and outgoing are controlled with other circuits on a two position lamp signalling switchboard specially designed, built and installed by the Post Office for the Brigade inter-communicating system.

Conclusion.

It is anticipated that the whole of London will be converted to the Gamewell system within the next 5 years.

The writer acknowledges, with thanks, the information supplied by Major C. C. B. Morris, M.I.Mech.E., Chief Officer of the Brigade, Messrs. Standard Telephones and Cables, Ltd., and Messrs. Automatic Telephone and Electric Co. Ltd.

Diakon : A New Material for Coloured Telephones

C. A. R. PEARCE, M.Sc. (Eng.), D.I.C.

The Author gives a brief description of the manufacture and properties of Diakon, a new moulding powder which is being used for coloured telephones.

Introduction.

FOR some time past it has been apparent that the moulding materials in use for coloured telephones are unsatisfactory. Trouble in service due to cracks and fading have been frequent and manufacturers have experienced serious difficulty in meeting their commitments from their inability to control the colour shades of the finished mouldings or to produce parts free from flaws. Yet so persistent has been the public demand that, despite the unsatisfactory position, it has been necessary to maintain relatively large supplies while at the same time searching for an alternative material. Recently a new moulding powder, Diakon, has appeared, which is available in a wide range of colours and which promises to be free from the difficulties associated with the use of the Thio-Urea and Urea Formaldehyde powders which have been used up to the present.

In justice it should be stated that there are many occasions when the Urea class of plastics can be used with success but they are, in the writer's opinion, generally unsuited to designs incorporating relatively large metal insets or including thick sections.

The Manufacture of Diakon.

The raw material from which Diakon is produced is supplied by the organic chemist. It is produced from coal, air and water but as received by the manufacturer it is a liquid very similar to water in appearance and about equal in density. This liquid is first filtered to remove dirt, etc., and is then mixed with the catalyst necessary for the subsequent chemical reaction. The mixture is then warmed and maintained at a steady temperature for a period during which it changes to a solid, Diakon. The transformation which occurs is not the creation of a new chemical compound, since the resultant Diakon still consists of the same carbon and hydrogen atoms which constituted the original liquid, and the catalyst (as its name implies) merely assists the change but does not itself undergo modification. The metamorphosis which occurs is one which the chemist terms "polymerisation," and is briefly the linking together into chains of the molecules which in the original substance were more or less dissociated. With Diakon the molecules may reach a length of up to 300 of those constituting the original liquid. The process occurs accompanied by the evolution of much heat and precautions have to be taken to prevent the reaction from getting "out of hand."

To avoid the contamination which would occur if attempts were made to break up large blocks of material into a form suitable for use in the moulding press a device is introduced whereby the liquid solidifies into small spheres instead of into a complete block. After the removal of the catalyst, etc., and thorough washing and drying the final powder emerges. Fig. 1 shows its appearance at this stage when viewed under a microscope but seen in bulk it somewhat resembles castor sugar.

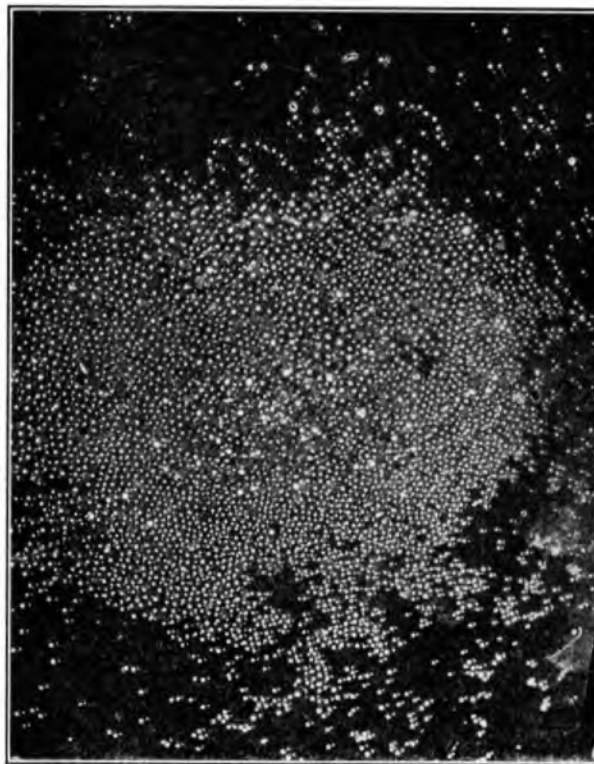

FIG. 1.—MICROPHOTOGRAPH OF UNCOLOURED DIAKON POWDER.

When Diakon granules, prepared as described above, are moulded, the resultant mouldings are completely transparent. For telephones, however, the powder is now mixed with carefully adjusted quantities of Ivory, Red, or Green colouring matter to give either of the three standard Post Office shades. At this stage the preparation of the "powder" is complete and it is purchased by the moulder for manufacturing into telephone parts, etc. It is estimated that over 60 tons of "powder" will be used in the preparation of coloured telephones for next year.

Unlike the bakelite class of materials used for black telephones, Diakon is not a thermo-setting material, i.e., heat and pressure do not harden it. In working bakelite a steel mould (Fig. 2) heated to about 170° C. is filled with "powder" and closed under a pressure of the order of one or two tons per square inch; this condition is maintained for about three minutes during which time the material is "cured"; at the end of this period the mould is opened and the finished part removed hot and hard and an exact reverse of the mould. With Diakon, and incidentally with cellulose acetate, another thermoplastic from which telephone cradles are made, the process is briefly as follows:—



FIG. 2.—MOULDING TOOL FOR THE PRODUCTION OF TELEPHONE CASES.

The mould is first closed under pressure and the Diakon is forced into the cold mould at a pressure of up to 15 tons/sq. in. from a cylinder in which it has been heated and to which the mould is connected. The Diakon must be at about 200° C. before injection may take place and at this temperature, although plastic, it is far from being fluid. Narrow vents are left to permit the exit of the air which originally fills the mould. When injection is completed the material remains for a short time under pressure until it has hardened sufficiently due to the falling temperature for the mould to be opened and the moulding removed. This whole process may be completed in about 90 seconds as against the three minutes necessary with Bakelite and ten minutes for the coloured Urea powders. An injection type press suitable for moulding telephone cradles is shown in Fig. 3.

Although the injection process is the economical method of producing Diakon mouldings it is possible to compression-mould the material by water-cooling the mould before removing the moulding, but only at the expense of speed of production. There is little difference between the results of the two methods as regards the appearance or the mechanical or electrical properties of the finished article.

The appearance of coloured telephones in Diakon is un-

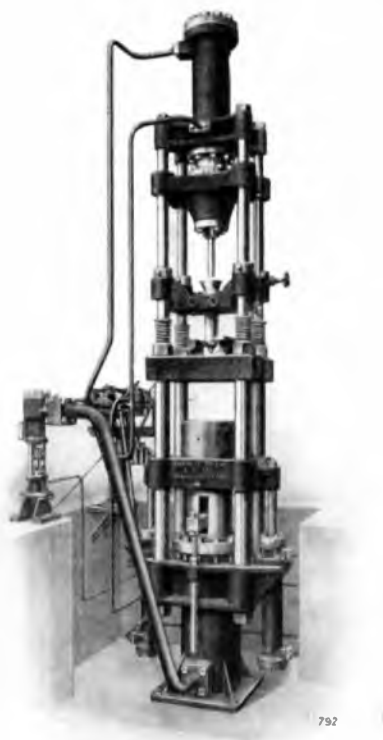

FIG. 3.—COMBINED INJECTION AND MOULDING PRESS.

doubtedly superior to those in any other moulding material at present available but the Post Office is, at this stage, primarily interested in their behaviour in service and, although it is as yet too early to predict complete satisfaction, there is every indication that the new powder will obviate most of the difficulties hitherto attendant upon the manufacture of coloured telephones and the trouble which has previously been associated with their use.

Mechanical Properties.

An indication of the working properties of Diakon is best obtained by comparison with those of bakelite as used for black telephones and the table below details some values obtainable.

Property	Diakon	Bakelite
Specific Gravity	1.18 to 1.20	1.35
Tensile Strength lbs. per sq. in.	6,500 to 8,000	6,500 to 7,500
Cross Breaking Strength lbs. per sq. in. (B.S.S.)	10,000 to 15,000	10,000 to 11,000
Impact Strength cm. kg/sq. cm.	2.5 to 4.0	1.4 to 1.6
Volume Resistivity at 20°C Megohms/cms.-	10 ⁹	5 × 10 ⁸ to 10 × 10 ⁸
Surface Resistivity at 20°C Megohms/cms.-		
(a) Freshly moulded	(1) 10 ¹⁰	(a) 1 × 10 ⁹ to 5 × 10 ⁹
(b) 24 hours water immersion	(b) 10 ⁹	(b) 10 ⁸ to 10 ⁸
Electrical breakdown at 20° C volts per .001"	480 to 500	300 to 350

There are several grades of Diakon available but their chief differences are in respect of their moulding properties. These differences do not result in any material change to the electrical properties of the finished moulding, and with the exception of the resistance and deformation when heated, only introduce minor alterations to the mechanical properties. The above figures include the whole range of values which will generally be encountered.

As already stated, Diakon, unlike bakelite, softens under heat and is therefore unsuitable for use at raised temperatures, but it is not anticipated that this will give rise to difficulty in this country.

Conclusion.

Although some telephones in the new material have been assembled and a number will have already found their way into service it must necessarily be some little time before a complete changeover can be effected, but it is anticipated that during the next three months Diakon instruments will be appearing in relatively large quantities. They may easily be distinguished by their fine translucent colouring.

In conclusion the author wishes to tender his grateful acknowledgements to Messrs. Imperial Chemical Industries for their very material assistance in the preparation of the article and their loan of the illustration forming Fig. 1, and to Messrs. The Telephone Manufacturing Company Ltd., and Messrs. John Shaw Ltd., for the remaining illustrations.

The Stability and Performance of the Single "Rectified-Reaction" Stage

F. C. WILLIAMS, M.Sc., D.Phil.,
Grad. I.E.E.
and ALAN FAIRWEATHER,
M.Sc., Grad. I.E.E.

A comprehensive theoretical and experimental analysis of the most common type of single "Rectified-Reaction" stage employing transformer feed-back is presented. The essential requirements for stability and optimum sensitivity are discussed and it is shown that an interesting feature of the behaviour of the device is the occurrence of true "trigger" and hysteresis effects when the valve is biased back beyond cut-off.

Introduction.

IN 1931 L. H. Harris¹ described a relay-operating apparatus utilising thermionic valves in which high sensitivity was obtained by the use of "Rectified-Reaction." The basic circuit of his original scheme is shown in Fig. 1. A year later T. R. Rayner and G. D. Turton² published details of a two stage arrangement

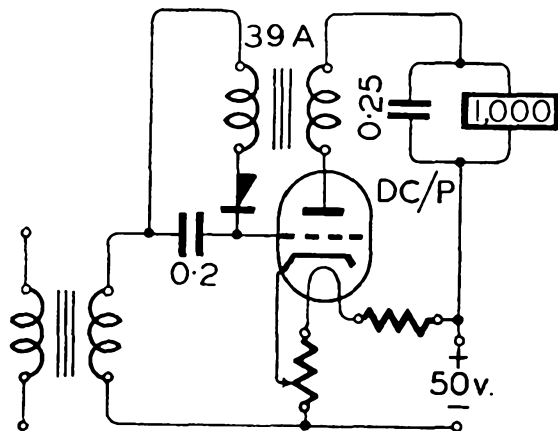

FIG. 1.

employing the same fundamental principle. In its simple form the device has been extensively applied, especially in Voice-Frequency signalling, and receivers incorporating it have been described by L. H. Harris³, by T. H. Flowers⁴, and by B. M. Hadfield⁵. Despite these numerous applications, however, no rigorous analysis of the circuit appears to have been attempted. In practice various phenomena present themselves which do not, at first sight, permit of ready explanation. Of these the chief is instability which may result in the generation of linear or relaxation oscillations. The present research was undertaken, therefore, with the object of explaining these phenomena and of developing scientific principles of design.

The apparatus was devised to facilitate the operation of a robust relay from a weak A.C. source, a problem which arises, for instance, in the relay-operating stage of a voice-frequency signalling receiver. The simple anode-bend rectifier which had performed this function hitherto was insufficiently sensitive: in the device under discussion greater sensitivity is obtained by relegating the process of rectification to a dry plate rectifier and using the valve in the dual role of A.C. and D.C. amplifier. Thus, referring to Fig.

1, the input signal is applied to the grid which is biased so that, with no input, a small anode current only is flowing. The resulting amplified oscillations in the anode circuit are rectified and produce a positive bias across the grid condenser with a resulting rise in anode current. Although non-linearity of the valve characteristics will lead to some rectification in the valve the true function of the latter is that of amplification.

Failure of the stage first became apparent when the anode relay held in despite the removal of the A.C. source: this was found to be due to the production of a spurious input signal as a result of self oscillation. From an inspection of Fig. 1 it is obvious that in the original circuit there are several possible mechanisms of oscillation.

STABILITY.

General Principles.

The exact formulation of the oscillation régime presents formidable difficulties and will not, therefore, be attempted since the results obtained from an approximate analysis are adequate for all practical purposes. As has already been pointed out several possible modes of linear oscillation exist; they may be segregated according to the character of the oscillatory circuit involved and the method of feedback employed. Thus the oscillatory circuit may be composed of components of inductance and capacitance which are separate physical entities and whose existence is intentional; for example, the secondary of the feed-back transformer and the coupling condenser or the relay and its associated shunting condenser. Alternatively these components may be stray or fortuitous such as might be introduced by coils possessing self-capacitance or connecting leads with mutual coupling, either inductive or capacitive. A reference to Fig. 2 will make this clear. The feedback may be classified in a similar manner.

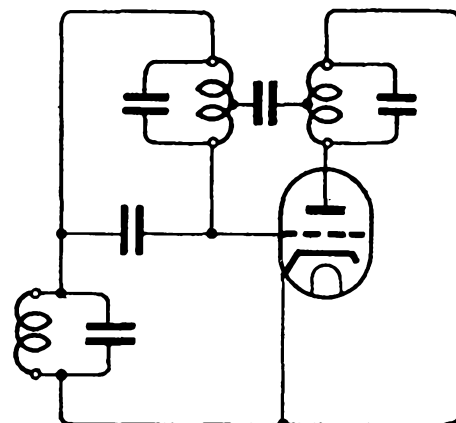

FIG. 2.

¹ British Patent No. 385,974, July, 1931.

P.O.E.E.J., Vol. 25, p. 190.

² British Patent No. 398,813, March, 1932.

³ *Loc. cit.*

⁴ *P.O.E.E.J.*, Vol. 26, p. 284.

⁵ *I.P.O.E.E. Printed Paper No. 162, P.O.E.E.J.*, Vol. 29, p. 43.

That which takes place via the mutual inductance of the anode transformer is essential to the operation of the circuit and may, under certain circumstances, lead to self-oscillation. On the other hand feed-back via the mutual capacitance between the windings of this transformer is fortuitous and can in fact be nullified by rearranging the circuit as shown in Fig. 3.

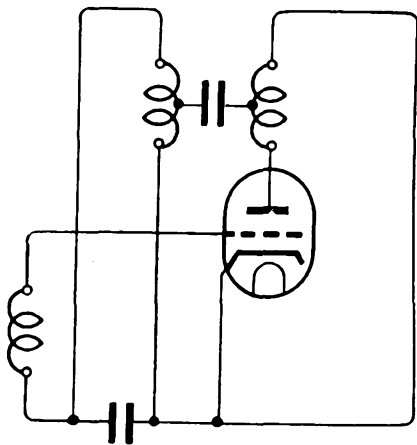

FIG. 3.

In this scheme the capacitance current no longer traverses the impedance of the secondary winding of the input transformer but finds a low impedance path to the cathode thus reducing the voltage fed back to the grid to a negligible amount.

Theory of Stability neglecting Stray Capacitances and Couplings.

Physical discussion. A fundamental requirement for any valve circuit to be capable of sustained oscillation is that the feed-back must be arranged so that an increase in anode current introduces an e.m.f. into the grid circuit tending to raise the grid potential or, in other words, grid and anode voltages must be approximately antiphased. The relative phases of these two voltages will obviously depend on the sense of the feed-back transformer connections. Now at small signal amplitudes rectifier conduction will be continuous and the voltage fed back to the grid will contain a relatively large alternating component. Hence it is clear that, with suitable transformer connections and an appropriately small value of the bias condenser, oscillations may build up until rectifier operation becomes discontinuous and proceeds in "pips" of negligible duration. Oscillation is then inhibited until the bias condenser discharges and permits continuous conduction once more. Thus with the transformer connected in the unstable sense, sinusoidal oscillations may be generated, the presence of which is independent of the presence of the rectifier. With increasing amplitude these may degenerate into relaxation oscillations of quite low period. Experiment has shown that oscillation can be prevented by the insertion of bias in the rectifier circuit so as to prevent continuous conduction. In the experimental set-up described later 4 volts was found to be sufficient.

For the purpose of establishing an approximate criterion for the commencement of linear oscillation the rectifier may be replaced by a resistance in series

with the secondary of the feed-back transformer and this will be done in the discussion which follows.

Before proceeding with a detailed analysis it is of interest to apply a comparatively little known artifice in order to ascertain what portion of the circuit is likely to self-oscillate and hence the oscillation frequency. This principle, due to one of the authors, is believed to be original; another example of its use has been given in a recent paper by H. O. Walker⁶. It may be stated briefly as follows: Consider any linear network possessing one or more closed loops containing inductance and capacitance. Suppose that one such loop be replaced by a generator, and that the impedance looking outwards from the generator terminals be calculated. Then, for self-oscillation to occur in the loop in question, it is necessary that the resistance component of this impedance should be capable of assuming negative values. The physical explanation of this is obvious; if the magnitude of the negative resistance component provided by the network is greater than or equal to that of the effective positive resistance of the loop then oscillation becomes possible.

The symbols used will have the meanings usually associated with them as follows:

- i_a = anode current (alternating component)
- V_a = anode voltage (alternating component)
- V_g = grid voltage (alternating component)
- g = $\delta i_a / \delta V_g$ = mutual conductance
- μ = $\delta V_a / \delta V_g$ = amplification factor
- ρ = $\delta V_a / \delta i_a$ = anode resistance.

Clearly,

$$g = \mu / \rho$$

It is apparent that the two circuits which might be capable of self-oscillation are (i) the anode relay together with its associated shunting condenser and (ii) the secondary of the feed-back transformer along with the grid condenser.

Considering the first of these the circuit of Fig. 1 reduces to Fig. 4 if it be supposed that all the feed-back voltage appears at the grid. Then, for any triode:

$$i_a = (\mu V_g + V_a) / \rho - K$$

where K is an arbitrary constant which will be neglected. Hence:

$$i_a = g V_g + V_a / \rho$$

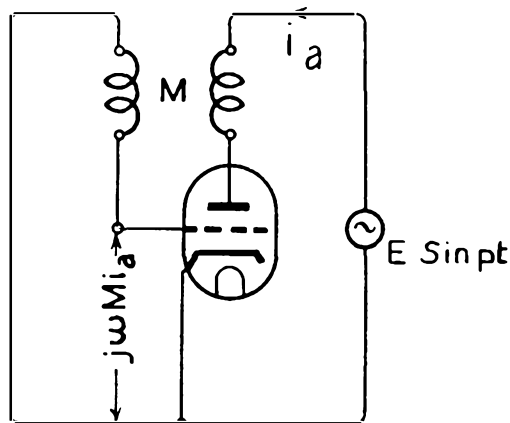

FIG. 4.

⁶ "The Wireless Engineer," Aug., 1937, p. 430.

$$= gj\omega Mi_a + (E - j\omega Li_a)/\rho$$

$$E = \rho i_a [1 + j(\omega L/\rho - g\omega M)]$$

So E/i_a cannot have a negative real part and oscillation of the relay circuit is impossible.

The second possibility (ii) requires no further consideration as oscillation is obviously possible. Hence it is to be expected that a detailed analysis should include in its findings the following:—

(a) One frequency of oscillation only which should be that of the coupling circuit.

(b) The possibility of self-oscillation should be dependent on the sense of the feedback transformer connections.

(c) A large bias condenser should be conducive to stability.

Analysis. Fig. 1 may be replaced by Fig. 5 and this may, in turn, be reduced to the equivalent circuit of

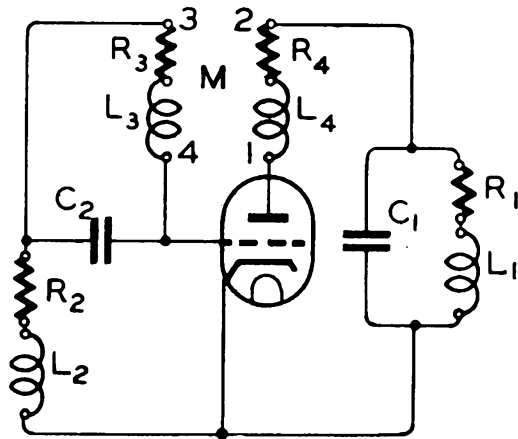

FIG. 5.

Fig. 6. At first sight the circuit Z_3Z_4 appears somewhat isolated but it must be recollected that point G is

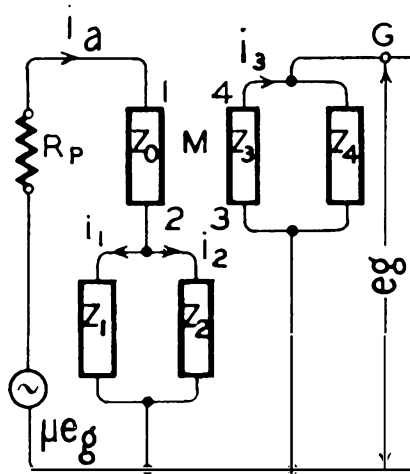

FIG. 6.

actually connected to the grid. The various symbols are defined as follows:—

$$Z_0 = R_4 + j\omega L_4$$

$$Z_1 = R_1 + j\omega L_1$$

$$Z_2 = 1/j\omega C_1$$

$$Z_3 = R_3 + j\omega L_3$$

$$Z_4 = 1/j\omega C_2$$

Then :

$$-j\omega Mi_a = i_3(Z_3 + Z_4) \dots \dots \dots (1)$$

$$i_1 = [Z_2/(Z_2 + Z_1)] i_a \dots \dots \dots (2)$$

$$\mu e_g = [R_p + Z_0 + Z_1 Z_2 / (Z_1 + Z_2)] i_a - j\omega M i_3 \dots (3)$$

$$e_g = \pm Z_4 i_3 \dots \dots \dots (4)$$

Substituting for i_a from (2) into (1)

$$-j\omega M [(Z_2 + Z_1)/Z_2] i_1 = i_3(Z_3 + Z_4) \dots \dots (5)$$

Substituting for e_g from (4) and i_a from (2) into (3)

$$(j\omega M \pm \mu Z_4) i_3 = [R_p + Z_0 + Z_1 Z_2 / (Z_1 + Z_2)] [(Z_2 + Z_1)/Z_2] i_1 \dots (6)$$

Substituting for i_3 from (5) into (6) i.e.

$$i_3 = -j\omega M [(Z_2 + Z_1)/Z_2 (Z_3 + Z_4)] i_1 [j\omega M \pm \mu Z_4] \\ [-j\omega M] [(Z_2 + Z_1)/Z_2 (Z_3 + Z_4)] i_1 \\ = [(R_p + Z_0) + Z_1 Z_2 / (Z_1 + Z_2)] [(Z_2 + Z_1)/Z_2] i_1 \dots \dots \dots (7)$$

Dividing by $[(Z_2 + Z_1)/Z_2]$

$$\left\{ \left[\frac{\omega^2 M^2 \pm j\omega M \mu Z_4}{Z_3 + Z_4} \right] - \left[\frac{(R_p + Z_0) + Z_1 Z_2 / (Z_1 + Z_2)}{(Z_2 + Z_1)/Z_2} \right] \right\} i_1 = 0 \dots (8)$$

For conciseness write

$$K = Z_1 Z_2 / (Z_1 + Z_2).$$

Then, substituting the full expressions for Z_3 and Z_4 ,

$$\left\{ \left[\frac{\omega^2 M^2 \pm j\omega M \mu / j\omega C_2}{R_3 + j\omega L_3 + 1/j\omega C_2} \right] - \left[\frac{R_p + Z_0 + K}{(Z_2 + Z_1)/Z_2} \right] \right\} i_1 = 0 \dots (9)$$

Multiplying throughout by $(R_3 + j\omega L_3 + 1/j\omega C_2)$

$$\left\{ (\omega^2 M^2 \pm M \mu / C_2) + [-R_3 - j\omega(L_3 - 1/C_2 \omega^2)] \right. \\ \left. [R_p + Z_0 + K] \right\} i_1 = 0 \dots (10)$$

$$\left\{ (\omega^2 M^2 - j\omega(L_3 - 1/C_2 \omega^2) (R_p + Z_0 + K) \right. \\ \left. + [-R_3(R_p + Z_0 + K) \pm M \mu / C_2] \right\} i_1 = 0 \dots (11)$$

Multiplying throughout by $-j\omega$

$$\left\{ -j\omega^3 M^2 - (\omega^2 L_3 - 1/C_2) (R_p + Z_0 + K) \right. \\ \left. - j\omega [-R_3(R_p + Z_0 + K) \pm M \mu / C_2] \right\} i_1 = 0 \dots (12)$$

$$\left\{ -j\omega^3 M^2 - \omega^2 L_3 (R_p + Z_0 + K) - j\omega \right. \\ \left. [-R_3(R_p + Z_0 + K) \pm M \mu / C_2] + (R_p + Z_0 + K)/C_2 \right\} i_1 \\ = 0 \dots (13)$$

Write

$$(R_p + Z_0 + K) = Z$$

and introduce the differential operator D by means of the following identities

$$D = j\omega$$

$$D^2 = -\omega^2$$

$$D^3 = -j\omega^3$$

Then

$$[D^3 M^2 + D^2 L_3 Z - D(-R_3 Z \pm M \mu / C_2) + Z / C_2] i_1 = 0 \dots (14)$$

For stable oscillation to result the solution of this will be of the form

$$i_1 = Ae^{rt} + Be^{at} (\sin \beta t + C) \dots \dots \dots (15)$$

Now consider the general cubic

$$ax^3 + bx^2 + cx + d = 0 \dots\dots\dots(16)$$

It may be inferred from a note due to Routh⁷ that

$$a \geq 0 \text{ when } bc \geq ad \dots\dots\dots(17)$$

Comparing coefficients in (16) and (17) it is clear that oscillation is possible when

$$-L_3 Z (-R_3 Z \pm M \mu / C_2 \geq M^2 Z / C_2) \\ (\pm M) I_3 \mu / C_2 \geq M^2 / C_2 - L_3 R_3 Z \dots\dots(18)$$

From this it is apparent that the possibility of self-oscillation occurring with any given stage depends very largely upon the sign of M , i.e. the sense of the feed-back transformer connections, and the magnitude of C_2 . The interpretation of the sign to be given to M in a specific case depends on the arbitrary directions which were assigned to the mesh currents at the commencement of the analysis.

It is now necessary to determine the frequency of oscillation. If the three roots ($x = a \pm j\beta$) and ($x = \gamma$) be substituted in the parent cubic (16), then the latter reduces to

$$x^3 - (2a + \gamma)x^2 + (a^2 + \beta^2 + 2a\gamma)x - \gamma(a^2 + \beta^2) = 0 \dots(19)$$

subject to the condition that ($\alpha = 0$). It is now required to ascertain β ; this may be done in either of two ways:

- (a) $[c/a]_{\alpha=0} = [a^2 + \beta^2 + 2a\gamma]_{\alpha=0} = \beta^2$
- (b) The critical condition is, from (17) $bc = ad$
i.e. $c = ad/b$

$$[c/a]_{\alpha=0} = [d/b]_{\alpha=0} \\ = [-\gamma(a^2 + \beta^2) / -(2a + \gamma)]_{\alpha=0} \\ = \beta^2$$

Consideration of (14) shows that the second of these is the simpler algebraically, so

$$\beta^2 = (Z/C_2) / L_3 Z \\ \text{i.e., } \omega^2 = 1 / L_3 C_2 \dots\dots\dots(20)$$

Thus there is only one frequency of self-oscillation and it is that of the coupling circuit; the physical necessity for this was demonstrated previously.

THEORY OF NORMAL OPERATION.

The circuit which will be discussed is shown in Fig. 7.

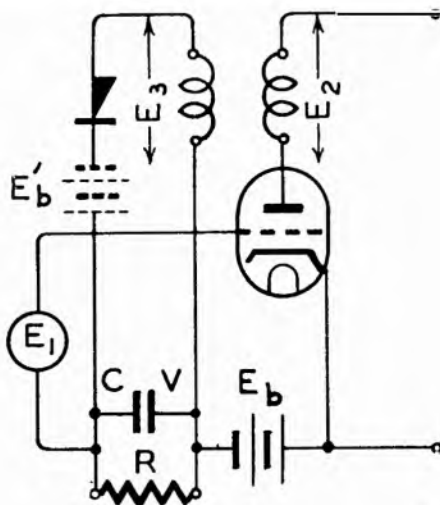

FIG. 7.

⁷ Advanced Rigid Dynamics, Ch. 3, p. 73.

Bias Below Cut-off.

Since the function of the valve is mainly one of amplification the linear approximation to its characteristic shown in Fig. 8 is permissible. Then with V_g measured as shown it is clear that:

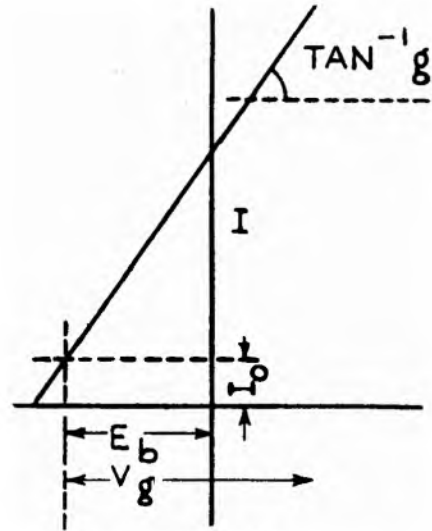

FIG. 8.

$$I = (I_0 + gV_g) \dots\dots\dots(21)$$

$$\delta I_a / \delta V_g = g \dots\dots\dots(22)$$

Let the input voltage have the form:

$$e_1 = E_1 \sin pt$$

It is apparent that the voltages associated with the feedback transformer can be calculated only if the load imposed on the secondary winding is known. Some assumptions regarding the rectifier characteristic are therefore necessary to permit the evaluation of this effective load. A typical input-output voltage characteristic of a rectifier of this type is shown in Fig. 9 in which V is plotted as a function of E_3 where V

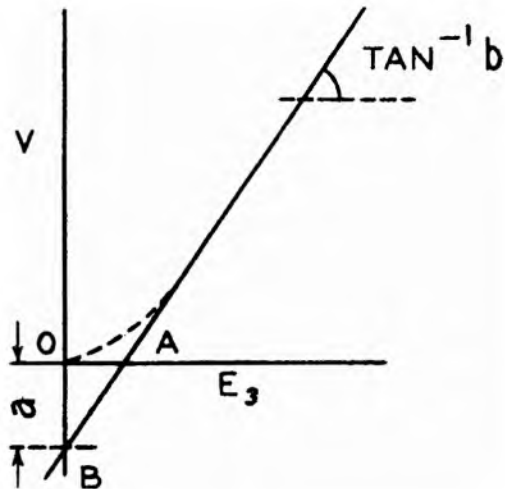

FIG. 9.

is taken as the direct component of the complex voltage developed across C . The straight line shows a linear approximation to this characteristic which is

valid when $V > 0$; this can be expressed in the form :

$$V = (bE_3 - a) \dots \dots \dots (23)$$

with the proviso that $V = 0$ except when

$$E_3 > a/b$$

This limitation governs the analysis given below. It may be noted that a/b defines the length OA on the figure and is approximately equal to the corresponding length $O'A'$ in Fig. 10 which shows the voltage-current characteristic of the rectifying device, be it diode valve or dry plate rectifier. If bias E'_b be introduced as shown dotted in Fig. 7 then it must be added in the

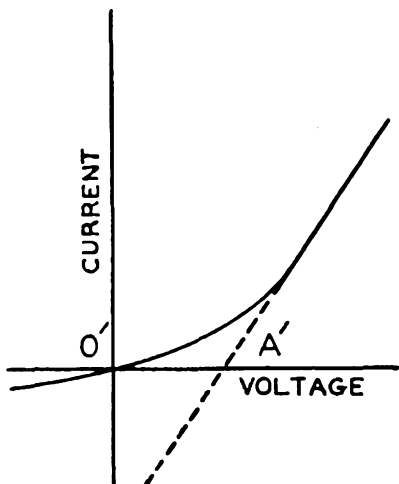

FIG. 10.

appropriate sense to $O'A'$ of Fig. 10 to yield an approximation to a/b , i.e., OA of Fig. 9.

It follows from (23) that the mean current entering the rectifier is :

$$I_m = V/R = (bE_3 - a)/R \dots \dots \dots (24)$$

where R is the rectifier load resistance (Fig. 7).

With true peak rectifier operation it has been shown⁸ that the corresponding fundamental current drawn from the transformer secondary is $2I_m \sin pt$ if the secondary voltage is $E_3 \sin pt$, and hence the effective resistance across the secondary is :

$$R_e = E_3 \sin pt / 2I_m \sin pt$$

Substituting for I_m from (24) it follows that :

$$R_e = R/2 (b - a/E_3) \dots \dots \dots (25)$$

If m is the effective amplification factor of the stage measured from the grid to the terminals of the secondary winding of the feed-back transformer

$$E_3 = E_1 m \dots \dots \dots (26)$$

Assuming a perfect transformer of $N:1$ ratio it then follows that :

$$E_3 = E_1 N \mu (R_e/N^2) / (R_e/N^2 + \rho)$$

Dividing throughout by (R_e/N^2) and substituting for R_e from (5) :

$$E_3 = E_1 N \mu / \left\{ 1 + \left[2\rho N^2 (b - a/E_3) \right] / R \right\}$$

$$E_1 N \mu = E_3 \left\{ 1 + \left[2\rho N^2 (b - a/E_3) \right] / R \right\}$$

$$(E_1 N \mu + 2\rho N^2 a/R) = E_3 (1 + 2\rho N^2 b/R)$$

$$E_3 = (E_1 N \mu + 2\rho N^2 a/R) / (1 + 2\rho N^2 b/R) \dots \dots (27)$$

and from (23)

$$V = \left\{ b \left[(E_1 N \mu + 2\rho N^2 a/R) / (1 + 2\rho N^2 b/R) \right] - a \right\} \dots (28)$$

But V is the mean grid voltage which, together with the steady bias voltage E_b , determines the mean anode current I ; hence from (21) the latter is given by:

$$I = I_0 + g \left\{ b \left[(E_1 N \mu + 2\rho N^2 a/R) / (1 + 2\rho N^2 b/R) \right] - a \right\} \dots (29)$$

subject to the proviso that :

$$I = I_0 \text{ (V being then zero)}$$

except when :

$E_3 > a/b$ (as pointed out in (23) et seq.) But from (25) when $E_3 = a/b$, $R_e = \infty$, a value which is relevant to all values of $E_3 < a/b$ despite (25) which is invalid for $E_3 < a/b$. It follows that when $E_3 \leq a/b$ then : $E_3 = N \mu E_1$ provided the primary inductance is sufficiently high. Hence : $I = I_0$ except when $E_1 > (1/N \mu) (a/b) \dots \dots \dots (30)$

It follows from (29) that, as E_1 is steadily increased from zero, I will remain at the value I_0 until E_1 exceeds $(1/N \mu) (a/b)$; thereafter I will increase linearly with E_1 , the slope of the $I - E_1$ curve then being from (29) :

$$\delta I / \delta E_1 = (g b N \mu) / (1 + 2\rho b N^2 / R) \dots \dots \dots (31)$$

Since b is generally of the order of unity (31) may be rewritten approximately as :

$$\delta I / \delta E_1 = g N \mu \left[(R/2N^2) / (R/2N^2 + \rho) \right]$$

$$\delta I / \delta E_1 = mg \dots \dots \dots (32)$$

where m is the stage gain E_3/E_1 calculated on the assumption that the rectifier and its associated load are equivalent to a resistance $R/2$.

That the result must be of this general form is obvious by inspection. According to (31) I would increase indefinitely with increasing E_1 , but actually a limit is imposed by circumstances outside the scope of this equation. It is apparent that, as E_1 increases, a point will be reached where V approaches E_b , and grid current sets in. Initially the flow of grid current will be limited to small pulses occurring at peak values of the ripple component of grid voltage. Such conduction results in a reduction of the effective value of R . It follows from (31) that the rate of increase of I will then be reduced; further increase of E_1 will lead to longer and longer pulses of grid current and, with sufficiently low values of grid ripple voltage (such as will be obtained with high values of C), continuous conduction may ultimately set in. Very low values of R will then obtain and it can be inferred that this will only occur with very large values of E_1 . It follows that grid current will limit the maximum value of I to a value approximately equal to, but ultimately somewhat greater than, the value I' which corresponds with the inception of grid current. The expected curve is summarised in Fig. 11. The actual curve will,

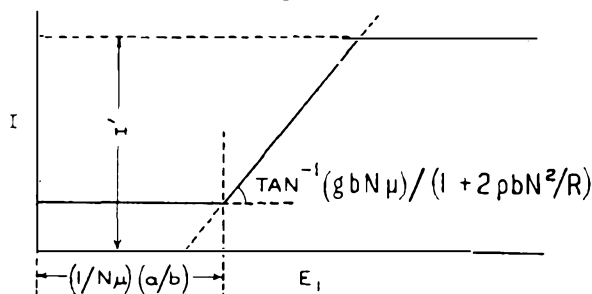

FIG. 11.

⁸ "The Wireless Engineer," August, 1937, p.403.

of course, show smooth transitions instead of the discontinuities of the predicted curve.

Comparison with simple anode-bend stage. It is clear that with half-wave rectification:

$$\begin{aligned} (\text{mean value of } I) &= g(\text{mean value of } E_1) \\ &= gE_1(1/2\pi) \int_0^\pi \sin \theta \, d\theta \\ &= gE_1/\pi \end{aligned}$$

and if the suffixes A.B. and R.R. denote operation with anode bend or rectified reaction respectively it follows that:

$$(\delta I/\delta E_1)_{A.B.} = g/\pi \quad \dots \dots \dots (33)$$

but $(\delta I/\delta E_1)_{R.R.} = mg$
 $(\delta I/\delta E_1)_{R.R.}/(\delta I/\delta E_1)_{A.B.} = m\pi \quad \dots \dots \dots (34)$
 which is a considerable improvement.

Bias Beyond Cut-Off.

The foregoing analysis was based on the assumption that the valve was not biased initially beyond cut-off. An alternative mode of operation, however, involves such biasing and it is evident that such a scheme will lead to an increased "delay" in current rise. The relevant phase of the operating conditions under such circumstances is shown on Fig. 12 where E_4 is now

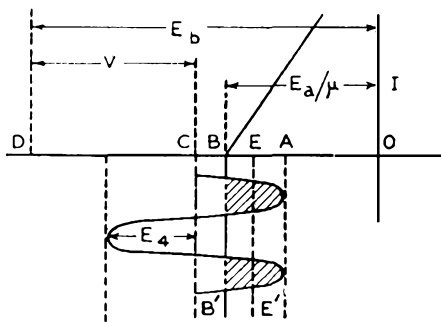

FIG. 12.

written for the peak value of the input signal. An exact solution of this condition appears to be impossible and a very approximate treatment only will be attempted. With the conditions shown, only that portion of the excursions of E_4 which lies to the right of BB' is effective in producing anode current. These portions of the input voltage are roughly equivalent to an input voltage of amplitude $AB/2$ symmetrically disposed with respect to EE' where $AE = AB/2$. Hence the voltage E_1 of the previous section can be replaced approximately by a voltage E'_1 , say, where:

$$\begin{aligned} E'_1 &= AB/2 \\ &= (AD-DB)/2 \\ &= [(V+E_4)-(E_b-E_a/\mu)]/2 \quad \dots \dots \dots (35) \end{aligned}$$

But from (30), since now $I_o = 0$, I and V are both zero except when:

$$E_1 > (1/N\mu)(a/b)$$

and replacing E_1 by the approximate expression for E'_1 given in (35) I and V are both zero except when:

$$[E_4 - (E_b - E_a/\mu)]/2 > (1/N\mu)(a/b)$$

i.e. except when:

$$E_4 > (2a/N\mu b) + (E_b - E_a/\mu) \quad \dots \dots \dots (36)$$

Again from (28):

$$V = \left\{ b \left[\frac{(E_1 N\mu + 2\rho N^2 a/R)}{(1 + 2\rho N^2 b/R)} \right] - a \right\}$$

Substituting for E_1 , as before:

$$V = b \left[\frac{\left\{ N\mu \left[\frac{(V + E_4) - (E_b - E_a/\mu)}{2} \right] + 2\rho N^2 a/R \right\}}{(1 + 2\rho N^2 b/R)} \right] - a$$

$$\frac{\delta V}{\delta E_4} = \left[\frac{bN\mu}{2(1 + 2\rho N^2 b/R)} \right] \left[\frac{\delta V}{\delta E_4} + 1 \right]$$

Taking b as unity (cf. (31) and (32)) this may be written:

$$\begin{aligned} \delta V/\delta E_4 &= (m/2) \left[(\delta V/\delta E_4) + 1 \right] \\ &= (m/2)/(1 - m/2) \end{aligned}$$

$$\delta V/\delta E_4 = 1 / \left[(2/m) - 1 \right] \quad \dots \dots \dots (37)$$

where m has the same significance as in (32).

Hence it follows that if:

$$\begin{cases} m < 2 \text{ then } \delta I/\delta E_4 \text{ is positive} \\ m = 2 \text{ then } \delta I/\delta E_4 \text{ is infinite} \\ m > 2 \text{ then } \delta I/\delta E_4 \text{ is negative} \end{cases}$$

The last of these results is obviously physically impossible but indicates a "trigger" effect associated with hysteresis: this is illustrated in Fig. 13, the

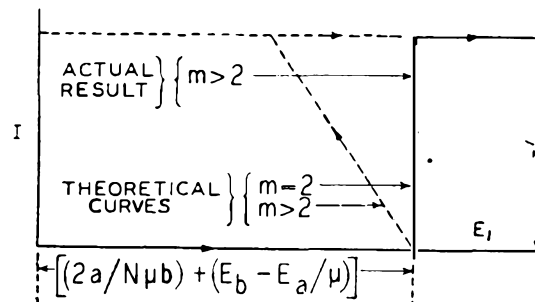

FIG. 13.

limiting value of I being set by the same considerations as before. It follows from these curves that when $m > 2$ I will remain at I' as E_4 is decreased below the value $[2a/N\mu b + (E_b - E_a/\mu)]$ given in (36). The value at which I will begin to fall again to zero is readily found, for it will remain at I' until V becomes less than E_b . Since the net bias is now approximately zero, the conditions are those examined previously and the appropriate expression for V is given by (28) with E_4 substituted for E_1 . Hence I commences to fall when:

$$\left\{ b \left[\frac{(E_4 N\mu + 2\rho N^2 a/R)}{(1 + 2\rho N^2 b/R)} \right] - a \right\} < E_b$$

or:

$$E_4 < \left\{ \left[\frac{(E_b + a)(1 + 2\rho b N^2/R)}{1} \right] - 2\rho N^2 a/R \right\} / N\mu$$

$$E_4 < \left\{ \left[\frac{(E_b + a)}{b} \right] + E_b 2\rho N^2/R \right\} / N\mu$$

or since in general $a \ll E_b$ and b is approximately 1,

$$E_4 < E_b^2 \left[\frac{(1 + 2\rho N^2/R)}{N\mu} \right]$$

or as before:

$$E_4 < E_b/m \quad \dots \dots \dots (38)$$

Once I begins to fall with decreasing E_4 it will do so with a slope governed by (31). The complete hysteresis loop is given in Fig. 14.

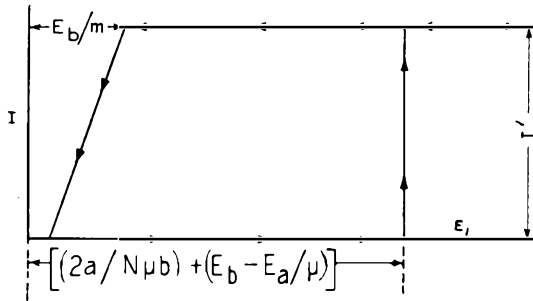

FIG. 14.

Influence of Curvature of Valve Characteristics.

Practical valve characteristics do not show the sharp cut-off envisaged in the above analysis, nor is any appreciable part of these characteristics strictly linear.

One result of this non-linearity is associated with the falling part of the $I-E_1$ curve of the preceding section. At the lower values of I this tends to become discontinuous, i.e. of infinite slope, for once V decreases the net negative bias is increased, g is decreased, and, correspondingly, m is decreased. Hence the criterion (38) becomes more than satisfied.

The magnitude of the initial delay with rising E_4 is also affected, for, with imperfect cut-off, some amplification is obtained on the tail of the characteristic. It follows that, with values of E_b corresponding with operating points on this tail, the mechanism envisaged in the preceding section is invalid; for some anode current flows even when

$$E_4 < E_b - E_a/\mu$$

If m' be the exact amplification ratio E_3/E_4 relevant to the particular operating point, the condition that I shall rise is, as in (23) et seq.,

$$\begin{aligned} &V > 0 \\ \text{i.e. } &E_3 > a/b \\ \text{or: } &\underline{E_4 > (1/m')(a/b)} \dots\dots\dots (39) \end{aligned}$$

Except where very high bias is used this equation supersedes (36); it is, however, exceedingly difficult to apply owing to the difficulty of computing m' . It may be noted that, in most cases, a discontinuity still occurs for, once (39) is satisfied, increasing V leads to increasing m' which, in turn leads to a further increase of V until the linear range is attained. The transition from the conditions examined under "Bias Beyond Cut-off" to the foregoing is gradual for similar reasons and it may be noted that the delay given by (39) is essentially greater than that of (30).

EXPERIMENTAL VERIFICATION

Test Conditions.

- Valve — Osram H42
- Rectifier — Mazda V914
- E_a = 220 V
- N = 1.75
- C = 0.5 μ F
- R = 0.5 megohm

Valve Characteristic; Graph 1.

From this graph and from other tests the following particulars were derived:

$$\begin{aligned} \mu &= 60 \\ \rho &= 28,000 \text{ ohms} \\ I' &= 3.5 \text{ mA} \end{aligned}$$

Rectifier Behaviour; Graph 2.

The values of b and a/b were derived from a separate series of tests; b was found to be 0.9 irrespective of the value of E'_b . The graph shows a/b plotted against E'_b and it may be seen that, in accordance with the statement made subsequent to equation (23), a/b is approximately equal to E'_b .

Behaviour with Bias slightly below Cut-off, i.e., $I_o = 0.5 \text{ mA}$.

General shape of the $I-E_1$ curve; Graph 3; Equations (30) and (31) and Fig. 11 are relevant. Results for two values of diode bias, -6 V and -2 V respectively, are given; the straight line boundaries show the expected results calculated from the above data. The experimental curves are seen to follow them very closely. The dotted lines show the upper parts of the curves plotted to one tenth of the original scale of E_1 ; it may be seen that, even with these high values of E_1 , I does not greatly exceed I' .

Voltage delay; Graph 4; Equation (30) is relevant. The graph shows the delay observed experimentally plotted as a function of the calculated delay $(1/N\mu)(a/b)$, the straight line indicating the expectation.

Variation of the slope of the rising portion of the $I-E_1$ curve with transformer ratio; Graph 5; Equation (31) is relevant. The smooth curve shows the expected form of the result; the four plotted points are experimental values and are seen to lie close to it. Further values could not be obtained as transformers of different ratios were not available.

Behaviour with Bias beyond Cut-off, i.e., E_b increased to -4 V thus making I_o unreadably small.

General form of the $I-E_4$ curve; Graph 6; Equations (36), (37) and (38) and Figs. 13 and 14 are relevant. As stated in the section dealing with the conditions which hold when bias exceeds cut-off, the position of the discontinuity with E_4 increasing is difficult of calculation but an approximate estimation yielded a value within 10 per cent. of that observed. The position of the fall of I with E_4 decreasing is easily computed from equation (38) and is shown on the right of the graph to ten times the scale of E_4 where the prediction is given by the straight lines. It may be noted that the tendency for this fall to become discontinuous was observed during the experiment.

Variation of initial delay with a/b ; Graph 7; Equation (39) is relevant. The linear relationship demanded by this equation is seen to be verified.

Variation of return delay (E_4 decreasing) with bias voltage E_b ; Graph 8; Equation (38) is relevant. This equation requires a linear relationship of slope $1/m$; experiment verifies this linear interdependence and the slope obtained is within 10 per cent. of $1/m$.

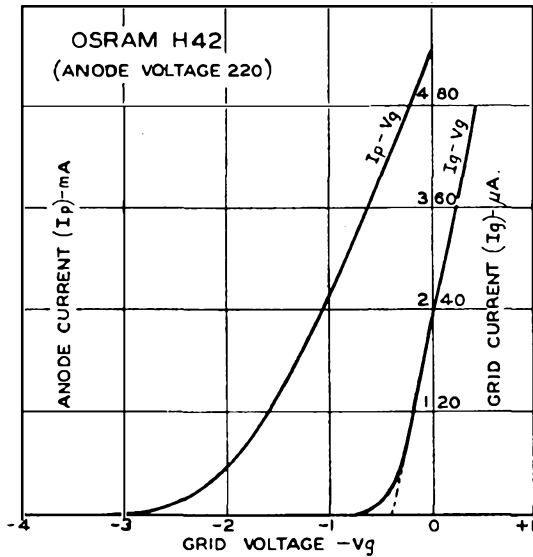

GRAPH 1. VALVE CHARACTERISTIC.

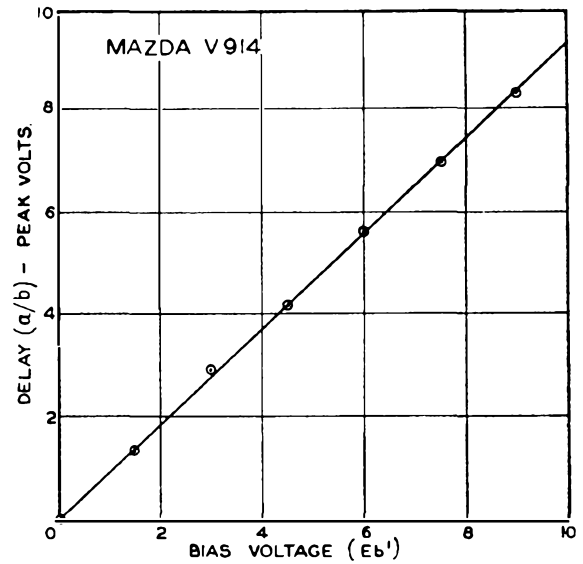

GRAPH 2. RECTIFIER DELAY VERSUS BIAS.

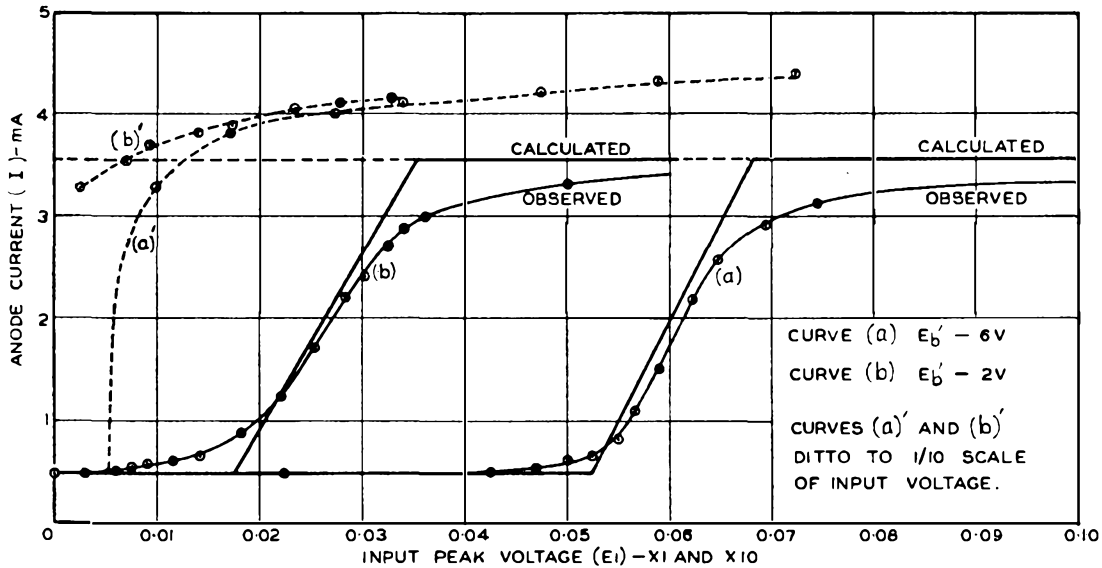

GRAPH 3 I AS A FUNCTION OF INPUT PEAK VOLTAGE WITH BIAS BELOW CUT-OFF.

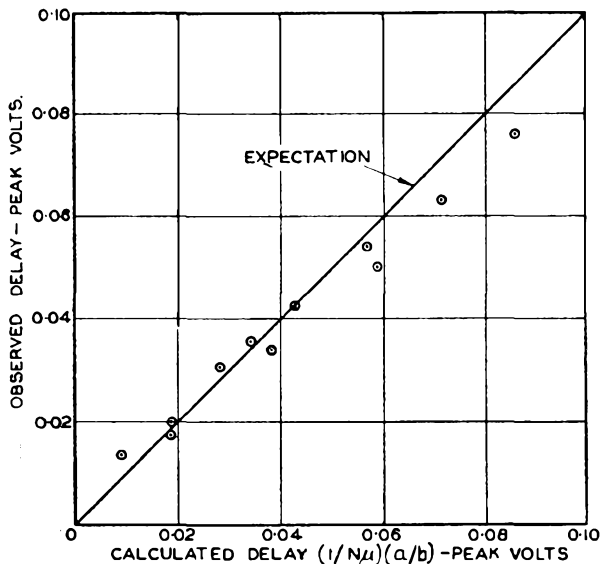

GRAPH 4 EXPL VERSUS CALCULATED DELAY

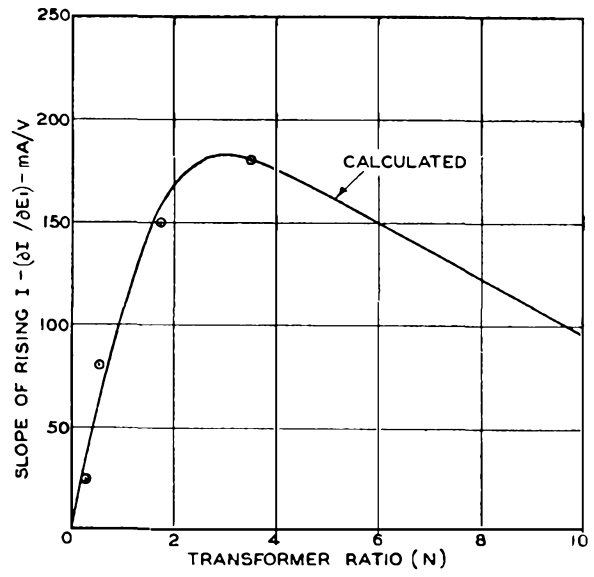

GRAPH 5. $(\partial I / \partial E_i)$ VERSUS N. 301

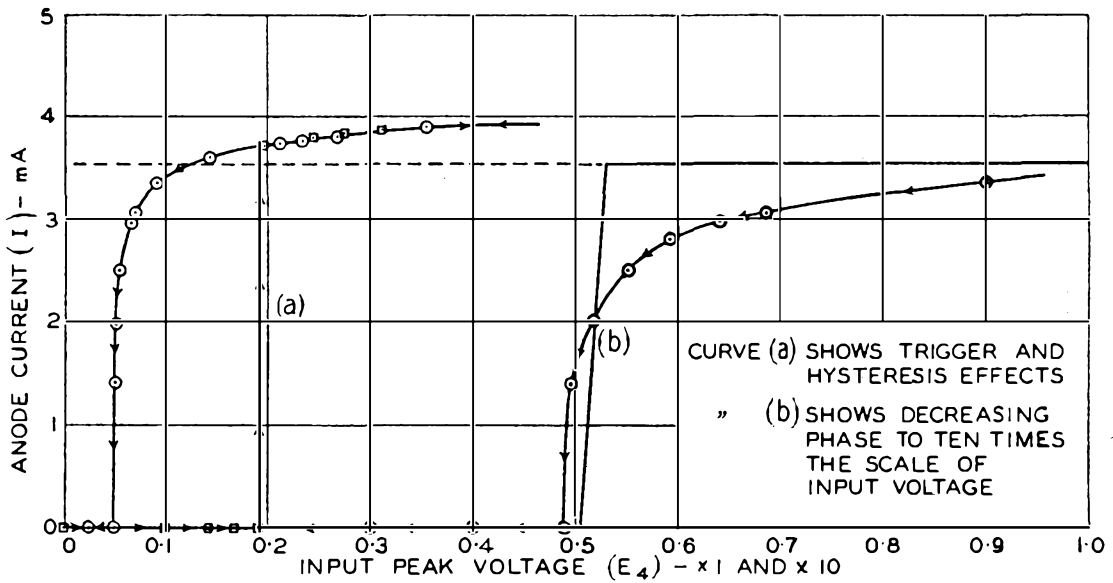

GRAPH 6. I AS A FUNCTION OF INPUT PEAK VOLTAGE WITH BIAS BEYOND CUT-OFF

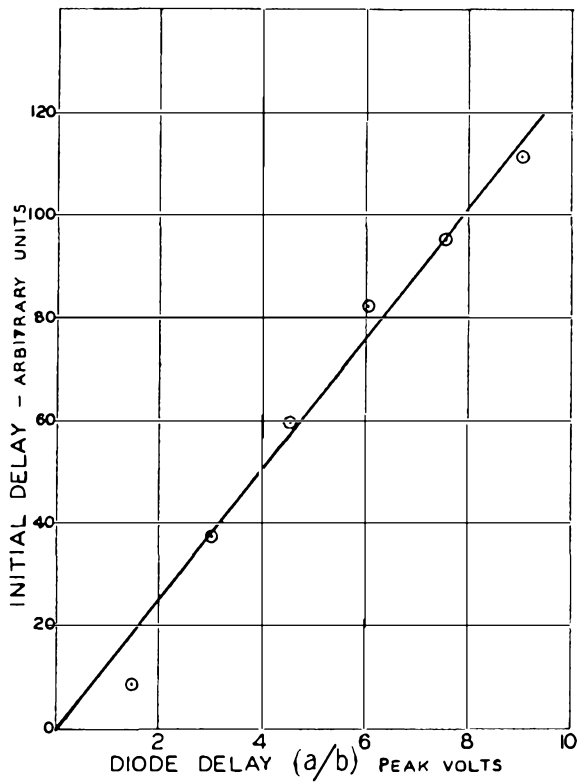

GRAPH 7. INITIAL DELAY VERSUS DIODE DELAY

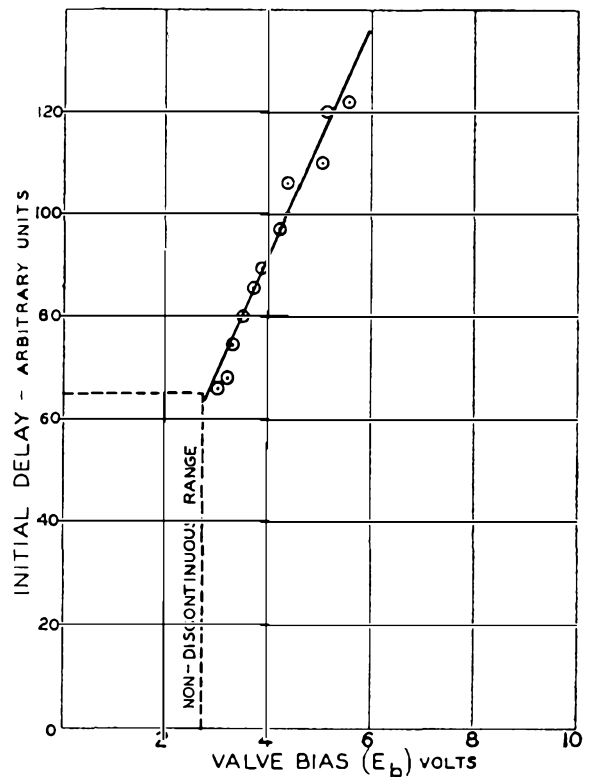

GRAPH 8. RETURN DELAY VERSUS VALVE BIAS

SOME PRINCIPLES OF DESIGN.

Stability.

In most circuits stability can be ensured by arranging that :

- (a) the windings of the feed-back transformer are connected in the correct sense ;
- (b) injection of the feed-back voltage takes place on the " earth " side of the secondary winding of the input transformer (see Fig. 7).

In the unlikely event of the unstable transformer connection being adopted then stability may be attained by means of :

- (a) a bias condenser of suitable capacitance ;
- (b) a highly damped secondary circuit for the feed-back transformer ;
- (c) sufficient rectifier bias (shown dotted in Fig. 7).

Smoothness of Response.

It will have been noticed that nowhere in the preceding analysis has any suggestion of an irregularity in the $I-E_1$ curve appeared. A reference however, to Fig. 2 of the original paper of L. H. Harris⁹ shows that, after the initial rapid rise of current the latter may increase very slowly over an appreciable range of input voltage, after which it rises more rapidly to its final steady value. Experiments have been carried out on a stage identical with the one used to obtain the graph referred to and the result has been verified. The precise reason for the effect is not clear but investigation suggests that :

- (a) it only occurs with the transformer windings connected in the stable sense ;
- (b) it is a function of frequency ; for any given frequency of input signal there appears to be a certain range of values of grid capacitance throughout which the irregularities make their appearance. For condenser values above and below this critical range they are absent.

The effect may, therefore, be avoided quite readily.

Sensitivity.

In practice it is usually required to have as great a sensitivity as possible ; this reduces ultimately to obtaining the highest possible value of $\delta I/\delta E_1$. From (31) :

$$\delta I/\delta E_1 = (gbN\mu)/(1+2\rho bN^2/R)$$

⁹ *Loc. cit.*

g and b are usually of the order of 2 and 0.9 respectively ; a valve with a high μ should therefore be chosen. It should be noted however that the advantage of a high μ exists only so long as the circuit parameters are such as to enable as large a portion of μ as possible to be used, i.e., so long as $(2\rho bN^2)/R \gg 1$. R will usually be fixed by rectifier back resistance or time-constant considerations. N remains, therefore, as a possible design variant. The best value of N is obtained when :

$$(\delta/\delta n)(\delta I/\delta E_1) = 0$$

i.e., when :

$$\begin{aligned} (1+2\rho bN^2/R) &= 4\rho bN^2/R \\ 2\rho bN^2/R &= 1 \end{aligned}$$

So :

$$N_{opt.} = \sqrt{R/2\rho b} \dots\dots\dots (40)$$

It may be inferred from Graph 4 that this condition is not critical provided N exceeds the optimum value.

A resonant circuit is sometimes connected in the input leads to provide some measure of discrimination between signals of different frequency but of similar amplitudes. From the analysis of the conditions regarding bias beyond cut-off it is clear that, provided the amplitude of the input signal is adequate, this discrimination can be improved by increasing the delay. This can be achieved in two ways :

- (a) increasing the rectifier bias E'_b and hence a/b
- (b) increasing the valve bias E_b ; this method should not be adopted unless the hysteresis condition is desired, i.e., unless a large signal is available to operate the relay which then is required to remain held despite subsequent reduction of the input.

Acknowledgement.

The research described in this paper was carried out partly in the Signalling Apparatus Laboratory of the Post Office Engineering Research Station and partly in the Electrotechnics Department of the Victoria University of Manchester. The authors' thanks are due, therefore, both to Captain B. S. Cohen, O.B.E., F.Inst.P., M.I.E.E., and to Professor R. Beattie, D.Sc. for the facilities provided.

Centralised "ENG" Service, Testing and Maintenance Control at Birmingham

A. L. BARTON

A description is given of the equipment and method of working adopted in the Birmingham area to control, from one central office the "ENG" service and all testing and fault work.

Introduction.

THE latest development in connection with the services dealing with subscribers' complaints is the installation of a fully centralised scheme of "ENG" service, testing and maintenance control. As the name implies, this scheme involves the centralising of equipment and facilities and, when completed, all fault complaints originated by subscribers connected to automatic exchanges in the Birmingham area will be dealt with at one centre. A partially centralised scheme covering the Manchester director area has been dealt with in a previous article¹.

In designing the present scheme the desire has been to increase further the efficiency of the "Engineering Fault Complaint and Repair Service" (ENG) and at the same time provide up-to-date accommodation, equipment and facilities for effecting the work of fault testing, the distribution of faults, and the control of the maintenance staff on an economical basis.

The "ENG" service is at present in use in London, Manchester, and Birmingham, as well as a number of other telephone areas, and provides prompt and effective measures for dealing with subscribers' complaints. This system has many advantages over the procedure of reporting faults to the traffic staff (known as the docket system) which is still in use at manual exchanges and in many automatic areas, and the success of the "ENG" scheme both from the Department's point of view and from that of public service makes an early expansion of such facilities to all suitable areas a logical development.

Under the "ENG" Scheme:—

- (a) Subscribers make complaints direct to the engineering staff by dialling "ENG" (Director Areas) or "97" (Non-Director Areas).
- (b) The fault is at once in the hands of the engineering staff and all delay due to the transfer of the complaint from the traffic to the engineering staff is eliminated.
- (c) Full details of the trouble are obtained from the subscriber at the time the complaint is made. Also, as technical officers record the complaints, they are generally able to deduce the nature of the fault from the information received.
- (d) The circuit is thoroughly tested with the subscriber on the line—a desirable feature.
- (e) It is often possible for a maintenance officer to examine the circuit and to locate the fault immediately, thus avoiding a re-occurrence of the trouble.
- (f) The fact that direct communication to the engineering staff is made possible has a good psychological effect upon subscribers, which re-acts to the benefit of the telephone service as a whole.

In addition to reducing the delay on faults, many complaints which under the docket system would be carried over to the next day are dealt with as soon as reported. From statistics for a number of manual exchanges in the London Area it was revealed that the percentage of "carried-over" faults totalled 11 per cent., whereas the figure for a number of comparable automatic exchanges where the "ENG" service is in operation was as low as 6 per cent. of the total faults reported. The number of written complaints is also considerably reduced under "ENG" conditions.

Centralisation.

By concentrating the "ENG" testing and control facilities at a central point various economies in equipment and staff are possible, and as "team working" may also be applied, a higher standard of service is obtained. Under "ENG" conditions a maximum delay in answering of 10 seconds is aimed at, and at centres where centralisation has been adopted the majority of the "ENG" calls are answered within 5 seconds from the receipt of the ringing tone.

As regards "ENG" and testing equipment, considerable economies are to be gained by centralisation. A slight increase in the amount of testing equipment, relative to the number and sizes of the exchanges which are to be centralised, is required at the central or controlling exchange, but the amount of equipment fitted at the "out" or controlled exchanges is restricted to that required for local testing, i.e., testing in connection with new subscribers' circuits and a small portion of fault testing which cannot be undertaken from the central desk, the effect being a considerable saving in the total equipment fitted in the area.

In order that testing may be carried out from the central desk under normal conditions or reverted to the local exchange if a cable breakdown or other abnormal circumstances occur, special switching facilities are provided on the testing selector circuits at the controlled exchanges. Fig 1. gives the circuit arrangements from which it will be seen that by throwing a key at the controlled exchange the circuit is restored to the local desk. At the larger controlled exchanges, where an appreciable amount of local testing is normally carried out, it is usual to connect at least one test selector circuit permanently to the local test desk.

With regard to staffing arrangements, it is necessary under decentralisation to provide adequate staff at all exchanges to maintain a high grade of service, and in order to do this it may mean that at certain exchanges uneconomical loads are carried by the staff operating the test desk. In the smaller exchanges the normal traffic over the "ENG" circuits, plus other exchange maintenance duties, may not constitute a full load, and difficulty is experienced in allotting other suitable work. By adopting

¹P.O.E.E.J., Vol. XXVII, Pt. 2, p. 116.

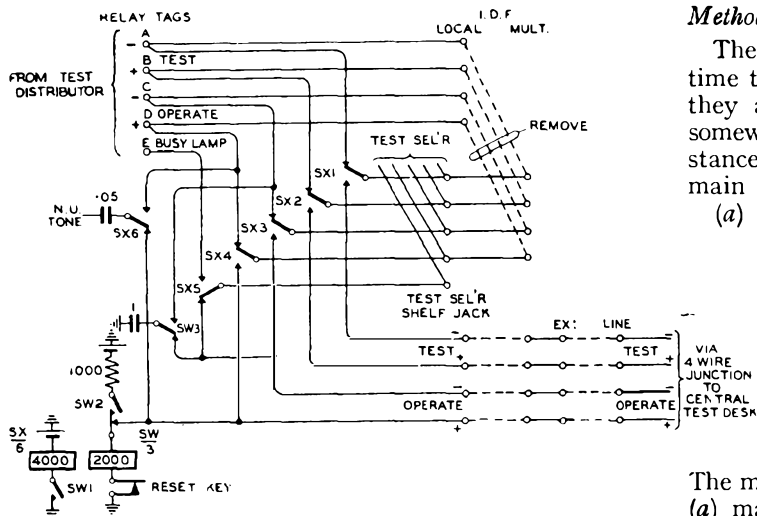

FIG. 1.—TEST SELECTOR SWITCHING CIRCUIT.

centralisation many such conditions are eliminated.

Further economies and a greater flexibility of the staff employed on the maintenance of subscribers' circuits are also made possible under centralised conditions. With the greater transport facilities now available, it is possible for maintenance officers to cover a much wider area, and a temporary rise of faults in one section may be dealt with by the staff normally located in another part of the centralised area.

Accommodation.

Consequent upon the introduction of the "ENG" service the question of improving the conditions of working assumed greater importance. Up to this time it had been the practice to install the testing positions close to the main distribution frame which is usually in the same room as the automatic equipment, but with the improved facilities for co-operation between the test desk and the M.D.F. now available, the installation of the desk in this position is not essential. Further, it is desirable when dealing with calls from the public, and for ease of operating that there should be as little noise as possible in proximity to the Test Desk.

With these points in view the present policy is to locate the "ENG" and testing positions in a separate room apart from the M.D.F. and the automatic equipment.² These conditions also allow the fault card cabinets, record tables and other equipment connected with fault procedure to be directly associated, and away from other important and delicate apparatus which might be adversely affected due to the dust caused by constant movements of staff. It is on these lines that the Birmingham scheme has been designed.

Methods of Control.

The methods of dealing with complaints from the time they are received by the "ENG" officers until they are cleared and the records completed, vary somewhat in different areas according to local circumstances; these, however, may be divided under two main headings as follows:—

(a) *Separate Testing and Maintenance Control* where "ENG" complaints are received, recorded and tested on a suite of testing positions, and separate control tables are provided for fault distribution and records, and

(b) *Combined Testing and Maintenance Control* where "ENG" complaints are received and the whole of the testing, fault distribution and control is carried out from testing positions.

The main difference in the two methods is that under (a) maintenance control tables take the place of testing positions for fault distribution and control purposes. As, however, under (b) the subscribers' fault cards and all information respecting the complaints are in the hands of the testing officers, and additional calls by maintenance officers to the control tables are eliminated, a higher standard of working is obtained. The provision of transfer circuits between the test positions and the control tables is also avoided. The Birmingham scheme is based on this combined principle, and in view of the large area

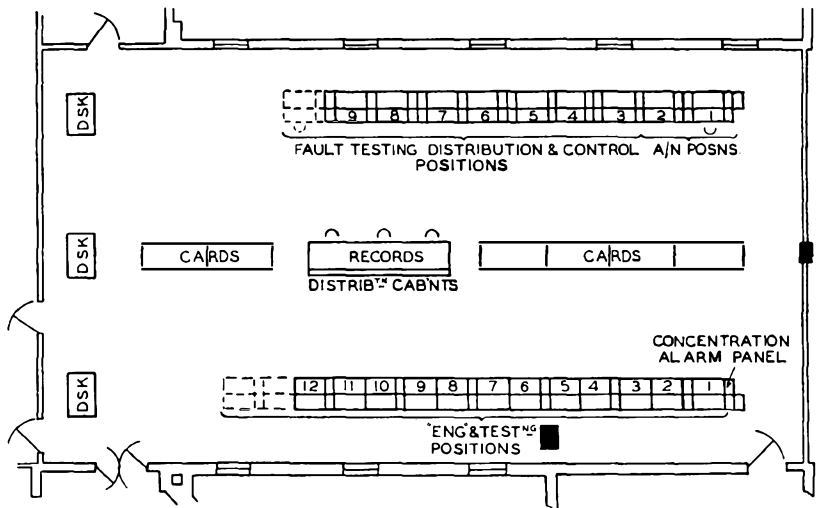

FIG. 2.—TEST DESK LAYOUT.

involved and the accommodation available, separate suites of testing positions for "ENG" and fault distribution are installed. (Fig. 2). As the centralisation of advice note work at Midland exchange is also contemplated two special A/N positions are provided and it will be seen that these are placed at the commencement of the control suite.

At the present time 32 automatic exchanges in the area come within the full "ENG" scheme and are centralised on the testing equipment in the Midland Building. A further 16 manual exchanges and U.A.X.'s are either tested and controlled, or, for

²P.O.E.E.J., Vol. XXIX, Pt. 2, p. 135.

fault distribution, are under the control of the Midland desk, making a total of 48 exchanges with approximately 78,000 stations.

The new test room which is approximately 72 ft. by 50 ft. is the largest in Great Britain and the equipment installed by Messrs. General Electric Co., Ltd., comprising 21 testing positions and 21 miscellaneous sections, is the largest "ENG" suite to be brought into service. Details of the various equipments are as follows:—

- 12 "ENG" and Testing positions.
- 7 Maintenance Control positions.
- 2 Advice Note Positions.
- 11 Miscellaneous Sections (Ordinary).
- 2 Miscellaneous Sections (Advice Note Work).
- 7 Miscellaneous Sections (Special Fault Card Distributors).
- 1 Miscellaneous Section (Concentration of Exchange Alarms).

The arrangement of the positions in two suites and the general layout of card cabinets, record tables, etc., may be seen by reference to Fig. 2.

When dealing with faults in a large area it is necessary to make arrangements whereby each maintenance control officer is responsible for a certain portion of the area, and to provide facilities for faultsmen to communicate with the particular officers dealing with the individual complaints. For the purposes of control, therefore, the Birmingham area is divided into six sub-areas each of which is controlled from a separate testing position. Fig. 3 shows the division of areas and the exchanges under each separate control.

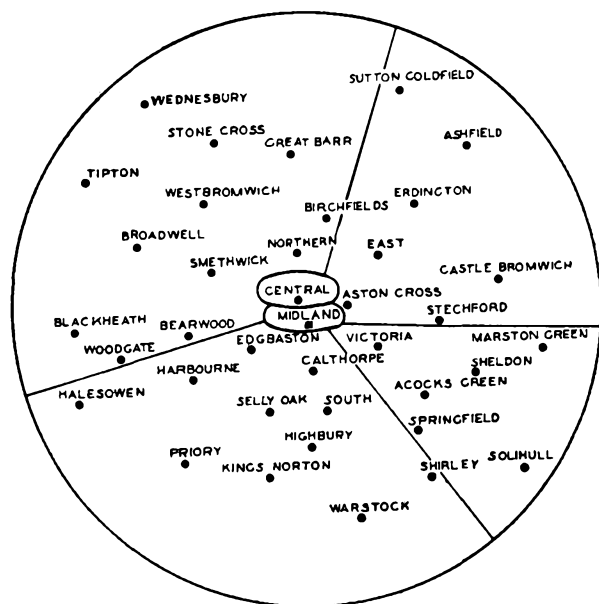

FIG. 3.—BIRMINGHAM CONTROL AREAS.

During slack periods and after normal hours of duty it is arranged that one testing officer may control more than one area. This is made possible by a special arrangement of the test selector circuits in the testing panels and by use of ancillary equipment on the incoming lines to the desk.

In order that the same codes for testing may be utilised over the whole area, and in order to provide

individual access to a particular testing position from the exchanges in each sub-area, additional levels of 2nd tandem selectors have been allotted and the director translations for each code in each area arranged as indicated in Fig. 4. It will be seen that "XXA" is the code for gaining access to the

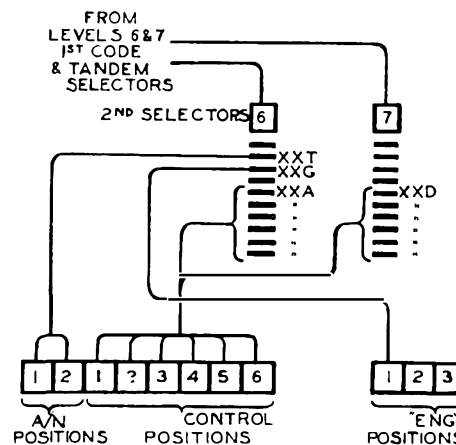

FIG. 4.—TRUNKING ARRANGEMENTS.

maintenance control positions from ordinary subscribers' circuits, and "XXD" from coin-box subscribers and call offices. Separate circuits are provided for the latter so that the testing officers may be aware that the call is from a call office and thus allow for the break period following the operation of button "B" and the return of the pennies inserted by the officer originating the call. A further code, "XXG," which is common to ordinary and coin-box subscribers, is used for the testing and maintenance control night service lines, and these circuits are terminated on Position No. 1 of the "ENG" suite which is permanently staffed. This code is also used by controlled exchanges for testing "Extension of Alarms" circuits. In order to simplify the testing operations, all these circuits are terminated on a separate miscellaneous panel fitted next to Position No. 1 at the end of the "ENG" suite of positions. See Fig. 2.

In the composition of the testing and control suite of positions it will be noticed from Fig. 2 that additional miscellaneous panels have been inserted to the right of each testing position. These are equipped with fault card distributors which will enable each testing officer to allocate separate pigeon holes to the various exchanges and to each member of the staff under his particular control. Pigeon holes for "Waiting Attention," "Special Report," "Filing," etc., are also included. The general arrangement of the positions is indicated in Fig. 5.

Owing to the volume of work undertaken and the number of staff on duty, also in order to minimise the noise in the room and the delay in obtaining a subscriber's fault card, a "fault-card call circuit" is installed on each "ENG" position. On the depression of a key by a complaint officer a lamp fitted on the top

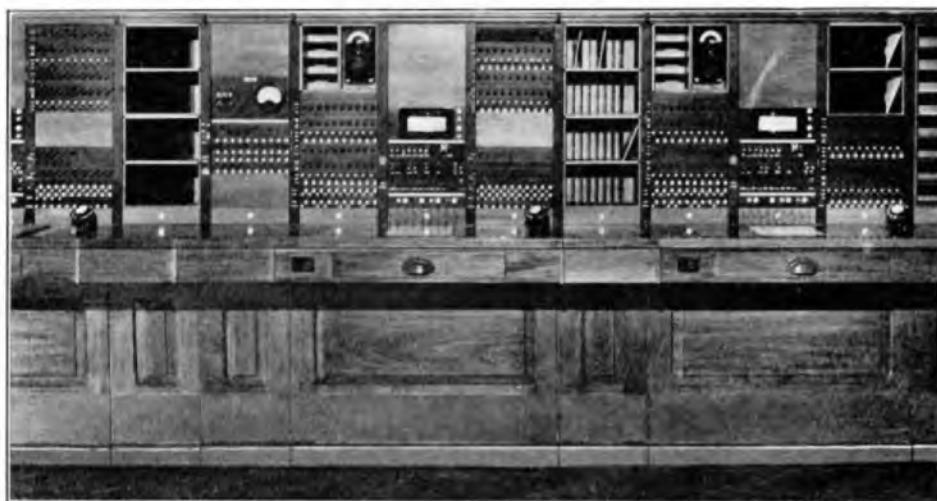

FIG. 5.—TESTING AND CONTROL POSITIONS.

of his position lights up and attracts the attention of a youth. The latter immediately ascertains the requirements, obtains the fault card from the cabinet, returns with it to the particular position, and extinguishes the lamp by restoring the key to its normal position.

In order to cover slack periods the circuit is provided with a pilot lamp and an associated alarm circuit fitted near the record tables where staff are situated throughout normal working hours and can give the necessary attention.

Fault Procedure.

The sequence of operations in dealing with subscribers' complaints is as follows :—

- (1) Calls are received over the "ENG" circuits and are answered by the complaint officers on the "ENG" suite of positions.
- (2) After ascertaining the subscribers' numbers and nature of the complaints the relative fault cards are obtained from the cabinets by using the fault card call circuit and details of the complaints are entered on the cards.
- (3) The complaint officers make initial tests of the circuits with the subscribers via test selectors to the particular exchanges concerned, and enter the results on the fault cards. The latter are then placed in the card distributors for collection.

For faults on common apparatus the co-operation of exchange maintenance officers is obtained by means of the special faults circuits at the time of carrying out the initial test.

- (4) After collection the fault cards are passed without delay via the special card distributor to the appropriate maintenance control positions dealing with the particular areas in which the faults are situated.
- (5) The faults are now handled by the maintenance control officers who pass details of the faults over the faultsmen's lines to the officers serving

the areas involved, make subsequent tests with the faultsmen, complete the entries on the fault cards and place them in the outgoing partitions for collections.

- (6) Completed cards are now collected, returned to the record tables via the special card distributor, and, when any further details required for exchange records or analysis purposes have been extracted, are placed in the pigeon holes for filing. Any fault cards for circuits requiring special attention are placed in the respective pigeon holes of the card distributor and subsequently dealt with.

In order to facilitate the distribution of cards at the record tables, a special type of card distributor which is open at the rear to allow the cards being placed in at the front and withdrawn at the back, is provided.

The pigeon holes are suitably labelled at both sides and it will be seen from the layout in Fig. 2 that the amount of walking between the two suites of positions is appreciably reduced by this arrangement.

Advice Note Work.

In order to deal with Advice Note Work on a centralised basis two testing positions and associated miscellaneous panels specially fitted up for the testing and recording procedure connected with this work, are provided at the non-growing end of the Maintenance Control Suite. From these positions it will be possible to deal directly with all such work in connection with subscribers' circuits on Midland exchange and to make final tests with the construction staff over the whole Birmingham area.

As all fault cards are centralised for maintenance recording purposes the preparation and filing of these and other records for all new work can be undertaken at the time the work is completed. Other advantages of centralisation are the concentration of clerical duties and a closer supervision of staff engaged on the work.

Ready-Reckoner for Losses Due to Mismatch

C. E. PALMER JONES

The author gives a series of abacs and a set of curves from which the loss at any frequency, due to the mismatch of senders and loads, may be readily determined.

Loss at One Frequency Due to Mismatch.

The communication engineer has frequently to match the impedances of senders (or "generators") and loads to avoid reflection, or "Mismatch," losses.

The abacs given here (Fig. 1) show at a glance the value of the mismatch loss when a 600 ohm matched condition has been disturbed in some way. It is essential to know whether the loss is to be calculated in terms of voltage, current or power. For example, if a 600 ohm generator be closed with a load of 100 ohms, there will be a loss in volts-across-load, a gain in current-through-load and, in the power-dissipated-in-load, there will be a loss when compared with the standard, matched condition. We are normally interested in the voltage if the load forms part of the

the shunt disturbance was the capacitance at a transposition pole in an aerial line at high carrier frequencies.

"Series Disturbances" enter into the design of amplifier couplings of various kinds, as well as the consideration of H.R. joints in any transmission system.

Losses at Other Frequencies.

So often do the losses due to reactive disturbances need to be evaluated over a band of frequencies that curves are given (Fig. 2) to hasten this process also. The reactance of an inductance or capacitance varies linearly with frequency so that it is possible to standardise a loss/frequency curve provided that a logarithmic scale of frequency be used, so that equal intervals

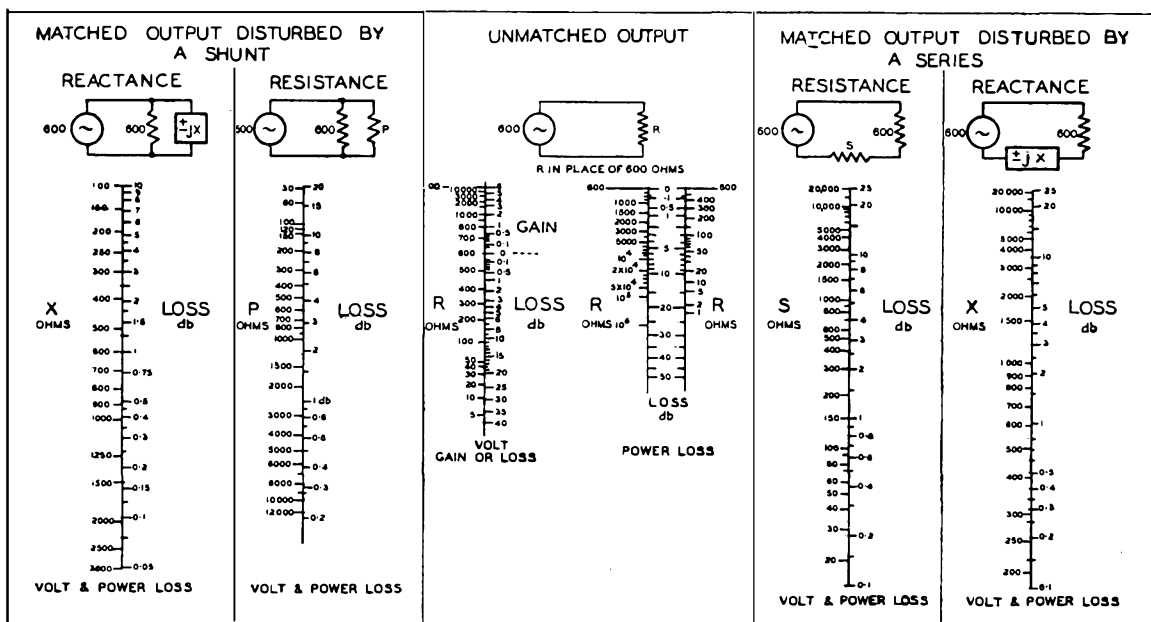

FIG. 1.—ABACS GIVING MISMATCH LOSS.

input circuit of a thermionic valve, or in the power in most other instances.

The particular conditions covered by the present abacs give, with one exception, the same loss in terms of both voltage and power. In the excepted condition, viz., Load Resistance Varied, separate charts are given for voltage and power.

A "Shunt Disturbance" may be an operator's headset across a telephone line, the capacitance across the secondary of an input transformer in an amplifier or the (low-frequency) inductance of a repeating coil. In one calculation rendered rapid by these abacs,

represent equal ratios. After calculating the frequency at which the load resistance and the disturbing reactance are equal, it is only necessary to register this frequency on a sliding scale against unity on the $\frac{\text{reactance}}{\text{resistance}}$ ratio scale. Then the standard loss/frequency curve will apply to the case in hand. The expected gain/frequency performance of an amplifier can thus be predicted from the input, output and coupling circuit constants.

Example:—What is the loss occasioned by the leakage inductance of the output transformer of a

Unit Amplifying No. 6 at, say, 5,000 c.p.s. ? The leakage inductance is approximately 20 mH. This is a series reactance of 628 ohms. Assuming the line impedance is 600 ohms, abac "Series Reactance Disturbance" gives the loss as between 1.00 and

1.05 db. The frequency at which 20 mH equals 600 ohms in reactance is 4,780 c.p.s., and if this frequency on the sliding scale is registered against unity the Series Inductance curve will give the law of loss due to the output transformer versus frequency.

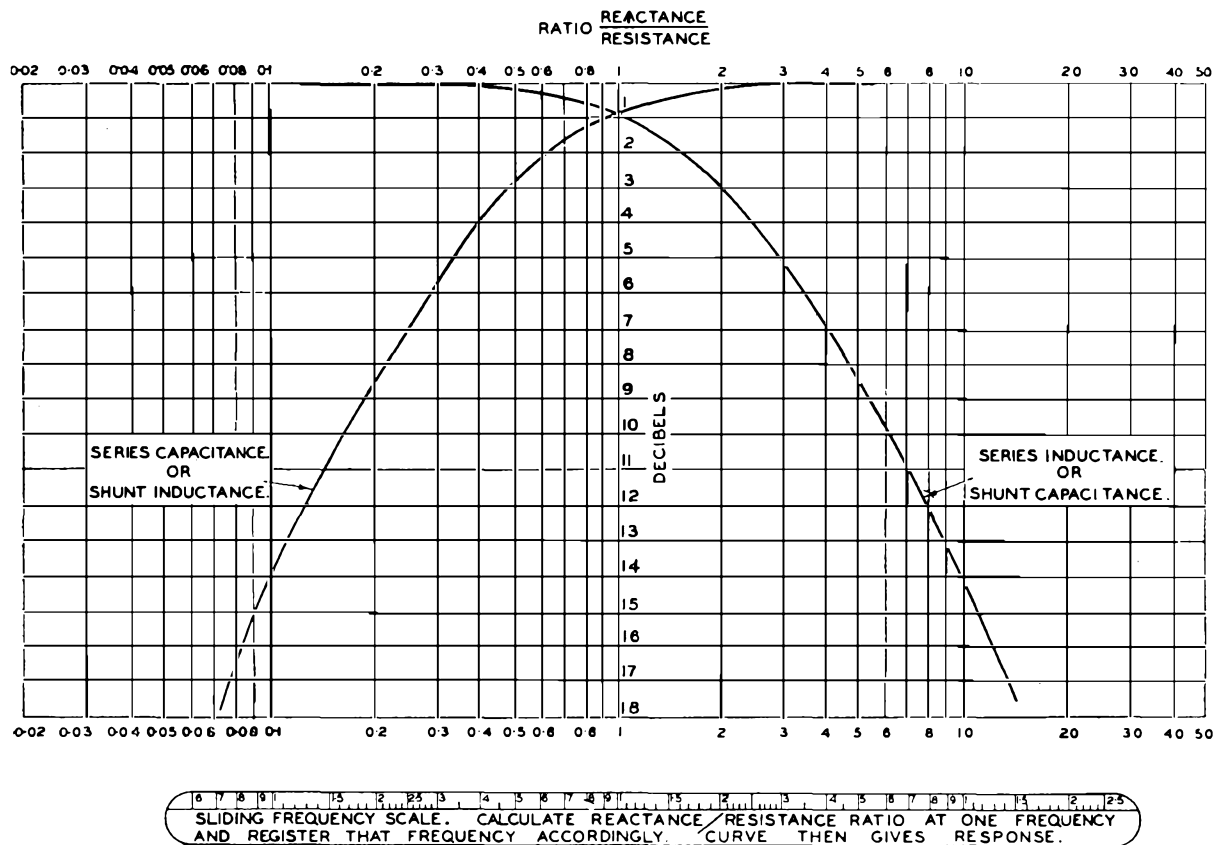

FIG. 2.—LOSSES DUE TO REACTIVE DISTURBANCES.

TELEGRAPH AND TELEPHONE PLANT IN THE UNITED KINGDOM.
TELEPHONES AND WIRE MILEAGES. THE PROPERTY OF AND MAINTAINED BY
THE POST OFFICE IN EACH ENGINEERING DISTRICT AS AT 30th SEPTEMBER, 1937.

Number of Telephones	Overhead Wire Mileages				Engineering District	Underground Wire Mileages			
	Telegraphs	Trunk	Exchange*	Spare		Telegraphs	Trunk	Exchange†	Spare
1,078,622	368	1,306	57,795	5,388	London	33,179	275,052	4,223,920	55,640
133,052	1,690	2,615	64,966	11,481	S. Eastern	6,077	114,658	418,889	57,750
157,765	2,318	13,085	125,205	9,767	S. Western	18,477	119,414	345,749	79,324
112,751	3,085	13,471	110,641	16,175	Eastern	13,059	123,976	246,984	55,920
129,505	3,466	13,993	83,080	24,687	N. Midland	8,717	192,510	297,736	113,016
146,130	1,871	8,268	96,836	17,192	S. Midland	9,623	169,546	439,251	61,518
76,363	1,200	7,301	71,250	11,145	S. Wales	5,396	73,840	174,623	43,814
193,210	1,766	9,597	104,976	23,300	N. Wales	12,387	199,452	552,852	100,080
230,247	996	1,555	38,727	9,100	S. Lancs.	8,725	116,476	817,352	52,842
96,819	1,023	2,095	39,932	18,329	N. Western	6,211	114,412	297,036	45,402
37,809	2,874	7,962	22,222	1,147	N. Ireland	1,140	9,338	97,637	15,222
272,158	4,823	16,201	113,447	27,585	N.E. Reg.	15,010	220,866	786,511	140,862
245,580	6,584	26,627	124,994	22,913	Scot. Reg.	8,296	196,066	541,919	83,640
2,910,011	32,064	124,076	1,054,071	198,209	Totals	146,297	1,925,606	9,240,459	905,030
2,872,457	32,741	130,302	1,034,780	200,273	Totals as at June 30, 1937	142,778	1,848,136	9,161,995	916,758

* Includes low gauge spare wires, i.e., 40 lb.

† Includes all spare wires in local underground cables.

Nomenclature and Symbols for Telecommunications

G. F. O'DELL, B.Sc., M.I.E.E.

This article reviews the steps taken to standardise the terms and symbols used in the telecommunication industry not only in this country but internationally, and describes the assistance given by the Post Office to the British Standards Institution and the International Electrotechnical Commission in this connection.

Introduction.

IN the preface to "Munera Pulveris," Ruskin takes to task an earlier writer for saying "Everyone has a notion, sufficiently correct for common purposes, of what is meant by wealth." Quite consistently he then states what he understands by wealth, so that readers may be clear on the exact sense in which he is using the word.

It is not enough, however, that authors should define the terms they intend to employ when they are not already in common use and well understood. Misunderstanding can be avoided and progress made only by obtaining as wide an agreement as possible to the use of one definite term for each idea. The growth of international co-operation is assisted if corresponding terms in various languages are correlated and defined.

In this country the body charged with the standardisation of engineering and industrial practice is the British Standards Institution (B.S.I.), which is the national standardising organisation, and issues the British Standard Specifications. It exists to assist British industry by preparing these specifications which are based on what is best in present practice, and do not attempt to attain an ideal which might be too costly to adopt. They provide a generally suitable standard of performance, quality or dimension, and an equitable basis for tendering.

The Institution is organised in four main divisions, the Engineering Division being further subdivided into thirteen Industry Committees. Of these, the Electrical Industry Committee, comprising representatives of many Government Departments, as well as of scientific and industrial organisations, is the one with which the telecommunications industry is principally concerned. The Electrical Industry Committee is also the British National Committee of the International Electrotechnical Commission (I.E.C.), and thus liaison is maintained with the rest of the world on electrical matters.

On purely telecommunication matters, international co-operation is maintained primarily through the three International Consultative Committees¹ (C.C.I., F., T. and R).

The British Standards Institution and corresponding organisations in other countries regard the standardisation of nomenclature as an important part of their functions. Broadly, for each branch of industry there is a panel specially concerned with the preparation of a list of terms in general use in the industry and of the precise definition for each term most acceptable to producers and users. Many of the panels, too, perform a similar function in respect of symbols for use on drawings and plans.

The B.S.I. has set up two panels for the consideration of terms, definitions and symbols for tele-

communications—one for telegraphy and telephony and the other for radio. On each of these the Post Office is represented, as well as manufacturers and other organisations.

Internationally, nomenclature and symbols are of interest to both the I.E.C. and the three C.C.I.s, and these bodies confer with one another to produce agreed lists.

Nomenclature.

Naturally it is not practicable to produce comprehensive lists of agreed terms and definitions until an industry has been firmly established, and by that time it is usually found that a number of terms has been introduced for the same idea, and occasionally the same term is used in two senses by different authorities. Confusion is therefore likely to arise and clarification can only be achieved by a change of practice of some of those concerned. There are thus good reasons for standardising nomenclature at an early stage in the development of an industry. Further, as it is inevitable that improvements and developments will occur, a continual revision and extension of the vocabulary is necessary.

For many years, the Post Office contributed to the work of nomenclature through its representative on the two B.S.I. panels mentioned. In 1928, however, a request was received that the Post Office should itself prepare a vocabulary for telegraphy and telephony which would serve as a basis for the revision of that published in 1926. The task was of such magnitude that the Post Office formed a special committee for the purpose, and as a result, its proposals, with some modification, were adopted by the B.S.I. and published as B.S.S. 204 of 1930.

Since this work was completed the committee has been expanded to include a radio representative, and its activities now cover the whole field of telecommunications. Since 1930 the development of the industry has been exceedingly rapid, and the committee is now engaged on a revision of B.S.S. 204 of 1930. In this revision it is proposed to follow the practice of including as much as possible in a general section common to the three branches of telecommunications (telegraphy, telephony and radio). As will be seen later, this practice has already been adopted for symbols.

Graphical Symbols.

On the completion of the 1930 publication on nomenclature, the Post Office was asked to undertake similar work in connection with graphical symbols. Similar procedure to that used for nomenclature was adopted, and the results, after slight modification by the B.S.I., were included in the Institution's publication No. 530 of 1934. This publication also includes graphical symbols for radiocommunication which were agreed by another panel of the Institution.

¹P.O.E.E.J., Vol. 29, p. 38

Shortly after this, the International Electrotechnical Commission invited its constituent national committees, in conjunction with the three international consultative committees on telegraphy, telephony and radio, to make proposals for graphical symbols covering all branches of telecommunications, and suitable for international as well as national use. The B.S.I. indicated that it would be willing for the Post Office to represent its interests at the conferences held to discuss the proposals. At this stage, as previously mentioned, the Nomenclature and Symbols Committee was enlarged to include a representative of radio. Before formulating its own proposals, the committee adopted the plan of considering all proposals which had been made for international symbols. By this means some idea of the views of other countries was gained and the work of the committee facilitated. The final proposals of the committee were prepared in a bulletin which also included the other proposals which had been considered.

The suggestions made by various countries were considered first by a joint meeting of C.C.I.F., C.C.I.T., and C.C.I.R. at Berne in June, 1935, and a week later these bodies were represented at the meetings of the I.E.C. at Brussels where the symbols agreed at the Berne meeting were adopted with but minor amendments to a few symbols.

The Post Office Nomenclature and Symbols Committee carefully reviewed the British symbols then in use in the light of the I.E.C. recommendations and re-drafted B.S.S. 530 to follow the recommendations of the I.E.C. so far as they can reasonably be adopted in this country. The draft was accepted by the B.S.I. and the new edition of B.S.S. 530 was published in 1937. This edition also includes a section detailing those items in which the symbols adopted by the B.S.I. differ from those recommended for international

	I.E.C. SYMBOL.	B.S.I. SYMBOL.
FUSE.		
UNISELECTOR.		
2 MOTION SELECTOR.		

FIG. 1.—DIFFERENCES BETWEEN I.E.C. AND B.S.I. SYMBOLS.

use. There are only three of such cases of any great importance—the symbols for fuses, uniselectors and two-motion selectors. The differences in these cases are shown in Fig. 1.

Although in many instances the symbols proposed by the Post Office were not adopted for general international use, in practically every case the British-desired symbol was permitted as an agreed alternative. In Fig. 2, the alternatives for a relay



FIG. 2.—RELAY SYMBOLS.

coil are shown; in this symbol, the Post Office definitely desires the rectangle to be blank, so that the resistance of the coil may be inserted when desired.

It is noteworthy that the conferences at Berne and at Brussels in 1935 were the first to give recognition to the "detached contact system" which has for some years been employed by the Post Office for relay and key contacts in circuit diagrams. B.S.S. 530 of 1937 includes typical diagrams showing the application of the symbols.

The use of arrowheads for various purposes has also been unified as shown in Fig. 3.

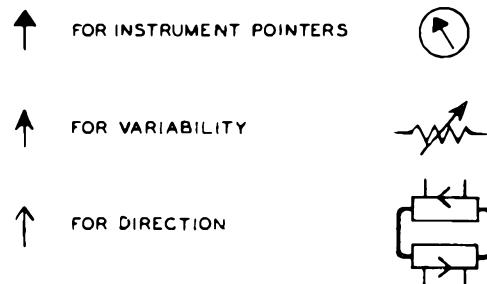

FIG. 3.—TYPES AND USES OF ARROWHEADS.

Changes of Symbols.

It was stated earlier that standardisation may necessitate a change in practice on the part of some in order to achieve uniformity. Two examples may be of interest. For many years, the usual German representation of a battery consisted of a short thick line for positive and a long thin one for negative. In order to conform with international usage, German engineers have recently faced the inconvenience of changing their own practice to bring it into line with that of other countries.

More recently, this country has faced a similar problem. For a number of years, the conventions for indicating a slow-operating and a slow-releasing relay were the reverse of those used on the Continent. In

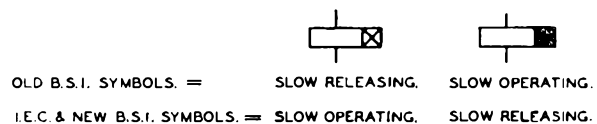

FIG. 4.—NEW AND OLD SYMBOLS FOR SLOW OPERATING AND SLOW RELEASING RELAYS.

order to rectify this position the standard international symbols have been adopted and special steps have been taken on new diagrams to indicate the new convention. The new and old symbols are shown in Fig. 4.

Conclusion.

As readers of the JOURNAL will be aware, special steps have been taken within the Post Office to give wide publicity to standard nomenclature and symbols and to ensure that they are brought into general use.

Copies of the B.S.I. publications on nomenclature and symbols have been issued to all the major staff

in the Engineering Department, and an Engineering Instruction embodying them is in course of preparation. The B.S.I. publications may be obtained on application to the Publications Department of the Institution, 28 Victoria Street, London, S.W.1. B.S.S. 204 of 1930 is 2s. 2d., and B.S.S. 530 of 1937, 2s. 3d. post free.

While in this brief summary emphasis has been laid on the part played by the Post Office in the development of standardised nomenclature and symbols, it is only fitting to conclude with a tribute to the pioneer work which the British Standards Institution has done in this as in many other fields.

Sir George Lee, O.B.E., M.C., B.Sc., M.I.E.E.

President of the Institution of Electrical Engineers.

We have pleasure in recording that our Engineer-in-Chief has been elected President of the Institution of Electrical Engineers. In his presidential address to the Institution in London on October 21st, Sir George Lee reviewed some of the activities of the Post Office Engineering Department in meeting the phenomenal growth of the telephone and telegraph services.

He mentioned that following the reduction in tariff rates in October, 1934, the net annual increase in the number of telephones had risen from 87,900 in 1933-34 to 247,983 in 1936-37 and that the number of trunk calls had grown from 39,582,000 in the half-year ended March, 1935, to 49,606,000 in the half-year ended March, 1937. New methods had been evolved to expedite the provision for this rapid growth. The reliability of development forecasting had also been improved and new methods of maintenance had been developed tending to reduce costs and ensure more reliable service.

Regarding trends of design, for the local exchange and its network, the P.O. has decided on a policy of complete mechanisation on the "Strowger" system. The main problems at the moment are the provision of new plant in large quantities and the improvement of maintenance and service conditions.

At present 90 per cent. of trunk circuits is underground. The amplifier, or repeater, reduced the necessity for so much loading. Now, with the arrival of the feed-back repeater, there is an economic possibility of carrier on underground circuits, and, for short distances, unloaded circuits with feed-back amplifiers. Loading is, therefore, being replaced in the newer cables by unloaded circuits. The new trend entails a large number of problems in signalling (calling, dialling, and clearing), as well as in the complexities of amplifiers and filter arrangements. On the operating side the trend is toward mechanisation, which is expected to lead to a quicker and cheaper system. In the international trunk system organisation and technical processes are proceeding steadily.

Within the past decade wholesale changes in equipment and technical practices have effected a complete metamorphosis in the operation of the telegraphs. There is a very important difference between the economics of telegraph and telephone services, in that the operating charges preponderate very considerably over all other charges in the case of telegraphs. The prime consideration in reducing the cost of service must therefore be providing the most efficient means for handling and signalling the telegrams. The policy was, therefore, to abolish from the inland service all the older systems and the whole of the heavily worked circuits have now been converted to teleprinter operation, while the very lightly loaded circuits have been converted to telephone working. A more recent development has been the introduction of an "ancillary" system of teleprinter working to facilitate operating on medium-loaded circuits. The combined effect of all the steps taken has been to secure a 65 per cent. improvement in the average hourly output, compared with that obtaining before the introduction of teleprinters. In addition, the transit of telegrams inside the offices from circuit to circuit, and from circuit to output, has been speeded up by ample provision of conveyor belts.

Sweeping as the changes in instrument room practice have been, even more radical has been the reorganisation which has taken place in the line network. The multi-channel voice-frequency system enables eighteen duplex telegraph channels to be worked simultaneously on a four-wire telephone circuit. The way has been paved for the establishment of a switched telegraph system utilising the familiar methods of automatic telephony. Experimental equipment comprising twenty-two teleprinter positions and six skeleton switching centres has been set up and subjected to engineering and traffic tests, with promising results, and from an engineering point of view there seems to be no doubt that a satisfactory system can be provided.

Micro Wave Demonstration Equipment

N. BOURDEAUX and
E. F. S. CLARKE

The apparatus described in this article was devised in 1933 to give a visual demonstration of a wireless beam transmission. It has also proved useful for showing some of the physical properties of radio waves such as polarisation, absorption and reflection. The demonstrations afforded by this apparatus are so readily convincing that it is thought there may be others who would like to build similar apparatus for themselves, more particularly perhaps for the purpose of demonstrating to students, and sufficient details of the units are given to enable this to be done.

Introduction.

THE apparatus operates at a wavelength of about 22 cms. and consists of a transmitter and receiver each mounted in a cabinet, with turntable base. The output of the receiver is used to control a "thyatron," and this in turn controls the brilliance of an ordinary electric lamp. Changes of signal level in the receiver are thereby converted into the visual form of light emitted by the controlled lamp.

The transmitter consists of a magnetron oscillator feeding a two-bay pine tree type aerial array and generates between one and two watts of high frequency energy. The pine tree array has been chosen on account of the simplicity of its construction and because it is typical of Post Office practice for overseas telephony on wavelengths of the order of 20 metres. The linear dimensions of the array being directly proportional to wavelength, these models therefore are to a scale of about 1/100th normal size. It is not intended to suggest that such an aerial would represent normal practice for transmission of these centimetre waves, in fact, apart from generating radio waves of the order required, neither the transmitter nor receiver conforms in the least to orthodox practice at these wavelengths.

The receiver is fed from a single-bay pine tree array. In the presence of the transmitted carrier the detector delivers an increased anode current and it is the D.C. changes which are developed in the detector anode circuit that are amplified and used for light control purposes. The detector as such is insensitive. With the H.F. power available and followed by a single stage of D.C. amplification it can normally be used satisfactorily only up to distances of from four to six yards from the transmitter. This, however, represents about twenty wavelengths and is ample for demonstration purposes. With critical adjustment of the transmitter and receiver it has at times been possible to double this demonstration range, but very stable supplies are required to maintain the adjustments. It is perhaps interesting to note that on wavelengths of the order of five metres a transmitted power of one watt can be used to provide a good telephony circuit over an optical path of about forty miles.

The design of the model arrays has been determined experimentally and they are built in a suitable way

to show clearly the essential electrical design. In order to render the array elements readily visible, $\frac{1}{8}$ in. diameter copper has been used for transmission lines, feeder system, radiators and reflectors, and the reflector curtain has been spaced at the second optimum position approximately three-quarters of a wavelength behind the radiators, instead of the normal first optimum at one-quarter wavelength. Using $\frac{1}{8}$ in. diameter copper it was found difficult to energise normal half-wave radiating elements. Using close spacing for the transmission line, however, quarter-wave elements were readily energised, hence the radiators in the models are all quarter-wave elements. The arrays have been slung from wooden towers shaped and painted to represent self-supporting lattice steel towers such as are used for short-wave arrays.

The general appearance of the apparatus is shown in Fig. 1, the transmitter being on the right and receiver on the left in their respective cabinets together with the lamp used for demonstration purposes. On setting up the apparatus the receiver is first switched on and the controls adjusted so that the lamp is on the point of glowing. The visible effect of a received signal is then to give some degree of illumination from the lamp dependent upon the signal strength. The transmitter is then switched on and adjusted to give a suitable output. The only

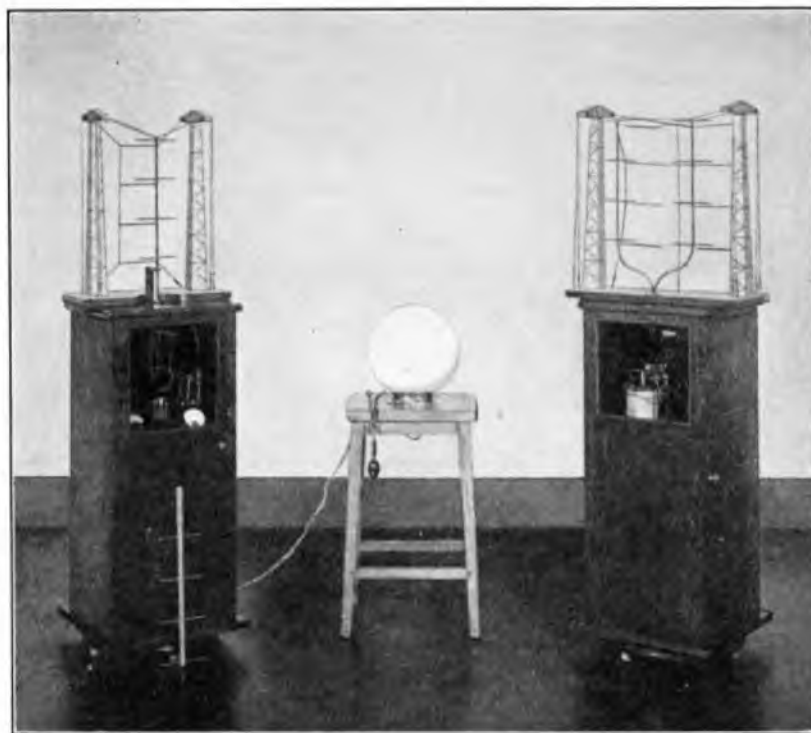

FIG. 1.—GENERAL APPEARANCE OF THE EQUIPMENT.

limitation here is that the maximum received signal should not overload the receiver; should overloading occur the transmitter power may be reduced or the spacing of the cabinets increased. Operating instructions are given later in a section dealing with the construction of the transmitter and receiver.

Demonstrations.

The polar diagram in the horizontal plane of either of the arrays can be shown by simply rotating the appropriate cabinet. A sketch of the horizontal polar diagram given by these arrays is shown in Fig. 2.

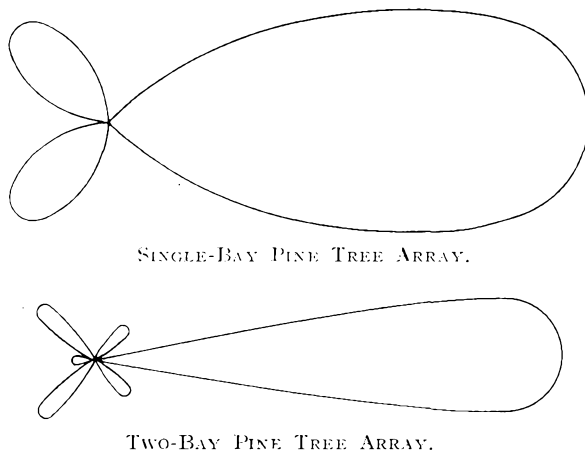

FIG. 2.—POLAR DIAGRAMS IN THE HORIZONTAL PLANE.

The narrower beam from the two-bay array is readily demonstrable and the additional minor lobes of radiation can be shown. These lobes are liable to be disguised if the apparatus is used in a confined space due to reflections from neighbouring conductors interfering at the receiver with the direct radiation from the transmitting aerial. They can be made more readily appreciable by initially adjusting the lamp circuit so that zero signal corresponds to slight illumination.

The effect of the reflector curtain may best be shown by lowering the back curtain of the single-bay array. The reduced signal and the back end pick-up can then be shown. A portable reflector consisting of half-wave elements mounted in an insulating rod is very useful for showing the effect of a reflector curtain spaced at various distances from the radiators. The normal first optimum position a quarter of a wavelength behind the radiators can be shown and the reinforcing action of the reflector on the main beam is made evident as well as the suppression of back end radiation.

The apparatus as shown in the photographs has not been arranged to show polar diagrams in the vertical plane. A universal joint in the mounting of the receiving array and associated detector could readily be fitted, but a possibly more useful alternative would be to mount the detector, fed from a single dipole, on the end of an insulating rod, and to use this as a probe to explore the electric field in any desired position. Since anode bend detection is used the filament and anode supplies can be made up as a

light, three-core, flexible lead of the required length. For demonstration work a quick changeover from normal reception to probe conditions is desirable, and this can best be provided by using the one detector for both purposes. A clip-on attachment on the end of the probe and a quickly attachable dipole would be easy to design, and with this arrangement it should be possible to effect the changeover in less than one minute.

One of the first things noticed when using the apparatus is the almost complete absorption of the waves by the human body when standing in the path of the beam. The relative absorption of various conducting, semi-conducting and insulating materials can be shown by placing specimens in the path of the beam. The specimens should, if possible, be large enough to cover all the elements of the receiving array so that a maximum effect may be obtained.

The reflection of wireless waves by conducting surfaces can be shown by directing the beam from the transmitter on to a flat metal sheet about 30 in. by 20 in. in area, and directing the reflected beam on to the receiver. Quite strong reflections are obtained in this way and they also serve to show the optical nature of the reflection. Usually it is possible to show a double reflection, from one metal sheet to another and thence to the receiver, but the insensitivity of the detector has to be remembered and the added length of the transmission path not made excessive.

Reflections such as are suffered by longer waves on reaching the Heaviside layer may be simulated by the use of a large ionised vapour tube, or array of tubes. In this case the ionisation density has to be much greater than that of the Heaviside layer, but the principle involved is the same. Such an arrangement is known to have been demonstrated by Mr. E. C. S. Megaw, of the G.E. Co., at the I.E.E. Overseas Conversazione in July, 1934.

The arrays used have horizontal radiators and therefore emit horizontally polarised waves, that is to say, the electric field is caused to vibrate in the horizontal plane at the transmitted frequency. (In this instance about 1,400 million cycles per second.) That this oscillation is confined to the horizontal plane may be shown by the use of a series of half-wavelength conductors mounted in an insulating rod at intervals of half a wavelength and all lying in the same plane. (The portable reflector previously mentioned is very suitable for this purpose and a suitable make-up is shown in the photograph of Fig. 1 resting against the receiver cabinet). When this is held in the path of the beam it can be shown that it only absorbs energy when the conductors are in the horizontal plane and shows maximum absorption when these lie in a plane parallel to the elements of the transmitting array.

These demonstrations show the general utility of the apparatus, but are by no means exhaustive in their scope. Additional demonstrations or adaptations will no doubt be apparent to the interested reader. For the benefit of those who may be desirous of constructing similar apparatus the rest of this article is devoted to a constructional description of the arrays, the transmitter and the receiver in sufficient detail to enable copies to be made.

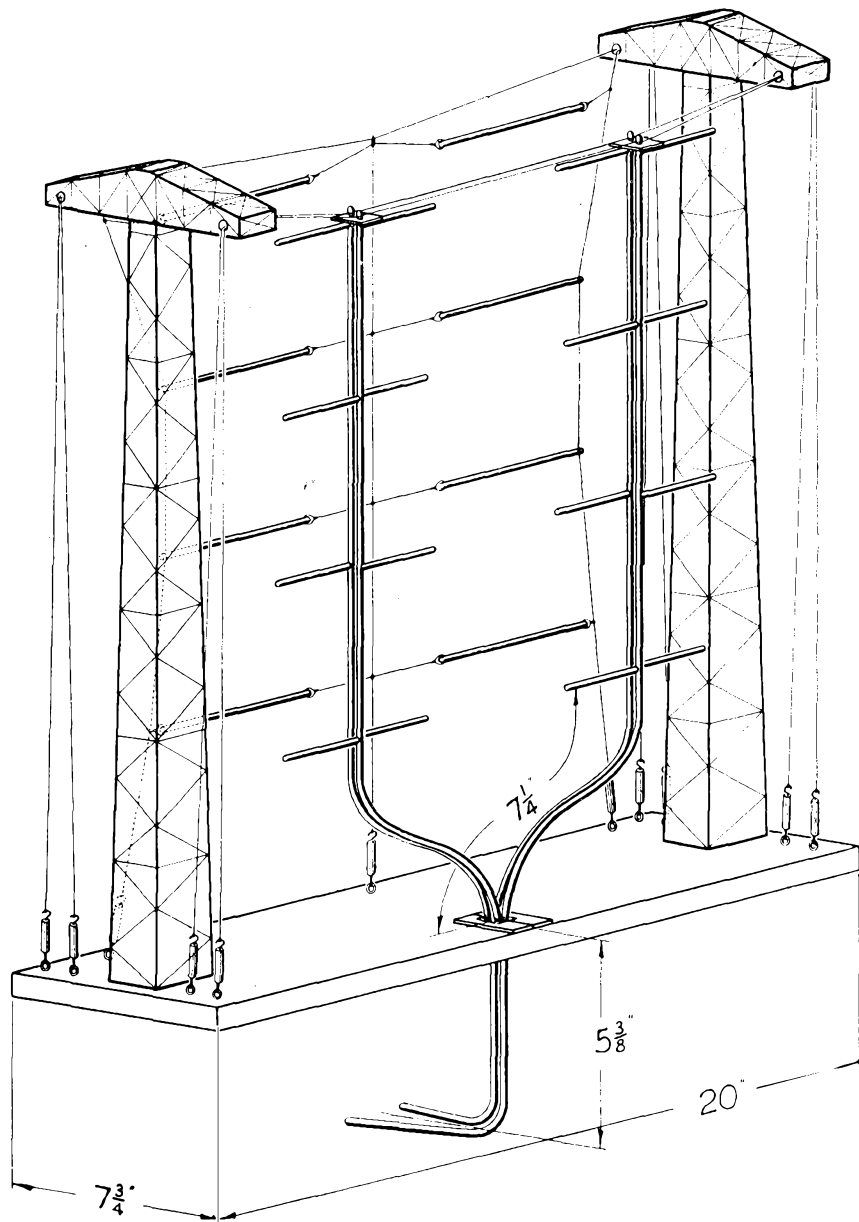

FIG. 3.—Two-Bay Pine Tree Array as used with the Transmitter.

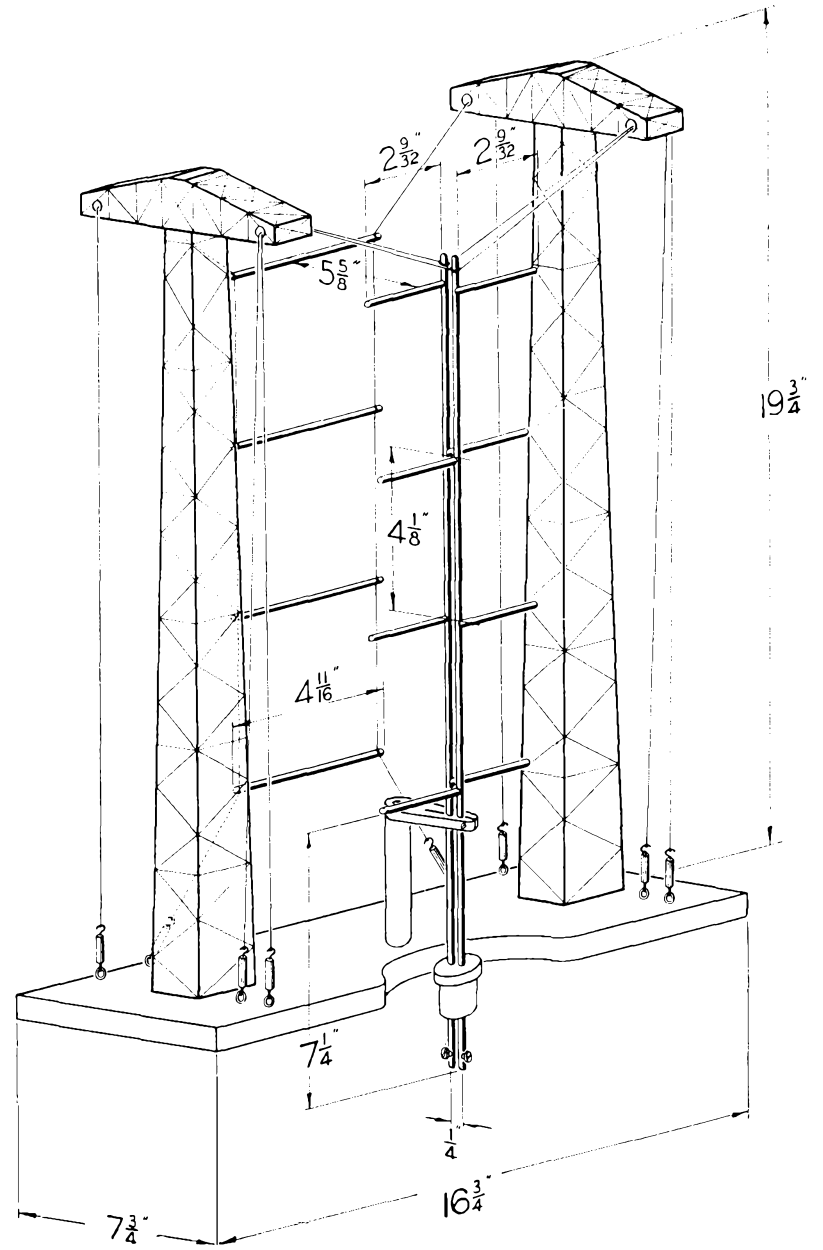

FIG. 4.—Single-Bay Pine Tree Array as used with the Receiver.

The Arrays.

As previously mentioned, these are of simple "Pine Tree" form, having vertical feeders and horizontal radiators, thus producing a field which is horizontally polarised. They are shown diagrammatically in Figs. 3 and 4. It will be seen that the radiators are spaced half wavelength apart on alternate sides of each feeder, the method of fixing consisting of turning down the end of each radiator to 1/16 in. diameter and fitting it into a hole drilled in the feeder, the joint being finally soft soldered. The feeders stand one behind the other and are fixed in this position by paxolin spacers which make the whole radiating curtain a fairly rigid unit.

The reflector curtains consist of horizontal members, half wavelength long, suspended immediately behind and parallel to each pair of radiators, the distance between the radiating and reflecting curtains being three-quarter wavelength. Copper rod, 1/8 in. diameter, polished and lacquered, is used for all feeders, radiators and reflectors.

The supporting towers are made of wood, painted to represent steel lattice, and are fixed to baseboards which can be clamped to the tops of the two cabinets which house the transmitter and receiver respectively. Each array is thus detachable and can be packed separately for transport. The supporting "ropes" are braided silk fishing line, brass strainers being provided to maintain their tension.

The transmitting array has two bays spaced one wavelength apart and the two pairs of feeders are spliced together just above the baseboard. From this point a single transmission line extends downwards and towards the anodes of the magnetron. It is important that the angle between the two feeders at the splice should be as small as possible, and that each curve in the transmission lines should have as large a radius as is practicable.

The receiving array is similar in all respects to the transmitting array except that a single bay only is employed. An additional bay would, of course, have provided a greater signal, but it was found that the range obtained with the single bay was ample for the purpose for which the apparatus was designed. Moreover, an excellent opportunity is afforded of comparing the polar diagrams of the two different arrays.

The vertical feeders are drilled at their lower ends to take the wire connections to the detector, and in order to facilitate their construction the lower portion is made separate from the remainder. The joint is effected by turning a shoulder on the lower portion and fitting it into a hole drilled in the upper portion,

the junction being made permanent by soldering. Additional support is given to the radiator curtain by an ebonite clamp, fixed to the baseboard, which grips both feeders. The connections to the detector are arranged to slide in the feeders and so effectively vary the length of feeder between the array and the grids of the detector valves. They are gripped, when in position, by two set-screws which provide a convenient means of adjustment and allow the detector, which is somewhat fragile, to be removed for transport.

The Transmitter.

Two types of generator are available for producing oscillations at these frequencies; positive grid triodes used as Barkhausen oscillators, and the split anode magnetron used in its "transit time" or "electronic" mode of oscillation. At the time the apparatus was built the General Electric Co. were developing in their Wembley laboratories a magnetron valve capable of producing electronic oscillations down to a wavelength of about 20 centimetres. This valve, designated type E.396A, gives a maximum output of electronic oscillatory energy of about two watts at about 22 centimetres wavelength. No modulation being required, the magnetron only requires power supplies and a simple electromagnet to operate it, and was thought to provide the easier solution to the generator problem and was adopted for this equipment.

To produce electronic oscillations the magnetron has to be mounted with its filament inclined at a slight angle (approx. 6°) to the magnetic field. The wavelength of the oscillations produced may be controlled by variation of the magnetic field and emission, and by adjustment of the anode lecher wire system. The magnet used and the magnetron mounting are shown side by side in the photograph (Fig. 5). The mounting is designed to allow the assembly to be partially rotated in the magnetic field

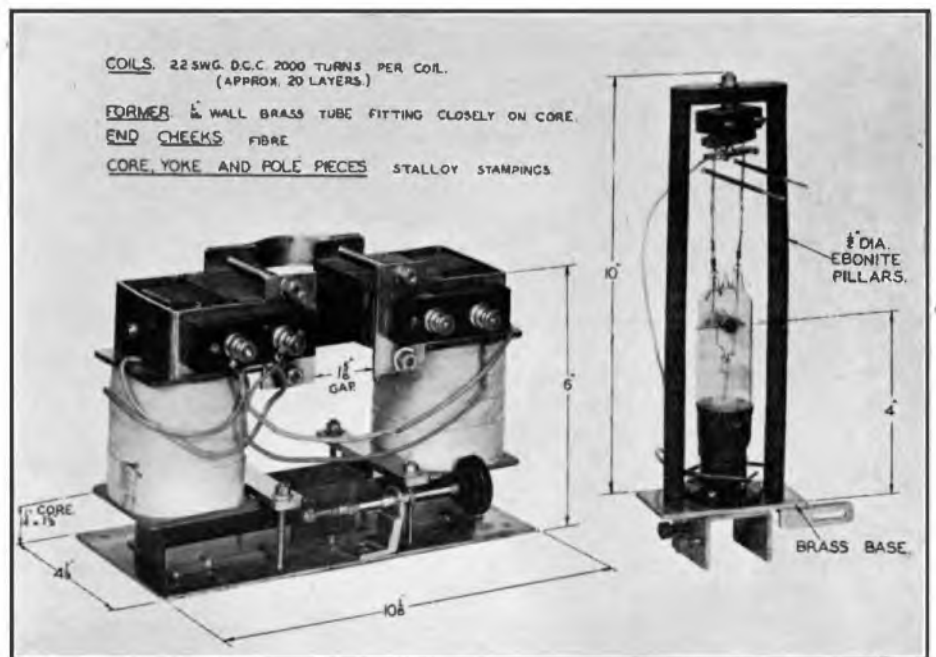

FIG. 5.—ELECTROMAGNET AND MAGNETRON SHOWING MOUNTING.

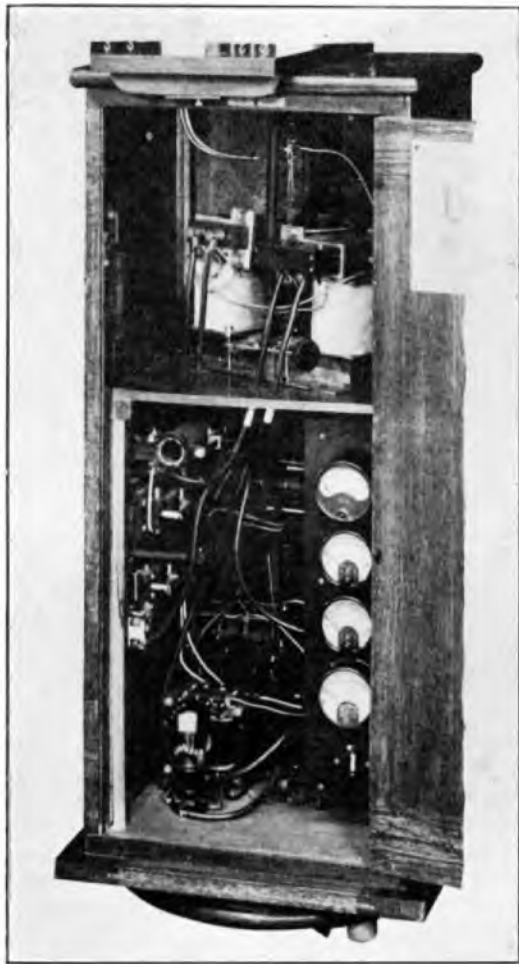

FIG. 6.—TRANSMITTER CABINET.

and an adjustable bridge on the anode lecher wires is provided. The taps on the lecher wires to feed the transmission line can be seen coming from positions just below the anode bridge; these tap positions are somewhat critical if optimum output is required. The dimensions and design of the magnet and magnetron mounting are also given in Fig. 5. The magnet cores and yoke are "U" stampings, and pole pieces of "I" stampings clamped together are clamped to the protruding arms of the "U" stampings above the energising coils. The magnetron mounting is built on a saddle which fits over the yoke between the coils and is held in position by two clamping screws. This mounting can be seen in position in Fig. 6.

The circuit diagram of the magnetron and power supplies is shown in the diagram of Fig. 7. It will be seen that the filament is heated with A.C., and that the magnet is supplied from the unsmoothed output of a metal rectifier. The H.F. output of the magnetron is consequently amplitude and frequency modulated. In the receiver, however, arrangements have been made to by-pass audio-frequency modulation, and this

therefore responds only to relatively slow changes in carrier amplitude. The magnetron can be used at its optimum output and wavelength, but for this purpose an anode voltage of 1,000 volts is required. It has been found in practice preferable to use an anode voltage of not more than 900 volts and consequently slightly lower output, because the oscillation conditions have been found to become increasingly critical with increase of anode potential. To avoid trouble due to anode voltage changes with load current and supply voltage variations a mercury vapour rectifier (the G.U.1) has been used. This, in practice, gives an output voltage regulation figure of about 0.6 volts per milliampere, due to the regulation of the transformer and resistance of the smoothing circuit. The anode current in the oscillating condition is of the order of 15 milliamperes. "Fine" and "coarse" controls have been fitted to both the filament and magnet circuits. With this particular valve and magnet the magnet current is 1 ampere and the filament current 3 amperes.

The assembly of the apparatus in the cabinet can be seen in Fig. 6. The magnet and magnetron are mounted on the shelf, and the power supplies, controls and meters are housed below. The panel on the right is fitted with meters which show the anode voltage, anode current, filament current and magnet current. Below the meters is a switch controlling the anode supply circuit. The filament and magnet control resistors can be seen mounted on the left wall of the cabinet. To protect the rectifier, the anode load should not be switched on until the rectifier cathode has thoroughly warmed up. The generator requires adjustment occasionally during the first half-hour after switching on, but subsequently will run for lengthy periods without further attention. As a safeguard against electric shock the H.T. positive lead, and consequently the array, has been arranged to be at earth potential. The cabinet used to house this apparatus measures 12 in. by 12 in. by 30½ in. inside and has a shelf 12 in. below the top. The side window measures 11 in. by 10 in. and the overall height of the complete transmitter is 57 in.

Although operating data for the magnetron is published, it is useful to have some ready means of telling when the valve is oscillating. The high frequency energy in the neighbourhood of the anode

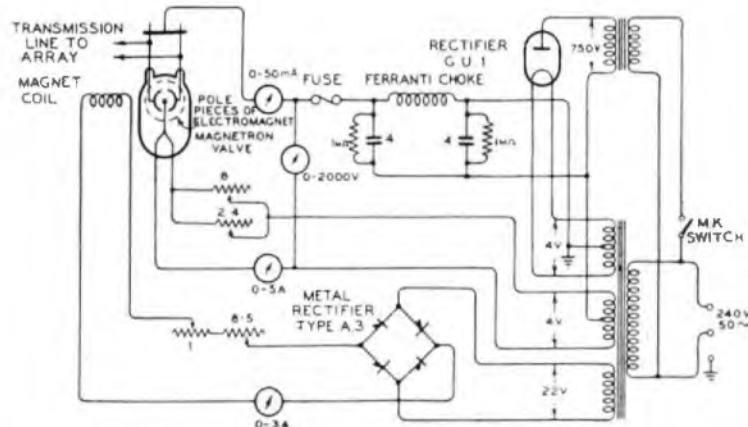

FIG. 7.—CIRCUIT OF THE TRANSMITTER.

lecher wires can readily be used to light a low voltage flash lamp bulb. A bulb having a short straight filament serves best and should be decapped and have short lengths of wire added to the connecting leads in the form of a dipole. The optimum length of these leads, with any particular lamp, will vary according to the wavelength used and has to be determined experimentally.

The Receiver.

The development of a receiver to operate at a frequency of the order of 1,400 Mc.p.s. was regarded as a matter of some difficulty, especially in view of the fact that no published data on the subject was available at the time. The problem was approached, therefore, along more or less orthodox lines, using standard production triodes of various types, including "Weco" valves, "Acorn" tubes, and high mutual conductance indirectly heated valves. The most successful was type D.E.V. having the electrodes brought out to platinum seals at four different points in the wall of the envelope. The seals are covered by little cylindrical caps with conical ends and electrical connection is made by short lengths of thin copper wire, some of which is left coiled up inside the caps. For this reason it was found necessary to remove the caps (by heating) and solder heavy copper wire leads direct on to the platinum sealing wires. To improve the mechanical rigidity of the joints, a small nick was filed on each side of the seals, the copper leads bound on with thin tinned copper wire and finally soldered. Care was, of course, necessary to avoid excessive local heating of the glass.

Referring to Fig. 8 it will be seen that the detector consists of two valves used as a balanced or "push-

pull" anode-bend rectifier. They are arranged horizontally and parallel to each other with the grid connecting wires adjacent and vertical, the distance between the two wires being the same as the spacing of the receiving array feeders to which they are connected. It will be seen in the photograph, Fig. 9,

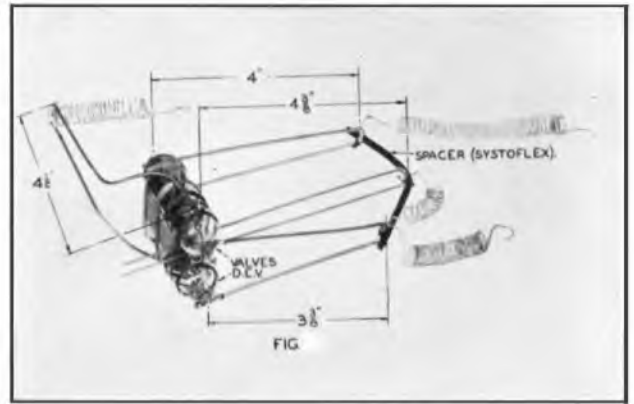

FIG. 9.—PUSH-PULL DETECTOR ASSEMBLY.

position has been found—a wire paper clip is very useful in this connection—the bridge can be made permanent by soldering. The grids are at the same steady potential as the negative end of the filaments, this potential being conveniently near the optimum operating condition. The filament current is supplied by three cells, type D.S.1, in series, the voltage being reduced to three by means of a pre-set resistor. The rectified current is shown on the (0-250) micro-

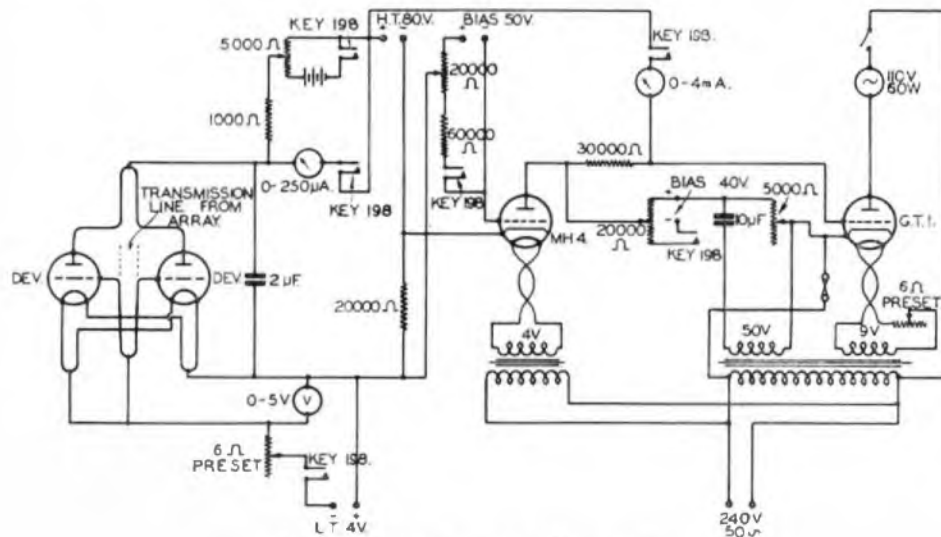

FIG. 8.—CIRCUIT OF THE RECEIVER.

ammeter which is mounted in a sloping front case, and can be read through the window of the cabinet. To balance out the steady detector current a local battery of three cells, D.S.6, is used in conjunction with a potentiometer and a fixed resistance of 1,000 ohms. The $2 \mu\text{f}$ condenser connected between

pull" anode-bend rectifier. They are arranged horizontally and parallel to each other with the grid connecting wires adjacent and vertical, the distance between the two wires being the same as the spacing of the receiving array feeders to which they are connected. It will be seen in the photograph, Fig. 9,

anodes and filaments of the detector valves is not intended to improve their rectification efficiency, such a capacitance being absurdly large at the operating frequency, but is inserted to prevent mains ripple, present as modulation in the received carrier, from affecting the operation of the lamp control circuit.

The D.C. amplifier, following the detector, consists of a triode valve, G.E.C. type MH4, with a load resistance of 30,000 ohms in its anode circuit. Grid and cathode of this valve are connected across the detector load resistance in series with a biasing circuit to oppose the steady potential drop across this resistance. The anode current of the MH4 is shown on a 0-4 milliammeter, also visible through the glass window, and is arranged to increase when a signal is received.

Coupling to the "thyatron" or gas-filled relay (GT1) is effected in a similar manner by means of a 30,000 ohms resistor and another biasing circuit. Superimposed upon the variable D.C. controlling voltage applied to the grid is a 50 c.p.s. A.C. component derived from a 50 volt winding on a mains transformer. The voltage applied to the grid has an appreciable phase angle relative to the primary voltage of the transformer by virtue of the 10 μ F condenser shown in series with the 5,000 ohm variable resistance. The latter varies both amplitude and phase of the A.C. component simultaneously. A refinement, involving, however, yet another variable control, would be the separating of these two factors. The single control is satisfactory in practice, but it should be wire wound and of a heavy duty type. Care should be taken not to leave it set at a low value of resistance for a long period of time.

The full A.C. mains voltage (210-240 R.M.S.) is applied to the anode of the GT1 in series with the controlled lamp (110 volt, 60 watt). This is external to the receiver and can be placed in any convenient position for demonstration purposes. It is covered by a spherical opal glass shade (actually a ceiling fitting) and connected to the apparatus by means of a length of flex terminating in a plug. The corresponding socket is fitted in the back of the receiver cabinet, a similar socket being provided for the mains supply. A pear switch for opening the lamp circuit is inserted in the flexible lead.

Referring to the circuit diagram (Fig. 8) it will be noticed that two transformers are used for supplying the two heaters and GT1 grid A.C. component. The winding used for the heater circuit of the latter, moreover, gives 9 volts whereas only 4 volts are necessary, 5 volts being dropped in the series resistance. This was done in order to use standard commercial transformers which were available at the time, but all three windings might well be included in a single transformer specially designed for the purpose.

All the components, including the three cells D.S.6

for the detector meter circuit, are mounted on or below the shelf. The four controls and the lever key are mounted on a small panel, shown in Fig. 10, and are readily accessible. The key has three positions. In the upper position all circuits are open; in the middle position the detector filament and all bias circuits are completed, while in the lower position both H.T. connections are also made. The batteries, which are small broadcast H.T. units, and the three cells D.S.1 are mounted on the floor of the cabinet.

Fig. 10 shows the apparatus mounted in the cabinet. The detector suspended from the transmission line, the control panel, component shelf and supply batteries are clearly shown. The cabinet itself is exactly similar to that used for the transmitter.

In conclusion, it is perhaps advisable to state that, although from the above description the construction appears simple, it was originally the result of some weeks of experimental work, some of which will necessarily have to be repeated if a satisfactory copy is to be made.

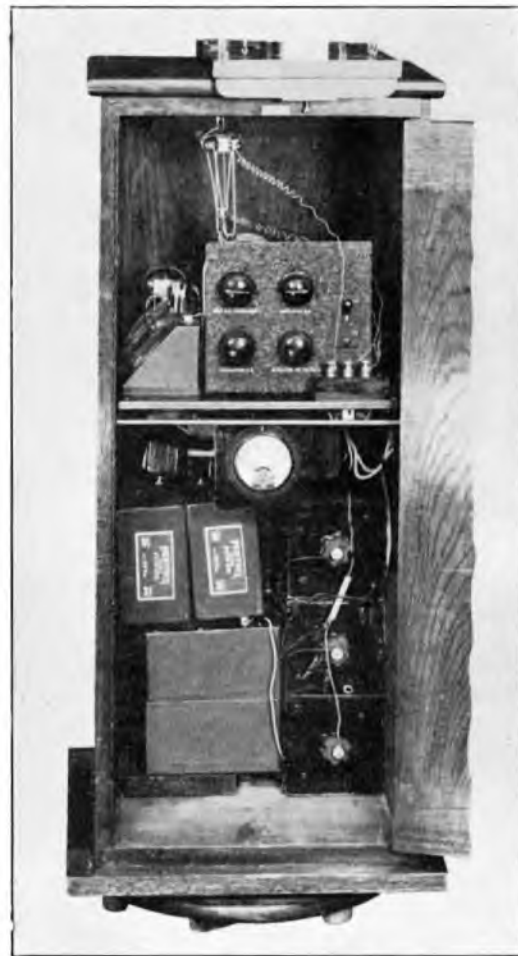

FIG. 10.—RECEIVER CABINET.

The Problems Associated with Impulsing in Non-Director Areas

H. WILLIAMS, A.C.G.I., A.M.I.E.E.
and S. RUDEFORTH

In this article, which is continued from the October issue, the authors extend their analysis of "pick-up" troubles to cover "subsequent pick-up." They also give details of the difficulties attendant upon impulsing over short lines and conclude with a summary of agreed impulsing limits.

II.—"PICK-UP" TROUBLES (Continued)

Subsequent Pick-up

A single impulse repeater working over a long junction to a selector, as shown in Fig. 12, will first be considered. During a train of impulses the repeater C relay is operated and a contact of C short-circuits the D and I relays. At the end of the train of impulses the

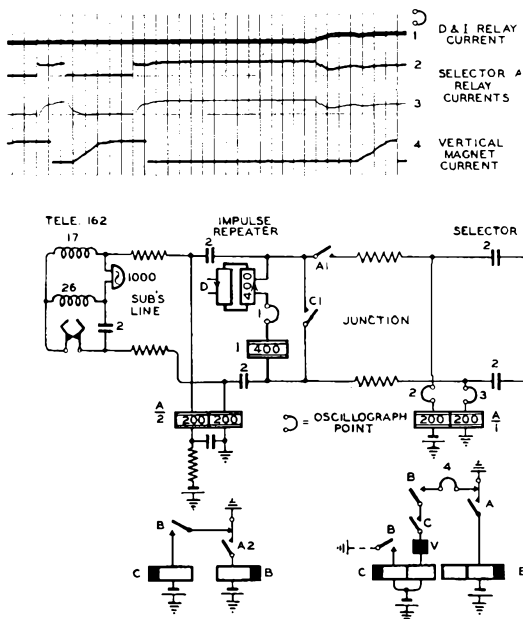

FIG. 12.—OSCILLOGRAM AND CIRCUIT OF A SINGLE REPEATER WORKING OVER A LONG JUNCTION TO A SELECTOR.

repeater C relay releases—since the A relay is once more held operated—and the D and I relays are again introduced into the loop. At the instant this occurs the current in the selector A relay does not immediately fall to the new "Ohm's Law" value but tends to fall to zero because of the inductance of the D and I relays. This effect is increased by the presence of the bridge condensers of the repeater, and the current in each winding of the selector A relay, on release of the repeater C relay, takes the form of a damped oscillation. This oscillation, if of sufficiently low frequency and high amplitude, may cause momentary release of the selector A relay and hence the selector to make an extra step. This effect is illustrated by the oscillogram, associated with Fig. 12. The oscillogram shows the growth of the D and I relay current, the change in the A relay current and the resulting pulse of current in the selector magnet incident on release of the repeater C relay.

Whether the extra step given to the selector will appear as an extra vertical or rotary step, or a

premature rotary step will depend upon the relative values of the release lags of the repeater and selector C relays. If the repeater C relay release lag is small compared with that of the selector C relays, the selector relays will not have had time to change from the vertical to the rotary movement before the momentary release of the A relay, so that an extra vertical step will ensue. If the selector E relay has operated and has connected the rotary magnet before the momentary release of the A relay then a premature rotary step will result.

The worst form of subsequent pick-up trouble occurs with two impulse repeaters and junctions in series. In this instance the 2nd repeater A relay armature flicks in addition to that of the selector A relay. The flicking of the A relays on release of the repeater C relays is more pronounced when the 1st repeater C relay releases.

The following factors tend to give false impulses to the selector for subsequent pick-up, the worst condition being when they are all simultaneously applied:

- Repeater and selector A relays in "heavy" adjustments with large make contact clearances.
- 46 volts on the repeaters and 52 volts on the final selector.
- "Lightly" adjusted selector, comprising light magnet, shaft restoring springs, detents, etc.
- Selector C relay "quick" releasing for a premature rotary step and "slow" releasing for an extra vertical or rotary step. (The terms "quick" and "slow" are, of course, purely relative.)
- "Quick" operating E relay.
- The 2nd repeater C relay release lag large, with the 1st repeater C relay release lag about the same or down to approximately 70 milliseconds less.
- Large D and I relay D.C. inductances. (The combined D and I relay D.C. inductances with 15 mA flowing may be as high as 69 Henrys.)
- Zero subscriber's line.
- With 2 and 3 junctions in series, the 2nd and 3rd junction resistances zero and only the 1st junction of high resistance.

The relationship between the repeater and selector C relay release lags has an important bearing on false impulse troubles incident upon subsequent pick-up. The release lag of the repeater C relay can vary between about 130 and 230 milliseconds, depending upon the adjustments within the allowable mechanical tolerances, and that of the selector C relay may vary between 100 and 150 milliseconds.

With two junctions in series it was found that, so long as the 2nd repeater C relay release lag was 10 milliseconds or so less than the 1st repeater C relay lag, no false impulse was given to the selector at the

end of the train of impulses. On the contrary, if the 2nd repeater C relay release lag was large, then the 1st repeater C relay lag had to be reduced to a value considerably less before the false impulses disappeared with reasonable values of junction resistance. Again, if the repeater C relay release lags were about equal

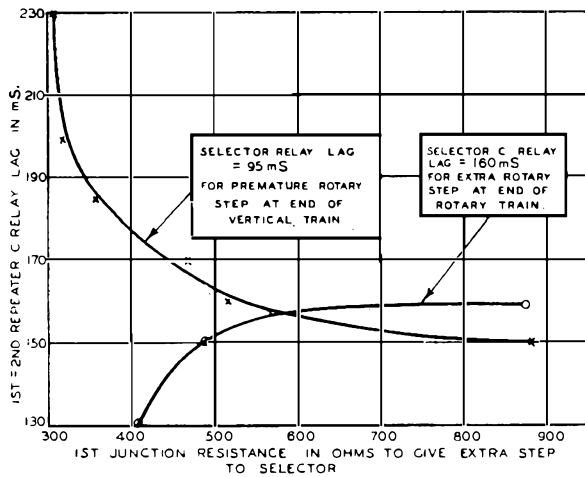

FIG. 13.—EFFECT OF VARYING 1ST AND 2ND REPEATER C RELAY RELEASE LAGS TOGETHER.

and very large or very low, then false impulses occurred for low values of junction resistance. Figs. 13 and 14 show these effects of the C relay release lags.

It was found possible to cause false stepping of a selector on a two-junction route, when all factors were adverse with the 1st junction resistance as low as 240 ohms, the 2nd junction resistance being zero. Moreover, by mixing various makes of repeaters and selectors these troubles could arise with shop-

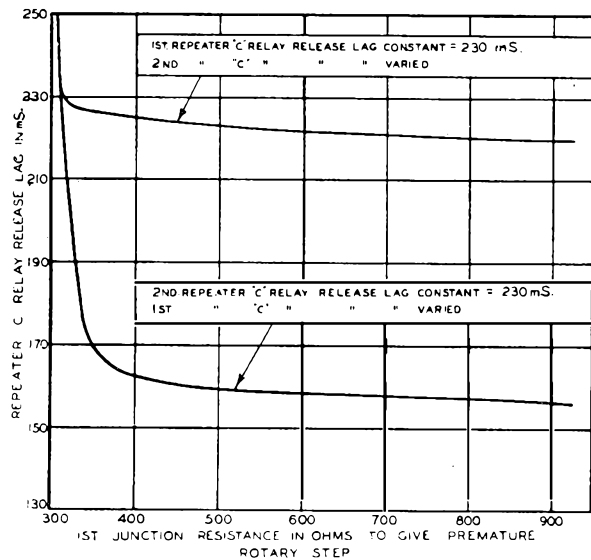

FIG. 14.—EFFECT OF VARYING 1ST OR 2ND REPEATER C RELAY RELEASE LAGS INDEPENDENTLY.

product adjustments (i.e. nominal adjustments) on the apparatus for junction resistances of 600-700 ohms.

Subsequent pick-up troubles using non-ballast impulse repeaters have been largely mitigated by the

rectifiers 1/6A connected across the 400 ohms winding of the repeater D relay, so much so that where false impulses to the selector resulted without a rectifier for a 240 ohms 1st junction resistance, this could be increased to 1,000 ohms by the aid of the rectifiers.

As previously explained the removal of the short-circuit across the repeater D and I relays incident upon the release of the repeater C relay at the end of a train of impulses causes an oscillation or surge to be set up in the next A relay windings, so tending to release that relay. The connection of a rectifier across the D relay winding causes an increase in the final value of the current when the C relay releases and reduces the effective inductance of the D and I relays so that the oscillation set up through the A relay winding is of correspondingly smaller amplitude, the tendency for the A relay to release being thereby reduced.

Incidentally, by the use of a rectifier the D relay need not be of the shunt field type, for a plain 400 ohms relay shunted by a rectifier serves the same purpose.

With a single junction no subsequent pick-up troubles occurred for a junction resistance of less than 2,000 ohms, even without a D relay rectifier.

In a subsequent article it will be shown that for two and three junction routes in series using repeaters fitted with 50 + 50 ohms A relays and ballast resistors, a D relay rectifier does not, when all factors are adverse, effectively cure subsequent pick-up trouble, but that a complete cure results by the use of an auxiliary C relay.

"Called Subscriber Answers" Conditions.

When the called subscriber answers, the D relays being operated, the flux in each of the repeater A relays is reversed so that the permissible junction resistances are less than they would be if only initial and subsequent pick-up (with D relay rectifiers) had to be taken into consideration. Apart from actual impulse distortion, therefore, the "called subscriber answers" condition limits the inter-repeater junction resistance to 800 ohms.

III. "SHORT LINE" IMPULSING

In Section I the factors which resulted in a low percentage make ratio of A relay make contacts when associated with long junctions, and hence a tendency for B relay failure were examined. Consideration will now be given to the conditions which tend to cause:—

(a) failure of the C relays to hold during impulsing if the percentage make ratio of the break contacts be too low and

(b) failure of the selector to step correctly if the selector A relay B.C.C.P. (break contact closed period) be less than the duration of pulses of current necessary to step the selector magnets satisfactorily.

C Relays.

The percentage make ratio of impulses necessary just to hold in the C relays appreciably increases as the impulse frequency is reduced. For the B relays, it has already been remarked that this limiting ratio is approximately constant over the impulse frequency range, 7-12 i.p.s. This difference between the C and B relays is due to the lower minimum release lags of the

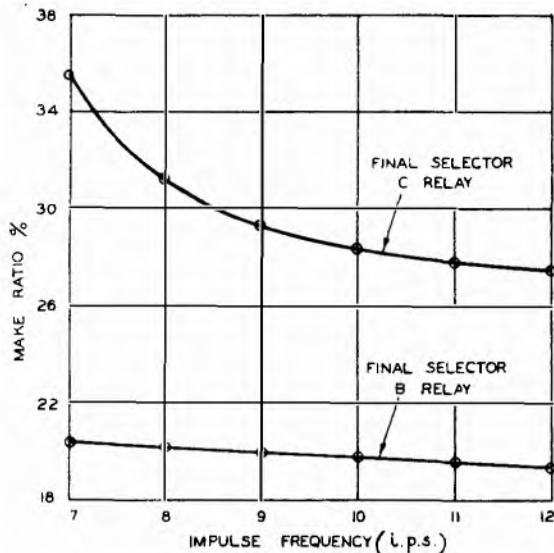

FIG. 15.—VARIATION WITH FREQUENCY OF THE PERCENTAGE MAKE RATIO NECESSARY JUST TO HOLD THE B AND C RELAYS.

former compared with the latter. Fig. 15 shows how the percentage make ratio of impulses necessary just to hold in sample final selector B and C relays (both in heavy adjustments), changes with impulse frequency. The curves were obtained with trains of 10 impulses and the release lags of the B and C relays were about 250 and 100 milliseconds, respectively. It will be appreciated from Fig. 15 that the C relays, energised via the break contacts of the A relays, are more likely to fail to hold during impulsing with the lower dial speeds.

It has been considered that C relays should function correctly on 46 volts with (a) a dial frequency of 12 i.p.s. and a 33 millisecond energised period and (b) a dial speed of 7 i.p.s. and an 80 millisecond de-energised period.

With the C relays in maximum mechanical (heavy) adjustments, it has been found that they readily meet the above conditions (a) and (b). Moreover, under "short line" impulsing conditions, with one junction or with two and three junctions in series they do not fail to hold during impulsing at frequencies of 7 or 12 i.p.s., provided that correct stepping of the selector magnets occurs at that frequency.

Selector Magnets.

The maximum dial speed (i.p.s.) with which it is possible to impulse under short line conditions is dependent on the maximum duration of the pulses of current required to step the selector magnets correctly. A considerable number of tests on the vertical and rotary magnets of pre-2000 type selectors has shown that the vertical magnets require pulses of at least 33 milliseconds duration for correct stepping of the selector to ensue, the duration of the pulses necessary for the rotary magnets being less than this.

If one impulse is given to a selector vertical magnet, and correct stepping occurs, it does not follow, if say nine such impulses were given to the magnet, that the selector wipers will be lifted to the 9th level; they may not reach the 9th level or they may overstep and go to the 0 level. Table 4 shows the behaviour of a selector when stepped by direct

impulses into the vertical magnet. The selector was originally adjusted to step correctly on 33.4 milliseconds impulse make period and definitely fail to give correct stepping with 32.5 milliseconds make period, the impulse frequency being 12 i.p.s.

TABLE 4

Impulse make period in milliseconds	Behaviour of Selector
<25	Refuses to step
25	Refuses to step
26.7	Occasionally fails to step on first impulse
27.5	Steps correctly
29.2	Understeps and oversteps
30.9	Completely oversteps
31.7	Completely oversteps
32.5	Occasional overstepping
33.4	Correct stepping
>33.4	Correct stepping

In general there are two distinct failure points. The overstepping occurs with certain make times owing to the momentum of the shaft when the magnet armature is in the mid-stroke position. Moreover, it is possible for a selector both to understep and overstep during a train of impulses, if the make period of the impulse is too low.

The effect on the make period of impulses required to step sample selectors correctly by varying the vertical magnet restoring spring tensions is shown in Fig. 16. From the point of view of short line impulsing,

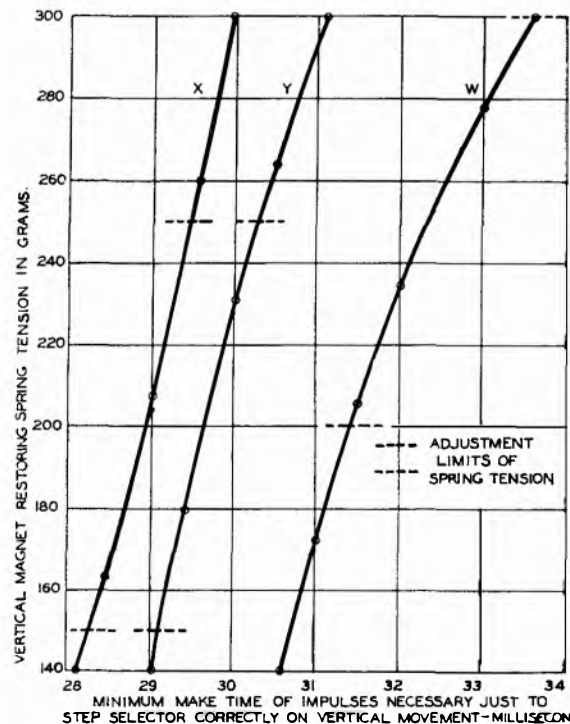

FIG. 16.—EFFECT OF VERTICAL MAGNET RESTORING SPRING TENSION ON THE MAKE PERIOD OF IMPULSES NECESSARY JUST TO STEP SELECTOR CORRECTLY.

samples X and Y are obviously much better than sample W. With large A relay B.C.C.P.'s, *i.e.*, under long line conditions, the magnets of samples X and Y will fail to release before that of sample W.

Adverse Factors for "Short Line" Impulsing.

Under "short line" conditions and dialling over one, two or three junctions, the higher the dial frequency the lower will be the selector A relay B.C.C.P. and the maximum permissible dial speed (in i.p.s.) is reached when, if the speed is further increased, the selector A relay B.C.C.P. falls below 33 milliseconds.

The factors which tend to diminish the A relay break contact closed period (B.C.C.P.) are tabulated below. In general, these factors are opposite to those required for onerous long line impulsing.

- (a) High dial speed—agreed upper limit = 12 i.p.s.
- (b) Low dial percentage break ratio = 63 per cent.
- (c) Voltage = 52 volts.
- (d) Subscriber's line and junctions of low insulation resistance.
- (e) Lightly adjusted A relays.
- (f) Heavily adjusted selector magnets.
- (g) Small A relay make contact clearances—or large break contact clearances.
- (h) "High" capacitance of subscriber's instrument condenser, bridge condensers, subscriber's line and junctions.
- (i) Short junctions and subscriber's line.

In regard to (c), although 52 volts on the selector A relay would cause a diminution in its B.C.C.P., it is found that the increased operate lag of the selector magnets due to the application of the lower voltage of 46 V is of greater importance. The tests were therefore actually made with 46 V on the final selector, but with 52 volts on the repeaters.

As regards (d), a leak across the lines tends to hold in the impulsing relays and hence to cause a diminution in the B.C.C.P.

Concerning (h) and (i), it will be appreciated that if the subscriber's line and junctions possessed negligible capacitance, then the lowest A relay B.C.C.P.'s would occur with zero lines, for the operate lag of the A relays would be lower and the release lag higher, by virtue of the increased line current. Actually, however, the cable capacitance tends to reduce the A relay B.C.C.P. in the manner already explained, whereas the resistance of the junctions tends to increase the B.C.C.P. In practice, therefore, the effect on the A relay B.C.C.P. will depend on these two opposing factors as well as on the insulation resistance of the lines. For long junctions, the resistance may have more effect than the capacitance and the B.C.C.P.'s will be higher than for shorter junctions in which the effect of the capacitance may off-set that of the resistance. With overhead lines, in which, although the capacitance is low, the insulation resistance may be low too, then in making laboratory tests to determine the maximum permissible dial speed with which it is possible to impulse, it would be reasonable to assume zero leaky "lines." This, in fact, has been done, but the effect of using

simulated 20 lbs. star quad cable on the permissible dial speed has also been considered and will be dealt with later.

The Short First Impulse.

When a train of impulses is dialled via one or more repeaters (or the equivalent), the selector A relay first break contact closed period (B.C.C.P.) is shorter than the subsequent B.C.C.P.'s. This difference between the first and other impulses applies also to the breaks of each repeater A relay make contact A1, with the exception of the first repeater. The first short impulse arises from the fact that the D and I relays are included in the loop before and during the first break of the dial contacts, these being short-circuited by a contact of the C relay after the first impulse has been dialled. When the dial contacts break and the A relays start to release, the current in the A relay windings takes the form of a damped oscillation as already explained under "Effect of condensers on impulsing" in the October issue of the Journal.

For the first repeater A relay only, the first short break of its A1 contact does not arise because of the differing conditions existing with the telephone, the first break of A1 being either about the same or a little longer than the subsequent breaks. Incidentally, if an A relay is impulsed in series with a D and I relay (*i.e.* with no capacitance present) and a C relay contact short-circuits the D and I relay after the first impulse, then the first B.C.C.P. of the A relay contacts is much longer than the remaining B.C.C.P.'s because the current is greater after the operation of the C relay.

Waveforms of A Relay Currents.

The foregoing effects are illustrated in the oscillograms shown in Fig. 17. The numbers indicate the

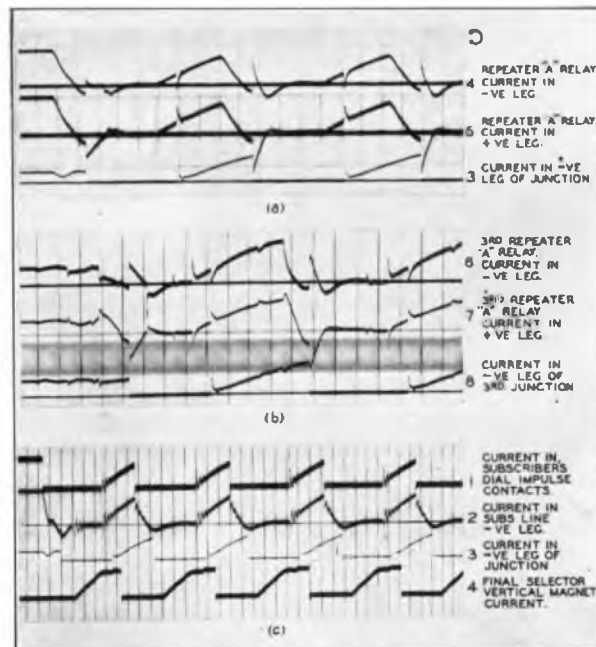

FIG. 17.—WAVEFORMS OF A RELAY CURRENTS (FOR POSITION OF OSCILLOGRAPH POINTS, SEE FIG. 1).

position of oscillograph vibrators in Fig. 1. Oscillograms (a) and (c) refer to a single junction repetition via one impulse repeater and Fig. 1 will serve to illustrate this if the 2nd and 3rd repeaters are assumed to be omitted. Oscillogram (b) refers to the 3rd repeater in a three junction route as in Fig. 1. The many surges in the waveforms shown in oscillograms (a) and (b) occur due to the opening and closing of the various A and C relay contacts.

Oscillogram (c) shows the current in the subscriber's dial contacts, in the negative leg of the subscriber's line, in the repeater A relay A1 contact and in the selector A relay break contact (magnet) circuit. For this oscillogram the relatively higher frequency oscillation in the dial impulsing contact circuit (1) is caused by the inductance and capacitance of the subscriber's telephone. The low frequency oscillation, upon which is superposed the high frequency, occurring in the negative leg of the subscriber's loop (2) is due to the repeater A relay inductance and the telephone condenser. The higher frequency oscillations do not appear in the A relay windings being damped out by the A relay inductance; similarly, these oscillations would not appear in the line if the D and I relays were always in the loop.

Permissible Dial Speed.

As already inferred this will depend on, and be limited by, the length of the first B.C.C.P. in a train of impulses, of the selector A relay since, in general, the first B.C.C.P. is shorter than the subsequent B.C.C.P.'s. Table 5 gives the average difference between the first and other B.C.C.P.'s of the selector A relay when the first B.C.C.P. is 33 milliseconds and the dial speed, 12 i.p.s.

TABLE 5

Number of impulse repeaters in tandem	Under "zero leaky line" conditions. Difference between first and subsequent selector A relay break contact closed period (B.C.C.P.) in milli-seconds
1	3
2	6
3	10

Tests with Shop-Product Apparatus in Nominal Adjustments. A series of three-junction route tests (see Fig. 1) was made on 20 impulse repeaters and 10 final selectors from each of five contractors. For each make of apparatus, three repeaters and a selector were picked out entirely at random, there being ten such combinations of a selector and three repeaters. The order of the repeaters along a three-junction route was also fixed at random. Under the conditions tabulated below, the break ratio of the dial impulsing contacts was changed until the selector only just stepped correctly, any further reduction in the break ratio resulting in faulty stepping.

Dial speed = 12 i.p.s.

Voltage at final selector = 46 V.

Voltage at repeaters = 52 V

Subscriber's line and junctions, zero resistance.

Subscriber's line leak = 50,000 ohms.

Junction leaks = 250,000 ohms.

All A relays shielded.

Telephone 162 used.

Out of the 50 tests made under the above conditions a dial speed of 12 i.p.s. could be met in 47 instances. Of the three failures, one was due to short-circuited turns on the selector A relay whereas the others were due to excessive vertical armature restoring spring tensions. Neglecting the above three failures, the dial impulsing contact break ratios for just satisfactory selector stepping at a dial speed of 12 i.p.s. were as given in Table 6.

TABLE 6

Contractor	Minimum dial contact break ratios % for just correct stepping of the selector over three tandem junctions.		
	Worst Result	Best Result	Average
" V "	61.0	54.5	56.5
" W "	62.5	53.0	57.5
" X "	56.5	50.5	53.0
" Y "	59.0	50.0	56.0
" Z "	61.5	53.5	58.0

In the above table a break ratio of over 63 per cent. would indicate failure of the selector to respond correctly with impulses of frequency 12 i.p.s. Contractor " X " gave the best result because selectors of this make operate more easily on the first impulse owing to the assistance given by the off-normal springs. It will be seen that on the average there is at least 5 per cent. margin in the dial break ratio.

Effect of A Relay Shields. On a three-junction route, taking off the A relay shields increases the maximum permissible dial speed by about 0.7 i.p.s. The reduction in permissible dial speed using A relay shields has been off-set to some extent by raising the minimum release current of the A relays from 5.5 to 6.5 mA.

Permissible Dial Speeds With Adverse A Relay Adjustments.

Table 7 summarises the results obtained on a number of samples of repeaters and selectors of differing makes using "zero leaky lines", telephone 162 conditions, subscriber's line leak of 50,000 ohms in all instances and junction leaks of 250,000 ohms and 50,000 ohms. In addition, the aforementioned factors (c) and (d) were applied. The dial speeds given in the table are based on a first selector A relay B.C.C.P. of 33 milliseconds. The "random" make contact clearance to which reference is made in Table 7 means that the make contact clearances were not definitely gauged but adjusted by eye to be somewhat adverse for short line impulsing; later, it was found that the make contact clearances for those particular tests were about 13-14 mils.

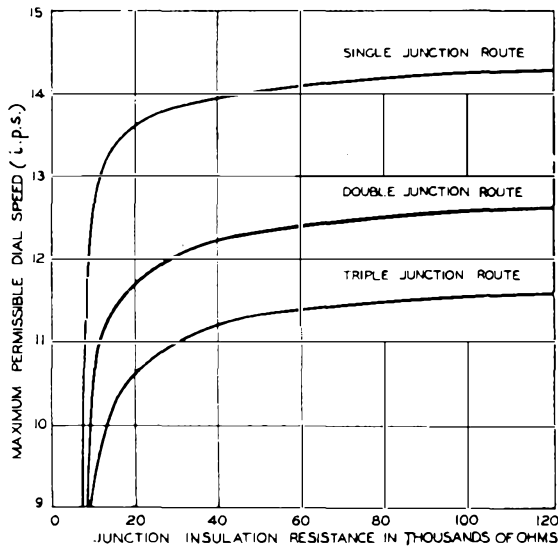

FIG. 18.—VARIATION OF PERMISSIBLE DIAL SPEED WITH JUNCTION INSULATION RESISTANCE.

It is seen from Table 7 that an impulse frequency of nearly 11.5 i.p.s. can be met on a three junction route with all factors adverse, and with 15 mil (nominal) A relay make contact clearances, provided that the junction and subscriber's line insulation resistances are not less than 50,000 ohms.

Effect of Low Junction Insulation Resistances.

Fig. 18 shows how the maximum permissible dial speeds change with junction insulation resistance for 1, 2 and 3 junction routes, telephone 162 conditions, using a particular set-up of repeaters and selectors having A relays in extreme light adjustments and 15 mil make contact clearances; the junctions are assumed to be of zero resistance. It is seen from Fig. 18 that the permissible dial speed falls off rapidly when the insulation resistance is less than about 20,000 ohms. The resistance of the junctions off-sets the effect of low insulation resistance to some extent but, with aerial lines, this is not appreciable until the maximum allowable junction resistances (as determined by the "long line conditions") are approached.

Effect of Line Capacitance.

Some tests were made to ascertain the effect on the permissible dial speeds of using 20 lbs. star quad cable for the subscriber's line and junctions. The wire-to-wire capacitance was about 0.066 μF per

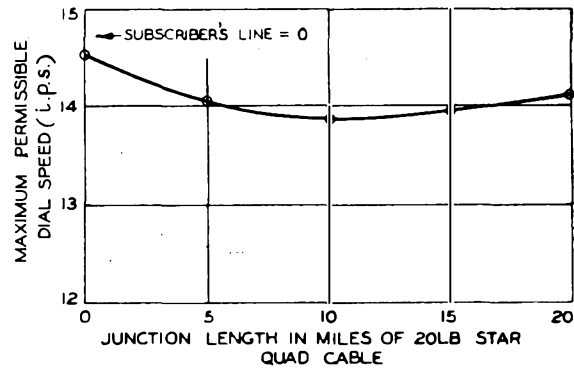

FIG. 19.—EFFECT OF LINE RESISTANCE AND CAPACITANCE ON THE MAXIMUM PERMISSIBLE DIAL SPEED.

mile, and the resistance 88 ohms per mile. Fig 19 shows that the maximum reduction in allowable dial speed for the single junction route occurs with about 10 miles of the cable. For a longer junction, the resistance off-sets the effect of the capacitance. Using 20 lbs. star quad cable for both the subscriber's line and junctions the maximum reduction in permissible dial speed from that obtained with zero lines may be taken as 0.8 i.p.s., 0.5 i.p.s. and 0.2 i.p.s., for one-, two- and three-junction routes respectively.

"Spread" Diagrams.

A typical diagram showing the impulse distortion in terms of A relay B.C.C.P. along a three-junction route is shown in Fig. 20. The conditions under which

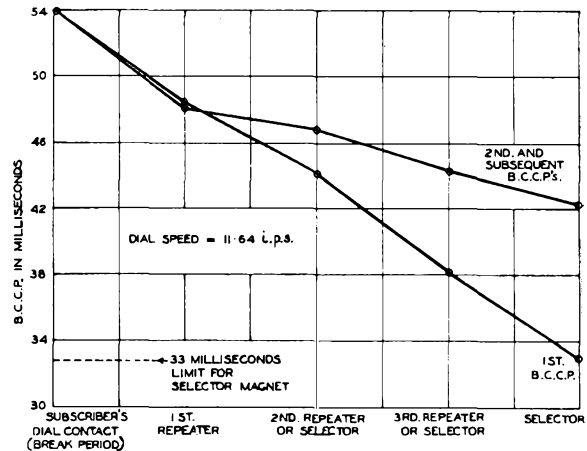

FIG. 20.—IMPULSE DISTORTION ON THREE-JUNCTION ROUTE

TABLE 7
MAXIMUM PERMISSIBLE DIAL SPEEDS
(Telephone 162 Conditions).

No. of Junctions in Tandem	"A" relays with "random" make contact clearances and releasing on minimum allowable release currents. Junction leaks = 250,000 ohms	"A" relays with 15 mil. make contact clearances and releasing on minimum allowable release currents.		"A" relays in mean mechanical adjustments. Junction leaks = 250,000 ohms.	
		With junction leaks of 250,000 ohms	With junction leaks of 50,000 ohms	With 12 mils. "A" relay make contact clearances	With 15 mils. "A" relay make contact clearances
1	13 i.p.s.	14.2 i.p.s.	13.9 i.p.s.	14.4 i.p.s.	14.7 i.p.s.
2	12 i.p.s.	12.9 i.p.s.	12.5 i.p.s.	13.2 i.p.s.	13.5 i.p.s.
3	11 i.p.s.	11.6 i.p.s.	11.4 i.p.s.	11.8 i.p.s.	12.2 i.p.s.

the spread diagram was obtained are as follows:—

- A relays in extreme light adjustments.
- A relay make contact clearances = 15 mils.
- Subscriber's line and junctions, zero resistance.
- Subscribers line leak = 50,000 ohms.
- Junction leaks = 250,000 ohms.
- Dial break ratio = 63 per cent.
- Voltage at repeaters = 52 volts.
- Voltage at final selector = 46 volts.
- Telephone, No. 162.

It will be noticed from Fig. 20 that for the first repeater A relay, the first B.C.C.P. is a little longer than the subsequent B.C.C.P.'s.

Other Telephone Conditions.

Certain conditions such as a cordless P.B.X. having two night extensions connected to the same exchange line impose a serious limitation on the maximum dial speed with which it is possible to impulse. Another possible adverse condition is that of a Plan 7 when the switch in the Bell-set 20 is placed in the "exchange-to-extension" position and the "Main" station dials; this is an incorrect use of Plan 7, but because it is done so frequently it was desired to cater for the condition if possible.

The dialling conditions existing under the above circumstances are depicted in Fig. 21. The increased capacitance across the lines, of 5 μF compared with 2 μF for Telephone No. 162, together with the inductance and resistance of the bells and indicator, are the factors which cause a further limitation in the allowable dial speed.

Concerning the incorrect use of Plan 7, the Post Office has designed a new bell-set called Bell-set No. 39. This bell-set, which is to be combined with Telephone No. 248 CB (minus base) as a table instrument in CB and auto areas, is so designed that dialling from the "Main" when the switch is in the "exchange-to-extension" position is not possible.

Incidentally, the new bell-set also prevents false holding of the exchange if the switch is left in the "main-to-extension, exchange held," position after the subscriber has replaced his telephone. The new instrument, however, will not be available for some time.

In regard to the P.B.X. with night extensions, this is receiving attention.

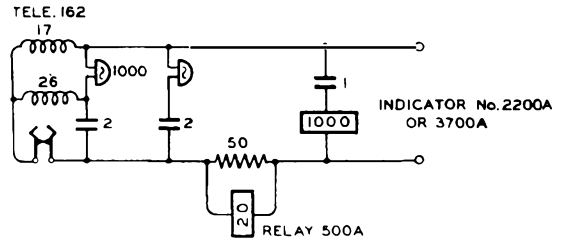

P.B.X. WITH TWO NIGHT EXTENSIONS.

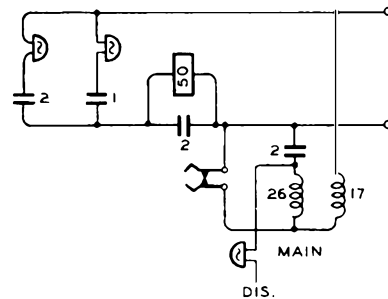

PLAN 7, WITH SWITCH IN EXCHANGE-TO-EXTENSION POSITION, DIALLING FROM THE MAIN STATION.

FIG. 21.

IV. SUMMARY OF AGREED IMPULSE LIMITS.

Table 8 gives the impulse limits, in terms of permissible dial speed and maximum allowable

TABLE 8

	Without D Relay Rectifiers	With D Relay Rectifiers
(i) SINGLE JUNCTION Dial speed using Tele 162 Junction resistance	12 i.p.s. 1,500 ohms	12 i.p.s. 1,800 ohms
(ii) DOUBLE JUNCTIONS Dial speed using Tele 162 1st junction not to exceed 2nd junction not to exceed The sum of the two junctions not to exceed	12 i.p.s. 500 ohms 1,500 ohms 1,600 ohms	12 i.p.s. 800 ohms 1,600 ohms 1,600 ohms
(iii) TRIPLE JUNCTIONS Dial speed using Tele 162 1st junction not to exceed 2nd junction not to exceed 3rd junction not to exceed The sum of the 1st and 2nd junctions not to exceed The sum of the three junctions not to exceed	11.5 i.p.s. 500 ohms 500 ohms 1,500 ohms 1,000 ohms 1,500 ohms	11.5 i.p.s. 800 ohms 800 ohms 1,500 ohms 1,000 ohms 1,500 ohms

junction resistances for subscriber's lines of 0-500 ohms which have been agreed by the contractors and the Post Office. These limits, of course, refer to Non-Director areas with pre-2000 type selectors and equipped with 200 + 200 ohms (non-ballast) 3000 type A relays.

Conclusions.

Certain impulsing limits, expressed in terms of maximum allowable junction resistances and dial speeds have been decided upon from tests which have been made with all factors, such as relay and selector adjustments, battery voltage, dial speed (with long junctions) and ratio adverse, but assuming nominal contact clearances. The impulsing limits have, therefore, been decided upon in view of the improbability of all factors including A relay contact clearances being simultaneously adverse.

The effect of the impulsing relay contact clearance is considerable and it is important that large make contact clearances on "heavily" adjusted A relays, or small make contact clearances on "lightly" adjusted A relays, be avoided. Little trouble, however, due to the effect of contact clearance, is to be anticipated if certain adjustment measures are taken. Details of these adjustments follow and the question of incorporating this information in existing instructions is under consideration.

(a) On an impulsing (A) relay having a make-before-break (K) spring-set, measure the travel; if this is more than 25 mils, adjust the make contact clearance to be about equal to the break contact clearance, as judged by the eye. If the travel is 25 mils or less, adjust the make contact clearance, by eye, to be slightly greater than the break contact clearance; after this adjustment it should be checked that the break contact clearance is not then less than about 10 mils. If it is, then the make contact clearance should be reduced slightly so that this condition is met.

(b) When the relay carries a make (M) spring-set in addition, adjust its contact clearance, by eye, to be about the same as that of the K spring-set make contact clearance.

With excessively "heavy" or "light" A relays and selectors the most probable dialling troubles likely to occur are:—

1. *Failure of the B relays to hold during dialling.* This may be due to (a) insufficient B relay release lag and (b) one or more A relays in the impulsing train in excessively "heavy" adjustments associated, perhaps,

with unduly large make contact clearances. In this regard it will be appreciated that the B relay at the first repetition stage is the least likely to fail but the A relay associated with that B relay may be a contributory cause of B relay or selector failure at the next and subsequent exchanges.

2. *Failure of the selector to step correctly* although the B relay holds during dialling. The most probable reasons for this are (a) the A relays are in excessively "light" adjustments with possibly low make contact clearances, (b) the selector magnet restoring spring tensions are too heavy so that the magnet operate lag is too high, (c) the insulation resistance of one or more of the junctions is very low and (d) if complaints are received from an isolated subscriber, his dial speed is possibly too high.

3. *Premature or extra stepping of the selector.* If the selector A relay be too "heavy" or the vertical magnet restoring spring tension too light, when the junction between a relay set, impulse repeater or equivalent, and the selector is long, a premature vertical step of the selector may occur immediately on looping the lines and before dialling commences.

Again, at the end of each train of impulses, when the C relays release, the selector may give an extra vertical step or premature or extra rotary steps, especially with two or more junctions in series; this trouble is associated with excessively heavy A relays or unduly light selector adjustments. The relationship between the repeater C relay release lags has also a considerable effect. An improvement will result if the 2nd (and 3rd with three junctions) repeater C relay release lag is low compared with that of the 1st repeater C relay; i.e. if the adjustments of the 2nd repeater C relay are heavier, within the allowable tolerances, than the first repeater C relay.

This investigation and subsequent ones have been carried out in collaboration with the 3000 Type Relay Circuit Sub-committee upon which the Contractors are represented. It is a pleasure to place on record a note of the co-operation which has been received on a long and tedious investigation.

As far as is known no such investigation has been made previously and it is thought that the information obtained will result in a better service with a decrease in maintenance.

A subsequent article will deal with impulsing in Non-Director Areas using equipment fitted with 50 + 50 ohms impulsing relays and ballast feed resistors.

Gerrard, Old and New

A. MILLER, A.M.I.E.E.

The author gives a brief history of the Gerrard exchange since its inception in 1895, and details the cabling work carried out during the last four years to enable the new automatic exchange to be installed on the same site as its magneto and C.B. predecessors, which is still a good theoretical as well as being the best practical centre.

Introduction.

GERRARD was one of the very early telephone exchanges set up by the late National Telephone Company and possesses many points of historical and engineering interest. Situated within a stone's throw of Piccadilly Circus, it has from its inception been the centre of theatre traffic and all the special features peculiar to the West End of London. These special features are reflected by a heavy evening traffic load.

The first magneto exchange was opened on a site adjoining that of the present exchange in November, 1895, but an exchange of sorts existed in Heddon Street, Regent Street, for some years prior to this date. A new central battery exchange was opened on the site of the present exchange in September, 1907. Messrs. P. T. Wood and A. Wright describe this transfer in an article in the "National Telephone Journal" of November, 1907, the following being an extract:

"Some years ago it became obvious that the present exchange building would not be large enough to contain the equipment and necessary quarters for operators, etc., at the rate the district was then developing, and a suitable site was sought for on which to erect new premises. After considerable difficulty the company obtained possession of two houses adjoining the present exchange and three more at the rear of the newly acquired ones. As soon as the site was cleared a large three-storey building covering the whole area was erected and allowance made for its extension over the ground at present covered by the old exchange. This building is one of considerable interest, having formerly belonged to the Pelican Club. In the basement prize fights and cock fights were at one time held, holes in the floor in which the posts were fixed to carry the rope forming the ring being still visible."

Mr. G. H. Gallard a year later in the same journal describes in detail the methods adopted at this transfer. He refers to the seven overhead cables led from a derrick on the roof of the old building. The site area of the new exchange was approximately 9,000 sq. ft. at that date. Additional premises were purchased in 1930 which increased the site area by another 2,000 sq. ft. This added area was of considerable value as at this time (1930) the lease of Shaftesbury Avenue post office was on the point of expiring. A new post office was consequently included in the exchange proposals.

It is interesting to note the foresight of early telephone engineers in choosing a site for the first Gerrard, for the position chosen in 1895 is still a good theoretical centre and is to-day of considerable value for a post office, in relation to prominence from the public point of view.

Conversion to Automatic Working.

Gerrard exchange came under review again in connection with the London scheme for conversion

of the telephones to automatic working. Site difficulties determined that the new automatic exchange should occupy the site of the old exchange. It is pertinent at this juncture to review the growth of Gerrard since 1907. Gerrard exchange proper had by this time reached maturity and a second full-size exchange known as Regent had been installed in the same building. The geographical position of Gerrard was also important from a junction point of view, hence it was used for a junction centre for direct, through and lending junction lines. The result was that something like 60,000 cable pairs (now all underground) were led into the building at this period.

Fig. 1 is a map of the area and will show the method employed to relieve Gerrard by easy stages. By 1930 junction traffic had grown with the consequent gradual and substantial increase in the network of junction cables. This allowed all junctions not directly required at Gerrard to be transferred to other routes and afforded considerable relief in the number of pairs to be handled at Gerrard. Whitehall exchange was opened in October, 1931, with facilities for two

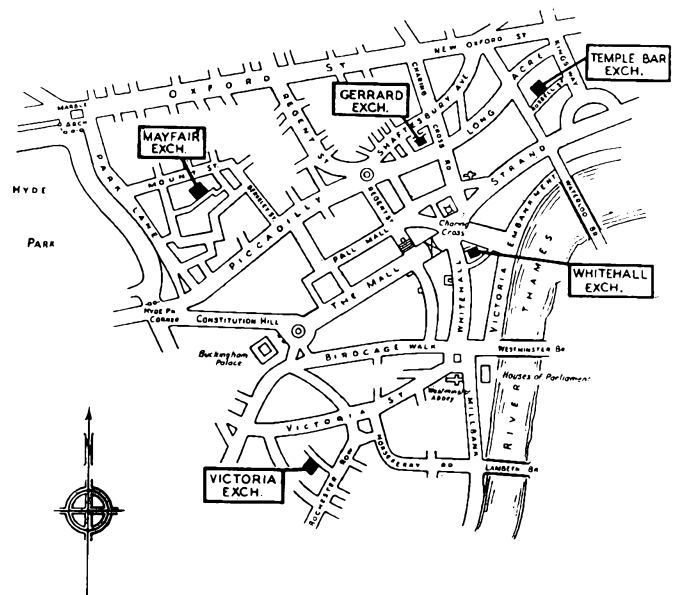

FIG. 1.—MAP OF AREA SHOWING GERRARD AND NEIGHBOURING EXCHANGES.

automatic units and relieved Gerrard of a section of its area. The new Mayfair exchange building had been opened with facilities for three automatic units, and Regent exchange was transferred in November, 1932, in its entirety to Mayfair building. Gerrard building then contained Gerrard exchange only and working circuits were reduced to more manageable proportions.

In order to describe the arrangements made it will first be necessary to review the building arrangements. At this stage the final plans for new Gerrard exchange-building had to be complete in all details in order that

preliminary work should later form part of the permanent structure. Existing cables were led in via a duct route in the basement. The basement floor was broken away and the right-hand half of a new cable trench constructed. The ducts were next broken away leaving the cables free to handle. These cables were then pushed over to the newly constructed part of the cable trench and the remainder of the trench completed. At this stage these cables presented an untidy tangled mass which looked something like a scrap-heap. These tangles were aggravated by the concentration of all twists and turns in order to give straight cable runs behind the muddle to cut into later.

The stanchions for the new building were then planted in position and a section of new ground floor constructed, but only so far as was necessary to carry the final and permanent test room. It must be remembered that this new building work had to conform to the final building plans. A new and permanent main frame was then constructed on this section of floor and then finally completely enclosed in a shell constructed of rolled steel joists and corrugated iron. This test room was of a temporary nature, but was also to form a permanent part of the ultimate exchange. It was suitably lined and heated, and then provided with a temporary battery for power leads, testing, etc., and also a small test desk. This shell was to remain for about two years and served to protect the test room while the remainder of the old building was demolished and a new building erected. Gerrard telephone exchange was still working on the second floor with its own test room on the third floor, the test room in the upper part being a relic of the days of a derrick and overhead cables.

A way having been cleared in the cable trench immediately below the new main frame for new and permanent cable racking, this was erected—short lengths of cable being terminated on the new frames and run to points A and B (Fig. 2). After jumpering the cable was cut between A and B and left looped in and out of the frame. The circuit then worked from

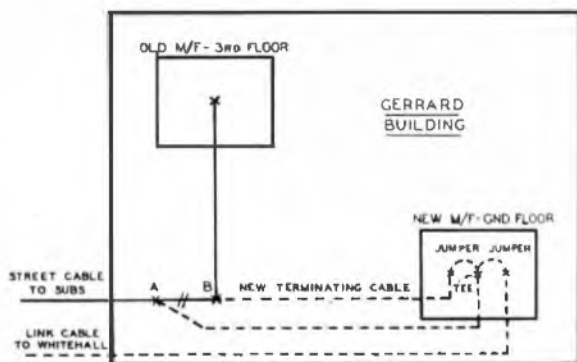

FIG. 2.—CABLING ARRANGEMENTS.

the street side to the new main frame on the ground floor, and thence to the old main frame on the third

floor. A link cable was then provided to Whitehall building and "teed" to the working circuit on the new frame. This having been done, Gerrard exchange was transferred to Whitehall building and converted to automatic working on December 31st, 1933. Tees were cut away and the whole of Gerrard building left spare with the exception of the test room very comfortably housed and protected against the house-breaker. The old building was then demolished and replaced by a fine imposing structure. The exchange or B side of the terminating cables which had served their purpose were taken up again for junction terminations.

The cabling scheme required about 100,000 man-hours and at one time nearly 100 men were employed in the building working in shifts on account of a very rigid time table. Fig. 3 shows the new cable chamber.



FIG. 3.—THE NEW CABLE CHAMBER.

A new automatic unit has been provided in Gerrard building, and on November 27th, 1937, Gerrard exchange was brought back to the old home by "tees" on its own main frame and the link cables to Whitehall thrown spare. This transfer was exceptional inasmuch as the whole of the cabling arrangements were prepared and carried out some four years beforehand, the only work involved so far as line plant was concerned was the "teed" connection on the main frames.

The writer is indebted to Mr. A. Holmes for the historical facts referring to Gerrard exchange.

Notes and Comments

Dr. Graham Bell—Memorial Tablet Unveiled by Sir George Lee.

On Wednesday, November 24th, Sir George Lee, the Engineer-in-Chief of the Post Office and President of the Institution of Electrical Engineers, unveiled a memorial tablet on the wall of the house at 16, South Charlotte-Street, Edinburgh, where Dr. Graham Bell was born. The tablet, which has been erected by the Institution of Electrical Engineers, bears the inscription "Alexander Graham Bell, Inventor of the Telephone, was Born Here, 3rd March, 1847."

Sir George, in sketching the career of Dr. Bell said that they were met to do honour to one of the sons of Edinburgh, Alexander Graham Bell, whose work and inventions had been of such lasting benefit to every country of the world. His most famous invention, the telephone, enabled them in these days to maintain conversation with intimate friends and relations all over the globe, and broadcasting as well was dependent upon the telephone as its primary means of transmission.

Bell's work, however, covered many phases of humanitarian and scientific activities. His work as a



teacher to the deaf and dumb and in the development of correct methods of teaching was one of the most consuming passions of his life, and many of these unfortunate people, still alive, blessed the name of Bell for enabling them to speak. His interest in the work of voice production was the direct stimulus to his efforts to invent the telephone.

His grandfather, Alexander Bell, was a recognised authority on the teaching of speech, and his father, Melville Bell, was even more famous in the subject of speech production, and was the inventor of a system known as "Visible Speech." After the birth of Alexander Graham Bell, the family moved to 13 Hope Street, and finally to 13 South Charlotte Street, where Bell lived as a boy. This was supplemented by a cottage at Trinity, then in the country, which provided an out-of-doors playground.

Sir George narrated Bell's career, including his connection with Edinburgh Royal High School, and recalled how he was taken by his parents to a farm in Canada in order to enable him to recover his health in the open spaces of that country. They settled down at Brantford, Ontario, where the son very quickly recovered his health. The demands on the services of both father and son from New England for lectures and teaching brought Graham finally to Boston, where he taught at the School for the

Deaf, and also lectured on voice production. Here he commenced his experiments to produce electric speech, and in June 1875 he first succeeded in transmitting intelligible speech over a wire. The story of the telephone was one of long suffering, work, and effort by Bell in which his genius finally attained success. He set out to invent the telephone; it did not come by accident. There was no previous theory to guide him, and he was working all the time on the frontiers of knowledge. His indomitable efforts and clear thinking finally solved all the difficulties.

In unveiling the tablet, Sir George said: "May it serve to remind us that genius is a very precious gift to humanity, and that such genius as Bell's is one of the landmarks in the progress of civilisation."

Exemption from the I.E.E. Graduateship Examination, Part 2.

The Institution of Electrical Engineers has agreed that a candidate who has passed the City and Guilds examination in Technical Electricity Grade 2 and the City and Guilds examination in Telephony Grade 3, or Telegraphy Grade 2, or Radio-Communication Grade 3, or Transmission and Lines Grade 2, may claim exemption from Part 2 of the Graduateship examination of the Institution of Electrical Engineers.

Binding.

This issue is the last of Volume 30 and readers are reminded of the binding facilities which are available. Full details will be found on page 342.

Circulation and Back Numbers.

Just over two years ago we were able to announce that for the first time the quarterly sales of the JOURNAL had passed the 10,000 mark. The demand has since grown steadily and 15,000 copies of the October issue have been sold. Many readers have been disappointed because we have not been able to supply them with copies owing to an issue having been completely sold out.

Of recent parts no copies of the July issue are available, although a few copies of the April and October issues

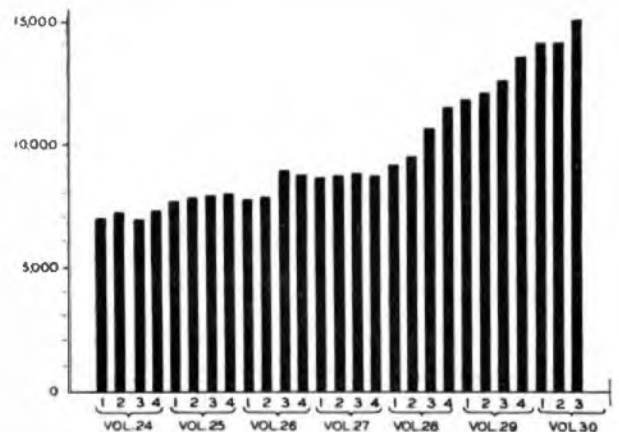

are still held. Readers can make sure of obtaining future issues by placing now, their order with the local agents, for the four parts of the new volume commencing in April next.

The Institution of Post Office Electrical Engineers

PRIZES AWARDED UPON THE RESULTS OF THE CITY & GUILDS OF LONDON INSTITUTE INTERMEDIATE EXAMINATION IN TELEPHONY, 1937.

The following awards were made on the recommendation of the City and Guilds of London Institute:—

First Prize of £3: To Mr. Stanley Jones, a student of the City of Liverpool Technical College.

Second Prize of £2 10s.: To Mr. Leonard William Ellen, Probationary Assistant Engineer, P.O. Engineering Department.

JUNIOR SECTION PAPER AWARDS RESULT

Annual award of Five Prizes of £2 2s. each for the best papers read by members of and at meetings of the Junior Section, 1936/37.

The Judging Committee has awarded the five prizes to the following:— J. Spinks, London Junior Centre, "Prieselectors *v.* Line Finders"; R. G. Cowen, Manchester Junior Centre, "Teleprinter Private Wires"; E. T. Edleston, Preston Junior Centre, "Television"; R. L. Shearer, Edinburgh Junior Centre, "Short and Ultra Short Wave Receivers"; W. H. Ridgway, Shrewsbury Junior Centre, "Subscribers Plan Number Installations."

The Judging Committee specially commended the following:— E. A. Thomas, Cardiff Junior Centre, "Modern Supersonic Heterodyne Radio"; A. Whiteley, Manchester Junior Centre, "Industrial Psychology and Scientific Management."

Junior Section Notes

Birmingham Centre

The success of the Junior Centre at Birmingham has been well maintained but the Committee now in office is looking forward to the present session surpassing the high standard previously attained. A record membership of nearly 150 together with the keenness and enthusiasm shown in the discussions bodes well for the future.

It will be seen from the current sessions programme that the scope of the papers is a wide one although it may not cover all the aspects of the Department's activities.

January 13th.—"Aims of Industry." M. H. Hastewell.

February 16th.—"Practical Overhead Construction." H. Cooper.

March 17th.—"First Stages of Auto." W. E. Penn.

April 6th.—"Annual General Meeting."

The Annual Dinner has been arranged for February 5th, 1938, when it is expected that the President of the Junior Section of the Institution, G. P. Milton, Esq., will be the guest of honour. In conclusion may we remind all who are not members to enrol now.

Coventry and Leamington Centre

Programme of forthcoming events:—

January 5th.—"Development Schemes from their Inception." By F. Whittington.

February 2nd.—"Transmission." By A. J. Leckenby.

March 2nd.—"Power Plant." By J. R. Milnes.

Derby Centre

Programme of forthcoming events.

January 19th.—"Police and Fire Alarm Systems." By L. W. Dunkley (Engineering Dept., Derby) and an Officer of the Derby Borough Police.

February 16th.—"Unit Auto Exchange Installation." By W. A. Mead (Derby).

March 16th.—"Railway Signalling Systems." By W. H. Somers, by courtesy of the L.M.S. Railway Co.

April 20th.—"Annual General Meeting."

Edinburgh Centre

The Syllabus for 1937/38 session has been arranged covering five meetings and two visits.

On 18th October a paper on "A. N. Control and Minor Works," was read by the Chairman of the Branch—Mr. A. P. Robertson.

On 15th November, Mr. W. J. Seath read a paper on "Local Line Development" which was an adaptation from the essay for which Mr. Seath was awarded a Certificate of merit from the I.P.O.E.E. in connection with that Institution's Essay Competition for the 1936-37 session.

There was a good attendance at both meetings but further improvement is possible in view of the recent growth of the staff. Members would help by attending all meetings and by seeking to enrol new members.

A number of our members attended the Senior Centre meeting at Edinburgh on 16th November, 1937, when one of our members—Mr. R. L. Shearer—was presented with a Diploma and a cheque for £2 2s. awarded by the I.P.O.E.E. for the paper on "Short and Ultra Short Wave Receivers," read by Mr. Shearer before the Edinburgh Junior Centre during the 1936-37 Session.

King's Lynn Centre

This session shows a record membership of 55 per cent. of the whole staff.

The opening night on Thursday, October 28th, 1937, proved a great success. An extremely interesting lecture was given on "Gas Precautions in Underground Plant," by Mr. H. F. Newsom. Messrs. E. J. Reynolds and W. R. Smith of the Cambridge Senior Section were welcome guests at the meeting, and their words of congratulation concerning the scope and value of the programme-matter arranged for the centre were much appreciated.

On Tuesday, November 9th, a visit to the King's Lynn automatic telephone exchange was conducted by Mr. P. C. A. Raby. A large number of members who are interested in "Auto" attended.

Forthcoming lectures are:—

Wednesday, November 24th—"Power and Secondary Cells." By S. E. Fincham

Thursday, December 9th—"Engineering Stores Procedure." J. S. Link.

Tuesday, December 21st.—"Maintenance Control." A. H. Triscott.

Leicester Centre

Programme of forthcoming events:—

- January 10th.—“Provincial Auto.” By R. W. Winson.
February 2nd.—“Colour Phenomena.” By E. Langton, B.Sc.
February 11th.—“Automobile Films.” By Morris Motors, Ltd.
March 4th.—Social Evening.

London Centre

The session commenced propitiously for the Centre when at its opening meeting a paper was read by Mr. R. Borlase Matthews Wh. Ex. A.M.Inst.C.E. M.I.E.E. F.R.Ae.S. entitled “A Review of American Electrical Practice of To-day.” The paper was illustrated by a very fine colour film taken by Mr. Matthews. The Centre was especially honoured by the presence of the Engineer-in-Chief and the Deputy Engineer-in-Chief at the meeting and a very warm welcome was accorded them.

The following programme has been drawn up which should prove most interesting and instructive: “Testing of Engineering Materials” J. Spinks Grad.I.E.E.; “An Hour With Camera and Print” H. G. Kraushaar; “V. F. Signalling in Telephony” T. H. Flowers, B.Sc. (Eng.); “Remote Control,” F. R. Moody; “Telephony and Planning for the Future,” J. N. Hill, A.M.I.E.E.; “Some Practical Applications of High Speed Photography” R. W. Palmer, A.M.I.E.E.; “Service,” H. M. Turner, A.M.I.E.E.; “Television,” The Gramophone Company.

Educational visits to the following places of interest have been arranged. “Brookmans Park,” “Central Electricity Board Control Room,” “Rugby Radio Station,” “Battersea Power Station,” “Denham Film Studios” “Taplow Repeater Station” “London Fire Brigade Headquarters,” “E.-in-C's Circuit Laboratory.”

The Centre offers its congratulations to Mr. J. Spinks, Grad.I.E.E., whose paper entitled “Preselectors versus Line Finders,” gained first prize in the competition of papers read before the Junior Section. He was presented with a cheque for two guineas, together with a certificate of merit, by the Regional Engineer. Congratulations are also offered to members of the Centre who were successful in the first part of the recent examination for Probationary Inspectors.

The increase of membership this session is very gratifying, and hopes are entertained for a record year.

Manchester Centre

The following programme has been arranged for the second half of the 1937-8 session:

- January 10th.—“The design and execution of Local Line Development Schemes.” E. S. Rusbridge, B.Sc., and A. Heaton.
January 26th and 28th.—Visits to Daily Mail offices, Manchester.
February 15th.—“Motor Transport.” C. A. Withers (Area Transport Officer).
February 23rd.—Visit to Messrs. Greengate and Irwell Rubber Co.
March 14th.—“Training Personnel for Industry.” A. H. C. Knox, B.Sc.
March 15th.—Joint meeting with the Senior Section, I.P.O.E.E. and I.E.E., at the Engineers' Club, Manchester.
March 19th.—Visit to a Derbyshire Lime Works.
April 4th.—Annual General Meeting and Debate.

The Manchester Centre continues to thrive and now has a membership of 308, and is still increasing.

As will be seen from the above, a most interesting programme has been arranged by the Committee.

An attendance of 85 was recorded at the first meeting, and a most interesting and instructive evening was spent by all.

An interesting afternoon was spent on Saturday, October 30th, when a party of 20 paid a visit to Strowger Works at Liverpool. After a most instructive tour of the works, the party was entertained to tea by the company. The thanks of the Centre are due to the Automatic Telephone and Electric Company for their kindness and hospitality.

Middlesbrough Centre

Session 1938-9 promises to be a very successful one judging from the titles of the papers to be given and the increasing enthusiasm of the members. Two very good lectures have already been given and we are greatly indebted to two gentlemen outside our immediate centre for giving us such a good “send off”

The first of these papers was on “Bridges” and was given by Mr. Thompson A.M.I.Mech.E., A.M.Inst.C.E., of the Cleveland Bridge and Engineering Co. Ltd. Various types of bridges were dealt with both at home and abroad the various points being supported by an excellent display of slides. Over fifty members were present and showed very great appreciation of Mr. Thompson's efforts.

“The Development of Magnetic Materials” was the title of the second of this series given by C. E. Morgan, Esq. Regional Engineer of Leeds. Over seventy members and visitors thoroughly enjoyed the lecture which was illustrated by an abundance of slides, novelties and curios. Capt. Robertson, Telephone Manager, was among the representative group of visitors who honoured us by their presence, and Capt. McDonald, Area Engineer, opened the discussion. The lecturer's replies contained a wealth of information and will be a definite help in the preparation for examinations. In his concluding remarks Mr. Morgan said he hoped the Juniors would make special efforts to attend the meetings and endeavour to cultivate the habit of speech making by asking questions and if at all possible by giving a small paper on items of interest to fellow members.

The Committee take this opportunity of inviting the junior staff to become members of the centre and thus avail themselves of the advantage of further education by these very interesting meetings. Monthly lectures will be given, the last of the season being 8th May, 1938.

Northampton Centre

The Annual General Meeting of the above Centre was held on the 20th October when the following officers were elected for the ensuing session:—

- Chairman—Mr. E. G. Mills.
Vice Chairman—Mr. A. C. Joyce.
Secretary—Mr. W. A. Tait.
Treasurer—Mr. A. D. H. Tull.
Librarian—Mr. E. D. Eyles.
Auditors—Mr. J. G. Garrett, Mr. F. T. Earl

In a resumé of the very successful 1936-37 session the Chairman referred to the excellent papers which were read before the Centre and the enjoyable trip made by 41 members and friends to Telephone House, Birmingham, which terminated the session.

A splendid programme has been arranged for the ensuing session and the Committee are looking forward to

an interesting and instructive term. The forthcoming events are as follow :—

- January 19th.—“ Automatic Telephony.” By W. E. Gill, A.M.I.E.E., Coventry.
February 16th.—“ Transmission.” By A. J. Leckenby, Coventry.
April.—Outing to be arranged later.
April 17th.—Annual General Meeting.

Norwich Centre

The 1937-38 Session was opened on the 29th October, when Mr. O. D. Robinson read an interesting paper entitled “ Recent Developments in Subscribers' Apparatus.” A lively discussion ensued.

The programme for the rest of the Session is as follows :—

- 1937—
November 29th.—“ Trunk Routing and Operation.” By C. W. Roe.
December 17th.—“ Detection of Gases in Manholes.” By F. Robinson.

Local Centre Notes

North Wales

The first meeting of the 1937-1938 Session was held in Morris's Ballroom, Shrewsbury, at 2.30 p.m. on Thursday, 7th October, 1937. The Chairman, Mr. H. Faulkner (Suptg. Engineer, North Wales District) presided over an attendance of 160 members and visitors, the latter including Mr. J. A. W. Gregory (District Manager, Gloucester), and members of the Gloucester, Chester, and Birmingham District Manager's staffs. The Chairman warmly welcomed approximately 30 new members enrolled during the summer recess.

The death of a Birmingham member, Mr. W. E. Radford, on the 20th August, 1937, was announced and the members recorded their sympathy by a standing vote of one minute's silence.

The Chairman then gave his “ Inaugural Address ” in which the positions of the District in the “ Engineering Dept. League Tables ” with regard to Costs, Expenditure, Faults, Rates, etc., were clearly shown, urging the District to greater heights (not always graphic statistical).

Mr. S. F. Hill, A.M.I.E.E., Sectional Engineer, Birmingham Maintenance, then read his paper “ Faults ” which was exceedingly instructive and destructive, particularly when typical fault cards were thrown on the screen. A series of appendices following the printed lecture also gave particulars of typical faults in all classes of work. The discussion following the paper was opened by the Chairman who said that it gave us much to think about and that everyone present would appreciate what could be done to reduce the number of faults. Both members and visitors took the opportunity of joining the discussion, many suggestions and methods of reducing the fault rate being put forward.

Following a hearty vote of thanks to the Author the meeting terminated at 5.40 p.m.

The second meeting of the Session was again held in Morris's Ballroom, Shrewsbury, on Thursday, 4th November, 1937, at 2.45 p.m.

This meeting was preceded at 2.20 p.m. by a presentation to Mr. J. T. Wells, late Secretary to the Centre, in appreciation of his services over a number of years.

Mr. Wells first came to Shrewsbury on the 1st November, 1920, becoming a Committee member in March, 1929, representing the Clerical grades.

1938—

- January 31st.—“ Generation, Distribution and Utilisation of Electricity.”—H. R. B. Lowne.
February 25th.—“ Control Switchgear.” By J. S. Fletcher.
March 28th.—“ Underground Construction.” By W. F. Privett.
April 11th.—Annual General Meeting.

Visits to places of interest are being arranged by the Committee.

Nottingham Centre

Programme of forthcoming events :—

- January 11th.—“ Fault Abatement.” By W. A. Arnold.
February 15th.—“ Debatable Points in External Work.” By F. Jeacock and L. Ward.
March 15th.—“ Carrier Current Telephony.” By J. W. Grieve.
April 5th.—Annual General Meeting.

His appointment as Secretary followed in March, 1931, in which office he continued until his promotion and transfer to the North Eastern Region at Leeds in August, 1937. It is mainly due to his initiative that the North Wales Centre is now the largest outside London, the present membership being over 300.

The presentation was subscribed by members of the staff at the Superintending Engineer's Office, Shrewsbury, members of the Institution in the North Wales District and members of the various Junior Centres. The Chairman, Mr. H. Faulkner, spoke of the high regard in which Mr. Wells was held in the North Wales District and at the Headquarters of the Institution, and congratulated him upon his recent promotion and transfer. Mr. Ferguson then spoke on behalf of the Clerical Staff at “ The Mount,” Mr. H. Green (Sectional Engineer, Bangor) on behalf of the Junior Centres, and Mr. S. T. Stevens on behalf of the Senior Centre and as his successor in the office of Secretary.

The Chairman then presented Mr. Wells with a fountain pen to replace many worn out in the service of the Institution, and a wrist watch to replace in some small measure the vast amount of personal time given to Institution matters. The total presentation included a standard electric reading lamp and photographic enlarger, Mr. Wells being a keen amateur photographer. Mr. Wells replied to the speakers in a witty speech, and expressed his thanks for the great honour done to him. He said that he had always looked upon his work for the Institution as a hobby and expressed a wish for its continued prosperity in the hands of the new Secretary. This terminated the presentation and the main business of the afternoon was proceeded with at 2.45 p.m.

The meeting was graced by the presence of a number of visitors, chief of whom was Mr. P. J. Ridd, Assistant Engineer-in-Chief, other visitors including Colonel Carter, Superintending Engineer, South Wales District; Mr. H. A. Thomas, P.O. Factory, Birmingham; members of the Shropshire Philosophical Society; Radio Engineers, and representatives of the District Manager's staffs at Birmingham, Chester and Gloucester.

After the Chairman's welcome to visitors and new members, Mr. G. K. Tait, B.Sc., Chief Inspector, Stoke-on-Trent, read a Paper entitled “ Radio Tele-

phony." The action of the "Speech Inverter" privacy device was illustrated by means of a special gramophone record made at the Radio Branch, Dollis Hill, and played to the meeting by means of a portable gramophone. Inverted and straight versions of the well known song, "I Passed by Your Window," were given on this record which excited much comment.

At the conclusion of the reading the Chairman asked Mr. Ridd to open the discussion. Mr. Ridd complimented the Centre on the high place it held in the Institution, being the largest Provincial Centre. In complimenting Mr. Turtle on his excellent Paper. Mr. Ridd said that he had learnt much and disclosed the interesting fact that he had been privileged to work with Dr. Hansford in setting up the first England-America radio telephone link.

Many members took the opportunity to discuss the Paper, and the meeting terminated at 4.45 p.m. with a hearty vote of thanks to the Author.

Members present at the first meeting of the session complained of not being able to hear the speaker at the back of the room, and on the second occasion a public address system comprising microphone, amplifier and two suitably placed loudspeakers were used to aid the speaker and proved a distinct advantage.

S. T. S.

Scottish Centres

CO-ORDINATING COMMITTEE

In accordance with the scheme devised by the Institution for the Scottish Region, two Centres—Scotland East and West respectively—have been formed and the officers elected.

The following Co-ordinating Committee has been formed:

Chairman:

J. J. McKichan, Esq., O.B.E., M.I.E.E.
EAST CENTRE

Vice-Chairman:

Mr. W. V. Ryder, M.I.E.E., Regional Engineer

Assistant Engineer:

Mr. F. A. Hough, M.Sc. (Eng.), A.C.G.I.

Inspector:

Mr. P. Quinn

Secretary:

Mr. T. Lawrie, H.C.O.
WEST CENTRE

Vice-Chairman:

Mr. T. Richardson, A.M.I.E.E., Assistant Telephone Manager (Engineering)

Assistant Engineer:

Mr. C. F. Perryman

Inspector:

Mr. T. N. Anderson, A.M.I.E.S.

Secretary:

Mr. F. W. Turner, H.C.O.

The Committee has met and arranged for a joint programme and for two joint meetings to be held at Edinburgh and Glasgow in October and January respectively. A successful session is fully anticipated.

JOINT MEETING

The first general meeting of the Scotland East Centre was held in Edinburgh on 19th October, 1937, and took the form of a joint meeting with the Scotland West Centre. Mr. W. V. Ryder, Vice-Chairman, presided over an attendance of about 200 members of both centres and the following visitors were welcomed:—Mr. B. O. Anson, Assistant Engineer-in-Chief; Mr. H. Faulkner, Superintending Engineer, North Wales District; Mr. C. A. Taylor M.C., Deputy Regional Director; Mr. E. B. Davies M.C., Staff Controller; Mr. W. Yule, Regional Finance Officer; the Telephone Managers of Glasgow, Edinburgh and Dundee; and Mr. H. E. Boyce, Deputy Finance Officer.

Mr. J. J. McKichan, O.B.E., Chairman of the Scottish Centres, delivered an address entitled "A Review of Regional Organisation." He stated that the form of organisation was an important factor in the quality of telephone service, described briefly the old form of organisation and recalled the fundamental principles which should govern the organisation of the Post Office as laid down in the report of the Bridgeman Committee. He described the new organisation and the difference between the aims and methods of the new regime compared with the old. He also gave particulars of the growth of work and staff under Regional conditions and of the work accomplished and in progress in the Scottish Region. He thanked the staff for their support and co-operation.

Mr. B. O. Anson also addressed the meeting and made interesting comparisons between the different organisations. He emphasised the importance of "esprit de corps" animating the staff and regarded this as even more important than the type of organisation and gave examples to illustrate the point. He was of opinion that the right spirit was evident in Scotland.

Messrs. C. A. Taylor, H. Faulkner, W. Yule, E. B. Davies, A. E. Coombs, O.B.E., and Major Darby, T.D., among others took part in the subsequent discussion.

Book Review

"Electrical Engineers' Handbook V. Electric Communication and Electronics." Edited by H. Pender, Ph.D., Sc.D., and K. McIlwain, B.S., E.E. 756 pp. Chapman & Hall. 25s.

This volume represents the development of what originally comprised the communication engineering and electronics portion of Pender's "Handbook for Electrical Engineers." It consists of 17 sections, ranging in subject from mathematics to medical application of electricity.

Each section or sub-section is written by recognised experts in the particular subject, and since the work is of American origin the list of contributors includes many well-known names from the Bell Laboratories and R.C.A. organisations. For example, the section on Electric Wave Filters is by T. E. Shea and C. E. Lane, the section on Radio Antennæ is by G. C. Southworth, and the section of Transmission in Space is by J. C. Schelleng. On the subject of Electrical Measurement, the Frequency Measurements sub-section is dealt with by W. A. Marrison, the Measurement of Primary Electrical Quantities sub-section by W. J. Shackleton

and J. G. Ferguson, and Measurements of Transmission Through Space sub-section by R. K. Potter. Again under Telephony A. A. Oswald is responsible for the sub-section on Radio Telephone Systems. These few names will indicate that the various branches of the subject are dealt with in an authoritative manner, and the book can be relied on to present the most up-to-date information on most questions relating to communication engineering. No book of this kind can, of course, give full details of any particular subject as it is necessary to compress into a section of a few pages what is often the subject of a complete volume. Nevertheless, the information given in this work will be of great assistance to communication engineers and particularly to radio engineers, as the information and data they require is common on both sides of the Atlantic and not influenced to the same extent by systems as with land line telephony and telegraphy. At the present time this is probably the most comprehensive handbook of the kind in existence, and it will prove of undoubted utility and of wide application.

A. J. G.

District Notes

Eastern District

LEIGHTON BUZZARD EXCHANGE

Leighton Buzzard exchange was transferred from CBS 1 to UAX 7 working on 17th November, 1937. The transfer is of more than usual interest as the exchange is a junction centre. Thirteen exchanges i.e. 4 CBS 1, 4 CBS 2, 2 CB 10 and 3 UAX 12, are connected, in addition to the parent exchange, which is Luton, CB.1. Five of these exchanges are dependent. Inter-dialling and multi-metering are provided at the 3 UAX 12 exchanges.

The exchange is equipped for 400 subscribers' lines and 80 junctions. At the opening date 330 subscribers' lines, 12 call offices and 56 junctions were connected. The exceptionally large number of junctions necessitated the installation of 5 E type racks and 2 D racks. The E racks are equipped with 16 2nd Selectors in addition to the junction relay sets.

The subscribers equipment is accommodated on 4 A type racks, and 4 B racks carry 59 local 1st Selectors and 13 Parent 1st Selectors, Secondary finders and controls.

The M.D.F. comprises 7 verticals, with 9 fuse mountings No. 4028 for main cable terminations, and 54 fuse-mountings No. 4001 for local distribution cables.

LITTLE GADDESSEN U.A.X. 5 RELIEF EXCHANGE

A difficult situation arose at this exchange due to the exhaustion of the U.A.X.5 equipment and to restriction on building extension. Due to the rapid growth of the area in residences and telephones it was obvious that U.A.X. 13 equipment would not provide for requirements for a reasonably long period and that the installation of a new U.A.X. 7 or 14 was desirable. To give time for a new site to be obtained, building erected, and a new exchange to be provided, a suggestion was put forward to open a relief U.A.X. 5 in the same building, and this proposal was ultimately agreed.

The relief exchange was opened on 27th October, 1937, and is working satisfactorily. The relief exchange bears the same name as the original exchange i.e. Little Gaddesden, but 4 figure numbers are allotted.

Subscribers on the new exchange dial 01 for the parent exchange, Boxmoor, for all calls including calls to other Little Gaddesden subscribers. As there is very little intercommunication between the relief and the original exchange, this arrangement is not causing any difficulty in practice.

If appreciable intercommunication arises between any numbers on the relief exchange the District Manager intends to advise the subscribers concerned that they may dial each other direct in the usual way by omitting the first two digits of the number required, but this situation has not yet arisen.

The relief exchange was opened with one unit but the installation of a second unit has been necessary. If more units are required, it will be necessary to outhouse the power plant in a temporary battery hut. Two batteries of Cells Secondary Stationary No. 6, are in use. They are charged from A.C. mains. Had a petrol engine been in use for the purpose, it would have been necessary to outhouse the power plant at the outset.

The layout of the plant is shown in the diagram. Sufficient space for working is available at the front and rear of the relief units.

An additional leading-in cable was provided to the exchange prior to opening and jointed in the cable trench,

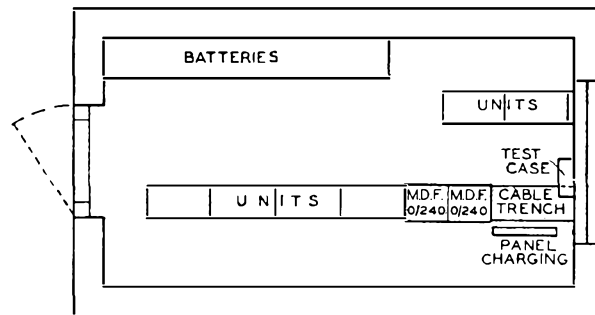

but with some difficulty, as the trench is obstructed by the additional 0/240 Main frame.

In the unlikely event of any further leading-in cables being required joints would be made outside the exchange.

As far as is known this is the first case of relief being effected by means of an additional U.A.X.5 in the same building.

J. B. S.

London

NEW AUTOMATIC EXCHANGES

Theydon Bois and Stapleford.—The above automatic exchanges which since 1933 have been of the By-path 4S and 4R type respectively were switched over simultaneously to the Department's standard U.A.X. types No. 7 and 12, at 1.30 p.m., on October 6th.

Both U.A.X.'s were installed by local staff and the number of subscribers' lines transferred was 216 for Theydon Bois and 32 for Stapleford. The former exchange is the tandem centre for Stapleford-Epping and Stapleford-Loughton routes, Loughton being the manual board centre for both automatic exchanges.

Ashford Non-Director Exchange.—Ashford (Middlesex) C.B.S. No. 1 exchange was successfully transferred to automatic working at 1.30 p.m. on November 24th. The new exchange installed by Messrs. Standard Telephones and Cables, Ltd., has an initial capacity of 900 lines, ultimate 2,000, and 630 lines were switched over at the opening. The battery was supplied by the Chloride Electrical Storage Co., Ltd., and the manual board centre is Hounslow.

Gerrard Automatic Exchange.—The transfer of 4,700 subscribers' lines from the Gerrard automatic exchange in the Whitehall building to the new equipment in Gerrard Building, Gerrard Street, W.1, was effected at 2.30 p.m. on November 27th. The new equipment, initial capacity 6,900 lines, ultimate 10,000 was installed by the General Electric Co., Ltd., the D.P. Battery Co., Ltd., supplying the battery of 4,000 Ah box capacity, 3,000 Ah plated capacity. Over 2,000 outgoing and incoming junctions were also brought into use.

This transfer was unique in that it was the first auto-to-auto transfer of magnitude in London, and necessitated the tapping off of outgoing calls on the 1st Code selectors and incoming calls on the test jack frames at automatic and tandem exchanges and on the outgoing junction multiples at manual exchanges with direct routes to Gerrard. In addition, junction change-over keys were thrown at 19 exchanges, while director translation changes were effected at 29 exchanges at the time of the transfer.

The synchronisation of all the operations at the 97 automatic exchanges in the London area required very

careful and thorough organisation. After the transfer test calls were passed from all director automatic exchanges in the area to the new Gerrard exchange and also to the old exchange which is now retained wholly for Abbey, previously a hypothetical exchange on Gerrard.

North Eastern Region

RADIO TELEPHONE LINK

The formal opening of the radio telephone link between trawlers and shore was performed by Sir Walter J. Womersley, M.P., the Assistant Postmaster General on Monday, October 25th, 1937. The service operates over a radius up to 200 miles from the transmitter. Sir Walter had a 'phone talk with skipper H. Edwards of the trawler "Spurs" owned by the Consolidated Fisheries, Ltd., and during the conversation the skipper complained about the poor prices realised for catches, and remarked "It makes you feel like swearing a bit."

This radio link has been made possible by the installation of a link unit at Humber radio station, situated at Trusthorpe near Chablethorpe and is designed for simplex working which necessitates an operator being present during the whole conversation for monitoring purposes.

The wavelengths used for transmitting and receiving are 163 and 149 metres respectively. The receiver used is a 6-valve superheterodyne type, employing a signal frequency stage, separate coils being used for each band of the oscillator section, but the band pass filter and radio frequency transformer ranges utilise common inductance.

Unit details :

The unit embodies three switches : —

One enables the wireless telephony officer to call and speak to a land line subscriber. The second enables the W.T officer to call and speak to the subscriber on the radio link. The other is a change-over switch enabling the operator to put either the receiver output to line or the land-line input to the W.T transmitter.

Speech level is controlled by three separate volume controls. One controls the land-line speech level ; the second controls the radio receiver level ; and the third controls the level of output from the W.T operator's local microphone. A volume indicator is embodied in the unit by which the operator can rapidly and accurately adjust the speech levels.

The service represents another stage in developing the use of radio links for the extension of the telephone network.

North Wales

AN UNUSUAL CASE OF SINKING OF CONDUITS AND CONSEQUENT STRETCHING OF CABLES ON THE BIRMINGHAM-MANCHESTER DUCT LINE AT TALKE ROAD, TALKE, STOKE-ON-TRENT.

During laying of the co-axial cable in the Stoke Section in July, 1937, an obstruction was reported to exist in the 3-way multiple duct at a point quite near to the Talke repeater station. On investigation, the obstruction was located at a slight bend in the road where the Road Authorities had previously experienced trouble due to the subsidence of both the carriageway and the footway. The duct line at this point is in the footway. Pilot holes indicated that a serious sinking of the conduits had occurred for the pipes were not laid bare until excavations, having depths of approximately 6 ft., 7 ft. and 8 ft. respectively had been made.

Using locally recruited casual labour of the ex-miner type, a trench of approximately 25 yards in length and varying in depth from 3 ft. 10 ins. at one end, gradually deepening to 8 ft. 9 ins. at its maximum and rising again

gradually to 2 ft. 8 ins. at the other end, was excavated. Its average width was approximately 4 ft.

An examination of the cable joints at the jointing points at each end of the section-length showed that the



joints were intact but drawn into the mouth of the duct, thereby stretching the cable by 10 ins. The photograph taken on completion of the necessary excavation will indicate the difficulty encountered as the terrain consisted chiefly of made up ground formed of ashes and clinkers from furnaces. The problem was to decide what would be the best plan to adopt in order to prevent any future sinking as this would have very deleterious effects on the co-axial cable. It was decided to fashion strong supports of timber obtained by splitting cut-down lengths of 36-ft. S poles thrown spare due to main line recoveries in this area. These were fixed horizontally and transversely to the run of the ducts at 5 ft. intervals, each end being firmly fixed in the side of the trench by undercutting the undisturbed earth. During the lifting of the ducts the BM-MR cable was hauled into the jointing boxes and the slack due to the stretching was cut out by re-jointing. The whole work was carried out without any interruption on a working circuit. Lengths of 4/8 std. stay-wire have been fixed securely to the ducts at three points, the two outer points being 21 ft. and 18 ft. 3 ins. respectively from the centre.

These stay-wires were maintained in a vertical position while the earth was being filled in and when the ground had been levelled off a footway marker was carefully fitted to the end of each stay-wire, the marker being level with the surface of the ground. Measurements were then taken and recorded of the vertical distance from each marker to a wire drawn up to a known tension between two fixed points and suspended above the markers. The measurements were 10 ins., 14 ins. and 16½ ins. respectively. These measurements were checked again on 2nd November, 1937, and were found to be 10½ ins., 14½ ins. and 16¾ ins. respectively. These results indicate that there has been little further sinking of the duct line other than normal settlement but it is proposed to make a further check of the measurements in three months' time.

ANNUAL DINNER

The Annual Dinner of the North Wales Engineering District Staff was held at Morris's Café, Shrewsbury,

on the 4th November. The Superintending Engineer, Mr. H. Faulkner, presided.

It was fortunate that the date of the dinner coincided with that of the I.P.O.E.E. Centre Meeting, and a record attendance was possible as a result. This year the principal guest was Mr. P. J. Ridd, Assistant Engineer-in-Chief, and as is usual at these functions a number of Engineering and Clerical Officers from other Districts, and from Headquarters, were present. The visitors included representatives of the Office of Works, the Surveyors, Traffic and Postal Branches, the Stores Department, the Mayor and prominent residents of Shrewsbury.

The toast of the Engineering Department was proposed by Mr. J. T. Foxell, Surveyor, G.P.O. North Wales District, and Mr. Ridd replied. Mr. J. H. Watkins, Assistant Superintending Engineer proposed the toast of the visitors in a happy speech and responses were given by Mr. H. A. Thomas of the Stores Department, Birmingham, and by Alderman Charles Beddard, Mayor of Shrewsbury.

Mr. S. F. Hill, Sectional Engineer, Birmingham, gave the toast of the Chairman and as usual the toast was received with musical honours.

Musical and humorous items were contributed by members of the North Wales District Staff and others, and the members of the Committee and the Hon. Secretary, Mr. J. P. Evans, deserve the hearty congratulations of the staff on the continued success of this annual function.

MR. T. EVANS

The staff of the Supt. Engineer's office assembled on November 29th, to bid farewell to Mr. T. Evans, Asst. Engineer, on his retirement after 44 years' service.

Entering the P.O. service in 1893 as a Telegraphist, Mr. Evans passed through the ranks of Junior Clerk, Sub. Engineer, 2nd Class Engineer and Asst. Engineer, and has ranged the country from Ireland and Scotland to London. Since 1919 he has been attached to the Technical Section of the N. Wales Superintending Engineer's office and his encyclopædic knowledge of the main routes of the N. Wales and adjoining Districts, combined with a phenomenal memory and genius for schemes of rearrangement must have been worth many thousands of pounds to the Department. His ability to produce lines "out of the hat" will make his place hard to fill.

May he continue to enjoy for many years his favourite pastime on the bowling green.

North Western

In addition to the completion of a number of U.A.X.'s 12 and 13, good progress has been maintained in duct laying throughout the District.

In one section, Penrith—Keswick, considerable lengths of very hard rock were encountered which needed blasting operations to be applied. The Gosforth - Barrow-in-Furness duct work is nearly completed. Its importance lies in the part it will play in the encirclement of the mountainous regions of the Lake District, and the exposed parts of West Cumberland, where it is not unusual for overhead routes, under wintry conditions, to be out of service for days.

Although difficulties from the amenity point of view are of particular importance, various sections of aerial cable have been erected in the Lake District in places where underground construction would have been prohibitive in cost.

Surveys and estimates have been completed for the duct work associated with the 77-mile leads in the Lancaster Section of the proposed Leeds-Carlisle-Edinburgh 12-channel carrier cable system.

Scottish Region

GLASGOW AUTOMATIC TELEPHONES

(Director System)

Halfway exchange, a relief exchange on Ibrox and Paisley, was opened on the 20th September, 1937. This is the first exchange in the Glasgow conversion scheme to be opened. The initial equipment is for 1 600 multiple lines and is of the 2,000 type.

A temporary auto-manual switchboard of 10 positions has been installed in the existing Central manual exchange to deal with Toll and assistance traffic. This is being extended to 30 positions to cater for Toll and assistance traffic from nine other Director exchanges which will be put into service prior to the opening of the new Joint Trunk exchange in January, 1940. Access to the Trunk Exchange is obtained by dialling "TRU."

C.C.I. equipment is not being provided at Glasgow. Direct dialling to manual exchanges is being employed instead. Halfway subscribers can dial direct to Central, Bell, Douglas, Ibrox, South, Govan and Langside C.B. exchanges.

Glasgow Tandem exchange will not be available until September, 1939. Direct dialling routes from each automatic exchange to each other automatic exchange will be set up meanwhile.

Initially the subscribers on Paisley Exchange, which is of the Keith line switch type of equipment, can dial direct to Halfway subscribers and vice versa.

The ENG service has been introduced and is being controlled initially on test desks at Halfway exchange.

GLASGOW AUTOMATIC TELEPHONES TRUNK AND LOCAL CABLES

The proposals for the transfer of Glasgow Central and Trunk exchanges have been considered and it has been decided to provide a tunnel approximately 200 yards long between St. Vincent Street and the Trunk exchange with a branch into the repeater station. The Engineer-in-Chief has agreed to the employment of the services of Sir Harley Dalrymple-Hay as Consulting Engineer for this project. The latter has called for a good deal of information including accurate cross sectional drawings showing the position and nature of the "foreign" services in Pitt Street and a longitudinal section showing the proposed line of the tunnel. Pilot holes have been opened for this purpose.

South Lancs

MANCHESTER AND LIVERPOOL TELEPHONE AREAS

On October 18th, 1937, the Manchester Telephone Area was formed under the managership of Mr. G. Manning, whose office is at Telephone House, Chapel Street, Salford. An inaugural meeting consisting of members of the staffs from the Engineering Department and the District Manager's Office, was held at Telephone House in the afternoon of the 18th, when a send-off was given to the new venture. Also, on November 1st, 1937, the Liverpool Telephone Area was formed under the managership of Mr. A. L. Barclay, whose office is at India Buildings, Water Street, Liverpool. Again, members of the staffs from the Engineering Department and the District Manager's Office, Liverpool, gathered at an inaugural meeting to wish the venture every success. It was very pleasing to note that at both meetings a happy spirit pervaded throughout, and expressions of goodwill and promises of co-operation from both sides were the order of the day.

Staff Changes

PROMOTIONS.

Name	From	To	Date
Morgan, J.	Asst. Suptg. Engr., S. Western	Suptg. Engr., S. Western	1-7-38
Semple, L. G.	Asst. Staff Engr., E.-in-C.O.	Suptg. Engr., S. Midland	1-5-38
Harris, L. H.	Asst. Suptg. Engr., Eastern	Actg. Suptg. Engr., N. Midland	1-4-38
Warren, A. C.	Asst. Suptg. Engr., S. Western	Telephone Manager, Bristol	15-11-37
McGowan, C. R.	Asst. Engr., E.-in-C.O.	Actg. Exec. Engr., E.-in-C.O.	21-9-37
Harrison, G. B. W.	Asst. Engr., E.-in-C.O.	Actg. Exec. Engr., London	1-10-37
McMillan, D.	Asst. Engr., E.-in-C.O.	Actg. Exec. Engr., E.-in-C.O.	21-9-37
Baker, T. W.	Asst. Engr., E.-in-C.O.	Actg. Exec. Engr., E.-in-C.O.	29-10-37
Longmore, F. W.	Asst. Engr., E.-in-C.O.	Actg. Exec. Engr., E.-in-C.O.	1-1-38
Jupp, J.	Asst. Engr., Test Secn., London	Senior Phys. or Chem., Test Secn., London	1-5-37
Richards, C. E.	Asst. Engr., E.-in-C.O.	Senior Phys. or Chem., E.-in-C.O.	1-5-37
Glover, D. W.	Asst. Engr., E.-in-C.O.	Chem. or Phys., E.-in-C.O.	1-5-37
Linch, R.	Asst. Engr., Test Secn., B'ham	Chem. or Phys., Test Secn., B'ham	1-5-37
Taylor, R.	Prob. Asst. Engr., E.-in-C.O.	Chem. or Phys., E.-in-C.O.	1-5-37
Bateson, E. L. H.	Chief Insp., E.-in-C.O.	Asst. Engr., E.-in-C.O.	14-10-37
Shields, A. V.	Chief Insp., E.-in-C.O.	Asst. Engr., E.-in-C.O.	14-10-37
Lewis, S. G.	Chief Insp., E.-in-C.O.	Asst. Engr., E.-in-C.O.	14-10-37
Dudley, J. C.	Chief Insp., E.-in-C.O.	Asst. Engr., E.-in-C.O.	14-10-37
Balcombe, F. G.	Chief Insp., E.-in-C.O.	Asst. Engr., E.-in-C.O.	14-10-37
Crank, F. G.	Chief Insp., E.-in-C.O.	Asst. Engr., E.-in-C.O.	14-10-37
Furieux, E. G.	R.O.I., Lowestoft	Asst. Engr., E.-in-C.O.	To be fixed later.
Arman, L. T.	Chief Insp., E.-in-C.O.	Asst. Engr., E.-in-C.O.	14-10-37
Bennett, S. Y.	Chief Insp., S. Western	Chief Insp. with Allce., S. Western	13-11-37
Marsden, C.	Chief Insp., N.E. Reg.	Chief Insp. with Allce., S. Western	21-11-37
Downes, A. D. W.	Chief Insp., Test Secn., London	Chem. or Phys., Test Secn., Ldn.	1-5-37
Horrigan, H. F.	Chief Insp., Test Secn., B'ham	Chem. or Phys., Test Secn., B'ham	1-5-37
Mullis, P. R.	Insp., S. Wales	Chief Insp., S. Wales	11-10-37
Siems, C. V.	Insp., E.-in-C.O.	Chief Insp., E.-in-C.O.	3-10-37
Duff, J. B.	Insp., E.-in-C.O.	Chief Insp., Scot. Reg.	13-10-37
Cotton, W.	Insp., N. Wales	Chief Insp., N. Wales	23-7-37
Knott, H. H. R.	Insp., E.-in-C.O.	Chief Insp., S. Western	1-10-37
Arram, H.	Insp., London	Chief Insp., London	25-7-37
Preston, I. G.	Insp., N. Wales	Chief Insp., N. Wales	2-5-37
Drinkwater, M.	Insp., S. Lancs.	Chief Insp., S. Lancs.	12-9-37
Twycross, A. E.	Insp., N. Midland	Chief Insp., N. Midland	17-10-37
Daines, W. J. J.	Insp., Eastern	Chief Insp., Eastern	10-10-37
Stone, M. C.	Insp., S. Western	Chief Insp., S. Western	22-8-37
Birch, F.	Insp., N. Wales	Chief Insp., N. Wales	25-4-37
Hills, J. E.	Insp., S. Midland	Chief Insp., S. Eastern	24-10-37
Shaw, A. F.	Insp., London	Chief Insp., London	13-4-37
West, W.	Insp., London	Chief Insp., London	1-5-37
England, J.	Insp., Eastern	Chief Insp., Eastern	1-10-37
Traviss, F. D.	Insp., S. Midland	Chief Insp., S. Midland	9-9-37
Goodwin, E. T.	Insp., Eastern	Chief Insp., Eastern	5-8-37
Wilkins, E. G.	Insp., S. Western	Chief Insp., S. Western	25-7-37
Moss, F. R.	Insp., S. Midland	Chief Insp., S. Midland	1-10-37
Holmes, F.	Insp., S. Western	Chief Insp., S. Western	18-7-37
Batch, G. B.	Insp., Eastern	Chief Insp., Eastern	30-7-37
Else, W.	Insp., London	Chief Insp., London	23-3-37
Powell, S. J.	Insp., S. Eastern	Chief Insp., S. Eastern	17-1-37
Woodley, E. T. M.	Insp., S. Western	Chief Insp., S. Western	16-9-37
Watt, J.	Insp., E.-in-C.O.	Chief Insp., E.-in-C.O.	9-7-37
Stacey, P. A.	Insp., E.-in-C.O.	Chief Insp., E.-in-C.O.	31-10-37
Hall, H. C.	Insp., London	Chief Insp., London	1-8-37
Cook, A. C.	Insp., E.-in-C.O.	Chief Insp., E.-in-C.O.	24-6-37
Price, J. W.	Insp., E.-in-C.O.	Chief Insp., E.-in-C.O.	1-9-37
Oldacre, A. G.	Insp., E.-in-C.O.	Chief Insp., S. Lancs.	19-9-37
Brandum, W. H.	Insp., London Post. Reg.	Chief Insp., London Post. Reg.	1-5-37
Hales, G. A.	Insp., S. Lancs.	Chief Insp., S. Lancs.	18-8-37
Ivory, J.	Insp., Test Secn., London	Chief Insp., Test Secn., London	21-2-37
Perkins, F. T.	Insp., E.-in-C.O.	Chief Insp., E.-in-C.O.	29-9-37
Roberts, E.	Insp., E.-in-C.O.	Chief Insp., E.-in-C.O.	29-9-37
Grant, C. G.	Insp., E.-in-C.O.	Chief Insp., E.-in-C.O.	22-9-37
Dye, F. W. G.	Insp., E.-in-C.O.	Chief Insp., E.-in-C.O.	29-9-37
Legood, F. J.	Insp., E.-in-C.O.	Chief Insp., E.-in-C.O.	12-8-37
Abbott, G. A.	Insp., E.-in-C.O.	Chief Insp., E.-in-C.O.	29-9-37
Cowley, F. H.	Insp., Eastern	Chief Insp., Eastern	1-7-37
Frost, J.	Insp., S. Lancs.	Chief Insp., S. Lancs.	8-8-37
Fisher, F. C.	Insp., London	Chief Insp., London	26-9-37
Brogden, A. E.	Insp., E.-in-C.O.	Chief Insp., E.-in-C.O.	10-10-37

PROMOTIONS—continued

Name	From	To	Date
Blois, W. H.	Insp., E.-in-C.O.	Chief Insp., E.-in-C.O.	14-10-37
Stonebanks, A. M.	Insp., E.-in-C.O.	Chief Insp., E.-in-C.O.	14-10-37
Davey, F. R.	Insp., E.-in-C.O.	Chief Insp., E.-in-C.O.	24-10-37
Reed, H. L.	Insp., N.E. Reg.	Chief Insp., N.E. Reg.	2-5-37
Buckingham, L. J.	Insp., E.-in-C.O.	Chief Insp., E.-in-C.O.	6-10-37
Gowland, J. W.	Insp., N.E. Reg.	Chief Insp., N.E. Reg.	29-10-37
Allan, F. W.	Insp., N.E. Reg.	Chief Insp., N.E. Reg.	27-10-37
Anderson, J.	Insp., N.E. Reg.	Chief Insp., N.E. Reg.	14-11-37
Bull, R. L.	Insp., Test Secn., London	Chem. or Phys., Test Secn., London	1-5-37
Pierce, J. G.	Insp., Test Secn., London	Chem. or Phys., Test Secn., London	1-5-37
Walker, E. V.	Insp., E.-in-C.O.	Chem. or Phys., E.-in-C.O.	1-5-37
Taylor, E. A.	Insp., E.-in-C.O.	Chem. or Phys., E.-in-C.O.	1-5-37
Kingston, F. G.	Insp., E.-in-C.O.	Chem. or Phys., E.-in-C.O.	1-5-37
Garrett, F. S.	Insp., Test Secn., B'ham	Chem. or Phys. Test Secn., B'ham	1-5-37
Collman, E. L.	Actg. T.O., Exeter	Reg. M.T.O., Leeds	To be fixed later.
Finney, C. W.	M.T.O. III, E.-in-C.O.	Actg. T.O., Exeter	To be fixed later.
West, P. S.	Tech. Asst., London	M.T.O. III, E.-in-C.O.	To be fixed later.
Squire, W.	Mech.-in-Charge, Gr. I, London	Tech. Asst., London	To be fixed later.
Rayner, L. W. W.	S.W.I., Test Secn., London	Asst. Phys. or Chem., Test Secn., Ldn.	1-5-37
Rickland, E. F.	S.W.I., Test Secn., London	Asst. Phys. or Chem., Test Secn., Ldn.	1-5-37
Terrett, L. E.	S.W.I., Test Secn., London	Asst. Phys. or Chem., Test Secn., Ldn.	1-5-37
Wright, V. B.	S.W.I., Test Secn., London	Asst. Phys. or Chem., Test Secn., Ldn.	1-5-37
Shuter, F. C.	S.W.I., Test Secn., Birmingham	Asst. Phys. or Chem., Test Secn., B'ham	1-5-37
Bowcott, H. J.	S.W.I., Test Secn., Birmingham	Asst. Phys. or Chem., Test Secn., B'ham	1-5-37
Edwards, W. T.	S.W.I., Test Secn., Birmingham	Asst. Phys. or Chem., Test Secn., B'ham	1-5-37
Evans, H. T. F.	S.W.I., Test Secn., Birmingham	Asst. Phys. or Chem., Test Secn., B'ham	1-5-37
Shotton, D. C.	S.W.I., Test Secn., Birmingham	Asst. Phys. or Chem., Test Secn., B'ham	1-5-37
Woodward, J. A. W.	U.S.W., Test Secn., Birmingham	Asst. Phys. or Chem., Test Secn., B'ham	1-5-37
Vincent, C. A. B.	U.S.W., Test Secn., Birmingham	Asst. Phys. or Chem., Test Secn., B'ham	4-8-37
Organ, R. M.	U.S.W., Test Secn., Birmingham	Asst. Phys. or Chem., Test Secn., B'ham	1-5-37
Taylor, P. E.	U.S.W., Test Secn., Birmingham	Asst. Phys. or Chem., Test Secn., Ldn.	1-5-37
Dale, A. G. L.	U.S.W., Test Secn., Birmingham	Asst. Phys. or Chem., Test Secn., Ldn.	1-5-37
Guy, J. A.	U.S.W., E.-in-C.O.	Asst. Phys. or Chem., E.-in-C.O.	29-8-37
Leedham, F. V.	S.W.I., N.E. Reg.	Insp., N.E. Reg.	28-2-37
Beer, W. C.	S.W.I., S. Wales	Insp., S. Wales	20-7-37
Blatchley, W. F.	S.W.I., S. Wales	Insp., S. Wales	3-10-37
Carpenter, C. H.	S.W.I., S. Wales	Insp., S. Wales	20-7-37
Frizell, C. T.	S.W.I., S. Wales	Insp., S. Wales	22-8-37
Hodgson, J. P.	S.W.I., S. Lancs.	Insp., S. Lancs.	24-6-37
Hunter, J. St. L.	S.W.I., S. Wales	Insp., S. Wales	27-6-37
Jaubs, C. E. J.	S.W.I., S. Wales	Insp., S. Wales	30-6-37
Lugg, J. V.	S.W.I., S. Wales	Insp., S. Wales	15-8-37
Read, E.	S.W.I., S. Wales	Insp., S. Wales	20-7-37
Rowland, H.	S.W.I., S. Lancs.	Insp., S. Lancs.	22-8-37
Shimmin, W. H.	S.W.I., S. Lancs.	Insp., S. Lancs.	13-7-37
Suter, F. H. C.	S.W.I., S. Wales	Insp., S. Wales	29-6-37
Williams, R. S.	S.W.I., S. Wales	Insp., S. Wales	15-8-37
Jempson, R. B.	S.W.I., S. Eastern	Insp., S. Wales	8-8-37
Graham, H. E.	S.W.I., S. Eastern	Insp., S. Wales	2-10-37
Knapp, C. R.	S.W.I., S. Eastern	Insp., S. Wales	8-8-37
Duke, A. E.	S.W.I., S. Eastern	Insp., S. Wales	10-10-37
Sturdy, G. H.	S.W.I., S. Eastern	Insp., S. Wales	10-10-37
Rouse, D. R.	S.W.I., S. Eastern	Insp., S. Wales	24-10-37
Grinstead, E. G.	S.W.I., S. Eastern	Insp., S. Wales	10-10-37
Coleman, R. P.	S.W.I., S. Eastern	Insp., S. Wales	3-10-37
Drewson, H. R.	S.W.I., S. Eastern	Insp., S. Wales	17-10-37
Gibbons, E. C.	S.W.I., S. Eastern	Insp., S. Wales	2-10-37
Janes, A. L.	S.W.I., S. Eastern	Insp., S. Wales	17-10-37
Thompson, T. W.	S.W.I., S. Eastern	Insp., S. Wales	17-10-37
Bowler, W. R.	S.W.I., Test Secn., Birmingham	Insp., Test Secn., Birmingham	2-2-37
Grant, J.	S.W.I., Test Secn., Birmingham	Insp., Test Secn., Birmingham	2-2-37
Snowling, J. W.	S.W.I., Test Secn., London	Insp., Test Secn., London	4-4-37
Tunncliffe, R. T.	S.W.I., N. Ireland	Insp., N. Ireland	11-3-37
Taylor, T. G.	S.W.I., N.E. Reg.	Insp., N.E. Reg.	18-4-37
Bleach, A. J.	S.W.I., N.E. Reg.	Insp., N.E. Reg.	12-8-37
Sturdy, F. H.	S.W.I., N.E. Reg.	Insp., N.E. Reg.	15-8-37
Sweeney, L.	S.W.I., N.E. Reg.	Insp., N.E. Reg.	31-7-37
Fox, H.	S.W.I., N.E. Reg.	Insp., N.E. Reg.	13-3-37
Bowman, J.	S.W.I., N.E. Reg.	Insp., N.E. Reg.	23-7-37
Janes, H. T.	S.W.I., London	Insp., London	13-1-37
Little, D. J.	S.W.I., London	Insp., London	1-8-37
Mahoney, J. W.	S.W.I., London	Insp., London	24-7-37
Musson, F. E.	S.W.I., London	Insp., London	14-8-37
Pierpont, S. H.	S.W.I., London	Insp., London	22-8-37
Wheeler, W. H.	S.W.I., London	Insp., London	1-8-37

PROMOTIONS—continued

Name	From	To	Date
Wright, S. C.	S.W.I., London	Insp., London	1-8-37
Roe, A. J.	S.W.I., N.E. Reg.	Insp., N.E. Reg.	23-7-37
Adams, W.	S.W.I., N.E. Reg.	Insp., N.E. Reg.	10-10-37
Campbell, K. W.	S.W.I., London	Insp., London	3-7-37
Essam, T. H.	S.W.I., London	Insp., London	18-7-37
Gunning, W. W.	S.W.I., London	Insp., London	18-5-37
Head, C. E.	S.W.I., London	Insp., London	10-7-37
Holmes, C. W.	S.W.I., London	Insp., London	1-1-37
Jack, A.	S.W.I., London	Insp., London	20-7-37
Jones, F. J.	S.W.I., London	Insp., London	15-7-37
Musgrave, A. H.	S.W.I., London	Insp., London	3-5-37
Turner, A. C.	S.W.I., London	Insp., London	17-7-37
Wood, A. J.	S.W.I., London	Insp., London	28-6-37
Wright, C. W.	S.W.I., London	Insp., London	4-7-37
Taylor, W. E.	S.W.I., N.E. Reg.	Insp., N.E. Reg.	10-10-37
Back, R. O. J.	S.W.I., N. Midland	Insp., N. Midland	18-7-37
Bishop, H. J.	S.W.I., S. Eastern	Insp., S. Eastern	24-10-37
Burke, T. F.	S.W.I., S. Lancs.	Insp., S. Lancs.	22-8-37
Cheetwood, E.	S.W.I., S. Lancs.	Insp., S. Lancs.	11-9-37
Conolly, E. J.	S.W.I., S. Lancs.	Insp., S. Lancs.	11-9-37
Dalton, H.	S.W.I., S. Lancs.	Insp., S. Lancs.	29-8-37
Foote, F. W.	S.W.I., S. Lancs.	Insp., S. Lancs.	12-9-37
Hammond, T. R.	S.W.I., S. Lancs.	Insp., S. Lancs.	1-8-37
Kelly, R. C.	S.W.I., S. Lancs.	Insp., S. Lancs.	9-9-37
Killoran, J. E.	S.W.I., S. Lancs.	Insp., S. Lancs.	22-9-37
O'Brien, A.	S.W.I., S. Lancs.	Insp., S. Lancs.	18-8-37
Owen, E. A.	S.W.I., N. Midland	Insp., N. Midland	23-8-37
Park, A.	S.W.I., S. Lancs.	Insp., S. Lancs.	8-8-37
Smith, A. H.	S.W.I., N. Midland	Insp., N. Midland	18-4-37
White, O.	S.W.I., S. Lancs.	Insp., S. Lancs.	15-7-37
Apperley, H. L.	S.W.I., S. Western	Insp., S. Western	18-7-37
Biggs, A. S.	S.W.I., S. Western	Insp., S. Western	25-7-37
Osman, A. S.	S.W.I., S. Western	Insp., S. Western	13-10-37
Price, C. A.	S.W.I., S. Western	Insp., S. Western	27-6-37
Ridout, J. D.	S.W.I., S. Western	Insp., S. Western	30-10-37
Silcox, W. G.	S.W.I., S. Western	Insp., S. Western	12-9-37
Westlake, C. E.	S.W.I., S. Western	Insp., S. Western	18-7-37
Whitting, W. G.	S.W.I., S. Western	Insp., S. Western	19-9-37
Wood, R. E.	S.W.I., N.E. Reg.	Insp., N.E. Reg.	17-10-37
Bull, A.	S.W.I., N.E. Reg.	Insp., N.E. Reg.	23-10-37
Alfred, T.	S.W.I., N. Wales	Insp., N. Wales	To be fixed later.
Cadman, P. T.	S.W.I., N. Wales	Insp., N. Wales	To be fixed later.
Cook, W. H.	S.W.I., N. Wales	Insp., N. Wales	To be fixed later.
Cunninghame, J. W. N. S.	S.W.I., N. Wales	Insp., N. Wales	To be fixed later.
Foster, S.	S.W.I., N. Wales	Insp., N. Wales	To be fixed later.
Grafton, L. H. C.	S.W.I., N. Wales	Insp., N. Wales	To be fixed later.
Geldart, D. F.	S.W.I., N. Wales	Insp., N. Wales	To be fixed later.
Hinton, G. B.	S.W.I., N. Wales	Insp., N. Wales	To be fixed later.
Hollins, J. S.	S.W.I., N. Wales	Insp., N. Wales	To be fixed later.
Howes, F. L.	S.W.I., N. Wales	Insp., N. Wales	To be fixed later.
Jones, H. W.	S.W.I., N. Wales	Insp., N. Wales	To be fixed later.
Kimber, R. H.	S.W.I., N. Wales	Insp., N. Wales	To be fixed later.
Laing, D. M.	S.W.I., N. Wales	Insp., N. Wales	To be fixed later.
Lamping, C. T.	S.W.I., N. Wales	Insp., N. Wales	To be fixed later.
Martin, J.	S.W.I., N. Wales	Insp., N. Wales	To be fixed later.
Morgan, M. T.	S.W.I., N. Wales	Insp., N. Wales	To be fixed later.
Nall, W. A.	S.W.I., N. Wales	Insp., N. Wales	To be fixed later.
Oultram, J. H.	S.W.I., N. Wales	Insp., N. Wales	To be fixed later.
Sanders, J. P. C.	S.W.I., N. Wales	Insp., N. Wales	To be fixed later.
Smith, F. L.	S.W.I., N. Wales	Insp., N. Wales	To be fixed later.
Spilsbury, J. C.	S.W.I., N. Wales	Insp., N. Wales	To be fixed later.
Stollard, A. F.	S.W.I., N. Wales	Insp., N. Wales	To be fixed later.
Stringer, F.	S.W.I., N. Wales	Insp., N. Wales	To be fixed later.
Vernon, H.	S.W.I., N. Wales	Insp., N. Wales	To be fixed later.
Clucas, F.	S.W.I., S. Lancs.	Insp., S. Lancs.	20-9-37
Biddolph, H.	S.W.I., S. Lancs.	Insp., S. Lancs.	18-8-37
Lillie, R.	S.W.I., Scot. Reg.	Insp., Scot. Reg.	7-1-37
Bannerman, C. S.	S.W.I., Scot. Reg.	Insp., Scot. Reg.	15-4-37
Macleod, N. M.	S.W.I., Scot. Reg.	Insp., Scot. Reg.	19-5-37
Gall, J. C.	S.W.I., Scot. Reg.	Insp., Scot. Reg.	31-10-37
Rae, S. C.	S.W.I., Scot. Reg.	Insp., Scot. Reg.	25-5-37
Gregor, F. C. L.	S.W.I., Scot. Reg.	Insp., Scot. Reg.	20-6-37
Miller, G. M.	S.W.I., Scot. Reg.	Insp., Scot. Reg.	28-4-37
Davie, J. C.	S.W.I., Scot. Reg.	Insp., Scot. Reg.	13-6-37
Forbes, B. R. D.	S.W.I., Scot. Reg.	Insp., Scot. Reg.	25-5-37
Colvin, M.	S.W.I., Scot. Reg.	Insp., Scot. Reg.	31-10-37

PROMOTIONS—continued

Name	From	To	Date
McKenzie, J.	S.W.I., Scot. Reg.	Insp., Scot. Reg.	31-10-37
Lindsay, H. L.	S.W.I., Scot. Reg.	Insp., Scot. Reg.	16-10-37
Bremner, R. C.	S.W.I., Scot. Reg.	Insp., Scot. Reg.	9-6-37
Train, R. F.	S.W.I., Scot. Reg.	Insp., Scot. Reg.	13-6-37
Thom, J. R. H.	S.W.I., Scot. Reg.	Insp., Scot. Reg.	25-7-37
Morrison, G.	S.W.I., Scot. Reg.	Insp., Scot. Reg.	14-4-37
Godfrey, J.	S.W.I., Scot. Reg.	Insp., Scot. Reg.	27-6-37
Dye, R. J.	S.W.I., Scot. Reg.	Insp., Scot. Reg.	7-6-37
Moore, E.	S.W.I., Scot. Reg.	Insp., Scot. Reg.	29-6-37
Scott, W.	S.W.I., Scot. Reg.	Insp., Scot. Reg.	26-7-37
Brock, J.	S.W.I., Scot. Reg.	Insp., Scot. Reg.	26-10-37
Haggart, J. M.	S.W.I., Scot. Reg.	Insp., Scot. Reg.	4-7-37
Ritchie, G. B.	S.W.I., Scot. Reg.	Insp., Scot. Reg.	6-6-37
Walker, W. F.	S.W.I., London	Insp., London	To be fixed later.
Beech, W. H.	S.W.I., London	Insp., London	To be fixed later.
Davey, W. C.	S.W.I., London	Insp., London	To be fixed later.
Stallard, T. H.	S.W.I., London	Insp., London	To be fixed later.
Barnes, F. (Junn.)	S.W.I., London	Insp., London	To be fixed later.
Kendall, C. E.	S.W.I., London	Insp., London	To be fixed later.
Hamilton, F. A.	S.W.I., London	Insp., London	To be fixed later.
Taylor, G. E.	S.W.I., London	Insp., London	To be fixed later.
Ireland, W. I.	S.W.I., London	Insp., London	To be fixed later.
Taverner, H. S.	S.W.I., London	Insp., London	To be fixed later.
Case, N.	S.W.II., N. Wales	Insp., N. Wales	To be fixed later.
Taylor, J. E.	S.W.II., N. Wales	Insp., N. Wales	To be fixed later.
Shipley, E. C.	Draughtsman I., E.-in-C.O.	Senior D'sman (Actg.), E.-in-C.O.	1-11-37
Gemmell, A. G.	Draughtsman II., E.-in-C.O.	Draughtsman I., E.-in-C.O.	1-11-37
Stagg, G. A.	Draughtsman II., E.-in-C.O.	Draughtsman I. (Actg.), E.-in-C.O.	To be fixed later.
Freeman, J. S.	Draughtsman II., E.-in-C.O.	Draughtsman I. (Actg.), E.-in-C.O.	To be fixed later.
White, R. G.	Draughtsman II., Eastern	Draughtsman I., Eastern	30-8-37
Potter, W.	Draughtsman II., S. Lancs.	Draughtsman I., S. Lancs.	6-8-37
Grinstead, P. A.	Draughtsman II., S. Eastern	Draughtsman I., S. Midland	31-10-37
Turner, H. S.	Draughtsman II., N. Western	Draughtsman I., N. Western	27-7-37
Bruce, J.	Draughtsman II., N.E. Reg.	Draughtsman I., N.E. Reg.	14-11-37
Dunsford, C. B.	Draughtsman II., N.E. Reg.	Draughtsman I., N.E. Reg.	24-10-37
Ivory, B.	Draughtsman II., N. Western	Draughtsman I., N. Western	27-7-37
Kensett, J. F.	Draughtsman II., London	Draughtsman I., N. Ireland	31-10-37
Todd, J. C. H.	Draughtsman II., N. Western	Draughtsman I., N. Western	27-7-37
Chivers, W. K.	Draughtsman II., London Post. Reg.	Draughtsman I., London Post. Reg.	19-10-37

DEATHS

Name	Rank	Location	Date
Townsend, S. B.	Reg. M.T.O.	Leeds	7-9-37
Lea, A. C.	Insp.	London	3-10-37
Evans, H. T. F.	Asst. Chem.	Test Secn., Birmingham	25-11-37

TRANSFERS.

Name	Rank	From	To	Date
Jeffs, H.	Prob. Asst. Engr.	N.E. Reg.	N. Wales	19-9-37
Mylius, W. A. J.	Repeater Officer, Cl. I.	Nevin	Lowestoft	3-10-37
Parker, K. L.	Insp.	Test Secn., London	E.-in-C.O.	5-9-37
Yeatman, H. G.	Insp.	E.-in-C.O.	S. Midland	1-10-37
Pocock, D. G.	Insp.	E.-in-C.O.	London	3-10-37
Perrin, F. W.	Insp.	S. Midland	E.-in-C.O.	1-10-37
Clarke, W. J. F.	Insp.	E.-in-C.O.	S. Western	17-10-37
Johnson, L. P.	Insp.	S. Western	E.-in-C.O.	10-10-37
Laver, K. S.	Insp.	Eastern	E. in-C.O.	1-12-37
Cawte, H. M.	Insp.	London	E.-in-C.O.	4-12-37

RETIREMENTS

Name	Rank	Location	Date
Partridge, T. T.	Suptg. Engr.	N. Ireland	30-9-37
Bull, W. J.	Chief Insp.	S. Wales	10-10-37
Brown, A.	Chief Insp.	N.E. Reg.	31-12-37
Failes, W. J.	Insp.	Scot. Reg.	15-10-37
Brown, J.	Insp.	London	31-10-37
Peel, W.	Insp.	London	31-10-37
Francis, A. R.	Insp.	London	12-11-37
Holden, G.	Insp.	N. Western	22-11-37
Moller, E. J.	Senior Draughtsman	E.-in-C.O.	31-10-37

APPOINTMENTS

Name	From	To	Date
Dallow, J. C.	Insp., E.-in-C.O.	Straits Settlements and Federated Malay States	2-8-37
Burkett, R. H. W.	Prob. Insp., N. Midland	Asst. Examiner, Patents Office	18-10-37

SECONDMENTS

Name	From	To	Date
Browne, J. C.	Insp., Eastern	Gold Coast	29-9-37

BOARD OF EDITORS

B. O. ANSON, M.I.E.E., Chairman.
 A. J. GILL, B.Sc., M.I.E.E., M.Inst.R.E.
 G. F. O'DELL, B.Sc., M.I.E.E.
 F. E. NANCARROW, A.R.C.Sc., M.I.E.E., M.Inst.R.E.
 P. B. FROST, B.Sc., M.I.E.E.
 J. STRATTON, A.M.I.E.E.
 J. READING, B.Sc.(Eng.), M.I.E.E., Managing Editor.
 H. LEIGH, B.Sc.(Eng.), A.M.I.E.E., Assistant Editor.

Copyright

The entire contents of this Journal are covered by general copyright, and special permission is necessary for reprinting long extracts, but Editors are welcome to use not more than one-third of any article, provided credit is given at the beginning or end thus: "From the *Post Office Electrical Engineers' Journal*."

The Board of Editors is not responsible for the statements made or the opinions expressed in any of the articles in this Journal, unless such statement is made specifically by the Board.

Communications

All Communications should be addressed to the Managing Editor, *P.O.E.E. Journal*, Engineer-in-Chief's Office, Alder House, Aldersgate Street, London, E.C.1. Telephone: NATIONAL 6321. Remittances should be made payable to "*The P.O.E.E. Journal*" and should be crossed " & Co."

Binding Cases

Binding cases are available, and may be obtained from the Local Agents for 1s. 9d. Subscribers can have their copies of Volumes bound, at a cost of 3s., by sending the complete sets of parts to the Local Agents or to the *P.O.E.E. Journal*, Engineer-in-Chief's Office, Alder House, Aldersgate Street, London, E.C.1. Orders for binding for Vols. 1-19 should indicate whether the original binding case with black lettering, or the later pattern with gold, is required. Cases with gold lettering will be the only type stocked from Vol. 20 onwards.

Back Numbers

The price of the Journal, which is published quarterly, is 1s. (1s. 3d. post free) per copy, or 5s. per annum post free. Back numbers can be supplied, subject to availability of stocks, at 1s. each (1s. 3d. post free). Orders for back numbers may be sent to the Local Agents or to the Publishers.

Advertisements

All communications relating to space reservations should be addressed to the Advertisement Editor, *P.O.E.E. Journal*, Alder House, Aldersgate Street, London, E.C.1. Communications regarding advertisement copy, proofs, etc., should be addressed to the Publishers, Messrs. Birch & Whittington (Prop. Dorling & Co. [Epsom], Ltd.), Station Road, Epsom, Surrey.

Post Office Electrical Engineers' Journal

Volume XXX April 1937—March 1938

INDEX

	PAGE NO.		PAGE NO.
A		F	
Andrews, W. E. T., and R. O. Boocock. A Route Distance Recorder	65	Fairweather, A. and F. C. Williams. The Stability and Performance of the Single " Rectified Reaction " Stage.	204
Anglo-Dutch Co-axial Cables	222	Fast Operating Differential Echo-Suppressor, A ..	180
B		Fault Localisation with Gas-Filled Cables	237
Baker, E. C. Young People's Telephone Exhibition ..	61	Fire Extinction in Telephone Exchanges	241
Barton, A. L. Centralised " ENG " Service, Testing and Maintenance Control at Birmingham	304	Fogg, G. H. and R. F. J. Jarvis. Formulae for the Calculation of the Theoretical Characteristics and Design of Coaxial Cables	138
Blair, D. C. Protection of Post Office Circuits in Northern Ireland	121	Formulae for the Calculation of the Theoretical Characteristics and Design of Coaxial Cables	138
Board of Editors	80, 172, 260, 342	Forth Bridge Cables	105
Boocock, W. and G. H. Walton. Loch Awe Submarine Cables	235	Frost, P. B. Present Tendencies of Power Development and their Repercussions upon Telecommunication Systems	1
Boocock, R. O. and W. E. T. Andrews. A Route Distance Recorder	65	" " Promotion to Staff Engineer	247
Book Reviews	69, 70, 75, 156, 164, 254, 334	G	
Bourdeaux, N. and E. F. S. Clark. Micro Wave Demonstration Equipment	313	Gas-Filled Cables, Fault Localisation with	237
Brogden, A. E. Centralised Routiner and Maintenance Control in Automatic Exchanges	58	Gerrard, Old and New	328
Brook, H.; and D. W. Cherry. Direct Underground Distribution in Residential Areas	152	Glazier, E. D. The Variation of the Holding Times of Telephone Calls	46
Brown, R. C. C. The Maintenance Aspect of Overhead Construction	56	Gracie, A. J. A. A Novel System of Duplex Transmission	15
Burgess, A. G. and L. E. Ryall. A Simple Transmission Measuring Equipment	52	H	
C		Hines, Capt. J. G., Retirement of	69
C.T.O. Inland Phonogram and Telephone-Telegram Installation, The	26	Hogg, T. E. and J. Sharp. The C.T.O. Inland Phonogram and Telephone-Telegram Installation	26
Carter, Col. H. Transfer to South Wales District ..	246	I	
Cement, The Production of Portland	200	Impulsing in Non-Director Areas, The Problems Associated with	191, 320
Centralised " ENG " Service, Testing and Maintenance Control at Birmingham	304	Institution of Post Office Electrical Engineers, The ..	71, 157, 248, 331
Centralised Routiner and Maintenance Control in Automatic Exchanges	58	Interference, A new Form of Radio	240
Chamney, R. M. Anglo-Dutch Coaxial Cables	222	J	
" " Promotion to Staff Engineer	68	Jarvis, R. F. J. and G. H. Fogg. Formulae for the Calculation of the Theoretical Characteristics and Design of Coaxial Cables	138
Cherry, D. W. and H. Brook. Direct Underground Distribution in Residential Areas	152	Johnston, A. E. Reproduction of Prints of Drawings and Diagrams in the E.-in-C.O.	225
Clark, E. F. S. and Bourdeaux, N. Micro Wave Demonstration Equipment	313	Junior Section Notes	71, 157, 247, 331
Coaxial Cables, Formulae for the Calculation of the Theoretical Characteristics and Design of	138	L	
Coaxial Cable System, The London-Birmingham ..	270	Lawrence, J. A. and A. G. Edwards. The Mechanical Impulse Regenerator.	261
Collard, J. London's Television Twin Cable Links ..	215	Lightning and Lightning Protection	173
Combridge, J. H. The Development of Stamp-Selling Machines in the British Post Office	18	Lee, Sir George, I.E.E. Presidential Address	312
Coronation, The—Telecommunication Arrangements ..	115	Local Centre Notes	158
Creepage of Underground Cables, The	180	Loch Awe Submarine Cables	235
D		London-Birmingham Coaxial Cable System, The ..	206, 270
Davies, B. Forth Bridge Cables	105	London Fire Brigade, The	284
Detection of Poisonous Gases in Underground Workings, The	110	London's Television Twin Cable Links	235
Development of Stamp-Selling Machines in the British Post Office, The	18	M	
Diakon—A New Material for Coloured Telephones ..	292	Maintenance Aspect of Overhead Construction, The ..	56
Diplex Transmission, A Novel System of	15	Maitland, C. E. A. Street Traffic Control centralised in the Telephone Exchanges in Amsterdam	81
Direct Underground Distribution in Residential Areas ..	152	Mechanical Impulse Regenerator, The	261
District Notes	73, 159, 249, 335	Method of Sub-localising Cable Faults when no " Good " Wire is available, An Accurate	99
E			
Echo-Suppressor, A Fast Operating Differential	186		
Edwards, A. G. and J. A. Lawrence. The Mechanical Impulse Regenerator	261		

	PAGE NO.
Metson, G. H. An Accurate Method of Sub-localising Cable Faults When no "Good" Wire is available	99
Micro Wave Demonstration Equipment	313
Miller, A. Gerrard, Old and New	328
Mobbs, H. J. Fire Extinction in Telephone Exchanges	241
Modern Developments in Television	37, 129
Morris, T. G. Police Telephone Systems	229
Mumford, A. H. The London-Birmingham Coaxial Cable System	206, 270

N

New Form of Radio Interference, A	240
Nomenclature and Symbols for Telecommunications	310
Notes and Comments	67, 156, 244, 330
Notes, District	73, 159, 249, 335
Notes, Junior Section	71, 157, 247, 331
Novel System of Duplex Transmission, A	15

O

O'dell, G. F. Nomenclature and Symbols for Telecommunications	310
---	-----

P

Palmer Jones, C. E. Ready Reckoner for Losses due to Mismatch	308
Partridge, T. T., Retirement of	245
Pearce, C. A. R. Diakon—A New Material for Coloured Telephones	202
Police Telephone Systems	229
Present Tendencies of Power Development and their Repercussions upon Telecommunication Systems	1
Problems associated with Impulsing in Non-Director Areas, The	191, 320
Problems involved in the Preparation of a European Trunk Switching Plan	32
Production of Portland Cement, The	200
Protection of Post Office Circuits in Northern Ireland	121

R

Radley, W. G. Lightning and Lightning Protection	173
Ready-Reckoner for Losses due to Mismatch	308
Rectified Reaction Stage, The Stability and Performance of the Single	294
Reproduction of Prints of Drawings and Diagrams in the E.-in-C.O.	225
Richards, C. E. The Detection of Poisonous Gases in Underground Workings	110
Route Distance Recorder, A	65
Rudeforth, S., and H. Williams. The Problems associated with Impulsing in Non-Director Areas	191, 320
Ryall, L. E. A Fast Operating Differential Echo-Suppressor	186
" " and A. G. Burgess. A Simple Transmission Measuring Equipment	52

S

	PAGE NO.
Sharp, J. and T. E. Hogg. The C.T.O. Inland Phonogram and Telephone-Telegram Installation	26
Soons, A. T. Tunnelling Work in Underground Line Construction	94
Stability and Performance of the Single "Rectified Reaction" Stage, The	294
Staff Changes	76, 165, 255, 338
Stamp-Selling Machines, The Development of, in the British Post Office	18
Stevens, S. T. Modern Developments in Television	37, 129
Street Traffic Control Centralised in the Telephone Exchanges in Amsterdam	81
Symbols, Nomenclature and, for Telecommunications	310

T

Tanner, G. F. The Production of Portland Cement	200
Television, Modern Developments in	37, 129
Television Twin Cable Links, London's	215
Thompson, H. S. Transfer to Northern Ireland District	246
Timmis, A. C. Problems involved in the Preparation of a European Trunk Switching Plan	32
" " The Creepage of Underground Cables	180
Transmission Measuring Equipment, A Simple	52
Tunnelling Work in Underground Construction	94

U

Underground Distribution in Residential Areas, Direct	152
---	-----

V

Variation of the Holding Times of Telephone Calls, The	46
--	----

W

Walmsley, T. Promotion to Staff Engineer	68
Walton, G. H. and W. Boccock, Loch Awe Submarine Cables	235
Walton, J. M. Fault Localisation with Gas-Filled Cables	237
Waterloo Bridge—Alteration of Post Office Plant	48, 103
Whenmouth, H. Waterloo Bridge—Alteration of Post Office Plant	48, 103
Williams, F. C. and A. Fairweather. The Stability and Performance of the Single "Rectified Reaction" Stage	294
Williams, H. and S. Rudeforth. The Problems associated with Impulsing in Non-Director Areas	191, 320
Wright, C. H. The London Fire Brigade	284

Y

Young People's Telephone Exhibition	61
---	----

SECTION II

TELEGRAPHY AND TELEPHONY

CIRCUIT APPLICATIONS

Westinghouse Rectifiers play an important part in Telephone and Telegraph Circuits for polarising and slugging standard relays, spark quenching, and discriminating circuits in addition to rectifying voice and radio frequency currents, operating as variable impedances, etc. A number of rectifiers have been standardised by the Post Office for these applications, and a few of these are considered below.

APPLICATIONS TO RELAYS

Polarised Relays

Polarised relays are used to obtain an additional signal by reversal of the applied potential to a line. In the circuit shown (Fig. 8), a positive will operate relay "A," a negative will operate relay "B." For use in current-operated circuits, the rectifier is connected in parallel with the relay.

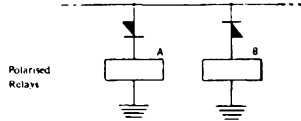

Fig. 8

Country Satellite

In the country satellite scheme, the principle is applied to obtain four signals on one line, by applying a light or heavy positive or negative.

Teleprinter Ancillary

- (a) The normal condition for teleprinter circuits with distant apparatus at rest is negative current to line. The calling relay at the near station is polarised by a rectifier and operated by a momentary reversal of current from the distant station.
- (b) Where a number of teleprinters operate in one office, two operators may plug in to one incoming call. Immediately one teleprinter is operated, a reversal of voltage occurs, and a rectifier-polarised relay cuts out the other machine.

14

D.C. APPLICATIONS

Metering

For multi-metering, an earthed meter is operated by positive pulses on a private wire. To prevent false operation of the meter in series with the line switching relay "K," a rectifier is used. In the line finder circuit, a rectifier has also been employed to maintain guard (retain the earth circuit) during the transit time of the metering contacts, thus avoiding the sparking associated with the use of make before break contacts.

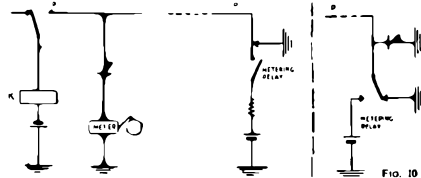
Fig. 9
Stopper Circuit for Positive Battery MeteringFig. 10
Alternative Meter Relay Circuit,
using rectifier to maintain guard
during transit of contacts

Both-way Loop Signalling between Exchanges

The calling relays at each exchange are earthed through their batteries. Any difference in battery voltage or earth potential between the two exchanges would cause a circulating current to flow, with false operation of the relays. Rectifiers in series with the relays prevent this, while allowing normal operation.

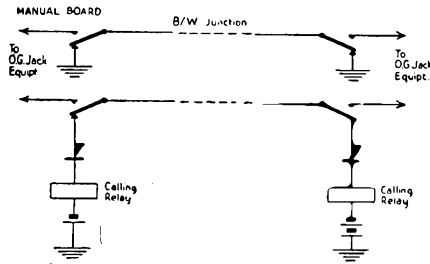
Fig. 11
Stopper Circuit on Bothway Junction to guard against operation due to
differences of potential of batteries and effect of earth potentials

15

YOU NEED THIS BOOK

Westinghouse Metal Rectifiers are being used in increasing quantities by Telecommunication Engineers. The principles of many circuits used in communication engineering are described in brochure D.P.11.H. which also deals with the design of power units for operation from A.C. Mains, of radio transmitters, carrier equipment, and telephone and telegraph apparatus. Write to Dept. P.O.E.E. for your copy of this invaluable reference.



METAL RECTIFIERS FOR TELECOMMUNICATION

WESTINGHOUSE BRAKE & SIGNAL CO., LTD., 82 YORK WAY, KING'S CROSS, LONDON, N.1



The Muirhead 600 ohm "Balanced H" Network Attenuator, with a maximum loss of 110 db.; adjustable in steps of 0.5 db.

SCREENED ATTENUATORS

A wide range of Attenuators for both Audio and Radio frequencies is available.

One of our Audio Frequency Attenuators, tested at a frequency of 1 Mc., showed an error in attenuation of less than 4 db. in 110 db.

Section 7 of our Catalogue describes over 100 Muirhead Precision Instruments of interest to every Communications Engineer.

■ MUIRHEAD & CO., LTD. ■

MAKERS OF PRECISION INSTRUMENTS FOR OVER 50 YEARS
 ELMERS END BECKENHAM KENT
 Telephone: BECKENHAM 0041-2

TURNER DIFFERENTIAL MILLIAMMETERS G.P.O. No. 17 & No. 18

Meet the most exacting demands for balancing currents in multiplex telegraph circuits.

A quality product of outstanding merit



FULL SIZE

Also manufacturers of G.P.O. Detector No. 4, and a comprehensive line of instruments for precision electrical measurements.

ERNEST TURNER ELECTRICAL INSTRUMENTS, Ltd.

CHILTERN WORKS,
 55-73 TOTTERIDGE AVENUE,
 HIGH WYCOMBE,
 BUCKS, ENGLAND

Telephone: High Wycombe 301.
 Telegrams: Gorgeous, High Wycombe.

A Selection of Books for Engineers and Students

FOUNDATIONS OF TECHNICAL ELECTRICITY

By E. Mallett, D.Sc., M.I.E.E., A.M.Inst.C.E., F.Inst.P., and T. B. Vinycomb, M.C., M.A., F.Inst.P. An invaluable book for students preparing for the National Certificate, City and Guilds, and other examinations. 188 pages. Illustrated. 5/- net (by post 5/5). "An excellent volume at a moderate price."—*Technical Journal*.

PRIVATE AUTOMATIC BRANCH EXCHANGES

By R. T. A. Dennison, of the Engineer-in-Chief's Office, G.P.O., London. 304 pages. Illustrated. 5/- net (by post 5/4).

THE CALL INDICATOR SYSTEM IN AUTOMATIC TELEPHONY

By A. G. Freestone, of the Automatic Training School, G.P.O., London. 124 pages. Illustrated. 6/- net (by post 6/4).

PRACTICAL TELEPHONE HANDBOOK AND GUIDE TO THE TELEPHONIC EXCHANGE

By J. Poole, A.M.I.E.E., Wh.Sc. Seventh Edition, revised and enlarged. 895 pages. 685 illustrations. 18/- net (by post 18/6).

OUTLINE NOTES ON TELEPHONE TRANSMISSION THEORY

By W. T. Palmer, B.Sc., Wh.Ex., A.M.I.E.E. 176 pages. 4/- net (by post 4/5).

"The book is remarkable for its thoroughness and accuracy, and should be regarded as an essential feature of any telephone engineer's library."—*Post Office Electrical Engineers' Journal*.

DEFINITIONS AND FORMULAE FOR STUDENTS (Telegraphy and Telephony)

By E. Mallett, D.Sc., M.I.E.E., A.M.Inst.C.E., F.Inst.P. States briefly the principal definitions and mathematical formulae required by the student of telegraphy and telephony. 37 pages. 6d. (by post 6½d.).

TELEGRAPHY

By T. E. Herbert, M.I.E.E., Superintending Engineer, Post Office Engineering Department. A standard text-book. 1,224 pages. 750 illustrations. Fifth Edition. 20/- net (by post 20/6).

Just Published

GENERATION, TRANSMISSION AND UTILIZATION OF ELECTRICAL POWER

By A. T. Starr, B.Sc., A.M.I.E.E. Covers the revised "Electrical Power" syllabus for the B.Sc. (Lond.). 480 pages. 18/- net (by post 18/6).

Order from a bookseller or direct from

PITMAN HOUSE, PARKER ST., **PITMAN** KINGSWAY, LONDON, W.C.2



TUNGSTONE BATTERIES

Are being regularly supplied to the
GENERAL POST OFFICE
MUNICIPAL CORPORATIONS
INTERNAL TELEPHONE SYSTEM
MANUFACTURERS, etc.

- Open or Enclosed types in Glass Containers.
- Large Capacities in Lead Lined Teak Boxes.
- **TUNGSTONE** High-pressure Die-cast Plates conform to British Standard Specification.
- **British Empire Lead** exclusively used.

TUNGSTONE ACCUMULATOR CO., LTD.,
SALISBURY SQUARE, LONDON, E.C.4
 Works: MARKET HARBOROUGH, LEICS.

ILFORD LIMITED

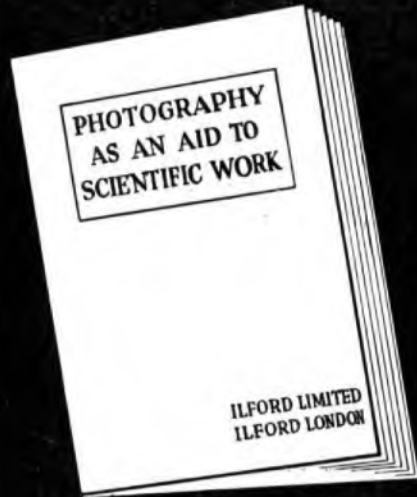

Write for a free copy of "Photography as an aid to Scientific Work"

FREE to Post Office Engineers a concise guide to sensitised material for scientific uses.



As an aid to engineers and research workers, Ilford Limited have prepared a practical book of reference containing particulars of their full range of photographic plates and films for Field and Survey Work, Laboratory Research and all Scientific Purposes.

These materials are the outcome of some sixty years of specialised study and are world famed for their consistency and reliability.

ILFORD
PLATES - FILMS - PAPERS

MADE IN ENGLAND BY ILFORD LIMITED, ILFORD, LONDON

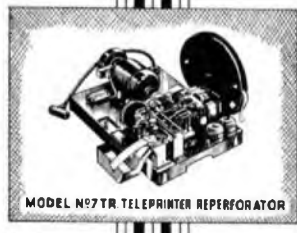
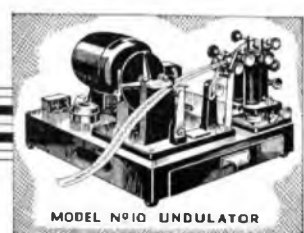
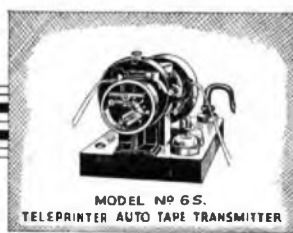

ILLUSTRATED are some of the instruments manufactured to provide printing telegraph machines to meet all modern communication requirements.

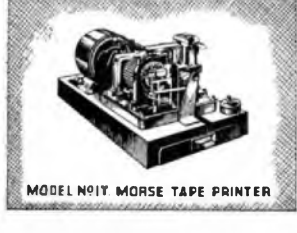

CREED & CO. L^{TD.}

Telephone :— *Telegraph House* Telex :—
Croydon 2121 **CROYDON** Croydon Telex 1082



INEXPENSIVE
TEMPERATURE-COEFFICIENTLESS
FIXED VALUE MICA CONDENSER
OF
HIGH PERMANENCE



0.0005 μ F to 0.06 μ F. $2\frac{7}{8}'' \times 1\frac{1}{4}'' \times 2\frac{1}{2}''$ high.
 0.07 μ F to 0.6 μ F. $4\frac{1}{2}'' \times 2\frac{1}{4}'' \times 5\frac{1}{2}''$ high.
 0.7 μ F to 1.0 μ F. $4\frac{1}{2}'' \times 2\frac{1}{2}'' \times 5\frac{1}{2}''$ high.
 (Sizes do not include feet or terminals).

FOR USE AT ALL FREQUENCIES

Mounted in cast aluminium cases.

Fitted with terminals or soldering spills as desired.

ANY VALUE FROM 0.0005 to 1.0 μ F.

Prices from 18/4 according to value.

Full particulars will be sent on application.

H. W. SULLIVAN LIMITED

Telephones :
 NEW CROSS 2911 (3 Lines)

LONDON, S.E.15

Telegraphic Address :
 "STANDELECT, PECK, LONDON"

"Sullivan" guarantees accuracy

FERRANTI

A.C./D.C. CIRCUIT TESTER

This new moving coil instrument measures D.C. milliamperes, D.C. volts, A.C. volts and ohms. D.C. readings are first grade in accordance with B.S.I. No. 89 and A.C. readings are correct within 3 per cent. at full scale reading. The instrument is complete with self-contained $1\frac{1}{2}$ -Volt cell.

RANGES

D.C. MILLIAMPS	0-1, 7.5, 30, 150 and 750.	
D.C. VOLTS	0-3, 15, 150, 300, 450 and 600.	1000
A.C. VOLTS	0-15, 150, 300, 450 and 600.	ohms
	20 to 4000 cycles per second.	per volt.
A.C. MILLIAMPS	0-1.	
RESISTANCE	0-50,000 ohms self-contained and up to 0-30 megohms with external D.C. source up to 600 V.	
DIMENSIONS	$3\frac{1}{8}'' \times 4\frac{1}{2}'' \times 2\frac{1}{4}''$.	
PRICE	£5 15s. including substantial case and all accessories.	

Write for List In. 1



FERRANTI LTD. HOLLINWOOD, LANCS., London Office: Bush House, Aldwych, W.C.2.

**AUTHORITATIVE
CORRESPONDENCE TRAINING
for
ENGINEERING
QUALIFICATIONS**

- **POST OFFICE EXAMINATIONS —**
Probationary Inspectors
Assistant Superintendents
Assistant Engineers
- **A.M.Inst.C.E., A.M.I.E.E., A.F.R.Ae.S.,
B.Sc.(Eng.), C. & G., etc.**

12 FIRST PLACES

*and HUNDREDS of PASSES have been
gained by T.I.G.B. students in the above
examinations. The T.I.G.B. Guarantees
training until Successful for the one fee.*

Write to-day for "The Engineer's Guide to Success"
— Free — which alone gives the Regulations for
Engineering Qualifications and contains the world's
widest choice of engineering courses — over 200
—including Electrical Engineer-
ing, Telephony, Telephonic Trans-
mission, Telegraphy, Radio
Engineering, Wireless and High
Frequency Engineering, Sound
Reproduction, Television, etc.
Mention branch, post or qualifica-
tion that interests you.



**THE TECHNOLOGICAL INSTITUTE
OF GREAT BRITAIN**

115 Temple Bar House, London, E.C.4

FOUNDED 1917

20,000 SUCCESSES

Fit
"Triplex"
Rapid
and be safe

THE
G.P.O.

DO

THE "TRIPLEX" SAFETY GLASS CO. LTD..
1 ALBEMARLE STREET · LONDON · W.1

**IT PAYS TO
ADVERTISE IN
TELEPHONY**

Because readers find so much of interest and value in each issue, advertisers get results. Out of 434 questionnaires returned by telephone men, 432 specified they subscribe to TELEPHONY—and 417 answered "Yes" to the query, "Do you read the advertising pages?" (4 answered "No"; 13 failed to answer this question.) We cordially solicit advertising—rates on request—and also new subscribers. Subscription price: \$5.00 U.S. money for 52 interesting and helpful issues.

TELEPHONY

Address: Odhams Press, Ltd., Technical Book Dept.,
85 Long Acre, London, W.C.2 (Telephone: Temple Bar 2468)
for a sample copy of TELEPHONY, or write direct to:
TELEPHONY PUBLISHING CORPORATION,
608 S. Dearborn Street, Chicago, Ill., U.S.A.

WHY

MOST

ELECTRIC VEHICLES

HAVE

Exide-Ironclad

BATTERIES

BECAUSE Exide-Ironclad Batteries, having the longest life in proportion to price, reduce battery costs to the minimum.

BECAUSE the patented slitted-tube positive plates alone combine immense stamina and the longest possible life with a high maintained voltage on discharge. This means high and uniform power throughout the day and on all gradients.

BECAUSE Exide-Ironclad After-Sales Service helps the owner to obtain maximum life and reliability from the batteries. A corps of experts regularly inspect batteries in service and advise on maintenance and operation.

THE CHLORIDE ELECTRICAL STORAGE CO. LTD.,
Battery Traction Dept., Exide Works, Clifton Junction,
Nr. Manchester. London office : 137, Victoria Street, S.W.1.

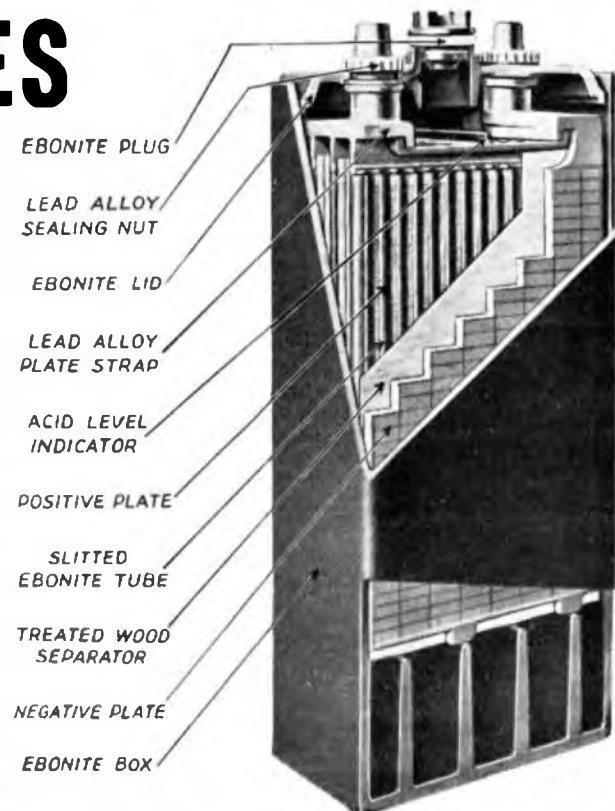

A SPOTLIGHT SHINES

RESTLESS energy, ceaseless research . . . keeping ahead . . . not just keeping in step with telephone progress . . . telephony problems being constantly probed — and solved. Such is Ericsson — serving the world's communication needs.

Here at Beeston, Nottingham, we are busy . . . making first class telephone material . . . famous all over the world for its wonderful quality and performance. Contractors to the Admiralty, War Office, Post Office, Railways, Mines, Colonial Govts., etc.

We manufacture, supply and instal complete automatic exchanges of the "director" and "non-director" type for any number of lines.



*Informative illustrated
literature sent post free.*

Ericsson

TELEPHONES LTD

Head Office : 22 Lincoln's Inn
Fields, W.C.2 Phone: HOLborn 69

(FACTORY : BEESTON, NOTTINGHAM)

THE HOME OF A GREAT TELEPHONE SYSTEM . . .

ON *Ericsson* PROGRESS

2. *Testing the hardness of materials.*



INDEX TO ADVERTISERS

Automatic Telephone & Electric Co., Ltd. iv & v
Bennett College ix
British Institute of Engineering Technology xxi
Creed & Co., Ltd. xiv
Ebonestos Industries, Ltd. xx
Elliott Bros. (London) Ltd. xxiii
Ericsson Telephones, Ltd. xviii & xix
Exide xvii
Ferranti, Ltd. xv
General Electric Co., Ltd., The ii & viii
Hall Telephone Accessories (1928), Ltd. xx
Ilford, Ltd. xiv
Institution of Post Office Electrical Engineers, The xxii
International Correspondence Schools, Ltd. xx
McGraw-Hill Publishing Co., Ltd. xxi
Muirhead & Co., Ltd. xii
Pirelli-General Cable Works, Ltd. xxiv
Pitman, Sir Isaac xiii
Smith, Frederick & Co. xxiii
Siemens Bros., & Co., Ltd. vi & vii
Standard Telephones & Cables, Ltd. x
Sullivan, H. W., Ltd. xv
Technological Institute of Great Britain, The xvi
Telephony Publishing Corporation xvi
"Triplex" Safety Glass Co., Ltd., The xvi
Tungstone Accumulator Co., Ltd. xiii
Turner, Ernest xii
Turners Asbestos Cement Co. iii
Westinghouse Brake & Signal Co., Ltd. xi

Hall Telephone Accessories (1928) Limited

Suppliers to the British Post Office, Air Ministry,
Admiralty & Foreign Government Departments.

Manufacturers of prepayment telephone
multi-coin collectors, precision
instruments, automatic stamp selling and
ticket selling machines, automatic slot
machines and fire alarm apparatus.

Registered

Office & Works: 70, DUDDEN HILL LANE,
WILLESDEN,

LONDON, N.W.10

Tel. WILLESDEN 5141/2.3.

I. C. S.

THE largest Institution in the world devoted to spare-time training by post offers Courses of Instruction to cover the following Examinations:

G.P.O. Probationary Assistant Engineer (Limited).

G.P.O. Probationary Inspector (Engineering Dept.).

Assistant Traffic Superintendent, Telephone Service.

P.M.G. Certificate for Wireless Operators.

**Provisional Certificate in Radio Telephony and
Telegraphy for Aircraft.**

Graduateship, I.E.E.

City and Guilds Electrical Engineering Practice.

Electric Installation and Telecommunications.

Institute of Wireless Technology.

Other Courses meet the requirements of all who desire a thoroughly practical and profitable technical education, and all who wish to qualify for responsible positions in Electric Power, Light and Traction Stations. Equally successful is our instruction for Telegraph and Telephone Engineers, Telegraphists and Telephonists, Radio Engineers, Radio Servicemen, and those who wish to study Television.

All instruction is by correspondence from textbooks specially prepared by many experts for tuition by post.

WRITE FOR OUR SPECIAL BOOKLET and state the particular subject or Examination in which you are interested.

Though highest in quality, I.C.S. Courses cost no more than those of other reputable schools teaching by post.

INTERNATIONAL CORRESPONDENCE SCHOOLS, LTD.
Dept. 108, International Buildings, Kingsway, London, W.C.2

Precision

For 38 years EBONESTOS INDUSTRIES LIMITED have been supplying, to the electrical and kindred trades, high quality precision mouldings in EBONESTOS Compositions, Bakelite, Urea, Diakon and other synthetic resins.

Our experience and up-to-date plant are at your service.

Telephone, and one of our technical representatives will be pleased to call and advise you upon any moulding problem.

EBONESTOS INDUSTRIES LIMITED

EXCELSIOR WORKS, ROLLINS STREET,
CANTERBURY ROAD, S.E.15 Tel.: New Cross 1913 (6 lines)

TRANSFORMER PRINCIPLES AND PRACTICE

By J. B. GIBBS

210 pages, 9×6, 191 illustrations, 15.- net

A SIMPLE, nonmathematical description of single-phase and three-phase transformers, autotransformers and instrument transformers, covering a wide variety of related problems such as transformer insulation, oil, coils and cores, cooling, testing, ratio adjustment and phase transformation; as well as care and operation of transformers.

TRANSIENT ELECTRIC CURRENTS

By HUGH HILDRETH SKILLING

*Assistant Professor of Electrical Engineering,
Stanford University*

349 pages, 9×6, illustrated, 25.- net

A CLEAR, simple and straightforward treatment of the transient flow of current and energy in electric circuits. A physical concept of transient behaviour is emphasized, while at the same time the rigorous mathematical theory is developed. The classical solution of networks with lumped parameters is thoroughly treated; methods of operational calculus are introduced; transient behaviour of transmission lines is discussed; and approximate and graphical solutions are considered.

TROUBLES OF ELECTRICAL EQUIPMENT

Their Symptoms, Causes and Remedy

By H. E. STAFFORD

Consulting Engineer

330 pages, 9×6, 297 illustrations, 22 tables, 18.- net

THE book covers the symptoms, causes and remedy of troubles of both A.C. and D.C. apparatus usually found in the average industrial plant. Almost every chapter includes also priceless practical hints on efficient operation and maintenance. The book tells, for instance, what power factor is, what it does to an industrial-plant power load, how to control it. It points out the value of a load survey and tells how to make one. It shows how to locate power losses. This practical, "how-to-do-it" book is an indispensable job manual for the electrical maintenance man. All formulae are illustrated by practical examples and all technical terms are explained in every-day English.

McGraw-Hill Publishing Co., Ltd.

ALDWYCH HOUSE

LONDON, W.C.2

LATEST EXAMINATION SUCCESSSES

Since the B.I.E.T. was founded ten years ago, we have specialised in preparing candidates for leading Technical Examinations, and our success may be gauged from the following remarkable results:

FOUR 1st PLACES

In the Probationary Inspectors and Assistant Superintendent of Traffic Examinations held in 1932-1935, B.I.E.T. candidates obtained Four First Places.

FIRST TWO PLACES

In the recent Limited Competition Examination for Assistant Superintendents of Traffic, the candidates placed First and Second on the List of Successes were trained by the B.I.E.T.

145 SUCCESSES

In the Probationary Inspectors and Assistant Superintendents of Traffic Examinations held in 1934 and 1935, 145 B.I.E.T. candidates passed the Examinations.

We teach successfully by correspondence and definitely guarantee—

"NO PASS—NO FEE"

You are advised to send for a copy of our General Prospectus "ENGINEERING OPPORTUNITIES." This Hand-book contains 268 pages of most useful information. It also contains particulars of all leading Engineering Examinations, including

Probationary Inspectors (*Open and Limited Competitions*).

Probationary Assistant Engineers (*Limited Competition*).

Assistant Superintendent of Traffic (*Open and Limited Competitions*).

City and Guilds, Special G.P.O. Examination, I.E.E., B.Sc., A.M.I.C.E., London Matric., etc., etc.

The Hand-book also outlines "up-to-the-minute" courses of Home-Study in *all branches* of Engineering.

Special Courses are offered in **Telegraphy, Manual Telephony, Automatic Telephony, Telephone Transmission, Electrical Technology, Wireless and High Frequency Radio Communication, Alternating Currents, etc., etc.**

Our 268 pages Hand-book should be on your Book-shelf. It will be gladly sent on request, FREE and without obligation. (*Please state subject or Examination of most interest.*)

British Institute of Engineering Technology

369 Shakespeare House,

17, 18 & 19 Stratford Place, Oxford Street,

London, W.1

THE INSTITUTION OF POST OFFICE ELECTRICAL ENGINEERS

PRINTED PAPERS

The following papers contributed to the proceedings of the Institution have been printed by authority of the Council and may be obtained, if still in print, from

"THE LIBRARIAN, The Institution of Post Office Electrical Engineers, G.P.O. (ALDER HOUSE), LONDON. E.C.1."

The prices do *not* include postage, and in every case, Members, Associate Members, and Associates have the privilege of purchasing copies at two-thirds the stated price.

No. 92	"TELEPHONE METERS AND COIN COLLECTING BOXES."—W. CRUICKSHANK, M.I.E.E., and F. McCLARENCE, M.I.E.E. 1923	1s.
No. 108	"SOME APPLICATIONS OF OPTICAL METHODS TO THE EXAMINATION OF ENGINEERING MATERIALS."—F. O. BARRALET, M.Inst.Metals, A.M.I.E.E. 1925	1s.
No. 109	"THE PROBLEM OF FLEXIBILITY IN SUBSCRIBERS' CABLE DISTRIBUTION."—HARVEY SMITH. 1925	1s.
No. 110	"TESTING OF TELEPHONE CIRCUITS AND APPARATUS WITH ALTERNATING CURRENTS."—E. S. RITTER, D.F.H., A.M.I.E.E., and G. P. MILTON. 1926	1s. 3d.
No. 111	"SCIENTIFIC ORGANISATION AND THE POST OFFICE ENGINEERING DEPARTMENT."—F. G. C. BALDWIN, M.I.E.E. 1926	1s.
No. 116	"THE DIRECTOR IN AUTOMATIC TELEPHONY."—C. W. BROWN, A.M.I.E.E. 1927	9d.
No. 117	"THE SUBMARINE LINK IN INTERNATIONAL TELEPHONY."—C. ROBINSON, B.A., A.M.I.E.E. 1928.	1s.
No. 119	"THE PROBLEM OF THE P.B.X. CONNECTED TO AN AUTOMATIC EXCHANGE."—C. W. BROWN, A.M.I.E.E., and R. J. HINES, B.Sc. 1928	9d.
No. 120	"SATELLITE EXCHANGES IN AUTOMATIC AREAS."—F. I. RAY, B.Sc., D.F.H., A.M.I.E.E. 1927	1s.
No. 121	"X-RAYS, AND THE STRUCTURE OF SOME ENGINEERING MATERIALS."—W. G. RADLEY, B.Sc. 1929	9d.
No. 122	"THE MEASUREMENT OF RELAY TIMES."—R. W. PALMER, A.M.I.E.E. 1929	9d.
No. 123	"MODERN ELECTRICAL ILLUMINATION."—J. J. EDWARDS, B.Sc.(Eng.), A.C.G.I., D.I.C. 1928	9d.
No. 124	"THE MEASUREMENT OF SOUND AND ITS APPLICATION TO TELEPHONY."—A. J. ALDRIDGE, A.C.G.I., A.M.I.E.E. 1929	9d.
No. 125	"THE DEVELOPMENT OF AUTOMATIC ROUTINERS IN THE BRITISH POST OFFICE."—A. SPEIGHT, A.M.I.E.E. 1929.	9d.
No. 134	"SOUND AND HEARING."—Capt. N. F. CAVE-BROWNE-CAVE, B.Sc., M.I.E.E. 1930	1s.
No. 136	"SOME DEVELOPMENTS IN TELEGRAPH TECHNIQUE AS APPLIED TO RADIO CIRCUITS."—H. FAULKNER, B.Sc., A.M.I.E.E., and G. T. EVANS. 1931.	1s.
No. 140	"SOME NON-METALLIC SUBSTANCES AND THEIR CHARACTERISTICS."—Capt. N. F. CAVE-BROWNE-CAVE, B.Sc., A.M.I.E.E. 1931.	9d.
No. 142	"PRIVATE BRANCH EXCHANGE INSTALLATIONS."—R. T. A. DENNISON. 1932.	1s. 3d.
No. 143	"ELECTRIC WAVE FILTERS."—G. J. S. LITTLE, B.Sc. 1931	1s. 3d.
No. 146	"LAYING ARMoured CABLE BY MEANS OF A MOLE-DRAINER."—L. G. SEMPLE, B.Sc.(Eng.), and R. O. BOCOCK, B.Sc.(Eng.). 1932.	9d.
No. 147	"DESIGN AND CONSTRUCTION OF ELECTRIC WAVE FILTERS."—R. J. HALSEY, B.Sc., etc. 1932.	1s. 3d.
No. 148	"STORES SPECIFICATIONS AND ACCEPTANCE TESTING."—CAPT. J. LEGG, B.Sc., A.M.I.E.E. 1933	9d.
No. 149	"RECENT DEVELOPMENTS IN UNDERGROUND CONSTRUCTION, LAYING AND LOADING ARMoured CABLES."—J. E. Z. BRYDEN, B.Sc.(Eng.), A.M.I.E.E., and T. HARGREAVES, A.M.I.E.E. 1933	1s.
No. 150	"TELEPRINTERS."—E. S. RITTER, M.I.E.E. 1933	1s.
No. 151	"RECENT REPEATER STATION INSTALLATIONS."—Major F. E. A. MANNING, M.C., B.Sc.(Eng.), M.I.E.E., A.M.I.Mech.E. 1933	1s.
No. 152	"SOME NOTES ON EXCHANGE EQUIPMENT FACTORY COSTING AND THE ECONOMICS OF PRODUCTION."—S. J. HUSBAND, Assoc.I.E.E. 1933	1s. 3d.
No. 153	"MODERN DEVELOPMENTS IN TELEPHONE TRANSMISSION OVER LINES."—J. STRATTON, A.C.G.F.C., and W. G. LUXTON. 1933	1s. 3d.
No. 154	"THE TELEGRAPH POLE."—W. H. BRENT, B.Sc., A.M.I.E.E. 1933	1s.
No. 156	"MODERN TENDENCIES IN THE SUPPLY OF POWER TO TELEPHONE EXCHANGES."—H. C. JONES, B.Sc.(Eng.). 1935	9d.
No. 157	"RECENT ADVANCES IN CARRIER TELEPHONY."—R. J. HALSEY, B.Sc.(Hons.), A.C.G.I., D.I.C. 1935	1s. 3d.
No. 158	"ULTRA SHORT WAVE RADIO TELEPHONE CIRCUITS."—D. A. THORN, B.Sc.(Eng.), A.M.I.E.E., and H. T. MITCHELL, A.M.I.E.E. 1935	1s.
No. 159	"MODERN ELECTRIC PASSENGER LIFTS."—R. S. PHILLIPS, A.M.I.E.E. 1935	9d.

Differential Moving Coil MILLIAMMETERS

For Telegraph Circuits



British
Instruments
for
British
Industries

T. 1098. WALL MOUNTING TYPE.



T. 1089. PANEL MOUNTING TYPE.



T. 1097. TABLE MOUNTING TYPE.

TABLE, WALL AND PANEL MOUNTING TYPES

INVALUABLE as line Milliammeters on Differential Duplex, Sub-Audio Frequency and many other Telegraph Systems, also for testing purposes in connection with Land Lines and Radio Communication.

Particulars will be sent on request.

ELLIOTT BROTHERS (London) LTD., Century Works, Lewisham, S.E.13

Telephone :
Tideway 3232

in association with

SIEMENS BROTHERS & COMPANY, LIMITED, Woolwich, London, S.E.18

Telephone :
Woolwich 2020

ANACOS

REGD

BRONZE & CADMIUM COPPER WIRES

SEND US PARTICULARS
OF YOUR JOB, AND OUR
TECHNICAL ENGINEERS
WILL PROVIDE YOU WITH
THE DATA YOU NEED.

FREDERICK SMITH & CO.

INCORPORATED IN THE LONDON ELECTRIC
WIRE COMPANY AND SMITHS, LIMITED
Anaconda Works, Salford 3, Lancs.

Tel. : Blackfriars 8701 (8 lines) Telegrams : "Anaconda Manchester."

AS SUPPLIED TO

**H.M. POST OFFICE
FOR
TELEPHONE LINES**

SILICIUM-BRONZE, COPPER

COPPER - CADMIUM

TAPES & BINDERS

PORTSMOUTH to GOSPORT



THE ILLUSTRATIONS SHOW THE LAYING OF 840 YARDS 160 pr/20 lb. P.C.Q.T. DOUBLE WIRE ARMoured SUBMARINE CABLE.

MADE AND LAID IN SEVEN DAYS TO MEET URGENT REQUIREMENTS OF THE G.P.O

TELEPHONE:
SOUTHAMPTON
2141 (5 Lines)

FIRELLI-GENERAL

CABLE WORKS, Ltd., SOUTHAMPTON.

TELEGRAMS:
"PICKAYBEL"
SOUTHAMPTON

Proprietors: FIRELLI, Ltd. and THE GENERAL ELECTRIC CO., LTD.