



EAC No. 66

THE MARCONI REVIEW

May-August, 1937



CONTENTS

THE MARCONI SCHOOL OF WIRELESS COMMUNICATION - PAGE 1

MARCONI AERODROME APPROACH BEACON EQUIPMENT,
 TYPE WBD.4 - - - - - „ 15

THE EXTENDED FEEDER MARCONI-ADCOCK DIRECTION
 FINDER - - - - - „ 23

THE MARCONI-STABILOVOLT SYSTEM - - - - - „ 31

MARCONI NEWS AND NOTES—

MARCONI COMPANY'S FORTIETH ANNIVERSARY - „ 36

BRITISH TRANSATLANTIC TEST FLIGHT - - „ 37

AIRCRAFT EXHIBITION - - - - - „ 38

REMOTE CONTROL - - - - - „ 40

MARCONI'S WIRELESS TELEGRAPH COMPANY LTD.
 Electra House, Victoria Embankment, London, W.C. 2



RIP

BORN
APRIL 25
1874

DIED
JULY 20
1937

GUGLIELMO MARCONI

THE MARCONI REVIEW

No. 66.

May-August, 1937.

Editor: H. M. DOWSETT, M.I.E.E., F.Inst.P.

Assistant Editor: L. E. Q. WALKER, A.R.C.S.

The copyright of all articles appearing in this issue is strictly reserved by Marconi's Wireless Telegraph Company Ltd.

THE MARCONI SCHOOL OF WIRELESS COMMUNICATION

- I.—HISTORICAL SURVEY: CHELMSFORD COLLEGE
 - II.—GENERAL LAYOUT OF THE COLLEGE PREMISES
 - III.—EQUIPMENT
-

I.—Historical Survey.

THERE are periods in the growth of any commercial organisation which stand out as of particular significance, and the great extension which has recently taken place at the Marconi Works at Chelmsford, the new buildings which have been occupied by the Marconi School of Wireless Communication, and the further constructional work in view for the accommodation of the Marconi Research and Development Departments, proclaim, as eloquently as only such facts can do, that the Marconi Company is entering a new phase of its useful life, a phase in which the centre of its activities is now definitely orienting towards Chelmsford, so that it is not surprising to find that the architecture of its new buildings has been given a dignity and modernity which provide a fitting setting for the skilled and highly technical work which is carried out therein.

Of particular interest is the expansion of Chelmsford College—the name by which the Marconi School of Wireless Communication has been known for so many years and under which it has built up such a high reputation. The old building stands on high ground in Arbour Lane. This has been modernised, extended, and converted solely into a residence for about 20 students; while behind and separate from it is the new college building in red brick, picked out in lines of white stone, with its glass-fronted and towered entrance hall, a landmark overlooking the railway cutting to Colchester.

Separate from the main building are several red-roofed green huts which are used for the assembly of transmitters and complete equipments—being more adaptable for this purpose than are the main laboratories—while towers and masts supporting experimental aerials, and copper tube feeder networks in the grounds are a reminder of the field work problems inseparable from the operation of wireless communication.

As a contribution to the general advance in the standard of technical education the training provided by the Marconi School of Wireless Communication is unique, but before discussing this feature some notes on the history of this institution may not be out of place.

The School was opened to serve the needs of a particular industry which, at the time, could not be met in any other way, as in this country the industry was then localised in the activities of one firm only.

Wireless Communication came into existence when, in 1896, the latest discoveries in physical science of that day were applied by an energetic inventor to the realisation of a dream of transmitting messages through space without the use of an intervening conductor. Progress was unexpectedly rapid. The Marconi Company was formed in 1898 and a technique developed which was naturally ahead of any experimental construction confined to demonstrating principles as employed at the Universities or elsewhere. Empirical theory based on experience also made its appearance. The frequent application of electromagnetic principles under circumstances which had never been met with before, created an art which had to be taught to the new recruits to the industry before they could be entrusted with any erection and installation work themselves.



Chelmsford College, 1920-1935.

The first three years of the Marconi Company saw a number of scattered coast stations established, several men fitting and operating ships' sets, experimental work on a small scale at some of the coast stations and on a very large scale at others. A group of young men all working with energy and enthusiasm and a small Works in full production—the whole forming a loosely knit and therefore thoroughly flexible organisation. New recruits to the staff looked to the more senior men to give them the new knowledge which had not yet become incorporated in the University syllabus. It was realised that a haphazard training of this kind was not

very satisfactory. The men immediately in touch with the experimental work which was being carried on were well off in this respect, but those men on shift duty or at isolated coast stations, for instance, were not so fortunate. In those early days, however, there were more jobs than men to carry them out, so that this disparity in training was partly discounted by shifting the men from one job to another every month or so, but as the organisation continued to grow, the men remained for longer periods in out-of-the-way stations without transfer, and it became evident that

centralised instruction for new recruits in the technique of wireless telegraphy had become a necessity. A residential School for the training of the probationer engineers of the Marconi Company was therefore opened at Frinton in September, 1901.

This was the first Wireless Telegraph Training College in the world, and it established a precedent in industrial technical training institutions. For at that date, although training schools were in existence for the instruction of premium pupils and premium apprentices at some of the larger engineering works, and the Cable Companies had schools for the training of their young operators, the Marconi School provided the first case where qualified electrical and mechanical engineers on full pay were given a training centre where they could be instructed in the latest developments of their profession.

In these days a telegraph training college is understood to mean an institution where men receive instruction to enable them to qualify for the Post Office licence to operate apparatus between ship and shore stations, but at the date of which we speak, marine operators, as a recognised body, did not exist and the Frinton School concentrated on the instruction of engineers. It was residential. The students were all selected men from the Universities and Technical Colleges. They were placed under the charge of a senior engineer for technical instruction, but in common with students engaged at the Universities on Post-graduate work they were allowed all the freedom necessary for independent study and self-expression in experimental research.

The first Engineer-in-Charge was T. Bowden, whose experience with the Marconi Company dated back to 1898. In August of the following year the present writer took charge for a short period. The work carried out at Frinton at that date covered experimental studies of tuned and coupled circuits employing Leyden Jar transmitting condensers, and experimental work on H.F. transformers of the Tesla Oscillation Coil type; Morse sending and Morse inker tape reception, instruction in the erection of stepped 150 feet masts and experience in the laying of earth plates. Coherer testing was carried out between the School at Frinton and the North Foreland Experimental Station, coherer reception being then at its peak as earlier in the year Marconi had received signals on the S.S. "Philadelphia" at a distance of 2,000 miles from Poldhu.

H.F. testing equipment was almost entirely restricted to the use of Hot Wire Ammeters and a Point Spark Gap for the determination of transmitter tuning, and the strength of signals at a distance for the testing of receiving equipment. For text books the students were not badly off, Maxwell's "Electromagnetic Theory," Hertz's "Electric Waves," J. J. Thomson's "Electricity and Magnetism," supplemented by S. P. Thompson's and Fleming's books on general electrical theory, electric machines and transformers; also a careful study was made of all Marconi Patent Specifications.

Several of the students of the year 1902 have since filled high positions with the Marconi Company and its associated organisations at home and abroad, and the names of many of them are on the Veterans' Roll.

Frinton was closed in 1904 and the School was transferred to the Hall Street Works at Chelmsford. For a time the students were absorbed directly in the personnel of the general research, development and testing staffs. It was a difficult commercial period for wireless. The magnetic detector had replaced the coherer,

The Marconi School of Wireless Communication.

small power sets were available for ships; the shipping companies recognised the value of wireless but were not prepared to pay for its installation. The British Government passed the first Wireless Telegraph Act making the operation of a wireless service subject to a Post Office licence. Transatlantic Wireless Communication was a fact but not a commercial success. The Fleming Valve was a new, but not a very sensitive detector and no one had yet realised its latent possibilities.

The next date which interests us is October, 1911, when the School was re-established as a separate department at the Broomfield Research Station at Chelmsford under R. G. Kindersley. An era of great expansion in the number of wireless stations under construction and open for traffic in all parts of the world had begun. It may be mentioned that the Marconi British Coast stations were transferred to the Post Office in September, 1909, and in view of the anticipated growth in the



Chelmsford College Hostel.

ship-to-shore traffic due to the greater shore facilities offered by the Post Office a larger number of operators was taken on by the Marconi Company during the following two years, and were trained at the operators' school at Liverpool. Now, at this date—1911—wireless was endeavouring to expand in another direction. The Imperial Conference had become wireless-minded and recommended that all the Dominions should be linked up by its means with the Mother Country. Engineers in consequence were engaged by the Marconi Company and sent to the school at Chelmsford and also to Poldhu for instruction.

The quenched gap and rotary spark transmitters were then in general use in the Mercantile Marine, associated with the magnetic detector and the Franklin Multiple Tuner—an historic instrument which in 1907 introduced for the first time an intermediate circuit, a variable coupling and a selectivity never before experienced—while crystal detectors, which had been known for some years, were gradually

The Marconi School of Wireless Communication.

gaining ground in the commercial field. In June, 1912, H. Dobell was appointed in charge of the School. On the 15th of that month the loss of the "Titanic" focussed public attention on the incalculable value of wireless for the saving of life at sea, some 700 people being rescued from a foundering ship, which at that time was considered unsinkable.

In 1912 the prosperity of the Marconi Company was in the ascendant. An agreement was entered into with the British Government for the erection of a chain of high power long-wave wireless stations throughout the Empire. Headquarter offices were opened in the Strand, London, at the famous building, which was soon known all the world over as "Marconi House," London, and a new works designed on modern lines with the most up-to-date high frequency and high tension testing equipment in the country was opened in time for the meeting of the International Radio Telegraphic Conference in June. These activities were associated with an

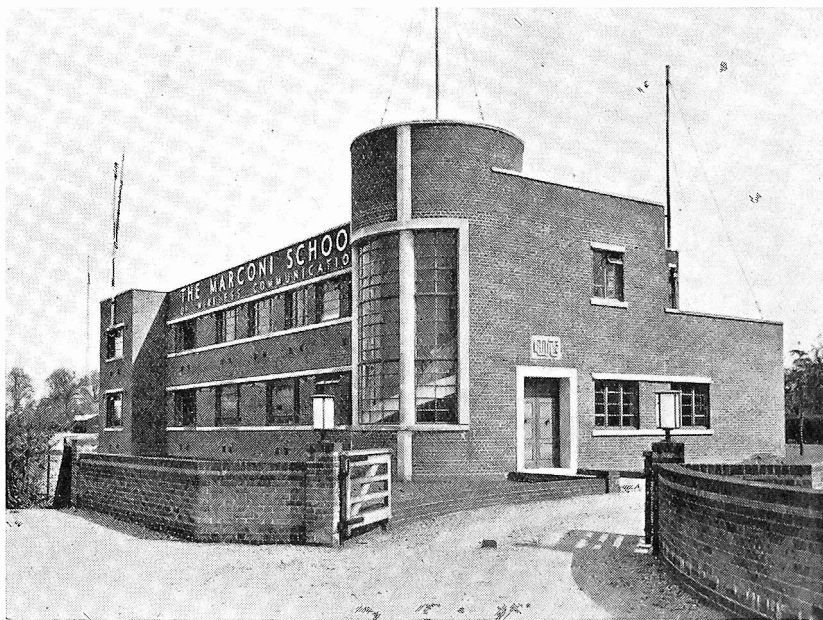

New College Building.

expansion of staff who were sent to Poldhu and other research stations and to Chelmsford for instruction. The following year was notable for a further increase in activity in providing apparatus for the Mercantile Marine, the tragedy of the "Volturno," which was burnt out at sea in April, being relieved by the saving through the use of wireless of 520 lives, and this led to an increase in the demand for ships to be fitted. Early in 1914 exhaustive tests were carried out at sea with the Bellini Tosi Direction Finding Apparatus, which led to its final adoption by the Marconi Company and the commercial form of this apparatus was then developed at Chelmsford and instruction in its use was given at the training centre there. Crystal Receivers were in general use with L.F. valve amplifiers. Half the Mercantile Marine of the world used Rotary Spark transmitters and the other half quench spark, and high power arc transmitters up to 100 kw. had made their appearance.

The Marconi School of Wireless Communication.

On the outbreak of the Great War every engineer available was soon engaged on foreign or war service and H. McCullum took over from H. Dobell from August, 1914, until August, 1916, at which date there was a temporary reduction, and finally, a cessation of the College activities at Chelmsford. H. Dobell, on active service, later organised for the War Office a training centre at the Crystal Palace for the instruction of engineers and officers of the Allied Forces in the use of Field Wireless.

As regards the Company's staff, new recruits were drafted for instruction direct into the research or development sections and this arrangement continued until 1920, when the need for a standardised refresher course for Marconi engineers returning from war service, and an increase in the number of foreign engineers under instruction at the Marconi Works made it advisable to reopen the College as a separate department.

A property with an adequate field area, which for many years had been used as a residential educational establishment, was therefore acquired for this purpose at Arbour Lane, known as Chelmsford College, the name of Chelmsford College being retained by the Marconi Company for its own institution. The school now resumed its original residential character, and under the direction of A. W. Ladner, appointed Superintendent of Instruction, its reputation as a sound training centre in experimental and applied wireless for the Company's graduate probationers, and in the theory and practice of the latest apparatus developed by the Marconi Company for customers' nominees, steadily increased.

From 1920 to the present date instructional papers on every phase of development in wireless have been prepared for the benefit of students, circuit problems have been mathematically analysed and experimental courses of instruction have been provided to cover all the applications of valve technique, measurement of field strength, development of broadcast transmitters and receivers, the technique of the Short Wave Imperial Beam Transmission and Reception, the study of ultra short waves, cathode ray developments, and television, covering adequately the latest advances reached to-day in all branches of wireless communication.

The School has always been staffed by engineers chosen for their special aptitude as instructors and lecturers, in addition to possessing the skill and initiative necessary to enable them to keep abreast with and participate in the general research and development work of the Marconi Company, and it is on record that the men appointed have, without exception, shown a sympathetic capacity to understand the working of a student's mind and an ability to encourage the student to develop his initiative under guidance into productive channels which have contributed in no small measure to the success of the institution.

It is, in fact, a live organisation with potentialities and possibilities for meeting the scholastic needs of the wireless community which are steadily increasing.

In 1935 the Directors decided to increase the College facilities in every way, and a large sum of money was allocated for this purpose; the writer once more became closely associated with the College as its Principal, supported by A. W. Ladner—who continued his valuable work as Superintendent of Instruction—and an increased staff.

New buildings have been erected, extra ground has been obtained for field work, and extensive additions to the plant have been made.

II.—General Layout of the College Premises.

The requirements of a training centre for wireless communication should include (A) a general experimental laboratory ; (B) sufficient ground space for aerial and field tests ; (C) a lecture room ; and (D) accommodation for quiet study.

In the layout of the new college—a plan of the main building is shown on Page 8—these features have been adequately met, and many other facilities are available in the new premises which not only benefit the student by permitting an expansion of the syllabus of instruction in several useful directions, but also aid the instructors in one of their essential duties, namely, the grading of new recruits to the staff according to their aptitude for work of widely different character in the various Research, Development and Engineering Departments of the Marconi Company.

The general design of the central building provides for a main experimental laboratory, the equipment in which will be discussed later, and two smaller laboratories for special research. There is a Standards Room, which is double screened with wire netting and is provided with a constant temperature cellar also screened in the same manner. The screening of the windows and the door presented special problems which were met by using metal frame windows, glazed back and front, with wire netting in between soldered to the metal frames. Both sides of the door are covered with light sheet steel and the steel frame connects up to the screening on the inside wall by means of the latch and hinges and on the corridor side by metal to metal contacts.

The Lecture Theatre has a seating capacity for 75 students, and can accommodate more. The natural lighting from the roof and windows is supplemented by special shadowless parabolic blackboard lighting fittings and an artificial lighting system under very effective control. An external projector room and winding room back on to the Lecture Theatre.

The students are provided with a common room, where they may read and study undisturbed, and there is a well equipped library of classic and modern technical works which are constantly being augmented, supplemented by engineering and wireless technical journals. The staff room, conference room and administrative offices are on the first floor, in addition to the editorial offices of the MARCONI REVIEW, a dark room and a printing and photographic room for the production of the instructional papers, charts and diagrams used at the College.

The main building has a flat roof and the walls support four short masts which provide facilities for ultra short wave aerial tests. Special arrangements have been made for obtaining sufficient heat in the laboratories in cold weather to satisfy the requirements for comfort of students from India and elsewhere, the low pressure hot water system with gravity circulation which has been installed providing for the introduction of fresh air through gratings behind the radiators which are finished flush with the wall, the air supply and heat being controllable. The heating system is completely automatic, employing oil fired boilers with thermostat control in addition to a time switch.

The cables, heating and gas service pipes are carried along the corridors above a false ceiling on each floor ; on the first floor the corridor is lighted by means of top lights with lay lights underneath, the lay lights being also used for artificial lighting in both corridors.

The Marconi School of Wireless Communication.

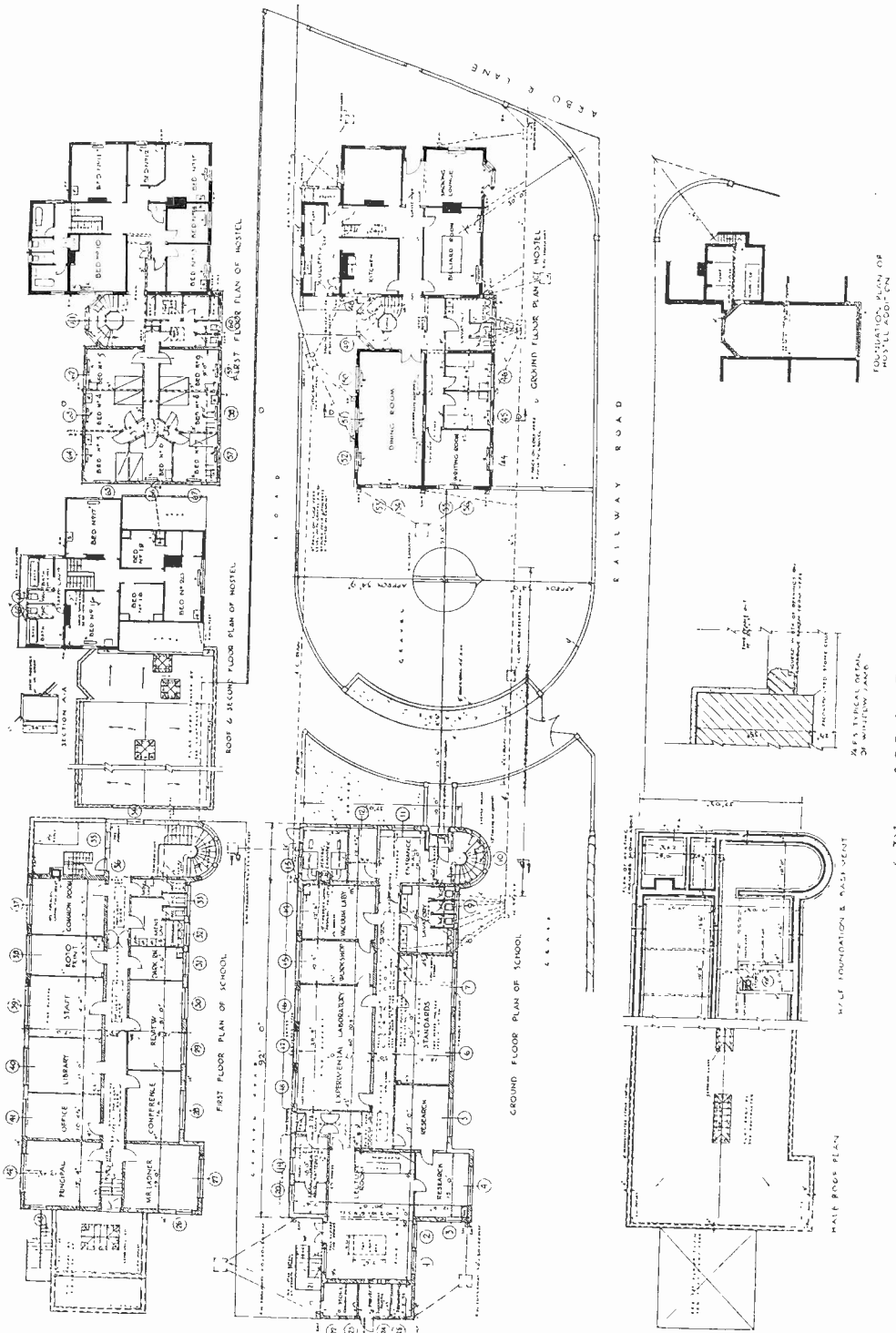

Plan of Main College Building.

III.—Equipment.

The General Experimental Laboratory is used for a wide range of light current experimental work such as the analysis of valve characteristics, the examination of wave forms, the investigation of small oscillators, simple measurements of circuit constants, and preliminary receiving experiments and is therefore equipped with A.C. and D.C. power supplies at various voltages and a large stock of components such as transformers, resistances, condensers and inductance coils and potentiometers, together with indicating and measuring instruments ranging from the precision type for valve characteristics to the more compact type suitable for circuit use. Cathode Ray Equipment is available when required and a Mechanical Synthesising Machine for the investigation of wave forms is also installed in the laboratory.

Workshop. While in the General Experimental Laboratory the student may be required to set up a small mechanical assembly, when the bench, lathe and drilling operations necessary can be carried out in the well-equipped workshop adjoining.

Standards Room. After some practice with experimental circuits the student may be given experience in high precision wireless measurements, for which purpose he will be allocated to the Standards Room, across the corridor, where measurements of impedance, attenuation, selectivity, fidelity and overall gain are carried out on broadcast receivers of several well-known makes, and the accurate measurement of frequency of any broadcast station within a wide range can be obtained. Much of the apparatus in this laboratory is of a highly specialised nature and it may be useful here to give a short description of the more important instruments.

1. The Frequency Measuring Equipment enables the frequency of a radiated wave to be measured with a minimum accuracy of one part in 100,000 over a frequency range of 150 to 15,000 Kcs. Provision is made for checking the stability of the master oscillator driving this apparatus against standard time signals, and a radio receiver covering the range of wavelengths likely to be encountered in practice enables an incoming signal frequency to be compared with the standard. The apparatus is also used to check the calibration of such apparatus as standard signal generators.

2. Two Standard Signal Generators covering frequency bands from 100 Kcs./sec. to 25 megacycles/sec. and 10 Kcs./sec. to 45 megacycles/sec. respectively for wireless receiver measurements such as sensitivity, selectivity—by the two signal method—fidelity, overload characteristics, cross modulation and other tests.

3. Modulated Test Oscillator which covers a range of 100 Kcs./sec. to 25 megacycles/sec. This is particularly useful for check-testing radio frequency circuits.

4. A Slide Back Voltmeter and Diode Voltmeter are incorporated in the same apparatus which may be used up to frequencies of 1,500 Kcs./sec. The slide back voltmeter has a normal range of 100 volts, but this can be increased. It produces no damping on any circuit to which it is connected. The diode voltmeter is used when damping is not a disadvantage.

5. An Acorn Valve Voltmeter is intended for ultra high frequency measurements. It may be used up to 50 megacycles/sec. and over a range of 0 to 2 and 0 to 12 volts.

6. Visual Frequency Response Measuring Apparatus, with which selectivity curves of circuits tuned to any frequency from 100 Kcs./sec. to 1,500 Kcs./sec. can be obtained. This instrument consists of a frequency wobbler and a specially designed output circuit which gives the selectivity curve of the test circuit in decibels on a Cathode Ray Oscillograph incorporated in the apparatus. The decibel scale is linear over a range of approximately 60 dbs. and selectivity curves of 20 or 40 Kcs. band width are indicated visually.

7. Broadcast Receivers of various types demonstrating circuits ranging from the simple straight receiver covering only medium and long wave bands to the more

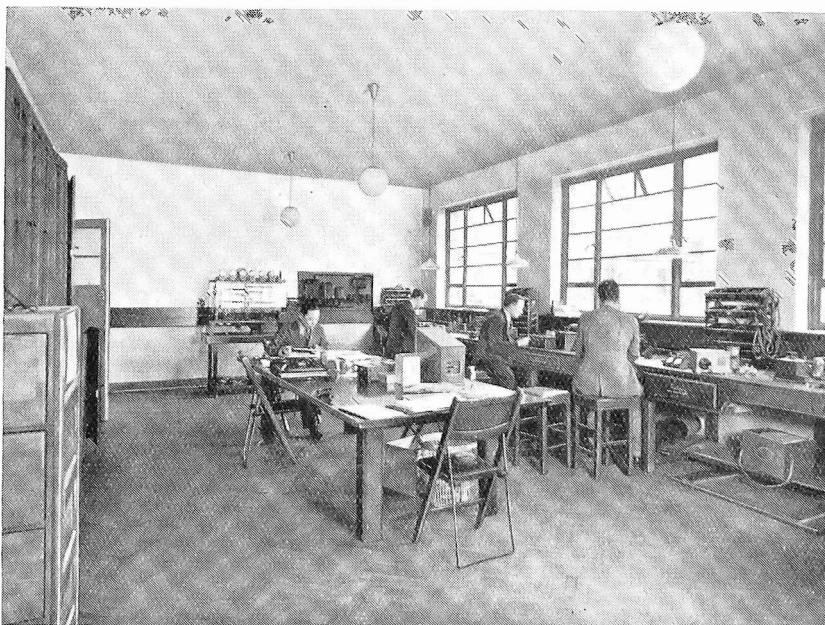

General Experimental Laboratory.

complicated superheterodyne receiver with automatic volume control and noise suppression, the short wave ranges extending to the television frequencies.

Apparatus for low frequency measurements includes:—

8. Universal Impedance Bridge capable of measuring inductance, capacitance and resistance over all ranges which are likely to be met in practice.

9. Output Voltmeter and Output Milliwattmeter, the former having a constant input impedance, and the latter a load impedance variable in steps from 25 to 20,000 ohms. These meters are used in measuring the performance of radio receivers and for L.F. measurements up to frequencies of 10 Kcs./sec.

10. 400 cycles/sec. Generator and Amplifier capable of giving 6 watts output with zero distortion as a 400 cycles/sec. generator or 10 watts output as an amplifier. The 400 cycles/sec. generator is used to modulate the standard signal generator when the distortion of R.F. valves or radio receivers is required. It is also employed for measurements of distortion in L.F. amplifiers and output valves.

II. Distortion Factor Meter, which enables the R.M.S. value of distortion in a fundamental wave of any frequency from 100 cycles/sec. to 5,000 cycles/sec. to be measured.

In addition to the above there are standard D.C. microammeters, milliammeters and voltmeters and A.C. voltmeters for calibration purposes and precision work.

Vacuum Laboratory. Some portion of the student's course is spent in the Vacuum Laboratory, where he is given instruction in the elements of glass blowing and if he shows sufficient skill in this he receives practice in the mounting of electrode assemblies in simple valves.

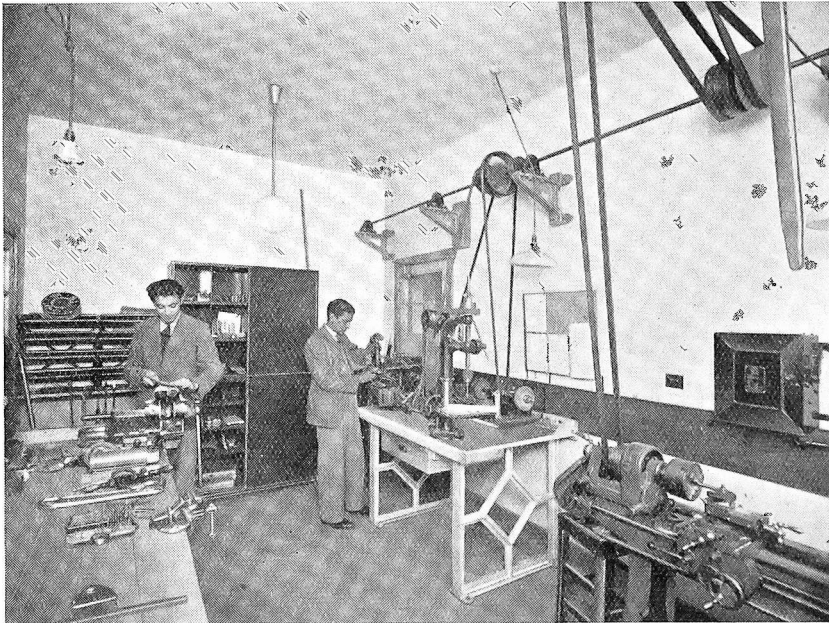

Workshop.

Transmitter Building. In the transmitter building the instructor usually obtains a better idea of the student's practical bent, his trustworthiness in the manipulation of power units and the use of high tension H.F., and the student may find scope for constructional skill in the conversion, for instance, of a transmitter circuit or the erection of a water-cooled valve assembly.

In this building a central power supply system and switch board provide five separate H.T. supplies for the various transmitters.

From the left, No. 1 Rectifier has a single-phase input and provides full wave rectified and smoothed H.T. at controllable voltages between 4,000 and 10,000, the maximum output power being of the order of 2 Kw.

No. 2 Rectifier has a similar circuit supplying power at voltages from 400 to 3,000 at approximately $1\frac{1}{2}$ Kw.

No. 3 Rectifier consists of a three-phase half wave circuit supplying up to 5,000 volts at 5 Kw.

No. 4 has a single-phase full wave supply giving 500 to 1,500 volts at .45 Kw. maximum.

No. 5 Rectifier is another single-phase full wave supply delivering 1,000 to 3,000 volts at $1\frac{1}{2}$ Kw.

The first two rectifiers employ hard vacuum valves and the last three mercury vapour valves, Nos. 3 and 5 using Type G.U.2, and No. 4 employing Type G.U.5 valves. All rectifier circuits are adequately fused and protected by a system of gate switches and circuit-breakers so that the dangerous parts of the circuits cannot



Standards Room.

be approached while the power is on. Suitable voltage controls are provided with each rectifier for raising and lowering the D.C. output volts.

Long Wave Transmitter. One end of the building is occupied by a long wave transmitter consisting of a number of units mounted in a frame which provide facilities for experimental circuit arrangements covering simple self-oscillator and driven circuits, and various modulation systems may be mounted up as desired. This apparatus is arranged to be readily demountable to achieve the maximum flexibility for instructional purposes and Nos. 1 and 2 power supplies are normally used with it. In conjunction with this transmitter it is proposed to build some high fidelity speech and modulating equipment so that present-day broadcast transmitter technique may be demonstrated.

An ultra short wave transmitter is built in a brass framework to provide screening and protection, but is readily accessible for experimental work. It consists of two C.A.T. 13 valves arranged in a push-pull self-oscillator circuit and operates normally in the region of 5 m. wavelength, on an artificial load coupled to the circuit by means

of a short concentric tube feeder. The circuit is fully metered and employing as it does water-cooled valves, permits the demonstration of cooled anode transmitter valve technique. The power supply is obtained from No. 3 rectifier, the operation of which is controlled by an automatic time delay switching system which prevents the application of H.T. to the set until both rectifier and oscillator filaments have reached their correct operating temperature, and also prevents the current being switched on to the oscillator filaments until the pump motor has been started up, thus ensuring an adequate flow of cooling water through the anodes.

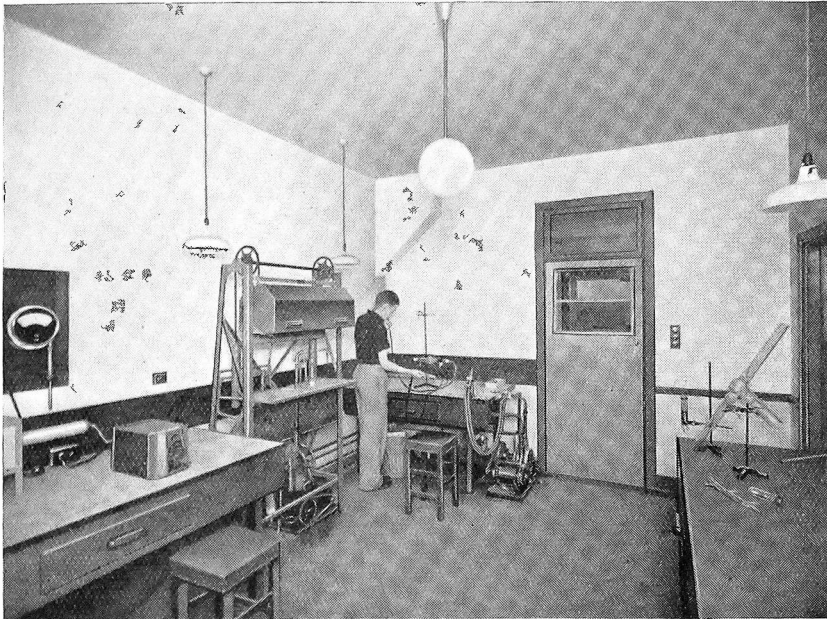

Vacuum Laboratory.

The short wave transmitter located beside the ultra short wave circuit consists of a Master Oscillator-Power Amplifier combination employing a Hartley oscillator using a single M.T.12 valve driving two M.T.12 valves in a push-pull neutralised amplifier circuit. This set is also built in a framework permitting adequate accessibility of all components, and at the same time affording a certain degree of screening. The normal power input of the amplifier is of the order of $\frac{1}{2}$ Kw. and the wavelength is approximately 20 metres. No. 4 power supply provides H.T. for the oscillator and No. 5 for the power amplifier. This transmitter is used to provide general instruction in short wave transmitter technique, and as a source of high frequency power for the various feeder and short wave aerial experiments.

A Crystal Controlled Drive Unit. This apparatus consists of a conventional quartz controlled oscillator followed by two stages of frequency multiplication, the last of which is designed to utilise two valves in push-pull, push-push, or parallel. A simple crystal oven is used with this apparatus to demonstrate the temperature coefficient of quartz crystals.

Additional and Auxiliary Apparatus includes a short wave Impedance Meter, which is used to match the impedance of a concentric tube feeder system in conjunction with the short wave transmitter; a portable cathode ray oscillograph, which may be coupled to any of the above-mentioned transmitters, to examine modulated radio frequency wave forms; wavemeters of various types for the measurements of radiated wavelengths, including both absorption and heterodyne systems; and both low and medium power magnetron oscillators which can be assembled for the investigation of ultra short waves and microwaves, employing suitable Lecher wire systems for such experiments.

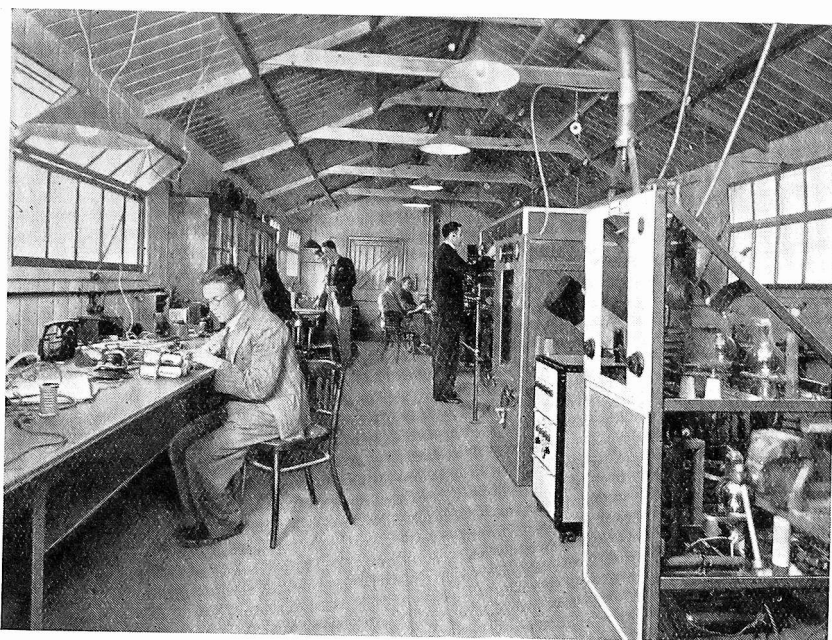

Transmitter Building.

Telephony Laboratory. The practical study of advanced circuit technique is provided in the Telephony Laboratory. This is a separate building in which is installed a complete modern Telephone Terminal Equipment together with Speech Inversion Apparatus for the training of customers' representatives who have had telegraphy but not telephony experience, in addition to being used for the training of probationers and private students.

This equipment was built at the College by the students themselves and is specially arranged so that its various parts can be adjusted easily, and additional gear has been included so that frequency response and characteristics of every part of the circuit can be obtained without difficulty.

In the adjacent room of this building is housed Direction Finding apparatus for the purpose of enabling students to gain first-hand knowledge of D.F. calibration, obtain practice in taking bearings and for the study of night effect.

In the grounds of the College various forms of aerials and feeders are always under test for frequency, attenuation, radiation and phase distortion measurements and correction.

H. M. DOWSETT.

MARCONI AERODROME APPROACH BEACON EQUIPMENT, TYPE WBD.4

The Medium Wave Beacon Equipment, Type WBD.4, described in the following article, is designed for the purposes of guiding aircraft along the correct approach path to an aerodrome when visibility is bad and of assisting its landing thereon by marker beacons which locate points on the approach path at known distances from the runway.

The complete control of the Main and Marker Beacons may be effected from a remote position, such as the wireless room in the Control Tower. An important feature is the facility with which the directive signals can be stopped and the Main Beacon used as a normal omni-directional transmitter on telegraphy or telephony from this control point when required.

This feature permits an approach beacon service and the normal low power communication with aircraft inside the bad weather "Controlled Zone" to be carried out on the same wavelength and with the same apparatus. The aircraft does not require to carry other than its normal medium wave apparatus on board and yet is not out of touch with the Controlling Station when listening on the Beacon wavelength.

The chief administrative objections to the use of medium wave approach beacons may thus be largely discounted.

THE Type WBD.4 Aerodrome Approach Beacon Equipment comprises a directive beacon transmitter (referred to as the Main Beacon) and two Marker Beacons.

The Main Beacon with an aerial system limited to 20 feet maximum height, has a range to aircraft of up to about 25 miles and by its means the correct course to be flown in foggy weather when approaching the aerodrome can be picked up and followed by the aircraft when permission to enter the Controlled Zone has been received from the ground. This transmitter is placed beyond the boundary of the aerodrome at the far end of the main runway.

The first or Distant Marker Beacon is situated on the approach line some three miles from the Aerodrome and passage over the Marker is indicated to the pilot by a distinctive signal lasting some ten or fifteen seconds according to the height and speed of the machine as it proceeds along the course.

The second or Boundary Marker is located at or just outside the aerodrome boundary, also on the line of approach and here a further distinctive signal warns the pilot of his position as he passes overhead.

On reaching the first marker the height of the machine is adjusted so that its normal gliding angle will bring it near enough to the ground to commence a landing when the second marker at the aerodrome boundary is reached.

The method by which the line of approach is marked out in space by the Main Beacon is the well-known "equi-signal" system, in which the radiated signal from the transmitter is directed alternately over the areas to the right and then to the left of the path to be followed.

The field patterns of these alternating radiations are so arranged that at any point along the approach line the field strengths of both are equal. A receiver anywhere along this line therefore picks up the two signals at equal strength. If the receiver is taken to one side of this line it enters a region in which one of the alternate radiations increases and the other decreases in field strength and the received signals are no longer of equal intensity.

The time periods during which the radiation is directed to one side of the approach line correspond to Morse dashes. The interval between these dashes is equal to a Morse dot and during the whole of each interval the radiation is directed to the other side of the line. It will thus be seen that at any point on either side of the line either dashes or dots will be predominant in the received signal, according to which side the receiver is situated. Along the actual approach line itself the dots and dashes are of equal strength and form a continuous unbroken signal.

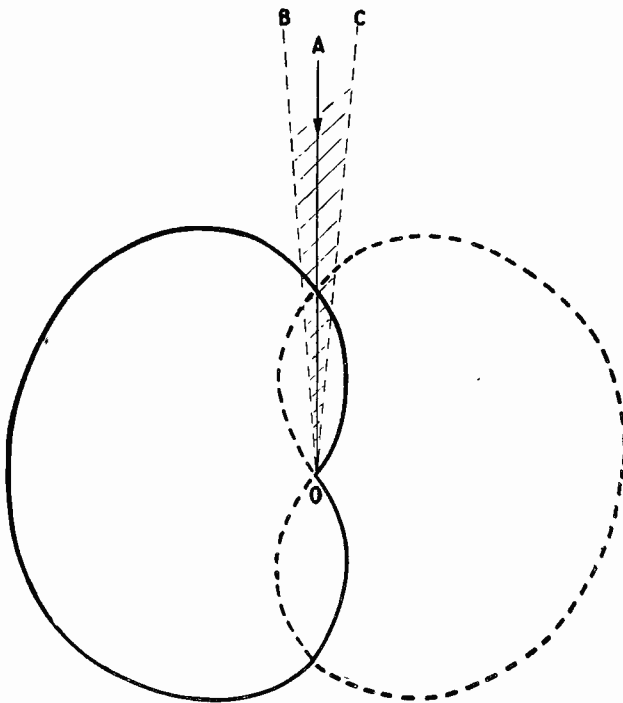

FIG. 1.

no width but appears as a zone C.O.B. inside which the signals are of apparently equal strength. A little beyond this zone to either side the dots or dashes predominate, the difference in strength between them increasing very rapidly as the angular displacement of the receiver from the line AO increases.

The cardioid field pattern is obtained by combining the radiation of a "frame" or closed loop aerial with that of an open aerial, the currents in the two aerials being 90 degrees out of phase. The reversal of the cardioid, which constitutes the change from one signal zone to the other, is effected by reversing the phase of the frame aerial

The principle is made clear by reference to Fig. 1, which shows the field strength pattern of the radiation during the "dash" period in solid line and during the "dot" period in dotted line.

The orientation of these field patterns is arranged so that the line of equal signal strength AO lies along the correct approach path to the aerodrome. The point O represents the position of the transmitter at the end of the runway.

As a certain degree of difference between the strengths of the two signals must exist before it can be detected by the discrimination of the receiver and human ear combined, it follows that in actual practice the equi-signal path is not a line having

current so that it becomes 90 degrees out of phase with the open aerial current in the opposite sense. The method of reversal of phase will be described later when dealing with the actual transmitting apparatus.

Suppose the dot and dash zones to be arranged on the respective sides of the approach path as shown in Fig. 1. A pilot entering the region served by the beacon will, if not on the approach path, pick up the beacon signal with either dashes or dots predominating.



FIG. 2.

The pilot knows that when he is flying along the correct line to the aerodrome the zone to his right is indicated by dashes and that to his left by dots. Therefore should dots predominate he will change course a few degrees to his right, that is, towards the weaker signal. He will maintain this course (increasing the angle of change slightly if the signals do not soon begin to approach equality) until the dots and dashes merge into one unbroken note. He then sets his course by compass along the equi-signal path of which the orientation is of course known.

If, due to drift or other causes, he diverges from the course, he is immediately warned of the fact and advised as to which side he has drifted by the dots or dashes commencing to predominate. The equi-signal zone rapidly grows narrower as the aerodrome is approached, its angular width being approximately three degrees under average receiving conditions in an aircraft. Under good reception conditions it will be of less apparent angular width.

When passing the Marker Beacons an audio frequency note is heard superimposed upon the directive beacon signal. The pitch of the note is rising and falling and this occurs at widely different speed in the case of the Distant Marker compared with that of the Boundary Marker note. The two are thus easily distinguished.

By the employment in the aircraft of a sensitive altimeter, corrected for the ground level of the objective aerodrome and for barometric pressure, these two Markers may be used to give invaluable assistance in landing the machine safely when vertical visibility is so low that the normal visual method of adjusting the glide to make a landing cannot be used.

Main Beacon Transmitter, Type WBD.4a.

The Main Beacon apparatus is illustrated in Fig. 2. This transmitter is really a combination of two separate amplifiers driven by a common crystal controlled master oscillator. The assembly is completely self-contained as illustrated, power being derived through a special multi-unit rectifier system arranged for connection to the normal alternating current power supply mains. Complete control of all

operations for local testing is carried out from the small unit shown in the illustration. Full remote control and monitoring is available. These features are described in detail later.

A rear view of the transmitter with covers removed is shown in Fig. 3.

At the left side of frame are seen the rectifiers for the frame aerial amplifier channel. A similar bank of units is in the corresponding right-hand compartment and provides the supplies for the open aerial amplifier.

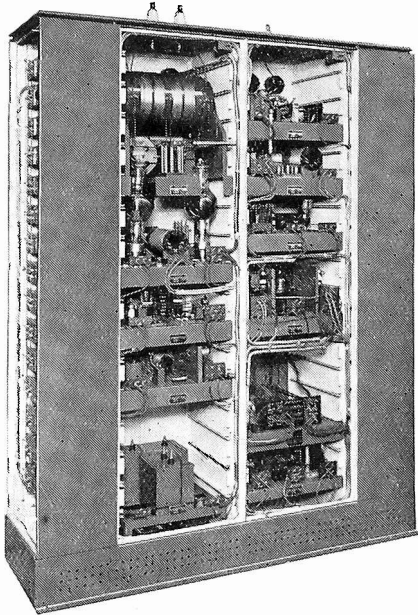

FIG. 3.

At the back on the left, starting from the bottom are :—(A) H.T. Smoothing Unit (frame amplifier), (B) Crystal controlled common drive, (C) Phase reversing signaller unit, (D) Frame amplifier channel, (E) Frame aerial tuning circuits.

The units in the right-hand compartment, also starting from the bottom are :—(A) Smoothing unit for open aerial amplifier supplies, (B) Control panel, (C) Phasing unit with first stages of both amplifiers, (D) Modulator, (E) Open aerial output stage, (F) Phase checking panel.

When desired the transmitter can be employed for omni-directional transmission of telegraphy or telephony. For this purpose the open aerial amplifier alone is used, the necessary circuit changes being effected through relays controlled from the remote or local control units. A switch on the transmitter changes over to remote or local control as required.

The crystal drive consists of a two-stage arrangement using MPT.42 valves. The crystal (which is ground for half transmitter frequency) is connected to the first valve, and the second valve acts as a frequency doubler. A condenser is provided for adjustment of the doubler anode circuit.

The phasing circuit consists of an inductive and a capacitive branch, each including a potentiometer. The potentiometer tappings are taken to the grids of the first stage valves of the frame and open aerial transmitters respectively, all of which are also located on the phasing panel.

In the case of the open aerial channel an MPT.42 valve drives two A.C.S.3 valves in push-pull. These are coupled to the aerial circuit through a screened H.F. transformer.

In the frame aerial amplifier two MPT.42's are employed, operating in the same manner, but the screens of these valves are controlled by the phase controller, the arrangements being such that whilst one screen is at operating potential the other is below earth potential. These valves energise opposite ends of the same

anode circuit, so that by bringing one screen potential up and the other down a reversal of phase of current in the frame amplifier is produced. The common anode circuit drives two A.C.S.3's in push-pull exactly as in the case of the open aerial channel.

A screened, secondary tuned H.F. transformer couples the A.C.S.3 anode circuit to the grids of the two D.E.S.1 output valves and these are coupled in a similar manner to the frame aerial through a second screened transformer.

The phase controller incorporates two gas relays (Type G.T.1) and two neon lamps and operates in the following manner. Each gas relay has a separate resistance in its anode circuit, the cathodes being inter-connected and a common H.T. supply being in use. The potential of either G.T.1 anode, therefore, falls if the valve is conducting, owing to the voltage drop in the anode resistance.

Each G.T.1 has its grid potentiometer fed from the other G.T.1 anode, the valves being then "interlocked" so that when one is conducting the other is not. Each G.T.1 anode feeds a time circuit consisting of a series resistance and condenser with a neon lamp across the latter. The time constants of the two circuits are different (corresponding respectively to a "dot" and a "dash" in Morse). When either valve is not conducting its anode potential rises causing its time circuit condenser to start charging: when the condenser potential reaches 180/200 volts the neon lamp discharges and the lamp circuit is so connected that this applies a large instantaneous positive potential to the grid of the valve which has not been conducting. This causes conduction in this latter valve to start which, through the interlock, stops conduction in the other valve—in effect, the gas relay "switch" is changed over. When the second valve time circuit has operated, the "switch" is changed back and so on.

The anodes of the gas relays are connected by external leads to the screens of the frame phasing valves (MPT.42's).

To assist the change over a condenser is connected between anodes. This is, of course, charged by the difference of potential between anodes, and when valve No. 1 is conductive, this side of the condenser has the lower potential. When the time circuit of valve No. 2 operates, the positive side of the condenser is taken with the anode of No. 2 to a potential near "earth" and the other side of the condenser (which is at lower potential) is instantaneously depressed below "earth" by virtue of the condenser charge. As the negative side of the condenser is connected to valve No. 1, the anode potential of this valve is also brought below "earth" and conduction stops.

The troubles which might otherwise arise, owing to the neons not completely discharging the respective time circuit condensers, are overcome by the use of two three-electrode valves (Type M.H.4). Each triode has its anode connected to the positive side of one timing condenser and its cathode to the other side. Its grid is connected to the interlock potentiometer tapping feeding the gas relay valve with which the particular timing condenser is associated. The result is that whilst the grid of gas relay No. 1 is negative and its timing condenser charging, triode No. 1 (across this condenser) has its grid biased past cut off and does not interfere with the charging. When neon No. 1 discharges and gas relay No. 1 commences to

conduct, however, triode No. 1 also conducts and completes the work of discharging timing condenser No. 1 already commenced by the neon lamp.

Since "keying" is effected by phase reversal only, there is a complete absence of the "key clicks" associated with other methods of beacon keying which tend to destroy the definite continuity of the note received along the equi-signal zone.

The signaller will operate with the triodes removed but is then faster in operation and more dependent upon equality of neons.

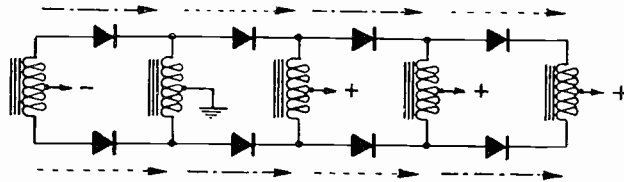

FIG. 4.

Means of checking the phase relationship of the currents in the open and frame aerials are provided. For this purpose each aerial circuit is coupled through small condensers to a common potentiometer from which a tapping is taken to the grid of an anode bend rectifier valve. The feed current to this valve is indicated by instruments on the transmitter and at the remote control point respectively. When the currents in the frame and open aerials differ by precisely 90 degrees, the reversal of the phase of the frame aerial current makes no difference to the potential on the grid of the valve, whatever the relative amplitudes, so long as the latter remain constant. Any divergence from 90 degrees phase relationship results in fluctuations of potential on the grid causing feed current variations which are revealed by the check meters referred to above. Incorrect phasing would, of course, produce field patterns of other than cardioid shape and destroy the formation of the correct equi-signal zone.

For working telephony the modulator consists of a single L.F. stage (P.X.4 valve) with a resistance in the anode circuit, the positive of the H.T. supply being earthed.

The junction of the resistance and the valve anode has, therefore, a potential below earth corresponding to the drop in the anode resistance determined by the instantaneous grid bias. The grid is fed by means of a microphone transformer, the primary of which is connected to the microphone circuit which is energised from a copper oxide rectifier.

The anode of the modulator is connected to the grid circuit of the magnifier valves of the open aerial channel so that the bias on the latter is controlled by the modulation.

For telegraph keying a relay is arranged to earth the screening grids of the same valves when the key is open.

Owing to the large number of different potentials relative to earth required by various parts of the transmitter a special rectifier system is provided.

Marconi Aerodrome Approach Beacon Equipment, Type WBD.4.

Each unit incorporates one transformer with a centre tapped secondary and two rectifying units. The units are interconnected as shown in Fig. 4, the current paths on positive and negative half cycles being as shown by the dotted and chain-dotted lines respectively. One secondary centre tap, several stages from one end, is earthed. Connections to higher or lower stages give voltages positive or negative with respect to earth. Voltage steps of approximately one hundred volts are used. Separate smoothing must, of course, be used on each output, but better regulation and smaller losses are obtained than would be possible if a smaller number of supply voltages in combination with H.T. breakdown resistances were used.

A steel frame is provided with runners into which the units slide so that it is an easy matter to add extra units or provide isolated supplies if required.

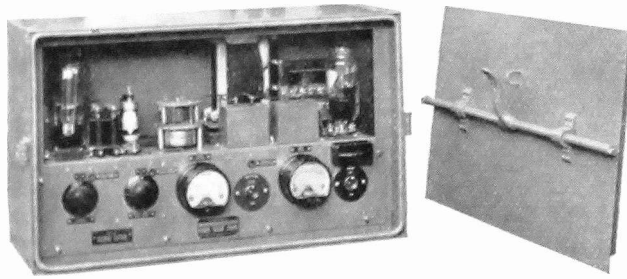

FIG. 5.

Marker Beacons, Types WBD.4b and WBD.4c.

The Marker Beacons are small mains operated self-oscillating transmitters of which the components are mounted in weathertight metal cases arranged for mounting on one of the Marker Aerial supporting poles.

Their construction is illustrated in Fig. 5. The aerials employed in each case consist of a long single wire T aerial supported on poles a few feet only in height and are placed athwart the line of flight.

The frequency of the radiated energy is automatically varied by means of a small motor-driven variable condenser connected across the flywheel circuit, which, in conjunction with a fixed condenser in series with it, causes the frequency to increase and decrease at a rate depending on the speed at which it is rotated by the motor.

The mean frequency of the marker is adjusted to that of the Main Beacon and varies through plus and minus 2 kcs., so that the beat note set up between the two transmissions is heard by the pilot as he passes through the restricted area over which the marker radiates as a "wobbling" note whose pitch rises and falls at a constant rate.

The rate of this "wobble" usually employed for the Distant Marker is of the order of $1\frac{1}{2}$ periods per second, distinguishing it from the Boundary Marker, of which the rate is approximately 5 periods per second.

conduct, however, triode No. 1 also conducts and completes the work of discharging timing condenser No. 1 already commenced by the neon lamp.

Since "keying" is effected by phase reversal only, there is a complete absence of the "key clicks" associated with other methods of beacon keying which tend to destroy the definite continuity of the note received along the equi-signal zone.

The signaller will operate with the triodes removed but is then faster in operation and more dependent upon equality of neons.

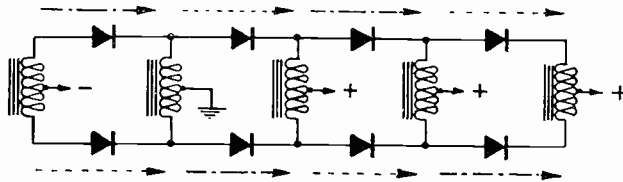

FIG. 4.

Means of checking the phase relationship of the currents in the open and frame aerials are provided. For this purpose each aerial circuit is coupled through small condensers to a common potentiometer from which a tapping is taken to the grid of an anode bend rectifier valve. The feed current to this valve is indicated by instruments on the transmitter and at the remote control point respectively. When the currents in the frame and open aerials differ by precisely 90 degrees, the reversal of the phase of the frame aerial current makes no difference to the potential on the grid of the valve, whatever the relative amplitudes, so long as the latter remain constant. Any divergence from 90 degrees phase relationship results in fluctuations of potential on the grid causing feed current variations which are revealed by the check meters referred to above. Incorrect phasing would, of course, produce field patterns of other than cardioid shape and destroy the formation of the correct equi-signal zone.

For working telephony the modulator consists of a single L.F. stage (P.X.4 valve) with a resistance in the anode circuit, the positive of the H.T. supply being earthed.

The junction of the resistance and the valve anode has, therefore, a potential below earth corresponding to the drop in the anode resistance determined by the instantaneous grid bias. The grid is fed by means of a microphone transformer, the primary of which is connected to the microphone circuit which is energised from a copper oxide rectifier.

The anode of the modulator is connected to the grid circuit of the magnifier valves of the open aerial channel so that the bias on the latter is controlled by the modulation.

For telegraph keying a relay is arranged to earth the screening grids of the same valves when the key is open.

Owing to the large number of different potentials relative to earth required by various parts of the transmitter a special rectifier system is provided.

Marconi Aerodrome Approach Beacon Equipment, Type WBD.4.

Each unit incorporates one transformer with a centre tapped secondary and two rectifying units. The units are interconnected as shown in Fig. 4, the current paths on positive and negative half cycles being as shown by the dotted and chain-dotted lines respectively. One secondary centre tap, several stages from one end, is earthed. Connections to higher or lower stages give voltages positive or negative with respect to earth. Voltage steps of approximately one hundred volts are used. Separate smoothing must, of course, be used on each output, but better regulation and smaller losses are obtained than would be possible if a smaller number of supply voltages in combination with H.T. breakdown resistances were used.

A steel frame is provided with runners into which the units slide so that it is an easy matter to add extra units or provide isolated supplies if required.

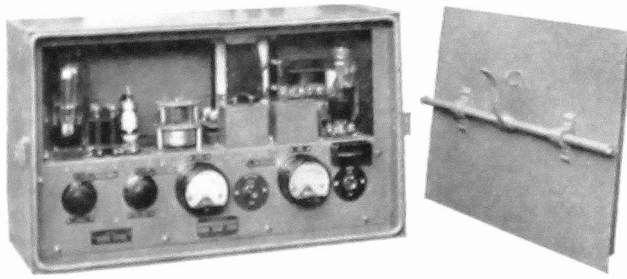

FIG. 5.

Marker Beacons, Types WBD.4b and WBD.4c.

The Marker Beacons are small mains operated self-oscillating transmitters of which the components are mounted in weathertight metal cases arranged for mounting on one of the Marker Aerial supporting poles.

Their construction is illustrated in Fig. 5. The aerials employed in each case consist of a long single wire T aerial supported on poles a few feet only in height and are placed athwart the line of flight.

The frequency of the radiated energy is automatically varied by means of a small motor driven variable condenser connected across the flywheel circuit, which, in conjunction with a fixed condenser in series with it, causes the frequency to increase and decrease at a rate depending on the speed at which it is rotated by the motor.

The mean frequency of the marker is adjusted to that of the Main Beacon and varies through plus and minus 2 kcs., so that the beat note set up between the two transmissions is heard by the pilot as he passes through the restricted area over which the marker radiates as a "wobbling" note whose pitch rises and falls at a constant rate.

The rate of this "wobble" usually employed for the Distant Marker is of the order of $1\frac{1}{2}$ periods per second, distinguishing it from the Boundary Marker, of which the rate is approximately 5 periods per second.

conduct, however, triode No. 1 also conducts and completes the work of discharging timing condenser No. 1 already commenced by the neon lamp.

Since "keying" is effected by phase reversal only, there is a complete absence of the "key clicks" associated with other methods of beacon keying which tend to destroy the definite continuity of the note received along the equi-signal zone.

The signaller will operate with the triodes removed but is then faster in operation and more dependent upon equality of neons.

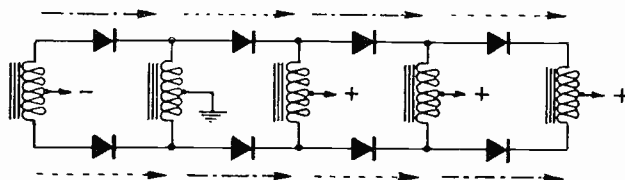

FIG. 4.

Means of checking the phase relationship of the currents in the open and frame aerials are provided. For this purpose each aerial circuit is coupled through small condensers to a common potentiometer from which a tapping is taken to the grid of an anode bend rectifier valve. The feed current to this valve is indicated by instruments on the transmitter and at the remote control point respectively. When the currents in the frame and open aerials differ by precisely 90 degrees, the reversal of the phase of the frame aerial current makes no difference to the potential on the grid of the valve, whatever the relative amplitudes, so long as the latter remain constant. Any divergence from 90 degrees phase relationship results in fluctuations of potential on the grid causing feed current variations which are revealed by the check meters referred to above. Incorrect phasing would, of course, produce field patterns of other than cardioid shape and destroy the formation of the correct equi-signal zone.

For working telephony the modulator consists of a single L.F. stage (P.X.4 valve) with a resistance in the anode circuit, the positive of the H.T. supply being earthed.

The junction of the resistance and the valve anode has, therefore, a potential below earth corresponding to the drop in the anode resistance determined by the instantaneous grid bias. The grid is fed by means of a microphone transformer, the primary of which is connected to the microphone circuit which is energised from a copper oxide rectifier.

The anode of the modulator is connected to the grid circuit of the magnifier valves of the open aerial channel so that the bias on the latter is controlled by the modulation.

For telegraph keying a relay is arranged to earth the screening grids of the same valves when the key is open.

Owing to the large number of different potentials relative to earth required by various parts of the transmitter a special rectifier system is provided.

Each unit incorporates one transformer with a centre tapped secondary and two rectifying units. The units are interconnected as shown in Fig. 4, the current paths on positive and negative half cycles being as shown by the dotted and chain-dotted lines respectively. One secondary centre tap, several stages from one end, is earthed. Connections to higher or lower stages give voltages positive or negative with respect to earth. Voltage steps of approximately one hundred volts are used. Separate smoothing must, of course, be used on each output, but better regulation and smaller losses are obtained than would be possible if a smaller number of supply voltages in combination with H.T. breakdown resistances were used.

A steel frame is provided with runners into which the units slide so that it is an easy matter to add extra units or provide isolated supplies if required.

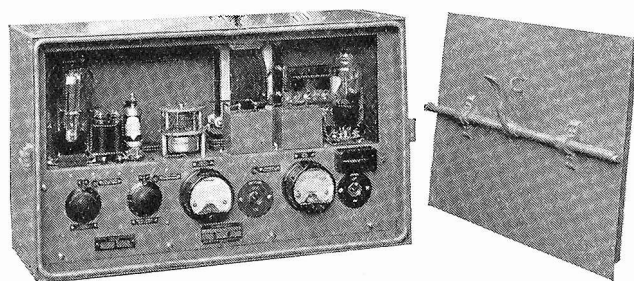

FIG. 5.

Marker Beacons, Types WBD.4b and WBD.4c.

The Marker Beacons are small mains operated self-oscillating transmitters of which the components are mounted in weathertight metal cases arranged for mounting on one of the Marker Aerial supporting poles.

Their construction is illustrated in Fig. 5. The aerials employed in each case consist of a long single wire T aerial supported on poles a few feet only in height and are placed athwart the line of flight.

The frequency of the radiated energy is automatically varied by means of a small motor-driven variable condenser connected across the flywheel circuit, which, in conjunction with a fixed condenser in series with it, causes the frequency to increase and decrease at a rate depending on the speed at which it is rotated by the motor.

The mean frequency of the marker is adjusted to that of the Main Beacon and varies through plus and minus 2 kcs., so that the beat note set up between the two transmissions is heard by the pilot as he passes through the restricted area over which the marker radiates as a "wobbling" note whose pitch rises and falls at a constant rate.

The rate of this "wobble" usually employed for the Distant Marker is of the order of $1\frac{1}{2}$ periods per second, distinguishing it from the Boundary Marker, of which the rate is approximately 5 periods per second.

conduct, however, triode No. 1 also conducts and completes the work of discharging timing condenser No. 1 already commenced by the neon lamp.

Since "keying" is effected by phase reversal only, there is a complete absence of the "key clicks" associated with other methods of beacon keying which tend to destroy the definite continuity of the note received along the equi-signal zone.

The signaller will operate with the triodes removed but is then faster in operation and more dependent upon equality of neons.

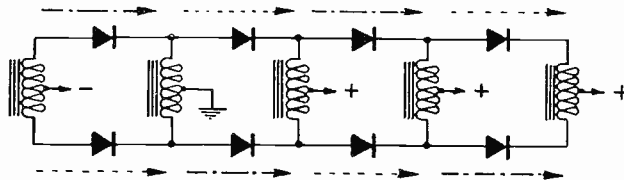

FIG. 4.

Means of checking the phase relationship of the currents in the open and frame aerials are provided. For this purpose each aerial circuit is coupled through small condensers to a common potentiometer from which a tapping is taken to the grid of an anode bend rectifier valve. The feed current to this valve is indicated by instruments on the transmitter and at the remote control point respectively. When the currents in the frame and open aerials differ by precisely 90 degrees, the reversal of the phase of the frame aerial current makes no difference to the potential on the grid of the valve, whatever the relative amplitudes, so long as the latter remain constant. Any divergence from 90 degrees phase relationship results in fluctuations of potential on the grid causing feed current variations which are revealed by the check meters referred to above. Incorrect phasing would, of course, produce field patterns of other than cardioid shape and destroy the formation of the correct equi-signal zone.

For working telephony the modulator consists of a single L.F. stage (P.X.4 valve) with a resistance in the anode circuit, the positive of the H.T. supply being earthed.

The junction of the resistance and the valve anode has, therefore, a potential below earth corresponding to the drop in the anode resistance determined by the instantaneous grid bias. The grid is fed by means of a microphone transformer, the primary of which is connected to the microphone circuit which is energised from a copper oxide rectifier.

The anode of the modulator is connected to the grid circuit of the magnifier valves of the open aerial channel so that the bias on the latter is controlled by the modulation.

For telegraph keying a relay is arranged to earth the screening grids of the same valves when the key is open.

Owing to the large number of different potentials relative to earth required by various parts of the transmitter a special rectifier system is provided.

Each unit incorporates one transformer with a centre tapped secondary and two rectifying units. The units are interconnected as shown in Fig. 4, the current paths on positive and negative half cycles being as shown by the dotted and chain-dotted lines respectively. One secondary centre tap, several stages from one end, is earthed. Connections to higher or lower stages give voltages positive or negative with respect to earth. Voltage steps of approximately one hundred volts are used. Separate smoothing must, of course, be used on each output, but better regulation and smaller losses are obtained than would be possible if a smaller number of supply voltages in combination with H.T. breakdown resistances were used.

A steel frame is provided with runners into which the units slide so that it is an easy matter to add extra units or provide isolated supplies if required.

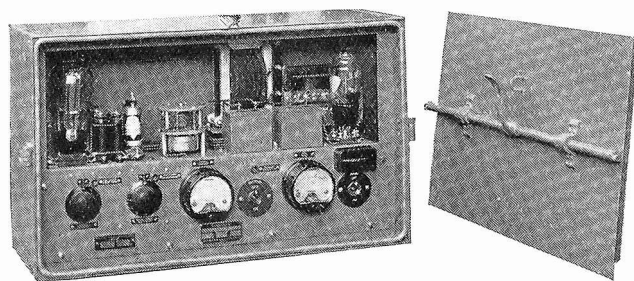

FIG. 5.

Marker Beacons, Types WBD.4b and WBD.4c.

The Marker Beacons are small mains operated self-oscillating transmitters of which the components are mounted in weathertight metal cases arranged for mounting on one of the Marker Aerial supporting poles.

Their construction is illustrated in Fig. 5. The aerials employed in each case consist of a long single wire T aerial supported on poles a few feet only in height and are placed athwart the line of flight.

The frequency of the radiated energy is automatically varied by means of a small motor-driven variable condenser connected across the flywheel circuit, which, in conjunction with a fixed condenser in series with it, causes the frequency to increase and decrease at a rate depending on the speed at which it is rotated by the motor.

The mean frequency of the marker is adjusted to that of the Main Beacon and varies through plus and minus 2 kcs., so that the beat note set up between the two transmissions is heard by the pilot as he passes through the restricted area over which the marker radiates as a "wobbling" note whose pitch rises and falls at a constant rate.

The rate of this "wobble" usually employed for the Distant Marker is of the order of $1\frac{1}{2}$ periods per second, distinguishing it from the Boundary Marker, of which the rate is approximately 5 periods per second.

The aerial current required to produce the necessary range of this interference field is very small, a fraction of an ampere in the low aerial provided being sufficient for the purpose.

Power can be taken from any suitable source near to each Marker site and need not necessarily be derived from the same supply that is used in the Control Tower.

Remote Control and Monitoring.

All three transmitters are capable of being switched on from the Control Tower, which is not necessarily close to either Main Beacon or Boundary Marker. Monitoring indications are available in the Control Tower to show that each transmitter is functioning correctly.

A special Control Unit for these purposes is provided with its own self-contained rectifier for operating line relays on the three transmitters. In the case of the Marker Beacons the relays merely have to switch on and off their respective transmitters but the Main Beacon relays also change over the transmitter connections for telegraphy and telephony.

Each of the three transmitters has a check circuit consisting of a few turns coupled to the aerial circuit and a copper oxide rectifier for transmitting D.C. (rectified H.F.) back to the Control Tower, where it energises a relay closing a local circuit. This circuit may be used to light conveniently placed lamps in the Control Tower from the local supply.

In the case of the Main Beacon a further indication of correctness of relative phase of frame and open aerial currents is given. The supply to the transmitter meter giving the corresponding indication is fed back over special lines to a second instrument at the Control Point. The microphone and Morse key for telephony and telegraphy communication respectively are connected to the remote control unit and brought into circuit automatically as required by the operation of the corresponding control switches.

THE EXTENDED FEEDER MARCONI-ADCOCK DIRECTION FINDER

During the past eighteen months investigations upon the subject of the remote control of Adcock aeriels has continued. These researches have embraced problems such as the location of the aeriels at distances of 0.5 to 8 kilometres by means of radio frequency feeders and telecontrol at distances up to 80 kilometres. Some of the problems remain unsolved or are uneconomic.

A number of commercial installations involving extended radio frequency feeders of various lengths up to 0.75 kilometre have been tested, while designs using coaxial feeders of 8 kilometres are still under experimental investigation.

It is the object of the present note to describe the circuits and performance characteristics of extended feeder Marconi-Adcock direction finders. The particular type discussed is capable of adequate air to ground sensitivity with feeders 1 kilometre long. The solution reached has to some extent solved difficult site and operating problems.

Centre Site versus Extended Feeder Operation.

IN many medium wave Adcock installations the local site conditions and operating requirements will allow the location of the direction finding building at the centre of the aerial system. In such cases it is usually possible to obtain very high sensitivity, the best quality of directional discrimination during the day and night time, employ twin channelling systems and also allow a number of additional receiving channels at a minimum cost. In practice the centre site installation is likely to remain the ideal solution and from a purely technical standpoint should be employed whenever practicable.

Occasionally cases arise where it is quite impossible to instal the ideal arrangement. The necessity for remote location of the aeriels may be occasioned by the desire for centralisation of administration and control at a point unsuitable for the aerial. Site imperfections such as poor direction finding accuracy, obstruction to aircraft or electrical noise, may demand the use of remote aeriels with full operational facilities at the control centre.

In comparing centre site location with remote operation, it will usually be found that the latter will suffer from a number of technical limitations such as :—

- (A) Lower sensitivity than centre site systems.
- (B) Poorer directional discrimination (finesse of minima).
- (C) Continuous zero clearing during night time not practicable without the use of telecontrol mechanisms.

On the other hand, the extended feeder design does possess the following advantages :—

- (1) Permits Adcock direction finding in control towers of airports.
- (2) Control centre may be in congested area subject to site errors, noise, and obstruction without a lowering of the day and night performance of the Adcock aerial.
- (3) Allows the installation of an Adcock direction finder in cases where centre site systems would be quite impracticable.

- (4) When used in conjunction with a short wave Adcock direction finder (with the medium wave direction finder in the short wave hut) will provide the dual services at a common centre without a lowering of the short wave direction finding accuracy.

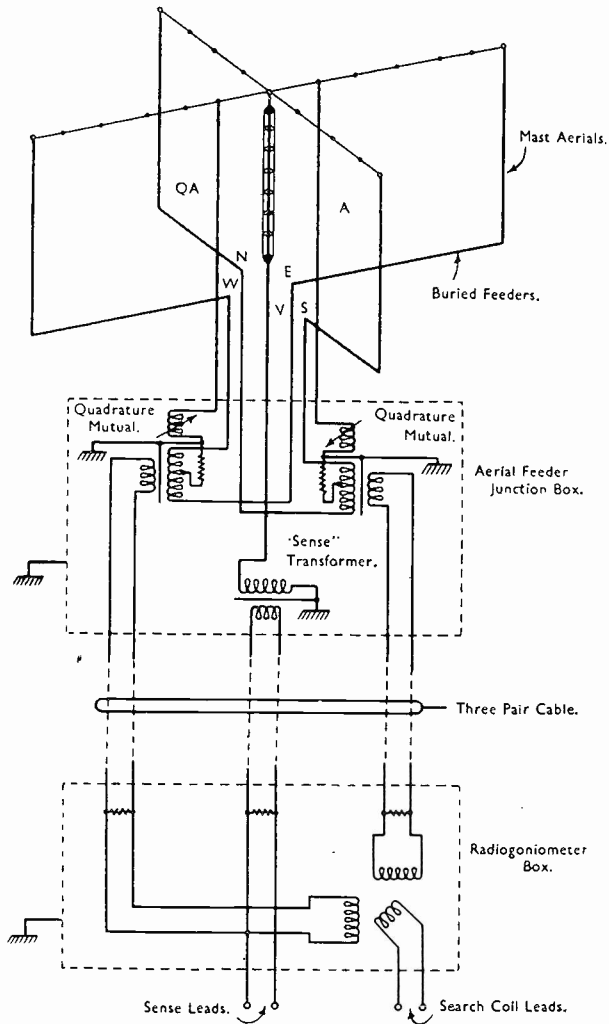

CIRCUIT ARRANGEMENT OF AERIALS,
EXTENDED FEEDERS, AND ASSOCIATED
EQUIPMENT.

FIG. I.

height and two 45 feet single wire aerials. The cage aerial is coupled to a feeder pair and is used for the "sense" circle and figure of eight zero clearing arrangements. The auxiliary vertical aerials are provided for polar diagram quadrature compensation

From the preceding remarks it will be seen that each type of aerial system possesses inherent advantages and each case should be treated upon its merits. For example, in the tropics where radio noise level may be high, the extended feeder system will not suffer on account of lowered sensitivity; in Northern latitudes where very large air to ground ranges are sometimes needed, a centre site location for the direction finder is most desirable.

Frequency Range of Extended Feeder Direction Finder.

The extended feeder system employs a modified type of DFG.10 Marconi-Adcock direction finder. The shielding of the input circuits has been improved, so that under any conditions direct reception will not degrade the accuracy. The standard frequency range is 150 to 375 Kcs.

The Aerial System.

The shielded "U" aerial illustrated in THE MARCONI REVIEW, No. 58, is employed. At the centre of the aerial system, the necessary feeder coupling transformers and variable quadrature compensating mutuls are housed in a weatherproof shielding case. This case also allows for the various feeders to be sealed off and terminated. Instead of a single vertical aerial being located at the centre of the aerial system, three such aerials are provided, namely, a four wire cage 90 feet in

at the centre of each spaced aerial system. Each figure of eight space pattern is independently compensated in a manner somewhat similar to the method described in THE MARCONI REVIEW, No. 58. By compensating each aerial member with preset variable mutuals it is possible to obtain equally sharp minima in the figure of eight position. This is obvious if one considers the vector diagrams of the whole aerial system. Final zero clearing of limited magnitude is provided in the receiver—this will be referred to later on.

Fig. 1 shows in schematic form the circuits associated with the aerials, feeders and radiogoniometer termination.

The three shielded transformers located at the aerial centre are carefully matched and balanced. In the early stages of the work dust cored toroidal shielded transformers were used. After careful tests comparing the stability of dust and air cored transformers the latter were finally adopted on account of greater precision of the overall direction finding calibration under varying weather conditions. From the point of view of attenuation no loss in sensitivity resulted in the adoption of air cored transformers.

The Feeder Cables.

Multipair feeder cables using three copper taped shielded and balanced pairs with paper string insulation are employed for linking the remote aerials to the direction finder. The following feeder characteristics measured at 330 kilocycles per second may be of interest to the reader:—

SUBJECT.	CHARACTERISTIC.
Cross talk between pairs	Greater than 90 decibels
Wave velocity	0.66 to 0.70 that of light
Attenuation	5 to 6 decibels per Km.
Surge impedance	60 ohms
Permissible phase difference with matched pairs ..	± 1 degree
Attenuation difference with matched pairs	± 0.1 decibel

In practice the tightly packed low impedance feeder cable has adequate stability of attenuation and delay characteristics as a function of frequency, and for moderate feeder extensions allows bearings to be observed upon signals under five microvolts per metre on the 900 metre wave.

It is usual to provide the feeder cable with four or five shielded pairs (depending upon the length); a number of combinations can then be compared and measurements made of the phase and attenuation differences. These measurements are carried out at several frequencies and the pairs most nearly matching in phase and attenuation are selected for use in the spaced aerial and sense finding circuits. This method has been found adequate and avoids the use of phase compensators which would be difficult to adjust (bearing in mind the fact that random variations in phase are to be corrected).

The method of measuring the minute differences in attenuation and phase angle is very simple, possibly novel; the test circuit schematic is shown in Fig. 2.

The test arrangements require the use of a well shielded standard signal generator. The signal of known and variable amplitude is fed into the two spaced aerial feeders via the shielded transformers. The far ends of the feeder pairs are terminated by the actual direction finder such as the special model of the DFG.10 instrument. The

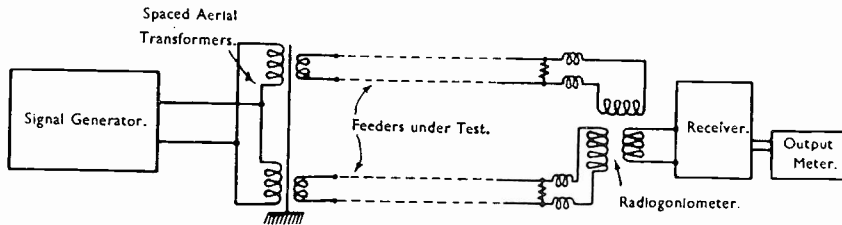

FIG. 2.

receiver output is measured by means of a milliwattmeter, care being taken to see that the complete amplifier chain including frequency changer is operating in a linear manner.

The differences in attenuation at various frequencies are observed by recording the angular position of the minima; thus if the attenuation and phase were equal in the two feeder paths shown in Fig. 2 perfect minima would be noted at 45 and 225 (with no residual signal). Minute differences in attenuation will result in the zero moving to some other position, while differences in phase will result in a blurring of the minima.

The formula for determining the difference in attenuation is given by:—

$$dB = 20 \log \frac{I}{\tan \theta}.$$

Where θ is the actual angular position of the minima.

Where dB is the actual difference in attenuation.

By observing these minute changes of the minima it is possible to measure amplitude differences considerably less than a tenth of a decibel.

A phase difference between the two opposing electromotive forces will result in an impure minima; this phase difference is measured by comparing the amplitude of the input signal when the radiogoniometer is at the minimum position (45 degrees) and when the search coil is fully coupled to either feeder. Low signal levels will be required in the latter position and high level signals at the minimum, in order to give equal receiver output. Having obtained a decibel ratio for equal receiver output, the phase difference of the two opposing electromotive forces may be calculated from the expression:—

$$\sin \theta = \frac{\sqrt{2}}{\text{Anti log } \frac{db}{20}}$$

Where θ is the difference in phase along the two pairs of feeder lines. The method is very simple if suitable circuit precautions are taken, and minute phase angles can be measured; in fact, special cathode ray circuits are necessary in order to allow equal precision of measurement.

Typical phase and attenuation difference curves are shown in Fig. 3; these relate to selected pairs used in a 400 metre extended feeder.

The Feeder Terminations.

The three matched feeders if not suitably terminated with a dissipative load equal to the surge impedance will have standing waves due to reflections. Reflections

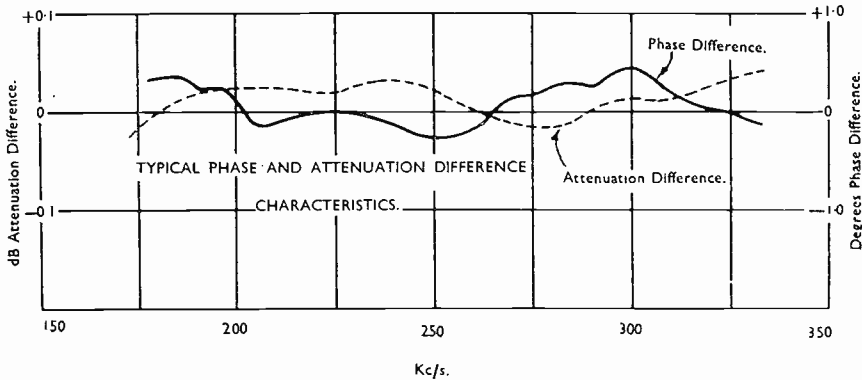

FIG. 3.

might be tolerated if precisely similar conditions in the spaced aerial feeders could be maintained; in practice, such reflections seriously degrade the accuracy and definition of the bearings. Tuned resistive terminations for all three feeders would present an ideal solution to the problem. From an operating point of view this solution is not practical as applied to the spaced aerial feeders. The sense feeder does use a series tuned termination circuit; this circuit at resonance has a resistance of 450 ohms, and bridges the feeder terminating resistance of 60 ohms; this latter figure represents the feeder surge impedance. The tuned sense finding termination is actually ganged to the main searching dial, and allows first class cardioid polar diagrams without any risk of sense reversals or phasing adjustments over the searching range.

The tracking of the tuned cardioid circuit with the main searching control must be such that correct phase relationship exists in the sense and spaced aerial combining circuits.

With the receiver adjusted for a cardioid at a midband frequency of 330 kilocycles, a cardioid maximum to minimum amplitude ratio of at least 100 to 1 is possible. If the searching control is operated to receive signals at a frequency of 300 or 360 kilocycles, the tracking does not allow phase misalignment greater than ± 5 degrees, which is adequate for sense determination.

In Fig. 3A the effects of mistracking upon the shape of the cardioid are shown. The full line shows a normal cardioid while the chain line shows a cardioid with a 15 degree phase shift between the spaced and vertical aerial E.M.F.'s. In the extreme case shown in Fig. 3A a front to back amplitude ratio of 8 to 1 is obtained, which is ample for sense determination.

The cardioid polar diagrams are obtained without any adjustments in the normal searching range, this results in slight misalignment in phase and amplitude, the former due to tracking errors and the latter due to aerial spacing. The sense

polar diagrams when making due allowance for inequality of amplitude and ± 5 degree phase shift are capable of minimum to maximum ratios of approximately 12 to 1.

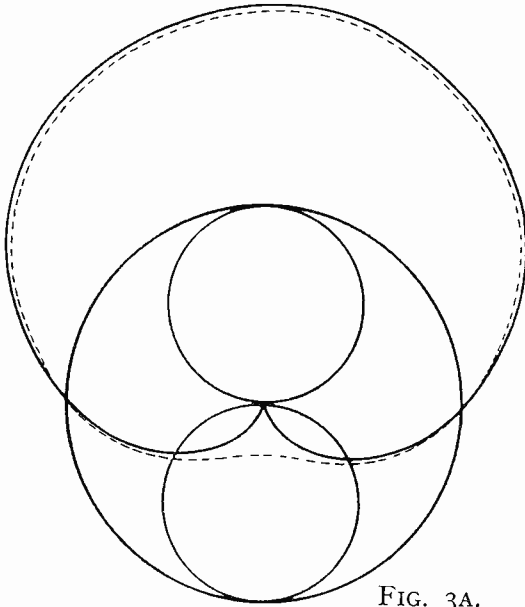

FIG. 3A.

If one considers the action of a tight coupled radiogoniometer at the minimum position, it will be seen that as no linkage of flux takes place between the field coils and the search coil, the effects of the latter circuit will not produce feeder reflections. The input impedance of the field coils at the point of minimum signal is thus reactive, and by suitable circuit design it is possible to make the spaced aerial terminations purely resistive. A 60 ohm resistance is shunted across each field coil termination; this solution has eliminated errors due to standing waves even under quarter-wave conditions.

The circuit schematic of the terminations and receiver input circuits is shown in Fig. 4. The methods of producing the cardioid and circle polar diagrams are shown clearly in Fig. 4 and need little comment. The phase angle of the current in the circle polar diagram position (of the "sense" "circle" and direction finding key) is nearly

The circuit schematic of the terminations and receiver input circuits is shown in Fig. 4. The

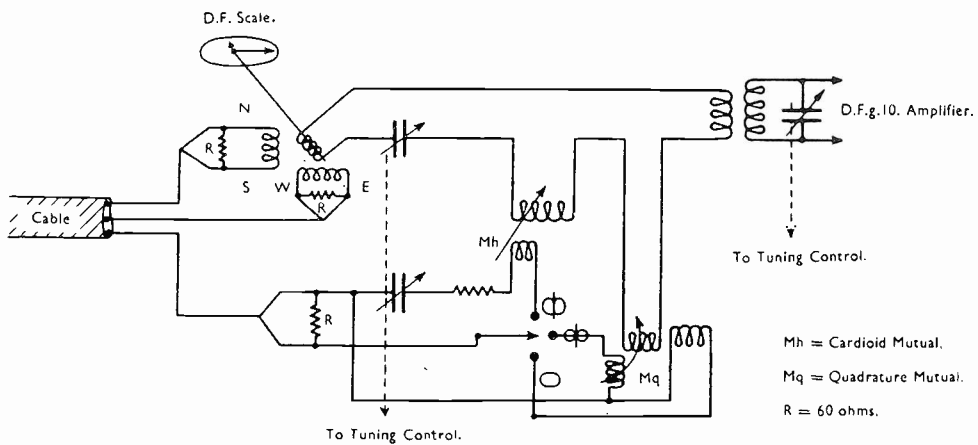

FIG. 4.

in quadrature with the electromotive force across the resistance R, while the ganged series tuned cardioid circuit provides a current in phase with the electromotive force across this resistance.

In the direction finding condition the reactance of the zero clearing mutual MQ is sufficient to ensure that the current lags by 90 degrees behind the electro-motive force existing across the resistance R . The dimensions of the zero clearing

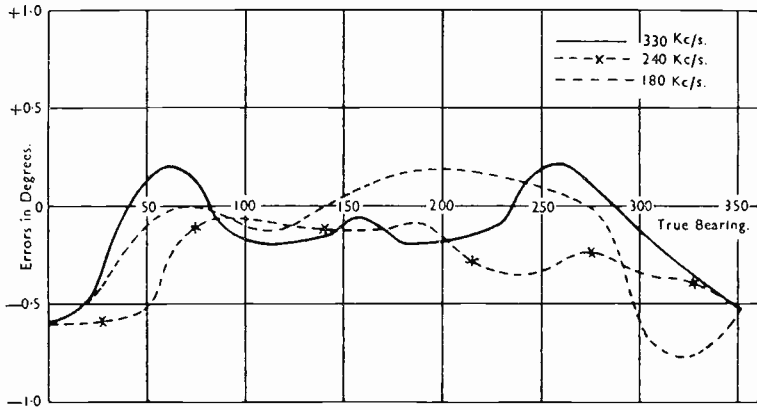

FIG. 5.

impedances are so chosen that only a limited amount of quadrature compensation is provided. It has been pointed out earlier in this note that the main space patterns of the two spaced aerials are quadrature compensated; the direction finding terminating network is distinctly complex, and is such that a 25 per cent. quadrature compen-

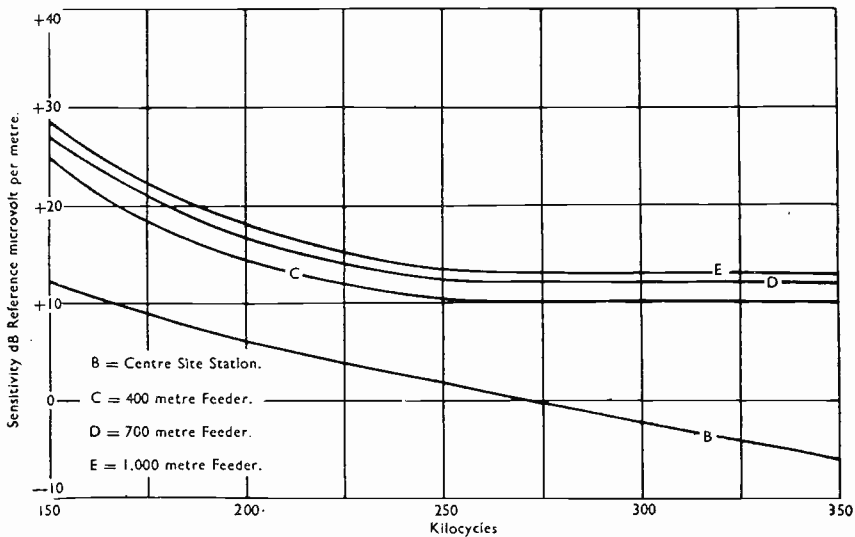

FIG. 6.

sation is not possible at the receiver without introducing errors in the bearing. The direction finder is designed so that a 5 per cent. quadrature correction is available; under this condition normal instrumental blurring of the minima can be eliminated, but under conditions of intense night effect the full advantages of the equivalent centre site device are not possible without inducing instrumental errors. A full

discussion of the complete circuit and the effects of quadrature compensation in low impedance circuits is outside the scope of this note.

Overall Accuracy (Excluding Site Errors).

After the feeders, shielded transformers, terminations and radiogoniometer have been tested to exacting limits, it is then possible to make overall accuracy curves. These error curves (which do not involve site limitations) are always taken using the complete system, namely, artificial aerials, feeders and the direction finder. A typical series of error curves taken at three frequencies are shown in Fig. 5. The curves given in this figure include quadrantal feeder and aerial errors, octantal radiogoniometer errors and reflection errors. The last named errors are negligibly low in practice, even when working on waves suitable for producing $1/4$ and $3/4$ standing waves. The instrumental results recorded in Fig. 5, when compounded with normal site errors, allow an accuracy of ± 2 degrees; in many cases a much higher operating precision is possible.

Sharpness of Minimum.

The zero clearing device fitted to centre site direction finders allows very sharp bearing discrimination to be obtained. Thus for an angular displacement amounting to ± 1 degree off true bearing, a continuous wave signal increment at the output of the receiver of 30 decibels is possible. This measurement does, of course, assume linear input/output conditions in the amplifier. If overloads permitted, this would represent a signal minimum to maximum ratio greater than 60 decibels. With the extended feeder system having correctly compensated individual space patterns, and using the receiver operated zero clearing device minima to maxima ratios of 35 to 40 decibels are usual. This discrimination of the observed bearing is adequate for direction finding.

Sensitivity.

Having described the general lines upon which the extended feeder type of Marconi-Adcock direction finder has been developed, the all-important question of effective sensitivity must be considered.

Fig. 6 illustrates the field intensity required in order to obtain swing bearings with the following arrangements:—

- B—Normal centre site installation.
- C—400 metre extended feeder.
- D—700 metre extended feeder.
- E—1,000 metre extended feeder.

By comparing curve B with D it will be seen that the loss in sensitivity at 300 kilocycles by using a 700 metre extended feeder amounts to 14 decibels. Thus an aircraft using arrangement B will allow a direction finding range overland of 400 Kms., while under equal conditions the extended feeder should give the same class of bearing at a distance of 270 Kms.

Conclusions.

The remote location of Adcock aerials has definite operating and site advantages, but these are obtained at the expense of lowered sensitivity. The type of equipment described in the present note is well established, and it is anticipated that as progress is recorded greater distances and considerably higher sensitivities will become commonplace.

S. B. SMITH.

THE MARCONI-STABILOVOLT SYSTEM

GLOW GAP VOLTAGE DIVIDERS WITH IGNITION GAPS

The following article, describing a new series of Stabilovolt tubes, is reprinted from a paper by L. Körös and R. Seidelbach appearing in "Helios," Vol. 42, No. 34, August, 1936.

THE problem of supplying stabilised power to sensitive amplifiers, early stages of radio transmitters, etc., has led to the development of a new type of Stabilovolt tube: the so-called Z Stabilovolt.

There is a great demand for constant voltages, independent of supply and load variations for application to the anodes and grids of valves in certain radio apparatus. To avoid establishing a special source of supply to the sensitive stages of such apparatus a Stabilovolt tube may be connected, with smoothing circuits if necessary, to a common source of supply of suitably high voltage, and from this tube supplies may then be taken to the appropriate terminals of the apparatus requiring the stabilised voltages. By means of such an arrangement convenient values of grid potential and high tension may be obtained simultaneously. The early stages of high gain amplifiers, similar stages of telephone and telegraph transmitters, oscillators, and other important items of Broadcasting Transmitters, can be supplied by such a system. All uncertainties caused by voltage variations in the early stages of such apparatus are eliminated, and high stability of frequency, to-day an item of greatest importance, is obtained.

Such an arrangement of supply, however, as will be explained later, presents certain difficulties of detail, which can often be solved by the application of fairly simple apparatus. The Z Stabilovolt tubes overcome these difficulties, and furthermore offer possibilities for other new applications.

Stabilovolt tubes are known to consist of a plurality of glow discharge gaps connected in series. Discharge in these gaps occurs in such a way that the free electrons always present in a gas-filled space attain, due to certain pre-determined potentials at the electrodes, such a speed that they ionise the neutral gas molecules, by collision. The electrons and ions form as the result of the new state of ionisation, in turn join the movement, and the ions release new electrons from the cathode. This cycle of events rapidly increases, and consequently the conductivity of an ionised gap rapidly increases as the current is increased, or in other words, a slightly increased voltage at the terminals of a discharge gap is sufficient to permit considerably more current to pass through the gap. Glow gap voltage dividers are so designed that the voltage of the gaps, from a minimum of current, say 5 mA to the maximum current limit, depends practically very little on the current intensity passing; this is the principle of the voltage regulating effect of Stabilovolt tubes.

In order to start ionisation, a higher than normal voltage will be required. The additional voltage necessary to strike the tube in normal glow divider gaps amounts to 20-50 volts. In the majority of cases this is not detrimental, as it is generally accepted that for the successful operation of glow gap discharges a striking voltage somewhat higher than the working voltage is required, and this excess voltage can be arranged at the supply. However, difficulties of ignition may result in certain boundary cases, such as when the Stabilovolt tube is connected into

circuit under load. The use of barretters greatly facilitates striking. It is a well known fact that when a circuit including a barretter is first switched on, the barretter being cold, an increased current will pass for a short time during which the barretter is being heated. This also occurs if the barretter is switched on after a short cooling period, and the increased current will cause a higher voltage than normal to appear at the electrodes of the gas discharge tube and will strike it. However, a barretter

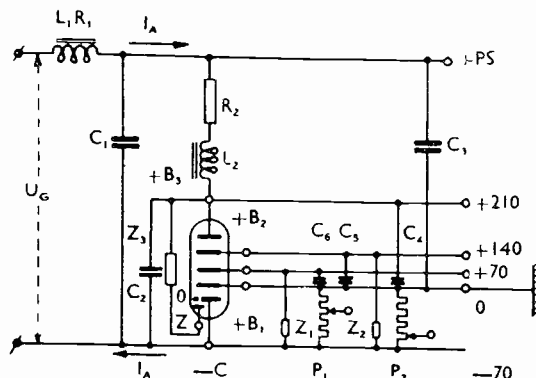

FIG. 1.

Anode and grid supplies for the first stages of a transmitter, i.e., Master Oscillator and early stages; Grid bias for these and later stages can be taken from the Stabilovolt tube. Anode voltage for the later stages can be taken from the termination of the smoothing system at +P.S.

The new Z electrode of the Stabilovolt tube is energised through the striking resistance Z_3 , from a suitable high voltage, thus securing certain striking of the —CO gap.

in Fig. 1 is not at present being considered. Potentiometers for grid bias are connected in parallel with the O-C gap of the Stabilovolt tube. The circuit formed by the O-C gap and its parallel potentiometers carries the total current of those valves which are supplied by the Stabilovolt tube, and this may reach a current intensity of 200 mA or more. Care should be taken that the O-C gap is not overloaded. For this purpose the combined resistance of all potentiometers connected in parallel with the O-C gap is made of such a value that only the permissible portion of the plate current passes through the O-C gap whilst the other part flows through the potentiometers. With such an arrangement it may happen that the resistance value of the potentiometers connected in parallel becomes so small that the excess voltage required for striking cannot be produced at the electrodes, the potential difference at the terminals of the parallel potentiometer system being too low to cause the gap to strike. Before the O-C gap strikes a voltage somewhat higher than the operating voltage is required at the gap electrodes, and at the terminals of the potentiometers, and because of this the grids of the various valves are biased more negative than normal, and a lower plate current flows. Now as the resistance

cannot be used in every case. In certain cases, especially in the fields of application mentioned at the beginning, certain difficulties arise on account of the dimensions required to obtain faultless striking.

Amplifiers, transmitters, etc., whose early stages are at a lower voltage than the later stages, can be supplied from a stabilised source in the early stages, and an un-stabilised supply in the final stages. This is shown diagrammatically in Fig. 1. In such cases it is usual to refrain from stabilising the voltage applied to the final stages, and to obtain this supply from the point P.S. the end of the smoothing system. The grid potential of these stages may be derived from the O-C gap of the Stabilovolt and this is often a great convenience when setting up the entire circuit. The anode and grid potentials of the earlier stages may be taken from the Stabilovolt tube in the usual way. The Z electrode of the Stabilovolt tube shown

of the potentiometers is chosen to be of such a value that at normal plate current the O-C gap strikes, it may be found that with a lesser plate current the voltage across the gaps is insufficient for striking, and with unsatisfactory proportioning of the circuit the O-C gap of the tube may not strike. With high resistance potentiometers nearly the whole of the plate current must pass through the O-C gap of the Stabilovolt tube. Because of this it is only possible to use the Stabilovolt tube with-

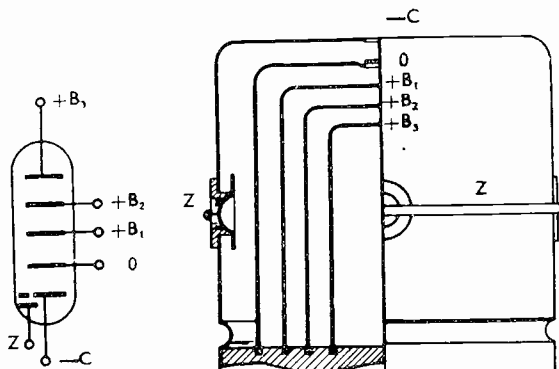

FIG. 2.

(a) Diagram showing the disposition of the electrodes of the new tube with Z gap and (b) part sectional view of the tube.

out auxiliary apparatus, when the O-C gap is capable of taking not very much less current than the entire plate current of the amplifier or transmitter, or the portions thereof being supplied from the stabilised source. In some cases recourse can be had to high resistance potentiometers by connecting a relay in the lead attached to the —C electrodes and switching an extra load across the O-C gap after ignition. The relay is held over by an electromagnet supplied from the extra load circuit, and the normal relay winding connected to the —C electrode is short circuited. This is not a very desirable solution and therefore a search was undertaken to provide a

better method of striking, without overloading the Stabilovolt. When supplying anode voltages in the early stages of apparatus, the difficulties do not occur because the current taken by these early stages is less than that taken by the later ones.

The problem was one of reducing the O-C gap striking voltages, and this problem was solved in a perfect way by the introduction of a fifth, or auxiliary striking gap, Z-C supplied from a sufficiently high voltage through the resistance Z_3 , Fig. 1. This striking gap circuit is independent of the main O-C gap across which the potentiometers are connected in parallel, so the load across the O-C gap does not affect the striking of the auxiliary gap. Now when ignition of the Z-C gap ionises the O-C gap, the excess voltage required for ignition of that gap is reduced too .1-2 volts, whilst in the old arrangement an excess of voltage of 20 to 50 volts was necessary. The ionisation of the O-C gap as a result of the discharge of the Z-C gap is ensured by the Z electrode surrounding the —C electrode, which is perforated at various points in accordance with a suggestion made by J. F. Tönnies. A current of about 1 mA is sufficient for operating the striking gap circuit; therefore when a Stabilovolt tube with a Z electrode is used on a circuit as shown in Fig. 1 the potentiometers connected in parallel with the O-C gap can be of sufficiently low resistance to avoid overloading that gap, and striking is assured. Even though the resistance across the O-C gap is below the maximum admissible value, no striking difficulties occur.

The following Z type Stabilovolt tubes are manufactured:—

STV 280/40Z	for	4 × 70	volts	division	and	40	m/A	max.	current	passing	in	the	gap.
STV 280/80Z	for	"	"	"	"	80	"	"	"	"	"	"	"
STV 280/150Z	for	"	"	"	"	150	"	"	"	"	"	"	"

circuit under load. The use of barretters greatly facilitates striking. It is a well known fact that when a circuit including a barretter is first switched on, the barretter being cold, an increased current will pass for a short time during which the barretter is being heated. This also occurs if the barretter is switched on after a short cooling period, and the increased current will cause a higher voltage than normal to appear at the electrodes of the gas discharge tube and will strike it. However, a barretter

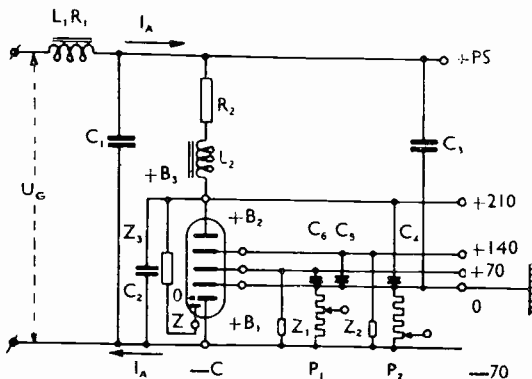

FIG. 1.

Anode and grid supplies for the first stages of a transmitter, i.e., Master Oscillator and early stages; Grid bias for these and later stages can be taken from the Stabilovolt tube. Anode voltage for the later stages can be taken from the termination of the smoothing system at +P.S.

The new Z electrode of the Stabilovolt tube is energised through the striking resistance Z_3 , from a suitable high voltage, thus securing certain striking of the —CO gap.

in Fig. 1 is not at present being considered. Potentiometers for grid bias are connected in parallel with the O-C gap of the Stabilovolt tube. The circuit formed by the O-C gap and its parallel potentiometers carries the total current of those valves which are supplied by the Stabilovolt tube, and this may reach a current intensity of 200 mA or more. Care should be taken that the O-C gap is not overloaded. For this purpose the combined resistance of all potentiometers connected in parallel with the O-C gap is made of such a value that only the permissible portion of the plate current passes through the O-C gap whilst the other part flows through the potentiometers. With such an arrangement it may happen that the resistance value of the potentiometers connected in parallel becomes so small that the excess voltage required for striking cannot be produced at the electrodes, the potential difference at the terminals of the parallel potentiometer system being too low to cause the gap to strike. Before the O-C gap strikes a voltage somewhat higher than the operating voltage is required at the gap electrodes, and at the terminals of the potentiometers, and because of this the grids of the various valves are biased more negative than normal, and a lower plate current flows. Now as the resistance

cannot be used in every case. In certain cases, especially in the fields of application mentioned at the beginning, certain difficulties arise on account of the dimensions required to obtain faultless striking.

Amplifiers, transmitters, etc., whose early stages are at a lower voltage than the later stages, can be supplied from a stabilised source in the early stages, and an unstabilised supply in the final stages. This is shown diagrammatically in Fig. 1. In such cases it is usual to refrain from stabilising the voltage applied to the final stages, and to obtain this supply from the point P.S. the end of the smoothing system. The grid potential of these stages may be derived from the O-C gap of the Stabilovolt and this is often a great convenience when setting up the entire circuit. The anode and grid potentials of the earlier stages may be taken from the Stabilovolt tube in the usual way. The Z electrode of the Stabilovolt tube shown

of the potentiometers is chosen to be of such a value that at normal plate current the O-C gap strikes, it may be found that with a lesser plate current the voltage across the gaps is insufficient for striking, and with unsatisfactory proportioning of the circuit the O-C gap of the tube may not strike. With high resistance potentiometers nearly the whole of the plate current must pass through the O-C gap of the Stabilovolt tube. Because of this it is only possible to use the Stabilovolt tube with-

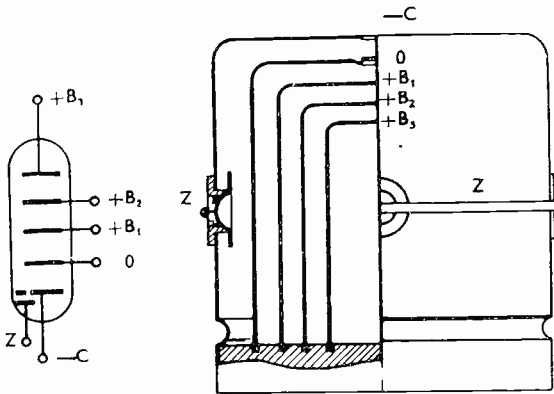

FIG. 2.

(a) Diagram showing the disposition of the electrodes of the new tube with Z gap and (b) part sectional view of the tube.

better method of striking, without overloading the Stabilovolt. When supplying anode voltages in the early stages of apparatus, the difficulties do not occur because the current taken by these early stages is less than that taken by the later ones.

The problem was one of reducing the O-C gap striking voltages, and this problem was solved in a perfect way by the introduction of a fifth, or auxiliary striking gap, Z-C supplied from a sufficiently high voltage through the resistance Z_3 , Fig. 1. This striking gap circuit is independent of the main O-C gap across which the potentiometers are connected in parallel, so the load across the O-C gap does not affect the striking of the auxiliary gap. Now when ignition of the Z-C gap ionises the O-C gap, the excess voltage required for ignition of that gap is reduced too .1-2 volts, whilst in the old arrangement an excess of voltage of 20 to 50 volts was necessary. The ionisation of the O-C gap as a result of the discharge of the Z-C gap is ensured by the Z electrode surrounding the -C electrode, which is perforated at various points in accordance with a suggestion made by J. F. Tönnies. A current of about 1 mA is sufficient for operating the striking gap circuit; therefore when a Stabilovolt tube with a Z electrode is used on a circuit as shown in Fig. 1 the potentiometers connected in parallel with the O-C gap can be of sufficiently low resistance to avoid overloading that gap, and striking is assured. Even though the resistance across the O-C gap is below the maximum admissible value, no striking difficulties occur.

The following Z type Stabilovolt tubes are manufactured:—

STV 280/40Z	for	4×70	volts	division	and	40	m/A	max.	current	passing	in	the	gap.
STV 280/80Z	for	"	"	"	"	80	"	"	"	"	"	"	"
STV 280/150Z	for	"	"	"	"	150	"	"	"	"	"	"	"

The first two are modifications of the well known earlier types of Stabilovolt tube, but the third represents a new type having entirely new data. The currents given in the table indicate the maximum current which the tubes are capable of handling. The circuit should be so arranged that should the load be accidentally disconnected from the tube, the resultant current in the tube will not exceed the given figure when the load is applied to the tube; the current passing in the tube falls in value by the current taken by the load.

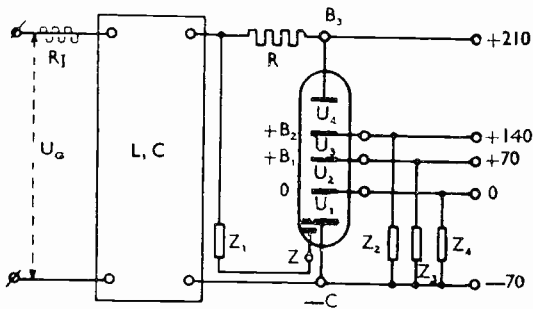

FIG. 3.

General scheme of connections of a stabilised supply system employing a Z Stabilovolt tube, where U_G is a source of supply, L.C. a smoothing system, R_1 representing the internal resistance of the power supply, R an added resistance or barretter, Z_1, Z_2, Z_3 and Z_4 resistances to facilitate striking of the intermediate gaps between the tube electrodes.

The Stabilovolt tube is connected as a floating battery between power supply and load.

When the load and supply are connected across the whole tube. In order to visualise the succession of striking of the various gaps, it is necessary to consider the supply voltage U_G slowly increasing from zero. With the Stabilovolt connected as in Fig. 3, the gap $+B_3+0$ will strike through the resistance Z_1 when a certain critical voltage U_G is applied. The next gap to strike will be $+B_2+0$ through the ignition resistance, Z_2 . At this time the $-CO$ gap has not struck and as this gap, the $+B_3+0$ and the $+B_2+0$ gaps have each a working voltage of approximately 70 volts, there remains for the striking of the $+B_1+0$ gap a voltage which is the difference between the applied total voltage and the sum of the working voltages of the $+B_3+0$ and $+B_2+0$ gaps. In the case of the four gap tube, as the working voltage is approximately 280 volts and the total applied voltage to the tube is slightly higher than this, there remain 140 volts at least for the striking of the $+B_1+0$ gap through the resistance Z_3 so the striking of this gap is certain. The last gap $-CO$ is provided with the Z electrode and as this electrode is supplied from the total applied potential through the resistance Z_4 , the Z gap will strike ionising the $-CO$ gap and causing striking of that gap at a potential very little greater (perhaps 2 volts) than its working voltage. Thus the

A Stabilovolt tube requires for striking purposes an excess voltage e_2 . A four gap tube if fitted with striking resistances does not require an excess of 4 e_2 , but only of e_2 . Fig. 3 shows a circuit arrangement including a Z-Stabilovolt tube in which, in addition to the striking resistance Z_1 assigned to the Z-C gap, further striking resistances Z_2, Z_3 and Z_4 are included. The effect of these resistances is that the individual gaps of the glow divider do not strike simultaneously but in succession, and only the last gap requires an excess voltage for striking. In the case of the other gaps a voltage of much higher value than required is available. If the succession of striking is chosen so that the last gap is the striking gap, the excess striking voltage required for the whole of the Stabilovolt tube is reduced to 0.1 to 2 volts.

This, however, will only hold good when the load and supply are connected

The Marconi-Stabilovolt System.

total overall voltage required for striking of the whole tube is only approximately 2 volts higher than the working voltage.

The Z tube therefore is particularly applicable to cases where the supply voltage and power cannot be easily increased above a certain limit, for example in the case of hand-driven generators. It has already been stated that the whole of the Z tube will ignite at a voltage very little in excess of the output voltage of the tube, but it must be realised that it is beneficial to connect the tube in series with a resistance to the terminals of the supply as in Fig. 3. Therefore the total voltage to be applied to the series resistance and stabiliser must be sufficiently high to allow for the potential difference at the terminals of the resistance at full load current, plus the voltage required by the tube. In the case of a fluctuating voltage, the lowest value must meet this requirement ; the higher value of the varying voltage will be handled by the system, and a substantially steady voltage will be obtained. As to the choice of the series resistances to fit the supply voltage, reference should be made to the paper entitled " Stabilised Current Supply," published by the Marconi Company.

Experience will no doubt reveal other features of these new tubes. In conclusion it may be stated that the Z tube can be used wherever the older tube has operated, and if not required the Z gap can be left disconnected.

MARCONI NEWS AND NOTES

MARCONI COMPANY'S FORTIETH ANNIVERSARY.

THE fortieth anniversary of the formation of the Marconi Company fell on July 20th. When the Company was formed on July 20th, 1897, the maximum range over which wireless messages had been received was ten miles, though later in the same year a distance of thirty-four miles was achieved. Persistent research and experiment, in face of not a little opposition and scepticism, brought steadily improved results until the Atlantic was bridged in 1901 and the whole Empire linked by a chain of wireless beam stations in 1928.

To-day, when wireless communication with the ends of the earth is a commonplace, wireless telephony between the Antipodes is taken for granted, broadcasting brings Viennese opera to the lonely outpost and American jazz to Vienna, and television enables people to sit in their homes and see the Coronation procession or the Centre Court at Wimbledon, the limited outlook of many scientists in 1897 seems incredible, and the vision and assurance of the founders of the Marconi Company appreciated at less than they deserve.

Wireless has created a new industry and given employment to many thousands of people. The manufacture of Marconi commercial wireless telegraph stations, broadcasting transmitters, aircraft and aerodrome installations, naval, merchant marine, military and police wireless equipment and wireless operating services on board ship provide employment for nearly 5,000 persons in England alone. Many thousands of people are also employed at the factories of companies associated with the Marconi Company in the British Dominions and other overseas countries throughout the world.

Apart from the employment provided by the Marconi Company itself it is estimated that the wireless industry, which has sprung from Marchese Marconi's inventions, employs 50,000 workpeople in Great Britain, and that the British radio industry alone has a turnover of £30,000,000 per annum. The combined figures for all countries in the world are beyond compilation.

The enormous amount of money spent on research by the Marconi Company has resulted in the acquisition of some thousands of patents which have revolutionised the art of wireless communication. Over 180 Marconi broadcasting stations have been supplied, and maintain Britain's reputation for workmanship in no fewer than thirty-two countries; Marconi aircraft and aerodrome wireless equipment is extensively used for communication and navigation by air transport companies throughout the world and are in use in more than thirty countries; while over

3,000 British ships alone carry Marconi wireless installations and thousands of people owe their lives to their use.

Such, in brief, is the astounding progress made during the forty years of the Marconi Company's existence. It indicates in some measure the debt the world owes to the pioneer workers of this Company for the establishment of a new industry and for all the advantages of wireless enjoyed to-day.

British Transatlantic Test Flight.

THE first British transatlantic test flight to be accomplished to schedule under commercial conditions, which took place at the beginning of July, provided data of an extremely valuable nature from a technical as well as from an aircraft operating point of view.

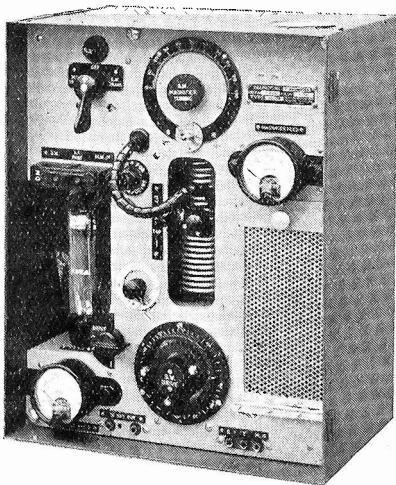

Marconi Short-wave Aircraft Transmitter, 16.9-75 metres.

One of the features of this flight was the excellent service rendered by the Meteorological and Wireless Departments. Weather problems on the North Atlantic, and more particularly the question of prevailing winds, had been the subject of careful study for some months before the flight took place, and the question of wireless communication and direction finding on both medium and short waves fully examined.

Apart from the expert navigation of the crew and the reliability of the aircraft employed, one of the outstanding features of the flight was the success attained by short wave wireless communication. More than one problem presented itself in regard to short wave communication on the North Atlantic ; but in a communication issued after the flight Imperial Airways stated that " examination of detailed reports as to the wireless service showed how admirably all technical difficulties had been overcome. By carrying out a considerable amount of preliminary test work, and by changing wavelengths as required to meet varying conditions during the actual flight, signalling from one shore station to another and also from shore bases to aircraft and between the aircraft in flight and ships in its vicinity, the flight was carried out with a precision which is an excellent augury for the success of a regular Atlantic air mail when this is making its scheduled flights."

This is a tribute to the work done by the Marconi Company on behalf of Imperial Airways, the wireless equipment on the "Caledonia" and also that at Foynes and Botwood being of Marconi design and manufacture.

Captain A. S. Wilcockson was in charge of the "Caledonia" on its first flight, and Mr. T. A. Vallette, the Marconi engineer who has been most closely associated with the equipment of the Imperial Airways flying boats, was allowed to make the first trip on this aircraft in order to observe the operation of the wireless service.

The Marconi wireless equipment on the "Caledonia," as well as on the "Cambria," which is also taking part in the transatlantic Service, is a development of that already fitted on the new Empire flying boats operated by Imperial Airways on the routes to Africa and India, and like these earlier installations has also been constructed in the aircraft establishment of the Marconi Company at Hackbridge, near the London airport at Croydon.

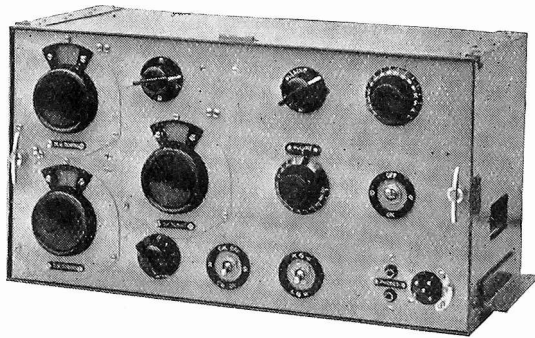

*Marconi Short and Medium Wave Receiver,
AD68/72.*

co-operate with both the British Air Ministry, the Irish Free State and the Canadian and American wireless systems, the wireless installations have to be far more flexible and cover wider wavebands than the earlier Empire boat equipment.

The wavebands used for communication were between 16.5 and 75 metres for long distance telegraphy, 95-185 metres telephony and telegraphy for long distance and approach work on the American side, and 500-1,000 metres for medium range and approach work on the British side. A direction finder and visual indicator were also incorporated in the equipment, the rotatable frame aerial for the direction finder being arranged so that it could be withdrawn into the hull of the aircraft when not in use.

Aircraft Exhibition.

THE static and flying displays of the Society of British Aircraft Constructors, an event which annually attracts aircraft experts from all parts of the world, took place this year at Hatfield, near London, on June 28th and 29th. As usual, the Marconi Company—a member of the Society—had a stand at the static display showing a wide range of wireless transmitting and receiving apparatus

for aircraft services, including new designs for commercial and military aircraft, wireless direction finding and "homing" devices, facilities for remote control of aircraft equipment, constant speed generators, ignition screening harness and aircraft wireless accessories.

Over 90 per cent. of British civil aerodromes on the Empire air routes, and many on the continent of Europe and in other parts of the world are fitted with Marconi wireless installations, and the Marconi Type D.F.G.10 aerodrome direction finding receiver, designed for use with either the Marconi-Adcock anti-night effect aerial



Marconi Stand at S.B.A.C. Exhibition.

system or with loop aerials was therefore of particular interest. It is a highly selective and easily manipulated instrument intended for directional reception and high precision direction finding, and can be used for the reception of continuous wave, interrupted continuous wave, or telephone signals.

A large number of these installations has been ordered for civil aerodromes throughout the Empire and foreign countries, including many for use on the Empire air routes.

The Marconi Company has followed up its initial success with the medium wave Marconi-Adcock direction finder system by the development of a similar receiver for use on short waves and this, the Type D.F.G.12, was also exhibited.

Remote Control.

ANOTHER interesting new exhibit was the Marconi AD68/72 medium wave direction finding receiver with remote controls. This set is designed for use in military and commercial aircraft either for general purpose and D.F. reception or as a supplementary direction finding receiver for aircraft already fitted with general purpose equipment. It covers a waverange of 180-2,000 metres. The receiver can be used with either a fixed aerial for "homing" or a rotatable aerial which enables bearings to be taken from other stations and also retains the special features of the "homing" system. The remote control unit enables the receiver to be placed in any convenient position in the aircraft and to be controlled by the pilot or the wireless operator.

The aircraft wireless installations shown were suitable for communication on all wave lengths down to the ultra short wave band of 1.8-2 metres, the latter being intended for communication between aircraft, aircraft and the ground, harbour headquarters and flying boats and similar services over medium distances.

Among the aircraft accessories were some sets of Marconi ignition screening harness, which is coming into universal use with the increase in the number of long distance air services relying very largely on efficient wireless communication carried on by means of sensitive short wave receivers and direction finders.