

# THE MARCONI REVIEW

March-April, 1935



## CONTENTS

SCATTERING, POLARISATION ERRORS AND THE ACCURACY OF SHORT WAVE DIRECTION FINDING	- -	PAGE 1
AN INVESTIGATION OF THE OPTICAL EFFECTS IN ELECTRICALLY STRESSED QUARTZ—PART II.	- "	9
THE MARCONI CATHODE RAY OSCILLOGRAPH	- -	" 19
A NOTE ON THE MARCONI INFRA-RED LIGHT BEAM LINK	- - - - -	" 26
MARCONI NEWS AND NOTES—		
CRYSTAL CONTROLLED WIRELESS BEACON	- -	" 29
BROADCASTING ACTIVITIES AT CHELMSFORD	- "	30
SHORT WAVE TELEPHONE FOR VENEZUELA	- -	" 31
ADDITIONAL TELEPHONE CHANNEL FOR SOUTH AFRICA	- - - - -	" 32
WIRELESS TIME SIGNALS IN THE ANTARCTIC	- "	32

MARCONI'S WIRELESS TELEGRAPH COMPANY LTD.  
Electra House, Victoria Embankment, London, W.C. 2

# THE MARCONI REVIEW

---

No. 53.

March-April, 1935.

---

Editor: H. M. DOWSETT, M.I.E.E., F.Inst.P., M.Inst.R.E.

Assistant Editor: L. E. Q. WALKER, A.R.C.S.

---

## SCATTERING, POLARISATION ERRORS AND THE ACCURACY OF SHORT WAVE DIRECTION FINDING

*One of the first attempts to develop the technique of short wave direction finding was made during the latter part of 1926. The results were described in "Short Wave Wireless Telegraphy," Journal I.E.E., June, 1927. Further development in which a type of Adcock aerial was used in the hope of reducing polarisation errors was described in the Journal of I.E.E., August, 1929.*

*Although the writer had no doubt of the interpretation of these original direction finding experiments, some more definite and conclusive alternative evidence is perhaps required. The part that scattered radiation plays in short wave direction finding is disclosed in the following article.*

*A full account of the experiments would take up too much space, but enough will be said to indicate the bearing of the results on the direction finding problem.*

**I**N the second article mentioned in the above summary the limitations of short wave direction finding were clearly realised. In fact, it was considered that the short wave Adcock aerial, as then developed, could not seriously enter the field as a navigating instrument, and that its use was confined to the investigation of short wave transmission problems, where it served a very useful purpose. The necessity of navigating aircraft over very long distances, such as, for instance, the Transatlantic route, has brought the question of short wave direction finding to the forefront again, if only because it is the only means of covering the ranges required. The medium wave 900M. beacons are out of the question because the power required to produce an adequate signal at these distances is entirely prohibitive.

The limitations referred to above are very evident to anyone who has experience of short wave direction finding. When using a frame for the reception of signals emitted by a station outside the skip zone, the wandering, and occasional complete absence, of the bearing, indicates a high degree of polarisation error, or Night Effect.

High angle rays partially or wholly horizontally polarised are indicated, and direct measurements of these ray angles and polarisations confirm this. These polarisation errors can be partially but not wholly eliminated by the use of an Adcock aerial. If the sending station is within the skip zone and has an aerial which emits equally in all directions, then neither an Adcock or frame shows any

sign of bearing, except, of course, in the case where the sender is so close that the direct ray is received with sufficient strength. This absence of bearing in the skip zone has been attributed to scattering, and evidence has been put forward\* that the region within the skip distance is illuminated by a fog of scattered radiation.

The picture suggested is that of a transmitter at T, Fig. 1, radiating in all directions. The receiver at R would receive nothing directly reflected from the Ionosphere, for this is not dense enough to reflect such a ray as TBR (if the receiver is in the skip zone), but would receive radiation scattered back from some point or points in the path of the direct radiation. Since these are supposed to be situated uniformly round the transmitter, the radiation at the receiver will come from every direction, and will thus exhibit no signs of direction.

The evidence in support of this picture is mainly based on directional measurements which are themselves in doubt. Again the ordinary pulse technique in which short pulses are projected up to the Ionosphere and reflected back has failed to indicate scattered signals, and I suppose a sceptical attitude towards the existence of such scattering is natural.

The existence of scattered radiation is put beyond doubt, and the part it plays in short wave direction finding is disclosed, in the experiments described here, which were undertaken with these objects in view, and also with the object of determining the limiting accuracy obtainable in short wave direction finding.

#### Ongar Scattering Experiments.

The absence of any observable scattering when using the normal low power pulse transmitters, suggests that a high power is necessary to bring the scattered signal above noise level. The

40 Km. transmitter at Ongar was recently available by the kind consent of the I. and I.C. at certain times, and appeared ideal for the purpose of recording scattered radiation. Arrangements were accordingly made to key this with pulses of very short duration, i.e., about 0.0002 sec., at a rate of 50/sec.

A receiver at Broomfield, near Chelmsford, 15 miles from Ongar, with a cathode ray indicator, was used, and by controlling the pulse frequency at the transmitter and scan frequency at the receiver from the 50 cycle mains a stationary picture of the emitted pulses could be obtained.

Fig 2 (A) shows a photograph of the signal pattern obtained, when transmitting on 30M. In addition to the direct ground ray G, Fig. 2 (B), there were single transient echoes at F<sub>1</sub>, and a permanent blurr of scattered echoes at S.

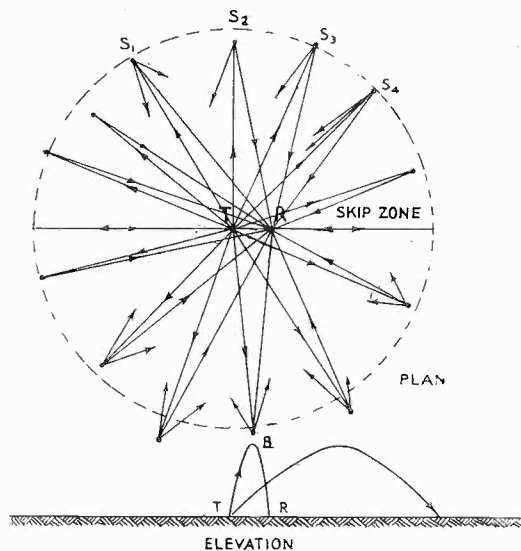

FIG. 1.

\* Journal I.E.E., *loc. cit.*

The frequency 10 megacycles was so high that no direct normal reflection from the Ionosphere was possible.

The significant characteristics of these echo signals are as follows. G is the unfading ground ray. It gives a well defined steady bearing, the accuracy of which is only limited by the instrumental imperfections of the Adcock and frame aerial direction finders used. The echoes of which F is an example are transient, and may last from a fraction of a second to a few seconds. The delay time is irregular, and may be anything from 0.7 to 3.6 milliseconds, and is such as might ensue from vertical reflections from regions of sufficient discontinuity in the Ionosphere. The echoes are generally circularly or elliptically polarised, sometimes right and sometimes left-handedly, which is of course a characteristic of vertically or almost vertically

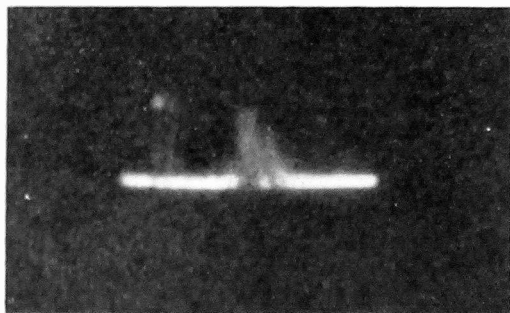

FIG. 2 (A).

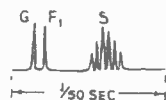

FIG. 2 (B).

reflected rays. This result, coupled with the time delay values, makes it reasonable to infer that these echoes are vertical or nearly vertical reflections from the Ionosphere. The F echoes show no characteristic direction on either frame or Adcock aerial.

The scattering echoes S have a rather sharply defined leading edge, the time delay of which is from 6 to 13 milliseconds, depending on the wave lengths used and the time of day, season, etc., and corresponding with an equivalent distance of travel of 900 to 2,000 km. or twice this if the outward and return paths are considered. For this reason they are unlikely to be vertical reflections, and indeed other evidence definitely shows that they are not.

The scattered radiation S shows no signs of direction on an Adcock aerial, and also no signs of circular polarisation.

It has been suggested that the path of S reflections is vertical, and that they are reflected from Ionic clouds at a height of from some 900 to 2,000 k.m. above the earth surface. There is very definite evidence against this view and in support of the supposition that the path or paths are nearly horizontal. This evidence is obtained by the study of emission from transmitting stations with beam aerials. If an Adcock aerial with a cathode ray tube indicator is used to determine the direction of arrival of the waves sent out by such a station, it is found that the signal received can be resolved into a direct ground signal (when it is within the direct ray range), and a delayed scattered signal which shows a very marked direction. When the receiver and transmitter are sufficiently close, this is the direction of the emitted

beam. A reference to Fig. 3 will make this clearer. Let T represent the transmitter and O the receiver. TS then represents in plan the central line of the beam

If energy is scattered back from some points  $S_1, S_2$ , along the beam, then the direction of the scattered energy received at O is OS, i.e., practically the direction of the beam, which agrees with the observed result. Vertical reflection would give no signs of direction, even from a beam transmitting aerial. Further, a more exact measurement of the direction OS shows that it is not quite identical with TS. Measurements of this angle enable the elements of the triangle TSO to be determined, and the distance of the scatter source S so determined agrees approximately with that derived from the time delay measurements, at least for waves from 30M. downwards. We may therefore conclude that the scatter signal S is mainly horizontally propagated.

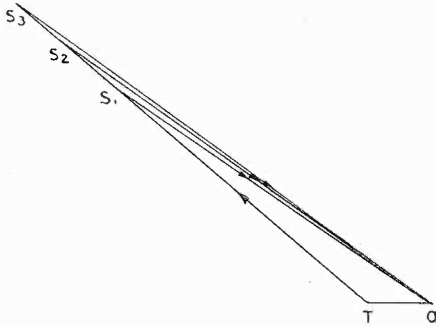

FIG. 3.

The significance of these results for direction finding within the skip distance is quite clear.

Where the distance is so great that the ground signal G is lost, the scattered signals F and S from an omni aerial will show no signs of direction. If a beam aerial is used quite a marked bearing may be obtained, but it is generally entirely wrong, being the direction OS instead of the true direction OT. The use of a cathode ray indicator for reception, instead of an aural method, may extend the region in the neighbourhood of the transmitter where bearings can be obtained, if provision is

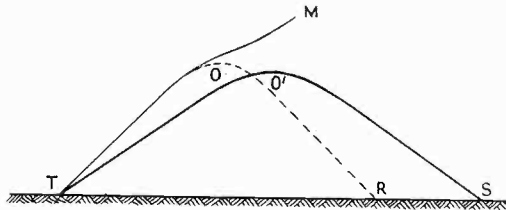

FIG. 4.

made for sending out pulses or very short Morse signals from the transmitter; for in such conditions it is possible to isolate the ground ray and obtain a direct bearing at distances at which it would be drowned by the scattered radiation in aural reception.

Experiments have indicated that this method of reception may gain some ground at the inner edge of the skip zone. The state of affairs that occurs in such conditions may be illustrated by Fig. 4.

Let T be the transmitter, R the receiver and S the edge of the skip zone, which we will assume is beyond R.

Then although TO'S is a possible ray, such rays as TOR are not possible because a ray projected at such an angle, TM, will escape. It may well be, however, that

small angle scatterings in the neighbourhood of O will reflect back some energy to R. The ray does not escape completely.

Such scattered energy, though weak, has been observed in pulse transmissions from  $DOD\lambda 41.45$  from Berlin. It gives a well marked correct bearing, and can be generally distinguished from other energy which is scattered back from regions beyond the skip.

Put in another way, the main signal, although skipping over the receiving station, is not entirely lost. The signal may be reduced some 30 to 40 dB., but sufficient remains to supply a signal on which a bearing can be obtained.

In practice such methods are not likely to be of much value except in the hands of a skilled and experienced operator.

In the organisation of navigating services, it should always be possible to evade these difficulties of D.F. in the skip zone by choosing a wave length such that the receiver is always outside the skip distance.

Although signals (which would not otherwise be there) are produced within the skip zone by the mechanism of scattering, no help is provided for direction finding, since these signals, in general, arrive from all directions.

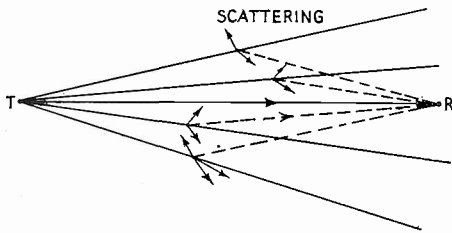

FIG. 5.

This scattering and its effect is mainly instrumental within the skip zone, while the polarization error is the main limitation to accurate direction finding outside the skip zone, although there is a residual effect due to the former.

For it is clear that there exist regions on the path of the rays where appreciable energy is scattered back over angles of approximately  $180^\circ$ , giving rise to the effects observed in the skip zone. It follows with almost complete certainty that there must be small angle lateral deviations of the main ray which will result in a cone of rays being received at R (Fig. 5) instead of one single ray of definite direction.

This inaccuracy due to the uncertainty of direction is essential, for no receiving device, the function of which is to indicate direction, can specify this direction with greater accuracy than that with which the actual direction of the waves is defined. Since this direction is spread over an appreciable cone of rays the accuracy of the D.F. will be limited to a degree depending on the spread of this cone of rays. It is possible to conceive of receiving arrangements which will eliminate the polarisation error, but not the scattering error. The limiting accuracy of short wave direction finding is therefore defined by this degree of scattering.

### Spaced Aerial Experiments.

The following experiments were designed and carried out with the double object in view: (1) of designing a directional indicator free from polarisation error, and (2) of determining the residual inaccuracy. These experiments originated in some carried out years ago and described in Journal I.E.E.

Two aerials were used, spaced apart a distance of the order of a wave length. These, coupled to a central receiver by means of cables, were used to determine the

direction of the received waves by measuring the phase difference of the E.M.F.'s induced in the aerials.

Consider now a plane wave the plane of incidence of which makes an angle  $\theta$  with the plane perpendicular to the line joining the two aerials. Suppose the ray direction of the normal to the wave surface makes an angle  $\alpha$  with the horizontal plane, then the phase difference of the E.M.F. at the two aerials is  $\frac{2\pi d}{\lambda} \sin \theta \cos \alpha$  whatever the polarisation of the signal E.M.F.'s at A and B.

Thus, if the aerials A and B only respond to the signal E.M.F. actually at A and B the quantity  $\sin \theta \cos \alpha$  is determined. For small angles of elevation  $\cos \alpha = 1$  and  $\sin \theta$  and  $\theta$  the wave direction is found.

In such circumstances the polarisation errors are eliminated. Unfortunately one essential part of the arrangement is the cable joining the aerials to the receiver. Whether this is an open or shielded cable, E.M.F.s will be set up in the horizontal members by the horizontally polarised component of the wave, and E.M.F.s will be transferred, by the coupling of this cable, to the aerials, which are not dependent only on the signal E.M.F.s at A and B, but on the distributed or mean E.M.F. between A and B. This arrangement will fail to eliminate the polarisation error due to the horizontal component of the wave.

According to the above this can be avoided if there is no transfer coupling between the outer sheath of the feeder and the aerials. This coupling can be made zero if frame aerials are used and so arranged that they lie in a plane perpendicular to the line of the cables, and also symmetrically with respect to a vertical plane through the cables. The arrangement is shown in Fig. 6, from which its function will be more clearly realised than from the description. Experiments can be devised to measure this transfer coupling, and adjustments can be made to reduce it to negligible value. The arrangement is then free from polarisation errors. To make practical use of it as a direction finder the whole aerial and feeder system should be made capable of rotation about a central vertical axis. When oriented so that the line joining the aerial is perpendicular to the plane of incidence,  $\theta$  and the measured phase difference is zero.

A sharp balance could be obtained indicating the true direction of the incoming waves. The aerial spacing necessary for sensitivity is, however, so large that this arrangement is clumsy and offers considerable practical difficulties.

It is more practical to use the system as a course indicator. In this case the line joining the aerials is set perpendicular to the course required. If the aeroplane or any other mobile unit is on the correct course the signals from it will arrive at the two aerials in phase, and a balance in the receiver will be obtained when the phase in the line is adjusted to  $180^\circ$ . Should there be a phase changing unit in one of the cables, then any deviation from the true course will be indicated by the change of phase necessary to balance the signals. If this change of phase is  $\delta\phi$  then  $\delta\phi = \frac{2\pi d}{\lambda} \sin \delta\theta$  or if  $\delta\theta$  is small,  $\delta\theta = \frac{\lambda}{2\pi d} \delta\phi$ , which gives the angular deviation from the true course.

This procedure is limited to small angular deviations, if the separation  $d$  of the aerials is large, for there is a certain amount of ambiguity in the above relation,

the maximum value of  $\theta$  being given by  $\frac{\lambda}{a}$ . Used as a course indicator this is not a serious matter.

A direct measure of the limiting D.F. accuracy can be made with this arrangement. Thus, if the aerials are set up so that the line joining their centres is perpendicular to the true bearing of the station to be observed, a balance on the receiver should be obtained when the relative phase of the two is exactly  $180^\circ$ .

The variability of the wave direction will then be shown by the variability of the phase balance position. This can be translated into directional variability by means of relation (1).

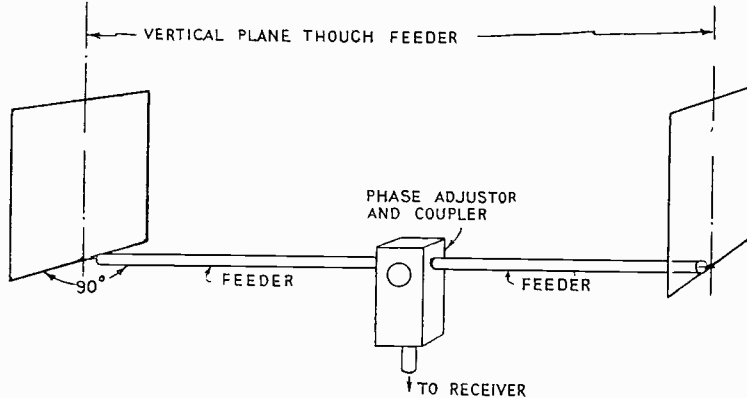

FIG. 6.

There is another way of determining this limiting inaccuracy due to scattering and consequent spreading of the rays over a small cone, which leads to a convenient method of measurement :

Consider the resultant E.M.F.s at two points A and B, more or less transverse to the direction of transmission.

Each separate ray of the bundle of rays received will contribute an E.M.F. at A and B, so that the resultant at A and B will be the sum of a more or less random set of vectors. But the effects at A and B are not entirely unrelated, and there will be a certain correlation between the resultant values at A and B and at the same time a certain diversity in the effects at these two points. The degree of correlation, or conversely diversity, will depend on the separation of the two aerials A and B.

Obviously, if they are very close, then for every component received on A there will be a practically identical one at B—identical both in phase and amplitude—and the resultants at A and B will also be identical.

On the other hand, if A and B are well separated the contribution to the two will not be identical in phase because the relative phase depends on the direction of the ray considered, which is accidental within a certain cone, and there will be a certain degree of diversity in phase of each individual contribution and consequently a certain diversity in both phase and amplitude in the resultants at A and B. This diversity effect at well separated points is now a well-known feature of short wave working and is, as has been demonstrated, a measure of the diversity in direction of the incoming signal.



**Correlation Coefficient.**

The correlation coefficient between the resultant E.M.F. at A and that at B can be calculated, and expressed as a function of: (1) the distance apart of A and B ( $d$ ); (2) the probable spread of the cone of rays.

This spread is defined as follows: Let  $\phi$  be the angle of any one of the rays with the true direction, then the probability that a ray will be between  $\phi$  and  $\phi + d\phi$  is

$$\frac{1}{\phi_0 \sqrt{\pi}} \cdot e^{-\phi^2/\phi_0^2} \cdot d\phi$$

and  $0.477\phi_0$  will be the probable error in direction.

The correlation should be unity when either  $d$  or  $\phi_0$  are zero, and should decrease as both increase.

For small values of  $\phi_0$ ,  $r$ , the correlation coefficient, can be expressed in the form

$$r = 1 - \left(\frac{2\pi d}{\lambda}\right)^2 \frac{\phi_0^2}{4}$$

which illustrates the above characteristics.

**Measurement of the Correlation Coefficient.**

If the correlation coefficient were unity there would always be a definite relation in amplitude and phase of the resultants at A and B, and an adjustment of the spaced frame arrangement should enable a perfect balance, as far as instrumental imperfections allow, to be obtained. If, however, the correlation were not perfect ( $r < 1$ ) no adjustment of the relative phases and amplitudes at A and B would result in a complete balance, and in the extreme case, where  $r = 0$  and the resultants at A and B are entirely unrelated, the energies are added and the resultant output would be entirely independent of the relative phase adjustment and there would be no signs of balance.

Thus  $r$  may be related with the degree of balance obtainable.

If  $\bar{V}^2$  is the mean square value of the output at the minimum, and  $\bar{U}^2$  is the mean square value of the output at the maximum, then

$$\frac{\bar{V}^2}{\bar{U}^2} = \frac{1 - r}{1 + r}$$

Substituting the above value for  $r$ , we get

$$\frac{\bar{V}^2}{\bar{U}^2} = \frac{\left(\frac{2\pi d}{\lambda}\right)^2 \frac{\phi_0^2}{4}}{2 - \left(\frac{2\pi d}{\lambda}\right)^2 \frac{\phi_0^2}{4}} = \frac{\left(\frac{2\pi d}{\lambda}\right)^2 \frac{\phi_0^2}{8}}{2 - \left(\frac{2\pi d}{\lambda}\right)^2 \frac{\phi_0^2}{4}} \quad \text{and} \quad \frac{\bar{V}}{\bar{U}} = \frac{2\pi d}{\lambda} \frac{\phi_0}{2\sqrt{2}}$$

The ratio  $\frac{\bar{V}}{\bar{U}}$  can easily be measured. It is the degree of balance obtainable.

We can then calculate  $\phi_0$  and the limiting probable error from the above relation.

In a concluding article results of such measurements will be described and discussed.

The bearing of these results on the performance of a newly-designed Adcock aerial erected in, as nearly as possible, an ideal site will also be considered.

T. L. ECKERSLEY.

# AN INVESTIGATION OF THE OPTICAL EFFECTS IN ELECTRICALLY STRESSED QUARTZ

## PART II.

*In the first part of this article formulæ were developed for the investigation of the linear and circular retardation in stressed quartz. In what follows, the experimental determination of these retardations, of the ellipticity of the vibration within the quartz, and of the piezo optical constant is described. The behaviour of the stressed quartz is compared with that of nitrobenzene.*

### Experimental Investigation along the Optic Axis.

TO undertake this investigation we employ the quarter-wave plate with an analysing nicol. This is the simplest form of elliptical analyser. Referring to Fig. 2, we shall suppose that the ellipse shown therein is the form of vibration of the light emerging from the quartz. OX and OY are the vibration directions of the crystal. Now, in order to extinguish the emergent ray, the axes of the quarter wave plate must first coincide with those of the emergent ellipse. The light then passes through the quarter-wave plate and in suffering a retardation of a quarter of a wavelength becomes linearly polarised in the direction OQ. In order now to extinguish this vibration the analysing nicol must be set in the direction OA.

When extinction has taken place the orientation of the quarter-wave plate gives the angle  $\theta$  which is the azimuth of the major axis of the ellipse. The angle between the nicol and the axis of the quarter-wave plate AOF is the angle I. The remaining angles  $i$  and  $v$  can now be computed from equations 7B and 7C of section 5

$$\cos 2i = \cos 2 I \cos 2 \theta$$

$$\tan v = \frac{\tan 2 I}{\sin 2 \theta}$$

Suppose that we fix the quarter-wave plate with its axes parallel to the vibration directions of the quartz; then extinction can only take place when the retardation is a multiple of a quarter of a wavelength, for in this case the emergent ellipse must always have its axes coincident with the vibration directions of the crystal. Then  $\theta$  will be a multiple of  $\frac{\pi}{2}$  and  $v$  will be a multiple of  $\frac{\pi}{2}$ . The angle I only can assume intermediate values.

When the angle  $\theta$  is zero, then from equation 3 of section 6 we have

$$\sin \delta = 0$$

and the phase difference must be equal to an even number of half wavelengths if the emergent ray is linearly polarised. If the emergent ray is elliptically polarised  $\delta$  will be an odd number of half wavelengths.

For the linearly polarised emergent ray we have

$$\tan I = 0; \cos v = \pm 1; \cos \frac{\delta}{2} = \pm 1.$$

*An Investigation of the Optical Effects in Electrically Stressed Quartz.*

---

If the emergent ellipse has its major axis horizontal, then the phase difference  $\nu$  of the principal constituents will be given by

$$\nu = \frac{\pi}{2}$$

and the equations 7A and 7B of section 6 reduce to

$$\cos \frac{\delta}{2} = 0$$

$$\tan 2 \epsilon = \tan i$$

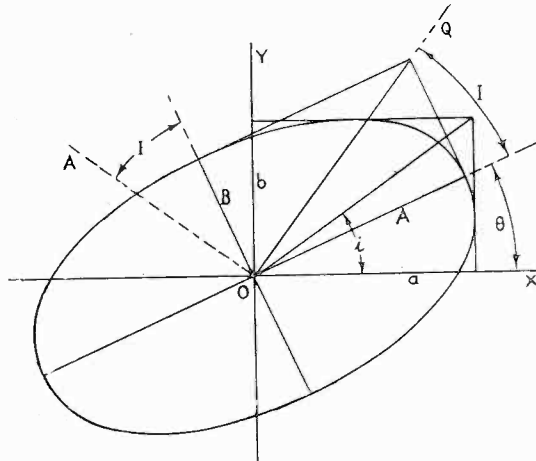

FIG. 2.

From the first of these modified equations we note that the phase difference between the elliptical components becomes

$$\delta = \pi, 3\pi, 5\pi,$$

$$d = \frac{1}{2}, \frac{3}{2}, \frac{5}{2}, \quad \text{etc.}$$

that is

$$d = \frac{2n + 1}{2}$$

From the second of these modified equations we have

$$\tan 2 \epsilon = \tan i$$

For a particular case in which the emergent ray is circularly polarised

$$I = 45, \tan i = 1$$

$$\epsilon = \frac{\pi}{8}; \tan \epsilon = k = 0.414.$$

When this is the case we have further from equation 12. section 5,

$$w = p$$

from which follows

$$d^2 = p^2 + w^2 = \frac{(2n + 1)^2}{4}$$

$$w = p = \frac{2n + 1}{\sqrt{8}}$$

when  $n = 1$ ,

$$w = p = \frac{3}{\sqrt{8}} = 1.0606.$$

In the experiments performed along the optic axis, two specimens were obtained, one of right-handed and the other of left-handed quartz. Each specimen was 7.12 cms. in length, and carefully ground and polished at the ends normal to the axis so that complete extinction could be obtained. Care also was taken that the light travel in the two specimens was parallel to the optic axis. The experimental layout is shown in Fig. 3.

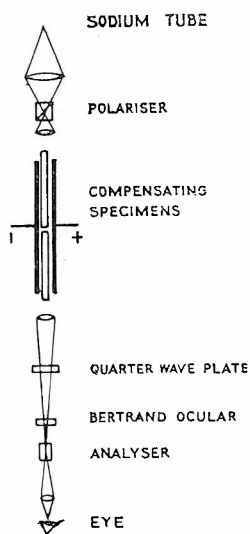

FIG. 3.

We have the polariser in the form of a nicol prism polarising the light from the source S, which was a sodium discharge tube. The light from this tube was first passed through a filter to eliminate some red rays due to the small trace of neon in the tube. After polarisation the light travelled through the specimens along the optic axis. Upon emerging from the crystal the light now passed through the quarter-wave plate which was rotatable against a circular scale. Finally, we have the analysing nicol also rotatable against a circular scale. If convenient, it is best to have projections from the quarter-wave plate and the nicol reaching to the one circular scale. The possibility of faulty readings is thus minimised.

The two crystals were stressed by applying to them the electric field across the electric axis. The thickness of the crystal along this axis was 0.87 mm. The width of the crystal along the mechanical axis was unimportant. It was of large enough dimension to allow 2 mm. margin each side of the electrode to prevent breakdown across the surface. Again, although the combined length of the crystals was over 14 cms., the actual length of the electrodes in this direction was only 13.2 cms. This was due to the necessity of providing the margin to prevent the electrical breakdown over the surface. Some attempt was made to cement the touching edges of the specimens with Canada balsam, but this was eventually abandoned owing to the surface breakdown.

The plane of polarisation of the incident ray was 45 deg. to the direction of stress.

Before stressing the quartz, the zero azimuth of the quarter-wave plate and the analysing nicol were set against the zero of the corresponding circular scale.

When a slight stress was applied extinction was again obtained, and the angles  $\theta$  and  $I$  were duly noted. Observations of these two angles alone provided all the experimental data needed to determine the value of the various quantities.

These remaining quantities are found as follows :—

Given  $\theta$  and  $I$

From  $\cos 2i = \cos 2\theta \sin I$

$$\tan v = \frac{\tan 2I}{\sin 2\theta}$$

*An Investigation of the Optical Effects in Electrically Stressed Quartz.*

we find  $i$  and  $v$

From  $\cos \delta = \cos v \cos i \dots \dots (45 \text{ deg. azimuth})$

we find  $\delta$

From  $\tan 2 \epsilon = \frac{I}{\sin v \tan 2i}$

we find  $\epsilon$

From  $w = d \sin 2 \epsilon$

$p = d \cos 2 \epsilon$

$d = \frac{\delta}{2\pi}$

we find  $w$  and  $p$

We can thus determine

$I, \theta, i, d, v, \epsilon, w$  and  $p$ .

TABLE I.

Observations along optic axis for two compensating specimens.

Volts	$d$	$p$	$w$	$k$	$P \times 10^8$
1,000	0.183	0.182	0.02	0.0451	2.150
1,500	.0275	0.274	0.02	0.0363	2.160
2,000	0.372	0.371	0.02	0.0276	2.210
2,500	0.465	0.464	0.02	0.0218	2.210
3,000	0.555	0.554	0.02	0.0183	2.220
3,500	0.650	0.650	0	0	2.230
4,000	0.765	0.764	0.02	0.0166	2.280
4,500	0.880	0.879	0.01	0.0116	2.280
5,000	0.965	0.964	0.01	0.0072	2.280
5,500	1.060	1.059	0.01	0.0052	2.300
6,000	1.159	1.159	0	0	2.300
6,500	1.280	1.279	0.01	0.0040	2.320
7,000	1.360	1.360	0	0	2.320

We define the piezo-optical coefficient by the retardation per unit length per unit electrostatic field within the quartz. This retardation is, of course, dependent on the wave length of the light passing through. In this case we are dealing with the light from a sodium lamp of wavelength  $5,890 \times 10^{-8}$  cms. Therefore, if  $l$  is the effective length of the electrodes of the quartz,  $e$  is the thickness along the electric axis;  $V$  the voltage equal to  $\frac{V}{300}$  statvolts; and finally, if  $d$  is the retardation, we have for the piezo-optical constant

$$P = 5,890 \times 10^{-8} \cdot d \cdot \frac{300}{V} \cdot \frac{e}{l}$$

The value of this constant was first given in terms of statvolts and not in terms of the practical unit, volts. There is no justification for making the change now.

We note with particular interest the fact that there appears to be no circular retardation along the optic axis for the application of the electric field. It has been previously supposed that the application of this field would bring about a rotation of the plane of polarisation of the light. If that were the case a simple

saccharimeter wedge would suffice to undertake the observations. Although this method was first adopted before the quarter-wave plate method of measurement, an actual and definite shift of the saccharimeter wedge band was not discernible. The dark band increased in light intensity only. This being the case, and assuming that only linear retardation took place on the application of the electric field, the Babinet compensator was applied. Although here a shift could be observed, the same effect of increase in the intensity was seen. It was decided, therefore, that the true effect was the sum of effects due to linear retardation and circular retardation together. For this reason the theory of Gouy was introduced into the investigation. Now we have discovered that the true effect is indeed one of pure linear retardation, but this is intermixed with circular retardation to a small degree. The latter may be likely due to imperfections in the quartz, faulty observations or inaccurate compensation of two quartz laminae.

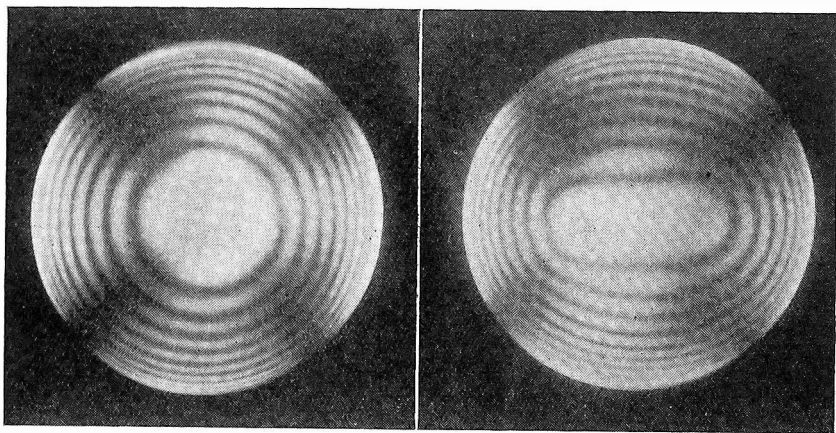

FIG. 4.

It is absolutely essential that the light passing between the two nicols is parallel, otherwise errors must occur, and we think that this may give the reason for the inability to employ the Babinet compensator. In order to obtain a perfectly parallel beam it was necessary to introduce a small aperture at the focus of one of the lenses. The size of this aperture was limited by the amount of light it would admit, and as the sodium lamp was not very intense, the aperture had to be relatively large.

We conclude therefore with the statement that the effect of an electric field across the piezo-electric axis of the quartz is to introduce a linear retardation alone, this linear retardation being superposed on the already existing circular retardation. By compensating for the circular retardation the linear retardation can be examined by itself, the ellipticity of the components being thus reduced to zero.

#### **Investigations at Small Inclinations to the Optic Axis.**

One specimen of the quartz was employed for these investigations. It was one of the two used in the experiments along the optic axis. Light was first allowed to pass parallel to the optic axis and then the crystal was rotated until a portion of the isochromatic rings came into view. These rings are shown in Fig. 4. It

was possible to observe 15 of them with ease as the quartz was rotated in the horizontal plane. In order to determine the retardation for any direction the portion of the black isochromatic ring was made to coincide with the vertical cross-wire. Then the quartz was stressed until the ring moved exactly half the distance between it and the adjacent ring. This distance was the mean of the distances between the ring in question and its right-hand and left-hand neighbour. The cross-wire was affixed to a micrometer screw. It was first shifted therewith the required distance and then the stress applied until the ring under observation coincided with it. The mean voltage was thus ascertained and the retardation computed. In this case the calculation was a little more complicated than in the preceding section, owing to the fact that the effective length of the light path between the electrodes was different for different orientations of the crystal. The formula therefore becomes

$$P = 5,890 \times 10^{-8} \times .5 \times \frac{300}{V} \frac{e}{l \sec r}$$

The retardation is, of course, one half, and  $r$  is the angle the light ray makes with the optic axis. If  $i$  is the rotation of the table supporting the specimen, then  $r$  is obtained from

$$\frac{\sin i}{\sin r} = \mu = 1.549 \quad (\text{mean index})$$

The resulting observations on 15 isochromatic rings is shown in Table 2. The second set of readings was obtained with a specimen cut with its optic axis 47 deg. 30 min. to the longer edge. With this specimen it was possible to take readings from 30 deg. to 60 deg. inclination to the optic axis. A third set of readings was taken with a specimen cut parallel to the optic axis so that for the central position the light travelled normal to this axis. With this specimen it was possible to obtain readings within 15 deg. of the normal to the axis. In both cases some compensation had to be provided, for without such compensation the rings were not distinct enough for the purpose of taking readings. As in the case of the first specimen readings were taken for half wave retardation, i.e., when the shift was equal to one half the space between two adjacent bands. In the table the three specimens are annotated A, B and C. A is the specimen cut normal to the axis. B is the intermediate 47 deg. 30 min. specimen, and C is cut parallel to the axis. In Fig. 5 we see the values of the piezo-optical constant plotted for the different observation angles. The shaded portions represent the range covered by the three specimens, A, B and C.

The distortion of the isochromatic rings is shown in Fig. 4. This photograph was taken by applying pure mechanical pressure, as it was not found convenient to photograph the distortion produced by the electric field. Both cases of distortion appear identical, but, of course, with mechanical pressure the distortion obtainable is much greater, as such intense electric fields are not readily produced.

If we take a set of axes at 45 deg. to the isogyres in the figure, we find that here the distortion of the isochromatic rings is similar to that produced by the introduction of a linear retardation plate. The rings in alternate quadrants are dilated and the rings in the remaining opposite quadrants are contracted.

It would appear that the curve of the piezo-optical constant is an ellipse in the plane containing the optical and the mechanical axes of the crystal.

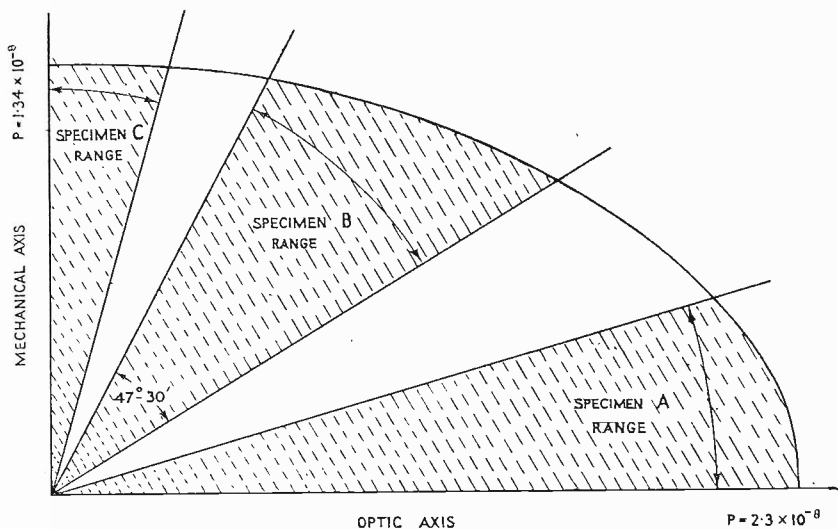

FIG. 5.

TABLE 2.

Observations inclined to the optic axis.

Volts	Inclination of light to axis		Inclination of light to long edge		Piezo-optical constant $\times 10^8$	Specimen
	Deg.	Min.	Deg.	Min.		
2,680	3		3		2.220	A $l = 13.2$ $e = 0.087$
2,680	6	20	6	20	2.220	
2,660	8		8		2.210	
2,650	12	30	12	30	2.200	
2,680	15	20	15	20	2.130	
4,800	30	15	17	15	1.825	B $l = 7.1$ $e = 0.07$
5,000	33	30	14		1.800	
5,600	40		7	30	1.675	
6,000	47			30	1.675	
6,200	54	30	7		1.500	
6,400	61	30	14		1.420	
6,500	74		16		1.35	C $m = 7.3$ $e = 0.070$
6,500	76	30	13	30	1.35	
6,600	78	30	11	30	1.345	
6,700	83	30	6	30	1.341	
6,700	90		0		1.340	



**Investigation Normal to Optic Axis.**

For this purpose two specimens were cut parallel to the optic axis. In one specimen, to which the electric field was applied, the thickness was across the electric axis, the light passing along the mechanical axis, and in the compensating specimen the light passed through parallel to the electric axis. As compensation was necessary, it was not possible to apply the field to both laminae, as in the previous experiments. This is the specimen C of Table 2. In the proximity of the mechanical axis readings are taken by observations on the system of fringes. For the mechanical axis, however, as nearly complete compensation is effected we have to resort to a Babinet compensator to obtain the fringes. The shift of the centre black band, that is, the band for zero retardation, is noted and the piezo-optical constant is computed therefrom. The result is given on the last line of Table 2.

**Discussion of Results.**

The results observed by these experiments tend to the conclusion that the distortion of the isochromatic rings is the secondary effect of the electric field. The primary effect of this field is to produce dilation or contraction along the mechanical axis ( $m$ ). This dilatation is given by

$dm = HV \frac{m}{e}$ , V being expressed in statvolts, and H being the piezo-electric constant, so that the stress will be

$$\frac{EHV}{e}, \text{ E being the elastic constant} \quad \dots \quad (1)$$

Now the retardation set up in stressed transparent members is given by the well-known photo-elastic expression (Reference 6, p. 185)

$$R = CTd$$

The retardation is in Angstrom units, the stress T is in bars  $\left(\frac{\text{megadyne}}{\text{cm}^2}\right)$  and  $d$  is the light path in mm. C is the stress-optical coefficient. Transforming this equation to suit our purpose we have

$$R = \frac{CTD}{10^5} \quad \dots \quad (2)$$

R is still the retardation in Angstrom units, T is in  $\frac{\text{dynes}}{\text{cm}^2}$  and D (along the optic axis) is in cms.

But the retardation with the piezo-electric effect is given by

$$R = \frac{PVD}{e} 10^8 \quad \text{Angstrom units.}$$

Substituting for T in equation 2 from equation 1 we have

$$R = \frac{CEHVD}{e \cdot 10^5} = \frac{PVD}{e} 10^8$$

which leads to

$$C = \frac{P}{EH} \cdot 10^{13}$$

If we now take

$$\begin{aligned} P &= 2.3 \times 10^{-5} \\ H &= 6.4 \times 10^{-8} \end{aligned}$$

$$E = 785 \times 10^6 \left( \frac{\text{gms}}{\text{cm}^2} \right)$$

we have on substitution

$$C = 4.67 \text{ brewsters}$$

which is a reasonable value to expect from quartz.

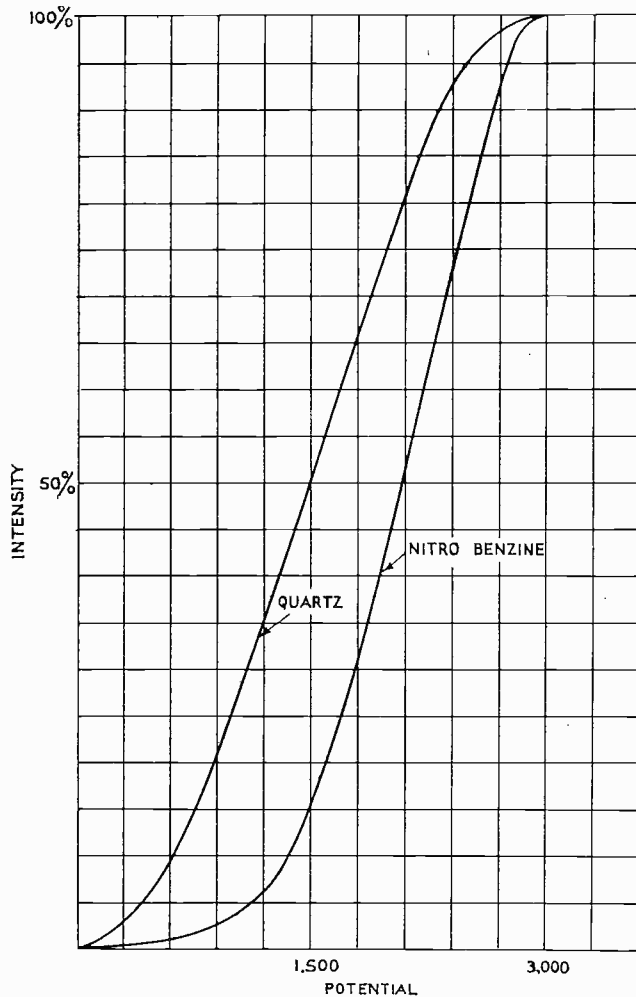

FIG. 6.

The conviction that the optical effect is secondary and that it is engendered by the stresses set up through piezo-electric activity is thus very strong.

**Commercial Applications of the Effect.**

A light relay was constructed from the two quartz laminae assigned to specimens A in the investigation. Light was polarised and passed through the laminae vibrating at 45 deg. to the direction of the electric stress. Although extinction was readily

obtainable with the sodium lamp with which the experiments were carried out, yet when a high power arc lamp was employed the extinction was by no means good. It was with the greatest difficulty that two laminæ could be obtained to give perfect extinction and this was only possible if the light within the quartz was perfectly parallel. In order to obtain so perfect a parallel beam it was necessary to stop down the aperture disposed at the focus of the collimating lens. This stopping down cut off the light to such an extent that but a small percentage of incident light ever passed through the analyser. For this reason it was apparent that the quartz cell was by no means as efficient as the nitro-benzene cell. (MARCONI REVIEW, No. 44, 1933.) For this reason it was not adaptable for Television work. The only advantage the quartz cell had over the nitro-benzene cell was that for the former the dielectric constant and therefore the capacity was much smaller. It appears that for the Kerr effect in liquids, the dielectric constant is directly proportional to the magnitude of the effect as measured by the Kerr constant. As far as potentials are concerned there is but little to choose. After a few hours' use the nitro-benzene cell provides half-wave retardation at about 3,000 volts. Table I shows that the quartz cell incorporating the two laminæ of effective length 13.2 cms. needs a potential of the same order for the same retardation.

The nitro-benzene cell has a further advantage over the quartz cell as seen from the intensity curves of Fig. 6, in which 3,000 volts is taken for half-wave retardation, giving maximum illumination.

For the nitro-benzene cell we have

$$I = a \sin^2 bV^2$$

for the quartz cell we have

$$I = a \sin^2 bV$$

where  $a$  and  $b$  are constants. The slope of the nitro-benzene curve being greater, it is possible to operate over a given range with less voltage and for this range the response is substantially linear.

Experience with the quartz cell in view of the difficulties in obtaining perfect compensation and a perfectly parallel beam of light within the cell tend to express its inferiority in comparison with the present-day nitro-benzene cell. If the piezo-electric property of quartz is to be employed for the purpose of controlling light intensity then other methods than those in which polarised light plays a part might be adopted.

#### **Nomenclature and Bibliography.**

As no textbook in the English language to the author's knowledge gives a thorough and readable account of Gouy's work and of the methods adopted experimentally to investigate the optical properties of quartz, the symbols used are of Mascart's "Traite d'Optique," which does deal with these matters. Preston's "Light" follows Mascart somewhat closely, so that the notation here adopted will be familiar.

#### **BIBLIOGRAPHY.**

1. Mascart. Traite d'Optique. 1891. Gauthier-Villars et fils; Paris.
2. Airy. Camb. Phil. Trans., V., IV., Pt. 1, p. 79; 1831.
3. Gouy. Journ. de Phys., V., IV., p. 149; 1885.
4. Beaulard. Journ. de Phys., V., II., pp. 393, 459, 472; 1893.
5. Wiener. Ann. de Phys. V., XXXV., p. 1; 1888.
6. Coker. Photoelasticity, Cambridge; 1931.
7. Ny Tsi Ze, Journ. de Phys., V., IX., p. 13; 1928.

L. M. MYERS.

# THE MARCONI CATHODE RAY OSCILLOGRAPH

*In view of the increasing use of Cathode Ray Tube Measurements in industry and physics, the Marconi Company have developed a Cathode Ray Tube and associated equipment which is described below and which is suitable for general work, including permanent photographic recording of results, and which can easily be adapted for special purposes.*

*The complete equipment was shown at the Conference on Industrial Physics held at Manchester in March of this year.*

CATHODE Ray Oscillographs have been used for some time for studies of wave form and their increased popularity in recent years have been due to the unique advantages possessed by this instrument. For nearly all radio engineering purposes the low voltage oscillograph is adequate. Where high voltages are to be studied suitable methods have been described for reducing the voltage to be examined.\*

In nearly all cases a self-contained unit is required, preferably requiring no battery supplies.

Gas focussed cathode ray oscillographs have several advantages over the high vacuum types as produced at the present time. Further research on high vacuum oscillographs will alter this position, therefore the equipment to be described has been designed to take either type of low voltage oscillograph without modification, although gas focussed tubes only are supplied at the present time.

Gas focussed oscillographs have two major disadvantages:—

- (A) Origin distortion.
- (B) Loss of focus at high frequencies.

The origin distortion is shown as a loss in sensitivity in the region of the electrical  $x$  and  $y$  axes of the oscillograph. This defect is shown in Fig. 1. A voltage equal in phase displacement and magnitude was applied to the  $x$  and  $y$  plates, the resulting deflection at  $45^\circ$  was then arranged to cut the electrical  $x$  and  $y$  axes of the tube in two places. At these points the origin distortion is shown as kinks in the image. Fig. 2 shows an approximate sine wave, the kink in the trace is due to origin distortion.

At high frequencies the focus of the oscillograph becomes progressively worse, Figs. 3, 4, 5, 6, 7 and 8 show the trace obtainable at 10, 20, 50, 100, 250 and 400 K.C. respectively. The tube may therefore be said to be satisfactory up to 250 K.C.

Neither of these two defects is present in the high vacuum oscillograph, but against this must be offset the disadvantages of higher voltage operation with reduced sensitivity and also a focus which is not so good as that obtained with the gas focussed oscillograph.

The equipment comprises three units for standard rack mounting:—

- (1) Power supply unit.
- (2) Time base unit.
- (3) Oscillograph unit.

And a camera to fit on the oscillograph unit.

\* Ref. MARCONI REVIEW, No. 51, page 4, 1934. A Piezo Electric Peak Voltmeter. L. M. Myers.

**Power Supply Unit.**

The power supply unit is arranged to supply heater, anode and cylinder voltages together with supplies for shifting the image as a whole in either or both the  $x$  and  $y$  axes. The anode voltage control is obtained by means of a potentiometer across the A.C. supply, varying the input to the high tension transformer. A meter is

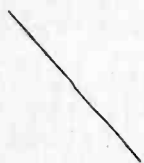

FIG. 1.

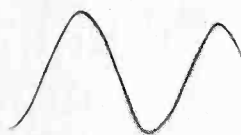

FIG. 2.



FIG. 3.



FIG. 4.

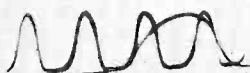

FIG. 5.



FIG. 6.



FIG. 7.



FIG. 8.

FIGS. 1-8.

provided to indicate approximately the anode voltage. The focussing control takes the form of a variable resistance in the cathode lead of the oscillograph.

The object of the  $x$  and  $y$  shifting controls is to permit the image to be placed in a given position on the oscillograph. The sensitivity of an electrostatically deflected oscillograph is inversely proportional to the anode voltage, hence the  $x$  and  $y$  shifting potentials must vary as the anode voltage, if the image is to remain in the same position when the anode voltage is varied. If this condition were not satisfied, then when the image was set in a given position, alteration of the anode

voltage to permit photographic recording or increased brilliancy of the oscillograph would cause the image to be shifted to one side of the oscillograph.

The shifting potentials are varied as the anode voltage by deriving them from a common source. Usually a total shift of 3 cm in both the  $x$  and  $y$  axes is provided, although this may be increased if required. The maximum anode voltage obtained from the rectifier is about 2,500, which is adequate for rapid photographic exposures, and for operation of the high vacuum oscillograph.

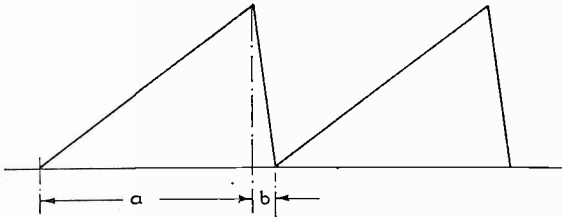

FIG. 9.

### Time Base Unit.

The common forms of time bases for cathode ray oscillographs are as follows :—

- (1) Linear voltage sweep.
  - (A) For electrostatic deflection.
  - (B) For magnetic deflection.
- (2) Circular time bases.
- (3) Spiral time bases.

The time base which has been found to be of the greatest general service is the linear time base, since the graphical representation of wave form is almost always performed in cartesian co-ordinates. Circular and spiral time bases are only of service in special applications. It is not found possible to provide a large frequency range if a magnetic time base is used, hence electrostatic deflection is used in conjunction with a linear time sweep.

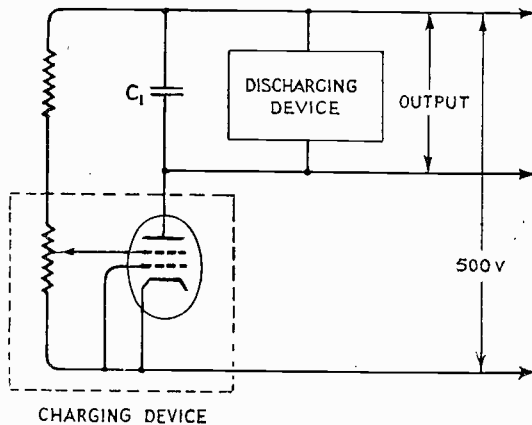

FIG. 10.

Usually the time sweep is connected to the  $x$  axis of the oscillograph since this results in a pattern of conventional form.

The requirements of a suitable time base are :—

- (1) Uniform motion of the cathode ray beam in the  $x$  axis and an extremely rapid return to the original position.
- (2) Wide frequency limit of operation.
- (3) Good synchronisation of the time sweep with the wave form to be examined.

The wave form of the required time sweep circuit must be of saw tooth form to satisfy condition (1) as shown in Fig. 9. The circuit used for this purpose is shown in Fig. 10. In order to produce the linear voltage sweep of the part "A" of Fig. 9 a condenser ( $C_1$  in Fig. 10) is charged at a constant current. Two forms of constant current device are known :—

- (1) Saturated diode.
- (2) Screen grid or pentode valve when used on the flat portion of its characteristic.

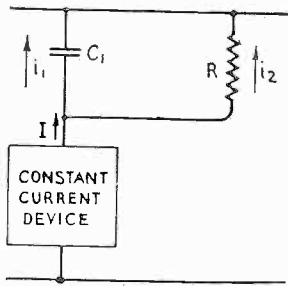

FIG. 11.

The saturated diode is unsatisfactory because :—

- (A) The current is not exactly constant when the anode voltage is varied.
- (B) In order to vary the charging current of the condenser and hence the velocity of the beam in the  $x$  axis, the filament voltage must be varied. Some time is necessary before the emission of the valve becomes approximately constant after alteration of the filament current, and hence a smooth control of beam velocity is impossible.

- (c) A diode having a tungsten filament is required and if the filament is to be supplied from unrectified alternating current, it is extremely difficult to eliminate the mains "hum."

If a screen grid valve be used as the constant current device, it is found that the anode current, although not constant, is more nearly so than that of the saturated diode, while objections (B) and (c) do not arise. Therefore, in the time base described a screen grid valve is used.

The rate of charging the condenser  $C_1$  is controlled by adjustment of the screen voltage of the screen grid valve. The rate of increase of sweep voltage with time is varied by adjustment of the capacity  $C_1$ . The capacity adjustment is variable in five steps and constitutes a coarse control for the velocity of the beam in the  $x$  axis. The screen grid adjustment forms the fine control and by use of the two controls the frequency of the sweep circuit may be adjusted between limits of one cycle to 200 kilocycles per second approximately.

While the charging of a condenser by means of a constant current device represents the ideal case, in practice it is necessary to consider the constant current device charging a condenser and resistance in parallel. The resistance is approximately constituted by the input impedance of the oscillograph and possibly a resistance shunt between the deflector plates and anode. Referring to Fig. 11,  $I$  is the total current to the circuit  $C_1 R$ .  $i$  the current in the branch  $C_1$  and  $i$  the current in the branch  $R$ .

$$I = i_1 + i_2 \text{ (constant)}$$

also the voltage developed across the circuit  $v$

$$v = i_2 R = \frac{I}{C_1} \int i_1 dt$$

$$\text{or } \frac{di_1}{dt} + C_1 R i_1 = C_1 R I$$

Then since

$$i_1 = I + e^{-C_1 R t}$$

$$v = \frac{I}{C_1} \int i_1 dt$$

$$\frac{dv}{dt} = \frac{i_1}{C_1} = \frac{I + e^{-C_1 R t}}{C_1}$$

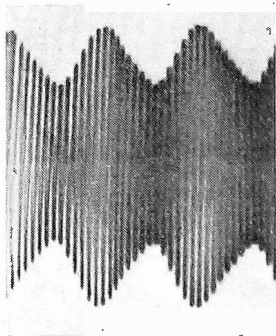

FIG. 12.

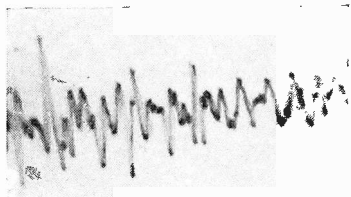

FIG. 13.

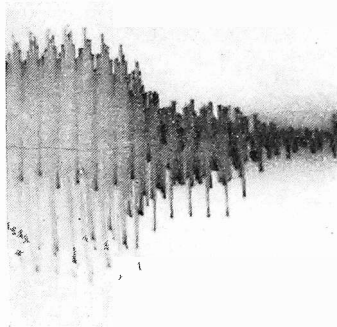

FIG. 14.

This should be constant, but the shunt resistance prevents this object being attained. Hence if permissible limits for non-linearity are set, and  $R$  is measured,  $C$  may be determined. In this manner the condenser values may be determined corresponding to limits of velocity and to limits non-linearity of the time sweep circuit;  $I$  is determined by the maximum discharge current ( $I_d$ ) of the discharging device and the sweep/fly-back ratio ( $S$ ) required. If the discharge current is constant

$$I = \frac{I_d}{S} \text{ approximately.}$$

At high frequencies the stray inductances and capacities must also be taken into account.

The return stroke of the time base circuit, the part "B" of Fig. 9 is performed by suddenly discharging the condenser  $C_1$ . Three devices are used for this purpose:—

- (A) A neon lamp may be used since a difference in voltage exists between the striking and extinction potentials of the lamp.
- (B) A grid controlled gasfilled relay (Thyratron) may be connected across the condenser.
- (c) An arrangement of high vacuum valves of normal pattern may be used.

The neon lamp circuit suffers from the disadvantage that the output of the time base is limited to the difference between the striking and extinction potentials of the lamp. In practice this is found to be of the order of 30-50 volts and hence the output of the time base would be insufficient

for normal purposes. Further, the lamp requires time to de-ionize after striking; this effect prohibits its operation at very high frequencies.

The gasfilled relay may be used to discharge the condenser, and will give adequate output if employed in the time base. The difficulty in connection with the use of



these relays is that time is required for the gas or vapour to de-ionize. Koller\* gives the following empirical formula for the time of de-ionization ( $t$ ) :—

$$t = \frac{0.0012 p I^{0.7}}{l_g^{3/2} x}$$

$p$  = Gas pressure.

$l_g$  = Grid voltage to surrounding space.

$x$  = Grid/anode clearance.

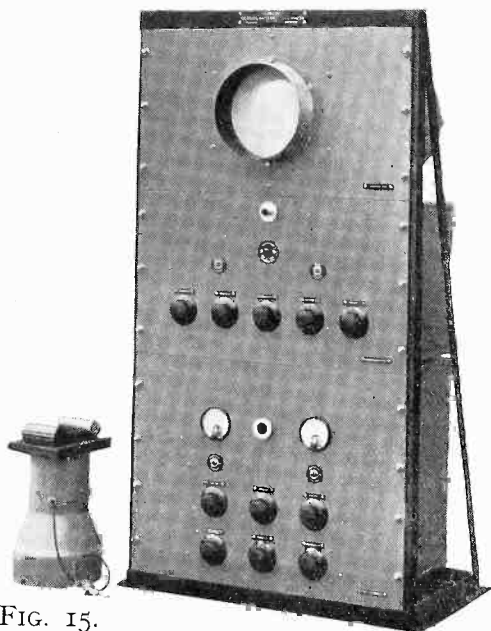

FIG. 15.

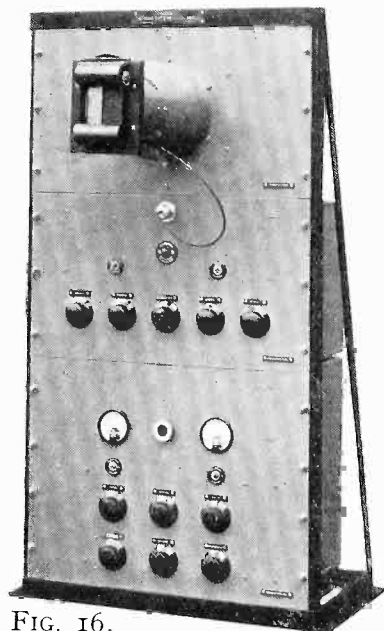

FIG. 16.

The time of de-ionization may therefore be varied by adjustment of the gas or vapour pressure and discharge current. It is found in practice that relays having rare gas fillings and adjusted to operate at high frequencies have an extremely short life. Mercury vapour relays have a satisfactory life, but the vapour pressure varies with temperature in the following manner† :—

Temperature °C.	Vapour Pressure in mms. of Mercury at 0°C.
0	0.00016
5	0.00026
10	0.00043
20	0.00109
60	0.0246

The de-ionization time will therefore depend on the bulb temperature and such relays will not be stable in operation near the limiting frequency of operation.

The discharge current of the relay must not be greatly reduced by means of resistances since the ratio of sweep/flyback times would become small.

\* Koller. Physics of Electron Tubes, p. 135.

† Ref. Kaye and Laby. Physical and Chemical Constants, p. 41.

Under these limitations, the mercury vapour tube used as a discharge device is not satisfactory for use at frequencies higher than the audio frequency range and even at 5,000 p.p.s. it is erratic in operation.

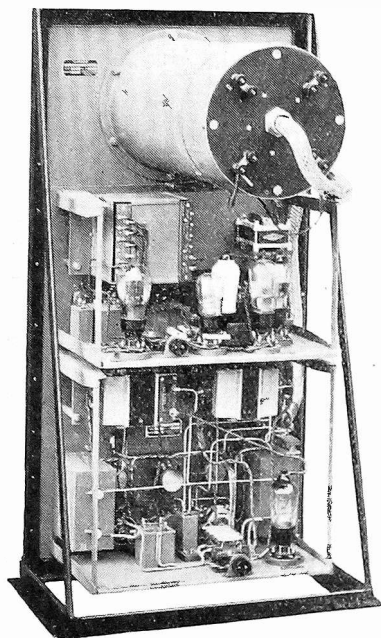

FIG. 17.

In order to cover a wide frequency band a discharge device which is purely electronic in character is required. For the time base shown in the photograph a system of three valves, working together as a modified multivibrator is used. The upper frequency limit of the time base is then set, not by the limiting frequency of the discharging device, but by the ratio of the discharging current to the charging current of the condenser and the minimum capacity of that condenser which it is possible to obtain.

The time base may be synchronised with the E.M.F. to be examined by applying a fraction of that E.M.F. to the discharging device. A small E.M.F. is sufficient for this purpose, and the control is effected by the potentiometer provided.

Fig. 12 shows a modulated carrier expanded by means of this time base. Figs. 3-8 also show the operation of the time base on wave forms up to 400 K.C.

#### Oscillograph Unit.

The Oscillograph Unit consists of a holder for mounting the oscillograph and is screened magnetically. The cowl on the front of the unit reduces the external illumination on the oscillograph and also serves as a support for the camera.

#### Camera..

The camera is made to take 8 exposure roll film or paper and is daylight loading. The shutter may be used for time exposures or in conjunction with the single sweep time circuit.

The time base may be changed from a recurrent time base to a single sweep time base\* by throwing a switch. A push button is provided for tripping the time sweep circuit and at the same time for opening the camera shutter, the speed of which is set to open for a period longer than the time period of the sweep circuit. The velocity controls on the unit vary the velocity of the sweep in exactly the same manner as for the recurrent time base. This circuit may be used for time sweeps of the order 8 millisecc or longer. The single sweep time base is especially suitable for the photography of amplifier and similar noises. Fig. 13 shows a record taken of an irregular wave form, exposure 5 millisecc.

Fig. 14 shows a record taken of the output of a microphone, suitably amplified, into which normal speech was transmitted.

Figs. 15, 16 and 17 show respectively views of the complete apparatus taken from the front with camera removed and attached and from the rear.

A. J. YOUNG.

\* Ref. MARCONI REVIEW, January-February, 1935, p. 26.

# A NOTE ON THE MARCONI INFRA-RED LIGHT BEAM LINK

*The following article describes a method whereby telephony over an infra-red light beam link is accomplished by modulating the light from a crater-neon lamp giving out light rich in infra-red. This light is sent out in a parallel beam and is received by a photo cell. The current obtained is amplified and passed through the earphone of a Strowger hand set.*

SOME few years ago the Marconi Company demonstrated a form of telephone link in which a beam of visible light was modulated by the telephone signals. For these experiments both a sodium and a neon discharge lamp were adopted

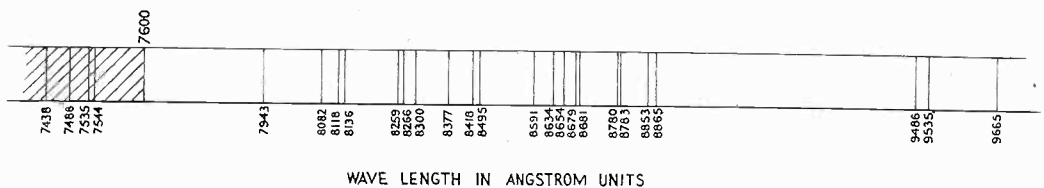

FIG. 1.

as a modulatable light source. These previous experiments have recently been resuscitated and modified for demonstration at the Manchester Conference on Industrial Physics in March of this year. The modification consisted of the introduction of an infra-red filter in the beam of light from the same neon crater lamp as used on the previous occasion.

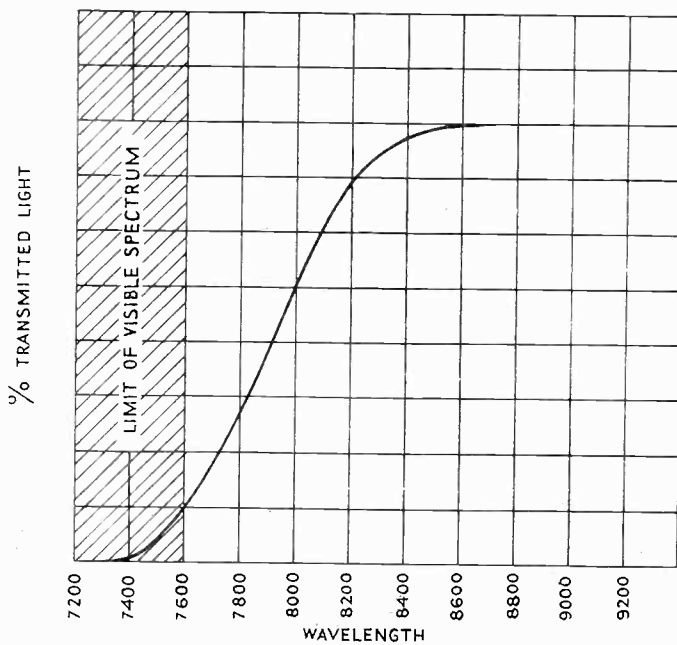

FIG. 2.

The spectrum of the neon lamp is shown in Fig. 1. It will be seen that a fair amount of energy in the infra-red spectrum is liberated. In Fig. 2 we have the curve of an average infra-red filter, this particular one being a Wratten 87. This filter cuts off at 7,600 Angstrom units. It is

The spectrum of the neon lamp is shown in Fig. 1. It will be seen that a fair amount of energy in the infra-red spectrum is liberated. In Fig. 2 we have the curve of an average infra-red filter, this particular one being a Wratten 87. This filter cuts off at 7,600 Angstrom units. It is

possible, therefore, to detect a faint red glow in observing bright incandescent light through it. An R. W. Wood filter, which was actually used in the demonstration, cuts off a little higher, so that very little visible light even from the sun can be seen.

In Fig. 3 we have the general layout for the combined transmitter and receiver at one end of the link. Exactly the same apparatus is used at the other end. A water-cooled crater-neon lamp, a drawing of which is given in Fig. 4, is modulated by a Strowger hand-set microphone, the signal from which is amplified by an MPT4 pentode.

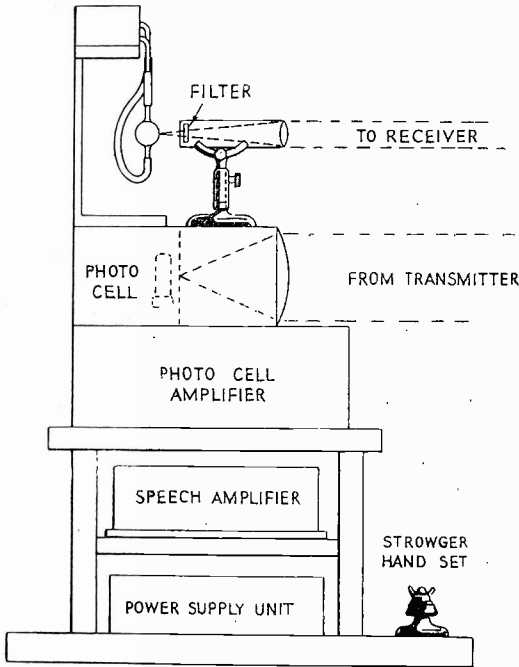

FIG. 3.

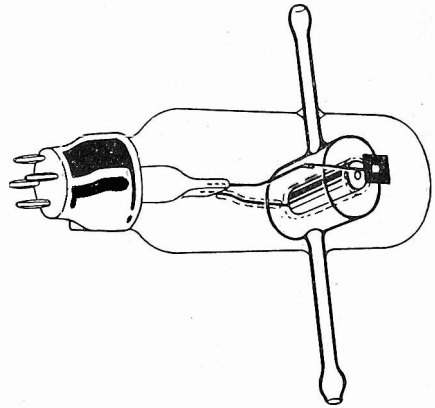

FIG. 4.

The electrical circuit can be seen from Fig. 5, which shows the amplifying scheme for both transmitter and receiver.

The light from the crater of the neon is collimated and sent out to the receiver station in the form of a narrow pencil. At the receiver station this parallel beam is incident on a large uncorrected lens which brings an image of the transmitting collimator in the plane of an aperture of about 3 mm. diameter. In this manner the light from the transmitter is allowed to pass through an aperture and to reach the sensitive surface of a CMG8 photo cell. The presence of the aperture is needed to eliminate all light other than that from the transmitter. This helps considerably to reduce the noise level of the receiving amplifier.

*A Note on the Marconi Infra-Red Light Beam Link.*

When the whole of the light from the crater-neon is modulated to give the signal, about 30 dB. amplification for a range of 50 yards is necessary to bring the signal on the photo cell to sufficient intensity for passing through the hand-set earphone. When the infra-red filter is introduced, however, the signal must be increased roughly

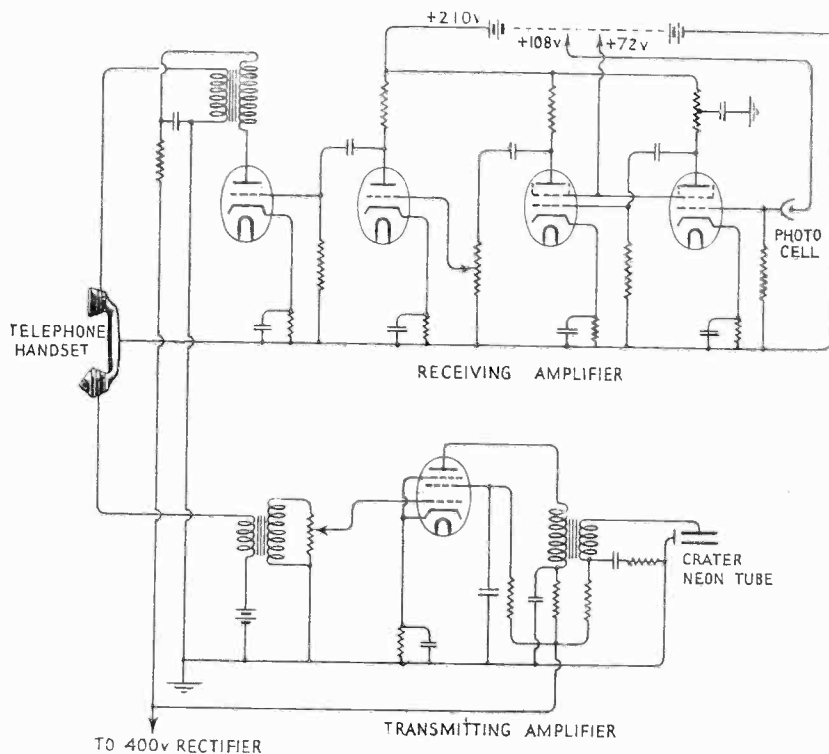

FIG. 5.

tenfold. For short distances up to 100 yards the second valve in the photo cell amplifier can be dispensed with.

At the Manchester Exhibition, the distance over which telephonic communication was established was about 30 yards, this being the longest distance allowed by the confines of the building in which the exhibition was held. The signal strength was adequate and well above noise level.

A commercial model of the apparatus described above is in course of production, and it is hoped to give a brief report of this at a later date.

# MARCONI NEWS AND NOTES

## CRYSTAL CONTROLLED WIRELESS BEACON

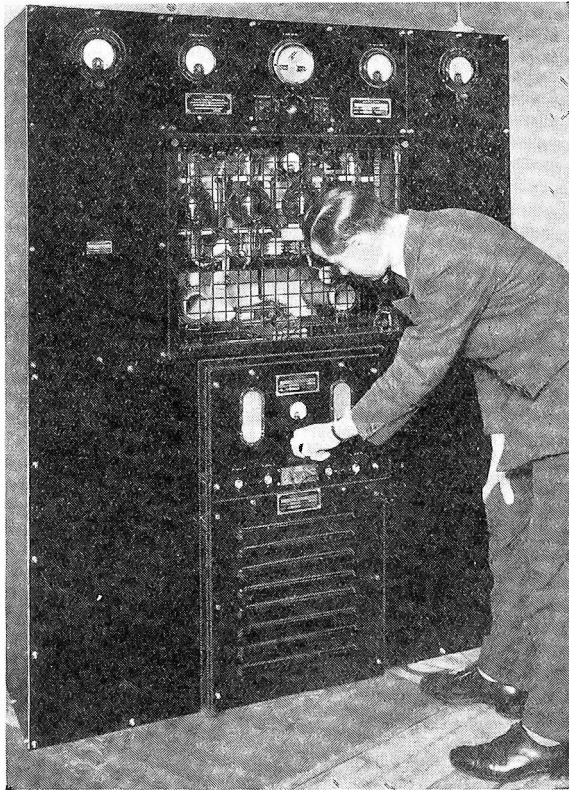

*Marconi Automatic, Crystal-Controlled Wireless Beacon.*

is to be installed at Cabo Vilano, North Eastern Spain, and the second, of 100 Watts aerial power, will be erected at Cape Columbine in South Africa:

These new beacons provide for the transmission of interrupted continuous wave signals on any wavelength between 950 and 1,050 metres.

### **Constant Frequency.**

The crystal control is of the low temperature-frequency coefficient type, which provides great constancy of the transmitted frequency, without the necessity for temperature-regulating devices, and over the extreme ranges of temperature likely to be experienced in practice the departure from the frequency assigned to the beacons will be less than one part in 5,000.

The oscillating crystal and its associated valve, which operates at half the allotted frequency, are followed by one stage of amplification, one frequency doubling

**T**HE increasing number of automatic wireless beacon transmitters of the type installed in many lighthouses and lightships as an aid to maritime navigation has made it more essential than ever for these stations to adhere closely to their allotted frequency in order to prevent mutual interference.

This requirement has led to the embodiment of crystal control in the latest type of Marconi wireless beacon to ensure that the wavelength of these transmitters can be stabilised with a very high degree of accuracy. Two of these new beacons have already been ordered by coastal authorities; the first one, of 250 Watts aerial power,

stage and a further stage of amplification on the allotted frequency of the transmitter. The whole of the master oscillator with the rectifiers, which supply the high-tension, forms a single unit. The unit is so arranged that it may be added to any existing beacon transmitter without undue complication, thus conferring the advantage of precise frequency stabilisation to beacons already in operation.

#### **Automatic Warning.**

As beacon stations normally function unattended it has been arranged that any cause of failure of a valve in the master oscillator unit is notified to the attendant by an audible warning. Then, by throwing over a single handle, the installation will continue to function as a simple valve-driven two-stage transmitter.

Every stage of the master oscillator unit has a duplicate valve connected up for service, and the spare valve can be thrown into circuit by means of a switch. By removing the defective valve and substituting a spare one, a stand-by becomes again available.

#### **Generator Unit.**

The rest of the beacon transmitter comprises an oscillation generator unit with its associated aerial tuning inductance and closed circuits mounted in a robust lacquered framework.

The oscillating circuit contains four valves, of which two are normally in use and the others spares. If either of the valves in use burn out, a relay automatically brings into circuit the reserve pair, and at the same time an audible warning is given to inform the attendant that a valve has become defective.

The signal apparatus which is used to modulate the transmitter, to give it its distinctive call sign, consists of a time clock which determines the periods when the beacon comes into operation, and the code sender or character wheel, which actually transmits the predetermined code allotted to the beacon. The clock and the code sender are normally supplied in duplicate.

#### **Broadcasting Activities at the Marconi Works.**

**T**HE continued interest in broadcasting throughout the world is illustrated by the great activity at the Marconi Company's Works, where no fewer than ten medium and long-wave broadcasting transmitters are going through the shops and test rooms.

The largest of these, which is nearing completion, is a 220-kilowatt long-wave transmitter to be installed at Lahti in Finland.

A 20-kilowatt station, which will be erected seven miles north of Jerusalem, is now undergoing its final tests, and a ten-kilowatt transmitter has been despatched to Radio Tupi for installation at Rio de Janeiro.

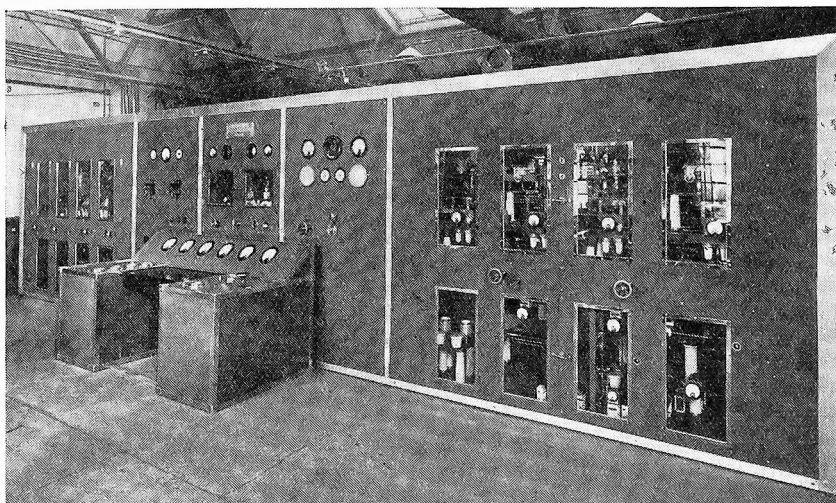

*Marconi 20 k.w. Broadcasting Transmitter for Jerusalem in the station test room at the Marconi Works, Chelmsford.*

---

Five half-kilowatt broadcast transmitters are rapidly nearing completion. Three of these are for relaying programmes from a main station, semi-automatic in operation, and are to be installed in small localities in Sweden, while the other two installations will be sent to Cairo and Alexandria respectively to replace temporary stations now giving alternative broadcasting services to those provided by the permanent main Marconi stations.

The Swedish relay stations consist of two units with a rectifier unit. Crystal drives with a precision of one in one million are incorporated. The installations are so arranged that warning of over or under modulation of the carrier wave is given by means of a bell alarm, thus obviating the necessity for constant attention by a skilled engineer.

These miniature broadcast stations fully comply with the recommendations of the C.C.I.R. Committee at Copenhagen, and their distortion factor will not be greater than 4 per cent. at 95 per cent. modulation.

#### **Short-Wave Telephone for Venezuela.**

**T**HE National Telephone Company of Venezuela have placed an order with the Marconi Company for the provision of a wireless telephone link between the cities of Maracaibo and Caracas in Venezuela.

Although these places are linked by wireless telegraphy they have as yet no connecting telephone service. The general condition of the country between Maracaibo and Caracas makes it difficult to maintain land-lines or cables satisfactorily,



and the proved reliability and efficiency of modern wireless telephone apparatus have turned the attention of the Venezuelan Company to wireless telephony.

Marconi S.8A telephone transmitters and Rg.34 receivers, with inverter gear for privacy of communication, will be installed at both centres to provide the service.

The opening of this service will provide facilities which have long been required by commercial and private interests, and the Venezuelan Telephone Company are to be congratulated on their initiative in providing these new channels of communication.

#### **Additional Telephone Channel for South Africa.**

**A**S a consequence of the popularity of the wireless telephone service between South Africa and Great Britain, it has been decided to increase the existing facilities in South Africa by the provision of a new high-power short-wave telephone transmitter, which will be installed at Klipheuevel.

The receiving station at Milnerton will also be enlarged to cope with the new traffic, and the new International type of Marconi receiving equipment, with inverter gear to enable secrecy of communication to be maintained, is being added to the installations already in use. Thus, an additional channel of impeccable quality will shortly become available for this important Empire service.

#### **Wireless Time Signals in the Antarctic.**

**W**IRELESS time signals are expected to give important assistance in the exploration and survey work to be carried out by the British Graham Land Expedition, which recently left England for the Antarctic under the leadership of Mr. John Rymill.

Nearly three years, including two winters of complete darkness, will be spent South of the Antarctic Circle, with the principal objective of exploring the 1,000 miles of almost unknown coast line between Luitpold Land and Charcot Land. This exploration is expected to determine whether the Antarctic Continent exists or whether there are two Continents or a series of islands.

Time signals from Buenos Aires will be received daily, with three Marconi portable short-wave receivers (25 to 50 metres waverange) specially designed for the purpose, by the exploring parties, by the party on board the expedition ship "Penola," and, during the dark months, at the winter base on the ice. The range of reception will vary from 2,200 to 3,000 miles.

The expedition will thus be able to utilise the simplest method of determining the longitude of its position at any time by comparing the time signals from Buenos Aires with local time as ascertained by astronomical observations, the difference between the two times giving the degree of longitude. This system is now being widely adopted by modern explorers and by survey parties in all parts of the world.