

THE MARCONI REVIEW

No. 31.

July-August, 1931.

Technical Editor: H. M. DOWSETT, M.I.E.E., F.Inst.P., M.Inst.R.E.

General Editor: W. G. RICHARDS.

1929-1930 DEVELOPMENTS IN THE STUDY OF RADIO WAVE PROPAGATION

It is essential that the progress made in the study of wave propagation problems applied to radio communication should be summarised from time to time, for the guidance and use of the radio engineer.

In the following article the modern conception of the Heaviside layer, the effect of magnetic storms on wave propagation, the use of ultra short waves and the question of beam transmission are briefly discussed, and the progress made during 1929-1930 in the solution of the problems associated with these questions given.

A PART from special technical developments involving the improvement of aerials, terminal transmitting and receiving apparatus, valves, etc., in fact the projection and reception of radio waves, a steady progress has been made in our knowledge of the processes of transmission upon which in the end the advancement of the art must depend. It is difficult to point to any outstanding advance in this knowledge, but experimental evidence and theoretical interpretation of this is gradually clearing away the fog of uncertainty in which the processes of transmission are wrapped, and the general nature of short wave transmission is now fairly clearly understood.

The prime factor in interpreting the vagaries of transmission is the Heaviside layer and the contributions to the investigation of this form an outstanding feature of the radio literature published during the last twelve months.

For the purpose of wireless analysis, the distribution of electron density, mean free path, recombination factors and ionisation processes are the most significant.

In Appleton's hands the interference methods of measuring the group time delay of signals reflected from the Heaviside layer, has resulted in a consolidation of our knowledge of the regions where the 80 to 400 m. waves are bent down to the earth.

In particular the evidence for existence of two reflecting and refracting layers has become practically overwhelming.

Transmissions on 100 m. are very striking in this respect, for the lower layer at an effective height from 100 to 120 km. is not always sufficiently dense (*i.e.*, $N < 10^5$ at times), to return the normal incidence rays and from time to time the rays escape through this layer to a higher one at 212 km. or so, the effect of which is made visible in much more rapidly changing interference fringes indicating a sudden discontinuous change of effective delay and corresponding effective height.

From these results we can picture the layer as increasing in electronic density from 80 km. to a little over 100 km., where $N = 10^5$ approximately, after which N falls away and then increases again to the same value or even higher value at a height of 212 km.

The distribution of density at greater heights requires shorter waves, and facsimile and pulse experiments are yielding further results which in time may be sufficient to give a picture of the electron distribution in such regions.

In connection with electron distribution in the layer an important theoretical advance is in the application by de Groot and Appleton of an integral equation due to Abel to the case of radio transmission. By the use of this a series of simultaneous observations which give the effective echo time delay as a function of the frequency can be made to yield the electron density distribution in the layer.

There is some doubt whether this method, which is based on geometrical ray optics,—admittedly an approximation—is admissible on the lower frequency ranges where the wavelength is comparable with the height of the Heaviside layer. The application of the method is also open to criticism where the ray passes through the lower to the upper layer.

In America the pulse method of investigation of the height of the Heaviside layer, has been advanced by some important investigations. Experiments by Hafstad and Tuve at short distances indicate an echo pattern which changes throughout the day and which may be interpreted as implying multiple reflection between the earth and Heaviside layer although the authors prefer to await further observations before making any definite interpretation. A result of some importance but of which the meaning is obscure, is that the later echoes are generally split into two or more. In confirmation of these results facsimile transmission between Chelmsford and Somerton on 60 m. and 120 m. waves undoubtedly show the existence of multiple echoes of which the simplest interpretation is that they represent repeated reflections between the earth and Heaviside layer at a height of about 210 to 250 km. On this interpretation as many as four complete reflections occur in passing over the relatively short distance of 227 km.

The results of these experiments made early in 1930 are interesting as they give almost identical figures for the effective height (which varies during the evening

in the same way) as those given by Kenrick and Jen for observations made at the same season a year before in America. Some of these pictures are also of interest as showing an undoubted record of the scattering which was investigated by direction finding methods by the author in the past few years.

This scattering is exhibited as a smudging of the facsimile picture, signals lasting in some cases for a period of some 20 milliseconds after the initial signal.

This is in general agreement with the delay times estimated from directional measurements made by the author.

The analysis of long distance facsimile results has given important information in regard to the nature of long distance transmission.

It has long been in doubt as to whether the signal proceeds from transmitter to the receiver in one long jump through the Heaviside layer or by multiple reflections between the earth and Heaviside layer.

The evidence indicates, at any rate in the cases examined, *i.e.*, New York, Somerton on 22 m., New York, San Francisco on 16-23 m., between Buenos Aires and Nauen on about 15 m., that the normal method is by multiple reflections between earth and Heaviside layer. There is in general a multiplicity of rays, the higher ones constituting longer paths, and the signals following these are delayed, with the result that a single impulse transmitted is generally reproduced at the receiver in multiple form.

Over Transatlantic distances, 3, 4, 5 or even 6 echoes are reproduced, spaced about a millisecond apart. An analysis of the time delays indicates that on 22 m. in the Transatlantic transmission there are in general four or five rays bent down from the Heaviside layer at an effective height of 340 km.

The maximum ray angle is about 35° . From this maximum angle the maximum density in the Heaviside layer may be deduced with fair accuracy. A value of 9×10^5 is obtained. Corresponding to this the minimum wave for long distance transmission is 8.7 m. Waves shorter than this escape through the layer. Although normal transmission proceeds in this manner there are indications that round the world echoes may proceed in a single jump for it is stated by O. Bohm* that, whereas the direct signal from Buenos Aires to Berlin showed multiple—the indirect echo showed none. Records of echo signals are always cleaner cut and of less duration, than the direct signal.

This reflection at 340 km. (in agreement with some results of Kenrick and Jen) may indicate a third layer at this height or a continuous increase in density from about 3×10^5 at 210 km. to 9×10^5 at 340 km. The evidence is not sufficient to decide yet.

* O. Bohm, Mehrfache und Doppler Effekt bei der austreuung wellen Telefunken Zeitschrift, Dec. 1929, Vol. 10, No. 53.

The results of all these measurements give a fairly clear though not accurately detailed picture of the Heaviside layer.

A study of short wave transmission on broad lines as the result of a whole year's continuous interception of all the regular short wave stations has been published by T. L. Eckersley and K. Tremellen, and the interpretation of the results is based on the conception of the Heaviside layer outlined above.

Charts have been prepared by means of which relative performances of all short wave stations at any time of day or year, wave length, etc., can be predicted with a fair degree of certainty.

The basic idea on which the charts have been prepared is that in the daylight regions for long distance transmission (outside the skip) attenuation proportional to the square of the wavelength is the main factor, and that, secondly, at night time, electron limitation is the main factor.

For daylight transmission there is no doubt that the attenuation proportional to the square of the wavelength is approximately correct (*i.e.*, in agreement with the observations), and the model of the layer outlined above gives a theoretical reason for this, for it is the 100 km. layer which is the attenuating region and the upper layer 210 to 340 which is the bending region. Where attenuation and bending occur in different regions the λ^2 law of attenuation results (see Eckersley-Appleton). The results based on the known mechanism have suggested the following transmission formula :—

$$E = \frac{3\pi\sqrt{W}}{\sqrt{d_0 d}} e^{-\alpha d \lambda^2}$$

W = power radiated (watts).

d = distance.

d_0 = skip distance.

λ = wavelength.

α = attenuation constant depending on latitude and time of day or night.

Results of signal intensity measurements generally give values less than calculated by the above formula but in a more or less constant ratio.

In connection with the electron limitation which occurs at night the facsimile results New York to Somerton on 22 m. afford a means of determining the recombination coefficient of the electrons and ions in the Heaviside layer at night. The method has been described in a letter to *Nature*, and depends essentially on measuring the maximum echo delay which is a measure of the maximum density in the layer. This decreases during the night on account of recombination. This recombination

accounts for the difference between early and late night transmission which is a feature of the long distance transmission results as well as of the observations of Appleton (Interference Methods), Breit, Tuve, Hafstad, Kenrick, Jen, etc. (Pulse Measurements in America.)

Measurements of this kind are valuable because the theoretical development of the behaviour of the Heaviside layer is hampered by insufficient physical knowledge of ionisation and recombination processes. Such physical measurements cannot be performed in the laboratory and quantum physics is not sufficiently far advanced to give theoretical values to the recombination and absorption coefficients.

Magnetic Storms.

The effect of magnetic storms in radio transmission has been the subject of further study. I. J. Wymore gives the results of the study on *long waves*. By studying statistically the results of field intensity measurements (E), he finds that there is a definite but slight increase of E following the height of a magnetic storm. It may require as many as 6 or 7 days for E to revert to normal.

Unpublished results on Beam Stations, Canada, South Africa and India, using traffic returns, show very marked correlation between magnetic storms and hours of traffic worked at 100 w.p.m. and over, especially during the year 1930, for during the first half of this year magnetic storms were very numerous. During and after such storms the hours worked at high speed are much reduced on the Canadian circuit, but very little reduced on South Africa and Indian circuit. The Australian circuit is most effected on the long path. The results show a correlation in magnetic storm effect with the magnetic latitude. Routes in high magnetic latitude are much more affected than those in low.

Interest has been revived in whistler atmospheric disturbances.

Further correlation between whistler storms and magnetic storms have been found. A connection between whistler storms and the earth current variations usually associated with magnetic storms has also been discovered. Such results help to form a mental picture of the mechanism of magnetic storms which together with theoretical researches of S. Chapman and R. Gunn should lead to a complete theory. This knowledge should be of value for radio telegraphic purposes.

K. Tremellen has found that Isolated Whistlers are definitely caused at certain times by local lightning flashes. Schelleng and Barkhausen have suggested an alternative theory of these and suggest that they are caused by multiple reflections between earth and the Heaviside layer. E. T. Burton observed similar disturbance on a submarine cable and has suggested a correlation with magnetic storms.

The long echoes observed by Jorgan Hals, Stormer, and Van der Pol have not yet received a satisfactory explanation. P. O. Pederson discusses the matter at length in a paper to the I.R.E., and concludes that the only possibility is that the echoes must travel out in space over a distance comparable with that traversed by light in the echo time, *i.e.*, 3 to 30 seconds. This conclusion is by no means accepted. The alternative, *i.e.*, that the echoes travel with very low group velocity in the Heaviside layer has been discussed by Appleton, Van der Pol and C. Breit, who show that serious difficulties attend this explanation connected with the enormous attenuation such transmissions must suffer unless they take place in a very rarified region of the Heaviside layer. In this connection the maximum density in the upper layer as determined by the facsimile results is of significance. Waves longer than 34 m. at normal times cannot escape into outer space. Echo results are obtained on shorter waves than this so the first explanation is possible.

On the other hand it is just possible that on occasions the regions at greatest height in the layer are just sufficient to hold down the rays, in which case long delay in the uppermost regions of the layer will occur. This region being where the attenuation is least it is possible that long delay echoes occur on the rare occasions on which the layer is sufficiently dense to refract such waves.

Further interesting data of the occurrence of long delay echoes has been published in "Comptes Rendus," by Galle and Talon, and summarised by Stormer in Proc. Roy. Soc., Edinburgh, Vol. 4, Part 2, No. 15.

Galle and Talon observed long echoes in Indo-China on 8th, 9th and 10th May, 1929, on a wavelength of 25 m. Many observations are given varying in delay between 2 and 30 seconds.

In connection with the escape of wireless waves into outer space through the Heaviside layer, Eckersley has discussed the question from the physical point of view, showing that the earth's magnetic field modifies the physical processes of transmission and that a wave suitably circularly polarised and oriented with respect to the direction of the earth's field can escape through the Heaviside layer in regions where, in the absence of such a magnetic field, the electronic density is sufficiently great to prevent escape. This paper gives a physical reason for the results predicted by the ordinary magneto ionic ray theory.

These results have an application to the long delay whistler echoes observed by Tremellen and Eckersley.

Ultra Short Waves.

These have been studied by Franklin, Mathieu and others in England, and the successful ultra short wave communication link between Rome and Sardinia has resulted.

Esau and Hahnemann in Germany have published results and Jagi and Uda in Japan. In America the Radio Corporation have made use of 3 m. waves in linking up by telephony the Hawaiian Islands. Experimental evidence shows that transmission on waves below about 8 m. is practically confined to the direct ray, *i.e.*, there is no evidence (except possibly on rare occasions) of any energy being reflected from the Heaviside layer on these waves. This is in accordance with the results obtained by the facsimile echo methods where it was shown that normally the short wave long distance limit lies between 8 and 9 m. Esau and Hahnemann show that the range of such short waves is practically confined to the optical range. These results are confirmed by experiments of H. Fassbender and G. Kurlbaum, made from an aeroplane on 3 m. When the receiver passes within the shadow of the earth's hump, signals are very rapidly reduced. Similar results were found in Honolulu where the transmitter had to be placed at such a height on a mountain that the straight line from transmitter to receiver was tangent to the earth's surface at the latter. From time to time reports of long distance ultra short wave transmissions beyond the optical range have been made, but they seem to be the exception rather than the rule.

Beam Transmission.

The gain of a Beam array over a single element of the array has been the subject of several studies both from the theoretical and practical point of view.

The behaviour locally is already well known and calculations have been made for a great variety of arrays by Southworth in which the fundamental element of the array is assumed to be a doublet and the effect of earth conductivity is neglected.

Over long distances the estimated gains are not always attained in practice (Schelleng Technical Publications of Bell Telephone Laboratories), and the loss due to incoherence in the ray, *i.e.*, irregular phase changes in the E.M.F. in the wave front is the subject of a calculation by Schelleng (also unpublished calculations by the author, which agree).

Signals fade differently at different points along the wave front, and the distance at which the fading at two points is in a purely random relation is found by Friis to be about 10λ .

It is then shown that the actual gain as compared with the theoretical gain drops off rapidly if apertures comparable or large compared with this distance of random fading, are used.

With regard to the theoretical calculation of the gain of an array over a single element of the array this is a very complicated function of that aperture if the aerial height is small, but tends to a very simple limit if a high uniform aerial is used as the element.

It can then be shown that in this case where the radiation is confined to a small vertical sheaf of rays the theoretical gain approaches the limit $2\pi\lambda$ aperture where the aperture is the ratio of the width of the array to the wavelength.

A useful summary of the progress in the study of Radio Wave propagation phenomena is given by G. W. Kenrick and G. W. Pickard. (Proc. I.R.E., Vol. 18, No. 4, April, 1930.)

The recent developments are given in Section B and E of this paper and a very complete bibliography is appended.

T. L. ECKERSLEY.



THE ENERGY MAGNIFICATION OF BROADSIDE AERIAL ARRAYS USED FOR RECEPTION

The energy magnification of aerial arrays used for transmission was first worked out by C. S. Franklin, and an elementary sketch of the method used was given by the author in EXPERIMENTAL WIRELESS, October, 1927. Taking a small aerial in free space as standard, Franklin calculated the energy magnification of a half-wave aerial as 1.095, while that of a broadside aerial of the Marconi-Franklin type with reflector was 9.6 per square wavelength of the aerial. It was rightly assumed that equal gains would be obtained on reception, but it is nevertheless of interest to examine the question from the receiving point of view.

(1). The Power Received by Single Aerial.

THE power received by a single aerial can be calculated by a method given by Zenneck. It is assumed that it is possible to obtain an aerial with other resistances small compared with its radiation resistance, that the earth is a perfect conductor and that the aerial is parallel to the electric force in the wave front. The effective E.M.F. on an aerial is calculated as follows:—

Let E = Maximum value of field strength in volts per cm. in the incoming wave.

I_x = Maximum value of current in the element dx of the aerial.

I_X = Maximum value of I_x at any point in the aerial.

θ = Phase angle between I_x (at all points in aerial) and E .

h = Length of aerial in cm.

λ = Wavelength in cm.

Then the energy received from the wave

$$= \int_0^h \frac{1}{2} I_x E \cos \theta dx = \frac{1}{2} E_0 \cos \theta \int_0^h I_x dx = \frac{1}{2} E \cos \theta I_X \alpha h$$

where $\cos \theta$ can be made unity by tuning and $\frac{1}{2}$ is factor due to E and I_x being maximum values, and

α = Same form factor that appears in the formulæ for radiation resistance.

For a small earthed aerial

$$R_{\text{Rad}} = 1580 \left(\frac{h\alpha}{\lambda} \right)^2$$

The Energy Magnification of Broadside Aerial Arrays used for Reception.

For a small dipole in free space

$$R_{\text{Rad}} = 790 \left(\frac{h\alpha}{\lambda} \right)^2$$

αh = effective height (or length)

$$\begin{aligned} \text{Hence the effective E.M.F. max.} &= E\alpha h \\ &= E \times (\text{Effective height}). \end{aligned}$$

Let R_R = radiation resistance of aerial,

R_D = effective resistance of detector in aerial,

both these resistances being referred to the maximum current in the aerial

$$\text{Current in aerial} = I_X (\text{max}) = \frac{E\alpha h}{R_R + R_D}$$

$$\text{Power to detector} = \frac{1}{2} R_D I_X^2 = \frac{1}{2} \frac{E^2 (\alpha h)^2 R_D}{(R_D + R_R)^2}$$

This is a maximum for $R_D = R_R$ when its value is $\frac{E^2 (\alpha h)^2}{8R_R}$

Various cases arise

(A) Small aerial in free space for which

$$R_R = 790 \left(\frac{\alpha h}{\lambda} \right)^2$$

$$\text{Maximum power to detector} = \frac{E^2 \lambda^2}{8 \times 790} = \frac{E^2 \lambda^2}{6320} \text{ watts.}$$

(B) Small aerial at the earth's surface for which

$$R_R = 1580 \left(\frac{\alpha h}{\lambda} \right)^2$$

$$\text{Maximum power to detector} = \frac{E^2 \lambda^2}{12640} \text{ watts.}$$

Thus in both these cases under the conditions assumed the maximum power to the detector is independent of the size of the aerial, a rather surprising result. It is the neglect of dead resistance, such as earth resistance, which is usually much greater than the radiation resistance that leads to this result.

(c) Half-wave aerial in free space or near the earth for which a correction factor must be applied to the formula $R_R = 790 \left(\frac{\alpha h}{\lambda} \right)^2$. This correction factor is due to the length of the aerial producing a concentration of field in the plane perpendicular to the aerial.

The Energy Magnification of Broadside Aerial Arrays used for Reception.

From formula $790 \left(\frac{h\alpha}{\lambda}\right)^2$ $R_R = 80$ ohms.

Accurate calculations give

Half-wave aerial in free space $R_R = 73.2$ ohms.

„ „ with lower end

at earth's surface $R_R = 104$ ohms.

lower end $\frac{1}{4}\lambda$ above earth $R_R = 69$ ohms.

If the formula $790 \left(\frac{h\alpha}{\lambda}\right)^2$ were correct the maximum power to detector would be as given in (A) that is $\frac{E^2\lambda^2}{6320}$.

Actual maximum power to detector = $\frac{E^2\lambda^2}{6320} \times \frac{80}{R_R}$

Thus a half-wave aerial in free space will deliver $\frac{80}{73.2} = 1.095$ times as much power to the detector as a small aerial in free space, *i.e.*, the energy magnification of the half-wave aerial relative to the small aerial is 1.095. This is exactly the figure found for transmission as might be expected since the same calculation is involved.

Let us compare these values with the wave energy going through an area of 1 sq. wavelength parallel to the wave front.

Amplitude of field in E S units = $\frac{E}{300}$ per cm.

Electric energy in unit volume 1 cc with this field strength } = $\frac{1}{8\pi} \frac{E^2}{300^2}$ ergs.

In one second per sq. cm. of wave front electric energy flowing through } = $\frac{1}{16\pi} \frac{E^2}{300^2} \times 3 \times 10^{10}$

The factor $\frac{1}{2}$ gives average value of $(\sin)^2$.

There is an equal amount of magnetic energy

Hence power through 1 sq. wavelength = $\frac{1}{8\pi} \frac{E^2\lambda^2}{3 \times 10^7}$ watts

= $\frac{E^2\lambda^2}{754}$ watts

We can therefore express the power delivered to the detector as a percentage of the total power flowing through one square wavelength parallel to the wave front.



| | | |
|--|-------------------------------|----------|
| (A) Small aerial in free space | $\frac{754}{6320} \times 100$ | = 11.93% |
| (B) Small aerial at earth | | = 5.96% |
| (C) Half-wave aerial in free space | 11.93×1.095 | = 13% |
| Half-wave aerial lower end at earth | | = 9.2% |
| " " " " $\frac{1}{4}\lambda$ above earth | | = 13.6% |

If the resistance of the earth is taken into account it will alter the value of the radiation resistance of aerials near earth, and so affect the amount of power that can be delivered to the detector.

(2). Power Received by Broadside Array without Reflector.

Consider an aerial array of the Marconi-Franklin type without a reflector, of dimensions large compared with the wavelength so that edge effects are negligible. In the first place let us suppose the array is correctly tuned, but is not coupled up to a receiving system, so that it has no damping other than that due to radiation. An electric magnetic wave of field strength E striking the aerial system squarely will be practically totally reflected, giving rise to a wave of field strength E travelling in the reverse direction, whilst there will be practically no field behind the aerial system.

Assume that in this case the current in one of the aerials is I_0 . If the aerial system is coupled up to a receiver the current induced in the aerials would be reduced to kI_0 where k is a fraction depending on the degree of damping introduced. The field strength of the wave reflected from the aerial will be kE and that of the wave that passes through the aerial will be $(1 - k)E$.

The power in the incident wave is proportional to E^2 , while the power in the reflected and transmitted waves are proportional to k^2E^2 and $(1 - k)^2E^2$.

Hence the fraction of incident power absorbed will be:—

$$\frac{E^2 - k^2E^2 - (1 - k)^2E^2}{E^2} = 2k - 2k^2 = 2k(1 - k).$$

This fraction is a maximum when $k = (1 - k)$, i.e., $k = \frac{1}{2}$ when its value is $\frac{1}{2}$. That is to say the aerial system without reflector can absorb 50 per cent. of the power in that part of the incident wave which strikes the aerial system.

(3). Power Received by Broadside Array with Reflector.

Now suppose a reflector system is placed at a suitable distance ($\frac{1}{4}\lambda$ or $\frac{3}{4}\lambda$ etc.) behind the aerial system, the receiver damping being adjusted so that the current in it is still $\frac{1}{2}I_0$. The wave, strength $\frac{1}{2}E$ which is transmitted through the aerial system will induce a current $\frac{1}{2}I_0$ in the reflector system and there will be no field behind the reflector system. Also the phases of the aerial currents in the aerial

The Energy Magnification of Broadside Aerial Arrays used for Reception.

and reflector system are such that they produce no radiation in the direction opposite to the incident radiation, but produce a wave of strength $-E$ travelling in the same direction as the incident radiation, so cancelling out the incident wave behind the aerial system. Hence all the energy in the incident wave is absorbed by the receiver. The aerial with reflector when properly adjusted behaves as an ideal black body.

Comparison of the figure for the broadside aerial array with reflector, with those for the single aeriels gives the following table:—

| Broadside aerial array with reflector compared with | Energy Magnification per square wavelength |
|---|--|
| Small aerial near earth | $\frac{100}{5.96} = 16.8$ |
| „ „ in free space | $\frac{100}{11.93} = 8.4$ |
| Half-wave aerial in free space | $\frac{100}{13} = 7.7$ |
| „ „ lower end at earth | $\frac{100}{9.2} = 10.9$ |
| „ „ „ „ $\frac{1}{4}\lambda$ above earth | $\frac{100}{13.6} = 7.4$ |

These figures though lower than the corresponding figures for transmission, may be correct for aerial arrays of very large extent in both dimensions. The transmission figures are worked out for arrays of moderate dimensions. Such arrays in reception will absorb energy from an area of wave front appreciably greater than the actual area of the array so that the energy magnification figures will be correspondingly increased. Thus an aerial system 2λ high might absorb the energy from $2\frac{1}{4}\lambda$ height of wave front. This would increase the effective area of the aerial by 12 per cent. and would bring transmission and reception figures into agreement.

In all these calculations the earth has been treated as a perfect conductor, a condition it is far from fulfilling. The effect of its resistance will be to decrease the energy received by a single aerial relative to that received by the beam array. If figures for the radiation resistance of an aerial taking earth losses into account could be obtained, it would be possible to calculate the percentage power absorbed by the aerial as shown in the first part of the article.

Although the foregoing calculation shows the energy magnification of a beam array in reception, it should be noted that the chief value of such an array for reception lies in its directivity which increases the signal to noise ratio.

The Energy Magnification of Broadside Aerial Arrays used for Reception.

Another point that arises is whether the radiation resistance of the aerial system when used for reception is the same as when used for transmission. First take the case of a single aerial array without a reflector. In reception a current I_0 produces a plane wave of strength E in one direction only. On transmission a current I_0 produces two plane waves of the same field strength E travelling in opposite directions. For a given current the aerial therefore radiates double the energy on transmission to what it does on reception. That is, the value of radiation resistance for reception appears to be half of that for transmission. The aerial array with reflector, when properly adjusted for reception radiates no energy at all, so that its radiation resistance is effectively zero. From the transmission point of view, the reflector will double the radiation resistance of the array.

The receiver loading on the aerial, however, will be correct when the aerial has been adjusted as a transmitting aerial, *i.e.*, when the aerial load as a transmitter is equal to the surge impedance of the feeder, the actual receiver load being also adjusted to this value. This follows from the fact that for the aerial without reflector the energy re-radiated from the aerial for a current of $\frac{1}{2}I_0$ is $\frac{1}{4}$ of the total energy in the incident wave, or $\frac{1}{2}$ the energy absorbed in the receiver. Hence the receiver load must be double the radiation resistance of the aerial from the reception point of view and equal to the radiation resistance of the aerial when transmitting. The effect of the reflector is to double the absorption of energy by the receiver for a given current. Therefore the receiver load must be doubled. It will then be equal to the radiation resistance of the aerial and reflector when transmitting.

Since the beam aerial with reflector when properly adjusted can absorb all the incident energy it would appear to be inadvisable to use reaction directly on the feeder of such a system.

My thanks are due to Mr. C. E. Rickard, O.B.E., for reading through the manuscript and correcting an error in the formulæ for radiation resistance.

E. GREEN.

RELAY BROADCAST TRANSMITTER

TYPE B.R.1a

One of the most recent developments in Marconi Broadcast designs is the production of an inexpensive, low power, high quality Broadcast Equipment suitable for the relaying of programmes transmitted by wire from a remote centre, and intended to function as a unit in a common wave broadcast system. The first of this design, the B.R.1A Broadcast Transmitter to be used in Sweden, is described below.

General.

THE B.R.1a Broadcast Transmitter is a self-contained equipment capable of direct operation from 3-phase mains, and of transmitting any selected wave in the band 200/250 metres, with a transmitted frequency of the exceptionally high constancy required by common wave working. Special care has been taken to secure simplicity of control, and warning and tripping devices have been incorporated which automatically secure the maximum of safety for both personnel and equipment. So effective are these that the equipment may safely be left in the casual care of an attendant whose time is mainly occupied by other duties.

Equipment.

The equipment is handsomely housed in a metal cabinet 12 feet long, 3 feet broad and 7 feet high (as will be seen from the photograph). The high frequency and modulation circuits are contained in six screened compartments in the upper part, whilst all switchgear, anode, grid and filament rectifiers for the smoothed D.C. supplies for the various amplification stages occupy the lower part, being positioned most favourably for their individual functions.

Safety gates are provided, which operate in such a manner that when any door is opened the main power is shut off. The general disposition of the components in the cabinet is shown in Fig. 1, the master oscillator and drive circuits being mounted in the left hand top sections, the power oscillator and aerial circuits in the middle sections, and the modulating circuits in the top right hand corner.

As will be seen from the simplified diagram of connections given in Fig. 2, the main power oscillator is driven from a constant frequency master oscillator, and is modulated by choke control from the output of a four stage modulator amplifier.

Crystal Oscillator and High Frequency Stages.

The extremely high frequency constancy stipulated has been obtained by quartz crystal control of the transmitted frequency combined with sensitive thermostat maintenance of the crystal temperature. An alternative crystal and a highly constant valve oscillator, each independently controlled by thermostat, are available

Relay Broadcast Transmitter. Type B.R.1a.

for instant substitution should the necessity arise, Very complete screening from external fields, particularly from the higher power stages, is supplemented by the isolation secured by weak coupling of the output to a screened grid frequency doubler stage operating without grid current. Four magnifier stages, individually screened and neutrodyned, complete the high frequency circuits ; the final stage is capacity coupled to the aerial in such a way as to produce effective harmonic reduction.

The circuit diagram of the master oscillator and doubler valve is shown in Fig. 5. It will be seen to consist of a P.610 valve which can be associated with

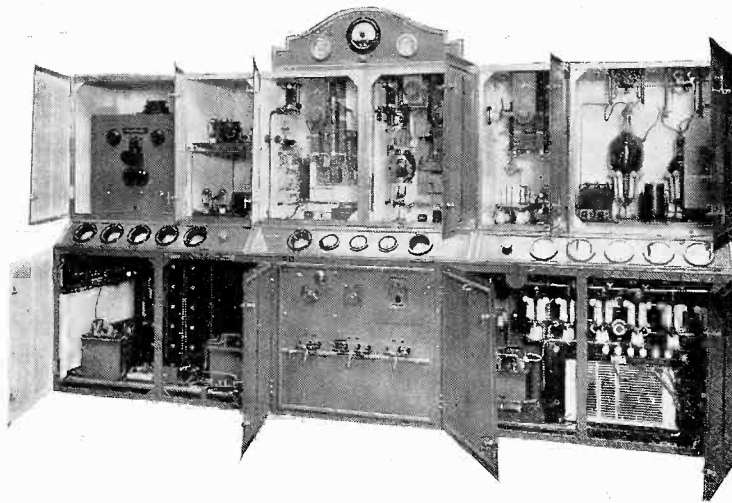

four alternative circuits by means of a rotary switch. Two of these circuits are designed to cover a waverange of 400 to 500 metres in two steps, and consist of two inductances and a variable condenser. The two inductances are used in series for the longer waves, and one of them is cut out for the shorter waves in the wave-range. The other two circuits consist of crystals which are tuned to twice the required spot wave of the transmitter.

The wavelength of the master oscillator is halved in the next stage of the drive which consists of an S.625 valve which serves as an isolator and doubler stage. This valve is provided with an output circuit which is, of course, tuned to twice the frequency of the master oscillator.

The input and output circuit of this stage, and the circuits of the rest of the drive will be seen from an inspection of Fig. 2.

Relay Broadcast Transmitter. Type B.R.1a.

The output of the doubler stage feeds into the input circuits of two L.S.5 valves working in push-pull. These valves are neutrodyned in the ordinary manner.

Following this comes one stage of magnification using an L.S.5 valve, and then the final stage using a screen grid valve, the output from which feeds the main oscillator, a D.E.T.3 valve.

The high frequency circuits in the case of the drive valves are tuned with condensers and variable inductances, and are all neutrodyned. The output circuits of the last stage of the drive and of the power oscillator are tuned by a variometer and tapped inductances. A capacity coupled aerial system is employed, and a switch is provided so that the normal aerial can be replaced by an artificial aerial consisting of variable inductance capacity and resistance in series to enable adjustments to be made.

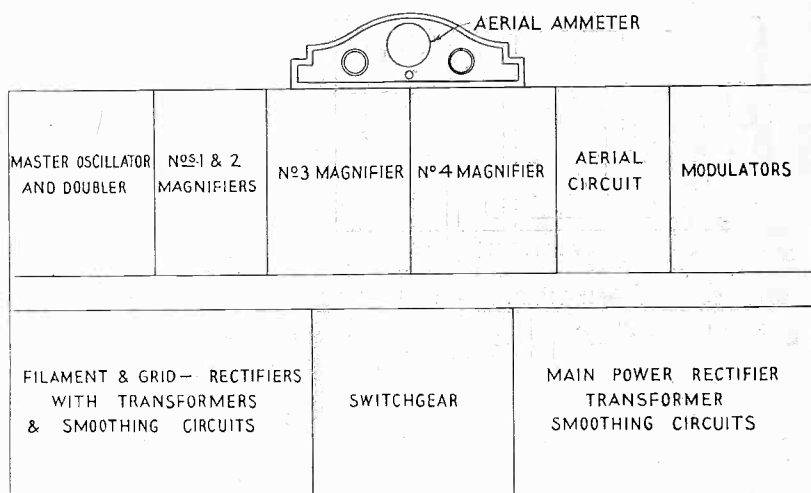

FIG. 1.

Modulator Stages.

Modulation is effected by choke control of the main oscillator. As the available input from the line is likely to be rather small, a four stage resistance capacity coupled modulator is provided, which is able to amplify a line signal of less than .3 volts to a value capable of completely modulating the final radio frequency stages by choke control and of producing aerial circuit inputs of either 250 watts at 80 per cent. modulation, or 200 watts at 100 per cent. modulation with the highest broadcast performance in linearity and response. As will be seen from Fig. 2, the line is terminated by a transformer, the primary of which is designed for a line of 600 ohm surge impedance. The secondary is bridged by a resistance, a tapping from which is taken to the grid of the first modulator amplifying valve, an L.S.5B. The speech input is thus controlled by this potentiometer, and the latter can be adjusted to give the required depth of modulation and compensate for variation in speech lines.

Relay Broadcast Transmitter. Type B.R.1a.

This first stage is followed by a similar stage, also employing an L.S.5B. valve. Both of these stages of amplification are housed in a separate screened box, which is situated on the left hand side of the modulator cabinet. Grid bias for the two valves is taken from a battery.

The two following stages of amplification are mounted in the modulator cabinet, and consist of a D.E.T.2 and M.T.9L. valve, the output of the latter being taken to the main oscillator anode. Grid bias for these stages are taken from the main grid bias supply to the transmitter, which is derived from rectified A.C.

All the modulator stages are resistance capacity coupled in the normal way.

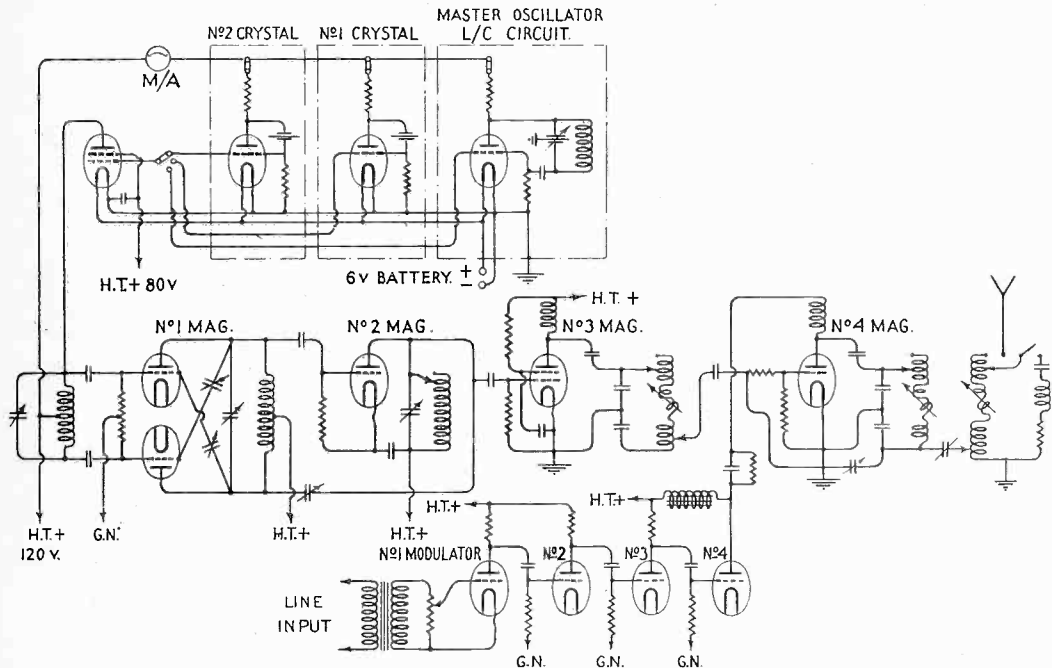

FIG. 2.

Protection Devices.

Protection of radio and modulator circuits during operation is provided by an aerial underload relay and an over modulation indicating and tripping device.

The aerial underload relay is combined with the aerial ammeter, occupies a prominent position in the installation, and trips the power input if any disturbance (such as valve failure) causes a diminution of aerial current. It can be set to trip on small reductions of current.

The over modulation device includes a sensitive relay operated by the output current of a small rectifier working off the modulated anode voltage of the final transmitter stage. The relay is mechanically biased against operation by normal modulation voltages, but is rendered sensitive by the nature of its circuit to over modulation peaks. Under such conditions its contact closes a lamp circuit, and the extent of lamp flicker is an indication of the amount of over modulation. The energy of the over-modulation peaks is also used to heat up a thermostat which is set to trip the power supply when over-modulation of excessive amount is experienced.

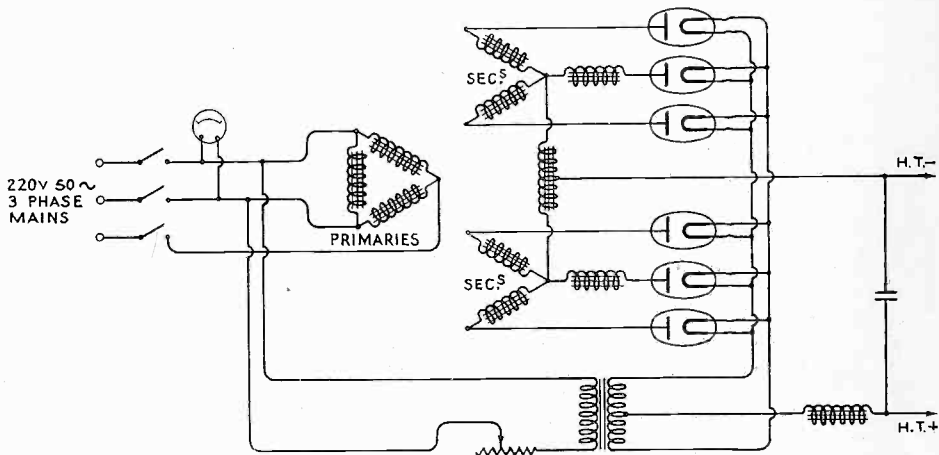

FIG. 3.

Power Supply.

The circuit of the main power supply system is shown in Fig. 3. Filament grid and anode power for the various amplification stages of the set are obtained from rectifiers operating from the 3-phase supply. To secure a steady voltage for filament heating in spite of wide mains voltage variations, floating batteries are used across each of the two filament supply rectifiers. For the same reason,

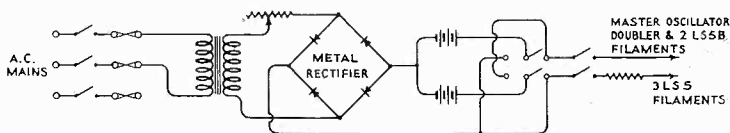

FIG. 4.

crystal valve high tension and filament heating for crystal valve, doubler and valves of the first two modulator stages are obtained from small independent batteries. The independent filament battery is interchanged daily by a switching operating with a similar battery floating or lightly charging on one of the filament rectifiers,

Fig. 4. In this way a constant condition of charge is maintained. The crystal valve anode battery is a small dry cell unit. Means exist in the transmitter for the automatic maintenance of the state of charge of all batteries, and for independent charging where required.

The main high tension D.C. power supply (4,000 volts) is obtained from a 3-phase valve rectifier working on the 3-phase double Y system. All other supplies are given by dry metal rectifiers on a single phase system. Rectified supplies for all purposes are at 4,000 volts, 500 volts, 450 volts, 20 volts and 6 volts.

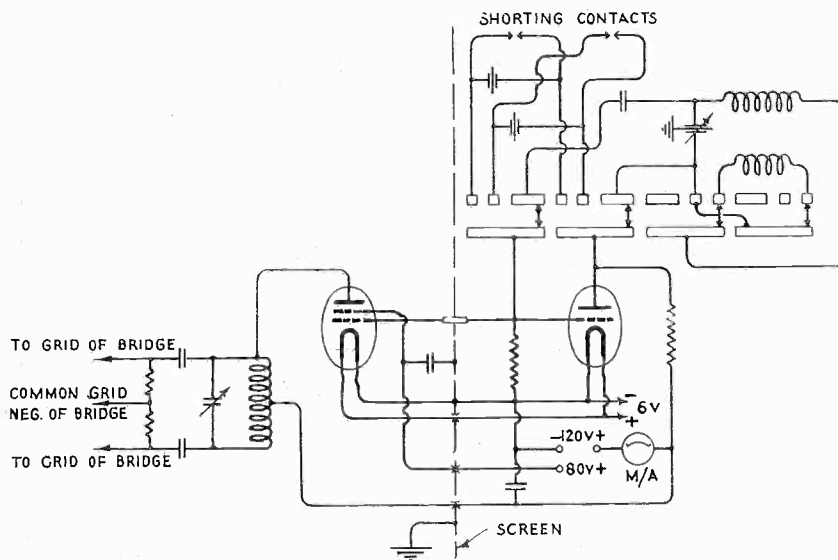

FIG. 5.

Operation.

Operation of the transmitter for starting, stopping or battery charging is simply and safely effected by the manipulation in proper sequence of a few switches centrally located on the transmitter unit. Electrical interlocking secures the safety of the equipment against incorrect sequence of operation. Operation includes continuous maintenance of thermostat circuit supplies to ensure constant crystal temperature, daily reversal of main filament polarity by reversing switch, and daily interchange of 6 volt batteries, together with the usual starting and stopping operations.

After being skilfully set up and adjusted, this equipment may be left for lengthy periods in the care of an attendant who is required only to carry out the manipulations above, and to note and report on the indications of the various protective devices.

THE MARCONI-ADCOCK DIRECTION FINDING AERIAL

In THE MARCONI REVIEW for June, 1930, a short description was given of a practical Direction Finder which is free from errors caused by "night effect," and some results obtained with it were illustrated.

In the following article the theoretical principles involved in the design are discussed, and it is shown that the results obtained are in accordance with these principles.

IN a recent article Mr. N. E. Davis has described the adaptation for Medium wave Direction finding, of what is generally known as the Adcock Direction Finder. The purpose of this is to eliminate the errors prevalent at night, and the success of the device is amply illustrated in his curve shown in Fig. 7 of his article. Although these results speak for themselves, there may still be some doubt as to how and in what condition such results could be repeated.

There is always some suspicion of an isolated result unsupported by any theoretical justification, especially in view of the fact that in certain quarters it has been stated that such justification is entirely lacking. Put crudely it has been stated that the arrangement as described cannot possibly work.

The present article is in the nature of a "special pleading" for the system.

In its elementary equivalent form, the aerial is of the simple U shape with the horizontal member shielded in a copper tube and earthed, as in Fig. 1. Such a system to be a perfect direction finder should receive nothing when the plane of the U is perpendicular to the plane of the ray, even when the wave is wholly polarised with the electric force in the horizontal plane. Consider the arrangement set up in this manner.

The E.M.F.s in the vertical members cancel since they are equal and in phase and acting in opposition in the circuit A B C. The horizontal electric force remains, which acting on the copper tube Feeder shielding the inner conductor sets up currents and charges on it. There can be no doubt that if the tube is thick enough and of good enough conductivity so that $2\sqrt{\sigma\lambda c} \frac{t}{\lambda}$ is a large quantity

Where t = thickness of wall
 σ conductivity of copper
 λ wavelength

the inner conductor will be entirely shielded from the direct effects of the currents and charges on the outer conductor. (A simple experiment can be performed by enclosing the inner conductor wholly in the tube when it will be found that no signal leaks through.)

The Marconi-Adcock Direction Finding Aerial.

The currents and charges on the shield can however act indirectly on the vertical aerials, on account of the effective coupling between this feeder and the vertical aerials, so that even though the horizontal wave field cannot act directly on the complete aerial it can act indirectly and produce a signal by induction from the charges and currents set up in the feeder.

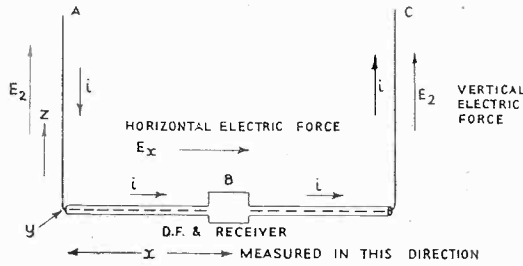

FIG. I.

In the first place it should be noted that the *currents* in the shielding tube are *horizontal* and on this account can produce no E.M.F. in the *vertical* aerials. For a varying horizontal current can produce only a horizontal E.M.F. according to the relation.

$$E_x = \frac{d}{dt} \int dx \frac{[i]t}{r} = - \frac{r}{c}$$

$$E_y = 0$$

$$E_z = 0$$

i being the current in the horizontal direction.

There remains only the effects of the charges which produce vertical electric forces of the form

$$E_z = \frac{d}{dz} \int dx \frac{[e]t}{r} = - \frac{r}{c}$$

(*z* measured in the vertical direction).

If the charges consequent on the oscillations set up in the shielding conductor can be reduced to zero by any means, the system will be a perfect D.F. and be free from night errors which, as is well known, are caused by the horizontal field in the wave. If the horizontal shielding members are open-ended, oscillations are set up by the horizontal electric force. The currents are then a maximum in the middle and the charges at the end. Such an arrangement, *i.e.*, an open ended feeder is very little use for eliminating night effect, since the voltages at the end of the shielding members are transferred to the vertical aerials.

The Marconi-Adcock Direction Finding Aerial.

If the ends of the feeder tubes are earthed and the distance between the vertical aeriels a small fraction of the wavelength, the system feeder and earth connections, is, in effect, a small untuned frame, the area of which is approximately equal to the length of the feeder multiplied by its height above the ground. Circulating currents will be induced in it by the horizontal electric force or by its equivalent the horizontal magnetic field in the vertical plane of the rays.

These can induce E.M.F.'s in the vertical aeriels of the main receiver only on account of the short vertical earthing strips at the ends of the feeder (as we have seen before the horizontal currents produce no effect).

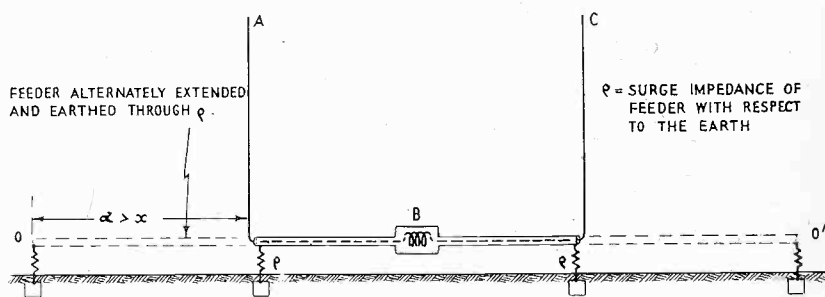

FIG. 2.

The height of the feeder above the ground should be a minimum and it should preferably be buried in the earth if this does not involve too much labour. In certain cases however (where a short wave direction finder is required) it is not convenient to keep the distance between the aeriels a small fraction of the wavelength and in such conditions it is more accurate to consider the feeder-earth system, as a cable.

For simplicity consider in the first case the feeder extended to infinity in both directions. When acted on by a uniform periodic horizontal E.M.F. the resultant is a uniform periodic current along the outside of the feeder.

Since the charge at any point is proportional to the gradient of the current, which is zero, the charge is everywhere zero. It is well known that the equivalent of an infinitely extended cable is a finite one terminated by the surge impedance.

The arrangement Fig. 2 is therefore equivalent to the infinitely extended cable and since there is no accumulation of charge (periodic) on the feeder it should produce no indirect action on the aeriels.

It will be remembered that periodic charges accumulate at or near the reflection points of such a cable. Now this feeder considered as a cable will have attenuation, let x be the distance at which any disturbance is reduced to less than 1 per cent. of

The Marconi-Adcock Direction Finding Aerial.

its original value. Then if the feeder is extended beyond the aerials a distance large compared with λ , any accumulation of periodic charge due to lack of accurate termination will be confined to regions well beyond the vertical aerials and will produce little effect.

Burying the feeder serves a double purpose ; it effectively reduces the area of the frame coupled to the vertical aerial and secondly it greatly reduces the attenuation distance λ on account of the extra attenuation produced by the earth leakage.

The arrangement of using a buried cable extended some distance beyond the vertical aerials should therefore be very effective and specially applicable to short wave direction finders where the elimination of the horizontal E.M.F. offers greater difficulties. In the longer wave cases where the horizontal E.M.F. at or near the surface of the earth is always small compared with the vertical forces the arrangement with feeders earthed at their ends should suffice unless the resistivity of the ground is particularly high.

This is the case in justification of the behaviour of the Marconi-Adcock type of D.F. It will be observed that the conception of the " Potential " of the feeder in any part of the argument has not been used, for as is well known there exists no potential function in the case of a varying electromagnetic field. Everything is explained in terms of the currents and charges on the feeder which can be definitely specified. The misuse of the idea of the potential of the earth had been responsible for the argument that the system cannot eliminate the horizontal component and for this reason it is not considered valid.

MARCONI NEWS AND NOTES

MARCONI ROTATING BEACON TRANSMITTERS.

MARCONI'S Wireless Telegraph Company Limited has now acquired from the British Air Ministry the full rights and drawings for the design and erection of wireless beacon stations of the rotating type.

For many years the Marconi Company has specialised in the design and production of wireless direction finding equipment, both transmitting and receiving. Marconi omni-directional fixed beacon transmitters have been installed at important coastal points in many parts of the world, and by the acquisition of the commercial rights for the rotating type of beacon station in addition, the Company is able to provide what in certain cases will undoubtedly prove a valuable alternative as an accurate aid to both aerial and maritime navigation.

First Contract for Rangoon.

Experimental rotating beacon stations have been erected at Orfordness, Gosport and Farnborough, which, after having been submitted to rigorous and exhaustive tests by the Air Ministry, the Radio Research Board, and other authorities, have been the subject of very favourable reports.

The first station of this type to be built as a commercial contract is to be erected by the Marconi Company at Rangoon, to the order of the Rangoon Port Trust, as a guide to shipping using the busy channel to and from the principal port of Burma.

A special feature of the rotating beacon system is that it requires only an ordinary wireless receiver and a stop watch to enable a ship or aircraft to take bearings, and it is therefore likely that the system will prove of considerable value in augmenting still further the application of wireless to navigation, especially in connection with the smaller classes of ships.

Method of Operation.

The system makes use of a vertical closed loop aerial rotating at a uniform speed of one revolution in 60 seconds. The radiation from such a loop is at maximum in the plane of the loop and at minimum or zero at right angles to that plane.

For the calculation of bearings, two distinctive signals—a "north signal" and an "east signal"—are transmitted at regular intervals as the loop aerial rotates, the periods between them being occupied by a steady dash. The normal method of observation at the wireless receiving station is to start a stop watch at the moment the north signal ends, after which the time taken for the zero signal to be reached will indicate the bearing of the observer from the beacon. If, however, the observer is practically due north or south of the beacon he may not be able to read the north signal owing to the directional effect of the transmission, in which case the east signal is taken as the basis for calculating the bearing.

It is evident that, the speed of rotation being one revolution per minute, the number of seconds from the reception of the north signal to the reception of the minimum signal multiplied by six gives the bearing in degrees. The necessity for calculation can be avoided by having a stop watch graduated in degrees.

The Rangoon Installation.

The rotating beacon to be erected by the Marconi Company at Rangoon will be similar to the station just built by the Air Ministry at Farnborough, which is of the most recent design and incorporates a number of new improvements.

It will operate on the wavelength of 1,050 metres (285 kilocycles) with a maximum power of 2 kilowatts to the anodes of the transmitting valves.

The system of operation will be to transmit a series of signals commencing at 5, 20, 35 and 50 minutes past each hour, the first minute of each transmission being utilised for signalling the identification letters of the station, VUR.

As practically all ships of any size using the port of Rangoon are fitted with wireless receivers, it is considered that when navigators have become accustomed to the operation of the rotating beacon it may be possible to dispense with the lightship which at present serves the channel for navigation purposes. Thus wireless will take the place of visual observation.

Fixed Beacons for Uruguay.

THE Marconi fixed omni-directional type of wireless beacon station, the navigational value of which has been proved by great experience, is by no means superseded by the rotating beacon, as is indicated by the fact that three new automatic wireless beacon stations of the former type are to be erected on the Uruguayan coast by the Marconi Company on behalf of the Hydrographic Department of the Government of Uruguay. The stations are expected to be placed in commission in the summer of 1932, two being installed in lighthouses—at Lobos Island and Cape Polonio—and the third in the English Bank Light Vessel.

Each transmitter is designed to operate on two definite wavelengths, one of 600 metres and one between 950 and 1,050 metres. Normal operation of the beacon signals will be on the higher wavelength in each case, but a telegraph keying circuit has been incorporated so that in case of emergency or special need the beacons can be used as wireless telegraph stations, and in this event the 600 metre wavelength would be necessary to communicate with ships and coastal wireless stations. Three Marconi Type R.G.27 receivers have also been supplied, so that if necessary complete transmission and reception services can be carried on, a feature which might prove of considerable value on lonely and isolated coast lines.

Sound Signal Combination.

In addition, the Marconi beacon in the English Bank Light Vessel will operate in conjunction with a submarine sound signalling device so that navigators can

estimate their distance as well as their direction from the light vessel. The sub-

marine sounding device is to be fitted by the Marconi Company, and arranged so that at stated periods the wireless beacon and the submarine sound oscillator will transmit simultaneously a series of dots at regular intervals. By counting the number of dots received by wireless before hearing the first dot transmitted through the water with the speed of sound (4,800 feet per second in water), the navigator can easily compute his distance from their source.

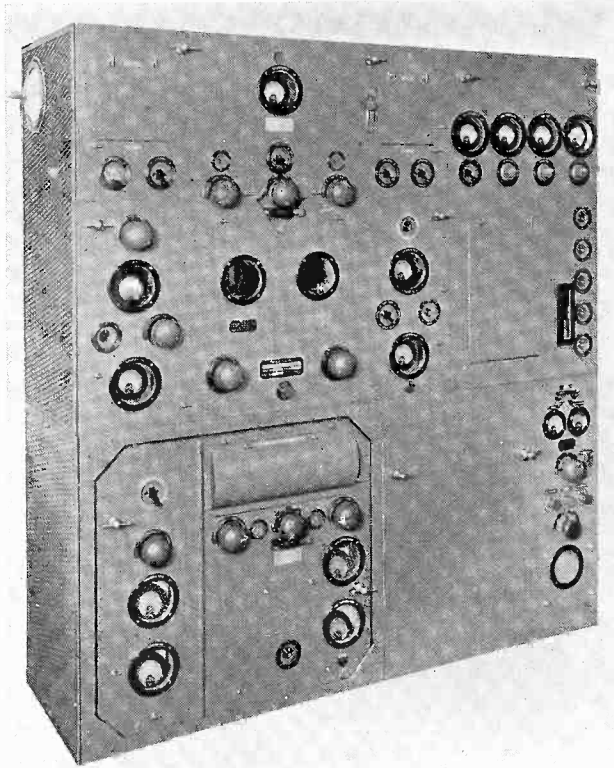

Marconi short wave telephone transmitter on "Monarch of Bermuda." (See page 28.)

Iceland Broadcasting Station.

THE high power broadcasting transmitter supplied by the Marconi Company to the Government of Iceland, which was put into commission early this year, has proved very successful.

The station, which is built on a site approximately six miles from Reykjavik, was erected to replace a low power broadcasting plant which had been in operation for some years, and it has greatly increased the broadcast service area.

The transmitter, which is of the Marconi P.A.13 type, embodying the latest improvements in broadcast technique, is capable of working on any wavelength between 1,050 and 1,300 metres, but the normal broadcast wavelength used will be 1,200 metres. The aerial rating is from 13—18 kilowatts, depending on the depth of modulation with a maximum of 100 per cent. The aerial is suspended from two 150 metre insulated steel masts.

Programmes are provided from a modern broadcasting studio located in Reykjavik.

Ship-to-Shore Telephony.

THE new luxury liner "Monarch of Bermuda," which will take her place on the New York-Bermuda run when she is completed, is the latest passenger ship to be equipped with special Marconi wireless telephone apparatus. This will provide an efficient means of communication with the wireless telephone stations at New York and Bermuda, and through these stations the ship will be linked with the telephone systems of the world. Bermuda already possesses a very efficient wireless telegraph service with the North American continent and the West Indies, and wireless telephone apparatus, operating on the Marconi Beam system, is being installed to provide telephone subscribers of the Island with an equally efficient wireless telephone service to New York and ships at sea. At New York telephone calls from Bermuda and from ships at sea can be connected to the telephone systems of the world. These facilities will be greatly appreciated by business travellers and tourists who will thus be able to keep in constant wireless telephone touch with New York from the ship and from land when they visit Bermuda.

Marconi Band Repeater Equipment.

The "Monarch of Bermuda" will also carry a Marconi Band Repeater installation which will be unique both as to the extent of the installation, and in the choice of entertainment available. A total of 39 loud speakers will be installed, distributed between private suites, public rooms and dancing spaces on deck. To provide programmes, a selection can be made from entertainment received from wireless broadcasting stations; from the ship's orchestra—the music of which is picked up by microphone and distributed throughout the ship from a central amplifier; or from music and other forms of entertainment by gramophone records. A control is fitted at each loud speaker position to regulate the volume from the loud speaker and to switch on or off as desired.

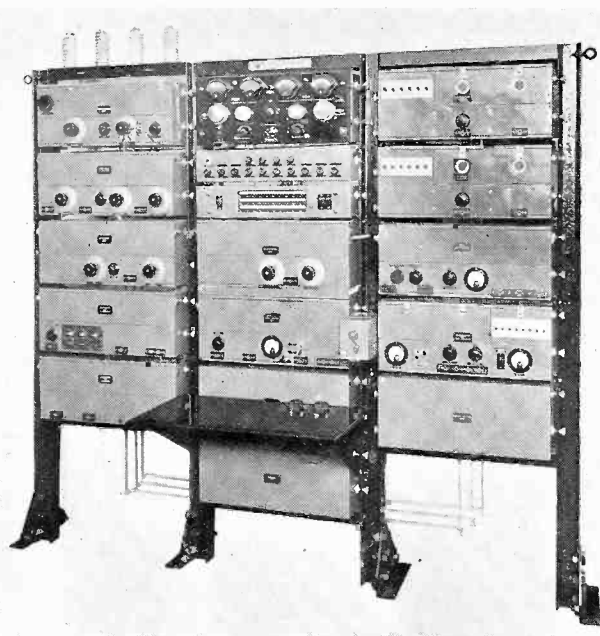

*Marconi short wave telephone receiver on
"Monarch of Bermuda."*

Standard Frequency Transmissions.

WE are asked by the Department of Scientific and Industrial Research to publish the fact that, at the request of the Post Office, arrangements have been made for additional standard frequency transmissions to be sent out by the National Physical Laboratory on the first Tuesday in the months of September and December of this year commencing at 9 p.m. G.M.T.

The standard transmission is preceded by the announcement "CQ de G 5HW" repeated several times. This announcement is followed by the standard wave transmission on 1,785 kilocycles (168.6 m.) in the form of a continuous dash, the whole lasting 10 minutes.

This procedure is repeated six times, *i.e.*, at 2100 (9 p.m.), 2110, 2120, 2130, 2140 and 2150 G.M.T.

British Regional Broadcasting.

THE second British Regional Broadcasting station has now been opened. It is situated at Moorside Edge, near Huddersfield, in Yorkshire, and is intended to cover the North of England. It is fitted with two Marconi P.B. high-power transmitters, which were manufactured at the Marconi Works at Chelmsford. They are similar to those installed in the first British Regional station at Brookman's Park, near London, and embody the most advanced ideas and the latest refinements

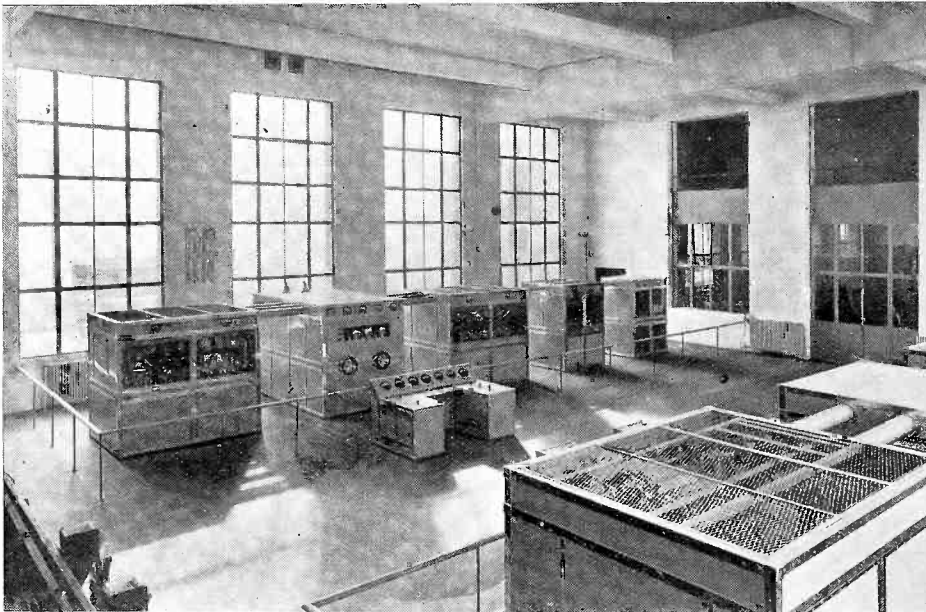

Transmitter hall at the North Regional broadcasting station of the British Broadcasting Corporation.

in broadcasting technique. The power of the new transmitters is from 50 to 75 kilowatts (C.C.I.R. rating), depending on the adjustments made.

The power of the new station is reported as "amazingly good" and the station "easy to tune in," while listeners have also been impressed by the uniform quality of the transmissions.

Wireless Communications for Africa.

FOR the establishment of a comprehensive system of wireless communications in Africa, the Marconi Company has received orders for the erection of a chain of wireless transmitting and receiving stations through the heart of that continent. The stations have been ordered by the Administrations of Uganda, Kenya Colony, Tanganyika, Northern Rhodesia, Southern Rhodesia, and the Union of South Africa, and they will be used both for the operation of the new Cape to Cairo air route and, in many cases, for general communication.

The apparatus to be installed, all of which is being manufactured at the Marconi Works at Chelmsford, is of the latest design for transmission and reception on medium and short wavelengths.

By the aid of these stations, linking up all the aerodromes and enabling aircraft in flight to keep in touch with the ground throughout the journey—the aircraft also being equipped with Marconi apparatus—the trans-African aviation service will constitute the most highly organised long distance air route in the world, and at the same time internal and external communications will be greatly facilitated throughout the Continent.

The sites for the stations have now been decided; they are to be in the proximity of

- Uganda—Kampala;
- Kenya Colony—Nairobi;
- Tanganyika—Moshi, Dodoma, and M'Beya.
- Northern Rhodesia—M'Pika and Broken Hill;
- Southern Rhodesia—Salisbury and Bulawayo;
- Union of South Africa—Germiston, Victoria West, and Cape Town.

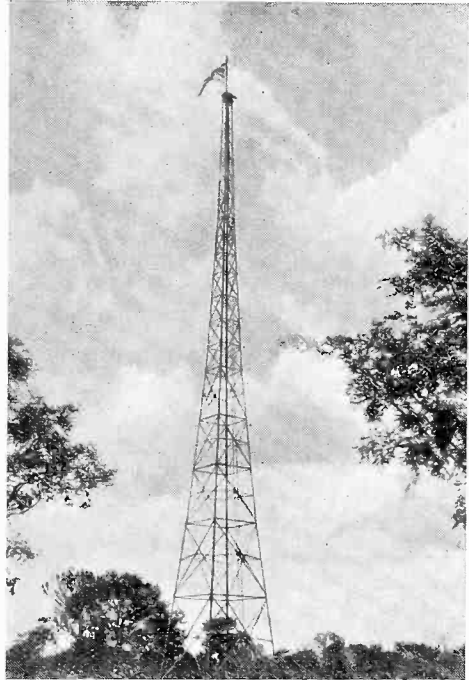

*The highest Union Jack in Rhodesia
—on the wireless mast at Broken Hill
Station.*

The wavelengths used for wireless communication between the aircraft and these stations will be 900 metres, and inter-aerodrome communication will take place on short waves.

For general communications special wavelengths have been allotted to the stations at M'Pika, Broken Hill, Bulawayo, Salisbury, Germiston, and Victoria West.

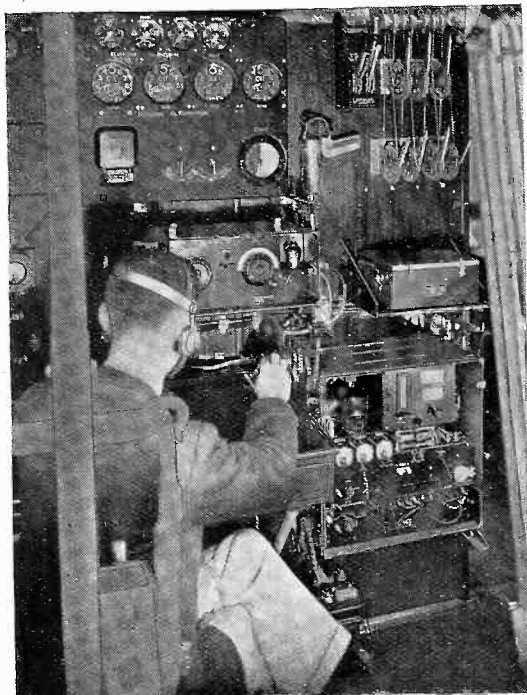

Marconi Type A.D.18a equipment installed in a flying boat.

Indian and African Air Routes.

THREE flying boats of the "Kent" type which have been built at Rochester for Imperial Airways Ltd., for use on their trans-Mediterranean air service between Genoa and Alexandria, serving both the Indian and African air routes, are fitted with the latest design of Marconi apparatus.

The Marconi Company were commissioned to equip the new flying boats with their Type A.D.18a aircraft apparatus, a powerful installation with an independent drive which ensures great constancy of the transmitted wavelength. A highly sensitive receiver incorporating a screened grid valve is used, and it is estimated that the flying boats have a wireless range of up to 500 miles.

Power for the A.D.18a installation is supplied by a wind-driven generator operating in the slip stream of the propellers, and in order to provide for the possibility of operating the wireless apparatus when the flying boat has descended on the water, arrangements have been made so that the wireless generator can be driven by the aircraft gas starter engine. A light mast is carried to support the aerial when the aircraft is at rest, but under normal flying conditions a trailing aerial will be used.

The Marconi Company have also received an order from the Blackburn Aeroplane & Motor Company Limited to equip two 10-seater civil aircraft, in course of construction by that Company for the Air Ministry, with the Marconi Type A.D.6m aircraft apparatus.

As in the case of the Type A.D.18a installations, the Type A.D.6m sets are operated by wind-driven generators. To enable the wireless gear to be operated when the aeroplanes are on the ground, hand-driven generators are supplied so that wireless communication can be carried on at any time. Light telescopic masts will also be carried to support the aerial during working from the ground. During flight the normal trailing aerial will be used.

New Marconi Station for India.

AS a part of the development plan for Bedi Port, Kathiawar, India, a Marconi coast station for communication with ships at sea is to be installed to the order of the Port Commissioner, Lieutenant-Commander Bourne, R.N.

Bedi Port is under the jurisdiction of His Highness Jam Sahib Shri Ranjitsinhji Vibhaji, who is keenly interested in the progress which is being made in this "Liverpool of Kathiawar," and the new coastal wireless station will be fitted with the latest type of Marconi marine equipment. The order has been placed through the Indian Radio Telegraph Company, Ltd.

The equipment will comprise a Marconi Type M.C.13 transmitter of $1\frac{1}{2}$ kilowatts power and the new Marconi Type 352 receiver. Operating on the interrupted continuous wave system, the Type M.C.13 transmitter incorporates the latest developments of valve transmission and is designed to meet all the requirements of modern telegraph services at sea. It is arranged to transmit on any wavelength between 600 and 800 metres. The Type 352 receiver is a highly selective and efficient instrument covering the exceptional wave range of 15 to 22,000 metres.