

6th FEBRUARY 1963

VOL. 135

NUMBER 3504

THE ORIGINAL
'DO-IT-YOURSELF'
MAGAZINE

HOBBIES *weekly*

FOR ALL
HOME CRAFTSMEN

FREE
Design
inside

MUSICAL
SAVINGS
BOX

Also in this issue

ATTRACTIVE SEAT
FOR THE GARDEN

NEW STAMPS IN
COLLECTORS' CLUB

STAR FEATURE:
DISC BREAK

CHEMISTRY

HOW TO MAKE
QUILT CUSHIONS

MODELLING
SHIP FITTINGS

PLANS FOR A
TOY TANKER

ETC. ETC.

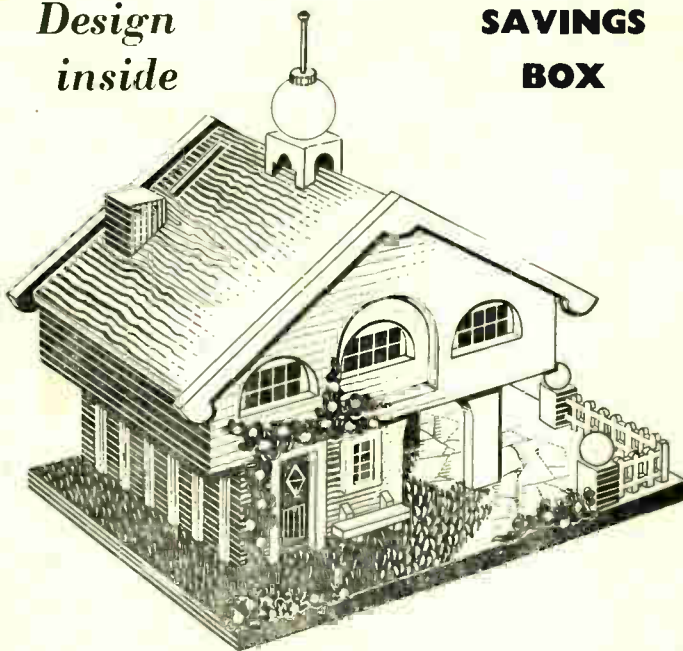

TYROLEAN CHALET



Up-to-the-minute ideas

Practical designs

Pleasant and profitable things to make

5^D



IAN McSHANE

THEY didn't actually have to use force to persuade Ian McShane to make a record — but it was tough and go. For Ian is an actor, and an actor he wants to stay, in spite of having the darkly handsome looks, and the husky baritone which could turn him into a disc idol. The songs are on reluctant Ian's first Columbia release — *Harry Brown and The Tinker* (45-DB4932).

Ian is already booked for stardom in the opinion of hardened critics after his

* * * * *

AT 15, Russ Sainty left Leyton secondary School, all set to become a jockey. He started training at Newmarket, earning five shillings a week, but lost the job through putting on too much weight. Then he joined Leyton Corporation and working as a horticulturist, grew the shrubs and flowers for the park.



performance as Harry Brown, a rebellious student, in *The Wild and the Willing*, the film which is causing a stir for its controversial portrayal of university life.

'I've no aspirations to be a singer', says Ian, 20 years old, Manchester born, and the son of ex-United footballer Harry McShane. 'And as far as singing in public goes, that's right out. Public appearances scare the living daylights out of me, anyway.'

An invitation to join a skiffle group in a local pub sparked his interest in singing. Trouble was that the group wanted him as a guitarist, as well as vocalist, but Russ didn't play the instrument. He learned fast, however, and taught himself the three-chord trick in a couple of easy lessons.

After winning a talent contest at the Rialto Cinema, Leyton, he decided to turn professional. Early in 1960 he was to be found at London's famed Two 1's

RUSS SAINTY

coffee bar, singing for experience only, and earning money by part-time jobs — tree-felling, labouring, growing and selling plants. Then he was signed for a tour of one-nighters and later passed his BBC audition, making his first broadcast in September on Easy Beat. Since then he's been a regular on the programme and on Saturday Club and Ring a Ding Ding.

Although born in the East End, Russ developed a liking for the country life when he was evacuated to Bletchley during the war and he has an ambition to have his own market-gardening firm.

'It was an ordeal even going into the recording studio. I'd never tried to sing properly before, and I hadn't a clue how it would work out. It was strange hearing my own voice on the play-back, but I reckon I managed to sing in tune most of the time. Everybody seemed satisfied with the results, and that was good enough for me.'

'Why did I make the record? Well, being in this film has helped my career enormously, and when I was asked to record these two songs from it — I don't sing them in the film, by the way — I felt that the least I could do was to agree'.

Previously Ian had turned down a suggestion that he record a number he performed in a television play *Thank You and Goodnight* (ABC TV 11th November). In it he plays a rock 'n' roll singer, Roddy Cain — and wears a black and gold jacket once used by Cliff Richard.

'I wasn't supposed to be a very good singer, so I didn't try too hard. But this rock 'n' roll is not for me — that's why I wouldn't record then'.

At school Ian had ideas of following his father, and becoming a professional footballer. But he decided that he would not make the grade, and was set to leave school at 16 to be an articled clerk. His father persuaded him to remain at school and in his final year Ian took part in a couple of plays, enjoyed acting so much, that he applied for a place at RADA, and was accepted. Towards the end of his studies there, an agent spotted him in a play and put him forward for the film part.

'I've been lucky so far', says Ian. 'I was ready to go into repertory, and make progress gradually, but I've had an important break right at the beginning of my career. Singing is a problem — it's nice to know that people want you to make a record, but you have to think how it might affect your career later on'.

Illustrated on front page

MUSICAL TYROLEAN CHALET

THIS Tyrolean Chalet makes a charming model, and it also has its practical uses for it serves as a money savings box. Incorporated is a musical movement which plays a selected tune when a coin is dropped into a slot in the roof.

This delightful novelty stands 7 in. high on a base measuring $7\frac{1}{2}$ in. by $5\frac{3}{8}$ in. The movement used is a Hobbies No. 2 but with the requisite adaptations a No. 1 movement could be utilized. The design could therefore be used as a cigarette or trinket box, the music being actuated by the lifting of a lid or a section of the model.

As can be seen from the illustration, there is much scope for artistic finishing to our model, which has been based on a

typical Tyrolean building. Its style will appeal to all modellers and it makes an extremely attractive gift.

The kit for making the chalet includes all wood planed to the correct thickness, decorative beading, wood balls, screws and pins. Suggestions will be given at the end concerning the finish to apply.

Apart from the base, which measures $7\frac{1}{2}$ in. by $5\frac{3}{8}$ in. and is cut from $\frac{1}{4}$ in. wood, all the other parts which go towards the makeup of the chalet are shown full size on the design sheet and are cut from the thicknesses indicated. Trace all the parts and transfer them to the wood by means of carbon paper before cutting out neatly with the fretsaw. In cutting, keep to the outlines as closely as possible, noting that piece 6, on which the musical movement is attached, is cut from piece 5 and later reinserted. This should ensure a perfect fit. A tiny hole is drilled in any corner of

piece 6 through which the saw is threaded and then the outline cut out with the fretsaw. Be particularly careful to keep the saw upright so as to ensure that piece 6 is a perfect fit when reinserted into piece 5 later on.

Construction throughout is by gluing and pins can be added if required for extra strength. Commence by gluing together the sides (pieces 1, 2 and 3) and (2, 3 and 4) to the back 5 as clearly shown in Fig. 1. Exact positionings are indicated by the dotted lines on piece 5 on the design sheet.

Next glue together 7, 8 and 9 as shown in Fig. 2, with piece 9 capping pieces 8 and 7. When dry, this section is then glued round the cut-out portion of piece 4 as seen in Fig. 3. Consult Fig. 4 which shows how the front (piece 10) is glued

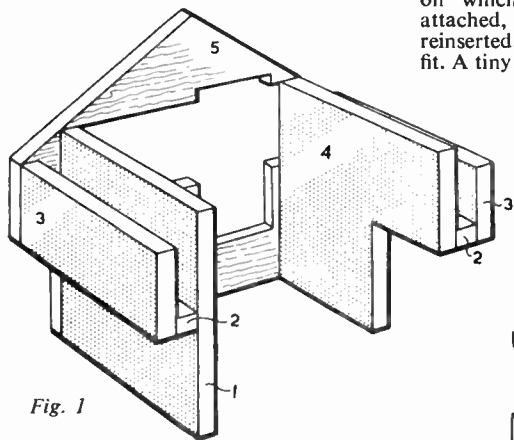

Fig. 1

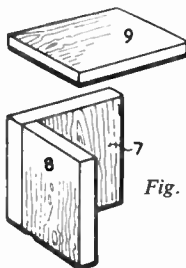

Fig. 2

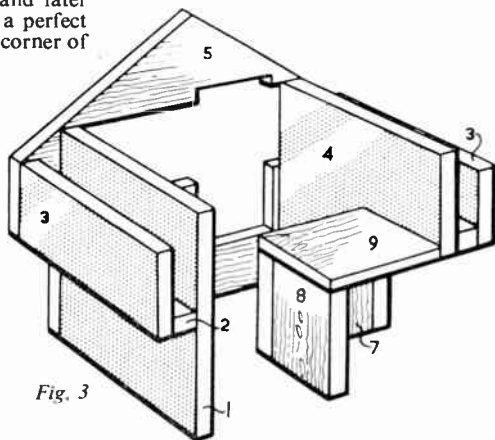

Fig. 3

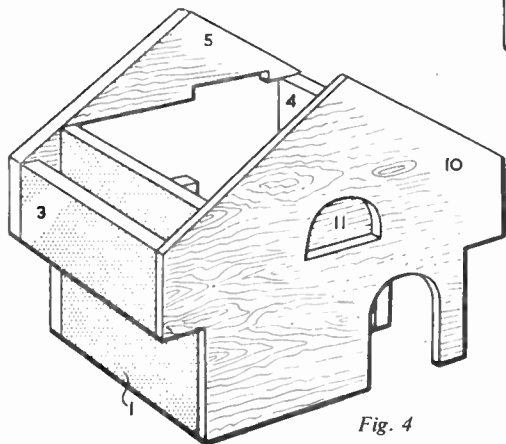

Fig. 4

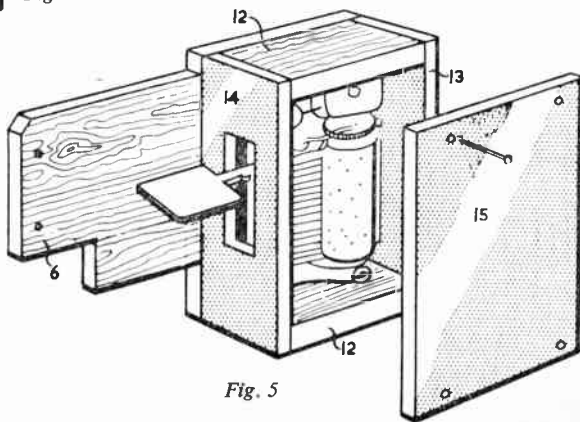

Fig. 5

in position. The backing piece (11) can next be glued behind the window opening.

Now take piece 6, which has been cut from piece 5 as already mentioned, and build up the movement container as seen in Fig. 5. First of all attach pieces 12 to piece 13 and glue these to piece 6, thus leaving an open end. Slip piece 14 by means of its slot over the plate of the musical movement and fix the movement to piece 6 by screws. At the same time pinning (not gluing) piece 14 to complete

Place the roof (piece 19) temporarily in position and test the action by putting coins through the slot to ensure that the coins are guided accurately on to the platform and that the movement starts satisfactorily. Then fix the roof (pieces 19 and 20) in position.

Fig. 7 shows the addition of other details on the model. The construction of the bench seat is self apparent. The balls on the fencing posts are secured by pins. Half-round beading is glued on the sides as shown by dotted lines on pieces 1 and 4. Piece 33 forms the door surround, pieces 22 the chimney and the mitred pieces 21 are glued to the eaves.

★★★★★★★★★★★★★★★★★★★★★
 ★ Hobbies kit No. 3504 for making ★
 ★ the Tyrolean Chalet costs only ★
 ★ 10/9 and contains all materials. ★
 ★ Kits from all branches and stock- ★
 ★ ists or by post from Hobbies Ltd. ★
 ★ Dereham, Norfolk (post 2/- extra). ★
 ★ The special No. 3 musical move- ★
 ★ ment with coin trigger action is ★
 ★ 15/11 (post 6d. extra) and tunes ★
 ★ available are Happy Wanderer, ★
 ★ Teddy Bears' Picnic, Oranges and ★
 ★ Lemons, and Bells of St Mary's. ★
 ★ ★★★★★★★★★★★★★★★★★★★★★★

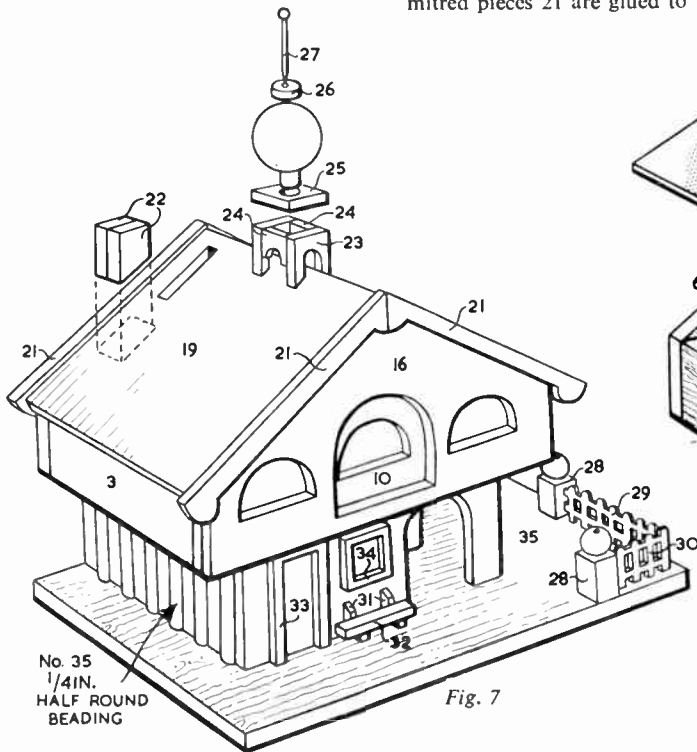

Fig. 7

No. 35
 1/4IN.
 HALF ROUND
 BEADING

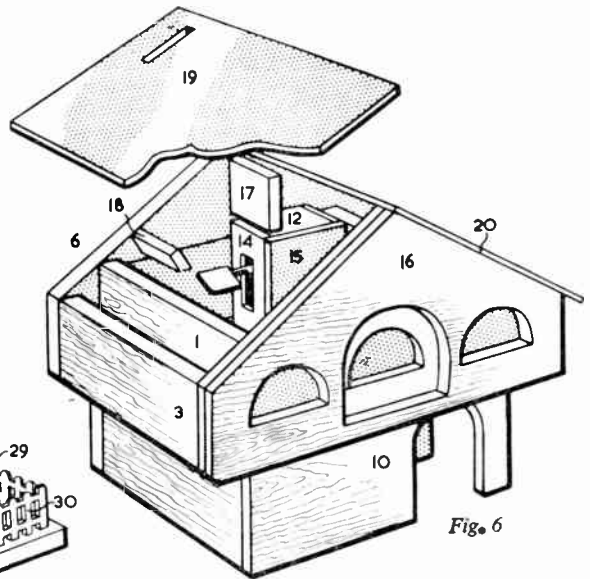

Fig. 6

the sides of the 'box'. The cover (15) is fixed to this framework by pins or screws. In any case, make the container so that the musical movement is accessible if it requires attention at any time. Piece 6 can now be put back in position in piece 5 and secured by four round-head screws into the sides 1 and 4.

Add the front overlay (16) seen in Fig. 6. Then glue on the guides (17 and 18) in the positions shown by dotted lines on piece 5. These guides will direct the coin on to the actuating platform of the musical movement. When the weight of the coin depresses the platform, the music starts and stops automatically at the end of one round of the tune.

Build up the roof ventilator with pieces 23 to 27, using a coloured modelling pin at the top, as shown in the illustration.

This completes the main assembly. Thoroughly clean up the wood with glasspaper, and fill the grain where applicable. Workers will use their own ideas of finish. It is suggested that various sections of the chalet should be stained different shades, extra applications of stain giving a deeper shade. Other parts such as the railings, the roof vent, seat, door and window frames will be painted. Full size illustrations of the windows and door are shown on the design sheet. For the base of the model we suggest green, possibly with the

addition of flock spray. Imitation crazy paving can also be simulated to good effect by painting.

Shrubs and floral decorations added to the base and shown climbing up the front, can be formed from plastic wood. In tubes, this can be squeezed direct in place and shaped with a pointed matchstick before it has time to harden. This will be painted in bright greens, reds and yellows etc. to suggest foliage and flowers.

Such a model can usefully be employed as a collecting box for charity, or for personal savings in the home. The coins eventually drop inside the chalet and savings are extracted by removing piece 5 by unscrewing at the back.

CHEMISTRY

AT HOME

EPSOM salt, or magnesium sulphate, $MgSO_4 \cdot 7H_2O$, is so named because it was found in a spring at Epsom by a Dr Drew in 1675. It also occurs in sea water, and as an efflorescence on the soil in some countries. None of these sources, however, is a cheap source of supply. It is manufactured by dissolving the mineral magnesite, which is magnesium carbonate, $MgCO_3$, in sulphuric acid, H_2SO_4 , when magnesium sulphate,

FACTS ABOUT EPSOM SALT

water, H_2O , and carbon dioxide, CO_2 , are formed:

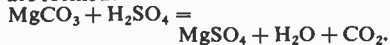

On evaporation of the solution magnesium sulphate crystallizes out on cooling.

Besides its value as a laxative magnesium sulphate is the starting point for the manufacture of other medicines, notably antacids, such as magnesia (magnesium oxide), MgO , magnesium hydroxide, $Mg(OH)_2$, and basic mag-

nesium carbonate, whose formula is variable owing to mixtures being formed, though it usually approximates to $3MgCO_3 \cdot Mg(OH)_2 \cdot 4H_2O$.

To prepare basic magnesium carbonate dissolve 12.5 grams of magnesium sulphate, and 15 grams of sodium carbonate (washing soda), $Na_2CO_3 \cdot 10H_2O$, each in 100 c.c. of boiling water. Mix the two solutions, and continue heating for 15 minutes. Let the white precipitate settle, decant off the clear upper liquid, and then filter off the basic magnesium carbonate, the principle of whose formation is:

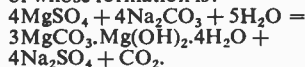

Wash the precipitate on the filter with repeated changes of water until one wash water shows the residue on the filter to be free of sodium sulphate, Na_2SO_4 , by its giving no white precipitate of strontium sulphate, $SrSO_4$, when strontium nitrate solution, $Sr(NO_3)_2$, is added to it:

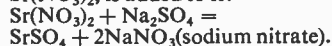

Remove the filter paper to a porous brick and let the whole dry. Basic magnesium carbonate may also be prepared from cold solutions, but precipitation is more complete when they are hot.

Basic magnesium carbonate forms a constituent of many indigestion tablets and mixtures. To show its action as an antacid acidify a few c.c. of water in a test tube with two or three drops of dilute hydrochloric acid, HCl . The water will redden blue litmus paper. Now add basic magnesium carbonate a few specks at a time. At first it dissolves with effervescence to form magnesium chloride, $MgCl_2$.

$$3MgCO_3 \cdot Mg(OH)_2 \cdot 4H_2O + 8HCl = 4MgCl_2 + 3CO_2 + 9H_2O$$

but finally ceases to dissolve. The mixture will not now redden blue litmus paper. In the stomach a similar reaction occurs, excess acid being neutralized.

Magnesium oxide is readily prepared from basic magnesium carbonate. Almost fill a small crucible with the basic carbonate, and heat strongly until the whole is red hot. The powder shrinks, steam, and carbon dioxide being given off:

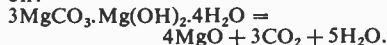

Continue the heating for about half an hour and let the whole cool. Note that a small portion of the white powder obtained no longer effervesces when dilute hydrochloric acid is added to it, thus showing that the carbonate has been completely decomposed to magnesium oxide.

As magnesium oxide will resist high temperatures without melting, it is used to line furnaces.

Magnesium hydroxide is readily prepared by stirring sodium hydroxide solution, $NaOH$, little by little into one of magnesium sulphate until a drop of the mixture just turns red litmus paper blue. White magnesium hydroxide is precipitated, and sodium sulphate left in solution:

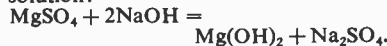

Filter off the precipitate, and wash it free of sodium sulphate on the filter, testing one wash water against strontium nitrate as in the case of basic magnesium carbonate. Then let the compound dry.

When testing for carbonates and bicarbonates we find that they both evolve carbon dioxide on adding an acid. How are we to distinguish between the two? We have seen that a soluble carbonate gives a white precipitate with magnesium sulphate solution. Now try adding sodium bicarbonate solution, $NaHCO_3$, to magnesium sulphate solution. No visible change occurs, though a reversible reaction takes place with production of magnesium bicarbonate:

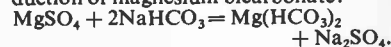

The absence of a precipitate shows that magnesium bicarbonate is soluble in water. We thus have a means of differentiating soluble carbonates and bicarbonates. A confirmation of the presence of bicarbonate is to be had by boiling the test solution, when a white precipitate of basic magnesium carbonate appears owing to decomposition of the magnesium bicarbonate:

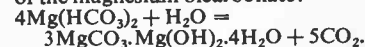

This reaction, like so many others, provides the basis for a conjuring act to

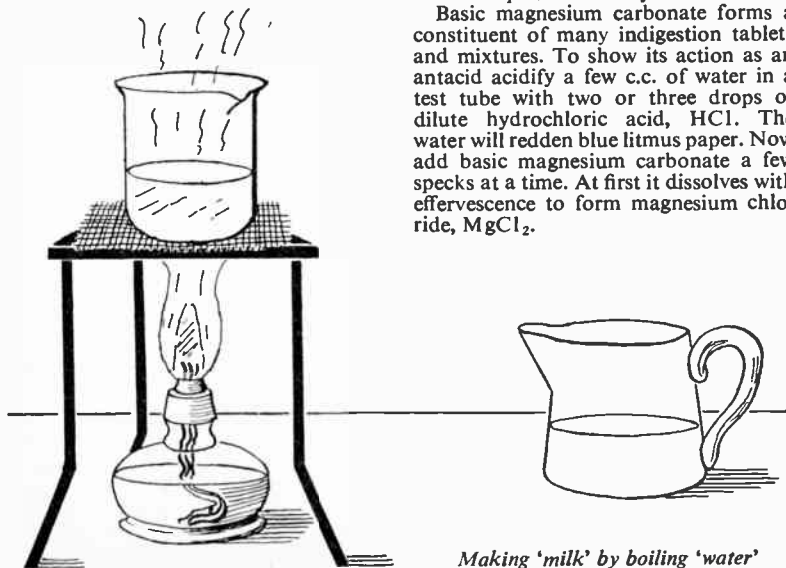

Making 'milk' by boiling 'water'

make your friends stare. Have ready mixed in a small glass jug solutions of sodium bicarbonate and magnesium sulphate. Pour some of the liquid into a beaker, and boil it up. What was 'water' is turned into 'milk'!

Insoluble salts produced by double decomposition usually precipitate at once on mixing solutions of the reactants. There is, however, an insoluble magnesium salt which does not do so. This is magnesium hydrogen orthophosphate, $MgHPO_4 \cdot 7H_2O$. It is produced on mixing solutions of magnesium sulphate and sodium phosphate, $Na_2HPO_4 \cdot 12H_2O$:

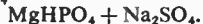
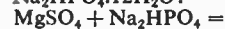

Dissolve 5 grams of magnesium sulphate in 30 c.c. of water and 11 grams of sodium phosphate in 175 c.c. of water. Mix the solutions with stirring. The liquid remains clear for a few moments, and then acquires a white opalescence, but no precipitate forms.

Let the liquid stand for a few hours. During this period the magnesium hydrogen orthophosphate separates out as beautiful needle-like crystals, often in groups of tufts. When no more form, filter them off, wash with a little cold water, and allow them to dry on a porous tile.

Electricity in the Home

By F. G. Rayer

THE use of electricity in the home is continually increasing, and every man-about-the-house should have the essential knowledge on how his home is wired. The book aims to give this information in the most straightforward manner possible, dealing specifically with installations in houses and flats, and omitting details outside the scope of private users.

Commencing with a short, but essential, theoretical treatise on electricity, it then describes the control and distribution of supplies. Fuses, wiring, joining, connecting, ring and power circuits, water heating, fittings, and other domestic appliances are fully covered.

Finally, there is a chapter dealing with the location and cure of faults. The importance of safety precautions is stressed throughout by this well-known contributor to the columns of *Hobbies Weekly*.

Published by Arco Publications. — Price 15s.

Make a Delta Glider

TAKE a rectangle of notepaper ABCD, and fold it in half longways by matching AB with CD, and pressing in the middle crease. Open out the paper, and press it flat as in Fig. 1.

Bend in corners B and C to the middle crease, so that the edges BX and CX are together, as in Fig. 2.

Fold over the triangular 'nose' along YZ to obtain Fig. 3. Bend inwards points Y and Z to meet at the middle crease, by folding as suggested, to ob-

tain Fig. 4. Bend the little triangle forward to cover points Y and Z, to form Fig. 5, before folding the wings along the middle crease. Fold the wings outwards along lines just above the middle crease (Fig. 6) to produce the completed 'Delta Glider'.

The toy will swoop nicely across a long room, or out of doors on a calm day. A paper clip 'weight' may be fitted to the nose, if the glider stalls or 'flutters' in flight.

(A.E.W.)

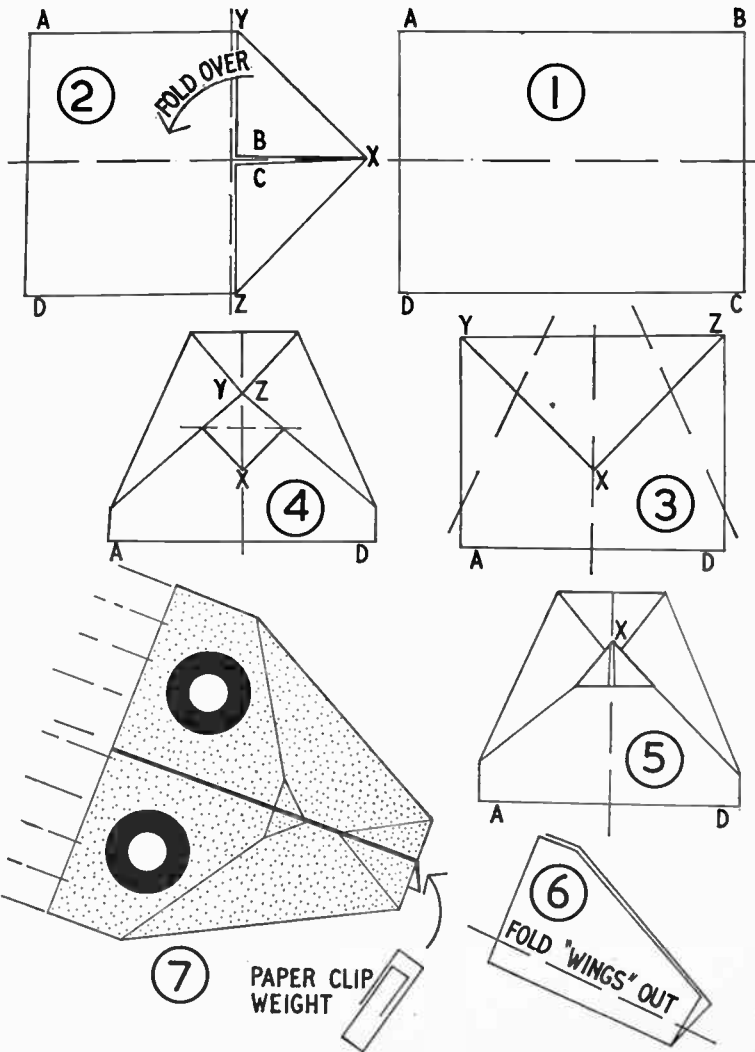

A job for the ladies

Making Quilted Cushions

QUILTED cushions are extremely decorative yet quite easy to make and the one shown in our illustration indicates an example of Italian quilting. Relief designs are achieved by inserting a soft piping cord between the double rows of stitching which form the pattern. This piping lies between the outer cover and a backing of butter muslin.

By Anne Bradford

Designs for such cushions are available in transfer form in a variety of sizes and it is advisable to procure one of these before buying the cover material. A needlework shop will be able to supply you with a ready-prepared transfer.

The design is now transferred on to a piece of butter muslin large enough to allow for turnings and this is temporarily basted to the back of the cover material. The latter should be preferably self-coloured since patterned material competes with the relief work which is then not seen to its best advantage. Moreover, we would mention that the work involved warrants a good quality cover.

We now outline the design from the

back by means of fine running stitches through both the muslin and the cover. By stitching the two lines of the pattern we make a kind of channel for insertion of the piping. This process binds the muslin to the cover and the basting may be removed. Note that this part of the work should be done carefully for the result will be seen on the face of the cover. Follow the lines of the transferred design with coloured thread which matches the cover and on completion we are ready for the piping.

You will need a bodkin for the piping process and some soft, quilting wool which is not unlike cotton wool. If the piping cord is too hard it will wear through the cover so it is essential to procure the softer material.

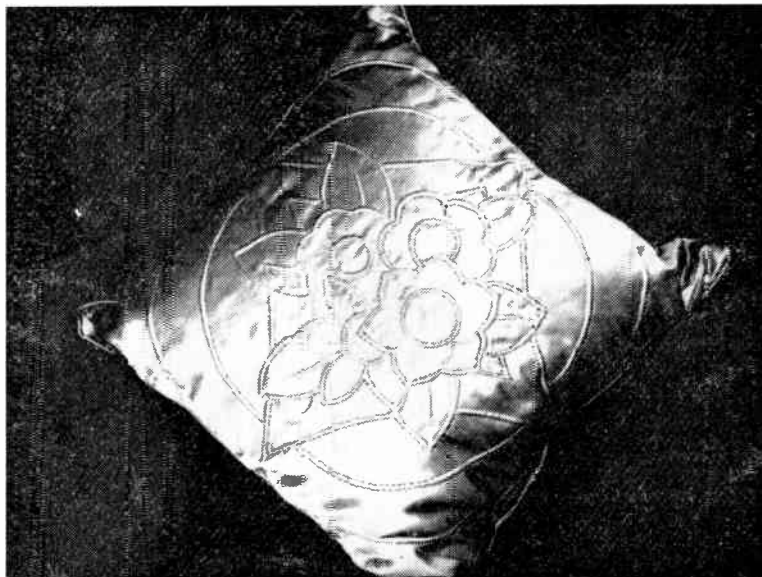

We again work from the back, piercing the butter muslin with the bodkin threaded with the piping wool and pulling along the channel. This is shown in the diagram. On the left is the face of the cover while on the right is the back from which you will observe small loops of surplus have been left at the junctions of the channels. We have to remember that the cover will probably be subjected to cleaning or washing in due course and if the piping shrinks there will be a slight puckering on the outside. To obviate this we thread the piping fairly loosely and where the design makes a turn take the bodkin through the muslin and reverse the direction at this point. A little surplus is then left at this point.

The diagram shows the back of the design and the running stitches with the channels for the piping cord as well as the little tufts of surplus at the junctions. Should you pull the cord tightly it is a simple matter to release it by pulling it back at one of these points. During this operation it is also advisable to inspect the front occasionally to determine that the piping is not causing the material to pucker. For all practical purposes it is wise to make a reserve of piping every two inches and this should be sufficient to counteract any shrinkage while washing.

The face of the cushion is completed with the finishing of the piping of the design and all that remains is the normal seaming of the whole case. Remember to leave one side open for the insertion of a cushion pad.

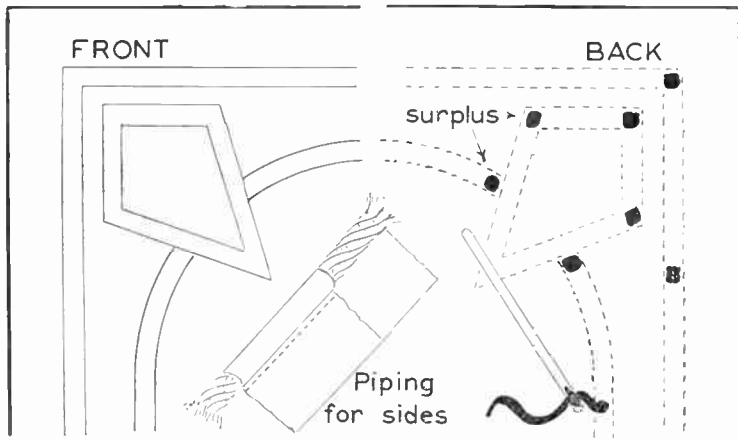

'Squiggles' can make a lot of Fun

TAKE a pencil and draw a squiggly line or simple scribble of loops with a twisty tail. Your drawing should not be recognizable as a 'real' object. Now you must stare at the paper and use your imagination to seek a resemblance between your rough handiwork and some actual 'thing'.

Perhaps your squiggle will suggest part of a crocodile or a leaping kangaroo. As soon as you spot the faint likeness, try and complete the picture with added pencil strokes. This curious game, similar to doodling, will provide an intriguing pastime during idle moments.

If you like, you can play the game of 'Squiggle' with a companion. You merely supply each other with tricky scribbled outlines which you each then try and doodle into funny pictures. Do not protest if you 'cannot draw'. Just use your imagination and make an effort. You may surprise yourself with your own skill.

For a bright youngster, you can make a thrilling 'Squiggle Book'. Print the strange title upon the cover of a cheap drawing book, or 'pad' made by stapling together some sheets of drawing paper. Put a few well-spaced interesting inked squiggles upon each page. Show your young friend how the squiggles may be doodled into amusing drawings and let the child have fun making up an unusual original comic.

(A.E.W.)

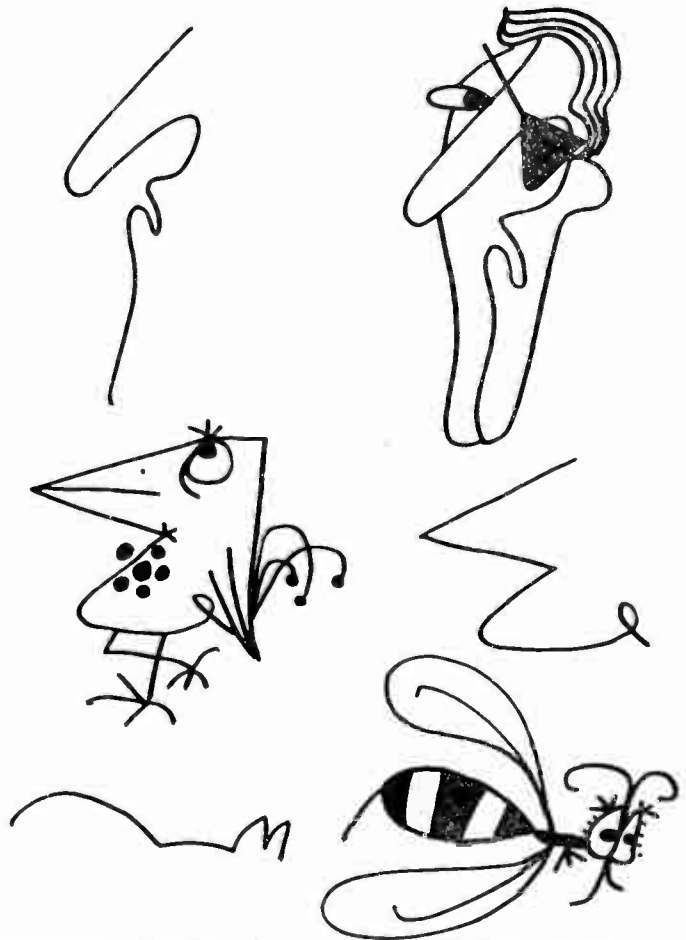

● Continued from page 300

Quilted Cushions

The cushion may be seamed in the usual fashion but if you wish it may be further enhanced by the addition of piping. For this you will require some additional strips of the cover material about one inch wide but cut on the cross. Iron out and stretch. The piping cord is placed in the centre of the prepared strips and you will find it easier to stitch close to the cord, thus completing before attaching to the cushion. It is then an easy matter to turn the cover inside out and machine the cover along with the prepared piping between the back and front.

Italian quilted cushions as described make really delightful gifts while providing the maker with real satisfaction. But remember that the best material to use is self-coloured satin and the like.



"COME AND HOLD THIS NAIL, MA! — I KEEP HITTING MY FINGERS!"

Mainly for Modellers

IN viewing models one finds more often than not that the binnacle (or 'bittacle' as it is termed by early writers) is usually represented by a block of wood. This is normal for a small miniature model, but most of the Hobbies' Old Time kits are of a scale that allows us to model them so that they can be recognized for the deck fitting they stand for.

The early binnacle consisted of a wooden case, which was designed to hold the compass, log glasses, watch glasses and lights to illuminate the compass at night.

In small vessels there was only one binnacle but the larger type carried two. One was designed for the steersman (or man at the wheel) the other for the navigating officer. In the latter case they

were sometimes of a portable type.

The type we will have to add to models of early ships, galleons, etc, was a wooden box or locker, described by Crocker in 1764, our earliest English authority to appear in print.

BINNACLES AND BELFRIES

By 'Whipstaff'

In 1805 Steel also refers to the binnacle as a wooden case or locker. The word 'bittacle' vanished from the seaman's language about the middle of the 19th

century and the term binnacle then became applied to the later types mounted on a solid tubular pillar of wood or metal.

In the time when the whipstaff was in use the helmsman, as shown in my sketch in an earlier article in this series, was housed a deck higher than the actual tiller and the binnacle was on the deck in front of the helmsman.

In order to model the binnacle of the early type shown in Fig. 1 which is suitable for most of Hobbies' galleon models, we need to have some idea of size in relation to the scale of our model. For the models 'Elizabeth Jonas', 'Golden Hind' etc, dimensions would be: length $\frac{3}{8}$ in., height $\frac{1}{8}$ in., depth $\frac{1}{8}$ in. The larger size of $\frac{1}{2}$ in. by $\frac{3}{8}$ in. by $\frac{1}{8}$ in. is suitable for such as the 'Royal Prince.'

In Fig. 2 we have the usual type of binnacle in use in the 18th century. Both types shown in Figs. 1 and 2 can be modelled at small scale by shaping from a block of wood and showing the panels by strips of cartridge paper glued on. For the larger model they can be built up of Bristol board or thin veneer.

In Fig. 3 we have the type of binnacle found in models of 18th century American vessels. This consists of a chest on four legs as distinct from our English type shown in the previous sketches.

These early binnacles are simple to model, later they became more elaborate. Figs. 4 to 6 show some of the later types, which can all be modelled in wood. For small dowels for this type of miniature bamboo dowels can be used.

Let us now consider the housing of the ship's bell — the belfry. Up to the close of the 16th century this was situated on the break of the quarter-deck, but shortly after it was moved to the fore-castle where it was situated on the central bay of the fore-castle bulkhead.

While the belfry at first was quite a simple affair, by the 18th century on the first and second rate ships of the line it became quite an elaborate affair. The arched frame from which the bell was hung was ornamented with carvings of cupids, dolphins etc.

The 18th century belfry cap characteristic of the period was made by two interesting arches supported in the simple types by square columns. This cap gradually became flatter, finally reaching the shape shown by the late 18th century belfry of Nelson's period.

Fig. 7 shows an early belfry and Fig. 8 one of the first decade of the 18th century. Fig. 9 shows a typical belfry of the late 18th century and Fig. 10 the type with flattened top that had evolved by the end of the 18th century. This is the type you would use on Hobbies' 'Victory' Kit No. 3198.

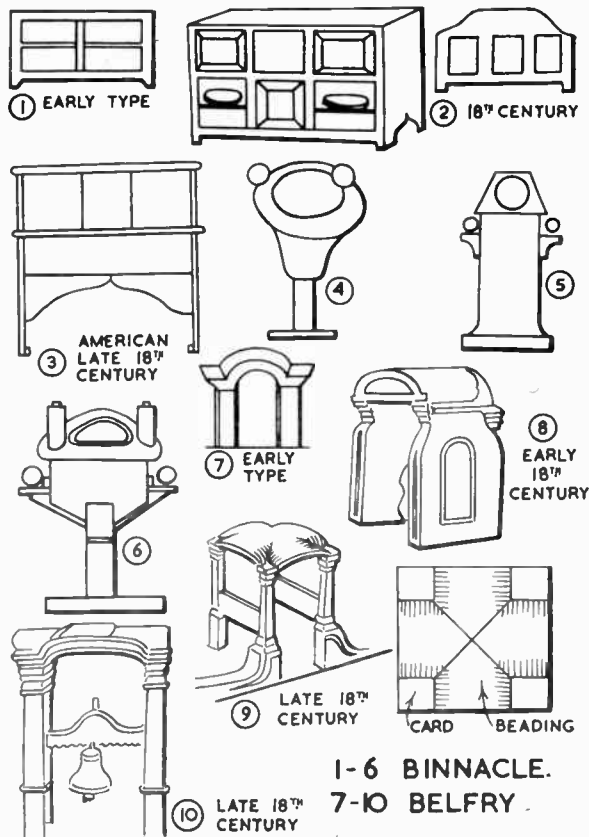

1-6 BINNACLE.

7-10 BELFRY.

● Continued on page 304



Superb fittings for DOLL'S HOUSES

Absolutely the last word in style and finish, these foreign lighting units and fittings for Dolls' Houses are complete with wiring and bulbs ready to plug into a 4-5 volts flashlamp battery. Their brightly coloured plastic shades with polished gold finish metal bases will give a distinctive appearance to all Hobbies-designed Dolls' Houses. The illustrations shows the fittings etc, approximately same size.



Dept 99

**DEREHAM
NORFOLK**

World Radio History

- 712 Table Lamp with flex, 2-pin Plug, and Bulb. 5s. 6d. Post 6d.
- 713A Table Lamp with flex, 2-pin plug and Bulb. 5s. 6d. Post 6d.
- 716 Wall Lamp with flex, 2-pin Plug and Bulb. 5s. 6d. Post 6c.
- 716A Wall Lamp with flex, 2-Pin Plug and Bulb. 5s. 6d. Post 6d.
- 727A Ceiling pendant Lamp, with flex, 2-pin Plug and Bulb. 5s. 6d. Post 6d.
- 762 On-Off Switch. 1s. 0d. Post 3d.
- 763 2-pin Socket (to fit all plugs on this page). 6d. Post 3d.
- 764 2-pin Plug (to fit all sockets on this page). 6d. Post 3d.
- 766 Bell Push. 10d. Post 3d.
- 775 Cap (with two 2-pin sockets) to fit on top of 4-5 volt flat battery. 1s. 3d. Post 3d.
- 781 Electric Bell 3v-6v. 4s. 11d. Post 3d.
- 882 2-pin Socket and Switch. 1s. 6d. Post 3d.

Replies to Readers

Record Player Speed

COULD you tell me how I can slow down the speed of a 78 r.p.m. record player to 45 r.p.m.? (R.C. — Hammer-smith.)

THERE is no simple way. Reducing speed by reducing the motor voltage tends to give irregular speeds. The usual record player has a 2 or 3-speed drive consisting of rubber belts round wheels, or rubber rimmed wheels running against other wheels, so that the motor always runs at correct speed. It might be possible to make something of this kind. A reduction drive to fit a 78 r.p.m. spindle, and equipped with a 45 r.p.m. turntable was once manufactured, but is no longer made. You might enquire at local surplus and radio shops for one of these. The necessary ratio could be obtained by any pair of wheels (as above) whose diameters are in the ratio of 45:78.

Jelly-cell Accumulator

PLEASE inform me how to calculate the capacity of a lead-acid accumulator, knowing the area of the plates and weight of paste added. Is it necessary to add this paste externally — can it not be formed by charging two lead plates dipped in sulphuric acid? Also could you give me more details of the 'jelly-cell' made by adding sodium silicate to the acid, and how does one know whether the cell is charged or uncharged in this case, as a hydrometer cannot be used? (J. W. — Chesterfield.)

REGARDING the accumulator, the capacity depends on other factors as well as plate size, and is best found by a discharge test of a charged battery — e.g., if the battery delivers 1 ampere for 20 hours the capacity at this rate is 20AH (ampere-hours). Capacity falls at higher discharge rates. To jellyify a cell, charge in the usual way, pour out acid, and allow cell to drain for half an hour. The electrolyte can be 1 part pure sodium silicate (1-200SG) to 3 parts cold sulphuric acid (1-400SG). Pour into cell immediately, and leave undisturbed. Jelly cells are charged at the indicated rate and time (e.g., AH capacity); or until the voltage ceases to rise. Distilled water is poured on the jelly before charging; excess is removed after charging. Cell plates have to be made from paste forced into lead grilles, to obtain reasonable capacity.

dealing with such items in particular is known. Books in your local library may include some details.

Testing Transistors

CAN you please tell me a method of testing transistors? (C.H. — East Grinstead.)

TRANSISTORS are tested by applying known voltages to base, emitter, and collector, and noting base, emitter, and collector currents with a meter. The currents for given voltages will be found in the maker's data. Some of the most important characteristics are:

Current Amplification: the change in collector current which arises with a change in base current (Alpha).

Collector Leakage Current

Emitter Leakage Current
In general, if these items are not significantly worse than the maker's data for the type, the transistor is in order. Mullard Ltd, Mullard House, Torrington Place, London, W.C.1 supply a *Reference Manual of Transistor Circuits* (12s. 6d.), which covers most of the data required for small receivers and amplifiers, and also deals with transistor alpha, etc.

Covers for Books

WHAT is the best glue or adhesive for permanently fixing plastic covers to books which are very roughly handled? (B.D. — Canterbury.)

THERE are many types of plastic, and due to the non-porous nature of this material, a suitable adhesive is difficult to find. We think the best way of covering books with this material is to fold over the edges inside the covers, and fix together with Sellotape. Covering with a self-adhesive plastic such as Fablon would also be quite effective.

● Continued from page 302

BINNACLES AND BELFRIES

Here, as with the binnacles, we must model according to our scale. In small models of the 'Elizabeth Jonas' type I model only a simple version as in Fig. 7. When I come to the larger type I model in more detail.

Ships' bells, which are very small, are best turned with a small round file, either in your hand-drill chuck or a lathe, using boxwood or holly, the latter for preference. In a small bell a piece of fuse wire is glued and bent to form a loop, or the bell can be merely glued in position. If fashioned by hand they are best carved on the end of a piece of dowel. For larger bells a tiny bead can be glued to the top.

For the construction of the belfry, the drawings can be followed, using wood dowel and stripwood. If your scale is large you can turn the pillars or

stanchions from softwood and carve the arch from a piece of wood, or the arch can be shaped from Bristol board.

Another way to make the 18th century belfry is very effective if the scale is not less than $\frac{1}{8}$ in. to the foot. A square of card is mounted on the four columns and the roof design built by using half round beading as shown in the sketch.

Photo-electric Cells

I WISH to make some not too serious experiments with photo-electric cells, using the Baird type mechanical disc. Could you recommend a cheap sensitive photo-electric cell which I may use; also a not too technical publication dealing with photo-electric gadgets in general. (F.H. — Fareham.)

OSRAM make various photo-cells, and price depends on sensitivity, size, and other factors. Some are intended for infra-red light, etc. Amplifiers are required. Typical circuits appear in the Osram Valve Manual, available from General Electric Co., Magnet House, Kingsway, W.C.2. Another type of cell, suitable for light-meters, etc, is the selenium cell, available from G.R. Products, 22 Runnymede Avenue, Bristol 4, and other suppliers. No book

LEARN

RADIO & T/V SERVICING for your OWN BUSINESS/HOBBY

● by a new exciting no-maths system, using practical equipment recently introduced to this country. *FREE Brochure from*

RADIOSTRUCTOR
DEPT. G81, READING, BERKS. 6/2/63

'LISSAM' Ebonised LEGS

The
NEW
'Slimmer
than
Slim'
Legs



BOXED
IN SETS
OF 4 LEGS

Complete with Ferrules,
Glides, and fixing plates

9 in. 14/9 set

15 in. 16/9 set

12 in. 15/9 set

18 in. 17/9 set

(Postage and Packing 2/- extra)

HOBBIES LTD, (DEPT 99), DEREHAM, NORFOLK

THE WORLD'S LOWEST PRICED ALL TRANSISTOR POCKET RADIO



ONLY
32/6
NO MORE
TO PAY

Britain's most popular set — powerful, brilliantly designed — yours for the amazingly low price of

32/6. (Lower than Japanese Home Prices.) Only 1 3/8" x 2 7/8" x 4 1/4". Performs perfectly for months on 1/2d. battery. Assembly easy using our simple A.B.C. plan. Send only 32/6 + 2/6 P. & P. (C.O.D. extra). All parts sold separately. Satisfaction Guaranteed.

CONCORD ELECTRONICS (Dept. BX102/3)
210 Church Road, Hove, Sussex

HEAR ALL CONTINENTS With H.A.C. Short-Wave Receivers

Suppliers for over 18 years of radio S-W Receivers of quality.

One-Valve Kit, Price 25/- Two-Valve Kit, Price 50/- Improved designs with Denco coils. All kits complete with all components, accessories and full instructions. Before ordering, call and inspect a demonstration receiver, or send stamped addressed envelope for descriptive catalogue.

'H.A.C.' Short-Wave Products (Dept. 22), 44 Old Bond Street, London, W.1.

'LOG CABIN' CLOCK

Kit No. 3018

This Kit contains design with instructions, panels of selected wood and a reliable 30-hour movement, 28/-, plus 2/6 postage.



HOBBIES LTD (Dept. 99) DEREHAM, NORFOLK

the
new patent
CLICK VALVE

is here on top
of the new
**CASCO
GLUE-ALL**

to make it easier — and cleaner — for you to glue just about anything including: wood · hardboard tiles · fabrics · textile · mats · lino · leather · cork · ceramics · canvas · plastic laminates · asbestos · glass · plaster

Handy Size 2/- Medium Size 3/6 Large Economy Size 5/-



from Ironmongers, Hardware Stores, Do-it-yourself Shops
LEICESTER, LOVELL & CO. LTD, North Brimsley, Southampton. Telephone: Rowlands 2131

HANDSOME VENEERED PANELS

ON 3/4 in. PLYWOOD, in oak, sapele or walnut.

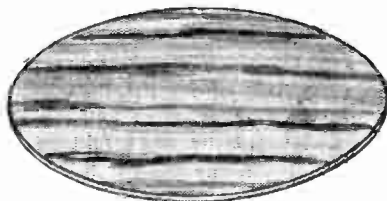

ROUND
Veneered both sides
22 in. diameter
21/-
(post 2/5)

SQUARE & OBLONG

Veneered both sides.
20 x 20 in. and
30 x 15 in.

18/6

(post 2/6)

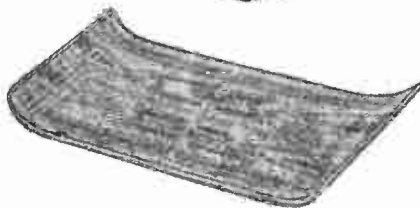
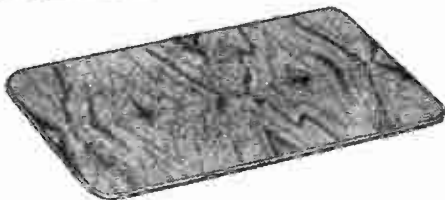

CURVED
ENDS
Veneered one side.
28 x 15 in. 27/6
36 x 15 in. 35/-
48 x 15 in. 52/6

HOBBIES LTD (Dept. 99), DEREHAM, NORFOLK

Attractive Bench for the Garden

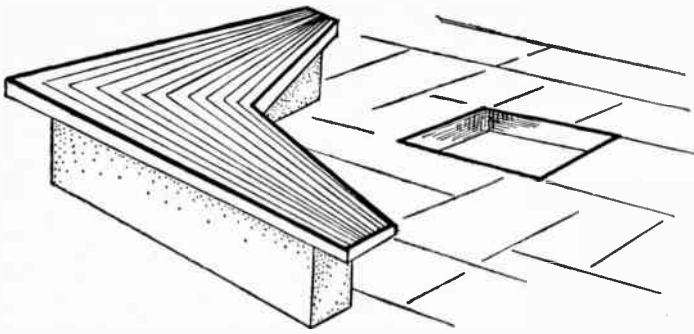

AN attractive bench, set in a sheltered corner of the garden, is all that is needed for the basis of an up-to-date barbecue area. It also provides a suitable seat for placing near an ornamental pool or fishpond. The dimensions given here can, of course, be altered to suit particular situations.

By A. Liston

The concrete plinth is L-shaped, and is cast in a mould made from 12 in. high pieces of wood and hardboard (Fig. 1), well supported on the outside by piles of old bricks and stones. Each arm of the plinth shown here is 3 ft. long and 9 in. wide.

The concrete of the plinth actually extends 6 in. below ground level, the L-shape being excavated to this depth (Fig. 2). Scrap pieces of metal rod or pipe A, hammered into the ground at 12 in. intervals give extra support. Each of the five crosspieces C of 2 in. by 2 in. wood is drilled to take two 8 in. long bolts B.

The crosspieces are tapered on the underside by $\frac{1}{2}$ in., and set in place, their bolts being embedded in the wet cement. A 1:2:3 mix of cement, sand, and gravel is used for this.

The positions of the crosspieces are shown in Fig. 3. The two end pieces E are 12 in. long, and are set 2 in. in from each end. The central crosspiece D is 24 in. long, and the two intermediate pieces F are 15 in. long. They are placed approximately 12 in. from the end pieces, or so that the ends of the three crosspieces are in line. Final trimmings can take place later.

The slats forming the top should not be added for at least a week after the concrete has been poured. These slats are of 2 in. by 1 in. wood screwed as shown to the crosspieces (Fig. 4). The two outer slats on each side S should be put in place first, then the others laid in position before being finally fixed.

The design shown here uses twelve

slats on each half of the bench, the longest being 42 in. and the shortest 24 in. A smaller number of slats can be used, if desired, but this will increase the width of the gap between them at the centre of the bench.

Finally, the edges of the slats and crosspieces are trimmed and an edging of $3\frac{1}{2}$ in. by $\frac{1}{2}$ in. wood is screwed in place all round. The woodwork is then varnished or sealed to withstand the weather.

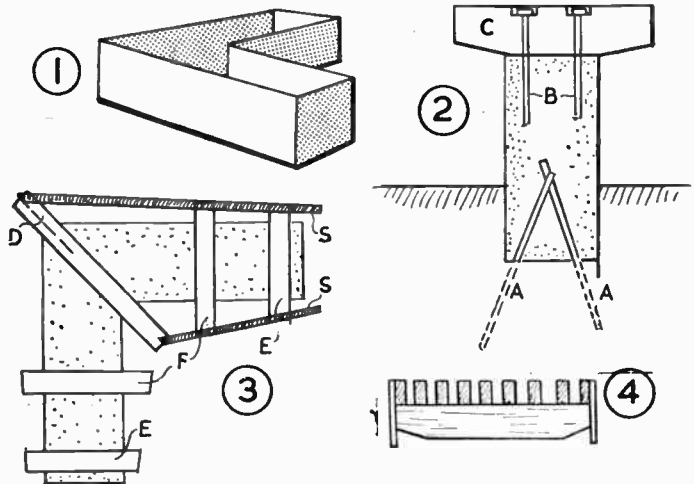

Miscellaneous Advertisements

PENFRIENDS home and abroad, all ages. S.a.e. for details. European Friendship Society, Olney, Bucks.

UNDER 21? Penfriends anywhere — details free. Teenage Club, Falcon House, Burnley.

WOULD YOU ENJOY painting flower pictures, etc.? Then read 'PROFITABLE ART' (free). Wonderful opportunities for beginners and others. POPULAR ART (HW), Clun, Salop.

LEARN RADIO & ELECTRONICS the NEW Practical Way! Very latest system of experimenting with and building radio apparatus — 'as you learn'. FREE Brochure from: Dept. H.W.10, Radiostructor, Reading.

100 DIFFERENT stamps free! Request 4d. upwards discount approvals. — Bush, 53 Newlyn Way, Parkstone, Dorset.

ENJOY WRITING? Then write for Profit. Send for 'Writers' Handbook' (free) detailing countless opportunities for beginner or experienced. — Writers' Ring (HW), 5 Edmund Street, Birmingham.

BUYING OR SELLING?

Classified advertisements on this page are accepted at a cost of 6d. per word prepaid Use of a Box No. is 1/- extra. Send P.O. with advertisement to *Hobbies Weekly*, Advert. Dept., Dereham, Norfolk. Rates for display advertising on application.

A TOY PETROL TANKER

THE various parts are cut out with a fretsaw and assembled as shown in the diagram. Windscreen and windows, together with other details, are then painted in.

Piece 1 is cut from $\frac{3}{8}$ in. wood and piece 2 from $\frac{1}{2}$ in. There are four pieces 3 required, three of these being $\frac{1}{2}$ in. thick and one $\frac{1}{4}$ in. They are glued together side by side as indicated. The two pieces 4 and the two pieces 5 are each $\frac{3}{8}$ in. thick.

When assembling, follow the dotted lines on the various pieces to ascertain the correct positions. The tank is made up by wrapping a piece of thin card or plywood round the pieces 5.

The wheels are Hobbies plastic wheels with $\frac{1}{4}$ in. tread. They are $\frac{7}{8}$ in. diameter and are realistically finished in black and red. They cost 1s. 4d. per set of four, postage 3d. from Hobbies Ltd. Dereham, Norfolk.

(M.p.)

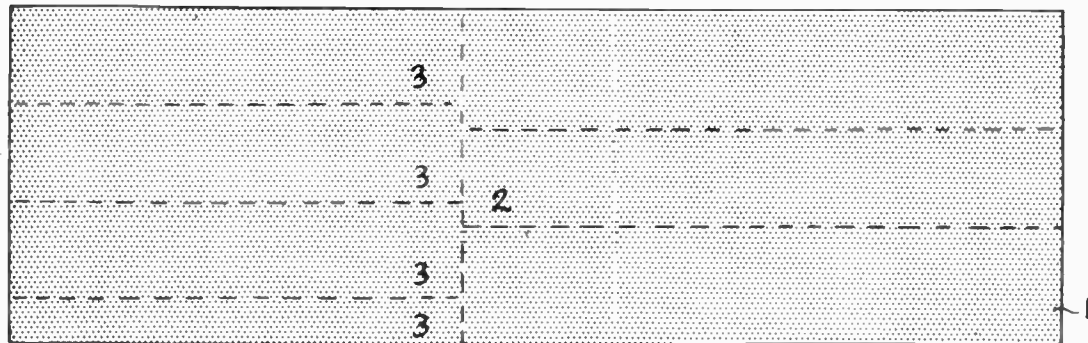
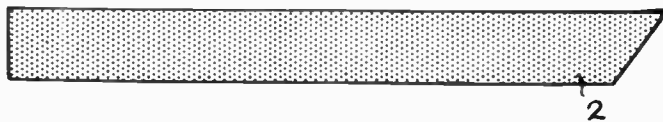
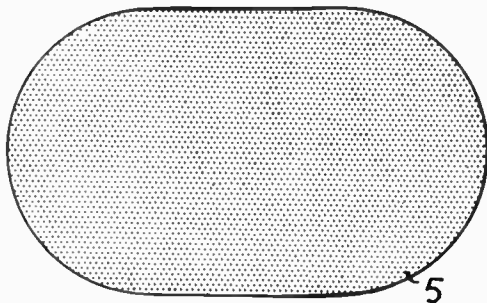
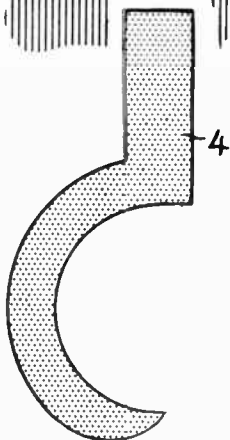
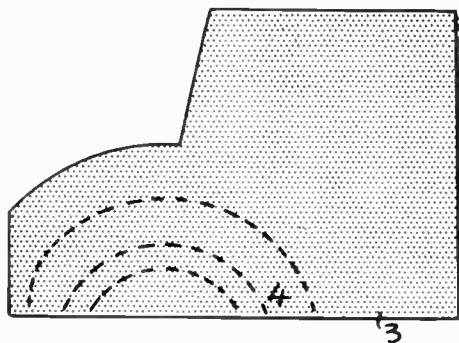
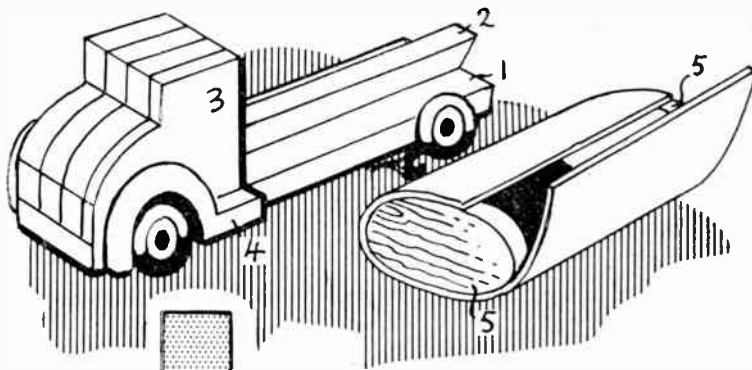



... even the fire extinguisher is there!

This Airfix 1/32nd scale 1910 bus is an exact replica of the Old Bill vehicle. Has a wealth of detail, crew and passengers. 130-part kit 6/-.

It's typical of the realism you get with Airfix models. They're just like the real thing! More than that, though, Airfix give you constant

scale, so that the models of every series are proportionately right; and a great ever-increasing range—there are 11 series now, with over 150 kits. At prices from 2/- to 12/6, Airfix are great on value too.

For endless modelling fun—make it Airfix.

**JUST LIKE
THE REAL THING!**

AIRFIX

**CONSTANT SCALE
CONSTRUCTION KITS**

From model and hobby shops, toy shops, and F. W. Woolworth.

STOP PRESS!

**LATEST AIRFIX PRODUCTION
PANZER 75mm ASSAULT
GUN**



A detailed HO/OO model, 3½ inches long, of the self-propelled gun used by German Panzer and Infantry Divisions in World War II. The 79-part kit has flexible track, German markings 2/-.

ALSO NEW: HO/OO model of Scammell 30-ton Tank Transporter, 3/-.

GET YOUR CATALOGUE

28 pages of models, facts and kit details from your dealer - only 9d



13th FEBRUARY 1963

VOL. 135

NUMBER 3525

THE ORIGINAL
'DO-IT-YOURSELF'
MAGAZINE

HOBBIES *weekly*

FOR ALL
HOME CRAFTSMEN

Project for the handyman

Also in this issue:

PLANS FOR A
PUSH-ALONG TOY

COLLECTORS' CLUB:
PEN FRIENDS

RESEATING YOUR
OLD CHAIRS

PICTURE QUIZ

DISC BREAK:
JILL GRAHAM

'TRICKS' WITH
A CAMERA

ETC. ETC.

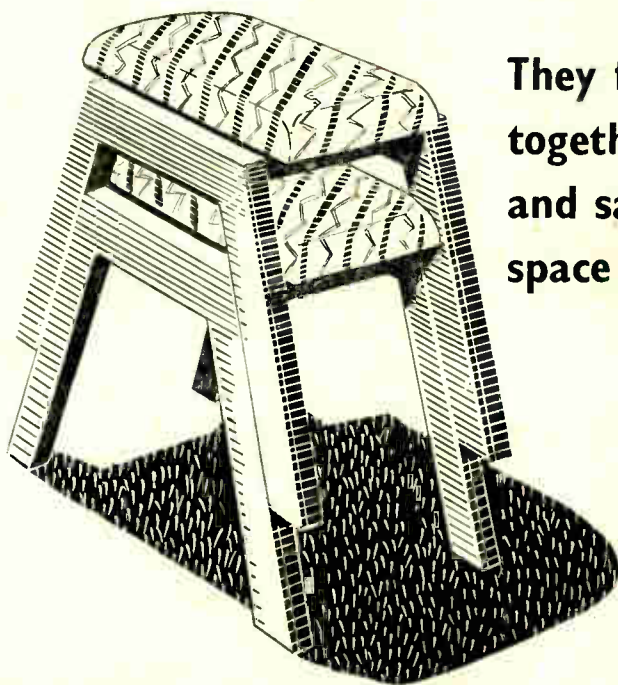

They fit
together
and save
space

STACKING STOOLS



Up-to-the-minute ideas

Practical designs

Pleasing and profitable things to make

5^p



Stamp Collector's Corner

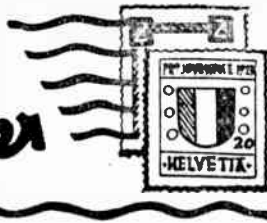

WE recently suggested the formation of a philatelic society and pointed out that this would have as its object the study of stamps and the encouragement of exhibitions. It is the common practice for the visiting society to provide the philatelic entertainment and the home society the refreshments.

Now we want to give suggestions as to the kind of philatelic entertainment that any society could get together and take away on a visit. Naturally it is not just a question of collecting together a number of stamps, sticking them into an album and passing the album around the company.

ARRANGING A DISPLAY

By L. P. V. Veale

It is rather important to know how many people are likely to be present. If it is a homely party of say eight people then they could very comfortably sit around a table with the specimens placed so that all could see. If on the other hand there are going to be about twenty people present then the exhibits will have to be passed round.

The sheets of paper from an album are not at all suitable for this; they are too flimsy and in consequence as they are passed from one to another the stamps would fall off.

There are one or two ways of overcoming this. The cheapest is to obtain pieces of cardboard, say one inch larger each way than the album page, and attach the page to the cardboard by stamp hinges. Viewers will then be able to pass the sheets round without damage. A better way is more costly. Again procure sheets of cardboard about the same size and also some sheets of clear cellophane material exactly the same size as the cardboard. Then using self adhesive tape bind them together on three sides, leaving one side open so that you can slip the album page between

and they will be perfectly protected. If you have a single stamp to pass round then place this between two small pieces of perspex bound by cellulose tape.

Another method of displaying material if there is not too much of it, is to fasten it all on to one large sheet of cardboard. Probably the best way of fastening such material as postcards or envelopes is by means of those invisible corners which are sold for holding photographs in an album. You can then remove any specimen at will and replace it without disturbing the other items. And of course single stamps can be mounted on such a sheet with ordinary stamp mounts. But as these might fall off if the cardboard is shaken it could be placed in a transparent envelope and that firmly fixed.

Now as to an example of an exhibit — one that should not cost much money but which will probably require the help of all members of the club to work together to collect the material. 'War Posts', to illustrate, the hazards of communication during the war years is a good idea. Many people have stored some of the cards and letters that they received during the last war and others may be available from the 1914-18 war. If you are lucky you might even pick up a reminder of the Boer War!

The Field Service Post Card of the 1914 war should be quite easy to obtain. This was issued to the soldiers in the trenches. One side was for the address and on the other side there were a number of phrases: I am quite well — I have been admitted into hospital — sick, wounded — and am going on well — and hope to be discharged soon — I am being sent down to the base — I have received your letter, and so on.

The soldier simply crossed out the sentences that did not apply, signed his name, added the date and sent it off. That did not require any censorship. A card that had any writing on it other than the name and the address was destroyed. If a soldier wrote a letter then it had to be censored by an officer. Naturally that would have been an impossible task if every soldier wrote many letters.

Sailors' letter were also examined to see that no information was given away. The cover would bear a hand stamp 'Received from H.M. Ship' and an officer would initial it and add the date.

Fairly common, too, are envelopes bearing stamped impressions such as 'Part of a mail captured by the Germans and delayed'. One such letter sent from Moscow to London dated 21st April 1916 was not received until 28th August 1916. Even letters sent to and from private persons were liable to be examined and those sent to Ireland or Eire were almost certain to be opened.

The examiner would have a number and having opened an envelope it would be sealed again by using a gummed strip bearing his number. If he found anything inside which should not have been there, such as photographs, then the letter would be returned with a label attached and inside a copy of the regulations which had been broken.

Prisoner of war correspondence is also very interesting and if it could be started with a cover bearing a post office notice: 'It is regretted that this item could not be delivered as the addressee is reported prisoner of war', that would form a very good introduction.

An airgraph should also appear in the collection. These are quite common. Don't forget the cards sent from civilians who were interned, such as in Hong Kong. It does not need a very acute imagination to realise the terrible worry that ensued if a sender had a letter returned and endorsed 'Returned from abroad—Service suspended'.

Although they cannot be called 'correspondence' the various leaflets that were dropped by the R.A.F. over certain towns when they were having such weeks as 'Wings for Victory' would add very much to the interest of the exhibit.

Now none of the items that have been mentioned are very valuable from the point of view of cash. But they might be very valuable to the owner for sentimental reasons. So if you borrow letters etc., remember this and promise to take great care of them.

NEWSPAPER TITLES

Christopher Robinson, aged 16, of 7 Duesbery Street, Princes Avenue, Hull, Yorks. writes:

'I wonder if any of your readers have a similar hobby to me . . . or, perhaps, some would like to try it. I collect the titles of newspapers. I have over a thousand. By 'title' I mean name, date, price, number, etc, on the top of the front page. I would be very grateful if readers would cut the top off their daily and weekly papers, and send them to me.'

(Perhaps readers would like to help Christopher's collection, and in the meantime start a similar collection themselves. — EDITOR).

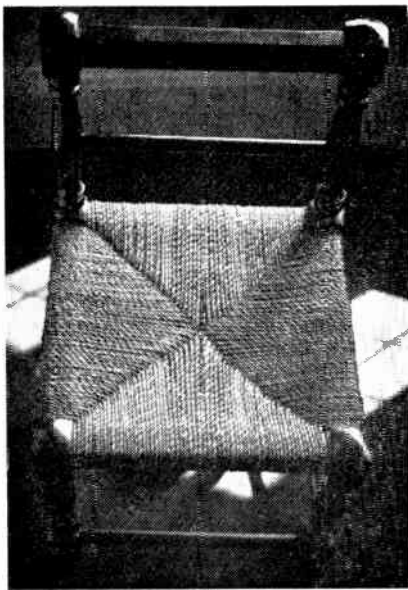

Seagrass seating

HOW TO RENEW CHAIR SEATS

By

H. Mann

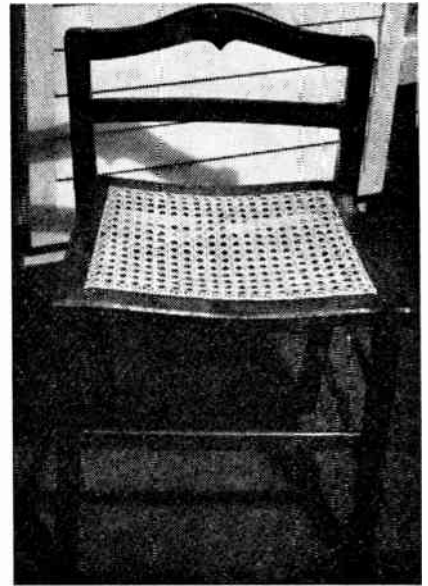

Cane seating

CHAIRS with damaged cane seating can be repaired to look like new quite easily and the following instructions will help you to weave a new seat.

The bulk of the old seating should be

cut away, the chair turned upside down and all the pegs knocked from the holes along the sides. The frame should now be cleaned up ready for the new cane work. If the cane is soaked in water for a day, drained, and surplus moisture

removed with a cloth it will become pliable and stretch when applied. On drying it will tighten up the entire weaving, producing perfect tension.

Start with a number 2 cane in the centre hole on the back rail, inserting a peg to wedge it in position. Take the cane across to the front rail, insert in the corresponding hole and peg down. The end of the cane is now threaded through the next hole and taken to the back, moving the peg to keep tight. Should you have to make a joint in the cane bring the finishing end up through the next hole and leave it projecting. A new cane is started in the same way.

You may have more holes in the

front rail than the back and if this is so keep them parallel but finish off by inserting the end of the canes in one of the side rail holes.

This operation should proceed until canes have been threaded from back to

FIG 1

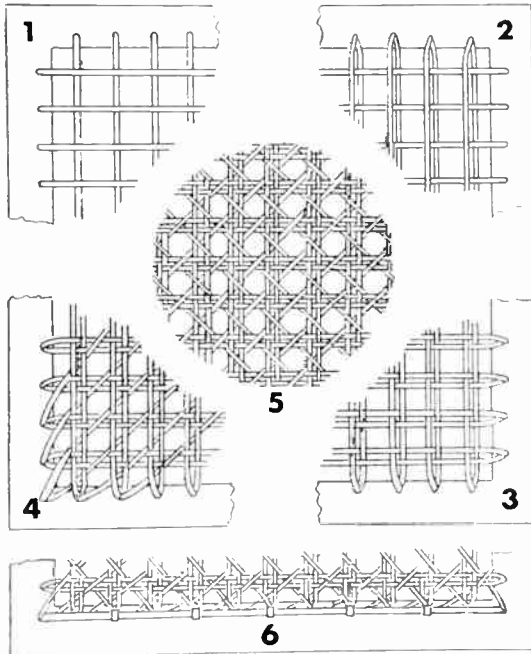
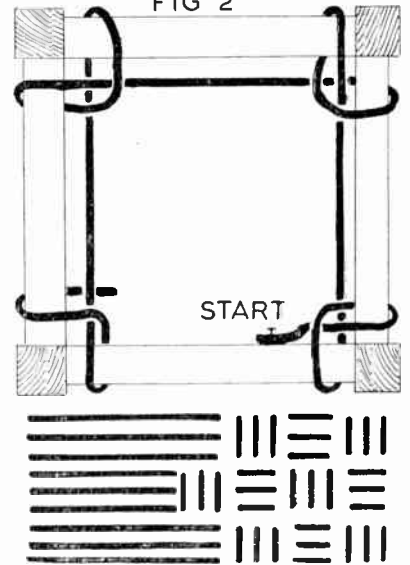

FIG 2



front. Then the same method should be adopted from side to side, completing the basic weave as shown in Fig. 1 (1).

The second stage involves the laying of second canes from back to front and side to side and is a repetition of the same method. The only difference is that these second rows lie on top of the side to side canes as shown in Fig. 1 (2). But when we come to the third stage, with the side to side canes, we start interlacing as shown in Fig. 1 (3). To be more precise, the canes are laid on top of the previous stage but carried under those of the first weaving.

Finally we weave the canes diagonally, starting at a corner with two canes, weaving over two and under two as shown in Fig. 1 (4). Pull these straight and make certain they are parallel. Repeat the diagonal weaving from the other corners of the frame, when the canes pass over three and under three as shown in Fig. 1 (5). Whenever the cane of the previous stage is at the top the cane in the final stage is always threaded underneath.

To maintain tension and prevent the seat from sagging when used, drive small pegs into every other hole, after which lay a beading cane over the holes.

We now have to hide the holes with their pegs and a length of wider cane is laced over these. To do this we pass a loop of fine cane upwards through every alternate hole. The wider cane may then be threaded through the loops, which are pulled taut and tied. Finally, peg the ends of the wider cane at each corner to hold it firmly in position and this beading, shown in Fig. 1 (6) provides a neat finish.

Seagrass is a popular material for making seats for chairs and stools since it is easy to use and the weaving is not quite so intricate as the cane method. As before, when reseating, old rush or cane is removed and the chair renovated as necessary when the weaving may commence.

About 1½ lbs. of seagrass which is available in different colours, is required for an average stool, and once again it will be an advantage to make it pliable by soaking in cold water. When working, the material should be twisted all the time where it will show.

A length of seagrass, say about 18 ft. long, is taken and the end laid on the inside of the front rail and fastened with a clout nail. If you will refer to Fig. 2 you will see that the cord is passed over the top of the right hand rail to the underside. It then passes over the front rail. The cord is taken to the back rail where it passes over the top, over the right rail and to the left rail. This process is repeated at the third and then the fourth corners.

Each threading should be pulled tight as woven but the cross-over stroke is made without further pulling so that we can make equal angles at each corner.

★★★★★★★★★★★★★★★★★★★★★

★ **SEAGRASS** ★

★ **COLOUR PER HANK** ★

★ Natural 2/6 ★

★ Green 2/9 ★

★ Red 2/9 ★

★ **BI-COLOUR** ★

★ Natural/Green 3/- ★

★ Natural/Red 3/- ★

★ (postage 2/- extra) ★

★ About 2 hanks required to ★

★ cover a stool. ★

★ **Hobbies Ltd. (Dept. 99) Dere-** ★

★ **ham, Norfolk** ★

★ *Send for details regarding* ★

★ *Ready-to-Assemble finest* ★

★ *quality fireside stool kits with* ★

★ *seagrass tops.* ★

★★★★★★★★★★★★★★★★★★★★★

Should the seat be wider at the front than at the back this can be obviated by passing an additional loop around the front rail after every two rows. This should have the effect of balancing any difference of the two rails.

Having completed about three inches of the weaving at each corner it will be found that a hollow space is left on the inside of the seat rail between the top and bottom layers of the rush. These pockets are stuffed with some of the old seagrass removed from the chair or with brown paper. This will add greatly

to the strength of the seat and give more comfort.

Continue working as already directed and when the joining of new cord becomes necessary, tie with a reef knot where it will be concealed underneath the surface. If any of two opposite rails become fully covered before the others—due to difference in dimensions—the gap should be covered by weaving across in the form of a figure eight.

Tie the finishing end to one of the cords on the other half of the seat, tucking away the end under adjoining cords.

An entirely different pattern, as shown in Fig. 2, can be made in a check design but here we have to employ another weaving method. First we wrap the seagrass from the front to the back rails. Start as before by tacking the end of the cord to a rail, wrapping over the rails backwards and forwards three times. The fourth turn is merely wrapped round the rail to make a space, then continue as before.

Then weave the cord under three and over three in the opposite direction to make the pattern, again leaving the fourth turn to wrap around the rail. When weaving in this direction you will find it a decided advantage to insert a ½ in. dowel rod through the cords according to the pattern. This will enable you to weave the cord quite easily. Another rod is then inserted when the three cords have been threaded and you wish to reverse the weave. This method is more suitable when the seat top is square.

Both cane and seagrass make delightful hand-woven seats which can be washed and look extremely attractive. They will last for a long time.

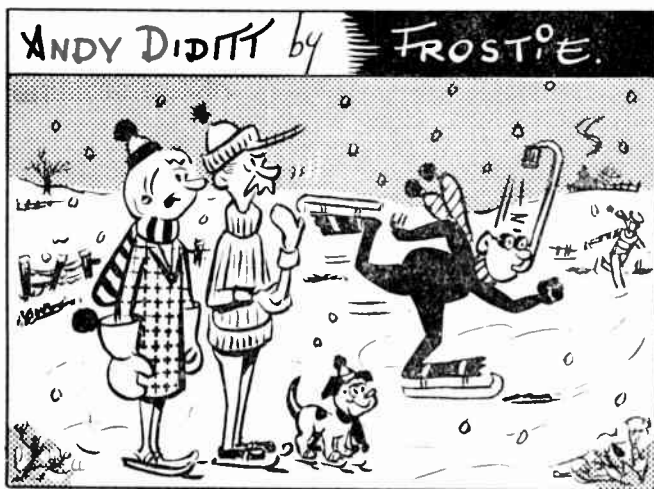

"ANDY'S PLAYING SAFE — HE WENT THROUGH THE ICE LAST TIME."

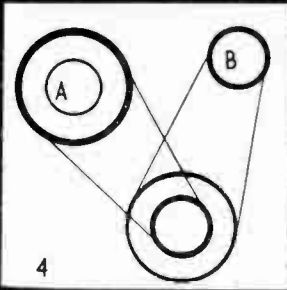
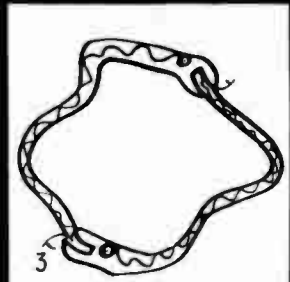
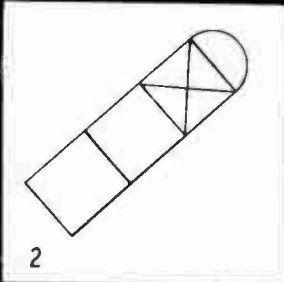
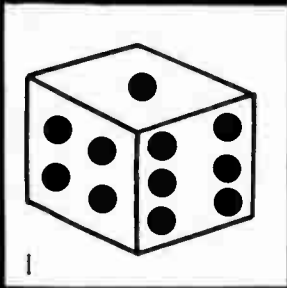

QUIZ GRAMS

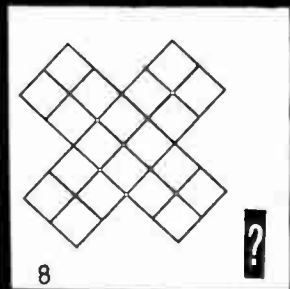
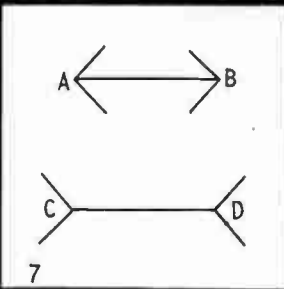
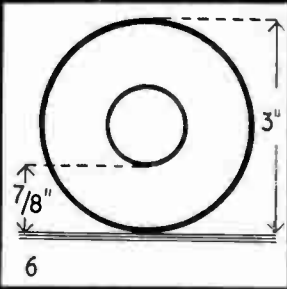
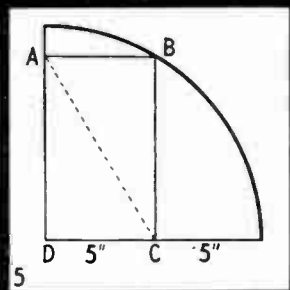

AN old Chinese proverb tells us that 'a picture is worth a thousand words'. We associate quizzes with oral or written questions, but it is a great help if an idea or problem can be illustrated. With these thoughts in mind a selection of 'Quiz Grams' has been prepared for your amusement. Some of the posers will only require common sense if you are to solve them correctly, whilst others may be harder or more

time-consuming.
Here are the questions:
(1) Can you see anything wrong with the die?
(2) Is it possible to draw the figure without lifting your pencil from the paper or crossing over a line?
(3) Here are two serpents busily swallowing each other. What is likely to happen?
(4) When the machinery is working,

which wheel will go round faster, A or B?
(5) The rectangle is drawn in a quadrant of a circle. What is the length of AC?
(6) What is the radius of the inner circle?
(7) Quickly now (and without using a ruler) is AB longer than CD?
(8) How many rectangles can you find?
Solutions

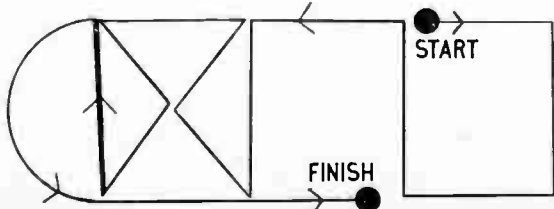

- (1) On a properly constructed die the spots upon opposite faces will always total seven. It will thus not be permissible for spots on adjacent faces to add up to seven!
- (2) Yes (see diagram).
- (3) Both snakes will probably choke!
- (4) Wheel B would turn considerably faster than A.

● Continued on page 315

Easy to make

A SIMPLE HAND LOOM

A SIMPLE loom for weaving scarves, ties, belts or string shopping bags is very easy to make, and will give hours of entertainment.

The loom shown here can produce a scarf or piece of material measuring approximately 9 in. by 40 in., but the sizes given can readily be altered to produce a larger or smaller article.

The method of construction is simple. The four upright corner posts are of $1\frac{1}{2}$ in. by $\frac{3}{4}$ in. wood, the shorter pair being 10 in. high and the longer pair 12 in. high. Two 10 in. long spars of 1 in. square stripwood are screwed between the uprights, the lower spars being 2 in. up from the bottom of the uprights, and the upper spars 1 in. down from the top.

The two 18 in. long sides of $\frac{1}{2}$ in. thick wood are then screwed in place 2 in. up from the bottom of the uprights. These sides taper from a height of 6 in. at the back to 4 in. at the front.

A 12 in. long strip of plywood, $1\frac{1}{2}$ in. wide, S, is shaped as shown to form a shuttle. An 11 in. long bar of 1 in. square stripwood B is cut away as

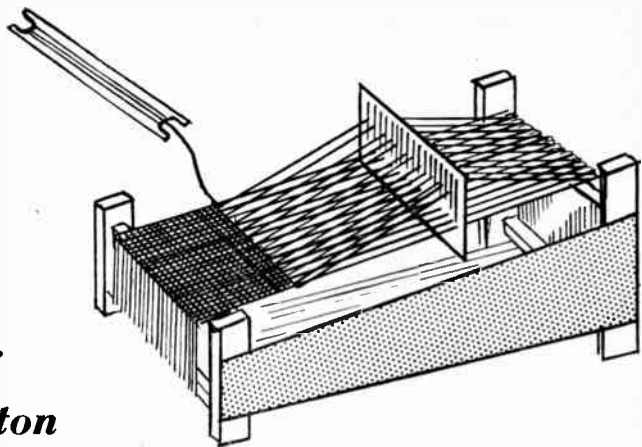

By
A. Liston

shown at each end to fit between the sides of the loom, and grooved along the top to take the heddle H, which rests on the bar when the loom is not in use.

The heddle itself is $9\frac{1}{2}$ in. long and 3 in. high. It can be made of plastic or plywood—or even tinplate when string is being woven. It is formed by cutting $2\frac{1}{2}$ in. long slits down from its upper edge, and drilling a line of holes, one between each slit, along the middle of the heddle. A strip of tinplate or fabric adhesive tape is put in place along the top of the finished heddle. The distance between the slits can vary, according to the thickness of the material being used. Slits sawn at $\frac{1}{8}$ in. intervals, with $\frac{1}{4}$ in. diameter holes between, for example, will allow about

60 threads, in the warp, as the long threads running along the loom are called. It is reasonable, however, to make a set of differing heddles for use with various thicknesses of material.

To set up the loom for weaving, the first thread is passed through a slit in the heddle, wound round the outside of the spars of the loom, and the ends tied together at the lower end of the loom. The next thread passes through a hole in the heddle, then it is similarly tied. The process of threading alternate strands through slots and holes is continued until the heddle is filled. The shuttle is then filled with wool or string, and the heddle raised as shown in the illustration of the finished loom. This raises every second thread, so that the

shuttle can be passed across between the upper and lower sets of thread, thus putting a cross thread in place. The heddle is then depressed, and the upper sets of threads becomes the lower set; the shuttle is passed back between them putting another cross thread in place.

As the woven section grows longer, it can be moved back and held in place against one of the spars with drawing pins. When changing the colour of wool in the shuttle, or re-filling it, the loose end of wool should be cut near the middle of the warp, and not at one of the sides. Pressing the heddle against the work at each step will keep the cross threads closely packed.

The finished article is cut from the loom, and the loose ends tied together to prevent fraying.

A little practice will show how easily patterns in different colours can be built up, using scrap lengths of wool to begin with. Using a very coarse heddle, with widely spaced holes, and thin string lengths of open-weave material can be produced for making into shopping bags

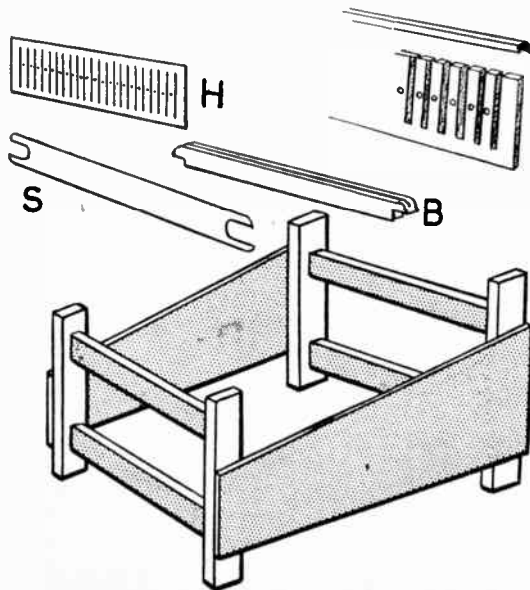

● Continued from page 314

QUIZ GRAMS

- (5) You can see that the radius of the full circle would be 5 in. + 5 in., or 10 in. BD, another radius, would also be 10 in. But BD and AC are both equal diagonals of the rectangle ABCD. Therefore, AC will also be 10 in. in length.
- (6) $\frac{5}{8}$ in.
- (7) No. Actually AB and CD are equal.
- (8) There are 117. (A.E.W.)

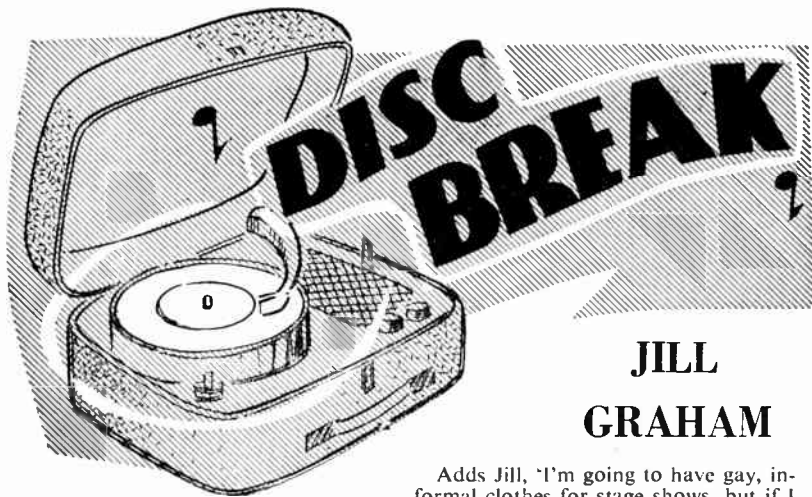

JILL GRAHAM

JILL GRAHAM is 18. She is 5 ft. 4 in. tall, has black hair and brown eyes, and shapely legs. But you would never know. For Jill is the girl who wears the trousers in the disc business. Her first Parlophone record was *Blow Joe and Mr Clown* (45-R4957).

'We wanted to make Jill different from other girl singers', says Dick James, her co-manager, a man who knows a thing or two about the business, and once recorded a top pop called *Robin Hood*. 'You get them in flouncy dresses, and you get them poured into figure-hugging gowns.

But Jill is so much the typical teenager, and we felt that to have her wearing slacks for public appearances would make her immediately recognizable.'

Adds Jill, 'I'm going to have gay, informal clothes for stage shows, but if I do night-club work, then I'll be wearing slinky, lounging pants. Sometimes, mind you, I envy other girls in pretty dresses, but I really like wearing slacks and shirt, it's very comfortable.'

Born on 18th September 1944, Jill, a former dental nurse, comes from Woolwich, and started singing with a group of friends who brought their guitars to her house, and played in the lounge.

'It was a horrible row, but nobody minded', she says. 'We were careful to play only when the neighbours were out.'

Once she worked up enough courage to take the stage, and sing to a Saturday morning audience of children at Shepherd's Bush Gaumont. The manager liked what he heard, and took her to a music publisher. He was interested, but



advised her to take lessons. She did, at Maurice Burma's School, where Helen Shapiro was discovered, and met Freddie Harper, one of the teachers, who now shares managerial duties with Dick James. After a year Jill went back to the publisher, who was more impressed, and a recording test was lined up with Parlophone.

An expert — but no longer enthusiastic — ballroom dancer, and holder of the Bronze and Silver Medals, Jill likes football, modern jazz, Sammy Davis, Jnr., Eydie Gorme, and Chinese food.

ADVICE ON FILLING THE GRAIN

A READER has sent us an interesting letter regarding the filling of the grain in fretwork projects. It cannot be stressed too emphatically that this filling has to be undertaken on all woodwork in which a fine finish is desired. It is no use trying to get a good surface by adding coat upon coat of paint or varnish, or by successive applications of polish. Each coat, naturally, tends to follow the contour of the surface of the wood, and a really flat surface is, therefore, never obtained.

Our correspondent mentioned that in his experience it is sometimes an advantage to fill the grain of the panel of wood being used *before* cutting out, particularly when delicate interior frets are being undertaken. As he says, this eliminates the necessity for cleaning out those fine frets, which tend to get filled

with the filler. Incidentally, he uses Polyfilla to fill the grain, which is quite satisfactory when dry and glasspapered smooth.

To carry on this theme to a later stage, it would appear that in some cases the panel to be worked on could also be finished by polishing or painting, etc, before cutting, although care would have to be taken when cutting, so as not to impair the finish.

Another suggestion is in the application of the design to the wood. Readers will know that we recommend the transferring of the design by means of carbon paper, but in the case of very delicate cutting, mistakes can occur and lines thicken. If the design is not required for further use, it can be pasted on to the material and the remains scraped off after cutting out the shapes.

To save this scraping off, our reader has used a double-sided adhesive tape which is applied to the wood, and the design then added to the top surface of the tape. This is then removed by pulling off the tape after the design has been cut. This, of course, is a more expensive way as the wood has to be fully covered with the tape in order that the design may lie flat all over.

We should be interested to hear of any other suggestions in a similar vein from other readers. (E.)

HINT FROM SOUTH AFRICA

A READER in South Africa has sent the following suggestion: 'Don't throw away those little screwtops from your toothpaste tubes; just stick a tiny artificial flower in them, and they make excellent little flower pots for your doll's houses and other novelties.'

Illustrated on front page

A STACK OF STOOLS

THE stools illustrated are not only designed for comfort, but for easy stacking to save space. As you will see from the sketch they seat nicely one on top of the other for storage and several can be placed in the same stack.

It is suggested that the woodwork should be left plain and finished by polish or clear varnish. If they are likely to receive rough treatment such as in a cafe you might try the new Polyurethane

glaze finish which is particularly resistant to hard wear.

The main dimensions are shown in the side and front views. Draw the shapes out on a large sheet of cartridge or brown paper before commencing work. Use this drawing as a guide so that all stools are identical in shape.

The legs A and the rails B are halved together as indicated in Fig. 2. Note the slots cut in the rails B. Both legs and

rails are cut from 1 in. thick wood.

Next cut the two cross pieces C also from 1 in. thick wood, and shape them to fit the rails. The assembly of these pieces is shown clearly in Fig. 3. You will of course use glue and screws where practicable.

The seat D consists of a piece of $\frac{1}{2}$ in. plywood 14 in. by 12 in., which is screwed and glued to the cross pieces C. It is covered after fixing.

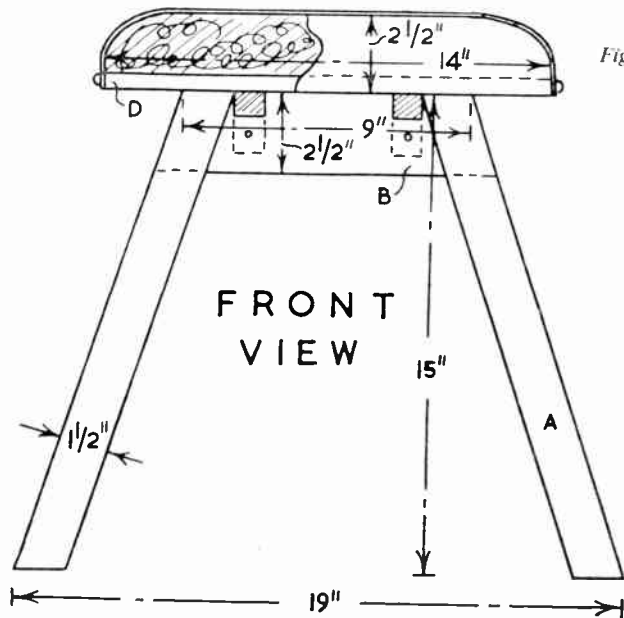

Fig. 1

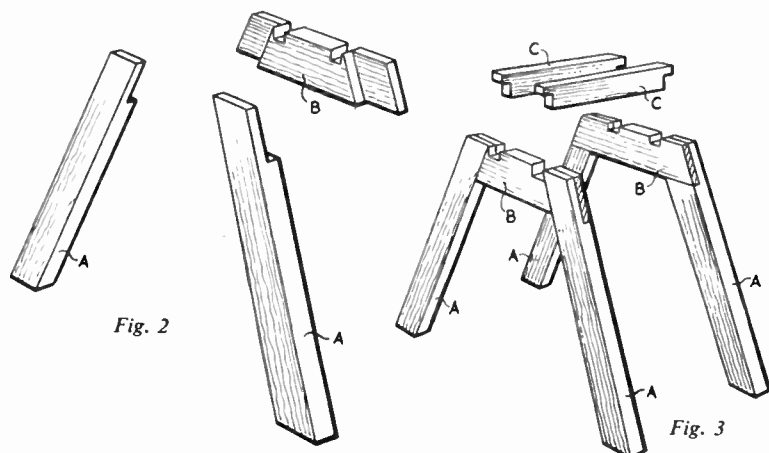
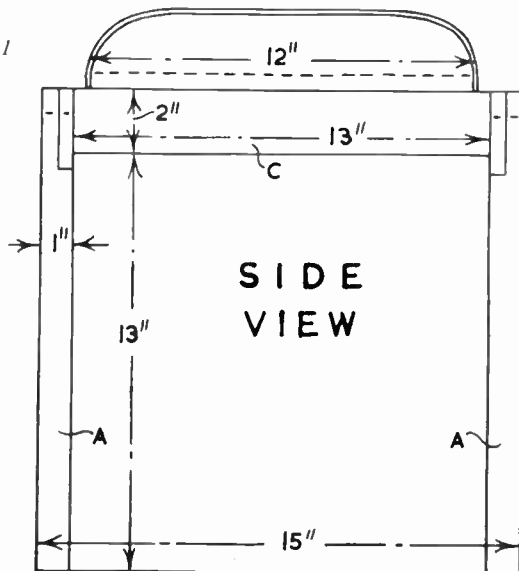

Fig. 2

Fig. 3

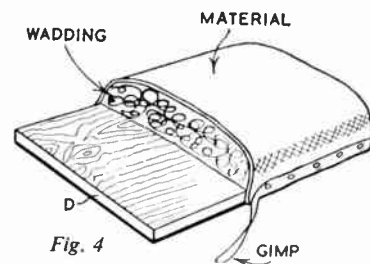

Fig. 4

The diagram in Fig. 4 shows how piece D is padded with wadding, kapok or plastic foam and then covered with suitable material. Tack the material around the edges and cover the tacks with decorative gimp which can be glued in place with a latex adhesive.

(M.h.)

'TRICKS' WITH A CAMERA

WHO said 'the camera cannot lie'? He could not have had a very extensive knowledge of photography as, properly handled, the camera can be a consistent and effective liar!

For proof of this fact, you have only to look at a picture of an angler with his catch proudly held out before him. Towards the camera, of course, for in that way the fish is nearer the lens and therefore rendered proportionally larger than the fisherman. By judging the distances accurately, a stickleback can be made to seem almost shark-size!

By A. E. Bensusan

Apart from such simple optical illusions, which can be adapted to a variety of subjects, you can have a great deal of fun while producing other trick photographs. These subjects always interest and amuse friends to whom they are shown, and you can even build up a complete album of different trick shots, all of them either highly improbable or, perhaps, quite impossible to believe but still recorded in the form of photographs for anyone to see.

It would need to be a very strong man who could support another on the outstretched palm of his hand, but it could be done. Photographically, at least, if not in fact, as you can see from Fig. 1. This shot relies on very careful placing of the two people who form the subject matter of the picture, for accurate alignment of the feet with the hand is essential to success.

The fine lining-up of the two parts of the subject is best carried out with the camera rather further away than

would normally be necessary. This is because a small vertical or horizontal error of viewfinder positioning would have a correspondingly smaller effect on the picture at a greater distance. The image on the film may be a little on the small side, but it can always be enlarged to fill the picture space when the print is made.

For the same reason, in order to minimise errors in lining-up the feet

with the palm of the hand, an ideal camera to use would be one which has the taking lens as part of the viewfinder arrangement, such as a single-lens reflex or an old fashioned stand camera. However, with practice, the displacement of the viewfinder from the centre of the lens on any other type of camera can be judged fairly well.

Another rather amusing trick photograph is that of the same person shown doing different things on one print—photographic twins, so to speak. There are several methods of producing this kind of shot, one of which needs either a shutter which is not interlocked with the film-wind and can be fired twice without moving the film to the next position, or a shutter which can be locked open on the 'time' setting so that two exposures may be made with a lens cap. If you adopt the latter method, an efficient lens cap can be obtained by blackening the interior of a suitably sized cardboard pill-box lid.

It is vital to have a perfectly black background for this picture, and to prevent any spill of light from reaching it. So that shadows are not thrown, the background should be as far as possible behind the person being used as a subject for the trick.



Fig. 1—The 'standing on hand' trick



Fig. 2—'Photographic twins'

First, be sure that your subject does not wear any clothing which would cause a reversed image to be seen backwards. Jackets and coats, with their one-way buttoning over, must be avoided. Place the person to one side of the background, and have him or her performing a part of the action while you make the first exposure. Then, without winding the film on or moving the camera, get the person to move over to the other side of the frame and perform the other part of the action so that the second exposure may be made. You may need to make a few attempts at this before you get the two parts properly matched but, once this is achieved, the result will prove well worth while.

Another method of gaining the same result is to make two separate negatives, one of each part of the picture, and again using the black background. Then, when contact printing or enlarging the shot, the negatives are sandwiched together in their most satisfactory relationship and printed together. Since the black background does not record on the negative, the film is clear except where the person is standing. This method, which was used for Fig. 2, is particularly suitable for cameras which have an interlock prohibiting two exposures on one negative.

The third method is to make two separate prints of the parts of the picture, carefully cut them out, and then paste them onto a plain background. The 'montage', as it is called, must later be photo-copied to provide a master negative.

If you carry out your own photographic printing or enlarging you have a greatly extended field of operation for trick pictures. Some quite impressive pictures may be made by using the 'double exposure' technique. Basically, this consists of printing two or more different negatives on to the same sheet of paper. Naturally, these negatives must have some aspect in common so that when they are combined in the single picture they tell the story you wish to put across to the viewer, as in Fig. 3.

It is important to mark the back of the paper with a soft pencil, in order to know which is the top of the sheet, or you might inadvertently have it upside down when exposing the second and any subsequent negatives. Keep the exposure very light for each shot as otherwise the combined strength of the images will make the final print far too dark all over.

A variation on this theme is to combine a picture of a person standing against a black background with a normal interior or exterior view. The view exposure must be a little heavier than that given to the person while printing. The result of this combination

Fig. 3—Double printing of Broadcasting House with a 'Radio Times' cover



will be a completely recognisable 'ghost' through which the scenery can be clearly seen.

There are countless other trick pictures

which may be taken without any special equipment or particular technical knowledge. It requires only a little ingenuity to produce them.

Miscellaneous Advertisements

PENFRIENDS home and abroad, all ages. S.a.c. for details. European Friendship Society, Olney, Bucks.

WOULD YOU ENJOY painting flower pictures, etc.? Then read 'PROFITABLE ART' (free). Wonderful opportunities for beginners and others. **POPULAR ART (HW)**, Clun, Salop.

100 DIFFERENT stamps free! Request 4d. upwards discount approvals. — Bush, 53 Newlyn Way, Parkstone, Dorset.

ENJOY WRITING? Then write for Profit. Send for 'Writers' Handbook' (free) detailing countless opportunities for beginner or experienced. — 'Writers' Ring (HW), 5 Edmund Street, Birmingham.

UNDER 21? Penfriends anywhere — details free. Teenage Club, Falcon House, Burnley.

LEARN RADIO & ELECTRONICS the NEW Practical Way! Very latest system of experimenting with and building radio apparatus — 'as you learn'. FREE Brochure from: Dept. H.W.10, Radiostructor, Reading.

WANTED — Hobbies secondhand Fretwork Machine. — A. Brown, 29 Deneside, Spennymore, Co Durham.

S.A.E. for Cheap Approvals or 1/6 Beginner's Mixed Stamp Packets. All proceeds Pestalozzi Children's Village. — Haydon, 25 Larch Crescent, Chilwell, Beeston, Notts.

IF you have taken a lot of care in making a musical box, be sure to make it worthy by including the best Swiss movement — a REUGE. Prices from 14/9. Wide range includes a charming Dancing Ballerina. Many tunes to choose from. Send for details in free booklet 'Profitable Leisure' **HOBBIES LTD, (Dept. 992), DEREHAM, NORFOLK.**

FRIENDS' WORLD, Postbox 708, Calcutta, India, offers pen friends everywhere.

BUYING OR SELLING?

Classified advertisements on this page accepted at a cost of 6d. per word prepaid. Use of a Box No. is 1/- extra. Send P.O. with advertisement to **Hobbies Weekly, Advert. Dept., Dereham, Norfolk.** Rates for display advertising on application.

It costs nothing to make—

A MODEL STOCKADE

By

T. S. Richmond

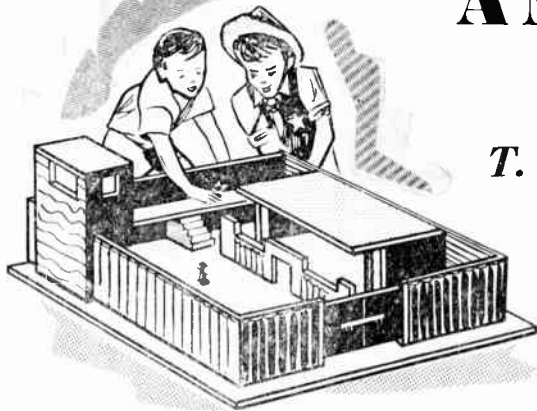

WITH children regularly 'looking-in' at 'Gunlaw', 'Cheyenne', 'Whiplash', and 'Rawhide', it is not surprising that model Cowboys, Indians, and replicas of weapons, etc. featured in these and many other 'Western' television programmes, take pride of place in their toy cupboards!

A hand-made fortress for staging miniature 'battles' is rather expensive to buy in the toy shops, but you, as a model-maker, can easily make your own for next to nothing, by utilizing a cardboard container as suggested here, and by using up those odd bits of plywood, etc. to be found in your 'scrap-box'.

Select a strong cardboard box of suitable dimensions, as shown in the sketch, around which can be built up a realistic stockade, with look-out towers, living-quarters, galleries, etc. Cut an opening for the gate in one of the sides. Glue the bottom of the box to a piece of 3-ply wood to make a stronger base.

A log effect to the sides can be created by gluing on strips of corrugated cardboard, or by simply painting on the 'logs' with poster-colour. A more realistic but expensive way would be to

positions indicated, so the complete tower can be slotted on to the side walls of the fort. Piece C fits inside, and is glued after finding correct height with a model figure stood on it. Finally glue on the roof piece D.

Make up the 'barrack' building with parts K (base), L (ends), front piece with

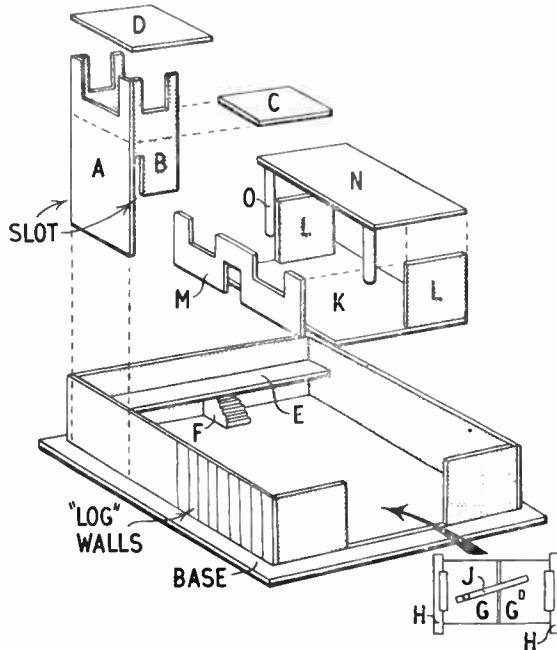

glue strips of reeded hardboard on around the walls.

One or two towers can be built up with pieces of plywood. Front piece A and sides B (cut two) have 'windows' as shown, and pieces B have slots at

windows, and a door M, and dowel-rod pillars O supporting roof piece N. Assemble with glue and fretpins.

Pieces of stripwood are used for inner platforms from which the soldiers fire over the walls, and these are supported on blocks F cut to represent steps. Like the floor of the tower, correct height is necessary for the models used.

An entrance door for the barricade is made of two pieces of wood G, hinged with cloth strips to pillars of wood H, the latter then being glued to edges of the opening in the box side. The swivel bar J keeps the gate locked against the enemy: a fretnail pivots the bar, and another is bent up for the latch.

Measurements of the parts described depends on size of the box used, and the finish given to the toy is also left to individual choice. A flag and mast, ladders up to the towers, and other authentic features can also be created.

HANDY SANDING BLOCK FOR MODELLERS

A HANDY sanding block particularly useful for modellers of small items is easily made to a T-section as illustrated. The advantage here lies in the fact that it can be easily clamped in the vice to provide a rigid surface, particularly for small parts which cannot be sanded effectively by any other hand method. The abrasive is pinned to the head of the block as shown, and by facing the block with very fine abrasive cloth it is also handy for sharpening edge tools.

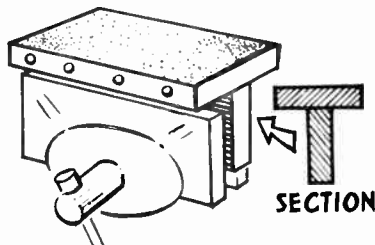

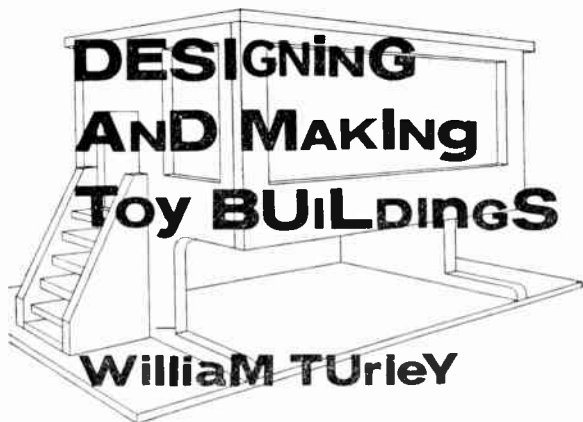

In this book the author shows the methods by which strong, attractive toy buildings can be made at home at a reasonable cost. All aspects of toy buildings are explained in detail, with comprehensive instructions for making six specific examples. The book is profusely illustrated with line drawings and photographs. *12s. 6d. net*

STANLEY PAUL



The
STRONGEST
handy glue

STILL ONLY

1/2 a large tube

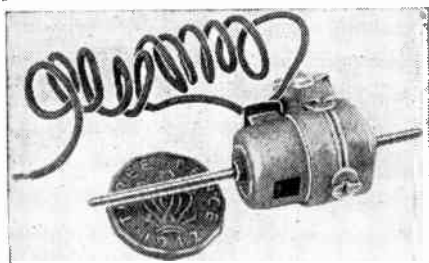

'SUPER ATOM' only
The smallest of all 2/11

ELECTRIC MOTORS
for working your
BOATS, PLANES, AND
CARS
THE 'SUPER Q'
KAKO RANGE

(Foreign)

In the Kako range there is a quality, peak performance Electric Motor for the needs of all modellers, whether you are motorising a Boat, Plane or Car. All the motors are reversible and designed for use on direct current. They have double permanent magnets, brass sleeve bearings, and being of all metal construction can be relied upon for strength.

Note: Illustrations shown here are slightly smaller than full scale.

Post orders to:

HOBBIES LTD

(Dept 99)

DEREHAM, NORFOLK

Available at all branches

321

World Radio History

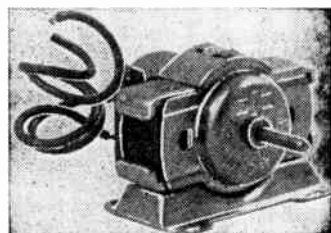

MODEL 'O' Typical of the
Handy size range 4/4

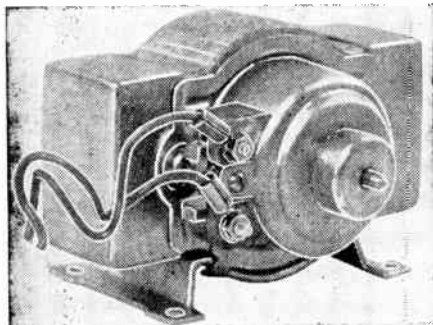

MODEL '5'
a sturdy job Value for
31/4

TYPES AVAILABLE IN THE
THE 'SUPER Q' RANGE

	Volts	Weight	Price	Post
Atom	1½-3	½ oz.	2/11	3d.
'01'	1½-3	¾ oz.	3/9	4½d.
0	1½-3	1½ oz.	4/4	4½d.
1	1½-3	1½ oz.	5/3	4½d.
2	1½-4½	2½ oz.	6/8	6d.
3	1½-4½	2½ oz.	7/10	6d.
4	3-6	5 oz.	15/8	9d.
5	4½-10	11 oz.	31/4	1/-

Handy for repetition work.

DEPTH GAUGE FOR A SAW

A CONSIDERABLE amount of time can be saved by fitting a depth gauge to your tenon saw, especially when doing repetition work. To do this it is only necessary to drill two comparatively small holes in the blade of the saw, and attach a piece of hardwood with bolts and wing nuts.

Slots in the wood allow it to be adjusted to suit the depth of the saw cut. With slight modification it can be used as a width gauge also, and this greatly adds to its usefulness.

Beech is generally used for most wood-work tools, but many other hardwoods may be utilized, such as oak or ash. A useful thickness for the depth gauge is $\frac{1}{4}$ in., but the exact size is not important, and can be varied somewhat.

The length of the gauge will vary according to the size of the saw, while the width depends partly on the depth of the cut you wish to make. Cut two slots near each end of the strip of wood to fit the bolts you are using, and these can be about $\frac{1}{8}$ in. or 2 B.A.

The two holes drilled in the saw should be in the upper half of the blade: say about three-quarters of the way up, and will correspond with the slots in the gauge. This will not materially weaken the blade, and being placed a good distance from the teeth, the saw can be sharpened very many times before the holes are reached.

The blade will not be difficult to drill if you use a good twist bit. Carefully mark the positions for the holes with a centre punch, and when drilling steel apply plenty of pressure, but with a slow motion and a good supply of oil.

The gauge is very useful when cutting dovetails and similar cuts, and can be adjusted to do an accurate and speedy job.

For a width gauge two strips of wood will be needed as shown in the end view, and these are both secured with two bolts as with the depth gauge. The outside one is a thin strip, and projects just beyond the saw teeth, while the inside strip determines the width of the cut. If you do much work of this kind several spacers of different widths will be useful, but as the width increases so must the length of the bolt be increased. (A.F.T.)

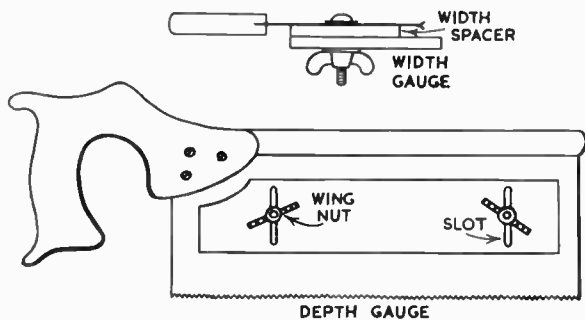

How to replace Broken Tiles

IF some of the wall tiles in your home are found to be loose then they should be repaired right away. Alternatively, the tiles should be removed from the wall and stored in a safe place. Don't allow them to remain in position because any sudden vibration could easily cause them to fall away unexpectedly on to the floor and break. In such a case it will mean purchasing new tiles to match the existing. If, however, the damaged tiles on the wall are already broken then there is no alternative but to obtain new ones.

Once the damaged or loose tiles are removed examine the cement backing. Glazed tiles are never put directly on to the brickwork. A cement/sand backing is first put on the walls to make a flat surface for the tiles. It is often found that the cause of loose tiles is the result of a crumbly backing coat. If this is found to be the case then remove the backing coat completely. Replace with a new cement/

sand backing using one part cement to three parts sand. Remember to wet the brickwork thoroughly to prevent the dry bricks absorbing the mixing water before the backing coat sets. Don't bother about trying to obtain a smooth surface on the mortar; if it is rough it will provide a better 'key' for the tile adhesive.

When the backing coat is hard, try the new tiles in place to ensure that they fit properly. If you have to cut a tile then this can be done by using a glasscutter. Simply score the glazed surface along the desired line of cut, place the tile on top of two panel pins which should be directly under the score line and press gently down on either side. This will snap the tile along the score line. Fractional parts of tiles may be removed by rubbing the edges with a carborundum stone.

The tiles should be fixed in position with a suitable tile adhesive. A simple method of keeping the tiles in place until

they are set is to position them correctly and then stick on a few strips of adhesive tape to prevent them moving.

Once the tiles are set in position grout up the joints with a neat mix of cement and water. Add just sufficient water to give a slurry consistency and then rub this into the joints to flush them off. A little whitening may be added to give white joints or, alternatively, coloured dyes may be added to give coloured joints to match the tiling. (F.K.)

LEARN

RADIO & T/V SERVICING for your OWN BUSINESS/HOBBY

● by a new exciting no-maths system, using practical equipment recently introduced to this country. *FREE Brochure from*

RADIOSTRUCTOR
DEPT. G81, READING, BERKS. 13/2/63

A PUSH-ALONG TOY ENGINE

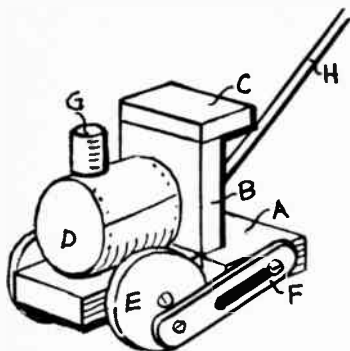

THIS attractive push-along toy is quickly made and painted. The main piece A is cut from $\frac{3}{4}$ in. wood, and pieces B, C, D and E from $\frac{1}{2}$ in. There will of course be two each of D and E.

The two pieces F are of $\frac{1}{8}$ in. plywood and are pivoted to the wheels and piece A as indicated in the diagram. The boiler is made from the two circles D and a piece of thin cardboard is wrapped round and pinned in place. The funnel G is a short length of $\frac{3}{8}$ in. round rod and the handle is $\frac{3}{8}$ in. round rod. The handle is glued into a hole drilled obliquely into piece B. Clean up and paint in bright colours. (M.p.)

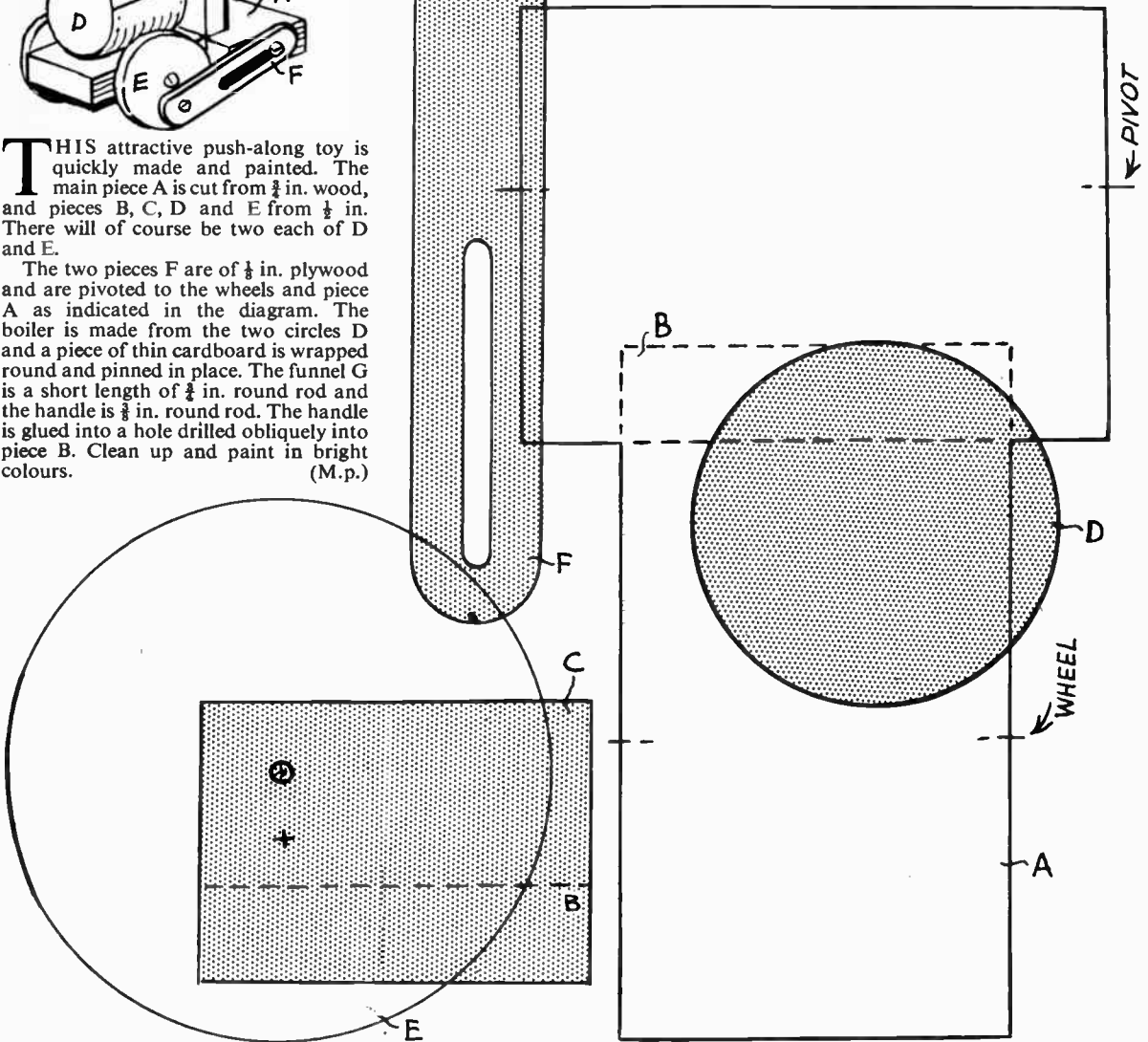
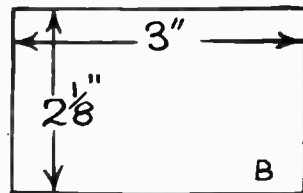



be prepared...

... with a tin of
Evo-Stik on your shelf.

There isn't a fixing job around the house or workshop that a tin of Evo-Stik won't tackle; and it usually costs much less than a 'bob-a-job'.

Table tops, wall panels . . . small jobs and large . . . different materials, difficult angles: Evo-Stik fixes them all. Faster, cheaper and a whole sight stronger than the contents of an average size tool chest. And its strength actually increases after use.

No need to scout around either. It's in every Ironmongers and most large stores.
TINS 7- and 4/3. TUBES 3/9 and 1/9.

a small deposit secures any article

'IMPACT'
EVO-STIK
REGD. TRADE MARK ADHESIVE

MANUFACTURED BY THE INDUSTRIAL ADHESIVES DIVISION OF EVOQUE LIMITED, COMMON ROAD, STAFFORD. STAFFORD 2241 (3 LINES) LONDON OFFICE: 450/2 EDGWARE ROAD, W.2. AMBASSADOR 2425 (5 LINES)

20th FEBRUARY 1963

VOL. 135

NUMBER 3506

THE ORIGINAL
'DO-IT-YOURSELF'
MAGAZINE

HOBBIES *weekly*

FOR ALL
HOME CRAFTSMEN

Also in this issue:

NOVELTY INDOOR
PHOTOGRAPHY

COLLECTORS' CLUB:
COINS

A HEARTH TIDY

DESIGNS IN WIRE
AND METAL

A CANNON FROM
A CIGAR TUBE

STARS FEATURED
IN DISC BREAK

RECORDING BY
TAPE OR DISC?

PATTERNS FOR
INSTRUCTIVE TOY

ETC. ETC.

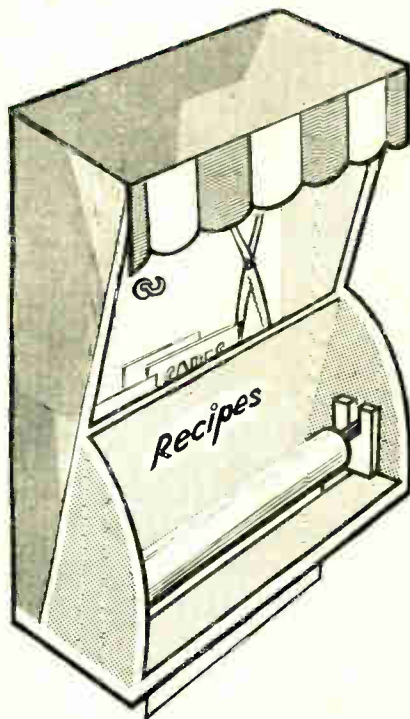

**PLANS FOR AN
ATTRACTIVE
AND USEFUL
DISPENSER**

KITCHEN FITMENT



Up-to-the-minute ideas

Practical designs

Pleasing and profitable things to make

5^D



COLLECTING pennies is a cheap hobby that makes no great demands on your time. The idea is to collect one coin for each date, except for those very few years when more than one type of penny was issued.

People will tell you that only the coins in mint condition that you buy from dealers have much value; this may be true, but it is more fun to restrict your collection to the pennies that come to you in daily circulation, and you must

CONCENTRATE ON PENNIES

By *S. Mazzarella*

always look for the finest specimen you can find for each year. In this way your hobby becomes never-ending, because even if you have a copy of every penny ever issued, there is always a good chance you might improve your collection any day by finding in your pocket some less worn specimen of a coin you have already got.

A centenary

Now is as good a time as any to start collecting. The bright new pennies of 1961 and 1962 that have appeared recently are not only the first we have had for twelve years, but they virtually celebrate the centenary of our bronze coinage, for modern bronze pennies replaced the old cumbersome copper ones in 1860.

Oddly enough, we have the French Revolution of 1789 to thank for our pennies of today. The Jacobins in France melted down a lot of church bells and not knowing what else to do with the miscellaneous metal they had collected, they added copper, and made coins from it.

Later Napoleon used up most of the remaining metal for making cannons, and more and more copper was added to what was left by the Mints, so that it was almost by chance that the best alloy for bronze coins was eventually dis-

covered — 95 per cent copper, 4 per cent tin, and 1 per cent zinc. Coins made from this alloy were lighter and tougher than the big soft copper coins then in use in England, and in 1860 it was decided to adopt it for our pennies, half-pennies, and farthings.

Even then all was not plain sailing. The Mint sent a pattern coin to Queen Victoria; she posted it back in a registered envelope, saying she approved of its design, but a greedy postman opened the envelope. Disappointed to find nothing but a peculiar bronze coin, he threw it down a lavatory. He was caught, but the lost pattern penny was never found.

Bun pennies

The new pennies, known now as 'bun' pennies, proved popular at once, and in 1869 the old copper coins ceased to be legal tender, though you may still buy them cheaply enough in an antique shop. Bun pennies were issued from 1860 to 1894, but it is not generally realized that in design they are not quite all the same.

In 1874-6 and 1881-2 the Royal Mint, overworked, placed contracts for the minting of coins with Ralph Heaton Ltd of Birmingham, and some of the pennies of these years have a small 'H' under the date to show that they were made by Heaton.

In 1860 the Queen was 41, yet she appeared as a young girl on the coins. As the years went by, various minute alterations were made (notably in 1874, 1881 and 1884) to thicken her features. By 1894 she was 75, yet on the pennies her features had scarcely altered, and finally in 1895 a new veiled bust was issued, which had already appeared on the gold and silver coins two years before.

There are too many varieties of bun pennies to be described here (see Seaby's *British Copper Coins and their Values* for further details). Suffice to say that there are no fewer than eight different pennies to be found for 1874 alone! In this year the Mint, apparently caught in a whirl of indecision, issued pennies (1) identical to those of 1873, (2) with the same obverse ('heads') but a slightly altered reverse ('tails'), (3) with a slightly altered obverse but the same

★★★★★★★★★★★★★★★★★★★★
★ NOTE TO ★
★ CORRESPONDENTS ★
★ All correspondence on any sub- ★
★ ject covered in this magazine ★
★ must be addressed to: The Editor, ★
★ Hobbies Weekly, Dereham, Nor- ★
★ folk. If a reply is required, queries ★
★ should be accompanied by a ★
★ stamped addressed envelope and ★
★ reply coupon inside back cover. ★
★★★★★★★★★★★★★★★★★★★★

reverse, and (4) with the altered obverse and altered reverse together. All these four varieties were also made by Heaton in Birmingham with an 'H' put under the date accordingly, so eight different permutations are to be found. I myself have collected six of the eight from my daily small change in the last few years.

Empress of India

In 1895 the penny caught up with history when 'Ind. Imp.' was added to indicate that the Queen was Empress of India, as indeed she had been for nineteen years already. This title remained on the pennies through succeeding reigns till 1949, when it disappeared, again after a time lag, since George VI had ceased being Emperor of India in 1947.

The reverse design, minus ship and lighthouse, which appeared in 1895, remained until 1937, when it was modified a little, and the lighthouse (popularly supposed to be the Eddystone) was brought back. We still have the 1937 design today.

Edward VII's reign was uneventful for pennies; the only things to notice are the new word 'omn.' (short for 'omnium' meaning 'of all') in the inscription and the fact that the king's head faces right, unlike Victoria's. This was because of an old tradition that successive sovereigns should face opposite ways on the coins.

Edward VIII tried to break this custom in 1936 when coins were prepared for issue with his head facing left like George V's, but no coins appeared except a few extremely rare brass three-penny bits.

The 'omn.' added in 1902 indicated that King Edward VII was 'king of all the Britains', i.e. of the whole British Empire. The phrase 'Britt. omn. rex (or regina)' made its final appearance in the first year of Elizabeth II, 1953, but it was then decided that the modern Commonwealth could not fairly be described as a collection of 'Britains', and the words 'Britt. omn.' were left out, slightly upsetting the balance of the design.

Some fallacies

George V's first issue of 1911 had the same design as Edward VII's. In 1912 and 1918-9 Heaton again made some pennies, and 'H' appears to the left of

the date on these. They are common, but others made in 1918 and 1919 by the King's Norton Metal Co., and which have 'KN' to the left of the date, are much rarer, though worth looking out for.

In 1922 it was found that there were too many pennies in circulation, and many of the bun pennies of 1860-94 were called in. No more pennies were struck till 1926.

On many of the 1911-26 pennies the outline of the head can be seen on the reverse side, and to counteract this the design was slightly altered in 1927. This only lasted one year, however, as in 1928 the head was made much smaller, and this new design lasted for the rest of the reign.

There are several popular fallacies

about George V's pennies. One is that 1920 pennies are worth £8. In fact they are common, but, of course, 1,920 pennies are worth £8!

Another story is that there are only six 1933 pennies in circulation. The truth is that only six were struck in that year, but three of them are in museums, and the other three under the foundation stones of public buildings.

A third fallacy is that the yellow-streaked pennies of this reign one sometimes sees contain gold. Of course they do not, but the bronze alloy from which they were made was badly mixed.

Recent ups and downs

Since 1937 the only changes in design have been the inscription changes of 1949 and 1954 already mentioned, and

of course, the new head for the new reign in 1953. But in other ways the modern penny has had a chequered career.

In June 1940 the minting of pennies stopped so that 800 tons of copper a year could be saved for munitions, and when in 1944 minting was resumed the pennies had practically no tin in them, an indirect result of the seizure of the Far East by the Japanese in 1942. The tin shortage lasted till 1945, and the 1946 issue were treated with 'hypo' to dull them, and discourage hoarding.

After 1949 came the longest break in minting in the history of the bronze penny; none were issued for general circulation until those of 1961, though occasionally a 1953 coin, probably from a Coronation set, may be seen.

A cheap coin-cabinet

One final tip: coins in good condition should not be allowed to rub against each other. Coin cabinets are expensive, but a cheap and easy way of making a home for your collection is to stick matchboxes together. Each penny may then have its own little drawer, labelled on the outside for quick reference.

Collecting pennies is a hobby that may be pursued as intermittently as one likes. It has few disadvantages, though the habit I have developed of glancing at the coins I get in shops always seems to make the shopkeeper think I suspect him of trying to give me the wrong change!

But next time your car is held up in a jam, or the underground is so crowded that you haven't room to open your newspaper, why not slip a hand into your pocket, and see what pennies you've got?

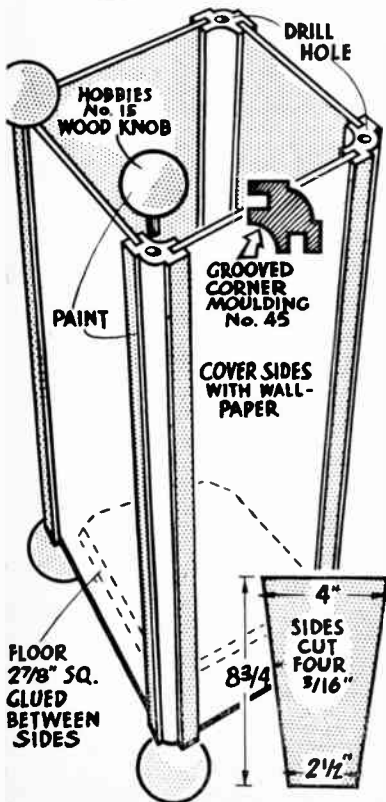

THIS useful tidy is quickly made, and looks most attractive when painted. It is in effect a small waste-paper basket, small enough to stand in the hearth.

Cut four sides from $\frac{3}{8}$ in. wood to the size shown in Fig. 1. These are slotted and glued into lengths of Hobbies No. 45 grooved moulding. Both ends of the moulding are then drilled to take No. 15 knobs. Holes should be $\frac{1}{4}$ in. diameter. The bottom consists of a piece of $\frac{1}{8}$ in. wood about $2\frac{1}{2}$ in. square, with the corners cut off to allow for the moulding. It can be glued and pinned in place as shown by the dotted lines.

Fill the grain

To finish off, the wood should be well sanded and the grain filled. Give one undercoat and one top coat to the inside, the moulding and the ball feet. The side panels are covered with pieces of wall-paper to match the room decoration or other decorative paper. Finish the knobs in a contrasting colour.

The No. 45 grooved corner moulding costs 1s. 3d. per 3 ft. length (postage and packing 2s. 0d. extra on any quantity) and the No. 15 wood knobs cost 1s. 6d. doz. (post and packing 6d.). These can all be obtained at your nearest Hobbies stockist or branch. (M.H.)

LEARN

RADIO & T/V SERVICING FOR YOUR OWN BUSINESS/HOBBY

● by a new exciting no-maths system, using practical equipment recently introduced to this country. FREE Brochure from:—

RADIOSTRUCTOR

DEPT. G81, READING BERKS.

20/2/63

BRASS, COPPER, DURAL, ALUMINIUM, BRONZE

ROD, BAR, SHEET, TUBE, STRIP, WIRE
3,000 STANDARD STOCK SIZES

No Quantity too small List on application

H. ROLLET & Co. Ltd.

6 CHESHAM PLACE, LONDON, S.W.1

Also at

Liverpool, Manchester, Leeds, Birmingham

DESIGNS IN WIRE AND METAL

An interesting and remunerative hobby can be developed by experimenting with various wires and sheet metals, in particular copper, because of its beautiful colour. The wire can be used in the designing of simple jewellery—necklaces, bracelets, brooches, ear-rings and belts—and, if after much practice, more valuable articles are desired, sterling silver wire may be obtained.

But the materials do not need to be expensive to produce an effective and beautiful piece of work. Even baling wire, the flat strip metal used on packing cases, can be worked up into designs for such articles as trivets, wall plaques, mirror or picture frames, candlestick decorations, and so on.

Sheet metals such as aluminium and copper foil can be obtained for making three dimensional designs and figures, or for flat articles like those which hang upon Christmas trees or in the backs of

wooden mallet. Any scratches which may have appeared can be removed with fine steel wool. A similar coil is then made at the other end of the piece of wire (Fig. 3).

For bracelets or necklaces a number

By Edna Knowles

of these motifs must be made, and care should be taken that they are all exactly the same size. Links may be formed by bending the centre looped portion, as shown in Fig. 3, and small rings of wire may be used to connect them (Fig. 4), or they may be hooked to each other (Fig. 5).

Rings are made by winding a piece of wire round a pencil (Fig. 6), and clipping

them off with the pliers. The ends should not be closed until the link of the coil has been passed through. These coils also form motifs of pleasing shape (Fig. 7).

All kinds of simple motifs may be designed of a more elaborate nature, such as those in Fig. 8. These, of course, may be linked in a variety of ways. Furthermore, wires of different gauges and even of different metals may be employed, as well as differently-sized units.

In order to get more accurate designs, a 'jig', or pattern made of old gramophone needles inserted into a piece of hardboard is often used. The wire can then be wound round this, so that all the curves of the design are identical.

It is amazing the number of different ideas for designs which will occur to you as experience and skill develop, and if lengths of wire are carried around in the

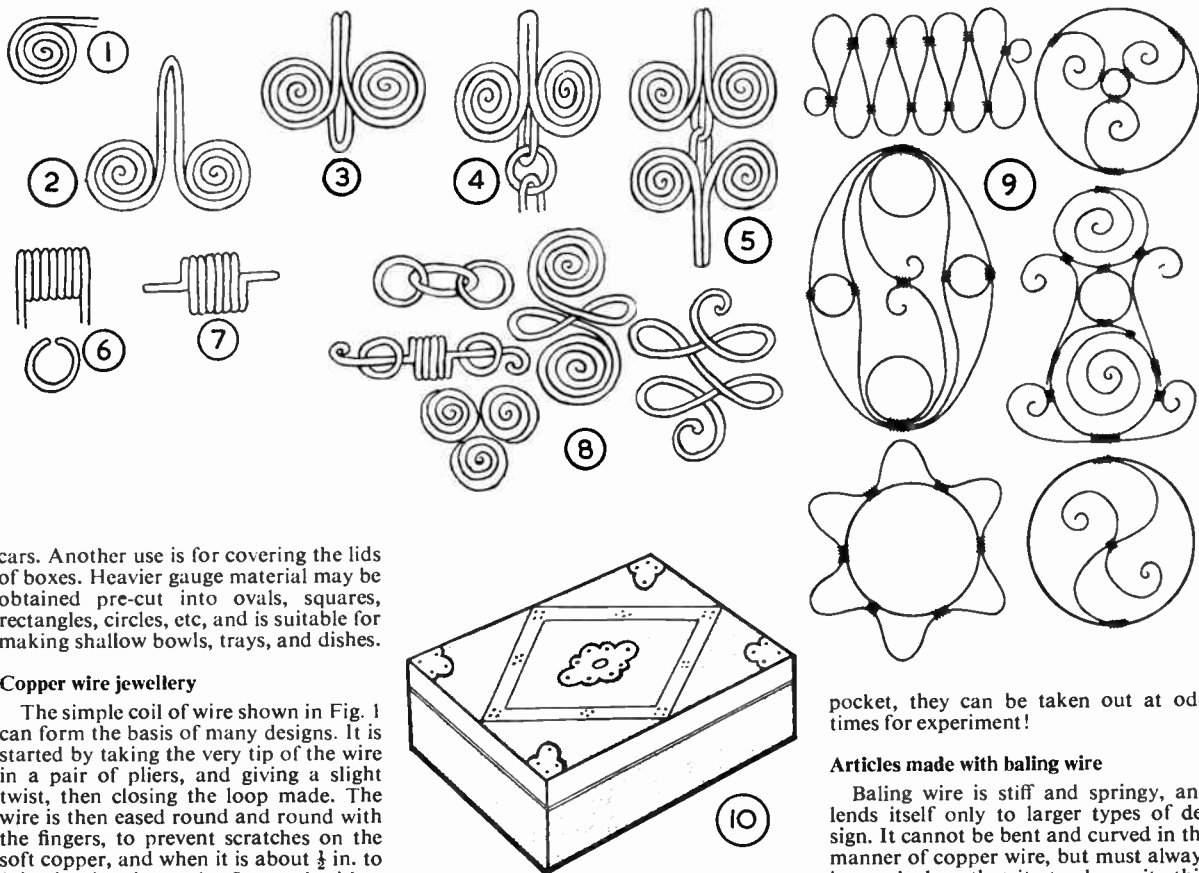

cars. Another use is for covering the lids of boxes. Heavier gauge material may be obtained pre-cut into ovals, squares, rectangles, circles, etc, and is suitable for making shallow bowls, trays, and dishes.

Copper wire jewellery

The simple coil of wire shown in Fig. 1 can form the basis of many designs. It is started by taking the very tip of the wire in a pair of pliers, and giving a slight twist, then closing the loop made. The wire is then eased round and round with the fingers, to prevent scratches on the soft copper, and when it is about $\frac{1}{2}$ in. to 1 in. in size, it can be flattened with a

pocket, they can be taken out at odd times for experiment!

Articles made with baling wire

Baling wire is stiff and springy, and lends itself only to larger types of design. It cannot be bent and curved in the manner of copper wire, but must always be worked so that it stands on its thin

edge. It is joined by stapling, or by a few rounds of copper or other more flexible wire (Fig. 9). It is not easy to get hold of the type of stapler necessary for this material, and it would only be worth while using this method if it were possible to borrow one, or have access to one from time to time. Consequently, joining with copper wire is usually the chosen alternative.

Also shown are some of the designs which can be made with this wire for trivets or wall plaques. Another use of baling wire is in making animal shapes, which can be fixed to wooden stands or suspended on ordinary wire.

Sheet metal designs — covering a picture frame

Aluminium and copper foil can be cut with ordinary scissors, and designs are impressed upon it with a knitting needle or other blunt instrument. To cover a picture frame, it is necessary first to draw a suitable design on paper, and also to cut out a paper pattern in four pieces, allowing for turnings when wrapped round the wood of the frame. Care must be taken with the diagonal corners. When satisfactory, the papers are laid out flat, and the design drawn on them.

The patterns are then placed on the metal foil, marked round with a pencil, and cut out. The design is then traced and transferred to the metal by means of

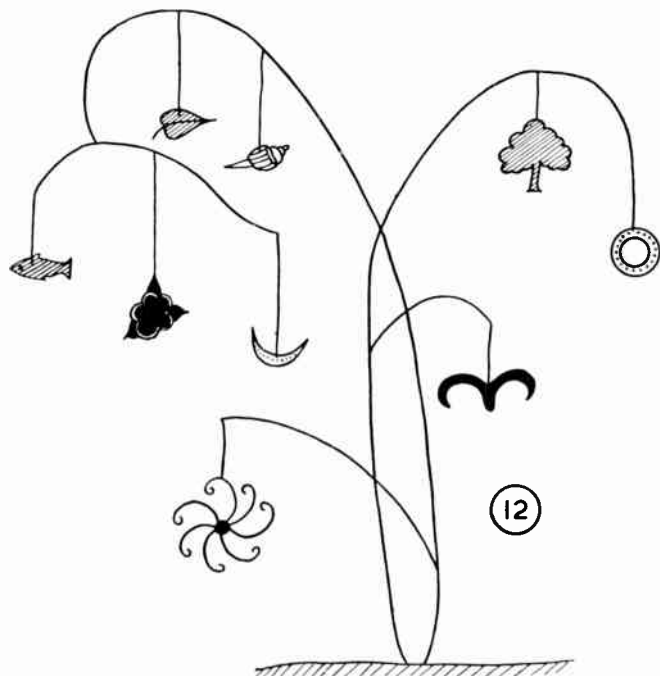
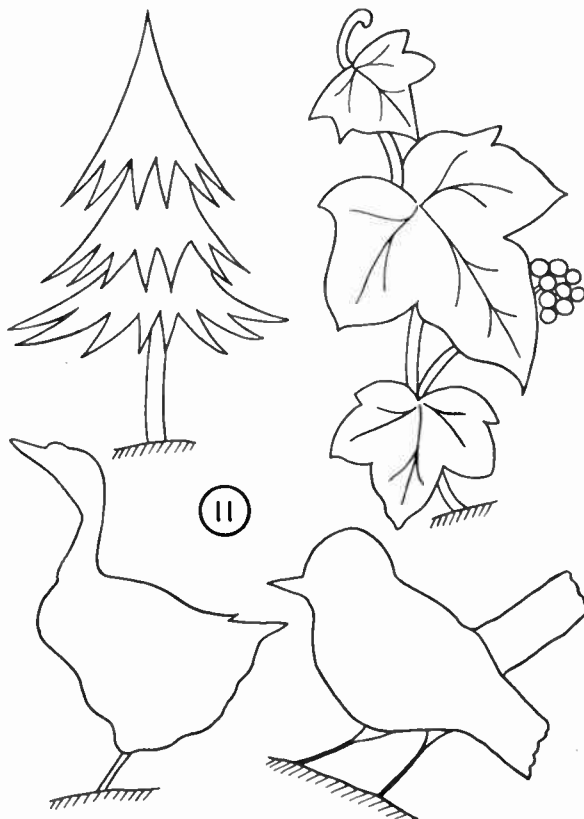

carbon paper, and finally impressed with a knitting needle, so that on the right side it shows up as a ridge. The more pressure used the more pronounced the ridge, of course. When the metal pieces are in position on the frame, they can be secured with the smallest of upholstery tacks.

Aids to making the design itself may be found among many household or workshop objects, such as cutlery, heads of nails, screws, and bolts; and even shells, cones, and fruits may be used, if hard enough, to make interesting indentations. A sharp tap with a hammer will do this, or alternatively, they can be drawn round with a pencil.

Decorating boxes

Covering boxes, or making decorative strips for the lids of boxes, can be done in a similar way by making a paper pattern first, and then tracing the design. Small tacks will secure the metal, and can even be used to make a pattern themselves, as shown in Fig. 10.

● Continued on page 330

THE PACIFIC TANK ENGINE

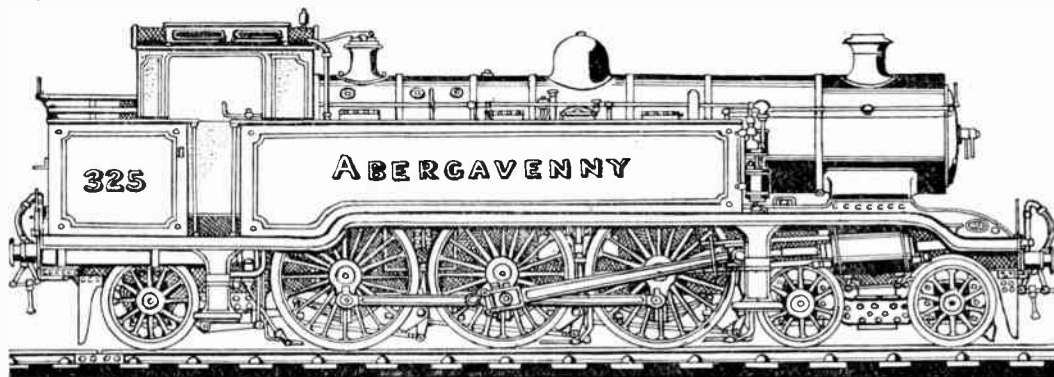

London, Brighton and South Coast Railway. Class J1 12—wheel tank locomotive No. 325 'Abergavenny'

IN the past the 4-6-2 wheel arrangement for passenger tank engines was a very popular design, being adopted by various British railways which included the Caledonian, Great Central and L.&N.W.

The first 4-6-2 or *Pacific* tank engine to run in this country was designed by Douglas Earle Marsh the Locomotive Superintendent for the London, Brighton & South Coast Railway. This was the *Abergavenny* No. 325 which was erected at the company's Brighton works in December 1910. When she appeared she was a most impressive engine, being finely proportioned, with neat and trim outlines.

She was given an extensive trial for some 18 months during which she ran the fastest and heaviest expresses between London, Eastbourne, Brighton and Portsmouth, being at the time painted in grey livery with black striping and white lining.

She was classified 'J1' and carried the following details: cylinders, 21 in. diameter x 26 in. stroke with inclination of 1 in 26; Wheel diameters, bogie 3 ft 6 in., coupled 6 ft. 7½ in. and trailing 4 ft. 0 in.; Wheelbase: 6 ft. 3 in. + 6 ft. 0 in. + 7 ft. 3 in. + 7 ft. 3 in. + 8 ft. 6 in., total 35 ft. 3 in. Total length over buffers 45 ft. 6 in.

An excellent boiler was provided having an outside diameter of 5 ft. 3 in. and length between tubeplates of 15 ft. 0 in. containing 110 tubes of 2½ in. diameter which gave 1,461.69 sq. ft. heating surface. The firebox 8 ft. 0 in. long and 3 ft. 4½ in. wide outside, gave 124.4 sq. ft. making the total heating surface 1,943.09 sq. ft., this including the 21 5½ in. diameter superheater flues which gave 357 sq. ft. Working pressure

was 170 lb. p.s.i. Weight in working order: on bogie 18 tons, on leading coupled axle 17 tons 5 cwt, on driving axle 19 tons 5 cwt, on rear coupled axle 16 tons and on carrying axle 16 tons 10 cwt, total 87 tons. The side tanks and a well tank under the bunker carried 2,232 gallons of water and the bunker held 3½ tons coal.

In February 1912 a second 4-6-2 Tank appeared from Brighton. This was No. 326 *Bessborough* which carried the

same main details as No. 325, but was provided with outside Walschaerts valve gear instead of inside Stephenson gear as on No. 325. She ran on the same duties as her sister, being classified J2, and both engines lively steady riding and free steaming soon became popular with the Brighton enginemen. It can be said that they were in reality an enlarged six coupled version of Mr Marsh's earlier 4-4-2 class I3 superheater tanks of 1908.

● Continued from page 329

ANIMALS AND OTHER MOTIFS

Animals, birds, fish, trees, sprays of leaves, flowers, etc, can be cut out of the sheet metal, and attached to hard-board or 3-ply wood. Mounted on wooden bases, they make very attractive ornaments, but if the metal is copper, it should be coated with colourless nail varnish to prevent tarnishing. Suggestions are shown in Fig. 11.

Mobiles

Cut-outs from single pieces of metal are more suitable for hanging up, for then they will spin round of their own accord in a slight breeze. These are often referred to as 'mobiles' for this reason. They may be abstract shapes, human figures, animals, flowers, leaves, trees, or in fact any type of object. Very ingenious frames are often made on which to hang these objects, such as is

seen in Fig. 12. They are very attractive when hung from the ceiling, but if this is not possible, the frames may be set in a firm base filled with plaster of Paris, which may itself be covered with designed copper foil.

For these displays, contrasting metals give a more interesting result, for some are shiny, some dull; and a worthwhile variation which gives a most unusual effect, is to paint the edges of the motifs with phosphorescent paint, so that they will show up in a dark room. A bottle of luminous paint is available from Hobbes price 2s. 6d. (by post 9d. extra).

All these branches of simple metal work are not only interesting in themselves, but offer scope for real artistic talent, and after a certain amount of practice and experiment many unusual and very acceptable presents can be made for children and adults.

A 'CIGAR TUBE' CANNON

FEW toys give greater pleasure than those which can be used for shooting at targets; consequently, every boy will appreciate the sturdy model cannon described here, which will 'fire' glass marbles for a good distance across the floor, and yet is quite safe to use. The main item needed for its construction is a metal cigar container or something similar.

Prepare the cannon for firing, by hitching two rubber bands to the steel loop and fastening their other ends to the front of the carriage, on each side, by means of drawing pins. Now, if you pull the loop backwards, and release it,

You may find that the gun will be more stable if you screw down a heavy washer on the rear of the gun carriage. Alternatively, you can fix a metal hook to the back of the carriage, by means of which you will be able to hook the cannon

By A. E. Ward

Use the tube to make the barrel and begin by boring a 1/10th of an inch hole in the bottom while the tube is supported upon an upright length of dowel, which is held firmly in a vice. This will ensure that the mouth of the tube remains undamaged.

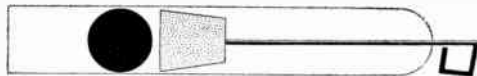

DETAIL - SHOWING INTERIOR OF BARREL

Obtain a piece of a thin steel knitting needle or suitable rod, about 4½ in. long, and push its pointed end deeply into a new cork, which should fit loosely into the barrel. Lower the cork into the tube, while letting the steel rod project through the bottom. Now very carefully, using pliers, bend round the end of the rod to make a strong loop to which rubber bands can be hitched.

Make the gun carriage from a scrap of ½ in. thick wood, measuring 1½ in. by 3½ in. Use a saw to gently taper the rear two inches of the carriage and round off the end with glasspaper.

The gun mounting is formed from a 2½ in. long strip of 1 in. wide sheet metal. Bend the middle of the strip around the cigar tube barrel and make use of a vice to bend out the ends of the strip, on either side, to make 'tabs' which can be tacked to the gun carriage. Bore two small holes in each 'tab', through which tin tacks can be driven. Straddle the gun mounting over the barrel and fix the mounting neatly to the gun carriage with tacks, so that the barrel is held firmly in position.

Saw the two ends off a large wooden bobbin to provide wheels for the gun carriage. The wheels should be at least 1½ in. in diameter. Drill a small hole on each side of the carriage, near the front, before securing the wheels to the carriage with screws.

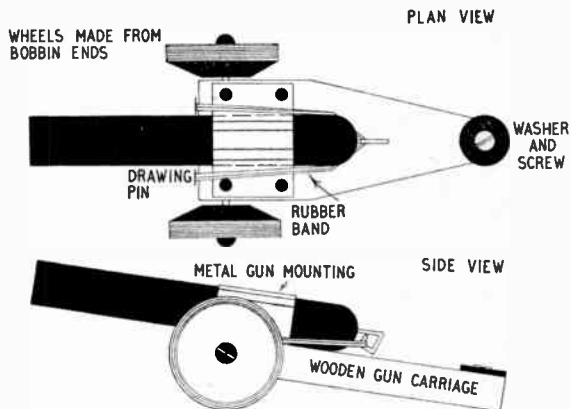

the 'firing pin' will be snapped forward by the tension of the rubber bands.

Fire your cannon by placing a marble inside the barrel and shooting the miniature cannon ball across the floor.

onto the back of a model lorry.

The little toy, attractively painted, will be strong enough to withstand much rough usage.

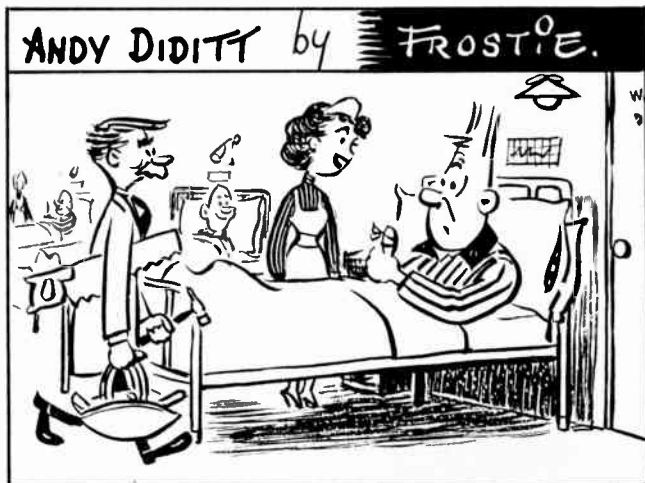

"NO! THAT'S NOT THE DOCTOR - IT'S THE CARPENTER, HE'S DOING A FLOOR REPAIR IN THE NEXT WARD."

USEFUL KITCHEN FITMENT

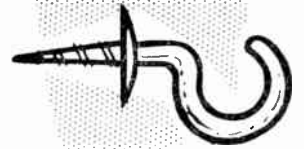

FIX CUPHO
A FOR HO
SCISSORS/
ETC

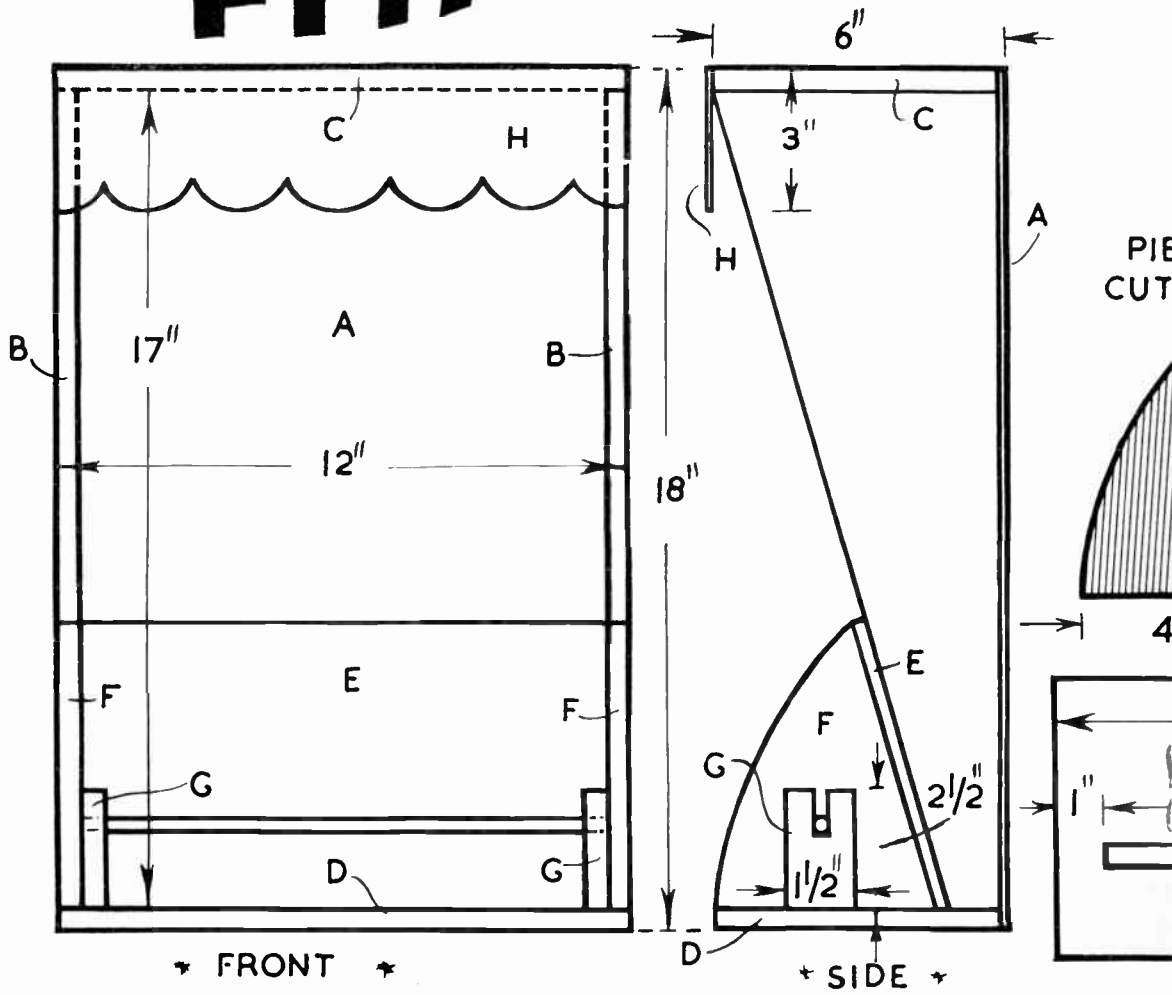

LOOKS INTO
LOADING
OPENERS

HARDBOARD
OR STOUT CARD

PIECES F
TWO 1/2"

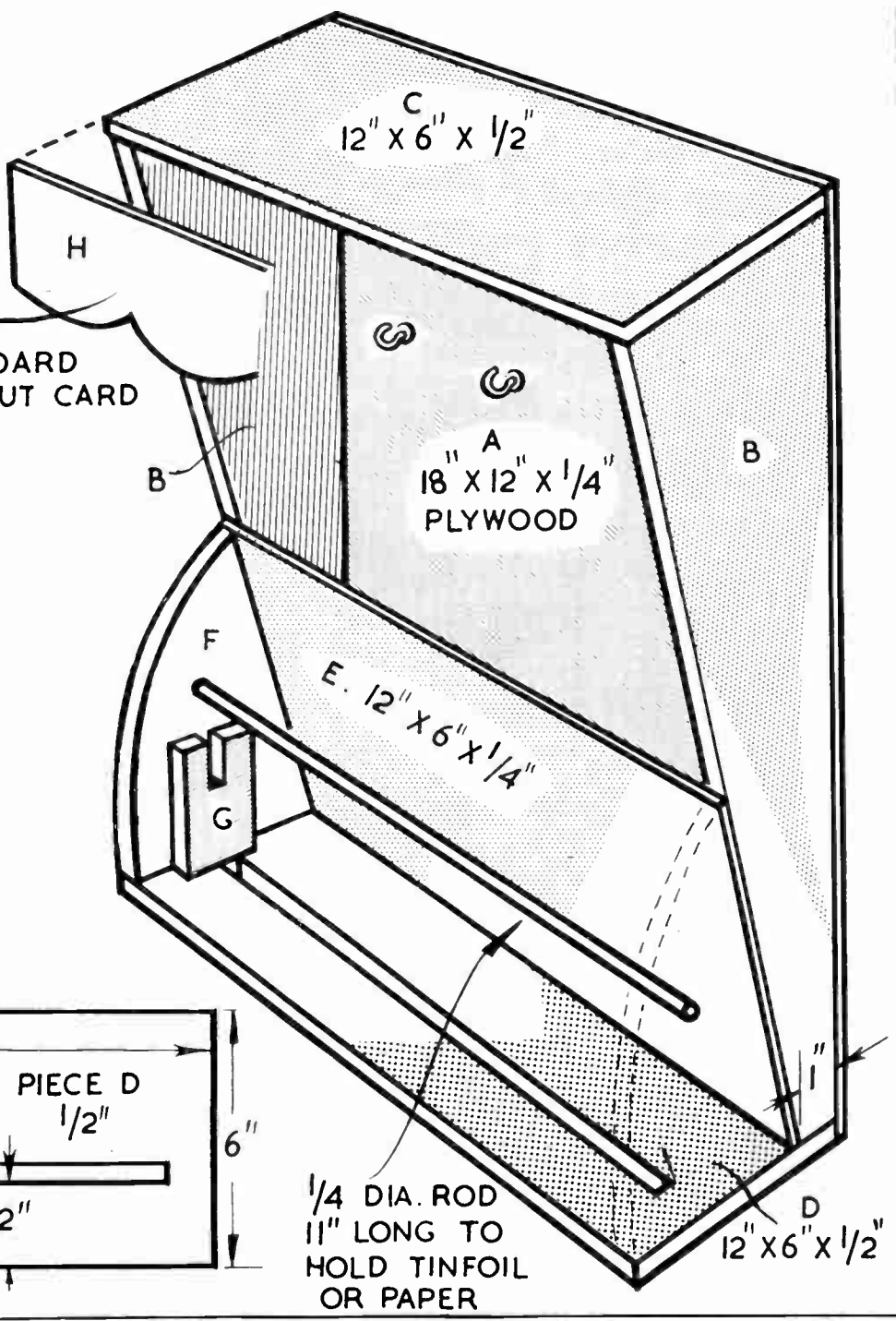
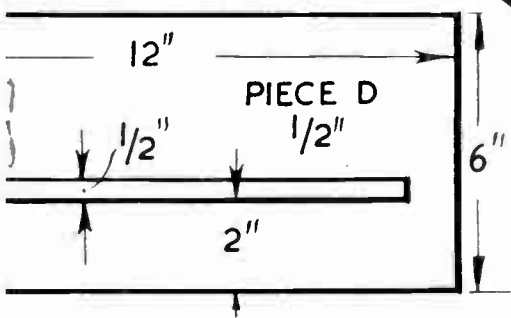
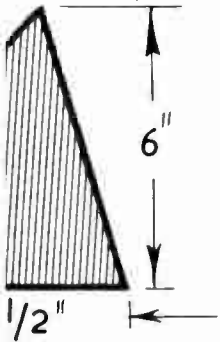

1/4 DIA. ROD
11" LONG TO
HOLD TINFOIL
OR PAPER

With a camera

Novelty Indoor 'Shooting'

By A. E. Bensusan

TABLE-TOP photography is a branch of the hobby you can enjoy all the year round! There is no worrying whether the sun will shine or the subject will be just as you want it, for you provide your own sun in the form of an ordinary electric bulb and you make the subject up to suit yourself.

Over the years, the name 'table top photography' has come to mean the taking of pictures in miniature; little scenes which you can arrange on a



Fig. 1—A big-game hunting scene in miniature

table or other quite small flat surface, but which leave the viewer of the photograph guessing as to the size of the

original subject. Was it a true-life picture or a model?

To make the most of this kind of photography you need to get fairly close to the subject. So, as the majority of cameras do not focus closer than three feet, the use of a supplementary close-up lens is desirable. An article on these lenses appeared in *Hobbies Weekly* dated 6th June 1962, and will give you all the technical information you require.

The size and scale of your miniature scene will depend on how close you are able to get with the camera. There is little point in arranging the subject in a tiny area if you cannot get near enough for it to fill, or almost fill, the negative. Similarly, if your supplementary close-up lens limits your backward movement, the scene must not be so large that you cannot get it all into the negative.

For the maximum clarity of detail, the subject should be arranged so that it almost fills the negative, with just the absolute minimum of space around the edges purely as a safety precaution. It is vital to remember that most table-top pictures depend a great deal on fine detail for their successful impact on the viewer, and every effort should be made to preserve it.

Since camera shake is also a prime cause of loss of definition, positive steps should be taken to eliminate it. Use a really rigid stand or tripod for the camera—you will need to give a short time exposure anyway, so some support is necessary—and trip the shutter with a flexible cable release. Guard against over-exposure and over-



Fig. 2—An abstract table-top of a press photographer covering world news

development of the film, too, for both have the effect of breaking up the detailed parts of the picture. Err on the conservative side when exposing and processing the film, rather than finish up with a grainy, poor quality result.

Lighting for table-tops presents no problems at all. The high-powered 'photoflood' lamps used for indoor portraiture are much too bright for placing near to small subjects, and ordinary domestic bulbs are more suitable. Wattages from 60 to 150 will come in useful, all in the 'pearl' category.

You do not even need a reflector for any of this artificial lighting, as that would also tend to give too concentrated a light and 'burn out' the more delicate tones of the photographs. Table lamps and standard lamps are ideal for 'table-tops', provided that the shades are temporarily removed.

Fig. 1 shows a typical subject to all intents it is a big-game hunting scene in the scrub-land of a tropical country but, in reality, it is just a carefully built miniature laid out on a metal tea-tray. The 'hunter' is actually a plastic toy cowboy, with the rifle already at his shoulder, bought for a few coppers. The hat was trimmed down from a broad stetson to a jungle hat, while the

bush jacket and trousers were made from scraps of brown paper glued in place.

The rhinoceros is also a plastic toy, and these two 'characters' are the only bought items. The ground was simulated by spreading sand out quite thinly on the tray base, while stones and gravel were used for the rocks. Tiny pieces of gorse and a few twigs represent the vegetation.

The background, which was placed so that it was just outside the depth of field of the camera lens, was made by cutting out a hilly profile from brown paper and shading it with pencil. This was glued to a sheet of white card and propped up at the rear. Sand was trickled along the bottom of this background to break up the sharp, straight line.

The sole illumination came from a 150 watt bulb suspended overhead to represent a high tropical sun. On medium speed film, the exposure was 1 second at an aperture of f11. The numerous models available give plenty of choice for a scene of your own setting.

The devising of suitable abstract subjects is also an interesting project. These are not meant to be realistic and capable of being mistaken for genuine life-size scenes, but rather as a means of

conveying an idea. An example of this form of 'table-top' photography is given in Fig. 2. The theme is the ability of the press photographer to cover happenings all over the surface of the world and shortly perhaps, even into space itself.

The part of the globe shown in the picture was cut out from stout card and the land-masses filled in with black ink. The plastic toy figure has a wire core which enables it to be set in any position, and was stood on a pile of books just behind the section of the globe.

The dummy press camera, which was the most intricate item to make, was built up from cardboard, fine wire and matchsticks and balanced on the figure's hands. The black background, again placed so as to be just out of focus, had a grey paper triangle stuck to its centre. The roughly cut grey stars were glued to the black part of the background.

In this case the lighting was provided by a 60 watt bulb and the exposure was 4 seconds at a lens opening of f16. A medium speed film was used.

Try your hand at 'table-tops'. They can give plenty of variety to any keen photographer who feels inclined to attempt a change of subject but is at a loss to know which one to choose.

3-ply Sculpture for Fretworkers

SOME very interesting and effective figures can be built up from layers of 3-ply wood or hardboard. The method described here will prove to be much more suitable for those who do

By A. R. Watts

not wish to carve from a solid block of wood. It is also much simpler, particularly for those who are proficient with a fretsaw.

The first step is to produce a drawing of

the figure from which to work. Animal shapes or imaginative figures will be the best. An example of such a shape is shown in Fig. 1. This is the pattern for the first piece of wood to be cut. The next piece will be somewhat similar in shape but slightly smaller all round. Both this and the remaining shapes will have to be produced in duplicate as one will be required for each side of the first piece. Further shapes, decreasing in size, are now produced as shown in Fig. 2. Note that the figure will stand on a flat base when completed.

After being smoothed down with glasspaper these various shapes are now glued each side of the central piece. If using hardboard ensure that the shiny surface is on the outside.

With a file and glasspaper the square edges of each shape are now rounded so that the final figure will have more the appearance of a single rather than a composite piece of wood.

Finally an eye could be bored right through the head or painted on the sides. Also the model could be polished, or painted and then varnished.

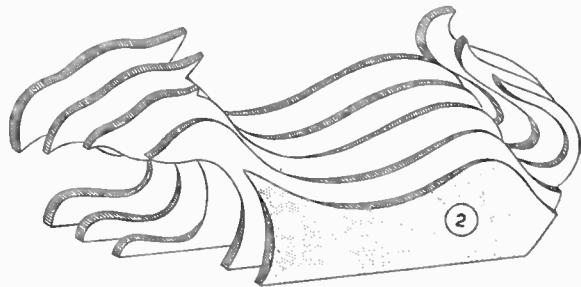
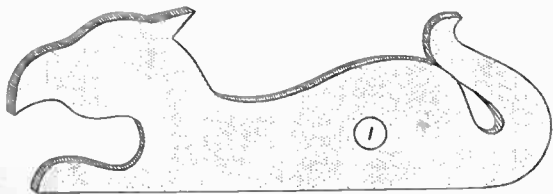

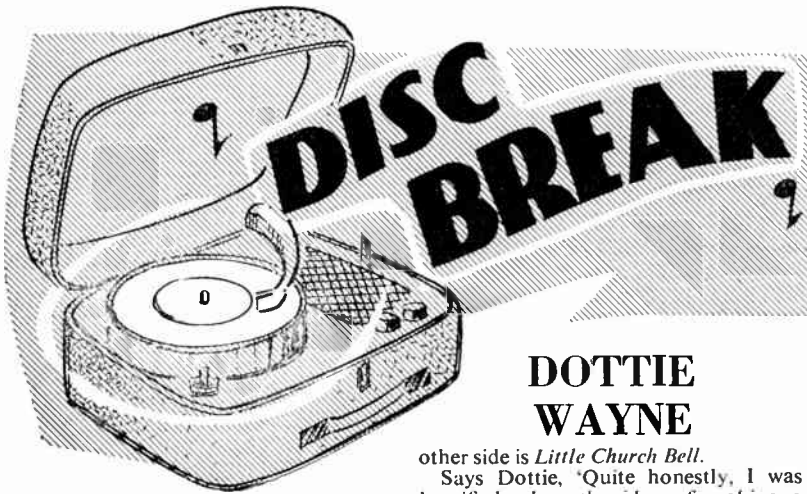

DOTTIE WAYNE

other side is *Little Church Bell*.

Says Dottie, 'Quite honestly, I was horrified when the idea of making a record in this style was first mentioned. I'm a Methodist and a regular church-goer and I thought this was going a bit too far. But my manager, Mr. Eric Easton, persuaded me to rehearse the song while he played piano. When I tried it out, I realized that it wasn't at all as I'd expected — in fact it was rather attractive.

DOTTIE Wayne's first disc was the Country and Western styling of *Silent Night* on HMV 45-POP1093. Dottie, a dizzy blonde comedienne in her stage act, stepped out of character and sang the carol absolutely straight, to a 'wagon-wheels' accompaniment of piano and rhythm, with a whistled chorus adding contrast. On the



'I don't think the treatment will offend anybody's ideas. Even though the carol is presented rather differently from the accepted fashion, the essential sincerity and simplicity have been retained.'

Dottie, aged 25, comes from Harrogate and at school had no plans for a showbusiness career, although with three other girls she formed a group which sang 'little French songs'. They had considerable local success and were included in a Top Town programme. But when she left school Dottie worked for three years in a bank. Then came an invitation to appear in a summer show at Filey.

'This put the cat right among the pigeons. I asked everybody for advice. Fifty per cent said "Yes" and the other half said "No". My mother wouldn't advise me at all, but said I could always go home if things didn't work out. So, as I didn't want to grow old remembering that I'd turned down a chance to go on to the stage, I decided to give it a try.'

After Filey, Dottie went to London and to make ends meet worked in the accounts department of a Kensington store. In her spare time she polished her act and was soon entertaining regularly in and around London.

Since then she has developed into one of the country's brightest female comedy acts, starring in the Crazy Gang's show *Young at Heart*, the 50th anniversary season of the *Fol-De-Rols* at Scarborough, two cabaret engagements at London's Savoy Hotel, Sunday concerts at Blackpool and a variety tour with Frankie Vaughan.

On television: she scored a big success on David Nixon's *Show Time* series and has also appeared on *The Kenneth McKellar Show*, *Face The Mike* and *Tonight*.

FROM accountant's clerk to one of Britain's most successful comedians—that's Terry Scott.

Born in Watford thirty five years ago, his first introduction to show business came during the war whilst he was in the Navy. In 1946 he went into repertory

and in 1949 after a successful BBC audition was given a year's contract. During this time he did just over 40 shows but at the end of the year, realising that he still had a lot to learn about the business, went back to the stage, doing variety, concerts, pantomimes, and radio work.

After five years of this 'all-round' variety, he made a spectacular entry into television with his little boy character. BBC television gave him a long-term

TERRY SCOTT

contract during which time he did three series of the 'Great Scott—it's Maynard' series and one series of 'Scott Free'.

Terry then made a successful entry into films with his amusing characterisation of a policeman in 'Blue Murder at St. Trinians' and followed that up with 'Carry on Sergeant', 'Too Many Crooks', 'Bridal Path', and 'I'm Alright Jack'.

Then came another successful television series—'Hugh And I'—in which he co-starred with Hugh Lloyd, during which time he was also appearing at the Whitehall Theatre.

Married, with three daughters, Terry lives in a remote cottage in Surrey.

Terry recorded 'Don't Light The Fire 'Till After Santas Gone' backed by 'My Brother' on Parlophone 45-R4967.



OVER 14? UNDER 17?

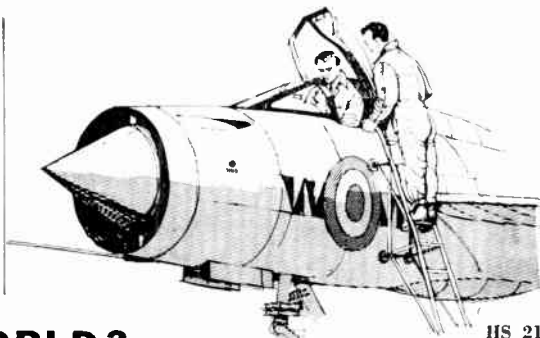

HS 21

WANT TO GET ON IN THE WORLD ?

Plan *now* a career that can take you all over the world. Train in a trade that will get you an interesting, well-paid job wherever you go.

What an apprenticeship in the R.A.F. can mean to you.

In three years as an R.A.F. apprentice you can gain valuable qualifications that would take you five years in industry: they are accepted for the award of the O.N.C. in Mechanical or Electrical Engineering as well as many other diplomas and certificates. They are also recognised by many Trade Unions.

As an R.A.F. apprentice you will live well, with unlimited opportunities for sport and over 6 weeks paid holiday a year. You will earn good money during your training—it goes up to £6.18.3 a week *all found*. You will have good chances of bettering your education by taking G.C.E. subjects during your course.

Your Prospects As an ex-apprentice you will have good prospects of senior N.C.O. rank and of being commissioned. Many officers started their career as apprentices—and some of them have reached Air Commodore rank or even higher.

2 Free Books Post the coupon *now* for two fully illustrated books giving details of the trades you can learn and the life you can lead in the R.A.F.

To: R.A.F. Careers Information Centre (G021), Victory House, Kingsway, London, W.C.2. Please send me, without obligation, the books: 'Highway For Youth', and 'A Fine Start In Life'. (Enquiries from residents in U.K. only.)



NAME

ADDRESS

DATE OF BIRTH

The Royal Air Force

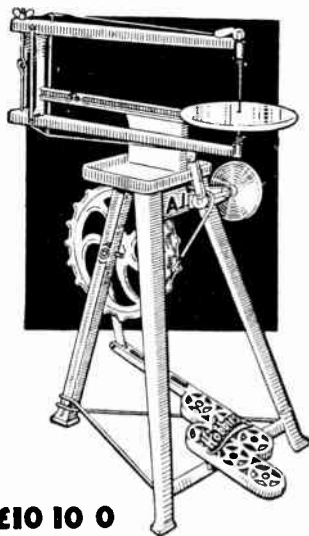

£10 10 0

'A.1' TREADLE SAW
A sturdy machine with cast metal legs, metal table, wooden arms, special saw tension action etc. Easy to treadle, smooth running and rigid. Provides a factory at home for the handyman — a machine for profit and pleasure.

THE 'MARVEL' BENCH MOTOR-DRIVEN SAW

To meet modern needs. Just plug in and switch on from any house lighting point. For either A.C. or D.C. mains, with 230/250 volt motor, flex, switch, etc.

£13 10 0

Also a Bench Machine without motor for 97/6.

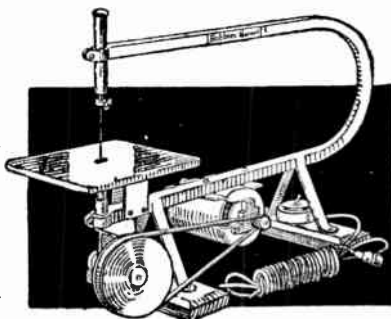

FAMOUS MACHINES AVAILABLE ON EASY PAYMENTS

A system is now in operation whereby a machine may be despatched carriage paid after the initial down payment, and subject to the completion of a simple form of Agreement. The slight additional cost over cash price is to cover extra clerical work, books, interest charges, etc. *It is impossible for us to allow this system to apply in any part of Ireland, or anywhere outside Great Britain.*

Agreement Forms are obtainable at any Hobbies Branch, where machines may be seen, and money paid each month. Or, you can do the business through Hobbies Head Office at Dereham, Norfolk, sending your instalments there.

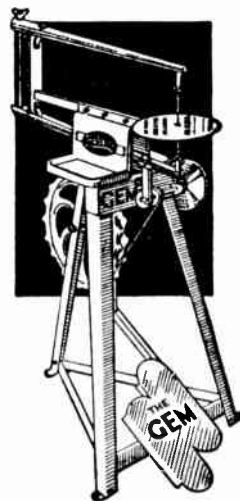

THE 'GEM'

£6 12 6

A lighter machine with pressed metal legs, but easy running and a reliable worker. Sound value and a machine for all kinds of work. Spare blades, instructions, and designs are included with each.

Hobbies Ltd (Dept. 99) DEREHAM NORFOLK

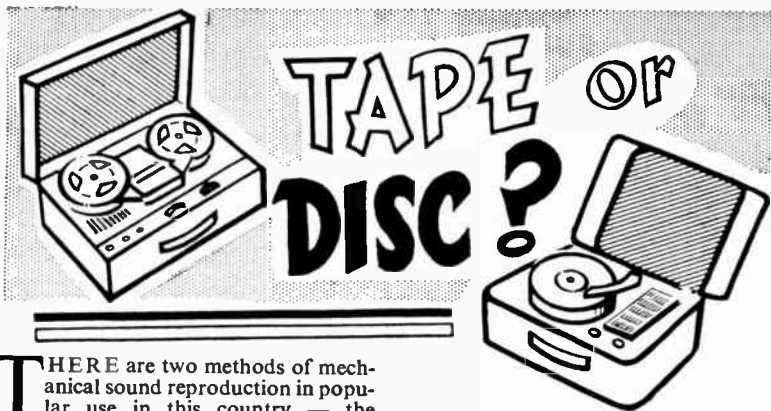

THERE are two methods of mechanical sound reproduction in popular use in this country — the gramophone (record player) and the tape recorder. The latter is, of course, the only popular method of sound recording in this country. Although disc cutting is now catching on in the United States at a domestic level, it has yet to do so in this country. However, presuming that there is no wish to record anything, but only to listen to music already recorded, then which is the better way, disc or tape?

By G. E. Gompers

During the past quarter of a century the gramophone has advanced by leaps and bounds. Before the war the electrical record player was used, almost exclusively, only in cinemas and theatres. Now it has completely replaced the old clockwork gramophone in the home, with the addition of the rather obvious but mysteriously delayed improvement of long playing discs.

The sapphire needle also permits a much finer grain, thus reducing surface noise. A light stylus makes it harder to break discs that are now supposedly 'unbreakable'. How now, considering all this, does the new style record player (it is no longer fashionable to call it a 'gramophone') compare with the tape recorder?

Firstly, it is essential to repudiate one very grave misconception about the tape recorder. Some people, always distrustful of anything new, (especially in the mechanical line), have advanced in all seriousness the astonishing theory that as magnetic tape is used it stretches, and must inevitably reproduce distorted sound! If this absurd view were true then tape recorders would not play such an important part in the development of electronics and automation.

Economically the tape recorder has a definite advantage over the disc machine. A 5½ in. spool of recording tape costs

28s. 0d., and has a full recording time of 1½ hrs. A 33½ r.p.m. L.P. disc cost around £2., and has, on the average, a recording time of 50 mins.

Of course the price quoted here for tape is only for unrecorded, but when we consider how easy it is to record from the wireless there is little likelihood of there being any great demand for pre-recorded tape. But even pre-recorded tape still has this economic advantage when considered in the light of playing time.

Although I have been assured by people who possess neither type of instrument that a tape recorder would have a much higher maintenance cost than an electrical record player, I have not found it so. The most persistently recurrent item of expense from all my hi-fi equipment is the replacement of damaged stylus heads for my record player.

It is true that generally speaking record players have better speakers than tape recorders. Manufacturers might

protest at this statement, but it is true. Of course, there are many tape recorders with superb speakers — for those people who can pay for this type of equipment. However, the inferiority of the speaker does not really count against the tape recorder, because by use of the cable a wireless speaker can be used.

One obvious advantage the record player has over the tape machine is that it is much easier to put a record on than to lace up a tape; and there is not the danger of being entangled. However, if you only want an excerpt from a recording, it is very much easier to find on tape with the aid of the fast wind and number index.

Another and far more important advantage that disc has over tape is that the bulk of the ready-made recordings are on disc, especially in the field of serious music. Although splendid recordings can be made from the radio on to tape, perfection is not so easily attained.

Even though a number of tape enthusiasts detest the idea of pre-recorded tape, because they say it saps the spirit of enterprise and experiment from the recording aspect, it is not at all unlikely that these might become more popular as the popularity of tape recorders rapidly expands well beyond the use by purely recording addicts.

Unquestionably, if I were to view this matter completely in the light of a music lover I would inevitably prefer disc as the simplest method to listen to recorded sound. But since my activities embrace not only discography but also research into the many aspects of magnetic recording I am apt to view both the tape recorder and the record player not just as individual machines, but as integral and vital units in the whole vast and complex framework of hi-fidelity.

Miscellaneous Advertisements

PENFRIENDS home and abroad, all ages. S.A.E. for details. European Friendship Society, Olney, Bucks.

UNDER 21? Penfriends anywhere — details free. Teenage Club, Falcon House, Burnley.

WOULD YOU ENJOY painting flower pictures, etc.? Then read 'PROFITABLE ART' (free). Wonderful opportunities for beginners and others. POPULAR ART (HW). Clun, Salop.

LEARN RADIO & ELECTRONICS the NEW Practical Way! Very latest system of experimenting with and building radio apparatus — 'as you learn'. FREE Brochure from: Dept. H.W.10, Radiostructor, Reading.

100 DIFFERENT stamps free! Request 1d. upwards discount approvals. — Bush 53 Newlyn Way, Parkstone, Dorset.

FRIENDS' WORLD, Postbox 708, Calcutta, India, offers pen friends everywhere.

ENJOY WRITING? Then write for Profit. Send for 'Writers' Handbook' (free) detailing countless opportunities for beginner or experienced. — Writers' Ring (HW), 5 Edmund Street, Birmingham.

BUYING OR SELLING?
Classified advertisements on this page are accepted at a cost of 6d. per word prepaid. Use of a Box No. is 1/- extra. Send P.O. with advertisement to *Hobbies Weekly*, Advert. Dept., Dereham, Norfolk. Rates for display advertising on application.

A ROCKING COUNTING FRAME

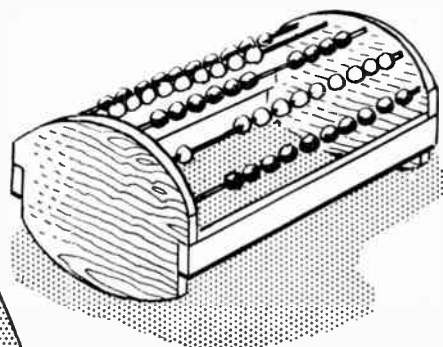

INSTRUCTIVE TOY

CUT two of piece A from $\frac{3}{8}$ in. wood and two of B from $\frac{1}{4}$ in. Pin pieces B to A as shown in the diagram.

The beads are painted and slipped onto lengths of wire which are then inserted into the ends A. The No. 81 beads can be purchased from Hobbies Ltd, Dereham, Norfolk., Price 1s. 0d. doz. postage 6d. in any quantity. They can also be obtained from branches or stockists.

(M.p.)

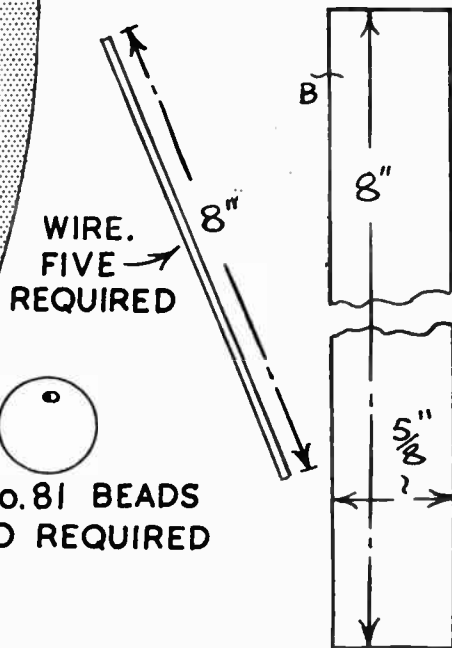
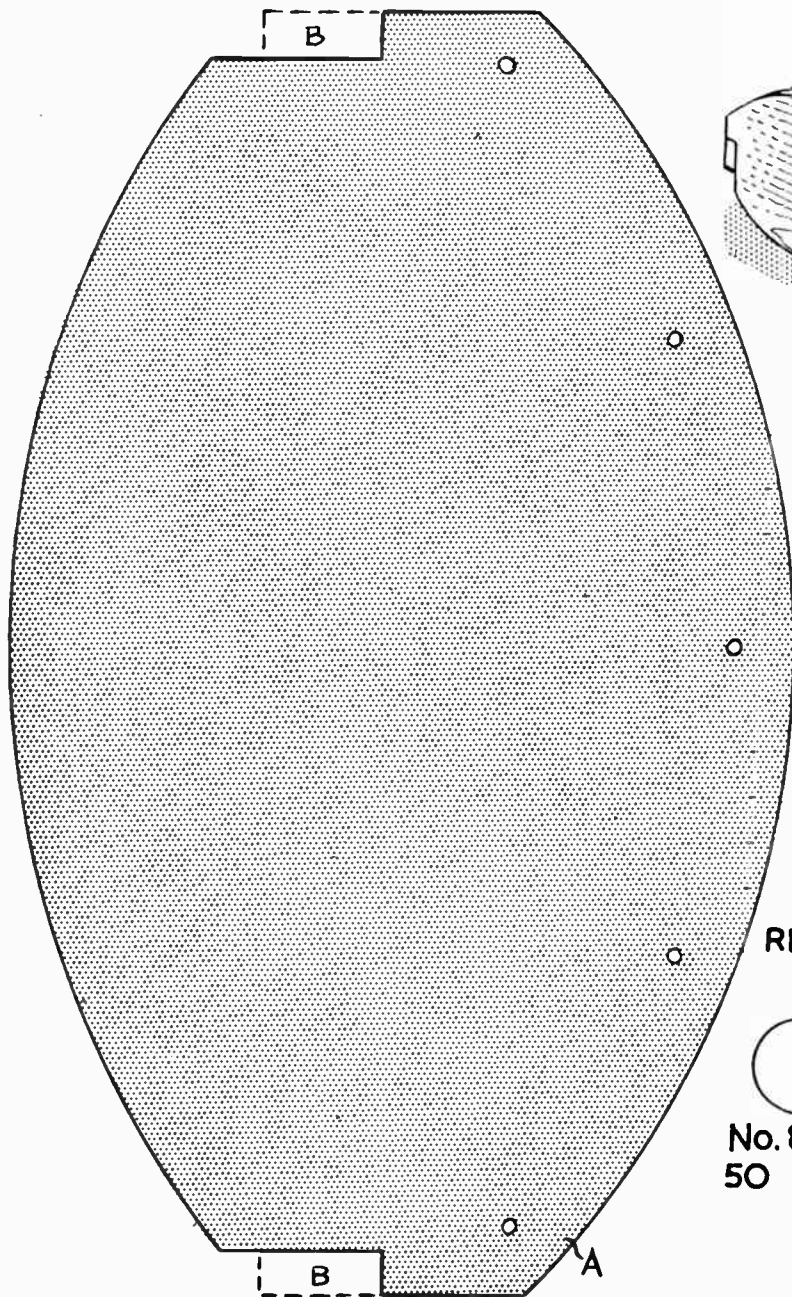

No. 81 BEADS
50 REQUIRED



THE WORK THAT PAYS FOR ITSELF PRACTICAL HANDYWORK FOR ALL

Complete in five volumes. Handsomely bound, with Gold Lettering and coloured tops. 3,000 Photographs and Diagrams. 76 Folding, colour and other plates.

Edited by S. G. Blaxland Stubbs, O.B.E., and J. St. Denys Reed, written by some of the finest craftsmen of the present day, this work is not just essential to the keen handyman but to every householder. Simply explained and clearly illustrated, it contains all the information you need to undertake EVERY odd job that crops up about the house, and actually to make furniture and fittings. **IT WILL SAVE ITS COST MANY TIMES OVER.** Examine it in your home **FOR A WEEK FREE.**

FREE EXAMINATION COUPON

To: EVERYBODY'S PUBLICATIONS LTD., 34/35 FARRINGDON STREET, E.C.4

Please send me, carriage paid, for 7 days' FREE Examination, **PRACTICAL HANDYWORK FOR ALL** complete in five volumes. I will either return the books in 8 days or send 17/6 deposit 8 days after delivery and eight monthly payments of 15/-, paying £6. 17s. 6d. Cash price within 8 days £6. 10s.

Mr., Mrs., Miss.....

Address.....

Occupation

Your Signature

(or of Parent if you are under 21)

Nearest Railway Station..... H.WKY.1

Tick (✓) where applicable

HouseOWNER	<input type="checkbox"/>
House/Flat Tenant	<input type="checkbox"/>
Living with Parents	<input type="checkbox"/>
Furnished Apts.	<input type="checkbox"/>

27th FEBRUARY 1963

VOL. 135

NUMBER 3507

THE ORIGINAL
'DO-IT-YOURSELF'
MAGAZINE

HOBBIES *weekly*

FOR ALL
HOME CRAFTSMEN

Also in this issue:

PATTERNS FOR
A TOY CRANE

COLLECTORS' CLUB:
NEW STAMPS

DISC BREAK:
CRAIG DOUGLAS

NOVELTY GAME

MONOCHROME PRINTS
FROM COLOUR

CHEMISTRY AT
HOME FEATURE

TEAPOT STAND
IN BRASS

ETC. ETC

*For those "Collectors Pieces" * **



DISPLAY CASES



Up-to-the-minute ideas

Practical designs

Pleasing and profitable things to make

5^D



CRAIG DOUGLAS

CRAIG DOUGLAS, who recently hit the charts with *Oh, Lonesome Me*, is 21 years old, 6 ft. tall, has blue eyes, and brown hair. Born in Newport, Isle of Wight, on 13th August 1941, he is one of three set softwains.



On leaving school he worked near his home on a farm, driving tractors and doing a milk round. Craig's mother soon recognized his singing talents, and persuaded him to enter a local talent contest, which he won.

He was spotted by agent Bunny Lewis, who brought him to London, and eventually to Decca, where he made his first disc *Sitting in a tree house*, in November 1958.

Since that time Craig has enjoyed great success, appearing on numerous TV and radio shows, and recently co-starring in the film *'It's Trad Dad'*, in which he played a singing-acting role.

As an entertainer he is frequently appearing at deb dances and social functions — at one of these he entertained, and was later introduced to Princess Alexandra. In a pantomime at Westcliff-on-Sea he played the part of Prince Charming.

BORN at Hudson Falls, New York, on 22nd September 1937, Annita Ray was educated at the Fairfax High School, Los Angeles and Hollywood Professional School.

Her first professional appearance as a singer was at the age of 15, when she did a three months engagement at Fan and Bill's Supper Club, Lake George, New York. After that came engagements in San Jose, Fresno, Bakersfield, Phoenix, Long Beach, Pasadena, Santa Barbara, Seattle, and Los Angeles.

In 1958, Annita joined Mickey Katz in Las Vegas for eight weeks, followed by a two month stint with Frank

ANNITA RAY

Ortega at Royal Nevada. A year later — this time with her own quartet — Annita played at the Riverside Hotel, then went on to the Wagon Wheel, Lake Tahoe for a sixteen week season.

February, 1960, marked the beginning of a two year period as vocalist with Ray Anthony, and during her time with his orchestra, Annita appeared at many of the country's leading nightspots.

Annita, who enjoys reading books, water skiing, chess, and fashion design,



ing, has three ambitions: to tour the world, become an actress — and have a hit record.

Wouldn't It Be Lovely, backed by *I'm In Love With Jim* was released in this country on 45-MGM 1177.

'THE MUDLARKS'



THE two brother-one sister vocal and instrumental group, The Mudlarks (real name is Mudd), consist of Freddy (28), Jeff (26) and Mary (23). They were born in Luton, Beds., worked for a while at the local Vauxhall Motors factory, and formed the Mudlarks in 1957.

While singing at a Luton charity concert they were spotted by disc-jockey David Jacobs and were later signed to a management contract by Bunny Lewis. Among their hit records on Decca are *Lollipop* and *Book of Love*. All three Mudlarks are married.

COLLECTORS' SHOW CASES

COLLECTORS will welcome these display cases which are designed to show off sizeable collections to advantage. The type of thing envisaged would be hand painted china, miniature cars or aeroplanes, old brasses, doll's of all nations in national costume and old coins. The coins could be mounted on a backboard, with a strut at the back. They should slope at an angle of about 45 degrees.

Three different designs are shown, giving enough variety to suit almost any collection. The construction has been simplified in all cases and should present no difficulties to the average handyman.

The design in Fig. 1 is especially for 'dolls of all nations' which is a popular collecting pastime particularly of young children. This display case is attractive and easy to make and can be stood on a sideboard or hung on a wall, using wall hangers.

No dimensions are given since these must suit the particular collection envisaged. Suitably arranged, the dolls could form a cavalcade of nations and create much interest.

Before commencing work you should enquire as to the size of glass which can be obtained locally and adapt the case accordingly. By inserting a central pillar made from a piece of stripwood grooved on each side, two pieces of glass can be used to gain extra length.

The corners are of Hobbies grooved

moulding which can be obtained in 3 ft. lengths from Dereham, Norfolk or from any branch or stockist.

No. 45, with $\frac{3}{8}$ in. groove, costs 1s. 3d. a length and No. 46, with $\frac{1}{2}$ in. groove, 1s. 6d. Postage and packing is 2s. 0d. extra on any quantity.

It will be seen from the diagram that the back, ends and glass will slip into the

ALL ILLUSTRATIONS ON OPPOSITE PAGE

grooves. A thin strip of packing should be inserted behind the glass to keep it tight.

Two pieces of stripwood across the back and front, at the top, will brace the sides together. Pin these down into the corners after the back, ends and glass have been fixed in their grooves. Hinge the lid between these two lengths of strip as indicated. The back, ends, bottom and lid could be of plywood.

To finish off, the background could be painted to give a scenic effect in keep-

ing with the particular dolls displayed. Suitable scenes can be seen in travel brochures.

The cabinet shown in Fig. 2 is made from $\frac{1}{2}$ in. wood in the form of a plain box with a back of plywood or hardboard. Set in the shelves sufficiently to allow for the cabinet doors. Suggested dimensions are shown but these can be altered to suit individual requirements.

Construction of the doors is shown in Fig. 3. The framing is of $1\frac{1}{2}$ in. by 1 in. wood halved together at the corners. The hinges are recessed and the glass is held in place by $\frac{1}{4}$ in. quarter round beading pinned in place. The legs are Hobbies No. 601 plain ferruled beech legs 9 in. high. They cost 9s. per set of four (postage 2s. 0d.) from Hobbies Ltd, Dereham, Norfolk. Fitting is easy by screwing into metal blocks.

The remaining design, shown in Fig. 4, is also suitable for scenic effects. The top, sides and bottom are of $\frac{1}{2}$ in. wood and the curved back of $\frac{3}{4}$ in. hardboard. Make up the glazed front as described for the large cabinet and hinge to the top as shown.

All the designs described would probably best be finished by painting. Fill the grain of the wood, apply an undercoat and then a finishing coat or coats of gloss enamel. The interior and shelves could be lined with flock paper or any of the plastic coverings available.

(M.h.)

Tape Recording from a Disc

IN all my articles for this journal I have always written on the assumption that my readers are people of limited means. Not that I object to rich people reading my work, but I recognize the fact that many problems are solved simply by digging deeper into one's pocket.

The problem of taping from disc, for example, can be made much simpler by getting the record player fitted with points, and recording from it in the same manner as one would from the wireless.

Although suspending the microphone in front of the player might seem amateurish, I myself have made many good tapes in this way. Choose a room that is preferably at the back of the house in order to eliminate traffic sounds; and then tell everyone in the house what you are about to do, so you will not be unnecessarily disturbed. Then you must hope and pray that there are no telephone calls or door bells ringing. The microphone has to be a fixed one.

Any movement of the mike while you are holding it will register in the tape recording as a variation of the sound volume. The best recordings I have made from discs are those with the microphone suspended over the back of a chair, at least 3 ft. away and at an angle of 45 degrees, from the record player on the floor. Whichever way you decide on this point of hanging the microphone higher than the player is an important one. Sound, and music especially, rises upwards. It is always better to hear an opera or concert from the balcony than from the pit!

I find that nothing ruins any tape recording so much as repeated adjustment being made while recording is in progress. If there is a brief test beforehand, there is no reason why both player and recorder will not work on while you are out of the room, and if you remove yourself from the scene of the recording, then you are also removing yourself from the temptation to meddle. Besides this,

remaining perfectly still for the whole of an L.P. side can be very irksome, indeed. It does not matter if the player goes on long after the disc has run out. The tape can always be wound back to its proper place.

The ability to get really good tape recordings from discs is a very useful asset. In my capacity as a record reviewer I take tapes of the best discs sent to me, because I always have to send the discs back. Apart from the personal pleasure I get from these recordings, they are very useful if another recording of a piece of music that I have only just reviewed is sent to me; for I am likely to have the former version still on hand to compare it with the new one.

However, from a more general aspect, since more and more people are joining record libraries, it is surely the only possible way to keep the recording after you have to return the disc. Also, of course, you can take tapes of your personal friends' best discs. (G.E.G.)

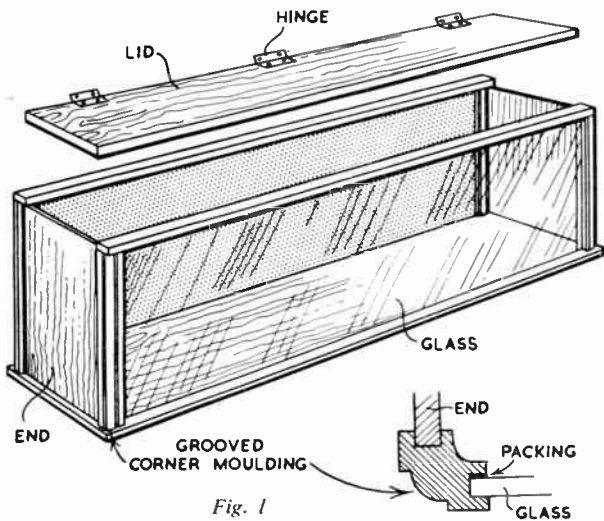

Fig. 1

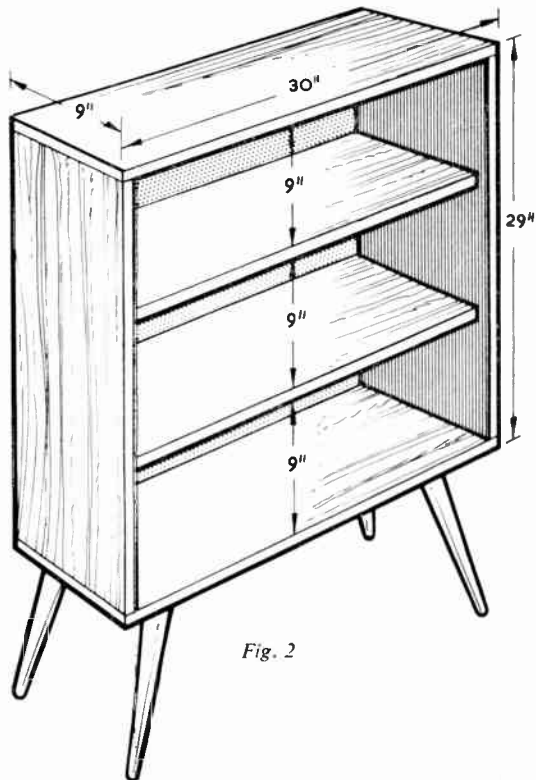

Fig. 2

DIFFERENT DESIGNS FOR SHOW CASES

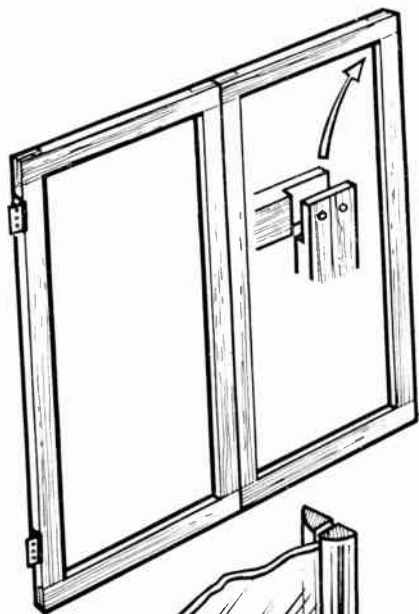

Fig. 3

SHOWING HOW GLASS IS
HELD BETWEEN 1/4 ROUND
BEADING

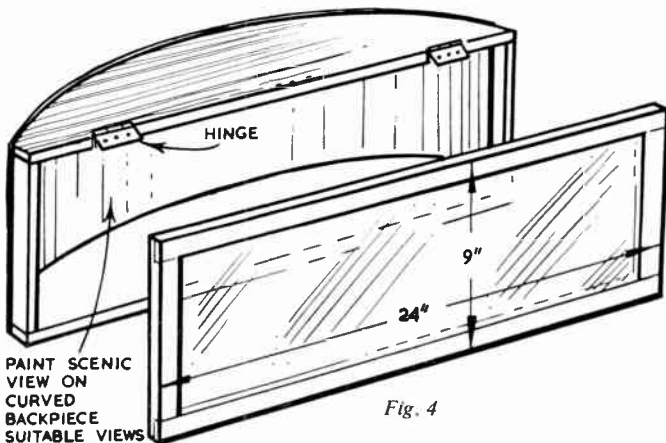

Fig. 4

PAINT SCENIC
VIEW ON
CURVED
BACKPIECE
SUITABLE VIEWS
CAN BE SEEN IN TRAVEL
BROCHURES ETC.

Black and white Prints from Colour Transparencies

WE are often told that it is difficult to make a black and white print from a colour transparency, and although this may be true so far as contact prints are concerned, we can make a monochrome negative by simple methods. The accompanying illustration has been made from an original colour transparency, and you can easily make your own negatives.

By S. H. Longbottom

No doubt you will recall that before the advent of panchromatic films our negative materials for black and white pictures were called orthochromatic. In other words, while sensitive to most colours, they were insensitive to dark red. Yet we were still able to take satisfactory photographs, although our subjects were in colour. Indeed, it is only during the last five years that popular orthochromatic films have been replaced by panchromatic, which are sensitive to all colours.

In view of the foregoing you may now realize that it is possible to make a negative from a positive colour transparency by preparing a new one on orthochromatic material.

For this purpose we may use sheet film, either orthochromatic or panchromatic, but since the former permits processing with the aid of a ruby light, I considered that Commercial Ortho cut film would be best for the experiment. This is regarded as slow negative material used primarily for copying work but you may judge the result for yourself.

We have two methods at our disposal, that is by contact or projection. In the former we make a negative by contact, placing the transparency and negative material emulsion to emulsion in a printing frame, and then exposing to artificial light. But we can achieve a much better result by projecting the coloured transparency on to the negative material by means of the enlarger.

When the transparency is placed in the negative carrier, and the image projected, we produce a positive image similar to one which the camera would see in daylight. A piece of negative material is positioned, an exposure made and after development we have an enlarged negative of the transparency in black and white. This method allows us



to enlarge the subject as much as we require, and to eliminate undesirable features of the picture — but now note the following points.

The whole process can be safely conducted with a ruby safelight for illuminating purposes, providing Commercial Ortho cut film is used. Focus the transparency on to a sheet of white paper bearing an oblong ruled out to, say, $2\frac{1}{2}$ in. by $3\frac{1}{2}$ in., the ultimate size of the negative. You must ensure that the transparency is clean and free from dust, the image is sharp, and correctly focused. Turn out the enlarger light, placing a piece of unexposed negative material in position on the prepared oblong. Should the sheet film have any tendency to curl, it may be advisable to fasten down with pushpins, since it must be perfectly flat. All that remains to be done is to make the requisite exposure by switching on the enlarger lamp.

Due to varying conditions it is impossible to quote exact data, but for your assistance I would mention that for this experiment an exposure of two seconds was made with a 60 watt lamp in the enlarger. You may develop in D61 — a negative developer; D163 — Kodak Special Developer or ID11 — Ilford fine grain developer for the appropriate time quoted. My advice would be to make a test with exposures

on one piece of film, using the same transparency, for 1, 2, 3, and 4 seconds, in conjunction with a 60 watt lamp. Give full development to ensure adequate contrast, and then judge the best. In theory such a test negative should also be printed to ascertain the best printing negative, but this is left to your discretion. Incidentally, the above times are quoted for an average transparency which is neither too thin nor too dense.

Remember that your original transparency must be reasonably sharp, for we cannot remedy any blurred images; it must be clean to avoid spots on the new negative, and of average density. When confronted with a dense transparency you may require a 100 watt lamp in the enlarger, while correct exposure can only be determined by test. You should also recognize the fact that red objects will be shown as black in the finished print, although other colours will be reasonably represented. You should, therefore, use some discrimination in the choice of transparencies which are to be subjected to this treatment.

The foregoing applies when Commercial Ortho cut film is used. It is available, although you may have to place an order with your photographic dealer. A box of twenty-five sheets, measuring

● Continued on page 347

A CENTRIFUGAL RAILWAY

A CURIOUS railway has been erected in the circus ring. At the top of a long steep incline, a performer wearing a crash-helmet is strapped into a little silver car! There is a roll on the drums as the glinting car begins to tear down the track. The audience gasps as the daring driver whizzes around the inside of a circular loop, then speeds up a gentler slope and finally flies across into a safety net. The audience applauds wildly. . . .

We have been watching a demonstration of the 'Centrifugal Railway', where at one time the car was actually riding upside-down against the metal track.

How is it possible for such a heavy

performs well, and supply a shoebox into which flying marbles can eventually drop.

Two forces keep the balls on course when they go up around the inside of the loop. Inertia, which tends to keep swiftly moving objects going straight onwards, causes the marbles to press against the track when the rail curves sharply upwards and over. If the speed and weight, or 'momentum', of the projectiles are great enough, inertia will not be overcome by gravity acting vertically downwards.

way down the long slope. Gravity will overcome the ball's inertia as the sphere runs up under the loop, and the marble will fall off the 'ceiling' of the track.

Now you will understand the mechanical principles underlying the circus act; although you must appreciate that the

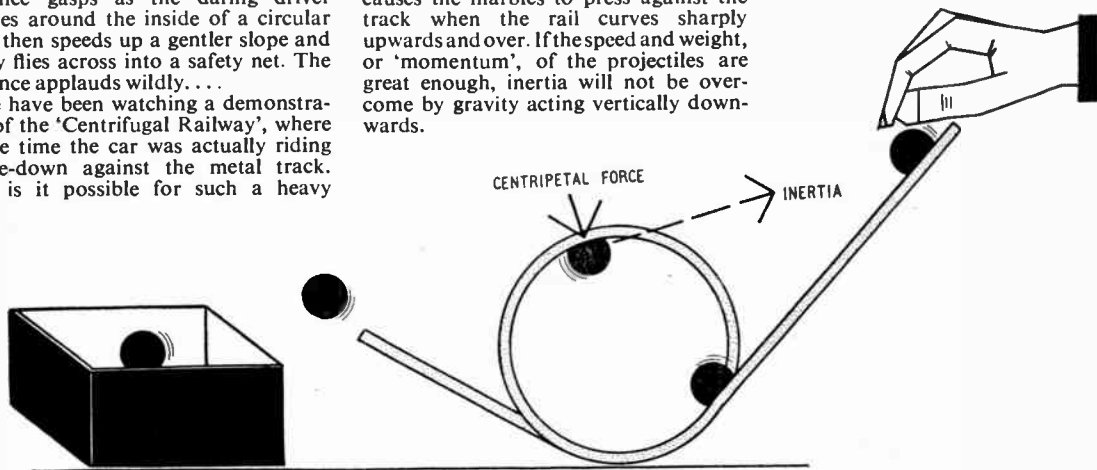

object to defy gravity in this manner? You must realise that the car is not in any way fixed to the railway.

To answer the question you may begin by building a 'Centrifugal Railway' yourself. A splendid model can be made with a seven ft. length of metal curtain railing (obtainable at Woolworths).

The rail must be fashioned into a 10 in. diameter circular loop, beginning approximately 15 in. from one end. This can be done with the aid of a large metal tin or drum. Let two persons support the cylinder between them, while you and a fourth helper take opposite ends of the pliable metal rail and slowly bend it around the drum.

You must produce a track having a long steep incline, then a smooth loop, followed by a shorter slope. (See the illustration.) Rest the top of the longer slope against a chair or stack of books, and support the lower part of the apparatus upon the floor. The 'base' of the arrangement may be held still by pressing flat stones or tiles against the tracks, on either side.

Roll a marble down the longer incline. The heavy glass ball should gain speed rapidly, then 'loop the loop' in apparent contradiction of gravity, before rushing up the shorter incline and off into space. adjust the track until the projectile

The second force acting upon the performance of the marble is the resistance of the track itself, which prevents the balls from shooting straight off the loop into space at tangents to the railway. This force, which opposes inertia, is named centripetal force.

You may investigate what happens when a marble attempts the loop at too slow a speed, by releasing a ball half

stunt is dangerous if the car travels too slowly, or the track and net are not rigged properly. Why not try and let pennies and half crowns, like daring motorcyclists, negotiate your amazing railway?

This principle could become the basis of a game if instead of a box the marbles are allowed to enter numbered grooves or holes on a suitable board. (A.E.W.)

● Continued from page 346

BLACK AND WHITE PRINTS

2½ in. by 3½ in. costs 13s. 3d. or almost 6d. each. If you wish to make further experiments you may use panchromatic cut film. The only disadvantages of this material are that it is much faster, requiring extremely short exposures, which are not always practicable, and it must be handled in total darkness without the aid of a safelight. Otherwise the tone renderings will be more faithful to the original colour transparency.

On the whole you should find that Commercial Ortho films will prove quite satisfactory for the majority of

transparencies, and once a test has been made, you will have sufficient data for many other negatives. These single sheets of cut film can be processed individually in small dishes, and are much more convenient than roll films. Different sizes are available, while the larger may be cut with scissors to make smaller negatives if required.

Once such a negative has been prepared, you may then make black and white contact prints or enlargements, and you will be surprised how simple this method is.

TOY CRANE

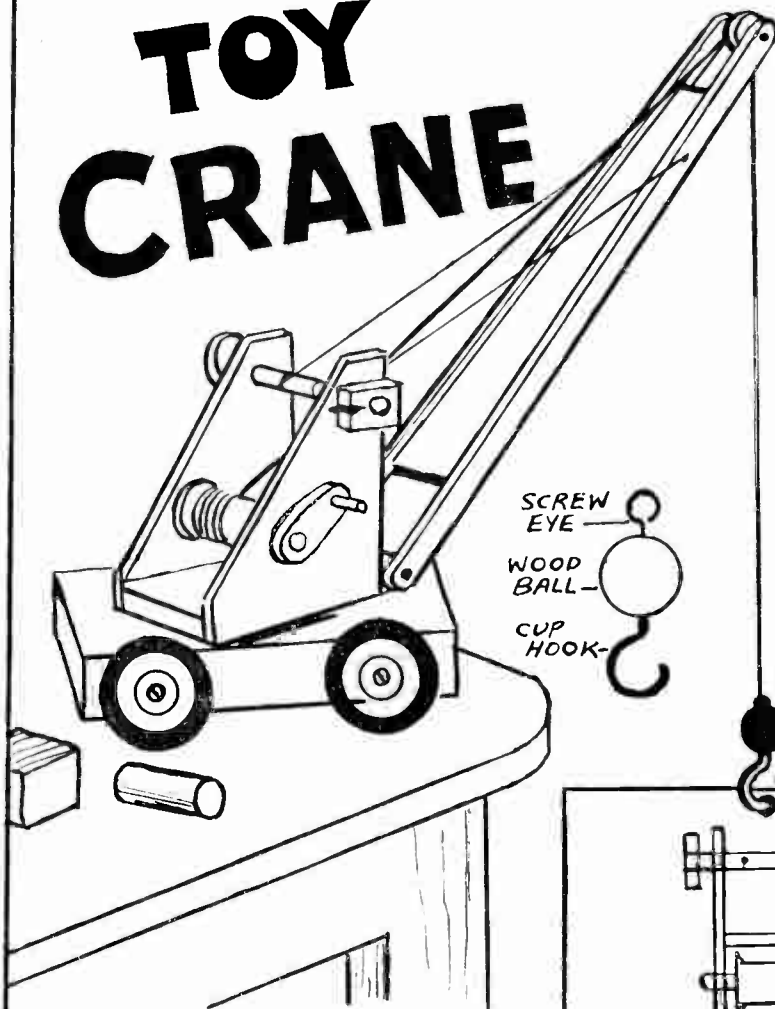

SCREW
EYE

WOOD
BALL

CUP
HOOK

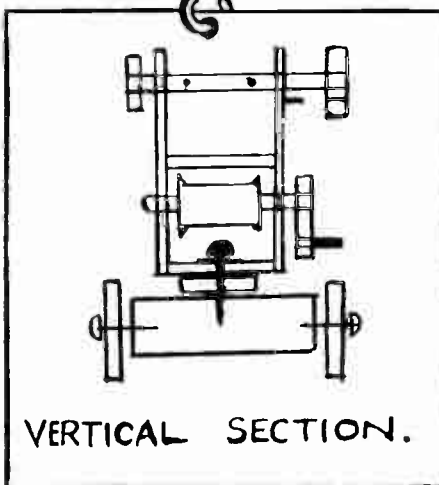
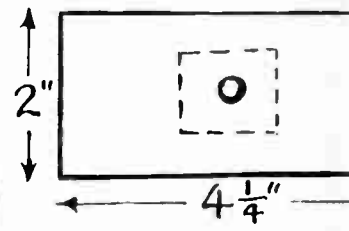
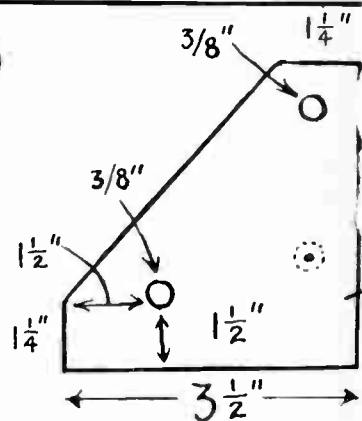

CUT PLYWOOD PARTS TO SIZES SHOWN. CHECK ANGLES FOR SQUARENESS. SEE THAT DOWEL SPINDLES RUN FREELY. PAINT CRANE IN GAY COLOURS.

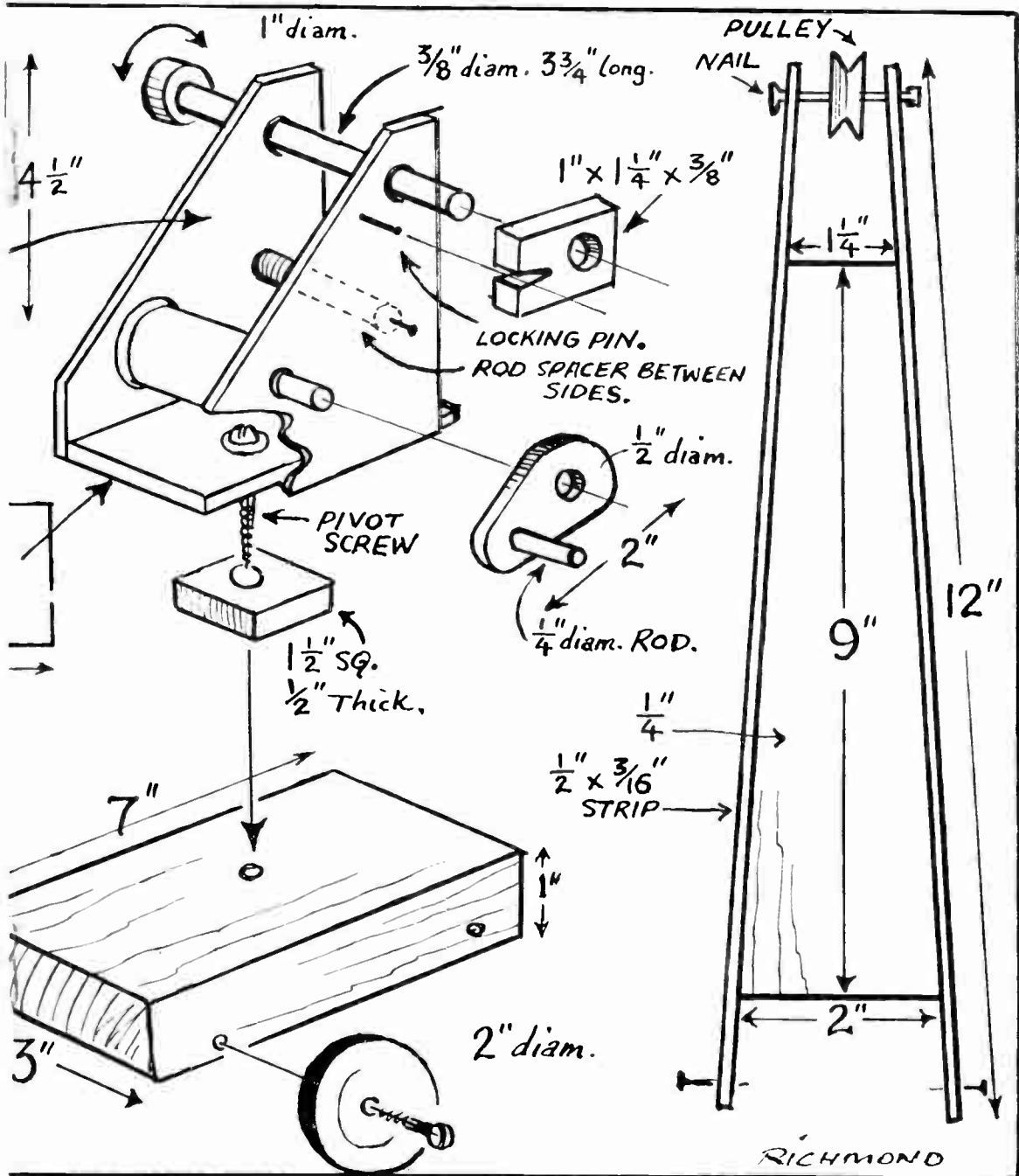

CHEMISTRY

AT HOME

If the world's vegetation all died, man and animals would slowly suffocate. If man and animals all died, plants also would die. Thus, with no visible connection, animal and vegetable life are interdependent.

ABOUT CARBON DIOXIDE — 1

The explanation of these startling facts lies in the carbon dioxide, CO_2 , and oxygen, O , in the atmosphere. Man and animals need to breathe oxygen to clear the tissues of waste matter. Exhaled air contains a good deal of carbon dioxide which has come from the blood by way of the lungs. It follows that the atmosphere is eventually going to be greatly enriched in carbon dioxide and greatly impoverished in oxygen if the carbon dioxide is not removed. Mammals suffocate in carbon dioxide. The balance is restored by plants, which breathe in carbon dioxide laden air, use the carbon C , from the carbon dioxide to build up their own tissues and return oxygen to the air.

Both these facts may be confirmed by simple experiments. Pour a little lime water, $\text{Ca}(\text{OH})_2$, into a test tube, put in a glass tube or drinking straw so that one end dips below the surface. Breathe in through the nose and breathe out through the tube or straw, so that the exhaled breath bubbles through the lime water. After a time the lime water

acquires a white cloudiness due to the formation of insoluble white calcium carbonate, CaCO_3 :



Carbon dioxide is soluble in water and such a solution may be used to demonstrate the utilization of the gas by plants. The carbon dioxide solution may be prepared by bubbling the gas through water for about half an hour. Generate the carbon dioxide in the apparatus shown in Fig. 1 from marble chips (calcium carbonate), and dilute hydrochloric acid, HCl . Calcium chloride, CaCl_2 , is left in solution:

$$\text{CaCO}_3 + 2\text{HCl} = \text{CO}_2 + \text{CaCl}_2 + \text{H}_2\text{O}.$$

Tie a small bunch of watercress to a stone, immerse the whole in the carbon dioxide solution, jiggling it to remove any air bubbles, arrange a funnel over the cress and clamp a test tube full of water over the funnel, as shown in Fig. 2. The inverted test tube of water is attained by filling the test tube with water in the upright position, closing it with the thumb, inverting it, dipping the mouth below the carbon dioxide solution and removing the thumb. The water will not then run out.

Place the apparatus in sunlight or bright daylight for eight or more hours. During this period gas slowly issues from the cress, is channelled to the test tube by the funnel, lodges at the top of the tube and drives out some of the water.

Again close the tube with your thumb,

remove it from carbon dioxide solution, invert it so as to bring the gas to the mouth end, and with the other hand light a wood spill, blow it out and, removing the thumb from the tube, plunge in the still glowing spill. It will burst into vigorous flame, indicating the gas is oxygen.

As most gases are heavier or lighter than air there arise two points. If heavier, does it lie in a concentrated layer on the ground? If so, it would benefit plants, but suffocate man and animals. If lighter, it would rise to the upper atmosphere, plants die quickly, man and animals slowly as they used up all the oxygen.

Again, simple experiments will solve these questions. Generate carbon dioxide as before, but this time instead of putting the end of the delivery tube into water,

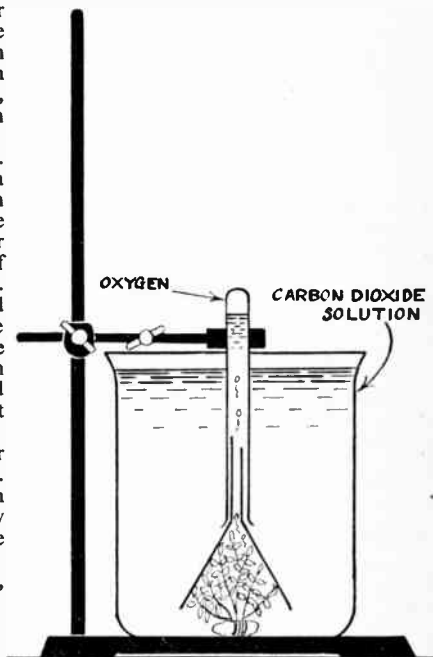

Fig. 2—The splitting of carbon dioxide by plants

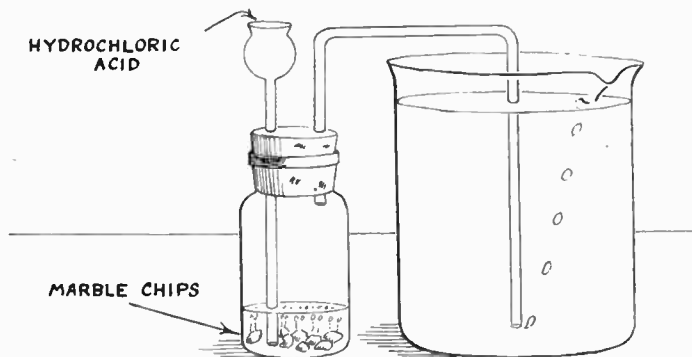

Fig. 1—Preparing carbon dioxide solution

put it into a jam jar whose edge has been ground flat. After a few minutes insert the tip of a burning spill into the mouth of the jar. If it goes out, the jar is full. If not carry on the generation until the spill goes out in the mouth of the jar. You now have a jar full of carbon dioxide. Cover it with a lightly greased glass plate.

You have also shown that carbon dioxide will not support combustion. This is a useful fact and test. In a jar of air the flame would continue to burn. Now bring the mouth of another jar, also with a flat ground rim, to the carbon dioxide filled jar, slide out the glass plate and invert the jars, taking care that the rims are well in contact.

After a few moments separate the jars. The lower one *should* contain air. Plunge a lighted spill into it. It is extinguished and therefore is *not* full of air. The upper jar will allow the spill to continue burning. Transference must therefore have taken place when the jars were inverted. Carbon dioxide is therefore heavier than air. There is no cause for alarm that a carbon dioxide layer is building up on the surface of the earth and that the fate of man and animals is thus sealed!

We have already seen that carbon dioxide gives a white turbidity with lime water. Now shake up some lime water with air. Little change occurs, for there is only a minute proportion of the gas in air.

Now fill another jar with carbon dioxide, leave it mouth upwards on the bench and put a jar of air upon it rim to rim so that the two mutually close each other. After some hours separate the two, pour into each a little lime water, close them both with glass plates and shake. The lime water turns cloudy in both jars, proving that some of the carbon dioxide has passed into the upper jar of air. Diffusion of carbon dioxide therefore takes place. This is what happens with the carbon dioxide from our exhaled breath and it becomes evenly distributed throughout the atmosphere, making life for both plants and animals possible, the concentration being low enough to be harmless to man and animals yet high enough for plant nutrition. The importance of this diffusion becomes even more apparent when we know that each adult human being pours about 100 gallons of carbon dioxide into the air every 24 hours!

The foregoing experiments have shown that the gas is heavier than air and will not support combustion. Using these facts a trick may be done to baffle your friends. Have ready a full jar of the gas. Stand a lighted candle in another jar, and bring the mouth of the carbon dioxide filled jar to it, tilting the latter as if you were pouring water. The candle goes out! As carbon dioxide is no more visible than air the non-chemically minded will be at a loss to explain this.

Some chemical fire extinguishers depend on carbon dioxide to produce a temporary non-combustion supporting blanket upon the flames.

In a further article more interesting experiments and startling tricks will be dealt with.

DOODLING WITH TRIANGLES

HERE is an easily prepared doodling and designing game that will fill an odd moment pleasantly. You will be required to invent symbols by manipulating a few black shapes upon a white background. Begin by marking out an equilateral triangle upon black cardboard. Let each of the three sides be 3 in. long. Indicate the mid-points upon the sides, and join them up, using a

identical in size), and try composing pleasing arrangements out of sets of four assorted, contrasting, or like hues.

By A. E. Ward

ruler, in such a manner that the large figure is divided up into four miniature equilateral triangles, all of identical size. Cut out the four shapes, using sharp scissors.

Put the pieces of cardboard upon a sheet of white paper, and arrange them so that, together, they will resemble a Maltese or Victoria Cross. Move the parts about to form other patterns. This pastime may keep you occupied for an hour, and you will be amazed at how many configurations of the four shapes you can assemble.

As you proceed, bear in mind that all the pieces must be employed for each construction, and never must you permit adjacent parts to overlap. You can vary the game by using coloured shapes. Cut out four shapes of each colour (all

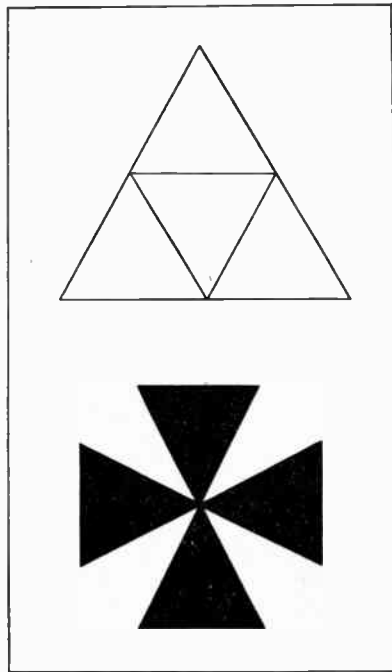

Miscellaneous Advertisements

IF you have taken a lot of care in making a musical box, be sure to make it worthy by including the best Swiss movement—a REUGE. Prices from 13/9. Wide range includes a charming Dancing Ballerina. Many tunes to choose from. Send for details in free booklet 'Profitable Leisure.' — **HOBBIES LTD, DEREHAM, NORFOLK.**

LOW PRICED Commonwealth Approvals. Attractive stamps from 1d. to 2/- each. Unusual Isles and Territories—Deslandes, 24 Redhill Avenue, Kirkby, Lancs.

PENFRIENDS home and abroad, all ages. S.A.E. for details. European Friendship Society, Olney, Bucks.

WOULD YOU ENJOY painting flower pictures, etc.? Then read 'PROFITABLE ART' (free). Wonderful opportunities for beginners and others. POPULAR ART (HW), Clun, Salop.

100 DIFFERENT stamps free! Request 1d. upwards discount approvals. — Bush, 53 Newlyn Way, Parkstone, Dorset.

ENJOY WRITING? Then write for Profit. Send for 'Writers' Handbook' (free) detailing countless opportunities for beginner or experienced. — Writers' Ring (HW), 5 Edmund Street, Birmingham.

UNDER 21? Penfriends anywhere — details free. Teenage Club, Falcon House, Burnley.

FRRIENDS' WORLD, Postbox 708, Calcutta, India, offers pen friends everywhere.

FREE — Interested in Marquetry? A special leaflet 'Making Pictures in Wood' by the fret-saw method is free for the asking. Send to **HOBBIES LTD, DEREHAM, NORFOLK.**

HOME BILLIARDS FOR FAMILY FUN

Tables in 3 sizes, 4 ft., 5 ft., and 6 ft. from £8. 8s. 0d. to £16. 16s. 0d., including snooker and billiard balls, cues, marker, and rules. Available at all branches. Send for full details from **HOBBIES LTD, DEREHAM, NORFOLK.**

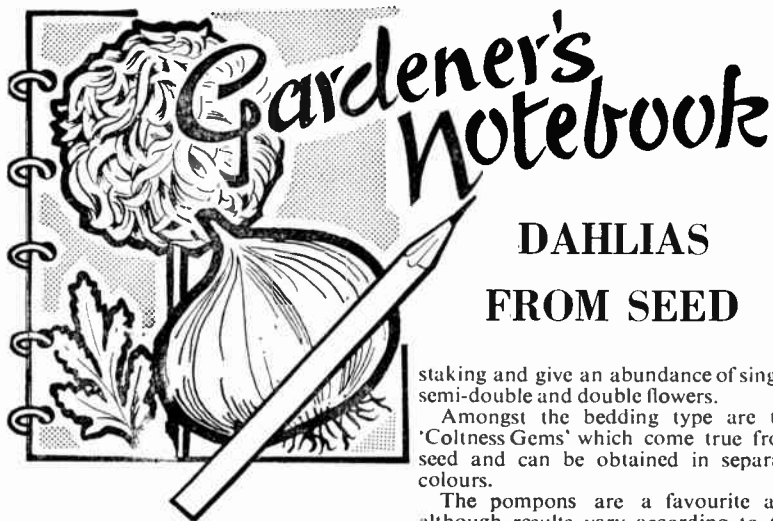

DAHLIAS FROM SEED

staking and give an abundance of single, semi-double and double flowers.

Amongst the bedding type are the 'Coltness Gems' which come true from seed and can be obtained in separate colours.

The pompons are a favourite and although results vary according to the selection of the seed they can be relied upon to give a reasonable percentage of pompons. Collarettes and cactus too are worth trying, for they are particularly useful for cutting.

The large and medium decoratives provide a wonderful display where tall plants are needed, but these will of course need staking. A small packet of seeds — the price of one plant will give you a dozen or two of sturdy plants which are sure to produce at least three or four worth saving for next year. The large decoratives will be a little later flowering than the bedding types.

By growing a few of each type annually and saving only a few of the very best each year you can gradually build up a stock of first class tubers and who knows,

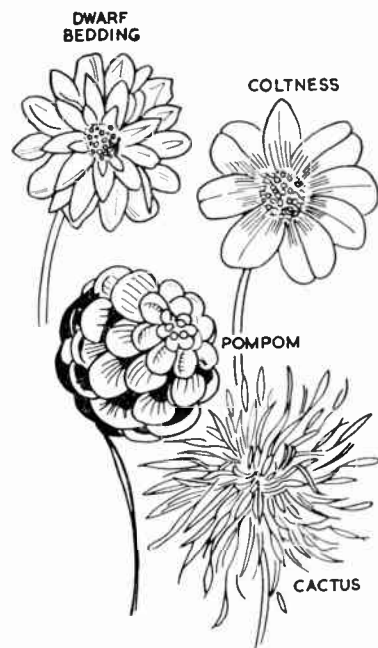

THERE are few plants which will so easily provide a lavish display of colour in summer and early autumn as Dahlias. Unfortunately these plants, especially named varieties, are often too expensive to be used in quantity. There is no need, however, to rule them out on this count because they can readily be grown from seed and treated as a half hardy annual. Plants grown from seed sown during the last week of March can produce the first blooms in July.

There are a number of varieties which can be obtained from various seed merchants and you will see them in the current catalogues.

For bedding, those listed as 'dwarf bedding' are ideal. They are hybrids which grow about 18 in. to 2 ft., need no

you could even find a 'winner' amongst them.

All the varieties mentioned need the same treatment initially. They should be sown directly into boxes containing if possible a good seed compost such as John Innes. Lightly covered with soil and placed in a greenhouse or frame they will quickly germinate. They can even be sown directly under cloches if the weather is fine and sunny. Wait until the weather is suitable and you will have no trouble with germination.

As soon as the first true leaves appear, prick them off into boxes, spacing them about 2 in. to 2½ in. each way. Alternatively soil blocks or pots can be used for the smaller types.

The large decorative types are planted into boxes in the normal way, but are transferred to pots when about 3½ in. high and are potted on if necessary and planted out during the last week of May or the first week of June.

For the bedding types, soil blocks may be utilized or they can be planted under cloches until ready for the garden. The cloches can be removed for watering and can be taken away altogether to harden the plants off. Place the cloches in position again if frost threatens.

Seedling dahlias require the same cultivation as tubers. They need a plentiful supply of moisture and adequate feeding. Well rotted manure can be incorporated in the soil before planting out. For a continuous display the seed pods should be picked off regularly.

(M.h.)

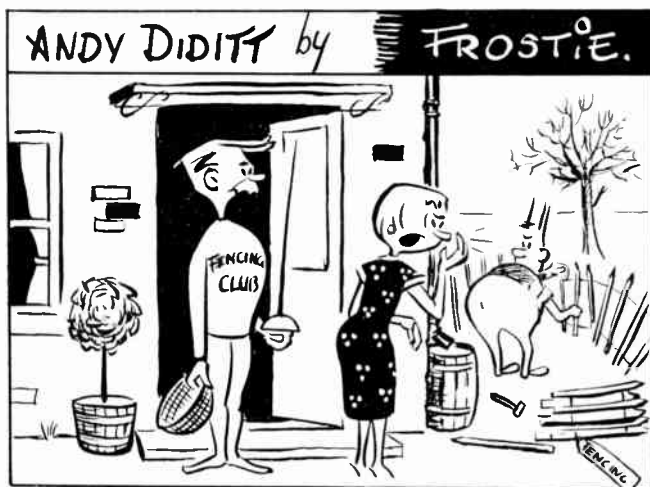

"ANDY! THE FENCING EXPERT YOU WROTE TO IS HERE — IN PERSON!"

FOR THE HOME, OFFICE, OR FACTORY

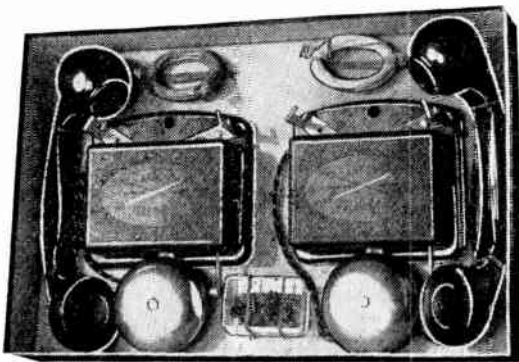

Arrow Telephones are REAL INSTRUMENTS. With automatic calling by bell, they work off ordinary 4-5V batteries, can be fitted up in a few moments, and give trouble-free operation.

75/-
post free

Each set consists of two complete instruments (full-size hand-sets) 30 ft. of line wire (can be extended if required) insulated staples, fixing screws and full instructions.

HOBBIES LTD, (DEPT. 99), DEREHAM, NORFOLK

Just the dishes for you!



Johnson's 'Vogue' Triple Purpose Set

You can set about your dark room work in a really professional way with the Johnson "Vogue" dishes. They come in sets of three and are separately coloured: Orange, Grey and White. You can identify them by their colours for each processing job and retain them for specific chemicals. Available in half plate and whole plate sizes. Set of 3 half plate dishes 6s. 9d. Set of 3 whole plate dishes 12s. 9d.

SOLD BY THE LEADING PHOTOGRAPHIC DEALERS



FOR CONFIDENCE IN PHOTOGRAPHY

FOR PERMANENT RESULTS... MODEL IT IN

Plastone

—the self-hardening modeling material. *Regd. Trade Mark*
Send for sample tin and booklet 4/9 (including postage) to Sole Manufacturers—
Harbutt's Plasticine Ltd., Bathampton, Bath, Somerset.

No. 1 MITRE-CUTTING TOOL AND CORNER CRAMP

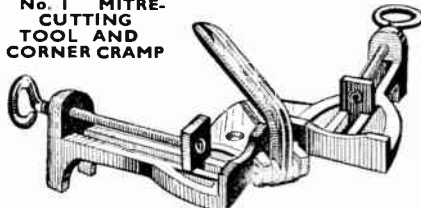

Will cut mitres on moulding and similar work up to 4 ins. wide. (post free) **55/-**

WOOD MITRE BOX

Made of selected hardwood. Size 9 ins. long. (postage 1/6) **5/6**

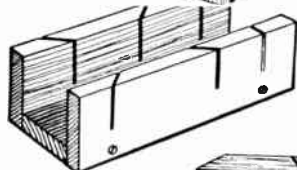

WOOD MITRE BLOCK
Made of selected hardwood. Size 9 ins. long. (postage 1/-) **3/-**



HOBBIES LTD (DEPT. 99) DEREHAM, NORFOLK

DESIGNING AND MAKING Toy BUILDINGS

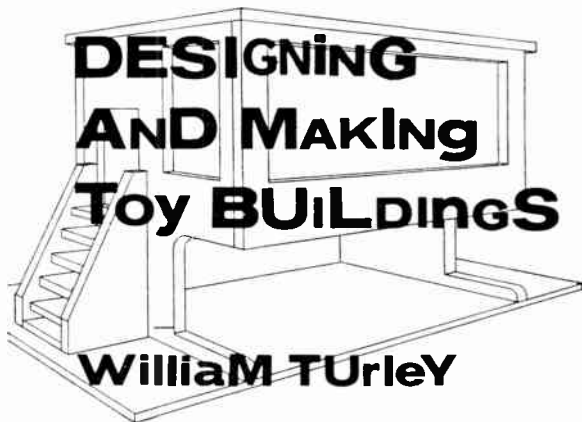

William Turley

In this book the author shows the methods by which strong, attractive toy buildings can be made at home at a reasonable cost. All aspects of toy buildings are explained in detail, with comprehensive instructions for making six specific examples. The book is profusely illustrated with line drawings and photographs. *12s. 6d. net*

STANLEY PAUL

VENEERING MADE EASY

TO-DAY, many amateur carpenters, cabinet and furniture makers are using veneer pieces and panels to add the finishing touch to woodwork. An elegant appearance may be given to wood surfaces by using real veneers, and real or imitation wood veneer papers, all of which are readily available in the handicraft shops and stores.

Various kinds of surface veneers may be applied to plain wooden partitions, walls and ceilings, in addition to furniture, these being a permanent and pleasing alternative to paint or varnish. Fine grained veneers have long been used in the professional cabinet making trades and to-day these fine finishes may be matched by the home worker, full scope being afforded as a result of new materials now available.

Veneer adhesive tapes

While paper and imitation wood grain and veneer papers may be pasted down to wood or other surfaces with conventional adhesives, the real veneer has to be applied with extra thin, fine kraft adhesive tapes specially made for combining veneers to wood. These tapes are different from normal adhesive tapes used for mending, reinforcing and similar work.

A new semi-transparent tape may be obtained which enables any joint defects to be seen before the veneer is glued up. The most simple or intricate designs made up from selected pieces of veneer may be held in position until dried out and the final sanding down takes place. The veneer panels themselves are placed together over the surface to determine harmony of colour, design or pattern and the pieces are not glued down until the handicraft worker is satisfied with the ultimate pattern.

Patterns may be self composed or use of pattern books may assist the newcomer to this interesting and useful work. Many workers are now decorating such items as wooden table mats, coffee tables, plain wooden boxes, cupboards—in fact anything produced in wood from medium to large in size. The veneers are first glued down to the surface or wood base, being held firmly in position at all joints on the surface by the application of strips of the new adhesive veneer tape. In this way, perfectly flat adhesion to surface is ensured. Time must be allowed both for the glue to dry out and the veneer to do its work. Fragile veneers must be carefully handled.

When the work is bone dry, thin tapes may be easily sanded off the surface of the joined veneers, thus leaving a fine, flat, close fit to the pattern. Such tapes

may also be moistened slightly and rubbed away by hand or duster. A final sanding down all over applied veneers will leave a fine smooth finish to the work. Any minute joints will thus be filled by the final sanding operation.

Further surface veneer treatment may consist of an application of lacquer or suitable varnish available in flat or egg shell finish, medium to high gloss cellulose, such being selected according to the work and individual taste. Such treatment will further harden the surface of the veneer and render it washable.

Popular grains

Alternatively, new British wood grain or veneer papers have become available in all the popular wood grains such as oak, cedar, and walnut. In sheets of 20 in. by 22 in. and in rolls of 12 yards, they may be cut and pasted down to any surface and will adhere firmly. Real Japanese wood veneer papers have again become available in sheets. They are made of real wood in all wood facings, have a rigidity similar to thin veneers but may be handled without undue risk. They may be cut with scissors, pasted with ordinary mediums and polished and varnished as desired. Adhesive tape is not needed in either of these paper-based grades of imitation or real wood grained papers.

The real beauty of the work is in composing the design and making use of fine figuring, and some experiment may be initially made to this end. When such materials are well applied, it is often difficult to differentiate between these and the more simple types of genuine wood veneers.

Plywood work

Plywood may be made up to any desired thickness with the aid of new plywood adhesive tapes, these being glued both sides for the purpose of ply combining or wood lamination. The process is generally described as the 'jointed board' principle. A number of strips of wood or pieces may be joined either flat or side by side to make up a thickness or a larger sheet to any size not normally available. These tapes are used along the following lines:

- (a) For jointing purposes on the outside boards a thin adhesive tape is used, this being placed on the external surface of the ply. When the size or thickness desired has been made up, the surface tape is easily removed by sanding down, damping or scraping. The tapes are thin but very strong, and it must be emphasized that normal adhesive tapes are not suitable for such work.
- (b) Where the outside boards consist of

a fine veneer, it is not usual to sand off the applied tape as this can damage the pattern. New tapes are therefore very absorbent, and may be readily soaked off. There are several varieties of veneer and plywood tapes and small strips may be tested to ensure that they are right for the work.

(c) For jointing the inner boards a new perforated tape has a single row of round holes. These allow contact to be made between the outer and inner boards by means of the glue or casein used for combining over a certain portion of the area occupied by the tape. Tapes with double rows of round holes are now made, thus assisting in increasing the area of surface contact. Oval holes are also now punched into adhesive tapes to offer additional areas of contact in ply combining. Tapes with three holes punched out ensure a maximum lamination of wood between inner and outer surfaces. Fine work of this kind, such as is required in the construction of models and aircraft, calls for the strongest and thinnest tapes made with good tack adhesive coating, thus assisting in keeping the work rigid. Both thick and thin adhesive tapes are made for all kinds of jointing and lamination, some new tapes being untearable in both directions. They have to be cut with a pair of sharp shears.

Where suitable tapes with hole perforations are not readily available, selected tapes of the brown kraft type may be punched with holes with leather or thong pincers made specially for producing holes of various diameters.

The handicraft specialist is able to advise the new user on the best tape and will obtain supplies if not readily available. (F.T.D.)

Quik-Tip

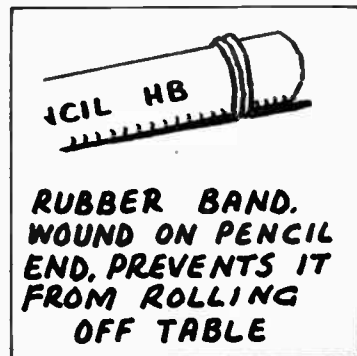

Make this Teapot Stand in Brass

CUT out the pattern from this page, or to avoid mutilation, trace it, and transfer to paper by means of carbon paper. Stick down to a sheet of brass, using a latex adhesive. Cut out the pattern, using a Hobbies metal cutting saw, and bend the tabs down to form feet. Polish with metal polish to give a sparkling finish. (M.p.)

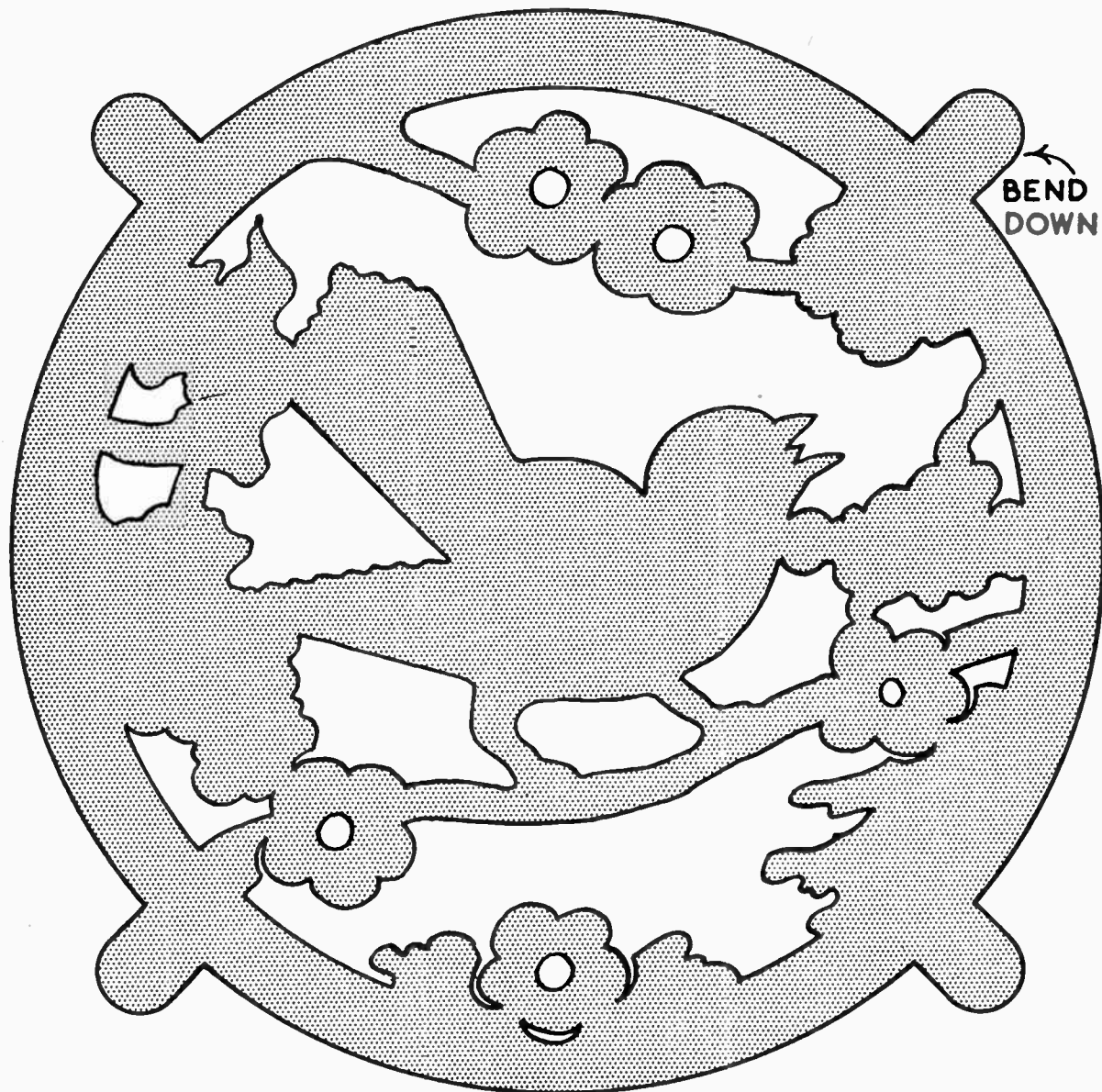

355

Single seat and two seat CANOES

COMPLETE AND READY
FOR THE WATER — OR
IN KIT FORM TO MAKE
YOURSELF

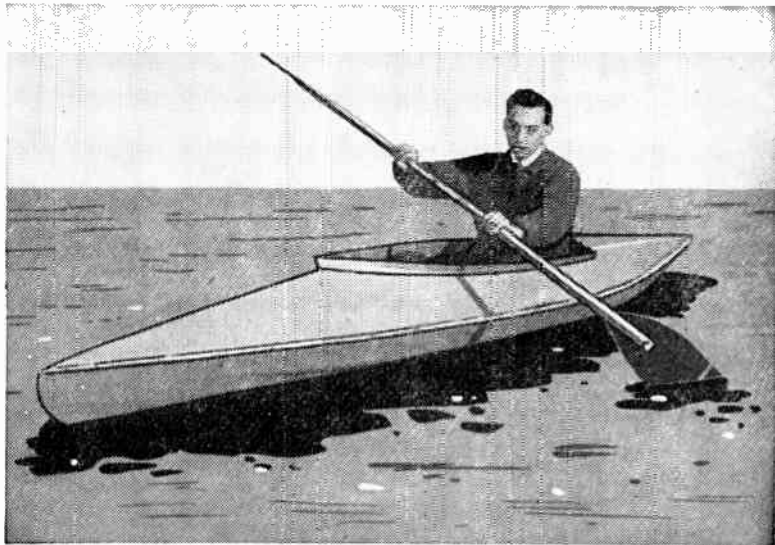

THE PBK 10 SINGLE SEATER

These popular craft are designed by that well-known authority, P. W. Blandford. With canvas skins, they are propelled by double-bladed paddles and are thoroughly at home on lake, river or canal — or even on the sea in experienced hands. They are offered as complete canoes, or as specially prepared kits, which include full building instructions. Easy terms are available, subject to the completion of a simple form of Agreement.

PBK 10 Single seat — 11 ft. long
28 in. beam — load 300 lb.
COMPLETE CANOE (without paddles)
CASH PRICE **£24.5.0** (part p. & p. £2 extra),
or EASY PAYMENTS **£6 DOWN** (plus £2
part p. & p.) & 6 monthly payments of £3.4.8.

COMPLETE KIT (except paint and
varnish and without paddles)
CASH PRICE **£15.10.0** (part p. & p. 15/- extra)
or EASY PAYMENTS **£4 DOWN** (plus 15/-
part p. & p.) and 6 monthly payments of £2.0.9.

DOUBLE-BLADED PADDLES, 47/6 Complete (part p. & p. 2/6 extra)

PBK 20 Two seater — 15 ft. long
32 in. beam — load 700 lb.
COMPLETE CANOE (without paddles)
CASH PRICE **£32.10.0** (part p. & p. £2.10.0
extra), or EASY PAYMENTS **£8 DOWN**
(plus £2.10.0 part p. & p.) & 6 monthly pay-
ments of £4.6.9.

COMPLETE KIT (except paint and
varnish and without paddles)
CASH PRICE **£22.5.0** (part p. & p. 20/- extra)
or EASY PAYMENTS **£5.10.0 DOWN**
(plus 20/- part p. & p.) & 6 monthly payments
of £2.19.4.

(DEPT. 99)

DEREHAM



NORFOLK