

12th APRIL 1961

VOL. 132

NUMBER 3409

THE ORIGINAL
'DO-IT-YOURSELF'
MAGAZINE

HOBBIES *weekly*

FOR ALL
HOME CRAFTSMEN

Also in this issue:

USING FLASH
IN PHOTOGRAPHY

COLLECTORS' CLUB

MAKE A CASTLE
FROM CARTONS

'FOUR-BARREL'
REPEATER GUN

A STRIPLIGHT
READING LAMP

EXPERIMENTS
IN CHEMISTRY

FRETWORK PLAN

ETC. ETC.

CHILD'S SAND CART



FREE

PLAN



Instructions for making
**MODERN
BEDSIDE
TABLE**

Up-to-the-minute ideas

Practical designs

Pleasant and profitable things to make



World Radio History

5^D



THE British Solomon Islands Protectorate comprises a scattered archipelago stretching about 900 miles in a south-easterly direction from Bougainville in the Australian territory of Papua and New Guinea. The group was first sighted by Mendana in 1568 who was convinced that he had discovered El Dorado, the 'Isles of King Solomon'.

THE SOLOMONS COMMEMORATIVE

Established as a British Protectorate at the end of the nineteenth century, the islands are administered by the High Commissioner for the Western Pacific. The new Constitution, which was brought into operation on the 18th October 1960, provides for the establishment of a Legislative Council and an Executive Council, and is considered to represent a considerable constitutional development.

To commemorate the introduction of



this new constitution a special issue of three postage stamps was released by the Government of the British Solomon Islands Protectorate on the 19th January 1961. The stamps will remain on sale for nine months or until stocks are exhausted, whichever is the earlier.

The new commemorative issue has been printed by Messrs. Joh Enschede en Zonen of Holland by the offset lithography process on C. A. (block capitals) watermarked paper in horizontal format size 38 mm. by 24 mm. perforation to perforation. The design, which is common to all three values, includes a portrait of Her Majesty the Queen with the St. Edward's Crown, and a frigate bird in flight. An interesting feature of these stamps is the omission of the customary white gutter, thus allowing the colour to extend to the perforation. The denominations and colours are as follows: 2d., green and black; 3d., red and black; 9d., purple and black.

The frigate bird depicted is to be seen around the coast of the British Solomon Islands, and other islands of the Western Pacific. It is the most completely aerial of sea birds, never alighting on the water or on level land, but flying in the air all day, and resting in trees or on a slope at night. Their food consists of fish and other creatures picked up from the surface of the water in flight.

Ceylon

A new 10 cent stamp was released by the Government of Ceylon on the 8th January, to commemorate the late Prime Minister, the Honourable S. W. R. D. Bandaranaike.

The special stamp has been printed by Messrs. Courvoisier S.A. of Switzerland by the photogravure process on un-watermarked paper in size 38 mm. by 25 mm. (see illustrations).

COVER FROM BOMBAY

A First Day Cover issued for Children's Day on 14th November 1960, has been received from MR N. M. LAM of Empire Terrace, Balaram Street, Grant Road, Bombay, 7, India. He says, 'I like very much to build up a nice collection of stamps issued by Great Britain, and will send Indian stamps, etc. in exchange.'

TO commemorate the centenary of the issue of the first postage stamps of St. Lucia, on the 18th December 1860, a special issue of three values has been prepared for the Government of St. Lucia by Messrs. Waterlow & Sons Limited. The stamps have been printed by the recess process on C. A. (block capitals) watermarked paper in vertical format size 30 mm. by 40 mm.

The stamps were released on the 18th December 1960, exactly 100 years after the first issue, and will remain on sale for six months or until stocks are exhausted, whichever is the earlier.

The West Indies dollar is equivalent to 4s. 2d. (i.e. \$4.80 equals £1 sterling).

St. Lucia, one of the four Windward Islands, lies in the Caribbean Sea about 24 miles to the south of Martinique, and some 21 miles to the north of St. Vincent.

ST. LUCIA'S SPECIAL ISSUE

There is little information on the early history of the island, but it was believed at one time that it was discovered by Columbus, although this cannot be confirmed from the known evidence of Columbus's voyages. The first recorded attempt at European settlement was made in 1605 when the *Olive Branch*, driven off course en route for Guiana, landed its sixty-seven passengers under the command of Captain Nicholas St. John. On the ship's departure, they were attacked by the Caribs, the aboriginal inhabitants of the island, and, after several days of severe fighting, the nineteen survivors took to their boat. Further attempts to occupy the island by both the British and French continued throughout the seventeenth and eighteenth centuries, and it changed hands intermittently with the fortunes of war until finally ceded to Britain by the Treaty of Paris in 1814.



THIS useful little toy can be quickly made up and painted to look every bit as good as a bought article. It could be made from odd pieces of wood or from Hobbies standard panels and stripwood.

The diagrams give all the necessary measurements, and show how the various parts are assembled. Use screws in preference to nails, and give added strength by using waterproof glue throughout.

The side view and front view in Fig. 1 show that the box portion of the cart can be made up separately. The cart is 18 in. long and 10 in. wide. The depth is 3 in. to suit Hobbies standard panels. The base (3) is cut from $\frac{3}{8}$ in. plywood, and is fixed under the sides (1) and ends (2), as shown in Fig. 2.

Continue by adding the axle supports (4) and the axles (5 and 6), as in Fig. 3. The axle supports are 2 in. by $\frac{1}{2}$ in. wood, and come level with the sides. The axles are 1 in. square stripwood and should

**THIS
ATTRACTIVE
TOY WILL
GIVE A
CHILD
MANY
HAPPY
HOURS**

SAND CART

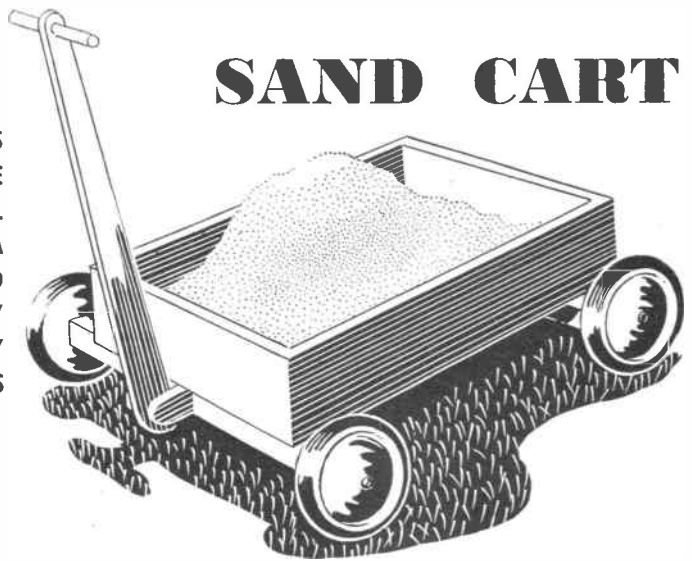

filled. The finish will depend almost entirely upon the thoroughness of this preparation. Give one undercoat and

two top coats for a high gloss finish. Rubber tyred wheels 3 in. diameter can be obtained from Hobbies Ltd, Dereham, Norfolk, price 1/3 each, post 6d. (M.h.)

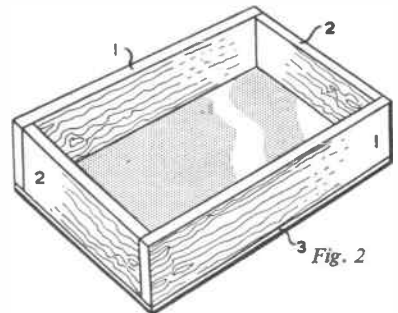
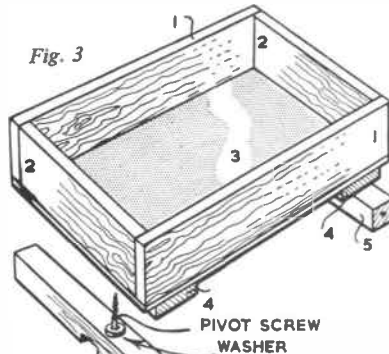
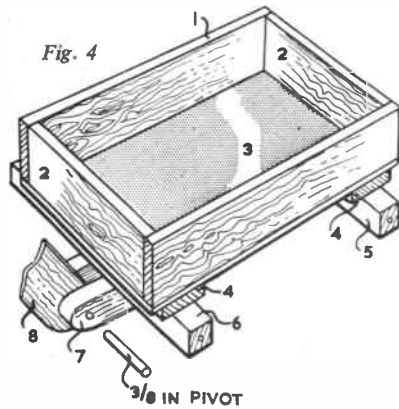

project about 1 in., as seen in the front view Fig. 1.

The front axle can be pivoted if required and the method is shown in Fig. 3. The handle supports (7) are halved into the axle and should be well glued for strength. They are of 1 in. square wood.

The handle (8) is $\frac{1}{2}$ in. thick and 2 in. wide at the bottom. It is pivoted by means of a piece of $\frac{3}{8}$ in. round rod (Fig. 4). Piece 9 is of $\frac{1}{2}$ in. round rod and should be about $4\frac{1}{2}$ in. long.

All parts should be thoroughly cleaned with glasspaper and the grain

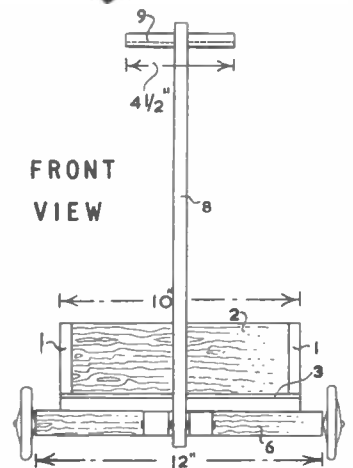
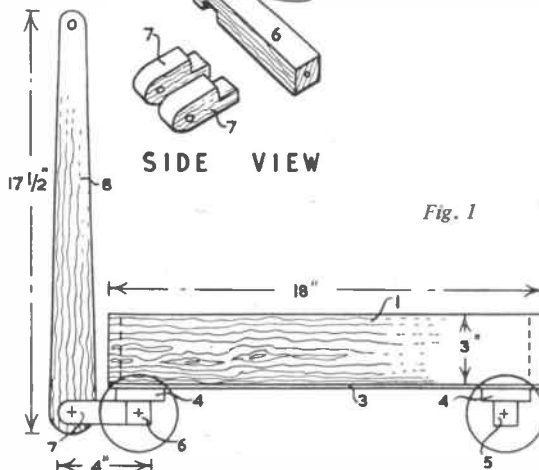

METHODS AND EFFECTS

HAVING examined some of the technical aspects of flash equipment we can now explore methods of use and some suggestions for subjects. The methods vary considerably and among these are direct light, bounced flash, diffused flash and synchro-sunlight.

A most important factor of the equipment we should mention is the film. You may have realised that flash produces very hard, intense illumination, so it is wiser to choose a film of soft gradation

— We cannot avoid shadows on the walls but these can be reduced by placing your subjects as near to the wall as possible. You should also watch out for articles likely to reflect the flash such as mirrors

By S. H. L.

spectacles, highly polished furniture and even glossy doors. This method is ideal for all unposed shots of family groups or parties in the home.

Do you know what we mean by the term 'bounced flash'? This means that the flash light is not directed straight at the subject but pointed towards the ceiling or a wall. Consequently, the ceiling takes the first impact of the brightest light, some of which is absorbed, but the rest 'bounces' back on to your subject.

Bounced flash gives more even lighting and the shadows are not quite so harsh. We have several ways of bouncing at our disposal. If the gun is adaptable it should be adjusted so that it points at the ceiling midway between the camera and your subject. Or you can ask someone to hold the gun while you press the camera trigger. Another way is to fit extension leads to the gun, placing the latter where required. But we must emphasize that we are obliged to compensate for the loss of light somehow or other and this is done by increasing the size of the aperture by two stops above the direct light method.

It will be true to say that portraits are better if taken with bounced flash since flash lighting is far too hard for this purpose. We always need a much kinder light to get the best results but with a little ingenuity we can always compromise by introducing some form of diffusion. You may fix a diffuser over the reflector, such as a white handkerchief; or a sheet of white tissue paper or muslin two feet square and placed over a hoop will be ideal. If such a gadget is held about a foot in front of the light — but not before the lens — you will produce a much kinder light with consequent higher print quality. Note that it is essential to make a round diffuser, for if you made a square or oblong one your subject would have that shape of lights in his eyes!

Alternatively, you may cover the metal reflector with a piece of thin, white cardboard, and again some of the sting will be taken out of the light and this

is almost as effective as the diffuser made from muslin. But remember that when the light is not as brilliant we have always to compensate by increasing the size of the aperture by a stop or so. Incidentally, all these recommendations are well worth an experiment or so and you will then discover which works best.

Synchro-sunlight is what you may expect — the flashlight is used as an auxiliary to sunlight or day light. In bright sunlight our pictures often result in the extremes of high contrasts and



Direct flash. Note the strong shadows.

Panchromatic films are advisable for roll film cameras although the 35 mm. owner will probably find the slower ones more to his advantage. We can, of course, diffuse our light and use fast panchromatic films but we will deal with this in due course.

Most flashguns fit on the camera somewhere above the lens, and consequently we get a vivid flash of light direct on our subject. This is the easiest way of taking a picture and extremely useful for indoor snapshots of the family at work or play. The flashgun is loaded with a bulb, the lead plugged in, the shutter set and reference made to the guide number. Divide the latter by the distance in feet between the gun and subject and the answer is the 'f' or aperture number. All you have to do is to pose your subject and shoot!



Here bounced flash was used, giving a much softer shadow behind the head.

deep shadows, a suitable example being when we take a picture against the sun and the face is in the shade. A flashlight will compensate this weakness and will be of real value, offering the benefit of uniform illumination.

In such instances it must be observed that daylight governs the exposure and we have to employ rather different methods for the use of flash. We determine the correct exposure by daylight in terms of an aperture to use at a speed of 1/25 second (this is the speed used for the flashbulb), then from the guide number of the bulb find the correct flash distance for that aperture. Place the flashgun at twice, or three times, this distance before taking the picture and then fire away. The types of subject responding to this treatment are those where the principal light-

ng (i.e. the sun) is coming from the back or side.

This is a most useful method for tricky, outside subjects but needs a little experiment to achieve a good balance of lighting, and we must not overdo the

your gun is fitted to your camera and you have no extension. Moreover, we must avoid double shadows. The moral is, let flash help you but do not let it get out of hand. As a rough guide I would suggest that if your subject is seated in the sun-

but this is not always practical and the only way is to reduce the power of the light by some means or other as suggested.

Photographs in this article are on Ilford film.

We have now discussed some of the



Example of normal daylight picture taken indoors at 1/25 secs. f6.3, FP3 film. No details in the shadows.



Picture taken in same conditions but with flash, cardboard reflector being used. Same speed but at f11. An example of synchro-sunlight.

assistance from the flash. For example, you may find it advisable to tone it down by employing methods suggested earlier such as a cardboard reflector, or diffusion. In fact this will be essential if

shine near a window you could use a PF1 bulb at 1/25 second at f11 or f8 when 10 ft. or 12 ft. away on a panchromatic film. Many will say that the flash should be removed further away

ways of using flash itself and have to consider some practical subjects. This will be the main topic of our next article when we will make some suggestions and introduce another interesting effect.

A Handy Storage Unit

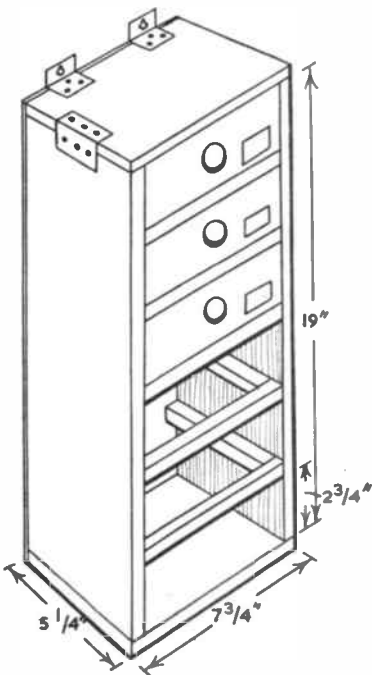

THIS set of drawers may be used in the workshop for storing in separate compartments small items such as screws, nuts and bolts, panel pins, rivets, and drills. Each of the six drawers is an Oxo tin measuring 6 1/2 in. by 5 1/2 in. by 2 1/2 in., which can be obtained from the grocer, though any similar box could be used, provided dimensions are changed to suit.

As shown in the diagram, the construction makes use of simple nail and glue joints, which should be quite adequate, but if thought necessary, four right-angled pieces of 1/8 in. mild steel may be used to give added strength. The frame can be made from any suitable wood which happens to be available, and here rough 1/2 in. wood coming from packing cases was used. The back of the frame is covered with hardboard or thin ply. Strips of 1/2 in. square wood are fixed inside at 2 1/2 in. intervals to hold the trays.

If possible, buy knobs which are designed to bolt to the box. Alternatively, knobs with screw fasteners can be

bought cheaply and screwed into small blocks of wood inside the tin. Two further pieces of right-angled steel can be used to hook the drawers on to screws in the workshop wall. Each tray may be partitioned to give separate compartments by securing pieces of 1/4 in. wood to the sides with small tacks through the tin.

Labels describing the contents should be glued to each box and covered with transparent material. (D.J.R.)

A free plan for making a Designagraph will be given with next week's issue. This ingenious instrument can be used by a youngster for making charming patterns and can also be put to good use for more serious purposes in the design field. Make sure of your copy of 'Hobbies Weekly'.

A CONTEMPORARY BEDSIDE TABLE

HERE is a practical bed-side table of modern design, which would be a useful addition to any bedroom. The central drawer is just right for small oddments, and behind it is an excellent hiding place for small valuables. The table is easily portable and, being three-legged, the whole structure is perfectly rigid.

Except for the legs and drawer face, construction is entirely of 9 mm. plywood, which should be chosen with a view to the final finish required. A cheap grade will do if the wood is to be enamelled, but for a highly polished finish a good quality veneered plywood is recommended.

Begin with the two curved pieces (A, Fig. 1), which are marked out as shown. The curve can be cut with a fret-

side only, take care to cut the housings into the veneered face of the bottom curved piece, but into the opposite face of the top piece.

By J. H. Parry

After a trial fitting, the table top is now ready for assembly. With well-fitting joints, a good quality wood glue is all that is necessary, but a few panel pins may be required to hold the back piece in place. See that the side pieces are square with the curved pieces, and clamp until the glue sets. Alternatively, place the whole top under an even weight such as a pile of heavy books.



purpose, but having marked and cut the top end of one leg, this can be used as a template for cutting the other two. The legs are attached to the body as shown in Fig. 7, using blocks of 1 in. by 1 in.

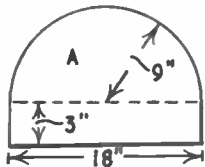

FIG. 1.

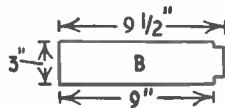

FIG. 2.

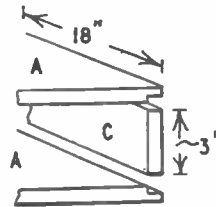

FIG. 3.

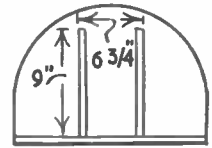

FIG. 4.

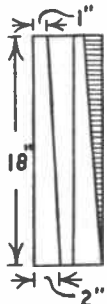

FIG. 5.

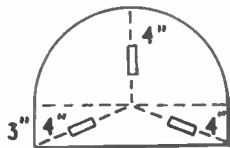

FIG. 6.

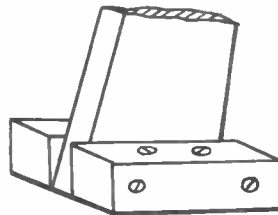

FIG. 7.

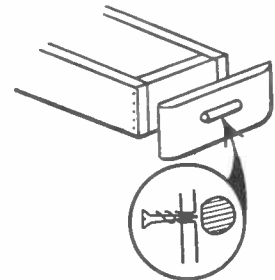

FIG. 8.

saw, after which the edges are cleaned up with glasspaper. Cut the two side pieces (B, Fig. 2) and one back piece (C, Fig. 3). C will be 18 in. long, and all three are 3 in. wide. The side pieces are housed into the curved pieces, the positions of the housings being shown in Fig. 4. Cut the housings by carefully removing three layers of ply. The inside back edges of pieces A are recessed, again to a depth of three layers of ply, to take the back piece (see Fig. 3).

If using plywood veneered on one

The legs are cut as shown in Fig. 5 out of $\frac{1}{2}$ in. hardwood. The length can be altered to suit individual needs, but 18 in. is a good average. Smooth down the cut edges with the plane, and round off the narrow ends to prevent damage to carpets, etc.

The positions of the legs are marked on the under side of the table, as in Fig. 6. They should be at such an angle to the table top that the lower ends do not protrude beyond the edge of the top. A slide bevel is the ideal tool for this

timber drilled and countersunk to take screws. See that the blocks are a flush fit with the side of the leg and the bottom of the table top. Glue and screw the blocks to the legs first, and then similarly fix the legs to the table top.

The drawer is a simple box construction, glued and panel pinned together, and 'faced' with a piece of hardwood (Fig. 8). This also acts as a stop to prevent the drawer being pushed

● Continued on page 23

MAKE A CASTLE FROM CARTONS

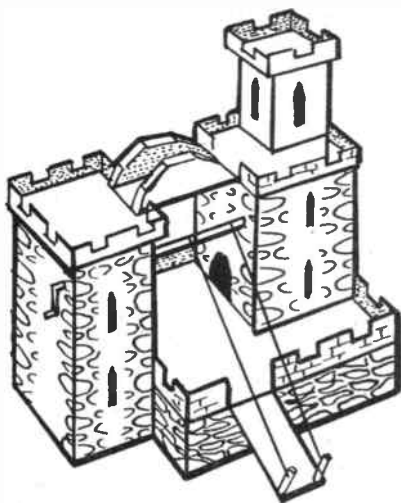

MODEL forts or castles which are large enough to house a whole army of toy soldiers can be made from empty cardboard containers and cartridge paper. The best type of box to use is the kind which has a corrugated paper filling between outer layers of thick paper, but this is not essential.

The castle shown uses four boxes, but more or less can be used according to the design and size of the model wanted.

First, the cartons are stuffed with enough crumpled newspaper to keep their shape, and then the flaps are glued down. The boxes are glued together in the chosen design as at A. When one box is glued on top of another, it should be fitted at the corner, so that at least two sides of each carton are flush with those below it. This gives added strength when the covering of cartridge paper is applied.

Battlements can be added by gluing lids to the tops of the cartons after the cut-out sections have been cut in the lids.

(B). These lids may be the same size as the cartons to which they are glued, or a little larger. Before deciding on the size of the battlements, it should be remembered that those lids that are the same size as the towers on which they stand are the easiest to cover with cartridge paper.

Adhesive tape can also be used to hold the pieces in position until a covering layer of paper has been applied.

The model is covered completely in cartridge paper, white shelving paper, or even ordinary brown wrapping paper. For the first layer, the paper is cut into squares of about 12 in., and after each piece has been coated with wallpaper paste, it is stuck in place.

The squares should overlap for strength, and each square should be trimmed and pasted over any corners before the next piece is pasted. The insides of the battlements are covered with a piece of paper cut as shown at C.

After the castle has been covered, it is left to dry out before the final layer of paper is applied. When this has been done, and is dry, the details are painted on. These will hide the joints in the paper covering.

The walls can be left white, and the stonework details added in ink or poster colours, as can the doors and windows. Another type of finish is to apply a fawn or grey water-

colour wash — it does not matter if this looks patchy — then paint in the stonework details over this with black ink or paint when it is dry.

Various extras can be incorporated, if desired. For example, a piece of thick card, hinged to the platform with sticking plaster, makes a drawbridge. It can be raised or lowered by a stiff wire or dowel windlass inserted in holes in two towers (D). A bridge connecting two towers can be made from two semi-circular cheese cartons, glued to a thick card base. An inkwell pressed into a hole cut in the platform can form a well. With a little ingenuity, other features can be copied from photographs and drawings of castles. (A.L.)

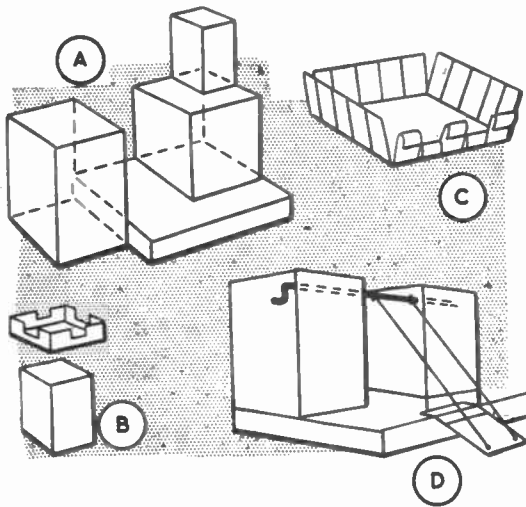

● Continued from page 22

A BEDSIDE TABLE

in too far. The length of the drawer is 9 in., but the other dimensions are best taken directly from the work. Make the drawer a fairly loose fit, and glue strips of felt underneath to prevent it from scratching the bottom of the table when in use. Before attaching the face piece to the drawer with screws from the inside, attach a small handle to it. A variety of these can be purchased quite cheaply, but it is a simple matter to make one out of a piece of $\frac{1}{4}$ in. dowel screwed from

the inside (Fig. 8).

Line the drawer with a gaily patterned self-adhesive plastic covering to facilitate cleaning. If the work is to be enamelled, use a contrasting colour for the plywood edges — black always looks well. If polishing is preferred, the problem of concealing the plywood edges can be overcome in one of two ways. They can be enamelled black as stated or covered with plastic material or veneer. Marquetry veneer is quite suitable for this

purpose, and very little of it is required. Cut the veneer across its grain into strips slightly wider than the plywood edges. Use contact adhesive, and the strips can be positioned at once without using adhesive tape to hold them in place. The edges can then be trimmed off flush with the plywood face almost immediately. Smooth down with fine glasspaper, and the work is ready for polishing. Note, however, that the plywood edges must be glasspapered perfectly flat before attempting to veneer in this way. If frequent cups of tea in bed are anticipated, the table top should be clear varnished, as this will withstand heat and hard wear much better than french or wax polish.

TOY PEG GUN

FIRES BROKEN MATCHES

* REPEATER ACTION

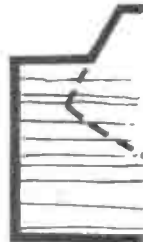

PIECES CUT TWO 1/8"

RUBBER BAND

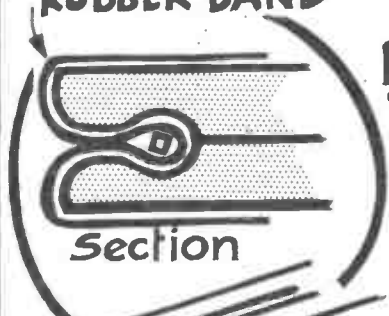

Section

PRESS PEG TO "FIRE"

PEG TAKEN APART ONE HALF SCREWED TO D

RUB BAND

T FRI

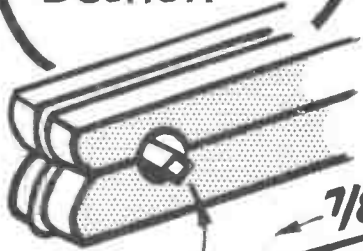

BROKEN MATCH

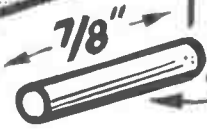

7/8"

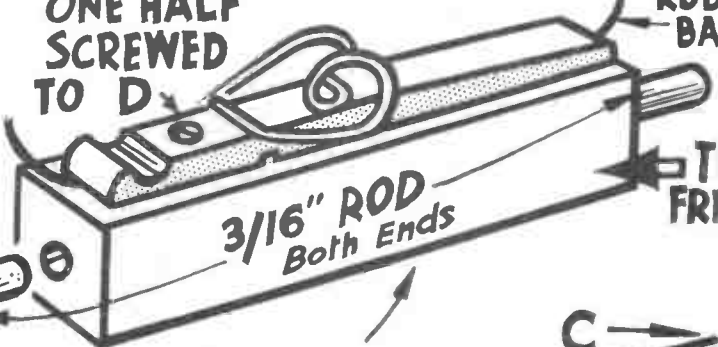

3/16" ROD Both Ends

PEG SCREWED ON EACH SIDE OF D

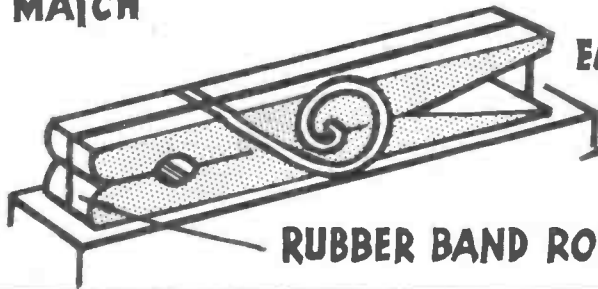

RUBBER BAND ROUND PEG

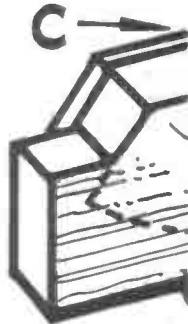

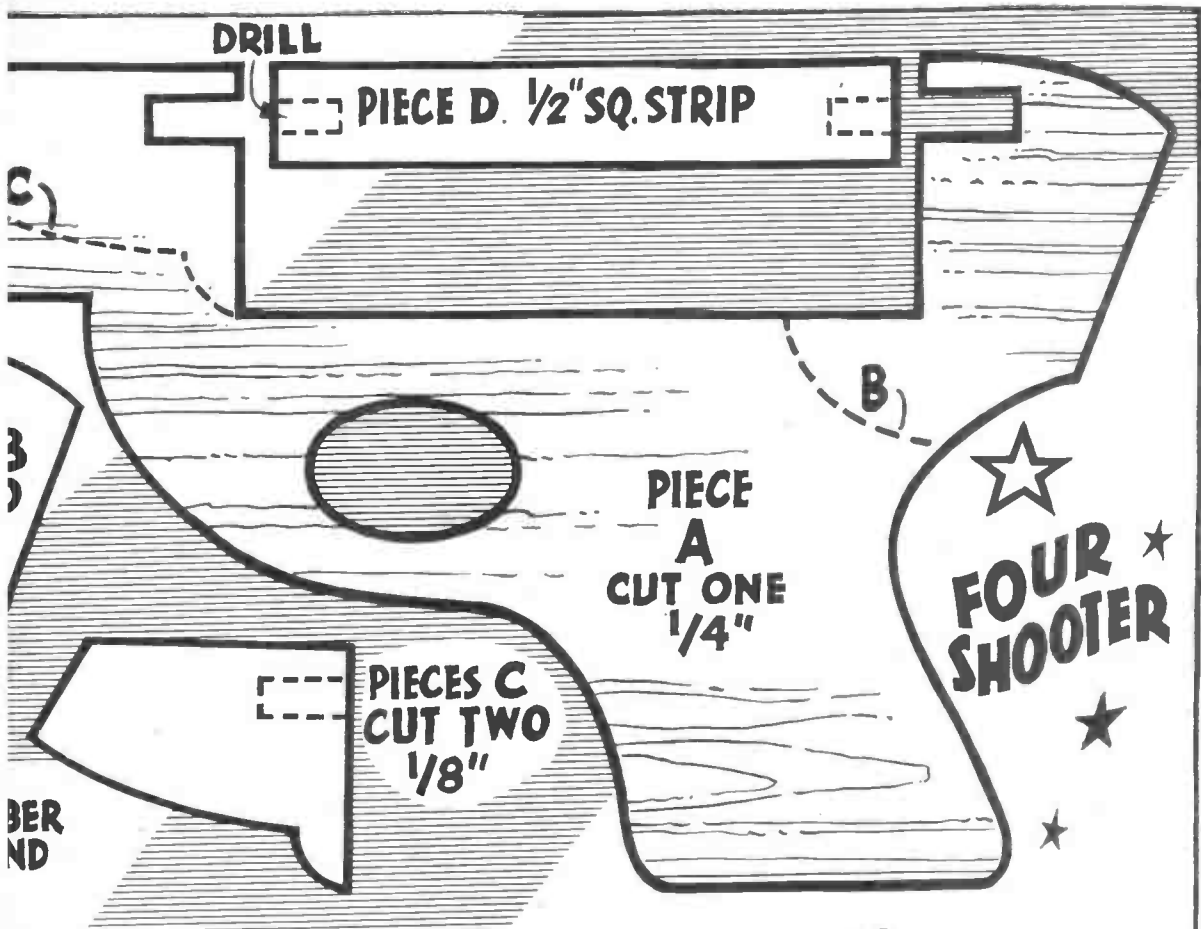

THIS PIECE REVOLVES
FREELY IN SLOTS IN A

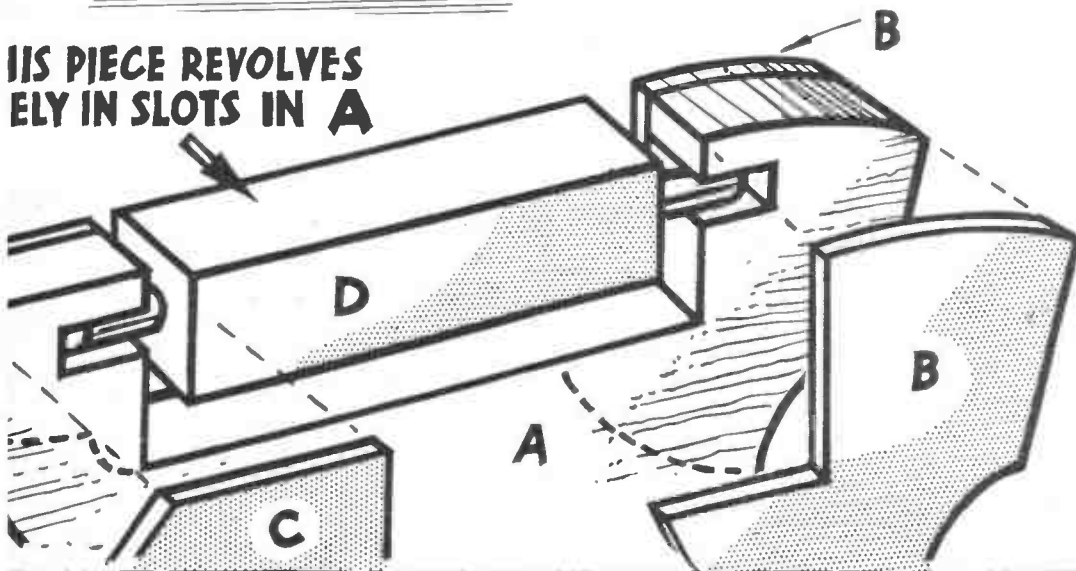

• PRINTED IN ENGLAND •

CHEMISTRY AT HOME

COMPOUNDS of the metal calcium, Ca, are ever present with us — and even in us, for the mineral matter of our bones consists mainly of calcium phosphate, $\text{Ca}_3(\text{PO}_4)_2$. The boiled egg you eat is cased in a shell of calcium carbonate, CaCO_3 , the plaster of Paris you use for odd jobs is calcium sulphate, $\text{CaSO}_4 \cdot \frac{1}{2}\text{H}_2\text{O}$, quicklime is calcium oxide, CaO , and the hydrated lime we dig into our gardens is calcium hydroxide, $\text{Ca}(\text{OH})_2$.

EXPERIMENTS WITH CALCIUM COMPOUNDS

Several calcium compounds are just as useful in the laboratory and many interesting experiments can be done with them. Let us start with calcium carbonate, which pharmacists sell as precipitated chalk. Whiting also is calcium carbonate. Mixed with linseed oil it gives us glaziers' putty. If you ever have the need to use large quantities of putty, you will find it infinitely cheaper to make your own. Many handymen try, but end up with a sticky, unmanageable mess.

Here is the right way to make it. On an old tin tray or lid make a cone of one pound of whiting. Make a hollow in the tip by pressing in a thick rod and pour in 4 fluid ounces of boiled linseed oil. Leave it to soak in. Then work up the putty until the oil is evenly absorbed.

Precipitated chalk is a gentle yet effective abrasive. Hence it may be used in silver polishes and tooth powders. The most tarnished silver brightens at once when rubbed with a special chalk-containing polish. To make up a supply, dissolve 8 grams of soap in 80 c.c. of hot water, H_2O , allow to cool, stir in 1 c.c. of strong ammonia (of specific gravity 0.88), NH_4OH , and then add 16 grams of precipitated chalk. Keep the product in a screw-capped bottle and shake before use.

Dentists have criticized some modern toothpastes for their too harshly abrasive nature. The danger is avoided by using a powder consisting of an intimate mix-

ture of one part by weight of precipitated chalk and one of orris root powder.

Like many other metals, calcium has a characteristic flame colour. Dip the tip of an iron wire, Fe, into solid calcium chloride, CaCl_2 , and then hold the tip in a spirit lamp or gas flame. A brick-red colour is imparted to the flame. Strontium, Sr, and lithium, Li, salts also give red colours in a flame, but comparison will show their distinct shade differences from each other. Again, if viewed through a piece of blue glass, the calcium flame appears green, whereas similarly viewed the strontium flame remains red, and the lithium flame is decolourized.

Gypsum and alabaster consist of hydrated calcium sulphate, $\text{CaSO}_4 \cdot 2\text{H}_2\text{O}$. By heating gypsum to 100 to 120°C. it loses three-quarters of its water and becomes plaster of Paris:



As is well known, this sets to a hard mass when mixed with water.

Now let us see what happens when calcium sulphate is anhydrous, CaSO_4 . First we must prepare the dihydrate, $\text{CaSO}_4 \cdot 2\text{H}_2\text{O}$. To a solution of calcium chloride add dilute sulphuric acid, H_2SO_4 , a little at a time until a filtered specimen no longer gives a white precipitate with dilute sulphuric acid. The white precipitate is, of course, the dihydrated calcium sulphate, and is

formed by simple double decomposition:
 $\text{CaCl}_2 + \text{H}_2\text{SO}_4 + 2\text{H}_2\text{O} =$



Filter off the calcium sulphate and run several lots of water through the filter so as to free the precipitate from hydrochloric acid, HCl. When one wash water no longer turns blue litmus paper red the hydrochloric acid is entirely removed and the precipitate may be allowed to dry in a warm room.

Now heat up the calcium sulphate to redness in a crucible (see diagram) and allow it to cool. At this high temperature the calcium sulphate loses all its water of crystallization and becomes anhydrous. Mix it to a paste with some water and let it stand awhile. It does not harden like plaster of Paris. That half molecule of water in plaster of Paris therefore confers the property of hardening with water. When hydrated calcium sulphate has been heated at too high a temperature it is known as 'dead burnt', because it is no longer 'live' when acted upon by water.

Our bones consist of about one-third organic matter and two-thirds mineral matter. As has already been noted, calcium phosphate makes up the bulk of the mineral matter. The proportion of calcium phosphate is roughly 80 per cent. Therefore bone ash, or bone which has been burnt white, cannot be regarded as a pure enough specimen of calcium phosphate for our laboratory stocks.

By precipitating calcium chloride solution with a solution of sodium phosphate, $\text{Na}_2\text{HPO}_4 \cdot 12\text{H}_2\text{O}$, containing ammonia, NH_4OH , we obtain the pure compound, while sodium chloride (salt), NaCl, and ammonium chloride (sal ammoniac), NH_4Cl , remain in solution:



Dissolve 23.8 grams of sodium phosphate in 220 c.c. of hot water, let the solution cool and stir in 8 c.c. of strong ammonia (of specific gravity 0.88). Into this solution stir one of 11.1 grams of calcium chloride in 100 c.c. of water. Wash the white precipitate of calcium phosphate by decantation in a large bottle, such as a winchester, fitted with a siphon. When a sample of one wash no longer gives a white precipitate of silver chloride, AgCl, with a few drops of silver nitrate solution, AgNO_3 , the calcium phosphate is free from chlorides.

Filter it off and let it dry. It then forms a white earthy powder.

Strictly speaking this calcium phosphate is tricalcium orthophosphate. Other phosphates exist, notably dicalcium orthophosphate, $\text{Ca}_2\text{H}_2(\text{PO}_4)_2 \cdot 5\text{H}_2\text{O}$. It is formed as a white precipitate on adding sodium phosphate solution to a cold solution of calcium chloride acidified with acetic acid, CH_3COOH .

• Continued on page 27

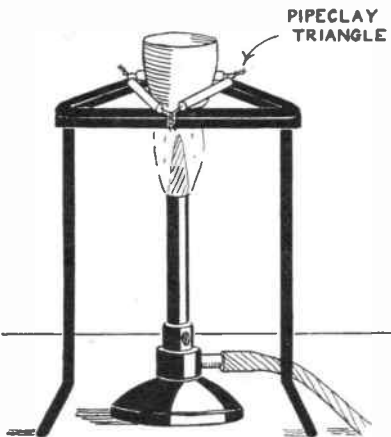

Making 'dead burnt' plaster of Paris

AN UNUSUAL READING LAMP

By *A. Liston*

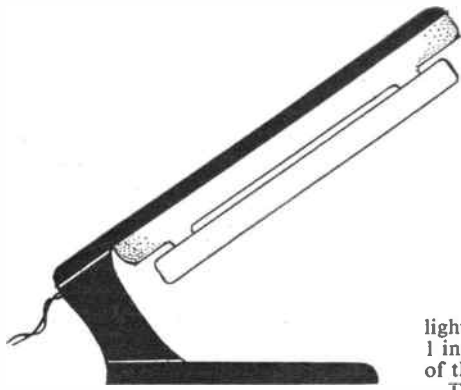

AN attractive desk lamp or reading lamp in the unusual style shown is very easy to make. The light fitting is of the type known as an architectural striplight, which can be

light fitting, and the rear end tapers to 1 in. along its last 2 in. The upper edges of the strip can be rounded off.

The parts are assembled as shown at D. First, the lampholder is wired up and screwed to the underside of the 15 in. strip, leading the wires from the rear of the holder. It is better to cut a small groove in the wood to let the flex

to be led away at the back, with a torpedo switch a few inches from the lamp.

A push switch can be inserted in a hole in the base if it can be incorporated within the thickness of the wood. If this is done, the flex is led down the front of the upright section and through a hole in the base to the underside of the

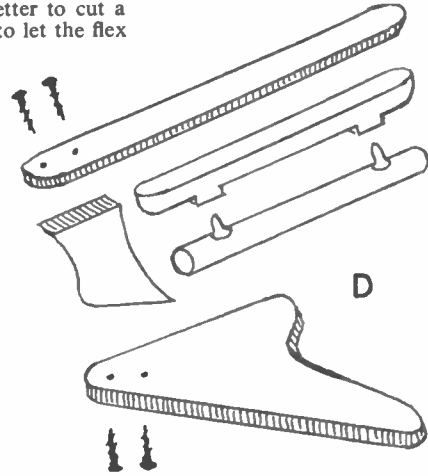
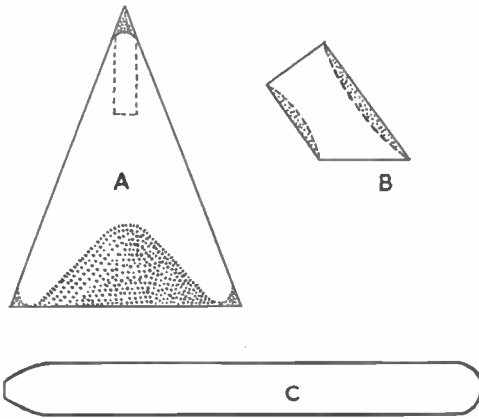

bought complete with plastic holder. The fitting shown has a 12 in. light and a 13 in. long holder, and the lamp is based on these dimensions. It can, of course, be modified to take a fitting of slightly different size.

The base A is made from a triangle of $\frac{1}{2}$ in. or 1 in. thick wood. It is 9 in. high and 7 in. wide at the base. The corners are rounded off, and a 2 in. deep V-shape is cut on the short side of the base, as shown. These cut-off sections are shown shaded.

The upright section B is a length of 2 in. by 1 in. wood, 3 in. long on the front edge, and $1\frac{1}{2}$ in. long on the rear edge, so that it stands at an angle, as shown. The front and rear edges may be made concave, if desired, as shown by the shaded sections, and the rear edges rounded off.

The upper strip C, to which the light is screwed, is 15 in. long and 2 in. wide, and is made of $\frac{1}{2}$ in. thick wood. The front end is rounded to the shape of the

pass under the holder than to file a notch in the plastic, as this sometimes proves brittle.

The upright section is then glued and screwed to the base, and the top section glued and screwed to the upright section. The flex is stapled to the upright section

switch. In this case, the lamp must stand on rubber studs to allow the flex to run below it.

The lamp can be stained, varnished, or painted in any suitable colour, and a piece of thin felt glued to the underside of the base to protect polished surfaces.

● **Continued from page 26**

CALCIUM COMPOUND EXPERIMENTS

Calcium acetate, $(\text{CH}_3\text{COO})_2\text{Ca}$, sodium chloride and hydrochloric acid, HCl, remain in solution:

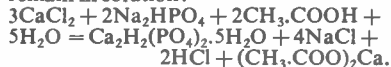

First dissolve 23.8 grams of sodium phosphate in 220 c.c. of hot water and let the solution grow cold. Dissolve 7.4 grams of calcium chloride in 100 c.c. of water, add 4 c.c. of glacial acetic acid and then stir in the sodium phosphate solution. The bulky white precipitate of

dicalcium orthophosphate fills the liquid. Do not filter it off at once, but allow the whole to stand a few hours. A startling change takes place. The bulky white precipitate changes to beautiful sparkling small crystals and sinks in the liquid.

It is now much easier to filter off. Wash it on the filter until it is shown to be free from chlorides by a sample of one wash water giving no precipitate of silver chloride on the addition of a few drops of silver nitrate solution. Then let the precipitate dry.

For camping enthusiasts

CHECKING YOUR EQUIPMENT

CAMPING enthusiasts must check over all their equipment before embarking on a tour and this will include such things as cooking utensils, stoves, ground sheets, sleeping bags, lamps and tents.

Although many cooking utensils are made from aluminium some are tinplate and cleaning for each is very much different. We trust that they were cleaned last year before being stored away, for any remaining traces of food which has gone stale could cause illness and perhaps stomach poisoning. All tinplate should be scoured with steelwool and then boiled in water containing powdered borax or soda. Rinse out thoroughly with cold water, dry, and leave out in the fresh air to sweeten. You should also make sure the vessels are watertight.

Aluminium ware should not be subjected to boiling in water which contains soda since this will react and turn them black. The alternative is to apply steel wool and boil in clear water only. You may have to use a large boiler or a bucket placed on a gas ring for this boiling process. Incidentally, if an aluminium plate or pan accidentally gets into the soda water by mistake it can be treated with a weak solution of nitric acid to restore the brightness — but give a thorough washing again after this treatment.

It is quite possible that your equipment includes a stove of some kind. The half pint Primus is popular since it only weighs just over 1 lb. and is compact. Any removable parts should be taken off and boiled in clear water to remove any possible collections of grease. Verify that all the parts are present and that there are two pricklers for cleaning — one may

break! If you are doubtful about the pump unscrew the plunger and check the condition of the washer. It should be reasonably pliable.

Leaks round the burner can be detected by pumping up and then placing the whole stove into a bucket of water. Should there be any looseness, a little tightening will remedy.

You may possess a canvas bucket for carrying your water and an examination of this is obviously indicated. Open out the bucket, pressing out to as near the usual shape as possible and place under a water tap. When filling for testing you may find that water pours out at the side but keep on filling. Ultimately you will find that the canvas swells, the leak stops and the bucket is water tight. If you now empty the water, dry and collapse the bucket it will be quite alright for use if you require it during the next few weeks.

One of the most important items of equipment for the camper is the groundsheet and to safeguard your health it is essential to prevent dampness from rising from the ground. A worn, cracked sheet is no use whatsoever and to use it in this condition is merely inviting trouble, so invest in a new one. At the same time small tears can be repaired if the edges are drawn together and sewn with fine stitches and then covered with a strip of vulcanized cycle patching. Small holes can be repaired with circular patches, one on each side.

The sleeping bag should now be given a thorough testing. Examine for tears, repairing each one individually. The bag has a filling of wadding and after some time there may be a tendency for this to go lumpy. It will be more comfortable if you try to even out this defect, securing

with a few stitches here and there if necessary.

No camping equipment is complete without some kind of lamp for the tent and unfortunately we cannot always rely on bicycle lamps. Even in this age we still find that a candle lamp is suitable, easy to carry, yet gives a soft homely light — and there is so little to go wrong provided you keep your matches dry and take precautions against fire.

What about your tent? There is no better way to test this than by erecting it, examining it from both the inside and outside for any weaknesses. The peg loops and tapes may require your attention or replacement, and if there is any break in the stitching at any point make reinforcements. If there is any weakness at the crown, where the pole emerges, sew in a new collar. Then test for waterproofing. Here you may need some assistance; ask a friend to direct a garden hose on the erected tent while you sit inside. Should you trace a leak you should apply one of the proprietary proofers. You can, of course, apply your own proofer. Make a solution of alum and another solution of soap; apply coating of each with large brush alternately.

Another gadget you may find useful is a screen for your stove. In gusty weather, this will help to keep the flames underneath whatever vessel is on the stove. All you require is some thin material like silk or fine cotton about 18 in. wide and 40 in. long. Sew an umbrella rib or length of wire to each end and then two others at equal distances from the ends, making a kind of box kite with prongs sticking out at the bottom. Stick it into the ground after fitting round the stove. (S.H.L.)

LET 'Plasticine'

★ HELP YOU DO-IT-YOURSELF Regd. Trade Mark
Special Trial Offer. We will send 4 lb. 'Plasticine' (any colour) with booklet 'Plasticine Modelling for Amateurs' Post free: 10/- U.K. only.
Harbutt's Plasticine Ltd, Bathampton, Bath

KITS for OLD TIME SHIPS

Hobbies range of Ship Models includes Elizabeth Jonas, Cutty Sark, Victory, Mayflower, etc. Complete kits of wood, sail material, guns, pulleys, cord, etc., with full-size patterns of parts and planed wood ready to cut out, shape and construct. A fascinating pastime.

Ask for free illustrated list at Hobbies Branches or from Hobbies Limited, Dept. 99, Dereham, Norfolk.

The Pistol all your chums will envy!

Webley AIR PISTOL



- ★ High Accuracy and Hitting Power
- ★ Perfect Balance
- ★ Robust Construction

Send for catalogue

WEBLEY & SCOTT LTD

34 PARK LANE, HANDSWORTH, BIRMINGHAM 21. West Bromwich 2821

One of the Windsor Group of Companies

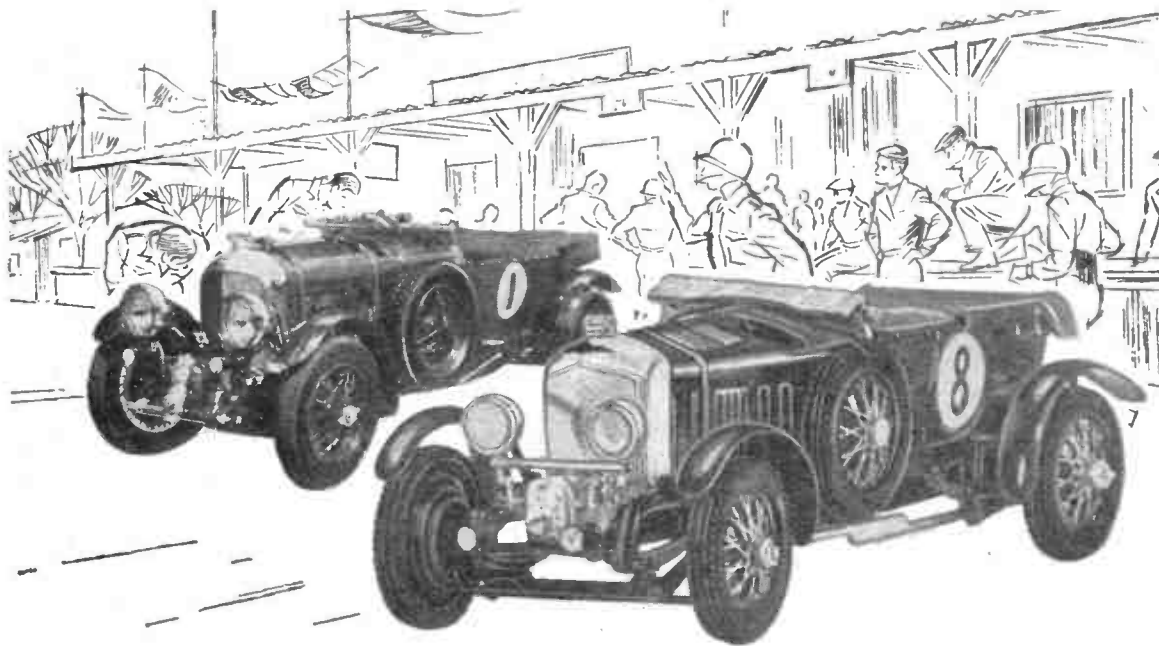

Just like the real thing!

Believe it or not, the nearer one is the Airfix model of the 1930 Bentley, 1/32nd scale (Kit 2/-). Behind it is a picture of the real thing.

That's how wonderfully realistic Airfix models are! Close attention to every detail gives them their faithful-to-the-original look—makes them true collector's pieces. And every Airfix series is to a constant scale. This means Airfix models look proportionally right, one against another, because they *are* right! You can't beat Airfix for realism—or value.

AIRFIX

Constant Scale Construction Kits

From Model & Hobby Shops, Toy Shops and F. W. Woolworth

There are over 100 Airfix models from 2/- to 10/6.

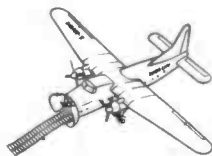

AIRCRAFT

Bristol Superfreighter 7/6

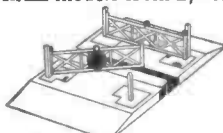

TRACKSIDE SERIES

Level Crossing 2/-



MODEL FIGURES

Lifeguard 2/-

BRITISH WARSHIPS

H.M.S. Cossack 2/-

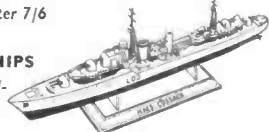

C.160

.STOP PRESS!

Latest Airfix Production

OO GAUGE DIESEL CRANE

A fully working model of the 15-ton diesel locomotive crane used on British Railways Western Region. 79 part kit 3/-

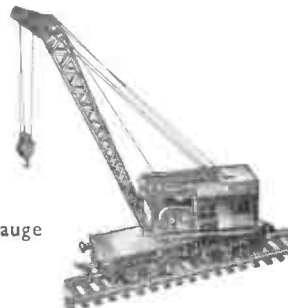

Also new: OO gauge 16-ton mineral wagon 2/-

Mosaitry House-Name Kits

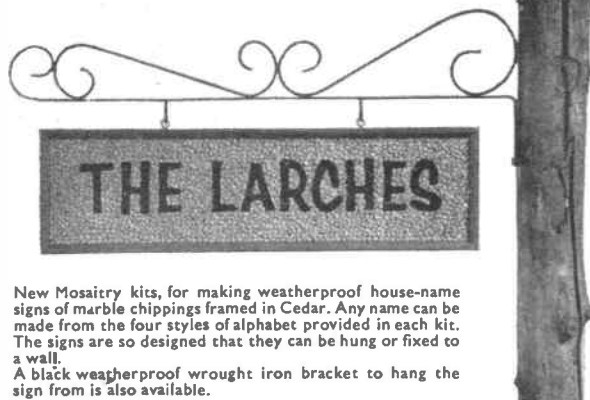

New Mosaitry kits, for making weatherproof house-name signs of marble chippings framed in Cedar. Any name can be made from the four styles of alphabet provided in each kit. The signs are so designed that they can be hung or fixed to a wall. A black weatherproof wrought iron bracket to hang the sign from is also available.



ATLAS Handicrafts
Descriptive leaflet "F19" from Desk "B"

House-Name Kits

18/6

from your
'ATLAS'
Stockist

SPRING ALLEY
MANCHESTER 4



The
STRONGEST
handy glue

STILL ONLY

1/2 a large tube

Completely new 54 page Edition
WHERE'S THAT CAR FROM?

Price 1/- (Postage 4d.)

Of all Booksellers

or

RALEIGH PRESS, Exmouth, Devon

100 DIFFERENT stamps free! Request 1d. upwards discount approvals. — Bush, 53 Newlyn Way, Parkstone, Dorset.

50 MIXED stamps 5/-. Try our 6d. in 3/- discount approvals. — E. C. F. Townsend, 92 Tenby Road, Edgware, Middx.

PROFIT AND PLEASURE are obtainable from **WRITING** (typewriter unnecessary) or **ARTISTRY**. Send for free fascinating bumper package 'PROFITABLE LEISURE'. — Writers & Artists' Ring (HW), 5 Edmund Street, Birmingham.

LEARN RADIO & ELECTRONICS the NEW Practical Way! Very latest system of experimenting with and building radio apparatus — 'as you learn'. FREE Brochure from: Dept. H.W.10, Radiostructor, 40 Russell Street, Reading, Berks.

WORKERS with sewing machines required for making cushion covers. Regular work guaranteed. Apply Dept. 28, Arnold Trading, 10 Shelley Road, Worthing, Sussex.

LEARN

RADIO & T/V SERVICING
for your **OWN BUSINESS/HOBBY**

● by a new exciting no-maths system, using practical equipment recently introduced to this country
FREE Brochure from:—

RADIOSTRUCTOR

DEPT. G81, READING, BERKS.

12/4/61

PERSONS (either sex) soft toy assembling in spare-time. The ideal profitable pastime. Everything supplied. Details s.a.e. Dept. H.W., Cuddycraft Supplies, East Road, London, N.1.

BUYING OR SELLING?

Classified advertisements on this page are accepted at a cost of 6d. per word prepaid. Use of a Box No. is 1/- extra. Send P.O. with advertisement to **Hobbies Weekly**, Advert. Dept., Dereham, Norfolk. Rates for display advertising on application.

Got your copy yet?

HOBBIES 1961
ANNUAL

180 pages — crammed with ideas
There may be a copy available at your newsagents
price only 2/-

If in difficulty send 2/6 (including postage) to:
HOBBIES LTD, DEREHAM, NORFOLK

30

"GLOBE-KING"

WORLD-FAMOUS KITS AND RECEIVERS

for the Radio Amateur and S.W. Listener. Catalogue Free, enclose stamp for postage. Kits from 79/6 obtainable at your dealers or direct from the sole manufacturers

JOHNSONS (Radio)

ST. MARTINS GATE — WORCESTER

FOR MODEL MAKERS

THE 'MIGHTY MIDGET' electric motor, only 1½ in. high. Runs at 10,000 R.P.M. from a 4½ V. torch battery. Minute current consumption. Complete with pulley, price 10/6, postage 6d. **MODEL BOAT PROPELLER**. 3 blades, shaft, pulley, and 5½ in. long stern tube, to run off above 'Mighty Midget'. Price 7/3, plus 6d. postage. **HOBBIES LTD.** (Dept. 99), DEREHAM, NORFOLK.

HULL

DO YOU KNOW?

HOBBIES LTD. have a branch at
179 FERENSWAY

where the manager and staff are always willing to give you the benefit of their experience with any of your handicraft problems. Why not pay a visit?

A VASE HOLDER

CUT one each of A and B from $\frac{1}{4}$ in. wood with a fretsaw. The pieces are simply slotted together without the use of glue. The holder can then be stored flat. The two pieces are cleaned up and painted. The plastic vase is Hobbies No. 6002, which can be obtained direct from Hobbies Ltd, price 1/-, post 4 $\frac{1}{2}$ d. (M.p.)

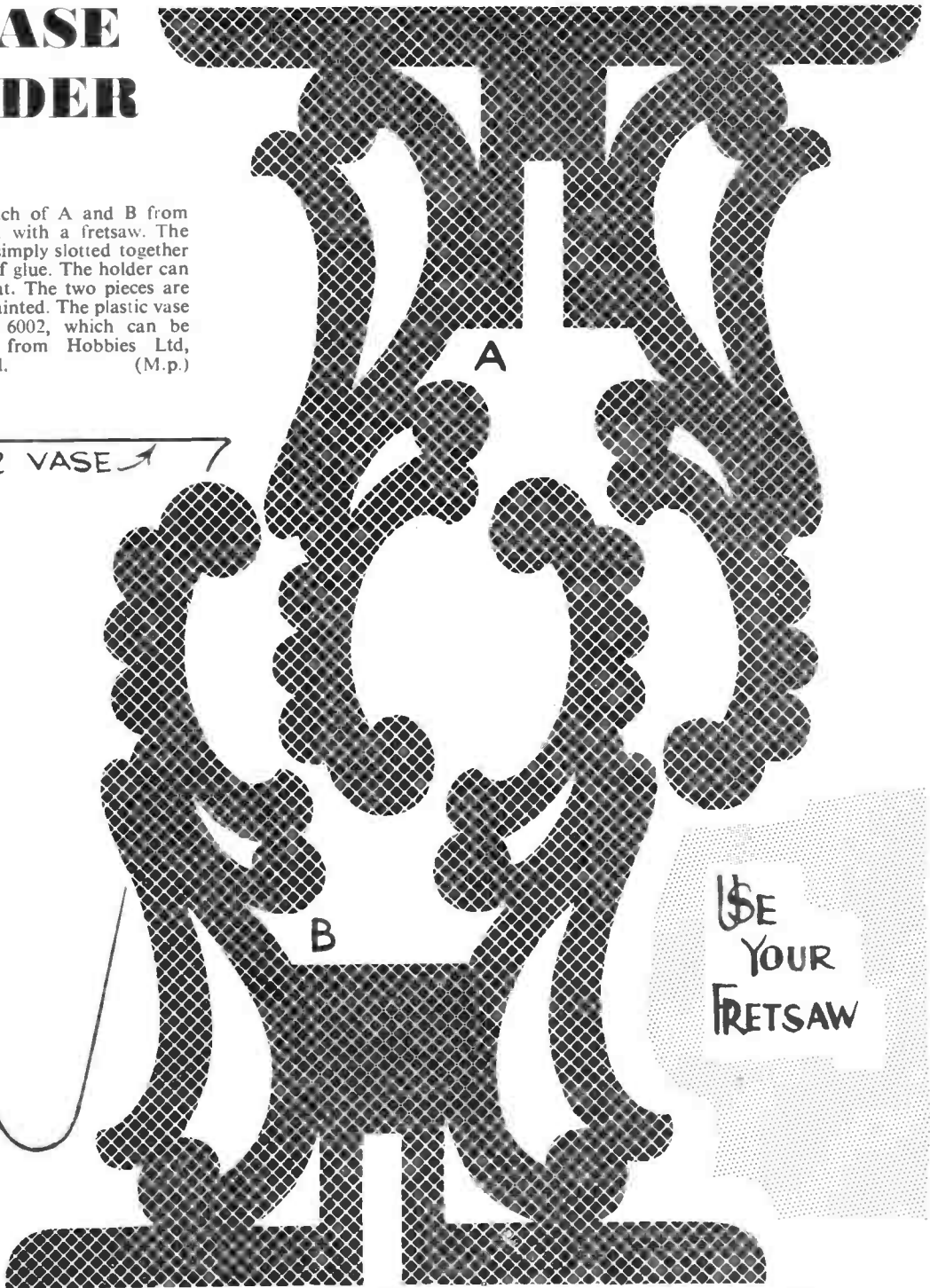
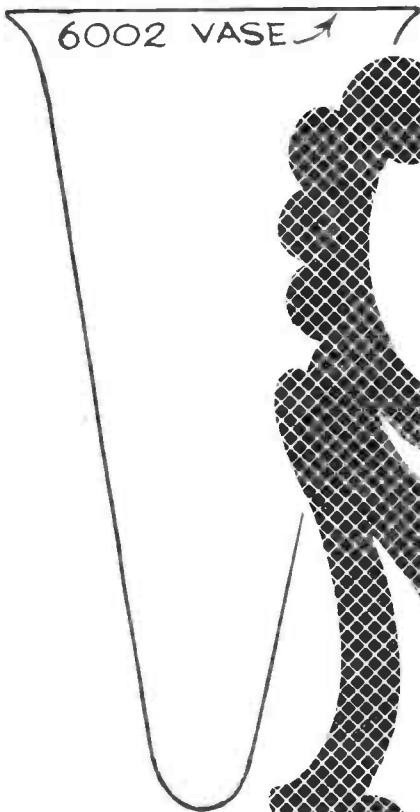

THE HANDYMAN'S GUIDE TO GOOD GLUING

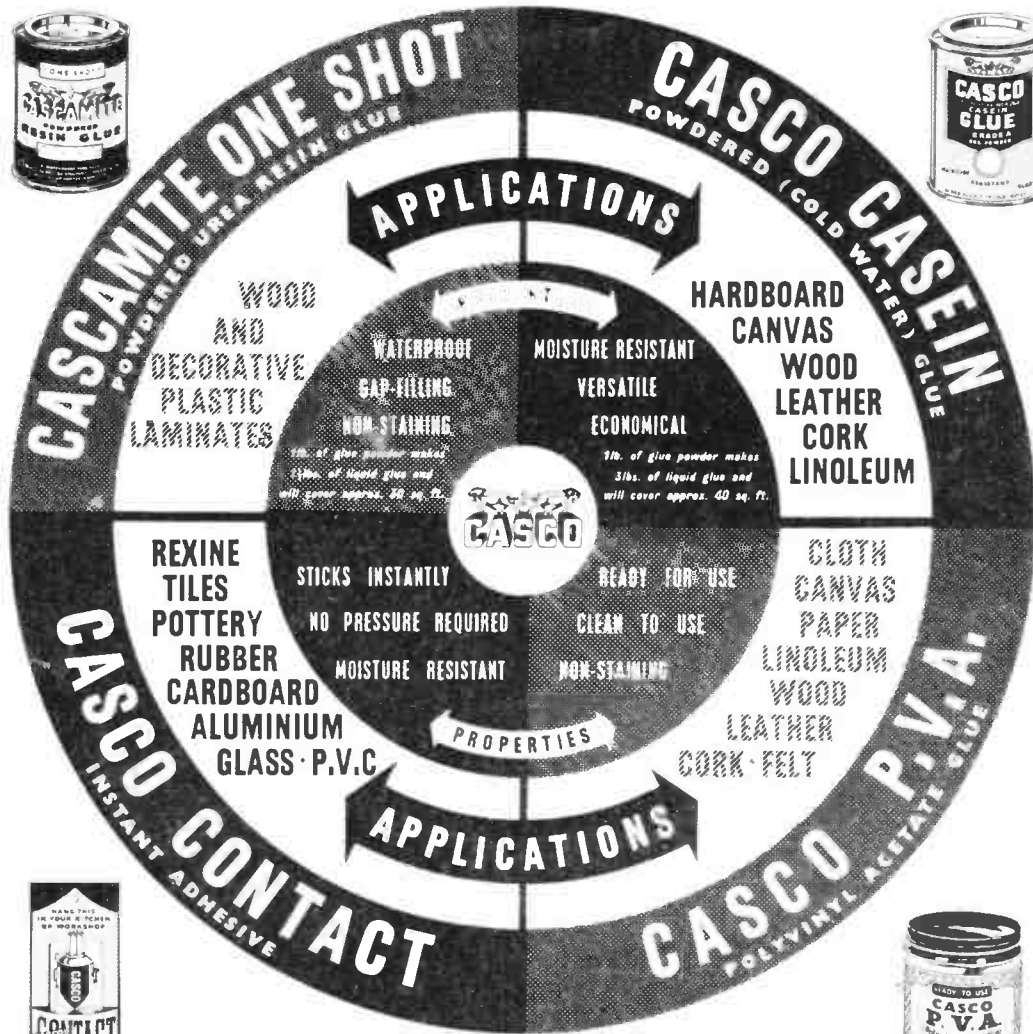

CASCO GLUES and ADHESIVES

Obtainable from Ironmongers, Hobbies Shops, Builders' Merchants, etc.

131 Manufactured by LEICESTER LOVELL & CO. LTD · NORTH BADDESLEY · SOUTHAMPTON · ROWNHAMS 2131 (8 LINES)

CUT OUT THIS CHART AND KEEP IT FOR READY REFERENCE