

HOBBIES WEEKLY

DECEMBER 10th 1958

VOL. 127

NUMBER 3293

IN THIS ISSUE

	Page
Bird Table - - - - -	161
Some Decorations to Make - - - - -	163
Japanese Lanterns - - - - -	164
Make Seasonable Serviette Rings - - - - -	165
Mainly for Modellers - - - - -	166
'Log' Candle Holders - - - - -	167
Patterns for The Pecking Canary - - - - -	168
A 'Television' Photo Frame - - - - -	170
Collectors' Club - - - - -	172
Formulas for the Handyman - - - - -	174
Patterns for Novel Christmas Cards - - - - -	175



All correspondence should be addressed to the Editor, Hobbies Weekly, Dereham, Norfolk



*A pleasing
project for
all lovers
of our
feathered
friends*

Make this attractive

BIRD TABLE

WITH 'THATCHED' ROOF

161

IT is time to think of providing extra food for the birds during the winter months. The robins and blue-tits especially will welcome any scraps that you can provide.

The table should be hung on a wall, preferably in a position sheltered from the prevailing winds, and if possible in the sun. It is advisable to hang it where it can be seen from the house so that the antics of the birds may be watched.

**FULL INSTRUCTIONS FOR
MAKING ON PAGE 162**

FOR ALL HOME CRAFTSMEN
Over 60 years of 'Do-it-Yourself'

World Radio History

4¹/₂^{ID}

Making up the BIRD TABLE

As will be seen in the illustrations the table consists of a roof, and a platform upon which the food is placed. Pieces of fat, coconut and peanuts may be hung underneath the platform from hooks placed there for this purpose.

Before commencing work study the diagrams and make any alterations to size you may think necessary. The measurements shown need not be strictly adhered to and can be increased or decreased according to the wood available.

Fig. 3—Enlarge squares to 1 in. and draw in shape of brackets.

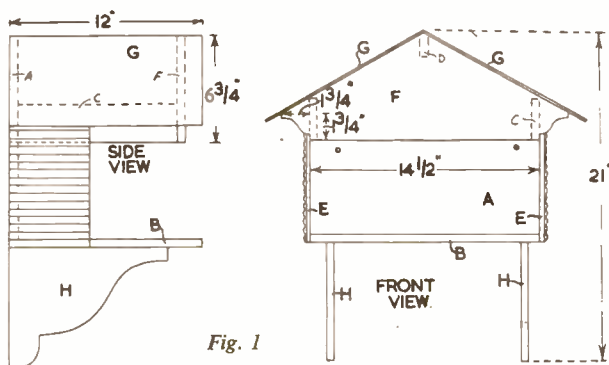
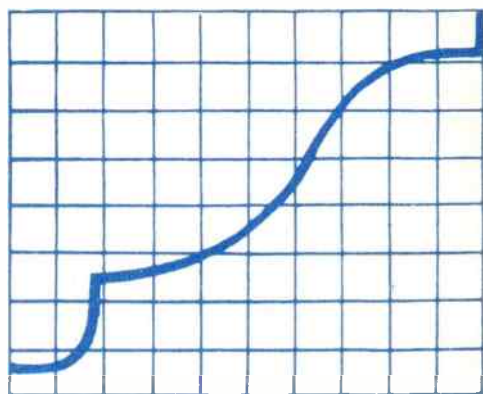

Fig. 1

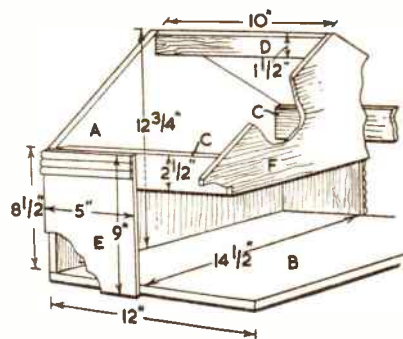

Fig. 2

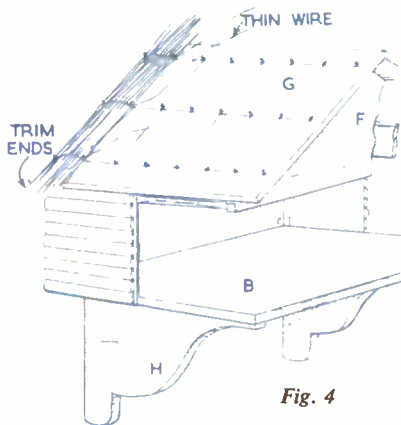

Fig. 4

The diagram in Fig. 1 shows the overall measurements and Fig. 2 the various parts in detail. The roof (G) and the side pieces (E) are cut from $\frac{1}{2}$ in. wood and the rest from $\frac{1}{4}$ in.

The back (A) $14\frac{1}{2}$ ins. wide and $12\frac{1}{2}$ ins. high is pinned to the platform (B) which

is $14\frac{1}{2}$ ins. by 12 ins. Now cut out and pin in position pieces (C), (D) and (F). Piece (F) is drawn out according to the measurements in Figs. 1 and 2. Note that the ridge piece (D) must be chamfered to take the roof slopes (G). The chamfer will be the same angle as the slope of pieces (A) and (F).

The roof slopes measure 12 ins. by ins. by $\frac{1}{4}$ in. and can be made up from one or more pieces if required. Chamfer to fit at the top and pin them in position.

The shape of the brackets (H) is obtained from the squared diagram in Fig. 3. Enlarge the squares to 1 in. and draw in the shape. Transfer to $\frac{1}{2}$ in. wood and cut out with a fretsaw. Pin the brackets in the approximate positions shown in Fig. 1, front view.

Rustic appearance

To give a rustic appearance Hobbies No. 35 $\frac{1}{2}$ in. half-round beading is cut into 5 in. lengths and pinned to pieces (E) as indicated in Figs. 1 and 2. The beading costs 9d. per 3 ft. length, postage and packing 1/6d. extra on any length.

The thatching is carried out as shown

in Fig. 4. Remember that the thatch is for appearance only and therefore need not be laid very thick. It is sufficient to cover the roof with a thin layer to give a neat and attractive finish. We recommend using grass gathered from the hedgerow for this purpose. Gather a few handfuls of flowering stalks and lay them out to dry for a few days before using.

Finish with creosote

Mark off the roof as shown in Fig. 4 and insert fretpins at intervals. Using fine wire obtained from an odd piece of flex, secure the grass as indicated, trimming the ends for a neat finish. The roof may be capped by a strip of tin, roofing felt or linoleum, pinned in position.

To keep the rustic appearance the whole table should be coated with creosote and allowed to dry thoroughly before putting into use.

To affix in position drill two $\frac{1}{4}$ in. diameter holes in the back, into which are inserted two 2 in. round-head screws. Drive these into prepared Rawlplugs in the wall.

(M.h.)

SOME DECORATIONS TO MAKE

THE Christmas season provides us with a good excuse for decorating our homes but there is no reason why you should maintain the old-fashioned idea of paper chains. You will probably have all the materials handy for making some of the following, most of which can be quickly improvised at the last moment if necessary.

Covered wooden hoops are extremely effective and these can be suspended in corners of the room or hung high on the walls. You may use a child's hoop, embroidery frame or make some from stout wire or basketry cane. The hoops are covered with gay ribbons or brightly coloured crepe paper, with a few baubles hung here and there. The size of the hoop is not important except where several

Twigs from your garden can be coated with ordinary white plaster of Paris and used for hanging small coloured baubles. The twigs may also be stuck in a large potato, sliced flat to form a base, when you will have an attractive arrangement for the centre of the table if the potato is disguised with a little additional trimming. You will have to use your own judgment on the size of twigs and since potatoes 'bleed' a little after cutting, a

by transparent scotch tape and cotton thread.

Strangely enough, snow is usually absent at Christmas time, except on the cards, but a nice snowman can be made from material that will not melt quite so rapidly. For this you will need an empty milk bottle, covered with cotton wool. Shape some old newspaper into a ball, tying round the neck of the bottle so that it forms a head, cover with cotton wool,

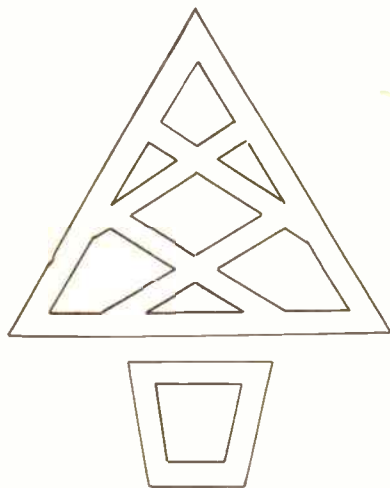

are to be used together. A further modification of this decoration is the introduction of a cut-out star in the centre, prepared from cardboard and covered with scraps of silver paper to make a glittering effect. Paper or ribbon is wrapped round the hoop frame until covering is completed, the end being fastened with a pin or thread. Silver paper can be attached to cardboard with glue.

A similar hanging effect may be achieved by covering ordinary coathangers with coloured crepe paper and then suspending various baubles, twigs and other symbols of the festive season, or perhaps crackers and presents. These arrangements should be hung at a reasonable height and in a position least likely to be a nuisance.

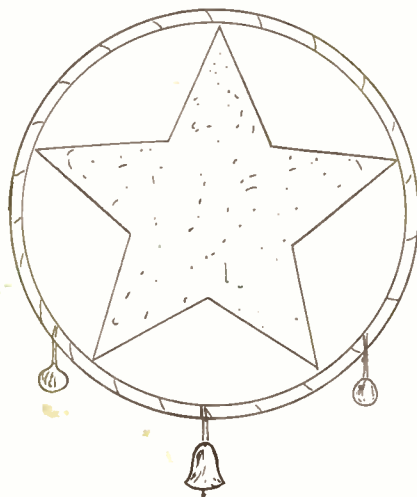

short period should be allowed for drying. Plaster for this purpose should be mixed to a creamy consistency in a bowl, the twigs dipped in and any surplus removed by shaking. Needless to say, it is advisable to perform this operation out of doors!

If you have not sufficient room for a real Christmas tree you need not despair. You may attach strips of green scotch tape to the window panes, or mirror, using the same material for hanging on the baubles, and making a 'tub' from red tape. Obviously, some care is required in attaching the tape to the exact pattern as shown in our sketch but this is simplified by preparing an outline on the glass with a piece of chalk. When the tape is finally discarded a little methylated spirit will remove any remaining deposit of the adhesive.

Another type of tree may be made by cutting out the shape of a fir tree from a piece of cardboard, colouring and adding touches of artificial frost here and there, and either providing a cardboard leg for support or sticking the trunk through a slot in the box to ensure a rigid base. Baubles are easily attached

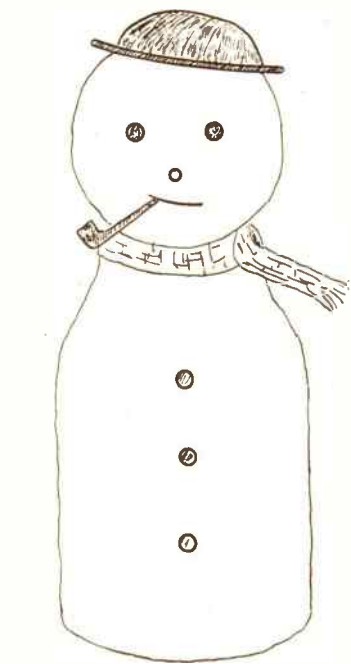

stick on eyes, nose and mouth cut out from coloured paper — and perhaps a few buttons down the front. You might also add a scarf made from ribbon, a hat cut from cardboard and a pipe for the finishing touches. White cotton, pins, and a little glue where required will assist in holding the materials and parts together.

All the decorations described will be enhanced by a few extra finishing touches and it is an easy matter to add artificial frost by first applying a thin coating of gum where required, afterwards sprinkling on the frost. Sprigs of holly and mistletoe may be incorporated with any or all of the decorations.

(S.H.L.)

Add a gay note with these

JAPANESE LANTERNS

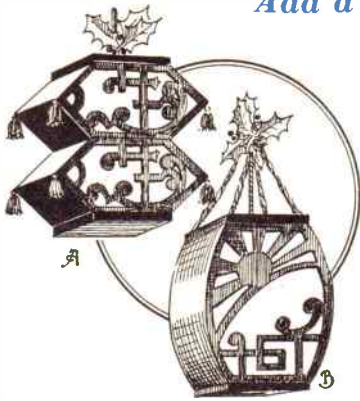

Both the lanterns are constructed of plywood and coloured parchment paper or fairly good paper that will bear being stretched and glued to the framework.

We will first deal with the design shown at (A). Two pieces of either $\frac{3}{8}$ in. or $\frac{1}{2}$ in. plywood 14ins. square are required for the front and the back, and eight pieces of $\frac{3}{8}$ in. plywood to act as side spacing panels. Here it should be noted that four of the latter panels only are shown inserted at the lower slopes of the shaped front and back (see the entirely blackened sections at the left side of sketch A). The remaining four side panels may, if desired, be filled with the parchment or the thin paper so as to get reflected light on the ceiling when the lamps are lighted. For setting out the design for the front and back panels we look at the detail, Fig. 1. Here, half only has been given of one panel as it will be noted the lower half is identical and can therefore be transferred to the wood using the centre line as guide. Set out on a sheet of paper the one inch squares shown in Fig. 1, and proceed to fill in the

larger has been glued, see also the sectional diagram in Fig. 2. Then above piece (B) is glued a third member in the form of a square frame, made up of four strips of narrow wood about $\frac{3}{8}$ in. thick,

WE show here how to make two attractive lanterns in the Japanese style which will be highly suitable as Christmas decorations. Each lantern has its own particular shape and character and each may be lighted by ordinary electric bulbs and hung from the ceiling.

That shown at (A) is about 14ins. high and 13ins. wide, while (B) is about 13ins. high and 10ins. wide. Regarding the depth of each from back to front no hard and fast measurement need be studied, but we suggest they be from 7ins. to 8ins.

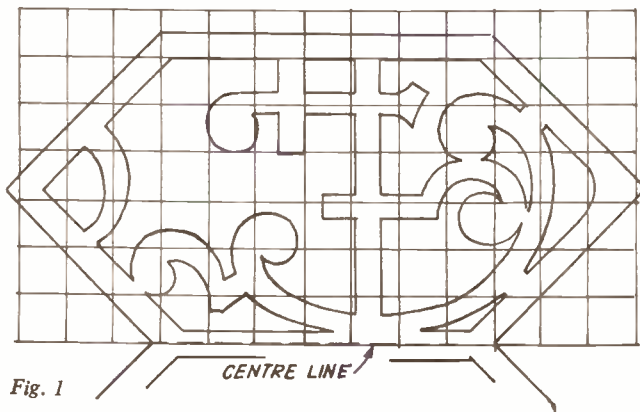

Fig. 1

It must be remembered at the outset that these lanterns need to be of light construction only, not exactly flimsy, but made suitable as purely decorative hangings. Again, the actual finish to be put into the work of making them need not be of the highest order, and we consider the home worker with any knowledge at all of light woodwork and decorative ideas should make a good job of them.

decorative interior work using the illustration as a guide while drawing. Complete the whole panel and use the fretsaw for the pierced work and the cutting to outline. Glasspaper the edges as neatly as possible and use the cut-out panel as a template for marking out the second panel.

The panels are connected at the top and bottom by a 7in. square of wood (A), Fig. 2, to which a stouter piece (B), $\frac{1}{2}$ in.

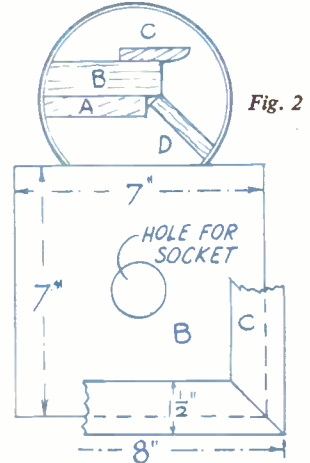

Fig. 2

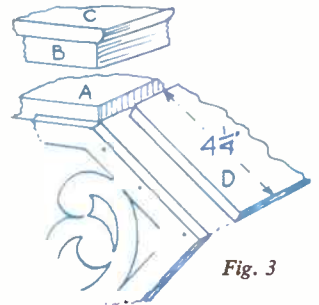

Fig. 3

mitred at the ends and glued together (see plan, Fig. 2.) After the parchment or other type of paper has been glued to the inside face of the back and front panels, the latter are glued and screwed to member (A) at top and bottom.

The manner of inserting the side panels (D), whether all eight are used or only the four, is shown in Fig. 3, and again in the circled diagram in Fig. 2. Fret pins may be put through the front and back panels into these side panels in addition to glue. Note the hole to be made in pieces (A) and (B) for the insertion of the electric bulb fitting.

Our second design, that shown as (B)

in our sketch, is very similar in construction to our first one, only instead of the four side panels of the (A) design just one length of parchment is used on each side. The front and back panels measure 13ins. by 10ins., and the outline and interior work is given in Fig. 4 with

lin. squares for enlargement from the smaller guide line illustration. The two panels are completed in a similar manner to our first design, with coloured (or white) parchment glued to the inside surfaces as before. To support the panels at top and bottom, two members as

Glue and screw the front and back panels to piece (E), adding along inside two strips of say $\frac{1}{4}$ in. square stuff for additional strength. For the curved sides of this lantern stout parchment should be used, and it should be trimmed neatly to the edges of the plywood after it has

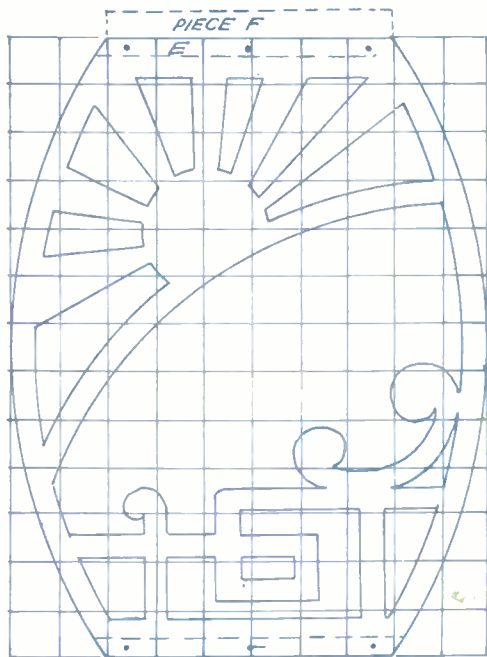

Fig. 4

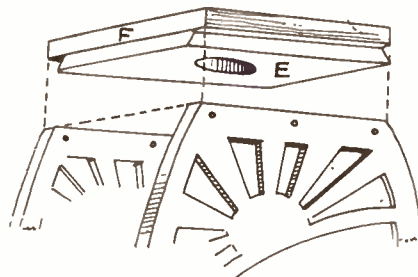

Fig. 5

shown in Fig. 5 are made. Piece (E) will be about $6\frac{1}{2}$ ins. by 6ins. with two edges only chamfered off as shown to suit the curvature of the front and back panels.

The upper member (F) may be of thicker wood and should be about 6ins. square and the top pieces should have a hole cut centrally to take the bulb fitting.

been glued on and when the glue has hardened that is. It must be noted that the lower supporting pieces (E) and (F) should have a circle cut in them sufficiently large to allow a small electric bulb being pushed up through the lantern to engage the socket fitting at the top. A square of paper or parchment may be glued over this opening afterwards if desired. This remark regarding the opening cut at the base of the lantern also applies to our first design.

The general woodwork may be stained black or dark brown, in complete contrast to the panels of paper which will show up sharply when the light has been switched on. (S.W.C.)

MAKE SEASONABLE SERVIETTE RINGS

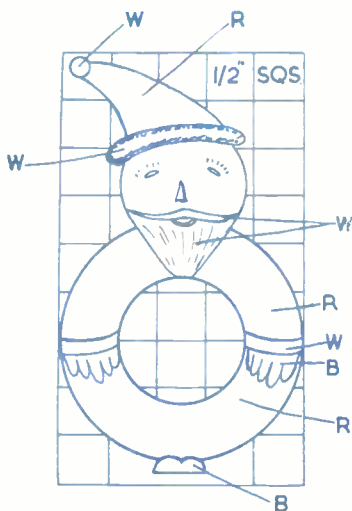

Fig. 1—W=White, R=Red, B=Brown or Black

IF you are giving a children's Christmas party this year, why not keep in the festive spirit by making a few of these novel 'Santa' serviette holders? You will find that they will cause a lot of amusement when the children take their places at the meal table.

The holders are made from off-cuts of 3-ply and Fig. 1 shows how the shapes are marked out. It is best to make a paper pattern of the shape first, then this can be pasted to the plywood. Note that the diameter of the centre hole which holds the serviette should be $1\frac{1}{4}$ ins. If you don't possess a $1\frac{1}{4}$ in. bit, then cut out the hole with your fretsaw. Smooth off the sawn edges with a rub of fine glasspaper.

The feet are made from odd pieces of timber shaped in the manner shown in Fig. 2. The width of the small recess should be made to suit the thickness of the plywood. Note that these feet are merely for decoration, and are not intended to keep the holders upright.

Once the serviettes are inserted, the holders cannot fall down. The feet should be glued to the cut-outs.

The final job is the painting of the holders and Fig. 1 gives some indication of the colour scheme to adopt. (F.K.)

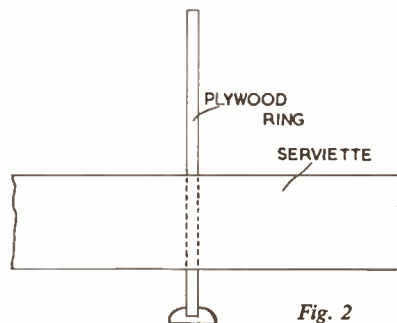
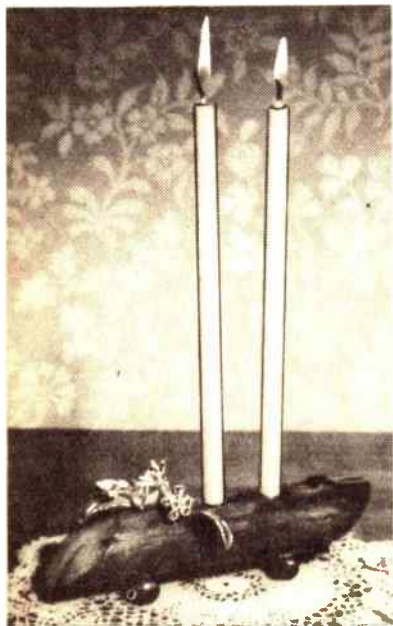

Fig. 2

'LOG' CANDLE HOLDERS



By S. H. Longbottom

LARCH poles are more often used for garden woodwork than for decorative purposes but here we have an idea for making log flower 'troughs' or candle holders to be used for the table. The log shown in our illustration is made from a piece of pole 6 ins. long and with a butt of $1\frac{1}{2}$ ins., but you may use a 2 in. butt since diameters vary considerably. You will also find it advisable to prepare a longer length of pole before drilling and shaping.

Since the yule log is symbolic of the Christmas season these ornaments will be found most appropriate if trimmed with real sprigs of holly or mistletoe. The one shown, however, holds a few sprays of artificial flowers made from stamens, petals and leaves as described in an earlier issue.

The wood must be quite clean before starting to shape and it is not advisable to use any wood covered with rough bark since this does not look well on a table laid with shining cutlery and crockery. You are recommended to obtain a piece of pole, stripping away loose, uneven bark, afterwards scrubbing thoroughly with soap and water. This treatment will raise the grain, leaving no alternative but a smoothing with glasspaper after the

wood has dried. Small spurs remaining from tiny branches should be filed flat and also smoothed. Now apply a coating of medium brown stain all over with the exception of the spurs mentioned which should be left in their natural state. This also applies to the ends after cutting, and they will look better left unvarnished.

Choice of sizes

Our next task is to provide the holes for the candles and decorative sprays, achieved by placing the miniature log in a vice between protective pieces of waste wood. The diagram indicates the positions suitable for the sprays and the candles using a $\frac{3}{16}$ in. drill, the diameter of the candles. The sprays should not be in a straight line but made irregularly and as deep as the wood permits using a gimlet or a $\frac{1}{16}$ in. drill. Here we have provided for a particular size of candle, but if your log has a larger butt you may be

and the question of floral decoration is more or less a matter of personal choice. As already stated you may make tiny artificial flowers from stamens, petals and leaves, but at the Christmas season there is no doubt that holly leaves look attractive. For this reason it is important that the sprays should not be glued into the holes permanently so that the decoration may be changed as desired. You may also provide for sprays around and between the candles if desired, but this is often best decided as the work proceeds when additional holes can be bored with the gimlet.

And if you wish to add a really Christmas touch to your logs there is the possibility of some glittering snow. All you need do is to paint a few patches with gum, dusting on the glitter. The latter is obtainable in small tubes at most crafts shops at very low cost. You will find that these logs are very quickly produced, yet look most attractive when

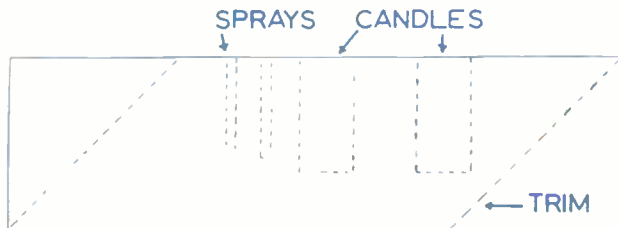

able to accommodate larger sized candles after determining their base diameter.

All that is now required to finish the shaping of the log is the trimming of each end to an angle of 45° and here you will find a mitre block useful. Should there be any remaining burr after drilling, smooth with glasspaper and retouch with stain if necessary. The ends should be smoothed off carefully by rubbing round and round on glasspaper.

Finishing touches

Finally, four wooden beads are attached as feet by means of long panel pins and the holder is ready for a coat of varnish. A first application may only serve as a sealer in which case a second coat should be given, but often this is not always needed and much depends on the absorbent nature of the wood.

It is important to leave any spurs which have been filed flat and the ends entirely free of stain and varnish for the appearance is greatly enhanced by leaving these in the natural state.

Our miniature log is now completed

decorated with the small artificial flowers. Incidentally, we may mention that the logs with the larger butts may be cut flat on the base, obviating the need for wooden beads, but make sure that this base is both flat and smooth.

NEXT WEEK

Next week's free design will be for a contemporary style kitchen stool which can be adjusted for different heights. The Christmas theme will again be much in evidence in many articles and readers are advised to make sure of their copy.

"TWEETIE PIE" THE PECKIN

**AN AMUSING
NURSERY NOVELTY**

BLOCK OF 1/4 IN.
WOOD GLUED
AT BACK

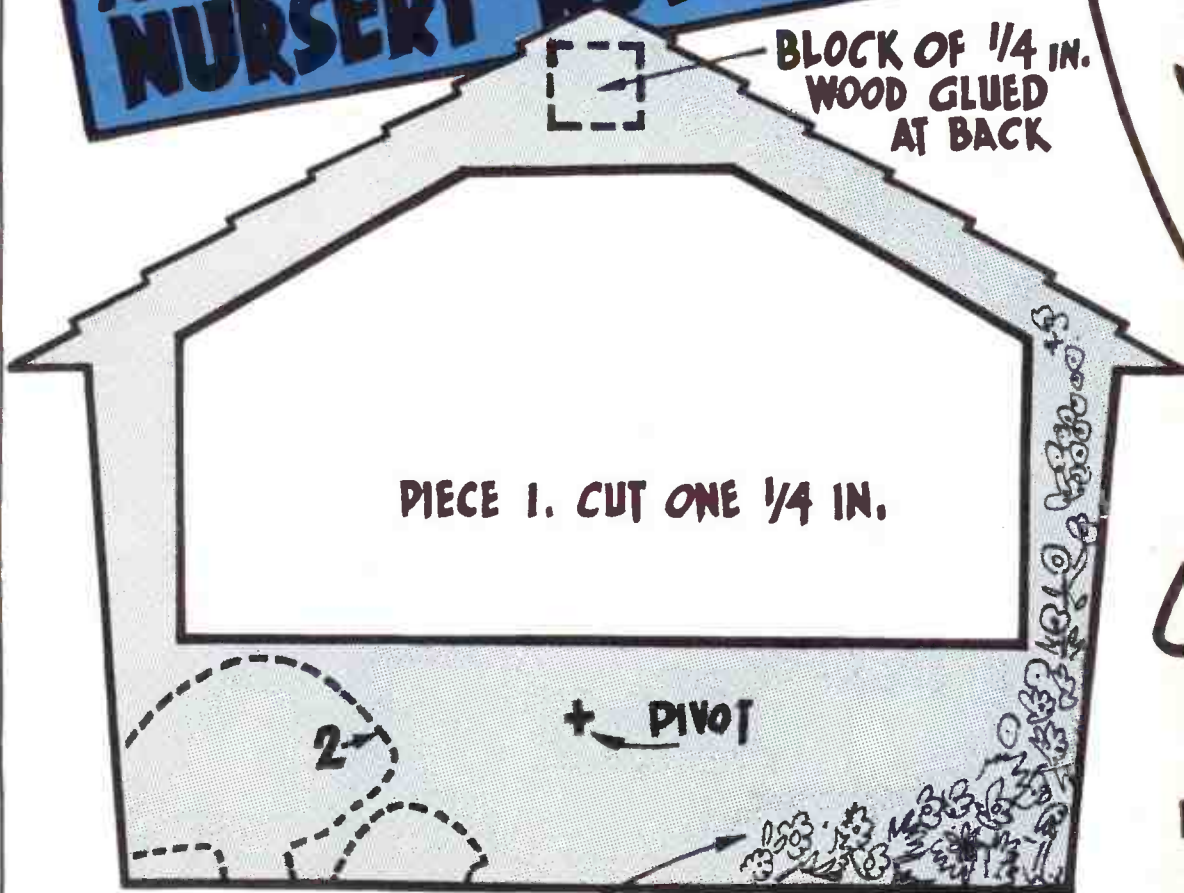

FLOWERS PAINTED ON

G CANARY



BIRD PIECE 3
CUT ONE 1/8 IN.

* SWING PENDULUM
& WATCH HIM PECK



PIECE 2 CUT ONE
3 IN. WOOD

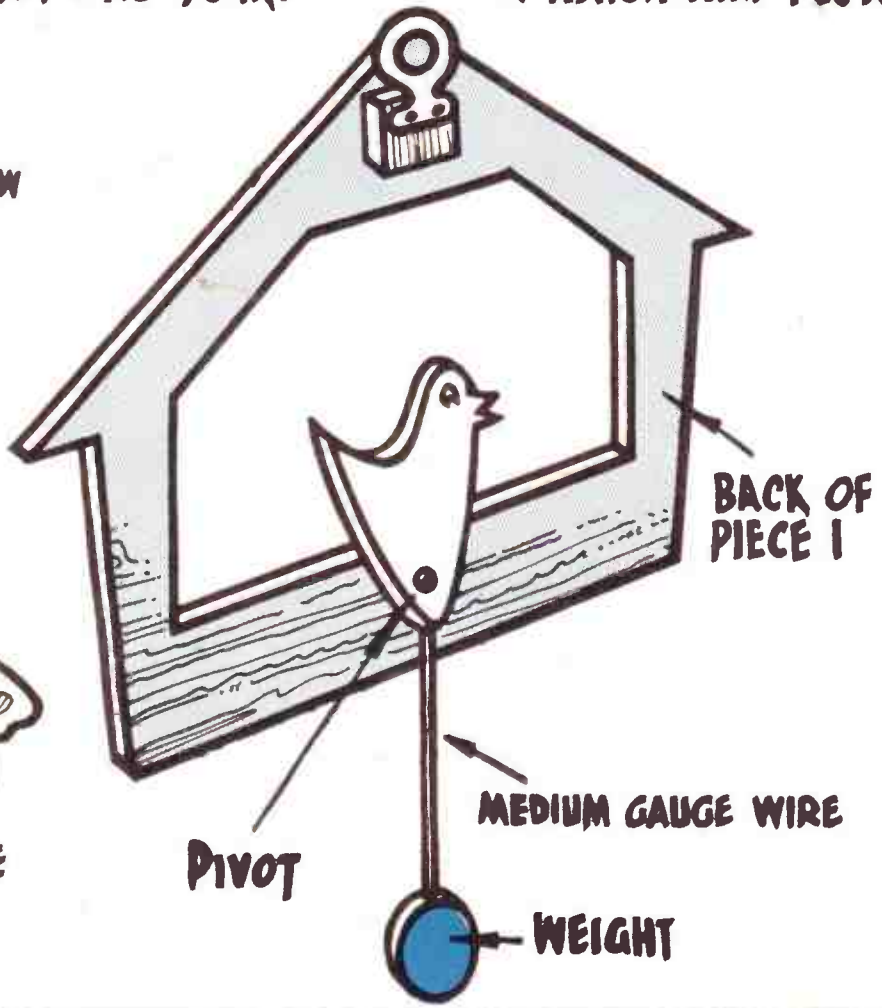

A 'TELEVISION' PHOTO FRAME

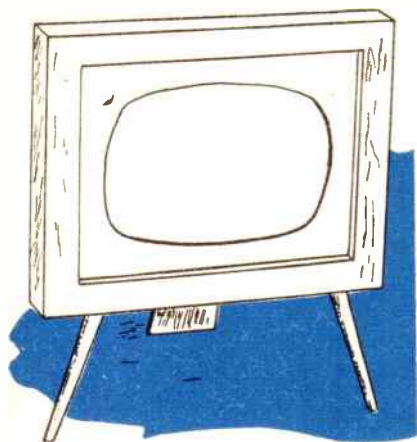

YOU can make some novel and fashionable picture frames, resembling television sets, from plywood and cardboard, and although the one to be described is intended to accommodate the popular size of 3½ in. by 2½ in. photographs, you will be able to modify to your own requirements by altering the dimensions.

We first make a 'cabinet' from a piece of plywood measuring 6 ins. by 5 ins., cutting out the centre aperture after marking out as shown in Fig. 1 and then the legs. This operation can be done with the fretsaw and afterwards the legs should be carefully rounded at the edges to give the appearance of rounded

spindle legs, but tapered and splayed in contemporary manner. The external and internal edges of the cabinet should be glasspapered and the whole stained a medium brown colour. Varnishing may be left until the frame has been completed.

Now take a piece of thin cardboard measuring 5 ins. by 4 ins. for the preparation of the 'screen'. This material should be pale grey and if not available you are recommended to apply a piece of suitably tinted pastel paper. This not only provides a surround for the picture but also adds to the illusion of the television set. Here an aperture must be cut out to resemble the shape of the tube as we see it and Fig. 2 gives an indication of the shape. In order to produce a balanced cut-out it is advisable to fold a piece of paper measuring 5 ins. by 4 ins. in half, then in half again, so that one quarter only remains visible. Measure a border of 1 in. from the top and side, rule and marking in a curve within these borders. The pattern is cut out with scissors and on opening out it will provide a balanced template for the aperture to be cut

out from the piece of cardboard. You should note that it is essential to lay this template exactly in the centre of the cardboard, marking the outline in pencil before cutting out. This portion is then glued to the back of the cabinet.

We now require a piece of card in the form of a U to act as a spacer and permitting photographs to be slotted in from the top quite easily. You will need another piece of cardboard the same size as before, that is 5 ins. by 4 ins., with a portion cut out as shown in Fig. 3, leaving a space measuring 3½ ins. by 2½ ins. — the photograph size mentioned. This portion is also glued on to the back of the 'tube'.

Finally, a further piece of cardboard 5 ins. by 4 ins. is required for the backing, prepared accordingly and glued to the spacer just described. It is advisable to make a slot in the centre of this piece, passing a small piece of tape through and fastening in position with a piece of gum strip before gluing to the spacer. Later this tape can be attached to the leg to prevent the latter from slipping when the frame is in position.

The leg itself is also made from cardboard, perhaps a little stouter, as shown in Fig. 4, scored to make a hinge, and the top portion glued to the back of the frame. The tape is now attached in position to support the leg as mentioned, and the frame is ready for a coat of varnish or polish.

(S.H.L.)

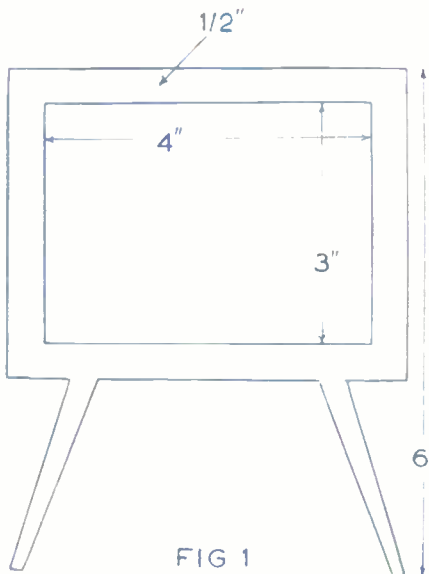

FIG 1

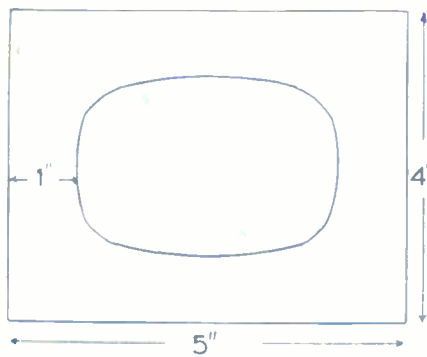

FIG 2

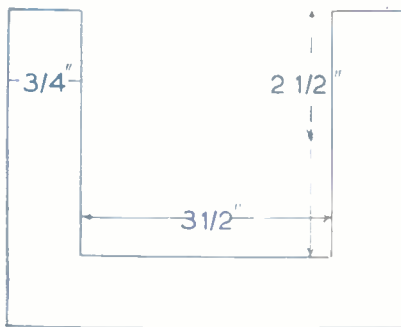

FIG 3

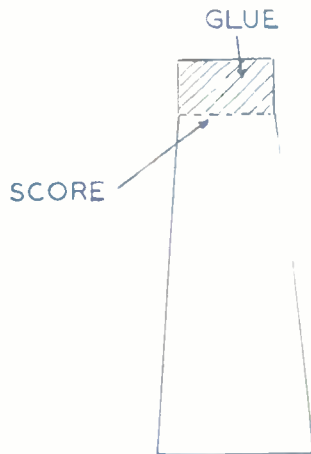

FIG 4

Follow the **FLUXITE** way to Easy Soldering



No. 12—The importance of cleanliness

Remember the key word to successful soldering - cleanliness. Filing or emery-clothing the portions to be joined makes them mechanically clean, but the essential is chemical cleanliness and that, in one world-famous word means FLUXITE.

FLUXITE is the household word for a flux that is famous throughout the world for its absolute reliability. In factory, workshop and in the home FLUXITE has become indispensable. It has no equal. It has been the choice of Government works, leading manufacturers, engineers and mechanics for over 40 years.



FLUXITE Limited, Bermondsey St., London, S.E.1 G.M.62



The world's strongest glues

STILL ONLY



A LARGE TUBE



with



kits & outfits

Hobbies kits for novel musical boxes are extremely popular for making up as gifts and for sale. Kits include materials and full instructions for making with a few simple tools. Musical movements are extra. Make your choice of tune from list below.

GET A KIT NOW!



Kit No. 3152

7/11 (post 1/3)

SWISS CHALET. Lift the lid to offer a cigarette and it plays a tune. Fit with Musical Movement No. 1.



Kit No. 3222

11/6 (post 1/6)

MUSICAL TAVERN. A savings box which plays a tune when you insert a coin. Fit with Musical Movement No. 2.

- Fit your box with one of these tunes
- No. 1 Movement. 15/6 (post 6d.)
 - C Swedish Rhapsody
 - D Silent Night
 - E Brahms' Lullaby
 - Y Anniversary Waltz
 - No. 2 Movement. 16/9 (post 6d.)
 - R Happy Wanderer
 - S Teddy Bears' Picnic



Kit No. 3250

12/6 (post 1/6)

GRAND PIANO. Kit includes printed keyboard. Fit with Musical Movement No. 1.

Other models detailed in free Booklet

To Hobbies Ltd., Dept. 993, Dereham, Norfolk. Please send free copy of Profitable Leisure and items detailed.

Kit No.....

Musical Movement.....

Name

Address

P.O. for..... enclosed



HERE is a hobby for all. The Armchair Traveller can tour the world without spending a penny on fares.

How does he do it?

Most enthusiasts collect stamps, labels, postcards, travel brochures, etc, combined with various models made from hobby kits. For example: an armchair tour of Switzerland would be all the more interesting to readers who had made a 'Swiss Chalet' Musical Cigarette Box (Hobbies). An authentic touch of this type adds reality to written and pictorial description — an important feature of the hobby.

Let's take an armchair tour of Russia. The Russia of 1880 when the people were ruled by an emperor. We will go to sea on the *Santa Maria* (Kit No. 2668) depicted on Spanish stamps of 1930.

Russian customs

In those days the Russian did nothing without first recognizing God. If he took a cup of water, he first crossed himself and offered a short prayer. Every house was blessed by a priest. Twelve times a year the parish priest went round his district into every house, sprinkling the rooms with holy water, and signing them with the sign of the cross. In every home were sacred pictures, each member had his guardian angel, and a picture of that angel in his bedroom. The day of his angel was kept as a sacred feast, on which all the family were gathered together and alms were given to the poor.

'Stamps 1905. 7 K. blue and red — Peter the Great Statue, Leningrad — 4/- mint. 10 K. blue and yellow — Alexander II Monument — 3/- mint. 1913. 10 K. blue — Nicholas II — 2d. used.'

It was great fun to ride in a Russian cab or 'drojki' in those days. But not so funny for the driver. Those who hired him had a peculiar way of giving their directions. If they wanted him to go to the right, they pulled his right ear; if to the left, they touched the other ear. When they wished him to drive faster, they gave him a hard kick. When they

wished to stop, they knocked his hat over his eyes.

The dress of the Russian peasant was simple: a hat without a brim, a sheepskin coat, coarse baggy trousers, tucked into large boots, and a long uncombed beard. 'Stamps 1922. Set depicting Russian peasant, labour and family, Sower.'

St. Petersburg, with a population of 700,000, was then the capital. Here stood the emperor's palace, full of marbles, pictures and curiosities of all kinds. There were 6,000 servants. A garrison of 500 soldiers to keep guard.



'Stamps 1925. 14 K. red — St. Petersburg — 3/- mint.'

Now we will exchange our galleon for the liner — *Empress of Britain* (Hobbies Kit No. 3206) and visit the Communist capital, Moscow. Here, with its imposing battlements is one of the world's most remarkable buildings — the Kremlin. Towers, belfries, spires, steeples, turrets, domes, ramparts, fortifications, all seem mixed up together in a fantastical medley and confusion. The green copper cupolas, glazed tiles and gold pinnacles dazzle and confuse the eye.

Big Ben of Westminster weighs 15 tons. But Moscow's Czar Kolokol, the king of bells, weighs 250 tons. Its cost in metal alone was £66,565. But like many other big bells, it is cracked and there is a large hole in it as well.

ARMCHAIR TRAVEL

— By R.L.C.

Moscow is a busy place and carries on a large trade with Asia. It was destroyed by Timour and the Tartars and was burnt by the Russians themselves. After Napoleon made his entry into it, in 1812, after the battle of Borodino, he intended Moscow to be his winter quarters. But the city was set on fire and he was obliged to retreat, losing his army of 600,000 men.

'Stamps 1913. 1 R. green — The Kremlin, Moscow — 1/- used. 1941. 1 R. red — Spasski Tower, Kremlin — 1/6 used.'

Here is an enjoyable pastime which is popular with all age groups.

CHRISTMAS GIFTS

Looking for a Christmas gift for someone? Then have a look at the back page and choose a Hobbies Fretwork Outfit or machine. You can guarantee that such a choice will lead to hours of real pleasure for the recipient. A real lasting gift for man or boy that is sure to be always appreciated.

Maybe you have a friend or relative who would appreciate a regular copy of this popular magazine. Make a surprise gift of a year's subscription through a newsagent. Or we will send the magazine each week by post. Subscription rates, including postage anywhere, are 12 months 28/6, six months 14/3, three months 7/2. Send your order with the relevant cost to Publishing Dept., Hobbies Weekly, Dereham, Norfolk.

YIPEE·E·E·E·E·E·E·E



CERTOFIX

Really
FIXES

CERTOFIX liquid glue can cope with all general repairs. It unites wood, glass, metal and almost all substances. It is clean in use; its joints are stronger than the materials it unites.

Sold at all Woolworth Stores

CERTOFIX



**You Can Make
a Modern
Table in
One Evening
with these legs**



FOR ALL CONTEMPORARY FURNITURE

A coffee table, TV table, footstool, etc. . . . all can be made in quick time with these Contemporary style legs. Beautifully turned in Scandinavian beech, they can be left in their natural colour, or stained. Each leg is threaded at one end to screw into a hardwood block (see inset) which, in turn, is screwed to the underside of a piece of plywood or suitable material which forms the table top. Simple . . . and a perfect job. The legs are obtainable in three sizes:—10 ins. 2/3 each, 15 ins. 2/6 each and 20 ins. 3/- each. Postage on 3 or 4 legs 1/6 extra. Legs from branches or:

HOBBIES LTD, Dept 99, Dereham, Norfolk

FULLY TRANSISTORIZED!

The VOXETTE TAPE RECORDER

NOW a brand new EXPENSIVELY TRANSISTORIZED tape recorder and play back machine AT EVERYBODY'S PRICE. Complete outfit ready to record and play back. £11. 19. 6., carr. 5/-.



No more to buy. Records anything — music, outdoor sound effects, sing-songs, parties. Ideal reporters, dictating, etc. Permanent recordings or tape can be used again and again. Further 3 in. spools obtained anywhere. With standard batteries (cost 1/8d. — months of normal use) you can record outdoors — anywhere! Perfect reproduction. Variable speed 1/2 to 3 1/2. Portable. Written guarantee. Or sent for 39/6 bal. 18 ftnly. pays. 13/- LISTS. GUITARS, WATCHES, RINGS, CABINETS, JEWELLERY, etc. TERMS.

Headquarter & General Supplies Ltd. (HOBW/41) 196-200 Coldharbour Lane Loughboro Junc., London, S.E.5. Open Sat.

FREE stamp album and 20 stamps. Request approvals, enclosing 6d. Additional gifts given. — Beeze, 8 Langland Villas, Mumbles, Swansea.

15/6 CRYSTAL RADIO kit. Easy-to-build with only a screwdriver and pliers. Post free — send 15/6 P.O. ALSO — 1 and 2 valve kits, headphones, etc. — send stamped addressed envelope for complete list to — Blanchard's Radio, Dept. HC8, 13 Gainford Gardens, Manchester, 10.

Completely new 54 page Edition

WHERE'S THAT CAR FROM ?

Price 1/- (Postage 4d.)

Of all Booksellers

or

RALEIGH PRESS, Exmouth, Devon

SAVE THIRTY SHILLINGS !

ELECTRIC DRILL ACCESSORY KITS

Sanding Discs — Backing Pad — Lambswool Bonnet — Grinding, Buffing and Wire Wheels with Arbor — Masonry Drill and Wallplugs — 3 Drills for Wood — 3 Drills for Metal — Postage Paid — 24/6 — (Usually 54/6). — Lists Free.

BARKERS, 70 WEST STREET, LEEDS 1

MUSICAL MOVEMENTS. The largest selection of tunes in England. — Richardson & Forder, 5 Chapel Place, London, N.17.

10,000 FORMULAS. Trade secrets, recipes, processes. Remarkable 900 page book. Only few available. Money back guarantee. 27/6 p. pd. — S. P. Ltd., 28(H.B.) Dean Road, London, N.W.2.

BECOME CHIROPODIST MASSEUR. Postal Schools (Dept. 27), 48A Abbey Street, Accrington.

100 DIFFERENT stamps free! Request 1/4d. upwards discount approvals. — Bush, 53 Newlyn Way, Parkstone, Dorset.

The amazing 'ABRAFILE' ROUND FILES



They bend to any shape you need!

New soft-core, parallel Round Files. Can be used as normal files or bent cold to almost any shape. Made on the 'Abrafile' Tension File patent of non-clogging teeth. Ideal for model making, craftwork, decarbonising engine parts, cleaning concave surfaces, and awkward corners in pipe bands, castings, etc. Fitted into varnished wooden handles and made in diameters 1/8" 1/4" 3/8" 1/2" 5/8" 3/4" 1" 1 1/8" 1 1/4" 1 1/2" 1 3/4" 2" 2 1/4" 2 1/2" 3" 3 1/2" 4" 4 1/2" 5" 5 1/2" 6" 6 1/2" 7" 7 1/2" 8" 8 1/2" 9" 9 1/2" 10" 11" 12" 14" 16" 18" 20" 22" 24" 26" 28" 30" 32" 34" 36" 38" 40" 42" 44" 46" 48" 50" 52" 54" 56" 58" 60" 62" 64" 66" 68" 70" 72" 74" 76" 78" 80" 82" 84" 86" 88" 90" 92" 94" 96" 98" 100". Also the 'Mousetail' — ideal for small work. Price 6d. each. From all leading hobby shops and ironmongers, or send 2d. stamp for illustrated leaflet to:



ABRASIVE TOOLS LTD.

COLNE ROAD, TWICKENHAM, MIDDLESEX

MAKE A MUSICAL BOX for as little as £21/- New kits and tunes available. Movements 13/- post free. Please send 3d. stamp for free illustrated catalogue. — The Swissrock Co., Dept. B, 202 Tulse Hill, London, S.W.2.

STAMPS FREE — Empire Packet including Spictorials and Victorians with approvals. — Robert J. Peck, 7A Kemp Road, Bournemouth.

Formulas for the Handyman

FOR the man who likes doing odd jobs around the house it is a big advantage to have some knowledge of chemical recipes. If you want to clean an alabaster ornament or to make a little pigment for a small painting job, chemistry can help. The regular appearance of articles in *Hobbies Weekly* giving selected recipes is aimed at supplying this knowledge.

Cleaning alabaster

Alabaster ornaments are still fairly common even in this plastic age, and alabaster is a stone which does not fare well in our rather smoky English atmosphere. Hence it is an advantage to know how it may periodically be cleaned. Make a mixture by weight of 1 part of pumice powder, 1 part of precipitated chalk and 2 parts of washing soda. Grind them together until a fine powder results. The mixture will keep indefinitely in a screw-top jar.

For use, mix it to a paste with cold water and work it over the article with a stiff paint brush or an old toothbrush. Let it dry on, and then wash it off with lukewarm water.

Knife handle cement

Knife blades which have come adrift from their handles can be firmly fixed in again with a simple cement. Grind together 4 parts by weight of rosin, 1 part of beeswax and 1 part of brick dust. Loosely fill the hole in the handle, heat the knife blade tang, but not so that it is red hot, and press it into place. The mixture melts and on cooling gives a firm bond.

White shoe dressing

This preparation is suitable for canvas tennis shoes and for white leather. Mix together 45 grams of pipe clay, 22.5 grams of whiting, 18 grams of zinc oxide, 11.5 grams of precipitated chalk, 0.8 gram of gum tragacanth and 0.4 gram of phenol. Make this into a paste with water and keep it in a wide screw-top jar. Take care not to touch the phenol, for it causes blisters in the neat state, though it is harmless in the mixture. If you do touch it, wash the skin at once with plenty of water.

For those who prefer a liquid white shoe dressing, the following recipe will meet their need. In 53 c.c. of warm water dissolve 3 grams of soap flakes and 0.5 gram of soda ash. Add 4 c.c. of a 50 per cent solution of gum acacia (that is, 2 grams of the gum dissolved in 2 c.c. of water) and then work in 40 grams of lithopone.

Iron cement

If you wish to fasten together two pieces of iron or to repair holes, a good cement can be made by mixing together 60 parts by weight of fine iron filings, 2 parts of ammonium chloride and 1 part of flowers of sulphur. Make this into a thick paste with water and apply to the cleaned work. This cement takes best on a roughened surface. Leave until dry and hard.

Another useful cement for iron can be made from 5 parts by weight of graphite, 1½ parts of whiting and 1½ parts of lead monoxide (litharge), all in fine powder. For use, mix some to a paste with boiled linseed oil and apply to the work, which must be free from moisture.

Casting alloy

For making small castings for models, or for producing seals and replicas of medals, it is a big advantage to have an alloy of low melting point in view of ease of melting and greater safety if any is spilt. There is an alloy which actually melts in boiling water, so that all one need do in using it is to part sink a vessel containing it in boiling water.

To make this useful casting material, first melt 2 parts by weight of tin, add 3 parts of lead and when these are incorporated, add gradually 5 parts of bismuth. Stir well with a wooden rod until all is evenly melted. Cast this into bars by pouring the molten alloy into troughs made by pressing a pencil in firmly packed soil.

Ivory bleaching

As we all know, ivory becomes yellow with age. With patience it may be restored to its original colour. First rub it with a thin paste of fine pumice powder and water, rinse and place it still wet in a closed clear glass screw-top jar standing in sunlight. The treatment may need to be repeated several times in badly discoloured specimens. The exposure in a closed vessel is necessary in order to keep the ivory moist. If the sun treatment were done without it, the ivory would tend to develop fissures.

Metal degreasing

Any of the ordinary grease solvents, such as trichlorethylene, solvent naphtha, petrol, white spirit or benzene can be used for this purpose. These are all rather strong smelling liquids and the fire hazard is notable with the last four. Where an odourless non-inflammable remover is desired, solutions of either

sodium metasilicate or caustic soda should be used. Make them up in the proportions of 1 ounce of sodium metasilicate in 4 fluid ounces of water and 1 ounce of caustic soda in 10 fluid ounces of water. The article may be swabbed with these liquids or immersed. In the latter case the liquid should be stirred, so as to help the process. Since the solutions are alkaline they are harmful to the skin. Consequently, such contact should be avoided. If any does get on the skin, wash it off with water, and rub on a little vinegar.

Gut preserver

Tennis racket gut which is showing signs of shabbiness can be revived and its life lengthened by a solution of shellac in methylated spirit, made up in the proportion of ½ ounce of shellac to 1 fluid ounce of meths. Simply put the ingredients in a small dry screw-top jar and shake occasionally until the shellac has dissolved. For use, either brush it on thinly or rub it on with a rag.

Kid glove cleaner

One of the finest and safest cleaners for kid gloves is skimmed milk. Put the glove on and with the other hand rub evenly all over with a piece of soft white cotton cloth previously soaked in skimmed milk. The treatment may be repeated until no more dirt comes away on the cloth. Finally, finish with a fresh rag dipped in the milk.

Metallic paints

Bronze, gold and silver paints can easily be made for oneself by mixing imitation bronze, gold and silver pigments with a special medium. The latter is made by dissolving ¼ ounce of celluloid in 2 fluid ounces of acetone, by putting them in a dry screw-top jar and shaking occasionally. When the solution is complete add 3 fluid ounces of amyl acetate and stir well until an even mixture results. The pigments can be stirred into some of this medium as required.

As a general guide to the amount of pigment needed, the above quantity of medium will take ¼ to 1 ounce of pigment according to the intensity desired. The vapour from this medium is inflammable. Brushes should be cleaned with a mixture of equal volumes of amyl acetate and acetone.

(L.A.F.)

'Personal' and permanent

NOVEL CHRISTMAS CARDS

THE two designs shown on this page are cut from $\frac{1}{8}$ in. or $\frac{3}{16}$ in. fretwood or plywood. The 'greetings' are cut out with a fretsaw and backed with coloured or silver paper.

The wood should be glasspapered and varnished before applying the decorations, which consist of Decorette transfers. These are easy to apply and cost 2/3d. per sheet, postage 3d.

The top one is No. 1004, and the lower No. 150. There are six designs on each sheet. Decorette transfers are stocked by all Hobbies Branches. (M.p)



XMAS GREETINGS

HINGED STRUT
AT BACK

BEST WISHES FOR XMAS

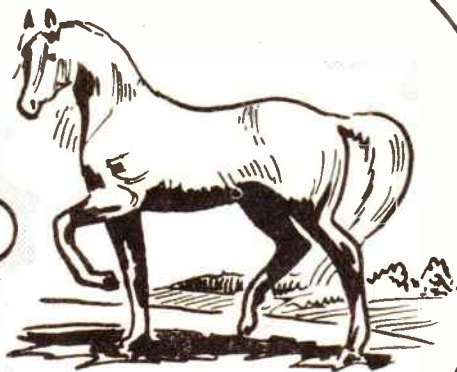

**YOU CANNOT
GO WRONG
... GIVE A**



**FRETWORK
OUTFIT OR
MACHINE**

REALLY PRACTICAL, LASTING GIFTS

The most popular fretwork machines and outfits in the world. Made in Hobbies' own factory in Norfolk, and all fully guaranteed. A Fretsaw can be used for almost any kind of cutting in wood, composition board, plastic, sheet metal, leather, card, etc. Any outfit or machine will ensure a lasting and useful hobby.



'CROWN' OUTFIT

With an efficient hand frame, spare saws, cutting table, drill, instruction book, glasspaper block and design. A very popular outfit.

(Postage 1/9) **25/-**

'A.1' OUTFIT

The set most beginners demand. Contains a Hobbies lever hand-frame, with special saw tensioning device, wide range of tools, designs and instruction handbook. In deep box, 15in. square.

40/-

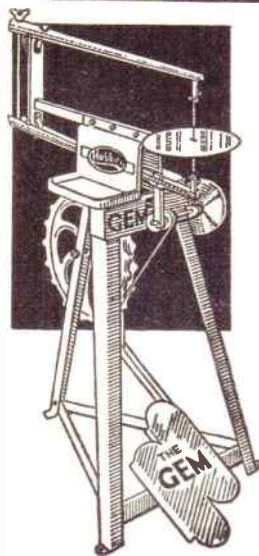

THE 'CHALLENGE' OUTFIT

Real value for the beginner. It contains all the tools necessary to make a start.

(Postage 1/6) **14/6**



'NATIONAL' OUTFIT

Containing a special comfortable grip hand-frame, spare saws, cutting table, drill, glasspaper and holder, designs and instruction book. A really sound outfit.

32/6

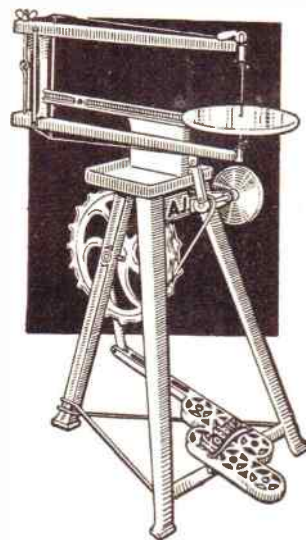

THE 'A.1' MACHINE

A sturdy machine with cast-metal legs. Easy to treadle, smooth running and rigid. Provides a factory at home for the handyman.

9gns.

THE 'GEM' MACHINE

An easy running and reliable machine, for all kinds of work. With pressed metal legs it is lighter than the A.1, but of robust construction.

£5/17/6

**THESE ARE TESTED TOOLS
GUARANTEED TO GIVE
EXCELLENT SERVICE**

(All post free, except where stated)

**ALL HOBBIES TOOLS FROM BRANCHES, STOCKISTS OR DIRECT
HOBBIES LTD, DEREHAM, NORFOLK**