

HOBBIES WEEKLY

APRIL 23rd 1958

VOL. 126

NUMBER 3260

IN THIS ISSUE

	Page
Ukulele - - - - -	33
Screen for Beach or Garden - - - - -	35
Dual-Wave Coils - - - - -	36
Aircraft Spotting - - - - -	38
Using Colour Prints - - - - -	39
Electro-Magnetic Crane - - - - -	40
Try Forecasting the Answer - - - - -	41
Collector's Club - - - - -	42
A Jobbing Handyman - - - - -	44
Patterns for Tunnel for 'OO' Gauge Track - - - - -	47



All correspondence should be addressed to the Editor, Hobbies Weekly, Dereham, Norfolk

★ *FREE design inside*
shows how to make

UKULELE

THE ukulele lends itself admirably for accompanying popular songs, and is increasingly being featured in rhythmic ensembles. Quite simple to play, these instruments do not demand a great knowledge of music, and for this reason are being increasingly taken up as a means of musical expression. Even a child can get a great deal of pleasure and entertainment from it, and with practice the ukulele becomes quite a feature instrument.

The one described here can be made up with only a few simple tools, but it will be appreciated that patience is also required. The job should not be rushed and where gluing is involved sufficient time should be allowed for this to set really hard.

Follow closely the measurements, instructions and positions given here and on the design sheet, from which all parts can be traced. Finishing the instrument is in particular a matter for individual choice, while the more experienced workers will undoubtedly find a use for

cramps and other workshop aids in their possession in order to facilitate assembly. Care taken in its making will result in an instrument which will give much pleasure — at a reasonable cost.

Making and shaping the body of the ukulele entails patience and careful work if a good job is to be made of it. Study the design sheet and read these instructions thoroughly in order to get a good idea of the various stages which go towards its making, before actually starting on the work.

The shapes of the body of the instrument, pieces 1 and 2, are transferred from the design sheet by means of carbon paper on to $\frac{1}{8}$ in. plywood. It will be noted that the face piece and the back

MAKE IT—
PLAY IT!



are the same outline, and that the circle is cut in the face piece only.

The fillet pieces on which will be glued the thin plywood sides, are $\frac{1}{8}$ in. thick and about $\frac{1}{8}$ in. wide. As seen on the design sheet they conform to the same shape as the outline of the face and back pieces but $\frac{1}{8}$ in. less to allow for the addition of

FOR ALL HOME CRAFTSMEN
Over 60 years of 'Do-it-Yourself'

4 $\frac{1}{2}$ D

the thin plywood sides. A glance at Fig. 1 will show what is intended. You will need 12 separate fillets (four each of pieces 3, 4 and 5), six being for the face piece and six for the back. Fig. 2 shows how the patterns should be laid out on the wood supplied in Hobbies kit in order to obtain economical cutting.

Blocks and fillets

Two end blocks of wood (10 and 11) are required. Their sizes are shown on the design sheet. They are cut from 3in. by $\frac{1}{4}$ in. stripwood and are squared up true before gluing in place. Note that block 11 is slightly rounded to conform to the curve of the body at that point. These blocks are glued to the inside surface of the back piece, being inset $\frac{1}{8}$ in. as shown on the design sheet. The fillets are glued round up to the blocks, being also inset $\frac{1}{8}$ in. to allow for the addition of the thin plywood sides as already mentioned.

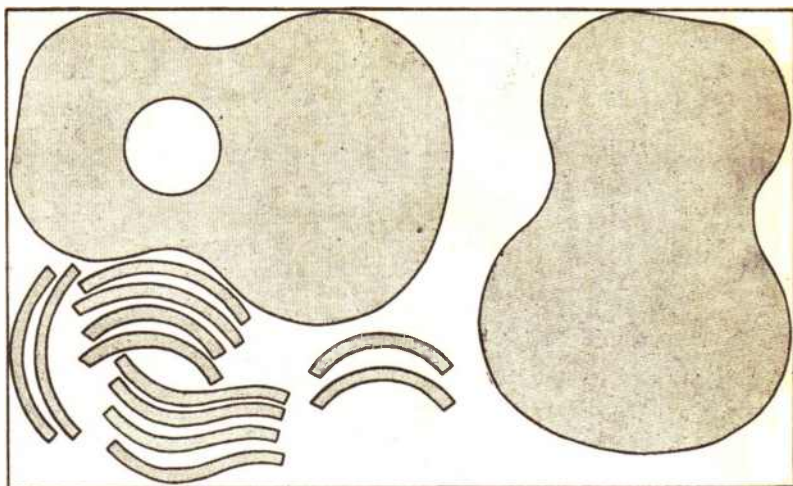

FIG. 2

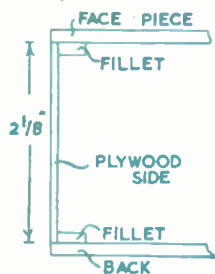

FIG. 1

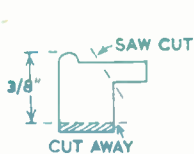

FIG. 3

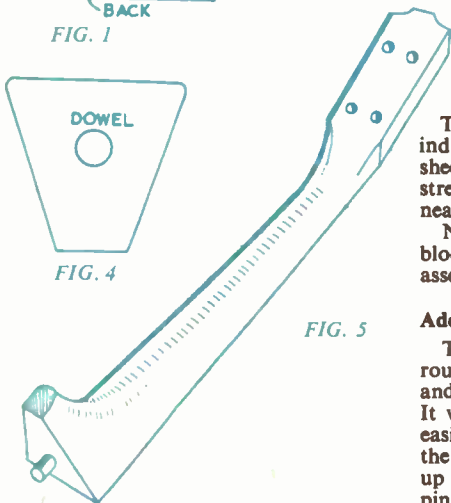
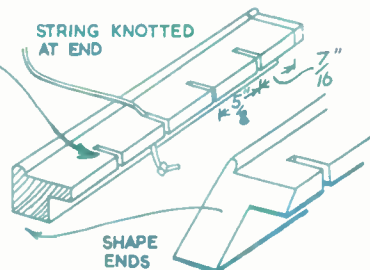

FIG. 4

FIG. 5

Mark the positions of the blocks on the interior side of the face piece and fix the fillets round this as for the back piece.

Next shape the bridge before fixing it on to the face piece. It consists of a 2 $\frac{1}{2}$ in. length of Hobbies $\frac{1}{4}$ in. No. 7 picture frame moulding. This is shaped and cut as shown in Fig. 3. The height is reduced to $\frac{3}{8}$ in. and four cuts are made where

while the glue is drying. It is essential that these plywood sides are fixed firmly to the fillets and workers can use their own ingenuity for binding. For instance, cut-off sections of motor inner tubes are found to be quite handy here. The use of wedges in appropriate places under the binding will also be found helpful in keeping the sides firmly in position.

Trim the plywood sides to the centre of the top block. Glue and pin the ends to the block as in starting, again ensuring a neat join, and wind binding around the whole casing until satisfied that the glue is thoroughly dry and that the desired shape has been maintained.

The neck is made from a solid block of hardwood such as mahogany or beech, shown full size on the design sheet. First mark the side view on the thickness of the wood and then saw to shape, working from each end. Keep the saw perfectly upright while cutting, securing the neck in a vice if possible.

Now mark out the plan of the neck and cut as before. Final shaping can be done with a Surform file or a wood rasp to the section and shape shown in Figs. 4 and 5. Finally plane and glasspaper the neck smooth and round off the underside to give a comfortable hold. Those who are working with a Hobbies kit of materials will, of course, have the neck practically shaped as required and only finishing is necessary.

Fret position

The neck can now be glued to the body. Bore a $\frac{1}{8}$ in. dowel hole in the end of the neck (Fig. 6, and design sheet) and a matching hole in the block (piece 10) of the body. Pins which have been inserted for fixing the thin plywood sides should be removed if they foul the dowel position. Note that the face of the neck is in line with the face piece of the body.

indicated to take the strings. The ends are chamfered off for effect.

The bridge is now glued in position as indicated by the dotted lines on the design sheet. Two fixing screws to give added strength should be inserted from underneath the face piece and into the bridge.

Now glue the face piece on to the blocks, ensuring of course that the assembly is in true alignment.

Adding the sides

The strips of $\frac{1}{4}$ in. plywood to be bent round to form the sides are 2 $\frac{1}{2}$ in. wide and cut to length (approximately 14ins.). It will be found that this thin ply can easily be cut to size with scissors. Find the centres of the end blocks, mark a line up with the setsquare and then glue and pin the squared ends of the plywood strips to the lower end block. This join will later be covered by a decorative overlay consisting of pearl acetate.

Apply plenty of glue to the fillets and plywood edges. Working both side pieces together, gently force them under the face and back pieces and flush up against the fillets. As the work progresses, bind round and round the instrument with plenty of string to hold the sides in shape

Next mark off on the neck the positions of the frets. Make a cut across these with a fine tenon saw, small back saw, hacksaw or fretsaw, and tap the fret wire in position. The fret wire is inset $\frac{1}{8}$ in. from each side of the neck and should be cut accordingly. The addition of plastic wood or glue will ensure a tight fit for the fret wires if the saw cuts have been made too large.

The nut at the top of the neck is a piece of $\frac{1}{8}$ in. plastic material or bone, which is glued in a sawcut as shown in the side view on the design sheet.

Those working with a Hobbies kit will find the pegs have to be shortened, as shown in Fig. 7, and holes drilled for the insertion of the strings.

The positions of the holes for the pegs are shown on the design sheet. These holes are drilled from the underside, ensuring a tight fit in order to obtain correct tuning. It is advisable to drill to the smallest diameter of the peg and then taper carefully with a reamer, round file or the tang of a large file, checking constantly the fitting of the pegs in their holes to ensure a tight fit.

For a finish to the instrument, the bridge, head and underside of the neck can be stained black and polished or

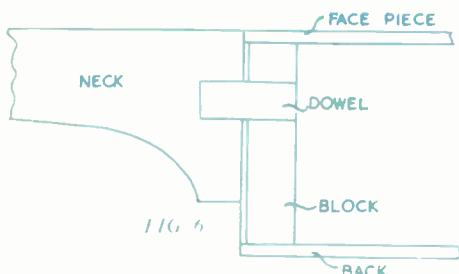
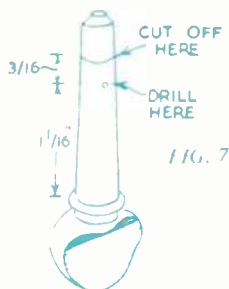

FIG. 6 painted ebony black, with the rest clear french polished. Individual workers will, of course, use their own ideas as to finish and quite a good effect can be obtained with enamel paint in varying combinations.

Shapes of the pearl acetate overlays (6, 7, 8 and 9) should be traced and cut with scissors, the interior portions being cut away with a sharp knife. The positions of 6, 7 and 8 are shown on the design sheet. Overlay 9 covers the join in the thin plywood at the bottom of the instrument. The overlays are added by gluing, and fret pins can also be inserted to add to the decoration and fixing. The gut strings are added as shown in Fig. 3.

A good tutor will deal with many



questions, such as tuning and playing this popular instrument.

Hobbies Kit No. 3260 for making a Ukulele contains suitable ply and other wood, partly shaped neck, pegs, fretwire, strings and decorative plastic material, etc. Kits obtainable from branches or Hobbies Ltd., Dereham, Norfolk, price 26/11 (post free).

Screen for Beach or Garden

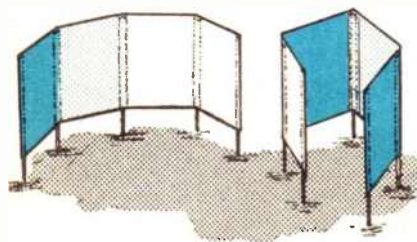

By *A. F. Taylor*

MANY uses will doubtless be found for this lightweight screen. Its chief use will be for those on holiday at the seaside where it can be either a sun- or a wind-screen. For bathers who wish to undress on the beach it can very quickly be made into a small tent, while if caught in a sudden shower very little alteration is needed to turn it into a shelter.

As a wind-screen it can make sitting on the lawn a pleasure, while the younger members of the family will have lots of fun with it in many ways.

It is light to carry about and when dismantled can be stowed away in a very small space. Sizes quoted here are for an average screen, but these may be altered

to suit your own particular requirements.

The screen consists of a length of material with pockets into which bamboo canes are inserted at equal distances. The projecting ends of these canes can then be pushed into the sand or soil in a straight line or arc to form a wind-screen, or to form a square for a tent.

About $3\frac{1}{2}$ yards of canvas or similar material will be needed to make the screen as shown in the sketch and the width may be between 36ins. and 48ins. or more if needed. It is not advisable however to exceed these measurements otherwise it will be rather cumbersome and not so easy to carry about.

Five bamboo canes between 5ft. and 6ft. long should be procured before sewing up the ends of the canvas and fixing the other three pockets. You will then be able to make the canes a good fit into them, but do not make them too tight.

It is only necessary to fold over the ends not forgetting to turn in the rough edges while doing so and sew along to make a neat pocket just large enough for the cane to slide in easily. Close the top by sewing across securely to keep the canes from pushing through.

The three intermediate pockets are formed by sewing a narrow strip of the canvas or a piece of upholstery webbing

or binding across the canvas and closing the top ends as before.

To turn the tent into a shelter you will need another piece of canvas about a yard square which can be slung over the top and secured at the corners with tapes or hooks.

It is also a good idea to sew one or two large pockets on to the canvas into which many odds and ends can be slipped. Food for instance could be housed here to keep it free from sand when on the beach.

The canes are removed and the canvas folded up or the entire gadget could be rolled up and tied with a cord or straps with a handle between.

For use on hard ground the canes may need pointing, but when these are rather large and hollow they should first be plugged with a hardwood and then pointed.

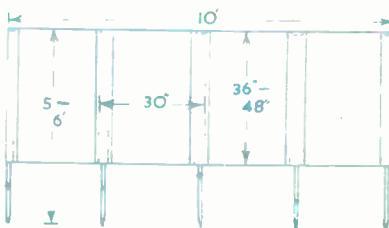

DUAL-WAVE COILS

MOST receivers are made so that Long Waves may be tuned, in addition to Medium Waves, so as to allow a greater choice of stations. It is very useful to be able to tune the L.W. band, and this is quite easily arranged.

One method, often used, is to have entirely separate coils for the M.W. and

compact piles. For the 1in. diameter tube, 3 piles, each having 90 turns, (giving 270 turns in all) will be suitable for this L.W. section.

If the M.W. section is wound upon a tube with a diameter of other than 1in., as previously explained, then the number of turns for the L.W. section can be as follows:

Diameter of Tube	Number of Turns
1½ in.	240 (3 piles of 80).
1¼ in.	240 (3 piles of 80).
1½ in.	210 (3 piles of 70).
2 in.	180 (3 piles of 60).

A few turns more or less will make no difference to results, and 36 S.W.G. or 38 S.W.G. wire may be used.

Switching

The L.W. section is switched out of circuit when M.W. reception is required by wiring an on/off type switch from point 2 to point 3. When this switch is

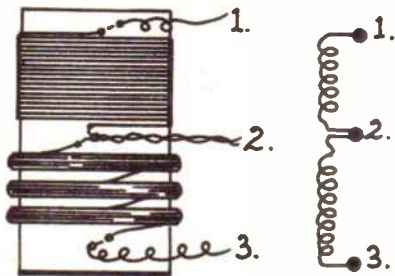

Fig. 1—Dual wave coil

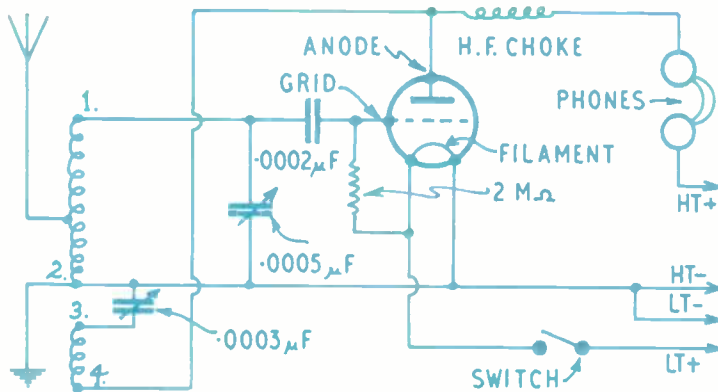

Fig. 2—One-valve circuit

L.W. bands, and to select the appropriate coil by means of a switch. Another method uses a dual-wave or dual-range coil, able to tune both wavebands. This type of coil is shown in Fig. 1 and can easily be used to replace the M.W. type of coil fitted in the crystal detector receiver.

The winding between points 1 and 2 is for medium waves, and can consist of 90 turns of 32 S.W.G. enamelled wire, on a 1in. diameter former. After ending the winding at point 2, a clear space of about ¼ in. is left. The long-wave section, between points 2 and 3, is then wound on. As a large number of turns will be required, thin wire (36 to 38 S.W.G.) is employed, and the turns are wound in

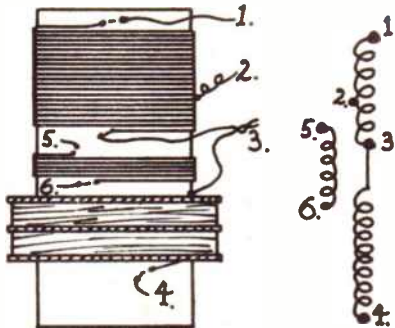

Fig. 4—Dual wave coil with reaction

closed, the L.W. winding is short-circuited, leaving the M.W. section operating.

Point 1 is taken to the fixed plates of the tuning condenser (and to detector, with crystal sets). Point 3 goes to earth.

By F. G. Rayer

(The moving plates tag of the condenser, and one wavechange switch tag, will also be wired to this point.) All turns throughout the coil must be in the same direction, as shown, and point 2 consists of two wires, one from each winding. Any of the forms of aerial coupling already described can be used to give more selective tuning.

Valve detectors

Crystal detectors can only give low volume, so valves or transistors are often used instead. The circuit for a valve

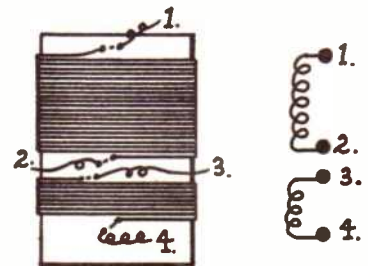

Fig. 3—Coil with reaction

detector, or 1-valve receiver, appears in Fig. 2. The coil, with .0005µF tuning condenser, remains exactly as for the crystal detector. Point 1 is connected to a fixed condenser of .002µF. The radio-frequency signals pass through this condenser, reaching the valve grid.

The valve itself has a filament, which is heated by current from a 1½V. or 2V. battery. The heated filament emits electrons which have to pass through the grid to reach the anode, to which they are attracted by a positive voltage derived from the High Tension battery. As a result, an amplified signal appears in the anode circuit, to operate the phones. The 2 megohm resistor allows the small voltage arising at the grid, due to rectification, to leak away. For this reason, this resistor is often termed a 'Grid Leak'.

An additional benefit also arises from the use of the valve. Amplified radio-frequency signals are present at the valve anode, and are prevented from passing

to the phones by the high-frequency choke. (This choke allows the audible part of the signal to pass.) The amplified R.F. signals thus have to pass through the coil winding shown between points 3 and 4, and through the variable $\cdot 0003\mu\text{F}$ condenser, to earth. In passing through the coil to earth, the amplified R.F. signals induce stronger currents in the main section of the tuning coil. This effect is known as 'Reaction' and gives a great increase in volume. The advantage is so great, that reaction is always provided in simple receivers of this kind.

Reaction coil

The crystal set cannot use a reaction winding, but it is easily added, as shown in Fig. 3. The exact number of turns is not critical, but about two-thirds the number used on the tuned winding will be satisfactory — that is, 60 turns, for a 90 turn coil. In Fig. 3 then, points 1 and 2 go to the tuning condenser, exactly as before. The reaction winding may be of very thin wire, to save space (38 SWG is satisfactory). Point 3 goes to the reaction condenser, and point 4 to the valve anode. It is important that these ends be correctly connected, or signals

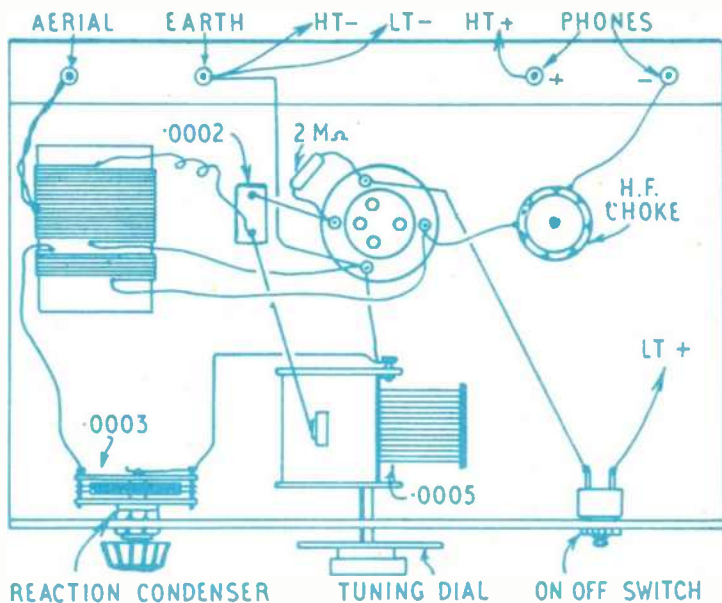

Fig. 6—Wiring plan of circuit in Fig. 2

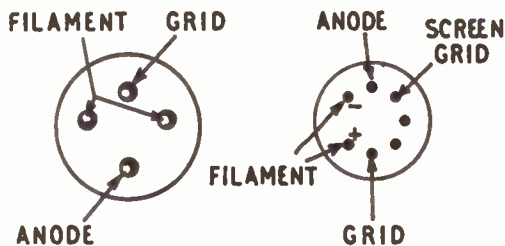

Fig. 5—Pin connections for HL2 and IT4, viewing valve from below

induced in the larger winding will be of wrong phase, so that adding reaction reduces volume, instead of increasing it. For the same reason, both windings must be in the same direction, as shown.

A solid dielectric condenser is usually fitted, for reaction control, values between $\cdot 0002\mu\text{F}$ and $\cdot 0005\mu\text{F}$ being normal. As this condenser is closed, volume increases, until the valve commences to oscillate. This sets the limit to the amount of reaction which can be applied. Reaction is particularly useful in building up the volume of weak stations.

Dual-wave with reaction

Reaction is also provided with dual-range coils. So as to obtain a fairly equal coupling on both M.W. and L.W. bands, the reaction winding is generally situated between M.W. and L.W. sections, its ends being points 5 and 6 in Fig. 4. With this coil, 1 goes to the fixed plates of the tuning condenser, 2 to aerial, 3 to wave-change switch, and 4 to earth. Lead 5

goes to the reaction condenser, and lead 6 to the valve anode. The turns of the L.W. section are shown wound between large card washers glued to the tube, and this is a convenient method. For 3 piles, 4 card washers must be cut. But winding the L.W. section in 2 piles instead of 3 does not materially influence results.

Once again it is essential that all the windings (M.W. section, reaction, and L.W. sections) be in the same direction. It is simplest to wind the M.W. section, leave about $\frac{1}{2}$ in. space, and wind the reaction section. The card washers can then be fitted, the top one being very near the reaction winding. The coil can then be finished by dividing the L.W. turns between the spaces provided, filling the top space before passing the wire over the centre washer to bottom space.

Valve connections

The valve in Fig. 2 is called a 'Triode' because it has 3 electrodes — filament, grid, and anode. Valves of this kind are not now regularly manufactured, but are easily obtainable from surplus stores, etc. They require a 2V. filament supply, which can be obtained from an accumulator, or from a dry battery. With the latter, a resistor of 10 ohms must be added, when using a 2-cell dry battery, to reduce the voltage from 3V. to 2V. Alternatively, a single $1\frac{1}{2}$ V. dry cell may

be used, if no accumulator is available. Pin connections for this type of triode appear in Fig. 5. It is very simple to connect up, as it only has 4 pins.

Modern valves have more pins, and usually more electrodes inside. Fig. 5 also shows connections for one of these, which will be suitable for a 1-valve receiver — the 1T4. This type of valve is *not* intended for use with a 2V. accumulator. Instead, a $1\frac{1}{2}$ V. dry battery should be used, for filament supply. It will be seen that an additional electrode (the screen grid) is provided. The valve may be used exactly as a triode, by wiring the screen grid to the anode. This is always done when using screen grid valves as triodes. When triode operation is not intended, the screen grid is wired directly to H.T. positive. The screen grid is not necessary in a 1-valve set, but will serve useful purposes in complicated circuits.

A H.T. battery voltage of about 60–65V. is usual, with a 1-valve set. It should be noted that this is very much greater than the $1\frac{1}{2}$ V. or 2V. filament supply. The H.T. voltage must therefore never be allowed to reach the filament for any reason whatever, or the valve will be damaged. Wrong valveholder connections, shorted leads, or similar errors, should thus be looked for, before inserting the valve.

The signal from the detector (valve or crystal) can be increased in strength by using an amplifier stage. A loudspeaker can then be operated.

Methods of adding an amplifier are dealt with in the next article in this series.

AIRCRAFT SPOTTING

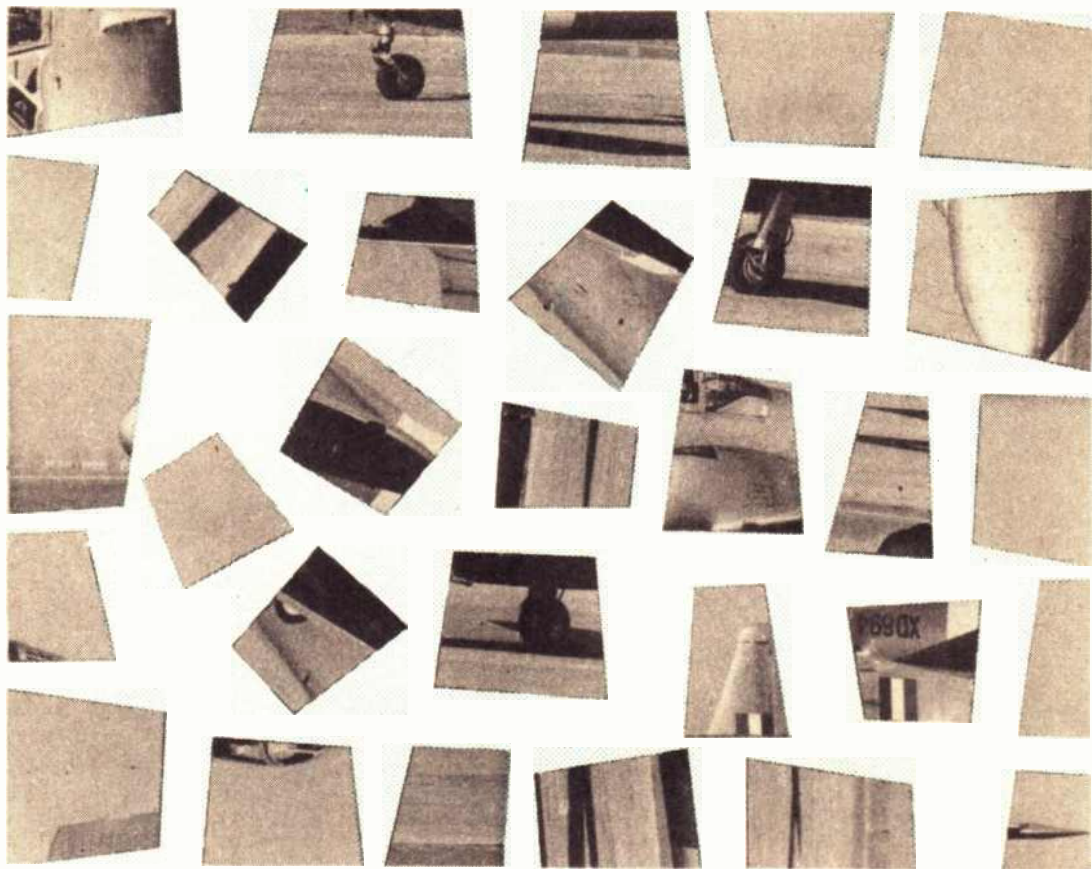

THIS month's puzzle spotlights an aircraft which is used solely to familiarise would-be pilots with the characteristics of jet powered aeroplanes. These types of machines are not designed to give exceptional performances in speed, altitude and endurance but their role in training pilots is vitally important.

This aircraft is a development of a piston-engined trainer which bears a similar name and which is in service with the Air Forces of Rhodesia, Burma, Eire, and Iraq. Chosen by the Royal Air Force as its basic jet trainer, the Mk. 3 version is now in full-scale production. It has the distinction of being the world's first military *jet* training aircraft in which pupil pilots will learn to fly from the very beginning of their flying career. In fact, the R.A.F. has adopted a scheme with this aircraft whereby pilots are given an

'all-through' jet training and the first batch of Service pupils to start their flying career from scratch on jet aircraft completed their course twelve months ago.

Powered by a single Armstrong Siddeley Viper turbo-jet it has accommodation for a crew of two (pupil and instructor), seated side-by-side in ejector-type seats. Unlike most of the present day jet aircraft, there are no security restrictions placed on its performance details and we know the maximum design speed to be 437 m.p.h. up to 10,000ft. It has a range of 580 miles and an endurance in excess of 2½ hours. The time it takes to climb to 30,000ft. is twenty one minutes. There is also accommodation for a variety of armaments to be fitted for training purposes. Two .303in. machine-guns can be fitted in the nose, plus two standard reflector sights, one in front of each seat. Various underwing

stores could be carried such as six 60 lb. rockets, eight 25 lb. practice bombs or two 250 lb. general purpose bombs.

A prototype of the Mk. 1 powered by an Armstrong Siddeley Viper ASV 5 engine flew for the first time in June 1954. Since that date considerable changes in a development programme have taken place, resulting in the Mk. 2, which has a shorter landing-gear than the Mk. 1 and is fitted with the more powerful Viper ASV 8 engine. The first of these Mk. 2's, on which the production types are based, made its first flight in the summer of 1955.

The main feature about this aircraft is the simplicity of the design. No swept back wings or streamlined fairings, but a straightforward rugged design capable of teaching the future pilots of the Royal Air Force.

(G.A.)

Solution next week

USING COLOUR PRINTS

SOME readers no doubt make use of colour prints cut from old magazines, calendars, or other published sources. It should be borne in mind however that the law of copyright makes this an offence if the projects made from them are intended for sale

unless permission is obtained.

Articles made up as suggested in the accompanying strip should prove popular with home-workers, and provide scope for those who are not too proficient when it comes to adding the artistic finish. (T.S.R.)



ALL THE FAMILY CAN JOIN IN MAKING MANY NOVELTIES AND USEFUL ARTICLES FOR THE HOME, USING COLOURED PICTURE'S CUT FROM YOUR MAGAZINES.

SOME SUGGESTIONS:- PULL-ALONG TOYS

JIG-SAWS	PICTURE BLOCKS	SPILL HOLDER	OVERLAYS
	CALENDARS		ETC.

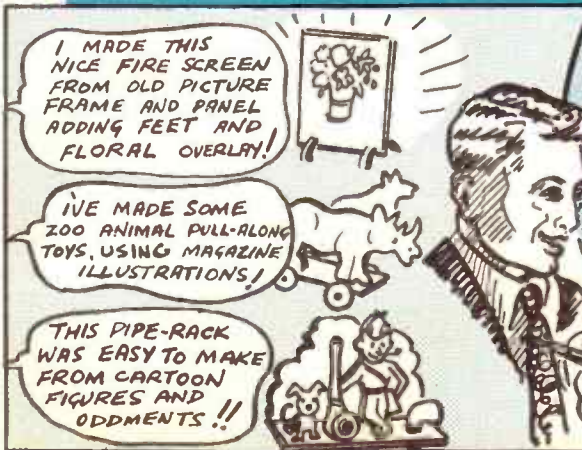

Popular with children

ELECTRO-MAGNETIC CRANE

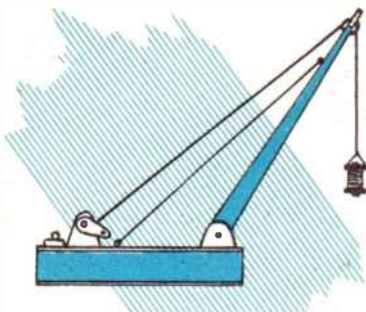

A CRANE is always a popular toy with children and this one is especially so on account of its very attractive feature. The usual crane picks up the goods with a hook, whereas this model does it by means of electro-magnetism.

When the current is switched on the magnet will pick up any iron or steel objects, transport them to where required and then release them only when the current is switched off. All this is accomplished without any handling or having to hook the objects on and should therefore have a very special appeal for the boy or even the girl who loves a novelty.

The power to operate the electro-magnet is supplied by a two or three cell flash lamp battery which is housed in the base of the crane. A push button switch is the easiest and quickest to operate and this is also placed in the base.

Quite a load can be picked up with the small magnet used in this model, but if it is needed to pick up larger objects the size of the bobbin can be increased, more finer wire wound on and the amount of current increased somewhat. When a finer wire is used so as to get more turns on the bobbin the current should not be too strong as this may cause the wire to be burned out.

Substantial baseboard

The baseboard is made as substantial as possible so that the crane will not topple over when a heavy object is being lifted. For this reason it is made in the form of a box to house one or two flashlight batteries. It could, of course, be fitted with wheels for moving it about but these can easily be added later if wanted.

Cut two pieces of wood, either ply or hardwood 6ins. long 4ins. wide and $\frac{1}{4}$ in. thick for the top and bottom of the base. Complete the box by gluing and tacking strips 1in. wide and $\frac{1}{4}$ in. thick round the sides — two pieces 6ins. long and the

two ends $3\frac{1}{2}$ ins. long. The bottom must of course be screwed on so that it can be removed easily when a new battery is required, and six small countersunk screws will do the job very well.

The two strips of wood for the crane arm (A) are 15ins. long, $\frac{1}{4}$ in. wide at the top and 1in. at the base. The arms may be of an even thickness of $\frac{1}{4}$ in. or they may taper off from $\frac{1}{4}$ in. at the base to $\frac{1}{8}$ in. at the top.

The crane arms may be raised or lowered at will and for this purpose are swivelled at the base on the two supports (B) cut from $1\frac{1}{2}$ in. square wood $\frac{1}{4}$ in. thick. These are glued and tacked in the position shown on the base plan. The pivots for the arms are thin round head screws.

A small block of wood $\frac{1}{4}$ in. thick is glued to the top of the arms to separate them and leave room for the pulley. About $\frac{1}{2}$ in. diameter is a suitable size for this but do not have it much smaller.

The winding mechanism (C) is fitted well to the back of the baseboard and consists of a length of $\frac{1}{4}$ in. dowel mounted between two supports with a handle

on one end. Near to the other end is a contact disc which transmits the current from the battery to the magnet.

Start by making the two supports (D) and fixing them securely to the base with glue and panel pins. Cut them from $\frac{1}{4}$ in. wood to the sizes given and when drilling the dowel holes make them a good fit, but not too tight. You should be able to turn the handle fairly easily and yet it should remain fixed when the handle is released without letting the load fall.

By A. F. Taylor

Alternatively, the winding spindle may be made to turn easily either way with the winding gear held, when desired, by the engagement of a ratchet pin in the serrated edge of disc (H).

Fix the supports 2 $\frac{1}{2}$ ins. apart measuring from the insides. The length of the dowel rod which goes through these supports is $3\frac{1}{2}$ ins. long, but before fixing this in position you will need two wooden discs, one for each end on the inside of the supports. These are for controlling the area on to which the crane cord is wound and both have a diameter of 1in., the one near the handle being $\frac{1}{4}$ in. thick while the other one, which is also the contact disc is $\frac{1}{8}$ in. thick.

Ensure smooth contact

On to the contact disc are fitted two metal bands each $\frac{1}{4}$ in. wide and spaced $\frac{1}{4}$ in. apart. These may be of brass or copper, should be a tight fit and the join soldered flush so as to make a smooth contact when revolved against the contact levers.

Glue both discs on to the dowel rod perfectly true and with very slight side play, then cut out the handle arm as shown at (E) from $\frac{1}{4}$ in. wood and glue this in position. The handle itself is a short length of $\frac{1}{4}$ in. dowel.

Make two contact levers from sheet brass or copper 2 $\frac{1}{2}$ ins. long and $\frac{1}{4}$ in. wide and bend to the shape shown at (F). Drill a small hole in the base of each and screw to the baseboard to make contact with the disc.

Now we come to the actual 'pick-up' mechanism or the electro-magnet. You may be lucky and have one already made, but it is quite easy to wind it yourself. The magnet bobbin from an electric bell will do very well, but it must be a fairly large one so that it will be heavy enough to keep the lifting line taut. Modern bells with a very small

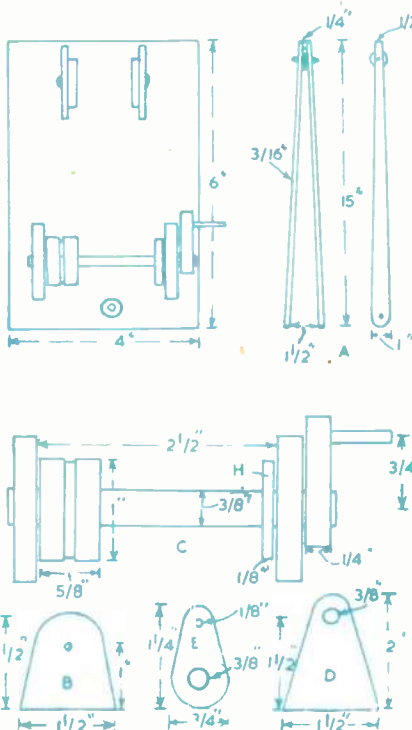

bobbin are useless and it is much better to make a substantial one yourself.

The core of the magnet consists of a piece of soft iron such as a nail. Get a large nail of $\frac{1}{4}$ in. diameter and cut it to about $1\frac{1}{2}$ ins. long, leaving the head on, which will be at the bottom, and form a large lifting surface. On to this wind a few turns of stout cartridge paper gluing it as you go — make this just over 1 in. wide and leaving the nail projecting at each end.

Cut two discs of thin ply $\frac{1}{4}$ in. diameter and glue on to the paper to form a bobbin about 1 in. long. Drill two small holes near the edge of the top one to take the lifting line as shown at (G). We are now ready to wind on the wire, and the length and size will determine the strength of the magnet. For ordinary work use 24 S.W.G. cotton-covered copper wire and wind on about 8 to 12 layers. A stronger magnet would require more layers and the size of the wire can be decreased to say 30 S.W.G.

Before starting to wind, the end of the wire is pushed through one of the holes in the top disc leaving about 2 ins. protruding, then when the winding is complete the other end is threaded through the remaining hole.

A press button switch is probably the most convenient form to use but you can have a small tumbler switch which is fitted on to the baseboard in a convenient position. A short strip of springy brass made to press down on to a round headed screw will answer the same purpose and is very easy to make. Wiring up is quite simple and requires no description, but a diagram is given in case of difficulty.

One or two cords from the top of the crane arm to the baseboard to keep the arm in the correct position will be needed and these can be either fixed or adjustable as required.

To complete the crane we need the lifting line and this also carries the current via the contact discs to the magnet on the end of the line. Very thin twin flex bell wire preferably silk covered, as this is more flexible, is required and

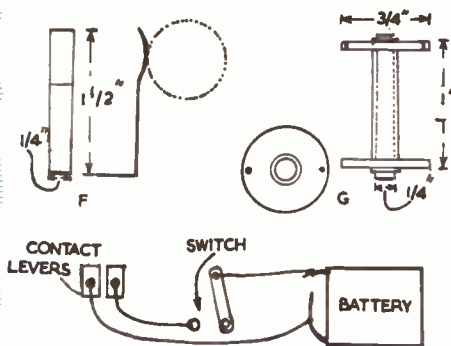

about a yard should be enough. One end is fastened to the contact discs by drilling two small holes and soldering the wires to the metal bands. The other end is threaded through the two holes of the magnet bobbin, made secure and joined to the two wires already pushed through these holes.

Now you can switch on the current after connecting the battery in the base and see how large a load it will lift. A coat of paint will give the crane a finish but this is not absolutely necessary.

Try Forecasting the Answer

HERE is another simple arithmetic trick where you supply the answer before the sum is even prepared! It sounds something like putting the cart before the horse, but let us first explain the presentation.

By S. H. Longbottom

Hand your friend a piece of paper and a pencil, asking him to write down any three digit number, that is, a number with three figures as shown in Fig. 1. Take back the paper, and, after allowing sufficient space for the addition of four other numbers underneath, write in the answer. This sounds impossible, but with a little more patience and the aid of the accompanying diagrams you will soon learn the solution.

At this stage the paper will appear exactly as in Fig. 1 and you may return it to your friend for him to add the second three-digit number, underneath the first. Taking the paper again, you write in the third number and this operation will now produce a result as in Fig. 2.

Finally, the paper is returned for a fourth number and you add the fifth,

giving a result as shown in Fig. 3, where you will find that the correct answer to the sum of these numbers was originally given in Fig. 1, although you have added some like your friend. You will be no doubt wondering how we could possibly forecast the answer before your friend inserted numbers unknown to you.

The solution is quite simple. From the first number written down by your

432	432	432	000	7865
	156	156	253	6692
	843	843	746	3307
		679	891	7619
		<u>320</u>	<u>108</u>	<u>2380</u>
<u>2430</u>	<u>2430</u>	<u>2430</u>	<u>1998</u>	<u>27863</u>
FIG 1	FIG 2	FIG 3	FIG 4	FIG 5

friend you add two thousand, and subtract two, i.e., 2,430. After your friend has inserted the second number a small calculation has to be made before you can add the third number. This third number which you have to add, is the result of subtracting the second number from 999. In this case 156 was written

down and when subtracted from 999 we are able to add 843. The same process was repeated for the fifth number.

If you wish to try the trick with four digit numbers remember add 20,000 and to subtract two in exactly the same way, and obtain your subsequent contributions by subtracting from 9,999 instead of 999 (See Fig. 5.)

Occasionally you may come across some smart person who will write down

some peculiar figures in an effort to confuse you, but all you have to do is to remember the formulae quoted, add 2,000 and subtract 2. In Fig. 4 we show the result of such a person writing down 000, but if we add 2,000 to this, and subtract 2 the correct answer of 1998 can be written in without any hesitation.



THE United States is a country of great diversity — vast cities and small villages, roaring factories and quiet fields; busy streets and small churches for meditation. Geographically, there is variety, too — lakes and deserts; prairies and mountain ranges; rocky sea-coasts and sunbaked plains. Stamps and labels are likewise varied.

American matchcover collectors hold annual conventions and the outstanding covers are exhibited. The outstanding matchcover collector of the year is presented with a plaque and his or her name is engraved on the annual honour plaque.

AMERICA

—By R.L.C.

Monthly meetings often end with a Shucking Contest, a contest to see who can remove the small staple from the book of matches, flatten the cover, and neatly place the matches in a container. The one who finishes in the shortest time is declared the winner, and receives a prize, plus all the matches shucked.

The famous 'Girlie' booklets, first introduced by the 'Chicago Match Corp. of America' in 1938 are the most popular of the 'Standard Designs'. These designs are printed up in large quantities in advance — with the space for the advertisement left blank — and stored flat without the matches in them. These are then offered to small advertisers in lots as small as one case or 2,500 matches.

The advertising copy which can be used is limited but it permits the small advertiser to get a series of matches at a small investment.

Most American manufacturers issue one or two 'Girlie' sets each year. These sets are composed of six, eight, or twelve to the set depending on the type of press on which they are printed. What would appear to be sets of four, ten, sixteen, etc. are actually poses from two or more sets issued in sequence.

Several collectors who specialize in the 'Girlies' have written up an index or check-list of all the poses of each set.

Other popular designs include Scenic Views of America, Hilly-Billy Jokes, Safety Slogans, Dogs, Wild Animals, Game Birds, etc.

American tobacco merchants issue some of the world's most attractive cigar

bands. A set coveted by collectors, portraying U.S. Presidents from Washington to Eisenhower is very rare.

Club members should save all British cigar bands for exchange with U.S. pen friends. Non-collectors can trade them for stamps or other items.

America is a paradise for hotel label collectors. Many are in colour and depict the particular hotel, or some scene characteristic of the name. For example: the present label of the Desert Inn at Palm Springs shows a desert scene, and Denver's Brown Palace Hotel — 'Where the World Registers' — a world map.

It takes a fast train, travelling a mile a minute, more than forty-eight hours to cross the Nation. Leaving from the eastern seaboard, it must first negotiate the Appalachian Mountains, then drop down to the broad, fertile central plain and skirt the outstretched fingers of the Great Lakes. Continuing westward, it winds through the Rocky Mountains, called the 'backbone of the continent', traverses the high tableland beyond,



surmounts the snow-covered coastal ranges, and finally descends to the sea.

'1869. 3c. blue — Locomotive — 1/9 used. 1926. Air. 10c. blue — Map of U.S.A. — 4d. used. 1928. Air. 5c. blue and red — Air Beacon, Sherman Hill, Rocky Mountains — 1/- used. 1934. Various Views — set of 10 — 5/8 used.'

New York, the world's second largest city, with its huge skyscrapers, busy streets and wonderful shops is the great gateway of America. In places like Fifth Avenue are the palace-houses of millionaires. In other parts of the city are great blocks of buildings like huge boxes in which swarms of poor people have their little rooms. Some of these buildings house as many as fifteen thousand people.

'1953. 3c. purple — New York in 1653 and 1953 — 3d. used.'

Washington (the capital) is a fine city and large sums of money are spent every year upon improvements. It is not a manufacturing city, but it has some of the finest buildings in America, the chief of which is the Capitol, where the National Assembly meets.

'1950. 3c. purple — Capitol — 4d. used

3c. green — The White House — 3d. used.

Millions of Americans take part in sports. About 3 million ski. Golf claims 5 million players. And some 20 million bowl at thousands of bowling alleys.

American boys and girls play many games. '1932. 2c. red — Skiing — 1/- mint. 1939. 3c. violet — Baseball — 4d. used. 1950. 3c. brown — Scouts and Badge — 3d. used.

The Stars and Stripes (American flag)

appears on a centenary stamp of 1945 — 4d. mint.

Rare stamps worthy of note include: 1847. 5c. brown — Franklin — £22 mint, £16 used; 10c. black — Washington — £65 mint, £40 used. 1851. 5c. brown — Jefferson — £110 mint, £35 used; 10c. green — Washington — £22 mint, £5 used. The above issues are imperforated. 1861. (perf.) 5c. bistre — Jefferson — £55 mint, £12 used; 15c. black — Lincoln

— £6 mint; 24c. blue — Washington — £100 mint, £13 used.

Members of the League of Hobbyists requiring thematic help or any further information on American stamps and labels should write to the Hon. Secretary, Raymond Cantwell, 48 Fourth Avenue, Slade Park, Headington, Oxford. Please enclose S.A.E. for reply.

A supply of American hotel labels are available to members only at 4/- a dozen.

Advertisers' Offers

IT'S FUN COLLECTING

scamps the Thematic way (i.e. by subjects) such as, airmails, animals, butterflies, sports, maps, ships, flowers, fish, music or railway engines. 1 packet of any of the above sent on approval. This month's speciality: 100 National Flags (stamp size), correct colours, 100% correct design, perforated and gummed, price 10d. post free.

H. Lennard Buttle, 83 Thames Side, Staines, Middx.

100 Different Stamps FREE!!

Request 3d. upwards discount Approvals. British Colonials or Foreign. Wants lists welcomed

Don't delay—Write today, enclosing 3d stamp for postage

C. T. BUSH (H), 53 NEWLYN WAY, PARKSTONE, POOLE, DORSET

10 CANADA (Cat. 3/11) 1/6; 10 Australia (Cat. 3/1) 1/-; 20 U.S.A. 2/-; all commemoratives. Super mixture 5/- Post 3d. extra. — A. J. McKenna, 19 Mount Rd., Fleetwood.

FREE — 50 British Colonials. Enclose 3d. for Bargain Approvals. — J. Gledhill, 85 Paddock Lane, Halifax.

STAMP BARGAINS at 1d. each! Commemoratives, pictorials, including stamps catalogued to 1/- Empire packet free! — Marton Stamps, Marton, Winsford, Cheshire.

AIRMAILS, Giants, Triangulars, Zoological, etc. 100 Free. Request approvals; postage. — Salter, 42 North Road, Rotherham.

STAMPS FREE — Empire Packet including Pictorials and Victorians with approvals. — Robert J. Peck, 7A Kemp Road, Bournemouth.

ROY'S STAMP SERVICE — Beginners and Juniors specially catered for. Send 3d. stamp requesting details and trial—Roy, 23 Adria Road, Birmingham 11.

'Space age' tip

The 'Space Age' is here. Stamps and labels are bound to appear soon depicting Sputniks, rockets, launching ramps, the moon, etc. Now is the time to file all press reports and take notes. Then, when the first rocket lands on the moon you will be able to stampise the story of the century entitled 'Conquest of Space'.

Astronomy is already a popular subject among stamp designers. The following check-list should prove useful. 'Argentine 1946. 15c. green on green — Astrolabe — 3d. used. Austria 1937. 12g. green — Signs of Zodiac — 3d. used. Brazil 1890. 20v. green — Southern Cross — 4d. used. Bulgaria 1936. 1 leva violet — Meteorological Station — 1/- mint. Colombia 1946. 5c. brown — Observatory — 2d. used. Japan 1949. 8y. green — Floating Zenith Telescope — 4d. used Monaco 1955. 200f. blue — Stars and Rocket — 6/- mint.'

This old PENNY RED AND approx 500 STAMPS for only 1/-

To introduce our approvals we will send you the famous PENNY RED issued in Britain 100 years ago, plus about 500 guaranteed unsorted stamps for only 1/- plus 3d. towards postage. Many scarce and interesting stamps have been found in these packets. Complete satisfaction or money refunded. Don't delay — send today.

UNIVERSAL STAMP CO.
(DEPT. H.W.5), 48 AIRE STREET, GOOLE, YORKS.

Hobbies

FOR STAMP ALBUMS

BRANCHES: LONDON
78a New Oxford St., W.C.1
(Phone MUSEum 2975)
87 Old Broad Street, E.C.2
81 Streatham Hill, S.W.2

GLASGOW
326 Argyle Street

MANCHESTER
10 Piccadilly

BIRMINGHAM
100a Dale End, Birmingham 4

SHEFFIELD
4 St. Paul's Parade

LEEDS
10 Queen Victoria Street

HULL
10 Paragon Square

SOUTHAMPTON
134 High St. (Below Bar)

BRISTOL
65 Fairfax Street

NEWCASTLE
42 Dean Street

GRIMSBY
88 Victoria Street

EVERYTHING YOU NEED TO ENJOY STAMP COLLECTING ALL ONLY 1/- WORTH 5/6

LARGE ALBUM & STAMP COLLECTION

1 LARGE ILLUSTRATED STAMP ALBUM. Spaces for thousands of stamps from all over the world. Coloured reproductions of great rarities. Many extras. Better than albums sold for 2/- up.

2 IMPORTED COLLECTION OF STAMPS. Exciting issues! Monaco — Grace Kelly Wedding. French Antarctica — Fantastic new country. China — Great Wall Airmail. Ethiopia — Red X. Estonia — Nazi Dorpat, etc. Total 57 different unusual stamps. FREE!!! AUSTRALIA 1956 OLYMPIC SEALS SET OF 4.

3 MIDGET ENCYCLOPEDIA OF STAMPS. Everything you want to know to enjoy the hobby and become an expert. Includes Stamp Dictionary and Stamp Identifier which shows how to recognise all foreign stamps. All 3 items regular 5/6 value for just 1/- to introduce our Bargain Approvals. A start on a lifetime of collecting pleasure! Satisfaction Guaranteed

SEND 1/- TODAY
JUST ASK FOR LOT AB1

FREE!
1956 OLYMPIC SEALS

BROADWAY APPROVALS · 486 OLD KENT RD LONDON · SE1 · Members: British Philatelic Association

A JOBBING HANDYMAN

WITH tradesmen's bills soaring to such heights it is not surprising that more and more people each year are becoming reluctant to employ tradesmen to carry out their home repairs. There are, however, many people who, for various reasons, still like to have their odd jobs done by others, particularly by spare-time employment. A good job done at a reasonable price is all that they expect. If you are handy with your hands and are fond of working with tools then why not cash in on this and become a jobbing handyman? If you are capable of turning out a good job then you can easily build up

Many readers will no doubt already possess a kit of basic tools but for the benefit of those who intend building up a kit from scratch here is a list of the basic tools which should be included in a handyman's tool kit: handsaw; tenon saw; claw hammer; try-square; chisels (½in., ¾in., 1in.); screwdrivers (large and small); files (half round and flat); steel plane; oilstone (medium and coarse grained); wood scraper; brace and bits; padsaw; axe; 2ft. folding rule; adjustable spanner; pointing trowel; soldering iron; decorating brushes; pliers; blowlamp; bradawl; putty knife; plugging chisel; marking gauge; and wire cutters.

leaves a stamped addressed postcard with his customers. By doing this, if his services are required at some future date, the postcard is sent to him asking him to call. He claims to have doubled his business by adopting this method. Why not try this idea also, or if you have a telephone, leave a printed card with your 'phone number. Remember, once you are in business always be businesslike.

You will often be asked to supply estimates for jobs and, where possible, these should always be given (free of charge of course). When building up your price, you should include a charge for your labour, a charge for the cost of the materials, a little for profit and any other expense you may have to encounter. Since your overheads are practically nil you will find that your charges will be well below those of the professional tradesmen.

By Finlay Kerr

a spare-time business which would give you much satisfaction as well as being profitable.

To become a good all-round handyman it is not essential to have served an apprenticeship at a trade although if you have had some training in one of the building trades this would be an advantage. The various jobs which a handyman would be expected to tackle include, laying lino; reglazing windows; dealing with broken door locks; repointing brickwork; replacing broken sash cords; concreting garden paths; erecting garden gates; general decorating, etc. Information on how to tackle these jobs and many others can be obtained from a good 'Do-It-Yourself' book or from magazines.

The best tools

If you intend becoming a jobbing handyman then it is essential that you should possess a kit of tools. There is no need, however, to purchase a full kit all at once for you will find that most of the jobs can be tackled with only the basic tools. When buying tools, always get the best quality you can possibly afford. The initial cost may be a little high but you will be amply repaid in service afterwards. Don't be misled by the slick appearance of the cheaper brands of tools for you will find that cheap tools will not give you good service. Remember, it is more economical to buy 'quality' tools.

After purchasing your tools, always treat them with the utmost care. Tools which are given proper care and attention will remain serviceable for many years. Always store your tools tidily in a proper tool box or chest.

In addition to the above-mentioned tools, the following materials will also be required: assorted sizes of nails; screws, nuts, washers and bolts; glass-paper; putty; linseed oil; fuse wire; lubricating oil; sash cord; solder and plastic wood.

It will be necessary for the jobbing handyman to have a workshop in which to work. True, much of the work will be done at the customer's home but some jobs will require a little preparation beforehand and, besides, you will require some place to store your tools and materials. A garden shed or a basement room having a bench and a vice would be ideal for this purpose. It is essential, however, that your workshop is weatherproof and dry otherwise you will be constantly troubled with rust.

Having dealt with the practical side of the job, here now are a few hints on the business angle.

First of all, it should always be remembered that the best way for the jobbing handyman to build up his business is by recommendations. Give good service at a reasonable cost and you will be surprised how quickly business will come to you. To obtain the first customers on your jobbing book, ask your local hardware store owner to display your card on his counter outlining your services or else insert a postcard advertisement in the window of any local shop running such a service. Shop window advertising is very popular nowadays and the cost is very small, ranging from 4d. to 1/- per week depending on the district.

Keep a record

Always keep a record of your customers and after finishing each job ask your customer to keep you in mind should he or she require other repairs carried out at a future date. One person I know who has a successful spare-time business doing house repairs always

A 'regular'

When buying materials for your jobs, always try and deal with the same supplier. Once you become known to him he will most probably class you as a 'regular' and allow you discount on the goods you purchase from him. This discount will mean extra profit for you.

If you are doing a job and you find that your customer requires further work done which is outside your scope then offer to find someone to do the work. You can then pass on the work to your favourite contractor, and, if you are businesslike, you will arrange to be paid a commission on all work you obtain for him.

If you follow along these lines and bear in mind that what people want is a good job done at a reasonable price you will be surprised how quickly you will be able to build up a spare-time business as a jobbing handyman.

★★★★★★★★★★★★★★
★ Next week we shall describe ★
★ how to make a handy cabinet ★
★ for storing tools. Also part 1 ★
★ of 'Learn to Swim' besides ★
★ other usual features for ★
★ modellers and 'Collectors' ★
★ Club'. ★
★ MAKE SURE OF YOUR ★
★ COPY — ORDER NOW ★
★ ★★★★★★★★★★★★★★

SHIPS IN BOTTLES



Cutty Sark
Three-Masted
Barque
Phantom
Clipper

Kits 4/11 each, plus 6d. postage and packing

The secret of how to bottle a fully-rigged model sailing ship, jealously guarded by the few who know, is now made available to everybody by our ship in bottle kits

COOPERCRAFT - SHIPDHAM - NORFOLK

Is This Saw in Your Kit?

You can cut almost anything in wood with this Coping Saw. The blade is 6½ ins. long and can be turned to cut at any angle. No tool-kit complete without one. Get yours NOW.

Buy from any Hobbies Branch or post free from Hobbies Ltd., Dept. 99, Dereham, Norfolk

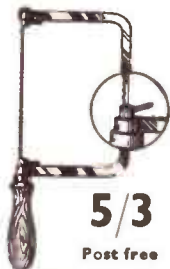

5/3

Post free

YOU CAN BECOME A HANDICRAFTS INSTRUCTOR

EXPERIENCE NOT ESSENTIAL

Men who enjoy making things in wood or metal can turn their hobby into a permanent and interesting Career. Short hours, long holidays and security in a job you would really enjoy, can be yours if you become a Handicrafts instructor. Let us send details of the easiest and quickest way to get the necessary qualification.

We guarantee "NO PASS—NO FEE"

If you would like to know about our unique method of preparing you for one of these appointments, write today, and we will send you our informative 144 page Handbook—free and without obligation. Mark your letters "Handicrafts Instructor".

BRITISH INSTITUTE OF
ENGINEERING TECHNOLOGY

595 College House, Wright's Lane
Kensington, London, W.8

BIET

HEAR ALL CONTINENTS

With H.A.C. Short-Wave Receivers

Suppliers for over 18 years of radio S-W Receivers of quality. One-Valve Kit, Price 25/- Two-Valve Kit, Price 50/- Improved designs with Denco coils. All kits complete with all components, accessories and full instructions. Before ordering, call and inspect a demonstration receiver, or send stamped addressed envelope for descriptive catalogue.

'H.A.C.' Short-Wave Products (Dept. 22), 11 Old Bond Street, London, W.1.

WOOD BENCH VICE



Price 7/6

A strong hardwood vice which can be screwed to the work bench. A real serviceable tool, well made, and fitted with long wood screws, 12 ins. long.

From branches or:
HOBBIES LTD.,
Dereham, Norfolk

The best tools you can lay hands on

"YANKEE" HANDYMAN PUSH DRILL

A simple push action automatically turns drill point into wood, plastic, plaster, or wallboard for screws, brads, nails, etc. No splintering. Magazine handle holds four drill points — room for four more.

21/- complete with 4 drill points.

STANLEY VICE

A new portable vice at an amazingly low price. Body of cast aluminium gives lightness combined with great strength. Clamped to table or workbench it holds work rigidly—either horizontally or vertically.

25/-



19/-

STANLEY BLOCK PLANE

There are many uses for the Stanley 220 Block Plane. Particularly useful for cutting against the grain and smoothing up ends. 7" long. 1½" cutter.

STANLEY

STANLEY WORKS (O B) LTD., RUTLAND ROAD, SHEFFIELD, 3.
SW60

● HALF PRICE SURPLUS!

WE HAVE SURPLUS STOCKS OF

THE MAMMOTH DE-LUXE GADGETS ANNUAL

● FOR 1953 - 1955 - 1956 - 1957 ●

MASSIVE - WIREBOUND - HANDSOME VOLUMES
NOW OFFERED AT 10/- FOR ANY TWO
(POST PAID)

● WHAT YOU
GET FOR 10/-

—etc. etc. These beautiful Annuals are a joy to own and will give endless pleasure to every kind of Hobbyist.

Two different Annuals—EACH containing fully illustrated instructions on HOW TO MAKE over 300 different novelties—Gadgets—Toys—Inventions—Gifts—Puzzles—Implements

What a BARGAIN!

● Don't Delay—Send 10/- Today to:

GADGETS ANNUAL (Surplus Dept)
SWAN HOUSE, KINGSBURY, LONDON, N.W.9

Yours
for
only
8/6d.

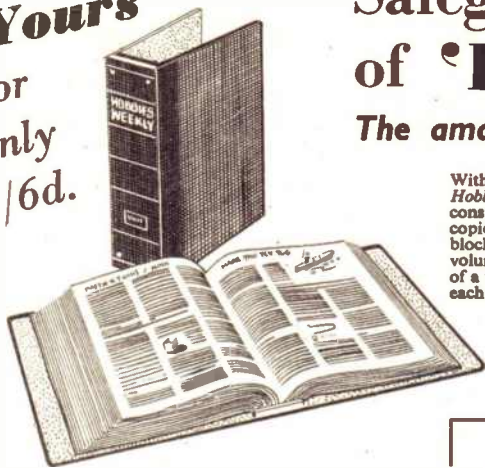

Safeguard your copies of 'HOBBIES WEEKLY'

The amazing 'EASIBINDER' (Pat.) makes it simple

With the new *EASIBINDER*, specially prepared for Hobbies, you can bind each copy of *Hobbies Weekly* as you get it, turning your favourite magazine into a permanent, easily-consulted library of immense value, and avoiding the delay and despair occasioned when copies are accidentally mislaid or destroyed. Carefully finished in black leather-cloth and gold-blocked on the spine, each binder is strong, serviceable and neat. It will hold two complete volumes (52 copies) and costs only 8/6. Each copy of the magazine is quickly inserted by means of a flexible steel wire, and can easily be removed if necessary. Easy-to-follow instructions with each *EASIBINDER*. Get one today and take care of your copies of *Hobbies Weekly*.

NOTE From the issue April 10th, 1957, there is a slight difference in the size of the magazine, and two sizes of *Easibinders* are available. Type A is for binding issues published before April 10th and Type B is for those printed subsequently. To avoid confusion, when ordering, please indicate clearly the type of *Easibinder* required. Indices for each completed volume 1/- each post free.

☆ One 'EASIBINDER'
holds two volumes
(52 copies)

☆ Easy to use

Post today



To: HOBBIES LTD., Dept. 99, Dereham,
Norfolk.

PLEASE SUPPLY EASIBINDERS
(Type) at 8/6 each.

NAME
ADDRESS
P.O. for
enclosed

* **GREAT CAMPING OFFER** *
RIDGE TENT SENT FOR 4/-



BRAND NEW de luxe 'Safety' Tent. All colours. Complete. Ideal cyclists, campers. Length 7' 3" sleeping base x 4' 6" wide x 3' 6" high x 12" walls, all approx. Weight 3 1/2 lb. Cash 55/-, or 4/- deposit and 9 monthly payments 6/-, 1 of 2/6. WITH FLYSHEET 83/6, or 9/3 deposit and 8 monthly payments of 9/9, 1 of 4/9. Both carriage 2/6. TENTS, TERMS.

★ **R.A.F. NEW WATERPROOF BACK PACKS**



One large FULLY ZIPPED Compartment. Onedictosame-size back to back, 4 Buttoned off separate side by side super-imposed Pockets. 2 strong adjustable webbing backstraps with easy release press studs. Made of genuine R.A.F. 100 per cent. waterproof material, all brand new. Ideal for Motor Cyclists, Hikers, Fishermen and 100 other uses. 4/11 only, post etc. 1/1. A fraction of original cost. Send immediately. Headquarter & General Supplies Ltd. (HOBW/8) 196-200 Coldharbour Lane Loughboro Junc., London, S.E.5 Open Sat.

4/11 POST ETC. 1/1
NO MORE TO PAY

'PAINTSPRAYING' HANDBOOK. Covers Car, Industrial & Flock Spraying. 3/6, post 4d. Catalogue of our Cellulose and Paints and all Allied Sundries 3d. — Leonard Brooks Ltd., 81 Oak Road, Harold Wood, Essex.

MODELS. You can make lasting stone-hard models with Sankey's Pyruma Plastic Cement. Supplied in tins by Ironmongers, Hardwaremen and Builders' Merchants. Ask for instruction leaflet.

HOW TO STOP SMOKING

and permanently overcome that ceaseless craving for tobacco. Save money, safeguard health. Send stamp for details of the world-famous inexpensive Stanley Treatment for tobacco habit.

THE STANLEY INSTITUTE LTD Dept. 30
12 Bridewell Place, London E.C.4.

LEARN it as you do it — we provide practical equipment combined with instruction in Radio, Television, Electricity, Mechanics, Chemistry, Photography, etc. — Write for full details to E.M.I. Institutes, Dept. HW47, London, W.4.

MAKE a MUSICAL BOX for as little as 21/6. New kits and tunes available. Movements 14/9 post free. Please send 3d. stamp for free illustrated catalogue. — The Swisscross Co., Dept. B., 202 Tulse Hill, London, S.W.2.

KUKLOS ANNUAL. Indispensable cyclists' handbook. Tours, resthouses, money-saving hints, 3/- post free. — Burrow, Publishers, 2 Imperial House, Cheltenham.

Makethe
KING'S
SHIP
from a
Hobbies
Kit
No. 3108
only 8/-



A delightful miniature galleon, 7 ins. long from branches or
HOBBIES, DEREHAM, NORFOLK

BECOME trained chiropodist. Quick, postal, practical. — GRADUATE SCHOOLS, 48a Abbey Street, Accrington.

MINIATURE GARDEN COMPLETE, 12" x 9 1/2" 20/-. 8 trees, centrepiece, container, compost, rocks, house, instructions. PYGMY TREES, etc. 20/-. 8 trees, 12 pots, compost, seeds, cuttings, instructions. BOOK: Jap and Minigardens 3/6. Pamphlets: Minigardens & Pygmy Trees 9d. Stamp all lists. — Station Nurseries, (H) Oaken-gates, (Salop).

VENTRILLOQUISM — Throwing your voice is easy. Particulars free or send 10/- for complete course. — Kimsing, 225e Highfield Road, Port Elizabeth, South Africa.

WHEELS (Hardwood and Rubber Tyred Metal), Cot, Pram and Doll's House Fittings and Papers, Beads, Transfers, Prints and other accessories. Stamp for new lists. (Trade supplied.) New address — JOYDEN CO., 91 Peplins Way, Brookmans Park, Herts.

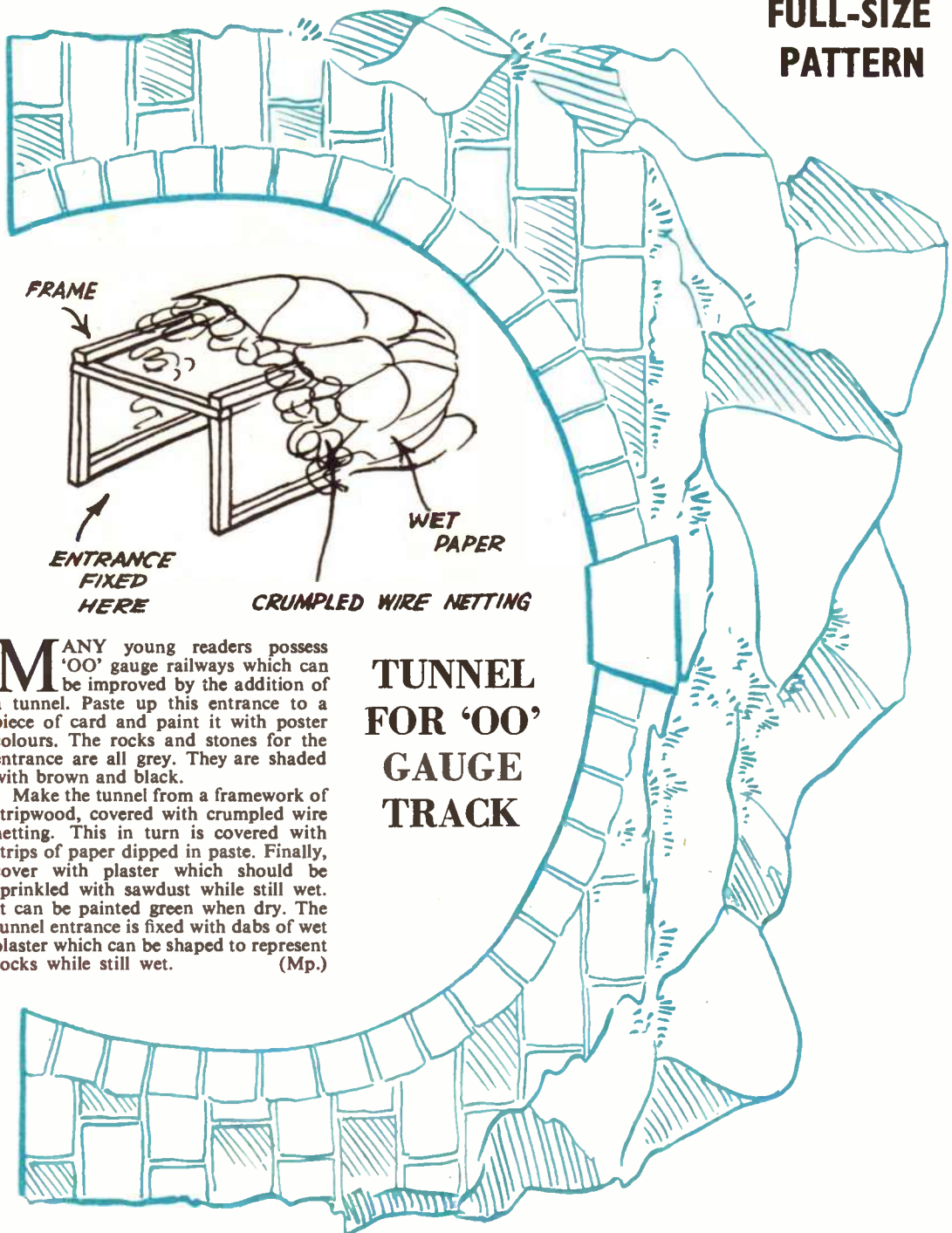

MANY young readers possess 'OO' gauge railways which can be improved by the addition of a tunnel. Paste up this entrance to a piece of card and paint it with poster colours. The rocks and stones for the entrance are all grey. They are shaded with brown and black.

Make the tunnel from a framework of stripwood, covered with crumpled wire netting. This in turn is covered with strips of paper dipped in paste. Finally, cover with plaster which should be sprinkled with sawdust while still wet. It can be painted green when dry. The tunnel entrance is fixed with dabs of wet plaster which can be shaped to represent rocks while still wet.

(Mp.)

TUNNEL FOR 'OO' GAUGE TRACK

Follow the **FLUXITE** way to Easy Soldering

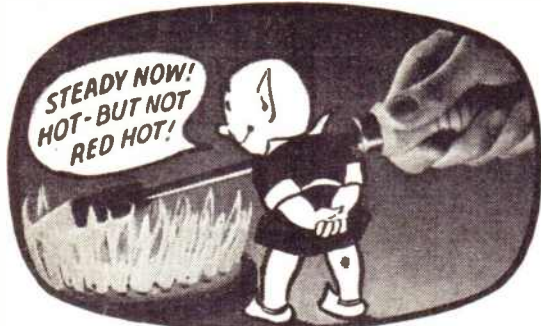

No. 3. Heating the Bit

A clean flame is best such as that of a gas ring, and care must be taken not to let the bit get red hot. When the flame turns green the bit is at the right temperature.

FLUXITE is the household word for a flux that is famous throughout the world for its absolute reliability. In factory, workshop and in the home FLUXITE has become indispensable. It has no equal. It has been the choice of Government works, leading manufacturers, engineers and mechanics for over 40 years.

FLUXITE
SIMPLIFIES ALL SOLDERING

FLUXITE Limited, Bermondsey St., London, S.E.1
G.M.53

For wood,
card,
plastic,
leather,
metal, etc.

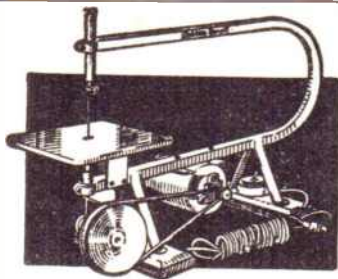

£12 - 5 - 0

**TREADLE
OR MOTOR
FRETSAWS**

Whatever the handyman or craftsman is cutting or making, one of Hobbies Fretmachines will help with the job. For toy making, fretwork, model making, it provides easy and speedy cutting in all kinds of material. A pleasure to use, a factory for output, a lifetime of service.

Obtainable at any Hobbies Branch or good class ironmonger or hardware stores. Or carriage paid U.K. from:

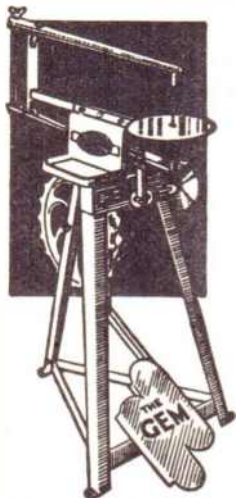

£5 - 17 - 6

HOBBIES LIMITED, DEREHAM, NORFOLK

News

for all 'do-it-yourselfers'!

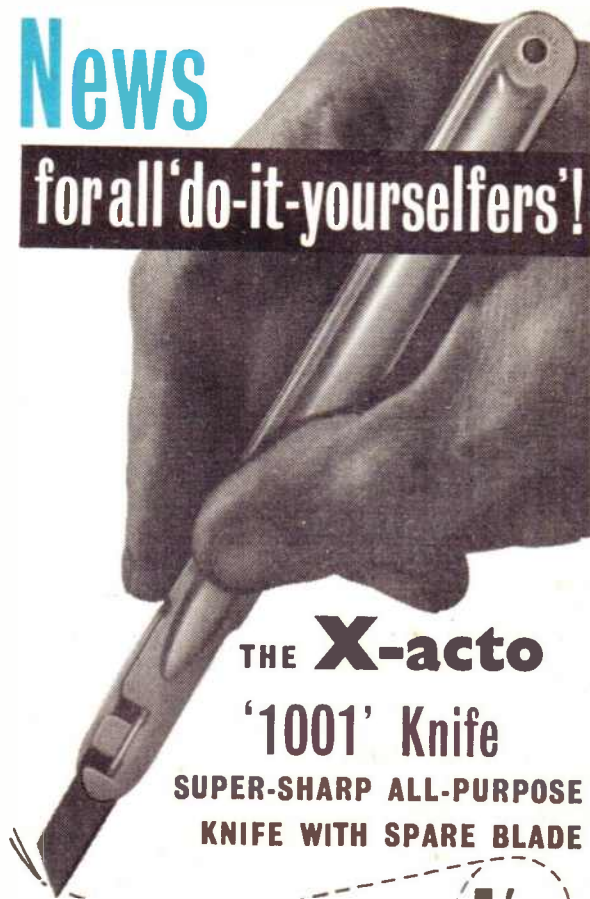

THE **X-acto**
'1001' Knife

SUPER-SHARP ALL-PURPOSE
KNIFE WITH SPARE BLADE

FOR ONLY

1/6

Whether you're laying lino or model-building, pruning the roses or simply sharpening the office pencils, you'll do it better with the '1001' Knife.

Each X-acto '1001' has a carefully balanced steel handle—easy to grasp—and reversible blade, with another 'spare' in the handle—all for only 1/6. Spare blades are 3 for 1/-. Get an X-acto '1001' knife—from all good model shops and ironmongers.

**Other X-acto
precision tools**

For greater accuracy there's a whole range of X-acto interchangeable blade knives—three weights of handle with a blade for every cutting job. Also plane, sander and modellers' tool sets. All precision-built for precision work, and so reasonable in price.

More skill at your fingertips with

TRIX **X-acto**

HANDYMAN KNIVES AND TOOLS

TRIX LTD. 5 CONDUIT ST. LONDON W.1.

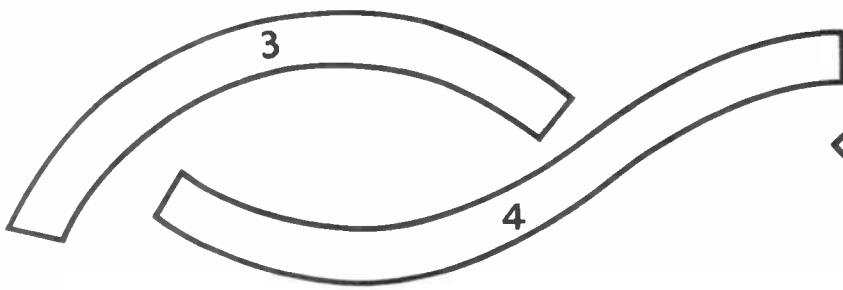

FILLETS 3, 4 AND
CUT FOUR OF EACH
(PLYWOOD).

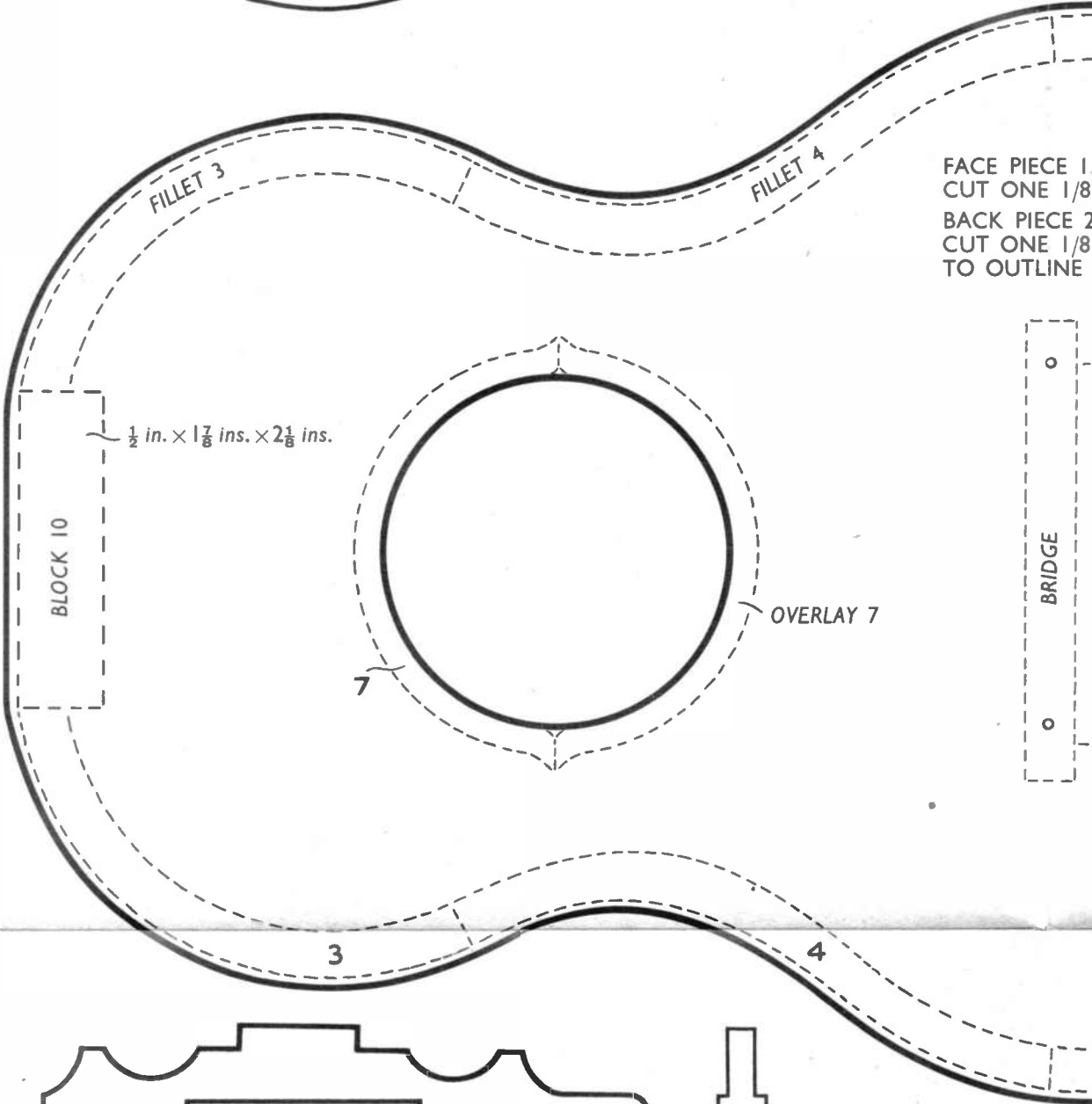

FACE PIECE 1
CUT ONE 1/8
BACK PIECE 2
CUT ONE 1/8
TO OUTLINE

$\frac{1}{2}$ in. \times $1\frac{7}{8}$ ins. \times $2\frac{1}{8}$ ins.

BLOCK 10

FILLET 3

FILLET 4

7

OVERLAY 7

BRIDGE

3

4

UKULELE



SIZE—
20½ ins.
LONG.

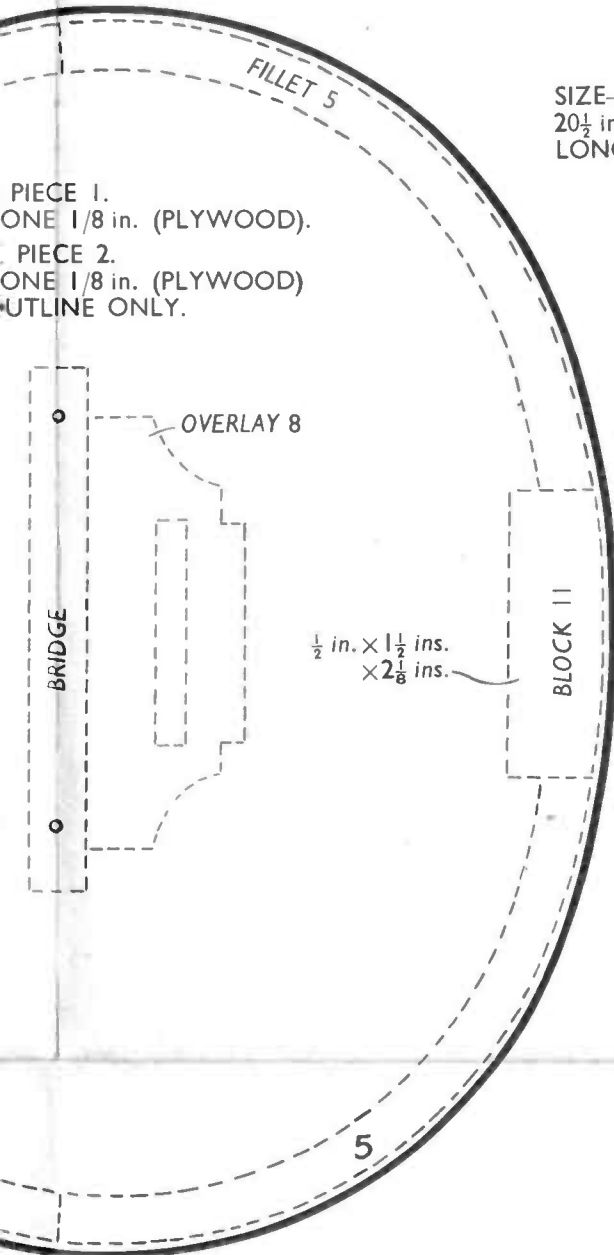

A KIT OF MATERIALS FOR MAKING THIS DESIGN IS SUPPLIED BY HOBBIES LIMITED, DEREHAM, NORFOLK. PRICE ON APPLICATION.

Use **Croid** POLYSTIK

IT'S DESIGNED FOR THE JOB

A cold liquid PVA adhesive combining instant grip with immense and lasting strength. Clean to use, non-staining. In polythene bottle with spreader 2/6.

AVAILABLE FROM ALL BRANCHES OF HOBBIES LTD.

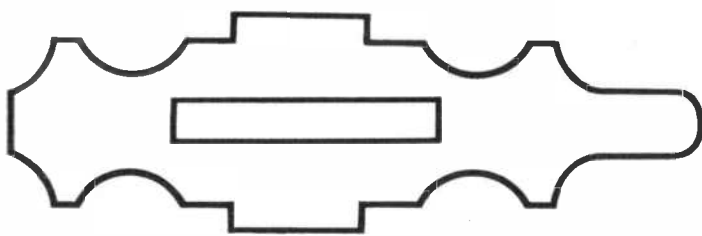
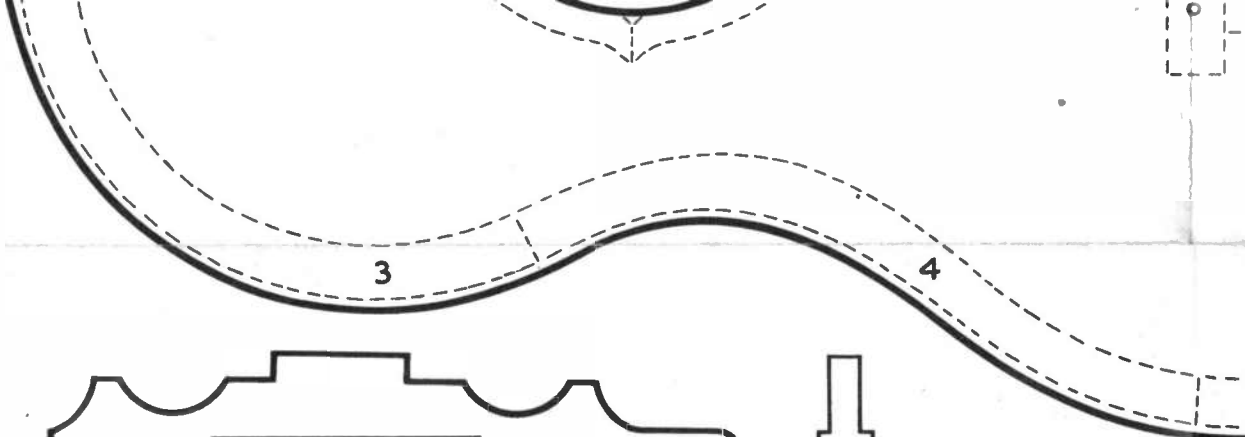

OVERLAY 6. CUT ONE FROM PEARL ACETATE.

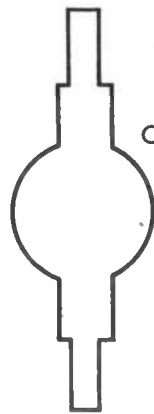

OVERLAY 9. CUT ONE FROM PEARL ACETATE.

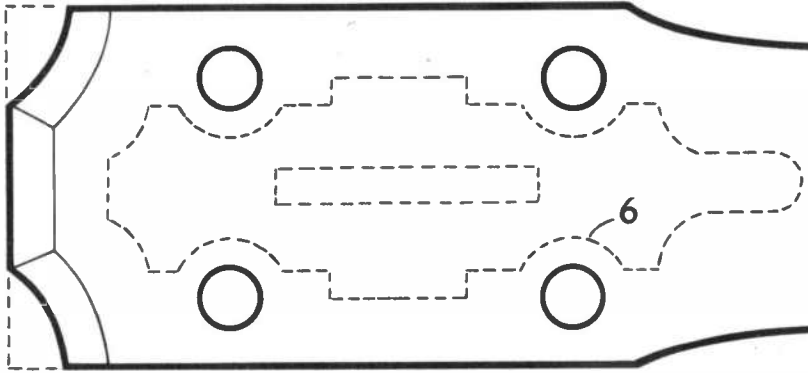

PLAN OF NECK

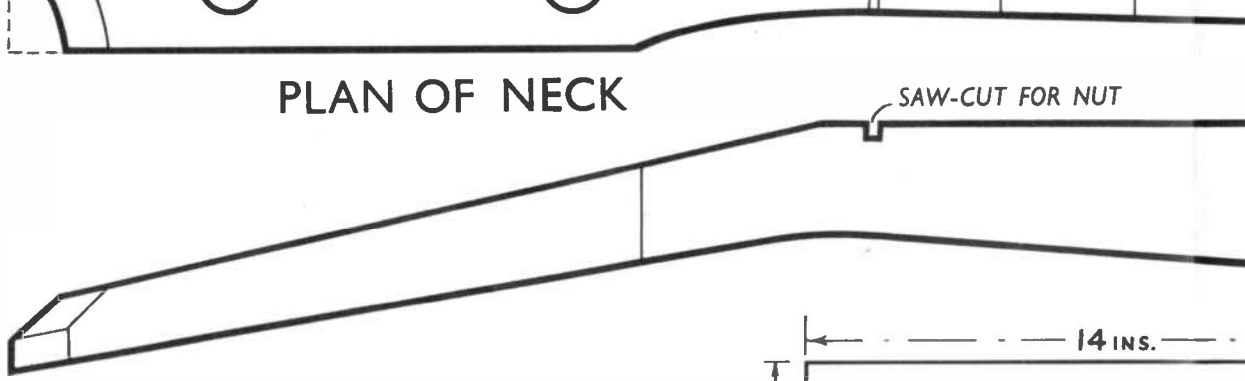

SAW-CUT FOR NUT

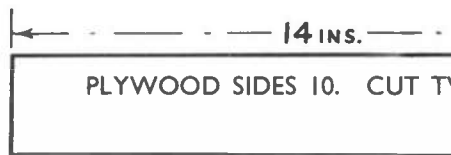

PLYWOOD SIDES 10. CUT TO

PRINTED IN ENGLAND.

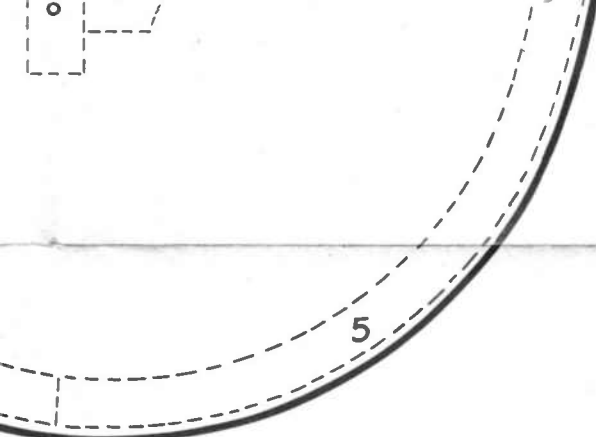

Use Croid POLYSTIK

IT'S DESIGNED FOR THE JOB

A cold liquid PVA adhesive combining instant grip with immense and lasting strength. Clean to use, non-staining. In polythene bottle with spreader 2/6.

AVAILABLE FROM ALL BRANCHES OF HOBBIES LTD.



NUT. CUT ONE FROM 1/16 in. PLASTIC.

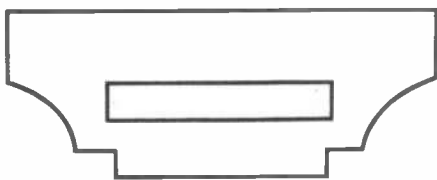

OVERLAY 8. CUT ONE FROM PEARL ACETATE.

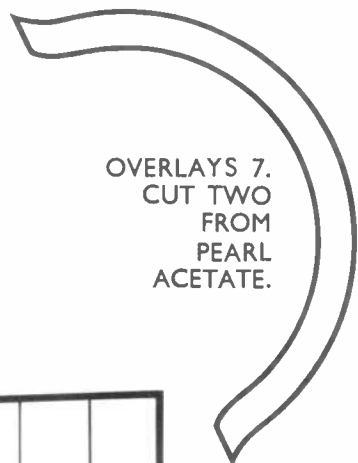

OVERLAYS 7. CUT TWO FROM PEARL ACETATE.

