

HOBBIES WEEKLY

JANUARY 29th 1958

VOL. 125

NUMBER 3248

IN THIS ISSUE

	Page
Old Well Plant Holder	289
A Working Model Catamaran	290
Magic Square Card Puzzle	291
Copying with an Enlarger	292
Interesting Locos - No. 6	293
The League of Hobbyists	294
The 'Gozinta' is a Teaser	295
Hobbies' Crossword No. 12	295
An All-dry Amplifier	296
Making Novelty Ninepins	297
Planning Your Tours	298
Designs for Craftwork	300
Patterns for Working Model Catamaran	303



All correspondence should be addressed to the Editor, Hobbies Weekly, Dereham, Norfolk

*FREE Design
inside to make
this charming
novelty*

VARIOUS kinds of ivy and other trailing plants are in fashionable demand these days for decorative purposes, particularly for use with contemporary furniture. This design for a holder of such plants in the form of an old well provides a charming setting to place on the sideboard, etc.

OLD WELL

PLANT HOLDER

It is designed to take a 3½ins. pot and the model is nearly 10ins. long and 7½ins. wide. As will be seen from the finished drawing, the plant overhangs in a natural and graceful manner. Smaller pot sizes can be accommodated in the measure-

ments given for this model, and for larger sized pots the dimensions would have to be increased proportionately. The assembly is quite simple, and the decorative finials and shaping to various parts give good scope for accurate fret-

cutting. With the exception of pieces 2 and 3 all parts are shown full size on the design sheet.

**INSTRUCTIONS FOR
MAKING ON PAGE 290**

289

FOR ALL HOME CRAFTSMEN
Over 60 years of 'Do-it-Yourself'

World Radio History

4¹/₂^D

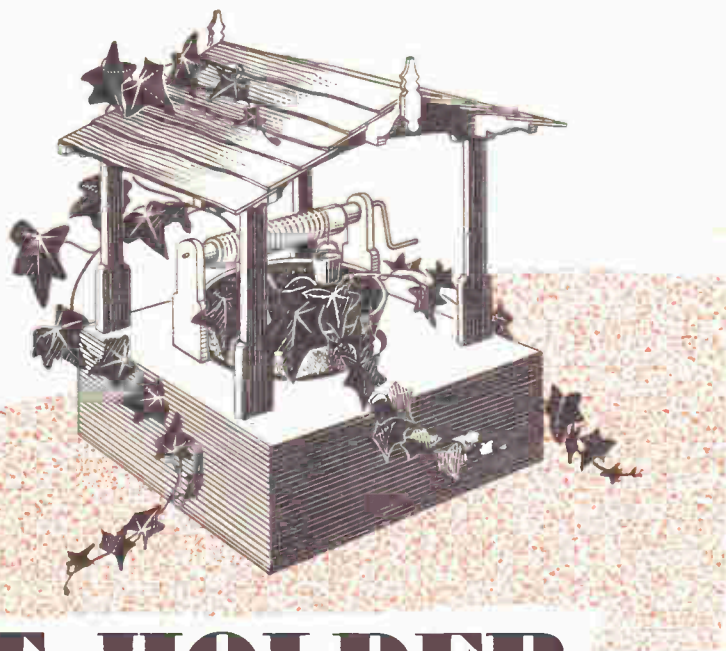

A Working Model Catamaran

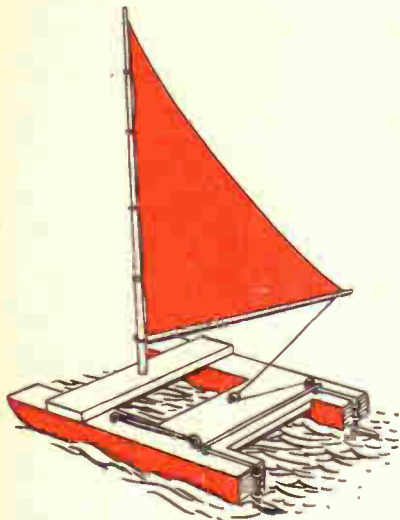

THE young fretworker will enjoy making and sailing this catamaran. Odd pieces of fretwood can be used throughout, but plywood should not be used.

Cut four pieces (A) and one piece (B) from $\frac{1}{2}$ in. wood and glue pieces (A) underneath (B) as shown by the dotted lines. Piece (C) is $\frac{1}{4}$ in. thick and is glued across the top of (B) about $\frac{1}{4}$ in. from the front as shown. The diagram at the bottom of the pattern page shows how pieces (A), (B) and (C) are glued together, thus forming the pontoons.

The ends (D) are now glued in place and the pontoons covered underneath with card or thin wood. It is essential to

FULL-SIZE PATTERNS ON PAGE 303

use waterproof glue when making this model.

The small mast, about 6ins. long is made from $\frac{3}{8}$ in. round rod and glued

into (C). The boom should be $\frac{1}{2}$ in. round rod which is pivoted to the mast by means of a long fretpin pushed into the end and then bent round the mast. The sail is a piece of thin cloth lashed to the boom and the mast with thread or cord.

The small detail on the pattern page shows how to construct the rudder from wire and wood. They are pivoted to the pontoons by means of small screw-eyes.

To get semi-automatic steering connect the two helms by means of a piece of wire as shown by the picture of the finished boat. Fix a weak elastic band from a screw-eye in (B) to one helm as indicated. The cord from the end of the boom passes through a screw-eye in (B) to the other helm.

When sailing with the boom on the other side change the cord from its present position, across to the other helm.

The catamaran will need two or three coats of enamel to give a good finish.

(M.P.)

● Continued from page 289

Making the Plant Holder

Trace the various pieces from the design sheet and transfer them to their appropriate thicknesses of wood by means of carbon paper. Make sure that all parts have been accounted for before cutting out with the fretsaw, and then clean up well with glasspaper.

BUY A KIT

Panels of wood, round rod and wire are included in Kit No. 3248 for making the 'Old Well' Plant Holder. The kit costs 10/3 from branches of Hobbies Ltd., Dereham, Norfolk (post free).

Now make up the assembly as shown at (B) on the design sheet. This consists of piece 4 on which is tenoned the roof supports (18) and windlass supports (6). Pieces 16 are cross beams which connect the roof supports.

The broken-away view at (D) shows how pieces 14, 15, 17 and 20 are glued together to form the roof. Pieces 19 are the cappings on the roof and pieces 20 overlap each other, as will also be seen on piece 14. When fixing the pieces 20, start at the outer edges of the roof, and work upwards to the ridge.

After adding the finials, the roof assembly is glued to the supports (18) and cross beams (16).

The windlass is completed as shown at (C), details of the individual parts being indicated. The 'rope' can be of thin cord glued on to the roller, and the bucket, which is purely for decorative purposes, is shaped from circles of wood glued together. The handle is fashioned from a piece of wire.

For finish, it is suggested that applications of brush polish would give a pleasing effect. If the model is painted, light colours such as cream should be used to give an effective contrast with the greenery. A tin lid, saucer or other receptacle should be placed underneath the pot to catch the surplus water.

★★★★★ROTARY SANDER★★★★★



To quickly glasspaper the inside or outside of sawn timber, attach glasspaper to the split end of a dowel pin, and insert uncut end in the chuck of a power drill.

This attachment can be rigged up in a few minutes. All that is needed is a dowel of suitable size to fit chuck of grinder. With a fine hacksaw cut down dowel to a length of, say, four inches, then insert glasspaper in slot, bending the paper so that the rough side lies over the dowel pin on both sides.

According to the fineness of the dowel pin it is possible to 'sand' wood in even small crevices.

(G.H.H.)

MAGIC SQUARE CARD PUZZLE...

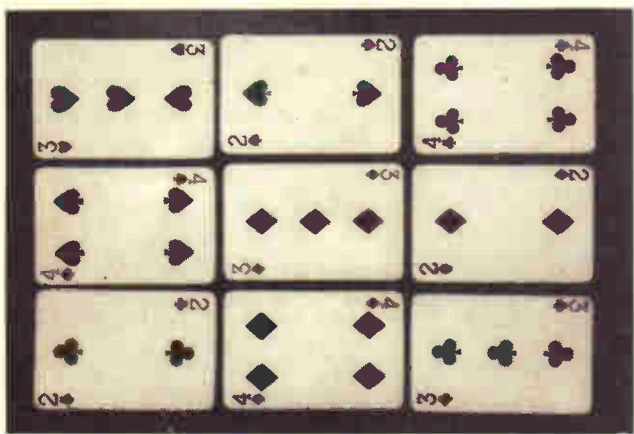

By S. H. Longbottom

... and Magic Number Cards

HERE we have a set of seven magic number cards which you should cut out and paste on to a card. Close observation of the cards will reveal that each one starts with a number which is double the preceding one, that is 1, 2, 4, 8, 16, 32, and 64. As a matter of fact, these, too, are the key numbers of the cards.

You may tell any person his age or any number he selects between 1 and 100. For example, hand your friend the cards, asking him to think of any number between 1 and 100. He looks at the cards and returns those to you which bear the selected number. All you have to do to find the selected number is to total the key numbers of the cards he returns.

We will assume that 68 is selected. This appears only on cards bearing the key numbers 4, and 64, which added together give the solution.

If you wish you may pencil in the key numbers on the backs of the cards when you can read off the total merely by observing the sum of the cards retained as having the number, and without taking them from your friend. These are best written in some kind of code, using dots or signs to guide you, but you must memorise these if you wish to be successful every time!

NO doubt from time to time you will have seen a magic number square where the sum of the numbers is alike whether added vertically, horizontally or diagonally. Our illustration shows such a magic square but formed by nine playing cards, using the 2, 3, and 4 values, and you will observe that the total is nine when added in any direction.

With a pack of playing cards three other magic squares, with differing totals, may be made in addition to the one shown, forming a tricky, but interesting puzzle.

Remove all the picture cards from a full pack of cards, but retain the aces which count as value one in the remaining forty cards. If you lay out one set of nine cards as shown there are still three other sets of nine to make and finally there will be four magic squares with four cards remaining.

With only a little experiment you will readily find the next two magic squares, but the fourth may prove the greatest puzzle. If you are unable to find the solution please turn to page 300 for the correct answer.

1	21	41	61	81
3	23	43	63	83
5	25	45	65	85
7	27	47	67	87
9	29	49	69	89
11	31	51	71	91
13	33	53	73	93
15	35	55	75	95
17	37	57	77	97
19	39	59	79	99

2	22	42	62	82
3	23	43	63	83
6	26	46	66	86
7	27	47	67	87
10	30	50	70	90
11	31	51	71	91
14	34	54	74	94
15	35	55	75	95
18	38	58	78	98
19	39	59	79	99

4	15	30	45	60	71
5	20	31	46	61	76
6	21	36	47	62	77
7	22	37	52	63	78
12	23	38	53	68	79
13	28	39	54	69	84
14	29	44	55	70	85

8	24	40	56	72	88
9	25	41	57	73	89
10	26	42	58	74	90
11	27	43	59	75	91
12	28	44	60	76	92
13	29	45	61	77	93
14	30	46	62	78	94
15	31	47	63	79	95

16	24	48	56	80	88
17	25	49	57	81	89
18	26	50	58	82	90
19	27	51	59	83	91
20	28	52	60	84	92
21	29	53	61	85	93
22	30	54	62	86	94
23	31	55	63	87	95

32	38	44	50	56	62
33	39	45	51	57	63
34	40	46	52	58	66
35	41	47	53	59	67
36	42	48	54	60	68
37	43	49	55	61	69

64	70	76	82	88	94
65	71	77	83	89	95
66	72	78	84	90	96
67	73	79	85	91	97
68	74	80	86	92	98
69	75	81	87	93	99

COPYING WITH AN ENLARGER

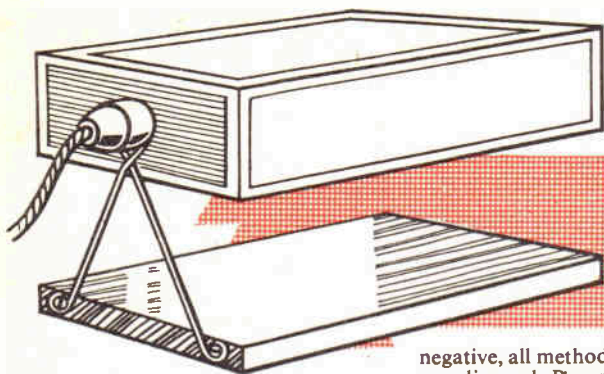

THERE are many advantages in knowing how to make an entirely new negative by using the enlarger for copying. It is far easier than by the camera, and much more accurate, since focusing is positive, not relying on fine measuring to ensure the original is within the limits of the frame, nor is a

negative, all methods of retouching are at our disposal. Paper will accept retouching medium as easily as celluloid film, providing a 'tooth' for pencil, charcoal or crayon, while water colours, or process white applied with a small atomiser — as used by artists — will completely obliterate the unwanted background. Again, a different grade of paper may be used to improve contrast of the new picture.

When satisfied that handiwork on the print is complete, copying is done with the aid of the enlarger. Where the negative has been lost, there is no alternative but to work from the print available, although this may be improved by slight retouching. Unglazed glossy paper will produce the best results for the surface may show in grained papers.

The boxes should be carefully tested for light leakage, sealing all joints with strips of passe partout if necessary. Moreover, it should be noted that these boxes work as a pair and it is necessary to provide for this by making a left-hand and a right-hand box.

Brilliant lights are *not* required, for they would reduce our control of exposure time. Instead, it will be found quite adequate to fit 15 watt pearl lamps.

Before proceeding to the actual process of copying it should be mentioned that provision must be made for holding the unexposed negative material in position while an exposure is being made. Most enlargers hold the negative sandwiched between two pieces of glass. All that is required is the replacement of

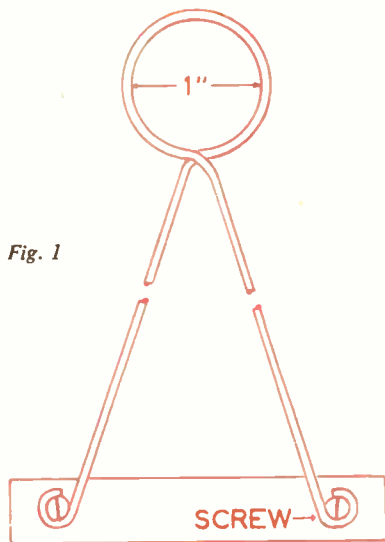

Fig. 1

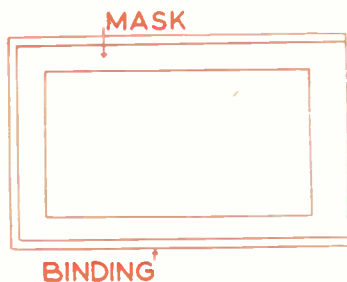

Fig. 2

Even illumination of the print is essential, with lamps of the same intensity lighting the subject from both sides of the enlarger baseboard. The angle should be 45° and the same for both lights which must be shielded from the negative material placed in the enlarger film carrier. To achieve this two boxes are required attached to a small stand with a wire lampholder fitted as shown in Fig. 1. The wire must be long enough to give a height of 10ins. to 12ins., with a hole for the holder cut in one end of the boxes, approximately at a point one-third of the width from one end (Fig. 3). This permits tilting to the required angle, throwing an even light on to the print.

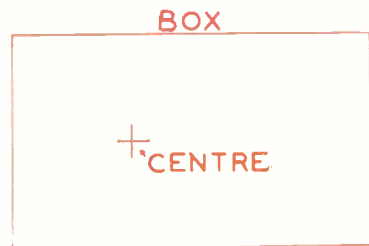

Fig. 3

supplementary lens required. Moreover, the enlarging lens is specially designed for dealing with the flat plane, and ideal for this work.

It will be obvious that one must resort to copying when a negative has been mislaid, but one of the chief advantages is that we can overcome the difficulty of retouching small negatives. It becomes possible to make an enlargement of a picture, eliminate any undesirable feature, strengthening or modifying others as we choose. Providing a good enlargement is possible from the original

these by a single piece of glass bound together with a suitable mask — just smaller than the film size — allowing new film to slot in. A mask of stiff but thin pliable cardboard will supply the need, holding the film quite firmly when placed in position (Fig. 2). Note that it is also an advantage to cut a piece of black paper to act as a backing, while assisting the loading of the film into this improvised holder.

The adapted negative holder is also used for focusing on the subject. Placing the print to be copied on the baseboard, with the holder in position, switch on the enlarger light. Adjustment is made until the print lies just within the confines of the illuminated area. Fine focusing follows, either with a

known sharp negative or with a small feather as previously described in these pages. The negative may be slotted into the holder for copying after focusing but remember that it must be emulsion side downwards, facing the baseboard, but do not insert until you are quite sure that the lighting is correct.

As already mentioned, we require even illumination on the print. The reflectors are positioned and a trial lighting made. Watch out for any 'hot spots' of brightness, but here is an infallible test. Hold a ruler edgewise across the centre of the print when uneven lighting will reveal a shadow at one side or the other, but will vanish when the lights are correctly positioned. See the arrangement in Fig. 4.

Stop down the enlarger lens to a small aperture and copying may proceed. With all lights extinguished but the normal safelight, a piece of film may now be inserted into the improvised holder and replaced into the enlarger. The sidelights are switched on for the approximate time of, say, 5 to 7 seconds and the exposure is made. Tests should be made to find the correct exposure time in the same manner as in printing or enlarging, and once you find the correct time for the particular negative material, do not change. Panchromatic films are not recommended, and although there are special cut films made

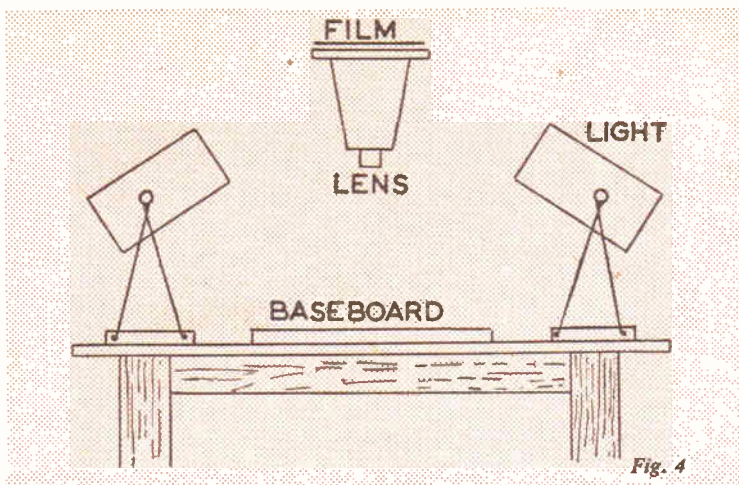

for this work such as Ilford Commercial Ortho, you may cut up an ordinary orthochromatic film into short pieces, storing between cards to flatten. The latter must be done in the dark-room, of course.

Full development of the negative is necessary or you will produce flat results. Increased development time always produces increased contrast, and the copy negative will be better for

being plucky. It is suggested that you also test the development times.

In practice, the process is quickly completed and while it is the only method of producing a new negative it will undoubtedly, improve an otherwise rejected picture if suitably retouched. If you have ever tried to spot out the tiniest pinhole, you may realise the advantage of working on a large print, finally copying as described.

Interesting Locos - No. 6

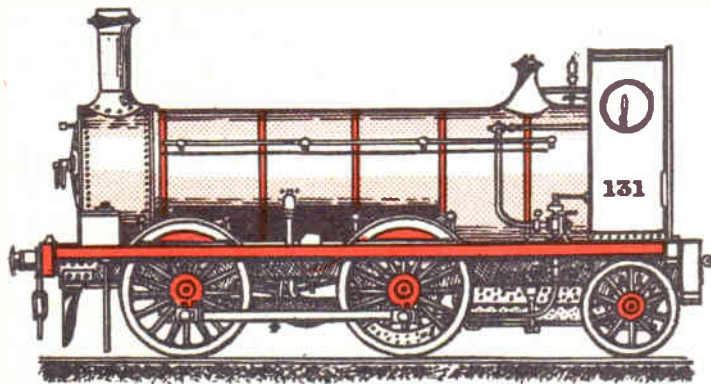

THE excellent little front coupled goods tender locomotive shown in our illustration was designed by Patrick Stirling at Kilmarnock for the Glasgow & South Western Railway in 1864 primarily for the goods and mineral traffic of the line.

No. 131 was one of a batch ordered from the then well-known firm of R. &

W. Hawthorn, and was delivered at the end of 1864.

It may be said that this class of engine was the first in which the familiar Stirling external characteristics first made their appearance. They had his well known domeless boiler and included Hawthorn's perforated steam pipe. The four coupled wheels were 5ft.

diameter and had steel tyres, whilst the trailing wheels were 3ft. 6ins. diameter and had wrought iron tyres. The cylinders were 16ins. by 22ins., the total heating surface was 930 sq. ft., and the boiler working pressure 120 lbs. per sq. in. The engines were provided with Mr. Stirling's well-known pattern of cab, with circular side windows. They remained in service on the G. & S.W.R. for many years.

Patrick Stirling was Locomotive Superintendent of the G. & S.W.R. from 1853 to 1866.

Details for an Inlaid Cigarette Box will be given in next week's issue. Also fretwork and toy projects and instructions to make a delightful Plaque in marquetry of the famous 'Mayflower' galleon,



Introducing — THE LEAGUE OF HOBBYISTS

ENROL YOUR FRIENDS

All members supplying proof of introducing another member to the club (as a new reader of 'Hobbies Weekly') will be presented with an illustrated stamp album, a helpful handbook entitled 'Let's collect Stamps', a perforation gauge, a watermark detector and a duplicate book. Details may be obtained from the secretary.

MANY of our hobbies, especially the 'collecting' ones, have enthusiasts in all parts of the world who are regular readers of *Hobbies Weekly*.

Readers from a wide area write to the editor for information about stamps, match labels, etc., and other important matters concerning the various 'collecting' hobbies. Although every effort is made to help, it has not always been possible to furnish a fully satisfactory

reply, particularly in cases where stamps have been enclosed for evaluation. These and many other services are now available free to enrolled members of 'The League of Hobbyists' — a world club possessing specialised information on philately, phillumeny and allied subjects. Membership is free and open to all regular readers of *Hobbies Weekly*, but it must be insisted that to enjoy all the League's benefits, readers must become certified members by first applying to the Hon. Secretary.

Remember, if your hobby brings you in contact with friends abroad, you are making a valuable contribution to world peace. Causes of war include fear and ignorance. What better way of removing them than by getting to know and understand the people of other lands? An exchange of stamps, etc., may lead to an exchange in ideas of home life, school life, sports, customs and so on. By encouraging pen friends on the above lines you are not only increasing your circle in an exciting way, but are getting the most out of your hobbies.

So come on hobbyists, wherever you may be; let's get together and make our club a big success.

The club's aim

The aim of the League of Hobbyists is to make it the world's best and to especially benefit members with a full and free exchange of knowledge and ideas.

Service provided

Free advice on any aspect of collecting as a hobby and the evaluation of stamps and labels (match, hotel, etc.).

Exchange of duplicates.

Regular news features concerning club activities and illustrated articles on all angles of collecting will appear in *Hobbies Weekly*.

Various competitions, closed to enrolled members. Prizes will include stamps, labels and albums.

Enrolled members

After enrolment, members are requested to enclose a stamped and addressed envelope with all letters requiring a reply, indicating their official club number in all correspondence, which must be addressed to the Hon. Secretary of the League and NOT to the Editor.

When put in touch with other enthusiasts they must regard themselves in honour bound to answer all correspondence.

How to enrol

Take the first step now by applying for enrolment. Fill in the coupon on this page or send details on plain paper and post to:

Raymond Cantwell,
Hon. Secretary,
'League of Hobbyists',
48 Fourth Avenue,
Slade Park,
Headington,
OXFORD, England.

Please enclose a stamp for return postage.

LEAGUE OF HOBBYISTS APPLICATION FOR ENROLMENT

Full Name

Address

Age

I am interested in the following departments
(Please tick)

Stamps ..	Hotel Labels ..
Match Labels ..	Cigar Bands ..
Cheese Labels ..	Buttons ..
Cigarette Cards ..	Coins ..

I also collect

Any other remarks/suggestions

I am a regular reader of 'Hobbies Weekly'
(please tick)

Name of Newsagent

Address

(Subscriber readers should indicate)

I hereby apply for Enrolment as a Member of
The League of Hobbyists.

(Signed)

Date

To save mutilation of the magazine, the above details may be submitted on plain paper.



This new protected set of match labels from Czechoslovakia is obtainable from the League's Hon. Secretary at 1/3 per set

AN ALL-DRY AMPLIFIER

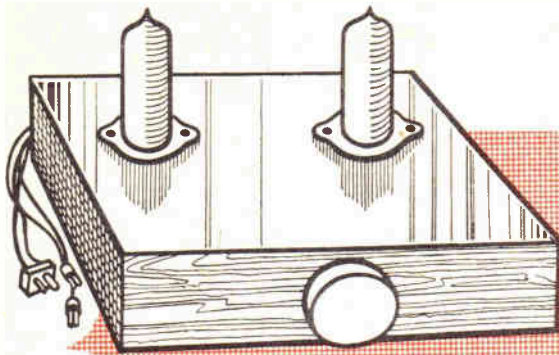

THIS amplifier will prove satisfactory for most purposes where a small battery-operated unit is required, as when bringing the volume from a crystal set up to speaker volume, or playing 78 r.p.m. records with a pick-up. Amplification is also sufficient for the type of microphone which gives a high output (e.g., a carbon mike), but *not* for condenser, crystal, or ribbon microphones, which need extra valves.

The valves

The first valve is a 1S5, but equivalents such as the DAF91 or 1FD9 may be used instead, without any modification to wiring. For output purposes, the popular 3S4 is employed. Equivalents which can be inserted in this position instead are the 1P10, N17, and DL92. Various other output valves could also be used, but for these, wiring to the valveholder tags would need changing.

The amplifier is intended to run from a $1\frac{1}{2}$ V filament supply. This can be obtained from a $1\frac{1}{2}$ V battery of the type made for all-dry portables. Alternatively, a $1\frac{1}{2}$ V torch or flash-lamp cell can be used, or a number of such cells connected in *parallel*. On no account must a 3 V (2-cell) battery, or any combination of cells in series, be used for low tension.

For H.T., a $67\frac{1}{2}$ V battery of any popular type is required. These batteries will have quite a long working life.

Other components

Two B7G (small 7-pin) valveholders are necessary. Small carbon resistors of 900 ohms, 100K (100,000 ohms), 680K (680,000 ohms), and $\frac{1}{2}$ megohm are used. These values are chosen to suit the valves, and it is best not to depart too much from them. A 1 megohm volume control, with switch, is also necessary. If this is a small or midget type, the chassis can be very shallow. If a control without switch is to hand, it can be used with equal success, a separate on/off switch then being wired in the L.T. negative lead.

The values of the condensers are not critical. In the .005 μ F position, anything from about .001 μ F to .01 μ F will suffice,

By F. G. Rayer

though rather large values (such as .01 μ F) tend to make reproduction low pitched. The coupling condenser of .01 μ F, or similar value, *must* be in perfect condition, and a reliable mica component is recommended. Any leakage in this condenser will result in a

necessary for each valveholder depends somewhat upon the kind of holder, but will usually require to be about $\frac{1}{4}$ in. in diameter, to clear the tags.

Side runners are of $\frac{1}{4}$ in. wood, giving a chassis 2 ins. deep, and are held by panel pins. Front and rear strips are then nailed on, a central hole holding the volume control. At the back, two twin socket strips provide for input and output connections. A bakelite or paxolin strip, with four terminals, would also be satisfactory.

Wiring points

Fig. 2 shows all connections, as no wiring is found above the chassis. Fairly thin tinned copper wire, such as 22 S.W.G., works easily, and if the tags are clean, good joints can be made without difficulty. Resin-cored solder is satisfactory, with a soldering iron sufficiently heated to melt it readily. The iron should always be removed as soon

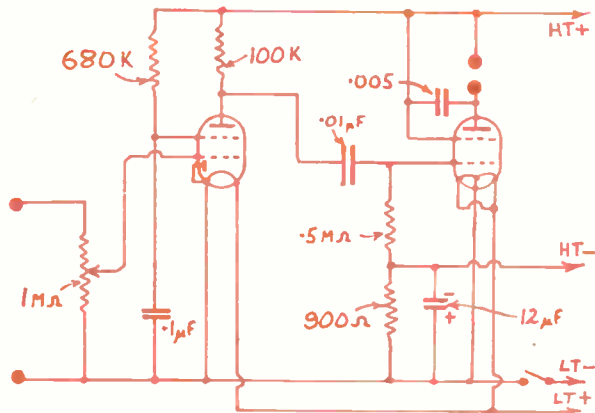

Fig. 1 The amplifier circuit

positive H.T. voltage reaching the output valve grid, which will spoil results and greatly reduce the life of the valve. The condenser marked .1 μ F can be this value, or .25 μ F or .5 μ F, if to hand.

The bias condenser, wired to H.T. negative, can be 12 μ F or 25 μ F. This component will have polarity marked on it, and the negative tag must be taken to the H.T. negative lead.

The chassis

This is easily made from thin wood, being 4 ins. by 6 ins. The size of hole

as the joint is made, as prolonged heating of some components may damage them.

In many places the wire ends of resistors and condensers are taken directly to the tags. Insulated sleeving can be placed over all leads, to prevent shorts. Valveholder tags must not touch each other, or other leads, etc. (This applies also to the *unused* holder tags, as the pins contacting these help to support the electrodes inside the valves.) As shown in Fig. 2, each holder has double spacing between two pins, and the

holders must be screwed down, so that this space is in each case in the position indicated, so that wiring to the other pins can be followed as shown.

Lengths of flex are used for battery connections, all passing out through a $\frac{1}{4}$ in. hole in the rear runner. The L.T. leads must never be brought into contact with the H.T. battery sockets, or taken to the H.T. battery in error. When wiring is completed, the 1S5 is inserted in the holder near the input sockets, and

pick-up. The older type of pick-up, either crystal or magnetic, can be very satisfactory for this reason. It is only necessary to connect the two leads coming from the unit to plugs which can be inserted in the input sockets. If one connection is formed by screened brading, this is taken to the plug which is inserted in socket (X) on the amplifier (Fig. 2).

If a microphone is used, it must be so placed that sounds from the loud-

(X) to the earthed phone terminal, and join the other socket to the remaining phone terminal. The headphones themselves are best disconnected, with most sets.

Fault tracing

A fault is very unlikely, but if no results are obtained, all connections should be checked. If no error is found, the valves should be examined in darkness. If the filaments are visibly lighted (a

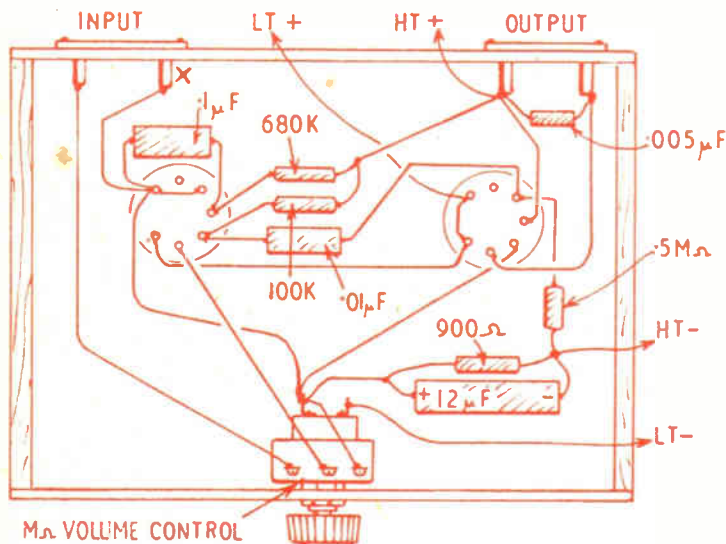

Fig. 2 Underneath wiring plan

the 3S4 in the holder near output sockets.

Speaker connections

Best results will be obtained from a loudspeaker of reliable manufacture, one of about 5ins. to 7ins. in diameter being suitable. It must have an output transformer, which may be fitted upon it by the maker, or purchased separately. The transformer primary is taken to the output sockets of the amplifier. The secondary, which usually consists of a winding of thick enamelled wire, is taken to the speaker coil tags, as in Fig. 3. If primary and secondary are wrongly connected, the speaker cannot operate.

Reproduction will be improved if the speaker is fitted in a cabinet. The transformer should also, if possible, be one for 'Battery Pentode'. That is, it will have a ratio of about 45 : 1. Some transformers have several tags. If the ratio is marked, 45 : 1 is suitable. If it is not indicated, however, the best tags to use can easily be found by trial, being those giving best volume and clarity.

Input circuits

With a pick-up, for record playing, volume will be best with a high-output

speaker do not reach it strongly, or uncontrollable howling will result, especially as volume is increased. A carbon microphone must have its usual 100 : 1 or 50 : 1 step-up transformer, and dry battery.

To amplify a crystal set, take socket

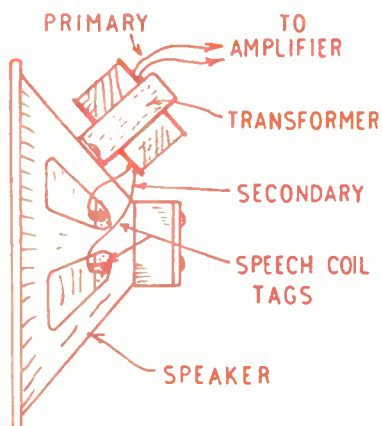

Fig. 3 How the transformer is wired

clear red), the L.T. circuit is in order. If they are not alight, suspect the L.T. battery, connections thereto, or the switch.

If the filaments are in order, but no signal is obtained, the speaker and transformer can be tested by touching leads from it on a $1\frac{1}{2}$ V cell, when it will click loudly if in order. If results are still absent, then the H.T. battery or connections should be suspected.

Making Novelty Ninepins

ANY child will love these little 'ninepins' for a gift.

All you require to make a set is a smooth dowel (a broom handle will do), and a few scraps of thin plywood.

Cut the dowel into lengths for the bodies and hats, and saw out the V-shaped grooves as shown.

The hat brim is a circle of thin plywood $\frac{1}{4}$ in. larger in diameter than the body.

Nail the hat and brim through to the body, and finally fit the arms ($\frac{1}{4}$ in. strips of plywood).

Paint the set of nine in bright colours, and supply a large marble to complete the game.

The appearance of the 'ninepins' can be varied as you wish, by cutting the

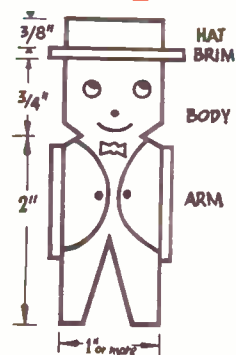

heads at an angle instead of flat as illustrated. (S.F.)

Out in the open

PLANNING YOUR TOURS

WITH the promise of springtime and summer ahead, we look forward to good times in the open air, and this is the time to plan and get our preparations made.

Hiking, camping and cycling may all come into our plans. To plot a hiking holiday is comparatively easy, for the trampler has no car to bother about, no garaging to arrange for, and though, of course, one's mileage is considerably less, yet quite a nice stretch of countryside can be covered during the course of a fortnight's walk. In R. L. Stevenson's words the real essence of your holiday hiking is to be 'free, free, free'.

Take it easy

Go easy. Rest frequently. Change your socks every hour if you feel like it. Have a good interval for the midday meal. Tramp afternoon and evening, but don't prolong your walk into the dusk; allow a margin for seeking supper, bed and breakfast. To the average trampler, fifteen to thirty miles on a fine day is a fair distance; even less on the first few days, when muscles have to be limbered and rendered flexible. Here one must 'generalise' somewhat, for just how far one should tramp in a day is a matter for the individual to decide, for we all differ in degrees, mentally and physically. Resist the temptation to accomplish too much in the time at your disposal.

There are many ways of enjoying a

tour. One may elect to explore some picturesque district, revelling in the scenery; you may follow the course of some river right to its source; or make a round of ancient castles, churches, historical places. An exploration of some region famed in literature, as Hardy's Wessex, the Scott Country, or the

By A. Sharp

Brontë moors, are among a large number of interesting districts. These are just a few suggestions. The reader may think of others equally admirable — Derbyshire, Yorkshire, Shakespeare's countryside, Phillpotts' Devon, the Scottish Borders, etc.

Wanderlust appeal

There is good fun in visiting a 'chain' of Youth Hostels or historical old inns. Youth hostels enable open-air lovers to spend a most enjoyable holiday in an enchanting way. Membership fees are low; armed with his member's card, the rambler can get a bed and other facilities for a modest sum.

In Scotland there are Hostels connecting various districts, including the Border Chain, Lomond, Trossachs Ring, Aberdeenshire Group, the Cairngorm Chain — the latter links up the valleys of the more famous northern

regions, and embraces some of the finest scenery of the Highlands. There is something about a tramping tour that appeals to the wanderlust that is inherent to most of us.

There is also much fun and adventure to be gained by a holiday under canvas. To ensure success and happiness in camp life it is essential that careful thought be given to the selection of equipment. The tent, seeing that it will be your shelter in all kinds of weather, is the most important item. Always make sure that it is really waterproof.

Tent types

For a fairly large party — six to eight — the 'Bell' type is excellent. Another useful type is the 'Gipsy', single or double, according to number of party. The 'Cottage' pattern with fly-sheet is also popular, and suitable for man and wife on holiday. Another useful pattern that may be recommended is the 'Chalet' with extension at the back for storing light luggage.

Here, again, the would-be camper must be guided by the size of his tent, and the amount he is prepared to spend on equipment. Veteran campers frequently make shift with just a rubber groundsheet and blankets. Others prefer a palliasse, which is stuffed with hay, straw, or dry heather on arrival at the camp site.

To the uninitiated all this may sound like 'roughing it', but by the exercise of ingenuity and foresight, camping can be brought to a point of comfort — and even luxury.

Do's and Don'ts

Keep to the paths, do not proceed through the fields at more than two abreast, in order to maintain a well-defined pathway. Carefully close and shut all gates. It is generally wise to do so.

Explorers Wanted!

Adventures await boys and girls keen to explore new country for themselves on foot or cycle. Areas for exploration include moorlands, mountains, downlands, river valleys, sea-shores, forests and villages. Opportunities abound for woodcraft, bird watching, nature study, photography, sketching, etc. Map your own route, fix mileage to suit yourself . . . and spend each night at one of the 300 youth hostels scattered throughout England and Wales. All provide simple accommodation for 3s. a night (1s. 6d. if under 16) and good companionship at the end of the day. There are also three-course suppers and breakfasts available at 2s. 6d. each, or you can cook your own food in the members' kitchen for 3d.



Don't
delay
Post
today

To Y.H.A., Trevelyan House, St. Albans, Herts. HW58/1

Please send me "Going Places" and details of Y.H.A. membership

Name

Address

Miscellaneous Advertisements

50 ITALIAN stamps free, to approval applicants enclosing postage. — Miller, 95 Bollington Road, Heaton Chapel, Stockport.

COINS — box of 250 mixed, 30/- including post. — Box No. 33, Hobbies Weekly Dereham, Norfolk.

MATCHBOX-SIZE crystal sets, all parts, instructions, 3/3. — R. Bailey, 44 Stanley St., Oldham.

75 DIFFERENT stamps free with approvals, 44d. postage. — Salter, 42 North Road, East Dene, Rotherham, Yorks.

STAMP BARGAINS at 1d. each! Commemorative, pictorials, including stamps catalogued to 1/-. Empire packet free! — Marton Stamps, Marton, Winford, Cheshire.

A WONDERFUL OPPORTUNITY FOR ALL

READERS OF HOBBIES WEEKLY!



Now's the time to join the
Scientific Book Club

121 CHARING CROSS ROAD, LONDON, W.C.2

A FIRST-CLASS BOOK EVERY
MONTH FOR ONLY 4/-

FREE!

You can obtain a copy of the famous *PEARS CYCLOPAEDIA* (published at 15s.) free if you enrol a friend. Send your friend's name and address with 5s. (4s. plus 1s. postage) for his first book, mentioning this offer, and your gift will be sent to you.

The Scientific Book Club is owned and controlled by Foyles, the world-famous booksellers.

FULL LENGTH
FULL SIZE

LOOK AT
THESE
TITLES!

Recent and forthcoming selections — at only 4s. to members — include:

INSIDE THE
ATOM

by Isaac Asimov

Published at 12s. 6d.

4s. TO MEMBERS

SCIENCE UNFOLDS
THE FUTURE

by J. G. Crowther

Published at 18s.

4s. TO MEMBERS

THE MOUNTAINS
OF PHARAOH

by Leonard Cottrell

Published at 16s.

4s. TO MEMBERS

THE MEN BEHIND
THE SPACE ROCKETS

by Heinz Garmann

Published at 21s.

4s. TO MEMBERS

★ Here is a wonderful money-saving opportunity for every reader of *Hobbies Weekly*! Each month, the Scientific Book Club brings to its members the fascinating story of the march of modern science, told in thoroughly dependable books by the front-rank scientific writers of our time—vivid, vital, constructive contributions to Man's unceasing struggle to solve the problems of the Universe. And although the ordinary editions of these books are sold to the general public at 12s. 6d., 15s., or more, THE PRICE TO MEMBERS OF THE SCIENTIFIC BOOK CLUB IS ONLY 4s.! Remember, too, that Scientific Book Club selections are *full-length and unabridged*. They are printed on good quality paper, well-bound, with an attractive picture jacket. These are, we say with certainty, books that you will be glad to read, proud to own. The Scientific Book Club brings these great books to you each month; helping you to build up, at remarkably low cost, a first-class collection of scientific books. Now is the time to join!

FILL IN THIS ENROLMENT FORM TODAY

To the Scientific Book Club, 121 Charing Cross Road, London, W.C.2

I wish to join the Scientific Book Club and agree to purchase the selected book issued each month to members at a cost of 4s. (postage 1s.). I agree to continue my membership for a minimum of six books and thereafter until countermanded.

You may enrol through your usual bookseller if he is a member of the Booksellers' Association

*I will pay for selections on receipt.

Hobbies/Jan. 58

Or if you wish to save time, postage and postal order costs, you may send an advance subscription. Six months 30s.; twelve months 60s.

*I enclose 30s./60s. (strike out amount not applicable).

* Place ✓ in the space above, as required.

Name

.....
BLOCK LETTERS PLEASE

Address

.....
Overseas enrolments should be accompanied by an advance subscription. Prices as for inland (except South Africa, Australia, New Zealand)

DESIGNS FOR CRAFTWORK

ONE of the greatest difficulties connected with craftwork is the problem of creating one's own original designs. Though many interested in this type of hobby may be capable of planning and constructing a sound model in wood or metal, they often lack the artistic ability to add those final touches which transform it into a thing of beauty.

The thought of sitting down and planning a simple square or rectangular fret suitable for a firescreen or some other purpose, would immediately deter many enthusiasts. However, there is a way which makes this a task that a child could undertake with reasonable success.

Paper folding

Have you ever tried paper folding? If not, give it a try and see if its possibilities are worth considering next time you are faced with the problem of design.

Take a square of old scrap or coloured paper of the required size and fold it from corner to corner three times. Then with sharp scissors, make a few interesting cuts into the two folded edges of the resulting triangle. Diagram (A).

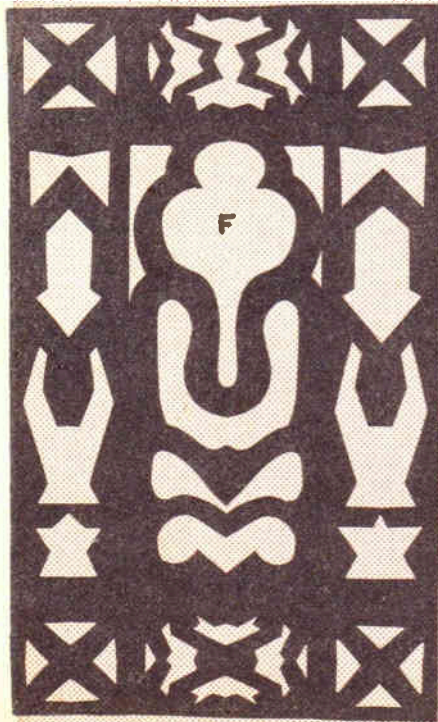

B.

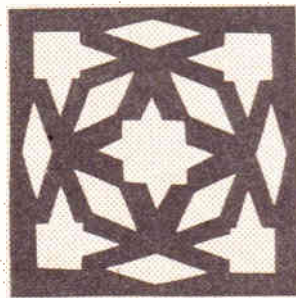

C.

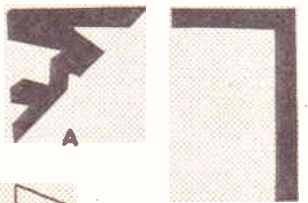

D.

E.

Diagrams (B) and (C) show but two of the great variety of shapes that can be obtained in this way.

Further suggestions for the use of these cut-outs include the making of decorative table mats, trays, plant stands and other models requiring a base.

Rectangular shapes can be folded as illustrated in diagram (D), and diagram (E) shows the effect after a few simple cuts. Designs for fretwork models are most interesting when produced in this way, and many and varied are models that can incorporate such designs.

Square and rectangular boxes, each with lids and sides of the same design can be made very attractive through the medium of fretwork. Others can be made in a more solid manner, and then enamelled after having the design transferred on to their various surfaces by the use of the cut-out template.

Diagram (F) shows how squares and rectangles can be combined on large models to achieve an elaborate and detailed effect that would not be otherwise possible for the average craftworker.

Linoprinting designs measuring some 3ins. by 3ins., when transferred to lino and printed side by side, give an excellent overall effect. These, when printed on fabric are most suitable for cushion covers and table cloths. Similarly a most effective border along the bottom of plain curtains can be printed by the use of these blocks.

Stencil patterns can also be cut out of scrap paper and then transferred to vellum.

Other possibilities include designs for pokerwork, pewter, and other crafts in metal. Indeed, it would appear that the possibilities afforded by such work are limitless.

Next time you undertake a design for one of the crafts mentioned, consider this quick and easy method. It really works!

(D.H.H.)

SOLUTION TO CARD PUZZLE

(See page 291)

3 2 4	6 5 7	9 8 10	8 A 6
4 3 2	7 6 5	10 9 8	3 5 7
2 4 3	5 7 6	8 10 9	4 9 2

502
MUHLE



**CONTINENTAL
MARQUETRY KIT**

9/6 Plus 1/1
Postage
& Packing

or send for free folder No. F6
which gives full details of all
"ATLAS" kits and veneers. Also
Brochure of all Handicrafts free
on request from . . .

Fred Aldous LTD.

DEPT. W THE HANDICRAFT CENTRE
P.O. Box 318 20-22 WITBY GROVE, MANCHESTER 4

**The best tools
you can lay hands on!**

STANLEY BENCH PLANES

41/-

For the hardest and toughest work.
Adjustable for coarse or fine
work, and thickness and
evenness of shaving.
9" long. 2" cutter.



No. 4 Plane.

**THE STANLEY
TRIMMING KNIFE**

Cuts lino, hardboard,
veneer, roofing felt etc.
1001 uses in the home and
garden. Spare double
ended razor sharp blades
carried in handle. Available
in 5 colours.



6/- complete with 5 blades
and blade guard.

**"YANKEE" HANDYMAN
PUSH DRILL**

A simple push action
automatically turns drill
point into wood, plastic,
plaster or wallboard for
screws, brads, nails etc. No
splintering. Magazine
handle holds four drill
points—room for four
more.



21/- complete with 4 drill
points.

STANLEY

STANLEY WORKS (G.B.) LIMITED, RUTLAND ROAD, SHEFFIELD, 5

EMI

Announce

**NEW PRACTICAL WAY
OF LEARNING AT HOME**

"HIS MASTER'S VOICE"
MARCONIPHONE - COLUMBIA

NEW—completely up-to-date methods of giving instruction in a wide range of technical subjects specially designed and arranged for self-study at home under the skilled guidance of our teaching staff.

NEW—experimental outfits and lesson manuals are despatched on enrolment and remain the student's property. A tutor is allotted to each student for personal and individual tuition throughout the course. Radio and television courses, with which specially prepared components are supplied, teach the basic electronic circuits (amplifiers, oscillators, detectors, etc.) and lead, by easy stages, to the complete design and servicing of modern Radio and T/V equipments.

If you are studying for an examination, wanting a new hobby or interest, commencing a career in industry or running your own full-time or part-time business, these practical courses are ideal and may be yours for moderate cost. Send off the coupon to-day for a free Brochure giving full details. There is no obligation whatsoever.

**Courses with Equipment RADIO • SHORT WAVE RADIO • TELEVISION • MECHANICS
CHEMISTRY • PHOTOGRAPHY • ELECTRICITY • CARPENTRY • ELECTRICAL WIRING
'HI-FI' • DRAUGHTSMANSHIP • ART etc. etc.**

EMI INSTITUTES

The E.M.I.
Factories at
Hayes, England.

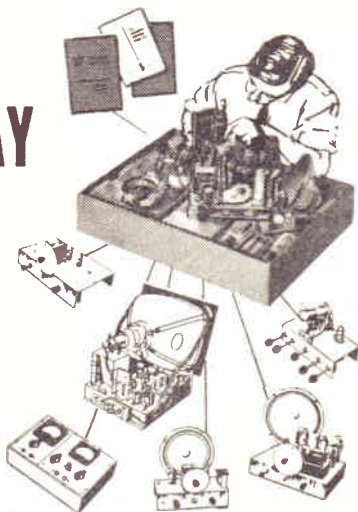

Fill in for **FREE BROCHURE**
E.M.I. INSTITUTES, Dept. 31 x, London, W.4

Name _____ Age _____
(If under 21)

Address _____

I am interested in the following subject(s) with/without equip-
ment _____
(We shall not worry you with personal visits)

FREE

**BLOCK
CAPS
PLEASE**

IC107
JAN./58

The only Home Study College run by a World-wide industrial organisation

CAYMAN ISLANDS

ANTIGUA BORNEO DOMINICA GRENADA
LEEWARD ISLANDS MALTA MOROCCO
MONTSERRAT QATAR, etc., etc. — a magnificent
collection 20 Commonwealth, mostly MINT, with
many pictorials — ABSOLUTELY FREE!

Send 4½d postage and ask to see Bargain Approvals.
Discount Available.

Both gifts and approvals will amaze you
BOWDEN, 20 HOBMOOR CROFT, BIRMINGHAM, 25

WHEELS (Hardwood and Rubber Tyred Metal), Cot, Pram and Doll's House Fittings and Papers, Beds, Transfers, Prints and other accessories. Stamp for new lists. (Trade supplied.) New address — JOYDEN CO., 91 Peplins Way, Brookmans Park, Herts.

BECOME trained chiropodist. Quick postal practical. — GRADUATE SCHOOLS, 48a Abbey Street, Accrington.

PAINTSPRAYING' HANDBOOK. Covers Car, Industrial & Flock Spraying. 3/6, post 4d. Catalogue of our Cellulose and Paints and all Allied Sundries 3d. — Leonard Brooks Ltd., 81 Oak Road, Harold Wood, Essex.

MODELS. You can make lasting stone-hard Models with Sankey's Pyruma Plastic Cement. Supplied in tins by Ironmongers, Hardwaremen and Builders' Merchants. Ask for instruction leaflet.

LEARN it as you do it — we provide practical equipment combined with instruction in Radio, Television, Electricity, Mechanics, Chemistry, Photography, etc. — Write for full details to E.M.I. Institutes, Dept. HW47, London, W.4.

MAKE a MUSICAL BOX for as little as 21/6. New kits and tunes available. Movements 14/9 post free. Please send 3d. stamp for free illustrated catalogue. — The Swisscross Co., Dept. B., 116 Winifred Road, Coulsdon, Surrey.

* GREAT CAMPING OFFER *



BRAND NEW de luxe 'Safety' Tent. All colours. Complete. Ideal cyclists, campers. Length 7' 3" sleeping base x 4' 6" wide x 3' 6" high x 12" walls, all approx. Weight 3½ lb. Cash 55/-. or 4/- deposit and 6/- monthly. With FLYSHEET 83/6, or 9/3 deposit and 9/9 monthly. Both carriage 2/6. **LISTS OTHER EQUIPMENT: TENTS, CLOTHING, WATCHES, ETC., TERMS.**



PURE WOOL SWEDISH RED CROSS SLEEPING BAGS
Brand new Government stock. Completely zipped full length on one side and especially zipped across the chest and around the head, which is held rigid with flexible stays that fold flat when packed. They must have cost £4 to make. These famous sleeping bags, comfortable to an amazing degree, are without doubt the finest model ever made and we offer them at a cost of less than the wool content! Send for one and see for yourself, on money back guarantee. Only 18/11, post, etc., 3/1. Folds up neatly for easy transportation. Full length and width, accommodates any size person. Send quickly or callers welcome. **LISTS, TERMS, ETC. TERMS.**

Headquarter & General Supplies Ltd.
(HOBW/96) 196-200 Coldharbour Lane
Loughboro Junc., London, S.E.5 Open Sat.

HOW TO STOP SMOKING

and permanently overcome that ceaseless craving for tobacco. Save money, safeguard health. Send stamp for details of the world-famous inexpensive Stanley Treatment for tobacco habit.

THE STANLEY INSTITUTE LTD Dept. 30
12 Bridewell Place, London E.C.4

K UKLOS ANNUAL. Indispensable cyclists handbook. Tours, resthouses, money-saving hints, 3/- post free. — Burrow, Publishers, 2 Imperial House, Cheltenham.

15/6! CRYSTAL RADIO kit. Easy-to-build with only a screwdriver and pliers. Post free — send 15/6 P.O. ALSO — 1 and 2 valve kits, headphones, etc. — send stamped addressed envelope for complete list to — Blanchard's Radio, Dept. HC7, 13 Gainford Gardens, Manchester, 10.

GENUINE Swiss Musical Movements. The best and largest selection of tunes in the country; lowest prices 16/3 each. Genuine Thorens Movements, 22/9 each. All guaranteed P. & P. 9d. extra on all orders. — Richardson & Forder, H.W. 5 Chapel Place, White Hart Lane, London, N.17.

STAMPS FREE — Empire Packet including Pictorials and Victorians with approvals. — Robert J. Peck, 7A Kemp Road, Bournemouth.

100 DIFFERENT stamps free! Request 4d. upwards discount approvals. — Bush, 53 Newlyn Way, Parkstone, Dorset.

STAMP COLLECTORS — FREE, famous Queen Victoria 1d. red (Plate number issue) together with packet assorted stamps. Send 3d. stamp and request fine quality Empire approvals. — Milton Lodge, Wessex Avenue, Bognor Regis.

NOW! OVER 300 MOULDS in the Sculptorcraft range



Illustrated above are a few of the many models in the Sculptorcraft range.

1. Toby Jug, available in three sizes.
2. Pixy on Log Posy Bowl.
3. Mme. Pompadour and Louis XV Bookends.

Send 1.6d. Postal Order for full colour catalogue to Dept. HW/1.

SEAMER PRODUCTS (SCULPTORCRAFT) Ltd., 23/27 EASTBOURNE STREET, LULL.

Sculptorcraft



BIRMINGHAM
100a Dale End, Birmingham 4
SHEFFIELD
4 St. Paul's Parade
LEEDS
10 Queen Victoria Street

BRANCHES: LONDON
78a New Oxford St., W.C.1
(Phone MUSEUM 2975)
87 Old Broad Street, E.C.2
81 Streatham Hill, S.W.2

GLASGOW
326 Argyle Street
MANCHESTER
10 Piccadilly

Head Office & Factories—HOBBIES LTD, DEREHAM, NORFOLK

KITS for OLD TIME SHIPS

Hobbies range of Ship Models includes Elizabeth Jonas, Cutty Sark, Victory, Mayflower, etc. Complete kits of wood, sail material, guns, pulleys, cord, etc., with full-size patterns of parts and planed wood ready to cut out, shape and construct. A fascinating pastime.

Ask for free illustrated list at Hobbies Branches or from Hobbies Limited, Dept. 99, Dereham, Norfolk.

HEAR ALL CONTINENTS With H.A.C. Short-Wave Receivers

Suppliers for over 18 years of radio S-W Receivers of quality. One-Valve Kit, Price 25/- Two-Valve Kit, Price 50/- Improved designs with Denco coils. All kits complete with all components, accessories and full instructions. Before ordering, call and inspect a demonstration receiver, or send stamped addressed envelope for descriptive catalogue.

'H.A.C.' Short-Wave Products (Dept. 22), 11 Old Bond Street, London, W.1.

Working Model Catamaran

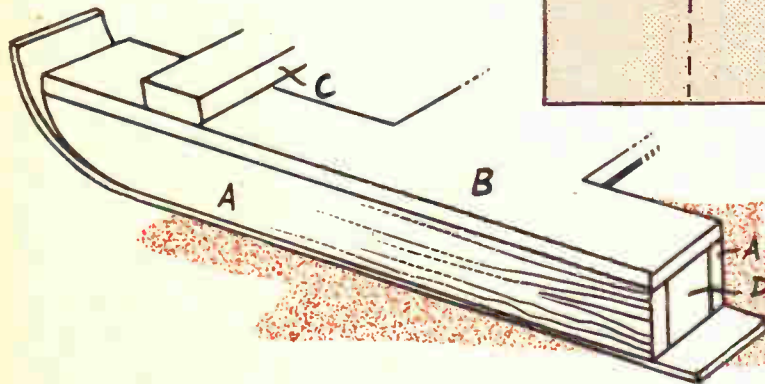
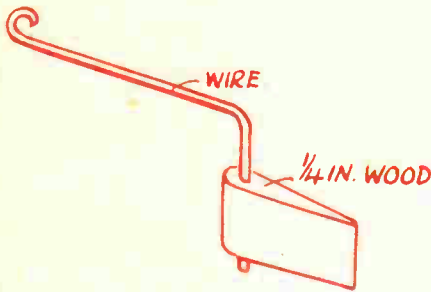

OUT of the BLUE

SUPER AIRCRAFT KITS

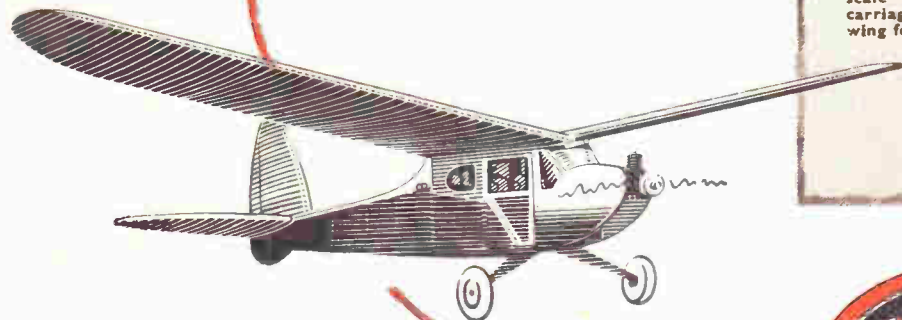
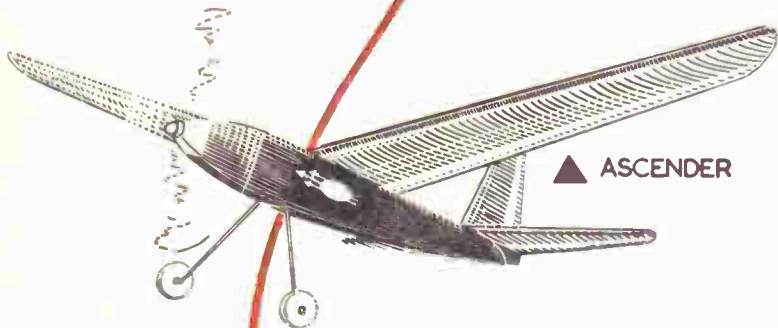
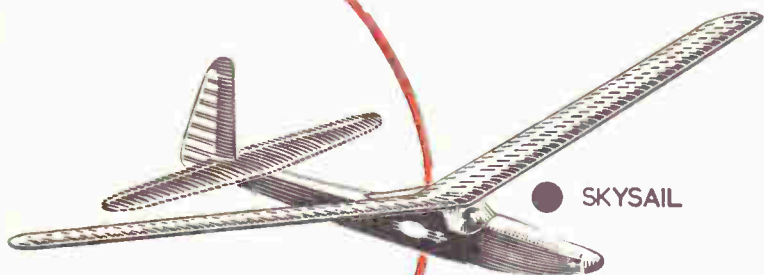

EXCLUSIVE FEATURES

These kits introduced by Hobbies have many important exclusive features. Designed to give top performance in their various classes. All sheet parts are die cut and there are super detail plans. Easy to build and fly.



SKYSAIL — A 36in. wing span glider for tow launching. 'Wingsaver' tow hook—printed dummy pilot — anti-warp wing bracing — jig-lock fuselage alignment.

6/6



ASCENDER — A 30in. wing span rubber duration model. Adjustable pitch propeller with replaceable blades — fixed tail surfaces for positive trimming — anti-torque automatic-action rudder.

10/11



CHAMPION — A 36in. wing span free flight power model. Suitable for .5, .75, .8 and 1 c.c. motors. Opening cabin door and complete cabin details — scale type light alloy undercarriage — optional polyhedral wing for high power.

18/6

DESIGNED FOR
THE NOVICE
AND EXPERT



From all Hobbies branches and model shops, or

HOBBIES LTD. (Dept. 99), DEREHAM, NORFOLK

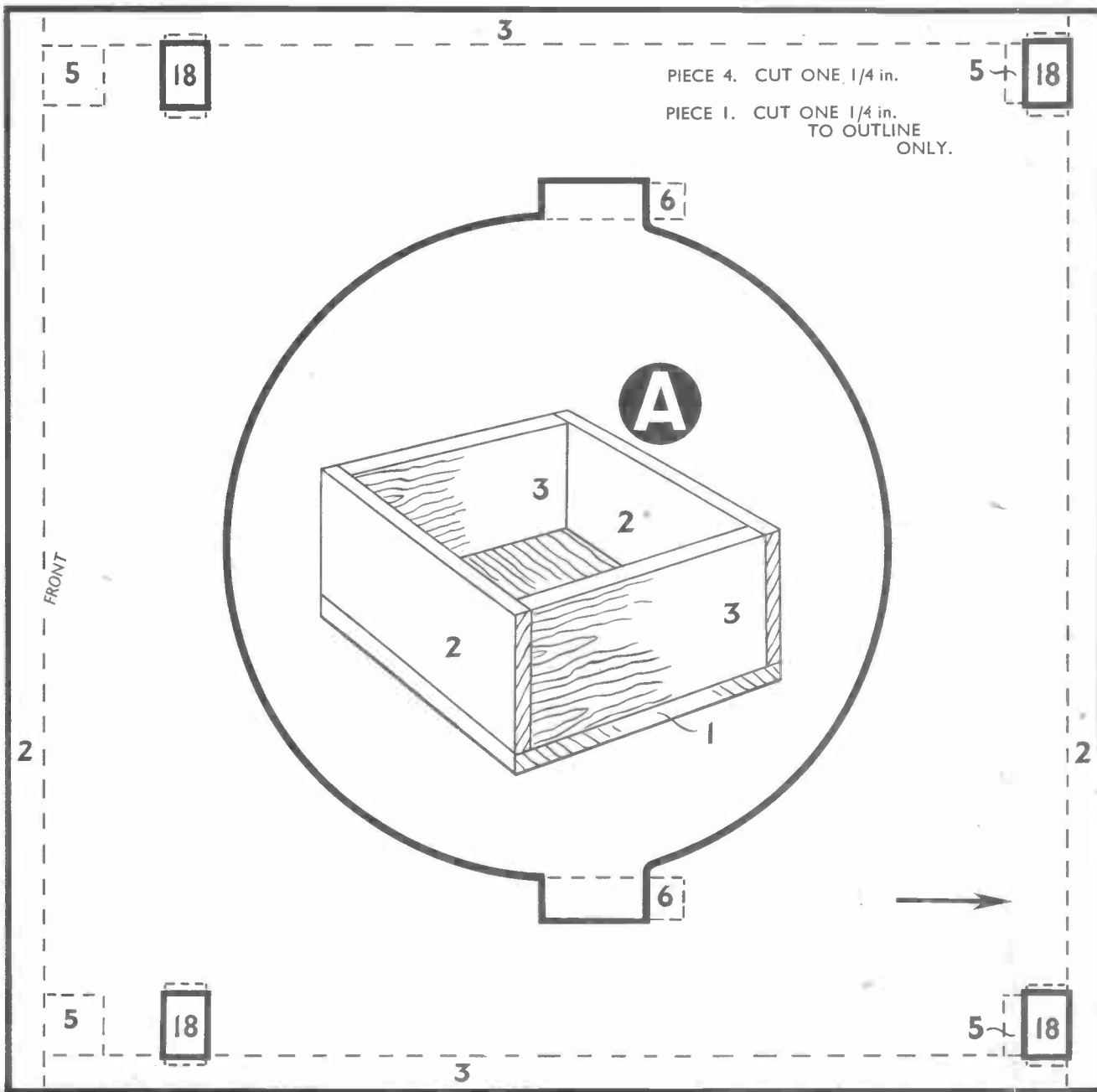

PIECE 4. CUT ONE 1/4 in.
 PIECE 1. CUT ONE 1/4 in.
 TO OUTLINE ONLY.

PIECES 5.
 CUT FOUR 1/4 in.
 GLUE UNDER
 PIECE 4.

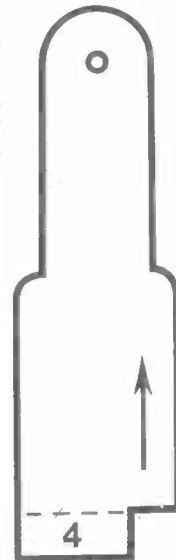

PIECES 6.
 CUT TWO 1/4 in.



PIECES 8.
 CUT TWO FROM
 3/8 in. ROUND RO

PIECE 9. CUT
 ONE FROM
 WIRE.

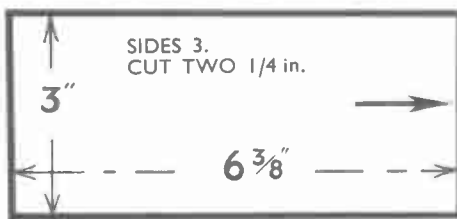
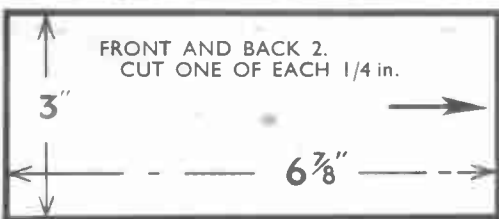

PIECE 7. CUT ONE FROM 1/2 in. ROUND

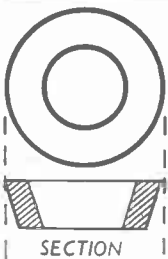

PIECE 11. CUT ONE 1/4 in.
 SHAPE TO SECTION.



PIECE 13. CUT
 ONE 1/16 in.

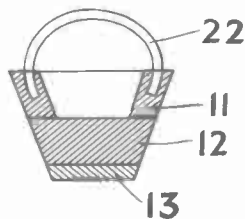

SECTION
 SHOWING CONSTRUCTION
 OF BUCKET.

THE ARROWS
 INDICATE GRAIN
 DIRECTION
 OF WOOD.

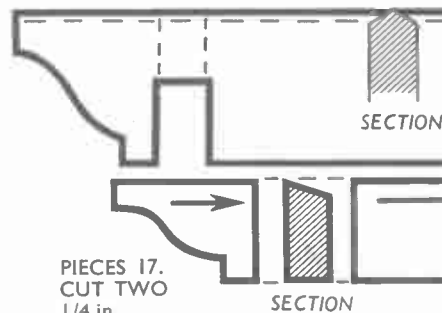

PIECES 17.
 CUT TWO
 1/4 in.
 SHAPE TO
 SECTION.

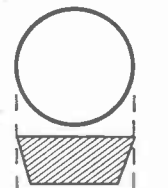

PIECE 12. CUT
 ONE 1/4 in.

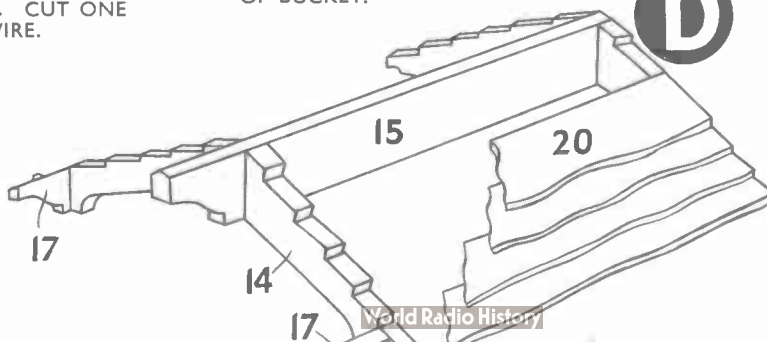

PIECES 19. CUT TWO 1/16 in.

PIECES 20. CUT TEN 1/16 in.

"THE OLD WELL" PLANT HOLDER

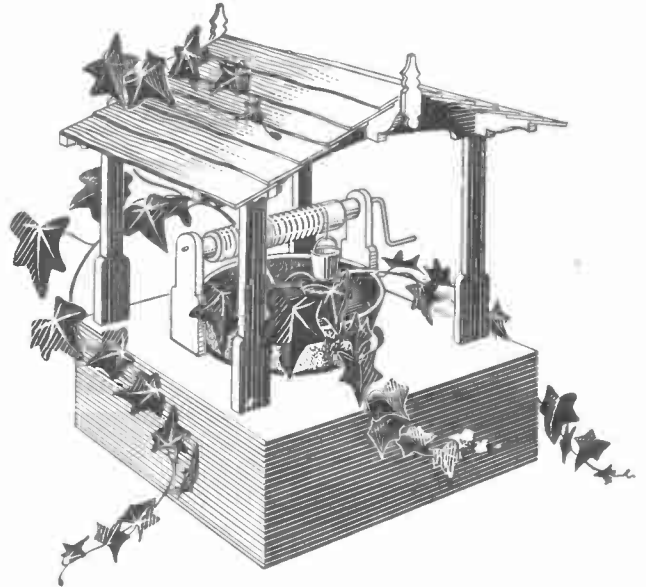

SIZE—
9 3/4 ins. HIGH.
7 1/2 ins. WIDE.

A KIT OF MATERIALS FOR MAKING THIS DESIGN IS SUPPLIED BY HOBBIES LIMITED, DEREHAM, NORFOLK. PRICE ON APPLICATION.

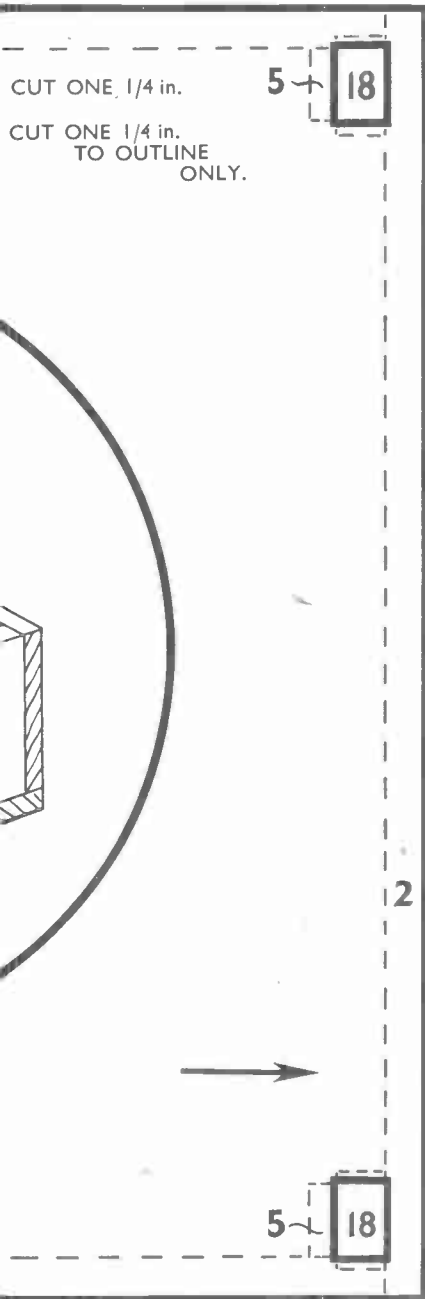

PIECES 5.
CUT FOUR 1/4 in.
GLUE UNDER
PIECE 4.

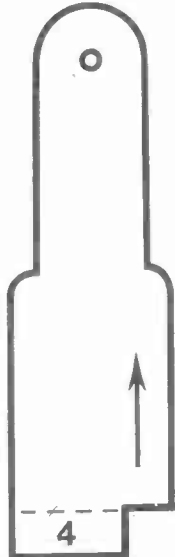

PIECES 6.
CUT TWO 1/4 in.



PIECES 8.
CUT TWO FROM
3/8 in. ROUND ROD.

HANDLE 10.
CUT ONE
FROM
WIRE.

PIECE 9. CUT
ONE FROM
WIRE.



HERE'S THE IDEAL PAINT PACK

6 intermixable colours in capsule form — just enough to do a small job and so economical. The Humbrol Art Oil Enamel Intermixable Paint Pack costs only 1/3 from "Hobbies" and Handicraft Shops everywhere.

"intermixable"
PAINT PACK
THE HUMBER OIL CO. LTD., MARFLEET, HULL



THE ARROWS
INDICATE DIRECTION
GRAIN
OF WOOD.



PIECE 7. CUT ONE FROM 1/2 in. ROUND ROD.

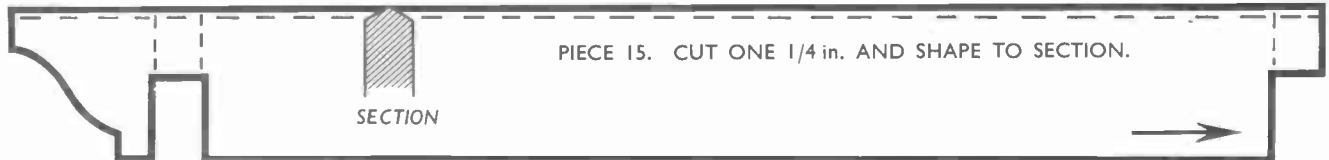

PIECE 15. CUT ONE 1/4 in. AND SHAPE TO SECTION.



PIECES 16. CUT TWO 1/4 in.
SHAPE TO SECTION.

PIECES 17.
CUT TWO
1/4 in.
SHAPE TO
SECTION.

SECTION



PIECES 18. CUT FOUR 1/4 in.



PIECES 19. CUT TWO 1/16 in.

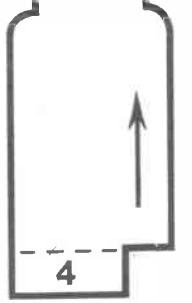
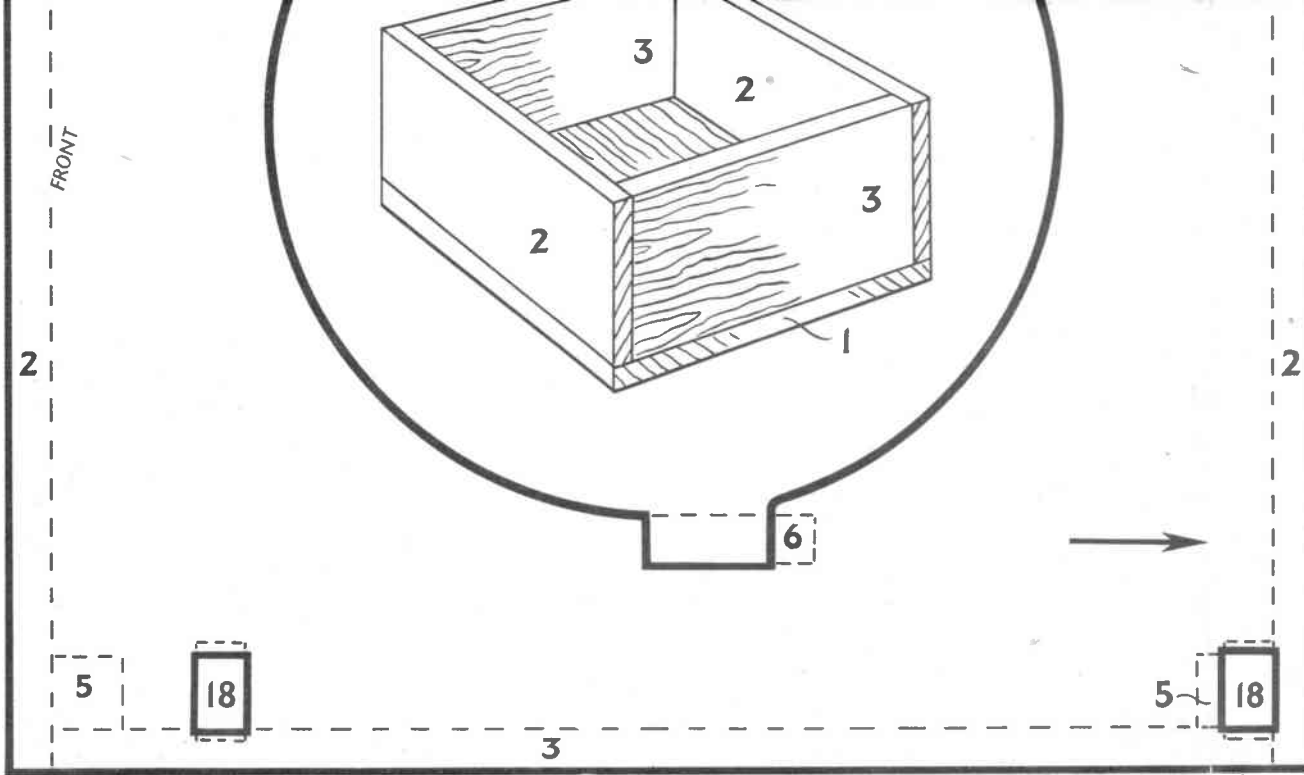

PIECES 6. CUT TWO 1/4 in.



PIECES 8. CUT TWO FROM 3/8 in. ROUND RO



PIECE 9. CUT ONE FROM WIRE.

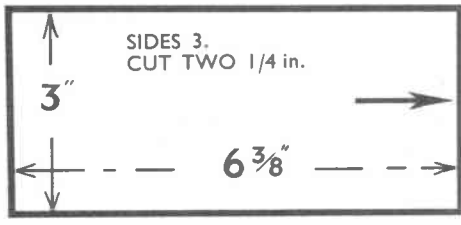
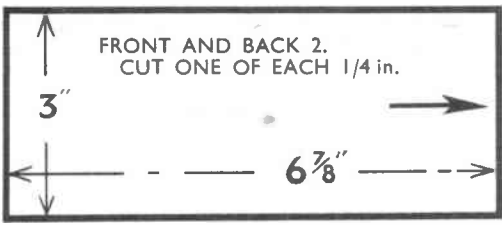

PIECE 7. CUT ONE FROM 1/2 in. ROUND

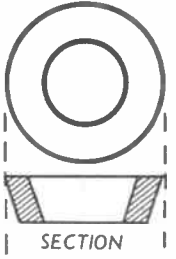

PIECE 11. CUT ONE 1/4 in. SHAPE TO SECTION.

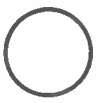

PIECE 13. CUT ONE 1/16 in.



PIECE 22. CUT ONE FROM WIRE.

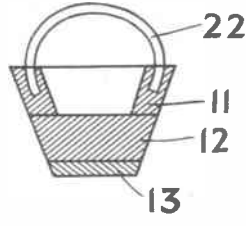

SECTION SHOWING CONSTRUCTION OF BUCKET.

THE ARROWS INDICATE DIRECTION OF GRAIN OF WOOD.

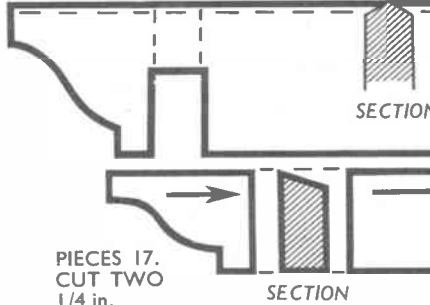

PIECES 17. CUT TWO 1/4 in. SHAPE TO SECTION.

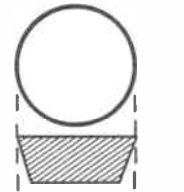

PIECE 12. CUT ONE 1/4 in.

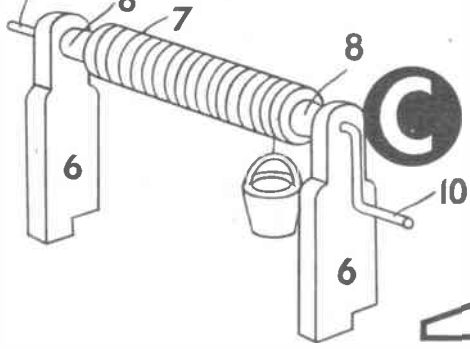
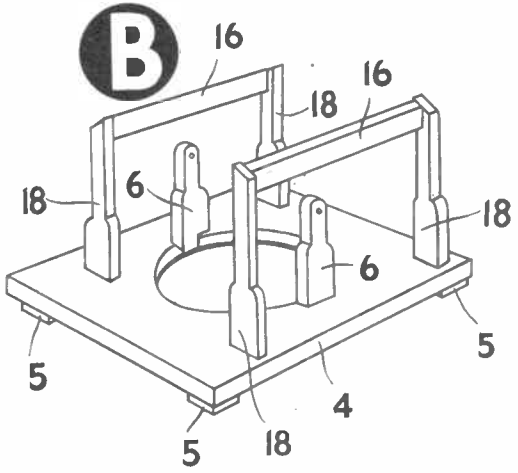
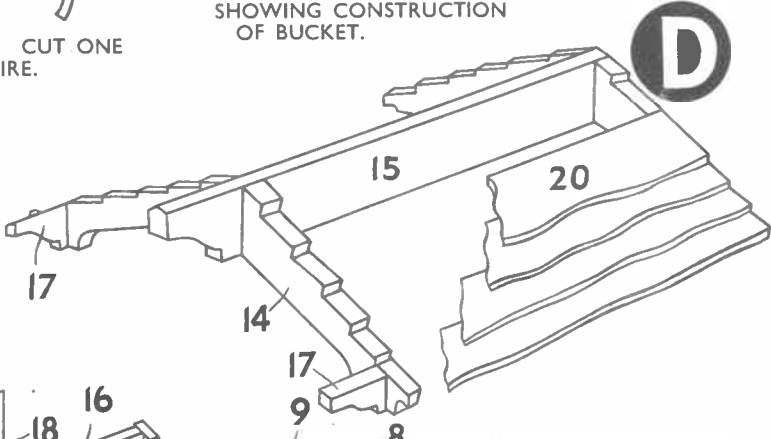

PIECES 19. CUT TWO 1/16 in.

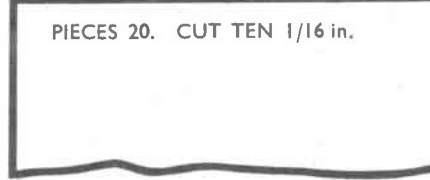

PIECES 20. CUT TEN 1/16 in.

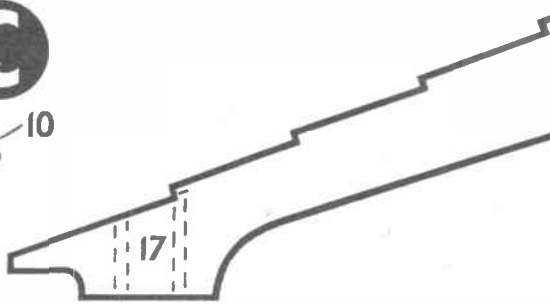

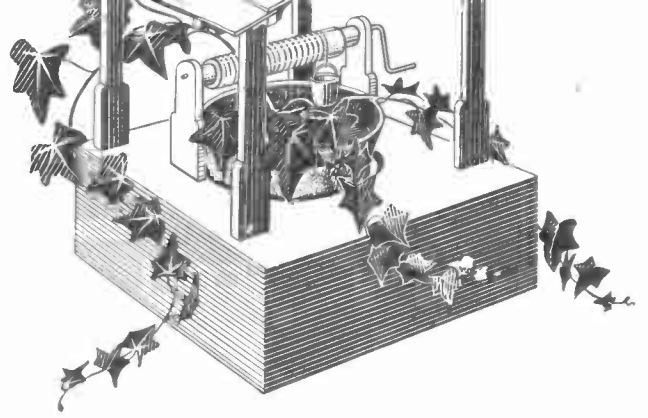

A KIT OF MATERIALS FOR MAKING THIS DESIGN IS SUPPLIED BY HOBBIES LIMITED, DEREHAM, NORFOLK. PRICE ON APPLICATION.

HERE'S THE IDEAL PAINT PACK

6 intermixable colours in capsule form — just enough to do a small job and so economical. The Humbrol Art Oil Enamel Intermixable Paint Pack costs only 1/3 from "Hobbies" and Handicraft Shops everywhere.



"intermixable"

PAINT PACK
THE HUMBER OIL CO. LTD., MARFLEET, HULL

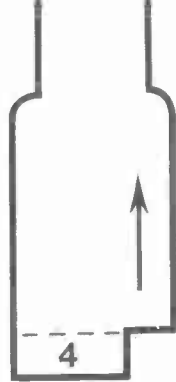

PIECES 6. CUT TWO 1/4 in.



PIECES 8. CUT TWO FROM 3/8 in. ROUND ROD.

HANDLE 10. CUT ONE FROM WIRE.

PIECE 9. CUT ONE FROM WIRE.



PIECE 7. CUT ONE FROM 1/2 in. ROUND ROD.

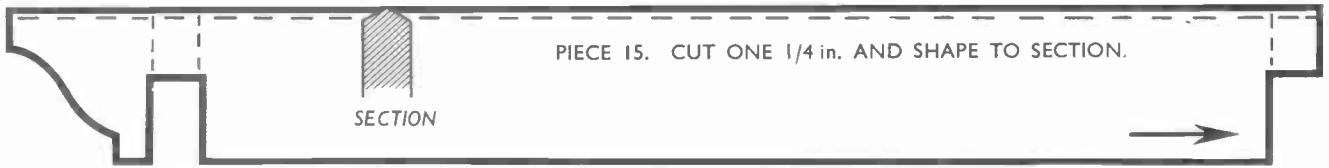

PIECE 15. CUT ONE 1/4 in. AND SHAPE TO SECTION.



PIECES 16. CUT TWO 1/4 in. SHAPE TO SECTION.

PIECES 17. CUT TWO 1/4 in. SHAPE TO SECTION.



PIECES 18. CUT FOUR 1/4 in.



PIECES 19. CUT TWO 1/16 in.



PIECES 20. CUT TEN 1/16 in.

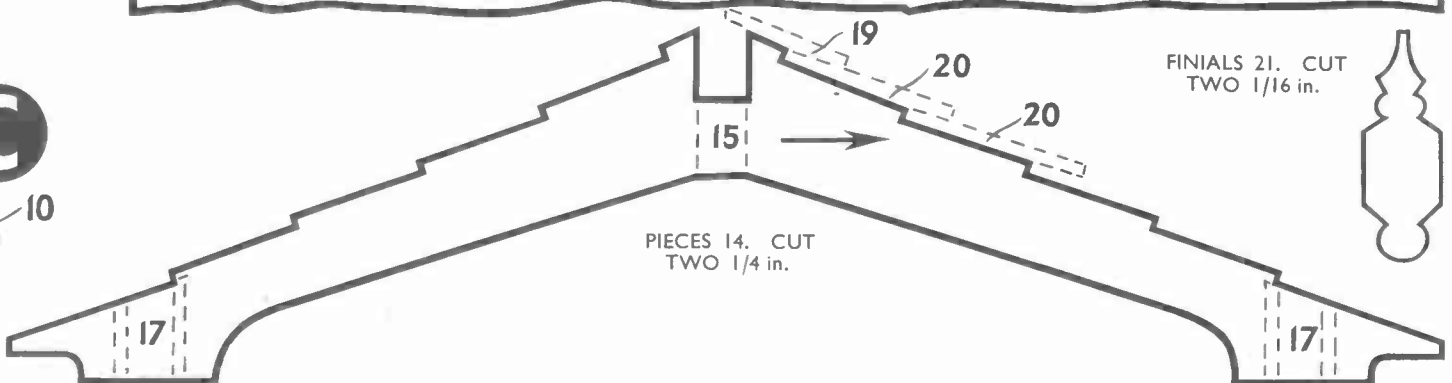

PIECES 14. CUT TWO 1/4 in.

FINIALS 21. CUT TWO 1/16 in.

THE ARROWS INDICATE DIRECTION OF GRAIN OF WOOD.

D

C