

HOBBIES WEEKLY

IN THIS ISSUE

	Page
Folding Playpen	305
Books to Read	306
A Word in Your Ear	307
Running Your Railway	308
Try This One	309
Make Your Own Sweets	310
Let's Collect Cheese Labels	311
Make a Console Cabinet	312
A Reference Book Stand	314
With Rod and Line	316
Military Button Collector	316
Patterns for 'Help Yourself' Containers	319



FEBRUARY 6th 1957

VOL. 123

NUMBER 3197

*Ideal for
keeping
Junior
out of
harm's way*



**FOLDS
FLAT FOR
EASY STORAGE**

Make a

FOLDING

PLAYPEN

THIS sturdy playpen will prove extremely useful when baby starts to crawl. Not only will it keep him away from the fire, but it will ensure that he keeps out of mischief while mother is working about the house or answering the door to tradesmen. It can be folded quite flat when not in use and stored out of sight.

The main dimensions are shown in the side view and end views in Fig. 1. The beads are optional and if these are not required the short cross-piece (E) can be dispensed with and the two dowels run right up to the top, thus making both ends identical.

The playpen is first made up in four complete sections which are then hinged together in pairs, one end and one side. The pairs are then joined together by means of dowels and small hook and eye catches on the outside.

Commencing with the sides, make up two as shown in Fig. 1. The main pieces, i.e. pieces (A) and (B), are $\frac{1}{2}$ in. square and are marked out with the positions of the $\frac{1}{4}$ in. diameter dowels and

centre rail (D). Lay the four pieces (A) together and mark all positions at once. The centre rail (D) is tenoned into the rails to a depth of $\frac{1}{2}$ in. as shown in Fig. 2. The dowels are also let in to a depth of $\frac{1}{2}$ in.

The pieces (A) can be simply placed on the top of the pieces (B) and secured by glue and a countersunk screw, or they can be jointed as shown in Fig. 3. In this case a screw should be inserted at

All correspondence should be addressed to The Editor, Hobbies Weekly, Dereham, Norfolk

*For Modellers, Fretworkers
and Home Craftsmen*

World Radio History

4¹/₂^D

PAGE 305

the side instead of at the top. Remember that in the latter case the pieces (B) will be longer to make up for the joint.

The ends are made up in a similar manner, with two 3/4 in. square pieces (C) instead of centre panels. If you wish to include coloured beads, allowance must be made for these on one end. Put a short cross-piece (E) in position as indicated in Fig. 1. This should be about 7 in. down from the top.

Suitable plain wood beads 1/2 in. diameter, are obtainable from Hobbies Ltd., Dereham, Norfolk, price 1/- per dozen. Holes are already provided in the beads, but they may have to be enlarged slightly with a moustail file or by drilling. The beads should be threaded on steel rods, such as steel knitting needles. Make sure that you can obtain something suitable before commencing construction.

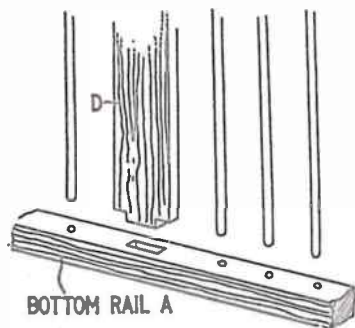

Fig. 2

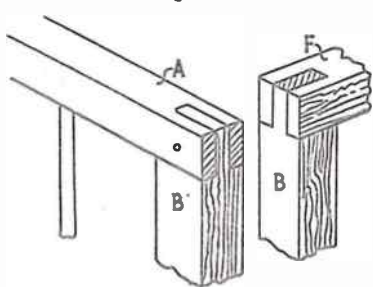

Fig. 3

Hinges should be recessed before screwing in position. They should be of the heavy type because they will be subjected to a good deal of strain. A view of one of the hinges is shown in Fig. 4.

The method of fixing the folding sections is indicated in Fig. 5. Note that the bottom and top are dowelled and secured by hook and eye catches. The dowels are simply pushed into holes in pieces (A) and then fixed by means of the hooks and eyes.

Clean up all the parts after assembly and give a light rubbing with oak stain. Allow to dry and finish off with two coats of clear lacquer. (M.h.)

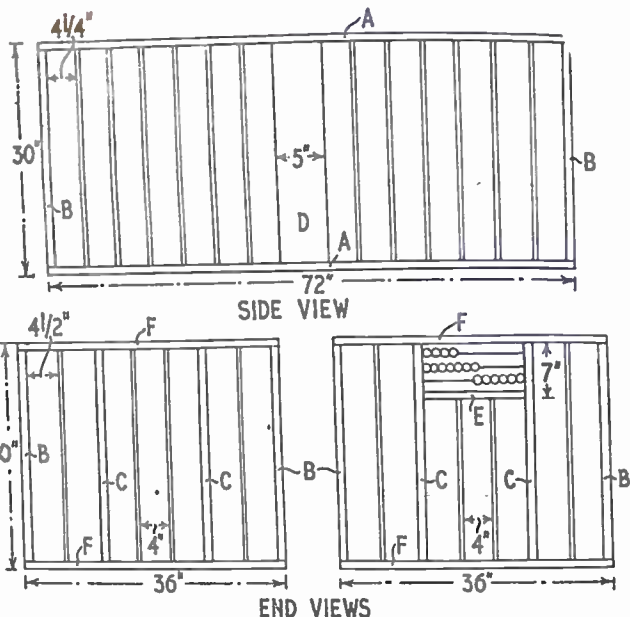

Fig. 1

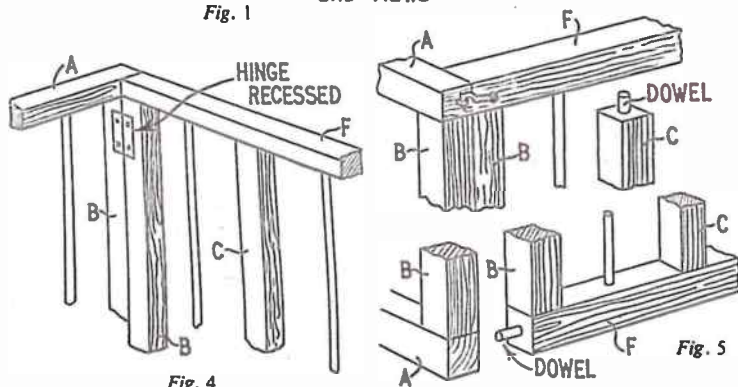

Fig. 4

Fig. 5

Books to Read

Develop, Print and Enlarge Your Own Pictures
by Jack O. Flynn, Alan Kellock and Albert J. Rosenberg

THIS ABC of darkroom work is so profusely illustrated that it can be truthfully called a practical demonstration of all the stages of home developing, printing and enlarging. No amateur photographer can fail to derive valuable knowledge from a study of its excellently displayed easy-stage lessons so clearly pictured in the medium itself.

Published by McGraw-Hill Publishing Co. Ltd., 95 Farringdon Street, London, E.C.4—Price 28/-.

Improve Your Television Reception
by John Cura and Leonard Stanley

WE believe this to be the first fully comprehensive book on the operation of the controls of a set written solely for the home viewer. It is a fascinating volume with an extensive use of tele-snaps and should lead to a substantial increase in the standard of picture reception. The section on 'Facts and Fallacies' is alone worth the modest price asked for this latest contribution by these two experienced authorities. Published by Iliffe & Sons Ltd., Stamford Street, London, S.E.1—Price 5/-.

A Word in your Ear

From the Editor

I HOPE that many of my readers are busily engaged on cutting out a military badge of their own design in order to enter their work in our competition, announced in the January 23rd issue. Don't forget, entries must be in my hands for judging by February 28th, and the winners of the junior and senior sections will receive a guaranteed watch. There are ball pens for senders of next-best entries.

Next week we shall publish another Crossword competition and on February 27th there will be details of another competition to test your ingenuity, for which prizes will again be offered.

FRETWORK COMPETITION

READERS will probably remember that the First Prize in our Junior Section in Hobbies 1956 Fretwork Competition was gained by young William J. Mowatt, who lives at Harray in the Orkneys. For his successful entry, William won a voucher for 12 guineas, with which he obtained goods from Hobbies Ltd.

Entries for the 1957 Competition, which closes on April 30th are now coming in, and it will be interesting to see if this youngster can stay in the prize list.

The First Prize in the Open Section, consisting of a voucher for 15 guineas and a Silver Challenge Cup and replica was, of course, won for the second time running by Mr. J. Burbeck of Bromyard, Hereford, who will, no doubt, be keen to see whether he can obtain a hat trick of successes.

The competition piece is for Novelty

Egg Timers, cut to the free design given in our September 12th, 1956, issue, and this year the design has been made easier for the juniors, as it is appreciated that youngsters just starting out on this rewarding hobby need some encouragement.

Make sure that your entry is received in my office at Dereham, Norfolk, by the stipulated date, and have a go at winning one of the valuable vouchers offered. New readers can obtain all details from our competition issue, price 6d., from the Editor.

CREOSOTE IN A GREENHOUSE

NO matter how careful we are in the compilation of this magazine, mistakes do inevitably creep in from time to time, and I am obliged to an expert, Mr. S. C. Gouldsmith of Verwood, Dorset, for correcting some information given in a reply to a reader.

The original query concerned the erection of staging for a greenhouse, and in our reply it was stated that creosote should be used to preserve the wood.

Mr. Gouldsmith rightly points out that the fumes given off by the creosote can be fatal to young plants for as long as six to eight months, and suggested Cuprinol or some such proprietary brand as a preservative.

Incidentally, if other readers have experienced trouble through using creosote in the greenhouse, this can be obviated by sealing the wood and thus preventing the fumes from poisoning the plants. To do this successfully, use two or three coats of aluminium paint or sealer on to the creosoted-treated wood.

VETERAN'S SUCCESS

NEWS of another success by a reader has reached me — this time from Canada.

In the Pacific National Hobby Show at Vancouver, Mr. W. Hunter of Stave Gardens, RL Ruskin, B.C., was in competition with exhibitors from all over the world. Consequently he has reason to be proud of obtaining Third Prize and a Certificate of Merit for his fretwork entry of a cathedral clock, which also won First Prize for fretwork at another exhibition.

Why I mention this achievement as outstanding is because Mr. Hunter is in his 85th year and suffered partial loss of sight about forty years ago. In a letter to me he says: 'I believe my fretwork hobby

Next week's free design is for making a model of Nelson's famous flagship, the 'Victory', approximately 22 in. long. There is plenty of detail to please fastidious modellers and it will make up into a really splendid model.

has prolonged my stay on this terrestrial sphere and keeps me in such good shape.' And from the picture which accompanied his letter, it seems that there may be a lot of truth in his words.

SILHOUETTE PRINTS

THE accompanying illustration shows a pleasing motif used by a reader in designing his own greetings cards. Actually this is part of a design published in *Hobbies Weekly*, which was intended to be used as a marquetry picture, but seeing its possibilities, Mr. S. W. Minton Beddoes of Knutsford, Cheshire, decided that it would give an ideal effect and he used his photographic knowledge to good purpose.



Young William

RUNNING RAILWAY

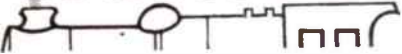

It is proposed to give full details of the best ways of operating an electrical train, both from battery and mains supplies. The interest of such a layout can be considerably increased by fitting speed and reversing controls, while using mains current, when it is available, is very economical.

It will be realised that many of the details given will apply equally well to other models driven by an electric motor — stationary models, boats, etc.

Speed control will be dealt with first, and the methods to be described can be used with any motor, whether driven from dry-battery, accumulator, or from the mains. The increased realism and interest obtained when the train can be

control over speed. Such a resistance can be made easily, or purchased. If the slider goes right off the resistance element, this will give an 'Off' position.

(B) is a circuit with two switches, very easy to fix up. One switch provides for starting and stopping the train, and the other allows full speed or half-speed running. This is quite effective in many models.

Finally, a stud controller is shown at (C). Here, a rotating arm contacts one of several studs, thus adjusting the amount of resistance in circuit. This gives speed control in a number of steps. With five studs, there will be full speed, and three reduced speeds, if one stud is left disconnected for 'Off'.

In all cases the controller is merely

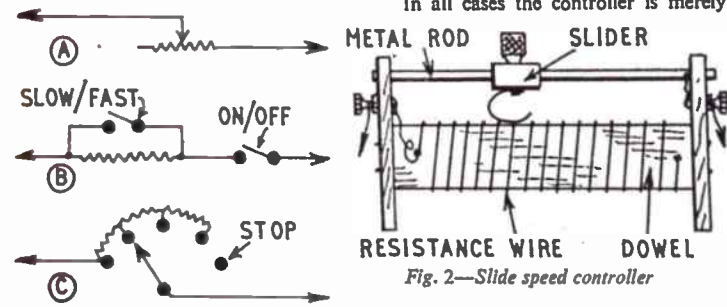

Fig. 1 Types of speed control

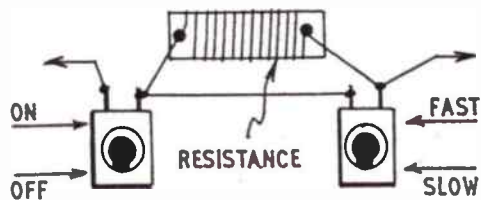

Fig. 2—Slide speed controller



Fig. 3—Two-speed control

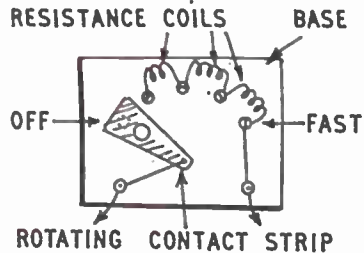

Fig. 4—A stud controller

run at any required speed is worthwhile, and is easily achieved.

Resistance Controller

All such speed controllers employ a resistance. This reduces the voltage, so that the train runs more slowly. By adjusting the resistance value, the model can be made to work at any desired speed.

Three convenient methods of achieving this are shown in Fig. 1. At (A) a variable resistance gives continuous

added in series with one lead to the model. No danger of shocks exists, due to the low voltage.

A Slide Controller

A very simple method of making a controller such as at (A) in Fig. 1 is shown in Fig. 2. The dowel rod should be of hard wood, about 3/16 in. to 1/4 in. in diameter, and 2 ins. to 3 ins. long. Two small pieces of 3-ply, about 1 in. by 1 1/2 ins. are nailed to each end of the

The resistance wire can be purchased, and may be of about 26 or 28 S.W.G., for the usual model. The thin iron wire which is sold by many hardware stores, for binding flowers, is also satisfactory.

SPEED CONTROL

Very thick wire will have a low resistance, so that a considerable length of wire is necessary to reduce the speed of the model. On the other hand, very thin wire will grow very hot, and only a very short piece may be required, so that the dowel cannot be properly wound. For this reason, wires thinner than about 32 S.W.G. are best avoided, with the average model.

The motor and battery should be connected up, and a length of the resistance wire added in circuit. The portion of resistance wire is slowly increased until the train only just runs. This piece is then cut off, and the controller is wound with it.

The wire must be as tight as possible, and twisted round small sprigs at each end. One end goes to a small terminal;

the other end is not connected to anything. The sliding contact is made by soldering a curved brass strip to a collar or short piece of brass tubing, so that it can slip smoothly along the metal rod, which is connected to the other terminal. If the length of wire has been selected as explained, moving the slider will control speed from maximum right down to very slow. It is helpful to varnish the wire, to hold it in place, lightly scraping the turns where the slider passes.

Continued on page 309

HERE is a Chinese Puzzle that is interesting and amusing. All that is required to make it is a piece of 3 in. square cardboard, which should be plain both sides. Carefully mark out with a pencil, as indicated in Fig. 1, and then cut out the pieces. (Three-ply wood cut out with a fretsaw, is more durable, of course.)

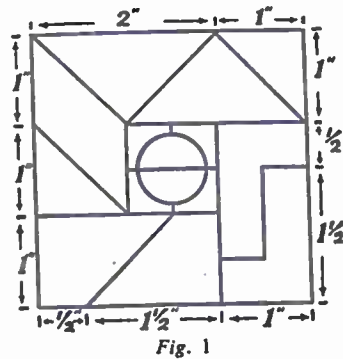

Fig. 1

A large variety of objects and designs can be outlined with the fifteen portions contained in the square.

If desired, a small case may be made for the puzzle, by using a piece of thick

cardboard, 3 1/2 ins. square, to which has been glued 3/16 in. wide strips forming a frame. Over this place another piece of cardboard, 3 1/2 ins. square, and fasten with two rubber bands.

Three examples of the quaint pictures that can be made are given in Figs. 2, 3, and 4, while two more are shown in the heading.

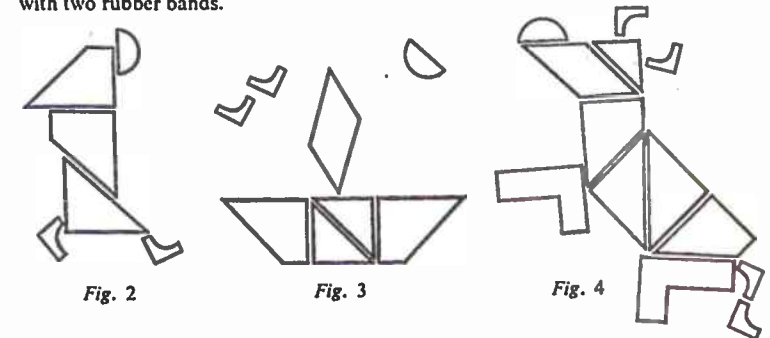

Fig. 2

Fig. 3

Fig. 4

Continued from page 308

Model Railway Running

The method in which circuit (B) is arranged is shown in Fig. 3. Two small, low-voltage toggle switches are used, mounted in a small control box. The arrows show the switch positions for 'On', 'Off', 'Fast', and 'Slow'.

When the one switch is in the 'Slow' position, the speed of the train can be at any pre-arranged level. A length of resistance wire is taken, as before, and included in one lead to the model. The length of wire is then adjusted until the train runs at the required reduced speed. This length of wire is then wound upon a strip of wood or other insulating material, the ends being secured by small screws or bolts. The 'Fast/Slow' switch simply shorts this resistance, or leaves it in circuit.

Stud Controller

This type is also easy to make up, requiring a wooden base about 2 ins. by 2 1/2 ins. by 1/4 in. thick. A brass strip about 1 1/2 ins. long is pivoted upon a screw, and can be moved to contact any one of a series of round-headed screws. Washers should be fitted on each side of the strip, so that rotation is easy, and it should be so bent that it presses down upon the contact screws. A small knob can be fitted to this strip.

Two small terminals are used for connections, and the train will run at full speed when the strip is at 'Fast'. A short piece of resistance wire is then taken, so chosen that it reduces speed a little, when in circuit. It is made into a compact coil by winding it round a small nail or rod, and the ends are looped, and secured under the screws. The other coils are then made, each being arranged to bring about a satisfactory reduction in speed.

Quite thin wire will do well for this type of controller, as there is no danger of breaking it, as is possible with the controller in Fig. 2. In addition, it does not matter if the wire grows very hot, as the coils stand in free air.

It is, of course, perfectly in order to use more studs, to give more intermediate speeds. It is also easy to arrange for any desired speed, with each stud, by adjusting the length and gauge of the resistance coils.

It is possible to use very thin copper wire in this type of controller, such as can be obtained by unwinding a length of ordinary flex into single strands. Copper wire has to be very thin to have appreciable resistance, and grows very hot, but this does not matter in the present case. The brass strip has to be

wide enough to bridge two studs, or the train will come to a halt each time the controller is adjusted.

Any of the speed controllers can be used in conjunction with a reversing switch, which will be described later.

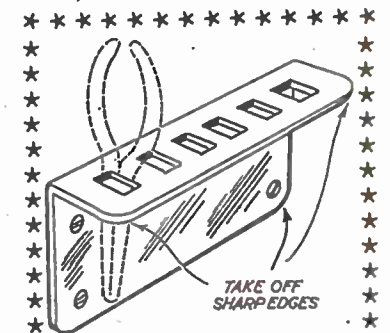

PLIERS RACK

THE sketch shows a rack for pliers bent from thin sheet metal. The slots to take the pliers are formed first. Drill at each corner and then cut out with a cold chisel, or fret out with a metal-cutting blade. Bend over the top flange and round off all sharp corners with a file. Fasten to the back of the workbench with woodscrews. (R.H.W.)

Some popular recipes

MAKE YOUR OWN SWEETS

MAKING your own sweets is a most fascinating hobby and besides the thrill of tasting a successful batch of pure confectionery, just think how much cheaper it is than the shop article! Perhaps you may be a little more enterprising and make sweets for your friends.

Pure home-made sweets are always in great demand, especially for parties or at Christmas time, and, provided the instructions are carefully followed, no difficulty should be experienced, and you ought to be able to turn out quite professional looking and delicious confections very quickly.

The first essential to success is absolute cleanliness, and all utensils used for sweetmaking should receive special attention before and after use. Any sugar sticking to the saucepan or other tools from a previous boiling may very well spoil your next batch by causing it to granulate.

For boiling the sugar and other ingredients a thick copper saucepan is best but one of aluminium or enamel may be used. A gas burner is, undoubtedly, the best form of heat on account of the ease with which it can be adjusted to the correct temperature. Provided there is a wide range of adjustment however, electricity is equally good.

Some sweetmakers use a confectioner's thermometer to determine the correct temperature to boil each batch of sweets, but as it is rather expensive to buy, there is another simple yet very efficient method which is used by many professional sweetmakers. If you prefer to use a thermometer, an instrument registering up to 350° could be obtained from a good hardware store that stocks cooking utensils.

Notes on boiling

Particular attention should be paid to the following notes on sugar boiling, as much of the success of your sweetmaking will depend on how well you carry out this operation.

The sugar is first placed in the pan with a little water and heated sufficiently to dissolve it, stirring all the time — it is then a syrup and ready for boiling.

More heat is now applied and the syrup must not be stirred or the pan jarred in any way. Any sugar that splashes up is washed down with very little warm water applied with a brush, being careful not to touch the boiling syrup.

The syrup starts to boil at 212° and the first stage is reached at 240°. If a little of this syrup is put into cold water it will form a 'soft ball' between the

fingers and it is this degree that is needed for fondant creams. Correctly boiled, the syrup should take from 10 to 12 minutes to travel from 212° to 240°.

'Hard ball' is reached when the thermometer registers 250° and is tested by dipping a fork into the syrup and removing a little which, when plunged into cold water, will form a stiff ball.

Further boiling will remove more water from the syrup to make it denser and at 265° we have reached the 'crack'

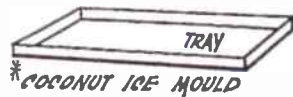
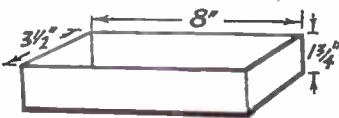
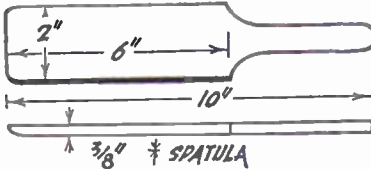

degree, or 'soft crack' as it is sometimes called. When tested in cold water as before, it becomes crisp and will break with a crack, and it is this stage which is used for most candies and caramels. The time needed to reach this degree from 212° is 20 minutes.

From now onwards the temperature will rise at a much quicker rate and, therefore, the process should be watched with more care.

At about 300° the syrup, when tested in cold water as before, will crack and be very brittle like an egg shell. This is known as the 'hard crack' degree, and is used for most toffees.

Above 320° sugar syrup changes colour from amber to brown until it starts to burn at about 350°. Before starting to make a batch of sweets it would be a good idea to read through these boiling temperatures again to make sure that you thoroughly understand them.

For stirring the ingredients in the pan a wooden spatula is very useful, and this can be made quite easily from a length of hardwood, Sycamore or a similar whitewood is best for the purpose — about 10ins. long, 2ins. wide and 1/2in. thick and shaped as shown. Round off the handle, and you may also bevel the sides and bottom of the

stirring portion if desired. Thoroughly glasspaper to remove any roughness and splinters.

BARLEY SUGAR

Barley sugar is an excellent form of toffee to start with, it is easy to make and needs few ingredients. Put 1 lb. granulated sugar, a scant 1/2 teaspoonful of cream of tartar with about 1 gill water in the pan and place on gentle heat. Stir well and see that all the sugar is dissolved before boiling point is reached. Continue boiling without stirring for about half an hour until 300° is reached.

Remove from stove and allow to cool a few minutes, then add a few drops of oil of lemon, a little yellow colouring and stir quickly. If stirred too much in this state the syrup will granulate and be spoiled — it is only necessary to just mix in the flavour and colour.

The juice of half a lemon may be used instead of the oil and a further improvement may be made by the addition of from 1/2 lb. to 1 lb. of glucose or maize syrup as it is sometimes called. (It is a heavy white syrup and prevents granulating besides adding to the medicinal value. Do not use powdered glucose). If you use glucose you will not need the cream of tartar, which also prevents granulation.

Now carefully pour the batch into the confectioner's frame, which was fully described in *Hobbies Weekly* of August 15th. A little olive oil rubbed on the wooden bars and slab before pouring will prevent sticking. When sufficiently cool, mark into squares with a knife, so that it will break up easily when cold. Pack immediately it is cold into air-tight tins or bottles, or wrap in waxed paper and keep airtight.

Quite a wide range of toffees can be made from this same formula by omitting the lemon and putting in some other flavour and appropriate colour. Oil of peppermint, cloves and all the fruit essences are suitable, but great care is needed with the amount used. Never over flavour any batch, and the same applies to colouring.

Acid drops are made by adding a little citric or tartaric acid either with or without a fruit flavour just before pouring out. Chopped peanuts, walnuts, figs, raisins, glace cherries and coconut may all be added in a similar manner either separately or in combinations.

COCONUT ICE

Coconut ice is another confection that is always popular and is easily made. Dissolve 1 lb. granulated sugar and 1 gill water over gentle heat, and you

• Continued on page 311

LET'S COLLECT CHEESE LABELS

Suggests

R. L. CANTWELL

TODAY, cheese-label collecting is a popular pastime among people of both sexes, of all ages and occupations. My own collection numbering hundreds of labels, which began in 1930, occupies several scrap albums. Most stationers stock these albums in various sizes at prices ranging from 7/6 to £1.

Use stamp tweezers for handling labels and mount them — one country to a page — with stamp hinges. Start with English labels. Your local grocer can help here with covers from the particular brands stocked. He will also be able to supply a list of manufacturers from whom labels can be obtained. Most firms too, are more than willing to help. Send your letter to The Publicity Officer, enclosing a stamped addressed envelope for reply.

Overseas collectors often advertise in English newspapers and periodicals for pen-friends with whom they may exchange duplicates. Many stamp dealers sell foreign cheese labels as a sideline.

I have secured interesting specimens by writing direct to firms abroad. Language difficulties are overcome by contacting the London embassy of the country concerned.

Cheese-making is as old as agriculture. English cheeses are famous all over the world. Praised by connoisseurs for centuries, sung about by Shakespeare and other poets, they have graced the festive board on many a memorable occasion.

There are references to Cheshire cheese in writings of the twelfth century. It is made in three colours: red, white and blue. Red Cheshire is the most widely known, Old Blue is the richest and rarest. Stilton is so-called after the village of that name in Huntingdonshire where it was first marketed at the Bell Inn.

Cheddar cheese has been a universal favourite at least since Tudor times. As early as 1600 in the reign of Good Queen Bess, William Camden wrote: 'West of Wells, just under the Mendip Hills, lies Cheddar, famous for its excellent prodigious cheeses made there, some of which require more than a man's strength to put them on the table, and of delicate taste.'

Caerphilly cheese is named after the Glamorgan village where it originated. Leicester cheese is shaped like a millstone. The County of Gloucester has



given its name to two cheeses: the single and double Gloucester. Double Gloucester is close and smooth in texture, similar to Cheshire, but (they say in Gloucester) superior to it in flavour. It is shaped like a large grindstone.

Gruyère cheese, made in Switzerland,

is strongly flavoured with herbs. The French Roquefort cheese is obtained from the milk of sheep and goats, Brie (French) and Neufchâtel (Swiss) cheeses from pure cow's cream.

The illustrations show English and foreign cheese labels from my collection.

• Continued from page 310

Making Sweets

can add 1/2 lb. glucose if desired. Then boil to just under 240°, take off the stove and beat up until nearly white, adding 1/2 lb. desiccated coconut while beating. Pour half into a greased tin; to the other half add a little red colouring and a little vanilla flavour. If this goes too stiff, it may be placed over a very low burner and thinned sufficiently to pour over the first batch.

A tin with a removable bottom is best for the job, as it enables the coconut ice to be turned out easily when cold. This is something you can make from a sheet of tinfoil — 23ins. long and 1 1/2ins. wide for the removable top which is bent to a rectangle as shown and soldered along one corner. Make the base to fit this loosely from a piece 8 1/2ins. by 4ins., so that the turn up is nearly 1/2in. high. This mould can also be used for fudge, nougat and other similar confections.

A tin of this size will hold about 1 lb. of coconut ice, so if there is any left over after filling, it can be spooned out into small pyramid lumps on to waxed

paper and allowed to set in the form of 'coconut ruffs'.

Most people like marzipan either in the bar form or moulded into fruit shapes, such as apples, oranges or strawberries, and although these take quite a time to make, they are well worth it.

Dissolve 1 lb. sugar with 1 gill water and boil to just under 240°, then remove from stove and stir in 6 ozs. ground almonds and beat up till stiff. About 2 ozs. of glucose may be added to improve it if desired. Turn the mixture on to a marble or enamel slab and knead to a soft pliable paste, dipping the fingers in icing sugar. Colour and mould into fruits.

For apples, add a little green colour as you knead and form into balls with a clove in one end and a strip of angelica for the stalk. Paint a rosy cheek and dust with icing sugar. Other fruits can be coloured and shaped accordingly. Marzipan potatoes are easy — make dents with a fork for eyes, roll in cocoa and leave to dry on waxed paper for a few hours.

Smarten up your old radio

MAKE A CONSOLE CABINET

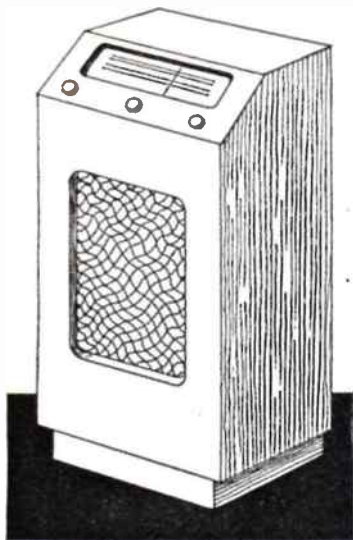

out to suit one's particular requirements, depending on the size of the set one has, and on the height and width one prefers for a cabinet of this type. A height equivalent to that of a normal sideboard would suit most people, but then some might like it higher than this, or lower.

The choice of veneer used must also be left to the reader.

When constructing the cabinet, it is, perhaps, best to start with the front. Fig. 1 shows how this is made.

It is composed of two sheets of plywood glued together. The first sheet is $\frac{1}{2}$ in. or $\frac{3}{4}$ in. thick and can be any common cheap plywood. The outer sheet is veneered on the surface and can be $\frac{1}{4}$ in. thick. This is $\frac{1}{2}$ in. or $\frac{3}{4}$ in. bigger all the way round except at the top, which should be flush with the thicker plywood. It is better to make the overlap too big than too small, as it can later be planed off after assembly.

Cut the boards carefully to make true rectangles, and before gluing together, draw out the shape of the loudspeaker aperture on the back of the thick board and bore holes (four or six of them), through the thick plywood only, for 2B.A. bolts. These are to hold the loudspeaker board later. They should be a tight fit for the bolts and should be

THERE is no doubt that the so-called console type of cabinet has much to recommend it in preference to the usual table model which must have a stand provided.

The console is a more compact and more imposing piece of work, and is a valuable addition as a piece of furniture.

There is no reason why the reader should not have such a cabinet, so long as he is passable as a woodworker. The design shown here is in the modern style and is fairly simple to make. Moreover, it is inexpensive.

If you have an old set which, though working perfectly, has an unsatisfactory cabinet, then here is the opportunity to rehouse it. Most table model sets could be successfully dealt with, but some might need a little ingenuity to make them fit to the design. For instance, some sets have their control knobs all on one side. If one couldn't alter this, then dummy knobs could be used to produce a symmetrical effect.

Most sets will need no modification, apart from shifting the loudspeaker from the chassis or old cabinet, and, perhaps, buying a new horizontal style dial. (These points will be touched on later.)

Those who build or buy their own chassis, of course, need have no work but to get ahead with the making of the cabinet.

No actual measurements are given, because, so long as the method of construction is grasped, one can work these

this case bolts cannot be used, and wood screws would have to be used from the inside of the cabinet to fix the loudspeaker board.

With the first method, remember to wipe out any glue squeezed on to the overlaps. This will avoid having to scrape out hard glue later when fitting in the side boards.

By A. Fraser

When the boards are glued, the next task is to saw out the aperture for the loudspeaker. This should be done with a fretsaw, later tidying up with file and glasspaper block.

A simple rectangle with rounded corners is shown in the illustration, but there is no reason why an ornamental design should not be used instead. Fretworkers will, no doubt, exercise their talents here.

The next part to make is the base.

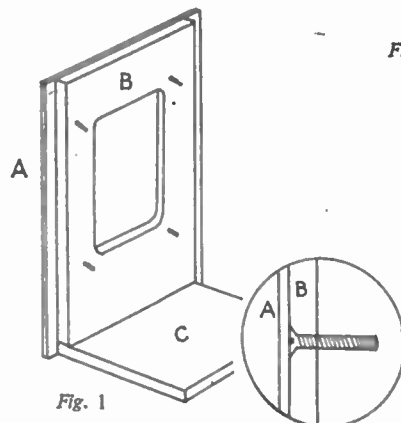

Fig. 1

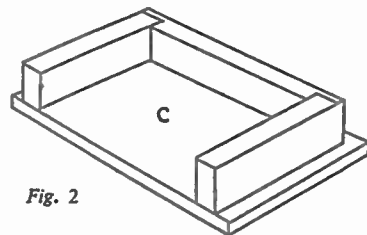

Fig. 2

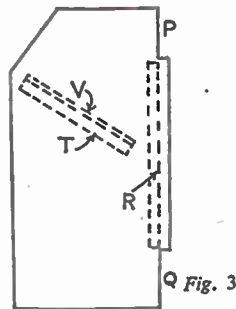

Fig. 3

countersunk on the side which is to be glued to the outer plywood. Put the bolts in, and then glue the boards together, using heavy weights to hold down until set. Fig. 1 inset shows how the bolts come in between the boards.

An alternative to the above is to start with thicker plywood and use a rebating plane to make the overlaps. In

First saw out the bottom of the cabinet (C in Fig. 1). This can be $\frac{1}{2}$ in. or $\frac{3}{4}$ in. plywood. The base proper or pedestal consists of three pieces of wood, jointed as shown in Fig. 2. These should be at least 1 in. thick, and about 4 ins. deep, although this last measurement can be altered to suit one's own fancy. The lengths of the pieces will depend on the

size of the cabinet one is making. The front and sides look well if set back about 1 in. from the outer limits of the cabinet.

The base should be attached to the bottom of the cabinet with glue and stout screws driven through the bottom of the cabinet into the pieces. This can be done either before or after the cabinet bottom is attached to the rest of the cabinet.

Next, the sides can be made. The shape of these is seen in Fig. 3. First saw out the rectangle, then attend to the corner shapes. The cut-outs at the back edge are to accommodate the cross boards (P) and (Q) (seen in later drawings). The dotted lines indicate the positions, first, of the battens on which the detachable back board will rest, and, secondly, the battens and baseboard on which the radio chassis will sit. These are referred to respectively as (R), and (T) and (V).

It will be noticed that the inclination of the radio chassis shelf (V) and (T) is exactly at right angles to the slope of the dial panel of the front of the cabinet.

It is advantageous to place this shelf fairly well down, so that the control knob spindles come well down to the front edge of the dial panel, so leaving plenty of space for the dial above.

When one has decided on the exact position of the shelf, one can either attach the battens (T) and (R) now, or wait until the cabinet has been partially assembled. Glue and screws should be used. These battens (T) and (R) can be about $\frac{1}{2}$ in. by 1 in.

One can now cut out the cross boards (P) and (Q). These should be $\frac{3}{4}$ in. thick. Their depths should be as much as possible, but (P) should leave enough space for the chassis to be withdrawn from the cabinet for repairs. (Q) can be much deeper, as it has only to allow space for the speaker to be withdrawn. Notice that (P) should have ventilation holes bored in it.

The cabinet parts already made can now be assembled. First join the bottom to the front with glue and nails or screws through the bottom of the cabinet.

Next, attach the sides, using glue again and adding nails or screws. Drive these through the sides into the edge of front (B section), and into the edge of the bottom (C).

After this, fix the back parts (P) and (Q). Figs. 4, 5 clarify the assembly.

Now set in the shelf for the chassis to sit on. When the battens (T) are fixed, saw out the board (V) from $\frac{1}{2}$ in. plywood. Drill holes for the screws which anchor the chassis (J), and then with glue and thin screws, attach the board to the battens.

Next, prepare the dial panel. This is made from two pieces of $\frac{1}{2}$ in. plywood glued together, as seen in (K, Fig. 4). The bottom edge must be chamfered to

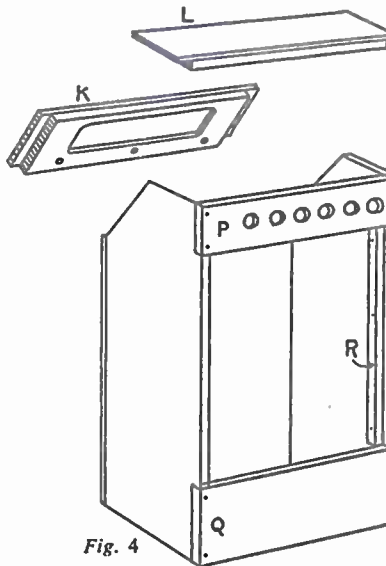

Fig. 4

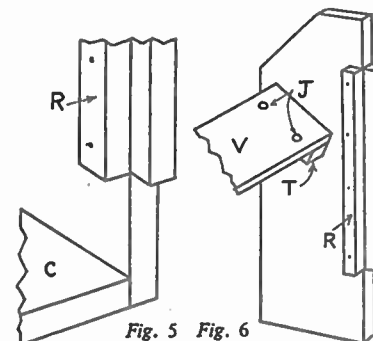

Fig. 5 Fig. 6

fit the top edge of the cabinet front.

Place the panel, temporarily, in position in the cabinet to test for fit. At the same time, slide the chassis in to ascertain the positions on the panel of the control spindles. Remove the panel and drill these holes. Replace panel (after inserting and fixing, temporarily, the dial) and make sure everything fits, and the drive drum is unimpeded. When satisfied, remove chassis and glue the dial panel into place.

Note that when making the dial panel, the aperture in the back piece of plywood is larger than that in the front piece in order to make a ledge for the glass dial to sit in. Do not glue together until this is checked.

The top of the cabinet is also made from two pieces of plywood glued together (L, Fig. 4). The lower interior piece can be thicker here, say, $\frac{1}{2}$ in. or $\frac{3}{4}$ in., as, no doubt, it will have to support the weight of the flower vase which it invites.

Next, saw out the back. This rests on

the battens (R), to bring it flush with (P) and (Q). Note the holes at the top for ventilation, and the cut-outs for the catches (Fig. 7).

Now clean up the cabinet, taking special care to level the sides by taking off with chisel and glasspaper block any projections of front, top and back. When perfectly smooth, both the sides should be covered with veneer, if one is fastidious, to conceal the ends of (P) and (Q) and the edges of front and top. Before gluing, damp the veneer. The veneer can be the thinnest available and should be smoothed out from the centre and pressed down with weights.

Veneered faced plywood has already been used for front and top, so these will be alright. One can, however, carefully paint (with appropriate colours) the edges of the cut-outs for the loudspeaker and dial, to conceal the light colour and laminations of the plywood.

Four strong rubber feet should be attached to the bottom of the base.

The cabinet can be stained and polished as desired, but avoid staining

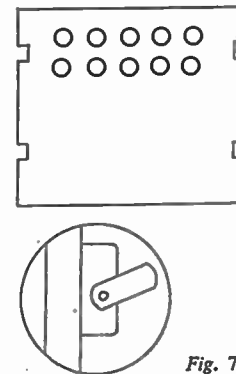

Fig. 7

if you are not expert at it, as it can spoil a good job. A plain waxing of the unstained wood can be as good as anything.

Lastly, fix in the loudspeaker mesh behind the aperture. This can be of woven material or expanded metal. Mount the loudspeaker on a sheet of hardboard (about $\frac{1}{2}$ in. thick), then attach the whole lot to the cabinet by drilling holes through the hardboard to coincide with the bolts protruding from the cabinet front. A washer and nut to each bolt then fixes the speaker assembly securely.

A horizontal dial, of course, is necessary and if the reader's set has not got this style or is not long enough, then a new one must be bought. Various sizes up to 13 ins. are available, but remember the bigger the dial length, the larger will the drive drum diameter have to be. The dealer will provide the drum necessary for the dial.

A REFERENCE BOOK STAND

Cut these divisional pieces from $\frac{1}{2}$ in. plywood to fit inside the trough, as at (A), the dimensions being given. These can be nailed in place and should not be more than 11ins. apart, if possible. It will be best to arrange the books in the trough first, and position the division pieces between them to suit. Punch all nail heads down a little and stop up holes level.

The book rest (C) shown both in Figs. 1 and 2, can be cut to the dimensions given from $\frac{1}{2}$ in. plywood. It is hinged to the trough with a pair of $\frac{1}{2}$ ins. brass butts, and along the bottom a strip of beading is glued and pinned down to keep the books from sliding off. It will be convenient at this stage to clean up the trough with glasspaper, ready for any subsequent finish.

For the legs cut four pieces of 1in. by 2ins. timber each 2ft. 6ins. in length. Lay these on their 2ins. faces in pairs on the bench, with their top ends touching, and bottom ends extended to the distance apart given. Hold them steady in place while a crossbar of 1in. by $\frac{1}{2}$ ins. wood is securely nailed across them at 9ins. up from floor level. The legs are then fixed to the ends of the trough, temporarily, at 4ins. down from the top, with two screws, to each leg.



THE writer, having a large number of reference books, frequently in use, designed the stand illustrated as a more convenient holder for them than the normal style of bookcase. The trough pattern permits such rather heavy volumes to be withdrawn easily, and without damage to the covers. The addition of a book rest is a great advantage when notes on the subject referred to have to be taken.

An end view is given at Fig. 1, and a part front view, in Fig. 2, with details as to sizes of timbers used. Make up the trough section by nailing together at right angles two boards, as in inset detail (A). Wood of $\frac{1}{2}$ in. thickness will do here, and it should be noted that board (A1) must be cut $\frac{1}{2}$ in. longer than (B2) to ensure inside measurements of the trough being the same. The ends can be cut from similar board, or from $\frac{1}{2}$ in. plywood, as preferred. These ends must each be a true square, so take trouble to mark off correctly, with a try square. Glue and nail the ends to finish off the trough.

It will be observed that the length of the trough is omitted, as, obviously, such length must in some degree be governed by the space required for housing the books, but for convenience in the cutting list, the length is given as 2ft. 6ins., which can be amended to suit personal requirements. The actual length can be easily computed by adding to the length of the massed reference books about $\frac{1}{2}$ ins., the extra being needed on account of two divisional pieces to be inserted in the trough afterwards, not only to ease the side pressure of a number of books, but also to form a support for the book rest to bear upon.

CUTTING LIST

Trough sides.(1). 2ft. 6ins. by 9ins. by $\frac{1}{2}$ in.*
Trough sides.(1). 2ft. 6ins. by 9 $\frac{1}{2}$ ins. by $\frac{1}{2}$ in.*
Trough ends.(2). 9 $\frac{1}{2}$ ins. by 9 $\frac{1}{2}$ ins. by $\frac{1}{2}$ in.
Trough divisions.
(2). 9ins. by 9ins. by $\frac{1}{2}$ in.
Bookrest. 1ft. 3ins. by 12ins. by $\frac{1}{2}$ in.
Legs. (4). 2ft. 6ins. by 2ins. by 1in.
Crossbars. (2). 1ft. 1in. by $\frac{1}{2}$ ins. by 1in.
Shelf. 2ft. 7ins. by 8ins. by $\frac{1}{2}$ in.*
*Length of these amended as required.

FITTINGS

1 pair $\frac{1}{2}$ ins. brass butt hinges
8— $\frac{1}{2}$ ins. round-headed screws

Pencil lines across the tops and bottoms of the legs, as shown in detail drawings (D) and (E), then remove legs and saw across on the lines. Replace the legs, and rescrew to the trough with $\frac{1}{2}$ ins. round-headed screws. Cover the top ends of the legs with strips of 1in. by $\frac{1}{2}$ in. wood, as at Fig. 1, as a finishing item to hide the sawn edges. These strips should have their ends neatly rounded off for effect.

The stand can now be completed by nailing a board across the crossbars below the trough as a shelf. The finish in stain varnish or paint is left to choice.

(W.J.E.)

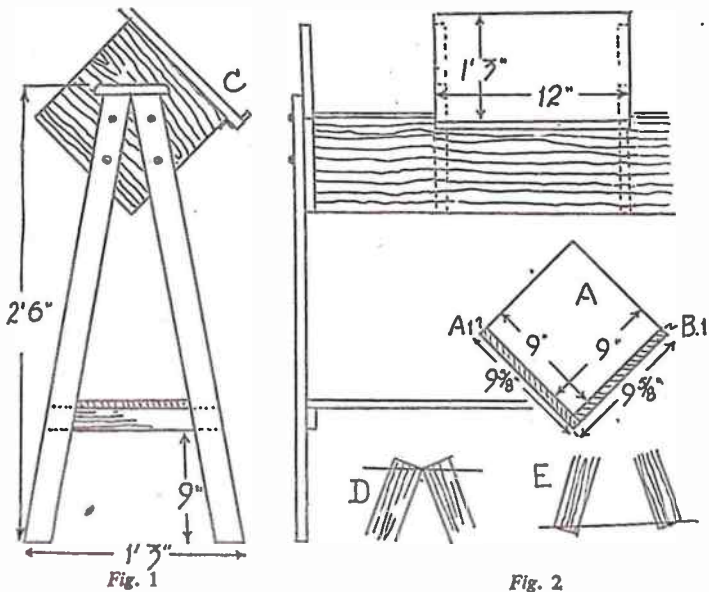

314

Fig. 2

It pays to be fussy...

When you've a gluing job to do, your success will depend very much on the performance of the glue you use. So choose a top quality product—it will cost you very little more and yet will give you the best possible means of doing a really good job. CASCO P.V.A. is just such a glue; and for household repairs, general handicraft work, model making, etc., you can make no better choice.

Here are the special advantages of CASCO P.V.A. Completely ready-to-use (no heating or warming required) . . . extremely clean in use (washes easily from brushes or fingers) . . . quick setting . . . non-staining . . . almost transparent when set . . . glues wood, paper, cloth and leather.



74

Recommended for "Build-It-Yourself" with **Easi-Bild** patterns

... for a general-purpose glue, insist on

CASCO P.V.A. GLUE

Obtainable from
Ironmongers,
Hobbies Shops, etc.
Price: 2/- per jar
(approx. 2 oz.)

Manufactured by: LEICESTER, LOVELL & CO LTD · NORTH BADDESLEY · SOUTHAMPTON

*can you identify this LIGHT CABIN MONOPLANE?



* One 180 hp. Blackburn Cirrus Bombarrier engine ... Maximum speed 127 mph. ... Cruising speed 110 mph. The Auster A.O.P.9 climbs at 920 ft./minute and has a range of 2.42 miles.

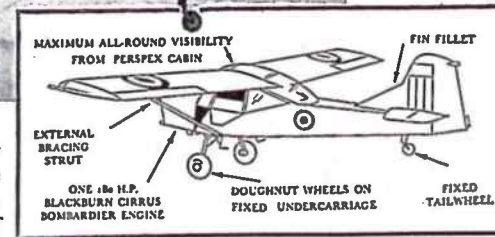

These rugged little aircraft can operate from tiny fields. Just now they are doing invaluable work spotting bandit hideouts in the Malayan jungle. If you join the Royal Air Force as an Apprentice (age 15-17) you could be a skilled technician servicing every kind of aircraft, from this type to the latest jets. Pay rates during training have nearly doubled under the new R.A.F. scale. For further details of an exciting career with a fine future, post the coupon now!

TO: ROYAL AIR FORCE (H.S. 254), VICTORY HOUSE, LONDON, W.G.2
I am over 14. Please send me details of entry for:

(A) The Apprenticeship Scheme | (B) The Air Training Corps
(Tick which you require)

NAME _____

ADDRESS _____

Date of Birth _____

(Applicants from British Isles only)

There's a career
for YOU in the **R.A.F.**

315

With ROD & LINE

WHILST at this season of 'February Fill-dyke' the trout-angler is looking forward with keen anticipation to the season of manifold delights ahead, the more 'general' devotee to the art of fishing, whose quarry includes pike, roach, dace, chub, and perch, endeavours to put in as much time as he can by the river or lake before the curtain comes down on his particular show in mid-March. It may happen that, after a prolonged period of flood and high water, the closing weeks are for him the 'cream' of the whole winter.

What about this February period? Ancient proverbs represent February as a month of sloppy, miry, muddy conditions, with every gutter a 'babbling brook'. February at its worst brings snow-filled hedgerows, hailstorms, rain, grey skies and a generally trying time, during which we wait patiently for the birth of spring. But there is another aspect to the month of 'fill-the-dyke, black or white' and 'this is a much brighter one. Days lengthen and this allows us to prolong our visits to the waterside for an hour or more each day. Winter may linger, but now we get a foretaste of the good time ahead; there are days when the sun shines warm and the air is mild, there are flowers, bird-song again, tassels on the brookside hazels, and 'palms' on the shallows. Richard Jefferies referred to such interludes of springlike weather as the 'February Pleasure'.

Choose your day
Those who take the riverside way in February should choose their day. Go prepared — often the river banks are miry and traces of winter flood-wrack abound. See to your footwear; put on your stout winter boots. Anyway, given a day of springtime promise, with the missel-thrushes shouting their joy to all the hills, and the river, flowing full and just a trifle coloured, gurgling and chuckling in low undertones by flood-washed banks, joy will surely be yours. Perhaps you will fish with renewed zeal, remembering that but a short time remains before the season is over.
Discerning pike anglers are aware that some very fine pike have been taken in years a-back during the last few weeks of

the season, which is, frequently, a likely period for catching 'old socks' — and a big 'un at that!

Some anglers maintain that these latter days comprise the best part of the winter angling, for many kinds of 'coarse' fish. Not always is this so, but over a length of years this back-end shows up well. In my old diaries there are several entries dated February and early March that deserved underlining with scarlet ink. One of the most outstanding days in my fishing career occurred on one 13th of March. It was a very lucky day, contrary to old superstition! The catch consisted of pike, perch, and roach — and some beauties, too, well worth recording.

February was a favourite month with the late J. W. Martin ('Trent Otter'). When he anticipated doing well with

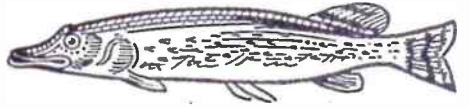

Pike are still good sport in February

perch and chub he used to say that the back-end of season was the best time, especially for the hog-backed 'serjeants' collected in some eddy after a flood. 'I fancy the month or so just named (February and March) to be the most fatal time for the perch', he wrote.

Roach often provide the angler with good sport at this back-end period. In medium rivers they are to be found, under normal water conditions, at tails of streams, ripply eddies, and long glides

FEBRUARY 'BAGS' By A. Sharp

about 3ft. to 4ft. deep, especially where there is a gravelly or sandy bottom.

On some streams, as certain reaches of the Derbyshire Derwent, nice mixed baskets of roach and grayling are to be made in February, under favourable conditions. Back-end grayling frequently show lively activity, and as they do not seek the spawning beds until April, they are still in nice condition for both rod and table. I have known the wet fly, fished downstream and across, do execution in February — a hackled pattern with tail of scarlet floss silk, or, maybe, a silver twist. The February Red (often deadly for trout in March) is another fly worth trying, and for myself I always put up a finely hackled Black Spider — a favourite fly with me, for both trout and grayling. I have also recollections of February days after a lot of rain and snow, with the river swollen but the 'grue' all gone and the water coming back to normal, when a well-scoured

red worm has done well.
Occasionally, these closing days of the 'general' season, (including the grayling) are to be numbered among the pleasant ones of the year. True, sometimes the weather in February can be vile, the streams thick and discoloured; but usually such conditions do not last long, and the sun shines again and with Nature in milder mood we may fill our keep-net by fishing the lay-bys and slacks and eddies under the banks. (A.S.)

QUEER HOBBIES OF THE WORLD Military Button Collector

MR. GARNER, of Camden Town London, started an original hobby which led him to surprising fortune. As a small boy he had always been struck by the polish and smartness of the soldiers of his day, especially their colourful uniforms with all the complicated regimental regalia thereon. At a very early age he started to collect military buttons, picking them up from all sources, not the least useful of

which were kindly old soldiers with no further use for their uniforms. Every possible kind of button from an army uniform, no matter what its age, source or origin, was of interest to Mr. Garner, and so assiduously did he collect these little-known objects that by 1925 he was able to dispose of his entire vast collection to an American millionaire for the princely sum of £30,000. (D.G.)

Make model buildings —



as simply
as this!

A new method—described in a new book on Pyruma Modelling. This shows how to turn empty match boxes into model buildings, by Pyruma 'Plasticraft'. It is one of the many methods of modelling in plastic Pyruma, shown in black and white and full colour pages, which enable you to build and finish in natural colours:—

MODEL FARMS, RAILWAY STATIONS, SIGNAL CABINS, AIRPORT BUILDINGS, DOCKS, SHIPS, FIGURES, ANIMALS, ASHTRAYS, BOOKENDS, DOLL'S FURNITURE, PLAQUES, RELIEF MAPS, ETC.



is a ready-to-use material, cheap to buy locally, and easy to work by following the Instruction Book offered below. Pyruma dries or can be baked to stone-hard permanence, then painted in natural colours. Sold by local Ironmongers and Hardwaremen, Hobbies shops and Art material Dealers, in airtight tins from 1/6 upwards.

Send Coupon and 6d. P.O. (not stamps) for this NEW Book of instructions to:—

J.H. SANKEY & SON, LTD.
Estd. 1857
Dept. H, ILFORD, ESSEX

Enclosed 6d. P.O. (not stamps) for PYRUMA MODELLING INSTRUCTION BOOK addressed to:—

NAME (Block letters).....
ADDRESS.....

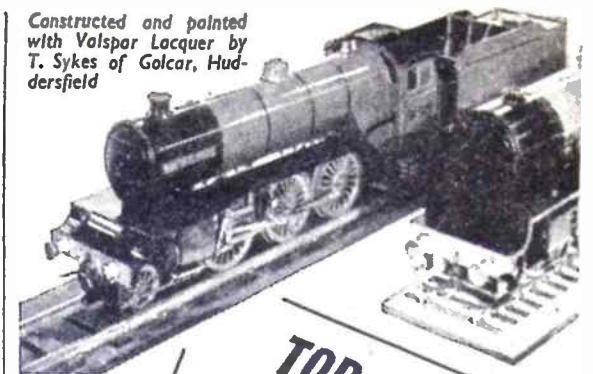

Constructed and painted with Valspar Lacquer by T. Sykes of Golcar, Huddersfield

TOP CLASS
MODELMAKERS
invariably choose

VALSPAR

2-4 Hour
LACQUER • VARNISH • WOOD STAIN
it's easy to see the reason why

Valspar is so versatile that a brilliant smooth finish is obtained on any type of surface however small or large — no runs, no brushmarks. Valspar Lacquer requires no knotting, priming or undercoating and is easily applied coat-over-coat.

- * PROOF AGAINST BOILING WATER, PETROL, OIL, ALCOHOL, ETC.
- * DRIES IN 2-4 HOURS
- * UNMATCHED HARDNESS AND ELASTICITY
- * FOR ALL SURFACES



GOODLASS, WALL & CO. LTD. 179/185 (A2) Gt. Portland St. London W.1
Please send me a free copy of the Valspar Handbook giving full details of how to use Valspar paints

NAME
BLOCK CAPITALS
ADDRESS

PATSY PLAY HOUSE FREE: 4 SETS of curtains for 4 windows. Laughter in child's own house is better than in the mansion of others. For 5/6 Children, outdoors as well as in, because materials are all Waterproof, collapsible and erected in a minute. Complete with jointed and Sectional sturdy framework. True to scale chimney, doorway, etc. Only play-house with unbreakable windows. Improved specification. Height 4' 3", depth 3' 4", length 3' 9". Cash 69/11, part car. 3/1, or sent for 5/-, bal. 18 fortnightly pymts. of 4/- Lists, Terms.

Cash Price 69/11 Part carriage 3/-

Complete transmitting and Receiving apparatus for two persons. Communicate at distances of a few yards, room to room, or will adapt for use up to a mile, from buildings or over country. Self-voice generating at normal telephons strength due to scientifically wound coils and armature. Sensitive diaphragm. No batteries or electricity—it just works! 12/11, post 2/1. For use in 5 minutes.

AMAZING GOVERNMENT SURPLUS NEW TELEPHONE INTERCOM MOBILE OR STATIC ONLY 12/11 POST 2/1

Headquarter & General Supplies Ltd. (HOBW/45), 196-200 Coldharbour Lane Loughboro Junction, London, S.E.5

STAMPS FREE — Empire Packet including Pictorials and Victorians with approvals. — Robert J. Peck, 7A Kemp Road, Bournemouth.

100 DIFFERENT stamps free! Request 3d. upwards discount approvals. — Bush, 53 Newlyn Way, Parkstone, Dorset.

SWISS MUSICAL MOVEMENTS. Before you buy send 2d. stamp for our illustrated brochure — Metwood Accessories (Dept. HW), Church St., Wolverton, Bucks. (Trade enquiries invited).

'PAINTSPRAYING' HANDBOOK. Covers, Car, Industrial & Flock Spraying, 3/6, post 4d. Catalogue of four Cellulose and Paints and all Allied Sundries 2/6. — Leonard Brooks Ltd., 81 Oak Road, Harold Wood, Essex.

LEARN it as you do it — we provide practical equipment combined with instruction in Radio, Television, Electricity, Mechanics, Chemistry, Photography, etc. — Write for full details to E.M.I. Institutes, Dept. HW47, London, W.A.

GENUINE Swiss Musical Movements. The best and largest selection of tunes in the country, lowest prices 16/3 each. Genuine Thorens Movements, 22/9 each. All guaranteed. P & P, 9d. extra on all orders. — Richardson & Forder, HW, 5 Chapel Place, White Hart Lane, London, N.17.

FREE Stamp Album and 20 stamps. Request approvals enclosing 4d. Additional gifts given. — Beeze, 8 Langland Villas, Mumbles, Swansea.

EVERY CAR THAT PASSES—YOU WILL FIND THE INDEX MARK ALPHABETICALLY ARRANGED IN WHERE'S THAT CAR FROM? Price 9d. from all Booksellers or from the Publishers (2d postage) **RALEIGH PRESS, EXMOUTH**

MODERNISE YOUR HOME WITH ARNOBOARD Send 1/6 for R. W. D. Kirkham's comprehensive illustrated book which shows you how; and FREE SAMPLE of Arnoboard, the prefinished plastic surfaced hardboard which works like ordinary hardboard. Finishes include wood grain, tile, marble effects, etc. Dept. 3, Arnolite Ltd, West Parade, Spring Bank HULL

MUSICAL BOX MOVEMENTS 14/9d. ONLY Complete kits 21/6d. SAE for details:— **SWISSCROSS CO., Dept. B, 116 Winifred Rd., COULSDON, SURREY**

GOVERNMENT SURPLUS BARGAINS. Inter-room Telephones, comprising 2 self-energised microphone/receivers and approx. 6yds. flex (may be extended if desired). No Batteries needed. Nothing to wear out. Complete 9/6, post 6d. Motors, Transformers, Switches, etc. 3d. stamps for illustrated list. Milligan's, 24 Harford Street, Liverpool, 3. Money Back Guarantee.

STOP SMOKING in 3 days or money back. Safe, pleasant, permanent. The only scientific way. No Will Power necessary. 'Conquered the habit in 21 days'—F.C. 'Within 2 days I was free from the tobacco habit'—W.G. 'Was a smoker for 2 years and broke the habit in 2 days'—F.N. 'I used to smoke 20 a day... now I have no desire to smoke'—J.M. Recommended by 'Health and Efficiency Magazine'. Complete course 6/6 (or \$1.00 bill). Details 2d. stamp. Sent under plain cover. **NATURE REMEDIES, 28 (H/164) Dean Road, London, N.W.2. Established 1928**

THE LATEST SENSATION in the **International Handicrafts Exhibition Olympia** were our **Plastic Moulds** for Wall Plaques for plaster casting

Prices 1/3 to 5/- each
Rubber Moulds from 1/- each
Illustrated catalogue 9d.
S.A.E. for list
TRADE ENQUIRIES INVITED

F. W. NUTHALL
69 St. Mark's Road
HANWELL, LONDON, W.7

The Handy Paint in Tubes **1/- PER TUBE** In 13 lovely colours and clear varnish

Starlon is perfect for handicrafts and small painting jobs. Quick drying. No brush marks. Brilliant finish. No waste—you squeeze out only the quantity required.

Starlon PLASTIC ENAMEL PAINT
Obtainable at handicraft shops everywhere
STARLINE, SOUTHEND-ON-SEA, ESSEX

It must be good . . .

HOBBIES LEVER FRAME

This is the most popular fretwork handframe in the world.

Prices
12in. 15/6
14in. 16/-
16in. 16/6
18in. 17/-
Post free

The top lever is a special feature, giving instantaneous tension to the sawblade. The lower wooden knob may be turned to raise or lower the bottom saw clamp, to give the precise tension required.

Hobbies Ltd., Dereham and Branches and Stockists.

Attractive and easy to make
'HELP YOURSELF' CONTAINERS

SIDES. CUT FOUR 1/16 IN.

HELP YOURSELF

FOR THE PARTY



Use as a Table Decoration

MAKE four or five of these attractive little containers and put them on one side for use when required. They are particularly suitable for parties when they can be filled with sweets or cigarettes.

Make them from 1/4in. or 1/32in. plywood as indicated. The holes are made with a leather punch and the pieces laced together with plastic thonging.

Finish the plywood with stain and polish before thonging together. The overlay should, of course, be glued in position as indicated by the dotted lines. To cut the overlays, pin three or four pieces of thin plywood between two pieces of waste 1/4in. wood and cut out the whole lot with a fretsaw. (M.p.)

BASE. CUT ONE 1/16

HELP YOURSELF

USE A HOBBIES FRETSAW

Novel
Electric
Lights

'Yacht' Kit No. 3110

23/11

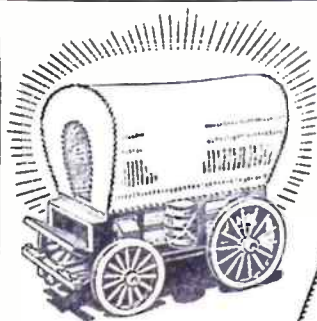

24/6 'Covered Wagon'
Kit No. 3156

Made easily
from kits by



Get a
Kit
Today

To Hobbies Ltd, Dept. 99, Dereham, Norfolk
Please send kit marked X

Covered Wagon No. 3156 24/6 post free Yacht No. 3110 23/11 post free

NAME.....
ADDRESS.....

STICK TO
SECCOTINE

Regd.

-it sticks everything!

Keep a tube
in the home



PER TUBE

Sole Manufacturers: McCaw, Stevenson & Orr Ltd., Belfast

NEW!

THE EASY PRACTICAL WAY
of learning RADIO · TELEVISION · ELECTRONICS

COMPLETE EXPERIMENTAL
COURSES IN RADIO ENGINEERING, and SERVICE

An entirely new series of courses designed to teach Radio, Television and Electronics more quickly and thoroughly than any other method. Specially prepared sets of radio parts are supplied and with these we teach you, in your own home, the working of fundamental electronic circuits and bring you easily to the point when you can construct and service radio receivers, etc.

With these outfits, which you receive upon enrolment and which remain your property, you are instructed how to build basic Electronic Circuits (Amplifiers, Oscillators, Power Units, etc.) leading to designing, testing and servicing of complete Radio and Television Receivers.

COURSES FROM 15/- PER MONTH

EMI INSTITUTES

associated with "His Master's Voice", Marconiophone, Columb'a, etc.

- Beginner's Radio Course
- Advanced Radio
- Short Wave Technique
- Lesson Manuals

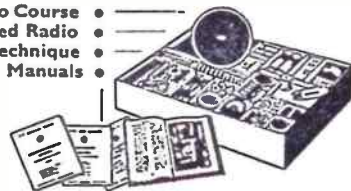

Experimental work includes construction of
Basic Oscillators, Amplifiers, Deflectors,
Power Units, 1, 2 and Multi-valve TRF and
Superhet receivers.

POST THIS COUPON TODAY

To E.M.I. Institutes, Dept. 31, Grove Park Road, London, W.4.
Please send me your FREE book on Practical Courses

NAME _____

ADDRESS _____

Feb 6

1C74