

Hobbies

WEEKLY

Complete with
FREE DESIGN
for a Lady's
Trinket Box

VOL. 114

NUMBER 2948

How you can make

AN ALL METAL WEATHER-VANE

WE see, on our travels up and down the country, all shapes and sizes of weather-vanes. Some are artistic and unusual in character, while others follow the more conventional type of weather-cock design, or the fox best associated with Church spires and farm buildings.

To make an acceptable vane, it is first necessary to decide upon its predominant subject, and the position in which it is to be erected. A great deal depends on the latter.

Setting Out the Design

Having decided upon the design, perhaps one or the other of those given with this article, proceed to set it out on the material chosen for the work. The best is zinc sheet of about 20 gauge, but mild steel will do equally well and is cheaper. For easy enlargement on to the metal, we have included here large-size details of the designs of the cock and the fox and the arrow head. These have been 'squared' so that an enlargement can be made to any length desired by simply scaling up the squares as required.

For instance, if it is desired to have a fox 15ins. long, then $\frac{3}{4}$ in. squares should be used, and the outline of the animal drawn through each, carefully following the detail in each square of

Patterns for the
Cockerel and
other parts are
given on page
79

the pattern during the process of enlargement. It will be noticed on the page of details that the 'feather' end of the arrow is also given, but this is only used if neither of the other figures is used.

In Fig. 1 of the constructional details is shown how the arrow head and 'feather' are riveted to a strip of metal, and also how this strip is made in two parts to encircle the vertical tubing which in turn revolves round the vertical rod in the post.

The Letters

The letters N, S, E and W are cut from the zinc or the steel sheet to the outline given in Fig. 2, the size of the letters being made proportionate to that

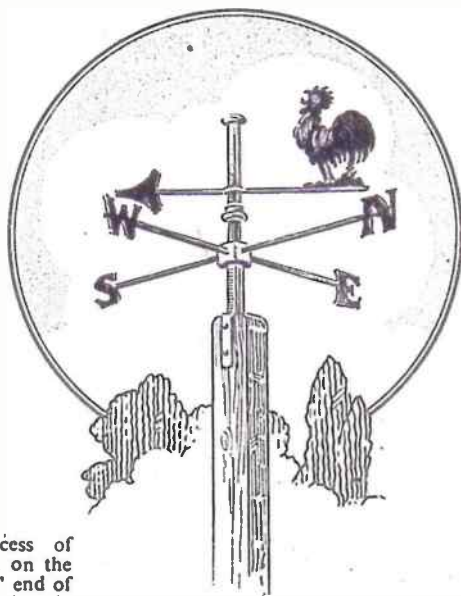

of the figures. Each letter is riveted to a metal crossbar, the ends of which are flattened and drilled to take the rivets. In place of the rivets small bolts and nuts may be used, if desired.

Crossbars

The crossbars are threaded at the inside ends and let into a metal collar as shown at Fig. 3, making sure that the holes in the collar are evenly spaced round the diameter, so that the rods all stand at right angles to each other. A hole for a grub screw must be drilled in

All correspondence should be addressed to The Editor, Hobbies Weekly, Dereham, Norfolk.

4^p

THE MAGAZINE FOR MODELLERS,
HANDYMEN AND HOME CRAFTSMEN

the collar, so that when the correct points of the compass are set, the grub screw fastens the collar in its true position on the revolving tube.

The making of the vertical rod is now undertaken and this is shown in Fig. 4. A piece of piping some 6ins. or more in length as (A) is let into and riveted to an inverted U shaped stirrup (B), which must be drilled to take the screws for fastening it to the top of the post (see also Fig. 5). Passing into the tube (A) is

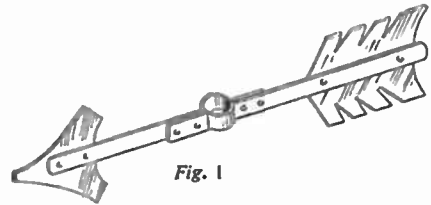

Fig. 1

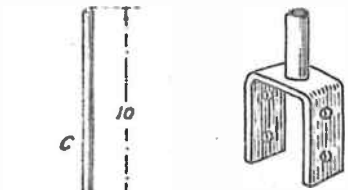

Fig. 5

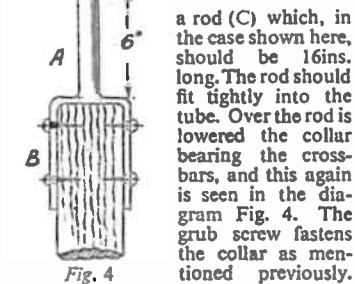

Fig. 4

File the extreme top of the central rod to a blunt point.

This completes the work upon the upright, the whole of which may be either painted or black-japanned as a preservative to the metal.

The moving part of the vane is now undertaken, and a section through this is given in Fig. 6. A piece of metal tubing (D) of large enough internal diameter to pass freely over the rod (C) is cut to required length, and a shaped



Fig. 2

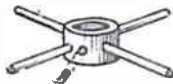

Fig. 3

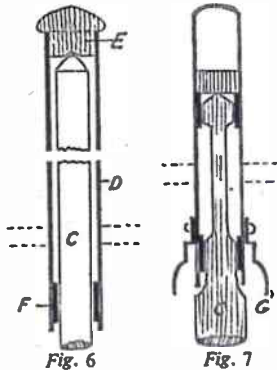

Fig. 6

Fig. 7

capping soldered in as at (E). A counter-sink is drilled beforehand to receive the pointed end of the rod (C) to get perfect freedom of movement when the vane is fitted.

A little way up from the lower end, and inside the tube (D), a band of brass or other metal should be soldered if too much freedom should be evident when the tube is placed over its rod as (F). It should be remembered, however,

that the whole tube must swivel freely about the central rod.

The dotted lines in Fig. 6 show approximately where the cross arm bearing the arrow and the 'figure' should come.

In Fig. 7 a rather more elaborate method of forming the top arrangement is shown. In this the rod (C) is diminished as shown and a top collar of brass, as well as a lower one, is introduced. The capping here may still

remain, but the resting plate for the pointed end of the rod can be kept a little way down from the top of tube (D). A terminal collar of spun metal makes a neat finish to the lower end of the rod, this terminal collar being tapped and screwed as (G) in Fig. 7.

This second method, however, although most generally used in good class weather-vanes need not be undertaken, and may be looked upon as optional. While erecting the vane give it one or two coats of paint, and then pour in some thick oil round the top piece of piping bearing the vane, and before it is placed over the bearing rod. This will ensure smooth action, and it should need no further attention for years.

The post to which the vane is attached should be anything from 8ft. to 10ft. above ground, and should be solidly concreted round. The vane may, of course, be put on a gable end of a house to good effect, the metal parts being supported by a metal bracket plugged and nailed to the gable brick-work. (361)

usual ways to match any existing woodwork or as an entire contrast.

To give a somewhat delicate appearance it would be nice if enamelled in a pale pastel shade, or if a light wood were used it could be left natural and just polished. (378)

FLOWER POT DECORATION

Ordinary garden flower pots can be made attractive by the following method. Apply a good coat of putty to the outside of the pot, and then attach an assortment of shells which can be obtained in quantity at the seaside. When set firm, apply a coat of varnish.

FOR THE GADGET FAN

An Auto-Server For Your Table

WHEN visitors are invited to tea or supper it is often found that the table is not large enough to hold all the items required. Perhaps the jam or salt is on the other side of the table.

Troubles such as these can be avoided, however, by the use of the auto table server described in this article. It has been designed as a self-service gadget, and it enables your guests to obtain the most used items on the meal table with a minimum of effort. It also eliminates the frequent asking for something, and

can be stood on it, thus helping to weight it down.

Fig. 3 shows the mechanism which is housed in the wood work of the pedestal, and it consists of the steering part of an old bicycle.

Obtaining the Part

It is possible that the local rubbish dump might provide just the thing, or failing this a cycle dealer would let you have an old frame which is of no further use to him.

With a hacksaw, cut off the four

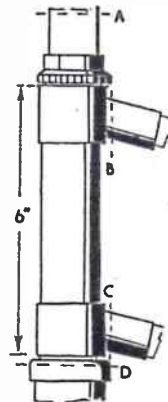

Fig. 2—How the steering piece is cut

helps to create a more friendly atmosphere by putting your guests at ease.

The design of the automatic server is clearly shown in Fig. 1, and is of the very simplest. The material required is easily obtained, and no difficulty should be experienced in its construction.

The server forms a centre piece for the meal table and is really a tray raised above the table on a pedestal which rotates easily, thus enabling anyone seated at the table to obtain what they want with a slight turn of the top.

Robust Mechanism

The mechanism is very robust and will stand quite a considerable weight with ease. The base has been made the same size as the top so as to keep it from overbalancing when loaded with goods. Having a large base does not encroach on the table space as various articles

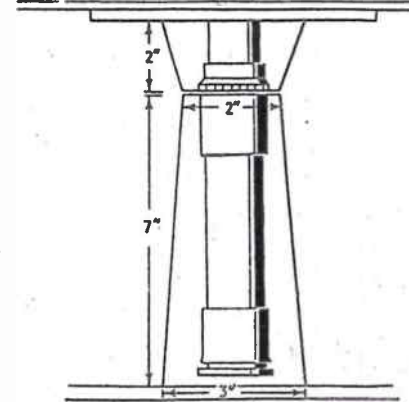

Fig. 3—The mechanism housed in the pedestal

pieces marked (A), (B), (C) and (D) in Fig. 2. (B) and (C) should be cut off as close to the main stem as possible, while (A) is left about 2ins. long, measuring from the ball bearing joint.

The cut at (D) may be a little more difficult to accomplish as it forms the foundation for the front forks. It may be necessary to make several saw cuts in order to get it down to a size suitable to fit into the wood pedestal, but it does not matter how much is cut off so long as the ball race is left complete.

File off all rough edges and any awkward corners, and if it is very dirty or rusty, it may be carefully taken to pieces and well cleaned before proceeding any further. Whatever its condition it would be a good idea to give it a good clean up and then oil the bearings at this stage.

The size of the pedestal will be determined by the length of the steering

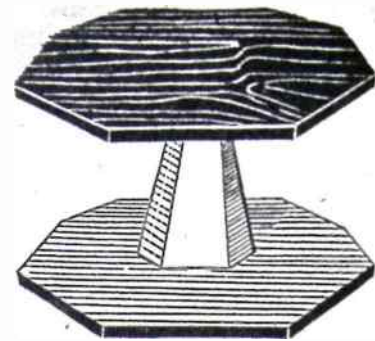

Fig. 1—The server ready for use

column. The measurements given here refer to a small one taken from a lady's cycle—the distance between the two ball bearings being 6ins.

There may be considerably more space on other types of cycle, especially the older models, but this will in no way affect our server.

As will be seen from Fig. 3 the pedestal is made up of two blocks of wood—the main support which is securely fixed to the base board and comes up to the top of the ball bearing race. The movable part above this, which is secured to the top board, is quite short.

Both these blocks are cut with eight equal sides and are made tapering. They could be made round in shape and either pattern can be left the same size along their entire length, but they certainly look much better if tapered off.

The bottom piece is shown 7ins. long and 3ins. wide at the base, while the top tapers off to 2ins. Any kind of straight grained hardwood is suitable for the job. Owing to the rather awkward shape of the steering column this section had better be made in two pieces and then glued together.

First taper off the block, then cut off the corners so as to form a perfect eight-sided figure, then cut the block in half lengthways. It will then be fairly easy by means of chisel and gouge to scoop out the two halves to fit the tubular column. Make this a good tight fit with the exception of the part at the bottom which must have plenty of room to enable the movable part to turn easily.

Keep Central

It is necessary when doing this operation to see that the column is kept central, otherwise the table will tilt somewhat and, if it is much out, the things are liable to slide off the top.

The two halves can now be glued together, and clamped up tightly until the glue has set firm.

The top block is made from a similar (Continued on page 66)

AUTO-SERVER FOR THE TABLE

(Continued from page 67)

piece of wood 3ins. square and tapering to 2ins.—the length will be about 2ins. and, therefore, the taper will be steeper. This block may be drilled out with two or three different sized drills, but here again it would probably be easier to split it in half and make it up the same as the base portion.

A slight gap of about 1/4in. is left between the two blocks to enable the top to swing round freely.

The top of the server is made from 1/2in. plywood 18ins. across and cut to an exact eight-sided figure. It may be fixed direct on to the block but it would be better and stronger if the block was

glued on to a smaller piece of ply first and then fastened on to the top. This smaller piece can be about 6ins. across.

The base of the server is best made of a more substantial plywood, say, about 1/2in. and is cut exactly the same size and shape as the top. This need not have any additional piece of ply, but can be screwed and glued on direct to the block.

The top may have a small beading fitted round the edge to keep things from sliding off if desired, but this is not really necessary.

The server can now be glasspapered smooth and finished in any of the

DESIGNING AND BUILDING MODEL RAILWAYS

By E. F. Carter

HAVING decided upon the purpose and plan of the proposed layout, the next job is that of interpreting the plan into terms of actual material, commencing with the sub-structure and baseboard upon which the railway will eventually be laid.

If the baseboard is to be mounted in the centre of the railway room with a gangway all round, the substructure will of necessity have to be more strongly braced than would be the case if the baseboard was laid round and fastened to the walls of the room. The understructure of portable layouts also must be very strongly braced in every direction.

Important Requisite

One of the most important, yet most frequently overlooked requisites of a model railway baseboard is that it is built perfectly flat, and that it maintains that characteristic; for no amount of subsequent track levelling will ever overcome the running troubles due to a bumpy baseboard, and a faulty foundation can cause untold operating difficulties.

When a plywood or pulp-board is used (unless the layout is a very narrow affair, such as would be built round the walls of a room) the major difficulty likely to occur is the sagging of the board between its supports. This can only be properly remedied by fitting diagonal cross-bearers of 2ins. by 1in. section as shown in Fig. 15, to which the baseboard should be screwed with countersunk screws.

After fixing in place it is extremely essential that all the woodwork is thoroughly dried out and then treated to a coat of good paint to prevent its future warping due to dampness, which will rapidly permeate into the wood and cause it to twist all over the place.

Undue Stress?

It may seem to the reader that undue stress is being laid on the prevention of the warping of a layout substructure, but in point of fact, the seriousness of this particular trouble cannot be over estimated, when its direct bearing upon the subsequent laying of the track is considered; particularly in 'OO' scale, where a quarter of a millimetre error in track level is sometimes more than sufficient to derail a 'touchy' locomotive at speed.

It will be readily understood then, that it is not enough to have the general level of the baseboard truly horizontal. The bumps, hollows, and 'blisters'

which are at times almost bound to occur—especially with 'artificial' boards—must be 'ironed out' permanently by being firmly screwed down to a rigid sub-base support.

Again, however strongly the substructure has been made, and however smooth and level the baseboard surface, it will avail nothing unless all the woodwork is dried and painted. A bare wood

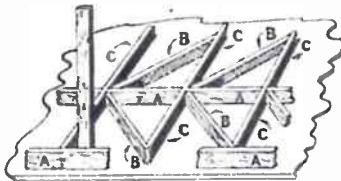

Fig. 15

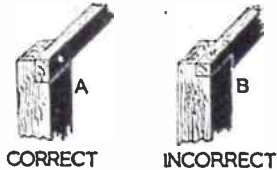

Fig. 16

substructure will shrink and expand according to the weather as well as the humidity, warmth, or coldness of the railway room. It will then literally tear itself away from the nails and screws which were designed to hold it firmly in

A MAN in America has a hobby that needs more than extremely good eyesight, more than ordinary patience, and a steady hand in a million. When he started his hobby, he had to make his own tools, and he little realised that the making of them by himself would cause such interest in the industry that usually manufactures them. For he is a miniature artist to end all miniature artists. He paints works of art, either copies of great paintings, or pictures of his own invention, on a canvas that is only 1/65th of a square inch in area! With a powerful watchmaker's eye-glass

place. As an old cabinet maker once remarked to the writer—'if wood is going to warp, nothing will stop it!'

Simple Answer

The answer is simple. Do not give the dampness a chance to get into the wood in the first place. Paint it just as soon as the structural work is finished and the wood has been dried out, for the time taken on this work will be time more than well spent.

The actual difference between the weight of an 'O' gauge layout and a 'OO' one is not very great, so the same type of substructure will be suitable for either scale; adequate strength being obtained by the use of 2ins. by 2ins. vertical and 2ins. by 1in. horizontal and cross-bearing members. The baseboard bearers should rest on steps cut in the tops of the posts as shown in Fig. 16. If the bearers themselves are cut at the ends, they will surely split when the edge of the layout is subjected to any excess weight.

The Best Material

Normally the best material to use for the baseboard of an 'O' gauge railway is 1/2in. grooved and tongued board, but in lieu of this material any good manufactured board can be used, providing it is not so hard that it is impossible to drive a nail into it. If such material is used, every nail and screw will have to have a lead-hole drilled before they will enter the board, and this paraphernalia adds very greatly to the amount of work to be done when it comes to fixing the tracks in place. (356)

clamped into his eye, a powerful lamp over his tiny easel, he paints away with a brush of his own design. This brush—and he has naturally made many—has been of great interest to brush-making firms, for it consists of a single solitary bristle. And that bristle is made from a human hair. After much trial and error, the artist discovered the right type of hair to use, how to shorten it and how to mount it in a handle so that it is springy enough to paint with in oils. Equipped with his unique brushes, he pursues a hobby that is not likely to be crowded with competitors! (280)

For the fretworker—

AN ATTRACTIVE TRINKET BOX

TRINKET boxes and similar small articles are always welcomed by workers as they are easily made up and are useful as presents or for sale.

In the article illustrated, the decorative work is confined to the overlays, and the whole job can be tackled confidently by beginners and experienced workers alike.

Construction

The box is made from 1/4in. wood, while 1/2in. wood is used for the overlays. Begin by transferring the design to the necessary wood, using carbon paper and a sharp pencil in the usual way. Make sure that the pieces are laid correctly as far as the grain of the wood is concerned. Arrows will be found on the pattern to indicate the direction of the grain in each piece.

First cut out the floor, two sides, front and back, and assemble, using glue and screws. Chamfer the top edge of the front and back as shown by the section on the design sheet. In assembling the pieces, the positions of the front and back are shown by dotted lines on the outlines of the sides.

Now cut the two side overlays from 1/2in. wood and glue into position. Here the worker may have to tackle each side separately as the overlays will require to be suitably weighted down while the glue dries.

The rectangular piece which forms

This handy article is made from Design No. 2948, given free with this issue. A parcel containing the necessary wood and hinges can be obtained from any Hobbies branch, or post free from Hobbies Ltd., Dereham, Norfolk, price 7/2, including tax.

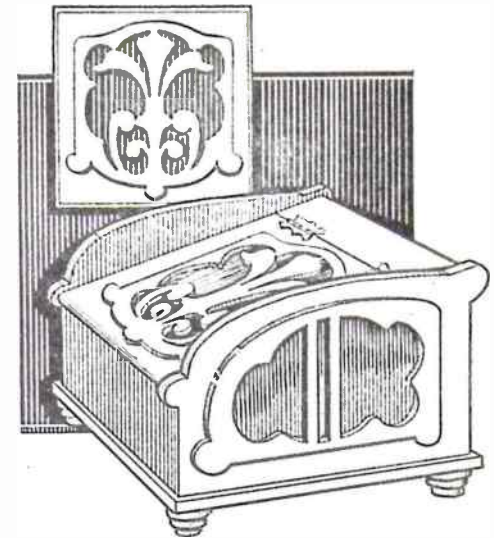

the main lid can be cut next. After cutting, it should be sawn in two where shown, separating what will be the fixed portion of the lid from the movable part. Now hinge the two pieces together, using Hobbies hinges No. 5308. Those who are working from a kit for this article will have had the hinges provided.

The 1/2in. overlay for the lid is cut next and glued into place, a suitable weight being placed upon it until the glue is quite hard. Next glue a stiffening block along the inside of the back as shown in the detail on the design sheet. Before the lid is secured in position, the front and rear edges are rounded as shown in the detail. Glue and screws should be used when securing the static part of the lid in position.

The feet are made up of the circular pieces shown on the design sheet, one of each size being required for each foot. They are glued together, left until hard and then secured in position on the underside of the box.

Now clean up the whole of the work and apply the finish. If a suitable wood has been used, the article can be left in its natural colour and wax polished, but inferior wood would look better if stained before polishing. Paint would also make a suitable finish if desired. Whatever the choice of finish, the box would possibly look better if the overlays contrasted in colour from the box proper. Whether they were made lighter or darker, would depend upon the general staining or painting scheme chosen, and the nature of the wood used.

Two Replies to Readers' Queries

Sticky Oilskins

I HAVE purchased a new cycling cape and leggings made of yellow oilskin. The last set I had became very sticky and I am wondering if there is any way I can prevent this whilst they are still new. (A.H.—Sidcup).

SINCE the oilskins are made waterproof by treating them with boiled linseed oil (or similar ingredient), it is impossible to eliminate the stickiness without ruining their wet resisting properties. The best plan is to obtain a set of rubber proofed garments which do not suffer in this way. Some amelioration of the worst effects of the stickiness can be obtained by rubbing the surfaces with French chalk (only

lightly) or you will turn it into a kind of white paint!

Casting Hollow Toy Soldiers

CAN you help me with information on the casting of hollow toy soldiers, please? (T.K.—Accrington).

FOR hollow casting, the mould usually has a footplate which is hinged, and the method of procedure is as follows:—the metal is melted and the mould prepared. The molten metal is then poured into the mould which is immediately turned upside down to allow the metal to run out again. At a certain stage in this operation, and one which can only be judged from experience and practice, the small hinged

foot on the base of the mould is swung over to stop any more metal running out. The metal which is unable to get away eventually forms the foot on which the toy soldier stands, and your first attempts may fail because there is not enough metal left to form a proper foot. You may imagine that when the molten metal is poured into the mould and then poured out again, the whole lot would tend to run out, but this is not so. As soon as the metal is poured into the mould, that which comes into direct contact with the sides of the mould will cool sufficiently to prevent it running, and the only metal which will run is the surplus which has run out as described, thus leaving you with a hollow soldier on a solid base.

There's fun to be had with this Electric Strength Tester

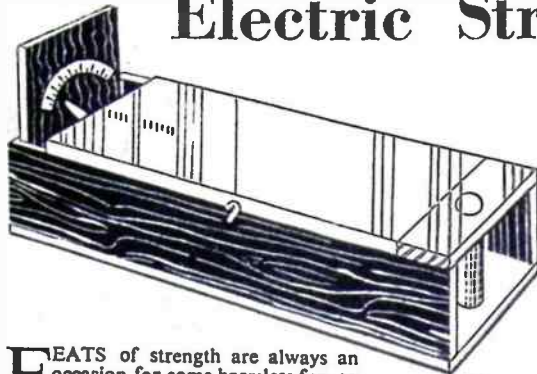

FEATS of strength are always an occasion for some harmless fun, so the ingenious little machine described here is sure to be popular with one's friends, as well as providing the handyman with a good deal of pleasure in making it up and getting everything working 'just right'. This toy measures the strength of one's hand grip by means of a pointer on a graduated dial, and when sufficient force is employed to bring the pointer up to 100, an electric bell rings to applaud the feat.

The toy centres round a strong spring, and the aim should be so to arrange the

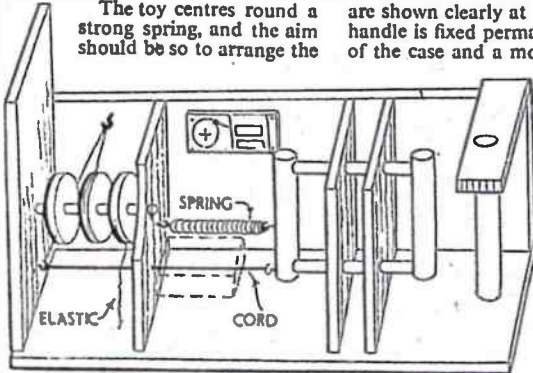

Fig. 1 (left)—
Showing how
the tester
works

works, in the manner described below, that a strong fellow giving it 'all he has' can just manage to pull off the effect. Two-handed efforts should be disqualified, as they spoil the fun.

Size Not Important

The exact size of the spring is immaterial, as the measurements can be varied if necessary to accommodate it; but one measuring between about 5ins. and 6ins. long is most suitable. A few minutes spent in tactful conversation at a local blacksmith's or engineer's yard usually procures the right thing for a shilling or so. It can be judged to be suitable if, when pulled hard between the hands, it stretches 2ins. to 3ins. in

of four pieces of the dowelling, is held between two partitions inside the case. The spring is held between the inner of these two partitions and a third one placed lower down, and the pointer is not actuated by the spring itself but by a cord fixed on the moving handle, the spring only acting as a resistance.

This cord passes through to the dial end of the case, goes round a hook, then round a disc on the pointer spindle, as shown. A piece of strong elastic on another disc pulls the spindle back to zero when pressure is released. There is a projecting screw on the pointer disc which closes the electrical circuit to ring the bell when the pointer comes sufficiently far over.

the writer's case he obtained a good spring for 2/- off an old eyeletting machine, but this is only one instance of many that will provide the type of thing needed.

Any small standard-type electric bell will serve for the job of indicating 'bull', the current being provided from a torch battery in the bottom of the case. The wood needs to be fairly thick, but need not be of an expensive variety— $\frac{1}{2}$ in. box wood serves admirably, and suggested measurements are all given in the Cutting List. A piece of $\frac{1}{4}$ in. dowel is needed for the spindle and handles, and some thicker dowel, about 1in. diameter also for the handles.

How It Works

The works are really quite simple, and are shown clearly at Fig. 1. The outside handle is fixed permanently in the front of the case and a moving handle, made

The Case

This consists of a base 20ins. by 8ins., two sides 20ins. by 6ins., and an end 9 $\frac{1}{2}$ ins. by 7ins. The sides are screwed on to the base and the end fits inside the sides, as seen at Fig. 1. The top is in two parts—a narrow fixed piece 8ins. by 2ins. and a lid 17ins. by 8ins., which is later hinged to the side, to allow access to the works for changing the battery and making any other little adjustments that may become necessary when the machine has been in use some time.

Before screwing down the narrow fixed piece of the lid cut a hole in it, centrally, 1in. diameter, and another similar hole in the base $\frac{1}{2}$ in. from the edge. The fixed handle, which is a piece of 1in. dowel 7ins. long, is glued in these two holes and then the top piece can be screwed into position.

Identical Pieces

Cut three identical pieces for the partitions, each 7ins. by 6ins. Choose two that are to carry the moving handle, and mark them with a horizontal line down the centre. Then on this line bore two $\frac{1}{2}$ in. holes in each, one 1in. from the top and the other 1in. from the bottom,

so that there is 3ins. between each pair of holes.

For the moving handle cut two pieces of 1in. dowel 5ins. long and two of $\frac{1}{2}$ in. dowel 6 $\frac{1}{2}$ ins. long. Bore two $\frac{1}{2}$ in. holes in the 1in. pieces, one $\frac{1}{2}$ in. from the top and the other $\frac{1}{2}$ in. from the bottom. Then glue the narrow dowels into one of the thicker pieces. Thread on both of the partitions, then glue on the other handle piece.

When the glue is dry, glasspaper the thinner dowels if necessary to ensure that this moving handle slides easily through the two partitions. Then screw the partitions into the case, spacing them 1in. apart and with the one nearest the fixed handle 3 $\frac{1}{2}$ ins. away from it.

The Spring

Put a hook in the centre of the moving handle for the spring, as seen at Fig. 1, and set the handles so that there is about 1 $\frac{1}{2}$ ins. between fixed and moving

handle. In this position, with the spring temporarily hooked on, it is easily seen where the third partition has to be, to take the other end of the spring.

Mark its position on the inside of the case, but before it is screwed down three holes have to be bored in it. Draw a vertical line down the centre, and on this line bore a $\frac{1}{4}$ in. hole 1 $\frac{1}{2}$ ins. from the bottom, for the cord to come through. Bore another $\frac{1}{4}$ in. hole centrally and 3 $\frac{1}{2}$ ins. from the bottom, for the spindle, and another small hole near the top right hand corner for the bell flex to pass through, as seen at Fig. 1.

When the position of the third partition is known, the exact length of the spindle can be easily seen. This is cut from $\frac{1}{4}$ in. dowel and is fixed between the end of the case and the third partition, projecting $\frac{1}{2}$ in. through each side and being secured with a split pin at each end. Cut the spindle ready, and bore a $\frac{1}{2}$ in. hole in the end of the case, centrally and 3 $\frac{1}{2}$ ins. from the bottom, to take it; but do not fix the spindle in until the discs have been prepared.

Making the Discs

The three discs are all 3ins. in diameter, and cut from the $\frac{1}{4}$ in. wood. Bore a $\frac{1}{2}$ in. hole in the centre of each to take the spindle, and round the edge of two of them make a groove for the cord and the elastic. Cut a pointer of thin wood 4 $\frac{1}{2}$ ins. long and fix it to the third disc—either glued on or let in flush as preferred. Then glue the three discs on to the spindle as shown at Fig. 1.

Place the pointer disc as near to the end as possible, taking care, of course, that it clears the end as it swings over, and space the other two evenly on the remainder of the spindle. When the glue is dry, fix the spindle into its place with the pin at each end, making sure that it turns easily in the holes.

Suitable Cord

Thin picture cord is most suitable for working the pointer, and a little experimenting is necessary to get it working correctly. Put a hook into the moving handle as shown, tie the cord on, and thread it through the hole in the third partition. Pass the cord round another hook in the end of the case, in a direct line with it, and take the cord under the pointer spindle to a hook placed exactly opposite the middle disc. From here the cord passes into the groove in the middle disc and the end is secured with a drawing pin on the underneath edge of the disc. This is done, with the spindle in such a position that the pointer inclines to the left.

Now try the effect of pulling on the spring and observe the amount of turn given to the pointer. This will, naturally, depend upon the amount of stretch provided by the spring. If the pointer moves about 100 degrees this will be

CUTTING LIST (for wood of $\frac{1}{4}$ in. thickness except where stated)		
No. of pieces	Description	Size
1	Base	20" x 8"
2	Sides	20" x 6"
1	End	9 $\frac{1}{2}$ " x 7"
1	Top, hinged part	17" x 8"
1	Top, fixed part	2" x 8"
3	Partitions ..	7" x 6"
1	Fixed handle ..	7" x 1" dowel
2	Moving handle	5" x 1" dowel
2	Moving handle	6 $\frac{1}{2}$ " x 1" dowel
3	Discs	3" diameter
1	Spindle	About 6" x $\frac{1}{4}$ " dowel
1	Pointer	4 $\frac{1}{2}$ " x $\frac{1}{2}$ " x $\frac{1}{4}$ "
1	Battery holder ..	3 $\frac{1}{2}$ " x 2 $\frac{1}{2}$ "
1	Battery holder ..	2 $\frac{1}{2}$ " x 1 $\frac{1}{2}$ "

sufficient, and it is only a question of arranging this movement centrally on the end board, by varying the position of the pin holding the end of the cord. But in extreme cases the amount of movement on the pointer can be increased by having a smaller pointer-disc, or decreased by a larger disc.

When this movement has been fixed satisfactorily, put the pointer to zero and pin a piece of strong elastic round the third disc, securing the end to the base of the case as seen at Fig. 1. This elastic needs to be strong enough to pull back the spindle when the spring is released, but must not be tight enough to break when the disc turns round its full movement.

The Dial

This is drawn out with indian ink on

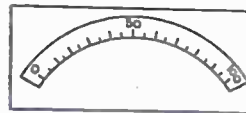

Fig. 2—The Dial



Fig. 3—Bell Contacts

WORKSHOP NOTES AND HINTS (6)

A Stripwood Tidy

even if kept in a small tub, the oddments get hopelessly jumbled.

This simple rack will solve the problem. For completeness sake, it is shown as a separate unit. Those who run youth clubs, etc., where handicraft is done, may care to have it quite separate and transportable but otherwise the back may be dispensed with and the rack made against the wall of a shed-workshop.

The box at the bottom may either be specially made (say, 15ins. by 4ins. by 4ins.) or an existing box adapted. It is partitioned into three or four divisions. The loops above can be cut from old inner tubes of tyres. Have them fairly slack to start. Where nailed down, put a small patch of leather, as otherwise the nail head will soon tear through the rubber.

If a separate back is needed, this can be cut from two planks, battened behind, or of thick plywood. Dowels can be kept in one compartment, moulding in another, stripwood in another, and so on. The bands prevent the pieces from flopping about. (314)

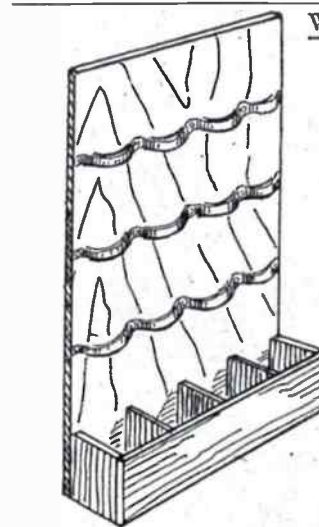

MOST keen woodworkers accumulate, after a time, a large number of 'loose ends' of stripwood, dowels, moulding and so on which are too good to throw away but which are a nuisance to keep, since

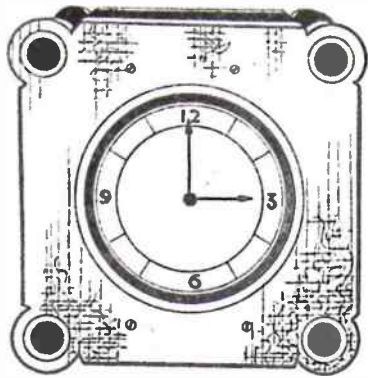

You can make a plastic CLOCK CASE

measure between the pieces of wood. An accurate measurement should then result. At the top of the case cut out a slot to admit the stud carrying the lifting ring. The ring, by the way, should be removed. In the bottom part of the wood case, cut out two grooves into which the feet of the clock can rest, as in the illustration. The clock should then be securely held, and be unable to turn when the clock is wound up.

The plastic (perspex would suit nicely), say, $\frac{1}{16}$ in. thick, should be cut into suitably sized pieces to cover the top and sides of the case. Cover top first. The material could be cemented on,

NO doubt many readers have in their possession one of the kitchen clocks of the American pattern. While these are usually quite good timekeepers, it cannot be said of them that they are artistic in appearance. In fact they are 'kitcheny' to look at, and distinctly out of place in any room but the kitchen. A plastic case, however, which can be easily made for them, will work a transformation, and make a rather commonplace article fit for any room.

Suits 4in. Clock

The drawings of such a case, given in this article, are suitable to a clock with a drum of 4ins. diameter, but many

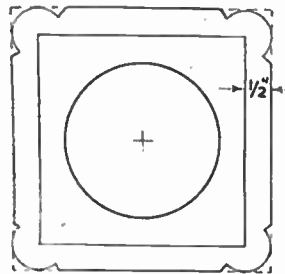

Fig. 2

readers will possess enough ingenuity to adapt them to any clock in their possession. First, make a case of $\frac{1}{16}$ in. thick wood, any kind, to completely enclose the clock, as at Fig. 1, (A) being a front view, and (B) a plan. This case should be a good fit, and should be well nailed or screwed together.

The depth of the case is that of the drum of the clock, measured from front to back, and must be exact. A good plan here is not to trust to just measuring across the sides of the clock, but to press two pieces of wood against front and back, and, allowing the pieces to extend below the clock a little, then to

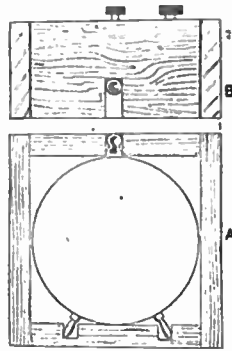

Fig. 1

and pinned for security's sake. Small panel pins would do or brass headed nails, the latter looking neater, naturally. When fitted, slightly round the sharp angles at top and bottom, then file the front and back edges truly level with the case. No need to cover the bottom, of the case unless desired.

Back and Front

The front and back pieces of the perspex are cut to the pattern shown in Fig. 2. A good plan here is to draw the shape on thin papers and stick to the perspex with gum. First draw the inner square to the same size as the wood case, in this instance, 5ins. each way. Draw an outer square, $\frac{1}{16}$ in. larger all round, and with a radius of $\frac{1}{16}$ in. put in the corner semi-circles, and finish the four sides. In the centre strike a circle, $\frac{1}{16}$ in. less all round than the clock face.

Now cut out the shape and inner disc with a fretsaw, and polish up the edges. The edge of the central hole is nicely bevelled with a file, and also polished. All that is necessary to finish

this part of the work now is to screw the front and back of the case in position. It should be noted here that while the front and back parts are identical in pattern, the hole in the back one does not need to be bevelled. An important point also is to take care when screwing on to get both level, or the clock will not stand firmly, but tend to wobble. Small round-headed brass screws will be needed to fix the parts.

Optional

An optional further embellishment is to cut in the perspex, four $\frac{1}{16}$ in. discs and cement these in the corner of the front as shown in the general view. These should be bevelled on their edges, and would look nicer if cut from a different coloured perspex to the rest. A combination of colours generally gives a richer effect.

If the reader possesses some little artistic talent, a final improvement is to renew the old paper dial. Some may have their own ideas on such renewal, but just as a suggestion, the old dial could be covered with a black paper, and numerals put neatly in with a white ink. A suitable design of modern dial, quite in keeping with this pattern of case is shown in Fig. 3. Here a double

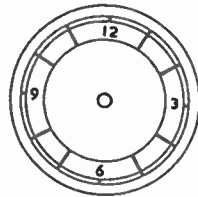
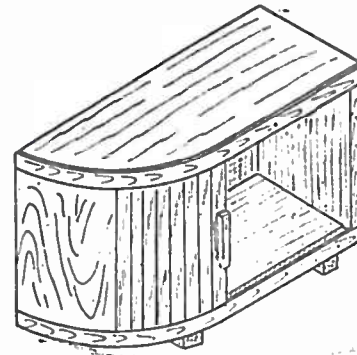

Fig. 3

outer circle is struck, which can be as shown in the drawing, or divided into minutes as preferred. The numerals, with the exception of 3, 6, 9, and 12, are indicated by short radial lines, terminating at an inner circle as shown.

The general effect should be novel and up to date, and make an attractive timepiece from a very ordinary clock. (360)

Watch next week for
full-size plans and
details for a 'Chuck'
Glider



Follow these instructions to make A CABINET WITH A SLIDING DOOR

suggested, and can be modified, if desired. The actual top and bottom consist of two separate parts pinned and glued together. The thinner member is actually cut out in two parts which, when glued in place, form the track. The remaining parts needed for the basic construction are detailed in Fig. 2.

How to Start

Start construction by cutting out the parts of Fig. 1. These are assembled as indicated in Fig. 3. It is important that the track so formed should be accurate and smooth, and any glue which has oozed into the track must be cleaned away. Wrap a piece of fine glasspaper around the end of a $\frac{1}{8}$ in. square stick and work right around the track to finish properly. This applies to both the upper and lower members.

Now cut out the back, end, two corner pieces and the vertical support. These are assembled as shown in Fig. 4. The end is assembled only temporarily, as this will have to be removed later to fit the sliding door.

The support must clear the track on both sides and should be located as far towards the curved end as possible. This will then give maximum cupboard space. It is possible to omit this support entirely, but it makes for a more rigid structure and is recommended. It also keeps articles placed in the cabinet from getting displaced towards the curved end, and so, possibly, fouling the door.

Two further vertical members of lin. by $\frac{1}{16}$ in. are then added as shown in Fig. 5. These fit directly between the top and bottom. Facing strips of $\frac{1}{8}$ in. ply are then pinned and glued around the top and bottom edges. Make as neat a job of this as possible.

10ins. of the curved section of the end is then panelled in with $\frac{1}{8}$ in. plywood—Fig. 6—attaching to the corner block and the vertical members. Top and bottom comes flush with the facing strips previously added and the whole can be glasspapered down. With really

(Continued on page 75)

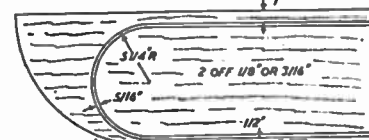
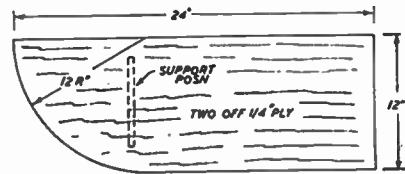

Fig. 1

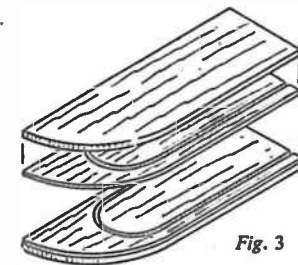

Fig. 3

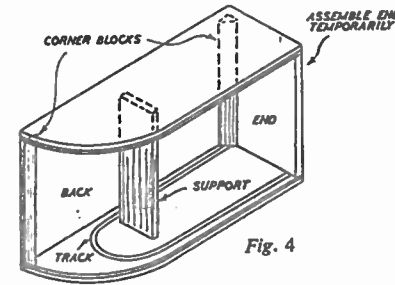

Fig. 4

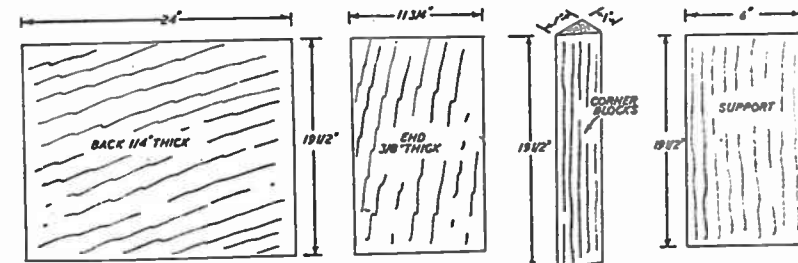

Fig. 2

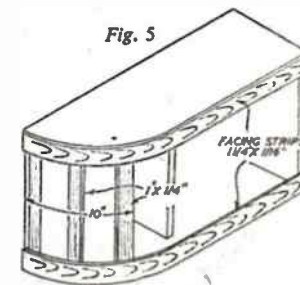
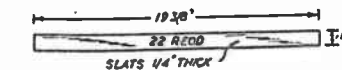
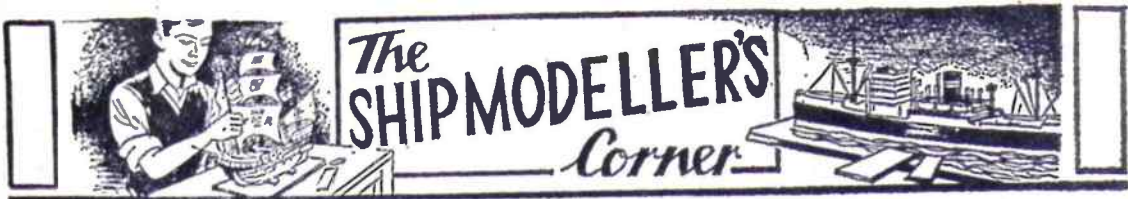

Fig. 5



PART 4

(which concludes the series)

THE heraldic devices on the sails of the 'Ark Royal' are problematical. Contemporary illustrations supposed to be of the ship vary greatly in the designs shown. The sketches included here are those I used on my own model, and are most likely to be those at the time the ship was Lord Howard's flagship. The flags shown are those listed as flown by the original vessel.

To complete the sails, in the small loops at the upper corners make small throat seizings to slip over the ends of the yards, and in the lower corners seize small single blocks, not larger than

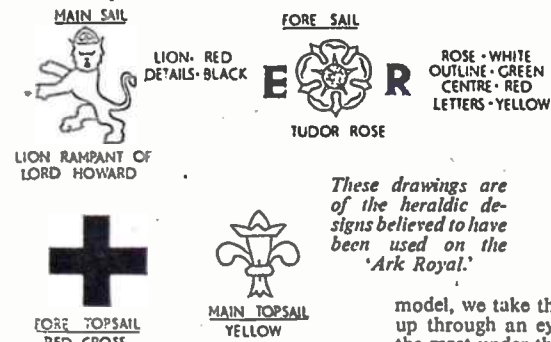

These drawings are of the heraldic designs believed to have been used on the 'Ark Royal.'

1/16 in.—slightly smaller if possible at this scale.

Running Rigging

In attacking the running rigging, commence with the lower yard lift. The standing end is secured to a small block under the top. It is actually secured to a small eye in the tail of the block already fixed in position under the top.

The running end is taken through the upper sheave of the sisters block at the end of the yard, back up through the block under the top and down to the samson post at the foot of the mast. Repeat on both sides of the model for the fore-yard and main-yard, in the case of the foreyard belay to the forecastle rail (see Fig. 1).

The topsail lifts we secure to a pair of small blocks under the mast cap, one to hang down on each side of the mast. The standing end of this rope is seized around the flagpole, slightly above the

Building the 'ARK ROYAL' from Kit No. 211 Sp.

By 'Whipstaff'

cap, take the running end to the yard-arm block, back up to the first block and down to the samson post or forecastle rail as before (see Fig. 2).

The standing end here can be fixed to an eyelet in the edge of the cap, and if you can do this it will improve your rigging, as it is more authentic.

Rig the standing lifts of the spritsail yard in the same manner and belay to the forecastle rail.

Next take the halyards of the fore and main lower yards. As we have not fitted cheeks and trestle trees to this model, we take the leads from the yard up through an eyelet on either side of the mast under the top and down to an eyelet in a small square opening to the side and aft of the mast, as in Fig. 3. Cut this hole about 1/16 in. square and 1/16 in. deep with a chisel and edge with a small coaming. Do this for both fore and main mast.

The mizzen halyard is rigged in the same manner, but, is belayed to the knight stepped in the upper deck.

The next lines are the topsail halyards. The foretopsail halyard consists of a piece of rigging cord joined to another short piece to form a Y. The two short ends are seized around the yard on each side of the mast, and the long end is then taken up through a hole drilled through the mast, under the cap, and secured to the mainstay by means of euphroses, as in Fig. 4. The running end is taken through a block seized on the mainstay and belayed to the forecastle rail on the after edge of the deck.

For the mainsail halyard, the top

ends in a pendant block, and a simple whip tackle is used, the standing end secured to an eyelet in the deck and the running end taken up through the block and belayed to the rail on the starboard side. The eyelet for the standing end should be on the port side of the deck.

Now, the mizzen lifts can be fitted, as in Fig. 5.

The spritsail halyard is taken through a small block on the under side of the bowsprit and belayed to the forecastle rail (see Fig. 6).

Adding the Sails

The sails should now be added, if you have not already fitted them, and rigging is then proceeded with before fitting the braces.

Commence with the buntlines on the topsails first. Fig. 7 shows these clearly. Sew these to the bolt ropes, bring up over the fore side of the sail, through the pendant blocks under the cap, and belay to bits at the foot of the mast.

For fore sail and mainsail there are

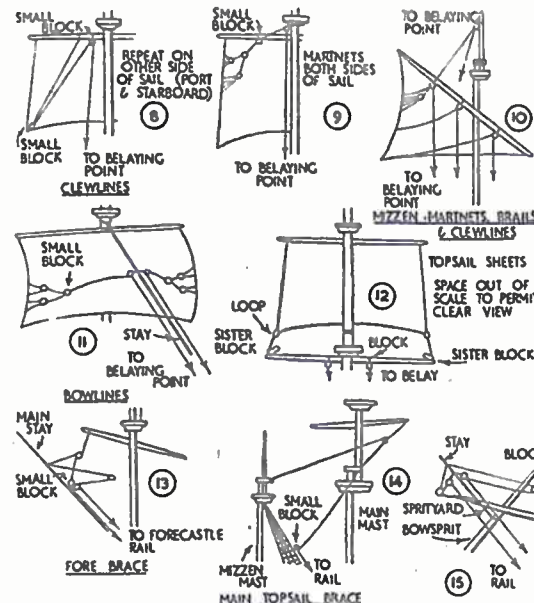
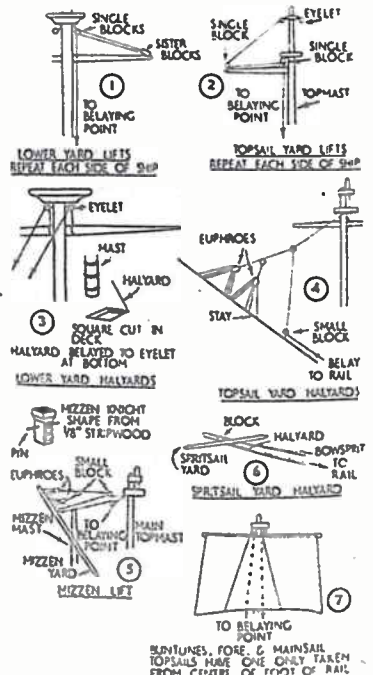

two to each sail, as in Fig. 7. Secure as before and belay to the bits at the foot of the mast.

The clew lines follow, as in Fig. 8. Secure the clew standing end around the yard near the clewline block, take the running end through the clewline block at the foot of the sail, up through the block on the yard and down to belay at the rails. These, of course, are on the aft side of the sails.

The next bit of rigging is only possible on this size model and with sails of fabric. They are the martnets for fore

and main sail. They can also, if desired, be shown on the mizzen sail (see Fig. 9). Fit the mizzen brails and clew line now. Take them through the small blocks on the mizzen-yard and down to belay at the taff-rail, as in Fig. 10.

Now, on all sails except the spritsail, we fit bowlines. Here again we can only do so if fabric has been used for the sails.

Fig. 11 shows the bowlines. Follow the sketch and belay to the most convenient rail for the purpose, bearing in mind which sail you are working on at the time.

Follow now with the sheets for fore and mainsail as in Fig. 12, and the topsail sheets, etc. These are fastened to the loop at the corner of the sail, through the lower sheave of the sister block at the end of the yard, along to the block in the centre of the yard and down the bits on deck.

The final rigging for the sails are the tacks for fore, main and mizzen sails shown in Fig. 12.

Our last piece of work at rigging is to fit the braces. Commence with the

mainyard. Attach a small pendant block to each end, secure the standing end of the brace to an eyelet in the outside of the hull, underneath the poop taffrail. The running end is taken through the pendant block and belayed to the half deck rail.

The fore-braces are rigged as in Fig. 13, and belayed to the forecastle rail. Rig next the foretopsail brace in the same manner to the maintopmast stay.

The maintopmast brace is shown in Fig. 14, and belayed to the bulwark rails.

Fig. 15 shows the brace for the spritsail yard.

Flags and Stand

This completes our little effort at ship modelling, based on available authentic information, and it only remains to add the flags to our model and provide it with a suitable stand.

And now that you have finished your first model to be rigged in detail, you will feel proud to own it. You will find it rich in detail and giving a realistic and authentic picture of the ships and rigging of this period of our maritime history.

If in Difficulty

If any difficulties arise during the building of this or any other model, do please write to us. We will do our best to solve your problems, and get you greater satisfaction from our hobby.

And if you cannot enlarge the sail designs, etc., to full size let our Editor know. He will pass your letter to me and I will be pleased to supply full-sized drawings. (368)

CABINET WITH SLIDING DOOR

(Continued from page 73)

accurate workmanship it should be possible to blend the two so effectively that the actual joint lines do not show. This is not all that important, however. The feet or 'legs' can also be added at this stage, or omitted entirely, if desired.

Now is the time to remove the end and make up and fit the sliding door. The door consists of twenty-two slats of good grained wood glued on to a strip of canvas or similar material, 18ins. wide and 24ins. long. Trim off any surplus length of canvas when all the slats have been glued in place. Leave to dry and then 'break' individual slats away, in case glue has oozed between them. In other words, make sure that the door assembly is flexible and can be bent into a curve, canvas backing inwards. The canvas is glued along the centre of the slats so that there is just under 1/16 in. of free slat projecting from

each edge of the backing (see Fig. 7). With the end removed it should now be possible to insert the first slat in the tracks (top and bottom) and slide the whole door in place. It is an advantage to slightly taper off the leading edges of the first and last slat to make for easy

sliding action. Check that the door does not jam and can be slid open and shut readily. A handle screwed and glued to the last slat makes for easy operation.

The end can now be replaced permanently and the cabinet finished off by adding a vertical strip of 1/8 in. ply to blend in with the facing strips, as shown in Fig. 6. Finish the woodwork according to taste. (373)

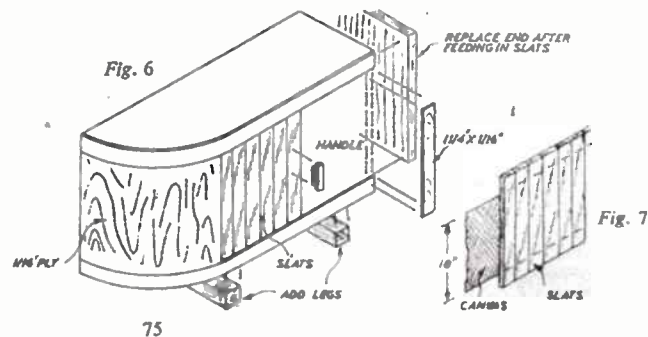

Some Experiments With Iron Filings

A FINELY divided substance often undergoes with ease a reaction which would be chancy with lumps.

Iron is such a substance. With iron nails most of the following experiments could be done only with difficulty, some not at all. Using iron filings the case is different.

Test First

As iron filings often contain sand or grit, first test your specimen. Sprinkle a thin layer on a sheet of paper and pass a magnet back and forth just above the filings. If, when all the filings have been attracted to the magnet, you find sand or other non-magnetic impurity, you will need to purify several portions in this way for these experiments. One treatment is usually not enough to

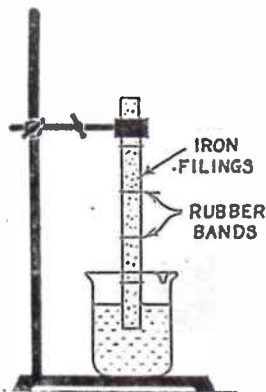

Fig. 2

separate entirely the sand, as a small proportion sticks to the filings and is carried up to the magnet. Three treatments may be needed.

The magnetic property of iron lends itself to a party trick. On a piece of cardboard or stiff paper draw the outline of an angry cat, with upright tail and arched back. Within the outline arrange a layer of iron filings. If you now bring up a magnet beneath the paper the iron filings will stand on end and closely resemble fur (Fig. 1). This trick never fails to raise a laugh.

As ferrous sulphide is a constant necessity in the home laboratory for producing sulphuretted hydrogen, it is useful to know how to make an emer-

gency supply should your stock run out.

Mix thoroughly 7 parts by weight of iron filings and 4 parts by weight of flowers of sulphur. Drop small portions of the mixture into a red hot crucible and cover with a lid after each addition. At intervals of about a minute remove the lid and examine it. When no more blue flames appear, add more of the mixture and carry on as before until all the mixture is used up. Allow it to cool and tip out the button of black ferrous sulphide.

You will find this is now only feebly attracted by the magnet, thus proving the iron has undergone a chemical change. If you drop a small piece into dilute hydrochloric acid, sulphuretted hydrogen will soon be evolved.

Potassium Iodide

Iron filings are used in one of the processes for making that useful laboratory reagent potassium iodide. The principle consists of forming an iodide of iron and then producing potassium iodide by double decomposition with potassium carbonate.

On the small scale, this is best done by grinding together in an evaporating dish 3 grams of iodine, 1 gram of iron filings and 10ccs. of water. Let the liquid stand until it becomes pale green (20 minutes to 1 hour). Then grind in 1 gram more of iodine and let it stand a further 20 minutes.

You will then have a solution of ferroso-ferric iodide. Pour it off into a wide test tube, add 2.8 grams of potassium carbonate and place the tube in a boiling water bath for 15 minutes. A precipitate of ferroso-ferric oxide forms, which you can filter off, wash and then dry in the oven as an extra specimen.

Evaporate the filtrate to the crystallisation point and allow it to cool down overnight, when potassium iodide crystals will be deposited. Drain and dry them in the usual way on a porous tile.

An interesting experiment on the composition of air can easily be done with iron filings. Since damp iron combines with atmospheric oxygen to form rust, we can, by letting iron rust in a measured amount of air, estimate the volume of oxygen in air.

Take a flat-bottomed glass phial and graduate it in five equal parts by putting on rubber bands at intervals of

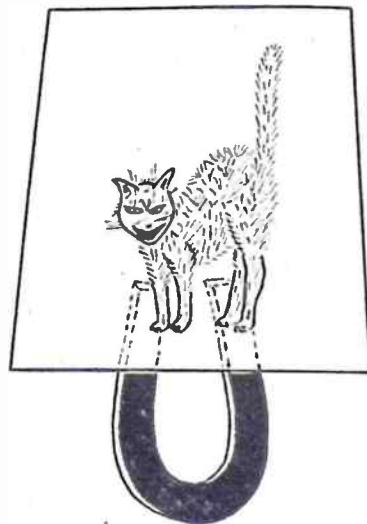

Fig. 1

a fifth of its length. Wet the inside of the phial by pouring some water in and pouring it out again. Sprinkle some iron filings in the phial, shake up and empty out the surplus. Some of the filings will remain sticking to the wall of the phial. Dip the open end of the phial into a beaker of water, and clamp it in position (Fig. 2).

No water will enter the phial, but after a few hours you will notice it has risen a short way and that the iron is rusting. For several days the water will continue to rise and then stop. If you read off the level you will find it is at the first rubber band—one fifth of the volume of air in the phial. Therefore air contains one fifth of its volume of oxygen.

Some Nitrogen

The remaining four-fifths of gas in the phial is nitrogen. If you remove the phial and pass in a burning spill it will be extinguished, as nitrogen does not support combustion.

When a mixture of iron filings, potassium carbonate and sulphur is heated, a little-known salt is formed. This is potassium ferric sulphide.

To prepare it, make a mixture of 4.1 grams of potassium carbonate, 3.4 grams of iron filings and 3.9 grams of flowers of sulphur. Heat the mixture strongly in a crucible closed with a lid. Use a crucible of such a size that it is about half filled by the mixture.

When the mass is red hot, let it cool. Then powder the residue and stir it up with two lots of 50ccs. of boiling water. After filtering, evaporate the filtrate to

(Continued on page 77)

An out-of-doors fan tells you how to ENJOY HIKING THIS YEAR

ARE you taking up hiking this year? It is grand fun, and one of the pleasantest ways of getting out-of-doors and seeing the countryside. It is inexpensive, is health-giving, invigorating, and interesting. 'Tramping in the country is the greatest and healthiest fun that city dwellers can have', said the Duke of Windsor, when as Prince of Wales he addressed a gathering of hikers.

Anyway, you do get value for your money and your exertions. And it makes no special calls upon your leisure time. In any case, you want something pleasant to occupy your time in the sunny hours at week-ends.

No Special Expense

Beginners at this pleasant pastime need not go to any special expense. No special clothes are needed, and no special equipment, save a medium-sized rucksack—and on short walks you can manage without that, taking your few wants in a haversack. But—and this is important—one must have really good strong boots, easy-fitting, non-slopping, and waterproof. See that they have stout soles, lightly studded. And remember—get them well 'broken in' before undertaking long walks. Wear them for short rambles at first, so that your feet get accustomed to them. Keep the leather soft with dubbin or oil.

Fresh from sedentary life at bench or office stool or other occupation of a more or less stand-still nature, and unused to cross-country walking, the beginner should go easy at first, limiting his or her walks to a few miles out and in—short tramps in the evenings and on week-end afternoons and every possible occasion, to become fit and hardened before undertaking a longer tour when the holiday season comes. Whitsuntide is often a good time to try a three or four day trip, and this year the countryside should be lovely and fresh. Granted a spell of nice weather, a few days in the open air will do you a world of good.

As already intimated you require no special outfit. Your usual 'knock-about' clothes (not your 'Sunday-go-to-meeting' rig) will do fine. When you are fully converted to the pastime you can, if you wish, don shorts, hiking shirt and hiking jacket or jerkin, or what not. If you start off with a rucksack, get one of the types with frame, and outside pockets. Webbing straps are preferable to leather ones.

On one-day tramps a rucksack is not necessary, but a small haversack, such as you can obtain from any Army stores, or dealers in hiking and camping outfits, will be found handy to carry your food, map, etc. Never bulge out your coat pockets with parcels of stuff. Carry them on your back or slung over your shoulder.

Sound Advice

If you intend to take up hiking seriously, join a local rambling club. It is also a good idea to become a member of the Ramblers' Association and the Youth Hostels' Association; you get many distinct and valuable advantages and facilities by so doing.

In planning a ramble, whether short or long, do not take on more mileage than you can comfortably cover in the given time on your schedule. Always travel 'at ease'. Whatever you do, be sure and guard against planning a walk which must be accomplished to a set programme that is cut fine. Allow at least a reasonable latitude; be free to choose this way or that if two roads lead to your destination. Have an objective, by all means, but reach it in the happiest way possible by hoping that you will arrive eventually; and even if you change your mind it does not really matter a lot.

Walk at a steady rhythm. Change your socks if needs be—presuming you carry a spare pair, and your toes begin to feel a trifle sore! Take a fair interval for lunch, more to rest than to feed, for meals when actually on the road must not be too heavy.

For the average beginner ten to fifteen miles are enough to start with; even less when your leg muscles have to be limbered and rendered flexible, especially if you do not have much country walking normally.

Points to Remember

Cultivate the country spirit. Country manners mean a lot to rambblers. Show courtesy to all, respect private property, never trespass knowingly. Avoid doing damage to growing crops in fields; always stick to the footpaths. Close all gates and secure them when you have passed through. If with a party and walking along a road do not scatter on the approach of a motor vehicle!

Where crops are growing, walk in single file or no more than two abreast on the path. Do not throw down lighted matches, and never leave any litter when you partake of an *al fresco* meal by the wayside. Another ramblers' rule—respect the country people's Sunday 'and do nothing in the villages likely to be distasteful to them'. And, for goodness sake, if wishing to dispose of paper bags, lunch wrappers, or left-over scraps do not dump such stuff into the first stream you come to, nor any other brook or burn, for folk living further down the valley may have to depend upon the water for domestic use. No stream should be made a dumping ground for empty sardine tins, etc.

There is not much fun tramping alone and it is better for the average beginner to link up with a pal or to join a club.

If you are tramping 'by the map' get the Ordnance Survey productions having a scale of one-inch to one mile, and learn to read it correctly.

Finally, beginners should remember that rambling, or hiking as many call it nowadays, has to be learned if one desires to get the best and the most out of it. There is so very much that goes to make a walking tour really outstanding, for the interests of the countryside are manifold. (347)

HOME CHEMISTRY

(Continued from page 76)

the crystallisation point and allow it to cool overnight.

Shining purple needle-like crystals of potassium ferric sulphide will have formed. Dry these on a porous tile.

Silver ferric sulphide is a closely related salt. You can make this by dissolving potassium ferric sulphide in

water and adding silver nitrate solution, when it is precipitated as a dark brown crystalline powder. Filter it off, wash well and dry it in the oven.

A conjuring trick baffling to a non-chemist friend is that in which iron filings are changed to copper filings—all in a few seconds! Put some iron

filings in a test tube, add a few ccs. of copper sulphate solution, shake well, and then tell your friend to watch what settles to the bottom of the tube. He will be astounded to note that the grey-black iron has vanished and in its place he will see red copper! What actually happens is that the iron filings become plated with a thin deposit of copper. (365)

HOME CONSTRUCTORS! MODELMAKERS! HANDYMEN!

SANDING & POLISHING

- the NEW, Easy, Rapid & Profitable Way!

This set is only a small part of the complete Wolf Cub Home Constructor Outfit. A comprehensive power workshop for drilling, grinding, polishing, sawing, sanding, wood turning, etc.

No. 6 SET
for
Wolf Cub

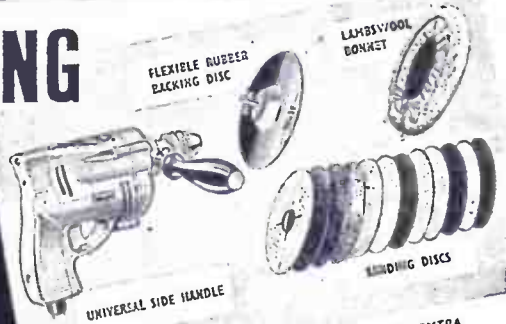

* CONTENTS OF NO. 6 SET AS ABOVE—DRILL EXTRA.
AMAZING ADAPTABILITY!

Build your Cub Drill into a fine Saw Bench—add a few parts and, hey presto! you've a splendid Lathe.

• Write at once for fully illustrated brochure
"Profitable Pleasure."

WOLF ELECTRIC TOOLS LTD · PIONEER WORKS · HANGER LANE · LONDON · W.5
TELEPHONE PERIVALE 5631-4 BRANCHES BIRMINGHAM · MANCHESTER LEEDS BRISTOL GLASGOW

FLEXIMOULD

FOR PLASTER CASTING

WALL PLAQUES, FIGURES, GARDEN ORNAMENTS, BOOK-ENDS, ETC. MADE IN YOUR OWN HOME. THE ALL-FAMILY HOBBY THAT ADDS POUNDS TO YOUR INCOME.

Write for

FLEXIMOULD
ILLUSTRATED LEAFLET to
DOHM LTD. (DEPT. H.)
167 VICTORIA ST., LONDON, S.W.1



YOU CAN BECOME A HANDICRAFTS INSTRUCTOR

EXPERIENCE NOT ESSENTIAL

Men who enjoy making things in wood or metal can turn their hobby into a permanent and interesting career. Short hours, long holidays, and security in a job you would really enjoy, can be yours if you become a handicrafts instructor. Let us send details of the easiest and quickest way to get the necessary qualification.

We guarantee "NO PASS—NO FEE"

If you would like to know about our unique method of preparing you for one of these appointments, write today, and we will send you our informative 144 page Handbook—free and without obligation. Mark your letters "Handicrafts Instructor".

BRITISH INSTITUTE OF
ENGINEERING TECHNOLOGY

BIET

595 Shakespeare House
Stratford Place, London, W.1

J. WOTTON (Dept. H.)
140 HOLLINGS ROAD, BRADFORD, YORKS.
ALL TYPES OF MOULDS

3/- each

TOYS, ORNAMENTS, PLAQUES, ETC.

New 1952 Illustrated Catalogue. Send 6d. stamps, refunded on first order over 10/-

KITS for OLD TIME SHIPS

Hobbies range of Ship Models includes Elizabeth Jonas, Cutty Sark, Victory, Mayflower, etc. Complete kits of wood, sail material, guns, pulleys, cord, etc., with full size patterns of parts and planed wood ready to cut out, shape and construct. A fascinating pastime.

Kits for models 7ins. long and upwards.

Ask for free illustrated lists at Hobbies Branches or from Hobbies Limited, Dept. 99, Dereham, Norfolk.



BRANCHES

LONDON

78a New Oxford St., W.C.1

(Phone MUSEum 2975)

87 Old Broad Street, E.C.2

(LONDON Wall 4375)

117 Waltham Road, S.E.17

(RODney 5509)

GLASGOW

326 Argyle Street

(Phone CENTral 3042)

Head Office & Factories—HOBBIES LTD., DEREHAM, NORFOLK

MANCHESTER

10 Piccadilly

(Phone CENTral 1787)

BIRMINGHAM

14 Bull Ring

SHEFFIELD

4 St. Paul's Parade

(Phone 26071)

LEEDS

10 Queen Victoria Street

(Phone 28639)

HULL

10 Paragon Square

SOUTHAMPTON

25 Bernard Street

BRISTOL

30 Narrow Wine Street

(Phone 23744)

Patterns for the Weather-Vane

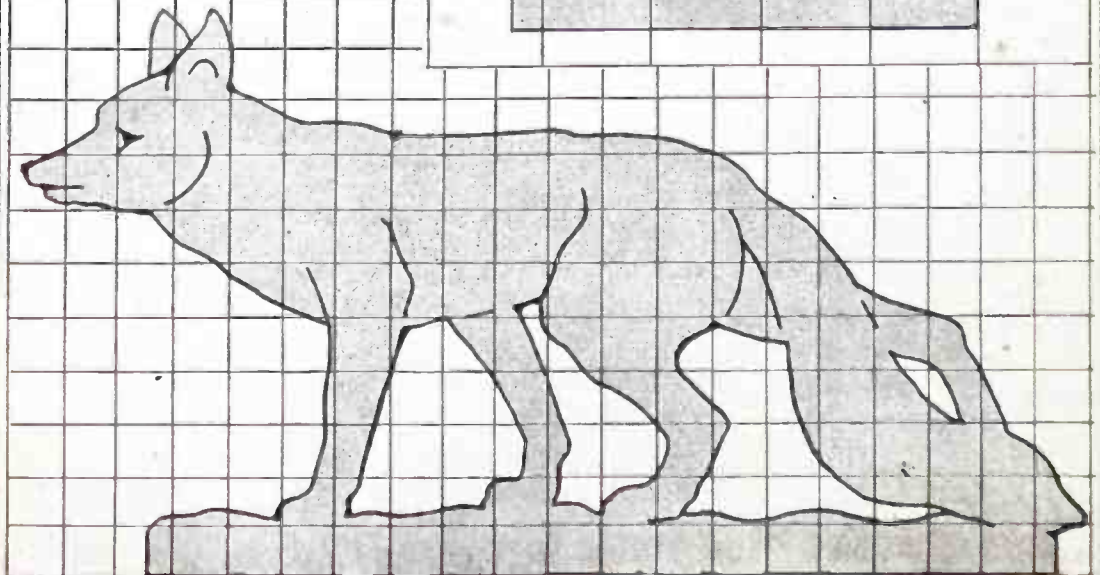
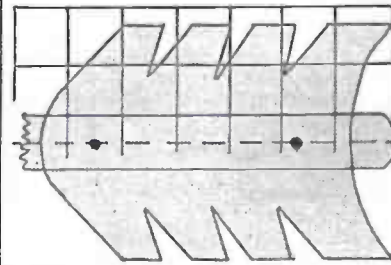
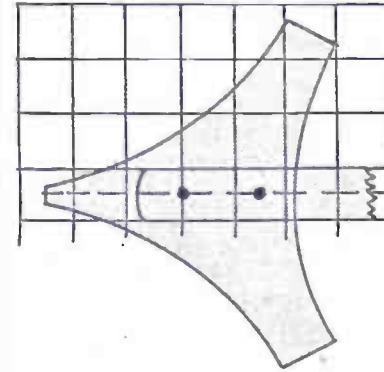

KARLENITE PLASTIC MARBLE

Crystalline! Veined! and sets Rock Hard!

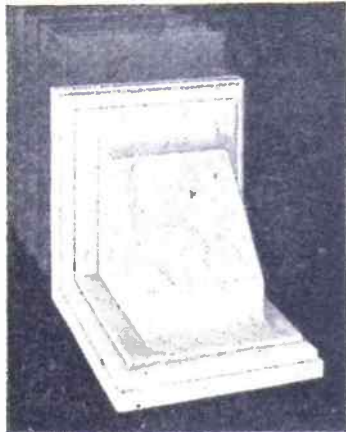

KARLENITE is an entirely new artificial stone plastic for casting Book-ends, Ash Trays, Wall Vases, Statuettes, Plaques, etc.

'Karlenite' sets rock-hard with a scintillating crystalline structure like marble or Alabaster for colour, veining, texture, density and hardness. It is enormously strong, highly resistant to heat and impervious to water. Literally any type of veining can be simulated in any combination of colours, and a wide range of 'Veining Pigments' is available for this purpose.

MAKE YOUR OWN Flexible MOULDS

INFINITE REPETITION CASTING

Perfect Detail!

ELASTOMOLD, PLASTIMOLD and RESIOMOLD are synthetic rubber materials for making permanent flexible moulds. Ideal for repetition casting of Book-ends, Wall Plaques, Statuettes, Ornaments and Models, in quantities of dozens, hundreds or thousands as needed.

The method of use is incredibly simple, and moulds can be prepared from models made of Wood, Metal, Plaster, Stone, Glass, Earthenware, Ivory, etc.

ELASTOMOLD, PLASTIMOLD and RESIOMOLD will faithfully reproduce even the most minute details of ornamentation and surface texture. They are equally suitable for casting articles in Cement, Plaster or 'Karlenite'.

Such moulds are virtually indestructible, but all materials are fully recoverable and may be used over and over again for making new moulds.

You can cast and mould in your own home.
Write to-day enclosing 1/- for full details of this easy, fascinating, and profitable hobby.

KARLENA ART STONE COMPANY LTD

Plastics 2.A. Division

55 DEANSGATE ARCADE . DEANSGATE . MANCHESTER, 3

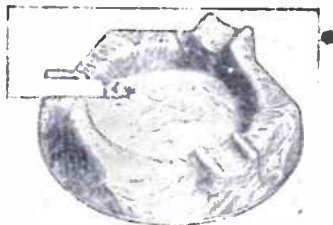

KARLENA accessories for Modern Art Moulding

MENISCOLOID

For completely eliminating air pockets and blowholes in plaster.

'Meniscoid' is a powerful 'wetting agent'. When added in minute quantities to plaster it immediately releases all trapped air and causes the plaster to flow into the crevices of the mould.

Water activated with 'Meniscoid' will readily 'wet' even wax, whereas untreated water contracts into beads when applied to the greasy surface.

'Meniscoid' is essential for accurate plaster casting, especially for fine detail work and particularly when using greasy moulds. It adds practically nothing to production costs.

AMAX 104

Plaster hardener.

This complex chemical salt not only gives harder plaster casts, but intensifies the whiteness to 'snow-blinding' degree. 'Amax 104' is most economical in use.

STONAX

A stone-hard synthetic wax for impregnating plaster casts. Gives a non-scratch, non-smear, high gloss finish.

GLASIC

A most effective glazing and water-proofing agent for cement and natural stone. Renders surfaces completely impervious to oil and water, etc; and also resistant to heat, abrasion and chemical attack. Simple to apply either by brushing or immersion. Also of general use in sealing damp walls and dust-proofing concrete floors, etc.

STIKTITE

Non-inflammable heat resistant cement which will literally stick anything to anything else including rubber, wood, paper, leather, glass and metal.

Being perfectly transparent it produces absolutely invisible joints of incredible strength. It has innumerable uses for model makers and craft workers and is particularly useful for building up separately cast pieces of 'Karlenite'.

'Karlena' offers a pattern making service by highly talented sculptors.

Moulds prepared to customers own specifications.