

SUPPLEMENT TO HOBBIES No. 2902.

# PHOTOGRAPH FRAME

TO TAKE POST-CARD SIZE PHOTOGRAPH.

THE ARROWS INDICATE THE DIRECTION OF GRAIN OF WOOD.

SIZE:—  
9½ins. HIGH.  
9¼ins. WIDE.

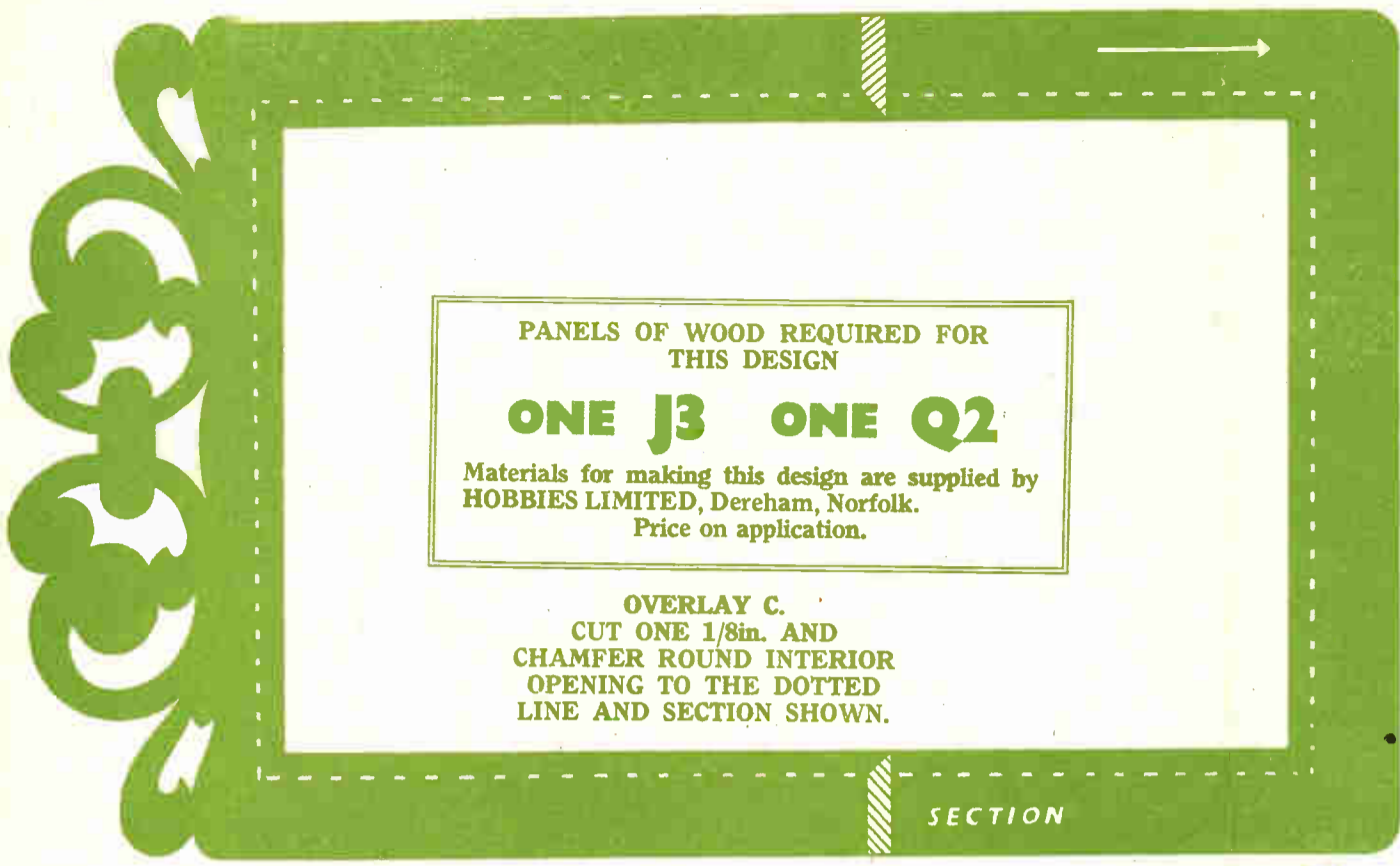

PANELS OF WOOD REQUIRED FOR THIS DESIGN  
**ONE J3 ONE Q2**  
Materials for making this design are supplied by HOBBIES LIMITED, Dereham, Norfolk.  
Price on application.

OVERLAY C.  
CUT ONE 1/8in. AND CHAMFER ROUND INTERIOR OPENING TO THE DOTTED LINE AND SECTION SHOWN.

SECTION

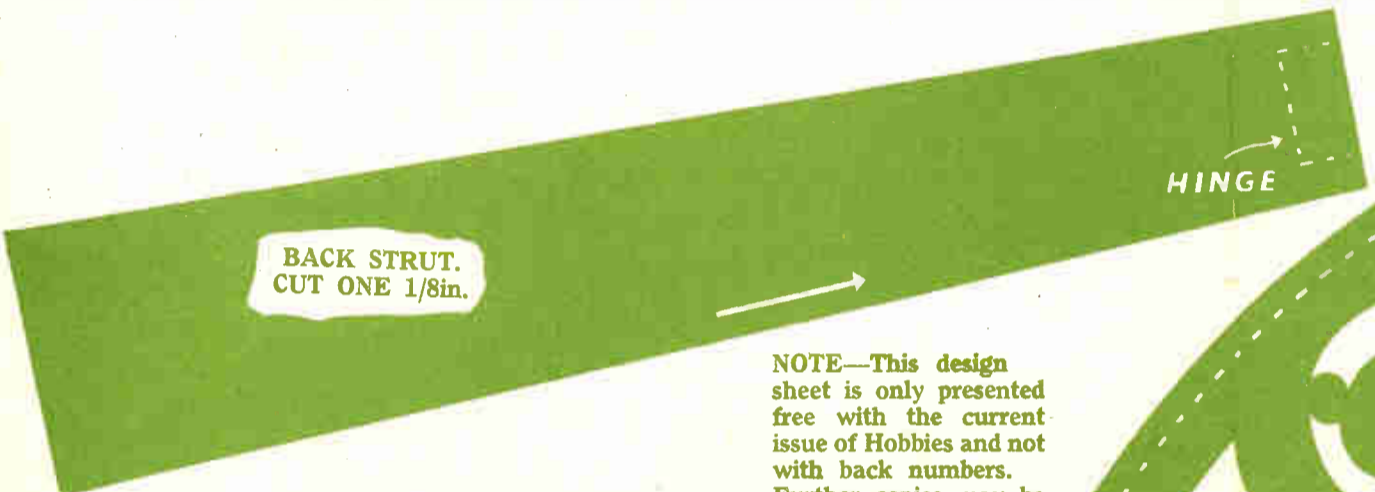

BACK STRUT.  
CUT ONE 1/8in.

HINGE

NOTE—This design sheet is only presented free with the current issue of Hobbies and not with back numbers. Further copies may be obtained.

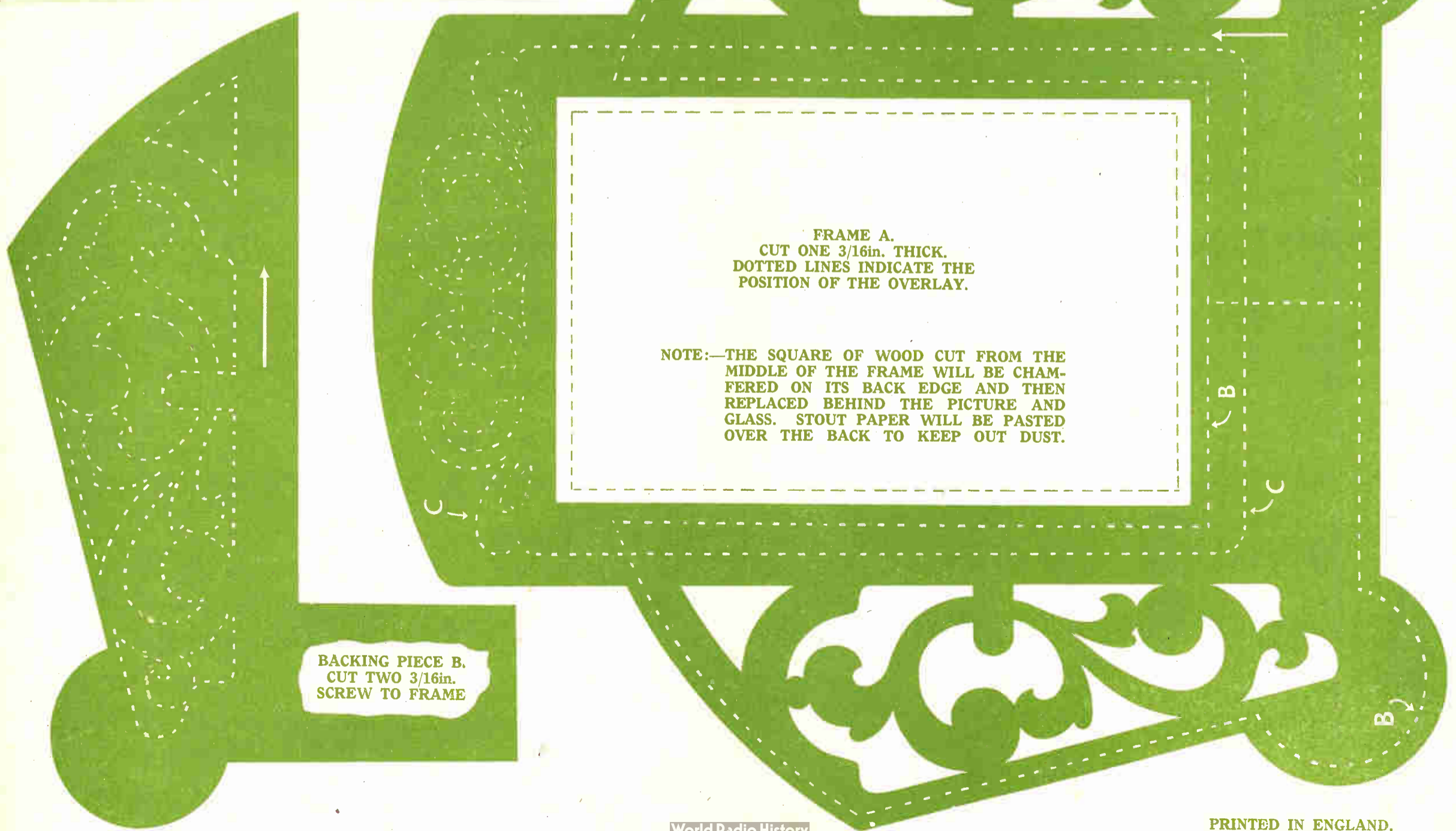

FRAME A.  
CUT ONE 3/16in. THICK.  
DOTTED LINES INDICATE THE POSITION OF THE OVERLAY.

NOTE:—THE SQUARE OF WOOD CUT FROM THE MIDDLE OF THE FRAME WILL BE CHAMFERED ON ITS BACK EDGE AND THEN REPLACED BEHIND THE PICTURE AND GLASS. STOUT PAPER WILL BE PASTED OVER THE BACK TO KEEP OUT DUST.

BACKING PIECE B.  
CUT TWO 3/16in.  
SCREW TO FRAME

## FRETWORK PHOTOGRAPH FRAME

**M**OST of us have somewhere in our collection of photographs a post-card-sized one which would be enhanced by framing, and the fretwork frame illustrated overleaf would do any picture justice. It is not difficult to make, and yet its distinctive design will please even the most fastidious.

Begin by cutting out frame (A). The dotted lines are ignored, of course, as these are included only to indicate the positions of the overlay (C) and the back pieces (B).

When cutting the centre piece from frame (A), start in a corner and cut the piece neatly, as it will later be required to back the actual picture placed in the frame.

Now cut out overlay (C), and chamfer round the interior edge to the dotted line, as shown in the section. This done, the overlay can be glued into position, the actual placing being indicated by the dotted lines on the main frame.

Next, cut the backing pieces (B), and screw to the back of the main frame in

the positions shown by the dotted lines. Use only fine fretwood screws as ordinary screws will almost certainly split the wood. Make sure, too, that the screws used are not so long that they show on the face of the frame.  $\frac{1}{4}$ in. screws will be ample.

Having got thus far, the remainder of the construction is easy. First, cut a piece of glass for the frame, and place it in position. Behind this, place the picture you have chosen for the frame. Now replace the rectangular piece of wood originally cut from the main frame (having first chamfered it as instructed on the design sheet), and finally paste a piece of stout paper over the back to exclude dust.

The back strut, which is cut from  $\frac{1}{4}$ in. wood, is fixed with a suitable hinge—tape would do quite well—and can be fitted in any position to give the desired slope.

For finishing, the frame can be stained and varnished, or merely wax polished if the quality of the wood used is reasonable. Alternatively, good quality enamel paint would not look out of place.



SUPPLEMENT TO HOBBIES  
No. 2912.

**BISCUIT BOX**  
OF EGYPTIAN DESIGN

SIZE:—6½ins. SQUARE  
8ins. HIGH.

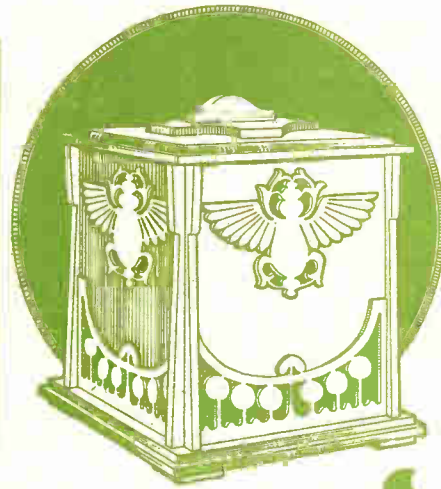

PANELS OF WOOD  
REQUIRED FOR  
THIS DESIGN  
**ONE H2**  
**THREE H4**  
**ONE Q4**  
Materials for making  
this design are supplied  
by HOBBIES  
LIMITED,  
Dereham, Norfolk.  
Price on application.



OVERLAYS.  
CUT TWO OF  
EACH 1/8in.

FEET.  
CUT FOUR  
1/8in.

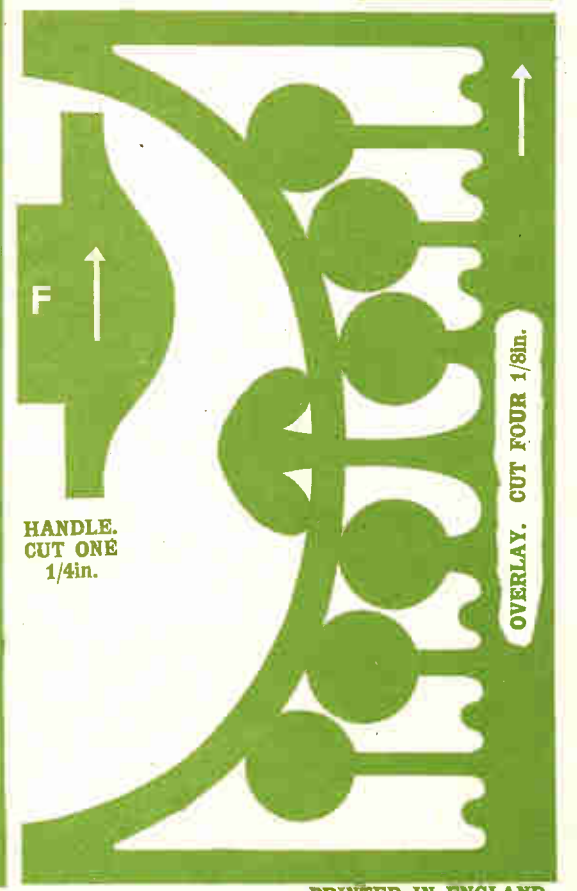

HANDLE.  
CUT ONE  
1/4in.

OVERLAY. CUT FOUR 1/8in.

THE ARROWS INDICATE  
THE DIRECTION OF  
GRAIN OF WOOD.

CORNER BUTTRESS PIECES. CUT TWO OF  
EACH SHOWN 1/4in. THICK.

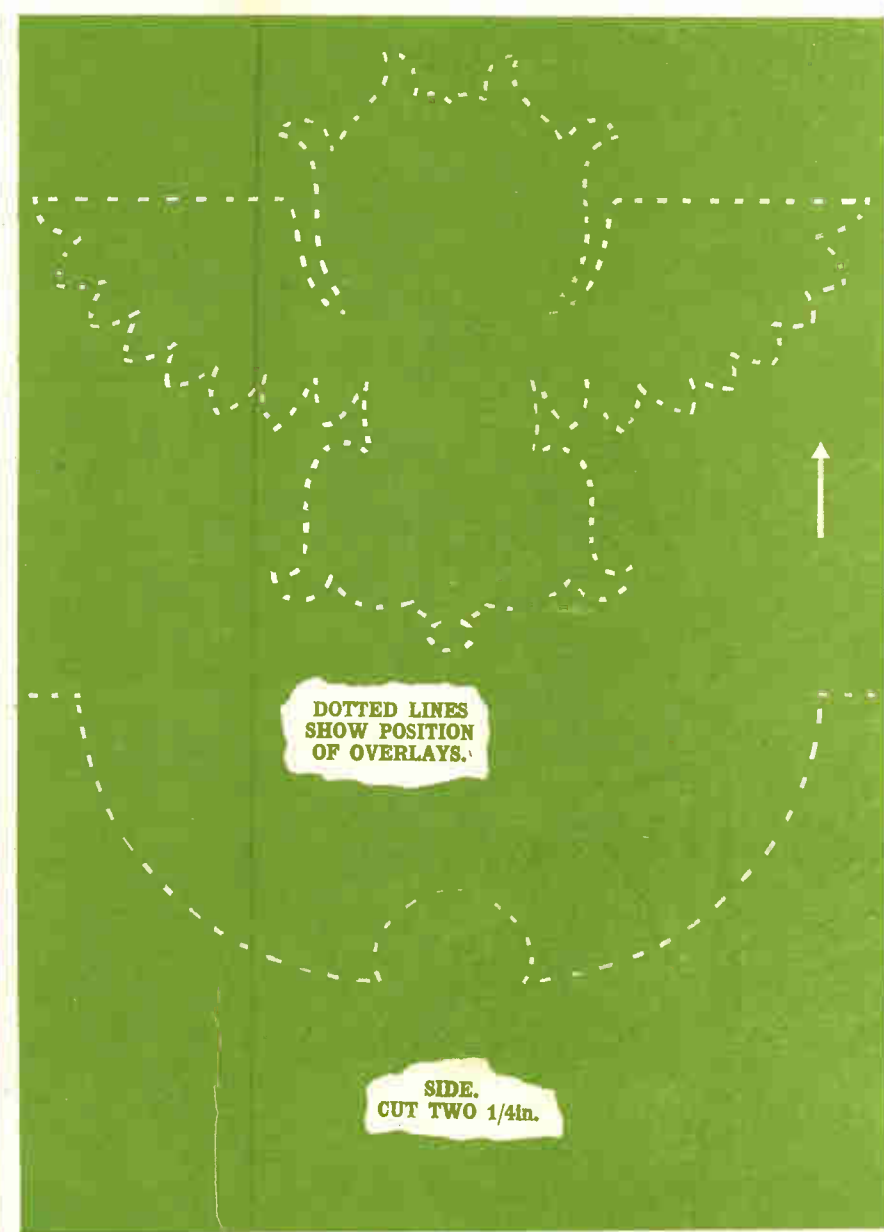
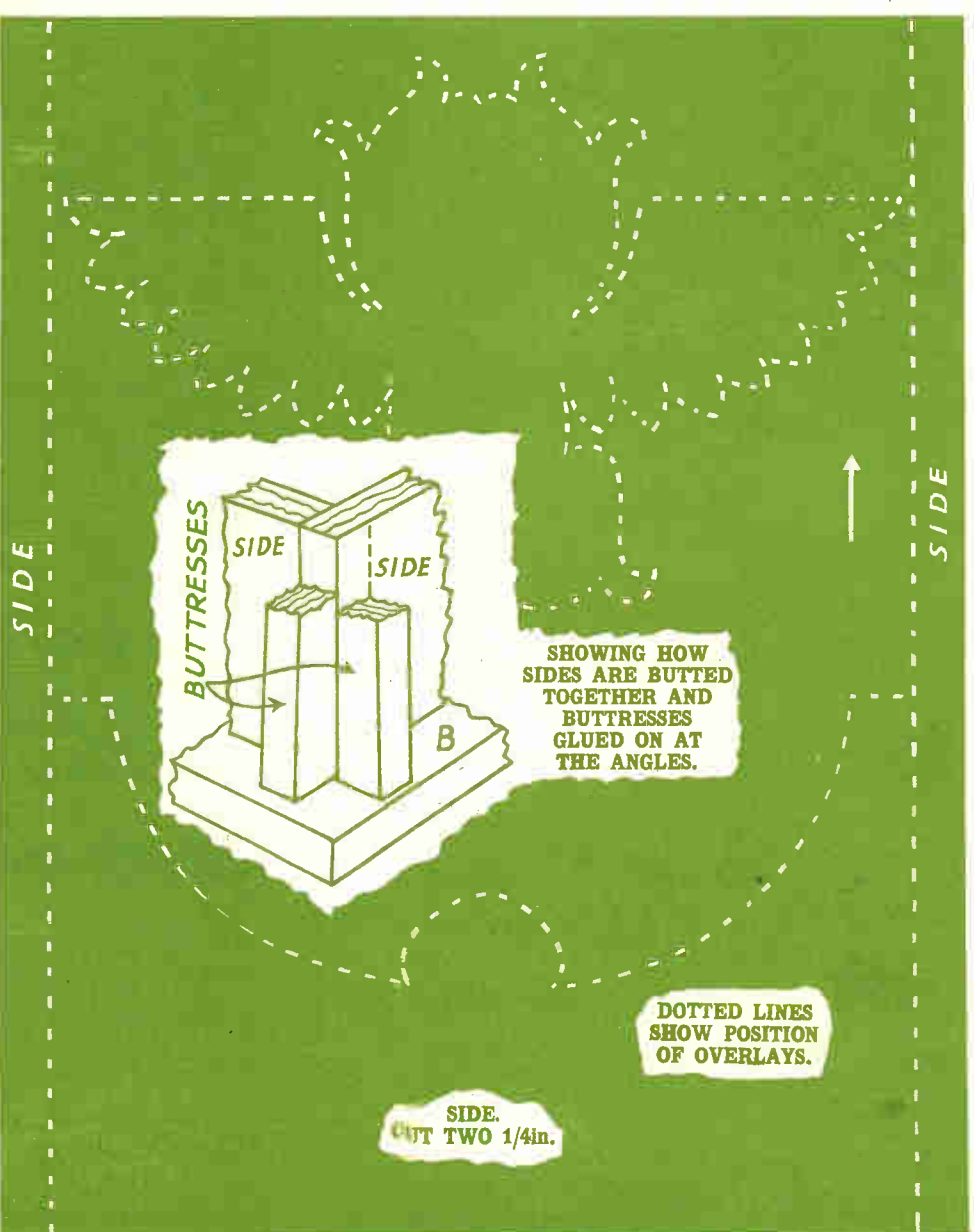
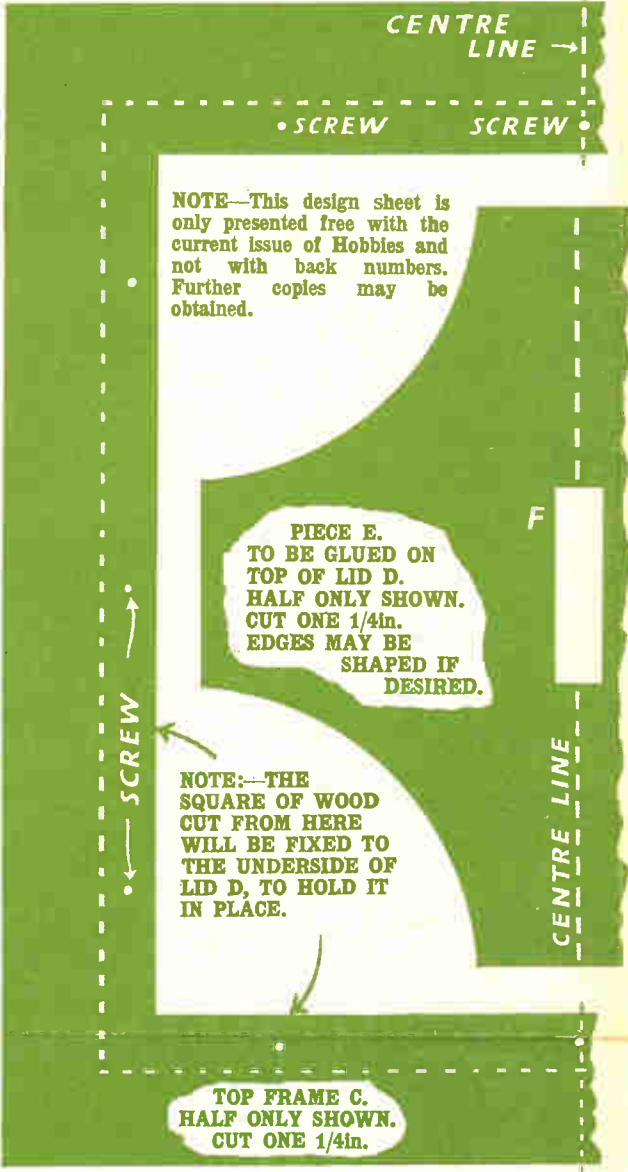
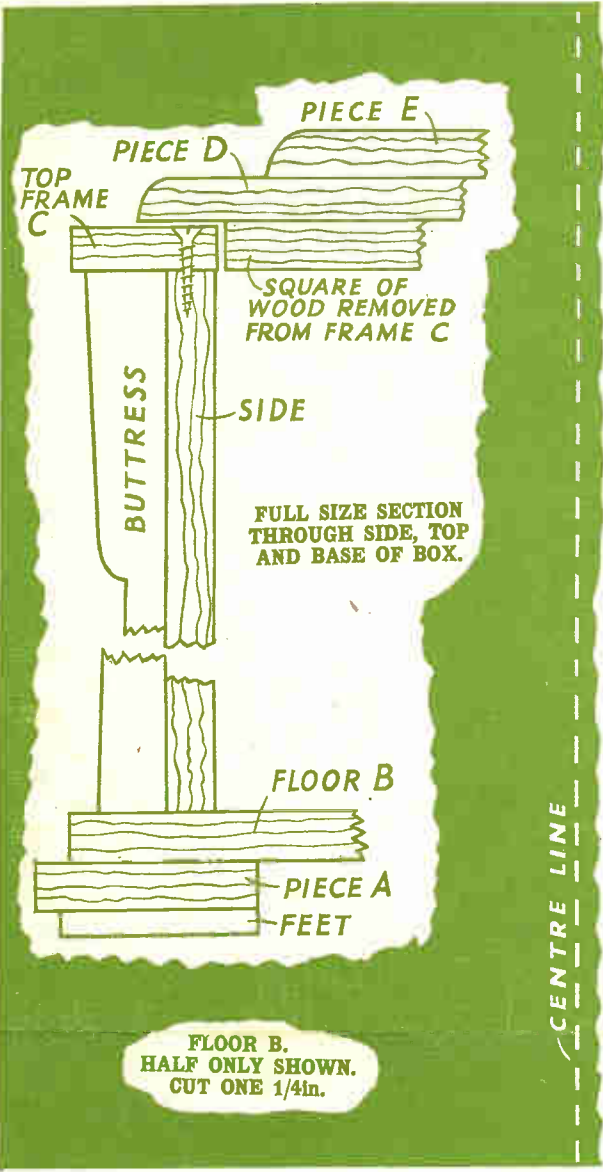

## EGYPTIAN STYLE BISCUIT BOX

**A** BISCUIT box of the type described here should find a welcome in most homes. It is of pleasing Egyptian design, and the fretwork, although not too difficult, will interest the worker who enjoys making the sort of article which requires care. This care will be amply repaid, too, for, properly made, the biscuit barrel should give long service and be always an object of pride.

The first consideration is to transfer the pattern pieces to the panels of wood. The sides, of course, need only be measured and drawn on, though some indication of the positions of the fretted overlays should be given. On the other hand the fretted overlays G and H (four of each) will have to be properly transferred as, in the case of G, only two are given in full; and, in the case of H, only one. The two G's, then, will need to be repeated once to get the four patterns, and the one H will need to be repeated three times to get the same number.

### Beginning Construction

To begin the cutting out and construction it is as well to work from the bottom upwards, excluding, perhaps, the feet, which could as well be glued to the box after it is finished. This is a matter of choice, but in any case there is no reason why they should not be cut out at the beginning. They are cut from  $\frac{1}{4}$  in. wood and four are needed.

Begin the main work by cutting out the four pieces A, only one of which is shown on the design sheet. These are cut from  $\frac{1}{4}$  in. wood, and care should be taken to see that the mitres are properly made so that when glued together they form a perfect square. Next cut the floor B and glue over the pieces A. You will now have what appears to be two squares of wood one on top of the other,

and one slightly smaller than the other. In fact, of course, the lower square is hollow in its centre.

### The Box Itself

The next step is to build up the box itself, and this is done by cutting out the four sides, two of which will be seen to be slightly wider than the others. This is so that when they have all been butted together as shown in the detail on the design sheet, the resulting box will be  $\frac{5}{16}$  in. square. This box can now be glued to the floor, making sure that it is in the centre, and pins can also be used, if desired, to give the article added strength. These pins will, of course, come through piece A as well as the floor, and care should be taken to see that they are driven cleanly up through the centre of the side panels. The corner buttress pieces come next. Four are shown on the design sheet and two of each of these must be cut. They are then glued to the sides of the box in the positions shown in the detail on the diagram, and serve not only to enhance the design, but also to hide the corner joints.

Now turn your attention to the top frame C, half of which is shown on the design sheet. Take extra care when cutting out the square from its centre, as this will later be used as the underside of the lid to centre this latter properly when it is placed on the box. It will be necessary to drill your hole and start the sawcut in one of the corners of the square to be removed, and not some distance from the line, as is usually the procedure.

When the piece has been cleaned up, glue it to the top of the box and buttresses, and also secure it with small fretscrews in the positions shown on the patterns.

Unless you have already done so, it

might now be an opportune time to glue in place the four feet, and this will then complete the making of the box itself, except for the fretted overlays which can be added later.

### Making the Lid

Now to make the lid. This consists of the piece D which is  $\frac{5}{16}$  in. square, the piece E and the square which came from the centre of the top frame. Pieces D and E look well if chamfered to the section shown in the diagram overleaf. The square of wood from the top frame is glued under piece D, and piece E is then glued on top of both, making sure that it is in the centre. To complete the lid the handle (F) is glued into the mortise in the piece E.

Now we come to the fretted overlays which will complete the box. They will also make or mar its appearance, so take care when cutting them out. Better to spend an extra half-hour over them and get a worth-while result, than to hurry them and spoil the whole box. When they have been cut and cleaned up, they are glued to the sides of the box in the positions shown by the dotted lines on the patterns.

### Finish

The biscuit box is now made and all that remains is to give it a finish. If good quality wood has been used, beeswax and polish may be sufficient to give the desired effect, but some workers may prefer to stain and polish the article. In this case it might be effective to stain the overlays a different colour from the box itself. If the box is stained medium oak, for instance, the overlays might well be stained light oak, or vice versa. Generally speaking, unless the box has been designed to fit in with a particular colour scheme, enamels are not advised.



NOTE—This design sheet is only presented free with the current issue of Hobbies and not with back numbers. Further copies may be obtained.

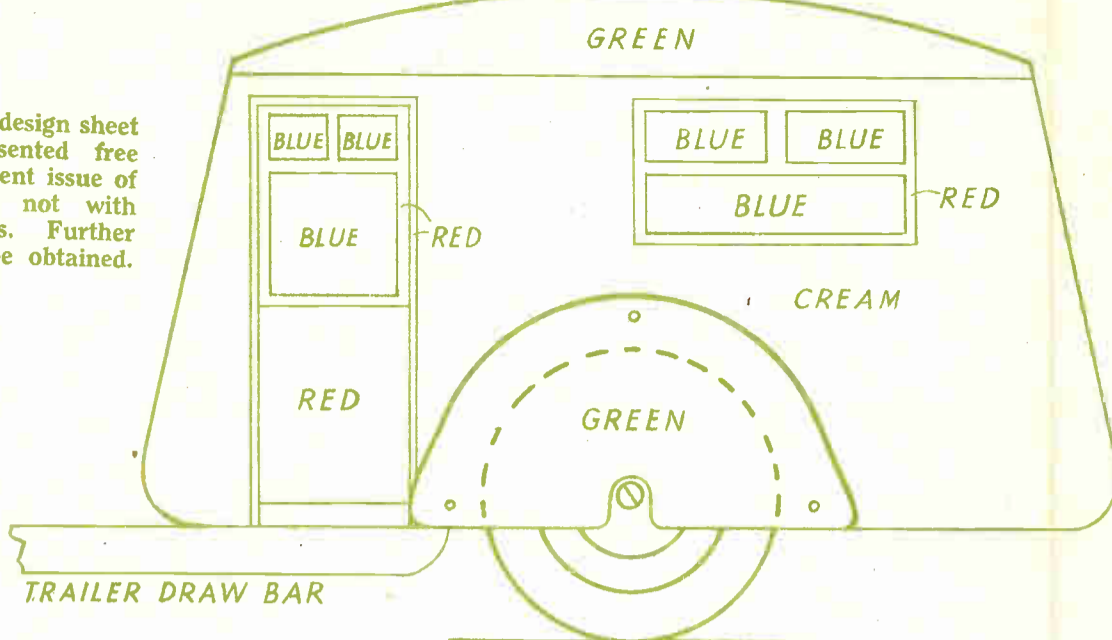

THE ARROWS INDICATE THE DIRECTION OF GRAIN OF WOOD.

SUPPLEMENT TO HOBBIES No. 2900.

**-PULL-ALONG-  
-MOTOR CAR-  
AND TRAILER CARAVAN**

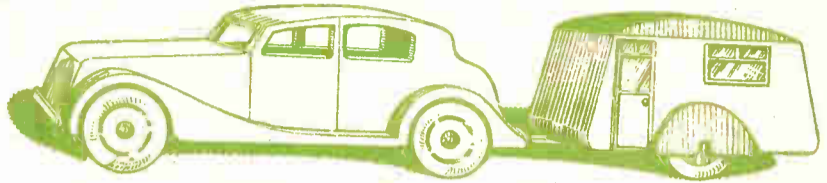

WHEELS TO BE 1 1/2 ins. DIA. AND 1/2 in. THICK.

—SIZE—  
LENGTH OF CAR 8 3/4 ins. HEIGHT 3 ins.  
LENGTH OF CARAVAN 5 1/2 ins. HEIGHT 3 3/8 ins.  
COMBINED LENGTH 14 1/2 ins.

PANELS OF WOOD REQUIRED FOR THIS DESIGN

**ONE H4, ONE ND8  
FIVE GD6**

Materials for making this design are supplied by HOBBIES LIMITED, Dereham, Norfolk. Price on application.

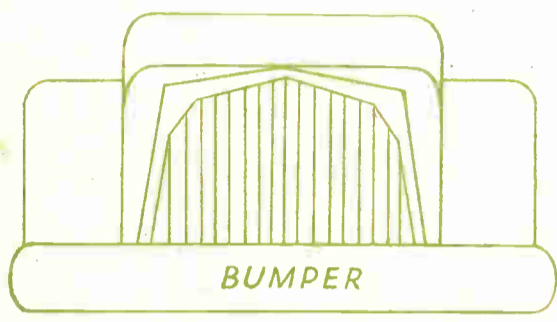

SHOWING HOW THE FRONT OF THE RADIATOR SHOULD BE PAINTED UP.

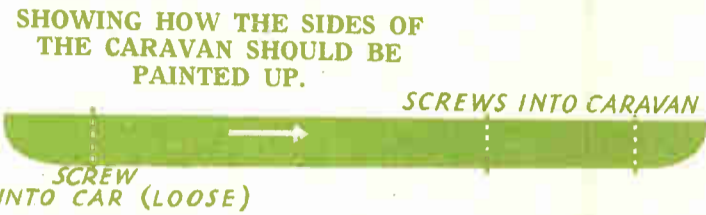

INTERIOR BODY SECTIONS OF CAR. CUT THREE 3/8 in. AND GLUE TOGETHER. SEE NOTE REGARDING THE PLACING OF TWO OUTLINES ON ONE OF THE PANELS OF 3/8 in. WOOD.

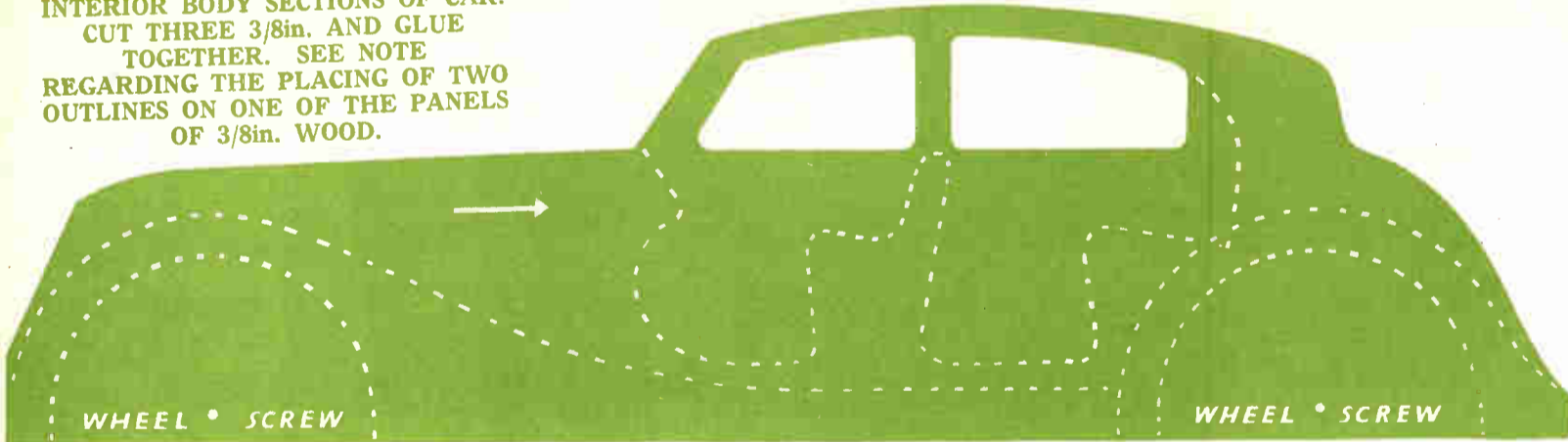

OUTER SIDE OF CAR. CUT ONE 1/4 in. DOTTED LINES SHOW POSITION OF MUDGUARDS AND INTERIOR BODY LAYERS.

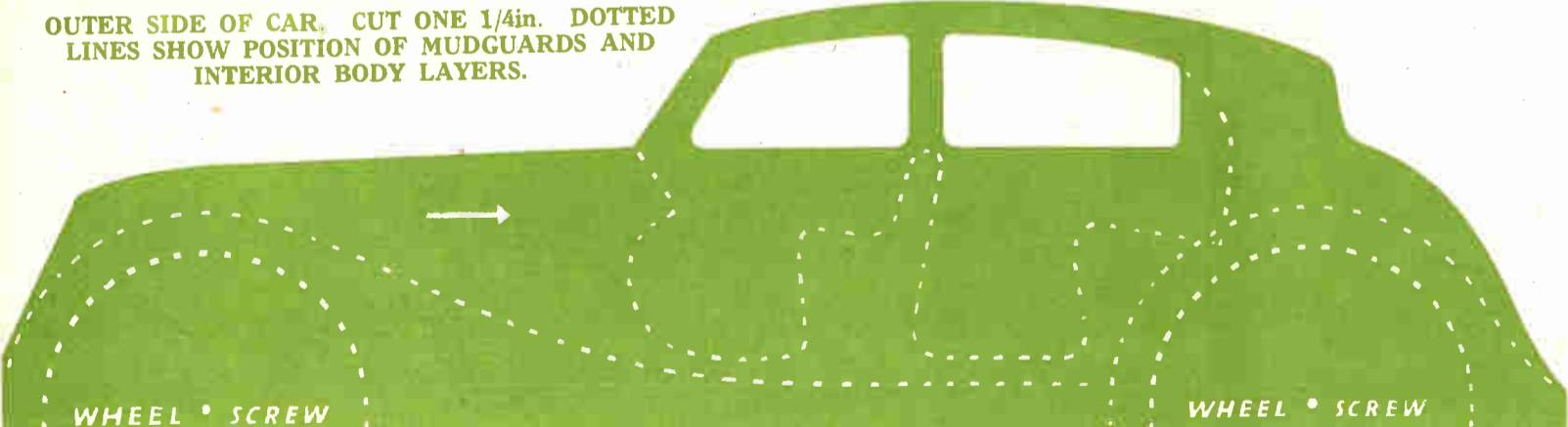

OUTER SIDE OF CAR. CUT ONE 1/4 in. DOTTED LINES SHOW POSITION OF MUDGUARDS AND INTERIOR BODY LAYERS.

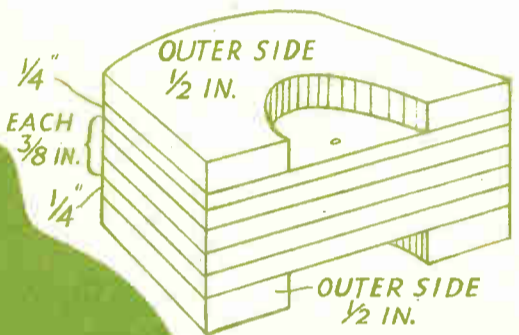
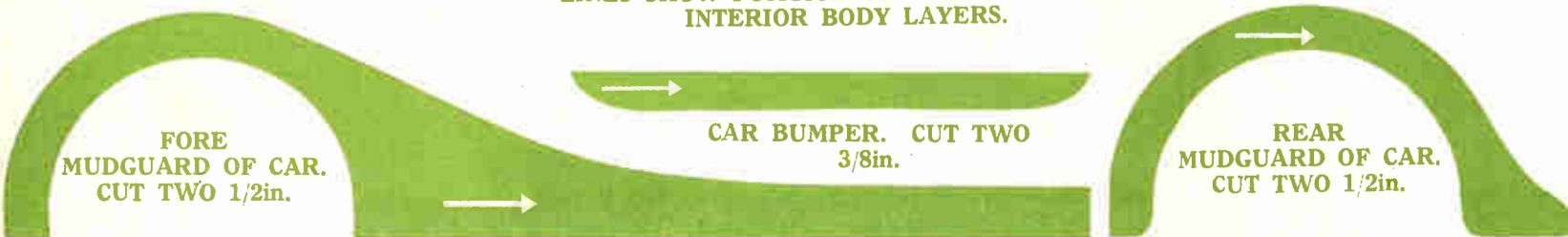

SHOWING HOW PIECES ARE GLUED TOGETHER.

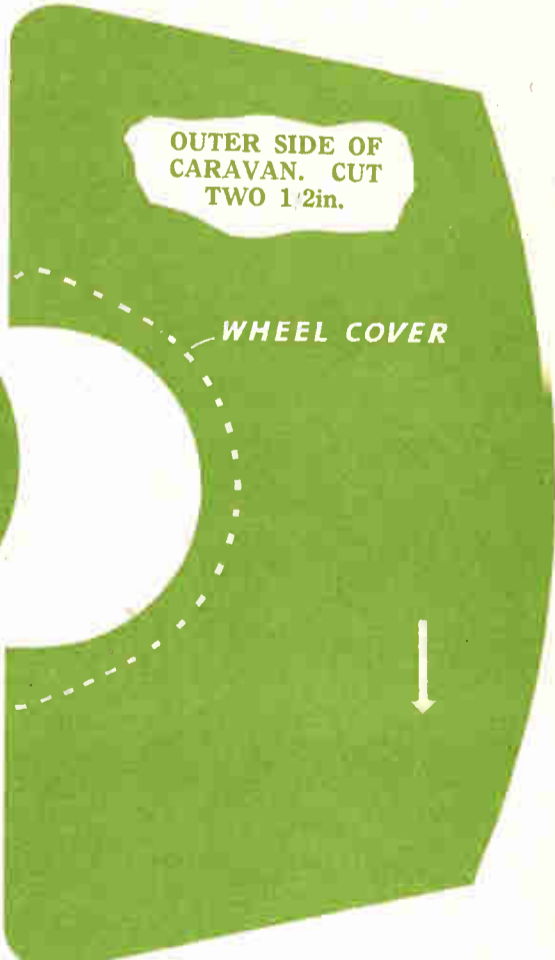
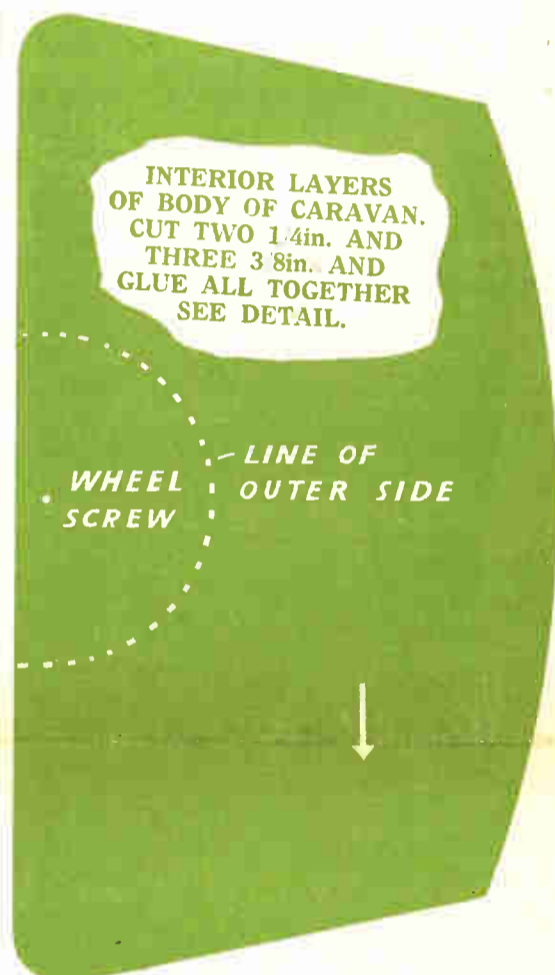

CARAVAN WHEEL COVERS. CUT FROM 1/4 in. WOOD.

# MOTOR CAR AND TRAILER CARAVAN

ANY child would be thrilled to own the motor car and trailer caravan described here. The total length of the two models is 14½ ins., and they are substantial enough to withstand any amount of rough handling, yet, being made on the block system—and without intricate cutting—they are simple enough to construct.

Begin with the car. First mark out the three interior sections on to the wood, making sure to get two of them on one panel as shown in the inset overleaf. This is important, and unless you follow the instructions, you will have insufficient wood to finish the job.

Glue and clamp the interior sections together and place aside to dry.

Now cut the two side pieces and the front and rear mudguards. Glue the sides to the interior section already made, and the mudguards to the sides. When thoroughly dry, clean up with files and glasspaper until the whole assembly is properly shaped and smooth.

Cutting and fitting the front and rear bumpers, and fitting four 1½ in. diameter wheels completes the construction of the car.

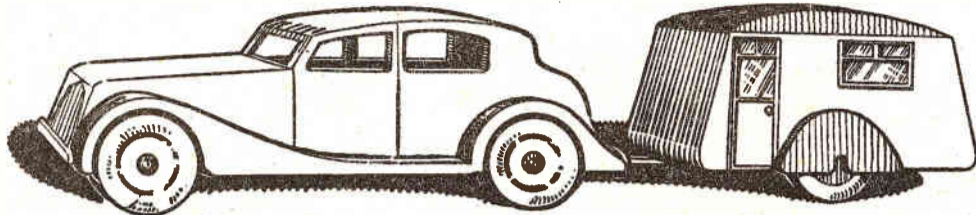

## The Caravan

The caravan is made in much the same way as the car. The interior layers consist of three ¾ in. pieces and two ½ in. pieces, and these should be cut and glued as with the car.

Next, cut the sides and glue them on to the interior of the caravan, keeping the whole clamped together until the glue has set. The caravan is completed by cutting and fixing the two wheel covers, and fixing two 1½ in. diameter wheels. The wheel covers should be pinned as well as glued, the pins representing the retaining bolts on a real caravan.

It now remains to fix the drawbar. This part is screwed firmly to the caravan, as shown, two screws being used, but only one screw is used for fixing the bar to the car, and this is driven in loosely. Thus, the drawbar is a fixture so far as the caravan is con-

cerned, but swivels correctly on the car when the latter is pulled round corners.

## Painting

A suggested scheme for painting the caravan is given overleaf, and you cannot do better than follow it. Do not paint the car the same colours, however, or you will spoil the effect. Cars are very seldom cream and green, and, in any case, a contrasting colour would be better.

A good black might do, but we would suggest something brighter—maroon, blue or red.

Whatever colours you choose, make sure to use good quality enamel paints—and do not be afraid to give more than one coat.

For those who wish, added detail can be given to the car by fitting a celluloid windscreen and windows, and painting in the outlines of the doors, etc.



SUPPLEMENT TO HOBBIES No. 2930

# TEA CADDY WITH AUTOMATIC DELIVERY

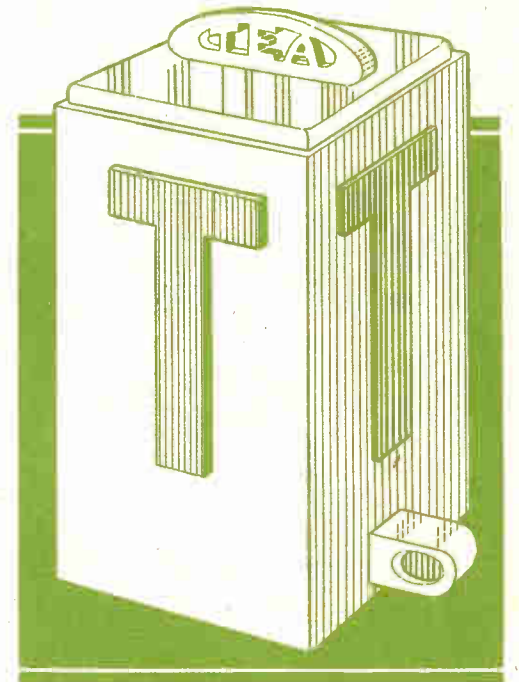

SIZE—  
3 3/8 ins.  
SQUARE  
6 1/2 ins.  
HIGH.

PIECE E. CUT FOUR 1/4 in.

THE ARROWS INDICATE DIRECTION OF GRAIN OF WOOD.

NOTE—This design sheet is only presented free with the current issue of Hobbies and not with back numbers. Further copies may be obtained.

PANELS OF WOOD REQUIRED FOR THIS DESIGN  
**ONE H4, ONE Q4, ONE Q2**  
Materials for making this design are supplied by HOBBIES LIMITED, Dereham, Norfolk.  
Price on application.

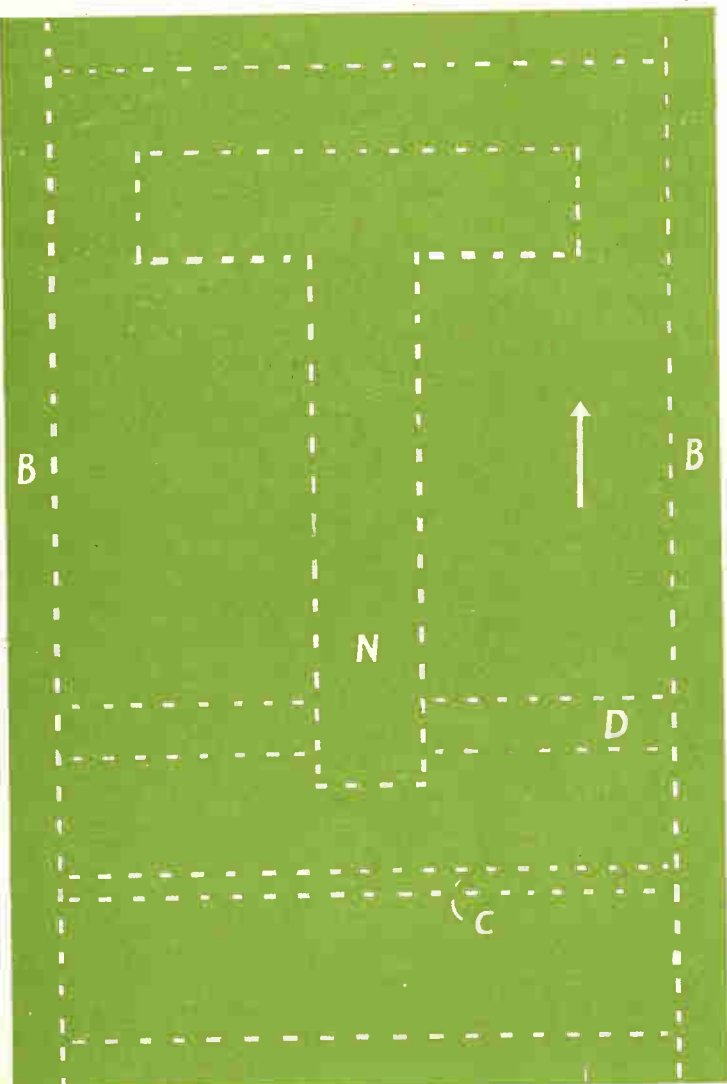

SIDE A. CUT TWO 1/4 in.

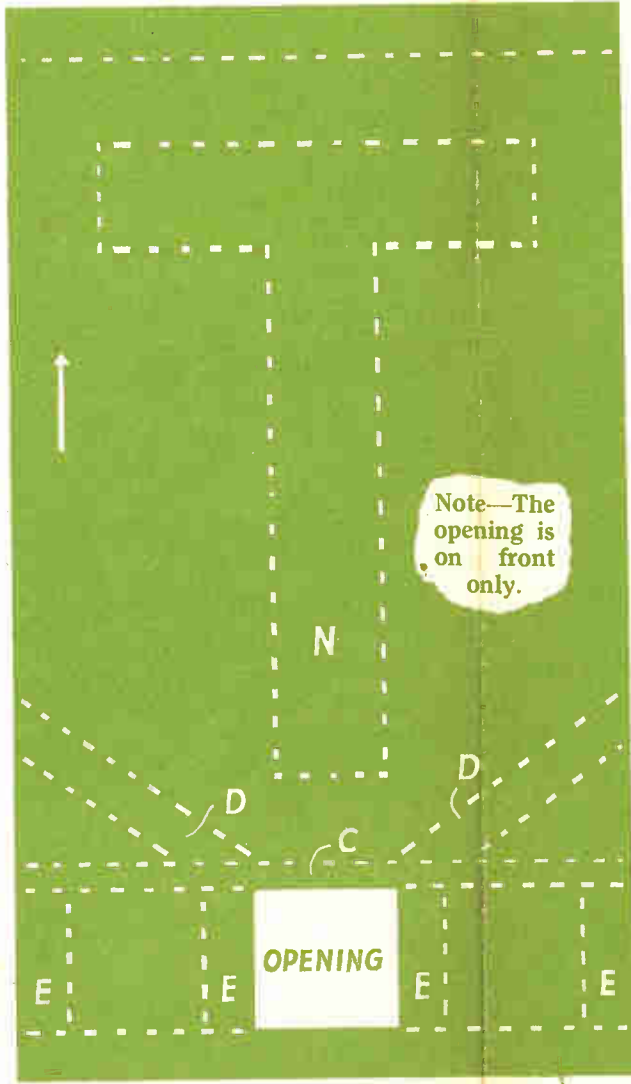

BACK AND FRONT B. CUT TWO 1/4 in.

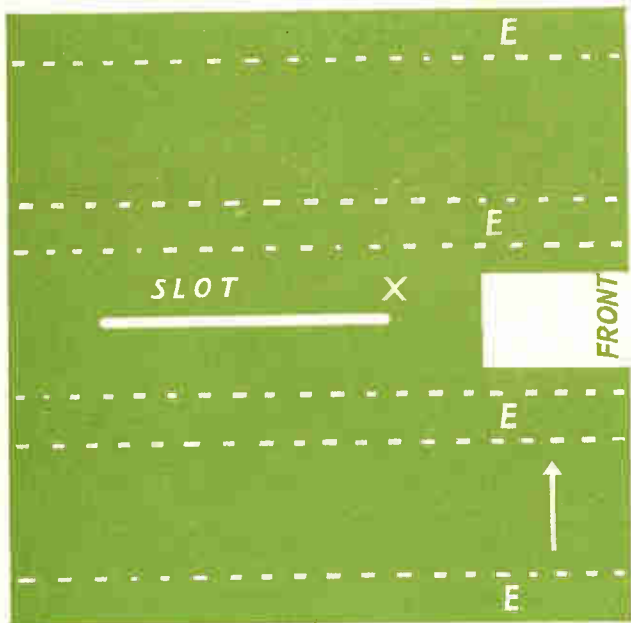

FLOOR C. CUT ONE 1/8 in.

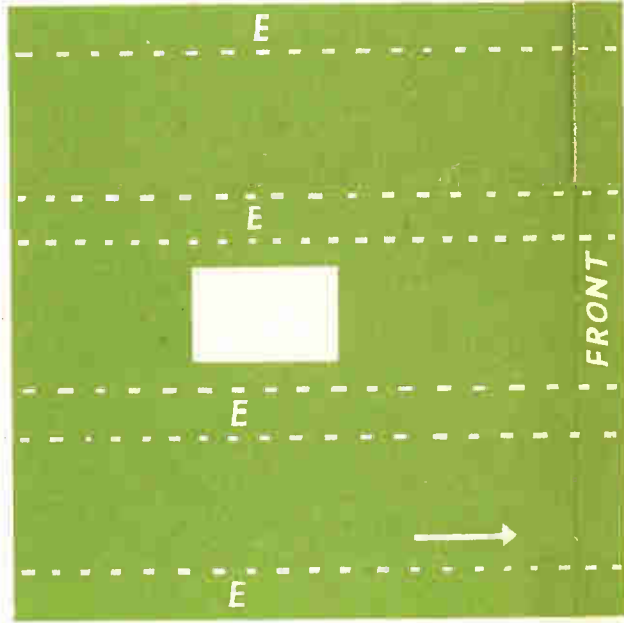

FLOOR J. CUT ONE 1/4 in.

Note that piece J must be glued in place and held in position while the glue is drying.

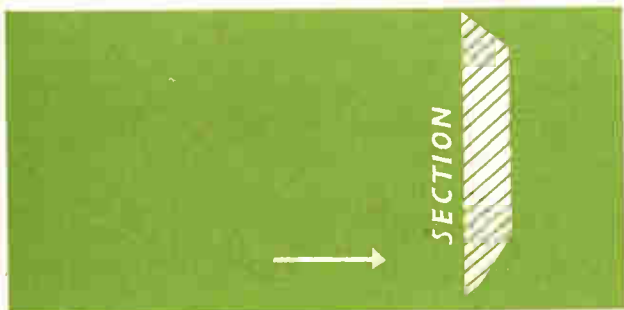
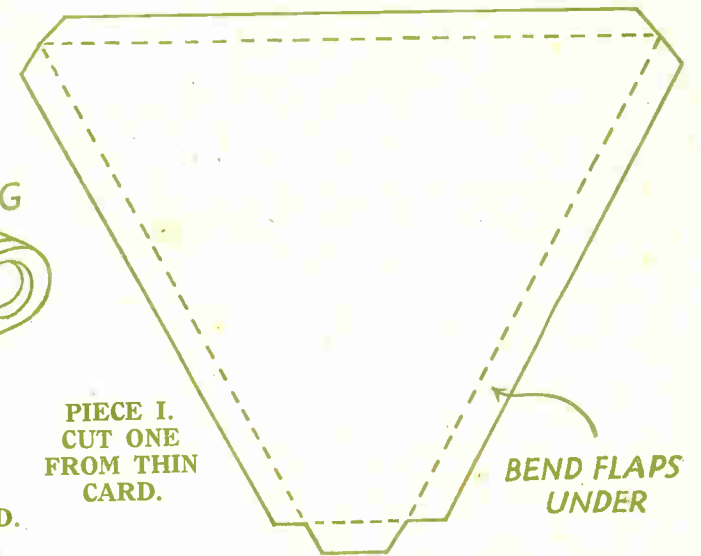
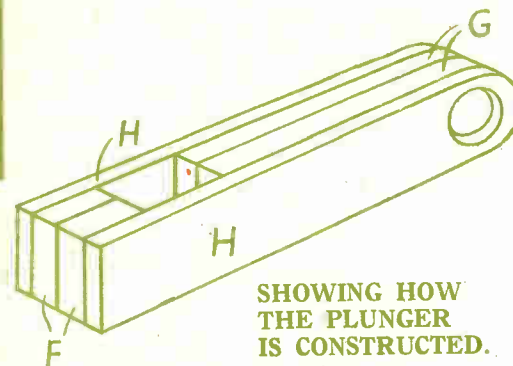

PIECES D. CUT TWO 1/4 in. AND SHAPE TO SECTION.



PIECES F AND G. CUT TWO OF EACH 1/4 in.

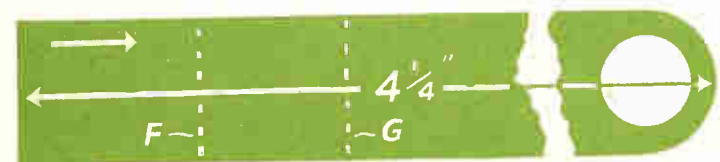

PIECE H. CUT TWO 1/8 in. EXTEND TO 4 1/4 ins.



PIECE M. CUT ONE 1/4 in.

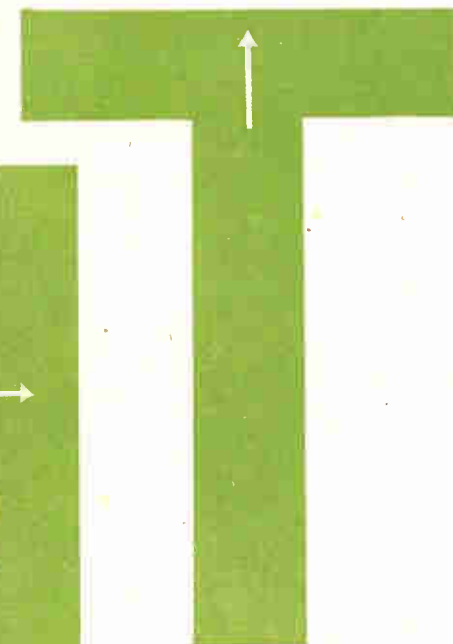
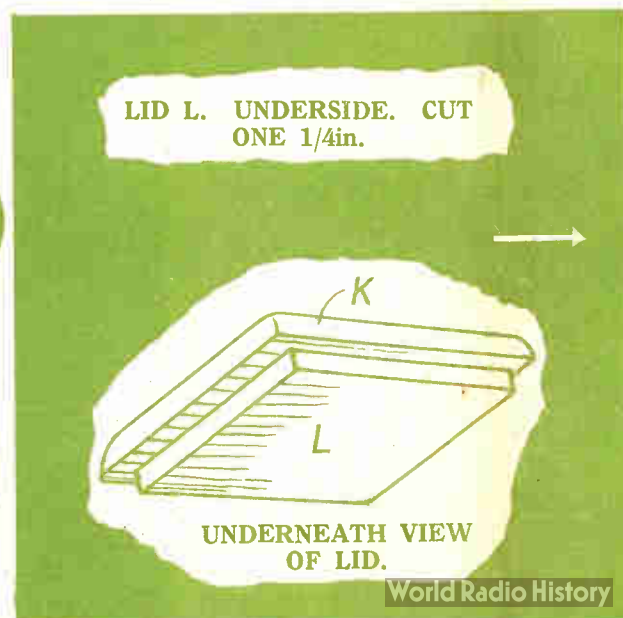

OVERLAY N. CUT 4, 1/8 in.







DECEMBER

This design sheet is only presented free with the current issue of Hobbies and not with back numbers. Further copies may be obtained.

SUPPLEMENT TO HOBBIES No. 2928.

PERPETUAL CALENDAR

CARD REQUIRED FOR THE MONTHS, SIX PIECES. CUT TO ABOVE SIZE.

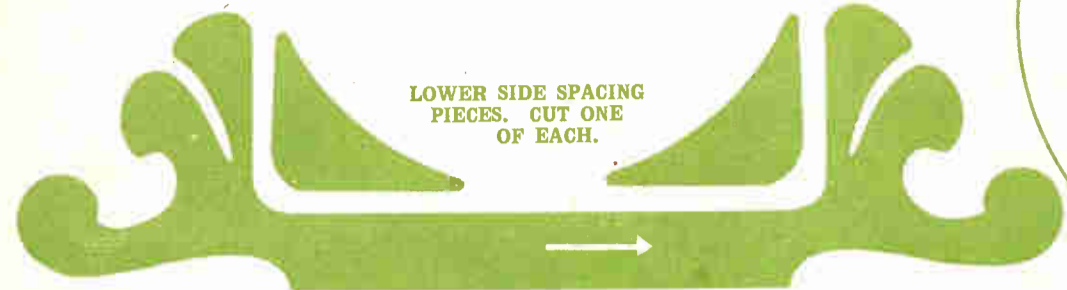

FRONT OVERLAY. (OPTIONAL). CUT ONE.

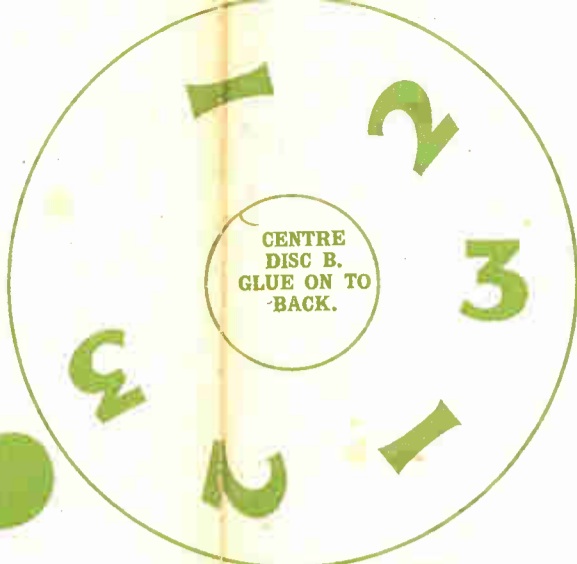
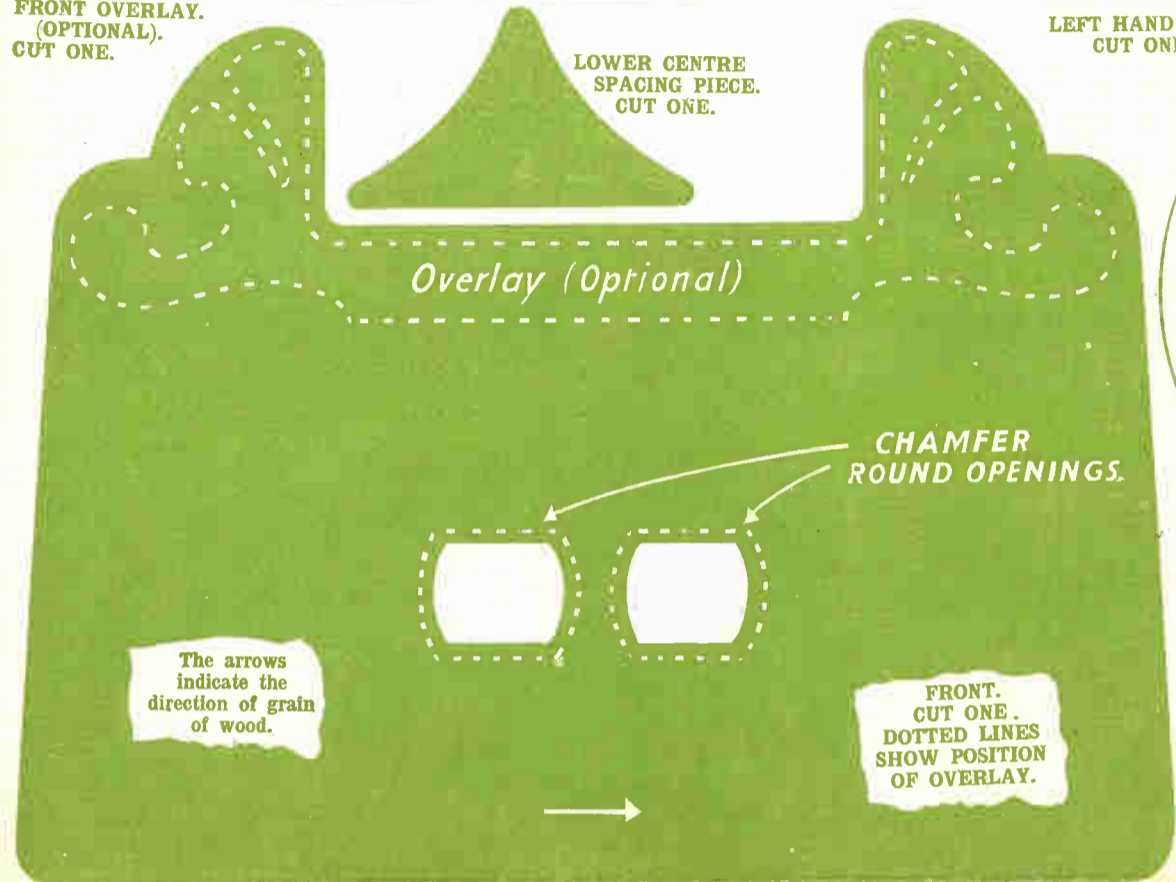

—SIZE— HEIGHT 5 1/2 ins. LENGTH 6 ins.

NOTE SHALLOW VEE GROOVES TO BE FILED ROUND EDGE OF DISCS AS GRIP FOR THE FINGERS.

TO MAKE THE MONTHLY CARDS, USING THESE PATTERNS, SEE THE INSTRUCTIONS ON BACK OF THIS SHEET.

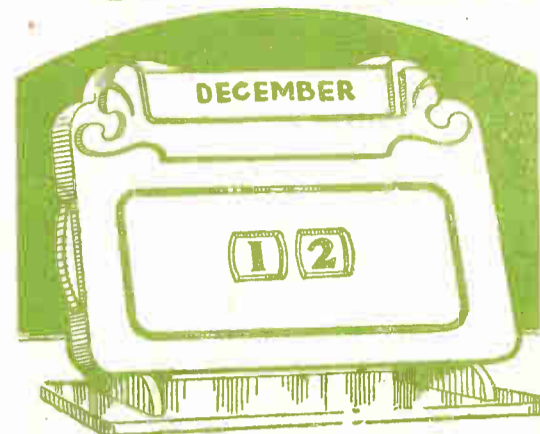

PANELS OF WOOD REQUIRED FOR THIS DESIGN

TWO Q3

Materials for making this design are supplied by HOBBIES LIMITED, Dereham, Norfolk.

Price on application.

JANUARY

FEBRUARY

MARCH

APRIL

MAY

JUNE

JULY

AUGUST

SEPTEMBER

OCTOBER

NOVEMBER

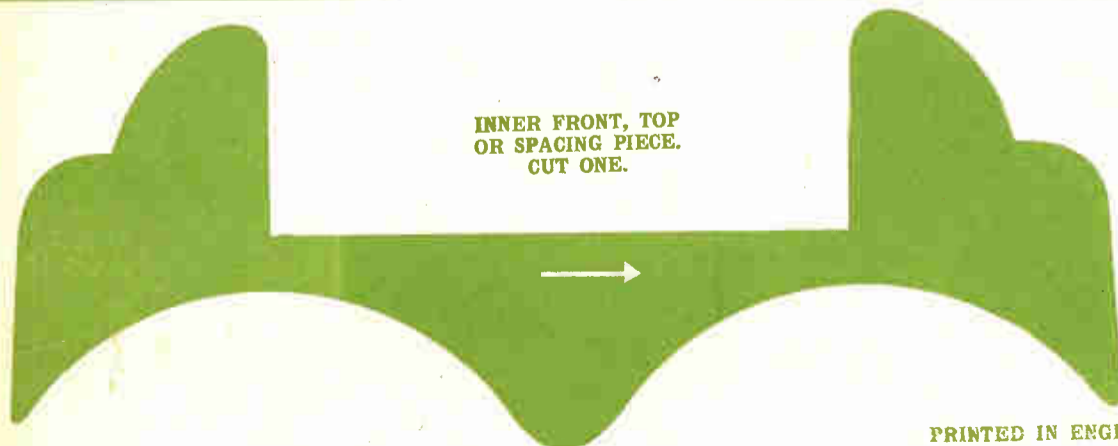
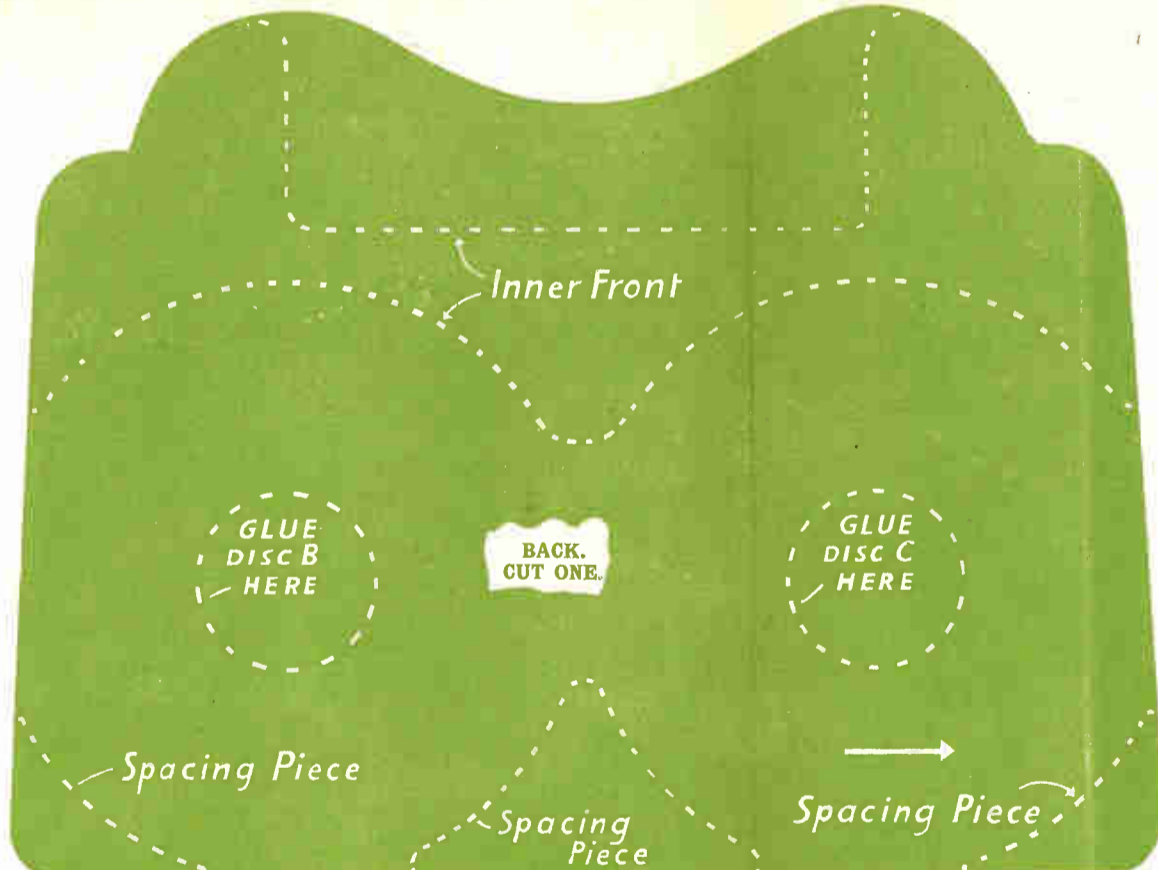

PRINTED IN ENGLAND.



# PULL-ALONG TRACTOR & TRAILER

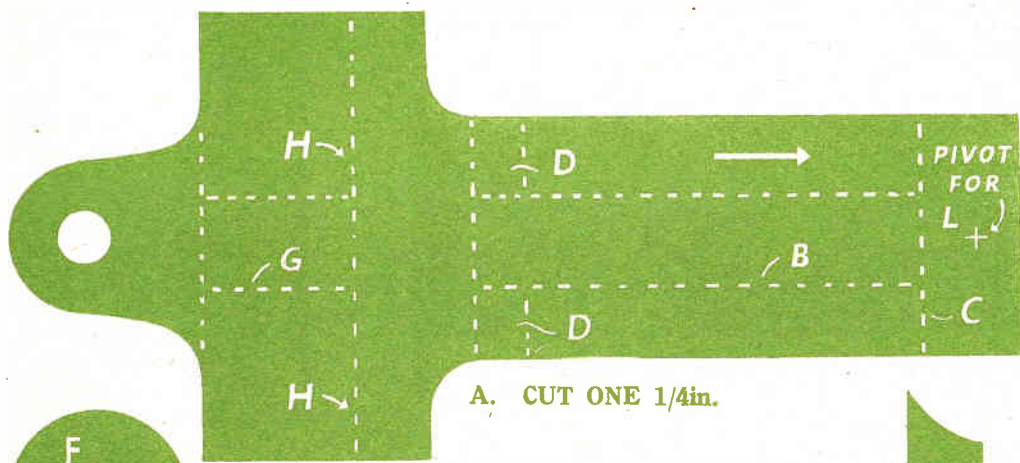
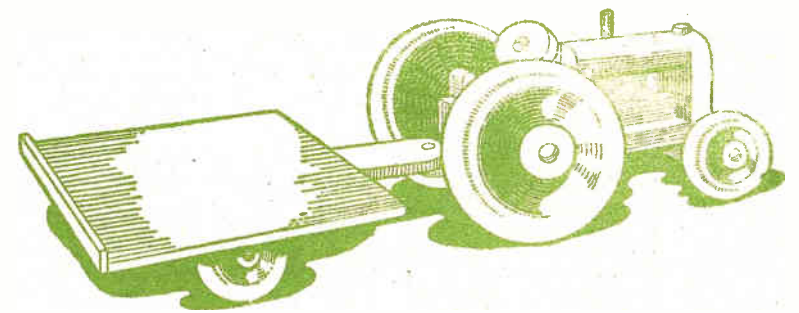

A. CUT ONE 1/4in.

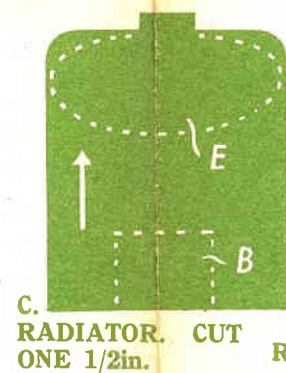

C. RADIATOR. CUT ONE 1/2in.

SHAPING THE RADIATOR CAP.

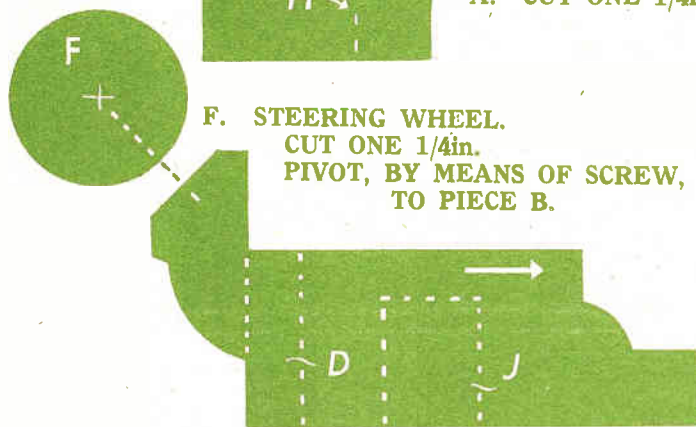
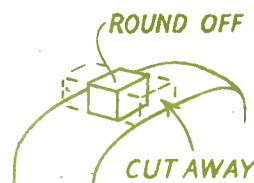

F. STEERING WHEEL. CUT ONE 1/4in. PIVOT, BY MEANS OF SCREW, TO PIECE B.

B. CUT ONE 1/2in.

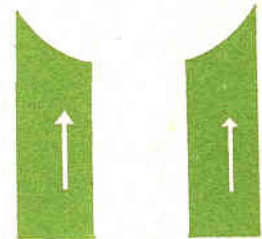

PIECES D. CUT ONE OF EACH 1/4in.

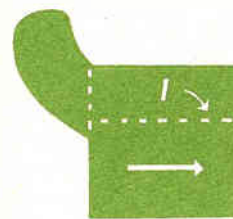

G. CUT ONE 1/2in.



PIECES I. CUT ONE OF EACH 1/4in.

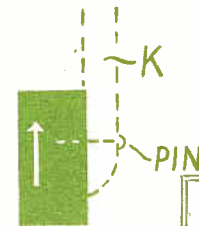

J. CUT ONE 1/2in. GLUE TO B.



E. TANK. CUT ONE 1/2in. SHAPE TO SECTION.

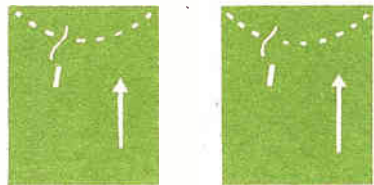

H. CUT ONE OF EACH 1/2in.

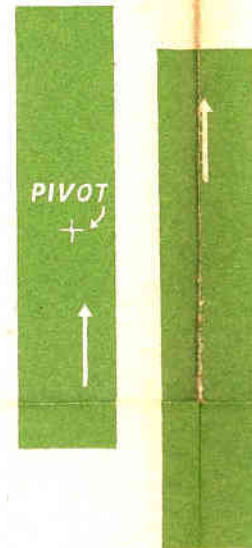

AXLE L. CUT ONE 1/2in. AND PIVOT TO A.

O. AXLE. CUT ONE 1/2in.

PANELS OF WOOD REQUIRED FOR THIS DESIGN  
**ONE Q4 ONE ND8**  
Materials for making this design are supplied by HOBBIES LIMITED, Dereham, Norfolk.  
Price on application.

SIZE:—  
12ins. LONG.  
3 1/4ins. HIGH.

NOTE—This design sheet is only presented free with the current issue of Hobbies and not with back numbers. Further copies may be obtained.

THE ARROWS INDICATE DIRECTION OF GRAIN OF WOOD.

SECTION

K. EXHAUST. CUT ONE FROM 3/16in. ROUND ROD. PIN TO J AND E.

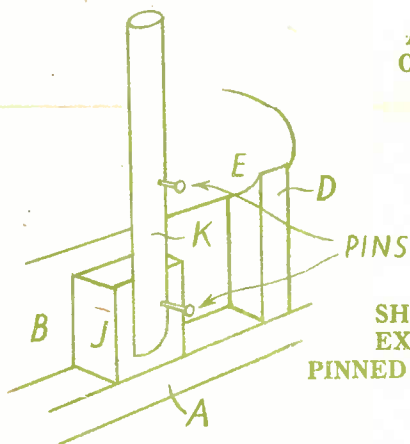

SHOWING HOW EXHAUST K IS PINNED TO J AND E.



Q. CUT ONE FROM 3/16in. ROUND ROD



PIECE R. CUT ONE 1/4in.

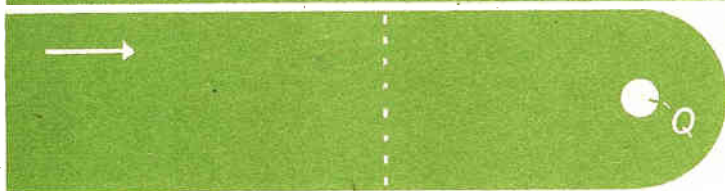

P. TRAILER BAR. CUT ONE 1/4in.

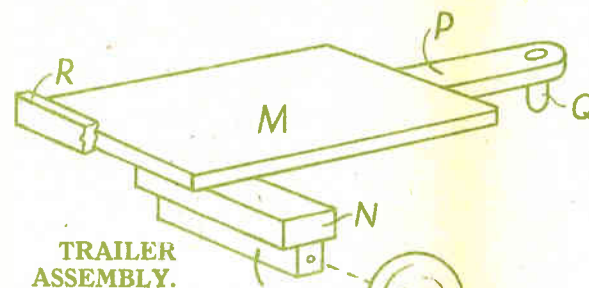

TRAILER ASSEMBLY.

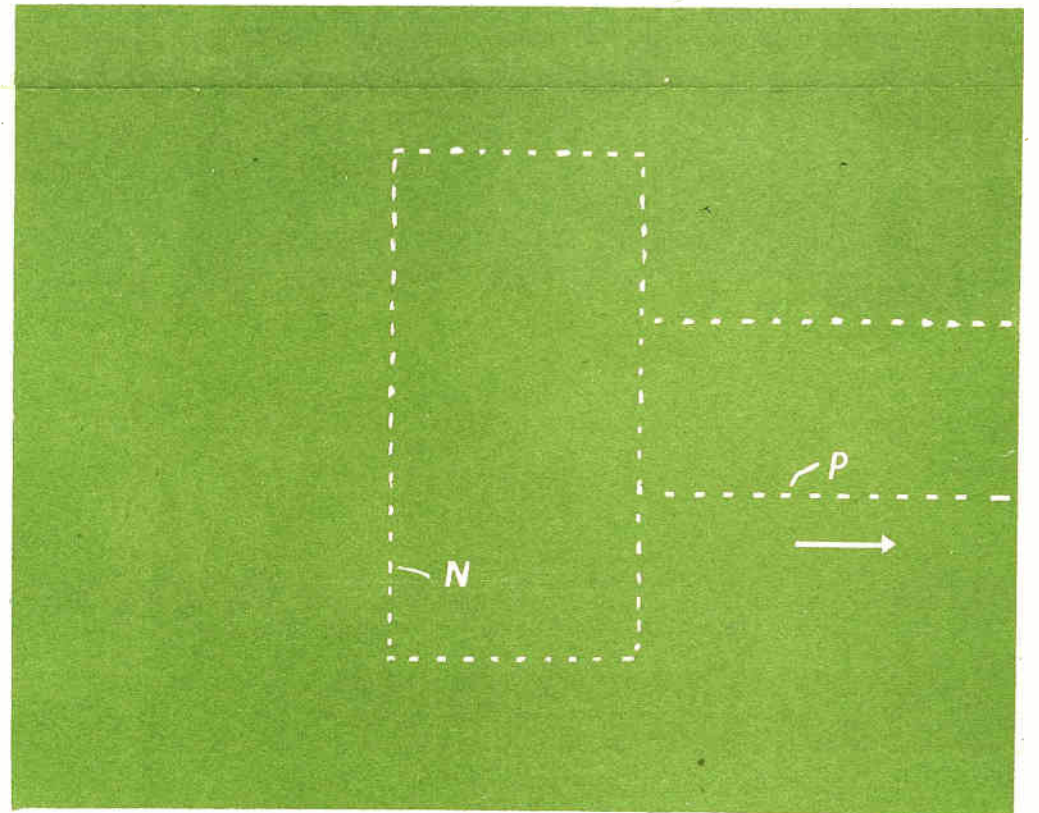

M. TRAILER FLOOR. CUT ONE 1/4in.

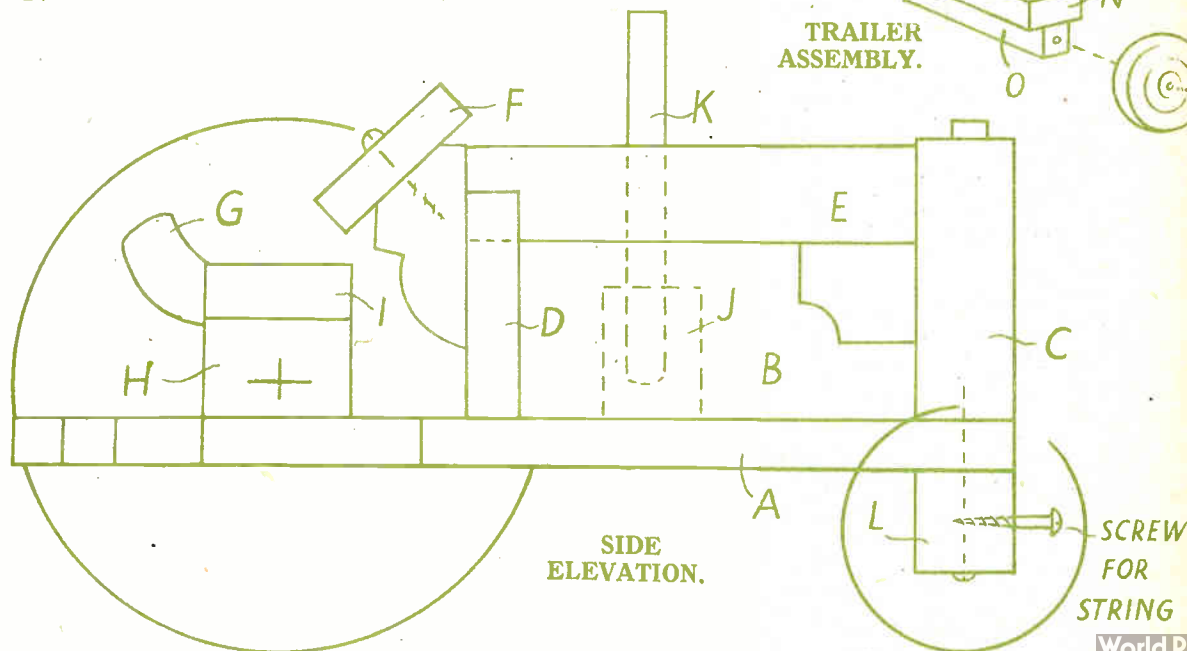

SIDE ELEVATION.

SCREW FOR STRING

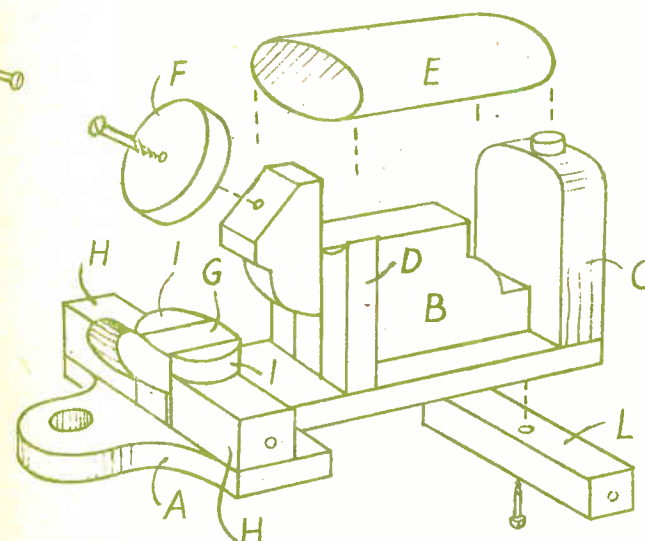

SHOWING CONSTRUCTION OF TRACTOR



N. CUT ONE 1/2in. PRINTED IN ENGLAND.



## Making the pull-along TRACTOR and TRAILER

**T**HIS realistic tractor and trailer will make an ideal present for any youngster. Although it is made up of small blocks, the general outline represents a true picture of the ordinary agricultural tractor. The finished toy complete with trailer is 12ins. long and 3½ins. high.

We will commence by making up the tractor. You will notice that each part is lettered and as near as possible the letters represent the sequence of assembly. Trace the various parts on to the wood and before cutting, check carefully to see that all parts are there.

### Beginning Assembly

When you have cut and cleaned up all the pieces, you can begin assembling. First glue the shaped piece (B) in position on (A). Next comes the radiator and the two pieces (D) on either side of (B). The tank (E) which is cut from ½in. wood is rounded off as shown by the section, and is glued in place next. If you wish, for the sake of strength, you can drive a ½in. screw right through the tank into piece (B). The screw will be counter-sunk and afterwards filled with wood-filler. The steering wheel (F) is pivoted by means of a ½in. screw to piece (B) in the position indicated on the design sheet. Pieces (G) and (H) are glued to piece (A) and the small pieces (I) are glued to (G) and (H) in the positions shown by the dotted lines. Pieces (I) and (G) form the seat.

The small block (J) is now cut out and glued as shown by the dotted lines in the side elevation to the lefthand side of (B). Shape the exhaust pipe (K) from a piece of ½in. round rod and pin as shown in the sketch to both (J) and (E). Round off

the small projection on the radiator to form the radiator cap. The front axle (L) is pivoted by means of a ½in. or 1in. screw to the underside of (A). The tractor is now complete except for the wheels which will be added after painting.

### The Trailer

Now for the trailer. The main piece (M) which is the floor, is cut from ½in. wood and to this are glued, on the underside, pieces (N) and (P). For the sake of strength these can also be screwed or pinned. The axle (O) is glued and screwed in place, and the long bar, piece (R), is glued to the back of (M) as shown in the constructional sketch on the design sheet. A small piece of ½in. round rod piece (Q) is now shaped and glued in piece (P). To connect the tractor and trailer this piece (Q) is simply dropped into the hole at the rear end of the tractor.

For pulling along, a small screw eye can be driven into the front axle (L). If a screw eye is not available, a ½in. fret pin bent over, or even a round-head screw will do.

The toy should be painted with quick-drying enamel, preferably in bright colours. We suggest red and yellow with a touch of blue here and there. Two coats will be necessary, cleaning the parts down with fine glasspaper between the coats. The wheels must also be painted, taking care that the paint does not run into the holes. When all is dry, the wheels can be screwed in position as shown in the diagrams on the design sheet. The small wheels are screwed to the front axle of the tractor and to the trailer. The larger ones are screwed to piece (H) on the tractor.

SUPPLEMENT TO HOBBIES No. 2924.

# MECHANICAL SWINGING BOATS

—SIZE—  
LENGTH 11ins. HEIGHT 10½ins.

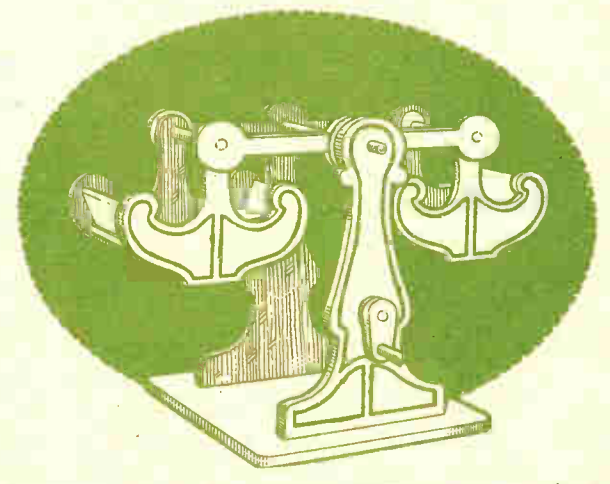

PANELS OF WOOD REQUIRED FOR THIS DESIGN  
**FIVE G4 ONE G3**  
Materials for making this design are supplied by HOBBIES LIMITED, Dereham, Norfolk.  
Price on application.

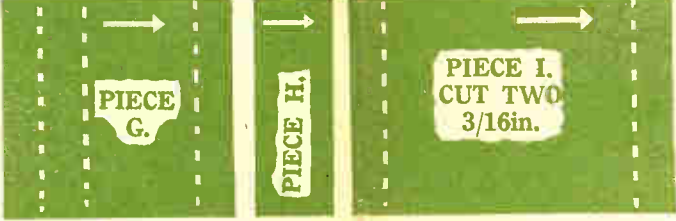
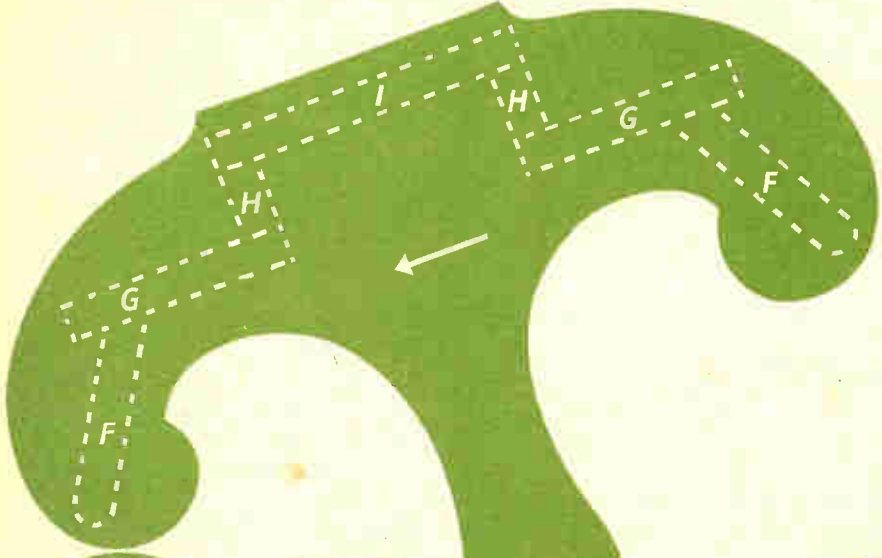

BOAT. INTERIOR PIECES. CUT FOUR OF PIECES F, G AND H.

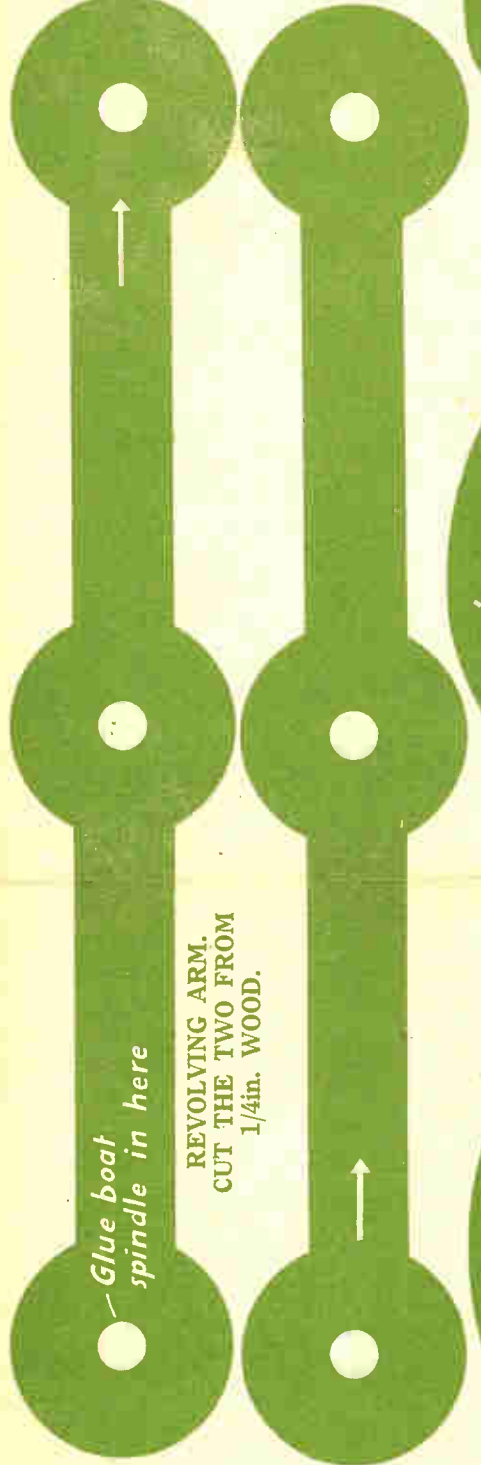

WASHER CUT TWO 3/16in.

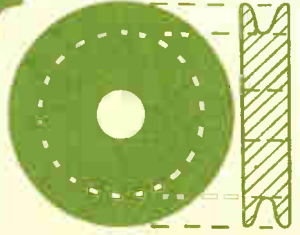

PULLEY ON UPPER SPINDLE. CUT ONE 1/4in.

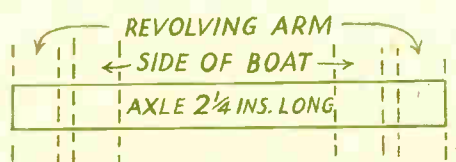

BOAT AXLE CUT TWO 1/4in. ROD



PULLEY ON CRANK SPINDLE D. CUT ONE 1/4in. AND FORM GROOVE.

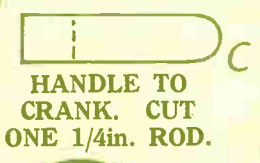
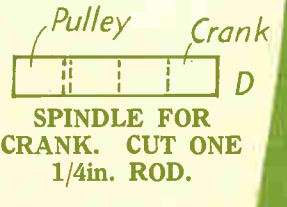
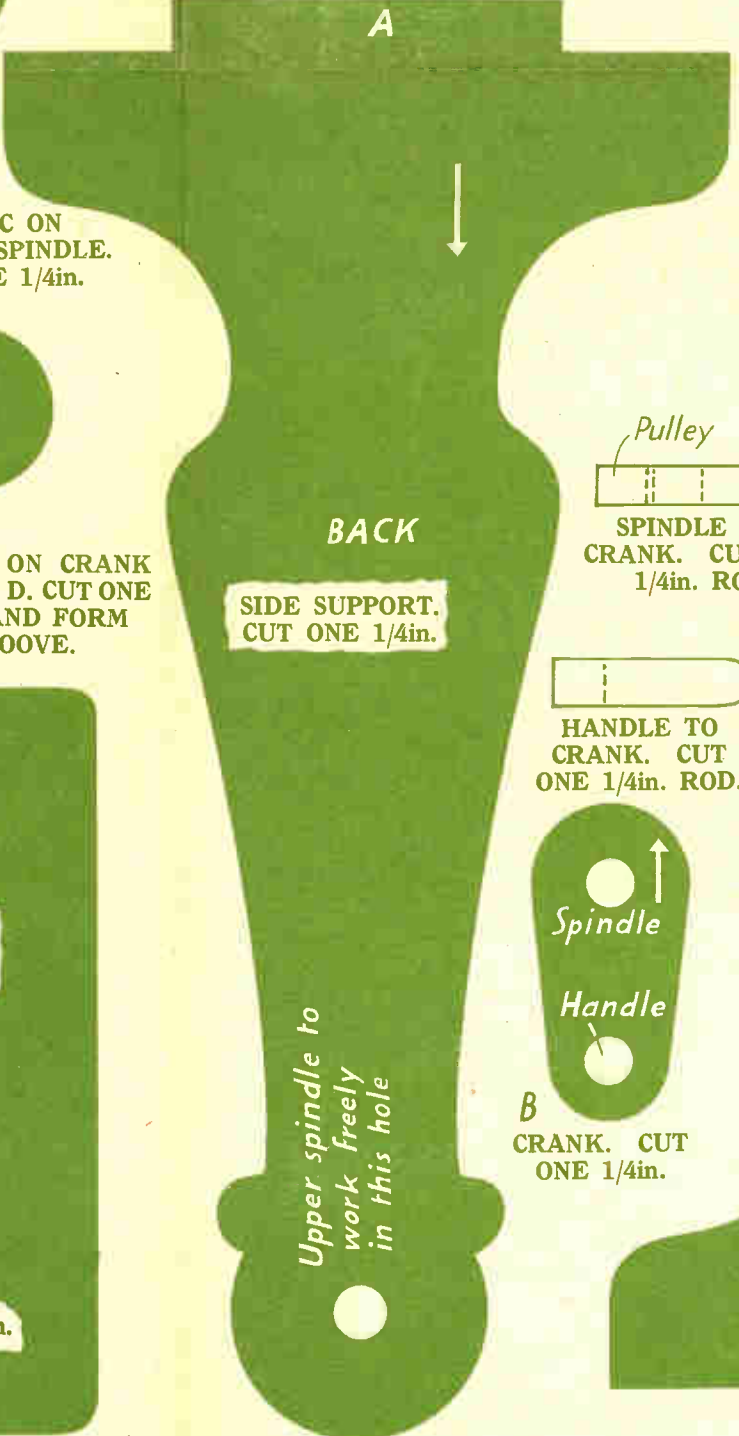

UPPER SPINDLE TO WORK FREELY IN THIS HOLE

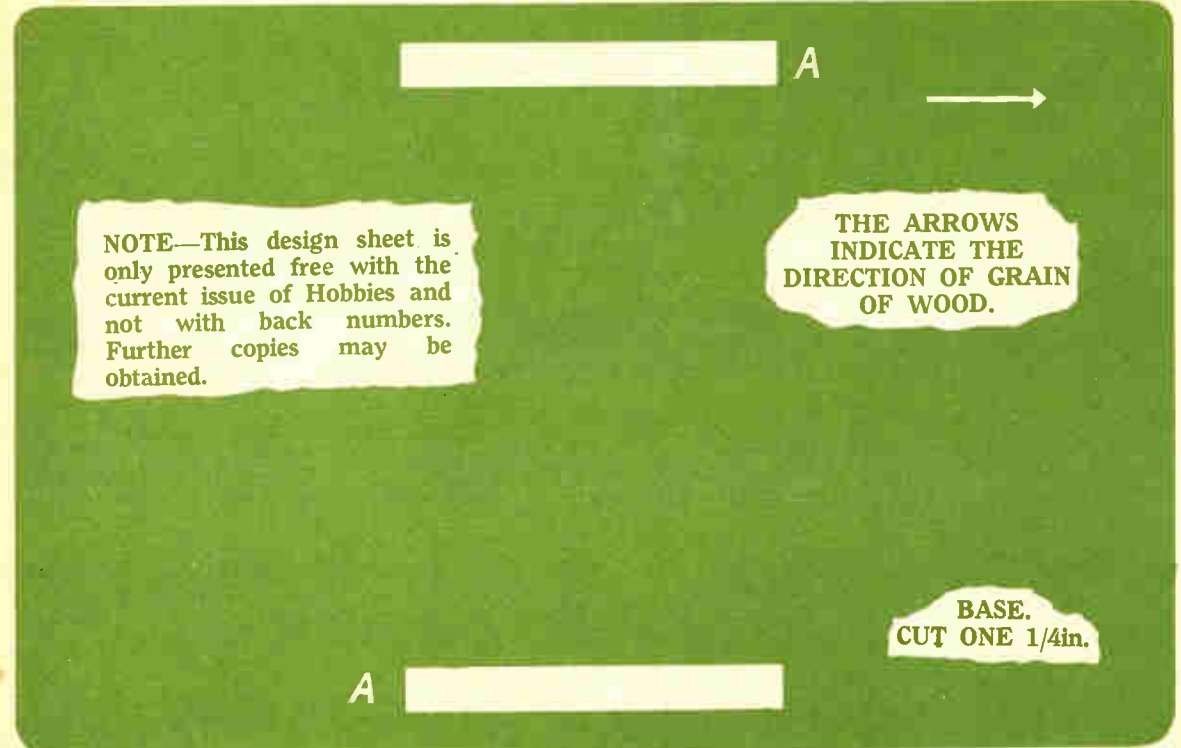
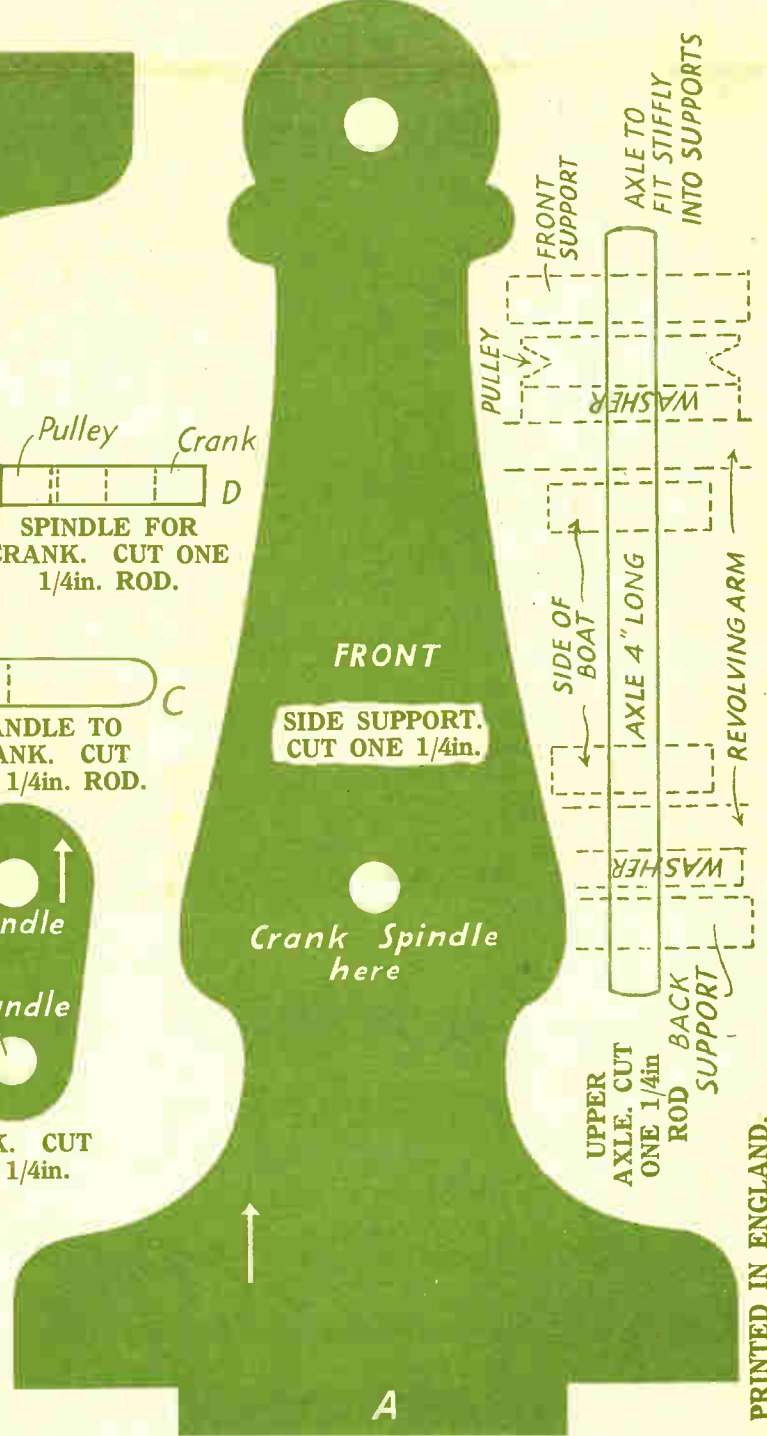

NOTE—This design sheet is only presented free with the current issue of Hobbies and not with back numbers. Further copies may be obtained.

THE ARROWS INDICATE THE DIRECTION OF GRAIN OF WOOD.



## Instructions for making the MECHANICAL SWINGING BOATS

**P**ROPERLY made up, this toy would be a welcome gift for any youngster, and those who are looking for suitable toys to make for Christmas might well include it in their list.

### Tracing the Patterns

The patterns should be traced off on to the wood in the usual way. Note how one of the side supports and the two revolving arms are placed on one panel, as shown in Fig. 1. If the parts are not

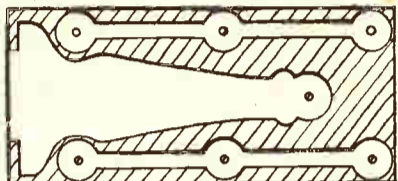

Fig. 1—How the parts should be laid out

laid out in this manner you will be unable to get them all out of the wood supplied.

Start construction by cutting the base and the two side supports. Take care with the mortises in the base and the tenons of the supports, ensuring that they are a firm fit. Note, too, that the crank spindle hole is cut in one side only, as the spindle does not continue right through the toy. As soon as these pieces have been cut and cleaned up, they can be glued together, and stood aside to harden. Make sure that the sides are standing vertically and, if necessary, put some sort of template between them at the tops to keep them equally spaced while the glue hardens.

You can now proceed with the swing boats themselves. These consist of four similar sides and the small pieces (F), (G), (H) and (I), which form the seats and floors. When these have been cleaned up and shaped to section, fit them together as shown by the dotted lines on the design sheet and glue and

pin them. Both boats can now be laid aside to set.

Next cut the two revolving arms and glasspaper them up quite smoothly. This is essential if the parts are to work without friction, and also applies to other moving parts.

Now cut and shape the necessary dowel pieces and the pulleys and parts for the crank and handle. When all these have been nicely cleaned up the whole toy can be assembled, and reference to Figs. 2 and 3 will show quite clearly the method. Run dowel pieces through the holes in the top of each swing boat and glue these in the holes at the ends of the revolving arms. Use the glue sparingly and be quite sure that none gets on to the spindle where the arms of the swing boats are to operate. Next, run the centre spindle through the rear side support and the revolving arms of the swing boats, adding the two washers, one between the rear arm and the rear support, and

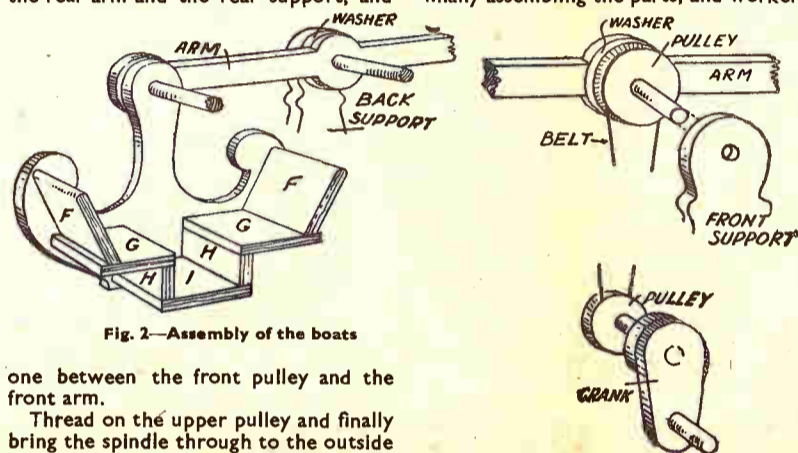

Fig. 2—Assembly of the boats

one between the front pulley and the front arm.

Thread on the upper pulley and finally bring the spindle through to the outside of the front side support. The revolving arms and pulley must be glued to the spindle, but no glue must find its way into the holes in the side supports as the action of the toy depends on the ability of this spindle to revolve freely.

Now assemble the crank spindle, the crank itself and the small pulley, as shown in Fig. 3, gluing all parts thoroughly but again ensuring that the spindle turns freely in the side support. The toy is completed by provision of a suitable belt which could nicely be made of a suitable elastic band, provided that the tension is not too great.

Now clean up the toy paying special care to the ends of the spindles. See that they are flush with the sides of their respective housings, and, when all is dry, clean away any excess glue.

### Use Gay Colours

The toy should be painted in gay colours, the brighter the better, and several coats of good paint topped off by a coat of varnish should ensure that it will withstand a lot of handling by young fingers. To make a really first-class job of painting the model, it might be preferable to put on the colour before finally assembling the parts, and workers

who are good with a brush might well wish to line the toy in the way shown in the illustration.

MODEL OF  
**THE 'CANBERRA'**  
BRITAIN'S FIRST JET BOMBER

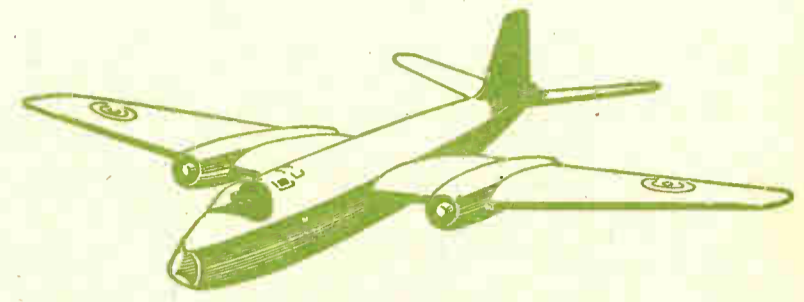

PANELS OF WOOD  
REQUIRED FOR THIS DESIGN

**ONE G3 ONE MD8 ONE LD6**

Materials for making this design are supplied by HOBBIES LIMITED, Dereham, Norfolk.  
Price on application.

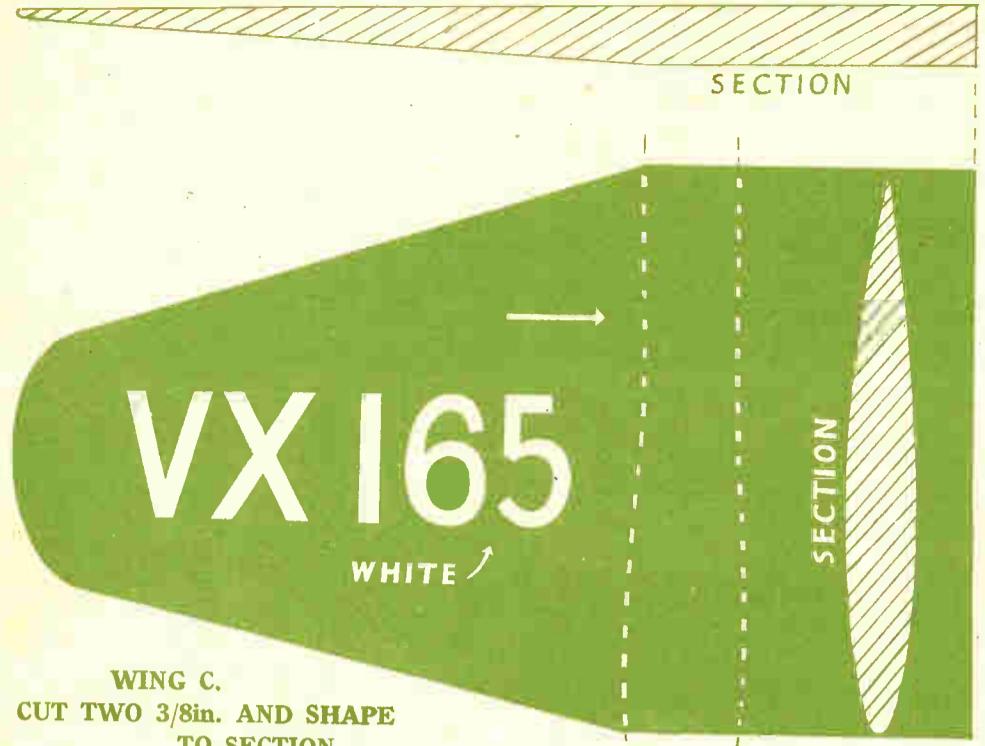

WING C.  
CUT TWO 3/8in. AND SHAPE TO SECTION.

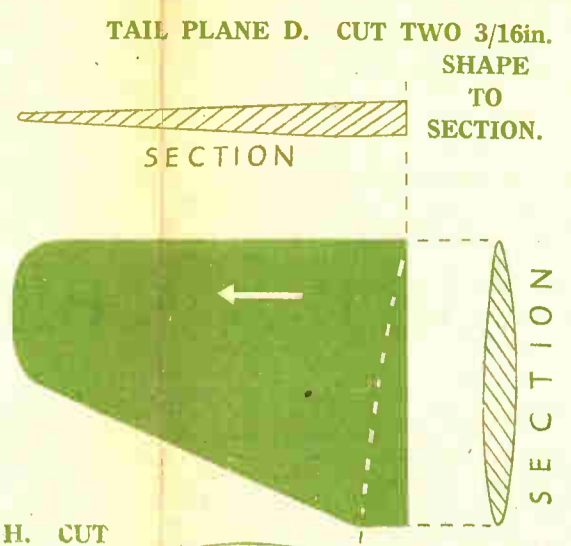

PIECE H. CUT TWO 3/16in. AND ROUND OFF.

SCALE—4m.m.—1ft.



ENGINE NACELLE E. CUT TWO 3/16in.  
ENGINE NACELLE F. CUT TWO 3/8in.  
GLUE TOGETHER ONE E AND ONE F.



PIECE G. CUT TWO 3/16in.  
GLUE TO FRONT OF ENGINE NACELLES.

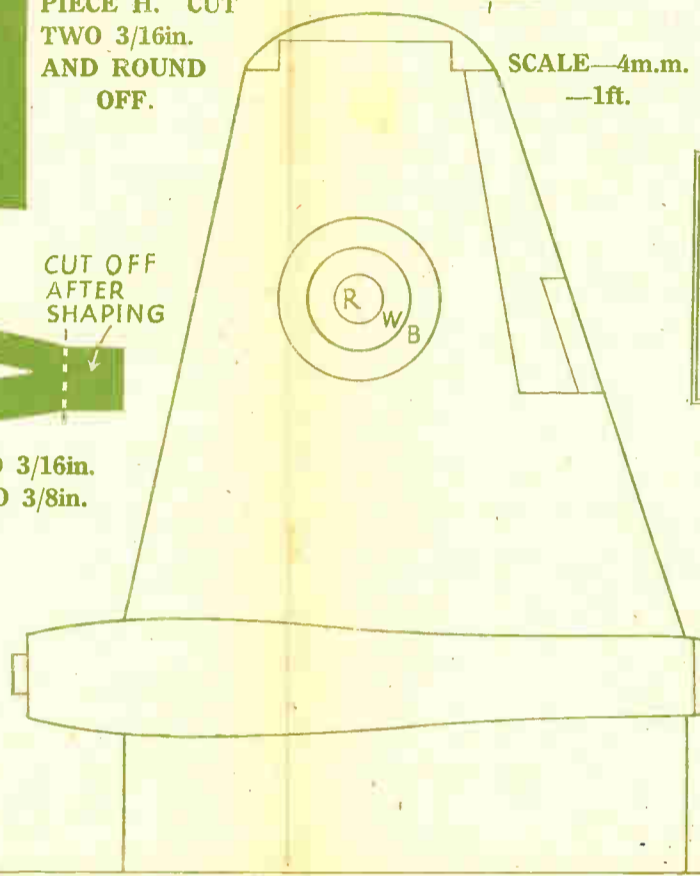

NOTE—This design sheet is only presented free with the current issue of Hobbies and not with back numbers. Further copies may be obtained.



PLAN (PART ONLY SHOWN).

Note—R, W, B—RED, WHITE, BLUE.

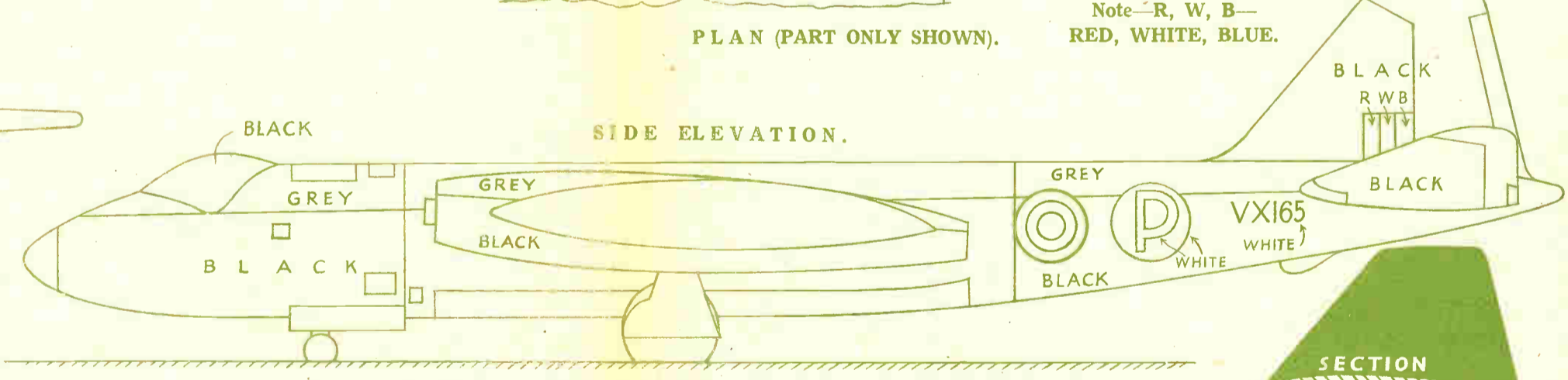

SIDE ELEVATION.

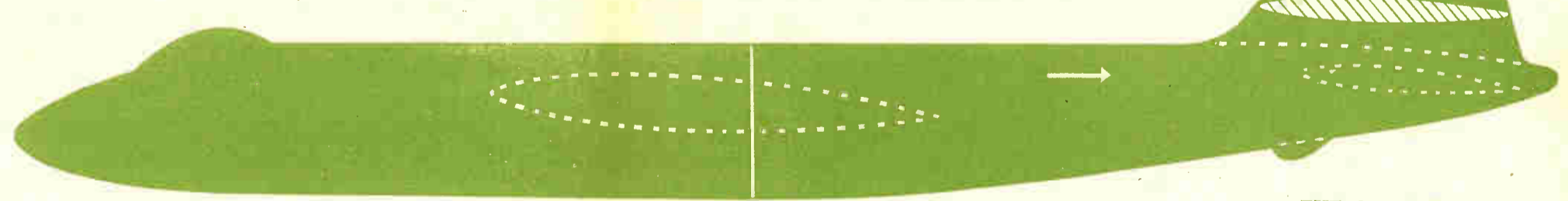
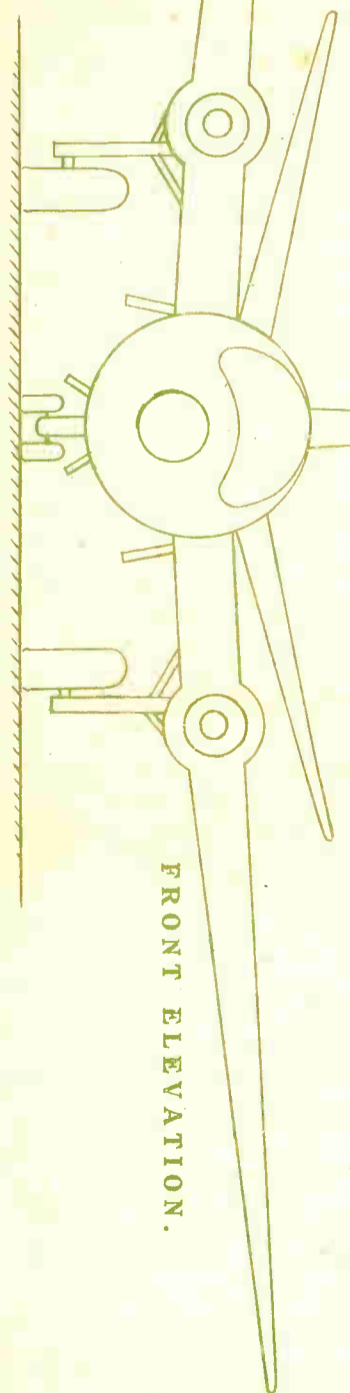

PIECE A OF FUSELAGE. CUT ONE 3/16in. (CUT IN TWO PIECES).

THE ARROWS INDICATE THE DIRECTION OF GRAIN OF WOOD.



PIECE B OF FUSELAGE. CUT TWO 1/2in.



## Full instructions for modelling BRITAIN'S FIRST JET BOMBER

**A** MODEL of Britain's first jet bomber, the Canberra, is a project worthy of any model maker, and the work is not intricate if the sequence of shaping and fitting is adhered to.

The model actually represents the Canberra B Mark 2 which carries a crew of three and is fitted with a transparent nose and visual sighting panel for the use of the bomb aimer. The Mark 2 is now in production and is the first version of the aircraft to go into service with the Royal Air Force. Few details of the performance can be disclosed, but extensive flight tests have confirmed that the Canberra has an exceptional performance both at low and very high altitudes. Its manoeuvrability is outstanding and it has the aerobatic qualities of a high-performance fighter.

### 4 mm. Scale

It may be of interest to those who have model railway layouts to know that this model is made to a scale of 4 mm. to the foot, so that the modeller with an OO gauge layout, and provision for an airport, might usefully incorporate the model.

Begin the construction with the fuselage, cutting the piece (A) and two pieces (B). It will be noted that piece (A) is cut in two sections. This is to enable both pieces to be cut from one G3 panel ( $\frac{3}{16}$  in.), together with the engine nacelles and two tailplanes. The pieces (A) are then placed between the two pieces (B), and the whole glued together and weighted to stop warping while the glue is drying.

While waiting, the worker can cut out the wings, shaping them to the sections shown and according to the outline of the front elevation. It should be noted that the tapering of the wings starts from outside each engine nacelle

and is confined to the under surfaces only.

By the time the wings have been finished, the body should be dry and can be shaped up according to the diagrams. When this has been done, the wings can be fitted into the fuselage in the slots provided. To get the required dihedral, fill the holes in the fuselage with plenty of glue and place the wings in. Then weight the body down and place suitable packing (e.g.—books) under the wings to lift them. When the amount of dihedral is right according to the front elevation, leave the whole thing until it is thoroughly set.

### The Tailplane

Next the tailplane is cut out, shaped and glued into the fuselage in the same way as the main plane. Any holes or cracks which remain in the fuselage after the wings and tailplane have been fitted, should be filled in with plastic wood, putty or a mixture of glue and sawdust.

Next deal with the engine nacelles which consist of two pieces (E) and (F). These pieces should be glued together and rounded. They are then slid on to the wings and glued into position as shown on the plan. To complete them, the pieces (G) are cut and glued to their fronts and the pieces (H) shaped and glued into the centre of each. Here again, any irregularities after the nacelles have been fitted, should be filled in with plastic wood. Finally, trim off the projection at the backs of the nacelles which were originally included in the patterns only to prevent the wood from splitting while being shaped.

When the whole thing has been thoroughly smoothed with glasspaper and given a coat of woodfiller, colour according to the instructions on the design sheet. The grey mentioned is actually sea grey and can be obtained by

adding a little blue to an existing grey before painting. All the lettering is white, and the R.A.F. markings, of course, are red, white and blue. The under surface and the tail fin are black, and the bubble and nose piece should also be painted black, as it will be found that any attempt to make these pieces look like glass by painting them, say, aluminium or silver, will fail. In actual fact, a black surface with the light reflected on it, looks much more like glass than does any other colour. The markings of the elevators, etc., are put in with pencil.

Workers will have noted that, in the side and front views of the aircraft, the undercarriage is shown in the down position, but that no provision has been made in the design sheet for making this undercarriage. This is because we feel that the model is better displayed on a pedestal and shown as in flight, but the modeller who wishes, can easily build up the undercarriage from suitable card and wood.

### Suitable Pedestal

To make a pedestal we suggest that two circles of suitable wood be cut with diameters of 3 ins. and 2½ ins. These are glued together with the smaller circle on top, and a steel knitting needle is run down through them. The sharp end of the needle is then fitted into the fuselage of the model at a point slightly forward of the trailing edge of the wings, and at an oblique angle in order that the plane will appear to be banking.

It may be that some of our workers will not feel capable of painting the R.A.F. circles on this model, and we would suggest to them that they secure suitable transfers of a diameter between ¾ in. and 1 in. These transfers can be easily obtained from a shop stocking model aeroplane accessories.

Drawer opening

K

OUTER FRONT OF DRAWER.  
CUT ONE.

# LETTER RACK

WITH DRAWER FOR PENS AND PENCILS



## DESIGN

No. 2920  
17.10.51

THE ARROWS INDICATE THE DIRECTION OF GRAIN OF WOOD.

SUPPLEMENT TO HOBBIES No. 2920.

PANELS OF WOOD REQUIRED FOR THIS DESIGN

**FOUR Q3**

Materials for making this design are supplied by HOBBIES LIMITED, Dereham, Norfolk  
Price on application

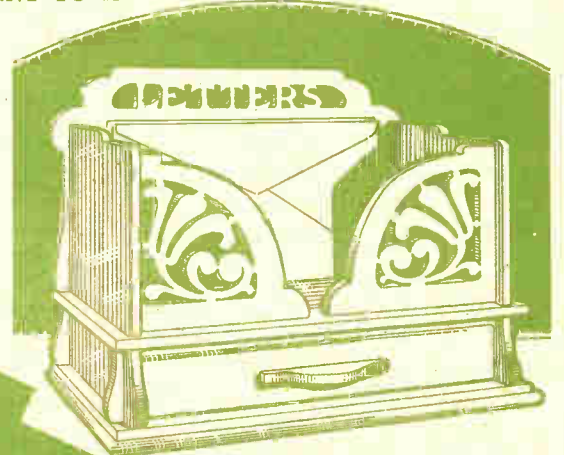

SIZE:—LENGTH 7 $\frac{1}{8}$ ins.  
DEPTH 3 $\frac{1}{8}$ ins.  
HEIGHT 6 $\frac{3}{8}$ ins.

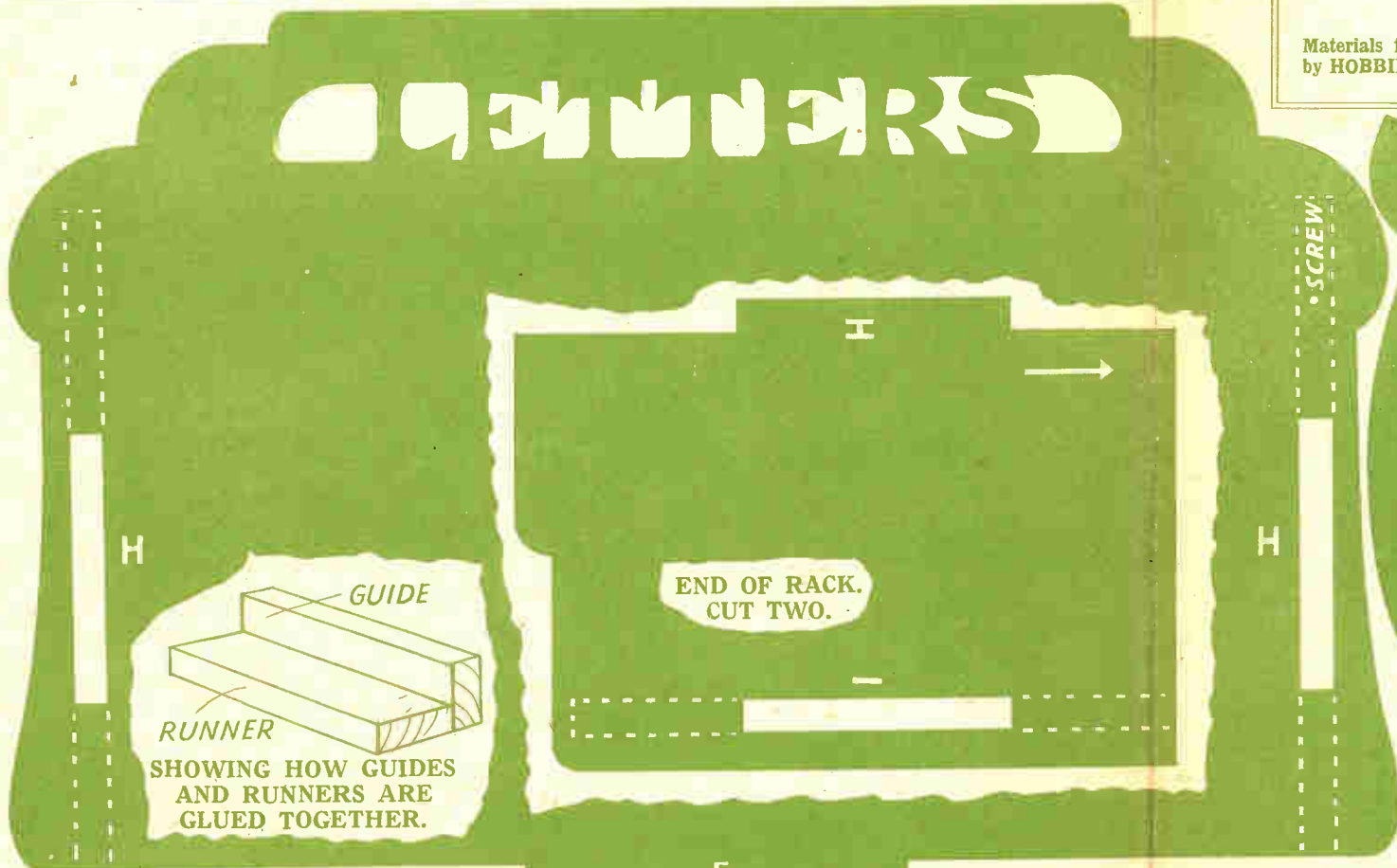

H

H

H

SCREW

END OF RACK.  
CUT TWO.

GUIDE

RUNNER

SHOWING HOW GUIDES AND RUNNERS ARE GLUED TOGETHER.

MAIN BACK. CUT ONE.

F



G

G

FRONT OF RACK.  
CUT ONE OF EACH.

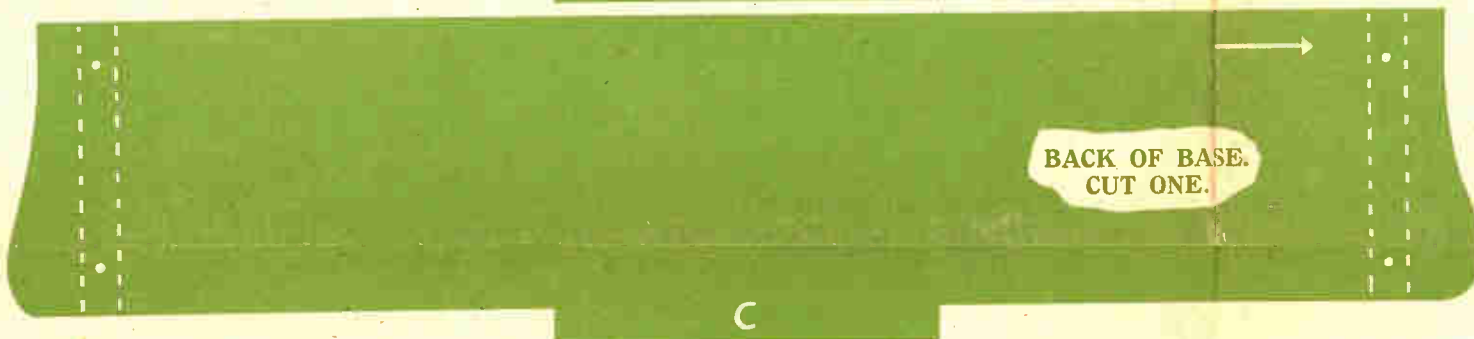

BACK OF BASE.  
CUT ONE.

C

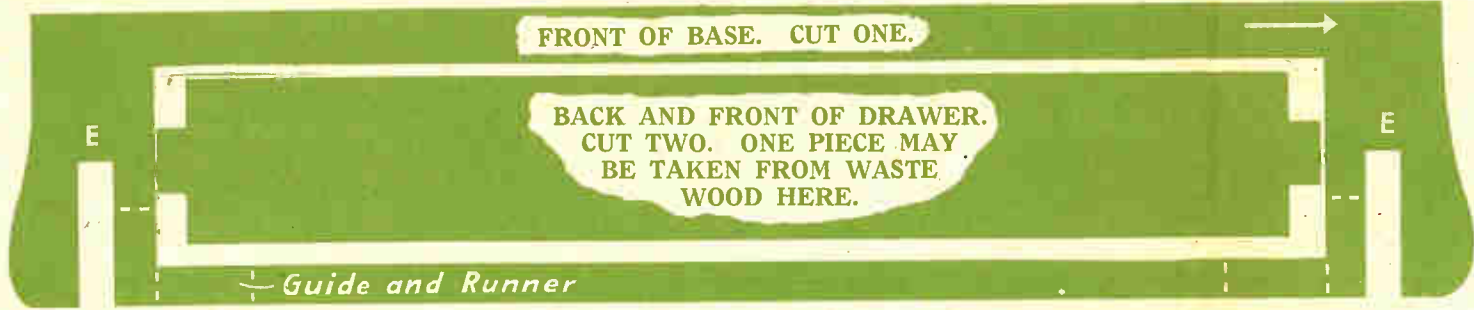

FRONT OF BASE. CUT ONE.

BACK AND FRONT OF DRAWER.  
CUT TWO. ONE PIECE MAY BE TAKEN FROM WASTE WOOD HERE.

E

E

Guide and Runner

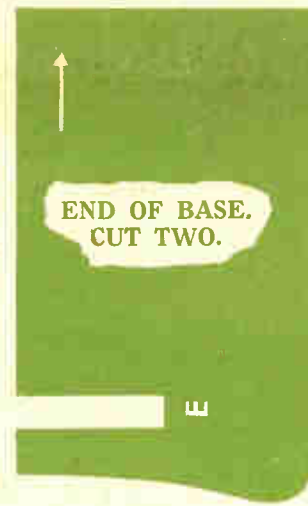

END OF BASE.  
CUT TWO.

E

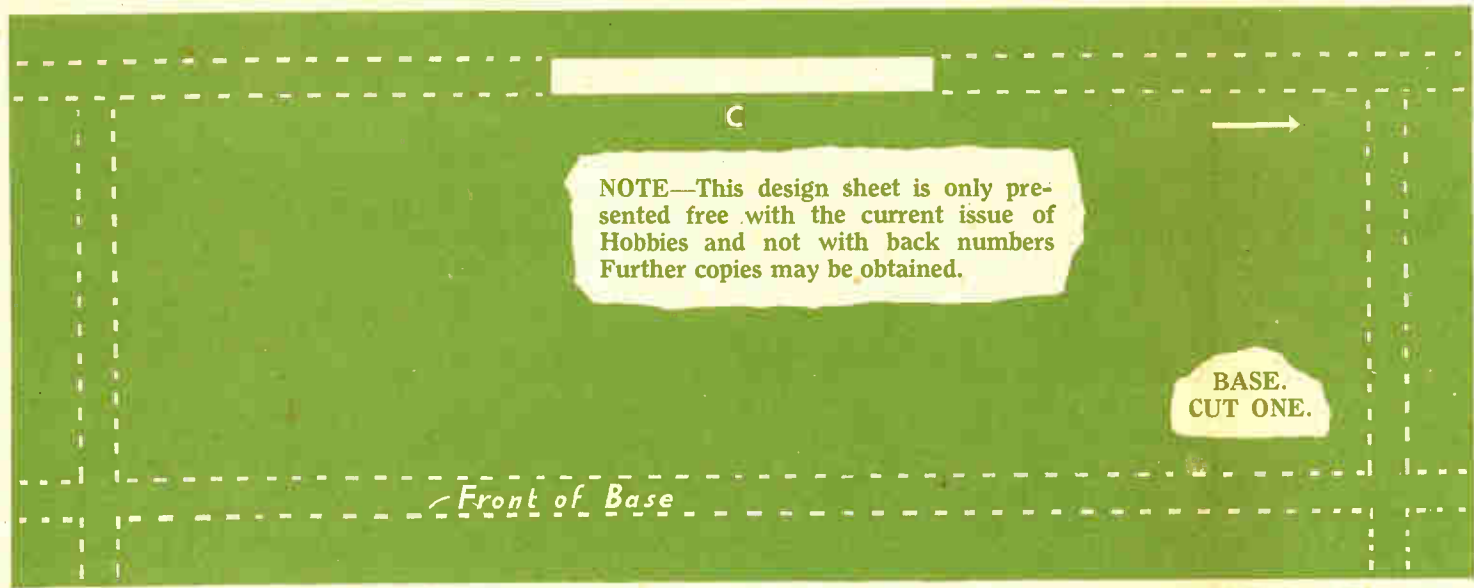

NOTE—This design sheet is only presented free with the current issue of Hobbies and not with back numbers. Further copies may be obtained.

BASE.  
CUT ONE.

Front of Base



END OF DRAWER. CUT TWO.

HANDLE.  
CUT ONE.

K

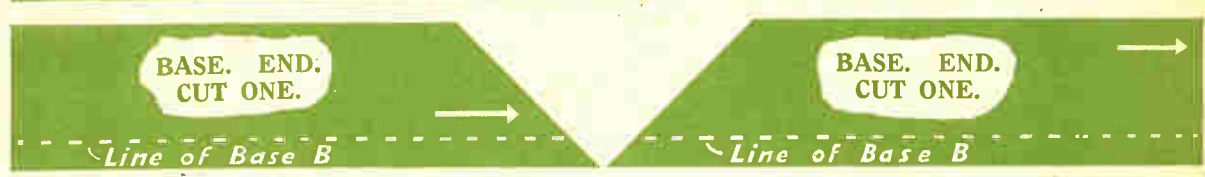

BASE. END.  
CUT ONE.

BASE. END.  
CUT ONE.

Line of Base B

Line of Base B



6 $\frac{1}{8}$ "  
2 $\frac{1}{8}$ " FLOOR OF DRAWER.  
CUT ONE.

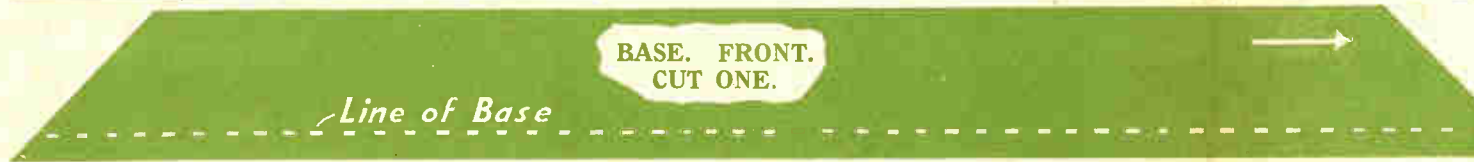

BASE. FRONT.  
CUT ONE.

Line of Base

GUIDES AND RUNNERS FOR DRAWER. CUT FOUR

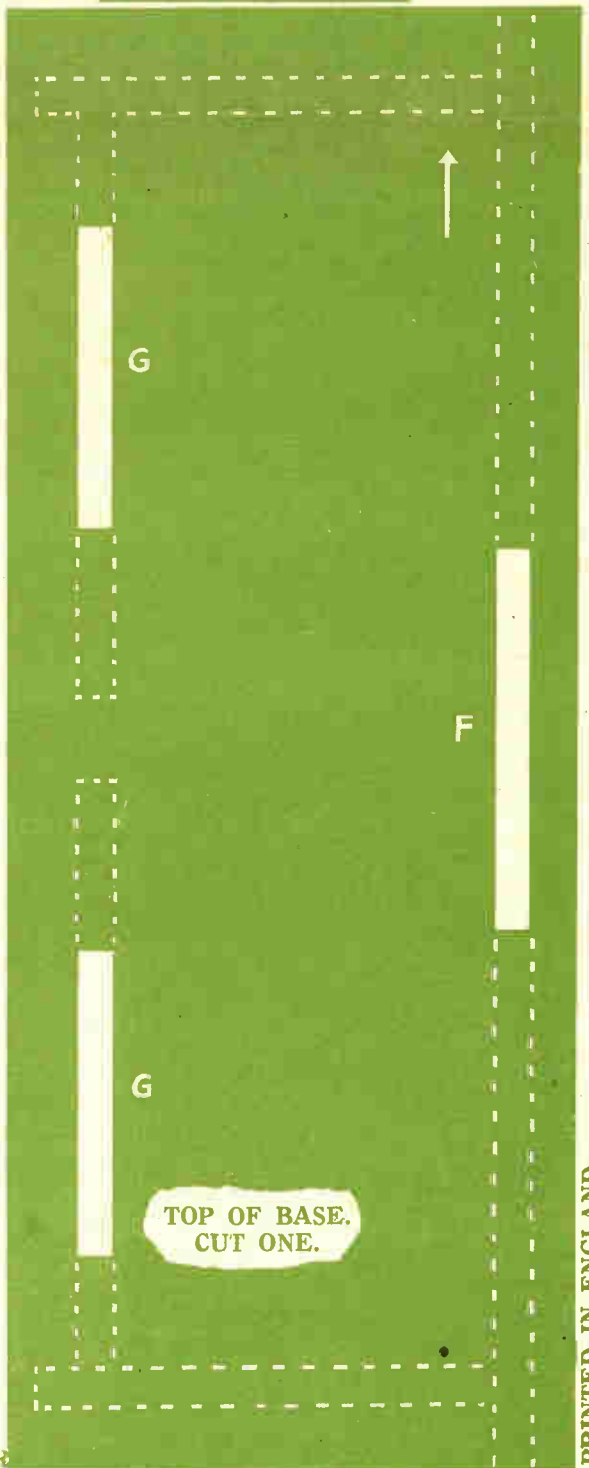

G

F

G

TOP OF BASE.  
CUT ONE.

PRINTED IN ENGLAND.



## How to make this useful LETTER RACK

**T**HERE are many of us these days who are haphazard in our methods of storing unanswered letters, etc., and a Letter Rack of the type illustrated would be a useful acquisition. It would make a nice present, too, for friends who forget to answer your letters, having mislaid them shortly after their arrival!

It should be noted here that there are a number of mortises and tenons to be cut in the construction of this article, and throughout the making of it, care should be taken to see that these joints

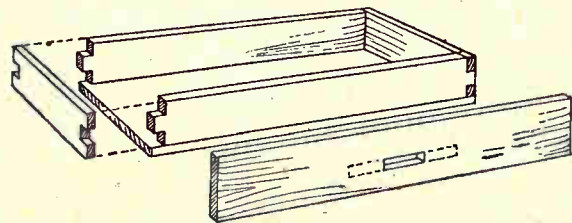

Fig. 1

are good fits. If this is not done the resulting article will be disappointing.

Begin the construction by making the complete base, including the drawer. First cut the base piece proper and then the four mitred pieces which form the underside of the base. Make sure that the mitres are a clean fit and glue into position on the underside of the base.

Next cut the front and back of the base and the two ends, and test the joints for fitting. When all is satisfactory they in their turn can be glued into position. Small pins may be used here and there if desired, but care should be taken to avoid splitting the wood, and it will be found, generally, that glue alone, if used properly, will make a more workman-like job.

Now cut out the four guides and runners for the drawer which is fitted into the base, and glue them into position as shown in Fig. 1. Another drawing of these pieces glued together is shown on the front of the design sheet.

You can now proceed with the top of the base which is cut out and glued into position so that the base piece now

forms a rectangular box into which will be fitted the drawer.

This part of the article is made up of two identical pieces for the back and front and two pieces for the ends, together with an outer front. The assembly of these parts is shown quite clearly in Fig. 2. When the drawer is so far assembled, the handle can be cut out and glued into position in the tenon on the front of the drawer.

This completes the whole of the work of the base, and it now remains to construct the letter rack proper. This comprises the two ends, the two fretted pieces which hold the letters in the rack, and the main back piece on which is fretted the word 'Letters'.

The assembly of these pieces is quite straightforward if the lettering of the mortises and tenons is followed when

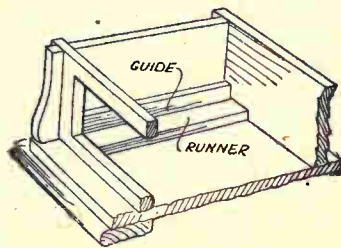

Fig. 2

the pieces are joined together, and reference to the drawing of the finished article will avoid any error in assembly.

To finish the article it should be primed with a good woodfiller and stained and polished to any desired shade. Alternatively the wood can be left in its natural colour and wax polished, or the whole can be treated with a good quality enamel paint. In any case, make quite sure before applying the finish that all the woodwork is nicely cleaned up and prepared.

SUPPLEMENT TO HOBBIES No. 2918.

**PULL-ALONG  
TIMBER LORRY  
AND DRUG**

SIZE: LENGTH 13½ins. HEIGHT 3½ins.

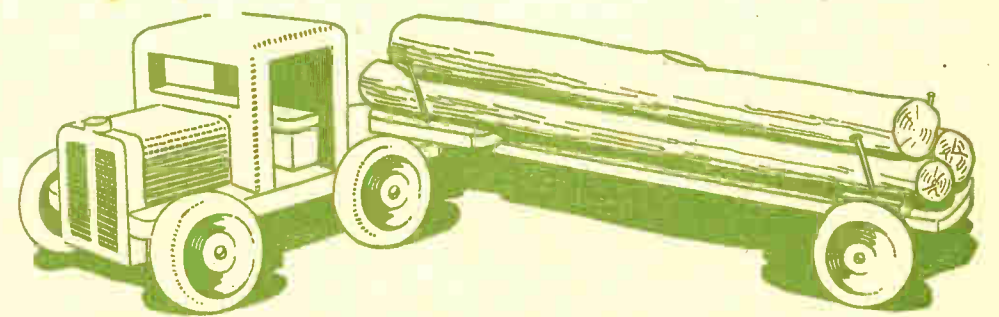

**PANELS OF WOOD REQUIRED FOR THIS DESIGN**  
**ONE H4**  
Materials for making this design are supplied by **HOBBIES LIMITED, Dereham, Norfolk.**  
Price on application.

**NOTE**—This design sheet is only presented free with the current issue of Hobbies and not with back numbers. Further copies may be obtained.

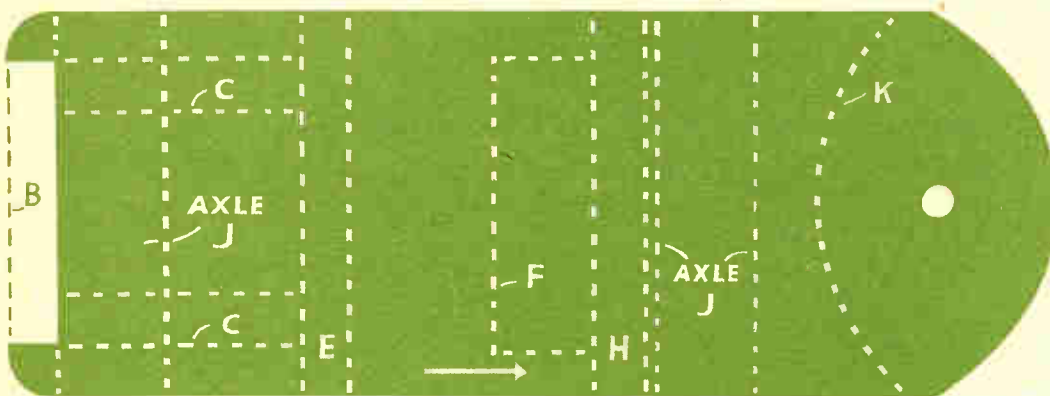

PIECE A. CUT ONE 1/4in.



PIECE B. CUT ONE 1/4in.

PIECE C. CUT TWO 1/4in.  
THE ARROWS INDICATE THE DIRECTION OF GRAIN OF WOOD.

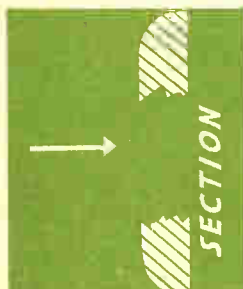

PIECE D. CUT ONE 1/4in. SHAPE TO SECTION.

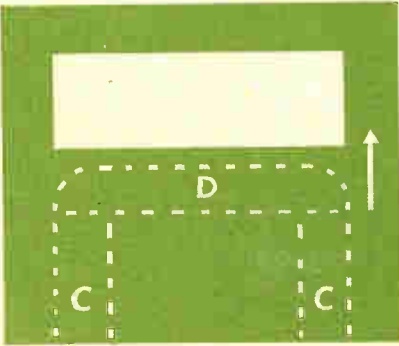

PIECE E. CUT ONE 1/4in.



PIECE F. CUT ONE 1/2in. SQUARE STRIPWOOD.



PIECE G. CUT ONE 1/4in.

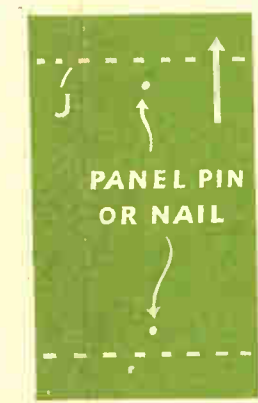

PIECE M. CUT ONE 1/4in.



PIECE I. CUT ONE 1/4in. SHAPE ALL SIDES TO SECTION.



AXLE J. CUT THREE 1/2in. SQUARE STRIP.

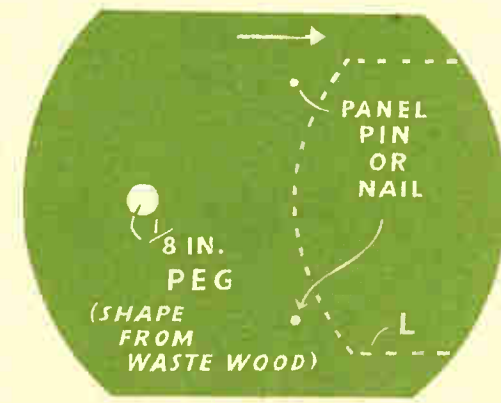

PIECE K. CUT ONE 1/4in.

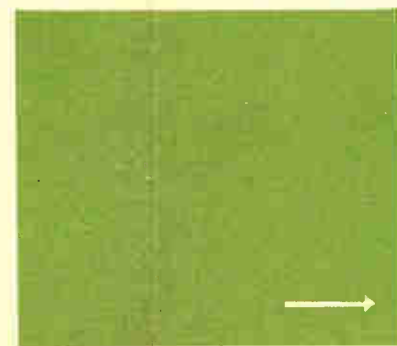

PIECE H. CUT ONE 1/4in.

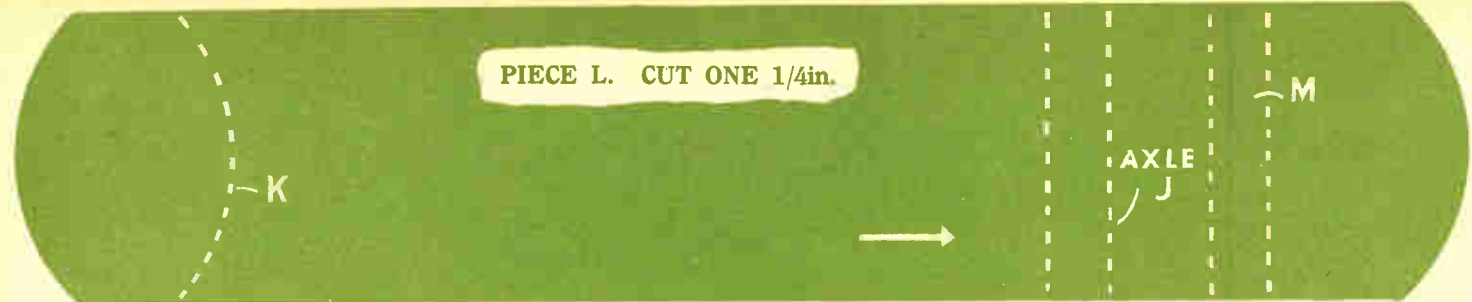

PIECE L. CUT ONE 1/4in.

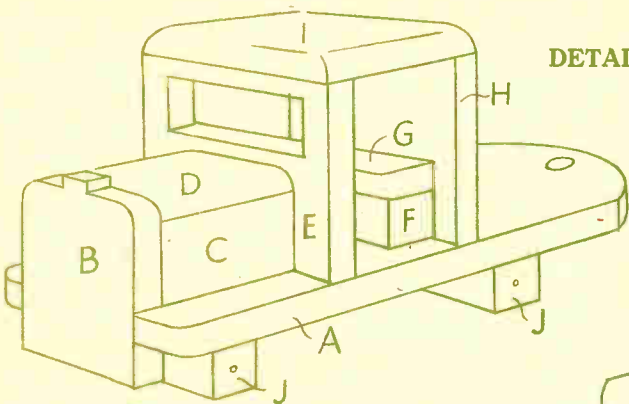

DETAIL SHOWING CONSTRUCTION OF THE LORRY.

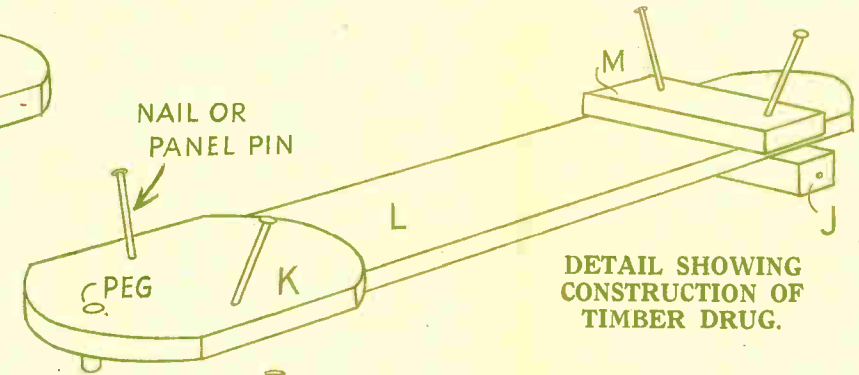

DETAIL SHOWING CONSTRUCTION OF TIMBER DRUG.

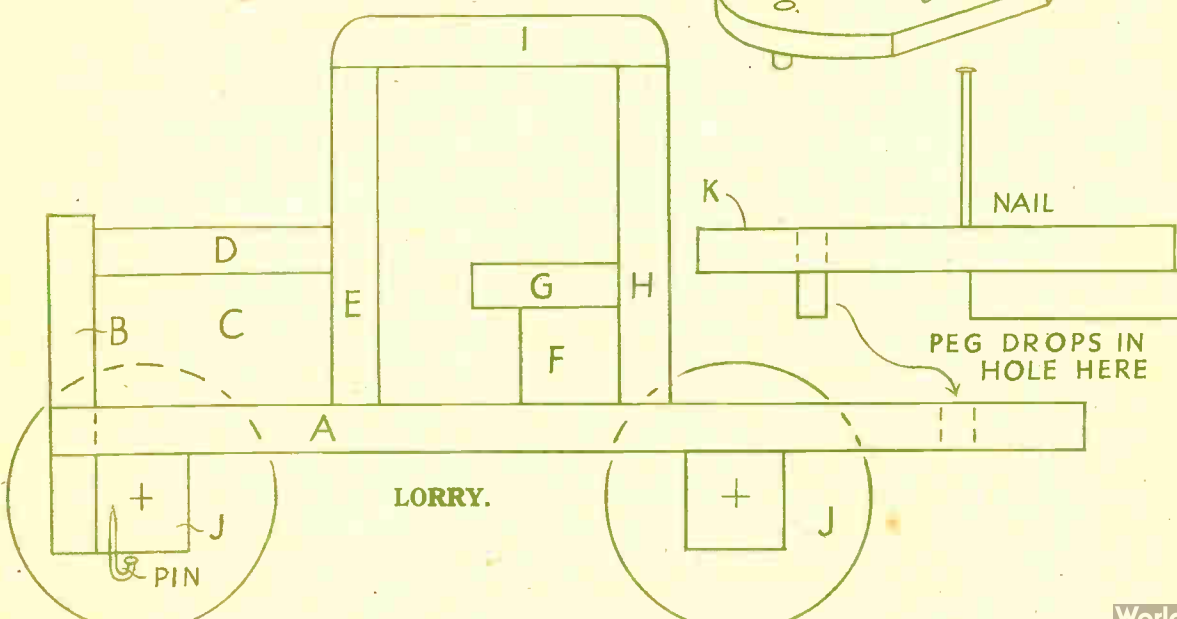

LORRY.

DRUG.

**NOTE.** The timber drug is fixed to the lorry by means of the small wooden peg. This must be a loose fit to enable the drug to swivel.

**T**HE construction of this pull-along timber lorry and drug is simplicity itself. The whole model is made entirely from ¼" material and ½" square stripwood, and when finished is a sturdy toy for any youngster.

Begin by transferring the patterns to the necessary wood, and then commence cutting with piece (A), which is the floor of the lorry itself. Next cut out all the component parts of the lorry—the cabin, seat, axles, bonnet, etc.—and shape pieces (D) and (I) to the sections shown.

Now assemble as shown in the diagram opposite, using good quality glue and pins where necessary.

The lorry can now be placed aside to dry and harden thoroughly while the worker concentrates on the construction of the drug. This consists of pieces (K), (L), (M) and (J). The cutting of these pieces is straightforward, and the assembly is just as simple, as the drawing opposite will show.

The ½in. peg, which is shaped from waste wood, is glued into the hole cut in piece (K), and will later serve as a swivel pin for the drug when it is attached to the lorry.

Nails or panel pins should be driven into position on the drug as shown in the illustration, and the whole toy is now complete except for the addition of the wheels. These should not be fixed in place, however, until painting has been completed.

**Attractive Colours**

Choice of colours is a matter for the individual worker, but he should see that they are bright and attractive as children quickly tire of any toy which is

dull. Two or three coats of good quality paint should be used in order to procure a smooth, solid surface.

Each coat should be left until it is thoroughly dry, and light glasspapering between each will improve the finished appearance. The use of a good woodfiller before painting is commenced will also ensure a smoother final surface.

Most workers will doubtless choose good quality enamels, but for the more impatient among us, cellulose is recommended, as it dries remarkably quickly and with a smooth surface.

**Assembly**

When all the parts, including the wheels, are finished to the satisfaction of the worker, the whole can be assembled. Screw the wheels into the centres of the axles, making sure that they are sufficiently free to allow the wheels to revolve easily. Small washers placed between the insides of the wheels and the sides of the axles, will ensure really free running.

The toy is now complete, and the drug can be dropped into place on the lorry, making sure that the peg on the drug is a loose fit in the hole at the back of the lorry so that the drug swivels easily when the lorry is pulled around corners.

The 'motive power'—a piece of string—is secured to the hook placed in position under the front axle.

All that remains is to supply the toy with a 'load', and for this it will be found that three pieces of a thin branch of a tree are admirable. The pieces of branch should be reasonably straight and suitably gnarled (where the twigs have been removed) to make them look like real pieces of timber.



SUPPLEMENT TO HOBBIES No. 2916.

# BOOK RACK

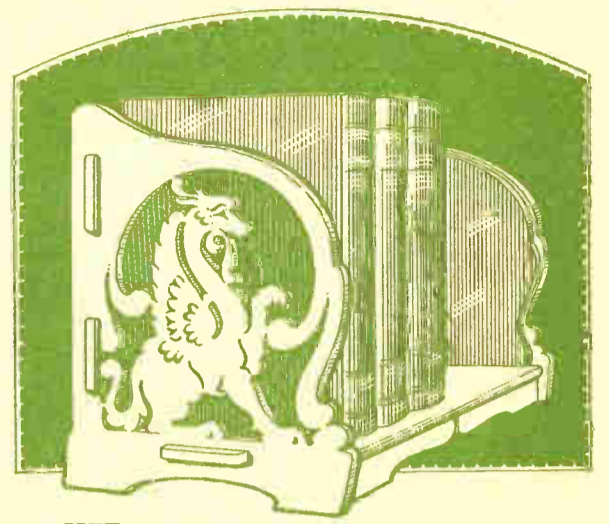

—SIZE—  
 LENGTH 11½ ins.  
 HEIGHT 8 ins.  
 WIDTH 6½ ins.

PANELS OF WOOD REQUIRED FOR THIS DESIGN  
**THREE H4 ONE Q4**  
 Materials for making this design are supplied by HOBBIES LIMITED, Dereham, Norfolk.  
 Price on application.

THE ARROWS INDICATE THE DIRECTION OF GRAIN OF WOOD.

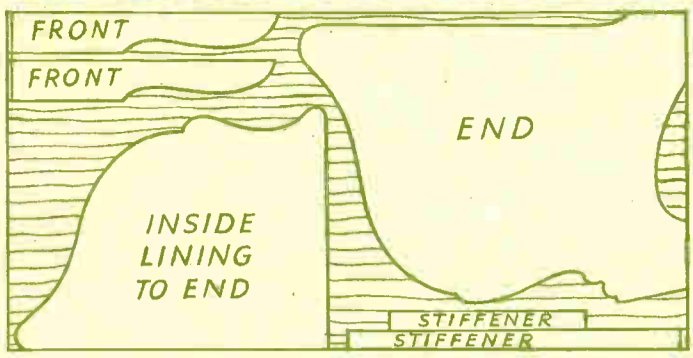

SHOWING HOW CERTAIN PARTS MUST BE ARRANGED ON THE H4 PANELS

NOTE—This design sheet is only presented free with the current issue of Hobbies and not with back numbers. Further copies may be obtained.

INSIDE LINING TO ENDS. CUT THE TWO FROM ¼ in. WOOD.

FLOOR FILLET. CUT TWO FROM ODD ¼ in. WOOD.

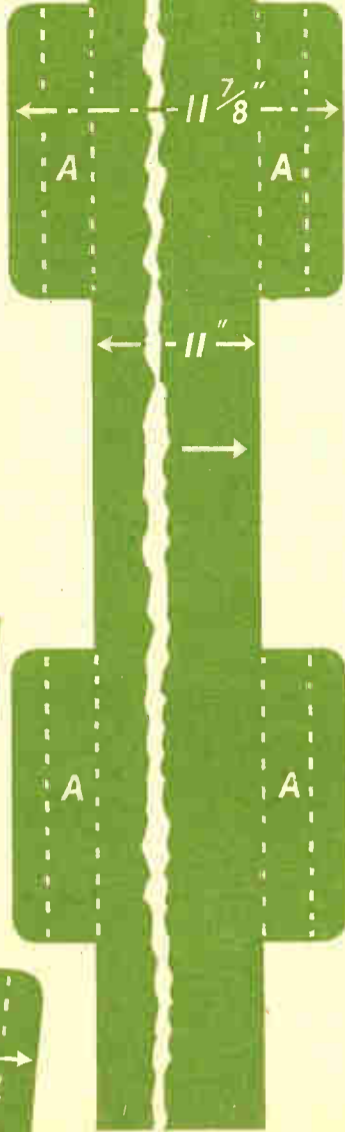

BACK. CUT ONE ¼ in. TO LENGTH SHOWN.

FLOOR. CUT ONE ¼ in. TO LENGTH SHOWN.

ENDS. CUT EACH FROM ¼ in. WOOD.

LINE OF STIFFENER AT BACK

FRONT (IN TWO PIECES). CUT TWO ¼ in.

CUT ONE PIECE 7 in. AND ONE PIECE 4 in.

STIFFENER BEHIND FRONT. CUT THE TWO PIECES FROM ¼ in. AND GLUE BEHIND THE TWO SHAPED FRONT PIECES.



## A BOOK RACK

**A** BOOKRACK is an article which is readily acceptable in most homes, and one as well designed as this would be sure of a welcome. For the most part, the construction is simple, but care should be taken when fretting out the griffin which forms the design for both ends.

As will be seen, the main components of the article are the two ends, the two inside linings for the ends, and the back (A) and floor (B). Six small stiffening pieces complete the components. It is important that the parts should be laid out on the wood as shown in the diagram on the front of the design sheet. If this plan is not followed the worker may have difficulty in getting all the necessary pieces from the wood supplied.

Begin by cutting out the two ends, remembering that it is advisable to cut the frets of the griffin before the main outline of the end is completed. This will overcome any tendency for the wood to split in the narrow parts of the front. Next, cut the inside linings and glue them to the ends in the positions shown by the dotted lines on the design sheet.

The back and floor should now be set out on the necessary wood, and this is easily done if the measurements given on the design sheet are closely followed. Take care to draw the tenons exactly to

ensure that they will be a good fit in the mortises which have already been cut in the ends.

When the back and floor have been properly cut out and glasspapered, try them for fit, and when you are quite satisfied that they fit perfectly, glue them carefully into position in the mortises of the ends.

All that now remains is to cut the two front stiffeners, one only of which is shown on the design sheet; the two additional stiffeners which fit behind those at the front; and the two floor fillers. These are all glued into the positions shown by the dotted lines on the design sheet, and the finished appearance of the article is made perfectly clear by the illustration.

To complete the rack, the worker may either stain and polish the work, or he may wish to leave the wood in its natural colours and merely wax polish it. If he favours this latter course, it would make the article more attractive if, instead of leaving the whole of the woodwork in its natural colour, he stained the linings of the end a dark colour in order to show up the griffins. Some workers, of course, may wish to use enamels to fit in with an existing colour scheme in the home. If this is done, be sure to use good quality paints and make quite sure that it is dry before the article is handled.



SUPPLEMENT TO HOBBIES No. 2914.

**MINIATURE GALLEON MODEL THE 'MARY FORTUNE'**

SIZE—LENGTH 7ins. HEIGHT 5½ins.

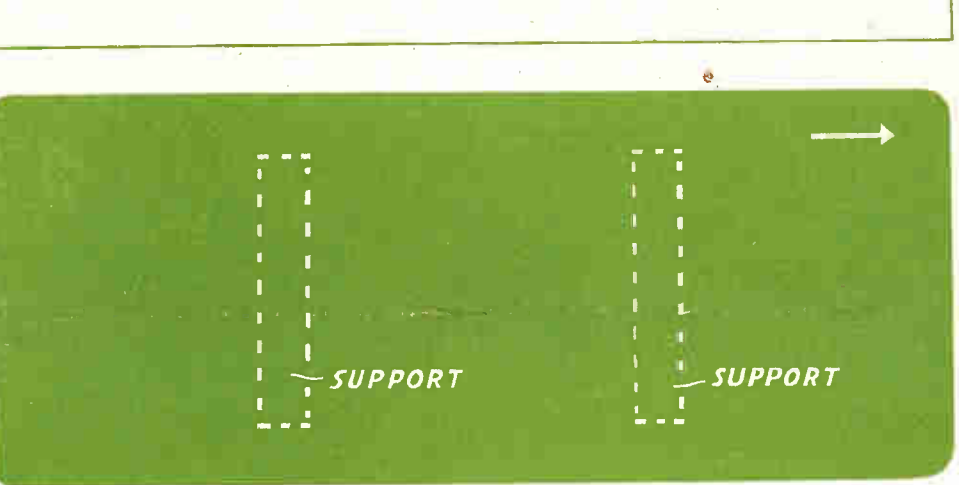
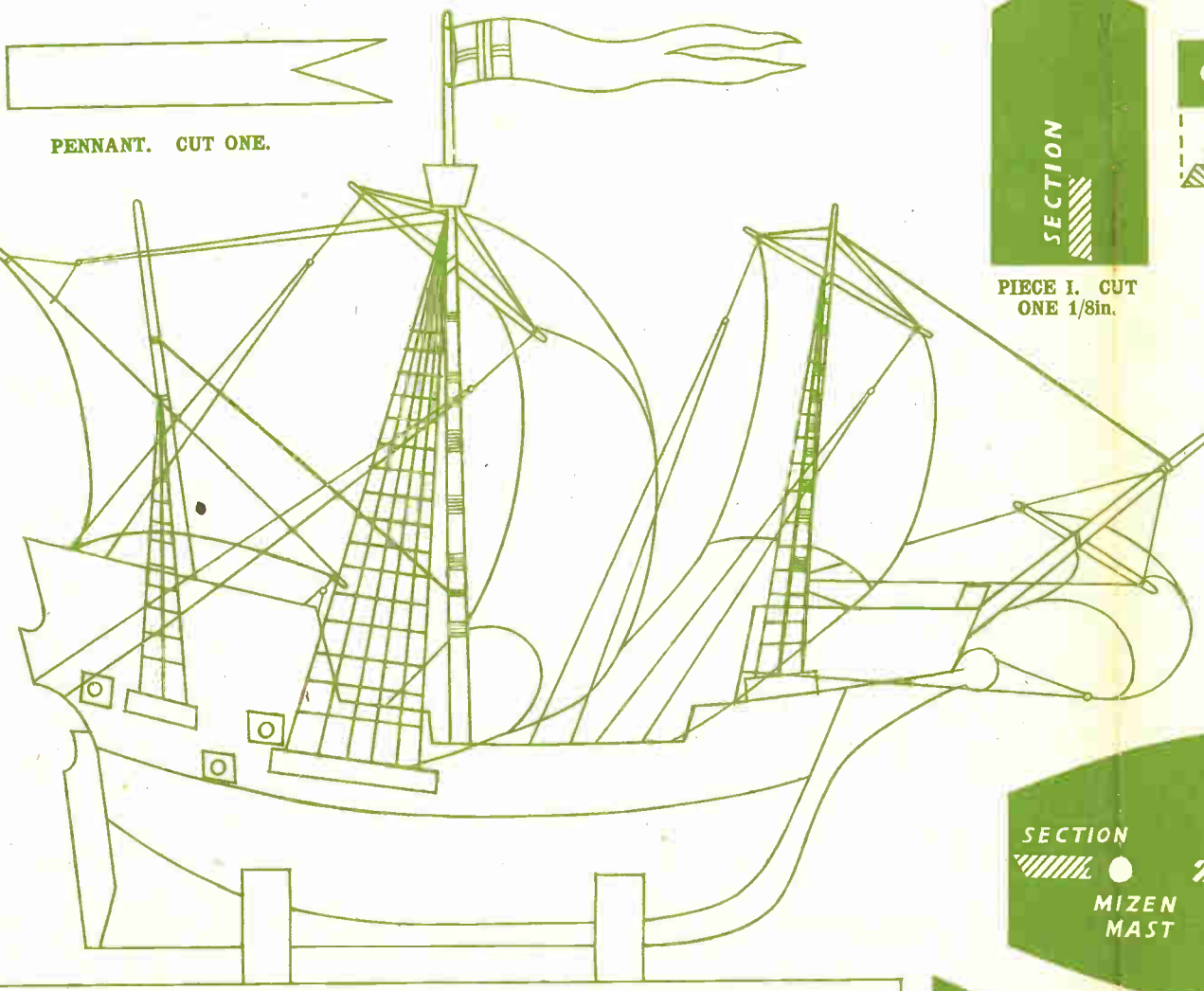

BASE. CUT ONE 1/4in.

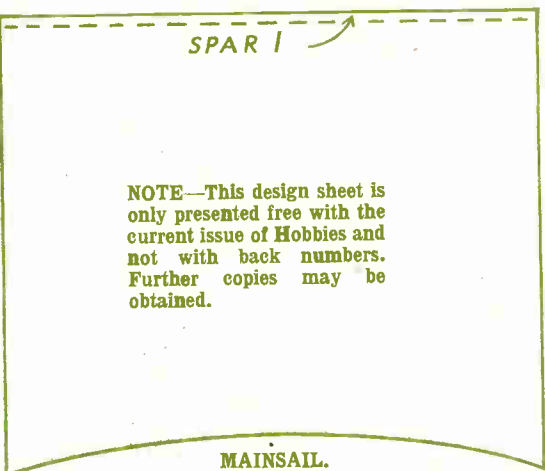

MAINSAIL.

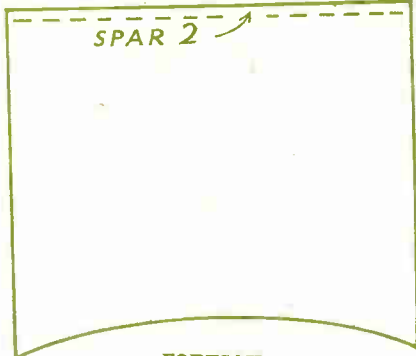

FORESAIL.

SAILS. CUT ONE OF EACH.



SPRITSAIL.

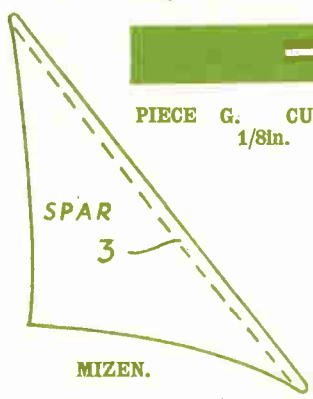

MIZEN.

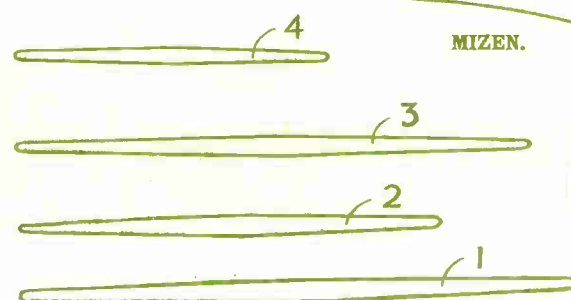

SPARS. CUT ONE OF EACH FROM 1/8in. ROUND ROD.

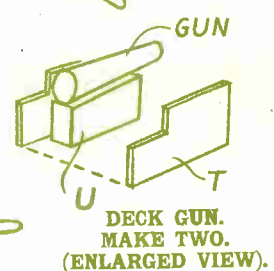

DECK GUN. MAKE TWO. (ENLARGED VIEW).



PIECE I. CUT ONE 1/8in.

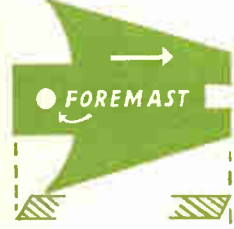

PIECE J. CUT ONE 1/8in.



PIECE K. CUT ONE 1/8in.

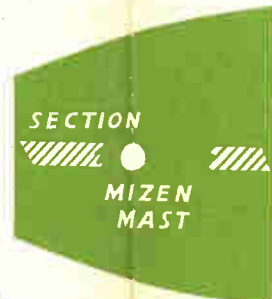

PIECE H. CUT ONE 1/8in.



DECK GUN. PIECE T. CUT FOUR FROM CARD.



PIECE F. CUT ONE 1/4in.



PIECE E. CUT ONE 1/4in.



GALLEON SUPPORT. CUT TWO 1/4in.

THE TWO SUPPORTS WILL DIFFER SLIGHTLY AND WILL BE TRIMMED TO CONFORM TO INDIVIDUAL SHAPING OF THE HULL.

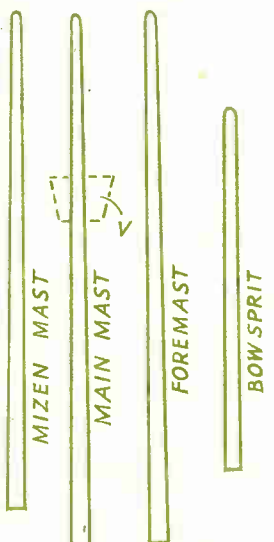

MASTS. SHAPE ONE OF EACH FROM 1/8in. ROUND ROD.



STEPS Q. CUT TWO 1/8in.



STEPS R. CUT TWO 1/8in.



PIECE U. CUT TWO 1/8in.



CHANNEL O. CUT TWO 1/8in.



CHANNEL P. CUT FOUR 1/8in.



BULWARKS N. CUT TWO FROM THIN WOOD OR CARD.



STEPS S. CUT TWO 1/8in.



FIGHTING TOP V. CUT ONE 1/4in. AND SHAPE.

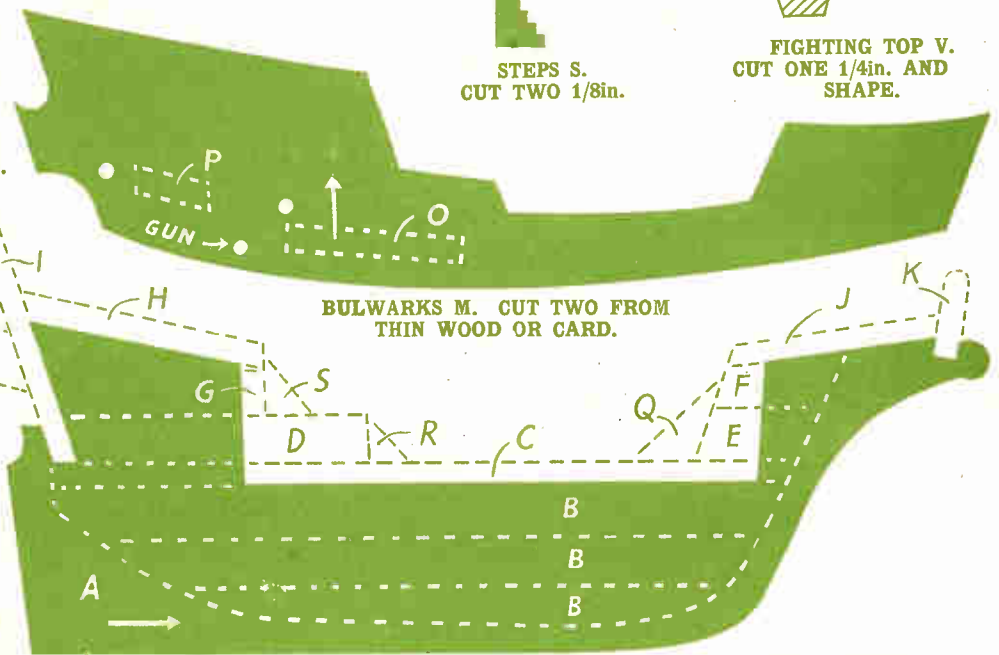

BULWARKS M. CUT TWO FROM THIN WOOD OR CARD.



PIECE L. CUT ONE 1/4in. AND SHAPE.

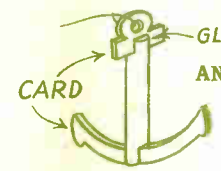

ANCHOR (ACTUAL SIZE). MAKE ONE FROM ROUND ROD AND CARD.

KEEL A. CUT ONE 1/8in.

THE ARROWS INDICATE THE DIRECTION OF GRAIN OF WOOD.

PIECE D. CUT ONE 1/4in. CHAMFER TO SECTION.

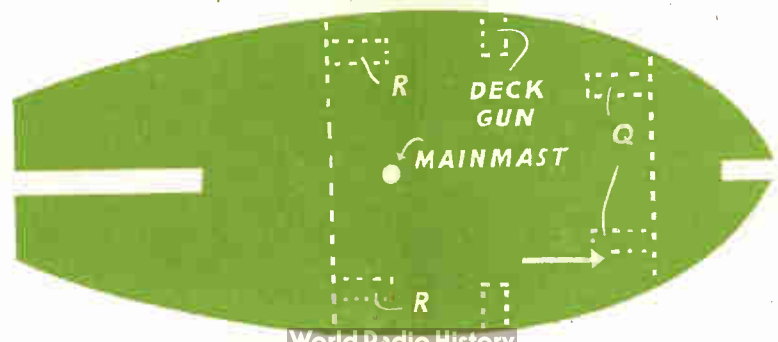

DECK O. CUT ONE 1/8in.

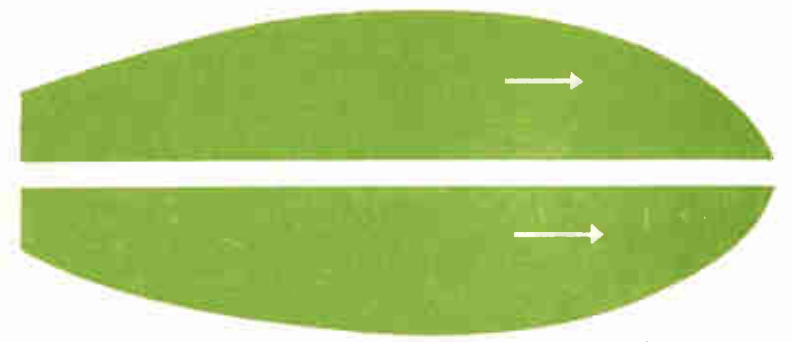

PIECE B. CUT THREE OF EACH 1/4in. GLUE TOGETHER.

PRINTED IN ENGLAND.



# Complete instructions for building THE 'MARY FORTUNE'

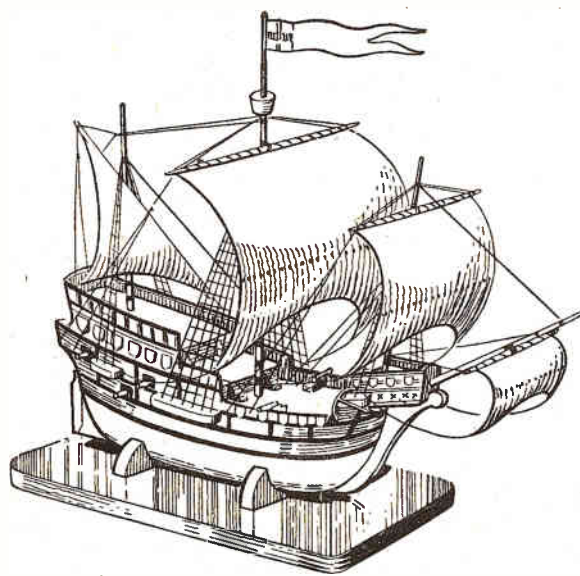

**T**HE subject of this design was one of the first ships made for the Royal Navy. It was one of four built to the order of King Henry VII, who was responsible for the first regular Navy, as hitherto ships had mostly been hired when needed.

It is a striking little model, and can be tackled by the not-too-advanced worker, as the main requisite is patience. The cutting out is simple enough and there are no intricate pieces.

## The First Job

The first job is to trace the parts on to the wood. All the main parts should be

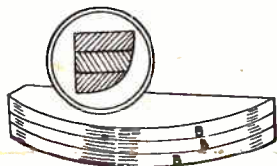

Fig. 1

transferred before cutting begins, so as to be sure of having enough wood for everything. The smaller pieces such as the steps, etc., can be marked and cut from waste wood later.

The pieces, it should be noted, have been lettered as near as possible according to the sequence of assembly.

You should begin by cutting out the hull pieces B. There are six of these, and after they are cut they should be glued

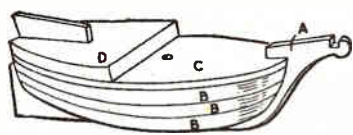

Fig. 2

together in two sets of three, and shaped to the section as shown in Fig. 1, and also according to the dotted lines on piece A on the design sheet. The finished sketch also gives an idea of this shaping.

Next cut the keel piece A from 1/4 in. wood, and be careful how you handle it before it is glued, because the neck of the bow has the grain running across it, and, if the piece is awkwardly handled, it may split.

together so that piece F is forward of piece E and the shaped ends fit as shown by the dotted line on the keel on the design sheet. When the glue is set these pieces must also be shaped so as to continue the contour of the hull. It will be found that it is not possible to do this shaping before the pieces are glued into position.

Now cut the pieces G and H and the stern piece I, and glue them into position, and follow this by dealing with the forward deck piece J and the bowsprit piece K. The hole in the bowsprit piece is at an angle of about 45 degrees to give the bowsprit an upward slope. It will be found quite simple to make this hole at the required angle if the job is tackled in the following manner. Before cutting the piece out, start the hole with a fine fret drill and then enlarge it with a rat-tail file, making sure to keep the file at the required angle. When the hole has been properly made, cut the piece out. Sloping holes are also required in the deck pieces H and J. It will be seen in the illustration that the foremast slopes forward and the mizzen mast slopes aft, so that the holes for these masts must be drilled and filed to the sizes and angles desired.

Piece L is now cut from 1/4 in. wood shaped to section, and then glued to piece I in the position shown by the dotted lines on the keel.

## The Bulwarks

Next deal with the bulwarks. These can be cut from the thin wood supplied or, alternatively, they can be made from thin card of postcard texture. They should be cut out and glued to the hull where indicated in the side view of the craft on the design sheet. As a safeguard, cut the bulwark pieces a little longer than the length shown on the design sheet and trim them up when they are finally glued. This extra length will allow for any fullness of the hull which may have been brought about through not removing sufficient of the waste wood during shaping. The forward bulwarks can also be cut and glued into position now. It is a good plan when gluing these thin pieces in position, to hold them temporarily with small household pins pushed in at intervals. These can be withdrawn as soon as the glue is set.

Proceed now with piece C, which forms the main deck. Clean this up, and glue into position on the keel. Piece D can also be cut and glued into position, and the shaped pieces B can now be glued one either side of the keel. The model should then look as the sketch in Fig. 2.

Pieces E and F, which form the forecastle, are the next to be cut, and these are glued

When you have gone thus far, the galleon should look like the sketch Fig. 3.

The channel pieces O (2) and P (4) can now be marked on waste wood, the holes drilled, and finally the pieces cut out and glued to the bulwarks as shown by the dotted lines on the design sheet.

## Deck Fittings

The next consideration should be the small fittings on the deck. Start with the steps, of which there are three sizes, represented by the pieces Q, R and S. Two of each are required, and they are glued as shown by dotted lines on the keel. To cut them out, use pieces of waste wood and draw the outline so that the steps themselves come at the edge of the wood as in A (Fig. 4). Cut out the notches with a fretsaw or razor blade as in B (Fig. 4), and finally cut out the main shape in the usual way.

The two deck guns come next, and these are made from pieces T and U. A

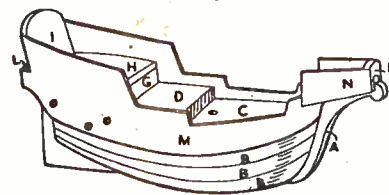

Fig. 3

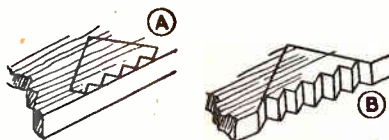

Fig. 4

diagram showing the method of construction is on the design sheet and no difficulty should be experienced. The materials used are card and dowel. The remaining six guns are shaped up from dowel rod and glued into the holes previously made in the bulwarks.

## Painting the Hull

Now paint the hull. First give the whole a coat of white. Below the waterline is left white, while the rest of the outside is painted a golden brown. The decks are then painted cream and the insides of the bulwarks red. Next line the decks with a sharp pencil and give them a coat of brush polish (such as 'Reward' French Polish) when they will be found to resemble scrubbed boards.

Continue painting the hull by putting on the dark brown bands as shown in the illustration, and painting the shields in various bright colours, adding a touch of gold here and there.

## Rigging

Now turn your attention to the rigging. First the mast and spars are shaped from 1/4 in. round rod as shown on the design sheet, where it will be found that the spars are numbered to match their corresponding sails. Fit the fighting top to the main mast and paint the dark brown bands on all three masts as shown in the illustration. These

bands represent binding.

Glue the main mast and mizzen mast into position and fix the stay X using the thread supplied. Then glue in the foremast and bowsprit and add the stay Y.

The next job is to make the shrouds, and these can be done easily by using the method detailed in Fig. 5. Thread is wrapped round the piece of card, which acts as a template, and the cross pieces are glued with transparent adhesive such as balsa cement. The illustration shows the main shrouds on the starboard side, and to make their opposite number on the port side all you have to do is turn the card over and proceed as before.

To fix the shrouds, tie their tops to the masts and thread the bottoms through the holes drilled in the channel pieces. Pull them tight and fix with a dab of Balsa cement. If you wish to show deadeyes, these can easily be represented by small blobs of Croid or similar glue. Balsa cement will not do for this job, as it has a tendency to evaporate.

## The Sails

Next cut out the sails from the parchment provided. Glue the spars into position on the sails and then lace with thread as in the illustration. The sails can now be lashed to the masts and the running rigging added as in the drawing. The pennant is cut from parchment and after it has been glued to the main mast it is bent a little to give it a lifelike appearance, and is finished by being appropriately painted.

The anchor can be made from card and round rod, as shown in the small draw-

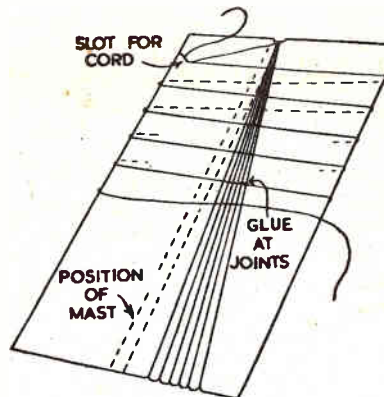

Fig. 5

ing on the design sheet, and is fixed in position over the channel near the bow.

## Making the Stand

The galleon itself is now complete and it only remains to make the stand. The supports (2) must be trimmed to fit the 1/4 in. keel piece and the rounded bottom of the hull. It will be found easier to polish the base piece before the supports are glued into position, and it should be given two or three coats of brush polish, and glasspapered between coats. Then scratch a little of the polish away where the supports are to be fixed and glue them into position. The supports will also have been polished before fixing.





18 1/2 ins. LONG.  
11 ins. WIDE.  
16 1/2 ins. HIGH.



SUPPLEMENT TO HOBBIES No. 2910.

# DOLL'S HOUSE

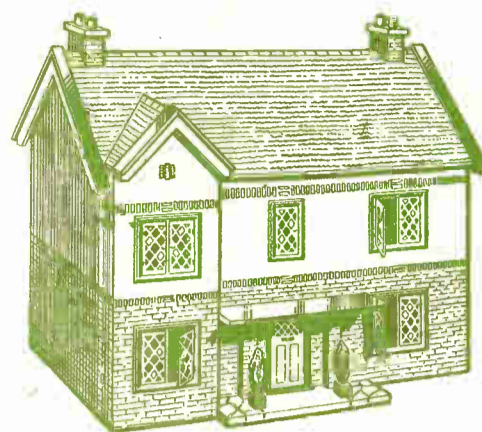

A COMPLETE SET OF MATERIALS IS SUPPLIED FOR MAKING THIS DOLL'S HOUSE. PRICE ON APPLICATION FROM HOBBIES LIMITED, DEREHAM, NORFOLK.

EXCEPT WHERE OTHERWISE STATED, ALL PARTS ARE CUT FROM 1/4 in. THICK MATERIAL.

CAPPING TO MAIN GABLES. CUT FOUR 1/8 in. STRIPWOOD.

EDGE OF ROOF SLOPE

No. 14. GABLE BOARDS TO MAIN GABLES. CUT FOUR 1/8 in. STRIP.

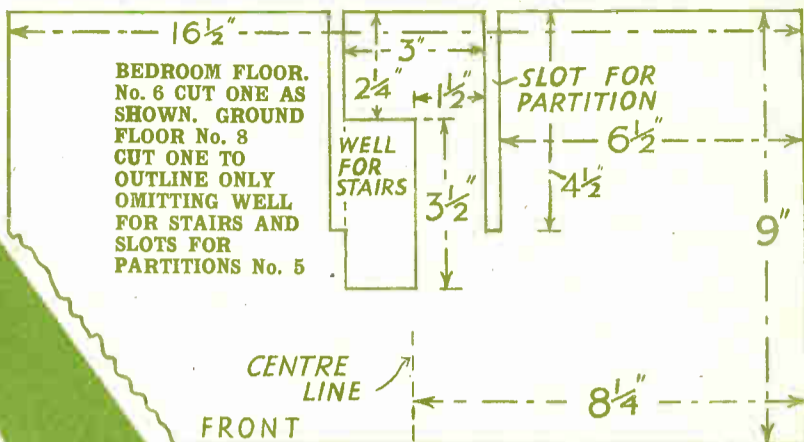

ROOF SLOPES, SMALL GABLE. CUT THE TWO TO LENGTH SHOWN AND BUTT TOGETHER AT RIDGE IN A SIMILAR MANNER TO LARGE GABLES.

CUT ONE THIS LENGTH - CUT ONE THIS LENGTH -

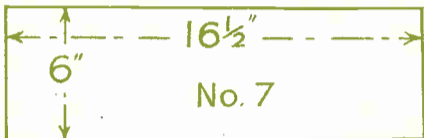
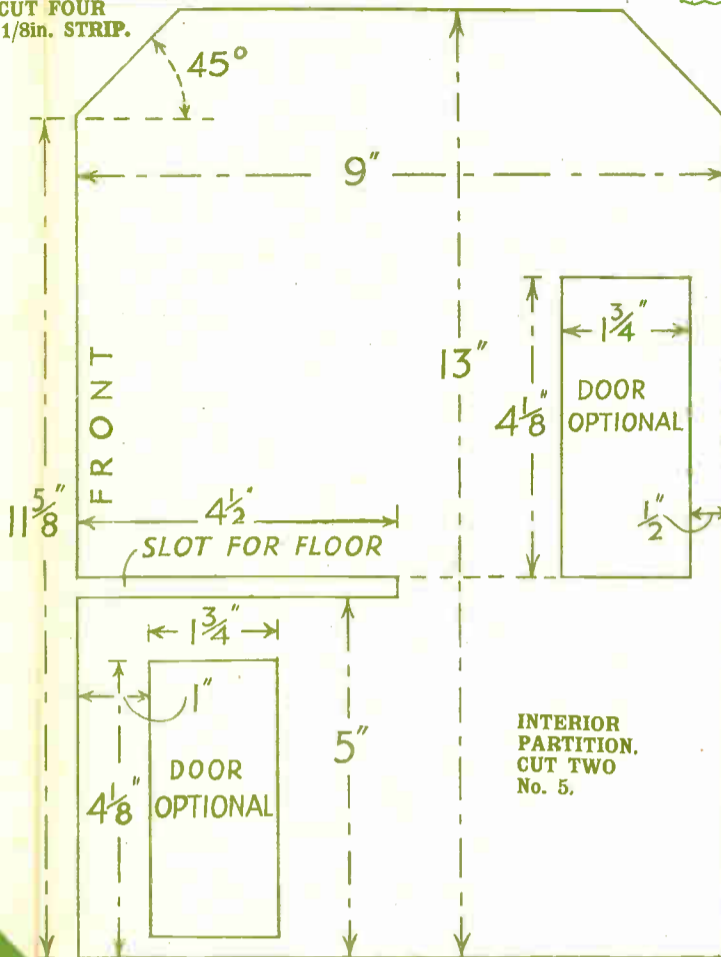

BEDROOM CEILING. CUT ONE.

No. 13

STEP AND HOOD TO FRONT DOOR. CUT ONE OF EACH.



NOTE This design sheet is only presented free with the current issue of Hobbies and not with back numbers. Further copies may be obtained.



GABLE No. 12 (OVER No. 10) FULL SIZE

SHRUB No. 23 CUT TWO FROM CARD AND GLUE TO TUB 22



DETAIL OF ROOF SLOPES SHOWING HOW THEY ARE BUTTED TOGETHER AT RIDGE AND NAILED.

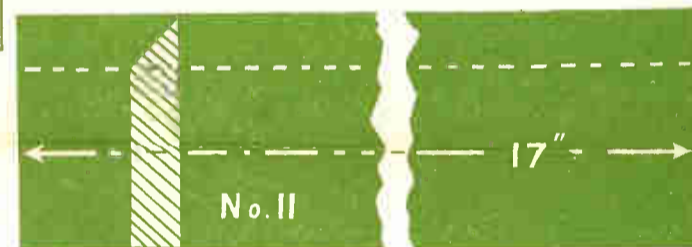

SHRUB TUB 22.

STRIP ABOVE MAIN FRONT OF HOUSE. CUT ONE TO LENGTH SHOWN AND CHAMFER TOP EDGE.

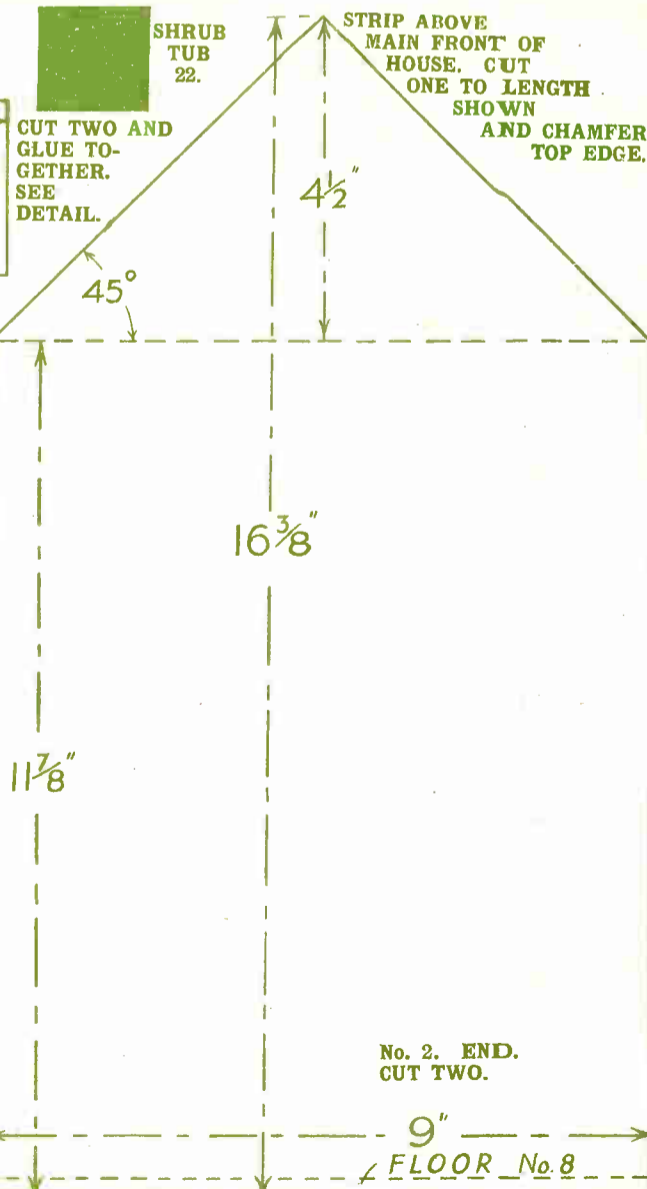

No. 2. END. CUT TWO.

FLOOR No. 8

PRINTED IN ENGLAND.

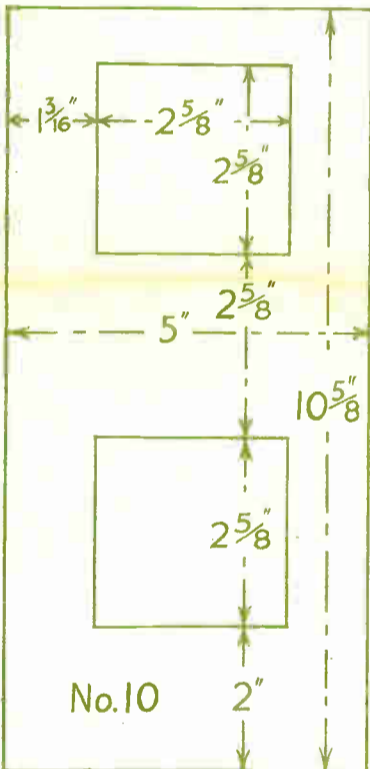

GABLE FRONT. CUT ONE FROM 3/4 in. WOOD AND GLUE ON FRONT.

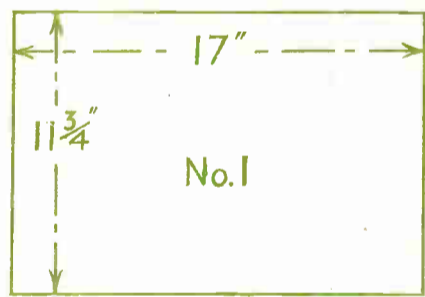

BACK. CUT ONE.

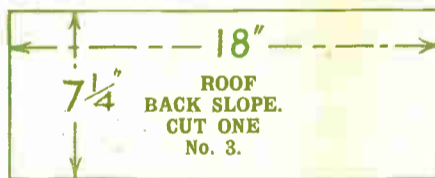

CUT TWO AND GLUE TOGETHER. SEE DETAIL.

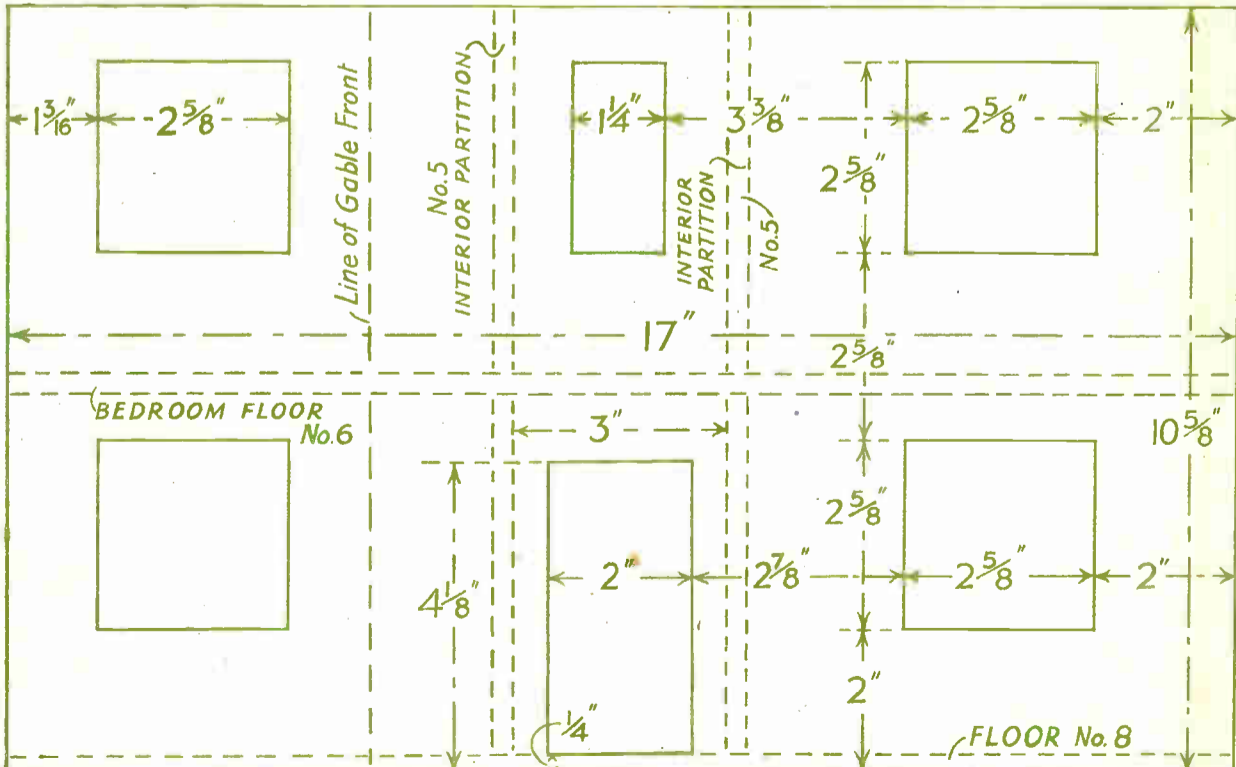

No. 9. FRONT OF HOUSE.

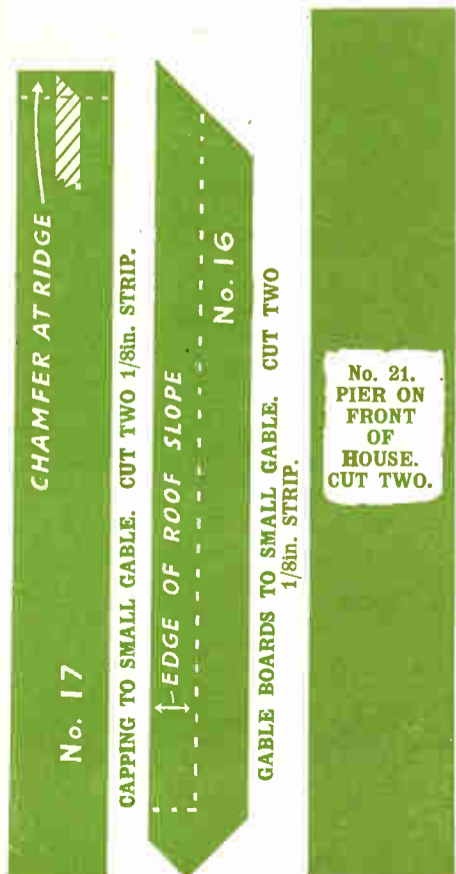



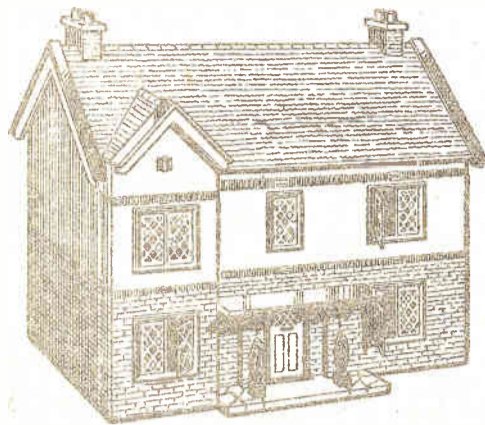

## How to make this ATTRACTIVE DOLL'S HOUSE

come to 'hang' these doors, it would be a good idea to number each in such a way as to be able to tell which door came from which hole. In this way you will ensure a perfect fit when the doors are replaced.

The partitions, bedroom floor and bedroom ceiling are now assembled as shown in Fig. 2. This section should then be put inside the shell already assembled, fitted up inside the roof slopes, and pinned from the back and sides. To overcome any tendency for the pins to pull out of the composition board, the edges should be first lightly smeared with glue. This will ensure that

**A**t some time or another, every little girl wants a doll's house, and here is one which will satisfy even the most critical. Yet, although it looks well, it is not exorbitant in price nor hard to construct.

All the pieces on the design are numbered, and as near as possible in sequence according to their assembly. The main construction is from  $\frac{1}{4}$  in. composition board while the gable boards, capping and decorative pieces along the front of the house are of  $\frac{1}{2}$  in. by  $\frac{1}{4}$  in. strip, and the projection on the left of the house is of  $\frac{1}{2}$  in. thick wood. The windows, front door, stairs and chimneys, as supplied, are ready-made from pressed metal, and are complete with imitation glass, door knocker, and everything necessary to give them an air of realism. They all work, too.

The overall size of the house is 18 $\frac{1}{2}$  ins. long, 11 ins. wide and 16 $\frac{1}{2}$  ins. high. This will be found to be of ample size for the requirements of most young ladies, and gives space for two hallways and four large rooms in which the owner can spend many happy hours in 'furnishing'.

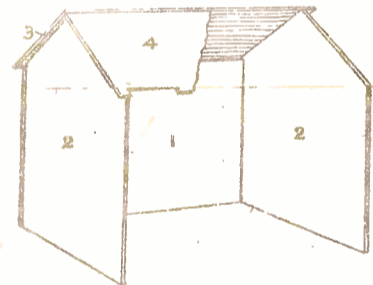

Fig. 1—Assembly of the main shell

See that all the parts are transferred to the boards before you begin cutting. The diagram shows how some of the parts are fitted together for economy.

### How to Begin

To begin construction, cut the back (1), the ends (2), the back roof slope (3) and the front roof slope (4). These are then assembled as shown in Fig. 1, the roof slopes being butted and pinned as in the detail on the front of this design sheet.

The next step is to cut the partitions (5), the bedroom floor (6) and the bedroom ceiling (7). Be careful to cut the slots in the partition pieces and the bedroom floor correctly, so that they are a good tight fit. This will make for strength when assembled. For those who intend to cut out the doors, which are shown on the design as optional, care is again needed. You must start in the corner of the door and cut carefully round the outline so that when you have finished, the rectangular pieces which are removed from the partition pieces are ready to be used later as the actual doors. To avoid any difficulty when you

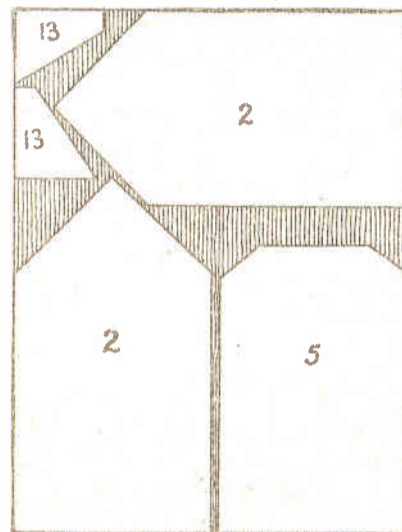

How to space some of the parts on the board for economy

the whole will set together rigidly. You can now cut the ground floor (9) and put it into place, again using glue and pins.

The next job is to cut out the front of

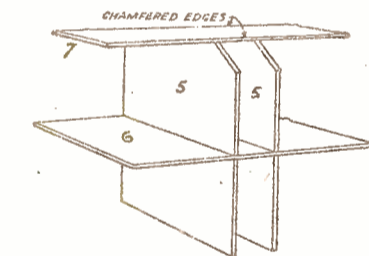

Fig. 2—Fitting the partitions, roof and upper floor

the house (9), and here every care should be taken to cut the openings for the door and windows accurately. Much of the final appearance will depend on these openings, as they will be clearly seen when the windows are opened by the young owner. When you are quite satisfied with the look of the front so far made, the gable piece (10) can be cut out (making quite sure to match the window holes with those of the front) and glued and pinned to the front.

This part should now be laid aside—suitably weighted to keep the gable piece tight to the front until the glue sets—and you can proceed with piece 11, which is cut out and glued and pinned under the front eaves of the roof. On top of this, above the main gable piece, is glued and pinned the top of the gable (12). The gable roof slopes can then be

cut out and assembled, being butted together in a similar manner to the roof itself. A detail of this part of the assembly is clearly shown in Fig. 3.

### Gable Boards

Next cut out and glue and pin the gable boards (14 and 15) in place as in Fig. 4 and the pieces 16 and 17, as shown in Fig. 3. Piece No. 18, which is the decorative strip running along the front of the house, is the next to be cut out and assembled. Fix this to the top edge of the front (9) where it will serve to hide the join when the front of the house is closed. The piece No. 19 fits on the gable piece of the front and serves the same purpose as piece 18. Now cut the two pieces 20 which form the front door step and the hood of the front door. These, together with the two piers (21) are assembled on the front as shown in Fig. 5. Glue and pins should be used to make a firm job.

Next, you can construct the two shrub tubs which are made from pieces 22 and 23 (four of 22 and two of 23); but do not glue these tubs in position until later, or they will probably suffer when you come to paper the house. The construction of the tubs is clearly shown in Fig. 6.

The next step is to hinge the whole of the front to the house proper, and the way to do this is shown in Fig. 7. The main construction is then complete, and the next job is to 'decorate' and add the fittings.

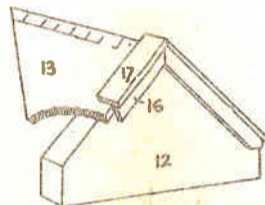

Fig. 3—Details of the gable roof slopes and the gable boards

Deal with the outside of the house first, using brickpaper for the bottom half of the house, cream or white paper for the top, and tile paper for the roof. All should be laid on carefully, making sure that there are no air bubbles, etc., in the paste and avoid wrinkles at any

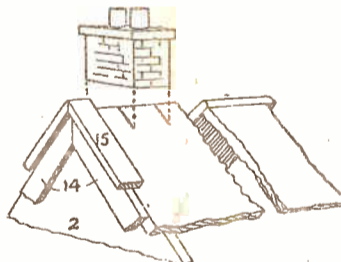

Fig. 4—How the ends of the house are finished and the chimney pots fixed

cost. The decorative strips (18 and 19) should be painted red or covered with red paper, and there should be a red strip round the house covering the division between the brick and plain cream surface of the walls. Fitting the chimneys is a simple operation, and the method will be seen from Fig. 4. Equally simple is the job of fitting the pressed metal windows and doors.

Leaving the outside for now, proceed to decorate indoors. In the downstairs rooms and hall, wallpaper will be used from floor to ceiling; but in the bedrooms and the upstairs landing the wallpaper should be only 5 $\frac{1}{2}$  ins. from

the floors, the rest of the height of the bedrooms and the ceilings being covered with the white or cream ceiling paper. The downstairs ceilings are also covered with this paper, while the floors are covered with the lino paper supplied.

In applying all these papers, do not forget the inside surface of the front of the house, which will, of course, need

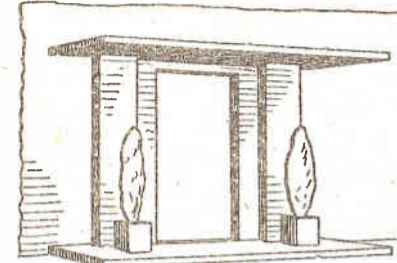

Fig. 5—The doorstep, hood and piers shown in place

the same pattern wallpaper as the downstairs floor for a height of 5 $\frac{1}{2}$  ins., and the bedroom wallpaper for the remainder. As with the outside papering, make sure to avoid air holes and other blemishes.

The doors inside can be painted on or cut out from thin cardboard suitably lined with panels. Those who have previously decided to use 'real' doors, and have cut out the necessary rectangles, should tackle the job of fitting them before they paper the walls. The doors themselves should be suitably painted and should be hinged with tape so that they open to the touch. When the wallpaper is later put on, these hinges will be nicely hidden.

The next job is to fit the staircase supplied, and this will be found a simple

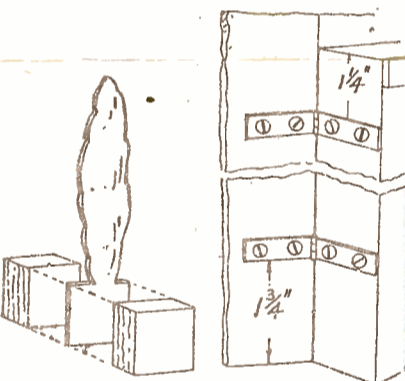

Fig. 6—Construction of the shrubs and tubs

Fig. 7—How the hinges are fitted

enough job. Those who wish, incidentally, can fix a small balustrade round the head of the stairs to give added realism to the house. Two suitable pieces of odd wood will do the job nicely. The last job inside the house is to fix the fireplaces, and this is easily done with small fret pins.

'Outdoors' again, paint the gable boards, capping, door hood and shrub tubs green. The shrubs themselves should be painted another shade of green. The door step should not be painted, as in its natural state it resembles stone.

All that now remains is to fit the two screw eyes into the end of the front and the hooks to the side of the house. The whole thing is then complete and will be the pride of its young owner for many years to come.



NOTE—This design sheet is only presented free with the current issue of Hobbies and not with back numbers. Further copies may be obtained.

SUPPLEMENT TO HOBBIES No. 2908.

**CAKE OR FRUIT STAND**

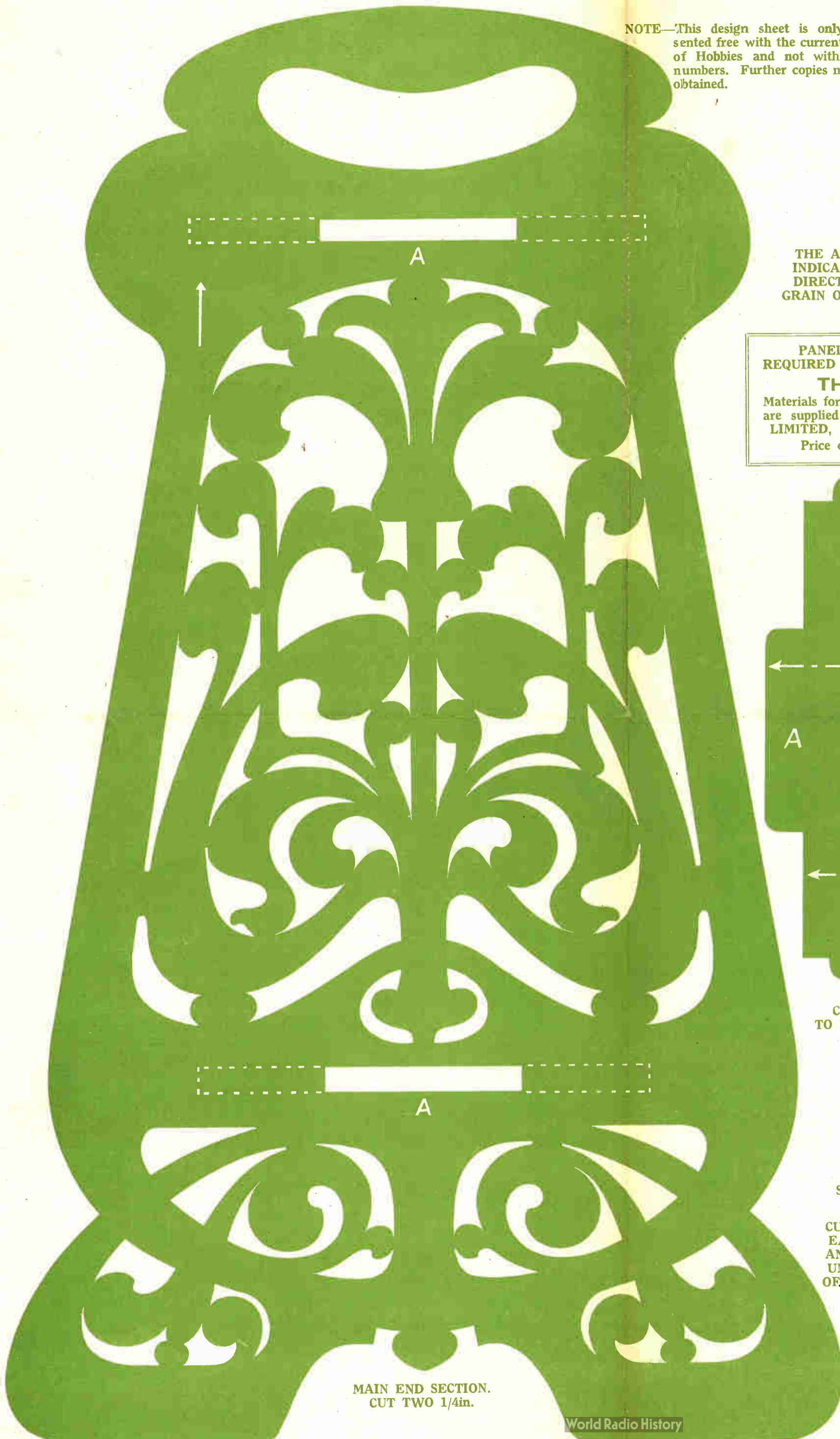

THE ARROWS INDICATE THE DIRECTION OF GRAIN OF WOOD.

PANELS OF WOOD REQUIRED FOR THIS DESIGN  
**THREE J4**  
Materials for making this design are supplied by HOBBIES LIMITED, Dereham, Norfolk. Price on application.



SIZE  
HEIGHT 14½ ins.  
WIDTH 8½ ins.

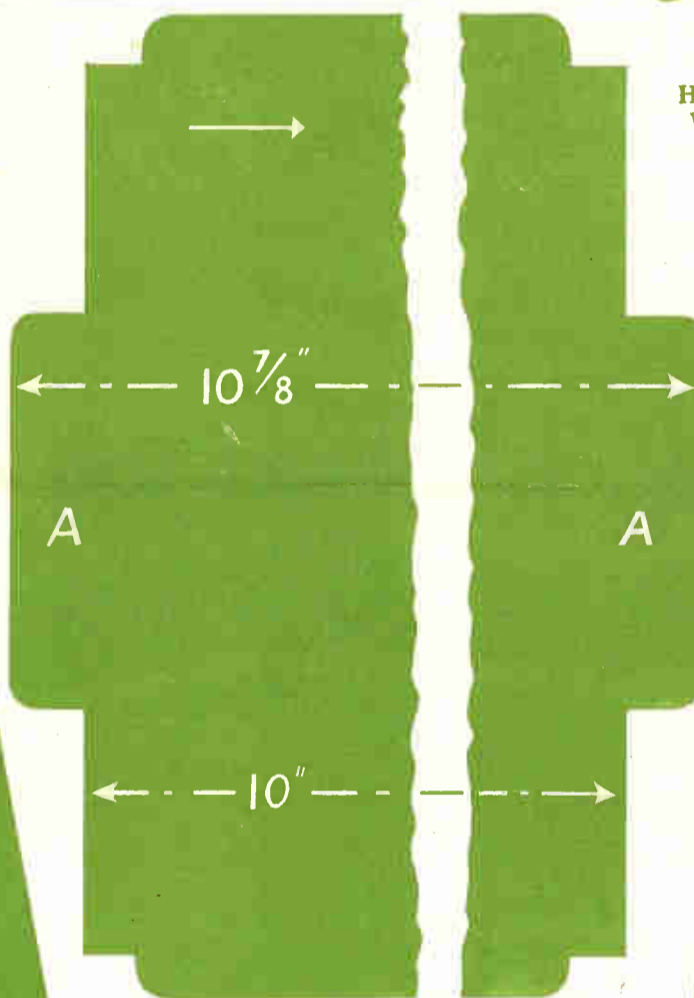

SHELF.  
CUT TWO 1/4 in.  
TO LENGTH SHOWN.

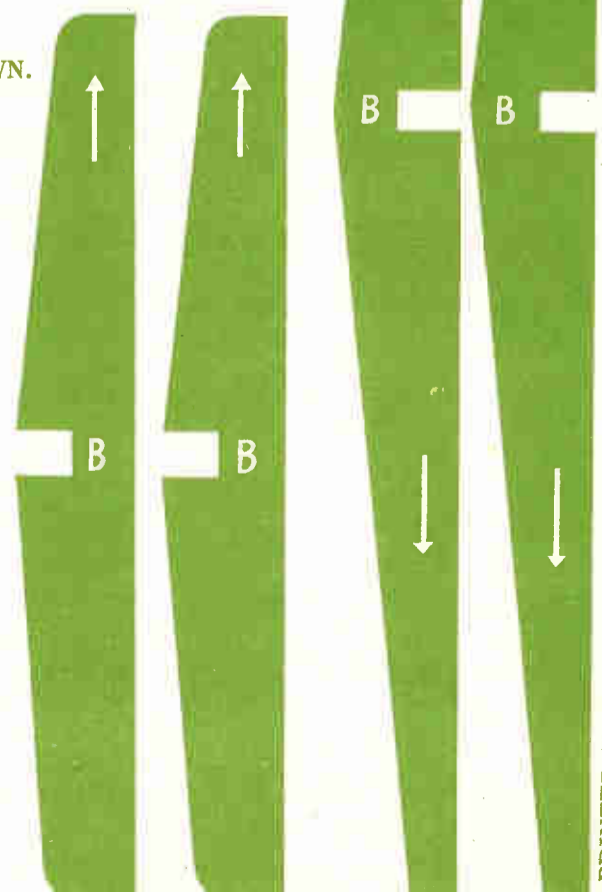

STIFFENING  
PIECES.  
CUT ONE OF  
EACH 1/4 in.  
AND FIX TO  
UNDERSIDE  
OF SHELVES.

MAIN END SECTION.  
CUT TWO 1/4 in.

# A CAKE OR FRUIT STAND

**T**HIS Cake or Fruit Stand is a useful article to make for the home, and will be found a handy size for carrying, and large enough to hold normal cake plates or fruit bowls. It is an admirable job for the ardent fretworker, too, because, as can be seen, the frets to be cut in the main end sections will need to be done carefully if the finished job is to look as well as it should.

## Duplicate Needed

First of all you will need to duplicate the pattern of the main end shown on the design sheet. In order to have a second part. This can be done by laying the pattern over a piece of carbon or another piece of white paper. Pin the three pieces down with drawing pins so there is no movement during the operation of marking out. Then go over the lines of the design carefully and with a fairly hard pencil. Where possible, use a ruler to get straight lines correct.

When the design part has been traced off in this way, the paper duplicate can be used as the pattern for the second piece of wood. Paste both pattern pieces on to the pieces of wood, making sure that the arrow on the design runs in the same direction as the grain of the wood. See that the patterns are put on perfectly flat, and allow them to dry thoroughly before you commence cutting.

While these two pieces are drying, you can prepare the shelves. For lack of space the ends only of one shelf are shown on the design, and here again you will need to trace off another set of patterns. When you have done this, cut each set down the centre (between the jagged lines) and space them out to an overall length of 10½ ins. Be sure that they are laid on perfectly square and join up both ends of each set with ruled lines.

## Cut Carefully

If the patterns pasted to the end sections are now dry, you can commence cutting, being extra careful to make a good job of the frets. Get the fretsaw right into the corner of the two mortises on each end, and keep slightly on the inside of the line to ensure a good fit. If you cut round the outside and make the hole too large you will not be able to get the shelves to hold properly. On the other hand, if the slots are small you can always glasspaper down the projecting tenons on the shelves until they fit.

Having cut out both main end sections and cleaned them up, you can now proceed to cut the shelves. These should be simple enough, but care should be taken to make the straight lines truly straight. When these are finished the tenons should be tested in their respective mortises and proved

correct, but do not glue together yet.

## Stiffening Pieces

To complete the work of construction, cut out the four stiffening pieces (B), halve them together, and glue them to the undersides of the shelves in the centre, and with the long arms running lengthways of the shelves. Be sure to get the pieces quite flat to the shelf before gluing, and then make sure that they are glued securely. To give extra strength, the pieces can be screwed with small fret screws, through from the tops of the shelves, but if this is done, make sure to countersink the screw heads and fill in the resulting holes with plastic wood or similar filler.

The shelves can now be glued into the main ends. Wipe away any superfluous glue before it has time to dry, and then leave the whole thing to set thoroughly. Make sure, incidentally, that all four feet of the article stand perfectly flat. A good plan is to put the stand on a table, so that all four feet rest square and then maintain this, until the glue has set, by putting two or three heavy books on the shelves to hold the whole thing in place.

Finish is a matter for the individual craftsman and depends largely on the type of wood used. Good quality oak, etc., can be left in its natural state and wax polished, but inferior woods should be stained before polishing.



SUPPLEMENT TO HOBBIES No. 2906.

# A CHILD'S PENCIL HOLDER

A SIMPLE PIECE OF FRETWORK SUITABLE FOR THE BEGINNER



SIZE 8ins. HIGH.  
8ins. WIDE.

PANELS OF WOOD  
REQUIRED FOR THIS DESIGN

**ONE J4**

Materials for making this design are supplied by **HOBBIES LIMITED**, Dereham, Norfolk.

Price on application.

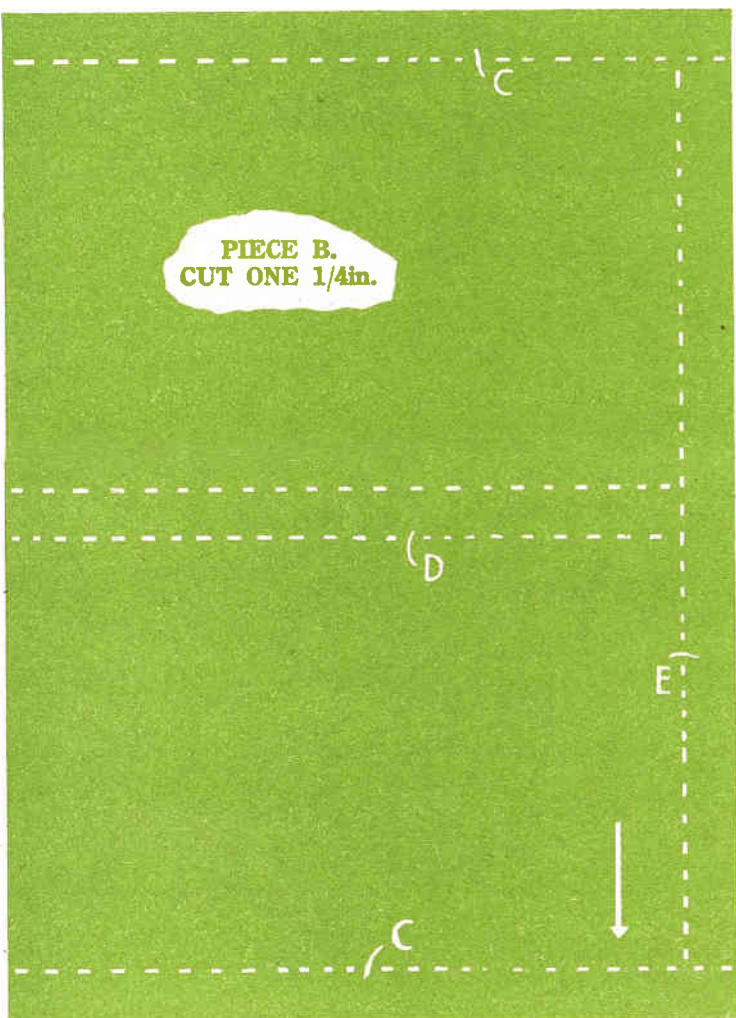

PIECE B.  
CUT ONE 1/4in.



PIECE E.  
CUT ONE 1/4in.



PIECE C.  
CUT ONE 1/4in.



PIECE C.  
CUT ONE 1/4in.



PIECE D. CUT ONE  
1/4in.

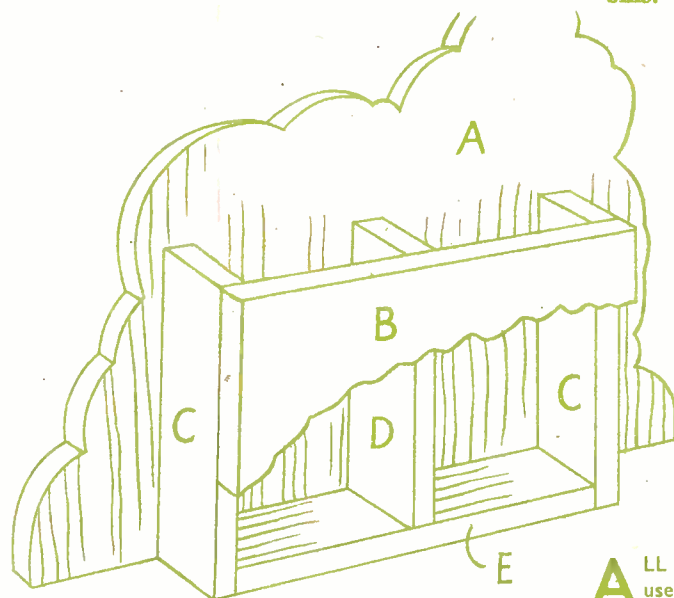

SHOWING THE CONSTRUCTION OF THE BOX.

THE ARROWS INDICATE THE DIRECTION OF GRAIN OF WOOD.

NOTE—This design sheet is only presented free with the current issue of Hobbies and not with back numbers. Further copies may be obtained.

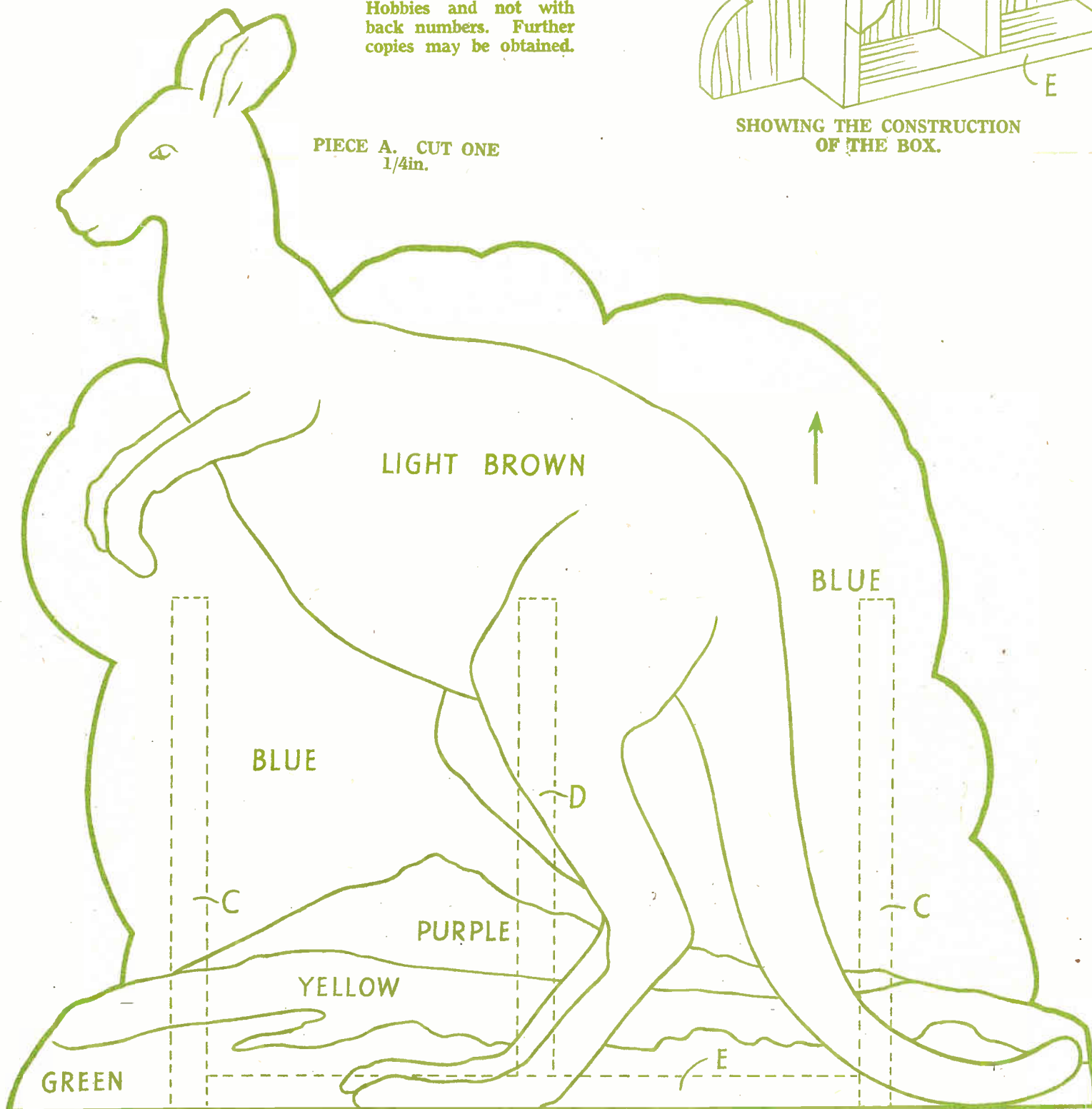

PIECE A. CUT ONE  
1/4in.

ALL children love to have pencils to use, even when they are only in the scribbling stage, and most would like to have a holder such as that illustrated.

It is attractive enough to ensure that they will treasure it—and in so doing, they will automatically safeguard their pencils. Instead of leaving them about in odd places (perhaps on the floor where they suffer from being trodden on and broken), the children will put their pencils in their 'Kangaroo Box' and all will be well.

The making of the holder is extremely simple, there being no intricate cutting and no difficult joints to worry about. In fact, it is an admirable model for a beginner at fretwork, and need not take long to make.

Nevertheless, the construction should not be done in a haphazard fashion. A little care in cutting the main outline of the front (piece A), and ensuring squareness in the pieces which form the box-like compartment behind it, will be amply repaid. Care should be taken with the finish, too, but more of that later.

Begin construction by pasting the pattern pieces to the wood, or if you prefer it, transferring the design from the pattern to the wood in the usual way. The latter method is, perhaps, the better one, as will be seen later. Make sure in either case that the arrows on the patterns are running in the same direction as the grain of the wood, otherwise you may come to grief at a later stage with pieces splitting.

Now cut out the main piece (A), making sure to get a nice clean edge, and finish with glasspaper. Next cut the large rectangular piece (B) and the smaller rectangles (C), (D) and (E). Note that there are two pieces (C). Clean up these pieces and assemble, together with piece (A), as shown in the sketch on this page, making sure that they fit squarely together. Glue and small fret pins should be used in the assembly, and the constructor should be careful to use a small fretwork hammer to avoid damaging the wood.

Before assembly, however, the paper patterns, if they have been stuck on, should be removed from the rectangular pieces. Otherwise, if left until after assembly, it will be found impossible to get them off, particularly from piece (D). The paper should not be removed from the main piece (A) until later.

The colour scheme for the front is fully outlined on the pattern, but, as the paper cannot be left on the wood

(owing to the presence of dotted lines, and the possibility of the paper peeling off after frequent handling by young people), arrangements must be made for the transfer from paper to wood of at least the main details of the kangaroo, etc., before the paper is removed.

If, at the outset, the patterns were traced on to the wood instead of being stuck down, then, of course, the problem does not arise, and painting can be proceeded with at once. Assuming, however, that the pattern has been stuck down, perhaps the easiest way to get the design through on to the wood is to run round the outline of the kangaroo, hills, etc., with a sharp hard pencil. If a moderate pressure is used, the indentation should be sufficient to make the pattern easily discernible after the paper has been removed. Do not overdo the pressure, however, or the finish may be spoiled by unsightly dents in the wood.

Thoroughly damp the pattern, so that the minimum of glasspapering is needed to remove it. Otherwise, you may find that, as well as taking off the paper, you have also taken off the surface of the wood—including the slight indentations! Take care, though, not to wet the wood itself more than necessary, or it will warp.

Now for the painting. Either water colours, poster colours or enamel can be used, but whichever medium you choose, prepare the surface of the wood first with a good filler. And, having applied the first coats of the various colours, do not be afraid to lightly glasspaper them down (when dry) and apply a second. A little extra trouble at this stage will lift your finished work out of the rut of 'amateur' woodwork, and give it that professional look which is so often the envy of those who, while they take every care with the actual cutting, etc., have never bothered to master the art of finishing.

The colour used for the pencil compartment can be any one of the colours used on the front, but for preference we would suggest blue, as this is the predominant colour of the pattern.

Whatever you do, avoid dull colours. Get the brightest you can find. Kiddies love colours, and the brighter they are the greater the attraction.

When you are fully satisfied with your painting work, give one or two coats of top-grade varnish (lightly glasspapering between each). You will then have made an article of which you can be justly proud, and one which any youngster will appreciate as a present.

PRINTED IN ENGLAND.





The arrows indicate the direction of grain of wood.

NOTE—This design sheet is only presented free with the current issue of Hobbies and not with back numbers. Further copies may be obtained.

BACKING TO LOWER RAIL FRETS. CUT ONE 1/4in. THICK

UPPER RAIL, PORTION ONLY SHOWN—NOTE DOTTED CENTRE LINE. CUT ONE 1/4in.

FULL SIZE SECTION OF MOULDING No. 308. TWO PIECES 21ins. TWO PIECES 16ins. THIS ALLOWS FOR TRIMMING AND MITREING AT ENDS.

LOWER RAIL, PORTION ONLY SHOWN—NOTE DOTTED CENTRE LINE. CUT ONE 1/4in.

OVERLAY C. CUT ONE 1/4in.

OVERLAY D. CUT ONE 1/4in.

DETAIL, SHOWING HOW TOP AND LOWER EDGES OF PANELS ARE DOVETAILED TO UPPER AND LOWER RAILS.

OVERLAY ON UPPER RAIL. CUT ONE 1/4in.

Centre Line

BACKING TO UPPER RAIL FRETS. HALF ONLY SHOWN. CUT ONE 1/4in. THICK.

ABCDEFGHIJK  
LMNOPQRSTU  
VWXYZ

FOR THE FORMATION OF THE WORDING AND ITS SPACING ON THE PANEL, SEE THE ILLUSTRATION AT TOP RIGHT OF THIS SHEET.

FORM THE WORDS BY CUTTING THE LETTERS AS REQUIRED FROM THE ABOVE.

CUT THE TWO WORDS ABOVE AND "AMEN" BELOW FROM ONE PIECE 1/8in. THICK.

ALPHABET 1/8in. THICK AND FIX BY MEANS OF GLUE.

OUR FATHER  
AMEN

NOTE—THE TWO LD6 PANELS SUPPLIED FORM THE STIFFENING RAILS FOR BACK OF TABLET. SEE DETAIL ON BACK OF THIS SHEET FOR SIZE AND POSITION.

PANELS OF WOOD REQUIRED FOR THIS DESIGN  
THREE K4  
TWO LD6  
TWO H2

Materials for making this design are supplied by HOBBIES LIMITED, Dereham, Norfolk. Price on application.

SIZE:  
HEIGHT, 27ins.  
WIDTH, 19 3/8ins.



SUPPLEMENT TO HOBBIES No. 2904  
THE LORD'S PRAYER TABLET  
SUITABLE ALSO AS A CHURCH NOTICE BOARD

Hobbies DESIGN No. 2904 27-6-51

PRINTED IN ENGLAND.



# LORD'S PRAYER TABLET

SINCE Hobbies' original design for a Lord's Prayer Tablet was discontinued some years ago, there have been many workers who have had a wish to make one. With the publication of this, an entirely new design, they will be able to satisfy that wish.

Sturdy in construction, and modern

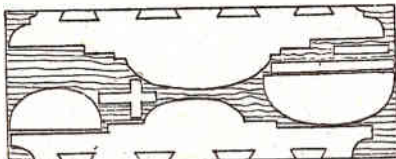

Fig. 1—How the pattern pieces are placed on the K4 panel

without being undignified, this new tablet is not hard to construct. The woodwork itself is straightforward, though it should, of course, be done carefully.

The most care is necessary when the worker comes to cut out the letters and mount them on the tablet, but more about this part of the work later.

## How To Begin

Begin construction of the tablet by taking one of the K4 panels (20ins. by 8ins.), and transferring on to it the pattern pieces for the upper rail, lower rail, overlays (D) and (C), the cross, and upper and lower backing pieces. Care should be taken to see that the pieces are transferred to the wood in the manner shown in Fig. 1, otherwise it is probable that the worker will find himself with insufficient wood to complete the job.

Now cut these pieces out, and clean

and cut the dovetails (A) and (B) at both ends of each.

When all the dovetails have been tested and prove a close fit in the top and bottom rails, the whole should be assembled. First butt the two long K4 panels together, gluing them along the joint, and then fit on the upper and lower rails, gluing the dovetails. Any surplus glue should be removed before it has time to set.

Fig. 2 shows clearly how the work so far done is assembled.

## Stiffening Rails

Next fix the three stiffening rails to the back of the tablet. These are cut

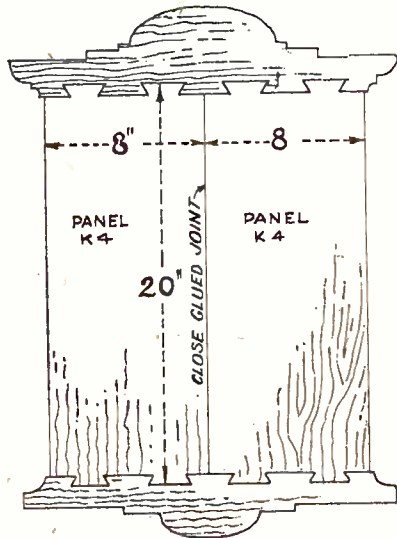

Fig. 2—Assembly of the panels and upper and lower rails

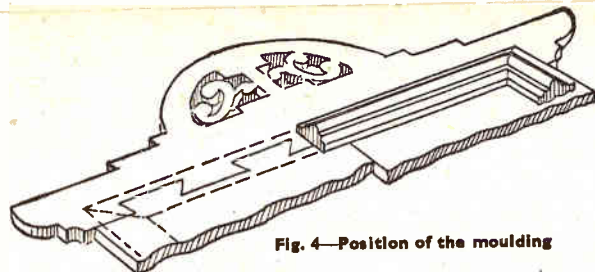

Fig. 4—Position of the moulding

them up. When cutting, particular attention should be paid to the fretwork in the upper and lower rails, as much of the final appearance of the tablet will depend on how well this work is done.

In cutting out these two rails, the worker will automatically cut the dovetails (A) and (B) in both pieces. Now take the two remaining K4 panels,

from the two LD6 panels. One of the panels is cut to length, trimmed up and used full width at the top of the back of the tablet, and the other panel is sawn in half and used in the positions shown in the detail at

Fig. 3. Brass screws of a suitable length should be used, and when finished, the whole assembly should be rigid.

## Backing Pieces

Now glue and pin the backing pieces to the upper and lower rail frets in the positions shown, and then fix the No. 308 moulding on the front of the tablet as

detailed in Fig. 4. Care should be taken with the mitres of the corners. To complete the tablet, you should now glue and pin the overlays (D) and (C), and the cross, to the face of the upper rail. The positions of these pieces can be seen in the illustration overleaf.

## The Lettering

Now comes the work of cutting out and fitting the lettering. The formation and the setting out of the wording on the panel can be seen in the illustration overleaf, and there should be a space of  $\frac{3}{8}$ in. between each line. The words 'Our Father' and 'Amen' are given in their entirety on the design sheet, and these should be cut from the  $\frac{3}{8}$ in. panels as shown.

For the rest of the wording, you will need to use the alphabet overleaf. The quickest way to get all the necessary letters cut out is to first transfer this alphabet to thin card, ivorine or some such material, and cut them out to be used as templates. You can then cut as many of each letter as required from the  $\frac{3}{8}$ in. wood. When you have all the letters cut out, arrange them on the tablet as

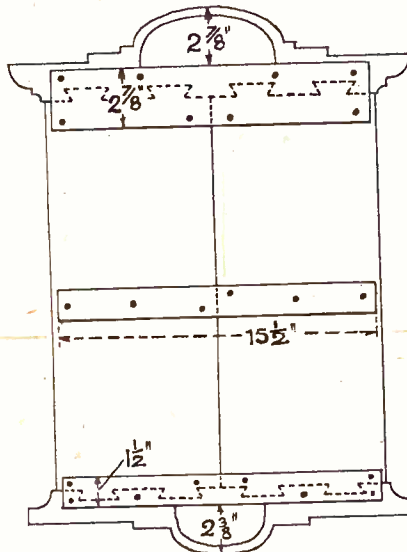

Fig. 3—How the stiffening pieces are placed

shown in the illustration overleaf, and when you are quite satisfied with the layout, glue them firmly to the tablet.

For finishing, the tablet should be left its natural colour and beeswaxed and polished. The lettering on the tablet should be painted black.



SUPPLEMENT TO HOBBIES No. 2898.

**FRETWORK CRUMB TRAY & SCRAPER**

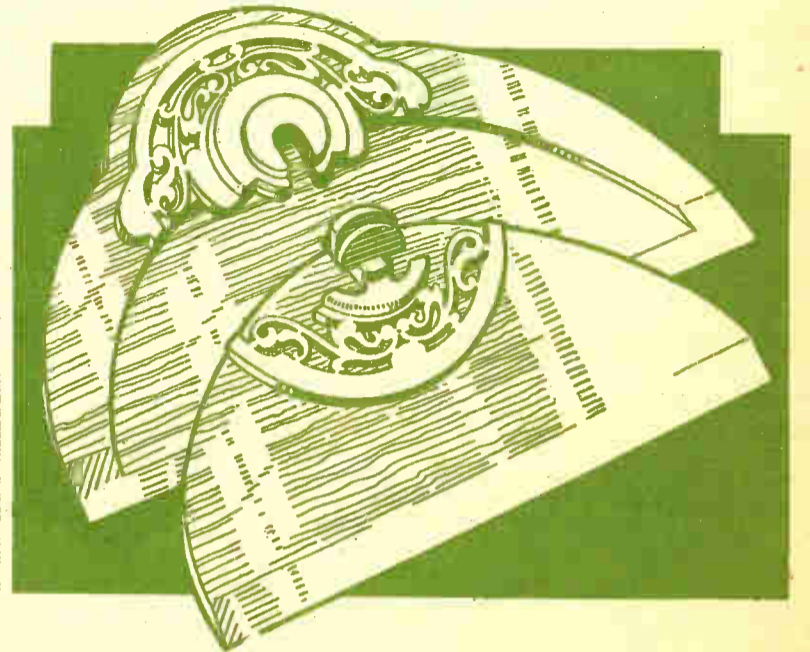

SIZE—6½ins. x 9ins.

PIECE A. CUT ONE 3/16in.

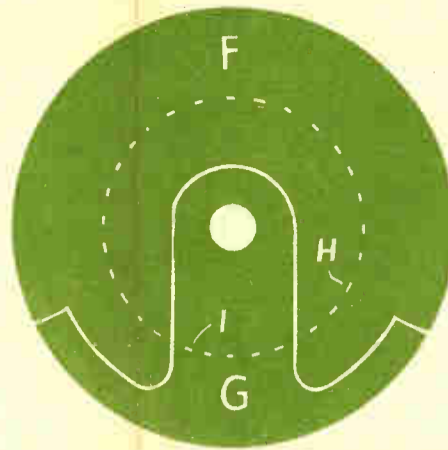
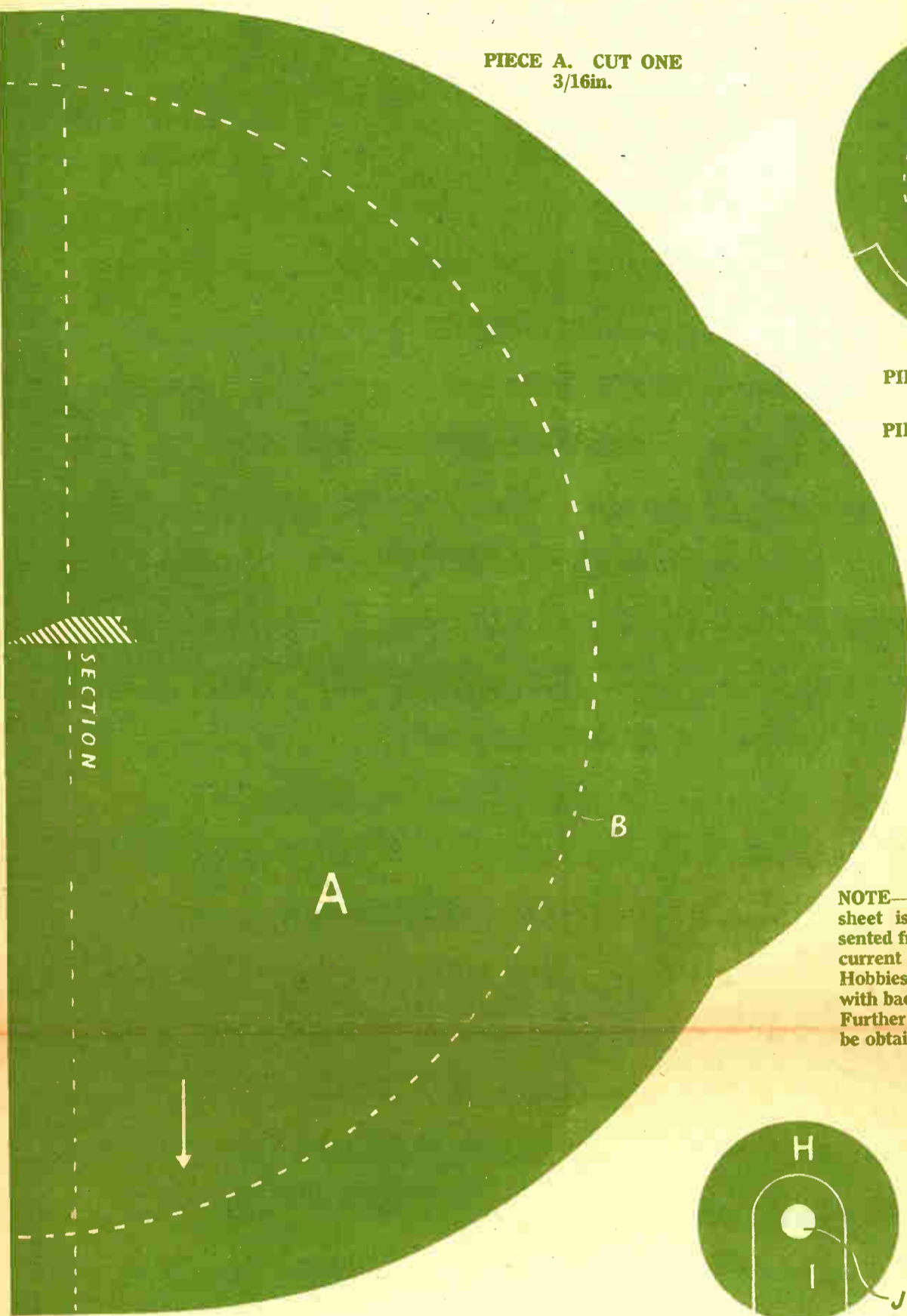

PIECE F. CUT ONE 3/16in. GLUE TO D.

PIECE G. CUT ONE 3/16in. GLUE TO E.

PANELS OF WOOD REQUIRED FOR THIS DESIGN

**Two H3**

Materials for making this design are supplied by HOBBIES LIMITED, Dereham, Norfolk.

Price on application.

NOTE—This design sheet is only presented free with the current issue of Hobbies and not with back numbers. Further copies may be obtained.

THE ARROWS INDICATE THE DIRECTION OF GRAIN OF WOOD.

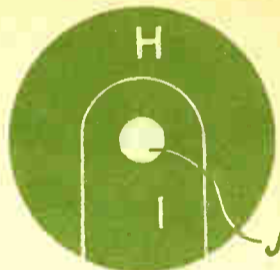

PIECE H. CUT ONE 3/16in. GLUE TO F.

PIECE I. CUT ONE 3/16in. GLUE TO G.

PIECE D. CUT ONE 3/16in. AND GLUE TO B.

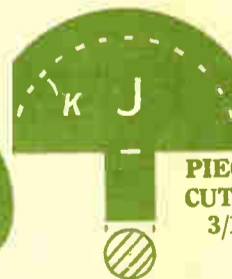
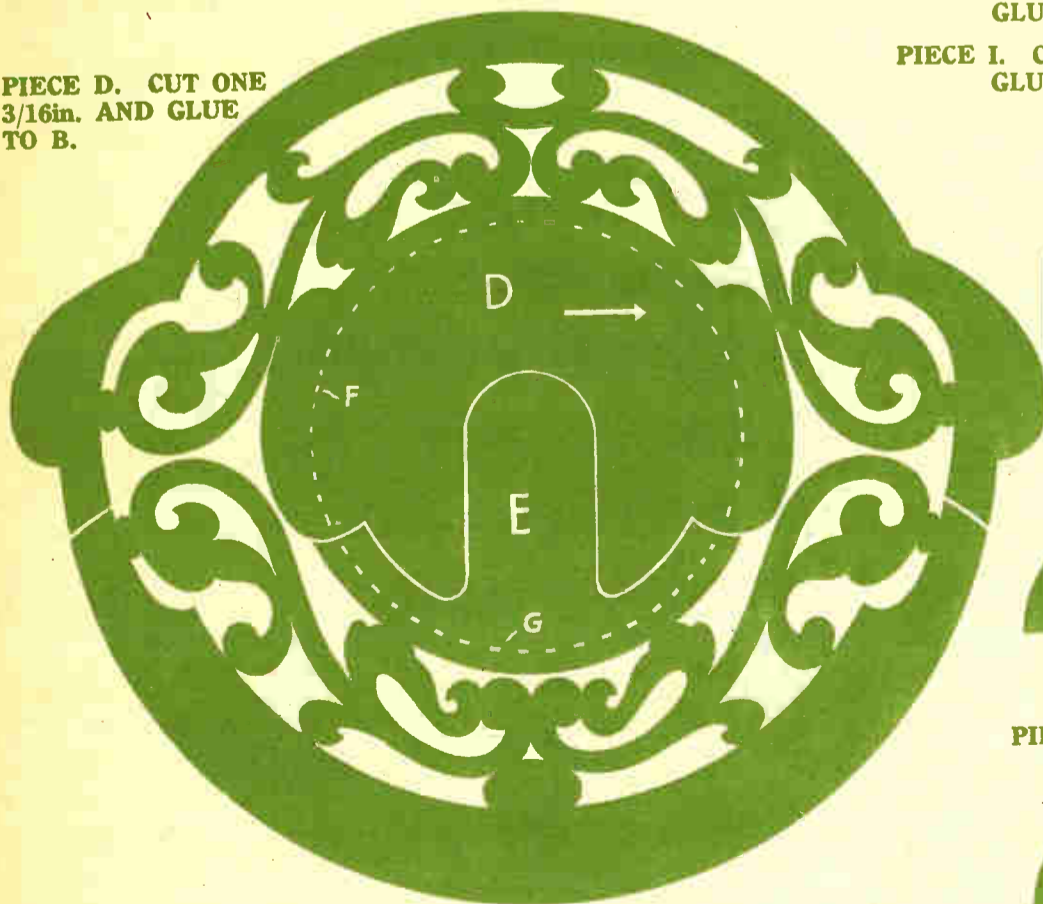

PIECE J. CUT ONE 3/16in.



PIECES K. CUT ONE OF EACH 3/16in.



PIECE B. CUT ONE 3/16in. GLUE TO A.

PIECE C. CUT ONE 3/16in.

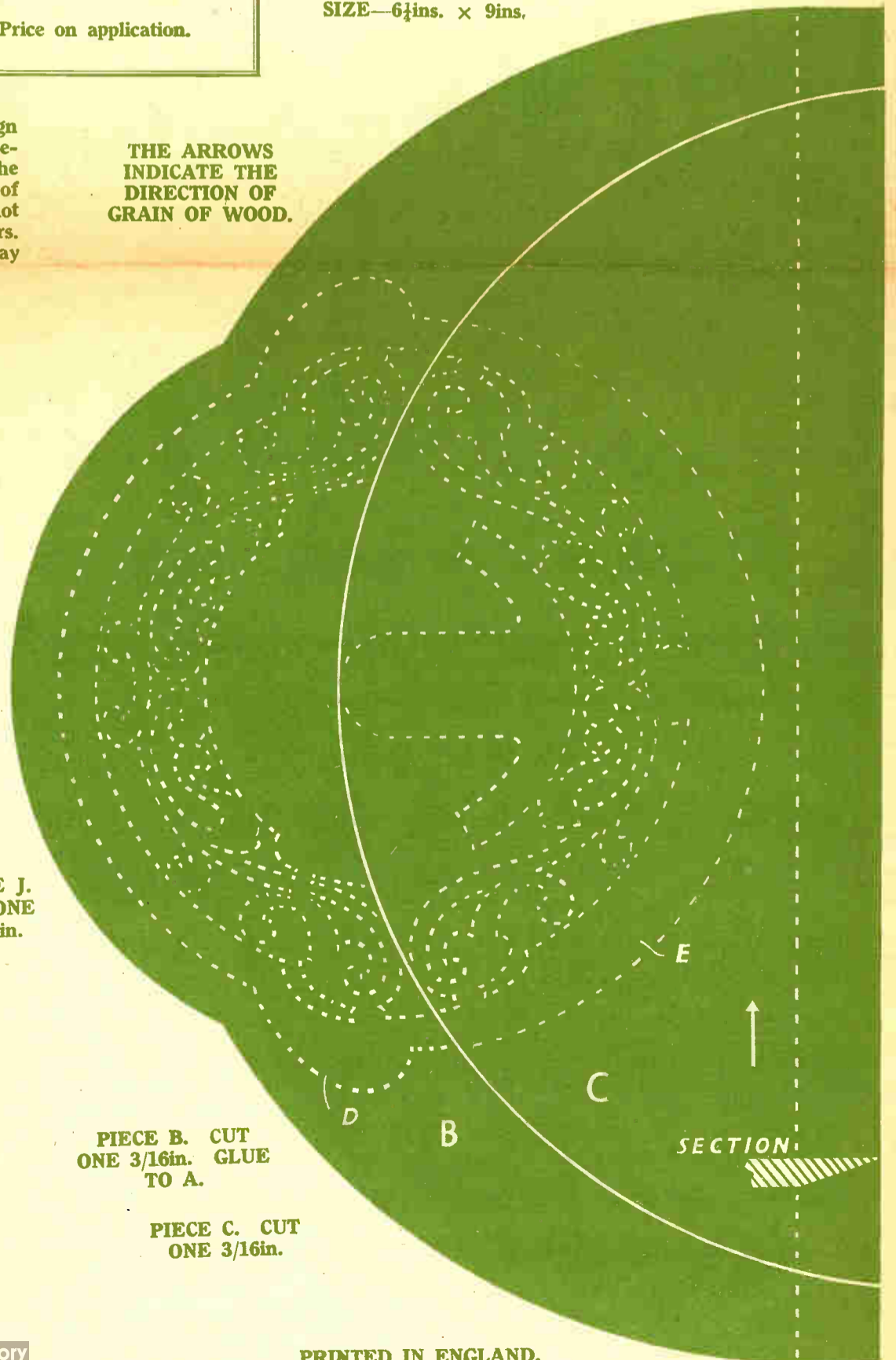

PIECE E. CUT ONE 3/16in. GLUE TO C.

# CRUMB TRAY AND SCRAPER

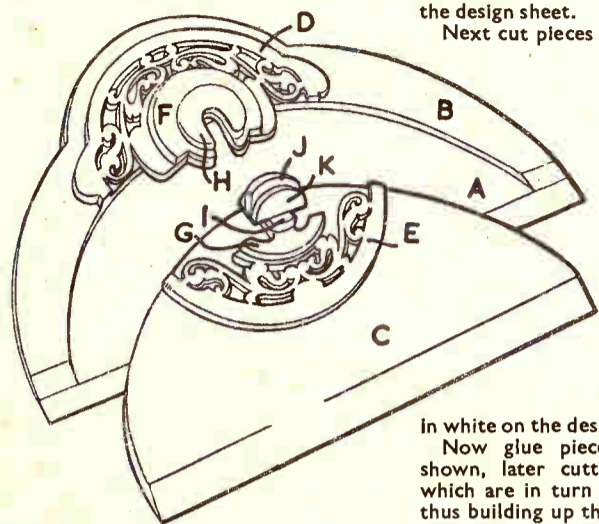

the design sheet.

Next cut pieces D and E, which make up the ornamental overlay. Cut them as a whole at first, and do not divide them until all of the work is finished. In this way, you will ensure a perfect fit of the pieces when the finished article is in use. When you are satisfied that the fretcutting has been done properly, separate the two pieces by cutting along the line shown in white on the design sheet.

Now glue piece D to piece B as shown, later cutting pieces F and H which are in turn glued on to piece D, thus building up the whole of the design on the tray. At the same time as pieces F and H are cut, incidentally you should cut pieces G and I, later dividing the four pieces by cutting along the white lines as shown overleaf.

Before putting the tray aside—and when you are quite sure that the glue is dry—chamfer the lip of the tray as shown in the section on the design sheet.

## The Scraper

Now to make the scraper. First cut piece C, and on to this glue the ornamental piece E, which you have already

cut, and the pieces G and I, which you also have to hand.

Now cut piece J and the two pieces K. Note that the pin of piece J is rounded as shown in the section. This rounded pin is glued into the hole in piece I, and the two pieces K are glued one to either side of piece J. When the lip of the scraper has been chamfered to the section shown on the design, the construction is finished.

Painting the crumb tray and scraper is not advocated, unless the paint used is of some high quality glossy finish, and if the article is to fit in with a particular colour scheme.

## Contrasts

Rather, we would prefer to see the parts stained and polished, and would suggest that the ornamental overlay and handles be stained a dark colour, and the actual tray and scraper something much lighter. In the event of the tray and scraper having been made from some nicely grained oak, for instance, they could be left in their natural colour and wax polished. The only really important thing about the colour scheme is that the ornamental work and handle should contrast from the tray and scraper.

For the man who owns a set of carving tools, it is an easy matter to make the article somewhat more attractive, by chamfering the edges of the fretwork after the design has been cut. If properly done, this will give the appearance of the design having been carved from the solid.

**T**HE fretwork crumb tray and scraper described here is a pleasing design, the scraper fitting snugly into the tray as can be seen, and would make a welcome present for any housewife. Yet it is straightforward in construction, and should not take the average worker an undue amount of time to make.

Having transferred the design, begin by cutting out the back A and the overlay B. Piece B is then glued to A in the position shown by the dotted line on



SUPPLEMENT TO HOBBIES No. 2896.

# MODEL GYPSY CARAVAN

SIZE:—12ins. LONG, 7ins. HIGH.

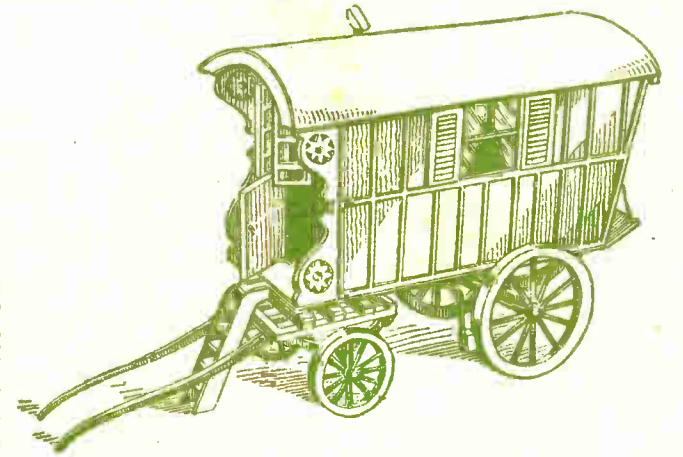

No. 34 STRAP HINGE FULL SIZE OF METAL. TO BE BENT AND PINNED TO SHAFTS

PANELS OF WOOD REQUIRED FOR THIS DESIGN

**TWO G4 TWO H2 TWO H3**

Materials for making this design are supplied by HOBBIES LIMITED, Dereham, Norfolk.

Price on application.

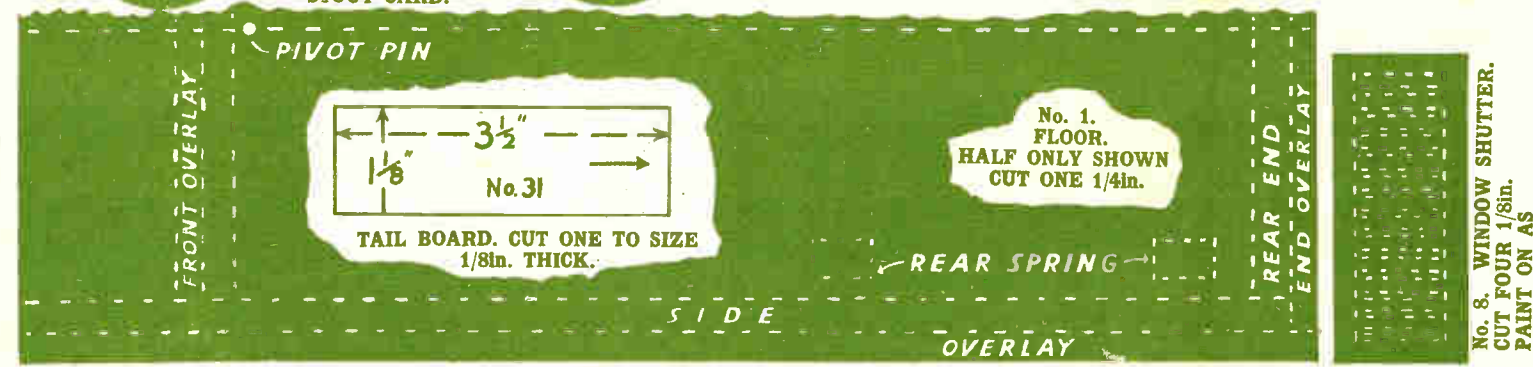
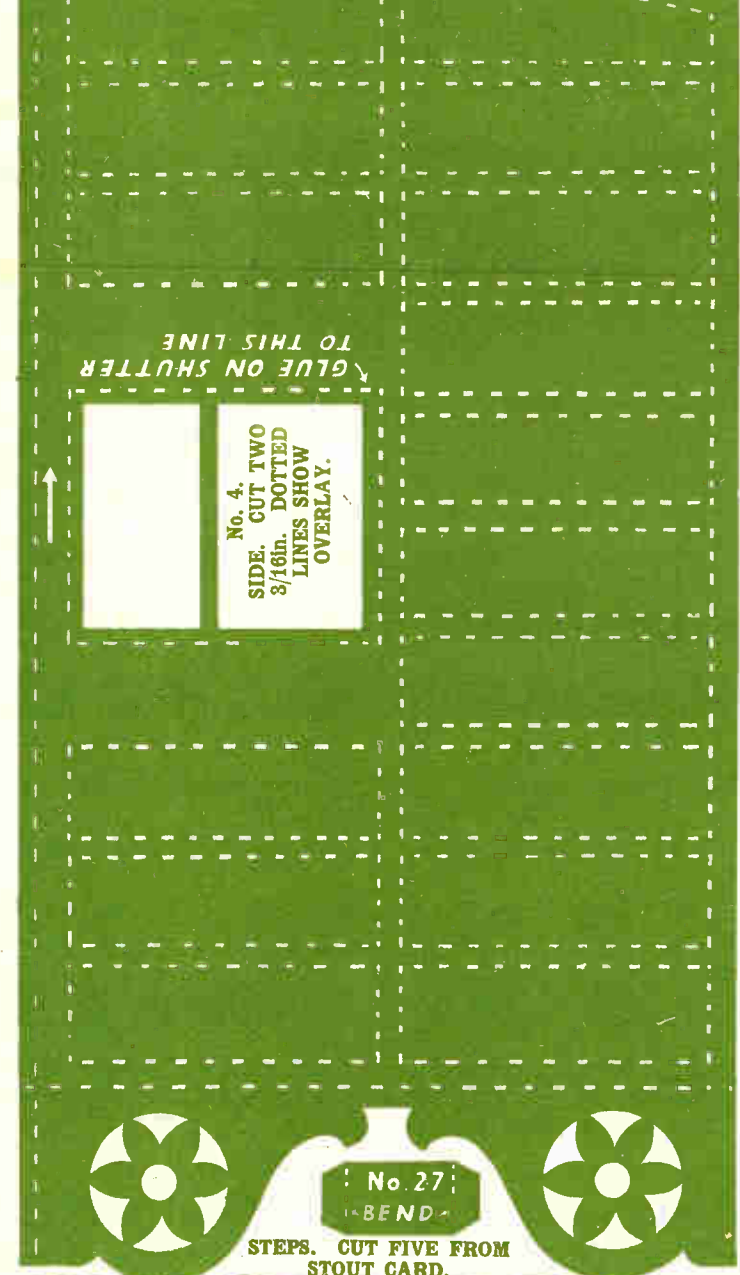
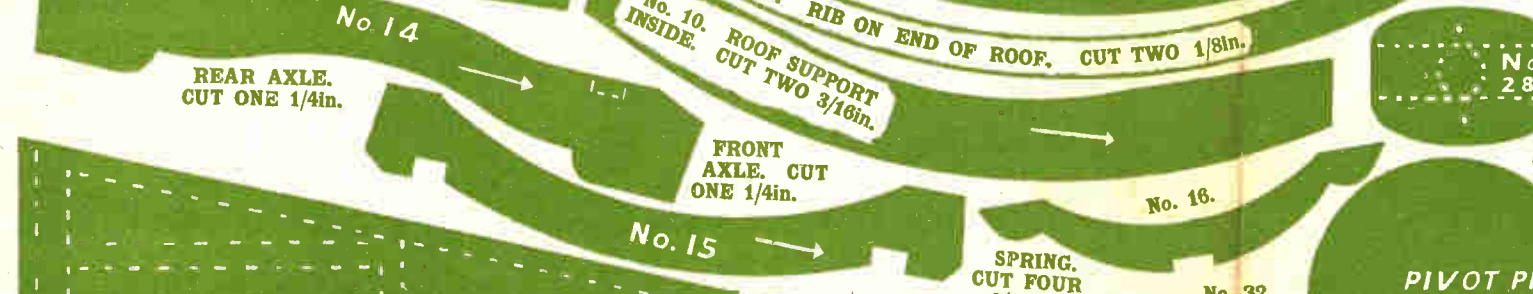
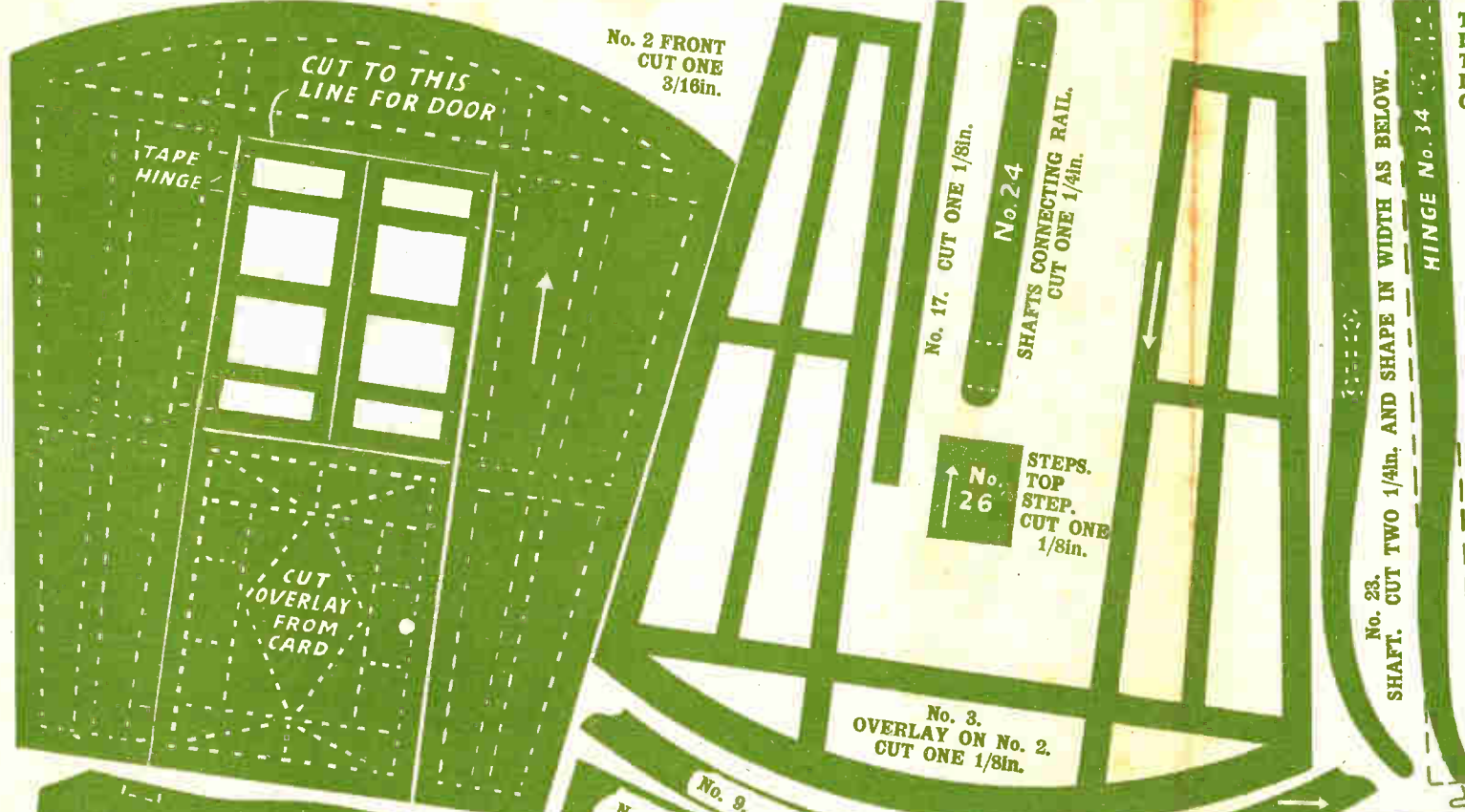



# Full instructions for making our MODEL GYPSY CARAVAN

**A**T first sight, this model Gypsy Caravan may appear a rather formidable proposition, especially to the beginner, but a little consideration will show that it is not as difficult as it looks. Indeed, anyone with a dependable fretsaw and a little patience should be able to make a workmanlike job of it.

It is constructed mainly of wood and card, and, when finished in gay colours, makes a realistic model. Its length is 12 ins. and height 7 ins. The thicknesses of the wood used vary between  $\frac{1}{8}$  in. and  $\frac{1}{4}$  in. A general idea of its construction can be gained from Fig. 1.

Begin by transferring the pattern to the wood, making sure that the patterns are transferred to wood of the thickness specified on each piece.

## Building The Body

Now cut out the floor (1), the front (2), the back (6) and the sides (4); and the front overlay (3), the back overlay (7) and the side overlays (5). When cutting

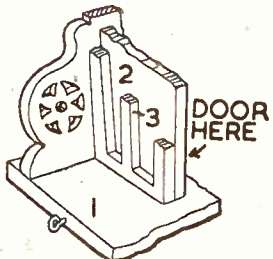

Fig. 2—Front and overlay detail

the front, note that the door and windows are cut right out, but this should not be done before the shapes of the window panes themselves have been removed. If you leave the cutting of the window panes until after the frames themselves have been cut out, you might have difficulty with the wood splitting.

Before assembling the shell, hinge the door and windows in the front with tape hinges, and affix the transparent window material to the insides of the windows. The window material should also be fixed to the insides of the back window, and the two side windows.

Glue the overlays to the sides and back and front, and, when these are quite dry, the main shell of the body can be assembled, being glued and pinned. Reference to Fig. 2 will show how the sides, front and bottom are butted together. Remember to slightly chamfer the bottom and top edges of the sides so that they fit correctly.

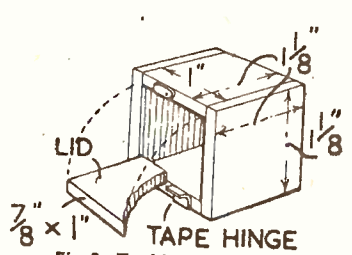

Fig. 9—Tool box details

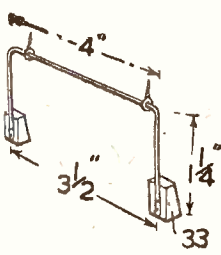

Fig. 10—Brake gear

Now cut the ribbed ends of the roof (9) and the inside roof supports (10). The roof itself (11) is a piece of stout card measuring 8 ins. by 5 ins., and this can be cut next, and the whole assembled, as shown at Fig. 3.

Before gluing and pinning the roof to the shell, make quite sure that the interior window material has not been forgotten, and that the 'curtains', if you intend to have any, are in place.

On the design for the front (2), you will note a dotted decoration on the door. This is optional, but adds considerably to the beauty of the model. The decoration is cut from thin card with a razor blade, and glued to the door.

The four window shutters (8) can now be cut out and glued in position.

## Turntable Assembly

The main part of the body is now complete, and can be placed aside for the glue to dry thoroughly while you proceed with the undercarriage. Begin with the pivoted turntable assembly. Cut piece 17, the two upper frames (21) and the main frame (20). Now cut the two card discs (22) and paste them to the upper frame pieces, as shown in Fig. 4. The first of the upper frame pieces is glued to the underside of the floor, and the second to the main frame. Piece No. 17 is also glued to the main frame, as shown in Fig. 4.

Next cut the axle (15) and the front springs (16). Fit the axle temporarily to the springs, but do not glue together. Glue and pin the springs to the main frame (20) where shown, leaving the axle in place until the glue has set. Remove the axle to await painting and assembly.

Proceed now by cutting out the rear springs (16) and rear axle (14). These can be assembled (see Fig. 5) and glued and pinned to the body. The position of the springs is clearly shown on piece 1 on the design sheet.

The wheels (12 and 13) are the next task, and they should be cut carefully or the appearance of the whole model will be spoilt. Particular care must be taken to see that they are true circles, and that the pieces cut out between the spokes are of equal size. To improve the finish of the wheels, pieces of thin card can be cut slightly wider than the width of the wheels, and glued round their edges, being later painted silver to represent steel tyres. The spokes should be shaped oval, and this can be done with a sharp pocket knife.

Now cut out the wheel hubs (18), and glue them to the centre of the wheels. The hub caps (19) should also be cut out, but do not glue these in place, as they are not put on until after the wheels have been screwed to the axles. You can now be-

gin the job of making the shafts (23), details of which are shown in Fig. 6. Note carefully their shape, and how each is cut separately from a solid piece of wood. The connecting bar (24) is cut and shaped next, and the whole fixed together.

The stay (30) for the shafts is now shaped from wire, which should be carefully hammered flat at the three points at which it is pinned to the shafts (see Fig. 7). The pins should be small and care must be taken to make a clean job of the assembly. Pieces of wire are shaped and hammered in the same way

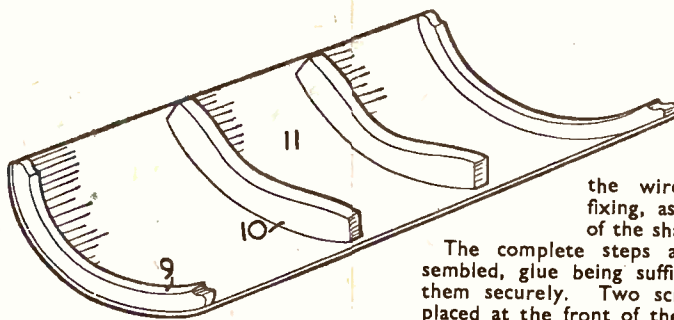

Fig. 3—The roof

to make the harness guides shown on the sides of shafts in Fig. 1. These having been fixed, you can make the hinges (34) shown 'in the flat'

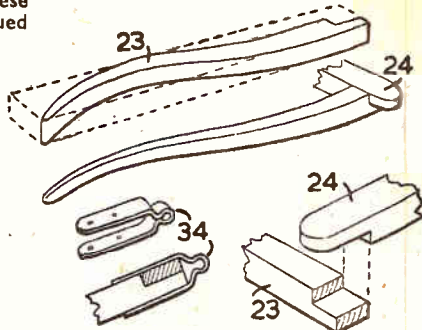

Fig. 6—How the shafts are made

on the design sheet. Cut them from thin tin and shape as in Fig. 6, later pinning them to the shafts as in Fig. 7.

Now put two small screw eyes in the main frame of the undercarriage, as shown in Fig. 4, and cut a piece of wire of a suitable length to slip through the lengths of the shafts and the screw eyes on the main frame, to act as a retaining pin. Do not assemble the parts yet, however, or you will need to take them apart for painting.

Next, proceed with the making of the steps at the front of the caravan. Cut the two side pieces (25) and five steps (27) from stout card. The top step (26)

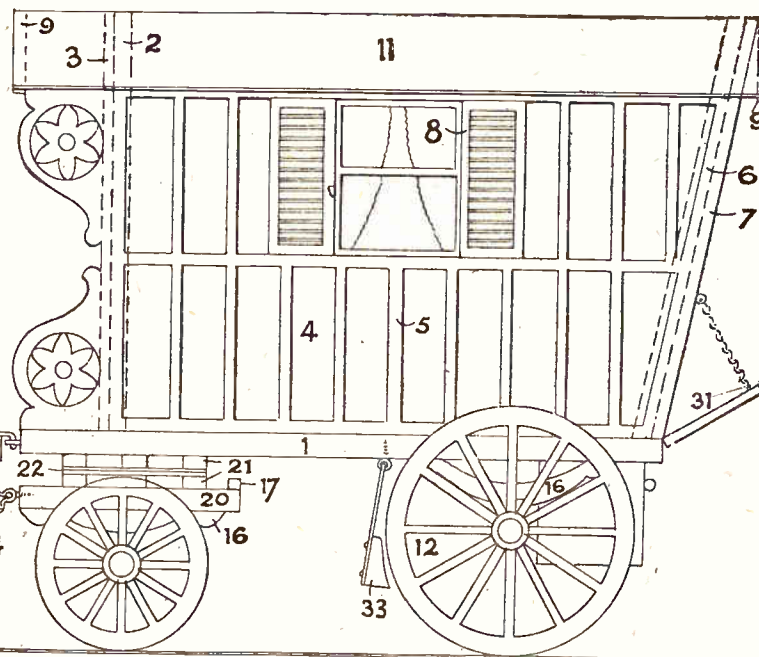

Fig. 1—Side view of the caravan

is cut from wood, and two hooked pieces (made from wire) are pinned on (see Fig. 8), hammering the wire flat before fixing, as in the case of the shaft stay.

The complete steps are easily assembled, glue being sufficient to hold them securely. Two screw eyes are placed at the front of the floor of the caravan (one is shown in Fig. 2), to hold the steps in the position shown in Fig. 1.

You can now make the tool box shown in Fig. 9. This fitting is optional, and is not shown on the design sheet. It can be made easily from scraps, however, and is recommended on the grounds of realism. It can be fitted to the underside of body as soon as it is made.

Other fittings—the tailboard (31), the brake assembly (Fig. 10) and chimney (28 and 29) and lamp (32) with bracket

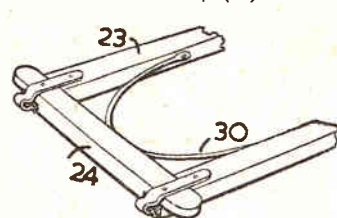

Fig. 7—The shafts assembled

(see Fig. 11) should now be completed, and the tailboard can be fitted to the body right away by means of a tape hinge.

## Painting

You are now ready for the task of painting and assembly.

The choice of colours is left to the reader, but it should be remembered that these caravans, especially when new, are gay and often startling in their colour schemes. For those who lack ideas for colouring, details of a scheme used with a prototype might help.

The body (including tailboard, and tool

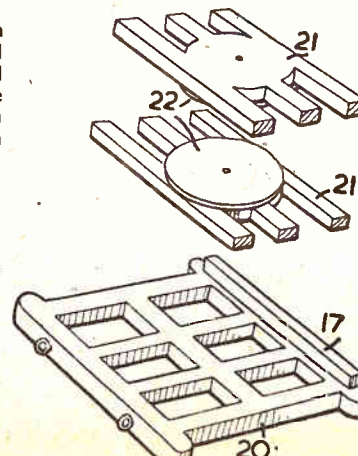

Fig. 4—Undercarriage assembly

box) was painted all over green. Then, when dry, the overlays were picked out in brown and later ruled with Indian ink. The six-pointed 'stars' at the front of the van are red on the outsides and gold inside, and gold is also used to paint the fancy leading edge of the sides.

The roof, window frames and window shutters are white, the shutters being lined to represent slatting.

## Undercarriage

The undercarriage parts (except the springs and brake 'mechanism', which are black) are painted with gay reds and yellows, and so are the wheels. All parts are lined with Indian ink. To get the lines round the wheels, use a compass. Avoid painting those parts of the front springs and front axle which have later to take glue, or you will have a bad joint.

The shafts are brown with black tips and hinges, etc., the steps yellow and lined on the sides with red and black, and the edges of the wheels (or the card tyres if

used) silver, to represent steel. The chimney is black, and the lamp is black, white and gold (the latter to represent brass).

This completes the main colouring, though the artistically minded will, doubtless, think of other embellishments to add to the effectiveness of the model.

## Assembly

Now for assembly. As soon as all the parts are quite dry, you can begin. Commence by screwing the back wheels into position, countersinking the screws so that the hub caps can be glued over them easily.

Next, drive the pivot pin through the turntable and into the floor of the van in the position shown on the design sheet, and then glue the front axle in position. The front wheels can now be fitted in the same way as the back, and the shafts attached by means of the retaining pin. The brake assembly can also be fitted now.

The chimney is glued to the roof and the lamp bracket pinned to the offside of the van, as shown on the design sheet. This completes the actual construction, as the steps, of course, are made detachable. So, all that now remains is to fix them in place.

The caravan is finished—and a picture it makes, too. And it looks so clean and cosy that one almost wishes it were a little bigger—big enough to use for a week-end camp, in fact!

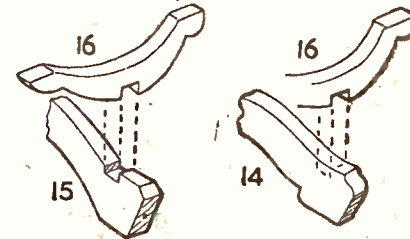

Fig. 5—The springs

## Refinements

With our prototype, the modeller added one or two refinements which you might also wish to incorporate in your model. They will greatly enhance the air of realism and thereby amply repay you for your trouble.

They represent the carving usually found in this type of caravan and can be easily done with files. Reference to Fig. 12 will show where the 'carving' is done. Both sides of the axle should be treated alike.

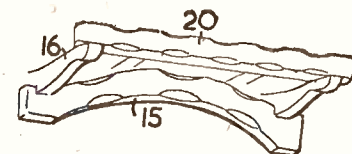

Fig. 12—How to chamfer the overlay and undercarriage

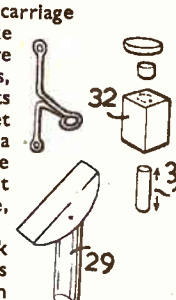
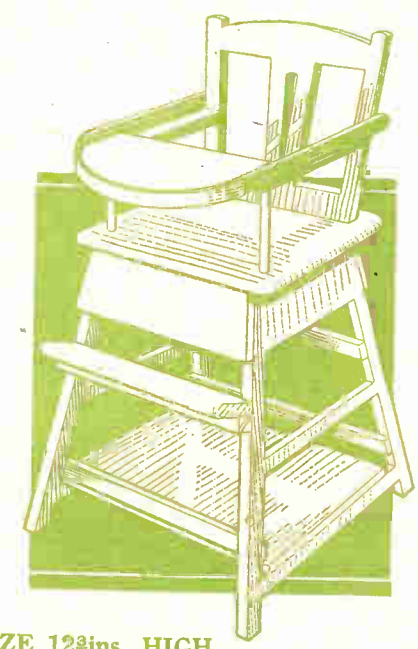

Fig. 11—The chimney and side lamp



SUPPLEMENT TO HOBBIES No. 2894.

# DOLL'S HIGH CHAIR



SIZE 12 3/4 ins. HIGH.

THE ARROWS INDICATE THE DIRECTION OF GRAIN OF WOOD.

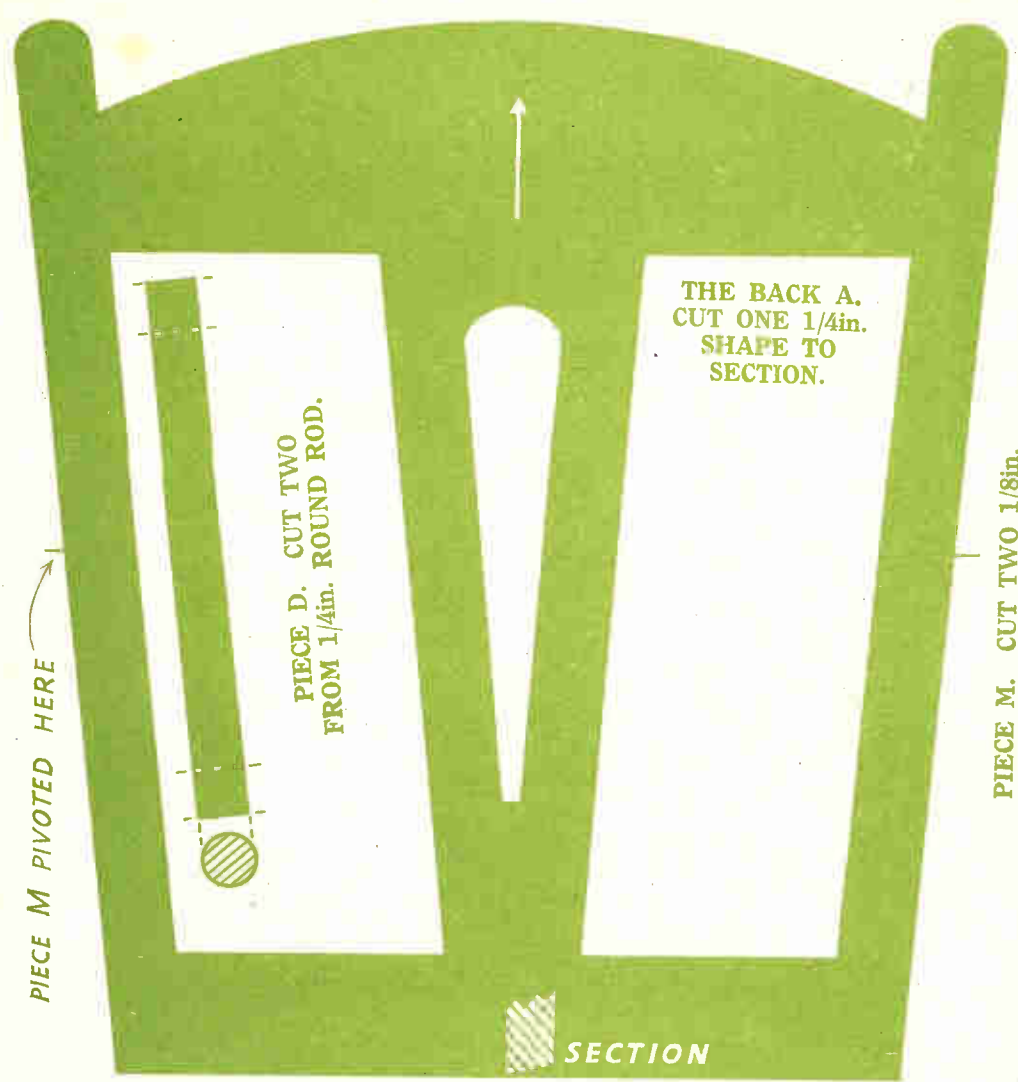

PIECE N. CUT ONE FROM CARDBOARD. GLUE ROUND FRONT OF PIECE L.

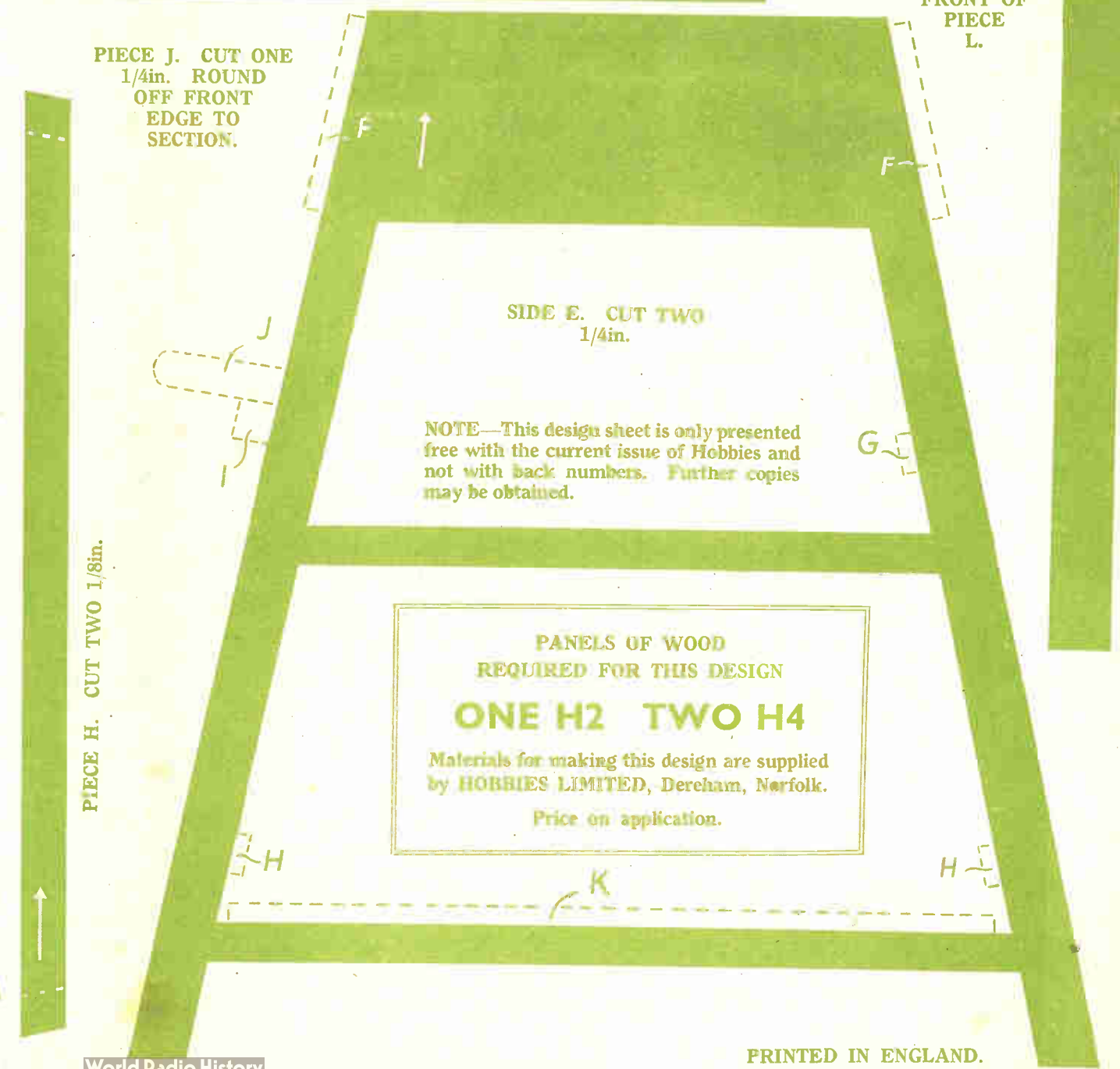
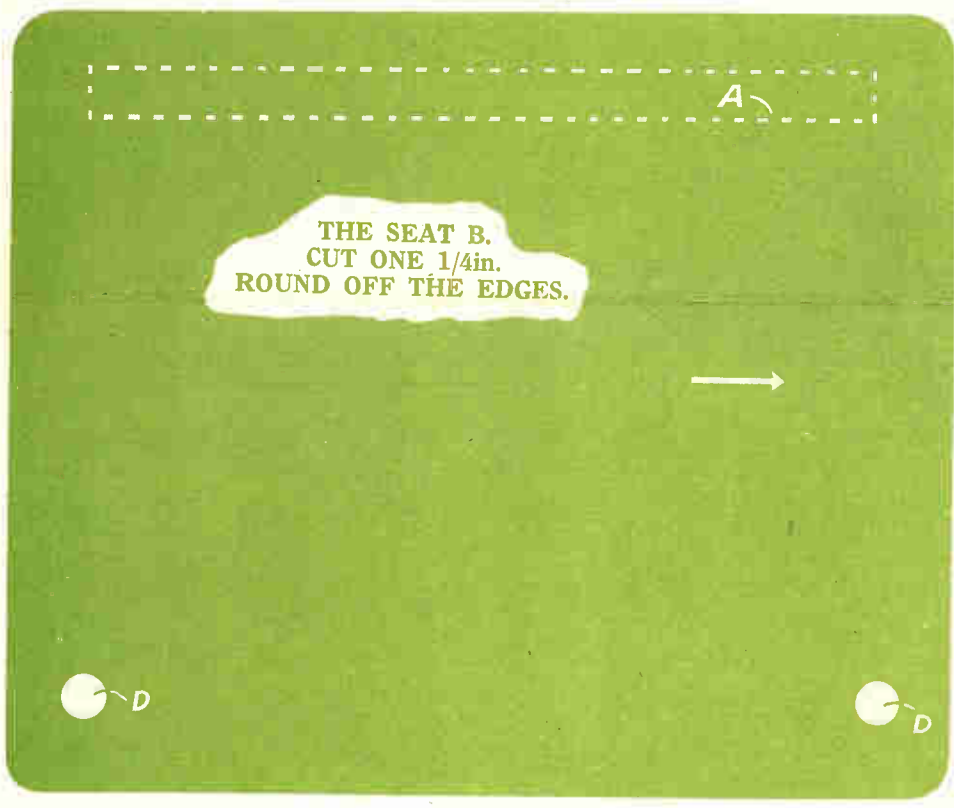

# DOLL'S HIGH CHAIR

**T**HIS is an easily constructed high chair, which will please any little girl; a chair into which she can safely put her doll for 'feeding'. It stands 12ins. high, and a glance at Figs. 1 and 2 will show that its making is not at all difficult.

All the parts, with the exception of piece K, are shown full size overleaf, so that the pattern can be pasted on to the wood if desired. Alternatively, it can be traced on to the wood, and this is, undoubtedly, the better way, for if you paste the pattern down, you will have the trouble of glasspapering it off afterwards—and, of course, you will not be able to use it again.

In the case of straight-edged pieces, there is no need even to trace the outline. Merely lay the pattern on the wood and make pin pricks at the corners of the pieces to be cut. Then, when the pattern is removed, the pin pricks can be easily joined with a pencil—and rule, of course—and the pieces are ready for cutting.

Whichever method you choose of transferring the pattern, remember that the arrows on the pattern indicate the direction of the grain of the wood.

The materials required for the chair are one panel of  $\frac{1}{2}$ in. thick wood, and two of  $\frac{1}{4}$ in., some  $\frac{1}{8}$ in. dowelling, a strip of thin cardboard, and some glue and pins.

## Making a Start

Before any cutting is done, drill the  $\frac{1}{8}$ in. holes in the seat (B) and arms (C) to take the lengths of dowelling. This is important. If the drilling is left until after the pieces have been cut out, the wood is likely to split, especially in the case of the arms.

The drilling having been completed, you should now cut out the pieces that make the chair itself—the back (A), the seat (B), the arms (C) and the dowel pieces (D). Note that the back is chamfered so that it leans back slightly from the seat. The arms also need to be chamfered, so that when they are attached to the back, they remain horizontal with the seat.

After the edges of the seat have been rounded off as shown, glue and pin the back to the seat (the exact position is marked on the pattern), and then glue the two dowels into the holes in the seat. Now insert the upper ends of

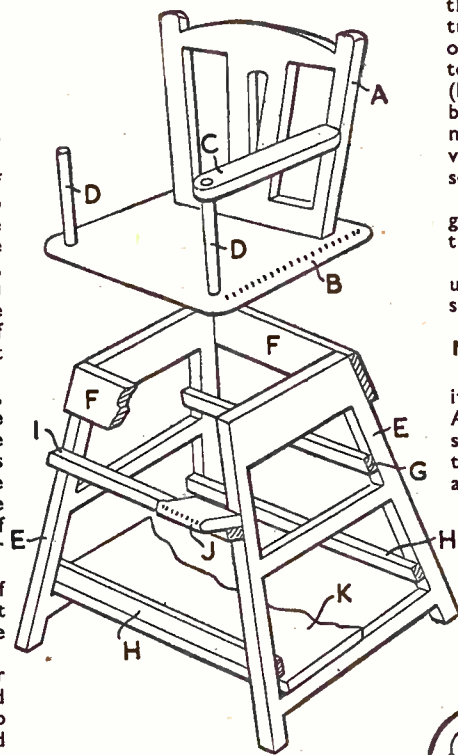

the underpart, the latter should be turned upside down and gently smoothed on a piece of glasspaper. This is necessary to remove the raised edges of the sides (E) and the supports (F), brought about by the slope of the sides, and if the modeller neglects this task, he will have very little surface on which to attach the seat.

It will also be found necessary to glasspaper the bottom of the legs so that the chair stands perfectly flat.

Once you are satisfied that the underpart is properly finished, glue the seat assembly to it.

## Now the Table

The chair itself is now complete, and it only remains to construct the table. A glance at Fig. 2 will show that it is a simple enough structure. First, cut out the table top (L), the two side pieces (M) and the strip of cardboard (N). Glue and pin the side pieces as shown in Fig. 2 and, after fixing, chamfer the ends of the side pieces to conform with the curve of the table top. Now glue the cardboard front into position, and the table is finished.

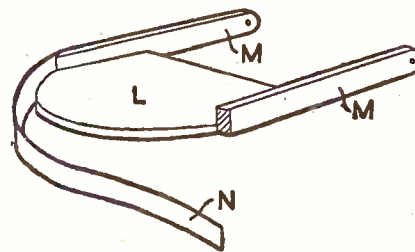

Two small screws are used to fix the arms of the table to the back of the chair. They should not be driven home too tightly as the table has to be able to pivot at the fixing points, as shown, in order that the doll may be placed in and taken out of the chair without too much discomfiture!

The model is now complete, and all that remains is to decide on the finish it is to receive. It would look quite well stained and polished, or, if desired (to fit in with a particular nursery colour scheme, perhaps), it could be enamelled. In either case, the preliminary use of a good woodfiller will ensure a more workmanlike finish.

the dowels into the arms and glue securely, at the same time gluing and pinning the other ends of the arms to the back in the positions shown.

The seat is now complete, and, having removed any surplus glue with a damp cloth, it can be laid aside to set securely.

## The Legs

Proceed by cutting out the pieces of the lower part of the chair. These are the sides (E), the strip supports (G, I and H), the larger supporting pieces (F), the foot rest (J) and the bottom (K). Remember to round the edges of J as shown.

The assembly of the pieces is simple, and can be easily followed from the drawing. Glue should suffice for most of the joints, but pins can be used when fixing the pieces F, and the step, if desired.

Before the seat assembly is fitted to



PANELS OF WOOD REQUIRED FOR THIS DESIGN

ONE H3 TWO H4  
ONE Q4

Materials for making this design are supplied by HOBBIES LIMITED, Dereham, Norfolk.  
Price on application.



DESIGN

No. 2892  
4-4-51

SUPPLEMENT TO HOBBIES No. 2892.

**FRUIT HOLDER**

SIZE:—LENGTH 10½ins. WIDTH 6¾ins.  
HEIGHT 6¾ins.

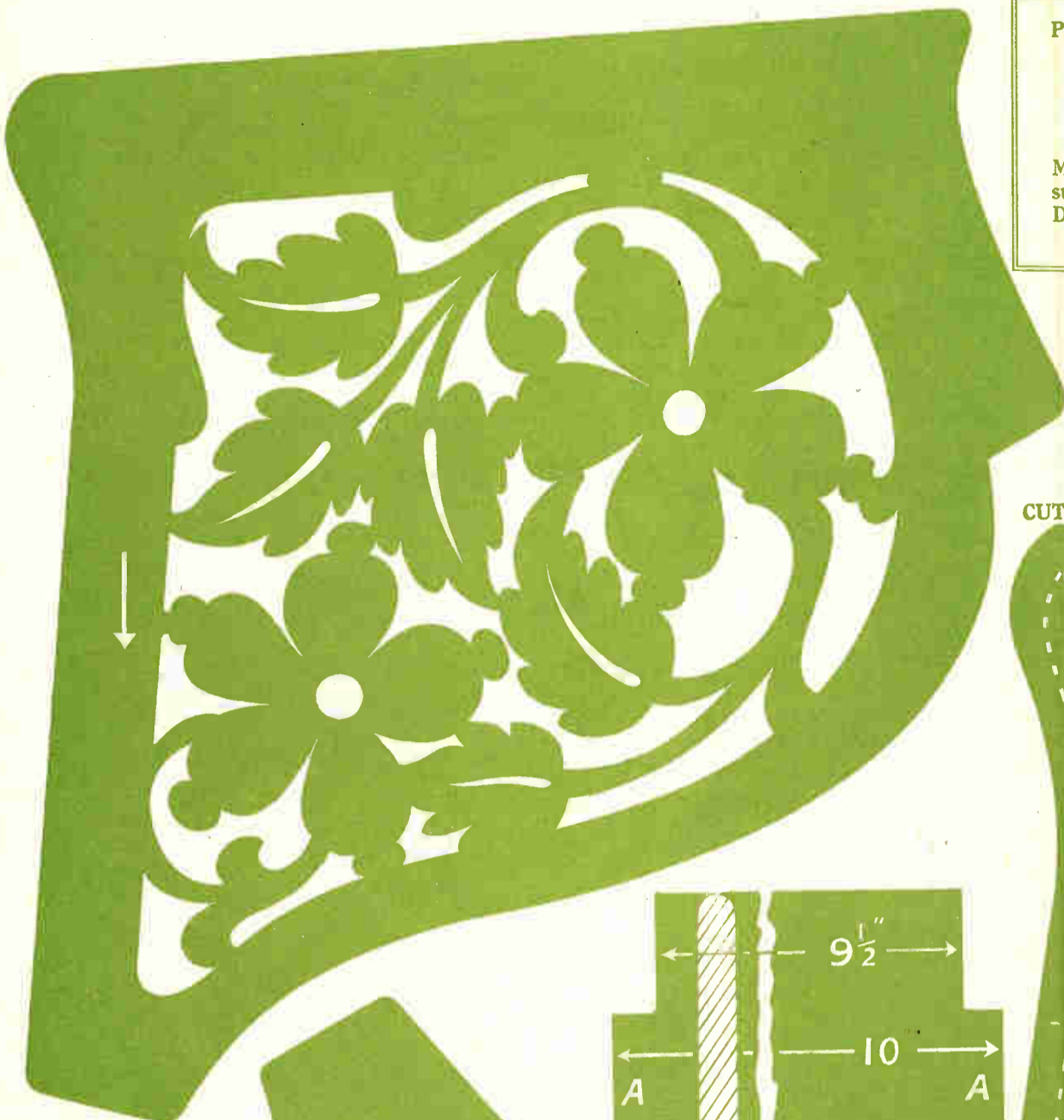

OVERLAY ON END. CUT ONE 3/16in. THICK.

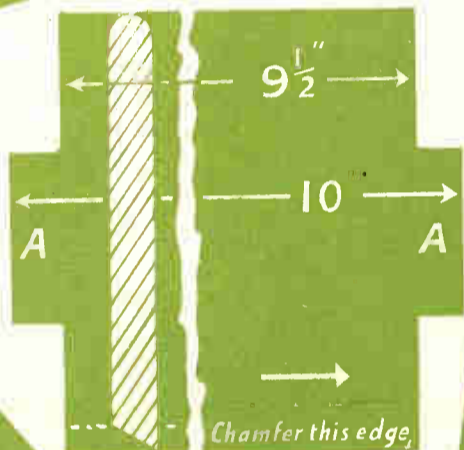

FRONT RAIL.  
CUT ONE TO LENGTH SHOWN 1/4in. THICK.

THE ARROWS INDICATE THE DIRECTION OF GRAIN OF WOOD.

NOTE.—This design sheet is only presented free with the current issue of Hobbies and not with back numbers. Further copies may be obtained.

OVERLAY ON END. CUT ONE 3/16in. THICK.

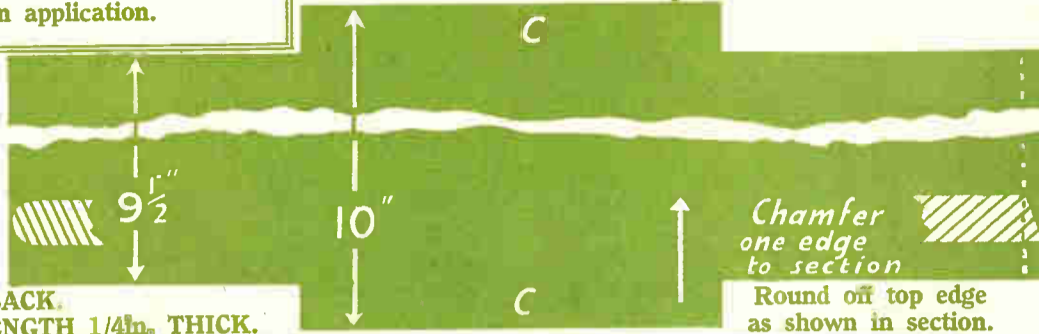

BACK. CUT ONE TO LENGTH 1/4in. THICK.

Chamfer one edge to section  
Round off top edge as shown in section.

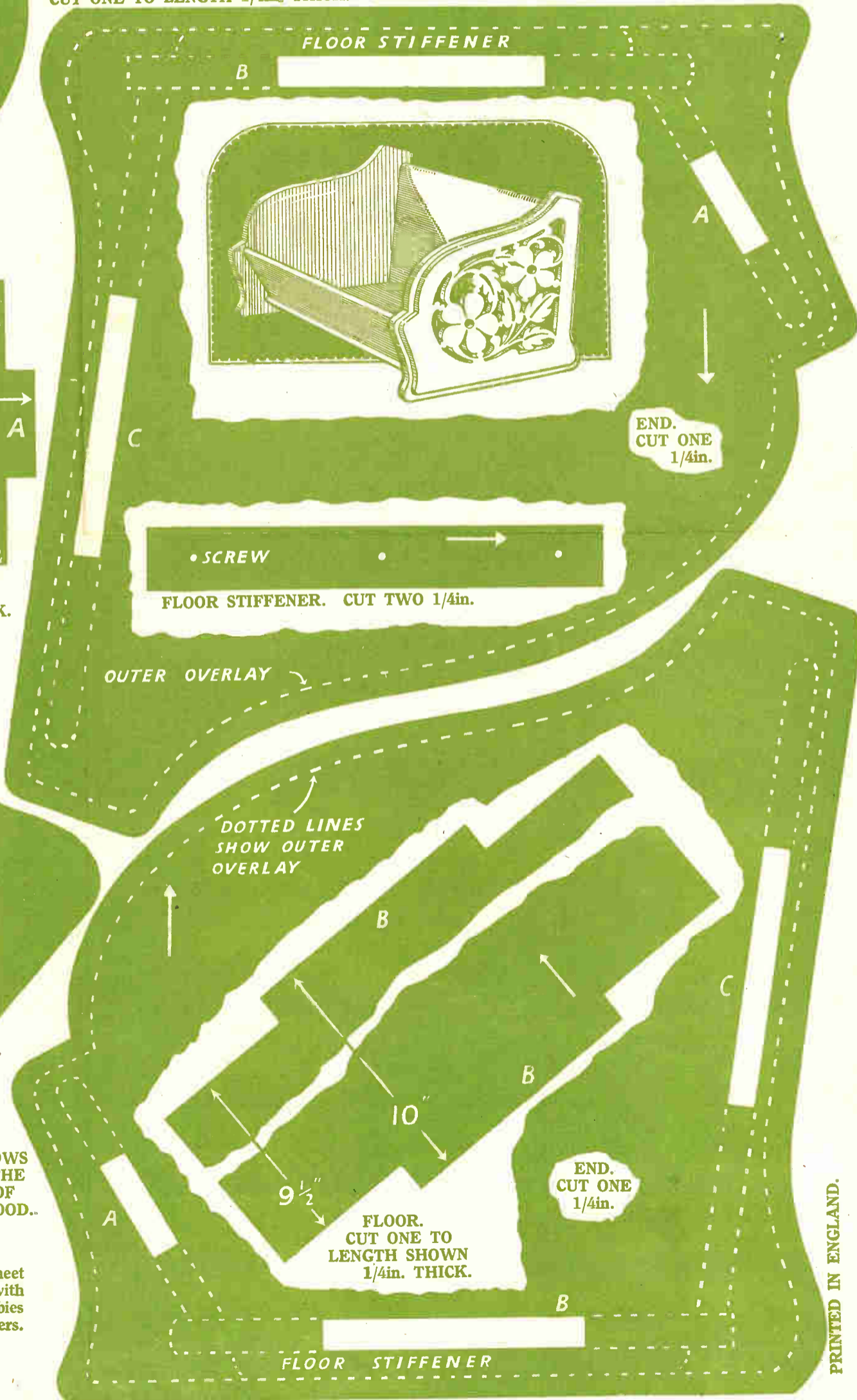

• SCREW  
FLOOR STIFFENER. CUT TWO 1/4in.

DOTTED LINES SHOW OUTER OVERLAY

FLOOR. CUT ONE TO LENGTH SHOWN 1/4in. THICK.

END. CUT ONE 1/4in.

PRINTED IN ENGLAND.

# A FRUIT HOLDER

THE patterns on the other side provide for an attractive fretwork fruit holder. You will see by the small diagram here that the construction is quite simple, and if you follow these instructions, you will have no difficulty in completing this useful article.

The first job is to trace the various parts on to the appropriate thicknesses of wood. The ends and overlays are shown full size, but the floor, front rail and back are shown condensed. In each of these three, the width is full size, but they must be extended to the measurements shown. You can now proceed to

cut out the various parts, paying particular attention to the mortises A, B and C, in the ends. Make these on the scant side if anything, to ensure a tight fit when the tenons of the front rail, floor and back are glued in position.

When all the parts have been cut out, clean them up with glasspaper and chamfer the various edges, as indicated by the sections. The parts are now ready for assembly, and this should be completed in stages. First, glue the overlays on the ends. These need not be pinned in position, but you must place suitable weights on them until the glue is thoroughly dry. Make sure, when you glue these overlays in position, that they are glued on the outside of the ends. Next glue the floor in position, in-

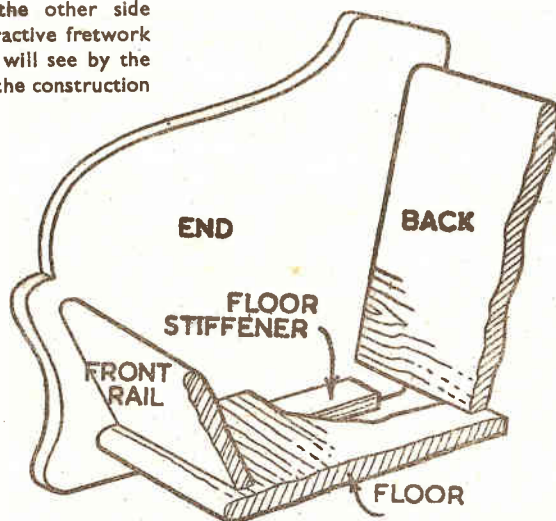

serting the tenons (B) into the mortises (B) in the ends. The front rail and back are glued similarly in place. To complete the construction, all that is needed is to glue and screw the two floor stiffeners in place. One of these is shown in the diagram, and their positions are dotted on the patterns of the ends.

The finishing is largely a matter of personal choice, but we suggest that a light stain and either polish or varnish would be suitable. Alternatively you could use a high-gloss enamel, picking out the flowers and leaves in different colours. If enamel is used, give two or three thin coats, and allow to dry thoroughly; otherwise the paint will be inclined to run in the fretted portions.





# FRETWORK DESIGN No. 246 SPECIAL

SUPPLEMENT TO HOBBIES No. 2890  
MARCH 21, 1951

## MODEL OF A TRAMCAR

SIZE:—12 1/2 ins. LONG, 6 ins. HIGH.

THE ARROWS  
INDICATE THE  
DIRECTION OF  
GRAIN OF WOOD

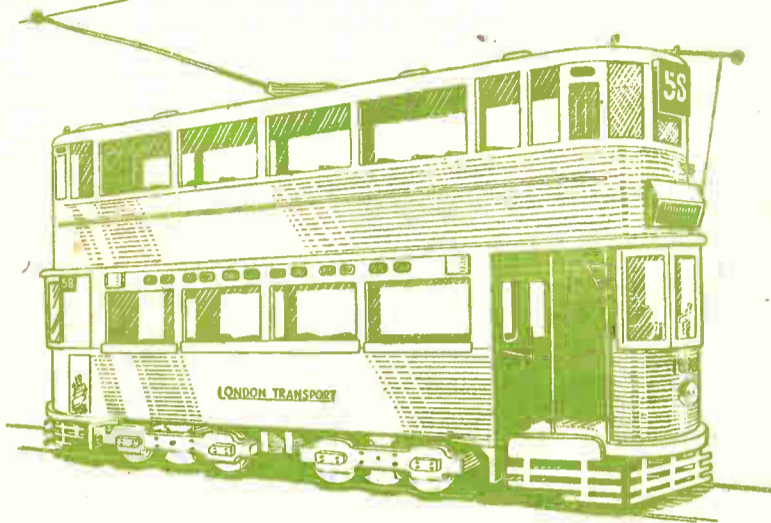

SCALE—APPROX. 3/8 in.—1 FT.

PANELS OF WOOD  
REQUIRED FOR THIS DESIGN

THREE H2 ONE Q2 ONE G3  
ONE H3 ONE Q4 ONE P.P.M.

Materials for making this design are supplied by  
HOBBIES LIMITED, Dereham, Norfolk.  
Price on application.

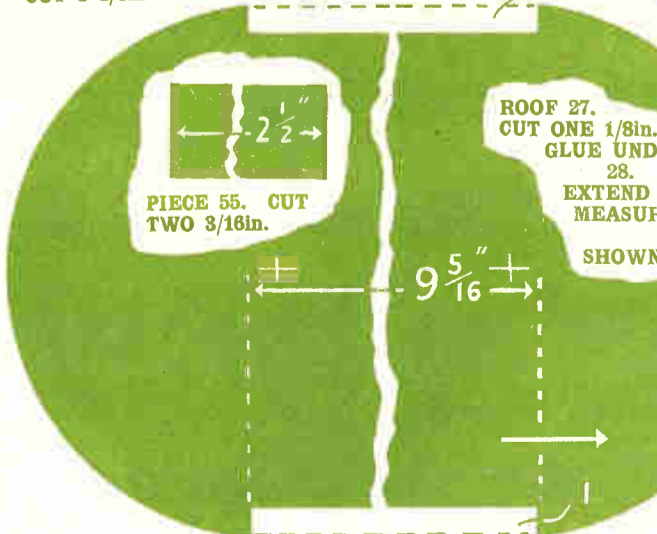
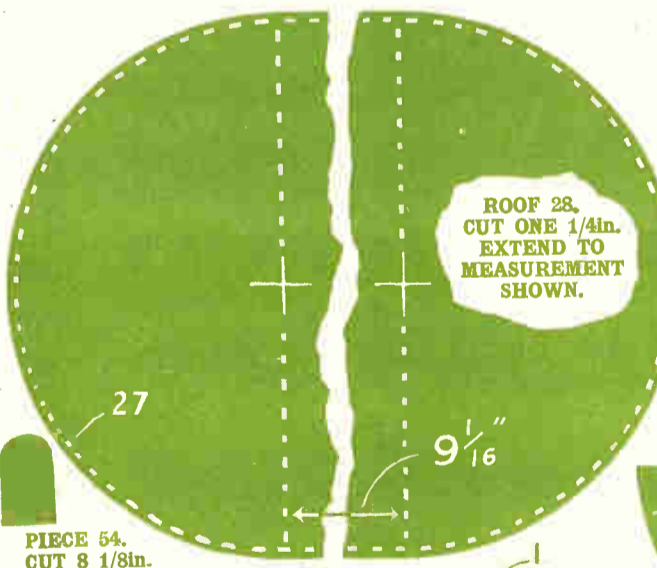
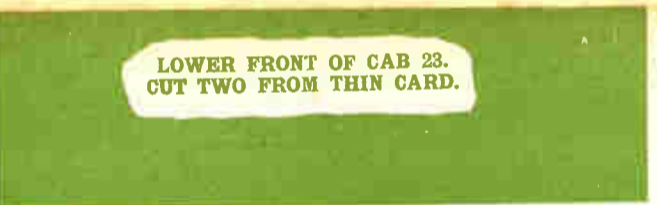

PIECE 54. CUT 8 1/8 in.

PIECE 55. CUT TWO 3/16 in.

ROOF 27. CUT ONE 1/8 in. GLUE UNDER 28. EXTEND TO MEASUREMENT SHOWN.

PIECE 40. CUT TWO 1/4 in. GLUE TO ROOF.

PIECE 26. CUT TWO FROM THIN CARD.

33  
VICTORIA DULWICH  
WHITE LINE

PIECE 33. CUT TWO FROM CARD. PAINT BLACK AND MARK DESTINATION IN WHITE.

PIECE 31. CUT TWO 3/16 in. AND SHAPE TO SECTION.

PIECE 32. CUT 4 1/8 in.

PIECE 37. CUT TWO FROM THIN CARD. GLUE TO 1. PAINT WHITE.

PIECE 38. CUT 4 FROM THIN CARD. GLUE TO 1. PAINT WHITE.

PIECE 48. CUT TWO 1/4 in.

SCREW

PIECE 25. CUT TWO FROM THIN CARD. GLUE TO 23.

BEND AT DOTTED LINES.

PIECE 29. CUT TWO 1/8 in. GLUE TO 26.

PIECE 3. CUT TWO FROM THIN CARD. GLUE TO 29.

LAMP 34. CUT TWO 1/8 in. GLUE TO 23.

SIDE 1. CUT TWO 1/8 in.

PIECE 47. CUT 4 1/8 in.

PIECE 24. CUT 4 1/8 in.

PIECE 44. CUT TWO FROM THIN WOOD OR CARD.

PIECE 49. CUT 4 1/8 in. GLUE TO 48.

PIECE 35. MAKE TWO FROM WIRE.

PIECE 36. CUT TWO FROM THIN CARD. GLUE TO 25.

PIECE 42. CUT TWO FROM THIN WOOD OR CARD.

PIECE 20. CUT TWO FROM THIN CARD.

PAINT ON

PIECE 18. CUT TWO FROM 3/8 in. BY 1/4 in. STRIPWOOD.

SEATING ARRANGEMENT (TOP FLOOR). (HALF ONLY SHOWN).

45 SECTION

46 BEND

PIECE 45. CUT TWO 1/8 in.  
PIECE 46. CUT TWO FROM THIN CARD.

TOP FLOOR 2. CUT ONE 3/16 in.

LOWER FRONT OF CAB 23. CUT TWO FROM THIN CARD.

PIECE 43. CUT TWO FROM THIN WOOD OR CARD.

PIECE 1. CUT TWO FROM THIN CARD (POST CARD).

HANDLE 19. CUT TWO FROM WIRE.

PIECE 16. CUT TWO 8/16 in. AND TWO 1/8 in.

NOTE.— This design sheet is only presented free with the current issue of Hobbies and not with back numbers. Further copies may be obtained.

SEATING ARRANGEMENT. LOWER FLOOR. (HALF ONLY SHOWN).

PIECE 52. CUT 4 1/4 in. PIVOT TO 49.

PIVOT FOR TURNTABLE 48

LOWER FLOOR 3. CUT ONE 3/16 in.

VENTILATORS 39. CUT 8. ROUND OFF AND GLUE TO ROOF.

STAIRS 15. (A, B, C, D, E, F, G AND H). CUT TWO OF EACH 1/4 in. THE STAIR UNIT No. 15 CONSISTS OF ONE OF EACH PART. (SEE INSTRUCTIONS).

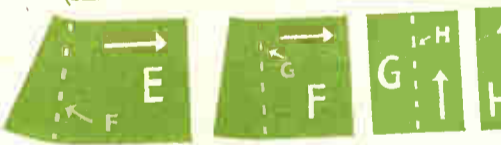

SEAT BLOCK 11. CUT 4 FROM 3/8 in. BY 1/4 in. STRIPWOOD.

SEAT 11. CUT 4 1/8 in.

PIECE 8. CUT TWO 1/8 in. GLUE TO 2.

G  
F  
E  
D  
C  
B  
A

PIECE 5. CUT TWO 3/16 in. GLUE UNDER PIECE 2.

PIECE 4. CUT TWO 1/8 in. AND SHAPE TO SECTION

SEAT BLOCKS. CUT TWO OF EACH FROM 3/8 in. BY 1/4 in. STRIPWOOD.

SEAT BACK 11. CUT 4 FROM THIN CARD.

SEAT 10. CUT 6 1/8 in.

SEAT 9. CUT 20 1/8 in.

PIECE 7. CUT TWO 3/16 in.

PIECE 6. CUT TWO 3/16 in.

PIECE 21. CUT TWO FROM WIRE.

PIECE 22. CUT TWO FROM WIRE.

SEAT BACK 10. CUT 6 FROM THIN CARD. (POST CARD).

SEAT BLOCK 10. CUT 6 FROM 3/8 in. BY 1/4 in. STRIPWOOD

SEAT BLOCK 9. CUT 20 FROM 3/8 in. BY 1/4 in. STRIPWOOD

SEAT BACK 9. CUT 20 FROM THIN CARD (POSTCARD)



# Any craftsman would be proud to make this MODEL LONDON TRANSPORT TRAMCAR

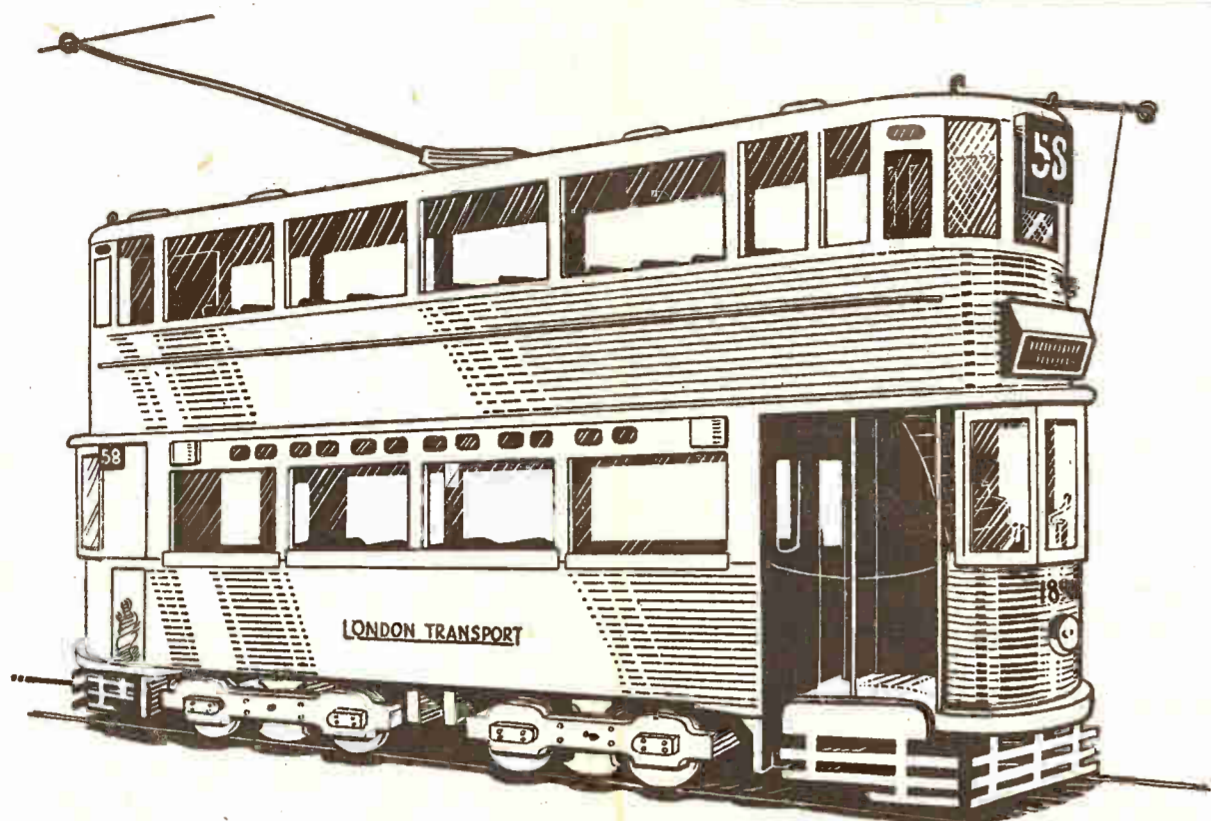

**M**ANY readers, no doubt, will be glad of this opportunity to make an attractive model Tram to remind them of a mode of transport now disappearing off the streets. We have prepared this design while details are still available. We are indebted to the Tramway and Light Railway Society, Harringay, London, for their help in supplying the necessary details for making this splendid little model.

All parts must be traced on the various thicknesses of wood, and cut out carefully. Clean them up as you go along, number them in pencil and put away in a convenient cardboard box to await assembly.

The next step is to pin in place the transparent material for the windows.

The next step is to pin in place the transparent material for the windows.

The positions of the fret pins are shown marked N on the design. Use the smallest size pins available. The top windows will be two pieces  $9\frac{1}{2}$  ins. long

by  $1\frac{1}{2}$  ins. wide, and the bottom windows, two pieces  $7\frac{1}{2}$  ins. by  $1\frac{1}{2}$  ins. Make sure when fitting the material over the bottom windows, that it comes behind the 12 small windows and that it does not come in the way of pieces 6 and 7, which will have to be glued in later. The protruding ends of the pins must be filed off.

Now fit the sides to the top floor (No. 2) so that the painted sides are facing each other. This will bring the extending pieces marked X in Fig. 1 at opposite ends of the floor. Now glue in place the lower floor (3) pieces 4 and 5, and

pieces 6, 7 and 8. Make sure that no excess glue goes on the one side, which must be taken away to complete the interior. Only glue one side in position.

Fig. 2 shows the construction so far, with the interior ready to take the seats, etc., and with the various parts numbered. Now that the side has been removed, complete the painting of the interior.

### The Seats

These are made up as shown in Fig. 3. Each seat comprises one of each part; seat, seat block, and back. Fig. 3 shows that those parts which belong together have the same numbers. Seats of three different lengths, 9, 10 and 11 are made up in exactly the same manner. Fig. 3 also shows the construction of seat 12, which, incidentally, has no back. The seating arrangement is shown on the design sheet, but note particularly that the four small seats No. 11 are all on one side of the lower floor. Having completed the interior and added any refinements which you may think necessary, you can now glue the remaining side finally in place.

The stairs are constructed as two separate units, and consist of one of each of A, B, C, D, E, F, G, H, and I, glued together, as shown in Fig. 4A. Each unit is glued to the lower floor in the positions indicated by the dotted lines. Note that the parts of the stairs which are seen, must be painted before gluing in place. Next glue together and shape pieces 16, as shown in Fig. 4B. The handle (No. 17) is bent from wire

and inserted in the position shown, after first drilling a hole. Paint and glue to the lower floor where indicated. Fig. 4C shows piece 18 which will be shaped from  $\frac{1}{8}$  in. by  $\frac{1}{8}$  in. stripwood, and the handle (19) and wheel (20) added afterwards. Paint and glue in position on the lower floor No. 3. Insert the wire uprights Nos. 21 and 22. The positions of the holes are shown clearly on pieces 3, 4, and 5.

### Completing the Cars

The pieces of card No. 23 are bent round each end of piece 3, and glued. They will overlap slightly on piece 1, and must be glued here also (see B and C Fig. 5). Pieces 24 and 25 are now glued together, as shown in Fig. 4D, and slipped in place. It is held there with small blobs of transparent glue, such as Balsa cement. Now glue this completed window framing to the underside of piece 3, and to the front of piece 23, as shown in Fig. 5D. The sketches A, B, C and D in Fig. 5 show clearly the various steps in completing the cab.

### The Top Deck

Bend piece 26 round the front of piece 2, and glue in place. This operation is rather tricky, and you will need to place one end in position first. Place on it a suitable weight, allow the glue to dry, and then complete the gluing and weight the other side. Cut a piece of transparent material  $1\frac{1}{2}$  ins. by  $\frac{1}{4}$  ins. and bend into place behind the window opening. A drop of glue will keep it perfectly in position. The roof is made up of pieces 27 and 28,

which are glued firmly together, the edges of piece 28 being rounded after gluing. Notice that the slots in piece 27 allow the completed roof to drop nicely

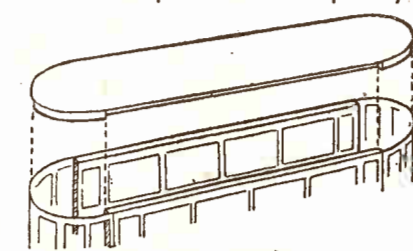

Fig. 6—Fitting the roof

into place between the sides (see Fig. 6). Glue piece 29 to 26 in the position shown. Glue piece 30 to 29. Paint black and mark the letters in white. Assemble pieces 31, 32 and 33, as shown in Fig. 5E. The destination will be painted in white ink or paint, on a black background. The head-lamps 34 are glued in place, as shown in the sketch of the finished article. Note that the back must be glasspapered slightly to fit the curve of piece 23.

Piece 35 is made from wire. It is pushed through the card piece 26 in the centre, and pushed into a small block of wood behind. This tiny block should measure about  $\frac{1}{8}$  in. by  $\frac{1}{8}$  in. by  $\frac{1}{8}$  in. and must be glued firmly to piece 26.

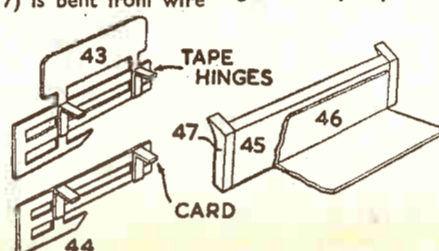

Fig. 8—The lifeguards

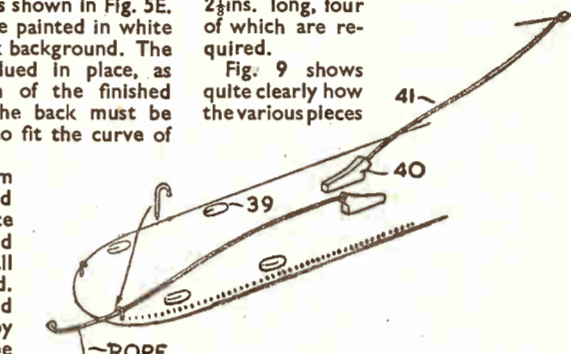

Fig. 7—Details of the roof

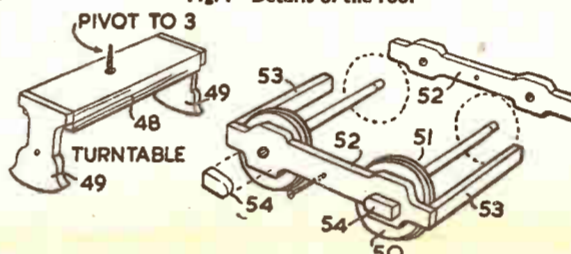

Fig. 9—Details of the undercarriage

Note here, too, that this block must be slightly glasspapered to fit the curve of 26.

Pieces 36 are glued in position as indicated, on the corner of piece 25. The colour is black with white lettering. The narrow strips of card 37 and 38 are next glued in place. If these are cut from white postcard, they need not be

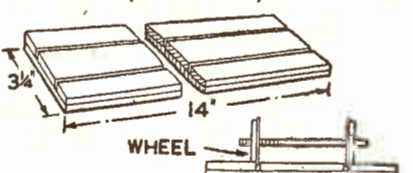

Fig. 10—Base construction

coloured. Their positions are dotted on piece 1. The eight ventilators No. 39 are rounded off and glued to the roof, as shown in Fig. 7. This sketch also shows pieces 40 and 41, which are glued side by side with the wire pieces facing in opposite directions. Four hooks can be made up from thin fret-pins, and inserted two at each end, as shown. When the arm is not in use, it can be hooked under one of these, and the rope, which is a piece of thread, is wound round a pin inserted in the side (1) near the stairs.

Fig. 8 shows pieces 45, 46 and 47 glued together. These are glued under the floor (3) directly under pieces 6 and 7. Piece 47 is clearly shown in the finished

are glued together, and also that piece 52 must be left until last to enable the wheels to be fixed to the axles. Pivot the bogies to pieces 49 by means of small screws, and finally pivot the turntable 48 to the floor 3 in approximately the positions shown. Note that the two bogies are equidistant from each end. Pieces 55 are now glued under the floor 3 and between the two bogies. It is not possible to show the exact positions of these on the design, but they will be seen on the sketch of the finished model.

The base is made up from four pieces of  $\frac{1}{8}$  in. wood, cut to the size shown in Fig. 10. The overall width of the base is  $3\frac{1}{2}$  ins., so that the three strips along the top must be cut to allow the wheels to run in the groove, as also shown in Fig. 10. Here we have given no measurements, so that the worker must measure the exact track of his model, and cut the narrow strips of board accordingly.

The experimental model which has been completed at our Works, was finished in red and cream, but the worker need not adhere to these colours. We suggest you paint your model in the colouring of your own local transport. In any case, the life-guards are made of wood, and should be coloured light brown. The undercarriage also will be made of metal, and should be painted dark grey. Remember, too, to colour the seats, so as to blend with the outside colouring.

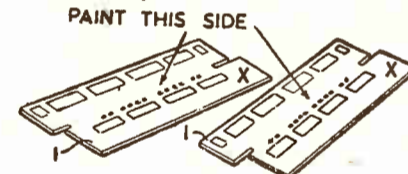

Fig. 1—Painting the sides

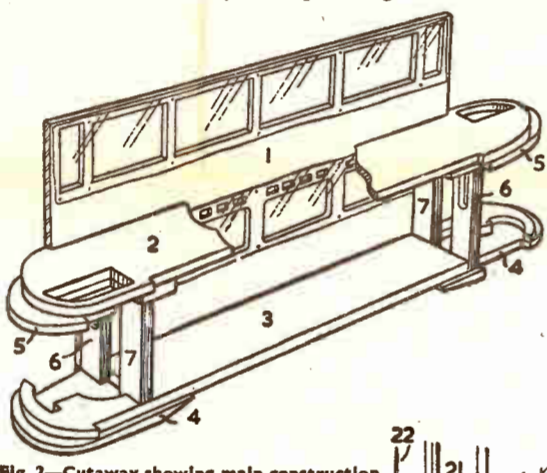

Fig. 2—Cutaway showing main construction

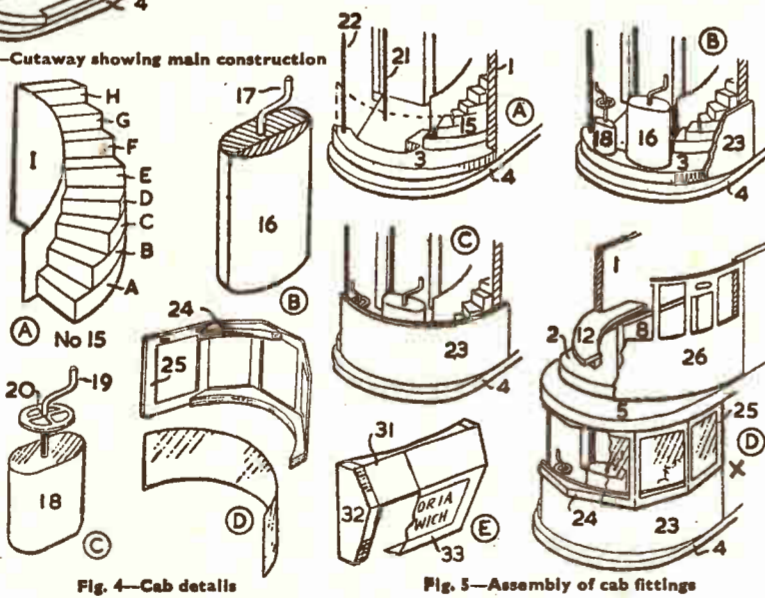

Fig. 4—Cab details

Fig. 5—Assembly of cab fittings

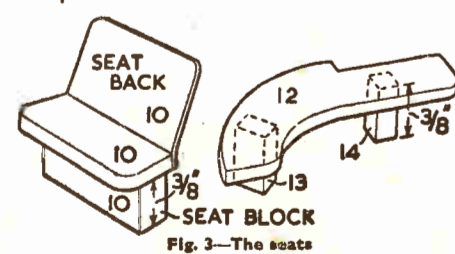
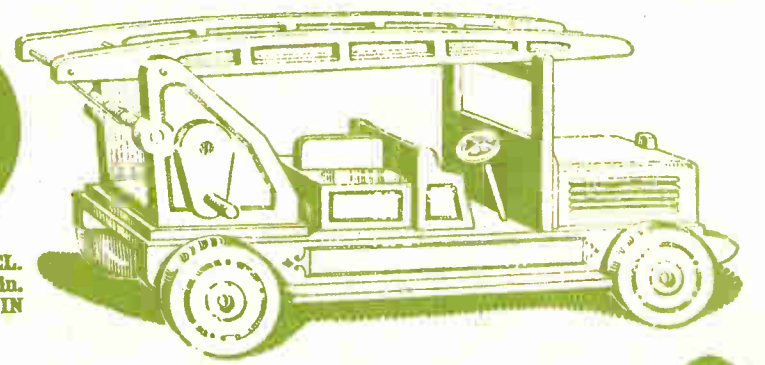

Fig. 3—The seats



SUPPLEMENT TO HOBBIES No. 2888.

**MECHANICAL FIRE ENGINE**



SIZE:—LENGTH 12½ ins. WIDTH 4 ins.

PANELS OF WOOD REQUIRED FOR THIS DESIGN  
**TWO Q4 ONE Q3 ONE G4**  
 Materials for making this design are supplied by  
 HOBBIES LIMITED, Dereham, Norfolk.  
 Price on application.

17 CUT ONE 1/4 in. FOR AXLE OF DRUM. LADDER PIVOT WIRE. LADDER PIVOT WIRE. PIVOT FOR PAWL. FOR CROSS SPINDLE. AXLE OF DRUM. NAIL OR SCREW.

20 WINDING DRUM. END. CUT ONE 1/4 in.

8 LADDER SUPPORT. CUT ONE 1/4 in.

25 LADDER. CUT ONE 3/16 in.

26 SIDE OF LADDER. CUT TWO 3/16 in.

3 R-H SCREW

17 BASE FOR Nos. 16. CUT ONE 1/4 in. SCREW PIVOT.

19 CUT ONE 1/4 in. SCREW FOR PIVOT.

The arrows indicate the direction of grain of wood.

23 RATCHET WHEEL. CUT ONE 1/4 in.

24 STEERING WHEEL. CUT ONE 3/16 in. AND PAINT IN RIM, ETC.

15 TOP OF REAR SEAT. CUT ONE 1/4 in.

14 BACK. (UNDER SEAT) REAR SEAT. CUT ONE 1/4 in.

13 FRONT OF REAR SEATS AND TOP UP-RIGHT. CUT 3 3/16 in.

11 SEAT FRONT. CUT ONE 1/4 in.

10 SEAT. CUT ONE 1/4 in.

9 SEAT END. CUT ONE 1/4 in.

21 CRANK. CUT ONE 1/4 in.

22 HANDLE. CUT ONE FROM 1/4 in. ROD.

12 SEAT BACK. CUT ONE 3/16 in.

10 SEAT END. CUT ONE 1/4 in.

5 TOP OF BONNET. CUT ONE 1/4 in.

5 SIDE OF BONNET. CUT TWO 1/4 in.

4 FRONT OF BONNET. CUT ONE 1/4 in.

2 CHASSIS. SIDE. CUT ONE 1/4 in.

27 RUNNING BOARD. CUT TWO 1/4 in.

2 CHASSIS. SIDE. CUT ONE 1/4 in.

18 PAWL TO ENGAGE THE RATCHET OF DRUM. CUT ONE 1/4 in.

19 SCREW FOR PIVOT.

NOTE.—This design sheet is only presented free with the current issue of Hobbies and not with back numbers. Further copies may be obtained.

ROUND ROD 1/4 in. DIA. WANTED.  
 ONE PIECE 2½ ins. LONG FORMING DRUM.  
 ONE PIECE 2½ ins. LONG FOR CROSS SPINDLE.  
 ONE PIECE 1 in. LONG FOR HANDLE.  
 ONE PIECE 2 ins. LONG FOR STEERING SPINDLE.

STEERING PILLAR. FLOOR. CUT ONE 1/4 in.

No. 4 FITS IN HERE

PRINTED IN ENGLAND.



# How to make the Pull-Along Model Fire Engine

HERE is another easily constructed pull-along model, which will give endless fun to the youngster. It is a simple straightforward piece of work, both in the cutting and putting together, and in the final finishing in paint.

The model, as can be seen, is of a simplified type of modern fire engine, complete with escape ladder which can be raised and lowered by a simple

In commencing to make the model, we take in hand the main floor (No. 1). This is a plain oblong piece with a shallow recess at the front into which piece No. 4 will later fit. The two chassis sides (No. 2) on the sheet, will next be prepared by pasting down the patterns shown, direct to the wood, and cutting them out carefully and accurately.

These will be glued and nailed beneath

from beneath, into piece No. 7 to make a firm fixing.

The seat for the driver and his companion is made up of pieces Nos. 9, 10, 11 and 12. All these are carefully cut and glued up—see detail (B) Fig. 2. The seat at the rear of the driver's seat, consists of pieces Nos. 13, 14 and 15.

Note here that one of the pieces No. 13 is glued as a division along the middle of the top (No. 15). The mechanism used for raising and lowering the escape ladder is contained in a separate unit which may be made up independently, and loosely screwed to the floor; note position of pivot screw on this part.

Parts Nos. 16 and 17 are cut from the sheet and accurately glued and nailed together. The sides (16) are stiffened by adding the 1/4 in. rod shown, as 'cross spindle' in the detail Figs. 3 and 4, and also by the wire on which the ladder is supported and pivoted.

Take good care in fixing the sides No. 16 to the base No. 17 that they come immediately opposite each other so that the moving spindle which forms the winding drum will turn freely in the holes made for it.

The drum is formed by gluing on the spindle the disc No. 20, sufficient clearance being allowed when spacing them, as the rod is passed through the holes in the sides. The actual makeup of these various parts is shown in the broken sectional detail Fig. 4.

Part (No. 18), the pawl, governs the ratchet wheel, and is loosely screwed to the inside face of the side (No. 16). It must be carefully fitted and fixed so that it drops into place in the ratchet wheel, to prevent its further turning when it is required to hold the ladder at any required angle.

## Winding Mechanism

Note from the diagram Fig. 4 that the winding mechanism when finally made up and completed, rests on a square seating piece (No. 19) which is glued to the floor, and that the pivoting screw passes first down through piece No. 17, then on through No. 19, into the floor, No. 1. A thin metal washer should be added beneath the head of the pivot screw.

The crank (No. 21) is glued to the spindle, as shown in the details, sufficient clearance being allowed between the side for it to move freely. The steering wheel (No. 24) may be cut as a solid circle of wood, or it may have the rim

and bars cut through, as shown by the dotted line, which would give a realistic effect. The rim and bars of the wheel may, of course, be just painted in, which would give the strongest form of wheel.

The steering pillar consists of a piece of 1/4 in. diameter rod 2 ins. long. The wheel will be glued to the top of this, and the pillar then let into the hole in the floor, as indicated on the pattern sheet.

The Escape Ladder is an independent unit, and simply pivoted by the wire, as mentioned. The ladder is composed of the three pieces, one No. 25 and two No. 26.

Cut the three pieces carefully and accurately from the patterns given, noting the holes at the pivoted ends of No. 26, which take the pivot wire on parts No. 16, and the cross wire to which the cord is to be attached for raising and lowering the ladder.

The steps of the ladder, piece No. 25, will fit between the sides (No. 25) and will be glued and pinned, or fine screws would make a better job.

It must be remembered to drill the holes for the screws or pins, whichever are used, before the inside fretted openings are cut, so as to prevent the splitting of the wood. The method of connecting up the winding cord from the drum spindle, then under the cross spindle to the cross wire at the extreme end of the ladder, is shown in our final diagram in Fig. 5.

## Finishing the Model

To finish the model, the two running boards (No. 27) are glued to the chassis sides (No. 2). Four turned wood wheels are supplied, with stout 1 in. round-head screws for fixing them. A 1 in. round-head screw is also provided for the pivot screw of the ladder turntable.

Little need be said regarding the painting of the fire engine, beyond that the wood should first be well cleaned and made smooth before the first coat is applied. When this has hardened it should be lightly glasspapered, and the finishing coat of paint or enamel put on.

Needless to say, the whole thing will be painted bright red, with, perhaps, grey to represent the tyres of the wheels, and black for certain lines, such as the vents on the bonnet sides and on the radiator front.

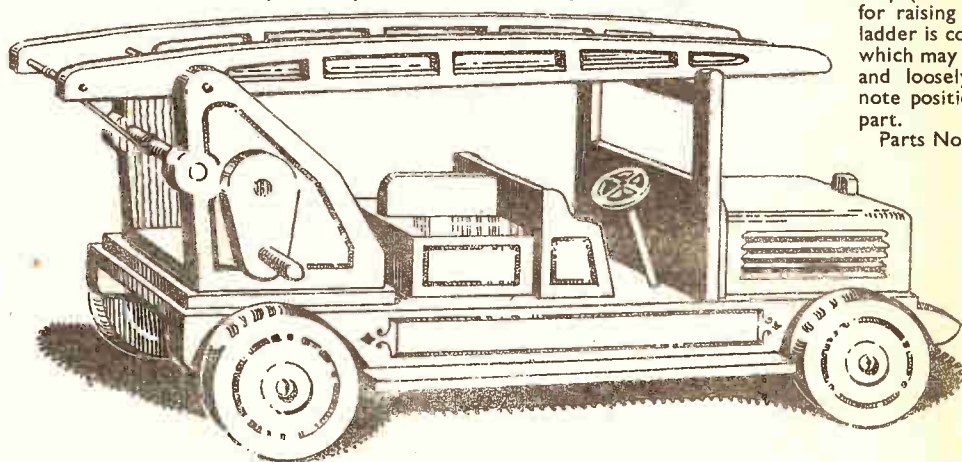

mechanical means. The overall length of the engine and ladder is 12 1/2 ins. and the height with ladder lowered and resting on its support, is 5 1/2 ins.

Full patterns for making will be found on the other side of this sheet. These patterns can be pasted to the wood, or the outlines of each part traced through carbon paper or ordinary tracing paper.

If the paper pattern itself is pasted down to the wood, it will, of course, have to be cleaned off later with glasspaper. As, however, there are quite a number of parts square or oblong in outline, the simplest way of transferring these to the wood, is by laying the patterns on the wood and pricking the corners with a sharp pointed instrument. These points can then be connected up with pencil, making a good solid line along which to cut.

No. 1 and flush with the edges (see detail Fig. 1). Holes will be bored in these sides to take the fixing screws of the wheels. To ensure a firm fixing for the wheels, the stiffeners (No. 3) are cut to outline shown, and glued inside the sides (No. 2)—see detail Fig. 2 (A).

## The Bonnet

Next in order of cutting and fixing will be part No. 4, the front of the bonnet. The double dotted line on the pattern of this part, indicates its position when fixed to floor No. 1. The sides and top of the bonnet are shown as Nos. 5 and 6 respectively on the patterns. The outline of these pieces may be pricked on the wood as previously suggested, ready for cutting. Clean up the edges and glue in place on the floor.

Piece No. 7—rear of bonnet—and also piece No. 8 can next be cut and glued together, and then glued to the bonnet sides and top, and to the floor. A couple of screws should be run up through the floor

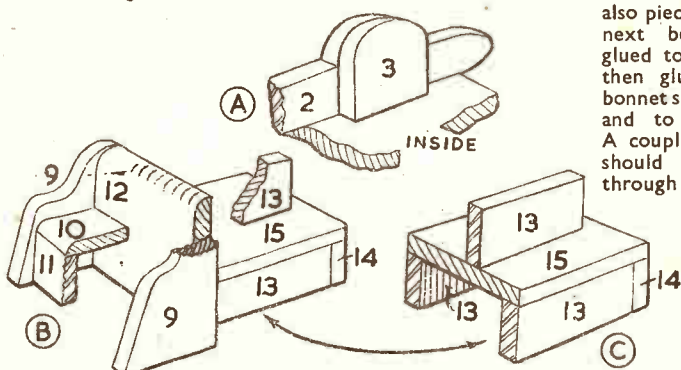

Fig. 2—The seats and detail of stiffener for wheels

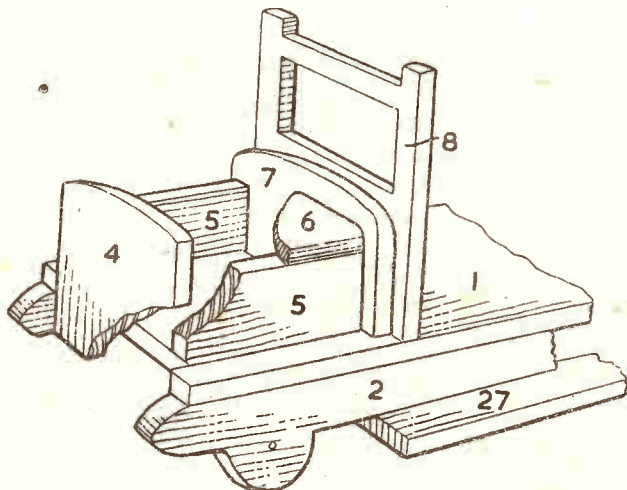

Fig. 1—The main floor, bonnet and chassis sides

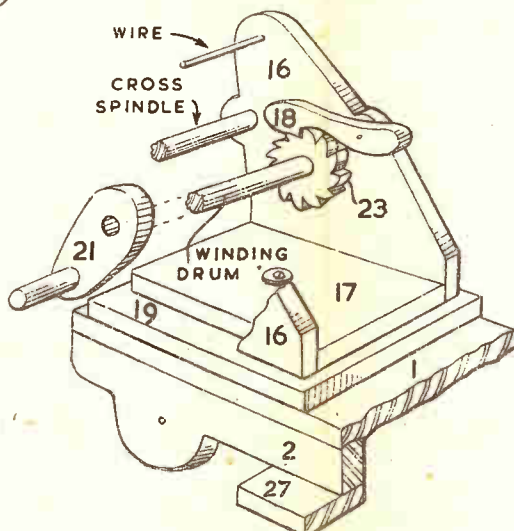

Fig. 4—Winding drum details

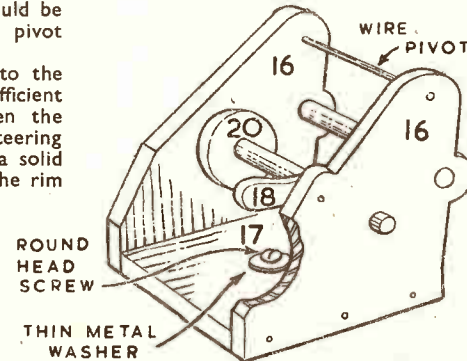

Fig. 3—How the escape ladder mechanism is pivoted to floor

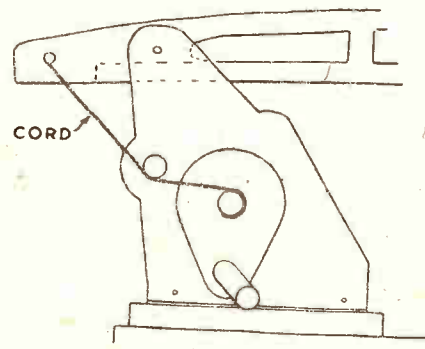
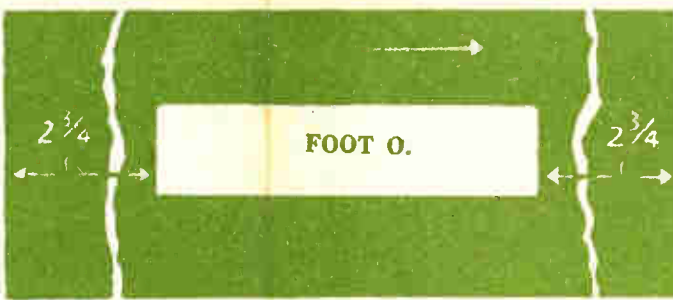

Fig. 5—The cord for working escape ladder



J. CUT FIVE  
1/8in.



CUT TWO 1 1/4in. EXTEND AS SHOWN.  
GLUE TO P.

SUPPLEMENT TO HOBBIES No. 2886

**FIREPLACE SCREEN**

SIZE—29ins. HIGH, 17 1/2ins. WIDE

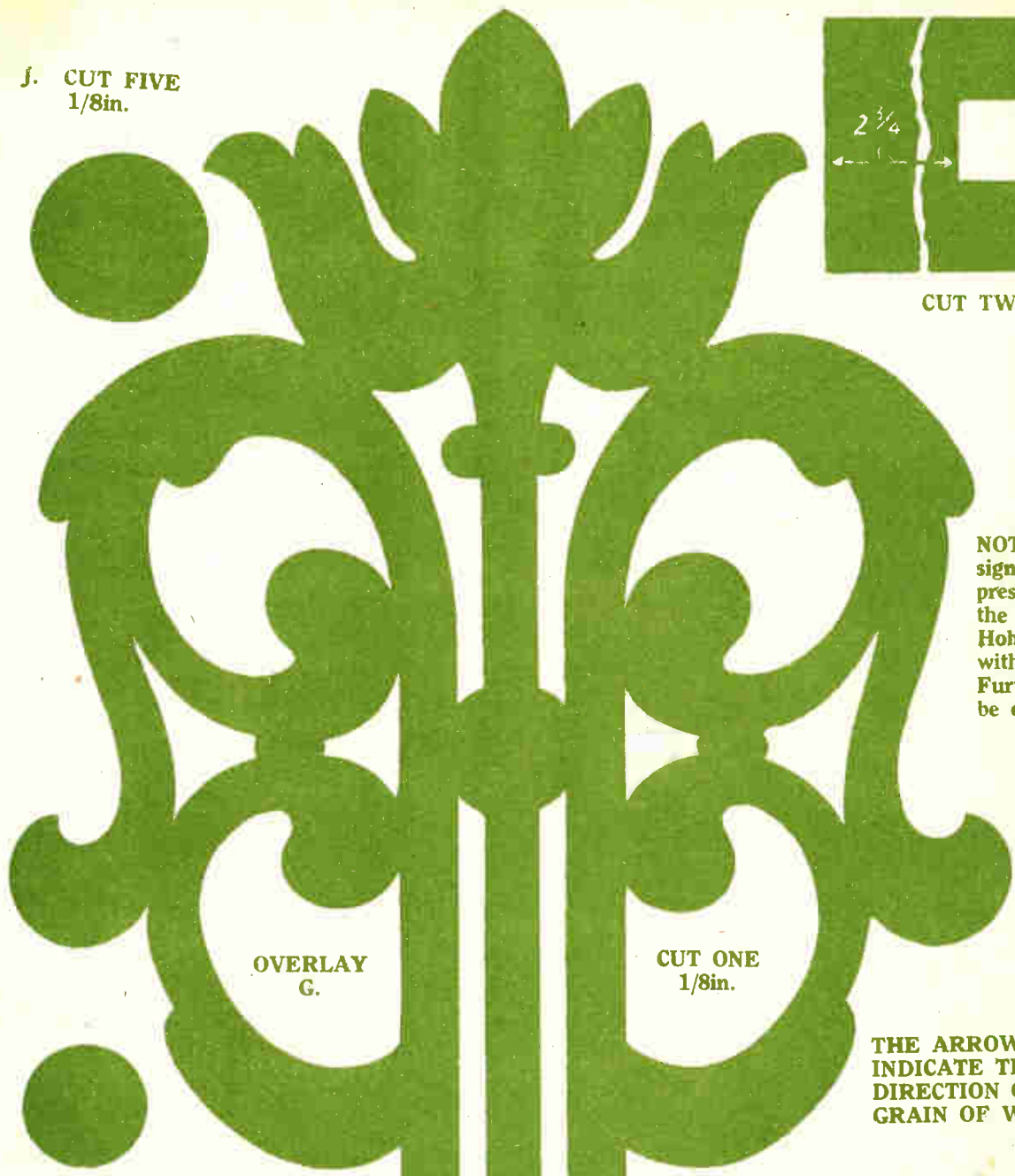
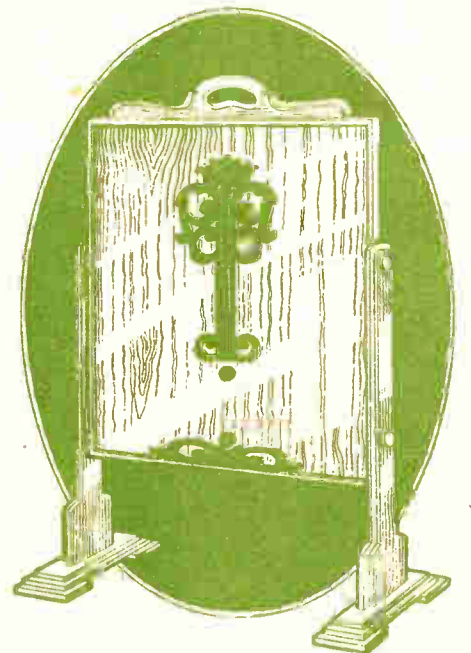

OVERLAY  
G.

CUT ONE  
1/8in.

NOTE.—This design sheet is only presented free with the current issue of Hobbies and not with back numbers. Further copies may be obtained.

THE ARROWS INDICATE THE DIRECTION OF GRAIN OF WOOD.

I. CUT ONE 1/8in.

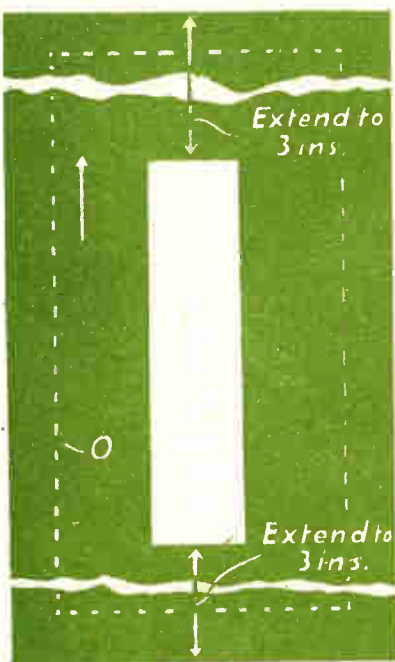

FOOT P.  
CUT TWO  
1/4in. EXTEND  
AS SHOWN.

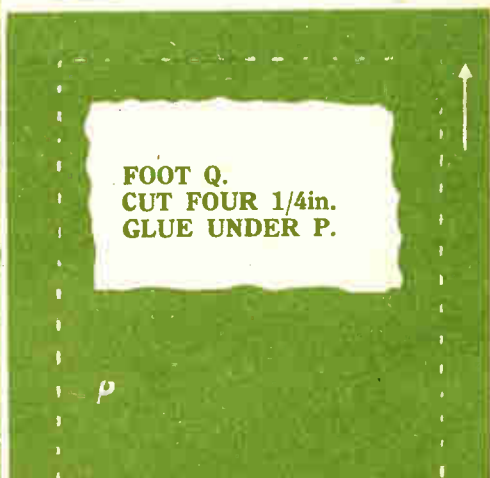

FOOT Q.  
CUT FOUR 1/4in.  
GLUE UNDER P.

NOTE.—THE MAIN SCREEN A IS MADE UP OF TWO PIECES OF 1 1/4in. WOOD 19ins. BY 8ins. AND HELD TOGETHER BY BATTENS AS DETAILED IN THE INSTRUCTIONS.

MITRED FRAME.  
E. CUT TWO  
PIECES 19 1/2ins.  
BY 3/4in. BY 1/4in.

BATTEN B. CUT TWO 16ins. BY 1 1/2ins. BY 3/4in.  
BATTEN C. CUT TWO 16ins. BY 1in. BY 3/4in.  
BATTEN D. CUT ONE 14ins. BY 1in. BY 3/4in.

F. CUT TWO PIECES  
16 1/2ins. BY 3/4in. BY 1/4in.  
MITRE THESE ROUND SCREEN  
AFTER BATTENS HAVE BEEN  
GLUED IN PLACE.

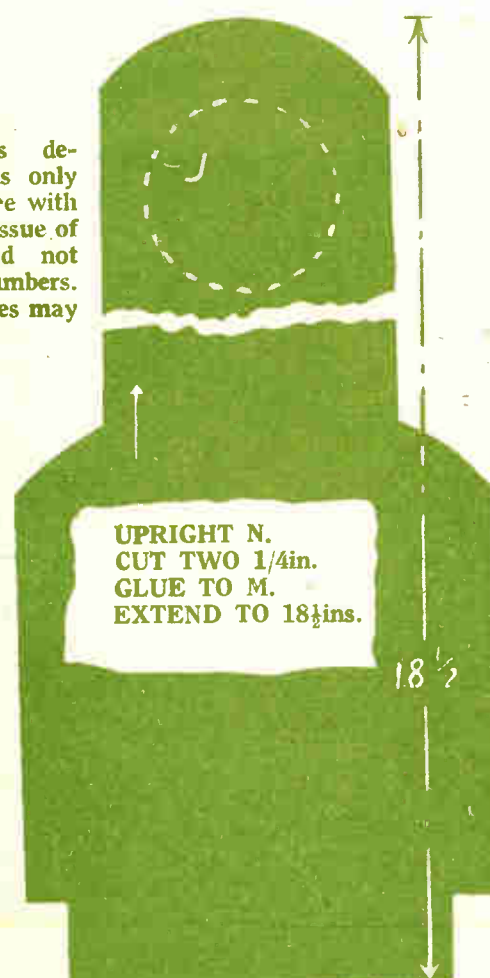

UPRIGHT N.  
CUT TWO 1/4in.  
GLUE TO M.  
EXTEND TO 18 1/2ins.

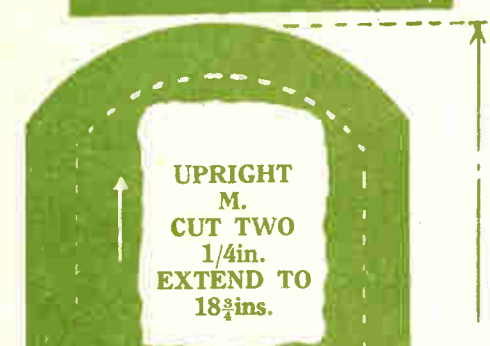

UPRIGHT  
M.  
CUT TWO  
1/4in.  
EXTEND TO  
18 3/4ins.

PANELS OF WOOD  
REQUIRED FOR THIS  
DESIGN  
**ONE H2 FIVE K4  
TWO LD6**  
Materials for making this  
design are supplied by  
**HOBBIES LIMITED,**  
Dereham, Norfolk.  
Price on application.

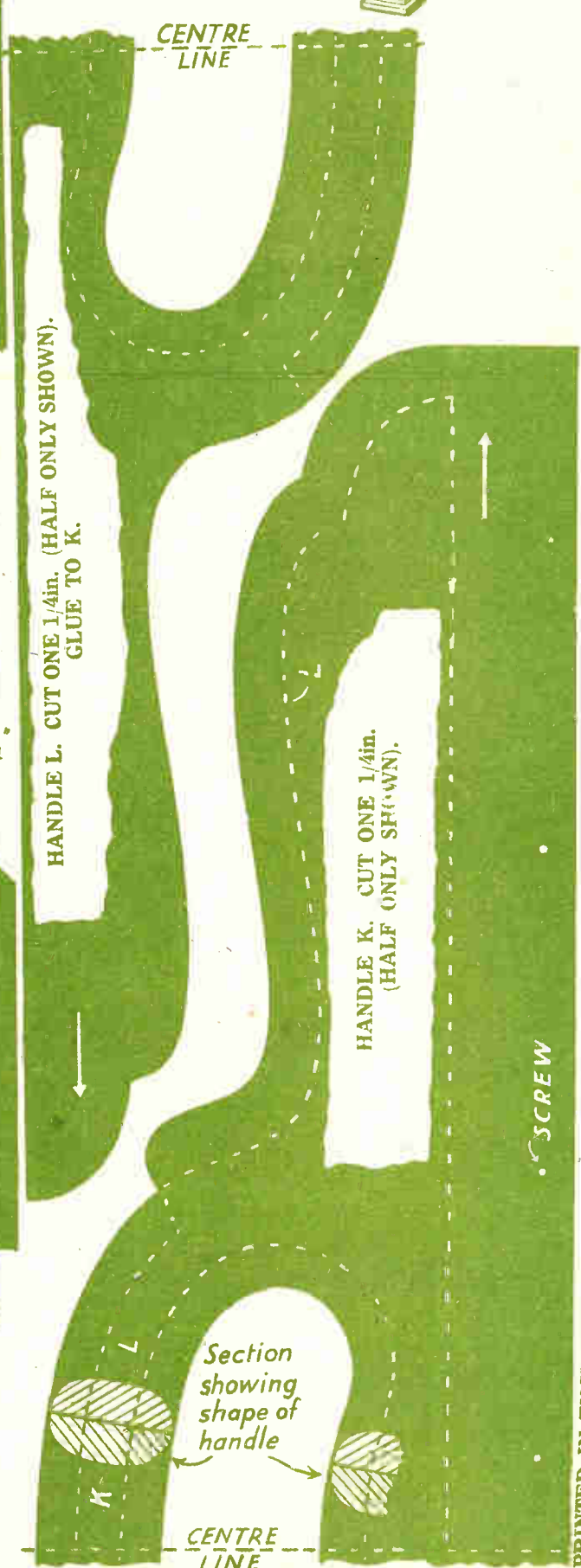

HANDLE L. CUT ONE 1/4in. (HALF ONLY SHOWN).  
GLUE TO K.

HANDLE K. CUT ONE 1/4in.  
(HALF ONLY SHOWN).

Section showing shape of handle

CENTRE LINE

SCREW

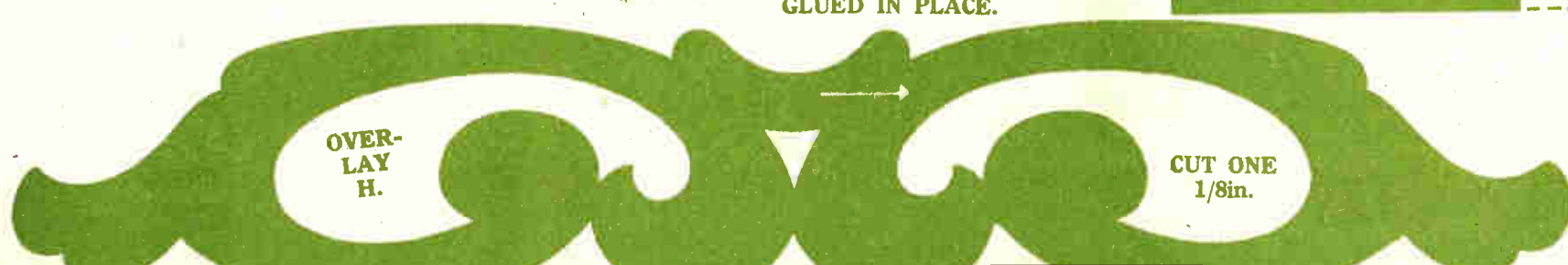

OVERLAY  
H.

CUT ONE  
1/8in.



# A FIREPLACE SCREEN

THIS completed screen can be made with the usual Hobbies panels of wood  $\frac{1}{2}$  in. and  $\frac{3}{4}$  in. thick with a fretsaw, and makes an attractive piece of work nearly 2ft. 6ins. tall. The patterns should be redrawn on to the wood in the usual way, cut out and cleaned. Note that the extension of certain parts of the design, where it has been impossible to get them full length on the sheet. Measure the distance between the arrowheads shown, and link up the ends of the patterns straight and true.

The construction can be in two complete sections, one the main panel portion, and the other two feet and legs holding them. The overlays of  $\frac{1}{2}$  in. wood

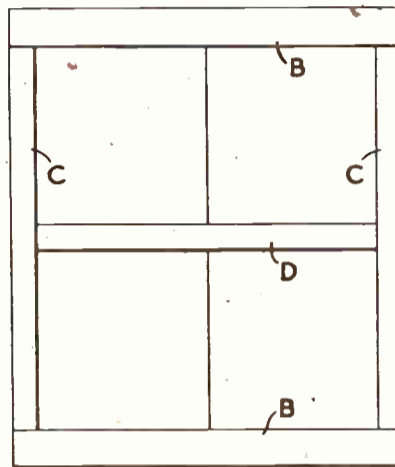

Fig. 1—The framework

are decorations for the front, and in the finished article should be stained to a darker shade than the main article. If, of course, you prefer to omit the fretted decorations, you can do so, and add a simple colour transfer to the centre of the flat panel.

This centre panel is completed on a framework as shown at Fig. 1. Two pieces 19ins. by 8ins. wide are glued flat together, and then a framework of battens (B), (C) and (D) put on the back, glued firmly with their edges flush. The side ones (C) come between the top and

bottom (B), and then the shorter one (D) goes across the middle to stiffen the whole thing.

Round the edge of this is put a flat strip composed of the frame (E) and (F). These  $\frac{3}{4}$  in. wide pieces are glued with the back edge flush with the back of the frame, so there is about  $\frac{1}{2}$  in. projection at the front. The corner ends are mitred carefully with plane or file, to make a good joint. A detail of one of the corners is given in Fig. 2.

When the framework is complete, you can add the handle along the top. The handle part (L) is cut from  $\frac{1}{2}$  in. wood and glued on the  $\frac{1}{2}$  in. piece (K). Note the position as indicated by the dotted lines. This allows an overlap at the bottom for screwing behind the frame, and also produces a double thickness for the hand hold. The shaded section of this is shown on the pattern, and a rounded effect is obtained by filing and glass-papering to make for comfort in handling. The completed handle stands with its upper portion (L) on the top edge of the frame, and is there glued in place and

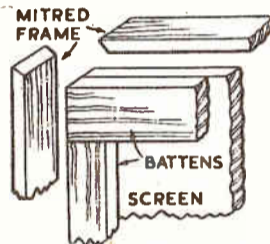

Fig. 2—Detail of construction

additional screws driven in from behind.

If you are polishing or staining the screen, the operation is best done now, before the overlays are put on, although their position should be marked carefully so they can be glued straight away afterwards.

The overlay (H) is at the bottom, with the small circular disc (I) put central about  $\frac{1}{2}$  in. above. The main overlay is fixed with the top  $1\frac{1}{2}$  ins. from the top of the main screen, and then the central disc (J)  $\frac{1}{2}$  in. below that overlay at the bottom. The position can be plainly seen in the picture of the finished

screen. The overlays when cleaned back and front, are stained darker as suggested, and before you glue them in place it will be necessary to scrape away any polished surface you may have made, in order to get the glue to hold.

The side uprights are alike, composed of the tall upright (N) glued on to the similar shaped one (M). In gluing, get the projecting tenon at the bottom in line with each other, so that the double thickness of it will pass later into the hole provided in the foot (P).

The foot itself, you will notice, is extended to 8ins. overall by 2ins. wide. A centre mortise is cut which should be tested first with the actual leg to ensure correct size and position. Above this bottom foot (P) is a smaller one (O) which is glued central in place and again seeing that the mortise cut in the centre is in line with the one beneath. This foot is  $5\frac{1}{2}$  ins. long overall, and 2ins. wide, you will note. Under the completed foot are glued two end pieces (Q). Cut them  $2\frac{1}{2}$  ins. square from  $\frac{1}{2}$  in. material, and glue under the main foot with  $\frac{1}{2}$  in. projection on each of three sides.

The main upright previously made can now be glued firmly in by the mortise and tenon joint, making sure that a tight and lasting fit is obtained. Note that the smaller of the uprights is on the outside when you come to fix the panel between. The main firescreen panel previously made can now be glued to the uprights and screws put in for further strength. Then long screws must be used, with a hole pricked through first to ensure the screw itself driving into the thickness of the main wood.

The panel is fixed to the upright with the screw hole  $8\frac{1}{2}$  ins. from the top. A further  $10\frac{1}{2}$  ins. below this is the second screw hole. Drill the holes carefully, using a flat-headed screw which is countersunk flush or below the surface of the upright. The screw head itself is covered by one of the circular discs (J) being glued over.

The whole screen is now completed, and the remaining woodwork is thoroughly cleaned, then stained and polished in the usual way.



SUPPLEMENT TO HOBBIES No. 2884.

# MODEL OF COLES MOBILE CRANE

SIZE:—LENGTH 12ins. HEIGHT ABOUT 10ins.

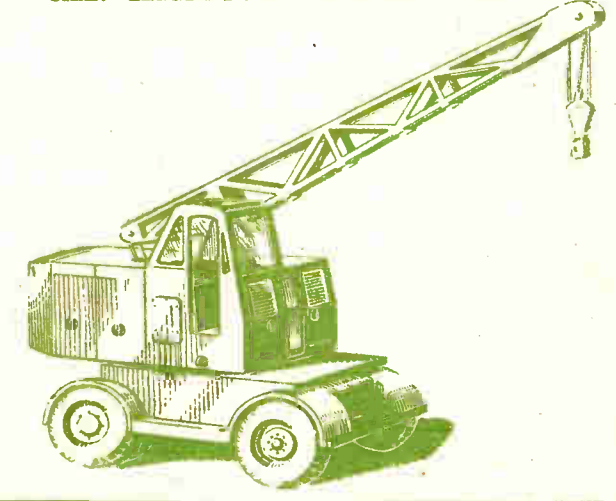

PANELS OF WOOD REQUIRED FOR THIS DESIGN  
**TWO Q2 TWO Q3 ONE Q4**  
Materials for making this design are supplied by HOBBIES LIMITED, Dereham, Norfolk.  
Price on application.

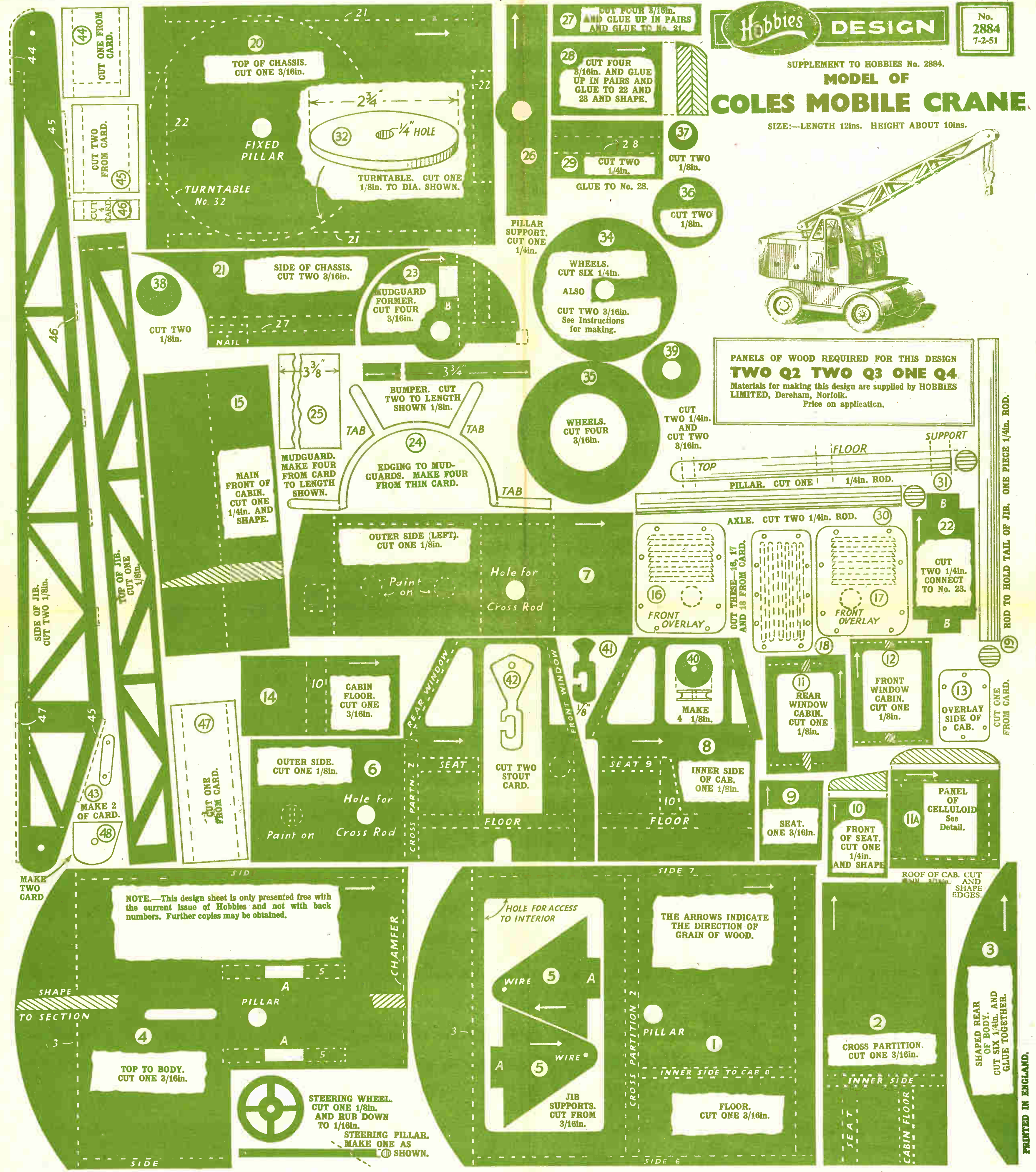

NOTE.—This design sheet is only presented free with the current issue of Hobbies and not with back numbers. Further copies may be obtained.

HOLE FOR ACCESS TO INTERIOR

THE ARROWS INDICATE THE DIRECTION OF GRAIN OF WOOD.

ROOF OF CAB. CUT ONE 3/16in. AND SHAPE EDGES.

PRINTED IN ENGLAND.



# How to use our patterns to construct a model of A COLES MOBILE CRANE

**P**ATTERNS are provided for an interesting model in making one of those modern lifting cranes. These mobile cranes are capable of lifting six tons, with full circle movement, driving petrol/electric or diesel/electric, with 17ft. cantilever jib. Whilst the model is built in wood, it is not entirely a working model, although the top cabin and the fixed jib will revolve on the chassis.

The parts are provided in the kit of wood to which a few pieces of card and string are required in addition. Actual material supplied, includes the celluloid

printed on in lines of black, and the picture of the finished model clearly shows this work to be done.

The chassis is built up according to the details shown, and then the axle put through for the wheels. These wheels are made as twin wheels for the rear axle, and single wheels for the front. Both are shown in sectional detail. The mudguards are of card and the guard parts (24) are cut carefully with the tabs bent inwards as seen in the diagram, to stiffen up the underside of the mudguard between the main body and along the running board.

top of the engine portion.

The actual door of the cab is an open aperture, but celluloid is fitted on all other sides, as seen in the diagram. There is even a piece in the top—in part 10. A hole is cut for this, and then the celluloid fits exactly into the aperture being glued on thin fillets which are in turn glued to the side of the opening. A sectional diagram shows this clearly.

Two are required at the top, one at the bottom, and one in the hanging hook. The cord for these pulleys fixes on the bottom axle holding the jib in place, passes round the top of the hook before coming back to where it started.

The pulley at the back end of the jib is merely to hold the fixing cord running to the axle inside the engine casing. Notice that the flat top of the jib is

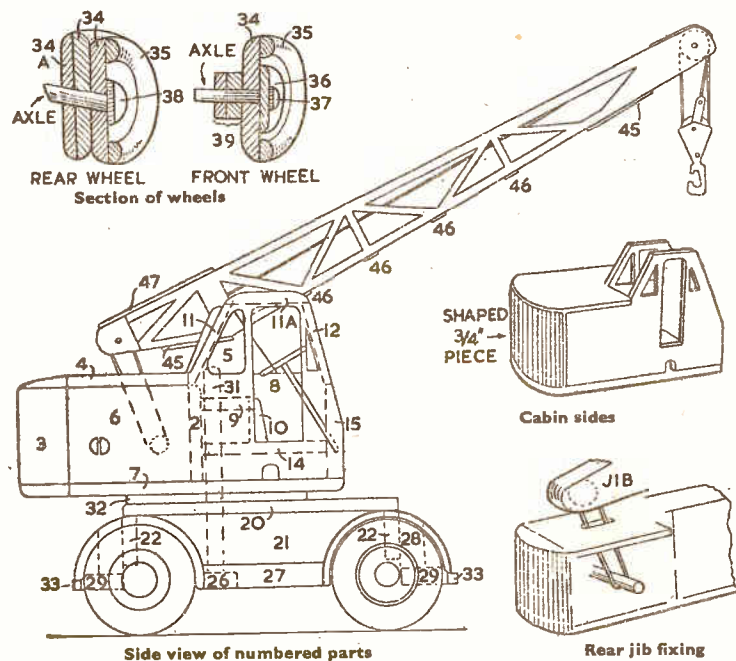

for the windows, the rod for the axles, and wire for fixing. The patterns clearly show shapes required, and are indicated in numerical order for their construction.

The best plan is to trace off the parts on to the wood, in order the pattern sheet may be preserved for reference. Notice where dotted lines show adjoining parts, and any shaping which has to be done. The various details here clearly indicate the construction, and the whole work of cutting is done with the fretsaw.

The finished model is painted with the chassis and undercarriage grey, and, perhaps, a yellow or brown cabin and jib. If you are making it as a toy, a bright colour will appeal to the youngster, but if you want it actually realistic, then the steel work, of course, will be painted grey. Markings on the upper portion are

The diagrams herewith also show the construction of the cabin portion with its projecting tail-piece in which the engine normally is contained. Notice the seat and floor portion inside, which can be made as a complete unit, and then glued to one side and the cross portion before the second side is added. In the floor portion (No. 1), there is an opening to allow access for the interior. Inside here you will see the axle glued into the sides. This axle will finally hold the jib upright by means of a piece of elastic or string holding the jib at the required angle.

This fixing piece runs through the top (4) and then over one of the pulleys in the bottom end of the jib. The circular turntable on the top of the chassis, is glued down and a 2in. spindle glued upwards to run through the floor and

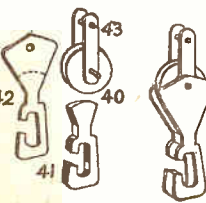
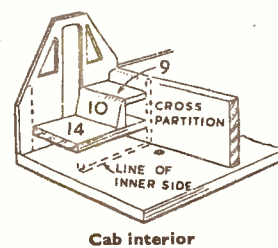
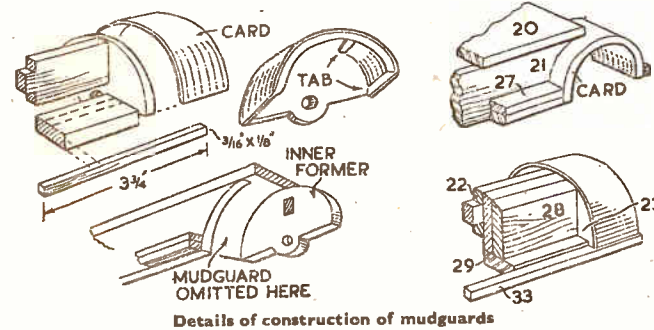

The hook and pulley

The construction of the jib is simple. The top girder pattern is glued between the sides. There is no girder pattern part for the underside, but there are four strips of card (No. 46) glued across at the points you see in the diagram of the side view. Note, too, further card (pieces 45) glued near the top and at the rear end, whilst a rounded piece is put above the pulley, and a flat piece at the bottom (No. 47).

The pulleys can be cut and grooved. Four of them are needed, 1/8 in. in diameter, shown as No. 40 on the pattern. Cut the tiny pulleys and file a groove in them before fitting in the jib.

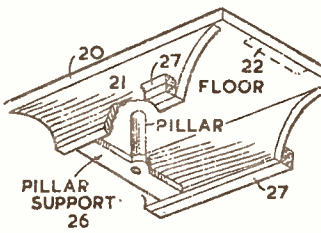

Underview of floor

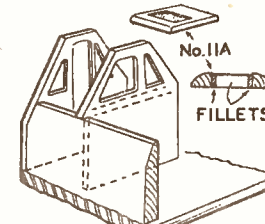

Top cabin light

uppermost. These pivot pins can be put in temporarily, but the jib itself must not be fixed in place until after it and the rest of the model have been painted.

A detail of the hauling hook on these lines is given, and patterns for the card and wood centre (41 and 42) are shown full size. Having made the three separate units—clean up all parts as usual, make sure they run and move satisfactorily and then finally paint in whatever colour is desired.

(We are indebted to Steels Engineering Products Ltd., of Sunderland (makers of the Coles Cranes), for plans and data from which this model was prepared).



SUPPLEMENT TO HOBBIES No. 2882

**PULL-ALONG TOY DONKEY CHAISE**

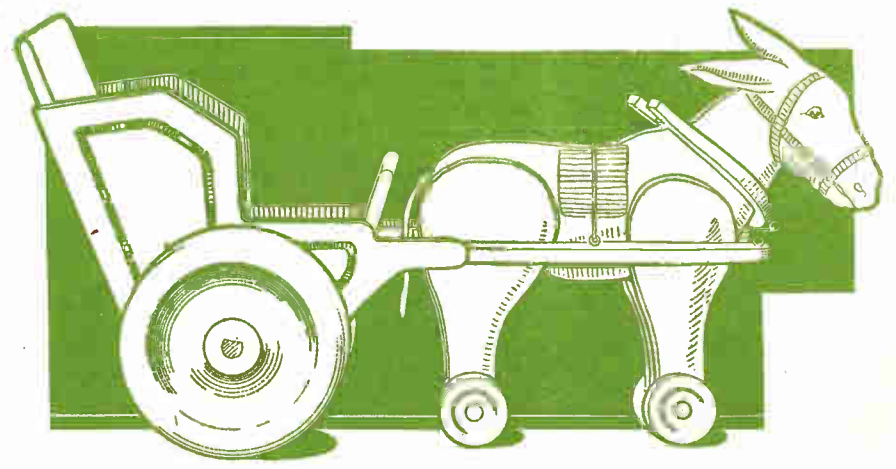

SIZE—15ins. LONG. 7ins. HIGH.

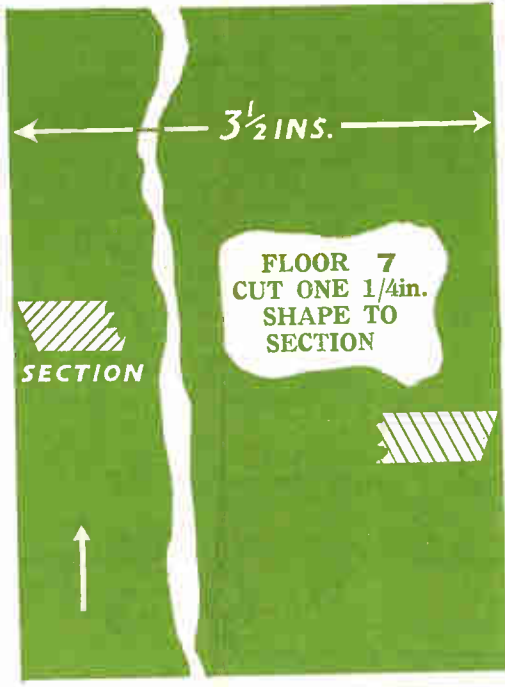
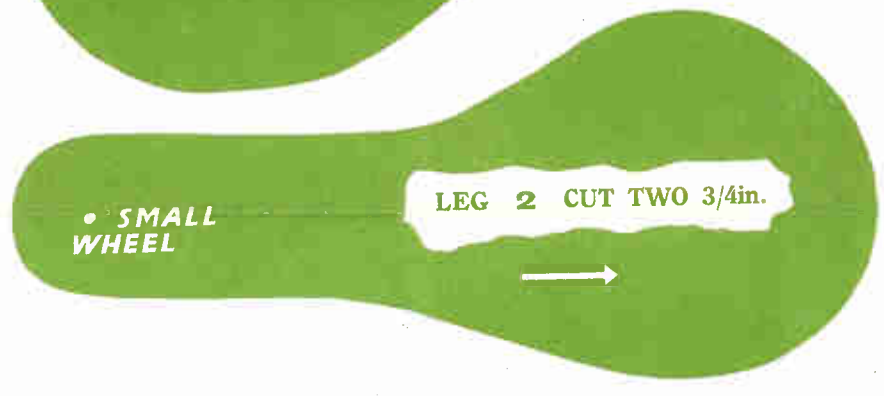
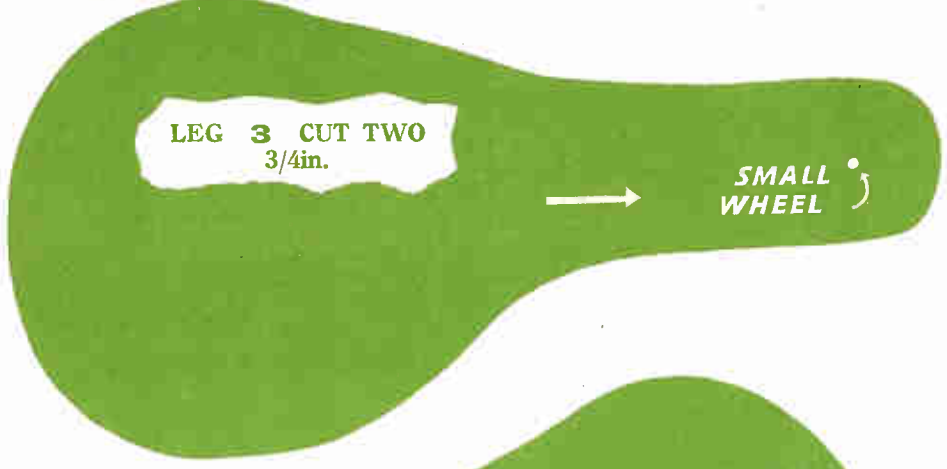
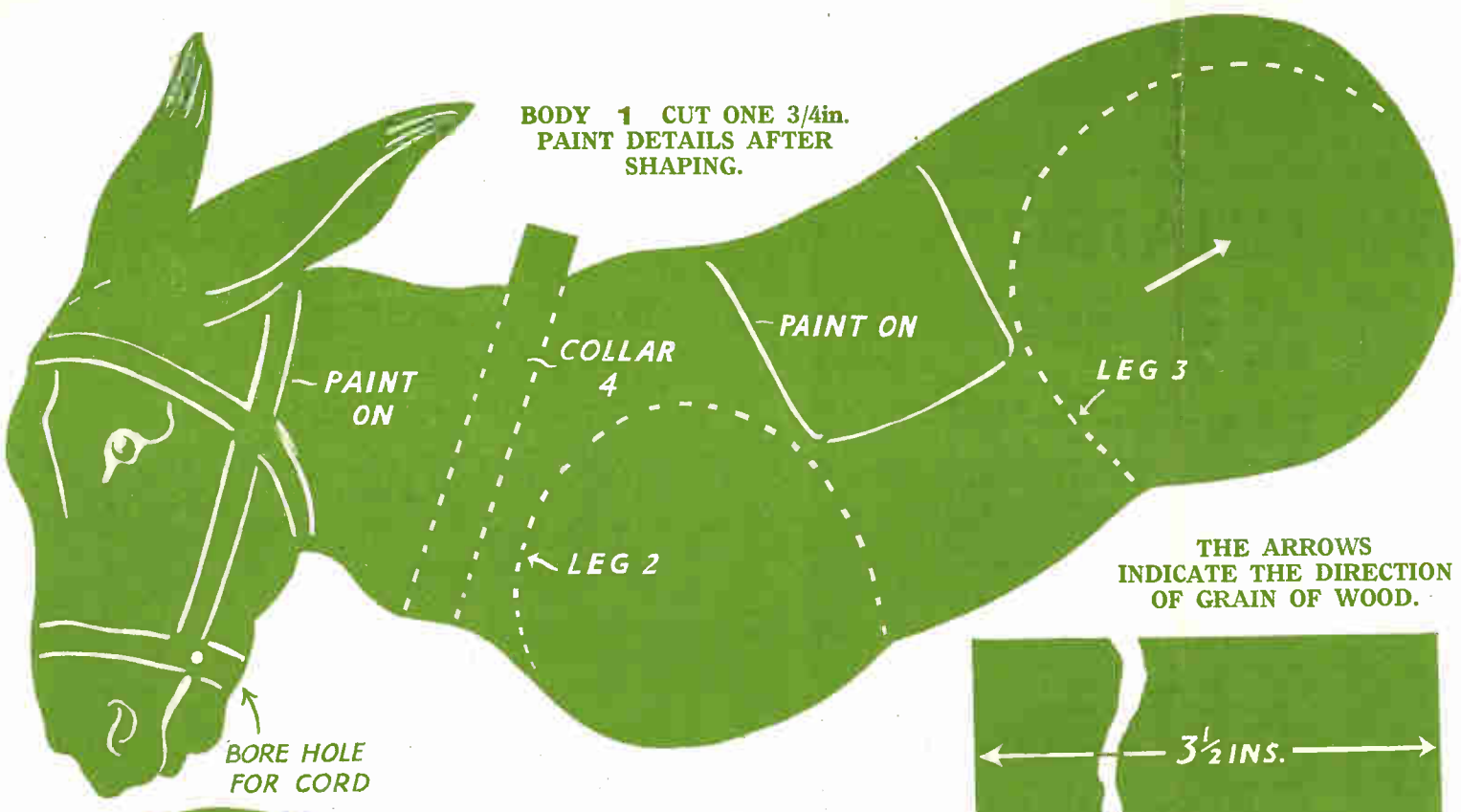

NOTE.—This design sheet is only presented free with the current issue of Hobbies and not with back numbers. Further copies may be obtained.

**PANELS OF WOOD REQUIRED FOR THIS DESIGN**

**Two H4 Two ND I2**

Materials for making this design are supplied by HOBBIES LIMITED, Dereham, Norfolk. Price on application.

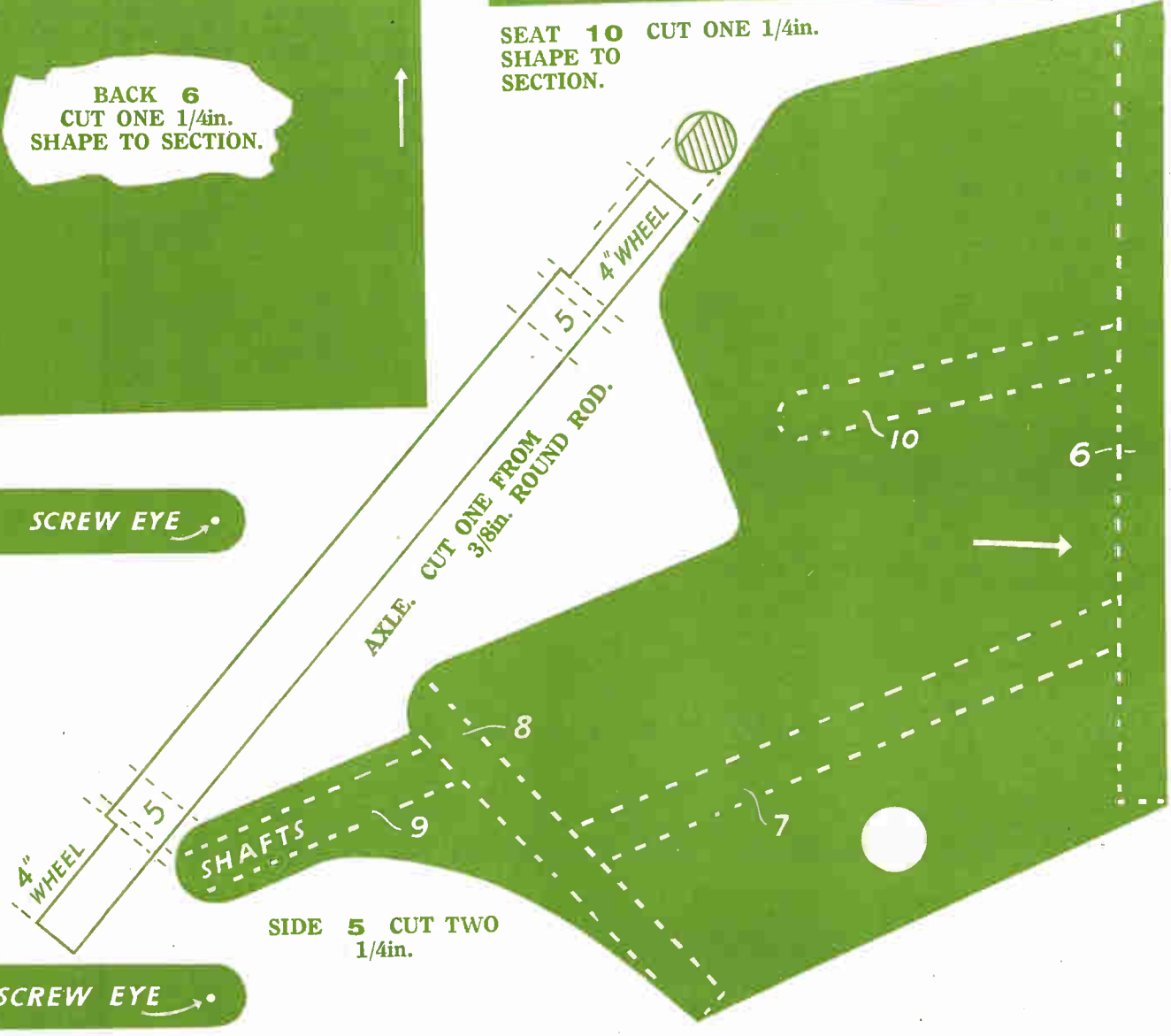
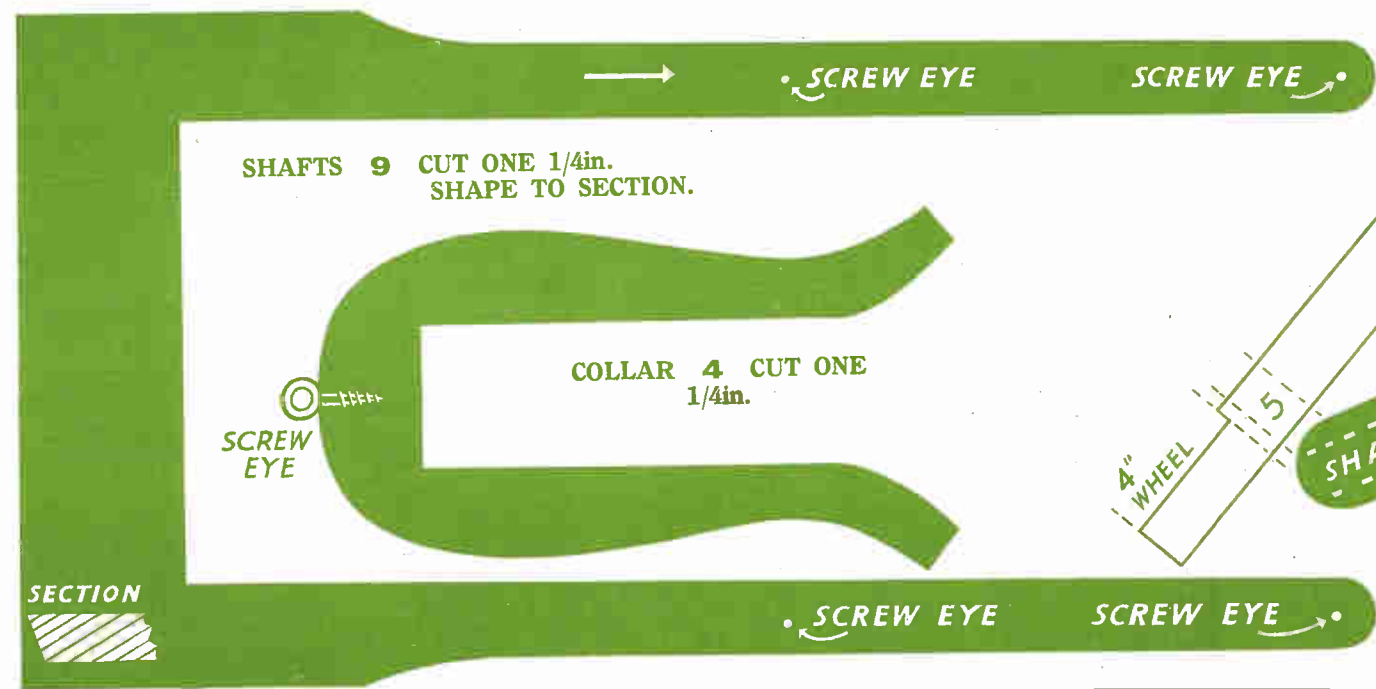
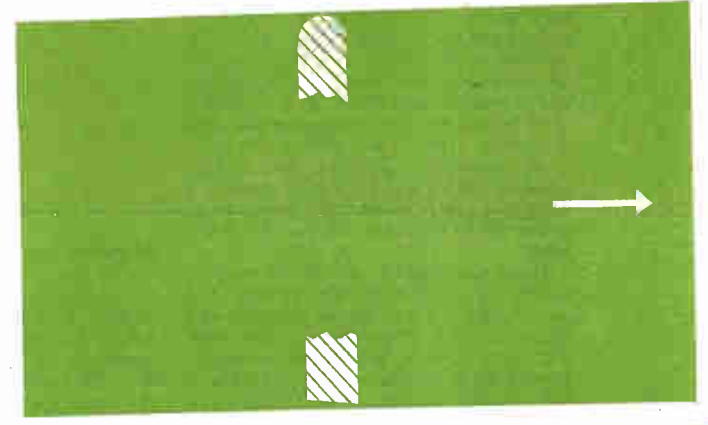
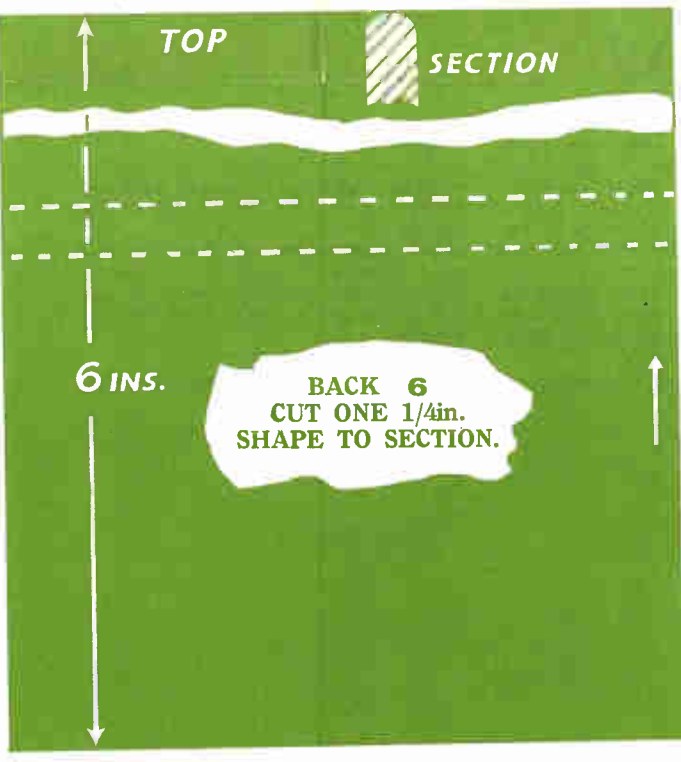
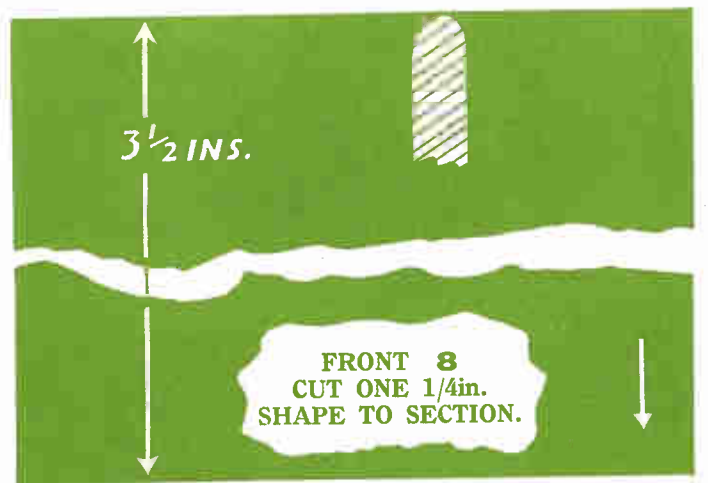



# MODEL DONKEY CHAISE

**P**ATTERNS on the reverse side provide for the making of the simple pull-along toy illustrated, all parts for which can be cut with the fretsaw quite simply, and the whole thing finished with bright painting. The kit includes the necessary wood, as well as the four small (1½ ins. diameter) and two large (4 ins. diameter) wheels. In addition, screws and fittings are provided, as well as the screweyes holding the donkey in position.

The animal is an independent unit fitted between the shafts by the cord running over its saddle, and at the front from the three eyelets seen in the picture. One eyelet is fixed to the top of each shaft, and the other to the bottom of the collar. When cord is strung through, they prevent the animal being pulled out. Before starting, notice the extension required of the three patterns, as they are broken through on the sheet for lack of space.

Note, too, the shaded portions indicating the shape of the ends in certain cases. Where the parts lean slightly, the end of the wood has to be chamfered with a file or small plane to allow it to bed to another part satisfactorily.

## Cart Construction

The construction of the cart itself is clear from the detail herewith, which is a drawing of the model with one side removed. Cut the two sides, and then glue between them, the back and the front, the angle of which parts being shown on the pattern of the sides.

The floor with its chamfered ends is then dropped and glued between the back and front, and the side is fitted at rightangles to the back. If you think fit, you can drive screws from the outside or, of course, add little blocking pieces under the seat and floor. In each side, a 7/16 in. hole is bored to allow the 3/8 in. axle to revolve freely. If you have not a bit 7/16 in., then use a 3/8 in. one, and enlarge carefully with a small file. The shafts are all in one piece, glued close to the front at the points shown on the pattern of the sides.

Note the position of the screweyes, which as previously mentioned, are used to hold the cord for keeping the animal in place. Here again, if you think the glue wants additional strength, screws can be driven through the sides of the cart into the edge of the shafts. In all these cases where screws are used, they must be flat-headed and sunk flush with the surface of the wood so that the

painting will cover them without visibility.

The large wheels are fixed firmly to the axle 5 3/8 ins. long. In the centre of each wheel, cut with a fretsaw, a hole with one side flattened. Note here, the shape of the axle where a flattened portion is filed across 1/2 in. inwards, as shown by the shaded end diagram. This flattened portion coincides with the same flat cut into the centre of the wheel, and so helps to bind the whole thing.

## Axle and Animal

Another method, of course, is to have the axle just fixed in without preparation, and then drive a short length of razor blade across the end of the axle into the grain of the wheel itself. This acts as a staple and will prevent likelihood of axle turning apart from the wheel. The axle rod has one wheel fitted, and then the other end of the axle rod pushed through the two sides of the cart before the second wheel is

in place. See the wheels revolve easily. Note the dotted lines on the pattern of the body, which indicate exactly where these legs are to be glued.

Put all four in place, and before the glue is set, stand the model up to ensure the legs are straight and all four wheels rest evenly on the ground. If this is done while the glue is still tacky, and before it has set, then any slight adjustment can be made. When satisfactory, weight the legs and body together and leave until set. When it comes to painting the animal, you can, of course, take the wheels off.

The only other part of the animal to fix is the collar, which is cut from 1/2 in. wood and glued at the angle shown by the dotted lines on the pattern of the sides. This pattern also shows the markings which can be painted on later, and should be drawn on the wood first with pencil, when the operation is ready.

## Painting

A hole is shown at the mouth of the animal which is where the bit would be actually. This hole is for a piece of cord to be strung right through, and act as a rein running from either side, pulling along the toy in use. All parts having been cleaned, should be given a coat of grey or cream flat paint. This is allowed to dry right into the wood before the second coat is added. For this, a darker grey is suitable for the animal, with

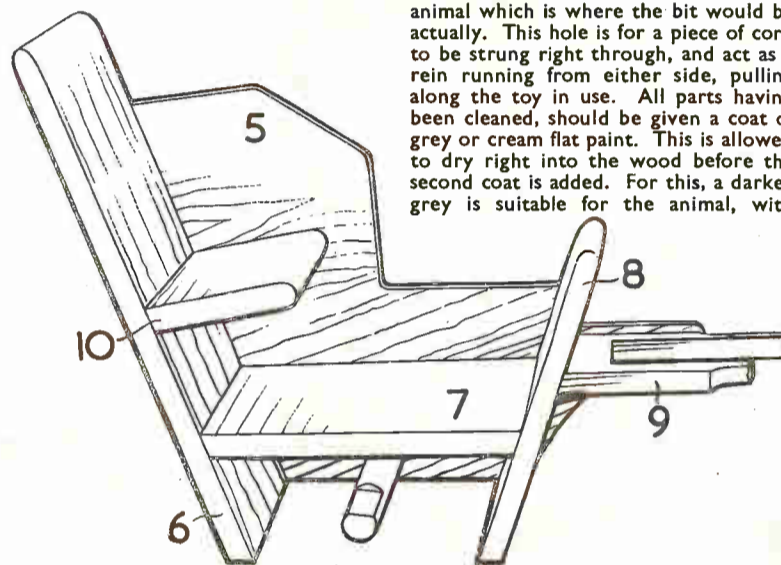

glued in place.

The animal can be undertaken next, and completed as a solid block. If you prefer the other way round, the numbered patterns are in their proper sequence and you can make the animal first. The main parts for the donkey are the body and legs, all cut from 3/4 in. wood. Small wheels are added to the legs at the position shown, and these should be screwed on before the leg itself is glued

brown and black markings for saddle, harness, features, etc.

The cart and large wheels can be made quite gay, and the shaped panelling marked on the side, as you see in the picture of the finished article. In the actual construction, by the way, you must remember to paint the cart before you finally add the large wheels, or you will not be able to get behind them to the sides.



SUPPLEMENT TO HOBBIES No. 2880.

# POT HOLDER

SUITABLE FOR FERN OR FLOWERS TO TAKE A FOUR-INCH POT

The Arrows indicate the direction of grain of wood.

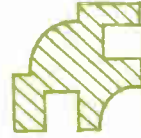

MOULDING No. 45. FOUR PIECES WANTED 7ins. LONG.

NOTE.—This design sheet is only presented free with the current issue of Hobbies and not with back numbers. Further copies may be obtained.

—SIZE—  
5½ins. SQUARE.  
7½ins. HIGH.

PANELS OF WOOD REQUIRED FOR THIS DESIGN  
**THREE H3 TWO G2**  
Materials for making this design are supplied by  
**HOBBIES LIMITED,**  
Dereham, Norfolk.  
Price on application.

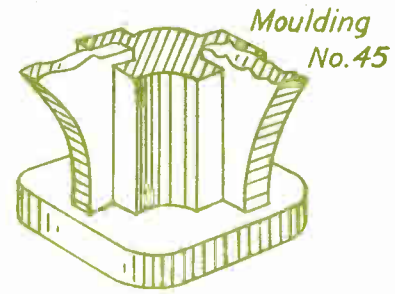

DETAIL OF FEET, ETC.

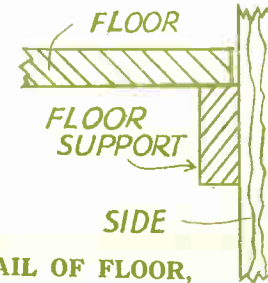

DETAIL OF FLOOR, ETC.

LINING. TO BE GLUED BEHIND FRETS OF SIDES. HALF ONLY SHOWN. CUT FOUR 1/8in.

OVERLAY STRIPS ABOVE TOP FRAME. CUT FROM 3/16in.

Corner Moulding No. 45

FLOOR SUPPORT.

FLOOR SUPPORT.

FLOOR SUPPORT.

FLOOR SUPPORT. CUT FROM 3/16in.

FLOOR FILLET.

FLOOR FILLET. CUT FROM 3/16in.

FEET. CUT ONE OF EACH 3/16in.

TOP FRAME. CUT ONE 3/16in.

Line of overlay strip

Screw into corner moulding

Side

OVERLAY STRIPS ABOVE TOP FRAME. CUT FROM 3/16in.



Lining at back

Floor Support

SIDE. CUT TWO 3/16in.



Lining at back

Floor Support

SIDE. CUT TWO 3/16in.

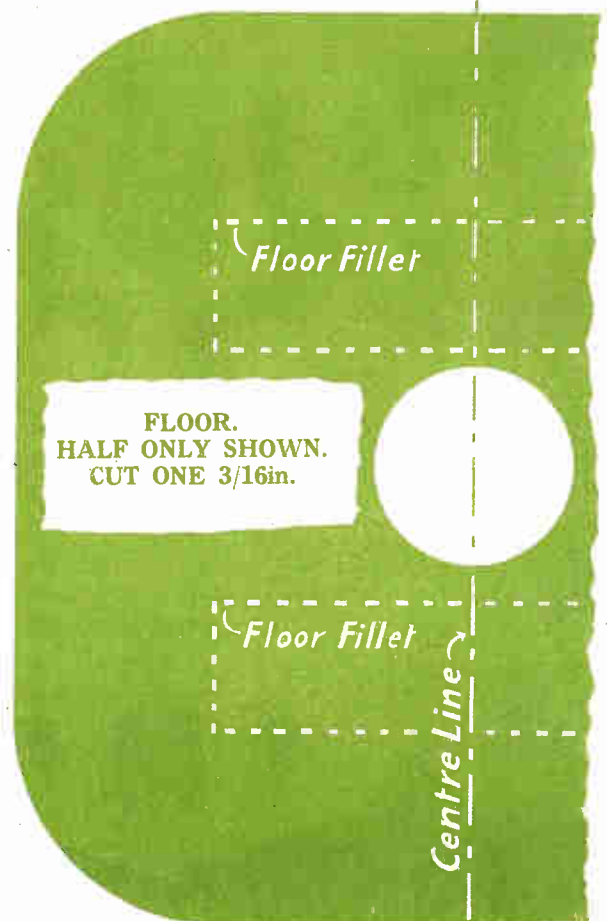

Floor Fillet

FLOOR. HALF ONLY SHOWN. CUT ONE 3/16in.

Floor Fillet

Centre Line

PRINTED IN ENGLAND.



---

# SMALL POT HOLDER

ALL the parts can be easily cut with the fretsaw, and construction is made simple by provision in the kit of a special grooved moulding to take the thickness of the sides. It is thus a simple matter to glue the side panels into these grooves forming an open box frame on which a rectangular top is fitted.

Patterns of two further sides will have to be redrawn, but this is simple by pinning the design again over a piece of carbon paper on to another piece of wood and drawing out the shape required. In the case of other pieces, too, only half the required size is shown, but here again it is a simple matter to duplicate on the opposite side of the centre line again.

In doing this you must be sure to get the lines quite straight, and the angles correct, otherwise the actual construction will be thrown out of true. The sides are shown with fretted decoration, and there is a lining piece behind those provided in the kit of material.

## Framework

The first job is to cut out the four sides and to fit them into the corner moulding in the form of an open box. This is stood upside down on the top frame, and when all edges are level and corner angles true, the parts are glued together to form an attractive rigid framework. The opposite end of the grooved moulding can be left projecting, and afterwards cut in line with the actual ends of the sides. Before the glue hardens, test that the whole thing stands square, and then you can add the rounded feet to the bottom of the moulding.

Glue and screw in position so that the screw is countersunk below the wood surface. A screw can also be added through the top, down into the grooved moulding at that end, because the screw head will later be covered by the overlay strips.

These can next be cut, and being mitred at each corner, fit together to form a plain frame. The outer edge can be rounded slightly to give a more effective appearance before gluing down. In fixing, remember to get an even projection of the top frame all round. Linings of  $\frac{1}{8}$  in. wood are glued inside the box frame, behind the fretted panels.

## Floor

The movable floor is fitted inside the framework, and this rests on floor supports glued  $\frac{1}{2}$  ins. upwards from the bottom. The position is indicated by the dotted lines on the patterns of the sides. These floor supports must be glued firmly and central inside each side, taking care to see they are level with each other, so the floor itself will rest evenly.

The floor itself is a  $4\frac{1}{2}$  in. square piece with a drainage hole in the centre. Wide sweeps are made at the corners so that the wood does not interfere with the interior moulding. The piece can be laid in by slipping upwards through the base, and then bringing down again flat on to the floor supports. To stiffen this floor piece there are also  $2\frac{1}{2}$  in. strips of wood glued on the underside. They should be across the grain, placed central, as shown by the dotted lines on the pattern.

## Finish

The whole work can be stained and polished, or given a coat of varnish. If the wood used happens to be of different colouring, the stain will be necessary to bring the whole lot down to one shade. When the stain has dried in thoroughly, a coat of varnish can be given over or, of course, french polish brushed on.

It will help in this connection if the inner linings are omitted until the fretted parts have been stained and varnished first, remembering that when you come to glue the lining pieces, the adhesive will not fix to the varnish, which has to be scratched off to give a hold.