

# Hobbies

## WEEKLY

January 19th. 1944

Price Twopence

Vol. 97. No. 2518

## THE "CRYSTAL GAZER" BATTERY LAMP

**H**ERE is another novelty electric lamp, and we give it the name "The Crystal Gazer" because it carries the outline of a more-or-less eastern figure gazing into the crystal. There is an upright back which is cut to simple outline and decorated in colour.

As a base to this, there is a box made to contain an ordinary four-volt battery, and when a renewal is required, the floor is made to take off by the removal and replacement of one or two screws.

Now the "crystal" which stands on top of the box consists of an upright circular frame having a covering of either green-coloured or blue-covered transparent celluloid or thin tissue paper, the latter stretched evenly over at the back.

At the rear of the "crystal" and standing, therefore, just in front of the coloured figure, is a fixed electric bulb, and it can be left to the imagination, the lighting effect given off when the lamp is switched on.

### The First Parts

Commencing work with the upright back we require a piece of  $\frac{1}{4}$ in. or  $\frac{3}{16}$ in. fretwood 7ins. long by 4ins. wide. On this draw a number of  $\frac{1}{4}$ in. squares (Fig. 1) and through these plot the outline and interior detail. Now, a word or two regarding the detail. Most of it consists of a

series of simple lines and circles which should not be difficult to anyone.

To heighten the effect of the features of the face, the eyes are to be made of simple oblongs of thin wood glued on in their respective places, while the mouth is also a separate thin piece coloured up later in contrast to the pinky-white of the face and forehead.

The head-gear consists of a crimson cap with black stripes upon it, and the pearls, of course, should be cream.

A reasonable amount of time and patience should be spent upon the colouring and general finish of the upright back as the whole effect depends upon this.

Those overlays representing the eye-lids and the brows should be painted a

cobalt blue, the lighting effect by this will be improved when the switch is to the "on."

The lower portion of the upright

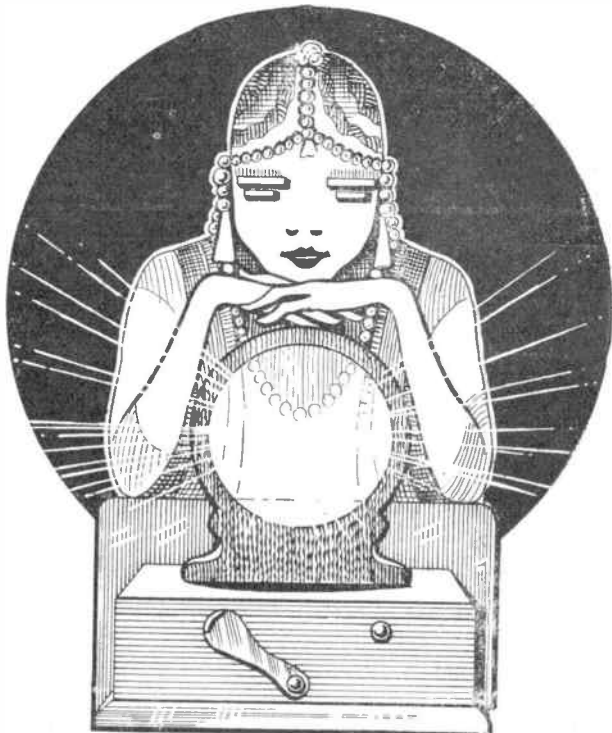

that part which stands at the back of the box, might be crimson in colour; while the top of the box should be cream or even white. All the painting should be in matt colours.

The battery box is formed throughout of 3/16in. wood and consists of top, bottom, front and two sides; note that the main painted upright forms the back of the box. The dimensions of the various parts are as follows. Their joining may be

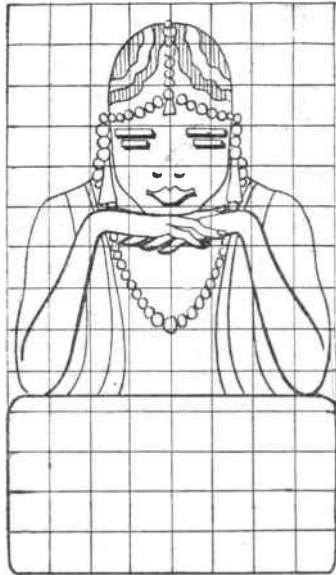

Fig. 1—Outline of main back and figure

seen from Fig. 2. Top 3 3/16ins. by 3 3/8ins., bottom 3 3/8ins. by 3 3/8ins., sides 3ins. by 1in., and front 3 3/8ins. by 1in. Cut all these pieces accurately with the fretsaw and clean up the edges with glasspaper. Cut the mortise in the top 1 1/4ins. long as shown in the top diagram in Fig. 2.

In assembling the parts, glue the sides and front to the top, keeping the back edges of the former flush, so they may later be glued and screwed to the upright back. Angle fillets

of wood or blocking pieces may be glued inside the box to further strengthen it with the upright.

Do not, of course, glue the bottom of the box on as this must be made removable. Prepare this piece by rounding off its edges and boring holes for the screws to pass freely through. Countersink the holes also to let the screws go well in below the surface.

The diagram on the right in Fig. 2

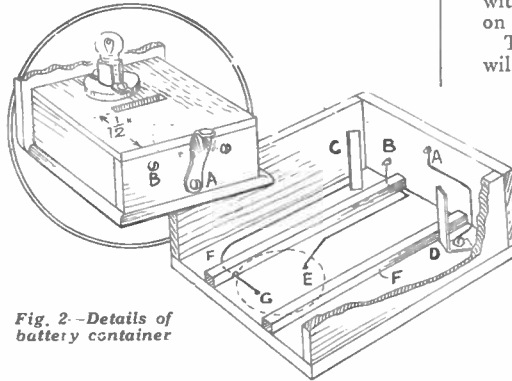

Fig. 2—Details of battery container

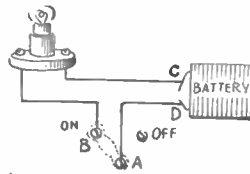

Fig. 3 (left)—The wiring diagram

shows the box inverted and with a portion of the near side cut away so as to make it clear how the wiring connections, etc., are made. Two fillets of wood (F) about 1/4in. square in section are glued to the underside of the top for the battery to rest on so as to clear the wiring.

At C and D screw on angle uprights formed from brass or copper strips. These will form contact with the plus and minus of the battery which may need to be wedged to hold it in place.

Now run a roundhead screw through the front of the box in the centre at A. Threaded to this include a

shaped brass strip handle as shown in the circled diagram in Fig. 2. From the projecting point of this screw inside, run a piece of japanned copper wire to the joint D.

Insert another roundhead screw at B, and from the back of this again run a wire through the fillet F and down through a hole in the top of the box at E. This wire, together with that connecting the battery at C with the hole at G will finally connect up with the terminals on the bulb holder on the top of the box.

The wiring diagram given in Fig. 3 will make all the connections clear

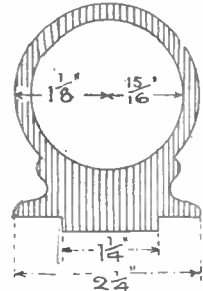

Fig. 4—Front frame

and understandable. A third screw will be put in the front opposite screw B, but this is only a dummy screw for the frame to rest above in the "off" position. The projecting end of the screw inside the box will be filed away flush with the surface of the wood.

The frame forming the "crystal" is shown in Fig. 4 with the necessary measurements for setting it out on the wood. If a piece of 3/16in. plywood could be obtained for this frame so much the better, as ordinary wood would be liable to split at the top.

Cut the tenon to fit the mortise and see a good fit is made before the gluing up is done. The completed frame should be coated with black or a dark brown stain before the transparent celluloid or the tissue paper is put on. The battery box should be stained and varnished.

# ALPHABETICAL HINTS

**J**AP guards, or splash guards, for bicycles are easily made from lino material and a few strips of tin. Guards of this nature are, of course, usually made from rubber or a stiff patent waterproof material. However, a guard made from lino, or floor oil-cloth, is ideal.

The size and shape shown is suitable for the needs of most bikes. Draw it out, then cut to shape with the scissors and cut the tin tab slots at the top, in the manner shown. A 1/4in. wood chisel will be handy for the slot-cutting, but a penknife will serve. In fact, a single cut, rather than an open slot, will do.

Two 3/8in. wide strips of tin or thin brass (the latter is preferred) are threaded through the slots as depicted in the smaller drawing. To attach the guard to the front mudguard, bend the tabs slightly circular, including the guard itself, then bend the tabs at right angles and place over the back end of the mudguard so the lower tab is above (and resting on) the stays of wire.

The tabs ends are bent around the mudguard and pressed well into the hollow so the wheel does not touch them. When thus attached, the guard, including the tabs, are enamelled with black enamel paint.

## J FOR JAP GUARDS

Now, the reason for keeping the lower tab above the wire stays will be obvious. The stays, of course, prevent the guard from sliding off. Lino material, including oil-cloth, is ideal stuff to use, but if you have a piece of waterproof coat cloth, use that.

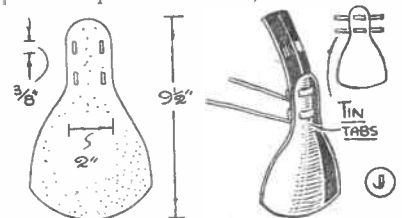

# Everyday bits and pieces provide materials for this BAGATELLE BOARD

THIS indoor game is a well established favourite and will help to pass many hours away. Owing to a possible difficulty now in buying the plywood, cups, pins, etc., for making the board, an effort has been made to dispense altogether with them, using only such materials as are likely to be easily got.

Fig. 1 shows a plan of the game giving the outside dimensions of the board. Usually plywood is used for the board, but as this is hard to get, it is suggested that  $\frac{3}{8}$  in. match-boarding be substituted as it can be tongued and grooved together.

Glue enough boards to make up the width and clamp up until the glue sets hard. Then trim up to the exact size. Use the board with the beaded edges underneath, leaving a smooth top surface for playing on.

Go all over this with glasspaper wrapped round a block, until the surface is as flat as it can be made, and entirely free from inequalities and roughness.

## Board Top

Now, on a sheet of paper the same size as the board, describe circles, representing the rings and cups, as seen in Fig. 1. The top ring is 4 ins. second and third rings, 5 ins. and bottom or fourth ring, 3½ ins. The cups are  $\frac{5}{8}$  in. Mark also the places where the pins come, shown by black dots.

Pin this paper to the board and pierce the centres of rings and cups with an awl to mark their positions on the wood. Places for the pins are marked similarly. With a pair of compasses strike the circles for the rings on the board as guides to fixing the rings on afterwards.

The framing to be mounted on the board consists of a top piece, Fig. 2, with a semi-circular cut out, two side strips and a bottom cross

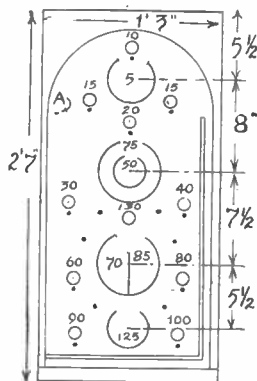

Fig. 1—General layout of board

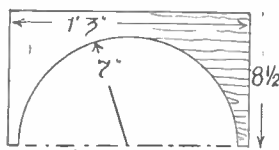

Fig. 2—Top piece shape

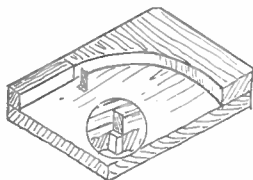
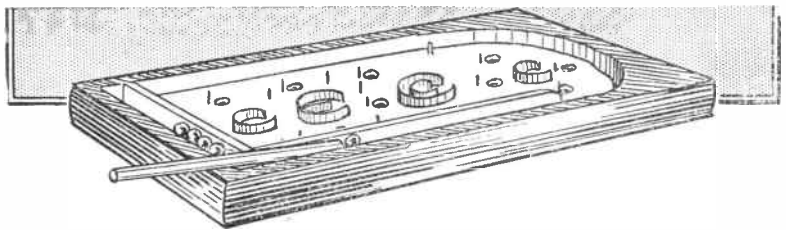

Fig. 3—Board construction



piece. Mark and saw out the top piece from wood  $\frac{3}{8}$  in. thick, and well glasspaper the edge of the "cut out."

The bottom piece is 1 in. wide and the side strips,  $\frac{1}{2}$  in. wide. All from the same thickness wood. See these parts fit neatly together and glue them to the board. The top and bottom pieces are screwed from underneath in addition.

## Clock Spring Strips

At point A, a tempered steel striking pin is fixed in the professionally made board. They are cheap, usually being sold for a penny each, but if one is not obtainable a good substitute can be found in a short piece of clock spring.

A small slot is cut to let this in the board about  $\frac{1}{4}$  in. from the side, and it is fixed tight there by a wedge-shaped piece of wood driven in from underneath, as shown in inset, Fig. 3, a detail of the board's construction. No part of the wedge should stick up above the board, so any surplus should be sawn off flat.

At points previously marked, bore the cup holes. Use a centre bit of the correct size, bore  $\frac{1}{4}$  in. deep and clean out the bottom of each hole to a flat surface. This will increase the depth of the holes to nearly  $\frac{1}{2}$  in.

At this stage the strips of wood forming the runway for the balls to travel up, and the compartment at the bottom for the balls to lie in ready for play, can be made.

Both are  $\frac{1}{4}$  in. thick and  $\frac{5}{8}$  in. wide. The runway strip is 20 ins. long and is fixed  $\frac{1}{4}$  in. away from the side, its beginning is also  $\frac{1}{4}$  in. away from the bottom of the board.

From this to the side the second strip runs across to form the ball compartment. The top end of the runway strip is bevelled down a little for a distance of 3 ins. Fix the strips with

glue and a few long thin pins.

To avoid having to buy the pins, usually driven in to mark the rings, cut some strips of tinplate from empty cans, width  $\frac{1}{2}$  in. and lengths given, and bend to ring form as in Fig. 4. The length at B is that for the top ring only.

## Tinplate Rings

Make them this way. For rings top, second and fourth, cut strips to length and bend a  $\frac{1}{4}$  in. of each end backwards. In the fold of the bends place a 1 in. wire nail, pinching the tin with pliers tightly round the nails. Now bend to ring form, as at C, letting the opening of the rings be large enough to allow the balls to run it easily—say 1 in.

The small tab at the back should have a hole punched in it and be bent outwards. The lengths of tin for the other rings are as follows. Second ring, outer 14½ ins., inner 8½ ins., bottom ring 10 ins.

## Fitting the Rings

The third ring is divided into two compartments as shown. Cut the tin for this to length given at D and bend up, with nails, as at E, fitting in an extra nail at the end of the dividing strip. Finish these rings with a coat of egg-shell enamel.

Now place the rings on their respective circles, pencilled on the board, and where the holes for the nails are to come mark places with an awl.

A couple of small discs of fretwood could also be glued underneath the board, at the top, to tilt it a little so that the balls run down well.

The rings and pins can now be fixed on, the awl marks being useful guides. The pins can be ordinary 1 in. shoemakers nails, panel pins, or veneer pins, in fact almost any pins or thin nails to be bought.

The usual balls for the game, 12 of which are required, are  $\frac{3}{8}$  in. steel, or erinoid ones. If these cannot be got selected playing marbles can be substituted, as near that diameter as possible. For a striker, or cue, a short piece of  $\frac{3}{8}$  in. round wood rod will serve.

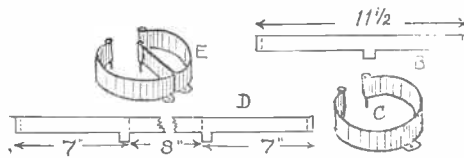

Fig. 4—Details and dimensions of the ring strips and fixing

# Improve your scenic effects by having proper MODEL RAILWAY LIGHTING

**S**TAGE effects are 90% trick lighting. If you doubt the fact try and see a theatrical stage by daylight; it will be a revelation. The marble pallisade which looked so solid last night now becomes what it is—a number of sheets of painted plywood. That very real lattice window boils down to a few crude lines on a backcloth. Yet actually all is the same as the night before, the only difference being the lighting.

There is a lesson here that might be taken to heart by model railway enthusiasts (in the presentation of their lines) for a model system is kindred in many ways to a stage setting.

## The Main Points

The essential aims for stage lighting are (1) to concentrate interest on important areas and items, (2) to subdue, by leaving in shade, unimportant areas or items and (3) to give a maximum impression of realism by skilful direction of illumination. A general principle of such illumination is that no light must ever shine straight at the audience.

In a model railway the general track level is the important area, while expanses of wall above back-scene level and trestle fronts, below track level, are relatively unimportant. Thus the first should have light concentrated on it, while the second mentioned parts should be in the shade.

## Over the Track

This broad scheme of illumination is best effected by having a series of fairly low-powered lights hanging over the track at intervals of six or seven feet rather than by any single high-powered lights.

The lamps should be fitted with shades as shown in the sketch, and the height and angle of shade so adjusted that the shadow limit (A) comes just along the top of the scenery at the back, or if the wall itself is being used as a "backcloth" not higher than the vertical height that would be accorded to a standard and proportional scene. In a horizontal direction the intersection of the shadow limits should be at roughly the same height (B).

The lights must be suspended nearly over the near edge of the track to illuminate the near side of vehicles, etc. To obtain the necessary limits

of shadow the shades will have to be tilted a little as shown. No light must shine directly into the eyes of operators round the track, though this will generally be prevented by the tilt of the shades. Should it not an extra flap (C) will effect this.

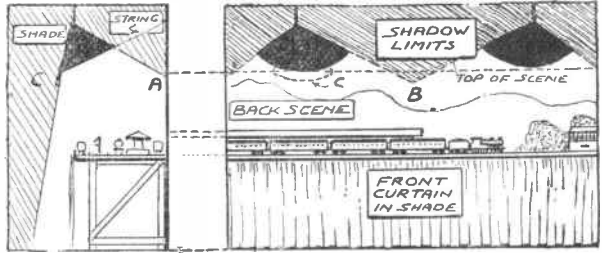

The shades themselves are readily made out of sheets of card rolled into wide cones and trimmed off top and bottom to a flat edge, the top hole being just large enough to go over the holder; the bulb keeping the shade in position. Inside, the shade should be painted white, or covered with white paper as this increases the light remarkably and also tends to diffuse the illumination more evenly.

While this system is in operation all central lights in the room are, of course, extinguished or the intriguing stage-like effect it gives to the lay-out is lost.

## Concentrated Illumination

This type of illumination is undoubtedly good, concentrates all interest on the track and gives everything the impression of being brilliantly illuminated despite the low power of the bulbs used. This effect, of course, is due to the fact that observers are standing in a pool of shade.

The ideal type of shade for this lighting is of trough shape and so angled that the light limits just touch the near side of the track and top of back scenery, the side intersections being as with round shades.

The actual wiring is best carried out on a system by itself, a dual cable going round the ceiling and "drop-

ping" lights at the required intervals, a screw hook being taken into the ceiling to a lath at each point of suspension. An adaptor at one end of the circuit fits into any handy lamp holder from which to draw current.

## A Switch Control

In the system a small switch board can be let into the circuit with two switches, one for the shaded lights and the other for the room's central light, if the latter is being used for committee meetings, etc. No switches are attached to the individual suspended lights, but if a single member is working on the track alone for any length of time it will be found an easy matter to remove the unwanted bulbs and so save current.

A second way that the concentration of illumination can be effected is by stretching blackout material along the level of, and in front of the bulbs. This gives a "bazaar stall" impression but this is not recommended unless there is a particularly good back scene, as the illumination of a large expanse of bare wall tends to a garish appearance.

## Interior Lighting

All this, of course, is quite apart from miniature lighting, like the illuminating of the inside of station buildings, signal cabins, etc. which is an art in itself if a good effect is to be secured as lights at track level tend to extenuate faults.

Thus ballast which looks quite effective with top lighting gives the impression of large lumps of rock outlined by heavy shadows under horizontal lighting and other items take on prodigious proportions. Side lightings also tends to extenuate faults, and out of scale items in stock. Much can certainly be done by diffusion to make this type of lighting effective, but consideration of such is outside the scope of this article which is intended to deal solely with most effective methods of general track illumination.

## Non-flying scale MODEL MOSQUITO



A design for making this fine model in wood is given with this issue. Suitable wood for making is obtainable from Branches of Hobbies Ltd., for 1/10, or post free from Hobbies Ltd., Dereham, Norfolk, for 2/5.

# Utilise all your space by converting bare corners to RECESS CUPBOARDS

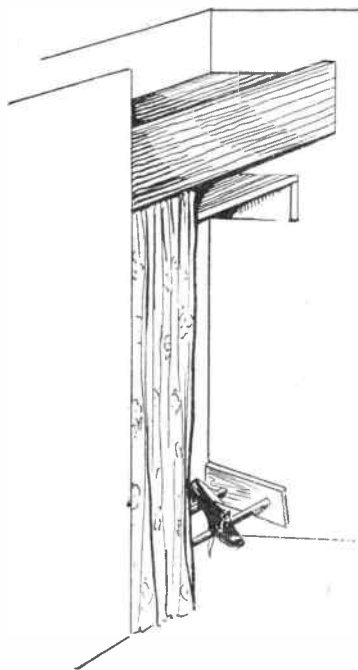

In these days, cupboard room and wardrobe space in bedrooms is at a premium, new furniture cannot be obtained, but additional people in the house frequently make a bigger demand than ever for clothes. Why not, therefore, utilise recesses and corners in making a canopied and curtained space available for hanging dresses, coats, etc., and containing a shelf for hats and a rack for shoes?

An illustration for a sensible one with a curtain across the front, is shown herewith, and the handyman should look round in his own home to see if such a convenient receptacle could not be built for the benefit of all concerned.

In most houses there is a recessed space where the fireplace and chimney walls project into the room. It is the space between this and another side wall which can frequently be conveniently built in to provide the cupboard space mentioned. In other cases a convenient corner can be allocated to the purpose.

It is impossible, of course, to give actual dimensions because they will

vary from house to house, but the method of carrying out is illustrated by the details herewith, and from these simple instructions. Very little wood is required, and as it will be painted over, odds and ends of secondhand boards can well be used.

## A Covered Top

The top of the recessed portion is covered in by boards to prevent dust floating down from the top. These boards rest on shelves which are fixed to the side walls. The height at the top should be 6ft. 6ins., or 7ft., and the width of these supporting boards should be not less than 3ins. to 4ins. wide by  $\frac{3}{4}$ in. thick. Their actual length, of course, will depend upon the depth of the recess.

Fix them securely to the walls with screws and plugs, and be sure to get them opposite each other so the cross board lies flat and true. These cross boards will measure a total of the depth of the recess, and extend to the front edge of the side board.

The front of this is covered by a hanging board stretched across the width of the recess, and covering both the wall pieces and the cross board.

## A Facia Board

This front board can have a strip of fancy moulding along the top front edge just to relieve the plainness, or if you can get a piece of skirting board with a shaped edge this will do very well placed upside down so the bead runs along the bottom.

Do not, however, fix this front board until accommodation has been made for the rail and its holders for the curtain. The detail herewith shows two suggestions for fixing these. The rail is of  $\frac{3}{4}$ in. diameter dowel, or better still, a piece of brass or copper rod if you can get it.

It rests in a semi-circular groove, cut in a small piece of thick wood, glued and firmly screwed to the side boards as shown in the picture. This curtain rod bears the rings which hold the curtain and allows for the sliding backwards and forwards of that material.

An alternative method is shown with a straight hook screwed behind the front board. A hole is driven through the dowel which is then passed over the end of the hook.

This serves to keep the dowel firm and a hook each end should be sufficient.

About a foot below this top board a shelf can be arranged to take hats or odd boxes. This is fitted in the same way as the top covering. A strip of wood is screwed to the wall each side, and on this the cross boards of the shelf itself are fixed. They need not be more than  $\frac{1}{2}$ in. or  $\frac{3}{4}$ in. thick.

## A Shoe Rack

At the bottom of the recessed space a fitting is provided for shoes to stand at an angle on a rack. This is clearly indicated in the details. The depth of the recess, of course, may vary, in which case the length of board will have to be greater.

Notice that the ends of the wood are cut at an angle of 30 degrees in order that the piece may be sloping. The two holes are bored for the cross rails of dowelling or even square strip, and these parts all glued together before the whole thing is fitted in. Get the dowel or strip sunk into the end boards and, if necessary, glue it there in place.

## Fixing the Rails

Do not forget in fitting them to allow the top one to come at least 3ins. out so the heel of the shoe may rest over it without hitting the back wall. Get the two rails and the two end boards together before fixing the whole thing into the space of the recess. The end board should then be screwed or nailed to the wall securely, making sure that they are in line with each other. and that the cross rails are horizontal.

The curtain material should be sufficiently long to cover the whole of the front, but not to drape along the floor. It is hung by means of curtain rings which slide on the top rod. It is best to have the end ring at one side fixed to a small hook, otherwise when you pull the curtain across, the whole thing comes over.

All the boards used should be painted if possible, using the same colour to match the rest of the room.

If a corner recess is being utilised, the actual construction will be the same, but the boards of the shelves of course, will have to be cut at an angle of 45 degrees to fit in.

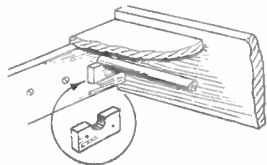

Back view giving details

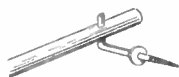

Hanging by hook

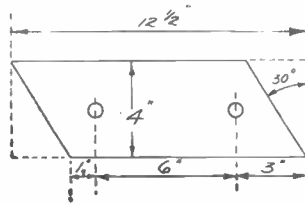

Shoe rack end board

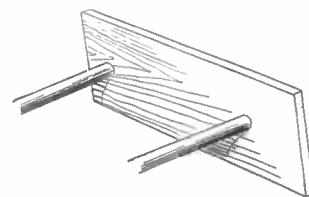

End board and shoe rails



## THE VALUE OF STAMP EDGING

IT is the instinct of many stamp collectors to tear off the edging of any stamp because it looks unsightly. This is a mistake, however, because not only can edging give much information about the stamp, it can also, in certain conditions, greatly enhance its value.

The most obvious use of edging is to protect the perforations from becoming blunted, torn or otherwise damaged. Presumably that is why a corner copy of a stamp with edging usually fetches slightly more at an auction than an ordinary specimen.

Then also it helps in various ways in the identification of stamps, as it is often easier to distinguish the colour, the paper, and the watermark when edging is attached.

### Making it Easy

In stamps printed in one colour on another it is often hard to distinguish the shade of the paper on a single stamp. With edging it is easier because on this there is no second colour to distract or confuse the eye.

An example is the G.B. Edward VII 3d. (1902-10) where it is frequently difficult to distinguish purple on yellow from purple on lemon. It is important to do so, however, because the first is common and the second scarce. When you test for chalk-surfaced paper with a detector pencil, it makes a little mark on the stamp. But if you have some edging then you can use the pencil on that and the stamp will not be defaced.

On many stamps the watermark is hard to distinguish, owing to the design of the stamp obstructing the light. With a piece of edging attached it is much easier to see what it is.

### Watermark Varieties

Stamp edging also affords a number of watermark varieties. Two examples can be given in the G.B. 1912-22 George V issue, one being the marginal mould watermark, which is a letter followed by a number, such as B1 or C3. The other is the word "POSTAGE" in large double-lined capitals running up the side of the sheet across the joining between the edging and the stamps.

Recently two strips of ½d. and 1d. stamps showing the word "POSTAGE" complete were sold at auction for a guinea each. A stamp with plate number attached is much scarcer than an ordinary stamp, and if the stamp be an early imperforate it may be very valuable indeed.

Many issues show the printer's

name (known as an imprint) in the middle of the edging at the bottom of the sheet. For example from 1894 onwards U.S.A. stamps carry the words "Bureau of Engraving and Printing" on the bottom margin. Stamps with imprint attached are more valuable than those without, especially if the inscription is complete.

### Price and Arrows

Some issues show marginal inscriptions of a different kind, for example the G.B. 1d. black. On both the top and bottom edges of a sheet of these there appear the words: "PRICE 1d. Per Label, 1/- Per Row of 12, £1. . . . Per Sheet. Place the Labels ABOVE the Address and towards the RIGHT HAND SIDE of the Letter. In Wetting the Back be careful not to remove the "Cement" (gum). A whole top or bottom row showing these words is extremely rare.

Sometimes there are arrows on the edging indicating where the sheet can be divided into equal sections (or panes). Thus a sheet of 240 1/- stamps might have arrows half way along each side, dividing the sheet into four panes, each of value £3.

In some Czecho-Slovakian issues, notably the 1936-37 set, rows of perforated blank strips are used to divide the sheet up into panes. They are better collected with these, of course, than without.

### The Jubilee

A feature that was added to the sheet edging of G.B. stamps in 1887 was the "Jubilee Line." This is a coloured line close to the stamps which runs right round the sheet and has usually rounded corners. Sometimes it is continuous and sometimes not.

In the latter case it is broken opposite the divisions between the stamps. There is often considerable difference in value between the two types. For example the Edward VII ½d. blue-green Control B is worth 9d. with continuous line, and £3-10-0 with non-continuous line. Sometimes the Jubilee line is double, in two different colours. This is when the stamps are in two colours, each line reproducing one of them.

### Date Lines

On some stamps from the bottom right hand corner of a sheet of Edward VII stamps you may see one or more "cuts" (breaks) in the Jubilee line. These cuts were made by the printers probably to indicate the year of printing.

Modern British stamps have three types of margin. There is the type known as Perforated Margin, which means that on the left and right hand sides of the sheet the horizontal perforations are continued to the edge of the sheet. Then there is the type where the horizontal perforations extend only one hole beyond the vertical perforations. Lastly there is the type where there is no extension at all, i.e. imperforate.

The second, the single extension hole, is the normal, the other two being scarcer. An example of the difference in price is shown by the G.B. George VI 1½d. old shade, Control, E39. With imperforate margin it is worth 1/6, and with perforated margin it is worth £15.

### Control Number

One of the most important points about stamp edging is the Control Number. On G.B. Victorian stamps the control consists of a single letter, and appears under the second stamp horizontally from the right hand bottom corner. The margins may be either imperforate or perforate.

On stamps of Edward VII the control is either a letter only or a letter and a number. This appears under the second stamp from the left hand corner. The control is an infallible way to distinguish the Harrison from the De La Rue printings.

The Harrison control is invariably A11, while this control does not exist in the De La Rue. George V controls until 1912 were in either of the two positions previously mentioned, and consist of a letter and a number.

### How to Collect

From 1934 onwards the position of the control was changed, appearing next to the third stamp vertically from the bottom left hand corner. It is what is known as a fractional control, that is a letter above a line and a number below the line.

These controls are best collected with blocks of six, showing the cylinder number and the corner of the sheet. The cylinder number is the little figure appearing just below the control which indicates the cylinder from which the sheet was printed. The number of all G.B. controls indicates the year of printing.

These few points of interest about stamp edging will make you think twice before tearing it off the next side copy you get. Stamp edging often contains as much to interest the collector as the stamp itself.

# Patterns for making a Tribal Class miniature MODEL DESTROYER

**T**HIS is an excellent type of model for inclusion in a miniature fleet, as a single item for display or as an attractive and original ornament, it is easily and quickly made by the beginner or expert alike. The model is drawn to the scale of  $60' = 1"$ , and may be decreased or increased in scale size to the readers choice.

The size shown is printed full size on cover iv and is very lenient on wood which is a consideration these days. The model is a replica of the famous "Tribal" Class destroyer and the proto-types possess an armament including eight 4.7" guns, in twin mountings, and four 21" torpedo tubes, this combined with a speed of 36 knots makes these vessels formidable opponents. A few pieces of wood, some wire, thread, and patience go to its construction.

## The Hull

First begin on the hull, which is cut from a length of soft wood to the size shown in the side elevation (A), and the plan view (C). The dotted lines (B), indicate the shape of the bow on the underside in order to make a sharp raked bow with the deck slightly over-hanging.

The gun turrets, four in number, are cut from hard wood as it is necessary to drill two holes in each to accommodate the guns. The guns, made from panel-pins, wire or bristles from an old brush, are passed into the holes and glued firmly, leaving

a short length protruding at the back of the turrets.

The upper decks and control tower require little des-

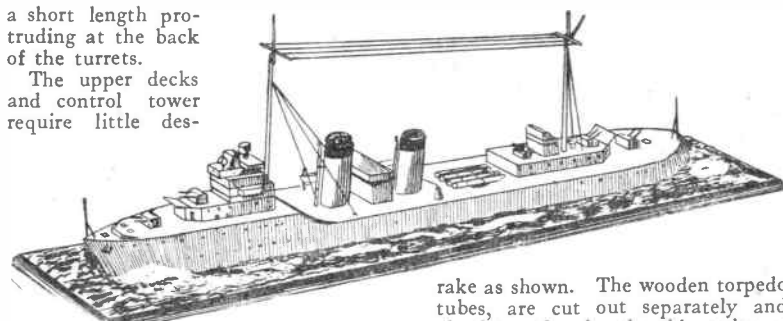

cription being simply of wood glued piece upon piece together. Care should be taken to cut accurately and thoroughly. Glasspaper all surfaces for paint will not cover any roughness and the smooth appearance associated with steel plating will be spoilt.

## Deck Details

The ship's boats, there are two, suspended on the model by wire davits, are carved from wood-splinters or matchsticks, and fitted to the starboard side of the vessel. The masts are cut from stiff wire set in holes drilled in the super-structure with wireless aerials of very fine copper or fuse wire.

The two funnels are oval in shape cut from soft wood and set at a slight

rake as shown. The wooden torpedo tubes, are cut out separately and glued together by the thin strips as indicated in the plan and side views.

The depth charges throwers, light anti-aircraft positions, fire direction tops, etc., are all easily made from odd pieces of deal or similar soft wood.

On completion the vessel may be painted "battleship" grey or dazzle painted in disruptive patterns. If desired the warship may be mounted on a simple stand as illustrated. First of all a block of wood about 8ins. by 3ins. by  $\frac{3}{4}$ in. deep is painted a greenish-blue on its upper surface and then lightly coated with colourless glue on top of the paint.

A strip of crumpled Cellophane is carefully pressed down upon it to represent the sea, white flecks of foam, bow wave and wake being added with white paint upon the strip, which is then trimmed off around the edges. The edges of the wooden block look best varnished and polished providing the wood is suitable.

The following list of vessels forming the "Tribal" Class may be of interest: Afridi, Cossack, Gurkha, Maori, Mohawk, Nubian, Sikh, Zulu, Eskimo, Mashona, Matebele, Punjabi, Ashanti, Bedouin, Somali, and Tartar.

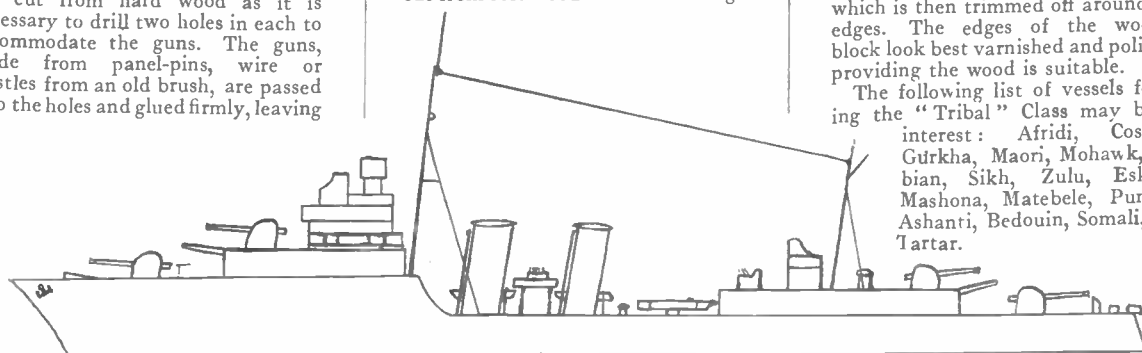

A

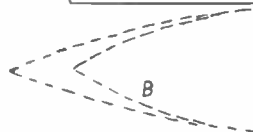

B

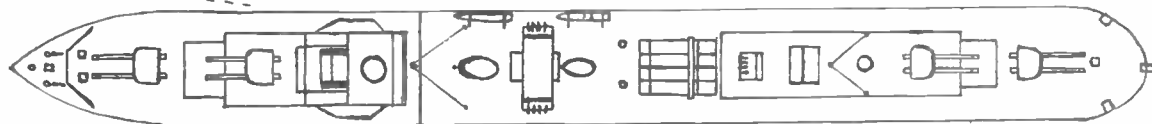

C

Copy these full-size details for an excellent little model.

There are not enough copies of Hobbies to go round; please share yours with a friend or the services

# MISCELLANEOUS ADVERTISEMENTS, etc.

The advertisements are inserted at the rate of 3d. per word or group of letters prepaid. Postal Order and Stamps must accompany the order, and the advertisements will be inserted in the earliest issue. Fretwork goods or those shown in Hobbies Handbook not accepted. Orders can be sent to Hobbies Weekly, Advertisement Dept., as below.

**LONELY?** Then write Secretary U.C.C., 5B.B. Hay St., Braughing, Herts. Genuine. Est. 1905.

**BE TALLER!** Quickly! Safely! Privately! No Appliances—No Tablets—No Dieting. Details, 6d. stamp.—Malcolm Ross, Height Specialist, BM/HYTE, London, W.C.1

**MODEL THEATRE & PUPPET MAKING.** Make and operate your own home theatre, 2/-. Obtainable from booksellers, or Guardian House, Walthamstow, London, E.17.

**A MODEL VILLAGE. HOW TO MAKE IT** using home materials. 2/-. Obtainable from booksellers or Guardian House, Walthamstow, London, E.17.

**TOYS.** Send for range of popular designs. Simple to make from scrap materials. For pleasure or profit. 2/6 only Post Free.—Harrod, 10 Beaconsfield Road, Maidstone.

**WANTED,** Hornby Dublo or Twin Trix.—E. Bushell, 104 Leighton Rd., Enfield.

**THE ART OF SCALE MODEL AIRCRAFT BUILDING.** By V. J. G. Woodason. Edited by Walter Buchler. Price 4/11 net. 8/6 cloth. "In this book the author has produced the most complete and accurate account of solid model making yet published. It is to be heartily recommended to the expert and to the beginner, and to those only interested in aircraft recognition instruction."—(The Aeroplane). **HOW I TOURED THE WORLD ON NOTHING.** By Walter Buchler (with pen and camera) 1/6. Our Giftware Dept. is interested in all manner of articles and curios suitable as gifts.—Useful Publications, 37 Aldwych, London, W.C.2. Tem. 2946.

**WANTED,** gauge 00 Locomotive. Electric.—J. Wyatt, 41, New St., New Bilton, Rugby.

**LONELY?** Join Friendship Circle. Details 6d.—Secretary, 34 Honeywell Rd., London, S.W.11.

**STAMPS FREE!!** Twenty Unused (2½d.)—G. H. Barnett, Lymington, Somerset.

**GENUINE WARTIME FORMULAS!!!** Haircream, or Setting Lotion, Table Jellies: Lemon Cheese Coffee Essence: Fruit Salts. All for 2/6, Post Free.—C. Womersley, "Northview," New Road Side, Rawdon, Leeds.

**PERFORATION GAUGE** and 15 assorted stamps free requesting bargain approvals. Loose stamps purchased. Best prices given.—Phillips. 124 Broadway, Peterborough.

**STAMP APPROVALS** for the beginner and more advanced collector. Free Gift to applicants sending postage.—Austin Bros. Approval Service, 20 Fulford Rd., West-Ewell, Surrey.

**LATHES.** Well tested, simplified diagrams (6) and clear instructions for any Handyman to construct a satisfactory Toy or Model Maker's Lathe from easily obtainable materials costing approximately 40/- No castings or machining needed. Price 3/6.—H. Barham. "Hilltop," Bradmore Green, Coulsdon, Surrey.

## ATLANTIC WAR STAMP FREE!



On November 1st, 1943, the FREE POLISH GOVERNMENT IN LONDON issued a new set of pictorial postage stamps for use by the FREE POLISH FORCES in this country and by POLISH SAILORS at sea. We have been fortunate in obtaining a supply of these historic War Stamps and have pleasure in offering YOU same ABSOLUTELY FREE. The stamp, as illustrated, depicts an actual incident of a Wellington bomber of a Polish Coastal Command Squadron sinking a German Submarine in the Atlantic. It is inscribed in Polish of course, "Polish Air Force in the Battle of the Atlantic"; and the stamp is printed in pink colour. You can get your copy of this most interesting stamp from us ABSOLUTELY FREE by writing to us and asking for our Lists and a selection of our stamps "on approval." This Polish issue can only be supplied FREE with an approval selection and if you send us 3d. in stamps also (to cover cost of List and postage of approvals to you). Do not delay; write immediately for this wonderful FREE OFFER to:—**WINDSOR STAMP CO. (Dept. 12), UCKFIELD, SUSSEX.**

## HOBBIES HANDBOOK for 1944

The new edition is now on sale. Revised and brought up to date. 68 pages. Large free design for making model Liberator Bomber. Coloured sheet of Miniature Planes. Interesting articles and instructions. All for **6d.**



From Hobbies Branches, news-agents, bookstalls, etc., or sent post free for 8d. from Hobbies Ltd., Dereham, Norfolk.

## MAKE NEW YEAR GIFTS AT HOME

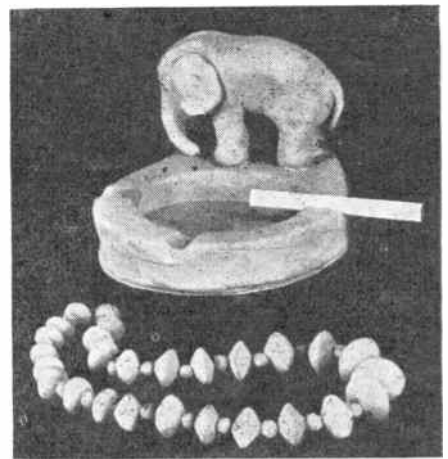

With Pyruma Putty Cement, the home plastic that bakes stone hard, you can make ashtrays, beads, toys and models of every description. From 1/3 a tin upwards, obtainable from your nearest ironmonger. Hobbies Shop, Bassett-Lowke Depot.

Write for Illustrated Instructions on model making

EST. 1857

**J.H. SANKEY & SON, LTD.**

ILFORD

ESSEX



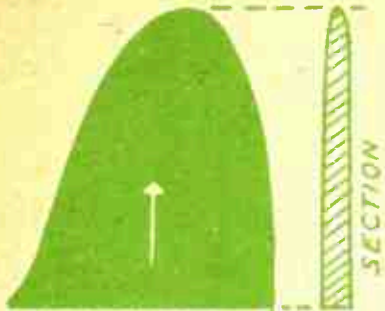

FIN AND RUDDER.  
CUT ONE FROM 1/8 in. 1  
AND SHAPE TO SECTION  
AND PLAN.

SHAPE TO PLAN.

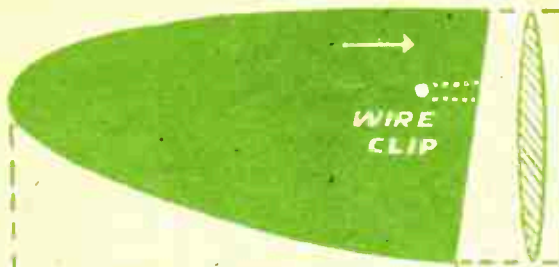

The arrow  
direction.



TAIL PLANE. CUT TWO 1/8 in. AND  
SHAPE TO SECTION AND GLUE TO  
FUSELAGE. MAKE ADDITIONAL  
FASTENING WITH WIRE CLIP.

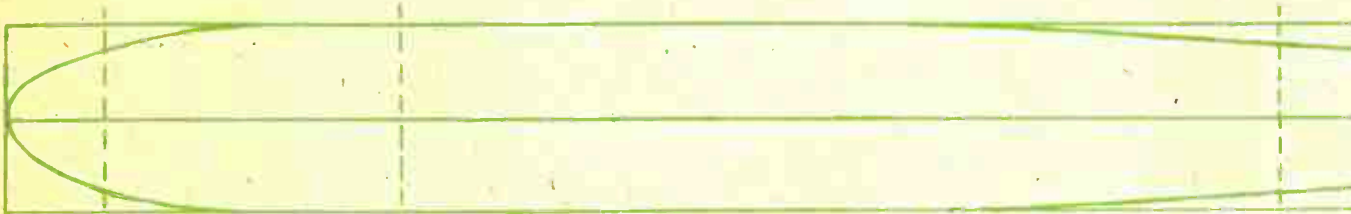

B PLAN SHOWING THE TWO THICKNESSES OF WOOD GLUED TOGETHER  
AND SHAPE MARKED READY FOR CARVING.



FUSELAGE. CUT TWO PIECES 1/2 in. THICK AND  
GLUE TOGETHER (see Plan above).

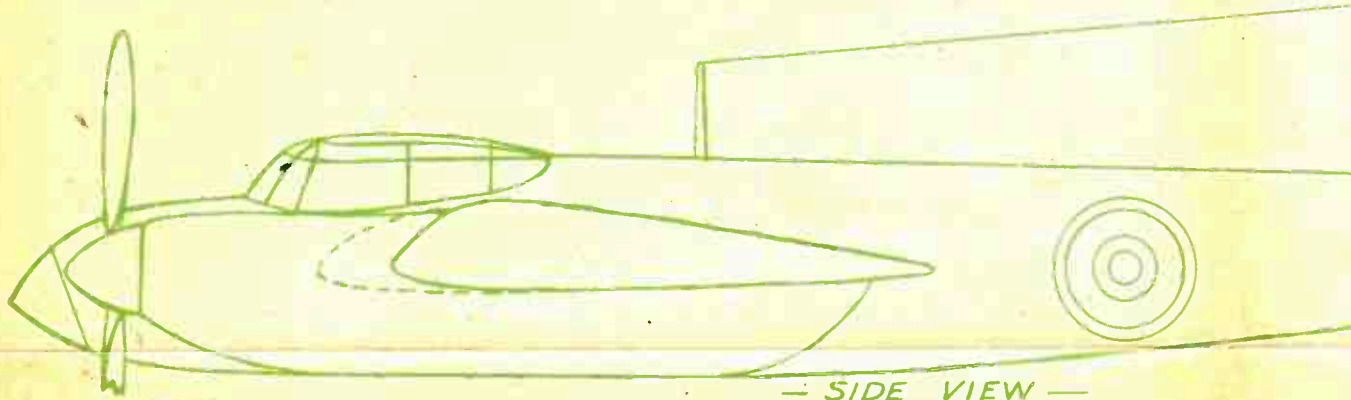

CROSS SECTION OF WING  
AT D.D.



ENGINE. CUT FOUR  
PIECES 1/2 in. THICK. GLUE TOGETHER  
IN PAIRS AND SHAPE UP AS PLAN  
BELOW.



The arrows indicate the direction of grain of wood.

SUPPLEMENT TO HOBBIES No. 2518.

## MODEL OF DE HAVILLAND MOSQUITO

TWO-SEAT RECONNAISSANCE BOMBER.

SPAN 54 IN. LENGTH 40 IN. 9 INS.

SCALE OF MODEL  
1/4 IN. = 1 FOOT.

PANELS OF WOOD REQUIRED FOR THIS DESIGN.

ONE ND8 ONE MD8  
ONE G2

The price is shown in Hobbies Weekly, Jan. 19th, 1944, but is subject to revision. See the current edition of Hobbies Handbook, or write for price to Hobbies Limited, Ditcham, Norfolk.

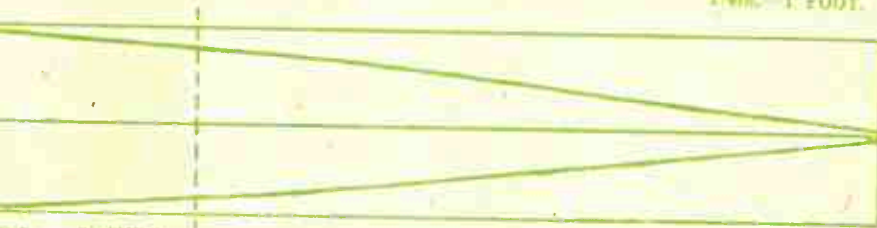

ED TOGETHER  
G.

C

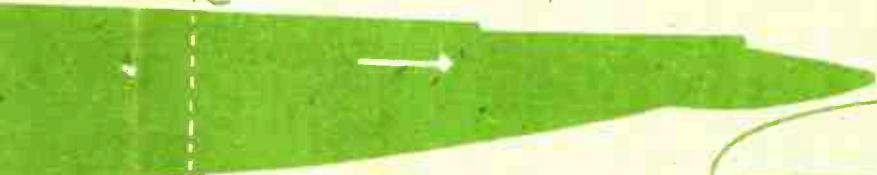

C

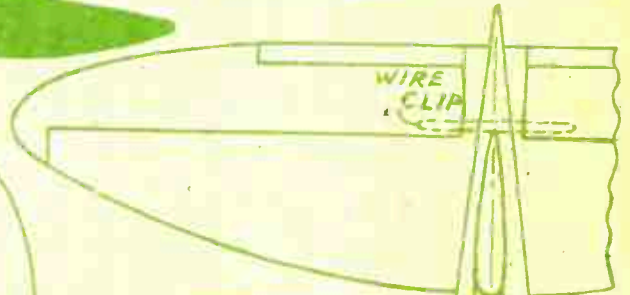

WIRE CLIP

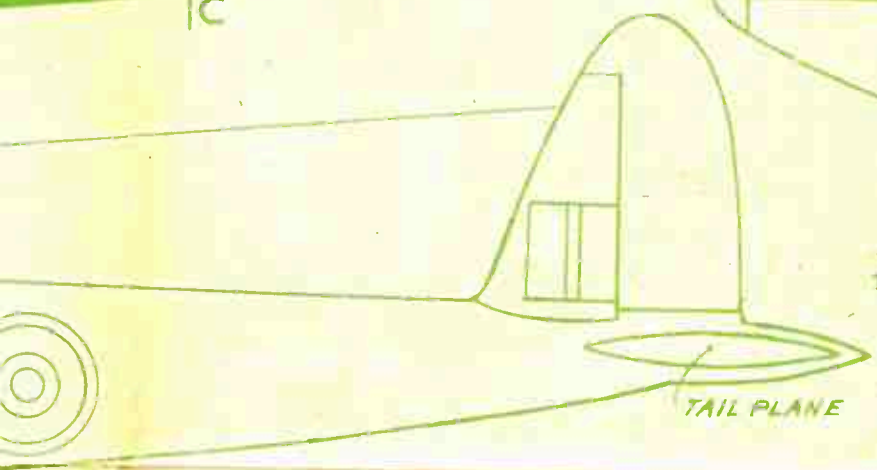

TAIL PLANE

WIRE CLIP TO BIND THE TWO TAIL PLANES TOGETHER.



R TOGETHER  
AS PLAN

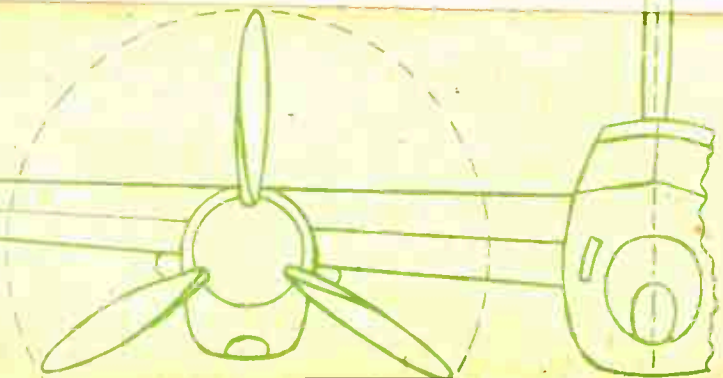

World Radio History -FRONT VIEW-

FUSELAGE. CUT TWO PIECES 1/2in. THICK AND GLUE TOGETHER see Plan above.

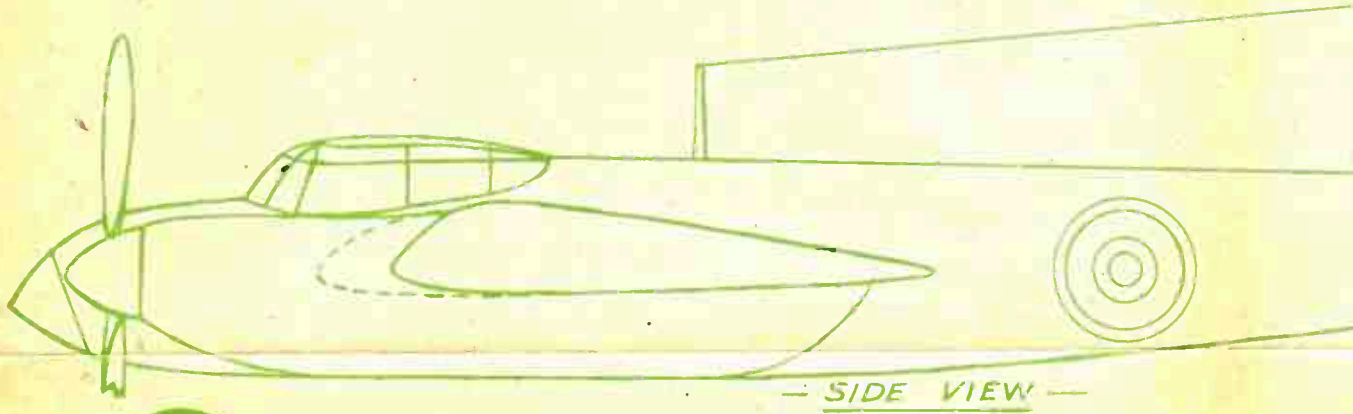

CROSS SECTION OF WING AT D.D.

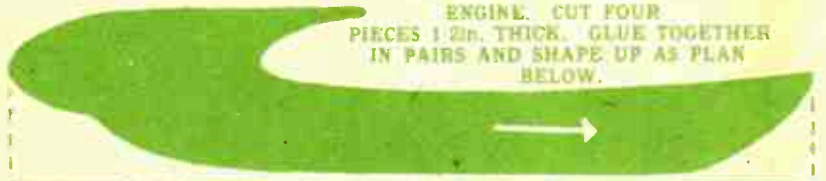

ENGINE. CUT FOUR PIECES 1/2in. THICK. GLUE TOGETHER IN PAIRS AND SHAPE UP AS PLAN BELOW.

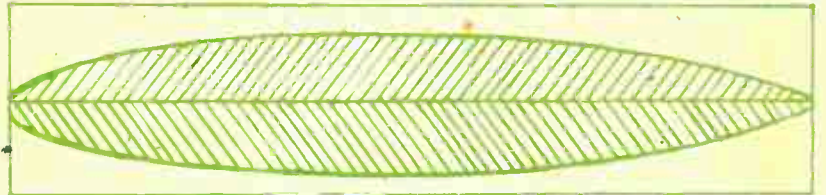

ENGINE. PLAN SHOWING THE TWO PIECES GLUED TOGETHER AND MARKED READY FOR SHAPING. SEE FRONT VIEW FOR ROUNDED TOP AND SHAPING TO SIDES AND UNDERNEATH.

WING G. CUT TWO 1/8in. AND SHAPE TO SECTIONS AND FRONT VIEW.

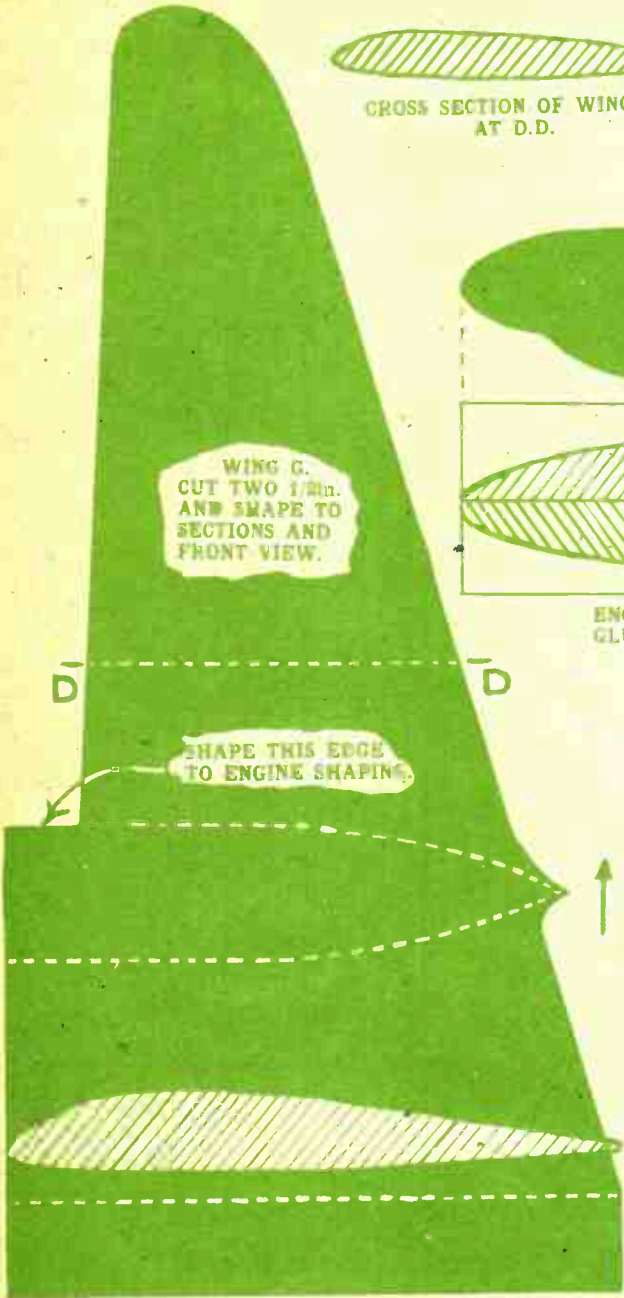

PROPELLER BLADES. CUT SIX FROM 1/8in. WOOD AND PARE DOWN AND SHAPE TO GET TWIST.

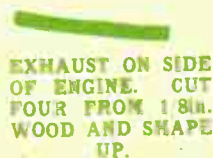

EXHAUST ON SIDE OF ENGINE. CUT FOUR FROM 1/8in. WOOD AND SHAPE UP.

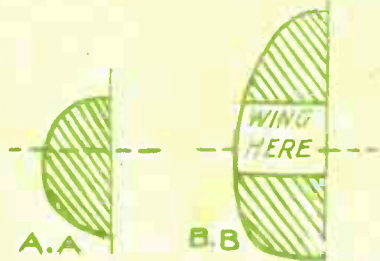

SHAPING CROSS SECTION LINES SH

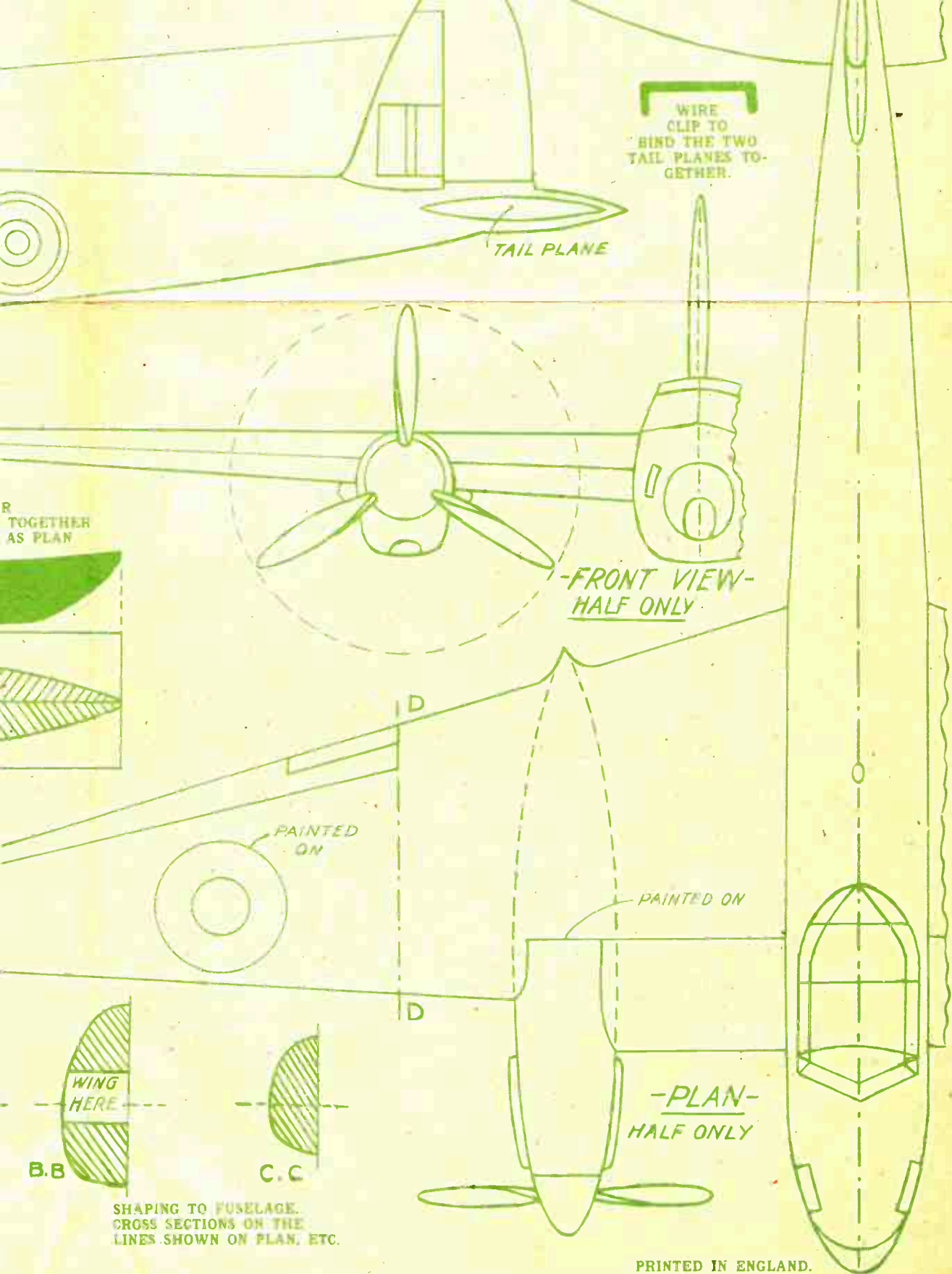

WIRE CLIP TO BIND THE TWO TAIL PLANES TOGETHER.

TAIL PLANE

-FRONT VIEW-  
HALF ONLY

PAINTED ON

-PLAN-  
HALF ONLY

PAINTED ON

D

D

WING  
HERE

B.B

C.C

SHAPING TO FUSELAGE.  
CROSS SECTIONS ON THE  
LINES SHOWN ON PLAN, ETC.

PRINTED IN ENGLAND.

# Non-flying model MOSQUITO

**A** NON-FLYING scale model of a Mosquito bomber can be made in wood from the full size patterns on the other side. A fretsaw to cut out the shapes, and a few tools, to round them off and fit them together are all that is needed for the work.

The great thing, of course, is to get the curves of the different parts accurate and alike, and then to finish off the model carefully with paint. The model is built as if in flight, so after completion it should be put on a tall rod or hung at the appropriate angle.

A plan and side view of the main parts are given, and from these the shapes and positions can be worked out quite easily. The fuselage consists of two  $\frac{1}{2}$  in. pieces, in the centre of which an opening is cut for insertion of the wing root. When the two fuselage pieces are cut to the shape shown, they are glued together, then the whole thing carefully rounded off.

## Shaping the Fuselage

Shaded sections at the bottom of the sheet show the exact shape on the lines A, B and C. The work of shaping is done carefully with rasp and file, and finished with glasspaper. Take care to get a balanced effect on each side of the centre line.

The wings are next cut to the shape shown, the end of it being just the right shape and size to fit into the opening in the fuselage. The

section of the actual shape of the wing is given by the shaded section on the pattern, and the two must be carefully curved down to be alike for balance.

## The Engine Units

The engines can be added before fitting the wing into the fuselage, or afterwards, whichever the individual worker prefers. Two pieces of  $\frac{1}{4}$  in. material go to form the original thickness of each engine. Glue them together, then mark on the top edge of the two pieces the shape shown in the plan. If you have  $\frac{1}{2}$  in. wood, two pieces of this glued together will make the correct size. If you have used two  $\frac{1}{4}$  in. pieces, the two sides must be planed or cut down so the whole lot is  $\frac{1}{2}$  in. thick.

Again, the shaping of the engine must be undertaken, and for this the various views on the plans and in the finished drawing can be carefully followed. Notice that the spinner is part of the engine itself.

## The Tailpiece

The tailpiece is composed of the flat plane and the upright rudder. The horizontal planes are glued close up to the fuselage in the position shown on the side view. Further to strengthen them, short headless nails should be driven into the fuselage and into the end of the plane. Of course, the shaping must be done before fitting.

A further suggestion to hold the two parts firmly, is the wire clip cut and shaped as shown on the pattern

sheet. This is driven into each plane and lies across the top of the fuselage. It is shown dotted in position in the plan.

The upright fin and rudder are cut carefully to the shape shown, and then shaped to a taper towards the outer edge. Notice the shoulder at the front end which beds down to the corresponding recess in the top of the fuselage. Here again, a couple of headless pins should be driven in to strengthen the joint between the fuselage and the upright part.

The addition of the propeller blades and the exhausts are minor small parts, the position of each being shown in the various drawings.

## Colouring

The model being completed, should be given a careful final rubbing over and then painted. The upper surfaces with the fuselage are the normal camouflaged colours of green and grey, but the underside of the wings is a light blue. The cockpit, aimer's cabin, etc., can be painted on as imitation Perspex, with aluminium paint or very light grey, the lining of the metal framework in black. The roundels on fuselage and wing are shown, and follow the normal colouring of the R.A.F.

The rest of the lining of flaps, spinner join, etc., are done very carefully in thin black lines, and much of this can be seen in the picture of the finished model, as well as on the plans themselves.