

The Journal of

THE BRITISH INSTITUTION OF RADIO ENGINEERS

FOUNDED 1925

INCORPORATED 1932

*"To promote the advancement of radio, electronics and kindred subjects
by the exchange of information in these branches of engineering."*

VOLUME 20

AUGUST 1960

NUMBER 8

THREE HUNDRED YEARS OF SERVICE

IN 1660 a Society was formed for "Promoting Physico-mathematical experimental learning." Two years later the Society was granted a Charter of Incorporation as "The Royal Society."

The Royal Society for Improving Natural Knowledge—to give the Royal Society its full name—is now the oldest scientific body in existence and is recognized throughout the world as a Society of great traditions which effectively engages in the advancement of science in all its aspects.

Since its foundation, the Society has enjoyed the patronage of the reigning monarch, and its Fellows have maintained its independence by payment of their annual subscriptions and by making their own rules. It is not a Government or State institution, although it is consulted by the British Government on all scientific matters, and organizes many international undertakings in which Britain is officially represented, such as the International Geophysical Year. These services are recognized by the Government providing the accommodation which houses the Society and making financial grants to aid the scientific research sponsored by the Society.

Although it is well known that King Charles II granted the first Charter to the Royal Society on 15th July 1662, the events leading to the formation of the society originated, in fact, from the time of Queen Elizabeth I. This is one of many interesting facts given in a volume published by the Royal Society and edited by Sir Harold Hartley, G.C.V.O., C.B.E., F.R.S.†

The archives of the Royal Society provide a written testimony to the very many Fellows who

have played a major part in the development of science. Sir Harold Hartley states that the purpose of the volume he edited is to "praise famous men and our fathers that begat us." In like vein was part of the Tercentenary Address given by Sir Cyril Hinshelwood, O.M., President of the Royal Society, on 19th July before a memorable assembly at the Royal Albert Hall, London.

Our modern life owes much to those men referred to by Sir Cyril as "... dedicated men who, by the concentration of their minds, the skill of their hands, and the sweat of their brow, work to uncover the secrets of nature." He reminded us too that "the full fruition of scientific work depends upon three things: the desire to know, the initiative to find out, and the awareness to apply." The third condition especially concerns the engineer and the need to develop technology so that the benefits of science may be available to all mankind.

It is this spirit of service that has animated the work of the Royal Society, whose membership "has known no restriction of race or nation." Sir Cyril Hinshelwood also emphasized the need to encourage all forms of scientific and engineering endeavour. Argument against the further development of science and individual technologies denies faith in the future. Sir Cyril urged that we should "... go ahead undeterred by any of the uncertainties. Faith in science is not incompatible with or exclusive of any other kind of faith. Indeed, there would seem to be no inconsistency in believing that scientific knowledge is itself one of the great instruments of higher ends."

More fitting tribute could not be paid to the purpose and achievements of the world's greatest learned Society.

G. D. C.

† "The Royal Society. Its Original Founders," published by The Royal Society, 1960.

INSTITUTION NOTICES

The Southern Section

As announced in the June issue of the *Journal* the Council was petitioned by members in the County of Hampshire to form a Section to serve the growing number of members in that area. In consequence a meeting was arranged on July 8th at the University of Southampton which was attended by over eighty members.

The following members were elected to the first Section Committee:

Commander J. S. Brooks (Associate Member).
Chairman.

K. R. McLachlan (Associate Member). *Hon. Secretary.*

A. E. Crawford (Member). *Hon. Treasurer.*

W. A. Gambling, Ph.D. (Associate Member).
Vice-Chairman.

J. M. Peters, B.Sc.(Eng.) (Associate Member).
Assistant Secretary.

K. E. Everett, M.Sc.(Eng.) (Member). *Membership Secretary.*

Sqdn. Ldr. S. F. Bettinson (Associate Member).
Programme Secretary.

K. Walker (Graduate). *Graduate and Student Representative.*

The Committee is drawing up a programme for the 1960-61 Session, and meetings will be held in Southampton, Portsmouth and Farnborough. Members who are able to offer any assistance to the Committee should write to the Honorary Secretary, K. R. McLachlan, A.M.Brit.I.R.E., Department of Engineering, The University, Southampton.

Certified Circulation of Journal

The Institution's *Journal* is one of the few technical journals in the radio and electronics field whose circulation is certified by the Audit Bureau of Circulations.

The first Certificate was issued to the Institution for the first half of 1953 and every subsequent Certificate has shown a consistent increase in *Journal* circulation.

The Audit Bureau of Circulations has now issued a Certificate for the first six months of 1960, showing that the *average* circulation per monthly issue was 7,571 copies. Sales and circulation to new members since June 1960 gives an even greater circulation.

London Meeting

The first London meeting of the Institution for the coming session will be on Wednesday, 28th September, at the London School of Hygiene and Tropical Medicine, starting at 6.30 p.m.

A discussion on the Land Colour Theory, with particular reference to its applications to colour television, will be opened by Mr. M. Wilson and Mr. W. N. Sproson.

North Western Section Visit

The Committee of the North Western Section has arranged a visit to the Winter Hill Television Station of the Independent Television Authority. The visit will take place on Saturday, 3rd September, at 3.30 p.m., and members wishing to participate should write to the Honorary Local Secretary, F. A. Mitchell, 12, Hillcrest Road, Olferton, Stockport.

Fellowships for Information Processing and Electronic Computing Research

The United Nations Educational, Scientific and Cultural Organization is offering six fellowships to be shared among Member States to enable qualified specialists to undertake research in the use of electronic computers for the purpose of mechanical translations, the theory of switching, or the use of computers for the reduction of geophysical data.

The fellowship will normally be for six months and will carry a travel grant and a monthly allowance varying according to the country of study.

Details of the fellowships may be obtained from the United Kingdom National Commission for U.N.E.S.C.O., Ministry of Education, Curzon Street, London, W.1, to whom application should be made before 31st August 1960.

Correction

The following amendment should be made to the paper "A wide-range fully-automatic digital voltmeter" published in the July issue of the *Journal*:

Page 539, Fig. 5. The right-hand contact of the lower half of the mechanical chopper should be connected to the "earthy" end of R2.

Some Reflections on Digital Computer Design †

by

W. RENWICK, M.A., B.SC., MEMBER ‡

A paper read at a meeting of the Computer Group held in London on 7th October 1959.

Summary: The factors influencing computing machine development, during the past decade, are reviewed from the point of view of the circuit engineer. The effect of new components such as the transistor and rectangular-loop ferrite core and of the introduction of new techniques of manufacture are considered. The reduction of the influence of the circuit engineer in computer design, is forecast due to the trend towards packaged construction and the introduction of novel concepts in design.

1. Introduction

During the last ten years, since the first stored programme electronic digital computing machines came into operation, there have been significant developments in all aspects of computer engineering. Pressure has been exerted by the users for larger and faster machines with more extensive facilities, and the introduction of new components and manufacturing techniques has also exerted considerable influence on the trend of machine design. It is perhaps, therefore, an opportune time to review those factors which have, or have had, a significant effect on computer development. One major change that has taken place has been in the attitude to reliability. As the role of electronic apparatus in all branches of engineering has become more vital, and as the complexity of the equipment increases, greater emphasis must be placed on the reliability of the system. For a long time reliability was a purely qualitative parameter which made impossible the comparison of the reliability of different equipments, but, in the last few years, attempts have been made to give this parameter a quantitative evaluation, using the methods of statistics.

Although the development of a computing machine is a co-operative effort by the logical, mechanical and circuit designers, the final

decision regarding what can or cannot be done, must rest with the circuit engineer, since his is the final responsibility for producing the working system. The factors influencing machine development are considered mainly from their effect on circuit design. Special reference will be made to the two computers built at the Cambridge University Mathematical Laboratory, EDSAC 1 and EDSAC 2.

EDSAC originally stood for Electronic Delay Storage Automatic Computer¹ since ultrasonic mercury delay lines² were employed as the storage elements. It exemplified the early group of digital computers, being a serial machine with a single address order code incorporating only a limited number of basic instructions. Although originally intended only as an engineering model, when it reached the stage of performing useful computations in 1949 and as its performance was improved, good use was made of the facilities it offered. In 1953 an engineered version of EDSAC 1, with extended facilities 1.E0 1³ was completed by J. Lyons and Co. In 1951 the decision was taken to design and construct a completely new machine, EDSAC 2.

EDSAC 2 is a parallel machine with single address order code and extended facilities including provision for both fixed and floating point arithmetic⁴. When the machine was started it was proposed to base the high-speed store on an improved mercury delay line, but, in 1953, the ferrite core matrix store was developed at M.I.T.⁵ and, as cores became

† Manuscript received on 1st January 1960. (Paper No. 573.)

‡ The Plessey Co. Ltd., Electronic Research Laboratory, Roke Manor, Romsey, Hants. U.D.C. No. 681.142.

available, plans were made for incorporating a core store.⁶ The control of the machine was designed according to a new concept which was first described by Dr. M. V. Wilkes in 1951⁷. The use of a switch matrix of rectangular-loop cores supplied a convenient method of engineering the system⁸. Transistors were in an early stage of development when the circuit design for EDSAC 2 was carried out, and thermionic valves are used throughout the machine. Plug-in construction was employed with about fifty thermionic valves per unit.

2. Reliability

Among the definitions of reliability in use are the following:

- (a) the "serviceability," or time during which the equipment was serviceable expressed as a percentage of the total time,
- (b) the "average operating time" between failures or the "mean error free time," and
- (c) the "frequency of failures" or the number of failures occurring in a specified period of operation.

Which definition conveys the most useful information depends on for whom it is intended. For example, in airborne equipment, the most important information is the probability that the equipment will operate without failure for a specified time. Although serviceability is frequently used as a measure of the reliability of a computer system, the mean error-free time conveys much more information to the user. Now that preventative maintenance techniques are generally employed, the average number of hours of preventative maintenance and repair required to secure one hour of correct operation would be a measure of reliability of interest to the engineering and maintenance staff.

When a comparison is made between two machines it should be remembered that the usefulness of a machine depends not only on the average operating time but also on the speed of operation. A measure of this parameter is the "error-rate" or the average number of correct operations between failures.

The most important aid to reliability, as defined in any of the above ways, is the prevention of faults. To increase the serviceability, or the time when the machine is available for use, the detection and correction of faults should take as little time as possible. Preventative maintenance and marginal checking reduce the probability of failure during the next operating period by detecting and correcting incipient faults during a scheduled maintenance period and thus increase the average operating time. The major factor affecting the prevention of faults is undoubtedly the reliability of the individual circuits, which reflects the reliability of the circuit design. Component reliability depends on the operating conditions which again are affected by the circuit design as well as by the mechanical layout. Figure 1 is an attempt to show how system reliability affects or is affected by the various factors in design.

3. Circuit Design

The aim of the circuit designer of a digital computer, or of any other piece of electronic apparatus, is to achieve circuits of maximum reliability within the limits imposed by the logical and, to a lesser extent, the mechanical design. Obviously the type of machine limits the choice of suitable circuits. For example, circuits suitable for a parallel asynchronous machine are quite different from those for a serial synchronous machine, and circuits for small plug-in unit construction require different treatment from those for a machine built of large units. To reduce the probability of circuit failure, the most suitable components must be chosen, and circuits with wide operating margins designed round them¹⁰.

Experience has shown that faults due to complete failure of a component are easily detected, while intermittent failures, because of the random way in which they occur, are much more difficult to locate. Some of the possible causes of intermittent faults are:

- (a) intermittent electrical contact, such as caused by a dry-soldered joint or a bad plug and socket connection;
- (b) drifting of components to the edge of their operating margin causing circuits to fail;

and

- (c) circuits being sensitive to the pulse-pattern.

Only in the initial choice of type, rating and siting of components can anything be done to reduce the chance of permanent failure. The solution to (a) above is self-evident and the technique of wrapped joints may give some

limit the low-frequency response. For the upper frequency limitation the only remedy is to keep the minimum transfer time or digit period long enough to eliminate faults. A possible marginal check which could be employed in asynchronous machines would be to increase the maximum frequency under test conditions, thus ensuring that there was a reasonable margin under ordinary operating conditions. Errors due to the

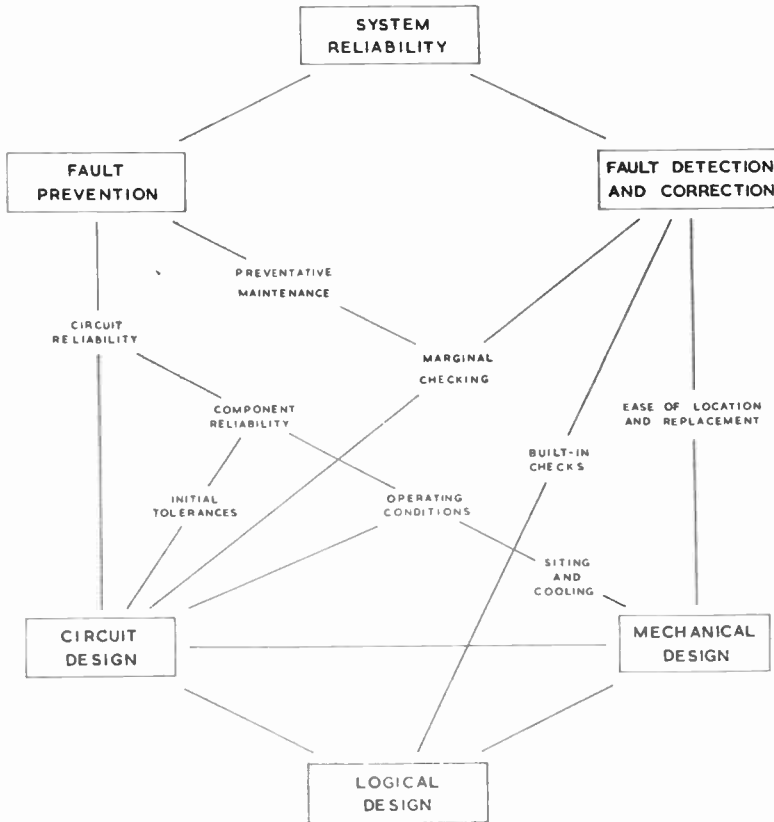

Fig. 1. Relation between system reliability and design factors.

improvement. The use of marginal checking can largely eliminate faults due to (b), by reducing the operating margins of the circuits, thus making an imminent failure into a complete breakdown. Pulse pattern-sensitive faults are due to the limited band-width of the circuits. Stray capacitances or transit-time effects put a limit to the upper limit of frequency response or to the minimum transfer time, while capacitance-resistance or transformer couplings

low-frequency cut-off can only be eliminated by using circuits which pass the zero-frequency component, that is, by using direct-coupled circuits. The restoration of the d.c. component by means of clamp diodes is only possible in synchronous machines. This was the solution adopted in EDSAC I and it would be interesting to know how many of the unexplained faults were due to the clamp diodes failing to hold the d.c. level.

In EDSAC 2 the design was based on direct-coupled circuits with the disadvantages of an increase in circuit dependence on component tolerances, a reduction in the response time of the circuits and the necessity for several stabilised power supplies, that their use entails. In the direct-coupled circuit, Fig. 2(a), the level at the grid of V2 depends on the actual values of R1 and R2 so that the anode swing of V1 must be large enough to compensate for the

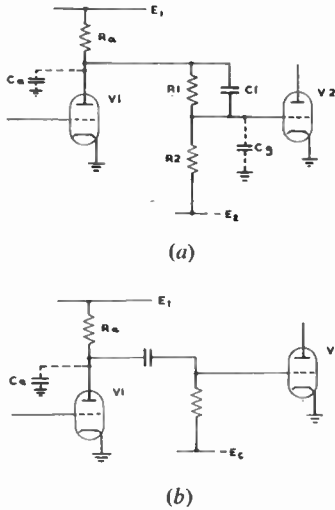

Fig. 2. (a) Direct-coupled circuit; (b) R-C coupled circuit.

variations due to tolerance in R1 and R2, as well as the reduction due to the potential change. In the R-C coupled case of Fig. 2(b) the swing at the anode of V1 need only be equal to the swing required at the grid of V2 and hence a very much smaller R_a is required. The disadvantages of direct-coupling are due to the large difference in input and output d.c. levels of a valve. With transistor circuits, however, the difference in input and output levels is much less and in many cases the maximum speed of operation of a circuit is not limited by external stray capacitances but by the intrinsic frequency response of the transistor.

When marginal checking is used and circuits which are operating near the limit of their margins can be detected before a failure is caused, it is possible to reduce the design tolerances and thus decrease R_a and the response time of the circuit, if the distribution

of components within the tolerance range is known. The flip-flop circuit, Fig. 3, used in the arithmetic circuits of EDSAC 2 (about 500 identical circuits) was designed for variations in the power supplies of $\pm 5\%$ and $\pm 3\frac{1}{2}\%$ in resistor values and for a minimum valve current 25% less than nominal. From measurements on a batch of high stability resistors it was found that the probability of finding two resistors one of which was more than $3\frac{1}{2}\%$ above nominal and the other more than $3\frac{1}{2}\%$ below nominal, was less than 1 in 10,000. Hence the probability of an individual circuit being unstable when the power supplies are out by 5% is controlled almost entirely by the probability of a valve not meeting the required specification.

The requirements for marginal checking limit the choice of circuit to those whose behaviour can be analysed when the proposed marginal check is applied, since it must be known that the circuit is behaving as designed. The assumption made is that if the circuit operates satisfactorily with the marginal check applied there is a high probability that it will continue to do so until the next marginal checking period. The inverting amplifier circuit of Fig. 4 is a simple example of the marginal checks applied in EDSAC 2. Variation of the -300V supply causes variation in the output level, thus checking that both the level, which is mainly determined by the values of the resistors, and the output swing, which is mainly determined by the valve characteristics, have adequate margins. Marginal checking facilities were added to EDSAC 1¹¹ but

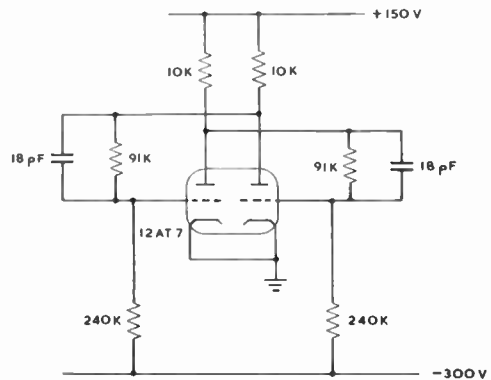

Fig. 3. Flip-flop circuit.

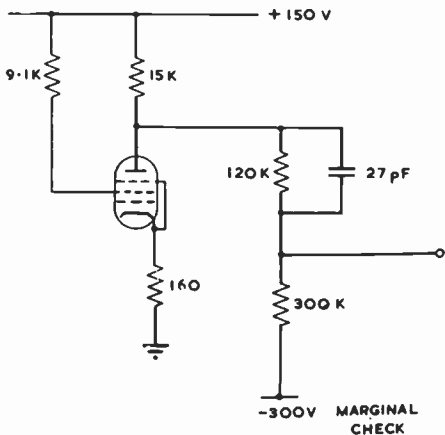

Fig. 4. Inverting amplifier.

a comparison between reliability before and after was complicated by the fact that other engineering improvements were incorporated in the machine at the same time. In EDSAC 2 marginal checks are applied by switching a 50-c/s voltage in series with selected h.t. supplies or reference voltages.

4. Logical Design Factors

There are two main ways in which the development of a computing machine can proceed. Either the logical designer can be given, by the circuit engineer, the specification of a set of logical elements with which he can design any logical system required, or the logical design can precede the circuit design. In the latter case the electronics engineer is free to fulfil the requirements of the logical design in the most economical and reliable way. As the scale and complexity of the system increases, responsibility for various aspects of design must be divided if the machine is to be completed within a reasonable time. Some decisions are forced on the logical designer by the nature of the elements used. For example when a serial or delay line type of store is employed the control of the machine must be synchronous with the digit frequency, and the store lends itself to serial operation. The full advantage of higher operating speed inherent in a parallel machine can only be obtained when a random access store is available.

In a non-synchronous parallel machine like EDSAC 2 the digit significance depends on the spatial position and the information as to whether the digit is one or zero is conveyed by the relative level of the digit lines. The information can therefore be sampled any time after setting up. On the other hand, in a serial synchronous machine like EDSAC 1 the time at which a pulse occurs conveys the digit significance and hence any delay in the circuits must be allowed for in the design. For this reason a fundamental circuit in this type of machine is a regenerating amplifier, which standardizes not only the pulse amplitude but also the pulse timing with reference to the machine clock. Many circuits have been described which perform basic logical functions and regenerate the input information one digit period later. The basic element is shown in Fig. 5, consisting of a logical network, some form of digit storage or

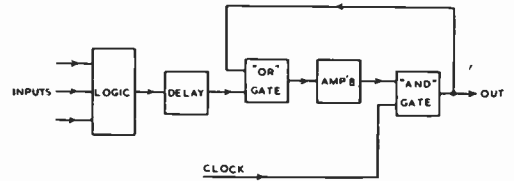

Fig. 5. Regenerating amplifier.

delay, an amplifier and clock pulse gate. The shape of the input pulse to the amplifier is unimportant; as long as it covers the leading edge of a clock pulse the positive feed-back connection will ensure that the output is a complete clock pulse. Circuits of this type have been produced with valves, delay lines and diodes as in EDSAC 1, with valves, transformers and diodes as in SEAC,¹² and with transistors, diodes and transformers using either linear or rectangular-loop ferromagnetic materials.^{13,14,15}

A common situation in a parallel machine is where one control circuit has to feed many circuits in parallel and it is important in this case that the control circuit should be designed to fail safe and not cause damage to the parallel circuits. In addition this means that the driving source should be capable of producing the required waveform into a large capacitive load. In EDSAC 2, for example, up to 41 gates

have to be operated in parallel and the feedback cathode follower shown in Fig. 6 is used for this purpose.

5. Mechanical Design Factors

Although decisions with regard to mechanical design must be made in the light of the engineering requirements, these decisions, once made, can exert a considerable influence on the circuit design. Because of the need to reduce the time for correcting a fault once it has occurred, the tendency now is towards a plug-in unit construction so that when the faulty unit is located, it can be quickly replaced by a similar fully tested unit. There is another school of thought, opposing the use of a large number of plugs and sockets, which supports the view that all interconnections should be soldered and all faults repaired *in situ*. This means that all components should be easily accessible to the maintenance engineer, and the component layout is essentially two dimensional, thus increasing the length of the interconnecting wires and the area of floor space occupied. It should be noted that the length of interconnections may be critical in the design of a very high-speed computer, where the delay (at least 1 millimicrosecond per foot) can become an appreciable fraction of the time between operations. Another disadvantage of the method of soldering all interconnections is the increase in the time required for correcting a fault, since not only must the faulty unit be located, but the actual faulty component itself must be found and replaced before the machine is again serviceable.

When a plug-in unit construction is employed, the size of the replaceable unit has to be decided. As a general rule, the larger the unit the smaller is the number of plug and socket connections required and the easier it is to locate a fault to a particular unit. On the other hand a large unit may mean that an excessive amount of equipment must be held spare. One disadvantage of the philosophy of replaceable unit construction is that facilities must be provided for thoroughly testing the units before insertion in the machine and equipment required may run to what is almost another small computer. With the introduction of transistors and printed wiring techniques, packaged construc-

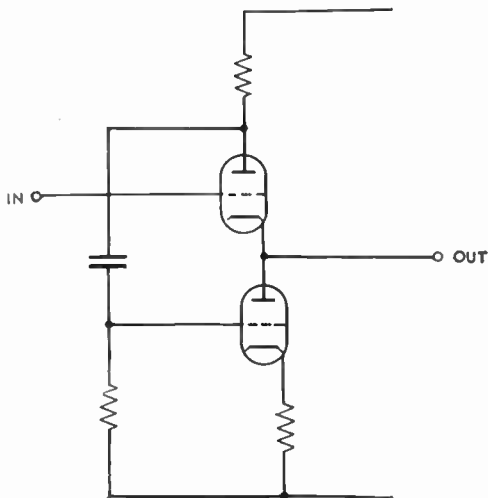

Fig. 6. Feedback cathode follower.

tion which has been extensively used in serial type machines, is being extended to all types of computer. To reduce the cost of development and manufacture, it is essential to make use of basic circuit building blocks, which are assembled in accordance with the requirements of the logical design. This use of standard packages usually means that there is a certain amount of redundant equipment but this should be more than compensated for by the reduced cost of manufacture and the increased reliability which should arise from the extra design and development effort put into the small number of standard circuits.

A parallel machine lends itself to the use of large plug-in units since the circuits required for each digit are identical. The bulk of the equipment in EDSAC 2, which is constructed in this way, is contained in five different types of unit each of which is repeated at least ten times. The remaining units, which are concerned mainly with waveform generators and the control of peripheral equipment, are repeated only once or twice. The same set of basic circuits is used in all the units.

6. Components

With the increased emphasis now placed on reliability there has been a great increase in the effort devoted to improving component reliability which ultimately governs the system

performance. The most important characteristic of the component is its expected life during which it will be free from sudden failure and from drift in its characteristics with time. The problems of the design engineer are eased by components with close selection tolerances or characteristics defined within close limits and free from drift due to operating conditions. The requirements for high-operating speeds with the necessary reduction in equipment size call for reduced component size. The best of the available conventional components fall far short of what the designer would wish with regard to the major requirements of long life, high stability and close tolerance. Valve characteristics can vary by as much as $\pm 40\%$ from nominal and in the case of transistors some parameters can vary by as much as 5 to 1. As another example, high-stability deposited carbon resistors with a nominal tolerance of $\pm 1\%$ could be outside this range when first put into a circuit since the maximum allowable drift in one year's shelf-life as specified by the Radio Components Standardization Committee is $\pm 2\%$. The overall stability for a Grade 1 resistor of this type under operating conditions is specified as better than $\pm 5\%$. Methods of quality control are now being more extensively used in component production and the special quality valves now available are an example where control is exercised during manufacture resulting in a much improved performance.

The introduction of the transistor and semi-conductor diodes has had a major effect on computer design making possible faster and more complex systems. If we consider the matched line of Fig. 7 it can easily be shown that the delay before the output voltage appears is given by $T = CV/I$, where C is the total capacitance of the line. In the case where the inductance is negligible, the time before the output voltage rises to V is given by the same expression. The delay time, therefore, is decreased directly by the reduced voltage swing required by transistors and indirectly by the high component density which is possible in transistor circuits, since this makes interconnections shorter and thus of lower capacitance. Perhaps the most important factor is the increased reliability which the transistor promises, enabling larger systems to be

assembled. The main disadvantage of transistors and other semi-conductor devices is the temperature dependence of some parameters, but because of the lower voltages required and the elimination of heater supplies, the power dissipation in the equipment is much reduced and cooling problems are eased. This reduction in dissipation and voltage should also have an improving effect on the reliability of other components in the circuit. Although the demands made on the associated components are less exacting as far as voltage and dissipation are concerned, reduction in size and increase in stability and reliability are required in large equipments. The evaporated metal or oxide film resistors promise a considerable increase in stability over carbon types.

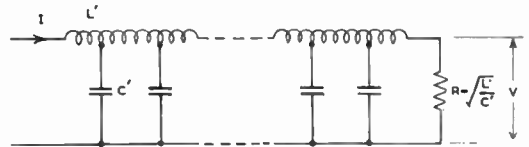

Fig. 7. Illustrating delay in matched line.

Experience of the reliability of semi-conductor diodes, which have been widely used in computer circuits, has been varied. Cases of high failure rates have been in equipment employing valves, with, consequently, the probability of high operating temperatures and high back voltages. In EDSAC 2, where point contact diodes are used to a limited extent, there was one circuit where the failure rate was high, and where finally they were replaced by thermionic diodes. In the remaining places where they are employed, it was possible to ensure that the ambient temperature was kept low. Undoubtedly the mixing of valves and semi-conductor devices in a circuit calls for careful design.

The limitation of the transistor as a high-frequency high-power switching device may well be overcome by the introduction of the *pnpn* structure.¹⁶ Its thyatron-like characteristics are already being used in core-driving circuits where high powers are involved. Another device which promises to extend the upper frequency limit of semi-conductor devices is the tunnel effect

diode. This device has a negative resistance characteristic and is reported to switch in one or two millimicroseconds.¹⁷

The introduction of the rectangular hysteresis loop ferrite core has also had a major effect on computer design. Before these became available, most storage systems were serial access devices such as magnetic drums, ultrasonic mercury delay lines and magnetostrictive nickel lines, which lent themselves to serial operation. The reliability of the cathode-ray tube store and other electrostatic storage systems using special tubes, operating in the parallel mode, was disappointing. The ferrite core made possible a reliable random-access, high-speed store thus enabling the higher intrinsic operating speed of the parallel type machine to be realized. As well as their use for storage, rectangular loop cores have found application in logical circuits where, however, they are subject to some disadvantages. In general, to achieve power gain with a core requires some other non-linear device such as a rectifier and this introduces problems of impedance matching. The operating speed is limited by the heating of the core due to the intrinsic losses in the material and there are other limitations due to the problems of driving large inductive loads from available power sources. Special core geometries such as the transfluxor¹⁸ have been produced which eliminate some of these disadvantages and other elements have been proposed for use in logical circuits,^{19, 20} where the logical operation is carried out by flux transfer between the various magnetic paths in the device.

7. New Developments

Computer design is influenced not only by the results of the continual development of new components but also by completely new concepts in the field. The logical outcome of the tendency towards packaged construction will be the functional module as the component of the future. Already in the U.S.A. there is a programme directed towards the production of such modules, consisting of conventional components manufactured to a unified mechanical design and assembled in standard functional circuits.²¹ Equipment design will then consist of assembling the specified modules into the complete

system. The component density that can be achieved in this way is about 5×10^5 parts per cubic foot. Research is also being carried out into the solid state or integrated circuit, in which the complete circuit would be made from a single wafer of silicon. These would be manufactured by shaping the silicon wafer by ultrasonic drilling and air-abrasion and by using diffusion techniques to fabricate diodes and transistors and associated components²². There seems no reason why component densities greater than 10^7 parts per cubic foot should not be reached.

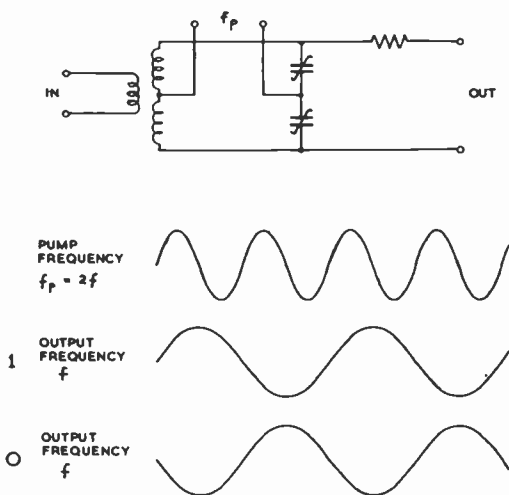

Fig. 8. Sub-harmonic generation in tuned circuit with non-linear reactance.

At temperatures a few degrees above absolute zero, superconducting switching and storage elements are being investigated, and it is conceivable that, if a solution to the difficult technological problems involved can be found, most of the high-speed computing system of the future will operate in a liquid helium bath. Switching times as low as 10 millimicroseconds have been reported.²³ In addition to the superconducting element or "cryotron", some work is being carried out on the behaviour of semiconductor materials at low temperatures. The "cryosar" is a switching and storage device which utilizes the phenomenon of impact ionization in germanium at liquid helium temperatures.²⁴

By making use of sub-harmonic generation in a tuned circuit including a non-linear reactance, majority logic can be carried out. The idea was patented by the late Prof. J. von Neumann in 1954,²⁵ and independently in Japan the same principle has been applied to computer design.²⁶ The operation depends on the generated sub-harmonic frequency having a number, which is equal to the order of the sub-harmonic, of stable phase relationships with the exciting frequency. If, for example, the circuit including the non-linear capacitance, of Fig. 8 has a resonant frequency of f_0 and is excited by a frequency of

sequential sets of circuits as shown in Fig. 9, it is possible to transfer information unidirectionally. Several computers using this element or "parametron" have been built in Japan with a pump frequency of about 1 Mc/s and a digit frequency of 20 kc/s. The reliability of the parametron should be high since it consists only of inductor, capacitor and resistor.

Von Neumann suggested extending the pump frequency to microwaves, thus making possible a digit frequency of several hundred Mc/s, and some experimental work at microwaves has been reported.²⁷

8. Conclusions

The importance which is attached to system reliability has meant that with existing methods of computer design and construction the circuit engineer has had a major influence on system design. New developments, it seems, will tend to reduce this influence and, perhaps in some cases, eliminate it altogether. The inevitable increase in the use of packaged construction, leading finally to the functional module as the component of the future, will confine his interest to a decreasing part of the whole system, so that in the end his function may be solely that of component design. On the other hand, computer design is now tending to embrace new branches of engineering and physics. The emphasis on solid state devices draws the electronics engineer closer to the physicist, making it difficult to tell where the transition takes place. The ideas of von Neumann referred to above, would require microwave engineers for their practical realization and it is doubtful if any engineering discipline will play other than a minor rôle in the design of a low-temperature computer. With the increasing complexity of the whole system, responsibility for the design will be centred in the systems engineers who, in the same way as the circuit engineer assembles components into a reliable circuit, will assemble the specified parts into a reliable computer system.

9. References

1. M. V. Wilkes and W. Renwick, "The EDSAC—an electronic calculating machine", *J. Sci. Instrum.*, 26, p. 385, 1949.

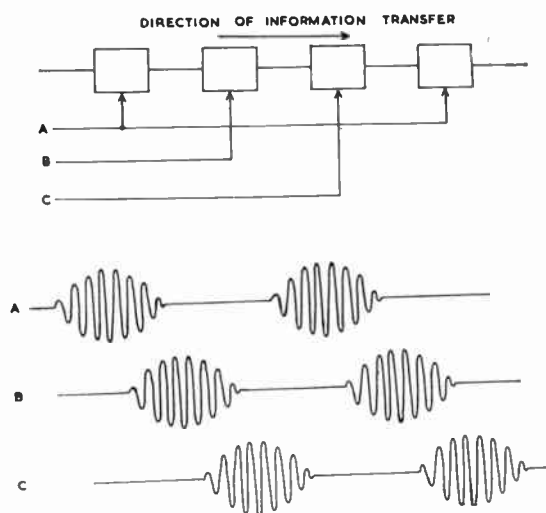

Fig. 9. Use of parametron elements to transfer information unidirectionally.

$2f_0$, the oscillation, generated at frequency f_0 under the correct circuit conditions, can take up either of two phase relationships differing by 180 deg. These two phases can be made to represent the binary digits 0 and 1. The phase in which the oscillation builds up can be controlled by the phase of a low level signal of the same frequency injected into the circuit. If, therefore, an odd number of equal amplitude signals, whose phases may differ by 180 deg., are added vectorially at the input, the output from the circuit will take up the same phase as the majority of the inputs. By modulating the exciting frequency or "pump" source with a three phase "clock" or digit frequency, and applying the three resulting pump supplies to

2. M. V. Wilkes and W. Renwick, "An ultrasonic memory unit for the EDSAC", *Electronic Engineering*, **20**, p. 208, 1948.
3. J. M. M. Pinkerton and E. J. Kaye, "LEO (Lyons Electronic Office)—Part 1", *Electronic Engineering*, **26**, p. 284, 1954.
4. "Programming for EDSAC 2", University Mathematical Laboratory, Cambridge, August 1958.
5. D. R. Brown and E. Albers-Schoenberg, "Ferrites speed digital computers", *Electronics*, p. 146, April 1953.
6. W. Renwick, "A magnetic-core matrix store with direct selection using a magnetic-core switch matrix", *Proc. Instn. Elect. Engrs.*, **104**, Part B, Supplement No. 7, 1957.
7. M. V. Wilkes, "The best way to design an automatic calculating machine". Report of Manchester University Computer Inaugural Conference. p. 16, July 1951.
8. M. V. Wilkes, W. Renwick and D. J. Wheeler, "The design of the control unit of an electronic digital computer", *Proc. Instn. Elect. Engrs.*, **105**, Part B, p. 121, March 1958.
9. W. Renwick and M. Phister, "A design method for direct coupled flip-flops", *Electronic Engineering*, **27**, p. 246, June 1955.
10. W. Renwick, "Design of computer circuits for reliability", *Electronic Engineering*, **28**, p. 380, September 1956.
11. M. V. Wilkes, M. Phister and S. A. Barton, "Experience with marginal checking and automatic routing of the EDSAC", *Convention Record of the I.R.E.*, 1953, Part 7, p. 66.
12. R. D. Elbourn and R. P. Witt, "Dynamic circuit techniques used in SEAC and DYSEAC", *Proc. Inst. Radio Engrs.*, **41**, p. 1380, October 1953.
13. D. Eldridge, "A new high-speed digital technique for computer use", *Proc. Instn. Elect. Engrs.*, **106**, Part B, p. 237, 1959.
14. R. Herman, "Transistor storage and logic circuits for binary data processing", *Proc. Instn. Elect. Engrs.*, **106**, Part B, Supplement No. 16, p. 663, 1959.
15. G. G. Scarrott *et al*, "The design principles of the neuron and resonant circuit logical elements". (Paper presented at the "Specialist Discussion Meetings on New Digital Computer Techniques", February 1959). *Proc. Instn. Elect. Engrs.*, **106**, Part B, p. 468, September 1959.
16. I. M. MacIntosh, "Three-terminal *pnpn* transistor switches", *Trans. Inst. Radio Engrs. (Electron Devices)*, **ED-5**, p. 10, January 1958.
17. H. S. Sommers Jr., "Tunnel diodes as high frequency devices", *Proc. Inst. Radio Engrs.*, **47**, p. 1201, July 1959.
18. J. A. Rajchman and A. W. Lo, "The transfluxor—a magnetic gate with stored variable setting", *R.C.A. Review*, **16**, p. 303, June 1955.
19. U. F. Gianola and T. H. Crowley, "The laddic—a magnetic device for performing logic". *Bell Syst. Tech. J.*, **38**, p. 45, January 1959.
20. H. W. Abbott and J. J. Suran, "Multihole ferrite core configurations and applications". *Proc. Inst. Radio Engrs.*, **45**, p. 1081, August 1957.
21. S. F. Danko *et al.*, "The micro-module, a logical approach to micro-miniaturization", *Proc. Inst. Radio Engrs.*, **47**, p. 894, May 1959.
22. T. A. Prugh *et al.*, "The D.O.F.L. micro-electrics program". *Proc. Inst. Radio Engrs.*, **47**, p. 882, May 1959.
23. E. H. Rhoderick, "Low temperature storage elements", *J. Brit.I.R.E.*, **20**, p. 37, January 1960.
24. A. L. McWhorter and R. H. Rediker, "The cryosar—a new low-temperature computer component". *Proc. Inst. Radio Engrs.*, **47**, p. 1207, July 1959.
25. R. L. Wigington, "A new concept in computing", *Proc. Inst. Radio Engrs.*, **47**, p. 516, April 1959.
26. E. Goto, "The parametron, a digital computing element which utilizes parametric oscillation", *Proc. Inst. Radio Engrs.*, **47**, p. 1304, August 1959.
27. F. Sterzer, "Microwave parametric subharmonic oscillators for digital computing", *Proc. Inst. Radio Engrs.*, **47**, p. 1317, August 1959.

REPORT OF EXTRAORDINARY GENERAL MEETING

An Extraordinary General Meeting of the Institution was held at the London School of Hygiene and Tropical Medicine on Thursday, 28th April 1960, at 6 p.m. The President, Professor E. E. Zepler, took the Chair, and was supported by other officers and members of the Council. When the meeting opened 152 corporate members had signed the attendance book.

The President stated: "The purpose of this meeting is to implement the wish frequently expressed by members* that we should submit to Her Majesty The Queen a Petition for the grant of a Charter of Incorporation. During the last eighteen months your Council has been very active in this matter and in consultation with our legal advisers it was agreed first to give opportunity to all corporate members to express their will in this matter.

"My colleagues and I have been encouraged by the weight of opinion coming from members. We have here a very good gathering and I have also been entrusted with 768 proxies from corporate members empowering us to vote in favour of the Resolution, notice of which was given on page 250 of the *April Journal*."

Professor Zepler stated that before formally putting the Resolution before the meeting, he and other officers would be pleased to answer any comments which members might care to make. Replying to one point on procedure, the General Secretary said that the Resolution before the meeting would authorize the Council to take such steps as they considered proper in the presentation of the Petition and the Council had, in fact, agreed that the Petitioners should be the President, some of the Immediate Past Presidents, and the Vice-Presidents of the Institution.

Other members enquired as to the prospects of obtaining a Charter and whether the result would in any way affect the intention of procuring the Institution's own building. Professor Emrys Williams and other officers pointed out that it was not possible to give any indication of the possible success of the Petition. A Charter of Incorporation was not lightly given and much would depend upon circumstances over which the Council had no control. The officers never-

theless felt that the Institution had reached the stage when it was justified in lodging a Petition, particularly by reason of the widespread recognition of the Institution as a learned society with adequate standards of membership. The matter of acquiring a building for the Institution was not at all related; the Council was, in fact, negotiating for new Institution headquarters.

Mr. J. F. Mazdon (Member) asked whether consideration had been given to changing the name of the Institution to "The British Institution of Radio and Electronic Engineers." The President replied that the Resolution allowed for that possibility but that it could only be considered after the result of the Petition was known.

There being no further questions the President formally moved the following Resolution:—

"That upon a consideration of the great development in recent years of Radio and Electronics as an independent science and with a view to advancing still further the science of Radio and Electronics and the engineering application thereof and maintaining in the interests of the public the highest possible standard of professional ability and conduct among Radio and Electronic Engineers the Council of the Institution be and they are hereby authorized to petition Her Majesty in Council for the honour of a grant of a Royal Charter incorporating the members of the Institution under the title of "The British Institution of Radio Engineers" or under such other title as to Her Majesty may seem fit for the purpose of promoting the advancement of the science and practice of Radio and Electronic Engineering and with such further objects, powers and privileges as the Council of the Institution shall think appropriate, and for that purpose to take all necessary and proper steps."

The Resolution was passed unanimously.

Mr. V. J. Cooper (Member) proposed a vote of thanks for the wisdom and leadership of the Council and for the work done by the General Secretary in preparations for presenting the Petition. The proposal was carried with acclamation.

The President thanked all members for their support and closed the meeting at 6.20 p.m.

* See reports of Annual General Meetings.

TELEPHONE PROGRESS

The 1959-60 Annual Report of the Telecommunication Engineering and Manufacturing Association quotes interesting statistics on the number of telephones installed in the United Kingdom and the major industrial countries throughout the world. The United States of America has the greatest number of telephones in use—66,645,000—and Great Britain comes next with 7,525,000. The principal criterion, however, by which telephone progress in each country may be measured, is to take the number of stations per hundred population and, to compare progress, to note the percentage of totally automatic telephones. In the United Kingdom there are 14.53 telephones per hundred population, but ten other countries have a higher proportion of automatic telephone systems. In this connection the rates of growth in the United Kingdom over the past year (2.3 per cent.) and over the past 10 years (53.4 per cent.) are the lowest of the sixteen countries quoted. Fortunately, these figures have been improved upon during 1959 and the Report quotes the Post Office statement that at the end of the year 60,000 orders for exchange service were still awaiting plant compared with 91,000 a year earlier.

Technical advances in the British telephone network have been referred to in the *Journal* over the past year or so, notably the introduction of the electronic telephone exchange†. The Association expresses disappointment that progress has not been quicker—the Highgate Woods prototype exchange will not be in public service until 1962. Other engineering improvements are, however, taking place at a greater speed, particularly in connection with coaxial cable repeaters to increase the number of channels and permit either multi-channel telephony or television alternatively on the same cable. The reduction in size of repeaters by using transistors and smaller diameter cables will save building costs and cheapen the shorter trunk circuits.

The Report refers also to some of the new services which are being provided in the United Kingdom, notably the system in the Manchester area whereby a telephone call may be made between moving motor cars and any telephone in the United Kingdom‡. This scheme is being extended to other parts of the country, and trials have recently been undertaken between trains running between Crewe, Manchester, Liverpool and Birkenhead, using the same fixed radio stations as for the South Lancashire Car Radio telephone service. The Post Office has authorized an extension of the use of tape recording machines to receive telephone calls, and these have been installed by a number of organizations who wish to relieve office work or accept orders outside office hours.

The Association views with favour the proposals for the British Post Office to operate to a greater extent as a self-contained business. Advantages which it is considered might accrue from the Post Office's greater financial independence from the present Annual Estimate procedure include the possibility of planning such services as trunk and television circuits on a long-term basis and before actual demands have arisen.

Exports of the British telephone industry have not shown any increase for 1959 over the previous year, due, it is stated, to growing overseas competition; exports for the year were valued at £25,894,000. It is pointed out in the Report that the considerable exports of radio-relay systems and short-wave radio transmitters and receivers for long-distance telegraph and telephone services are not brought out separately in the Board of Trade returns, and cannot, therefore, be quoted. Comment on this general inability of the Government's Central Statistical Office to distinguish between radio equipment and the equipment made by other industries has of course been made in the Institution's *Journal*.§

† "Subscriber trunk dialling in the British Post Office." *J. Brit.I.R.E.*, 19, pp. 45-6, January 1959; "An experimental electronic telephone exchange," *ibid.*, p. 726, November 1959.

‡ Industrial notes, *J. Brit.I.R.E.*, December 1959, page xvii.

§ "Standard industrial classification." *J. Brit.I.R.E.*, 19, page 368, June 1959.

DISCUSSION

on

“Oscilloscope Tube with Travelling-wave Deflection System and Large Field of View”

Seymour Goldberg† : The paper by Niklas and Wimpffen¹ on a travelling wave oscilloscope tube has recently come to my attention and I wish to comment on a statement referenced to our earlier work² on such devices. It is implied in the Niklas-Wimpffen paper that we feel it advantageous to locate the focusing lens between the deflection system and screen. Quite to the contrary, the specific point was made in our publication that the optimum lens position was squarely coincident with the deflection plate position and this is made possible through the use of magnetic focus and therein lies one important advantage for the use of magnetic lenses. We further pointed out that with the lens in this optimum position it is advantageous in improving sensibility, scan and writing speed to locate the deflection plates (and its coincident focusing lens) as close to the screen as possible until the limit of screen resolution is obtained.

Dr. W. F. Niklas (Associate Member) and **J. Wimpffen** (*in reply*)‡ : It can be shown quite readily that one class of magnetic lenses, namely, units producing a homogeneous field parallel to the axis of the electron beam, do indeed require the same location as the centre of deflection for optimum positioning. However, somewhat less conventional designs permit the positioning of a magnetic focusing lens between the centre of deflection and the screen without the loss in sensitivity otherwise resulting from

the use of a conventional lens in such a position. Such an unconventional lens may comprise a sphere consisting of apertures formed by axially magnetized hollow ferromagnetic cylinders, the centre of curvature of the sphere coinciding with the centre of deflection. The deflected electron beam penetrates such an “aperture mask” under orthogonality for all deflection angles. Thus, beam focusing will occur without loss of deflection. Such a design while involving appreciable practical difficulties, has been considered previously for post-focus tri-colour picture tubes³.

It should be pointed out further that it is certainly possible to achieve coincidence of electrostatic focusing and deflection. A unipotential focusing lens⁴ was described several years ago, which permitted deflection of the electron beam inside the lens space. It is quite correct that such a structure is cumbersome in practical use; however, the complexity of a system does not invalidate its fundamental properties and resulting advantages in principle.

References

1. W. F. Niklas and J. Wimpffen, “Oscilloscope tube with travelling-wave deflection system and large field of view,” *J. Brit.I.R.E.*, **18**, pp. 653-660, November 1958.
2. K. J. Germeshausen, S. Goldberg and D. F. McDonald, “A high-sensibility cathode-ray tube for millimicrosecond transients,” *Trans. Inst. Radio Engrs. (Electron Devices)*, **ED-4**, No. 2, pp. 152-158, April 1957.
3. S. Kaplan, Private communication.
4. E. Atti and J. Hall, “A bi-functional einzel electron optical lens.” Presented at I.R.E. Conference on Electron Devices, Washington, D.C. (October 25-26, 1956).

† Edgerton Germeshausen & Grier Inc., Boston, Mass.; communication received by the Institution 9th July, 1959.

‡ The Rauland Corporation, Chicago, Ill.; reply received by the Institution on 11th June, 1960.

U.D.C. No. 621.385.832

APPLICANTS FOR ELECTION AND TRANSFER

As a result of its July meeting the Membership Committee recommended to the Council the following elections and transfers.

In accordance with a resolution of Council, and in the absence of any objections, the election and transfer of the candidates to the class indicated will be confirmed fourteen days after the date of circulation of this list. Any objections or communications concerning these elections should be addressed to the General Secretary for submission to the Council.

Direct Election to Member

LEEVERS, Frederick Norman, B.Sc.(Eng.). *Twickenham, Middx.*
POLONSKY, Joseph. *Issy-les-Moulineaux, France.*
SUTTLE, Gp. Capt. Charles Edward P., O.B.E., R.A.F. *Weston-super-Mare.*
*WASSEF, Air Comdre. Yousef, Egyptian Air Force. *London, W.I.*

Transfer from Associate Member to Member

LUDGATE, Gp. Capt. Felix Edgar, R.A.F. *High Wycombe, Bucks.*
REYNOLDS, Peter Harold. *Beaconsfield, Canada.*
ROBINSON, John D. M., C.B.E. *Marlborough, Wilts.*
WILLIAMS, Wg. Cdr. Robert Wesley, R.A.F. *Stammore.*

Direct Election to Associate Member

GREENHALGH, David Constantine, B.Sc. *Chelmsford, Essex.*
LAKER, Peter Keith. *Lee on Solent.*
LOH, Shiu Chang, Ph.D., B.Sc. *Hong Kong.*
*MURTHY, Maj. Pillalamarri V. R., B.Sc., Indian E.M.E. *New Delhi.*
NICHOLS, Kenneth Graham, B.Sc., M.Sc. *Letchworth.*
STACHERA, Henryk Stanislaw, Ph.D., B.Sc. *Southampton.*

Transfer from Graduate to Associate Member

BROWNE, Denis George, B.Sc. *Reigate, Surrey.*
DAVIES, Mervyn William. *Sydney, Australia.*
EDWARDS, Lt. Cdr. Vivian Cecil W., B.Sc., R.N. *Plymouth.*
GUYOT, Christian. *Saint Germain-les-Arpajon, France.*
HART, Bryan Leonard, B.Sc. *Croydon.*
HAYWARD, John Ramsay. *London, N.20.*
KRISHAN, Bal Jhanb, B.Sc. *Rochester, U.S.A.*
LEWIN, Douglas William. *Billerica, Essex.*

THOMAS, William James. *Great Yarmouth.*
WHITAKER, Flt. Lt. Peter, R.A.F. *Bognor Regis.*
WILSON, Samuel. *Southall, Middlesex.*

Direct Election to Associate

BUTLER, Hubert Harry. *Ripon, Yorks.*
HUGGINS, Victor Jackson. *Ashford, Middlesex.*
*TYLER, Eric. *New York, U.S.A.*

Direct Election to Graduate

BARBOUR, John Cyprian. *Wembley, Middlesex.*
BATCHELOR, Peter Leslie. *Enfield.*
BEDDOES, Edward William. *Ruislip.*
CULPIN, Millice James. *Harlow.*
GRASBY, Charles William. *Stafford.*
McKAY, Eric Martin, B.Sc. *Berkhamsted, Hertfordshire.*
MANNING, Graham Erwin. *North Chingford, Essex.*
MANSELL, Denis Herbert. *Waltham Abbey.*
NORTH, Flg. Off. Thomas William Tertius, R.A.F. *Letchworth.*
PETERSEN, Robert Laurence, B.Sc. *East Molesey.*
RAY, Asoke Kumar, M.Sc. *Edinburgh.*
SAYERS, Laurence Thomas. *Brighton.*
TAUTE, Willem, B.Sc. *Germiston, South Africa.*
WHITELEY, Michael Christopher. *Waddington.*
WILDERS, Bernard Francis. *London, E.C.1.*

Transfer from Associate to Graduate

STEWART, Robert. *Basingstoke, Hampshire.*

Transfer from Student to Graduate

NEED, Richard John. *London, N.6.*

STUDENTSHIP REGISTRATIONS

AFSAR, Ali Khan, B.Sc. *Lahore.*
AIVALIOTIS, John. *Athens.*
AMPAH, Stephen, B.Sc. *London, N.W.2.*
APPARAO, G. D. V., B.Sc. *Madras.*
AVERY, Elliott George. *Lancaster.*
BARNACLE, John. *London, E.7.*
BENTLEY, John. *Stockport.*
BIRD, Alan Richard. *Norfolk.*
BOWKER, Anthony. *Didcot, Berkshire.*
BRAVINSKY, Gary. *London, N.W.3.*
CARTWRIGHT, George. *Walsend-on-Tyne, Northumberland.*
CHAMBERS, John. *Tunbridge Wells.*
CHIN, Yun Foo. *Perak, Malaya.*
CONSTANTINOU, Christos Nicola. *Kyrenia, Cyprus.*
COYTE, Raymond George. *Stevenage.*
CVIEGORN, Akiva. *Haifa, Israel.*
DAY-LEWIS, Frederick John. *Tyngsboro, Mass., U.S.A.*
DELIWEIS, Demetrius. *Lesvos, Greece.*
DICK, Ian. *Holmbrook, Cumberland.*
DOS SANTOS, Artur. *Bromley.*
FADIL, Gunay. *Kyrenia, Cyprus.*

FERROFF, Viacheslay Constantinovich. *Brisbane.*
GHOSE, Purvshottam, B.Sc. *London, S.W.11.*
GOKHALE, Madhu. *Bombay.*
HAIDER, Iftikhar. *Lahore.*
HARTNELL, Desmond. *Stammore, Middx.*
HENNELL, Jon Francis. *Waltham Cross.*
HOLLINGSWORTH, Geoffrey. *Birmingham.*
KAKIRDE, Shrikrishna, M.Sc. *Madras.*
KARLETTIDES, Sofoulis. *Athens.*
KING, Noel Robert Bruce. *Salé, Cheshire.*
LEWIS, Frederick. *Ashford Common, Middlesex.*
*LONGSTAFF, Reginald. *Newton Abbot, Devon.*
MILLWARD, George. *Darlington.*
MORPHAKIS, Andreas. *Kyrenia, Cyprus.*
MOSLEY, John. *London, S.E.27.*
MUKHOPADHYAYA, Himanshu Kumar. *Parganas, India.*
PANGRATIS, Alexandros. *Ampelokipi, Greece.*
PAPADIMAS, George. *Athens, Greece.*

PASZKIEWICZ, Ireneusz. *London, N.22.*
PATEL, Sudhirchandra. *Bombay.*
*PIRES, Harold. *London, S.E.13.*
ROSENBAGH, Eleizer. *Kfar Kadina, Israel.*
ROY, Plt. Off. Bankim Chandra. *Kawardha, India.*
RUTGERS, Willem. *Oegsteest, Holland.*
SALGAR, Anand. *Bombay.*
SANTRA, Ajit Behari. *Midnapore, India.*
SCOTT, Thomas. *Calderbank, Lanarkshire.*
SIOW, Keng Cheng. *Singapore.*
STERGIOU, Sotorios. *Athens.*
THOMPSON, John. *South Shields.*
UNTHANK, Arthur. *Tadley, Hampshire.*
WATKINS, Alan. *Southampton.*
WELSH, Michael. *Bracknell, Berkshire.*
WESCOTT, Philip George. *Hitchin.*
WHELAN, John Gerard. *Touradgl, Australia.*
WHEELER, Edwin. *Cobham, Surrey.*
WINDLE, Kevin Joseph. *Yougna, Co. Cork.*
XERRI, Charles. *Malta, G.C.*

* Reinstatements.

Microwave Valves : A Survey of Evolution, Principles of Operation and Basic Characteristics †

by

C. H. DIX, B.SC., and W. E. WILLSHAW, M.B.E., M.SC.TECH.‡

A paper read at a meeting of the Institution in London on 30th September 1959

In the Chair : Mr. G. A. Marriott, B.A. (Immediate Past President)

Summary : After a brief description of the evolution of the different classes of microwave valves, the principal modern types are discussed under the headings of their mode of operation : 'O' type interaction, 'M' type (crossed field), variable reactance amplifiers; and the maser. A brief survey is given of the performances obtained. 89 references.

List of Contents

1. Historical Introduction
2. Principles of Operation of Modern Valves
3. "O" Type Interaction
 - 3.1. The Klystron
 - 3.2. Waves in Beams
 - 3.3. The Travelling Wave Tube
 - 3.4. Focusing of "O" Type Systems
 - 3.5. Noise Performance
 - 3.6. Backward Wave Interaction
4. "M" Type (Crossed Field) Interaction
 - 4.1. General Characteristics of Linear Injection System
 - 4.2. Space Charge Amplification Effect
 - 4.3. General Field of Use of Linear Injection System
 - 4.4. The Magnetron
 - 4.5. The Amplitron
5. Beams and Circuits
 - 5.1. "O" Type Beams
 - 5.2. "M" Type Guns
 - 5.3. Slow Wave Circuits
6. Other Interaction Mechanisms
7. Variable Reactance Amplifiers
 - 7.1. Diode Type
 - 7.1.1. Up-Conversion
 - 7.2. Beam Type
 - 7.3. Ferrite Type
8. The Maser
9. Survey of Performance of Established Types of Valves
 - 9.1. Low Power Klystrons
 - 9.1.1. Reflex Klystron
 - 9.1.2. Heil Tube
 - 9.1.3. Retarding Field Oscillator
 - 9.1.4. Monotron
 - 9.2. High Power Klystrons
 - 9.2.1. C.W. Type
 - 9.2.2. Pulsed Type
 - 9.3. Travelling Wave Tubes
 - 9.3.1. Low Noise Performance
 - 9.3.2. Medium Power Tubes
 - 9.3.3. Electronically Tuned Amplifiers
 - 9.3.4. Modulation
 - 9.3.5. Harmonic Generation
 - 9.3.6. High Power Operation
 - 9.4. "O" Type Backward Wave Oscillator
 - 9.5. Magnetron
 - 9.5.1. Pulsed Type
 - 9.5.2. C.W. Type
 - 9.6. The Amplitron (and Stabilitron)
 - 9.7. Crossed Field ("M" Type) Backward Wave Oscillator
 - 9.8. Crossed Field ("M" Type) Amplifier
10. Conclusions and Acknowledgments
11. References

† Manuscript first received 18th August 1959 and in final form on 19th May 1960. Paper No. 574.)

‡ Research Laboratories of The General Electric Company, Ltd., Wembley, England.

U.D.C. No. 621.385.6.029.64/5.

1. Historical Introduction

Since the main period of exploitation of valves specially suited for operation at the highest frequencies dated from the beginning of

the last war, it is only natural to overlook the long preceding period in which ideas were being formed and experimental work carried out on means for generating and amplifying the highest radio frequencies. It is however appropriate to summarize this early work particularly from the point of view of noting how in this, as in so many other fields of endeavour, a new science and technology has developed from the observation of apparently unexplained and unimportant phenomena.

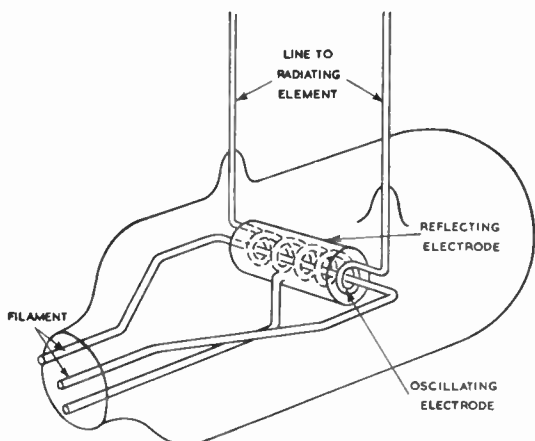

Fig. 1. Barkhausen-Kurz oscillator.

In 1919 it was noted by Barkhausen and Kurz¹, during tests for the presence of gas in transmitting valves in which the grid was held at a high positive potential and the anode at a negative one, that oscillation could be maintained in a circuit connected between grid and anode, or between other pairs of electrodes (Fig. 1). The explanation was given that electrons are accelerated from the cathode to the positive grid through which some of them pass. These are then retarded in the grid anode space and turn back to the grid, some of them again passing through, and being reflected at the cathode to repeat the behaviour. It is this to and fro motion which results in the oscillations which have a frequency expression for zero anode voltage of the form

$$f = \text{const} \sqrt{V_0/d_g}$$

V_0 being the accelerating grid potential and d_g the grid cathode distance. Thus for the first time was reported the generation of electrical oscilla-

tions depending primarily on the oscillatory motion of electrons in a vacuum, and not on the excitation of oscillatory currents in a tuned circuit, and this discovery might be said to represent the starting point of the whole field of modern microwave valves.

Subsequent work on this device called generally the 'retarding field' generator, by Gill and Morrell, reported in 1922² and subsequently by many others, showed that this simple type of operation had many variants including one in which with adequate emission, a negative resistance could be provided by the tube over a frequency band. As typical of performance we may note the report by Fay and Samuel³ of a valve fitted with a squirrel-cage grid capable of dissipating 150 watts which oscillated at between 450 and 600 Mc/s with an output of eight watts and an efficiency of five per cent at the optimum frequency. It is of particular interest to this Institution to note the report by Ullrich and McPherson⁴ in 1936 of use of the retarding field valve of the form shown in Fig. 1 in a cross-channel communication trial at a wavelength of 17.4 cm. In this valve a spiral grid of expanded length approximately 1.24 times the optimum wavelength, provides coupling to the parallel wire output line. Amplitude modulation at constant frequency was achieved by simultaneous variation of grid and anode potentials, and a radiated power of 0.5 watt was obtained. A similar valve was used in the receiver, operated just below the self-oscillation condition with quenching signal.

During this period investigation was also being carried out on another device, the magnetron, which had been originally studied by Hull⁵ in 1921 as a simple cylindrical vacuum diode having a magnetic field along the filament axis. By use of a sufficiently high magnetic field, the 'critical field', the flow of electrons to the anode may be cut off due to bending of the electron paths.

In 1928 Zacek⁶ showed that oscillations were generated in such a system when the magnetic field is near to the above critical value. The relationship, $\lambda H = \text{constant}$, was found experimentally and in 1929 Okabe⁷ confirmed this and showed that this relationship could be

derived from the assumption that the oscillation period is equal to the time taken for an electron to travel from cathode to anode and back. Thus the periodic motion of the electrons was itself the seat of oscillations, and no external resonant circuit was necessary to determine frequency. It was found that in order to obtain useful output it was necessary to tilt the diode in the magnetic field by a few degrees and this was finally explained in the following way. Due to the use of a small cathode/anode ratio the radial d.c. electric field is very high close to the cathode and comparatively small elsewhere. Consequently electrons move with

magnetic field, by tilting the magnetic field as indicated in Fig. 2(b).

This interaction process, which has been called the 'electronic' regime of the magnetron, resulted in the generation of the shortest wavelengths and the first work on resolution of the molecular resonance in ammonia was carried out at a wavelength of 11.3 mm in 1933 by Cleeton and Williams⁸, by the use of a magnetron oscillator of this type having an anode diameter of only 0.55 mm.

Although this oscillation process has been described in terms of a single circular anode, in 1924 Habann⁹ described a system in which the anode is divided into two sections with a circuit coupled between them (Fig. 2(c)). Since the interaction process is concerned with purely radial fields, electrons interacting within the angular sectors subtended by the segments act independently, so that the two classes of electrons A and B are now emitted simultaneously.

Oscillations of this class give a maximum efficiency of about 15 per cent. and need a magnetic field given by $H = 10,700/\lambda$, where $\lambda =$ wavelength in cm. and voltage near the critical value

$$V_c = \frac{e}{8_m} H^2 a^2$$

where $a =$ anode radius.

By 1939 this arrangement had enabled powers of the order of 3 watts to be obtained at wavelengths in the 10-cm region¹⁰.

Experiments on magnetrons with slotted anodes carried out in many parts of the world showed that oscillations with good efficiency could be obtained with magnetic fields greatly in excess of that necessary just to cut off the electron beam from the anode, and without tilting of the magnetic field, provided that a circuit tuned to the wavelength generated was connected across the slots. The results of the vast amount of data reported were eventually crystallized in a paper by Posthumus¹¹ in 1935 in which the behaviour was described in terms of continuous interaction of electrons with a rotating r.f. field, the regime of oscillation being called the 'travelling wave' regime. Figure 3 shows the basic arrangement, where the anode is split up into an even number of segments, alternate ones being connected to the two ends

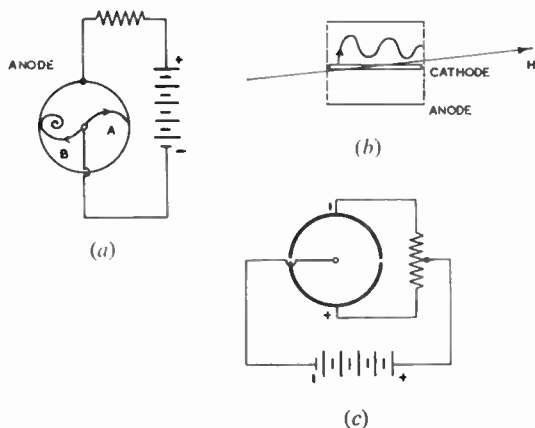

Fig. 2. (a) Electronic oscillations in magnetron. (b) Axial field. (c) Habann's split-anode arrangement.

almost constant velocity once they have left the cathode, with a nearly constant angular velocity eH/m due to the magnetic field. Now in the presence of radial r.f. fields of the oscillating frequency $\omega \cong eH/m$, electrons "A" in Fig. 2(a) travelling to the cathode during a positive half cycle of r.f. voltage are given an increased radius of curvature and strike the anode, having absorbed energy during one half cycle. Electrons "B" leaving during the negative half cycle execute spirals whose radius of curvature successively decreases to zero due to continuous transfer of energy to the electric field. At this point the maximum energy will have been extracted from the circular electron motion and it is necessary for electrons to be removed if they are not to begin to absorb energy. This may be done by imparting a drift along the

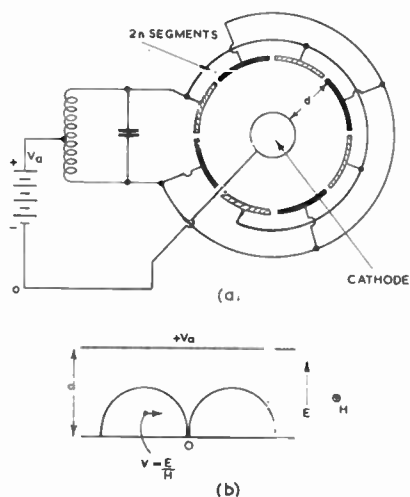

Fig. 3. Travelling-wave magnetron.

of the tuned circuit. When oscillating this system produces a standing wave of potential on the anode, which has two oppositely travelling wave components and oscillations are excited when voltage and magnetic field are such that the mean velocity of the electron beam around the system is equal to the velocity of one of these components. Contrary to the case of the electronic regime of oscillation described earlier, this arrangement operates with a cathode/anode diameter ratio which is not small, at least when the number of slots is not small, so that a radial d.c. electric field exists over the whole of the interaction space. It can be shown very simply that electrons emitted into the planar system of Fig. 3(b) have a translation motion of $v = E/H$ with a superimposed circular motion of angular velocity $\omega_c = eH/m$ and in the circular system this allows adjustment of the mean angular velocity, which is proportional to V_a/Hd to equal that of the travelling wave ω/n ($d = \text{anode-cathode distance}$). This results in

$$\frac{\omega}{n} \propto \frac{a}{Hd}$$

or $\lambda \propto Hd/V_a n$. This relationship had been found experimentally in all the earlier work where this mode was made use of. The superimposed circular motion of angular velocity ω_c has little effect on the velocity matching relationship.

With growing understanding of the behaviour of the magnetron, powers of the order of 30 watts were obtained by 1937¹² at wavelengths near 50 cm with efficiencies in the neighbourhood of 40 per cent, using conventional glass envelope transmitting valve practice. In 1939 Linder¹³ reported the generation of a power of 20 watts at 8 cm wavelength, with an efficiency of 22 per cent, in a special two-segment magnetron with a glass envelope and having an anode length of a quarter-wavelength.

It was at about this stage that the immense activity of the wartime years took the magnetron from being an interesting experimental microwave valve to one of immense practical capabilities and we shall take up this further story later.

During the course of this work studies of the classical triode valve in which the anode current is controlled by the grid had shown that a fundamental difficulty for the highest frequencies was the excess grid control power needed due to electron inertia. In 1935 proposals were made by Arsenjewa Heil and O. Heil¹⁴ for avoiding this limitation and also of avoiding the power dissipation limit of very high frequency circuits. These proposals were of particular importance since for the first time, a new mechanism specially suited for the genera-

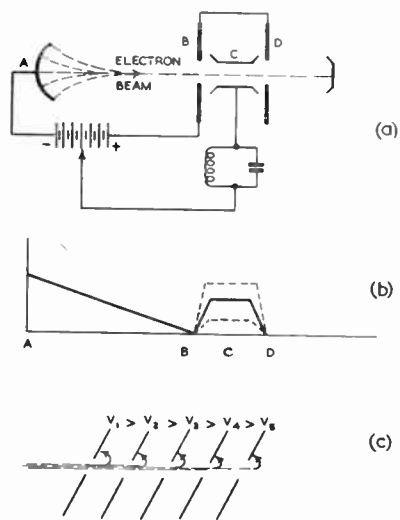

Fig. 4. Heil oscillator. (a) General arrangement. (b) Potential variation along electron beam. (c) Retarded collection.

tion of very high frequencies was suggested which events have proved to have been of great practical significance.

Figure 4 shows the arrangement proposed by the Heils in which an electron beam accelerated by d.c. fields in the space AB and subsequently retarded and accelerated in the spaces BC and CD has additional r.f. fields, due to the resonant circuit, impressed on it both at the gap BC and CD. The effect of the r.f. fields at the first gap is to vary periodically the beam velocity, with resulting variations in time of transit of electrons through the drift electrode C. Fast electrons catch up on slow ones and by adjustment of the potential of electrode C it can be arranged that the resulting "bunches" of electrons cross the gap CD when the r.f. field is opposing them, so that energy is given to the r.f. field and self oscillation is possible. Simple calculations suggested that an electron efficiency of about 35 per cent could be achieved. This method of forming electron bunches is the basis of the whole class of modern devices which include notably the klystron and the travelling wave tube. It was also suggested that since the emerging beam contained considerable kinetic energy this might be removed by passing it through retarding electric fields set up by a number of electrodes, in order to reduce electron velocities to zero. Such an arrangement has been used in modern tubes to increase efficiency.

Now these ideas needed the addition of efficient circuits to make them effective in the generation of the highest radio frequencies. In the invention of the "klystron" by the Varian Brothers¹⁵ reported in 1939, this was achieved by the use of efficient hollow cavity circuits of low loss, and separate input and output circuits enabled an amplifier to be produced. Figure 5 shows the arrangement proposed. Hahn and Metcalf¹⁶ mention that a useful power of 50 watts was obtained with a collector efficiency of 20 to 30 per cent at a frequency of 360 Mc/s using valves of this class. With such an arrangement detection could also be achieved by measurement of collector current.

A final aspect of the application of the velocity modulation principle which was to have far reaching consequences was the description

by Hahn and Metcalf in 1939 of a tube having a bunching gap followed directly by an electron decelerating region. After passing through the gap, in which velocity modulation takes place, the beam enters a region where its direction of motion is reversed with the result that it returns to the bunching gap. Bunches of current are again formed, faster electrons now travelling

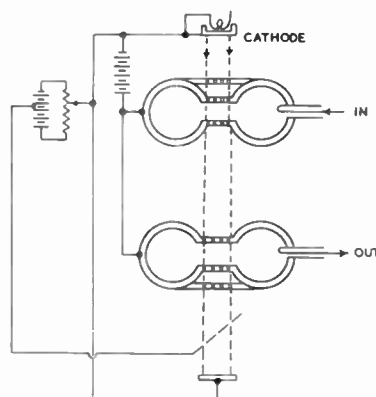

Fig. 5. Varian brothers klystron.

further than slow ones, and energy is injected into the circuit coupled to the gap, which may be sufficient to result in self oscillation. Oscillations were observed down to a wavelength of 14 cm, with a beam current of 1mA, and with a current of 30mA a power of 4 watts was achieved at a wavelength of 50 cm. Such a performance provided a firm basis for development of the reflex klystron when the need for a convenient local oscillator arose at the start of the 1939-45 war.

In this introduction we have attempted to give a summary of the most fruitful lines on which work had proceeded in the 20 years of the pre-war period. No mention has been made of the work on oscillation in diodes by Benham¹⁷ and Llewellyn¹⁸, or on the beam deflection tube by Colebrook¹⁹ and Hollmann and Thoma²⁰ or of numerous other investigations of interest to the generation of the very highest frequencies. Looking back, and bearing in mind all the problems of developing an entirely new physical and engineering technique we can but marvel that so much progress was made in these early years, both in achievement and understanding, with such limited facilities.

2. Principles of Operation of Modern Valves

The magnetron and klystron use quite different mechanisms of transfer of energy from d.c. power source to a.c. output as already briefly described, and as it turns out, most devices of significance today use one or other of these two interaction processes. They have been called the "O" type and "M" or crossed-field type and we shall now discuss these more generally.

3. "O" Type Interaction

3.1. *The Klystron*

The kinetic energy of an electron beam is used as the source for the radio frequency power. The beam is accelerated by the d.c. supply, bunches are formed by the velocity modulation-and-drift process and these are passed through a second gap connected across a circuit resonant at the input frequency. As the first bunch passes through, it induces a current in the cavity which causes a field to oppose its passage, as would be expected from Lenz's Law. The cavity will thus start to oscillate, and succeeding electron bunches will aid this process, so that the amplitude of the oscillation builds up to a steady state, in which the kinetic energy lost by an electron bunch in passing through the cavity is just equal to that dissipated in the cavity together with that delivered to the external load.

From this picture, the characteristics of the two-cavity klystron emerge. To get adequate r.f. field for interaction with the beam, the Q 's of the cavities must be high, and the output cavity must not be too heavily loaded. A narrow bandwidth is therefore to be expected. If we attempt to increase the bandwidth by staggering the cavity frequencies at least one cavity is not now excited at its resonant frequency, and we find that due to the decreased efficiency of interaction, the gain is decreased. A quantitative study²¹ shows that there is a gain-bandwidth product limitation. This product may be increased however by the introduction of further cavities, suitably spaced, between the input and output cavities²². If, for example, an unloaded cavity tuned to an intermediate frequency is introduced between the input and output cavities, this cavity resonates

at a large amplitude and may be arranged to modify the beam bunching, so that more efficient interaction occurs in the output cavity. This principle can be extended and four, five and six-cavity klystron amplifiers have been made²³.

One enormous practical advantage of this arrangement which should be noted is that the coupling between input circuit and output circuit is very low due to the isolation provided by the drift tubes between cavities. Therefore high gain may be obtained with stability, providing care is taken to minimize external coupling.

In order to obtain efficient energy transfer from klystron cavity to beam and vice versa, the transit time of the beam through a cavity should be appreciably less than half the period of the r.f. signal with the result that fairly high beam voltages are necessary. The size of the gap across which the interaction fields are produced will also be affected by the power level at which it is desired to operate, since if these fields become too high, field emission from the edges of the gap will occur, causing loss of energy. The beam voltage must therefore increase with increasing power, a requirement that also arises in the design of the electron gun. This process can continue until voltage breakdown outside the valve sets a limit, and klystrons producing r.f. powers of 30MW at 3,000 Mc/s and operating at 370kV with a beam current of 190A are in use²⁴.

3.2. *Waves in Beams*

Study of the conditions in the electron beam when it has passed through a modulating gap were carried out by Hahn²⁵ and Ramo²⁶ in 1939, and led to the realization that r.f. waves could propagate along an electron beam without any other structures being present. These waves, the fast and slow space-charge waves, consist of electron velocity and electron density variations propagating along the beam in much the same way as voltage and current variations propagate along a transmission line. In the fast wave, which travels somewhat faster than the beam, the velocity and density fluctuations are in phase as shown in Fig. 6, i.e. there are more electrons where the electron velocity is higher than the d.c. velocity. This means that

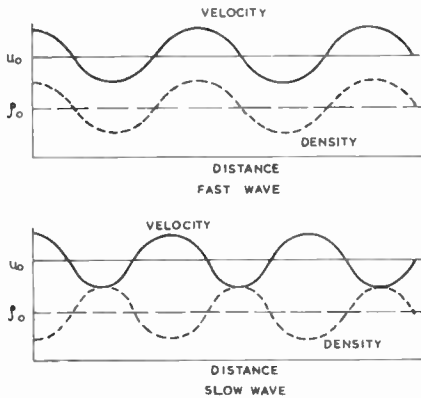

Fig. 6. Space-charge waves.

the mean beam energy is increased above the d.c. value and hence such a wave can only be set up by feeding the r.f. energy on to the beam. In the slow space-charge wave, which travels slower than the beam, the velocity and density fluctuations are out of phase, and there are more electrons at points where the velocity is below the d.c. velocity. The mean beam energy is less than the d.c. value and such a wave can be set up on a beam by taking r.f. energy from it.

The velocities of these waves are related to the beam velocity through the plasma frequency, their propagation contents being given by

$$\beta_s = \beta_c + \beta_p$$

and

$$\beta_f = \beta_c - \beta_p$$

where

$$\beta_c = \frac{\omega}{u_0} \quad u_0 = \text{mean electron velocity}$$

$$\beta_p = \frac{\omega_p}{u_0} \quad \omega_p = \text{plasma angular frequency}$$

In a klystron cavity producing only velocity modulation, both fast and slow space-charge waves are set up with equal amplitude, and interference between these two waves produces a maximum of density modulation or bunching some distance along the beam.

3.3. The Travelling-Wave Tube

A device in which the above ideas are of significance is the travelling-wave tube, invented independently by R. Kompfner²⁷, working at

Birmingham during the last war, and by J. R. Pierce at the Bell Telephone Laboratories²⁸. Here also the kinetic energy of an electron beam is used as the source of energy for amplification, but we now meet for the first time in an amplifier, the ideas of continuous interaction between an electron beam and an r.f. wave travelling with the same velocity. Although a new concept in amplifiers, this approach was used, as mentioned earlier, by K. Posthumus¹¹ as early as 1935 in accounting for the behaviour of multi-gap magnetrons.

To see how the travelling-wave tube works, consider the r.f. fields within a helix. An r.f. wave propagates along a helix very much as if it were guided along the wire of the helix at the velocity of light, consequently if the helix pitch angle is ψ , the axial velocity of an r.f. wave propagating along it is very nearly $c \sin \psi$

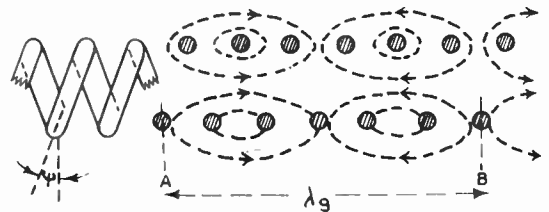

Fig. 7. R.f. electric fields with helix.

where c is the velocity of light. The r.f. wave is thus slowed down to a velocity which can easily be reached by an accelerated electron beam. The significant r.f. fields within the helix have the form shown in Fig. 7 where the wavelength is $\lambda_0 \sin \psi$. It should be noted that in an actual valve the structure is very many wavelengths long.

Suppose that an electron beam is injected along the axis of the helix, at exactly the same velocity as that of the wave, and the electrons and the wave flow along the tube together. Under these conditions the electrons are acted upon by the same r.f. fields over a period of very many r.f. cycles. Consider what happens to the section of beam that enters during one complete r.f. cycle, as in the region AB in Fig. 7. The electrons in the early half of this section experience a continuous retarding force as they pass through the tube and will therefore fall

back towards the mid-point of the wavelength where the retarding field is zero.

In doing so, they lose kinetic energy, which passes to the field which is decelerating them. Similarly the electrons in the later second half of the section are accelerated, and take energy from the field. Eventually all electrons bunch around the mid-point with no nett interchange of energy, and this will be true for all other sections of the electron beam.

Suppose now that the electron beam is injected rather faster than the speed of the wave. The electrons will be acted on by the r.f. fields in the same way, but now the early electrons have to give up more energy to move back to the bunching point whilst the later ones need to absorb less energy to reach the same point; the energy difference is passed to the r.f. field propagating along the tube, which therefore grows. As this field increases, it is able to exert more influence on the beam, and hence the growth is an exponential one. We note that the wave goes more slowly than the beam, and its amplitude increases as the beam decreases. These are the characteristics of the *slow space-charge wave*, and such amplifiers are often called *slow-wave amplifiers*. The interaction can be regarded as taking place between the slow space-charge wave and the circuit wave, and the resultant growing wave, which propagates on both the beam and the circuit, has predominantly the characteristics of the slow space-charge wave.

The gain of the travelling-wave tube is in theory limited only by the signal levels involved. No signal input below the beam noise level can have any significance, hence a minimum input level is fixed. The maximum efficiency obtainable is of the order of 20 per cent, hence for a given beam power, a maximum output level results and it appears possible to make tubes with sufficient gain to span these levels. In practice, however, much lower gains are made use of and a value of 50 db is still regarded as exceptionally high.

The bandwidth of the tube is very large. The helix has an almost constant velocity of propagation independent of frequency, and provided the beam diameter is suitably chosen, very wide frequency ranges, e.g. of 10 : 1, can be achieved.

The upper frequency limitation comes from the fact that at higher frequencies, the r.f. fields concentrate more closely to the helix, and hence decrease towards its axis where the beam is, while at the lower frequency end, the tube length measured in wavelengths, becomes too short to maintain the gain. In practice, other limitations arise, notably in coupling to feeders.

Clearly, in dealing with very broad-band amplifiers, with high gain, the question of stability arises, and particularly so in travelling-wave amplifiers since in contrast to the klystron the slow-wave guiding structure always provides a direct connection between the output and input. At some frequencies within the electronic r.f. bandwidth, there will certainly be reflections at the output coupler or beyond it which, after propagating back along the helix without interaction with the beam, arrive at the input to the tube with amplitudes greater than the input signal. Under suitable phase conditions, not difficult to satisfy in a structure many wavelengths long, the tube will oscillate. This trouble is overcome by having an attenuating region in the slow-wave structure, whose attenuation is considerably greater than the overall gain of the tube. A tube to give 30 db gain, for instance, might have total electronic gain of 65 db, and an attenuator of 35 db which would give a stable combination. In practice this situation is helped by the fact that the power of the forward growing wave is carried partially on the beam, hence this wave is attenuated by something less than the cold circuit attenuation. In high power tubes the circuit is frequently completely interrupted and connected to an external matched load, since the power levels involved are too high to be conveniently dissipated within the tube.

Detailed analysis by Sensiper²⁹ of the r.f. fields set up by the helix showed that limitation of maximum power arises through interaction of the beam with so-called space-harmonic fields, discussed later, and that for broad-band helix tubes there would be an upper limit of operating voltage at about 10kV.

To increase the power beyond this limit other r.f. structures than the helix must be used. The most successful of these have been the cross-wound helix³⁰, in which the fields due to the

fundamental of each helix add, while those of the backward wave space-harmonic cancel (see Section 3.6), the ring and bar circuit³¹ which is a development of the cross-wound helix, and the loaded waveguide circuits developed by Chodorow³² and Nalos³³. With these, powers of more than 1 MW (pulsed) at S-band and 20kW at X-band have been achieved, but only over the relatively narrow bandwidths of about 10 per cent.

3.4. Focusing of "O" Type Systems

In order to ensure that the electron beam of a travelling-wave tube travels along the helix axis to the collector without being dissipated on the helix, some method of beam focusing is necessary. This requirement of focusing is one that applies to all "O" type devices, klystrons, travelling-wave tubes, and backward wave amplifiers and oscillators yet to be mentioned. In early tubes the focusing was nearly always effected by a uniform magnetic field produced by a solenoid and for high-power high frequency tubes this is still the same.

At lower levels and frequencies, the use of periodic fields produced by permanent magnets is however developing^{34, 35}. The advantage of this type of magnetic focusing is that the leakage fields produced by it are very small compared with those of a uniform permanent magnet having a similar field strength along its axis with the result that the size is much less.

Various systems of electrostatic focusing have also been proposed^{36, 37} and during the past year or two, tubes have started to appear using this. As with magnetic focusing, the focusing action may be a uniform one, e.g. as in the "Spiratron," described by Tchernov³⁸, or a periodic one, as in the "Estiatron Amplifier"³⁹, or the "Ophitron" oscillator, referred to later. An attraction of electrostatic focusing is that the d.c. fields which are always in some places at right angles to the direction of electron motion continuously remove residual gaseous ions from the beam while the tube is operating. The presence of these ions causes unwanted modulation on the signal at quite high levels, and their removal during manufacture, which would otherwise be necessary, is a painstaking and expensive procedure.

3.5. Noise Performance

A quantity frequently of great interest in amplifiers is the noise factor. In the beam type of amplifier, the electron beam is randomly emitted from the surface of a cathode at about 1,100°K with the result that the beam density and velocity both contain fluctuations which can result in noise figures of about 30 db in "O" type devices.

In a slow space-charge wave amplifier the noise cannot be removed from the electron beam by filtering, since the signal on the beam represents a deficit of energy as already described. It could be removed only by feeding correlated noise energy on to the beam, which is impossible. It is for this reason that there has recently been an increasing interest in amplifiers which do not use the slow space-charge wave interaction and amplifiers of this type are discussed later. It has however been shown by Watkins⁴⁰ that if the velocity of the beam in the electron gun is suddenly changed in a pre-determined way, the noise figures of the amplifier can be considerably reduced. In a velocity change of this kind, called a velocity jump, the impedance of the beam, defined as the ratio of changes of velocity and charge density is modified and, as in a transmission line, this modifies the amplitude of waves propagating along it. The two sources of beam noise produce two sets of uncorrelated space-charge waves, starting at the cathode, where the r.f. impedance conditions are infinite for the velocity modulation and zero for the current modulation. Peter⁴¹ showed that to produce the least noise in the amplifier, there is an optimum value of r.f. impedance for such a beam at the point where it enters the circuit, and the three-region gun which he designed to produce this has been used generally and achieves a noise figure as low as 5 db.

More recently Currie⁴² has shown how noise may be further reduced by allowing the electron stream to drift for a relatively long period at a very low voltage, comparable with the noise voltage present, resulting in some correlation between the noise sources. Recent calculations by Siegman *et al*⁴³ indicate that noise figures of 1.5 db may be obtained in this way and in practice figures of 2 db at 3,000 Mc/s have been observed.

In all work on low noise amplifiers, achievement has overtaken prediction so frequently that only one limit (0 db) can now be confidently considered.

3.6. Backward Wave Interaction

Nearly all microwave slow wave structures are periodic, and it is from their periodic nature that the space harmonics referred to above arise. Their existence was first pointed out by Hartree⁴⁴ in the case of the multiple cavity magnetron. Mathematically they are the Fourier components of the propagating wave, but it is perhaps easier to see how they affect interaction by considering the interaction between an electron and a wave travelling along a periodic structure (Fig. 8). When the electron is opposite a gap in the structure it will experience a force due to the r.f. field. The electron will drift to the next gap at the same velocity as the wave, and hence interact with the same field. It is then said to be interacting with the fundamental component. If however the wave is going much faster than the electron it is possible for the field to reverse $2n$ times while the electron is shielded from it by the conducting member of the circuit, and on arrival at the next gap the field is still in a phase favourable for interaction. The electron is then said to be interacting with the n th forward space-harmonic and the time taken for the electron to move through one pitch of the structure is

$$\frac{p}{u} = \frac{p}{v} + \frac{2\pi n}{\omega}$$

where p = structure pitch
 u = electron velocity
 v = wave velocity

hence

$$\beta_n = \beta_0 + \frac{2\pi n}{p}$$

The same interaction process takes place when beam and wave are travelling in the opposite directions, where the electron interacts with a backward travelling space-harmonic. Since the electron now interacts with a field which will subsequently affect electrons further back along the beam, a feed-back mechanism is introduced, and if the total interaction, deter-

mined by the product of efficiency of interaction and the distance over which it takes place, is sufficiently great, self-oscillation will occur, and the device will be a backward wave oscillator. This form of oscillation was first described by Epsztein⁴⁵ in 1950.

This is an extremely convenient form of oscillator, since the frequency at which oscillation occurs is determined by a voltage: the frequency sets itself to that value for which velocities of the beam and the interacting wave component of the circuit are equal. The oscillation is always excited in the first place by the

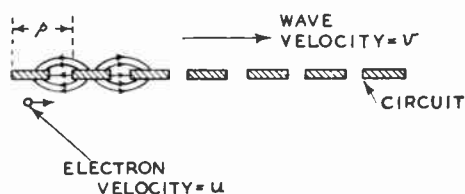

Fig. 8. Space-harmonic interaction.

microwave noise present in the beam and the spectrum obtained improves in quality as the current is increased beyond the starting current. A matched termination is required at the beam collector end of the line to absorb power reflected by the output load, and any reflection of power by this causes periodic variation of power and frequency slope as the voltage is swept. Tunable low-power oscillators of this sort have been made for use between wavelengths of about 60 cm to 1.5 mm, the limits being set by the size and makeability of the structure. The structure most frequently used is the interdigital line⁴⁶; but a helix can also be used⁴⁷, while at higher frequencies periodically-loaded waveguide structures are more frequently employed, since their size is larger for a given frequency.

This interaction process is also used in the backward wave amplifier. This is a voltage tunable amplifier, the circuit of a backward wave valve being provided with an input coupling at the beam collector as well as the normal output coupling at the gun. As the current is increased towards the region of the start of oscillation current, signal gain is

observed over a narrow frequency range, centred on the frequency at which oscillation would occur if the current were sufficiently high. To obtain a useful gain, it is necessary to operate quite close to the start of oscillation current, e.g. at above 0.9 of this current. As the valve is tuned over its range, the start of oscillation current varies considerably, hence if a constant gain bandwidth is desired, it is neces-

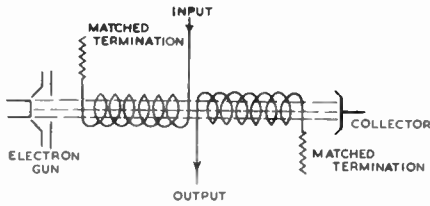

Fig. 9. Cascade backward-wave amplifier.

sary to vary the current as the line voltage is changed. The gain-bandwidth product has been improved by Currie and Forster⁴⁸, using two circuits to give a cascade backward wave amplifier. In this arrangement, shown in Fig. 9, the input circuit is first traversed by the beam, the signal on the circuit moving in the direction opposed to the beam. The beam then passes through a second similar circuit, and produces further gain. With this arrangement the current can be reduced to about 0.8 of the start-oscillation current, and hence the operation is less critical. Cascade backward wave amplifiers with 20 db gain and 8 Mc/s bandwidth at 3,000 Mc/s have been made by Currie in the United States with best noise figures of 2 db.

Fundamental limitations to the efficiency in "O" type devices arise from the high space charge density required in electron bunches, causing bunches to break up due to electron repulsion and, in travelling wave systems, from the slowing down of the beam and consequent inability to keep wave and beam sufficiently in step. These limits do not occur in crossed-field valves, which are next considered, since in these the r.f. energy is not obtained from the electron kinetic energy, and the electrons are displaced during bunching so that increase of space charge density is not a primary requirement.

4. "M" Type (Crossed Field) Interaction

4.1. General Characteristics of Linear Injection System

Crossed field interaction has been used in magnetrons of various sorts for many years, as has been described in the opening section. The cylindrical magnetron oscillator, however, is the most complicated and analytically intractable example of this type of interaction. To make an easier approach, let us consider instead a linear injection crossed-field amplifier. By this is meant an amplifier having a straight slow-wave guiding structure, and a strip beam injected at one end parallel to the slow-wave structure as in Fig. 10(a). Over the region of interaction, in addition to the r.f. field there are also a transverse static electric field E and a static magnetic field H both at right angles to the direction of the average beam velocity and to each other, the electric field being in the direction of the transverse electric r.f. field.

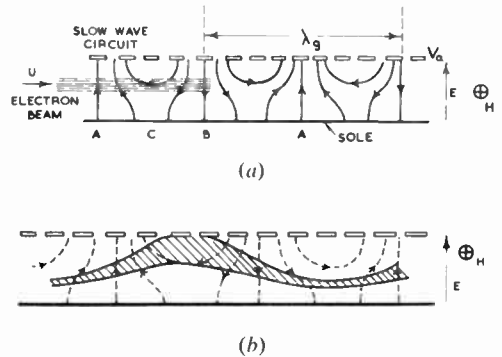

Fig. 10. (a) Crossed field interaction. (b) Electron beam displacement in crossed fields.

In such a system, neglecting for the moment any effects produced by the r.f. fields, an electron has an average velocity equal to E/H and also executes a circular motion, the radius of which depends on the injection velocity. It is zero if this is E/H which is the condition for transverse electric and magnetic forces to balance.

Let us now add the r.f. field produced by a wave propagating along the structure at a velocity equal to the average beam velocity E/H . This has two components of electric field, one axial, parallel to the direction of the beam,

and the other transverse, parallel to the direction of the static electric field. Where the latter adds to the static field, as at A, Fig. 10(a), the electron velocity is increased, and similarly where it subtracts, as at B, the electron velocity is reduced. Between these points, there are positions where it is zero and only axial components exist as at C, and these velocity changes will result in electron bunches being formed around these positions. These are at the same time the regions where the axial component of the r.f. field is in opposition to the axial motion of the beam and its effect is to produce a net transverse displacement of the electrons towards the r.f. structure at a velocity $=F_{axial}/H$. The electrons consequently descend a d.c. potential gradient, but maintain a nearly constant velocity since the contribution to this by the transverse motion is small. The work done on them by the d.c. field is passed directly to the r.f. field. The role of the electrons is to provide a movable barrier on which d.c. and r.f. fields push in opposition so that interaction can take place between them. Of course those electrons entering the interaction space when the axial field is accelerating are directed away from the delay line and some will finally reach the base electrode or "sole" before they can be focused into the position for favourable interaction. The deformation of the beam due to the r.f. is shown in Fig. 10(b).

As the electrons are continuously displaced towards the r.f. circuit, the axial bunching does not cause any large increase in space-charge density. Ultimately, a large proportion of the beam is collected on the circuit, which must therefore be made substantial enough to be able to dissipate the heat which is generated.

From this very qualitative description it is not difficult to see that the efficiency is a function simply of the ratio of the velocity $v = E/H$ to the velocity v_a which electrons would have on arriving at the anode if the magnetic field were to be removed. This is given by the expression

$$\frac{1}{2} mv_a^2 = eV_a.$$

The efficiency is therefore

$$\eta = 1 - \frac{\frac{1}{2} mv^2}{\frac{1}{2} mv_a^2}$$

and this can be increased for given values of V_a by decreasing v . This involves increasing H ,

and moving the injection point nearer to the lower potential "sole." A limit is set by interference with the bunching process, mainly due to space charge forces.

In practice it is often more convenient to arrange the beam and circuit into a circular arc, thereby reducing the size of magnet required.

As with "O"-type valves, interaction with forward or backward wave components is possible, and amplifiers and voltage tuned oscillators have been produced.

4.2. Space-charge Amplification Effect

One problem in crossed field systems is the existence of a strong space-charge amplification effect which results in very high noise power

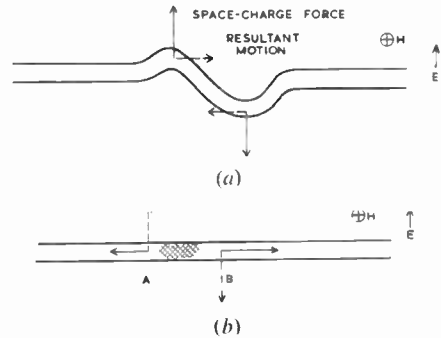

Fig. 11. Space-charge amplification in crossed fields. (a) Effect of small displacement. (b) Effect of density increase.

output, and low gain in amplifiers, if other r.f. fields are not present to give order to the beam. This is the so-called Diocotron effect which has been investigated in recent years by Epzstein⁴⁹, Webster⁵⁰, Mourier⁵¹ and others. This process is particularly important in the electron gun region, but by paying particular care, it is now possible to reduce the effect so that stable gains of about 20 db are available in crossed field amplifiers.

The process may be explained by considering the space-charge forces in a linear beam which is disturbed. In Fig. 11(a) a thin linear beam in a crossed field system is assumed to suffer a small transverse perturbation due to noise. The forces on the beam electrons, shown by the full arrows, produce under the crossed field action

the resultant movements shown by the dotted arrows. This produces an increase in charge density between A and B. Consider on the other hand the result of a local increase of space-charge density. This produces space-charge forces as shown by the full arrows in Fig. 11(b) and the resultant motion increases the initial perturbation, which therefore continues to grow.

4.3. General Field of Use of Linear Injection System

The interaction system described has been used particularly for high power backward wave oscillators, and also for high power pulsed amplifiers. Its high efficiency is particularly important here and the modest gain so far achievable is easily made up by lower power driver stages. In the backward wave oscillator full use is not however made of the possible interaction space between beam and circuit since the beam is continuously removed from the interaction region during its passage through it, and the current available for interaction at the end remote from the gun is small. In principle this difficulty could be reduced by arranging for continual emission of electrons along the length of the lower potential electrode to supply electrons as fast as they are removed from the circuit, but although this arrangement has been tried out it has not so far been successful. However in a modified form in which the cathode is made continuous and the interaction space is bent to the form of a circle and joined end to end at the output point, it becomes a magnetron.

4.4. The Magnetron

In the magnetron, strong circuit and beam feedback occur. Operation is now no longer possible over the whole bandwidth of the slow wave circuit but only at the discrete frequencies for which the electrical path length around the circuit is a whole number of circuit wavelengths. These are the resonant modes of the circuit system. In a practical magnetron the slow wave circuit may be made up of "N" equal elements of resonator form each of which produces a phase change varying from 0 to π radians over a certain frequency band. Excluding the electrical length of zero, the total phase change around the circuit varies from 2π to $2\pi N/2$

over a smaller frequency band, and there are thus $N/2$ frequencies at which oscillation is possible. For a number of reasons valves are usually designed for operation with a circuit phase change of π per element.

The interaction process involved is precisely the same as that described for the linear injection system and the resultant form of the beam is indicated in Fig. 12 where there is an inner core of circulating electrons, some of which are moving out to the delay line under the action of the retarding fields whilst others are moving back towards the cathode under the action of accelerating fields. Around this core are spokes

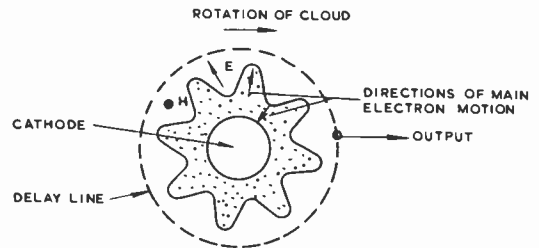

Fig. 12. Electron cloud in magnetron.

of charge equal in number to the number of circuit wavelengths round the system and formed by the electrons which are moving out and which drive the r.f. wave generated in the circuit. Operation takes place at voltage and magnetic field such that to a first order, the mean electron velocity is equal to the ratio E/H as in the linear case. Complications can arise both in design and operation, when due to the particular phase/frequency relation of the circuits the conditions for excitation of one or more of the other possible resonant frequencies of the system are also satisfied for either fundamental or harmonic waves, and many of the difficulties of designing and operating magnetrons have arisen from this cause.

For efficient operation of a magnetron, voltage and magnetic field must be such that in the absence of oscillations very little current is drawn to the anode. Once the voltage for oscillation is reached, the anode current increases very rapidly with increase of r.f. voltage, and the anode voltage hardly changes, resulting in the

familiar low differential impedance of the magnetron. Increase of efficiency may be obtained by increasing magnetic field since with given circuit wave velocity the ratio between kinetic energy of electrons arriving at the anode and the potential energy of such electrons is thereby reduced as already described for the linear injection system. A limit arises due to the resulting displacement of the electron cloud inwards towards the cathode and out of the r.f. field.

The cathode in a magnetron functions under rather different conditions from those of other valves. Electrons emitted from its surface at unfavourable r.f. phases are rapidly accelerated by the r.f. field and return to the cathode with significant velocities. The back-bombardment power which the cathode receives in this way is a few per cent of the total input power, and the difficulty of providing adequate dissipation for this constitutes the limit to the maximum power obtainable from high-power magnetrons. On the other hand most of the electrons used may be produced by secondary emission, and emission densities of 20 A/cm² are commonly encountered in S-band magnetrons, so that it is unusual for this parameter to limit maximum power.

4.5. *The Amplitron*

A more recent development of a valve of the crossed field family retains a re-entrant electron beam, as in a magnetron, but interrupts the continuity of the circuit, and has an input and an output coupling. This arrangement has been particularly studied in the U.S.A. as the "Amplitron"⁵². A similar arrangement for a backward wave oscillator, called the "Carmatron"⁵³ has been studied in France. The interaction must now take place progressively in the direction from the input to the output circuit, hence the direction of the magnetic field is now specified.

Some of the characteristics of the amplitron might be guessed at from the foregoing. It has a small insertion loss over the pass-band of the r.f. circuit when no anode voltage is applied. When correct anode power is applied, but without an adequate r.f. input it produces very large noise-like outputs within the circuit pass band, caused by space charge amplification of noise within the circulating electron beam. When an

adequate r.f. signal is supplied, the r.f. fields capture the electrons as in a magnetron, and the device behaves as a locked oscillator. It can then deliver output powers up to about 10 db above the input level. As the frequency is varied, the efficiency also varies, showing a peak when the electron bunches arrive back in the right phase at the input coupling. It has a high output efficiency and hence is useful as a high-power low-gain output valve. It can also be used as a very stable oscillator, when it is called a "stabilitron," by placing a large mismatch produced by a resonant cavity across the output circuit. The anode circuit now has a large standing wave along it, as has a magnetron circuit, and hence oscillations at this frequency build up and eclipse those of other frequencies. The oscillation frequency can be controlled by tuning only the external cavity, a facility which gives a considerable advantage over a magnetron, in which reasonable tuning range can be achieved only with considerable complexity in design.

In the carmatron, backward wave oscillations only are produced, and in distinction to the stabilitron these can be voltage tuned over a moderate range, about 10 per cent. The delay line is in this case matched at one end and the r.f. voltage increases round the system with a maximum at the output circuit. The main basic advantage over the linear beam crossed field backward wave oscillator is in the use of the cathode emitting from the whole of its circumference.

5. Beams and Circuits

Foregoing sections have assumed the formation of appropriate electron beams, and the availability of suitable slow-wave circuits. We will now examine briefly one or two of the main arrangements used for each of these important parts of microwave valves.

5.1. "O" Type Beams

In many cases, particularly at the shorter wavelengths, limits of safe emission current densities result in the need for a cathode much larger in area than the beam. Consequently converging beam systems are used and the Fig. 13(a) shows the so-called Pierce gun from which

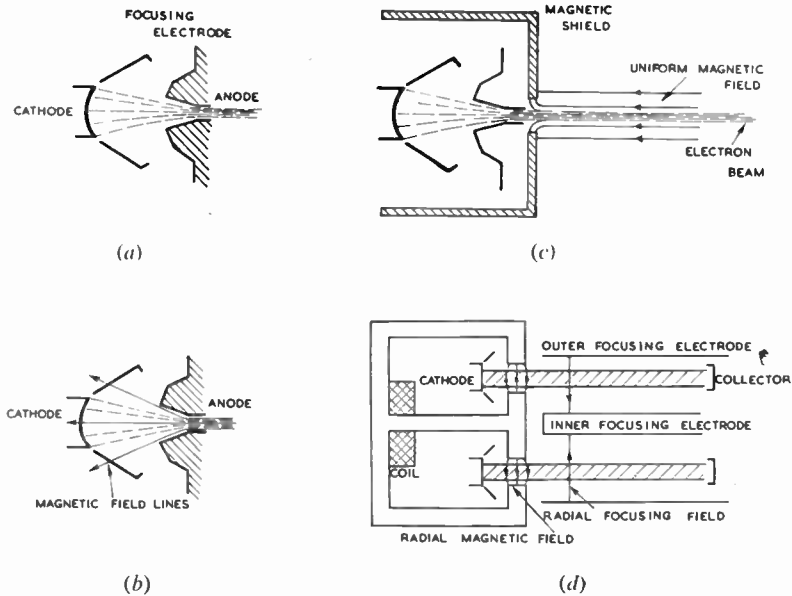

Fig. 13. Electron guns for "O" type valves
 (a) Pierce gun. (b) "Confined flow" Pierce gun. (c) "Brillouin" flow. (d) "Harris" flow.

most "O" type guns are derived. In this a solid cone of electron flow is obtained by using only part of the space-charge flow between concentric spheres and replacing the effects of the missing parts of electrodes and space charge by those of suitably shaped electrodes.

In order to keep the generated small section beam flowing in a straight line a magnetic field is used with lines of force always parallel to electron flow as in Fig. 13(b). To reduce the magnetic field to a minimum, it may be arranged to fall rapidly to zero before reaching the anode, as in Fig. 13(c) the resulting radial field imparting rotation to the beam at this point. A balance is thereafter set up between the forces on individual electrons due to circular motion, space charge, and rotation in the magnetic field, and the beam may be maintained focused with minimum magnetic field called the Brillouin field.

Developing this, the force due to rotation in the magnetic field may be replaced over the straight part of the beam by a radial electric force, giving the Harris flow system of Fig. 13(d) which is of particular interest for systems using annular beams.

5.2. "M" Type Guns

In crossed field systems only two kinds of electron injection systems have found general use.

In magnetrons and other continuous cathode arrangements, electrons are emitted all round the cathode under the combined action of the d.c. electric and magnetic fields, and thereafter follow paths determined mainly by the action of the r.f. fields, as already described.

In devices using an injected electron beam, electrons leave a flat cathode lying parallel to the magnetic field and start to describe a cycloidal motion. By doubling the electric field at the maximum extension of this motion the beam can be arranged to continue in a straight line parallel to the electrodes which define the limits of the interaction space, as shown in Fig. 14(a). As yet no design procedure has been arrived at for determination of the effect of space charge. Such a system may be extended in use by wrapping it around the arc of a circle in the direction of beam propagation, or by using a circular magnetic field, with cathode, gun and line electrodes lying along the lines of force as shown in Fig. 14(b).

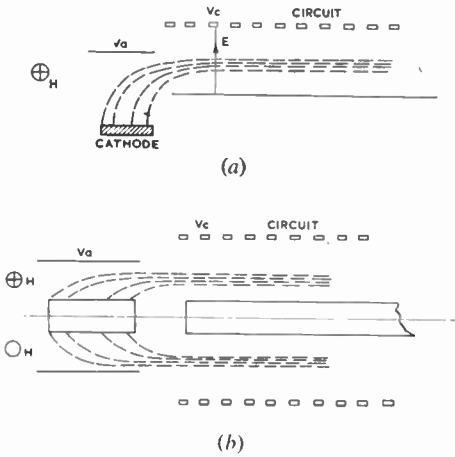

Fig. 14. Crossed-field guns
(a) Strip beam. (b) Annular beam.

In "M" type systems the forces necessary to keep the beam focused after initial formation are generally available from the effects of the d.c. electric and magnetic fields required for the basic interaction process.

5.3. Slow Wave Circuits

Many of the interaction processes used in microwave valves which have been described so far depend on the continuous energy interaction between a beam and circuit wave travelling at the same velocity, which may vary from less than a twentieth of that of light to more than one half. The circuits used all employ metal elements, usually a few per wavelength and since the tangential electric field is at all times zero over the surface of these elements, a single pure wave cannot be produced as already noted, and an infinite family is generated.

The simplest type of circuit capable of producing a wave of this velocity is the wire or strip helix. This allows slow waves to be produced with constant velocity over a wide frequency band, but it is thermally less robust than other systems. (Fig. 15(a)).

A variant of this is the interdigital line in which a wave travels along a slot in a flat plate of the form in Fig. 15(b). In this case, since the electric field reverses sign on passing each successive gap, the fundamental component of the

total field distribution travels in the opposite direction to energy flow, i.e. it is a backward wave.

Other forms of slow wave circuits may be looked on as derived from the earliest slow wave circuit commonly used, the coupled resonator system of the magnetron. At the usual working mode of the magnetron, with currents in adjacent cavities in opposite phase, the effective velocity with which a wave is transmitted round the system is simply $c \cdot 2p/\lambda$, where p is the circuit pitch measured at the anode, but this varies rapidly as the frequency is changed from the resonant value. However by increasing coupling between cavities, for example by using straps, this variation of velocity may be reduced, and a system of tightly coupled resonators gives a slow wave circuit particularly suited for operation with very high powers. (Fig. 15(c)).

Such a structure is shown in Fig. 16(a) where the resonators are the TM_{010} cavities between transverse discs and tight electric coupling is obtained by a large common centre coupling hole. Magnetic coupling may be obtained also by the use of slots at the point "x" resulting in different dispersion characteristics. The system shown in Fig. 16(b) can be thought of as derived from this, the resonators being formed from a

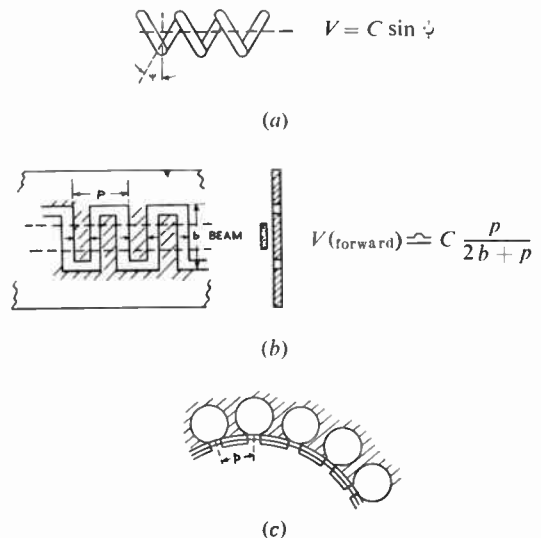

Fig. 15. (a) Helix. (b) Interdigital line. (c) Magnetron circuit showing double ring straps which are connected to alternate segments.

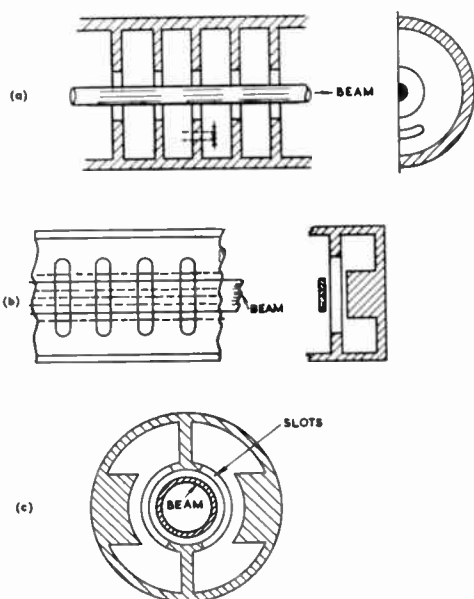

Fig. 16. Slow-wave circuits.

number of closed slots in a metal plate which by themselves would resonate in the half-wave mode along their lengths. They are coupled capacitively by a ridge projecting from one side of the surrounding enclosure, the amount of coupling and therefore the bandwidth being governed by the clearance between the edges of the slots and the ridge. With such a structure interaction may be obtained with a flat beam such as used in a crossed field system, with a velocity constant over at least 30 per cent frequency band.

These arrangements and many others may be extended in various ways to meet beam geometry and other practical requirements. By bending the last structure into a semi-circular form, and adding a similar one, a system suitable for an annular beam and using "O" type interaction may be derived as shown in Fig. 16(c).

6. Other Interaction Mechanisms

The interaction mechanisms described in the two preceding sections have made use of a beam suitably focused and travelling near to a circuit supporting an electromagnetic wave of velocity close to the beam velocity. For very short wave-

lengths of the order of a few millimetres there has been considerable interest in avoiding such an arrangement due to the small dimensions involved in the circuit.

A number of systems involving alternative mechanisms have been described, analysed, and even investigated experimentally involving for example, the interaction of beams with fast electromagnetic circuit waves, or with waves carried by other beams, but since these have not so far resulted in practical devices, they will not be discussed further here.

However, all mechanisms described so far have the property of transferring d.c. energy to r.f. energy through the agency of the motion of free electrons. Recently, efforts have been directed towards the use of r.f. energy as an alternative source and we shall now turn our attention to arrangements making use of this principle.

7. Variable Reactance Amplifiers

In the variable reactance amplifier energy is generated by variation of the reactance of a circuit element. This reactance may take a number of forms; the capacitance of a suitable solid-state diode⁵⁴, the effective self or mutual inductance of a ferrimagnetic material, or the reactance of an electron beam. In all these arrangements the primary source of energy is a high-frequency power source whose function is that of varying this reactance. Rapid progress has been made in this form of amplifier due particularly to very striking advances in the technique of preparing suitable diode variable capacitances, and this has led in turn to a stimulus to research on devices using the other forms of variable reactance.

The simplest way to grasp the basic principles involved is to consider an oscillating lumped resonant circuit as shown in Fig. 17(a), from which the usual energy source has been removed and in which the spacing of the capacitor plates is increased every time the oscillating voltage has a maximum, whatever the sign, and reduced to normal when the voltage is zero. The mechanical work involved in separating the plates, at the time when they carry maximum charge, is directly transferred to electrical energy and appears as a voltage increase. Instead of

decaying due to the resistive damping, the energy in the circuit may consequently be maintained constant or increased or decreased with time according to the displacement of plates used, or the variation of capacitance. The step function change of capacitance at double the oscillation frequency may be replaced by a sinusoidal one, and may be achieved through an electrically variable capacitance thus giving an elementary form of variable reactance oscillator or amplifier whose energy is supplied by a source of double the circuit frequency, called the "pump" frequency, suitably phased to the fundamental oscillations. (Fig. 17(b)).

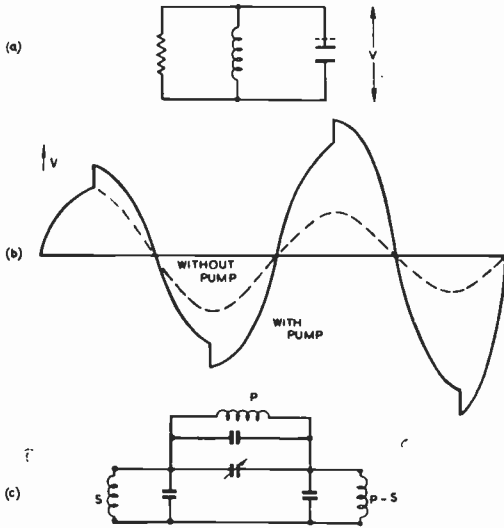

Fig. 17. Lumped-circuit parametric amplifier model.

Simple analysis shows that the power injected into the system from the pump frequency source appears as an effective negative resistance in parallel with the damping resistance. If this negative resistance is greater than the damping resistance, amplification of an applied signal at the fundamental frequency takes place. If the negative resistance is made smaller than the damping resistance, say due to increase of pump power, the system self oscillates.

It may be difficult to maintain the exact frequency and phase relationship between the signal to be amplified and the pump signal, and

for small differences between the signal frequency s and half the pump frequency p , the signal and pump voltages will periodically drift in and out of the condition for favourable interaction, with the result that the signal will have a periodic variation of amplitude from maximum gain to maximum loss. Analysis of the resulting signal waveform shows two equal amplitude signals of frequencies s and $p - s$. The additional signal, called the idler signal, must be allowed to be generated if amplification is to be achieved, i.e. the bandwidth of the circuit must be sufficient to cover the frequency range from s to $p - s$. Where s is very different from $p - s$ the circuit is arranged to be separately resonant to all these frequencies, s , p and $p - s$, as shown in Fig. 17(c).

7.1. Diode Type

The heart of a practical amplifier is the electronically variable capacitance, which in the most successful work so far has been the semiconductor diode. This is formed from bringing together two pieces of n -type and p -type semiconductor each of which contains mobile charges of opposite sign, and the consequent diffusion of these across the interface brings about a potential gradient of such a sign as to stop further movement. The region within which the gradient exists is swept free of mobile charges and is therefore a non-conducting and dielectric region. Increase of the potential gradient by the addition of a voltage across the two conducting boundaries of the region will increase the length of the non-conducting region, i.e. decrease the capacitance, and vice versa. Thus we have a convenient basic form of capacitance, and application to microwave amplification involves suitable adjustment of size. Figure 18 shows the physical form of a typical diode together with its equivalent circuit, and capacitance characteristic. The value of R_s , the series resistance, depends on the bulk resistance of the material and a measure of the highest frequency at which amplification can be obtained is given by the parameter

$$f_{max} = \frac{1}{2} \frac{1}{2\pi CR_s}$$

In present day diodes this figure can be as high as 30-60 kMc/s, but with improvements in

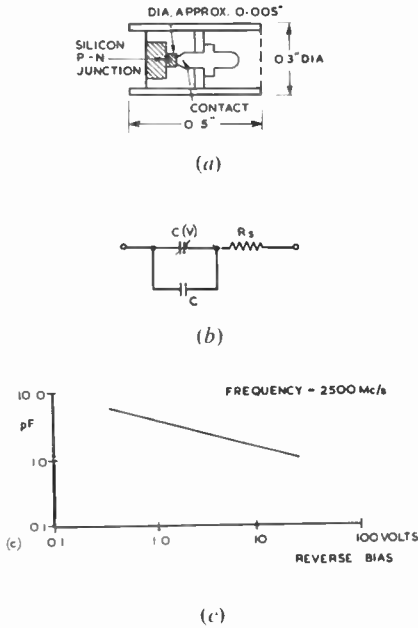

Fig. 18. Variable capacitance silicon diode.
 (a) Construction of variable-capacitance diode.
 (b) Equivalent circuit of *p-n* diode.
 (c) Capacitance characteristic.

techniques both of making and mounting diodes this figure is being steadily increased.

The principal noise contributed by the variable capacitance diode is thermal noise originating in its series resistance and although this is small, it may be further reduced by cooling.

Since amplifiers of this kind operate by virtue of a negative resistance generated at signal frequency, it is necessary for them to be isolated from the effects of load impedance change if instability effects are to be avoided. This may be achieved with a ferrite circulator (Fig. 19), by which any signal reflected by the output load including thermal noise originating in it is absorbed in a dummy load and is not allowed to reach the amplifier.

An amplifier using the simple principles so far outlined and operating at 5,000 Mc/s with a pump frequency of 10,000 Mc/s has been described by Uenohara⁵⁵ giving a gain of 20 db with 3 db bandwidth of 4 Mc/s. By adjustment of coupling, bandwidth may be varied, while (power gain) times bandwidth remains constant. The noise figure in a normal communication system is 5 db, this being increased over its

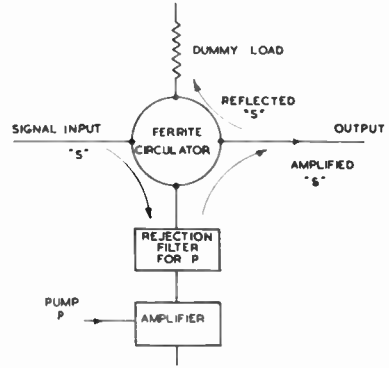

Fig. 19. Arrangement of cavity parametric amplifier.

minimum value by 3 db due to the need for the circuit bandwidth to be doubled to accommodate the image frequency. For the type of signal encountered in radio astronomy where the signal is in the form of incoherent noise, the noise factor is 2 db.

An amplifier using widely displaced signal and idler frequencies has been described by Helfner and Kotzebue⁵⁶ for operation at 1,200 Mc/s. This uses a waveguide cavity resonant at three frequencies with $s = 1,200$ Mc/s, $p = 3,500$ Mc/s, $(p - s) = 2,300$ Mc/s. This has a 3 db bandwidth of 0.5 Mc/s with a gain of 16 db. The noise factor was 5.5 db measured without circulator which would have cut out noise due to reflections from the output load.

The above two examples indicate the limitations in bandwidth which arise in the use of variable capacitance diodes in simple resonant circuits. Attention has therefore been directed to systems making use of travelling wave circuits in which signal, pump and idler signals can be transmitted with the same velocity satisfying the relations

$$p = s + (p - s);$$

$$\beta_p = \beta_s + \beta_{p-s};$$

$$\frac{d\beta_p}{df} = \frac{d\beta_s}{df} + \frac{d\beta_{(p-s)}}{df}$$

over the working frequency band. Using the system of Fig. 20 in which a central parallel plate transmission line is used for the pump power and coaxial systems for signal and idler. Engelbrecht⁵⁷ has reported operation over a 30

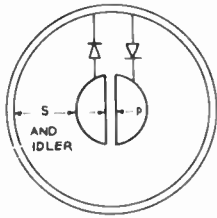

Fig. 20. Concentric travelling wave parametric amplifier.

per cent. band around 400 Mc/s with pump frequency of 900 Mc/s with gain of about 10 db and noise figure of 3.4 db. Such arrangements have the advantage that gain in the reverse direction is low.

7.1.1. Up-conversion

In the negative resistance amplifier described so far, output power can be taken at idler frequency equally as well as at the signal frequency. Analysis shows⁵⁸ that the following relation holds:

$$\frac{P_s}{s} = \frac{P_{p-s}}{p-s}$$

where P_s and P_{p-s} are the powers available at signal and idler frequencies. If $(p-s) \gg s$ then $P_{p-s} \gg P_s$ and there is thus merit in arranging for the negative resistance gain at the signal frequency to be relatively low, and therefore stable, and for output power to be taken at the idler frequency, taking advantage of the multiplying factor $(p-s)/s$. This is particularly of interest for the lower microwave frequencies but it is still a negative resistance amplifier and the stability conditions mentioned earlier need to be satisfied.

From this discussion it follows incidently that when the output is extracted at the signal frequency there is an advantage in using a high ratio between pump and signal frequency, since the circuit noise generated in the idler circuit due to resistance will be *de-amplified* in the power ratio $s/(p-s)$ in being transferred to the signal frequency.

We now assume that the circuit arrangement is such that the impedance presented to the variable capacitance diode at the idler frequency is zero, whilst it is high at the upper side band frequency. As noted earlier, negative resistance

amplification at the signal frequency cannot take place under these conditions. However according to Manley and Rowe⁵⁸ power is generated at the frequency $(p+s)$ according to the relation

$$\frac{P_s}{s} - \frac{P_{p+s}}{p+s}$$

The significance of the negative sign here is that power *input* at one frequency results in power *output* at the other. Thus power amplification is obtained directly by frequency change, without the limitations of negative resistance amplification.

Results have been reported on an amplifier using this principle⁵⁹. With signal input of 400 Mc/s and pump of 9,000 Mc/s an output signal is generated with a gain of 11 db and bandwidth of 22 Mc/s. It is passed to a 9,400 Mc/s amplifier of 7.6 db noise figure with a resulting overall noise figure of 1.9 db.

As mentioned earlier this is a field which is advancing rapidly; work on improved crystals is likely to increase the top frequency at which amplification is possible. One problem is however the provision of a pump signal of very high frequency and suggestions have already been made for easing this, both by the use of pump frequency harmonics or by the use of more than one pumping frequency. Also by use of the up-converter amplifier which gives an output signal greater in frequency than for the pump and by adding the pump frequency in a number of stages, a very high frequency pump source, may be achieved⁶⁰. For stability, directional coupling systems for low forward loss are required and more work is required here, although in some arrangements stable operation can be obtained without them by carrying out amplification in two or more stages and only transferring to the required output frequency at the last stage⁶¹.

7.2. Beam Type

Apart from the semi-conductor diode, use has also been made of an electron beam as an electronically-variable reactance in a number of ways.

In a proposal made by T. J. Bridges⁶² the beam is made to act as a reactance by twice interacting with the r.f. field due to a cavity. At

the first interaction, velocity modulation takes place, as already described, and after drifting for a suitable length of time the resultant bunches interact for a second time with the cavity field, but with a 90 deg phase displacement and thus behave as a reactance. Variation in the value of this reactance at the pump frequency p is obtained by variation of the beam current and this again is obtained by velocity modulation. Such an arrangement which has been shown to give useful amplification is limited in use as a low noise amplifier due to the inevitable beam fluctuations⁶³.

In a proposal made by Louisell and Quate⁶⁴, this fact is made use of. If as shown in Fig. 21 the signal is applied to the beam by means of a modulating cavity (or other suitable circuit), this cavity absorbs noise energy from the beam, with the result that slow-wave noise signals are increased, and the fast-wave signals decreased.

A fast wave is then generated at the pump frequency of about twice the signal frequency. (This may be done by injecting appropriately phased energy at two places suitably spaced.) The fast and slow signal waves now interact with the fast pump wave and both signal waves

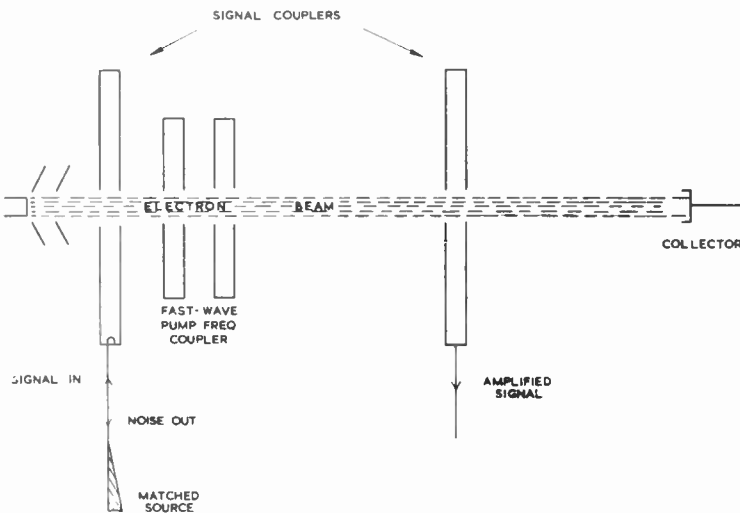

Fig. 21. Beam-type parametric amplifier.

No final experimental noise figures have in fact been published but at a signal frequency of 4.150 Mc/s, pump of 8,300 Mc/s and a beam of 2,450V, 18mA, with pump power of 140 mW, a gain of 20 db has been obtained.

This form of variable-reactance beam amplifier represents a direct analogy with the earlier arrangements described, and other less obvious derivations are being studied. Since amplification of weak signals is of particular interest, methods of dealing with the noise generated by the electron beam have received particular attention. From our earlier discussion (Section 3.2.) on waves in beams, we remember that it is only from the fast wave that noise can be removed by absorption.

are amplified, energy being provided by the pump wave. Analysis shows however that the fast signal wave, the noise-free one, is amplified more than the slow one, so that a noise-free amplification system is possible. The mechanism is basically a wide band one, but this property means that noise at idler and various harmonic frequencies can be amplified and transferred to the signal band if suitable operating parameters are not chosen, and this problem is being studied at the present time.

Some experimental results on this important class of amplifier have been reported⁶⁵. In this work the growth of both signal and idler waves has been demonstrated. A signal amplification of 50 db has been achieved at a frequency of

4,200 Mc/s using a 500V 5.3mA beam with 100mW pumping power at a frequency of 8,400 Mc/s. No noise results have so far been reported.

Another form of beam amplifier already shown to have important low noise properties is that due to Adler⁶⁶ and shown in Fig. 22.

A beam is injected along an axial magnetic field and the input signal applied transversely through a pair of deflecting plates. The magnetic field is such that the natural frequency of rotation of electrons due to it is close to the signal frequency, thus the transverse deflection

fast waves are valid. In particular the input beam noise at the signal frequency is absorbed in the input coupler.

Adler has reported that a 500 Mc/s tube with a band width of about 10 per cent gave a gain of 20 db with a noise figure only a little above 1 db.

T. J. Bridges, working at Bell Telephone Laboratories, has indicated in a private communication that at a frequency of 4,000 Mc/s with bandwidth about 2 per cent a noise figure of 3 db has been achieved, the gain being again about 20 db.

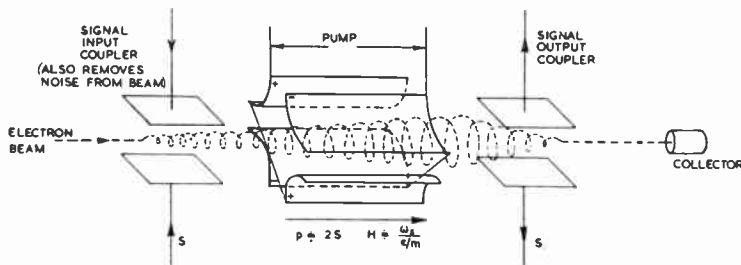

Fig. 22. Adler amplifier.

results in a spiral electron motion of increasing radius as the beam passes through the plates.

The beam passes to the pump region formed by four plates of transverse cross-section as shown. The plates are excited by the pump signal in such a way as to result in the alternating polarity shown and the field set up within them, which has approximately double the signal frequency, increases from zero at the centre to a maximum at the electrode surfaces. This arrangement gives a component of rotating field in the same direction as the beam and with approximately the same angular velocity, resulting in an increase in effective beam radius, the larger the initial radius, the larger the increase. Thus amplification of the radial motion generated by the input coupler is achieved. Finally the beam passes through an output coupler into which energy is injected with consequent reduction in beam radius.

Since interaction with all circuits is essentially of fast wave nature, r.f. fields being in phase all along input, output and pump circuit electrodes, the earlier considerations regarding noise in

7.3. Ferrite Type

The first form of solid-state variable reactance amplifier made use of the variable magnetic coupling between signal and idler circuits which may be achieved in ferrites^{67, 68}.

In a practical form the ferrite is placed in a steady magnetic field and an r.f. magnetic field of the pumping frequency is applied perpendicularly to this field. The latter is adjusted so that the frequency of precession of magnetization of the ferrite is equal to the pump frequency, so that the precession is excited. Signal and idler circuits are arranged so that their r.f. fields are perpendicular to each other and to the pump frequency fields. Since the precession motion results in components of magnetization of the pump frequency appearing in both signal and idler circuits, variable reactance coupling between these circuits at the pump frequency is achieved.

M. T. Weiss⁶⁹ has published results on a device of this type. Using single crystal manganese ferrite with a pump power of 3kW peak at 9,000 Mc/s, oscillations were generated at

4,500 Mc/s with a power of 100W peak. With reduced pumping power amplification was obtained with gain of 25 db at 1 Mc/s bandwidth. Pulse operation was used in this experiment and indeed has been used so far in all amplifiers of this type in view of the large pump power required and consequent heating of the ferrite. Attention has been concentrated on reducing ferrite losses, and it seems likely that with further research a useful amplifier can be devised. One of the reasons for continuing interest in this type of amplifier, in spite of lack of useful performance to date, lies in the existence, within the material, of many modes of resonance other than that mentioned above, leading to the possibility of operation at very high frequencies by the use of the "built in" circuits provided by these modes (see for example, Reference 70.)

8. The Maser

The methods which have been described so far for the amplification and generation of microwave energy have been concerned mainly with the interaction of electrons with electromagnetic fields developed from the viewpoint of the classical ideas of the dynamics of electron motion. During the past few years, following earlier work in the field of microwave spectroscopy, the possibility of making use of the internal energy in gases and solids for the generation of coherent radio frequency power has been explored, since these consist of large numbers of molecules each having a number of possible arrangements of their constituent parts with corresponding well defined energies⁷¹. Molecules exist at all these energy levels, the number at the different levels being related, under equilibrium conditions, by the expression

$$\frac{N(W_1)}{N(W_2)} = \frac{N_1}{N_2} = \exp \left[-\frac{W_1 - W_2}{kT} \right]$$

Thus if W_1 is greater than W_2 , N_1 is less than N_2 . Now this equilibrium may be disturbed by adding energy from a source of frequency f such that $hf = W_1 - W_2$ (h being Planck's constant) and the populations of the two states may be equalized, although since the probability of interaction is the same for both energies there will be a continual process of relaxation tending

to restore the system to thermal equilibrium. It is the absorption effect represented by this process which was studied in ammonia gas in 1933 by Cleeton and Williams⁷² at frequencies around 24,000 Mc/s making use of very small magnetrons working in the "electronic" mode.

In 1954 Townes⁷³ succeeded in separating molecules of the upper and lower energy states and making use of the energy of relaxation of the upper energy molecules to generate energy at the frequency given by $hf = \Delta W$. Figure 23 shows schematically the arrangement used, in which a beam of gas molecules is emitted from the source (a chamber maintained at an ammonia pressure of a few millimetres of mercury) in a well-collimated beam. The beam travels first through a filter formed by a space

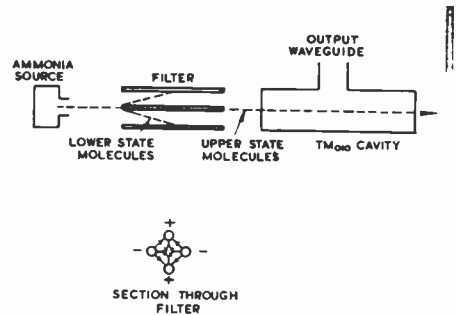

Fig. 23. Ammonia maser.

in which the molecules are subjected to transverse electric fields formed by a number of longitudinal rods of differing polarity. The lower state molecules are directed towards the region of increasing field, i.e. towards some of the rods, and out of the beam, the upper state ones are directed towards the region of zero field, i.e. the axis, and are therefore focused in a beam. This enters a cavity resonant at the appropriate frequency, supporting a TM_{010} mode in which no variation of electric field is present along its axis. Energy emission from molecules takes place in passing through a cavity, and either amplification or self oscillation can take place depending on circuit losses.

Such an arrangement provides a very stable oscillator. By beating two oscillators together, a stability of a few parts in 10^{10} has been

achieved, the power obtained being of the order of 10^{-10} watts (See also Reference 74). Very good noise performance may be achieved as an amplifier, in which the beam current is adjusted to be less than that necessary for self oscillation, since there is no source of noise equivalent to the fluctuating beam of an electron beam amplifier.

This first use of the energy levels of molecules of gases for radio-frequency power generation and amplification provided the stimulus for extensive work in this field, particularly in the direction of using solids in which much higher concentration of active elements is present, and where the resonant frequencies of the energy transitions can be altered conveniently. In the solid, the convenient physical means of sorting out favourable and unfavourable molecules used in the gas cannot be used, but extensions of the simple principle already described have enabled suitable arrangements to be evolved. The most used so far is the three-level maser which uses one of the methods proposed by Basov and Prokhorov⁷⁵, and Bloembergen⁷⁶.

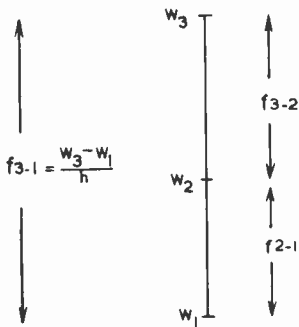

Fig. 24. Energy levels in three-level maser.

In this, three energy levels are used instead of two and by using an additional “pumping” frequency the problem of physical separation of molecules of two different levels is avoided in the following way. By using in a non-magnetic crystal a small percentage of magnetic ions, the discrete levels of the individual ions which are observed in a magnetic field, may be preserved and may be varied by change of magnitude and direction of magnetic field. These energy levels correspond to different orientations of the axis

of the spinning electrons which are the seat of the magnetic properties. Three energy levels may be selected shown as w_3, w_2, w_1 in Fig. 24 having equilibrium populations $N_3 < N_2 < N_1$. By applying sufficient energy at the frequency $f_{3-1} = (w_3 - w_1)/h$ the populations N_3' and N_1' may be equalized, providing the “relaxation time,” that is the time for return to the original population distribution on the removal of the exciting radiation, is long enough.

This process will disturb somewhat the population of the intermediate state resulting in a new equilibrium population N_2' .

If $N_2' < N_1' = N_3'$ a net emission of radiation at the frequency $f_{3-2} = (w_3 - w_2)/h$ occurs since the energy emitted in change of the greater number of higher level ions to the lower level will be greater than that absorbed by the smaller number of lower energy changing to the higher level under the action of the self excited field. Similarly if $N_2' > N_1' = N_3'$ a net emission of radiation occurs at the frequency $f_{2-1} = (w_2 - w_1)/h$. By choice of materials, magnetic field, relaxation times, it is possible therefore to arrange for amplification or self-oscillation to occur at one of the above two frequencies if a suitable amount of pump energy of the greater frequency f_{3-1} is applied. The factor of relaxation time is a particularly important one. At room temperatures this is much too short, and it is therefore necessary to operate at low temperature for effective operation; relative relaxation times may be adjusted by the admixture of suitable additives. The temperature of liquid helium (4.2°K) has been used, but investigation of materials have had as one aim the increase of this temperature.

This description has been concerned with the basic principles which may be made use of. In the embodiment of the principle, whose most important application at the moment is as a negative-resistance type amplifier, the active material is placed in a cavity capable of resonating both to pump and signal frequencies and is connected to the remainder of the system by a circulator or other form of directional coupler as in the negative resistance parametric diode amplifier.

Such an amplifier operated at 2,800 Mc/s with a pump frequency of 9,400 Mc/s and pump

power in range 1-30 mW gives a gain of up to 30 db with a bandwidth of about 100 kc/s. With gain reduced to 10 db, a bandwidth of 500 kc/s is obtained. The equivalent noise temperature of maser amplifier and necessary circulator is about 25°K corresponding to a noise figure 0.3 db⁷⁷. The material used in this case is the paramagnetic salt potassium cobaltcyanide containing 0.5 per cent chromium, and the amplifier is operated at 1.25°K. With modified coupling of the amplifier to load, self-oscillations were obtained. The optimum efficiency of -28 db was obtained with a pump power of 1 mW resulting in a power of a few microwatts.

An amplifier has also been operated at u.h.f.⁷⁸. A cylinder of potassium cobaltcyanide with 0.5 per cent chromicyanide impurity was used in a TE_{112} cavity pumped at 5,300 Mc/s, surrounded by a loop coupled to the 300-Mc/s signal source, thus allowing uniform saturation throughout the volume. The necessary adjustment of the energy levels, arising from the splitting of two doublets, which have at zero magnetic field an effective frequency difference of 5.120 Mc/s, is carried out with a magnetic field of about 60 oersteds. Preliminary results showed a gain of 10 db with a bandwidth of 100 kc/s and the noise temperature appeared to be limited by the non-reciprocal element by which the amplifier was coupled to the rest of the receiver.

Maser amplifiers as developed so far have rather narrow bandwidth due to the use of high- Q cavity circuits. Work has therefore been carried out on systems of a travelling-wave nature in which bandwidth may be increased; the need for a circulator for stability under reflection conditions is avoided and the power output also increased due to the larger amount of active material involved.

The experimental three-level travelling-wave maser described by de Grasse, Schulz-Du Bois and Scovil of the Bell Telephone Laboratories⁷⁹ is probably the most advanced of this type. The active material produces an equivalent negative resistance in the slow-wave structure and a propagating wave having an exponentially increasing amplitude is obtained. The use of a slow-wave structure in this simple way produces a device which has gain in both directions, and would therefore require very good matches at

both input and output terminals to give stable operation. Unidirectional travelling-wave amplification is however obtained by using a slow-wave structure which has regions of circular polarization of the magnetic field in which an active material is placed which has circularly polarized signal frequency transitions. These can only produce negative resistance for one direction of signal wave propagation and this feature therefore helps in avoiding instability due to reflections from the output of the tube. To achieve complete stability unidirectional loss is also incorporated which is effective for waves reflected from the output terminal. This is achieved as for the unidirectional gain by the excitation of an absorptive paramagnetic

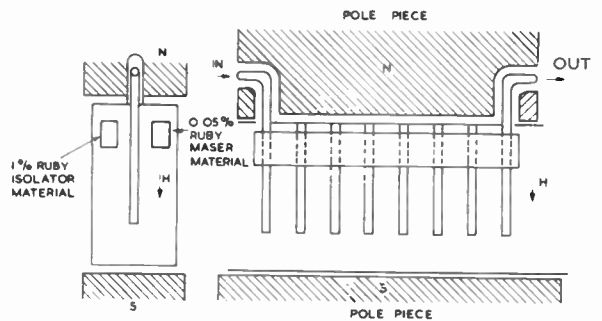

Fig. 25. Travelling-wave maser.

material through a circularly polarized magnetic field. The same material as for amplification is used, but with increased density, so that the equilibrium is not disturbed by the pump power and selective loss occurs in the two possible directions of transmission. Absorptive ferromagnetic material may also be used, and has the advantage of not increasing significantly the pump power required.

Figure 25 shows schematically the arrangement used for a final amplifier operating in the 6 kMc/s range, in which the directional selectivity of amplifying and isolating material is obtained by placing these on opposite sides of a comb type slow-wave structure where the circulating component of r.f. magnetic field has opposite signs. The pump power is propagated by the TE_{10} mode of the rectangular guide, independently of the slow-wave circuit which to a first order does not couple to it.

With this amplifier operated in a helium bath at a temperature of 1.6°K a net forward gain of 23 db was obtained with a 3-db bandwidth figure of 25 Mc/s. Greater bandwidth may be obtained by stagger tuning the maser material. The passband of the structure allowed operation over a band of about 6 per cent and the pump frequency of about 19 kMc/s, and the magnetic field of about 4,000 oersteds needed to be adjusted by 3 per cent to cover this band. With an output power of -22 dbm the amplifier gain was reduced by 0.5 db, and the recovery time after saturation by a large signal was of the order of 10^{-1} sec due to the long relaxation time in the active material used. A pump power of 100 mW was used, but this could be reduced to 10 mW by circuit modifications. The noise factor was about 1.04 db, most of this being due to the input cable, the input connection of which was at room temperature.

These results show that very low noise amplification with acceptable characteristics over useful bandwidths has already been achieved with these new amplifiers and there is little doubt that further advances towards devices practicable for our normal communication systems will be made.

9. Survey of Performance of Established Types of Valves

In this Section we summarize briefly the performance and potential performance of those valve types which one can broadly define as established. It will be appreciated that the high rate of advance, and the continually changing requirements of systems made possible by this advance, may result in the word "established" being used very loosely.

9.1. Low Power Klystrons

9.1.1. Reflex klystron

The reflex klystron has been one of the most generally used valves in the microwave field. Giving a power of a few tens to a few hundred milliwatts over a mechanically tuned frequency range which may be quite wide, with an electronic tuning range of the order of 1 per cent obtained by variation of reflector potential, it has been widely used as a local oscillator and as a general purpose measurement oscillator.

Designs have been produced to operate down to a wavelength of about 4 millimetres with a power even here of a few tens of milliwatts. By use of a low loss cavity suitably coupled, extremely high frequency stability and pure frequency spectrum have been achieved. At 10,000 Mc/s a short term stability resulting in a frequency deviation of only a small fraction of a cycle is obtained with good design.

9.1.2. Heil tube

The Heil tube, based on the original ideas of O. Heil mentioned in Section 1, covers the same general field of application as the reflex klystron; it is a two-gap single circuit device which in principle can be arranged to cover a wide frequency range. In a given design for example, the range 4,400-5,000 Mc/s may be covered with a single circuit with powers in the range 100 mW-4 W.

9.1.3. Retarding field oscillator

Allied to the reflex klystron is the retarding field oscillator developed particularly at Ohio State University. As far as is known this has not been exploited commercially, but it has very interesting possibilities. It uses a highly converging beam (convergence of order 100/1), making it particularly suitable for the shorter millimetre wavelengths, and this is acted upon simultaneously by the r.f. field of the single resonant cavity and the retarding field of the reflector as shown in the Fig. 26. By careful design of electron trajectories good performance is obtained. With a beam voltage of 600V a power of 1W has been obtained at frequency of 10,000 Mc/s, and with <800V a power of

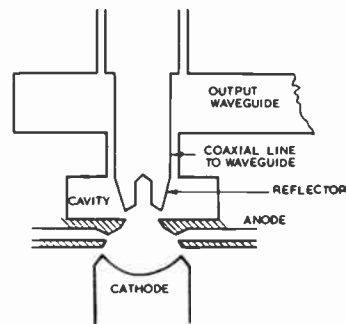

Fig. 26. Retarding-field oscillator.

175 mW at frequency of 50,000 Mc/s. In the latter case a tuning range of about 15 per cent was obtained with one external cavity⁸⁰.

9.1.4. Monotron

The monotron is a single cavity klystron oscillator where negative resistance power generation is obtained from a previously accelerated beam by allowing it to spend a sufficiently long time in the interaction field. As developed at 10,000 Mc/s frequency an efficiency of about 1 per cent is achieved. By allowing the velocity modulated beam to drift, large r.f. currents are developed and these may excite a second cavity as in a normal klystron. As developed by Picken and Trevena⁸¹ this arrangement has given a maximum output of 280 watts at about 9,600 Mc/s with an efficiency of about 20 per cent, the voltage being about 8 kV. The advantages of the system are the high frequency stability in the monotron cavity, resulting from the large gap spacing and high *Q*-factor possible. Furthermore, since the two cavities are coupled by the beam only, the frequency is independent of loading conditions and thus the device is particularly useful as a very stable c.w. source.

9.2. High Power Klystrons

9.2.1. C.W. type

As already indicated the properties of the klystron make it particularly suited for high power operation, since robust single-gap circuits can be used, and the beam is collected mainly on a separate electrode which can be water cooled. The very good isolation between input and output circuits makes stable operation very easy to obtain. Powers of at least 2 kW may be obtained at 30 per cent efficiency at 10,000 Mc/s with gain of 40 db and electronic bandwidth of 20 Mc/s. By mechanical tuning a frequency range of the order of 10 per cent may be covered. At lower frequencies correspondingly higher powers and efficiencies may be achieved. A typical design using four cavities gives a power of 20 kW at 40 per cent efficiency at 900 Mc/s with gain of 50 db at 2 Mc/s bandwidth. Higher gain-bandwidth products may be obtained with increased number of cavities although increased gain brings with it increased difficulties both in internal and external feed-

back. However, gains as high as 120 db have been reported. Such tubes have found particular application in long distance communication systems using tropospheric scatter propagation, where electronic bandwidth requirements are not too large. By operation of the collector at reduced potential increased efficiency may be obtained, but design needs to be carried out with particular care if deleterious effects, due particularly to secondary emitted electrons, are to be avoided.

9.2.2. Pulsed type

The need, over ten years ago, for stable amplifiers for electron accelerators, resulted in rapid advances in the power of pulsed klystrons from the war-time values of tens of kilowatts.

As a result of the inspiration of W. W. Hansen of Stanford University tens of megawatts are now obtained at 3,000 Mc/s using beam voltages of several hundred kilovolts, with mean powers of many kilowatts and efficiencies of at least 40 per cent. Power gains of the order of 40 db are again obtained with bandwidths of a few megacycles.

These amplifiers allow extremely high power sources to be obtained by paralleling, and effective powers of many hundred of megawatts at frequencies around 3,000 Mc/s are thereby achieved for use in linear accelerators.

The more advanced radar systems made possible by these stable low noise pulsed amplifiers, involving for example, phase comparison techniques or frequency modulation, are of course particularly of interest in the field of long range radar and allow the maximum information to be derived from a given transmitter power and receiver sensitivity.

By the use of many cavities with suitable staggering of their tuning, increased bandwidth may be obtained and King reports a bandwidth of 5 per cent obtained in a 2.5 MW klystron at 3,000 Mc/s, with a gain of about 60 db and efficiency of greater than 20 per cent⁸².

9.3. Travelling-wave Tubes

Turning now to "O" type amplifiers of the travelling wave type and sketching the frequency limits we note that tubes have not so

far been made for use below 400 Mc/s, or above 200,000 Mc/s, and in their present form they are unlikely to exceed these limits.

9.3.1. Low-noise performance

Broad-band low-noise amplifiers can generally give some improvement in the noise figure obtainable from mixer or detector crystals at frequencies between 1,000 and 15,000 Mc/s, while at the same time providing protection for the crystals against damage by overloading, since tubes of this type usually have a saturation limit of a few milliwatts. A noise figure of the order of 6 db is available at frequencies in the region of 3,000 Mc/s, and considerably lower figures have been obtained experimentally. It must be admitted however that for economic and practical reasons they have not yet found general application here. Developments of other types of low-noise amplifiers, already described, have so far not approached the gain bandwidth product of the low-noise travelling-wave tube in this frequency range, and it seems probable that where a broad-band receiver is desired, this type of tube will continue to offer the best performance for some time.

9.3.2. Medium power tubes

High-gain broad-band amplifiers of a few watts output are in use with gains up to 50 db and bandwidth up to 50 per cent, and experimental gains considerably higher have been measured. Where neither the noise figure nor the output power performances have to be particularly exacting, it is possible now to make light-weight tubes focused by periodic permanent magnets with gains as high as required. The immediate future holds the promise of electrostatic focusing with even greater reduction in weight and size.

A rapidly growing use in this field is that of transmitter valves in microwave relays. Here the broad-band linear characteristic makes the helix circuit particularly attractive, and the power levels required, generally less than 20 watts, create no difficulty.

9.3.3. Electronically-tuned amplifiers

Electronically-tunable filters can be provided by backward wave amplifiers. These are

essentially low-power devices and, although very good noise performance has been reported⁸³, are probably best not used as first stage amplifiers due to the supply circuit complication that this entails. At present amplifiers of this type have been made only in the 3,000 Mc/s band giving a gain of 20 db with bandwidth of 10 Mc/s at 3,000 Mc/s. An electronic tuning range of 50 per cent has been obtained.

9.3.4. Modulation

As a switching or level control device, the travelling-wave tube offers a smooth electronic control over a very wide range. A tube having a cold loss of 80 db and a gain of 40 db, for example, would provide electronic amplitude control over 120 db range, with a response time of about 10 millimicroseconds. In addition, if appropriately designed, an input range of 20 db over which the output remains constant can be achieved. Phase modulation can also be produced, so that the tube can be used for side-band generation, or frequency shifting. In general both amplitude and phase modulation are produced together and although the effect of either can be made predominant, it is not possible to make them independent.

9.3.5. Harmonic generation

The travelling-wave tube is a very good harmonic generator and is useful as a generator of microwave power whose frequency can be accurately controlled by a low-frequency crystal oscillator. Effective amounts of harmonic power at over the 100th harmonic have been produced.

9.3.6. High power operation

Experimental tubes for high-power use have been developed, but as indicated these have restricted bandwidths. At 9,000 Mc/s a c.w. power of 1 kW has been obtained with a bandwidth of 3,500 Mc/s. For pulsed use, power of about a megawatt has been achieved at 3,000 Mc/s with a bandwidth of 10 per cent and a gain of 20 db. As mentioned previously, inadequate power dissipation in the attenuator makes high gain difficult to achieve.

9.4. "O" Type Backward-wave Oscillator

This device has made particularly rapid progress during the last few years. It is a wide-

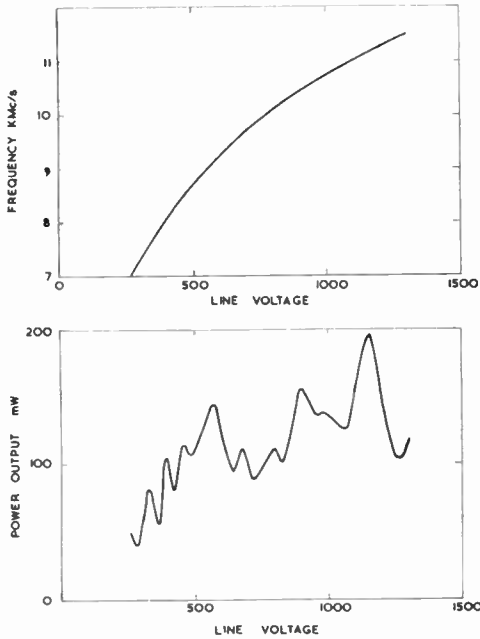

Fig. 27. Backward-wave oscillator characteristics.

range electronically-tuned oscillator giving a power in the range of 10 milliwatts to several hundred milliwatts at present available from frequencies of about 500 Mc/s to at least 20,000 Mc/s. Experimental models have been built to frequencies as high as 150,000 Mc/s. Since the r.f. circuit is basically a matched transmission line, over the working frequency band, operation is particularly insensitive to variation of load impedance. Typical operating characteristics are shown in Fig. 27.

Oscillators of this type which have been used as local oscillators in wide-band receivers and as swept frequency test sources in impedance and other measuring equipment have made use of permanent and electro-magnets to focus the electron beam. Such systems are rather bulky and heavy and further suffer from spurious modulation if the gas pressure is not low enough.

A considerable improvement has been made by the use of electrostatic focusing in such a system and a new device, the "Ophitron", offers this advantage. The photograph, Fig. 28, shows this side-by-side with a magnetically-focused type. Both cover the frequency range of about

7 to 11.5 kMc/s with about the same power output of upwards of a few tens of milliwatts. The noise power output of the ophitron is very low, due to the focusing system, the signal/noise ratio being of the order of at least 160 db for a 1-c/s bandwidth at all frequencies up to 50 Mc/s from the carrier.

9.5. Magnetron

9.5.1. Pulsed type

Along with the reflex klystron, the magnetron self-oscillator has been so far the most widely used microwave valve. In addition to its main advantages of compactness and good efficiency, it offers relatively low anode voltage, and insensitivity to operating conditions. The deceptive simplicity of its construction initially concealed unexpected traits of character which for a time gave it the reputation of a most unreliable device. However continuing experience in design and manufacture, together with a real attempt to understand the finer aspects of performance, have gradually led to improved designs and it seems likely that for situations where its basic self-oscillator characteristics are compatible with system requirements it will continue to be used in preference to alternative devices.

Effort has been particularly concentrated on designs for pulse operation and powers up to 10 MW at 1,000 Mc/s, and 20 kW at 100,000 Mc/s have been produced with mean powers of approximately 1,000 times less. Such valves



Fig. 28. The "Ophitron".

operate with voltages up to about 70 kV and the provision of the necessary magnetic field is usually made with a compact permanent magnet. Valves for much lower powers are, of course, available. Probably the largest single use of magnetrons is now in the field of marine radar for which one requirement is covered by a compact design of valve giving a peak output at about 9,735 Mc/s of 5 kW, mean of 5 watts, with an operating voltage of 5 kV with a weight complete of 4 lb. Such valves are usually fixed in frequency, particularly at the high-power level, but mechanical means of tuning have been evolved by means of which a frequency variation in the range 5-30 per cent is achieved.

9.5.2. C.W. type

Although magnetrons have been developed for c.w. operation their general use has been somewhat restricted. Mean powers of the same value as achieved in pulse designs are in general available. Typical industrial use has been in electro-medical equipment, in domestic cooking, and to some extent on industrial heating equipment. In one application of particular interest to this Institution a c.w. magnetron has been used for long periods as a frequency modulated transmitter oscillator in a 3,600 Mc/s tropospheric scatter trial link⁸⁴, operating with an output power of about 600 W and peak frequency modulation of about 15 kc/s, achieved by variation of anode current.

Another c.w. magnetron of particular interest is the voltage-tunable magnetron which has the usual parallel resonant circuits replaced

effectively by resistances. Developed in the U.S.A.⁸⁵ this valve has close resemblance in operation to a backward-wave oscillator and is used in a special circuit designed to provide wide band resistive loading. A power of 3 W is obtained over the frequency range 2-4 kMc/s, the frequency being adjustable by variation of anode voltage, to which the frequency is proportional. By modification of the load circuit to give higher impedance loading a power of 10 watts is available at 45 per cent efficiency over a 10 per cent tuning band.

9.6. The Amplitron (and Stabilitron)

The amplitron is an important device again of interest to high power generation, in view of its efficiency, which lies midway both in design and performance between the magnetron and the crossed field amplifier. It has been particularly developed in the United States⁵² as a low-gain output amplifier for use in radar systems. Its major features relative to the magnetron are shown in Fig. 29(b). Operation at a given power level is at similar conditions of magnetic field, voltage, etc., as for a magnetron but there are no intentional re-entrant circuits to determine frequency; performance as a low gain amplifier is obtained over a frequency band of the order of 10 per cent by feeding in power at one end of the circuit and taking it out from the other. At frequencies of the order of 1,000 Mc/s powers of several megawatts have been obtained with extremely high efficiency (in a range 50-70 per cent) and powers appropriate to the frequency have been obtained at frequencies as high as 5,000 Mc/s.

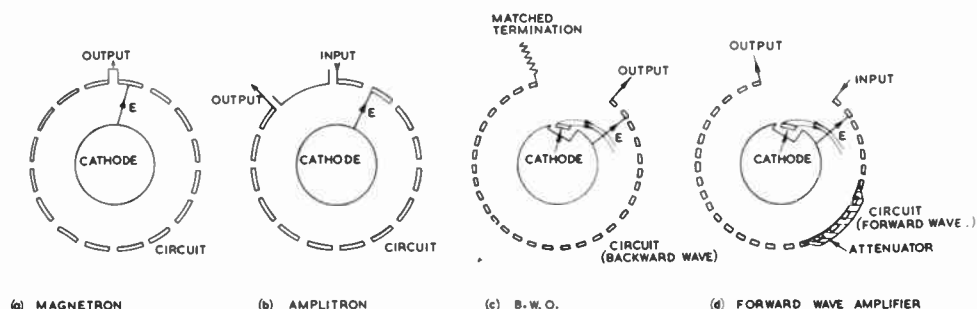

MAGNETIC FIELD INTO DIAGRAM

Fig. 29. Crossed-field valves

By reflecting part of the output power back to a resonator coupled to the input circuit a self-oscillator of extremely stable characteristics is achieved. This has been called a stabilatron⁸⁶ and thus may be used as a driver for the amplifier to give an extremely powerful and efficient high power source.

9.7. Crossed Field ("M" Type) Backward Wave Oscillator

This is a high-power voltage-tuned oscillator capable of covering a relatively large tuning range, and its main features are indicated in Fig. 29(c). As developed for c.w. operation it has an electronic tuning range of 20-50 per cent and power of a few hundred watts is obtained at 3,000 Mc/s with higher powers at lower frequencies, with an operating voltage range of 2-5 kV. Efficiencies lie in the range 20 per cent to 50 per cent depending on frequency. Amplitude modulation may be achieved with change of beam current.

Valves have also been designed for pulse operation with normal duty cycle (c. 1/1,000), 200 kW with 50 per cent efficiency at 20 per cent bandwidth being obtained at 3,000 Mc/s, with 50 kW at 10,000 Mc/s. These valves require operating voltages in the range 15-40 kV on which the frequency is directly dependent, consequently special care is needed to ensure constant frequency during the time of a pulse⁸⁷.

9.8. Crossed Field ("M" Type) Amplifier

Although the original work on this tube (see Fig. 29(d)) was carried out under conditions of c.w. operation⁸⁸, most of the development has been in the field of high power pulsed operation where the high efficiency available from "M" type devices is of particular attraction. Powers of several megawatts at efficiencies in the range 40-50 per cent have been obtained at frequencies around 1,000 Mc/s with a gain of the order of 15 db. A bandwidth of the order of 15 per cent has been achieved. The operating voltage is in the region 50-70 kV.

Noise generated in such an amplifier as already indicated, and so far a noise level about 30 db below the signal, measured in a receiver of a few Mc/s bandwidth, may be expected⁸⁹.

10. Conclusions and Acknowledgments

In this paper we have attempted to summarize the whole history of evolution and development of the fascinating field of microwave valves and amplifiers, and to give a simple account of the principles lying behind the more important of the devices which have been produced. Of necessity this can only be an outline of the subject and in particular the final section dealing with performance and field of application has to be very brief.

In preparing this survey the authors have, of course, drawn extensively on the considerable literature and in no sense has it been possible to make acknowledgment to all those who have made contributions.

A very large amount of work is still proceeding in the field, and one confidently expects that a survey of this kind written in ten years' time will contain a further long list of quite new devices brought to fruition in the vast new field of microwave communication engineering.

11. References

1. H. Barkhausen and K. Kurz, "Die kürsten, mit Vakuumröhren herstellbaren Wellen," *Phys. Zeits.*, **21**, p. 1, 1920.
2. E. W. B. Gill and J. H. Morrell, "Short electric waves obtained by valves," *Phil. Mag.*, **44**, p. 61, 1922.
3. C. E. Fay and A. L. Samuel, "Vacuum tubes for generation of frequencies above one hundred megacycles," *Proc. I.R.E.*, **23**, p. 199, 1935.
4. E. H. Ullrich and W. L. McPherson, "Micro-ray communications," *J. I.E.E.*, **78**, p. 629, 1936.
5. A. L. Hull, "The effect of a uniform magnetic field on the motion of electrons between coaxial cylinders," *Phys. Rev.*, **18**, p. 31, 1921.
6. A. Zacek, "Über eine Methode zur erzeugung von sehr kurzer elektromagnetischen Wellen," *Hochfrequenztechn.*, **32**, p. 172, 1928.
7. K. Okabe, "On the short-wave limit of magnetron oscillations," *Proc. I.R.E.*, **17**, p. 652, 1929.
8. C. E. Cleeton and M. H. Williams, "Magneto-static oscillator for the generation of 1 to 3 cm waves," *Phys. Rev.*, **44**, p. 421; **45**, p. 234, 1933.
9. E. Habann, "Eine neue Generatorröhre," *Hochfrequenztechn.*, **24**, p. 115, 1924.
10. E. G. Linder, "Description and characteristics of the end-plate magnetron," *Proc. I.R.E.*, **24**, p. 633, 1936.
11. K. Posthumus, "Oscillations in a split anode magnetron," *Wireless Engr.*, **12**, p. 126, 1935.

12. A. F. Harvey. "High Frequency Thermionic Tubes," p. 165 (Chapman & Hall, London, 1943).
13. E. G. Linder, "The anode-tank-circuit magnetron." *Proc. I.R.E.*, **27**, p. 732, 1939.
14. A. Arsenjewa Heil and O. Heil, "Eine neue methode zur erzeugung kurzer, ungedämpfter, elektromagnetischer Wellen grosser Intensität," *Z. f. Phys.*, **95**, p. 752, 1935.
15. R. H. Varian and S. F. Varian, "High frequency oscillator and amplifier." *J. Appl. Phys.*, **10**, p. 321, 1939
16. W. C. Hahn and G. F. Metcalf, "Velocity-modulator tubes," *Proc. I.R.E.*, **27**, p. 106, 1939.
17. W. E. Benham. "Theory of the internal action of thermionic systems at moderately high frequencies." *Phil. Mag.*, **11**, p. 457, 1931.
18. F. B. Lewellyn and L. C. Peterson. "Vacuum-tube networks." *Proc. I.R.E.*, **32**, p. 144, 1944.
19. F. M. Colebrook "Ultra short and decimetre-wave valves." *Wireless Engr.*, **15**, p. 198, 1938.
20. H. E. Hollman and A. Thoma, "Die Dynamick quer-und längsgestinerter elektronen-strahlen," *Hochfrequenztechn.*, **49**, p. 109, 1937.
21. K. R. Spangenberg. "Vacuum Tubes." p. 541 (Chap. 17. 4, First order bunching theory) (McGraw-Hill, New York, 1948).
22. K. R. Spangenberg, *op. cit.*
23. K. H. Kreuchen *et al.*, "A study of the broad band frequency response of the multicavity klystron amplifier," *J. Electronics*, **2**, p. 529, 1957.
24. J. Shaw. "High-power Klystron Work of the Stanford Microwave Laboratory." *Congrès International Tubes Hyperfréquences, Paris, May, 1956.* Paper No. 3.04.
25. W. C. Hahn, "Small signal theory of velocity modulated electron beams," *G.E. Review*, **42**, p. 258, 1939.
26. S. Ramo, "Space-charge and field waves in an electron beam," *Phys. Rev.*, **56**, p. 276, 1939.
27. R. Kompfner. "Travelling wave valve, a new amplifier for centimetric wavelengths." *Wireless World*, **52**, p. 369, 1946.
28. J. R. Pierce, "Theory of the beam-type travelling wave tube." *Proc. I.R.E.*, **35**, p. 108, 1947.
29. S. Sensiper. "Electromagnetic Wave Propagation on Helical Conductors." Sc.D. Thesis, M.I.T., 1951.
30. M. Chodorow and E. L. Chu, "Cross-wound twin helices for travelling wave tubes." *J. Appl. Phys.*, **26**, p. 33, 1955.
31. C. K. Birdsall and J. L. Everhart, "Modified Contra-Wound Helices." Hughes Aircraft Company Report.
32. M. Chodorow and R. A. Craig. "Some new circuits for high power t.w.t.'s," *Proc. I.R.E.*, **45**, p. 1,106, 1957.
33. E. J. Nalos, "A hybrid type t.w.t. for high-power pulsed amplification." *Trans. I.R.E.*, **ED-5**, No. 3, p. 161, 1958.
34. A. M. Clogston and H. Heffner, "Focusing of an electron beam by periodic fields." *J. Appl. Phys.*, **25**, p. 436, 1954.
35. J. T. Mendel, C. F. Quate and W. H. Yocom, "Electron beam focusing with periodic permanent magnetic fields." *Proc. I.R.E.*, **42**, p. 800, 1954.
36. K. K. N. Chang. "Electron flow in periodic fields," *Proc. I.R.E.*, **45**, p. 66, 1957; "Biperiodic electrostatic focusing for high density electron beams." *ibid.*, p. 1,522.
37. R. Kompfner, J. S. Cook and W. H. Yocom, "Slalom flow." *Proc. I.R.E.*, **45**, p. 1,517, 1957.
38. Z. S. Tchernov. "The Spiratron T.W.T. with Electrostatic Focusing," *Congrès International Tubes Hyperfréquences, Paris, May 1956.* Paper No. 5.03.
39. D. Blattner and F. Vaccaro, "Electrostatically focused S-band t.w.t." *I.R.E. Conv. Rec.*, 1958, Pt. II.
40. D. A. Watkins, "T.w.t. noise figure." *Proc. I.R.E.*, **40**, p. 65, 1952.
41. R. W. Peter, "Low-noise travelling wave amplifier," *R.C.A. Rev.*, **13**, p. 344, 1952.
42. M. R. Currie and D. C. Forster, "New mechanism of noise reduction in electron beams." *J. Appl. Phys.*, p. 94, 1959.
43. A. E. Siegman, A. W. Shaw and D. A. Watkins, "Low-noise guns, low potential drift region." *Proc. I.R.E.*, **47**, p. 2, 1959.
44. D. R. Hartree, C.V.D. Report. (See M.I.T. Radiation Series, Vol. 6, p. 32.)
45. B. Epsztein, I.R.E.-A.I.E.E. Electron Tube Conf., Ottawa, 1952; P. Guenard, O. Doehler, R. Warnecke and B. Epsztein, "New u.h.f. oscillator valves with wide electronic tuning band," *C. R. Acad. Sci., Paris*, **235**, p. 236, 1952.
46. P. Palluel and A. K. Goldberger, "The O-type carcinotron tube," *Proc. I.R.E.*, **44**, p. 333, 1956.
47. D. A. Watkins and E. Ash. "The helix as a backward wave circuit structure." *J. Appl. Phys.*, **25**, p. 782, 1954.
48. M. R. Currie and D. C. Forster. "Low noise tunable preamplifiers for microwave receivers." *Proc. I.R.E.*, **46**, p. 570, 1958.
49. B. Epzstein, "Effets de la charge d'espace dans les tubes à champs croisés," *C.R. Acad. Sci., Paris*, **244**, p. 2,902, 1957.
50. H. F. Webster, "Structure in magnetically-confined electron beams." *J. Appl. Phys.*, **28**, p. 1,388, 1957.
51. G. Mourier, "Surface waves in electron beams in the presence of a magnetic field." *C.R. Acad. Sci., Paris*, **247**, p. 1978, 1958.
52. W. C. Brown, "Description of operating characteristics of the platinotron, a new microwave tube device," *Proc. I.R.E.*, **45**, p. 1,209, 1957.

53. O. Doehler, B. Epsztein and J. Arnaud, "Operational characteristics of the carmatron tube," *Proc. I.E.E.*, **105B**, p. 529, Suppl. No. 10, 1958.
54. E. D. Reed, "The variable-capacitance parametric amplifier," *Trans. I.R.E.*, **ED-6**, p. 216, 1959.
55. M. Uenohara, "Parametric Amplification at 6 kMc/s using Semi-conductor Diodes," 16th Conference on Electron Tube Research, Quebec, 1958.
56. H. Heffner and K. Kotzebue, "Experimental characteristics of a microwave parametric amplifier using a semi-conductor diode," *Proc. I.R.E.*, **46**, p. 1,301, 1958.
57. R. S. Engelbrecht, "A low noise non-linear reactance travelling wave amplifier," *Proc. I.R.E.*, **46**, p. 1,655, 1958.
58. J. M. Manley and H. E. Rowe, "Some general properties of non-linear elements—Part I—general energy relations," *Proc. I.R.E.*, **44**, p. 904, 1956.
59. P. P. Lombardo, "Low Noise 400 Mc/s Reactance Amplifiers," Solid State Circuits Conf., Philadelphia, 1959.
60. See programme for Electron Devices Meeting, Oct. 30-31, 1959, Washington.
61. L. S. Nergaard, "Non-linear capacitance amplifiers," *R.C.A. Review*, **20**, p. 3, 1959.
62. T. J. Bridges, "A parametric electron beam amplifier," *Proc. I.R.E.*, **46**, p. 494, 1958.
63. G. Wade and H. Heffner, "Gain, bandwidth and noise in a cavity type parametric amplifier using an electron beam," *J. Electronics & Control*, **5**, p. 497, 1958.
64. W. H. Louisell and C. F. Quate, "Parametric amplification of space charge waves," *Proc. I.R.E.*, **46**, p. 707, 1958.
65. A. Ashkin, "Parametric amplification of space charge waves," *J. Appl. Phys.*, **29**, p. 1,646, 1958.
66. R. Adler, "Parametric amplification of the fast electron wave," *Proc. I.R.E.*, **46**, p. 1,300, 1958.
67. H. Suhl, "Proposal for a ferromagnetic amplifier in the microwave range," *Phys. Rev.*, **106**, p. 384, 1957.
68. M. T. Weiss, "A solid state microwave amplifier and oscillator using ferrites," *Phys. Rev.*, **107**, p. 317, 1957.
69. M. T. Weiss, "Ferromagnetic resonance: non-linear effects and garnets," *J. Appl. Phys.*, **29**, p. 421, 1958.
70. W. L. Wherry and F. B. Wang, "Experimental study of modified semi-static ferrite amplifiers," *J. Appl. Phys.*, **30**, (Supplement), p. 150S, 1959.
71. J. P. Wittke, "Molecular amplification and generation of microwaves," *Proc. I.R.E.*, **45**, p. 291, 1957.
72. C. E. Cleeton and N. H. Williams, "A magneto-static oscillator for the generation of 1-3 cm waves," *Phys. Rev.*, **44**, p. 421; **45**, p. 234, 1934.
73. J. P. Gordon, H. J. Zeiger and C. H. Townes, "The maser—new type of microwave amplifier, frequency standard and spectrometer," *Phys. Rev.*, **99**, p. 1,264, 1955.
74. J. C. Helmer, "Maser oscillation," *J. Appl. Phys.*, **28**, p. 212, 1957.
75. N. G. Basov and A. M. Prokhorov, "On possible methods of producing active molecules for a molecular generator," *Zsh. Eksper. Teor. Fiz., U.S.S.R.*, **28**, p. 249, 1955.
76. N. Bloembergen, "Proposal for a new type solid state maser," *Phys. Rev.*, **104**, p. 324, 1956.
77. J. W. Meyer, "The solid-state maser—a super cooled amplifier," *Electronics*, **31**, April 1958, p. 66.
78. R. H. Kingston, "A u.h.f. solid state maser," *Proc. I.R.E.*, **46**, p. 916, 1958.
79. R. W. de Grasse, E. O. Schulz-Du Bois and H. E. D. Scovil, "The three level solid state t.w. maser," *Bell Syst. Tech. J.*, **38**, p. 305, 1959.
80. C. J. Carter and W. H. Cornet, "Low voltage operation of the retarding-field oscillator at X-band and in the millimetre wavelength region," *Trans. I.R.E.*, **ED-5**, p. 139, 1958.
81. J. R. Picken and D. H. Trevena, "A new development of the monotron oscillator," *Proc. I.E.E.*, **105B**, Suppl. 12, p. 966, 1958.
82. P. G. R. King, "A 5% bandwidth 2.5 MW S-band klystron," *Proc. I.E.E.*, **105B**, Suppl. 12, p. 813, 1958.
83. M. R. Currie and D. C. Forster, "Gain and bandwidth of backward wave amplifiers," *Trans. I.R.E.*, **ED-4**, p. 24, 1957.
84. G. T. Thompson and W. J. Lucas, "Propagation measurements at 3,480 Mc/s over a 173-mile path," *Proc. I.E.E.*, **105B**, p. 58, 1958.
85. T. R. Bristol and G. J. Griffin, Jr., "Voltage tuned magnetrons for f.m. applications," *Electronics*, **30**, p. 162, 1st May, 1957.
86. W. C. Brown, "A new microwave tube device," *Proc. I.R.E.*, **45**, p. 1,209, 1957.
87. M. Favre, "Results obtained in cross field carcinotrons under pulsed conditions," *Proc. I.E.E.*, **105B**, Suppl. 10, p. 533, 1958.
88. R. Warnecke, W. Kleen, A. Lerbs, O. Doehler and H. Huber, "The magnetron type travelling wave tube," *Proc. I.R.E.*, **38**, p. 486, 1950.
89. O. Doehler, A. Dubois and D. Maillart, "An M-type pulsed amplifier," *Proc. I.E.E.*, **105B**, Suppl. No. 10, p. 454, 1958.

GRADUATESHIP EXAMINATION—MAY 1960—PASS LISTS

This list contains the results of all successful candidates in the May Graduateship Examination. A total of 408 candidates entered for the Examination which was held at fifty-six centres.

LIST 1: The following candidates have now completed the Graduateship Examination and thus qualify for transfer or election to Graduateship or a higher grade of membership.

BAILEY, Kenneth Alan (S) *Bletchley*.
 BAMFORD, Thomas Arthur (S) *London, N.22*.
 BHAT, Manohar Ganesh (S) *Bombay*.
 BRIGHT, Norman Harry (S) *Stafford*.
 CHAKRAVARTY, Amarendra Nath (S) *Calcutta*.
 CHAN, Peter Kiu (S) *London, N.7*.
 CHHABRA, Surinder Lal (S) *Ferozepore Cantt.*
 COTTRILL, Norbert Francis (S) *London, W.2*.
 CULPIN, Millice James *Harlow, Essex*.
 CUSSONS, Ashley Roy (S) *Dorking*.
 DOWDING, Peter *Chigwell, Essex*.
 DUNN, Alan George (S) *Hull*.
 FOOKES, Reginald Arthur (S) *Caringbah, N.S.W.*
 HANDA, Jagdish Rai (S) *Agra*.
 HEMAN DAS, Baiwani (S) *New Delhi*.
 INNES, John Somerville (S) *Clayfield, Queensland*.
 JOHN, Kannampuzha Pavanny (S) *Trichur*.
 JOHN, M. T. (S) *Gothuruthy*.
 JONES, Peter (S) *Romford, Essex*.
 JOSEPH, C. Devasia (S) *Erameli*.
 JOYCE, Arthur (S) *London, S.W.12*.
 KHANNA, Kishan K. (S) *Bombay*.
 KRISHNAMOORTHY, T. Sundaresan (S) *Nagpur*.
 LEVI-MENZI, Gad (S) *Haifa*.
 LUTER, Michael Edward (S) *Easi, Cowes*.
 MCKAY, Eric Martin *Berkhamsted*.
 MANNING, Graham Erwin *North Chingford, Essex*.
 MENON, M. P. S. M. (S) *Ernakulam*.
 MEYER, Flg. Off. Leighton Francis, R.N.Z.A.F. *Christchurch, New Zealand*.
 MUTHURAGHAVAN, Navaneetham *Bangalore*.
 NARAYANA MENON, Pottekkat (S) *Poona*.
 NEWALL, Lionel Maurice *London, S.W.16*.
 PISHARODY, A. P. Unni Krishna (S) *Cherpalcheri*.
 RAE, Alexander Watson (S) *Glasgow*.
 RAMADORAI, T. C. (S) *Madras*.
 RAO, Krishna Bhaskar (S) *Ernakulam*.
 ROTTIER, Leslie Joseph *Harlow Essex*.
 SADASIVA DASS (S) *Jalahalli*.
 SHELTON, Roy George Alexander (S) *Johannesburg*.
 SIMMONS, Donald *Totton, Hampshire*.
 SIMMS, Terence (S) *Soissons*.
 SMALE, Phillip Herbert (S) *Hitchin*.
 SMIKT, Oded (S) *Rishon le Zion, Israel*.
 STACEY, Peter John *Harry Coventry*.
 STOKES, Roy (S) *Cambridge*.
 UPENDRA, Dattatreya Bhardvaj (S) *Bombay*.
 VAIDIAN, T. M. Alexander (S) *Thevalakara*.
 VAN DEN HAAK, Willem (S) *Leiden, Holland*.
 VAN DE NEUT, Cornelius Ambrosius (S) *Pretoria, Transvaal*.

LIST 2: The following candidates have now satisfied the requirements of Section A and are now eligible to enter for Section B.

ABRAHAM, Manimalathu Idiculla (S) *Ranny*.
 ADEBOYEJO, Michael Oluseyi (S) *London, W.9*.
 AHMED, Ghulam (S) *Rawalpindi*.
 ATTWELL, David Brian (S) *Lagos*.
 BENNETT, Wilfred (S) *Stoke-on-Trent*.
 BOWN, Kenneth Albert (S) *Staines, Middlesex*.
 CARISLE, James Allison (S) *Nottingham*.
 CHAN, Ping Cheung (S) *Hong Kong*.
 CHAWLA, Hari Krishan (S) *Tambram*.
 CHHABRA, Charanjit Singh (S) *Haldwani*.
 CHILDE, Percy (S) *Kowloon, Hong Kong*.
 COUSINS, Ralph Walter (S) *Burlington, Ontario*.
 CRAMP, Donald Henry (S) *Mitcham, Surrey*.
 DALE, Collis Seymour (S) *Lincoln*.
 DAWSON, John Sydney (S) *Walsend*.
 DUARTE CATULO, Fernando Jose Eugenio (S) *Goa*.
 EYLES, Frank William (S) *Nantwich*.
 FIROZGARY, Merwan Khodamorad (S) *Nasik City*.
 FIRTH, Peter Thomas (S) *Sheffield*.
 FOLLAND, Edward Phillip *Teheran*.
 GODBOLE, Madhukar Narhari (S) *Bombay*.
 GOLDSMITH, Geoffrey Grant (S) *Beckenham*.
 HADDAD, Tcwfik (S) *London, N.4*.
 HARIHARAN, Varadarjan (S) *Tripunithura*.
 HILTON, William *Darwen*.
 HOLMES, Alfred Stanley *Cobham, Surrey*.
 HUGHES, Thomas George (S) *Bolton*.
 HUMPHREYS, Humphrey Ioan *Stevenage*.
 KAPOOR, Gopal Krishan (S) *Kharagpur*.
 KAPUR, Tilak Raj (S) *Bombay*.
 KARTHIKEYAN, Muthukumarasamy (S) *Madras*.
 KENT, Derek Wilfred (S) *Enfield*.
 KEOWN, Douglas Grierson *Glasgow*.
 KHOO, Poon Tong (S) *Singapore*.
 KORB, Hans Arno Fritz (S) *Ennetbaden, Switzerland*.
 KULKARNI, Madhukar Ramchandra (S) *Poona*.
 LEWIS, Arthur Dennis (S) *Hanworth*.
 LIDDARD, Ralph Remo (S) *Maraisburg, South Africa*.
 LIM, Jin-Twan (S) *Rangoon*.
 MALIK, Mohammad Riaz (S) *Leeds*.
 MALL, Madon Mohan (S) *New Delhi*.
 MATHEWS, Koshy (S) *Thiruvalla*.
 MOYDEN, Frederick John (S) *Wallasey*.
 NAIR, V. K. Radhakrishnan (S) *Kuthiathode*.
 NIELSON, Mervyn Leslie (S) *Woomera, South Australia*.
 NORTON, Martin Augustus (S) *Harrow*.
 OGBU, Christian Okonkwo (S) *London, N.5*.
 OLEJNIK, Swietoslaw (S) *London, N.6*.
 ONIANWA, Christopher Afamefune (S) *London, N.19*.
 ONYIA, Augustine Ndudi (S) *Chelmsford*.
 PANG, Ee Ang *Singapore*.
 PANSHIKAR, Manohar A. (S) *Bombay*.
 PATANGE, Yeshwant Kondiram (S) *Satara City*.
 PATANKAR, Gopalkrishna Vasudeo (S) *Simla*.
 PATET, Niranjan Kumar (S) *Dehra Dun*.
 PATHANIA, Dharam Singh (S) *New Delhi*.
 PRESTON, George Cyril (S) *Carshalton*.
 PUNIA, Atma Singh (S) *Agra*.
 RAO, H. Narayana (S) *Kannankulamkara*.
 RAJPUT, Dhir Singh (S) *Agra*.
 RAMAN, Ganapathi (S) *Madras*.
 RAPPAL, Vadekkathala Devassy (S) *Madras*.
 REINER, Joseph (S) *Te-Aviv*.
 RINTOUL, Donald Alexander (S) *Stanmore*.
 SAINI, Babulal (S) *Barrackpore*.
 SARBJEET SINGH *New Delhi*.
 SCHJERVE, Olav (S) *Stavern, Norway*.
 SHARMA, Kamal Kishore (S) *Bangalore*.
 SHINDE, Manohar Bhimrao (S) *Shahapur*.
 SKINNER, Alan Stanley (S) *Woodbridge*.
 SINGLA, Ratanlal *New Delhi*.
 SLOLEY, Thomas Edward Sheridan (S) *London, S.W.15*.
 SMITH, Alan (S) *Belfast*.
 SURI, Pran Nath (S) *Lucknow*.
 SURYANARAYANA HERLE, (S) *Parampalli*.
 TALMACIU, Josef (S) *London, S.W.7*.
 TAYLOR, Ronald John Ian (S) *London, N.W.10*.
 WHELAN, Nicholas Kevin (S) *London, S.E.24*.
 WHITELEY, Ronald Cooper (S) *Germiston, Transvaal*.
 WILLIAMS, Paul David (S) *Carlingford, N.S.W.*.
 WILLIAMS, Robert Hywel (S) *Lausanne, Switzerland*.
 WILSON, James Albert (S) *Ardglass*.
 WOOD, Norman (S) *Hitchin*.
 WRAY, Alan (S) *Stevenage*.
 YOHANNAN, Kudill Abraham (S) *Ernakulam*.

(S) denotes a Registered Student.

Operational Facilities in the RCA Colour Television Tape Recorder †

by

A. H. LIND ‡

Presented by Dr. H. R. L. Lamont §

A paper read on 3rd July 1959 during the Institution's Convention at Cambridge.

Summary: The design of the recorder makes many new operating facilities available as integrated parts of the recorder. The electrical delay adjustments are intended to make greater precision readily available and facilitate tape interchangeability. A detailed account is given of the manner of making the adjustments to reduce quadrature errors at the heads.

1. Description of the Recorder

A brief description will first be given of the RCA TRT-1AC Television Tape Recorder. In Fig. 1 is shown the portion of the equipment located at the operating position. The rack on the left contains video circuits and a built-in picture monitor. The one in the centre contains the tape transport and audio circuits. The rack on the right contains the control panel, a built-in c.r.o. waveform monitor, and video signal handling and processing circuits. The two remote equipment racks contain the capstan and head wheel servos, the shoe position servo and power supplies and may be located at the operating position or at any convenient position within 25 or 30 feet of the operating position. The space occupied by the colour processing chassis is less than 60 per cent. of the capacity of one of the three racks occupied by the monochrome recorder; the colour processing equipment can be added to the monochrome recorder without making any changes to the latter.

A very substantial portion of the design effort was devoted to facilities that make the recorder

convenient and versatile in operation. Only highlights of the major facilities, all of which are incorporated in the basic TRT-1A, are covered here. Several of the facilities are located on the tape transport as shown in Fig. 2. The master erase head is located near the top

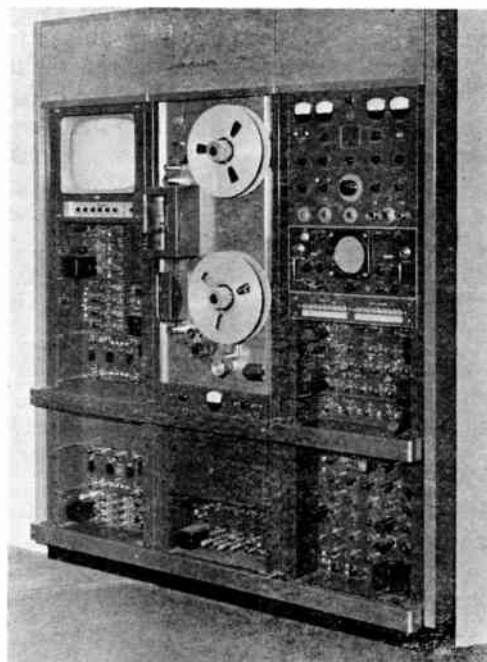

Fig. 1. The RCA TRT-1AC television tape recorder showing the racks mounted at the operating position.

† Manuscript received 1st June 1959. (Paper No. 575.)

‡ Radio Corporation of America, Cherry Hill, N.J., U.S.A.

§ Director, European Technical Relations, Radio Corporation of America, 36 Berkeley Square, London, W.1.

U.D.C. No. 621.397.61 : 621.395.42

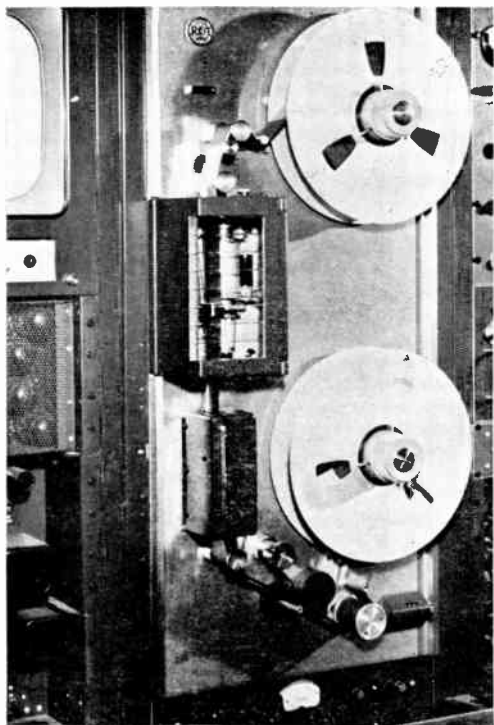

Fig. 2. General view of the tape transport mechanism.

of the tape path between two tape guide posts. Two guide posts are used to insure that the tape maintains good contact with the erase head. The master erase head very thoroughly erases the entire width of the tape shortly ahead of the video head assembly. It is energized only in the record mode of operation. The ability to erase selectively is a convenience that permits more efficient use of tape and studio time. Next, following the tape path beyond the video head assembly to the audio head enclosure, it should be noted that there are three head mounts as shown in detail in Fig. 3. Each mount supports two heads, one near each edge of the tape. Those mounted farthest from the transport panel are the audio track heads. In addition to the erase head which is first and the record/playback head which is second, the third head has been added to provide simultaneous monitoring of the audio track during recording. Control switching circuits are included to switch the record/playback head automatically to the input of the playback amplifier when a recorded tape is being played.

This is necessary to obtain exact lip sync of picture and sound in playback.

There are also three heads mounted close to the transport panel. They are first the erase head and second the record/playback head for the cue track channel. The third head provides simultaneous monitoring of the control track during recording. Its output is brought to the oscilloscope switcher so the recorded control track can be quickly checked on the waveform monitor. These heads and the associated circuitry are part of the basic machine.

Following the tape path further to beyond the capstan in Fig. 2 the tape measuring roller is encountered. It is tightly coupled to the tape by virtue of the large angle of tape wrap, the tape tension between the capstan and the take-up reel, and the high static friction surface of the roller. The measuring roller and gear train connecting its output to the visual display counter is accurately calibrated to measure tape length in feet. It can also be calibrated to measure tape length in terms of time if preferred.

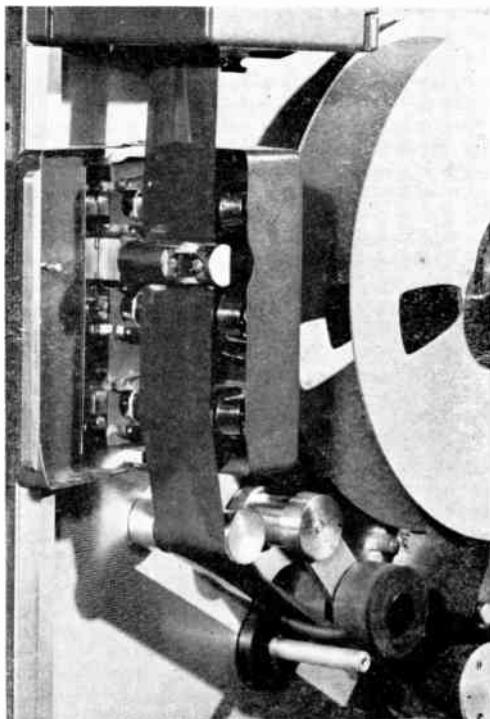

Fig. 3. Close-up view of the audio head enclosure.

Among the operating controls centralized on the Control Panel, the top panel in the right-hand rack in Fig. 1, are several directly associated with the facilities on the tape transport just described. The meter at the upper right corner indicates current in the Master Erase Head. Directly below this meter are two knobs and two push-button switches. They are the cue channel playback level, the cue channel record level, recording release push-button and "cue only" record push-button. To the left of the cue channel controls is a similar set of two knobs and two push-buttons for the audio channel. In addition to the controls being similar, the record amplifiers, playback amplifiers and bias and erase oscillators for the two channels are identical and plug-in types.

During normal recording of both video and audio, the master RECORD push-button is used to place the entire machine in the record mode. If, however, it is desirable to record audio or cue signals later or re-record on these tracks, this can be accomplished by using the AUDIO RECORD and/or CUE RECORD push-buttons. In such a case the machine is started in the playback mode and at the desired instant either or both of the push-buttons are operated. The recorded video continues to play back while the other channels are in the record mode. When the end of the recording is reached the RELEASE button or buttons can be operated which switches the channels back to the playback mode. It is also possible, of course, to stop the recording by pushing the machine STOP button.

The large knob in the lower centre of the panel and the push-button directly below it are associated with the control of tape winding. Pushing the button labelled WIND places the machine in the tape wind mode which is controlled by the WIND speed knob. The control of speed and direction of tape winding is continuous and adjustable from a maximum in one direction to a maximum in the other. By means of this tape winding control and the footage counter on the tape transport recorded passages can be located very quickly and the beginning of the recording can also be exactly cued very quickly.

Another facility built-in, not intended as operating instrumentation, but nonetheless very

useful for checking operating conditions and for setting-up, is the built-in automatic wavemeter for checking deviation in the f.m. modulator. It consists of the meter located in the centre of the modulator chassis plus a selector toggle switch and associated circuitry. Two tuned circuits are set to the extremes of the desired deviation range of modulation. One extreme corresponds to the tip of sync and the other to the peak of white. If the sync tip or low frequency limit is to be checked that tuned circuit is selected and the output of the modulator is gated into the wavemeter during the sync period. Proper adjustment is indicated by a maximum meter reading. In a similar fashion the frequency at peak white is checked by a gating circuit which feeds a signal to the wavemeter (now switched to the peak white tuned circuit).

2. The Quadrature Adjustment

The electrical adjustment for precision quadrature of the video heads has been the subject of considerable discussion and some misunderstanding. This problem in precision that arises in quadruplex recording (four heads multiplexed in time sequence) relates to the quadrature relationship of the four heads. The important consideration for interchangeability, of course, is that the signal pattern recorded on the tape be highly precise and standard. Figure 4 shows diagrammatically five video tracks recorded and the location of the television lines recorded on each. The distance A is that travelled by a head in 90 deg of rotation. The tracks are longer than A which results in the same signal being recorded on the beginning of track II as is recorded near the end of track I. This overlap permits switching from head to head without jeopardizing the continuity of signal. The corresponding points of the signal near the end of track I and the beginning of track II should be separated by a distance equal to A . Further, the corresponding points of the signal near the end of any track and the beginning of the next track should be separated by a distance equal to A .

Thus, if the recording is perfect, $A = b = c = d = g$. If $g \neq b \neq c \neq d$ errors exist in the placement of the pattern on the tape. Such errors can be generated by the lack of exact

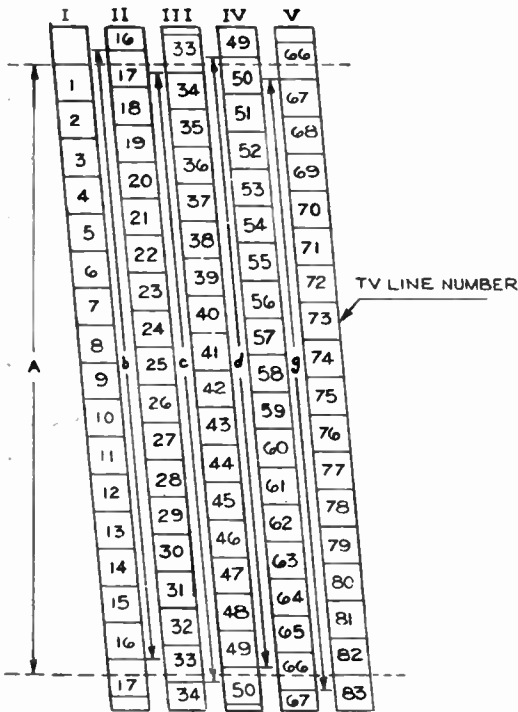

Fig. 4. Television line pattern on recorded video tracks.

90 deg angular spacing between the four video heads. If the angle between heads 1 and 2 is greater than 90 deg, head 2 will not have advanced far enough along track II at the instant line 16 ends, therefore distance b will be greater than A . This error can be corrected by the introduction of electrical delay in the 2 head channel so that the end of line 16 arrives at head 2 just enough later than it does at head 1 so that head 2 is in the right position to make $b = A$. A second solution is mechanical adjustment to return head 2 to its correct 90 deg spacing. Thus either electrical or mechanical adjustment can be used to approach a perfectly recorded pattern on the tape. Since it is not yet possible to manufacture video head assemblies that provide satisfactory accuracy some means of vernier adjustment is necessary. The adjustable electrical delay approach has been chosen for this equipment.

Quadrature errors are also of concern in the reproduction of a recorded tape. If the recorded pattern is perfect, timing errors in the output

signal of the playback machine will result if the playback heads do not follow each other in perfect time—space relationship. Thus if the playback head scanning track II is less than 90 deg behind the head that scans track I it will arrive at the end of line 16 too soon. This situation also can be corrected by the introduction of the proper electrical delay to the output of the head scanning track II.

There are two four-channel delay amplifier chassis: one is used in the recording channels and the other is used in the playback channels as illustrated in Fig. 6. These chassis are mounted in the left-hand rack (Fig. 1), the second and third up from the foot of the rack.

The net effect of quadrature errors is that the timing errors injected into the output signal appear as lateral displacements in the "bands" of picture information that is contained in the recorded tracks. The defect is most pronounced in vertical edges in the displayed picture since they appear discontinuous. Figure 5(a) is a photograph of a television tube which results from a signal that has passed through a properly set-up recording and playback cycle. Displacement errors are not detectable. Figure 5(b) shows the effect in the same scene when one head band occurs 0.03 microsec too early. The displacement error is thus 0.03 microsec. The scene requires careful scrutiny to detect the error. Figure 5(c) shows the effect in the scene when one head band occurs 0.03 microsec too late and the next one occurs 0.03 microsec too early. In this case the displacement error is 0.06 microsec. Figure 5(d) shows the effect in the scene when one head band occurs 0.06 microsec too late and the next band occurs 0.06 microsec too early. In this case the displacement error is 0.12 microsec which is one picture element. The disturbance is now quite pronounced and can be even more apparent when motion is added to the scene. Figure 5(e) shows the effect in the scene when one head band occurs 0.12 microsec too late and the next band occurs 0.12 microsec too early. This displacement error of 0.24 microsec can result from a head wheel having only 0.06 microsec errors in individual head gap positions.

In order to establish limits for manufacturing tolerances it was necessary to determine what



(a)



(b)



(c)



(d)

Fig. 5. Illustrating the effects of quadrature errors on the timing of bands of information.

- (a) Properly set-up recording and playback cycle.
- (b) One head band 0.03 microsec early.
- (c) One head band 0.03 microsec late and next one 0.03 microsec early.
- (d) One head band 0.06 microsec late and next one 0.06 microsec early.
- (e) One head band 0.12 microsec late and next one 0.12 microsec early.



(e)

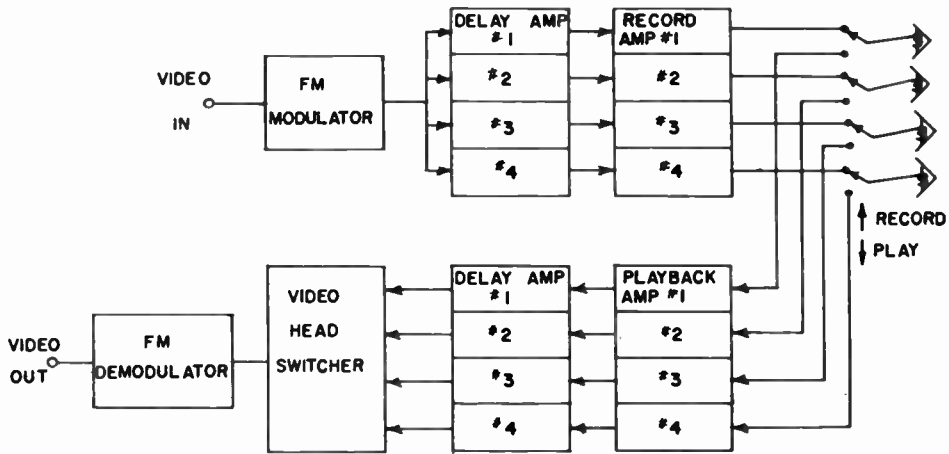

Fig. 6. The delay amplifier system.

inaccuracy in signal timing is tolerable. It can be quickly deduced that head band discontinuities in excess of one picture element are quite readily discerned. Subjective tests made under conditions where one head band could be displaced by precisely known and controlled amounts indicated that the inaccuracy in head band position should be held to within $\frac{1}{3}$ to $\frac{1}{2}$ of a picture element to be considered unobservable. When operating under U.S. standards with a spacing of 4.5 Mc/s between picture and sound carriers the maximum usable transmitted video frequency component is approximately 4.2 Mc/s. The picture element has a time duration of one-half the period of this wave. Thus the picture element is approximately 0.12 microsec. The size of such a picture element as measured along a scanned line on a 21-inch picture tube with a raster adjusted just to fill the width of the screen with active picture information is approximately 0.043 in. In the case of British 405-line, 50-field standards with a nominal 3 Mc/s bandwidth the picture element is approximately 0.17 microsec in duration. Thus the same incremental delay in a tapped delay line will result in a finer degree of positional control with respect to the picture element.

Video head assemblies enter the process at least twice before an input signal is reproduced: once in recording and once in playback. The maximum possible errors in the reproduced picture are the sum of the differences between the

plus and minus extreme deviations for each of the head assemblies. Thus if the reference is chosen as the mid-point between the extreme deviations in each case and a maximum allowed deviation exists in both assemblies, the maximum possible error in the reproduced picture is four times the maximum allowed deviation



Fig. 7. Head band displacement due to quadrature error.

from effective quadrature. Thus if the maximum displacement between the extreme bands in the reproduced picture as shown in Fig. 7 is to be half a picture element or 0.06 microsec, the maximum allowed deviation from effective quadrature for any head is 0.015 microsec. Thus the delay line taps were chosen to be at 0.03 microsec increments which permits setting the delay in the channels to within a maximum inaccuracy of ± 0.015 microsec. It is perhaps of interest to point out that 0.015 microsec in time corresponds to a distance of 23.4 micro-inches along the video track on the tape. This is less than $\frac{1}{3}$ of the gap dimension in the video head. The maximum error case happens only when both the record and playback head assemblies have complementary pairs of heads at the opposite extremes of the tolerance and the playback assembly is tracking so that the head with the maximum plus tolerance error is

playing back the track recorded with the head having the maximum minus tolerance error and vice versa. The chance that this combination will occur is quite small; thus on the average the maximum displacement will be less than 0.06 microsec or an effective quadrature error of less than 0.03 microsec. The foregoing description assumes that both head assemblies had been adjusted to within their tolerance of ± 0.015 microsec and then left untouched. If the delay lines are adjusted during playback (which in no way affects the record adjustment) the maximum displacement in Fig. 5(d) can be reduced to 0.03 microsec or an effective quadrature error of ± 0.015 microsec. Furthermore, improperly made recordings which have as much as 0.6 microsec displacement error can be corrected in playback, while on the air if necessary, to a maximum displacement error of 0.03 microsec.

3. Measurement and Correction of Quadrature Error

How does one check quadrature? How does one set the delay lines to achieve it? If there are observable horizontal displacements in the reproduced picture that do not change in relative position when the tracking phase is adjusted so that each track series (recorded by the same head) is played back by each of the four playback heads in turn, then the quadrature errors exist on the tape. If the horizontal displacement pattern shifts under these playback conditions, the errors can exist in the playback head assembly and on the tape. A simple, quick check to establish that adequate quadrature accuracy exists is the following. First, record a test pattern such as vertical lines or multi-burst signal. Second, play back the recording with each track series being played back by each of the four heads. (The equipment has full range control in track phasing.) If none of the four conditions of playback result in observable picture displacements, the head channels are in satisfactory effective quadrature. This is a self-checking test that can be made on a television tape recorder without the need of special test tapes and requires only a source of suitable test signal.

A second test is to play back a pre-recorded alignment test tape of known high precision in

track pattern. When such a tape is played back, any displacements that appear are associated with the playback head assembly and associated head channels. Should displacements exist, they can be readily measured by means of the playback delay lines by merely adjusting the delay-line tap switch to correct the displacement and observing from the switch positions the amount of incremental delay required to obtain the correction. Thus, a built-in precision measuring means is available.

To set the delay lines for precision quadrature, the following steps are recommended. First, in final test at the time of manufacture delay line settings are determined for precision effective quadrature on the test machine. This information will be supplied with the head assembly panel. When this panel is installed in a recorder in the field, the record and playback delay lines should be set to these switch positions. Second, after this preliminary set-up, a standard alignment test tape should be played back. If displacements appear, a trimming adjustment of the appropriate playback delay lines should be made to correct the displacements. The playback head channels are now standardized to the alignment test tape. Third, the changes made in the playback switch positions should be made in the corresponding record channel switch positions. Fourth, make a test recording of a vertical line pattern, multi-burst or similar signal. Play this recording back with head for head tracking and scrutinize for displacements in the picture. Should there be a displacement, its magnitude can be determined by adjusting the appropriate *playback* delay switch. After the measurement is made, the playback switch should be returned to its standardized position and the measured delay set into the corresponding record delay line switch in the same direction of rotation as was found necessary in correcting the error with the playback switch. As a further check, a test recording can be made again and scrutinized for displacements. If reasonable care was used, it is unnecessary to repeat the process. In brief, the technique is to standardize the playback delay adjustments by means of the standard alignment test tape. Then standardize the record delay adjustments by using the standardized playback delay lines as a reference.

Once the record channels are standardized, they should not be touched for the duration of use of that head assembly panel. It is also unnecessary to make any further adjustments in the playback channels, unless it becomes desirable to compensate for errors in a poorly or improperly recorded tape.

It is also possible to adjust the record and playback channels for precision quadrature by using the self-checking facilities in the machine and requiring only a source of suitable test signal, such as a vertical line pattern. When using this technique, the data taken should be written down in organized, tabular form since specific calculations must be made in the course of alignment. Assume initially that no information is available on the proper delay line settings for the head assembly panel. First, set all delay line switches to the same mid-position tap. Next, record a vertical line or similar test pattern. In order to identify the track series on the tape, the signal on track 1 can be recorded at a lower than normal level or preferably be recorded at normal level and periodically switched off. The test recording is next played back and scrutinized for displacement errors under the condition where the tracks are played back by the same heads as recorded them. In case of doubt, the playback head channels can be quickly identified by operating the push-button switch on the equalizer chassis for the desired channel. When actuated, this switch reduces the level of signal in that channel so that the resulting band in the picture becomes noisy. If there is a slight displacement error, a trimming adjustment can be made in the appropriate playback delay line. At this point, the switch settings of all delay line switches should be recorded. Next, observe the displacement error pattern when track series 2 is played back by head 1 and when track series 4 is played back by head 1. Choose the one showing the greatest displacement error. Measure the delay correction required in channels 2, 3 and 4 to match the position of channel 1 which is the reference. If the delay line switch must be rotated clockwise to obtain the correction, the measured value has a positive sign. If it must be rotated counterclockwise, the measured value has a negative sign.

In the following equations, the measured dis-

placement errors are designated D_2 , D_3 , and D_4 . The time errors in the record head channels can then be calculated from the expressions

$$\begin{aligned} e_2 &= \frac{1}{4} (D_4 + D_3 + D_2) \\ e_3 &= \frac{1}{2} (D_4 + D_3 - D_2) \\ e_4 &= \frac{1}{4} (3D_4 - D_3 - D_2) \end{aligned}$$

if recorded track 2 is played back with head 1.

Should the measurements be made with track series 4, played back with head 1, the equations become

$$\begin{aligned} \frac{1}{4} (3D_2 - D_3 - D_4) \\ \frac{1}{2} (D_2 + D_3 - D_4) \\ \frac{1}{4} (D_2 + D_3 + D_4) \end{aligned}$$

After calculating the time errors e_2 , e_3 , and e_4 from either set of equations, the corresponding record delay line switches are adjusted by these amounts. If e_2 is positive, record switch 2 should be rotated clockwise by the amount of e_2 . Similarly, switches 3 and 4 should be set. The record channels are now standardized. Now a second test recording should be made and played back with head 1 playing back the track 1 series. Next adjust the playback delay lines to eliminate the displacement errors. A further check can now be made by playing back in the three other tracking modes and scrutinizing the picture for displacement errors. Should there be any, the process can be repeated. However, this alignment technique is one that converges very rapidly and normally does not require a second step if the first one is carried out carefully.

4. Conclusions

The design of the RCA TRT-1A television tape recorder makes many new operating facilities available as integrated parts of the recorder. In addition, features such as the electrical delay adjustments are an advance in the art which make greater precision readily available and subsequently will aid in achieving tape interchangeability with highly acceptable performance.

5. Appendix : Head Wheel Quadrature Error Measurement

The effective recording gaps of a video head wheel are nominally at 90 deg quadrature locations about the periphery of the "head wheel." For purposes of calculation place gap 1 at the polar reference of 0 deg. The angular errors in the gap positions are then ϵ_1 , ϵ_2 , ϵ_3 , ϵ_4 , respectively with $\epsilon_1 = 0$ by virtue of the reference

choice. However, it is usually simpler to think in terms of errors in signal timing since the input and output signals are time functions (Fig. 8).

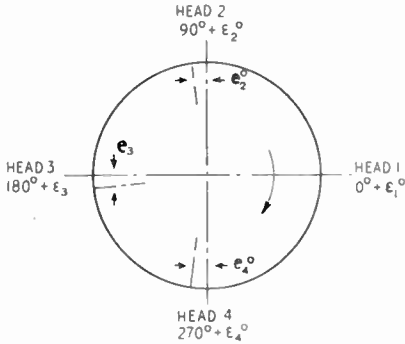

Fig. 8. Quadrature errors.

The wheel rotates at a nominal speed of 240 revolutions per second. In terms that are the order of magnitude of the errors, an error of one microsecond in timing corresponds to an angular error of 311.04 seconds of arc. The errors e_1, e_2, e_3, e_4 are errors in time corresponding to the ϵ_x errors in angle. If e_x is a positive quantity, the pattern recorded by magnetic head x will be located on the tape so that the signal will occur too early when played back with an ideal head assembly. Thus a positive value for e_x represents an advance in timing of the signal on tape (or a negative time delay). Also, if e_x is a positive quantity, the timing of the signal played back by head x from a perfectly recorded tape will be such that a delay will occur.

Designate the positional errors on the recorded tape due to slightly misplaced (mis-timed) video tracks as E_1, E_2, E_3, E_4 where one track is arbitrarily chosen as a reference and thus the associated positional error $E_x = 0$. From the paragraph above it is evident that if e_2 is a positive quantity then E_2 is a negative quantity. When E_2 is the error in the pattern recorded by head 2, $|e_2| = |E_2|$ and the resulting error when track 2 is played back by head 2 is the sum of the two

$$e_2 + E_2 = \text{net error} = 0.$$

If a head wheel with positional errors e_2, e_3, e_4 records and then plays back a tape with the same head recording and playing back each track, the recorded errors E_2, E_3 and E_4 will

cancel out with the playback errors e_2, e_3 and e_4 . In this case

$$E_2 + e_2 = 0 \quad E_3 + e_3 = 0 \quad E_4 + e_4 = 0$$

However, if head 1 plays track 2, head 2 plays track 3, head 3 plays track 4 and head 4 plays track 1 the errors will not cancel. In this case it is convenient to choose track 2 as a reference since it is played back by 1, the reference head. For clarity designate the reference track by a leading subscript. The ${}_1E_x$ is the positional error of track x with track 1 being the reference. Thus

$$\begin{aligned} {}_1E_1 &= 0 & {}_1E_2 &= y = -e_2 \\ {}_1E_2 &= x = -e_2 & {}_1E_4 &= z = -e_4 \end{aligned}$$

If track 2 is the reference

$$\begin{aligned} {}_2E_1 &= -x & {}_2E_3 &= y - x \\ {}_2E_2 &= 0 & {}_2E_4 &= z - x \end{aligned}$$

The errors appearing in the head bands on playback will be

$$\begin{aligned} D_1 &= e_1 + {}_2E_2 = 0 + 0 = 0 \\ D_2 &= e_2 + {}_2E_3 = e_2 + y - x = e_2 - e_3 + e_2 \\ D_3 &= e_3 + {}_2E_4 = e_3 + z - x = e_3 - e_4 + e_2 \\ D_4 &= e_4 + {}_2E_1 = e_4 - x = e_4 + e_2 \end{aligned}$$

The errors D_2, D_3, D_4 can be measured in the resulting picture by introducing corrective delay to eliminate the error. The positional errors e_2, e_3, e_4 can then be calculated

$$\begin{aligned} 2e_2 - e_3 &= D_2 \\ e_2 + e_3 - e_4 &= D_3 \\ e_2 + e_4 &= D_4 \\ e_2 &= \frac{1}{4}(D_2 + D_3 + D_4) \\ e_3 &= \frac{1}{2}(D_3 + D_4 - D_2) \\ e_4 &= \frac{1}{4}(3D_4 - D_3 - D_2) \end{aligned}$$

If track 4 is the reference

$$\begin{aligned} {}_4E_1 &= -z = e_4 \\ {}_4E_2 &= x - z = e_4 - e_2 \\ {}_4E_3 &= y - z = e_4 - e_3 \\ {}_4E_4 &= 0 = 0 \end{aligned}$$

The errors appearing in the head bands on playback will be

$$\begin{aligned} D_1 &= e_1 + {}_4E_4 = 0 \\ D_2 &= e_2 + {}_4E_1 = e_2 - z = e_2 + e_4 \\ D_3 &= e_3 + {}_4E_2 = e_3 + x - z = e_3 + e_4 - e_2 \\ D_4 &= e_4 + {}_4E_3 = e_4 + y - z = e_4 - e_3 \end{aligned}$$

Solving for e_2, e_3 and e_4

$$\begin{aligned} e_2 + e_4 &= D_2 \\ -e_2 + e_3 + e_4 &= D_3 \\ -e_3 + 2e_4 &= D_4 \\ e_2 &= \frac{1}{4}(3D_2 - D_3 - D_4) \\ e_3 &= \frac{1}{2}(D_2 + D_3 - D_4) \\ e_4 &= \frac{1}{4}(D_2 + D_3 + D_4) \end{aligned}$$

Note on "Ultraharmonic and Subharmonic Resonance in an Oscillator" †

by

B. R. NAG, M.SC.TECH. ‡

In a letter received by the Institution on 11th December 1959, Professor V. V. Migulin, of the Chair of Theory of Oscillators in the Faculty of Physics, Moscow State University, draws attention to a number of Russian papers dealing with ultraharmonic and subharmonic resonance in an oscillator. I was not acquainted with the contents of these at the time of writing the paper which was published in the July 1959 *Journal*.

In my paper expressions for the amplitude and phase and the conditions of stability of synchronized ultraharmonic and subharmonic oscillations in an oscillator with cubic non-linearity were deduced. Special attention was devoted to pointing out the distinctive characteristics of the two types of resonance with reference to the dependence of the zone of synchronization on the amplitude of the synchronizing signal and the possibility of hysteresis within the region of synchronization. Experimental results obtained with an elec-

tronic differential analyzer were also presented for comparison with the calculated results.

I understand that the amplitude and conditions of stability of synchronous ultraharmonic oscillators^{1, 2}, the possibility of jumps in amplitude and phase only by varying the frequency³, the existence of regions of stable phase in which it would be impossible to enter by varying the frequency^{4, 5, 6} and the possibility of synchronization by complicated signals⁷ have been studied in a number of papers listed by Professor Migulin.

References

1. L. Mandelstam and N. Papalex, *Z. f. Phys.*, **73**, p. 223, 1931. (In German.)
2. L. Mandelstam and N. Papalex, *Zh. Tekh. Fiz.*, **2**, p. 775, 1932.
3. V. Siforov, *Radiotekhnika*, **1**, No. 5, p. 3, 1946.
4. R. Chochlov, *Vestnik Moskovskogo Universiteta*, No. 8, 1954.
5. R. Chochlov, *Vestnik Moskovskogo Universiteta*, No. 12, 1954.
6. T. Gailit and I. Minakova, *Radiotekhnika*, **11**, No. 7, p. 50, 1956.
7. L. Martynenko, *Radiotekhnika i Elektronika*, **3**, No. 2, p. 277, 1958.

† *J. Brit.I.R.E.*, **19**, pp. 411-36, July 1959.

‡ University of Wisconsin, U.S.A., received by the Institution 15th February 1960.
U.D.C. No. 621.373.4.

Members are reminded that the Papers Committee will be pleased to receive comments on papers which have been published in the *Journal* for consideration for publication as a written discussion. Short complete papers are also welcomed, particularly those giving advance details of aspects of a larger project. Advice on the submission of papers can be obtained from the Secretary, and a leaflet "Guidance for Authors" will be sent on request to those preparing papers.

A Tunnel Diode Crystal Calibrator †

by

L. G. COX, B.SC. ‡

Summary : A diagram showing the ratios of circuit constants for the five possible modes of operation of a series tunnel diode circuit is given. A tunnel diode crystal calibrator with a relatively flat output in the h.f. band is described, and circuit details of a 100 kc/s or 1000 kc/s calibrator are given.

1. Introduction

The switching time between the low and high voltage states of a tunnel diode is extremely short. As a consequence, a tunnel diode relaxation oscillator can produce very short pulses and can be a prolific generator of harmonics.

2. Modes of Operation

The basic equivalent circuit for a series connected tunnel diode is shown in Fig. 1(a). R_N is the diode junction resistance, and C is the associated junction capacitance. R_T is the total circuit resistance which includes the bulk resistance of the semi-conductor, and L is the total circuit inductance. The diodes used have an internal lead inductance of approximately 2 millimicrohenries.

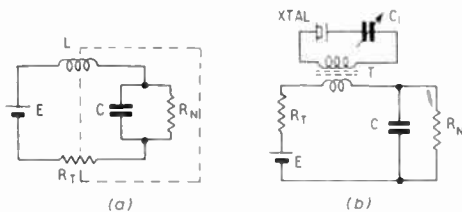

Fig. 1. Equivalent circuits of tunnel diode oscillators (a) free-running (b) crystal-controlled.

There are a number of possible modes of operation, corresponding to regions indicated in the diagram of Fig. 2. The modes of operation are as follows : when the total series resistance R_T exceeds the magnitude of the negative

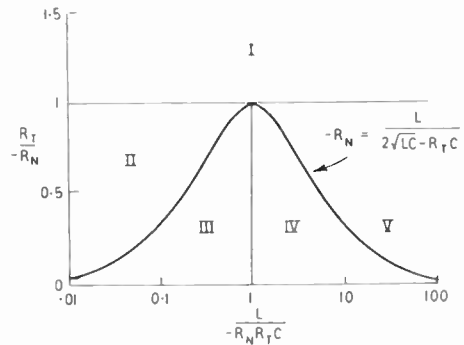

Fig. 2. Regions of operation of tunnel diode circuit of Fig. 1(a). Region I, switching; Region II, exponential pulses; Region III, amplification; Region IV, sinusoidal oscillation; Region V, relaxation oscillation.

resistance R_N , the device can only switch between high and low voltage states as the supply voltage is altered—corresponding to Region I. If, however, $R_T < -R_N$, there are four other modes of operation.

If the series inductance is small, with $L < -R_N R_T C$, the circuit is stable and oscillations will not occur. If, in addition,

$$-R_N < L/[2 \sqrt{(LC) - R_T C}]$$

a single exponential pulse is produced (Region II) when the voltage is applied. Alternatively if

$$-R_N > L/[2 \sqrt{(LC) - R_T C}]$$

(Region III), amplification is possible. When $L > -R_N R_T C$ the circuit is unstable and oscillations occur (Regions IV and V). If

$$-R_N > L/[2 \sqrt{(LC) - R_T C}]$$

sinusoidal oscillations are produced (Region IV), but if

$$-R_N < L/[2 \sqrt{(LC) - R_T C}]$$

relaxation oscillations are produced (Region V).

† Manuscript first received 7th June 1960 and in final form on 11th July 1960. (Contribution No. 28.)

‡ Radio and Electrical Engineering Division National Research Council, Ottawa, Canada.

U.D.C. No. 621.382.2 : 621.373.421.13

Although the boundaries between the regions are distinct, there are no abrupt changes from one mode of operation to another because R_N varies with the voltage across the diode. If R_T , R_N and C are constant and L is increasing, sinusoidal oscillations, which are produced in Region IV, gradually change shape as the boundary to Region V is crossed, and become semi-rectangular deep in Region V.

3. Calibrator Design

The calibrator consists of a crystal-controlled relaxation oscillator which accurately sets the 100 kc/s repetition frequency, and a triggered relaxation oscillator which produces short pulses with a suitable harmonic content. Both relaxation oscillators are operated far into Region V, and produce pulses with rise and fall times of the order of 1 nanosecond.

3.1. Crystal-controlled Oscillator

The repetition frequency of the free-running relaxation oscillator of Fig. 1(a) is principally determined by the inductance L . If another circuit is coupled to the oscillator by replacing the inductor L in Fig. 1(a) with transformer T in Fig. 1(b), the oscillator may be locked easily by means of a quartz crystal in the secondary circuit. The variable capacitor $C1$ allows the harmonics of the crystal calibrator to be synchronized with standard frequency transmissions. The differentiated output from the crystal-controlled oscillator is used to trigger the short-pulse generator.

3.2. Pulse Generator

An h.f. calibrator should have reasonably constant output across the h.f. band. The maximum pulse width permissible depends upon the pulse shape, but in general should not be greater than $1/f$ microseconds, where f is the highest frequency in the band in Mc/s. A periodic rectangular waveform has a frequency spectrum whose envelope is given by

$$C_n = \frac{2 A_{avg} \sin \pi n F / f_0}{\pi n F / f_0}$$

where the repetition frequency is F , pulse width is $t_0 = 1/f_0$ and average amplitude is A_{avg} . The peak pulse amplitude of a tunnel diode relaxation oscillator is relatively independent of pulse width. As the pulse width is decreased the

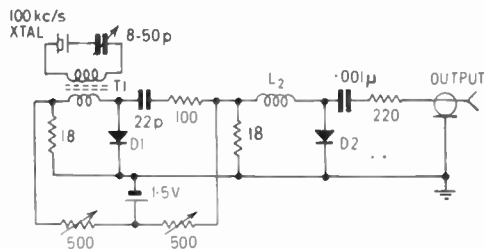

Fig. 3. Complete circuit diagram of 100 kc/s crystal calibrator.

average pulse amplitude, and the amplitudes of the lower harmonics, are thus decreased.

A pulse width of 23 nanoseconds was chosen as a compromise which would give a relatively constant amplitude in the h.f. band, and a usable amplitude at low frequencies. Although the amplitude of the 100 kc/s fundamental is down 40 db from the crystal-controlled oscillator fundamental, the amplitude of the 300th harmonic is only 8 db below the fundamental. The first minimum is at 43 Mc/s.

The complete circuit diagram of the 100 kc/s calibrator is shown in Fig. 3. The output from the crystal-controlled oscillator diode $D1$ is differentiated by the 22 pF capacitor and 100 plus 18 ohm resistors, and the portion of the differentiated output developed across the 18 ohm resistor triggers diode $D2$, causing a single output pulse for each trigger pulse.

4. Circuit Details

The basic circuit of Fig. 3 was also used when constructing a dual frequency 100/1000

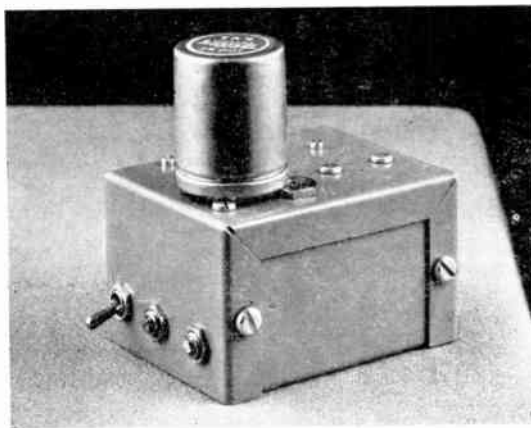

Fig. 4. Front view of calibrator.

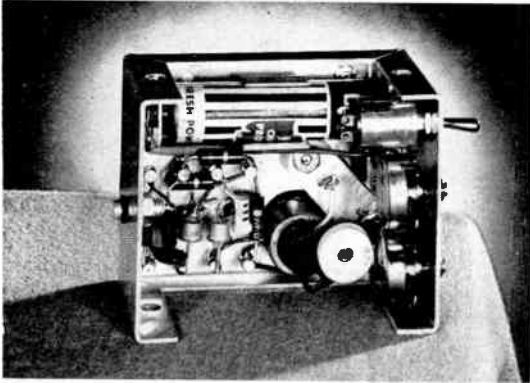

Fig. 5. Crystal calibrator showing construction details.

kc/s calibrator, the only addition being a second transformer, trimmer and crystal, with an s.p.d.t. switch to connect in the desired resonant circuit.

The 100-kc/s calibrator unit, which was built in a $1\frac{1}{2}$ in. \times $2\frac{1}{8}$ in. \times $2\frac{3}{4}$ in. case, is shown in Figs. 4 and 5. Miniature components—potentiometers, switch and coaxial connector—were used to conserve space.

Transformer T1 was wound on a Ferroxcube III D 14/8 pot core with 0.001 in. gap, with 27 and 200 turns for the 100 kc/s, and 7 and 70 turns for the 1000 kc/s primary and secondary. The tuning slug was not used. The inductance L2 of the pulse generator consists of three Ferroxcube III shielding beads on a short length of wire, which produces a free-running repetition frequency of 18 Mc/s. The diode D2 is normally biased to a point just below the peak of the diode characteristic, and is triggered once by each pulse from D1.

The free-running frequency of the relaxation oscillator must be higher than the crystal frequency for synchronization. When using a Bliley KV3 100-kc/s crystal and a Sony germanium tunnel diode, the oscillator locked to the crystal if the free-running frequency were between 100 and 163 kc/s.

An attempt was made to use a dual frequency crystal (Bliley SMC 100), but the oscillator tended to lock at sub-multiples of 1000 kc/s, such as 111.1 kc/s, rather than 100 kc/s. Similarly bar-cut 100-kc/s crystals are not suitable because other modes of crystal vibration are set up, causing a much smaller pull-in range for

the proper mode. The best crystal of those available for the purpose was a square crystal, the Bliley KV3 mentioned previously. There was not the same difficulty with 1000 kc/s crystals although the pull-in range was smaller.

The output from the pulse generator stage is taken through a 0.001- μ F capacitor and 220-ohm resistor to minimize the loading effects of external circuits on the calibrator.

5. Test Results

Both the 100 and 1000 kc/s calibrators produced a broad spectrum of harmonics with the first minimum at approximately 43 Mc/s, although the low frequency output was much less than the output of the crystal oscillator stage alone.

With a commercial v.h.f. receiver containing a built-in b.f.o., distinctly audible beat notes were obtained with the 100 kc/s calibrator at frequencies up to 150 Mc/s. An R54/APR4 radar receiver having a fairly high noise figure was used to test the 1000 kc/s calibrator, with an auxiliary signal generator as a b.f.o. Beat notes were observed every megacycle to 600 Mc/s and with gaps to 900 Mc/s.

The current drain from the 1.5V penlight-type cell was 15-20 mA with tunnel diodes having 5 mA peak current. Separate voltage dividers were used for simplicity despite the extra current required.

Changes of the oscillator diode temperature have a small effect on frequency, but the temperature stability of the calibrator depends principally upon the temperature coefficient of the crystal itself. The variable trimmer has a characteristic of -750 parts in 10^6 to help compensate the positive crystal characteristic.

6. Conclusions

The crystal-controlled tunnel diode calibrator is a very compact spectrum generator with an output usable to hundreds of megacycles, and fairly flat across the entire h.f. band. The discharge time of the penlight cell as a power source is estimated to be approximately 50 hr.

7. Acknowledgment

The author is indebted to J. K. Pulfer for his helpful advice and discussions.

of current interest . . .

Swedish Instruments Conference and Exhibition

The British Nuclear Energy Industry is taking an important part in the fifth International Instruments and Measurements Conference and Exhibition which is being held in Stockholm from 10th–17th September. There are to be no fewer than twenty-six papers on nuclear subjects, fourteen from the United Kingdom Atomic Energy Authority, one from the Department of Scientific and Industrial Research and eleven from Industry. It is interesting to note that this large group of papers led the organizers to add a new Section on "Reactor Control" to the proceedings.

Two of the papers are being given by members of the Institution. Mr. S. R. Wilkins (Member) will read a paper on "Some Recent Advances in Portable Measuring Instruments" while Mr. G. D. Smith (Associate Member) is co-author in a paper on "Recent Developments in Health Physics Monitoring Instruments."

There will be ten individual exhibits by British firms and organizations in the associated exhibition, while half a dozen other Companies are exhibiting as the "English Component Group" through a Swedish Company.

Low-power Television Station at Sheffield

The B.B.C. has recently announced that the low-power television station at Sheffield now under construction will be ready for service in the autumn. It is intended to give improved reception in parts of Sheffield where reception of Holme Moss on Channel 2 is difficult on account of ghost images and interference.

The station is located at Tapton Hill, about two miles west of the City Centre, and will use Channel 1 with horizontal polarization. It will work unattended, and will relay the television signals from Holme Moss. The station is already working on reduced power and it will continue to do so throughout the normal hours of transmission until it is ready for full-power service.

Simplified Servicing

With the aim of enabling faults or failures in television receivers to be traced without the aid of a service manual Philco (Great Britain) Ltd. have developed a system of colour identification known as CODENTA which is based on colour identification of circuits and components in a receiver. This has been combined in a new series of receivers with an improved system of unitized construction whereby almost all the main assemblies in the receiver can be quickly detached in a matter of seconds without the use of tools. It is claimed that this system will greatly simplify the work of maintenance, fault diagnosis and repair and minimize the amount of technical knowledge and skill required to service these receivers.

Colour coding, as the term is normally understood, is confined to coloured wiring but with "Codenta" each circuit and its associated components (sound, vision, power, etc.) are also identified by colour printed on the upper side of the printed wiring board or metal chassis, and valves, part numbers and functions of components are also clearly marked and named. The service mechanic can thus see at a glance the identity of each part of the circuit and what function it performs.

Seven colours are used to identify the circuitry, as follows: blue= sound, yellow= vision, red= power, pink= line, purple= frame, green= synchronizing, white= component nomenclature. Consequently, if a failure occurs on vision, the service mechanic need only check the parts of the circuit coloured yellow, and similarly, a sound defect would indicate an examination of the blue-coloured parts of the chassis.

Nuclear Safety Advisory Committee

The Minister of Power and the Secretary of State for Scotland have set up a Nuclear Safety Advisory Committee under the Chairmanship of Sir Alexander Fleck, K.B.E., F.R.S.; he will be assisted by twenty-three other members among whom is Colonel G. W. Raby, C.B.E., a Vice-President of the Institution.

Recommended Method of Expressing Electronic Measuring Instrument Characteristics

5. A.C. BRIDGES †

*Prepared by the Technical Committee of the Institution
and based on a report compiled by J. Powell, M.Sc. (Associate Member)*

Introduction

A.C. Bridges are the subject of this fifth set of recommendations in a series¹⁻⁴ which has the objective of influencing uniformity in the presentation of information on the features, characteristics and performance of electronic measuring instruments and thus assisting in their comparative assessment and selection by potential users. The establishment of standards of performance is not the objective of these recommendations.

The oscillator and balance detector may or may not be incorporated in any particular instrument. The recommendations have been framed to include both cases so that comparative assessment of oscillators and balance detectors, for use in conjunction with a given bridge, is possible.

There are many derived electrical quantities measured by bridge methods which are not treated in Parts 2 and 3. This is because the derived quantities are measured in terms of those quantities which do appear there.

Alternating current bridge techniques are widely employed for the measurement of a number of other indirect parameters which can be related to the electrical quantities of resistance, inductance and capacitance. Except in so far as the electrical characteristics are concerned recommendations have not been included for instruments specifically designed for the measurement of such parameters.

Table of Contents

1. General details	3.4 Incremental inductance	4.12 Frequency
1.1 Power supply requirements	3.5 Magnification factor	4.13 Percentage difference
1.2 Temperature range	3.6 Capacitance	
1.3 Construction and finish	3.7 Power factor	5. Balance detector
1.4 Valve and/or transistor complement	3.8 Dissipation factor	5.1 Amplifier
1.5 Accessories	3.9 Transformer turns ratio	5.2 Type of indicator
1.6 Ancillary equipment	3.10 Impedance	5.3 Meter overload protection
1.7 Dimensions	3.11 Phase angle	5.4 Terminals
1.8 Weight	3.12 Frequency	5.5 Screens
	3.13 Percentage difference	
2. Bridge network	4. Measurement accuracy	6. Oscillator
2.1 Type of network	4.1 Resistance	6.1 Type of oscillator
2.2 Frequency range	4.2 Conductance	6.2 Frequency drift
2.3 Scale	4.3 Inductance	6.3 Frequency range
2.4 Type of measurement	4.4 Incremental inductance	6.4 Calibration accuracy
2.5 Terminals	4.5 Magnification factor	6.5 Re-setting accuracy
2.6 Screens	4.6 Capacitance	6.6 Frequency adjustment
	4.7 Power factor	6.7 Frequency variation
3. Measurement range	4.8 Dissipation factor	6.8 Modulation
3.1 Resistance	4.9 Transformer turns ratio	6.9 Harmonic ratio
3.2 Conductance	4.10 Impedance	6.10 Output impedance
3.3 Inductance	4.11 Phase angle	6.11 Signal level
		6.12 Terminals
		6.13 Screens

† Approved by the Council for publication on 17th February, 1960. (Report No. 19).
U.D.C. No. 621.317.733.023

TECHNICAL COMMITTEE

FEATURE	METHOD OF EXPRESSION	REMARKS
Part 1—GENERAL DETAILS		
1.1 Power supply requirements	.. volts d.c./a.c. .. c/s .. watts (Voltage change \pm .. %)	Maximum supply voltage variation for which the stated measurement accuracies hold good should be given.
1.2 Temperature range	.. °C to .. °C	Maximum ambient temperature range for which the stated measurement accuracies hold good.
1.3 Construction and finish		Where these features conform to particular specifications the latter should be named.
1.4 Valve and/or transistor complement	Type numbers	
1.5 Accessories		Details of any connectors, standard components, brackets or platforms which are not fixed to the instrument, but are included with it, should be given. Adaptors available for extending the range of measurements should be specified.
1.6 Ancillary equipment		Where specific oscillators or balance detectors are recommended for use in conjunction with the instrument their features should be expressed in accordance with the recommendations contained herein.
1.7 Dimensions	Height .. in. (... cm) Width .. in. (... cm) Depth .. in. (... cm)	Over all projections.
1.8 Weight	.. lb. (... kg)	
Part 2—BRIDGE NETWORK		
2.1 Type of network		If the network is based on the well-known configurations, e.g. Wien bridge, or if the configuration changes with measurement of different quantities, this should be stated.
2.2 Frequency range	.. c/s to .. c/s	Frequency range over which the stated measurement accuracies hold good should be given. Extensions to either limit should be accompanied by the relevant measurement accuracies.

METHOD OF EXPRESSING CHARACTERISTICS OF A.C. BRIDGES

FEATURE	METHOD OF EXPRESSION	REMARKS
2.3 Scale		Scale multiplying factors should be stated. If the scale is not direct reading give inscription details.
2.3.1 Calibration	Linear, logarithmic, square law, etc.	
2.4 Type of measurement	Two, three or four terminal. Unbalanced, balanced, or balanced with centre point earthed.	If measurement of components can be made <i>in situ</i> this should be stated.
2.5 Terminals		
2.5.1 Oscillator	Coaxial, screw, etc.	State whether balanced or unbalanced.
2.5.2 Balance detector	Coaxial, screw, etc.	State whether balanced or unbalanced.
2.6 Screens		Details of bridge screening should be given.

Part 3—MEASUREMENT RANGE

3.1 Resistance	.. Ω to .. M Ω	If a range switch is employed the range for each switch position should be quoted.
3.2 Conductance	.. μ mhos to .. mhos	Range for each range switch position should be quoted.
3.3 Inductance	.. μ H to .. H	Range for each range switch position should be quoted. If mutual inductance can be measured this should be stated.
3.4 Incremental inductance	.. μ H to .. H	Quote d.c. source open circuit voltage and impedance, permissible range of d.c. current values and the accuracy of the measuring meter, and the range for each range switch position.
3.5 Magnification factor	0 to ..	Range for each range switch position should be quoted and the range of frequencies for which the scale gives true readings.
3.6 Capacitance	.. pF to .. μ F	Range for each range switch position should be quoted.
3.7 Power factor	0 to ..	Range for each range switch position should be quoted and the range of frequencies for which the scale gives true readings.

FEATURE	METHOD OF EXPRESSION	REMARKS
3.8 Dissipation factor	0 to ..	Range for each range switch position should be quoted and the range of frequencies for which the scale gives true readings.
3.9 Transformer turns ratio	.. :1 to .. :1	
3.10 Impedance	.. Ω to .. $M\Omega$	Range for each range switch position should be quoted. Where impedance is measured as a combination of resistance and reactance it should be stated whether the components are measured as series or parallel values.
3.11 Phase angle	0° to \pm .. $^\circ$	
3.12 Frequency	.. c/s to .. c/s	Continuous or stepped coverage should be stated and in the latter case the minimum step quoted.
3.13 Percentage difference	\pm .. %	This is the difference existing between the component under test and a selected standard expressed as a percentage of the standard.

Part 4—MEASUREMENT ACCURACY

Where it is possible with a particular instrument to make measurements of an electrical quantity under different bridge conditions the accuracy of measurement under each condition should be stated.

4.1 Resistance	\pm .. % or \pm .. Ω	} The accuracy for each range switch setting should be quoted.
4.2 Conductance	\pm .. % or \pm .. mhos	
4.3 Inductance	\pm .. % or \pm .. μH	
4.4 Incremental inductance	\pm .. % .. \pm .. μH	
4.5 Magnification factor	\pm .. % or \pm ..	
4.6 Capacitance	\pm .. % or \pm .. pF	
4.7 Power factor	\pm .. % or \pm ..	
4.8 Dissipation factor	\pm .. % or \pm ..	
4.9 Transformer turns ratio	\pm .. %	The accuracy in each part of the range should be quoted.

METHOD OF EXPRESSING CHARACTERISTICS OF A.C. BRIDGES

FEATURE	METHOD OF EXPRESSION	REMARKS
4.10 Impedance	$\pm \dots \% \text{ or } \pm \dots \Omega$	The accuracy for each range switch setting should be quoted. } The accuracy in each part of the range should be quoted.
4.11 Phase angle	$\pm \dots ^\circ$	
4.12 Frequency	$\pm \dots \% \text{ or } \pm \dots \text{ c/s}$	
4.13 Percentage difference	$\pm \dots \%$	

Part 5—BALANCE DETECTOR

5.1 Amplifier	YES/NO	
5.1.1 Type	Frequency selective (fixed or variable), aperiodic, etc.	
5.1.2 Frequency range	$\dots \text{ c/s to } \dots \text{ c/s}$	
5.1.3 Gain	Variable/fixed	State whether the gain is variable continuously or in steps.
5.1.4 Sensitivity	$\dots \mu\text{V}$	Minimum voltage producing an effective indicator response.
5.1.5 Selectivity	\dots	State as an equivalent Q value.
5.1.6 Input impedance	$\dots \Omega$ shunted by $\dots \text{ pF}$	State whether the input is balanced or unbalanced.
5.2 Type of indicator		Where the indicator sensitivity is adjustable this should be stated, and if more than one indicator is used the relative sensitivities should be stated.
5.2.1 Visual	Meter, cathode ray or cold cathode device, etc.	
5.2.2 Aural	Headphones	State impedance.
5.3 Meter overload protection	YES/NO	State the form of protection.
5.4 Terminals	Coaxial, screw, etc.	
5.5 Screens		Details of balance detector and terminal screening should be stated.

Part 6—OSCILLATOR

6.1 Type of oscillator	LC, RC, mains supply, crystal, etc.	
6.2 Frequency drift		
6.2.1 Short term	$\dots \% \text{ or } \dots \text{ c/s}$	Maximum change in frequency over any period of 10 min. within a 7-hr. period commencing 60 min. after switching on. During this 10-min. period the supply voltage and temperature are assumed to be sensibly constant.

TECHNICAL COMMITTEE

FEATURE	METHOD OF EXPRESSION	REMARKS
6.2.2 Long term	.. % or .. c/s	Maximum change in frequency over 7-hr. period commencing 60 min. after switching on. During this 7-hr. period the supply voltage and the temperature are assumed to be sensibly constant.
6.3 Frequency range	.. c/s to .. c/s in .. bands	Frequency range of each band should be stated.
6.4 Calibration accuracy	.. %	Maximum error at any value of the output frequency in relation to the calibration of the main frequency control.
6.5 Re-setting accuracy	.. %	Re-setting accuracy of the main frequency control.
6.6 Frequency adjustment	\pm .. %	Variation provided for on a nominally fixed frequency.
6.7 Frequency variation	\pm .. %	Maximum variation produced by bridge loading changes.
6.8 Modulation (sinusoidal)	YES/NO	
6.8.1 Depth	.. %	
6.8.2 Frequency	.. c/s	
6.9 Harmonic ratio	.. db	Ratio of signal to total harmonic power at the output terminals with maximum signal level under matched conditions.
6.10 Output impedance	.. Ω	State whether balanced or unbalanced output.
6.11 Signal level	.. V (open circuit)	Maximum r.m.s. value of the signal. If the level is adjustable this should be stated and whether stepped or continuous variation is provided.
6.12 Terminals	Coaxial, screw, etc.	
6.13 Screens		Details of oscillator and terminal screening should be stated.

List of the Recommendations in this Series

1. "Amplitude-modulated or frequency-modulated signal generators," (January 1958). 2. "Cathode-ray oscilloscopes," (January 1959). 3. "Low frequency generators," (March 1960). 4. "Valve voltmeters," (April 1960).

Aviation Medicine and Electronics †

by

G. H. BYFORD, PH.D.‡

A paper read at a meeting of the Medical Electronics Group held in London on 21st October 1959.

Summary: The problems and environmental conditions in Aviation Medicine are discussed with reference to the electronic equipment which is used to measure centrifugal acceleration, angular acceleration and vibration. The problems of high altitude and very high speeds are described. Some engineering developments which would aid considerably this field of research are put forward.

1. Introduction

In 1875, two of the three occupants of a balloon died after prolonged ascent to 28,000 ft. It was a scientific ascent complete with instruments, and the report of the survivor gives us the first recorded fatality due to lack of oxygen at height. Aviation medicine had arrived.

In 1959, after an expenditure which in indices competes with astronomical distances, flight is no longer just a problem for the engineer; if men are to profit by the achievement of modern aircraft they must not just survive, but must retain sufficient of their faculties to appreciate their surroundings and control their vehicle in its hostile environment. It was to make these things possible that the many aviation medical laboratories were formed throughout the world.

Some of the laboratory equipment is unusual by the standard of conventional medical research, but most would pass unnoticed in any large hospital. Electronics, of course, has penetrated almost every field of measurement; aviation medicine is no exception and the things to be measured are those which interest physiologists everywhere. It is only the problems and the environmental conditions which are different, and so in what follows rather more attention is sometimes given to the pur-

pose of electronic equipment and the conditions under which it is used, than to circuit details.

2. Centrifugal Acceleration

It is common experience that the occupants of a motor car taking a corner at speed are flung to one side by the action of centrifugal force, a linear acceleration. An aircraft is normally banked when turning a corner and the centrifugal force tends to push the crew member down into his seat, the same thing in effect as increasing his weight. When this apparent weight is twice the subject's normal weight on the ground, he is said to be at "2g" and therefore in a 5g turn the 12-stone pilot would weigh 60 stones.

The human body comprises a heterogeneous collection of masses of different densities, supported in or by tissues of varying elasticity. It is not surprising then that the steady state of this complex mass-spring system is disturbed as g increases; heavy organs such as the heart and liver move downwards with relation to the bony skeleton and muscles which are normally required to support tissues in a given position fail to do so.

Body fluids are similarly affected; blood in particular is of great importance in this field. The heart is equipped to pump to the brain a column of fluid weighing approximately 8 oz. When this weight is increased under g the heart cannot cope adequately, the supply to the brain is reduced or ceases altogether and then in a few seconds vision fades completely—"black-out"—followed a little later by unconsciousness.

† Manuscript received 21st October 1959. (Paper No. 576.)

‡ Royal Air Force Institute of Aviation Medicine, Farnborough, Hants.

U.D.C. No. 621.37/9 : 613.69.

In the early days of aviation medicine, studies of these conditions were made in aircraft during flight, but the expense and inconvenience of the method soon led to the introduction of the human centrifuge, a machine designed to reproduce the same forces on the ground. The centrifuge at the Institute of Aviation Medicine, shown in Fig. 1, consists of a symmetrical arm carrying a horizontally-pivoted car at each end.

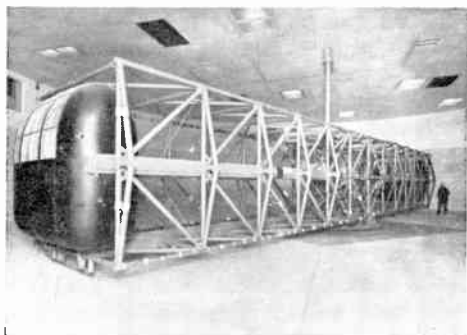

Fig. 1. The centrifuge arm.

The centre of gravity of the cars is below their pivot point and therefore when the arm rotates the lower part of the cars swing outward, so that the resultant of the earth's $1g$ and the centrifugal g , always passes through the vertical axis of the car. Hence the subject is forced down into the seat with an apparent weight dependent upon the angular velocity of the arm.

The arm is 60 ft in length, is driven by a 2,500 h.p. Ward-Leonard servo, has a rotational weight of 40 tons and is capable of reaching $30g$ in nine seconds. The electrical consumption at full torque is of the order of three megawatts: those with experience of physiological recording will appreciate the difficulties of recording from an inaccessible subject sitting on top of this potential source of interference. All power leads are connected to the arm via slip rings in the motor pit, some 20 ft. below ground level, and all signal leads, individually screened, are taken up two storeys before connection to special slip rings and then to the recording room. There are 90 signal slip rings—30 mercury troughs with stainless steel paddles, and 60 silver rings with silver-graphite brushes. Each is separated from its neighbour by an earthed shield and the normal noise level of

the overall system is of the order of three microvolts. In general the mercury troughs are used for the lowest signal levels.

In the recording room (Fig. 2) are a number of different amplifying and recording systems capable of handling between them most of the physical and physiological signals met in acceleration research.

- (a) Six channels of 2 kc/s bridge amplifiers. These cater for resistance or inductance transducers.
- (b) Six channels of 2 Mc/s f.m. amplifiers. Normally used for blood pressure measurement in conjunction with capacitance manometers.
- (c) 12 d.c. pen amplifiers, permanently connected to the pens of an electroencephalograph (e.e.g.). High voltage outputs are provided for use with a c.r.o.
- (d) 12 a.c. e.e.g. preamplifiers.
- (e) 12 d.c. amplifiers, drift corrected and having two fixed gains of 10 and 100.
- (f) 18 galvanometer photographic recorder.

The outer vertical strips of the distribution panel—left foreground of Fig. 2—carry the terminations of all slip rings, cables from the decompression chamber and other laboratories. To the inner strips are connected, by permanent cabling, all the input and output terminals of the items (a) to (f), together with a number of other facilities, such as commoning sockets, reversals, etc. By the use of this panel it is possible to set up with patch cords almost any configuration for amplifying and recording, and to leave more than one experiment connected

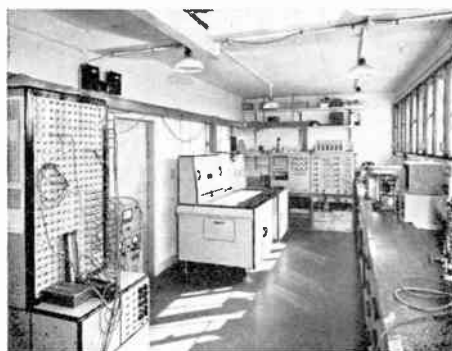

Fig. 2. The recording room.

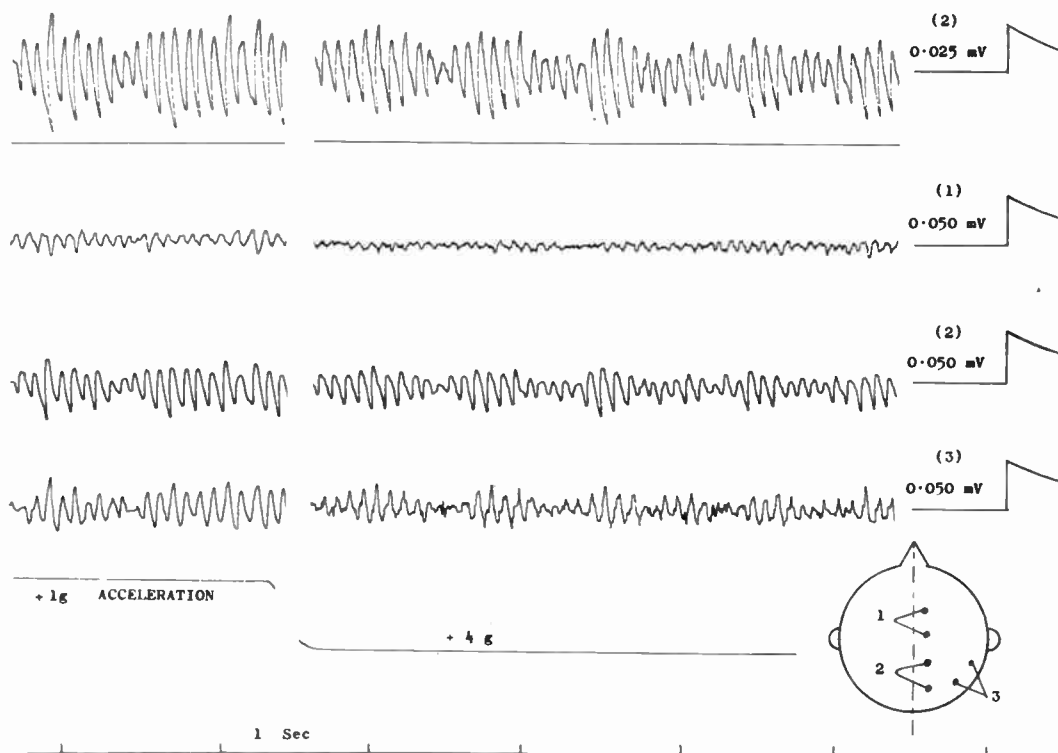

Fig. 3. The electroencephalogram during positive acceleration. Saline pad electrodes. Input leads (150 ft.) direct from subject to recorder via slip rings. Eyes closed. Time constant = 0.3 sec. High-frequency cut-off - 6 db at 50 c/s.

whilst another is assembled. It has been necessary to exercise considerable care in the matter of cable screening connexions, the general principle being that each complete recording circuit shall have one earth only from the subject to slip rings, and one only from slip rings to recorder. Only in exceptional cases are signals carried on a cable screening. The recording room is completely screened by a copper mesh in the walls, floor and ceiling, and by copper sheet on the doors.

A closed-circuit television camera is available in the centrifuge car, the signal output being at video frequency and connected by coaxial lead via the slip rings. Most of the normal physiological variables have been recorded at one time or another; the e.e.g. is possibly one of the more difficult exercises and a record before and during *g* is shown in Fig. 3.

3. Angular Acceleration

If a subject were seated, with eyes shut, on a piano stool and rotated at constant velocity, he would, as he was started, correctly report the direction of the rotation. After a while he would imagine himself stationary and when stopped would have the impression of rotating in a direction opposite to that of the turning stool; the illusion would last some appreciable time after the subject had come to rest. The pilot of an aircraft experiences just these sensations during a spinning manoeuvre.

The origin of these illusions is in those parts of the inner ear termed the semi-circular canals, which respond only to angular acceleration. Hence there is absence of sensation during constant velocity and the wrong sensation during the period of deceleration, negative acceleration in one direction being the same as positive

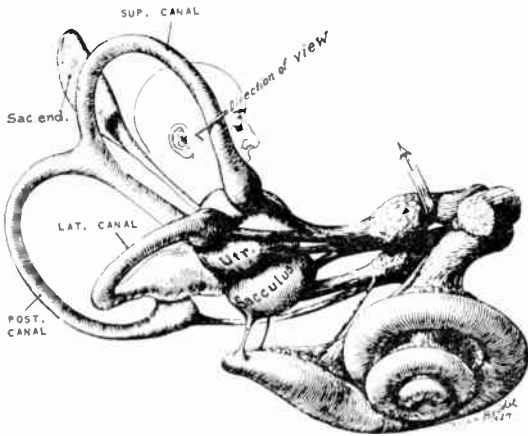

Fig. 4. Semi-diagrammatic drawing of the vestibular apparatus. Physiological angular acceleration transducers—posterior, lateral and superior canals. Physiological linear acceleration transducers—utricle and saccule. Magnification X 2.5.

acceleration in the opposite direction. There are six of these semi-circular canals, two for each of three mutually perpendicular axes; the diameter of the semi-circle is approximately 1 cm and that of the canal 1 mm (Fig. 4). Together with the utricle, which contains the sense organs for linear acceleration, this system presents an example of miniaturization superior to any man-made transducer.

To investigate the mechanism of this rotational sense, the subject must be turned about an axis passing approximately through his ears: this is accomplished in any of the three planes by means of the apparatus shown in Fig. 5.

Briefly this consists of a turntable A, revolving about vertical YY' axis, upon which is mounted a stretcher B, revolving about its longitudinal axis PP'. By altering the inclination of the struts M supporting the stretcher it is possible to change the stretcher axis from the horizontal to about 20 deg. from the vertical. For the near vertical experiments the stretcher may be folded into a seat and the whole operated as a straightforward rotating chair.

The two angular rotations are produced by split-field velocity servos with electronic control. Each servo is driven from a separate function generator in order that the angular acceleration programmes may be varied independently at will. As some experiments have to be carried out in darkness, a programme control unit is

incorporated; this consists of a series of adjustable time-delays operating appropriate circuits for control of the function generators.

As in the centrifuge, closed circuit television is available for observation of the subject; this time the video signal is passed through two sets of slip rings, or alternatively, radiated from the camera control unit which houses a low power r.f. output circuit.

Of particular interest in this branch of research are the eye movements associated with sensations of rotation. These have been recorded either by the conventional corneo-retinal potential or, when the smallest eye deflexions are to be measured, by the use of a contact lens, light source and photo-electric cell. The eye movements (or nystagmus) are of sawtooth waveform, Fig. 6, and are made in an attempt to maintain a stationary retinal image whilst the subject's head is rotating.

4. Vibration

In an emergency, aircrew may have to use an ejection seat. The seat with its occupant is fired out of the aircraft using a high explosive cartridge similar to that of an ordinary gun, producing a stimulus which, from the physical

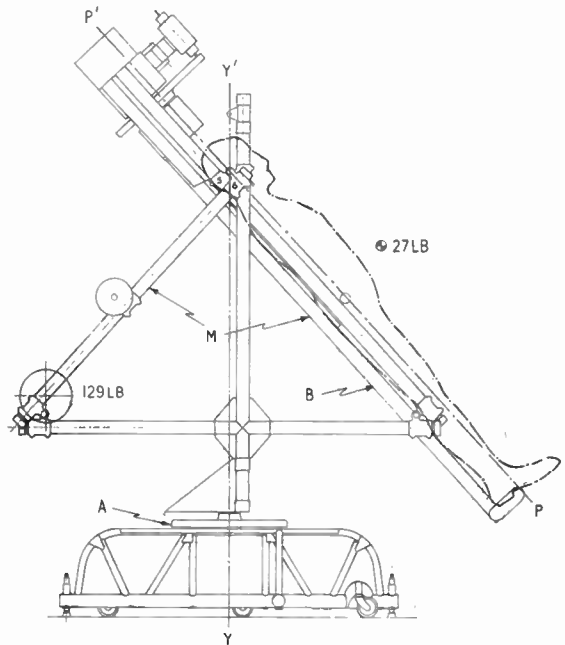

Fig. 5. Angular acceleration : apparatus for stimulating the semi-circular canals in two planes simultaneously

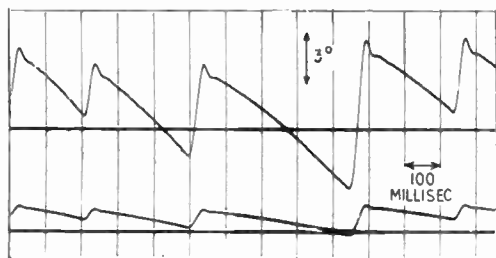

Fig. 6. Horizontal nystagmic movements of the eye resulting from rotation of the subject at constant angular acceleration about a spinal axis, in the seated position.

point of view, may be regarded as a square wave or impulse, of force or acceleration. The man-seat combination is by no means a simple mechanical system and it exhibits the multiple resonances to be expected from any similar set of purely physical characteristics. The matter is further complicated by the sudden linear deceleration when the ejected seat meets the wind blast on leaving the aircraft, and later by the opening shock of the parachute. Similar shocks, but along a different anatomical axis, occur during crash deceleration on the ground. An aircraft, particularly a military one, produces noise and vibration over a wide frequency spectrum, ranging from the highest audible to the violent sub-audio of turbulent air.

All these problems of vibration demand a knowledge of the dynamics of the human body—body ballistics—before we can begin to design and specify measures which will protect the aircrew or enable them to carry out efficiently the control of the aircraft.

The more academic studies utilize any one of a number of sinusoidal vibrators having amplitude capabilities varying from a few thousandths of an inch to 20 ft. or so. Some are basically electromechanical and others electrohydraulic but most have some form of electronic control, possibly with the addition of analogue computers for the simulation of actual flight conditions.

The more applied problems make use of test rigs where an actual ejection seat may be fired up a pair of rails and brought down again under control; or a rocket driven sled, arrested under control by allowing a tapered needle to pierce a membrane in the end of the water filled sled base.

Measurements made during these experiments generally involve the use of long trailing cables. Telemetry is a possibility here, but as with all ground simulators, the transmitter would have to withstand rather severe environmental conditions and would introduce additional complexity with no compensating gains in utility. The problems of attaching suitable acceleration transducers to the subject, and of securing physiological measurements free of artefacts is exceedingly difficult and has not yet been satisfactorily overcome.

5. Airborne Recording

Physical recording in or from aircraft is a well established practice and 1,000 channels of quasi-simultaneous records are not uncommon in the U.S.A. The requirements of the engineer in the air are quite different from those of the physiologist, whose bandwidth demands are generally wider and the number of channels considerably fewer.

We are faced with the choice of installing the actual recorder in the aircraft or using telemetry and recording on the ground—it is in most cases simpler to record in the air. Pens, galvanometers and magnetic tape have all been used successfully, but it will be appreciated that

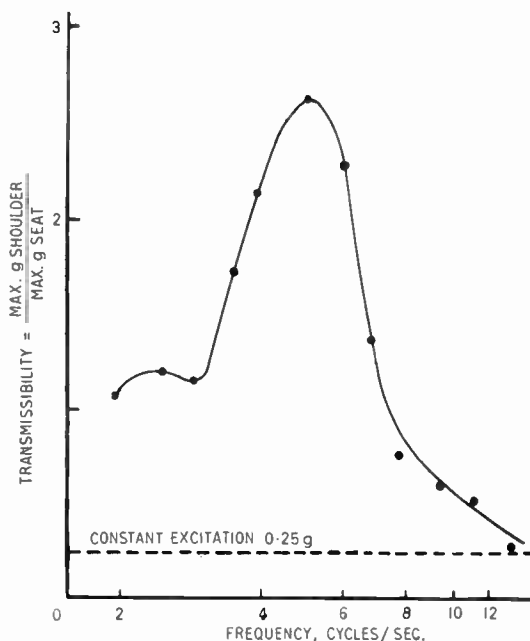

Fig. 7. Whole-body resonance curve obtained from sinusoidal stimulation.

space is very much at a premium. Coupled with the inconvenience of being unable to check the recording until the aircraft has returned from its flight, this has prompted an investigation into the use of radio telemetry.

Figure 8 shows some electrocardiogram recordings taken from an f.m.-a.m.-f.m. system at a range of 50 miles and 10,000 ft. The installation in the aircraft is small and simple, but the ground station is neither; it is in addition a single purpose installation which, unlike the portable instruments used in airborne recording, cannot be used for normal ground experiments. A multi-channel wideband

altitude experiments is the decompression chamber. Essentially this is a closed cylinder, which can be evacuated under control to reproduce the reduced atmospheric pressures as simulated height above sea level is increased: it may also be refrigerated.

To operate at high speed efficiently, a modern aircraft must travel at high altitude and for this reason the air pressure in its cabin is increased to an apparent height at which ordinary flying clothing may be worn. Loss of this pressure may rapidly raise the cabin altitude to a point where danger comes not only from the lack of oxygen but also from the large

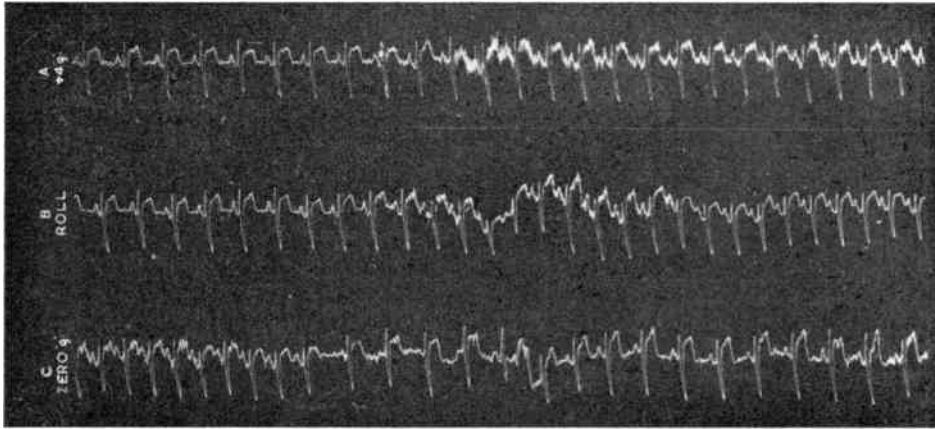

Fig. 8. Electrocardiogram recording during changing aircraft attitude. Altitude—10,000 ft. Aircraft—Meteor 619. Range—50 miles.

telemetry system would also be very expensive, but if it would save abortive flights due to recording failure, the expense might be justified.

6. High Altitude

The cause of early ballooning fatalities at high altitude are now well understood. A progressive lack of oxygen brings with it a form of intoxication, a feeling of well-being which masks the seriousness of the situation: later acute depression sets in, the subject may be too weak to put matters right and unconsciousness follows.

The dangers in the air are obvious, and once again for equally obvious reasons the aircraft under real conditions is not a suitable laboratory. The ground simulator for high

pressure difference existing between the inside and outside of the body. Some form of protection must be provided to meet this situation.

Aircrew forced to abandon an aircraft at say 60,000 ft. face some five minutes of free fall before the parachute deploys; during this period they must be protected in many ways, one of them by the provision of emergency oxygen.

In common with the other branches of aviation medicine, there is the need for both pure and applied research; the "reasons why" are a necessary preliminary to the development of satisfactory protective measures. The principal physiological characteristics to be measured are blood pressure and flow; respiration rate, flow and volume; oximetry; the e.e.g.; and gas analysis; together with the asso-

ciated physical conditions. For the most part conventional equipment is used, although difficulties may be encountered in making satisfactory recordings when the subject is wearing a full set of cumbersome flying clothing.

7. The Climatic Laboratory

At supersonic speeds, even at high altitude where the ambient temperature is -50°C , the friction of air on the skin of the aircraft may well produce cockpit temperatures in excess of 180°C . The pilot has to work normally in the latter heated condition and to survive cabin pressure failure, when the temperature falls drastically; in addition, on ejection above Mach 1, air friction may cause serious burns.

The climatic laboratory provides facilities for ground experiments of this character and a wide variety of climatic conditions can be produced in the main chamber: temperatures within the range -10° to $+80^{\circ}\text{C}$, winds up to 80 miles/hour, artificial sun, humidity up to 100 per cent., rain, and dry air. In addition there is a smaller hot-cockpit for very high temperature work. There is of course a great deal of electrical control gear in this laboratory, but clearly any measuring equipment actually within the chamber must withstand severe climatic extremes; high humidity and voltage do not go well together, neither do transistors and large temperature variations.

Physiological measurements consist largely of slowly varying quantities such as temperature and pulse rate, and in addition a variety of apparently simple physical measurements. Everyone will have at school heated a block of copper, dropped it in a water-filled container, measured the water temperature rise and thereby calculated the specific heat of copper—substitute a man for the copper block and the whole experiment bristles with obvious difficulties. This is typical of the complexities introduced when basically simple physical procedures are taken over for the measurement of physiological quantities.

8. Conclusions

Unfortunately for the modern aviator, the stresses discussed here do not occur singly in

the air; they are all associated with the psychological stress inseparable from flight and taken together pose a formidable problem for solution by a very mixed team of physiologists, engineers, physicists and psychologists.

Looking a little into the future, a few engineering developments of considerable value might be listed :

- (a) High gain, wide-band, multi-channel, short distance telemetry which could be carried in two pockets.
- (b) Large screen, very low dose cine X-ray equipment.
- (c) A method of measuring very small eye movements without physical attachments to the eye.
- (d) Catheter manometers smaller than those now commercially available.
- (e) Simple blood and gas flow transducers.
- (f) A reliable, easily operated oximeter.

This list is by no means exhaustive and would involve considerable development time, but such instruments would find applications quite unconnected with Aviation Medicine.

9. Bibliography

1. H. G. Armstrong, "Principles and Practice of Aviation Medicine" (Bailliere, Tindall & Co., London, 1952).
2. C. S. White and O. O. Benson, "Physics and Medicine of the Upper Atmosphere" (University of New Mexico Press, Albuquerque, 1952).
3. J. Pennell, E. L. Beckman and L. H. Peterson, "Development of Biological Research Apparatus for use in Acceleration and Deceleration Studies" (U.S. Naval Air Development Center, Report NADC-MA-5206, 1953).
4. G. H. Byford, "The Distribution and Accuracy of 'g' in a Human Centrifuge" (Flying Personnel Research Committee. Memo. 97-1958-Air Ministry, London).
5. "Disorientation: A Cause of Pilot Error", U.S. Naval School of Aviation Medicine. Report No. NM001-110-100.39, 1955).
6. G. H. Byford, "Instrumentation and the Human Centrifuge". N.A.T.O., Advisory Group for Aeronautical Research and Development, Aero Medical Panel, Aachen, 1959.
7. "Space Medicine Electronics". A Symposium by the Franklin Institute, 1959. (The Franklin Institute, Philadelphia 3, Pa., U.S.A.)

Radio Engineering Overseas . . .

The following abstracts are taken from Commonwealth, European and Asian journals received by the Institution's Library. Members who wish to consult any of these papers should apply to the Librarian, giving full bibliographical details, i.e. title, author, journal and date, of the paper required. All papers are in the language of the country of origin of the journal unless otherwise stated. The Institution regrets that translations cannot be supplied; information on translating services will be found in the publication "Library Services and Technical Information."

WAVEGUIDE MEASUREMENTS

In a paper from the Microwave Laboratory of the Danish Academy of Technical Sciences, the propagation constants for the TE_{11} -like modes in a circular waveguide containing a slender, magnetized ferrite-rod have been measured for various ferrites at 4,600 Mc/s by means of a tuneable waveguide cavity technique due to van Trier. The saturation magnetization, the dielectric constant and the permeability of the demagnetized ferrite have been derived from these results. The maximum values of the ratio of Faraday rotation to insertion attenuation as calculated from the propagation constants appeared to be between one and two orders of magnitudes higher than the theoretical values based on the assumption of a Lorentzian resonance line shape. This emphasizes the need for a more satisfying loss-theory for microwave ferrites.

"Cavity measurements of the TE_{11} propagation constants of a circular waveguide containing a magnetized ferrite rod," E. V. Sorensen. *Acta Polytechnica Scandinavica* (282/1960) Electrical Engineering Series 7. Copenhagen 1960, 19 pages.

PROGRAMMING IN ANALOGUE COMPUTERS

A study is made in a Roumanian journal concerning the precision of the solution given by analogue computers of linear differential equations with constant coefficients in order to find the condition of minimum error in a given problem and a given computer. A statistical criterion for the comparison between the different possible programmes of the same problem is found. A specialized treatment is then adopted and the optimum programme for family of problems currently encountered in applications found. In the case treated, a minimum error occurs when the use of coupling potentiometers with a grounded terminal is avoided and the coefficients of transfer of the coupling nets have values such that maximum (in modulus) tensions at the outputs of all the amplifiers in use are equal to the unity tension of the computer.

"A contribution to the problem of optimal programming in analogue computers," V. M. Popov. *Automatica si Electronica, Bucharest*, 43, pp. 122-125, May 1960.

SOLID-STATE INVERTER

A new solid-state inverter has been developed by a Canadian company to provide an emergency power source for a ship's gyro compass. It is claimed that the use of transistors in a switched mode enhances its reliability. Rated at 240 VA continuous duty with good voltage regulation, frequency stability and output waveform, the inverter operates at a conversion efficiency of over 75 per cent, and a power factor of 0.8 at full load. The inverter includes a novel phase-lock circuit and it is suggested that this type of unit is probably typical of the class of static solid state devices which will replace rotating machines in many applications in the future.

"Solid-state inverter provides reliable emergency power," A. E. Maine. *Canadian Electronics Engineering*, 4, pp. 19-25, May 1960.

MEASUREMENT OF LIFE-TIME CARRIERS IN SEMI-CONDUCTORS

Methods of measuring the life-time of minority current carriers in semi-conductors are described by a Czech engineer in a recent paper which particularly refers to the method of determining the phase shift of signal from the semi-conductor sample with a light signal from the source used to illuminate the sample. Details are given of a measuring equipment employing these techniques and its shortcomings are discussed and possible modifications suggested. Attention is drawn to the possibility of indicating the life-time by means of a pointer instrument.

"Measuring the life-time of minority current carriers in semi-conductors by the phase method," S. Koc. *Slaboproudy Obzor, Prague*, 21, No. 2, pp. 103-106, February 1960.

DRIFT IN THE IONOSPHERE

Investigation of ionospheric drift by the well-known spaced receiver technique utilizing fading on pulsed transmission has been in progress at the Research Department of All India Radio since January 1958 and formed a part of the programme for the International Geophysical Year. This work was described in a paper given at the recent Convention of the Institution of Telecommunication

Engineers and the authors showed that there is some uncertainty as to the origin of this drift system at ionospheric heights. If the drifts were due to the effect of solar and lunar gravitational tides upon a uniformly rotating sphere, one would expect the drift vector to exhibit a predominant semi-diurnal periodicity. Experimental observation indicates that this is not always the case. In fact there is hardly any regular behaviour in diurnal variation of the phase of the drift system. One would, therefore, like to enquire whether earth's magnetic field exercises any influence on the drift system and is responsible for irregular variation of its phase. It is likely that such an influence should exist as the ionosphere consists of charged particles. The authors have correlated the magnetic *K* index (Alibag figures) with the magnitude of the drift velocity with a view to finding out any interdependence. The analysis shows that so far as the magnitude of the drift velocity is concerned, it is fairly independent of the variation in the values of *K*; in fact large magnetic storms have failed to produce any significant change in the magnitude of drift velocity. The variation of east-west and north-south components of the drift velocity during a "quiet" day does not indicate any correlation with *K*; but on "disturbed" days, the northward velocity of the north-south component increases in synchronism with increase in *K*.

"Geomagnetic field and ionospheric drift," S. N. Mitra and K. K. Vij. *Proceedings of the Institution of Telecommunication Engineers, New Delhi*, 6, pp. 10-16, February 1960.

TELEVISION CABLE LINKS

In a new German coaxial cable television link system, the amplitude of the transmitted television signals is controlled automatically by special pilot frequencies as in carrier frequency telephone links. The selective band-stop filters required at both ends of a transmission link for these pilot frequencies produce ringing interference in the picture. The effect of this ringing on the transmitted test patterns and test signals is described. Due to the transmission system the television signals suffer a certain amount of distortion which is shown by oscillograms of test signals.

"Operational experiences with new coaxial cable television links." R. Rasch. *Nachrichtentechnische Zeitschrift*, 12, pp. 452-456, September 1959.

GROUND RADAR SYSTEM

An 8mm radar installation developed in Holland has recently been described, which is distinguished from the more familiar and widely used 3 cm radar systems by its higher resolution. This is due to the

fact that with a shorter wavelength a shorter pulse length (0.02 μ sec) and narrower angular beam width (0.3°) can be obtained. The narrower beam calls for a higher pulse repetition frequency. In view of the short pulse length it was necessary when designing the modulator to keep the stray capacitances as small as possible. A pulse-correcting network is incorporated to ensure a good reflected pulse shape under all circumstances. A series of p.p.i. photographs illustrates the results obtained.

"An 8 mm high-resolution radar installation." J. M. G. Seppen and J. Verstraten. *Philips Technical Review*, 21, pp. 92-103, 1959/60 (No. 3). (In English.)

CHARACTERISTICS OF CARCINOTRONS

Spurious modulation phenomena which frequently appear in long-beam tubes are examined in a French paper. The very troublesome existence of these phenomena in electronic tuning u.h.f. generators of the "Carcinotron O" type has necessitated their thorough experimental investigation. The outcome of this investigation is that ionic plasma oscillations in the beams of some of these tubes are the source of a spurious amplitude modulation of the electron current, hence of the u.h.f. power output. This amplitude modulation is converted to frequency modulation which is equally troublesome. The parameters responsible for these two types of spurious modulation, and the origin of these phenomena are analysed. The remedies put forward to overcome them are examined; they are of an engineering nature (vacuum improvement) and electronic (ion traps and slow electron traps).

"Spurious modulation phenomena in beam tubes of the carcinotron O type," D. Reverdin. *Annales de Radioélectricité*, No. 60, pp. 147-68, April 1960.

CYLINDRICAL ANTENNA

The electromagnetic field generated by a cylindrical transmitting antenna, which is fed by a voltage of given, non-sinusoidal time variation has been determined theoretically in a Swedish paper. The mathematical formulation chosen yields a mixed wave equation problem. By considering a combined e.m.f. and current generator feeding method related to an infinite antenna it is shown that the field can be considered as built from an infinite set of elementary travelling waves being reflected at the antenna ends. The waves are determined exactly and their relationship to the travelling wave antenna theory of Hallén is demonstrated.

"Transient electromagnetic waves around a cylindrical transmitting antenna," P-O. Brundell. *Ericsson Technics*, 16, pp. 137-62, 1960.

TELEVISION FRAME TIME-BASE

As a result of research work for an M.Sc. Thesis of the University of Melbourne, what is claimed to be a new circuit for a vertical time-base has been developed. The circuit calls for no close tolerances, undesirable values or special components, and these features are obtained by the use of a high-gain negative feedback loop. It is claimed that the time-base is almost completely independent of valve characteristics, and of mains voltage fluctuations, and that the flyback voltage pulse is rectangular and hence of very small amplitude.

"A new vertical time-base," E. M. Cherry. *Proceedings of the Institution of Radio Engineers Australia*, 21, pp. 387-393, June 1960.

PARAMETRIC AMPLIFICATION

A recent article by a French engineer offers a synthetic theory of parametric amplification. The problem is as follows: given a diode acting as a non-linear capacitance, what linear circuit has to be associated with it to produce an amplifier?

The parametric amplification equation is set out and some of its general properties are examined. This gives as special cases the conventional types of "up converter" and "down converter" parametric amplifiers, and also negative resistance amplifiers of degenerate or non-degenerate type. The article ends with the examination of the noise figure of a negative resistance amplifier.

"Theory of parametric amplification using diodes," F. Dachert. *Annales de Radioélectricité*, No. 60, pp. 109-19, April 1960.

TROPOSPHERIC PROPAGATION AT V.H.F.

An analysis of v.h.f. field strength recordings for propagation beyond the horizon is presented in a paper given at last year's Convention of the Australian I.R.E. The study resulted from measurements made to establish the interference field strength between common channel television transmitters when the propagation path is over undulating country without mountain ranges. The received field strength is shown to be greater in band I than in band III for points well beyond the horizon. There is a marked dependency of field strength and fading rate on meteorological conditions up to an altitude of about 6000 feet. When tropospheric layers (dn/dh greater than normal) occur, there is a simultaneous decrease in the fading rate and an increase in field strength. The effect of layer thickness, layer height, and rate of change of dielectric constant through the layer is shown. Under standard atmospheric conditions

the received field strength is found to agree well with that calculated for diffraction around the earth and reflection from the troposphere. The average observed field strength exceeded for 10 per cent. of the time during winter at points well beyond the horizon is found to agree with values extracted from F.C.C. and C.C.I.R. curves, but large discrepancies occur in the case of field strength values exceeded for 50 per cent. of the time.

"Tropospheric propagation at v.h.f.," J. M. Dixon. *Proceedings of the Institution of Radio Engineers Australia*, 21, pp. 398-406, June 1960.

COLOUR FLYING SPOT SCANNERS

Flying spot scanners as signal sources for colour television have an advantage over cameras, in that they are completely free from register errors. In work on colour television wide use is therefore made of flying spot scanners for generating the three primary-colour signals. Two types have been developed in the Philips Research Laboratories, one for colour slides and one for opaque matter (colour prints, small objects). In both systems the flying spot is generated in a special scanning tube. The optical system of the slide scanner consists of an objective lens, a cruciform arrangement of dichroic mirrors and correction filters. Three photomultiplier tubes are used. The three video channels each contain an after-glow compensation circuit, a gamma correction circuit and an output amplifier that distributes the signals. The print scanner is designed round the principle of the integrating-sphere photometer.

"Flying spot scanners for colour television," H. van Ginkel. *Philips Technical Review*, 21, No. 8, pp. 234-50, 1959/60. (In English.)

MICROWAVE PLASMA EFFECTS

Experiments in microwave propagation in a coaxial line containing a glow discharge in a magnetic field are described in a Swedish paper. A signal passing through the discharge is attenuated if the signal frequency lies within a certain band, the lower limit of which is the gyromagnetic frequency. The attenuation is caused by absorption of the signal in the discharge. According to a simplified theory, there should be a frequency band with low transmission similar to the one measured but the transmission attenuation should be caused by reflections from the discharge and not by absorption.

"Microwave propagation in a plasma-filled coaxial line," B. Enander. *Ericsson Technics*, 16, No. 1, pp. 59-75, 1960. (In English.)