

# The Journal of THE BRITISH INSTITUTION OF RADIO ENGINEERS

FOUNDED 1925

INCORPORATED 1932

*"To promote the advancement of radio, electronics and kindred subjects  
by the exchange of information in these branches of engineering."*

VOLUME 19

AUGUST 1959

NUMBER 8

## MEETING DIFFERENT NEEDS

WHILST members who are able to attend the Institution's Conventions derive the maximum advantage from such meetings, every member ultimately benefits because of the Institution's policy of publishing all the papers in the *Journal*. Consideration has been given to producing these papers in a separate book form, which may have certain advantages. It would, however, inevitably mean an extra charge to members, thus departing from the principle of distributing *all* the Institution's proceedings to *every* member and keeping down costs.

Publication in the *Journal* of papers read and discussed at the 1959 Convention will therefore be spread over the next few months. In order to achieve a balanced content of technical information, every *Journal* will also include papers dealing with branches of radio and electronic engineering other than television.

Future *Journals* will also feature contributions originating from the specialized Groups, two of which—Medical Electronics and Computers—have already made their impact on the *Journal*; reports and other papers from these Groups are scheduled for early publication. Early next year, these contributions will be supported by papers obtained through the Radar and Navigational Aids Group. This is the third of the specialized Groups to be formed and details are given on page 456 of this *Journal*.

The Committees of these specialized Groups will also make valuable additions to the programme of meetings in London; during the 1959-60 Session there will be some eighteen meetings directly organized by the Group Com-

mittees. These are in addition to the regular monthly meetings arranged by the main Programme and Papers Committee. Thus the majority of members able to attend London meetings will have an increasing range of topics within their own special fields.

Whilst the holding of a Convention must be relatively infrequent, the Programme Committee is conscious that many subjects warrant more time than can be given during an evening meeting. This is particularly the case when a series of short papers provides a more suitable means of dealing with a theme than does a single paper. During the 1958-59 session, two half-day symposia were organised—on Radio Telemetry and Large Capacity Storage Devices—and proved to be very popular. This "miniature Convention" approach will, therefore, be repeated during the coming session where the subject justifies such a course.

The Council has also borne in mind those members who cannot attend meetings in London, but who support their local Section. It is intended that all the specialized Groups, in association with Section Committees, will sponsor meetings in other centres.

In these several ways the value of the Institution proceedings, both in the *Journal* and through meetings, will be greatly increased and provide members with the opportunity to derive the maximum benefit from their professional body whatever their different needs.

Such activity, however, requires the maximum co-operation from every member who is able to contribute to Institution proceedings by speaking at meetings and/or submitting a paper for publication. Will you help? G. D. C.

## ELECTION OF HONORARY MEMBERS

**N**OTICE of the Council's proposal to confer Honorary Membership of the Institution on Eric K. Cole was given in the January 1959 *Journal*.

The presentation of the Certificates to Mr. Cole and Dr. Zworykin\* and their acknowledgment by signing the Roll of Honorary Members, took place after a Banquet in Downing College on the 2nd July.

In his speech proposing the health of the new Honorary Members the President, Professor E. E. Zepler, referred to Mr. Eric Cole's pioneering work in helping to establish the radio industry in Great Britain, and his continuing interest in the work of the Institution. Professor Zepler called on Rear Admiral Sir Philip Clarke, K.B.E., C.B., D.S.O., a Past President, to read the citation of the award of Honorary Membership to Mr. Eric K. Cole. This read as follows:—

"Just before the formation of the Institution in 1925, a business had been started to manufacture wireless equipment to the design of the owner of the business, who was then in his early twenties. From such beginnings Eric Kirkham Cole applied himself to the application of radio and electronic science with such ability that the companies bearing his name are well renowned and established throughout the world.

"Since the advancement of science for the benefit of man would be impossible without such pioneering work in the field of manufacture, the Council of the Institution records that the work of Eric Kirkham Cole has been of the greatest service to the development of radio and electronic science. This testimony therefore gratefully acknowledges his many services to the profession and to the work of the Institution.

"This award of Honorary Membership was confirmed by the membership assembled in Cambridge on the Second day of July in the year Nineteen-hundred and Fifty-nine."

After thanking the President and members of the Institution for the honour bestowed upon him, Mr. Cole said:

"It is vitally important that engineers should recognize the economic and political consequences of their work. Not only is the world becoming smaller in terms of travelling time but also it is becoming a more tightly knit unit. It certainly does not require the foresight of a

Jules Verne to know that the peeping eye of television will increasingly enable every section of humanity the opportunity of seeing, as well as of hearing, what else goes on in this world. Indeed, as one or two papers in the Convention programme show, scientists are already investigating the possibilities of hearing and seeing something of the universe about us.

"Our problem as engineers is to continue to make such researches and to contribute to man's knowledge of the universe as a whole. By doing so, we create problems requiring political decision. In a free country we are able to give expression to our individual view as to whether it is right or wrong to listen to and to see the other man's point of view. Political consideration can never, however, limit the right of man to continue to prise open the secrets of nature.

"This I believe to be part of the concept of all our learned societies. They encourage not only the discovery of new ideas, but how best to put into production scientific discoveries so that the individual may make his free choice as to whether or not to use such gifts of nature.

"As the attendance at this Convention shows, the work of our learned societies is not in any way governed by nationality, creed, colour, or political opinion; by bringing together all who are interested in the development of radio and electronic science, our Institution does indeed perform an invaluable service not only to the people of this country, but to the world as a whole. I feel not only pleasure, but pride, that you should have wished to include me in such a distinguished membership. I promise, as indeed does every member on his election, to advance the interests of the Institution and the work that it does, whenever I have the opportunity.

"To conclude, Mr. President, I have seen the Institution grow from infancy to the maturity it now has attained and, if I may, I should like to congratulate all who have been actively associated with the Institution from the earliest days and have done so much to bring it to its present position of importance, coupled with the high prestige it now enjoys in scientific circles not only in these Islands but throughout the world."

\* The citation of Dr. Zworykin's Certificate of Honorary Membership will be included in the September *Journal* in connection with the publication of his Clerk Maxwell Memorial Lecture.

## 1959 Convention Diary<sup>†</sup>

### Thursday, 2nd July

The domestic television receiver formed the basic subject of the day's papers. The first group dealt mainly with manufacturing methods: printed wiring was the main consideration, although it was emphasized that such techniques applied to many other branches of radio and electronic equipment production. Other papers described television receiver design, and an account of the receivers produced in the U.S.S.R. caused considerable interest. Problems associated with X-radiation from cathode ray tubes also led to keen discussion. The vexed question of the desirability of maintaining the d.c. component at the receiver was discussed at some length, and this particular meeting had to be adjourned to a later date (see Saturday's diary).

In the evening the Hall of Downing College was filled by delegates attending a special Dinner given in honour of the Institution's two new Honorary Members. The occasion was used as an opportunity to present scrolls of Honorary Membership to Mr. E. K. Cole, C.B.E., and Dr. V. K. Zworykin. An account of the ceremony, including the reply of Mr. E. K. Cole, is given on the opposite page.

### Friday, 3rd July

Today's "Convention News" contained references to the preceding night's banquet which bridged the gap in the proceedings between Thursday evening and Friday morning! Whether or not delegates attended that particular Banquet, everyone enjoyed reading the quips made by Mr. Cole and Dr. Zworykin.

The emphasis on the papers read during the third day of the Convention was directed to the transmission side of broadcasting; overseas contributions to the session on television recording added especially to the interest. The final session of the day dealt with colour television, and at its conclusion delegates adjourned to the "D.C. Lab." to see a large

screen projection demonstration of static and live shots from a studio elsewhere in the Cavendish building.

In the evening the Convention Banquet was held in the Hall of Gonville and Caius College. The dinner was preceded by a Sherry Party given by the President in Gonville Court. This was particularly enjoyable on what turned out to be a fine summer evening; indeed, it might be noted that the 1959 Convention well upheld the tradition that the Institution always appears to select for such occasions a favourable spell in the changeable English meteorological cycle!

Professor N. F. Mott, F.R.S., Master of the College and Cavendish Professor of Physics, was the guest of honour. In proposing his health, the President paid tribute to the very many ways in which Professor Mott and the staff of the Cavendish Laboratories had helped in contributing to the success of the Institution's Convention.

In his reply, Professor Mott made references to the increasing scope of the researches undertaken in the Cavendish Laboratories; as a result of this work he strongly advocated closer association between physicists and engineers and he praised the Institution's efforts in promoting such opportunities for exchange of ideas.

It is hoped to publish a fuller account of speeches in a later issue of the *Journal*. It is however, appropriate in these notes to add that on behalf of the Officers and Council of the Institution, Mr. V. J. Cooper, Chairman of the Convention Committee, made a presentation to Mr. George Crowe, Chief Technical Assistant of the Cavendish Laboratory. The presentation was made to mark the Institution's thanks for Mr. Crowe's help and to congratulate him on his forthcoming retirement after 51 years' service with the Cavendish Laboratories.

The reply on behalf of the guests was made by Mr. C. O. Stanley who, in a characteristic speech, pointed out the valuable service which the Institution provided in establishing recognized qualifications for radio and electronics engineers.

<sup>†</sup> The first part of the Convention Diary was published in *J. Brit.I.R.E.*, July 1959, p. 387 and will be concluded in the September issue.

## INSTITUTION NOTICES

### Annual General Meeting

The 34th Annual General Meeting of the Institution will be held at the London School of Hygiene and Tropical Medicine, on Wednesday, 2nd December, 1959, at 6 p.m. The formal notice and Agenda will be published in the September issue of the Journal. Members wishing to nominate a member for election to Council should send the nomination to the General Secretary not later than 21 days after the issue of the Council's list. The proposal must be supported by ten Corporate Members and be accompanied by the written consent of the member nominated.

### Radar and Navigational Aids Group

Under its policy of establishing Specialized Groups of members who are professionally concerned with one or other of the many aspects of radio and electronic engineering, the Council has appointed a committee of members who are active in the field of radar and navigational aids.

The constitution of the committee is as follows:—

K. E. Harris, B.Sc. (Member)—Chairman  
E. L. T. Barton, O.B.E. (Member)  
C. M. Cade (Member)  
J. W. R. Griffiths, Ph.D. (Associate Member)  
R. N. Lord, M.A. (Associate Member)  
W. J. O'Brien (Member)  
D. M. O'Hanlon (Associate Member)  
H. R. Whitfield (Member)  
Captain F. J. Wylie, R.N. (Retd.) (Member)

The new Committee will be principally concerned with the arrangement of meetings in collaboration with the Programme and Papers Committee; it will also assist in the procurement of papers for publication only.

The Inaugural Meeting of the Group will be held in London on Wednesday, 28th October, when short addresses dealing with different aspects of radar and navigational aids will be given.

### The Training of Radio Apprentices

The South Western Section of the Institution has arranged a symposium on the training of radio apprentices in conjunction with the Royal

Air Force Radio Apprentices School. It will be held at the R.A.F. Station at Locking, near Weston-super-Mare, on Wednesday, 7th October, 1959.

The programme includes three papers dealing with the R.A.F. Apprentice training, industrial apprenticeship training, and the psychological aspects of this training. There will be ample opportunity for discussion on these three papers and other items. Facilities will be available to visit selected parts of the Apprentices School.

The Section Committee hopes that this will provide an opportunity for a comparison and interchange of views between industry and the Services. The meeting will last from 10.30 a.m. to 4.30 p.m. Members wishing to take part should write to the Symposium Organiser, Flt.Lt. D. R. McCall, B.Sc., A.M.Brit.I.R.E., c/o 27 O.M.Q., R.A.F. Locking, Weston-super-Mare, Somerset.

### Facilities for Overseas Members

For the convenience of members and journal subscribers outside Great Britain, the Institution has set up local banking accounts or made other special arrangements for the payment of subscriptions, etc. The following banks accept payment in local currency.

CANADA: Imperial Bank of Canada, 304, Bay Street, Toronto.  
SOUTH AFRICA: Barclays Bank D.C.O., 40, Simmonds Street, Johannesburg.  
NEW ZEALAND: The Bank of New South Wales, Auckland.  
AUSTRALIA: The Bank of New South Wales, 341, George Street, Sydney.  
INDIA: The State Bank of India, 40, St. Mark's Road, Bangalore 6.  
PAKISTAN: The National Bank of Pakistan, PMA Building, Nicol Road, Karachi 2.  
FRANCE: Barclays Bank (France) Ltd., 33, Rue du Quatre Septembre, Paris.

Other countries where banking arrangements have been made in order to facilitate payment in sterling only:—

GREECE: Any branch of the Ionian Bank.  
ISRAEL: Any branch of the Bank Le Leumi Israel B.M.

# The Design of Dual-Standard Television Receivers for the French and C.C.I.R. Television Systems†

by

C. J. HALL, B.SC.‡

*A paper read on 2nd July 1959 during the Institution's Convention in Cambridge.*

**Summary:** There are several regions near the borders of France with Germany, Switzerland and Italy where a demand exists for a television receiver capable of functioning on either the French or C.C.I.R. systems. An inspection of typical television receivers for each of the two systems shows that there are essential differences in all parts of the circuit except the power supply, frame time-base and audio frequency sections. Consequently direct switching from one system to the other could involve a very large number of switching operations, including many in critical circuits where switching may introduce difficulties. It is therefore necessary to see whether, by a suitable compromise, it is possible to use the same circuits for both systems with little or no degradation of performance. Where an acceptable compromise cannot be found the problem may be simplified by duplicating circuits and simply switching the h.t. supply. The extra cost of material in this case must be balanced against the extra complication of switching in critical circuits, taking account of the limited demand for dual-standard receivers which restricts the amount of effort which can reasonably be spent on development. The design of a complete dual-standard receiver is treated section by section, alternative methods of switching are examined against the background of current practice and a preferred solution is outlined where possible or the lines along which such a solution may be sought are indicated.

## 1. Introduction

There are a number of regions in Europe where television transmissions on two or more different Standards can be received. This paper is concerned with the French and C.C.I.R. Standards, this being the most difficult case because these Standards differ in almost all their principal characteristics, but the techniques described are equally applicable to other Standards.

In Fig. 1 are shown the main regions of France where dual-standard receivers may be required and in Table 1 the chief characteristics of the two Standards are set out. It is clear from the Table that the only sections of the receiver which can function without modification on both Standards are: the frame timebase, the audio frequency section and the power supply. For the other sections there must be either the

duplication of functions with switching or the use of circuits which, by a suitable compromise in design, provide acceptable performance on both Standards without switching.

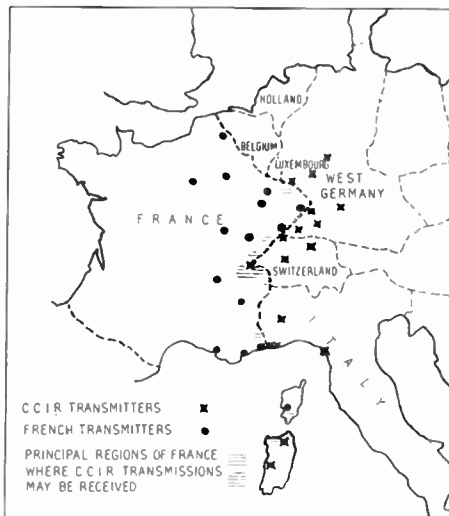

Fig. 1. Map showing the principal regions of France where transmissions on the C.C.I.R. Standard may be received.

† Manuscript received 6th May, 1959. (Paper No. 512.)

‡ Pye Ltd., Cambridge; attached to Television Grammont, Malakoff, Seine, France, as a liaison engineer.

U.D.C. No. 621.397.62

**2. General Considerations concerning Switching**

A certain number of switching operations must necessarily be included and the tendency in recent designs has been to combine the "Standards Switch" with the normal channel selector mechanism so that the user need only set the selector to the desired channel and the receiver is automatically adjusted to receive the Standard employed by the transmitter corresponding to the selected channel. The elimination, in this way, of the "Standards Switch" knob is in line with the general trend towards simplification of the operation of television receivers. However, in order to simplify the mechanical arrangement linking the channel selector with the switch, it is desirable that the latter should be placed near to the channel selector and should not be too bulky. This condition limits the number of separate switching operations that can conveniently be accommodated to about ten and requires that most of the switching operations be such as to allow the use of fairly long connections between the switch and the circuit. Certainly, mechanical arrangements can be designed which permit separate switch wafers to be placed in various parts of the chassis near

to the circuits being switched but it is preferable to avoid these complications.

**3. General Considerations concerning Circuit Design**

The conditions to be fulfilled by the circuit designer can be stated as follows:

- (a) The number of separate switching operations must be kept as small as possible, and in any case not more than 10 or 12.
- (b) Switching should be limited, as far as possible, to circuits which permit the use of reasonably long connections between circuit and switch.
- (c) Duplication of circuits should be kept to a minimum for reasons of economy.
- (d) The overall performance of the receiver on each of the Standards must be in all respects comparable with that of single-standard receivers.

The block diagram of Fig. 2 shows the functional changes which are necessary in switching from one Standard to the other. The chief requirements are:

- (1) Change of vision i.f. bandwidth.

**Table 1**  
Principal Characteristics of the French and C.C.I.R. Standards.

	French Standard	C.C.I.R. Standard
Vision Modulation	positive	negative
Sound Modulation	A.M.	F.M.
Field Frequency	50c/s Interlaced	50c/s Interlaced
Lines per Frame	819	625
Line Scan Frequency	20.475kc/s	15.625kc/s
Vision Bandwidth	10Mc/s	5 Mc/s
Carrier Spacing	11.15Mc/s	5.5Mc/s
Sound Carrier Frequency above or below Vision Carrier Frequency	either	above
Equalizing Pulses	no	yes
Frame Pulse Duration	0.5 line	2.5 lines
Complete Line Period	48.8 μsec	64 μsec
Line Sync. Pulse Duration	2.5 μsec	5.8 μsec
Line Blanking	9 μsec	11 μsec
Frame Blanking	2.0 msec	1.6 msec
Black Level	25%	33%

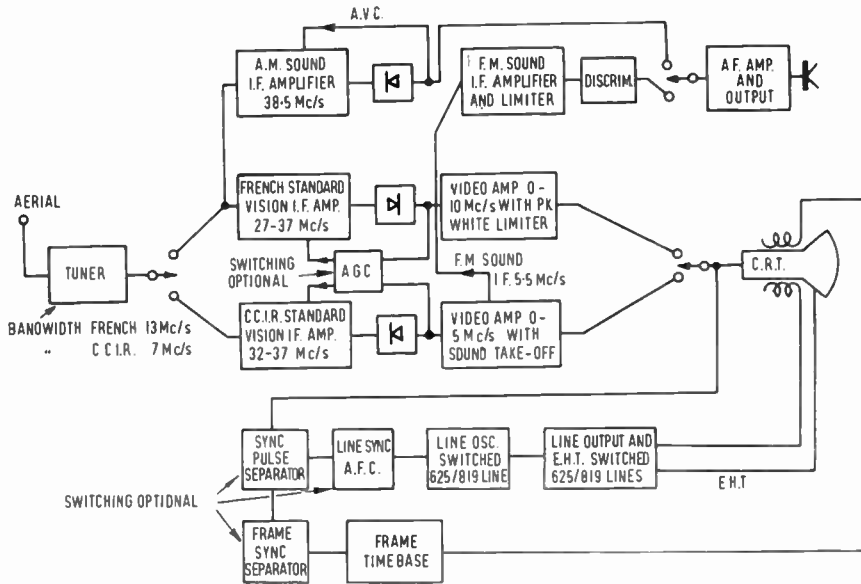

Fig. 2. Block diagram showing the functional requirements in a dual-standard receiver.

- (2) Inversion of the video signal to compensate for the change of polarity of vision modulation.
- (3) Change of sound channel from a.m. to f.m. with change of intermediate frequency to allow inter-carrier operation for the C.C.I.R. Standard.
- (4) Change of video amplifier characteristics.
- (5) Change of line oscillator frequency and corresponding changes to the line output stage.
- (6) Incidental changes which may be required in the sync. separator and vision a.g.c. circuits.

tuner which is required concerns the addition of a mechanical arrangement to operate the standards switch. If, as mentioned above, the number of switching operations is small, so that the operating force required is small, a very simple mechanism will be sufficient. A typical arrangement is shown diagrammatically in Fig. 3 for a 10-channel tuner. The disc "A" is carried on an extension of the turret-spindle and therefore rotates with the turret when the channel selector knob is turned. This disc can be fitted with up to 10 cams, "B", which, engaging with

The different requirements of the two Standards should be provided for with the minimum of duplication of valves and components and without complicated switching operations. Some ways of approaching these problems are examined in the following sections.

#### 4. The Tuner

Turret-type tuners are to be preferred since they allow complete freedom to adjust the bandwidth of the r.f. circuits on each channel to suit the transmission standards of that channel. The only significant modification to a normal

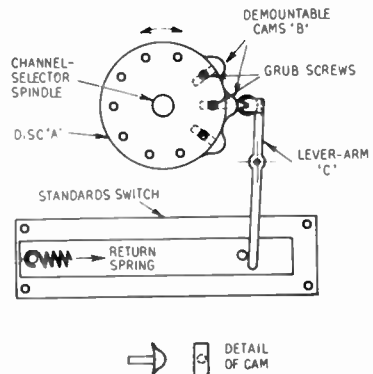

Fig. 3. Illustrating the principle of linking the standards switch with the channel selector.

the lever arm, "C", cause the switch to move to the left-hand position against the force of the return spring. Thus for any of the 10 positions of the channel selector the required position of the standards switch is chosen by either fitting or omitting the corresponding cam on the disc "A".

**5. The Vision Intermediate Frequency Amplifier**

The vision i.f. passbands required by the French and C.C.I.R. Standards are shown in Fig. 4. The relative positions of vision and sound carriers are determined by the requirement that, on the channels in Band I the local oscillator frequency should be above the signal frequency.

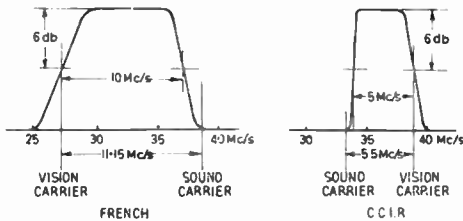

Fig. 4. I.f. response curves.

If two quite separate i.f. amplifiers are to be employed for the two Standards, then the intermediate frequency can be chosen for each Standard independently of the other. However, it is usual, for reasons of economy, to arrange that at least part of the i.f. amplifier is common to both Standards. In this case it is clearly preferable to have the narrower (C.C.I.R.) i.f. band fall within the wider (French) i.f. band. Further, it is then possible for the high attenuation provided at the sound carrier frequency of the French Standard to serve for adjacent channel sound carrier rejection for the C.C.I.R. Standard. This is shown in Fig. 5, the carrier frequencies indicated having been chosen to minimize harmonic feedback troubles. With this arrange-

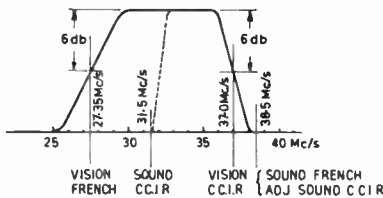

Fig. 5. Superposition of French and C.C.I.R. i.f. response curves.

ment the shape of the passband for the wide band Standard has to be held to rather finer limits than usual and narrowing of the bandwidth to mitigate the effects of noise is not permissible as it would spoil the C.C.I.R. passband. It is nevertheless a workable system whose advantages considerably outweigh its disadvantages.

The design of a dual-purpose i.f. amplifier to provide alternative response curves as shown in Fig. 5 may be approached in either of the two ways illustrated in Fig. 6. The first method (Fig. 6(a)) is the less economical but raises no unusual design problems and the switching required for the i.f. amplifier itself is very simple, consisting only of a change-over of h.t. supply. The switching required after detection is a separate problem and is considered in a later section.

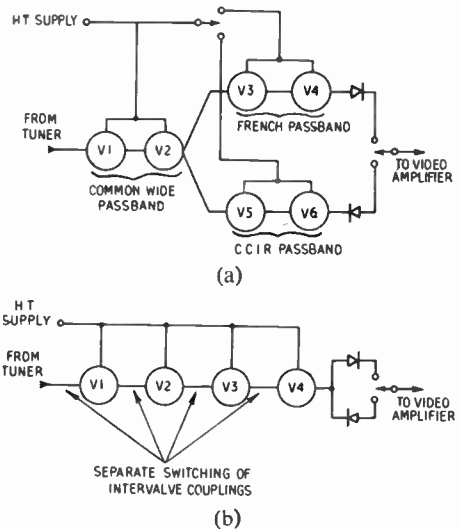

Fig. 6. Alternative constructions for a dual-standard vision i.f. amplifier.

The second method (Fig. 6(b)) is more attractive since it requires few additional components as compared to the normal single-standard receiver, but switching of signal-carrying circuits is unavoidable and a rather large number of switching operations may be required. In one example of this approach to the problem, switching is used at each of four intervalve coupling circuits demanding a total of seven changeover operations and involving a



rather cumbersome mechanical construction in order to place each switch section near to the circuit on which it operates. Although such arrangements can be and are used, it seems desirable to look for a more elegant solution.

Clearly if all the tuned circuits forming the narrow-band (C.C.I.R.) response curve were grouped together in a single filter forming one

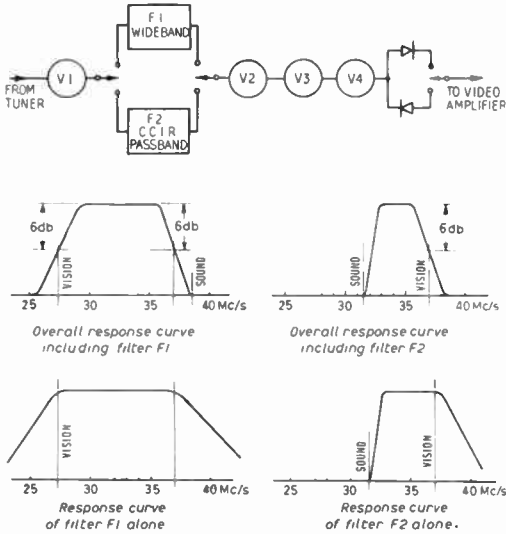

Fig. 7. Preferred arrangement for the vision i.f. amplifier.

of the interval couplings, the switching requirements would be simplified. This variant is shown in Fig. 7 together with the response curves required for the various sections of the amplifier and the overall response curves. The problem here is the design of the network F2 to have sufficient attenuation below the passband in the region 28-32Mc/s to satisfy the requirements of sound carrier rejection and adjacent channel selectivity. For the other network F1, all that is needed is a flat response from 27 to 37Mc/s and this can conveniently be met by a pair of transitionally coupled circuits.

The network F2 may consist of double, triple or quadruple tuned circuits together with one or two rejector circuits to increase the attenuation at the frequencies of the sound carrier and the adjacent channel vision carrier (31.5 and 30.0Mc/s in this case). In Fig. 8 response curves are shown for two, three or four coupled circuits in the maximally-flat condition and of

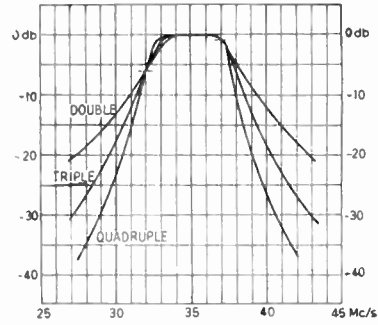

Fig. 8. Calculated response curves of flat double, triple and quadruple tuned circuits for the filter F2. Reference points 32 Mc/s -6db and 37 Mc/s -1db.

the required bandwidth. It can be seen that the selectivity with two circuits is such that the necessary attenuation is unlikely to be obtained even with the addition of rejector circuits, when allowance is made for the spurious responses which usually accompany the use of rejectors. The triple-tuned response is more promising and a three-circuit coupling network, with two rejectors, was constructed for test purposes. The circuit diagram and response curve are given in Fig. 9. Capacitive coupling was chosen for ease of adjustment, but it would be preferable in a production design to use mutual inductive

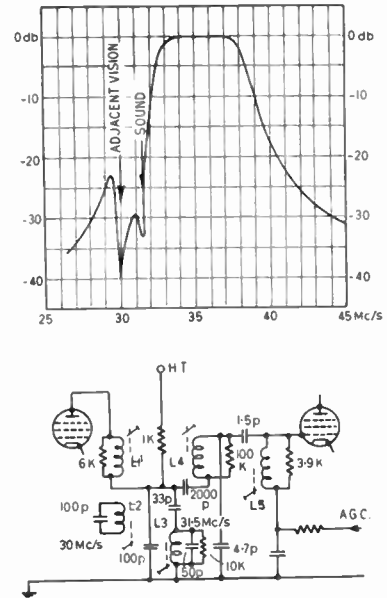

Fig. 9. Triple tuned circuit with rejectors forming the filter F2.

coupling between the second and third circuits, since this would allow the five coils to be accommodated on three formers. The sound carrier rejection is correct for intercarrier working and the adjacent vision rejection of 40db may be taken as satisfactory.

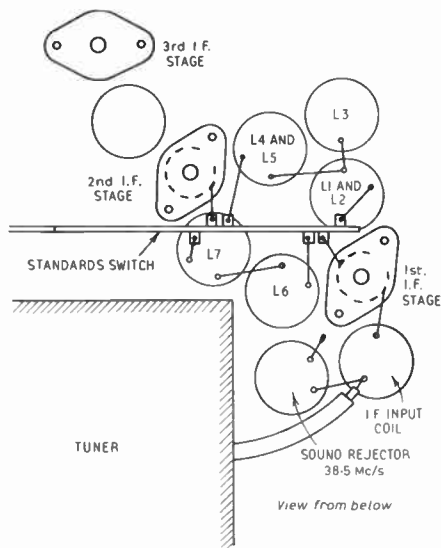

Fig. 10. Layout for switching in the vision i.f. amplifier.

The use of a four-circuit coupling would certainly allow additional attenuation at and below 30Mc/s to be obtained, but it is doubtful if the added complication is justified.

From the above it appears that the required response characteristics can be obtained fairly easily and the arrangement of Fig. 7 is practically realizable. There remains the question of positioning the changeover switch. Since the entire switch assembly must, for the mechanical considerations already mentioned, be mounted near the tuner, the layout of the i.f. amplifier must be such as to bring the circuits concerned near to the end sections of the switch. This can conveniently be arranged as shown in Fig. 10. Here a slider-type switch is mounted behind and below the Tuner and the networks F1 and F2 (respectively L6/L7 and L1 to L5) are installed between the first and second i.f. stages.

### 6. The Sound Intermediate Frequency Amplifier

If the intercarrier system of sound reception<sup>1</sup> is adopted for the C.C.I.R. Standard, as is the universal practice, then the sound channel

requirements for the two Standards are completely different. The French Standard requires amplification at 38.5Mc/s and a.m. detection, the C.C.I.R. Standard amplification at 5.5Mc/s, limitation and f.m. detection. No real advantage is gained by abandoning the intercarrier system and adopting the same intermediate frequency for both Standards as, in order to conserve the "overlapping" of the vision i.f. response curves (Fig. 5), it becomes necessary to interchange the vision and sound carrier frequencies for the French Standard. This, in turn, means that the French Band I channels cannot be received as the local oscillator would have to work below signal frequency. Alternatively, if the frequencies indicated in Fig. 5 are conserved, the sound i.f. amplifier must work on different frequencies for the two Standards, as with intercarrier sound, or an auxiliary frequency-changing operation must be carried out (in this case from 31.5Mc/s to 38.5Mc/s). These difficulties, together with the inherent advantages of the intercarrier sound system, leave little doubt as to which solution should be chosen.

The two frequencies at which amplification is required, when the intercarrier system is used for the C.C.I.R. Standard, are sufficiently widely separated to allow one valve to amplify at both frequencies without switching, as is done in a.m./f.m. radio receivers. This is illustrated in Fig. 11, one stage only being common in order to have an efficient limiter for the f.m. system.

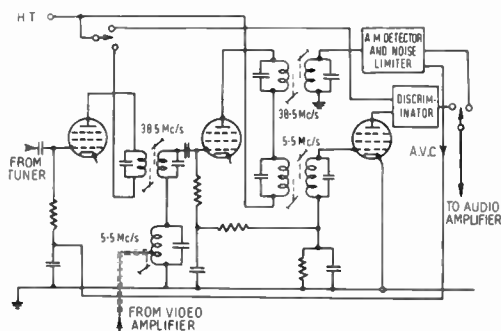

Fig. 11. Basic circuit of dual-standard sound i.f. amplifier.

In a more economical arrangement, the pentode limiter might be abandoned and the a.m. rejection obtained by employing a ratio detector supplemented by a diode limiter or by

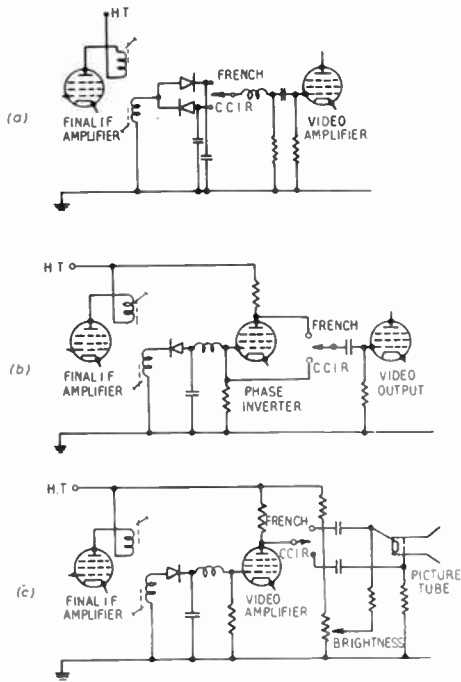

Fig. 12. Alternative arrangements for inverting the video signal.

The above requirements can easily be met if the use of switching in the video signal circuits can be accepted, and the majority of current designs require at least one such switching operation. Some typical arrangements are shown in Fig. 12. In the first of these (a) separate detectors are provided so that the video signal after detection always has the same polarity. In the second example (b) there is a common detector and the video signal is inverted after detection when receiving a positively modulated carrier (French Standard). In the third case (c) the video signal is not inverted but is applied to either cathode or grid of the picture tube. However a switched phase inverter is still required in order to provide a video signal which always has the same polarity for the synchronizing circuits.

The need has been indicated for avoiding switching operations in signal carrying circuits whenever possible, in the interests of mechanical simplicity and flexibility. A means of achieving this in the present case is shown, in several forms, in Fig. 13.<sup>3</sup> Here separate diodes are employed for positive and negative modulation, as previously in Fig. 12(a), but the diode required

“envelope feedback”.<sup>2</sup> However the performance is somewhat inferior to that provided by the pentode limiter and can therefore hardly be recommended since dual-standard receivers will usually be used for fringe-area reception, often in very unfavourable conditions.

**7. The Video Amplifier and the Polarity of the Video Signal**

The majority of dual-standard receivers use the same video amplifier, or at least the output stage, for both Standards, the amplifier being designed to meet the specification of the higher definition Standard. Associated with the video amplifier are the circuits for extracting the sound “intercarrier” for the C.C.I.R. Standard and for providing attenuation at this frequency (5.5Mc/s) in the video chain. The circuit providing this attenuation must be removed when the receiver is operating on the other Standard. In addition means must be provided for maintaining the correct polarity of video signal in spite of the inversion of the polarity of modulation between the two Standards.

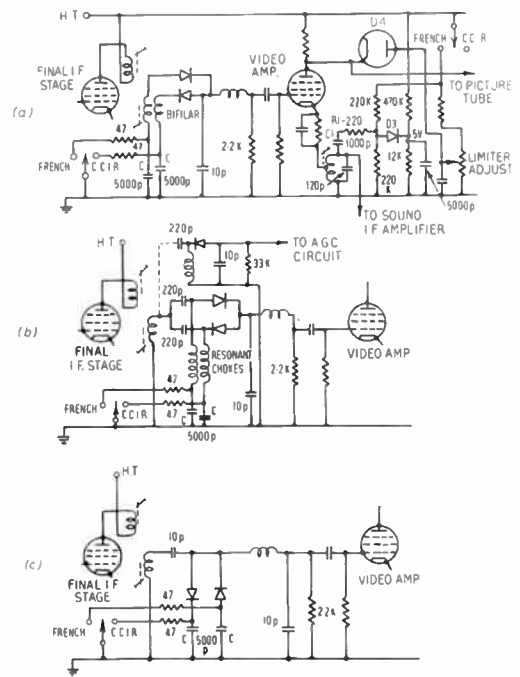

Fig. 13. Inversion of video signal by switching diodes.

is selected by switching in the return circuit where, as only d.c. and low frequency currents are present, the i.f. and higher video frequencies being bypassed by the capacitors C, connections of any reasonable length may be used between switch and circuit.

In Fig. 13(a) an additional diode (D3) serves to eliminate the sound rejector and take-off circuit, when not required, by introducing the damping network R1/C1, while the diode D4 is a conventional peak white interference limiter which is operative only for the positive modulation Standard (French). Both of these auxiliary circuits are switched simply by applying or removing the h.t. supply voltage and they can therefore be controlled by a single switch section which, at the same time, switches the sound i.f. amplifier (Fig. 11).

Very few, if any, dual-standard receivers pass the d.c. component of the video signal and this is easily understood upon consideration of the difficulties involved, which include:

- (1) The necessity of changing the operating conditions of the video amplifier.
- (2) The avoidance of a change of black-level on switching from one Standard to the other.
- (3) The desirability of avoiding large variations of black-level when the contrast control is adjusted, but compensation is required in opposing senses for the two Standards.

The elimination of the d.c. component therefore brings about a notable simplification of the design and reinsertion at the picture tube is rarely used because of the difficulty of providing a d.c. reinsertion circuit which is immune to the effects of impulsive interference on both Standards, the interference pulses being in opposing senses, relative to the video signal, for the two Standards.

### 8. Automatic Gain Control—Vision

The difficulties involved in finding a suitable vision a.g.c. system for a dual-standard receiver depend almost entirely on whether an “average signal level” or a “true carrier level” system is required. The former type, in which the control voltage is proportional to the average value of the composite video and sync. signal, is equally suitable for either Standard and, provided

its inherent limitations are accepted, is the most convenient solution to the problem.

The latter type provides a control voltage which is a true measure of received signal strength and independent of picture content. Systems of this type, using the black level of the video signal as reference, are well-known for both positive and negative<sup>4</sup> modulation standards, but involve certain additional complications when applied to dual-standard receivers.

It has been shown in an earlier section that the most convenient way of dealing with the opposite modulation polarities of the two Standards is to invert the vision detector diode so that the video signal always has the same polarity. If, however, a “black-level” a.g.c. system is to be operated from the detector output it will be necessary, on switching from one Standard to the other, to introduce a phase-inversion into the a.g.c. loop in order to compensate the inversion of detector polarity. Further consideration shows that if, as is usual, the contrast is to be varied by adjusting the a.g.c. threshold then the control range will not be the same for both Standards, since the black-level does not stand at the same modulation percentage in both cases and, in addition, the sense of variation of the contrast control potentiometer will have to be inverted.

Because of these difficulties, “black-level” a.g.c. is not widely used in dual-standard receivers and, in those receivers which do employ it, the same polarity of detection is maintained for both Standards so that no phase inversion is required in the a.g.c. loop. It is, however, then necessary to invert the video signal after detection as in Figs. 12(b) and 12(c). The latter disadvantage could be avoided if, in a circuit having separate vision detector diodes, a third diode were added to provide a signal of constant d.c. polarity for the a.g.c. circuit (Fig. 13(b)). The additional loading on the final i.f. transformer would be small since the relatively narrow bandwidth which is sufficient for a.g.c. purposes would permit the use of a high resistor as detector load.

### 9. Synchronizing Circuits

Under difficult reception conditions the quality of the received picture is closely dependent on the efficiency of the synchronizing arrangements

and it is therefore very desirable, in a dual-standard receiver, to provide means of approaching optimum performance on both Standards even at the cost of additional switching operations. This is specially true of the sync. pulse separator, where quite small deviations from optimum conditions can cause a noticeable deterioration in the stability of synchronization when the signal to noise ratio of the received signal is low.

Referring to the conventional self-biasing sync. separator circuit shown in Fig. 14, the

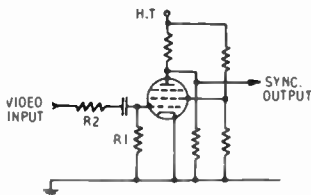

Fig. 14. Basic sync. pulse separator circuit.

simplest modification that can be made consists in changing, by switching, the value of R1. This provides a means of adjusting the extent to which the sync. pulse tips are clipped by grid current in order to compensate for the difference, between the two Standards, of the sync./signal ratio and of the mark space ratio of the line sync. pulses.<sup>5,6</sup> The lower mark/space ratio of the French Standard (1/18.5) as compared with the C.C.I.R. Standard (1/10) causes the clipping level to move down towards black-level, whereas in view of the lower sync./signal ratio (French 25%, C.C.I.R. 33%) the clipping level requires to be moved in the opposite direction. Certainly, if optimum conditions are established for the French Standard, satisfactory sync. separation will also be obtained for the C.C.I.R. Standard under good reception conditions, but the clipping level will be too near to the sync. pulse tip for correct operation when the signal/noise ratio is low. The clipping level may be moved away from the sync. pulse tip either by increasing R2 (Fig. 14) or by reducing R1, the latter alternative being the easier to arrange.

The situation is further complicated by the necessity, for the C.C.I.R. Standard, to render the sync. separator immune, as far as possible, from blocking effects in the presence of impulsive interference. To this end some C.C.I.R. receivers

include interference clipping or cancelling circuits before the sync. separator, and these may be included in a dual-standard receiver provided arrangements are made to avoid excessive clipping of the sync. pulse for the French Standard. A well-known circuit<sup>7</sup> which can conveniently be incorporated in a dual-standard receiver is shown in Fig. 15. Here, a valve having two control grids is employed as sync. separator, the video signal being applied to the second control grid and the inverted interference pulses to the first grid.

The majority of current dual-standard receivers, probably to avoid complication, use a straightforward sync. separator without interference cancelling circuits.

Synchronization of the line oscillator requires an automatic frequency control system for which any of the conventional discriminator or coincidence detector circuits may be employed. However the requirements of the two Standards in respect of control range are somewhat different since the sync. pulse frequency of C.C.I.R. transmitters is maintained constant within much closer limits than that of the French Standard whose field rate is locked to the mains supply

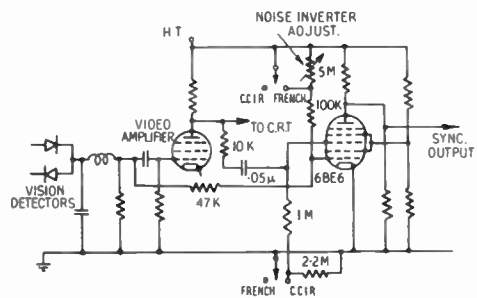

Fig. 15. Sync. separator with noise inversion.

frequency. For this reason, the pull-in range of the control system should be wider for the French Standard ( $\pm 2\%$ ) than for the C.C.I.R. Standard ( $\pm 1\%$ ). This is achieved in some receivers by switching components so as to change the time-constant in the control loop but the more usual practice is to adopt a compromise value of pull-in range for both Standards.

The separation of the frame sync. pulse from the complete sync. signal presents no special difficulties but, when it is necessary to deal with a frame pulse of different form for each Standard,

a circuit should be adopted which includes an effective clipping action after integration (or differentiation) of the complete sync. signal. In this way the action is made less dependent on the critical choice of time-constant in the integrating (or differentiating) circuit and a compromise value can be found which gives clean separation on both Standards.

**10. The Line Timebase**

The basic operation carried out on switching from one Standard to the other is change of the line oscillator frequency. This presents no difficulty with the three commonly used types of oscillator: the multivibrator, the blocking oscillator and the sine-wave oscillator. For the first two the necessary change of frequency may be brought about by the switching of a d.c. bias voltage, while for the sine-wave oscillator the use of two separate oscillator coils with change-over switching is a suitable solution. None of these circuits is disturbed by the use of reasonably long connections between switch and circuit.

The interest in this section therefore attaches mainly to the behaviour of the output stage. In order to maintain optimum operating conditions and efficiency in a line output stage at two different scanning frequencies, it will generally be found necessary to change the output transformer ratios, the flyback time and the grid-drive conditions of the output valve. The switching that would be required for this purpose is too complicated to be acceptable and it is in any case doubtful whether the switching of transformer ratios is practicable because of the high peak voltages involved. No attempt is therefore made to achieve optimum operating conditions at both frequencies. The compromise that is usually adopted consists in designing for optimum operation at the higher of the two frequencies and then providing, at the lower frequency, just the minimum modification of the conditions necessary to maintain the same scanning energy, without changing either the transformer ratios, flyback time or the components associated with the drive waveform.

The principal change which occurs when the scanning frequency is switched to a lower value concerns the voltage developed across the deflector coils during scan and therefore the voltage across all sections of the transformer.

This voltage is given (neglecting resistance) by the expression

$$V_s = L \frac{di}{dt} = \frac{L \cdot i_{pp}}{t_s}$$

when the deflection current is linear.

where  $V_s$  = voltage developed across the deflector coils during scan.

$L$  = inductance of the deflector coils.

$i_{pp}$  = peak-to-peak deflection current.

$t_s$  = scan time =  $\frac{1}{f_s} - t_r$

$f_s$  = scanning frequency.

$t_r$  = flyback time.

$V_s$  therefore decreases with decreasing scanning frequency. Consequently the voltage drop across the primary section of the output transformer also decreases and, with constant h.t. supply voltage, the anode voltage and current of the output valve will therefore increase. New operating conditions will establish themselves at the lower frequency with higher current consumption and greater scanning energy than at the higher frequency. The obvious way to reduce the scanning energy to its former value is by a suitable reduction of the h.t. supply

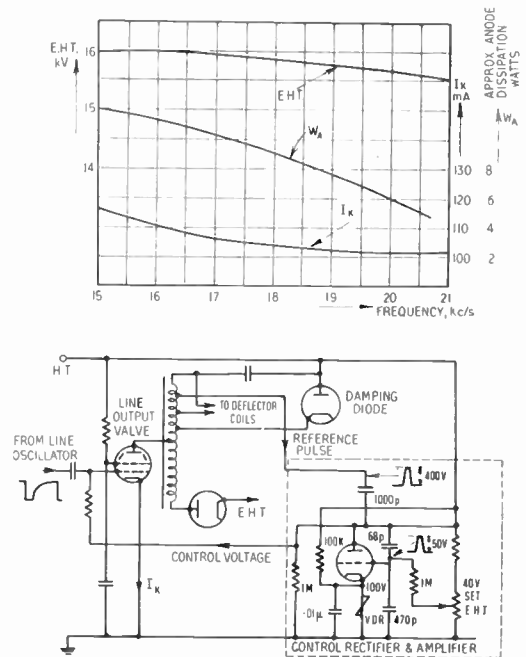

Fig. 16. Stabilized line output circuit.

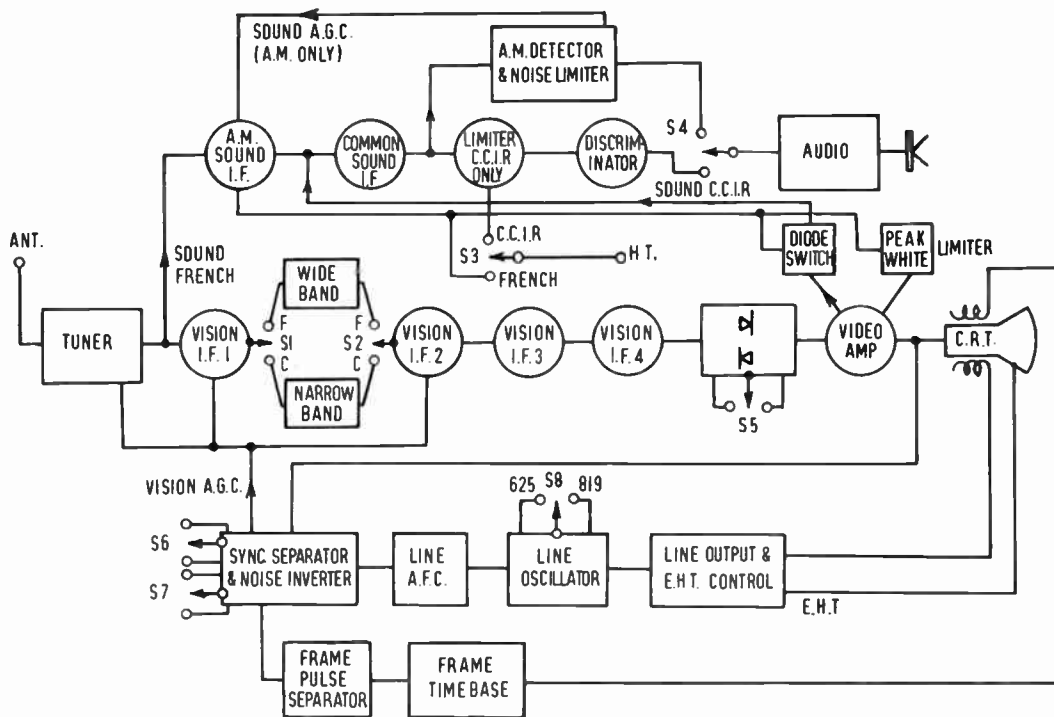

Fig. 17. Block diagram of complete dual-standard receiver.

voltage. This method has been widely employed with fairly satisfactory results although there is some inconvenience involved in equalizing exactly the scanning energy (and therefore the picture width and e.h.t. voltage) since suitable pre-set voltage-dropping resistors tend to be large and easily damaged by overload.

Recently a better solution has appeared in the use of automatic stabilizing circuits<sup>8</sup> which are simple and reliable and which provide overall stabilization of scanning energy against all external causes of variation, whether deliberate change of scanning frequency, variation of supply voltage or ageing of valves. The basic circuit (Fig. 16) uses a feedback system to maintain constant the peak voltage developed across the deflector coils during flyback (and therefore the scanning energy) by controlling the grid voltage of the output valve. Where a high degree of stabilization is needed, as in the present case, a triode pulse rectifier may be used to provide sufficient gain in the control loop. The details of this circuit and its variants have been very fully described in recent publications<sup>9</sup> and will not be elaborated further here.

It may be seen from the curve given in Fig. 16 that the e.h.t. (for zero beam current) remains satisfactorily constant (2.5% variation); the scanning current varies by the same amount and the percentage variation of picture width will be approximately one half of this value.

Three points are worthy of note in connection with this circuit.

- (a) The change of oscillator frequency causes some variation in the shape and amplitude of the grid drive waveform and consequently there will be some change in the proportion of the scan time for which the output valve conducts. This is of little importance provided that the circuit has been designed (by suitable choice of output transformer ratios) so that the diode conducts throughout the scan and can therefore compensate for small variations of pentode conduction. The increase of pentode current with decreasing frequency shown in Fig. 16 ( $I_k$ ) is attributable to this cause.
- (b) The anode dissipation of the output valve increases with decreasing frequency

because the anode voltage during scan increases rapidly as the frequency decreases, as explained above, and there is also a small increase of anode current as noted. For this reason it is essential to choose a valve having a high anode dissipation rating.

- (c) The boost voltage decreases with decreasing frequency, consequently if this voltage is used for such purposes as supplying the focus electrode of the picture tube or the anode voltage of the frame oscillator, it will be necessary to switch into circuit a voltage divider at the higher scanning frequency. Alternatively, to avoid additional switching, the high-voltage required may be obtained by rectification of the flyback pulse, which has constant amplitude, from a suitable auxiliary winding on the output transformer.

### 11. Conclusion

An assortment of circuits and techniques have been described which may be used as building blocks in putting together the complete design of a dual-standard receiver. One combination, which is a reasonable compromise between performance, economy and simplicity is outlined in Fig. 17. Such a receiver requires two or three valves and two or three germanium diodes more than the corresponding single-standard receiver of equivalent performance. The number of switching operations (eight) is not large and only two of these, in the vision i.f. circuits, are of a "critical" nature.

The emphasis throughout has been placed on simplicity which, allied with a small number of special techniques, enables the changeover of Standards to be made with a small number of switching operations and this in turn leads to simpler and more flexible mechanical design. It may be concluded that the realization of dual standard receivers does not present excessive difficulties and that they need be neither unduly expensive nor complex as compared with normal television receivers.

### 12. References

1. S. Deutsch, "Theory and Design of Television Receivers" Chapter 14, p. 457. (McGraw Hill, New York, 1951.)
2. A. J. H. Nieveen van Dijkum, "An intercarrier sound circuit", *Electronic Applications Bulletin*, **15**, No. 4/5, p. 61, 1954.
3. W. Bruch, "The use of diodes as switch elements" (Abstract) *Radio Mentor*, No. 12, p. 805, December, 1957.
4. P. L. Mothersole, "Automatic gain control circuits in television receivers for negative modulation systems", *J. Brit.I.R.E.*, **18**, pp. 307-16, May, 1958.
5. S. Deutsch, *loc. cit.*, pp. 64-66.
6. W. Heiser, "Sync.-separator analysis". *Electronics*, **23**, July, 1950, pp. 108-111.
7. M. Marks, "A noise immune sync. separator", *Electronics*, **25**, April, 1952, pp. 124-127.
8. "Stabilization of line and frame output circuits" *Electronic Applications Bulletin*, **18**, No. 4, p. 129 *et seq.*, 1957.
9. Papers in *Electronic Applications Bulletin*, **17**, No. 7, **18**, Nos. 3 and 4. *Funk Technik*, 1957, No. 15; 1958 Nos. 23 and 24.



# Assessment of X-Radiation from Television Receivers†

by

A. CIUCIURA, B.SC.(ENG.)‡

*A paper read on 2nd July 1959 during the Institution's Convention in Cambridge.*

**Summary:** The possibility of predicting, at the design stage, the X-radiation properties of a particular receiver under development is achieved by establishing X-ray properties of cathode-ray tubes in terms of their spread, e.h.t., and beam current, and by defining properties of e.h.t. supplies in terms of mean potential, spread and internal impedance. The two sets of properties are allowed to act simultaneously and final results are evaluated statistically in terms of a number of receivers exceeding the present permissible dose-rate of 0.5 mr/h, the amount of X-radiation emitted in an extreme case and the amount of shielding required, if any. The specific cases quoted were taken from measurements on tubes and valves operated under laboratory conditions.

## 1. Introduction

With the increasing use of ionizing radiations in the ever widening field of human endeavour, there is parallel increase in awareness of its effects on living organisms. In so far as television receivers are concerned the amount of radiation produced is normally well below the level of any direct injury, nonetheless it is a contributing factor in the make-up of the background radiation. There is evidence indicating that an increase in the background radiation leads to an increase in the rate of genetic changes<sup>1, 2, 3</sup>.

The problem of X-radiation from television receivers, and particularly from cathode-ray tubes, is not a new one. For years American published data contained a warning to the effect that operation of tubes above 16kV (absolute value) may produce harmful X-rays and special shielding precautions may be necessary. In this country some work on the subject was carried out by individual manufacturers<sup>4, 5</sup>, and various industrial associations. This is reflected in the insertion of an X-radiation clause in the revised issue of B.S.415: 1957.<sup>6</sup> (See Appendix 1.)

The approach normally taken in this country was to measure the X-radiation from cathode-ray tubes operated under conditions similar to

those in a television receiver. A few years back it was possible to assume large margins of safety and yet still be within the permissible limits. With time the demand for brighter and bigger pictures was answered in the only possible way—increase in e.h.t. and beam current. As improvements in manufacturing techniques enabled the use of thinner glass in the cone of the cathode-ray tube, the situation became increasingly difficult. Finally, the International Commission on Radiological Protection (I.C.R.P.) in April 1956 (Geneva Meeting) reduced the permissible dose rate for television receivers from 0.6  $\mu\text{r}/\text{sec}$  to 0.15  $\mu\text{r}/\text{sec}$ , that is, by a factor of four. In this way the safety margins disappeared and the new situation compelled a complete revision of the approach to the problem.

## 2. Sources of X-Radiation in Television Receivers

The International Commission on Radiological Protection recommended in 1954, that "Any electronic tube operating at potentials above 5,000 volts shall be considered a possible source of X-rays, and, if necessary, radiation barriers shall be provided". On this basis the possible sources of X-rays in a television receiver are: line output valves, cathode-ray tube and e.h.t. rectifier.

Although the peak anode potential for line output valves may be in excess of 7 kV, it is of short duration (18 per cent of the cycle with

† Manuscript received 13th March 1959. (Paper No. 513.)

‡ Mullard Radio Valve Co. Ltd., New Road, Mitcham Junction, Surrey.

U.D.C. No. 537.531:621.397.62:614.898

18  $\mu$ sec max.) and occurs at the time when the valve is cut-off. No case of measurable radiation from these valves has been reported.

The e.h.t. rectifier may be working with a peak inverse potential in excess of 20 kV. Although the valve is cut-off for most of the time the d.c. inverse voltage is nearly the same as the e.h.t. potential. Under such conditions a small back emission is possible and this is responsible for generation of X-rays. If the walls of the rectifier are relatively "transparent", some X-radiation may be detected on the outside. In some instances it was noted that the e.h.t. rectifier was a primary source of X-radiation in a television receiver.

On account of its small size, the problem of shielding the e.h.t. rectifier does not present any difficulty. Furthermore, the bulb itself is of simple construction and instances are known when a complete solution of the problem was effected by using lead glass. Under some fault conditions the e.h.t. rectifier can still be a source of strong radiation. (See Section 7.)

The fundamental principle of operation of cathode-ray tube is the same as that of an X-ray tube; the final anode operates at d.c. potential and a continuous stream of electrons hits the target. It is unfortunate that the beam of electrons designed to excite the phosphor produces also the unwanted radiation. With direct-viewing tubes the thick walls of the bulb, required by mechanical considerations, intercept the radiation either completely (at low potentials) or pass only a small fraction at higher potentials. In contrast the projection tube, with its thin walls and high anode potential, produces a large amount of radiation. Some manufacturers recommend screening equivalent to 0.5 mm of lead.

Because of its bulk, X-ray shielding of the tube is a major problem. The screen must be visible to the viewer, hence transparent material for this part of the tube must be used. For the rest, either the tube or the cabinet must be coated with a suitable material—at the best a time-consuming process.

Up to now the design of the bulb for a cathode-ray tube was concentrated on required mechanical strength, dimensional accuracy and optical properties. In the future the X-radiation performance may well receive more attention.

### 3. The Need for Analytical Approach

In Fig. 3 is shown a graph relating the number of tubes exceeding the permissible dose of 0.5 mr/h as a function of e.h.t. Some of these tubes have been released for operation at 18 kV (design centre rating). Taking into account all possible factors it is conceivable that in a television receiver designed for this voltage some tubes may be working at about 20 kV. According to the graph 99 per cent of these tubes will exceed the permissible dose at 20 kV.

Apart from establishing the possibility of reaching the permissible dose-rate, such a simple approach does not give a true account of the situation and is open to criticism. The criticism can be expected to be severe, for on its outcome depends whether the receiver manufacturer has to provide the screening.

This example also illustrates the need for harmonious co-operation between the tube manufacturer and the receiver manufacturer. While the latter can control receiver performance, the intrinsic properties of the tube are outside his influence. In order to protect himself, the former may quote values with such large margins of safety that the receiver manufacturer will be forced either to disregard his recommendations or, in some cases, to incur an unnecessary expenditure.

It is the author's belief that the present situation on X-radiation is at a critical stage; its disregard may involve some hazards, but if carefully controlled it can be kept within bounds with only small additional expenditure. The purpose of this paper is to establish a control mechanism.

### 4. X-Radiation Properties of Cathode-ray Tubes

#### 4.1. Preliminary selection

The first difficulty encountered in the assessment of X-radiation from cathode-ray tubes is the large variation in performance between individual tubes. Any specification, if it is to have practical application in mass production, must cover a large number of tubes; the smallest range must cover at least tubes released under the same type number. For this reason, before the final assessment is attempted, it is necessary to carry out at least some of the

measurements to be described, over a long period of time. On the basis of these measurements it should be possible to determine the extent of variations and the range of tubes to be included in one specification. Since B.S.415 : 1957 clearly states that : "The X-radiation from any equipment . . . , shall nowhere exceed 0.5 mr/h when measured on the outside surface of the equipment housing," the specification should be prepared on a sample of tubes from a production line which is known to be most abundant in X-radiation. The measurements should be carried out at a point on the cathode-ray tube which will produce maximum radiation on the surface of the receiver.

4.2. Geometric distribution of X-radiation

The distribution of X-radiation on the surface of a modern cathode-ray tube is shown in Fig. 1. In contrast with earlier tubes, the amount of radiation passing through the screen is negligible in comparison with other areas. The area of most intense radiation is in the region of the face to cone joint. This area coincides with transition in glass thickness from a thicker face plate to a thinner cone.

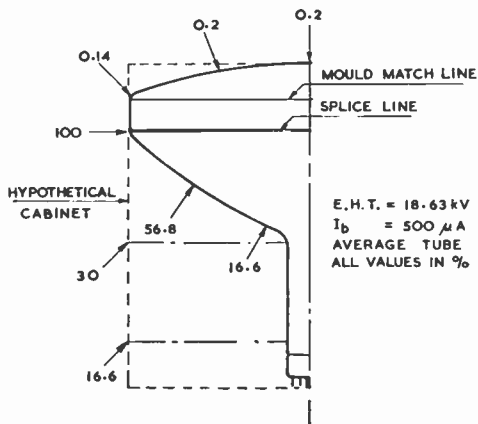

Fig. 1. Distribution of X-radiation on the surface of a modern tube.

British Standard 415 : 1957 is in terms of radiation on the outside surface of the cabinet. For the purposes of measurements this can be simulated by a rectangular box large enough to enclose the tube. The distribution of X-radiation along the surface of such a hypothetical cabinet is also shown in Fig. 1.

For the range of tubes examined experimental results indicate absence of any marked differences in the level of radiation for various planes passing through the tube axis. Although the amount of radiation varies from tube to tube, the relative distribution remains approximately the same. For these reasons the data shown in Fig. 1 gives, with some accuracy, the distribution of X-radiation (on a percentage basis) which is valid for a range of tubes.

4.3. Tube spreads

The variation in the amount of X-radiation produced by a population of tubes can be obtained by operating the tubes at a constant potential and current, and reading the dose-rate on an instrument whose distance is fixed in relation to the tubes.

However, more informative results can be derived by some reorganization of the experiment. In order to put the readings on an absolute basis a calibrated X-radiation monitor is required. The instrument used by the author is described in Appendix 2. By placing the pick-up device on the surface of the hypothetical cabinet on the area of maximum radiation, results are obtained which are of direct interest to the user. Further improvement can be introduced by keeping the beam current constant and adjusting the potential until the X-ray monitor registers 0.5 mr/h—the permissible dose-rate.

As mentioned before, the final specification should be prepared on a production line sample of tubes within the range considered and which is particularly abundant in X-radiation. Since the assessment can be carried out only on a statistical basis, the sample must be a large one, at least 100 tubes. A convenient way to display the results is to plot them in the form of a histogram which gives number of tubes reaching 0.5 mr/h at various potentials.

A moment of reflection will show that at low potentials the level of radiation will be such that all the tubes will be below the permissible dose-rate, while at high potentials all tubes will be radiating in excess of 0.5 mr/h. Therefore there is some justification for a "cumulative" type of plot. The discussed graph can be converted into the new type by a running summation of the number of samples. Specially

ruled papers are available, used by statisticians, which are admirably suited to these purposes. An example may illustrate the problem under consideration more clearly.

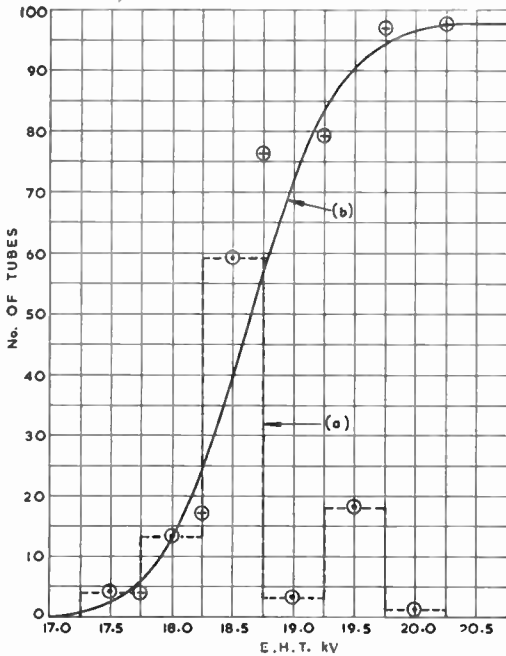

Fig. 2. (a) Histogram of X-radiation from a sample of 98 cathode-ray tubes. (b) Cumulative graph.

In Fig. 2 are shown results of measurements made on a sample consisting of 98 tubes. The histogram is plotted as curve (a), and the cumulative curve as (b). In Fig. 3 the results of Fig. 2(b) are shown on arithmetic probability paper. The scales of this paper are so arranged that a normal distribution (Gaussian distribution) appears as a straight line. Note a large scale expansion for very small and very large percentages.

Taking into account all the factors mentioned up to now, the results in the form of Fig. 3 state

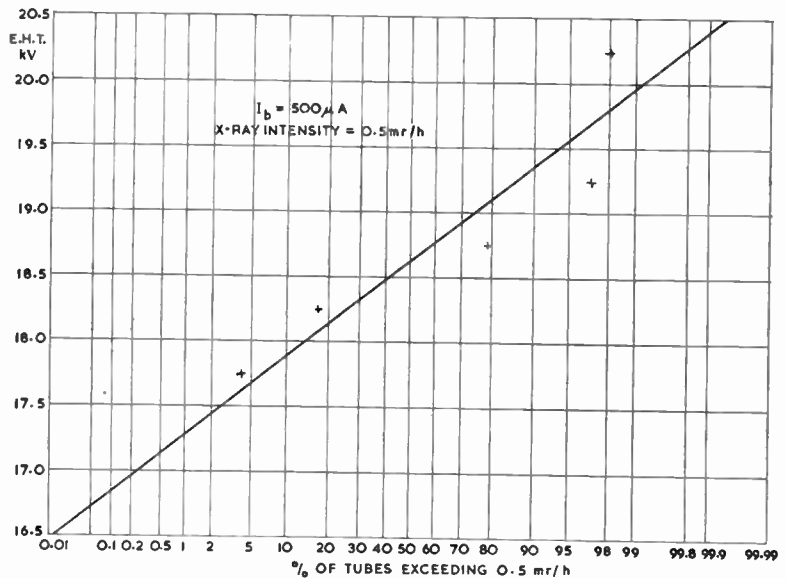

Fig. 3. Cumulative graph of X-radiation from cathode-ray tubes plotted on arithmetic probability scale.

that the X-radiation from a large sample of tubes covered by the specification should not be greater than stated in the graph, and this is the maximum radiation that can be measured on the receiver surface. It also gives, directly, information as to the number of tubes at any potential which may exceed the safe dose-rate when operated at  $I_b = 500 \mu A$ .

At this point the validity of  $500 \mu A$  may be questioned. The current passing through the tube under normal operating conditions is a variable quantity and therefore a source of doubt and argument. However, it will be shown later that further computations can provide a satisfactory answer (Section 6.2).

4.4. X-radiation variations with potential and current

Theoretically the rate of X-ray production is proportional to  $IZV^2$

where  $I$  = electron current,

$V$  = applied potential,

$Z$  = atomic number of the target material.

Measurements carried out on cathode-ray tubes show proportionality with beam current (Fig. 4), but there is a considerable departure from the  $V^2$  relationship (Fig. 5). Several

factors contribute to this situation. At low potentials there is a doubt as to the validity of the square law. The absorption of bulb walls is a function of X-ray wavelength, and therefore of applied potential. The attenuation of heterogeneous radiation is accompanied by a process of filtering, i.e. radiation of shorter wavelengths is less attenuated than that of longer wavelengths. On this basis the effective "bandwidth" of radiation passing through the walls of the tube increases with increase in e.h.t., and hence there is an increase in the rate of energy flow.

Measurements made on large samples of tubes show some variation in the amount of X-radiation as a function of potential. The results shown in Fig. 5 were obtained from an average tube selected from the group used to produce results in Fig. 3. For this tube 0.5 mr/h is developed at 18.63 kV which corresponds with the value for 50 per cent of tubes in Fig. 3.

4.5. Long term stability

Proposed information on the X-radiation performance of cathode-ray tubes consists of: intensity distribution on the surface of the tube (Fig. 1), spread due to tubes (Fig. 3), variation with current (Fig. 4), and with potential (Fig. 5). The information should cover at least one type of tube, and be prepared on tubes taken from

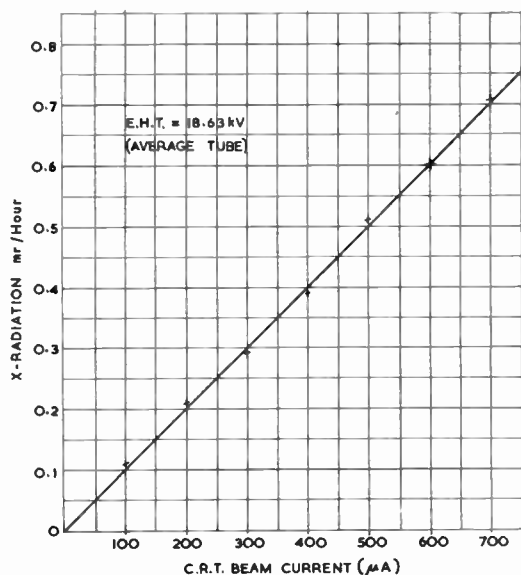

Fig. 4. X-radiation as a function of beam current.

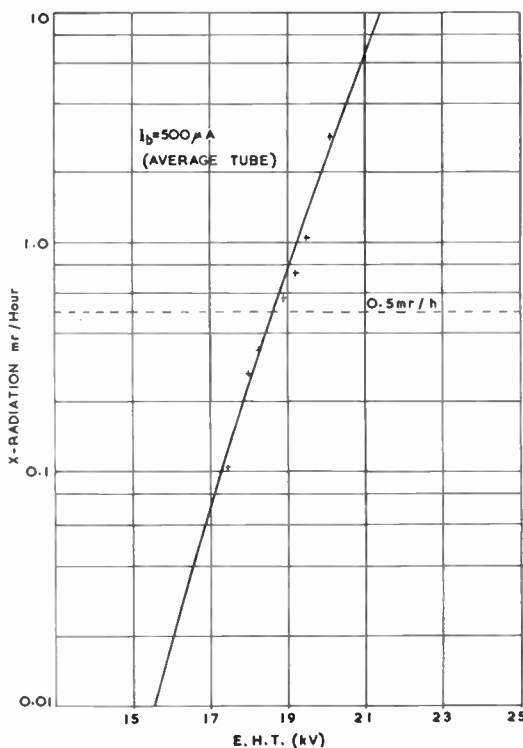

Fig. 5. X-radiation as a function of applied potential.

a production line known, from previous measurements, to be specially abundant in X-radiation. These data are comprehensive and should answer many questions posed by the receiver designer.

By releasing this information the tube manufacturer takes on responsibility for tube performance. If it is to be effective it must be supported by measurement during the production run. There should be a continuous check on tube spreads (Fig. 3) and an occasional check on the lines of Fig. 1 and Fig. 5.

From a long-term point of view, the tube replacement poses a difficult problem. Every effort should be made to see that tubes reaching the replacement market do not constitute a greater radiation hazard than the original tubes.

5. Properties of E.H.T. Supplies

5.1. Regulation

If the e.h.t. potential at zero beam current is  $V_0$ , then at a current  $I_b$  passing through the tube it is expected to be  $V = V_0 - R_i I_b$ , where  $R_i$  is the internal resistance of the supply. The

value of  $R_i$  is determined by the line time-base design; for time-bases used in this country it varies between 5 megohms and 10 megohms, and for stabilized time-bases (coming into use on the Continent) it can be between 1 megohm and 4 megohms. For the purposes of computation the minimum value of  $R_i$  is required.

5.2. *Design value*

Since the e.h.t. value is a function of beam current passing through the tube, there is some confusion when it is specified on its own. In order to resolve the difficulty, at least one tube manufacturer specifies tube ratings at zero beam current, irrespective of e.h.t. regulation. In this paper the above interpretation is used.

Television receiver design in this country is based on the design centre rating system. Roughly, it implies that with nominal components, valves and mains input, the receiver must be operated within the valve (and tube) manufacturers' ratings. Thus the nominal e.h.t. value, which is normally quoted, can vary about the mean value.

5.3. *Spreads*

The spreads in e.h.t. can be divided into two main groups—those due to components, valves, etc., which are within manufacturing controls, and those due to variations in the mains voltage.

Since the amount of X-radiation emitted by the cathode-ray tube is particularly sensitive to e.h.t. variations, this parameter requires attention. It is in the interest of receiver manufacturers to keep this parameter as constant as possible for other reasons, hence this requirement is already being met. For the purposes of computations to be described a graph of e.h.t. spreads is required.

The Electricity Supply Regulations, 1934, permit the supply at a customer's terminals to vary by  $\pm 6$  per cent from the declared value. Wedmore and Flight<sup>8</sup>, investigated the manner in which the mains voltage varied in 1934, but there is a lack of more recent information. They noted that on occasions the mains voltage may fall below the nominal but it is very seldom above it. In general they found that the variations in the mains voltage approximate to the normal distribution. Since in these considerations the upper limit is of primary importance,

it is possible to work on the assumption of normal spread.

As the variations in the e.h.t. due to manufacturing processes are entirely independent of the mains voltage variations, the two can be added statistically. In forthcoming discussions it will be assumed that the quoted spreads include all possible factors which may be encountered in the viewer's home (but excluding drops due to  $R_i$ ).

In practice, with a receiver designed for 16 kV, the spreads during production will be limited to about  $\pm 1$  kV. For the majority of receivers used in this country, a 6 per cent change in the mains voltage is reflected as the same percentage change in the e.h.t. At 16 kV it corresponds to 1 kV. Adding these spreads statistically, the total spread is 1.41 kV.

6. **Computations**

6.1. *Combined effect of spreads*

Specific cases will be quoted here because it is felt they illustrate the method of approach more clearly than a discussion in general terms. Since a graphical approach is considered, the proposed method applies equally well to any situation and for any form of distribution.

The simplicity of some of the statistical problems is very deceptive. It is recommended that whenever possible a qualified statistician should be consulted.

For the purposes of illustration, the spread of X-radiation from cathode-ray tubes is taken from Fig. 3 and the e.h.t. spread from the previous paragraph, that is, 16 kV design value with normal spread of 1.41 kV for  $3\sigma$  limits. The two spreads are drawn to the same scale in Fig. 6.

Because of overlap between two graphs there is a chance that some combination of e.h.t. and tubes may produce X-radiation in excess of permissible dose-rate. The chance of this occurring can be expressed as

$$\frac{\int_{-\infty}^{+\infty} ab \, dV}{\int_{-\infty}^{+\infty} a \, dV} \times 100 \text{ per cent}$$

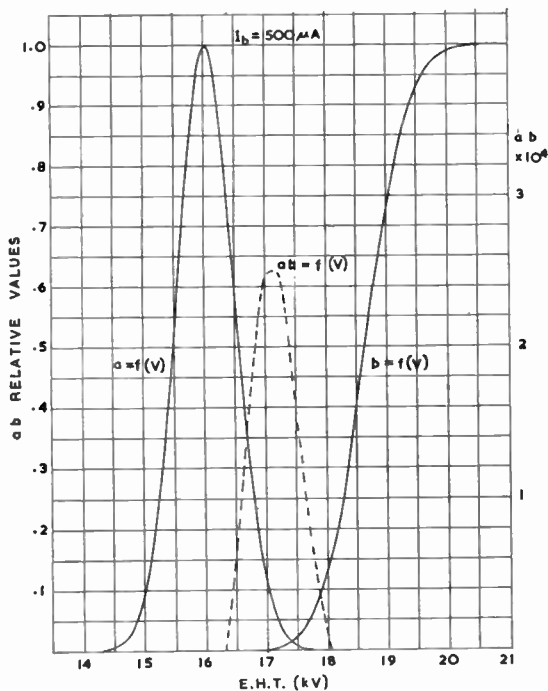

Fig. 6. Cumulative graph of X-radiation from cathode-ray tubes  $b = f(V)$  and e.h.t. spread  $a = f(V)$  plotted on the same scale. The product  $ab = f(V)$  is shown to another scale.

Since only the area of overlap is of any interest, it can be redrawn on a large scale and from this the curve  $ab = f(V)$  can be obtained. This curve is also shown in Fig. 6, but to a different scale.

For the case under consideration, the spread in e.h.t. is assumed normal, hence

$$a = N \exp\left[\frac{1}{2} \left(\frac{16 - V}{\sigma}\right)^2\right]$$

where  $V$  = applied potential in kV

$$\sigma = \text{spread in e.h.t.}, \frac{1.41}{3} = 0.47 \text{ kV}$$

$N$  is a constant, in this case unity.

Substituting

$$a = \exp[-2.27(16 - V)^2]$$

The values of  $b = f(V)$  are obtainable from Fig. 3. The computation of  $ab = f(V)$  is shown in Table 1.

The area under the curve  $a = f(V)$  is

$$\int_{-\infty}^{+\infty} a \, dV = N\sigma\sqrt{2\pi}$$

From the graph  $N = 200 \text{ mm}$   $\sigma = 9.42 \text{ mm}$  (taking in Fig. 6 one division as 10 mm), hence the required area is 4,720 mm<sup>2</sup>. The area under the curve  $ab = f(V)$  must be taken from the graph, and this was found to be 2,375 mm<sup>2</sup>, but unity on scale  $a = f(V)$  corresponds to  $4 \times 10^{-4}$  on the scale for  $ab = f(V)$ , hence the sought area is equal to 0.95 mm<sup>2</sup>. The required answer is :

$$\frac{0.95}{4720} \times 100 \text{ or about } 0.02 \text{ per cent}$$

It will be recollected that  $a = f(V)$  applies to the beam current of 500 μA therefore  $b = f(V)$  must also be at the same beam current. The above example states that in a large sample of television receivers operating at 16 kV and 500 μA, ( $R_i = 0\Omega$ ;  $3\sigma = 1.41 \text{ kV}$ ) there will be not more than 0.02 per cent of sets with X-radiation in excess of 0.5 mr/h.

Repeating the above calculations for various values of e.h.t. and spread a universal set of graphs may be obtained as shown in Fig. 7.

6.2. Effect of e.h.t. regulation

Since the amount of X-radiation produced by a cathode-ray tube is proportional to the beam current, graphs in Fig. 4 and 5 can be combined in one graph as shown in Fig. 8.

Table 1  
Calculation of  $ab = f(V)$

$V$ , kV	16.6	16.8	17.0	17.2	17.4	17.6	17.8
$a$	.441	.234	.103	.038	.012	.003	.00064
$b \times 10^{-3}$	.24	.80	2.4	6.6	17	37	75
$ab \times 10^{-4}$	1.05	1.87	2.48	2.5	1.98	1.1	.48

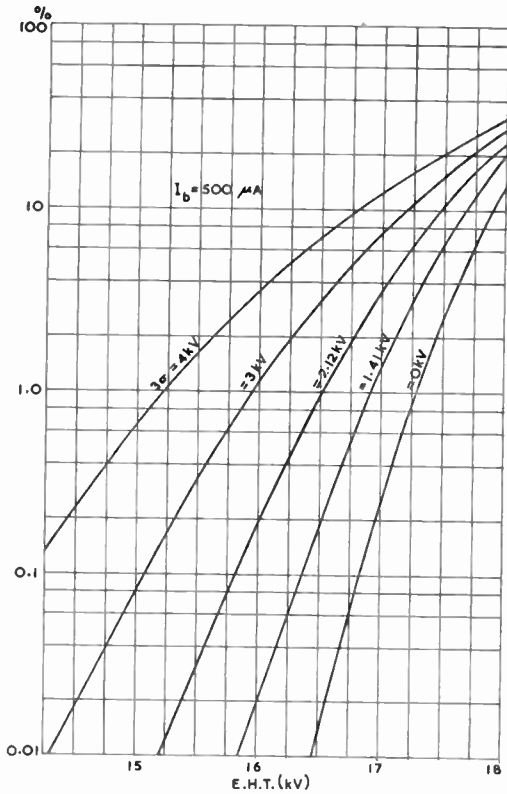

Fig. 7. Probability of number of receivers exceeding the permissible dose-rate of 0.5 mr/h as a function of e.h.t. potential and with e.h.t. spread ( $3\sigma$  limits) as parameter.

Considering an e.h.t. of 18 kV (say) and  $R_i$  of 10 megohms, then at  $I_b = 50 \mu A$  it is only 17.5 kV, at  $I_b = 100 \mu A$  it is 17 kV and so on. By plotting these points in Fig. 8 for various values of  $R_i$  the effect of e.h.t. regulation is clearly demonstrated.

One interesting fact emerges from inspection of Fig. 8. The maximum X-radiation does not coincide with the maximum beam current. For each value of  $R_i$  there is a specific value of beam current for maximum radiation. This value lies well within magnitudes encountered in practice. Figure 8 therefore furnishes the answer as to the choice of beam current for the purposes of calculation of maximum X-radiation from television receivers.

### 6.3. Computation of number of receivers exceeding permissible dose rate

In these calculations it is assumed that the tubes employed are those covered by specifica-

tions in Figs 1 to 5, and the e.h.t. spreads are normal. If either of these factors is different, a new set of results must be prepared for Fig. 7.

Again a practical example will be used. A television receiver under development is to be operated at 17 kV, design centre rating, the e.h.t. regulation is expected to be 5 megohms minimum, spread normal and 1.41 kV for  $3\sigma$  limits, and the maximum average beam current 500  $\mu A$ . Plotting the e.h.t. regulation in Fig. 8, (starting at 17 kV), it is found that maximum radiation occurs at about 150  $\mu A$  (Fig. 8, point A). Calculations in Fig. 7 are made for  $I_b = 500 \mu A$ . Hence either Fig. 8 needs to be recalculated or the e.h.t. so adjusted as to keep the dose-rate constant. The latter can be done just by drawing a horizontal line through the point A to intersect  $I_b = 500 \mu A$  parameter. Thus the effective value of e.h.t. is read as 15.3 kV. Referring now to Fig. 7, a point is sought corresponding to 15.3 kV and  $3\sigma = 1.41$  kV. As the value sought is off the scale, it may be

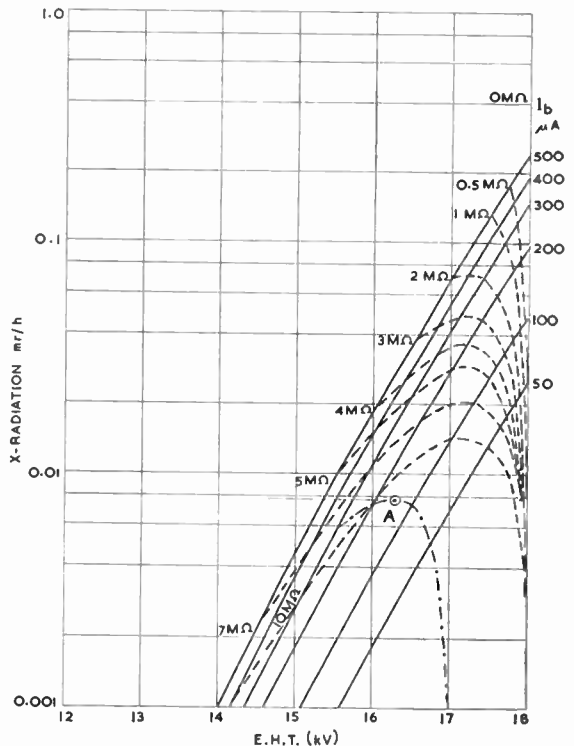

Fig. 8. X-radiation as a function of e.h.t. potential with beam current as a parameter. Loci of e.h.t. as a function of beam current for various values of  $R_i$  are shown dashed.



concluded that the proportion of receivers radiating in excess of 0.5 mr/h will be well below 0.01 per cent.

In Table 2 are shown results of calculations covering theoretically possible modes of tube operation. The first column in Case A is the only one applicable to receivers designed in this country.

6.4. Adjustments to another dose-rate

The calculations can be easily adjusted to any future changes in the permissible dose-rate. Assuming that there is a reduction from the existing value of 0.5 mr/h to 0.1 mr/h, this alteration is reflected in Fig. 5 as a reduction in e.h.t. from 18.63 kV to 17.3 kV, a difference of 1.33 kV. This implies that in Fig. 6 the function  $b = f(V)$  should be shifted to the left by that amount. Since Fig. 7 was prepared in terms of variable e.h.t., it is more convenient for the function  $b = f(V)$  in Fig. 6, to remain unchanged and for the function  $a = f(V)$  to

move to the right by that amount. For the case discussed in section 6.3 (e.h.t. = 17 kV,  $R_i$  min. = 5 megohms, spread 1.41 kV, effective e.h.t. = 15.3 kV) it was found that not more than 0.01 per cent of receivers were exceeding 0.5 mr/h. If the dose-rate is lowered to 0.1 mr/h, 1.33 kV must be added to the effective e.h.t., making a total of 16.63 kV. From Fig. 7 the point defined by this potential and the spread of 1.41 kV corresponds with 0.3 per cent. Thus changing the permissible dose-rate from 0.5 mr/h to 0.1 mr/h increases the number of receivers exceeding it from well below 0.01 per cent to 0.3 per cent.

6.5. Maximum X-radiation

So far only the proportion of receivers radiating in excess of the limit dose-rate has been calculated. It is of interest to find the level of radiation for a limiting case. Table 2, Case E, shows that for receivers designed for 18 kV,  $R_i = 1$  megohm, and 2.12 kV spread (effective

**Table 2**  
X-radiation within theoretically possible modes of tube operation.

CASE A						
16 kV Design Centre, $R_i=5$ M $\Omega$ . Maximum radiation occurs at 150 $\mu$ A, effective e.h.t. 14.35 kV.						
e.h.t. spread, kV		1.41	2.12	3.0	4.0	
% of sets exceeding 0.5 mr/h		—	—	0.012	0.16	
CASE B						
16 kV Design Centre, $R_i=1.0$ M $\Omega$ . Maximum radiation occurs at 500 $\mu$ A, effective e.h.t. 15.5 kV.						
e.h.t. spread, kV		1.41	2.12	3.0	4.0	
% of sets exceeding 0.5 mr/h		—	0.03	0.34	1.6	
CASE C						
18 kV Design Centre, $R_i=5$ M $\Omega$ . Maximum radiation occurs at 150 $\mu$ A, effective e.h.t. 16.25 kV.						
e.h.t. spread, kV		1.41	2.12	3.0	4.0	
% of sets exceeding 0.5 mr/h		0.06	0.45	2.0	5.0	
CASE D						
18 kV Design Centre, $R_i=3$ M $\Omega$ . Maximum radiation occurs at 250 $\mu$ A, effective e.h.t. 16.65 kV.						
e.h.t. spread, kV	0.0	0.5	1.41	2.12	3.0	4.0
% of sets exceeding 0.5 mr/h	0.03	0.10	0.35	1.50	4.2	8.5
CASE E						
18 kV Design Centre, $R_i=1.0$ M $\Omega$ . Maximum radiation occurs at 500 $\mu$ A, effective e.h.t. 17.5 kV.						
e.h.t. spread, kV	0.0	0.5	1.41	2.12	3.0	4.0
% of sets exceeding 0.5 mr/h	2.6	3.5	6.4	11.0	16	20

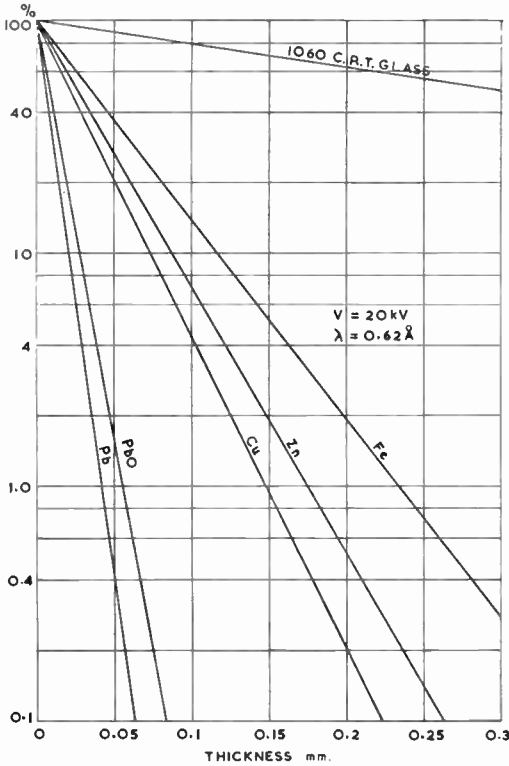

Fig. 9. X-radiation transmission graphs for various materials.

e.h.t. = 17.5 kV), not more than 11 per cent of sets will exceed the limit dose-rate of 0.5 mr/h. If the limit is set at 0.01 per cent, what is the level of radiation? Referring to Fig. 7 the 0.01 per cent level crosses the  $3\sigma = 2.12$  kV parameter at 15.2 kV. The difference between the effective e.h.t. and this potential is 2.3 kV. Now in Fig. 5 an average tube is producing 0.5 mr/h at 18.63 kV, therefore at  $18.63 + 2.3 = 20.93$  kV it will be radiating 6 mr/h. Hence for this particular case it may be concluded that not more than 0.01 per cent of receivers will exceed 6 mr/h.

Although the dose-rate is well in excess of the permissible value, it can be produced by less than 0.01 per cent of receivers. However, this example indicates that in an extreme case the level of radiation can be very high, and there is a need to limit it. With the reduction in the percentage of receivers exceeding the permissible dose-rate, the radiation rate of the limit receiver will also fall.

6.6. Computation of the required attenuation

In the previous section it was found that not more than 11 per cent of sets were exceeding the limit dose-rate of 0.5 mr/h and 0.01 per cent of sets were exceeding the dose-rate of 6 mr/h. If it is desired to reduce the level of radiation so that not more than 0.01 per cent of sets are exceeding the permissible dose-rate of 0.5 mr/h, the required attenuation is 6/0.5 or 12 times.

6.7. Shielding

Assuming that a need for shielding is established, the problem is how this can be achieved. The results in Figs. 1 to 5 apply to the area of maximum radiation on the surface of a hypothetical cabinet. Normally a larger cabinet than the hypothetical will be used, but this can be neglected. If the cabinet is of wood or plastic, the transmission of these materials is so high that its effect can also be neglected.

Considering the case discussed in the previous section, the required attenuation is 12 times or

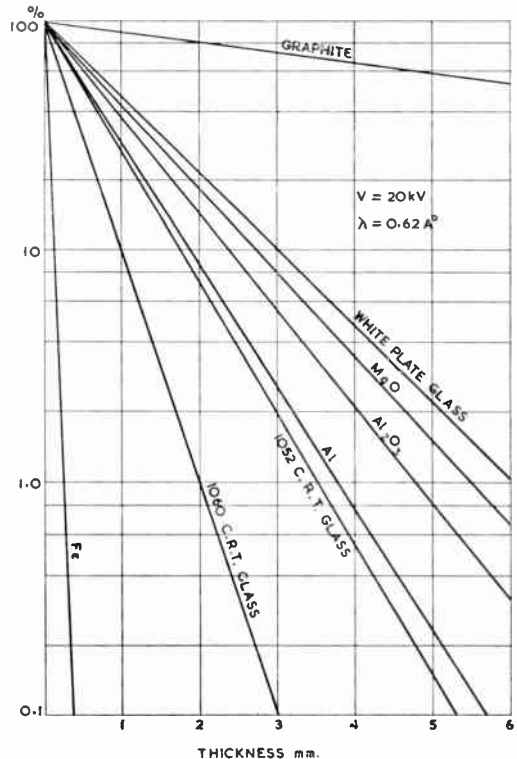

Fig. 10. X-radiation transmission graphs for various materials.

down to about 8 per cent. Examination of Fig. 1 shows that the screen area of the cathode-ray tube is quite safe, but the sides and the back of the cabinet must be shielded. In Figs. 9 and 10 attenuation graphs for several materials are given for X-radiation at 20 kV. From these it can be seen that 2.1 mm of aluminium will be required, but only 0.08 mm of iron and 0.023 mm of lead. It is interesting to note that the attenuation of lead monoxide is nearly as good as of lead, and a layer of 0.03 mm will be sufficient. On this basis a good layer of white lead paint could be used. No doubt other suitable materials can be found.

Because of rapid reduction of attenuation with reduction in wavelength (and increase of potential), the materials should be examined at the highest potentials at which the receiver is expected to operate.

#### 7. X-Radiation from E.H.T. Rectifier under Fault Conditions

It has been found that an e.h.t. rectifier, which is completely satisfactory under normal operating conditions, can be a source of intense X-radiation under fault conditions. Such a situation occurs when the heater of the valve becomes open-circuited and the bias on the cathode-ray tube is adjusted to be within its grid base. The tube provides a d.c. path which holds the cathode of the rectifier at or near the chassis potential. The amount of cold emission from the cathode is sufficient to produce a radiation level well in excess of the permissible dose-rate. On one type of rectifier, operated on the limit for the peak inverse voltage, dose-rates up to 20 mr/h (limit 0.5 mr/h) were measured at a distance of 6 inches.

In so far as the average viewer is concerned it is doubtful whether he will have the receiver running for any length of time without the picture on the tube. The main concern is thus for the service engineer. Apart from provision of satisfactory screening, it may be possible to recommend to the trade to begin fault tracing when justifiable by checking the e.h.t. rectifier for heater continuity.

#### 8. Conclusions

This paper establishes the possibility of X-ray emission from cathode-ray tubes and e.h.t.

rectifiers incorporated in television receivers. At least on the samples of tubes discussed, it has aimed to show that the X-radiation situation is a border line case; its neglect may involve certain hazards, yet some control can keep it within bounds.

In developing the methods of control particular attention has been directed to the interests of both the tube and the receiver manufacturer. However, it is possible to separate the control requirements of the parties concerned. The specifications for cathode-ray tubes provide data on physical characteristics of X-radiation. The form of presentation is largely independent of operational conditions, and yet readily adaptable for further analytical processing by the receiver designer according to his own requirements. The outlined computations are simple and can be applied at the design stage. Since the factors governing the rate of X-ray emission are defined, it should be possible to adjust the design for minimum radiation.

Measurements of X-radiation on a completed receiver is a difficult task. The method discussed points the way in which such measurements should be designed. It is believed, in fact, that if the tubes and receivers are properly controlled, there is no pressing need for measurements on the finished products.

#### 9. Acknowledgments

The author wishes to take this opportunity to express his gratitude to all those concerned in the preparation of this paper. In particular his thanks are due to the Directors of The Mullard Radio Valve Company Ltd. for the permission to publish this paper, to the C.R.T./T.D. Department for the permission to reproduce Fig. 3, and to Mr. W. W. Bryant, of Quality Control Department, for advice on statistical problems.

#### 10. References

1. Medical Research Council, "The Hazards to Man of Nuclear and Allied Radiations". (Cmd. 9780.) (London: H.M. Stationery Office, 1956.)
2. Report of the United Nations Scientific Committee on the Effect of Atomic Radiations. (General Assembly—Official Records: Thirteenth Session, Supplement No. 17 (A/3838). (London, H.M. Stationery Office, 1958.)

3. N. Chisholm, "X-rays from television sets" (letter), *The Lancet*, **270**, p. 54, 7th January, 1956.
4. L. B. Bourne, "X-ray hazards from television apparatus and cathode-ray tubes" (letter), *The Lancet*, **271**, p. 510, 8th September, 1956.
5. L. B. Bourne, "X-ray hazards during the manufacture of cathode-ray tubes and television sets," *XIth International Congress on Occupational Health, Helsinki, 1st to 6th July, 1957*, **3**, p. 196.
6. British Standards Institution, "Safety Requirements for Radio or other Electronic Apparatus for Acoustical or Visual Reproduction". B.S.415 : 1957.
7. Recommendations of the International Commission on Radiological Protection (Revised December 1st, 1954), *British Journal of Radiology*, Supplement No. 6, p. 72.
8. E. B. Wedmore and W. S. Flight, "Voltage variation at consumers' terminals", *J. Instn Elect. Engrs*, **76**, pp. 685-701, June, 1935.
9. W. J. Oosterkamp, J. Proper and J. J. F. de Wijk, "Dosimetry of very weak X-radiation generated in television receivers and X-ray diffraction apparatus", *Philips Tech. Rev.*, **19**, pp. 264-267, No. 9, 1957/58.

### 11. Appendix 1:

#### Extracts from British Standard 415 : 1957

The following is an extract from B.S.415 : 1957 of the complete clause on X-Radiation.

#### "X-Radiation from Cathode-Ray Tubes.

16. The X-radiation from any equipment containing electronic devices, such as high voltage cathode-ray tubes and rectifying valves, shall nowhere exceed 0.5 mr/h when measured on the outside surface of the equipment housing.

*Note.*—Experience has shown that electronic devices, for example cathode-ray tubes and rectifying valves operating at approximately 15 kV peak voltage or peak inverse voltage and higher, are capable of generating X-rays which can be dangerous to the user unless suitable precautions are taken. Although some forms of screening may be required, the method of protection is left to the designer of the equipment.

The danger to servicing personnel operating such devices without protection may be more serious and a suitable warning notice should be affixed to the equipment."

The spirit of the clause is probably reflected in the following extract from the same Specification, Appendix E "Notes on the requirements of the Specification", section on X-radiation.

"... The introduction of an X-radiation limitation in this edition is intended primarily as a warning to designers that there is some possibility of danger; it is unlikely that any special precautions will be required if the e.h.t. does not exceed 15 kV. An implosion guard of glass in front of the tube screen would in any case introduce a very considerable degree of absorption".

### 12. Appendix 2 : Measurement of X-Radiation

#### 12.1. Description

For X-radiation measurements Mullard Geiger-Müller Counter Tube Type MX 108 was used in conjunction with Panax Ratemeter Type 5054. This instrument has linear response and the output is shown on a meter calibrated to give 0-400, 0-2,000, 0-10,000 and 0-40,000 counts/min.

#### 12.2. Calibration

The tube was calibrated by the Philips Research Laboratories, Eindhoven.<sup>9</sup> During the calibration the number of counts was measured at a constant dose-rate as a function of the half value layer as shown in Figure 11. The tube was also checked for proportionality of counts with dose-rate and, after taking into account the dead time, was found to be linear.

Fig. 11 shows that the tube has a linear wavelength response up to the half value layer of 0.5 mm Al (applied potential 20 kV). Since the filtration used during calibration was lower than that due to the glass envelope of a normal television tube, the calibration was extended up to 30 kV by introducing the applied potential as a parameter.

The dose-rate calibration of the MX 108 tube as a function of the number of counts is shown in Fig. 12. This graph covers only the more sensitive ranges, and calibration up to 40,000 c/min are available.

#### 12.3. Assessment

Although great care was exercised in the selection and calibration of the instrument, it can be criticized on several counts. Unfortunately the prospects of development of an improved equipment for use in the factory in the near future are small. While the presented

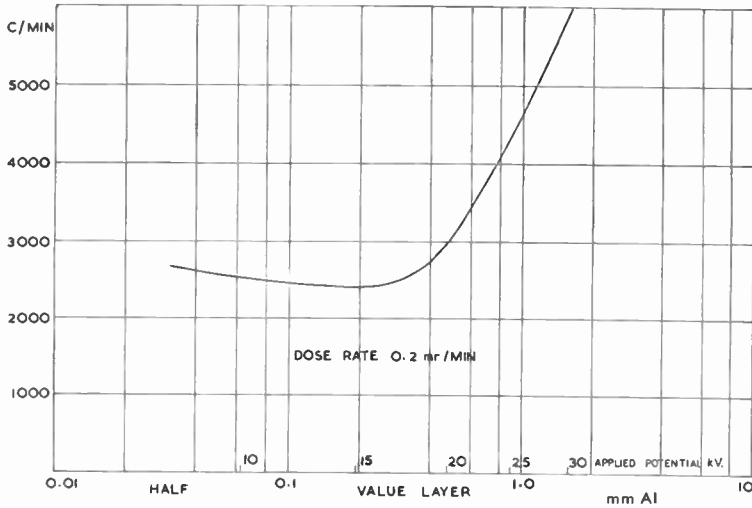

Fig. 11. Response of MX 108 G.M. Tube as a function of half value layer.

results could be subject to some errors, they certainly are not misleading. In view of the

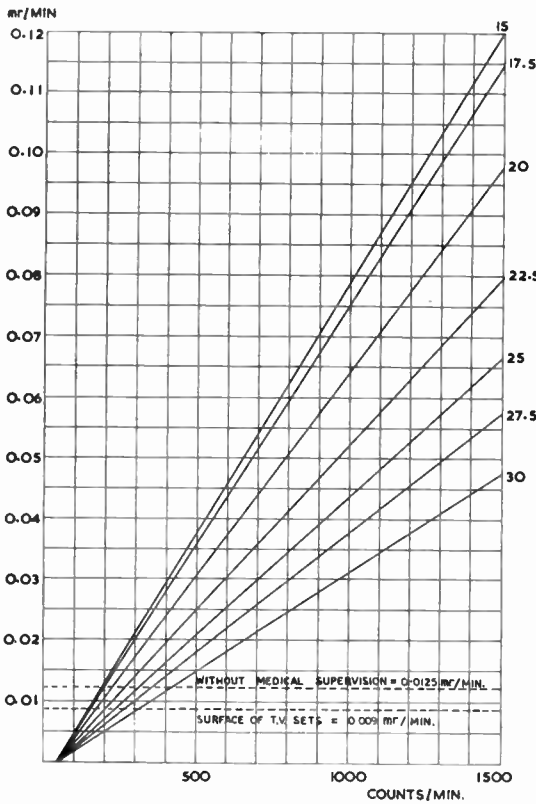

Fig. 12. Calibration of MX 108 G.M. Tube.

present controversy on the danger of X-radiation from television receivers it was felt that the work should be carried out with the available equipment and reviewed later, if necessary, in the light of new measuring techniques. Naturally, the method of approach outlined in the paper is independent of the method of measurement.

### 13. Appendix 3 : X-Radiation Data

#### 13.1. The Roentgen

The internationally accepted unit of X-ray quantity is determined by the ionization produced in a fixed mass of air and is defined as follows :

“The roentgen shall be the quantity of X- or gamma radiation such that the associated corpuscular emission per 0.001293 grams of air, produces, in air, ions carrying 1 e.s.u. of quantity of electricity of either sign”,

The mass of 1 cm<sup>3</sup> of dry atmospheric air at 0° C and 760 mm of mercury pressure is 0.001293 gm. The current produced by the limit dose-rate in an ionization chamber of volume *S* at a temperature *t*° C and pressure *P* mm Hg is

$$4.62S \frac{t + 273}{273} \cdot \frac{760}{P} \times 10^{-17} \text{ amperes.}$$

#### 13.2. X-radiation spectrum

For a “white” radiation the spectrum is of

the form shown in Fig. 13. The shortest wavelength emitted may be found from the formulae :

$$\lambda_{\min} = \frac{12.354}{\text{kV}} \text{ angstrom units}$$

At 20 kV

$$\lambda_{\min} = 0.62 \text{ angstrom units}$$

Depending on the target material and the applied potential, the spectrum may have narrow bands of intense radiation, called "characteristic radiation".

### 13.3. Absorption

For homogeneous radiation the fundamental law of absorption is an exponential law, given by the formula :

$$I = I_0 \exp(-\mu d)$$

where  $\mu$  = linear absorption coefficient  
 $d$  = absorber thickness.

The mass absorption coefficient is often used and this is the linear absorption coefficient divided by the density or  $\mu/\rho$ .

Half value layer (h.v.l) is the value  $d$  in the above equation for a specified substance usually Al, Cu, or Pb which attenuates the X-radiation by 50 per cent. The absorption increases rapidly with wavelength, consequently the longest wave-

length emitted is a function of the absorption properties of the vessel in which the radiation is produced. An introduction of an absorber in an X-ray beam produces more severe attenuation at longer wavelengths than at shorter and the beam is "hardened".

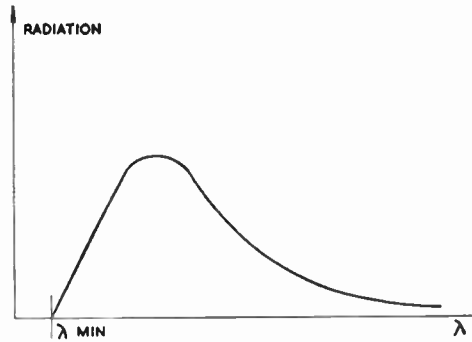

Fig. 13. Wavelength spectrum for "white" radiation.

Transmissions of several materials for monochromatic X-radiation at 20 kV ( $\lambda = 0.62 \text{ \AA}$ ) are shown in Figs. 9 and 10.

### 13.4. Background radiation

The natural background radiation level in London is 0.013 mr/h (*British Journal of Radiology*, May 1956).

Points from the discussion on this paper will be published in a subsequent issue of the *Journal*.

## SECOND INTERNATIONAL CONFERENCE ON MEDICAL ELECTRONICS

THE second of the International Conferences on Medical Electronics was held at the Unesco building in Paris from June 24th to June 27th;\* over 400 delegates attended from seventeen countries. Associated with the conference was an exhibition of commercial medical electronics apparatus together with demonstrations of scientific equipment.

The conference was opened by M. Anjaleu of the French Department of Public Health, who invited representatives to give reports on the progress of medical electronics in their respective countries. The opening session concluded with five special lectures by speakers from Germany, France, U.S.A. and Great Britain, one of which, on "Automation in Medical Research," was given by Mr. W. J. Perkins (Chairman of the Institution's Medical Electronics Group). Over 150 papers were presented in the following sessions covering Biochemistry, Manometry, Physiology, General Medicine, Electroencephalography, Respiration, Computers, Cardiology, Oculography, Ultrasonics, Radiology and Obstetrics. Five of the papers were given by members of the Institution, as follows:—

K. Copeland (Associate Member):

"Instruments for stimulating and recording in conjunction with microelectrodes."

H. W. Shipton (Associate Member):

"A photographic averaging technique for the study of evoked cortical potentials in man";

"A multiple point recorder for small animal locomotory activity" (as co-author);

"A simplified averaging technique for the detection of evoked cortical responses."

W. J. Perkins (Member) and E. A. Piper:

"An analogue computer for protein metabolism analysis."

The Executive Committee of the Interim Committee which was set up in 1958 met at the beginning of this year's Conference, and agreed

\* The first Conference was held in Paris from 26th to 28th June 1958—see *J. Brit.I.R.E.*, 18, p. 505, August 1958.

† Author of several papers in the *Brit.I.R.E. Journal on Medical Electronics*, notably "A toposcopic display system applied to neurophysiology" (with W. Grey Walter), *J. Brit.I.R.E.*, 11, p. 260, July 1951.

to form an International Federation for Medical Electronics. As laid down in the draft statutes of the Federation, its object is to encourage the development and dissemination of knowledge in medical electronics throughout the world by holding an International Congress at regular intervals. Membership is open to any person who has a professional interest in medical electronics, and these members form the General Assembly. The control and direction of policy is to be vested in a Council comprising two delegates from each country represented in membership of the Federation. The responsibility for the fulfilment of the scientific and business obligations is given to an Executive Committee elected at the General Assembly.

At the closing session of the Conference Dr. V. K. Zworykin was elected President of the Federation, with Professor A. M. Monnier, Professor of Physiology at the Sorbonne, Dr. M. Marchal, Director of L'Ecole des Hautes Etudes, Paris, and Dr. C. N. Smyth, of University College Hospital, London, as Vice-Presidents. The other officers elected, who comprise the Executive Committee, were Dr. A. Remond, Centre National de la Recherche Scientifique, Secretary, Mr. B. Shackel of E.M.I. Electronics Ltd., Treasurer, with Dr. C. Berkley of the Rockefeller Institute, Mr. W. J. Perkins, of the National Institute of Medical Research (the Brit.I.R.E. representative), and Dr. R. C. G. Williams of Philips Electrical Ltd. (the I.E.E. representative). The two delegates put forward by the British delegation to represent them on the Council of the Federation were Professor R. Woolmer of the Royal College of Surgeons, and Dr. A. Nightingale of the Physics Department of Guy's Hospital. After some discussion a proposal to arrange a Congress in London in 1960 was finally agreed.

The British delegates to the International Federation are still considering the formation of a British National Committee. Meanwhile, they have formed a provisional group with Professor Woolmer as Chairman and Dr. Nightingale as Secretary; Mr. W. J. Perkins is also a member of the Committee of this Group. An invitation has been received from the U.S.S.R. to hold the 1961 Congress in Moscow.

W. J. P.

# Technical Information

## Aslib Electronics Group

Just over a year ago the Engineering Group of Aslib decided that an Electronics Group should be formed. The membership has now grown to a total of 175, of whom 147 are in the United Kingdom and 28 abroad; the Institution, which has been a member of Aslib for a number of years, has affiliated to this new Group.

The first annual report of the Group states that in the first instance the Steering Committee of the Group concentrated on ascertaining what activities, not of interest to the general membership of Aslib, but useful to members of the Electronics Group could be undertaken successfully. Meetings have been held on problems of information retrieval and machine translation, and a "Handlist of Basic Reference Material" was prepared.

Future activities which are being considered include a survey of the extent and adequacy of published abstracts relating to the field of electronics and an investigation of internal abstract bulletins. Systems of classification used by members of the Group will be studied and a survey made of existing book lists, accession lists, etc. Co-operation between libraries of Group members and exchange of information on the preparation of translations are other matters being discussed.

## D.S.I.R. Technical Digests

Between 1954 and 1957, the Department of Scientific and Industrial Research published a series of Technical Digests based on interesting ideas appearing in British technical literature. This was intended as an experimental attempt to assist industry to deal with the vast current output of technical literature. When the experiment ended, requests were received from readers for the continuance of the Digests in a more permanent form. Publication of the Digests is now restarting on a subscription basis.

Initially, the new series will be based on the reading of some 300 British scientific and technical journals. As facilities permit, the coverage will be extended to any other suitable technical literature. The technical scope of the Digests

will be as wide as possible, from major plant or processes down to the simplest workshop gadget. Although based primarily on the latest technical developments, older ideas of interest will not be excluded.

For convenience, each item will be printed on a separate loose sheet. The Digests will give the essential details in simple terms, with reference to the original article for readers seeking fuller information. A monthly pack of about 15 items will be distributed for an annual subscription of £3 3s. 0d. (including postage).

## R.I.C. Specifications and British Standards

Specifications, published by the Radio Industry Council over the period 1949 to 1953 for use by industry with the intention of their eventually becoming British Standards, have been withdrawn and work is proceeding as quickly as possible on their revision and submission to the British Standards Institution.

One R.I.C. specification, dealing with electrolytic capacitors, has already been revised and issued as a British Standard (B.S. 2134).

Two more Resistors, Fixed, Carbon, and Ceramic Capacitors, Type 1—are in the printers' hands, and another—Resistors, Fixed Wirewound—has been approved by the B.S.I. Technical Committee.

Specifications at various stages of preparation include Resistors, Variable, Composition; Ceramic Capacitors, Type 2; Capacitors, Mica, Fixed; Climatic and Durability Testing; Capacitors, Metallised, Paper Fixed; R.F. Cables; Valveholders; Screening cans for valves; Resistors, Variable, Wirewound; Capacitors, Variable; Connectors; Transformers; Cartridge Fuses; Wafer Switches; Toggle Switches; Terminals; and Ceramic Insulators.

The Radio and Electronic Component Manufacturers' Federation and the British Radio Equipment Manufacturers' Association, both constituent associations of the R.I.C., and the Electronic Engineering Association, are all concerned in progressing the new specifications. Representatives of the Institution also serve on these B.S.I. Technical Committees.



# Phosphors for Cathode-Ray Tubes in Industrial and Low Scanning Speed Display Systems †

by

M. D. DUDLEY, M.B.E., B.SC.‡

*A paper read on 4th July 1959 during the Institution's Convention in Cambridge.*

**Summary:** Cathode-ray tube displays for industrial television, radar and facsimile systems need phosphors having a very wide range of colour, texture and persistence. The characteristics of these phosphors are discussed, with particular emphasis upon those for use in high-resolution and low scanning speed displays. A recently developed combination of phosphors enables images to be stored for several minutes before presentation by controlling the persistence with infra-red radiation.

## 1. Introduction

Three main classes of cathode-ray tubes are used in picture or image-forming telecommunications instruments, such as television, radar and facsimile transmission equipment. These are flying-spot scanners, visual displays and special tubes for the photography of the received image. It is the purpose of this paper to discuss some aspects of the choice of the phosphor in each cathode-ray tube, dealing in particular with scanning speeds lower than those commonly met with in television practice.

Flying-spot scanners are generally of two types, depending upon whether the object to be scanned is transparent (diascope scanning) or opaque (episcopes scanning). Television and radar simulation systems usually employ a diascope arrangement, since transparent photographic films or plates are a normal and convenient source for transmission. For this purpose the colour of the phosphor is of little significance, provided that the light from it can be adequately detected by the photo-multiplier. Facsimile and other systems at present being examined may be required to accept printed matter of relatively low reflectivity and contrast range; such materials, which usually appear white, may in fact reflect little light at the ends of the visible spectrum, and therefore the dominant colour and efficiency of the phosphor

must be taken into consideration as will the persistence, or excessive noise will be introduced into the system.

## 2. Properties and Applications of Different Types of Phosphor

Figure 1 summarises the dominant hue and persistence of the commonly used phosphors and shows the relationship of those suitable as flying-spot scanners. It is found that those materials with the shortest persistence such as Ackermanite, which are deep violet in colour, are generally unsuitable for episcopes scanners owing to the low reflectivity of the subject material. An interesting exception to this statement, however, occurs in a radar map injection system introduced recently by Decca: in this system the image of an extreme-violet scanner tube is projected by means of a lens on to a large Perspex block, the corners of which are attached photomultipliers. Writing in white ink on the reverse surface of the block produces internal scattering of ultra-violet light from the scanner tube, which is then guided by the shape of the block to the photocells at the corners.

In another form of this equipment, installed chiefly in closed-circuit airfield communications systems, the scanning tube is also used for receiving purposes, and may be up to 21-in. in diagonal. When receiving, the extreme violet of the phosphor is unpleasant to observe for any length of time, but becomes tolerable, or even pleasant, with the addition of a relatively small proportion of phosphor emitting in the orange-yellow and possessing relatively long persistence.

† Manuscript received 1st May 1959. (Paper No. 514.)

‡ Ferranti, Ltd., Gem Mill, Chadderton, Oldham, Lancashire.

U.D.C. No. 621.385.832:661.14:621.397.1/2

By means of well-known types of compensation networks it is frequently possible to use phosphors with much longer persistence than would seem reasonable at first glance: for example, the decay time of zinc oxide phosphors, about one microsecond, is quite large compared with the time taken to change from black to

scale batches of consistent quality are manufactured, and the c.r.t. manufacturer is thus able to exert precise control of the phosphor deposition process. Green and yellow zinc sulphides are also commonly available and might be used should the reflectivity or contrast of the scanned surface benefit from their choice.

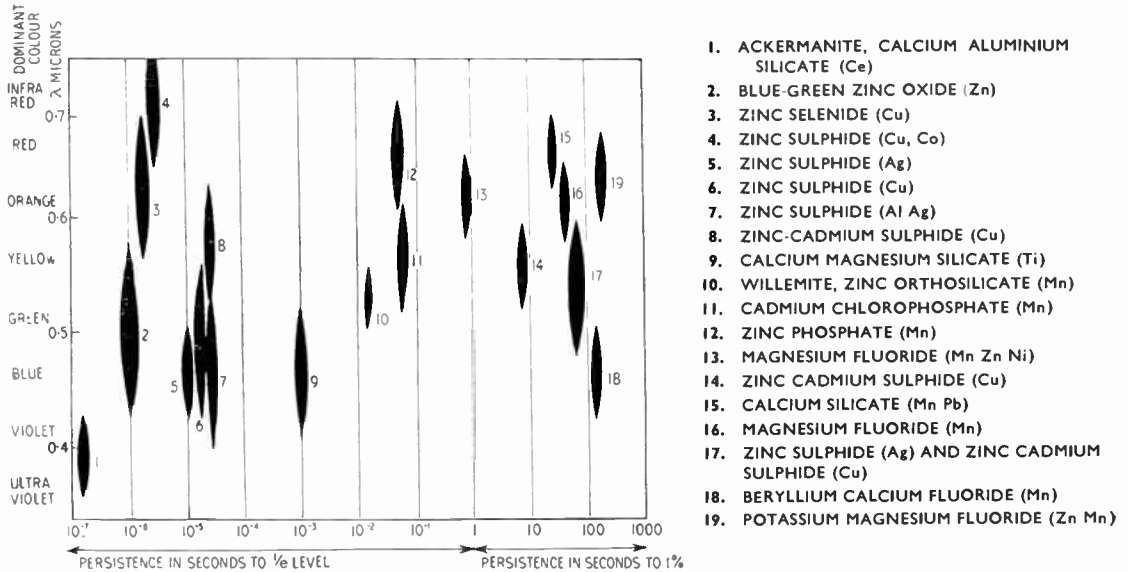

Fig. 1. Table showing the colour and persistence of phosphors commonly used in cathode-ray tubes.

white in a television system. Nevertheless, satisfactory bandwidth can be achieved without excessive noise and the colour is generally suitable for systems operating by reflected light.

When the scanning rate is slower than normally used in television, advantage can be taken of the higher conversion efficiency of silver-activated zinc sulphide phosphors, despite their relatively long persistence. Figure 2 shows a section of typewritten text reproduced by a facsimile system operating at a line repetition frequency of 800 c/s, there being eight hundred lines per frame. A standard grade of blue silver-activated zinc sulphide was used for the scanning tube, in order to achieve sufficient light output at reasonable values of e.h.t. (25 kV) and beam current (40 microamperes). A further advantage to be found from the use of zinc sulphide in this application is that it is a component of the blue-yellow mixture used in television receiving tubes. Consequently, large-

Flying-spot scanning equipment may be required to operate with red or orange light as, for example, might be the case where a silicon photo-voltaic cell or solar battery is to be used as the detecting agent in a transistorised instrument. Recently-developed zinc selenide phosphors provide good light output combined with a persistence intermediate between the zinc oxides and zinc sulphide class (see Fig. 1). Zinc selenides may thus be of some considerable future interest.

The preparation of white or panchromatic scanning tubes for use in the colour-photo-graphic industry has been undertaken, and some difficulties have appeared during this work, because it is not easy to control a mixture of phosphor components possessing differing physical and chemical properties. In the first place, the individual crystals comprising the screen appear to be "clumped" in groups having the same dominant colour, and this causes each

using the  $f$  number of the lens.

In any actual lens the amount of light that goes through is limited by the edges of the lens and the metal work of the mount. The amount of light getting through depends on the actual path that the light takes inside the lens, and this depends in turn on the position of the object point from which it comes. When the object point is away from the lens axis the calculation of the amount of light going through is apt to be complicated. As a result the only straightforward way is to deal with the light passing power of a lens when the light is a parallel beam coming from a point at infinity on the lens axis. The amount passed through when the object point is nearer the lens, and still on the axis, is slightly less than the amount passed through by the lens when the object point is at infinity, but in dealing with depth of field this difference can be neglected.

When the light arriving at a lens is a parallel beam from a point at infinity the path of the largest diameter beam that gets through the lens is shown on p. 61. The beam goes into

Fig. 2. Text reproduced by a low-speed facsimile system, recording directly upon document printing paper, 800 lines per frame, one frame per second.

monochrome channel to possess a granular appearance if a sharp image is required. The resolution provided by normal television receiving tubes is not sufficient for colour grains to be objectionable, but the effect is readily seen on close examination of the screen.

Finely milled phosphors, deposited under closely controlled conditions, show a considerable improvement in texture and consequently white scanning tubes can now be made to produce acceptable results in certain circumstances; so far as the writer is aware, however, they have not been used for colour television transmission purposes. It is worth remarking at this point that the use of a phosphor combination of three components, intended to produce full spectral coverage in the visual range, provides a more pleasing television picture than does the two-component phosphor at present used in all television receiving tubes.

### 3. Requirements for Photographic Displays

Generally speaking, photographic materials are exposed most satisfactorily by phosphors having high light output and short persistence, consequently the zinc sulphides are most widely used for this purpose. Blue or blue-green zinc sulphide phosphors are almost universal for photographic recording. Here again, the quality of texture and freedom from blemishes depends to some considerable extent upon reliable

batches of phosphor being available to the tube manufacturer. The facsimile example in Fig. 2 has been recorded directly on to a thin, cheap form of photographic paper intended for duplication purposes, one frame only being required to produce adequate exposure. It is possible, at a much lower writing speed, to record directly upon sensitized paper which requires no further chemical treatment. A blue zinc sulphide, activated with aluminium, has been used in a recording tube for this purpose.

As the resolution of a display system is increased, the presence of phosphor defects, particularly those of the photographic display tube, become increasingly apparent. This has led to the development of several carefully controlled deposition techniques, the object of which in each case is to provide a dense phosphor layer of controlled particle size and thickness, free from phosphor mounds, dirt or voids. Very thin layers can now be prepared which will yield spot sizes about 0.0005-in. in diameter without excessive halation due to refractions within the layer. In order to achieve spot sizes smaller than this, however, homogeneous phosphor coatings formed by evaporation are required, and the techniques for preparing these are being developed at the present time, notably by Feldman in the United States. We may expect that such evaporated materials will provide the means for the photography of c.r.t. images completely free from the presence of phosphor blemishes, and there are indications of success in this direction. The use of a transparent phosphor on a dark background may be expected also to assist in the removal of halation due to internal reflections in the face of the tube.

### 4. Requirements for Visual Displays

The visual presentation of an acceptable picture from a low-speed scanning system (i.e., one operating at less than 50 frames per second) is a problem which is but partly solved at the present time, and in some cases the trend is towards the avoidance of low-speed displays altogether. In their place the image is stored and represented as a continuous picture by means of chemical or electronic storage. Such systems as employ direct-viewing electronic storage tubes suffer from a great increase in cost and complexity, together with a limitation of picture size to about four inches across at the

present time, although tubes much larger than this are being developed. Indirect storage systems have also been devised, containing electron storage surfaces by means of which low-speed scanning systems can be converted to normal television standards. These, too, involve much additional complexity, together with some loss of definition. They offer the advantage, however, of a bright, relatively flicker-free picture, which can be readily displayed at a number of points by using ordinary television monitors. Chemical storage devices include means by which the incoming signal is photographed and processed immediately, followed by projection by ordinary optical methods.

By far the most widely used method of visual presentation is still the direct-view cathode-ray tube, using a long-persistence phosphor when the frame repetition rate falls below 50 frames per second. At speeds between 5 and 50 frames per second, flicker becomes very apparent and can cause both discomfort to the operator and apparent loss of resolution in the display. Phosphors based upon magnesium or potassium-magnesium fluoride appear at the present time to be the only possible choice in these applications because they show the least decay in the first few milliseconds after removal of excitation. The standard materials in this range, however, have a persistence which may be found too long for use in equipment with a frame rate faster than one per second.

The art of picture presentation at a frame duration between 1 and 10 seconds is sufficiently well known and will not be dealt with here, except to mention the common use of fluoride phosphors in this country, and in America the double-layer combination of zinc and zinc-cadmium sulphides, activated with copper or silver. In the latter phosphor, the long persistence is best shown when the initiating energy is radiated in the blue to ultra-violet region, there being less afterglow present as a result of electron bombardment. Consequently a layer of blue or violet zinc sulphide of short persistence constitutes the rear surface of the phosphor. A yellow filter removes most of the blue flash that always accompanies the trace in these tubes; even so the rapid initial decay generally renders double layer combinations unsatisfactory as a means for preventing flicker.

## 5. Infra-red Control of Persistence

An inconvenience which arises from the use of both fluoride and sulphide phosphors of very long persistence is that successive images, if different, will interfere with each other unless an interval between presentations of at least 30 seconds is allowed. This interference is, of course, a well-known advantage in some radar systems, providing the means by which a succession of "paints" from a track across the screen indicate the direction of motion of the object being observed. Unfortunately, too long a persistence causes considerable confusion when the range of the radar equipment is changed, and it may be helpful to be able to erase the afterglow from time to time. It has long been known that the afterglow of some zinc sulphide phosphors is quenched by infra-red radiation, and use was made of this principle after the war, an infra-red lamp being placed over the tube of a radar set while changing ranges. Thus, in a low speed system, we may use infra-red sensitive phosphors to reduce the dead time separating successive images, providing that the amount of infra-red is kept low enough to avoid heating the screen appreciably.

By the use of the doubly activated zinc sulphide (Cu, Pb) a further advantage may be obtained from the infra-red technique; this phosphor has a natural persistence of many hours duration, and consequently its light output after the first few seconds is so low as to be imperceptible, even in a darkened room. The presence of radiated infra-red energy of wavelength in the region of one micron produces marked shortening of the persistence, so that the afterglow is released at a greater rate, and the image or trace again becomes visible. Thus by regulation of the amount of infra-red stimulation we may shorten or lengthen the persistence at will, the brightness of the afterglow being greater as its duration is shortened. Phosphors with this type of behaviour were first investigated by Franz Urbach in Vienna, and subsequently by Fonda and Mason. Unfortunately the zinc sulphides do not appear to be as efficient as some other materials known, but they do have the advantage of being stable in air at high temperatures and insoluble in water. Both these properties are necessary in a phosphor which is to be incorporated in a cathode-ray

tube having good performance and a long life. The storage property of doubly-activated zinc sulphide is best observed when the phosphor is excited with ultra-violet, violet or blue light, the stored energy re-appearing as a consequence of direct electron bombardment.

In the absence of infra-red, then, an image may be stored on a cathode-ray tube screen as it is received, and released when required for viewing by the operator. During the viewing period the level of infra-red radiation may be increased steadily to compensate for the decay of the phosphor, which of course is exponential in the presence of a constant infra-red level. By increasing the infra-red radiation at the correct rate we may make an attempt to hold the light output as nearly constant as possible until complete extinction is reached.

Towards the end of the viewing period the signal level, as compared with the background which has been stored by the phosphor, has weakened considerably, and this distorts the contrast range, resulting in the loss of half tones. The performance of visual storage phosphors, in their present state of development, is roughly equivalent to that of a conventional double-layer screen when the storage material has about 6 watts of infra-red energy incident upon each square foot of its area. Thus a 14-in. type of cathode-ray tube, operated at 20 kV e.h.t. and fitted with a viewing hood will store a picture of one milliampere-second exposure for several minutes. Under the effect of controlled infra-red stimulation the picture may again be made visible for about 20 seconds. Figure 3 shows a photograph taken from the screen of a 21-in. cathode-ray tube during routine testing of the storage effect, one minute interval having elapsed since the picture signal was removed, the picture in this case being derived from a television system at normal scanning speed. In passing it may be mentioned that both long-persistence

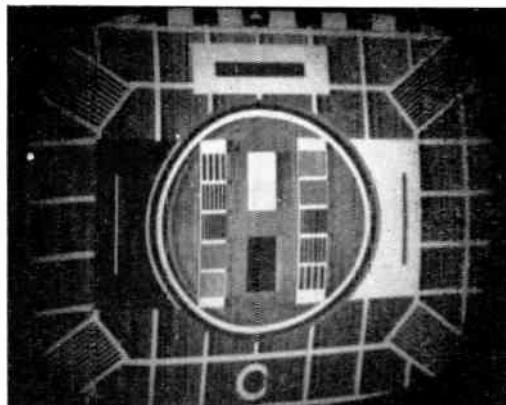

Fig. 3. Photograph of stored image on 21 in. direct-viewing phosphor storage tube. One minute after initial reception of the signal.

zinc sulphides and infra-red stimulated phosphors may be deposited upon screens external to the cathode-ray tube; the activating image, in blue or ultra-violet light, is then projected by means of a lens or Schmidt system.

## 6. Conclusion

Within the last twelve years a wide range of c.r.t. phosphors possessing special advantages has appeared, and it is now possible to "tailor" accurately the colour and persistence of a display to meet the requirements of a given system. In particular, phosphors can be prepared which permit spot diameters of less than one thousandth of an inch, and others which provide a considerable measure of information storage.

## 7. Acknowledgments

The author is indebted to Mr. E. Lyth, of Ferranti Ltd., for the sample of received facsimile shown in Fig. 2, and to Mr. I. Whitney for the photograph of Fig. 3.

## of current interest . . .

### “Technical Education”

This new journal on Technical Education is an excellently produced addition to the small number of periodicals dealing with this field. It is mainly concerned with Technical Colleges and Colleges of Advanced Technology, but it will, to some extent, cover the work of Universities, Secondary Modern, Technical and Grammar schools, together with technical training in industry.

*Technical Education* is published by Evans Bros. Ltd., price 2s. 6d. per month.

### Professional Institutions

“As a nation we do not, perhaps, take the pride we should in our professional bodies. In our field the professional institutions not only comprise the finest body of qualified people in the world, but possess standards of competence and efficiency, combined with integrity, which exert great influence throughout the Commonwealth. In technical education we owe a great debt to these institutions, not only for their zeal in safeguarding standards but also for the uniformly forward-looking approach to new developments both in technology and method which inspires them. The evolution of new schemes of training for technicians, craftsmen and other operatives who work below the professional level owes much to them and their members. The advisory committees of the City and Guilds of London Institute—for example—which number over two hundred, are all assisted by members appointed by the professional institutions.” From *Technical Education*, April 1959.

### More Channels for Mobile Radio

Double the number of radio channels have now become available for private mobile services as a result of approval by the Postmaster-General of the recommendations in the Third Report of the Mobile Radio Committee. This increase in radio channels in the lower v.h.f. band is being obtained by introducing equipment capable of operating on channels 25 kc/s wide instead of 50 kc/s.\*

\* See “Mobile Radio Development.” *J. Brit.I.R.E.*, 15, p. 527, October 1955.

The new channel-spacing came into force on 1st June, 1959. All new land-mobile schemes in the v.h.f. low band will have to use equipment meeting the 25 kc/s specification. With few exceptions, the new equipment standard will also apply to additions or replacements for existing systems. There is a “Five Year Plan” for the change-over of existing services to 25 kc/s equipment to be completed by 1st June, 1964.

### Developments in Long-distance Submarine Telephone Cables

The American Telephone and Telegraph Company and the British Post Office have developed terminal equipment the use of which will increase the capacity of submarine telephone cables without any modification to the submarine cable itself.†

The new British technique uses improved channelling equipment which enables telephone circuits to be provided in a bandwidth of 3 kc/s instead of the 4 kc/s normally used. An increase in cable capacity of one-third can be achieved.

The American technique, known as Time Assignment Speech Interpolation, is based on the fact that, on any group of circuits comprising separate “go” and “return” channels, at least half are idle at any instant while speech passes in the opposite direction; and the American equipment has been developed to utilize these idle channels to carry additional conversations. The cable capacity can thus be doubled.

Both these techniques will have their use depending upon the increased capacity required; where necessary the two techniques could be used together to provide about 2½ times the number of circuits available in an unmodified system.

An agreement, which was submitted to the House of Commons for approval on 14th July, has been drawn up between the Post Office and the American Telephone and Telegraph Company defining the terms and conditions on which the equipment, and the related patent rights and technical information, will be exchanged.

† See “Inauguration of Trans-Atlantic Telephone Cable System,” *J. Brit.I.R.E.*, 16, p. 632, November 1956.

# A Comparison of Telemetry Systems †

by

A. COWIE, B.SC.\*

*The opening contribution to the Symposium on Radio Telemetry held in London on 25th March, 1959.*

*In the Chair : Mr. I. Maddock, O.B.E. (Member)*

**Summary :** The factors influencing the choice of modulation system to be employed are reviewed. The transmission of a number of information channels is discussed with reference to time division and frequency division multiplex systems.

## 1. Introduction

The problem to be solved in telemetry systems is that of transmitting information to a distant observation point while achieving accuracies comparable with the best laboratory instruments, despite the vagaries of a radio frequency path. The rate at which information inputs change and the number of such signals required set further problems for both the transmitter and the recorder.

In order that the telemetry system may be readily used in missiles of all types, it must be flexible in its capabilities and economic from the point of view of maximum information for minimum consumed power since this factor controls the weight to be carried. Installed bulk, reliability, stability and simplicity in setting up are other important factors to be borne in mind.

## 2. Transmitter Design

The transmitter output stage consumes most power and in the interest of economy a free oscillator transmitter without any form of driving stages has tended to be the arrangement used. This has its penalties in the form of frequency instabilities (drift) and thus requires a receiver having a relatively wide bandwidth.

## 3. Modulation Systems

As high accuracy is an essential condition, it follows that a high signal/noise ratio is required at the output. Amplitude modulation can be ruled out for a number of reasons:

(1) High signal/noise ratio and wide bandwidth will demand high power to achieve a

given range.

(2) Accurate amplitude modulation of an oscillator or a power output stage is not easy when both linearity and amplitude stability of the order of 1 or 2% may be called for. The power demand of such a modulator will be at least as great as that of the transmitter output stage.

A modulation system is therefore required where such limiting factors have a minimum effect. The alternatives are:

- Frequency modulation (f.m.)
- Pulse position modulation (p.p.m.)
- Pulse width modulation (p.w.m.)
- Pulse code modulation (p.c.m.)

Considering pulse code modulation, this demands additional complications in encoding devices in the transmitter, as generally none of the inputs to be handled are naturally encoded.

The pulse systems employing position or width modulation are similar in transmitter complexity, but there can be no doubt that p.p.m. is more economical in transmitter power. This system is used on the 600 Mc/s Pulse Telemetry System which is to be described later.<sup>4</sup>

Returning now to f.m. this is difficult to apply directly at the high radio frequencies used for telemetry. Frequency modulation can however be readily arranged at a sub-carrier frequency where both voltage/reactance and direct reactance control can be used. Considerable distortion can be tolerated in employing this sub-carrier to modulate the transmitter. In fact a form of pulse modulation is used on the 24-channel Telemetry System where the pulse recurrence frequency is the sub-carrier frequency.<sup>1, 2, 3.</sup>

† Manuscript received 18th March, 1959. (Contribution No. 21.)

\* Royal Aircraft Establishment, Trials Department, Fleet, Hants.

U.D.C. No. 621.398

#### 4. Multiplexing Considerations

We must now consider the question of how to handle a number of inputs simultaneously and to do so we must discuss the frequency response required of the system. The inputs generally required fall quite readily into two groups:

- (1) Static and quasi-static quantities. The frequency range is from d.c. to, say, 30 c/s or 100 c/s.
- (2) Vibration and high frequency phenomena. (50 c/s to 3000 or 6000 c/s.)

In the first group of inputs another objection to a.m. can be seen, namely the difficulty of handling d.c. inputs. The second group presents problems very similar to those in multiplex telephony or telegraphy, and the multiple sub-carrier technique can be used. In telephony, however, a.m. with or without single-sideband techniques is used, but this is not acceptable in telemetry on grounds of accuracy and signal/noise ratio. If the signal is applied to the sub-carrier using frequency modulation, acceptable conditions of modulation are obtained and, if sufficient care is taken in the design of modulation and demodulation circuits, the frequency response can be extended to zero frequency. This system (frequency division multiplex) is used in the 6-channel H.F. Telemetry System.<sup>5</sup>

The lower band of signals can be most economically handled by a sampling technique. Given a sine wave signal for which just over two points on the wave are known over an adequate number of waves, then the sine wave can be defined in amplitude, frequency and phase. Thus by sampling more frequently than twice per cycle of the highest frequency it is desired to transmit, the wave form can be re-established on reception. In practice, to avoid the need for a mathematical reconstitution, more samples per cycle are desirable.

Sampling is done by means of a commutator-type switch of, typically, 24 segments which can be rotated by a small motor at speeds up to 120 rev/sec. It is necessary to take account of the actual switch speed in designing the receiving equipment for optimum performance. The input to the switch, which may have more than one commutation, may be voltage and/or inductive transducers. The switch output, suitably applied to the modulator, results in the sub-carrier

being modulated in frequency to correspond in turn with the inputs as sampled by the switch. This method—time division multiplex—is used in the 24-channel Telemetry System<sup>1, 2, 3</sup> and can be used as a variant on the 6-channel System.<sup>5</sup>

In the 600 Mc/s System<sup>4</sup>, the number of channels is controlled by the number of pulse generator units used and the ability to sort and measure the resulting records. Up to 20 channels can be handled satisfactorily.

#### 5. Conclusions

The *switched or sampling type of system* is limited in its frequency response by the switch speed but is very simple, small and economical in power. It will work with very small r.f. signal levels, giving high output signal/noise levels and hence its range and accuracy are high.

The *pulse position system* is again limited in frequency response in the same way as in a switched system but this time by the pulse recurrence frequency to which limits are set by power dissipation and power requirements. The system will also work with fairly small signals to give good output signal/noise levels.

The *6-channel system*, a frequency multiplex system, has some inherent difficulties. Although it has a high information rate, very linear amplitude modulation of the output is required to overcome crosstalk, making a high power a.m. modulator necessary to achieve good total modulation, and the sub-carriers have to be added in voltage so that each channel has only a small modulation depth on the carrier. Because both the f.m. modulation index and the a.m. modulation depth are low the system has a low output signal/noise ratio at threshold.

#### 6. References

1. W. M. Rae, "The airborne sender for 24-channel telemetry." To be published.
2. F. F. Thomas, "455 Mc/s telemetry ground equipment." To be published.
3. F. G. Diver, "Transportable ground receiving and recording equipment for 24-channel telemetry." To be published.
4. F. T. Hardwick, "A 600 Mc/s pulse telemetry system." To be published.
5. T. C. R. S. Fowler, "A six-channel high frequency telemetry system," *J. Brit.I.R.E.*, **19**, pp. 493-507, August 1959.



# A Six-Channel High-Frequency Telemetry System †

by

T. C. R. S. FOWLER, B.SC.‡

*A paper first read before the South Western Section in Bristol on 25th February and repeated in the Symposium on Radio Telemetry in London on 25th March 1959.*

**Summary:** A frequency-multiplex f.m.-a.m. system is described which provides six continuous channels via which waveforms with frequency components in the approximate band 10 c/s to 10 kc/s may be simultaneously telemetered; extension of the frequency coverage to include the band 0-10 c/s is achieved by the use of commutated reference levels. A radio frequency in the 465 Mc/s band and sub-carrier frequencies between 250 and 500 kc/s are used. A short historical introduction is followed by descriptions of the system and of units of the flight and ground equipment, and details of operational results. Future uses of the system are discussed and methods of increasing the useful range are suggested.

## 1. Introduction

Towards the end of 1950 investigations were started at Filton into the design of a system to telemeter simultaneously, from a missile in flight, a number of vibration waveforms in the frequency band 50-6000 c/s, with an overall amplitude accuracy of  $\pm 10$  per cent. and a range sufficient to cover the boost phase—say at least two miles. The flight sender was to be usable together with an R.A.E. 24-channel sender§, the two transmitters, tuned some megacycles apart in the 465 Mc/s band, sharing a common missile aerial system.

A six-channel frequency-multiplex f.m.-a.m. system was selected for development; work proceeded, with encouraging results, and by the autumn of 1952 ground-to-ground transmission tests had been made, and the system was ready for flight trials.

The first two flight tests were carried out at Aberporth in December 1952, with successful results, and the practical use of the system there started in 1953; the use of the system at Woomera began in 1955. Although it incorporates various improvements and additions, the present Bristol H.F. Telemetry system is

basically similar to the system as first tested in 1952.

As anticipated, the system has been used for a wide variety of telemetry purposes in addition to the original one of vibration measurement; examples are rotation rate measurements via transducers giving an a.c. output, the monitoring of voltage waveforms in electronic equipment, pressure and acceleration measurements via inductance transducers, and voltage measurements in the frequency range 0-12 c/s via 24-channel high-speed switches. A wide-band channel, for optional use in place of two of the original channels, specifically for voltage histogram telemetry, was introduced in 1955; special d.c.-coupled ground equipment on this channel enables strobed low-speed records to be produced via the standard strobing equipment of the R.A.E. 24-channel Telemetry system.

At the time of writing well over 750 H.F. Telemetry channels have been used in Bristol flight tests, the total of flight senders used being over 150. Reliability and ease of use have been found to be extremely good.

Further details of operational results will be given later in this paper.

† Manuscript first received 29th January 1959, and in final form on 29th April 1959. (Paper No. 515.)

‡ Bristol Aircraft Limited, Guided Weapons Engineering Department, Filton, Bristol.

U.D.C. No. 621.398

§ "Telemetry as an aid to guided weapons research," *British Communications and Electronics*, 3, pp. 130-133, March 1956; W. M. Rae, "The airborne sender for 24-channel telemetry." (To be published.)

2. Outline of the System

2.1. Performance

The present system enables waveforms in the frequency band 10-10,000 c/s to be telemetered simultaneously on up to six continuous channels, with some falling-off in response outside the approximate band 50-2,000 c/s, coverable by calibration. Signals in the additional band 0-10 c/s are telemetered via sampling switches which sample also a number of reference levels for calibration purposes. The use of these time-multiplexed "standards" makes possible the telemetering of "d.c." quantities via a.c.-coupled channels; time-multiplexed flight standards are also used on d.c.-coupled channels to render negligible slow level drifts in the system, which would otherwise cause errors; reduction of these drifts to a low enough level to obviate the need for flight standards for good accuracy in d.c. measurements is difficult in practice.

Under reasonably good signal-to-noise conditions, such as should normally be realized over the greater part of the usable range, the accuracies of measurements of amplitude via the H.F. Telemetry system are estimated to be as follows:—

(a) without time-multiplexed flight standards,  $\pm(5+T)\%$ , (b) with time-multiplexed flight standards,  $\pm(3+T)\%$ , where  $T$  represents the additional allowance to be made for the transducer and/or flight amplifier, if any, used in the measurement;  $T$  may be as much as 5 in the case of barium titanate accelerometers, or as little as 1 or 2 in the case of inductance transducers. Voltage measurements do not in general require the use of transducers or flight amplifiers at present, so that accuracies estimated at  $\pm 3$  per cent. are obtainable; if it is required to telemeter low voltages (of the order of 1 millivolt, say) the value of  $T$  may be kept low by the use of a sampling switch preceding the amplifier.

Frequency accuracies of better than 1 per cent. are readily obtained, and, in addition to the obvious application of measuring rotation rates via voltage pick-offs, it has proved expedient to telemeter in audio-frequency form various other quantities having relatively slow rates of change, high accuracy being obtainable even in bad signal-to-noise conditions.

The average useful range of the present system is of the order of twenty miles; it is hoped that future improvements, particularly in radio link efficiency, may increase this range to forty or fifty miles. It is, of course, possible to increase range if a reduction in overall signal bandwidth is tolerable; the use of only two channels instead of six (giving a range increase estimated at about 50 per cent., in practice), and the use in the output circuits of the ground equipment of additional (RC) low-pass filters giving appreciable attenuation above about 2 kc/s (giving a range increase of perhaps 100 per cent.) are methods which have been used a number of times in Bristol flight trials.

2.2. Nature of System

The quantities to be telemetered are conveyed over the radio link in the form of the frequencies of a number of sub-carrier waveforms which, added together, are used to amplitude-modulate the 465 Mc/s band transmitter.

A frequency-multiplex system was selected to meet the requirement for the simultaneous telemetering of a number of continuous waveforms; the alternative of using high-frequency electronic sampling, and reconstituting circuits, was not considered preferable. The high-frequency time-multiplex system would have the disadvantage of an appreciably more complex flight sender; it would probably give the advantage of improved accuracy of amplitude measurement, over the same flight ranges.

Table 1  
The Sub-carrier Frequencies and Deviations

Channel	1	2	3	4	5	6	A
Centre frequency (kc/s)	270	310	350	390	430	470	290
Maximum deviation (kc/s)	$\pm 6$	$\pm 6$	$\pm 6$	$\pm 6$	$\pm 6$	$\pm 6$	$\pm 15$

The use of frequency-modulation of the sub-carriers was also decided on without difficulty, the representation of quantities in amplitude form being ruled out because of susceptibility to r.f. signal strength variation effects.

The use of amplitude-modulation for the radio link followed from the decision to use existing a.m. equipment; had a suitable 465 Mc/s band f.m. system been available it might well have been preferred.

Details of the sub-carrier frequencies are given in Table 1.

The use of a six-channel system with the channels 1 to 6 in Table 1 was decided on after initial calculations in 1950; the wide-band channel A, for optional use in place of channels 1 and 2, for voltage histogram telemetry, was introduced in 1955. The sub-carrier bands were chosen to lie within an octave to obviate direct harmonic interference, and to lie well above the highest significant sideband (possibly about 230 kc/s) of the frequency-modulated sub-carrier of the R.A.E. 24-channel system, in case of interference due to overlapping of the sub-carrier bands when the two systems were used together. The maximum deviations used approximate to the maximum usable in practice; these are governed by the required signal bandwidth and the sub-carrier channel bandwidth. (If these bandwidths are taken as 6 kc/s and 24 kc/s respectively for channels 1 to 6, and 6 kc/s and 48 kc/s for channel A, and if sidebands greater than 2 per cent. of the unmodulated level are regarded as significant, then the maximum usable modulation indices are shown by f.m. theory to be about 1.0 and 2.5 respectively, giving the maximum deviations of  $\pm 6$  kc/s on channels 1 to 6 and  $\pm 15$  kc/s on channel A.)

On channels 1 to 6 the output stages of the ground equipment are a.c.-coupled, so that slow drifts in level (e.g. thermal drifts) are not transmitted to the recorders, and slow sub-carrier frequency drifts of up to  $\pm 2$  kc/s are tolerated, the effect of these drifts on the a.c. calibration being negligible. On channel A the equipment is d.c.-coupled, and has been designed to give reasonable freedom from drift.

2.3. Functions of Units

The various units of the system are indicated in the block diagram, Fig. 1. The functions of

these units will first be described briefly; fuller descriptions will be given later.

In the flight vehicle the quantities to be telemetered are required to cause frequency-modulation of the sub-carriers generated in the oscillator units; these units are of two main types, modulated respectively by voltage and inductance variations; senders can contain oscillator units of both types, if required.

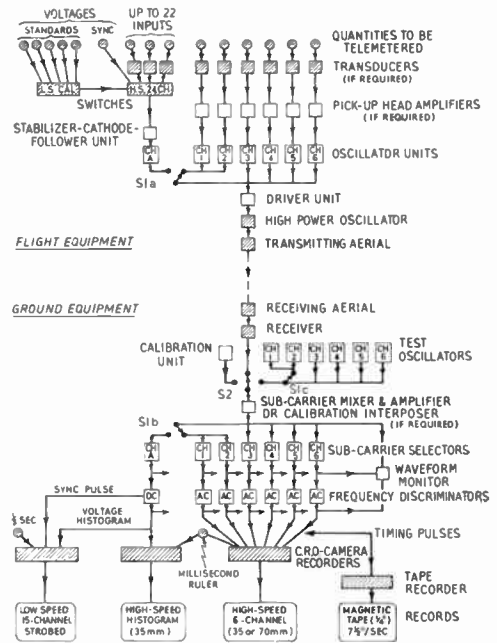

Shaded blocks represent units for use with other systems. Switches S1a, S1b, S2 and S3 are symbolic, representing the substitution of the units indicated.

Fig. 1. Block diagram of the Bristol H.F. Telemetry System.

Transducers are used to convert other physical quantities to be telemetered to voltage or inductance form.

Pick-up head amplifiers, units having a high input impedance, are used between crystal accelerometers (and other transducers of high output impedance) and oscillator units.

The stabilizer-cathode follower unit provides a stabilized h.t. supply and an input cathode follower with voltage limiters for the channel A oscillator unit.

Up to 22 voltages may be telemetered via the 24-way high-speed switch on channel A, the

remaining two switch contacts being used for (a) a synchronizing pulse and (b) voltage "standards" sampled by a 12-way low-speed ("calibration") switch. Alternatively the low-speed switch may be dispensed with, one contact of the high-speed switch being used for each calibration voltage; five of these are used as a rule, in which case only 18 contacts are available for signal voltages; but each "standard" appears in each histogram cycle, which may be desirable sometimes.

Low-speed switches (not indicated on the block diagram) have been used, to a considerable extent in recent years, on channels other than channel A, to sample signal voltages; nor has the use of the high-speed switches been confined to channel A.

The sub-carrier waveforms from the oscillator units are added together by means of a resistance network; the resulting complex waveform is amplified in the driver unit, which amplitude-modulates the output of the high power oscillator with the waveform.

The amplitude-modulated 465 Mc/s band wave is radiated by the transmitting aerials to the receiving aerials and receiver.

The receiver reproduces the complex sub-carrier waveform; this is fed to the input terminals of the sub-carrier selectors, each of which filters out one particular sub-carrier.

The separated sub-carrier waveforms are fed into the frequency discriminators, which reproduce the sender input waveforms. The channel A discriminator also generates a synchronizing pulse for use in the production of strobed records.

The discriminator output waveforms on channels 1 to 6 are recorded on one film (generally 35-mm) in a 6-channel c.r.o.-camera recorder, while the normal channel A records are a high-speed 35-mm film histogram record and a strobed low-speed record. Magnetic tape records are also made in some cases, for replay into frequency-analysing equipment.

The calibration unit, connected in place of the receiver, is used to produce pre- and post-flight calibration square waves on the records.

Sometimes it is required to interrupt the recording at intervals during the flight and inter-

pose calibration square waves of short duration; the calibration interposer is used for this purpose.

Later versions of the sub-carrier selectors incorporate circuits for calibration and calibration interposing; when selectors of this type are used the calibration unit and calibration interposer are of course unnecessary.

Test oscillators and the sub-carrier mixer and amplifier are used to synthesize a complex sub-carrier waveform for ground equipment test purposes.

The waveform monitor is a c.r.o. unit incorporated in the later ground sets to facilitate the checking of the various waveforms.

Some further details of the units will now be given; with reference to the circuit diagrams which follow, it should be noted that the valve types given are those which have been used in practice—in many cases improved "equivalents" which are now available could probably be substituted with advantage.

### 3. Details of the Flight Equipment

#### 3.1. Transducers

The H.F. Telemetry system has been designed for use with transducers of existing types, designed and produced independently for use in various other systems; as the use of the system has been extended transducers of new types have been introduced. Examples of transducers used so far are:

Barium titanate accelerometers (for telemetering vibrations in the frequency band 10 c/s to 10 kc/s),

Variable inductance acceleration and pressure transducers (as used with the R.A.E. 24-channel telemetry system),

Rotary flowmeters (giving an alternating voltage output in the frequency band 0 to 1500 c/s) and

Variable capacitance pressure pick-ups (used with d.c. polarization to give a voltage output, for the measurement of gas pressure fluctuations in the frequency band 10 c/s to 10 kc/s, in a high temperature environment).

#### 3.2. Switches

The switches used are the 24-channel high-speed switch and the 12-channel low-speed

switch as used with the R.A.E. 24-channel Telemetry system; typical speeds are 100 rev/sec and one revolution in three seconds, respectively.

### 3.3. Pick-up Head Amplifiers

These units, having an input impedance of the order of 30 megohms, have been designed for use between barium titanate accelerometers and oscillator units. Two versions are used, one with a single cathode-follower valve stage—used where voltage amplification is not required, the other containing a cathode follower followed by an amplifier stage of adjustable gain. (Voltage attenuation, required when large vibration amplitudes are to be measured, is obtained by fitting suitable capacitors in parallel with the transducers.)

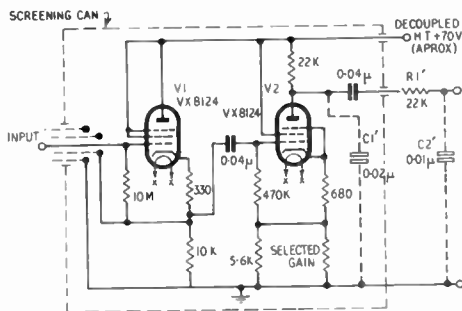

Fig. 2. Circuit of Pick-up Head Amplifier (2-valve version).

Figure 2 shows the circuit of the two-valve head amplifier. The gain is adjustable between about unity and 7 by selection of the indicated resistor in the cathode circuit of the amplifier. The components indicated by broken lines are not part of the unit as manufactured, but are added in some installations for the measurement of low-frequency vibrations in the presence of vibrations of larger amplitudes at high frequencies; with the components added the transmission factor falls off above about 50 c/s, being about 2 db down at 250 c/s, 10 db at 1000 c/s and 25 db at 3.5 kc/s.

The head amplifiers are of course usable in other applications where a high input impedance is required, and are used with the capacitance pick-ups referred to in the sub-section 3.1.

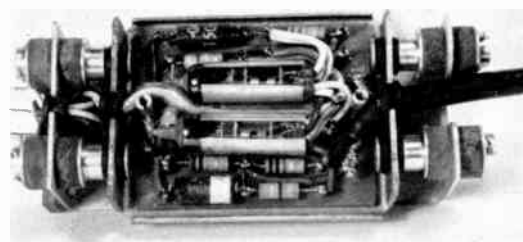

Fig. 3. Two-valve Pick-up Head Amplifier, with screening cover removed.

The form of construction used provides for the individual screening and anti-vibration mounting of each head amplifier, so that these units can be mounted independently close to the associated transducers in the various locations in the missile. The mountings have been designed to give a good degree of flexibility coupled with the ability to withstand large forces without fracturing. The rubber in the mountings provides a certain amount of damping.

Similar but larger anti-vibration mountings have been widely used for other, heavier, assemblies in Bristol missiles, and the individual head amplifier mountings are sometimes dispensed with, the units being attached to larger shock-mounted structures.

Figure 3 shows a two-valve head amplifier in its mounting cradle, with the screening cover removed.

### 3.4. Oscillator Units and Stabilizer/Cathode Follower Units: the Modulation Generator Unit

The oscillator units, in which the sub-carrier waveforms are generated, are divisible into two groups, namely:

Oscillator units type I, with a single transistor oscillator valve stage, designed for use on channels 1 to 6 with inductance transducers of types used with the R.A.E. 24-channel system; and oscillator units type IV, with a reactance valve and transistor oscillator, for use on channels 1 to 6 and channel A with voltage inputs.

(The designations "type II" and "type III" were used for units resembling the type IV but having in addition one and two voltage amplifier

stages respectively; these have not been developed beyond the experimental stage, separate amplifier units having been preferred in practice.

Oscillator units type I for channel A operation have not so far been required; neither have units for mixed—i.e. sequentially-sampled—voltage and inductance inputs; there seems no reason why units of both these types could not be produced if required, however.)

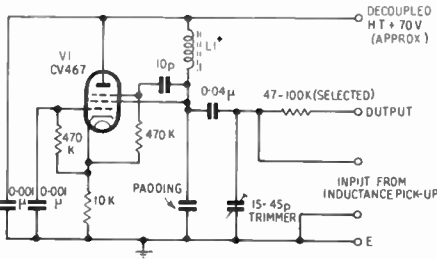

Channel	L1 (μH)	Channel	L1 (μH)
1	1870	4	1208
2	1580	5	1079
3	1368	6	978

Fig. 4. Circuit of Oscillator Unit Type I

Figure 4 shows the circuit of the oscillator unit type I. The values shown for the inductance L1 are such that the inductance swing of the transducer, connected as indicated, produces, very approximately, the normal 12 kc/s frequency swing. Figure 5 shows a typical frequency/pressure graph.

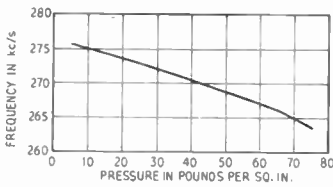
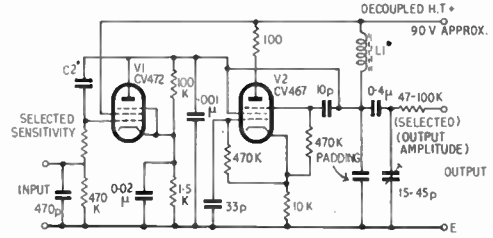

Fig. 5. Frequency/pressure characteristic of Oscillator Unit Type I and 0.70 lb./in.<sup>2</sup> inductance-type pressure transducer (Channel 1).

Figure 6 shows the circuit of an oscillator unit type IV as used on channels 1 to 6. These units are designed for full modulation by an input swing of approximately 1.5 volts; Fig. 7 shows a typical frequency/voltage graph.



Channel	C2 (pF)	L1 (μH)
1	3.9	932
2		812
3	3.3	719
4		645
5	2.7	585
6		535

Fig. 6. Circuit of Oscillator Unit Type IV for channels 1 to 6.

Figure 8 shows an oscillator unit type IV; a similar “slide-in panel” construction is used for the other oscillator units and the stabilizer/cathode follower unit. The two valves and the coil, which is encapsulated, are on the side of the panel not shown in Fig. 8.

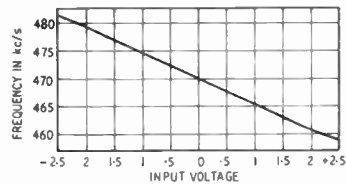

Fig. 7. Frequency/input voltage characteristic of Oscillator Unit Type IV (Channel 6).

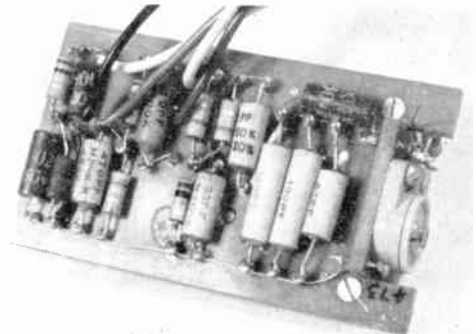

Fig. 8. An Oscillator Unit Type IV.

The circuit used in oscillator units for channel A differs slightly from that shown in Fig. 6, the phase-shifting network associated with the reactance valve having two CR stages instead of one; component values are selected to give a very low level of amplitude-modulation. Appreciable amplitude-modulation is of course undesirable since it involves unnecessarily low r.f. modulation depth at times; the simpler circuit of Fig. 6 is satisfactory on channels 1 to 6 however, the bandwidth on these channels being relatively narrow and the amplitude-modulation level low.

Figure 9 shows the circuit of the stabilizer/cathode follower unit. Valve stages V1 and V2 stabilize the h.t. supply to the cathode follower V3 and the channel A oscillator unit (this is, incidentally, the only stabilized supply used in the flight equipment). A 60-volt dry battery is used, under zero current conditions, as a voltage reference, the available neon tubes having been found unacceptably microphonic when vibration-tested.

On channel A the maximum input swing at the cathode follower input point is  $\pm 3$  volts, giving an input swing of approximately  $\pm 2$  volts at the oscillator unit and a sub-carrier frequency swing of about 20 kc/s, from 275 to 295 kc/s; a negative voltage of up to -12 volts is required at the cathode follower input to produce the sync. frequency of 305 kc/s, the frequency/voltage characteristic becoming non-linear above 295 kc/s.

The diode limiters associated with the cathode follower prevent any excessive signal voltage from producing a spurious sync. pulse, the signal voltages being fed to the 24-channel switch via

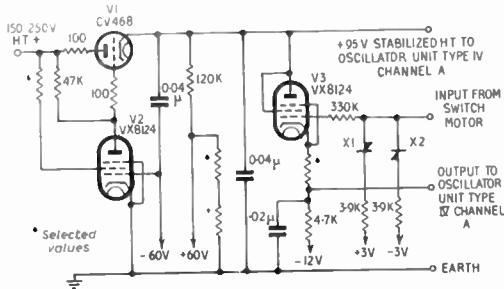

Fig. 9. Circuit of Stabilizer/Cathode Follower Unit.

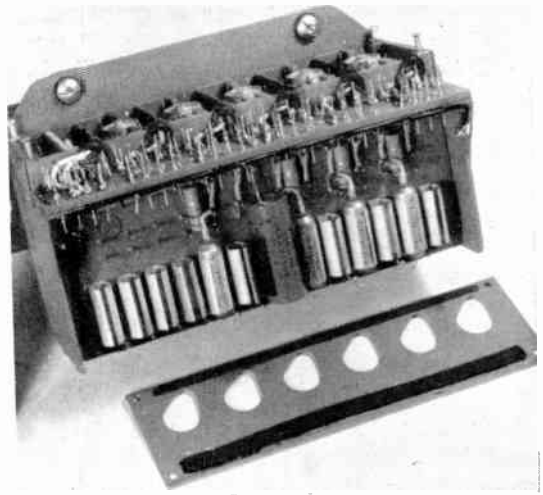

Fig. 10. A Modulation Generator Unit for channels A and 3 to 6.

resistors of about 330 kilohms while the sync. voltage source is of relatively low impedance.

All the oscillator units of a sender, and the stabilizer/cathode follower (if used), are fitted in screened compartments in the modulation generator unit chassis; earlier versions of these also contained the driver unit, but the later driver units were designed for mounting on the structure of the high power oscillator. Figure 10 shows a modulation generator unit constructed for 5-channel use (channels A, 3, 4, 5 and 6); the stabilizer/cathode follower and the channel A oscillator unit are fitted in the compartments otherwise occupied by the oscillator units on channels 1 and 2 respectively. The output resistors of the oscillators and the input resistor of the driver unit form the adding network to produce the multiple sub-carrier waveform.

### 3.5. Driver Units

Three different methods have been used to provide the necessarily linear amplitude-modulation of the high power oscillator.

Series anode modulation was first used; the driver unit (type I) was a four-valve unit which was mounted in the compartment provided in the earlier modulation generator units. The system had the disadvantage of requiring a

rather high h.t. voltage and a special l.t. supply at a positive potential, and is now obsolete.

Grid modulation had been ruled out initially since it appeared to be impossible to achieve the requisite linearity; work in 1954 showed this to be incorrect; it was found possible to obtain about the same modulation depth as with the series anode modulation method (i.e. about 35 per cent.) with a considerable saving in power consumption and without the disadvantages mentioned above. The new (type II) unit, a two-valve unit consisting of the original h.p.o. driver with certain modifications, superseded the type I unit.

In 1956, to increase the modulation depth and hence the range of the system, a shunt anode modulation circuit was developed. Figure 11

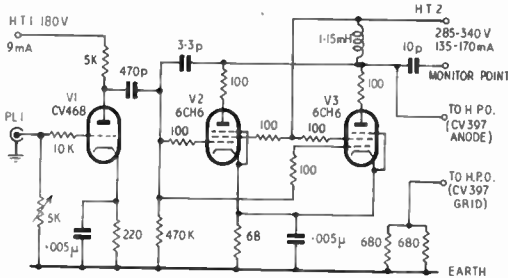

Fig. 11. Circuit of Driver Unit Type III.

shows the circuit of the resulting driver unit (type III); Fig. 12 shows one of these units fitted to a high power oscillator (the screening cover for the driver unit has been removed). A considerable increase in modulation depth, to at least 70 per cent., was made possible by the new unit, which has latterly superseded the grid modulation unit in Bristol G.W. trials.

### 3.6. High Power Oscillator and Transmitting Aerial

These are exactly similar to those used for a 24-channel R.A.E. Telemetry sender. Two senders sharing a common aerial system have been used in the majority of Bristol G.W. rounds: all three combinations—two 24-channel, a 24-channel and an h.f. sender, and two h.f. senders—have been used. Various frequency separations have been used; a separation of about 18 Mc/s is now usual. The good frequency stability of the high power oscillators

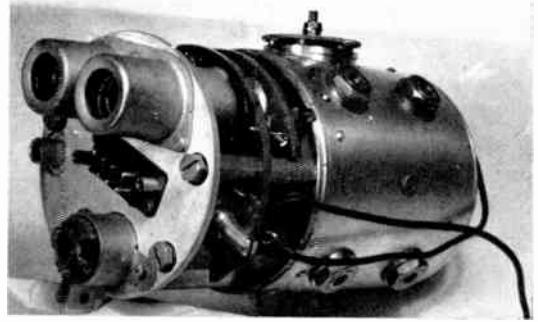

Fig. 12. 465 Mc/s High Power Oscillator with Driver Unit Type III.

has no doubt facilitated their use with the common aerial system.

### 3.7. Power Supplies

Dry batteries for h.t. supplies and lead-acid batteries for l.t. supplies have been used throughout for H.F. Telemetry senders in Bristol G.W. rounds.

The supply voltages are approximately as follows:—

H.T.1 180 volts	L.T.1 6 volts
H.T.2 400 volts	Switch motor 6 volts

(Series anode modulation senders, now obsolete, were used with an H.T.2 supply of about 500 volts and an additional 6-volt supply).

Power consumption figures for 6-channel senders, each with three pick-up head amplifiers of the two-valve type (chosen as a typical case) are estimated to be as follows:—

(a) Series anode modulation	120 watts
(b) Grid modulation	80 watts
(c) Shunt anode modulation	110 watts

The addition of a high-speed 24-channel switch and a low-speed 12-channel ("calibration") switch would add about 20 watts to each of these figures.

## 4. Details of the Ground Equipment

### 4.1. The Receiving Aerial and Receiver

These are similar to those used with the R.A.E. 24-channel Telemetry system; the receiver, in which a 45 Mc/s i.f. is used, incorporates video stage modifications—to extend the bandwidth to cover the H.F. Telemetry sub-carrier band—which make it usable in either telemetry system.



4.2. The Sub-carrier Mixer and Amplifier

This unit may be used between receiver or calibration unit and the sub-carrier selectors as an extra sub-carrier amplifier of adjustable gain; it functions as a mixer and amplifier when used in conjunction with the test oscillators to feed a multiple sub-carrier waveform to the sub-carrier selectors.

4.3. The Sub-carrier Selectors

These units incorporate band-pass filters comprising a number of *m*-derived and prototype

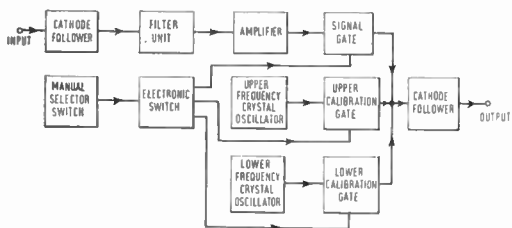

Fig. 13. Block diagram of Sub-carrier Selector incorporating calibration oscillators.

sections, and valve stages to provide amplification and a high input impedance. The later sub-carrier selectors incorporate also circuits for the calibration of the ground equipment: Fig. 13 is the block diagram of one of these selectors. The following alternative outputs may be selected by means of the manual switch:

- (a) "Signal only" (i.e. sub-carrier separated from the complex input waveform);
- (b) "Calibration only" (upper and lower calibration frequencies alternately, switched at about 50 c/s) and
- (c) "Calibration interposed" (sub-carrier signal interrupted at about 25 c/s for short

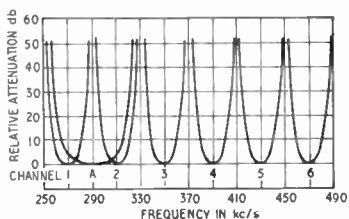

Fig. 14. Relative attenuation/frequency characteristics of Sub-carrier Selectors.

intervals in which the two calibration frequencies are interposed).

Details of the uses of the calibration waveforms are given in sub-sections 4.7 and 4.8.

Figure 14 shows typical relative attenuation/frequency curves of sub-carrier selectors.

4.4. The Frequency Discriminators

A number of versions of discriminators have been produced; all operate on the "constant-area pulse" principle, which gives a good degree of linearity over a wide bandwidth; Fig. 15 shows the basic block diagram of these discriminators.



Fig. 15. Basic block diagram of Frequency Discriminators.

The discriminators in a set of six for channels 1 to 6 are identical to each other; each is usable on any of these channels. A front-panel meter indicating the mean frequency has proved a useful feature. A limiter and CR stage are used to provide the "constant-area" pulse. The output is a.c.-coupled.

The channel A discriminators are d.c.-coupled in the stages following the constant-area pulse generator, which is a multivibrator which in the absence of an input signal is self-running at a little over 200 kc/s. Good d.c.-stability is obtained after a warming-up time of about 30 minutes. A "sync separator" is included by means of which is produced a separate sync. pulse that is used in the production of strobed records in the standard R.A.E. 24-channel Telemetry strobing equipment.

The filters in the signal-frequency stages of the discriminators are of considerable importance since they serve to reject both sub-carrier frequency components and system noise components (mainly from the r.f. link in practice) above the required signal frequency band. The later versions of the discriminators incorporate filters designed to combine good step-function response with a good transmission/frequency response, in particular for histogram telemetry, though of course these properties are desirable

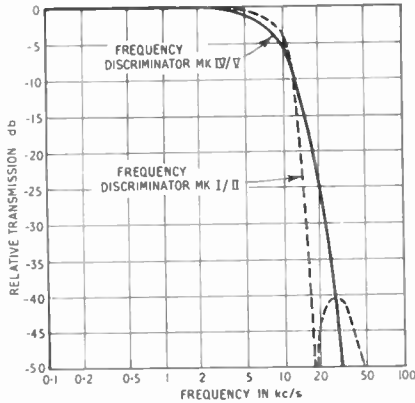

Fig. 16. Relative transmission/frequency characteristics of signal frequency stages in Frequency Discriminators Mks. I/II and IV/V.

in many other applications. The relative transmission/frequency characteristics of the signal-frequency stages in the older (Mk. I/II and newer (Mk. IV/V) discriminators are shown in Fig. 16; the superiority of the step-function response of the newer units is illustrated in Fig. 17, which shows square waves at 500 and 1500 c/s recorded over an H.F. Telemetry link via discriminators Mks. I and IV. The 1500 c/s square wave frequency was chosen to give an idea of the quality of histogram reproduction obtainable, the half-cycle at this frequency being approximately representative of a "sample" from a 24-way 120 c/s switch.

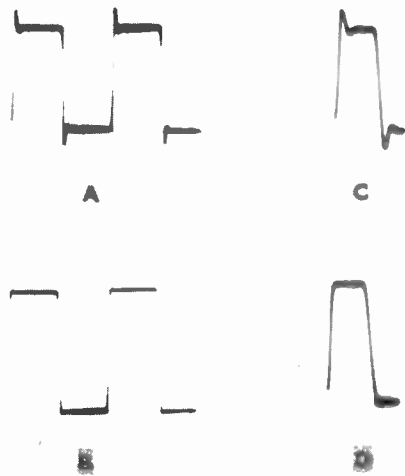

Fig. 17. Waveforms recorded via an H.F. Telemetry channel. The input waveforms were square waves at 500 c/s (A & B) and 1500 c/s (C & D); the Frequency Discriminators used were the Mk. I (traces A & C) and Mk. IV (B & D).

4.5. The C.R.O.-Camera Recorders

Both 70-mm and 35-mm 6-channel recorders have been used, each with a seventh cathode-ray tube to record the "millisecond ruler" waveform from the standard timing equipment. Latterly only 35-mm recorders have been used, with a film speed of 48 inches per second: Fig. 18 is an enlargement of a portion of one of these records.

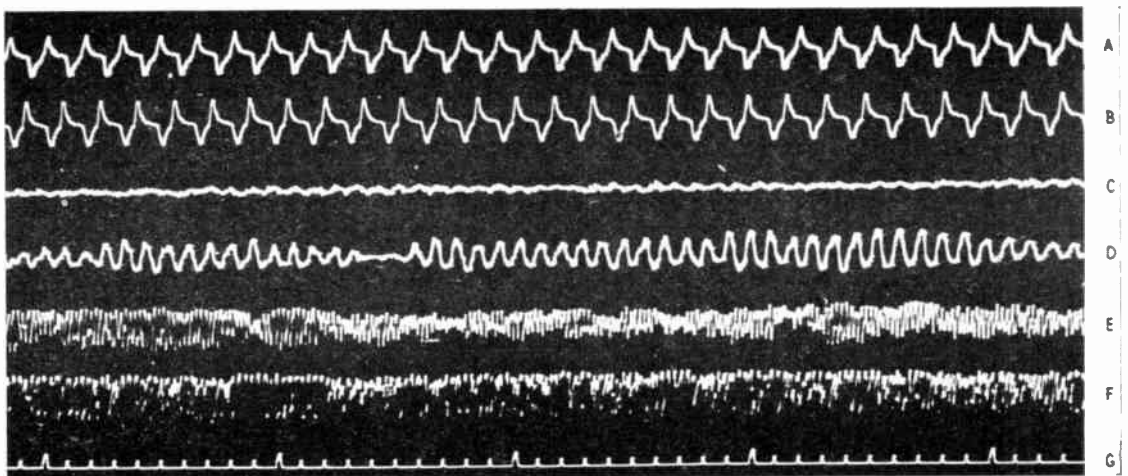

Fig. 18. Enlarged portion of 6-channel 35-mm flight record. Traces A and B are from rotary flowmeters; C, D, E and F are from crystal accelerometers; G is the "millisecond ruler" timing trace.

For histogram records (made on 35-mm film) and strobed (low-speed) records the normal R.A.E. 24-channel Telemetry recording equipment is used. Figure 19 is a photograph of the major part of a strobed low-speed record obtained via channel A. The recorder has 15 tubes, the deflections on each of which are produced by the voltage histogram, the required signal and calibration channels being picked out by brilliance modulation; the original records measure about 24 in. by 30 in. The cessation of signals and the onset of noise at the end of transmission are clearly shown in Fig. 19; a similarly clear indication of the cessation of signals is obtained on the high-speed film records under reasonably good r.f. signal strength conditions.

#### 4.6. The Magnetic Tape Recorder

A standard commercially-available  $\frac{1}{4}$  in. tape recorder has been used to record, at  $7\frac{1}{2}$  inches per second, vibration waveforms for replay into electronic analysing equipment.

#### 4.7. The Calibration Unit

This unit contains twelve crystal oscillators, a pair to each of the channels 1 to 6, at the upper and lower channel deviation limit frequencies respectively (i.e. at  $\pm 6$  kc/s about the centre frequency, for each of these channels). The six upper-limit frequencies are added together to form one complex wave, the six lower-limit frequencies to form another. The two complex waves are electronically switched, in turn, to the output stage, and, when applied to the sub-carrier selectors, produce at the output terminals of the frequency discriminators calibration square waves which are recorded on the flight records shortly before launch, and sometimes also shortly after the flight.

#### 4.8. The Calibration Interposer

This unit contains twelve crystal oscillators as in the calibration unit, and amplifier stages through which are fed the complex sub-carrier wave from the receiver or test oscillators. An electronic switch is set by a two-way manual switch to give either of the following outputs:—

- (a) "Calibration interposed" (sequence as in 4.3(c) except that here all the waveforms are multiple ones) and
- (b) "Calibration only" (calibration frequencies only, as from the calibration unit).

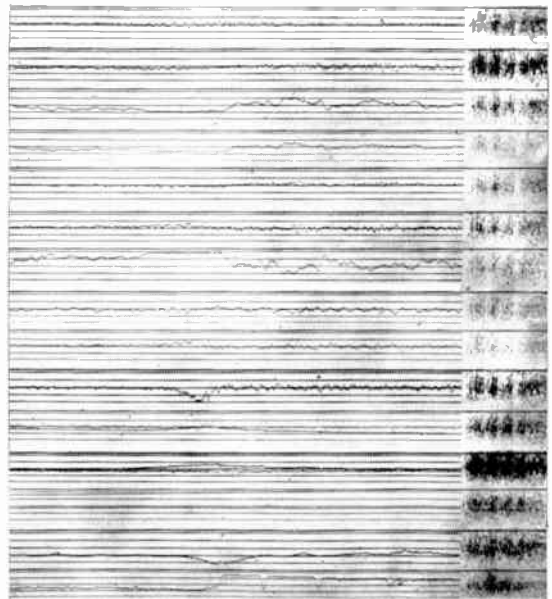

Fig. 19. 15-tube strobed channel A flight record (major part).

Sockets are provided from which the uninterrupted output of the sub-carrier amplifier may be fed to the sub-carrier selectors, so that each channel trace can be recorded with or without interposed calibration waves, as required.

Calibration interposing enables "d.c." as well as "a.c." measurements to be made using a.c.-coupled discriminators and recorders and without the use of a commutation switch at the sender end. The method has, however, the disadvantage of requiring extremely drift-free sub-carrier oscillators if a reasonable degree of accuracy is to be obtained with a narrow sub-carrier-band system. For this reason it has only been used for flight recording in conjunction with oscillator units type I, giving d.c. measurements of moderate accuracy together with a.c. measurements of greater accuracy. Drifts due to reactance valve variations in oscillator units type IV have precluded the use of calibration interposing in d.c. voltage telemetry; for this a sampling switch and flight "standards" are invariably used. On inductance channels also, of course, the use of flight "standards" would appear desirable if maximum accuracy is required.

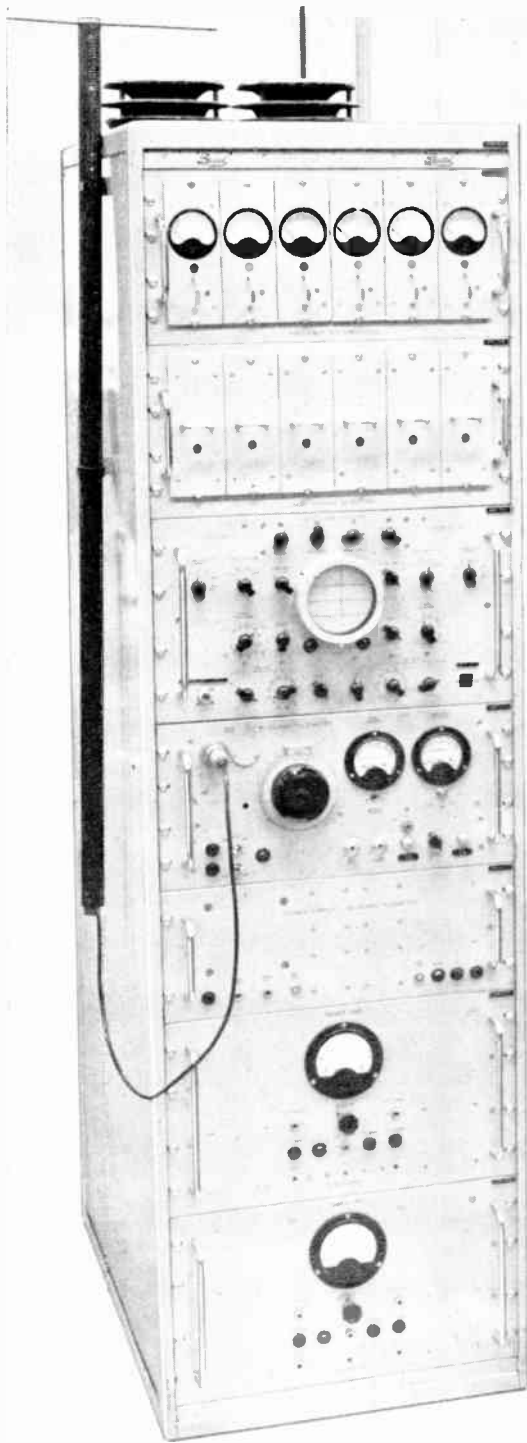

Fig. 20. A Test Ground Set for channels 1 to 6.  
(Usually mounted on a trolley for mobility.)

Calibration interposing has proved useful as a means of obtaining a quick check of sub-carrier frequency and deviation during the preparation of senders.

#### 4.9. *The Test Oscillators*

Each of these units incorporates a transitron sub-carrier oscillator and reactance valve and an RC audio-frequency oscillator of adjustable frequency, waveform and amplitude which provides a modulating signal; modulation from an external source is also provided for, and internal and external sources may be used together to produce compound waveforms. The test oscillators are coupled to the sub-carrier mixer and amplifier, in place of the receiver, to test the remainder of the ground equipment; comparison of input and output waveforms on each channel, using a double-trace oscilloscope, showed, in the early days of development, that extremely accurate reproduction of waveforms should be possible (the distortion due to the frequency-multiplexing and de-multiplexing process being negligible), provided an r.f. link of good linearity and signal-to-noise ratio proved realizable.

#### 4.10. *The Waveform Monitor*

This is a double-trace oscilloscope unit, selector switches on which facilitate the rapid monitoring of the output waveforms from the receiver, sub-carrier selectors and frequency discriminators. Either independent time-bases or a common one may be used.

#### 4.11. *Ground Sets*

Apart from the receiving aerial, calibration unit and recorders, the ground equipment is housed in a single rack, the complete assembly being termed a "ground set"; in addition to units of types described above, it includes stabilized power units. The test ground sets, used in missile preparation areas, are similar but relatively self-contained and mobile, each carrying an aerial and requiring no associated recording equipment, in general. Figure 20 shows a test ground set: the rack-mounted units, starting at the top, are frequency discriminators, sub-carrier selectors, waveform monitor, receiver, and three power units. The power consumption is about  $1\frac{1}{2}$  kilowatts.

5. Survey of Results

5.1. Ease of Development and Use

No major inherent system difficulties have been encountered either during the initial development period or during the period of practical use and further development. Cross-talk has not proved a major problem; the linearity necessary to keep cross-talk down to an acceptably low level—say less than 1 per cent.—has proved easily realizable.

The use of flight senders built by E.M.I. Ltd., to an R.A.E. specification similar to the Bristol one, in Bristol G.W. rounds, started in 1956 (E.M.I. senders are intended ultimately to be used in all cases, in place of Bristol senders). Both E.M.I. senders and a number of senders of a different configuration, built and used in free-flight models by another Department of Bristol Aircraft Ltd., have been used without difficulty in conjunction with the original Bristol-built ground set at Aberporth.

The majority of H.F. Telemetry senders flown have been in twin-sender installations, with a common aerial system. The other sender has generally been an R.A.E. 24-channel Telemetry sender, but twin H.F.T. senders have also been used without difficulty.

5.2. Usefulness

The system has been used for telemetering a considerable variety of quantities; the versatility of the system in practical use has not been unexpected, in view of the relatively wide signal bandwidth, the multiplicity of channels, the usability of either voltage or inductance transducers of existing types, and the variety of channel combinations which may be used. A channel A

sender gives, for example, the capacity of an R.A.E. 24-channel sender for voltage telemetry plus four continuous channels on which quantities in the frequency band 10 c/s to 10 kc/s may be telemetered. The ability to monitor certain quantities continuously during flight while still having adequate capacity for time-multiplexed information has been of considerable importance in some cases.

5.3. Average Ranges

The H.F. Telemetry system, having a higher information capacity, is naturally inferior in range to the R.A.E. 24-channel Telemetry system, with the same transmitter power. Table 2 gives estimated average range figures for H.F. Telemetry with the various modulation systems and various numbers of channels, based on practical results; it should perhaps be pointed out that practical ranges, especially for low-trajectory flights, may be considerably less than the free-space range.

5.4. Reliability

Operational results have generally been good and acceptable; occasionally records have been poor, but, in Bristol flight tests up to the end of 1958, there has only been one case of total failure to obtain an H.F. Telemetry record; this was due to incorrect operation of the only c.r.o.-camera recorder.

Duplication of c.r.o.-camera recorders prevented total absence of records in three other cases of recorder failure. No cases are known of failures due to any of the other ground equipment units during flight recording.

In-flight failures of the flight units have been remarkably few in spite of high vibration levels

Table 2  
Estimated Average Ranges of various H.F. Telemetry Systems

Modulation System	Driver Unit Type No.	Number of Channels	Range in Yards
Series anode	I	6	20,000
Grid	II	6	20,000
Grid	II	2	35,000
Shunt anode	III	5	40,000
Shunt anode	III	2	60,000

in many cases. The pre-flight vibration-testing which has been carried out on all Bristol flight units originally resulted in an undesirably high proportion of rejections of completed units due to valve failures; pre-wiring shock-testing of valves was therefore introduced, resulting in the rejection of about 25 per cent. of the valves from some batches and a much lower proportion of rejections of the completed units.

Figures have been compiled of the in-flight failures of Bristol H.F. Telemetry units up to the end of 1957; these are given in Table 3.

In five of the eight cases of failure listed, a large proportion of the required information had been obtained by the time the failure occurred. In some cases the failures may have been due to faults in other parts of the sender, e.g. in power units or in the high power oscillator.

The majority of failures in the flight equipment are thought to have been attributable to thermionic valve failures, and the inherent simplicity of the flight sender, in which there are only four valve stages (three in the driver unit and one in the transmitter) common to all channels, is considered to have been a major contributory factor to the good overall reliability achieved. Reasonably rugged construction of flight units, the practice of vibration testing these units, and the use of anti-vibration mountings are also considered to have contributed towards good reliability.

5.5. *Validity and Accuracy Tests*

Some mention of the various tests which have been made from time to time to check the validity and accuracy of records may be of interest.

The validity tests include the use of two channels to telemeter the same waveform; in the second test flight in December 1952, for example, three waveforms—one from a crystal accelerometer, one from a sine-wave oscillator (at about 2500 c/s) and one “zero input”—were each telemetered on two channels, with excellent results.

Channels with zero inputs have been used frequently to test for noise and microphony, which, in the case of vibration traces, would often be difficult to distinguish from the true vibration signal; good “straight line” traces have been obtained from these channels provided the r.f. signal strength has been reasonably good; the noise due to low r.f. signal strength is easily identifiable on the multi-channel records if these include one “zero input” channel, since it occurs simultaneously and to very approximately the same extent on all the traces.

In some measurements waveforms of a distinctive nature are used, for example the flow-meter, waveforms in Fig. 18, from traces of this nature rotation rates may be measured with a high degree of accuracy, and with no doubt as to validity.

A test of the accuracy of voltage telemetry via a histogram on channel 1 was made early in 1955, in conjunction with the second flight test in which a 24-channel high-speed switch was used with an H.F. Telemetry sender. Analysis Group personnel measured from the histogram record a number of fixed voltages which had been measured independently prior to the flight. 729 readings were taken; none differed from the

**Table 3**  
Details of In-flight Failures of Units (up to the end of 1957)

Units	Number of Units used	Number of Failures (Known or Suspected)	Number of Channels involved per Failure
Pick-up Head Amplifiers	283	1	1
Stabilizer/Cathode Follower Units	14	0	1
Oscillator Units	630	4	1
Driver Units	117	3	All

pre-flight measurement value by more than 3½ per cent. of the full-scale signal swing; six differed by more than 2½ per cent. These results were considered to confirm the predicted accuracy of 2½ per cent. from a record with a reasonably good signal-to-noise ratio; in this respect, channel A was expected to prove superior to any of the channels 1 to 6.

## 6. Conclusions

### 6.1. *Assessment of the System*

In the light of the results outlined above, the system is considered to have been fully satisfactory in respect of ease of development and use, versatility and reliability, and fully up to expectations in respect of accuracy and range. It has been of significant practical value in the development of the Bloodhound missile, providing the wide information bandwidth required for certain measurements and not available from other systems in use at the time.

It is thought that the accuracy available is likely to be adequate for many types of measurement for an indefinite time, but that increases in range—in which the system, in common with other systems of high information bandwidth, is inherently at a disadvantage in comparison with systems of lower information capacity and similar transmitter power—are likely to be required in the future.

### 6.2. *Future Use of the System*

It is considered that the sender simplicity and the method of channel separation—by the use of band-pass filters—are significant reliability factors in favour of the frequency-multiplex system for multi-channel high-frequency telemetry; other advantageous features are the low cost, small size and ease of installation and use of the sender.

It is felt, therefore, that it is desirable to extend the range, and hence the use, of the H.F. Telemetry system as far as possible. The follow-

ing are considered to be methods by which major increases in range are to be gained:—

- (a) the use of transmitters of higher power;
- (b) the use of high-gain (narrow-beam), following, receiving aerials;
- (c) improvements to the r.f. circuits in the receivers; and
- (d) the use, where possible, of additional filters to reduce the output bandwidth of the ground equipment.

Methods (a) and (d) would often be impracticable; methods (b) and (c) should however be capable of providing considerable increases in range over those quoted above.

In addition to telemetering information in the forms described above, it is thought that the system may prove of use for telemetry information in digital forms, with the digits of a number transmitted either sequentially on one channel or simultaneously, in parallel, on all six channels; the use of ternary or quaternary codes may prove preferable to the binary code in this application, to make more efficient use of the available resolving power.

The H.F. Telemetry system with a single coaxial feeder between sending and receiving points in place of the r.f. link may prove useful (as it has already) in certain ground-to-ground telemetry applications. The system complete with r.f. link may, in addition to use in tests of pilotless flight vehicles, prove of use in certain tests of manned aircraft, motor vehicles and small marine craft.

## 7. Acknowledgments

The author would like to acknowledge the contributions towards the development and use of the H.F. Telemetry system made by other organisations, in particular the Royal Aircraft Establishment and E.M.I. Electronics Limited, and to express his appreciation of the encouragement and assistance given by Bristol Aircraft Limited in the preparation of this paper.

---

The four other papers presented at the Symposium will be published later together with a report of the Discussion.

# APPLICANTS FOR ELECTION AND TRANSFER

As a result of its June and July meetings the Membership Committee recommended to the Council the following elections and transfers.

In accordance with a resolution of Council, and in the absence of any objections, the election and transfer of the candidates to the class indicated will be confirmed fourteen days after the date of circulation of this list. Any objections or communications concerning these elections should be addressed to the General Secretary for submission to the Council.

The following elections and transfers were recommended at the June meeting:—

## Direct Election to Full Member

GERMANY, Leslie Walter. *Cambridge.*

## Direct Election to Associate Member

CUCKSON, Harry. *Farnham, Surrey.*  
DIBSDALL, Lt. Col. Dennis, B.Sc., R. Sigs. *Eastbourne.*  
GRAHAM, James Wilfred, B.Sc.(Hons.). *Cambridge.*  
HARRISON, Alban Joseph, B.Sc. *Bishop's Stortford.*  
HILL, Major Kenneth John, R. Aust. Sigs. *Victoria, Australia.*  
INGAMELLS, Edward Howard. *Luton.*  
SLINN, Shaun Joseph. *Crawley.*  
TUCKER, Major Kenneth William, R.A. *Rhosneigr, Anglesey.*  
VENNING, Bryan Hamilton, B.Sc.(Eng.). *Lynnington, Hants.*  
VIDLER, Arthur Francis, B.Sc. *Wrexham, Denbighshire.*

## Transfer from Associate to Associate Member

SAVEL, Josef. *Prague.*

## Transfer from Graduate to Associate Member

McCARTHY, Kenneth John. *New Barnet.*  
SQUIRES, Terence Leighton. *Chelmsford.*  
STEPHENS, William George Sinclair, B.Sc.(Eng.). *St. Andrews, Fife.*  
TOPPING, Douglas Randall Peter. *Slough.*  
VARGHESE, Capt. Jacob, B.Sc. *New Delhi.*

## Transfer from Student to Associate Member

MEADOWS, Desmond Frederick. *Gulldjord.*  
SMITH, George Donald. *Northampton.*

## Direct Election to Associate

BAGGS, Joseph Gordon. *Reading, Berks.*  
EDDISON, Hugh Thomas Drew. *Gulldjord.*  
JONES, Gwynne, B.Sc. *Rhondda, Glams*  
NORRIS, Lieut. Alan Richard Bradley, R.N. *Southsea.*  
WARDMAN, Derek. *Leeds.*  
WHITEHEAD, Alan Thomas. *Bancroft, Northern Rhodesia.*  
WILLS, Gordon Henry. *Nairobi, Kenya.*

## Transfer from Associate to Graduate

TOZER, Barry Osmond. *Littlehampton.*

## Direct Election to Graduate

HICKEY, Major Douglas, R.A. *Gravesend.*  
MATTHEWS, Eric Griffiths. *London, W.14.*  
OSBORNE, Flg. Off. Donald, R.A.F. *Christchurch, New Zealand.*  
SKINNER, John Michael. *Malvern.*  
STEVENS, Peter Stanley. *Wellington, New Zealand.*  
WEATHERILL, Flt. Lt. Louis, R.A.F. *Saffron Walden.*

## Transfer from Student to Graduate

KENNY, Gerald. *Cambridge.*  
NARASIMHAN, K. Srivasachary L. *Agra, India.*

The following elections and transfers were recommended at the July meeting:—

## Direct Election to Full Member

FRENCH, Ronald Richard. *Reading.*

## Transfer from Associate Member to Member

KAY, Anthony Arthur. *London, N.6.*  
SRIVASTAVA, Aftab Jung, B.Sc.(Hons.), M.Sc. *Madras.*

## Direct Election to Associate Member

FINLAYSON, Alan Austin Stuart, B.Sc. *Winchester.*  
LANE, John. *London, N.20.*  
NICOLSON, John. *London, S.W.2.*  
POVER, Brian Sydney. *Evesham.*

## Transfer from Associate to Associate Member

COLLIER, Geoffrey Louis. *Redcar.*

## Transfer from Graduate to Associate Member

BELL, Ernest Clifford, B.Sc.(Eng.), (Hons.). *Bradford.*  
DENNING, Frederick Richard. *Great Shellford.*  
GILES, Henry Alfred. *London, S.W.13.*  
GREEN, Lawrence Young. *Cambridge.*  
McKENZIE, John George. *Mitcham.*

## Transfer from Student to Associate Member

MARTENS, Alexander E. *Willowdale, Ontario.*

## Direct Election to Associate

ASPINALL, Charles Deacon. *Nairobi.*  
BARRY, William Charles. *Redhill.*

BURLING, Kenneth George. *Reading.*  
CHILD, Cecil. *Ashtead, Surrey.*  
COLLETT, John Francis. *Lusaka, Northern Rhodesia.*  
CONNETT, Capt. William James, Royal Signals. *Bulford.*  
COX, Henry Arthur. *London, E.5.*  
DAS, Capt. Gopal, B.E., B.Sc., Indian Signals. *Chelmsford.*  
HOW, Frederick William. *Limassol, Cyprus.*  
LATIF, Muhammad Abdul, B.Sc. *Peshawar.*  
LILBURN, Wilfred. *Ilford.*  
NEMADE, Raghunath Shankar, B.E. *Bangalore.*  
PANG, Ee Ang. *Singapore.*  
POCOCK, Leslie James. *Reading.*

## Direct Election to Graduate

BECKER, Simcha. *Givataim, Israel.*  
FISHER, Ronald John. *Orpington.*  
HANNA, Richard Guy Crawford, B.Sc. *St. Albans.*  
HAWTHORNTHWAITE, Thomas William. *Malvern.*  
INGLIS, Alastair, B.Sc. *Gourock.*  
JAMES, David Michael, B.Sc. *Lewes.*  
KEY, Alfred John, B.Sc. *Exeter.*  
NRI, Cyril Onuora. *Coventry.*  
OVENDEN, William John Samuel. *Welling.*  
PICKERING, Noel. *Manchester.*  
TSANG, Hing Seng, B.Sc.(Eng.). *Hong Kong.*  
VISWANATHAN, S. *Madras.*

## Transfer from Student to Graduate

KHADILKAR, Narayan Shankar. *Akola.*  
LANGDON, Paul Stephen Moriarty. *Malvern.*  
RAMA SESHU, Kasarabada, B.Sc. *Bombay.*  
SHAH, Rajendra Kantilal, B.Sc. *Bombay.*

The names of 41 students registered at these meetings will be published later.



# Some Aspects of Television Transmission over Long Distance Cable Links †

by

H. MUMFORD ‡

*A paper read on 3rd July 1959 during the Institution's Convention in Cambridge.*

**Summary :** An outline of the basic properties of 0.375 in. diameter coaxial cable and the combined or alternative multi-channel telephony/television systems based on it is given. Most of the required transmission limits for such systems have now been agreed internationally and a "hypothetical reference circuit" evolved for which such limits can be stated. Although limits have tended to be agreed by national experiments on the various television systems, two basic subjective laws, the Weber-Fechner law and Riccò's law, on which limits must ultimately be based, are illustrated and discussed. Television transmission is fundamentally a waveform matter but for design purposes it is necessary to use frequency responses. The paper describes two simple guides to estimating these: (1) by reference to two simple minimum phase networks, and (2) by an extension of the paired-echoes method. The advantages of using a reduced carrier level are briefly pointed out and a number of synchronizing systems reviewed.

## 1. Introduction

Since there are now about a thousand television stations in the world there is a considerable demand for the transmission of television signals between studios and these stations. This arises because it is much cheaper to transmit a signal a hundred miles or more to another broadcasting station than to have a separate studio and originate another programme. Switching between several programme sources and transmitters is most easily handled as an extension of the telephone network and routes must therefore be capable of transmitting telephone or television channels as required. International links are also needed and the circuits extending from a few miles to a thousand or so may be over buried coaxial cables or microwave links.

Coaxial routes only are considered in this paper. The equipment, which is required to have a life of many years, needs large teams of engineers to develop it and there are thus a number of aspects to be considered. This paper deals with three. Firstly, all distortions must be kept below the thresholds of visibility and the

communications engineer must be something of an experimental psychologist. Secondly, since the allowable distortions are small, simplified methods of assessing them may be used. Thirdly, a particular problem, that of synchronizing two oscillators one at each end of the route, is discussed.

## 2. General Description of the Coaxial Route

The planning and design of long distance television links is helped by the definition, by international agreement, of a hypothetical reference circuit. This route is 2500 km long and for television transmission purposes is supposed to be divided into three equal sections, the ends and junctions being at video frequency.<sup>1</sup> It is this type of circuit with which this paper deals. The transmission path is a 75-ohm 0.375 in. diameter coaxial cable, one for each direction of transmission. Several coaxial tubes and a number of telephone pairs, some for control purposes, are normally laid up in one cable. Repeaters are required at intervals of several miles. These repeaters are unattended and power may be fed to six or more stations on each side of a power-feeding terminal by applying up to 2,000 volts a.c. between the inner conductor of the go and return cables. Adequate safety measures for the high voltage as well as alarm

† Manuscript received 16th March, 1959. (Paper No. 516.)

‡ British Telecommunications Research Ltd., Taplow Court, Taplow, near Maidenhead, Berkshire.

U.D.C. No. 621.372 : 621.397.743

and changeover facilities are provided. Compensation for changes of gain due to cable and equipment temperature variation and valve ageing is by transmitting pilot frequencies. These control networks which automatically correct the gain and response to restore the pilot level to normal.

Electrically the frequency limits for television transmission are set by the skin effect in copper. Below a frequency of a few hundred kc/s the skin depth becomes comparable with the conductor thicknesses. The effective inductance and hence the group delay of the cable changes more rapidly and an economic balance must be struck between the bandwidth and the amount of equipment required to equalize this group delay variation. As the frequency is increased the decreasing skin depth confines the current to the facing surfaces of the inner and outer conductors. The cable is then properly screened and the attenuation continues to rise proportionally to the square root of the frequency and an economic balance must be struck between repeater section attenuation and maximum practicable power output from a repeater. Such considerations lead to the main systems given in Table 1,<sup>2, 3, 4</sup> for 0.375 in. cable, in which system 3 is American practice. The telephone channels are transmitted as single sidebands with 4 kc/s channel spacing, the number of channels being enough to serve a fair sized provincial city. The full upper sideband and a vestigial lower sideband

0.5 Mc/s wide carry the television signal. In all cases the upper sideband is transmitted, the television carrier frequency being at the lower end of the television band. This has the advantage that the carrier is placed at a frequency where the random noise in the system is lower, but has the disadvantage in the case of the first three systems of the second harmonic of the carrier falling in the video band. To avoid the consequent pattern forming interference (amongst other reasons) the linearity of the repeaters must be kept high. This is achieved by negative feedback which is about 35 db at the lower frequencies. The last major parameter of the system is the modulation depth. If the video signal is to be recovered by envelope detection of the modulated carrier a low modulation index, not exceeding about 40 per cent, must be used, since single sideband transmission gives envelope distortion at high modulation depths. By using a product demodulator at the receiving terminal this difficulty is overcome and modulation depths corresponding to a suppression of the carrier can be used. It will be noted that the modulation index becomes infinite for a suppressed carrier system and it is usual to define modulation depth in terms of excess carrier ratio (e.c.r.). This is the ratio of the maximum peak carrier amplitude to the peak to peak modulation amplitude. Thus the modulation depth of 40 per cent corresponds to an e.c.r. of approximately 1.7.<sup>5</sup> Two reduced carrier modulation depths are in use. An e.c.r.

Table 1

	Nominal Repeater Spacing	Total Bandwidth	Capacity	Television Characteristics	
				Video Bandwidth	Carrier Frequency
1	6 miles	60kc/s to 4 Mc/s	960 Tp or 1 TV	3 Mc/s	1.056 Mc/s
2	6 miles	60kc/s to 6.2 Mc/s	1,200 Tp or 1 TV	5 Mc/s	1.056 Mc/s
3	4 miles	300kc/s to 8.3 Mc/s	1860 Tp or 600 Tp+1 TV	4.2 Mc/s	4.139 Mc/s
4	3 miles	300kc/s to 12.5 Mc/s	2,700 Tp or 1,200 Tp+1 TV	5 Mc/s	6.799 Mc/s

Tp=telephone channel

TV=television channel

of 0.5 in which sync.-pulse tips and peak white have the same carrier amplitude is used in the American system. A slightly lower modulation depth, e.c.r.=0.65, in which peak white and black level correspond to the same carrier amplitudes and the sync.-pulses project above this level has been proposed by the C.C.I.T.T.<sup>1</sup> Although the high level carrier systems in this and other countries give excellent results, low level carrier modulation has important advantages and is being more widely used. Increasing the sideband level relative to the carrier helps the system loading and the consequent freedom from quadrature distortion in the product demodulators which must be used with a reduced carrier is a considerable advantage. However, a carrier supply of the correct phase is required at each receiving terminal for the product demodulator and this complicates the equipment.

In a 12.5 Mc/s system the total attenuation of the 2,500 km hypothetical reference circuit is about 20,000 db and the total propagation time about 10 milliseconds. This attenuation must be compensated by the repeater gain and kept constant within a few decibels and the propagation time must be kept constant within a fraction of a microsecond. These accuracies demand precision engineering in every aspect.

**3. Subjective Basis for Transmission Limits**

Most of the permissible distortion and interference in a broadcast television system is properly allowed to the studio—transmitter—domestic receiver path, thus leaving very little distortion for any long distance link. The communications engineer is, therefore, especially interested in the threshold levels at which interference becomes apparent and in any relaxations which are possible subjectively. Limits determined from these thresholds are now nearly all agreed internationally but it is of interest to consider two laws which give some fundamental guidance. They are the Weber-Fechner law and Riccò's law.<sup>6</sup> These are most simply demonstrated by considering the visibility of a circular spot on a uniformly illuminated background. Figure 1 shows the results of about 90,000 observations in experiments carried out by Blackwell.<sup>7</sup>

The minimum visible value of fractional contrast is plotted against the angle which the diameter of the test object subtends at the eye. The fractional contrast is defined as the difference in brightness between the spot and the background divided by the background brightness. Above about one degree the threshold fractional contrast tends to a constant 0.3 per cent for the range of brightness encountered in television, say, between 0.5 and 20 foot-lamberts. This threshold rises somewhat as the background brightness is reduced. Where the threshold fractional contrast is constant it may be surmised that the threshold contrast corresponds to a threshold subjective sensation and an equation can be written as

$$\delta S = \frac{\delta B}{B} \dots \dots \dots (1)$$

where  $\delta S$  is the minimum increment of sensation which can be perceived and  $\delta B$  is the brightness difference causing it. This is the Weber-Fechner law and is approximately true for brightnesses above 1 foot-lambert. As the diameter of the test object is reduced below one to two degrees the fractional contrast must be raised for it to be visible. The graph becomes asymptotic to a line which makes the threshold contrast inversely proportional to the area of the test object. This is Riccò's law which was originally stated for the absolute threshold where the background was in complete darkness, but which is also true for differential contrasts. The asymptote intersects with the horizontal portion of the curve.

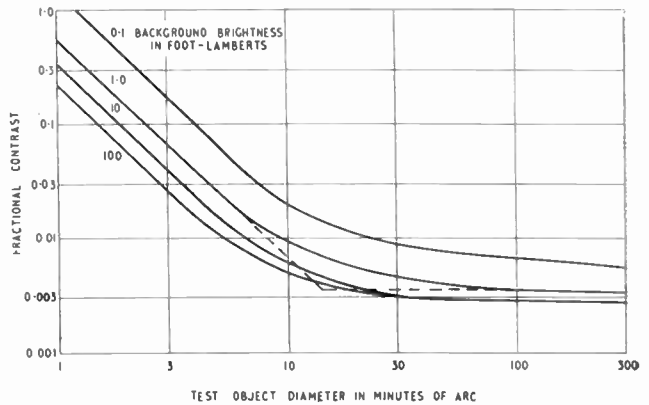

Fig. 1. The variation of fractional contrast with diameter for threshold visibility of a circular spot on a uniformly illuminated background.

at fourteen minutes of arc at a brightness of 1 foot-lambert.

These two laws apply to the visibility of images in television. To find out whether a voltage change in a system producing a large area image will be visible on the cathode-ray tube screen it is necessary to find the voltage which produces a 1 per cent change (say) in brightness. This change has been taken as "just certainly visible" in American practice.<sup>2</sup> The sensitivity to interference is not constant but increases as the background brightness is reduced. It has a shallow maximum at about one foot-lambert below which the sensitivity of the eye begins to fall. Random noise, for instance, will be most visible at about one foot-lambert. However, when the interference changes with the carrier level in the system, it may be more visible at other brightnesses. Thus the single frequency interference produced by carrier harmonics will generally be more apparent in either the lightest or darkest parts of the picture depending on the e.c.r.

The application of Riccò's law to the decrease of visibility with image size is not so apparent. We have to find some connection between the frequency variable and the area of the image on the screen. The image will be rectangular due to the line structure instead of circular. Vertically, correlation between lines will make subjective areas which are much longer. In addition because the cathode-ray tube spot has a significant size there is a further source of loss of definition.

When a high single frequency  $f$  is applied to the system the pattern is most visible when the bars are vertical. The width of one half cycle across the screen, in minutes of arc subtended at the eye at a viewing distance of four times the picture height, is given by

$$w = 573 \frac{ln}{fk} \dots \dots \dots (2)$$

- where  $l$  is the total number of lines in the system
- $n$  is the number of frames per second and
- $k$  is the horizontal blanking factor which is between 0.82 and 0.84 for practical systems.

The pattern thus extends out of the field of

distinct vision vertically and does not change with frequency. Horizontally the width and consequently the area of the bars is inversely proportional to frequency and its visibility would be expected to increase directly until the bar width was between one and two degrees. Using the asymptotic variation at one foot-lambert one would expect the frequency response to show a 6 db per octave slope down to the frequency at which the angle given by eqn. (2) was 14 minutes as shown by the dotted curve in Fig. 1. Figure 2 shows data for the threshold visibility of single frequencies and eleven bands

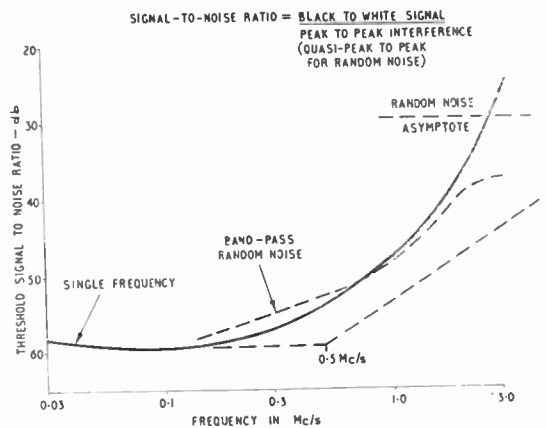

Fig. 2. Signal noise ratios for the threshold visibility of single-frequency and random interference in a 405-line television system.

of random noise each approximately 300 kc/s wide, distributed through the video spectrum. These are from experiments carried out by the Radio Branch of the British Post Office on the 405-line system. If an allowance is made for the cathode-ray tube spot size, which could increase the weighting at 3 Mc/s by 7 db, to data from the Cuban Telephone Company,<sup>1</sup> the asymptotic expression shows a reasonable agreement with the experimental curve.

The curve for random noise is in good agreement with the single frequency noise in the middle of the band. This indicates that the vertical subjective distribution of the noise pattern does not change with mean noise frequency and that the same basic frequency response as for single frequency interference can be used. By assuming that frequencies which give the same half cycle width on the screen are

equivalent one can compare the experimental weighting curves for the various television systems in use. This has given excellent results in nearly all the cases on which it has been tried by the author. It will be noted that as the curves for the various systems do not differ widely, international effort has concentrated on obtaining a single compromise curve, which can be obtained as the frequency response of a practical network for noise weighting. The departure of the curves for single frequency and random interference above 1.6 Mc/s can be explained as due to the non-linearity of the eye and cathode ray tube characteristics. This was suggested some years ago by the British Post Office and has recently been confirmed experimentally.<sup>8</sup> A simple demonstration that the non-linearity can give this effect is as follows. Assume a cathode ray tube brightness-grid voltage characteristic of

$$B = (0.76 + 1.94V)^{2.5} \dots \dots \dots (3)$$

where the constants have been chosen so that when

$$\begin{aligned} V=0 & \quad B=0.05 \text{ foot-lamberts} \\ V=1 & \quad B=12 \text{ foot-lamberts.} \end{aligned}$$

By assuming a grid voltage of  $V + \delta V$ , expanding by the binomial theorem, dividing by  $B$  and putting in a background brightness of  $B=1$ ,

$$\frac{\delta B}{B} = 4.85 \delta V + 7.05 (\delta V)^2 \dots \dots \dots (4)$$

It is now assumed that the noise comprises a large number  $n$  of equal amplitude sinusoids each of peak amplitude  $\delta V \sqrt{(2/n)}$  where  $\delta V$  is the total r.m.s. voltage. If this combined voltage is put into the squared term of eqn. (4) then difference and second harmonic products are formed. The difference products are of low frequency and much more visible than the others which are neglected. There are  $\frac{1}{2}n^2$  difference products each of amplitude  $(\delta V)^2 2/n$  giving a total low frequency r.m.s. voltage  $\delta V_h$  equal to  $\delta V$ .

When the impressed noise band  $\delta V_1$  is at low frequencies the second terms of eqn. (4) is negligible. Now if the mean frequency is moved to the top of the band the first term becomes negligible due to the subjective weighting and the difference intermodulation products of r.m.s. value  $\delta V_h$ , due to the squared term predominate. For the same fractional contrast change to be caused by  $\delta V_1$  and  $\delta V_h$ , and

combining the two new equations:

$$\frac{\delta V_h}{\delta V_1} = \frac{4.85}{\sqrt{7.05 \frac{\delta B}{B}}} \dots \dots \dots (5)$$

If we assume an r.m.s. fractional brightness change of 0.003 the difference in level between  $\delta V_h$  and  $\delta V_1$  is 30 db and the random noise curve would be expected to flatten out at a level 30 db above the low frequency limit. This exercise gives a rough approximation to the experimentally-determined curves.

**4. Conversion of Transient to Frequency Responses**

Subjective tests also determine limits for the permissible waveform distortion<sup>9</sup> of a television system but for design purposes the transient response must be transformed to amplitude-frequency and phase or group-delay frequency responses. Here some guides are needed, preferably simple ones, as the final form of distortion will be largely unknown. If we assume that the transient response must fit limits set by the rating factor method of the Research Branch of the British Post Office,<sup>1</sup> then the tolerances for low frequency distortion, say below 50 kc/s, will correspond to transient limits to the amplitude variation of the tops of 40 microsecond bars and 50 c/s square waves. Two simple networks, together with their step function and amplitude-frequency responses, are shown in Fig. 3 and 4. From Fig. 3(a) it

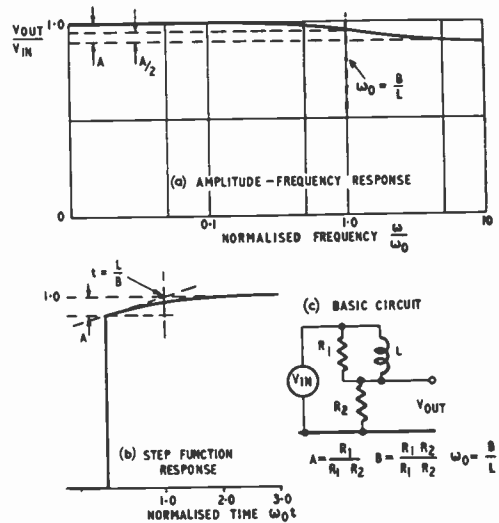

Fig. 3. Amplitude-frequency and step function responses of a simple LR circuit.

can be seen that the initial amplitude of the exponential transient is the same as the fall in the amplitude response and the time constant is equal to the reciprocal of the angular frequency at the half-way point in the amplitude variation.

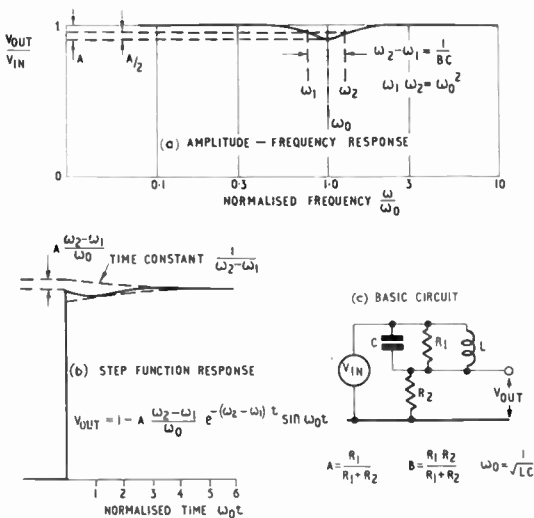

Fig. 4. Amplitude-frequency and step function responses of a simple LCR circuit.

In Fig. 4(a) the effect of a dip in the frequency response is to cause a transient in the step function response. The initial amplitude of its envelope is equal to the product of the fractional bandwidth measured at points  $\omega_1$  and  $\omega_2$  half way down the dip and the maximum fractional amplitude of the dip. The time-constant of the envelope is the reciprocal of the difference between  $\omega_2$  and  $\omega_1$ , and the period of the transient is  $1/\omega_0$ . The transients are accurate within a few per cent for variations up to 1 db and  $\omega_2 - \omega_1 < \omega_0$ . Reversal of the polarity of the frequency response variation reverses the sign of the transient. From consideration of Fig. 3 a rating factor of  $\frac{1}{2}$  per cent would require a frequency response flat within approximately  $\pm 0.1$  db between 1c/s and 50 kc/s.

At the upper video frequencies the method of paired echoes first described by H. A. Wheeler in 1939, and widely used since then, is a most useful guide.<sup>9</sup> In this, cosinusoidal variations in the amplitude response and sinusoidal variations in the phase response correspond to pairs of echoes in the impulse response of the system. For instance, a small cosinusoidal ripple

in the frequency response of fractional amplitude (a) and period  $1/T$  produces an impulse response in which the output pulse is accompanied by two positive echoes of amplitude  $\frac{1}{2}a$  one leading by time  $T$  and the other lagging by time  $T$ . This analysis applies directly to single sideband signals. Where, however, signals are double sideband (as at video frequencies below 0.5 Mc/s in television transmission or in the case of the colour sub-carrier in N.T.S.C. type colour television) the analysis requires extension to band-pass systems. If there is a variation of amplitude response which is cosinusoidal about the carrier frequency then echoes are produced as additional amplitude modulations of the carrier as above. Any variation of the response which is symmetrical about the carrier frequency can thus be subjected to Fourier analysis, each harmonic component producing one pair of echoes.

However, the result of attenuating one sideband more than the other, that is, a skew-symmetrical distortion, is to bring into being an additional set of sidebands whose resultant is in quadrature with the original carrier as shown in Fig. 5. An example of skew symmetry is a sinusoidal variation of amplitude-frequency response in the impulse response the in-phase modulation

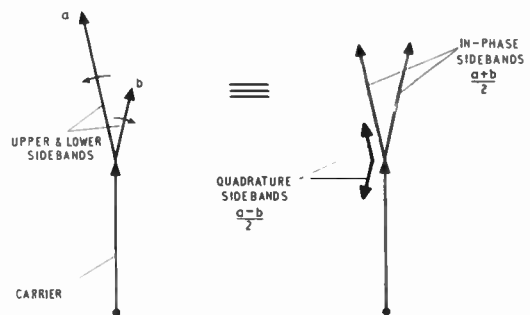

Fig. 5. In-phase and quadrature components for an amplitude modulated carrier whose sidebands have been attenuated by different amounts.

waveform is undistorted but a pair of echoes, the leading one positive and the trailing one negative, appear modulated onto a carrier in quadrature with the original. The results for amplitude and phase variations are summarized in Table 2 and a simple derivation given in the Appendix.

It will be seen from Table 2 that if the in-phase component only is important then any unavoidable errors in the double sideband region of the spectrum of a television channel should be skew-symmetrical (sinusoidal) about the carrier in amplitude. An unusual feature which this analysis brings out is that in the case of a symmetrical (cosinusoidal) phase error the carrier phase is changed by  $a$  radians and a deliberate offsetting of the re-introduced carrier at the receiving terminal is required to remove the quadrature component. This is shown by eqn. (21) of the Appendix.

Amplitude and phase distortions in the upper frequency spectrum of an N.T.S.C. type colour television system will give crosstalk between the two sets of colour data transmitted on the sub-carrier.<sup>10</sup> Macdiarmid has proposed a modulated pulse test which is an extension of the rating factor method for colour television<sup>11</sup> but no published information on colour transients is known to the author as yet by which link frequency response tolerances could be set by the above methods.

**5. Methods of Synchronization**

The general trend of systems to synchronous working was mentioned earlier. In this a carrier supply must be generated at each receiving terminal to supply a product demodulator. For television transmission this carrier must be held exactly to the frequency of the incoming signal and in correct phase within a few degrees. Although this complicates the terminal two real advantages can be obtained. Firstly, there is no direct addition of waveform distortion due to the quadrature components of several systems in tandem and secondly the

modulation depth can be increased greatly, since the modulated envelope is no longer important.

Figure 6 shows the in-phase and quadrature modulating components for a  $2T$  pulse in a

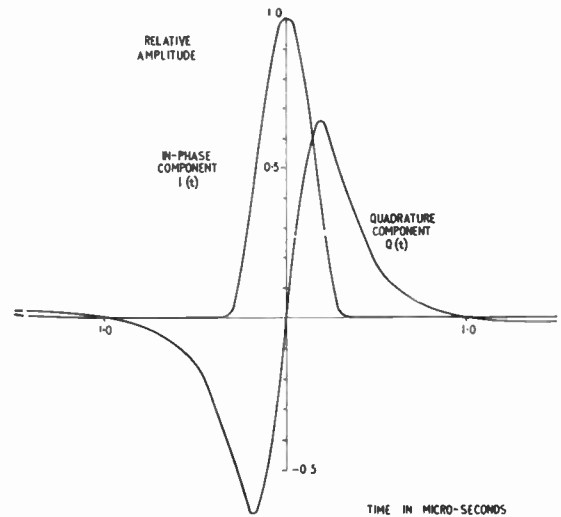

Fig. 6. In-phase and quadrature modulating functions for a  $2T$  pulse in a 405-line system with linear shaping to give a 0.5 Mc/s vestigial sideband.

405-line system with a 3 Mc/s video bandwidth assuming that the vestigial sideband response is linear, rising from zero at 0.5 Mc/s below carrier to unity 0.5 Mc/s above it.

The instantaneous amplitude of the modulated carrier will be

$$V = \sqrt{[V_0 \pm I(t)]^2 + Q(t)^2} \dots\dots\dots(6)$$

where  $V_0$  is the peak amplitude of the carrier.

**Table 2**

		Echoes produced in impulse response output		
Variation about carrier frequency		Carrier on which modulated	Sign of leading echo	Sign of trailing echo
sinusoidal	amplitude	quadrature	-	+
cosinusoidal	amplitude	in-phase	+	+
sinusoidal	phase	in-phase	-	+
cosinusoidal	phase	quadrature	-	-

For low values of  $V_0$  the envelope will be distorted by the presence of  $Q(t)$ . A check shows that for an e.c.r. of 1.7 a rating factor of over 1 per cent is obtained each time an envelope detector is used. Since a rating factor of 5 per cent is suggested for the overall route it can be seen that quadrature distortion will take up over half this assuming the direct addition of three demodulators. Any estimate of the increased distance over which a signal can be transmitted by the use of the reduced carrier as opposed to a pre-emphasised high level carrier system is not easy. However, using the simplest theory in which the maximum transmission level is set by the second harmonic of the carrier falling in-band a comparison is easily made with a system without pre-emphasis. Let it be assumed that the second harmonic voltage is proportional to the square root of the distance. This not strictly true but gives a pessimistic answer. If the distance is increased  $n$  times the r.m.s. random noise voltage at the output increases by  $\sqrt{n}$  and the output video signal must therefore be raised by  $\sqrt{n}$  too. However, the increased video voltage permits the total second harmonic voltage to be raised by  $\sqrt{n}$ . Since this is the assumed increase with distance the carrier level can be left as before. Thus the excess carrier ratio must be decreased by  $\sqrt{n}$  i.e. the distance increase inversely with the square of the e.c.r. and going from 1.7 to 0.65 gives an improvement in distance of nearly 7 times over flat transmission.

When the modulation depth is increased beyond 100 per cent (e.c.r.=1) the envelope of the modulated signal no longer corresponds to the modulating signal and the carrier reverses in phase for part of the video voltage range.

The output from a product demodulator is

$$I(t) \cos \theta + Q(t) \sin \theta \dots \dots \dots (7)$$

$\theta$  is the error angle between the incoming carrier and the local oscillation. It must be kept within a few degrees to avoid quadrature distortion. Product demodulation thus requires a correctly phased synchronized local oscillator. Because of the very low frequency variations in picture level it is not possible to separate the incoming carrier directly with a filter. Two ways of overcoming this difficulty have been used. Firstly if the whole waveform is used an output

which is independent of carrier phase reversals must be obtained. An example of this, termed the squaring method,<sup>2</sup> is to pass the carrier through a square-law device and extract the second harmonic since

$$\sin^2 \omega t = \sin^2 (\omega t + \pi) = \frac{1}{2} - \frac{1}{2} \cos 2 \omega t \dots \dots (8)$$

the second harmonic does not reverse with the carrier.

The local carrier supply can also be squared and the two second harmonics compared in a phase sensitive detector. The output from the phase-sensitive detector is filtered to give a control voltage which can be applied to a reactance valve to pull the local oscillator into synchronism. The only condition for there to be zero output from the phase-sensitive detector is that the local oscillator and incoming signal are 90 deg. or 270 deg. out of phase and the system becomes phase locked in one of these two conditions, one of these can be set up to give correct video output polarity the other then reverses it.

The second method is to gate out the sample of carrier which occurs during each line synchronizing pulse as this is always of the same phase and use it as a reference. For this, the carrier supply frequency stability is not so important since locking-in can take place for a frequency difference of up to half the sampling rate, whereas in the carrier squaring method sidebands occur at field frequency and to avoid any tendency to lock to these the maximum frequency difference is half the field frequency. It will be noted that in all synchronous systems the receiving and transmitting terminal oscillators are initially unsynchronized so that there is an interval termed the locking-in time during which the oscillators synchronize. This interval will be from say 100 milliseconds for a gating system to a second or so for a squaring system. Four practical systems may be evolved from the two methods of obtaining a reference carrier. These are :

- (I) Squaring method. Polarity recognition from the video output.
- (II) Squaring method. Polarity recognition by using an e.c.r. of 0.65.
- (III) Gating method. Position of carrier sample by using an e.c.r. of 0.65.
- (IV) Gating method. Position of carrier sample by modulating an additional carrier.



System I is used in the Bell Telephone network. For polarity recognition the white-positive video signal is d.c.-restored and its positive edge separated and rectified. The horizontal synchronizing pulses, if the signal is the wrong way up, can be made to give greater output than a uniform picture signal and to operate a relay with reversing contacts. In order to avoid changeover on a peaky video signal the 50 c/s component in the picture signal due to the vertical blanking can be made to inhibit the reversal. Such a system requires careful design to avoid being baffled by particular signals and test signals must be frame blanked.

System II is to transmit at an e.c.r. of 0.65 and determine the positions of the horizontal synchronizing pulses by means of an envelope detector. The video output can then be tested for polarity at these intervals and correction made if necessary, if there is no output the reversing switch must be left as it was. Such a system requires test signals to have horizontal synchronizing pulses inserted. Other signals must be of high enough frequency for the reversing switch to be un-operated and their polarity must be unimportant (e.g. a high frequency sinusoidal test signal).

Further ways rely on gating the incoming signal. System III, used in the German network,<sup>3</sup> is to transmit at an e.c.r. of 0.65 and envelope detect to find the positions of the horizontal synchronising pulses. The leading edges of these pulses then open a gate which samples the incoming signal during the horizontal synchronizing pulse interval. The resulting bursts of carrier are then compared with the local oscillator in a phase-sensitive detector and a correcting voltage obtained.

System IV is to use some other channel to transmit data on synchronizing pulse position. Such additional channels, though instinctively disliked by the engineer, are coming into use for such functions as bringing stand-by channels into service.<sup>12</sup> Figure 7 shows an experimental pair of terminals in which the normal pilot signal at 308 kc/s is amplitude modulated with the fundamental horizontal synchronizing pulse frequency. At the receiving terminal the pilot is applied to an envelope detector. The zero cross-overs of the output sine-wave initiate gating pulses which are delayed to positions

from which they can gate out samples of carrier during the horizontal synchronizing pulse intervals. The terminals of Fig. 7 use two frequency translations to modulate a 1.056 Mc/s carrier. They can provide up to 5 Mc/s bandwidth and are provided with built-in delay line waveform correctors and stabilized power supplies. Normally pilot signals are re-generated at intervals between 300 and 500 miles and it would be necessary in practice to have television

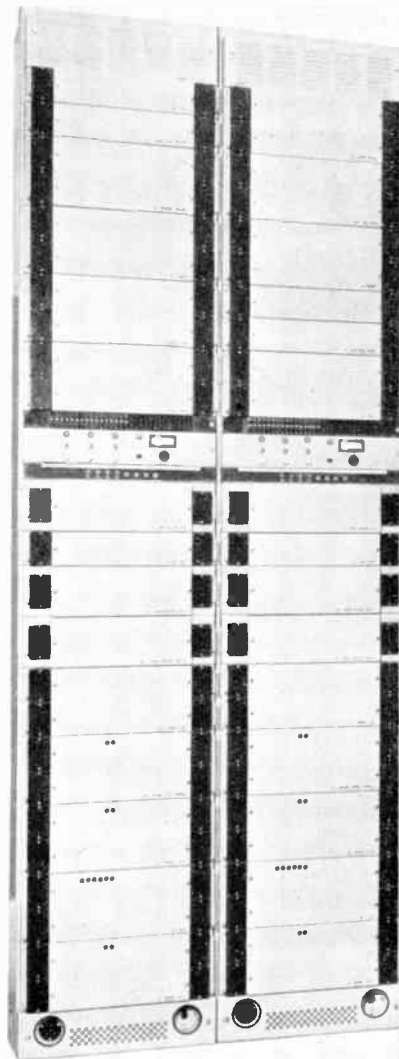

Fig. 7. Experimental reduced carrier transmitting and receiving terminals using a 308 kc/s reference path for synchronization.

translating terminals at these points or provide a separate synchronizing carrier. A slight complication is due to the horizontal synchronizing pulses travelling by two routes, one via the main transmission path, the other via the 308 kc/s pilot reference channel. Because of the filtering required to extract the fundamental from the horizontal synchronizing pulses there is an additional delay of some 40 microseconds in the reference signal path. It is then only possible to match the main signal synchronizing pulse at the receiving terminal with a gating pulse derived from the synchronizing pulse before it. If the television signal is locked to the mains supply and a tolerance of +3 - 5 per cent allowed in frequency then the total phase shift in the reference circuits must be kept to 360 deg. over this frequency range. This requires an additional circuit which measures the incoming frequency and provides a correcting voltage to control the delay.

Four synchronizing systems have been described and there is still scope for ingenuity in devising others. For instance, no advantage has been taken of the fact that polarity information is only really required during the locking-in intervals. Synchronous operation has advantages but it restricts the types of signal which can be transmitted and requires further specifications for the link, e.g. minimum signal and noise levels for which synchronization must take place.

**6. Conclusions**

The outline of the systems used for transmission over long distance by coaxial cable has demonstrated that precision engineering to very close tolerances in every way is required. It has been shown that some of the basic transmission parameters are in reasonable agreement with basic subjective laws. Several ways of transmitting synchronizing data have been reviewed, each of which has its own engineering advantages and disadvantages. It must also be concluded that the single television channel, especially when compared with the large number of telephone channels, seems very wasteful of transmission space. Much work is going on on quantized coding methods which may reduce the transmission difficulties and on bandwidth reduction to conserve the spectrum.

**7. Acknowledgments**

The author wishes to thank British Telecommunications Research Limited for permission to publish this paper, also Mr. D. G. Holloway and several colleagues for most helpful discussions. The information given in Fig. 1 is reproduced by kind permission of the Optical Society of America and that of Fig. 2 by kind permission of the Engineer-in-Chief of the Post Office.

**8. References**

1. C.C.I.T.T. 1st Plenary Assembly, Geneva, 10-20 December, 1956. Red Book Vol. 1, June, 1957.
2. "The L3 coaxial system" *Bell Syst. Tech. J.*, 32, No. 4, July, 1953.
3. K. Barthel, "Fernsehübertragung auf Kabelstrecken". *Arch. elektr. Übertrag.*, 9, August, 1958. p. 341.
4. R. H. Franklin and M. B. Williams, "Recent development in line transmission systems". Institution of Post Office Electrical Engineers Paper No. 213, 1958.
5. D. W. Harling, "Long cable links for television". *Brit. Commun. Electronics*, 5, p. 416, No. 6, June 1958.
- [6. Y. le Grand, "Light, Colour and Vision" (Chapman and Hall, London, 1957.)
7. H. R. Blackwell, "Contrast thresholds of the human eye", *J. Opt. Soc. Amer.*, 36, p. 624, 1946.
8. R. Fatehchand, "Visibility of noise on television pictures", *Nature*, 181, p. 1797, 1958; and "Theoretical and experimental characteristics of random noise in television," *J. Brit.I.R.E.*, 19, p. 335, June, 1959.
9. P. Mertz, "Influence of echoes on television transmission", Monograph 2144. Bell Telephone System Technical Publications, November, 1953.
10. W. F. Bailey and C. J. Hirsch, "Quadrature cross-talk in N.T.S.C. color television", *Proc. Inst. Radio Engrs*, 42, p. 84, January, 1954.
11. I. F. Macdiarmid and B. Phillips, "A pulse and bar waveform generator for testing television links", *Proc. Instn. Elect. Engrs*, 105, Part B, p. 440, 1958.
- I. F. Macdiarmid, "Waveform distortion in television links." *Brit.I.R.E.* 1959 Television Engineering Convention Paper. To be published.
12. E. C. Thompson, "Automatic line-switching for L3 carrier", *Bell Labs. Record*, 36, p. 340, September, 1958.

**9. Appendix 1 :**

9.1. *Variation in amplitude response*

Let the input signal be

$$(1 + m \cos \omega_s t) \cos \omega_c t \dots\dots\dots(9)$$

where  $\omega_s$  is the angular frequency of the signal and  $\omega_c$  is that of the carrier. Here the  $\omega_s$

component can be considered as one term in the Fourier expansion of a pulse signal. Also let the amplitude response of the system be

$$1 + a \sin(\omega - \omega_c)T \dots\dots\dots(10)$$

This has a sinusoidal variation of amplitude response with which is skew symmetrical about the carrier frequency and has a period along the  $\omega$  axis of  $1/T$ . The output is then

$$[(1 + m \cos \omega_s t) \cos \omega_c t] [1 + a \sin(\omega + \omega_c)T] \quad (11)$$

If the input signal is expanded into its components at  $\omega_c - \omega_s$ ,  $\omega_c$  and  $\omega_c + \omega_s$  and each multiplied in turn by the amplitude response, substituting the appropriate value of  $\omega$  in each case and re-arranging, the output is

$$\begin{aligned} &(1 + m \cos \omega_s t) \cos \omega_c t + \\ &+ \frac{1}{2} a m \cos \omega_s (t + T) \sin \omega_c t - \\ &- \frac{1}{2} a m \cos \omega_s (t - T) \sin \omega_c t \dots(12) \end{aligned}$$

We see that the output comprises the signal modulated by  $\omega_s$  but two new signals have now appeared modulated on a sinusoidal carrier at right angles to the original. The two new signals have amplitudes  $+\frac{1}{2}a$  and  $-\frac{1}{2}a$  and are displaced in time by  $+T$  and  $-T$  respectively. Similarly for an amplitude response

$$1 + a \cos(\omega - \omega_c)T \dots\dots\dots(13)$$

the output is

$$\begin{aligned} &[(1 + m \cos \omega_s t) + \\ &+ \frac{1}{2} a m \cos \omega_s (t + T) + \\ &+ \frac{1}{2} a m \cos \omega_s (t - T)] \cos \omega_c t \dots(14) \end{aligned}$$

i.e. the original signal is accompanied by two positive echoes modulated onto the same carrier.

9.2. Variation in phase response.

Let there be a phase variation with  $\omega$  of peak amplitude  $a$  with zero error at the carrier

frequency, i.e.

$$0 = a \sin(\omega - \omega_c) T \dots\dots\dots(15)$$

then for the input in (9) the output will be

$$\begin{aligned} &\cos \omega_c t + \\ &+ \frac{1}{2} m \cos [(\omega_c - \omega_s)t - a \sin \omega_s t] + \\ &+ \frac{1}{2} m \cos [(\omega_c + \omega_s)t + a \sin \omega_s t] \\ &= \cos \omega_c t - \\ &- \frac{1}{2} m [\cos(\omega_c - \omega_s)t \cos(a \sin \omega_s T) - \\ &- \sin(\omega_c + \omega_s)t \sin(a \sin \omega_s T) - \\ &- \cos(\omega_c + \omega_s)t \cos(a \sin \omega_s T) + \\ &+ \sin(\omega_c + \omega_s)t \sin(a \sin \omega_s T)] \dots\dots(16) \end{aligned}$$

If  $a$  is very small

$$\cos(a \sin \omega_s T) \rightarrow 1 \dots\dots\dots(17)$$

$$\text{and } \sin(a \sin \omega_s T) \rightarrow a \sin \omega_s T \dots\dots\dots(18)$$

By substituting and re-arranging the output becomes

$$\begin{aligned} &[(1 + m \cos \omega_s t) + \\ &+ \frac{1}{2} a m \cos \omega_s (t + T) - \\ &- \frac{1}{2} a m \cos \omega_s (t - T)] \cos \omega_c t \dots\dots(19) \end{aligned}$$

This is the original signal plus two echoes one negative and advanced by time  $T$  and the other positive and lagging by time  $T$ . Similarly a phase error

$$0 = a \cos(\omega - \omega_c) T \dots\dots\dots(20)$$

gives an output

$$\begin{aligned} &(1 + m \cos \omega_s t) \cos(\omega_c t + a) - \\ &- \frac{1}{2} a m [\cos \omega_s (t - T) + \cos \omega_s (t + T)] \sin \omega_c t \quad (21) \end{aligned}$$

This is an undistorted output modulated onto a carrier phase shifted  $a$  radians together with two negative echoes modulated onto a quadrature carrier.

# GRADUATESHIP EXAMINATION—MAY 1959—PASS LISTS

These lists contain results for *all* successful candidates in the May Examination. A total of 435 candidates entered for the examination which was held at 63 centres.

**LIST 1: The following candidates, having completed the requirements of the Graduateship Examination, are eligible for transfer or election to Graduateship or higher grade of membership.**

## Candidates in Great Britain

BRODIE, Robert George. *London*.  
 CACHIA, Saviour. (S) *London*.  
 CHAPPELL, Edgar Raymond Reginald. *Cardiff*.  
 CLAYTON, Robert Alexander Alfred. (S) *London*.  
 DAVIS, Eric Cambridge. (S) *London*.  
 DOBLE, Reginald George. (S) *London*.  
 FRENCH, William Robert. (S) *Birmingham*.  
 HALL, Ephraim. *London*.  
 HARVEY, Edwin. (S) *Bristol*.  
 HODSON, Derrick Frank. (S) *London*.  
 HOPKINS, Roland Michael Terrence. (S) *London*.  
 JONES, William Owen. *Cardiff*.  
 KERWOOD, Mrs. Dilys Joyce. (S) *Birmingham*.  
 LAM, Chun Ming. (S) *London*.  
 LEONG, Kok Hung. (S) *London*.  
 MULLAN, John. *Manchester*.  
 OLSEN, George Henry. (S) *Newcastle-upon-Tyne*.  
 WALKER, William. (S) *Glasgow*.

## Overseas Candidates

AHMAD, Habeeb. (S) *Bombay*.  
 AHMAD, Jalal-Ud-Din. (S) *Rawalpindi*.  
 BALASUBRAMANYAM, T. R. (S) *Madras*.  
 BEN-ARI, Moshe Josef (S) *Tel-Aviv*.  
 CHANDRASEKHARAN, Chempath. (S) *Madras*.  
 CHAWLA, Bhupendra Nath. (S) *Delhi*.  
 CRIDLAND, William Wyndham. (S) *Toronto*.  
 ELSTEIN, Moses Herbert. (S) *Tel-Aviv*.  
 GANDHI, Jai Krishan. *Bangalore*.  
 GOVINDARAJAPURAM, R. Gayatri. (S) *Bombay*.  
 MITRA, Gobinda Lal. (S) *Kanpur*.  
 SAMEL, Shrinivas Shantaram. (S) *Bombay*.  
 SETHI, Girdhari Lal. *Bangalore*.  
 SOOD, Baldev Krishen. (S) *Bombay*.  
 STEYN, Marthimus Jacobus Dewald (S) *Cape Town*.  
 SUJAN, Chander Sobhraj (S) *Bombay*.  
 VISWANATHAN, G. S. (S) *Bombay*.

**LIST 2: The following candidates were successful in the parts indicated.**

## Candidates in Great Britain

ARMSTRONG, Thomas James Turner (S) 3. *London*.  
 BIEGUN, Ephraim (S) 3. *London*.  
 BIRCHAM, John (S) 1. *London*.  
 BURLEIGH, William Allison (S) 3. *London*.  
 CLAXTON, Geoffrey Dudley (S) 3. *Lowestoft*.  
 CURLEY, Michael Joseph Colm (S) 4. *Dublin*.  
 CUSSONS, Ashley Roy (S) 1. *London*.  
 DALE, Collis Seymour (S) 1, 3. *London*.  
 DOWLING, Patrick Joseph (S) 3. *Dublin*.  
 DUNN, Alan George (S) 3. *Manchester*.  
 EIDE, Arnfinn (S) 3. *London*.  
 EVANS, Maurice Rayner Thomas (S) 3. *London*.  
 GRIFFITHS, William Thomas Gwynne (S) 3. *London*.  
 HAIGH, Fred Ellison (S) 3. *Newcastle-upon-Tyne*.  
 HART, Princewill (S) 3. *Bristol*.  
 HARTWELL, Edward Harman (S) 1. *Southampton*.  
 HISCOCK, David John (S) 3. *Birmingham*.  
 HURST, Leslie (S) 1, 3. *Manchester*.  
 INSON, Eric Gilbert (S) 2. *Cardiff*.  
 KAVANAGH, Bryan John (S) 3. *Dublin*.  
 KIRKUS, John Rodger (S) 1. *Southampton*.

LAMBERT, Keith Walter (S) 3. *Cardiff*.  
 McAVOY, James (S) 3. *London*.  
 MANN, Richard Barnaby (S) 5. *Cambridge*.  
 MURPHY, Matthew (S) 4. *Dublin*.  
 NOAKES, Michael Ernest (S) 2, 3. *London*.  
 OBIOHA, Raphael Francis (S) 2, 3. *London*.  
 OXBOROUGH, Derek Mervyn. 3. *London*.  
 PARKER, William Robert (S) 3. *London*.  
 PERYER, Michael Gregory (S) 3. *London*.  
 POULSON, Barrie Kenneth (S) 2, 3. *London*.  
 PURI, Devindra Nath. (S) 2. *London*.  
 ROPER, Russell (S) 1, 3. *Newcastle-upon-Tyne*.  
 SKINNER, John (S) 2. *Bristol*.  
 SMALE, Phillip Herbert (S) 3. *London*.  
 THOMAS, David Geoffrey (S) 1, 3. *Cardiff*.  
 THOMAS, David Price (S) 4. *Cardiff*.  
 TIMMS, Anthony Francis (S) 1, 3. *Birmingham*.  
 WILD, William George (S) 3. *London*.  
 WILSON, James Albert (S) 3. *Belfast*.  
 ZUGIC, Velimir (S) 1, 3. *London*.

## Overseas Candidates

ABAVINDAKSHA, Menon I. M. (S) 1, 3. *Bangalore*.  
 ABRAHAM, V. T. (S) 2. *Ernakulam*.  
 AKINMADE, Samuel Adegbenmisoye (S) 3. *Lagos*.  
 ALEXANDER, Vaidian T. M. (S) 2. *Ernakulam*.  
 ARUMUGAM, Arikesavanallur Ramasubramanian (S) 2, 4. *Madras*.  
 AZIZ, Ismail Bin Abdul (S) 3. *Kuala Lumpur*.  
 BERGER, Israel (S) 1, 3. *Tel-Aviv*.  
 BHASIN, Karam Chand (S) 3. *Delhi*.  
 BHOWAL, Kamal Kanti (S) 2. *Lucknow*.  
 CAPNISTOS, Emman (S) 2. *Athens*.  
 CHEUNG, Leung Fat (S) 1, 3. *Hong Kong*.  
 DEY, Swadesh Kumar (S) 1. *Delhi*.  
 DIAS, Cyril Francis (S) 4. *Delhi*.  
 DOGRA, Yash Pal (S) 4. *Delhi*.  
 DUTTA, Subal Chandra (S) 3. *Bangalore*.  
 FIROZGARY, Merwan Khodamorad (S) 3. *Bombay*.  
 FISHER, John Alexander (S) 3. *Adelaide*.  
 FOOKES, Reginald Arthur (S) 3. *Sydney*.  
 FRISCH, Abraham (S) 3. *Tel-Aviv*.  
 HEMAN DAS BALWANI (S) 5. *Delhi*.  
 HOSANGDI, Rabindranath Radhakrishna (S) 4. *Bombay*.  
 HUNG, Cheung Loy (S) 1, 3. *Hong Kong*.  
 INNES, John Somerville (S) 2, 3. *Brisbane*.  
 ISAAC, Ponnazhath Varghese (S) 2, 4. *Ernakulam*.  
 IUSTER, Nelu (S) 3. *Tel-Aviv*.  
 JOHN, Kannampuzha Pavanny (S) 2. *Ernakulam*.  
 JOHN, Manakil Thomas (S) 2. *Ernakulam*.  
 JOSEPH, C. Devasia (S) 2. *Ernakulam*.  
 JOSEPH, K. T. (S) 2, 4. *Ernakulam*.  
 KAPOOR, Onkar Nath (S) 4. *Delhi*.  
 KAUSHAL, Ram Sarup (S) 3. *Delhi*.  
 KHATRI, Dinjayal Tahilram (S) 4. *Bombay*.  
 KONKAR, Vishwanath Anant (S) 1. *Bangalore*.  
 KUMAR, Ravi K. (S) 2, 4. *Ernakulam*.  
 LEUNG, Cheuk Sing (S) 3. *Hong Kong*.  
 LEUNG, Kam Por (S) 3. *Hong Kong*.  
 LEVI-MINZI, Gad. (S) 5. *Tel-Aviv*.  
 LIMAYE, Madhav Achyut (S) 2, 4. *Bombay*.  
 LOGAN, S. (S) 2. *Madras*.  
 MANTEL, Juval (S) 4. *Tel-Aviv*.  
 MENON, M. P. Sethu Madhava (S) 2. *Ernakulam*.  
 MEYER, Leighton Francis. 4. *Christchurch*.  
 NAGARAJA, Birur Shamanna (S) 3. *Bombay*.  
 NAGARAJA SETTY, C. S. (S) 3. *Mysore*.  
 NAIK, Vishwanath Waman (S) 2. *Bombay*.  
 NAIR, P. Bala Krishnan (S) 2, 4. *Ernakulam*.  
 NARAYANA MENON, Pottekkat (S) 4. *Bombay*.  
 NEUMANN, Shimon Siegfried (S) 3. *Tel-Aviv*.  
 NIGAM, Surendra Kumar (S) 1, 3. *Lucknow*.  
 ONDRICH, Milan (S) 1. *Toronto*.  
 PAI, Krishnananda N. (S) 2. *Bombay*.  
 PATANGE, Yeshwant Kondiram (S) 1. *Bombay*.  
 RADHAKRISHNAN, Gopalaswamy (S) 2. *Madras*.  
 RADHAKRISHNAN NAIR, V. K. (S) 2, 3. *Ernakulam*.  
 RAJPUT, Dhir Singh (S) 1. *Delhi*.  
 RAMADORAI, T. C. (S) 4. *Madras*.  
 RAO, Krishna Bhaskar (S) 2. *Ernakulam*.  
 REINER, Joseph (S) 1. *Tel-Aviv*.  
 RESHEF, Amos (S) 1, 3. *Tel-Aviv*.  
 RUTTEMAN, Maarten Hendrik (S) 1. *Toronto*.  
 SABBAB, Prosper Benjamin (S) 1, 2, 3. *Tel-Aviv*.  
 SAUNDERSON, John Joseph (S) 3. *Woomera*.  
 SHARMA, Om Prakash (S) 2. *Bombay*.  
 SHELTON, Roy George Alexander (S) 1. *Johannesburg*.  
 SHINDE, Manohar Bhimrao (S) 3. *Bangalore*.  
 SMIKT, Ojed (S) 1, 2, 3. *Tel-Aviv*.  
 SWAMINATHAN, Muthiah (S) 1. *Madras*.  
 TALGERI, Gurudutt Shripadrao (S) 2. *Bombay*.  
 TALWAR, Satish Kumar (S) 4. *Agra*.  
 TAT LIM ONG, (S) 3. *Kuala Lumpur*.  
 TERZOPOULOS, Christos (S) 2. *Athens*.  
 USMAN, Mirza Mohd (S) 4. *Dhahran*.  
 VENKATESWARAN, K. (S) 1. *Madras*.  
 VIRINDER SINGH (S) 1. *Delhi*.  
 WALKER Rainer George (S) 3. *Toronto*.  
 ZEGEL, Melle (S) 3. *Montreal*.

(S) denotes a Registered Student.

# Television Receiver Production in the U.S.S.R.†

by

A. Y. BRATEBART‡

*A paper read on 2nd July 1959 during the Institution's Convention in Cambridge.*

**Summary:** Information concerning the circuits and engineering features of television receivers being produced in the Soviet Union is given. The prospects for future receiver production development are also discussed.

On 1st January, 1959, about three million television sets were in use in the Soviet Union. 1,200,000 sets will be produced in 1959, and by 1965 the annual output will have risen to 3,500,000 so that in six years' time there will be approximately 18,000,000 sets operating in the U.S.S.R.§

The standardization of manufacturing processes, as well as the unification of circuit units and their centralized production, is common practice in the U.S.S.R. The aim of the programme is to attain maximum unification in the production equipment for complex mechanization and automation processes in order to

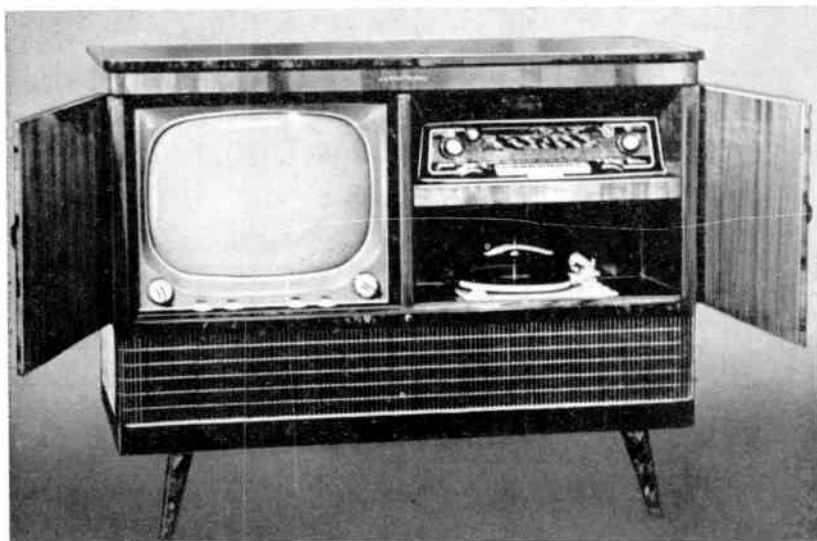

Fig. 1. The combined television-radio-gramophone set "Crystal-103."

The increase in the rate of production of television receivers will be accomplished by increasing the output of existing factories. This will be achieved by applying mechanization and automation methods to such processes as production of individual elements, assembly, wiring and alignment.

decrease the prices of receivers and to simplify their servicing. Such unified circuit units include the tuner, deflection yoke, line and frame output transformers, power supply sources, etc. In addition, the receiver parameters have been normalized to give three receiver classes.

All television receivers with 21-in. (or greater) picture tubes, with the maximum number of

† Manuscript received 1st July 1959. (Contribution No. 22.)

‡ State Committee for Radio Electronics, Moscow. U.D.C. No. 621.397.62

§ Editorial note.—At the January 1959 Census the population of the U.S.S.R. was 208,826,000.

# СХЕМА ТЕЛЕВИЗИОННОГО ПРИЕМНИКА „СПУТНИК-2”

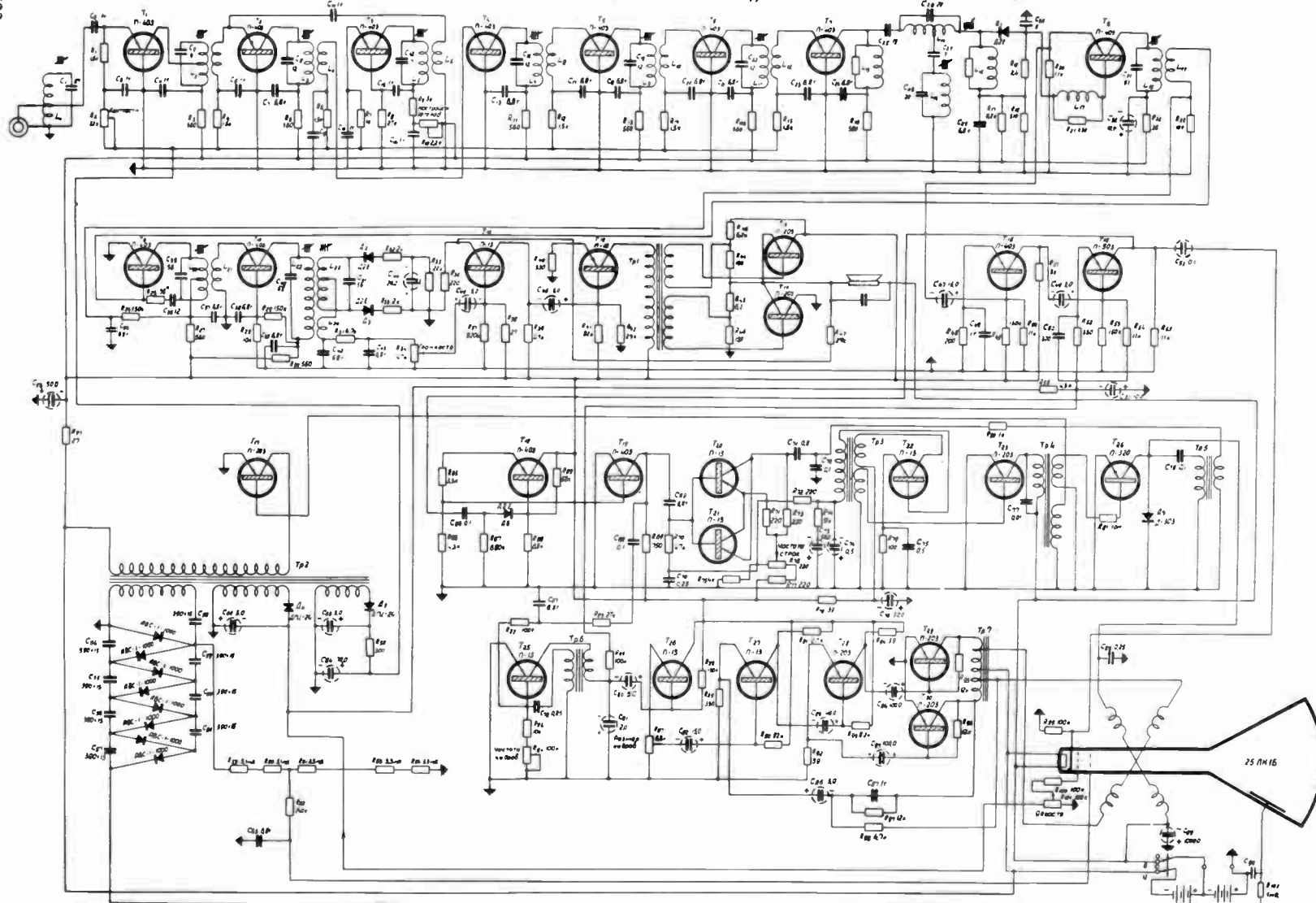

Fig. 2. A reproduction of the circuit diagram of the transistorized television receiver, "Sputnik-2," as shown during the presentation of the paper.

automatic controls and with high quality sound, belong to the first class. The most wide-spread class however is the second, with 17-in. picture tubes. The third class sets are the cheapest, with picture tubes not exceeding the 14-in. size.

In addition to these three classes, a certain quantity of projection and extra high-quality models are being produced. The latter combine television receivers, radios, magnetic-tape recorders and record players. (See Fig. 1.)

The chassis of all models in any of the classes are being unified as far as possible. The main difference between sets in the same class will be their cabinets.

All first and second class models as well as a number of third class models, are equipped for f.m. broadcast reception. This is done because of the continuous growth in Russia of the number of f.m. transmitters.

At present 70-degree picture tubes with magnetic deflection and electrostatic focus are being used in practically all receivers. However, set manufacturers are already making preparations for the transition to 110-degree tubes. Experimental models of such sets have already been developed and their mass production is to start this year (1959).

In mass-production and experimental models wide use is made of fast-acting automatic gain controls, automatic brightness controls, noise-immune synchronization circuits, stabilization of picture dimensions, phase correction in video amplifiers and remote and push-button controls. At present work is being carried on with the aim of introducing automatic frequency control circuits for tuners. Such circuits would permit the tuners to be considerably simplified and would provide easier, more accurate tuning for the inexperienced user. "Magic-eye" indicators are not being used in the U.S.S.R., since they are regarded as having no prospects. Research work is also being conducted to develop electro-luminescent screens.

In the U.S.S.R. great interest is shown in the possibility of using crystal diodes and triodes in television receivers. Crystal diodes have completely replaced vacuum diodes in all models in the power supply circuits, detector circuits, and pulse circuits. Research work is being carried

on in an attempt to replace all valves with transistors, with the aim of increasing reliability, decrease the power consumption and make it possible for reception to be carried on under adverse power supply conditions (tourist-type sets, automobile sets, portable sets for out-of-the-way spots, etc.).



Fig. 3. The transistorized television receiver "Sputnik-2."

In 1957, the television set "Sputnik" was developed in the U.S.S.R. This set, except for the picture tube, contained only crystal diodes and triodes and was exhibited at the International Exhibition in Brussels. The "Sputnik" was designed for a 12 volt automobile battery supply, consumed about 12 watts, weighed 6.5 kg, and had a sensitivity of about 200  $\mu$ V. Picture dimensions were 150  $\times$  113 mm.

In 1958, a new model with 200  $\times$  150 mm picture dimensions was developed, which was displayed at the New York Exhibition (Figs. 2 and 3). Known as the "Sputnik-2," this set is also designed for an automobile battery power supply and has a number of improvements compared with the first model. Noise-immune synchronization has been introduced, the resolution increased to 500 lines, and the sensitivity increased to 100  $\mu$ V, while the power consumption and weight remain unchanged.

At the present time, the development of an experimental model of a 17-in. receiver containing only crystal diodes and triodes, with the exception of the picture tube, is near completion. This set can be powered from batteries or from the usual a.c. line. Mass production of transistorized sets is due to start in 1961-62.

# Radio Engineering Overseas . . .

The following abstracts are taken from European and Commonwealth journals received in the Library of the Institution. Members who wish to borrow any of these journals should apply to the Librarian, stating full bibliographical details, i.e. title, author, journal and date, of the paper required. All papers are in the language of the country of origin of the journal unless otherwise stated. The Institution regrets that translations cannot be supplied.

## H.F. TRANSISTORS

A Czech paper considers the problems involved in the measurement of high frequency characteristics of transistors by introducing the transformation relationships between the measured values of the real and imaginary components of the input and output admittance and the parameters of the equivalent circuit. Line and vector circle representations of the transistor input circuit facilitate considerations with regard to the validity of the Giacoletto equivalent circuit of the transistor, or the accuracy of measurement, as well as the determination of some of its circuit properties. From the no-load admittance diagram of the output circuit of the transistor it is possible to determine its collector resistance, capacitance and the cut-off frequency.

"Measurement of the high frequency characteristics of transistors." S. Vojtasek, F. Zajic and M. Stanek. *Slaboproudny Obzor*, 20, pp. 361-367, June 1959.

## TRANSISTOR CIRCUITS

A design formula for a bistable multivibrator with junction transistors is derived in a Czech paper. Second order parameters are neglected to obtain simple relationships in which the nominal values of resistors can be used. The region of realizability is expressed in terms of inequalities thus facilitating choice of values. On the basis of the presented design procedure a complete transistor decade circuit is worked out. The overall power consumption is 60 mW. The decade state indication arrangement put forward by the author permits direct read-out of the number of pulses received. It is possible to use this arrangement not only with transistor decades which use low voltage supplies but also in vacuum tube type dividers with any type of interstage coupling.

"Design of a junction type transistor divider chain and indication of its state." V. Spany. *Slaboproudny Obzor*, 20, pp. 378-381, June 1959.

## WIND-DRIVEN POWER SUPPLIES

It is usual for a mains supply with Diesel-generator stand-by equipment to be employed for supplying power to microwave relay stations. The installation and the maintenance of high voltage lines, however, frequently causes excessive costs in regions with a mains supply network having wide meshes or in mountainous regions. For this reason the Federal German Post Office has carried out

tests extending over several years in order to determine the extent to which the power supply for a decimetric radio repeater station can be provided by wind-driven generators independently of the mains supply and with a minimum of use of stand-by equipment. The means and the conditions for a successful result of the test are described.

"The wind driven power supply for the s.h.f. radio relay station Schoneberg (Eifel)." G. Rosseler. *Nachrichtentechnische Zeitschrift*, 12, pp. 352-360, July 1959.

## ISOLATORS

New resonance type ferrite isolators have been developed for use in frequency modulated radio links for 960 channels in the 4000 Mc/s band, 1800 channels in the 6000 Mc/s band and 120 channels in the 7000 Mc/s band. It is possible to obtain, in comparison with earlier designs, higher ratios of reverse to forward attenuation (up to 150:1) and an increased stability against temperature effects. The isolator for the 4000 Mc/s band operates over a fixed band of 400 Mc/s width (reverse attenuation 26 db, forward attenuation 0.3 db), the isolator for the 6000 Mc/s band over a fixed band of 500 Mc/s width (reverse attenuation 30 db, forward attenuation 0.2 db) and the isolator for the 7000 Mc/s band over an adjustable band of 300 Mc/s width (reverse attenuation 50 db, forward attenuation 0.4 db). The reflection coefficient is less than 1 per cent. in each case. The 300 Mc/s band of the 7000 Mc/s isolator is adjustable to three successive ranges. The band from 6325 to 8025 Mc/s can be covered by two models.

"New isolators for radio links." J. Deutsch, W. Haken and C. von Haza-Radlitz. *Nachrichtentechnische Zeitschrift*, 12, pp. 367-70, July 1959.

## A.F. TELEMETRY

A tele-voltmeter has been described by an engineer with the Australian Postmaster General's Department which may be used to monitor up to 22 voltages at a remote installation, with an accuracy of 3 per cent. The information is transmitted over a standard telephone channel as a saw-tooth voltage of variable frequency in the range 500—2,500 c/s. The inputs are connected by means of a 25-position uni-selector stepping switch.

"Variable audio frequency tele-voltmeter." H. R. Harant. *Proceedings of the Institution of Radio Engineers, Australia*, 20, pp. 338-343, June 1959.