

# JOURNAL OF The British Institution of Radio Engineers

(FOUNDED IN 1925 - INCORPORATED IN 1932)

*"To promote the advancement of radio, electronics and kindred subjects  
by the exchange of information in these branches of engineering."*

Vol. XIV No. 1 (Series 102)

JANUARY 1954

## INSTITUTION NOTICES

### Members in the New Year Honours List

The Council of the Institution congratulates the following members:—

Rear-Admiral (L) Charles Philip Clarke, C.B., D.S.O. (a Vice-President of the Institution), on his appointment as a Knight Commander of the Military Division of the Most Excellent Order of the British Empire. (A note of Admiral Clarke's career was given in the January, 1953, *Journal*.)

Mr. Norman Charles Robertson, M.B.E. (Member), on his appointment as a Companion of the Most Distinguished Order of Saint Michael and Saint George. (A note of Mr. Robertson's career was given in the August, 1953, *Journal*.)

Mr. Paul Maxwell Carment (Associate) on his appointment as a Member of the Most Excellent Order of the British Empire. (Mr. Carment is an engineer at the Headquarters of No. 90 Group, Royal Air Force.)

### Convention Arrangements

Included with this issue of the *Journal* is a leaflet giving the first detailed announcement of arrangements for the 1954 Convention on Industrial Electronics, to be held at Christ Church, Oxford, from July 8th to 12th.

The Convention will be officially opened on the afternoon of Thursday, July 8th, by the President, Mr. W. E. Miller, M.A.(Cantab.), and his address will be followed by the first technical session, "Industrial Applications of Electronic Computers." In the evening the Clerk Maxwell Memorial Lecture will be given.

The papers to be read and discussed on Friday, July 9th, will be primarily concerned with "Electronic Methods of Testing." The morning

session will deal with "Industrial Applications of X-rays and Ultrasonics," while in the afternoon papers will be read on "Applications of Radio-active Devices."

An Institution banquet will take place on Friday evening in Christ Church, and members will be invited, in due course, to make arrangements for their ladies to attend.

On Saturday, July 10th, papers will be read on "Electronic Control," those in the morning discussing Sensing Devices (Transducers), those in the afternoon Actuators.

On Sunday afternoon, July 11th, the theme will be "Electronic Aids to Production," and a discussion on "How electronics can aid production" will be opened by Mr. Walter C. Puckey, President of the Institution of Production Engineers. The proceedings on Sunday evening will take the form of a film show and discussion groups.

Visits and special demonstrations are to be arranged for Monday morning, July 12th.

### Special Premiums for the 1954 Convention

The Council has approved the award of a number of special Premiums for papers presented during the 1954 Convention on Industrial Electronics.

These will be as follows:—

- (a) For the most outstanding paper given at the 1954 Convention, a special Industrial Electronics Premium of 50 gns.
- (b) For the most outstanding paper in each session, a special Institution Premium of 20 gns.

The above awards are in addition to the ten annual premiums awarded by the Council for outstanding papers published in the *Journal*.

Section Activities . . . . .

**MADRAS SECTION —**

At the first meeting of the Section for the 1953-4 session, Mr. V. V. L. Rao (Member), Radio Engineer with the Government of Madras, gave an excellent introduction to the difficult subject of Information Theory. He demonstrated the extension of Hartley's law by the recent theory of Shannon, and using interesting examples from everyday life, gave a clear picture of the statistical character of the term "information." Mr. Rao's excellently prepared charts and diagrams contributed largely to the success of his paper.

Professor R. Filipowsky, Dipl.Eng. (Member), Head of the Electronics Department, Madras Institute of Technology, continued the subject of modern communications by discussing on August 20th recent advances in pulse communications systems. The "classical systems" of time-division multiplex with constant p.r.f. (equidistant time intervals for sampling) have conquered many fields of application including multichannel radio relay links, telemetering equipment and industrial servo systems. There is a well-established knowledge about the theoretical characteristics of the various possible combinations of pulse-modulation and radio-frequency carrier modulation. Prof. Filipowsky considered that "p.a.m.-f.m." was one of the most efficient combinations but improvements were still possible. Finally he discussed delta-modulation, quasi-synchronous systems for mobile installations, Eaglesfield's idea of aperiodic pulse-transmission for each amplitude-quantum and his own patent on a complexity-depending sampling process with "automatic auction circuits."

**KARACHI SECTION —**

The first technical meeting of the Section was held at the N.E.D. Engineering College, Karachi University, on September 26th, when Mr. A. Aziz (Associate Member) read a paper on "Propagation of H.F. Waves." After discussing the mathematical basis of the theory of reflection of waves by the ionosphere, Mr. Aziz dealt with the question of choice of frequency for obtaining a given range. In conclusion he derived expressions for the energy losses of waves passing through the ionosphere.

The second meeting of the section was held on October 17th when a paper was read on "Cathode Follower Amplifiers" by Mr. R. K. Andrews (Associate Member), the local honorary secretary.

**MERSEYSIDE SECTION —**

At the opening meeting on October 1st, the Honorary Secretary of the Section, Mr. J. Gledhill, B.Sc. (Associate Member), described an impedance bridge used for rapid measurement of the modulus of transformer input and output impedance over a wide frequency range. The need for this bridge was due to deficiencies in the practical transformer with its various loss parameters, when making measurements on line transmission equipment. In conclusion Mr. Gledhill discussed the accuracy to be obtained with the bridge.

On November 4th "Multi-Channel Tuners for Television" were discussed in a joint paper by Mr. S. L. Fife (Associate Member) and Mr. W. E. Hosey, B.Sc. After first surveying the immediate requirements of such tuners in receivers manufactured for home and export to standards laid down by the B.B.C., and the F.C.C. and C.C.I.R. respectively, the authors discussed the requirements which provision of an alternative television service in this country would entail. They then described a number of current designs and gave information on development work for u.h.f. channels.

**WEST MIDLANDS SECTION —**

The first technical meeting of the Session took place on October 27th, when Mr. H. W. Shipton (Associate Member) read a paper on "New Techniques in Electro-physiology." He pointed out that, in the past few years, recording the electrical activity of the brain had become a standard process for which electronic apparatus was available commercially. Nevertheless, as an aid to investigation into the physiology of the brain, the electrical method had not contributed as much as had been expected. New techniques were being developed to overcome the limitations of present-day procedures.

Mr. Shipton then described and demonstrated a multi-channel display system—the electro-toposcope—which promised to be a valuable tool for future investigation into the workings of the brain. The prototype of this equipment has been described in a paper in the *Journal*,\* and Mr. Shipton briefly discussed a proposal for the storage of information provided.

\* W. G. Walter and H. W. Shipton, "A toposcopic display system applied to neurophysiology." July 1951, pp. 260-73.

# A HIGH-DEFINITION GENERAL-PURPOSE RADAR\*

by

J. W. Jenkins,† J. H. Evans,‡ G. A. G. Wallace‡ and D. Chambers, B.Sc.†

*Read before the Institution in London on November 11th, 1953.*

*Chairman: Mr. J. L. Thompson (Vice-President).*

## SUMMARY

The determination of the parameters of frequency, pulse width, bandwidth and beamwidth is discussed. The equipment is then described in detail showing how the desired design features were realized. It operates in the 3-cm waveband and uses a variable pulse width, an automatically-centring time base, and a plastic aerial of good dimensional stability.

### 1. Introduction

The equipment described in this paper is a flexible general-purpose surveillance radar with high performance, designed to reconcile the conflicting demands of range and resolution. It is small and compact enough to be mobile, yet capable, with very minor modification of filling the roles of

- Local aircraft control,
- Airfield surface movement control,
- Harbour and ferry control
- and other similar applications.

In all these applications, reliability and ease of servicing must be the prime consideration, and the equipment was designed using experience gained over a period of years with a marine radar. During the development, however, it soon became apparent that few parts of the marine radar were directly transferable to the new role but its influence is clearly visible in the finished product.

### 2. General Description

The equipment is split into three main units: the main rack, the scanner unit and the display console.

The main rack is shown in Fig. 1; this contains the transmitter-receiver, the transmitter modulator, the waveform generator and a power

supply unit. Heaters and an air blower are fitted in the rack, the former to keep the equipment dry when not in use and the latter to provide forced air cooling for the magnetron and other components which dissipate large amounts of heat.

A display console is shown in Fig. 2, and here consists of a control unit flanked by two indicators, each having 15-in display tubes. Although the figure shows two indicators, any number may be installed, either together or remotely as required. The form of presentation is a p.p.i. (plan position indicator) display. In other words, the radar echoes appear as a map with the station at the centre of rotation, which is usually, but not necessarily, at the centre of the tube. Fig. 3 (a) shows the type of picture which is obtained, Fig. 3 (b) giving for comparison a map of the area surveyed.

Each indicator is self-contained with independent range switching and gain control, and contains part of the i.f. amplifier, the video amplifier and a power unit. The time base waveform is fed to the rotor of a magflip and the magflip output, varying with scanner rotation, is then taken direct to the 3-phase deflector coil system.

Each indicator is provided with means for off-setting the centre of rotation from the centre of the cathode ray tube. This may be used when only part of the station coverage is of interest or where it is convenient to divide the area under surveillance between a number of indicators.

The console centre unit carries controls common to the whole equipment, the master timing unit and ancillary gear peculiar to the individual installation.

\* Manuscript first received May 22nd, 1953, and in revised form November 7th, 1953. (Paper No. 248).

† Research Division, A. C. Cossor, Ltd., Highbury Grove, London, N.5.

‡ Development Division, A. C. Cossor, Ltd. (Mr. Evans is an Associate Member of the Institution; see *J. Brit. I.R.E.*, April 1953, page 200.)

U.D.C. No. 621.396.963.325.

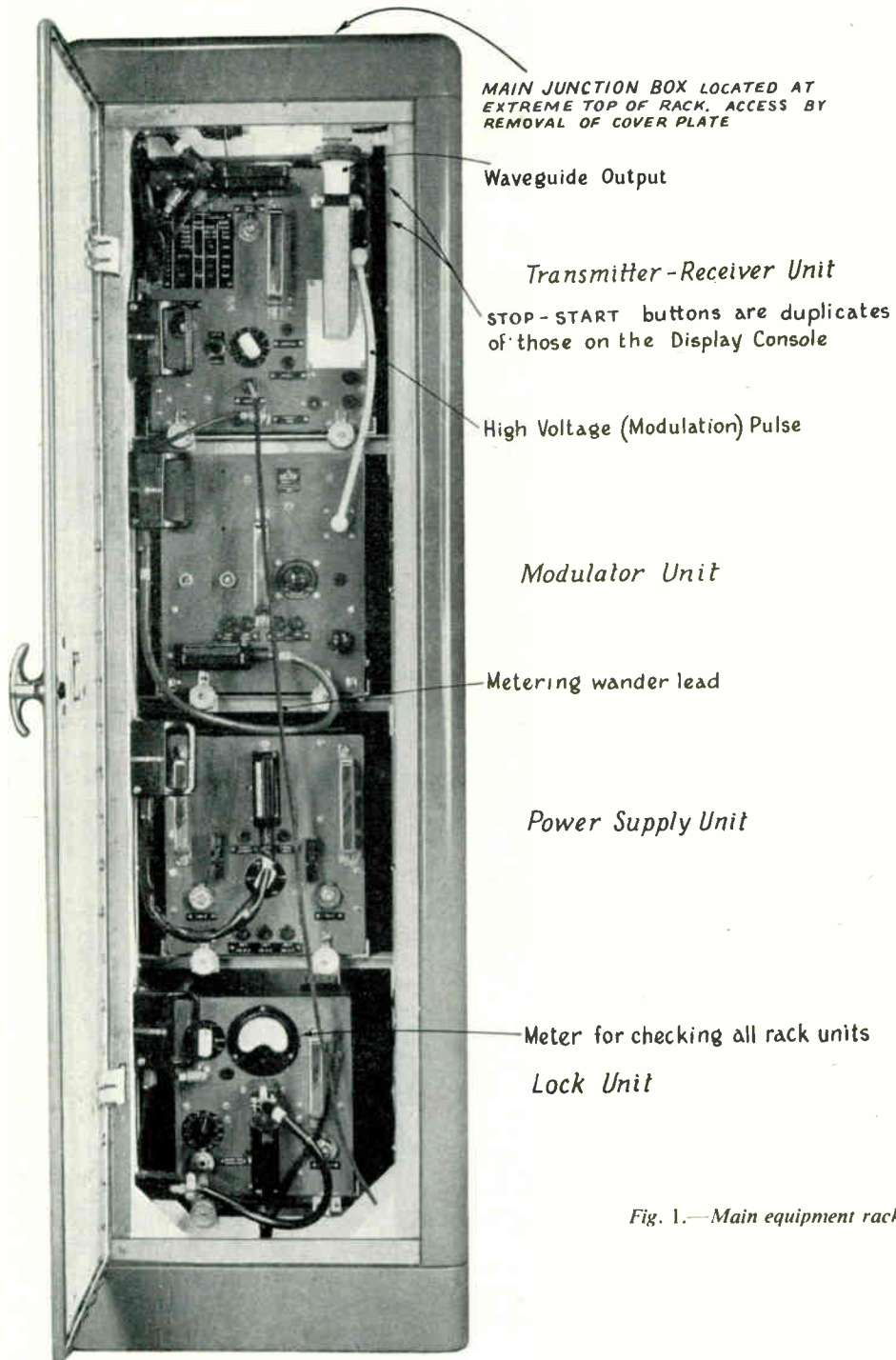

Fig. 1.—Main equipment rack.

### 3. Basic Design Considerations

It was decided to design the radar to work in the 3-cm band as this offers the best compromise between range and picture resolution. The principal objection to this band, the susceptibility of performance to precipitation, proves to be not very substantial.

Two effects must be considered, namely, signal attenuation by rain and the appearance of rain clutter\* on the display. Although signal attenuation by rain increases with increasing frequency, so does the gain of an aerial of fixed aperture. These two effects oppose each other and a comparable system using any given physical size of aerial is markedly better at 3 cm than 10 cm, at least within the range (20 miles) of this equipment.<sup>1</sup>

The visibility of a target submerged in rain clutter depends on the relative amplitudes of the two echoes. The rain echo amplitude is determined by the volume illuminated by the pulse; by reducing pulse length the rain echo is thus reduced, but the echo from a target small compared with the space occupancy of the pulse (such as an aircraft), is much less affected.† In this equipment the problem is attacked by making pulse length, and hence resolution, variable and under the control of the operator. A fairly long pulse is normally used, but for maximum resolution the pulse length is reduced and it is found that targets can be followed in heavy precipitation with little loss of range. The effect of varying pulse length is discussed more fully below.

The magnetron chosen (English Electric Type M505) gives a peak output of some 50 kW, with an efficiency of 40 per cent. The next larger valve available, giving a nominal 200 kW at an efficiency of 50 per cent. (corresponding to a 41 per cent. increase in range), was reluctantly rejected owing to the inordinate space demand of the higher voltage supplies required.

\* Clutter—unwanted reflections from any source.

† See also "Discussion," pages 21-23, (Contribution by Mr. B. C. Fleming-Williams) for further explanation.

#### 3.1. Pulse Length and Beamwidth

The maximum range of a radar equipment increases with pulse length. On targets whose extent in range is short compared with the pulse space duration, this is due to the integrating effect of the p.p.i. screen and the human eye. On long targets there is also the additive effect of signals being received from different areas of the target simultaneously. In a p.p.i. radar, however, the discrimination in range is inversely proportional to pulse length so there is a conflict between the operating conditions required for maximum range and maximum resolution. To overcome this difficulty the pulse length is made continuously variable and a control provided to enable the operator to choose either of two preset values. The



Fig. 2.—Display console (twin indicator).

maximum and minimum pulse lengths which can be set are  $1\ \mu\text{sec}$  and  $0.05\ \mu\text{sec}$ ; the factors governing the choice of these are described below.

If the c.r.t. spot is small compared with the size of the echoes as seen on the screen, the definition of the picture depends on the aerial beamwidth and the pulse length. Considering a point target, finite beamwidth causes the echoes to spread over an arc whose angular width is that of the beam and finite pulse length

Fig. 3.—(a) Plan position indicator photograph.  
(b) Map of area surveyed.

gives a spread in range equal to half the range occupance of the pulse. The length of arc occupied by the echo thus increases with range as it approaches the edge of the indicator tube, but the length of the echo signal along the radius remains constant.

Optimum picture quality is obtained when these two factors are equal, this for convenience being at half the picture radius so that an echo from a point target at half maximum range appears roughly circular. At greater ranges it tends to become an arc and at less it is elongated along the radius.

On a display of maximum range  $R$ , this condition demands that

$$\frac{1}{2}R\mu = \frac{1}{2}c\gamma$$

where  $\mu$  = angular width of the radiated beam in radians.

$c$  = speed of propagation,  
 $3 \times 10^8$  metres/second

$\gamma$  = pulse duration in seconds.

The minimum length of echo which can appear is the right-hand term in the equation given above, i.e.,  $\frac{1}{2}c\gamma$ , half the range occupance of the pulse. For the applications envisaged, a range discrimination of about 20 ft at short ranges was considered necessary and the minimum pulse length was fixed at 0.05  $\mu$ sec, corresponding to a spread of about 25 ft on the display. By careful adjustment of gain to work on signal peaks, however, the echoes can be distinguished when the target objects are separated by a distance of 15 ft.

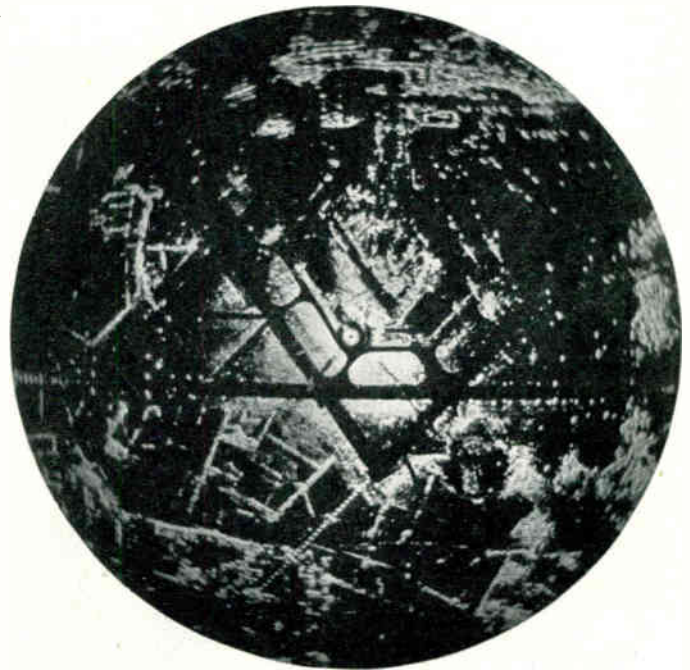

(a)

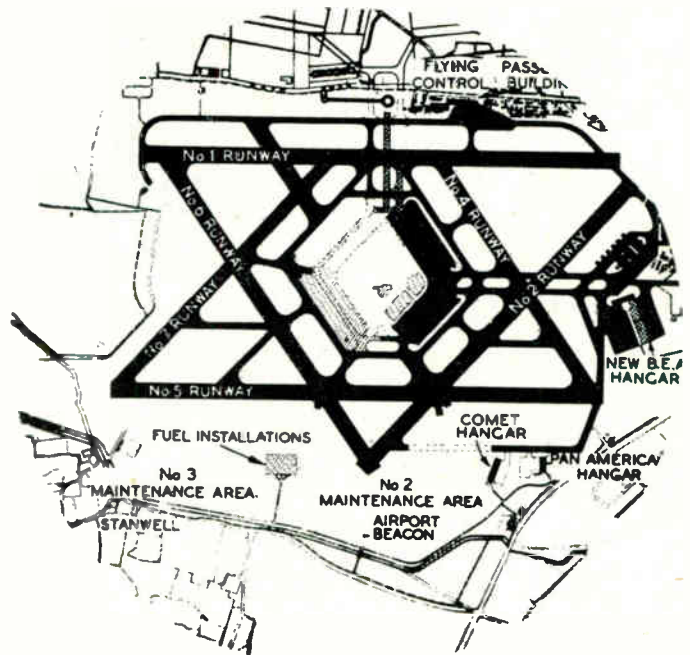

(b)

Thus, for  $\gamma$  equal to  $0.05 \mu\text{sec}$  and  $R$  equal to 2,000 yd the beamwidth  $\alpha$  has to be about  $0.5 \text{ deg}$ . This is obtainable at 10,000 Mc/s with an aerial having a 12-ft aperture.

Mechanical considerations limit the maximum rotational speed of such an aerial to about 20 r.p.m. or 120 deg per sec, when a  $0.5\text{-deg}$  beam sweeps over a point target in  $1/240 \text{ sec}$ . For adequate painting of the indicator tube at least four pulses must be received, making the minimum recurrence frequency almost 1,000 pulses per second. The duration of the longest pulse is governed by the manufacturer's mean power rating of the magnetron and the pulse repetition frequency. The duty cycle or occupancy factor (p.r.f.  $\times$  pulse length) is limited for the valve chosen to  $10^{-3}$ , setting a maximum pulse length of  $1 \mu\text{sec}$  for the p.r.f. of 1,000 c/s. It follows that as pulse length is reduced the p.r.f., which is variable, may be increased in inverse proportion. The value set depends on the applications for which the equipment is used, since, as previously explained, maximum range requires maximum pulse length.

### 3.2. Picture Scale

For a 15-in diameter tube the picture scale on the 2,000-yd range is about 6.5 in to the mile (300 yd per in), allowing 13 in of usable screen diameter. This was considered to be adequate for the applications intended for this equipment, but the scale can be increased by a factor of 2 if required.

### 4. Synchronizing System (Fig. 5)

All pulses driving the various elements of the system are derived from a pre-pulse obtained from a master timing unit.

Due to the a.c. coupling between the time base output circuit and the c.r.t. scanning coils, with consequent loss of the d.c. component of the waveform, a finite time must be allowed between the start of any time base and the instant when the c.r.t. spot passes through zero range (i.e. the centre of rotation) (Fig. 4). The transmitter must fire at this time. After the pre-pulse there is a short variable delay before the time base starts and a longer fixed delay before the transmitter fires. The variable time base delays are controlled individually and automatically so that each display is correctly centred.

### 4.1. Pre-pulse Unit

This is the master timing unit and is mounted in the centre unit of the console. It is a conventional multivibrator generating a rectangular pulse of some  $50 \mu\text{sec}$  duration. The leading edge is differentiated to form the pre-pulse and the trailing edge fires the transmitter.

### 5. Modulator and Transmitter

The magnetron used in the equipment, the English Electric M505, requires a drive pulse of 12 to 14 A at 10 to 12 kV. As in all magnetrons, the pulse top must be flat to avoid frequency modulation and because of the short pulse width the rise and fall times must be short, approximately  $0.02 \mu\text{sec}$ .

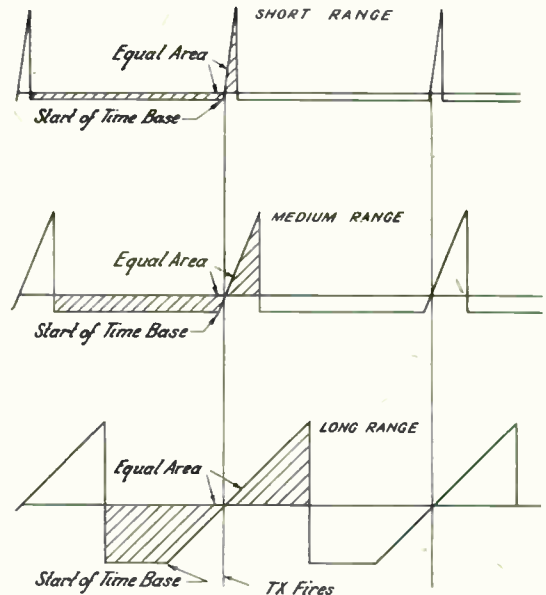

Fig. 4.—Time base and transmitter timing.

The magnetron driving pulse is obtained from a modulator situated immediately below the transmitter-receiver unit in the main rack. Hard valves are used throughout the modulator, giving the following advantages compared with gas-filled types:—

- (a) A continuously-variable pulse width is more readily obtainable.

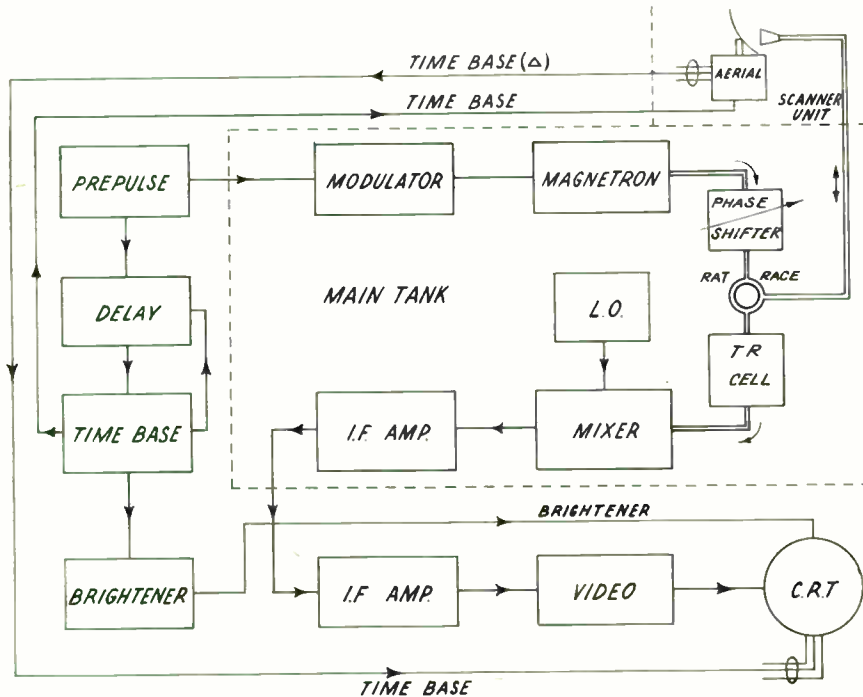

Fig. 5.—  
Basic block  
diagram.

- (b) There is negligible jitter.
- (c) They are, in general, more reliable and have longer lives.
- (d) Better pulse shapes are obtainable due to absence of artificial delay lines and a pulse transformer.

5.1. Modulator Circuit (Fig. 6)

The pre-pulse is unsuitable for direct use as an accurate trigger, so it is amplified and inverted in V1.

The differentiated output from V1 is used to trigger V2, a blocking oscillator, which gives a large steep-fronted pulse developed across a low impedance, which triggers V3, the pulse-forming blocking oscillator.

V3 normally generates a pulse of some 5 μsec duration but the pulse is terminated by V4, a third blocking oscillator, at the instant required to make the pulse from V3 of the desired duration.<sup>2</sup>

An analysis of the action of triggered blocking oscillators is outside the scope of this paper; the

basic principles are covered in the literature,<sup>3</sup> and it is proposed to consider the subject in more detail in a separate paper. It may be of interest, however, to outline their salient features.

The blocking oscillator valve is normally held beyond cut-off as its grid is returned to a large negative potential. When a positive trigger pulse large enough to overcome this bias is applied, anode current flows and induces a voltage in the anode transformer secondary. This voltage is fed back to the grid in phase with the trigger voltage and causes a further increase in anode current. This regenerative action rapidly drives the grid into the far positive region until a condition of equilibrium is satisfied. Even in quite small receiving valves the cathode current is then of the order of amperes.

During the pulse the transformer primary current rises and eventually the transformer saturates, the grid voltage is no longer maintained and the regenerative action is reversed. The pulse then quickly terminates and the valve remains cut off until the arrival of the next trigger pulse.



The duration of the blocking oscillator pulse is normally determined by its circuit constants, but, as mentioned earlier, in this application the pulse is artificially terminated by a negative pulse from the third blocking oscillator, V4. A large rectangular pulse appears in V3 grid circuit and is integrated (R1 and C1) into a sawtooth which is applied to V4 grid. When the sawtooth voltage overcomes the fixed negative grid bias, V4 current rapidly increases by the blocking oscillator action. The resultant V4 screen current, being drawn from V3 grid circuit, reduces V3 grid voltage until degeneration occurs in V3, cutting off the output pulse. This pulse length is thus determined by the time taken for the integrated square wave to overcome the fixed bias on V4 grid, and the pulse length control is conveniently the bias potentiometer (R4).

5.2. Driver Valve

The output valve V5 (Standard Telephones & Cables P552/IE) can be regarded as a switch, open between pulses, permitting the coupling capacitor C2 between V5 and the magnetron to charge, and closed during pulses, permitting C2 to discharge via the magnetron and switch valve.

The magnetron impedance during pulses is about 1,000 ohms, small compared with R2, R3 and V5 anode impedance, as this valve is operated above the knee on the  $I_a-V_a$  curve. Hence, during the pulse the magnetron current is determined by the characteristics of V5, and for a given grid drive the pulse amplitude is determined by V5 screen potential. The e.h.t. supply to the valve is 15 kV.

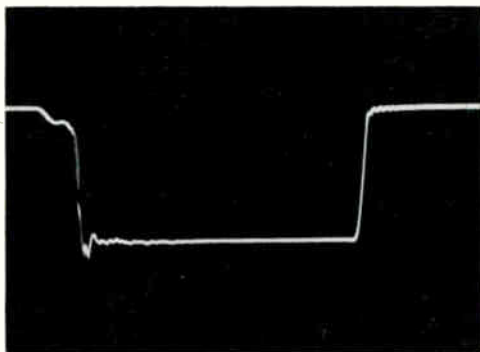

Fig. 7.—Magnetron pulse.

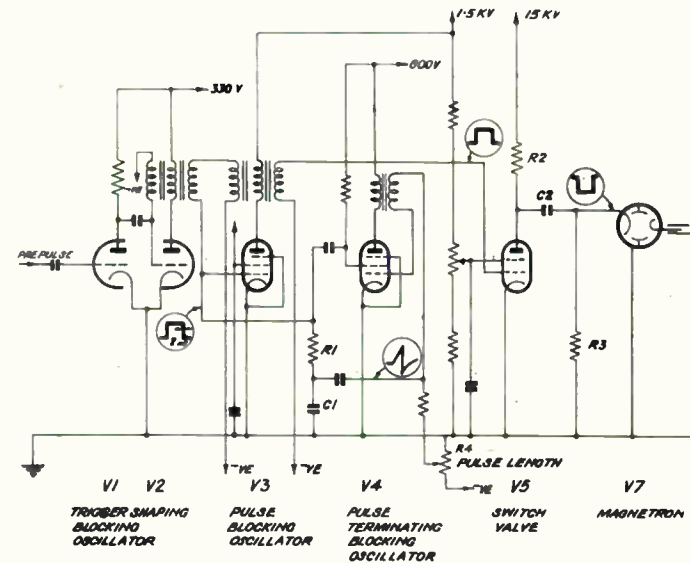

Fig. 6.—Basic modulator circuit.

Because V5 is operated over the "tetrode" portion of its characteristic, a reasonably small change in voltage at the anode of the valve makes a negligible change in the current flowing. Thus, although the charge in C2 decreases during the pulse, the same current continues to pass through the magnetron and a flat-topped current pulse is obtained. For the same reason careful regulation of the e.h.t. supply voltage is not required.

The driver valve, V3, has to supply a grid drive of nearly 1,000 volts at 1 to 2 amp, which, in the blocking oscillator circuit shown, is readily obtained from a 10-W output pentode.

Figure 7 shows a photograph of the magnetron pulse and it will be seen that the requirements of fast rise and fall and flat top are adequately met.

5.3. *Power Supplies and Safety Devices*

The e.h.t. is obtained from a voltage doubler circuit and is controlled by a delay valve so that it cannot be applied until the switch valve and magnetron have warmed up. The delay is preset to about 4 minutes.

When the e.h.t. is switched on, the surge current is limited by a resistor connected in series with the e.h.t. transformer primary for the first 100 milliseconds.

A trip device is incorporated in the delay valve which cuts the e.h.t. when the current exceeds twice normal. This circuit continues to re-apply the e.h.t. about every 20 seconds, but if the overload is still present the e.h.t. immediately trips again. Thus, the mean rectifier current is

limited to a safe value and even a short-circuit between the e.h.t. supply and earth will not damage the rectifier or transformer.

Thus a momentary short or overload such as an anode-to-grid arc caused by gas occlusion in the switch valve will not blow the fuse or render the equipment unserviceable for more than a few seconds.

All supplies are fused and interlocked to prevent damage to components by failure of any one.

5.4. *Magnetron and Transmit-Receive System* (Fig. 4)

The output pulse is applied to the magnetron cathode, the anode being earthed as is standard

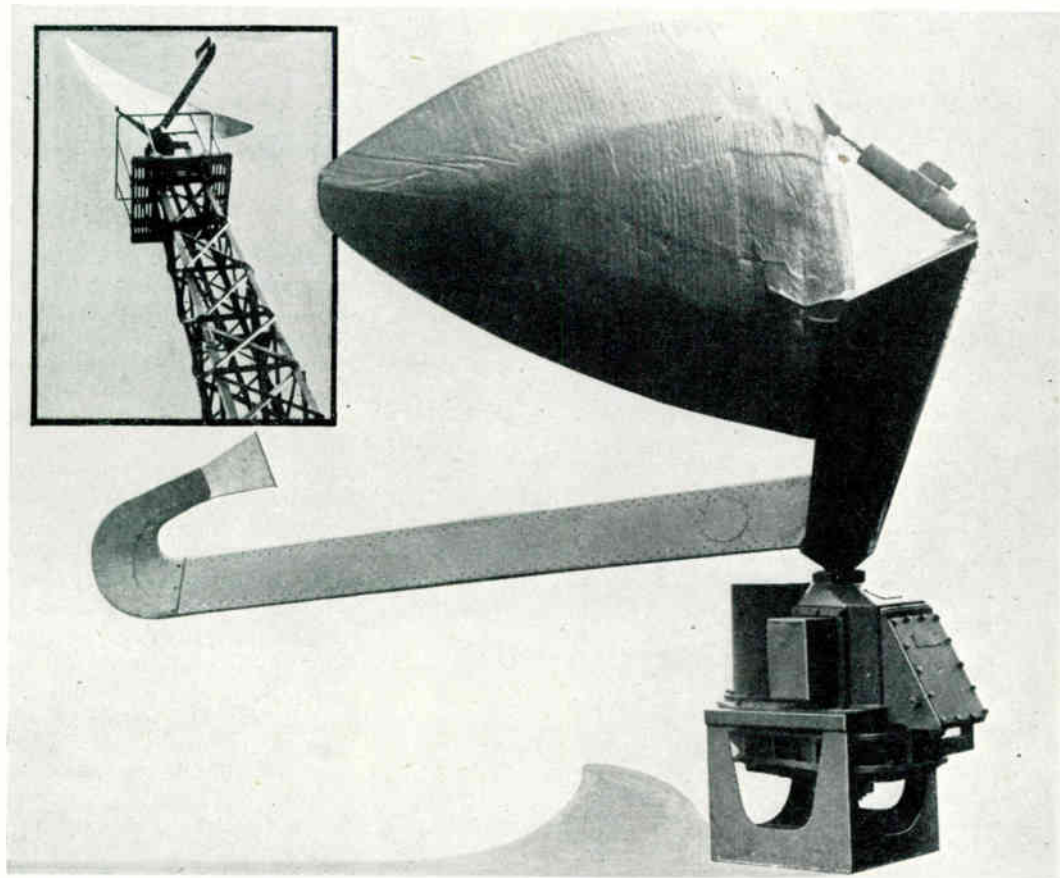

Fig. 8.—Scanner.

practice. Heater supplies are derived from a low-capacitance transformer, and this, together with R3 in Fig. 6, is mounted inside a sealed oil-filled can which forms the support for the magnetron and its associated magnet.

The efficiency of the magnetron is about 40 per cent. and a 50-kW pulse is available at the output. This is fed via the waveguide, including the phase shifter and the rat race, to the aerial, which is common to the transmitter and receiver.

The phase shifter is adjusted to make the magnetron impedance between pulses present an effective short-circuit across the junction with the rat race, reflecting received signals into the TR cell and thence to the receiver.<sup>4</sup> The magnetron impedance is matched to the guide during pulses and this arrangement is found to discriminate satisfactorily between transmitted and received signals without need for an anti-TR cell.

6. Scanner Unit

The waveguide runs through the centre of the aerial turning mechanism via a rotating joint and thence to the horn.

6.1. Reflector (Fig. 8)

The reflector, made of "Durestos" plastic, has the form of a portion of a paraboloid of 57 in focal length; it is 12 ft wide and 3 ft high, giving beamwidths of 0.6 deg horizontally and 2.5 deg vertically. Durestos has the merit of great strength, durability, lightness, and a negligible temperature expansion coefficient; as it is manufactured by a moulding process, the paraboloid shape is readily reproducible within very close limits. The front surface is made conductive by spraying with zinc and aluminium.

The reflector is pivoted and can be tilted to vary the angle of elevation of the beam. For some applications the tilt is preset to the mean elevation required and the vertical coverage is adjusted on installation to an optimum value.

In aircraft control applications, however, the elevation is controlled by an actuating motor

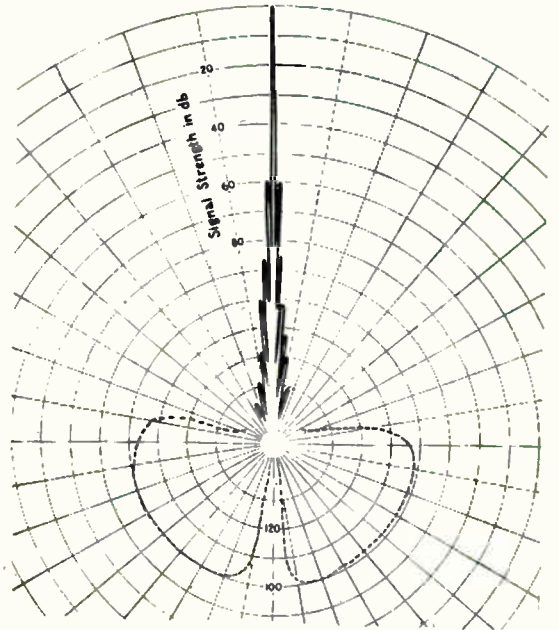

(a)

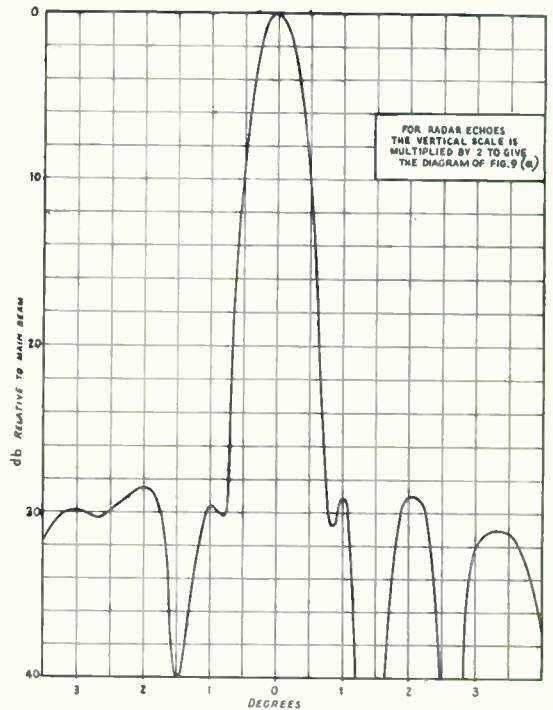

(b)

Fig. 9.—(a) Polar pattern of signal strength. (Broken line shows peak extent of minor side lobes.) (b) Aerial polar diagram. One-way transmission only.

which is under the control of the operator. A repeater on the console indicates elevation angle and the operator uses his control of elevation to "look over" the top of objects causing permanent echo clutter for long-range working, reducing the angle for final approach control and airfield surface movement indication.

### 6.2. Aerial Polar Diagram

All "beam" aerials, of course, transmit side lobes in addition to the main beam. The polar diagram of the semi-paraboloid used is shown in Fig. 9 and it will be seen that the side lobes adjacent to the beam will give responses at least 55 db down on echoes received via the main beam.

However, it is considered that the side lobes immediately adjacent to the main beam are only of secondary importance; their effect is to give an apparent increase in beamwidth. As target response must be very strong for an appreciable side lobe signal to be received it follows that the target range must be short. Hence, the apparent increased beamwidth has little effect on picture quality.

More annoyance is caused by long arc responses appearing on the picture due to signals from the side radiation centred around 120 deg from the main beam. This is where the plastic aerial shows up to greatest advantage, as the accuracy and stability of its profile reduce these to 100 db down for radar echoes. Thus, in general, remote side lobes are well below target signal level and cannot obscure the picture.

### 6.3. Turning Gear

The scanner is turned by a 1/2-h.p. d.c. or 3/4-h.p. a.c. geared motor, available in various versions to suit all the usual mains supplies.

Two magslips for time base angle resolution are geared from the main shaft. If the distance from the aerial to the display consoles is inordinately long, however (more than 150 yd), or more than two indicators are fitted, the three phase magslips are replaced by a servo repeater system. The servo repeater then drives the number of magslips required, and is situated conveniently near to the indicators.

## 7. Receiver

The centimetric signals are fed via a Ferranti TTR31M TR cell to the mixer, a CV253 crystal and a 723 A/B klystron local oscillator, giving an output centred on 45 Mc/s.<sup>4</sup>

Later versions of the equipment will use G.E.C. SIM-2 and SIM-5 crystals in a balanced mixer with an English Electric K302 klystron, as it is found that this combination gives a worthwhile improvement in performance.

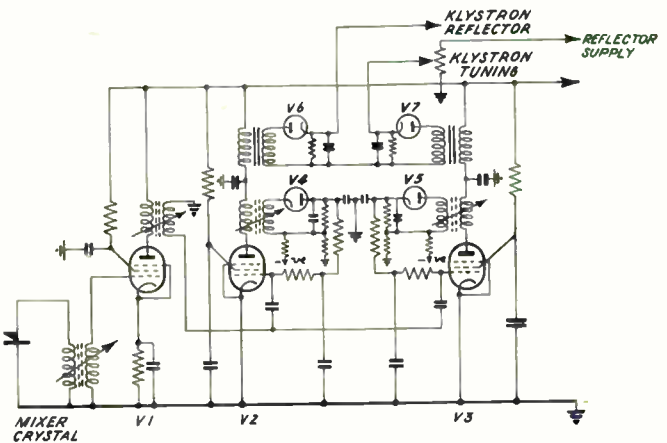

Fig. 10.—Basic a.f.c. circuit.

### 7.1. Automatic Frequency Control Unit (Fig. 10)

The local oscillator frequency is corrected for warming-up drifts, etc., by an automatic frequency control system to maintain the intermediate frequency in the centre of the amplifier pass band.

A simplified circuit is shown in Fig. 10. Briefly, a small sample of the transmitter pulse is mixed with the local oscillator output and the difference frequency is amplified in V1, a wide band amplifier.

The output from V1 is split and applied to two amplifiers, V2 and V3, tuned respectively to 40 and 50 Mc/s. The outputs from these valves are rectified (V4 and V5) and the resultant video pulses are again amplified by V2 and V3, this time using the valves as video amplifiers.

The amplified pulses are rectified a second time (V6 and V7) and smoothed; the resultant d.c. potentials are connected in opposition in series with the klystron reflector supply.

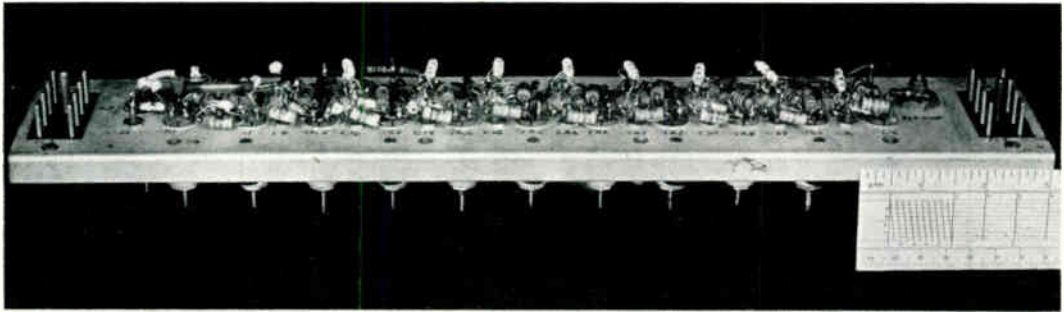

Fig. 11.—Wideband i.f. amplifier.

Normally the system is balanced, because when the frequency difference between the transmitter and local oscillator is 45 Mc/s the outputs from V6 and V7 are equal. Any change of frequency of either the magnetron or the klystron will unbalance the system and cause a voltage to appear in series with the klystron reflector supply the polarity being such that the local oscillator frequency is adjusted until the correct frequency difference is restored.

### 7.2. I.F. Amplifier (Fig. 11)

The i.f. amplifier comprises five flat staggered triples each of bandwidth 30 Mc/s and of gain 25 db giving an overall bandwidth of 20 Mc/s and 125 db gain (Fig. 12).

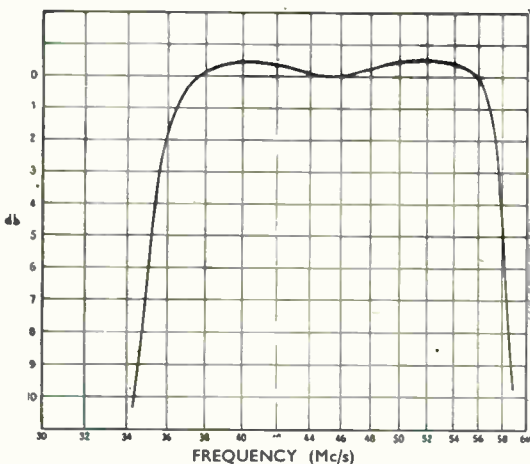

Fig. 12.—Overall i.f. response.  
Transmitter i.f. strip + indicator i.f. strip.

The flat staggered triple is adequately described elsewhere.<sup>5</sup> Essentially it comprises three pentode amplifiers, one of very wide bandwidth tuned to the centre frequency and the other two of rather narrow bandwidth tuned respectively above and below the centre frequency, the combination of the three giving an amplifier of wider bandwidth and higher gain than can be obtained with cascade circuits.

The first triple comprises a cascode low-noise stage and two pentodes with ground wave suppression and swept gain waveforms applied to the grids. The cascode is again well documented.<sup>6</sup> As will be seen from Fig. 13 it comprises a triode, neutralized by  $L_1$ , followed by a grounded grid triode. Broadly speaking the combination gives the noise figure of a triode with the gain of a pentode of equal mutual conductance.

Ground wave suppression, as its name implies, cuts off the amplifier for the duration of the transmitted pulse and swept gain is used to prevent saturation of the picture by short-range signals. For instance, in harbour applications clutter from sea wave crests can completely obscure the picture out to quite considerable distances. The receiver gain is therefore arranged to vary logarithmically with range, the slope being preset and the amplitude under control of the operator.

The amplifier is split after the third triple; the first part is located in the transmitter-receiver unit and the remainder duplicated in each indicator. A bifurcating resistive pad is fitted in the centre console to give the outlets required for each indicator.

Fig. 13.—Basic diagram of i.f. and video amplifier.

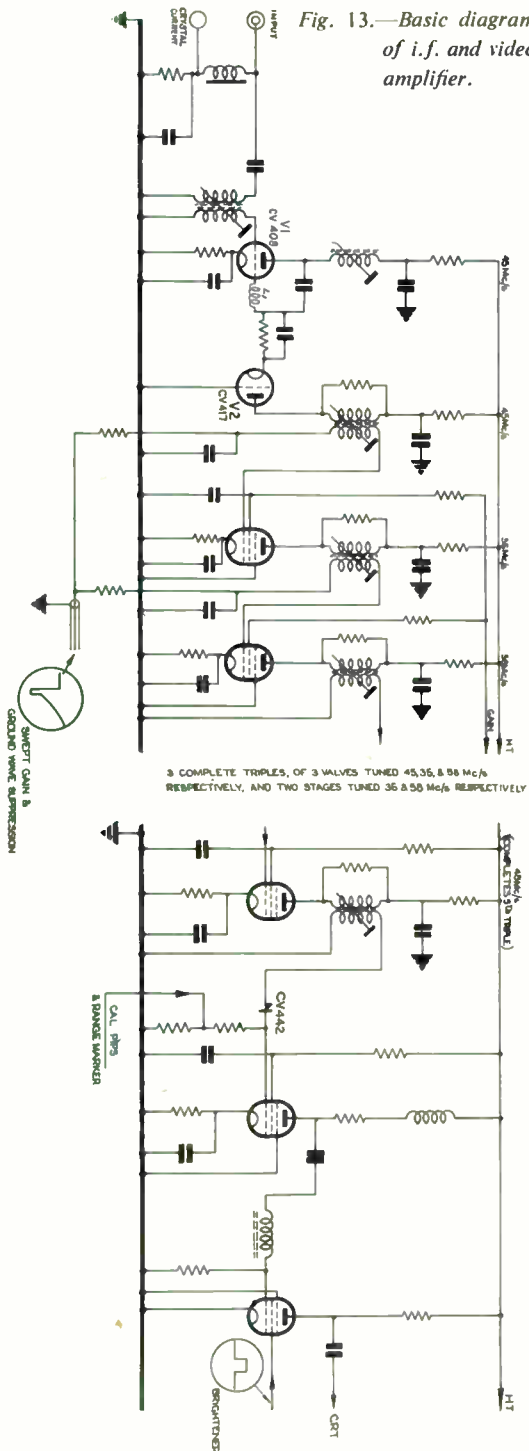

It was found that very close attention had to be paid to both the sending and receiving coupling circuits. Tuned transformers cannot be used because of the impossibility of damping the leakage inductance. The well-known series matching circuit,<sup>7</sup> when damped sufficiently to give the required bandwidth, presents sufficient mismatch to give multiple echoes from reflections in the cable.

It was therefore decided to use a coupling valve with 80Ω anode load, feeding into a correctly terminated cable. Even then, if one indicator amplifier is disconnected the unused outlet must be terminated by 80 ohms.

### 7.3. Video Amplifier (Fig. 13)

The second detector is a germanium crystal feeding a video amplifier and output stage. The video bandwidth is 12 Mc/s, compensated in amplitude and phase in anode and cathode circuits. A response curve is shown in Fig. 14 but in practice the video amplifier was designed to pass a pulse of 0.03 μsec time of rise or fall with just perceptible overshoot.

A short time constant is not used. Although this device gives a "crisp" picture and covers errors in amplifiers it distorts long signals and the result tends to be artificial. In certain applications it can be dangerous as small signals following a large signal can get lost in the "dead time" caused by the differentiation of the trailing edge of the pulse.

The output valve is normally "on" and supplies some 65V grid drive to the c.r.t. across the anode load resistor limited to 470 ohms by the wide bandwidth required. Thus the valve would dissipate some 30 watts under no-signal conditions. To reduce mean dissipation the screen is keyed by the c.r.t. brightener waveform so that it is only passing full current during the time base sweep. The mean dissipation is therefore well below the 10 watts permissible for the valve.

## 8. Display System

### 8.1. Time Base

As electromagnetic time base deflection is used, a linearly-rising current waveform is required through the deflector coils, calling for a trapezoidal voltage waveform from the time base unit (Fig. 15). Its duration is between

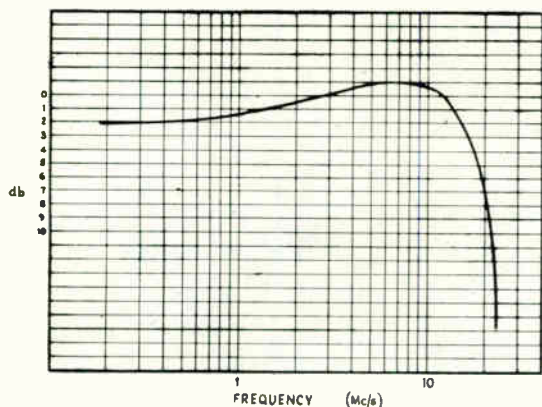

Fig. 14.—Typical video response curve.

5  $\mu$  sec and 250  $\mu$  sec, corresponding to ranges of 0.5 and 20 miles.

Due to the a.c. coupling between the time base circuits and the c.r.t. deflection coils, zero current in the coils occurs some time after the start of the sweep; circuits are therefore provided for synchronizing the point of zero current with the transmitter pulse.

8.2. Delay Circuits

Each console may be set to a different range scale, and the time base speeds may therefore vary from one to another, hence the delay required between the time base start and the transmitter pulse must be adjusted to the range scale in use (Fig. 5). This is done in the delay circuits V5 and V6 (Fig. 16).

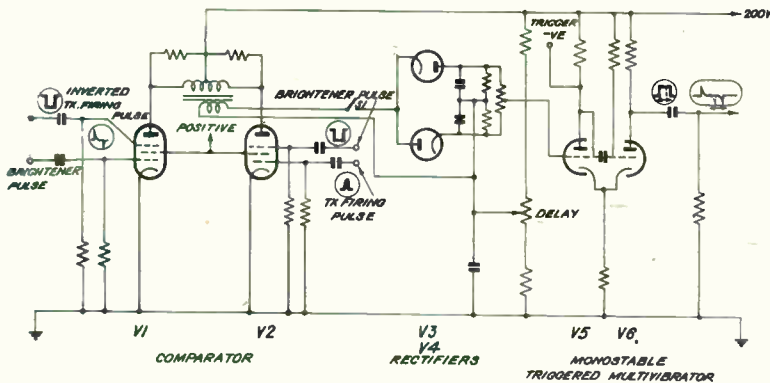

Fig. 16.—Basic comparator and time base delay circuits.

These valves (physically one double triode) comprise a monostable cathode-coupled multivibrator<sup>8</sup> (commonly known as a “flip-flop”). On receipt of a triggering pulse the circuit generates a rectangular pulse of duration dependent on the bias voltage on the grid of V5 and the circuit time constants. The trailing edge of this square wave is then differentiated and fires the time base. Thus the start of the time base is controlled by the “delay” potentiometer, which is adjusted until zero range coincides with the transmitter pulse.

8.3. Comparator

Switching range scales, together with warm-up drift and changes in p.r.f., will cause timing errors between the zero range and the transmitter pulse; a variation of the order of  $10^{-7}$  sec will cause considerable annoyance. To eliminate these errors the centring is made automatic in operation by means of a servo unit called the comparator.

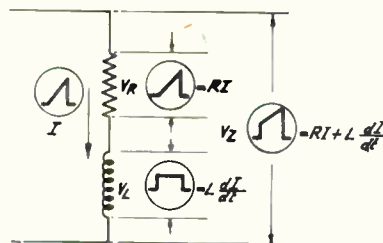

Fig. 15.—Scanning waveforms.

This generates an output voltage whose polarity depends on the time relationship of two reference signals. This voltage is applied in series with the reference voltage of the delay circuit controlling the start of the time base, thus advancing or retarding the time base with respect to the transmitter pulse.

The reference voltages are respectively the transmitter firing pulse and the differentiated leading edge of the c.r.t. brightener pulse, which occurs at zero time base current.

A simplified circuit is also shown in Fig. 16. V1 amplifies

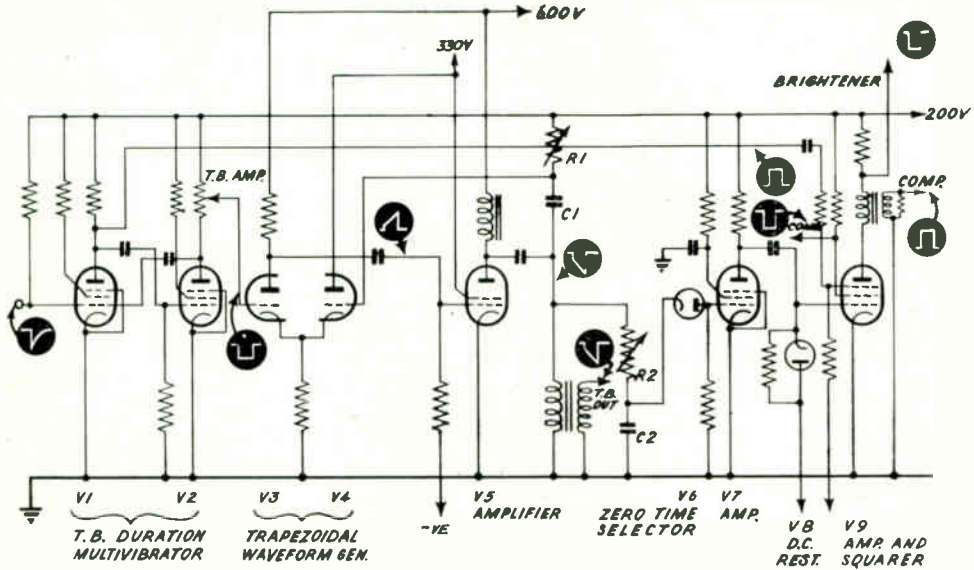

Fig. 17.—Basic time base circuit.

a differentiated version of the brightener pulse and V2 a pulse corresponding in time to the transmitter firing pulse. The two valve anodes are fed from a centre-tapped transformer and the circuit is so arranged that the first valve to receive its grid drive pulse prevents the other valve from conducting. Thus a pulse of polarity dependent on which of the two reference pulses occurs first is obtained from the transformer secondary. This, after rectification, is added to the delay valve reference voltage.

The gain of the feedback loop is approximately 50 times. Thus a time difference of  $1 \mu\text{sec}$  between the time base crossing the centre of rotation and the firing of the transmitter (a range error of 160 yd) is reduced to a time difference of  $0.04 \mu\text{sec}$  or a range error of 3 yd.

#### 8.4. Waveform Generator

The time base is a trapezoidal voltage waveform generated in the feedback circuit of Fig. 17.

V1 and V2 form a triggered multivibrator which, on receipt of the timing pulse from the delay circuit, generates a rectangular wave whose duration is controlled by the time constant between V2 anode and V1 grid; this duration is that of the time base.

The negative-going rectangular pulse at V3

grid initially cuts off V3, the voltage rise at the anode appears at V5 grid and V5 conducts. The voltage at V5 anode drops and is fed via C1 to V4 grid until V3 begins to conduct due to the decrease in current through the common cathode resistor. Equilibrium occurs when V3 and V4 grid voltages are substantially equal. The voltage at V5 anode then drops at such a rate as to maintain the voltage at V4 grid. The net result of this is a trapezoidal voltage waveform giving a linearly rising current through the output transformer. The linearity is controlled by the differentiating time constant R1, C1.

The time base sawtooth is fed to the aerial unit (or to the aerial repeater if fitted) and applied to the rotor of a magstrip transmitter. Coupled to the rotor is a delta-wound three-phase stator. The rotor is geared 1 : 1 to the aerial and, as the aerial rotates, the time base waveform applied to the rotor is resolved into a three-phase waveform across the stator windings.

The connections from the stators are brought back to the display console and joined, again in delta, to the three-phase c.r.t. deflection coils. Thus the time base waveform in the deflection coils is resolved into a time base sweep on the c.r.t. following the direction of the aerial; as this turns the time base follows, resulting in a rotating radial scan.



### 8.5. Brightener Circuit

The c.r.t. spot is normally invisible and is brightened as it crosses the centre of rotation (zero range).

To synchronize the brightener pulse, the time base waveform is applied across the capacitor-resistor network R2, C2 which is adjusted to have the same time constant as the scanning circuits. The resultant sawtooth voltage is applied to the cathode of V6. The voltage impressed on V6 thus has the same form as the current in the deflector coils and is zero when the current in the coils is zero. Therefore, after this instant, diode V6 conducts. The resultant voltage drop through the anode load of V6, which is also the grid leak of V7, is amplified, squared and inverted in V7 and V9.

The brightener pulse is terminated by a gate pulse from V1 anode applied to V9 suppressor. The commencement of the brightener pulse is adjusted by R2 to coincide exactly with the transmitter pulse and zero range.

### 8.6. Range Marker (Fig. 18)

The range marker is a  $0.1 \mu$  sec pulse of preset amplitude covering 0-4,000 yd on short and 0-40,000 yd on medium and long ranges respectively. The range is set by comparing an accurate sawtooth voltage waveform with a d.c. reference level. This latter is adjusted by a

cam-corrected potentiometer carrying the range scale.

The sawtooth, triggered by the pre-pulse trailing edge, is generated in a phantastron V1,<sup>9</sup> and is applied to the cathode of a diode V3. The reference voltage is applied to the diode anode and as the sawtooth runs down past the reference point the diode conducts, cutting off V4. The resulting rise at the anode triggers the blocking oscillator (V5) generating the  $0.1 \mu$  sec pulse. This pulse is injected into a cathode follower (V6) acting as a preset limiter, and thence in series with the grid leak of the first video amplifier.

A fixed frequency oscillator, generating pips at  $\frac{1}{2}$ -mile,  $\frac{1}{4}$ -mile or 2-mile intervals, is available in the waveform generator in the main rack for setting-up purposes; the output from this is mixed with the range pip in the cathode follower (V7).

### 8.7 Display Tube

The c.r.t. has a 15-in diameter long-persistence fluoride screen, it uses electrostatic focus and electromagnetic deflection and is operated with 10 kV h.t. It was found convenient to inject video signals to the grid and the brightener waveform to the cathode.

In many applications the radar will only be required to survey part of the coverage area. If the centre of sweep was always in the tube

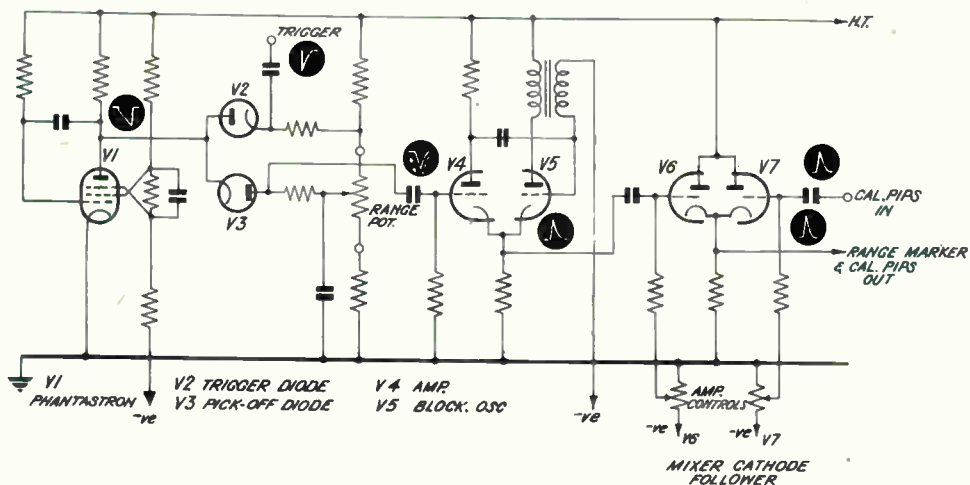

Fig. 18.—Basic range marker circuit.

centre, a large part of the tube area would be wasted. It is arranged, therefore, to offset the centre of sweep as required by feeding a preset value of direct current through any two of the three deflector coils.

The offset obtainable by this means is variable up to one tube radius. In other words, the presentation can be arranged with the station position just off the picture.

### 9. Console Centre Unit

The console centre unit carries the pre-pulse unit and master controls for the main rack, but in other respects is arranged as required for the service in which the radar is to be used.

At the moment three alternatives are available.

1. A v.h.f. radio telephone system.
2. A v.h.f. receiver for monitoring air-field radio.
3. A cathode ray direction-finding repeater.

Also, as previously mentioned, the console carries the scanner reflector angle-of-tilt control, and a repeater showing the elevation selected.

So that the pre-pulse unit is independent of the main switch on either indicator it uses the main rack power supplies which are brought to the centre unit for monitoring purposes.

### 10. Power Supplies

The power supplies for the main rack (transmitter-receiver, modulator and waveform generator units) are generated in a power unit in that rack and are principally +600 V, +330 V, +200V (stabilized) and -150V (stabilized), all from conventional circuits.

The modulator supplies of +15 kV, +1.5 kV and -1.5 kV are generated in the modulator

itself as it is inconvenient to take these from unit to unit.

Each indicator generates its own supplies of +600V, +330 V, +200 V (stabilized) and -100 V (stabilized) from conventional metal rectifier circuits, but e.h.t. for the c.r.t. is produced in a hard valve voltage doubler.

The supply to the equipment is 180 V 500 c/s obtained from a motor generator and regulated

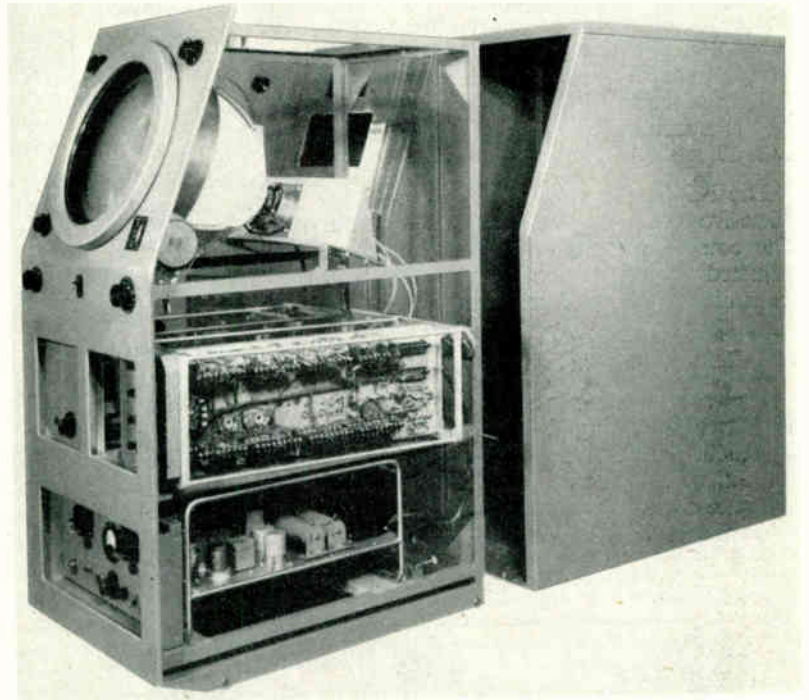

Fig. 19.—Display console withdrawn for servicing.

by a carbon pile. The high supply frequency is very attractive because of the ease of filtering and the saving of iron in transformers and chokes.

The motor generator and the aerial motor inputs are arranged to suit the local supply. Both direct and alternating current versions are available, the latter in either single or three phase and at all the usual supply voltages and frequencies.

The total consumption from the mains including the aerial motor and the blower for magnetron cooling is about 2 kW.

## 11. Servicing

Most components in a complicated electronic equipment are liable to fail at some time during its life. Consequently, provision is made for any item to be replaced with the minimum disturbance of the rest of the equipment and the minimum loss of operational time. The units are designed so that they can be made completely accessible whilst still operating. Most valves and all h.t. and bias supplies are metered and in general a fault can be located without removing a unit from its rack.

All main rack units can be withdrawn on to a servicing tray for testing. Similarly, the indicators can be withdrawn from the console, and operated in the withdrawn positions, wheels and runners being fitted for this purpose. Most units are square-sectioned in elevation, and connections are arranged so that they can be operated with any face upwards (Fig. 19).

Plug-in sub-chassis units are also used wherever practical. For instance, I.F. amplifiers, the a.f.c. unit and some power units are all replaceable complete in a matter of minutes. The duplication of indicators is also of great assistance in servicing; complete units can be transferred from one indicator to another for checking and localizing faults. A fault on one indicator will not affect another, as they are completely independent.

## 12. Acknowledgments

The authors wish to emphasize that a project of this nature is essentially a team effort and consider that it would be invidious to single out any member of that team for special mention. Thanks

are due to Mr. B. C. Fleming-Williams, Director of Research, A. C. Cossor, Ltd., and the directors of that company for permission to publish this paper, and to Mr. P. Took and the staff of the Technical Publications Department for their assistance in its preparation.

## 13. References

1. D. E. Kerr, "Propagation of Short Radio Waves," Chapters 7 and 8. (McGraw-Hill, New York, 1951. M.I.T. Radiation Laboratory Series, Vol. 13.)
2. A. C. Cossor, Ltd., Prov. Pat. Spec. No. 4244/53.
3. B. Chance, V. Hughes, E. E. McNichol, D. Sayre, and F. C. Williams, "Waveforms," pp. 205-238. (McGraw-Hill, New York, 1949. M.I.T. Radiation Laboratory Series, Vol. 19.)
4. L. D. Smullin and C. E. Montgomery, "Microwave Duplexers," pp. 262-323. (McGraw-Hill, New York, 1950. M.I.T. Radiation Laboratory Series, Vol. 14.)
5. G. E. Valley and H. Wallman, "Vacuum Tube Amplifiers," pp. 176-200. (McGraw-Hill, New York, 1948. M.I.T. Radiation Laboratory Series, Vol. 18.)
6. H. Wallman, A. B. McNee and C. P. Gadsen, "A low-noise amplifier." *Proc. Inst. Radio Engrs*, 36, June 1948, pp. 700-708.
7. L. A. Moxon, "Recent Advances in Radio Receivers," p. 93. (Cambridge University Press, 1949.)
8. Reference 3, pp. 197-200.
9. Reference 3, pp. 166-171.

## DISCUSSION

**R. T. A. Howell:** I have been associated with similar problems and can appreciate the difficulties the designers had to face. Their comments would be of interest on several points.

Firstly, as the aerial has a 12-ft wide reflector does not this reduce the definition at minimum range as the minimum beamwidth would seem to be 12 ft?

Secondly,  $2\frac{1}{2}$  deg vertical beamwidth seems rather narrow in elevation, and if used on a 30-ft tower corresponds to a minimum range of some 250 yards.

Lastly, we have found that although high definition is very desirable, in certain applications it becomes rather difficult as small echoes are just points up to half a mile. We have found difficulty in distinguishing between pedestrians and small flocks of birds. We have also found that the non-technical observer sees a pedestrian echo far faster with a much wider beam, say 1 deg or so.

**T. W. Welch (Associate Member):** My business is with ships and their radar, and there is no doubt in my mind that the vastly improved detection capabilities of some currently produced marine

equipment is due as much to the narrow receiver bandwidth which the use of long pulses permits as to the higher mean transmitted power represented by the long pulse itself. Whilst the provision of a pulse-length variable from 0.05  $\mu$ sec to 1.0  $\mu$ sec and the achievement of a 20-Mc/s bandwidth to suit the former is a very creditable performance, it seems a pity to waste some of the detection potential of the longer pulse lengths by omitting to switch the bandwidth to suit them.

I also notice that the authors dismiss the idea of using a fast time-constant circuit in the video amplifier. It has been found, notably by the New York Harbour Authority, that a 3-cm set can compete with a 10-cm equipment only if it has a fast time-constant circuit to prevent precipitation echoes from saturating the display.

**B. C. Fleming-Williams:** Referring to the remarks regarding rain and sea clutter, may I point out that improving the discrimination of a radar equipment is one of the best ways of improving the ratio of signal to clutter.

With sea clutter, the power reflected from rough water is proportional to the area illuminated at any one instant; this area will be proportional to the pulse width times the beamwidth of the aerial. The power from a small target is substantially independent of these factors, hence the signal/clutter ratio is improved with higher discrimination.

In the case of rain clutter, the power reflected is proportional to the volume illuminated, and hence reducing vertical coverage gives some further improvement.

For the above reasons the present equipment gives far better results than might be expected merely from wavelength considerations.

Differentiation is simple to insert in a display system, but although it will help to keep clutter off the screen, small targets may easily be lost at the same time. Very short pulse length with adequate receiver bandwidth and swept gain can be better under many circumstances. If the receiver i.f. is overloaded by clutter, differentiation will not show a signal in this, but swept gain, by reducing the overload, will do so.

It is quite an interesting problem to consider if given a free choice what wavelength should be chosen for a high discrimination surveillance

radar. With a wavelength much greater than 3 cm the aerial structure problem gets serious; with a wavelength much less than this the law relating precipitation, drop size and wavelength begins to make the rain clutter problem very serious and the resulting radar may be satisfactory in fog but unusable in rain.

For a general-purpose radar at a reasonable price, I believe 3 cm is about the best wavelength to choose.

**P. H. E. Hope-Ross** (Associate Member): I was under the impression that the critical wavelength for rain was between 5.5 and 5.7 cm, and that hence this wavelength has been chosen for cloud warning equipments.

**S. F. Watson:** Can the authors give any indication of the equipment supplied for checking the equipment, for example, an echo box or a standing-wave detector?

**R. N. Lord** (Associate Member) (Communicated): Would the authors give some further information on the scanner? Has any effect been noticed of the wind causing jitter of the scanner, and have they any information as to the efficiency of sprayed metal as the reflecting surface particularly as regards oxidization effects?

In proposing a vote of thanks to the authors, **Group Captain E. Fennessy** said that the paper described a type of radar system which was becoming increasingly important, both in the marine field and in the air. One of the current problems in the marine world was the increasing use of ship-borne radar, which enabled more and more craft to get into the estuaries and into the approaches to the ports. There still remained, however, the problem of getting them into position and handling them within the ports, which called for a much better type of radar than could at present be carried on board ship. In handling ships in narrow, congested waters it was necessary to see the shape of the ship, its aspect, and the way it was responding to the helm; these were the types of marine problem calling for high-definition radar such as had been described.

There was a similar problem with air transport: aircraft could be landed by radar, but on the airport there remained the problem of finding their location and directing them to the apron to set down passengers; high-definition radar would have increasing use in this application.

## AUTHORS' REPLY

Although the reflector has a 12-ft aperture, the power distribution across the face is far from linear, being maximum at the centre and zero at the edges. Hence the beam appears concentrated, and assuming, say, a (cosine)<sup>2</sup> distribution the source appears to be only 4 ft wide at the 3-db points. The 2½-deg vertical beamwidth is again measured at the 3 db down points and although Mr. Howell's calculation is quite correct on this basis, at greater angles there is still radiation, adequate for satisfactory painting at short ranges. As a matter of interest, at Douglas, Isle of Man, one of these equipments was required to give coverage down to 60 deg depression from a 60-ft tower. This was done by adding a gap filler horn, into which was fed 10 per cent. of the transmitted power.

One would infer, from Mr. Howell's last remark, that he is using a display far smaller than the one described in this paper, i.e., it is not large enough to use the discrimination of his set. We have found no difficulty in distinguishing pedestrians from small flocks of birds. We also do not agree that a technical observer is necessarily better than a non-technical observer. In our experience competent officers rapidly build up a knowledge of the site and the equipment and can detect changes in performance and unusual echoes far sooner than technical observers with less operating experience.

We have given considerable thought to the problem of pulse length and bandwidth. In general, we agree with published results of increased performance as bandwidth is decreased towards the optimum for a given pulse length. When the equipment was envisaged the sensitivity at fixed 20 Mc/s bandwidth was adequate. Since that time, however, other applications have required greater sensitivity and the decision as to whether bandwidths should be switched or whether to compromise on a fixed narrower bandwidth has yet to be taken.

In any event the improvement to be gained by decreasing bandwidth is not as marked as would appear at first sight. Owing to the high definition, with a wide bandwidth echoes stand out against a fine-grain noise background and are thus easier to

see than if they appeared against a noise background composed of noise spots of comparable size.

The short time-constant circuit we have decided, after many hours of operational experience, would be of little help in a high-definition radar. We find that even the heaviest rain storms are broken up into small patches of varying density. Under these circumstances a short time-constant circuit would be useless. As Mr. Fleming-Williams has pointed out, definition is a far more potent weapon than a short time-constant circuit.

In reply to Mr. Hope-Ross, 5-6 cm has been claimed to be the optimum wavelength for cumulonimbus detection, not the wavelength of maximum clutter amplitude under precipitation conditions.

Apart from the built-in servicing facilities, test equipment is supplied to the user's requirements.

We do not fit a standing-wave detector, as there are no adjustments in the waveguide system, and changes can only result from gross mechanical damage. This becomes immediately apparent from rings on the display; visual inspection will locate the faulty component which is then substituted by an interchangeable replacement.

We do not normally fit an echo box, as experienced operators on a fixed site can make an incredibly accurate estimate of performance. If the picture is normal there is little likelihood of any significant deterioration in the equipment.

There are also commercially available centimetric noise generators which accurately determine receiver sensitivity, and power meters for measuring transmitter output power. These, coupled with the built-in servicing aids, amply cover all servicing requirements.

The scanner is robustly constructed, being 6 in thick over a large portion of its area, and no vibration or flexing troubles have been encountered. We have experienced no difficulties with metal spraying. The efficiency of reflection is comparable, within experimental error, with that of a metal plate. The surface is painted, and scanners exposed to the weather for nearly two years show no observable deterioration.

NOTICES

**The 1954 Physical Society Exhibition**

The 38th Exhibition of Scientific Instruments and Apparatus arranged by the Physical Society will be held at the Imperial College of Science and Technology, Imperial Institute Road, London, S.W.7, from Thursday, April 8th to Tuesday, April 13th. Applications for tickets should be made to the Secretary-Editor at the offices of the Society, 1 Lowther Gardens, Prince Consort Road, London, S.W.7. Tickets will *not* be sent out until the beginning of March.

As in previous years the comprehensive Handbook of the Exhibition will be available at the Exhibition and copies can be obtained on application to the Secretary-Editor at the address above. The price of the publication is 6s. (by post 7s. 3d.).

**Department of Scientific and Industrial Research**

In a recent written answer in the House of Commons it was stated on behalf of the Lord President of the Council that there will be a gradual expansion in the Department of Scientific and Industrial Research during the next five years. Under the programme, the total resources of the department should, by 1959, be adequate to cover 95 per cent. of the activities projected in the 1947/8 report.

In particular there will be an increase of staff of 1,000 (total staff will then number 5,100) and an increase of £900,000 in the annual net vote. In addition, there will be a building programme of about £6,000,000.

**Improvement in B.B.C. Coverage**

As part of its plan to make local improvements in the coverage of the Home Service the B.B.C. has opened a new low-power transmitting station at Hampstead, near Cromer. The new station has a power of 2 kW.

Under the Copenhagen Plan, it must use the same wavelength as the Northern Home Service, 434 metres (692 kc/s), and it therefore carries that service.

A new low-power Home Service transmitter at Bexhill was brought into operation on Sunday, November 8th, to replace the temporary low-power transmitter at Hastings. The new transmitter uses the same wavelength, 206 metres, and has a power of 2 kW.

**Back Copies of the Journal**

The Librarian is anxious to acquire the following back copies of the Institution's Journal:—

September 1952; January 1953.

Members willing to dispose of the above copies are invited to return them to the Librarian, who will remit the cost of 5s. per copy.

Please note that these are the *only* issues which are now required.

**Shortage of Graduate Teachers in Mathematics and Science**

The National Advisory Council on the training and supply of teachers declared recently that the shortage of graduate teachers of mathematics and science constitutes a national problem. The recruitment of these teachers is inadequate, both in quantity and quality, and the problem will grow more acute in the years 1955 to 1960 when the annual requirement will be far above the present figure.

The Council concluded that the shortage is a direct result of the competition between industry and the schools, only 15 per cent. of the graduates entering the teaching profession.

Although some falling off of the defence programme may ease the general demand for graduates, industry is now accepting the policy of greater employment of science graduates and consequently any reduction in defence demands will be offset by increased demands for civilian purposes.

It is interesting to note that the Council has found on analysis a lowering of the quality of graduates leaving universities during years 1938 to 1953. The number of men obtaining first-class honours degrees has fallen from 14.7 per cent. in 1938 to 4 per cent. in 1953.

**Special Courses in Higher Technology**

The Regional Advisory Council for Higher Technological Education for London and the Home Counties has recently published Part Two of the Bulletin of Special Courses in Higher Technology commencing in the spring and summer of 1954. There are nine courses of direct interest to radio and electronics students and engineers at various colleges in London and the Home Counties.

Copies of the Bulletin may be obtained from the Secretary, The Regional Advisory Council, Tavistock House, South Tavistock Square, London, W.C.1, price 1s. 6d., post free.

# A SCINTILLATION COUNTER FOR RADIOACTIVITY PROSPECTING\*

by

D. H. Peirson, B.Sc. and J. Pickup†

## SUMMARY

A transportable scintillation counter instrument, sensitive to gamma rays, has been designed for use in surveying for radioactivity. Use of a single cold cathode valve in the counting-rate meter circuit, which is triggered directly by the counter, and a new form of recording microammeter leads to simplicity and compactness. Recordings are shown of radioactive anomalies detected from the air. The stability and reliability of the instrument have proved satisfactory and have been further tested by use in a geological survey by car for 500 hours over rough road surfaces in tropical climates.

### 1. Introduction

For some years the equipment of a geologist prospecting for radioactive minerals has included a gamma-ray detector with associated electrical circuits and indicators. In general this equipment has been designed for maximum portability and to permit reliable operation whilst carried by the user in the field. Lately the speed and convenience of radioactivity survey has been increased by using more sensitive and complicated equipments mounted in motor cars<sup>1</sup> and aircraft. This paper describes a transportable scintillation counter instrument suitable for such applications and considers its use in airborne surveying. The design is based on a simple cold cathode valve circuit and a novel form of recorder.

A radioactivity survey will consist of measuring the variations in the level of the gamma-ray activity of the earth's surface. These may be due to (a) localized radioactive anomalies of high concentration such as surface exposures of uranium or thorium mineral, or to (b) a change in the mean activity of the surrounding rock as in a transition from an inert sedimentary formation to a granite region of slightly higher activity. In both types of occurrence a few feet of overburden produce severe attenuation of the gamma-ray flux owing to the high absorption in soil and rock.

The theoretical and instrumental problems of radioactivity prospecting from aircraft

\* Manuscript received November 4th, 1953. (Paper No. 249.)

† Electronics Division, Atomic Energy Research Establishment, Harwell, Berkshire.

U.D.C. No. 621.387.4.

have been discussed by Peirson and Franklin<sup>2</sup> and Godby, Steljes et al.<sup>3</sup> The latter paper contains many details of operational procedure.

### 2. The Scintillation Counter

In its simplest form the gamma-ray detector used for radiation survey and prospecting will be based on one or several Geiger Müller counting tubes. However, where sensitivity is a primary consideration the Geiger-Müller tubes are replaced by a scintillation counter. The detecting element in this case is a crystal of sodium iodide (activated with thallium) which scintillates under irradiation by gamma-rays. These scintillations are in turn detected by a high-gain photomultiplier tube. The detection of radiation by this method has been described by Sharpe and Taylor,<sup>4</sup> and also by Birks.<sup>5</sup>

In designing a radiation measuring instrument for portable or transportable use it is important to observe the following comparison between the use of Geiger-Müller and scintillation counters. Thus a Geiger-Müller tube with halogen quenching and operating from a few hundred volts will provide output pulses of a uniform amplitude of about 20 V. A scintillation counter for measurement of gamma radiation with an 11-stage E.M.I. photomultiplier tube at 2,000 V will produce output pulses of variable amplitude, depending upon the energy of the gamma radiation, with a lower limit determined by the photo-cathode noise level. As described by Hardwick and Franklin<sup>6</sup> the Geiger-Müller pulse may be accommodated by simple cold cathode valve circuits and registered as a current that measures the counting rate. The cold cathode valve, robust, reliable and

having a low power consumption, has proved very useful in radiation instruments designed for measurements in the field where these qualities are important.

In the scintillation counter the requirements of sensitivity and of stability, in discriminating in favour of signal pulses and against noise pulses, are more stringent. The simple combination of scintillation counter and a single cold cathode valve has been made possible by the development of the Mullard VX8086.<sup>7</sup> The sensitivity and stability are adequate for use as a counting-rate meter valve working from commercially available photomultiplier tubes.

### 3. Recording

It is obviously desirable to preserve for later analysis some record of the radioactivity as measured by the counting-rate meter circuit during the survey flight. The counting-rate meter current of  $50 \mu\text{A}$  maximum available from the cold cathode valve is insufficient to operate the usual robust and relatively insensitive form of recorder without some form of amplification. This amplification may be obtained by conventional circuits using hard (hot cathode) valves or, more economically, by a cold cathode valve "power amplifier".<sup>8</sup> However, the system of recording to be described required no additional amplification, but measured directly the counting-rate meter current.

The recording microammeter\* consists of a large 0.50 microammeter movement having a thin pointer blade "a" passing about 2 mm above a metal knife-edge "b". Over the knife-edge is drawn thin, heat-sensitive paper 4.5 in wide "c" as shown in Fig. 1. At regular intervals the insulated knife-edge is energized by an induction coil so that a spark is drawn between it and the earthed pointer. The puncture in the paper is clearly marked by exposure of the black undercoat around each hole; repetition of this marking allows a record to be made of the movement of the pointer over the chart. The record is effectively continuous provided a sparking rate is maintained which is adequate for a given paper speed. Thus the difficulty of moving the pointer of a sensitive meter movement, having a necessarily low restoring torque,

against the friction of a recorder chart is overcome by remote marking by spark. At the same time a complicated inking system is avoided.

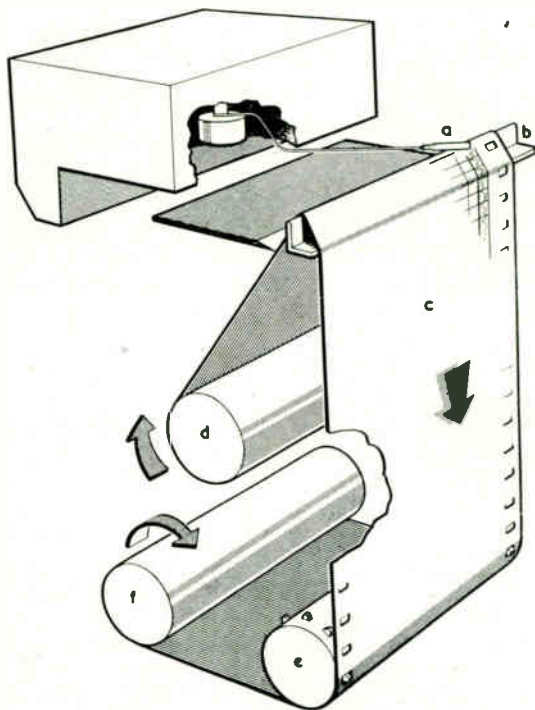

Fig. 1.—Schematic diagram of recording microammeter.

In the initial design the recorder chart is moved by a uniselector type "stepping" motor operated by clockwork-driven contacts. The same contacts, through an intermediate relay, interrupt the primary of the induction coil which is of the standard car ignition type.

### 4. The Airborne Survey Instrument

The complete instrument is divided into three separate units for convenience of installation and operation. Illustrated in Fig. 2 are the probe unit (withdrawn from the spring mountings of the transport cage) which contains the scintillation counter; the recorder unit, containing the ratemeter circuit and the recording microammeter, and the power unit which is operated from a 12-V accumulator and supplies the other units with h.t. and e.h.t. voltages. Fig. 3 shows a closer view of the recorder. The circuit

\* Suggested by S. N. Pocock and developed, on behalf of A.E.R.E. Harwell, at the laboratories of the Edison Swan Electric Co., Ltd., Enfield.





*Fig. 2. — The airborne survey instrument.*

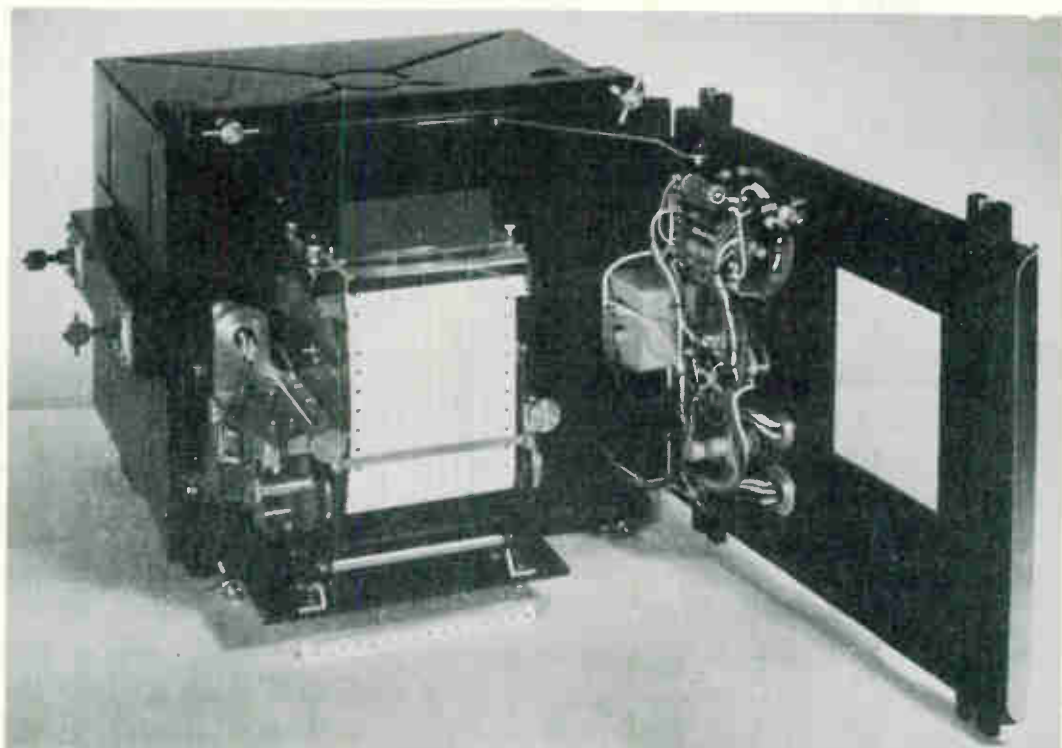

*Fig. 3. — Recorder unit.*

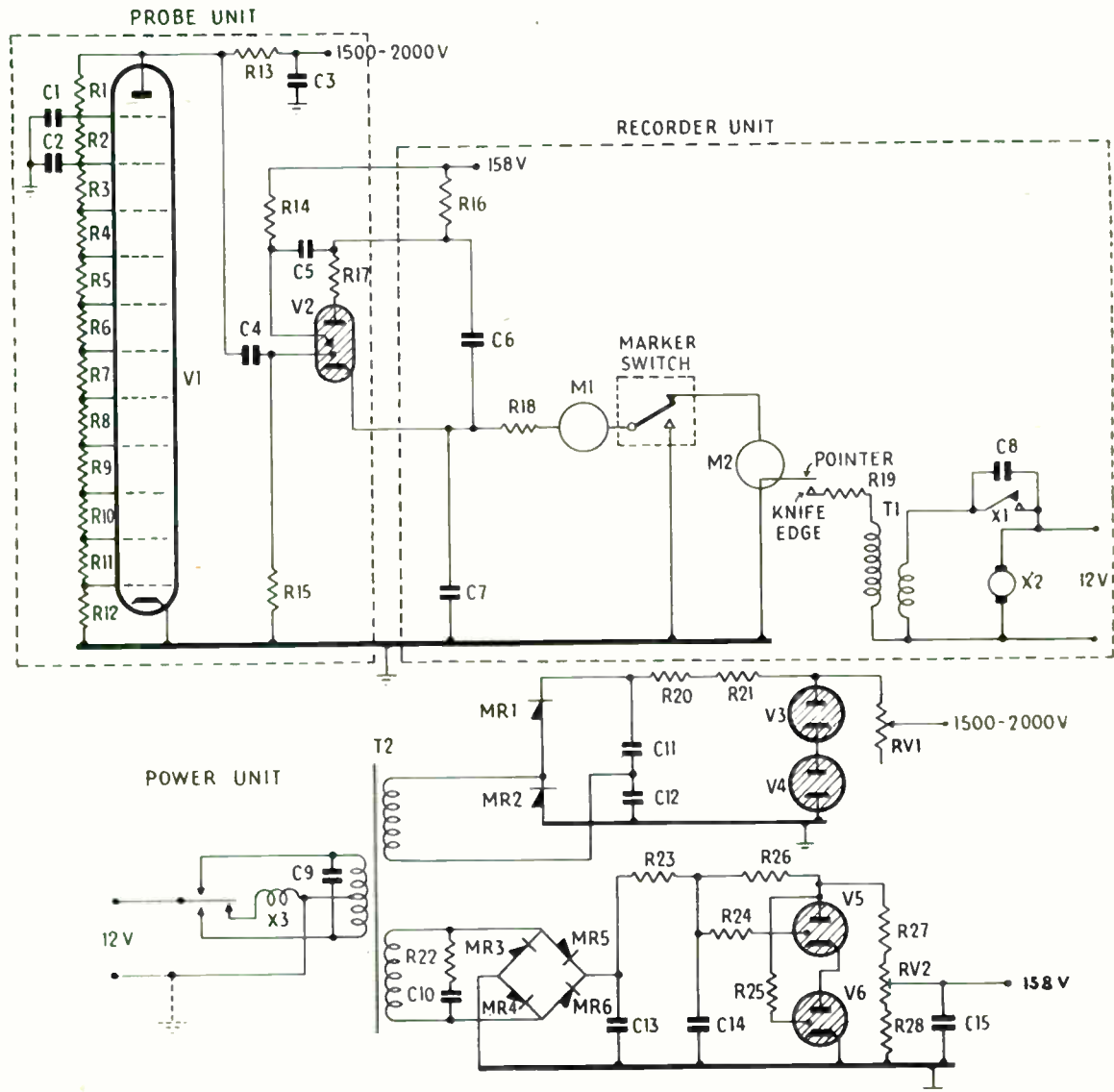

Fig. 4.—Circuit diagram of detector.

R1 to R12	2.2 M
R13	1 M
R14	100 M
R15	10 M
R16	330 k (5%)
R17	2.2 k
R18	120 k
R19	10 k
R20	3.3 M
R21	3.3 M
R22	330 Ω
R23	1.5 k
R24	470 k
R25	270 k

R26	18 k
R27	6.8 k
R28	150 k
RV1	6-way switch and fine control total 10 M
RV2	25 k
V1	Type E.M.1.6260
V2	CVX2255 (VX8086)
V3	Corona stabilizer (1,000 V)
V4	Corona stabilizer (1,000 V)
V5	CV286
V6	CV286

C1	50 p
C2	50 p
C3	.001 μ
C4	100 p
C5	22 p
C6	3,300 p + .01 μ (5%)
C7	24 μ
C8	.5 μ
C9	2 μ
C10	.1 μ
C11	.25 μ
C12	.25 μ
C13	2 μ
C14	2 μ
C15	1 μ

T1	Ignition coil
T2	Vibrator transformer Secondary 1. 1.6 kV Secondary 2. 300 V
X1	Coil interruptor
X2	Constant speed motor
X3	Vibrator (12-V non-sync.)
MR1	K3/70T
MR2	K3/70T
MR3	K8/10T
MR4	K8/10T
MR5	K8/10T
MR6	K8/10T

diagram is shown in Fig. 4. The units are fully tropicalized, hermetically sealed against the effects of humidity and fitted with anti-vibration mountings.

#### 4.1. Probe Unit

The sodium-iodide crystal (activated with thallium) of dimensions  $1\frac{1}{2}$  in diameter and 1 in length is fitted in a sealed aluminium case containing a reflecting layer of magnesium oxide and is optically coupled (Fig. 5) to the photomultiplier cathode through a perspex plug smeared lightly with silicone grease. The anode of an 11-stage photomultiplier tube E.M.I. type 6260 (V1) is coupled to the "auxiliary cathode" of the cold cathode valve V2. A negative pulse of sufficient amplitude from the photomultiplier tube will cause breakdown of the auxiliary gap between it and the "trigger" electrode. After a delay of about 20  $\mu$ sec, breakdown of the main gap between anode and cathode occurs. Automatic bias for the auxiliary gap is provided by a priming current through R14.

The presence of luminous aircraft instruments will often increase the "background" counting rate in the scintillation counter. It is desirable to replace these instruments with those of the non-radioactive type and as an additional precaution to screen the crystal with an annular lead shield of 2 in thickness.

#### 4.2. Recorder Unit

When the main gap of V2 becomes conducting, capacitor C6 discharges through the limiting resistor R17 and the valve. Upon extinction of V2, C6 recharges from 158V through R16, R18, the microammeter M1 and the recording microammeter M2. The current through M1 and M2, suitably smoothed by the time constant R18.C7 ( $\sim 3$  sec) measures the pulse rate and is displayed for visual observation on M1 and recorded on M2 which has a Sangamo-Weston 6-in movement. Not shown in the circuit diagram of Fig. 4 is a five-position switch which, in conjunction with the meter M1 and suitable close-tolerance resistors, may be used to check certain circuit voltages without interrupting the recording from M2. Similarly a changeover switch may be inserted to decrease the ratemeter sensitivity by reducing the value of C6, for measurements on the ground in regions of high radioactivity.

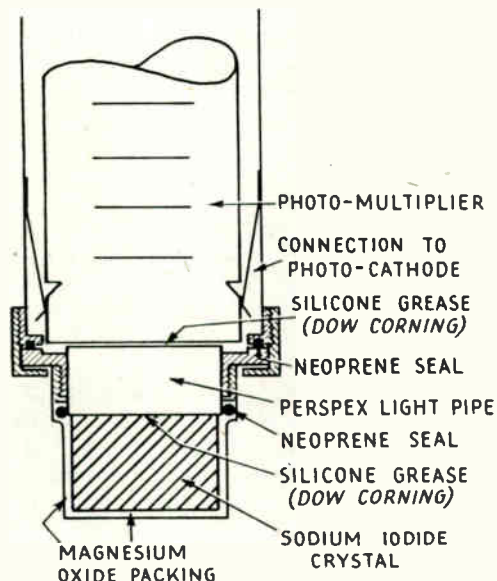

Fig. 5.—Assembly of photomultiplier tube and crystal.

The system of driving the recorder paper is conventional. The paper is drawn over the knife-edge from the spring-loaded sending spool "d" (see Fig. 1) by the sprocket teeth on a motor-driven spool "e", and thence to the receiving spool "f" which is connected by a slipping belt to the driving spool. The capacity of the sending spool is 75 ft of paper; paper speed may be varied by interchange of gear wheels between the governed motor (X2, Fig. 4) and driving spool. Also driven by the motor is the cam which operates the primary interrupter X1 of the "Lucas" 12-V ignition coil T1. The secondary winding of the coil is connected, through an interference suppressor R19, to the insulated knife-edge. The pointer blade of the recording microammeter is connected to the movement coil at the negative side which is earthed. The sparking circuit is completed by ensuring that one terminal of the 12-V accumulator is also earthed.

With a paper speed of 2.5 ft/hr. it was found that a minimum sparking rate of 5 per second was required to give adequate definition of the recorder trace. This rate applied to a ratemeter time constant of 3 seconds and should be increased for shorter time constants. The pointer blade which fitted tightly over the pointer was

pressed from duralumin tube of 0.003 in wall thickness. Slight oxidation of the blade after running for about 20 hours may upset the balance of the recording microammeter which is operated with the pointer moving in a horizontal plane. Use of a blade material more resistant to oxidation than duralumin, which was chosen for lightness, would lessen this effect.

Wandering of the spark from a vertical path between pointer blade and knife-edge is minimized by using recorder paper of 0.002 in thickness, the thinnest consistent with durability. The heat-sensitive paper used is manufactured by Recorder Charts, Ltd.

Datum marks alongside the record of radio-activity are provided by the remote "marker" switch which momentarily interrupts the trace. It is felt that a more presentable synchronization with navigational, magnetometer and other records taken in the same flight would be obtained through heated fixed pens marking at the extremities of the chart.

#### 4.3. Power Unit

The design of the vibrator power unit is conventional and is described briefly.

The e.h.t. voltage is provided by MR1 and MR2 in a voltage-doubler circuit the output of which is stabilized at 2,000 V by the corona stabilizers V3 and V4. Adjustment of the operating voltage for the photomultiplier tube is made by RV1 which is in series with the resistance network R1 to R13 of the photomultiplier tube V1.

The h.t. voltage is stabilized at 180 V by V5 and V6, after rectification in the bridge circuit of MR3 to MR6. The voltage applied to the valve may be adjusted to the nominal value of 158 ( $\pm 5$ ) by the pre-set control RV2. It should be noted that some samples of the valve VX8086 in the counting-rate meter circuit are inclined towards instability at the higher voltages in this range. When necessary this tendency has been corrected without loss of performance by reducing the h.t. voltage some 5 V below the threshold of instability.

The two stabilizer circuits are designed to accommodate variations in the primary supply voltage from 11 to 14.5. When installed in an aircraft this primary supply is obtained either from a centre tapping of the 24-V aircraft accumulators or from a separate 12-V accumulator on

continuous charge, through a dropping resistor, from the aircraft supply. Suppressors are fitted to the supply leads to prevent interference with the aircraft radio.

### 5. Operation

Satisfactory operation of the combination of scintillation counter and cold cathode valve VX8086 depends upon a matching of photomultiplier tube gain and valve sensitivity. The photomultiplier tube gain should be approximately  $2 \times 10^7$  (this is slightly above the average of production tubes) or greater and the valve input sensitivity in the circuit of Fig. 4 should be 1.5 V. Selection of photomultiplier tube according to gain could be avoided by use of the 14-stage E.M.I. tube type 6262.

#### 5.1. Plateau

Using a clear crystal of sodium iodide with efficient optical collection by the photo-cathode it can be shown<sup>8</sup> that, in the crystal, the energy of the electron, secondary to an incident gamma-ray and which is just detectable above the photomultiplier noise level is of the order of 10 keV.

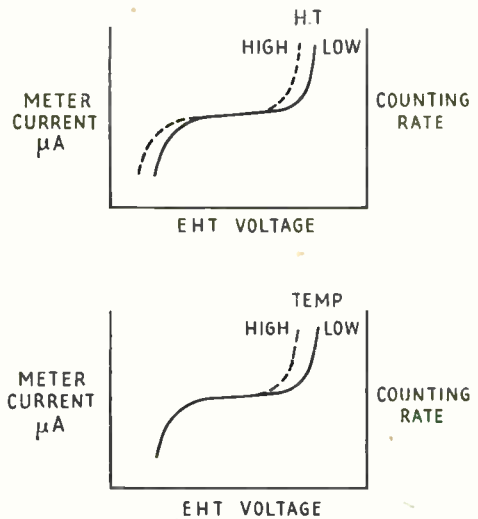

Fig. 6.—Operational characteristics of scintillation counter.

Since the photomultiplier tube gain varies with voltage ( $v$ ) as  $v^7$ , then a decrease in operating voltage of (say) 25 per cent. will raise the discrimination level from 10 keV to 75 keV. These

levels lie well below the main distribution of energy in the spectrum of the natural gamma-ray background activity, which extends to above 1 MeV (for uranium and thorium), with a predominant contribution around 0.2 MeV due to back-scattering. Therefore the stated change in voltage should not affect appreciably the registered counting rate. In fact plateaus of 500 V in length have been obtained with the best specimens of crystal, whilst a length of 200 V is usual with crystals of moderate quality. A typical plateau slope is 0.05 per cent./V comparable with the results from the average Geiger-Müller counting tube. The critical dependence upon operating voltage of photomultiplier tube gain is thus not reflected in the relation between counting rate and voltage in the plateau region. This property is important in the scintillation counter used for radioactivity survey in that it simplifies the setting up procedure and makes much less stringent the demand of stability from the power supply. Clear single crystals of thallium-activated sodium iodide may be grown by the method of Kyropoulos as described by Owen.<sup>9</sup>

Alteration of the h.t. voltage applied to the valve V2 will vary the input sensitivity of the counting-rate meter circuit, i.e., the level of discrimination applied to the pulses of variable amplitude from the scintillation counter. Adjustment of the h.t. voltage, as described in Section 4.3 and subject to the stability restriction, may be used in conjunction with adjustment of e.h.t. voltage to select a suitable operating point for the scintillation counter. Variation with h.t. voltage of the counting rate versus e.h.t. voltage characteristic is shown schematically in Fig. 6. The effect of increasing temperature as experienced in tropical climates is to shorten the plateau, by 100 V for 25°C rise. This is due to the increase in the number of noise pulses arising from the cathode of the photomultiplier tube. In practice the scintillation counter is operated at 100 V above the bottom bend of the plateau.

### 5.2. Sensitivity

The sensitivity of the airborne survey instrument is determined by the size of crystal and the constants of the ratemeter circuit. With the value of C6 shown in Fig. 4 meter and recorder currents of 10, 25 and 50  $\mu$ A correspond approximately to a counting rate at the photomultiplier tube of 800, 2,200 and 5,200 per minute. The

non-linearity of scale reading arises from counting losses during the recovery time of C6 in the ratemeter circuit.

Using a crystal as defined in Section 4.1 the counter will register 2,000 pulses per minute in a "typical" gamma-ray background at ground level. At an operating altitude of 500 ft above ground with the crystal shielded laterally in an aircraft reasonably clear of radioactive contamination the background counting rate is reduced to 600 per minute.

This background counting rate, which is of random occurrence, will fluctuate statistically thereby setting a lower limit to the detectability of the signal from a radioactive anomaly. A signal equal to three times the standard deviation of the background counting rate may be detected above the fluctuations; with an integration time of six seconds, i.e., twice the recorder time constant, this corresponds to about 230 counts per minute. The relation of this signal to the strength of the radioactive deposit is complicated and has been calculated fully elsewhere.<sup>2,3,10</sup>

An increase of sensitivity may be obtained by using longer crystals (of 2 to 3 in) in the present arrangement. A more significant increase is possible by using the new E.M.I. photomultiplier tube type VX5046, which has a 5-in diameter cathode, and a crystal of comparable size. Further increase in crystal size is limited by constructional difficulties and by light losses in transmission over large paths in the crystal. Since any signal is measured against fluctuations of a background counting rate, the sensitivity of detection is roughly proportional to the square root of the crystal volume.<sup>2</sup>

### 5.3. Flight Records

Figures 7 and 8 show records of activity measured in a Dakota aircraft flying at a speed of 160 m.p.h. and a height of 500 ft above natural radioactive anomalies occurring in territory previously unsurveyed. Fig. 7 represents the response to a localized deposit and Fig. 8 the effect of a more extensive one.

## 6. Conclusion

Two new principles are embodied in the design of the airborne scintillation instrument in an effort to achieve the maximum simplicity and reliability.

The combination of scintillation counter and cold cathode valve is extremely compact. The

recording microammeter measures the counting-rate meter current directly, thereby avoiding the complication of amplification.

The existence of a flat plateau in the counting rate-voltage characteristic of the scintillation counter simplifies considerably the design of the power supply and the adjustment of the instrument.

The complete instrument has satisfactorily completed tests in flight and more rigorous and prolonged trials mounted in a car surveying dirt roads in tropical climates.

**7. Acknowledgments**

This paper is published by permission of the Director, Atomic Energy Research Establishment, Harwell. Figs. 7 and 8 are published with the permission of Mineral Search of Africa (Private), Ltd.

**8. References**

1. D. H. Peirson. "A transportable radioactivity monitoring equipment used for geological surveying by car." Report No. EL/R750, 1951, Atomic Energy Research Establishment, Harwell.
2. D. H. Peirson and E. Franklin. "Aerial prospecting for radioactive minerals." *Brit. J. Appl. Phys.*, 2, October, 1951, pp. 281-291.
3. E. A. Godby, J. F. Steljes, et al., "Aerial prospecting for radioactive materials." Report No. CRR-495, 952, N.C.R., Canada.
4. J. Sharpe and D. Taylor. "Nuclear particle and radiation detectors—Part 2: Counters and counter systems." *Proc. Instn Elect. Engrs*, 98, Part II, April 1951, p. 209.
5. J. B. Birks. "Nuclear scintillation counters." *J. Brit. I.R.E.*, 11, June 1951, pp. 209-220.
6. E. Franklin and J. Hardwick. "The design of portable gamma- and beta-radiation measuring instruments." *J. Brit. I.R.E.*, 11, October 1951, pp. 417-434.
7. Mullard Radio Valve Co., Ltd., Patent Application 26866/50.

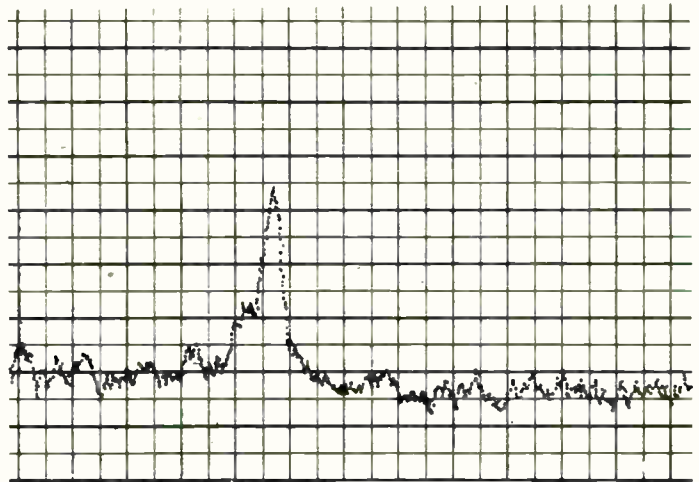

Fig. 7.—Flight record—localized radioactive deposit.

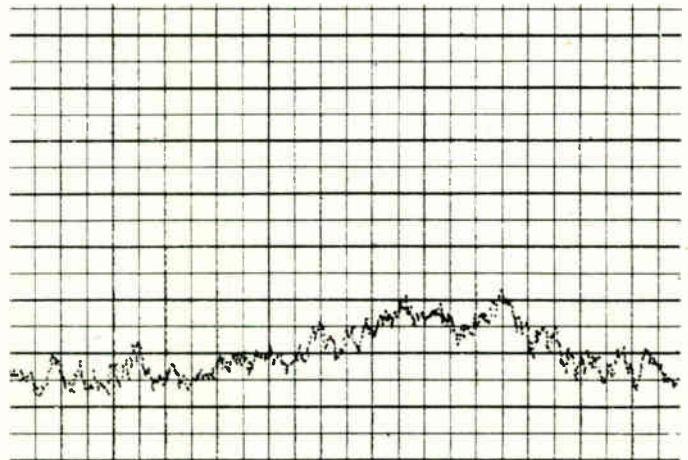

Fig. 8.—Flight record—extensive radioactive deposit.

8. D. H. Peirson. "Some cold cathode valve circuits used in the measurement of radioactivity." Report No. EL/R1204, March 1953, Atomic Energy Res. Est., Harwell.
9. R. B. Owen. "The growth of large single crystals of alkali halides for scintillation counting." *J. Sci. Instrum*, 23, July 1951, p. 221.
10. J. F. Steljes. "Aerial prospecting and the absorption of  $\gamma$ -radiation," (Correspondence). D. H. Peirson and E. Franklin (Reply), *Brit. J. Appl. Phys.*, 3, June 1952, pp. 203-4.

# AN AUTOMATIC RECORDER OF AERIAL RADIATION DIAGRAMS\*

by

E. G. Hamer, B.Sc.(Eng.) (*Associate Member*), and J. B. Lovell Foot†

## SUMMARY

The requirements of a machine which will plot the radiation pattern of aerials automatically are briefly outlined, and a design that meets these requirements is then described. The basis of the design is the automatic comparison of a local audio-frequency signal, and a signal of the same audio-frequency proportional to the unknown radio-frequency signal. Such a system has the advantage of being readily adaptable for a wide range of radio-frequencies. Arrangements are made for mounting large aerials at various heights and for the presentation of results in different ways. Facilities are also provided for indicating the relative field intensity when it is desired to plot by hand.

### 1. Specification of Plotting Machine

The importance of the electrical characteristics of the aerial in a radio system has been realized to a much greater extent in recent years. Unfortunately, the characteristics of an aerial are difficult if not impossible to predict analytically, unless the aerial is of a simple type. For this reason a great deal of time must often be spent in tedious and routine measurements. One of the important characteristics of an aerial is its radiation pattern (or, as it is sometimes known, polar diagram), and in many instances a series of pattern measurements have to be made as the electrical and mechanical adjustments are varied. After an adjustment to the aerial under test, a whole series of measurements of the radiated field strength at a number of different angular positions may have to be made and plotted before the next adjustment can be carried out. Owing to the long time taken to do this, serious errors may be caused by many slowly varying parameters, and it is often found that the beginning and end of a diagram do not join up.

The accuracy of measurement depends on two main factors. These are:—

- (1) The accuracy with which the amplitude of the received signal is measured.

\* Manuscript first received on October 28th, 1953, and in final form on December 12th, 1953. (Paper No. 250.)

† Communication from the Staff of the Research Laboratories of The General Electric Company, Limited, Wembley, England.

U.D.C. No. 621.397.67.012.12.

- (2) The accuracy with which the angle of rotation of the aerial under test is measured.

In the first case, if we assume that we plot the diagram fast enough to eliminate errors external to the plotting equipment, there remain errors introduced by the detector, and errors due to the inability of the recording pen to follow closely the varying amplitude of the received signal. An overall accuracy of  $\pm 5$  per cent. is considered satisfactory for most work; this was achieved in the machine to be described.

In the second case, the accuracy of angular measurement required depends to a great extent on the frequency of operation and the type of aerial under test. Most v.h.f. aerials radiate over a wide angle and the change of amplitude with angular movement is gradual. It is seldom necessary in such cases to have an accuracy of better than 2 deg. In the case of the centimetric wave bands, much smaller angles of radiation can be obtained and it is necessary for the plotting equipment to be accurate to within about  $\frac{1}{4}$  deg. In centimetric work particularly, it is very desirable to plot continuously as the aerial under test is slowly rotated, since there is a danger of missing important radiation which may fall between discrete points of measurement.

The need for an automatic machine that will plot the radiation pattern has been realized in the past and several papers have been published on machines for this purpose.<sup>1</sup> Each individual

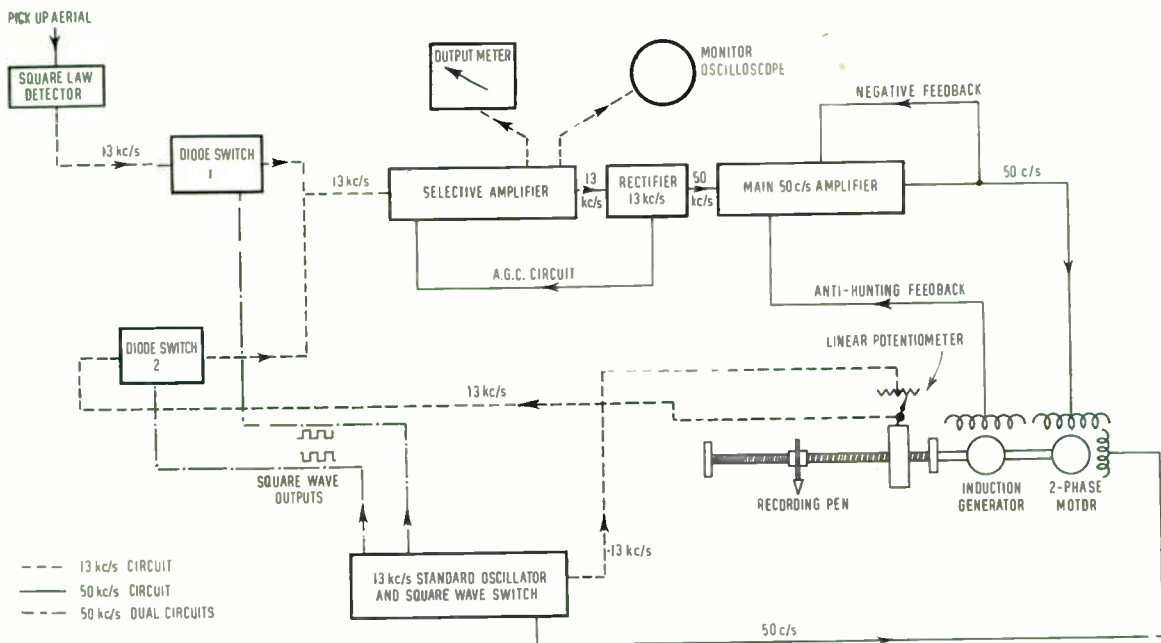

Fig. 1.—Block diagram of automatic radiation diagram plotter.

machine has had its limitations and in some cases these have been:—

- (a) Low electrical sensitivity requiring the aerial under test to be in close proximity to the pick-up aerial.
- (b) Not readily adaptable for a wide range of radio-frequencies.

It was felt that a step towards the ideal electrical characteristic would be as follows:—

- (a) Frequency range from 40 Mc/s to 10,000 Mc/s with easy adjustments.
- (b) Sensitivity sufficient to allow for an aerial separation of at least 10 wavelengths at the lowest frequency with a radiated power of 100 milliwatts.
- (c) Facilities for the diagrams to be plotted on polar or linear paper.
- (d) Adaptability for plotting relative field strength, or relative power.
- (e) Immunity from spurious signals, man-made noise, microphony, etc.

- (f) Full facilities for either hand or automatic plotting.
- (g) A dynamic range of at least 60 db variation in field strength before the main equipment has to be reset.
- (h) Adequate speed of response of the recording pen, and a total plotting time of less than 5 minutes.
- (i) Accuracy: amplitude  $\pm 5$  per cent.; angle of rotation 2 deg for v.h.f. band,  $\frac{1}{4}$  deg for centimetric bands.

Some of the requirements of the mechanical design are as follows:—

- (a) Portability.
- (b) Mast and turntable to carry a weight of 300 lb.
- (c) Mast to be non-metallic, and to provide a range of heights of 5 to 25 feet.

The importance of the height at which the measurements are made, and the separation



between the aeriels have been discussed in previous papers.<sup>2</sup> Briefly recapitulating, the separation of the aeriels should be greater than 10 wavelengths to avoid appreciable errors due to induction field components at v.h.f. At centimetric wavelengths the aerial separation may be thousands of wavelengths but in this case the physical distance is quite small.

The height should be such that, for vertically polarized components, the angle of the reflected wave does not lie near the "Brewster Angle," and the aeriels should be above the minimum effective height.

## 2. General Electrical Design Principles

The design of the automatic plotting equipment may be conveniently divided into electrical and mechanical problems, although these overlap in some cases. It is proposed to deal in the first instance with the electrical design problems.

Several alternative methods could be used to measure the level of the received signal; for example, the received carrier could be rectified and the resultant d.c. output amplified and used to operate a recording mechanism. The main difficulties inherent in this method lie in the design of a stable electronic d.c. amplifier, or mechanical servo amplifier when low field strengths are experienced.

In an alternative method, the received signal carrier level may be compared with the level of a locally generated signal, and the error signal used to operate a servo mechanism which adjusts the local signal level to be the same as that of the received signal. For convenience, this would probably be done at a low intermediate frequency, the signals being switched on alternately for the purposes of comparison. To avoid difficulties due to break-through, this might be achieved by switching the h.t. supplies to the oscillator feeding the aerial under test (or the local oscillator in the pick-up equipment) for the signal, and the local standard i.f. source.

Another alternative, adopted in the machine to be described, is to modulate the signal feeding the aerial under test, and to compare the received signal after demodulation with a locally generated, identical audio-frequency. A system of diode gate switching may be used for alternating the signals if a low frequency is

employed for modulating the carrier; this obviates the possibility of break-through occurring, and the amplitude of the output of the local oscillator may be varied by means of a precision potentiometer rather than by a piston attenuator which would probably be needed for the i.f. comparison method. This eases the design of the servo mechanism which has only to drive a light potentiometer with a low inertia rather than a heavy piston attenuator.

Figure 1 shows the block diagram of a machine using comparison of signals of low frequency and employing a two-phase servo motor to operate the recording mechanism and potentiometer. The phase of the a.c. supply to the control winding of the motor will depend upon which is the larger of the two signals being compared, and is arranged so that the system is self-correcting. If the motor is driving a linear potentiometer to which a pen with a linear motion is mechanically coupled the movement of the pen will be proportional to the unknown input voltage.

To minimize the effects of microphony and spurious signals, and for ease of design, a modulating frequency of between 10 kc/s and 20 kc/s is used, and the amplifier is made selective by the use of "parallel-T" feedback networks. The known and unknown signals are switched alternately at a repetition frequency of 50 c/s, and if the signal levels are different, there will be a 50-c/s component after demodulation of the selective amplifier output. The rectified output is then amplified and used to supply the control phase of the servo motor. The auxiliary winding of the motor is supplied from the 50-c/s supply mains, and the switching voltage is synchronized with the mains supply from which it is derived. To prevent hunting at low signal input levels a voltage from an induction generator mounted on the same shaft as the servo motor is fed back into the 50-c/s amplifier. As the selective and 50-c/s amplifiers are included in the servo loop any errors due to slow variation of the gain are eliminated; and in fact the selective amplifier is fitted with a.g.c. circuits to extend its operating range by avoiding overloading of the valves.

An alternative method of measuring the unknown voltage is one using a double linear potentiometer. This method proposed by Lecaine and Katchky<sup>3</sup> compares the unknown received signal against a standard signal which

may be derived from a monitor in the transmitting aerial circuits. It has the advantage that the pattern obtained is not affected by variations of the transmitted power; and the motion of the potentiometer is proportional to the received field strength. Referring to Fig. 2,  $E_m$  and  $E_s$  are the signal inputs from the monitor in the transmitting aerial feed, and from the receiving aerial. The twin gang potentiometer is at a position where  $\theta$  is the ratio of its present angular position to its maximum angular position.  $e_m$  and  $e_s$  are the monitor and signal outputs.

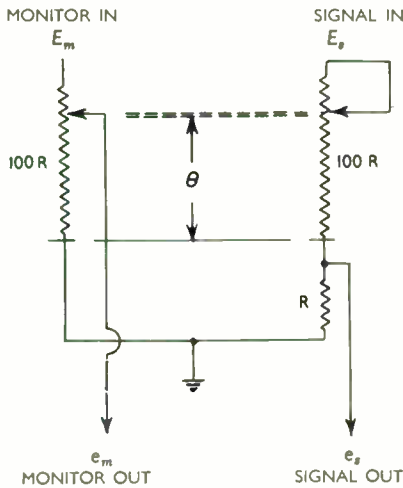

Fig. 2.—Twin potentiometer used for comparing monitor and received signals.

$$\text{Signal output} = \frac{R}{100 R \theta + R} E_s = e_s$$

$$\text{Monitor output} = \theta E_m = e_m$$

Now if 10 times  $e_s$  is compared against  $\frac{1}{10}$ th of  $e_m$  and the two kept equal by means of the system described (gating circuits and servo control of  $\theta$ ) then:

$$\frac{\theta E_m}{10} = 10 E_s \frac{R}{100 R \theta + R}$$

$$\approx \frac{E_s}{10 \theta}$$

$$\therefore \theta^2 = \frac{E_s}{E_m}$$

$$\theta = \sqrt{\frac{E_s}{E_m}}$$

In the system described the standard source  $E_m$  would have a constant level and hence  $\theta \propto \sqrt{E_s}$ , and if square law detectors are used  $\theta$  will be proportional to the received field strength.

The approximation used gives an error of 0.1 per cent. at 1 per cent. of full scale and less at larger readings.

### 3. Detailed Description of Electrical Circuits

#### 3.1. Pick-up Head

Diagrams which are required to have a linear power scale are plotted by using a full-wave bridge of germanium or silicon rectifiers connected to the pick-up aerial. The input-output characteristic of the circuit is measured to ensure that the rectifiers are being operated on the square law part of their characteristic; and under these conditions the audio frequency output voltage is proportional to the received radio-frequency power.

#### 3.2. Selective Amplifier

Figure 3 is a block diagram of the selective amplifier and switching unit. The unknown signal is fed to a calibrated attenuator included in the circuits of a pre-amplifier; negative feedback is used to stabilize the gain of the pre-amplifier at 20 db, and the output is fed to one of the diode switches. The other diode switch is fed with the known reference voltage, and the diode switches are operated sequentially by 50-c/s square waves. The pre-amplifier raises the level of small unknown signals above the level of the residual switching noise. After the diode switches the alternating outputs from the unknown and local sources are fed to a four-stage selective amplifier, using two "parallel-T" feedback networks. In this instance the "parallel-T's" are tuned to a centre frequency of 13 kc/s and have an overall bandwidth of  $\pm 1.5$  kc/s at the 3-db points. The output is then rectified and there will be a 50-c/s component if the signal levels are different; this output is taken through a 90-c/s cut-off  $m$ -derived low pass filter to the 50-c/s amplifier. Auxiliary outputs are taken from a position before the rectifier to operate a monitor

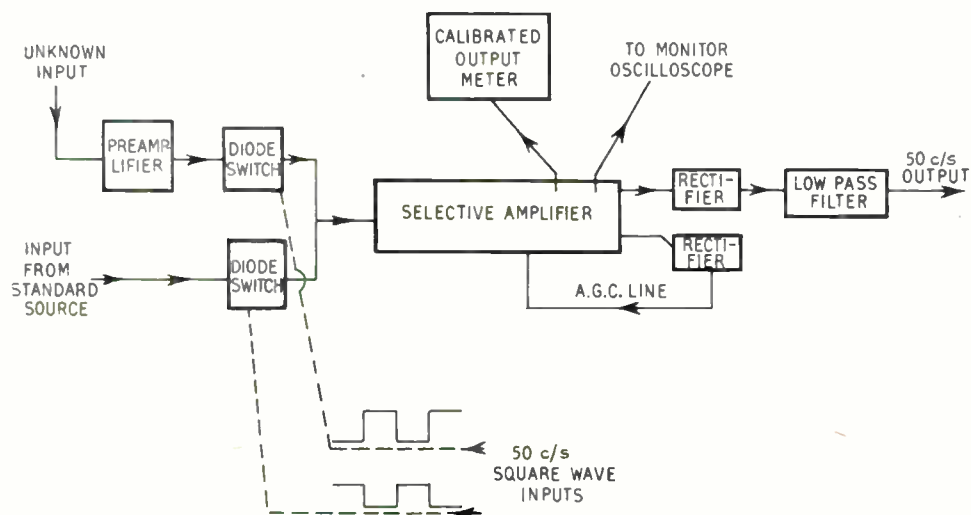

Fig. 3.—Block diagram of selective amplifier.

oscilloscope and a rectifier meter. The rectifier meter is calibrated and used in conjunction with the calibrated input attenuator for hand plotting. Automatic gain control may be applied over the latter half of the amplifier when plotting automatically, and this increases the 13-kc/s signal range to 70 db before either overloading or switching noise causes errors. As the a.g.c. part of the amplifier is in the servo loop any slow variation of gain will not cause errors when plotting automatically. With no a.g.c. in use the overall maximum gain from input to rectifier is 110 db.

### 3.3. Square Wave Generator and Standard Audio Frequency Oscillator

A 50-c/s supply from the mains is taken to a phase shifting unit and then drives a pair of squaring valves. The output from the squaring valves drives cathode followers connected to diode clamp circuits; and in this way four square wave outputs are obtained. Outputs A and B are wave 1 either positive- or negative-going, and outputs C and D are wave 2 phase-shifted 180 deg (electrical degrees) from wave 1 and either positive- or negative-going. The two negative-going square waves are connected to

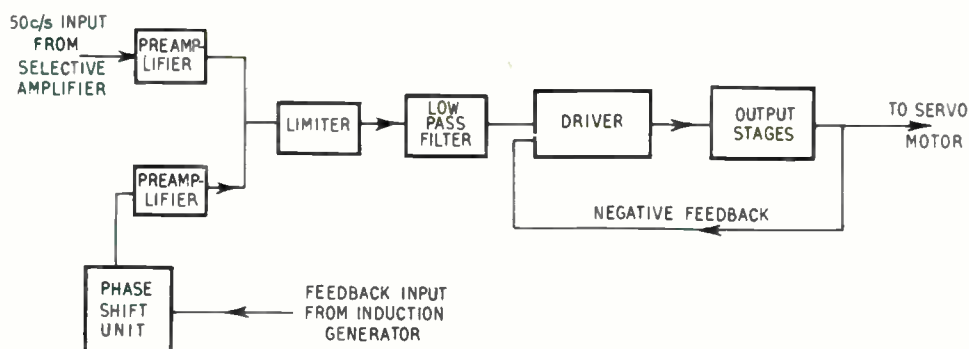

Fig. 4.—Block diagram of 50-c/s amplifier.

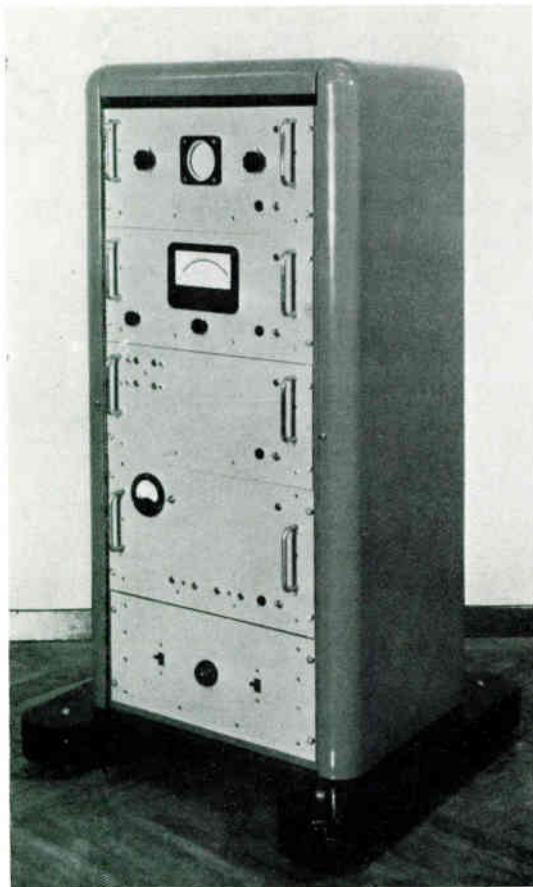

Fig. 5.—Front view of rack carrying electrical circuits.

their appropriate diode switches. By varying the phase shift control the current in the servo motor control winding supplied from the 50-c/s amplifier can be set to be in quadrature with the current supplied from the a.c. mains in the auxiliary winding.

Included in this panel are the standard 13-kc/s oscillator and buffer amplifiers which feed the level controls and the potentiometer on the control console.

### 3.4. 50-c/s Amplifier

A block diagram of the 50-c/s amplifier is shown in Fig. 4. The output from the selective amplifier is combined with the feedback voltage

from an anti-hunting induction generator mechanically coupled to the pen servo motor. The phase of the feedback voltage may be varied by a suitable network to ensure that it is normally in antiphase with the incoming 50-c/s voltage. A diode limiter is used beyond this point to prevent the output stage of the amplifier and servo motor from being over-excited by large out-of-balance signals. The limiter feeds a low-pass filter, a driver valve, and then a pair of push-pull output valves, which give a maximum output of 30 W. The negative feedback circuit includes the driver valve and output transformer to give a low output impedance to the amplifier. This serves two purposes:—

- (a) Eddy current braking of the motor occurs when balance conditions are approached.

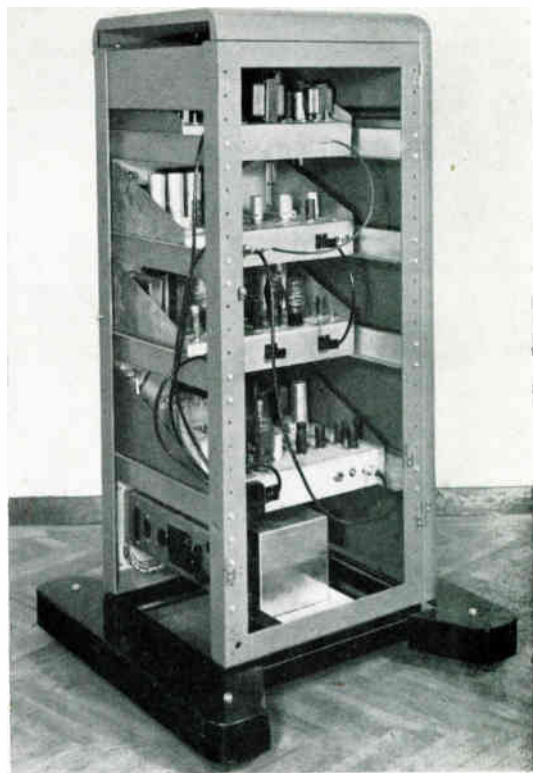

Fig. 6.—Rear view of equipment rack.

- (b) Effects due to the large changes of effective impedance of the motor winding as the speed is varied are minimized.

As previously mentioned, an additional safeguard against any tendency to hunting at low input signal levels is provided by means of a feedback voltage from an induction generator mounted on the same spindle as the servo motor. This voltage is fed back into the main 50-c/s amplifier in antiphase with the original signal driving the servo motor. If the servo motor overshoots, the phase of the driving voltage will change by 180 deg, but the feedback voltage will be still in the same phase, and hence will now add to the input 50-c/s signal. With the motor at rest, there will be no feedback voltage: hence there can be no errors due to the damping effect of the induction generator. If, however, too much feedback is applied, the speed of the motor and hence the speed of response will be reduced, and the pen may not follow if the unknown input signal is varying rapidly. A motor balance meter is fitted to the console to show if failure to follow occurs; and in this case the turntable speed must be reduced by the use of hand control until the critical part of the diagram being plotted has been passed.

### 3.5. Monitor Oscilloscope

An oscilloscope is arranged to monitor the output from the 13-kc/s section of the selective amplifier, and its linear time base operates at a repetition frequency of 25 c/s in order that the rectangular pulse envelope of 13 kc/s may be seen. By observing the heights of the pulses, a check can be kept that the servomechanism is adjusting the amplitude of the local signal to be the same as that of the unknown signal.

The oscilloscope unit may also be used in conjunction with a "resistance-capacitance" variable frequency oscillator as a frequency monitor. By observing a Lissajous pattern, the audio frequency of the local standard source, and the unknown source can be compared.

This completes the description of the electronic part of the apparatus. Figures 5 and 6 are photographs of the electronic equipment mounted in a standard 4 ft 6 in rack cabinet. The top panel is the oscilloscope unit, the second panel the selective amplifier, the third panel the standard audio-frequency source and square wave generator, the fourth panel the

50-c/s amplifier, and the fifth panel the control and supply unit.

## 4. Mechanical Details

### 4.1. Mast and Turntable

Figure 7 is a photograph of the turntable and a detachable mast. Several masts of different length are provided. These are constructed

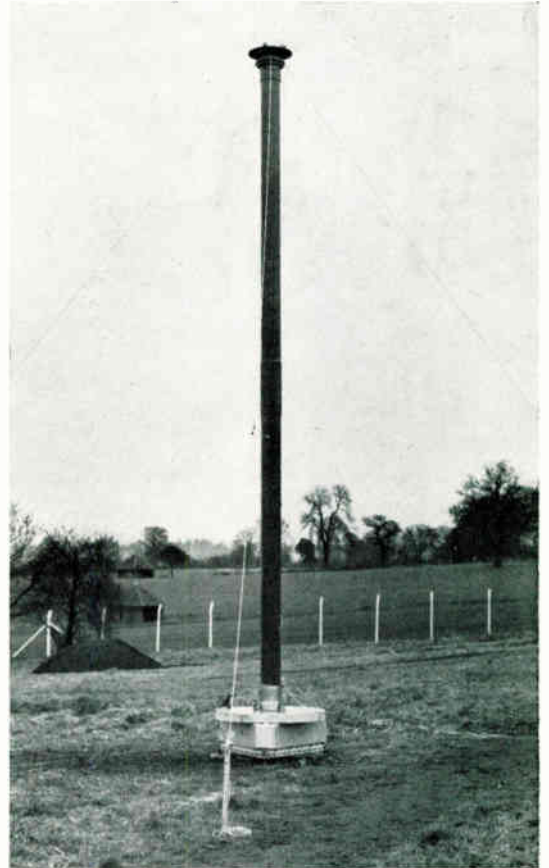

Fig. 7.—View of the turntable and mast.

from impregnated cardboard tubes, with Tufnol fittings, and the longer ones are guyed by nylon ropes secured to a non-metallic ballrace. Laminated plywood is used for the turntable disc, and this is centred by means of a large ballrace; the downward thrust is carried by three rubber-tyred wheels. One of these wheels is

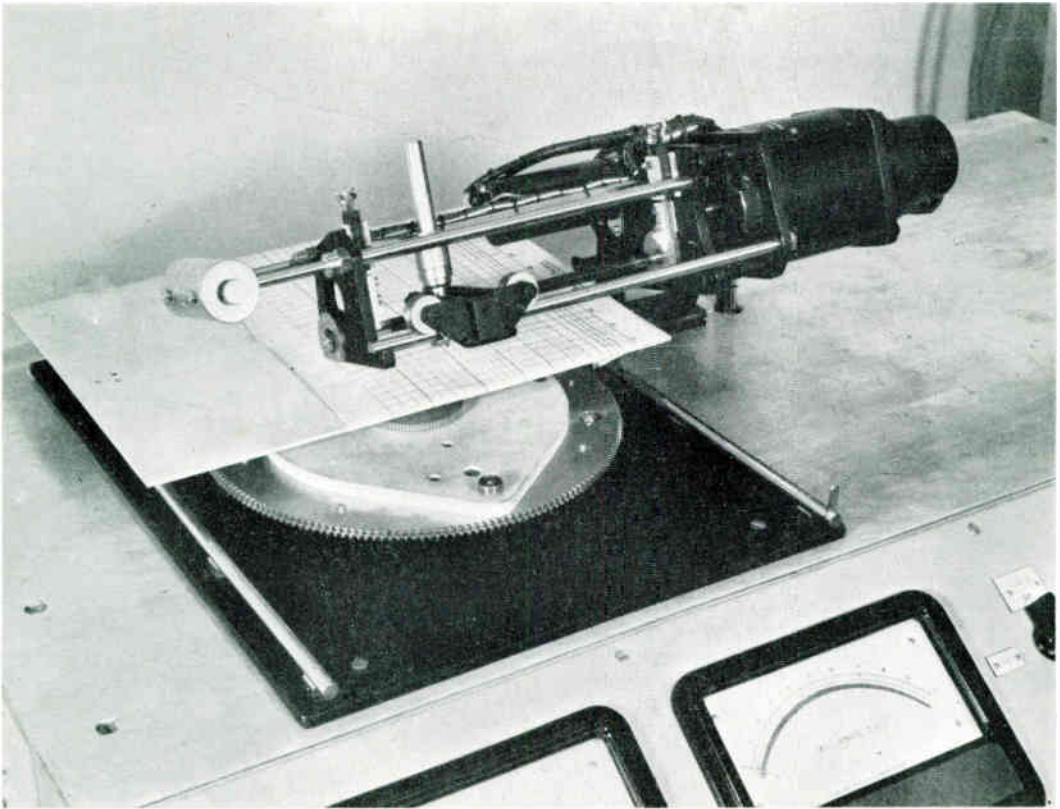

Fig. 8 (left).—General view of the desk console.

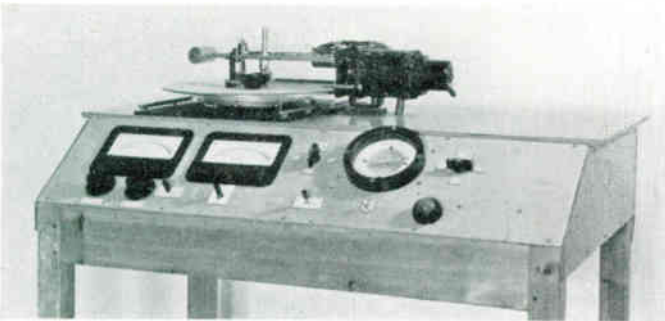

Fig. 9 (top).—View of the plotting table and pen mechanism.

driven by a reduction gearing from a small reversible electric motor. A selsyn is geared up through anti-backlash gears with a ratio of 12 : 1 to the turntable, and is used to indicate the angular position of the mast. The whole structure is carried on a lightweight framework, and is fitted with three levelling screws, and weather shields.

#### 4.2. Desk Console

Figure 8 is a view of the desk console showing the plotting mechanism on the top, and the control panel at the front. The meters indicate the level of the standard source, and the motor control winding voltage. The circular scale is a fine-angle indicator, calibrated 0 deg to 30 deg for 360 deg rotation of the pointer. Other

controls are fitted for manually operating the pen mechanism, turntable motor, selsyn, and the automatic angle selector. Contacts are arranged on the selsyn spindle and turntable so that by pressing a start button the mast will turn either a complete 360 deg, or at 5 deg or 10 deg intervals as required. Smaller angles are obtained by using the turntable motor control switch in conjunction with the fine-angle indicator.

Figure 9 is a close-up view of the plotting table and pen mechanism. A selsyn electrically connected to the selsyn at the mast turntable is geared down by 12:1 ratio gears to drive a spindle. To this spindle three different arrangements of table can be attached:—

(1) A circular table for the polar plotting of diagrams, (2) A rack-operated table for the linear plotting of diagrams; (3) A special cosine law movement table for use when diagrams have to be amended to the same total radiated power.

The pen mechanism is shown in more detail in Fig. 10. The servo motor drives the pen by a lead screw, and the linear potentiometer is coupled to this lead screw by suitable anti-backlash gearing. In this way the audio-frequency output is linearly proportional to the movement of the pen. Limit switches are fitted to prevent any damage which might be caused if the pen were allowed to overrun its normal limits. Coloured ball pen refills are used to mark the paper. The whole of the pen carriage is arranged to swing clear of the plotting table when it is desired to change the paper on the plotting table.

## 5. Operation of Equipment

When in use for automatic plotting, the size of a diagram may be varied by altering the reference level from the standard source. This is done by means of a step attenuator and variable potentiometer in conjunction with the set-level meter on the desk console. The console level controls are designed so that over the whole of their range the selective amplifier cannot be overloaded. For

patterns outside this range the attenuator on the selective amplifier rack panel may be altered.

Accuracy of angular measurement is ensured by the use of geared selsyns and the total error from all sources is less than  $\frac{1}{2}$  deg. No gearing is used on the fine-angle selsyn so that it rotates one complete revolution for a change of angle of the main turntable of 30 deg. Trip-operated switches are fitted on the turntable and selsyn spindles which operate at 0 deg and at every 5 deg and 10 deg intervals; hence, by the use of an auxiliary relay and selector switch, the mast can be automatically turned 5 deg or 10 deg steps when hand plotting. Eddy current damping is used to prevent overrun of the turntable motor, and of the pen motor when the limit or control switches are operated.

The time taken for the pen to traverse from zero to its maximum value is 5 seconds and hunting is not experienced even when the unknown input is slowly reduced to zero and the pen approaches the centre of the table.

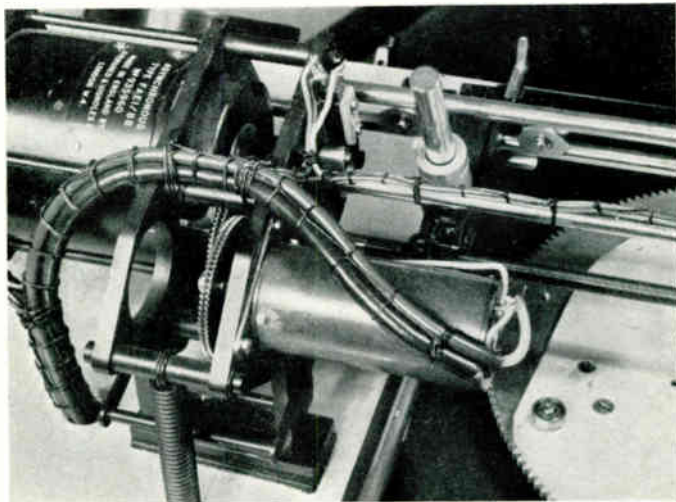

Fig. 10.—Close-up view of the pen mechanism.

## 6. Alignment of Equipment

Certain precautions must be taken when the equipment is aligned initially to secure optimum results, and the following procedure is adopted:—

- (a) With no input signals from the standard and unknown sources the gain of the

50-c/s amplifier is increased until the residual switching noise is just sufficient to make the servo motor jitter but not rotate. Under these conditions the servo loop circuit is operating at its maximum usable gain.

- (b) An input is applied from the local source only, and with the servo motor spindle locked, the phasing control of the square wave generator is varied until the current in motor control and auxiliary windings is in quadrature.
- (c) The motor is then disconnected from the potentiometer and allowed to run, and the phase of the feedback voltage is arranged to be in antiphase with the input voltage at the point where these two signals combine.
- (d) The equipment is then connected in its normal manner, the standard reference voltage increased to its maximum value, and a variable input voltage applied. The amplitude of the feedback is then slowly increased until hunting does not occur as the pen approaches the zero signal position.

If these alignment methods are not carried out the following may occur:—

- (e) Too large an amount of feedback will slow down the speed of response of the pen.

- (f) Insufficient gain causes errors similar to those owing to backlash, as the pen will take up different positions according to which way it approaches the balance position.

## 7. Conclusions

The equipment described meets nearly all the requirements of the specification quoted earlier in the paper, and has been arranged so that any errors or faults can easily be observed and checked. The speed of response is adequate to give a great saving in the time taken for plotting, and yet avoid serious design difficulties. The time taken to obtain a complete diagram is 4 minutes; and the equipment is readily adaptable to a wide range of radio-frequencies.

## 8. Acknowledgment

The authors wish to thank the Ministry of Supply for permission to publish this paper.

## 9. References

1. "Polar diagram plotter." *Wireless World*, 52, February 1951, p. S4.
2. E. G. Hamer, "V.h.f. aerial radiation pattern measurements." *Electronic Engng*, 25, October 1953, pp. 427-431.
3. H. Lecaine and M. Katchky, "Microwave antenna beam evaluator." *Electronics*, 20, August 1947, pp. 116-120.



## EDUCATION IN THE RADIO AND ELECTRONICS INDUSTRY\*

*A Report of a Discussion Meeting held by the Merseyside Section in Liverpool on December 3rd, 1953*

### SUMMARY

The discussion of education problems is frequent among the Local Sections of the Institution at their meetings, quite apart from the publication in the *Journal* of general reports approved by the General Council. The first, and probably the most important of these reports was the "Post-War Development Report—Part Two," followed by "Education and Training in the Radio Industry." This discussion shows the present position in technical education for the Radio and Electronics Industry on Merseyside. Those taking part dealt with education at the universities and in technical colleges, as well as training within industry and government departments.

#### Introduction

In introducing the discussion the Chairman, Mr. R. A. Spears, said that it was intended that its scope should include "education for the industry" as well as "education in the industry." He referred to the shortage of radio engineers and to the low pass rate for examinations held by the Institution and other bodies.

#### University Education

Mr. J. Durnford, B.Sc.(Eng.),† dealt with the work of the Universities in training engineers.

It has been stated that our economic survival depends—among other things—upon the rapid development and effective application of scientific invention and research. Experience during the last war has shown that this calls for men in whom are combined the characteristics of both the scientist and the engineer.

Such "engineer-scientists" may be defined<sup>1</sup> as those "capable of interpreting scientific progress in relation to industrial possibilities and of applying scientific methods of analysis to the problems which arise in each progressive stage of development." It is with the training of such men that engineering and other applied science departments of a university should be primarily concerned.

Entrants to an engineering course should have a good general education, ability in mathematics and science, and, more difficult to assess, the

correct temperament. With respect to the latter, desirable attributes are an ability to think clearly and analytically, a lively and scientific mind, and in the words of Professor Cramp, spoken in 1911, "a high coefficient of self-instruction." To ensure that entrants do possess such characteristics requires a closer co-operation between the schools and the universities than exists at present.

The university training aims at establishing a sound scientific foundation, at developing an analytical outlook and at encouraging a healthy questioning attitude. It is often thought that the relative leisure of university life is favourable to the development of such personal qualities, but it must be realized that in engineering departments crowded time-tables and intensive homework leave the student very little time.

An important consideration to the universities is the obligation of industry—and to-day it is not putting it too strongly to call it an obligation—to be responsible for the greater part of the practical side of the training. This obligation is only now becoming generally recognized, although a number of the larger concerns have, for some time, run "college apprentice" courses, usually for one or two years after graduation.

It is almost always of benefit to both sides—the employer and the graduate—that the latter should first obtain experience of the various products or activities of a concern, and also that he should have the opportunity to find out which field is most suited to his interests and ability. I personally feel that such post-graduate courses should be regarded as essential and that, without comparable experience, a man should not be allowed to take up a professional post immediately on graduation.

\* Discussion meeting No. 5. The opinions expressed by the speakers in the discussion do not necessarily coincide with the views of the Institution as a body.

† Electrical Engineering Department, University of Liverpool.

U.D.C. No. 378 : 621.37/9.

Although electrical engineering has been a university subject for more than 50 years, the courses in it have often suffered from the fact that mechanical engineering could claim priority or was given undue emphasis; complaints to this effect were voiced in 1936<sup>2</sup> and probably earlier. In a similar way the courses in light current or communication engineering before and during the war were subordinated to those on the electrical power or heavy current side. It was not, in fact, until the end of the war that electronics was generally recognized as a new field, requiring a new and wider approach. The fruitful wartime co-operation of the physicist and the engineer had shown the need for including more basic physics of materials, and for a broader treatment of circuit theory, for example, so that steady state and transient analyses might be brought closer together. The relative emphasis on the scientific and technical aspects of a subject must to some extent be a matter for individual belief; the true engineer, however, wants to apply his mathematics and science and, at least as a student, promptly jibs if they appear too "pure" and unrelated to practical requirements.

It may be helpful, at this stage, to outline the engineering course at Liverpool University, following in the main a path leading to the first degree in Electrical Engineering (Electronics).

In common with other universities, we are privileged in being able to decide for ourselves the content and treatment of any course; in spite of this it does not appear that in practice any significant differences exist between universities, at least not in the earlier parts of a course.

The engineering course is nominally a four-year one, but effectively it is only three, since 80 per cent. to 90 per cent. of the students start with the second year, termed Final Part I (1st Year); this is followed by Final Part I (2nd Year) and, lastly, Final Part II. The training is intended to be broad-based, tapering off to relative specialization in each branch in the final year. In the Final Part I (1st Year) no distinction is made between the intending electrical, civil and mechanical engineers and all do the same lectures and laboratory work. At this stage there are two lectures a week in electrical engineering and six lectures a week in mathematics.

In the Final Part I (2nd Year) the mechanical and electrical courses separate from the civil course, and, to a slight extent, from each other, but no distinction is yet made within the electrical group.

In this year the electrical students have four lectures a week on electrical subjects and seven lectures a week on mathematics; on an average about one-and-a-half afternoons per week are devoted to laboratory work. The results at the end of this year determine the division into Honours and Ordinary Degree candidates.

In the Final Part II Year the electronics students have nine lectures a week, three of which are taken in common with the electrical power students, and two lectures a week on mathematics.

The subjects are:—

Electronics 1 and 2	3½ lectures a week (average)
Electronic Circuit Theory	.. 1 " "
Electrical Circuit Theory	.. 1 " "
Electrical Technology	.. 1½ " " (average)
Electro-magnetism	1 " "
Communications	.. 1 " "
Mathematics	.. 2 " "

Three afternoons a week are devoted to laboratory work and one to miscellaneous design problems. In one term the practical work forms the basis of a thesis; in this a group—of one or two students—tackles an experiment as a piece of research, constructing some of the equipment if necessary, and at the end each member writes a separate thesis. The net progress that is made is often much less than with well-tried laboratory experiments, but most students benefit considerably from having to plan the work themselves and sort out their own mistakes. As far as possible the students are encouraged to choose their own problems, on the grounds that this results in greater interest. In addition to the thesis, each student has to prepare and deliver a short paper—lasting about 25 minutes—on a topic the information for which is obtained from the literature. This aims at developing the ability to extract, condense and present information in a lucid manner, at the same time accustoming the student to speaking in public.

During the final year the Honours and Ordinary candidates do the same work, except for mathematics; in the final examinations, however, the Honours student has to take all eight of the papers

set, whereas the Ordinary candidate is required to take only five, some of which are compulsory. In addition, both must have reached a satisfactory level in practical work.

It can be seen from the above short survey that a Liverpool Electronics graduate has indeed a broad-based training; in fact a closer analysis shows that he spends only 40 per cent. of his lecture time on electrical subjects, and 30 per cent. on mathematics.

### Training in the Post Office

Mr. F. J. Behets\* then followed with an account of the training facilities and courses of the Post Office Engineering Department.

The recruitment and training of personnel for the Liverpool Telephone Area is governed by a National Policy which is varied to suit local conditions. Both youths and adults are accepted as recruits.

The youth is recruited and trained to become eventually skilled in the installation and maintenance of the more complicated internal telephone equipment associated with automatic telephone exchanges and repeater stations.

The adult is recruited and trained to take his place in working parties performing external duties such as cabling and jointing. Such training as these men require is given on the jobs and by attendance at specialist courses at the N.W. Regional Training School in Manchester. Such courses are held on underground and overhead constructions, cable jointing, telephone fitting and external maintenance.

The youth is given a specialized training following a definite syllabus. He is recruited usually at the end of the summer term from grammar schools or technical schools between the ages of 16 and 17½ and should normally have obtained the General Certificate of Education (Ordinary Level) in mathematics and physics. Youths without the General Certificate of Education will quite often satisfy an interviewing panel and, whilst not quite up to the education standard, are accepted if they show interest and ability by way of their hobbies and other activities.

The youth commences duty on a 101-week training course. This course is split into three main parts, the greatest part being spent in

training on the job, with and under the eye of skilled personnel; the other two parts are attendance at the "A" and "B" courses held at the N.W. Regional Training School, Manchester.

The "A" course with a duration of five weeks is taken during the youth's first six months of service and consists of lectures and practical instruction in overhead and underground construction, fitting, and in the more simple forms of telephone equipment, together with the relevant technical and theoretical study.

The "B" course has a duration of eight weeks and is taken during the second half of the 101 weeks' training. The purpose of this course is to give a broad picture of internal construction and maintenance work and to consolidate the experience gained by the youth during his initial practical training. Greater detail is given in the less technical types of work and an introduction is made to the more advanced techniques.

For the other 88 weeks of his training the youth is allocated in turn for specific periods to different types of duties, and works directly with and under supervision of skilled men. He progresses from the more simple outdoor duties to the maintenance duties in the manual and automatic telephone exchanges and repeater stations. Each period spent on the different types of work is covered by a syllabus, on which tests are given.

During the whole of the 101 weeks the training officer is responsible for the steady progress of the youth through the syllabus and for periodic interviews, the inspection of note-books, and the tests held. Note-books are maintained at every phase of the training and are subject to scrutiny from time to time by the supervising officer to whose staff he is allotted.

Parallel with his practical training the youth undertakes theoretical training by attendance on one day per week at the day continuation classes organized by the local technical colleges. He is entered at the first-year level of the Telecommunications Engineering Course covering Mathematics for Telecommunications Principles I, Telecommunication Principles I, and Elementary Telecommunications Practice. The youth will take the college examination in mathematics, and the City and Guilds examinations in the other two subjects at the end of the session. If he is successful the youth will progress to the second-year day course the following year and, if unsuccessful, will repeat the first year course. He is expected to have

\* Post Office Engineering Department.

obtained the first-year certificate before the completion of his 101 weeks' training.

At the end of that 101-week period and prior to call-up for national service, the youth is given a test in theory and practice and, if satisfactory, is upgraded to the technician grade just before departure for the forces. He is also encouraged to continue his studies whilst serving.

On return to duty from military service the man is expected to continue his studies by attendance at the telecommunications evening courses run by the technical colleges and financially assisted under a departmental scheme; he will take a full course or single subjects dependent upon his capabilities until his limit in that direction is reached. The holding of City and Guilds Certificates at the first-year level in Telecommunications Principles and Elementary Telecommunications Practice is the normal entry to the panel for promotion to technical officer, whilst an Intermediate Group Course Certificate gives entry to the panel for promotion to the supervising grades.

With regard to his work the youth—now a technician—is allocated to a particular section of the engineering division by a small interviewing panel, who have in their possession his record as a youth-in-training. Once allocated the man will be progressed in his duties over the years by attendance at the Engineering Department Central Training School at Stone in a sequence of training courses from the basic level to the most complicated specialist duty level, each progression being dependent on a pass on the previous course. Such sequences are held in automatic telephony, telephone transmission, radio, power, etc.

There is also within the engineering department some direct recruitment to the supervising grades by competitive examinations which are held for appointments to the assistant engineer and executive engineer grades. For each grade, one examination is limited to Post Office employees and another is an open competition. In the case of the open competition for executive engineer, candidates are normally university graduates having an honours degree in mechanical and electrical engineering or physics, and appointments are made by selective interview.

The training of these entrants is provided by initial courses, including management, at the central training school, and by attachment on the various duties they may be called upon to perform.

### Training in Industry

Mr. E. E. Prince\* described a very similar training scheme which exists in the industry, and he pointed out that his problem was similar to that of Mr. Behets in that the training with which he was concerned was principally for automatic telephone exchange work.

There are, in the main, three classes:

- (a) the ordinary apprentice,
- (b) the junior student, and
- (c) the graduate apprentice.

The junior students are boys usually from grammar schools who have attained the General Certificate of Education (Ordinary Level); it is compulsory for them to have passes in mathematics, physics and English. Although the Post Office do not insist on a pass in English, my particular organization considers it particularly important.

They are started off on a four years' apprenticeship, which has the Ministry of Labour's approval, with the result that they are reserved from National Service until the end of their training. Of the first four years' training they spend the first 12 months in going round the main factory departments, including, fairly early, a tour of about six weeks in the training school so that they may learn to use soldering irons, wiring pliers, etc. During the summer months of their first year, when the technical schools are closed, they are sent out on installation work to an exchange in its early stages, in order to see the floor being laid out, and to help erecting the racks, cable runways, etc.

During the second year they proceed with their technical studies, and at the same time continue the factory experience on some rather more intricate and specialized work in inspection and functional testing which they are now able to understand.

The second summer is reserved for Post Office maintenance. A reciprocal training scheme has been arranged and in return Post Office engineers are given a training period.

The third summer is spent on installation of switches, bank jiggling, final testing, and commissioning.

The last year is not spent on practical training. Their proper place inside the organization has been decided during their previous training, and in their fourth year they are started off in one of the engineering departments, such as the circuit design

\* Automatic Telephone and Electric Co. Ltd., Liverpool.

and equipment sections, or the switching and development laboratories.

As a rule, the department chosen is the one to which they will return after National Service. Usually these students are selected for the Royal Corps of Signals.

From the academic point of view the training scheme is much the same as the Post Office, but the company does not at present grant any day release until the third year. They are expected, in the third year, to attend one evening class a week. It is interesting to note that they generally elect to take radio, which is a definite pointer to the direction in which they desire to specialize.

The difficulty my organization has experienced with the graduate apprentices is probably typical of the experience of other companies. In the first place they are prepared to stay only for the two years' course, and even that only because they feel this to be almost essential for acceptance by the industry as an engineer.

They also give the impression that they expect to be treated as specially favoured people and to be spoon-fed. This is, of course, a generalization, and there are some very good graduate apprentices. However, the majority are anxious to avoid work which has only training purposes.

It is worth considering that some of the practical training which is now given to graduate apprentices should come before the student enters university. This would not only avoid some of the problems which are experienced to-day, but give the undergraduate an engineering sense prior to his university training. Alternatively, the practical academic training could be arranged perhaps as a sandwich course.

### Technical College Education

Mr. J. E. MacFarlane, B.Sc.(Eng.),\* then described the further education facilities available at the College of Technology, Liverpool.

One of the greatest developments in engineering in the last 20 years has been in electronics and it has to be dealt with in a variety of ways. In further education the technical colleges cater for a wide range of students, and for a large city like Liverpool there is the main college of technology with other feeder colleges.

The course has been split up into three groups: craftsmen, technicians and professional engineers.

\* Electrical Engineering Department, College of Technology, Liverpool.

At a technical college there are students from three groups. Earlier work is carried out at the branch technical colleges, and their work will, of course, grow as the years go on. Considering the City and Guilds of London Institute Telecommunications Engineering Syllabus, there is a six-years' part-time course to the Final Technological Certificate level. Quite a number of students are excused the first year if their previous education has reached a certain minimum level in mathematics and science.

The next two years' study leads to the Intermediate Group Course Certificate in Telecommunications Engineering. This course is "semi-craft" in nature.

After a further two years, students proceed to the Final Group Course Certificate which trains them for posts as technicians. Hundreds of this type are needed on the factory floor even though some will go into laboratories and design offices.

After the Final Group Course Certificate there is the full Technological Certificate which is fully professional in content, but the number of students who reach this stage is limited.†

If we consider the courses in Electrical Engineering the following figures may prove of interest in comparing the relative number of students at an eight-year interval.‡

The 1952-53 totals are: 380 attending electrical engineering classes, and 243 telecommunication classes. Compared with 1944-45, there has been an increase in students of 30 per cent. and in telecommunications of 15.6 per cent.

It appears from these figures that more people are going in for electrical engineering than telecommunications. However, considering the university as well, it is safe to say that greater numbers are qualifying in light current than heavy current.

With regard to the National Certificate Schemes on Merseyside, if anyone wishes to take a Higher National Certificate in electrical engineering with radio, telecommunications or electronics, the nearest place is the Wigan Mining and Technical College. It is hoped that more laboratory accommodation will be available in Liverpool next year to enable this course to be taken.

† The Institution requires the full Technological Certificate in Radio and Telecommunications Engineering together with a pass in Part I of the Graduateship Examination before election to graduateship or higher grade.

‡ These figures are based on students attending the Liverpool College of Technology, and are not claimed to be typical of the whole country.

**Training of Servicemen**

The last contribution was made by Mr. W. E. Potter,\* who described the training for the radio and television service mechanic. This training was based on the Radio and Television Retailers' Association apprenticeship scheme of five years' duration and during this period the apprentices are encouraged to qualify for the Radio and Television Service Certificates. These examinations are conducted by the Radio Trades Examination Board and City and Guilds of London Institute.

The main difficulty of the retailers is recruiting the right type of boy. With the advent of television, the training now requires that the youth has a good fundamental knowledge of mathematics and physics and he must attend evening classes two nights a week for three or four years.

The requirements in training and preparation for the appropriate examination tended, in Mr. Potter's opinion, to discourage many boys from entering the trade. In many cases the youngster who was prepared to undertake the necessary training as a technician preferred to enter industry.

(Note.—The work of the Radio Trades Examination Board serves both industry and trade in promoting the efficiency of radio mechanics and technicians.)

**References**

1. "Education and Training for Engineers." *J.Instn Elect. Engrs*, 90, Part 1, June 1943, pp. 223-33.
2. E. Mallett, Wireless Section; Chairman's address. *J. Instn Elect. Engrs*, 80, February 1937, pp. 174-8.

Other useful references include:—

3. "Careers Encyclopaedia," p. 534. (Avon Press, 1952.)
4. "The Future Development of Higher Technological Education." Report of the National Advisory Council on Education for Industry and Commerce. (H.M.S.O., 1950.)
5. "A Note on Technology in Universities." (Prepared by the University Grants Committee.) (H.M.S.O., 1950.)

\* Representing the Radio and Television Retailers' Association.

6. "The Education and Training of Technologists." Report of a Study Group set up by the F.B.I. Industrial Research and Education Committees. (Federation of British Industries, 1949.)
7. Correspondence in *Wireless World*: August 1953, p. 363; September, p. 416; October, p. 466; November, p. 529; December, p. 582; January 1953, p. 19.

**Institution Reports on Education and Training**

The following is a list of the more important references on this subject published in the Institution's *Journal*.

"Post-War Development Report, Part II." *J.Brit. I.R.E.*, 4, November 1944, pp. 151-161.

This report drew attention to the post-war needs of the industry and the necessity for providing professional training and qualifications.

"Annual Report 1948-9." *J.Brit.I.R.E.*, 9, July 1949, pp. 245-246.

A histogram of entries and results in the Graduateship Examination over ten years pointed to low standards of training and reaffirmed the opinion stated in the "Post-War Development Report."

"Annual Report 1949-50." *J.Brit.I.R.E.*, 10, August 1950, pp. 265-266.

The considerable growth in interest in radio training was shown by the very large increase in the number of candidates in the radio examinations of the City and Guilds of London Institute, particularly after 1946.

"Education and Training in the Radio Industry." *J.Brit.I.R.E.*, 10, August 1950, pp. 290-294.

As a result of an investigation by the Education and Examinations Committee a special article was published in the *Journal* which has been widely requested by students and technical colleges.

"Annual Report 1952-3." *J.Brit.I.R.E.*, 13, September 1953, pp. 430-435.

The histogram of Graduateship Examination entries and results given in the 1949 Report is extended up to and including 1952. Reference is made to the continuing low standard of candidates for the examinations of the Institution and the City and Guilds of London Institute.