

SIMPLE HOME PROJECTS

8 PAGE SUPPLEMENT No.3

DECEMBER 1975

CONTENTS

RADIO-PICKUP LINK	1
RANDOM NUMBER SELECTOR	3
SOUND-TO-LIGHT DISPLAY	4
12V PA SYSTEM	7

output signal of the link can be very loosely coupled to portable radios which do not have external aerial sockets simply by winding one or two turns of wire round the rod of the ferrite aerial.

The device was originally designed to fit inside a turntable and pickup enclosure with a coaxial output socket that could be coupled into any medium wave radio. The prototype system had a low output magnetic cartridge so it was necessary to bring the level up with the pre-amplifier stage of Tr3 before using the resulting signal to modulate the supply voltage feeding the RF oscillator, (Tr1). To

RADIO PICKUP LINK

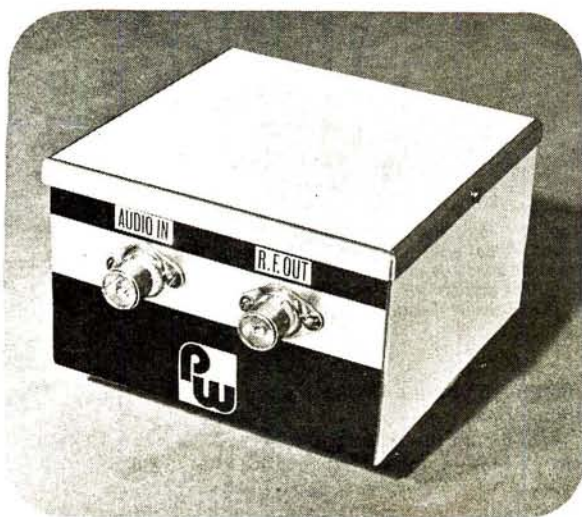

This simple project enables a microphone or record player pickup to be used through a radio that does not have auxiliary input connections. Access to the aerial of the radio is necessary but this is no problem because the

Bits and Pieces

R1 470k Ω	R5 1.2k Ω
R2 1k Ω	R6 4.7k Ω
R3 10k Ω	R7 470k Ω
R4 1.2k Ω	R8 100k Ω
All 1W 10%	
TC1 180pF trimmer	C4 0.33 μ F
C1 1000pF	C5 10 μ F 12V
C2 150pF	C6 2 μ F 12V
C3 10 μ F 12V	C7 1000 μ F 18V
L1 Aerial Coll. (Blue) Range T2 transistor type. (Danco).	
T1 6.3V heater transformer	
D1-D4 1N4001	
Tr1/3 BC108	
PCB (WKF Electronics)	
Coaxial connectors (2) to suit. Metal screening box.	

allow the variations in the output voltage of different pickups VR1 introduces a controlled amount of negative feedback thus adjusting the gain of the pre-amplifier. The supply to the oscillator is controlled by emitter follower action of Tr2. The quiescent voltage is set by R4 and R5 and this is modulated by the audio signal at the base of Tr2.

It has been found that the pre-amplifier will accept input signals from low impedance moving coil microphones and some crystal types but the quality associated with the latter leaves a lot to be desired. For those who wish to use the unit with crystal cartridges that have quite high outputs leave out the pre-amplifier circuitry and increase the value of R3 to about 100k Ω , the input from the crystal going between the base of Tr2 and earth.

An ordinary 6.3V heater transformer was used for T1. Current consumption is minimal and a 6V 50mA miniature transformer will do the job just as effectively. Alternatively,

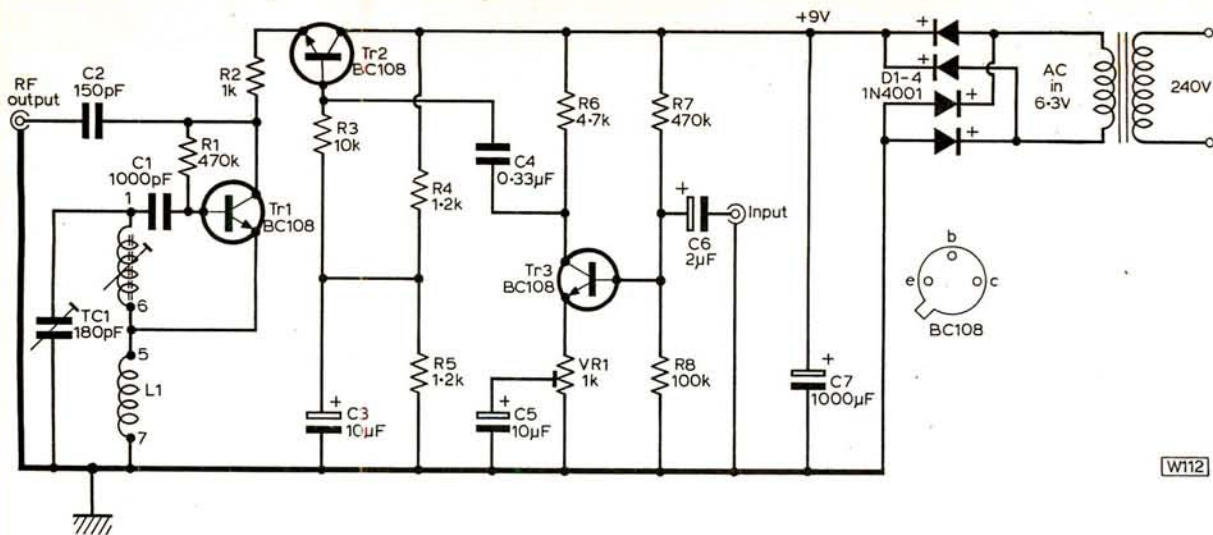

W112

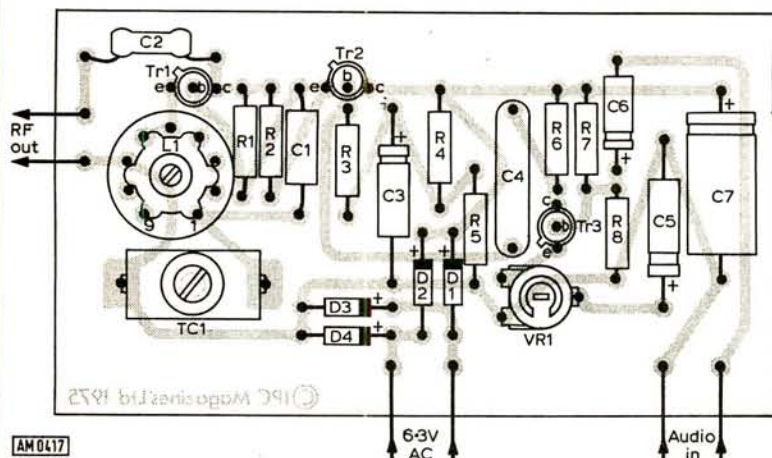

AM 0417

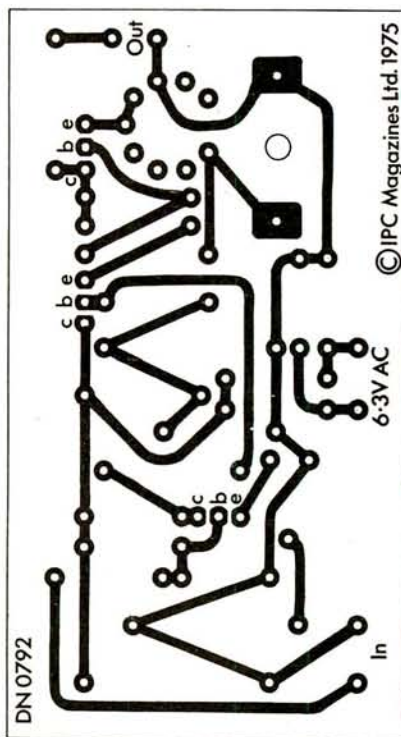

© IPC Magazines Ltd. 1975

Top, circuit of the Radio-Pickup Link with, below, printed circuit board (actual size) and component layout. In the photograph, left, the 6-3V supply is obtained from a 6-0-6V secondary, using one half only. The coil shown is not the one specified. It was used for later experiments with the Link on other frequencies.

run the unit from a 9V battery by leaving out D1/4 and the transformer.

When built the unit should be housed in an aluminium case which is connected to the earth rail of the circuit. This is to prevent radiation which might interfere with other radio sets within a short range. Input and output connections should be made via screened coaxial cable.

When setting up you should adjust it so that signal is heard on a quiet part of the medium waveband of the radio.

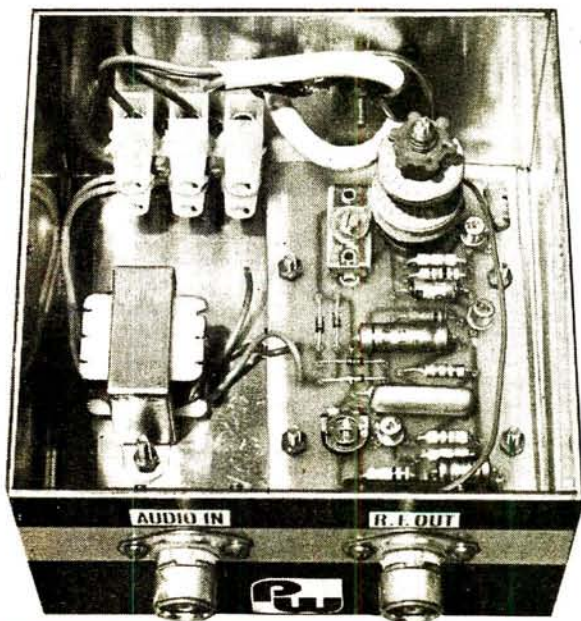

RANDOM NUMBER SELECTOR for games

Bits and Pieces

R1	2·2k Ω	C1	0·22 μ F
R2	4·7k Ω	C2	0·22 μ F
R3	4·7k Ω	IC1	SN7410
R4 to R10	100 Ω	IC2	SN74177
All	1/4W 10%	IC3	SN7447
LED1	MAN3610 or MAN3620 or equivalent common anode display.		
S1	push-to-make push button switch		
S2	single pole on-off switch		
	14 pin DIL sockets (3) 16 pin DIL socket (1)		
	Printed circuit board (WKF Electronics)		

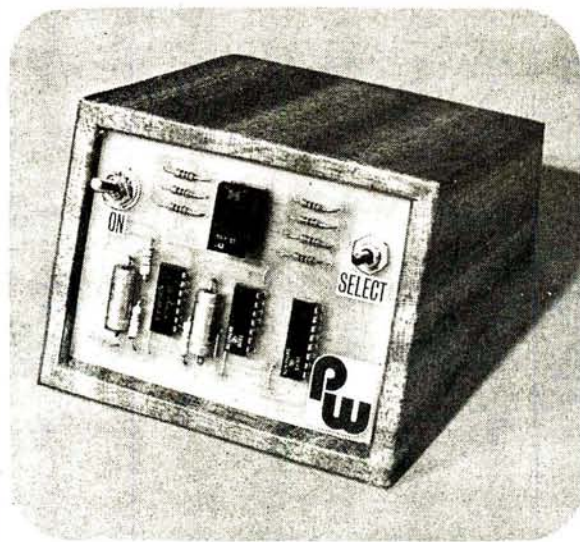

All the components are mounted on one circuit board which forms the front panel. Leads run from the PCB to the internal battery. The cabinet can take any convenient form but the sloping front feature should be retained. The circuit of the Selector is shown below.

This electronic dice uses a seven-segment light emitting diode LED1 to display the normal dice numbers, one to six. A conventional binary counter is modified to give a scale-of-six count and this is driven by a high frequency oscillator. The output from the counter feeds a binary to seven-segment code converter which drives the display.

Apart from the few discrete components used to set the speed of the oscillator, integrated circuits are used throughout. This, coupled with the printed circuit board design, make the project very straight-forward. It would be an ideal "starter" project for someone who has not yet used logic integrated circuits.

The two three-input NAND gates (IC1a/b) form the oscillator which operates at a few kilohertz. The frequency is set by C1, C2 and R2 and R3. When the pushbutton switch S1 is open R1 ensures that the logic level at pin 3 of IC1a is "0". Under this condition the oscillator does not function. However, as soon as this pin is taken to logic level "1" (by pressing the button) the oscillator starts to work and makes the binary counter (IC2) start to cycle. The integrated circuit used here is a presettable four stage binary counter.

In this application only three stages are needed to give a count of six so the first stage of the SN74177 is bypassed. Under normal circumstances a binary counter would start counting from 000 to 111 (giving eight codes which would represent the denary numbers zero to seven). For a dice neither zero nor seven are wanted so steps have to be taken to suppress the codes 000 and 111. This is done

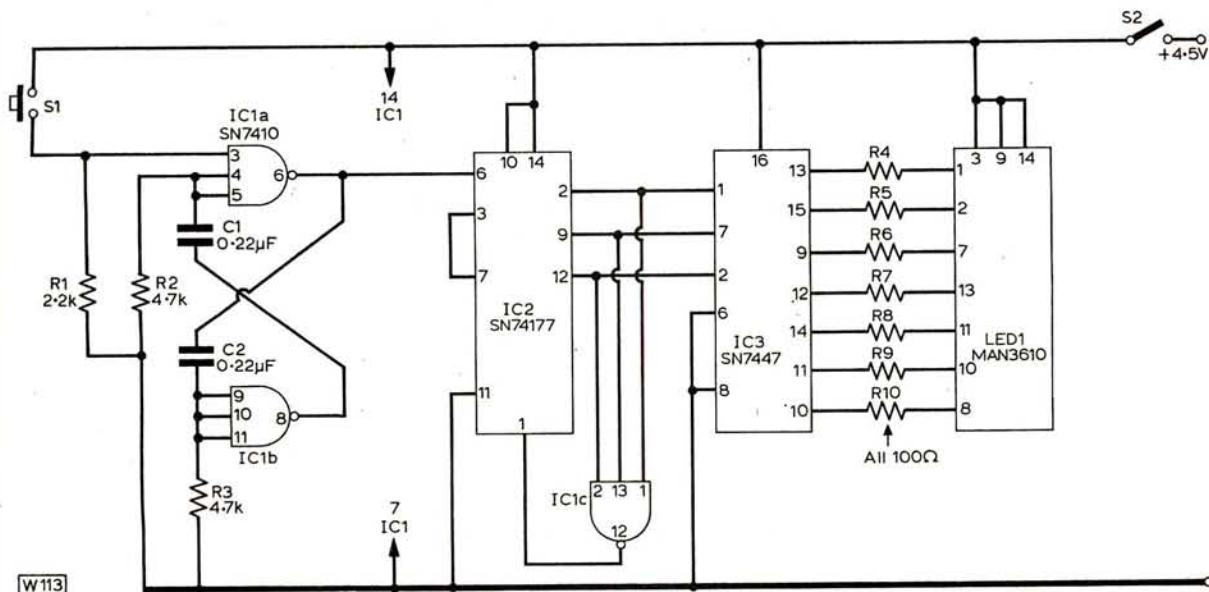

W113

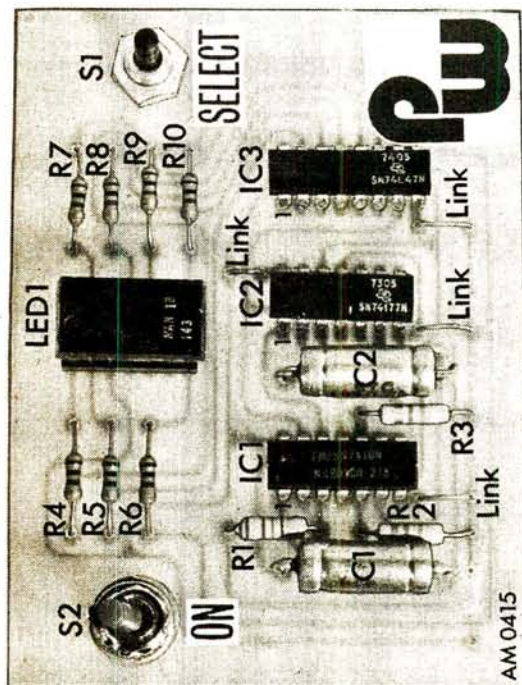
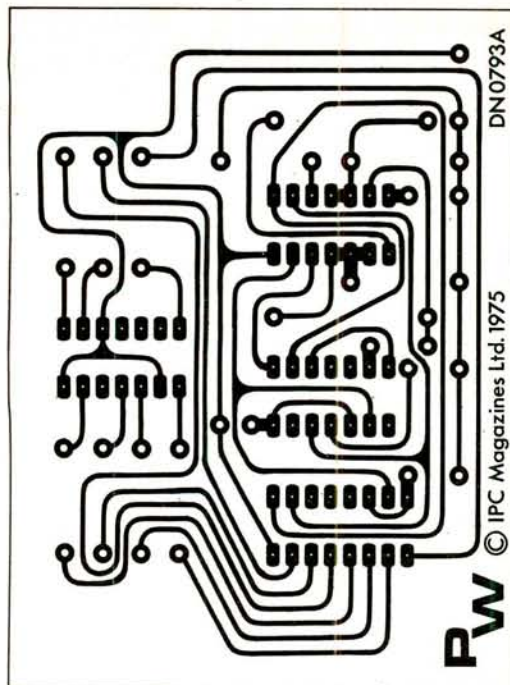

Top, circuit board layout shown actual size, with, below, layout of components on the board. Check carefully that the ICs are inserted the correct way round.

by making the counter reset to a pre-determined code immediately after the count six.

The start of the code 111 is detected by the NAND gate IC1c and this puts a signal on the reset input (1) of the integrated circuit. Being a programmable input counter it is possible to preset the code to the reset value, in this case 001. Thus IC2 counts sequentially from 001 to 110 (one to six). Because the oscillator operates at high speed the count cycle occurs many hundreds of times a

second as long as the push button switch is pressed and it is impossible to predict at what number the counter will stop when the finger is removed from the button.

The binary coded numbers produced by IC2 are decoded by IC3 to seven-segment codes which are fed to the respective elements of the seven-segment display. When the button is pressed the LED appears to display the figure eight. This is because the segments are being switched on and off very rapidly as the counter is cycling round the sequence one to six, but as soon as the push-button is released a number between one and six will be displayed on the LED. This number stays until the device is switched off or until the button is pressed again.

Current consumption by the device is comparatively high being, on average, just over 100mA. Therefore it is suggested that a reasonable capacity battery be used to power it; the prototype used a standard 4.5V flat cycle lamp battery. Space has been left on the printed circuit board for the switch and pushbutton to be mounted on either side of the LED. However these could be mounted in remote positions. The cabinet style can be left to the individual as all the electronic components are mounted on the single board giving the constructor a wide variety of mounting options.

SOUND-TO-LIGHT DISPLAY

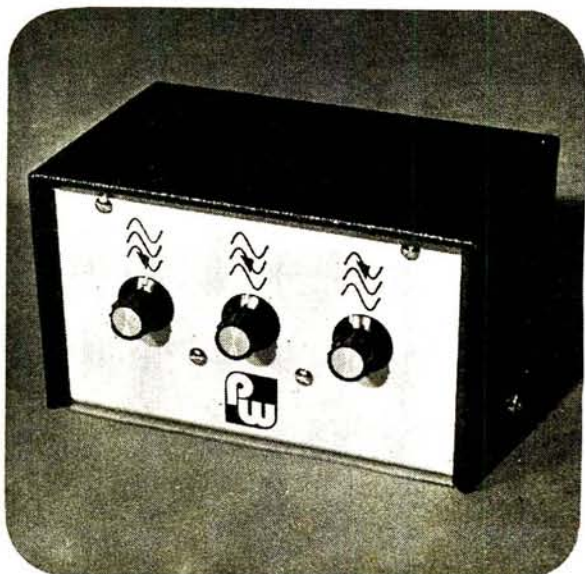

If you want to make a sound to light converter for domestic parties there is no simpler one than this. Although it comprises only the basic features it works remarkably well and has plenty of sensitivity so that it will work off the loudspeaker terminals of almost any amplifier.

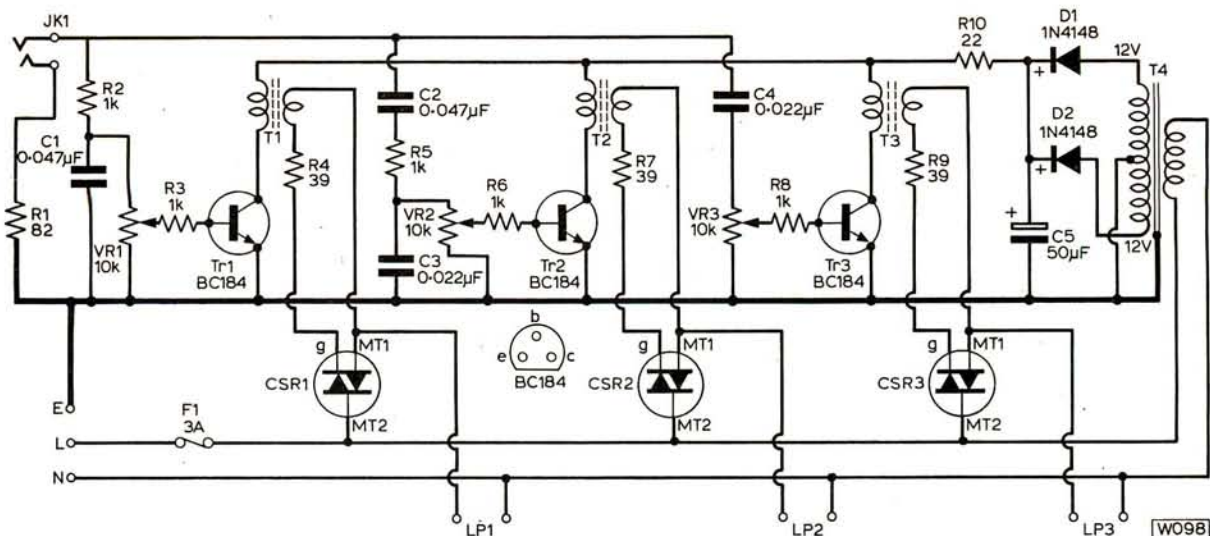

W098

Bits and Pieces

R1 82Ω 1W	R6 1kΩ
R2 1kΩ	R7 39Ω
R3 1kΩ	R8 1kΩ
R4 39Ω	R9 39Ω
R5 1kΩ	R10 22Ω ½W

All ½W 10% except R1 and R10

VR1/2/3 10kΩ linear, PCB mounting

C1 0.047μF C3 0.022μF

C2 0.047μF C4 0.022μF

All 250V

C5 50μF 20V

D1/2 1N4148

Tr1/2/3 BC184

T1/2/3 Pulse transformer

T4 Mains transformer 240V primary, 12-0-12V 50mA secondary

CSR1/2/3 TXAL 228B Triac (400PIV 5A) with insulating kit. Connector blocks 3-way and 6-way. Fuse holder PCB mounting and 3A fuse. Metal for heatsink. JK1 input socket. Metal case 150mm wide, 90mm high and 90mm deep, or similar. LP1/2/3 240V coloured lamps to a maximum of 500W per channel. The pulse transformers, mains transformer and triacs are obtainable from Radio Component Specialists. PCB (WKF Electronics)

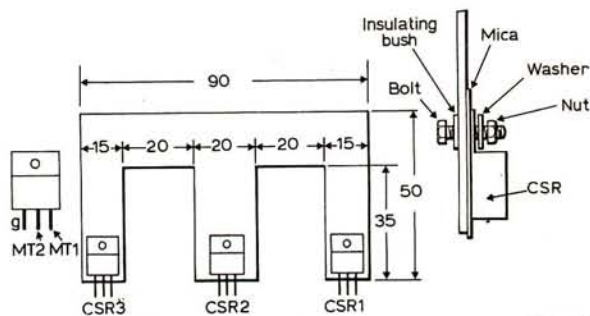

18SWG aluminium heatsink

W099

Top, circuit of the Sound-to-Light Display. Above, details of the aluminium heatsink for the three triacs, dimensions being given in mm. Insulating kit must be used with each triac. Check with ohmmeter that each is isolated from heatsink.

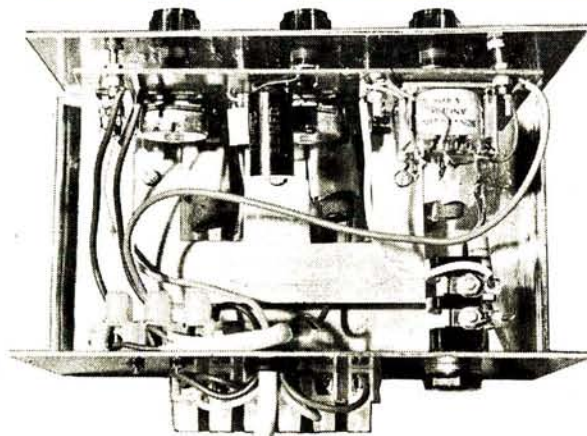

The audio signal is taken from across the loudspeaker terminals of the amplifier and fed to socket JK1. Note the 82Ω resistor linking the earthy connection of the jack socket and the earth rail of the converter. This is to prevent damage if the amplifier output is earthed on one side and, inadvertently, the wires become crossed over. You MUST ensure that the earth of the amplifier corresponds to the earth of the input jack otherwise all signals will be shorted out. Fortunately no damage would result, because of R1, but the unit will not work if wrong in this detail.

The audio signal is fed to three separate transistor amplifier stages and simultaneously through frequency selective networks to pass bass frequencies to VR1, middle frequencies to VR2 and high frequencies to VR3. The transistors are operated without bias hence the input signal has to exceed a certain minimum amplitude before the transistors start to conduct. When this happens current pulses pass through the primary of the pulse transformers in the collector circuits and these pulses are coupled to the gate circuit of each triac, switching it on for the duration of that mains half cycle. Sensitivity to bass, middle and high frequencies is adjusted by VR1, VR2 and VR3 respectively. The lamps are standard 240V coloured ones with a maximum load of 500W per channel.

Construction is simplified by making use of a printed circuit board and there should be no problems with assembly. If the potentiometers having printed circuit tags are unobtainable ordinary potentiometers can be used but use jumper wires to go into the board locations.

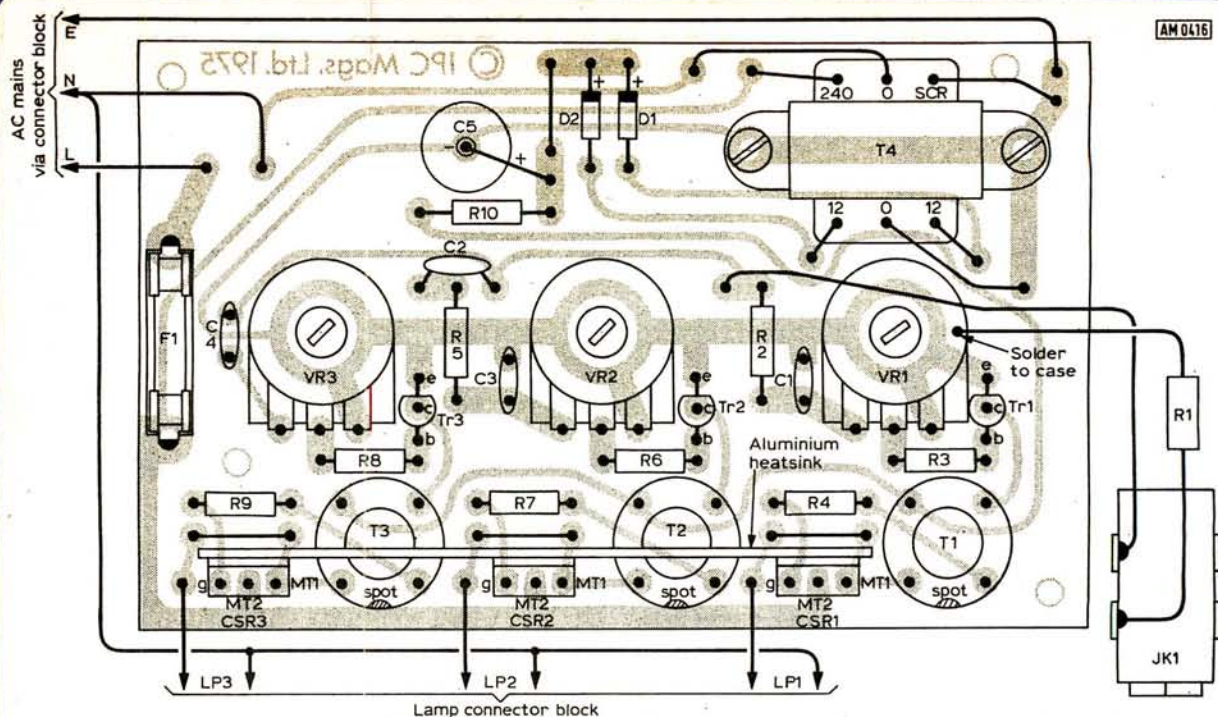

Lamp connector block

The printed circuit board, actual size, is given on the left with the parts layout at the top. Note that the heatsink is fitted at right-angles to the PCB.

When fixing the potentiometers make sure to insert them so that the spindle protrudes on the copper side of the board.

Care should be taken to insert the pulse transformers (T1, T2 and T3) the correct way round, noting the spot, and similarly insert the triacs in the right way. The best way of carrying out the latter stage is to bolt the triacs on to the aluminium heat sink, making sure to use the insulating plastic bush and mica sheet, and then offer up the triac pins to the circuit board so that the triacs are on the side of the heatsink opposite to that which faces the potentiometers. The leads for transistors Tr1 to Tr3 should be carefully formed before they are inserted into their respective holes.

Under no circumstances should the unit be operated without a fuse somewhere in the system. There is provision for a fuse on the circuit board but if difficulty is experienced in getting a suitable fuse holder then operate the unit with a fused plug but the rating should not exceed 3A. Connect a shorting link across the fuse contact pads.

Mains input connections are made to a three-terminal mains connector and the outputs to the three lights are made via similar connectors fixed to the rear of the cabinet. If you use the metal cabinet as specified make sure there is ample separation between the rear side of the front panel and the copper side of the circuit board. Preferably sandwich a thin layer of insulating material between the two, a piece of blank Veroboard or Formica would be ideal. Likewise ensure that the heatsink does not foul on the metalwork of the cabinet. As a final safety precaution the metal cabinet MUST be connected to the earth lead of the mains plug.

When operating, parts of the circuitry are live to mains voltages hence a soldering mistake or a finger in the wrong place when carrying out tests COULD prove very dangerous. If you are in doubt consult with a more experienced constructor before embarking on the project.

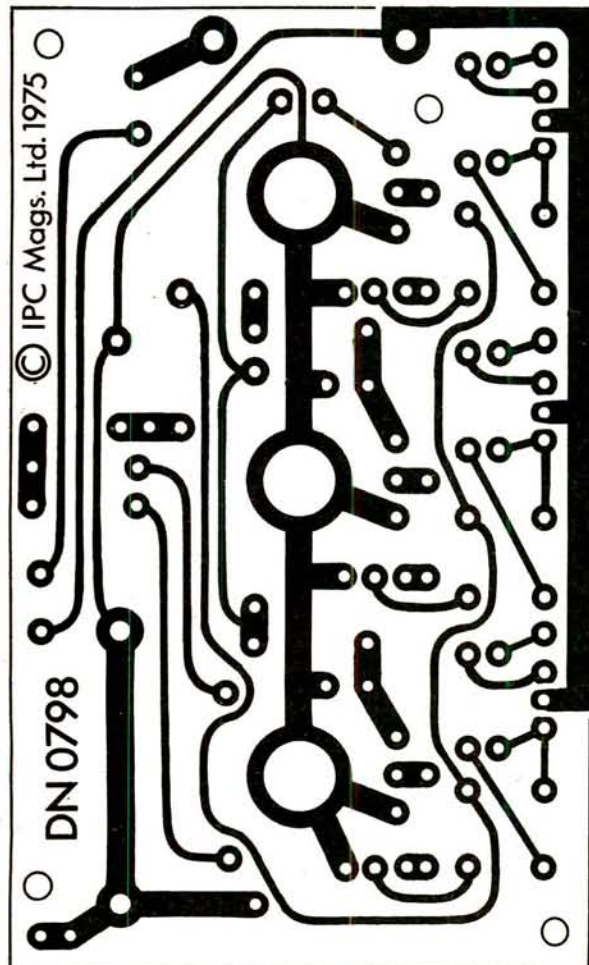

12V PA SYSTEM



The output transistors of this amplifier are fitted to the backdrop of the chassis which acts as a heatsink. The arrangement can be seen in the photograph at the right, with the PCB mounted on the bottom of the chassis with spacers.

Although this is a Public Address amplifier it is not a very powerful unit by normal public address standards. Nevertheless, when used with a directional re-entrant horn loudspeaker, it is very effective and would be ideal for amplifying the voice of a speaker at an average sized garden fête or it could be used as a mobile amplifier for advertising from a moving car. It provides an output of just over 2 watts RMS into an 8Ω loudspeaker increasing to about 6 watts when used with a 3Ω loudspeaker. Two alternative inputs are provided, one for a 600Ω moving coil microphone and the other for, typically, a cassette tape recorder output. SK2 is the microphone input and, in the case of the prototype, maximum power output was obtained when using a Foster Low Impedance Microphone, type DF100.

Other microphones may be used but they MUST be moving coil (dynamic) types and should be of low impedance. SK1 is the phono input the sensitivity of which is set by the value of R1. A value of 470kΩ is suitable for a Philips cassette tape recorder allowing maximum output when VR1 is set at maximum, without any undue distortion. To obtain higher input sensitivity R1 should be reduced.

No great claims are made for the musical quality of the amplifier except to say that it is more than adequate when used with directional loudspeakers which, in themselves, leave much to be desired as far as frequency response is concerned. An LED is used as an on-off indicator.

The circuit is straight-forward and conventional. Tr1 serves as a pre-amplifier having fixed gain, the output level of which is manually adjusted by the volume control VR1. C3 is present to reduce the gain of this stage at high frequencies to prevent spurious high frequency oscillations. This component can be varied in value if a more mellow tone is required from the amplifier. Increasing its value to 1500pF gives a more acceptable quality for music but makes speech a little muffled.

Tr2 provides the drive to the complementary output pair which operate in Class B thus lowering power con-

Bits and Pieces

R1 470kΩ	R6 68kΩ
R2 470kΩ	R7 270Ω
R3 100kΩ	R8 27kΩ
R4 4.7kΩ	R9 680Ω
R5 270Ω	
All ½W 10%	
VR1 10kΩ log	VR2 100Ω min. horiz. preset
C1 16μF	C5 16μF 16V
C2 0.022μF	C6 0.1μF
C3 680pF	C7 100μF 16V
C4 16μF 16V	C8 500μF 16V
D1/2 OA91	LED1 MV5025 or GP
Tr1 BC108	Tr2 BFY51
Tr3 AD161	Tr4 AD162

With mounting kits for Tr3/4

SK1, phono socket. SK2, jack socket. SK3, loudspeaker socket. S1, single pole two way slide switch. S2, single pole on-off slide switch. Cabinet 200 x 125 x 50mm aluminium case or similar. Printed circuit board (WKF Electronics) Four-way tag strip. Suitable re-entrant loudspeakers are available from Radio Component Specialists.

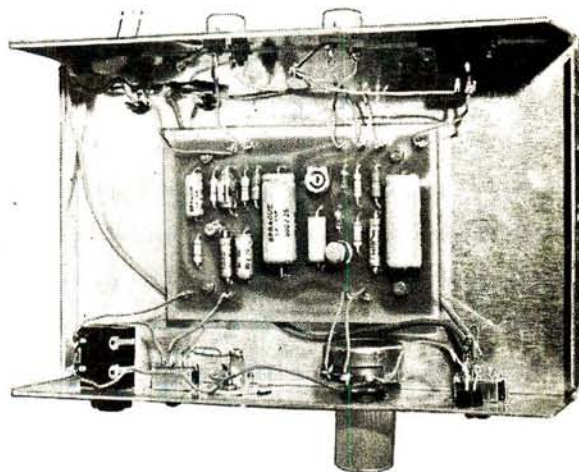

sumption. The quiescent current is set by adjusting VR2 from minimum resistance until the total current consumption is about 35mA under no signal conditions. If you do not have a meter to check the current start with VR2 set to minimum resistance and play some music from a tape through the system with VR1 set about half way. It will sound very distorted, due to crossover distortion in the output stage. Slowly increase the value of VR2 until the distortion JUST disappears, the optimum setting of the control.

There are few problems to be encountered in assembly. Use mica spacers and insulating bushes when mounting Tr3 and Tr4 to the outside of the chassis and drill clearing holes for the leadouts. Ensure that all diodes, transistors and electrolytic capacitors are fitted to the circuit board with the correct polarity. When fixing the circuit board into the cabinet make sure that the spacers used do not short across between the earthed area of the PCB's foil and any other part of the PCB.

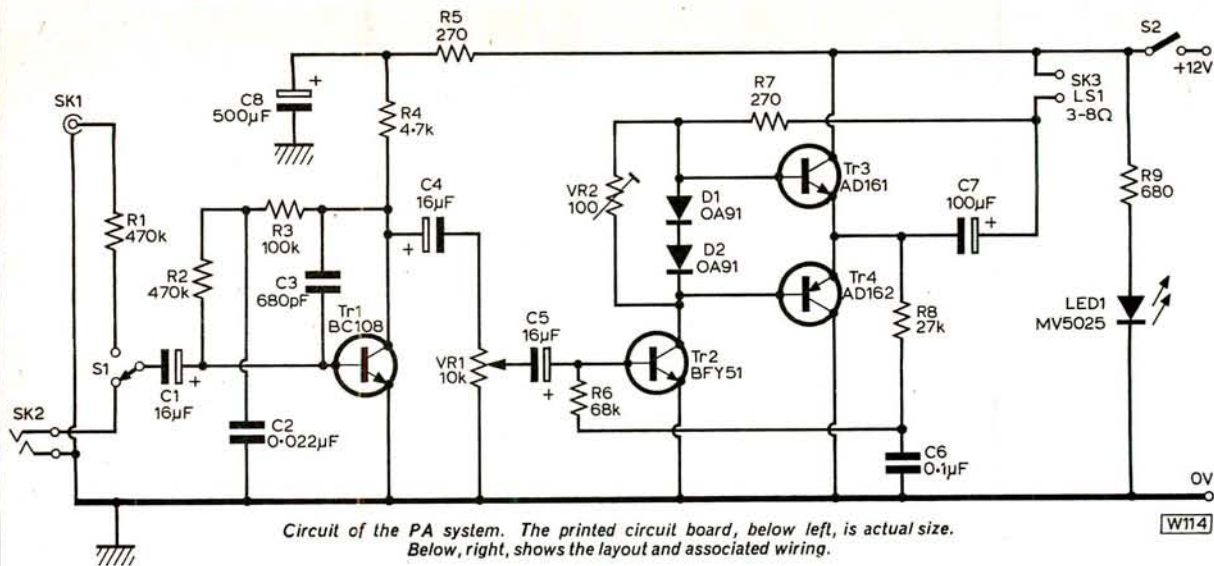

Circuit of the PA system. The printed circuit board, below left, is actual size. Below, right, shows the layout and associated wiring.

WT14

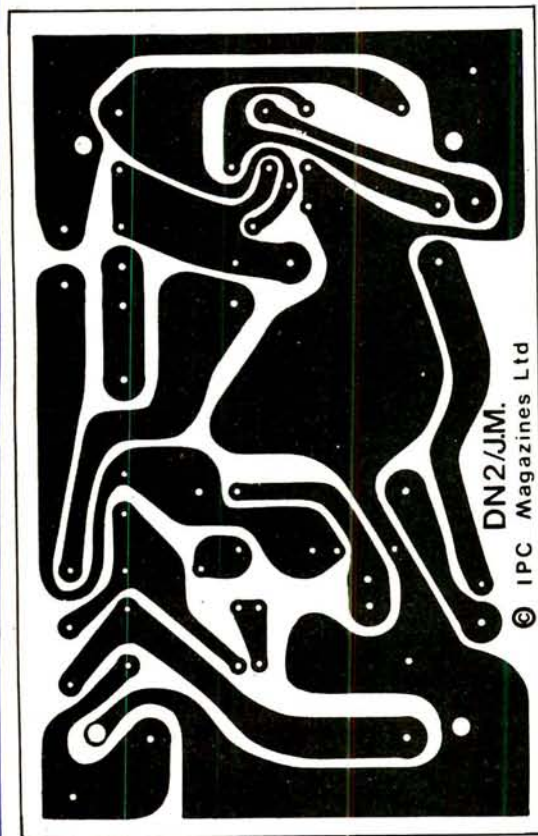

DN2/J.M.
© IPC Magazines Ltd

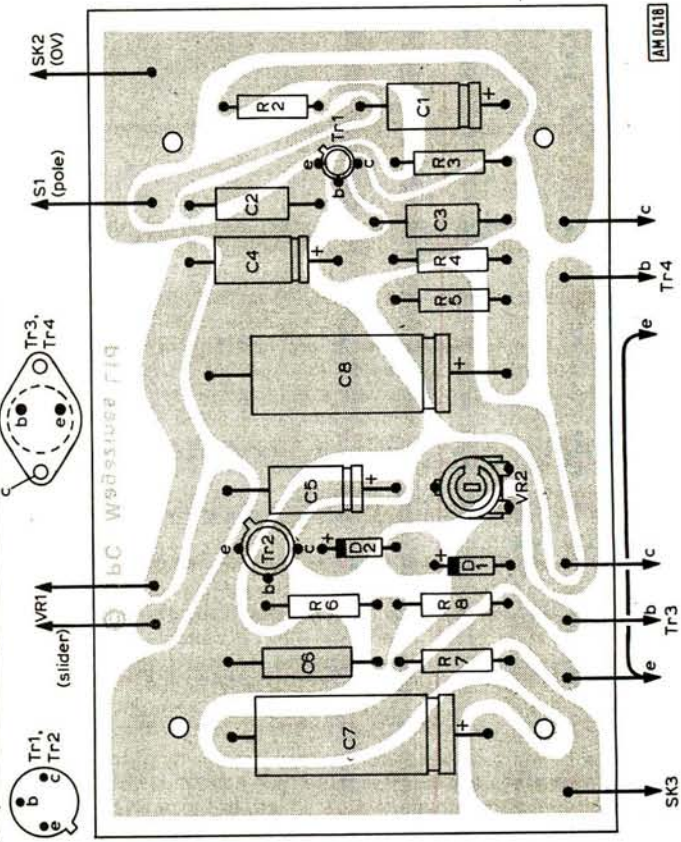

IMPORTANT NOTE

This circuit can only be used with negative earth vehicles if it is intended to mount the unit under the dashboard. With the same application in mind make sure that the loudspeaker leads do not make contact with the chassis of the vehicle and that the speech coil is isolated from the metal work of the loudspeaker. Remember that the car should be properly suppressed electrically to avoid interference when using the amplifier while moving.

Fully drilled epoxy glassfibre printed circuit boards which have been roller-tinned can be obtained for these projects from:—
W.K.F. Electronics, Welbeck Street, Whitwell, Worksop, Notts., S80 4TW.
Radio-Pickup Link, 12V PA System and Random Number Selector are each 98p plus 10p post and packing. The Sound-to-Light Display is £1.15 plus 10p post and packing.