

DECEMBER 1983  
U.S. \$2.50  
CANADA \$2.95  
Bipad No. 71613

THE RECORDING INDUSTRY MAGAZINE

# Mix<sup>®</sup>

Interview: Godley and Creme

**Tape-to-Disk  
Special Issue**  
• Mastering,  
Pressing, and  
Duplication

**Dennis Lambert  
Understanding the  
Audiophile**

**Special Report:  
Stereo Mastering  
Recorders**

**Stan Freberg  
Audiooptics  
Producing the  
Spoken Word**

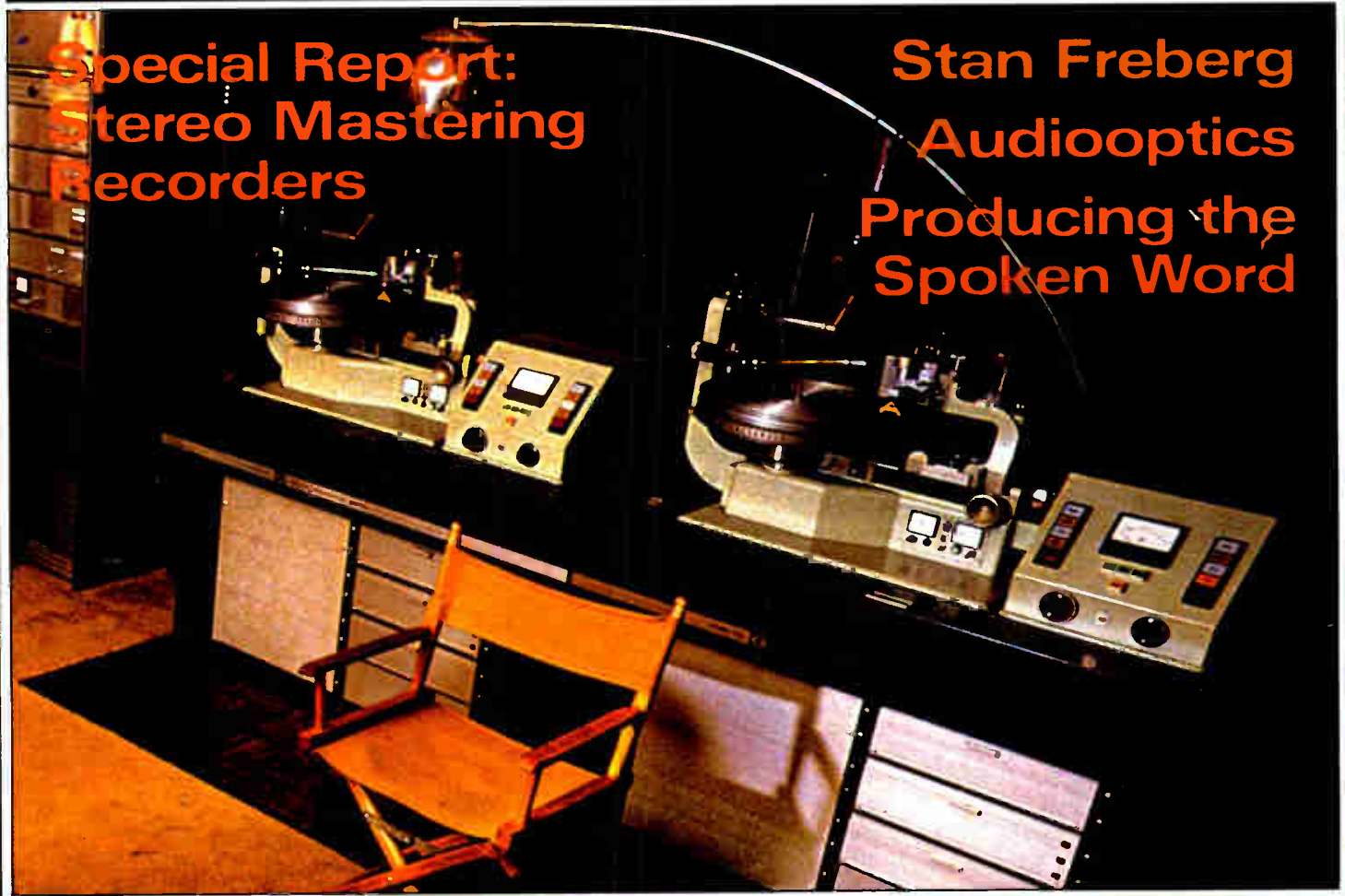

# INTRODUCING THE RAVEN. THE DREAM BECOMES REALITY.



A lot of people have always dreamed of owning a Harrison. Now, we can help make that dream a reality—with a new console that offers you high Harrison quality while also remaining highly affordable. The Raven.

The Raven is the latest in a long line of renowned Harrison consoles, with the same outstanding engineering and workmanship as its predecessors. With the latest in Harrison technology in circuit design and signal handling. With Harrison's new VSI Fader which gives it the capability of interfacing simultaneously with automation and your video system. In addition, a high degree of field programmable signal path options allows you to tailor the Raven to your needs. Harrison quality is built in through features like transformerless balanced +4 (or +8) inputs and outputs, DIN standard Eurocard connectors, laser-trimmed thick-film resistor networks, and socketing of all integrated circuits. And, the Raven is designed to be ergonomically correct.

Best of all, even as the Raven is built to our high standards, it's also built for your budget. That makes it a rare bird indeed. The stuff that dreams are made of.

**Additional Raven Features:** Minimum audio-path design  State-variable equalizer  24 tracks, plus direct outs  4 mono sends, plus 1 stereo send (all sends switchable main/monitor)  Automatic PFL  Optional non-interrupting stereo solo  Dual switchable mic inputs to each module  Extensive communications  P&G faders.

For more information call or write:

 **Harrison**

P.O. Box 22964, Nashville, TN 37202  
(615) 834-1184 • Telex 555133

Circle #001 on Reader Service Card

World Radio History

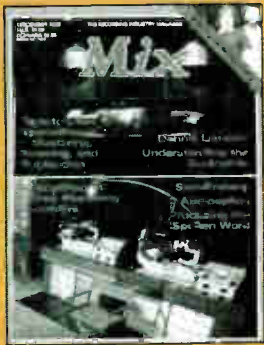

**Cover:**  
 (Top) Future Disc Systems, Hollywood, CA, features a computer controlled disk mastering console built by Cybersonics.

Photo: David Hernandez

(Bottom) Neumann VMS-70 operated by Zuma computer at Masterfonics, Inc., Nashville, TN.

Photo: Donald Putnam

(Corner) Godley and Creme.

Photo: Sherry Barnett

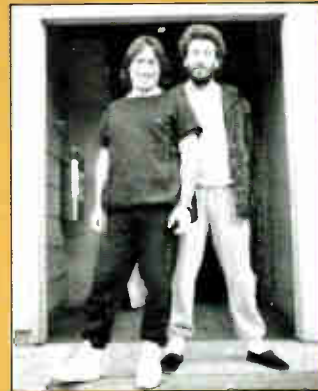

**Kevin Godley and Lol Creme** were one-half of the influential British band 10cc, they pioneered the Gizmo, and now in addition to their own musical work, the pair have become top video directors, working with Duran Duran, The Police and others. Is there anything these two can't do? Iain Blair looks at the duo's long, colorful career starting on Page 129.

## DEPARTMENTS

- 5 FEEDBACK
- 6 CURRENT
- 8 SESSIONS/  
STUDIO NEWS
- 81 LUNCHING WITH  
BONZAI:  
STAN FREBERG  
by Mr. Bonzai
- 84 BOOKSHELF
- 111 PREVIEW
- 147 CLASSIFIEDS
- 150 ADVERTISERS'  
INDEX

## LISTINGS

Mastering,  
Pressing and Tape  
Duplication  
Facilities

- 40 LOCATION INDEX
- 42 EASTERN LISTINGS
- 52 CENTRAL LISTINGS
- 63 WESTERN LISTINGS

## VIDEO

- 135 MUSIC VIDEO  
PRODUCTION  
by Lou CasaBianca
- 139 VIDEO NEWS  
by Mia Amato
- 142 VIDEO INTERFACE  
by Neal Weinstock
- 145 HARDWARE/  
SOFTWARE

## AUDIO

- 13 MASTERING/  
PRESSING/  
DUPLICATION  
UPDATE  
By George Petersen
- 22 DIGITAL  
DISCUSSIONS  
by George Currie
- 24 SPECIAL REPORT:  
STEREO  
MASTERING  
RECORDERS  
by George Petersen
- 37 AUDIO  
APPLICATIONS:  
MIXING FOR  
MASTERING  
by Ken Pohlmann
- 86 UNDERSTANDING  
THE AUDIOPHILE  
by David Wilson
- 91 AUDIOOPTICS:  
TECHNIQUES AND  
APPLICATIONS  
by George Bowley
- 100 SOUND ON STAGE
- 104 PRODUCER'S DESK:  
DENNIS LAMBERT  
by James Riordan
- 106 PRODUCING THE  
SPOKEN WORD  
by Harvey Kubernik

## MUSIC

- 116 SESSION PLAYER  
by Carol Kaye
- 118 MUSIC NOTES
- 126 PLAYBACK
- 129 GODLEY & CREME  
by Iain Blair

For his special report this issue, George Petersen looks into the world of **stereo mastering recorders**, offering an in-depth look at top-of-the-line analog and some digital mastering machines. Page 24



This month we kick off our new **Audio Applications** column, a nuts and bolts look at topics of interest to the studio engineer. Ken Pohlmann, who brought us the Digital Discussions column and other features, now presents this monthly update of techniques and technology. Page 37

This is our annual **Tape-to-Disk** issue, featuring the most complete and up to date **listings of mastering, pressing and tape duplication facilities** available. The directory begins on Page 40.

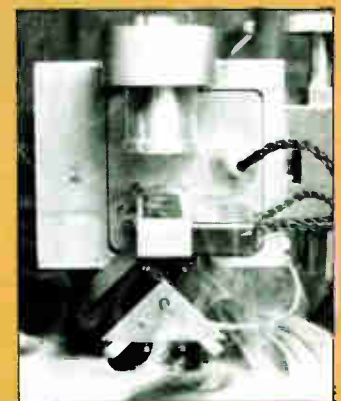



# LION SHARE RECORDING STUDIOS

Probably the most progressive studio in the United States (if not the world). The first world class studio to offer full digital audio recording and editing capability. With 32-track digital audio recording, digital stereo mastering and electronic editing, Lion Share provides top artists a sound quality unmatched by any other studio. Lion Share now maintains first generation audio from multi-track recording through studio, disk and cassette mastering, and all the way to the consumer through the Compact Disc. Leading artists and producers are demanding total digital audio capability. Lion Share Recording Studios. Los Angeles (213) 658-5990.



MITSUBISHI X-800  
DIGITAL RECORDER

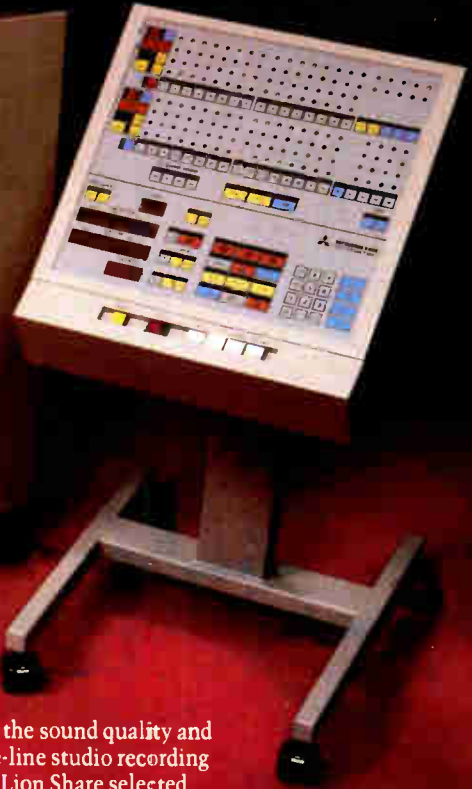

MITSUBISHI  
X-800



## 32-Track DIGITAL

After exhaustive investigation into the sound quality and technical performance of top-of-the-line studio recording systems – both analog and digital – Lion Share selected the Mitsubishi digital system. Why Mitsubishi? A major factor was the 32-track standard: 24-track is just not enough. Mitsubishi is the only manufacturer delivering new technology 32-track machines now. Please call or write to discuss your future in digital audio.

### DIGITAL ENTERTAINMENT CORPORATION

A SUBSIDIARY OF MITSUBISHI ELECTRIC SALES AMERICA INC.

Headquarters: 69 North Street • Danbury, Connecticut 06810 • Tel. (203) 744-3226 • Telex 703547  
New York City: Suite 1530 • 555 W. 57th Street • New York, NY 10019 • Tel. (212) 581-6100  
Los Angeles: 733 N. Fairfax Avenue • Hollywood, CA 90046 • Tel. (213) 651-1699 or 468-0817



# Mix

PUBLISHER/  
EDITOR

David M. Schwartz

PUBLISHER/  
GENERAL MANAGER

Penny Riker Jacob

ASSOCIATE PUBLISHER/  
ADVERTISING DIRECTOR  
Hillel Resner

MANAGING EDITOR  
Blair Jackson

ASSISTANT EDITOR  
George Petersen

MUSIC EDITOR  
David Gans

EDITOR AT LARGE  
Mr. Bonzai

CONTRIBUTING EDITORS  
Mia Amato

Lou CasaBianca  
Bruce Pilato  
Ken Pohlmann  
James Riordan  
Neal Weinstock

ADVERTISING DEPARTMENT  
ACCOUNT EXECUTIVES  
Jeffrey Turner  
Kathy Arnold

CLASSIFIED DEPT./STUDIO SERVICES  
Kathy Arnold  
Tad Welch

ART DIRECTOR  
Tim Gleason

DESIGN & PRODUCTION  
Bonnie Blair Ofshe  
Gretchen Treuting

TYPESETTING  
Pat Pall  
Naomi Feinn

CIRCULATION MANAGER  
Mary Holland

CIRCULATION ASSISTANTS  
Allison Hershey Renee Barron

ACCOUNTING DEPARTMENT:  
Mark Elsberg  
Linda Simpson

TRAFFIC MANAGER  
Ron Ward

PROJECTS DIRECTOR  
Craig Wingate

ADMINISTRATIVE ASSISTANT  
Patsy Messerer

Mix Magazine is published at 2608 9th St., Berkeley, CA 94710 and is ©1983, by Mix Publications, Inc. This is Volume Seven, Number Twelve, December, 1983. Mix (ISSN 0164-9957) is published monthly. Subscriptions are available for \$24.00 per year. Single or back issue price is \$3.00. Subscriptions outside U.S.A. are \$36.00.

Please address all correspondence and changes of address to Mix Magazine, 2608 Ninth St., Berkeley, CA 94710 (415) 843-7901

Controlled circulation postage paid at Berkeley, CA and additional mailing offices.

Mix Magazine is distributed in recording studios, pro-audio stores, music stores and other related businesses. If you have a recording or music related business and would like to distribute Mix, please give us a call.

Display advertising rates, specs and closing dates are available upon request.

This publication may not be reproduced or quoted in whole or in part by mimeograph or any other printed means, without written permission of the publishers.



Dear Mix,

I read with great interest the article by Tom Lubin on machine alignment and would like to make a few comments.

In our experience, all mechanical adjustments to a head should be completed before the electronic alignment to eliminate the need for retrimming due to shifts in level and response. Additionally, coarse adjustment of the azimuth is most easily obtained by displaying two channels on an oscilloscope in dual mode. This makes it very easy to see the shifting to either side of true point and the peak output of both channels at that point. This method eliminates the need for comparing the shift between two different frequencies, although it does require the complication of test equipment. Fine tuning can then be accomplished by an x-y display.

Also, we regularly recommend to our customers the use of 250 nW/meter as O.V.U. While this may decrease headroom and lead to distortion unless critically monitored, we feel it offers the greatest flexibility as it is easier to record at minus levels than at plus levels and less damaging to the meters as well. We have had great success with this approach even on older semi-pro machines such as the TEAC A-2340, A-3340, etc. Larger machines have been set at 370 nW/meters for some applications with excellent results.

The only real criticism I have is the recommendation on cleaning procedures. Under no circumstances do we recommend the use of alcohol based cleaners. These definitely shorten pinch roller life and can, under some circumstances, cause condensation during evaporation possibly leading to earlier head failure due to rust. We recommend a trichlorotrifluoroethane cleaner for metal parts and a rubber cleaner for the pinch roller. The TEAC solutions, HC-1 and RC-1, are superb. It is our philosophy that cleaning should be done so often that little or no oxide buildup is ever noticeable. If so, we recommend shortening the maintenance interval until this condition is

achieved. We have heard of the use of silicon polish on stationary parts to reduce wear and have found it to be of some use, especially for machines with severe wear. We do not know about the possibility of tape contamination and would appreciate any feedback you could give us on this.

Lastly, we fully agree with the use of High Frequency to set bias level as it produces a more precise result with less effort. Perhaps Mr. Lubin should have informed the reader that the use of 10kHz as opposed to 1kHz will lead to more pronounced effects of wow and dropout, especially on edge tracks.

Anyway, thanks for the article. Anything that raises the general level of knowledge in our industry can only help us all.

Sincerely,  
Jack LeRoi  
Chief Service Technician  
Pi Keyboard and Audio  
Cleveland, OH

Dear Mix,

Lou CasaBianca's "Origins of Music Video" provides a good chronological overview of this developing genre. However, please let the record show that the Beatles' rooftop concert in "Let It Be" could not have stopped traffic on Abbey Road—that sequence is filmed on top of the Apple offices on Saville Row, across town from EMI's Abbey Road studios. In fact none of "Let It Be" takes place at Abbey Road, the interiors being done at the cavernous Twickenham film studios. This is a shame, because we don't have any footage of the Beatles at work at EMI Abbey Road, the studio where almost all their great work was accomplished; at least none that are in circulation. Perhaps that could be Lou's next assignment—tracking down video of the Beatles at work at Abbey Road. Best of luck with the series.

Regards,  
Gordon Whiting  
Sonic Arts Corp.  
San Francisco, CA

—page 128, FEEDBACK

# CURRENT

## RIAA Hosts Engineers

During the recent Audio Engineering Society conference in New York, the Recording Industry Association of America (RIAA) hosted a dialogue with members of the Society of Professional Audio Recording Studios (SPARS) and engineers affiliated with Japanese electronics firms and their U.S. subsidiaries. Attending this first-ever gathering of RIAA and Japanese firm engineers were representatives from several of the largest firms based across the Pacific: Matsushita/Technics, Mitsubishi, Pioneer Electronics, Sansui Electronics, Sharp Electronics, and Sony Corp. Topics covered in the discussions included Compact Disc player and disc compatibility; prerecorded cassette equalization compatibility with new cassette decks; and Japanese proposals for standardization of a digital audio tape (cassette) format in Japan. Representing the RIAA were technical executives from a host of record industry giants, including A&M, Atlantic, Capitol, CBS, MCA, Motown, PolyGram, RCA and Warner Bros.

The joint RIAA/SPARS seminar, which was attended by reps from ten SPARS member studios, covered such areas as the latest in digital recording equipment; a report on the International Compact Disc standard; and improvements in studio preparation of master tapes for prerecorded cassette duplication. Among the subjects covered by the Engineering Committee's meeting were stereo TV; anti-piracy systems; prerecorded cassette equalization; and compact discs.

At its annual fall meetings in California, the Electronic Industries Association's Consumer Electronics Group (CEG) approved a number of new programs, while renewing its commitment to

several existing ones. On the engineering front, the CEG board approved funds for research on such topics as electro-magnetic compatibility, high definition television, multichannel TV sound, and product safety. The CEG board also agreed to establish a new model technical high school, convert existing CEG textbooks and lab manuals to videotape, and to offer financial support for the upcoming PBS series, "New Tech Times." The Government and Consumer Affairs wing of CEG authorized the continued support for the Home Recording Rights Coalition and the Audio Recording Rights Coalition, both of which are seeking to block enactment of royalty taxes on home

The upcoming CES show, which of course is sponsored, managed and produced by the CEG, promises to be the largest winter show ever, with some 1,225 exhibitors coming to Las Vegas January 7-10 for the event. In addition to the Las Vegas Convention Center, the Hilton's Pavilion and Grand Ballroom, and various rooms and suites at the Riviera Hotel that were utilized last year, the Winter Show will also now include a brand new, 120,000 sq. ft. addition to the Convention Center known as West Hall, and additional space at the Riviera and Sahara hotels. The show is expected to draw about 75,000 visitors, including about 7,500 visitors from outside the United States. For more information about CEG or the CES show, call Allan Schlosser at (202) 457-4919.

## COMMTEX Expo in Dallas

COMMTEX International, which has developed into the top exposition of audio-visual, video and microcomputer equipment in this

country, is expanding its exhibition schedule for the upcoming expo, to be held January 20 to 23 in the Dallas Convention center. Among the types of equipment and materials (software/courseware) to be displayed are: projection equipment and techniques; video cameras, recorders, disks, monitors and related equipment; audio tape recorders and duplicators; remote access and retrieval systems; programmers and other multi-projector devices; microcomputers; student response systems; screens; projection tables; tapes; films; filmstrips and much more. In all, more than 500 manufacturers and producers are expected to exhibit their latest products in the Convention Center's huge space. For more info, call Robert Milko at NAVA (the trade organization of the audio-visual communications industry) at (703) 273-7200.

## Altec Looks Ahead

The financially struggling Altec Corporation recently filed for protection from creditors under Chapter 11 of the Federal Bankruptcy Code. According to Altec Lansing president William Fowler, the company's serious indebtedness stemmed from the acquisition by the LTV-Ling Altec conglomerate of a company called Escon fifteen years ago. Escon has not been part of Altec for the past five years, but the debts have remained. Fowler says that filing under Chapter 11 will not adversely affect Altec's production of sound equipment, nor have there been layoffs because of the move. Meanwhile, Altec has moved all of its manufacturing to the company's modern facilities in Oklahoma City and has phased out some low volume lines.

## notes

At *JBL*, *Debra Watson* has been appointed Marketing Services Manager Professional Division and *Juergen Wahl* has become Applications Engineer for *JBL* and *UREI* Professional Products. . . . *Tom Kobayashi*, Executive VP of *Glen Glenn Sound* since 1981, has been promoted to President of the Company. . . . *Otari Corp.* has appointed *Jeff Phillips* to the newly created post of Technical Sales Support. . . . *Transco Products Corp.*, a leading supplier of master recording blanks, has been purchased by *Robert Cosulich* and *Fred Buehler*, long time management personnel. . . . *Studer* has opened a Northwest field office in Walnut Creek, CA, headed up by *Fred Layn*, who was formerly with the New York office. . . . The 1983 Video Production Association's Monitor Award for Engineering Achievement was presented to *Lexicon* for their

Model 1200 Time Compressor and other contributions to digital processing. . . . *BTX* has appointed *James R. Lucas* Manager of Western Area Sales. . . . *Joseph A. Giordano* has been named product planning and development director and *Joseph L. Leon* has been moved to marketing director for professional markets at 3M's Magnetic Audio/Video Products Division. . . . *Ampex Corp.* received an Emmy Award from the National Academy of Television Arts and Sciences for its role in the development of its digital optics systems. . . . *Henning Moller* has rejoined *Bruel and Kjaer* to provide marketing and applications support to the company's recently introduced line of professional microphones. . . . *NorthWestern, Inc.*, Portland, OR, has taken over distribution of the last remaining AG 440-C recorders from *Ampex*. . . . *Crown Interna-*

*tional* has announced the appointment of *Secom Systems* of Chamblee, GA, as representatives for their professional products in Georgia, Alabama, Mississippi, Tennessee, North and South Carolina. . . . *Agfa Gevaert* has announced the appointment of *Burlington Audio* of Oceanside, NY, to market and distribute Agfa audio tape products. . . . *Sproch Sales, Inc.*, of Fort Lauderdale, FL was dubbed 1983 Rep of the Year at the *Electro-Voice* National Sales Meeting. . . . *Ursa Major, Inc.* has expanded their domestic sales representation with the addition of *Givan-Flanagan Associates*, in Massachusetts; *Lienau Associates, Inc.*, in Maryland; *Lassers, Sangwin, Lassers*, in Illinois; *R.L. Graham Associates*, in Kansas; and *Meyer, Ross and Fleming, Inc.*, in California. . . .

# STOP SLAVING OVER YOUR MASTERS

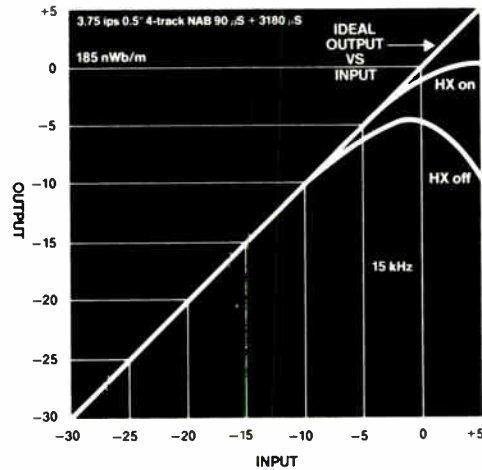

Over the years, pre-recorded cassette sales have steadily increased to the point that with some releases they now equal the sales of phonograph records. This growing market penetration made it essential that the technical quality of the pre-recorded cassette be improved to equal or better that of the phonograph record. Dolby HX-Professional, developed by *Dolby Laboratories* and *Bang and Olufsen*, represents a breakthrough in cassette duplication quality. ElectroSound and Cetec Gauss are the first two companies to be licensed to manufacture duplicating slaves which include the new circuitry, which results in startling improved high frequency response.

This new generation of duplication slaves provides such an improved response that the limitations of the duplicating master, typically recorded at 3.75 ips, becomes the major quality constraint. Dolby Laboratories now makes available the first Dolby HX-Professional package for a duplication master recorder, the Otari MTR 10. The module is easily field retrofitted, and requires no significant change in normal alignment procedures. Modules for other recorders will be announced over the next few months.



Dolby Laboratories Inc., 731 Sansome St., San Francisco, CA 94111, Telephone 415-392-0300, Telex 34409, 346 Clapham Road, London SW9, Telephone 01-720-1111, Telex 919109. "Dolby" and the double-D symbol are trademarks of Dolby Laboratories Licensing Corp. S83/5342.

## NORTHEAST

*Rubber Rodeo*, recently signed to Polygram, are recording their first disk for the label at *Bearsville Studios*, with *Hugh Jones* producing and engineering. Also at Bearsville, *King Crimson* has started preproduction work on their next LP at the facility's rehearsal barn, and will soon begin recording in studio A with *Brad Davis* engineering, *Ray Niznik* assisting. . . . At *Inner Ear Recording* in Queens, NY, *Edo Jasper* and *Jack Kelly* recently completed mixing their "telescope opera" called "Eutro" for Imeon Productions, with *Steve Vakis* engineering. And the *Otis Bros.* are mixing their new album, which was produced by *Bob Guida* and *Pat Conte*. . . . Among the many projects currently cooking at *Normandy Sound* in Warren, RI are a pair spearheaded by producer *Rick Harte* of Ace of Hearts Records. Rick has been busy with *The Lairs* and the *Del Fuegos*, with engineer *Phil Greene* at the board, assisted by *Joe Moody*. . . . The new *Man Parrish* record is being recorded in Brooklyn aboard the *Aura Sonic Mobile* Audio Unit for Elektra Records. The band is producing themselves, with engineering by *Steven Remote*. . . . *Trod Nossel* studios in Wallingford, CT, is continuing work on the forthcoming album by the *Yale Alley Cats*. That record will include both studio material and songs recorded live at Woolsey Hall by TNRS chief engineer *Richard Robinson*.

## SOUTHEAST

Guitar ace *Pat Travers* is finishing up work on his next album for Polydor Records at *Bee Jay* recording studios in Orlando, FL. *Barry Mraz* is producing, *Andy de Ganahl* engineering. Also working at Bee Jay is the red hot south of the border band *Menudo*, recording Spanish language commercials for McDonald's and Proctor & Gamble with engineer *Dana Cornock*. . . . Lots of exciting action at *Woodland Sound Studios* in Nashville: the *Statler Brothers* cut tracks there for their fall TV special, with *Bill Walker* producing, *David McKinley* at the board (with assistance from *Tim Farmer*, *Andy Benefield* and *Ken Cribblez*; *Merle Haggard* worked on vocal overdubs for his next CBS album, with *Rick McCollister* engineering, Ken Cribblez seconding. Woodland engineers *Ed Hudson* and *Ron Reynolds* are also working on a Haggard project, this one a new live LP. And the *Oak Ridge Boys* have now completed the vocals for their next MCA release with producer *Ron Chancey*, engineer *Les Ladd* and a very busy Ken Cribblez. . . . Country stars the *Bellamy*

*Brothers* are mixing their new Warner Bros. album at *New River Studios* in Ft. Lauderdale, FL. *Steve Klein* is producing, with *Dennis Hetzendorfer* at the board, assisted by *Ted Stein*. . . . At *Morrisound Recording* in Tampa, FL, *The Outlaws*, featuring original members *Henry Paul* and *Huey Thomasson* have been recording some new material, with *Jim Morris* and *Tony Morris* engineering. Also at Morrisound, *Vincent Bryant* has completed a dance/funk project with *Chuck Busch* producing. . . . Miami's *Criteria Recording Studios* has been active on several fronts. Japanese artist *Hir-moi Gi* is finishing up his forthcoming album for CBS-Sony with producer *Masatoshi Sakai*, engineer *Tom Suzuki* and Criteria's *Bob Castle* assisting. Meanwhile, the Criteria Cutting Center mastered funkster *George Clinton's* new 12", "Nubian Nut," with *Mike Fuller* acting as mastering engineer; and Criteria's *Wheels*, the studio's remote recording division, completed work on an HBO special "Making of a Record," which spotlighted *John Cougar* at work on his new album, "Uh Huh." The special was taped in Cougar's native Indiana. Co-producer *Don Gehman* was on hand, as were technicians *Ross Alexander* of Synergetic Services and Criteria media specialist *Richard Achor*. . . . Here's a name to look out for: *Billie J. HelmKay*, a 17-year-old female country-pop singer from Saskatchewan, travelled to Nashville's *Sound Emporium Studios* to record his first single for Comstock Records. Comstock artists the *O'Roark Brothers*, who have charted three singles, are also working at Sound Emporium. *Patty Parker* is producing both acts, with *Jim Williamson* engineering. . . . Current activity at *Music City Music Hall* includes *Jerry Lee Lewis*, now overdubbing vocals for his next MCA album with *Ron Chancey* producing and *Les Ladd* engineering; and RCA-Nashville artist *Razzy Bailey* recording with producers *Norro Wilson* and *Tony Brown*, and engineer *Bill Harris*.

## NORTH CENTRAL

At *Pinebrook Studios* in Alexandria, IN, *David Culross* cut some orchestral tracks, and John Innes orchestral and vocal tracks for a "Messiah" project. Engineers on both included *John Bolt*, *Steve Archer* and *Dan Meyer*. . . . Ex-Little Feat lead guitarist *Paul Barrere* has been in at Cincinnati's *QCA Studios* recording his second solo album for Mirage/Atlantic with *Ric Probst* engineering, *Jim Greene* assisting. . . . Hard at work at *Multi-Trac* studios in Redford, MI are the underground band *Negative Approach*, who just finished their first LP with producer *Corey Rusk* and engineer *Lloyd Grace*; *Joe Pullin & the Missiles*, who completed an EP with pro-

ducer *John Rapp* and engineer *Breck Watt*; and *Karen Newman*, who cut a demo with producer *Paul Stanley* and engineer *Rick Canzano*.

## NORTHWEST

*Sylvester*, who has continued his winning ways with a series of hits for Megatone Records, is working on his latest dance disk for that label at SF's *Automatt* with *Tip Warrick* producing and *Steve Fontano* engineering. . . . *Triad Studios* in Redmond, WA, recently saw the up-and-coming group *Queensryche* recording a demo project for their next LP, while the band *Allies* made a five-song EP there with producers *Marlin Greene* and *David Kincaid*. . . . At *T&B Audiolabs* in SF, *Rhythm Riot* has been laying down overdubs for a project produced by *Ira Walker*, bassist for one of the Bay Area's hottest local bands, *Billy Satellite*. Engineering is *Jaimie Bridges*. Also at T&B are *Noh Buddies*, recording their debut album for Sansei Records with engineer *Gregory Jones*. The band's music mixes rock with traditional Asian forms, and the buzz on the street about this group is growing every day. . . . Activity at *Montage Recording Studio* in Newark, CA, includes final mixes for an album by Max Lynx and the recording of a four-song EP by *Atom*, with *Dave Hartzheim* engineering, and *Alan Tomlinson* and *Randy Spendlove* assisting. . . . If you've seen *Francis Coppola's* intriguing and innovative new film "Rumblefish", you were no doubt intrigued by the percussive soundtrack by *Police* drummer *Stewart Copeland*. That soundtrack was entirely recorded at San Rafael's *Tres Virgos Studios*, with engineers *Robin Yeager* and *Gordon Lyon*.

## SOUTHWEST

Austin's *Reelsound Recording* had its remote truck on hand recently to record some live dates by ex-Led Zep belter *Robert Plant* for a "King Biscuit" radio show. Three Texas shows were captured for the special, which was recorded and produced by *Peter Kauff*, with *Malcolm Harper*, *Mason Harlow* and *Greg Klinginsmith* engineering. Reelsound also worked a live show by *Oingo Boingo* for an RKO network special. *Rob Dollinger* produced with the same engineering trio as above. . . . *Omega Audio* of Dallas provided remote recording for a series of 26 30-minute TV specials shot over three weeks in Orlando, FL, for a show called "Church Street Station." Among the artists appearing on the shows were such top names as *Charlie Rich*, *Tanya Tucker*, *T. G. Sheppard*, *Terry Gibbs*,



# The Composer Package



Paul Bliss bought his first Soundcraft console in 1978. As a song writer and record producer, he has always enjoyed the benefits of composing straight onto tape – that's why so many of his songs have been hits for performers as varied as Uriah Heep and Olivia Newton John.

But we amazed him with the Producer Package. With the Series 1600 console and Series 760 multitrack, Paul found he could take an affordable leap from 8 to 24 track recording. And that took him from the realm of demos to top quality masters, all in a home studio facility.

"I recorded the master of 'Casualty' for the Hollies in my studio, and we overdubbed the vocals with Graham Nash over in the States. The engineers in the studio in LA were quite amazed at the quality of my recording.

"Where the Series 1600 really scores for me is the patchbay. That lets me connect up my keyboards,

synthesizers and drum machine to the console and tape machine with just 5 multicore cables. And lets me patch anything to anything without leaving my chair.

"Soundcraft call the 1600 and 760 the Producer Package. It really feels like it was designed especially for me. So perhaps they should call it the Composer Package too."

## Soundcraft The Producer's choice

Soundcraft Electronics Limited, 5-8 Great Sutton Street,  
London, EC1V 0BX, England. Tel: 01-251 3631. Telex: 21198.

Soundcraft Electronics USA, 1517 20th. Street,  
Santa Monica, California 90404. Tel: (213) 453 4591. Telex: 664923.

Soundcraft Canada Inc. 1444 Hymus Blvd. DORVAL  
Quebec Canada H9P 1J6 Tel: (514) 685 1610 Tlx: 05 822582

Gary Morris and Gail Davies. Audio engineers for the show, which begins airing in January, were Paul Christensen, Marvin Hlavenka, Michael Parks, Garry Jones, Tim Yawn and Eric Brooks.

## SOUTHERN CALIFORNIA

*Missing Persons*, whose "Spring Session M" LP was one of last year's biggest hits by a new artist, is recording its second album at *Westlake Audio*, with Bruce Swedien and the group producing, and Swedien and Matt Forger engineering. Also at Westlake are *Mr. Mister*, recording with Peter (Men at Work) McIan, his associate engineer Paul Ray and assistant engineer Ric Butz; and Luther Vandross, mixing his next Epic album, which he and Marcus Miller produced, with Ray Bardani engineering and Steve Bates assisting. . . . *Quad Teck* studios has been in rockabilly heaven recently: *The Blasters* recorded three songs for an upcoming film there, with Blaster Phil Alvin producing. Pat Burnette engineering and Ken Gordon also assisted on that project. . . . *Tim Pinch Recording* of Glendale has been doing a lot of work in the San Francisco Bay Area of late—projects include *DFX2* and *Patrick Simmons*, recorded at Keystone Palo Alto, *Y&T* captured in San Jose and Salinas, *Greg Kihn* at Wolfgang's in SF, and metal shouter *Ronnie James Dio* at the San Jose Civic. Closer to home, TPR handled a live radio broadcast of the *Long Beach Blues Fest*, and a con-

cert at the Greek Theatre with *Culture Club*. . . . TV rules at *Evergreen Studios* in Burbank. Composers Barry Devorzan and Joe Conlan have been recording their score for the series "Just Our Luck" there, under the music supervision of David Franco, and engineer Rick Riccio has worked on sessions for the series "St. Elsewhere" and "Knots Landing," as well as the forthcoming mini-series "Princess Daisy," which is being scored by Lalo Schifrin. Assisting Riccio have been Mike Hatcher and Gary Luchs. . . . Meanwhile, at *Group IV Recording*, TV thememaster Mike Post scored an episode of the new "Bay City Blues" series with engineer Dennis Sands supervising and assistance from Andy D'adario. . . . *Skip Saylor Recording* has been kept busy working on the soundtrack for a PBS special called "Breaking and Entering." Producing are Topper Carew and Henry Johnson. . . . *Emmylou Harris'* excellent new album, "White Shoes" was recorded at Magnolia Studios with Brian Ahern producing and Donovan Cowart engineering. Ahern also recently completed the second album by Karen Brooks, with Brad Hartman engineering. . . . *Lion Share Recording* has seen myriad activity lately, including projects by *Musical Youth*, produced by Peter Waterman and Peter Collins, engineering by John Arrias, assisted by Larry Fergusson, Tom Fouce and Artie Farkas; Stanley Clarke, produced by Clarke, with engineering by Eric Zabler assisted by Steve Schmitt; and the *Isley Brothers*, produced by McKinley Jackson, engineered by Frank Clark, and assisted once again by Arte Farkas.

## STUDIO NEWS

*T&B Audiolabs* of San Francisco has added MDM TA 2A time aligned nearfield monitors, as well as Ellinger quad noise gates. . . . At *Montage Recording Studio* in Newark, CA, new equipment includes two more F-300 expander gates for the now-full Scamp rack; a stereo send modification for their Lexicon 224 digital reverb; an EMU Drumulator digital drum computer; and "The Tube," a special edition tube condenser mike from AKG. Also at Montage, David Hartzheim has been promoted to studio manager. . . . Three 3M 32-track digital mastering systems have been sold to major studios in Nashville. Two were purchased by Norbert Putnam of the *Bennett House*, another by Bill Roach's *Castle Recording Studios*. . . . After 16 years as chief engineer at Orlando, FL-based *Bee Jay Recording Studios*, Bill Vermillion has resigned to pursue his own interests. Besides engineering for such artists as Cameo, Long John Baldry and Molly Hatchet, Vermillion was responsible, in large part, for the design of Sphere's Eclipse C Console. . . . In Nashville, Pat Patrick, part owner of *Audio Media Recorders*, has acquired *Sound Lab Studio*. Patrick hopes this will facilitate a rapid growth in ad agency clients and independent label projects. . . . *Unique Recording* in New York has added a Yamaha DX-7 digital synthesizer, a PPG Wave 2.2 digital synth and sequencer, a second Emulator with J.L. Cooper mod., a Sony DRE 2000 digital reverb, and a set of eight Neve 1077 mike preamp and EQ modules. ■

Coming in April

# Video Production Listings

Plan now to be included in our 4th annual Video Focus (NAB) issue, which will be taking a close look at Music Video Production, new hardware and software and important trends to watch. If you or your company are involved in video production/post production and would like to be included in the directory listings for this issue, fill out and return the form below by January 1, 1984.

Please send me a listing questionnaire for the April issue.

Also send me advertising information (Ad closing date: February 7, 1984)

**Mail to:**

Mix Publications  
2608 Ninth Street  
Berkeley, CA 94710

Name \_\_\_\_\_ Title \_\_\_\_\_

Company \_\_\_\_\_

Type of Business \_\_\_\_\_

Address \_\_\_\_\_

City \_\_\_\_\_ State \_\_\_\_\_ Zip \_\_\_\_\_

Phone \_\_\_\_\_

# Electro-Voice Introduces 12 Channels of Sound Value.



---

## The Electro-Voice Model EVT 5212 12-Channel Tapco Stereo Mixer.

---

**NEVER BEFORE HAVE SO MANY  
BEEN ABLE TO SOUND SO GOOD  
FOR SO LITTLE.**

The EVT 5212 Stereo Mixer is the first mixer to be engineered by the newly assembled electronics design team at EV in Buchanan.

It results from research into not only how a board should perform, but how it should function from an operational standpoint. It's no surprise, therefore, that the 5212 offers carefully structured gain throughout, delivering clean, transparent sound. Its flexible input modules feature 3-band EQ and a wide variety of other controls. Output functions provide the usual feeds, including effects send and return masters. Frequency response is a wide 20-20,000 Hz  $\pm$ 1dB, with

THD of less than .05%. EIN is -128dB referenced to 150-ohm input source.

Other features include color-coded control knobs, sloping rear panel for easy hook-up and take-down, separate plug-in PC boards for easy servicing and a built-in front-panel BNC connector for a high-intensity mini lamp.

Words alone can't tell you how great this board looks and feels, or how good it sounds. Get a hands-on demonstration of the EVT 5212 at your EV dealer, or for information write: Greg Hockman, Director of Marketing, Music Products, Electro-Voice, Inc., 600 Cecil Street, Buchanan, MI 49107.



**Electro-Voice®**  
**SOUND IN ACTION™**

a **gulton** company

Circle #004 on Reader Service Card

# AMPEX GRAND MASTER® 456

Confidence is what you buy in Ampex Grand Master® 456. Confidence that lets you forget about the tape and concentrate on the job.

That's because we test every reel of 2" Grand Master 456 Professional Studio Mastering Tape end-to-end and edge-to-edge, to make certain you get virtually no tape-induced level variations from one reel to the next. The strip chart in every box of 2" 456 proves it.

No other studio mastering tape is more consistent. No other mastering tape is more available, either. With Ampex Grand Master 456 you have the confidence of knowing we stock our tape inventory in the field. Close to you. So we're there when you need us.

Confidence means having the right product at the right time. That's why more studios choose Ampex tape over any other studio mastering tape.

## AMPEX

Ampex Corporation • One of The Signal Companies 



# Industries in Transition



When the earnings of engineering  
engineer Andy Klein to a  
playback of Waylon's "Honky-Tonk  
and Roll" album at Disc Mastering  
Inc. in Nashville.

by George Petersen

The past several years have brought significant changes to the record and tape industries. Cassette tape sales of releases by major label artists are taking an increasingly larger portion of the total number of units sold. While this can partially be attributed to the popularity of Walkman-type players and improved auto sound systems, the vast strides made in the area of pre-recorded cassette sound have also been important. Record labels, tape duplication firms, and the manufacturers of bulk tape, cassette recorders, duplication equipment, and related gear (such as loaders and shells) have all contributed greatly towards this goal.

Meanwhile, the record mastering and pressing industries have also been advancing their state of the art. After a decade of declining record quality, consumers are now demanding better pressings, and the major record labels have started to realize the need for better product. Today, improved vinyl formulations, half speed master-

ing, analog 1/2" and digital masters, and quality improvements in the manufacturing process itself, have proven that the disk is capable of superb performance if attention is paid to all areas of the tape-to-disk process.

However, technical considerations aside, one of the most obvious changes in the pressing/tape duplication industry has been the emergence of regional independent labels and the distribution of product by bands and

## U.S. Compact Disc Facility Opening

After eighteen months of planning, negotiations, testing and construction, Digital Images Incorporated will open the first compact disc manufacturing plant in the United States. Dave Drake, D.I.I. president, says the firm, slated to go on-line next month, will offer custom transferring of Sony PCM-1610 digital tapes to the compact disc format. All digital transfers, laser encoding, manufacturing, packaging, indexing and sub-coding will be handled at Digital Images' facility in Northern

Virginia (near Washington, D.C.).

Drake estimates the plant's CD production capacity will be 12,000 discs per day, or 3-4 million per year. The company will accommodate both large and small orders, with a minimum of 500 discs.

The digital transferring charges are expected to range from \$950 to \$1200, depending on sub-code, indexing, and time code requirements. Disc prices (with jewel box and one-color labels) will range from \$2.50 to \$3.00 each, depending on quantity ordered. For more information, contact: Digital Images, Inc., Box 17229, Washington, D.C. 20041. (703) 450-6544.



*Cetec Gauss high speed duplication equipment in action at Bonneville Productions in Salt Lake City.*

—from page 13

musicians themselves. While the number of major label releases has decreased, the number of independent releases has risen dramatically, and mastering/pressing and tape duplication facilities have moved with the changes.

## HX Professional Acceptance Growing

The HX Professional system for improving high speed tape duplication, introduced two years ago by Dolby Laboratories and Bang & Olufsen, has received increasing acceptance by record labels and duplication facilities alike. The Warner Communications Group (comprised of Warner Bros., Elektra/Asylum and Atlantic Records) was the first major label to adopt the system, followed by A&M/CTI, and Capitol. CBS is currently testing the system, having installed ten slaves equipped for the process.

John Baxter, Technical Manager at Dolby Labs, commented on the system: "Now that several tape duplication houses have installed new production facilities incorporating Dolby HX Professional, a number of major record labels are anxious to specify that the process be used in the production of their pre-recorded cassettes. They recognize that the ability of Dolby HX Professional to give an intrinsically more accurate recording of high frequency signals enables them to make higher quality recordings without increasing their duplicating costs. The fact that an HX Professional recording does not require special playback equipment is a further attractive feature of the system."

In almost all tape recorders, a supersonic bias current (at a frequency typically 5 times the maximum audio frequency) is added to the audio record current in order to linearize the record characteristic of the tape. In conventional recorders, the magnitude of the bias current is a compromise between the requirements for optimally recording high-frequency signals and those for optimally recording low-frequency signals.

However, even nominally optimum bias is a compromise for a given tape, because that bias level which gives best performance in one area, such as distortion, will not provide the best results

in another area, such as frequency response. One reason for this inconsistency is a phenomenon known as "self-biasing," which occurs on signals that are rich in high frequencies, such as music scored with an abundance of percussion instruments, cymbals, or sibilant voices.

In such cases, the high frequencies in the signal being recorded act as recording bias and add to the bias already present, leading to tape saturation—the very highest frequencies don't get recorded at all, resulting in a dulling of the sound, and the generation of considerable distortion.

Dolby HX Professional is a special bias-related circuit which adapts to the signal being recorded to provide

kept optimally biased on such program material, and the usual effects of tape saturation are significantly reduced.

While the improvement will depend on the particular tape formulation, with Dolby HX Professional high frequencies can be cleanly recorded at levels higher by 6 dB or more than with the conventional fixed-bias technique. The degree of improvement possible is similar to that which a high-performance tape formulation provides over a conventional one.

At the present time, HX Professional licenses have been granted to Electro Sound and Gauss and both of these companies are offering cassette duplication slaves and retrofit kits for existing systems.

0 dB (Dolby Level)

*Spectral analyses of two 32:1 high speed cassette recordings of the same selection of music show the highest levels accumulated over time at each frequency. Both recordings were made on duplicator-grade iron oxide tape. In this example, the Dolby HX Professional provided a high frequency headroom improvement of up to 10 dB.*

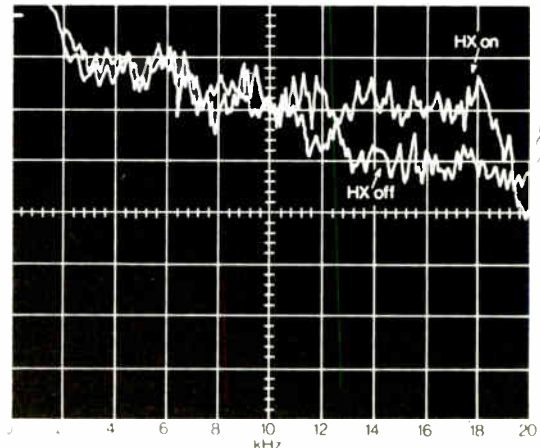

truly optimum bias at each moment in time. It constantly monitors the signal being recorded, which is a combination of the program material *and* the recording bias. If it senses the total effective bias increasing as a result of self-biasing, it instantly lowers the bias from the recorder's oscillator to keep the total effective bias constant. Thus, the tape is

Dolby Labs is also marketing HX Professional modules for the Otari MTR-10 and MTR-12 recorders, and modules for the Otari DP-80 high speed duplication system should be available in the near future. For more information, contact Dolby Laboratories, 731 Sansome Street, San Francisco, CA 94941 (415) 392-0300.

## DUPLICATION SERVICES

- CASSETTES:** CUSTOMIZED DUPLICATION OF ALL LENGTHS AND QUANTITIES FOR EVERY APPLICATION — AV, EDUCATION, ENTERTAINMENT, COMPUTER, ADVERTISING/MARKETING. BLANK CASSETTES AVAILABLE IN BULK.
- AV SERVICES:** SPECIALIZED AV DEPARTMENT HANDLES PULSING, MASTERING, DUPLICATING, LOADING AND FINISHING FOR EVERY FORMAT, AVI LABELLE, AUDISCAN, DUKANE, KODAK, COUSINO, MACKENZIE, BELL & HOWELL, SINGER, OPTISONICS, ELBA, TIFFEN, TELEX, AND WOLLENSAK.
- 8-TRACK:** COMPLETE 8-TRACK CARTRIDGE SERVICE INCLUDING DUPLICATING, LOADING AND PACKAGING.
- PRESSINGS:** COMPLETE PRESSING AND PACKAGING FOR 7", 10", 12", AT 33 1/3 AND 45 R.P.M.
- PACKAGING:** CUSTOM DESIGN; SINGLE, MULTIPLE OR PROCESS COLOR PRINTING. CUSTOM OR STOCK MAILERS, CASSETTE CASE LINERS, SHRINK WRAPPING.
- LABELS:** CUSTOM DESIGN, PRINTING, APPLICATION — ALL FORMATS.
- SHIPPING:** ROUTINE DISPATCH AND BULK MAILING SERVICE
- EQUIPMENT:** CUSTOM DESIGN, MANUFACTURE, MODIFICATION AND INSTALLATION. SALES AND SERVICE FOR TELEX, LABELLE, SHURE, AND OTHER NEW AND PRE-OWNED EQUIPMENT.



media international incorporated

247 East Ontario Street ■ Chicago, Illinois ■ 60611 USA ■ 312/467-5430

**TOTAL RECORDING DUPLICATING EQUIPMENT AUDIO**

Circle #006 on Reader Service Card

Jack Brown, the president and founder of Rainbo Records, a custom pressing house in Santa Monica, CA, says of the changing industry, "It's more than just a ripple. The four-billion dollar industry went way down. The majors are scared, compressed and taking a beating. There are no more small distributors — they've all been gobbled up by the majors. Today, bands who couldn't get a shot with a major are getting out there, raising the money, creating their own product, and doing whatever it takes to get it into the marketplace. They aren't all successful, but they do it. I have a lot of respect for them."

The trend towards more custom releases is prevalent on both coasts. James Miller, of Tracy-Val Corporation, a New Jersey record plating firm, observes "a lot more acetate work rather than stamper work," and is seeing an increase of independent and custom projects.

Another trend which is growing in popularity nationwide is the use of 1/2" mastering machines by recording studios. Paul Stubblebine, disk cutter at San Francisco's The Automatt, notes, "The trend towards 1/2" is almost 100% on major label projects, and it's starting to show up on independents as well."

In Nashville, Randy Kling of Disc Mastering Inc., reports "a very good portion" of 1/2" masters coming in, and he recently installed a new Neumann SAL 74B 550 watt transformerless cutting amplifier to complement his Studer A-80 1/2" playback machine with transformerless line amplifiers.

Gary Rice, of Future Disc Systems, a mastering studio in Hollywood, reports business is "outrageous" after being open for less than one year. He plans to add a Mitsubishi X-80 digital mastering recorder in the near future, and about 80% of their work is 30 ips 1/2". When asked about some of the low frequency problems which can occur at 30 ips, Gary explains, "We use a modified Ampex ATR-102, and the low frequency problems don't exhibit themselves since we switched to a Saki 1/2" glass head stack. With our machine modified for preview, we ran between both sets of heads, and the difference was fantastic. The bottom end was ultra smooth."

Also in Hollywood, Bill Lightner of K Disc Mastering says "business is quite good," and they are involved with about 70% label work. K Disc recently added a fifth Neumann lathe (VMS-70) to keep up with the demand, and they are considering adding another mastering room

—page 16



## ...only Sony Audio Cassette Copiers & Duplicators

As incredible as this statement might sound, it's absolutely credible. Only Sony high speed audio cassette copiers and duplicators carry a two year guarantee against head wear. No more costly and frequent replacement of heads with Sony duplicators.

This exclusive and unprecedented guarantee is made because Sony, unlike other duplicator companies, doesn't depend on someone else to make the most important part of a duplicator—record and playback heads. When a company doesn't make its own heads the performance of a duplicator can be compromised.

All Sony copiers and duplicators feature the unique ferrite and ferrite heads. These remarkable heads produce crisper, cleaner, more precise sound, and last up to 200 times longer than conventional heads.

There are models to cover a wide range of requirements all with the quality of sound performance that makes Sony stand out from all the rest. Contact us for the name of your local authorized dealer.

**SONY** AV PRODUCTS  
NATIONAL DISTRIBUTOR  
**educational electronics corporation**

213 NORTH CEDAR • INGLEWOOD, CALIFORNIA 90301 • (213) 671-2636

Circle #007 on Reader Service Card

# Audiophile quality at commercial prices from **EUROPADISK, LTD.**

Now at prices comparable with ordinary commercial pressings, Europadisk offers a new, economical version of our 150 gram Ultimate Audiophile Pressing. Made

to the same exacting standards, our new, lighter pressing still assures surfaces and weight comparable to the best imports.

Send for complete information.

**EUROPADISK, LTD.**  
75 Varick Street  
New York, NY 10013  
(212) 226-4401  
TXW 710 581 2034

Circle #008 on Reader Service Card



ATHENIA, manufacturers of a complete line of superior quality audio C-O cassettes, in all configurations; sonic sealed, screw type and computer grade. Also manufacturers of custom and standard Norelco boxes.

**SALES OFFICE**  
1455 VETERAN'S HIGHWAY, HAUPPAUGE, N.Y. 11788 **516-348-7900**  
**MANUFACTURING PLANT**  
2200 INDUSTRIAL WAY SO., TOMS RIVER, N.J. 08753 **800-526-2305**

Circle #009 on Reader Service Card

—from page 15

Award Record Manufacturing, of Inglewood, CA, is now completing the construction of a new 7800 square foot headquarters and manufacturing facility in Los Angeles, at 5200 W. 83rd Street, near the International Airport. According to George Abajian and Martin Ansoorian, Award's owners, the new \$550,000 plant will allow for a production increase beyond their current output of 12,000 records per day.

Jim Bosken, of Cincinnati's QCA Custom Pressing reports the firm has been involved with a number of upgrading projects, including the addition of a Neumann mastering system, and a separate plating room.

The new plating room, which utilizes a clean room environment with stainless steel walls and special filtration systems, was installed to accommodate QCA's nickel metalizing process, designed by K.R. Smith of Carmel Valley, California. Bosken says the process involves "metalizing the face of the master lacquer with nickel rather than silver. You don't have to strip the metal off, so there's no high end loss. The remaining metalized nickel is harder than electroplated nickel, lasts longer, and you can get more mothers from it."

Frankford/Wayne Mastering Labs, with studios in New York City and Philadelphia have been involved with a large number of digital projects recently and are now in the process of adding a second Sony PCM-1610 system in New York, according to Lynn Steele. They are also now offering digital tape preparation services for the compact disc.

Masterdisk's new room should be on-line by January 1, 1984, reports Aimee Chiariello, production manager for the New York City-based mastering house. The new room will be compatible to their other two rooms, and will be equipped with a Zuma computer and a Neumann console and lathe. Masterdisk also added a Sony PCM-1610 digital system last summer.

Irby Mandrell, president of Mandrell/Gray, Inc., announced that the company will locate its record and tape production facilities at 38 Music Square East, in the heart of Nashville's Music Row. The firm will provide manufacturing services to recording studios, artists and independent labels across the country. Vice president and chief of operations is James E. Gray. Irby Mandrell is the father of the singing Mandrell sisters, and is also the president of Mandrell Management, an artist management and development company.

Gray says the company was

—page 19



The 6120 is an original — not just a warmed-over copy of some other duplicator. It's brand new, and offers you more time-saving, quality features in one compact package than any other duplicator on the market today.

**FAST**

16-to-1 copying speeds from reel or cassette. Reel modules run at either 60 or 120 ips and cassettes run at 30 ips, which means you can copy up to eleven one hour programs in less than two minutes!

**EFFICIENT**

The 6120 accepts either 7" (178 mm) or 10½" (267 mm) reels, so you don't waste time rethreading from one reel format to another. All key setups and adjustments are made easily from the front of the system, so you don't have to waste time moving or disassembling the 6120. Accurate monitoring and precise adjustments of audio and bias levels are made possible even at high speeds, because of quick response LED level indicators. All cassette slaves are independent, so a jammed tape won't shut down the entire system, and a LED indicator warns you of an incomplete copy in case a cassette tape jams or ends before the master.

**If you want good duplicates start with a great original**  
**The new Telex 6120**

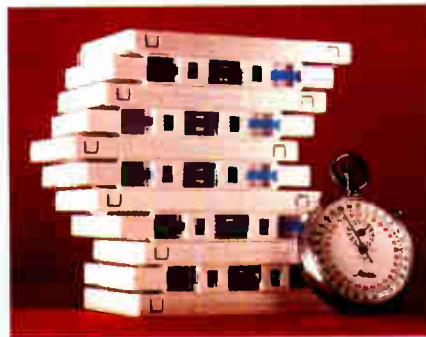

You can produce eleven C-60 cassette tapes in less than two minutes!

**EASY AUTOMATED OPERATION**

The 6120 practically runs itself. The system features automatic end-of-tape stop and auto recue on the reel master, and a choice of manual or auto rewind on the cassette master, providing virtually uninterrupted operation. Changes in equalization are made automatically when you change speeds on the reel master, thereby reducing setup time and avoiding errors.

**EXPANDABLE**

The modular, building block concept lets you buy just what you need today and expand the system to meet your growing needs tomorrow. Modules simply plug together. There's no need to add people or space as the system grows, because the 6120 is so compact that even a full system can be operated by one person.

**QUALITY TRADITION**

For over 20 years now, Telex has been the choice of those who are fussy about the quality of their duplicate tapes. The brand new 6120 is made in the U.S.A. in the Telex tradition of quality, so parts and service are always available. To learn more about the 6120, write today for complete specifications and production capabilities. While you're at it, make an appointment to see our special 6120 video tape presentation entitled "Beating Real Time".



TELEX COMMUNICATIONS, INC.

9600 Aldrich Ave. So., Minneapolis, MN 55420 U.S.A.  
 Europe: Le Bonaparte—Office 711  
 Centre Affaires: Paris-Nord, 93153 Le Blanc-Mesnil, France.

Call Toll Free in U.S. 800-828-6107  
 In Minnesota Call (612) 884-7367

- Send me literature
- I want an appointment to see the special 6120 video tape presentation.

Mail coupon to:  
 Telex Sales Information Center  
 P. O. Box 480 Cathedral Station  
 Boston, MA 02118

\_\_\_\_\_  
 Name

\_\_\_\_\_  
 Title

\_\_\_\_\_  
 Company/Organization

\_\_\_\_\_  
 Address

\_\_\_\_\_  
 City State Zip

\_\_\_\_\_  
 Best time to contact

\_\_\_\_\_  
 Phone No.

# HANK WARING'S FULL DIMENSION STEREO

by David Goggin

This is the story of a dedicated knob-twister—Hank Waring: disk mastering engineer, maintenance wiz, and one of those electronic nuts who is never satisfied. There is a bit of the mad scientist in Hank, and on one of the limbs of his family tree sits Thomas Edison, Hank's great uncle. Hank has a tall tale to tell.

He was mastering records at Capitol in the late Fifties and early Sixties, 'round about the time they were trying to find a way to make records that were compatible with both mono and stereo cartridges. Hank developed his own cutting system that made the sum of the left and right channels stay at the same amplitude as in mono. He went on to start a successful mastering facility called DCT Recording and was cranking out as many as 500 disk masters a month. He claims credit for such classics as The Buffalo Springfield's "Again", numerous Three Dog Night records, and Steppenwolf's "Born to be Wild." Hank's system (which he calls Full Dimension Stereo) was perhaps too subtle for the day, or perhaps it got lost in the confusion of new formats, new excitors, and new enhancers.

Hank left the business for about five years in the Seventies to pursue some financial adventures and in 1976 started up Quad Tech Studios, a facility comprised of two 24-track rooms, the FDS mastering room, and a tape duplication operation. Lately he has been working with some of the more aggressive L.A. bands like The Blasters, and Rank and File. He claims to have saved many disaster projects from re-mixing by putting the tapes through his odd rackloads of modified gear, the only FDS system in the world.

"I wanted to get more realism in sound," he explains. When I process a master tape, each track is split into two signal paths. Then each of those is split into eighteen areas of the audio spectrum for processing—if needed. This is a demand system and kicks into action only when it is needed."

Why eighteen levels? "Because I don't like to work in octaves. You hear the metallic sound of filters and equalizers then. Eighteen worked out best," he continues.

That elusive step from tape to disk is one that constantly confounds recording engineers. Hank had to learn from working with limited

equipment in the old days.

"When I started out I couldn't afford vertical depth control on my disk cutter, so I designed this system to solve the problem. We correct problems before they get to the cutter by a feedback system that utilizes a sum and difference circuit. We avoid vertical lift, so you don't lose the transient peak response."

How does he do it? "We have noise gates, we have parametric and parabolic equalizers, there is an enhancer circuit—enhancers are equalizers—you might call it automatic equalization. We use tubes where tubes do the best job and transistors where they work best. My cutting system sounds like a combination of a Neumann and a Westrex. I've also developed a system for cassette and tape mastering that accounts for high speed duplication problems."

It's a hybrid and idiosyncratic system to say the least. Hank spent ten grand on the guts of his device with a manufacturer who agreed to destroy the plans after completion. His components have all been

invited me to bring some records that I thought were well recorded. I listened to the "Barry Lyndon" soundtrack because there are some wild dynamics and the primitive drums are real boomers. The FDS system rounded out the individual instruments and gave them a noticeable warmth and clarity. My old albums got punchier and much less tinny and new highly produced albums *did* sound better. Was I hypnotized by Hank Waring?

I phoned Bill Robinson, grand gentleman of the recording world who was Capitol's director of recording for almost 20 years. Bill was a part of the major recording changes of the last three decades and recently heard a demonstration of Hank's FDS process. He evaluated it as follows:

"There appears to be some enhancement—but good enhancement. He's come up with something that increases the apparent loudness 3 to 6 dB without taking up any more groove space. I couldn't believe it. His process created more of a stereo image than the original

*Hank Waring demonstrating his FDS system*



modified. "It's like Rolls Royce buys GM transmissions and modifies them to their specs," he adds.

And how does it sound? He

record I listened to. If I had something like that I would patent it and market it, but he just wants to make masters for people, I guess." ■

—from page 16

formed with the idea of delivering prestige, high quality tape and record products, even on small orders. Among the many services the company will offer are up-to-date mailing lists, posters, display materials, and promotional aids. Mandrell/Gray, Inc. also plans to offer a series of seminars dealing with record and tape manufacturing, small label promotion, and independent distribution.

John Eberle of Nashville Record Productions, the oldest non-label associated cutting room in the city, reports they are moving into more label work, having completed Ronnie Milsap's *Keyed Up* album for RCA, and Amy Grant's *Ageless Medley* project for Word. John feels "people in Nashville are really thrilled with 1/2", 30 ips masters, particularly with the transformerless Studer, Ampex ATR, and MCI machines."

Mastering business has been steady at Masterfonics in Nashville and they have been running two shifts a day, according to owner Glenn Meadows, who feels "Nashville has weathered the recession better than either coast." Glenn has also seen a lot of interest in his other company, Master technologies, which has three JVC digital systems for rental and now offers digital format transfers: Sony PCM-F1 to JVC, and Sony PCM-1610 to JVC and vice-versa.

CMS is another company offering JVC digital rental services, and they are located in Altadena, in Southern California. Gene Shiveley says the firm rents to customers west of the Mississippi, as well as Canada and Mexico, and expects their new digital editing facilities (with the JVC AE-900 editor) will be operational sometime in January or early February.

Gordon Whiting of San Francisco's Sonic Arts Corporation reports they have been involved with a wide variety of projects ranging from punk and rockabilly to jazz. Recently they have been recording their own "Classical Digital" line of records directly onto a Sony PCM-F1 and have been transferring the tapes direct to disk, without editing, for an exceptionally clean product.

A number of record pressing plants have diversified into the cassette duplication area over the past year. Alshire International completed their cassette facility (which features ten Cetec Gauss 2400 duplication slaves) last summer and has been busy ever since. Wakefield, a mastering and pressing facility in Phoenix, AZ, has in-

# RTW Peak Meters

Accuracy...Reliability...Quality

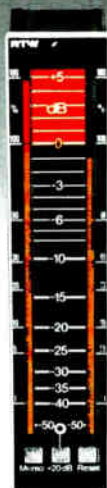

## Stereo Peak Program Meter Model 1108

- 301 segment accuracy
- Peak Hold function
- +20dB scale expansion

## Stereo Peak Program Meter Model 1227

- 10 inch scale for distant viewing
- 201 segment accuracy
- Peak Hold function
- +20dB scale expansion

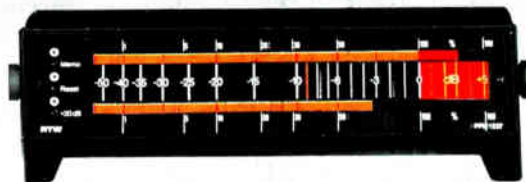

Available exclusively through



**auditronics, inc.**

3750 Old Getwell Rd.  
Memphis, TN 38118, USA  
Tel.: (901) 362-1350  
Telex: 533356

Circle #011 on Reader Service Card

The world's largest state-of-the-art cassette duplication facility continues to give you incredible sonic excellence. GRD was first to introduce cassette duplication at a reasonable cost, and elevated the cassette to audiophile quality. This year GRD has taken the next step into the future with Digital Mastering. AGFA's super-extended normal bias 612 tape and high bias 627 tape. GRD will faithfully reproduce your most demanding programs without compromise in Real-Time at unreal prices.

HIGH QUALITY PRINTING  
AND ASSEMBLY  
CUSTOM LOADED BLANK  
AGFA CASSETTES, CHROME, 612  
(602) 252-0077  
P.O. BOX 13054  
PHX., AZ 85002  
Canada Division  
(403) 283-8068

THE RECORDERS Quartz lock Auto  
Bias 30 2000 Hz 0.25% w/r m.s.  
Lab B - more than 57 dB  
S/N ratio

Circle #012 on Reader Service Card

# FROM OUR HANDS TO YOUR HANDS

*The Otari MTR-90 Series II  
8, 16, 24 Channel Master Recorders*

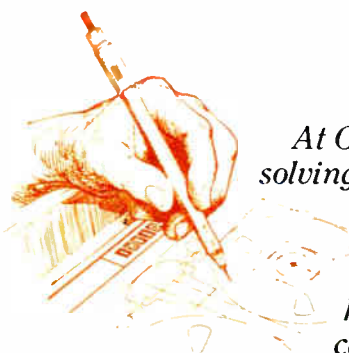

*At Otari, the focus of our work is on innovation and problem solving. These values are carefully reinforced by our dedication to quality; they are inherent in every tape recorder we engineer.*

*The new, second generation MTR-90 Series II multi-channel recorders are the embodiment of this philosophy. We have refined the features and extended the performance and capabilities of the MTR-90 by working closely with industry leaders who demand the extra measure of technology and commitment. With recording and film/video post-production facilities depending on the MTR-90, we've stayed close to the needs of today's media production houses. The new Series II machines are the logical result; a microprocessor-controlled recorder specifically designed to easily interface with any SMPTE-based video editing system, machine controller or synchronizer.*

*Once again, we've advanced the industry's most advanced recorders. And, kept the same dedication to the craftsmanship we've always had.*

*From our hands to yours, the new MTR-90 Series II recorders are engineered like no other tape machines in the world; with the quality you can hear and feel.*

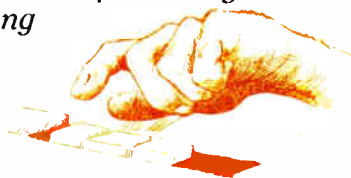

**OTARI** Technology You Can Touch.

Otari Corporation, 2 Davis Drive, Belmont, CA 94002  
Tel: (415) 592-8311 Telex: 910-376-4890

Circle #013 on Reader Service Card



—from page 19

roduced a high quality cassette duplication line, with cassette production facilities located in a Pasadena, CA, plant.

Also in Phoenix, Liv Singh, owner of GRD has seen an interest in real-time cassette distribution, and has expanded his duplication capacity to 125 machines running 24 hours a day. The company added a Sony PCM-F1 and a 3/4" VTR for digital mastering of real-time cassettes.

Another real-time cassette duplicator, Audiohouse in Denver, CO, has noted an upswing in duplication business, and has upgraded with 20 Denon DRM-3 auto-bias cassette decks in addition to the 20 Nakamichi LX-3 recorders they had, raising their total capacity to 1280 tapes per day. George Chapekis, owner of the company, also sees stereo video cassette duplication as another area of interest and expects to expand into that field next year.

Mike Callett, production vice-president at Bonneville Productions in Salt Lake City, reports the company has completed the installation of an Apex imprinter for direct imprinting onto cassette shells, and is in the process of adding Dolby HX encoding equipment onto their Gauss slaves.

Kenneth Bacon Associates, a full-service cassette duplication firm in Novato, CA (San Francisco area) moved to larger facilities and added a four track voiceover and narration studio earlier this year. Lois Bacon, co-owner of the company, says the studio was designed mainly for assisting clients with spoken word productions, and notes they have hired a staff graphics designer for packaging layouts and designs.

Sal Viola, owner of Arcal Productions, a 125 machine real-time duplication facility in Redwood City, CA, reports their facility, which opened last May, has been growing with a variety of duplication projects. Their stock music library of 12 record albums or tapes has been selling well, and a recent large duplication project involved audiophile tape editions of Vietnamese music cassettes.

Mother Dubbers tape duplication in Dallas does a lot of spoken word accounts, but recently installed an Infonics 200A duplication system which is capable of playing 15 ips, +6 dB two track studio masters for high quality music duplication runs. The 200A provides two equalization modes: flat NAB, and direct equalization while duplicating.

Paul Mooradian at IAN Recording Group in Andover, MA says

the firm will be moving to a larger facility sometime early next year. He also notes an increase in cassette computer software duplication projects and that IAN is looking into the feasibility of offering floppy disc duplication services in the near future. The company has upgraded to an Otari DP-7000 bin loop system, has installed a second AVA 2001 automated loader, and has taken delivery of a new Ryobi 480 full color offset press for cassette insert printing.

Paul Cooper, of Eva-Tone Soundsheets Inc., in Clearwater Florida, has observed a rise in the

popularity of Soundsheets as marketing and promotional tools. A number of record companies have used the Soundsheets as samplers to introduce new artists to the public; and computer program distribution, musical greeting cards, and education are just some of the varied uses the medium offers. Cooper claims the Soundsheets can be played as many times as a hard record if handled with the same care, and notes that some Soundsheets (particularly the Beatles' promotional disks from the 1960s) have become collectors' items. ■

## CMS Digital Rentals

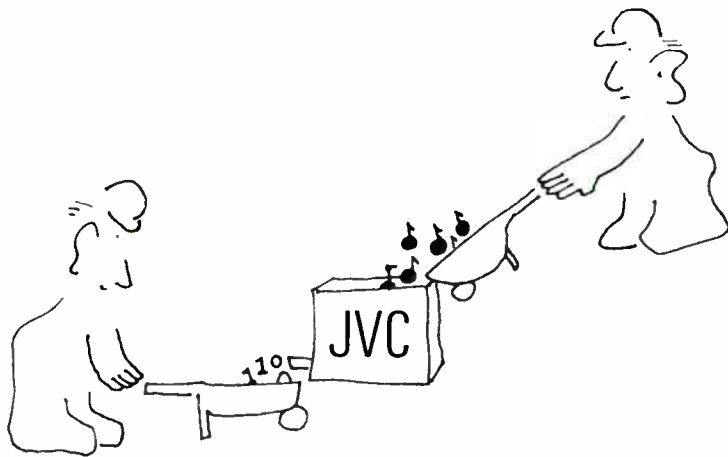

Rental makes Digital affordable  
75% savings on tape costs · 40% more Dynamic Range  
(213) 797-3046

*Sach*

Circle #003 on Reader Service Card

# DIGITAL DISCUSSIONS

## Phase 2

Editor's note: Over the past year or so we have been presenting Digital Discussions, Ken Pohlmann's serialized primer on understanding digital technology. We now embark on a new phase of Digital Discussions in which manufacturers involved with the evolution of digital audio will share their ideas, philosophies and developments on this emerging technology and its impact on the recording industry.

## An Update on Sony Digital Recording

*Sony recently introduced the CD Modular System for multiple professional compact disc players, consisting of the CDS-3000 control unit and CDP-3000 player(s), designed for professional audio production applications.*



**By George Currie, Vice President and General Manager, Sony Professional Audio Products**

With the introduction of the Sony Digital Compact Disc and the availability of consumer digital playback equipment, the impact of digital audio has spread rapidly beyond the professional community. The CD system is sending shock waves throughout the industry and is generating the first real excitement since the recording boom of the mid-seventies.

The impact of these developments at the professional level is already apparent. The demand for professional digital hardware is increasing as top artists, engineers and producers realize digital audio is here to stay. If the product is to be released in the CD format a digital master must be created, either initially recorded digitally or transferred to digital.

Sony has been marketing professional digital audio equipment in the U.S. for almost five years. Among professionals, we have passed the introductory phase and are now in the state of serious implementation. At this point there are over 50 Sony digital mastering systems operating in this country. Many of these systems are owned by rental houses, and through their network of operations a great number of artists have been exposed to the dramatic differences of recording digitally.

Sony's commitment to the pro-

### The CD off and running . . .

The Compact Disc is off to a fast start in Europe and Japan, according to industry executives. Hans Gout, senior director, Compact Disc, PolyGram Record Operations International, estimated that a total of 500,000 CD players will be sold in Europe and Japan in 1983 and that number is expected to double next year. Some 12 million discs are estimated for production abroad this year and the figure could jump to 35 million in '84, he said.

During a recent Compact Disc presentation sponsored by the Los Angeles Chapter of the National Academy of Recording Arts and Sciences, John Briesch, vice president of audio sales and marketing for Sony Consumer Products Co. notes that 18 manufacturers are or soon will be selling 22 CD player models in the U.S. In addition, both Sony and Denon offer professional units for radio station use. "Over the next five years," predicts Briesch, "we will see an overwhelming number of products, in-

cluding car and Walkman CDs, which will total over two million units."

"In addition, software production will double when the CBS/Sony plant opens in Terra Haute, IN in the spring," noted Emiel Petrone, vice president marketing/Compact Disc coordinator—U.S.A., Polygram Records Inc., and a leading spokesman for the Compact Disc Group (CDG), an association of 29 hardware and software manufacturers who officially launched their group at last summer's Consumer Electronics Show, in Chicago. "By the end of this year 260 classical, 177 pop, and 23 jazz titles will be on the U.S. market," Petrone said, citing the 460 titles listed in the new CDG catalog."

A number of record companies are introducing CD recordings for the first time in the new catalog. Among them are A&M, Arista, Capitol, Delos, GRP, and Windham Hill. Additional software members represented in the new

—page 34, CD

professional recording industry is broad based. With the recent acquisition of MCI, a leading multitrack equipment manufacturer, the strength of American studio expertise is wedded to the vast resources of Japan's research and development. We envision for the future a total digital signal path from microphone to console, to storage medium, whether it is tape or some form of solid state electronics.

We are all excited by the audible benefits of digital recording. The music that is being recorded digitally is more real, more dynamic and more exciting than ever before. However, the medium's ability to faithfully preserve information for posterity may be regarded as its most valuable long-range contribution.

To encourage and facilitate the preservation of irreplaceable analog recordings, Sony has issued a listing of studios in the U.S. that are equipped to offer digital transfer of analog masters. An added bonus, of course, is that digital transfers are ready for mastering as Compact Discs. (A copy of the list may be obtained by writing to: PCM-1610 Studios, Sony Professional Audio Products, Sony Drive, Park Ridge, NJ 07656.)

In pop music production, a

dependable and versatile multitrack system has long been awaited. Our PCM-3324 digital multitrack is now being delivered and has been performing reliably on major projects in New York, Nashville, San Francisco and Los Angeles. Two machines, purchased by John Moran of Digital Services Recording, have been running constantly on a rental basis to clients throughout the country.

One of the first musicians to purchase the multitrack system is rock innovator, Frank Zappa, whose first digital release, "Zappa, Volume One," was recorded in England with the London Symphony Orchestra. Zappa's 8,000 razor blade edits made for the finished master provided a true test of the machine's editing capability. In addition, Zappa is transferring his entire catalog of 35 album masters to the digital format for preservation and re-release.

Education is very important in ushering in a new technology. Sony's first intensive digital audio workshop/seminars were recently conducted in New York and Los Angeles by Curtis Chan, national engineering manager for digital audio.

Nearly all the owners of Sony PCM-1610 equipment attended and

were given a refresher course and an update on the state-of-the-art. Future seminars are scheduled for the DAE-1100 digital audio editor and the PCM-3324 multitrack. As time goes on this program will be expanded to accommodate new products and developments in digital audio.

For the future, Sony is working on new forms of recordable digital laser discs. When this technology becomes available, recording studios will have the ability to take a digital master tape and directly encode it into a laser disc. The recording would be done in real time, would be permanently encoded and would provide an economical way of making small numbers of discs. Sony is also investigating the possibilities of an erasable disc, which would not only have recording capability, but would also have the capacity for erasure and re-recording.

Digital recording is now a powerful force in the recording industry. Developments and refinements are progressing at an accelerated pace. Applications within the broadcast television and film industries are the next areas where we will feel its impact. Since its inception, Sony has been a leader in digital technology—a position we plan to maintain. ■

## The Sony PCM-F1 made digital audio recording affordable—the RTW analog to digital interface makes it practical.

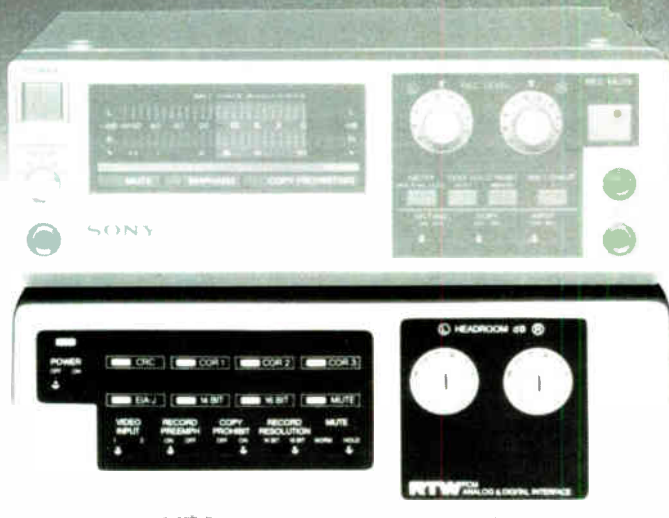

The RTW A to D interface translates PCM-F1 code directly to PCM-1610 standard, enabling use of the F1 with Sony's professional editing systems, and for compact disc mastering. It also provides balanced line level inputs and outputs with headroom adjustment, selective or parallel interface to two VCR's, manual pre-emphasis control, and expanded display of the error correction status.

Available now, exclusively through



**auditronics, inc.**

3750 Old Getwell Rd.  
Memphis, TN 38118 USA  
Tel: (901) 362-1350  
Telex: 533356

Circle #014 on Reader Service Card

# Stereo Mastering Recorders

by George Petersen

Of all the equipment in a recording studio, the two track mastering recorder is one of the most crucial, representing the studio's final stage of sound manipulation before a mix goes to the disk mastering house, cassette duplicator, or digital facility. For this reason, the performance of the two track recorder becomes paramount. And mastering facilities as well must depend on the uncompromised operation of their playback decks for their reputation and very livelihood.

The performance specifications of today's analog machines can be truly awesome, particularly when listening to a well engineered direct-to-two track recording on a 1/2" machine at 30

ips. However, recording specs alone do not a two track make, as most mastering recorders are also designed to accommodate the usually mundane (yet sometimes creative) job of tape editing.

Features such as real time counters, zero locaters, splicing blocks, variable speed search, manual (hand) shuttling, built-in monitoring, and tape dump all contribute greatly to the tape editor's job.

Most large studios set up separate tape editing rooms—this avoids tying up the studio's main recorder, which could otherwise be involved in more lucrative activities, such as mixing sessions. Of course, another advantage of having additional two track machines is the availability of the second recorder as a spare.

The selection of a two track recorder is an important decision for any studio, large or small. While this is not an area where a studio should try to cut corners, price should not be the sole limiting factor, as audio performance, tape format, features, serviceability, editing flexibility and even reel capacity are other important considerations.

In this special report, we will examine top of the line analog master-

ing recorders from major manufacturers. A brief survey of digital machines has also been included, however we will be following the developments of this technology in greater depth through our Digital Discussions column.

## ACES ACTR 2

The British-made ACES ACTR 2 is a single speed two track recorder available in either 1/4" or 1/2" tape width configurations. The unit's transport system is essentially similar to that of the 16 and 24 track machines in the ACES line, and is mounted on a thick aluminum top plate which lifts for servicing. The maximum reel capacity is 10 1/2" NAB.

The deck's two spooling motors are Papst eddy current AC, and the capstan drive is a DC servo motor which allows operation at a precise 15 ips or 50% varispeed. A large diameter motion sensing roller reduces flutter, and controls the interlocked logic circuitry and electronic braking system.

The ACTR 2 is enclosed in a floor standing console and the fully  
—page 26

## Digital Two Tracks: Hybrid Alternatives for the Studio

Certainly one of the most cost-effective ways for an analog recording studio to offer digital recording is through the acquisition of a digital two track machine. Most studios with stereo digital recorders are content to simply offer mixing and direct-to-digital two track services, and rent digital multitracks from outside firms when the job requires it.

The economic realities of today's recording studio market dictate that hybrid facilities (analog multitrack/digital two track) will be with us for a long time, until digital becomes more of a universal recording medium. The growing public acceptance of the compact disc is another factor which will push more and more studios into the digital realm, as the demand for digital product increases.

At present, there is a good selection of digital two track machines

in a variety of configurations and prices to suit almost any studio.

At the lower end of the price

### Mitsubishi X-80



World Radio History

spectrum are the Technics P-100 digital cassette recorder and the Sony PCM-F1 digital processor. The P-100 is an integrated digital system which combines a 14 bit PCM processor and tape recorder into a single unit. The digital information is stored on a standard VHS videocassette. The unit's control layout is essentially similar to that of an analog cassette deck, with the selection of the analog/digital input selector and "edit" switches for programmable operation.

The Sony PCM-F1 is a lightweight, compact digital processor which can record digital audio signals onto any VCR. Three way powering (AC/DC/batteries) is provided, and either 14 or 16 bit quantization can be selected.

The dbx Model 700 digital audio processor became available in the U.S. this month. Priced under \$5000, the system uses CPDM (Com-panded Predictive Delta Modulation)

—page 30



# How to Build a Better Compact Professional Recorder

Follow this step-by-step guide to build your own rugged, reliable, high-performance professional recorder.

1. For your design team, hire the same engineers responsible for world's premier multi-track recorder, the STUDER A800.
2. Employ meticulous Swiss and German craftsmen for all fabrication and assembly.
3. Use solid aluminum alloy die-castings for transport chassis and headblock.
4. Use the finest Swiss and German machine tools for milling, drilling, and tapping.
5. Use only professional-grade mechanical and electronic components.
6. Make your own audio heads to ensure the highest quality.
7. Apply gold plating to audio switching contacts.
8. Include the following standard features: Balanced and floating + 4 inputs and outputs • Calibrate uncalibrate switches • Self-sync • Tape dump • Edit mode • Full logic transport control • Servo controlled capstan motor • Front panel input and output mode switching • Universal power supply • Rack mount.
9. Provide the following options: Rugged, steel-legged console • Transport case • Monitor panel • Remote control • Variable speed control • Balanced mike inputs.
10. Support your finished product with a worldwide parts and service network.

If you can do all of this for under \$2100\*—by all means go ahead! (Even Dr. Willi Studer would be proud of you.) But first, we suggest you consult with your Revox Professional Products dealer. He'll provide you with a ready-built PR99...so you can concentrate on building your reputation as an audio professional.

## REVOX

Studer Revox America, Inc. • 1425 Elm Hill Pike • Nashville, TN 37210 • (615) 254-5651

\*Manufacturer's suggested list price \$2095.00. Contact dealer for further pricing information.

Circle #015 on Reader Service Card



# SPECIAL REPORT

—from page 24

regulated dual toroidal power supply is located in the cabinet's base for greater stability, better cooling and to minimize hum pick up. The ½" version is priced at \$5000, and is distributed in the U.S. by ACES (USA) of Rochester, NY.

## AEG-Telefunken M 21

The AEG-Telefunken Magnetophon M 21 is a ¼", four speed (3¾ to 30 ips), IEC/NAB/AES equalization two track recorder which became available in the U.S. this month. Although this machine is not

Telefunken's top two track model, it represents their "new generation" of magnetophons with complete microprocessor control of all transport functions and amplifier adjustments. Data concerning tape speed, tape emulsion, and equalization are entered into the control system which automatically adjusts level, bias, motor speed, tape tension, etc.

The M 21's standard features include 12½" reel capacity, return to zero, LCD display of functions and tape position, ± 10% pitch control, and an easy-to-use one hand transport control lever. Options include a ten key keypad

for simplified data entry, an adjustable tilt/height editing desk mount, a cue speaker/amp panel and a tape marking device. The M-21 is distributed in the U.S. by Gotham Audio (of Los Angeles and New York City) and is priced at \$7380 in a two track configuration.

**ANT Telecommunications, formerly AEG-Telefunken Telecommunications is pleased to announce a special promotional loaner program for qualified disc mastering facilities. For more information please contact Martin Munzer at Solway, Inc.†**

**The telcom challenge to Professional Digital Recorders**

telcom c4 challenges professional digital recording systems to offer for the same price:

- half the dynamic range of telcom c4,
- comparable serviceability,
- similar standardisation,
- interchange ability and
- last but not least the telcom quality of natural sound.

Take an existing analogue recorder (two track or multitrack), add telcom c4 and listen to the results! telcom c4 is the exceptional compander. Only this noise reduction system surpasses digital without the cost of completely new equipment and problems usually associated with implementing new technology. telcom c4 creates improved headroom, and high frequency resolution; lower distortion from tape, better crosstalk attenuation plus a 30dB gain in dynamic range.

**\$650.00 per card\***

telcom c4 is used in connection with ATR's, VTR's, line and satellite transmissions. telcom c4 in its new format will fit your standard noise reduction frame. Find out more about telcom and how you can make the telcom test.

† This is a limited offer subject to cancellation at any time.  
\* Price is subject to change

Contact: Solway Inc., P.O. Box 7647, Hollywood, Fl. 33081. Tel: (305) 962-8650, Telex 467257

**ANT** Nachrichtentechnik  
Lindener Str. 15 D-3340 Wolfenbüttel  
Phone (05331) 83-1 Telex 95651 ant d

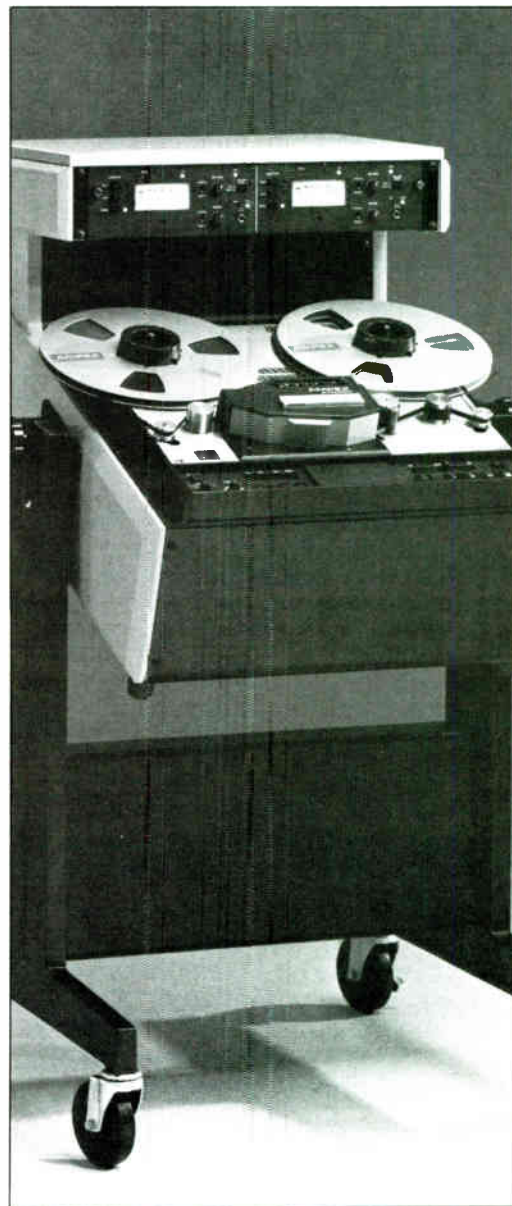

Ampex ATR-800

## Ampex ATR-800

The Ampex ATR-800 is a versatile ¼" or ½" microprocessor controlled two track machine made for a variety of broadcast and studio applications. This three speed (3.75/7.5/15 or 7.5/15/30 ips, field convertible) recorder provides for both NAB and IEC recording and is available in con-

—page 29

Circle #016 on Reader Service Card

# RESPONSE OF A KLIPSCHORN,<sup>®</sup> SIZE OF A SHOE BOX.

The new kg<sup>2</sup> just introduced at SCES offers working professionals a quality, full-range minimonitor.

A rear mounted, 10" passive radiator provides substantial, clean bass. A new crossover and voice coil provides an uncommon richness to vocals. Exceptional 100° horizontal and vertical dispersion allows a multitude of placement options. Real wood cabinetry assures you of a loudspeaker that looks as good as it sounds.

Specifications are: 35 Hz to 20 kHz  $\pm$  3 dB, sensitivity of 90 dB/SPL one watt one meter.

The new kg<sup>2</sup> is simply one of the best minimonitor options on the market today. See and hear it at your KLIPSCH<sup>®</sup> dealer. He's in the Yellow Pages.

 **klipsch**<sup>®</sup>

A Legend In Sound.<sup>™</sup>

P.O. BOX 688, HOPE, ARKANSAS USA 71801

Circle #017 on Reader Service Card



# The Ramsa WR-8118. Two of the most versatile mixers you'll ever own.



First, it's a meticulously designed and engineered sound reinforcement console. Push a button. It's now a meticulously engineered recording console. That's the extraordinary beauty of the Ramsa WR-8118.

As a PA mixer, it gives you the flexibility to handle up to 18 mic and line signals. As a recording mixer, the WR-8118

accepts multiple tape inputs and easily handles multi-channel recording, overdubbing and mixdown.

Functions like stereo tape monitoring are switchable to become stereo effects sends for PA. And PA monitor sends can be switched to effects sends for recording or mixdown.

And whichever mode you're working in, you'll have a truly remarkable console at your finger tips. There's switchable high and low EQ with continuously variable midrange. Twelve-point bar graph meters let you monitor every signal that passes through the board. And the solo function lets you isolate

and monitor any of the 18 input or four group signals.

But the only way to really appreciate what has gone into the Ramsa WR-8118, or its smaller 12 channel version, the WR-8112, is to see your nearest Ramsa dealer for a hands-on demonstration.

The Ramsa WR-8118. One versatile mixer that's two versatile mixers.



Please send me more information about the Ramsa WR-8118 and WR-8112.

Name \_\_\_\_\_  
PLEASE PRINT  
 Address \_\_\_\_\_  
 City \_\_\_\_\_ State \_\_\_\_\_ Zip \_\_\_\_\_  
 Phone (     ) \_\_\_\_\_

Return Coupon To: Panasonic Industrial Company, Professional Audio Systems, One Panasonic Way, Secaucus, N.J. 07094.

MX

**Panasonic**  
 PROFESSIONAL AUDIO SYSTEMS

# SPECIAL REPORT

Fostex A-2

—from page 26

sole, pedestal and rack mount versions.

The ATR-800 was designed for editing, and features an extra wide head assembly for better tape access, recessed controls which prevent tape snagging, a single point search-to-cue, and electronic hours/min/sec tape display "hands-on-reel" and tape dump modes, and unique interchangeable transport control panels which can be moved to accommodate left- or right-handed operating and editing procedures. The machine also incorporates a quick change head assembly which allows head conversions without constant realignments, and a  $\pm 10\%$  variable speed control is standard.

A wide range of options is available, including microphone preamps, a neopilot tone playback kit (with special head stack and electronics), DIN hubs, a remote control, dbx/Dolby noise reduction interfaces, and a selection of head assemblies.

## ACS/Hammond 6000

This German-made two track recorder is distributed in the U.S. by Hammond Industries of Madison, Alabama. The ASC 6000 is a three speed, 10½" capacity, three motor deck which features a digital tape counter, peak reading meters, line/mike mixing (with a separate master gain control), and a twin playback head option. The 6000 is priced at \$1795.

## Fostex A-2

The A-2 is the two track cousin in the Fostex line of 4, 8 and 16 track personal multitrack recorders. This compact, three head, two speed (7½/15 ips with  $\pm 10\%$  pitch control) unit uses 7 inch reels, providing 24 minutes of recording on an 1800' tape at 15 ips.

The three DC motor transport (with a servo capstan motor) is governed via an IC logic control circuit located on a hinged PC board for simplified servicing. Calibration controls are also readily accessible, placed under a flip down bottom panel.

Editing features include an LED tape counter with return to zero, tape lifter defeat, a pop up head shield, and an edit (tape dump) switch. A factory sync resolver modification is available, and a remote control, punch in/out footswitch, flight case, and rack mount adapters are optional. The Fostex A-2 has a list price of \$850.

—page 30



## GE 27 STATE VARIABLE THIRD OCTAVE EQUALIZER

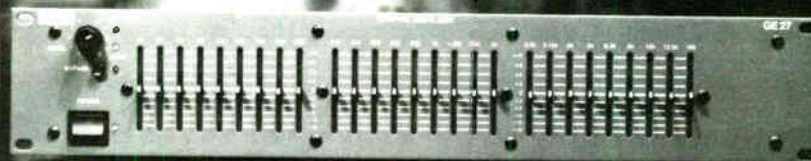

### THE NEW STANDARD IN GRAPHICS

The GE 27 State Variable filters maintain a constant ⅓ octave bandwidth at all slider positions, unlike all other graphic designs which suffer increasing bandwidth with decreasing amounts of boost or cut. The consistent precision of the GE 27 allows significantly greater feedback control without adverse effect on overall sound quality. And it yields a much higher degree of system accuracy in less time, due to reduced adjacent filter overlap at moderate amounts of boost/cut...a difference you can hear and appreciate.

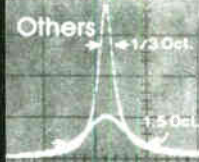

The GE 27 State Variable design has indeed revolutionized the ⅓ octave format, creating a new standard against which all other graphic equalizers will be compared, regardless of cost. And yet the GE 27 is only \$449 suggested list price.

Which proves that smart technology doesn't have to be expensive.

**RANE**  
CORPORATION

6510 D 216th SW  
Mountlake Terrace  
WA 98043 (206) 774-7309

Circle #018 on Reader Service Card

—from page 29

## MCI/Sony JH-110B

The MCI/Sony JH-110B is a quartz-controlled three speed recorder which comes in a wide range of configurations: ¼" or ½" tape, 10½" or 14" reel capacity, recording or playback-only, high- or variable-profile cabinets, and a rackmount version.

The JH-110B offers totally transformerless electronics, NAB/IEC switching,  $\pm 20\%$  speed control, a relay-free transport with DC torque motors, and a modular design for improved serviceability.

Editing on the machine is facilitated by a number of standard features (microprocessor controlled

return to zero with four additional memory points, a pre-settable counter, and a manual velocity control with "paper bucket" and "hand spool" modes), and optional accessories such as a monitor panel, DIN hub adapters, a remote transport control, and the MCI AutoLock synchronizer. The ¼" JH-110B is also available in a version with

—from page 24, *Digital*

rather than Pulse Code Modulation (PCM), and while designed for recording onto ¾" VTRs, it can also work with ½" VHS or Beta recorders.

Early tests of Model 700 prototypes have indicated the unit compares favorably with more expensive PCM processors, although CPDM tapes cannot be transferred *directly* to the 16 bit compact disc format, and must first go through an intermediate analog stage.

The JVC BP-900 is a two channel PCM processor designed to work with any NTSC format ¾" VCR. The unit operates with 16 bit linear quantization and a 44.1 (or 44.056) kHz sampling frequency which is suited for compact disc mastering. A variety of accessories are available for disk mastering, tape editing, and dual machine synchronizing with the system. JVC also manufactures a full line of ¾" VCRs.

Another ¾" VCR-based digital system is Sony's PCM-1610 processor which provides two channels of PCM digital audio at a sampling frequency of either 44.1 or 44.056 kHz. Two U-Matic ¾" video recorders, the BVU-800DA and the VO-5850DA, were developed by Sony specifically for digital audio recording. When these are used with the PCM-1610 processor and DAE-1100 digital audio editor, a complete digital editing and dubbing system can be assembled.

The Mitsubishi X-80 is a fixed-head, reel to reel (¼" tape at 15 ips), two channel digital audio mastering recorder. The machine utilizes 16 bit linear PCM technology and has a set sampling frequency of 48 kHz. The Mitsubishi system allows either razor blade editing (actual physical splicing of the tape, as with analog) or electronic editing via the XE-1 editing system controller. The X-80 is also available in a large studio console version (the

X-80A) with an overhead meter bridge, and is distributed in Europe as the AEG-Telefunken MX-80 and MX-80A.

For those of us who have enough problems already, we look upon this multi-formatted digital world as yet another challenge for the future. Obviously more standardization of the medium is necessary, but such a phase is bound to be painful for both manufacturers and studios. The DASH (Digital Audio Stationary Head) standard proposals put forth by Sony/MCI, Matsushita, and Studer are a step in the right direction, but many more such steps will have to be taken before any kind of digital standardization becomes reality.

Until then, we will see a growth of hybrid analog/digital studios, and it may be a long time from now when studios completely abandon their analog mastering decks in favor of these digital wonders.

—George Petersen

Sony PCM 1610

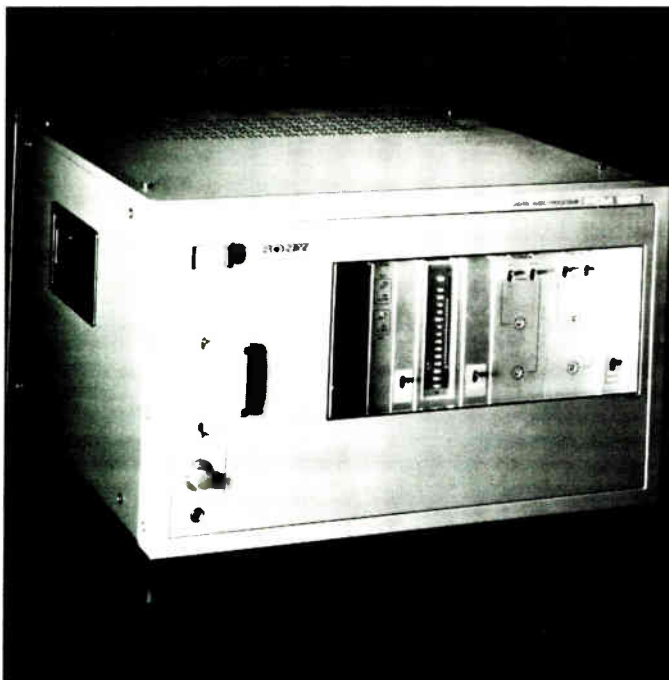

JVC DAS Series 90 System



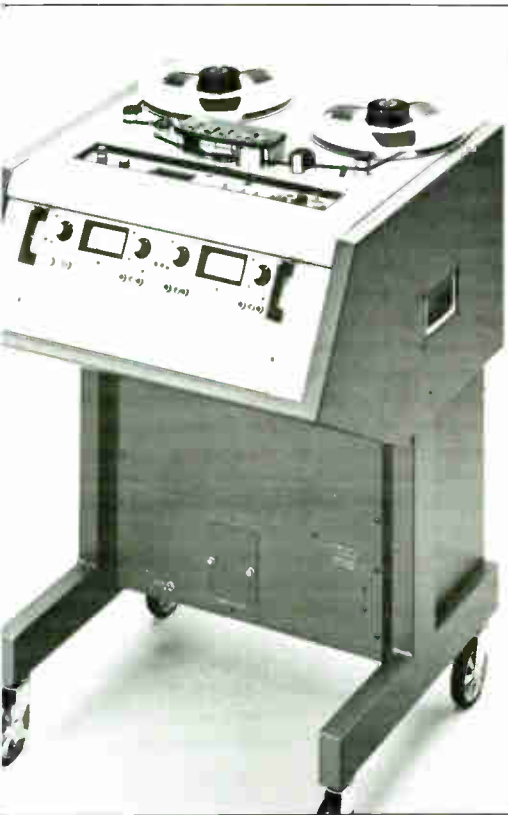

MCI/Sony JH 110B

center track recording for time coding applications.

### Otari MTR-12

The Otari MTR-12 is a microprocessor controlled mastering recorder capable of handling reels up to 12½" in diameter. Available in ¼"/1½" two track and ½" four track versions, this 7.5/15/30 ips machine provides separate repro EQ, record EQ, and phase compensation as well as two preset master bias adjustments for each speed. IEC or NAB equalization is switch selectable.

Standard transport functions include return to zero, back timing, cue and shuttle modes, tape dump, and one hand microprocessor assisted reel rocking for convenient editing.

Standard features include a monitor speaker, splicing block, test oscillator, synchronizer editor interface, ±20% variable speed, and transformer



Otari MTR-12

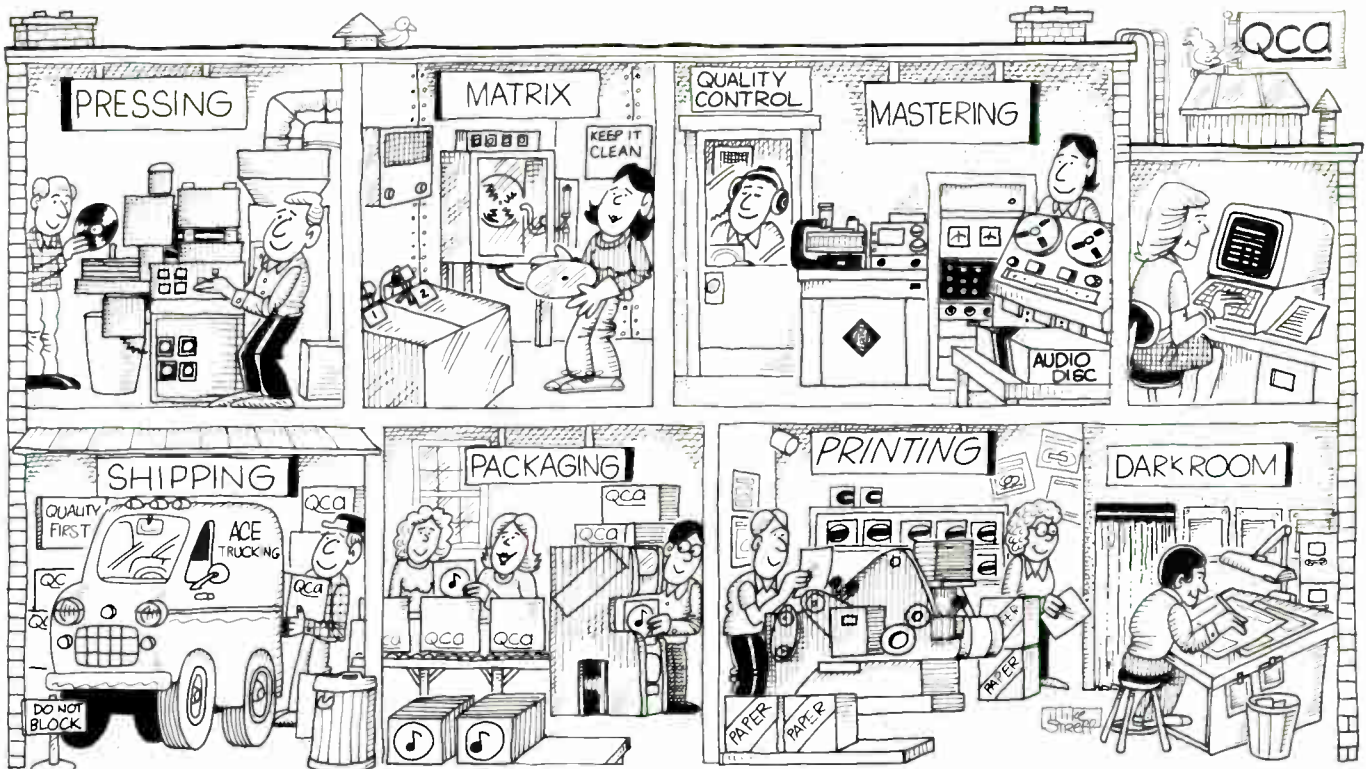

### Q. C. A. is your one stop in record production.

Mastering, electro-plating, record pressing, typesetting, color separation, and printing all under one roof. What does this mean to you? It means consistently the highest quality standards in all aspects of your record production. It also means one source for convenience in ordering, pricing, billing, and delivery.

As a recording studio or independent label you specialize in producing excellent master tapes, let Q.C.A. handle your record manufacturing requirements.



Q. C. A. CUSTOM PRESSING ♦ 2832 Spring Grove Avenue ♦ Cincinnati, Ohio 45225 ♦ (513) 681-8400

Circle #019 on Reader Service Card



*Soundcraft SCM 20*

or electronically balanced inputs/outputs. A variety of accessories are available, including two remote control units, a ten memory autolocator, and an RS-232 C serial input transport control interface. The 1/4" MTR-12 is \$6800, and the 1/2" two track version is priced at \$8400.

## Soundcraft SCM 20

The Soundcraft SCM-20 is a fully-microprocessor controlled mastering recorder which was unveiled at the Fall 1983 AES convention. The recorder can be programmed to automatically align itself to five different types of tape and three equalization standards at any of its three tape speeds. A center track is available for time coding.

Standard features include a remote unit, noise reduction switching outputs, 14" reel capacity, and varispool. Editing is simplified via open tape head access, built in monitoring, and three edit modes: dump, rock and roll, and tape stepping.

The SCM-20 is available in 1/4" or 1/2" versions and can be ordered with serial and parallel ports for external control.

## Studer A80/VU

The Studer A80/VU two track line is built around the same transport as the A80/VU multitracks and is available in both 1/4" and 1/2" tape formats in a variety of head configurations, including prelistening machines for disk cutting applications.

All A80/VU models feature electronic tape logic, servo controlled



*Studer A80/VU*

spooling and capstan motors with a  $\pm 7$  semi-tone variable speed control, and a straight-line tape path design which eliminates the need for tape lifters and facilitates editing. An electronic tape timer with return to zero locator is standard. Each amplifier channel is a self-contained unit with its own voltage regulator, playback, record and switching electronics. Transformerless line output amplifiers are supplied. Tape speeds are set at either 7 1/2/15 or 15/30 ips.

Servicing the A80/VU is simplified via its hinged transport chassis, multiple test points, and

modular sub-assemblies. Virtually all assemblies are interchangeable between any machine in the A80/VU line since identical sub-assemblies are used.

## Tascam 52

The model 52 is the top of the line two track machine in the extensive TEAC/Tascam collection of recorders. The Tascam 52 offers 7 1/2/15 ips recording on 10 1/2" reels of 1/4" tape with a

—page 34

*Tascam 52*





# ONE-INCH THE NEW STANDARD.



In the world of SMPTE there are no excuses. Get it now and get it right, in sync, on time. No matter how smart your SMPTE controller/editor is, you can't work fast if the recorder can't keep up. Our one-inch 85-16B has the high motor torque and Tach rate (30 pulses per second) you need to achieve fast "lockup" and stable operation with today's new editing systems. It will "park" where your controller tells it to, on the cue, every time. With the 85-16B you only lose one track to code. Our superior control of crosstalk gives you 15 fully usable tracks for Audio! No need to waste a track as a guard band to keep code out of the mix! You get everything from the wheels to the reels: the console, the built in dbx\* and TASCAM full function record controls. With TASCAM, you can always get what you want without paying for extras you don't need.

In Video production you have to think big, but if you think Hard you'll see that TASCAM means business—Multitrack, Multi-image and much more. Talk to your dealer to get our equipment working on your bottom line.

**TASCAM**  
TEAC Production Products

\*dbx is a trademark of dbx, Inc.,  
Newton, MA.  
Copyright 1982, TEAC Corporation of  
America, 7733 Telegraph Rd.,  
Montebello, CA 90640

Circle #020 on Reader Service Card  
World Radio History



Brooklyn Bridge  
Centennial Celebration,  
May 24, 1983.

The moment of truth.  
It happens in recording studios,  
dupe and post-production houses,  
and with ENG teams at the  
edge of history. And as it happens,  
more of these moments are being  
recorded on Maxell.

Our reputation is growing as  
surely as our product line. And the  
line is growing. With expanded  
formats in KCA and KCS  
 $\frac{3}{4}$ " U-matics. Additional Beta and  
VHS cassettes in critical new  
lengths. New instant-start audio  
cassettes. And the industry's first  
broadcast quality HGX Pro  
 $\frac{1}{2}$ " Videocassette in Beta and VHS.

How do you measure success  
in our world? To us, it's a measure  
of quality. Unvarying quality.  
To assure it, we manufacture, test  
and assemble every element from  
oxides to housings. So in that  
pivotal split-second, the moment is  
immortalized. And in your hands,  
our science turns to art.



**In your hands,  
our science turns to art.**

**maxell**

Maxell Corporation of America, 60 Oxford Drive, Moonachie, N.J. 07074 201-440-8020

Circle #023 on Reader Service Card

World Radio History

# AUDIO-APPLICATIONS

by Ken Pohlmann

It is with great expectations that I begin this series of articles on applications with the intent of providing a bit of education on practical audio dilemmas. In other words, I hope to help people get better results or otherwise clean up their act by learning to reflect a little on their audio technique. Too often, I think, the correct way of doing things is lost in the shuffle—it disappears somewhere between the technical jargon and people's impatience to press new equipment into action without fully learning how to use it.

Studio users sometimes lose sight of the professional standards necessary to maintain a high quality product. The result is that slightly faulty equipment and sloppy technique increasingly interfere with achieving the optimal solution to the task at hand. People accept slight hums, out of phase cables, mediocre-sounding microphones, speakers with deficient bass response, a little tape saturation, automation buzz in a mix, an unfortunately audible click track, and a multitude of other slight errors and defects which individually are hardly worth worrying about, but collectively can significantly lower the sound quality of a studio's output. We're all guilty of it, to a greater or lesser extent, but the mark of a true professional is the ability to constantly evaluate one's work and never cease to believe that perfection is just around the corner.

Now, no one likes to calibrate every morning, read instruction manuals every afternoon, or spend their evenings looking for ground loops, but on the other hand, why pay good money for good equipment, and then under-utilize it? I think it boils down to two things—first, to best use a piece of gear, you have to know a little about how it works. Second, a little extra effort to learn about a task is going to make the task easier. So, in the spirit of enhancement and laziness, this series of application notes has been prepared. Incidentally, I suspect there might be some controversy involved in this endeavor. In discussions of "the best way to do this is . . ." everyone has their own opinion based on their own experience. I can only plead for open-mindedness. After using single-sided razor blades all your life, and then

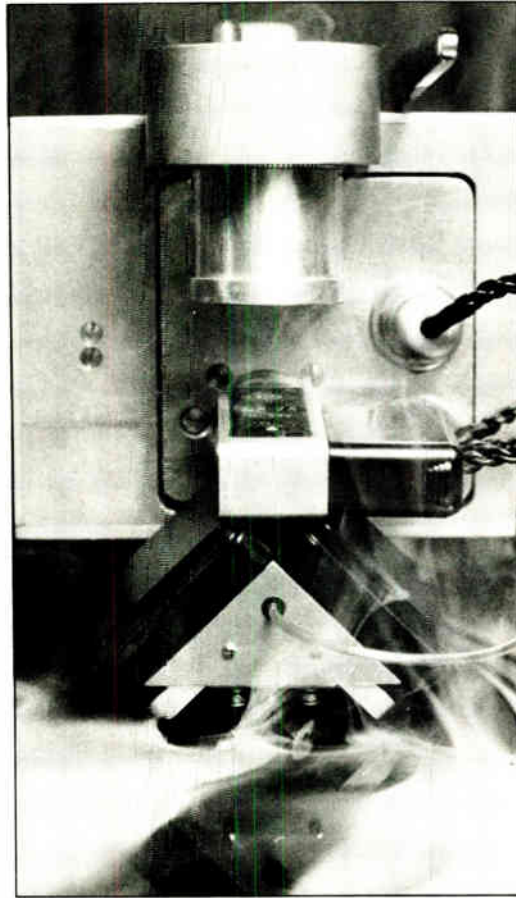

"CUTTER HEAD IN ACTION." COURTESY OF JOHN GOLDEN, KDISC MASTERING

## Mixing for Mastering

someone shows you how to use surgical scissors, who knows—maybe you should consider switching.

Other articles in this December issue of MIX have perhaps set your mind thinking of disk mastering and the incredible complexities involved in transferring from oxide to lacquer. In talking to disk mastering engineers, and listening to their horror stories, one rapidly learns that the secret to the best transfer begins back in the mixdown room. It is critically important to understand the limitations inherent in mastering and properly design your mix to take them into account. One of my limitations is that I've never operated a cutting lathe; so rather than rely on my experiences and assumptions as a mixing engineer, I decided to consult a cutting engineer to try to head

off any pressing problem. Mike Fuller is the chief cutting engineer at Criteria in Miami. He took time off from his current projects (Kenny Rogers—"Eyes That See In The Dark", Rod Stewart—"Body Wishes", Dionne Warwick—"Heart Breaker", and America—"Your Move") to outline some important aspects of cutting trouble-free disks.

A transfer to disk takes the signal from the relatively forgiving medium of magnetic flux to the hard limitations of mechanical movements; phase, frequency and amplitude range, and peculiarities in waveform such as sibilants all influence the quality of the transfer and the amount of playing time on the disk. Phase is perhaps the most critical aspect; since the stereo groove is modulated by the resultant of two stylus motions at 45 degrees to the disk surface, out-of-phase signals result in an hourglass shaped groove which can be untrackable by the playback stylus. The mixing engineer must monitor his phase information on an oscilloscope or phase meter to check stereo imaging which could cause cutting problems. Also, listening to the mix in mono reveals how much information would be lost in mono playback. Surprisingly, mono is alive and well; almost half of all radio listeners listen to mono radios. Of course, phase considerations begin at the microphones; at least one record company I know is careful to center their tympani precisely between their spaced-apart microphone pair to reduce out-of-phase information. If phase problems are present on a tape sent to the cutters, the engineer can apply remedies, but only at the expense of affecting the mix. In extreme cases an elliptical equalizer with low frequency crossover of 50 to 100 Hz must be employed to gradually move the lows closer to a mono conditions, achieving complete mono at perhaps 20 Hz.

Even properly phased low frequency information can contribute to cutting problems because it demands the greatest groove excursions. The amount of low frequency in a mix is dependent mainly on aesthetic considerations, but groove physics quickly determines how much can be cut on a disk; a muddy sound often signals the tolerance level. Sub lows at 40 Hz and lower are often not needed on disks and high pass filters remove them, and their complications. The panning of low fre-

## "WHEN THE SOUND COUNTS . . .

Finally a speaker system with the performance of multi-amplifier systems, but without the added cost of one or two additional amplifiers and an active crossover.

The SOUND CODE SYSTEMS model 3004-R achieves the performance of systems costing many times more through the use of modern construction techniques and designs.

The model 3004-R incorporates an advance computer aided crossover design rivaling any multi-amplifier system. With the use of low DCR air core inductors and high voltage mylar film capacitors, insertion losses and audible distortion have been virtually eliminated.

The 3004-R utilizes a wide angle "Constant Directivity" high frequency horn, which eliminates the objectionable "Beaming" characteristic of conventional horn designs. This horn, coupled with our high power aluminum diaphragm driver, eliminates the distortion and poor high frequency characteristic of lesser phenolic and other compression driver designs.

The low end of the audio spectrum is handled by two 15 inch cone drivers. This helps to better distribute the power load and decrease the distortion related to excessive cone travel of single driver systems.

Consider the well thought out mechanical features such as; tilt back wheels and handles for single person ease of handling, durable charcoal carpet covering and 16 gauge steel grill. This makes for an "All-In-One" enclosure that fills the needs of today's market.

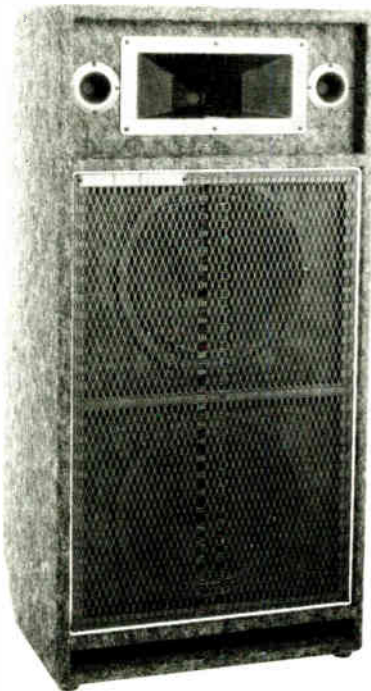

### Specifications:

Usable Frequency Response:  
25Hz to 18,500Hz

Measured Frequency Response:  
30Hz to 15,360Hz (+1, -3db)

Sensitivity:  
99.5db (1 watt / 1 meter)

Power Handling:  
300 Watt RMS power amplifier

Dimensions:  
49"(H)x24"(W)x18"(D)

. . . SOUND CODE SYSTEMS™<sup>99</sup>

P. O. Box 2198, Garden Grove, CA 92642-2198 • (714) 636-3543

quencies, particularly hard-panned, high level drums, can create phase and thus cutting problems entirely independent of microphone related phase troubles and the elliptical equalizer is again called upon. On the other frequency extreme, high amplitude, high frequency information can overload the cutting head (analogous to tape saturation, but much more costly) and protection circuits must be used to limit these highs. Similarly, the explosive energy of sibilants, primarily on vocals, can belabor a cutting head. While sibilants could be removed by the cutting engineer, cymbals and other frequency-related instruments would also suffer. The solution lies in the use of a de-esser in the recording studio. Of course, master tapes with hiss would require equalization which would result in a dull sound, and tape dropouts find no remedy at all in the cutting room.

In the quest for louder playing disks, a careful decision must be made to determine how sophisticated the groove can be made before low budget turntables would begin to fail to track. Other factors such as record warpage would necessitate an even more conservative choice. Similarly, the greater the desired bass amplitude, the less playing time is available simply because wide excursions take a lot of disk real estate. The fact must be faced—this is as loud as we can cut the disk with this time length. An L.P. side length of 18 to 20 minutes accomodates loud levels but longer times (sometimes over 30 minute stereo sides) necessitate lower volumes.

Finally, a few things to remember before you book cutting time: Have all editing and assembling completed, use blank biased tape between songs to eliminate paper tape dropout, have takes completely labeled, use a 10 inch reel, include complete tones (e.g., SPARS standard of 1K, 10K, 15K, 100 and 50 Hz, 30 seconds each at 0 VU, Dolby reference or dbx encoded tones.)

It is critical to talk to the cutting engineer and discuss cutting philosophy especially with respect to the idea that cutting employs different equalization to optimally accomplish the transfer. The mixing engineer should listen to the transfer either firsthand or to reference acetates to be certain before pressing begins. Many artists are recognizing that extra sweetening is often best handled in the cutting room. As Mike Fuller noted, cutting is coming to be recognized not as the first step of production, but rather as the last creative step in recording.

If you're an engineer who believes in "fix it in the mix", now you can "repair it in the groove". But try to plan ahead, and use cutting in a constructive manner, rather than as a last resort. ■

Circle #024 on Reader Service Card



# Otari just raised the quality of pre-recorded cassettes.

The new DP80 "Faster Masters" high-speed audio duplicating system: **Quality comes up to speed.** The new DP80 Master Reproducer runs 7½ ips masters at an amazing 480 ips. By doubling the o.d. marginal standard which relied on 3¾ ips masters plugging along at 240 ips, we've just taken the music cassette out of the early seventies and raised its quality to a higher level. The new DP80 will produce the kind of cassettes the discriminating new music buyers of the 80's want.

High production yields are still an essential aspect of the new DP80. This 64:1 system may be expanded up to 20 slave recorders and has been engineered with advanced design electronics and

these important features:

- Normal and chrome tape capability.
- Front accessible, plug-in modular electronics.
- Advanced dual capstan, D.C. servo drive for reduced tape skew and wear.
- Long-life Sendust ferrite heads.
- Status monitoring (optional).

Contact Mike Pappas, Otari Industrial Products Manager, for complete information on the duplicator that can bring your business up to speed — in both product and profits.

OTARI Industrial Products Division, 2 Davis Drive, Belmont, California 94002, (415) 592-8311  
TWX: 910-376-4890

*The 480 ips Master Reproducer: the heart of the "Faster Masters" DP80 system.*



**OTARI**®

*Technology You Can Trust*

**Audio Tape Duplicators & Video Tape Loaders**

# TAPETODISK

## Listings of Mastering, Pressing and Tape Duplication Facilities Throughout the United States

All company information listed has been supplied to the Mix by companies responding to questionnaires mailed in July, 1983. Verify critical information with the companies directly. The Mix is not liable responsibility for the accuracy of the information supplied herein by the companies.

### Page/Location

#### ARIZONA

- Phoenix
- 67 GRP Recordings
- 74 The Talking Machine
- 74 Wakefield Manufacturing
- 75 Winter Sun
- Scottsdale
- 74 Universal Audio
- CALIFORNIA
- Berkeley
- 68 Fantasy Studios
- 71 Sound Idea
- Burbank
- 63 Aspire International
- 64 Dekum Recording
- 68 KM Records
- 68 Kendan Recorders
- Camarillo
- 70 Record Technology
- Canoga Park
- 64 AIR Recording Studios
- Chatsworth
- 64 Mobile Fidelity
- 74 Taping
- City of Industry
- 70 Stoughton Printing
- Compton
- 69 PRC Recording
- El Cajon
- 66 Fantare Recording
- Emeryville
- 72 Mark Starr Recordings
- Fullerton
- 65 Bambi Records
- Glendale
- 68 MCA Whitney
- Hollywood
- 62 A&M Records
- 62 Allen Zentz Mastering
- 63 Artisan Sound Recorders
- 65 Capitol Records
- 66 Future Disc
- 67 Gold Star
- 67 JVC Cutting Center
- 68 K Day Mastering
- 69 Motown Hitsville
- 64 Music Lab
- 70 Project One A/V
- Inglewood
- 67 Award Record Mfg
- 65 Custom Duplication
- Irvine
- 65 The Creative World
- 64 The Pressing Plant
- Lafayette
- 67 H.R. Productions
- Los Angeles
- 64 Audio Video Craft Int'l
- 65 Buzzy's Recording Services
- 65 D.T. Recorders
- 68 The Mastering Lab
- 69 Precision Language
- 71 Richard Simpson
- 72 Studio Masters
- 75 Hank Warner Disc Mastering
- Mountain View
- 71 Renner
- North Hollywood
- 63 Audio Cassette Duplicator
- 64 Present Time Recorders
- 71 Sound Image
- 72 Sound Master
- 72 Takeda Record Service
- 75 West American Sound
- Novato
- 68 Kenneth Barton Associates
- Oakland
- 64 Capitol Studios
- 74 Tape Service
- Oceanside
- 68 The Fxxel Company
- Palo Alto
- 70 Recording Etc
- Pasadena
- 69 Audio Engineering Associates
- Redwood City
- 62 Arpa Productions
- Sacramento
- 65 Brandt's Recording Studios

### Page/Location

- 71 Bill Rose Productions
- San Diego
- 62 Audio Sound & Video Studios
- 68 Lightning Corp
- 71 Swansat Recording
- San Francisco
- 65 The Automatt
- 65 Gary Sound
- 67 High Speed Tape Duplication
- 71 Sound Arts Corp
- San Mateo
- 70 Realtime Duplication
- San Jose
- 63 Audiodyne
- 71 Sounds Unique
- Santa Clara
- 71 Star Studio & Sign
- Santa Monica
- 70 Professional Cassette Equip
- 70 Reverb Records
- Saugus
- 68 K Disc Mastering
- Sunnyvale
- 65 Bay Area Tape Sales
- 65 Davkore Company
- Torrance
- 66 Tynasty Studio
- Universal City
- 74 Video Record Albums
- Van Nuys
- 64 ML Tape Duplicating
- Venice
- 68 Master Digital
- CANADA
- Burnaby, B.C.
- 69 Praise Sound
- St. Laurent
- 45 Disques SNB
- Toronto
- 44 M. Cassette Press Studios
- COLORADO
- Boulder
- 74 Tapes Again
- Denver
- 63 Audiohouse
- 70 Rainbow Ventures
- 71 Soundmark LTD
- CONNECTICUT
- Norwalk
- 47 Cook Laboratories
- FLORIDA
- Clearwater
- 45 Eva Tape Soundsheets
- Fort Lauderdale
- 42 Alpha Records
- 47 Audio Duplication Service
- 42 Central Audio Video
- Hialeah
- 44 Musical Records Int'l
- 47 Musical Tapes Int'l
- Hialeah Gardens
- 49 Miami Tape Int'l
- Miami
- 42 Pat Appleton Studio
- 48 Centra Cutting Center
- Tampa
- 49 Progressive Music Studios
- Winter Garden
- 47 Magwax Corp
- GEORGIA
- Mableton
- 46 Georgia Record Pressing
- Marietta
- 45 Diversified Sound
- ILLINOIS
- Barrington
- 59 Northwest Communications
- Batavia
- 53 Audio Addressess Co
- Chicago
- 54 Audio Mixers Recording Co
- 54 Genesis Recording Int'l
- 56 Koeman Records Production
- 57 Media International Int'l
- 60 Slana Records Management Ltd
- 61 Sireersville Studios
- Morton Grove
- 56 Industrial Audio Film Services

### Page/Location

- Park Ridge
- 58 Century Sound & Slide
- Skokie
- 64 S.Y. Recording
- IOWA
- Council Bluffs
- 54 ElectroSound Tape Services Inc
- Des Moines
- 62 Trad Productions
- INDIANA
- Mishawaka
- 53 Audio Services Company Inc
- Michigan City
- 56 Indiana Int'l
- KENTUCKY
- Nebo
- 68 Tynasty Tuneshop
- LOUISIANA
- Ville Platte
- 64 New Flatie Record Mfg Co
- MARYLAND
- Silver Spring
- 43 TB Sound Studios
- MASSACHUSETTS
- Andover
- 43 Star Recording
- MICHIGAN
- Ann Arbor
- 64 Star Sound
- Detroit
- 60 Special Recordings
- 62 Tantis Productions
- East Detroit
- 54 Elephant Recording Studios
- Grand Rapids
- 51 AR Electronic Services
- Pontiac
- 58 A&F Music Services
- Southfield
- 56 K&R Recording
- 60 Ron Rose Productions
- Warren
- 52 American Sound Corp
- MISSOURI
- Arnold
- 57 Midwest Custom Pressing
- Independence
- 58 Audiographix
- Springfield
- 52 Aard Vark Recording
- NEW JERSEY
- Camden
- 49 Recorded Publications Lab
- Cranbury
- 46 Hub Servall Record Mfg
- East Newark
- 50 Son Plastics Company
- Dynamic LP Stereo Int'l
- Glen Rock
- 42 ASR
- Haworth
- 52 Tru-tone Records
- Hillsdale
- 47 Cassette Productions Int'l
- Mountainside
- 42 Beatway Group
- Newark
- 49 Peter Pan Industry
- Northvale
- 49 Preferred Sounds
- Oakhurst
- 60 Sound Arts Company
- Somerdale
- 52 Tracy Val
- NEW MEXICO
- Taos
- 70 Rainbow Cassette Studio
- NEW YORK
- Bethpage
- 42 Audio Tech Labs
- Bronxville
- 47 International Recording
- Clarence
- 46 The Groove Shop
- Ferndale
- 43 The Cutting Edge
- Huntington
- 43 Crystal City Tape Duplicators
- Huntington Station
- 46 Greater Great Records
- Long Island City
- 42 Apollo Record Company
- 47 Cassette Recording Corp
- New York City
- 42 AAA Recording
- 42 Angel Sound
- 42 Audio Matrix
- 43 Cue Recordings
- 43 Disc Communications
- 45 Europadisk
- 45 Executive Recording
- 45 Franklin Wayne Mastering
- 47 The Master Cutting Room
- 49 Masterdisk
- 49 PRC Recording
- 49 Quik Cassette Corp
- 49 Ransteere Audio
- 50 RGH Record Manufacturing

### Page/Location

- 50 Romaba Record Corp
- 50 Servisound Inc
- 50 Sound Technique
- 50 Soundwave Recording
- 50 Sterling Sound
- 50 Sunshine Sound
- 51 Variety Recording
- 52 WEA Teletronics
- Oceanside
- 42 Burlington Audio Tapes
- Port Chester
- 46 Goodtime Sound
- 47 Jan Productions
- Rochester
- 45 Synapse Recording
- NORTH CAROLINA
- Burlington
- 42 American Multimedia
- Charlotte
- 46 HMC Productions
- OHIO
- Cincinnati
- 56 RIT Album Productions
- 64 UCA Custom Pressing
- 60 Fine Record Productions
- 67 Studio Pressing Service
- Cleveland
- 58 Bixie Record Mfg & Recording
- 61 Suna Recording Studio
- Columbus
- 66 Magnate Studios
- 57 Musical Inn
- Toledo
- 54 Hunt Recording Studio
- OREGON
- Portland
- 66 Diaski Tapes
- 69 Northwestern Inc
- 70 Rex Recording
- PENNSYLVANIA
- Bethlehem
- 49 Mysos Oak Records
- Lancaster
- 54 Spectrum Fidelity Magnetics
- Mechanicsburg
- 47 National Cassette Duplication
- Olyphant
- 70 WEA Manufacturing
- Philadelphia
- 43 Diskmakers Int'l
- 46 Franklin Wayne Mastering
- 52 Virtue Recording
- Pittsburgh
- 46 George Heid Productions
- SOUTH CAROLINA
- Greenville
- 47 Custom Recording & Sound
- TENNESSEE
- Kingsport
- 59 Phonadisc Lab
- Memphis
- 52 Artistry Mastering
- 56 Mastercraft Recording
- Murfreesboro
- 61 Volunteer Record Pressing
- Nashville
- 42 Cassette Connection
- 53 Chameley Productions
- 54 Custom Tape Duplicators
- 54 Disc Mastering Int'l
- 54 Dixie Record Pressing
- 56 Independent Producers Corp
- 56 Masterphones
- 57 Nashville Record Productions
- 60 Sound of Nashville
- 60 Southern American Pressing
- 62 Woodland Sound
- TEXAS
- Dallas
- 52 A&R Record & Tape Mfg
- 56 Mother Dubbers
- 59 The Pressing Plant
- Houston
- 53 Cooksound
- 54 Creative Sound Productions
- 54 Dupli Tapes Int'l
- 57 Mushroom Station Studios
- San Antonio
- 58 Toney Records Int'l
- Waco
- 54 Hix Recording
- UTAH
- Salt Lake City
- 65 Binnville Productions
- VERMONT
- Burlington
- 51 Resolution
- VIRGINIA
- Chesapeake
- 45 Funk Pinewood Recording
- Virginia Beach
- 46 International Audio
- WEST VIRGINIA
- Parkersburg
- 50 Sweetness Productions
- WYOMING
- Cheyenne
- 71 Rocky Mountain Recording

# "I prefer Apollo Master blanks for my most critical work."

## Vladimir Meller

Custom Mastering Engineer  
Columbia Records Mastering Studios,  
New York City



"I believe they give as quiet a cut as you can get through conventional mastering."

## "The Apollo has all the pluses mastering engineers look for."

We designed into the Apollo lacquer all the features the mastering engineers have been asking for: better flatness, less noise, clean cutting, longer stylus life, better uniformity and consistency. Ultimately, the Apollo results in better records.

### "Absolutely flat."

All aluminum blanks used for the Apollo are micropolished using a process originally developed for magnetic computer disks. This multi-step process resurfaces the aluminum blanks and creates a fine finish, free from defects and with an improved flatness.

### "Free of ticks and pops."

Our elaborate lacquer manufacturing process insures that all particles and gels which could cause cutting problems are removed. Moreover, the new formulation resists lacquer buildup on the stylus, thus reducing groove wall scoring and loose debris in the groove, which contribute to ticks and pops.

### "Least abrasion."

The unique Apollo formulation reduces the cutting friction when contacted by the heated stylus. This results in lower abrasion, thus extending the stylus life. And, of course, the formulation does not use any abrasive ingredients in the first place.

### "Very consistent from batch to batch."

The excellent consistency of the Apollo lacquer masters is the result of complete control we have over the critical raw materials and the blending of the formulation. In addition, the extensive process and quality control methods assure the maintenance of tight manufacturing tolerances.

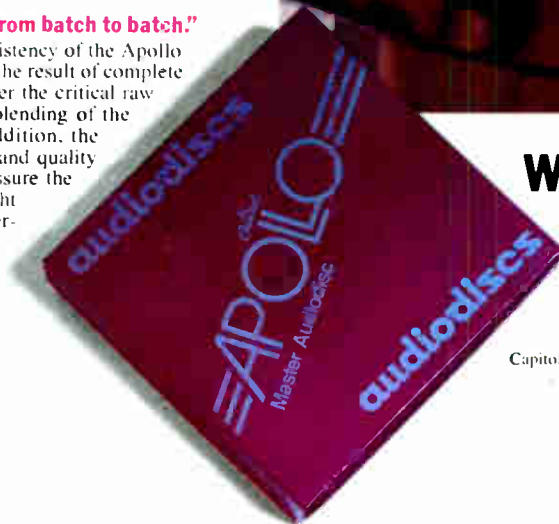

We've Mastered the Master.

Capital  
**APOLO**™

Master Audiodisc.

Capitol Magnetic Products, 6902 Sunset Boulevard, Hollywood, CA 90028.

© 1983 Capitol Magnetic Products. A division of Capitol Records, Inc. All Rights Reserved.

Circle #026 on Reader Service Card

# TAPETO DISK TAPETO DISK TAPETO DISK TAPETO DISK TAPETO DISK

## Listings of Mastering, Pressing and Tape Duplication Facilities Throughout the United States

### Eastern

**AAA RECORDING**  
MASTERING, PRESSING & TAPE DUPLICATION  
130 West 42nd Street (Room 552), New York, NY 10036  
(212) 221-6626  
Contact: Warren Allen Smith, President

**ALPHA RECORDS, INC.**  
PRESSING  
1400 NW 65th Ave., Plantation, Ft. Lauderdale, FL 33313  
(305) 587-6011  
Contact: Dick Smith, President

**AMERICAN MULTIMEDIA, INC.**  
TAPE DUPLICATION  
Rt. 8, Box 215-A, Tucker Street Ext., Burlington, NC 27215  
(919) 229-5559  
Contact: Tim Millard, Plant Manager  
**MASTERING**  
Tape machines: JVC Digital, Otari, Studer, Ampex  
Monitor speakers: UREI 813, JBL 4440  
Signal processing: Ampex, EXR, Prime-Time, Super Prime-Time 224, 274X  
Engineers: Sewer  
Rates: Call for rates  
Credits: High priority  
Other services: Complete video production, multi-track mix downs, Grass Valley Digital Video Editor, Chyron Graphics Generator, complete assortment of UREI ORBAN dbx Processors

**TAPE DUPLICATION**  
Duplicator: Exabyte Sound 8000 20 slaves; Otari DP 7000 40 slaves; Ampex 15 slaves; Gauss 7200  
Capacity: 1,000,000 weeks  
Method of duplication: In cassette, on loop  
Mastering equipment: JVC Digital, Otari, Studer, Ampex  
Tape used: All major brands in stock  
Shell used: All major brands  
Duplicating speed: 16 | 32 | 64 |  
Type of loading: 46 King 790 types  
Packaging availability/Fulfillment services: 4 automatic labeling and printing lines  
Rates: Call for rates  
Other services: Complete in-house film processing, color separations, four-color process printing, inserts, labels, brochures, books

**ANGEL SOUND, INC.**  
TAPE DUPLICATION  
1576 Broadway, New York, NY 10036  
(212) 765-7460  
Contact: Sandy Sandova, President

**APON RECORD COMPANY, INC.**  
MASTERING, PRESSING & TAPE DUPLICATION  
P O Box 3082 Steinway Station, Long Island City, NY 11103  
(212) 721-5599  
Contact: Andrew Fontana, Manager

**PAT APPLESON STUDIOS, INC.**  
TAPE DUPLICATION  
1000 NW 159 Dr., Miami, FL 33169  
(305) 625-4435  
Contact: Pat Appleton, President

**ASR**  
21 Harrison Rd., Glen Rock, NJ 07452  
(201) 652-5600  
Contact: Larry Block

**AUDIO DUPLICATING SERVICE**  
TAPE DUPLICATION  
915 NE 3rd Avenue, Fort Lauderdale, FL 33304  
(305) 764-0333  
Contact: Kevin Brant, Production Manager  
**TAPE DUPLICATION**  
Duplicator: MTI Corporation  
Capacity: 60,000/month  
Method of duplication: In loop  
Mastering equipment: Ampex ATH 100 dbx Parametric other EQ equipment  
Tape used: BASF & AGFA  
Shell used: IPS, USI  
Duplicating speed: 2 | 64 |  
Type of loading: Electrosound  
Packaging availability/Fulfillment services: Complete packaging & in-house custom design  
Rates: Available upon request  
Other services: Blank cassettes, marketing

**AUDIO-TECH LABORATORIES**  
MASTERING & TAPE DUPLICATION  
1158 Stewart Avenue, Bethpage, NY 11714  
(516) 433-0171  
Contact: Owner

**AUDIO MATRIX, INC.**  
PRESSING  
915 Westchester Ave., Bronx, NY 10459  
(212) 589-3500  
Contact: Bob Stillman, General Manager

**BESTWAY GROUP (Peerless Audiophile Div.)**  
MASTERING & PRESSING  
1105 Globe Ave., Mountainside, NJ 07092  
(201) 232-8383  
Contact: Paul Stevens

**BURLINGTON AUDIO TAPES, INC.**  
TAPE DUPLICATION  
106 Mott St., Oceanside, NY 11572  
(561) 678-4414  
Contact: Ray Schwarz

**CASSETTE CONNECTION**  
TAPE DUPLICATION  
41 Music Square East, Nashville, TN 37203  
(615) 248-3131  
Contact: Karen Irby

**CASSETTE PRODUCTIONS, INC.**  
TAPE DUPLICATION  
109 Prospect Place  
Hillsdale, NJ 07642  
(201) 666-3300  
Contact: Julius A. Konns, President, Wayne M. Konns, Vice President, Kevin Yatarola, General Manager, Paul Antepara, Plant Manager  
**TAPE DUPLICATION**  
Duplicator: 6 custom designed Dublin high speed duplicators with 14 slaves each  
Capacity: 70,000/wk  
Method of duplication: Bin loop  
Mastering equipment: Ampex  
Tape used: BASF CR02, BASF LHD and Ampex 406 407  
Shell used: Various  
Duplicating speed: 16 | & 8 |  
Type of loading: King 790  
Packaging availability/Fulfillment services: All forms  
Rates: Write for price list  
Other services: Mastering from digital source, PCM F.

**CASSETTE RECORDING CORP.**  
TAPE DUPLICATION  
41-34 27th Street, Long Island City, NY 11101  
(212) 937-3344  
Contact: John Moriarty, General Manager

**CENTRAL AUDIO VISUAL, INC.**  
TAPE DUPLICATION  
1212 South Andrews Ave., Ft. Lauderdale, FL 33316  
(305) 522-3796  
Contact: M. Lewis, Vice President

**COMMERCIAL AUDIO**  
TAPE DUPLICATION  
77 South Witchduck Road, Virginia Beach, VA 23462  
(804) 497-6506  
Contact: Alan Sawyer, Manager

**COOK LABORATORIES, INC.**  
MASTERING, PRESSING & TAPE DUPLICATION  
375 Ely Ave., Norwalk, CT 06854  
(203) 853-3641  
Contact: E.G. Cook, President



**CRITERIA CUTTING CENTER**  
Miami, FL



**CRITERIA CUTTING CENTER**  
**MASTERING, TAPE DUPLICATION**  
 1755 N.E. 149th St., Miami, FL 33181  
 (305) 947-5611

Contact: Marjorie Curry, Studio Manager

**MASTERING**

**Cutting lathes:** Tandem lathes, Scully LS 76 with Ortofon D-SS 731 and 732

**Console:** Cybersonics MC 200+

**Tape machines:** MCI modified '4' and '2' Mitsubishi & JVC Digital

**Monitor speakers:** Custom designed Ed Long Time-Aligned, Yamaha MS-100, Auratones, Acoustat, Electrostat

**Signal processing:** Sontec MES 430B EQ, Sontec DFC 200 dynamic range control. All available Criteria redq gear

**Engineers:** Mike Fuller

**Rates:** Custom cutting - \$125/hr Laquer 45's \$75 set LP's \$190/set

**Credits:** Bee Gee's, Rod Stewart, Kenny Loggins, Barry Manilow, Eric Clapton, Eddie Money, Dionne Warwick, Franke & the Knokkouts, John Cougar, Chillwack, Pat Travers

**Other services:** Full recording services available. We use exclusively Apollo lacquers

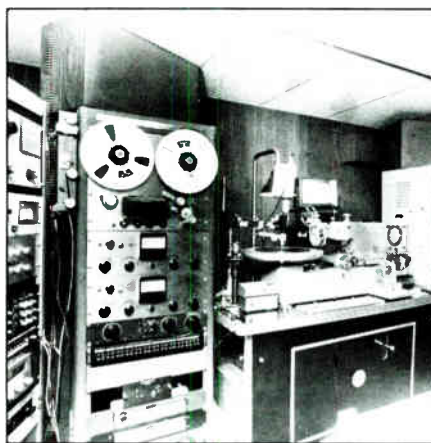

*THE CUTTING EDGE  
 Ferndale, NY*

**CRYSTAL CITY TAPE DUPLICATORS, INC.**

**TAPE DUPLICATION**

48 Stewart Ave., Huntington, NY 11743

(516) 421-0222

Contact: Frank Russo, President

**TAPE DUPLICATION**

**Duplicator:** Otari DP7500 bin loop, Pentagon in cassette

**Capacity:** 12,000 pieces per shift, per day

**Method of duplication:** In cassette, bin loop

**Mastering equipment:** Otari, Scully

**Tape used:** CBS, Agfa, BASF

**Shell used:** Data Packaging, IPS

**Duplicating speed:** 16 1/2, 32 1/2, 64 1/2

**Type of loading:** King, Electro Sound

**Packaging availability/Fulfillment services:** Shrink wrap, custom packaging

**Rates:** Please call for rates

**Other services:** Cassette labels, inserts, specialists in computer software duplication

**THE CUTTING EDGE**

**MASTERING, PRESSING & TAPE DUPLICATION**

P.O. Box 217, Ferndale, NY 12734

(914) 292-5965

Contact: Paul Gerry, Owner and Chief Cutting Engineer

**MASTERING**

**Cutting lathes:** Scully Lathe with Westrex 3DII Cutterhead, Ransteede Audio 250 watt per channel cutting amps, video monitoring

**Console:** Custom-built setup for direct to disk

**Tape machines:** Ampex 351 specially modified for tape-to-disk transfer

**Monitor speakers:** JBL 4311's, Auratones, Altec Voice of The Theatre

**Signal processing:** Fairchild 670 compressor, Ashly Parametric EQ dbx 1 & 2, Graphic EQ, Pultec EQ, UREI 1176N and misc other gear

**Engineers:** Paul Gerry

**Rates:** 12" \$70/side, 45 \$40/side; many more services available.

Write for free brochure

**Credits:** on request

**Other Services:** Pressing and tape duplication

**PRESSING**

**Presses (Mfg. and quantity):** all 12" pressing work is audiophile quality by an outside facility

**Rates:** on request

**Other services:** Disc cutting and tape duplication

**TAPE DUPLICATION**

**Duplicator (Mfg. and quantity):** All tape duplication is handled by outside top-quality tape duplicators

**Method of duplication:** In cassette and in bin loop depending on job specifications

**Rates:** on request

**Other services:** Record pressing and disk cutting

**DB SOUND STUDIOS, INC**

**MASTERING**

8037 13th Street, Silver Spring, MD 20910

(301) 585-2776

Contact: Jules Damian, President

**MASTERING**

**Tape machines:** Ampex

**Monitor speakers:** JBL

**Signal processing:** dbx

**Rates:** \$65/hr. 16 track, \$35/hr. 2 track

**Credits:** Gil Scott Heron, Tim Eyermann & East Coast Offening, BBS Unlimited, "Lahn Hussel", Vernon Burch, Hugh Masekela,

Jerry "Swamp Dog" Williams, Honey Combs, Truetones, Earlston Ford & the Ford Singers, Skip and the Casuals

**DISC COMMUNICATIONS LTD.**

**MASTERING, PRESSING & TAPE DUPLICATION**

743 Fifth Avenue, New York, NY 10022

(212) 371-0390

Contact: Jerry Rendich

**DISKMAKERS, INC**

**PRESSING & TAPE DUPLICATION**

925 N. 3rd St., Philadelphia, PA 19123

(215) 627-2277

Contact: Paul Deny, General Manager

**PRESSING**

**Presses (Mfg. and quantity):** 10 presses Tracey Val

**Capacity:** 80,000 wk

**Vinyl used:** Keser and Lenahan

**Rates:** Write for price list

**Other services:** Mastering, plating and labels

cont'd



*CUE RECORDINGS, INC.  
 New York, NY*

**CUE RECORDINGS, INC.**

**MASTERING, PRESSING & TAPE DUPLICATION**

1156 Avenue of the Americas, New York, NY 10036

(212) 921-9221

Contact: Mel Kaiser, President

**TAPE DUPLICATION**

**Duplicator:** Electrosona (5)

**Method of duplication:** Bin loop

**Mastering equipment:** Scully

**Tape used:** Columbia

**Shell used:** Sonic seal and screw type

**Duplicating speed:** 120 ips

**Type of loading:** Electrosona 1800

**Packaging availability/Fulfillment services:** Full packaging

**Other services:** Custom duplicating in Manhattan

**CUSTOM RECORDING & SOUND, INC.**

**TAPE DUPLICATION**

1225 Pendleton St., Greenville, SC 29610

(803) 269-5018

Contact: Jere Davis, General Manager

# The Time Has Come

- Highest quality cassette and open reel tape duplication
- Custom length blank audio and video cassettes

Isn't it time you heard things **ian's** way?

**ian** Communications Group, Inc.

76 Bellevue Rd. Andover, MA 01810 (617) 475-4056

Circle #027 on Reader Service Card

# When it comes to professional Audio/Video/Printing...

## We deal you a full house.



When it comes to top quality audio, video, or print services, AMERICAN MULTIMEDIA is your best bet! Whether your needs are big or small, we deal it straight with:

**AUDIO:** We have multi-track sound recording, digital time compression/expansion, analog and digital mastering, using all the big names in sound processing: Lexicon, Neve, DBX, Otari, JVC, Studer, Aphex, and much, much more.

**DUPLICATING:** We offer music, spoken word, and computer cassettes, produced on the finest equipment available: Electro Sound, Otari, and Gauss loop-bin slave duplication systems. We inventory all major brands of tape (including chrome) for your selection, and with our 36 King 790 type loaders, we can supply you with any quantity you need. To top it off, our four finishing lines make your product as great to look at as it is to hear!

**VIDEO:** Our video department uses only the best: Grass Valley Group 300 production switcher with DVE, Ikegami HK357, HL79, and Ampex cameras, Chyron RGU, and much more. We are completely mobile, too! We can do 1", 3/4", and 1/2" formats to meet your specific needs.

**PRINT:** For that added touch, our own in-house printing department offers full-color features to handle any label, insert, brochure, booklet, poster, or any other literature your product requires.

Each of our departments gives you quality service on which we'll stake our reputation. Here at AMERICAN MULTIMEDIA, quality is no gamble!



### American Multimedia, inc.

For information call or write: American Multimedia, inc. • Rt. 8, Box 215A • Burlington, N.C. 27215 • (919) 229-5559

Circle #028 on Reader Service Card

World Radio History



Listings of Mastering, Pressing and Tape Duplication Facilities Throughout the United States

## Eastern

### TAPE DUPLICATION

Duplicator: Electrosound 10 slave  
Capacity: 30,000/wk  
Method of duplication: Bin loop  
Mastering equipment: Scully and Ampex  
Tape used: CBS and AGFA  
Shell used: Shape  
Duplicating speed: 16:1  
Type of loading: King  
Packaging availability/Fulfillment services: All types  
Rates: Write for price list  
Other services: Labels and insert cards

### DISQUES SNB LIMITED

**MASTERING & TAPE DUPLICATION**  
8400 Cote de Liesse, St-Laurent, PQ H4T 1G7 Canada  
(514) 735-2271

Contact: Sabin Brunet, President

### MASTERING

Cutting lathes: VMS-70 Zumaudio computer control  
Console: Neumann SP

Tape machines: Telefunken (Preview & Record Play), Studer (Record Play)

Monitor speakers: Klein & Hummel, Tr-Amp

Signal processing: Dolby's, dbx, Orban Parametric EQ's, NTP LIM/COMP, Neumann GV 74-B transformerless

Engineers: Sabin Brunet, Emile Lepine, Alain Lalancette

Rates: Mastering LP: \$96 per side; 45 rpm: \$46 per side; Studio time: \$80/hr. Ec'd tape copy: \$84 CANADIAN FUNDS

Credits: DGG, Polygram, Virgin, Ansta, RSO, Phillips  
Other services: Pressing/cassette duplication (real time), ec'd tape copies

### PRESSING

Presses (Mfg. and quantity): Pressing available on demand

### TAPE DUPLICATION

Duplicator: Real time duplication

Capacity: 500 per 8 hour shift

Method of duplication: In cassette

Mastering equipment: AKAI/Sony

Tape used: AGFA

Shell used: Ampex

Duplicating speed: Real time

Type of loading: Semi-automatic

Packaging availability/Fulfillment services: In-house packaging, no direct printing on cassette, complimentary printing of insert card; labels and related printing services available.

Rates: On demand

### DIVERSIFIED SOUND

#### TAPE DUPLICATION

3391 Lilla Lane, Marietta, GA 30060

(404) 433-1156

Contact: Tom Smith, Kelly Monroe, Owners

### DYNAMIC RECORDING

#### PRESSING & TAPE DUPLICATION

2846 Dewey Avenue, Rochester, New York 14616

(716) 621-6270

Contact: Dave Kaspersin, Owner

### EUROPADISK, LTD.

#### PRESSING

75 Varick St., New York, NY 10013

(212) 226-4401; TWX 710 581 2034

Contact: Wes Phillips, Production Manager

#### PRESSING

Presses (Mfg. and quantity): Two Hamilton automatics; two Toolex-Alpha automatics

Capacity: 8,500 LP's per day

Vinyl used: Teldec (imported from Germany)

Rates: Three types available: Ultimate Audiophile, Audiophile, and Europa-Classical. Prices range from 59c to \$1.21 depending on type and quantity.

Credits: All RCA digital and 5 Series; Moss Music Group digital Telarc; Vanguard Digital; Audiophon; CRI; Musical Heritage digital; the Franklin Mint (classical product).

Other services: Central plating internationally renowned, audiophile quality.



**EVA-TONE SOUNDSHEETS, INC.**  
Clearwater, FL

### EVA-TONE SOUNDSHEETS, INC.

#### MASTERING, PRESSING

P.O. Box 7020, Clearwater, FL 33518

(813) 577-7000

Contact: James Dunne, Vice President Marketing/Sales. Call 1-800-EVA-TONE.

### EXECUTIVE RECORDING LTD.

#### MASTERING

300 W. 55th St., New York, NY 10019

(212) 247-7434

Contact: Gene Sayet, Boss

### FINK/PINEWOOD RECORDINGS

P.O. Box 5241, Chesapeake, Virginia 23324

(804) 627-0957

Contact: Bill Johnson, Executive Producer

#### MASTERING

Cutting lathes: Bayport Record Pressing, Chesapeake, Virginia

23324

Rates: \$85/hr

#### PRESSING

Presses (Mfg. and quantity): Bayport Pressing, Chesapeake,

Virginia 23324

Capacity: Unlimited

### FRANKFORD/WAYNE MASTERING LABS, INC.

#### MASTERING & PRESSING

1697 Broadway, New York, NY 10019

(212) 582-5473

Contact: Tom Steele, President; Norvell Miller, General Manager

#### MASTERING (6 Cutting Rooms/Mastering Suites)

Cutting lathes: (8 lathes total) 1 Neumann equipped with Compudisk Computer, 4 Scully/Ranstelee equipped with Compudisk Computers, 1 Scully/Ranstelee equipped with Capps Verpitch computer, 2 Scully-Ranstelee fully automated. Lathes equipped with the following cutting systems: 1 Neumann SX-74/SAL-74 with tracing simulator, 5 Neumann SX-74 with custom Ranstelee driver electronics, 2 Westrex 3DIIAH/RA-1700 driver system  
Consoles: 6 Ranstelee Audio custom consoles (3 are digitally equipped)

Tape machines: 5 MCI/Sony JH-110MB ¼" and ½", 1 Scully/Ranstelee custom 2B0M, 1 Ampex ATR-102, 1 MCI JH-110B, 1-3M 64-2-½", 6 Technics Pro RS-1520, 4 Ampex AG-440B, 1 Sony BVU-200B/PCM-1600 digital, 2 Sony PCM-10/100 digital, 2 Sony VC-5800 Umatic, 2 Sony Beta SL-2000/2500, 1 Sony PCM-F1/RTW

Monitor speakers: 4 JBL 4350B, 2 JBL 4343, 4 JBL 4330, 4 JBL 4311, 2 Altec/Mastering Lab, 4 ADS-300, 4 Auratone 5C, 2 ROR cubes, 4 Technics Pro

Signal processing: Equalizers by Sontec, UREI, Pultec, Technics Pro, Orban; Ranstelee Audio. Limiters by Sontec & CBS Labs  
Digital processing by AMS, Sony and Ampex. Noise reduction: Dolby, dbx, CBS CX. Custom audio processing equipment by Ranstelee Audio Labs

Engineers: Dom Romeo, Tom Coyne, Herb Powers Jr., Tom Steele, Don Grossinger plus 2 freelance engineers.

Rates: Client attendance \$90 to \$160 per hour (depending on room and availability) LP masters \$100/side, 45 masters \$40/side, LP refs D/F \$100, 12" single refs D/F \$60, 45 refs D/F \$40 Other prices upon request.

cont'd

**COMPUTERIZED disc mastering**

**FRANKFORD/WAYNE MASTERING LABS**

**quality and service since 1966**

1697 Broadway, New York, NY 10019 (212) 582-5473

132 N. 12th Street, Philadelphia, PA 19107 (215) 561-1794

Circle #029 on Reader Service Card

DISKMAKERS

RECORDS

We press  
7" and 12" records.

White, blue, and black  
12" jackets always in stock

CASSETTES

High speed duplication  
saves you money.

Custom loaded blanks.

Apex label printing directly on cassette.

SEND FOR OUR FREE PRICE LIST

**Philadelphia Plant**  
925 North 3rd Street,  
Philadelphia, Pa. 19123  
(215) MA-7-2277 / (212) 966-3185  
Washington, DC area (301) 340-6280

Circle #030 on Reader Service Card



Custom  
Length  
Chrome  
Cassettes

## Rolls Royce of Custom Cassettes

BASF Chrome  
Tape Only

## UNITED TAPE COMPANY

10746 Magnolia  
N. Hollywood, CA  
(213) 980-6700.  
Ask for Steve

Circle #031 on Reader Service Card

# RECORD PLATING

HIGHEST QUALITY • FAST SERVICE  
• PERSONAL FOLLOW THRU

We make every effort to meet your  
quality and time demands

TRACY-VAL CORPORATION  
201 Linden Ave., Somerville, NJ 08883  
(609) 627-3000

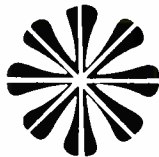

Circle #032 on Reader Service Card

Credits: Eddie Grant, Paul McCartney, Evelyn King, Melba Moore, Heaven 17, Flock of Seagulls, Manhattans, Freeez, D Train to name just a few, plus approximately 50% of the Billboard disc/dance singles and LPs  
Other services: Digital to Analog Transfers/Recording: Frankford Wayne has three complete in house Sony PCM-1600/1610 PCM-10/100 or PCM F1 digital processors and recording transfer systems "1" two track record/playback direct to disk, half-speed mastering, package pressing plans for LPs or 45s CD digital master preparation

FRANKFORD WAYNE MASTERING LABS, INC.  
MASTERING & PRESSING  
134 N. 12th St., Philadelphia, PA 19107  
(215) 561-1794

Contact: Lynn Steele, General Manager, Tom Steele - President, Clara McLeod - Studio Manager  
MASTERING (2 cutting rooms mastering suites)  
Cutting lathes: 1 Scully Banstele automated lathes 2 equipped with CompuDisk computer. All lathes equipped with Westrex 3DIIAH Cutterheads and Banstele customer driver systems  
Console: 2 Banstele Audio Labs custom with full facilities. 1 is digitally equipped  
Tape machines: MC1 Sony JH 110MB 1/4" & 1/2" 4M M64 2 track Technics Pro RS 1520 Ampex Inovonics 300 custom, Technics cassette Sony VO 5600 digital Umatic Sony Betamax digital PCM  
Monitor speakers: 2 JBL 4343B 2 JBL 4330 2 Altec Mastering Lan 2 JBL 4311  
Signal processing: Equalizers by Sontec, UREI, Lang, Sound craftsman Pro Banstele custom. Limiters by Sontec, CBS Labs Digital processing by Ampex ADD 1 DDI, Sony PCM Noise reduction: Dolby A&B dbx I & II CBS CX Encodina Custom audio processing equipment by Banstele Audio Labs  
Engineers: Nimrit Sarikananda Tom Steele  
Rates: Client attendance - \$90/hr LP Masters - \$100/side, 45 Masters - \$40/side 12" single masters \$75/side LP refs D/F \$100, 45 Refs D/F \$40, 12" single masters \$75/side LP Refs D/F \$100, 45 Refs D/F \$40 12" single refs \$60 Other rates including complete package pressing plans for 45 or LP upon request  
Credits: Grever Washington Jr. The O'Jays Teddy Pendergrass Denise Williams The Sounds of Philadelphia Gamble Huff Bell to name just a few  
Other services: Digital to analog and analog to digital transfers Complete in house PCM digital facilities in the following Sony formats PCM 1600/1610, PCM 10/100 PCM F1 "1" two track playback direct to disc half speed custom mastering CD digital master preparation Package pressing plans for LPs or 45s

GEORGIA RECORD PRESSING  
PRESSING  
P.O. Box 811, 905 Bankhead Highway, SE, Mableton, GA 30059  
(404) 948-4138  
Contact: Kevin Fields - General Manager

GOLDEN CREST RECORDS  
MASTERING, PRESSING & TAPE DUPLICATION  
220 Broadway, Box 2859, Huntington Station, NY 11746  
Toll free (800) 645-5318; NY (516) 423-7090  
Contact: Mark Wolfson - Executive - VP

GOODTIME SOUND RECORDING  
TAPE DUPLICATION  
101 Westchester Ave  
Port Chester, New York 10573  
(914) 939-1066  
Contact: Lucy Novy - Studio Manager

THE GROOVE SHOP  
MASTERING  
10815 Bodine Road, Clarence, New York 14031  
(716) 759-2608  
MASTERING  
Cutting lathes: Neumann VMS 70/SX 74 system with custom cutting electronics and Zuma Audio Computer  
Console: Neumann with custom transformerless electronics  
Tape machines: Studer A 80  
Monitor speakers: UREI 813A time aligned JBL 4411 4401  
Signal processing: ProGraph programmable EQ UREI Parametric dtx De-essing, UREI and EMT limiters, Dolby A and dtx noise reduction, EMT gold foil reverb  
Engineers: Bob Grotke Vince Morette  
Rates: Call or write for brochure  
Other services: Precision reference cutting high speed cassette mastering

HAUPPAUGE RECORD MANUFACTURING, LTD.  
PRESSING & TAPE DUPLICATION  
15 Gilpin Avenue, Hauppauge, New York, 11788  
(516) 234-0200  
Contact: Donald L. Olesen - Executive Vice President



Listings of Mastering, Pressing and Tape  
Duplication Facilities Throughout the  
United States

## Eastern



GEORGE HEID PRODUCTIONS  
701 WASHINGTON ROAD  
PITTSBURGH, PA 15228

GEORGE HEID PRODUCTIONS  
Pittsburgh, PA

GEORGE HEID PRODUCTIONS  
TAPE DUPLICATION  
701 Washington Road, Pittsburgh, PA  
(412) 561-3399  
Contact: George Edward Heid, Owner  
TAPE DUPLICATION  
Duplicator: Otari (1 master & 4 slaves), Gauss (1 master & 2 slaves)  
Capacity: Typical production of C 45 cassettes, 150 per hour, 1200 per 8 hr. day for either system  
Method of duplication: Bin loop  
Mastering equipment: Ampex and Otari  
Tape used: Aqta/Gevaert (normal and high bias formulas) (612/812 627/827)  
Shells used: IPS, Magnetic Media, Shape, & Data Packaging  
Duplicating speed: 16 1, 32 i & 64 i  
Type of loading: Semi-automatic and fully automatic (Otari DP2700 & King 790)  
Packaging availability/Fulfillment services: Automatic labeler/graphic art & printing  
Rates: Upon request, please call  
Other services: Complete studio production available for recording, editing, and creating the original program material. Special packaging (binders, mailing containers, etc.) Mailing service available

HMC PRODUCTIONS  
5457 Monroe Rd., Charlotte, NC 28212  
(704) 536-0424  
Contact: Hank Poole, Chief Engineer

HUB-SERVALL RECORD MFG. CORPORATION  
Cranbury-South River Road, Cranbury, NJ 08512  
(609) 655-2166  
Contact: Barry Ruegg, Vice President Sales, Jean Stembel, Director Customer Relations  
PRESSING  
Presses (Mfg. and quantity): 11 12" Tracy Val Presses with Hamilton Automaton  
Capacity: 25,000 per day  
Vinyl used: Keycor, Vitac  
Rates: Upon request  
Credits: Arista, JEM/Passport, Savoy, SON, Shanachie, Musical Heritage, Capitol, RCA, Bruno Dean, Moss Music, Pickwick, Columbia  
Other services: Plating jackets labels, DJ services distributor shipping



IAN RECORDING GROUP, INC.  
Andover, MA

IAN RECORDING GROUP, INC.  
TAPE DUPLICATION  
76 Bellevue Rd., Andover, MA 01810  
(617) 475-4056

Contact: Richard Berberian, President

**TAPE DUPLICATION**

Duplicator (Mfg. and quantity): Otari DP-7000 bin loop system,  
Otari DP-4050 in cassette

Capacity: 5,000 per day

Method of duplication: In cassette, bin loop

Mastering equipment: Otari MTR-10-4, Otari MTR 10-2

Tape used: Scotch, BASF, AGFA, Magnetic Media

Shell used: IPS, Magnetic Media

Duplicating speed: 8-1, 16-1, 32-1, & 64-1

Type of loading: Otari DP 2700, AVA 2001 computerized  
loading

Packaging availability/etc.: Automated labeling, shrink wrap-  
ping, etc

Rates: On quotation basis varying with type of tape, length, quan-  
tity, printing required, packaging required, etc Complete  
packages available

Other services: blank audio and video cassettes, full color in-  
house print shop for custom labels & inserts, shrink wrapping,  
drop shipping, warehouse

INTERNATIONAL RECORDING CO.  
MASTERING  
49 Desmond Ave., Bronxville, NY 10708  
(914) 337-5726

Contact: Claire Rie, President.

JAN PRODUCTIONS  
TAPE DUPLICATION  
106 Mott St., Oceanside, NY  
(516) 678-4414

Contact: Jan Schwartz, President

MAGNETIX CORP  
MASTERING, PRESSING, TAPE DUPLICATION  
770 West Bay Street, Winter Garden, FL 32787-2699

THE MASTER CUTTING ROOM, INC.  
MASTERING  
321 W. 44th St., New York, NY 10036  
(212) 581-6505

Contact: Randi Greenstein, Traffic Manager

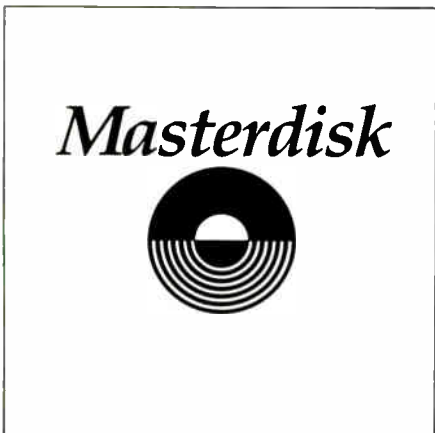

MASTERDISK CORP.  
New York, NY  
listing on following page

# "You Supply the Recording" We'll Produce the Rest



LAYOUTS/ARTWORK/COMPUTER TYPESETTING/COLOR SEPARATION  
FINAL NEGATIVES/COLOR KEYS/4 COLORS PRINTING/POSTERS/RECORDS  
LABELS/JACKETS/COMPLETE CASSETTE & 8 TRACK LABELS/6 AUTOMATIC  
SMT RECORDS PRESSES/L.P. & 45/MASTERING/STAMPERS/COMPLETE  
CASSETTE & 8 TRACK/MANUFACTURING/HIGH SPEED DUPLICATION

PROSOUND INC.  
RECORD PRESSING  
DIVISION OF MIAMI TAPE  
(305) 558-0152

UNIVERSAL LITHO & ALBUM INC  
(305) 557-2552 557-2562

MIAMI TAPE INC.  
(305) 558-9211 558-9212

8180 N.W. 103 St. Hialeah Gardens, Florida. 33016

Circle #033 on Reader Service Card

**NEW YORK'S  
FINEST DISC  
MASTERING IS IN  
HAWORTH, NEW JERSEY...**

THE CUT IS CLEARER -  
THE AIR IS CLEANER -  
THE STAFF IS TOP  
NOTCH AND OF  
COURSE THE  
EQUIPMENT  
IS STRICTLY  
STATE OF  
THE ART.



Let us prove it to  
you, mention this ad and  
get one hour complimentary  
studio time with your first 4 hour  
booking. Manhattan chauffeur service.  
Custom pressing packages also available.

**TRY US...THE COUNTRY'S  
NEVER SOUNDED BETTER!**

Trutone Records Disc Mastering Labs,  
163 Terrace Street, Haworth, N.J. 07641 201-385-0940

Circle #034 on Reader Service Card

# Sample extraordinary sound.

Introducing the **SHAPE MARK 10 Audio Cassette.**



Increasingly sophisticated audio equipment calls for a superior state-of-the-art cassette to match. Our **SHAPE MARK 10** cassette is the answer. The **MARK 10** maintains the trueness of the recording with a lasting tape quality for unmatched sound.

Built to challenge the compact digital disc, the **MARK 10** features a specially formulated crystal shell providing a unique product rigidity designed to offer maximum optical clarity. Together with the specially designed bridge insert, where crucial tape guidance features have been isolated, and components designed to enhance the 3-piece shell construction, the **MARK 10** is truly the cassette of the future...available now. Rollers, gated away from the tape bearing surface, are precisely molded to eliminate the effects of ID to OD eccentricity and skew. All liners and leaders are created from a specially formulated anti-static polyester. In addition, our stringent manufacturing controls ensure consistent, repeatable part-to-part performance with optimum side A and side B quality. The **MARK 10** is available with standard, chrome, or metal tape sensing features ideal for mastering and digital recording.

Sound impressive? It is. Give it a try.

## SHAPE<sup>®</sup>

SHAPE, INC.  
P.O. Box 366, Biddeford Industrial Park  
Biddeford, Maine 04005  
[207]282-6155 Telex 944325 SHAPE INC BIFD

Circle #035 on Reader Service Card

**Impress me!**

I want to sample the extraordinary  
sound of the **MARK 10** audio cassette.  
Clip this, attach your business card  
and mail to:

Michael Tremblay, National Sales Manager  
Audio Products  
SHAPE, INC.  
P.O. Box 366, Biddeford Industrial Park  
Biddeford, Maine 04005

**MASTERDISK CORP.**  
**MASTERING**  
 16 West 61st St., New York, NY 10023  
 (212) 541-5022  
 Contact: Jill Dix, General Manager  
**MASTERING**  
 Cutting lathes: VMS 70  
 Console: SP79  
 Tape machines: 6 Studer A-80s  
 Monitor speakers: Altec model A-19s  
 Signal processing: Sonlec equalizers, Aphex Aural Exciters  
 Engineers: Bob Ludwig, Howie Weinberg, Bill Kipper, Alan Moy  
 Rates: Upon request  
 Credits: The Police, Rolling Stones, Journey, David Bowie, Joan Jett, Bryan Adams, Kinks  
 Other services: Sony digital, BVU-800 video, DPU 1610 delay line, PCM 1610 processor

**McCLEAR PLACE STUDIOS LTD.**  
**MASTERING**  
 225 Mutual St., Toronto, Ontario, Canada  
 (416) 977-9740  
 Contact: Traffic Manager

**MIAMI TAPE INC.**  
**MASTERING, PRESSING & TAPE DUPLICATION**  
 8180 N.W. 103 St., Hialeah Gardens, FL 33016  
 (305) 558-9211  
 Contact: Carlos O. Garcia, President  
**MASTERING**  
 Cutting lathes: Haeco  
 Tape machines: MCI  
 Monitor speakers: JBL  
 Signal processing: EQs parametric (Orban), Dolby, dbx, Burwen, UREI limiters  
 Engineers: Jorge Garcia  
 Rates: On request  
 Credits: On request  
 Other services: Assembly, editing and copies. We also manufacture stampers.

**PRESSING**  
 Presses (Mfg. and quantity): 4-SMT LP - 2-SMT 45's. Fully automatic  
 Capacity: 100,000 LP's & 100,000 45's monthly.  
 Vinyl used: Kaiser  
 Rates: On request  
 Credits: On request  
 Other services: Complete litho services - jackets, label & artwork for record industry.  
**TAPE DUPLICATION**  
 Duplicator (Mfg. and quantity): 4 SMT LP, 25 MT 45 & ITS 4 SMT LP, 2 SMT 45s.  
 Capacity: 150,000 units monthly  
 Method of duplication: Bin loop  
 Mastering equipment: Electrosonnd  
 Tape used: 8 track - CBS cassette - AGFA  
 Shell used: Elmar  
 Duplicating speed: 64:1, 32:1  
 Type of loading: 8 track - Electrosonnd, cassette - D&D MK2000.  
 Packaging availability/etc. Full packaging.  
 Rates: On request

**MUSICAL RECORDS CO.**  
**MASTERING, PRESSING, TAPE DUPLICATION**  
 780 W. 27th St., Hialeah, FL 33010  
 (305) 887-2638  
 Contact: Alba V. Eagan, General Manager

**MUSICAL TAPES INC.**  
**MASTERING & TAPE DUPLICATION**  
 770 W 27th St., Hialeah, FL 33010  
 (305) 885-9156  
 Contact: Larry Fernandez, General Manager

**MYSTIC OAK RECORDS**  
**TAPE DUPLICATION**  
 1727 Elm St., Complex C, Bethlehem, PA 18017  
 (215) 865-1083  
 Contact: Bill Byron, Coordinator

**NATIONAL CASSETTE DUPLICATION**  
 P.O. Box 1152, Mechanicsburg, PA, 17055  
 (717) 766-0943  
 Contact: Chen Baldwin, Sales

**PETER PAN INDUSTRY**  
**PRESSING**  
 88 St. Francis St., Newark, NJ  
 (201) 344-4214  
 Contact: Al Cohen, Custom Pressing Sales Manager  
**PRESSING**  
 Presses: Southern Maine & Tool Co.  
 Vinyl used: Keycor Century, Tenneco  
 Rates: Low  
 Other services: Fulfillment, blister sealing, radio frequency sealing, warehousing, heat sealing, shrinkwrap, order picking, mail order



Listings of Mastering, Pressing and Tape Duplication Facilities Throughout the United States

## Eastern

**PRC RECORDING COMPANY**  
**MASTERING, PRESSING & TAPE DUPLICATION**  
 422 Madison Ave., New York, NY 10017  
 (212) 308-2300  
 Contact: David A. Grant, President

**PREFERRED SOUNDS INC.**  
**TAPE DUPLICATION**  
 135 Ludlow Ave., Northvale, NJ 07647  
 (201) 768-8007  
 Contact: Al Santoro, Vice Presiden: Sales

**PROGRESSIVE MUSIC STUDIOS**  
**TAPE DUPLICATION**  
 1904 S. MacDill Ave., Tampa, FL 33629  
 (813) 251-8093  
 Contact: Ken Veenstra, Owner/Manager

**QUIK-CASSETTE CORP.**  
**TAPE DUPLICATION**  
 250 West 57th St., Room 1400, New York, NY 10019  
 (212) 977-4411  
 Contact: Mark Milchman, President

**RANSTEELE AUDIO, INC.**  
**MASTERING**  
 1697 Broadway, New York, NY 10019  
 (212) 265-5563  
 Contact: Thomas Steele, Owner

**RECORDED PUBLICATIONS LABORATORIES**  
**MASTERING, PRESSING & TAPE DUPLICATION**  
 1100 State Street, Camden, NJ 08105  
 (609) 963-3000  
 Contact: William Young, Marketing Manager

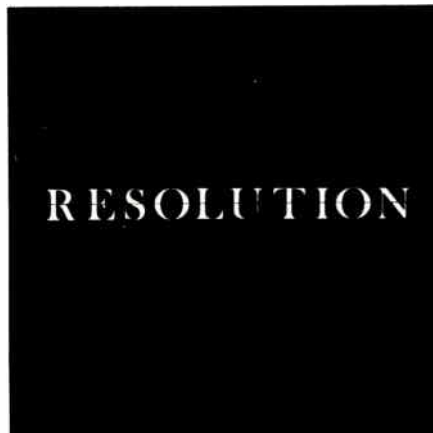

**RESOLUTION, INC.**  
 Burlington, VT

listing on following page

**Bin Loop System available in Monaural or Stereo**

**DEPEND ON IT!**  
**Magnefax works...**  
 98% of all of our tape duplicating systems produced since 1959 are still in operation.  
 Crystal sharp copy after copy, up to 2400 per shift, reliable and easy to use.  
 Best of all...affordable. Bin Loop systems start at under \$20,000.

Professional 1/4" and cassette tape duplication systems. Unique, compact Bin Loop model shown. Available in most track configurations.

**mmmmmm**  
**magnefax**  
**International, Inc.**  
 Route 1, Rogers, AR 72756  
 (501) 925-1818  
 TLX 53-64-33 AIDC LRK

Circle #036 on Reader Service Card

# REAL-TIME CASSETTE DUPLICATION

cassettes that sound  
as good as your master

## RESOLUTION DOES IT ALL

- custom length loading
- duplication in any quantity
- normal & chrome tape
- label & insert printing
- packaging
- shipping

**WE DO IT FAST  
AT THE RIGHT PRICE**

**CALL TY FOR INFORMATION**  
[802] 425-2111 or [802] 862-8881

**RESOLUTION**  
299 COLLEGE ST.  
BURLINGTON, VT 05401

Circle #037 on Reader Service Card

disques SNB Itée.



“DISK MASTERING  
AT ITS BEST”

8400 COTE DE LIESSE, ST-LAURENT, PQ, CANADA H4T 1G7  
Telephone: (514) 735-2271 Telex: 05-824886

Circle #038 on Reader Service Card

**RESOLUTION, INC.**  
TAPE DUPLICATION  
299 College St., Burlington, VT. 05401  
(802) 862-8881  
Contact: Ty Atherholt, Manager  
TAPE DUPLICATION  
Duplicator: 100 NAD high end decks, real time  
Capacity: 800 real time duplicates per day  
Method of duplication: In cassette, bin loop  
Mastering equipment: MCI JH 110 B transformerless, Sony PCM-F1 digital  
Tape used: AGFA Gevaert Premium, normal or chrome  
Shell used: Best five-screw American made  
Duplicating speed: real time, 1:1  
Type of loading: Custom loading by us using new King loaders  
Packaging availability/Fulfillment services: Full packaging services  
Rates: Very competitive with high speed dupl. rates  
Other services: Digital mastering, test cassettes, shrink wrapping, full printing services, drop shipping. All materials and workmanship full guaranteed

**RGH RECORD MANUFACTURING CORP.**  
MASTERING & PRESSING  
750 Eighth Ave., New York, NY 10036  
(212) 354-4336  
Contact: George Srolovits, President

**ROMABA RECORD CORPORATION**  
PRESSING  
33-34th Street, Brooklyn, NY 11232  
(212) 499-3060  
Contact: Theodore Kolsky, President

**SERVISOUND, INC.**  
TAPE DUPLICATION  
35 West 45th Street, New York, NY 10036  
(212) 921-0555  
Contact: Nat Levy, President

**SOUND-ARTS COMPANY, INC.**  
TAPE DUPLICATION  
5 Cindy Lane, Oakhurst, NJ 07712  
(201) 493-8666  
Contact: Frank Gspann, Vice President  
TAPE DUPLICATION  
Duplicator (Mfg. and quantity): Otari DP7300 with 17 slaves  
Capacity: 10 to 20m/day  
Method of duplication: In cassette, bin loop  
Mastering equipment: Scully, Otari MTR-10  
Tape used: AGFA, Scotch, Ampex  
Duplicating speed: 64:1, 32:1, 8:1  
Type of loading: King 790  
Packaging availability/etc.: Shrink film, etc.  
Rates: On request  
Other services: Computer software & special packaging.

**SOUND TECHNIQUE INC.**  
MASTERING  
130 West 42 St., New York, NY 10036  
(212) 869-1323  
Contact: Gladys Hopkowitz, President  
MASTERING  
Cutting lathes: Scully lathe with Capps Van-Pitch & Van-Depth computers.  
Console: Custom  
Tape machines: MCI-JH-110M, MCI-JH-110-B, Studer Revox PR-99  
Monitor speakers: Dahquist DQM-9, Technics SB-7000, Minimus 11  
Signal processing: Teletronix LA-3A, Dolby, dbx  
Engineers: Gladys Hopkowitz, Sidney Feldman, Chief Engineer  
Credits: All types of music, ranging from classical through contemporary, including jazz and reggae  
Other services: 1/2 inch 2-track mastering, AV pulsing and DuKane 30/50 mastering

**SOUNDWAVE RECORDING STUDIOS, INC.**  
MASTERING  
2 West 45th St., Suite 903, New York, NY 10036  
(212) 730-7366  
Contact: Carol Baker, President

**SPECTRUM FIDELITY MAGNETICS, INC.**  
TAPE DUPLICATION  
1770 Lincoln Highway East/P.O. Box 218, Lancaster, PA 17603  
(800) 441-8854; (717) 295-9275  
Contact: John O Yoder, President; Wendy J Rineer, Director Customer Relations  
TAPE DUPLICATION  
Duplicator (Mfg. and quantity): Ampex BLM 200A w/10 slaves  
Capacity: 80,000/wk  
Method of duplication: Bin loop  
Mastering equipment: Ampex-Inovonics



Listings of Mastering, Pressing and Tape  
Duplication Facilities Throughout the  
United States

## Eastern

Tape used: BASF, Mag Media, Ametai, CBS  
Shell used: IPS, Mag Media, Trans Am  
Duplicating speed: 64:1  
Type of loading: Ava Automated  
Packaging availability/etc.: Yes, in house  
Rates: Upon request.  
Other services: BT duplication & packaging

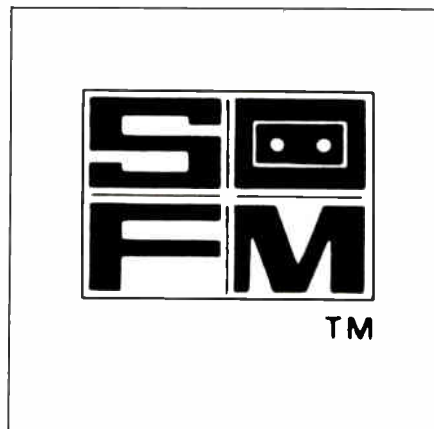

**SPECTRUM FIDELITY MAGNETICS, INC.**  
Lancaster, PA

**STERLING SOUND, INC.**  
MASTERING  
1790 Broadway, New York, NY 10019  
(212) 757-8519  
Contact: John Kubick, Studio Manager

**SUN PLASTICS CO., INC. - DYNAMIC LP STEREO RECORDS, INC.**  
PRESSING  
900 Passak Ave., East Newark, NJ 07029  
NJ: (201) 482-6749; NY: (212) 349-0777  
Contact: Jerry Salerno, President

**SUNSHINE SOUND INC.**  
MASTERING  
1650 Broadway, New York, NY 10019  
(212) 582-6227  
Contact: Frank J Trmarco, President

**SWEETSONG PRODUCTIONS**  
PRESSING, TAPE DUPLICATION  
P.O. Box 2041, Parkersburg, WV 26102  
(304) 489-2911  
Contact: Roger Hoover, Owner



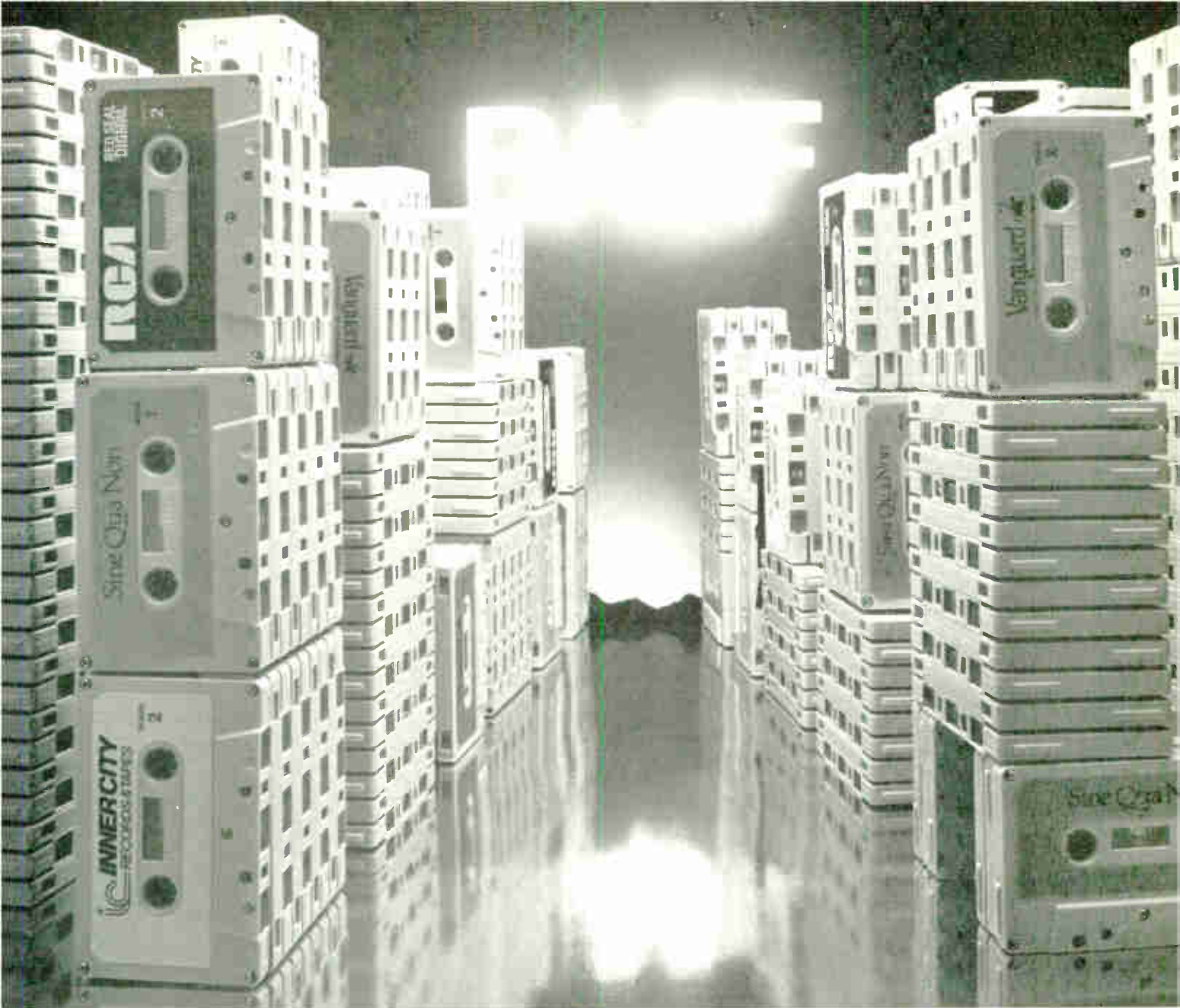

# THE ROAD TO PLATINUM IS PAVED WITH BASF PURE CHROME.

The only place to be in the recording business is #1. And with cassettes taking over nearly 50% of the industry's pre-recorded sales this year, the best way to get to the top is on BASF Pure Chrome duplicating tape.

BASF Pure Chrome helps you climb the charts faster because it duplicates your sounds more perfectly than any other brand. Technically speaking, BASF Pure Chrome offers extended high frequency Maximum Output Level (MOL), plus the world's lowest background noise. And our exclusive Pure Chrome formulation is extremely clean and stable at even the highest duplicating speeds. The payoff? Audio performance that's virtually indistinguishable from a studio master recorded at 15 I.P.S.



Best of all, just about anyone can change over from ferric oxide to BASF Pure Chrome with the greatest of ease—and without any need for additional equipment or expenses.

Find out why such major names as RCA Red Seal Digital, Sine Qua Non, Vanguard and Inner City all put their trust in us. Switch to BASF Pure Chrome duplicating tape. Because when you put "CrO" on your label, you're not just guaranteeing the public the pure music they're paying for. You're paying your way to platinum with BASF Pure Chrome.

 **BASF**  
Chrome Audio & Video Tapes

**TRACY-VAL CORPORATION**  
**RECORD PLATING**  
 201 Linden Ave., Somerdale, NJ 08083  
 (609) 627-3000  
 Contact: James Miller, President, Joan Miller, Office Manager  
**PRESSING**  
**Presses (Mfg. and quantity):** 42 high speed rotary plating positions  
**Capacity:** Master in tiers and stampers 200 per day  
**Rates:** On request  
**Credits:** Artists: EMI, JFM, Savoy, Sire, QED, Nonesuch, Capitol, RCA, Columbia, Elek, Vox, Tommy Boy, Streetwise



**TRUTONE RECORDS DISK MASTERING LABS**  
 Haworth, NJ

**TRUTONE RECORDS DISK MASTERING LABS**  
**MASTERING & PRESSING**  
 163 Terrace St., Haworth, NJ 07641  
 (201) 385-0940  
 Contact: Adrienne Bowath, Prod. Coordinator  
**MASTERING**  
 Cutting lathes: Neumann VMS 70, Scully w/Chips Varytech II  
 Console: Neumann & Custom  
 Tape machines: Studer A-80, Ampex ATR 100, MCI JH 210B  
 Monitor speakers: UREI B15A, JBL Air Force  
 Signal processing: UREI Plates, Neumann  
 Engineers: Carl Howarth, Phil Austin, Steve Houb  
 Rates: Upon request  
 Credits: Upon request  
 Other services: High quality short run cassette dupl.

**VARIETY RECORDING STUDIO**  
**MASTERING, PRESSING, TAPE DUPLICATION**  
 130 West 42nd St., Room 551, New York, NY 10036  
 (212) 221-6625  
 Contact: Fred Vargas, Owner

**VCA-TELETRONICS**  
 231 E. 55th St., New York, NY 10022  
 (212) 355-1600  
 Contact: Will Roth, General Manager  
**TAPE DUPLICATION**  
 Duplicator: 2", 1", ¾", ½" video with or without time code and Dolby  
 Mastering equipment: Sony 1", and professional ¾" & ½" video equipment  
 Rates: On request

**VIRTUE RECORDING**  
**MASTERING, PRESSING & TAPE DUPLICATION**  
 1618 N. Broad St., Philadelphia, PA 19121  
 (215) 763-2825  
 Contact: Frank Virtue, President

**WEA MANUFACTURING INC.**  
**PRESSING & TAPE DUPLICATION**  
 P.O. Box 321  
 Olyphant, PA 18447  
 (717) 383-2471



Listings of Mastering, Pressing and Tape  
 Duplication Facilities Throughout the  
 United States

## Central

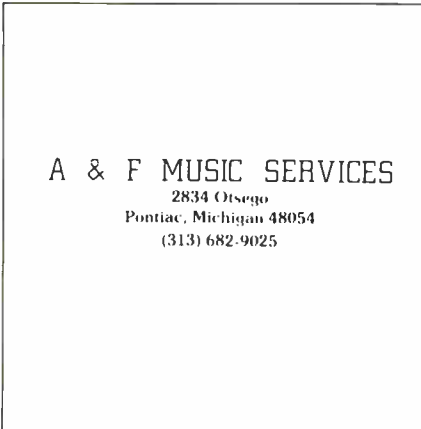

**A & F MUSIC SERVICES**  
 2834 Otsego  
 Pontiac, Michigan 48054  
 (313) 682-9025

**A & F MUSIC SERVICES**  
 Pontiac, MI

**A & F MUSIC SERVICES**  
**TAPE DUPLICATION**  
 2834 Otsego, Pontiac, MI 48054  
 (313) 682-9025  
 Contact: Frank Merwin, Manager

**A&R RECORD & TAPE MANUFACTURING**  
**MASTERING, PRESSING & TAPE DUPLICATION**  
 902 N. Industrial Blvd., Dallas, TX 75207  
 (214) 741-2027, or 748-7460  
 Contact: Vera McGrew, V.P., Cathy Stearns, Sales  
**MASTERING**  
 Cutting lathes: Neumann VMS 70 computer assisted with Sal 7YB transformerless cutter and tracing simulator  
 Console: Neumann with EMT, Ortofon and Sontec outboard EQ  
 Tape machines: Studer A-80, B-62, Otari MX 5050, 30 ips  
 Monitor speakers: JBL 4311, Crown ESS 224, Auratone, Real Time  
 Signal processing: EMT PDM Compression, OrtoFon EQ, Neumann EQ, Dolby A, B, dbx I  
 Engineers: Dick McGrew, Mark Malone  
 Rates: Competitive, quoted for particular job  
 Credits: Numerous jazz groups, Monterey Festival, rock bands, Van Cliburn Competition, Miami Symphony, Portland Symphony  
 Other services: Record pressing, tape duplicating, direct disk recording on location, Audiophile mastering  
**PRESSING**  
 Presses: Full automation process controlled 5 LTA  
 Capacity: 200,000 LP's, 400,000 45's  
 Vinyl used: Virgin, Keycor, Vitek, Teldec, Tenneco, Color available  
 Rates: Highly competitive. Special rates for volume accounts  
 Credits: USAF, Bonneville Productions, Beto, numerous rock groups, and aespel groups, Country Music, Time Broadcasts, Austin City Limits  
 Other services: Album production, Design, printing, packaging, Individual mailing, Mailing lists for promotion, Audiophile disk manufacturing, Sample available

**TAPE DUPLICATION**  
 Duplicator: 10 slave Otari DP6000 stereo bin  
 Capacity: 650 C-60/hr  
 Method of duplication: Bin loop, Real Time  
 Mastering equipment: Dolby License, full EQ and processing available  
 Tape used: AGFA exclusively  
 Shell used: Optional with customer, Normally 5 screw  
 Duplicating speed: 240 - 60 ips

Type of loading: King Automatic  
 Packaging availability/etc.: You name it!  
 Rates: On request, Very reasonable  
 Other services: Label and insert printing, Packaging, mailing  
 Sample available: Audiophile Real Time duplication



## Aard-Vark Recording

**AARD-VARK RECORDING SERVICE, INC.**  
 Springfield, MO

**AARD-VARK RECORDING SERVICE, INC.**  
**TAPE DUPLICATION**  
 335 S. Jefferson, Springfield, MO 65806  
 (417) 866-4104  
 Contact: Bill Jacobsen, President

**AMERICAN SOUND CORPORATION**  
**TAPE DUPLICATION**  
 25133 Thomas Drive, Warren, MI 48091  
 (313) 536-9100  
 Contact: Don Armstrong, Sales Manager

**ARC ELECTRONIC SERVICES INC.**  
**TAPE DUPLICATION**  
 2557 Knapp N.E.  
 Grand Rapids, MI 49505  
 (616) 364-0022  
 Contact: Ron Harkai, President



**ARDENT MASTERING, INC.**  
 Memphis, TN

**ARDENT MASTERING, INC.**  
**MASTERING**  
 2000 Madison Ave., Memphis, TN 38104  
 (901) 725-0855  
 Contact: Larry Nix, Chief Engineer

**MASTERING**  
 Cutting lathes: Neumann VMS 70 with Zuma digital computer control  
 Console: Neumann  
 Tape machines: MCI ½" 2 track available  
 Monitor speakers: JBL  
 Signal processing: Limiters: Neve, EMT, EQ's, Neve, Neumann, Proc. Outer Ear, EXR, Noise reduction, Dolby, dbx  
 Engineers: Larry Nix, Al Smith  
 Rates: On request  
 Credits: Bar-Kays, Amazing Rhythm Aces, Jessie Winchester, Robin Trower, Charlie Rich, ZZ Top, Staple Singers, Paul Butterfield, Con Funk Shon, Memphis Horns, Issac Hayes, Point Blank, Tony Joe White

AUDIO ACCESSORIES CO.  
 MASTERING & TAPE DUPLICATION  
 38 W. 515 Deerpath Road  
 Batavia, IL 60510  
 (312) 879-5998  
 Contact: John S. Maloney, Sales Manager

AUDIOGRAPHICS DIV./HERALD PUBLISHING HOUSE  
 MASTERING & TAPE DUPLICATION  
 3225 S. Noland Road  
 Independence, MO 64055  
 (816) 252-5010  
 Contact: Jerry Riegle, Director; Dennis Kaleikau, Production Manager

AUDIO MIXERS RECORDING COMPANY, INC.  
 TAPE DUPLICATION  
 740 N. Rush St., Chicago, IL 60611  
 (312) 943-4274  
 Contact: Studio Manager

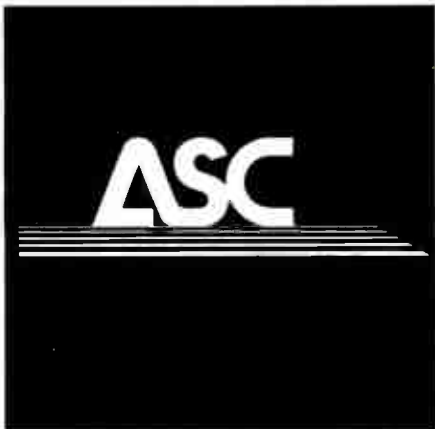

AUDIO SERVICES COMPANY, INC.  
 Mishawaka, IN

AUDIO SERVICES COMPANY INC.  
 TAPE DUPLICATION  
 3016 Home St.  
 Mishawaka, Indiana 46545  
 (219) 255-5198  
 Contact: Phillip L. Ostrander, President

BODDIE RECORD MFG. & RECORDING  
 MASTERING, PRESSING & TAPE DUPLICATION  
 12202 Union Ave., Cleveland, OH 44105  
 (216) 752-3440  
 Contact: Louise Boddie, Vice President

CENTURY SOUND & SLIDE  
 MASTERING, TAPE DUPLICATION  
 1018 Busse Hwy, Park Ridge, IL 60068  
 (312) 696-0675  
 Contact: Al Tallman, Owner

CHUMLEY PRODUCTIONS, INC.  
 MASTERING, PRESSING & TAPE DUPLICATION  
 2802 Foster Avenue, Nashville, TN 37210  
 (615) 833-6184  
 Contact: P.E. Chumley, President

COOKSOUND  
 TAPE DUPLICATION  
 6626 Hornwood, Houston, TX 77074  
 (713) 772-1006  
 Contact: Emily Getz

CREATIVE SOUND PRODUCTIONS  
 TAPE DUPLICATION  
 9000 Southwest Freeway, Suite 320, Houston, TX 77074  
 (713) 777-9975  
 Contact: Edward Smith, President  
 TAPE DUPLICATION  
 Duplicator: (Jan bin loop (3 slaves), Intonics (2 slaves))  
 Capacity: 25/90 per shift  
 Mastering equipment: Ampex 2 track & 4 track  
 Tape used: Alfa 6, 1, 811, Ampex 607/608, Ampex 603/604  
 Shell used: Data Pak Pathfinder 5-screw, IPS 5-screw  
 Duplicating speed: 16 1/2 & 32 1/2  
 Type of loading: King automatic loaders  
 Packaging availability/Fulfillment services: Custom labels, full-color caseliners, shrink  
 Rates: Call for quotations  
 Other services: Custom bulk tape loading to any length w/ Ampex, AGFA, Capitol. Catalog available upon request

# SUCKER.

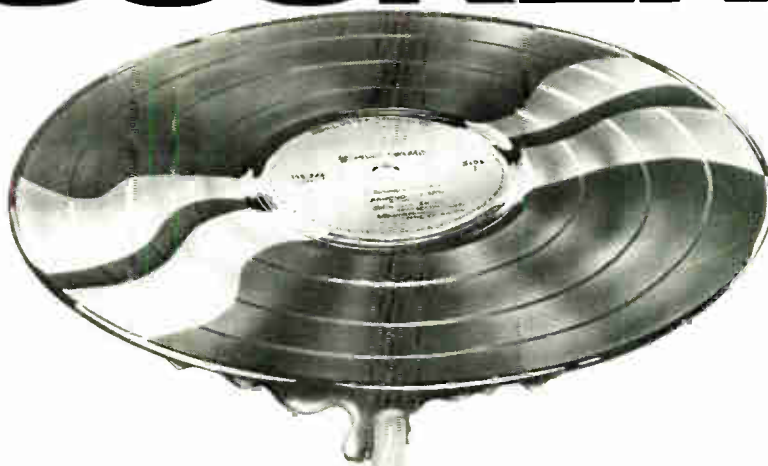

They said they could handle it.  
 And you believed them.  
 Next time—before you find yourself  
 in a sticky situation—call Ardent.  
 Our professionals and state-of-the-art  
 equipment offer everything you'd  
 expect in recording, mastering  
 and video capabilities.

**ARDENT.**  
 Ahh—the sweet taste of success.

24 track & 46 track studios •  
 Automated mixing • Neumann  
 Mastering Equipment • One inch  
 video tape production and editing  
 • Ikegami EC 35 • Ultimatte 4 •  
 Chyron IV Graphics • NEC E-FLEX  
 digital effects • Steadicam

## ARDENT

2000 Madison Avenue • Memphis, TN 38104  
 901-725-0855 / 726-6553

Circle #040 on Reader Service Card

## What was Nashville's best kept secret? NASHVILLE RECORD PRODUCTIONS



Specializing in all your record production needs with  
 state of the art equipment and professional staff.

- Featuring
- ... Three disc mastering studios
  - ... Artwork and typesetting
  - ... Record and Jacket production
  - ... Price competitive

Let our creative specialists show you the difference.  
 Call or write.



**Nashville Record Productions, Inc.**  
 469 Chestnut Street Nashville, Tennessee 37203  
 (615) 259-4200

Circle #041 on Reader Service Card

*Midwest  
Custom  
Record Pressing Company, Inc.*

— COMPLETE MANUFACTURING PLANT —  
Specializing in Records, Album Jackets & Cassettes. "No order too small!"  
Convenient Midwest Location

Write or Call for Free Brochure & Professional Assistance!

#6 Grandview Pk. Dr., P.O. Box 92  
Arnold, Missouri 63010 (314) 464-3013



Circle #042 on Reader Service Card



**Professional  
Music Quality  
Cassette  
Duplication**

- Studer A80 MR Mastering
- Gauss Series 2400 Duplication
- Dolby HX PRO
- King Loading
- Apex On-Cassette Printing
- Premium Tape & Materials
- Optimum Quality Control
- Prompt Personalized Service

RAINBOW CASSETTE STUDIO  
P.O. Box 472, Taos, NM 87571  
(505) 776-2268

Circle #043 on Reader Service Card

CUSTOM TAPE DUPLICATORS, INC.  
TAPE DUPLICATION  
341 Hill Ave., Nashville, TN 37210  
(615) 256-1728  
Contact: Cat Tant, President



DISC MASTERING, INC  
Nashville, TN

DISC MASTERING INC.  
(formerly known as Randy's Roost)  
MASTERING  
Thirty Music Square West, Nashville, TN 37203  
(615) 254-8825  
Contact: Randy Kling, President  
MASTERING  
Cutting lathes: Neumann SX 74 head SAI 74h cutting amplifier  
Console: Neumann ST75  
Tape machines: Studer A 80 MKII Studer B 67 & B 77  
Monitor speakers: Tannoy Super Reds  
Signal processing: Neve 2067 EQ Neve limiter/compressor  
Rev x 5710 J)  
Engineers: Randy Kling, Lois Walker  
Rates: Available upon request  
Credits: Alabama, John Denver, Leon Everette, Elv, James  
Galway, Vern Goslin, Waylon Jennings, Crispy Lane, Loretta  
Lynn, Barbara Mandrell, Dolly Parton, Charley Pride, Jerry Reed,  
George Strait, Jimmy Sturr, Jimmy Swagart, Sylvia, The White  
Animus, Chet Atkins, Booger Whitaker, Les Paul, Alice Cooper  
Other services: Distribution, Quad products & Tannoy pro audio  
home speakers

DIXIE RECORD PRESSING, INC.  
PRESSING  
631 Hamilton Ave.  
Nashville, TN 37203  
(615) 256-0922  
Contact: Greg Gann, Production Manager

DUPLI-TAPES INC.  
TAPE DUPLICATION  
4545 Bissonnet, Houston, TX 77401  
(713) 432-0435  
Contact: Gail Moseley, President

ELECTROSOUND TAPE SERVICES INC.  
TAPE DUPLICATION  
2101 S. 35th St., Council Bluffs, IA 51501  
(712) 328-8060  
Contact: Marvin King, President

ELEPHANT RECORDING STUDIOS  
MASTERING, PRESSING & TAPE DUPLICATION  
21206 Gratiot Ave., East Detroit, MI 48021  
(313) 773-9386  
Contact: John Glaeser, Owner

GENESIS RECORDING, INC  
TAPE DUPLICATION  
645 N. St. Clair, Chicago, IL 60611  
(312) 649-5711  
Contact: Larry Root, President  
TAPE DUPLICATION  
Duplicator (Mfg. and quantity): Maxiplex & Tolex  
Capacity: 2000 average per 8 hr. shift  
Method of duplication: Bin loop or in cassette  
Mastering equipment: Studer, Ampex, Scully  
Tape used: Ampex & AGFA  
Shell used: Magnetic Media  
Type of loading: King Mockett MK Series  
Packaging availability/etc.: Bulk or individual packages and  
shipping



Listings of Mastering, Pressing and Tape  
Duplication Facilities Throughout the  
United States

**Central**

Rates: On request  
Other services: High speed tape duplication, packaging and  
shipping

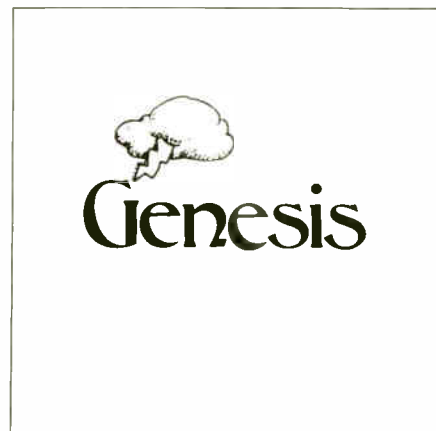

GENESIS RECORDING, INC  
Chicago, IL

HANF RECORDING STUDIO  
TAPE DUPLICATION  
1825 Sylvania  
Toledo, OH 43613  
(419) 474-5793  
Contact: Jim Thompson, General Manager



HIX RECORDING CO. INC  
Waco, TX

HIX RECORDING CO., INC.  
TAPE DUPLICATION  
1611 Herring Ave., Waco, TX 76708  
(817) 756-5303  
Contact: David Hix, President; Homer Hix, Vice President

# TRANS-AM INDUSTRIES

## C-O CASSETTES

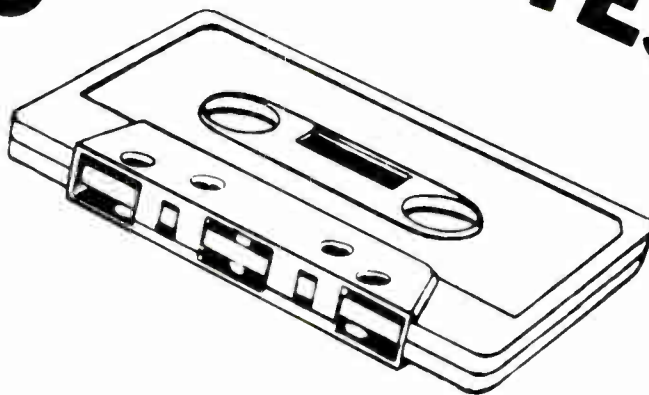

**Immediate  
Delivery  
Meets All Industry  
Standards  
Provides High  
Reliability**

**Sonic  
Sealed  
Screw Type  
Tabs In  
Tabs Out  
Colors Available**

**ENGINEERED FOR HIGH SPEED LOADING  
CAPACITY 80 MILLION PER YEAR**

*Call or Send for Price List and Samples*

**TRANS-AM INDUSTRIES**

845 BROAD AVE., RIDGEFIELD, N.J. 07657  
Tel: (201) 945-2000 • Telex: 133396

Circle #044 on Reader Service Card

# OUR GOAL IS TO RELIEVE THE AUDIO INDUSTRY OF THE HIGH COST OF TAPE HEADS

## Replacement Heads For:

24 TRK M.C.I. .... JH Series Machines ..... \$1550. per head  
24 TRK 3M ..... M-79 Series Machines ..... \$1550. per head

16 TRK M.C.I. .... JH Series Machines ..... \$1375. per head

2 TRK M.C.I. .... JH110A or B 1/2" ..... \$ 380. per head  
2 TRK M.C.I. .... JH110A or B 1/4" ..... \$ 180. per head

Other replacement heads available. . . . . Call for Delivery

FREE mounting on your base plate and best of all . . .  
**IN STOCK & AVAILABLE NOW!**

Stocking Distributors of: Woelke / Nortronics / Telex / Tascam / Revox



15904 Strathern Street / Van Nuys, CA 91406 / (213) 994-6602 / Tlx: 66-2922

Circle #045 on Reader Service Card

## Master Technologies, Inc.

28 Music Square East, Nashville, Tennessee 37203

### Nashville's First Digital Rental Firm

2.5 Years and 80+ Albums Mastered

- 3 Complete JVC DAS-90 Systems Available
- Digital to Digital Editing From Sony F-1
- Disc Mastering Using JVC CD-90 D.D.L.

### CALL TODAY FOR FREE IN STUDIO EVALUATION

Judge for Yourself if Digital "Sounds" or not  
Full List of Albums Mastered Available  
JVC Tapes are Now Accepted by Phillips for CD

Contact Glenn Meadows or Judy Sidler  
**615-242-0101**

Circle #046 on Reader Service Card

INDEPENDENT PRODUCERS CORP.  
TAPE DUPLICATION  
1609 McGavock St., Nashville, TN 37203  
(615) 244-4236  
Contact: Jerry Moore, General Manager.

INDUSTRIAL AUDIO/FILM SERVICES  
TAPE DUPLICATION  
6228 Oakton, Morton Grove, IL 60053  
(312) 965-8400  
Contact: Lauren Leifer, President

INFONICS, INC.  
TAPE DUPLICATION  
P.O. Box 1111, 238 Hwy. 212, Michigan City, IN 46360  
(219) 879-3381  
Contact: Carol Lant, President

JRC ALBUM PRODUCTIONS  
(JEWEL RECORDING CO.)  
MASTERING, PRESSING & TAPE DUPLICATION  
1594 Kinney Ave., Cincinnati, OH 45231  
(513) 522-9336  
Contact: Linda York, Vice President.

JOEY RECORDS INC.  
MASTERING, PRESSING & TAPE DUPLICATION  
6703 W. Commerce, San Antonio, TX 78227  
(512) 432-7893  
Contact: Joey Lopez, President  
**MASTERING**  
Cutting lathes: Sub-contracted to Ardent Mastering, 2000 Madison Ave., Memphis, TN 38104  
**PRESSING**  
Presses (Mfg. and quantity): 8 Fine Bit Presses  
Capacity: 2000 LPs, 4000 45s per 8-hr shift  
Vinyl used: Lenahan Plastics pure vinyl  
Rates: 60 LPs, .26 45s  
**TAPE DUPLICATION**  
Duplicator: Liberty Tape Duplicator  
Capacity: 3000 cass, 2000 8 trk per day  
Method of duplication: Bin loop  
**Mastering equipment:** 3M  
**Tape used:** Ampex 603 for cass, Ampex 456 for master  
**Shell used:** El Mar Plastics  
**Duplicating speed:** Radio 32 I  
**Type of loading:** Otari & King loaders

K&R RECORDING  
MASTERING, PRESSING & TAPE DUPLICATION  
29111 Greenfield, Southfield, MI 48076  
(313) 557-8276  
Contact: Bob Gajewski, Manager

KIDERIAN RECORDS PRODUCTION  
MASTERING, PRESSING & TAPE DUPLICATION  
4926 W. Gunnison, Chicago, IL 60630  
(313) 399-5535  
Contact: Ray Peck, President

MAGNETIC STUDIOS, INC.  
TAPE DUPLICATION  
4784 N. High St., Columbus, OH 43214  
(614) 262-8607  
Contact: John Fippin, President

MASTERCRAFT RECORDING CORP.  
MASTERING, TAPE DUPLICATION  
437 N. Cleveland, Memphis, TN 38104  
(901) 274-2100  
Contact: Howard Craft, Owner Manager

MASTERFONICS, INC.  
**MASTERING**  
28 Music Square East, Nashville, TN 37203  
(615) 327-4533  
Contact: Glenn Meadows, President.  
**MASTERING**  
Cutting lathes: Room 1: (2) Neumann VMS-70 operated by Zuma computer; SAL74B amplifiers, SX74 cutter heads. Room 2 Scully lathe w/Capps computer; Westrex 3DIIAH cutter head, Westrex RA1700B amplifiers  
Console: Room 1: Neumann SP75. Room 2 Neumann SP72  
**Tape machines:** Room 1 Studer A80 preview machine; Studer A80R and B67 copy machines (2 track)  
**Monitor speakers:** Room 1 Modified Westlake TM 1's w/TAD drivers. Room 2: John Gardner cabinets w/BL woofers and TAD high-frequency drivers.  
**Signal processing:** Sontec parametric EQ, Neve stereo compressor/limiters, Sontec DRC 200 compressor/limiter  
**Engineers:** Glenn Meadows, Jim Loyd, Brian Burr

Rates: Please call for rates  
 Other services: Ampex ATR-102 1/2" 2 track for rent Master Technologies offers JVC Series 90 digital 2 rack rental, editing and mastering. Call Masterfonics for details



MASTERFONICS, INC.  
 Nashville, TN

Contact: Duane Lundeen, President  
**TAPE DUPLICATION**  
 Duplicator: Ampex, Grandy, Magnelax, Telex (6 lines total)  
 Capacity: 20,000 units per shift  
 Method of duplication: In cassette, bin loop  
 Mastering equipment: Studer & Ampex  
 Tape used: Agfa, BASF, Capitol, Ampex, Columbia  
 Shell used: Elmar, Sorco, Mag Media  
 Duplicating speed: From 4:1 to 64:1 depending on product  
 Type of loading: High speed King  
 Packaging availability/Fulfillment services: Shrinkwrap, custom boxes, cartons, albums, etc  
 Rates: From 21 unit  
 Other services: Duplicating & AV equip sales, services, design, installation—new, used, reconditioned (Low cost financing avail on some equip.)

MIDWEST CUSTOM RECORD PRESSING CO., INC.  
 PRESSING & TAPE DUPLICATION  
 P.O. Box 92, Arnold, MO 63010  
 (314) 464-3013  
 Contact: Rick Schaumberger, President

Rates: \$50/hr. studio mastering, \$30/hr. editing  
**TAPE DUPLICATION**  
 Duplicator: Infonics 200A, Magenlax bin loop.  
 Capacity: How many would you like? We'll meet your deadline!  
 Method of duplication: In cassette & bin loop  
 Mastering equipment: Ampex, MCI  
 Tape used: AGFA PE 611, BASF, CBS, Ampex  
 Shell used: Magnetic Media, Lenco and data packaging  
 Duplicating speed: IN cassette, 10:1; bin loop, 45:1  
 Type of loading: Automatic King model 700s  
 Packaging availability/Fulfillment services: Labeling, cassette binders, Poly & Norelco boxes, shrink wrapping—full packaging service available.  
 Rates: Call (214) 980-4840 and ask for A Peel

MUSHROOM STATION STUDIOS  
 MASTERING  
 5511 Memorial Dr., Houston, TX 77007  
 (713) 868-9326, 868-9724  
 Contact: J.C. Freeman, COE

MUSICOL, INC.  
 MASTERING, PRESSING & TAPE DUPLICATION  
 780 Oakland Park Ave., Columbus, OH 43224  
 (614) 267-3133  
 Contact: John Hull, V.P.

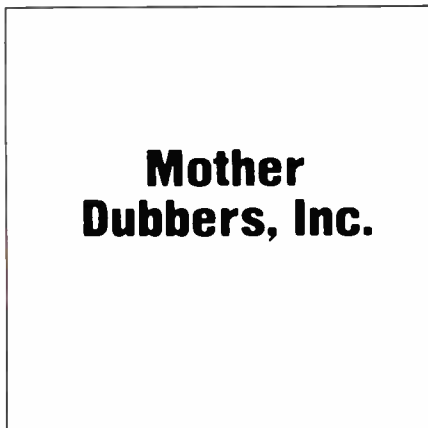

## Mother Dubbers, Inc.

MOTHER DUBBERS, INC.  
 Dallas, TX

MOTHER DUBBERS INC.  
 TAPE DUPLICATION  
 13626 Gamma, Dallas, TX 75234  
 (214) 980-4840  
 Contact: Arnett Peel, President  
**MASTERING**  
 Console: Tapco-EV 12 x 4 x 2 x 1  
 Tape machines: Ampex 440 MCI JH 100B, TEAC 80-8, 40-4  
 Monitor speakers: ADS 810s  
 Signal processing: UREI LA-3A, UREI 1176LN Crown EQII, abx 157, UREI 565  
 Engineers: Russell Smith

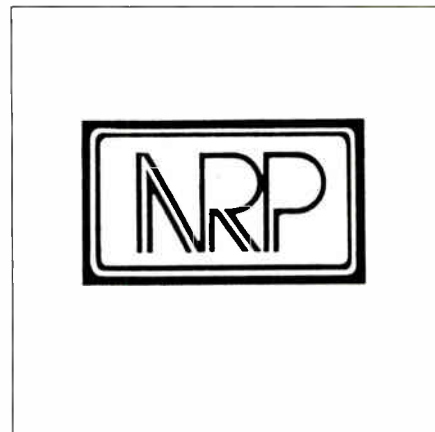

NASHVILLE RECORD PRODUCTIONS, INC.  
 Nashville, TN

NASHVILLE RECORD PRODUCTIONS, INC.  
 MASTERING, PRESSING & TAPE DUPLICATION  
 469 Chestnut St., Nashville, TN 37203  
 (615) 259-4200  
 Contact: George Ingram, Co-owner

cont'd



MEDIA INTERNATIONAL  
 Chicago, IL

MEDIA INTERNATIONAL, INC.  
 TAPE DUPLICATION  
 247 E. Ontario, Chicago, IL 60611  
 (312) 467-5430

# 120 PROFESSIONAL PRODUCT LINES AND GREAT TAPE—CHEAP!

REEL TO REEL  
 AMPEX • AGFA • 3M

VIDEO  
 AMPEX • AGFA

LEADER • SPLICING TAPE  
 • SPLICING BLOCKS •  
 ERASERS

MICS • TAPE RECORDERS • MIXERS • AMPLIFIERS • TURNTABLES • SIGNAL PROCESSING • TEST EQUIPMENT • SPEAKERS • HEADPHONES • INTERCOMS



**CLONE CASSETTES**  
 (Buy wholesale from the manufacturer)

6 GRADES OF CASSETTES - ANY LENGTH - MADE TO ORDER - POPULAR LENGTHS STOCKED

AGFA  
 AMPEX  
 MAG MEDIA

TOLL FREE IN ALL 50 STATES  
 1(800) 356-5844 IN WIS. 1 (800) 362-5445  
 LOCAL (608) 271-1100 • 6729 SEYBOLD RD., MADISON, WI 53719

Circle #047 on Reader Service Card

# LAY OUT A LOT LESS AND LAY DOWN THE BEST.

**Celebrating our 10 year anniversary with prices that deserve a celebration.**

We appreciate the support and loyalty that professional musicians and producers have given Soundcraft for the last 10 years. And to show you just how much, we're making the world's hottest selling mid range console available for a lot less.

We're calling it the biggest price break in our history. Consider the 28/24 model 2400 with bargraph/spectrum analyzer reduced from \$55,500 to \$39,950. Or the 28/24 model with VU meter bridge reduced from \$48,800 to \$35,950. Or the 24/16 model with 24 track monitoring reduced from \$38,700 to \$29,950.

And in typical Soundcraft tradition, the price is all we've cut. Every other aspect of the Series 2400 maintains the highest material and musical standards possible.

So why not join our 10 year celebration. When you do, you'll get the finest mid range console for just a song.

Prices are FOB Santa Monica, California. Consult your local dealer for details or contact:

## Soundcraft

**Soundcraft Electronics**  
1517 20th Street, Santa Monica, CA 90404  
(213) 453-4591 Telex: 664-923

**Soundcraft Electronics Canada, Inc.**  
1444 Hymus Blvd., Dorval, Quebec, H9P 1J6  
(514) 685-1610 Telex: 05-822582

**Soundcraft Electronics Limited**  
5-8 Great Sutton Street, London, EC1VOBX,  
England Telephone: 01-251-3631 Telex: 21198







Listings of Mastering, Pressing and Tape Duplication Facilities Throughout the United States

## Central

### MASTERING

Cutting lathes: Neumann & Capps computer two

Console: Spire & Neve

Tape machines: Studer & MCI

Monitor speakers: Super Ficus & Electro-Voice Sentry 3s

Signal processing: Parametric & graphic EQ, reverb, limiting/compressor

Engineers: Glen Builar; Chief Engineer: Jon Eberle; Studio Mgr.: Doug Lawrence; Engineer

Rates: \$80 per side - 12" \$40 per side - 7"

Credits: Ronnie Milsap; Amy Grant; Rick & Janie Carnie; Richard Lee; Sha-na-na; Tupperware; American Airlines; U.S. Govt.; PSA; Sperry; New Holland; Drifters; Bill Anderson

Other services: Editing, reference acetate, 1/2 speed cutting, tape duplication, album packaging

### PRESSING

Presses: 24 Southern Machine & Tool automatics; LPs and 45s; Capacity: 1,000,000 per month

Vinyl used: Lenanan

Rates: 5R LPs - 2R 45s; large runs per quote

Credits: Same as mastering

Other services: Same as listed above; printing record labels

### NORWEST COMMUNICATIONS

#### TAPE DUPLICATION

123 South Hough St., Barrington, IL 60010

(312) 381-3271

Contact: Mark Karney, Owner

### PHONODISC LAB

#### MASTERING, PRESSING & TAPE DUPLICATION

P.O. Box 3950, 2006 E. Center Street, Kingsport, TN

37664

(615) 246-2610

Contact: Rick Salyer, President

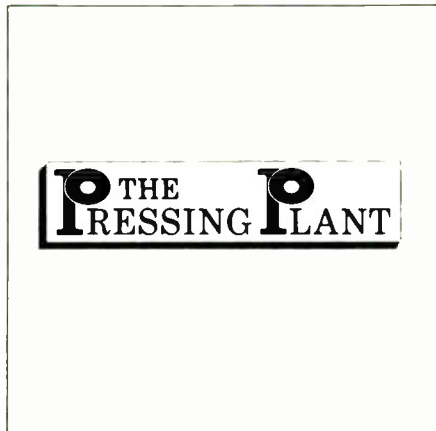

THE PRESSING PLANT  
Dallas, TX

### THE PRESSING PLANT

#### PRESSING

2727 Irving Blvd., Dallas, TX 75207

(214) 630-6401

Contact: Phil Kuan; Art Bruma; Eery; Sals; Fraps

**"Recording game show theme songs  
or music for a "Norman Lear" T.V. series  
demands my very best...**

**and a very good  
Recording Console."**

HAL HIDEY/HAL HIDEY STUDIOS



### THE "SPECKMIX" RECORDING CONSOLE

**A complete 16 input-8 output recording console with 16 track monitoring, full function input modules with 3 band parametric EQ, and +4 output levels. Available with "Jensen" mike preamps. Also available, a complete line of "SPECKMIX" expander consoles. Under \$4,400.00**

**SPECK ELECTRONICS • (213) 897-4188  
12455 Branford St., Unit 2, Arleta, Ca. 91331**

Circle #048 on Reader Service Card



The most valuable stop

your music can make

between the live session

and the pressing plant.

- ★ Neumann, Neve, Studer, Quad-405-2, & Tannoy mastering equipment
- ★ Engineers: Randy Kling, Lois Walker
- ★ Booking hours to midnight
- ★ Represented *every week this year* on the pop and country charts!



**DISC MASTERING INC. • THIRTY MUSIC SQUARE WEST  
NASHVILLE, TENNESSEE 37203 (615) 254-8825**

Circle #049 on Reader Service Card

## COMPLETE TAPE SERVICES

TO MEET YOUR DEADLINES AND YOUR STANDARDS

Mother Dubbers specializes in making "impossible" jobs possible.

We'll do what it takes to get your job done on time without sacrificing quality.

- Duplicating For All Quantities & Formats — cassette, reel-to-reel, 8-track
- Full Service Eight Track Recording Studio For Advertising, AV & Music Demo Clients
- Music & Sound Effects Library

**Mother Dubbers, Inc.**  
13626 Gamma Road  
Dallas, Texas 75234  
214/980-4840

Circle #050 on Reader Service Card

PROGRAMMING TECHNOLOGIES, INC.  
TAPE DUPLICATION  
6666 N. Lincoln Ave., Lincolnwood, IL 60645  
(312) 676-9400  
Contact: Charles Farmer, Sales Manager



QCA CUSTOM PRESSING  
Cincinnati, OH

QCA CUSTOM PRESSING  
MASTERING, PRESSING & TAPE DUPLICATION  
2832 Spring Grove Ave., Cincinnati, OH 45225  
(513) 681-8400  
Contact: Keith Myers, Sales Representative  
MASTERING  
Cutting lathes: Neumann VMS 66 with Zuma Disc Computer  
Console: Neumann SP 172 with SAL 74 amplifiers  
Tape machines: MCI JH 110M  
Monitor speakers: UREI 811s, Advent, Auratone  
Signal processing: Sontec Parametric equalizer, ETM 156 limiters  
Engineers: Todd Deasey, Jim Bosken  
Rates: 12" LP \$75/side, 7" 45s \$35/side, 7" 33 1/2 \$50/side Session time \$70/hr  
PRESSING  
Presses (Mfg. and quantity): 7 SMT automatics  
Capacity: 60,000 12" per week, 75,000 7" per week  
Vinyl used: Tenaco, Keycor KC500 & KC600  
Rates: Call for complete price list

RITE RECORD PRODUCTIONS, INC.  
MASTERING & PRESSING & TAPE DUPLICATION  
9745 Mangham Drive, Cincinnati, OH 45215  
(513) 733-5533  
Contact: Phil Burkhardt, Production Manager

RON ROSE PRODUCTIONS/RECORDING STUDIO  
TAPE DUPLICATION  
29277 Southfield Rd., Southfield, MI 48076  
(313) 424-8400  
Contact: Don Wooster, V.P.  
TAPE DUPLICATION  
Duplicator: ITelex, 3 Magnafax  
Capacity: 3,000 C-60 per day; 2,500 reel to reels per day (3 min)  
Method of duplication: In cassette, bin loop  
Mastering equipment: MCI, Otari, Teac  
Tape used: Ampex 456, 632, AGFA 526, Ampex 603, 604  
Shell used: Mag Media, Kyrac Special on request  
Type of loading: Two King loaders  
Packaging availability/etc. Labeling, boxing, expeditary  
Rates: Call  
Other services: Computerized expediting, 3/4" video editing, commercial recording, 24 track audio post

SOLID SOUND  
TAPE DUPLICATION  
P.O. Box 7611  
Ann Arbor, MI 48107  
(313) 662-0667  
Contact: R. Martens, President

SOUND OF NASHVILLE, INC.  
A Division of Southern American Record Pressing Co., Inc.  
MASTERING, PRESSING & TAPE DUPLICATION  
305 11th Ave. S., Nashville, TN 37203  
(615) 244-1124  
Contact: Martha Ivanits, Sales Manager



Listings of Mastering, Pressing and Tape Duplication Facilities Throughout the United States

## Central



SOUND OF NASHVILLE, INC.  
Nashville, TN

SOUTHERN AMERICAN RECORD PRESSING CO  
MASTERING, PRESSING & TAPE DUPLICATION  
305 11th Ave. S., Nashville, TN 37203  
(615) 256-2521  
Contact: John Ivanits, President

SPECIAL RECORDINGS, INC.  
TAPE DUPLICATION  
3026 East Grand Blvd., Detroit, MI 48202  
(313) 873-4655  
Contact: Tony Caminita, Vice President & General Manager

STANG RECORDS MANAGEMENT LTD.  
MASTERING, PRESSING & TAPE DUPLICATION  
P.O. Box 256577, Chicago, IL 60625  
(312) 399-5535  
Contact: Pete Stanos, President

STREETERVILLE STUDIOS  
TAPE DUPLICATION  
161 E. Grand Ave., Chicago, IL 60611  
(312) 644-1666  
Contact: Dorothy Schweigert

STUDIO PRESSING SERVICE  
MASTERING, PRESSING & TAPE DUPLICATION  
320 Mill St., Cincinnati, OH 45215  
(513) 761-8294  
Contact: B. Hyrne, President

SUMA RECORDING STUDIO  
MASTERING, PRESSING & TAPE DUPLICATION  
5706 Vrooman Road, Cleveland, OH 44077  
(216) 951-3955  
Contact: Michael Bishop, Studio Manager/Engineer

SPECIFICATIONS  
Tape Speeds 60 / 120 / 240  
Duplicating Ratio: 64:1  
Bias Frequency: 10 MHz  
Reel Size 7", 10 1/2", 14"  
Loop Bin For Cassettes Available  
DC Servo System

ACCURATE SOUND CORPORATION  
3515 Edison Way,  
Menlo Park, CA 94025  
(415) 365-2843  
Telex: 34-8327

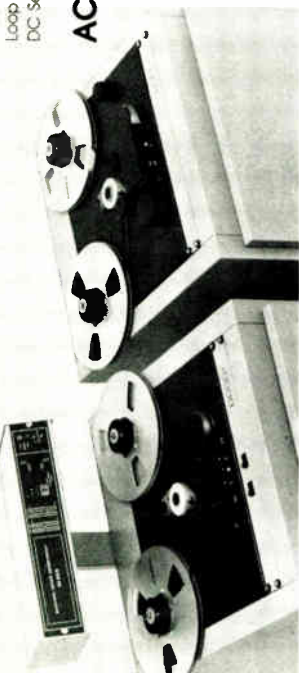

**SYSTEM 200**  
High Speed  
Audio Duplicator

Circle #051 on Reader Service Card



INTRODUCING  
MAGNETIC MEDIA'S NEW

**XM-1**

---

**XM-2**

---

**XM-3**

---

**BULK  
CASSETTE TAPES**

THE FINEST MAGNETIC MEDIA  
NORMAL BIAS TAPES EVER PRODUCED.  
IDEAL FOR MAGNETIC MEDIA'S  
SCREW-TYPE C-O CASSETTES.



**MAGNETIC MEDIA**

Magnetic Media Corporation, 500 Eastern Parkway, Farmingdale, NY 11735 • (516) 293-1010

Circle #052 on Reader Service Card

World Radio History



## RAINBO RECORDS

1738 Berkeley Street  
Santa Monica, California 90404

Our 44th Year

Custom Pressing  
Completely Automated

ANY PICTURE, COLOR,  
SHAPE, SIZE AVAILABLE

LABELS—SLEEVES—JACKETS

No Order Too Small

10-DAY TURN AROUND

**P** PRESSING

**P** PRINTING

**P** PLATING

**P** MASTERING

"One of the oldest and most complete  
record pressing services for today's  
generation"

Phone  
(213) 829-0355

Circle #053 on Reader Service Card

### Central Listings cont'd



S Y RECORDING  
Skokie, IL

S Y RECORDING  
TAPE DUPLICATION  
7876 N. Lincoln, Skokie, IL 6007  
(312) 982-9693  
Contact: Sarah Yonas, Owner; Paul Berolzheimer, Manager

TANTUS PRODUCTIONS, INC  
TAPE DUPLICATION  
18461 W. McNichols, Detroit, MI 48219  
(313) 533-3910  
Contact: Mary Ann McGrath, Studio Manager

TRIAD PRODUCTIONS, INC  
TAPE DUPLICATION  
1910 Ingersoll Ave., Des Moines, IA 50309  
(515) 243-2125  
Contact: Connie Seader, Production Coordinator

TRUSTY TUNESHOP RECORDING STUDIO  
TAPE DUPLICATION  
Rt. 1, Box 100, Nebo, Kentucky 42441  
(502) 249-3194  
Contact: Mrs. Elsie Childers, Owner

VILLE PLATTE RECORD MFG CO  
MASTERING, PRESSING & TAPE DUPLICATION  
120 E. Cypress, P.O. Box 10, Ville Platte, LA 70586  
(318) 363-2104  
Contact: Bill S. Lewis, Manager

VOLUNTEER RECORD PRESSING, INC.  
PRESSING, TAPE DUPLICATION  
P.O. Box 956 - 1142 Haley Rd., Murfreesboro, TN 37130  
(615) 890-3222  
Contact: Jimmy Denton, President



WOODLAND SOUND STUDIOS  
Nashville, TN

WOODLAND SOUND STUDIOS  
MASTERING  
1011 Woodland St., Nashville, TN 37206  
(615) 227-5027  
Contact: Mary Jane Turner, Mastering/Pressing Manager  
MASTERING  
Cutting lathes: Neumann  
Console: Neumann  
Tape machines: Studer, A.M., Sony, Fuji, Reo  
Monitor speakers: Wharfedale, Custom, MCM 4, Auralex  
Signal processing: Various  
Engineers: Dennis Purcell, Terry Dineen  
Rates: Per hour, per unit, approximate. Wholesale negotiable  
Credits: Willie Nelson, Barbara Mandrell, Ronnie Milsap, Oak Ridge Boys, Wilson Pickett, Donny Hathaway, The Clarks, Sylvia  
Armani, Ed. Dantes

## Western

A&M RECORDS  
MASTERING  
1416 N. Labrea Ave., Hollywood, CA 90028  
(213) 469-2411  
Contact: Denise Porter  
MASTERING  
Cutting lathes: Scully lathes fitted with Clapps computer fully redesigned by A&M  
Console: Custom designed and built by A&M  
Tape machines: MCI with ATR heads and modified ATR electronics  
Monitor speakers: Assembled by A&M with Tannoy and EV components with H&H amps  
Signal processing: Modified UA EQ limiters and filters, CSQ for mono disks and De'Sing equipment designed by A&M  
Engineers: Bernie Gruniman, Frank Deina, Bob Carbone  
Rates: On request  
Credits: Michael Jackson, Supertramp, Donna Summers, Herb Alpert, Prince, Brothers Johnson, Steely Dan, Quincy Jones, Gary Band, The Police, etc.

ACCU - SOUND AND VIDEO STUDIOS  
4274 1/2 El Cajon Blvd.  
San Diego 92105  
(619) 281-6693  
Contact: John Meiner, Owner

ALLEN ZENTZ MASTERING  
MASTERING  
7083 Hollywood Blvd., Suite No. 302, Hollywood, CA 90028  
(213) 851-8300  
Contact: Nancy Boycott, Studio/Trainer Manager

ALSHIRE INTERNATIONAL  
MASTERING, PRESSING & TAPE DUPLICATION  
1015 Isabel Street, Burbank, CA 91506  
(213) 849-4671, 843-6742  
Contact: A. Sherman, President  
MASTERING  
Cutting lathes: Neumann, VMS, SAE, 48" VHS, tape transfer  
Zuma long bed, variable speed lathe  
Console: IVC custom console  
Tape machines: MCI, W, V, Sony, Reo, Studer  
Monitor speakers: Custom, BL, Wharfedale  
Signal processing: Dolby, dbx  
Engineers: Larry Easter, Stan Baker  
Rates: On request  
Other services: Full bass-to-tape editing  
PRESSING  
Presses (Mfg. and quantity): Ten, SM3 automatic  
Capacity: 50,000 weekly  
Vinyl used: New or stock  
Rates: Quoted on request  
Other services: Wholesale to 7.5 weeks, retail work  
TAPE DUPLICATION  
Duplicator: D.D. 2400 Cetera/Gross series  
Capacity: 15,000 copies per shift, 10,000 copies per week  
Method of duplication: Hot lock  
Mastering equipment: 21,400 Cetera/Gross  
Tape used: BASF  
Duplicating speed: High speed, 1.64-1.88  
Type of loading: King 790 automatic cassette loader  
Packaging availability/Fulfillment services: Apex products, duplication cassette, shrink wrap, and stock  
Rates: Per unit on request

ARCAL PRODUCTIONS INC  
TAPE DUPLICATION  
2732 Bay Rd., Redwood City, CA 94063  
(415) 369-7348  
Contact: Sal Viola



## REAL-TIME DUPLICATION

ARCAL PRODUCTIONS, INC.  
Redwood City, CA

**ARTISAN SOUND RECORDERS**  
MASTERING  
1600 N. Wilcox Ave., Hollywood, CA 90028  
(213) 461-2751  
Contact: Greg Fulginiti, Chief Engineer and Managing Director

**MASTERING**  
Cutting lathes: Neumann Zuma  
Console: Neumann  
Tape Machines: Studer  
Monitor Speakers: Custom  
Signal Processing: Sontec/Neumann  
Engineers: Greg Fulginiti  
Credits: Asia, Pat Benatar, Heo Speedwagon, Rick Springfield, Barry Manilow, Peter Gabriel, Elton John, John Lennon, Human League, David Grisman, Madness, Sammy Hagar, Heart, Grateful Dead, Berlin

**ASR RECORDING SERVICES INC.**  
8960 Eton Ave., Canoga Park, CA 91304  
(213) 341-1124  
Contact: Bill Dawson, V.P. Sales

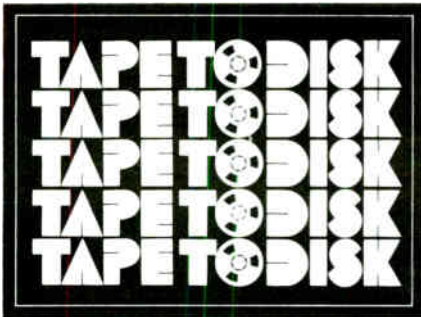

Listings of Mastering, Pressing and Tape Duplication Facilities Throughout the United States

## Western

**AUDIODYNE**  
TAPE DUPLICATION  
P.O. Box 825, San Jose, CA 95106  
(408) 287-3520  
Contact: L.H. Chiaramonte, Owner/President

**AUDIO CASSETTE DUPLICATOR CO.**  
TAPE DUPLICATION  
6143 Morella Avenue, North Hollywood, CA 91606  
(213) 762-ACDC  
Contact: Steve, Owner

**AUDIO ENGINEERING ASSOCIATES**  
MASTERING, PRESSING & TAPE DUPLICATION  
1029 N. Allan Ave., Pasadena, CA 91104  
(213) 798-9127  
Contact: Sara Bebee, General Manager

**AUDIO-VIDEO CRAFT, INC.**  
TAPE DUPLICATION  
7710 Melrose Ave., Los Angeles, CA 90046  
(213) 655-3511  
Contact: Marti Hasen, Manager Tape Duplication



## AWARD

AWARD RECORD MFG., INC.  
Inglewood, CA

**AWARD RECORD MFG., INC.**  
MASTERING, PRESSING & TAPE DUPLICATION  
11016 La Cienega Blvd., Inglewood, CA 90304  
(213) 645-2281  
Contact: Marty Amsoorian, President  
**PRESSING**  
Presses (Mfg. and quantity): Lenex automatics  
Capacity: 12,000 per day  
Vinyl used: Pure Virgin Key or Century KC 600  
Rates: Furnished upon request  
Credits: Concord Jazz, Capitol Production Music, Library of Congress, Sonic Arts, Youngheart Music  
Other services: Printing, mastering, matrix, & packaging, tapes and picture records



View through observation window at Kenneth Bacon Associates' new Novato tape duplication facility. One bank of real time decks in the mastering room can be seen through the rear window.

KENNETH BACON ASSOCIATES, INC.  
Novato, CA

**KENNETH BACON ASSOCIATES, INC.**  
TAPE DUPLICATION  
24 Commercial Blvd. Suite E, Novato, CA 94947  
(415) 883-5041  
Contact: Kenneth A. Bacon, President  
**TAPE DUPLICATION:** High Speed In-Cassette — Otari, Sony, Arpa, Wollensak Hi-Speed Bin Loop — Accurate Sound 124  
4-track staggered head — slave — real time — Onkyo  
Capacity: 1,500 C-60 per shift  
Method of duplication: In-cassette & bin loop  
Mastering equipment: Otari MK 2400, Otari MX 5050, TEAC 40-4, AIWA & ONKYO cassette decks  
Tape used: AGFA PFM 468 PE 526 PE 619 PE 627 etc. as required by job  
Shell used: Kyrac Mag Media  
Duplicating speed: 1.78 ips, 3 1/4 ips, 15 ips, 30 ips, 60 ips as required by job  
Type of loading: King, Otari, Audio  
Packaging availability etc. Yes  
Rates: Trade rates to recording studios  
Other services: Custom computer and flat sheet labels, computer feed labels for 5" and 7" reels and reel boxes, blank label stocks, blank pre-loaded cassettes, boxes, inserts, shrink wrap mailers, equipment and supplies division sells most equipment and supplies used by professional duplicators and master distributor AGFA Gevaert video mastering and cassette tapes

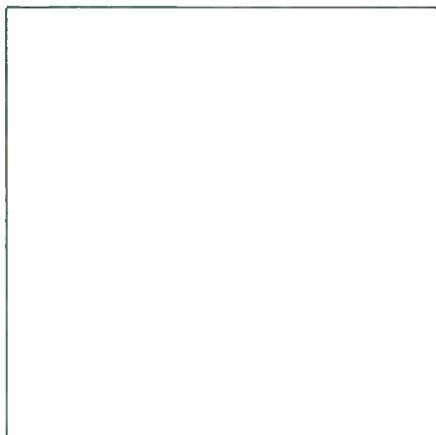

AUDIOHOUSE  
Denver, CO

**AUDIOHOUSE**  
10288 E. Jewel Ave. No. 45  
Denver, CO 80231  
(303) 751-2268  
Contact: George Chapekus, Owner  
**TAPE DUPLICATION**  
Duplicator (Mfg. and quantity) 20 Denon DPM-20 Nakamichi CX-1  
Capacity: 1400 C-90/day  
Method of duplication: real time  
Mastering equipment: Revox B7 MKII  
Tape used: All brands  
Shell used: Mac media  
Duplicating speed: real time  
Packaging availability/Fulfillment services: Shrink wrap available  
Rates: As low as 9¢ for C-90  
Other services: Dolby B, C, D, E, Apex processing

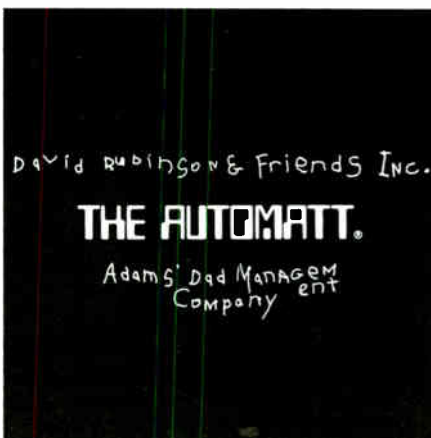

THE AUTOMATT  
San Francisco, CA

**THE AUTOMATT**  
MASTERING  
829 Folsom Street, San Francisco, CA 94107  
(415) 777-4111  
Contact: Paul Stubblebine, Mastering Engineer  
**MASTERING**  
Cutting lathes: Scully Westrex  
Console: Custom  
Tape machines: MCI  
Monitor speakers: UREI, Rogers LS-5A, BL, Yamaha Auratone  
Signal processing: All types available  
Engineers: Paul Stubblebine  
Rates: 12 master \$110, 2 bet \$100, 7 master \$40, 7 bet \$40 EQ & Run-down \$125/hr  
Credits: Blue Oyster Cult, Herbie Hancock, Con Funk Shun, Translator, Holly Near, Jane Fonda, Romeo Void, Red Rockers

# QUALITY & PERFORMANCE



The DOD Dual 15 band graphic equalizer R-830A offers quality and performance at an incredible price.

The R-830A was designed for both professional sound reinforcement and studio recording use. With balanced and unbalanced inputs and outputs, low cut and bypass switches with LED indicators, center detented potentiometers, 12 db of boost or cut, and illuminated power rocker switch, the DOD R-830A offers a great deal of flexibility. The DOD R-830A has two sets of 15 band EQ sliders on 2/3 ISO centers placed at 25, 40, 63, 100, 160, 250, 400, 630, 1K, 1.6K, 2.5K, 4K, 6.3K, 10K, and 16KHz. Each R-830A is individually tested at the factory to insure a high level of reliability, quality and performance.

**Specifications:**  
 Intermodulation distortion: <0.01%  
 Signal to noise ratio: >95 db  
 Maximum input level: Balanced + 20 dbm  
 Unbalanced + 24 dbm  
 Maximum output level: Balanced + 20 dbm  
 Unbalanced + 17 dbm  
 Input impedance: (ref: 1mW/600 ohms)  
 Output impedance: Balanced 80K ohms  
 Unbalanced 40K ohms  
 EQ control range: Balanced 940 ohms  
 Unbalanced 470 ohms  
 Suggested retail: ± 12 db  
 299.95

Call or write:  
 DOD Electronics Corp.  
 2953 South 300 West  
 Salt Lake City, Utah 84115  
 (801) 485-8534



Listings of Mastering, Pressing and Tape Duplication Facilities Throughout the United States

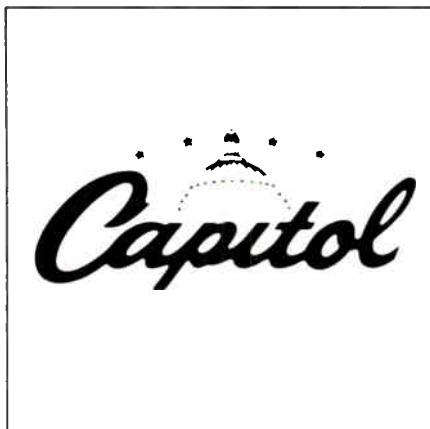

CAPITOL RECORDS, INC.  
Hollywood, CA

**BAMCO RECORDS**  
PRESSING  
1400 S. Citrus Ave., Fullerton, CA 92633  
(714) 738-4257  
Contact: G. Baker, Manager

**CAPITOL RECORDS INC.**  
MASTERING  
1750 No. Vine St., Hollywood, CA 90028  
(213) 462-6252  
Contact: Barbara Hein, Office Manager

**BAY AREA TAPE SALES**  
TAPE DUPLICATION  
1059 Huckleberry Court, Sunnyvale, CA 94087  
(408) 730-TAPE  
Contact: Walt Neal, Owner.

**CORY SOUND CO.**  
TAPE DUPLICATION  
1255 Howard St., San Francisco, CA 94103  
(415) 861-4004  
Contact: Phil Markinson, Owner.



**BONNEVILLE PRODUCTIONS**  
Salt Lake City, UT

**THE CREATIVE WORD**  
TAPE DUPLICATION  
17885 B-2 Sky Park Circle, Irvine, CA 92714  
(714) 549-0138  
Contact: Bryan Hill, President

**CUSTOM DUPLICATION INC.**  
TAPE DUPLICATION  
3404 Century Blvd., Inglewood, CA 90303  
(213) 670-5575  
Contact: Rick Hively, Sales Manager

**BONNEVILLE PRODUCTIONS**  
TAPE DUPLICATION  
130 Social Hall Ave., Salt Lake City, UT 84111  
(801) 237-2559  
Contact: Dave Michelson.  
**TAPE DUPLICATION**  
Duplicator (Mfg. and quantity): Gauss 1200 system (4 systems).  
Capacity: 20,000 pieces/day.  
Method of duplication: Bin loop.  
Mastering equipment: Ampex ATR 104  
Tape used: BASF  
Shell used: Magnetic Media (5 screw)  
Duplicating speed: 64:1  
Type of loading: King 790's.  
Packaging availability/etc.: Yes  
Rates: Call for quote.  
Other services: Complete 24 track recording, three studios, video sweetening.

**DAVKORE COMPANY**  
TAPE DUPLICATION  
1270 Lawrence Station Rd., Bldg. G, Sunnyvale, CA 94086  
(408) 734-2796  
Contact: Chris Webber, Owner.  
**TAPE DUPLICATION:**  
Duplicator: Magnefax Bin-loop Duplicator, stereo  
Capacity: 4,000 cassettes per day  
Method of duplication: In cassettes, bin loop  
Mastering equipment: Revox & Tandberg reel to reels  
Tape used: Agfa, BASF Chrome, Magnetic Media  
Shell used: Magnetic Media, Data-pack  
Duplicating speed: 16:1  
Type of loading: King & Electro-Sound loaders  
Other services: Duplication for Atari & Commodore computer tapes

**DCT RECORDERS**  
MASTERING & TAPE DUPLICATION  
4007 W. 6th St., Los Angeles, CA 90020  
(213) 461-2841  
Contact: Pat Burnette

**BRANDT'S RECORDING STUDIOS**  
MASTERING, TAPE DUPLICATION  
1030 48th Street, Sacramento, CA 95819  
(916) 451-3400  
Contact: Charles M. Brandt, Chief Engineer & Owner



**DIDAKSO TAPES**  
Portland, OR listing on next page

**BUZZY'S RECORDING SERVICES**  
TAPE DUPLICATION  
6900 Melrose Ave., Los Angeles, CA 90038  
(213) 931-1867  
Contact: Jill Shapiro.

**ADVANCE**  
RECORDING PRODUCTS

**Pro Audio Dealers  
for 3M, Agfa,  
Ampex**

**We Also Load  
Custom Cassettes**

**Call Toll Free**  
Inside CA  
**1-800-858-1061**  
Outside CA  
**1-800-854-1061**

**7190 Clairemont Mesa Blvd.  
San Diego, CA 92111  
(619) 277-2540**

Circle #055 on Reader Service Card

# get loaded

**at a price  
you'll like**

**At last a  
professional  
cassette  
loader that  
does not cost  
a King's  
ransom**

Vacuum splicing block complete with internal pump  
Set tape length directly in minutes  
Safe 120 ips loading  
Digital integrated circuitry for dependable accuracy  
Completely portable 12W x 19L x 6H  
Weight 29 lbs.  
Designed for heavy-duty professional use  
Produces 500 to 700 cassettes per 8-hour shift  
Models start at \$1,800.00  
Cue-tone loading available

**Telephone 213-450-4499  
or write for brochure today**

**PCE  
Professional Cassette  
Equipment Co.**  
2909 Ocean Park Blvd.  
Santa Monica, CA 90405

Circle #056 on Reader Service Card

**DIDAKSO TAPES**  
**TAPE DUPLICATION**  
 1519 S.W. Marlow Ave., Portland, OR 97225  
 (503) 297-8751  
 Contact: Bob Seal

**DINKUM RECORDING SERVICES**  
**MASTERING & PRESSING**  
 301 N. Hollywood Way - H, Burbank, CA 91505  
 (213) 464-7418, 843-2308  
 Contact: Jo Hansch, President

**DYNASTY STUDIO**  
**MASTERING & TAPE DUPLICATION**  
 1614 Cabrillo Ave., Torrance, CA 90501  
 (213) 328-6836  
 Contact: Phil Kachatanun, Owner

**THE EXCEL COMPANY**  
**MASTERING & TAPE DUPLICATION**  
 102 North Ditmar, Oceanside, CA 92054  
 (619) 722-8284  
 Contact: Bill Berry, Account Representative

**MASTERING:**  
 Console: Langevin by Cetec  
 Tape machines: Ampex AG 440 1-track and 2-track, Ampex ATR700, Revox A700  
 Monitor speakers: Custom installation using JBL speakers  
 Signal processing: Crown and JBL amplification, Fairchild reverbation  
 Engineers: Richard Garwood and Bill Kottcamp  
 Rates: Mastering and editing \$35/hr  
 Other services: New recording studio; instruments and musicians available

**TAPE DUPLICATION:**  
 Duplicator: Pentagon (15 Slave), Wollensak (5 Slave)  
 Capacity: Magnetax (17 Slave)  
 Method of duplication: In cassette, bin loop  
 Mastering equipment: Ampex ATR700, Revox A700  
 Tape used: Cassette: Aqia 611,811, Mag Media Cobalt Reel: Ampex 406 456  
 Shell used: Magnetic Media  
 Duplicating speed: Cassette Mono:12X stereo:16x Reel:60ips  
 Type of loading: 2 King computer-modified 790 loaders, 675 C-60/hr  
 Packaging availability/Fullfillment services: Labeling, Shrinkwrap, Blister Card

**Rates:** Please call for price quote  
**Other services:** Automated labeling, world-wide shipping, average 24-hour order turnaround

**FANFARE RECORDING STUDIOS**  
**TAPE DUPLICATION**  
 120 E. Main St., El Cajon, CA 92020  
 714) 447-2555  
 Contact: Carol Compton, Studio Manager

**FANTASY STUDIOS MASTERING**  
**MASTERING**  
 10th and Parker, Berkeley, CA 90028  
 (415) 549-2500  
 Contact: George Horn  
**MASTERING**  
 Cutting lathes: Neumann mastering system utilizing the Zuma audio computer, Studer tape machines  
 Rates: LP lacquers \$105/side, 45 lacquers: \$35/side, mastering room run down and EQ \$100/hr  
 Other services: Mastering from Mitsubishi digital master tapes

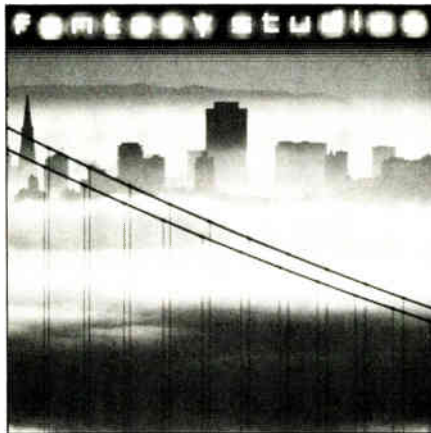

**FANTASY STUDIOS MASTERING**  
 Berkeley, CA



**FUTURE DISC SYSTEMS**  
 Hollywood, CA

**FUTURE DISC SYSTEMS**  
**MASTERING**  
 3475 Cahuenga Blvd. West, Hollywood, CA 90068  
 (213) 876-8733  
 Contact: Gary Rice or Steve Hall  
**MASTERING:**  
 Cutting lathes: Cybersonics DM2002-SA lathe with Ortofon DSSB2! (green head) cutting system  
 Console: Cybersonics MC2003 fully automated mastering console  
 Tape machines: ATR102 1/4" and 1/2" mastering machine, ATR102 copy machines  
 Monitor speakers: Custom Bi-Amped monitors  
 Signal processing: Sontec equalizer and compressor/limiter  
 Engineers: Steve Hall Chief Engineer  
 Rates: Upon request  
 Credits: Al Jarreau Sheena Easton Jean-Luc Ponty, Donna Summer, Martin Briley, Jaco Pastorius, Bow Wow Wow, The Fixx, Bill Summers

CLINT FRIZZELL  
 MEN AT WORK  
 MERLE HAGGARD  
 FRANK ZAPPA  
 FRIZZELL AND WEST  
 TENNESSEE ERNIE FORD  
 CLINT EASTWOOD  
 DUKES OF HAZZARD  
 TANYA TUCKER  
 ROY ROGERS  
 SHIRLEY BASSEY  
 PATRICE RUSHEN  
 PORTER WAGONER  
 JONI MITCHELL  
 BELLAMY BROTHERS  
 JIM STAFFORD  
 STEVEN SOULES  
 PAUL ANKA  
 JOHN SCHNEIDER  
 ROBERTO CARLOS  
 STEPHANIE WINSLOW  
 TOM SULLIVAN  
 BJ THOMAS  
 PAT BOONE  
 DAVID FRIZZELL  
 DJ ROGERS  
 ROGER WILLIAMS  
 MOODY HERMAN  
 SUBRAMANIAM  
 HAL GALPER  
 MERLE HAGGARD  
 TOMMY TUTONE  
 SHIRLEY BASSEY  
 LAZZARD  
 DONE  
 TROJAN BAND  
 ONE FROM THE HEART  
 PRAIRIE LEAGUE  
 MADE RUNNER  
 MITCHELL

**Kdisc mastering**  
 6550 Sunset Boulevard, Hollywood, CA 90028 (213) 466-1323

Circle #057 on Reader Service Card



**GOLD STAR RECORDING STUDIOS, INC.**  
**MASTERING, PRESSING & TAPE DUPLICATION**  
 6252 Santa Monica Blvd., Hollywood, CA 90038  
 (213) 469-1173



**GRD RECORDINGS**  
 Phoenix, AZ

**GRD RECORDINGS**  
**TAPE DUPLICATION**  
 376 E. Alvarado, Suite 2, Phoenix, AZ 85004  
 (602) 252-0077

Contact: Liv Singh Kha'sa, Owner  
**TAPE DUPLICATION**  
 Duplicator: 100 Denon DR-F8 Real Time recorders  
 Capacity: Orders up to 10,000  
 Method of duplication: In cassette, bin loop, real-time  
 Mastering equipment: Otari: Denon Orban limiting Lexicon reverb  
 Tape used: AGFA 511 AGFA chrome metal on request  
 Shell used: Mag Media  
 Duplicating speed: 1 1/2 ips (Real Time)  
 Type of loading: Otari  
 Packaging availability/etc.: 4 color printing, labels assembly shrink  
 Rates: C15 \$1.05 each, C30 \$1.07 each, C45 \$1.12 each, C60 \$1.24 each, C75 \$1.18 each, C90 \$2.00 each (all prices real time, subject to change)  
 Other services: Record and produce new music high-speed duplication for voice, custom load blank cassettes

**HI SPEED TAPE DUPLICATING**  
**TAPE DUPLICATION**  
 940 Howard St., San Francisco, CA 94103  
 (415) 543-7393  
 Contact: John Trnava, Engineer

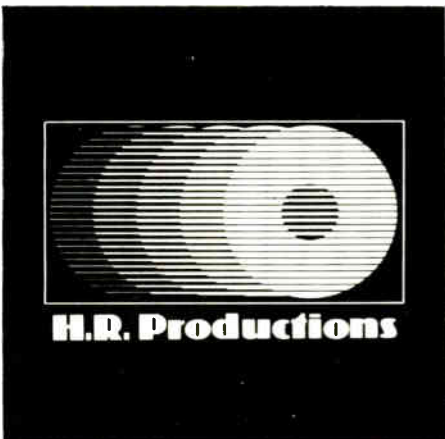

**H.R. PRODUCTIONS**  
 Lafayette, CA

**H.R. PRODUCTIONS**  
**MASTERING, PRESSING & TAPE DUPLICATION**  
 3099 Diablo View Rd., Lafayette, CA 94549  
 (415) 930-7573  
 Contact: Hillel Resner

**PRESSING**

Credits: H.R. Productions has provided custom record pressing and album manufacturing for numerous clients throughout the western U.S. We specialize in high quality short-run projects for small companies and producers on tight budgets



**JVC CUTTING CENTER, INC.**  
 Hollywood, CA

**JVC CUTTING CENTER INC.**  
**MASTERING, PRESSING & TAPE DUPLICATION**  
 6363 Sunset Blvd. Suite 500, Hollywood, CA 90028  
 (213) 467-1166  
 Contact: Larry Boden, Chief Engineer  
**MASTERING**  
 Cutting lathes: Neumann VMS 7C with JVC quartz lock motor w Zuirra computer  
 Console: JVC Custom Disc Mastering console  
 Tape machines: MCI w/custom heads & playback electronics/JVC digital DAS-40  
 Monitor speakers: Fostex LS-3  
 Signal processing: Sontec & JVC equalizers and limiters dbx & Dolby  
 Engineer: Joe Gastwirt  
 Rates: Upon request  
 Credits: Adrian Belew Dokken, Paul McCartney Miles Davis, Ramsey Lewis, Winton Marsalis, Isley Brothers, Jethro Tull, Ronald Shannon Jackson

**Other services:** JVC Digital-DAS 900-rentals, remote, and digital editing. Sole distributor for Adamant/JVC cutting styli, JVC test records

**PRESSING:**  
 Pressing: JVC Custom presses  
 Vinyl used: JVC Custom compounds including JVC super vinyl  
 Rates: Upon request  
 Credits: Mobil Fidelity Sound Labs, Telarc, Delos Records  
 Other services: Complete printing and art service, including jackets and inserts  
**TAPE DUPLICATION**  
 Duplicator: JVC Custom duplicators  
 Method of duplication: Bin loop  
 Rates: Upon request  
 Other services: Complete printing and art service including jackets and inserts



**KM RECORDS, INC.**  
 Burbank, CA  
 listing on next page

PREMIUM QUALITY...  
 MEANS AN

**"AWARD  
 RECORD"**



- Pressing
- Printing
- Plating
- Masters
- Cassettes
- Picture Records

**SINGLES • ALBUMS  
 TAPES**

**Your Tape to  
 Finished Product**

**Any Quantity**

**AWARD  
 RECORD MFG.,  
 INC.**

11016 LA CIENEGA BLVD.,  
 INGLEWOOD 90304

**(213) 645-2281**

Circle #058 on Reader Service Card

PROFESSIONAL CASSETTE EQUIPMENT  
TAPE DUPLICATION  
2909 Ocean Park Blvd., Santa Monica, CA 90405  
(213) 450-4499  
Contact: Dean Theodos, Owner



PROJECT ONE A/V  
Hollywood, CA

PROJECT ONE A/V  
TAPE DUPLICATION  
6669 Sunset Blvd., Hollywood, CA 90028  
(213) 464-2285

Contact: Mana or Dalton, Owners

TAPE DUPLICATION

Duplicator (Mfg. and quantity): 30 Audio cassette decks, 5 reel to reel recorders, 5 3/4" Umatic, 12 1/2" video decks, Dolby A dbx Type I

Method of duplication: In cassette, bin loop

Mastering equipment: Ampex ATR 102, Sony PCM F1, Sony 5850 3/4" Umatic

Tape used: AGFA 611/627, TDK, Maxell, Sony, Scotch 3M



Listings of Mastering, Pressing and Tape Duplication Facilities Throughout the United States

## Western

Shell used: Magnetic Media, Maxell, TDK, Sony, 3M  
Duplicating speed: Real time or hi speed  
Type of loading: King  
Packaging availability/Fulfillment services: Custom painted labels and inserts  
Rates: Call or write for catalog or quote. No job too small  
Other services: The most complete mastering tape store in L.A. Dealers in AGFA, Ampex, Scotch 3M, TDK, Maxell, Sony. Both audio and video professional tape at wholesale prices

RAINBO RECORDS MANUFACTURING  
MASTERING & PRESSING  
1738 Berkeley St., Santa Monica, CA 90404  
(213) 829-0355; 829-3476

Contact: Jack G. Brown/Steve Sheldon, President/General Manager

MASTERING

Special working arrangement with all top mastering studios



RAINBO RECORDS MANUFACTURING  
Santa Monica, CA

RAINBOW CASSETTE STUDIO  
TAPE DUPLICATION  
P.O. Box 472, Taos, NM 87571  
(505) 776-2268  
Contact: Tony Isaacs, Production Manager

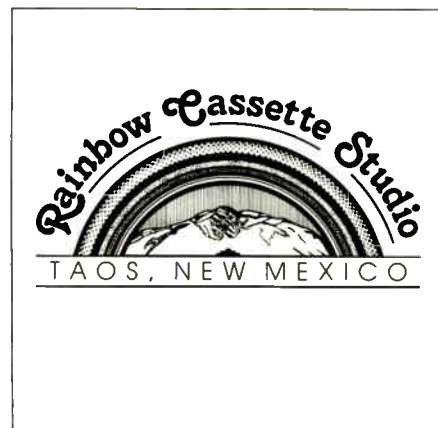

RAINBOW CASSETTE STUDIO  
Taos, NM

RAINBOW VENTURES, INC.  
PRESSING & TAPE DUPLICATION  
2219 West 32nd Avenue  
Denver, Colorado 80211  
(303) 433-7231  
Contact: Michael Moryn, Studio Manager

BILL RASE PRODUCTIONS, INC.  
MASTERING, PRESSING & TAPE DUPLICATION  
955 Venture Ct., Sacramento, CA 95825  
(916) 929-9181  
Contact: Bill Rase, Owner

RECORD TECHNOLOGY, INC.  
PRESSING & TAPE DUPLICATION  
486 Dawson Dr., Camarillo, CA 93010  
(805) 484-2747  
Contact: William Bauer, President

RECORDING ETC.  
TAPE DUPLICATION  
663 Cowper St., Palo Alto, CA 94301  
(415) 327-9344  
Contact: Dennis Reed, Owner

RECORTEC, INC.  
TAPE DUPLICATION  
475 Ellis St., Mountain View, CA 94043  
(415) 962-0220  
Contact: Ed Wong, Vice President

REELTIME DUPLICATING  
TAPE DUPLICATION  
2563 S. El Camino Real, San Mateo, CA 94403  
(415) 345-7335  
Contact: Jappi Singh or James Hay, Owner/Manager

best (best) adj. 1. Surpassing  
all others in quality, most excellent.



"THE BEST CUSTOM RECORD  
MANUFACTURING IN THE WORLD."

FOR MORE INFORMATION ABOUT DISK  
MASTERING, MANUFACTURING & JACKET  
PRINTING, CALL OR WRITE TODAY.

## SONIC ARTS

665 HARRISON STREET • SAN FRANCISCO, CA 94107 • (415) 957-9471 • TELEX 176-123

Circle #062 on Reader Service Card

**GOLD STAR RECORDING STUDIOS, INC.**  
**MASTERING, PRESSING & TAPE DUPLICATION**  
 6252 Santa Monica Blvd., Hollywood, CA 90038  
 (213) 469-1173

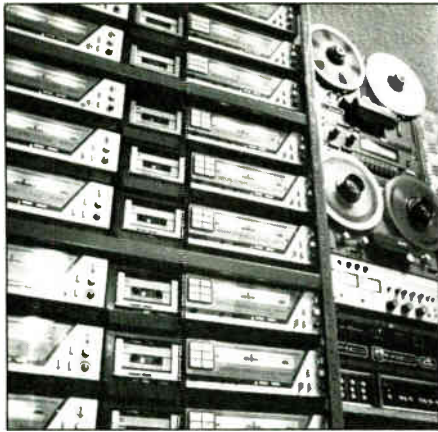

**GRD RECORDINGS**  
 Phoenix, AZ

**GRD RECORDINGS**  
**TAPE DUPLICATION**  
 376 E. Alvarado, Suite 2, Phoenix, AZ 85004  
 (602) 252-0077

Contact: Liv Singh Khalsa Owner  
**TAPE DUPLICATION**  
 Duplicator: 100 Denon DR-F8 Real Time recorders  
 Capacity: Orders up to 10,000  
 Method of duplication: In cassette, bin loop, real-time  
 Mastering equipment: Otari Denon Orban limiting Lexicon reverb  
 Tape used: AGFA 611 AGFA chrome metal on request  
 Shell used: Mag Media  
 Duplicating speed: 1 1/2 ips (Real Time)  
 Type of loading: Otari  
 Packaging availability/etc.: 4 color printing, labels, assembly, shrink  
 Rates: C15 \$1.05 each, C30 \$1.07 each, C45 \$1.12 each, C60 \$1.23 each, C75 \$1.85 each, C90 \$2.30 each. (all prices real time subject to change)  
 Other services: Record and produce new music, high-speed duplication for voice, custom load blank cassettes

**HI SPEED TAPE DUPLICATING**  
**TAPE DUPLICATION**  
 940 Howard St., San Francisco, CA 94103  
 (415) 543-7393  
 Contact: John Trnadac Engineer



**H.R. PRODUCTIONS**  
 Lafayette, CA

**H.R. PRODUCTIONS**  
**MASTERING, PRESSING & TAPE DUPLICATION**  
 3099 Diablo View Rd., Lafayette, CA 94549  
 (415) 930-7573  
 Contact: Hillel Resner

**PRESSING**  
 Credits: H.R. Productions has provided custom record pressing and album manufacturing for numerous clients throughout the western U.S. We specialize in high quality short-run projects for small companies and producers on tight budgets



**JVC CUTTING CENTER, INC.**  
 Hollywood, CA

**JVC CUTTING CENTER INC.**  
**MASTERING, PRESSING & TAPE DUPLICATION**  
 6363 Sunset Blvd. Suite 500, Hollywood, CA 90028  
 (213) 467-1166  
 Contact: Larry Boden, Chief Engineer  
**MASTERING**  
 Cutting lathes: Neumann VMS 70 with JVC quartz lock motor w. Zuma computer  
 Console: JVC Custom Disc Mastering console  
 Tape machines: MCI w/custom heads & playback electronics/  
 JVC digital DAS-90  
 Monitor speakers: Fostex LS-3  
 Signal processing: Sontec & JVC equalizers and limiters dbx & Dolby  
 Engineer: Joe G-stewart  
 Rates: Upon request  
 Credits: Adnan Belew, Dickken, Paul McCartney, Miles Davis, Ramsey Lewis, Winston Marshall, Isley Brothers, Jethro Tull, Ronald Shannon Jackson  
 Other services: JVC Digital DAS 900-rentals, remote and digital editing Sole distributor for Adamant/JVC cutting styli, JVC test records  
**PRESSING:**  
 Pressing: JVC Custom presses  
 Vinyl used: JVC Custom compounds including JVC super vinyl  
 Rates: Upon request  
 Credits: Mobil Fidelity Sound Labs, Telarc, Delos Records  
 Other services: Complete printing and art service, including jackets and inserts  
**TAPE DUPLICATION**  
 Duplicator: JVC Custom duplicators  
 Method of duplication: Bin loop  
 Rates: Upon request  
 Other services: Complete printing and art service including jackets and inserts



**KM RECORDS, INC.**  
 Burbank, CA  
 listing on next page

PREMIUM QUALITY...  
 MEANS AN

**"AWARD  
 RECORD"**



**AWARD**

- Pressing
- Printing
- Plating
- Masters
- Cassettes
- Picture Records

**SINGLES • ALBUMS  
 TAPES**

**Your Tape to  
 Finished Product**

**Any Quantity**

**AWARD  
 RECORD MFG.,  
 INC.**

11016 LA CIENEGA BLVD.,  
 INGLEWOOD 90304

**(213) 645-2281**

Circle #058 on Reader Service Card

"From One Serious Music Maker To Another"

## TAPE IT EASY

PROFESSIONAL BLANK AUDIO AND VIDEO TAPE SUPPLIES AT VERY LAID BACK PRICES

FINE CASSETTE AND TAPE TRANSFERS

SHORT LENGTHS OF HI BIAS OR NORMAL BIAS CASSETTES NOW IN STOCK



**PROJECT ONE A/V**  
AUDIO/VIDEO VISIONARIES  
ANALOG/DIGITAL DUPLICATION

from one of L.A.'s major wholesale distributors

TDK



MAXELL

**AMPEX**



(213) 464-2285  
For Samples and Catalog

Project One A/V  
6669 Sunset Blvd., Crossroads of the World  
Hollywood, California, 90028

Circle #059 on Reader Service Card

Audiophile Quality  
Cassette  
Manufacturing

**Moonvalley**  
Cassette

- Audio Cassette Mastering
- Stereo Duplication
- Printing/Package Design

Hi-output/Low Noise AGFA Tape in 5-screw Premium Cassettes duplicated with OTARI 16:1 bin loop equipment.

Moonvalley Cassettes  
10802 N. 23rd Ave.,  
Phoenix, Arizona 85029  
602 - 864 - 1980



A division of Wintersun, Inc.

Circle #060 on Reader Service Card

**K M RECORDS, INC.**  
MASTERING & PRESSING  
2980 N. Ontario St., Burbank, CA 91504  
(213) 841-3400

Contact: Jim Auchterlonie, Bill Riley, Sam Broadhead

**MASTERING**  
Cutting lathes: VMS-70, SX-74, SAL 74-B  
Console: Neumann SP-78  
Tape machines: Modified MCI JH-110  
Monitor speakers: Custom  
Signal processing: EMT 140.  
Engineers: Michele Stone.  
Rates: Upon request.  
Other services: Half speed mastering

**PRESSING**  
Presses (Mfg. and quantity): Toolex-Alpha (6)  
Capacity: 12,000/day  
Vinyl used: KC 600, Teldec, Quiex  
Rates: Upon request.  
Credits: Nautilus, Angel, Moss, Discovery, Varese/Sarabande  
Other services: In house metal processing, printing labels, jacket covers and liners, jacket fabrication

**KDISC MASTERING**  
MASTERING & PRESSING  
26000 Springbrook Ave., Saugus, CA 91350  
(805) 259-2360 or (213) 365-3991

Contact: Sharon Summerfeld, Customer Relations, Bill Lightner, Vice President.

**MASTERING**  
Cutting lathes: Scully/Capps w/Westrex heads  
Tape machines: Studer A-80  
Monitor speakers: JBL  
Signal processing: Neve, API, ITI-Sontec, Sphere, dbx, Dolby.  
Engineers: 6  
Rates: Call for information.

**PRESSING**  
Presses: SMT 5-12" 1-7" Dual  
Vinyl used: Keycor  
Rates: Call for quotes  
Other services: Matrix, printing (jackets & labels)

**KDISC MASTERING**  
MASTERING & PRESSING  
6550 Sunset Blvd., Hollywood, CA 90028  
(213) 466-1323

Contact: John Golden, Studio Manager, Bonnie Kipper, Traffic Manager.

**MASTERING**  
Cutting lathes: Neumann.  
Console: Custom & Sphere  
Tape machines: Studer, Ampex-ATR  
Monitor speakers: Custom JBL, Celec-Gauss.  
Signal processing: Neve, API, ITI-Sontec, Sphere, dbx, Dolby  
Engineers: John Golden, Carol Hibbs, Bill Lightner.  
Rates: Call for rates.  
Credits: Merle Haggard, Patrice Rushen, A Taste of Honey, Friz-zell & West, Burnto Bros., Pat Boone, Men at Work, Tom Scott, Clint Eastwood, etc.  
Other services: Studer 1/2" 2 track preview machine and Ampex ATR-102 1/2" 2 track record machine

**KENDUN RECORDERS**  
MASTERING  
721 S. Glenwood Place, Burbank, CA 91506  
(213) 843-5900

Contact: Jeff Sanders, Director of Mastering, Kent Duncan, Engineer, Lindy Griffin, Engineer

**MASTERING**  
Cutting Lathes: Neumann VMS 70/SX 74  
Console: Sierra/Sphere Custom with Graphic EQ/Transformerless  
Tape machines: A800 1/2" & 1/4" Preview and Studer A80 copy machine.  
Monitor speakers: Sierra/Hidley, Yamaha, Auratone.  
Signal processing: Dolby/dbx/Sontec  
Engineers: Jeff Sanders, Lindy Griffin, Kent Duncan.  
Rates: \$125.00 per hour EQ & rundown; \$115.00 LP Master; \$45.00 Single Master  
Credits: REO Speedwagon/ Jefferson Starship/Paul Kantner/Santana/Greg Gudry/The Third World Band/Stan Bush/Stevie Wonder/Chuck Mangione/Heart/Isley Bros  
Other Services: Zuma Computer/1/2" to 1/2" copies.

**LIGHTNING CORPORATION**  
TAPE DUPLICATION  
7854 Ronson Rd., San Diego, CA 92111  
(619) 565-6494

Contact: Mike Larsen, President  
**TAPE DUPLICATION**  
Duplicator (Mfg. and quantity): Wollensak (3M) 10, Pentagon  
Capacity: 26 cassettes/run (8,000 C-60/day)  
Method of duplication: In cassette  
Mastering equipment: Ampex. Otari 2 and 4 track reel to reel; BIC & Superscope cassettes  
Tape used: BASF, DPS  
Shell used: Magnetic Media (5 screw), white or black  
Duplicating speed: 30 ips (16 1)  
Type of loading: King

Packaging availability/etc.: Complete albums, boxes, labels, shrink-wrap  
Rates: C-30 \$1.00; C-60 \$1.15; C-90 \$1.40  
Other services: Voice studio, remote recording, video taping 3/4 and 1/2", multi-media slide shows and sound tracks

**MASTER DIGITAL INC.**  
TAPE DUPLICATION  
202 Main St., Venice, CA 90291  
(213) 399-7764

Contact: Paul Addis, Vice President Sales  
**TAPE DUPLICATION**  
Duplicator: 16 bit digital Sony or analog  
Method of Duplication: Real-Time only  
Mastering equipment: Studer B67 Sony PCM 1600  
Tape used: Sony UCXS - BASF chrome - custom loaded to length  
Shell used: Shape  
Duplicating speed: Real-Time  
Packaging availability/Fulfillment services: Color stock typeset J cards & labels  
Rates: \$3.00 & up  
Other services: Film & video production, digital audio recording, digital transfers for compact disk



THE MASTERING LAB  
Los Angeles, CA

**THE MASTERING LAB**  
MASTERING  
6033 Hollywood Blvd., Los Angeles, CA 90028  
(213) 466-8589  
Contact: Susan Fridgen, Studio Manager



RECORDING STUDIOS

MCA WHITNEY RECORDING STUDIO  
Glendale, CA

**MCA WHITNEY RECORDING STUDIO**  
MASTERING & TAPE DUPLICATION  
1516 W. Glenoaks Blvd., Glendale, CA 91201  
(213) 245-6801

Contact: Frank Kejmar, Studio Manager  
**MASTERING**  
Cutting lathes: 2 Neumann VMS 70, Tandem w/Zuma computer  
Console: Neumann w/custom electronics  
Tape machines: Studer A80 w/custom electronics, ATR-100, Hitachi D2200M  
Monitor speakers: UREI 813

**Signal processing:** Sontec parametric.  
**Engineers:** Steve Hall, Dave Hernandez.  
**Rates:** Upon request  
**Credits:** Blondie, Pat Benatar, The Knack, Berry White, Love Unlimited Orchestra, Aretha Franklin, Andrae Crouch, One Way, E.T., Crusaders, Tanya Tucker, Suzie Quatro, etc  
**TAPE DUPLICATION**  
**Duplicator (Mfg. and quantity):** 12 Ampex reel to reel. Otan cassette  
**Method of duplication:** In cassette  
**Tape used:** BASF Pro I  
**Shell used:** Magnetic Media  
**Duplicating speed:** 8 I  
**Packaging availability/etc.:** Labelling, insert card, delivery.  
**Rates:** Upon request  
**Other services:** Professional 24 track recording

**ML TAPE DUPLICATION**  
**TAPE DUPLICATION**  
 6935 Valjean Ave., Van Nuys, CA 91406  
 (213) 988-2737  
 Contact: Bill Ball, Owner

**MOBILE FIDELITY SOUND LAB**  
**MASTERING, PRESSING & TAPE DUPLICATION**  
 21040 Nordhoff, Chatsworth, CA 91311  
 (213) 709-8440  
 Contact: Pete Senoff

**MOTOWN/HITSVILLE STUDIOS**  
**MASTERING**  
 7317 Romaine St., Hollywood, CA 90046  
 (213) 850-1510  
 Contact: Diane Martin, Studio Manager.  
**MASTERING**  
**Cutting lathes:** Neumann VMS 70 with SX/SAL 74, CompuDisk Computer Technics  
**Console:** Neumann SP 77  
**Tape machines:** Teletunken/M15A ¼" & ½", Sony PCM 1610 & FI with Preview  
**Monitor speakers:** UREI 813  
**Engineers:** John Matouček  
**Rates:** Digital included with mastering

**MUSIC LAB, INC.**  
**TAPE DUPLICATION**  
 1831 Hyperion Ave., Hollywood, CA 90027  
 (213) 666-3003  
 Contact: Manager

**NORTHWESTERN INC.**  
**TAPE DUPLICATION**  
 1224 SW Broadway, Portland, OR 97205  
 1 (800) 547-2252; 1 (503) 226-0170  
 Contact: Paul Buescher, Sales Manager  
**MASTERING**  
**Console:** Altec  
**Tape machines:** Ampex ATR102-ATR 800  
**Monitor speakers:** Altec 604  
**Signal processing:** Spectra Sonics, Echoplex  
**Engineers:** Gary Shannon, Bob Lindahl  
**Rates:** \$50.00 per hr  
**TAPE DUPLICATION:**  
**Duplicator:** AudioTek 2000 BL  
**Capacity:** 4000 per day C-45  
**Method of duplication:** In cassette, bin loop  
**Mastering equipment:** Ampex ATR 102-104  
**Tape used:** Ampex 603  
**Shell used:** Kyrac  
**Duplicating speed:** 32.1  
**Type of loading:** 2-King 760 automatic  
**Packaging availability/Fulfillment services:** Shrink wrap, inserts, labels  
**Other services:** Reel to reel/at speed Ampex A6 440-C, 6 slaves.

**OUTBACK STUDIOS**  
**TAPE DUPLICATION**  
 489½ Cavour St., Oakland, CA 94618  
 (415) 655-2110  
 Contact: Nancy Dyer, Traffic Manager

**PRAISE SOUND PRODUCTIONS**  
**MASTERING, PRESSING, & TAPE DUPLICATION**  
 7802 Express St., Burnaby, B.C., Canada  
 (604) 420-4227  
 Contact: Paul Yaroshuk, U.S. office: 1308 Meador St., Unit C5, Bellingham, WA 98225 (206) 671-9562

**PRC RECORDING CO.**  
**PRESSING & TAPE DUPLICATION**  
 18700 Laurel Park Rd., Compton, CA 90220  
 (213) 979-8545  
 Contact: Debbi Scofield, West Coast Sales Rep  
**PRESSING:**  
 Richmond Indiana plant:  
 Capacity per day: 7" - 140,000; 12" - 110,000



Listings of Mastering, Pressing and Tape Duplication Facilities Throughout the United States

## Western

Compton, CA plant Capacity per day: 7" - 60,000; 12" - 60,000  
**Rates:** Upon request  
**Credits:** Upon request  
**TAPE DUPLICATION:**  
 Richmond, Indiana plant only  
**Capacity:** 70,000 per day  
**Method of duplication:** In cassette, bin loop  
**Mastering equipment:** Gauss  
**Duplicating speed:** 32.1, 64.1  
**Type of loading:** King  
**Packaging availability/Fulfillment services:** Complete  
**Rates:** Upon request

**PRECISION LACQUER**  
**MASTERING**  
 1008 North Cole Ave., Los Angeles, CA 90038  
 (213) 464-1008  
 Contact: Kate Emenne, Studio Manager.

**MASTERING**  
**Cutting lathes:** CompuDisk - Ortofon  
**Console:** Custom/NTP  
**Tape machines:** Ampex  
**Monitor speakers:** K&H, Horrible Tones - 604E  
**Signal processing:** NTP, UREI, Ortofon, Stephen's ears.  
**Engineers:** Stephen Marcussen  
**Rates:** Call for information  
**Credits:** Steve Wonder, Fleetwood Mac, Rod Stewart, Pointer Sisters, Steve Nicks, Lindsay Buckingham, Tom Petty, Mick Fleetwood, Bette Midler, Duran Duran, Joan Rivers

**PRESENT TIME RECORDERS**  
**TAPE DUPLICATION,**  
 5154 Vineland Ave., N. Hollywood, CA 91601  
 (213) 762-5474  
 Contact: Bob Wurster

**THE PRESSING PLANT**  
 (Formerly International Automated Media)  
**MASTERING & PRESSING**  
 17422 Murphy Avenue, Irvine, CA 92714  
 (714) 474-2015  
 Contact: Mike Malan, General Manager

**MASTERING**  
**Cutting lathes:** Sontec CompuDisk, Technics Quartz drive, Neuman Lathe & SK-74 head with custom electronics  
**Console:** Custom high speed, minimum electronics  
**Tape machines:** Studer A 80 ¼" & ½", Soundstream. Others upon request  
**Monitor speakers:** UREI 813, Auratones Others upon request  
**Signal processing:** Dolby, dbx, Sontec EQ, PSE Limit/Expand/Noisegate.  
**Engineers:** Bruce Leek, Richard Donaldson  
**Rates:** 12" Full Speed \$100.00 a side; \$175.00 for ½ Speed. Room time for rundown \$110.00 an hour Call for singles.  
**Credits:** A&M, CBS, Delos, Nautlus, Telarc, Warner Brothers, Fleetwood Mac, Joe Jackson, and many others too numerous to mention  
**Other services:** ½ Speed, Audiophile Complete matrix in house for instant plating after mastering  
**PRESSING**  
**Presses:** 6 Toolex Alpha  
**Vinyl used:** Teldec, Vitec, Keycor Custom blends  
**Rates:** Call for rates  
**Other services:** Complete Matrix services available

**THE MASTERING LAB**

**AN INDUSTRY LEADER IN DISK MASTERING**

**SINCE 1967**



**213-466-8589**

**LOS ANGELES**

Circle #061 on Reader Service Card

PROFESSIONAL CASSETTE EQUIPMENT  
 TAPE DUPLICATION  
 2909 Ocean Park Blvd., Santa Monica, CA 90405  
 (213) 450-4499  
 Contact: Dean Theodos, Owner



PROJECT ONE A/V  
 Hollywood, CA

PROJECT ONE A/V  
 TAPE DUPLICATION  
 6669 Sunset Blvd., Hollywood, CA 90028  
 (213) 464-2285

Contact: Maria or Dalton, Owners

TAPE DUPLICATION

Duplicator (Mfg. and quantity): 30 Audio cassette decks, 5 reel to reel recorders, 5 3/4" Umatic, 12 1/2" video decks, Dolby A, dbx Type I

Method of duplication: In cassette, bin loop

Mastering equipment: Ampex ATR-102, Sony PCM FI, Sony 5850 3/4" Umatic

Tape used: AGFA 611/627 TDK, Maxell, Sony, Scotch 3M



Listings of Mastering, Pressing and Tape Duplication Facilities Throughout the United States

## Western

Shell used: Magnetic Media, Maxell, TDK, Sony, 3M  
 Duplicating speed: Real time or hi speed  
 Type of loading: King  
 Packaging availability/Fulfillment services: Custom painted labels and inserts  
 Rates: Call or write for catalog or quote. No job too small  
 Other services: The most complete mastering tape store in L.A. Dealers in AGFA, Ampex, Scotch 3M, TDK, Maxell, Sony. Both audio and video professional tape at wholesale prices

RAINBO RECORDS MANUFACTURING  
 MASTERING & PRESSING  
 1738 Berkeley St., Santa Monica, CA 90404  
 (213) 829-0355; 829-3476

Contact: Jack G. Brown/Steve Sheldon, President/General Manager

MASTERING

Special working arrangement with all top mastering studios



RAINBO RECORDS MANUFACTURING  
 Santa Monica, CA

RAINBOW CASSETTE STUDIO  
 TAPE DUPLICATION  
 P.O. Box 472, Taos, NM 87571  
 (505) 776-2268  
 Contact: Tony Isaacs, Production Manager



RAINBOW CASSETTE STUDIO  
 Taos, NM

RAINBOW VENTURES, INC.  
 PRESSING & TAPE DUPLICATION  
 2219 West 32nd Avenue  
 Denver, Colorado 80211  
 (303) 433-7231  
 Contact: Michael Moryc, Studio Manager

BILL RASE PRODUCTIONS, INC.  
 MASTERING, PRESSING & TAPE DUPLICATION  
 955 Venture Ct., Sacramento, CA 95825  
 (916) 929-9181  
 Contact: Bill Rase, Owner

RECORD TECHNOLOGY, INC.  
 PRESSING & TAPE DUPLICATION  
 486 Dawson Dr., Camarillo, CA 93010  
 (805) 484-2747  
 Contact: William Bauer, President

RECORDING ETC.  
 TAPE DUPLICATION  
 663 Cowper St., Palo Alto, CA 94301  
 (415) 327-9344  
 Contact: Dennis Heed, Owner

RECORTEC, INC.  
 TAPE DUPLICATION  
 475 Ellis St., Mountain View, CA 94043  
 (415) 962-0220  
 Contact: Ed Wong, Vice President

REELTIME DUPLICATING  
 TAPE DUPLICATION  
 2563 S. El Camino Real, San Mateo, CA 94403  
 (415) 345-7335  
 Contact: Iqbal Singh or James Hay, Owner, Manager

best (best) adj. 1. Surpassing  
 all others in quality, most excellent.



"THE BEST CUSTOM RECORD  
 MANUFACTURING IN THE WORLD."

FOR MORE INFORMATION ABOUT DISK  
 MASTERING, MANUFACTURING & JACKET  
 PRINTING, CALL OR WRITE TODAY.

## SONIC ARTS

665 HARRISON STREET • SAN FRANCISCO, CA 94107 • (415) 957-9471 • TELEX 176-123

Circle #062 on Reader Service Card

**REX RECORDING CO**  
**TAPE DUPLICATION**  
 1931 SE Morrison, Portland, OR 97214  
 (503) 238-4525  
 Contact: Russ Gorsline or Rhiner Johnson



**ROCKY MTN. RECORDING**  
 Cheyenne, WY

**ROCKY MTN. RECORDING**  
**MASTERING & PRESSING**  
 8305 Christensen Rd., Cheyenne, WY 82009  
 (307) 638-8733  
 Contact: Georgia Alexander Sales

**SEACOAST RECORDING**  
**TAPE DUPLICATION**  
 926 Turquoise St., San Diego, CA 92109  
 (619) 270-7664  
 Contact: Jack Elliott Owner

**SHUR-SOUND & SIGHT, INC.**  
**TAPE DUPLICATION**  
 3350 Scott Blvd., Bldg. #5, Santa Clara, CA 95051  
 (408) 727-7620  
 Contact: Glenn L. Cardon Vice President

**RICHARD SIMPSON**  
**MASTERING & PRESSING**  
 6331 Santa Monica Blvd., Los Angeles, CA 90038  
 (213) 462-2545  
 Contact: Richard Simpson, Owner  
**MASTERING**  
 Cutting lathes: AM 32B with SX 68 cutting head VG66 amps  
 Tape machines: MCI JH 110M 2 VP  
 Monitor speakers: Altec 604  
 Signal processing: Orban parametric EQ 622B Inovonics compressor limiter  
 Engineers: Richard Simpson  
 Rate: 1 000 7" 45's \$518 includes mastering plating (full process) labels and sleeves  
 Credits: John Denver Elvis Presley Johnny Mathis Henry Mancini Mac Davis Bill Withers Willie Nelson Leon Russell, Glenn Campbell, movie sound track 10" & "Victor Victoria" numerous projects for major as well as small independent labels and artists  
 Other services: 12" LP and cassette packages

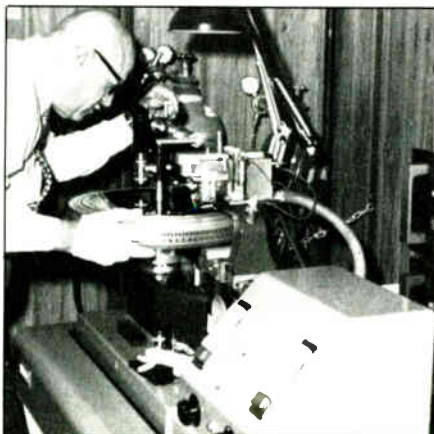

**SONIC ARTS CORP. THE MASTERING ROOM**  
 San Francisco, CA

**SONIC ARTS CORP. / THE MASTERING ROOM**  
**MASTERING, PRESSING & TAPE DUPLICATION**  
 665 Harrison St., San Francisco, CA 94107  
 (415) 781-6306, 957-9471  
 Contact: Ron Sullivan Custom Accounts  
**MASTERING**  
 Cutting lathes: Neumann fully automated and computerized VG66 amp w/Neumann SX cutting head  
 Console: Custom  
 Tape machines: Neumann, Telefunken, 3M, Inovonics, Ampex  
 Monitor speakers: Altec 604 w JBL woofers  
 Signal processing: Parametric and graphic EQ, Inovonics, Dolby A and dbx noise reduction, UREI and Inovonics limiters, AKG echo chamber  
 Engineers: Leo de Gar Kulka Kenneth Lee (asst)  
 Rates: \$25 per 1/4 hr, plus lacquers - 7" \$40/side 12" \$50/side  
 Credits: Philips Warner Bros Concord jazz, Ralph Records, DDG, Catero, and many local labels  
 Other services: Half speed mastering digital mastering  
**PRESSING**  
 Vinyl used: Keycor, Teldec  
 Rates: Call or write for brochure  
 Other services: Jacket label and poster printing, colored vinyl, promotional buttons, stickers matchbooks, and T-shirts  
**TAPE DUPLICATION**  
 Mastering equipment: 3M  
 Tape used: AGFA PE 611  
 Shell used: Data packaging  
 Packaging availability/etc.: Album art reproduction labels  
 Rates: Call or write for brochure

**SOUND IDEA PRODUCTIONS**  
**TAPE DUPLICATION**  
 P.O. Box 9587, Berkeley, CA 94709  
 (415) 832-5171  
 Contact: Glenn Davidson Owner

**SOUND IMAGE STUDIO**  
**MASTERING**  
 6556 Wilkinson, North Hollywood, CA 91606  
 (213) 762-8881  
 Contact: Chuck Kopp Studio Manager



**SOUND MASTER AUDIO/VIDEO RECORDING STUDIOS**  
 North Hollywood, CA

**SOUND MASTER AUDIO/VIDEO RECORDING STUDIOS**  
**MASTERING**  
 10747 Magnolia Blvd., North Hollywood, CA 91601  
 (213) 650-8000  
 Contact: Barbara Inqolsby Studio Manager  
**MASTERING**  
 Cutting lathes: Cybersonics with Ortolon cutting amplifiers and head  
 Console: Cybersonics  
 Tape machines: MCI and Ampex  
 Monitor speakers: House  
 Signal processing: Everything  
 Engineers: Brian Inqolsby Joe Beniche, Ken Inqolsby  
 Rates: On request  
 Credits: Elton John Olivia Newton John Joe Cocker, many others  
 Other services: 24 track automated recording studio and full production video complex

**SOUNDMARK, LTD.**  
**TAPE DUPLICATION**  
 4950-C Nome St., Denver, CO 80239  
 (303) 371-3076  
 Contact: Ray Pryor Sales Rep



**FOR SUPER DEALS ON CASSETTE RELATED PRODUCTS**  
**CALL TOLL FREE ANS. SERVICE 800-824-7888 Ask for operator 751**

**EVERYTHING**  
**FOR THE CASSETTE PRODUCER & USER**  
**KENNETH A. BACON ASSOCIATES**  
 24-E Commercial Blvd., Novato, CA 94947  
 (415) 883-5041

Circle #063 on Reader Service Card

# ALSHIRE

## Custom Services

- CASSETTE TAPE DUPLICATING
- DELUXE-QUALITY-PURE VINYL PRESSING
- STATE OF THE ART MASTERING
- QUALITY PLATING SERVICE
- WAREHOUSING AND DROP SHIPPING

*Personalized  
On Time Service*

P.O. BOX 7107 • 1015 ISABEL STREET  
BURBANK, CALIFORNIA 91510  
TELEPHONE: (213) 849-4671  
TELEX: 1-910-498-2759

Circle #064 on Reader Service Card

## The Finest Cassette Duplication in Real Time Just Got Finer

### Equipment:

20 Nakamichi LX-3  
20 Denon DR-M3  
Revox B77  
Tascam 40-4  
Ecoplate II  
Aphex Type B  
Symetrix CL-150  
DBX 150  
Ampex, BASF, TDK, Maxell, Agfa

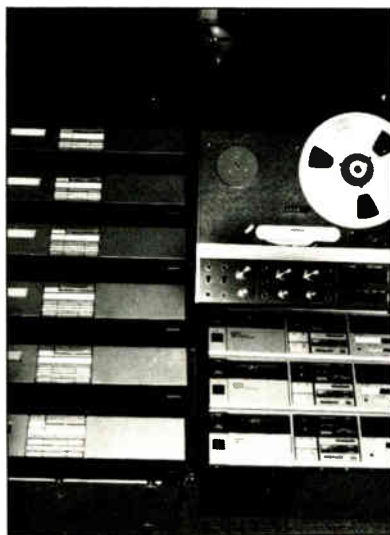

Audiohouse is committed to bring you clean, crisp cassette copies at the lowest possible price. Rates upon request.

### AUDIOHOUSE

10288 E. Jewell Avenue #45  
Denver, CO 80231  
(303) 751-2268

Circle #065 on Reader Service Card

TAPETODISK  
TAPETODISK  
TAPETODISK  
TAPETODISK  
TAPETODISK

Listings of Mastering, Pressing and Tape Duplication Facilities Throughout the United States

## Western

SOUNDS UNIQUE  
TAPE DUPLICATION  
2514 Seaboard Ave.  
San Jose, CA 95131  
(408) 262-8793 (pm)  
Contact: Mike Steiner, Owner

MARK STARR RECORDINGS  
1609 64th St., Emeryville, CA 94608  
(415) 658-0109  
Contact: Gary Wood, Owner



STOUGHTON PRINTING CO.  
City of Industry, CA

STOUGHTON PRINTING CO.  
JACKET & LABEL PRINTING  
130 N. Sunset Ave., City of Industry, CA 91744  
(213) 961-3678 or (213) 686-2753  
Contact: Ace or Jack Stoughton  
Other services: Sleeves and picture disks

STUDIO MASTERS  
MASTERING  
8312 Beverly Blvd., Los Angeles, CA 90048  
(213) 653-1988  
Contact: Larry Wood, Executive Vice President  
MASTERING  
Cutting lathes: Neumann VMS 70 with SAL 74 electronics  
Console: Neumann SP-272 with EMT PDM compressor limiter  
Tape machines: Studer A-80's (1/2" and 1/4" formats)  
Monitor speakers: TM-1  
Signal processing: Orban/Parasound parametric EQ, Orban Sibillance controller  
Engineers: Chief engineer Don Blake  
Rates: Call for rates  
Other services: State of the art complete service studio. Live recording, mix, mastering, dub, edit

TAKEDA RECORD SERVICE  
MASTERING, PRESSING & TAPE DUPLICATION  
11542 Burbank Blvd. #2, No. Hollywood, CA 91601  
(213) 760-6644  
Contact: James Takeda, Sales & Service Consultant  
MASTERING  
Cutting lathes: AM32B with SX68 cutting head, VG66 amps



# USE THE LEADER!

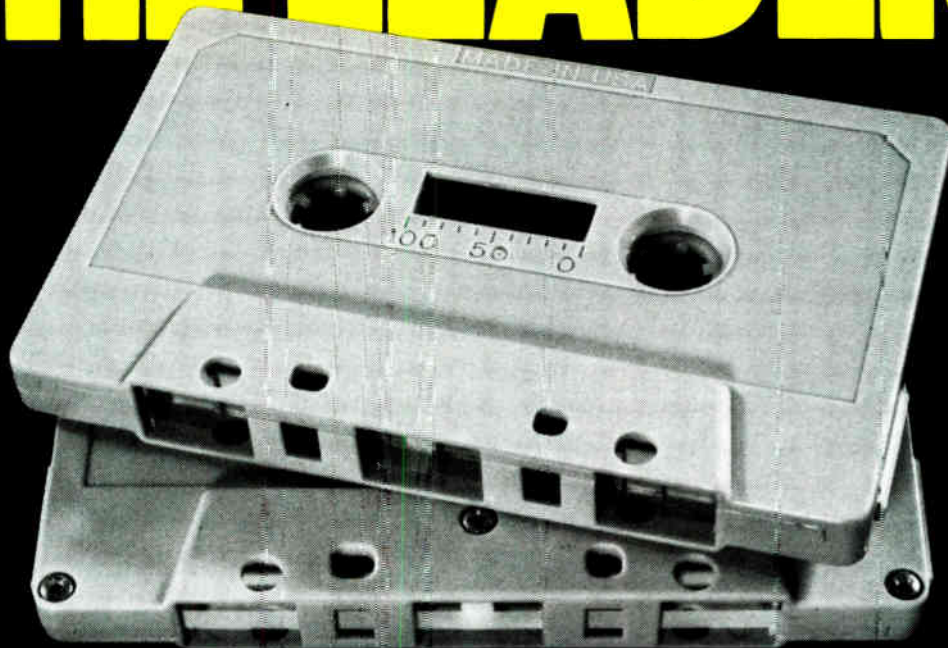

What makes Lenco the leader? Precision production and exacting quality control. Our sonic and five screw C Ø cassettes are American made. And we're proud of our national reputation and distribution.

Now, with Lenco's new Los Angeles warehouse, your order is delivered even quicker.

Lenco's innovative engineering allows loading at ultra-high speeds without scatter wind or linerburn. Lenco's quality duplicates itself with our accessories, including Soft Poly, Ampex and Norelco style boxes.

**Use the leader...**

Write or call:

# LENCO

10240 Deerpark Road / P.O. Box 160 / Waverly, NE 68462 / (402) 786-7488

Circle #066 on Reader Service Card

World Radio History

# RMR

IF IT IS WORTH  
REMEMBERING . . . .

. . . . IT IS WORTH  
RECORDING

RECORDS PRESSED  
with pure vinyl

ALBUM COVERS PRINTED  
- our stock or your custom

NO MINIMUM QUANTITY  
ALL UNDER ONE ROOF

for

QUALITY CONTROL  
and GOOD DELIVERY



**ROCKY MOUNTAIN  
RECORDING**

**8305 Christensen Rd.  
Cheyenne, Wyoming 82009**

**(307) 638-8733**

Circle #067 on Reader Service Card

Tape machines: MCI JH 110M 2 VP  
Monitor speakers: Alter 604  
Signal processing: Orban parametric EQ 622B Inovonics Compressor/limiter  
Engineer: Richard Simpson  
Credits: Willie Nelson, Henry Mancini, Elvis Presley, Glenn Campbell, John Denver, Mark Davis, Leon Russell, movie sound tracks plus numerous projects for majors as well as small independent labels and artists  
Rates: Call (213) 760-6644 and ask for Jim  
**PRESSING**  
Presses: Record pressing done by top quality facility  
Capacity: Any amount  
Vinyl used: Keycor  
Rates: \$518.00/This package includes 1000 7" 45 RPM pressings in white dustier, mastering, processing, labels & test pressing \$1791.00 1000 12" LP (same package as 7") includes custom designed & custom printed album jackets shrink wrapped  
**TAPE DUPLICATION**  
Duplicator: Duplication done by top quality facility  
Capacity: Any amount  
Method of duplication: In cassette, in loop  
Other services: Complete tape-to-disk tape-to-cassette manufacturing, complete printing service, labels, album covers, cassette inserts, Complete album production, designing layouts, color separation, litho printing, fabrication & shrink wrapping  
Packaging availability: We specialize in total packaging  
Rates: Call (213) 760-6644 or write for competitive quotes



Listings of Mastering, Pressing and Tape Duplication Facilities Throughout the United States

## Western

**TAPE SERVICE UNLIMITED**  
TAPE DUPLICATION  
3249 Grand Ave., Oakland, CA 94610  
(415) 834-6912  
Contact: Walt Lee, Owner

**TAPELOG**  
TAPE DUPLICATION  
10511 Keokuk Ave., Chatsworth, CA 91311  
(213) 882-4433  
Contact: Don Hollingsworth or Kristin Criselli

**TAPES AGAIN**  
TAPE DUPLICATION  
1135 Pearl St. Ste. #7, Boulder, CO 80302  
(303) 447-8787  
Contact: Martin Rose, President

**UNIVERSAL AUDIO CORP.**  
MASTERING, PRESSING & TAPE DUPLICATION  
6540 E. Lafayette Blvd., Scottsdale, AZ 85217  
(602) 994-5528  
Contact: John A. Michaelson, President

**VIDEO RECORD ALBUMS OF AMERICA**  
TAPE DUPLICATION  
Number 8471, Universal City, CA 91608  
(213) 462-1099  
Contact: Troy Cory, Owner



**TAKEDA RECORD SERVICE**  
North Hollywood, CA

**THE TALKING MACHINE**  
MASTERING  
6733 N. Black Canyon Highway, Phoenix, AZ 85015  
(602) 246-4238  
Contact: Corjer Bittner  
MASTERING  
Cutting lathes: Smully with Zima digital computer and Ortolon DSS 132 digital read  
Console: Custom Electronics  
Tape machines: MCI and Otari  
Monitor speakers: UREI B13 Time Align  
Signal processing: Dolby A mix UREI LA 4 compressor Orator, Treble Limiter, Echo Plate reverb  
Rates: 12" masters \$60, side 7" 45 master \$40, side 12" EP master \$27, side \$22, 11" set \$45, 7" 45 set \$3.00, 12" EP set \$25.00  
Other services: Edit, assemble and tape copy



**TALKING MACHINE**  
Phoenix, AZ



**WAKEFIELD MFG., INC.**  
Phoenix, AZ

**WAKEFIELD MFG., INC.**  
MASTERING & PRESSING  
P.O. Box 6037, 1745 W. Linden, Phoenix, AZ 85005  
(602) 252-5644  
Contact: an Account Executive  
MASTERING  
Cutting lathes: Neumann VMS 70 SM 74 head SAI 74B clear tracks Zima digital read  
Console: SP 172  
Tape machines: Studer A 8, Otari MR 10 MK II 4  
Monitor speakers: UREI B13  
Signal processing: Sentez parametric EQ, Dolby, ubx Neumann EQ, PDM limiter

**DUPLICATION RIVALING the MASTER**

**DUPLICATION**

C30 as low as 99¢  
Includes printed labels  
Send for price list

**REMASTER**

Redwood City, CA 94063  
2732 Bay Road  
ARCAL  
(415) 369-7348

Circle #068 on Reader Service Card

Engineers: Roger Seibel  
 Rates: Contact an Account Executive  
 Credits: ECM, June Appal, Titanic, 1750 Arch, Rounder  
 Other services: Digital mastering Sony BVU-200B and PCM-1610  
**PRESSING**  
 Presses (Mfg. and quantity): SMT automatics  
 Vinyl used: Keycor KC-600, Vitec Quix I and II, Teldec available  
 Rates: contact an Account Executive  
 Credits: Angel Records, ECM Records, Rounder Records, American Gramophone, 1750 Arch Records, Titanic Records  
 Other services: Complete tape-to-disk manufacturer. All printing (labels, jackets, stickers, inserts, etc.), complete matrix department  
**TAPE DUPLICATION**  
 Rates: Contact an account executive  
 Other services: Complete duplicating and printing services  
 Engineer: Joel Brooks

**HANK WARING DISC MASTERING**  
**MASTERING**  
 4007 W. 6th St., Los Angeles, CA 90020  
 (213) 383-2155  
 Contact: Hank Waring

**WEST AMERICAN SOUND**  
**TAPE DUPLICATION**  
 8120 Webb Ave., North Hollywood, CA 91605  
 (213) 768-6100

**WINTER SUN**  
**TAPE DUPLICATION**  
 10802 N. 23rd Ave.  
 Phoenix, Arizona 10802  
 (602) 864-1980  
 Contact: Mark Bruno, Manager

*Don't Miss*

The  
 Mix Directory  
 of  
 Video Production  
 &  
 Post-production  
 Facilities

NAB/Video Music  
 Special Issue  
 April '84

*Call or Write*

For details on listings and  
 advertising deadlines.

**415/843-7901**

Mix Magazine  
 2608 Ninth Street  
 Berkeley, CA 94710

**Correction:**  
 In our October issue on page 135 we incorrectly spelled the Timrep Company as TIMEREP.

**MCA WHITNEY**  
**RECORDING STUDIO, INC.**

**DISC MASTERING**  
**24 Trk. Facilities**

**Neve Consoles**  
**Three Live Studios**  
**High Speed Duplication**

**Studios (213) 507-1041**  
**Tape Duplication (213) 507-1052**  
**1516 W. Glenoaks Blvd., Glendale, CA 91201**

Circle #069 on Reader Service Card

**RECORD PRESSING & TAPE DUPLICATING**

Are you wondering where you can go to get the best possible PRICE, SERVICE and QUALITY for a complete customized package deal for your record pressing and tape cartridge duplication? LOOK NO FURTHER!!

**ONE CALL DOES IT ALL**  
*"IT IS A SERVICE YOU WILL APPRECIATE"*

**JAMES TAKEDA**  
**(213) 760-6644**

**SERVICES OFFERED:**  
 Disc Mastering, Processing, Labels, Record Pressing, Album Jacket Layout, Designing, Color Separation, Offset Printing, Album Fabricating and Shrink Wrapping, Cassette and 8 Track Duplicating, and more...

**SEND FOR YOUR FREE PRICE QUOTATION**

 **Takeda**  
**Record Service**

11542 Burbank Blvd. #2, North Hollywood, CA. 91601,  
 Phone: (213) 760-6644

Circle #070 on Reader Service Card



# Announcing the mixers that the competition has been trying to build for ten years.



If you've made a real study of what's available in live performance mixing consoles, you've probably reached one depressing conclusion: You can't get everything you want... without paying a lot more than you want to.

But we saw the need for a truly great line of mixers—priced like the competition's "economy" models. So we assembled perhaps the most impressive team of research scientists, circuit engineers, and experienced soundmen ever, and gave them the challenge of creating the best live performance mixers in the business.

The results of their efforts speak for themselves—in a hundred little details that you might not even see or appreciate until you've had a chance to spend some time with these remarkable mixers.

## Specifications For Perfectionists

In noise performance, Fender mixers are within about 1dB of the theoretical minimum. So no matter how

long you wait, nobody's going to come out with a mixer that's significantly quieter. Thanks to Fender your mixing console doesn't have to contribute to the noise floor of your system.

The mixing consoles' fully professional +24dBm main outputs (at less than 0.05% THD), deliver a clean, noise-free mix—even if the controls should happen to be set wrong. And with 84dB of gain at your command, the faintest signals come through loud and clear.

## Features You Can Get Excited About

Every channel has a 3-band, 5-frequency equalizer with truly natural sound, switchable 48v phantom powering, LED's to indicate overload and signal present, a continuously variable 40dB pad, balanced transformerless separate lo-Z input plus hi-Z, and an effects insertion patch point with pre/post EQ switching.

On most models, you also get stereo outputs, two separate monitor mixes, patchable 9-band graphic

equalizers, effects panning, a built-in high output headphone amp, and much more.

## Human Engineering To Make Life Easy

All this sophisticated technology isn't worth much if you can't use it easily and comfortably, so we put an enormous amount of thought into how our mixers work in actual performance situations.

For example, our knobs are color-coded in different shades of blue, so you'll recognize them no matter what kind of light you're working under. And each one is a raised pointer that lets you feel its setting without looking down. All inputs and outputs are specially designed to eliminate interface problems with outboard accessories. And the meticulous circuit layout and thorough engineering practices eliminate the unpredictable grounding problems you get with other mixers.

## Pricing That's Friendly To Your Wallet

We haven't neglected another very important

"human factor": cost. Compare, and you'll discover that spec for spec, feature for feature, Fender value beats everything else around. And they're as rugged as every Fender product has to be—thanks to the most exhaustive testing and quality control programs ever used in the industry. Every signal path—input to output—and every specification is checked and re-checked before the mixer leaves our factory.

Come to your Fender Pro Sound dealer and see the complete line: 8-, 12-, and 16-channel mixing consoles with fully professional specs. And 6-, 8-, 12-, and 16-channel powered mixers with built-in 200 watt/channel audiophile-quality power amplifiers. Or for more information, write Fender Pro Sound, 1300 E. Valencia Drive, Fullerton, CA 92631.

You'll find a combination of design integrity, performance, and value that no competitor can even come close to matching.

Even with a 10 year head start.



## You put everything you got into making your record the best it can be.



But before everyone hears your work, they're going to see it. Let the quality of your graphics reflect the excellence they can expect to find in your music.

Stoughton can provide all of your record-related printing needs in one stop. Top-quality lithography and fabrication of jackets and sleeves for both albums and 45's, single or multi-color. Labels in all sizes and styles, including picture disks. And, of course, posters and any other graphic material you may need to promote your product.

If it's worth doing, it's worth doing right. Come to the source.

## stoughton printing co.

130 N. Sunset Avenue, City of Industry, CA 91744  
From Los Angeles: (213) 686-2753  
(213) 961-3678

*Quality Printing For The Record Industry Since 1965*

©1983 Stoughton Printing Co.

Circle #072 on Reader Service Card

## Audiophile Quality and Service

The people at KM Records are masters at their craft and treat each recording as "solid gold." From tape to record the cost-effective way, because we do it all in-house: mastering, matrix electroforming, record pressing, label and jacket graphics and printing.

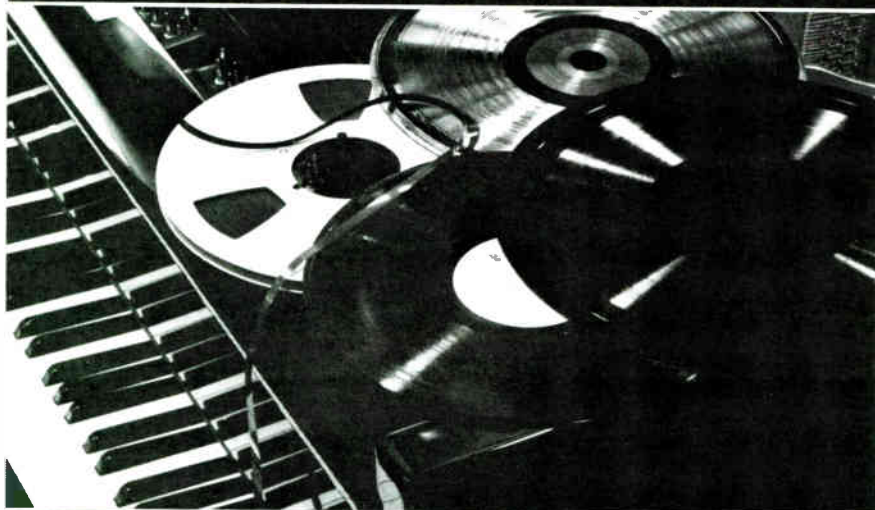

## KM Records — always a sound choice.

2980 N. Ontario Street, Burbank, CA 91504  
Tel. 213 841-3400 or TWX No. 910-498-5700

Circle #073 on Reader Service Card

**Technical  
Writers  
Wanted  
for  
Mix**

Would you like to write concise audio equipment evaluations and comparisons? Drop us a line with your specialty and a sample of your writing and we'll be in touch.

Editor  
Mix Magazine  
2608 Ninth Street  
Berkeley, CA 94710

## AUDIO VIDEO Retailer

**SELL MIX IN  
YOUR STORE!**

It's easy.  
It's profitable.  
It's a service your  
customers will  
appreciate.

Call Craig Wingate at  
(415) 843-7901  
for details.

# SYSTEMS OF THE 80'S

\*ITAM model 1610  
1" - 16  
track, 7½,  
15 & 30  
ips, + 4  
in/out, full  
function  
remote  
standard.

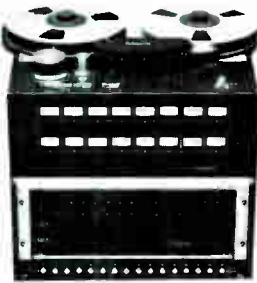

Whether you're building an 8 or 16 track studio, these Professional Performers from Allen & Heath, Otari and Itam will give you master quality results for the price of a semi-pro - 10 dBm system.



\*Allen & Heath's amazing #1616, 16 track recording console with full 16 track monitoring, + 4 in/out.

Both as shown above for under \$16,000

**\*Both Consoles Feature:**

- \*External Power Supply with Phantom Power option.
- \*3 Band EQ with Mid sweep and selectable shelving.
- \*Long travel fader. \* Peak LED on all inputs.
- \*Insert points on inputs and outputs.



\*Otari #MK III-8,  
½"-8 track,  
+ 4 in/out



\*Allen & Heath #168, 8 track recording console with full 8 track monitoring, + 4 in/out.

Both as shown above for under \$9000

At Professional Audio, we sell quality recording systems to fit your budget and your needs. Stop by today for a *FREE* "Hands On" demonstration with a qualified professional.

*Professional Audio Services  
& Supply Company*

IN BURBANK  
CALL 213-843-6320

NOW IN VENTURA COUNTY  
CALL 1-805-496-2969

99 East Magnolia ■ Suite 215 ■ Burbank, California 91502

# THIS IS THE CONSOLE



The challenge to console manufacturers of the eighties is to design new mixing systems that match the dynamic range, distortion specs, and frequency response now possible on digital magnetic tape. AUDIOARTS/WHEATSTONE has taken this challenge and designed the 8X Recording and Production Console. Today, through careful engineering, the technical performance of the 8X is approaching all possible theoretical limits, resulting in the smoothest, most transparent console we have ever built.

Today, studio clients are demanding greater complexity in audio processing for their work; features like three-band sweepable EQ, 24-track monitoring, mixdown subgrouping and stereo monitoring enable the creative engineer to meet those demands.

So if you're choosing a mixing system to upgrade your studio, expand your track format, or add a Studio B, take a good look at the 8X.

## THESE ARE THE DEALERS:

AUDIOTECHNIQUES, INC. Stamford, CT .....	(203) 359-2312
MILAM AUDIO COMPANY Pekin, IL .....	(309) 346-3161
LAKE SYSTEMS Newton, MA .....	(617) 244-6881
AUDIO ARCHITECTS Nashville, TN .....	(615) 320-0463
PROFESSIONAL AUDIO Burbank, CA .....	(213) 843-6320
CONN AUDIO/VIDEO Satellite Beach, FL .....	(305) 773-2433
SOUND GENESIS San Francisco, CA .....	(415) 285-8900
AUDIO ASSOCIATES Oklahoma City, OK .....	(405) 840-3636
PEIRCE-PHELPS, INC. Philadelphia, PA .....	(215) 879-7236

(Prices starting at \$9800)

Call or Write:



**AUDIOARTS® ENGINEERING**  
A DIVISION OF WHEATSTONE CORPORATION

5 COLLINS ROAD, BETHANY, CT 06525 (203) 393-0887



# FREBERG

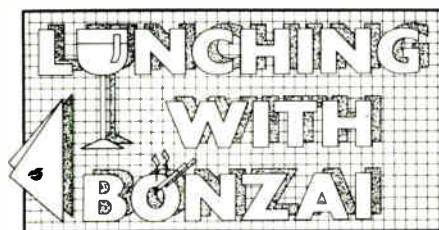

by Mr. Bonzai

"I was a very quiet and introverted child, like my friend Ray Bradbury. We had very similar parallels in childhood. We are now helping to design an indoor theme park for the Six Flags people in Baltimore."

Think of it. Stan Freberg and Ray Bradbury creating an amusement park! Humor and science fiction might be just the E-ticket to save the human race.

I met Stan Freberg not because I recognized his face, but because I overheard his voice in a crowded L.A. supermarket. I did a mental double take, looked around, and pushed my way through the shopping carts to shake this man's hand. He cordially introduced his 12-year-old son Donovan and we made plans for a lunching. I thought it would be revealing fun to meet with two generations of Frebergs.

The first week that we tried to meet was taken up with cancellations due to his work on some Jenó's Pizza commercials. The next week was interrupted by a sudden need to transport his props and archives from a warehouse that was being torn

down. He told me that he was having trouble getting an eight-foot rubber pizza into his basement. I also learned that he was getting flack from The Magic Castle, an unusual L.A. nightclub, because he was storing the 12-foot soup can from the Heinz "Great American Soup" commercials in their garage. "It's getting a little dented from the busboys squeezing by," he told me.

It was altogether appropriate that I met Stan Freberg because of his auditory presence. His imaginative use of character voices, sound effects, and unlimited music have forever altered the course of popular audio. Those of you who have followed his career as a distinctive musical satirist and the man who created an unmatched success in humorous advertising would be tickled to tour his home in Beverly Hills. He lives in an eccentric sanctuary: a villa filled with elegant 16th century Spanish antiques, an occasional plumbing problem that cracks the plaster (as on the day I arrived), and the biggest knick-knacks in the domestic world. (Remember the U.S.-shaped briefcase from the cover of "The United States of America?" album?)

Because of the forced Freberg archival project, I was invited to join Donovan, Stan, and his son-in-law Todd Fisher (brother of Princess Leia) in the refurbished basement. Todd is a recording wiz who once had a state-of-the-art mobile van that he used to record such acts as The Beach Boys. Today he is creating new electronic interfaces for Stevie Wonder's studio laboratory. The four of us sorted through old records, tapes, and props



PHOTO MR. BONZAI

and magazine clippings from the past thirty years.

Stan began his career at the age of 17 when he voiced cartoons for Warner Bros. with Mel Blanc. "Donovan and I find at least one of those old cartoons on the Bugs Bunny/Roadrunner Show every Saturday morning," he informed me. His son is already voicing an animated ABC show, "The Littles", which airs at 9:30 AM, and before that was the voice of Bill Melendez's "Charlie Brown." It conjured up a heartwarming image when I thought of the two of them sharing the Saturday morning TV.

The first Freberg record was "John and Marsha," released in 1949. It is simply the voice of a man and woman repeatedly uttering each other's names and expressing inquisitiveness, sensuality, laughing lunacy. Add to that vocal a soap opera music bed and you have a single that sold half a million copies.

His "St. George and the Dragonet", a 1957 Dragnet spoof set in medieval times, sold a million copies in three weeks, resulted in a recreation on the Ed Sullivan Show, and is credited as the fastest rising single in the history of the record business.

When asked how he arrived at a career that combined a lavish in-

come and a hilarious lifestyle he simply replied, "It was just one of those lovely things that happened. I wanted to make records, even if I didn't get paid for them."

The success of his recording career was propelled by his fame as a radio comic. In 1957, he took over Jack Benny's network slot and his legendary show was the very last network radio comedy series. The double album culled from the programs won the Grammy as Comedy Album of the Year. As a record industry footnote, Stan was one of the founding members of NARAS, and wrote their credo. In the opening segment of the radio show he had an argument with himself, which eventually grew into a multi-voiced tirade among six or seven Frebergs. It was live radio, but he had pre-recorded the argument to the memorable delight of radio audiences.

"That was the first time that I had done it," he told me. "We did it the hard way, in mono, by taking the outputs of two recorders and going into a third machine. Overlap, overlap, overlap. I also did a record that was a take-off on Les Paul and Mary Ford." Bonzai: But he was doing true multi-tracking on the tape recorder he built with the help of Ampex . . .

Freberg: Yeah, he was the first to do

it. I was very interested in the way it sounded, but he wasn't about to tell me his secrets. I did experiment with a musical conductor by the name of George Burns, who was also a mathematics major. He helped me figure out how to get musically correct results by re-recording at different speeds—how to start in one key at a certain speed and then end up in the right key after re-recording at a different speed. The most interesting and well-known multi-tracking thing that I ever did was for the radio advertising bureau in which I dropped the ten-ton maraschino cherry into Lake Michigan.

[The 60-second spot promoted the unlimited possibilities of radio production as opposed to the restrictions of TV. The tightly choreographed piece of audio art is a montage of moving mountains of whipped cream and the sound of the Royal Canadian Air Force dropping the big cherry.]

Bonzai: Did you use a multitrack recorder on that one?

Freberg: No, we didn't have them yet. I had to use seven mono machines lined up with different sound effects going into an eighth machine. It all depended on a sense of timing and I wanted the sounds to overlap so that you would hear a new sound coming in while the old one was

**MASTERDISK**

(212) 501-5022

**FINE DISK MASTERING FOR DISCERNING CLIENTS**

**DAVID BOWIE**

**KANSAS**

**DEF LEPPARD**

**THE CLASH**

**THE POLICE**

**HALL & OATES**

**THE ROLLING STONES**

**PAT METHENY**

**JOURNEY**

**THE KINKS**

**BRYAN ADAMS**

**MASTERDISK CORP.**  
16 WEST 61 STREET  
NEW YORK, N.Y. 10023

decaying. The man from the ad bureau conked out after the seventh take. He told me that all seven sounded fine. "Why do you keep stopping," he pleaded. I told him that it wasn't *swinging* yet. The booth gradually emptied until the only survivors were my wife Donna, who is my associate producer, the engineer, and myself. The master take is number 72. When I got what I wanted, I stopped. Remember, each of the machines had to be re-cued each time. The engineer, Ralph Valentine, had to take ten days off to recuperate after that 15 hour session.

**Bonzai:** Do you have a reputation for taking a long time?

**Freberg:** Only among the more jealous people on Madison Avenue. It takes what it takes, that's all. It's like Michaelangelo hanging on the ceiling of the Sistine Chapel and the Pope is yelling "When will it be done?" He answered, "When I'm finished." I have already heard the finished recording in my mind and I stay in the studio until the performance syncs up with the tape in my head.

There was *one* job where I did 114 takes for a TV commercial. It was a 12-hour day and I never did get it. I had to cash it in because the actor couldn't remember his lines. The man just about had a nervous breakdown.

I even wrote the lines on the back of the Cheerios box and he still couldn't do it. My wife deduced the solution on the way home. He was a stand-up comedian and I had him sitting at a kitchen table. He would stand up and do it perfectly while we were reloading tape, then he would sit down and blow it every time.

[Stan's commercials are an irritating legend on Madison Avenue. He somehow manages to grab his audiences, lead them through an auditory labyrinth, mock the medium, and still generate astronomical increases in sales. His "Today the pits . tomorrow the wrinkles!" campaign for Sunsweet Prunes caused a 400% sales boost. He achieved incredible radio penetration with a series of public service announcements he produced for the Presbyterian Church. National surveys were the stuff of The Guinness Book of World Records when it was found that he had accomplished almost 100% total recall with radio audiences.]

**Bonzai:** How did you get involved in producing religious commercials?

**Freberg:** I was approached by Reverend Charlie Brackbill, a minister who worked in their radio and television department in New York. He flew to California and told me that if I could soft-sell Chun King Chow Mein,

then I should be able to do the same for God. I backed off at first because of the seriousness, but Charlie said that if I didn't at least try, I was doing a disservice to God. Eventually I agreed—I guess I was just in awe of the client at first.

**Bonzai:** Do you have any advice for aspiring advertising people?

**Freberg:** Perhaps they should get into some other line of work. I'm not so sure that we need so much advertising and I've seen the blood drain out of 1000 faces when I've made this statement at ad banquets.

**Bonzai:** But wouldn't that diminish your income?

**Freberg:** Maybe a little, but what if it did? That would be a small price to pay for not being assaulted day and night by too much advertising. I once said that suppose Proctor and Gamble didn't do any soap advertising—do you think that people would be any dirtier? If we had a moratorium on advertising, people would eventually go staggering into drugstores with headaches and gradually they'd figure out which remedy gave them the fastest relief.

**Bonzai:** Your odd musical compositions have been a key factor in your recording career and your commercial projects—where did you get your background in music?

## Le Mobile would like to thank the following for making 1983 our best year yet:



**We didn't take a truck  
and try to turn it into a mobile unit.  
We took a sound studio and put it on wheels.**

le MOBILE

**PAT BENATAR**  
"Live From Earth"  
(Chrysalis) Neil Geraldo,  
producer

**PAT BENATAR**  
HBO Special  
Rising Star Productions

**DAVID BOWIE**  
HBO Special  
CPI/Tall Pony Productions

**DAVID BOWIE**  
DIR Broadcasting

**PETER GABRIEL**  
"Plays Live"  
(Geffen) Neil Kernon,  
engineer

**HALL & OATES**  
ABC TV Music Awards  
Neil Kernon, producer

**KANSAS**  
"Drastic Measures"  
(CBS) Kansas/Neil Kernon,  
producers

**1983 MONTREAL  
JAZZ FESTIVAL**  
Alain deGrobois,  
CBC producer

**THE POLICE**  
Showtime Special  
Concert Productions Inter-  
national

**RICK SPRINGFIELD**  
Movie, "Forever One"  
Forever One Productions

**SPYS**  
"Behind Enemy Lines"  
(EMI-America) Ed Gagliardi/  
Al Greenwood, producers

**SUPERTRAMP**  
First Choice, Canadian  
Cable TV  
Concert Productions Inter-  
national

**TOM TEELEY**  
"Tales of Glamour and  
Distress"  
(A&M) Neil Kernon/  
Tom Teeley, producers

**211 W. 56th Street, Suite 20J  
New York, N.Y. 10019  
(212) 265-1979 (514) 430-6309**

# Best On Our Bookshelf

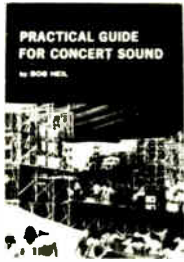

**PRACTICAL GUIDE FOR CONCERT SOUND**  
**Bob Heil**  
 Excellent coverage of fundamentals of sound reinforcement, beginning and intermediate information for all sound technicians (4) \$10.00



**THE PLATINUM RAINBOW**  
**Bob Monaco, James Riordan**  
 How to approach the music business rationally. It covers almost every angle of the industry, creative and business. The best of its kind. (2) \$9.95

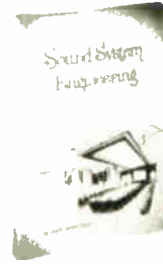

**SOUND SYSTEM ENGINEERING**  
**Don & Carolyn Davis**  
 The best book on electronic sound reinforcement systems. Integrates all available, useful information in a concise, logical form. (3) \$21.95



**BUILDING A RECORDING STUDIO**  
**Jeff Cooper**  
*M.Arch., S.M., S.B., B.S.A.D.*  
 A step by step guide to studio construction for small or large budgets. Detailed and fully illustrated. (1) \$30.00



**PRACTICAL TECHNIQUES for the Recording Engineer**  
**Sherman Keene**  
 The most comprehensive treatise on the "real world" of recording. Thorough, in-depth, understandable. (5) 29.75



**MUSICIAN'S GUIDE TO INDEPENDENT RECORD PRODUCTION**  
**Will Connelly**  
 Straightforward advice on the entire process of record-making for the aspiring producer. Hardcover (6) \$12.95

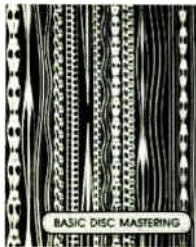

**BASIC DISK MASTERING**  
**Larry Bodin**  
 A primary reference source for engineers and producers. The only book to deal comprehensively with disk mastering. (7) \$10.95

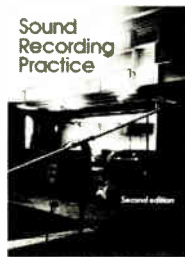

**SOUND RECORDING PRACTICE** edited by **John Borwick**  
 Updated handbook compiled by the Association of Professional Recording Studios, designed for the user. (8) \$55.00

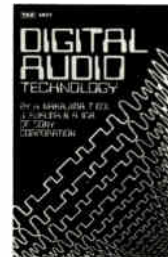

**DIGITAL AUDIO TECHNOLOGY**  
**H. Nakajima, T. Doi, J. Fukuda, A. Iga, of Sony Corp.**  
 Authoritative handbook covering fundamentals of digital PCM recording, audio and video disk systems. Hardcover (9) \$18.95

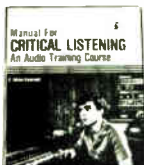

**CRITICAL LISTENING**  
 An audio training course, 10 self-study lessons, text, and 5 pre-recorded cassettes. Fine tune your hearing to recognize audio subtleties. (10) \$129.95



**VIDEO PRODUCTION GUIDE**  
**Lon McQuillin**  
 Lively, comprehensive coverage of both studio and location production from the viewpoint of the producer and director. (11) \$28.95

## Best On Our Bookshelf

Please indicate how many copies of each title

			PRICE
_____ 1	_____ 6	_____ 11	_____
_____ 2	_____ 7	_____ 12	_____
_____ 3	_____ 8	_____ 13	_____
_____ 4	_____ 9	_____ 14	_____
_____ 5	_____ 10	_____ 15	_____

Include \$2.00 postage & handling per title (\$3.00 outside U.S.)

Subtotal \_\_\_\_\_

California residents add 6.5% sales tax \_\_\_\_\_

Enclosed check or money order for total (U.S. funds) \$ \_\_\_\_\_

Name \_\_\_\_\_

Address \_\_\_\_\_

City \_\_\_\_\_

State \_\_\_\_\_

Zip \_\_\_\_\_

Mail to: MIX BOOKSHELF, 2608 Ninth St., Berkeley, CA 94710

Please allow 4 - 6 weeks for delivery.

World Radio History

Please write for our complete catalog of audio, video and music books.

—from page 83, **BONZAI**

**Freberg:** I learned it all the hard way, by not going to music school. Actually, I listened very carefully and I also had great teachers—Billy May and Judd Conlon. On "The United States of America" album I wrote the music and lyrics and Billy orchestrated it. He can write in any style, but he also writes with a sense of humor. He does shocking things and goes into totally strange keys for a great humorous effect. I wrote "Take an Indian to Lunch This Week" not just for the Indians. It's a satirical comment on the stuffed shirt liberals' patronizing of blacks, as well. Remember, I did this before the civil rights movement got going. Anyhow, Billy May, totally on his own, brought in the strains of "Dixie" at the end of this song. Brilliant.

One time I conducted the Omaha Symphony Orchestra for the world's first 6½ minute commercial. It was for The Butternut Coffee company and we didn't mention their name until the fifth minute. Billy rode back with me on the train and gave me 2½ days of lessons on the way. I can still see the two of us lurching back and forth with the baton.

**Bonzai:** "I've heard that you have plans to record some parodies of the music of the 70's and 80's . . ."

**Freberg:** I'm working on that album

now. I'm waiting for Rod Stewart to have another hit.

**Bonzai:** Why do you single him out?

**Freberg:** Because he's satirizable. He's one of the few singers today that has a recognizable style. And he and I have the same throat doctor. Dr. Kantor has his gold record on the office wall, which I thought was the least that Rod could do. I told Dr. Kantor that I didn't find his singing voice all that great and the implication was that I should have heard it before it got worked on. Stewart has terribly abused his voice—he must have nodes on his vocal chords the size of cauliflowers.

**Bonzai:** I hear you may mount a stage version of the USA album . . .

**Freberg:** Yeah, Burt Reynolds wants me to do it at his dinner theater in Florida for a six week run.

**Bonzai:** And you would appear in it as well as direct?

**Freberg:** I daresay.

**Bonzai:** Would you like to take it to Broadway after that?

**Freberg:** There's a strong possibility we might do that.

**Bonzai:** Donavan, do you plan to follow in your dad's footsteps?

**Donavan:** I think so, but I'm not really sure what I want to be. I suppose I want to continue to be an actor, but that's a shaky field to go into. If I don't

go into the industry I think I'll fall back on computers and become a scientist. I love computers.

**Freberg:** I don't feel that the schools today are very adequate. I think Donavan gets more out of watching Nova on TV than he does from going to three months of science classes.

**Bonzai:** Have you ever done any teaching?

**Freberg:** I taught a class in telecommunications at USC, but I had to rename the class. It used to be called "Broadcasting the Arts and Sciences" and I asked them what that meant. Nobody talks like that in real life. I said that Walter Cronkite wouldn't say to his wife, "Well, dear, I'm going down to CBS now and broadcast a few of the arts and sciences." I renamed the class "Freberg on Communications." I was an unorthodox teacher and did away with the finals. A couple of people from the class have gone on to become quite successful.

Stan Freberg is a loving father, the clown in the back of the media classroom, an impish eccentric, and a timely 20th Century joker. I hope that you were able to imagine his distinctive sarcastic drawl and his hypnotic leisurely speaking rhythms as you read of his exploits. ■



# TELEX®

## AUDIOCOM

### For Communications Behind The Scene

AUDIOCOM. The closed circuit intercom for small, large, portable or fixed installations at concerts, stage productions, film or TV studios, stadiums or race tracks, industrial or public safety applications. AUDIOCOM belt packs or wall mount stations can be "daisy-chained" by the dozens over five miles without degradation in signal quality or strength. AUDIOCOM interfaces with other sound systems and telephone circuits. AUDIOCOM includes headsets, mics, cables, switchboards, signalling kits, even battery packs for remote locations; the complete intercom system for communications behind the scene.

Quality products for the audio professional.



# TELEX

TELEX COMMUNICATIONS, INC.

9600 Aldrich Ave So., Minneapolis, MN 55420 U.S.A.

Europe: Le Bonaparte—Office 711, Centre Affaires Paris-Nord, 93153 Le Blanc-Mesnil, France.

Circle #078 on Reader Service Card

# Understanding the Audiophile

by David Wilson

To try to understand the audiophile merely by definition as "one who loves sound" is to be literally correct, but woefully inadequate in human insight. There are many folks out there who would, at least partially, fit the above definition, but are obviously not true audiophiles. For example, the pre-adolescent with a "bleacher buster" glued to his ear loves sound, or at least the rhythmic pulses of pain which assault his senses and the sensibilities of those around him.

Also never to be confused with the audiophile is the casual consumer of various and sundry electronic entertainment appliances. This is the guy who, when he gets a few disposable bucks, chooses to spend it on a stereo. Last year it was a large screen TV. Next year it will be a personal computer. He will derive from each acquisition a modicum of pleasure, and even utility. But an all-consuming, totally involving passion? Nope. In short, this is merely a consumer who buys whatever electronic bauble strikes his fancy at the moment. This is not to say that the size of the purchase is inconsequential, for it

may well run into several thousands of dollars. But the study, the weighing of options, the *involvement* in the selection of the system, were not a part of a life-long pursuit. What little research was invested in the purchase of the stereo probably came from a single issue of *Consumer Reports*, *Stereo Review*, *Playboy*, or any of a number of other rags, all of which are considered technically worthless by most audiophiles.

So what is an audiophile? He (or she . . . more women audiophiles all the time), is in love not only with the sound of music, but more specifically, the sound of the actual musical event—the presence, the sense of space, the dynamics of being there when it happened. The audiophile pursues this elusive goal, sometimes carefully and logically—sometimes intuitively and with almost careless abandon . . . but always with a hunger, a passion, a religious zeal. Among sophisticated audiophiles, the standard of accuracy is the sound of live, unamplified acoustic music. However, very well engineered and produced studio recordings can also work their

magic with the audiophile, but only under certain circumstances, as we will see.

How old are they? The age range of audiophiles is very wide, from around 15 up to the 60's and 70's; not too many "child prodigies" because those under 15 usually lack the discernment to appreciate the art of refinement . . . which is what high fidelity is all about. They also usually lack sufficient disposable income to realize any but the most modest of audiophile equipment fantasies.

A susceptible person becomes infected with acute audiophiliosis when he hears a sound system do sonically satisfying things he didn't think were possible . . . and he wants that for himself! It's a revelation of sorts, enlightening and thrilling, and (if you have the recessive audiophile gene) once you've experienced it, you want more and more and *more* of it.

So, once infected, the audiophile proceeds to seek out recordings and equipment which satisfy his cravings for more accurate tonal balance, clearer transient response, more lucidity of low level detail, and a more dimensionally

## The Author's Audiophile Habitat

The overall character of the listening room is slightly on the live side of neutral, but the reverberant field is symmetrical. Carpeting is wall to wall and the rear wall is almost completely absorptive. These factors contribute to a soundstage which is large and precise. The actual "focal point" of the system is located at a moderate low frequency null point.

The preamp, turntables, and smaller tape deck are located in an alcove which was custom-built to pro-

—page 98, *HABITAT*

(Right) David A. Wilson and his wife Sheryl Lee

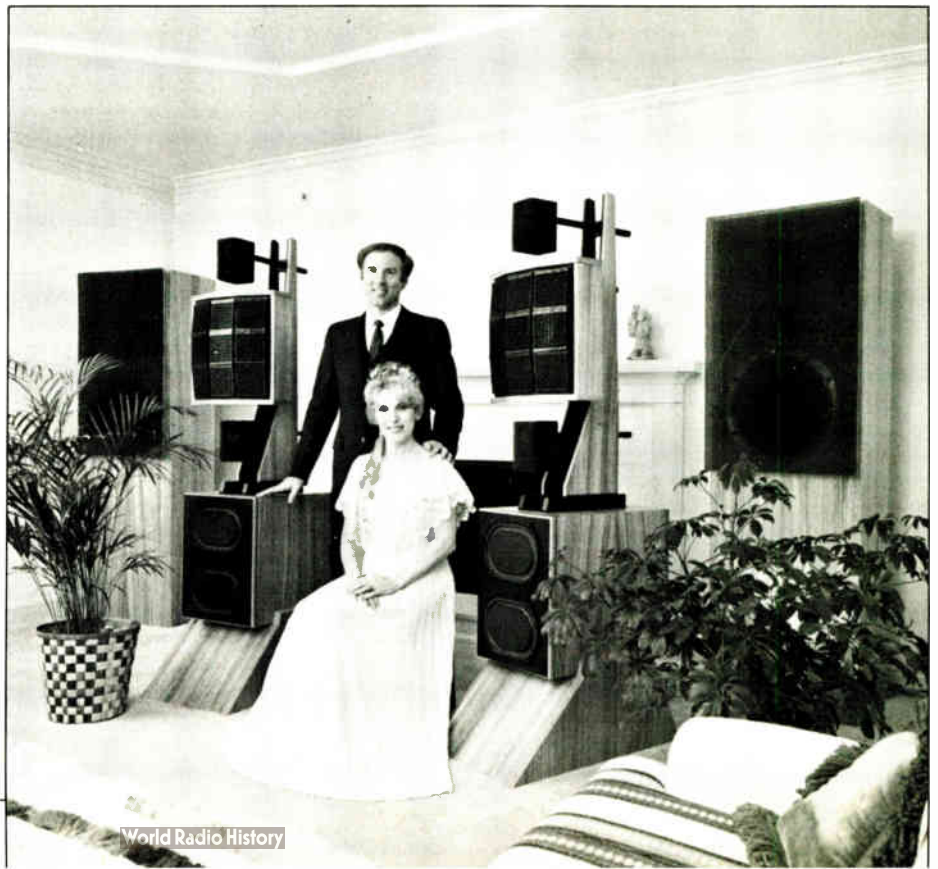

convincing sound stage. In short, he desires recordings which are more musically accurate and/or convincing.

With all of today's sophisticated technology, surely our audiophile is thrilled by countless state-of-the-art offerings from the recording industry. Ironically he is not, and therein lies a seemingly basic conflict between what the discriminating audiophile desires in a recording, in terms of accuracy to musical values, and what the studio recording industry feels it has to produce. There are enough *great* recordings extant to prove that the industry has the talent and the technology to satisfy the most fastidious listener. Yet the signal processing used to make a given recording sound reasonably spectacular on a trashed-out AM radio makes that same recording sound unbelievably bad on a decent component stereo system. Unfortunately some of these processing techniques have crept into the production of countless otherwise excellent recordings. The indiscriminately overprocessed record ends up being a sort of "sonic twinkie" . . . hardly palatable to someone accustomed to the haute cuisine of naturally spectacular-sounding recordings. The most serious and obvious victim of overprocessing is the recorded sound of the human voice. All too often it comes off as being over-bright, lacking in harmonic richness and warmth, with sibilants that can cut glass. As if these "signal processing excesses" weren't enough, most commercial records are pressed in vinyl of only moderately good quality . . . or worse. Noisy lacquers, hastily matrixed and sometimes carelessly pressed, result in records of grossly inferior quality. Produced and manufactured to sell cheaply and be acceptable only to the most indiscriminating consumers, the "standard release" further alienates the audiophile. In desperation, the audiophile seeks out higher quality imports and ultra-high quality "audiophile recordings".

Ironic, isn't it? And sad, because there is not another audience in the world which is as appreciative as the approximately 150,000 audiophiles in America, of the creative genius of those engineers and producers who understand and care. Audiophiles show their appreciation by buying great recordings. Oh, sure, they will make cassette copies of "OK" records, but audiophiles will not want to lose the quality of a great recording by making a cassette of it—they will buy the *great* record.

How does the audiophile judge quality in recordings and equipment? We've already alluded to a preference for "natural sounding" recordings, but what about equipment?

—page 88

## RECORD PLAYBACK EQUIPMENT WHICH IS POPULAR AMONG SERIOUS AUDIOPHILES

BRAND	CONFIGURATION	PRICE RANGE
<b>Phono Cartridges</b>		
Accuphase	Moving Coil (MC)	
	Jewel Cantilever (JC)	\$300-500
Denon	MC, Boron Cantilever (BC), Aluminum Cantilever (AC)	80-1000
Dynavector	MC, IC, AC	150-1500
Grace	Moving Magnet (MM), IC, AC	60-200
Grado	Moving Iron (MI), AC	15-500
Kilpsch	MC, IC, BC, AC	200-1000
Kiseki	MC, IC, BC	600-3500
Koetsu	MC, BC, IC	650-1300
Monster	MC, BC	500
Shure	MM, AC, BC	45-250
Stanton	MM, Induced Mag (IM), AC	40-250
Vanden Hul	MC, AC, BC	400-1300
<b>Turntables</b>		
Denon	Direct Drive (DD), Hard Rubber Mat	200-6200
Goldmund	Direct Drive	
	Acrylic Platter (AP), No Mat	2300-11,000
Linn-Sondek	Belt Drive (BD), Felt Mat	1000
Oracle	BD	
	Soft Rubber Mat	1000-3000
Sota	BD, Soft Rubber Mat	750-1250
Thorens	BD, Hard Rubber Mat	250-1750
<b>Tone Arms</b>		
Goldmund	Linear (L), Servo(s), R	2900
Grace	P, F, Removable Cart. Mount (R)	225-325
Linn Products	Pivoted (P), Fixed Cart. Mount (F)	200-650
SME	P, R	300-1750
Souther	L, R	850
Sumiko	P, F	1200
Syrinx	P, F	250-700
Technics	P, R	450
<b>Loudspeakers</b>		
Acoustat	Full-Range Electrostatic (FRE)	1300-5000
B&W	Staggered Cone (SC)	450-3500
Dahlquist	SC	400-1200
GNP	SC	350-1800
Infinity	Ribbon/Hybrid (R/H)	150-30,000
KEF	SC	300-2200
Magnapan	Ribbon/Hybrid (R/H)	475-3000
Pyramid	SC, R/H	370-1750
Quad	F-RE	1780-3310
Soundlab	F-RE	1200-6000
Spica	SC	420-600
Stax	F-RE	3100-5800
Theil	SC	350-1500
Vandersteen	SC	630-3000
WAMM	Electrostatic Tweeters SC Sub-Woofer	42,000
<b>Power Amplifiers</b>		
Acoustat	FET Class AB	1100
Audio Research	Vacuum Tube	2000-6000
Bel	Transistor Class A	1300-2400
Conrad-Johnson	Vacuum Tube	850-4350
Hafler	Transistor Class B	350-750
Krell	Transistor Class A	1800-6000
Mark Levinson	Transistor Class B	1750-6500
PS Audio	Transistor Class B	430-1200
Threshold	Transistor Class B	1300-3300
<b>Preamps</b>		
Acoustat	FET	800
Audio Research	Vacuum Tube	1000-3500
Conrad Johnson	Vacuum Tube	300-2850
Counterpoint	Vacuum Tube	500-1600
Denneson	Transistor, FET	500-3500
Hafler	Transistor	150-400
Mark Levinson	Transistor, FET	1250-6000
Spectral	FET	2400-3500

—from page 87

"Natural" or "accurate" would both be apt descriptors, but these adjectives tend to mean different things to different people. All of which brings us to a point of schism among audiophiles. When discussing the merits of a piece of equipment, audiophiles seem to become polarized into one or the other of two dichotomous "camps"—the "meter-readers" or the "golden-ears". Meter-readers believe that any phenomenon which is audible can be measured, quantized, and repeatedly demonstrated to a high statistical probability. Carried to excess, this attitude suggests "if it can't be measured, it doesn't exist." Golden ears believe that there are many audible phenomena which are not measurable but, nonetheless, important. It is not a simple matter of "objective" vs "subjective", just because one group is dealing in numbers and the other group in sensory perceptions. Both approaches have their validity, and have produced worthwhile contributions to the science and art of audio. The author's attitude is that, if a piece of equipment measures good and sounds bad, it is bad.

As was mentioned earlier, we are dealing with enthusiasts who derive great pleasure out of perceptive listening. And, like anyone who loves doing something, and does it a lot, some audiophiles become very skillful listeners. Many audiophiles will claim to hear things which seem incredible or preposterous to non-audiophiles. These perceptions, even more than published specs, tend to influence equipment purchasing decisions among audiophiles. Essentially, the total novice relies only on his ears, although he doesn't really trust them, and is ignorant of specifications. The beginning enthusiast relies primarily on specs, still not trusting his ears. Very experienced listeners tend to rely on, and trust, their own ears or the observations of trusted reviewers and critics. Most experienced audiophiles have developed a healthy skepticism of the relevance of many specifications. The most enlightened audiophiles understand how to interpret meaningful specifications. This, plus perceptive listening provides them with great insight and usually accurate observations.

Where do audiophiles turn for advice on equipment and recordings? Beginning enthusiasts, in the U.S., usually read only the commercial magazines such as *Stereo Review* (circulation est. at 400,000-500,000) or *High Fidelity*, primarily because of newsstand availability, breadth of scope and format (lots of color pics, attention to popular music, low cost equipment etc.). I would emphatically state that many readers of these magazines are not audiophiles. More experienced

audiophiles, i.e., those who have been burned a few times when they have bought equipment based only on measured performance reviews, become more selective in their reading. "High-end" audiophiles (i.e., serious audiophiles who tend to buy and trade expensive equipment) like investors, subscribe to private circulation newsletters and "underground" magazines for variety of opinion and depth of insight. These publications include *The Absolute Sound* (Sea Cliff, New York), *Stereophile* (Santa Fe, New Mexico), *International Audio Review* (Berkeley, California), *Sensible Sound* (Snyder, New York), and *High Performance Review* (Stanford, California). The only commercial U.S. publication widely read by the audio cognoscenti is *Audio*. These publications are often lively, controversial, and a very useful advance indicator of audio-equipment trends. Recording engineers would find them fascinating.

Audiophiles buy a lot of stereo equipment. The average amount spent is in the range of \$650-\$1,000 per year; high-end types spend considerably more than that. It is easier, believe it or not, to track buying preferences and their rationale among high-end audiophiles than among beginning enthusiasts, because the high-end uses sonic performance as the major consideration, whereas beginners prioritize price and features. The market is glutted with low-priced, feature-laden, mediocre equipment clones, but of greater interest and significance are the high performance offering of smaller firms.

Loudspeakers are the most conspicuous components of any system. Audiophiles are often willing to sacrifice very high SPL capability and very extended bass in order to achieve cleaner resolution of low level detail, accurate tonal balance, and more expansive sound stage performance. These qualities are not really mutually exclusive, it's just that it takes a lot of space and money to do it all. Typical studio monitor speakers, even though they are quite dynamic, are not popular among audiophiles because they are perceived as performing poorly in the above-mentioned sonic areas. Dipole radiators, such as full-range electrostatics, and various ribbon configurations, are popular as are some cone-type systems whose drivers are staggered to achieve alignment in the time domain.

Many audiophiles prefer the sound of tube power amplification to that of solid state. Fine quality tube units often render an extremely accurate mid-range harmonic structure and expansive soundstage (dynamic channel separation). Tube power amplifiers almost without exception, however, are

# NEOTEK

## USA

### East

Massachusetts  
Lake Systems  
617-244-6881

Pennsylvania  
Tek Com  
215-627-6700

### Midwest

Illinois  
Pyramid Audio  
312-339-8014

Wisconsin  
Flanners Pro  
Audio  
414-785-9166

Michigan  
HY James  
313-471-0027

### South

Tennessee  
Valley Audio  
615-383-4732

Florida  
Pro Audio  
General Store  
305-752-0330

### West

Colorado  
Listen UP  
303-778-0949

California  
Neotek West  
213-387-7999

California  
Recording &  
Broadcast Supply  
415-457-7566

Utah  
Trax Productions  
801-237-2435

## International

### Hong Kong

Today's Audio Company  
Telephone 5-412050  
Telex 60185 SRFEL HX

### Taiwan

Linfair Engineering  
Telephone 321-4455  
Telex 22563 LINFAIR

### Japan

Unicus Incorporated  
Telephone 662-8518  
Telex UNICUS J29440

### Greece

Omikron Corporation S.A.  
Telephone 363-7979  
Telex 219559 OMIK GR

### Italy

Scientel Audio  
Telephone 225608  
Telex 213687





# Sound

## Thinking

# NEOTEK

Joining aesthetics and technology.

Versatile and affordable audio consoles  
for recording, sound reinforcement and  
production applications.

Neotek Corporation  
1158 West Belmont Avenue  
Chicago, Illinois 60657  
Telephone 312-929-6699

Circle #079 on Reader Service Card

**ATTENTION MCI 500C/D OWNERS:  
Your mic-inputs will sound much better with  
the MPC-500C/MPC-500D mic-preamp cards!**

- **990 OP-AMP** offers higher slew rate and output current, lower noise and distortion, and better sound than stock 5534.
- **JE-16B MIC-INPUT TRANSFORMER** provides one-third the distortion, 15 dB higher input levels and better sound than stock JE-115-KE.
- **SERVO/DC COUPLING** eliminates coupling and gain-pot capacitors resulting in much better sound without DC offset problems.
- **ON-CARD REGULATION** eliminates the need for the MCI "swinging transistors." Reduces crosstalk and improves sound quality. And more!

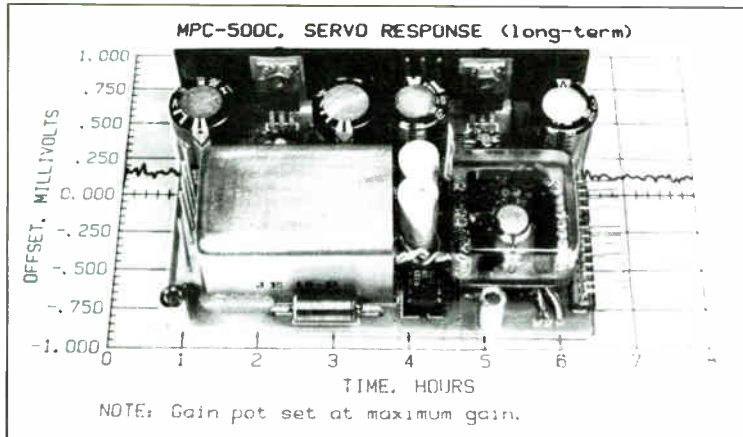

**THE HARDY CO.** BOX AA631 EVANSTON, IL 60204 (312) 864-8060

Circle #080 on Reader Service Card

# 40,000 MPH\*

\*40,000 MILES PER HEAD of tape travel — routine performance for Saki premium quality audio heads. We are the world's leading manufacturer of professional long-life audio and instrumentation heads. **Ask about our 2-track, 1/2 inch format.**

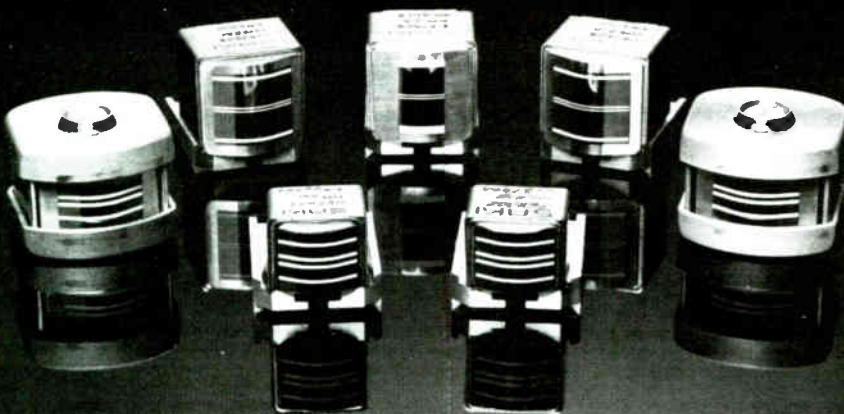

**SAKI SAKI MAGNETICS, INC.**  
A CALIFORNIA CORPORATION

8650 HAYDEN PLACE, CULVER CITY, CALIFORNIA 90230 (213) 551-1111 (TOLL FREE) (323) 6100

Circle #081 on Reader Service Card

underdamped in the low frequencies, slow in transient response and sometimes lacking in textural definition. They tend to be very forgiving of upper mid-range and high frequency grit and harshness. In contrast, many solid state amplifiers, particularly those which are biased class B or AB, which use electrolytic or tantalum capacitors in the signal path, and have small, high source impedance power supplies, tend to sound bright, thin, edgy, and lacking in soundstage specificity. Conscientious amplifier designers who use class B or AB biasing can, by paying close attention to the above and other details, produce exceptional sounding amplifiers. Class A amplifiers, properly executed, are (theoretically) the best solid state has to offer. They can be very smooth, yet detailed in the trebles. . . clean and dynamic. They are expensive and large because of the heat they must dissipate. In case you haven't noticed, the author firmly believes that different amplifiers, having similar published specs, can sound quite different.

To a certain extent, the same differences noted in the sound of tubes vs. solid state in power amps also hold true for preamps. The major qualifier, however, is that tube preamps don't usually have output transformers, so their sound is more purely that of the tube circuit itself. Bass can be quite extended and reasonably tight. Upper mid-range and trebles can be very linear, lucid and extended. Although their noise floor is high by solid-state standards, the author believes that the real glory of the tube is most apparent in preamp applications. The FET is (in its transconductance mode) the solid state analog of the tube, offering most of the tube's sonic strengths but with a very low noise floor. Can most audiophiles hear the differences between these circuit topologies? Yes. Can many audiophiles hear the sonic fingerprints of the recording and mastering chains used to produce today's records? Yes!

What about the pickup system? The most popular audiophile cartridges are those which exhibit a fairly fast transient rise-time (5 u sec to 12 u sec on the CBS STR 112 test record), portray a good soundstage, and preserve dynamic contrasts. This usually means a moving coil design with either a jeweled, boron or beryllium cantilever, and a hyper-elliptical stylus. A great deal of attention is currently being focused by the audiophile on the linearity of mechanical transmission and subsequent damping, of vibrations by the stylus cantilever, cartridge body, arm-tube, bearing mechanism, turntable, mat/platter system, and turntable

—page 146, *AUDIOPHILE*

# Audiooptics

## Techniques and applications in the next generation recording studio

by George A. Bowley  
Audioptic Technologies, Inc.

Can you envision a recording studio without electricity and wires???—where musicians are playing optic guitars instead of electric ones?—where there are no ground loop problems because there are no cable shields to cause them?—where there are no electrical interference or hum problems because the “wires” are made of glass?

The next generation recording studio may very well use light instead of electricity to create music; to transfer and process audio signals, and even to produce the final master recording. Amidst the current preoccupation with digital recording, enhanced signal processing techniques and evolving video markets, the recording community has not yet recognized a new technology knocking at the studio door; waiting to be let in. Its concepts are new and its application in the recording environment (and audio media in general) are revolutionary.

This technology is called Audiooptics—a term created by the author to describe the integration of the principles of audio engineering with the science of optics to effect improvements in the way we reproduce sound and transmit audio signals. Light has not been previously con-

sidered as a viable replacement for electricity because there has been no practical way to harness it. However, with the advent of optical fibers, which channel light down tiny “light pipes”, it is now possible to contain and manipulate light in many of the same ways we now process electrical signals. In fact, fiber optic communication links have now been perfected to the point where they are now com-

monplace in a number of commercial and military systems; including possibly your own telephone. More recently, it has been discovered that optical fibers can be used to detect vibrations, acoustic pressure, magnetic fields, electrical current, rotation and other energy fields—creating a new realm of optical sensors.

—page 93

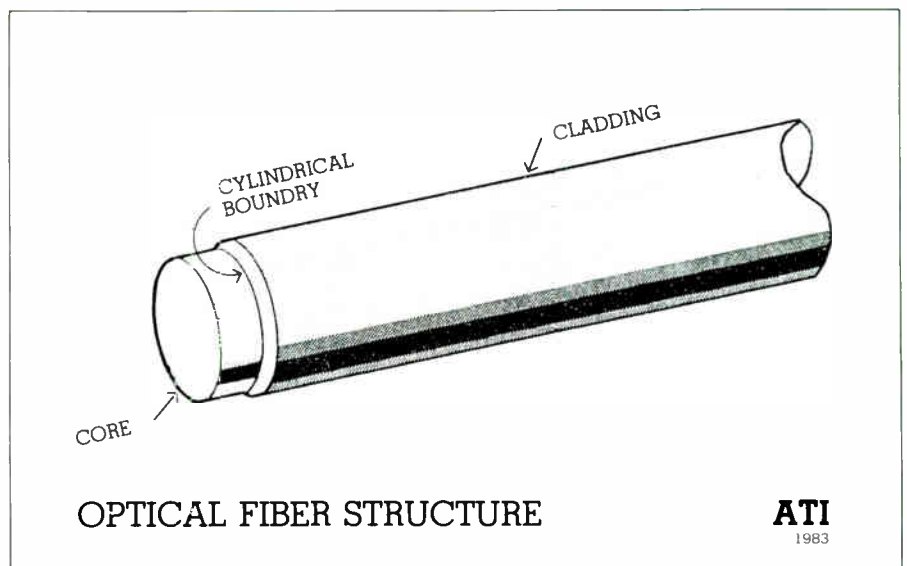

Figure 1

There is no power amplification system like the SPECTRA SONICS Model 701. As the most complete power amplification system available, the 701 Power Amplifier may be employed with measureable improvements in performance, expandability, reliability, and serviceability.

#### A POWER AMPLIFIER PERFORMANCE BREAK-THROUGH

The performance of the 701 Power Amplifier is second to none. Extremely low noise and distortion are only a part of the 701's exceptional performance characteristics. Amplifier overload due to audio program peaks are virtually eliminated by the 701. Recovery time for up to 1000% peak overload is less than one microsecond, resulting in higher sound pressure levels when operating on audio program material. Even with two ohm loading stability is not a problem with the 701. The amplifier is unconditionally stable, thus preventing thermal "avalanche" of the amplifier.

**GET THE WHOLE STORY**  
SPECTRA SONICS has, for your convenience, published a comprehensive brochure on the 701 power amplification system. The brochure fully explains the benefits that can be realized with the use of the 701 power amplification system.



# The Complete Amplifier

**SPECTRA SONICS** 

3750 Airport Road Ogden, Utah 84403 (801) 392-7531

Circle #082 on Reader Service Card

© 1983 Spectra Sonics

Audiooptics takes advantage of the many performance improvements afforded by these fiberoptic sensor and communication concepts to eliminate the many problems present in audio systems today—such as induced noise and hum, cable attenuation, frequency response constraints, nonlinearity and electrocution hazards. However, before we get into a discussion of how audiooptics can be applied in the next generation recording studio and how it can be used to improve system and signal performance, let's take a brief look at how an optical fiber works, and how it is used in the three major functions of audiooptic technology: Fiberoptic communications; fiberoptic sensors and optical signal processing.

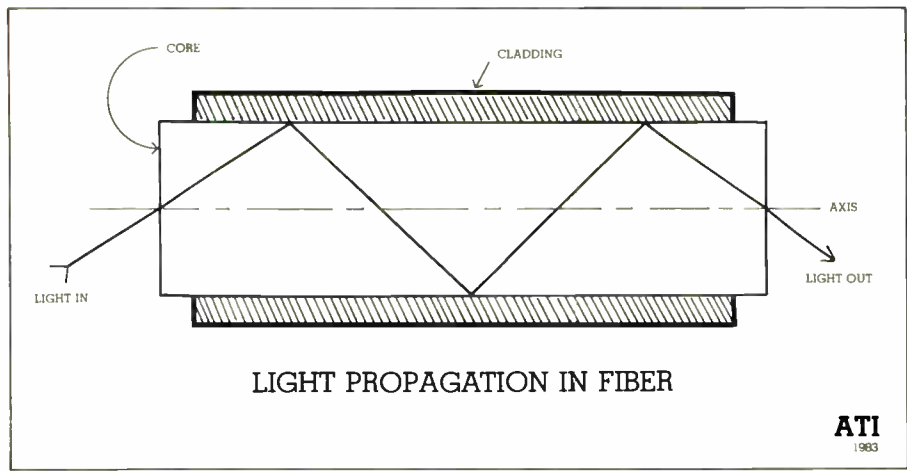

Figure 2

### Optical Fiber

An optical fiber is not a hollow glass tube as some would suspect, but a thin strand of two concentric glass materials, as shown in Figure 1. The two glasses differ in that one glass allows light to travel at a speed slightly faster than the other glass. They are said to have "different indices of refraction". The inner glass (the "Core"), and the outer glass (called the "Cladding"), form a cylindrical boundary where they meet which runs the length of the fiber.

A law of physics (Snell's Law) states that, when light hits such a

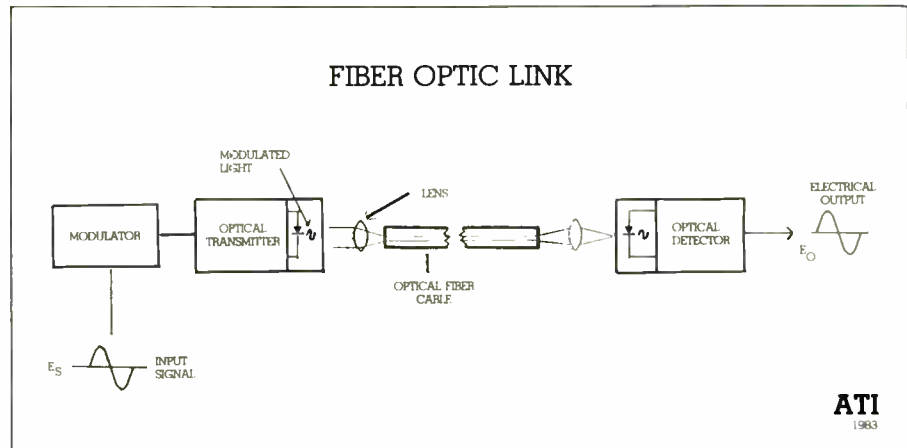

Figure 3

## PULSAR LABS, INC.

### Matrix Mixing Consoles

## NOW AVAILABLE WITH 5-BAND SWEEP EQ

### 80 SERIES SPECIFICATIONS & FEATURES

<p><b>INPUT</b></p> <ul style="list-style-type: none"> <li>Active balanced line in (XLR)</li> <li>Stereo 1/4" balanced line in</li> <li>Line/mic switch</li> <li>Phase reverse switch</li> <li>High pass filter</li> <li>EQ in/out switch</li> <li>Mute switch</li> <li>Variable gain (45 dB)</li> <li>Two monitor sends</li> <li>Two effects sends</li> <li>Direct out (1/4")</li> </ul>	<ul style="list-style-type: none"> <li>Access in &amp; out (1/4")</li> <li>3 level 3 LED</li> <li>Cue send</li> <li>100 mm fader</li> </ul> <p><b>EFFECTS</b></p> <ul style="list-style-type: none"> <li>Two individual effects modules</li> <li>5 band EQ dual peak reading meters (effects &amp; monitors)</li> <li>Access in/out on effects &amp; monitors</li> </ul>	<ul style="list-style-type: none"> <li>Cue send</li> <li>100 mm fader</li> <li>Effects may be switched into the matrix</li> <li>LED metering on effects &amp; monitors</li> </ul> <p><b>TALKBACK</b></p> <ul style="list-style-type: none"> <li>Priority interrupt cue system</li> <li>48 volt phantom power</li> <li>Dual stereo headphone jacks</li> <li>LED dual peak reading meter on cue</li> </ul>
		<p>Extensive headphone monitoring</p> <p><b>FEATURES</b></p> <ul style="list-style-type: none"> <li>Totally modular - no point to point wiring</li> <li>Active gain stages for low noise and extended dynamic range</li> <li>5 band graphic or parametric EQ</li> <li>Total patching through access in/out on all modules</li> <li>Solid oak frame/steel sub-frame</li> </ul>

PULSAR LABORATORIES, INC. 3200 GILCHRIST RD. MOGADORE, OHIO 44260

216/784-8022

Circle #083 on Reader Service Card

power

PROFESSIONAL  
AUDIO MIXER  
MPA 801

power



DEALER  
INQUIRIES  
WELCOME

Power audio products represent the joint efforts of European craftsmanship and American design talents.

MPA 801 answers problems created by competitive music mixers!

3 phono inputs each with dual RCA jacks  
These inputs can convert to microphone via front panel switches  
Separate mono 1/4" phono jacks provided for microphone mode.

2 auxiliary controls  
each auxiliary control selectable to 2 stereo inputs  
full mixing of any 2 of 4 stereo line level sources.

FULL 3 BAND EQUALIZATION OF PHONO / MIC AND AUXILIARY INPUTS  
MONO/STEREO OPERATION FRONT PANEL SELECTABLE  
STEREO LEVEL DISPLAY MONITORS MIX BUSS.

2 microphone mixing controls  
talk over provisions from both  
2 band microphone equalization  
record out excludes microphone mix.

FULL POWER BANDWIDTH AT RATED OUTPUT  
SIGNAL PROCESSING LOOP STANDARD.

POWER MPA 801 in any MUSIC MIXING system provides the features most requested by demanding D.J.'s. Attention to signal path electronics results in music reproduction which is best described as "transparent". To those who understand, the MPA 801 will reproduce a 20 KHZ sine wave at + 20 dbm with no slewing or TIM distortion.

power  
ALAGATRONICS INC. NYC

141 FIFTH AVENUE 10010 - Phone 212 473 0515  
NEW-YORK CITY

Circle #084 on Reader Service Card

boundry of materials with different indices of refraction at a small enough angle, the light will be totally reflected back off the boundary. In the case of an optical fiber, any light entering one end of the fiber will continue to reflect off the cylindrical boundary and propagate within the inner glass core down the length of the fiber. The light then exits the other end as shown in Figure 2. Optical fibers can be as small as a human hair or as big as a pencil lead, depending upon their intended use and desired optical properties.

### Fiberoptic Communications

In 1970, researchers at the Corning Glass Works discovered that light attenuation in glass optical fibers could be reduced from 1000 dB/kilometer to less than 20 dB/kilometer, and the communications industry started to seriously consider fiberoptics as a viable alternative to more costly wire systems.

A light source, such as a laser, Light Emitting Diode (LED) or other source, is modulated by the analog or digital information to be transmitted. The modulated light travels down the length of the fiber as illustrated in Figure 3. When the light exits the fiber at the other end, it illuminates a detecting device such as a phototransistor or PIN diode, which converts the varying light back to an electrical signal for subsequent reproduction.

During the past ten years, significant improvements have been made in fiberoptic communications systems. Light attenuation in the fiber has been reduced to under 1/2 dB/kilometer and more sophisticated fiberoptic transmitter and receiver devices have been perfected. Fiberoptic systems have replaced a number of major telephone trunk lines, and are now being used to interconnect computers and cable television systems.

### Fiberoptic Sensors

The mechanics involved in the propagation of light within an optical fiber have been greatly simplified for the purposes of this article, and there are a number of other physical and optical parameters involved. All these factors result in a system operating in precise equilibrium: that is, the light exiting the fiber is essentially equal to the light entering the fiber; less any losses due to connections and other intrinsic optical losses.

If any parameter of this light-propagating system were changed; such as altering the index of refraction of one of the glasses, or causing a discontinuity in the core/cladding glass boundary, the system equilibrium can be tipped off-balance causing

## eastcoast sound specialties



Let us help you design a complete 8 track studio for under \$3000 complete with 8 track machine, mixer, noise reduction, monitors and amplifier.

We carry all major brands including:

**Technics, Ampex, Audioarts, Ashley, Itam, Fostex, Otari, Tascam, Urei, Orban, AB, Crown, BGW, TMS Studiomixer,**

**Deltalab, Eventide, Lexicon, Symetrix, Master Room, Ramsa, DBX, Aphex, Audio Technica, EXR, Senheiser, AKG, Speck, Community, NEI, Sound Tracs, Synergy and more.**

#### FAMOUS PRICE GUARANTEE

Eastcoast Sound guarantees the absolute lowest prices anywhere. If you can beat our price on any system within 30 days after you purchase, we will refund to you the difference.

40 Main St. • Danbury, Ct. 06810 • (203) 748-2799

Circle #085 on Reader Service Card

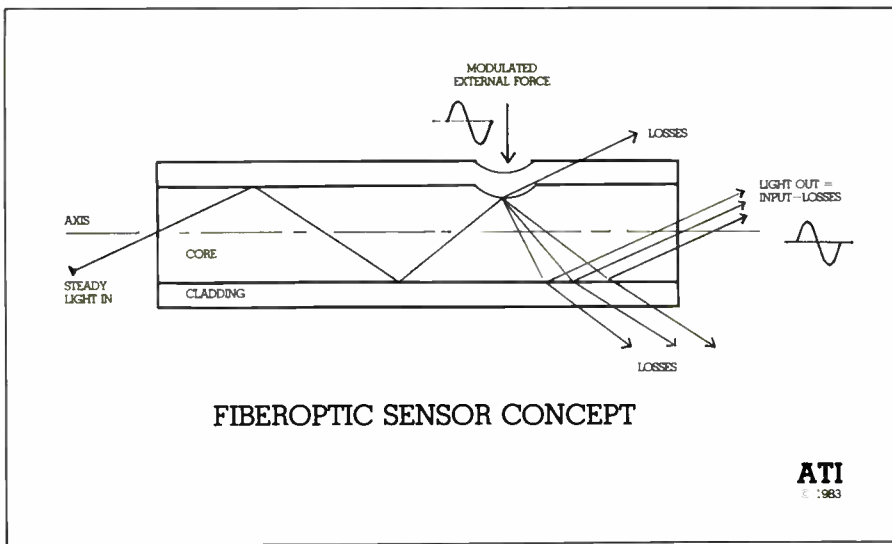

Figure 4

light losses within the fiber before it exists the other end, as shown in Figure 4. It has recently been shown that a number of different energy fields acting upon a fiber's surface (such as pressure, acoustic waves, and magnetic fields) can modify the physical characteristics of the fiber and cause some light to be lost. The net effect is that the light traveling down the core is modulated in direct proportion to the variation of that ex-

ternal field. The fiber therefore acts as an extremely sensitive sensor of external energy.

### Optical Signal Processing

Optical signal processing involves the modification of a particular signal to another desired state while such a signal is still in the form of light. As with electrical processing, the intensity, phase and frequency spectrum of an optical signal can be

altered to achieve specific qualities and effects. One obvious method is to insert devices in the path of the light; such as a density or polarization filter which can alter the amount of light that passes. Passing light through diffraction gratings, slits and prisms can separate the optical path into various wavelengths. Lenses can concentrate, diffuse and route light in different directions.

More esoteric optical signal processing techniques involve the use of Liquid Crystal Displays (LCDs) used as variable filters, masks, photographic negatives and other apertures in conjunction with optically sensitive surfaces and devices such as Charge Coupled Devices (CCDs) to alter the nature of the optical signal. Frequency spectrums can be changed; phase relationships altered and other special effects (such as tremolo, vibrato, flanging, pitch transposition, etc.) can be created in the optical domain. Optical modulators can heterodyne signals to create multi-channel paths, and optical switches on chips the size of an integrated circuit can route these signals to any desired location.

### Audiooptics

What do these basics of fiberop-

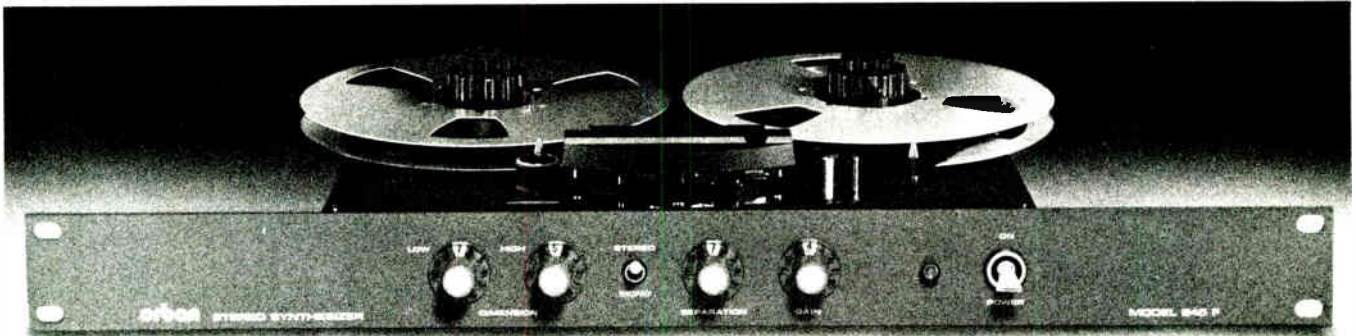

## Introducing the 5th (9th, 17th, or 25th) track.

Orban makes an amazing little device that greatly expands your multitrack capabilities. Our new 245F Stereo Synthesizer uses a patented technique for processing mono tracks into pseudo-stereo during mixdown. So you can save tracks by recording instruments like drums, strings, synthesizer, organ, horns, or electric guitar in mono, and then expanding them into convincing pseudo-stereo during the mix rather than taking two tracks.

The 245F is particularly useful in processing *intrinsically* mono sources—like many electric and electronic instruments. And unlike many other ambience-generating techniques, our stereo synthesis is completely mono-compatible: There's no phase cancellation or comb-filtering when the stereo channels are summed.

For \$399, you won't find a better, more cost-effective way to save tracks and get more on your master. Call or write for details.

**orban** Orban Associates Inc. 645 Bryant St.  
San Francisco, CA 94107 (415) 957-1067  
Telex: 17-1480

Circle #086 on Reader Service Card

tic communications, fiberoptic sensing and optical signal processing have to do with the next generation recording studio? Answer: they all comprise a new technology—audiooptics—that combines these optical capabilities with the needs of audio systems; developing applications which improve performance and minimize problems inherent with counterpart electrical methods.

For example, fiberoptic communications systems can replace almost all studio audio signal paths; with plastic/glass fiberoptic cables directly replacing common audio cables. There would be no more frayed cable shields that pull out of connectors; no more grounding problems or looking for that elusive loop that is humming the monitors off the wall; no more zaps and electrical shocks because there are no metal connections involved; no more worries about radio frequency interference, dimmers, static or any other external noise sources since light is not affected by electrical phenomena. Frequency response constraints imposed by the low-pass filtering effects of coaxial audio cables would be eliminated because an optical fiber has a linear bandwidth up to 20-400 *mega*Hertz! In addition, very long audio transmission paths can be supported due to the low signal attenuation factors of optical fibers and their insusceptibility to induced noise.

Fiberoptic sensors can be used to sense vibration and acoustic pressure, which makes them attractive replacements for microphones, musical instrument pickups and sound monitors which presently employ elec-

tromagnetic, capacitive and piezoelectric principles. An optical fiber senses in a linear fashion; that is, it has no low and high end drop at the end of the audio frequency spectrum, and therefore eliminates any non-linear characteristic particularly experienced in capacitive and inductive pickup devices. A fiber is geometrically flexible and can be configured in a number of shapes from planar (flat) to spherical designs to fit various physical configurations.

Optical signal processing allows us to perform equivalent sound modification functions with light; heretofore only accomplished electrically. Primary console functions can be executed through optical switches, optical summing units (mixing), optical mask transforms (EQ), optical modulators (channel routing) and other applications of optical technology. Mask and modulation techniques can also be used to generate other special effects such as phasing, tremolo, vibrato, delay, pitch transposition and the like.

### The Next Generation Recording Studio

Armed with a basic knowledge of audiooptics, let's walk through the hypothetical scenario shown in Figure 5, to illustrate some potential applications of optical devices in a recording studio environment.

Musicians are assembled in "Studio A" for an optical recording session. One guitarist is playing a fiber optic guitar, using strings made of optical fibers instead of steel strings. When its fibers (strings) vibrate, they modulate the light inside the core;

creating an optical musical signal without the need for magnetic pickups (See "The Fiber Optic Guitar" by George Bowley; Audio Engineering Society Preprint #1828 G-3). A second guitarist has fiberoptic vibration sensors attached to various parts of his acoustic guitar.

The acoustic guitar pickup outputs are optically mixed within the instrument to create a composite musical signal, representing the instrument's total harmonic content. The piano, drum set and other instruments also contain built-in or externally attached fiberoptic sensors, eliminating some of the need for external miking. These sensors are extremely flexible and can be molded in different shapes to fit in various places inside each instrument to reproduce a wider range of harmonics.

The optical output of each instrument feeds into its own fiberoptic cable, eliminating the need for electrical audio cables and noisy connectors. All cables plug into a fiberoptic snake which either mates each signal path with a multi-fiber cable trunk routed to the control room, or optically multiplexes the signals onto a single fiber buss line.

Vocalists are singing into fiber optic microphones which are, again, sensors geometrically configured to enhance specific pickup frequency and directional requirements. Some microphones are built with fiberoptic intensity modulation sensors, which vary the amplitude of the light in the fiber core. Other microphones are designed with interferometric fiberoptic sensors which detect the very small changes in the phase of the light. These phase microphones are so sensitive that they could pick up a fly's footsteps. Both microphone types also use fiberoptic cables to transmit the "optical vocals" to the control room.

Special fiberoptic headphones worn by each performer are fed by optical cables from an optical monitor buss coming from the control room. These optical signals are demodulated within the headset by tiny battery-operated photodetectors.

Ambience microphones are not readily seen when entering the studio. They are imbedded in the studio walls and ceiling in the form of hundreds of feet of optical fibers which pick all sounds impinging on these surfaces. The composite optical output of these imbedded fibers therefore represents the total "sense" of the room's characteristics, impossible from employing point sensors at various locations, or by using several overhead microphones to detect a portion of the room's airborne sound. This output can be used as an addi-

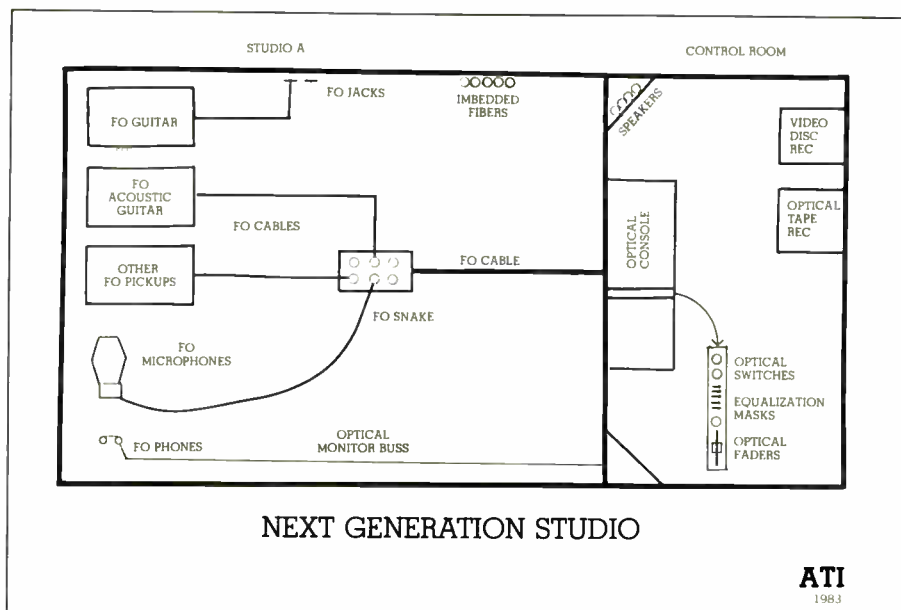
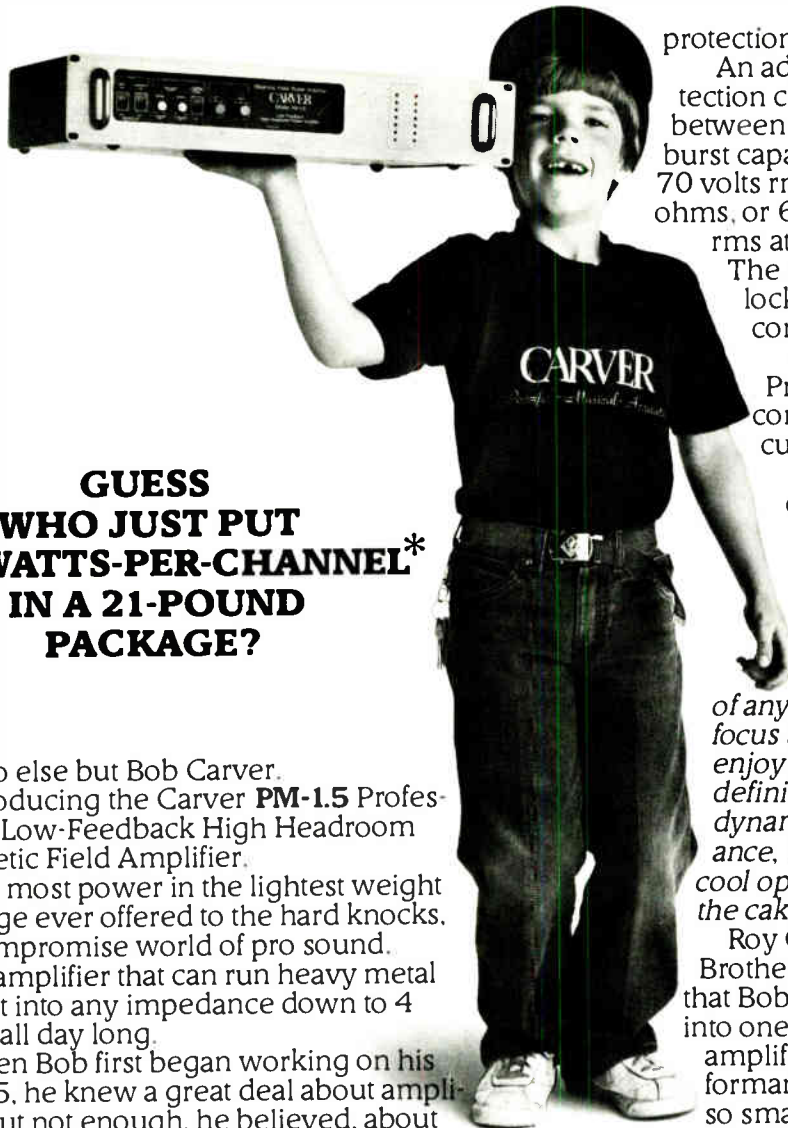

Figure 5





**GUESS  
WHO JUST PUT  
450 WATTS-PER-CHANNEL\*  
IN A 21-POUND  
PACKAGE?**

Who else but Bob Carver. Introducing the Carver **PM-1.5** Professional Low-Feedback High Headroom Magnetic Field Amplifier.

The most power in the lightest weight package ever offered to the hard knocks, no-compromise world of pro sound.

An amplifier that can run heavy metal flat-out into any impedance down to 4 ohms all day long.

When Bob first began working on his PM-1.5, he knew a great deal about amplifiers but not enough, he believed, about the night-in night-out requirements (and wish dreams) of the pro sound world. And so he spent much time consulting with a large number of sound reinforcement professionals, including the "pros' pro," Clair Brothers.

Clair Brothers asked for lower input ac line current, greater transformer thermal capacity, dual modes of precision balanced inputs with 1% resistors, back-to-front cooling with a fully proportional fan system that can just tick over at idle or blast 1000 ft/min. to keep output transistor temperatures constant. They wanted greater noise immunity and unbelievable long-term, high-power operation, as well as a 3/16" front panel with deep-recessed controls.

Others wanted rear rack-mounts, adjustable protection circuit thresholds, front panel selectable clipping eliminator, and even a sequential, soft-start power-up mode.

Now that the PM-1.5 has undergone thousands of lab test hours and seven months of hard road testing, Clair Brothers, Bob, and you get all that and more.

The PM-1.5 is designed to run balls-to-the-wall, even into 4 ohms day and night without compromising itself or your drivers. Because the PM-1.5 has three special adjustable speaker

protection circuits.

An adjustable Short-Term Speaker Protection circuit adjusts dynamic headroom between 60 and 77 volts with a short term burst capability of 70 volts rms at 8 ohms, or 60 volts rms at 4 ohms.



Front-panel adjustable protection circuits.

The circuit locks-in to the control setting after 0.5 seconds.

An adjustable Long-Term Speaker Protection circuit matches the time constant of the output shutdown circuit to your PA or monitor system.

Finally, the Clipping Eliminator detects clipping lasting longer than 30 milliseconds and attenuates the input signal just enough to pull the PM-1.5 out of clipping.

As for sound quality, consider this quote from **The Audio Critic Magazine**, "... the equal of any power amplifier in transparency, focus and smoothness. We especially enjoy hearing spatial detail, instrumental definition and completely natural dynamics. At this level of sonic performance, the astoundingly small size and cool operation become icing on the cake..."

Roy Clair and Ron Borthwick of Clair Brothers said it this way, "We are amazed that Bob was able to put the same wattage into one-fourth the volume of conventional amplifiers without sacrificing audio performance. It's hard to believe that an amp so small and lightweight can put out so much clean power. But it does!"

Whether you run a megawatt sound company, a struggling bar band, or a recording studio gearing up for digital, the PM-1.5 will pay you. In increased portability and reduced freight costs. In freedom from expensive blown drivers. In sheer sonic excellence.

Write for a detailed brochure today or give your local pro store no peace until they order you 21 pounds of pure power.

\***Power:** 8 ohms, 450 watts/chan, 20 Hz-20 kHz both channels driven with less than 0.1% THD. 4 ohms, 600 watts/chan, rms 20 Hz-20 kHz both channels driven with less than 0.1% THD. 16 ohms, 300 watts/chan, 20 Hz-20 kHz both channels driven with less than 0.1% THD. 2 ohms, 525 watts/chan, at clipping, 1 kHz, with less than 0.2% THD. Note: 2-ohm specification for information purposes only. Operation at 2 ohms is permissible but not recommended. **IM Distortion:** Less than 0.1% SMPTE. **Frequency Response:** -3 dB at 3 Hz, -3 dB at 80 kHz **Damping:** 200 at 1 kHz **Gain:** 26 dB. **Noise:** Better than 115 dB below 450W A-weighted **Input:** Balanced to ground, XLR or phone. **Impedance:** 15k-ohm each leg, balanced to ground **Bridging:** 1200W into 8 ohms, 1000W into 16 ohms, accessed through rear-panel recessed switch. **Dimensions:** 19 in wide, 3 1/2 in high, 10 13/16 in deep. Weight: 21 lbs.



**CARVER**

(206) 483-1202 P.O. Box 664 Woodinville, WA 98072

—from page 86, *HABITAT*

vide equipment access and effective cable routing. The turntables rest upon a surface of Gibraltar-like solidity. All windows are double thermopane and overlook a quiet valley in Marin County, California. Ambient noise levels are quite low.

The reference speaker is the Wilson Audio Modular Monitor (WAMM), driven below 55 Hz by the Brown Electronics BEL-2002 100w/chan, class A amplifier, and above 55 Hz by two Krell KMA 200A (revised) 200 watt mono class A power amplifiers. Four separate 30 amp circuits were wired to the listening room to provide adequate current capacity for the power amplifiers and isolation for remaining components. Monster Powerline II speaker wire connects the Krells to the WAMM full-range arrays. Vampire wire connects the BEL to the sub-woofers. The 55 Hz electronic crossover is part of the WAMM system. The reference preamp is the Spectral DMC-10 Beta. Voltage step-up and impedance matching are accomplished using a John Curl custom FET headamp. All interconnects in the system are Monster "Reference" balanced-bandwidth.

Two phono pickup systems are used: the Goldmund Studio with Goldmund T-3B arm, and an Oracle Delphi with a modified EPA-100 arm. Several cartridges are used, including the Accuphase AC-2 (in the Goldmund), van den Hul Type I, Kiseki Blue, Kiseki Agaat, Dynavector 17-D and monster Alpha I. All are moving coil types. The reference headshell is the Orsonics.

We employ two tape recorders for recording and evaluation purposes. The Revox A-77 MK 4, 7½ and 15ips half-track, ¼ inch recorder (Wilson-modified) has been with us for years, and has produced over a dozen records. Our "big" machine is the Ultramaster.™ The Ultramaster's transport is a Studer A-80 RC MK II, 15 and 30 IPS, half-track, ½ inch analog recorder. A custom-built low inductance record head is used. Record and playback electronics, using a custom R/P equalization, are totally custom-made by John Curl using all specially selected high speed devices.

With the advent of a fine FM program in the Bay Area hosted by John Sunier, I now have reason to own a high performance FM tuner. For this purpose a Tandberg TPT-3001 is used in conjunction with a Finco FM4g antenna with rotor system. ■

—from page 96, *AUDIOOPTICS*

tional signal source, or as a reference signal to "tune the mix" during mastering. The imbedded fibers can be installed in sections and shaded (areas of varying fiber density). Then, using optical beamforming techniques, directionality can be detected and controlled for stereo enhancement or other mixdown purposes.

So far, electricity has not been used at all in the recording process (except for the demodulation process in the performer's earphones). Instrumentalists may want to parallel their instruments with outboard amplifiers and other electrical devices, but since primary optical signal paths are unaffected by any electrical phenomena, peripheral electrical equipment will not induce noise into the program material.

Signals from the studio pass into the control room either via the fiberoptic cables, or via special fiberoptic connectors mounted on the studio walls. The optically multiplexed signal line is then decoded and routed to respective channel module inputs in the mixing console. Optical switches perform inter-console routing. Signals are split or combined by optical couplers and lenses. The faders are actually optical attenuators which vary light intensity through variable density filters, polarization techniques, interferometric balancing or other methods.

Equalization is accomplished by introducing variable or predetermined masks into the optical path (mentioned previously) or other Fourier Transform devices which alter the frequency spectrum as desired. In this hypothetical recording session, the recording engineer has placed slides #23, 46 and 92 into the optical EQ reader of each submaster module to set up the desired overall system frequency response. He has also inserted mask slide #14 into channel 3's module to provide 10 db of optical attenuation at 200 Hz to get rid of an instrument resonance. Three other EQ knobs on each module vary other optical mask parameters to provide variable spectrum transform functions on each channel.

Outboard optical devices are patched in when needed to provide special effects. Optical phase shifters are employed to create the usual flanging effects, vibrato, delays and pseudo-stereo signals. Variable density filters act as tremelo devices. Variable frequency masks can provide specific frequency spectrum effects. Optical saturation units can serve as limiters and compressors without problems of electrical transients and non-linear response.

The mixing console produces a

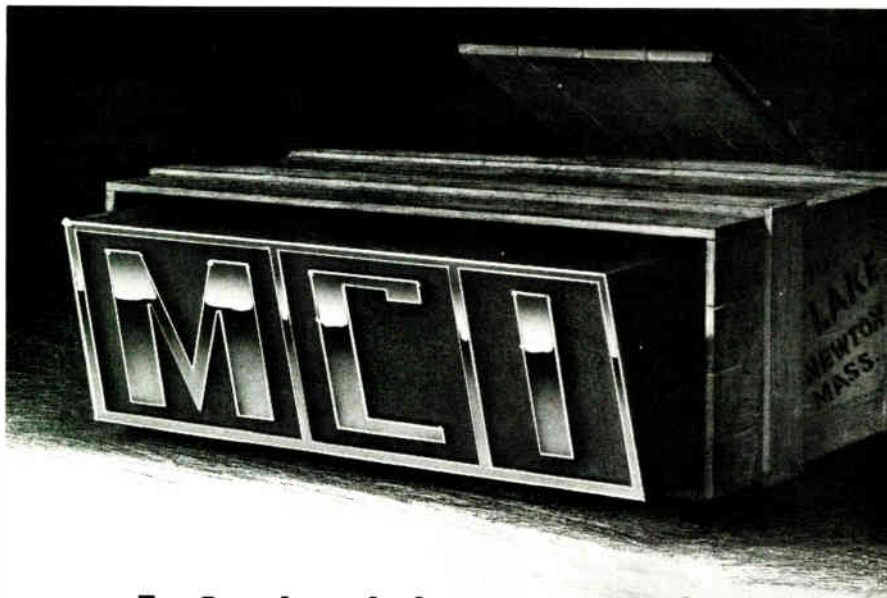

## Lake is giving you a line.

**MCI/Sony is now at Lake.** New England's largest audio/video dealer has just added the complete line of MCI/Sony tape recorders and consoles to their list of carefully selected products for the professional. Lake's service, engineering and design

**LAKE**  
LAKE SYSTEMS  
CORPORATION

capabilities are there to serve you whether you need a microphone or a full turn-key system.

Call the pro audio people at Lake Systems Corporation, 55 Chapel Street, Newton, Massachusetts 02160 (617) 244-6881. Leasing plans are available.

Circle #088 on Reader Service Card

composite optical signal output which is sent directly to an optical recording head without the need for recorder electronics, equalization and other circuitry. If magnetic recording tape is the storing medium, the optical signal can be converted to a magnetic field and transferred to the tape. In another system, the optical signal can be directly used to expose the photoresist of a video disk which, when etched, will provide a master for quantity production of disks for optical laser playback systems. There are no noise reduction units in this system because noise is at a minimum already!

Unfortunately, nothing is perfect. Current technology does not yet provide for a reverse process whereby light in a fiber can be converted back into a high power audio signal. That is, there is no "fiber optic amplifier" or "fiber optic speaker" from which one can "hear" the light from the fiber. Therefore, there is a point in the studio monitoring process where the fluctuating optical signal must be detected by a photodetector; converted back to electricity and processed by a power amplifier and monitor speaker in the normal fashion.

However, fiber optics can still play a significant new role in the studio monitoring process to optimize the quality of the mixdown. In our scenario, for instance, optical fibers can also be imbedded in the control room walls and ceiling to detect the intensity and phase of all of the sound emanating from the monitor speakers. This sensor output can then serve to establish (and help correct) the stereo balance and equalization of the mix from a total room aspect. Optical fibers sewn into the monitor speaker grilles can act as control sensors to monitor and adjust speaker amplitude and phase balances and directional characteristics.

## State of the Art

The fiber optic communications aspects of the optical studio scenario are well within the existing state of the art, and quantum improvements can be effected today in audio communication. Fiber optic sensors are also a reality (as is my Fiber Optic Guitar and follow-on instrument pickups). Much fiber optic sensor research is still ongoing within the military and industry, but a sufficient number of prototype devices have been built and employed which prove the feasibility of their application within environments such as the recording studio. Postulated signal processing applications are a little more esoteric and, although backed-up with current scientific research, it may take awhile longer to implement some of

these concepts in the consumer marketplace—but it's on the lab bench and on the way!

Audiooptic Technologies, Inc., is in the process of developing a number of audiooptic devices which have been conceptually described in this article; not only for recording studio application, but also for music, broadcasting, sound reinforcement, consumer electronics and audio-visual markets as well. It is hoped that this article has stimulated the reader's interest and that, together, we can provide mutual audiooptic contributions to the next generation recording studio. ■

George Bowley is President of Audiooptic Technologies, Incorporated (ATI), and owner of SYNC Records and Three E11 Music Publishing Companies. George is an electronics engineer and professional guitarist who has been involved in various aspects of the music, broadcasting and recording media for over thirty years. He is currently directing research and development of optical designs for application in the audio media, and welcomes further inquiries into the field of Audiooptics. He can be reached via ATI, Post Office Box 2458, Springfield, Virginia 22152.

# The Industry Standard

Nestled alongside Big Stony Creek, surrounded by the mountains of the George Washington National Forest in Southwestern Virginia, Sontec Electronics continues its major contribution to the quality of recorded sound.

Sontec's best known product is the **MES-430B Mastering Equalizer**... more disk masters are processed through the 430 than any other equalizer. The companion unit, the **DRC-400 Dynamic Range Controller**, now being delivered as rapidly as hand-crafted production permits, gives the cutting engineer complete control over musical dynamics with insignificant program degradation.

Once the signal is processed, the **Sontec Compu-disk\* Lathe Controller**, created by Gerry Block, provides control over all the important groove parameters with an accuracy unmatched by any other method.

**Equalization ... Dynamic Range Control ... Groove Control ... a completely integrated system for maximizing the potential of analog disks ... all available from one source ... SONTEC.**

So, if you're concerned with the quality of audio for disk mastering or studio operation, remember our name. If you have an immediate need to know, please call or write, outlining your area of interest.

 **sontec**electronics

Audio Drive, Big Stony Creek, VA 24094, 703-626-7256

\*Compu-disk is a registered trademark of Sontec Electronics

Circle #089 on Reader Service Card

# SOUND ON STAGE

## Contractor Expo Set for '84

Contractors Expo '84 will be held at the Sahara Hotel in Las Vegas next April 24-26. Workshops and Expo will be aimed at Contractors only. Four educational programs will be held simultaneously. Fire/Life Safety will be the focus of topics for one track chaired by John Pieroth (Signal Communications—Seattle, Washington). The twelve hour audio presentation will be the responsibility of Harold George (Indiana Electronics Co-Op, Granger, Indiana). Topics and speakers for the "Managing a Contractor Company" segment, will be the responsibility of Bob Ancha (Ancha Electronics—Elk Grove Village, Illinois). The Video and the Contractor series will be supervised by Chairman Vic Coskey, (Coskeys Electronics, New Brunswick, New Jersey).

Forty-eight hours of workshops covering four learning tracks and 12 hours of exhibits should attract contractors from all over the hemisphere, says Conference Chairman Harold Lander (Signal Communications—Seattle, Washington). "Our surveys show that the most important reason contrac-

tors attended our 1983 meeting was education. Almost equally important were product displays. In 1984 we'll offer plenty of both," he continued. The exhibits have been expanded to one hundred four booths and forty-seven demo rooms.

A survey of the contractors attending last year's conference indicated 71.6% had the final say in purchasing goods and services, 16% specified and 11.1% recommended. These findings seem to indicate the owners of the contractor companies were a majority of those attending.

The NSCA Conference will be held in close proximity to the Electronic Distribution Show and overlapping on two of their show dates. Badges from either show will be accepted and honored on either expo floor. An admission fee will be charged for the contractor educational programs.

For more information about the 1984 Contractor Expo, contact National Sound & Communications Association, Headquarters, 5105 Tollview Drive, Suite 201, Rolling Meadows, Illinois 60008.

## Nova Sound Reinforces Paul Anka and Donna Summer Tours

Nova Sound Research has teamed up with Innovative Audio/Schubert Systems Group to provide Paul Anka with sound reinforcement for his 1983 World Tour. The signal processing equipment of George Massenburg, Dirk Schubert and Jim Gamble heads up the Nova/Innovative house and monitor system. Mike Abbott is house engineer on the tour, with Ken Fowler as assistant engineer; Alan Bonomo is monitor engineer, with Chip Croop assisting.

Nova Sound has also provided sound reinforcement for the 1983 Donna Summer U.S. Tour. The firm assembled a large monitor system, con-

sisting of 20 cabinets—eight cabinets (3,500 watts) are utilized by Donna, herself, while the remaining 12 are for the band, which includes three keyboard players, a drummer, percussionist, bass player, guitarist, saxophonist and two backing vocalists.

## Multipair Audio Cables

Pro-Co Sound, Inc. has announced the availability of Helix™ Multipair Audio Cables for portable sound systems, recording studios and sound reinforcement.

Pro-Co Helix cable is custom-made in 16- and 29-pair configurations. Each pair is twisted to reject common-mode noise and 100% foil shielded to eliminate interference and crosstalk.

The stage box is formed and



## Island Sound System Upgrades

Mud Island, a Mississippi river theme park near downtown Memphis recently overhauled the sound system at the island's 5,000 seat amphitheater.

The new sound package was provided by Phase Audio, Inc., a Memphis-based sound contracting firm, with consultation from acoustician Stephen Durr of Nashville.

The new speaker system, featuring a central cluster arrangement, includes a combination of JBL and Gauss speakers with a specialized crossover design incorporated into the system to achieve a flatter response. Phase Audio also installed White equalization for the main speakers and on-stage monitors.

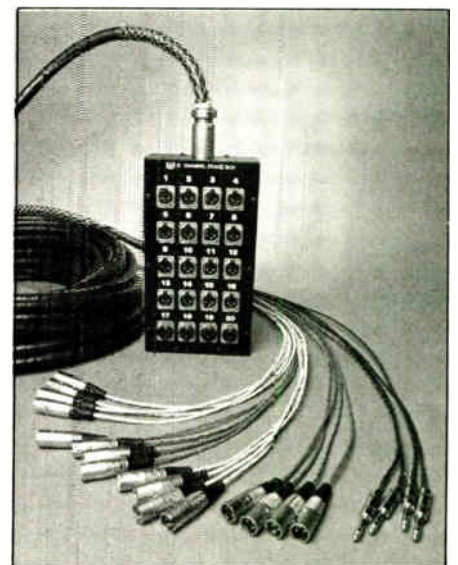

welded from 18-gauge cold-rolled steel and finished in black epoxy paint. A hefty industrial wire-mesh cable grip provides positive strain relief. Male and female XLR and special 3-conductor latching-type phone jacks are available; all channels are wired in balanced configurations. All connectors are located in the cover of the box, secured with vibration-proof rivets and clearly identified with bold silkscreened numbers.

Standard connectors are diecast Neutrik XLR-types with nylon cable clamps, rubber strain relief boots and shielded Switchcraft 3-conductor phone plugs. Pro-Co Sound, Inc., 135 East Kalamazoo Avenue, Kalamazoo, MI 49007, 800-253-7360.

Circle #090 on Reader Service Card



which can be concealed under hair and is custom fitted to the performer. The new system is available in both wireless and hard-wired versions, in either black or tan colors to match skin or beard, and can be ordered with other microphone capsules (such as the Audio Technica ATM831) as well. Prices begin at \$200 for the basic microphone/headband combination.

Circle #092 on Reader Service Card

### Cerwin-Vega V-19

The V19 is an ultra compact vocal sound reinforcement speaker or moderate power keyboard monitor employing a 12-inch woofer and a high efficiency compression driver with a

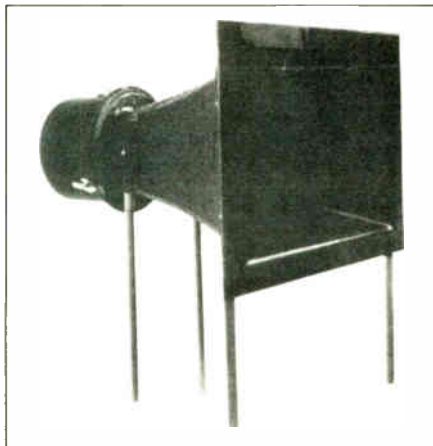

### New Mid-Bass Horn from Design Direct

Design Direct Sound has introduced the DBM line of mid-bass horns, true exponential flared horns specifically designed for the entire fundamental frequency range of most musical instruments and the human voice. Its frequency response is designed for 250Hz to 1.5kHz with a sensitivity of 100 dB. The pattern is 80 ° vertical by 65 ° horizontal while incorporating a 10 inch cone transducer. Dampening material is 3/8 inch end grain balsa core which is placed over the entire surface, to eliminate ring or hangover. Design Direct Sound, 6850 35th N.E., Suite #1, Seattle, WA, 98115, (206) 527-4371.

Circle #091 on Reader Service Card

### Nady Headmic

Nady Systems, Inc., of Oakland, CA, have introduced the HeadMic™, a lightweight miniature performer's headset microphone system. The HeadMic features a Countryman Associates Isomax™ directional mike capsule mounted on a headband boom



## EASTERN ACOUSTIC WORKS FIRST PRIZE WINNER OF THE JAPAN AUDIO CONSULTANT SOCIETY COMPETITION DOES IT AGAIN:

Introducing the RCF L15/P200 Driver.

It takes a winner to make a winner. And when the EAW based Unicus system was recently selected the best performing high level sound system by 800 participating audio consultants, architects, mixing engineers and theater owners . . . selected Number One, the best of 14 names from around the world, EAW didn't stop and rest on its laurels. No way.

We went on to design another sure-fire winner: the RCF Driver. And here's what's in it for you:

**More power handling and**

**reliability:** with 300 watts long term (100 hours), with sine wave signal and 600 watts long term (100 hours), with an EIA pink noise signal — more than any commercial driver available.

**More bass output:** its long travel voice coil provides + - 9 mm peak to peak linear travel — more than any JBL, EV, TAD, or Gauss 15-inch drivers.

**Lower distortion:** the hand-crafted high tech European cone and suspension reduce resonances and breakup modes at all power levels.

**The most massive magnet** on any 15-inch loudspeaker in the industry provides unsurpassed control of the 100 mm (4") voice coil, also the largest in the industry.

**The RCF Driver:** it's new, it's part of our finest Laboratory Series, it's in our acclaimed tradition of winners. And it's waiting for you.

For more information, contact us today.



PO Box 111  
Framingham, Mass 01701  
(617) 620 1478



Circle #093 on Reader Service Card



horn flare.

The ER122 woofer in the V-19 system is a high performance, low frequency loudspeaker with extended midrange bandwidth, low distortion and high power handling capacity.

The H-25 high frequency compression driver is coupled to an ABS horn flare specially designed for wide and uniform horizontal audience coverage angles. It exhibits linear, peak-free response over a three octave range from the crossover at 2.5kHz to beyond 16kHz.

The H-25 is protected by a self-resetting relay which senses long-term power and removes input to the driver before failure due to overpowering. Suggested list price of the V-19 is \$300. Circle #094 on Reader Service Card

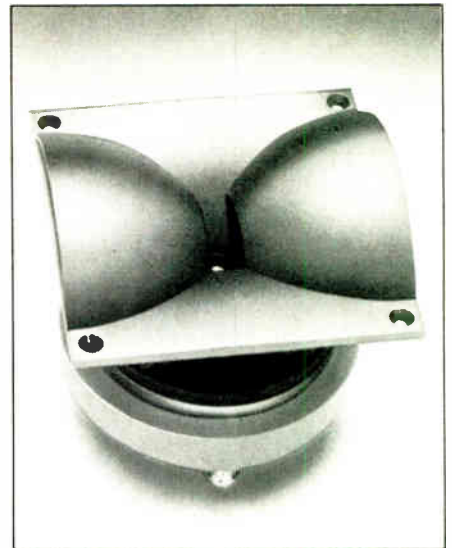

### JBL Debuts the 2370 Bi-Radial Horn

James B. Lansing Sound, Inc. has introduced the model 2370, designed for uniform on and off axis frequency response in the horizontal plane from 630 Hz to 16 kHz.

The 2370 features a compound flare configuration, minimizing the need for horn overlapping, virtually eliminating lobing and comb filter effects. Consistent horizontal dispersion eliminates midrange narrowing and high frequency beaming problems.

JBL's horn features an integral throat that will accept any one-inch diameter compression driver. Its flat front design allows for flush mounting on baffles; to facilitate installation, mounting tabs are provided for either enclosures or clusters. To ensure freedom from resonances, the lightweight horn bell is constructed of injection molded reinforced high-density structural foam.

Circle #095 on Reader Service Card

### New Electro-Voice Two-Way Sound Reinforcement Speaker

Electro-Voice has developed a two-way speaker system intended for sound reinforcement applications where a wide, controlled coverage angle and high efficiency are desired.

The components of the FR15-2 are housed in a handsome oak-grain vinyl enclosure with a detachable beige grillcloth. T-nuts are embedded in the sides of the cabinet to facilitate suspension. Low frequencies of the FR15-2 are handled by a rugged 15-inch EVM-15L Series II woofer mounted in a 4.3-cubic foot optimally vented enclosure. Frequencies above the 1500-Hz crossover point are handled by a compression driver on a 90° x 40°

# TRULY WIRELESS

NADY SYSTEMS, the Wireless Innovators, leaves the competition dangling with the introduction of the new 49-HT Handheld Microphone. With all transmitting elements self-contained, the 49-HT eliminates the unsightly wire antenna found on other 49mHz 'wireless' mics, while featuring Nady's exclusive 3-channel capabilities and an Audio-Technica PR60 mic element. The truly wireless 49-HT offers the discriminating musician, vocalist or speaker proven Nady technology and extra features at a price so low, you'll look twice. Go with the choice of the pros. GET NADY NOW.

**NADY SYSTEMS**  
INC.

**The Wireless Innovators**  
1145 65th St.  
Oakland, CA  
94608  
415-652-2411

Nady 49 Systems also available with lavalier microphone and for musical instruments.

Circle #096 on Reader Service Card

World Radio History

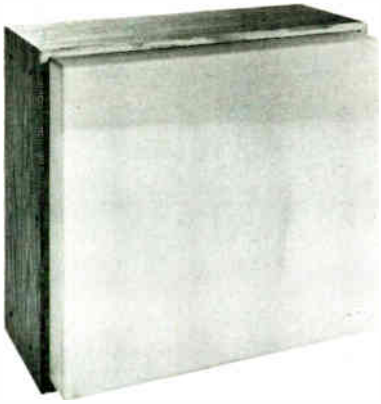

constant-directivity horn.

The frequency response of the FR15-2 is essentially flat from 50 to 15,000 Hz. The speaker's sensitivity is rated at 98 dB SPL with a 1 watt input, measured at 1 meter on axis. The long-term power-handling capacity is 200 watts, measured using shaped pink noise with a 6-dB crest factor.

The FR15-2 weighs 94 pounds and measures 28 3/8 x 31 1/2 x 16 5/8 inches (h/w/d).

Circle #097 on Reader Service Card



## Heil Unveils Pro 400B

The Heil Pro 400B incorporates their exclusive MOD-U-PAC design which allows the entire left or right side of the amplifier to be unplugged and a new spare module plugged in for instant service.

The unit's "Auto-Match" circuit automatically selects either balanced or unbalanced inputs, eliminating additional transformers. L.E.D. "clip" lights monitor each channel.

R.M.S. continuous sine wave output switched in the mono mode is 515 watts @ 8 ohms. Used in two channel configuration, the Pro 400B produces 250 watts per channel into a 4 ohm load. The amp will produce well over 320 watts into a 2 ohm load. T.H.D. is .09% or lower, 10 Hz-30kHz ± 1 dB @ 4 ohms. The amplifier uses massive heat sinks and a huge power supply. Size 19" x 13" x 7". Weight: 36 lbs.

Circle #098 on Reader Service Card

THE INTERNATIONAL TOURING TALENT WEEKLY

# PERFORMANCE

**ITINERARY SECTION:**  
lists tour dates and locations each week

**BOX OFFICE:**  
financial statistics each week on recent concerts

**TOPS IN PERFORMANCE:**  
reflects total gross dollars generated by an act during a 6-week reporting period, listed weekly

For more information, call or write:  
PERFORMANCE Magazine, 1020 Currie St., Ft. Worth, TX 76107  
(817) 338-9444

FREE sample copy — send your request on letterhead to Dept. M

Circle #099 on Reader Service Card

# HARBINGER

Ronnie Montrose is known for his high technical standards. When he conceived of an acoustic isolation, direct device; he came to Harbinger. The result of Ronnie's requirements and Harbinger's engineering, is the Harbinger Iso-Box.

The ability to meet the needs of exacting professionals like Ronnie makes Harbinger the leader in Pro Audio.

For stage, studio, and tour support; it's Harbinger.

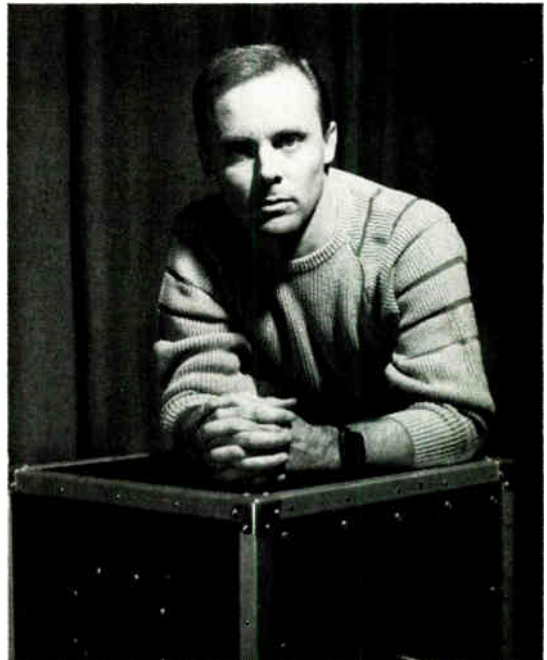

HARBINGER

For your audio needs, write or call:

960 O'BRIEN DR., MENLO PARK, CA 94025 (415) 329-8282

Circle #100 on Reader Service Card

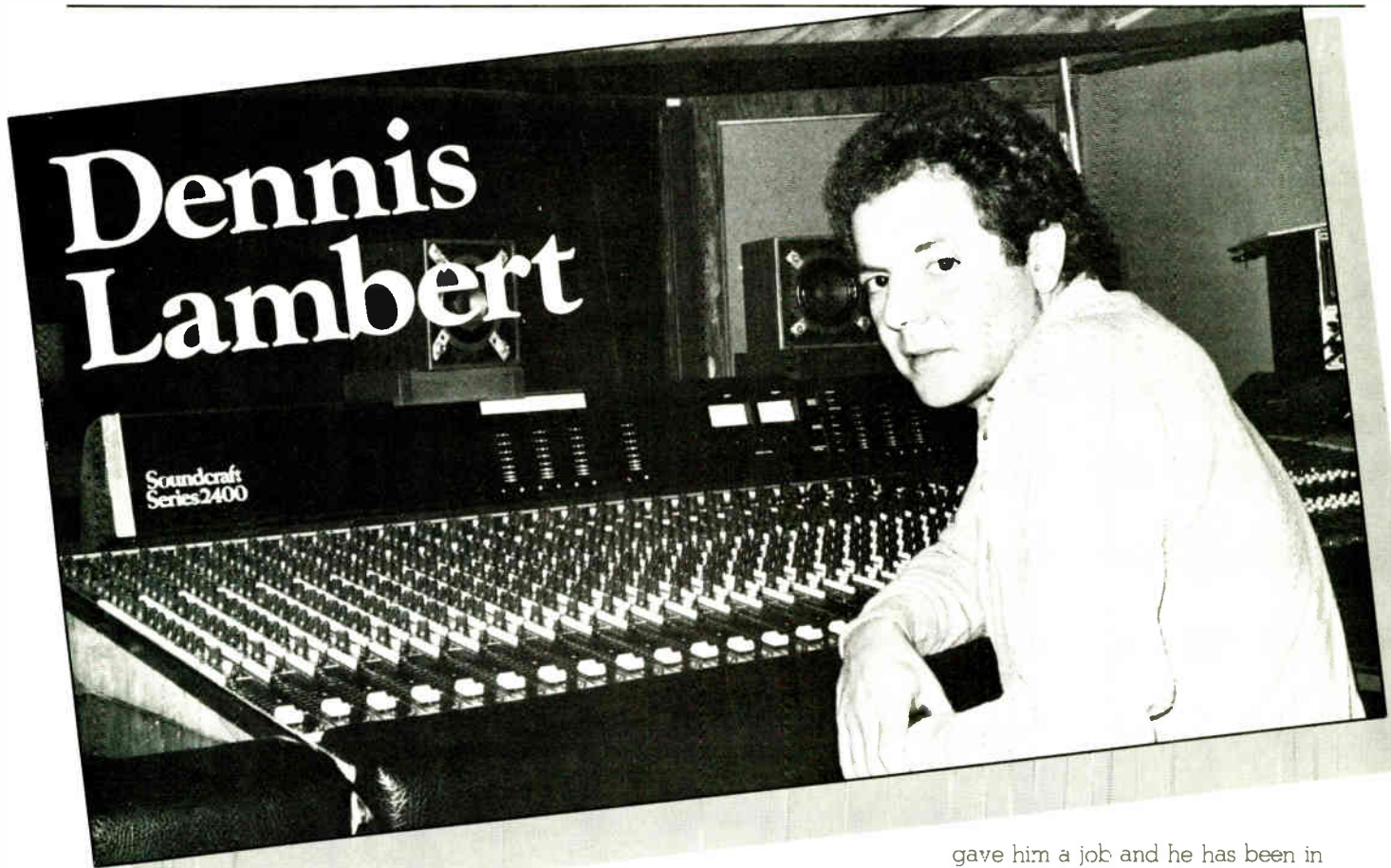

by James Riordan

Dennis Lambert's introduction to the entertainment business came during childhood when his vocal talents led to regular appearances on a popular syndicated television show based in New York. Signed to a record deal at age fourteen Dennis became fascinated with the production process. He also took great interest in the business side of the recording industry, being signed by one of the first independent production companies and his records leased to Capitol Records.

"I was intrigued with the whole process of making records. I thought that production might be an interesting way to continue in show business without being a performer. I had been performing for years by this time, even though I was only fourteen, and I was tired of singing Broadway type music to older audiences. I tried to learn as much as I could by going to a lot of sessions and volunteering to do anything that I could do. When I got out of school I

got a staff songwriter position with a company called FGG which was owned by Ritchie Gottherer and Jerry Goldstein. They let me have an office and a piano and I was able to spend a year or so concentrating on converting all my musical knowledge to playing and writing."

By 1965 Lambert had written a huge hit for Freddie & The Dreamers entitled "Do The Freddie" and had acquired the reputation as a talented producer as well. At 17 he was offered a staff production job at Mercury by Quincy Jones and Shelby Singleton, and shortly afterwards produced The Nashville Teens as well as negotiated their American record deal.

Lambert then joined a publishing/production venture with Don Costa and Teddy Randazzo. "They offered me a situation where I could bring my little publishing company over there and produce for them. I introduced them to my brother, Eddie, who had taught me what I felt I knew about contemporary music, because while I was busy singing Broadway standards he was busy do-whopping on street corners. They

gave him a job and he has been in the music business ever since. [Ed Note: Eddie Lambert is the Creative Director of the A&R Department at Motown Records.]

"I was only with Don and Teddy for a year when I got drafted. Not being in college I had no protection from the draft. Two years later when I got out Don [Costa] had moved out to L.A. and invited me to join his company again. About a year later I became involved with Steve Binder, Daniel Melnick and David Susskind in a company called T.A. Records [Talent Associates]. During this time we signed Seals & Crofts and I wrote the hit song in the *Billy Jack* movie, "One Tin Soldier."

Lambert would later supply main title themes to several motion pictures including "Junior Bonner", "Shaft In Africa", "Skatetown USA", and "Tunnelvision". He also wrote the theme used for the "ABC Movie Of The Weekend". Since his first trip to England, Dennis had been friends with Brian Potter whose songwriting talents he respected. When Dennis secured a job for Potter with Don Costa, Potter relocated to America and the songwriting team of Lambert & Potter was born. The duo wrote many



million sellers for artists such as the Four Tops, The Grass Roots, Hamilton, Joe Frank, & Reynolds and many others, adding up to thirty-two gold records. "It was a good time to be a producer/songwriter because there were still a lot of artists that needed to have material written for them. As time went on more and more acts wrote their own songs and fewer of them wanted the kind of producer who was known for being a songwriter. There was a period where that was the ultimate curse for a producer. During that period we had to stress the producing side of our talents and hope that writing less would not be terribly frustrating, which it was. We would seek out those few artists who still needed our specialties."

"When I started a producer was either a song man or a songwriter, or both. In the seventies there evolved a lot of technically oriented producers who were primarily engineers because of the development of bands who were very much self-contained, material wise. They didn't really want or need a producer who could write, find, or change songs. They wanted someone who could create their sound with them and help them technically. Today, there are a lot of producers who help create the whole music backdrop for their records; people such as Quincy Jones, who I admire very much, or Arif Mardin, Luther Vandross, Mike Chapman, and others. I feel I belong to this type which I call the musician/producer, or songwriter/producer. Their contribution can be very different from that of an engineer/producer. There are a lot of great new producers who are young and tuned into electronics and the new music. It's become very important for the veteran producers like myself to keep very tuned in to what is happening musically and technically. You have to be very aware of what is happening so that you can best help the artist get what he or she wants on their record."

Lambert believes that today is a great time to be in the record business, especially if one is interested in developing new talent. "This is the best time in years to develop new acts. It hasn't been this good for new artists since the late sixties. The criteria for a new artist has also changed over the years. New artists today must be able to come off very well in a live performance. They must have a personality that can come across on stage or be captured on video. The first criteria must still be the music, the voice, the songs, or something that will sustain them over the years. The music must be the first thing, but the visual appeal must be there as well."

Does the songwriting producer

view a new act differently? Is he less concerned about the material or is it important that he can write songs for them? "If I like an act and they don't write it's an immediate negative. Then I ask myself if the act has someone who can write for them like a Jim Steinman for Meatloaf, for example. Do they have a knack for picking out and changing obscure songs into exciting ones? If they don't write it becomes a negative because even if I think I can write for them that's not the same animal as a writing artist. If I'm looking at an established artist who is not a writer, then that can be a positive for me. Someone like Chakka Khan, George Benson, Al Jarreau, or Dionne Warwick for example would be an incentive to write material for."

Lambert has produced artists such as Glen Campbell, Santana, The Righteous Brothers, The Four Tops, The Manhattans, Player, The Temptations and many more. He has also written a book, *Producing Hit Records*, published by MacMillan. "I felt that there was a real need for a book like this. I would have loved to have had something to refer to when I was starting out, but there really wasn't anything. I tried to make it technical enough to be fulfilling in that area and at the same time cover the

broad realities of what this business is about, how to get an act off the ground and how to make the right deal for them."

Lambert advises people who are breaking into the record production business to "recognize that they are part of the new audio/video age with the incredibly versatile and relatively inexpensive equipment, mixing consoles, multi-track machines, etc., to make master quality recordings at home. It wasn't too long ago that this kind of thing was totally unaffordable for private use. But it's now possible to experiment and get a lot of hands on experience in your own home. It's not an easy business. It's rare that anyone finds their way into producing today without being an engineer or a musician. The pure song man who had that knack to put the right song with the right artist is a dying breed. There is a lot of garage recording going on today with young bands; all these young guys with guitars and rhythm machines and electronic gear. Someone can be the organizer of all of this. Nothing beats practical experience."

Dennis Lambert is currently producing the solo album for Dennis Edwards, the lead singer of The Temptations. ■



Hear Tres Virgos on Stewart Copeland's  
**RUMBLE FISH** soundtrack  
now on A&M records and tapes.

(415) 456-7666

TresVirgos   
Studios

Circle #101 on Reader Service Card

# Confessions of a Spoken Word Record Producer

by Harvey Kubernik

I have always been fascinated by the human voice, especially the variances of meaning conveyed in its subtleties. During a seven-year weekly stint for Britain's *Melody Maker*, I did stories and interviews in the studio and on sound stages, and paid close attention to producers' vocal overdub techniques and artists' voice-to-microphone relationships.

This experience was the foundation and blueprint for my Freeway Records production house and record label. Freeway's spoken word albums demonstrate a jigsaw puzzle recording strategy, averaging fifteen to twenty-five studios in the collaboration. The Freeway Records trilogy is a spoken word and musical journey through Southern California. Urban and suburbanite vocal chords were taken from Watts, the Barrio, the beaches, the Valley, Los Angeles and Hollywood to build this vinyl collection agency.

It was in 1970 that I was walking down Selma Ave. just after graduating from Fairfax High School, and noticed a sign above a bank building that read: Mystic Sound. So I went up to the studio owner, Doug Moody, and told him I wanted to be in the record business. We talked for a few hours and I remember saying, "But I don't want to be in a band, playing 4/4 time, wearing buckskin jackets, doing sweet harmonies and having my friends join me on stage for encores." Moody replied, "You don't have to."

Somehow we started discussing spoken word albums: Lenny Bruce, Lord Buckley, Richard Pryor. Moody then pulled out boxes of spoken word tapes on Robert F. Kennedy. Ten years later I found myself in the same building, walking past the dusty Coca-Cola machine, and into the studio with Moody at the dials as we began working on "Voices of the Angels".

Doug Moody and his Mystic Sound have been very supportive in their guidance and use of the studio. When you do business with Moody, or record with him, you are dealing with a man who has been in the sound business over 50 years. It's like Benny Goodman giving you a clarinet lesson. Moody was at Glen Miller's last session and even behind the glass for Fats Waller.

Moody purchased the studio in 1968, and poured fifty-thousand dollars into restoration and construction. The 20' by 20' recording room has varying wall finishes, from hard plaster with a retractable curtain to cork, to fluted cedar and redwood. "The studio's floor is soft tile," says Moody. "It was originally a cement floor. Too harsh. Then hard tile. Too brittle. Now we've chosen soft vinyl."

"When I record spoken word sessions at Mystic, I often remove the curtain, carpets and all equipment in the area to obtain the harshest, crispest sound for the voices. Isolation booths are available for recording, but in the spoken word things we've done the last few years, most of the poets preferred to stand and operate in front of the microphone.

"I purposely recorded Wanda Coleman's 'Where I Live' and Walter Lacey's 'Meatrack Man,' both on VOA, with Mystic's terrific acoustic echo chambers. Walter Lacey is a poet who goes into a trance when recording. He just turns it on, often without notes or paper. I sent Lacey's voice directly to the two track, and then doubled it with a signal sent to

the echo chamber for a fat delay."

Dennis Dragon is an unofficial A&R man for Freeway, securing unique and wonderful talent for the label, and has produced several tracks in the catalogue.

Dragon has also played drums and percussion with The Beach Boys, The Byrds and Johnny Rivers. He owns a Grammy Award for engineering the 1975 Record Of The Year, "Love Will Keep Us Together" by Captain & Tennille.

Parts of the Freeway Records spoken word albums were done at Dragon's former studio, Rear Entry, and most recently Dragon and partner Dave Gordon's studio, Surf Bowl, both in Malibu.

"I love working with spoken word projects," says Dragon. "It's spontaneous and you just go for it. I love the honesty. With Freeway's spoken word projects, the technical is secondary to the excitement."

Dragon loves to experiment with voices. "Echo can enhance the message, the information and extend the philosophy. Also, these days, people, especially those who don't regularly listen to information/educa-

**"I**n spoken word situations, even more than in music recording, people put themselves on the line. You can't hide behind the instruments or other players. Spoken word sessions and albums are also a good outlet for my thoughts and lyrics away from the context of my band."

**—Chuck Dukowski, co-founder/bassist, Black Flag, and a contributor to Freeway Records' two double albums, "Voices of the Angels" (Spoken Words), and "English as a Second Language" (Talking Package).**

tion oriented records, come to spoken word albums with resistance.

Sometimes they have to be hit over the head with something added to the dry voice," he charges.

"I've never had a big room to work with so I have to use artificial ambience," says Dragon.

"We record Tuff Muffin, a Freeway Records' regular at Dragon's studio. The lead singer has a lot of sibilance in her voice and we have to add some peak limiting. I don't use Dolby and I print at a low level, which reduces the chances of print through.

"Last year Dragon and I recorded the Allen Ginsberg and Harold Norse reading in the cavernous First Unitarian Church in Los Angeles." Dragon was the sound engineer and used a Revox tape recorder and confesses that peak limiting can be crucial. "We overloaded sometimes with Ginsberg. We didn't have the benefit of a sound-check and I had never heard Ginsberg perform. He sure knew how to yell."

"These spoken word sessions offer some heavy naked emotion," adds Dragon. "I get some feedback that I haven't seen or heard before. I like to present some of the scene out here, contrasting the Valley, East L.A. What I like to do is take the beach community, and then get so intrinsically into that area that it becomes absurd, especially sequenced next to people who rarely come to the beach.

"Listeners are confronted by spoken word albums," he continues. They can't drown their problems in loud music or a guitar solo. Some of this is hard to digest. There's a reality presented that might threaten security. But this is also very entertaining. It's not pure escapism. I think it's a feedback thing. Listen, learn and better yourself. These spoken word recordings make me aware of areas and information going on over the other side of the hill. I enjoy anyone who can deliver."

While the principal recording of Freeway Records' "Voices of the Angels" (VOA) was done at Mystic Sound and Kitchen Sync in Hollywood, I felt, "English as a Second Language" (ESL) should be constructed and honed at the beach. I went to Radio Tokyo Studio on the recommendation of Gary Stewart, who introduced me to this eight track facility, owned and operated by Ethan James.

Ethan James is also a musician with a rock and roll background. As a keyboardist, he's backed Chuck Berry, Donna Loren, The Olympics, and for four years was a member of Blue Cheer. James is also a fan of

FOR THE BEST IN AUDIO RECORDING

# BASF & AGFA TAPES AT LOW PRICES

- BASF cassette tape
- AGFA cassette and mastering tapes
- Cassettes loaded in premium 5-screw shells
- Accessory boxes, liners, labels

Send today for our price list and specs!  
Or call: (313) 662-0669

## WORLD CLASS TAPES

P.O. Box 7611  
Ann Arbor, Michigan  
48107

Circle #102 on Reader Service Card

## For better sound, try this on your PZM.

For more ideas on how to use PZM microphones, write for your free copy of PZM APPLICATION NOTES.

**CROWN**  
1718 W. Mishawaka Road, Elkhart, IN 46517

Circle #103 on Reader Service Card



*The author with poet Wanda Coleman*

spoken word recordings, and is a fixture on the L.A. poetry reading circuit. In the '60s he lived in San Francisco and attended many poetry gatherings in Golden Gate Park and other word parties.

Radio Tokyo is a converted house. James, with partner Lisa Mitchell, owns Ear Movie Records and has just issued a compilation album, "The Radio Tokyo Tapes."

The recording room is 300 square feet, cramped and pretty much dead, with near-field monitors to listen back. There's a Tascam machine, Sound Workshop board, DeltaLab delay, Roland Analog delay, Audio pulse delay line, and speakers: JBL 4311, Yamaha NS-10M and Auratones. The mikes we used for our vocal recordings were Sennheiser 421, Shure SM-57, and AKG 414.

"I think recording the spoken word and especially poetry is needed in our culture and society," says James. "I really like recording two tracks. You save a generation and can't go back and change anything. And on the Freeway tracking sessions there's almost no censorship. It reminds me of the street talk I heard years ago in San Francisco.

I wanted to try new things with "ESL". One idea was a "melting" concept that would weld backing tracks, not necessarily music or incidental music, but layered treatments and coatings that pushed the voice and words forward. I wanted to expand the poet's vision in this format, for the voices to be the bread and the new music ingredient to be the butter.

Ethan understood that the voices and information should not be

diluted by instrumental backing. "When I heard Wanda Coleman's piece," says James, "I was familiar with it because I had seen her read and perform. I listened to her poems, checked out the energy and thought of the 'melting' in terms of movie music. When I heard her 'Bad Night' I figured out a way to take her voice and words further. I love her work, she makes you feel the experience. The impact is conveyed. Her use of breath and space is exceptional. The message isn't washed out."

Dennis Cooper was another poet transferred to James for "aural embroidery." "I love Dennis Cooper's detached delivery," notes Ethan. "Cooper plays tricks with words and their designs. A pop posture is presented, but it's very mental.

The "melting" track illustrated his concept. "I used plucked piano, autoharp, and some backing vocal techniques." A new nutritious word meal was then prepared!

Then there's Ivan E. Roth's riveting poem, "Beach Party Post." James fused ratchets, hammers and synthesizers to Roth's classic. "Ivan has a vocal style that winds corners. I put him in a 'Fritz Lang' movie, a very industrial setting. I've seen him perform all over the city, and he's an articulate reader. Punk rock poetry," he suggests.

Ethan James has produced other voices for "VOA" and "ESL", and even rounded up contributors for the stable. "I love recording kids and older voices," he chirps. "Jack Hampton on "ESL" is over 70. He has to be heard! On this new album set things have become more developed. There are acoustic guitar elements, and some double-tracked vocals, extensive usage of synthesizer and some drum machines meshed with the voices.

"Henry Rollins from Black Flag recorded his 'Henry' piece here at Radio Tokyo. On the left speaker, Rollins is reading from a four year old journal while simultaneously improvising current Black Flag status and feelings on the right," James continues. "These albums are somewhere between rap music and poetry LP's. If anything blows my mind about these albums, it is that virtually anyone can record for the label. Years ago you had to be a singer, vocalist, performer, artist or in a band, especially one that toured and worked before you could go on vinyl. You almost had to be a rock star, and pretend you were saying something," he grins. "Here you don't have to be in a band, or even known. You are allowed to participate. This isn't an elitist trip. What is happening is that something is swelling and growing around this

# MARKET RESEARCH-

the study of consumer  
needs and preferences;



External PSU, phantom  
power, phase reverse,  
16 track monitoring.  
Cue, Dim on talkback,  
3 Aux sends on  
channels and monitor.  
2 returns Meter bridge,  
oscillator inject points.  
Direct outputs.  
Normalised inputs.  
Fader reverse Slate. . .

**16-8-16**  
**- the result of**  
**market research.**

Circle #104 on Reader Service Card

**SOUNDTRACS**

affordable quality

**Approximately \$6500**

Dealer list and brochure from: Soundtracs Inc. 262a Eastern Parkway, Farmingdale, NY 11735 (516) 249-3669

In Canada: Omni Media Corporation Ltd. 9653 Côte de Liesse, Dorval, Québec H9P 1A3 (514) 636 9971

# IT JUST KEEPS GETTING BETTER

CATCH IT IN THE MIX IN '84

## FEBRUARY - (NAMM Show Special Issue)

· Independent Engineer & Producer Listings

Ad Closing: **Dec. 7, 1983**

Materials Due: **Dec. 15, 1983**

## MARCH

· Southeast Studio Listings

· Religious Recording Update

Ad Closing: **Jan. 7, 1984**

Material Due: **Jan. 15, 1984**

## APRIL (NAB Show Special Issue)

Listings of Video Production & Post-Production Facilities.

· Spring '84 Video Music Update

Ad Closing: **Feb. 7, 1984**

Materials Due: **Feb. 15, 1984**

spoken word process," he explains. "New people and voices are going in front of microphones without any sort of track record or chart background. That's exciting. It confuses most of the local music critics and writers. New rules are being created in these sessions. There's a lot of passion displayed here."

Michael Hamilton, owner of Kitchen Sync Recorders on Sunset Blvd., is a fan of spoken word recordings. Like Ethan James, Hamilton lived in San Francisco for a long time, attending many poetry gigs. "These albums and recordings present spontaneous realism. Sometimes we did dual voice production. Basically a hard right/hard left with 50 db of isolation between channels on tape. When we went to the mastering lab the 50 db of isolation at one kilohertz was cut in half. It's not quite as separated or isolated on vinyl as it was on the master tape.

Hamilton convinced me that an EQ'd tape transfer would be the best way of presenting this collaborative collection to a mastering lab who would pin close to 30 minutes per side without problem. "There are over 20 studios involved in these albums. We have to equalize," he charges, "and we have to make a copy that sounds like it was done on the same planet.

"What I like most about working with Freeway," adds Hamilton, "is that people are invited to sessions and to go on tape. It's spontaneous and you don't even know if any of the things on tape are going to be usable. I've met a lot of people through their voices. Some of these artists, unlike singers, instinctively know how to work a mike. Sometimes a few extra takes may be done, but a person can become a professional in five minutes.

"It seems the people we record from the west side of town," he observes, "are upper class kids who come prepared to have fun and a wacky time. The spoken word sessions are fun oriented, free form. They want effects on their voices, and some even improv off the top of their heads. Others from East Hollywood, downtown, East L.A. and the grittier parts of Hollywood, take this tape and recording process very seriously. I've noticed that the artists from lower class families, and the parts of L.A. away from the beach rarely want anything added to their dry voice. These sessions are an escape from their tough lives. They don't want gimmicks and effects cluttering the message; they want a direct communication with the person who is listening. Most feel there's a chance someone will hear what's going on and want to hear even more."

# TOPS IN THE BUSINESS

NOW AVAILABLE: **NEW MIX T-SHIRTS**

- LACOSTE-STYLE KNIT (w/fashion collar) white, navy, \$22.50 ea.
- FRENCH CUT (women's sizes) navy, black, \$8.00 ea.
- CREW NECK (men's sizes) navy, black, \$8.00 ea.
- CAPS (adjustable) navy, red, \$5.00 ea.
- All shirts available in S, M, L, XL. 10% off on orders of 5 or more shirts. Order now for your staff and customers.

Mail to: Mix T-Shirts, P.O. Box 6395, Albany, CA 94706. Enclose check or money order payable to Mix Magazine.

ITEM	NO.	COLOR	SIZE	PRICE

Add \$1.50 for postage and handling per item.

CA residents add 6.5% sales tax to T-Shirt total.

**TOTAL** \_\_\_\_\_

Name \_\_\_\_\_

Address \_\_\_\_\_

City \_\_\_\_\_ State \_\_\_\_\_ Zip \_\_\_\_\_

# PREVIEW

## dbx TO OFFER CPDM CIRCUIT CARDS

dbx Inc. has announced plans to offer its CPDM (Companded Predictive Delta Modulation) digital recording technology to manufacturers on an OEM basis, to allow for the production of professional, open reel, fixed head CPDM digital recorders. This digital format was originally developed for the dbx Model 700 Digital Audio Processor. Additionally, a design for a transcoder is under development to convert, in the digital domain, the CPDM format to the PCM (Pulse Code Modulation) format necessary for the mastering of Compact Discs, according to Lance Korthals, Director of Marketing and Sales for dbx Professional Products Division.

Circle #130 on Reader Service Card

## YAMAHA REV1 DIGITAL REVERBERATOR

At the recent New York AES show, Yamaha introduced a sophisticated digital signal processor designed to accurately simulate the natural acoustic properties of virtually any environment, from concert hall to recording studio.

The REV1 allows control over such variables as: sound directly from the source, "early reflections" bouncing off boundary surfaces, and "subsequent reverberation" in which the reflections are multiplied. Sophisticated electronic control can be maintained to compensate for, or simulate, the acoustic properties of any environment, accounting for such variables as room size, room shape, contents, acoustic absorption coefficient, and listening positions.

With its unique combination of hardware and software, the REV1 can create and control up to 40 early reflections and provide up to 99 seconds of subsequent reverberation.

The front panel of the 19-inch rack-mountable main unit includes basic controls for recalling any of 30 preset and 60 user-programmable effects and modifying them to some degree. The remote control unit includes 64 pushbuttons (most of which are illuminated), 10 control knobs, LED numeric display windows, twin 16-LED level displays, and a very high resolution (5 1/8" x 1 1/2") LCD window that graphically depicts adjustments as they are being made.

The REV1 will be available in April, 1984. Price has yet to be announced.

Circle #131 on Reader Service Card

## AUDIO MIXERS FROM RAMKO

Ramko's P-4M and P-5MX mic/line mixers are the latest addition to their PRIMUS audio group. Both are offered in

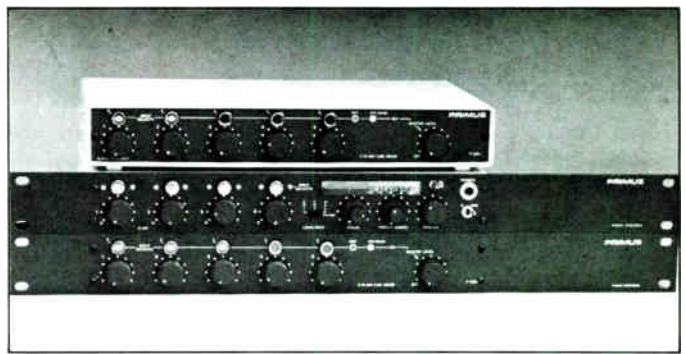

mono and stereo versions and are available in 1 3/4" table top or rack mount configurations. The P-4M provides 4 mixing channels and 6 balanced inputs with selectable Hi/Lo shelving EQ for channels #1, #2 or all. Other features are selectable peak/VU solid state meter ballistics, phone driver, phones, master and monitor controls and cue on all inputs.

The P-5M is designed to function as both an expander for the P-4M (combined will provide 11 inputs and 9 channels) and as a stand alone 5 channel mixer with send/receive on each channel. Both units feature XLR type connectors, balanced inputs and outputs, gain select on all inputs, (mike thru +26dBm, s/n of -83dB, .008% distortion and a response of +0, -1.5 dB, 10 Hz-20 kHz. All units utilize conductive plastic controls, long life switches and are covered by a three year warranty. Prices begin at \$331.00.

Circle #132 on Reader Service Card

## DP80 HIGH SPEED DUPLICATION SYSTEM

OTARI's Industrial Products Division has announced the introduction of the new Model DP80 high-speed audio duplication system.

The new duplicator will accept 7 1/2 ips masters and will reproduce them at a 64:1 duplication ratio (480 ips).

The DP80 system, consisting of a Master Reproducer and up to 20 slave recorders also features normal and chrome tape capability; advanced, dual capstan, D.C. servo drive for reduced tape skew and wear; long life sendust ferrite heads and status monitoring.

Typical system price for one master reproducer and 5 slave recorders is approximately \$110,000. The system will be available in January, 1984.

Circle #133 on Reader Service Card

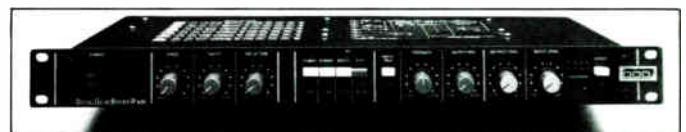
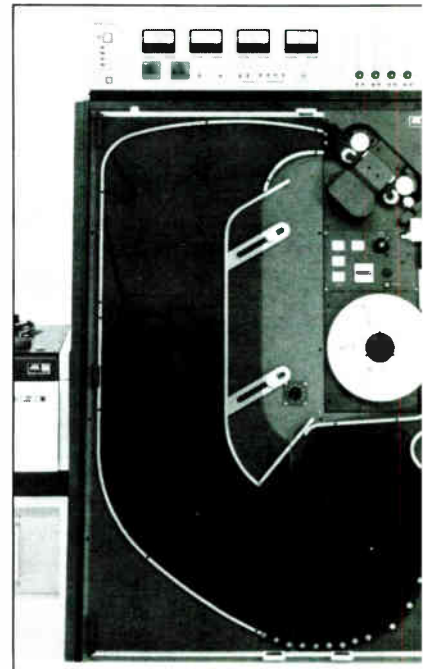

## R-908 DIGITAL DELAY

The DOD Electronics R-908 Digital Delay is a full function, PCM digital signal processor with up to 900 milliseconds of

delay. The R-908 features a selector switch panel for fast and easy settings for flanging, chorusing, doubling and echo, and a sweep width of 10 to 1. The sweep and filter circuits are engineered so there is no "dropping out." Suggested retail price is \$399.95.

Circle #134 on Reader Service Card



### DELTA OMEGA™ 2000 POWER AMP

The Crown Delta Omega 2000 Power Amplifier actively controls the voice coil of the loudspeaker using electronic circuitry to significantly reduce effective radiated distortion by the adjustment of a single control.

The Delta Omega circuit allows the amplifier itself to evaluate the effects that the amp-to-speaker cables, the crossover network, and the speaker coils have on the sound.

Delta Omega incorporates a velocity-control system at the amp/speaker interface in which the speaker velocity informs the amp, while the amp controls the velocity.

The essence of the Delta Omega operation is to compare the wave-form current of the voice-coil output with the amp input, and add the necessary compensation to correct any non-linearities introduced by the load. It is not just a variable damping system, since the Delta Omega circuit actively controls signal velocity as needed to correct voice-coil behavior.

The amp can produce 600 W continuous average output power into 8 ohms, from DC to 45kHz, no more than .05% THD.

Circle #135 on Reader Service Card



### ADB-1 ACTIVE DIRECT BOX

Stewart Electronics has introduced the Model ADB-1 Active Direct Box.

Designed for wide frequency response, low distortion.

# The control electronics behind the 833 Studio Reference Monitor System

Meyer Sound's 833 Studio Reference Monitor System is standardised for: consistent response — giving a growing number of professional engineers and producers more creative control. The C833 controller shown regulates frequency and phase response, and has Meyer's exclusive Speaker Sense™ circuitry to prevent driver overload. The 833 handles up to 400W, with power and headroom that lets you feel the full effect of the music — and performs consistently for longer

than previous speaker designs. Effectively linear time response and improved 'coherence'\* ensure clear and controllable stereo imaging.

\*See our new brochure on the 833.

**To see the difference in our speakers, or hear the difference in our system — see us at AES in New York — or contact Meyer Sound.**

Circle #106 on Reader Service Card  
World Radio History



Meyer Sound Laboratories Inc.  
2194 Edison Avenue, San Leandro,  
California 94577, USA.  
Telephone: (+1510) 569-2866



tion and low noise characteristics, wide dynamic range versatility is allowed for by an input that can handle 6V P-P in the instrument position. In the speaker position the unit can handle up to 400W RMS. Either a self-contained 9V battery (on-off switch is provided for long battery life) or any phantom supply from 9-60V will power the box.

Phase distortion and hum pickup are eliminated by a transformerless design, and RF protection is on both input and outputs.

The ADB-1 has a full two year warranty and sells for \$119.50.

Circle #136 on Reader Service Card

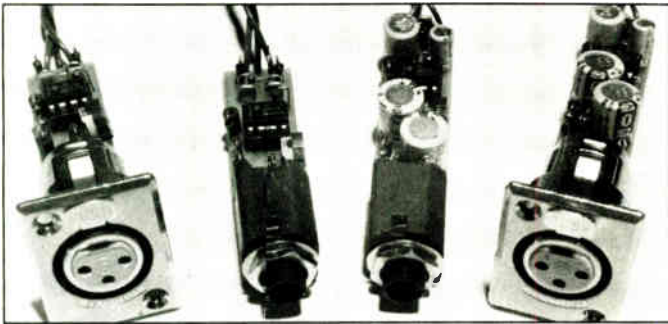

### BENCHMARK DIA-1 AND 2

Benchmark Sound Company has released their new Differential Input Amplifiers designed to retrofit into existing equipment, such as monitor amps, recording consoles, limiters, and other "semi-pro" devices. The DIA-1 is a DC coupled device intended for use with split supplies from  $\pm 9$  to  $\pm 42$  VDC. The DIA-2 is an AC coupled version intended for use with a single positive supply from  $\pm 18$  to  $\pm 58$  VDC. Cost is about \$24 each in quantity.

Circle #137 on Reader Service Card

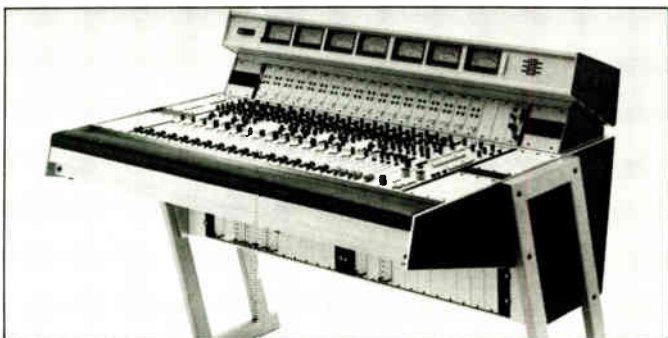

### AUDITRONICS 300 SERIES

The Auditronics 300 Series Audio Production Console is designed for 4 or 8 track production with sub-mastering to stereo and/or mono, and features up to 32 mono or stereo inputs with or without equalization, auxilliary sends and returns, monitoring facilities including cue and stereo solo, a complete user-programmable internal and external logic system, remote control and interface capability to external switchers or editors for audio-follow-video, and a wide variety of options and accessories for signal processing, routing, or user customization.

Circle #138 on Reader Service Card

### AGFA-GEVAERT PEM 526 BIN MASTERING TAPE

The Magnetic Tape Division of Agfa-Gevaert, Inc., has announced that their PEM 526 Bin Mastering Tape is now

available in 2400 foot lengths, replacing the previous 3280 foot lengths.

The length has been changed to meet user needs for easier handling and to allow its use on a greater variety of equipment. Widths remain  $\frac{1}{4}$ ",  $\frac{1}{2}$ " and 1" and are available on hubs.

Circle #139 on Reader Service Card

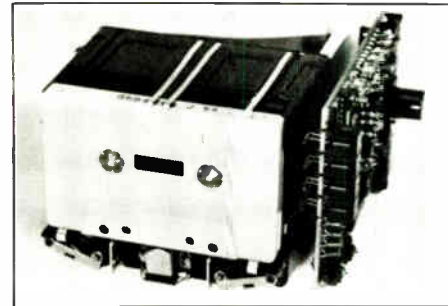

### CASSETTE TAPE TRANSPORTS

The Reproduction Technologies Inc. 8000 series of OEM cassette tape transports include door, slot, drawer and front panel load.

The 8010 door load is mechanically controlled, has one motor single direction drive, erase, record play/heads. The 8240 slot load has electronic soft touch controls, one motor bi-direction drive, a 4-channel playback head with dual switching preamplifier. The 8025 drawer load has local soft touch mechanical control or remote control (model 8030), two motor single direction drive, pull-out drawer mounting, and erase, record/play heads.

The 8320 flat load (shown) is CMOS local and remote controlled, four motor bi-direction, 4-channel playback head or optional erase, record/play heads. Prices range from \$78.00 to \$650.

Circle #140 on Reader Service Card



### SOUNDCRAFT TS-24 IN-LINE CONSOLE

The TS-24 marks the beginning of a new range of consoles using in-line technology to supplement and complement Soundcraft's existing range of split format consoles.

In mixdown mode, the TS-24's I/O modules can be used as two completely separate inputs. Each module has 6

auxiliary sends; however, more sends may be generated through the use of extra grouping facilities.

Standard on the TS-24 is fully parametric EQ, balanced inputs and outputs, VU and peak metering, and a comprehensive patch bay including 96 tie lines for external equipment.

Expected delivery of the TS-24 is spring of 1984.

Circle #141 on Reader Service Card



### SONOSAX SX-S MIXER

Sonosax has introduced their new portable mixing console, the model SX-S, that is completely autonomous and useable

with batteries, accumulators, or an external power supply. The 8-input version weighs 7.4 kg., and the one with 6 inputs, 6.2 kg.

The SX-S is also available with the Dolby System A incorporated into it.

Circle #142 on Reader Service Card



### PUBLISON INFERNAL MACHINE 90

Publison's infernal machine 90 is a stereo digital audio computer, designed for a wide variety of effects, including: Delay from 0.02 sec to 5 minutes; high quality echo with digital feedback, deglitched pitch-shifting, with various algorithms according to input sound; association of echo and pitch-shifting; an effect similar to a magnetic tape running reversed; and a great variety of effects using memorized sounds. The memory capacity depends upon selected option, and can attain 5 minutes.

Principal features include: 18 bits A/D conversion, 20 kHz frequency response, 32 bits internal signal bus and floating inputs and outputs.

Circle #143 on Reader Service Card

## Announcing...the New Cost-Effective

# ECOPLATE™ III,

size 56" x 38" x 9", scaled for the Cost-Effective Studio

IF YOU'VE BEEN "GETTING BY" WITH SOMETHING LESS THAN A TRULY PROFESSIONAL REVERB SYSTEM, THEN THE NEW ECOPLATE III IS FOR YOU. PLATE REVERBS ARE THE STANDARD OF THE INDUSTRY WITH THE SMOOTH, BRIGHT SOUND OTHER SYSTEMS TRY TO IMITATE. NOW, FOR ONLY \$1695, YOU CAN STEP UP TO THE BEST. OR, IF YOU ALREADY OWN AN ECOPLATE OR OTHER FINE REVERB, THE III CAN GIVE YOU A SECOND SYSTEM FOR A MODEST PRICE.

- Reverb Time:** Variable .5 to 5 sec.
- Signal to Noise:** 65 db
- Frequency Response:** 80-20 KHz
- Input:** -10 or +4 dbm 10K ohms, unbalanced, 10K ohms
- Stereo Outputs:** +4dbm (+24dbm max.) 50 ohm unbalanced
- Size & Weight:** 56" x 38" x 9", 109 lb.
- Equalization:** Both Hi and Lo Variable

New Shock-Mounted Plate Tension System is Pre-tuned at the Factory Eliminating Tuning Problems.

## STUDIO TECHNOLOGIES, INC.

6666 N. Lincoln Ave., Lincolnwood, IL 60645 • (312) 676-9400  
An affiliate of Programming Technologies, Inc.



Only \$1695

Circle #107 on Reader Service Card



# PHIL RAMONE

## ON MICROPHONES



**M88RP**  
Printed Ribbon  
Microphone

"A critical link in the recording chain is the choice of microphones. If that first stage is wrong or distorted, no amount of equalization or processing will give you back the sound that you originally intended to record.

"There are no hard rules or scientific formulas. No single mic is best for every sound. So I try to make a point to stay in touch with current microphone technology, and I'm impressed by the Fostex Printed Ribbon mics — for a number of reasons.

"First, they have a very open, clean sound, plus they can absorb the hard drive that rock 'n' roll demands. I know this is a subjective opinion, but I've used the M88RP, for example, on strings, guitars and vocals with fine results.

"Secondly, the workmanship and quality show the care taken by Fostex in making these finely-crafted tools.

"Finally, I think the Printed Ribbon technology is just as impressive in Fostex headphones. Musicians simply like to work with them. One of the best moments in the studio was when we tried the T-Series headphones and the musicians said how great it was to be able to play and really hear themselves.

"In fact, it was the Fostex T-Series headphones that prompted me to try their RP microphones.

"Now we're both glad, because I bought them, not vice-versa."

**Fostex**  
PRO SOUND DIVISION

FOSTEX CORPORATION OF AMERICA  
15431 Blackburn Avenue, Norwalk, CA 90650 (213) 921-1112

# The A Team



by Carol Kaye

We definitely had a clique going for session work in L.A. back in the sixties. Our core group of players would back just about every pop, R&B, movie and TV theme hit that came out of Hollywood. We became so efficient and professional that we really kept the nonprofessionals out of the studio. We would recognize and help out the young players that showed promise, but we kept a tight ship and anyone who wasn't there to play their very best and treat it like a business didn't get invited back to the next date.

I've mentioned a few of the people already who were getting a lot of the work back then. Let me go into just a little more detail, though, so you might be able to better appreciate some of the unsung heroes of that time. The heavy guitarists (sometimes as many as six on one date!) were Barney Kessel, Howard Roberts, Glen Campbell, Rene Hall, Mike Post, Arthur Wright, Tommy Tedesco, Tony Rissi, Allan Reuss, Don Peak and a few others. Besides working most of the movie soundtracks and jingle dates, these guys backed such artists as Johnny Mathis, Elvis, Ray Charles, Sam and Dave, Sonny and Cher, Jan and Dean, the Righteous Brothers, the Beach Boys and most of the Motown hits.

Drummers such as Paul Humphrey, Earl Palmer, Jesse Sailes and, of course, Hal Blaine, turned out hit after hit on dates for the Four Tops, Supremes, Mamas and Papas, Johnny

Rivers, Herb Alpert, Phil Spector, and many of those previously mentioned. As far as keyboards, the above dates employed the likes of Larry Knechtel (later with Bread), Leon Russell, Mac Rabinac (Dr. John), Mike Rubin, Don Randi, Clare Fischer, Mike Melvoin, Al DeLory, Gene Page, Art Hiliary and Joe Sample. Ray Brown (on acoustic string bass), Joe Osborne and I handled most of the bottom end back then. Other specialists, such as Steve Douglas and Plas Johnson on sax helped to keep these sessions cooking.

No matter who played these sessions, timing was of utmost importance. Keeping the rhythm and the beat locked in laid the foundation so that the hooks and creative rhythmical lines could bounce off of the singer or lead player.

We usually worked from a skeleton chord chart. Often one of us would jot down the chords while the singer ran it down or played us the demo tape. The arrangers would usually let us know how much latitude we had for adding lines or fills. We developed quite a catalog of licks that the arrangers remembered and drew from on future dates.

Fortunately there was room for variety and experimentation, despite the structure that we worked hard to maintain. Sometimes it was this experimentation that really made the difference, like a fatiguing Mel Torme session I remember for the song "Games People Play", where we had been overworked and everyone was dragging and the song was going

nowhere. The horn section looked at me like they needed help, so I changed my bass pattern to a wall-to-wall funk symphony in order to keep the beat alive. I wasn't sure if that would help, but after the session everyone thought it was a great part and the record went on to be a number one.

Finally, by about 1970, the young musicians started to get good enough in their studio techniques, with the right equipment and attitudes, to really "cut it" on the dates. Many of the sons and daughters of our group began moving into the studio, cranking out hit records with their special synthesizers, vocal arrangements and high level musicianship, taking over where we left off.

The musicianship has gotten much more advanced today, the vocals have developed tremendously and the technology has created a whole new perspective on the way the tunes come together. The basics haven't changed, but the times have and it's beautiful to see so many well-trained younger musicians going on to create better records than ever.

So do I miss it? You bet. I miss the players, the clowning around, and I miss that thrill that use to raise the hair on my arms when we came into the homestretch of the "hit" take. You could always tell which one that was. It was a job well done and it was a very special kind of high.

Thanks for your letters. We'll be getting to some of your questions shortly, but next time we'll be talking to a couple of other session players to pass along some other observations. ■

# GREAT DRUM SOUND. INSTANTLY.

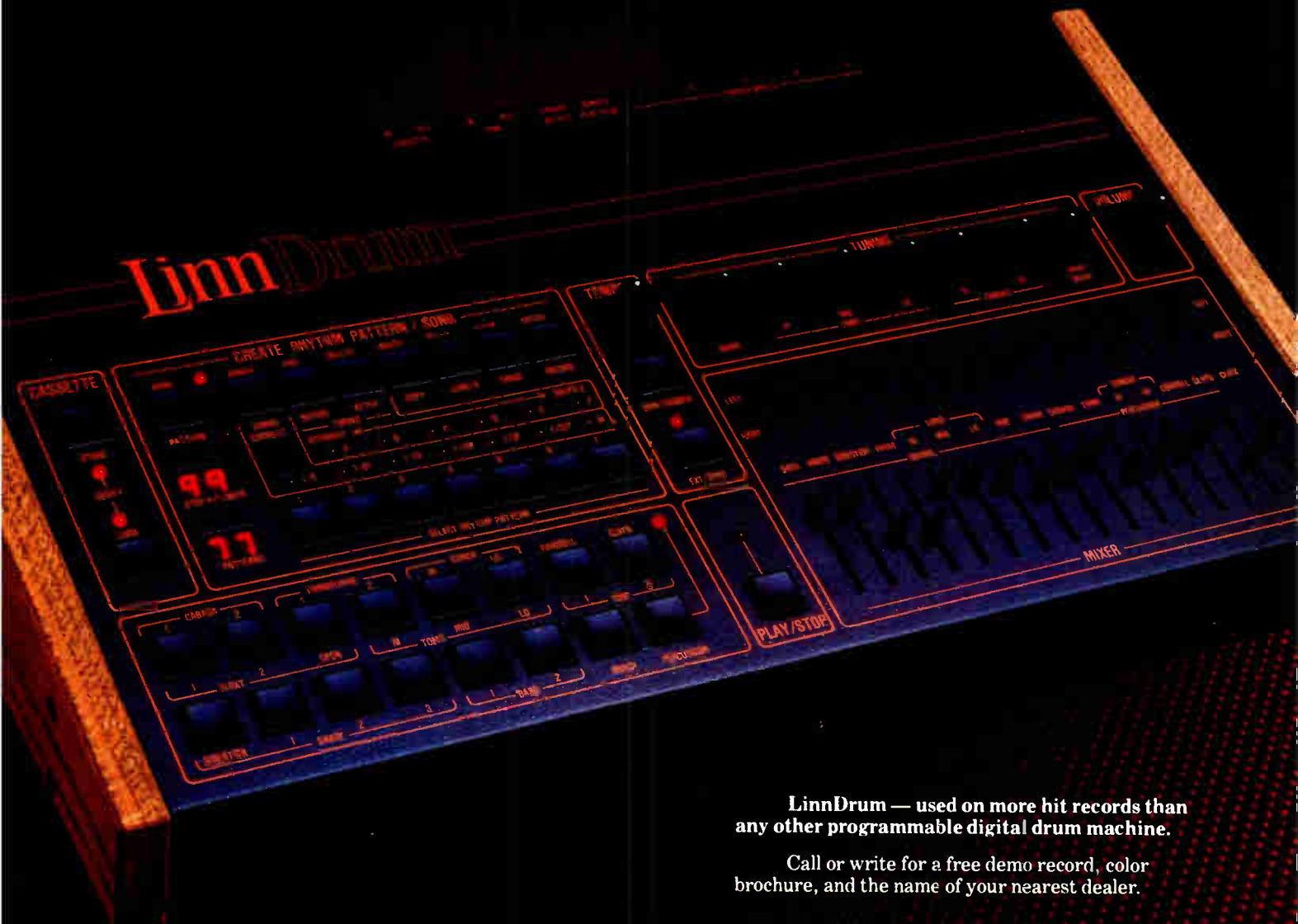

**LinnDrum** — used on more hit records than any other programmable digital drum machine.

Call or write for a free demo record, color brochure, and the name of your nearest dealer.

From the inventors of the digital drum machine LINN ELECTRONICS, INC.

**Linn**

18720 Oxnard Street, Tarzana, California 91356 • (213) 708-8131

## Motown Museum: Open House at Hitsville

Berry Gordy started Motown Records in 1959 with an \$800 loan and operated it out of his house on West Grand Boulevard in Detroit. Within a few years he was able to move to more handsome quarters, and Motown had expanded into seven more houses on the block by the time Gordy took the bulk of the operation to Los Angeles in 1972.

"We were like a horizontal eight-story building," laughs Esther Edwards, Gordy's sister and Motown's corporate Secretary and Senior Vice President, who oversees the Detroit operation. One of the houses was used for artist development, tutoring the talent in makeup, dress, and even etiquette. In another house, replicas of stages where Motown acts were due to play were constructed to aid in the planning and rehearsal of their intricately choreographed routines. Mixing and mastering facilities filled one house, financial and foreign sales operations another, and yet another house was occupied by the personal managers.

The hub of this wheel of creative energy was the white house with blue trim at 2648 West Grand. In addition to the main switchboard and several key administrative offices, this building contained the homemade living-room studio in which the hits that defined and refined the Motown Sound



*The Motown Museum.*

were cut. For a time after Motown left Detroit, there were no touchstones for the public to connect with the source of the much-loved Motown Sound. "We'd have people wearing backpacks knocking at the front door asking to see where it all began to Tamla Records, as we are known outside the United

States," says Mrs. Edwards. "We were embarrassed that we had nothing to show people who came here from so far away, so we opened up the Motown Museum."

The tiny rooms where Berry Gordy lived when he worked on the Lincoln-Mercury assembly line are now covered with album covers and a collection of memorabilia detailing the early days of the company. Closets are filled with sequined jackets and patent-leather boots collected from various groups, and photographs of the stars and Motown personnel through the years serve as a family album. Among the great pictured here are the Temptations and the Supremes, who at one time traded harmonies on Detroit street-corners as the Primes and the Primettes. Mrs. Edwards managed some of these artists herself for some time. "I've really enjoyed watching their progress," she says.

In much the same shape as when Smokey Robinson, the Jackson Five, Stevie Wonder, the Supremes and the other stars of the Motown galaxy recorded there, the studio is primitive by today's standards. Patch cords protrude from the walls and ceiling, allowing microphones to be placed wherever necessary to accommodate the instruments and players at each session. There were no isolation booths,

*Seven channels of handmade sound, marked with Dymo tape.*

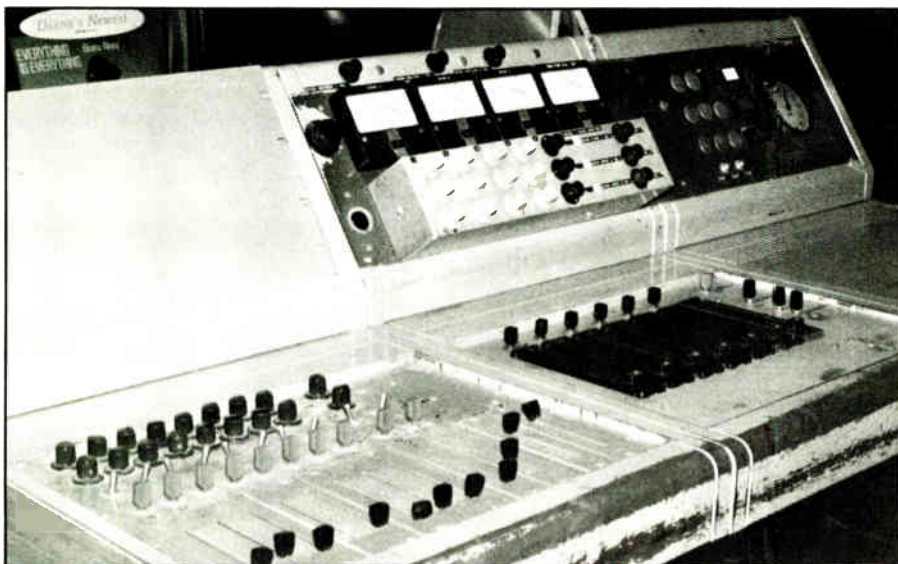

PHOTO: SUSAN BOREY

just a few burlap-covered partitions which provided only modest separation of the musical elements. A vintage Ludwig drum set still rests in one corner, surrounded by a few of these baffles, and a grand piano stands against another wall with its keys exposed. The vibraphone that rang out on songs like "Stop! In the Name of Love" occupies another corner, resonating in sympathy with the endless tape of great music recorded here that plays throughout the house.

Visitors who linger in the studio during the informal tour discover historic details such as the penciled horn and string charts strewn around the studio on dubiously balanced music stands. As you look and listen it's easy to imagine the look and feel of the session that produced this or that favorite song.

The control room's centerpiece is a mixing console with seven channels, each with a slider, tone control and "echo" knob marked with Dymo labels. "At first we had just two tracks to work with," Mrs. Edwards explains. "Then we went to four and then to

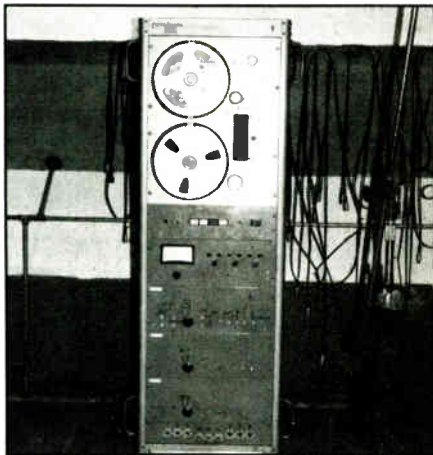

PHOTO: SUSAN BOREY

*This is the 1/4" deck on which Motown hits were mastered.*

seven." Most of the gear was custom-built in the basement by Gordy's enthusiastic and adventurous young staff. In the label's Detroit heyday there were about 400 employees, averaging about 25 years old, according to Mrs. Edwards. "The chief engineer was 18 when he was hired in. He had so many ideas for things he wanted to create, and sometimes he'd stay here all night working things out. Berry was the kind of person you could do that with—he was open to other people's ideas about how to do things better." Gordy always had his solid vision of the desired result, Mrs. Edwards notes, "and he looked for people to work with who had the soul

for what he was doing. He knew exactly what he wanted."

For a time the studio was open 24 hours a day. "The artists worked when the spirit hit them," Mrs. Edwards recalls. "Sometimes they'd come in at 2:00 or 3:00 in the morning to try one thing or another in the studio." These days the hours are more moderate—the

## Kevin Rowland Opens His Mouth For Dexys

The organizers of the New Music Seminar have made a terrible mistake, and now they're finding out about it the hard way. After chasing down Kevin Rowland of Dexys Midnight Runners and persuading him to be a guest speaker, they are now squirming in horror while Rowland rips their convention and everything it stands for.

"The term 'New Music' is ridiculous," Rowland says, pulling at one of the two gold earrings he wears. "Most of it isn't actually new; most of the hits sound like the same old thing regurgitated. I don't want to be associated with a term like 'New Music.' I don't want to do the same thing as

Motown Museum is open to the public on Fridays, usually from noon to five—but during those times people can be found perusing every nook and cranny of Hitsville, U.S.A., looking for a glimpse—or perhaps standing quietly, listening for a lingering echo—of the foundations of a great American musical phenomenon. —Susan Borey

everyone else."

Later in the evening, at a Phonogram Records reception, Rowland is more relaxed and not nearly as belligerent. Call it the fighting Irish spirit, or being able to say what's on his mind, or just plain pigheadedness—the fact remains, Kevin Rowland's tongue has gotten him a lot of what he calls attention and what we call trouble.

Just prior to his public lambasting of the New Music Seminar, Rowland was thrown off Bowie's European tour for insulting the audience and calling the Thin White Duke "a wanker." Furthermore, since the inception of Dexys in 1978 Rowland has waged an ongoing battle with the British music press which has gotten so bad that the two rarely even speak to each other nowadays.

None of this seems to faze Rowland, who's just an angry young man who sings rock and roll. Expressing himself openly is the only way he can keep his frustration with the music industry at a minimum. Despite the fact

—page 124

## Farther

A steer awakens from a nightmare and exclaims to his sleeping wife, "The golden arches! The golden arches got me!" Cows and chickens cease a discussion of physics and resume their traditional barnyard vocalizations when the farmer comes into the barn. And as two dinosaurs giggle at a furry little creature walking by, a third looks skyward at the snowflakes which are starting to fall.

That last image is about a philosophical as Gary Larson gets in his second collection of cartoons, *Beyond the Far Side* (Andrews and McMeel, \$3.95). Well, there is a panel that shows people emerging from a large broken jar labeled "humans" while a voice in the clouds says, "Uh-oh." But for the most part, Larson plays it for laughs with anthropomorphic animals, cowboys and the occasional scientist at the blackboard. If you've enjoyed the Far Side cartoons that grace Music

Notes every month, you'll love *Beyond the Far Side*. —D.G.

### THE FAR SIDE BY GARY LARSON



T H E O B E R H E I M D M X

# “LET ME OVERTURN A MYTH HERE...”

**this is the greatest drum box  
for sound and programmability,  
followed by the Linn.\***

Stewart Copeland (The Police)

The most successful producers, songwriters, and professional musicians have moved up to the sounds of the DMX. You've heard these sounds in recordings by producers Richard Perry and Jay Graydon, and by artists such as The Police and Herbie Hancock, just to name a few. These professionals have chosen the DMX because of its ability to adapt to any musical application with uncanny realism, instead of sounding like just another drum machine.

Oberheim's dedication to producing **studio quality, full frequency response** digital drum recordings has not stopped with the standard set of drums normally found on other drum machines. All of the voice cards in the constantly expanding DMX Library of Sounds are **user changeable**. Some of the new percussion recordings include a complete set of **Electronic Drums**. Other sounds include Conga, Timbale, Cowbell/Clave as well as special sound effects. In addition, the DMX has now been expanded with **more memory** and over **45 NEW FEATURES**.

-  Double the memory of any other drum machine (over 5000 events)
-  Unique "freeze frame" Step Mode programmability
-  Programmable Tempo
-  User changeable Voice Card Library
-  Performance Oriented Design for unrivaled ease of operation.

Your music is your personal statement—don't you deserve the best?

Notice to DMX owners:  
The new retrofittable DMX Memory Expansion Update is available at a nominal charge through your nearest Oberheim Service Center.

\*From *Melody Maker* interview  
June 18, 1983



**OBERHEIM  
ELECTRONICS, INC.**  
Some things are better than others  
2250 So. Barrington Ave.  
Los Angeles, CA 90064

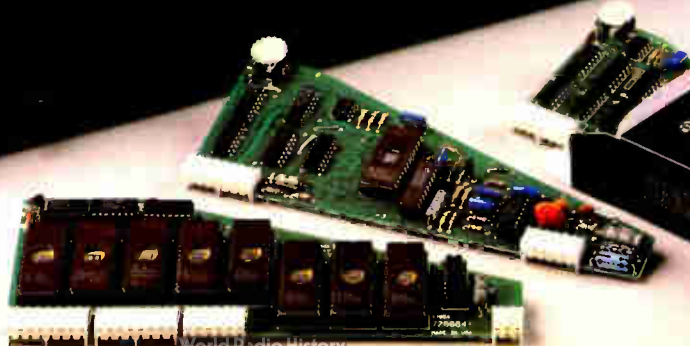

Circle #109 on Reader Service Card



**MORE THAN 1/3 OFF!**

# SUBSCRIBE TO *Mix*

THE RECORDING INDUSTRY MAGAZINE

One year \$18  
 Two years \$32  
 Outside U.S. add \$12 per year

Check/Money Order  
 Bill me  
 Visa/MC \_\_\_\_\_  
 Expires \_\_\_\_\_  
 Signature \_\_\_\_\_

**\*CASH BONUS! Send payment (check/M.O.) with order and receive 2 free copies of Mix.**

Co. Name \_\_\_\_\_  
 Name \_\_\_\_\_  
 Address \_\_\_\_\_  
 City \_\_\_\_\_ State \_\_\_\_\_  
 Zip \_\_\_\_\_ Phone \_\_\_\_\_

**Where did you get this copy of Mix?**

**Please check the appropriate boxes in order to help us process your order.**

**OCCUPATION**

170  Technician 720  Musician  
 171  Producer  Student  
 172  Engineer  Sales  
 Owner/Manager  Other

**TYPE OF BUSINESS**

Recording Studio: 185  Video prdn/broadcast  
 110  4-track 210  Manufacturer  
 120  8-track 260  Mastering/pressing/duplication  
 130  16-track 310  Retailer  
 140  24-track 410  Mfr's. representative  
 100  Other 610  School  
 175  Sound Reinforcement  Other

MIX READERS' INQUIRY SERVICE ISSUE: DECEMBER 1983, CARD EXPIRES APRIL 1, 1984

NAME \_\_\_\_\_ Phone ( ) \_\_\_\_\_  
 COMPANY \_\_\_\_\_ TITLE \_\_\_\_\_  
 ADDRESS \_\_\_\_\_  
 CITY \_\_\_\_\_ STATE \_\_\_\_\_ ZIP \_\_\_\_\_

Check each advertisement or editorial place for corresponding number and circle below (Maximum 20 items):

001	021	041	061	081	101	121	141	161	181
002	022	042	062	082	102	122	142	162	182
003	023	043	063	083	103	123	143	163	183
004	024	044	064	084	104	124	144	164	184
005	025	045	065	085	105	125	145	165	185
006	026	046	066	086	106	126	146	166	186
007	027	047	067	087	107	127	147	167	187
008	028	048	068	088	108	128	148	168	188
009	029	049	069	089	109	129	149	169	189
010	030	050	070	090	110	130	150	170	190
011	031	051	071	091	111	131	151	171	191
012	032	052	072	092	112	132	152	172	192
013	033	053	073	093	113	133	153	173	193
014	034	054	074	094	114	134	154	174	194
015	035	055	075	095	115	135	155	175	195
016	036	056	076	096	116	136	156	176	196
017	037	057	077	097	117	137	157	177	197
018	038	058	078	098	118	138	158	178	198
019	039	059	079	099	119	139	159	179	199
020	040	060	080	100	120	140	160	180	200

**PLEASE CIRCLE AN ENTRY FOR EACH CATEGORY:**

- Type of Firm:**
  - Recording Studio
  - Sound Reinforcement
  - Equipment Retailer
  - Equipment Mfg.
  - Record/Tape Processing
  - Video/Broadcast
  - Recording/Music School
  - Other
- Job Function:**
  - Owner/Manager
  - Sales/Marketing
  - Producer
  - Engineer
  - Technician
  - Consultant
  - Student
  - Musician/Performer
- Sex**
  - Female
  - Male
- # of Years in Industry.**
  - Less than 1
  - 1 - 3
  - 4 - 7
  - 8 - 12
  - 13 or more
- Trade Shows You Attend.**
  - AES
  - NAB
  - NAMM
  - CES
  - SMPTE
  - SPARS
  - PEPS
- This Inquiry Is For:**
  - Immediate Purchase
  - Files
- Purchasing Authority:**
  - Recommend
  - Specify
  - Approve
- Where did you get this copy of MIX?**
  - Subscription
  - Recording Studio/Prodn. Facility
  - Newsstand
  - Audio/Video Retailer
  - Other

**Circle number 200 above for 12 monthly issues of MIX MAGAZINE and we will bill you for \$18.**

MIX READERS' INQUIRY SERVICE ISSUE: DECEMBER 1983, CARD EXPIRES APRIL 1, 1984

NAME \_\_\_\_\_ Phone ( ) \_\_\_\_\_  
 COMPANY \_\_\_\_\_ TITLE \_\_\_\_\_  
 ADDRESS \_\_\_\_\_  
 CITY \_\_\_\_\_ STATE \_\_\_\_\_ ZIP \_\_\_\_\_

Check each advertisement or editorial place for corresponding number and circle below (Maximum 20 items):

001	021	041	061	081	101	121	141	161	181
002	022	042	062	082	102	122	142	162	182
003	023	043	063	083	103	123	143	163	183
004	024	044	064	084	104	124	144	164	184
005	025	045	065	085	105	125	145	165	185
006	026	046	066	086	106	126	146	166	186
007	027	047	067	087	107	127	147	167	187
008	028	048	068	088	108	128	148	168	188
009	029	049	069	089	109	129	149	169	189
010	030	050	070	090	110	130	150	170	190
011	031	051	071	091	111	131	151	171	191
012	032	052	072	092	112	132	152	172	192
013	033	053	073	093	113	133	153	173	193
014	034	054	074	094	114	134	154	174	194
015	035	055	075	095	115	135	155	175	195
016	036	056	076	096	116	136	156	176	196
017	037	057	077	097	117	137	157	177	197
018	038	058	078	098	118	138	158	178	198
019	039	059	079	099	119	139	159	179	199
020	040	060	080	100	120	140	160	180	200

**PLEASE CIRCLE AN ENTRY FOR EACH CATEGORY:**

- Type of Firm:**
  - Recording Studio
  - Sound Reinforcement
  - Equipment Retailer
  - Equipment Mfg.
  - Record/Tape Processing
  - Video/Broadcast
  - Recording/Music School
  - Other
- Job Function:**
  - Owner/Manager
  - Sales/Marketing
  - Producer
  - Engineer
  - Technician
  - Consultant
  - Student
  - Musician/Performer
- Sex**
  - Female
  - Male
- # of Years in Industry.**
  - Less than 1
  - 1 - 3
  - 4 - 7
  - 8 - 12
  - 13 or more
- Trade Shows You Attend.**
  - AES
  - NAB
  - NAMM
  - CES
  - SMPTE
  - SPARS
  - PEPS
- This Inquiry Is For:**
  - Immediate Purchase
  - Files
- Purchasing Authority:**
  - Recommend
  - Specify
  - Approve
- Where did you get this copy of MIX?**
  - Subscription
  - Recording Studio/Prodn. Facility
  - Newsstand
  - Audio/Video Retailer
  - Other

**Circle number 200 above for 12 monthly issues of MIX MAGAZINE and we will bill you for \$18.**



NO POSTAGE  
NECESSARY  
IF MAILED  
IN THE  
UNITED STATES

**BUSINESS REPLY CARD**

FIRST CLASS PERMIT NO. 2994 BERKELEY, CA

POSTAGE WILL BE PAID BY ADDRESSEE

**Mix Magazine**  
**P.O. Box 6395**  
**Albany, CA 94706**



NO POSTAGE  
NECESSARY  
IF MAILED  
IN THE  
UNITED STATES

**BUSINESS REPLY CARD**

FIRST CLASS PERMIT NO. 217 CLINTON, IOWA

POSTAGE WILL BE PAID BY ADDRESSEE

**Mix Magazine**  
**P.O. Box 1960**  
**Clinton, Iowa 52735**

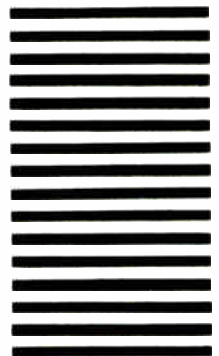

NO POSTAGE  
NECESSARY  
IF MAILED  
IN THE  
UNITED STATES

**BUSINESS REPLY CARD**

FIRST CLASS PERMIT NO. 217 CLINTON, IOWA

POSTAGE WILL BE PAID BY ADDRESSEE

**Mix Magazine**  
**P.O. Box 1960**  
**Clinton, Iowa 52735**

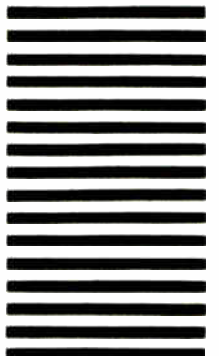

## W O R D S M I X

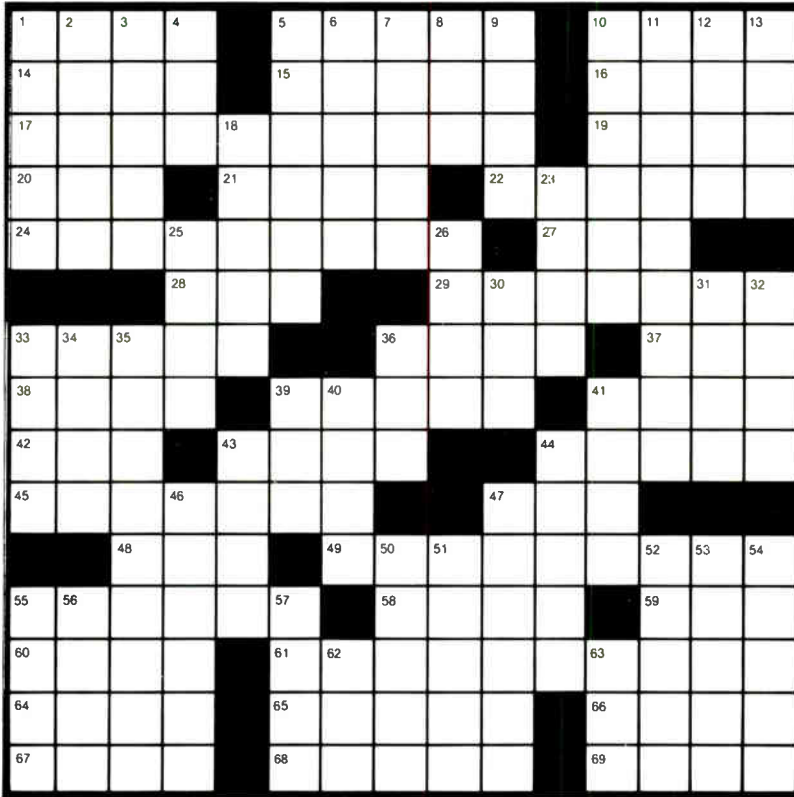

### "PHONO FHREAK"

©1983 Armand E. St. Martin

#### ACROSS

1. Top
5. Lines
10. School grps.
14. Type of school
15. Brilliance of success
16. \_\_\_\_\_ of thumb
17. Lover of 45A
19. Biblical name
20. Amin
21. Infrequent
22. Alerted
24. A 49A for 17A
27. Humor
28. Buck's companion
29. Part of 11D
33. Orient, to -ians
36. State of confusion
37. Brief history
38. Highland family
39. Redacts
41. Got off
42. Type of dance
43. Grand \_\_\_\_\_
44. Certain tires
45. Home systems
47. Parseghian
48. State, river, or Indian
49. Integral part
55. Adjust in advance
58. Body \_\_\_\_\_
59. \_\_\_\_\_ off
60. Sites
61. Privacy device for 17A
64. Inquires
65. Nod
66. Milky prefix
67. Aerie
68. Tone deaf (2 wds)
69. Report card letters

7. Bend, to Pierre
8. Cure, to a Cockney
9. State of perturbation
10. Certain dog
11. Rotating platform
12. An agave
13. Monitor
18. Navy's P-3
23. Aristae
25. East of \_\_\_\_\_
26. Editor's word
30. CIA predecessor
31. Strap; thong
32. Harvests hay
33. Succeedingly doubled frequencies (abbr.)
34. Strip of wood
35. More items for 17A

36. An audio proportionment
39. I was, to Nero
40. Platter
41. Mexican custard
43. Soccer great
44. Soup
46. Defy
47. Sign \_\_\_\_\_ (get a contract)
50. Busy airport
51. Wife of Jason
52. Certain heaters
53. Relative
54. S.A.T.'s
55. Scheme
56. Compass \_\_\_\_\_
57. Particle of comparison
52. Self
63. Line or hat

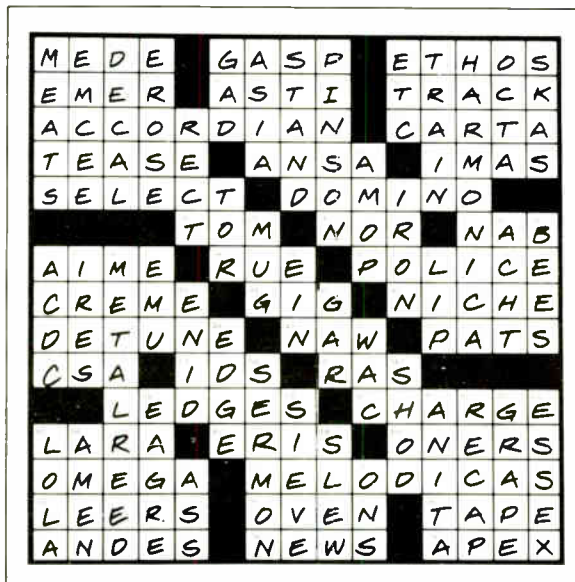

### solution to November Mix Words

#### DOWN

1. \_\_\_\_\_ of Jacks
2. Uncut
3. Para followers
4. See 1A
5. Add new macadam
6. A mellow yellow

## Commentary And Here's to You, Jackie Robinson

A brace of less-than-bracing concerts at my hometown baseball stadium provides some food for thought on the subject of unfortunate trends in live music. While Hollywood doesn't charge admission to the tapings of its programs, it appears that rock and roll does—and a handsome ticket it is, too. For the "Day on the Green" concerts featuring Simon and Garfunkel (with no supporting act), The Police (with four bands opening) and David Bowie, patrons paid \$17.50 to get in—and at that, we had to watch on the monitors.

I saw Bowie in 1978 at Houston's Summit Arena, and there were video screens—the Summit's permanent system, which is used for basketball, hockey and indoor soccer as well as the musical events. The giant image of Bowie (and occasionally other members of the performing ensemble) enhanced the experience in the 17,000-seat arena, giving the audience the option of looking at the people on stage or at whatever shot the video director had chosen for the moment. The cameras didn't get in the audience's way, and the arena was surprisingly intimate even without visual augmentation.

Now video is commonplace at concerts, and the acts design their presentations around it. The first time I noticed the tail wagging the dog with a vengeance was at the Us Festival, in September of 1982. Two huge Eidophor projection screens (which only operated after dark) and the grainy but chromatically intense DiamondVision screen (daylight and evening) dominated the visuals and dwarfed the performers. Many who were close enough to see the flesh-and-blood performers ended up watching the video, though, because a gigantic camera crane hulked around in front of the stage like a tall and unruly fan in a ten-gallon hat, only bigger, seeing to it that nobody's sight lines remained unobstructed for long.

At the Jamaica World Music Festival at Montego Bay last November, spectators had to deal with the cameras—and they didn't even get to see the video, since the proceedings were being taped for later packaging but no arrangements were made to

compensate the ticket buyer for his inconvenience.

The Police concert at Oakland demonstrated that 65,000 ecstatic fans can't be wrong. There was much pleasure in the upcast arms and singing throats when the trio hit the stage—and the high ticket prices and miserable viewing conditions were forgotten for the moment. But the fact that old curmudgeons such as yours truly managed to get excited *despite* the tragically wrong conditions of our spectatorship speaks volumes for the amazing charisma of The Police—and offers absolutely no justification for the setting. It's barely excusable at \$10 a ticket, but at nearly twice that (after you pay the mandatory computer ticket agency service charge) it's a crime.

If I'm going to have to watch a concert on television, I'd rather do it at home where I can control the sound, the picture is clear, and I can enjoy the performance without stepping in the noisome byproducts of other people's overindulgences. The popcorn is fresher at home, too, and the beer is cheaper.

It can be successfully argued that rock benefits from the electricity a huge crowd can generate, but I submit that there's a law of diminishing returns in effect. When half the audience finds itself a Reggie Jackson home run away from the stage watching video while unidentifiable blobs of light bob on an overlit set—and when the sound arrives nearly half a second behind the visual image—it isn't even a truly shared experience any more. It's physically impossible for 50,000 people to clap their hands and sing along, no matter how potent the glow on the stage (or image on the screen) might be, because when the venue is that big the people don't all hear the music at once.

Sure, The Police were awesome (one of the very, very few instances where that overworked '80s buzzword is justified), but I'd sure like to be able to see them and hear them live some time. I'd gladly have paid \$17.50 to see The Police, or Simon and Garfunkel—*especially* the latter—in a 3500-seat auditorium, a 10,000-seat amphitheatre, or even a 17,000-seat arena, but *only* if I could see and hear. I can see the economic logic behind the move to larger venues, but the *only* advantage is financial; the esthetic end is suffering in a very big way.

Simon and Garfunkel proved the old adage that a great song can transcend a bad performance. It was heart-breaking to see these two gifted craftsmen and their skilled band, performing some of the greatest songs ever

written, in a situation so utterly lacking in intimacy. This is fireplace music, coffee house music, concert-hall fare at best; it is not suitable for baseball stadiums. I don't regret having attended—a moment or two of magic managed to survive the trip across the stadium to my eyes and ears with some energy intact—but I didn't have to pay for my ticket. Had I invested nearly twenty bucks for my reserved seat at this outdoor television show, I'd have wanted to storm the box office before the gig ended.

Music video is as exciting in its infancy as film, broadcast television and

multitrack were in theirs. It took a while for those technologies to find their proper modes of expression and to develop their own traditions—and for the creative community to find their voices and wrest control from the engineers. For the time being, the dollar signs are obscuring the view; *these* visionaries are giving vision a bad name.

As long as people pay for these non-concerts, the acts and promoters will continue to stage them. Let's hope they don't kill off live music in the process.

—D.G.

## Original Jazz Classics: Fantasy's Treasure Trove Runneth Over

Fantasy Records threw open a Fort Knox when it initiated the Original Jazz Classics, a series of \$5.98-list reissues of great titles from the catalogs of Prestige, Riverside, Milestone and other defunct labels whose wealth now resides in Fantasy's Berkeley, California vault. These records, mostly out-of-print jazz classics from the '50s and early '60s, have in recent years been available only to ardent, price-no-object collectors—and rereleasing them has turned into perhaps *the* major wrinkle in jazz marketing in 1983.

In the spirit of faithful revivalism, the albums have been packaged in their original covers, many of which have a campy graphic charm (e.g. the marching E.T.-like creatures on *Miles Davis With Horns*). Hard-to-find jewels by Miles Davis (pre-cool), John Coltrane, Charles Mingus, Thelonious Monk, Eric Dolphy and a host of other heroes hit the stores last February in the first wave of releases, 40 titles strong. Thirty more were added to the list last summer, and as you read this 20 more are headed for the record racks.

Avid public response to the series has stoked enthusiasm for the project at Fantasy. "We've made believers out of a lot of people," says National Sales Director Kirk Roberts. If distributors were at all reticent at first, the sales momentum generated by the initial release eased their minds, and "orders for the next 30 came in at double the rate of the first ones. This time

we'll be out in time for Christmas—and with the discounts the stores are giving them, people can afford to buy four or five at a time with no strain."

Proferring historic vinyl is nothing new at Fantasy. In the mid-'70s the label came up with the "Twofer," a specially priced double record of classic material—a format which has since been imitated by other labels. Like Twofers, the OJC series is the brainchild of Fantasy President Ralph Kaffel, who was a wholesale record distributor in Los Angeles before taking the wheel at Fantasy in 1971. Having handled these older jazz works in their first go-rounds, Kaffel can claim a particular savvy for selecting OJCs that will be both noteworthy and popular.

"It's hard to say what prompted the Original Jazz Classics," says Kaffel. "Twofer sales were substantial but diminishing. You can't expect catalog titles to sell at the same rate forever; the novelty has worn off. Still, I knew there was a large collector's market, and people are always bemoaning having to deal with paying \$50 or \$60 for the originals—if they could find them.

"But the real impetus for the new series was the example set by the Japanese," Kaffel continues. "They're sticklers for originality, and they've been packaging jazz classics in facsimile form. The belly bands we've been using [paper strips around the album with modern commentary on its historical significance] came from the Japanese reissues—they use them to translate the English into Japanese."

Japan's love affair with jazz is notorious. The Japanese go to impressive effort and expense in its pursuit, importing American jazz players for concerts and supporting a network of journals and record labels. For Fantasy, the facsimile effort might seem to involve nothing more strenuous than tripping down into the basement. In

—page 124

# DOCTOR CLICK

The Doctor Click Rhythm Controller makes it possible for the first time to synchronize the world of sequencer, drum machine, synthesizer composition with any one of the systems on the market or combinations of the systems on the market. Furthermore, the Doctor Click will cause sequencers, drum machines and synthesizers to play in time with a human drummer. It will also read click tracks and sync codes. The internal metronome provides both beats per minute and frames per beat calibrations.

## THE DOCTOR CLICK RHYTHM CONTROLLER BREAKS THE BRAND BARRIER

SEQUENCERS		DRUM MACHINES		SYNTHESIZERS*	
DSX	Bass Line TB303	Linn LM-1	CR5000	Prophet 5	Modular Moog Juno 6
Prophet 10	CSQ600	LinnDrum	CR8000	Prophet 10	OBX Juno 60
Polysequencer	SH101	DMX	CR68	Prophet 600	OBXa Polysix
Pro One	Emulator	Drumulator	CR78	Prophet T8	OB8 Poly 61
Model 800	Fairlight	TR808	KPR-77	Minimoog	JP4 Voyetra-8
Microcomposer MC4	Synclavier	Drumatics TR606		Memorymoog	JP8
Chroma					

\*(VCA, VCF, VCO, Gate, Trigger or Arpeggiator as provided on each unit.)

Measures  
17½" x 11" x 4½" x 2½".  
Weight is 8 pounds.

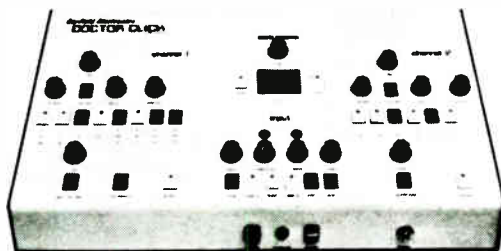

Warranty is one year.  
Call or write for location  
of your nearest dealer

## ONE DOCTOR CLICK CONTAINS ALL OF THESE PROBLEM SOLVING DEVICES

- 4 Fixed Clock Outputs
- 2 Variable Clock Outputs
- 2 Metronomes
- 2 FSK Sync Code Decoders  
(Covers Linn, Oberheim, Roland)

- 2 Rhythm Envelopes
- Pulse Counter
- Pulse Shaper
- Gate Output

- Headphone/Speaker Output
- Roland 5 Pin DIN Sync Output
- External Clock Input
- Footswitch Controls

The brand to brand problems of timebase, voltage level and polarity are solved by the Doctor Click's diverse output capability.

The ability of the Doctor Click to connect to many units at once coupled with its footswitch control capability makes it ideal for multiple sequencer, drum machine, synthesizer live applications.

Since the Doctor Click metronome produces beats per minute and frames per beat calibrations it is always convenient to get just the tempo you need. It is even possible to get fractional tempos such as 118½ beats per minute.

The Doctor Click's two independent rhythm actuated envelopes allow VCF, VCA and VCO parameters of synthesizers to be modulated in 32 rhythm values ranging from four measure cycle to 64th note triplet with variable attack, decay, sustain and amount. This eliminates the problem of rhythmic drift when using a conventional LFO.

The ability of the Doctor Click to transform metronome click tracks into timebase clocks allows frames per beat music film work to be

done with virtually any sequencer, drum machine or synthesizer. The ability of the Doctor Click to read live tracks allows sequencers, drum machines and synthesizers to play in sync with the varying tempos of a human drummer or a built click track.

The ability of the Doctor Click to accept external clocking or either of the types of FSK sync to tape codes allows sequencers, drum machines and synthesizers to be synced to any existing track.

The pulse shaper circuit turns a pulse from an instrument into a trigger waveform allowing synthesizers to sync to a drum fill.

The headphone output allows click tracks in multiples of the tempo to be generated and is capable of driving a speaker.

The pulse counter can be used to program sequencers in higher timebases, quickly combining greater rhythmic resolution with step programming accuracy.

The step programming switch can be used to step program sequencers that normally do not have this capability.

Used on tracks by Brian Banks, Tony Basil, John Berkman, Michael Boddicker, Kim Carnes, Suzanne Ciani, Joe Conlan, Chris Cross, Bill Cuomo, Jim Cypherd, Paul Delph, Barry DeVorzon, Don Felder, Paul Fox, Dominic Frontier, Terry Fryer, Albhy Galuten, Lou Garisto, Herbie Hancock, Johnny Harris, Hawk, James Horner, Thelma Houston, Michael Jackson, Quincy Jones, Jeffrey Kawalek, Gordon Lightfoot, Jerry Lilledahl, Johnny Mandel, Manhattan Transfer, Paul Marcus, Jason Miles, NBC Movie of the Week, Randy Newman, Keith Olsen, Paramount, Joel Peskin, Oscar Peterson, Greg Phillingaines, Jean-Luc Ponté, Steve Porcaro, Phil Ramone, Lee Ritenour, Steve Schaeffer, Mike Sembello, Mark Shifman, John Steinhoff, Sound Arts, Ian Underwood, Universal, Donna Washington, Stevie Winwood, Pia Zadora.

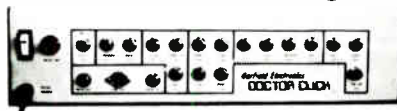

GARFIELD ELECTRONICS P.O.B. 1941, BURBANK, CA 91507 (213) 840-8939

Introducing  
**THE  
 SOUND EFFECTS  
 LIBRARY  
 FOR  
 PROFESSIONALS**

- 3000 STEREO EFFECTS
- 30 HOURS OF SOUNDS
- 125 TAPES at 7½ or 15ips
- PRICED FROM \$1500.00
- NO ROYALTY PAYMENTS EVER

"Some of our Clients."

- \* ABC
- \* NBC
- \* CBS
- \* Walt Disney



86 McGill Street,  
 Toronto, Ontario,  
 Canada. M5B 1H2  
 (416) 977-0512

Circle #111 on Reader Service Card

<p>CONNECTORS AND MICROPHONE CABLES</p>	<p>BLANK-LOADED AUDIO CASSETTES</p>
<p>TAPES &amp; CASSETTES from</p> <p>AMPEX    MAXELL          AGFA    TDK          BASF    3M</p>	<p>EMPTY REELS AND BOXES</p>
<p>NAB BROADCAST CARTRIDGES</p>	<p>CASSETTE BOXES, LABELS, ALBUMS</p>
<p>ACCESSORIES</p>	

Ask for our  
**44 PAGE CATALOG**  
 of  
**PROFESSIONAL  
 SOUND RECORDING  
 & DUPLICATING SUPPLIES**

Recording Supply Div. of Polyline Corp  
 1233 Rand Road, Des Plaines IL 60016  
 (312) 298 - 5300

35

Circle #112 on Reader Service Card

—from 122, *Jazz Classics*

truth, the process was more involved, coping with tapes in various states of disrepair and hounding the files of critics and collectors for mint-quality covers they could reproduce. The working principle was to stay historically pure while bringing the audio up to contemporary standards.

The sonic restoration was in the hands of Fantasy's master masterer, George Horn, and engineer Gary Hobish. Except for two or three albums for which no master tape could be found, Hobish notes, the process was one of doctoring, Dolbyizing and remastering from the original tapes. "In spite of ancient tape—with problems like old splices and print-through—we didn't have to give them a whole lot of special treatment," he says. "I tried to remain true to the producer's intent. As a matter of fact, whenever we ran across electronically-simulated stereo we took it back a step."

Hobish had to take great care when dealing with tapes dating back to the '40s. Acetate, the backing medium of that era, inevitably becomes weak and brittle, and thus can disintegrate when wound at high speeds. The processing of these recordings couldn't have been done without high-grade machinery. Played back on a Studer A80 VU through a Neumann console, the masters were cut on a Neumann 66 EMS lathe with an SX74 cutter head and a Zuma Audio Computer. Sontec equalizers were also employed, but Hobish suggests that a cleaner renovation was the natural byproduct of improved technology more than anything specific. "We have better equalizers today, and the quality of the lacquer discs and other equipment is so much more

advanced that it's possible to cut a hotter disc." While they were cutting, a new Dolby master tape was dubbed, making this a restoration/archive project, too.

Preserving the jazz legacy of the '50s and early '60s—a rich transitional period between bebop and the assorted modern and free jazz threads of the '60s—is certainly a noble endeavor, profit motive allwithstanding. "We're trying not to prostitute the concept," Kaffel asserts. "I try to put out what will sell but what is also deserving of the term 'jazz classic.' We want to be discriminating." And where do Kaffel's own tastes fall? "They're pretty well reflected in the OJC choices," he laughs. "One of my own favorites was one by the Billy Taylor Trio—which was probably the weakest seller in the line."

The jazz world stands to benefit greatly from series such as the OJCs, providing invaluable historical links to the dominant strains in present-day jazz—which is itself in a fairly nostalgic frame of mind at present. Listening to George Russel's *Ezz-Thetic*, propelled by the protean sax blowing of Eric Dolphy, the musical distance between that session and what's currently coming out of New York seems a great deal shorter than 22 years. Kaffel feels that the jazz world maintains a consistently high awareness of history. "Merchandising takes different forms," he says. "Two-fers and OJCs were unnecessary and superfluous several years ago, when a lot of these records were still available.

"Eventually we'll run out of classics, but by that time another form of merchandising will have been developed," says Kaffel.

—Josef Woodard

—from 119, *Rowland*

that his last album, *Too-Rye-Ay*, scored a top ten hit ("Come On Eileen") and went platinum in Europe and gold here, Rowland remains annoyed.

"I honestly don't think we're over the barrier. We've only had one hit single here (in the States) and at the moment we're in danger of being seen in some quarters as a singles group only. The fact is we made an album with 10 songs on it and 'Come On Eileen' is just one of them. Radio should play the whole album! We're having trouble getting our LPs played on the radio here, so there's not an overall picture coming over of what we're about."

According to Rowland, what Dexys Midnight Runners is all about is *not* really a blending of traditional Celtic music and modern-day pop, as

most critics have labeled them, nor is it an update of what Van Morrison was doing in the early 1970s. "Van Morrison," says Rowland with a tone of urgency in his voice, was "quite a bit different than us. My interpretation is a lot different; I come from a different generation and another part of Ireland. I'm just looking back on my roots to make Dexys something else. I don't see it as any merger."

Rowland says the next Dexys album will be a vast departure from his current sound. Also gone will be the Irish ghetto look that so perfectly tied into the last record. "I wouldn't say we're going to have a look (with the next album). It's not that political, really. I mean, you wear different clothes than you did last year, don't you?"

—Bruce C. Pilato

# "We Don't Miss a Sound"

Whether you need a P.A. system to get the sound out to your audience or a monitor system to get the sound back to you, Carvin has over 25 different matched systems of which one will be right for your application.

We sell "DIRECT" from our manufacturing plant in California, which means that you can save hundreds of dollars. We also give fast Mail-Order service with low freight rates! Another big plus at Carvin is our ten day trial with your money back if not satisfied. When in southern California, visit our showrooms for a personal demonstration.

To receive your 84 page color catalog of P.A. systems, tube and solid state guitar amps, electric guitars and basses, and guitar parts send \$1 (or) \$2 to rush by 1st class mail.

*"Because quality sound reinforcement is critical in the music business, we rely on Carvin."*

— Terry, Dale & Warren,  
Missing Persons

MX 1644	16 in 4 out P.A. /recording board	\$1898
DCA 800	800w (bridged) stereo power amp	\$ 549
EQ 2029	29 band 1/3 octave Equalizer	\$ 279
XC 1000	Stereo electronic crossover	\$ 279
750M	Pro monitor, w/Magnalab	\$ 169
790E	Pro monitor, w/15" EV	\$ 259
1330E	Horn loaded bass bin w/15" EV	\$ 279
R540E	90° radial horn w/EV driver	\$ 279



CALL FREE 800-854-2235  
Calif. 800-542-6070

# CARVIN

Dept MX 52, 1155 Industrial Ave.,  
Escondido, CA 92025

Circle #113 on Reader Service Card  
World Radio History

**CARVIN CATALOG**  
 \$1 for Bulk Mail     \$2 for First Class Mail

Name \_\_\_\_\_ Street \_\_\_\_\_ City \_\_\_\_\_ State \_\_\_\_\_ Zip \_\_\_\_\_ MX 52

# Born to Laugh at Convention

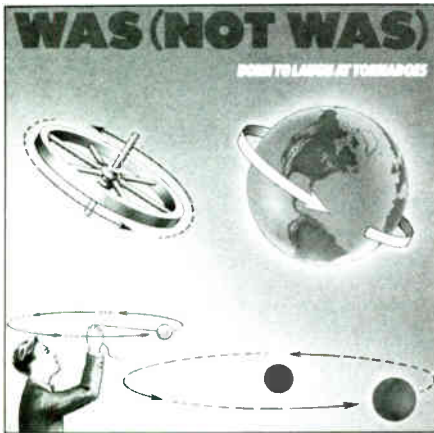

## WAS (NOT WAS) Born to Laugh at Tornadoes Geffen GHS 4016

*Produced in Detroit by Don St. Was, David St. Was and Jack Tann for John Lewis Productions; Don Was—Recording Zengineer, assisted by Michael Brown and Warren D. Woods, Jr.; all songs mixed with nerves of steel by David Thoener at Record Plant, NYC, except "Shake Your Head," "Man Vs. the Empire Brain Building" and "The Party Broke Up," mixed by the Detroit Wasmopolitan Mixing Squad: Duane Bradley, Ken Collier and Don Was at Sound Suite, Detroit. Recorded at Sound Suite, Detroit, and other locations; Originally mastered by Greg Fulginiti at Artisan Sound Recorders, L.A.*

### Careful Casting

*Born to Laugh at Tornadoes*, the second album from Detroit's Was (Not Was), boasts an impressively diverse lineup of big-name ringers in addition to the Was brothers' usual repertory company of skilled players. But it's not like some arranged studio marriage intended to inflate sales potential at the expense of artistic merit, nor are the guests overpaid puppets bending to the will of some Man with a Plan. Was (Not Was) *auteurs* Don Fagenson and David Weiss simply and without fanfare chose the right people for the parts they had in mind. How fortunate that their talent can attract such talent.

Getting Mel Torme to sing "Zaz Turned Blue" was the highlight of making *Tornadoes*, says Fagenson. "Once the song was written we could never think of anyone else to do it." Weiss had met Torme in the course of his day gig as jazz critic for the Los Angeles *Herald Examiner* and

was on good terms with the singer, so he approached him with the idea.

"It is great testimony to him that he was willing to try this," says Fagenson. "It's clearly not his usual song." The form is not alien to Torme—it's a delicate cocktail ballad—but the content is another story altogether. I don't think he ever sang a line like "Steve squeezed his neck." Torme "found nuance—both musically and lyrically—that David and I didn't even know we'd written into the song."

"Shake Your Head," a rap track jammed to the ratters with Weiss' uniquely twisted but marginally useful insights ("You can't drink lava from plastic glasses. You can't influence the masses") ended up being sung by Ozzy Osbourne, but several other renditions were recorded first—none of which caught the spirit of the song. "I mentioned to our attorney, Fred Ansis, that we were having trouble finding the right singer," says Fagenson. "Fred suggested we try Ozzy, who he also represents and who happened to be in New York. It was so absurd that we had to try—and he was perfect!"

### The Triumph of Zengineering

"Does the lack of funk bother you?" Fagenson asked me. "People expected a certain kind of thing after our first album, I guess, but

*[Born to Laugh at Tornadoes]* is a very natural thing to me, there's a real cohesiveness to it. It fits in fine to me, but there have been people who said, 'I thought you sounded like Rick James.'"

It's not so much the lack of funk as the presence of more styles. Fagenson is a real dyed-in-the-wool studio junkie, and perhaps he just happened to be studying funk during the making of the first album, *Was (Not Was)*. "I really liked the Beatles' *White Album* when I was growing up," he notes. "Never was there more of an anthology than that. From 'Martha My Dear' to 'Revolution #9,' there was one of everything—and yet it made perfect sense." With the encouragement of Ze Records' Michael Zilkha and Geffen's A&R people, Fagenson and Weiss have been allowed to roam freely across the musical landscape.

That's the way it's always been for the Was brothers, really, since they first teamed up in front of a stereo tape deck during their junior high school years. Both Fagenson and Weiss were musicians, but their intellectual affinity encompassed other disciplines including the psychedelic radio plays of the Firesign Theatre.

Fagenson dropped out of college pretty early and went to work in an eight-track studio, playing bass in a bar band at night. He eventually arrived at what he called "The School of Reckless

Don Fagenson (Was)



PHOTO: LAUREN GIBBS



Engineering" (later renamed "Zen-engineering" out of respect for Geffen's uptown image), a pragmatic, life-affirming approach based on the belief that "the best way to engineer is not to engineer at all." The function of an engineer, Fagenson explains, is to protect the delicate path between the artist's inspiration and the listener's ear. "Anything that gets in the way can ruin the art," he says.

Most of the tracking of *Tornadoes* was done at Detroit's Sound Suite, where Fagenson has a very creative arrangement. "We do overall, flat-rate things with studios. In this case, we had the Sound Suite from midnight on, every night—all the time, until the next session came in. If there wasn't anything booked the next day I stayed for 48 hours. I can't work the other way."

Fagenson believes—and *Was (Not Was)* illustrates—there's a better way to work than the union-wage, three-hour session arrangement. "There's a way to be fair with the studio and the musicians without sticking to this time-clock thing that's counter-musical." The Detroit musicians who work with *Was (Not Was)* are friends as well as professionals, says Fagenson, "and when their sessions are done they hang out. It's very loose, and there's a lot of people in the studio most of the time—and it's fun."

Fagenson engineers his own sessions, and says "even if I'm just listening to another guy playing, I'm into the music and not the levels. On this album there are some tracks—some background vocals, the Simmons toms on 'Bow Wow Wow Wow'—which are distorted because I wasn't paying attention when I cut them. But I kept them because they felt right."

The only guiding principles of Engineering, it seems, are survival and fun. If it's enjoyable, and commercial enough to earn another shot, then it's a success. "I like working with a lot of different people," Fagenson observes. "In the end, that's why I worked in all the different studios [Media Sound, Sigma, the Record Plant and 39th Street in New York, Criteria in Miami, and Gnome in Detroit]—because it's fun. I love being in new studios."

#### Tech Talk

Equipment is "secondary" to the Engineering concept, says Fagenson. About the only item he uses consistently is a dbx 160 compressor/limiter. "I was raised listening to radio stations that compress the shit out of everything, so that's the sound I think a record is supposed to have," he says.

Compression is the only effect Fagenson uses when tracking. "Sometimes by accident I'll get a good sound with the EMT 250, and I'll print it on a separate track." For the most part, though, Fagenson prefers to record dry and handle the effects when mixing—but "from the first sessions, I'm always thinking mix."

—David Gans



#### STEVE SMITH Vital Information Columbia FC 38955

*Produced by Steve Smith; engineered by Phil Green, assisted by Tom Soares; recorded at Normandy Sound, Warren, Rhode Island*

Journey fans might be a bit surprised by this first album from the group's drummer, Steve Smith, but *Vital Information* is actually a somewhat predictable move for Smith. He attended the Berklee School of Music (where he also came the other members of the *Vital Information* band) then went on to tour with Jean-Luc Ponty, Ronnie Mottrose and Tom Coster. He still plays with Coster when not pounding out million-sellers with Journey, so not only are his jazz influences well-rooted, they're very much still with him.

*Vital Information* is a very blend of jazz and rock, with an emphasis on the latter. The band comes on loose but strong on bassist Tim Landers' brash "Looks Bad Fee's Good." "Questionable Arrivals" showcases guitarist Dean Brown and saxman Dave Wilczewski in a high-energy setting intensified by Smith's double bass drum work. Wilczewski's "Stoughton to Stockholm Samba" is, as the title implies, a Euro-Americanized Latin tune that sets up some great soloing from guitarist Mike Stern, lately an associate of Miles Davis. The group wails on a sort of traditional jazz "head" on "V.G.," then takes it outside on the title track with some frantic sparring. "All That Is" brings to mind the short-lived band Group 37 with slow and haunting melodies and mechanized-sounding rhythmic passages. Smith's drumming on the tune recalls former Group 87 drummer Terry Bozzio.

Smith has succeeded where many others have failed in putting together a diverse but cohesive-sounding record. He shows talent for arranging and writing as well as a solid feel on drums through every tune. He catches every angle and makes things happen. Journey fans already know how skillful a drummer Smith is, but *Vital Information* should help get that point across in other worlds.

—Robin Tolleson



**MAGNETIC SCIENCES**

**For the Finest  
Tape Recording  
Heads and the  
Ultimate in  
Relapping  
Services.**

**We carry a full line of heads  
in stock including . . .  
1/2-inch, 2-track heads.**



We also provide precision relapping and optical alignment of all magnetic recording heads and assemblies. If you need optimum performance from your tape recording equipment you need our services. Call or write:

**JRF COMPANY**  
101 LANDING ROAD, LANDING, NJ 07850  
201/398-7426

Circle #114 on Reader Service Card

**jensen transformers**  
By REICHENBACH ENGINEERING

**The Best  
Direct Box Transformer  
is Now Twice as Good.**

**the JE-DB-E**

**Unsurpassed Audio Quality**

- Twice the level handling at critical low frequencies, (+19 dBv @ 20 Hz).
- Half the distortion; less than 0.15% @ 20 Hz, decreasing by 1/2 for each octave higher.
- Very wide bandwidth for a clean top end (-3 dB @ 70 kHz).
- Two Faraday shields fight hum in the mixer and amp.; Mu metal case for 30 dB magnetic shielding; each shield has separate lead.



**Proven Reliability**  
Every transformer fully tested.  
Write or call for information, including a schematic to build your own direct box.

10735 BURBANK BOULEVARD  
N. HOLLYWOOD, CA 91601  
(213) 876-0059

*(Visitors by appointment only - Closed Fridays)*

Circle #115 on Reader Service Card

—from page 5, **FEEDBACK**

Dear Mix,

Your usually excellent publication was unfortunately marred by incomplete coverage of the US Festival (and erroneous, I might add).

I am referring to the brief article in September's issue written by Josef Woodard. As the most significant event in sound reinforcement anywhere in the world this year, the US Festival deserved more than you gave it.

The errors, specifically:

1. It was not "3 days and 25 acts", as you reported . . . but 4 days and 32 acts. Mr. Woodard must have left early.

2. The Glen Helen Region Park *bowl* comprised a 54-acre area, not the 500 acres you noted. Even if Clair and Showco had brought every piece of gear in the shop, 500 acres would have been a LOT of audience area to cover.

3. The "two main towers 300 feet out" were NOT sound towers. They were put up exclusively for the television cameras and the auxiliary lighting instruments for video production. What *was* there: 4 towers 600 feet out, containing the Showco Arena System on delayed lines.

"While Clair Bros. did much of the stage monitoring, some acts chose

to use their own". Untrue. Clair serviced 30 of the 32 acts . . . nearly *all* of the show . . . while Showco provided a separate system for two of that company's major accounts, David Bowie and Van Halen. No group which performed at the festival brought "its own system". Groups which OWN their "own system" on Planet Earth can probably be counted on one hand . . . unless you are speaking of semi-pro, nightclub-type acts who are not national touring groups.

David Scheirman  
Concert Sound Consultant  
San Diego, CA

Woodard replies:

Mr. Scheirman had indeed picked up some bugs with his fine-toothed comb, and I stand humbly corrected on the abovementioned counts. But, to reply: the 4th day was an experimental afterthought, an ill-attended country day that took place a full week after the main Memorial Day event and didn't propose nearly the demands in terms of sound reinforcement. The 500-acre figure refers to the Park and not the bowl. The designation of the two main towers is my oversight, but the two acts, Bowie and Van Halen, did, in fact use their "own" monitoring systems, that is, systems hired by them for more than just single shows. So they don't hold the pink slip, need we quibble? I do appreciate the corrections—facts are the objective. But let's not get captious.

Since when are "night-club type acts" automatically "semi-pro" and automatically discountable because of their limited possession or dispossession of equipment? World class touring bands are not born spontaneously out from under cauliflower leaves . . . some of them even start in night clubs.

—Pat Pall, *Mix* Typesetter

The Largest Single Source for  
**USED RECORDING EQUIPMENT**  
is Sye Mitchell Sound

**CONSOLES**

from Neve, Trident, Sphere, MCI, Harrison, Soundcraft, etc.

**TAPE MACHINES**

from Studer, MCI, Ampex, 3M, Otari, Soundcraft, etc.

**OUTBOARD EQUIPMENT**

from EMT, Orban, AKG, Eventide, BGW, Lexicon, UREI, Deltalab, Crown, etc.

**MICROPHONES**

from Neumann, AKG, Sennheiser, Audio-Technica, Electro-Voice, etc.

FREE EQUIPMENT LIST  
EQUIPMENT SEARCH SERVICE  
LEASE / FINANCING  
COMPLETE STUDIO PACKAGES  
CUSTOM INSTALLATION  
STUDIO DESIGN

Authorized Dealer for:

EXR, Usra Major, BGW, Sphere, Audio-Technica, Tangent,  
Agfa Tape, Anvil, Audio Envelope

We ship anywhere in the world

**CALL TOLL FREE**

(Touch-tone phone only)

Call 800 number listed below. Listen for beep tone on the line.

Punch **4041** after you hear the tone. You will hear our recorded message.

After message, please leave your name and phone number. We will call you back.

Call **1-800-722-5372** (California residents, call **1-800-821-7693**)



22301 Cass Ave., Woodland Hills, CA

**SOUND**

91364 • (213) 348-4977 or 274-3633

Circle #116 on Reader Service Card

Stay current in the recording industry and build your technical knowledge by using the Mix Bookshelf. See the selections on page 84 or send for our free catalog.

# GODLEY & CREME



PHOTO: SHERRY BARNETT

by Iain Blair

The images are sexy, provocative, off-the-wall, and always unique. In one scene, nearly naked girls fight each other with pillows astride a symbolic pole. In another, demented prisoners hurl hammers at the camera. In another, a group of robot legs complete with suspenders and stockings performs a crazy dance. All these images are a product of the fertile imaginations of Kevin Godley and Lol Creme, and for true aficionados of video promos their names are already

virtually synonymous with a stylish inventiveness usually sadly missing from other, more pedestrian efforts in the field. For this is the British duo that brought to your screens such delights as Duran Duran's "Girls On Film," "Every Breath You Take" by The Police, and their latest, inspired masterpiece, Herbie Hancock's "Rockit," featuring the mad robot dancers.

But directing music videos is only the most recent in a long string of accomplishments for this multi-talented and multi-faceted pair. Their fruitful and longstanding partnership has produced everything from a succession of hit records (they were half of the seminal British band 10cc) and book projects to movie scripts and even inventions (they pioneered The Gizmo.) Constantly on the go, and constantly juggling their various interests and priorities, Godley and Creme were recently in Los Angeles for a few days to discuss their latest film ideas with the studios, in between working on their Police Special in Toronto and shooting a follow-up to "Rockit" in London. Mix caught up with them at their West Hollywood hotel and finally forced them to sit down for a few minutes.

In person, they are friendly and articulate, and seem totally unaffected by all the success and the current

## GUYS ON VIDEO

# A magazine to watch...



Visit with Mix at the home of Les Paul, the legendary recording artist credited with the invention of the electric guitar and multi-track recording, as well as this year's Grammy winner for his lifetime achievement.



Tour the Ampex Museum, the elaborate display tracing the development of audio and video recording technology from the 19th century to the present.



Explore futuristic animation techniques with Computer Image, the Denver-based originators of the medium of image manipulation by computers.



plus:

- Criteria Recording Studios
- Producer David Rubinson
- Studio Bassist Carol Kaye
- Engineer Jim Gaines
- Convention Updates

MIX Video, the hour-long electronic magazine of audio, video, and music production takes you behind the scenes for the sights and sounds of entertainment technology.

Volume One, the first in the series, explores yesterday's developments, today's trends and tomorrow's techniques. It's an action reference for the studio, classroom, or home, filled with the material you want to learn and need to know.

MIX Video is available in stereo (mono compatible) on VHS or Beta cassettes. If not absolutely satisfied it may be returned within 10 days for a complete refund. Mail the attached coupon today.



© 1983 Illustrated Mix Productions

**YES** Please send me the MIX VIDEO, VOLUME ONE at this special introductory price of **\$39.95**.  
(CA residents add \$2.60 sales tax)

NAME \_\_\_\_\_ COMPANY NAME \_\_\_\_\_

ADDRESS \_\_\_\_\_

CITY \_\_\_\_\_ STATE \_\_\_\_\_ ZIP \_\_\_\_\_

Make payable to Illustrated Mix Publications. Mail to: Illustrated Mix Publications, 2608 Ninth St., Berkeley, CA 94710

CHECK OR MONEY ORDER ENCLOSED Check one:  
 VHS  Beta

CHARGE TO  VISA  MASTERCARD \_\_\_\_\_ CREDIT CARD NUMBER \_\_\_\_\_

SIGNATURE \_\_\_\_\_ EXP DATE \_\_\_\_\_



PHOTO: SHEEHY BARNETT

*Godley and Creme with design plan for set of Police video "Wrapped Around Your Finger", from "Synchronicity."*

hoopla surrounding their latest project with The Police. "It does keep us off the streets," admits Creme, the short one. "But not out of trouble!" adds Godley, the taller one. Listening to them talk is a bit like watching a very fast ping-pong game—the ball of the conversation gets tossed back and forth with snappy one-liners and pithy jokes, and they tend to finish each other's conversations. At times sounding rather like a music-hall comedy routine or a crazy double-act, Godley and Creme are however very serious about their work, and have justifiably forged a reputation as one of the most creative and exciting collaborations at large in the fields of music, film and video. And unlike most partnerships which blossom only to end in a horror story of acrimony and mutual accusation, these two guys seem to have found the perfect balance.

"We grew up together in Manchester, England, and started working together on ideas and projects from the word 'go,'" recalls Godley. "We wrote music, shows, got into painting, and even invented a huge book complete with 3-D models of 'The Charge of the Light Brigade.' We were also always interested in film, and in fact, we both originally met on a film-set, at my house! I think I was 13 at the time, and I was shooting an 8mm version of Dracula," Godley explains. "Well, I desperately needed a hunchback, so I auditioned Lol in the living-room, and he was perfect." "It was my first brush with showbiz," adds Creme, "and later we both began playing around in various groups, doing session work and demos, and writing songs. Later, we met Graham Gouldman and Eric Stewart, the other half of 10cc. Eric had

set up his own studio, called Strawberry Studios, and that's where we recorded our first hit, 'Neanderthal Man.' We wrote it in the back of a taxi on the way to a session, and it went to No. 1! No one was more surprised than we were," adds Creme.

To promote the single, Godley and Creme quickly formed a band called Hotlegs, made an album, and toured with bands like The Moody Blues. "But we failed to come up with another hit," says Godley, "so we started getting more into production." The two got their hands on the first Moog in Britain, and in between doing sessions for the likes of Paul McCartney, Wayne Fontana and the Mindbenders, and Freddie and the Dreamers, worked on their own projects. In 1972, Godley and Creme reemerged along with Stewart and Gouldman as 10cc, one of the most successful British bands of the '70s. Many stories have subsequently circulated about the true origins of the band's name, but both insist that Jonathon King christened the project 10cc, "because it's the average amount of semen ejaculated by a healthy male!" "Besides, who were we to argue," adds Creme.

The success story of 10cc is well documented. Their first single, "Donna," went straight to No. 2, and the follow-up, "Rubber Bullets" shot up the charts to No. 1 in July '73. Over the next few years, the band went from strength to strength, producing a succession of hit singles and albums, including global smashes like "I'm Not In Love," and "Art for Art's Sake." So it came as quite a shock, to both fans and other members of the band, when Godley and Creme suddenly announc-



*Service for Professionals  
by Professionals*

## PRO AUDIO EQUIPMENT

- Equipment Rental
- Signal Processing

## FULL SERVICE VIDEO

- Production
- Editing
- Rental

## VIDEO DUPLICATION

**415/781-2603**

**AUDIO-VIDEO  
RESOURCES**  
60 Broadway  
San Francisco, CA 94111

Circle #118 on Reader Service Card

### The Affordable

## Digital Real Time Third-Octave Spectrum Analyzer

- Full 30 Bands • Six Memories • Quartz Controlled "Switched Capacitive Filtering" to eliminate drift • Ruggedized for Road Use • Microprocessor Controlled • Built-in Pink Noise Source • "Flat," "A," or "User Defined" Weighted Curves may be employed
- ROM User Curves Available.



**GOLD LINE**

Box 115mx • West Redding, CT 06896  
**(203) 938-2588**

**SEND FOR COMPLETE LITERATURE:**

NAME \_\_\_\_\_  
COMPANY \_\_\_\_\_  
STREET \_\_\_\_\_  
CITY \_\_\_\_\_  
STATE \_\_\_\_\_ ZIP \_\_\_\_\_

Circle #119 on Reader Service Card

# JOURNEY

## First, you have to hear yourself!

Now Journey depends on new ATM63 dynamic microphones for full control of their monitor and live concert sound. With better rejection of not just off-axis sound, but everything else on stage.

Even with a stack of Marshalls up close, the monitor mix is cleaner, with better separation than ever before.

Find out what Journey's Steve Perry, Jonathan Cain, Neal Schon, Ross Valory,

and Steve Smith heard on stage...and why monitor mixer Chris Tervit and producer/live mixer Kevin Elson insist on the ATM63. Now at leading music and sound specialists.

## The ATM63

chosen by JOURNEY  
because...

When you  
sound right to yourself,  
you sound great to everyone!



audio-technica®

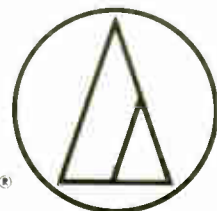

Audio-Technica U.S., Inc., 1221 Commerce Dr. Stow, OH 44224 • (216) 686-2600

Circle #117 on Reader Service Card

ed they were leaving in '76. "It may have seemed sudden to everyone else," explains Creme, "but in fact we'd been planning it for some time. When the band first took off, we decided to give it four or five years, because we were already interested in so many other areas, and we always wanted to move on at some point."

However, the split was far from amicable. "It was like a divorce I guess," comments Creme. "It was extremely difficult, and in a way it was made far worse by the fact that we decided to leave when the band was so huge. People understand more if things are going badly, but we had to follow our instincts to leave. We needed the creative freedom and space to develop other projects, and the pressure in 10cc to keep coming up with hits, coupled with touring and recording etc. just made it impossible for us," adds Godley. "In order to grow, we had to leave, painful as it was."

At first, it seemed as if they'd made a major mistake in quitting the success and security of the band. Having concentrated all their efforts on an invention called The Gizmo, a device which fitted onto a guitar giving it an orchestral-type sustain, Godley and Creme then spent a year and a half ("and a fortune") on "Consequences,"

the album especially conceived and written to demonstrate The Gizmo. Both were commercial flops. Undeterred, the couple decided to turn their energies to their first love—film, and after a few years "in the wilderness," working on more albums and book projects, they finally shot their first video in '79. "It was called 'An Englishman in New York,'" and we just did this storyboard, hired a technical director to help out, and went for it," explains Creme. "It taught us a hell of a lot about shooting, and by some miracle it worked!"

The move paid off, for Godley and Creme suddenly found themselves besieged with offers to shoot videos for other artists as well. Since then, they have directed many famous and award-winning videos, including the celebrated "Girls On Film" clip, "Mind of a Toy" for Steve Strange (best video of '81), three tracks for Paul McCartney and Ringo Starr (BAFTA award) and cuts for Status Quo, Graham Parker, Joan Armatrading and The Police amongst others. And in between, they have kept recording several successful albums, including "L," "Freeze Frame" and "Ismism," as well as directing themselves in their own videos.

Most recently, they were asked to shoot an hour special of The Police

called 'The Synchronicity Concert' for Showtime after the success of their earlier work with the band. "The first thing we did with them was the video for 'Every Breath You Take,' which turned out great, as we were all thinking along the same lines of a 40's jazz jam session look" explains Godley. "We shot it at the Charlie Chaplin Soundstage at A&M in Hollywood in black and white, keeping it very 'hard'—so there were no grays. We enhanced that contrast look in the edit as well, and it was eventually released in four versions—B&W, red, blue and yellow."

The Police were so pleased with the results—"I'd never really been happy with our videos before, but their imagistic approach is totally right for us," commented Sting at the time—that Godley and Creme were then hired to shoot the follow-up singles. "For 'Wrapped Around Your Finger,' we used a very stark set and just filled it with thousands of candles laid out in spirals and rows," explains Creme. "That gave it a very mysterious, 'Sorcerer's Apprentice' type of feeling. We also filmed it at double-speed, so that when we edited it at normal speed, the band were all moving in slow motion, but their mouths were in sync to the track. It worked really well, but of course during the actual shoot itself, all you could

## Great Recordings Start Here

**Your console is the heart of your studio. When it comes to producing a great recording, your choice of equipment makes all the difference. APSI makes that choice easy with the Model 3000 Multitrack Recording Console. The Model 3000 will help you maintain control of your signals and voices - control that is critical to good recording.**

**The Model 3000 provides a powerful and comprehensive operating system with mixing flexibility and features never before available. It is modular and adaptable to an extraordinary degree, and the quality and versatility have been proven over years of use. When every signal counts, can you afford to settle for less?**

**Make the Model 3000 your choice. Call us and let's discuss your requirements - we'll build a Model 3000 especially for you.**



**AUDIO PROCESSING SYSTEMS, INC.**  
Innovation and Excellence in Sound

90 Oak St., 4th Floor, PO Box 8, Newton Upper Falls, MA 02164 (617) 965-1200

Circle #120 on Reader Service Card

## SOUND SYSTEM

# BUZZ

ITS TOO BAD YOU  
CANT ALWAYS KEEP IT CLEAN

BUT NOW  
ITS ONLY TEMPORARY  
INTERFERENCE WITH  
A  
**MODEL PS-1**



In addition to reducing RFI the PS 1 can also protect your sound reinforcement equipment from:

HIGH VOLTAGE TRANSIENTS  
UNEXPECTED POWER UP TRANSIENTS  
IMPROPER LINE POLARITY

linear & digital  
systems, inc.  
46 marco lane  
centerville, oh.45459

Circle #122 on Reader Service Card

## THE BEST IN AUDIO CASSETTE DUPLICATION

From seminars and sales presentations to the highest quality reproduction of music, Spectrum Magnetics provides the best in audio cassette duplication. Our high-speed bin-loop equipment captures the fine fidelity of your master . . . at prices you'll find hard to duplicate.

But our quality work doesn't end there. At Spectrum Magnetics we load your programs into quality housings, label the cassettes as you require, protect them in Norelco boxes, and shrink wrap each box for added protection. And our turnaround is fast . . . it's service you can depend on.

Call us today TOLL FREE  
and find out more.  
800-441-8854  
(in Pennsylvania call 717-295-9275)



Spectrum Magnetics, Inc.  
1770 Lincoln Highway East  
P.O. Box 218  
Lancaster, PA 17603

Circle #123 on Reader Service Card

hear was this Mickey Mouse-type vocal."

The next video, "Synchronicity II," was shot in London and on location at Loch Ness in Scotland. "It was very eerie up there, but we didn't see the monster," laughs Creme. "Back at the studio, we used a sort of post-nuclear set featuring three mountains of the band's equipment, each about 25' high, so that they looked like piles of garbage made out of guitars, drums and mikes, etc. But no sooner had we started shooting than one pile caught fire, which was very exciting, and then Miles Copeland, the band's manager, turns up and announces that there's been a change of plan and that "King of Pain" is now the next single!"

"Synchronicity II" was also the scene for the debut of the 'Hot Head' camera mount, according to Godley and Creme, "It's an amazing device featuring a remote, go-anywhere mount that's operated by a video monitor, so it gives you the kind of shots you can't normally get," explains Godley. "So, when we were asked to film The Police special in Montreal, we took it with us and suspended it over the band. That way, we could get tight or wide shots from above, and we could also swing around and pan to any member of the band, or to the audience, on a 360 degree basis." The special was also another first for Godley and Creme. "We'd never done a live shoot before, so we approached it like a video shoot, but trying to bring a whole new dimension to it by using the Hot Head and taking a bit more care," adds Godley.

The special concert was shot live at Le Spectrum club in Montreal during the band's Canadian tour. "It only held 800 people, and The Police wanted to capture that intimacy" comments Creme. "We shot on 1" tape, and used a total of 10 cameras to get all the shots we wanted, as we were directing from the truck outside the club. Apart from the Hot Head, we used a Betacam in the audience, solely for audience shots, so that we could build the relationship between the band on stage and their fans. We also used it on the band's private plane flying into the gig, as well as on the streets before the gig, so that we got a little bit of documentary footage to parallel the gig itself."

The audio end of the shoot also presented some interesting angles, according to Godley. "After we'd assembled all our footage, we finished the edit to a rough monitor mix of the live show. At a later date, we will remix the soundtrack with the band present as well to the cut picture. The original sound was recorded by Le Studio mobile, and we did a little bit of post-sweetening to the rough cut. We dubbed on some audience noise at The

Master's Workshop Studios in Toronto, because unfortunately there was no real audience reaction that was usable recorded on the original." Both Godley and Creme had nothing but praise for the Toronto facility. "It's a great place—they have customized set-up so that any domestic IBM computer can be interfaced with the system for editing sound and sound effects in the same way that we edit video," explains Creme. "It's a wonderful system, and it makes the whole process so much easier. In fact, we're so impressed that we're now going to install a similar set-up at our own Limehouse Studios in London. We reckon that it can be used very creatively to examine and test components, such as the structure of a song."

All the post-production work for the special was completed in Toronto in a marathon ten day session, and Godley and Creme plan to return to The Master's Workshop Studios there to do the final soundmix. They also used a Dubner computer video animation system for the first time, "for the top and bottom credits, and some small sequences in the special," adds Creme. "We were very impressed with it." The Synchronicity Concert special was executive produced by The Police and is due to air this month (December) on The Showtime Channel.

Meanwhile, Godley and Creme are due back in London to shoot a follow-up to Herbie Hancock's "Rockit" video, again using the specially customized robots built by British artist and sculptor Jim Whiting. "Herbie was so knocked out by them that he wants a whole stage show to be built around them!" adds Creme. It is a measure of the video's success that the instrumental, by a black artist, is now on heavy rotation on MTV and zooming up the charts. And as if all this weren't enough, the pair also recently completed shooting an 80 minute TV pilot called "Rebellious Jukebox" which is centered around a video-jukebox and includes The Police and various other bands in a live club setting. They also won the Silver Lion at Cannes for Best Advertisement of the Year for their Wrangler commercial.

But it is the silver screen that their sights seem to be most set on these days, as they themselves admit. "Films are what we've always wanted to do, and we've got a couple of projects we're working on right now," says Creme. "Our main interest now is in directing," agrees Godley, "and that's what we've always done in our music, by producing and dealing with concepts. The great thing now is that we'll be able to combine music and film, and do the soundtracks as well as direct—it's the perfect marriage for us." ■



# CONCERT VIDEO

by Nocturne



**F**ew bands and entertainment organizations have achieved the phenomenal success of Journey and its management company, Nightmare Productions. Guided by their manager, Herbie Herbert, the band has been a proponent of video since their very first live concert shoot (a multi-camera production, shot on 2" quad at San Francisco's Winterland in 1977).

Nightmare and CBS Records

were among the first U.S. companies to use the services of British director Bruce Gowers to direct a series of music videos, in this case for Journey. Produced in 1978, long before the arrival of MTV, these videos along with the band's marathon touring schedule were directly responsible for Journey's multiplatinum album success.

Working with the late Bob Becher, Journey video taped or arranged videotaping for almost all of their major concerts. The step from video ar-

chiving and MTV, to live large screen projection video seems almost inevitable in Journey's attempt to create greater audience satisfaction and enjoyment in large outdoor and indoor venues

In a move designed to give fans greater value for their entertainment dollar, Nightmare brought in a super Eidophor projector and large screen (22.5 x 30) video system and 7 cameras, which were switched live,

—page 137

# BACK ISSUES

## FILL IN THE BLANKS

- 1980 August, Southeast Studio Listings. Opryland Mixing. South Florida Recording. Recording School Listings.
- 1980 September — SOLD OUT.
- 1980 November — SOLD OUT.
- 1981 January — SOLD OUT.
- 1981 February, Southeast Studio Listings. Ray Stephens. Norbert Putnam. Ardent Recording.
- 1981 March, Southwest Listings. History of the Tape Recorder. Producer's Role. Indian Creek Recording.
- 1981 April, Northeast Listings. Todd Rundgren's A/V Studio. Women in Audio. History of the Tape Recorder. Pt. 2.
- 1981 May, AES Spring Update. Mike Love's Studio. Envelope Controlles Filters. Women in Recording. Pt. 2.
- 1981 June, Video Focus. Moogy Klumman. Video Equipment Manufacturers. Introduction to Video.
- 1981 July, Recording Services Listings. Recording School Listings. Remote Recording Maintenance.
- 1981 August, Studio Design Listings. Dealing with the Bldg Dept., Building Materials. Monitor Field.
- 1981 September, S. Cal. Listings. Tape Editing. Creative Record Promotion. John Ryan.
- 1981 October, North Central Listings. Digital Reverberation Survey. Chicago Music History.
- 1981 November, 1982 New Products. Studio Monitor Report. Synthesized Drums. Larry Carlton. Al Kooper.
- 1981 December, Tape to Disk Listings. Lee Ritenour. Tape Tips. Sony Compact Disk. High Speed Duplication.
- 1982 January, Northwest Listings. Mixing Consoles. Grateful Dead's Studio. Linasey Buckingham.
- 1982 February, Southeast Listings. Digital Synthesizers. Dave Edmonds. John Meyer.
- 1982 March, Northeast Listings. Car's Studio. Microphones. Phil Ramone.
- 1982 April, Video Focus. A/V Studio Listings. Video Music Satellite. Mike Nesmith. Legal Issues in Video.
- 1982 May, Southwest Studios. Quarterflash. Charlie Pride's Studio. Digital Recording. Fantasia. Digital Soundtrack.
- 1982 June, Concert Sound & Remote Recording. Drum Machines, Pt. 2, Keyboard Artists Forum, Video Legal Issues.
- 1982 July, Studio Design. Listings of Designers. Suppliers. Power Amp Report. Quincy Jones.
- 1982 August, 5th Anniv. Issue. History of Recording. Asia. Oscar Peterson. Bill Porter.
- 1982 September, S. Cal. Listings. Film Sound. The Dregs. Video Synchronizer Survey. Digital Discussions, I.
- 1982 October, N. Central Listings. Studio Monitors. John Cougar. Digital Discussions, II.
- 1982 November — SOLD OUT.
- 1982 December, Tape to Disk. Record Restoration. Starting Out in Video. Digital Discussions, IV.
- 1983 January, Northwest Listings. Multi-track Analog Tape Recorders. Record Restoration. Michael Palin.
- 1983 February — SOLD OUT.
- 1983 March, Southeast Studios. Echo, Reverb & Delay, I. Buddy Bue. Electronic Religion. Phil Dunne.
- 1983 April, Music Video. Video Production. Post Production Listings. Missing Persons. Echo, Reverb & Delay, II.
- 1983 May, Northeast Listings. Donald Fagen, Mixing Console Forum. Echo, Reverb & Delay, III.
- 1983 June, Sound Reinforcement/Remote Recording. Showco. Frank Zappa. Mixing Console Forum, II.
- 1983 July, Southwest Listings/Recording School Listings. Audio Special Effects, Josef Zawinul, Education Update.

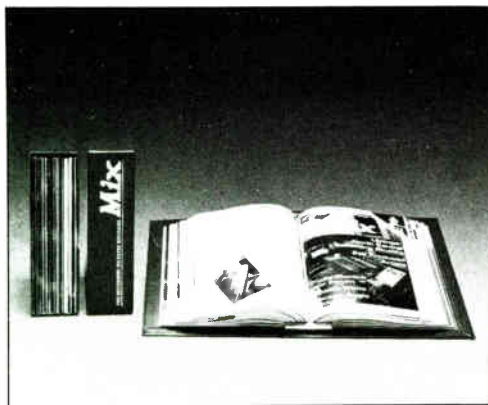

## BINDERS KEEP IT TOGETHER

MIX MAGAZINE is a year-round reference tool. Keep your issues protected, ordered, and readily-accessible.

**LIBRARY FILES:** 12 issues are organized for storage and slide out individually for use.

**BINDERS:** 12 issues are bound for protection and open flat for easy reference.

Both hand-crafted styles are bound in textured crimson leatherette, embossed with the gold-leaf embossed MIX logo and gold transfer slips for indexing volume and year. **SATISFACTION GUARANTEED OR YOUR MONEY REFUNDED!**

NAME \_\_\_\_\_  
 ADDRESS \_\_\_\_\_  
 CITY \_\_\_\_\_ STATE \_\_\_\_\_ ZIP \_\_\_\_\_  
 CHECK M O     VISA     MASTERCHARGE  
 CREDIT CARD # \_\_\_\_\_  
 SIGNATURE \_\_\_\_\_ EXP DATE \_\_\_\_\_

Quantity \_\_\_\_\_ Price per unit \_\_\_\_\_  
 \_\_\_\_\_ **BACK ISSUES @ \$3.00 (\$4.00 outside U.S.)** \$ \_\_\_\_\_  
 Check specific issues above and return entire sheet  
 \_\_\_\_\_ **LIBRARY FILES @ \$6.00, 3 for \$17.00** \$ \_\_\_\_\_  
 \_\_\_\_\_ **BINDERS @ \$8.00, 3 for \$22.00** \$ \_\_\_\_\_  
 Add \$1.50 shipping per file/binder (\$3.00 outside U.S.) \$ \_\_\_\_\_  
 CA residents add 6.5% sales tax on binders \$ \_\_\_\_\_  
 Total \$ \_\_\_\_\_

M.A. • MIX BACK ISSUES/BINDERS, 2608 Ninth Street, Berkeley, CA 94710. Allow 4-6 weeks for delivery.

—from page 135, *Concert Video*

creating another more personal dimension to Journey's live concert performances.

As fate would have it, members of the Who's management saw the video projector system coverage of Journey in concert and decided that large screen video would be a must for the Who's last tour. They contacted Nightmare (which, in addition to managing Journey, also provides road management and tour production services for hire) to see if they would be interested in providing video services for the Who.

Nocturne, a division of Nightmare, is managed by Pat Morrow, and can provide lights, sound reinforcement systems, rigging, staging and personnel as well as large screen video projection and videotaping. Working with Showco's Robin MacGruder, Nocturne put together a video projection package for the Who's last tour. It was the extensive use of video by the Who which generated interest by many artists in the possibility of large screen video for their own concerts.

**P**rior to the Who, Nocturne had provided live video production for the Marlboro Music Festivals in Tulsa and Dallas with country headliners Barbara Mandrell, Merle Haggard, Hank Williams Jr., and Ricky Skaggs. The first regular use of live video in a rock concert context was by the Bill Graham organization at Winterland, and one of the first groups to use it was Led Zepelin at Nebworth in England in the mid '70s. Only recently have the technological barriers to the efficient use of this medium been surmounted. The system now used by Nocturne can be assembled in 90 minutes and can be struck in a half hour.

The basic elements of the system are essentially all the gear that would typically be involved in a live television shoot plus the video projection system. The crew line up would be as follows: Director, who does live switching; Assistant Director, who works with lighting; Engineer; Assistant Engineer; Four Camera people; and a Projectionist.

The company has two directors on staff, Paul Becher and Mick Anger, who have handled virtually all the directorial duties from its start. Mick Anger has also directed videotape productions for MTV, the most recent for Sammy Hagar. Paul Becher just completed 3 songs for AC/DC, and will be directing the next music video clips for Journey. Each director does his own

—page 138

# MICROPHONICS

SENN MD421U . . . . . \$208	AKG C414EB-P48 . . . . . \$595
SENN MD431U . . . . . \$224	AKG C460B . . . . . \$245
SENN MD441U . . . . . \$289	BEYER M88 . . . . . \$218
SENN HD414 . . . . . \$ 44	OTHER MODELS . . . . . Call

(800) 431-3232 **MICROPHONICS** (212) 438-6400  
P.O. Box 37, Brooklyn, NY 11204

Circle #105 on Reader Service Card

## Presenting the Otari 5050 Mark III/8 ... with Service



Service . . .

The key to your success  
when purchasing a  
professional multi-track.

With this in mind, PRS provides a  
quality assurance program in which every machine  
is individually tested and calibrated. This ensures  
trouble free operation and maximizes performance.

Service . . . it's what PRS is all about.

**PRS**

**Professional Recording and Sound**  
1616 Soldiers Field Road  
Boston, MA 02135  
617 254-2110  
outside MA. 800 343-3001

A Group Four Company

Circle #125 on Reader Service Card

—from page 137, *Concert Video*

live switching, which creates a more direct flow of camera moves and dissolves than might otherwise be the case. In the typical live situation the director calls his shots through a technical director. This also requires a thorough knowledge of the music being played so that both director and crew have a tightly coordinated shooting plan. Recently Mick Anger, who directed both the Police and Bowie tours for *Nocturne*, contrasted the production styles of the two groups. "Bowie's stage show was very tightly structured and very theatrical, with the band in costume and the precise use of props and set designs. Some of the songs were fully choreographed, with Bowie never 'breaking character.' The Police did virtually a different show each night, changing the order of the songs, moving around the stage and in general responding more directly or playing off the audience's feedback."

**N**octurne has acquired several complete video packages in a bid to increase its ability to service multiple projects. This past summer the company handled large screen live video projection for *Journey*, *Simon & Garfunkel*, *David Bowie* and the *Police*.

The truly state-of-the-art video equipment which *Nocturne* supplied for the 1983 *Police* North American Tour had to be compact and extremely rugged. Only the most roadworthy gear would withstand the constant loading, unloading, forklifting, and trucking as well as extremes in temperature and humidity for seven weeks. All the hardware was shipped in 25 road cases custom made by *Starcase*. The foam lining was precisely cut out for each piece to minimize the vibration and shock from loading and hauling.

The head end of the system comprised four *Hitachi* SK-91 broadcast cameras equipped with *Diode-Gun* Saticon tubes. These tubes are the top performers in the  $\frac{3}{8}$ " class providing extremely high resolution and signal to noise (700 lines at 60 dB) along with great depth of modulation and colorimetry. The tubes were crucial in producing film-like images on the giant screens. Even with all the backlighting and point source lighting these tubes displayed virtually no lag or comet tailing.

The cameras were equipped with *Triax* backs which convert the analog video signal to a digital signal so no line loss would occur on the 500 foot or more runs to the control room. The *Triax* system, so called because of its triaxial cable, sent video, intercom, genlock sync, program return video,

and camera power over a single half-inch wide cable. Before the advent of triax, multiple signals would only be handled by a multicore cable, an inch and a half thick with line amps every 250 feet. The triax cable also sent camera control signals from the digital command unit in the control room. This allowed the engineer to ride iris, gain, black level and set white and black balance from the control room as well. The digital command unit also converted the digital signal back to a standard analog video signal for switching, and projection.

A variety of lenses were used for the different camera positions. Two cameras on tripods were on platforms in front of the stage left and right. They were equipped with *Fujinon* 14:1 zooms, a roving hand-held camera on stage had a 14:1 and could switch to an extremely wide angle 7:1 zoom. The fourth camera was on a tripod on the control tower in the rear center of the stadium equipped with a *Fujinon* 30:1 zoom with a 2X extender, allowing 60:1 closeups. This lens was considerably larger than the camera itself and required a special heavy duty *Vinton* tripod and lens mount to support it. The control package consisted of six road cases which stacked to create three 19 inch rack units.

The director's rack contained two *Videotek* 9" *Trinitron* monitors for program and preview, a *Sony* PVM-410 monitor bank containing four 4 inch monochrome camera monitors, a *Grass Valley* 1600-1A switcher and associated control equipment. The engineer's rack contained an *Ikegami* high resolution monitor, two monochrome preview monitors, *Tektronix* waveform monitor and vectorscope, *I.S.I.* sync generator, and five *Hitachi* digital command units for the four cameras and one spare. The third rack contained 2 *Sony* 5850  $\frac{3}{4}$ " VCR's, *Shure* audio mixer, audio amplifier and two monitor speakers. The three racks were interconnected with color coded cables which allowed the system to be set up in a matter of minutes, once installed.

Two types of video projection systems were used on the tour. For indoor shows (usually a hockey rink or sports arena) a *G.E.* model 5055 projector was employed. This single lens unit uses three light valve imaging units converged around an optical beam splitter and a high intensity xenon lamp. The beauty of the *G.E.* is that it is small, portable (can be lifted by two people) and is always in perfect convergence allowing relatively quick setup by an experienced operator.

For the outdoor shows (which were usually held in baseball stadiums) two of these systems were mounted on

airlifts. Their screens were on either side of the stage. They were supplemented by a *Super Eidophor* projecting onto a screen directly above the stage. The difference in brightness between the *G.E.* and the *Eidophor* is analogous to 16 mm and 35 mm film projectors. The image from a *Super Eidophor* is truly impressive with brightness and resolution equaling that of a feature film.

**T**he *Eidophor* projector itself is about the size of a large refrigerator with two accompanying 19 inch racks of equipment, one containing a power supply and rectifier, the other containing all the control electronics. The *Eidophor* must be run by a highly trained operator and is generally set up and tested the day before the show. It also uses a light valve system, but has a separate light source and optical path for each of the three primary colors. The light valve differs greatly from a home video projection system, which employs three CRT's, each with phosphor of a primary color, mounted in a lens assembly with the CRT producing both the light and the image. This system works well for the home where 6 feet is pretty much the size limitation as defined by room height. But a CRT system is not bright or sharp enough for theatrical video projection. A light valve system uses a high intensity white light source (Xenon or arc bulb). The light valve is a glass plate coated with a special type of opaque oil which becomes transparent where it is excited by an electron beam, allowing the light source to shine through. This yields razor sharp images without any of the spill, lag, or retention associated with glowing phosphors.

For daytime shows, a *Mitsubishi DiamondVision* system was used where it was available. This is the only system that produces a viewable picture in broad daylight. The *DiamondVision* system is not a projection device at all, but rather an array of some 40,000 high intensity red, blue, and green CRT's each about a half inch wide. These tubes are controlled by a computer which reads the standard incoming video signal and in turn, switches each of the appropriate lights on and off to form a moving image, like a sophisticated electric scoreboard but capable of full color and shading.

Through the use of extremely rugged state-of-the-art video equipment, *Nocturne* was able to provide reliable, high quality live video programming for this tour, enhancing the rock concert experience and setting a precedent for the future of large entertainment events. ■

# VIDEO NEWS

by Mia Amato

## FOUND: LANDMARK SOUND-SYNC FILMS

"Most people, if asked what was the first talking picture, would probably say "The Jazz Singer". That was certainly the first modern, electronically recorded sound film, but it was not the first theatrical talking picture."

According to *Art Shifrin*, Thomas Edison's film production company pioneered synchronized sound on films released as early as 1912 using the crude techniques available to cylinder recording. Shifrin has successfully restored two reels of that landmark film with their original soundtracks and transferred them to videotape, with the aid of a grant from *Ampex Corporation* and technical expertise of New York's *Sound Shop*.

How did Edison's sync system work? "It was sheerly mechanical," says Shifrin. "Edison was a man who thought in mechanical metaphors." Early sound recording required that the artist or speaker shout or play directly into a large, ball-shaped horn. Edison's players were able to move about or dance a critical few feet away from the horn thanks to a mechanical sound amplifier.

"A photo taken in the studio shows that the recording phonograph was placed on a platform on the stage," explains Shifrin. "It was linked by wires and pulleys to a film camera in the extreme rear of the room." In theatres, the recorded cylinder was played on a phonograph at the front of the audience, and it, too, was linked by wires and overhead pulleys to the gears of a film projector at the rear. Slippage was a problem; a memo from one of Edison's engineers recommends changing some wires because they had been "chewed by rats."

The first talkies premiered at three Manhattan studios in 1912. Front page news in its day, the "kinetophone" sound-film dropped out of history, and

probably would have remained in news-morgue limbo except for the efforts of Shifrin, a recording history buff and manager at *Abekas Video System*, which designs video still-stores. He is the inventor of an electronic playback device for cylinder recordings. The first model was sold to Sweden's national broadcasting company, which has hundreds of cylinder recordings from the turn of the century in its vaults. In the Swedish radio archives, Shifrin found the kinetophone recordings.

"They asked me if I knew what they were," he recalls. "They are readily distinguished from typical cylinders

because they're so much bigger—about the size of a tomato juice can. I took some back with me, and rigged my prototype to play them.

"The quality of the sound is wonderful when you consider they were recorded through a horn," he adds. The cylinders were stamped with Edison's company name and dated. The material: "conversations, gunshots, sound effects." Shifrin realized he'd stumbled across movie soundtracks recorded some thirteen years before "The Jazz Singer."

At the Edison museum in New Jersey, Shifrin gained access to the inventor's chronological files, much of

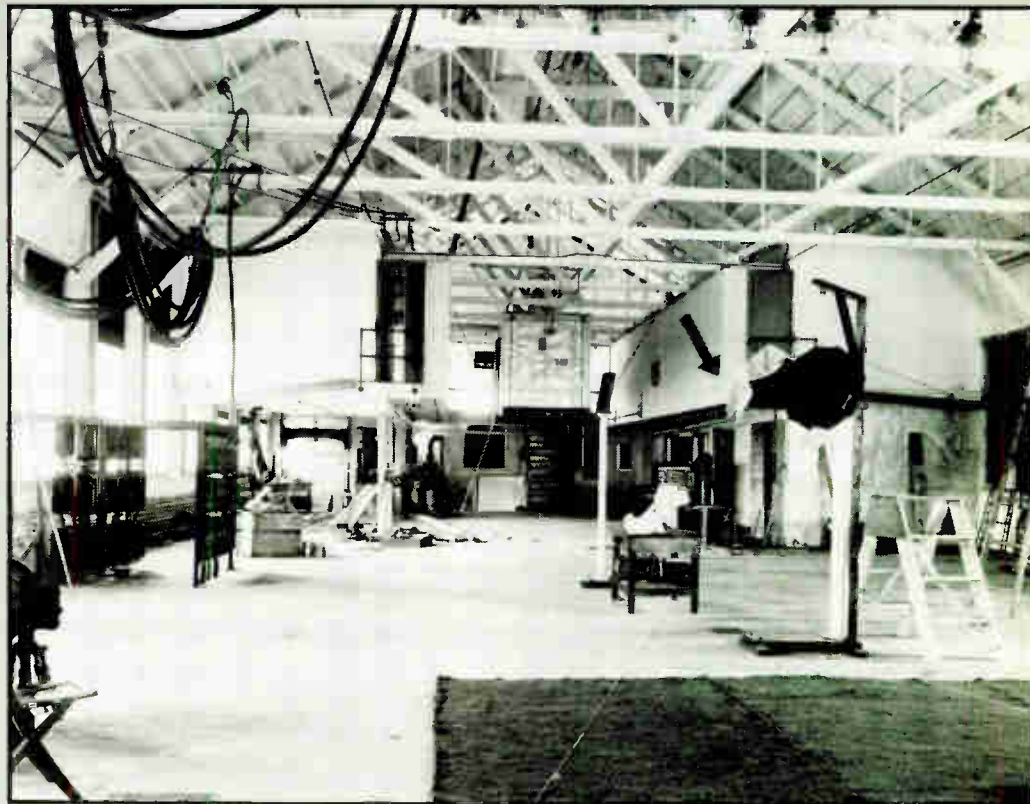

*The Edison Kinetophone Studio in the Bronx, operating between 1912 and 1914. Note the synchronizer cord (black arrow) running between the camera booth and recorder. The high ceiling and hard walls caused severe echo problems.*

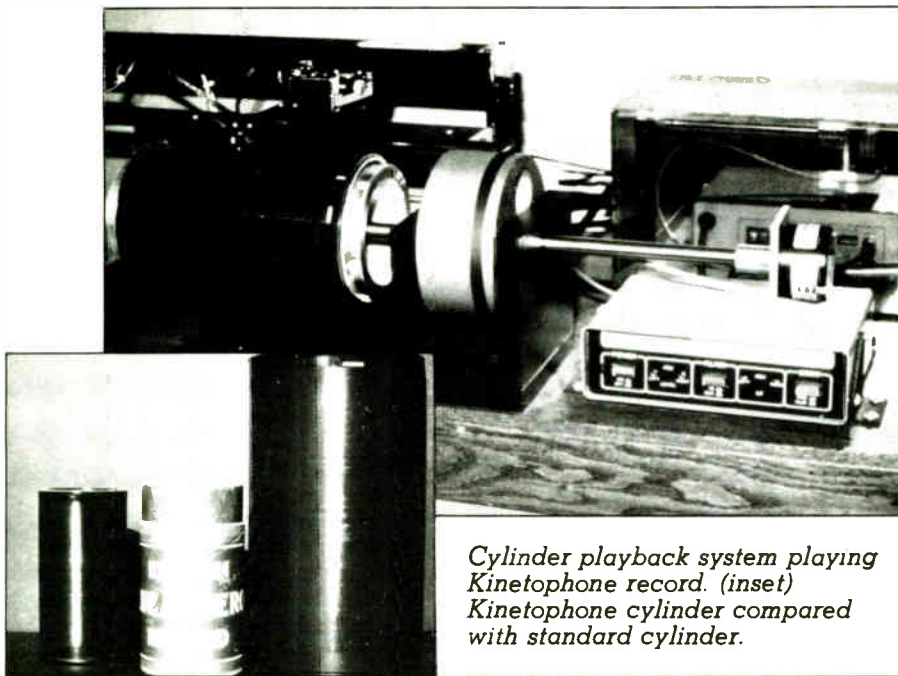

*Cylinder playback system playing Kinetophone record. (inset) Kinetophone cylinder compared with standard cylinder.*

them uncataloged. "Not only did we find some 500 documents relating to kinetophone," says Shifrin, "but we found seven reels of identified film. Six of the seven films have surviving soundtracks on cylinders."

The material includes opera, vaudeville acts, and a lecture by Andrew Carnegie. "We've also found what I think may be the first attempt at location sync sound, the first reel of a Civil War drama, shot, we believe, in Van Cortland Park."

According to newspaper accounts, Edison's talkies enjoyed a four-month run at the Keith-Orpheum theatre chain, playing major cities in the U.S. and even Tokyo and Hong Kong. But why were the inventor's efforts doomed to obscurity?

"In the first place, the films were not as well done as some of the silent pictures of the time," surmises Shifrin. "Edison had no budget to attract big stars. If he'd gotten a Broadway Star, as Warner Bros. did when it picked Jolson for "The Jazz Singer," it might have been better accepted." Secondly, World War I broke out in 1913, just as Edison was launching European distribution. (Which probably accounts for how the cylinders wound up in Sweden.)

After the war, Western Electric introduced the condenser microphone and electronic recording found its way to the film industry. The Vitaphone system stored soundtracks on 16" disks played at 33 $\frac{1}{3}$  RPM. All the projectionist had to do was drop a needle at the start of the film and all was in sync.

Says Shifrin, "The Vitaphone was a logical extension of the kinetophone, but modern, for it used

electronics instead of mechanical technology. Both can be considered the forerunners of time coding and the current methods of computerized synchronization of sound to film."

Shifrin stresses that work on restoring these early "talkies" cannot continue without a source of funding and he is in discussions with some large "consumer-oriented high-tech" companies to promote this research.

#### LA DOLCE VIDEO

Rockamerica's *Ed Steinberg* sends this report of Italy's *On Video* festival:

"The festival was put on by the City of Rome, and took place in the *Matatoria*, an old slaughterhouse the size of several football fields . . . in the center were two movie screens, screens that make American drive-ins look like nothing. In between the screens, a bandshell with live music. There was a boxing ring (!), galleries for art, rooms with TV monitors and cassette machines to watch tapes. There was the video cafe where I was, which seated about 300 and had a Barco 50' screen playing video art and rock tapes. *RAI* [Radiotelevisione Italiana] had a bank of TV monitors outdoors which ran programs continuously. Everything was going on at the same time."

The video cafe part of the show was run by *Soft Video*, an Italian firm run by *Giacomo Mezzoni*, who flew Ed in from New York to show rock tapes and give a short lecture on music video. West coast video promoter *Claude Santiago* was there as well.

"In Italy rock video is in a prehistoric state," Ed says. "Record companies won't spend more than a few hun-

dred dollars, but American and British videos are very much in demand, and there is a big interest in progressive music there."

While in Rome, producers of the Italian TV network *RAI* asked Ed to curate a selection of American rock videos for a magazine format show called *Eye and Ear*. Licensing for videos in Europe is particularly tricky, he adds, as permission from local distributors is required and theft and bootlegging is widespread.

*Technisphere* in New York will be editing a second season of *New York Hit Parade*, a clip show produced there for *RAI*. The assemblage of top-ten pop clips with street-beat wraparound by suave host and line producer *Franco Scipiani*, is handled by *Mark Brownstone*, head of postproduction. Location taping in 3/4-inch has been supplied by *Video News Service*.

"Last spring we did thirteen 15-minute programs, editing from 3/4-inch to 3/4-inch, then bumped up to two-inch PAL for shipping overseas," *Brownstone* said. This year the show will be edited to one-inch prior to conversion to PAL, as *Technisphere* recently acquired a Hitachi HR-200B Type C recorder for mastering.

*Brownstone* said *RAI's* New York office concerns itself with obtaining releases for the videos selected for the show.

"*RAI* scheduled the show for Sunday afternoon, right before the big soccer games, so ratings were good and it had a very large audience," he adds. "I'd say it is possibly a very good showcase for American bands."

#### NOTES FROM ALL OVER

Former head of *Stiff U.S.*, *Bruce Kirkland*, has announced the formation of *Second Vision*, a company which will assist recording companies in promotion and coordination of videos in stores, clubs and TV outlets. First project will be the Swiss electronic band *Yello*. The clip for "Smile" and artist *Will Powers* was directed by *Todd Rundgren* for island Records. *CSI Productions* (Compton, CA) has produced three clips for *Joan Baez* in conjunction with her current European tour. *Jim Sudalnik* directed. *Michael Branton* of Videowest flew to West Germany earlier this year to document *Rock Palast*, an outdoor concert that drew 18,000 to hear *Joe Cocker*, *Steve Miller Band*, *Stray Cats*, *U-2* and other acts. (Branton has some great helicopter footage.)

*Plastic Opera Company* taped its first clip at the *Dallas Communications Complex for Driving School*, a band headed by *Carmine Rojas*, bass guitarist for David Bowie. The video is called "The Guiding Light." *Plastic Opera* is run by two sisters, *Kayce Geer* and *Sharon Little*. ■

# The Softouch™ System Designed by Hard-nosed Engineers

**SOFTOUCH is the first audio editing system to offer an intelligent building-block approach to editing for video/film and audio post-production.**

The SOFTOUCH system allows users to start with as little as a two-transport synchronizer based on SMPTE time code, yet build to a fully configured 6 or 8 transport system by adding modules to meet changing needs and budgets. Any combination of multi-track audio, video or sprocketed film transports are precisely synchronized and controlled. Sound



effects assembly, sweetening, dialogue replacement, Foley, re-recording, overdubbing, and telecine applications are accomplished with a single system at a cost far less than many

multi-track audio transports.

SOFTKEYS™ allow frequently-performed, multi-step routines to be executed repeatedly at a touch of a single key.

SOFTOUCH provides a convenient RS-232/422 computer interface to BTX's CYPHER™ time code system and other studio equipment. For a demonstration, contact:



The BTX Corporation, 75 Wiggins Avenue, Bedford, MA 01730. Tel: (617) 275-1420, Telex: 95-1887  
In California: 2750 West Silverlake Drive, Los Angeles, CA 90039. Tel: (213) 664-5980

Circle #126 on Reader Service Card

World Radio History





Roads to Murder," has just come out. Some scenes from the Mystery Disc were demonstrated; it is a fairly standard whodunnit, but the audience selects action and solves a murder. The show's structure is quite reminiscent of the board game, "Clue." Shot originally on 3/4" video on a budget of \$225,000, plus a cost of \$9.50 pressing per disk, plus promotion and distribution, Mystery Disc has sold 9,000 copies at \$29.95. However, it is soon to come out in interactive CED, too—the sequel is already out in CED. The sequel, with similar costs, took 6 months to make, the original a year.

(By the way, there may seem to be some confusion about the spelling of disk or disc. Sandra Devlin says Latin is more suitable to art, Greek to science, so she leaves "disk" to computer people and says "disc." This curmudgeonly observer, preferring consistency, believes the Greeks were a whole lot better artists than the Romans, too.)

Ms. Devlin spoke often and lengthily on technical issues in producing interactive disks. She suggested, for example, that shooting on 16 mm films at 30 frames per second, where possible, is most preferable. That way, assembly of all the still frame, audio, and other components can be achieved in the film-to-tape transfer. 30 f.p.s. is important (as opposed to the normal 24) because still frames are often taken from moving footage, and a 1:1 transfer ratio means all of the frames are usable as flicker-less stills.

Devlin also discussed the importance of assembling a slide-tape-film show of all the elements to go on a disk, thus making sure everything works before sending it all off to be pressed. 3M has recently begun pressing in California, but various producers seemed to concur that the best pressings are made by Sony in Japan, with a six week turnaround. Sony's John Hartigan said that, "62 percent of all level two disks have programming errors, even with that slide-tape emulation process." Thus the turnaround time becomes even longer. Peter Crown, of Romulus Productions, hazarded a guess that an interactive disk may wind up costing 50 percent more than a similar idea done "normally."

But then, what is a "normal" interactive videodisk program? Romulus made an educational disk for the government, and has already sold an adaptation to RCA, for consumer release as a game about Skylab. All sorts of other deals were in the offing that day with Devlin, too. And the buzz words "music video" were on many a lip, too. Hot categories tend to inspire crossovers: or, in Latin, interfaces. Cards were exchanged, deals were struck, soon we'll know. ■

## PROTECT YOUR INVESTMENTS

### DISKUS™ PRODUCTS for Storage and Filing

Compact Digital/Audio Discs  
8" Mix Down Disks  
5 1/4" Computer Diskettes

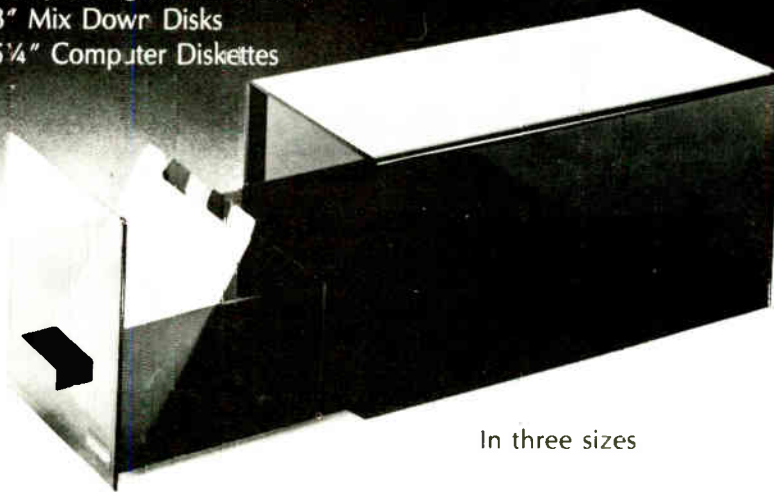

In three sizes

DISKFILE 125 Holds 125+ 5 1/4" Diskettes — 26 C/D's — \$59.95

D'SKUS JR. Holds 75+ 5 1/4" Diskettes — 16 C/D's — \$39.95

DISKFILE 8 Holds 115+ 8" Floppy Disks \$79.95

D'SKUS Dividers 5 color coded index tabbed dividers — one set included with purchase of each DISKFILE. Extra sets of dividers 5 1/4" \$2.49, 8" \$2.99. Shipping & Handling \$3.75 each unit CA residents add 6.5% sales tax.

DISKUS PRODUCTS 6003 Bandini Blvd., Los Angeles, CA 90040 VISA or M/C call (213) 726-3088 Patent Pending. © 1983 DISKUS PRODUCTS

Circle #127 on Reader Service Card



## Modular Tape Synchronizers!

**Buy only what you need!** From basic audio-audio/audio-video record and layback, through multi-slave chase operations for mixing, right up to television sound editing, SYSTEM 2600 will precisely fill your immediate requirements.

**Add modules as you grow!** With SYSTEM 2600, you can expand without ever obsoleting equipment you've already purchased.

**And every SYSTEM 2600 synchronizing combination gives you:** 1:100-frame offset adjustment • DC and FM capstan control • internal interfacing (no extra boards or hidden costs) • "Smart-Lock" fast re-synchronizing • tach pulse/control track updating • automatic drop frame offset calculation • "Splice-Trap" • NV data retention through power-down • LTC, VITC or pilot tone • NTSC, PAL and SECAM.

**Also available:** separate, remote-able, Master, Slave, Event/Edit and Data Entry control panels for cueing, looping, and trimming • LED and video monitor display • computer interfacing.

Call or write for complete details! Dealer inquiries cordially invited.



**ADAMS•SMITH**

34 TOWER STREET, HUOSON, MA 01749 U.S.A.

TEL: 617-562-3801 TWX: 710-347-0096

NEW YORK 516-352-2341 LOS ANGELES: 213-388-8218

Circle #128 on Reader Service Card

IF YOU'RE IN THE STUDIO

YOU'RE IN THE MIX!



From coast to coast and in 43 foreign countries, audio, video, and music professionals read *Mix Magazine*! For the latest industry news, illuminating articles on hardware and production techniques, exclusive interviews with today's movers and innovators, as well as

the last word on the marriage of audio and video, *Mix* is your best source for the information you need to help you do your job in these competitive times.

Don't miss an issue — Subscribe today!

# HARDWARE | SOFTWARE

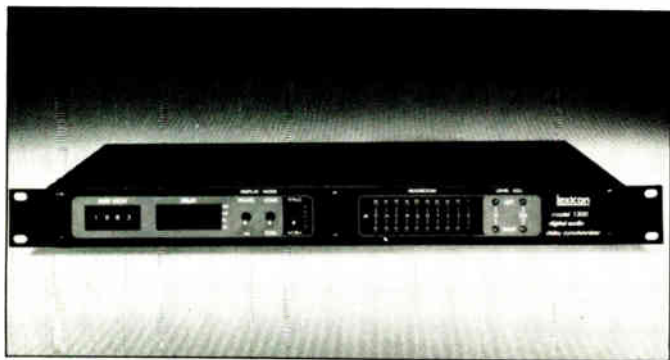

## Lexicon 1300

Lexicon's Model 1300 audio delay synchronizer effectively solves "lip-sync" problems that result from the increasing use of digital video processors and synchronizers. The system decodes the hysteresis and frame offset information from any video synchronizer to provide frame accurate audio synchronization in any broadcast or production setup.

Three standard decoding options are supplied: pulse-width decoding, "wild-feed"/genlock decoding or serial data decoding, each with its own interface panel and software. The removable Delay Configuration Control Module can be configured to conform to any delay/sync decoding scheme presently in use and provides software/hardware flexibility for future configurations.

The system has an optional Remote Video Sensing Module which allows audio synchronization information from the video section of the facility to be communicated via RS-422 to the Model 1300 mainframe located in the audio area. The Model 1300 system is available in mono or stereo configurations. It will allow synchronous operation of multiple units in master/slave configurations.

## Philips VP 832

This is an industrial, or level two, LV player. It includes RS232C interface for programmability. What one would want to program is the unit's random access capability: within 3 to 5 seconds, at maximum, any frame on a 12 inch videodisk can be accessed. In practice, frames can usually be accessed much faster, if they are banded fairly close together—say, within one radial inch of disk space. In fact, a full motion picture can be randomly assembled from various frames dispersed over that one radial inch.

The unit will also interface easily, through its microcomputer controller, with a compact disk player. It plays both standard (CAV) and extended play (CLV) LV disks.

## Panasonic OMDR

Panasonic makes the cheapest optical memory disk recorder around. It operates in color NTSC, and will record still frames with access time of 0.5 seconds. The only problem with it is that picture quality is merely equal to ¾" videotape; therefore, it cannot be used for professional mastering of

widely distributed disks. However, it can be used for all sorts of single generation applications—including as a test for shows later to be mastered for pressing.

It interfaces through RS232C port to CD players and to a whole series of Panasonic still frame video tape recorders. The OMDR will record up to 15,000 still frames on an 8 inch disk.



## Audio & Design TCR 1

Audio & Design's TCR 1 Portable Time Code Reader operates for up to 2000 hours from one set of internal batteries, reading time-code from serial time-code outputs.

Apart from reading SMPTE/EBU time-code, at the flick of a switch the unit will display "user bit" code. Drop-Frame and Color Frame are indicated below the frame count digits. The TCR 1 also has an output through which the time-code can be accessed "cleaned-up". This will be found useful if the source tape is not the master and where the time-code may have degenerated.

The LCD display may be illuminated for 20 seconds by pressing the illumination button. Alternatively, when the TCR 1 is AC powered, the LCD display will be continuously illuminated.

The TCR 1 measures 5 3/8" (37 mm) x 1 3/4" (45 mm) x 7 1/2" (190 mm) and will sell for a recommended retail price of \$495.00.

## Sony SFA 1000

The Sony Still Frame Audio Adapter is capable of recording up to 40 seconds of 10 bit digital audio on a still frame of video. Actually, this 40 seconds of sound is not literally fitted onto one frame, but onto 39 frames. At that rate, one side of a totally still frame video disk would play for 15.4 hours. At the other extreme, that is, a still frame lasting two seconds, consuming 9 frames of video, the total disk side would last 3.3 hours. In practice, most disks would last much closer to the motion video standard of one hour's length, even with many still frames dispersed throughout the program.

Still frame frequency response is rated by Sony at 3500 Hz, -3 dB; there is a remote control supplied, and RS-232 interface is optional. The SFA-1000 is made to interface, right out of the box, with Sony's LDP-1000 LV player and SMC-70 microcomputer. (\$1,000)

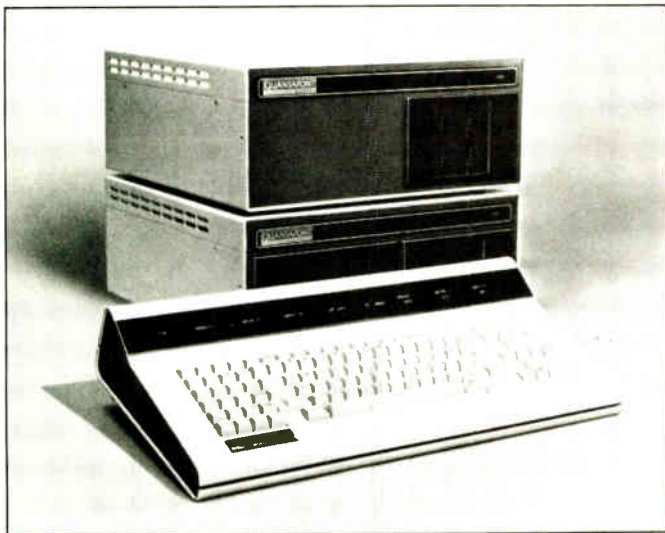

## Quanta Model Q8

The Quanta Model Q8 Titling System was engineered to achieve the highest base resolution of any broadcast character generator now available. It features 26 nanosecond base resolution and each raster scan line affords 2048 individual pixels, delivering reproduction of fonts, logos and other graphics with unprecedented clarity, brilliance and accuracy.

The Q8 is supplied with 12 resident fonts stored on discs (three faces in four sizes each), and they are all readily accessible through the keyboard. Any number of additional font styles and up to 400 pages of text can be stored in the

unit's dual, floppy disc system. Also, a second channel can be incorporated into the Q8 to give the operator two keyboards for simultaneous on-air editing operation.

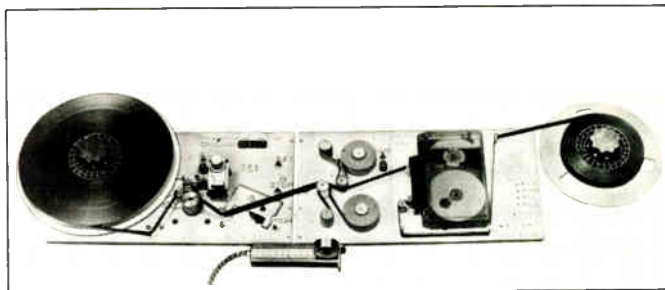

## Audico Videotape Reloader

Video cassette housings can now be easily loaded and reloaded at substantial savings with the Video Cassette Tape Loader/Reloader/Rewinder manufactured by Audico, Inc., on Elk Grove, IL. The system can be equipped to load the exact tape lengths needed directly into Umatic, VHS and Beta housings. The reload feature automatically removes old tape without taking the housings apart, thus enabling their convenient reuse. The whole process takes 2 to 3 minutes.

Another feature allows for the direct transfer of prerecorded and blank tape between cassette housings. For archival applications, a number of shorter originals can be transferred and stored in one full-length housing, thus saving a generation, reducing storage space, and freeing housings for reuse. Prices for the basic loading system begin at \$4,275. ■

## RESEARCH ASSOCIATES

*We're the Ampex and Studer People*

- **Fast delivery** on most Ampex and Studer parts
- **Complete selection** of professional equipment for the recording and broadcast industries:
  - Studer • Ampex • JBL
  - Crown • Urei • Moseley
  - Marti • Dorrough
  - Orban • Autogram
  - Soundcraft
  - Neumann
  - Sennheiser • EV
  - Audicord • CRL
  - Ampex Magnetic Tape
  - Modular Audio Products

- **Call us for prices**

In Los Angeles call **463-9655**

In Phoenix call **254-0036**

In Denver call **694-9390**

*All other areas call*  
**(303) 594-9464**

**RESEARCH ASSOCIATES, INC.**

4445 Northpark Dr., Suite 209  
Colorado Springs, CO 80907

—from page 90, *AUDIOPHILE*

suspension. All these have a very audible effect on the sound.

What about digital audio? Obviously, digital is the language with which audio and video software can communicate, so it is here to stay. However, audiophiles are divided and increasingly skeptical of the claims made by the PCM digital manufacturers of the "sonic perfection" of their systems. They are very good (virtually perfect) in some respects, such as freedom from hiss, low frequency and mid-range tonal balance, and pitch accuracy. Audiophiles are becoming increasingly disenchanted, however, with the way current PCM systems handle high frequency musical information (phase shift, beat frequency harmonic foldback, etc.) and low-level information (bit-word length too short). It's not perfect yet. Many thousands of audiophiles refuse to buy digital records. There is a growing demand for 60's vintage RCA and Mercury recordings among high-end audiophiles.

How important is the audiophile to the recording industry? On an absolute current dollar volume basis, the audiophile does not represent one of the largest market segments, but the record buying market is changing.

Recently, a three year demographic study was conducted by the RIAA in conjunction with the National Association of Recording Merchandisers (NARM). The results of that study are summarized in *Audio Times*, Vol. 25, No. 7, July 1983. The study found that the demographics of the music recording industry are shifting progressively to a more mature consumer. Retail sales of unsophisticated music categories are declining dramatically, as are purchases by the 15 to 19 year-old age group. Those sales are being made up in the 20 to 24 and 25 to 34 year-old age groups. These older buyers have more discretionary income, are more discriminating in their tastes, include more audiophiles, and have better stereos. This age group constitutes 26.4% of the total population of America. This is an important market segment to understand!

Audiophiles are not a bunch of mystics who can always hear the "forces of nature". They are discriminating listeners who love sound (we all do), but usually don't make their living at it. They can be a valuable advance indicator of the viability of new audio gadgets and trends. They are a perceptive and disproportionately influential voice in the recording market place. It would pay us to lend an ear. ■

**Equipment For Sale**

**PROFESSIONAL AUDIO EQUIPMENT**

Shop for pro audio from NY's leader, no matter where you live! Use the Harvey Pro Hot Line (800) 223-2642 (except NY, AK & HI). Expert advice, in-depth parts dept. 34 video systems available. Broadest selection such as Otari, EXR, Ampex, Tascam and more. Write or call for price or product info.

Harvey Professional Products Division  
25 W 45th Street  
New York, NY 10036  
(212) 921-5920

**CUSTOMIZED RECORDING/PA EQUIPMENT** used to record YES and others. MCI 24-track, MAU is 30 in. console, 24-track dolby. All in portable road cases. Could be used in studio or live recording. Well maintained. Call for details and prices.

Randy Blevins B.A.E. Inc.  
615-361-8429.

**AUDIOHOUSE SELLS** Valley People, MICMIX, Echoplate, Symetrix and EXR Exciter at the best prices. (303) 751-2268.

Looking for Eventide SP2016 or H949? Space Station, Banner, RTA, ADR, Scamp? Need AKG, BGW, dbx, E/V, Neumann, Orban, Sennheiser, Shure, Technics, UREI or White products? Best price & service. Contact John:

UAR (512) 690-8888  
8535 Fairhaven  
San Antonio, TX 78229

**NEUMANN MASTERING SYSTEM** including tape machine, SX68 head, VG66 Amplifier Rack, level sets, HF limiters, Elliptical Equalizer and variable pitch and depth. \$38,500. Dolby M16 16 track noise reduction. \$8,500. Call Jim at (513) 681-8402.

**LOW OVERHEAD MEANS LOWEST PRICES.** We carry most major lines of pro audio & recording equipment. **Get your best price, then call me.** 3M Tape and accessories at factory prices.

**S.C.M.S.**  
East U.S. Toll free:  
**(800) 438-6040**  
West & N.C.: (704) 889-4509

**FOR SALE**  
Used Sony PCM 100 Digital Audio Processor. Excellent condition, \$4,000. Also have new PCM F-1, PCM 701, and CDP 101, Contact Audio Services Corp.  
(213) 980-9891  
Ask for Greg.

**BLANK AUDIO AND VIDEO CASSETTES**

direct from manufacturer below wholesale. Any length cassettes. 4 different qualities to choose from. **Ampex & AGFA MASTER TAPE** from 1/4" to 2". Cassette duplication also available. VHS T-120's. \$11.25. Brochure.

**ANDOL AUDIO PRODUCTS, INC.**, 4212 14th Ave., Dept. MX, Brooklyn, NY 11219  
**TOLL FREE: 1-(800) 221-6578** ext. 4 or NY RES. (212) 435-7322 ext. 4

**THE ULTIMATE STUDIO MONITORS!** TANNOY DREADNAUGHT monitors with 3-way electronic, time compensating crossovers and parametric equalizers. \$12,000.00 list. Best offer over \$7995.00 UREI 813A with grilles. List \$3700.00; \$2200.00. All speakers as new. 512-366-3691.

**FOR SALE: PACKAGE SYSTEM** MCI JH-114, 16-track machine, w/ALLI. MCI JH416, 24 MF W/16 IO's. Exel. cond. \$27k, extras. Bulk cassettes in stock. Contact Steve Simmons at (405) 232-1566.

**FOR SALE: DOLBY M16** Noise Reduction System \$7,500.00. EMT 140-S Reverb Chamber \$5,250.00. Neumann U87 Microphone \$700.00 16 Audio Designs Slide Faders, never used, still packaged \$650.00 Call 713-520-6690. Ask for David.

MCI JH16 RECORDER -  
Excellent shape 12K  
Eventide Harmonizer 910 650.00  
Fostex 2 track recorder 750.00  
Tangent 3216 console 11K  
LANE MUSIC CENTER  
(812) 886-4266

**Reliable Music**

**The Finest in Professional Audio With Service to Back It Up!**

Crown, JBL, Tascam/TEAC, Yamaha, Biamp, Technics, Orban, Gauss, Eventide, dbx, UREI, Neumann, AKG, Sennheiser, Beyer, Sony, Shure, Otari, MICMIX, MXR, RTS, Revox, Cetec-Vega, E-V, Omnicraft, Symetrix, Sescom, Ursa Major, Whirlwind, Audio-technica, Ramsa, Lexicon.



(704) 375-8662  
1001 S. Independence Blvd.  
Charlotte, N.C. 28202

**BUILD YOUR OWN STEREO PLATE REVERB SYSTEM** for less than \$350. No exotic parts, minimum of mech. ability. **COMPLETE DETAILED PLANS .... \$41.00** \$43.46 in TN

**HOW-TO ENTERPRISES**  
RT. 2, BOX 96  
GALLATIN, TN 37066

**REELS & BOXES:** 5", 7", large & small hub cassettes, Ampex tape & other recording supplies.

W-M Sales Co.  
1118 Dula Circle  
Duncanville, TX 75116  
(214) 296-2773

**USED RECORDING EQUIPMENT** Bought & Sold. We have Neumann & AKG tube mics of all kinds. API 550's & other misc. outboard equipment. (415) 441-8934, 527-4789

**COMPLETE DISC MASTERING SYSTEM.** Scully/Westrex complete with 3DIIAH cutter, 14" preview machine, EQ's, limiters, Dolby, monitors, and amp. (901) 794-7586 Steve

**CHRISTMAS SPECIALS**

Keyboards, synthesizers, multi-track. **SUPER LOW PRICES.** Scotch 226 mastering tape sale. Crown DC300 A's from \$450. Korg PS61, \$1,000. We have Linn. Call Scott or Tom for details. (800) 354-7252.

**RIDICULOUS!** Modules for your MCI 416 (black face) console, 8 modules \$4,750. Available immediately. Randy Blevins. (615) 361-8429.

**FOR SALE:** MCI JH416-20 20x24 console. Also MCI JH114-16 w/ALLI. Package price \$30,000. Call Jam Productions (214) 526-7080. Dallas, TX.

**FOR SALE:** 3M M64 2 track \$2000., 3M M64 4 track/2 track \$3000. Both excellent condition. Mark Levinson mono preamp (pair). Call Billy at (602) 241-0667.

**FOR SALE:** NEVE 8068II console 32 x 32, Studer A800 24 track w/remote, Ampex ATR100 2 track recorder, 4 sp. w/remote. Also additional outboard gear. Contact Michael Matos at (205) 871-4221 or 1-800-633-4397.

**FOR SALE:** 24 track Quantum mixing console. Components: QM-168 16 track board Phantom Power; QM-120 8 track expander; dual patch bays. Excellent condition. \$11,000 (price negotiable). (619) 346-0075.



**THE X3500 PLATE REVERB.** ONLY \$1,395! Just send for our free demo tape and literature and see why we say, "HEARING IS BELIEVING."  
**Cornerstone Systems**  
703 So. Second Street  
Milwaukee, WI 53204  
(414) 643-0879

**FOR SALE:** Crown DC300A-used. Tascam model 58 & 52-both new. For more information, contact Randy at 800-654-6744.

**FOR SALE:** MCI JH-100 16 track w/auto locator II + SMPTE interface card & spare transport cards. \$12,500. Good condition. Going Studer 24. (214) 630-6196.

**AMPEX MM-1100** 16 track, search-to-cue and remote. Low hours, in spec, excellent conditions, priced to sell. Dick Brown. (816) 747-3476.

**MARSHALL** time modulator Model 5002, 3 yrs. old w/A.C. power supply - \$900. Orban 418A stereo limiter - \$550. Orban 516EC 3-channel de-esser - \$425. Call Bob (312) 495-2241.

**TUBE MICS FOR SALE.** Call Bill at (312) 751-1216.

**MCI EQUIPMENT:** MCI JH 24 trk. auto-locator III, super heads, a well-maintained machine, and MCI JH45 synchronizer. For individual or package price. Call Eric at Sound 80, Inc., 612-339-9313.

**FOR SALE: TANGENT 3216** recording console, fully loaded, good price, excellent conditions. Call Steve Hasday at (212) 582-0210.

**JBL SPECIALS** - full warranty, showroom demos.  
(5) E110 - \$100 each; (5) E120 - \$127 each; (10) E130 - \$132 each; (8) E140 - \$132 each; (3) 4401 studio monitor - \$275 pair; (4) 3101A - \$48 each; (2) 2311 - \$44 each.

Call for other demo prices  
**NEWCOMER SOUND**  
(614) 268-5605

JBL, TASCAM, YAMAHA, UREI, DBX, ASHLY, SHURE, LEXICON, BOSE, SOUNDCRAFT, KLARK TEKNIK, AKG, BEYER, & MANY MORE. JBL FACTORY AUTHORIZED RECONING

Spectrasonics board - 20 in, 8 out, 24 monitors. TT patch bay, producer's desk, Phantom Power, in-board tape deck mount, in use at Cleo award-winning facility. \$11,500 or best offer. Call John Rotondi at Sound Services, Inc. (213) 874-9344.

**FOR SALE:**

TTM mainframe w/24 dbx K9 \$8,000  
 Teletronix LA-2A \$750  
 Dolby M24 \$10,500  
 ATR 100 2 trk. \$3,500  
 Hammond B3 w/Leslie 122 \$4,000  
 615-366-1890

**DISK MASTERING SYSTEM.** Scully lathe, Capps computer, Neuman VG 74 cutting amps, SX 74 head, SP 66 cutting rack. In working order. Steve or Doug, Masterdisk 212-541-5022.

**AUDIOTRONICS 501 16 x 16 4** echo buses, 5 years old, upgraded and must sell. (214) 793-4116.

**SOUND WORKSHOP Series 30, 16** inputs, 28 mainframe, mint condition. Used less than 50 hours, 26 TT124 patchcords, crimp tool, talkback mic. Owner has new job and must sell \$9,100 or best offer. Bill Watkins (502) 499-6143.

**NEUMANN KM56 microphones (2)** (tube/nickel capsule), power supplies, interconnects, extensions and elastic suspensions. \$495.00 each. Otari MX-5050 B2HD mint, 50 hours. \$1575.00. (914) 591-8066, evenings/wknds.

**TANGENT 1632 24 x 24** mint \$11,000. Ampex MM 1000 16 trk. w/TK heads, remote, servo, ex. cond. \$10,500. Ampex 440 C \$3200. Echo Plate \$1800. Sentry III, JBL 4312's, BGW amps, baby grand piano, brand name mics, 2 dbx mainframes with 903, 904, 905, 906 units + much more. \$75,000 of rec. eq., will sell for \$47,000 or separately. (313) 241-6695.

**NEOTEK SERIES 1E** recording console 24x8 w/patch bay pedestal, excellent condition. \$9,000. Also large inventory of new, used & demo tape machines & signal processing. Call EAR Pro Audio (602) 267-0600

**Equipment Wanted**

**USED MICROPHONES & out-board equipment.** (312) 751-1216.

**WANTED:** Ampex AG440s in trade on new Ampex ATR 800s. Ampex sales, service & parts. Northwestern Inc. 1-800-547-2252

**WANTED:** Studer, Neve/Necam. Will consider separate or complete package. Private party. Reply to Dept. VR at Mix Magazine, 2608 Ninth Street, Berkeley, CA 94710.

**Instruction**

**"PRACTICAL TECHNIQUES FOR THE RECORDING ENGINEER"**

Not a conventional recording book. See "The Best on Our Bookshelf" section in this magazine.

**THE CORRESPONDENCE COURSE:** Private instruction in recording theory from a world-class author/lecturer. Certificate course. Two textbooks, homework, final exams, unlimited dialog with the author via cassette. Installment plan.

**FOR SCHOOLS - complete course materials.** Teacher's Manual (lesson plans for two textbooks, reading, homework, suggested session content), Student's Workbook, Final Exams.

**FOR INFORMATION OR TO ORDER contact:** S.K.P.

1626 N. Wilcox No. B-677  
 Hollywood, CA 90028

Order by phone using Visa or Mastercard by calling (805) 969-6639.

**LEARN FROM THE PROFESSIONALS**

**ELECTRIC BASS**

By Carol Kaye:  
 How to Play the Elec. Bass ..... \$4.95  
 Elec. Bass Lines #1 ..... 3.95  
 Elec. Bass Lines #2 ..... 3.95  
 Personally Yours ..... 4.95  
 C. Kaye Elec. Bass Cassette Course ..... 35.00  
 Elec. Bass Lines #3 ..... 3.95  
 Elec. Bass Lines #4 ..... 4.95  
 Elec. Bass Lines #5 ..... 3.95  
 Elec. Bass Lines #6 ..... 3.95  
 How to Play Elec. Bass Chords ..... 4.95  
 and:  
 Easy Elec. Bass (Carroll/Kaye) ..... 4.95  
 Jazz Improvisation - Bass Clef (Most) ..... 5.95

**GUITAR**

Joe Pass Guitar Style ... 6.95  
 J. Pass Guitar Style Cassette ..... 9.00  
 Jazz Guitar Solos (Pass) ..... 4.95  
 J. Pass Guitar Chords ..... 3.95  
 J. Pass Chord Solos ..... 4.95  
 Jazz Duets (Pass/Ellis) ... 5.50  
 Jazz Duets Cassette .... 7.95  
 Laurindo Almeida Guitar ..... 6.00

Foreign postage: \$2.00 1st book, \$1.00 ea. additional. \$1.50 for cassette. \$8.50 C.K. Bass Cassette Course - \$13.50 to Australia, N.Z. & Asia.

Sorry, no CODs. Calif. add 6% tax. Good store discounts.

**GWYN PUBLISHING CO.**  
 177 Webster St., Suite 272,  
 Monterey, CA 93940  
 (408) 476-3510 - (408) 462-3834

GOOD MUSIC MAKES A HAPPY WORLD

Free Catalog

**THE MUSIC BUSINESS INSTITUTE**

A career program in music: Course includes recording, studio, concert & video production; artist represen-

tation & management; retailing and wholesaling; record promotion & marketing; copyright & music publishing; & more. Employment assistance. Accredited. Financial aid available. Write for free brochure & career guide. MBI, Suite 400-MX, 2970 Peachtree Rd. N.W., Atlanta, GA 30305. (404) 231-3303.

**COME TO THE NATIONAL RECORDING WORKSHOP**

Experience "hands-on" training, intimate classes & an all pro staff. This state approved program offers a 160-hr. certificate & a job placement service. CALL (301) 467-7900 COLLECT.

**Instruments for Sale**

**OBERHEIM 4 voice polyphonic** programmable synthesizer. Good condition. Used mainly in studio. \$1795. Jon Hornyak (901) 276-1074.

**Maintenance Services & Repair**

**SPEAKER RECONING:** 48-hour turnaround on most speakers. Gauss, JBL, Altec, Renkus-Heinz, Emilar warranty station. Call or write for info: **ALL STAR SOUND** (805) 653-6661 1070 E. Front #1, Ventura, CA 93001

**SPEAKER REPAIR OF CALIFORNIA** 4334 Sunset Blvd. #2, L.A., CA 90029. Experts since 1939 - speaker rebuilding, tailoring, \$3.50 - \$9 per cone-inch. Microphone repair. Freight free return after 3-day cleaning, glueing, centering & fatiguing; as for Rod Stewart, Zappa, Who, Heider, Glen-Glenn. (213) 666-4161

**SPEAKER REPAIRS**

Factory authorized service center Altec • EV • Gauss • JBL • UREI Replacement diaphragm assemblies in stock.

AST Sound, 250 W. Broadway, NY, NY 10013; (212) 226-7785

**WE REPAIR SPEAKERS - Stereo,** auto, commercial, reconing, 24-hr. turn-around/5-yr. warranty. Replacement diaphragm discounts JBL, EV, Vega, Altec, Advent, Gauss, etc.

**THE SPEAKER EXCHANGE**

804 W. Fletcher Ave. Tampa, FL 33612 813-962-0981 We pay return freight.

**API CONSOLE SERVICE**

Wolff Associates will refurbish, repair, update or modify your API consoles. Factory experience, refer-

ences available. Factory replacement parts. Grounding, hum & noise elimination. Will travel anywhere. Call Paul (703) 241-2880

**Miscellaneous**

**USERS GROUPS NOW FORMING**

for Midi Chroma and Prophet V. Services include: Computer interface information, software & data exchange, & group newsletter. For more information Contact the R<sub>2</sub> Network (213) 768-7448

**50,000 records for sale** in every monthly issue of **GOLDMINE,**

the world's largest record-collecting magazine. All types of music, all eras. Plus, articles on recording stars, past & present, record & music book reviews. Samples \$2.50. 1 year: \$20.

**GOLDMINE**

Dept, ACO, 700 E. State St., Iola, WI 54990

**THE SONG BROKERS**

Free song-matching service for producers. JENPET Music International 3262 Central Alameda, CA 94501 (415) 523-9876

**Record & Tape Services & Supplies**

**WHO TALKS ABOUT SOUND?** Nobody but A + R, because WE MAKE THE BEST SOUNDING CUSTOM RECORDS. Hear for yourself; call for free sample. (214) 741-2027

A + R Records & Tapes 902 N. Industrial Blvd. Dallas, TX WHEN QUALITY MATTERS

**RECORDS PRESSED JACKETS PRINTED**

Our stock or your custom. No minimum quantity. RMR, 8305 Christensen Rd., Cheyenne, Wyoming 82001, 307-638-8733.

**DISC MASTERING - Cut**

from your tapes at low cost - Plating, Pressing, Labels & Jackets - LPs, EPs & 45s. Write for free information: THE CUTTING EDGE, Box 217, Ferndale, NY 12734, (914) 292-5965.

**CUSTOM LENGTH CHROME CASSETTES**  
**Rolls Royce of Custom Cassette**

BASF Chrome tape only UNITED TAPE COMPANY 10746 Magnolia N. Hollywood, CA (213) 980-6700. Ask for Steve

**PROFESSIONAL RECORDING SUPPLIES**

We are a major distributor of Ampex, Agfa & 3M bulk & reel master tape from 1/4" to 2". We also stock empty reels, boxes, video cassettes, Norelco boxes & other recording supplies. We manufacture custom length bulk cassettes using top quality tapes. Cassette duplication service available. Please call or write for our FREE catalog.

**Advance Recording Products**

7190 Clairmont Mesa Blvd., San Diego, CA 92111  
In Calif.: (800) 858-1061  
CA Phone No: (619) 277-2540  
Outside Calif.: (800) 854-1061

**AGFA MASTERTAPE & CASSETTES.** Super prices. Example: 1/4" x 2400' bulk = \$10.53 and C-60 for 86c (case quantities). Send for wholesale price list. **WORLD CLASS TAPE**, Box 7611 Ann Arbor, MI. 48105 (313) 662-0667

**RECORD PRESSING**

Top-quality LP packages at super low prices. Album design available. Check us first!

H.R. Productions  
(415) 930-7573

**CASSETTE DUPLICATION** in Real Time using Nakamichi cassette decks for impressive quality. Fast turn-around. Best rates. Labels, inserts & shrink wrap available, from 10 to 10,000. **AUDIOHOUSE (303) 751-2268**

**AGFA CHROME & normal bias BLANK CASSETTES. CUSTOM LOADING** to the length you need. Your music deserves the best - your budget deserves a bargain.

GRD  
P.O. Box 13054  
Phoenix, AZ 85002  
(602) 252-0077

**REAL-TIME**

Cassette Duplication C45 as low as 98c. 4-color printing, foil labels, shrink wrap. Send for complete price list & services inc. bulk price on AGFA & chrome tape. CAT, 4013 N. Black Canyon Hwy, Phx, AZ 85015 (602) 234-3468

**Real Time Cassette Duplication**

Normal / chrome from digital or analogue masters. Custom loaded lengths. Printing, packaging, shipping. **RESOLUTION, INC.**

299 College Street  
Burlington, VT 05401  
(802) 862-8881

**CASSETTE FLEA MARKET!**

Now you can write your own ticket on bulk cassettes loaded with BASF music/voice quality tape. No reasonable offer refused.

Fuller Sound  
(213) 660-4914

**FACTORY DIRECT PRICES ON 3M TAPE.**

**We can save you money.**

We ship from stock.  
Small quantity orders O.K.  
**STUDIOWORKS**  
(800) 438-5921

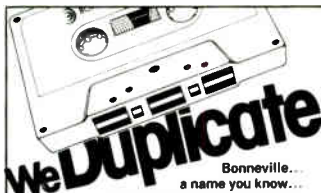

Bonneville... a name you know... a reputation you can depend on.  
• One of the nation's largest and most technically advanced audio facilities • Custom cassette tape duplication: Music, Voice (lectures, etc.), Computer software.

Tape Duplication Hotline 801/237-2677

**BONNEVILLE PRODUCTIONS**  
130 Social Hall Avenue  
Salt Lake City, Utah 84111



**Recording Services**

award-winning videoman & author of Mix's Video Interface

**WEINSTOCK SCRIPTS!**

430 West 119 St.,  
NYC/212-666-7484

he'll show you his reel, as the saying goes...

**CASSETTE DUPLICATION** featuring the all-new Otari high speed duplicators for that super high quality and fast turnaround service. Call or write for complete list of blank tapes, duplicating and other services. **Loose-cut recordings.**, 14430 North 19th Ave., No. 235, Phoenix, AZ 85023. (602) 863-6284.

Let us service your duplication need with our Otari hi-speed stereo duplication equipment. We use TDK tape for your cassette copies. With or w/o Dolby or dbx decoding. Real-time available. Competitive rates on any quantity. **Hoerner Audio Productions (206) 481-3477**

**Studio for Sale**

Recording studio with 24-track & full video capabilities accompany this 3-bedroom 3-acre property. Denver is only 40 min. from this private retreat w/decks & sunshine - \$165,000. For information on this or other mountain property contact: **Horne Real Estate Co., Box 732, Evergreen, CO 80439. (303) 674-5136**

Classifieds continued on next page

**How to place a Mix Classified**

Please print or type in **CAPITAL LETTERS** and lower case where you want the same to appear in your classified ad. There are 8 lines to the inch and approx. 32 characters to the line. \$50/inch - 1" minimum. Additional lines \$10 per line. **Bold Type** \$10 per line. Black border \$10 extra. Logos or display advertising up to 4" will be charged at \$75/inch.

**DEADLINE IS 6 WEEKS PRECEDING ISSUE DATE.**

Multiple insertion categories available (check one).

- Employment Wanted
- Equipment Rentals
- Equipment Wanted
- Instruction
- Recording Services
- Rehearsal Space
- Employment Offered
- Miscellaneous
- Equipment For Sale
- Maintenance Services

Name \_\_\_\_\_

Address \_\_\_\_\_

Phone \_\_\_\_\_

If paying by:  VISA  MASTERCARD Card #: \_\_\_\_\_

Exp. Date \_\_\_\_\_ Name on card: \_\_\_\_\_

Signature \_\_\_\_\_

Payment by check or money order must accompany ad.

Mail to: **Mix Classified 2608 9th St. Berkeley, CA 94710 (415) 843-7901**

STATEMENT OF OWNERSHIP, MANAGEMENT AND CIRCULATION		
1A. TITLE OF PUBLICATION		
MIX	1B. PUBLICATION NO	2 DATE OF FILING
3 FREQUENCY OF ISSUE	4A NO. OF ISSUES PUBLISHED ANNUALLY	4B ANNUAL SUBSCRIPTION PRICE
Monthly	12	24.00
4 COMPLETE MAILING ADDRESS OF KNOWN OFFICE OF PUBLICATION (Street, City, County, State and ZIP Code) (Not printer)		
2608 Ninth Street / Berkeley, CA 94710		
5 COMPLETE MAILING ADDRESS OF THE HEADQUARTERS OF GENERAL BUSINESS OFFICES OF THE PUBLISHER (Not printer)		
Same		
6 FULL NAMES AND COMPLETE MAILING ADDRESS OF PUBLISHER, EDITOR, AND MANAGING EDITOR (This item MUST NOT be blank)		
PUBLISHER (Name and Complete Mailing Address)		
David M. Schwartz / Penny Jacob C/O Mix-2608 9th St./Berkeley, CA		
EDITOR (Name and Complete Mailing Address)		
David M. Schwartz C/O Mix-2608 9th St./Berkeley, CA		
MANAGING EDITOR (Name and Complete Mailing Address)		
Penny Jacob C/O Mix-2608 9th St./Berkeley, CA		
7 OWNER (If owned by a corporation its name and address must be stated and also immediately thereunder the names and addresses of stockholders owning or holding 1 percent or more of total amount of stock. If not owned by a corporation, the names and addresses of the individual owners must be given. If owned by a partnership or other unincorporated firm its name and address, as well as that of each individual must be given. If the publication is published by a nonprofit organization, its name and address must be stated. (Items must be completed.)		
FULL NAME COMPLETE MAILING ADDRESS		
Mix Publications, Inc. 2608 Ninth St./Berkeley, CA 94710		
David M. Schwartz c/o 2608 Ninth St./Berkeley, CA		
Penny Jacob c/o 2608 Ninth St./Berkeley, CA		
Rudy Hirschel c/o 2608 Ninth St./Berkeley, CA		
8 KNOWN BONDHOLDERS, MORTGAGEES, AND OTHER SECURITY HOLDERS OWNING OR HOLDING 1 PERCENT OR MORE OF TOTAL AMOUNT OF BONDS, MORTGAGES OR OTHER SECURITIES (If none are named, so state)		
FULL NAME COMPLETE MAILING ADDRESS		
9 FOR COMPLETION BY NONPROFIT ORGANIZATIONS AUTHORIZED TO MAIL AT SPECIAL RATES (Section 2172 (EMM) only)		
The purpose, function, and nonprofit status of the organization and the exempt status for Federal income tax purposes (Check one)		
<input type="checkbox"/> HAS NOT CHANGED DURING PRECEDING 12 MONTHS <input type="checkbox"/> HAS CHANGED DURING PRECEDING 12 MONTHS                 (If changed, publisher must submit explanation of change with this statement)		
10 EXTENT AND NATURE OF CIRCULATION		
A TOTAL NO. COPIES (Net Press Run)	AVERAGE NO. COPIES EACH ISSUE DURING PRECEDING 12 MONTHS	ACTUAL NO. COPIES OF SINGLE ISSUE PUBLISHED NEAREST TO FILING DATE
B PAID CIRCULATION		
1 Sales Through Dealers and Carriers, Street Vendors and Counter Sales	29,129	30,500
2 Mail Subscription	3,449	6,173
C TOTAL PAID CIRCULATION (Sum of 10B1 and 10B2)	2,680	3,954
D FREE DISTRIBUTION BY MAIL, CARRIER OR OTHER MEANS SAMPLES, COMPLIMENTARY, AND OTHER FREE COPIES	6,129	10,127
E TOTAL DISTRIBUTION (Sum of C and D)	20,844	19,283
F COPIES NOT DISTRIBUTED	26,973	29,410
1 Office use, left over, unaccounted, spoiled after printing	300	300
2 Return from News Agents	1,856	790
G TOTAL (Sum of E, F1 and 2 should equal net press run shown in A)	29,129	30,500
11 I certify that the statements made by me above are correct and complete		
SIGNATURE AND TITLE OF EDITOR, PUBLISHER, BUSINESS MANAGER, OR OWNER		
Penny Jacob - Publisher		

PS Form 3526 July 1987

(See instructions on reverse)

## Business Opportunities

**YOUR OWN RECORDING SCHOOL/STUDIO.** National Audio Educational franchises now available for private ownership! Operate fully equipped school/studio in your community. State approved courses developed over 14-yr. period. Turn-key business including studio construction, equipment, pre-training, marketing, advertising, grand opening and on-going assistance. Low initial investments.

Dawn Audio  
756 Main St., Farmingdale, NY  
11735  
(516) 454-8999

## Employment Offered

**ELECTRONICS SPECIALIST WANTED.**  
Must have strong background in

guitar and pro audio applications.

For position in marketing, sales and promotion. Send resume to:

Chesbro Music Co.  
17421-B East Gale Ave.  
City of Industry, CA 91748

## Studio Space for Rent

FOR LEASE - Excellent, heart-of-Hollywood location (one door south of Sunset Blvd.) 7,000 sq. ft. @ \$1.10 per sq. ft. & monthly at \$7,700. 5 acoustically designed studios, 5 storage rooms, 2 offices, one supply room, one maintenance room, five restrooms (one w/stall shower & employee locker room), canteen area, truck loading dock and full sliding door, personnel door w/handicap ramp, central air conditioning/heat, silent alarm systems. Truck & employee parking, ample customer parking. Concrete block, class A bldg., high ceilings. Contact Ed Van Sloten (213) 467-8542.

## Changing Your Address?

Planning on moving? Please let us know six to eight weeks in advance so you don't miss a single issue of the MIX. Attach your old address label to this coupon and print in your new address below.

(Please print your new address here)

Name \_\_\_\_\_

Company \_\_\_\_\_

Address \_\_\_\_\_

City \_\_\_\_\_ State/Zip \_\_\_\_\_

Mail to:  
MIX Publications, 2608 9th Street,  
Berkeley, CA 94710

# ADVERTISERS INDEX

### PAGE ADVERTISER

60 Accurate Sound Corporation  
65 Advance Recording Products  
143 Adams-Smith  
72 Alshire Custom Services  
44 American Multimedia  
12 Ampex MTD  
26 ANT Telecommunications  
74 Arcal  
53 Ardent  
16 Athenia Industries  
133 Audio Processing Systems (APSI)  
132 Audio-Technica U.S.  
131 Audio Video Resources  
80 Audioarts Engineering  
72 Audiohouse  
19, 23 Audiotronics  
67 Award Recording Manufacturing  
71 Kenneth A. Bacon Associates  
51 BASF  
141 BTX Corporation  
41 Capitol Magnetics Products  
97 Carver Corporation  
125 Carvin Corporation  
21 CMS  
107 Crown International  
151 DeltaLab Research  
4 Digital Entertainment Corporation  
59 Disc Mastering Inc.  
45 Diskmakers  
143 Diskus Products  
50 Disques SNB Ltd.  
64 DOD Electronics  
7 Dolby Laboratories  
94 Eastcoast Sound Specialties  
101 Eastern Acoustic Works  
15 Educational Electronics Corporation  
11 Electro-Voice  
16 Europadisk, Ltd.  
76-77 Fender Professional Sound Products  
115 Postex Corporation of America  
45 Frankford-Wayne Mastering Labs  
57 Full Compass Systems

### PAGE ADVERTISER

123 Garfield Electronics  
131 Gold Line Connector  
19 GRD  
103 Harbinger  
90 The Hardy Company  
2 Harrison Systems  
43 IAN Communications Group  
127 Jensen Transformer  
127 JRF Company  
66 K-Disc Mastering  
27 Klipsch & Associates  
78 KM Records  
98 Lake Systems  
83 Le Mobile  
73 Lenco, Inc.  
134 Linear & Digital Systems  
117 Linn Electronics  
49 Magnetax International  
61 Magnetic Media Corporation  
56 Master Technologies  
82 Masterdisk  
69 The Mastering Lab  
36 Maxell Corporation of America  
75 MCA Whitney  
15 Media International  
112 Meyer Sound Laboratories  
47 Miami Tape Inc.  
37 Microphonics  
54 Midwest Custom Record Pressing Co.  
35 Milam Audio  
68 Moonvalley Cassettes  
60 Mother Dubbers  
102 Nady Systems  
53 Nashville Record Productions  
88-89 Neotek Corporation  
120 Oberheim Electronics  
95 Orban Associates  
20, 39 Otari Corporation  
28 Panasonic/Ramsa  
103 Performance Magazine  
124 Polyline Corporation  
94 Power USA

### PAGE ADVERTISER

79 Professional Audio Services & Supply (PAS)  
65 Professional Cassette Equipment Co. (PCE)  
137 Professional Recording & Sound (PRS)  
68 Project One A/V  
93 Pulsar Laboratories  
31 QCA Custom Pressing  
62 Rainbo Records  
54 Rainbow Cassette Studio  
29 Rane Corporation  
146 Research Associates  
50 Resolution  
74 Rocky Mountain Recording (RMR)  
90 Saki Magnetics  
48 Shape, Inc.  
70 Sonic Arts  
99 Sontec Electronics  
15 Sony A/V Products  
38 Sound Code Systems  
124 Sound Ideas Sound Effects Library  
9, 58 Soundcraft Electronics  
109 Soundtracs Inc.  
59 Speck Electronics  
92 Spectra Sonics  
134 Spectrum Magnetics  
56 Sprague Magnetics  
78 Stoughton Printing Company  
25 Studer Revox  
114 Studio Technologies  
128 Sye Mitchell Sound  
75 Takeda Record Service  
33 Tascam  
17, 85 Telex Communications  
34 Tentel  
B/C TOA Electronics  
46 Tracy-Val Corporation  
55 Trans-Am Industries  
105 Tres Virgos Studios  
47 Trutone Records Disc Mastering Labs  
46 United Tape Company  
107 World Class Tapes



# INTRODUCING EFFECTRON II FROM DELTALAB

**LOW COST,  
FULL BANDWIDTH,  
HIGH PERFORMANCE,  
DIGITAL DELAY.**

The EFFECTRON™ II is an enhanced EFFECTRON. We have added many features per our customers suggestions. These features depend on Model and include increased flanging range, external infinite repeat, increased input range, stereo output and even lower prices!

The EFFECTRON II series is still the only low cost, full bandwidth (16KHZ), high performance line of digital delay processors. Visit your local dealer and check it out !!!  
Listen and Compare . . . .



ADM-1024  
Full  
Second Delay  
\$599\*

ADM-64  
Flanger/Doubler  
\$299\*

ADM-256  
1/4 Second Delay  
\$449\*



\*Manufacturer's Suggested Retail

Music & Electronics . . . Naturally!

# PORTABLE. POWERFUL. PROFESSIONAL.

AFTER THE FIRST SET, YOU'LL WONDER HOW YOU GOT BY WITHOUT IT.

If you're like most working musicians, there's an odd assortment of semi-professional sound gear that takes up a lot of your space. Like an old familiar song, you face the frustration of inadequate sound and the anxiety of wondering whether or not your gear will get you through the night.

## Introducing a new tune. THE TOA MX106™ SELF-POWERED MIXING SYSTEM.

Portable, compact, powerful and loaded with professional performance and features, the MX106 is engineered to help turn the typical, marginal P.A. into a first-rate sound system. The rugged MX106 moves around easily, sets up quickly and delivers recording studio sound quality.

## EVERYTHING YOU NEED STARTS WITH THE INPUTS.

Six inputs accept either balanced or unbalanced sources: low or high impedance mics, guitars, keyboards, drum machines—you name it. On each input you get three band eq., a trim control and peak reading detection circuitry. Goodbye overloading and distortion.

## AN INTEGRAL POWER AMPLIFIER.

The internal power amp is rated at 300 watts into 2 ohms! It's short-circuit and overload protected. And a specially designed rolled aluminum heatsink guarantees excellent heat dissipation for maximum system reliability. Our AutoComp™ feature keeps operating headroom at an optimum level, protecting speaker systems from damaging square waves.

## MASTER CONTROL.

The MX106 has a full one-octave graphic equalizer with a bypass switch. There's two auxiliary inputs with pan and level control, and fluorescent bar graph meters. There's even a built-in electronic Analog echo unit instead of the conventional reverb.

We've provided a complete patch-bay for the interface of peripheral electronics and our exclusive BUSS-LINK™ lets you easily increase mixing capacity.

## SOUNDS GREAT, BUT HOW MUCH?

For \$719.00\* you can't buy a more powerful and compact professional sound package.

\*Manufacturer's U.S. Suggested Retail

Add to this the specs. that engineers like to talk about.

## MX106 SPECS:

MIXER	
Freq. Resp.	-0. -3dB, 30Hz - 20kHz
THD	<0.05% (-4dBm @ 1kHz)
EIN (Noise)	-130dBm (20Hz - 20kHz)
POWER AMP	
Freq. Resp.	-0. -1dB, 5Hz - 40kHz
THD	<0.1% (200 mW to 200 Watts RMS, 20Hz - 20kHz) Typ. below 0.05%
Rated Power (RMS):	300 Watts (2 ohms) 200 Watts (4 ohms) 120 Watts (8 ohms)

Ask for a demo at your nearest dealer or contact us direct for full technical data.



**TOA** Professional Sound & Communications

480 Carlton Court, South San Francisco, California 94080 (415) 588-2538

In Canada: 10712-181 Street, Edmonton, Alberta T5S 1K8 (403) 489-5511



Dealer Inquiries Invited  
©1983 TOA Electronics, Inc.