

51-55



# WORLD-RADIO

## DOMINION & FOREIGN PROGRAMMES

The Official Foreign & Technical Journal of the B.B.C.

Vol. XII No. 296

Registered at the G.P.O. as a Newspaper.

FRIDAY, MARCH 27, 1931

Two Pence

### PRINCIPAL CONTENTS

My Friends—the Announcers  
By "Yodeller"

Frequency Charts of the Brussels Checking Station, for February

Warsaw's New Station

Short-Wave Notes

Which Station Was That?  
Replies to Queries

## WORLD-RADIO

Station Identification Panel

### HILVERSUM (Holland)

(Revised)

Frequency: 1,004 kc/s.

Wavelength: 298.8 m.

Power (Aerial): 8.5 kW.

Approximate distance from London: 232 miles.

Call: "Hier Hilversum, Holland!"  
Sometimes also: "Hier AVRO!"  
or: "Hier Algemeene Vereeniging Radio Omroep!" or other broadcasting companies. Very seldom calls in other languages.

No interval signals. Man announcer.

Closes down with the words "Ik wensch U goeden avond; wel te rusten!" ("I wish you good-night. Sleep well!")

(The change from 1,875 metres takes place on April 1.)

Copyright

A booklet containing a reprint of these panels can be obtained from the B.B.C. Publications, Savoy Hill, W.C.2. Price 1s.

Letters should be addressed to The Editor, "WORLD-RADIO," Savoy Hill, Strand, London, W.C.2.

RATES OF SUBSCRIPTION to "World-Radio" (including postage). Twelve months: Inland 13s., Canadian 13s., Foreign 14s.; Six Months: Inland 6s. 6d., Canadian, 6s. 6d., Foreign 7s. Address—"World-Radio," 3-11, Southampton Street, Strand, London, W.C.2.

# Somebody's going to get better radio!



# Mullard

THE MASTER VALVE

Advt. The Mullard Wireless Service Co., Ltd., Mullard House, Charing Cross Road, London, W.C.2

Arks.

# LISTEN CRITICALLY to your portable!

*Listen to its demand for more power.  
Listen to its improved performance  
when you fit this new H.T. dry battery.*

Because it is a portable, battery space is limited. Yet its valves make terrific demands for power. A thousand to one its demands are not being satisfied. It wants still more power to show you what it can do. Fit a Fuller Dry H.T. W.O.P. 100. This magnificent battery has a *guaranteed* emission up to 20 milliamps; it gives you greater power from the same battery space. It will put vitality into your portable; it will give you a clearer tone, a greater volume, a much increased range of stations. Fit a Fuller—and listen to the difference it makes.

Obtainable through Fuller service Agents or any reputable dealer.

*Full list of sizes and types post free.*



Fuller dry H.T. battery for portables W.O.P.100 (reads 108 volts) 10" x 5" x 3" 15/- Complete range of standard super power and grid bias batteries available.

## FULLER DRY H.T. BATTERIES



### L.T. ACCUMULATORS

Mammoth plates for modern valves; micro-porous paste; patent double grease-cup terminals; patent non-slip metal carrying handle; LDG 2 v. 60 a.h. 9/6. MSG 2 v. 22a.h., 4/6.



### "NON-SPILL" L.T. ACCUMULATORS JELLY ACID TYPE

For Portable Receivers. Standard on well known Portables. Micro-porous pasted plates. Indestructible separators; large non-spill vents. Can be used in any position. JU-19, 18 a.h., 13/- Also JAP 11, 22 a.h., 13/6.

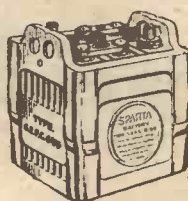

### CAR BATTERIES

Patent double grease-cup terminals eliminate risk of acid creep. A type for every car. Ask for lists 104a and 105a.

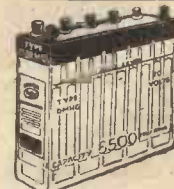

### H.T. "WET" ACCUMULATORS

Dry-charged; micro-porous pasted plates. Grease-cup terminals. Moulded glass boxes. MHG, 10 volts, 3,000 milliamp. hours capacity, 5/- DMHG, 6,500 m.h., 6/9. Also DMGH, 6,500 Milliamps, 6/9.

FULLER ACCUMULATOR CO. (1926) LTD., CHADWELL HEATH, ESSEX

# WORLD-RADIO

Vol. XII No. 296

Registered at the G.P.O. as a Newspaper.

FRIDAY, MARCH 27, 1931

TWO PENCE

## My Friends—the Announcers!

By "YODELLER"

A SHORT while ago, I noticed in these columns a considerable amount of correspondence advocating the more frequent announcement of station names so that listeners might identify them more easily. The idea seemed to me to be an excellent one—if employed for the benefit of those who have only recently acquired a wireless set. But for others, who, like myself, have been listening almost nightly since the very inception of wireless telephony, announcements are almost unnecessary. We find that stations can be identified within a few moments by the announcer's voice.

And now, after so many years of close as-

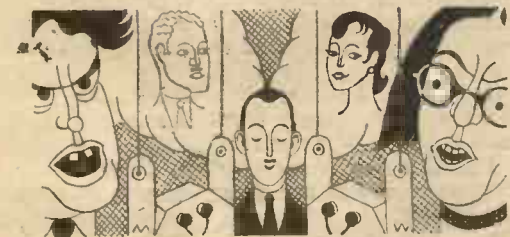

sociation with these invisible gentlemen—and ladies—I have come to feel that I know them all, personally, and by sight.

Each announcer I have clothed in imagination's garments. I have given them their several walks in life, and have painted in their features, their forms, and even their little—to themselves—unsuspected oddities and mannerisms. And I would like to wager that practically every listener has, unconsciously, if not consciously, done precisely the same thing. One cannot help it. One hears these voices daily, and one becomes attached to them. They are one's intimate friends.

I once saw a letter from a wireless enthusiast asking for the publication of certain popular announcers' photographs. This, to me, would be an awful thing. It would destroy the whole romance of the business. The gentleman with the charming accent who treats us with such distinctive German courtesy, and whom I see, in my mind's eye, as a sort of Rudolph Valentino-cum-Ivor Novello-cum-Beau Brummel, may be in reality a fellow with a broken nose, three snaggle teeth, unbrushed hair, and untrimmed finger nails. Whilst, where the lady announcers are concerned, the disillusion might be ten times more terrible. No, thank you very much—but no photographs, please. The announcers are my personal friends. I would have them remain so.

It is curious how personal one's feelings become for these queer, unscen folk. One of the best-known voices on the Continental "ether" must be that of the gentleman from Radio Toulouse. He is certainly one of the easiest to identify. A short while ago, he was off the "air," and another Frenchman took his place. I found myself positively hating this fellow. I pictured him as an unsympathetic little busybody, snarling with unholy joy, delighted at the thought that his comrade was ill, maybe dying—and hoping that he would die. In all probability he was a harmless little fellow, possibly quaking with fear at every appearance before

the microphone, praying that the man for whom he was making himself such an unwilling substitute, would buck up and return from his joyous week-end in Paris. I don't know. But when Mr. Toulouse returned to his post, I found myself nodding and smiling to his superpolite French of the Midi, cheered immensely by his good-natured "*Chers auditeurs*," and listening to his string of advertisements—face powders, wireless goods, furniture, and patent medicines—with the utmost pleasure. A friend was back with us again!

No, as long as we have the announcers' voices, we have little need of station identification signals.

Who can mistake the Barcelona man? I see him dressed in a little short coat, a cloak over one shoulder, velvet knee breeches, and white stockings with buckled shoes over them. He is probably clad in the most correct dinner jacket and black tie, and doesn't even wear "sideboards" and ear-rings. A gay spark, this gentleman, as he carries on an animated conversation—with himself. A ventriloquist of no mean ability, who conducts amazing conversations concerning his advertisements and programme announcements with the little people who are himself. No! I cannot possibly picture him without the cloak and white stockings, "sideboards," and large gold ear-rings.

Then there is the man from Prague. I see him, seated in a huge arm-chair, a little fellow with bald head, large, cheery mouth, and eyes which are always smiling. A lady is singing before the microphone. Mr. Prague sprawls out in his chair, his eyes closed, his mouth slightly open, snoring gently. He sleeps. Suddenly the lady's song is ended. The lady steps back, and a boy pokes the sleeping announcer in the tummy. Mr. Prague opens his eyes in great surprise, raises both arms above his head, staggers unsteadily to his feet, and says in a voice which holds a certain amount of sleepy astonishment—"Al-loooo—Pra—a—haa!" Completely awakened, now, by his own voice, he gives himself a hearty dig in the ribs, and fires forth a mighty burst of cacophonous Czechoslovakian syllables—just to let the station manager know he really is awake at last—bows deeply to the next artists, then, with a merry smile, and another yawn retires to the arm-chair again. A moment later he is fast asleep, tired out by the exertion of having had to say "Al-loooo—Pra—a—haa" to the world. Here again, I am most probably all wrong, but that is how I see Mr. Prague.

The Vienna gentleman, I would not like to offend. Perhaps he has been a judge, an income-tax collector, or even a very superior police official. His voice is stern, I'm sure he never smiles. His dress is formal, his trousers knife-edge creased, his tie the acme of perfection, his hair immaculate. He is about fifty, has no family, is not even married. I don't know how Austria prevailed upon him to take on the job of announcer. But they evidently did, and he does his work with the utmost correctitude and perfection. Were I a member of the studio audience, and felt a sudden tickling in the throat which denoted an impending cough, I would shoot myself—if my revolver had a silencer—

rather than risk one cold glance from Mr. Vienna's eagle eye.

Mr. Frankfurt is quite unlike this. He is late, must hurry, get on with things, get things done. His hair is wild, and his tie streams out behind him as he rushes to the microphone. A most genial spirit this, and he smiles happily as he rushes through his speech and hurries away to arrange the thousand and one things which await his immediate attention. Despite his haste, I'm sure this gentleman would lend me a pound if I asked him. But, of course, I may be wrong. Perhaps he wouldn't!

Miss Berne—ah, here I pause. A little thing, neat of face, and neat of figure, would make a wonderful wife—no, I'm sure she must still be single. She bustles up to the microphone, lays her notes on the table before her—she writes a small, copperplate hand, as legible as an engraving—and, knowing just what she wants to say, says it without hesitation and without fault. Would run a house as she runs her job. Ah me!—but I am already married. What a pity!

Mr. Munich is very conversational. I feel awfully sorry for him at times. He must have suffered a great loss, or perhaps led a hard life. Maybe the cost of living is high in Munich. I dunno. But something makes him sigh at frequent intervals. Must put him in touch with Miss Berne.

The Oslo announcer is, I believe, a very dark-haired gentleman, who, displaying no emotion whatever, stands rigidly before the "mike" and does his "spiel" with the utmost dispatch. A funny language, Norwegian. "Gobley-gobley, gobley, gobeldy"—oh most explicit!

One of my greatest pals is the Jaddie at Radio Paris. A great fellow, this. The gentleman with the unburstable lungs. Listen to him when he does his daily "Bourse" dozen. "Tubize - troiscentscinqtantequinze - Mexican - Eagle-troiscentscinqtantequinze - Central Meaning - sixcentscixtantequinze"—and so on, all

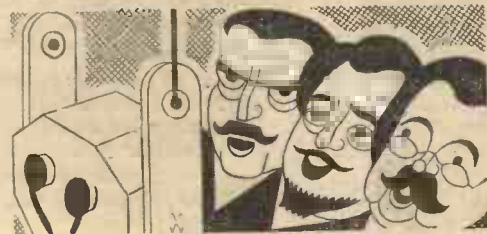

without taking breath. Dashed good. If I could do that, I'd apply for a job in the submarine artillery. I think he must be married, and makes the most of his time when before the microphone.

I could go on *ad infinitum*. I know 'em all. They are all great friends of mine. They will all, most probably, send me their photographs after reading this, just to show me how far from correct were my descriptions of them. But anybody can get a photograph taken—I could myself—but I haven't the money—and I shall utterly refuse to have my little mind pictures shattered by a mere photograph.

I think I should make a jolly good announcer  
(Continued at foot of col. 2, page 488)

## Warsaw's New Station

(From our Warsaw Correspondent)

THE new powerful transmitter at Raszyn began testing not, as anticipated, in the middle of December last, but at the end of January. The initial tests were not announced, as they were irregular and took place late at night, and consisted of gramophone records.

At the beginning of February the Raszyn transmitter introduced itself to the world at large in English, French, and German, in addition to Polish.

On Friday, February 20, Raszyn, for the first time, relayed a symphony concert from the Warsaw Philharmonic Hall. Since then, it has transmitted, from time to time, usually

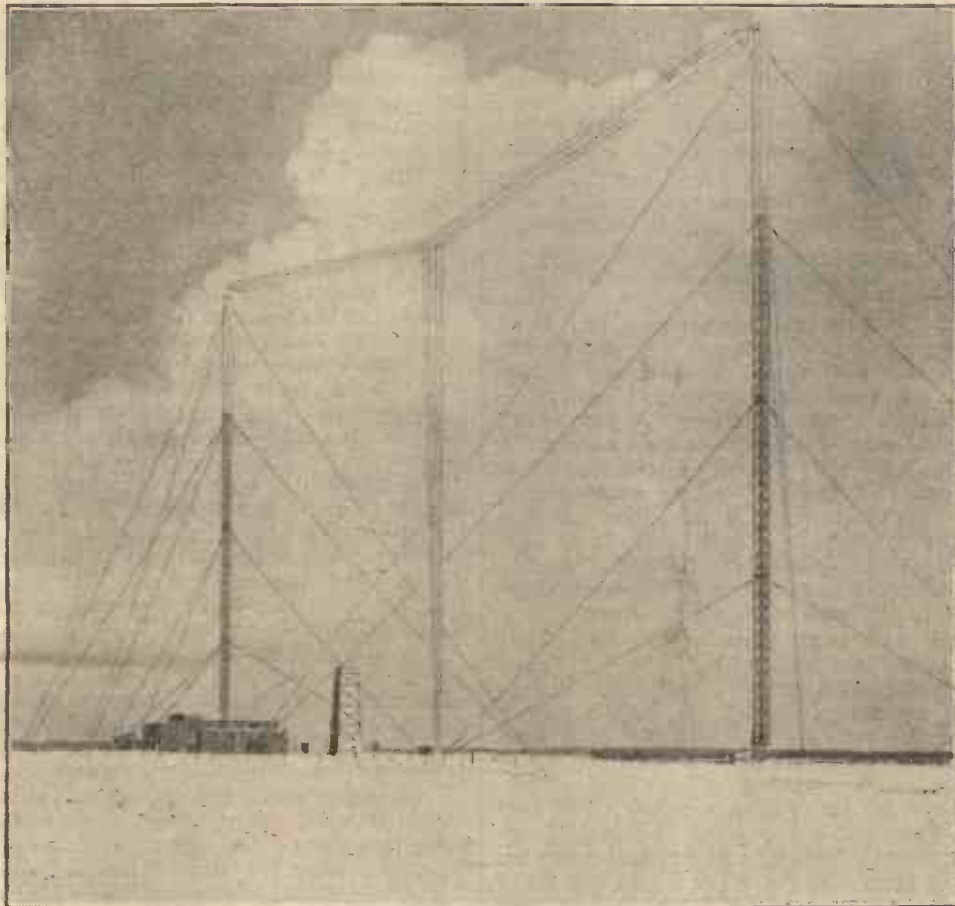

Aerial of Warsaw's high-power station

from 9 p.m. (G.M.T.), some of the items of the less powerful Warsaw (Mokotow) station.

### Raszyn and its Listeners

Most of the letters received by the new station from distant parts of Poland indicate that Raszyn is heard fairly distinctly by crystal set users within a radius of 250 miles. Many such letters were received from listeners living near the Polish-Soviet border, also in the south-easterly Poland.

Several letters arrived from Egypt and Palestine, where—in Tel-Aviv and Jerusalem—Jewish emigrants from Poland had an opportunity of hearing a well-known Zionist, who appeared before Polskie Radio microphone in Warsaw, and gave an account, in Hebrew, of the Jewish situation in Palestine. This talk, which was an additional item to the regular programme, was translated immediately into Polish.

Raszyn has renewed experimental broadcasts until April 18 (which marks the close of the five years' period of Polskie-Radio's activities) when, it is anticipated, the official opening of the station will take place. The new station will broadcast on the wavelength of 212.5 kc/s., (1,411.8 m.)

### The Fate of Warsaw II

The present Warsaw transmitter, of 14 kW., broadcasting from Mokotow, will, it is expected, be transformed, early in April, into a regional station, and will be known as Warsaw II.

For the last quarter of 1930, the following is a classification of the matter composing the Warsaw programmes: music, literature, lectures, talks, news bulletins, plays for children and young people, gramophone records, church relays, and other outdoor broadcasts. Music transmissions occupied 341 hours, or 33.2 per cent. of the whole programme time; and gramophone records 171 hours, or 16.6 per cent. of the total time.

Thus the time devoted to music broadcasts equalled 512 hours, or about 50 per cent. of the whole programme time. Of this, serious music

represented 50.8 per cent.; light music, 21 per cent.; dance music, 17.9 per cent.; operas, 7 per cent.; and operettas, 4 per cent.

There is a growing demand for light music and dance music. Next in importance come the news bulletins, which equalled 8.7 per cent. of programme time.

### MY FRIENDS—THE ANNOUNCERS!

(Continued from previous page)

myself. I am sure I should. I saw a Chinese station advertising for a gentleman of good personal appearance, well educated, able to speak Ti-hi, Wu-hu, Who-Flung, and Ho-There, and who is *au courant* with bird-nest pie, Mah Jong, pigtails, Chinese ink, Chinese crackers, and Chinese junk. The advertisement concluded—"said announcer to be entirely responsible for everything connected with the studio, its administration and, finally, its execution."

No, I do not think I will apply for a job as announcer in a Chinese broadcasting station. I do not like the sound of that last word, with China in the unsettled state which it is at present. A much safer occupation—writing articles for *World-Radio*.

## The Ruling Passion

I YAWNED as the clock struck 9.30 p.m., and stretched myself out in an attitude of well-simulated tiredness. "Ah well," I said, pushing in the switch of my two-valver, "Bed for me."

There followed a chorus of comment, including a sarcastic enquiry after the state of my health, this coming from my younger brother. "What's going to happen to Jack Payne if you're not listening?" murmured Dad. "I expect he'll be able to manage without me for once," I replied. "I've got something special on in the morning, so I guess I'll turn in now. Good-night, everybody."

As I made my way upstairs I could not repress a chuckle, as I thought of the morning's work in question.

I speedily undressed, set the alarm clock, and was very soon in the land of oblivion.

\* \* \*

BRITRRR . . . My dream was rudely shattered by the raucous clatter of the alarm, 3.0 a.m. . . . I jumped up and silenced it, praying that the noise had not penetrated to the ears of the sleeping household. After having forced my eyes into a state of blinking wakefulness, I glanced out of the window. "Hmm. Not very hopeful," I ruminated. The sky was bleakly opaque, and a fitful wind was beating inwards from the sea.

I shivered involuntarily; bed looked very inviting. But no, my blood was up. Others were doing it, why not I.

Pulling on my dressing-gown, I crept along the passage, the stairs creaking alarmingly during the descent.

Switching on the light, I devoutly hoped that the local constabulary would not be suspicious at the signs of activity. I crossed over to the cupboard in which my set is housed, removed the speaker leads, and substituted a pair of 'phones which had been languishing in retirement for some time past. Placing the current copy of *World-Radio* conveniently to hand, I put on the headphones and switched on. The resultant combination of morse, atmospherics, and over-reaction nearly burst my ear-drums, and more than ever feeling that I was indeed on a fool's errand, I set to work, the dial happening to be set at 170°.

Slowly I tuned downwards. Crash after crash of atmospherics, but no sign of the familiar whistle. Lower and lower I turned till I had passed over half the dial without result. Ah! what was that? Surely music. I was not left in doubt for long, for Mühlacker came pouring in, evidently on an engineers' test. This, however, held no interest for me. Where was Germany? A mere stone's throw away. I was out for bigger things. There were but 5° to go when I picked up a very faint carrier wave, which gradually resolved itself into speech. What was the fellow saying? A spasm of morse made it impossible to distinguish even the language. A glance at my European station chart told me that the wavelength was approximately 280 m. What did that chap say in his article in *World-Radio*? Here it is. Blue network; hardly anything to correspond there. Red network; Ah, 282 m.—WTIC. I wonder . . . Music followed, a long arrangement of Rubinstein's "Melody in F," through which I waited patiently for the next announcement.

It came. "You are listening to WTIC, Hartford, Connecticut. This programme is coming to you through the courtesy of the — Coat Company." It was enough; I was mentally shaking hands with America. What cared I by whom the programme was sponsored? I pushed in the switch with a sigh of satisfaction—3.45 a.m. Now to sleep the sleep of the just.

G. M. A.

# Via Ether

## Holy Week

THE coming week's broadcasting programmes are largely in keeping with the character of this solemn period. Thus Hilversum's usual SUNDAY afternoon transmission is the relay from Amsterdam of Bach's "St. Matthew Passion," rendered by William Mengelberg and his Concertgebouw Orchestra. In looking through the programmes I note that Bach's immortal work is also being broadcast from a number of stations during the week. The most important among these, I have no doubt, is that emanating on GOOD FRIDAY from Bach's own church—the Church of St. Thomas, Leipzig. This is being relayed by Leipzig, Berlin, Breslau, Heilsberg, and Königs Wusterhausen. The orchestra is the famous Gewandhaus Orchestra, the choirs the *Thomanerchor* and *Gewandhaus Choir*, eminent singers from the Opera House, Herren Günther Ramin and Max Fest at the harpsichord and organ respectively—all under the conductorship of Professor Straube. Listeners may remember last year's transmission of this work, which was on that occasion relayed by the London Regional transmitter.

## "Parsifal"

THE performance of Wagner's *Parsifal*, which is to take place at 6 p.m., on SUNDAY, at the Warsaw Opera House, will be relayed by the Polish group of stations; while at 9.30 p.m. on THURSDAY the Berlin group is to give us the Third Act of this *Bühnenweihfestspiel*, as Wagner termed this work. A new opera, *Die Richterin*, by a German composer who, so far, is unknown to me, is announced from Hamburg for 7 p.m. on MONDAY. The libretto is by a well-known German writer, F. A. Beyerlein, and from a cursory glance at the list of its characters I gather that the author is treating an historical subject of the period of Charlemagne. I also note that at 6.30 Stockholm is relaying from its Opera House the performance of *The Marriage of Figaro*. Several important operatic broadcasts are to take place on TUESDAY. First of all, at 6.35 p.m., there is the relay by the Munich group of stations of Verdi's *chef d'œuvre*, *Othello*, which is being performed at the Munich Opera House. At 7.30 the Berlin group is giving an operatic version of Bizet's *L'Arlésienne*, a "Schäferspiel" (a pastoral opera), *The May Queen*, by Gluck, is to be heard from Mühlacker-Frankfurt at 7.45; and at 8 p.m. Radio-Paris will broadcast the inseparable twins *I Pagliacci* and *Cavalleria Rusticana*. Two GOOD FRIDAY plays by British authors are announced for that day: Lord Byron's *Cain* and John Masefield's *Good Friday* are to be transmitted from Hamburg and Stockholm respectively.

## "Phantasy and Parody"

In this country we do not particularly celebrate April 1 in our broadcasting—intentionally, anyhow; but Continental broadcasting stations have in previous years availed themselves of All Fool's Day to spring many a "surprise" on the listener. I do not know what their intentions are this year, but I see that Hamburg

is announcing a humorous concert under the heading "Phantasy and Parody," for 8.25 p.m. on WEDNESDAY. No doubt this year the proximity of Good Friday does not permit full play to be given to the programme-builders' ingenuity and flair for practical jokes.

## Hilversum and Huizen

THE time has arrived for another move in the Hilversum-Huizen game, and on April 1 Hilversum resumes its proper wavelength of 298.8 m., while Huizen takes over once more its allotted wave of 1,875 m. By this time we all ought to be fairly familiar with the extraordinary circumstances of this exchange; nevertheless, I frequently find myself slightly confused. Of course, the confusion arises from the simple fact that neither the Hilversum nor the Huizen transmitters alters its wavelength at all, but that the broadcasters associated with each of these stations transmit their programmes alternately from the two stations. Thus from WEDNESDAY next the A.V.R.O. and



A future broadcasting celebrity? The infant son of Mr. James Haupt, who is known to listeners to NBC stations in America as a tenor singer, an announcer, and as a director of musical programmes

V.A.R.A. will, during the next three months, broadcast their programmes from the Hilversum station, using, of course, their own wavelength of 298.8 m. A similar state of things applies to the K.R.O. and other broadcasters associated with Huizen. So, in every sense, Hilversum will be Hilversum and Huizen Huizen, as was pointed out in some appropriate verses published in these columns last year. I feel I must apologise for expatiating on this subject, but I do so mainly for the guidance of the new readers who have not yet participated in the excitement of the Dutch broadcasting game.

## The Sunday Afternoon Amsterdam Concerts

WHILE I am on the subject of Hilversum, I must mention again the extraordinarily enjoyable concerts which have been coming from the Concert Hall, Amsterdam, under the conductorship of Willem Mengelberg, on Sunday afternoons. I was listening to last Sunday's concert, in which Beethoven's Fourth Piano Concerto (Op. 58) was broadcast. I was much struck with the brilliance of the pianist, although at the time I did not know his identity. I see now that it was Walter

Gieseking. Unfortunately, no programmes of these concerts appear to be available in time for printing in *World-Radio*, and we are compelled to rely on the understanding of the announcements, which are certainly quite reasonably clear. It was a pity that two such excellent transmissions as that from Hilversum and the "St. Matthew Passion" relayed from the Queen's Hall by the National transmitter should have coincided in point of time. But we are often confronted by broadcast *embarras des richesses*.

## The Menace of the Open Window

I HEAR from a resident of Vienna that the headquarters of the Austrian Federal Police has issued a solemn warning to all broadcasting listeners "not to use unduly loud loud speakers," and especially not after 10 p.m.; also that windows must be kept closed while loud speakers are turned on, particularly at night time. This applies also, it is pointed out, to little Karli's piano-practice and any other sort of musical performance, or affliction. Though Austria has a law of July 21, 1925, expressly referring to the inconsiderate use of receivers and loud speakers, the present position in Austria is that one may use a loud speaker "discreetly," and damped down, even late at night, at one's own risk, just as motor-car drivers may drive at any pace they like, provided they do not hurt anybody, nor scare him or her overmuch. But it is generally understood that this spring and summer, as the open window becomes popular (which it never is in Austria in the winter), the police are going to be much stricter, and heavy fines will be imposed upon people who annoy their neighbours.

## Strong Words during Music Relay

THE following letter reaches me from a correspondent in Poland: "On Tuesday, March 10, at 10.40 in the evening, during music relay from a restaurant in Warsaw, many Polish-speaking listeners were very unpleasantly surprised to hear a sentence from an unknown announcer, who—evidently addressing another man—used a strong word not to be reproduced in printing. Immediately after the incident the relay was cut up, which made an impression as though the men of the orchestra had a quarrel between themselves. It was explained the next day that a man came up from one of the tables insisting that the band should play a piece that was his favourite. The conductor of the music refused to satisfy the demand and tried to explain to the man that the orchestra had a fixed list of items booked for relay by the broadcasting authorities. His refusal was then followed by swearing of not a stylish quality. The incident took place in the immediate neighbourhood of the microphone, so that the words could be heard distinctly, and some of the listeners might have taken the foul language to themselves. It was established later that the unfortunate amateur-announcer was an engineer. He was upset by taking too many drinks." No comment of mine seems necessary.

ETHERVIATOR

# Dominion and Foreign Broadcasting Intelligence

## The New Zealand Earthquake Disaster (From our New Zealand Correspondent)

AT 12.50 p.m. on Tuesday, February 3, a wireless message saying "Serious earthquake, Napier. All communications destroyed. Medical assistance urgently required," was picked up by H.M.S. *Philomel* in Auckland harbour, having been transmitted by H.M.S. *Veronica* in Napier Harbour. That was how Auckland, New Zealand's largest city, first heard of the disastrous earthquake which wrecked four towns, killed over 220 people, injured about 2,500 others, and did damage to buildings and properties estimated at nearly five million pounds.

"All communications destroyed," said this first message; meaning that roads, railways, and telegraphic lines were all out of commission, and that radio alone was the connecting link between the stricken area and the outside world. All day H.M.S. *Veronica* and two merchant steamers at Napier sent out messages to the rest of the Dominion calling for assistance and giving what details were available in regard to the devastating tragedy. As a result of the speed with which the information came by means of wireless, warships were rushed to Napier, doctors, nurses, and medical supplies were dispatched in all haste, and every other possible form of aid for the injured and homeless people put into action. There is no doubt that owing to the existence and the speed of radio communication, when all other means failed, many lives were saved and also much suffering on the part of the injured, who would otherwise have had to wait hours longer before doctors and nurses arrived to bring them relief.

For two days immediately following the earthquake disaster wireless was practically the only means of communication with the stricken area, and the Government sent a special truck equipped with a short-wave transmitter and receiving set to the area on the day of the disaster. One of the Hastings "B" class stations was still in action after the earthquake and established communication with Gisborne, which, in turn, passed messages on to the rest of the North Island. Late on Tuesday evening a Napier amateur short-wave transmitter got his plant into operation and became the official channel of communication with the Post Office receiving station in Wellington, and other amateurs were directed to keep "off the air" to avoid interference. As the evening wore on a series of official wireless messages were obtained by this means and were broadcast by the YA stations in the four chief cities. All these stations were operating, long after they would normally have closed down, for several evenings, and started earlier in the day than usual in order to give further earthquake news.

Never have New Zealanders had brought home to them the use of wireless as they had during this nerve-racking period, and never have they had cause to thank modern invention as they thanked broadcasting at this time. Wireless allowed order to be evolved from chaos, saved lives and agony, and ended the suspense of countless people who would otherwise have gone days without information in regard to their loved ones who were in the stricken area at the time of the disaster.

## Russia's Thirty-eight New Stations (From our Washington Correspondent)

A report just issued by the U.S. Department of Commerce states that by 1932 Soviet Russia plans to place in operation twenty-two additional stations of 100,000 watts power, or double the output of the highest powered

American stations, in addition to 133 stations ranging in power from 1,000 to 100,000 watts. Forty-five new stations are already planned, of which thirty-eight will be installed during 1931. The total cost of construction has been placed at approximately £10,000,000.

The report estimates that there are now 2,764,000 receiving sets among the Russian population. Of these, 2,100,000 are in rural districts. Russian progress in wireless development may be judged from the fact that in 1929 there were only 400,000 receiving sets in use.

The industry is working to capacity and unable to cope with the demand for receiving sets from all parts of the country. The Soviet Government is doing its utmost to stimulate the industry, both from the standpoint of station installations and the manufacture of receiving sets. According to the current report, 1,800,000 sets will be produced in 1931, which would then give one set to every thirty-five of the population.

Popular interest in wireless is fostered by the formation of civic radio clubs, the best known being "The Friends of Radio," with 300,000 members. Magazines and pamphlets containing information and programmes are distributed to all persons interested.

Hitherto, little information has been available, but the report just released by the Department of Commerce shows that an intensive development of the wireless industry and broadcasting activities is an important part in the Five Year Plan, now being pushed to completion.

## AUSTRIA

### New High-power Station (From our Vienna Correspondent)

At a cost of more than £100,000 Ravag is about to erect a station with 75kW to 120 kW energy, thirty miles at least of Vienna, as Rosenhügel is now inadequate. Ravag requires one of the most powerful stations on the Continent, for she is now being rapidly outclassed. The new station cannot be erected very near Vienna, as there would be interference with the transmitting and receiving stations of "Radio Austria," the commercial company. The Vienna Forest and the Danube are detrimental to broadcasting transmission. But at a distance of thirty miles from the forest and the river there is a wide choice of sites, and tests are being made at a number of places to assist in providing material for the ultimate decision.

## DENMARK

### New Broadcasting House (From our Copenhagen Correspondent)

The new Danish broadcasting building, which is situated on Kongens Nytorv (King's New Square), in proximity to the Royal Theatre in Copenhagen, is now approaching its completion. At the time the building was projected the number of licensed listeners in Denmark was about 160,000. Since that time broadcasting in Denmark has greatly developed, and there are now about 450,000 licensed listeners. The number of transmission hours have been increased accordingly. As development on such a scale could not be foreseen, and the new building does not provide for a correspondingly large future increase, the Broadcasting Council has resolved to buy the adjacent building. In the second floor of this new building, the Secretary and the administrative offices will be housed.

### Shakespeare from Copenhagen

On Thursday, April 2, from 7 p.m. till 7.55 p.m., the stations of Kalundborg and Copenhagen will broadcast a Shakespeare programme. The station orchestra will play old English melodies, which will be followed by a performance of *The Merchant of Venice*.

## FRANCE

### (From our Paris Correspondent)

#### Aeroplane Broadcasting Service

After trains, it is now the turn of commercial and tourist aeroplanes to be fitted with a wireless service enabling passengers to listen to concerts during their voyage. The inauguration took place recently on the Paris-Berlin route, when passengers on two aeroplanes were able to don earphones and enjoy a concert *en route*.

#### Paris-Madagascar Flight

The aeroplane of Mr. Goulette, who, with several companions, is flying from Paris to Madagascar, is equipped with a transmitting and receiving set, thus enabling his flight to be followed closely.

## GERMANY

### The Problem of Broadcast Plays (From a Correspondent)

Plays specially written for transmission by wireless are one of the chief troubles of those who organise the programmes in Germany. According to Dr. Hans Flesch, who has been responsible for many performances before the microphone in Berlin, the biggest successes hitherto have been adaptations of real plays, and not those specially written for broadcasting. Experiments are now being made with play reading before the microphone, with well-known actors and actresses taking the different parts. This method, if successful, will be used to broadcast well-known classics of the theatre. Records will be made in future of any play which can be adjudged to have had a success, so that this can be repeated. This will be an innovation for German stations. Several plays for broadcasting have been commissioned from well-known writers, and it is hoped by continued experiment along these lines to obtain a really first-class gramophone repertoire.

#### A "Clearing House" for Plays

A new company (Programmdienst für den deutschen Rundfunk, G.m.b.H.) has been formed in Germany with a view to simplifying distribution of plays specially written for broadcasting. The company has official broadcasting sanction, and authors, instead of having to submit their works to each broadcasting company, need only communicate with this special organisation which conducts all negotiations, and also copies the manuscripts free of charge. Fees for accepted plays will be payable through the new company. It is hoped that the financial side of writing for broadcasting will thus be rendered more attractive.

## HOLLAND

### Huizen's New Studios

#### (From our Correspondent at The Hague)

The demands on the studios of the Catholic Broadcast in Holland (K.R.O.) have steadily increased, and further new studios were opened on Saturday evening, March 7. They were dedicated by his Excellency the Archbishop of Utrecht (Monsignor J. H. G. Jansen). In the curious conditions at present existing here this is counted as the Huizen station, though at present the Hilversum station is being used on the medium wave.

## NORTH AFRICA

### Weekly English Talks

#### (From our Algiers Correspondent)

A series of talks in English is being broadcast from Algiers station each Tuesday night at 10 p.m. The series, which started on March 24 and will continue until April 21, will have as its subject "Algeria."

# WHAT WILL BE YOUR INCOME WHEN YOU RETIRE?

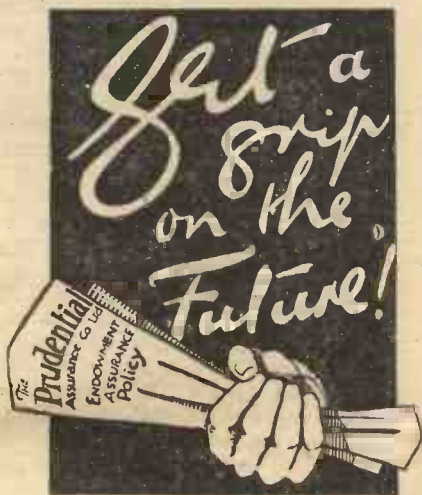

YOU will wish to live as comfortably as you did during your working days.

But no man expects to receive a pension equal to his salary. Would it not be wise therefore to secure an income sufficient to make up the difference between salary and pension?

For a yearly outlay well within the means of middle-class people you can ensure a

## GUARANTEED INCOME OF, SAY, £300 A YEAR AT AGE 60.

Should you die before the income becomes payable a substantial sum, with guaranteed Bonus additions, would be available for your dependants.

IF YOU WOULD  
 :: LIKE A ::  
 GUARANTEED  
 INCOME OF  
 £300 A YEAR AT  
 60 OR EARLIER,  
 FILL IN AND  
 FORWARD THIS  
 COUPON.

TO  
**THE PRUDENTIAL ASSURANCE CO. LTD.**  
 Holborn Bars, London, E.C.1.

Please send me particulars of an Endowment Assurance Policy with Guaranteed £3 per cent. Bonus which will enable me to secure an income of

£.....at age..... My age next birthday is.....

Name.....  
 (Mr., Mrs. or Miss)

Address.....

.....

## Foreign Languages

### Aids to Listening

#### FRENCH

Dimanches . . .

**C'**EST avec le plus vif intérêt que les Continentaux suivent le conflit survenu en Angleterre au sujet de la fermeture (*closing*) des cinémas le dimanche.

Quel contraste entre le Jour du Seigneur observé chez Albion et celui fêté en France, en Belgique et en Allemagne!

Je me souviens avoir débarqué à Londres un dimanche. Pas de théâtres, pas de spectacles, pas d'amusements. Alors que tant de choses en Angleterre ont évolué, les moeurs gardent, elles encore, l'empreinte de cette époque victorienne qui eut sur le caractère britannique une influence si marquante.

Dimanche soir, dix heures et demie.

De toutes les stations européennes de T.S.F., sauf de celles de Grande-Bretagne, parviennent les flons-flons de la musique de brasserie, les rythmes syncopés du jazz, les roulades des chanteuses et les roucoulements (*cooing*) des artistes de cafés-concerts.

Voici Léon Raiter, accordéoniste à Radio-Paris; l'orchestre de Dajos Béla à Koenigs Wusterhausen; le "dance-band" du Caveau de Strasbourg; les tangos des "boys" de Chantilly d'Anvers relayés par Radio-Bruxelles; le jazz du "Palace" de Copenhague.

On danse à Rome, on charlestone à Vienne, on s'amuse à Katowice. Seul, Londres échappe à cette folie générale. Une voix grave, singulièrement grave au milieu de cette abondance de chansons et de rires, rappelle aux hommes qu'ici-bas tout n'est que poussière.

Lorsqu'au caprice du condensateur, l'on accroche (*tunes-in to*) brusquement une station anglaise, l'on est ramené d'un monde factice (*artificial*) et enjôué à une réalité sévère et profonde.

Le dimanche anglais! Que d'encre n'a-t-il pas fait couler! Que de caricaturistes n'a-t-il pas tentés! Vers 1863, le célèbre dessinateur français Gavarni illustre un livre d'Emile de Labédollière, livre qui, à l'époque de son apparition (*at the time of its publication*), obtint un certain succès.

L'ouvrage est intitulé: "Londres et les Anglais" Je le dénichai, il n'y a bien longtemps, au Vieux-Marché, à Bruxelles. (Il faut savoir que le Vieux-Marché est à Bruxelles, ce que sont le Marché aux Puces à Paris, le Petticoat Lane et la Rag Fair à Londres).

J'achetai le livre pour un peu plus d'un penny, mais j'eus la surprise de constater que les chargés (*cartoons*) de Gavarni, au nombre de vingt-quatre, avaient été arrachées. Je me consolai cependant, grâce au texte.

Certains passages sont demeurés d'une actualité brûlante (*burning topical interest*). En 1861, il y a exactement soixante ans, pendant la Semaine Sainte (*Holy Week*), nous dit l'ouvrage de Labédollière, le lord-chambellan avait autorisé les lieux publics à rester ouverts.

L'année suivante, une pétition fut organisée afin que ces établissements fussent fermés et qu'il n'y fût pas même donné de concerts.

Le lord-chambellan ne voulut pas retirer sa permission et les pétitionnaires provoquèrent à Whitehall, un grand "meeting," sous la présidence du révérend Brymer Belcher, pasteur à Pimlico.

On y lut des lettres de l'archevêque de Canterbury et de l'évêque de Londres exprimant leur sympathie pour le mouvement de protestation. L'autorisation fut cependant maintenue et pendant tous les jours de la Semaine Sainte, à l'exception du Vendredi-Saint (*Good Friday*), des représentations théâtrales furent données. Chose curieuse, le public

qui y assista manifesta en faveur de l'observance du repos religieux!

C'est alors que, le 15 avril, fut donné avec le plus grand succès, la première du bel opéra de Verdi "Le Trouvère" (*Il Trovatore*) interprété par Mesdames Gardosa, Tagliafico, Didée et Messieurs Santley, Tagliafico, Lucchesi, Rossi et Tamberlik. Un seul théâtre resta fermé pendant la Semaine de la Passion, celui de Haymarket. Il annonça, par voie d'affiches (*by posters*) que, s'il ne suivait pas l'exemple de ses confrères, c'était simplement parce qu'il avait besoin de faire des réparations avant l'ouverture de l'Exposition, "for no other reason than the necessity for cleansing and repairing the house previous to the opening of the National Exhibition" dit le texte original anglais.

L. Q.

#### SPANISH

Buenos Aires. El discurso del Príncipe

**E**L sábado, 14 de Marzo, fué un día memorable para el mundo radiofónico. A las seis de la tarde, el Príncipe de Gales, al inaugurar oficialmente la gran Exposición Anglo-argentina en Buenos Aires, iba a pronunciar un discurso que había de ser radiado a lo largo y a través (*along and across*) del Atlántico—una distancia de unas siete mil millas—recogido (*picked up*) por los aparatos receptores de la B.B.C., y retransmitido por las principales estaciones británicas a las antenas (*aerials*) de los muchos millones de radioyentes que, con los nervios en estado de tensión, estarían contando los minutos y segundos y preguntándose (*wondering*) si la maravilla que nos tenían prometida (nos habían prometido)—con ciertas reservas y salvaduras (condiciones)—iba a realizarse, o si nos esperaba un chasco (*disappointment*), una desilusión, un fracaso, como en otras tantas ocasiones semejantes había sucedido.

De la redacción (*editorial offices*) de un diario de la tarde me telefonearon preguntándome si podía tomar notas taquigráficas (*shorthand*) del discurso, el cual, según tenían entendido, se pronunciaría en español, pues querían ser de los primeros en publicar una traducción completa. Pero yo, recordando lo (que había) sucedido en ocasiones anteriores con retransmisiones de esta clase, no quise comprometerme a nada. Tenía un miedo muy grande a (*of*) los parásitos, o ruidos atmosféricos que suelen acompañar la recepción a larga distancia.

Se acercaba la hora, y nos sentamos delante del receptor, esperando el aviso de Londres de que se iba a dar principio (principiar) al gran ensayo (prueba, experimento). Éste no se hizo esperar. Cogí (*I took up*) papel y un lápiz, dispuesto a hacer un gran esfuerzo para apuntar (*to take down*) todos los discursos íntegros, palabra por palabra, si las condiciones atmosféricas lo permitían. Pero a los pocos momentos comprendí que mis deseos iban a quedar frustrados. En medio de un verdadero *mare magnum*, de una serie continua de tremendas oleadas (*waves*) que representaban a las mil maravillas (maravillosamente bien) una terrible tempestad en el mar, se oía una voz que en tonos indistintos decía algo en inglés, pero yo ni una sola frase completa ni inteligible pude sacar (*make out*). ¡Vaya (*what*) un chasco!—dije, muy disgustado—¡Nuestro gozo en un pozo! (dicho español que se aplica a un caso como éste). El que hablaba era el presidente (*chairman*), Sir Herbert Gibson, que principió su discurso preliminar en inglés y lo terminó en español.

Pero todavía nos quedaba alguna esperanza. El Príncipe iba a tomar la palabra, y él tiene una voz ideal para el micrófono: suave, armoniosa, bien timbrada. Sus primeras palabras, pronunciadas pausadamente (despacio), salieron con una claridad que contrastaba notablemente con la voz confusa del orador que le había precedido. Continuaron las molestas oleadas

atmosféricas, o etéreas, o lo que fueran, pero no se perdió ni una palabra del discurso, cuya última parte fué pronunciada en español, un español no precisamente *perfecto*, como aseguraron algunos periódicos,—pues se notó alguna que otra (*an occasional*) faltita en la acentuación de sus palabras, y la vocal "o" no salió con la pureza que exige (requiere) el castellano,—pero, dado (en vista de) el poco tiempo que el Príncipe llevaba estudiando (había estudiado) el idioma, su primer ensayo público merece los mayores elogios (alabanzas—*praise*). Según el *New York Times*, nunca se había radiado un discurso en español que fuese tan fácil de escuchar y entender.

Terminó el acto de la inauguración con un discurso del Presidente de la República, pero éste lo leyó con una velocidad tal que si se hubiera tratado de un concurso (*contest*) de rapidez de dicción, de seguro (indudablemente) él se habría llevado un premio.

Peró habíamos logrado nuestro deseo; habíamos oído hablar al Príncipe desde el otro hemisferio, y estábamos contentos.

De la inmensa popularidad del Príncipe en la República no cabe duda. Sobre este punto el citado diario americano dice:—

"Jamás un visitante extranjero se ha hecho tan popular como el Príncipe de Gales, que indudablemente sería elegido Presidente de la República Argentina mañana si él quisiera ocupar el puesto."

En esto habrá alguna exageración, pero nadie negará que el Príncipe es nuestro primer propagandista comercial.

W. F. BLETCHER.

#### ESPERANTO

**D**UO.—Kio nova en la Esperanta etero?  
Radio.—Nu, estas signo de vivo el Bruselo.

Duo.—Ha! Ĉu la nova Instituto intencas rekomenci la interrompitan serion de ĉiusemajnaj disaŭdigoj, kiujn ni ĝuis dum la funkciado de *Radio-Belgique*?

Radio.—Bedaŭrinde, ankoraŭ ne temas pri tio, sed okazos io, kio donos al ni Esperantistoj oportunun por remalfermi la demandon pri tio.

Duo.—Interese. Kio estas?

Radio.—Mi ricevis leteron de D-ro Kempeers, Vicprezidanto de Belga Ligo Esperantista, per kiu li informas min pri dialoga diskuto, kiun oni intencas disaŭdigi merkredon, ran de Aprilo, el Bruselo (508.5 m., 20 kW.). Ĝi estos franclingva, daŭros dek kvin minutojn kaj havos kiel temon: "Ĉu oni devas paroli Esperante?"

Duo.—Je kioma horo?

Radio.—Inter la 20.30 kaj 21.40, horo de Greenwich. La precizan horon oni sciigos nur poste. Vi trovos ĝin, sendube, en *World-Radio*. Se vi sukcese aŭskultas, ne forgesu informi la Instituton.

Duo.—Al kiu adreso mi skribu?

Radio.—Al la Institut National de Radiophonie, ra Rue du Bastion, Bruxelles. Samtempe vi kaptos la okazon por demandi pri la restarigo de la ĉiusemajna Esperanta disaŭdigo, ĉu ne?

Duo.—Kompreneble, kaj mi esperas, ke multaj aliaj agos same.

Radio.—Mi legis en la gazetaro, ke oni serĉas permeson starigi Radiostacion en Luksemburgo, preĉipe por celoj de reklamado. Jen nova kampo, kiun ni devas klopodi venki, por aldoni ĝin al nia teritorio Esperanta. Laŭ tio, kion mi legis, oni intencas disaŭdigi en diversaj lingvoj. Pro sia centra situacio, la stacio povos tiel atingi grandan nombron da diverslandaj aŭskultantoj, ĉar ĝi estos, kompreneble, tre altpotenca.

Duo.—La nombro estus eĉ pli granda, se oni aldonus Esperanton al la lingvoj uzotaj. Per ĝi oni atingus landojn, kiujn oni ne atingus.

(Continued at foot of col. 2, page 499)



# TECHNICAL SECTION

## Mystery of the Ether

By RALPH STRANGER

Author of "Mystery of Electricity" "Mystery of Magnetism," etc.

(Continued from page 361, March 6, 1931)

THE present state of scientific thought is such that Professor A. S. Eddington would like to nail up a notice over "scientific premises": "Structural alterations in progress—No admittance except on business." He would keep out such people as you and I, *i.e.*, students of science who would like to have something definite to go by, some concrete starting point with a well-defined path that would lead to the desired goal—a better understanding of the laws of nature. Unfortunately there is no such starting point at the present time; there is a blurred patch, ill-defined, and bristling with contradictions; there is a rough trail winding here and there which seems to lead us nowhere.

New and startling ideas are being advanced from all quarters. The quantum theory leads us to believe that an ether wave is not only a wave but also has properties of a solid particle. Radiation exerts an appreciable pressure on the bodies it happens to reach. Energy is said to possess mass. Ether waves can act as solid particles and knock electrons out of their atoms. The scientists know that radiation will behave now as a wave, now as a particle, and they have acquired a habit of treating it accordingly on these occasions by a sort of scientific instinct. To remind themselves of this fact they are talking of *wavicles*, which are partly waves and partly particles. Later discoveries have shown that a particle such as an electron will also behave as a particle and as a wave. It has been established experimentally that both the proton and the electron are associated with ether waves, if not actually products of these waves.

While we were dealing with bits of matter of some tangible size we had the ordinary laws of mechanics to guide us, and experienced no trouble in predicting how any portion of matter would behave in various circumstances. But it is a different thing when we come to deal with bits of matter of the size of an electron or a proton. The ordinary mechanics fail in this case; we are dealing with something new, something unknown, something that we cannot even see. During our experiments the electron and the proton refuse to behave as purely solid particles; they show that somehow or other they are mixed up with ether waves. They behave in such a way that one is almost tempted to describe them as "bottled" or "frozen" waves. To cover this extraordinary, or, at least, quite unexpected, behaviour, a new type of mechanics had to be developed.

### Wave Mechanics

The originators of wave mechanics are Prince L. de Broglie and Professor Schroedinger. Their idea of electrons and protons is that they are particles of matter associated with a group of waves having a definite range of wavelengths. Both the proton and the electron represent localised energy. Their mass is made up of two components: the material mass and the energy mass, the latter increasing with the increase of speed at which the particle travels. The resultant combined mass of an electron travelling at a great speed is larger than that of an electron travelling more slowly.

Thus it would appear that the energy of an electron, or proton, resides not within the boundaries of the particle, but outside it. We

know that a particle is there, because we know that energy is there. Thus it may be that there is no such thing as an ultimate solid particle; that which we have up to the present taken to be a solid particle, such as a proton or an electron, may be merely localised energy which travels in space. It may be that, according to our laboratory standards, this localised energy behaves now as a particle, now as a wave, and, if the proton is a different thing to an electron, there must be two kinds of localised energy which attract each other and which form the foundations of our universe.

### Localised Energy

How can energy become localised? It is very difficult to explain this clearly in everyday language, as one has to interpret highly involved mathematical conceptions into something that can be imagined in the mind's eye, but still this particular case can be imagined a good deal easier than, for instance, Einstein's idea of fourth dimension, time-space, gravitation bumps in the ether, etc.



By courtesy of Cambridge University Press.

### Electron diffraction pattern on photographic plate

Let us imagine, in the first place, that we can see waves in the ether. I shall specify these waves a little later, but for the moment let us think of them as being similar to sea waves, *i.e.*, waves that possess a crest and a trough. Let us imagine that we can see a single train of waves spreading in a certain direction with a certain speed. Thus we may visualise, over the whole expanse of our imaginary sea, a line of crests passing our eye at the rate of, say, fifty crests a minute. Let us fix to each crest a little red mark so that should other waves come into existence we can always identify our original crests.

Now let us imagine another train of waves proceeding in the same direction as the first train, but having a different wavelength, and travelling at a different speed. Let us mark the crests of this second train of waves with a blue mark. The rate at which the red and blue marks are passing before us we shall call *wave or phase velocity*.

Thus the two sets of waves are travelling in the same direction; they have different wavelengths and different phase velocities. While we are watching it may happen that we shall see a red and a blue mark side by side, the two crests coinciding. We shall probably find that such an event will take some time to happen

again. The rate at which the red and the blue marks pass before us together is very much slower than the rate with which individual marks pass. Let us call the rate of speed of the pairs *group velocity*. We now know that group velocity is much slower than wave or phase velocity. If there are fifty red marks passing our eye each minute and, say, forty-five blue marks passing, there will only be five pairs passing our eye each minute.

Just as two musical notes of almost equal pitch will produce "beats"—*i.e.*, notes of much lower frequency—so our marked waves will produce a "beat wave" (represented by a coincident pair of marks in our analogy) which will travel at a much lower speed, which we have called group velocity. Since, when two marks coincide, two crests coincide and the disturbance at this point will be much greater than elsewhere, it follows that the energy at that particular point will be at its maximum.

In the same way we can imagine a number of ether waves, each having a different wavelength, and each travelling with a *different velocity*, but all in the same direction, producing a sort of a beat wave which will travel much slower than the individual waves, possibly as slow as, say, a fast-moving electron.

Thus it is not inconceivable that the electron and the proton are merely "beat waves"—the result of a number of ether waves having an exceedingly small wavelength, and therefore an exceedingly high frequency. It is also not inconceivable that such a "beat wave" once produced in the ether may acquire a permanency and exist as a sort of a frozen or bottled wave till something happens to dissolve it into its native ether.

You have, no doubt, noticed that I am talking of ether, or electro-magnetic waves possessing different velocities. Do not *all* electro-magnetic waves travel with the velocity of light? The theory of relativity implies that there are ether waves which may travel faster or slower than light waves, at least the waves which are responsible for the "bottling" of energy. Such waves appear to be a kind of auxiliary ether waves existing purely for "bottling" purposes. It is the "bottled waves" that will produce by radiation other waves that will spread with the velocity of light.

The fact that electrons and protons are some sort of waves, or at least are associated with ether waves, has been proved experimentally. Professor G. P. Thomson carried out some very significant experiments which prove that the electron, which up to the present we have taken to be a solid particle, or, at least, a bubble in the ether (Sir Oliver Lodge), behaves as a wave would behave under the same circumstances. What Professor Thomson did was to fire a stream of electrons on to a photographic plate through a specially-made gold screen. This gold screen was much thinner than the finest gold leaf, and represents one of the most precious pieces of apparatus in our laboratories.

In the ordinary way if a beam of light waves is allowed to fall on a photographic plate through an exceedingly fine aperture the plate will show a series of dark and light rings called diffraction rings. If we fired a stream of particles direct on to a photographic plate we would obtain a well-defined image, corresponding in size to the sectional area of the particle beam. Now, if we place a thin gold screen between the source of emission of either particles (or waves) and the photographic plate, this is what will happen. When we are firing solid particles they will collide with molecules of the screen, suffer deflections in varying degrees and will spread

(Continued in col. 2, page 497)

# February, 1931

# Frequencies of European

Measured at the Brussels  
Technical Committee of the Union

The letter T indicates wireless telegraphy transmission,

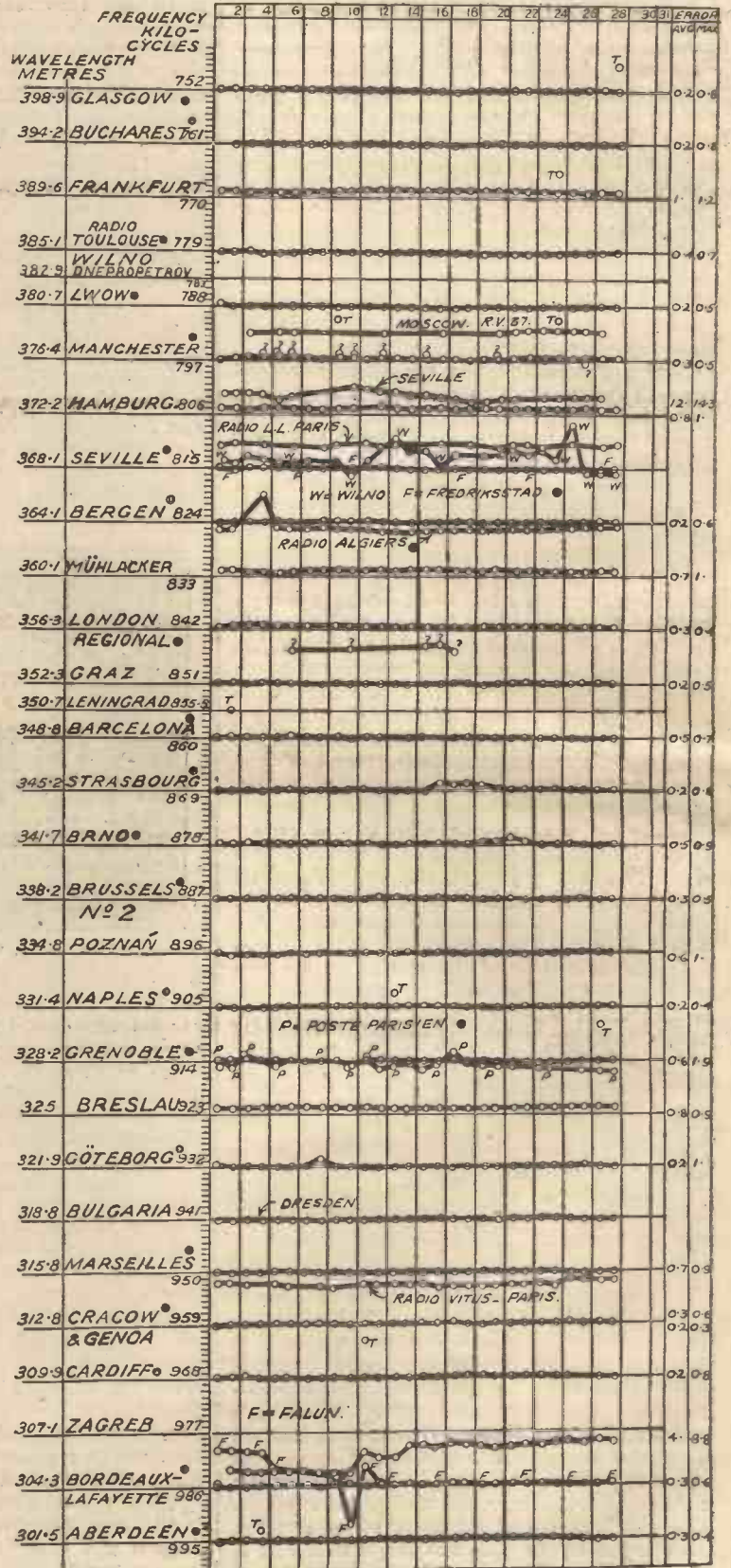
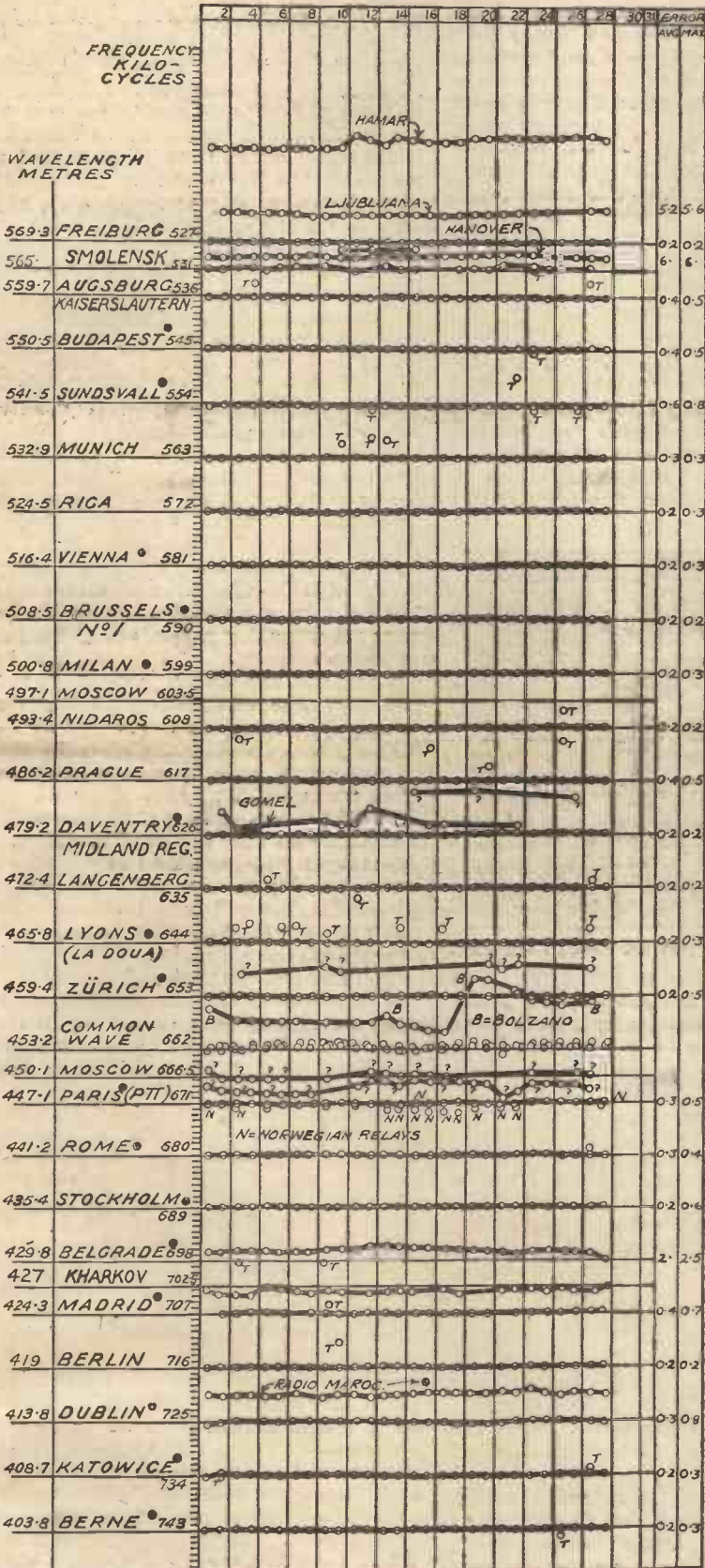

# Broadcasting Stations

## February, 1931

Laboratory of the  
Internationale de Radiodiffusion

Stations marked • are provided with U.I.R. wavemeter.

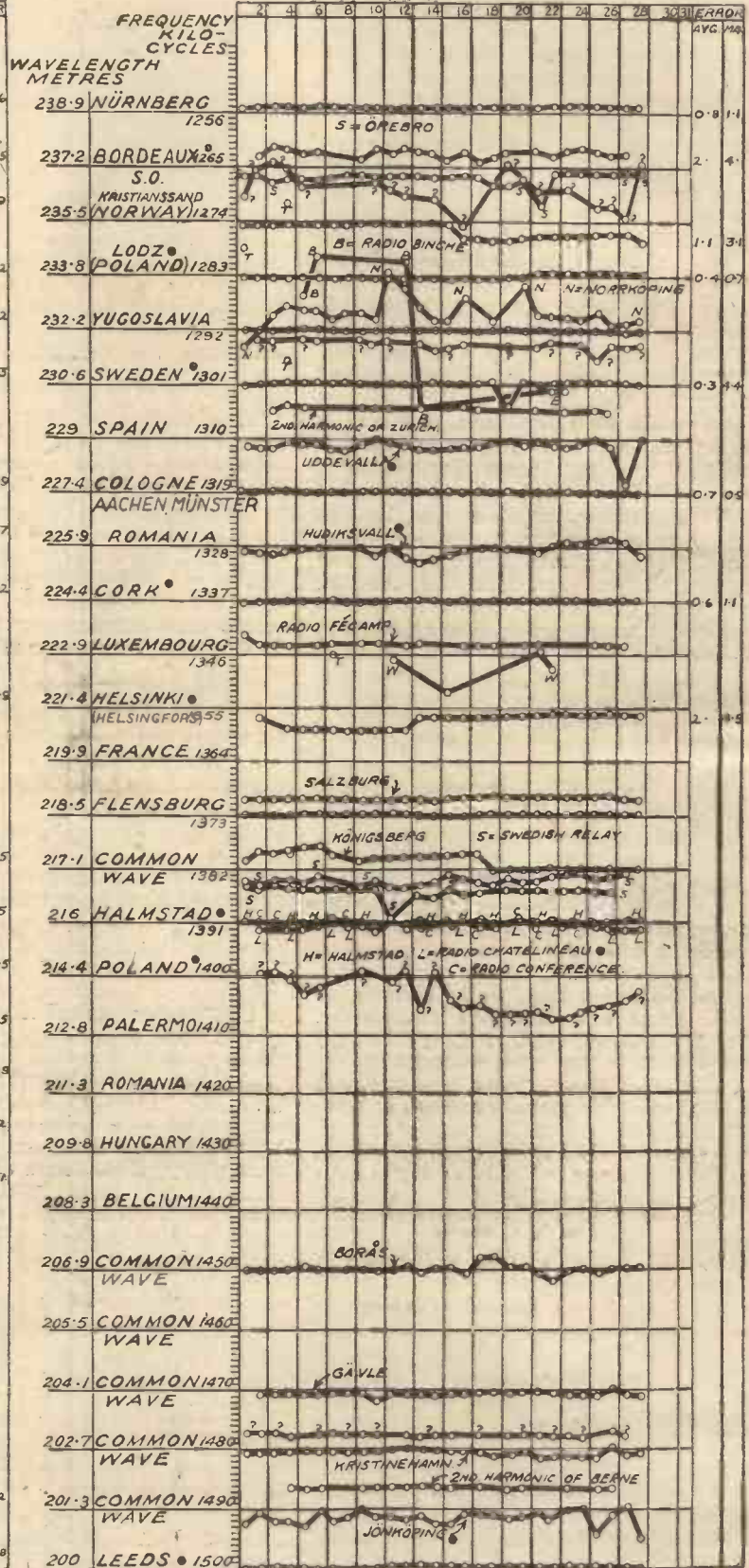
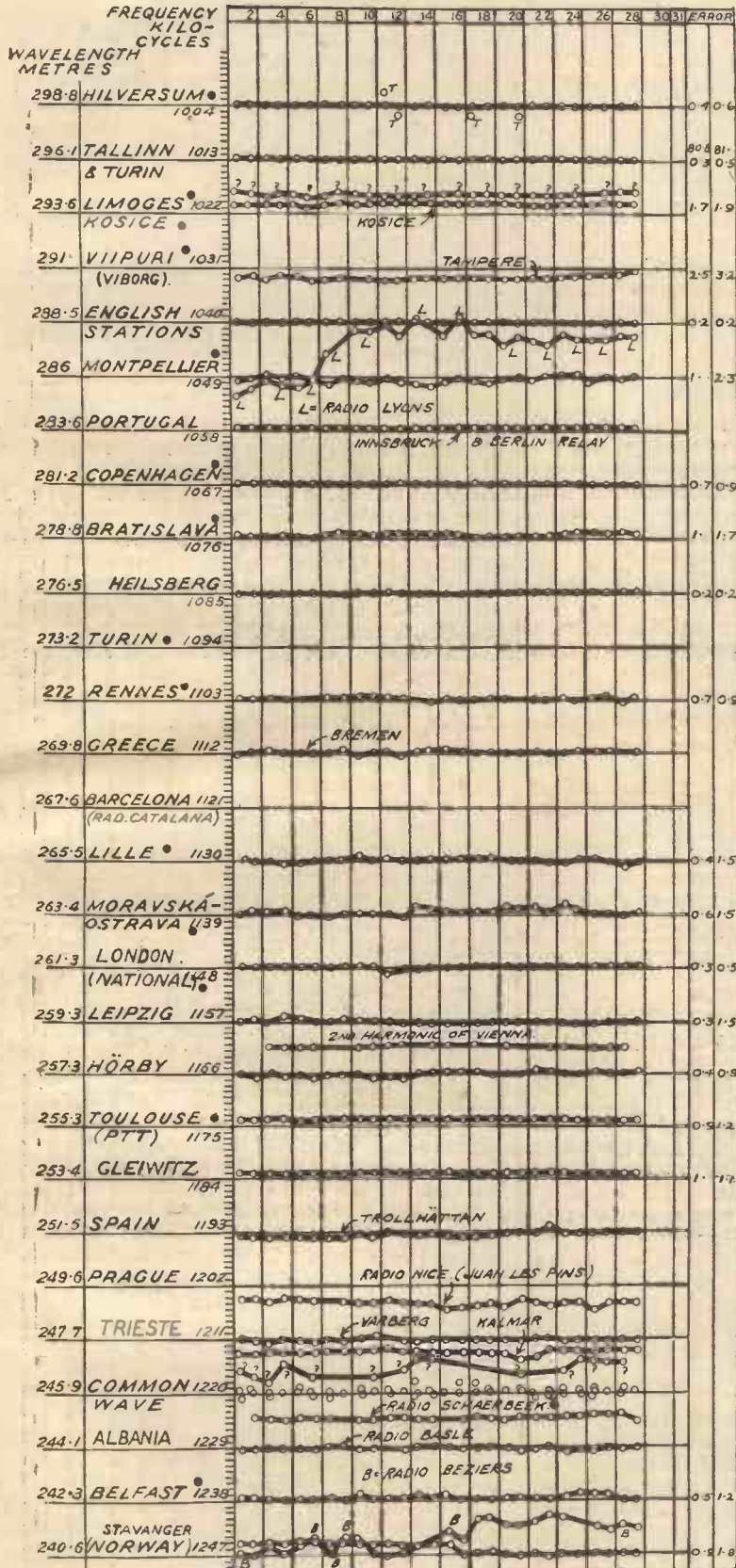

# Faraday and his Contemporaries

## 6.—Of Science and her Votaries

By Professor W. CRAMP

The last of a series of six talks, the first of which was broadcast from London (Regional) on Thursday, Feb. 19

I PROPOSE, in this final talk, to make use of facts that we have gleaned concerning Faraday and his contemporaries to derive conclusions that may be helpful to us, who are their heirs and successors. I intend to compare their characters and personalities with the object of finding some common factors to which their success may be attributed, and which we might ever keep in mind, whether for our own good or for the benefit of those whom we teach.

Now, as we scan the lives of these men, there is one quality which I think is common to all. Examine any period in the life of any one of them, and you will find generally that there was an unswerving aim at a very definite target; there was a firmness of purpose and a relentless pursuit of an object, through success and failure, with a complete disregard of personal convenience—and I am afraid sometimes of the convenience of others—there was what we may call a "selfish devotion" to the work in hand. And by "selfish" I do not mean "self-seeking," but rather "unaltruistic." We see it in Ampère's obstinate pursuit of Julie Carron, as well as in his work; we see it in Dalton's concentration, so that he "never had time to get married"; and we see it in the pertinacity of Cavendish, Lavoisier, Stephenson, Armstrong, and Tyndall.

Faraday, more than any, managed to season this quality with a gentle altruism which won the love of all who knew him. Yet even so, I often think that Mrs. Faraday must have had many and many a lonely evening, while in Cavendish—the other extreme—unsociability was almost a disease. Coupled with this quality, and forming part of it, was an immense capacity for work, and an intense curiosity, coupled with a love of exact knowledge for its own sake regardless of health, wealth, and pleasure. Picture Tyndall and Frankland rising at 4 a.m. to teach one another, or Ampère turning to mathematical research after eight hours' teaching!

As regards monetary rewards the situation is very plain. For example, it would have been easy for Faraday to make a fortune. In 1830, by consulting work which he humorously called "professional business," he made £1,000, and he could have continued thus to make money. But when he found such work incompatible with his researches he abandoned it completely. In 1832 his fees had sunk to £155; in 1837 they were £92; in 1838 zero, and from 1839 to 1845 never more than £22 per annum, except once. Not to such an extent was this oblivion to Mammon developed in all the men of science. Davy, for example, had more regard for wealth, and so had Armstrong and Kelvin; but in none was its pursuit a controlling factor.

### Attributes in Common

I have said that every man had a love of exact knowledge, and I put stress upon the adjective. For a love of knowledge is common enough, it is the "hate of doubtful knowledge," discontent with second best—in short, thoroughgoing thoroughness that characterises the great philosopher. "I cannot but doubt," says Faraday, "that he who has most power of penetrating the secrets of Nature and guessing by hypothesis at her mode of working, will also be most careful to distinguish the knowledge which consists of assumption, by which I mean theory and hypothesis, from that which is the knowledge of facts and laws."

Words like these show the temper of the mind which succeeds in "penetrating the secrets of Nature." In all the votaries of science, then, we find a great common factor, which consists

in fortitude, patience, self-control and mental stability, coupled with a fervour and faith that is almost a secular religion. But can a mind display these qualities without having also clear ideas about its relationship with the universe? It is extremely doubtful. And so we are not in the least surprised to find that seven at least of these men had strong religious beliefs.

Priestley was a Nonconformist minister, Faraday was a Sandemanian, Dalton was a Quaker, Ampère was a devout Roman Catholic—and that at a time when "Liberty, Equality and Fraternity" was the popular cry in France. Maxwell taught in the Sunday school for many years; Kelvin always began his first lecture in the morning with the third collect in the morning prayer; and last, but by no means least, Huxley showed the courage of his sincere religious convictions by refusing to countenance the errors of "revealed religion" at a time when such unconventionality meant social ostracism.

### Influence of Religion

Thus we see that, though of very different sects, not one of them was ashamed to say "I believe." Let us recognise at once that to say what you *do* believe is far more difficult than to say what you *don't* believe; but it seems to me clear that if any man intends his life to be one calm, continuous, uni-directional effort he will do well to begin by getting a strangle-hold upon the fiends of doubt. To succeed in this entails the construction and maintenance of a fundamental framework of belief into which subsequent experiences can be fitted—a haven where the naggings of the fiends can at any time be silenced. In Faraday, Sandemanianism led to one day per week on which no work was done; it led to a gentleness and manly humility which even now are proverbial; it led to constant public service without pay; it led him to write "Religious conversation is generally in vain . . . in my intercourse with my fellow-creatures, that which is religious and that which is philosophical have ever been two distinct things." This saying I regard as an interesting comment upon the recent B.B.C. series on "Science and Religion."

In most things, Davy was a sharp contrast to Faraday, yet just as the latter was frequently asked to preach at his church, so Davy at one time was pressed to take orders in the Church of England, and he always had a strong religious bent. Again, though quick and energetic, he had a vein of contemplation and meditation. Like Maxwell, Ampère and Oersted, he was no mean poet, and his poems often took a religious turn. And, if further evidence of similarities is sought, it will be found in an appreciation of music and of humour. Faraday played the flute, sang occasionally and loved opera. Davy certainly appreciated music, and so, of course, did Wheatstone, Maxwell, and Kelvin, who played the French horn. Ampère's musical ability, on the other hand, is made clear to us in a letter from his wife. She says: "The little one amuses himself with singing as splendidly as you do; it vexes me to find that he cannot follow an air." This is all the more strange, since Ampère was a mathematician, and mathematics so often go with music, as was exemplified in Mozart. Ohm had no ear for music, either, so there is no absolute rule in these matters. As regards humour, Faraday loved a romp with children, and, when well, was always ready for fun in his spare time. Maxwell's humorous verses are well known; while Ohm, Huxley, Dalton, Ampère and Wheatstone all had a similar vein.

It is easier, of course, to find points of difference among such strong characters. Take, for example, the attitude of Faraday and Davy towards the Royal Society. "On the 19th June, 1820," says Davy's brother, "Sir Joseph Banks, who had been for so many years President of the Royal Society, died. My brother immediately came forward as a candidate for the office thus rendered vacant." And, after Sir Humphrey had been elected, he writes: "My brother continued to take the chair in a full Court dress; to have the splendid mace of office placed on the table before him, and to sit covered." Davy did not scruple to remain President for as long as his health lasted, and, indeed, occupied that office for seven years. Again, his character comes out in his attitude towards the doctors when his health began to fail; for his brother says: "He was rather disposed to follow the advice which was most agreeable to the convivial epicurean habits of London society." Finally, we know that he accepted knighthood as soon as it was offered; that he was presented by the coal trade with a service of plate valued at £2,500 for his invention of the safety lamp; and a baronetcy was conferred upon him at that time.

As a contrast, place beside all this the attitude of Faraday under somewhat similar circumstances. When repeatedly pressed to accept the presidency of the Royal Society, he always refused, feeling that he could not do justice to its obligations. In health or illness, his manner of living was simple and unpretentious, without being ascetic. Any time during the last twenty years of his life he could have had a title, but he did not desire it; and for thirty years he acted as adviser to the Trinity Brethren for a nominal fee, giving them unstinted and extensive service, which resulted in the use of electric lighthouses around our coasts, supplied by electro-magnetic machines of which he was the first and true inventor. We do not read that for these things Faraday received any "service of plate" valued at £2,500! Sharp contrasts of a different kind might easily be drawn between Maxwell and Ampère, Priestley and Lavoisier, and others.

### Their Domestic Lives

For the sake of any of the fair sex who may have been listening to my talks, I will conclude by saying a word about the domestic lives of these men. Nearly all married, and, in almost every instance, the result brought great happiness. The story, indeed, of a successful investigator often involves a self-sacrificing woman in the background, and it certainly was so with Faraday, Maxwell and Priestley. On the other hand, it would be hard to deny that the advent of children renders self-devotion to research much more difficult, if not ethically wrong, and it so happens that neither Davy nor Faraday nor Maxwell nor Kelvin had children. Dalton and Cavendish never married, while Davy was thirty-five when he married, and Tyndall was fifty-six.

Even in the matter of children, however, the rule is not without exceptions. Ampère had a son, and Priestley and Oersted had large families. Oersted, as the secret of his life, said, "In my family I am as happy as a man can be. I have a wife whom I love, and children who are dear to me, and who are prosperous"; whilst Faraday, twenty-eight years after his marriage, could say that, "It was an event which more than any other contributed to his earthly happiness and healthful state of mind." Domestic peace was, if not absolutely essential, at least a great aid to these votaries of Science.

I can hardly close my six talks upon a more appropriate note than this, and, in bidding farewell to my listeners, my hope is that, from the lives and the work of Faraday and some of his contemporaries, at least some students will find inspiration, and all teachers an intention, to blend biography with bookwork.

Correspondence

Co-operative Short-Wave Research

To the Editor of WORLD-RADIO

SIR,—I was disappointed to find that my letter of December last, suggesting amateur co-operation in wireless research, did not elicit any response from your readers. However, it is reassuring and gratifying to find one's views endorsed by no less an authority than Professor Appleton. In his article of the 13th inst., on co-operative short-wave research, he quotes instances of amateurs' success that might well be repeated on a larger scale; and, moreover, it is interesting to learn that the individualities of amateur receivers do not offer such a serious obstacle to their co-operative employment as might have at first been supposed. Finally, Professor Appleton points out one interesting line of research that awaits amateur co-operation and also promises to give details of this and other suitable fields of enquiry in a future article.

Now that so competent a leader points the way, it is to be hoped that amateurs in this country will consider whether it would not be worth while to amalgamate their resources, and substitute the force of numbers for the inadequacy of the individual.

Yours faithfully

J. SHACKLETON BAILEY.

St. Bartholomew's Hospital, London, E.C.

A Short-Wave Convert

To The Editor of WORLD-RADIO

SIR,—Being a canny Scot, it was only after much cogitation that I decided to build the Two-Valve Short-Wave Superheterodyne Adaptor described in a recent number of WORLD-RADIO. I had long been of the opinion that short-wave listening merely consisted of logging weak 'phone signals. This supposition was quickly dispelled when I tuned in 2XAF on Sunday evening.

The following report of reception on March 1 may be of interest: Broadcast set S.G.-v-1.

9.45 p.m.—Close of service relayed from N.B.C Studios, New York.

10 p.m.—Programme from WGY—"Just a song at Twilight"; "The Sweetest Story Ever Told," "Down in Dixieland," "All Hail to thee, Columbia," etc., etc.

These were received at full loud speaker volume, and the quality was very good. There was slight irregular fading, which was not objectionable. Thanking you for a very satisfactory circuit.

Yours faithfully,

N. A. M. McK.

Annan, Dumfries.

MYSTERY OF THE ETHER

(Continued from page 493)

out just as shot spreads out when fired from a gun. On hitting the photographic plate they will produce a blurred image larger than the area of the original beam, and there will be no clearly-defined pattern.

If, instead of firing a beam of particles, we cause the emission of a train of waves so that they have to pass through the screen we shall have quite a different picture. Owing to the regular spacing of the molecules in the screen the latter will act as a diffraction grating—a diffraction grating in optical work is a glass screen finely ruled with a large number of lines so that the glass offers a large number of rough grooves and fine surfaces. Now, if the distance between the molecules in the screen approximates to the wavelength of the emitted wave, the photographic plate will show a series of diffraction rings similar to those shown by light falling through a pin hole. The pattern thus obtained will consist of a series of dark and light rings, the radii of which will bear definite ratios to each other.

When Professor Thomson fired a stream of electrons, presumably solid particles, they left an image identical with those left by waves! By bringing a magnet near the beam of electrons he found that the diffraction pattern was shifted, and thus proved that the dark rings were produced by electrons "hitting" the photographic plate, electrons which, however, failed to be deflected by the molecules of the screen as solid particles should be deflected, but behaved as waves would behave.

On measuring the wavelengths of these "electron-waves" it was discovered that they had an exceedingly short wavelength, i.e., a very high frequency. Their frequency proved to be a million times that of visible light, higher than the frequency of X-rays, but not as high as that of the hardest gamma rays, or that of cosmic rays. Professor Thomson's results were confirmed by other scientists both in Europe and in America, as well as in Japan. Moreover, Professor A. J. Dempster, of Chicago, achieved similar results with protons. The above experiments prove that waves of extremely high frequency are associated with both electrons and protons when they are in motion.

(To be continued)

CIRCUIT OF PARAPHASE AMPLIFIER

In response to requests from readers interested in the possibilities of the paraphase amplifier, the accompanying diagram is re-printed from the article entitled "Thoughts on Receivers and Reception" — *World-Radio*, December 12, 1930, and the essential values are indicated below. The theory of the circuit, and the method of balancing, were described in the original article.

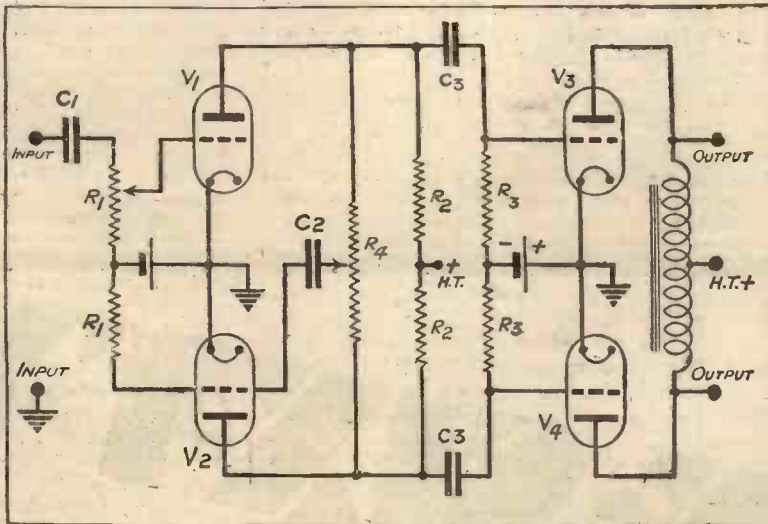

- R<sub>1</sub> 500,000 ohms
- R<sub>2</sub> 40,000 "
- R<sub>3</sub> 250,000 "
- R<sub>4</sub> 200,000 "
- C<sub>1</sub> 0.1 mfd.
- C<sub>2</sub> 1.0 "
- C<sub>3</sub> 0.1 "
- V<sub>1</sub> } μ = 20
- V<sub>2</sub> } R = 8,000 ohms
- V<sub>3</sub> } μ = 3 to 4
- V<sub>4</sub> } R = 1,500 ohms (approx.)

Output choke, 16 to 20 henries, centre tapped. Grid bias, according to valves and H.T. voltage. Decoupling resistance, and condenser to first stage are not shown in the diagram.

**TANNOY**  
PRODUCTS

**Mains Units**

**NOW COST LESS**

TYPE P.2 150v at 15 m/a.  
**H.T.** Or 120v at 20 m/a. Westinghouse  
**£3 : 7 : 6**

TYPE C.F.2.  
**H.T. AND L.T.**  
120v. with 2 variable tappings. 2, 4, or 6v.  
**£5 : 0 : 0**

TYPE G.B.1.  
**H.T., G.B., AND L.T.**  
120 or 150v. 3 positive tappings. up to 14v. 2, 4, or 6v.  
**£4 : 15 : 0**

Dalton St., West Norwood, S.E.27

HERE IS THE

**Radio Gramophone Cabinet**

YOU ARE LOOKING FOR

INSTAL A  
**'LANGMORE'**

and have your Gramophone, Wireless Set, Loud Speaker and Batteries all in one Cabinet.

The Langmore No. G4, as illustrated, is very strongly constructed of selected oak. Size over all 3ft. high x 21in. wide x 15in. deep.

**The Top Section**  
Size 4in. deep, gives ample accommodation for Gramophone and Pickup.

**The Centre Section**  
10in. high, is for the Wireless Set, to take a Panel either 18in. x 7in. or 18in. x 8in.

**The Bottom Section**  
14in. high, gives accommodation for Loud Speaker and Batteries.

The whole of the back is enclosed by double doors so that all parts are easily accessible. ALL are fitted with hinged top-heavy platform to take a 12in. turntable for the Gramophone and a substantial baseboard for the Wireless Set.

Model G4

**Price 60' -**

Packed Free and sent Carriage  
Paid to any address in Great Britain.

BEAUTIFULLY FINISHED  
JACOBAN OAK

TRADE ENQUIRIES INVITED

**THE MISCELLANEOUS TRADING CO., LTD.,**  
13 & 17, New Oxford Street, LONDON, W.C.1. Phone 1 Holborn 4894.

# STAY OUT OF THE NORTH



8/6

WHEN the North Regional Station opens you can bid farewell to all your logs and foreign reception.

Unless, of course, you possess a *Watmel Wave Trap* to eliminate this new interference.

Fix the Wave Trap *anywhere* between your aerial and set, and reception of any desired station will come through at full volume and without a trace of distortion.

You can fit the Wave Trap to *any* type of set.

*Be Prepared—Buy one to-day*

### A FREE BLUE PRINT

Write for the Blue Print of the T.31 S.G. Imperial Three Receiver—A new highly selective wide-range set. Simple to construct and easy to operate. Free to Constructors.

**WATMEL WIRELESS CO., LTD.**  
Imperial Works, High Street, Edgware  
Telephone: Edgware 0323.

(M.C.24)

## SIMPLEST and BEST DX SHORT 2 WAVE PIN COILS

Set of 4. 3-5-7-9 7/6 Post Free

DX COILS Ltd., London, E.8

THE LISTENER

IS WELL WORTH READING

IT COSTS THREEPENCE

EVERY WEDNESDAY.

## Short-Wave Notes

GENERAL conditions for short-wave reception have been very good during the week—March 16 to 22—W8XK, on the 25-metre band, being well heard after midnight. On Thursday morning, from 12.30 until about 3, many American stations were coming through well, ranging from W8XK on 25.25 metres to WGN on 417 metres, the "star" stations being W2XAF (31.48) and WTIC, Hartford, Connecticut (283).

We learn that a change has been made recently in the regular schedule of the Toronto short-wave station, VE9GW (49.22 metres), which, although using a power of only 27.5 watts, is occasionally heard in this country. The revised times of transmission are as follows: *Weekdays*, 11.45 a.m. to 3 p.m. and 8 p.m. to 5 a.m. the following morning. *Sundays*, 5.30 p.m. to 4.15 a.m. (Monday morning). These times are, of course, G.M.T.

It will be of interest to learn, from the reports of listeners overseas, how they received the special afternoon transmission from G5SW (25.53) in connection with the Boat Race on Saturday last, at what was, for this station, an unusual time. A further afternoon transmission will take place on Sunday next—March 29—when, between 3 and 4.45 p.m., a special short-wave relay of the Jubilee Concert at the Albert Hall, London, will be radiated.

Referring to the remark made by "Vernier" in his notes "Below 100 Metres" (*World-Radio*, of March 6), two readers, residing in Dublin and Guernsey respectively, write to say that they also have received Bound Brook, W3XAL (49.18) on what appears to be his first harmonic—namely, on 24.59 metres.

We have received a report indicating that a newcomer to the 49-metre band—Strasbourg, France, call letters ANC—is operating on a wavelength of 47.77 metres. Up to the time of going to press, however, we have no official news of the station, or details of times of transmission.

### Readers' Reports

*Vatican* (50.26). Good LS reception, at Leigh-on-Sea, on the afternoon of March 6. A talk, repeated in Italian, German, French, and English. (Super-het. adaptor plus SG—v—2 set)

*Moscow* (50). Several reports mention the announcement: "Moscow... on a wavelength of 1,304 metres and, at the same time, on a wavelength of 50 metres." Heard, at fair 'phone strength, at London, S.W.10, 6.45 to 10 p.m., Mar. 13 (o—v—1 receiver); at Liverpool, good 'phone strength, from 8.40 p.m., Mar. 15; at London, W.2, 9 p.m., Mar. 8 (o—v—1 set)—heard to announce next transmission at 9 p.m., on Thursday following; at Reading, on various

dates, fair L.S. strength on super-het. adaptor, plus 2S.G.—v—1 set); also at Sheffield, 9 p.m., Mar. 5—good L.S. strength on o—v—2 receiver, and at Coventry, 9.30 p.m., Mar. 8—good L.S. strength on o—v—2 receiver.

*Chicago* (49.83). Heard at Dover, fair 'phone strength, 10.30 to 11 p.m., Mar. 8. Steady but faded towards 11 p.m. (o—S.G. det.—2 set).

*Toronto* (49.22). Received at Langwith (Derbyshire), weak 'phone signals but increasing to moderate LS strength, 12.30 to 2 a.m., Mar. 19. Slight fading and very bad static. Announcement heard, also request for reports. (o—v—2 set.)

*Richmond Hill* (49.02). Received at Dover, from 11 p.m., Mar. 8, at fair 'phone strength, music clear but speech indistinct. Similar results on four following nights (o—S.G. det.—2 set).

*Saigon* (49). Received at Mapperley, Notts, usually at medium L.S. strength, from 2 to 3.15 p.m.; occasionally rapid fading. Sometimes continues until 4.15 p.m., as on Mar. 12, when usual English announcements were omitted. Heard at Dover, 2 to 3 p.m., Mar. 8, at fair 'phone strength, on o—S.G. det.—2 receiver. Gramophone records and English announcements. Also heard, at good 'phone strength, at Ripon (Yorks), 9 p.m., Mar. 13 (o—v—2 set).

*Pittsburgh East* (48.86). Received, at good 'phone strength, at Dover, on evenings of Mar. 8, 9 and 10. Very clear on Mar. 9 (o—S.G. det.—2 set).

*Tegucigalpa* (48.62). Heard at Windlesham (Surrey), 12.20 a.m., Mar. 15. Fair to good L.S. strength. Interval signal, three cuckoo calls. Announcements ever quarter hour. (Super-het. adaptor, plus S.G.—v—1.)

*Moscow* (46.6). Received at Coventry, 4 p.m. (and at 8 p.m.), Mar. 9 and 10. Good L.S. strength. Same programme on each occasion also transmitted by Moscow on 50 metres (o—v—2 set). Also heard, on several occasions, at Mapperley (Notts), and relays of Moscow (1,304 metres) also noted. (S.G.—v—2 set.)

*Constantine* (45). Heard at Dover, 11 p.m., Mar. 13. Good L.S. strength, speech clear, music (records) rather distorted (o—S.G. det.—2 receiver).

*Georgetown* (43.86). Heard at Langwith (Derbyshire), from 1 to 2 a.m., Mar. 16. Signals, at first weak on 'phones, increased to fair LS strength by 2 a.m. No static, but slight fading. (o—v—2 receiver.)

*Rabat* (32.26). Heard at Liverpool, 7 to 8 p.m., Mar. 15, at good 'phone strength, on o—v—1 receiver. Also well received, on various dates, at London, W.2 (o—v—1 set).

*Lyngby* (31.51). Heard at Dover relaying Copenhagen, 10.30 a.m., Mar. 8. Good L.S. strength and very steady. Sunday morning transmissions usually well received (o—S.G. det.—2 set). Also heard at Coventry, good L.S. volume, 6.30 to 7.45 p.m., Mar. 10 (o—v—2 set).

*Buenos Aires* (28.98). Numerous reports received regarding the Exhibition broadcast which appears to have been well received from LSX. Morse interference reported in some cases. Regular reception at good L.S. strength reported from Dover (o—S.G. det.—2 set).

*Schenectady* (17.34). Short-wave propagation tests (as announced), television transmission, heard at Gateshead-on-Tyne and at Guernsey, 2 to 3 p.m., Mar. 6.

*Bandoeng* (15.93). Received as a strong, steady signal at Coventry, 2.20 to 3.40 p.m., Mar. 10. Musical programme (o—v—2 set).

# SAY SIX-SIXTY

Write for FREE BOOKLET giving full details of the whole Six-Sixty range.

THE POWER UNIT THAT SUPPLIES THOSE EXTRA VOLTS—SAY SIX-SIXTY FOR 200 VOLTS H.T. Automatic Grid Bias too, safeguarding your valves. Replaces existing batteries in a moment—takes no more room. Price £6:6:0. An extra winding for L.T. enables you to use the unit at any time as a complete mains-drive for A.C. Valves.

# PROGRAMME SECTION

## Continental Programme Events

### SUNDAY, MARCH 29

- Concerts**  
 1.10-4.10 p.m. Hilversum: Bach's "St. Matthew Passion."  
 5.5 p.m. Munich: Bach's "St. Matthew Passion."  
 6.5 " Frankfurt, Mühlacker: Bach's Mass in B Minor.  
 7.0 " Copenhagen: Mozart-Wagner concert.  
 7.40 " Hilversum: Orchestral.  
 8.0 " Brussels No. 1: Orchestral.  
 8.0 " Brussels No. 2: Beethoven chamber music.  
 8.15 " Mühlacker, Frankfurt: Orchestral.  
**Operas and Operettas**  
 5.40 p.m. Langenberg: "Tristan and Isolde" (Wagner).  
 6.0 " Warsaw, Katowice: "Parsifal" (from Warsaw Opera House).  
 7.30 " Rome: "Lilac Time" (Schubert).

### MONDAY, MARCH 30

- Concerts**  
 8.0 p.m. Milan-Turin: Concert "Radio Marelli."  
 8.0 " Munich, Langenberg, Leipzig: Music from Regensburg Cathedral.  
 8.30 " Brussels No. 2: Bach's Mass in B Minor.

- Operas and Operettas**  
 6.30 p.m. Stockholm: "Marriage of Figaro" (Mozart).

- Plays**  
 8.15 p.m. Frankfurt, Mühlacker: "Pitt, the Orator" (radio play).

### TUESDAY, MARCH 31

- Concerts**  
 7.0 p.m. Stockholm: Danish music.  
 7.40 " Hilversum: Orchestral.  
 8.10 " Milan-Turin: Symphony concert.  
 11.30 " Munich: Organ, vocal and Viola.

- Operas and Operettas**  
 6.35 p.m. Munich: "Othello" (Verdi).  
 7.45 " Mühlacker, Frankfurt: "The May Queen" (Gluck).  
 8.0 " Radio-Paris: "I Pagliacci" and "Cavalleria Rusticana."

### WEDNESDAY, APRIL 1

- Concerts**  
 7.0 p.m. Copenhagen: German Folk Songs music.  
 7.45 " Munich: Orchestral.  
 9.0 " Radio-Paris: "Redemption" (Gounod).  
 9.10 " Copenhagen: Chamber music.  
 10.20 " Barcelona: Orchestral and vocal.

- Operas and Operettas**  
 8.0 p.m. Rome: Opera relay.  
 8.10 " Milan-Turin: "Donna Juanita" (Suppé).

### THURSDAY, APRIL 2

- Concerts**  
 7.15 p.m. Warsaw, Katowice: Philharmonic concert.  
 7.45 " Rome: Compositions by I. Pizzetti.  
 8.0 " Breslau, Königs Wusterhausen: Symphony Concert.  
 8.0 " Brussels No. 2: Handel and Bach concert.  
 8.25 " Hilversum: "The Death of Jesus" (oratorio).  
 8.45 " Radio-Paris: Symphony concert.  
 9.30 " Berlin, Breslau, Heilsberg, Königs Wusterhausen, Leipzig: Third act of "Parsifal."

### Plays

- 7.15 p.m. Copenhagen: "The Merchant of Venice."  
 7.30 " Langenberg: "The St. Jacob's Pilgrimage" (a legendary play with music).  
 8.35 " Munich: "Everyman" (Hofmannsthal).

### FRIDAY, APRIL 3

### Concerts

- 5.0 p.m. Leipzig, Berlin, Breslau, Heilsberg, Königs Wusterhausen: Bach's "St. Matthew Passion."  
 6.35 " Frankfurt, Mühlacker: Schubert's Mass in A Flat.  
 7.10 " Langenberg: Brahms's "German Requiem."  
 7.15 " Warsaw, Katowice: Sacred concert.  
 7.30 " Milan, Turin: Sacred concert.  
 8.0 " Brussels No. 2: Beethoven and Wagner concert.  
 8.0 " Frankfurt, Mühlacker: Chamber music.  
 8.0 " Rome: Sacred music.  
 9.0 " Copenhagen: Handel concert.

### Plays

- 7.0 p.m. Hamburg: "Cain" (Lord Byron).  
 8.40 " Stockholm: "Good Friday" (John Masefield).

### SATURDAY, APRIL 4

### Concerts

- 6.30 p.m. Vienna: Song Recital by Herr Richard Mayr of Vienna Opera House.  
 7.0 " Munich: Orchestral.  
 7.10 " Budapest: Wagner and Bach concert.  
 8.45 " Mühlacker, Frankfurt: Bach concert.  
 9.5 " Copenhagen: Modern dance music.  
 9.30 " Radio-Paris: Chamber music.

### FOREIGN LANGUAGES

(Continued from page 492)

eĉ se oni uzus ses naciajn lingvojn. Supozeble, la organizantoj ne atentis la clogantojn mem.

Radio.—Ho, tute ne. Luksemburgo estas tiom malgranda. Krom tio, ili jam povas aŭskulti facile la programojn el la najbarlandaj stacioj. Sed, diru al mi, kiun lingvon parolas la luksemburganoj?

Duo.—Mi ne precize scias. Laŭ artikolo, kiun mi legis lastatempe en lingvista gazeto ili parolas indiferente, jen france, jen germane. Krom tio, laŭ mia informinto, ekzistas luksemburga dialekto. Li ne diris, kio ĝi estas, sed mi kredas, ke ĝi estas membro de la grupo de altgermanaj dialektoj, en kiu troviĝas la visgermana kaj la alzaca.

Radio.—Interesa lando por la lingvisto.

Duo.—Jes, la verkinto de la gazetartikolo, al kiu mi aludis, rakontas tre amuzajn epizodojn el vizito al tiu ŝtato. Laŭ li, hoteletoj, policistoj, fervojistoj k.t.p. parolas al la vojaĝanto en miksaĵo de franca kaj germana lingvoj. Se oni demandas france, ili respondas germane; oni tuj translingviĝas, kaj ili ruze evitas la ĉason, reparable france.

Radio.—Kia konfuza situacio por nelingvisto, kia mi! Mi prokrastos mian viziton al tiu lando, ĝis kiam Esperanto estos ĝenerale uzata tie.

Duo.—Kredu min, amiko, nenie en la mondo oni pli bezonas ĝin.

RADIO-DUO.

## MAKE YOUR SET A FINE PIECE OF FURNITURE

WITH AN OSBORN RADIO CABINET.

Model No. 214. A Radio Cabinet, 4ft. high, 2ft. 2ins. wide, 1ft. 6ins. deep. The battery and loud-speaker compartments are at the bottom and are partitioned off. Size of haffle board behind fret is 24ins. x 24ins. Metallic fabric for fret front is included. Openings at top and back. Cabinet takes panel 2ft. x 9ins. or smaller. RADIO - GRAMOPHONE COMBINATION. For the small sum of 5/- extra this cabinet can be made 4ins. higher and converted into a Radio-Gramophone Cabinet, complete with motor board.



MODEL No. 214.

### PRICES.

- Machined Ready to Assemble: Oak, £3 0 0. Mahogany, £3 5 0.  
 Assembled Ready to Polish: Oak, £4 0 0. Mahogany, £4 5 0.  
 Assembled and Polished: Oak, £5 0 0. Mahogany, £5 15 0.  
 All Models Carriage Paid.

Send Coupon and 3d. in stamps for 56-page illustrated catalogue.

**CHAS. A. OSBORN, Dept. W.R.,**  
 The Regent Works, Arlington St., London, N.1. Telephone: Clerkenwell 5095. And at 21, ESSEX ROAD, ISLINGTON, N.1 (1/2 mile from the Agricultural Hall). Telephone: Clerkenwell 5634.

### COUPON

Please send me your 56-page illustrated catalogue, for which I enclose 3d. in stamps.

NAME \_\_\_\_\_  
 ADDRESS \_\_\_\_\_  
 \_\_\_\_\_  
 \_\_\_\_\_  
 DEPT. W.R.

## FAMOUS FOREIGN STATION

gives  
**100% BRITISH PROGRAMME**  
 every Sunday  
 from 2 to 3 p.m.



TUNE IN TO  
**RADIO PARIS**  
 1725 metres  
 for the latest  
 Decca dance  
 & song successes

Full programme and catalogues from:

THE DECCA RECORD CO., LTD.  
 BRIXTON ROAD, LONDON, S.W.9.

(Dept. 233), 1-3,

SHORT-WAVE STATIONS

Table with columns: M., Kc/s, Station Name, and Schedule. Includes entries like 70.1 Khabarovsk (U.S.S.R.), 67.65 Doberitz (Germany), 61 Radio LL (France), etc.

For Long and Medium Wave Stations see page 521.

Last Week's Log

(March 15-21)

By "THE SEARCHER"

THE complete change in the weather, which took place during the latter part of the previous week, naturally produced rather unsettled conditions, from a wireless point of view, at the beginning of the period from March 15 to 21. Huge changes in temperature, such as we have recently experienced, are bound to produce a crop of atmospherics for a period of greater or lesser duration. These pests were very bad during the first two days of the week, and on the Monday there was really no pleasure in long-distance work. On the Tuesday, they were both less frequent and less violent, being confined mainly to crashes at intervals. From the Wednesday to the Saturday inclusive, there was hardly an atmospheric to be heard, and conditions improved from night to night. Saturday, March 21, was, in fact, one of the best spring days for long-distance reception that I can remember for several years.

On that night, the four-valve set was able to bring in twenty-five stations at full loud speaker volume, whilst with the seven-valver the number was three times as great.

The long-wave stations are outstandingly good just now. Huizen, giving the Hilversum programmes, is always a splendid signal, and equally good is Warsaw. The seven-valver will separate this station from the Eiffel Tower when the two are working, but with a less selective set it is a case of listening to Warsaw when the Eiffel Tower is silent, and vice versa. Radio-Paris, Motala, Kalundborg, Oslo, and Zeesen have all furnished fine reception.

On the medium waves, Budapest was not quite up to the mark on Wednesday and Thursday, though excellent on other nights. Munich is there if you have sufficient high-frequency amplification. Vienna has been extremely good, and Brussels No. 1 is suffering less from background noisiness. Milan is nearly always good, but Langenberg has varied a little. Rome, Stockholm, and Katowice have come in well, and Witzleben maintains the increase in strength which has recently become noticeable. Sottens is one of the best of European stations, thus keeping up the reputation which, as old readers may remember, the original Berne station gained when he first came into operation four or five years ago.

Frankfurt is generally good. Toulouse shows fine strength, but his quality often suggests over-modulation. Lw6w is always good, but Hamburg has been heterodyned. Muhlacker is completely reliable, and I can generally obtain good reception from Graz. Barcelona is showing satisfactory strength. Strasbourg is fading rather less than he was, Brno comes in at respectable strength, and Brussels No. 2 is a huge signal.

A little lower down the band are two excellent stations, Breslau and Göteborg. There is little to choose between them in quality, but Göteborg is slightly the stronger signal.

Turin seems to have increased his power; at any rate, he is coming in much more strongly than he was. Bordeaux is terrific. Hilversum (Huizen programmes) is suffering at the moment from interference.

Below this point, reception is not too good at the moment, for there is a considerable amount of fading. The outstanding station in this part of the band is Heilsberg, whose strength is always remarkably steady.

TO OUR READERS

When replying to advertisements please mention "World-Radio"

Interference between Stations

(March 15-19)

THE period between March 15 and March 19 has brought but little change in the general aspect of the broadcasting bands as regards interferences.

The Russian telegraphic station, RAX, mentioned previously on 170 kc/s, was found on the 17th on 178 kc/s, between Radio-Paris and Königs Wusterhausen; he was giving telephony on that night, but was again on 170 kc/s the next day, transmitting morse.

On the medium-wave band there are certain zones which are, and for a long time have been, particularly badly affected by interference. Those zones are quite definite, and the first to be met with, going down the wavelenghts scale, is the one surrounding the International Common Wave of 662 kc/s—viz., from Langenberg (exclusively) to Rome (exclusively). There is, first, Lyons-la-Doua on 644 kc/s heterodyned, as stated previously, by Tartu, relaying Tallinn. Zürich, on 653 kc/s, is very often jammed by Bolzano, which ought to work on the Common Wave (remarkable for the heterodyne whistles produced by the eight stations using it—Helsinki having gone back for the time being to 1,355 kc/s). On 671 kc/s the weak station of Paris PTT is heterodyned by the three Norwegian relays, Aalesund, Rjukan, and Notodden.

The second zone of interference goes from Manchester to Muhlacker. Hamburg (806 kc/s), is heterodyned by two stations: on one side by Seville (803 kc/s), which begins its evening transmissions at 9 p.m.; on the other side by Radio LL, Paris (810 kc/s), which works on Tuesdays and Thursdays from 6 to 7.30 p.m., on other days from 6 to about 10.30 p.m. And lastly, Algiers and Bergen are badly heterodyning each other on 824 kc/s. L. B.

Which Station Was That?

(Answers to Correspondents)

BROMIUM (Bath): Moscow-Popoff; short-wave transmitter relaying Trades' Unions. ELSEE (Oswestry): Regret, cannot trace. MERCURY (Leeds): Moscow Popoff (see reply to BROMIUM above). JAKE (Scarborough): North Regional testing. JOURNALIST (Fleetwood): Leningrad; special late transmission for night-workers. THE BASS KING: If you mean that the call heard was W8XK, then relay of KDKA. Please answer questions in the order given in coupon. IRISH TYRO (Castelrea): Radio Idzerda, The Hague. LANCASTRIAN (Harrow): Radio Strasbourg; announcements in both French and German. XXX (Darlington): Possibly Sverdllovsk, but cannot confirm. LOVE O' MIKE (Claygate): This was definitely Warsaw; a violin concert. There is no station between Warsaw and Eiffel Tower. WET PAINT (Gateshead-on-Tyne): Bordeaux-Sud-Ouest. ELMO MIGHTY (Bristol): (1) W2XAF, relaying WGY. DUN-IT (Preston): (1) WTAM, possibly relaying WBAL, from which station you heard the call. They are both in the NBC net; (2) Radio Idzerda, The Hague. LAST CHANCE (Bucton): Regret, cannot trace. BUCKIS (Newport, Mon.): Yes, without doubt. Riga. S. W. F. (Birmingham): Radio Vitus (Paris). INQUIRER (Halifax): Brussels No. 2; outside relay. OH-KAY BABY (Birkenhead): (a) Leningrad; (b) wireless fog beacons. NOVICE (Bedwas): Cannot trace as no wavelength estimated. EUCLID (Yardley): Yes, Dublin. INQUISITIVE (Newton Abbot): Cork relaying Dublin. SARAH (Hull): W2XAF, Schenectady; N.B.C. programme. ETHERSEARCHER (Huddersfield): This was Stockholm; a late broadcast of gramophone records. GUY'S NIGHTBIRD (London Bridge): Please number your queries: (1) possibly Moravská-Ostrava, but cannot confirm as no broadcast was advertised for that time; (2) Radio Idzerda, The Hague. ENERGY (East Ham): Moscow-Popoff. S. W. PENTODE BANG (Colwyn Bay): Moscow-Popoff (RFN), 50 m.; (b) On 50.1 m., not Utrecht but Eindhoven (Holland); (c) Yes. May we remind you of the terms of your listening licence? BEGINNER (Godalming): Cabaret evening (at Cologne studio with audience), relayed by Langenberg. STINKS (Stortford): Huizen. HUMPTIDUM (Hendon): Yes, short-wave transmitter relaying Moscow (Trades' Unions) broadcasts. POSITIVE (Edinburgh): Nidaros relaying Oslo. HOZOIT (Pontardulais): Possibly a test by Lodz. P. F. P. (Ventrnor): Moscow (50 m.). BONNSIDE (Glasgow): Leningrad; early morning concert. PUZZLER (Hytna): Warsaw; relay of foreign transmissions. MURRAY (London): WLW, Cincinnati. PHARM (Muttley-Plymouth): Sottens (Switzerland) testing. ALGERNON (Urmston): Warsaw-Raszyn, high power transmitter. SONNY (East Ham): Regret, cannot trace. LONERIDER (Southsea): Cologne (common wave). BEAGLER (Shoreham-by-Sea): Kharkov. ENERGY (East Ham): (2) Leningrad. SAMOSAM (H.W.6): Sottens (Switzerland) testing. SUPER-HET (Westcliff-on-Sea): Apparently Moravská-Ostrava, although not mentioned in programmes; Jack Hylton and his orchestra broadcast from Prague the previous week. D.X. FAN (Leicester): "Ici Librado" (Brussels No. 2). MACFEN (Woking): So far as we have been able to ascertain, no foreign station advertised a relay on that date; apparently, a direct "pick-up" on your receiver. FOGHORN (Burnham): Lille PTT. CAROLUS (Norwich): Surely Barcelona [EA1]; gramophone records. S. F. P. (Southampton): Radio Normand (Pécamp-France); (2) about 500-550 metres is the usual range; (3) we do



not quite understand your question; other conditions being equal, the greater the power transmitted, the better your reception; (4) Bucharest will be found just above Frankfurt and Budapest above Munich. **TELEPHONES** (Sutton Valence): Moscow, new short wave transmitter. **MAGIGIAN** (Stockport): Sottens (Switzerland) testing. **KEDGE** (Norbiton): With further reference to our reply published in issue of February 20 last, KUKU is the phantom call of a mythical U.S.A. station, used in a burlesque skit broadcast through the N.B.C. net by the Cuckoo Club. **W. M. (D. bin)**: (1) probably Radio Maroc on 32.26 metres; (2) Moscow transmits on 1304 and 50 metres simultaneously; (3) further remarks noted but cannot write to you as no address given. **DOUBLE ELL** (Derby): (1) Toulouse PTT; relay of local fête; (2) a test, possibly by Lodz. **CHEERIO** (King's Lynn): Göteborg; gramophone records. **STOW** (Midlothian): Regret, cannot trace without some indication of WL. **ALLCOCK** (Rhiwbina): Lodz relaying Warsaw. **BABI** (Anglesey): From the details supplied it appears to us that you were not tuned in on the "long waves"; regret, cannot trace. **I. T. C. (Hove)**: No Aberdeen, which was broadcasting at the time; an amateur transmitter. **2V** (St. Annes): (10) according to wavelength the only station in the Columbia System would be WLAC, Nashville (Tenn.), on 204 m.; (2) details too vague; regret, cannot trace. **EGHIB** (W. 1): Surely Leningrad: details tally with programme. **W. J. N. (Saundersfoot)**: Lahti relaying Helsinki. **2V** (St. Annes): (7) harmonic of Radio Toulouse or possibly Radio Beziers. **THREE VALVER** (Weymouth): You do not say whether a.m. or p.m.; a test by the new transmitter. **MILLI-AMP** (Cardiff): A relay of the Huizen mid-day programme; possibly by a Dutch experimental station. **STRADIO** (Canning Town): You do not say whether a.m. or p.m.; regret, cannot trace. **VAN DEN DEE** (E. 1): Yes, W2XAF relaying WGY, Schenectady. **B. L. C. (Bristol)**: (1) REN, Moscow (46.6 m.); (2) W1XAZ relaying WBZ, Springfield (Mass). **SURPRISED** (Gatford): Rome. **WALTERS** (Pontypridd): (1) regret, cannot trace. **LSX**, Buenos Aires, is on 28.98 m.; (2) cannot trace from condenser reading, only. **OBBERON** (Bolton): Leningrad. **JAMMY DENTONIAN** (Swindon): (1) details far too vague to trace short-wave transmission; (2) W2XAF, relaying WGY, Schenectady. **WOOD-SPOILER** (Hessle): WTIC, Hartford, or WTAM, Cleveland: (2) very vague, but if WL correct might tally with WIOD, Miami Beach. **JULIUS CAESAR** (Caterham Valley): Lodz relaying Warsaw. **CURIOSUS** (Sheffield): Apparently, the call was misunderstood; G5HK is a British experimental transmitter at Sheffield. **MOLLY** (Faversham): Cannot trace; you do not say what you hear. **BAD EGG** (Whitstable): Sottens (Switzerland) testing. **XXXX** (Earby): Possibly Tiflis, but cannot confirm as programmes are not available. There is no other station between Oslo and Leningrad. **CURIOSUS** (Belfast): Kharkov; relay of foreign stations. **GOBLIN** (King's Heath): (1) Malmö relaying Stockholm; (2) Montpellier PTT. **MILLHAND** (Croydon): Brussels No. 1. **OH KAY BABY** (Birkenhead): San Sebastian (EAJ 8). **WHEREAMI** (Enfield): Katowice. **R. R. G. (Stowe)**: Regret, cannot trace. Your details are too vague, as many stations were broadcasting talks at that time. **BLUE HEAVEN** (Inverness): (1) yes, Sottens (Switzerland) testing; (2) regret, cannot trace. Radio Paris was closed down at that time. **SWADA** (Menai Bridge): Do you not mean "when trying for Bandoeng" and not Bangkok? Possibly Saigon, on 18.5 m., working with Casablanca (Morocco). **CURIOSUS** (Edinburgh): (1) Algiers; (2) Barcelona (EAJ1). **WESTON** (Salop): Brussels No. 1; gram. records. **WYAMARUS** (Wakefield): North

Regional transmitter: engineers' test. **DUNOVARIAN** (Dorchester): (1) Huizen; (2) Moscow-Komintern. **NAN** (Maldon): Lwów (Poland). **M. B. (Earl's Court)**: Huizen; relay of a concert from Utrecht military barracks; Turin is on 296 m., not 273 m.; see under "Deviations" in Wavelengths page. **HOPELESS HORACE** (Sheffield): (1) Wilno; (2) Kharkov. **MAHRUD** (Basingstoke): Possibly CT1AA, Lisbon. **I ASKEW** (Edinburgh): Sottens (Switzerland): The call is "Ici poste national Suisse" or "Ici Radio Suisse Romande." **C. G. J.** (Portsmouth): (110) far too vague; possibly British experimental transmitter; (2) if French, Rabat (Morocco). **KILLOCH** (Glasgow): Yes, LSX, Monte Grande, Buenos Aires. **CHUCK** (Waste): (4) if on about WL stated, WGY, Schenectady, but this transmission would not come between London Regional and Brussels No. 2. **CHEE-CHAKO** (Southampton): Fécamp (Normandy). The call was: "Ici Radio Normandie." **ETHER** (Wolverhampton): Leningrad relaying Moscow (T.U.); German transmission. **J. B. M.** (Newcastle-on-Tyne): Radio-Idzerda, The Hague. **BURFORD** (Farnborough): Copenhagen direct. **QUERY** (N.22): This was Huizen; a relay of concert from Utrecht barracks, and, later, gramophone records. **WESTWARD** (Cardiff): WTAM, Cleveland. **BLACKY** (Portsmouth): Radio-Idzerda, The Hague. **ALF** (Stockton-on-Tees): Not advertised, but apparently Zagreb; a relay of foreign transmissions. **MUCKABOUT** (Drury Lane): (c) Gleiwitz relaying Breslau; (d) Barcelona (EAJ1). **G. H. W. (Bolton)**: Turin relaying Milan. **ELECT** (South Bank): Radio-Idzerda, The Hague; gramophone record of Wembley Military Tattoo. **R. H. M. B. (Evesham)**: Algiers. **BOBUS** (Richmond): San Sebastian (EAJ 8). **PUR-BECK** (Tottenham): Turin; see under "Deviations" in current issue. **NU-UN** (Beckenham): Yes, Reykjavik. **FLUMMOXED** (Wembley): You do not say whether a.m. or p.m.; Gleiwitz relaying Breslau. **MOGGLES** (Glasgow): Not advertised, but apparently Göteborg; gram. records. **INVICTA** (Margate): Huizen (orchestral, vocal, and choral concert relayed from Amsterdam). **ARREW** (Aldridge): Regret, cannot trace morse stations in these columns. **P. E. (Priestley)**: CT1AA, Lisbon. **NIGHTSHIFT** (Petershire): Toulouse PTT: local relay. **AJAX** (Gainsborough): Experimental television transmission; sound through London National and vision through London Regional stations; (2) yes. **HOODCH AYE** (Glasgow): Moscow-Popoff. **QUERY** (N.22): Reykjavik. **NEWCOMER** (Westcliff-on-Sea): VK2ME Sydney, N.S.W. **EARLY BIRD** (New Malden): A test by Northern Regional. **THETA** (Leicester): Possibly WOO, Ocean Township (N.J.) on 23.36 m. The broadcast was also carried out by LSX, Buenos Aires. **SNOWBALL** (Manchester): W1XAZ relaying WBZ, Springfield. **PUZZLED** (Exeter): Kharkov; early morning physical exercises. **CAN'T SLEEP** (Hayes): Sottens (Switzerland) testing; relay of records from Lausanne studio. **AUDI-TEUR** (Sefton Park): CT1AA, experimental station at Lisbon. **YOUNG ENQUIRER** (Liverpool): Moscow Popoff short-wave transmitter on 50 m. **JOE HOE** (Camberwell): (1) Kharkov on 426.3 m.; early morning transmission; (2) Sottens (Switzerland). The call was "Ici Radio Suisse Romande" (a relay of gram. records from the Lausanne studio). **AFTER THE BALL** (Wylde Green): There is no American broadcasting station on a WL between 352.7 and 361.2 m.; possibly KOA, Denver. **ALPHA** (Addison Gardens): "Ici Radio Suisse Romande" is the call from the Lausanne studio testing through Sottens. **MIMSY TOVE** (Annan): Moscow-Popoff (50 m.) relaying Moscow (T.U.); (2) regret cannot trace. Please number your queries.

**READ INSTRUCTIONS IN IDENTIFICATION COUPON**

**Free Query Service**

Each query should be numbered and the questions on the coupon carefully answered. Letters must be addressed to the Editor, *World-Radio*, Savoy Hill, W.C.2.

**The Alternative Postal Service**

In addition to the free service of "Which Station was That?" printed in these columns, replies to queries can be obtained within forty-eight hours of receipt of details, on payment of 6d. per query, in stamps or P.O., accompanied by stamped addressed envelope (marked in left-hand top corner "Postal Query Service"), and coupon, as per conditions for "Free Queries."

**IDENTIFICATION COUPON (No. 113)**

This coupon is valid for ONE QUESTION only, and should be cut out and attached to a separate sheet, upon which the following questions should be answered in the order shown, and a duplicate copy of questions and answers enclosed. No coupon more than one month old is valid.

1. Time and Date of reception.
2. Approximate frequency in kilocycles per sec. (or wavelength in metres).
3. Nearest known stations, above and below.
4. Call or interval signal, if heard.
5. Language.
6. Type of receiver in use and strength of signal.
7. Details of programme or signal received.
8. Name and address.
9. Nom de plume. (*Proprietary names must not be used.*)

**Schedule of Advance Programmes**

(STRICTLY COPYRIGHT)

For the benefit of traders who may wish to make arrangements for demonstrating, we are printing each week a schedule of the programmes to be transmitted by the National, London Regional, and Midland Regional stations. It will be noticed that these schedules concern programmes to be transmitted a fortnight hence, and it is felt that they will also be of particular service to those of our readers living abroad who will be able to use them in connexion with the reception of the Experimental Short Wave Station, G5SW, which relays the National (5XX) programme from 7 p.m.

**SUNDAY, APRIL 12**

|                   | NATIONAL                        | LONDON REGIONAL    | MIDLAND REGIONAL   |
|-------------------|---------------------------------|--------------------|--------------------|
| AFTERNOON         | Church Cantata<br>Military Band | Light Music        | Studio Orchestra   |
| EVENING PROGRAMME | Hotel Orchestra                 | Symphony Orchestra | As London Regional |

**MONDAY, APRIL 13**

|                          | NATIONAL   | LONDON REGIONAL                         | MIDLAND REGIONAL                                      |
|--------------------------|--|---|---|
| MORNING                  | Organ Recital  | Studio Concert                          | As London Regional                                    |
| AFTERNOON                | Orchestral Concert<br>Gramophone Records<br>Restaurant Music | Restaurant Music<br>As Midland Regional | As London Regional<br>Cinema Orchestra                |
| FIRST EVENING PROGRAMME  | Talks<br>Vaudeville  | Band Concert<br>French Talk             | Light Music<br>As London Regional                     |
| SECOND EVENING PROGRAMME | Chamber Music<br>Dance Music                                 | Orchestral Concert<br>Dance Music       | Military Band<br>As London Regional<br>(till 11 p.m.) |

**TUESDAY, APRIL 14**

|                          | NATIONAL   | LONDON REGIONAL                            | MIDLAND REGIONAL                  |
|--------------------------|--|--|-----------------------------------|
| MORNING                  | Cinema Organ   | Instrumental Concert                       | As London Regional                |
| AFTERNOON                | Restaurant Music<br>Gramophone Records<br>Cinema Orchestra | As Midland Regional<br>As Midland Regional | Cinema Organ<br>Studio Orchestra  |
| FIRST EVENING PROGRAMME  | Talks<br>Light Music<br>Organ Recital                      | Light Music<br>Girls' Choir                | Light Music<br>Band Concert       |
| SECOND EVENING PROGRAMME | Musical Comedy<br>Programme<br>Dance Music                 | Orchestral Concert<br>Dance Music          | Concert, (contid.)<br>Dance Music |

**WEDNESDAY, APRIL 15**

|                          | NATIONAL                                     | LONDON REGIONAL                      | MIDLAND REGIONAL                         |
|--------------------------|--|--------------------------------------|--|
| MORNING                  | Gramophone Records<br>Organ Recital          | Organ Recital<br>As Midland Regional | As London Regional<br>Studio Orchestra   |
| AFTERNOON                | Restaurant Music<br>Symphony Concert         | Gramophone Records<br>As National    | As London Regional                       |
| FIRST EVENING PROGRAMME  | Talks<br>Symphony Concert                    | Light Music<br>German Talk           | Studio Orchestra<br>As London Regional   |
| SECOND EVENING PROGRAMME | Symphony Concert<br>(Part II)<br>Dance Music | Review<br>Dance Music                | As London Regional<br>As London Regional |

**THURSDAY, APRIL 16**

|                          | NATIONAL   | LONDON REGIONAL                         | MIDLAND REGIONAL   |
|--------------------------|--|---|--|
| MORNING                  | Cinema Organ   | As Midland Regional                     | Ballad Concert   |
| AFTERNOON                | Studio Concert<br>Abbey Evensong<br>Restaurant Music | Cinema Orchestra<br>As Midland Regional | As London Regional<br>Studio Orchestra                     |
| FIRST EVENING PROGRAMME  | Talks<br>Studio Concert                              | Light Music<br>Orchestral Concert       | Studio Orchestra<br>Chamber Music                          |
| SECOND EVENING PROGRAMME | Talk<br>Orchestral Concert<br>Dance Music            | Vaudeville<br>Dance Music               | As London Regional<br>As London Regional<br>(till 11 p.m.) |

**FRIDAY, APRIL 17**

|                          | NATIONAL                               | LONDON REGIONAL                            | MIDLAND REGIONAL                       |
|--------------------------|--|--|--|
| MORNING                  | Studio Concert<br>Organ Recital        | Gramophone Records                         | As London Regional                     |
| AFTERNOON                | Gramophone Records<br>Restaurant Music | As Midland Regional<br>As Midland Regional | Studio Orchestra<br>Cinema Orchestra   |
| FIRST EVENING PROGRAMME  | Talks<br>Revue                         | Dance Music<br>Chamber Music               | As London Regional<br>Studio Orchestra |
| SECOND EVENING PROGRAMME | Play<br>Dance Music                    | Military Band<br>Dance Music               | As London Regional                     |

**SATURDAY, APRIL 18**

|                          | NATIONAL                    | LONDON REGIONAL              | MIDLAND REGIONAL                    |
|--------------------------|-----------------------------|------------------------------|-------------------------------------|
| MORNING                  | Cinema Orchestra            | As National                  |                                     |
| AFTERNOON                | Light Music<br>Cinema Organ | As National                  | Commentary on Rugby<br>Match        |
| FIRST EVENING PROGRAMME  | Talk<br>Popular Programme   | Light Music<br>Play          | Military Band<br>As London Regional |
| SECOND EVENING PROGRAMME | Dance Music                 | Military Band<br>Dance Music | Studio Orchestra                    |

USE YOUR SET AS A SHORT  
WAVE RECEIVER  
WITH A KELSEY  
ADAPTOR AND  
LISTEN ALL  
OVER THE  
WORLD

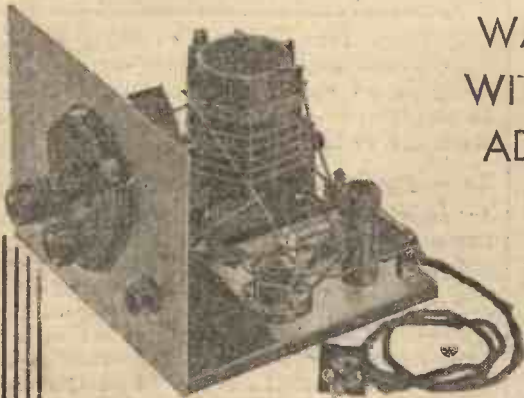

By placing the plug from the Kelsey Short Wave Adaptor into the detector valve socket of your set and the detector valve into the Adaptor itself, your set is converted into a short wave receiver, capable of picking up stations between 16 to 52 metres from all over the world. No further batteries or valves are needed, no alterations to your set are necessary; simply insert the Kelsey Short Wave Adaptor between your aerial and set and you will get new thrills out of radio. The Kelsey Short Wave Adaptor for use in battery sets only.

**KELSEY SHORT WAVE ADAPTOR**  
COMPLETE  
assembled ready for use and specially packed  
for immediate delivery. Sent C.O.D., you  
pay the postman.

**37/6**

**PETO-SCOTT CO. LTD.**

77, City Road, London, E.C.1. Phone: Clerkenwell 9406-7-8.  
62, High Holborn, London, W.C.1. Phone: Chancery 8266.  
33, Whitelaw Rd., Chorlton-cum-Hardy, Manchester. Phone: Chorlton-cum-Hardy 2028.  
7, Albany Road, Newcastle, Staffs. Phone: 67190.

Please send me C.O.D./CASH (strike out that which does not apply) (1) complete Kelsey Short Wave Adaptor, (2) Complete Kit for the Kelsey Short Wave Adaptor.

NAME .....  
ADDRESS .....  
W.R. 27/3.31 .....

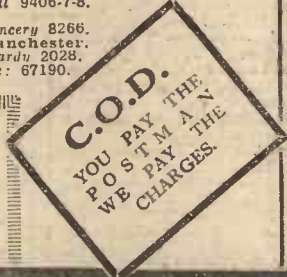

Do you  
Know what's going  
on in your set —  
or are you working  
Blindfolded?

Are you trusting to luck to give you good radio reception? If so, it is well-nigh certain that you are not getting anything like as good a result as your set can give.



Work with a "Sifameter." Know that each circuit in your receiver is getting the exact amount of power with which it can cope most efficiently, no more and no less.

A "Sifameter" will measure accurately for you, testing your Low Tension, High Tension, Grid Bias and Plate Current—every essential measurement to enable you to "feed" your valves correctly and so get maximum range and power.

The "Sifameter" measures 0-15 volts for L.T. and G.B., 0-150 volts for H.T. and 0-50 milliamps for Plate Current.

Get a "Sifameter" to-day and give your set a chance. Any radio dealer can supply, but should you have any difficulty write us.

**PRICE 10/-**  
**FULLY GUARANTEED**



SIFAM ELECTRICAL INSTRUMENT CO., LTD.,  
BUSH HOUSE, ALDWYCH, LONDON, W.C.2.

For that station out of  
"speaker range" use  
these sensitive 'phones



Ericsson Telephones pull in those distant foreigners—clear and pure. Comfortable for "long spells."

All good dealers stock them, or direct from

**ERICSSON TELEPHONES, LTD.**

120, 2,000 and 4,000 ohms.

67/73, Kingsway, London, W.C.2.

**12/6**



BRITISH  
SUPERSENSITIVE  
TELEPHONES.

NATIONAL PROGRAMME

193 k/cs (1,554.4 metres) (35 kW.)

(Daventry)

(March 29-April 4)

SUNDAY (MAR. 29)

10.30-10.45 a.m.—Time Signal (Greenwich). Shipping Forecast. Time Signal (Greenwich) at 3.0 p.m. 3.0 p.m.—The Albert Hall Diamond Jubilee Celebration. Concert in aid of the Musicians' Benevolent Fund. The B.B.C. Symphony Orchestra. The London Symphony Orchestra. Conductors: Sir Henry Wood, Adrian Boult, Malcolm Sargent. Soloists: Conchita Supervia, Keith Falkner. God Save the King (Conducted by Adrian Boult). Overture, The Mastersingers (Wagner). Conducted by Sir Henry Wood. Conchita Supervia and Orchestras: Grand Rondò de Cendrillon (Cinderella) (Rossini). Conducted by Sir Henry Wood. Orchestras: Aria on the G String (special setting) (Bach). Conducted by Malcolm Sargent. Second and Third Movements, Pathétique Symphony (Tchaikovsky). Conducted by Malcolm Sargent. Keith Falkner and Songs (Stanford). Conducted by Adrian Boult. Orchestras: Enigma Variations (Elgar). Conducted by Adrian Boult. 4.45 p.m.—For the Children. 5.5 p.m.—The Victor Olof Sextet. Gladys Palmer (Contralto). Sextet: Selection, Coppelia (Delibes). Gladys Palmer: Si mes vers avaient des ailes (If my Songs had Wings) (Hahn); Nuit d'Étoiles (Starry Night) (Debussy); Le Capitif (Gretchaninov). Sextet: Suite, English Folk Songs (Vaughan-Williams). Legende (Wiensavski). Gladys Palmer: Dawn (Holst); Sweet Chance that led my Steps (Head); Requiem (Homer). Sextet: Negro Melody, Deep River (trans. Coleridge-Taylor); Guitare (Lalo); Welsh Air, David of the White Rock (arr. Perry); Polichinelle (Rachmaninov, arr. Bernards). 6.0-6.15 p.m.—Bible Reading. 8.0 p.m.—A Religious Service from Westminster Congregational Church. 8.50 p.m.—"The News." Weather Forecast, General News Bulletin. 9.0 p.m.—Shipping Forecast; Time Signal (Greenwich) at 9.0 p.m. 9.5 p.m.—The Crucifixion (Stainer), relayed from St. Marylebone Parish Church. St. Marylebone Parish Church Choir. David Leitch (Tenor). Robert Butler (Baritone). At the Organ, Samuel Smith. Organist and Master of the Chorists, Ronald G. Tomblin. 10.30 p.m.—Epiologue.

MONDAY (30)

10.15 a.m.—The Daily Service. 10.30 p.m.—Time Signal (Greenwich), Shipping Forecast. 10.45 p.m.—"The Day's Work in other Lands"—XIII. Mr. Paul Sheldon: "A Clove Picker in Zanzibar." 12 noon.—Organ Recital by Edgar T. Cook, Margaret Hale (Contralto). Time Signal (Greenwich) at 1.0 p.m. 1.15 p.m.—An Orchestral Concert. The National Orchestra of Wales (Leader, Louis Levitus), conducted by Warwick Braithwaite. 2.0-2.30 p.m.—Gramophone Records. 4.0 p.m.—Light Music. Moschetto and his Orchestra, from the May Fair Hotel. Time Signal (Greenwich) at 4.45 p.m. 5.15 p.m.—The Children's Hour. 6.0 p.m.—Talk. 6.15 p.m.—"The First News." Time Signal (Greenwich) at 6.30 p.m. 6.40 p.m.—The Foundations of Music.

(Continued from page 504) 10.45-11.30 a.m. (London).—Daventry National Programme. 3.30 p.m.—A Pianoforte Recital by Arthur Benjamin. 4.0 p.m.—A Light Symphony Concert. The City of Birmingham Orchestra, conducted by Leslie Heward; Muriel Sotham (Contralto); Eda Kersey (Violin). 5.30 p.m.—Robert Maitland (Baritone): Four Serious Songs (Brahms). 6.0 p.m.—Daventry National Programme. 7.15 p.m.—Interval. 7.30 p.m.—The Wireless Military Band, conducted by Charles

Debussy Preludes, played by Stanislas de Niedzielski (Pianoforte). 7.0-7.20 p.m.—"New Books." Mr. Desmond MacCarthy. 7.25 p.m.—The Rt. Hon. the Earl of Cottenham: "How to Use Speed Properly." 7.45 p.m.—The Weekly Theatrical Cartoon: Sir John Martin-Harvey. 7.50 p.m.—Vaudeville. Mostly Musical, including Sydney Baynes' Orchestra. Playing throughout the Programme. Josephine Trix (Light and Syncopated Songs). Stanelli and Edgar (Comedy on two Violins). The Wireless Singers. "Shingled Shakespeare" by Frank Burton. The Hairdresser (Ivan Samson). The Lady (Lilian Harrison). Myra Cohen and Thelma Nurick (Pianoforte Duets). Leslie Sarony (Comedian). Time Signal (Greenwich) at 9.0 a.m. 9.0 p.m.—"The Second News." Weather Forecast, Second General News Bulletin. 9.15 p.m.—Shipping Forecast; New York Stock Market Report. 9.20 p.m.—Flying Talks—IV. Lieut.-Col. F. C. Shelmerdine (Director of Civil Aviation): "The Development of Civil Aviation during the Past Year." 9.35 p.m.—In Memory of Anna Pavlova. A Concert of the music to which she danced. The B.B.C. Orchestra, conducted by Walford Hyden. Dionysius (Tcherepenn); Pizzicato (Delibes); Le Cygne (The Swan) (Saint-Saëns); Valse Caprice (Rubinstein); The Three Palms (Spendiarov); Serenade (Drigo); Variation (Coqueretterie de Columbine) (Rimsky-Korsakov); Gavotte Pavlova (Glow Worm) (Lincke); Bacchanale (Glazounov). 10.30 p.m.—A Pianoforte Recital by Eduard Steuermann. 11.0 p.m.—12.0 midnight.—Dance Music. Time Signal (Greenwich) at 11.30 p.m.

TUESDAY (31)

10.15 a.m.—The Daily Service. 10.30 a.m.—Time Signal (Greenwich) Shipping Forecast. 10.45-11.0 a.m.—"What is Good Food?"—II. Miss E. M. Hume: "Light and Diet." Housewives' News. 12 noon.—Edward O'Henry at the Organ. Time Signal (Greenwich) at 1.0 p.m. 1.0 p.m.—Light Music. Leonardo Kemp and his Piccadilly Hotel Orchestra. 1.55 p.m.—Experimental Transmission for the Radio Research Board by the Fultograph Process. 2.5-2.30 p.m.—Gramophone Records. 4.0 p.m.—A Sonata. Elsie Owen (Violin). Kathleen Thomson (Pianoforte). 4.30 p.m.—The Prince of Wales Cinema Orchestra, conducted by Frank Westfield. Time Signal (Greenwich) at 4.45 p.m. 5.15 p.m.—The Children's Hour. 6.0 p.m.—Mr. Frank Prewett: "Country Life." 6.15 p.m.—"The First News." Time Signal (Greenwich) at 6.30 p.m. 6.40 p.m.—The Foundations of Music. Debussy Preludes. Played by Stanislas de Niedzielski. 7.0-7.20 p.m.—"The Cinema." Mr. Francis Birrell. 7.25 p.m.—Mr. John Bingham: "An Undergraduate in the Foc'sle, II." 7.45 p.m.—The Wireless Military Band. Conductor, B. Walton O'Donnell. Franklyn Kelsey (Bass). Sascha Lasserson (Violin). Time Signal (Greenwich) at 9.0 p.m. 9.0 p.m.—"The Second News." Weather Forecast, Second General News Bulletin.

SATURDAY (4)

10.15-11.0 a.m. (London).—Daventry National Programme. 1.0-2.0 p.m. (London).—Daventry National Programme. 3.30 p.m. (London).—The J. H.

9.15 p.m.—Shipping Forecast; New York Stock Market Report. 9.20 p.m.—Talks for the Summer. 9.40 p.m.—Jack Payne and his B.B.C. Dance Orchestra and an Item from The London Palladium. 10.40 p.m.—12 midnight.—Dance Music. Time Signal (Greenwich) at 11.30 p.m.

WED. (APRIL 1)

10.15 a.m.—The Daily Service. 10.30 a.m.—Time Signal (Greenwich) Shipping Forecast. 10.45-11.0 a.m.—"The Week in Westminster." Miss Megan Lloyd George, M.P. 12 noon.—Gramophone Records. 12.45 p.m.—Organ Recital by Leonard H. Warner. Time Signal (Greenwich) at 1.0 p.m. 1.15-2.30 p.m.—Light Music. Frascati's Orchestra. Directed by Georges Haeck. 3.30 p.m.—A Symphony Concert. The Bourne-mouth Symphony Orchestra, conducted by Sir Dan Godfrey. Lloyd Powell (Pianoforte). Time Signal (Greenwich) at 4.45 p.m. 4.45 p.m.—Reginald New, at the Organ. 5.15 p.m.—The Children's Hour. 6.0 p.m.—Mr. J. S. Blunt: "Easter at St. Catharine's Monastery, Mount Sinai." 6.15 p.m.—"The First News." Time Signal (Greenwich) at 6.30 p.m. 6.40 p.m.—The Foundations of Music. Debussy Preludes. Played by Stanislas de Niedzielski. 7.0-7.20 p.m.—Talks on Farming—VII. Sir Daniel Hall, K.C.B., F.R.S., Chief Scientific Adviser, Ministry of Agriculture. 7.25 p.m.—Mr. Peter Manniche, Warden of the International People's College, Elsinore: "The work of the International People's College, Elsinore." 7.45 p.m.—The Ridgeway Parade. (New Series.) A Song and Dance Show. Written by Holt Marvell and Philip Ridgeway. Devised and Produced by Philip Ridgeway. Time Signal (Greenwich) at 9.0 p.m. 9.0 p.m.—"The Second News." Weather Forecast, Second General News Bulletin. 9.15 p.m.—Shipping Forecast; New York Stock Market Report. 9.20 p.m.—Mr. Filson Young: "The Return of the Fishing Fleet to Fleetwood." 9.35 p.m.—Chamber Music. Parry Jones (Tenor). String Quartet. 11.0 p.m.—12 midnight.—Dance Music. Time Signal (Greenwich) at 11.30 p.m.

THURSDAY (2)

10.15 a.m.—The Daily Service. 10.30 a.m.—Time Signal (Greenwich); Shipping Forecast. 10.45-11.0 a.m.—"Other People's Standpoints"—VI. Mrs. H. A. L. Fisher: "The Young People." 12 noon.—Reginald Foort at the Organ. Time Signal (Greenwich) at 1.0 p.m. 1.10-1.50 p.m.—Lenten Dinner—Hour Service. 2.0-2.30 p.m.—Gramophone Records. 3.0 p.m.—Evensong from Westminster Abbey. 3.45 p.m.—Jack Payne and his B.B.C. Dance Orchestra. 4.30 p.m.—Light Music. The Grosvenor House Orchestra, directed by Joseph Mecus. Time Signal (Greenwich) at 4.45 p.m. 5.15 p.m.—The Children's Hour. 6.0 p.m.—The Rev. Archibald Fleming, D.D.: "Good Friday—Why Friday and Why Good?" 6.15 p.m.—"The First News." Time

Squire Celeste Octet. Mabel Ferguson (Mezzo-Soprano). 3.30 p.m. (Midland).—A String Band Concert. The Band of H.M. Royal Artillery (Mounted), conducted by T. J. Hillier. 4.45 p.m. (London).—Reginald Foort at the Organ. 4.45 p.m. (Midland).—Reginald New at the Organ. 5.15 p.m. (London).—Jack Payne and his B.B.C. Dance Orchestra. 5.15 p.m. (Midland).—Children's Hour. 6.0 p.m. (Midland).—As London. 6.15 p.m.—"The First News." 6.40 p.m.—Sports Bulletin. 6.45 p.m. (London).—The Frank

Signal (Greenwich) at 6.30 p.m. 6.40 p.m.—The Foundations of Music. Debussy Preludes. Played by Stanislas de Niedzielski. 7.0-7.20 p.m.—"This Surprising World." Mr. Gerald Heard. 7.25 p.m.—Mr. W. Olaf Stapledon: "The Re-making of Man." 7.45 p.m.—An Orchestral Concert. Marie Wilson (Violin). The B.B.C. Orchestra, conducted by Percy Pitt. Overture, Euryanthe (Weber); Lament (Percy Pitt). Marie Wilson and Orchestra: Concerto No. 1, in G Minor, Op. 26 (Max Bruch). Orchestra: Suite, Philemon and Baucis (Gounod); Waltz, Voices of Spring (Strauss). Time Signal (Greenwich) at 9.0 p.m. 9.0 p.m.—"The Second News." Weather Forecast, Second General News Bulletin. 9.15 p.m.—Shipping Forecast; New York Stock Market Report. 9.20 p.m.—"The Way of the World." Mr. Vernon Bartlett. 9.35 p.m.—A Pianoforte Recital by Solomon. Rhapsody in G Minor and Intermezzo in C (Brahms); Prelude in G Sharp Minor and Prelude in G Minor (Rachmaninov); Scherzo in B Flat Minor (Chopin). 10.0 p.m.—"Little Flower of the Wood" by Leonard Merrick. Adapted for the microphone by Michael Talbot. Produced by Lance Sieveking. 10.40 p.m.—12 midnight.—Dance Music. Jack Payne and his B.B.C. Dance Orchestra. Time Signal (Greenwich) at 11.30 p.m. 12 midnight-12.5 a.m. (Friday).—Experimental Transmission for the Radio Research Board by the Fultograph Process.

FRIDAY (3)

10.30 a.m.—Time Signal (Greenwich), Shipping Forecast. 10.45-11.30 a.m.—Devotional Service, relayed from St. Martin-in-the-Fields. 3.30 p.m.—Reginald King and his Orchestra. Linda Seymour (Contralto). Jan Van Der Gucht (Tenor). Orchestra: Hymne à Sainte Cécile (Gounod); Sérénade Hongroise (Joucièse). Jan van der Gucht: Ich weiss dass mein Erlöser lebt (I know that my Redeemer lives), and Mein liebster Jesus ist verloren (My dearest Jesus, I have lost Thee) (Bach). Orchestra: Selection, Manon (Massenet). Linda Seymour: There (Parry); To Music (Schubert); Auf dem Kirchhofe (in the Churchyard) (Brahms). Orchestra: Sursum Corda (Elgar). Jan van der Gucht: Loveliest of Trees (Butterworth); Spring Sorrow (Ireland); May Day Carol (Essex Folk Song) (arr. Deems Taylor). Orchestra: Serenade (Delius, transcribed Reginald King); Passepié (Gillet). Linda Seymour: Morning Hymn (Henschel). Christ went up into the Hills (Hagemann); Maruts (Stormclouds) (Holst). Orchestra: Canonetta (Tchaikovsky); Overture, Impresario (Mozart). Time Signal, Greenwich, at 4.45 p.m. 5.0 p.m.—Poetry Reading. 5.30 p.m.—A Violin Recital by Albert Simmons. 6.0 p.m.—The Gershom Parkington Quintet. Maria Sandra (Soprano). John Morel (Baritone). Quintet: Petite Suite de Concert (Coleridge-Taylor). John Morel: The Birds (Alec Rowley); The Philosopher (Harold Rawlinson); The Heart worships (Holst). Quintet: Lotus Land (Cyril Scott); Maria Sandra: Swing low, sweet Chariot (H. T. Burleigh); The Knight of Bethlehem (D. Cleghorn Thomson); Hear de lambs a-cryin' (Lawrence Brown); By an' by (H. T. Burleigh). Quintet: Spanish Dance

Walker Octet. Howard Fry (Baritone). 6.45 p.m. (Midland).—Light Music. The Royal Pump Room Trio, Leamington Spa. Musical Director, Edna Willoughby. 7.45 p.m. (London).—A Pianoforte Recital by Laffitte. 7.45 p.m. (Midland).—"Come, Pipe a Song," The Midland Studio Chorus. 8.15 p.m.—"Little-Flower-of-the-Wood," by Leonard Merrick. Adapted for the microphone by Michael Talbot. Produced by Lance Sieveking. 8.55 p.m.—Regional News.

(Moszkovski). John Morel: A the Syghes that came fro' my Heart (15th Century) (Unaccompanied, written for one voice only); When the Heart is at ease (Arne); The Crucifixion (Arr. Arms Fisher) (Negro American Folk Song). Quintet: Nocturne in Mists (Grey). Maria Sandra: Recit. and Air, Omra mai fu (Händel); The Virgin's Slumber (Song (Max Reger); Alleluia! a joyous Easter Hymn (Arr. G. O'Connor-Morris). Quintet: There is a green Hill far away (Gounod). Time Signal, (Greenwich), at 6.30 p.m. 7.15 p.m.—Interval. 7.30 p.m.—B.B.C. Concert. Relayed from the Queen's Hall, London. Parsifal (Wagner). The B.B.C. Symphony Orchestra (Leader, Arthur Catterall), conducted by Sir Henry Wood. Tatiana Makushina, Walter Widdop, Harold Williams, Horace Stevens. Prelude. The Scene between Kundry and Parsifal in Klingsor's Enchanted Garden (Act II). Kundry (Tatiana Makushina); Parsifal (Walter Widdop); Klingsor (Harold Williams). 8.30 p.m.—Shipping Forecast. 8.35 p.m.—Interval. 8.45-10.0 p.m.—Parsifal (continued). Prelude, Act III: Good Friday Scene. Entrance to the Castle of the Grail. Amfortas' Prayer and Closing Scene (Act III). Parsifal (Walter Widdop); Amfortas (Harold Williams); Gurnemanz (Horace Stevens). Transformation Music and Closing Scene (Act I). Time Signal (Greenwich) at 9.0 p.m.

\* If any news of importance is received during the day, it will be broadcast at 8.35 p.m.

SATURDAY (4)

10.15 a.m.—The Daily Service. 10.30 a.m.—Time Signal (Greenwich), Shipping Forecast. 10.45-11.0 a.m.—Mr. J. S. Hicks: "Chicken Rearing." Time Signal (Greenwich), at 1.0 p.m. 1.0-2.0 p.m.—Light Music. The Commodore Grand Orchestra, directed by Joseph Muscant. 3.30 p.m.—London Regional Programme. 4.10 p.m.—Arsenal v. Chelsea. A Running Commentary on the second half of the match by Mr. George F. Allison. Time Signal (Greenwich), at 4.45 p.m. 5.15 p.m.—The Children's Hour. 6.0 p.m.—Interlude. 6.15 p.m.—"The First News." Time Signal (Greenwich), at 6.30 p.m. 6.40 p.m.—Interval. 6.45 p.m.—The Foundations of Music. Debussy Preludes. Played by Stanislas de Niedzielski. 7.0 p.m.—"The Month in Scotland." Mr. A. Noel Skelton, M.P. 7.20 p.m.—"The Week's Work in the Garden," by the Royal Horticultural Society. 7.30 p.m.—From the Popular Operas. Stiles Allen (Soprano). Hubert Thorpe (Tenor). Easter Richardson (Bass). The Wireless Chorus (Chorus Master, Stanford Robinson). The B.B.C. Orchestra, conducted by Joseph Lewis. Time Signal (Greenwich), at 9.0 p.m. 9.0 p.m.—"The Second News." Weather Forecast, Second General News Bulletin. 9.15 p.m.—Shipping Forecast. 9.20 p.m.—"The Scoop"—XII. A Serial Detective Story. Miss Dorothy Sayers: "The Final Scoop." 9.45 p.m.—Vaudeville. 10.25 p.m.—12 midnight.—Dance Music. Ambrose's Band, from The May Fair Hotel. Time Signal (Greenwich) at 11.30 p.m. 9.0 p.m. (London).—The London String Players (Leader, Jean Pougnet). Conducted by Herbert Menges. Lia Rosa (Soprano). 9.0 p.m. (Midland).—"From the Musical Comedies." The Midland Studio Orchestra. Directed by Frank Cantell. Walter Payne (Baritone). 10.15 p.m.—"The Second News." Weather Forecast, Second General News Bulletin. 10.30-10.35 p.m. (Midland).—Experimental Transmission for the Radio Research Board by the Fultograph Process. 10.30 p.m.—12 midnight (London).—Dance Music.

# REGIONAL PROGRAMMES

(London)

842 kc/s (356.3 m.)  
(70 kW.)

(Midland)

626 kc/s (479.2 m.)  
(38 kW.)

(March 29—April 4)

## SUNDAY (MAR. 29)

- 3.30 p.m. (London).—A Pianoforte Recital by Kathleen Long.
- 3.30 p.m. (Midland).—An Afternoon Concert. The Midland Studio Orchestra, directed by Frank Cantell. Stanley Dobson-Hopper (Baritone). Dorothy Daniels (Pianoforte).
- 4.0 p.m. (London).—The Central Band of H. M. Royal Air Force, conducted by Flight-Lieutenant J. Amers. Arthur Cranmer (Bass). Thea Philips (Soprano).
- 5.0—5.30 p.m. (Midland).—Organ Recital by Gilbert Mills.
- 7.50 p.m. (Midland).—A Religious Service from St. Martin's Parish Church, Birmingham.
- 8.0 p.m. (London).—A Religious Service from the Studio, conducted by Prebendary B. F. Relton.
- 8.45 p.m. (London).—The Week's Good Cause. Appeal on behalf of The Skilled Employment and Apprenticeship Association, by Dame Henrietta Barnett, D.B.E.
- 8.45 p.m. (Midland).—Davertry National Programme.
- 8.50 p.m.—"The News." Weather Forecast, General News Bulletin; Regional News.
- 9.5 p.m.—Sunday Orchestral Concert—XXI. The B.B.C. Orchestra (Leader, Arthur Catterall), conducted by Sir Henry Wood. Eduard Steuermann (Pianoforte).
- 10.30 p.m.—Epilogue.

## MONDAY (30)

- 10.15 a.m. (London).—Davertry National Programme.
- 11.0—11.30 a.m. (London).—Experimental Television Transmission by the Baird Process (356.3 m. Vision; 261.3 m. Sound).
- 12 noon.—A Light Classical Concert. Mildred Watson (Soprano). The British String Quartet: Jessie Snow (Violin); Alan Bartlett (Violin); Ernest Tomlinson (Viola); Edward Robinson (Violoncello).
- 1.15 p.m.—Light Music. Leonardo

- Kemp and his Piccadilly Hotel Orchestra.
- 2.0—3.0 p.m.—Lozells Picture House Orchestra, conducted by Ernest Parsons.
- 4.0 p.m. (London).—Davertry National Programme.
- 5.15 p.m. (London).—Jack Payne and his B.B.C. Dance Orchestra.
- 5.15 p.m. (Midland).—Children's Hour.
- 6.0 p.m. (Midland).—As London.
- 6.15 p.m.—"The First News."
- 6.40 p.m. (London).—An Orchestral Concert. The B.B.C. Orchestra, conducted by Joseph Lewis. Elena Danieli (Soprano).
- 6.40 p.m. (Midland).—Vaughan Williams' Songs. A Recital by Maurice Milbourn (Tenor).
- 7.0 p.m. (Midland).—A Military Band Concert. Don Pedro and his Band.
- 8.0 p.m.—Monsieur E. M. Stéphan: French Talk.
- 8.30 p.m.—Regional News.
- 8.35 p.m. (London).—The Wireless Military Band. Conductor, B. Walton O'Donnell. Edith Gunthorpe and Cecil Baumer (Pianofortes).
- 8.35 p.m. (Midland).—Light Music. Pattison's Salon Orchestra, under the direction of Norris Stanley, Emmelyn Walter (Soprano).
- 9.30 p.m. (Midland).—"Canteen Cantata."
- 9.45 p.m. (London).—American Dance Records.
- 10.15 p.m.—"The Second News." Weather Forecast, Second General News Bulletin.
- 10.30 p.m.—12 midnight (London).—Dance Music.
- 10.30—11.0 p.m. (Midland).—As London.

## TUESDAY (31)

- 10.15 a.m. (London).—Davertry National Programme.
- 11.0—11.30 a.m. (London).—Experimental Television Transmission by the Baird Process (356.3 m. Vision; 261.3 m. Sound).

- 12 noon.—An Instrumental Concert. The Chelsea Octet.
- 1.0 p.m.—Reginald New at the Organ.
- 2.0—3.0 p.m.—The Midland Studio Orchestra, directed by Frank Cantell.
- 4.0 p.m. (London).—Davertry National Programme.
- 5.15 p.m. (London).—Jack Payne and his B.B.C. Dance Orchestra.
- 5.15 p.m. (Midland).—Children's Hour.
- 6.0 p.m. (Midland).—As London.
- 6.15 p.m.—"The First News."
- 6.40 p.m. (London).—The Gershwin Parkington Quintet. Dorothy Tillett (Soprano).
- 6.40 p.m. (Midland).—The Midland Studio Orchestra, directed by Frank Cantell. Gertrude Entwistle (Contralto).
- 7.40 p.m.—The Ridgeway Parade (New Series).
- 9.0 p.m.—Concert of Contemporary Music—III. The Brosa String Quartet: Brosa, Wise, Rubens, Pini. The B.B.C. Orchestra, conducted by Frank Bridge.
- 10.15 p.m.—"The Second News." Weather Forecast, Second General News Bulletin.
- 10.30 p.m.—12 midnight (London).—Dance Music.
- 12 midnight—12.30 a.m. (Wednesday). (London).—Experimental Television Transmission by the Baird Process (356.3 m. Vision; 261.3 m. Sound).

## WED. (APRIL 1)

- 10.15 a.m. (London).—Davertry National Programme.
- 11.0—11.30 a.m. (London).—Experimental Television Transmission by the Baird Process. (356.3 m. Vision; 261.3 m. Sound).
- 12 noon.—Quentin Maclean at the Organ.
- 12.45 p.m.—The Midland Studio Orchestra, directed by Frank Cantell.
- 1.45 p.m.—Gramophone Records.
- 2.15—3.0 p.m.—A Ballad Concert. Elsie Coram (Soprano). Clifton

- Yates (Baritone). Kathleen Curry (Violin). Alec Templeton (Pianoforte).
- 3.30 p.m. (London).—Davertry National Programme.
- 5.15 p.m. (London).—Clive Erard and his Band, from The Amateur Dancers' Club.
- 5.15 p.m. (Midland).—Children's Hour.
- 6.0 p.m. (Midland).—As London.
- 6.15 p.m.—"The First News."
- 6.40 p.m. (London).—A Brass Band Concert. The Abram Colliery Prize Brass Band, conducted by J. Jennings. William Bernard (Tenor).
- 6.40 p.m. (Midland).—The Music of German and Sullivan. The Midland Studio Orchestra, directed by Frank Cantell. Harold Howes (Baritone). Nellie Southworth-Elkington (Soprano).
- 7.55 p.m. (London).—The Weekly Theatrical Cartoon. Sir John Martin-Harvey.
- 8.0 p.m.—Talk.
- 8.30 p.m.—Regional News.
- 8.35 p.m. (London).—String Orchestral Concert. The Bromley Chislehurst Orchestra. Dale Smith (Baritone).
- 8.35 p.m. (Midland).—A Military Band Programme. The Birmingham Military Band, conducted by W. A. Clarke. Edgar Wheatley (Violin). Ida Sargent (Songs at the Piano).
- 9.45 p.m.—The Wireless Singers, conducted by Stanford Robinson.
- 10.15 p.m.—"The Second News." Weather Forecast, Second General News Bulletin.
- 10.30 p.m. (Midland).—Experimental Transmission for the Radio Research Board, by the Photograph Process.
- 10.30 p.m.—12 midnight (London).—Dance Music.
- 10.35—11.0 p.m. (Midland).—As London.

## THURSDAY (2)

- 10.15 a.m. (London).—Davertry National Programme.
- 11.0—11.30 a.m. (London).—Experi-

## FRIDAY (3)

- 10.30 a.m. (London).—Shipping Forecast.

# PROGRAMMES FOR SUNDAY

(March 29)

The Frequencies and Wavelengths given in the following programmes are those published by the stations in question. For more accurate measurements, readers are referred to our Table of Frequencies and Wavelengths.

**NOTE: THE HOURS OF TRANSMISSION ARE REDUCED TO GREENWICH MEAN TIME**

### BARCELONA (Spain)

- Radio-Barcelona (EAJ1). 860 kc/s (349 m.); 8 kW.
- 8.0—9.0 a.m.—Topical Review.
- 11.0 a.m.—Chimes and Weather.
- 1.0 p.m.—Sextet Selections and Gramophone Records. March, Castilla and Valencia (Herdero de Santiago). Intermzzo. Réve enchanteur (Van Dyck). Selection from "Madame Pompadour" (Fall). "Cello Solo: Farewell Boy" (de Smetsky). Puck chérchant femme (Derksen). Czardas, Honka (Michiels). Nocturne in B Flat (Chopin). Selection (Lincke). Selection from "La Bohème" (Puccini). A Rialto (Travaglia). March, El Meson de la Florida (Sama).
- 3.0 p.m.—Programme for Hospitals and Benevolent Institutions, with Gramophone Records.
- 4.0—5.30 p.m.—Interval.
- 5.30 p.m.—Gramophone Records.
- 6.0 p.m.—Orchestral Selections.
- 6.30 p.m.—Soprano Song Recital from the Works of Schumann.
- 7.0 p.m.—Agricultural Talk in Catalan.
- 7.10 p.m.—Orchestral Concert. Selection from "Aragon" (Albeniz). El Pastoret (Sancho Marraco). Selections from "Blue Beard" (Offenbach). Serenade (Cattolica).
- 7.50 p.m.—Song Recital. Si mes vers avaient des ailes (Hahn). A Dream (Bartlett). D'une prison (Hahn). Meine Liebe ist grün (Brahms).
- 8.20 p.m.—Picturesque Suite for Orchestra, Orient (Delmas).
- 9.0 p.m. (approx.).—Close Down.

### BERLIN (Germany)

- Königs Wusterhausen. 183 kc/s (1,635 m.); 35 kW.
- 6.0 a.m.—Concert from Hamburg.
- 7.0 a.m.—5.0 p.m.—Programme from Berlin (Witzleben).
- 5.0 p.m.—Rural Talk.
- 5.30 p.m.—Leaves from the Diary of a Tour on the Western Front.
- 6.0 p.m.—Talk: Nietzsche and Music.
- 6.30 p.m.—J. F. Perkonig reads from his own Works.
- 7.0 p.m.—See Hamburg.
- 9.0 p.m.—News and Dance Music from Berlin (Witzleben).
- 11.0 p.m. (approx.).—Close Down.

- 7.0 a.m.—5.0 p.m.—Programme from Berlin (Witzleben).
- 5.0 p.m.—Rural Talk.
- 5.30 p.m.—Leaves from the Diary of a Tour on the Western Front.
- 6.0 p.m.—Talk: Nietzsche and Music.
- 6.30 p.m.—J. F. Perkonig reads from his own Works.
- 7.0 p.m.—See Hamburg.
- 9.0 p.m.—News and Dance Music from Berlin (Witzleben).
- 11.0 p.m. (approx.).—Close Down.

### BERLIN (Germany)

- Witzleben. 716 kc/s (418 m.); 1.7 kW.
- Transmits at intervals from 6.0 a.m. (Gymnastics).
- 3.0 p.m.—Orchestral Concert.
- 4.45 p.m.—Topical Programme.
- 5.0 p.m.—Dietzschmidt Recital. Talk with the Poet and Reading.
- 5.40 p.m.—Talk: Verdi's Duets, with illustrations.
- 6.25 p.m.—Alfons Paquet reads from his own Works.
- 6.50 p.m.—Sports Notes.
- 7.0 p.m.—Popular Orchestral Concert.
- 9.0 p.m.—Weather, News and Sports Notes, followed by Dance Music.
- 11.0 p.m. (approx.).—Close Down.

### BERNE (Switzerland)

- Radio-Bern. 743 kc/s (403 m.); 1.1 kW.
- Transmits at intervals from 9.30 a.m.
- 1.55 p.m.—Running Commentary on the International Football Match, Italy v. Switzerland, relayed from the Wankdorf Stadium.
- 3.45 (approx.)—4.30 p.m.—Gramophone Records.
- 6.25 p.m.—Sports Results.
- 6.28 p.m.—Time and Weather.
- 6.30 p.m.—Talk: Palm Sunday, relayed from Basle, 941 kc/s (319 m.).
- 7.0 p.m.—Violin Recital relayed from Zürich, 653 kc/s (450 m.).
- 7.40 p.m.—Choral and Soloist Concert relayed from Zürich.
- 9.0 p.m.—Sports Notes, News, Weather and Close Down.

### BRUSSELS (Belgium)

- Radio-Belgique. 590 kc/s (509 m.); 20 kW.
- 5.0 p.m.—Orchestral Concert. Overture, "Czar and Carpenter" (Lortzing). Petite Suite (Bizet). Minuet (Boccherini). Rigaudon (Lortzing). Album Leaf for Violin, Cello and Pianoforte (Schlegel). Invitation to the Waltz (Weber). Suite, En Bretagne (Baton).
- 6.0 p.m.—Gramophone Records.
- 6.15 p.m.—Gramophone Records: Selections from "King David" (Honegger).
- 6.45 p.m.—Gramophone Dance Records.
- 7.30 p.m.—Le Journal Parlé.
- 8.0 p.m.—Orchestral Concert conducted by M. Meulemans. Overture, "Carnaval romain" (Berlioz). Symphonic Variations for Pianoforte (César Franck). Serenata (Meulemans). Spanish Caprice (Rimsky-Korsakoff). Pianoforte Solos: (a) Die Spinnerin (Raff), (b) Fantaisie-Impromptu (Chopin), (c) Prelude (Alpacrts), (d) Waltz, Scherzo (Chabrier). Triumphant March (de Boeck). In the interval, Stories in Prose and Verse.
- 10.0 p.m.—Le Journal Parlé.

### BRUSSELS No. 2 (Belgium)

- 887 kc/s (338.2 m.); 20 kW.
- Programme in Flemish.
- 5.0 p.m.—Dance Music.
- 6.0 p.m.—Gramophone Records.
- 6.15 p.m.—Orchestral Concert. Symphony in C (Haydn). Les petits riens (Mozart).
- 6.45 p.m.—Gramophone Records.
- 7.30 p.m.—Le Journal Parlé.
- 7.55 p.m.—Music Review.
- 8.0 p.m.—Concert from the Works of Beethoven, with Introductory Talk. Quartet No. 3. Songs from the Cycle "An die ferne Geliebte." Quartet No. 10.
- 9.30 p.m.—Dance Music.
- 10.0 p.m.—Le Journal Parlé.

### COLOGNE (Germany)

- Westdeutscher Rundfunk. 7,319 kc/s (227 m.); 1.7 kW.
- See Langenberg Programme.

### COPENHAGEN (Denmark)

- 1,067 kc/s (281 m.); 1 kW. Relay by Kalundborg, 260 kc/s (1,153 m.).
- 7.30 a.m.—Gymnastics.
- 9.0 a.m.—Divine Service from the Elias Church.
- 10.30 a.m.—Weather and News.
- 11.0 a.m.—Town Hall Chimes.
- 11.2 a.m.—English Lesson. Reading: "Rugby Chapel" (Matthew Arnold).
- 11.30 a.m.—A Celebration with Speeches and Music relayed from the Nikolaj Hus.
- 1.0 p.m.—Talk in German.
- 1.20 p.m.—Lesson in French.
- 1.40 p.m.—Orchestral Concert. Højby Skytemarch (N. J. Nielsen). French Comedy Overture (Kéler-Béla). Waltz from "The Count of Luxembourg" (Lehár). Selection for Strings: La Mélancolie (Ole Bull, arr. Halvorsen). Spanish Military Fantasia (Binding). Andante religioso (Henriques). Danish Rhapsody (Lindhardt). Reading: Swedish Melodies (Meissner). Rustle of Spring (Sinding). Waltz from "Im Reiche des Indra" (Lincke). Minuet from "Leonora Christina" (Siegfried Salomon). Viennese Song, Im Prater blüh'n wieder die Bäume (Engelberger). March, Quand Madelon (Bousquet and Roberts).
- 3.30 p.m.—Programme for Children.
- 4.0 p.m.—Divine Service from the Garrison Church.
- 5.20 p.m.—Gramophone Records.
- 5.50 p.m.—Weather and News.
- 6.15 p.m.—Time and Sports Notes.
- 6.30 p.m.—Talk (to be announced).
- 7.0 p.m.—Town Hall Chimes.
- 7.2 p.m.—Concert. Part I. Programme from the Works of Mozart. Overture, "Così fan tutte." Ballet Music from "Idomeneus." Serenade from "Don Juan." Overture, "Il Seraglio." Part II. Programme from the Works of Wagner. Introduction to the Third Act of "Lohengrin." Procession to

the Minster from "Lohengrin" Sailors' Chorus from "The Flying Dutchman." Wolfram's Song from "Tannhäuser." Introduction to the Third Act of "Tannhäuser." Star of Eve, Aria from "Tannhäuser." Overture, "Rienzi."

- 8.15 p.m.—"The Apology"—Play in One Act (Otto Benzon).
- 8.45 p.m.—Concert of Austrian Peasant Music for Two Violins and Double Bass.
- 9.15 p.m.—Recital of Pianoforte Duets. Ballsenzen Op. 109 (R. Schumann).
- 9.45 p.m.—Dance Music from the Palace Hotel.
- 11.0 p.m. (in the interval).—Town Hall Chimes.
- 11.30 p.m. (approx.).—Close Down.

### CORK (Ireland)

- (6CK). 1,337 kc/s (225 m.); 1.5 kW.
- 8.30—11.0 p.m.—See Dublin.
- 11.0 p.m.—Weather Forecast, Time, National Anthem and Close Down.

### CRACOW (Poland)

- Poljskie Radio. 959 kc/s (312.8 m.); 1.5 kW.
- 9.15 a.m.—Divine Service from the Cathedral, Poznań.
- 10.58 a.m.—Time Signal, Bugle Call from the Tower of St. Mary's Church, Weather Report and Programme Announcements.
- 11.15 a.m.—See Warsaw.
- 12.30 p.m.—"The St. Matthew Passion"—Oratorio (Bach), relayed from Amsterdam.
- 2.20 p.m.—Agricultural Talk.
- 2.40 p.m.—Gramophone Records.
- 2.45 p.m.—Agricultural Report.
- 3.25 p.m.—See Warsaw.
- 3.35 p.m.—Gramophone Records.
- 3.40 p.m.—Talk from Liczy, 788 kc/s (381 m.): The Feminine Form throughout the Centuries.
- 3.55—5.0 p.m.—See Warsaw.
- 5.0 p.m.—Miscellaneous Items and News.
- 5.25 p.m.—Gramophone Records.
- 5.35 p.m.—Programme Announcements.
- 5.40—8.0 p.m.—See Warsaw.

Programmes for Sunday—(Cont.)

8.0 p.m.—Literary Programme. 8.20—11.0 p.m.—See Warsaw. 11.0 p.m. (approx.)—Close Down. DUBLIN (Ireland) (2RN). 725 kc/s (413 m.); 1.5 kW. 8.30 p.m.—Vocal and Instrumental Concert. 11.0 p.m.—Time Signal, Weather Report, National Anthem and Close Down. FRANKFURT-am-MAIN (Germany) 770 kc/s (390 m.); 1.7 kW. Relayed by Cassel, 1,220 kc/s (246 m.). Transmits at intervals from 6.0 a.m. (Hamburg Relay) 3.0 p.m.—Concert from the Kurhaus, Wiesbaden. 4.45 p.m.—Nicolaus von Kues, the Philosopher of the Late Gothic. 5.30 p.m.—Programme arranged by the Frankfurter Zeitung. 5.55 p.m.—Sports Notes. 6.5 p.m.—First Part of the "Mass in B Minor" (Bach), from the Saalbau. 7.30—9.30 p.m.—See Mühlacker. 9.30 p.m.—Time, Weather, News and Sports Notes. 9.50 p.m.—Tziganic Music from Budapest. 11.0 p.m. (approx.)—Close Down. HAMBURG (Germany) Norag (ha, in Morse). 806 kc/s (372 m.); 1.7 kW. Relayed by Bremen, 1,112 kc/s (270 m.); Flensburg, 1,373 kc/s (218 m.); Hanover, 530 kc/s (566 m.); and Kiel, 1,292 kc/s (232.2 m.). 6.0 a.m.—Chimes and Concert from the Liner "Albert Ballin" in Hamburg Harbour. 7.15 a.m.—Time, Weather, News and Programme Announcements. 7.40 a.m.—A Dialogue on Economics. 8.55 a.m. (from Kiel).—Confirmation Festival relayed from the Parish Church, Eutin. 10.15 a.m.—Travel Talk, with Musical Illustrations. 10.40 a.m.—Concert from the Ostermann Restaurant. 11.15 a.m. (from Bremen).—Musical Programme, Recitations and Talks. 12 noon.—Weather Report. 12.5 p.m. (from Hanover).—Orchestral Concert from the Wireless Exhibition. Finale from "Romeo and Juliet" (Bellini). Entr'acte and Ballet Music from "Ali Baba" (Cherubini). Spanish Rhapsody

(Richardy). San Sebastian (Du fort). Bohemian Suite (Moor). Traumwald-Walzer (Fucik). A Country Wedding Festival (Czihulka). Deutschermeister Regiments-Marsch (Jurek). 1.30 p.m.—Talk: Confirmation. 2.0 p.m.—Programme for Children. 3.0 p.m. (from Hanover).—Concert from the Works of Künneke from the Wireless Exhibition. Römische Suite. Tango, Kindchen, du darfst nicht so schrecklich viel denken. Selection from "Wenn Liebe erwacht" Onestep, Ueberleg dir's nochmal. Selection from "Der Tenor der Herzogin". 4.0 p.m. (from Hanover).—Concert from Bad Nenndorf. Overture, "The Magic Flute" (Mozart). Entry of the Guests into the Wartburg (Wagner). Selection from "The Circus Princess" (Kálmán). Cradle Song for Two Violins and String Quintet (Koromunda). Waltz, Wiener Bonbons (Joh. Strauss). March, Einzug der Hellebardiere (Blankenburg). 5.0 p.m.—Das Puppenspiel vom Doktor Faust" (Dr. Hansjürgen Wille. Music by Siegfried Schefler), under the Direction of the Composer. 6.0 p.m. (from Hanover).—Mandoline Concert of Marches and Dances from the Wireless Exhibition. 6.30 p.m.—Talk: Traffic Regulations for Sports Boats on the Elbe. 6.40 p.m.—Sports Notes. 6.55 p.m.—Weather Report. 7.0 p.m.—Variety Concert. 9.0 p.m.—News Bulletin. 9.30 p.m.—Dance Music. HEILSBURG (Germany) 1,085 kc/s (276.5 m.); 75 kW. Relayed by Danzig, 662 kc/s (453 m.). Transmits at intervals from 6.30 a.m. (Concert). 5.10 p.m.—The German North-East Mark—Historical Sketches, with Introductory and Explanatory Notes by Dr. Walther Ziesemer. 6.20 p.m.—Sports Talk: Riding. 6.30 p.m.—Military Band Concert. 8.0 p.m.—Manfred Lommel Recital. 8.45 p.m.—Concert and Dance Music. 9.15 p.m.—News; Sports Notes. 9.30 p.m.—Dance Music from Berlin (Witzleben). 11.0 p.m. (approx.)—Close Down.

HILVERSUM (Holland) 160 kc/s (1875 m.); 8.5 kW. (transmitted from Huizen). 8.30—11.40 a.m. (approx.)—Programme of the Workers' Radio Society (V.A.R.A.). 8.30 a.m.—Football Notes. 8.35 a.m.—Talk by Mr. Lantinga. 9.5 a.m.—Concert by the Dresden String Quartet, with Choral Selections, Recitations and Address. 11.40 a.m.—4.40 p.m.—Programme of the Algemeene Vereeniging Radio Omroep (A.V.R.O.). 11.40 a.m.—Time and Talk. 12.10 p.m.—Gramophone Records. 12.40 p.m.—Weekly Book Talk. 1.10 p.m.—The St. Matthew Passion—for Soloists, Choir and Orchestra (J. S. Bach), conducted by Dr. Willem Mengelberg, relayed from the Concert Hall, Amsterdam. 4.10 p.m.—Gramophone Records and Sports Notes. 4.50—5.40 p.m.—Programme of the V.A.R.A. Programme for Children. 5.40 p.m.—Programme of the Liberal Protestant Radio Society (V.P.R.O.) Vocal and Instrumental Concert. 7.40 p.m.—till Close Down.—Programme of the A.V.R.O. 7.40 p.m.—Orchestral Concert. Overture, "Don Juan" (Mozart). Ballet Suite (Lully-Mottl). Solo Selections. Petite Suite (Debussy). Symphonic Poem, Phaëton (Saint-Saëns). 9.10 p.m.—Recitations. 9.40 p.m.—Concert of Light Music. 10.40 p.m.—Gramophone Records. 11.40 p.m. (approx.)—Close Down. HUIZEN (Holland) 1,004 kc/s (298 m.); 8.5 kW. (transmitted from Hilversum). 8.10—9.10 a.m.—Programme of the Christian Radio Society (N.C.V.R.) Divine Service. 9.40 a.m.—4.40 p.m.—Programme of the Catholic Radio Society (K.R.O.) 9.40 a.m.—High Mass from the Dominican Church, Zuolle. 11.30 a.m.—Talk by Mr. Terwisscha van Scheltinga. 11.40 a.m.—Sextet Concert. 1.10 p.m.—Talk by Mr. Fred Thomas. 1.40 p.m.—Talk by the Rev. Father J. van Heugten. 2.10 p.m.—Choral Concert. 4.10 p.m.—Programme for Hospitals 4.45 p.m.—Programme of the N.C.R.V. Divine Service from the Reformed Church at Haarten.

7.25 p.m. till Close Down.—Programme of the K.R.O. 7.25 p.m.—Talk by Dr. Haest. 7.50 p.m.—Football Notes. 7.55 p.m.—Orchestral Concert. 10.20 p.m.—Choral Epilogue. 10.40 p.m. (approx.)—Close Down. JUAN-LES-PINS (France) 1,205 kc/s (249 m.); 1.2 kW. 12.30 p.m.—News Bulletin, Amusement Guide. 12.40 p.m. (approx.)—"La Visite de Coloquinte"—Sketch (Edouard Bigot), with the collaboration of Monsieur Vermez. After the Sketch, Concert and Gramophone Records. 2.0 p.m.—The Marseillaise. 2.10 p.m. (approx.)—8.30 p.m.—Interval. 8.30 p.m.—News Bulletin, Amusement Guide, Weather Report and Music Hall Programme. An Hour at the Eden Micro with Radiolo and Filofil. 10.0 p.m.—The Marseillaise and Close Down. KALUNDBORG (Denmark) Kalundborg Radio. 260 kc/s (1,153 m.); 10 kW. Sec Copenhagen Programme. KÖNIGSBERG (Germany) Ostmarken Rundfunk. 1,382 kc/s (217 m.); 1.7 kW. Sec Heilsberg Programme. LANGENBERG (Germany) Westdeutscher Rundfunk. 635 kc/s (473 m.); 17 kW. Relayed by Aachen, Cologne and Münster 1,319 kc/s (227 m.). Transmits at intervals from 5.40 a.m. (Lesson in Self-Defence) 10.0 a.m.—Programme Dedicated to Youth, relayed from the Gürzenichsaal, Musical Selections and Address. 11.0 a.m.—Fritz Dietrich in an Original Programme. 11.20 a.m.—Talk: What Everyone should know—Housing and Lodging Laws. 11.40 a.m.—Talk: A Traveller who is not conversant with the Language of the Country. 12.0 noon.—Orchestral Concert, conducted by Eysoldt. March (Sousa). Hamlet Overture (Em. Bach). Selections (Renée): (a) Reminiscence, (b) Canzonetta. Selections from "Die toten Augen" (d'Albert). Waltz, Weaner Madeln

(Ziehrer). Czardas, Zigeunerschnsucht (Niklas-Kempner). Potpourri, Kontraste—a Short Cut through the World of Music (Robrecht). Character Piece, Es waren zwei Königskinder (Ailboud). 1.30 p.m.—Dialogue for Girls. 1.50 p.m.—Lesson in Chess. 2.25 p.m.—Talk: Bee-keeping. 2.45 p.m.—Talk on Westphalia. 3.5 p.m.—Talk: Music for Workers. 3.30 p.m.—The Rhenish Martyrs' Memorial Service in Bonn Cathedral, relayed from Bonn. Organ Solo, Tiento del cuarto tono (Antonius Cabezon). In monte Oliveti (Orlando di Lasso). Agnus Dei from the Coronation Mass, with Orchestra and Soprano Solo (Mozart). Tenebrae factae sunt (M. Haydn). Address: The Martyrs Creed with Soprano Solo and Orchestra (Joh. Jos. Veith). Hagios o Theos (Fried. Könen). Love, for Soprano Solo, Mixed Choir and Organ (J. J. Veith). 4.30 p.m.—An Entertainment. 5.10 p.m.—Talk: A journey in the Iberian Peninsula—Nature in Portugal. 5.40 p.m.—"Tristan und Isolde"—Opera in Three Acts (Wagner), followed by Orchestral Concert. 10.0 p.m. (approx.)—Close Down. LEIPZIG (Germany) Mitteldeutscher Rundfunk. 1,157 kc/s (259 m.); 2.3 kW. Relayed by Dresden, 941 kc/s (319 m.). 6.0 a.m.—Concert. 7.0 a.m.—Agricultural Talk. 7.30 a.m.—Organ Recital from St. George's Church, Rötha. 8.0 a.m.—Instrumental Concert. 10.0 a.m.—Talk: Educational Science. 10.30 a.m.—Johann Sebastian Bach in his Cantatas. 11.0 a.m.—Orchestral Concert. Overture in E Flat Major, Op. 20 (Scharzer). Anacron—for String Orchestra, Op. 50 (Walter Niemann). Seven Dance Myths (Frischenschlager). Hungarian Dances (Kodály). Overture, Am Rhein, Op. 90 (Hugo Kaun). Ländliche Hochzeit, Op. 26 (Goldmark). 1.0 p.m.—Weather, Time and Topical Talk. 1.15 p.m.—Agricultural Hints. 1.30 p.m.—Nikolaus Schwarzkopf reads from his Novel "Der Banbar." 2.0 p.m.—Gramophone Records. 3.0 p.m.—Two One-Act Plays:

YOU CAN JUST PLUG IN!

Your mains provide better and more certain reception, with greater economy and considerably less trouble than any battery, however good it may be.

Most mains supply alternating current, which for radio purposes has to be converted into direct current; and for this a rectifier is necessary.

Of the various types of rectifiers, the Westinghouse is acknowledged to be the most efficient. Unlike valve or chemical rectifiers, it does not burn or wear out. It outlives your set! Its use—with certain other components—converts "battery-run" into "mains-run" radio; it is most suitable for fitting into amateur-built sets.

Prices are from 15/-, according to the type required.

If you are buying a mains-set, you will do well to make sure that the Westinghouse Rectifier is incorporated—you will find it in most good makes.

Complete technical details are given in an interesting and lucid manner in our forty-page booklet, "The All Metal Way, 1931," which contains chapters on radio-sets, eliminators, battery-chargers, moving-coil loudspeakers, etc. The coupon will bring you a copy by return of post (please enclose 3d. to cover cost).

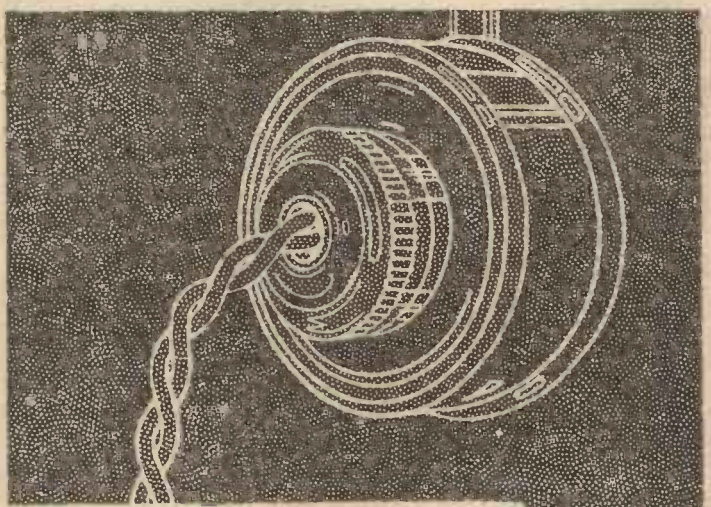

METAL RECTIFIERS

The Westinghouse Brake & Saxby Signal Co. Ltd., 82, York Road, King's Cross, London, N.1.

Telephone: North 2415.

Please send your forty-page booklet, "The All Metal Way, 1931," for which I enclose 3d. in stamps: PLEASE WRITE IN BLOCK LETTERS.

NAME .....

ADDRESS .....

Programmes for Sunday—(Cont.)

(a) "The Murder," (b) "The Fairy-Tale" (Kurt Goetz). 4.30 p.m.—Orchestral Concert. Ballet Overture (Kremsler). Suite, Carnival Miniatures (von Kaskel). Selections for Violin and Piano: (a) Rondo (Mozart-Kreisler), (b) Melody (Gluck-Kreisler). Mazurka brillante in A Major (Liszt). Selections from "Der Rosenkavalier" (R. Strauss). Three Pieces for Violin and Piano: (a) Slavonic Fantasia (Dvorak-Kreisler), (b) Romance Sans Paroles (Tchaikovsky), (c) Caprice No. 20 (Paganini-Kreisler). Selection from "Don Cesar" (Dellinger). March from "Young Heidelberg" (Müllöcker). 6.0 p.m.—Wilhelm Raabe Programme. Talk and Readings. 6.30 p.m.—Concert by the Dresden Philharmonic Orchestra, relayed from the Gewerbehause, Dresden. Slavonic March (Tchaikovsky). Overture, "The Thieving Magpie" (Rossini). Prelude and Berceuse (Jarnfeldt). Selection from "The Bartered Bride" (Smetana). Academic Festival Overture, Op. 80 (Brhms). Two Elegiac Melodies, Op. 34 (Grieg): (a) Herzwunden (b) Letzter Frühling. Rhapsody on Swabian Folk Melodies (Kaempfert). Waltz, Tales from the Vienna Woods (Joh. Strauss). 8.0 p.m.—A Conversation with a Robot (Mechanical Man) on the Superfluity of the Soul. 8.20 p.m.—Concert from the Works of Benatzky, followed by Concert of Light Music from Berlin (Witzleben). 11.0 p.m. (approx.)—Close Down.

MOTALA (Sweden) 222.5 kc/s (1,348 m.); 40 kW. See Stockholm Programme. MÜHLACKER (Germany) Süddeutscher Rundfunk. 833 kc/s (360 m.); 75 kW. Relayd by Freiburg, 527 kc/s (570 m.). Transmits at intervals from 6 a.m. (Programme from Hamburg). 10.15 a.m.—Evangelical Service. 11.0 a.m.—Promenade Concert from the Schlossplatz, Stuttgart. 12 noon.—Topical Talk. 12.15 p.m.—Passion Music for Organ, relayed from the St. Nicholas Church. 1.0 p.m.—Gramophone Records of German Folk Songs. 2.0 p.m.—Young People's Programme. 3.0 p.m.—See Frankfurt. 4.15 p.m.—Ludwig Bäte reads from his own Works. 4.45 p.m.—"La dame blanche"—Opera (Boieldieu, arr. Oswald Kühn). 5.55 p.m.—Sports Notes. 6.5 p.m.—See Frankfurt. 7.30 p.m.—Song Recital of old French Legends. 8.15 p.m.—Scandinavian Music. 9.30 p.m.—Programme Announcements, News and Sports Notes. 9.50 p.m.—Tziganic Music from Budapest. 11.0 p.m. (approx.)—Close Down.

MUNICH (Germany) 563 kc/s (533 m.); 1.7 kW. Relayd by Augsburg, 536 kc/s (560 m.); Kaiserslautern, 536 kc/s (560 m.); and Nürnberg, 1,256 kc/s (239 m.). 9.0 a.m.—Catholic Service with Sermon by the Rev. Peter Lippert. 9.45 a.m.—Chimes from Our Lady's Church. 10.10 a.m.—Programme to be announced. 11.0 a.m.—Military Band Concert, relayed from Feldherrnhalle. Conductor: Hugo Brathuhn. 12.5 p.m.—Time Signal, Weather Report and Programme Announcements. 12.15 p.m.—Agricultural Talk. 12.55 p.m.—"Flowers"—a Gramophone Sequence. 1.30 p.m.—Talk for Chess Players. 2.15 p.m. (from Nürnberg)—Concert. Soloists: Eva Heintz of Berlin (Cellist) and Fritz Binder (Pianist). Sonata in B Minor for Pianoforte and 'Cello (Atterberg). Allegretto grazioso (Schubert-Cassado). Après un rêve (Fauré). Toccata (Frescobaldi-Cassado). 2.50 p.m.—Orchestral Concert, conducted by Karl List. Fantasia and Mozart's Reich (Urbach). Romance (Tchaikovsky). Still wie die Nacht (Bohm). Serbian Melodies (Gal). Cello Solo: Dance of the Elves (Popper). Fantasia, Nachruf an Franz Schubert (Fetras). Interlude by a Children's Choir from the Municipal Singing Academy, conducted by Herr Rudolf Kirmeyer. Blumengeflüster (v. Blon). Norwegian Dances (Grieg). Overture, "Il Guarany" (Gomez). 4.25 p.m.—Weather and Sports Notes. 4.35 p.m.—Talk: A Forgotten People of Asia. 5.0 p.m.—Introductory Talk to the following transmission. 5.5 p.m.—"The St. Matthew Passion" (Bach), for Solo Voices, Choir, Orchestra and Organ, relayed from the Odeon. Conductor: Hans Knappertsbusch. 8.0 p.m.—Gramophone Concert. 9.20 p.m.—Time Signal, Weather Report, News Bulletin and Sports Notes. 9.45 p.m.—Concert by the Hugo Weis Orchestra, relayed from the Café Luitpold. 11.0 p.m. (approx.)—Close Down.

OSLO (Norway) Kringkastingselskapet. 280 kc/s (1,071 m.); 75 kW. Relayd by Fredrikstad, 815 kc/s (368 m.); Hamar, 511 kc/s (587 m.); Notodden, 671 kc/s (447.1 m.); Porsgrund, 662 kc/s (453 m.); and Rykan, 671 kc/s (447.1 m.). 9.20 a.m.—Chimes and Divine Service from St. Saviour's Church. 12 noon.—Choral and Orchestral Concert, relayed from Fredrikstad. 4.50 p.m.—Chimes and Divine Service from the Fagerborg Church. 6.15 p.m.—Weather and News. 6.30 p.m.—Talk: Among the Redskins. 7.0 p.m.—Time Signal. 7.2 p.m.—Norwegian Programme. 9.0 p.m.—Weather and News. 9.15 p.m.—Topical Talk. 9.35 p.m.—Old Dance Music. 10.30 p.m.—Gramophone Records. 11.0 p.m. (approx.)—Close Down.

PARIS (France) Eiffel Tower (FLE). 207 kc/s (1,445 m.); 15 kW. Time Signals (on 2,650 m., 113 kc/s at 9.25 a.m. and 10.25 p.m. (pre liminary and 6-dot signals). 6.0 p.m.—Le Journal Parlé. 7.10 p.m.—Meteorological Forecast. 7.30 p.m.—Gramophone Concert. PARIS (France) Poste Parisien. 914 kc/s (329 m.); 1.2 kW. 9.0 a.m.—Picture Transmission. 8.25 p.m.—Gramophone Records, Talk and News Bulletin. 9.0 p.m.—Concert with the collaboration of Artistes from the Opéra and Opéra-Comique. Jubel-Ouverture (Weber). Romance sans paroles, for Violin and Orchestra (Fauré). Symphonic Poem, Eine Nacht auf dem Kahlenberg (Moussorgsky). Ballet Music from "Faust" (Gounod). Minuet (Paderewsky). Sérénade (Saint-Saëns). Tournoi (Boëllmann).

PARIS (France) Radio-Paris. (CFR). 174 kc/s (1,725 m.); 17 kW. 7.45 a.m.—Gramophone Records. 8.0 a.m.—News and Press Review. 8.30 a.m.—Physical Culture Lesson. 10.30 a.m.—Advanced Book-keeping Lesson. 11.30 a.m.—Gramophone Records. 12 noon.—Religious Address by M. le Chanoine Hellier. 12.30 p.m.—Organ Recital. Minuet (Beethoven). Victory March (Lefebvre). 12.45 p.m.—News Bulletin. 1.0 p.m.—Song Recital from the Works of Crémieux. The Composer at the Pianoforte. Le Baiser. L'Heure Exquise. La Valse d'Amour. Chanson Venitienne. 1.15 p.m.—Bilboquet takes up Boxing. 1.30 p.m.—Gramophone Dance Records. 2.0 p.m.—Concert of Decca Records. 4.0 p.m.—Gramophone Records. 5.0 p.m.—Lenten Sermon by the Reverend Father Pinard, relayed from Notre Dame. 7.0 p.m.—Agricultural Report and Racing Results. 7.15 p.m.—Economic and Social Notes and News. 7.30 p.m.—Radio Paris Guignol. 8.0 p.m.—"Espérance en la fatalité domestique" Sketch (Benjamin). 8.30 p.m.—News and Sports Review. 8.45 p.m.—Concert. Gramophone Records: (a) Ballet Music from Isolante (Messager), (b) Three Viennese Waltzes: Liebesleid, Liebesfreud und Schön Rosmarin (Kreisler). Waltz, Liebesleid (Joh. Strauss). Songs: (a) Dis-moi (Larrieux), (b) Il neige (Bemberg), (c) Une ou deux Femmes (Boyer), (d) Les vieilles maisons (Verdun and Boyer). Gramophone Records: (a) Quadrille from "Orpheus in the Underworld" (Offenbach), (b) Selection from "Trois jeunes filles nues" (Moretti), (c) Amiens (Lincke). Ma Provence (Marafioti). Elles font tout comme Papa (Scott). Les Cloches en Folie (Buxeuil). Quand on aime (Szulc). Gramophone Records: (a) Selection from "Rigoletto" (Verdi), (b) Selections from "Mas-carade" (Lacôme). In the interval at 9.15 p.m.—Press Review, News and Time Signal.

POZNAN (Poland) 896 kc/s (335 m.); 1.9 kW. 8.30 a.m.—Topical Review. 9.15 a.m.—Religious Programme from Wilno, 779 kc/s (385 m.). 11.0 a.m.—Time and Chimes from the Town Hall. 11.5 a.m.—Agricultural Talks. 11.45 a.m.—Talk for Housewives. 2.0 p.m.—Service relayed from the Cathedral. 3.30—4.15 p.m.—Interval. 4.15 p.m.—Gramophone Records with a Commentary by B. Busiakewicz. 5.15 p.m.—Programme for Children. 5.45 p.m.—Vocal and Orchestral Concert. Suite, Peer Gynt (Grieg). Overture, "Martha" (Flotow). Slavonic Dances (Dvorak). Suite (Armandola). Tenor Solos: Polish Songs. 6.45 p.m.—Miscellaneous Items and News. 7.0 p.m.—See Warsaw. 10.0 p.m.—Time, News, Sports and Police Notes. 10.15 p.m. (approx.)—Close Down.

ROME (Italy) Ente Italiano Audizioni Radiofoniche (IRO). 680 kc/s (441 m.); 75 kW. Relayd by Naples, 905 kc/s (332 m.) and 2RO, 11,810 kc/s (25.4 m.). 9.0 a.m.—Reading from the Bible. 9.15 a.m.—Gramophone Records of Sacred Music. 9.45 a.m.—Sports Notes and Amusement Guide. 10.0 a.m.—The Third Canto of the "Paradiso" relayed from the "Casa di Dante."

12 noon.—1.0 p.m.—Quintet Concert. Waltz from "La reginetta delle rose" (Leoncavallo). Tango (Grothe). Waltz, The Wild Rose (Ganglbauer). Melody, Mistica (Tirindelli). Selection from "La donna perduta" (Pietri). Stornellando (de Micheli). Barcarolle and Minuet for Violin and Pianoforte (Grieco). Foxtrot (Strong). Onestep, Constantinople (Carlton). 3.30 p.m. (from Naples)—Programme for Children, Weather and Sports Notes. 4.0 p.m.—"In patris memoriam"—Oratorio (Perosi), relayed from the Augusteo. Sports Notes in the intervals. 6.50 p.m.—News and Announcements, followed by Gramophone Records. 7.10 p.m.—Sports Notes, Press Review. 7.30 p.m.—Time Signal and Announcements. 7.35 p.m. (approx.)—"Lilac Time"—Operaetta in Three Acts (Schubert). In the intervals: Talk and Topical Review. 9.55 p.m. (approx.)—News.

SCHENECTADY (U.S.A.) General Electric Company (WGY). 790 kc/s (379.5 m.); 50 kW. Relayd at intervals by W2XAF on 9,530 kc/s (31.48 m.) and by W2XAD on 15,340 (19.56 m.). Transmits at intervals from 2.55 p.m. 11.0 p.m.—2.0 a.m. (Monday)—Programme from New York. 11.0 p.m.—Catholic Hour. 12.0 midnight.—Lodent Big Brother Club. 12.30 a.m. (Monday)—R.C.A. Programme. 1.0 a.m.—Chase and Sanborn Choral Orchestra. 2.0 a.m.—Talk: Our Government, relayed from Washington, D.C. 2.15 a.m.—5.0 a.m.—Programme from New York. 2.15 a.m.—Atwater Kent Programme. 3.15 a.m.—National Dairy Productions. 3.45 a.m.—Sunday at Seth Parker's. 4.15 a.m.—Muriel and Vee Piano Team. 4.30 a.m.—Russian Cathedral Choir. 5.0 a.m.—Doc Peyton and the Hotel Kenmore Orchestra, relayed from Albany, N.Y. 5.30 a.m. (approx.)—Close Down.

STOCKHOLM (Sweden) Radiotjänst. (SASA). 689 kc/s (436 m.); 75 kW. Relayd by Boden, 214 kc/s (1,229.5 m.); Göteborg, 932 kc/s (322 m.); Hörby, 1,166 kc/s (257 m.); Motala, 222.5 kc/s (1,348 m.); Östersund, 389 kc/s (770 m.). Sundstval, 554 kc/s (542 m.). 9.30 a.m.—Report of the Workers' Society for Adult Education. 10.0 a.m.—Divine Service Relay. 11.45 a.m.—Weather Report. 12 noon.—Elementary French Lesson relayed from Malmö, 1,301 kc/s (231 m.). 12.30 p.m.—Choral Concert relayed from Malmö. 1.0 p.m.—Reading. 1.30 p.m.—Symphony Concert relayed from the Stockholm Concert House. Overture, No. 3, Leonora (Beethoven). Iberia Suite (Albeniz). Symphony in F Major No. 3 (Brahms). 3.0 p.m.—Programme for Children, relayed from Örebro, 1,265 kc/s (237 m.). 3.30 p.m.—Gramophone Records. 4.30 p.m.—Talk: The Names of Swedish Towns, relayed from Uppsala, 662 kc/s (453.2 m.). 4.55 p.m.—Chimes from the Town Hall. 5.0 p.m.—Evensong, from St. Peter's Church. 6.15 p.m.—"The Cradle Song"—Comedy (Martinez Sierra). 7.20 p.m.—Chamber Music relayed from Göteborg. 8.40 p.m.—Programme of Readings, Songs and Oboe Solos. 9.15 p.m.—Concert of Light Music. 10.0 p.m. (approx.)—Close Down.

TOULOUSE (France) Radiophonie du Midi. 779 kc/s (385 m.); 8 kW. 12.30 p.m.—Catholic Service. 1.0 p.m.—Orchestral Music. 1.30 p.m.—Agricultural Report. 1.45 p.m.—Protestant Service. 5.0 p.m.—Transmission of Pictures. 5.15 p.m.—Dance Music. 5.30 p.m.—News Bulletin. 5.45 p.m.—Songs from (a) "Romeo and Juliet" (Gounod), (b) "The Barber of Seville" (Rossini). 6.0 p.m.—Koster Brandes Concert. Ballet Music from "Faust" (Gounod). Réverie (Eprinchard). Sur le lac (Godard). Military Symphony (Haydn). Forest Murmurs from "Siegfried" (Wagner). Second Suite from "Peer Gynt" (Grieg). Selection from "Le

Chemineau" (Leroux). Selection from "Le Déluge" (Saint-Saëns). Wedding March (Wagner). In the interval, News. 8.0 p.m.—Musical Programme. 8.55 p.m.—Fashion Review. 9.0 p.m.—Time Signal. 9.2 p.m.—Song Recital. 9.20 p.m.—Orchestral Selections from (a) "The Mastersingers" (Wagner) and (b) "The Damnation of Faust" (Berlioz). 9.40 p.m.—Song Recital. 10.0 p.m.—Military Music. 10.15 p.m.—Spanish Songs. 10.30 p.m.—News Bulletin. 10.40 p.m.—Concert Arranged by the Vocalion Gramophone Company of Hayes. 11.15 p.m.—North African News. 11.30 p.m.—Septet (Saint-Saëns). 11.45 p.m.—Vocal Tangos. 12 midnight (approx.)—Close Down.

VIENNA (Austria) Radio-Wien. 581 kc/s (517 m.); 20 kW. Relayd by Graz, 851 kc/s (352 m.); Innsbruck, 1,058 kc/s (283 m.); Klagenfurt, 662 kc/s (453.2 m.); Linz, 1,220 kc/s (246 m.); and Salzburg, 1,373 kc/s (218 m.). 9.30 a.m.—Organ Recital. 10.5 a.m.—Concert by the Vienna Symphony Orchestra. Overture, "Anacreon" (Cherubini). Symphony No. 44 in D Major (Mozart). Pianoforte Concerto in F Major, Op. 103 (Saint-Saëns). Symphony No. 6 in B Minor (Tchaikovsky). 12.45 p.m.—Time and Programme Announcements. 12.50 p.m.—Viennese Mandoline Orchestral Society Concert. 2.0 p.m.—"Mount Calvary"—a Relay from Hems. 2.45 p.m.—Orchestral Concert. 4.15 p.m.—Talk on Magic. 4.30 p.m.—Talk: Family and Society in Africa. 5.0 p.m.—Trio Music from the Works of Austrian Composers. 6.0 p.m.—Talk: Heinrich Mann and his Works, on his Fiftieth Birthday. 6.30 p.m.—Time, Sports Notes and Programme Announcements. 6.40 p.m.—Recital on Two Pianofortes. Two Selections (Joh. Strauss): (a) Persian March, (b) Emperor Waltz. Russian Fantasia (Marian Rawicz). She's funny that way (Neil Moret). Hungarian Rhapsody, No. 12 (Liszt). 7.15 p.m.—"Greatness"—Radio Play in One Act (Rudolf Jeremias Kreutz). 8.15 p.m. (approx.)—News Bulletin. 8.25 p.m. (approx.)—Orchestral Concert from the Works of Alfred Grünfeld. Overture, "Der Lebe-mann". Waltz, Rheingurs. Pizzicato. Waltz Song, An mein Wien. Violin Solo: Hungarian Fantasia. Lilli-Walzer. Flirt-Gavotte. Selection from "Der Lebe-mann". Little Serenade for String Orchestra, arr. Otto Römisch. Diner-Walzer. Ballet Suite from "Die Schönen von Fogaras". Concert Polka, No. 2 (arr. Römisch). Concert Polka No. 3 (arr. Arnold Wilke). Lebe-mann-Marsch.

WARSAW (Poland) Polskie Radio. 212 kc/s (1,411 m.); 158 kW. 9.15 a.m.—See Poznan. 10.58 a.m.—Time, Bugle Call from the Tower of St. Mary's Church at Cracow, Weather and Programme Announcements. 11.15 a.m.—Concert by the Warsaw Philharmonic Orchestra. Symphony in F Major No. 8 (Beethoven). Concerto in D Minor for Pianoforte (Mozart). 12.15 p.m.—Introductory Talk to the following transmission. 12.30 p.m.—"The St. Matthew Passion" (Bach), relayed from Amsterdam. 2.20 p.m.—Talk for the Country Housewife. 2.40 p.m.—Gramophone Records. 2.45 p.m.—Agricultural Talk. 3.25 p.m.—Programme for Children. 3.35 p.m.—Gramophone Records. 3.40 p.m.—See Cracow. 3.55 p.m.—Novelty Programme. 4.10 p.m.—Orchestral Concert. 5.0 p.m.—Miscellaneous Items. 5.25 p.m.—Gramophone Records. 5.35 p.m.—Programme Announcements. 5.40 p.m.—Talk: A Hundred Years Ago. 5.45 p.m.—Music Talk: "Parsifal". 6.0 p.m.—The First Act of "Parsifal"—Opera (Wagner), relayed from the Grand Theatre. 7.45 p.m.—Talk by Mr. Makarczyk. 8.15 p.m.—Literary Programme. 8.50 p.m.—Theatre Review. 8.20 p.m.—Talk on "Parsifal". 8.30 p.m.—Relay from the Grand Theatre (continued). 10.50 p.m.—Weather, Police and Sports Notes.

EVERYTHING **The G.E.C.** ELECTRICAL  
*your guarantee*  
**GECOPHONE**

**THE FAMOUS  
 20 GUINEA  
 PORTABLE  
 NOW  
 £15.15.0**

**THE BEST  
 VALUE TO-DAY  
 IN PORTABLES  
 JUDGED ON  
 PERFORMANCE  
 JUDGED ON  
 PRICE**

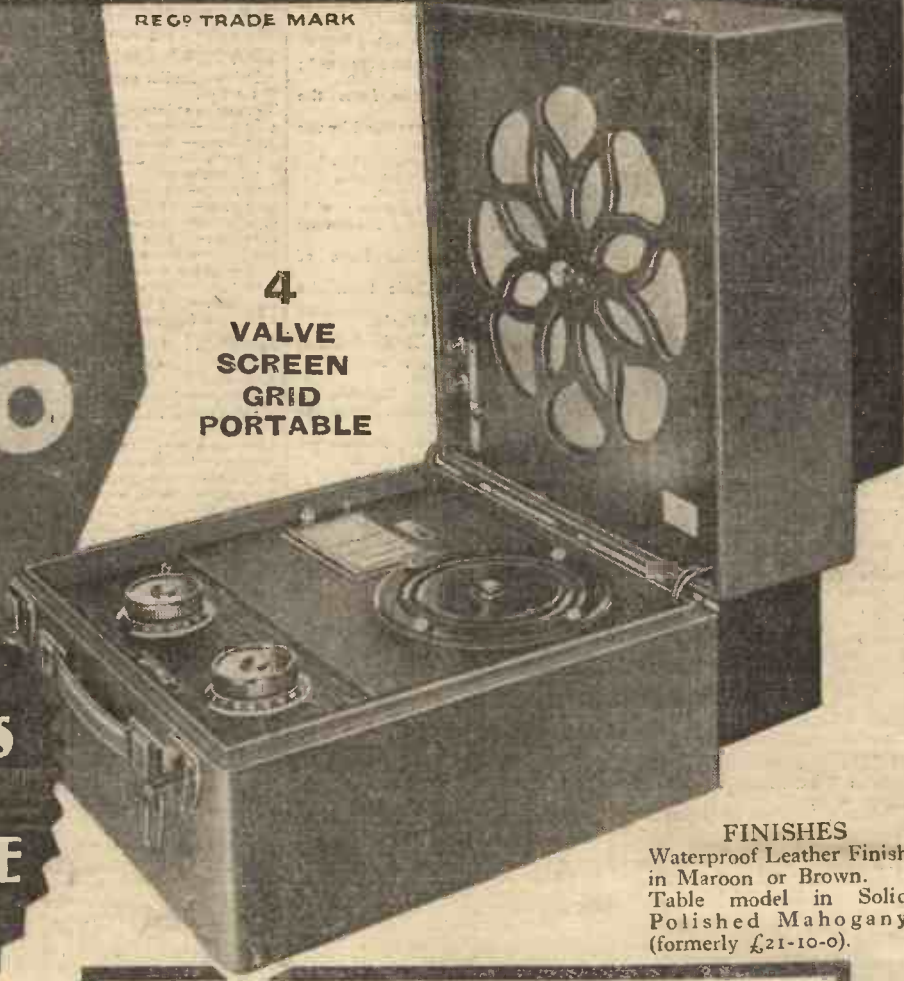

REGD TRADE MARK

**4  
 VALVE  
 SCREEN  
 GRID  
 PORTABLE**

**FINISHES**  
 Waterproof Leather Finish  
 in Maroon or Brown.  
 Table model in Solid  
 Polished Mahogany  
 (formerly £21-10-0).

**THE POINTS THAT COUNT—**

- 1 Screen grid circuit gives great sensitivity which allows many Home and Foreign stations to be received.
- 2 Selectivity is such that separation of powerful stations is complete.
- 3 The GECOPHONE "Stork" Loud Speaker fitted into the lid is capable of handling immense power. Thus you are certain of pure reproduction at any volume.
- 4 Equipment includes the latest OSRAM VALVES (with the OSRAM P.2 Output Valve) MAGNET Batteries and MAGNET unspillable Accumulator. A turntable for directional tuning is provided.
- 5 Low current consumption of 11 milliamps.
- 6 The case is waterproof leather finish, very distinctive and very robust. Choice of brown or maroon colours. Also table model of solid polished mahogany.
- 7 Simplicity of operation.

**HIRE PURCHASE**

You can either buy the GECOPHONE Portable for Cash (£15.15.0) or Hire Purchase—deposit £1.11.0, 12 monthly payments of £1.4.10

Complete with OSRAM Values, MAGNET Batteries, MAGNET Unspillable Accumulator and Turntable, and including Royalty.

FILL IN AND POST THIS COUPON TO-DAY.

Portables have come and portables have gone, but during the three years the GECOPHONE has been in the highest-class market it has established an unassailable reputation for performance and reliability. To-day you pay 5 guineas less than last year, and 8 guineas less than the year before for exactly the same set, with the addition of constant improvements to keep pace with broadcasting developments. You cannot possibly buy another set which offers such good value.

Fill in the coupon below for leaflet which reproduces the models in actual colours. This will be sent POST FREE. Your local dealer will demonstrate the set in your own home without placing you under any obligation. We have arranged this with the trade.

MADE IN ENGLAND

Sold by all  
 Wireless Dealers

**COUPON**

Please send me particulars of GECOPHONE Portable Receivers.

Name ..... Address .....

The General Electric Co. Ltd.  
 Magnet House  
 Kingsway  
 London  
 W.C.2

Cut out coupon and paste on postcard or enclose in unsealed envelope. Halfpenny postage in either case. W.R.

PROGRAMMES FOR MONDAY (March 30)

NOTE: THE HOURS OF TRANSMISSION ARE REDUCED TO GREENWICH MEAN TIME

ALGIERS (N. Africa) 825.3 kc/s (363.4 m.); 13 kW. 12.30 p.m.—Orchestral Concert. 7.0 p.m.—Weather Report and Shipping Notes. 7.15 p.m.—Transmission of Pictures. 7.30 p.m.—Talk on Films. 7.35 p.m.—Variety Items. 8.0 p.m.—News Bulletin. 8.10 p.m.—Solo Selections. 8.30 p.m.—Operetta Music. 8.45 p.m.—Symphony Concert. 10.45 p.m.—Dance Music.

BARCELONA (Spain) Radio-Barcelona (E.A.1). 860 kc/s (349 m.); 8 kW. Transmits at intervals from 11.0 a.m. 4.30 p.m.—Concert. Fortune March (Siede). Andante from the Quintet in F Minor (Brahms). Intermezzo, Ritorna amore (Campa). A Night in Venice (Salvat Vilaseca). Spanish Dance No. 10 (Granados). 6.0 p.m.—Trio Music and News. 6.30 p.m.—Gramophone Records. 8.30 p.m.—Recital of Popular Catalan Songs with Introductory Talk. 8.45 p.m.—Sports Notes. 9.0 p.m.—Chimes, Weather and Exchange. 9.5 p.m.—Humorous Review of the Week's Events in Verse. 9.20 p.m.—Concert of Sardanas by the Coblá Barcelona. 10.0 p.m.—News Bulletin. 10.5 p.m.—Musical Anecdotes in Catalan. 10.20 p.m.—Orchestral Concert. Meditation (Glazounoff). Canto di Passione (Pennati). Valse triste (Sibelius). Andante from the Third Symphony (Schumann). Nocturne (d'Ambrosio). Selections from "Parsifal" (Wagner). Midnight on Maundy Thursday (Turina). Military Polonaise, Op. 40, No. 1 (Chopin). 11.20 p.m.—Gramophone Records. 12 midnight (approx.).—Close Down.

BERLIN (Germany) Königs Wusterhausen. 183 kc/s (1,635 m.); 35 kW. Transmits at intervals from 5.20 a.m. (Hamburg Relay). 3.30 p.m.—Concert from Berlin (Witzleben). 4.30 p.m.—Nikolaus Schwarzkopf reads from his Novel "Judas Iscariot." 5.0 p.m.—German for Germans. 5.30 p.m.—Talk: The Beginnings of Christianity. 6.0 p.m.—Elementary English Lesson. 6.30 p.m.—Agricultural Talk. 6.55 p.m.—Weather for Farmers. 7.0 p.m.—Upper Silesian Wireless Report relayed from Breslau. 923 kc/s; (325 m.). 8.0 p.m.—See Munich. 8.50 p.m.—See Leipzig. 9.15 p.m.—News and Concert from Berlin (Witzleben).

BERLIN (Germany) Witzleben. 716 kc/s (418 m.); 1.7 kW. Transmits at intervals from 6.0 a.m. (Gymnastics). 5.50 p.m.—Wireless Portrait—Arnold Schönberg. 6.40 p.m.—Concert of Light Music. 8.0 p.m.—News; Sports Notes. 8.10 p.m.—A Man with Books and Gramophone Records. 9.15 p.m.—Weather, News, Sports Notes and Concert of Light Music.

BERNE (Switzerland) Radio-Berne. 743 kc/s (403 m.); 1.1 kW. Transmits at intervals from 11.27 a.m. 5.15 p.m.—Gramophone Records. 6.0 p.m.—The Sonata for Pianoforte and Cello from Beethoven to Hindemith. 7.0 p.m.—Time and Weather. 7.2 p.m. (approx.).—Talk: The Sermon on the Mount. 7.30 p.m.—Passiontide Concert. Three Biblical Scenes (Schütz): (a) The Pharisee and the Publican, (b) Easter Dialogue, (c) The Child Jesus in the Temple. The Seven Words from the Cross for Solo Voice, Choir and Orchestra (Schütz). 8.25 p.m.—Orchestral Concert of German Opera Music. 9.0 p.m.—News and Weather. 9.15 p.m.—Musical Programme. 9.40 p.m. (approx.).—Close Down.

BORDEAUX-LAFAYETTE (France) (P.T.T.). 986 kc/s (304 m.); 35 kW. Transmits at intervals from 12.45 p.m.

7.30 p.m.—News, Exchange and Market Prices. 7.40 p.m.—Talk on Sport. 7.55 p.m.—Result of the Prize Draw. 8.0 p.m.—Children's Programme. 8.15 p.m.—Charades. 8.30 p.m.—Gramophone Concert: Light Music followed by "Cavalleria Rusticana"—Opera (Mascagni). After the Programme, Amusement Guide and Time Signal.

BRUSSELS (Belgium) Radio-Belgique. 590 kc/s (509 m.); 20 kW. 5.0 p.m.—Dance Music from the Hotel Atlanta. 6.0 p.m.—Programme arranged by the Catholic Radio Society. 6.45 p.m.—Gramophone Records. 7.15 p.m.—Travelogue: Iceland. 7.30 p.m.—Le Journal Parlé. 8.0 p.m.—Variety Programme with Introductory Talk: Humorous Characters in Songs. 9.0 p.m.—Debate: The Love of Animals. 9.15 p.m.—Dance Music from the Hotel Atlanta. 10.0 p.m.—Le Journal Parlé.

BRUSSELS No. 2 (Belgium) 887 kc/s (338.2 m.); 20 kW. Programme in Flemish. 5.0 p.m.—Gramophone Records. 5.45 p.m.—Organ Recital from the Carmelite Church. 6.15 p.m.—Religious Programme. Gramophone Record: Domine Deus (César Franck). Talk: Palm Sunday. Gramophone Record: Van Jezus en Sint Janneke (De Voght). Prelude in E Minor (Bach). 6.45 p.m.—Gramophone Records. 7.15 p.m.—Talk on Photography. 7.30 p.m.—Le Journal Parlé. 7.55 p.m.—Variety Item. 8.0 p.m.—Gramophone Records of Armenian Songs. 8.20 p.m.—Introductory Talk to the following transmission. 8.30 p.m.—Concert, conducted by M. Désiré Defaux, relayed from the Royal Conservatoire. Mass in B Minor (Bach). In the interval, Theatre Talk: J. Janssens and his Work. 10.0 p.m.—Le Journal Parlé.

BUDAPEST (Hungary) 545 kc/s (550 m.); 23 kW. Transmits at intervals from 8.15 a.m. (Concert). 6.30 p.m.—Talk by Julius Lippav. 7.0 p.m.—Danish Concert, conducted by Ernst von Dohnanyi, followed by Concert from the Café Ostende.

COLOGNE (Germany) Westdeutscher Rundfunk. 1,319 kc/s (227 m.); 1.7 kW. See Langenberg Programme.

COPENHAGEN (Denmark) 1,067 kc/s (281 m.); 1 kW. Relay by Kalundborg, 260 kc/s (1,153 m.). Transmits at intervals from 6.30 a.m. (Gymnastics). 2.20 p.m.—Talk for the Housewife. 2.30 p.m.—Concert of Wind Instrument Music. Kongebøde-March (Jespersen). Entr'acte from "La Vie Parisienne" (Offenbach). Overture, "Berlin wie es weint und lacht" (Conradi). Nina-Waltz (Waldteufel). Selection from "Les Cloches de Corneville" (Planquette). Selection from "The Witch" (Enna). Intermezzo from "Cavalleria Rusticana" (Mascagni). Florentine March (Fucik). Reading. Christian IX March (Lumbye). Overture, "Les Dragons de Villars" (Maillart). Waltz, Gold and Silver (Lehár). Selection from "Orpheus in the Underworld" (Offenbach). Spanish Dances Nos. 2 and 5 (Moszkovsky). Fatinitza March (Suppé). 4.40 p.m.—Exchange Quotations and Fish Market Prices. 4.50 p.m.—Talk in French: The Paris Season. 5.20 p.m.—English Language Lesson. 5.50 p.m.—Weather Report. 6.0 p.m.—News and Report of the Workers' Radio Society. 6.15 p.m.—Time Signal. 6.30 p.m.—Talk: The Child as an Artist. 7.0 p.m.—Town Hall Chimes. 7.2 p.m.—Talk on the following transmission. 7.10 p.m.—Concert by the Odense Choral Society, relayed from the Fyns Forsamlingshus in Odense. "Finnish Spring"—a Lyrical Humoresque (Carl Nielsen). "The Crusaders"—Cantata (Niels W. Gade). 9.20 p.m.—News Bulletin. 9.35 p.m.—Dance Music from Nimb's Restaurant.

11.0 p.m. (in the interval).—Town Hall Chimes. 11.30 p.m. (approx.).—Close Down.

CORK (Ireland) (6CK). 1,337 kc/s (225 m.); 1.5 m. 1.30 p.m.—Weather Forecast and Gramophone Records. 6.0 p.m.—Exchange, News Bulletin and Gramophone Records. 6.15 p.m.—Programme from Dublin.

CRACOW (Poland) Polskie Radio. 959 kc/s (312.8 m.); 1.5 kW. Transmits at intervals from 10.40 a.m. 4.45 p.m.—Song Recital. 5.45 p.m.—Miscellaneous Items, Sports Notes and Programme Announcements. 6.10 p.m.—Agricultural Report. 6.25 p.m.—See Warsaw. 6.30 p.m.—Gramophone Records. 6.40 p.m.—Radio Journal. 7.0 p.m.—Review of Books. 9.15—9.15 p.m.—See Warsaw. 9.15 p.m.—Gramophone Records. 9.50 p.m.—See Warsaw. 10.0 p.m. (approx.).—Close Down.

DUBLIN (Ireland) (2RN). 725 kc/s (413 m.); 1.5 kW. 1.30—2.0 p.m.—Time Signal, Weather Report, Stock Exchange Quotations and Gramophone Concert. 2.0—6.0 p.m.—Interval. 6.0 p.m.—Gramophone Records. 6.15 p.m.—Programme for Children. 7.0 p.m.—Gramophone Records. 7.20 p.m.—News Bulletin. 7.30 p.m.—Time Signal. 7.32 p.m.—Irish Lesson by Sile Ni Dhubhghaín. 7.45 p.m.—Talk by Laurie Gaffey: Trout Fishing in the Holidays. 8.0 p.m.—Concert by the Dublin Philharmonic Society. 10.0 p.m.—"What Fools Men are!"—a Play. 10.30 p.m.—Time Signal, News Bulletin, Weather Report and Close Down.

FRANKFURT-am-MAIN (Germany) 770 kc/s (390 m.); 1.7 kW. Relay by Cassel, 1,220 kc/s (246 m.). Transmits at intervals from 5.15 a.m. (Mühlacker Relay). 5.45 p.m.—Dialogue: What is Fame? 6.5 p.m.—Time, Weather and Economic Notes. 6.10 p.m.—English Language Lesson. 6.45 p.m.—Orchestral Concert. 7.45 p.m.—Tales (Herbert Eulenberg), told by the Author. 8.45 p.m.—"Pitt, the Orator"—Radio Play (Otto Brues). 9.30 p.m.—Time, Weather, News and Sports Notes. 9.50 p.m.—Dance Music. 11.0 p.m. (approx.).—Close Down.

HAMBURG (Germany) Norag (ha, in Morse). 806 kc/s (372 m.); 1.7 kW. Relay by Bremen, 1,112 kc/s (270 m.); Flensburg, 1,373 kc/s (218 m.); Hanover, 530 kc/s (566 m.); and Kiel, 1,292 kc/s (232.2 m.). Transmits at intervals from 5.20 a.m. (Time and Weather). 12.15 p.m.—Gramophone Concert. 1.0 p.m.—Weather and Ice Report. 1.5 p.m.—News Bulletin. 1.15 p.m.—New Gramophone Records of the Week. 1.45 p.m.—Market Prices. 1.50 p.m.—Exchange Quotations. 2.25 p.m.—Shipping Forecast. 2.40 p.m.—Exchange Quotations. 3.15 p.m. (from Hanover).—Recital of Coloratura Arias and Songs, relayed from the Hanover Wireless Exhibition. Overture, "L'épreuve villageoise" (Grétry). Bravour Variations on a Theme by Mozart with Flute obbligato (Adam). Overture, "The Nuremberg Doll", (Adam). Two Songs with Flute obbligato: (a) Aria from "The Nuremberg Doll" (Adam), (b) Aria from "The Pearl of Brazil" (David). Finale for Orchestra (Drigo). Coloratura Waltz, Nymphen und Sylvane (Bernberg). 3.55 p.m.—Reading for Young People. 4.25 p.m.—Talk: The Economic Importance of Haiti to Germany. 4.55 p.m. (from Kiel).—A Dialogue on Schleswig-Holstein Culture. 5.20 p.m.—Variety Programme. 6.0 p.m.—See Königs Wusterhausen. 6.30 p.m.—Dialogue: The Housewife as an Economic Factor. 6.50 p.m.—Exchange Quotations. 6.55 p.m.—Weather Report. 7.0 p.m. (from Hanover).—"Die Richterin"—Opera in Three Acts (Hermann Grabner), played by the

Göttingen Municipal Theatre, and relayed from the Union Hall, Göttingen. 9.15 p.m.—News Bulletin. 9.45 p.m.—Dance Music from the "Rote Mühle," Hanover. 10.50 p.m.—Ice Report.

HEILSBURG (Germany) 1,085 kc/s (276.5 m.); 75 kW. Relay by Danzig, 662 kc/s (453 m.). Transmits at intervals from 5.30 a.m. (Gymnastics). 6.0 p.m.—Wind Instrument Concert of Chamber Music. 6.30 p.m.—Weather Report. 6.35 p.m.—Talk: Giacomo Puccini. 7.0 p.m.—"La Tosca"—Opera in Three Acts (Puccini), followed by Weather, News, Sports Notes and Gramophone Records. 11.0 p.m. (approx.).—Close Down.

HILVERSUM (Holland) 160 kc/s (1,875 m.); 8.5 kW, (transmitted from Huizen). 7.40 a.m. till Close Down.—Programme of the Algemeene Vereening Radio Omroep (A.V.R.O.). 7.40 a.m.—Time and Gramophone Records. 9.40 a.m.—Daily Service. Cadet March (Sousa). Waltz, Donausagen (Fucik). Overture, "Albin" (Flotow). Musical Comedy Potpourri (Fetras). Dance of the Derivishes (Bendix). Nur Fiolen (Berkowitz). Selection (Morena). Extase (Ganne). Elections (Heymann): (a) Frag nicht wie, frag nicht wo, (b) Bischen dies' und bischen das. Sag' ja (Buder). Aus dem Eislaufplatz (Strecker). 11.55 a.m.—Octet Concert. Overture, "The Black Domino" (Auber). Suite archaïque (Gabriel Marie). Minuet (Bolzoni). Hungarian Rhapsody No. 4 (Liszt). Violin and Pianoforte Selections: (a) Mid-night Clocks (Heuberger-Kreisler) (b) Syncopation (Kreisler), (c) Mazurka (Wieniawski). Selection from "Adrienne Lecouvreur" (Cilea). Serenata a la Sevillanita (Magliani). Waltz (Ziehrer). Cradle Song (Swart). Rosetime (Mannfred). Selection from "The Czardas Princess" (Kálmán). Adlonmarch (Heinecke). 1.40—2.10 p.m.—Interval. 2.10 p.m.—Ballad Concert. Sonata in D Minor for Pianoforte (Gemini). Violin and Pianoforte Selections: (a) Etude in C Major and Two Mazurkas (Chopin), (b) Prelude in G Minor (Rachmaninoff). Pianoforte Solos: (a) Chant de Roxane (Szymanovsky), (b) Minuet (Porpora-Kreisler), (c) Scherzo-Tarantella (Wienlavsky). 2.55—4.10 p.m.—Gramophone Records. 4.10 p.m.—Programme for Children. 4.55 p.m.—Gramophone Records. 5.10 p.m.—Orchestral Concert, Overture, "The Golden Cross" (Brüll), Ballet Music from "Les Erynnies" (Massenet). Scandinavian Rhapsody (Svendsen). Italian Caprice (Tchaikovsky). Overture, "The Gipsy Baron" (Joh. Strauss); Selection from "Wienerbrut" (Joh. Strauss). Two Spanish Dances (Moszkovsky). Military March (Saint-Saëns). 6.40 p.m.—Weekly Book Talk. 7.25 p.m.—Gramophone Records. 7.40 p.m.—Orchestral Concert, Overture, "Die Felsenmühle" (Reisiger). Ballet égyptien (Luigini). Mazurka, Le Mousmé (Ganne). Selection from "The Merry Wives of Windsor" (Nicolai). Waltz, Dreams on the Ocean (Gungl); Selection from "La Mascotte" (Audran). 8.40 p.m.—Concert by a Women's Choir. 9.10 p.m.—Orchestral Concert (continued). Overture, "Ten Maids and No Man" (Suppé). Waltz, Veichen am Wege (Fetras), Selection from "The Love Parade" (Schertzing). 9.40 p.m.—Weather and News. 9.50 p.m.—Orchestral Concert. Jazz Paraphrase (Fox). True Love (Klages-Geer). Where are you now? (Belfis). The Kiss Waltz (Burke). Foxtrot Parody on "Aida" (Briegel). Selection from "Schön ist die Welt" (Lehár). Tango, In Madrid (Nelson). Six Waltzes (Robrecht). The Lantern Song (Nicholls). Tra-ra, jetzt kommt die Marschmusik (Heymann). 10.50 p.m.—Gramophone Records. 11.40 p.m. (approx.).—Close Down.

HUIZEN (Holland) 1,004 kc/s (298 m.); 8.5 kW, (transmitted from Hilversum). 7.40 a.m. till Close Down.—Programme of the Christian Radio Society (N.C.R.V.). 7.40 a.m.—Time Signal and Reading. 7.55—9.10 a.m.—Morning Concert. 10.10 a.m.—Programme for Hospitalists. 10.40 a.m.—Reading. 11.10 a.m.—Gramophone Records. 12.10 p.m.—Organ Recital from a Church in Amsterdam. Hymn for Organ: Wilt heden nu treden (Jan Zwart). Choral Prelude, Psalm 43. Prelude and Fugue in D Minor (J. S. Bach). Two Choral Preludes (J. S. Bach). Sonata No. 2 (Guilmant). Cantabile (Franck). Chorale No. 3 (Franck). 1.25 p.m.—Gramophone Records. 1.40 p.m.—Programme for Schools. 2.15 p.m.—Gramophone Records. 2.55 p.m.—Dressmaking Lesson. 3.25 p.m.—Programme to be announced. 3.40 p.m.—Programme for Hospitalists. 4.40 p.m.—Lesson in Handicrafts for Young People. 5.25 p.m.—Concert. Trio in C Minor for Flute, Violin and Pianoforte (Telemann). Pianoforte Solos: Two Choral Preludes (Bach-Busoni): (a) Nun komm' der Heiden Heiland, (b) Nun freut euch, lieben Christen. Contralto Solos (Telemann): (a) Einsamkeit, (b) Der Schäfer, (c) Glück. Sonata for Flute and Pianoforte (Telemann). Arioso for Contralto, Violin and Pianoforte: Dank sei dir, Herr (Händel). Sonata in C Minor for Flute, Violin and Piano (Quanz). Contralto Solos (Schubert): (a) Der Lindenbaum, (b) Geheimes, (c) Lied eines Schiffers an die Dioskuren. Violin Solos: (a) Aria (Tenaglia), (b) Réverie (Zutphen). Selection for Contralto, Violin and Pianoforte (Lambrechts-Vos). 6.40 p.m.—Gramophone Records. 7.25 p.m.—"The St. John Passion"—Oratorio for Solo Voices and Instruments (J. S. Bach). In the interval: Gramophone Records. 10.25 p.m.—News Bulletin. 10.35 p.m.—Gramophone Records. 11.10 p.m. (approx.).—Close Down.

JUAN-LES-PINS (Nice) (France) 1,205 kc/s (249 m.); 1.2 kW. 12.30 p.m.—News Bulletin, Amusement Guide and Concert. Indian March (Sellenick). Les fiancés de Rosperden (Goguillot). Pianoforte Solo: Under the Palm-tree (Albeniz). Miller's Dance (de Falla). Selection from "The Magic Flute" (Mozart). Selection from "La Juive" (Halévy). "Cello Solo: Largo (Händel). Ave Maria (Schubert). Polka (Gomez). Hoster Valsen (Hellestrom). Roses of Picardy (Haydn Wood). Where my Caravan has rested (Hermann Löhr). Ten Little Mites from Town (Crawford). My Angel (Rapee). Hymn to Night (Rameau). Neapolitan Night (Zamenick). "Cello Solo: Ave Maria (Gounod). Ou peut-on être mieux (Grétry). Selection (Primi). La Cinquantaine (Gabriel-Marie). La ronde sous la cloche (Coppola). Selection from "I Pagliacci" (Leoncavallo). 2.0 p.m.—The Marseillaise. 2.10—3.30 p.m.—Interval. 3.30 p.m.—News, Amusement Guide, Weather Report and Concert. Selection from "Il Trovatore" (Verdi). Selection from "Aida" (Verdi). "Belote-Valet Maitre"—Play (Marcel Laporte). Aria from "Aida" (Verdi). Aria from "Othello" (Verdi). Aria from "Rigoletto" (Verdi). 10.0 p.m.—The Marseillaise and Close Down.

KALUNDBORG (Denmark) Kalundborg Radio. 260 kc/s (1,153 m.); 10 kW. See Copenhagen Programme.

KÖNIGSBERG (Germany) Ostmarken Rundfunk. 1,382 kc/s (217 m.); 1.7 kW. See Heilsberg Programme.

LANGENBERG (Germany) Westdeutscher Rundfunk. 635 kc/s (473 m.); 17 kW. Relay by Aachen, Cologne and Münster, 1,319 kc/s (227 m.). Transmits at intervals from 5.45 a.m. (Lesson in Self-defence). 12.5 p.m.—Orchestral Concert, conducted by Wolf. March, Die Brautwerber (Becker). Schatz-Walzer (J. Strauss). Overture, "Der Wildschütz (Lortzing).



Programmes for Monday—(Cont.)

**Two Selections (Mendelssohn):** (a) Venetian Gondola Song, (b) Spring Song. Russian Suite, An Evening in St. Petersburg (Meyer-Helmund). Overture, "Die Geschöpfe des Prometheus" (Beethoven). Scherzo No. 1 and Moment musical (Schubert). Potpourri Reminiscences of Grieg (Urbach).

1.30 p.m.—Meat Market Prices.

2.30 p.m.—Tidal Report, Time and Economic Notes.

2.50 p.m.—Programme for Children.

3.20 p.m.—Young People's Programme.

4.0 p.m.—Vocal and Instrumental Concert. Soloists: Agnes Lenbach (Contralto). Karl Heinrich Diener von Schönberg (Pianist), and Fritz Lang (Viola). Pianoforte Sonata in C Major, Op. 2 (Beethoven). Three Songs (Schubert): (a) Der Kreuzzug, (b) Suleika, (c) Im Abendrot. Pianoforte Solos: Three Old Pieces: (a) Divertimento (Wagenseil), (b) Minuet (Rameau), (c) Andante (Croft). Two Songs to Viola accompaniment (Brahms): (a) Gestillte Sehnsucht, (b) Geistliches Wiegenlied.

5.0 p.m.—Talk: The Stars in April.

5.15 p.m.—Talk on a Journey in the Iberian Peninsula—Civilised Portugal.

5.40 p.m.—Spanish Conversation.

6.0 p.m.—Weather Report, Time Signal, Economic and Sports Notes.

6.15 p.m.—Topical Talk.

6.25 p.m.—Talk on Economics.

6.45 p.m.—Songs and Dances from all over the World.

8.0 p.m.—See Munich.

9.0 p.m.—News, Sports Notes, Concert and Dance Music.

11.0 p.m. (approx.)—Close Down.

**LEIPZIG (Germany)**  
Mitteldeutscher Rundfunk. 1,157 kc/s (250 m.); 2.3 kW. Relayed by Dresden, 941 kc/s (319 m.). Transmits at intervals from 8.45 a.m. (Economic Notes).

3.30 p.m.—Concert from Berlin (Witzleben).

4.30 p.m.—Weather and Time.

4.55 p.m.—Economic Prices.

5.0 p.m.—Review of New Books.

5.50 p.m.—The Wireless Management speaks. Talk by Dr. D. E. Kurt Fischer: Who collaborates?

6.0 p.m.—Talk: The Reorganisation of Sickness Insurance.

6.30 p.m.—Gramophone Records.

7.15 p.m.—Four Dialogues.

8.0 p.m.—Sacred Music by the Regensburg Cathedral Choir, relayed from the Cathedral Regensburg. Organ Prelude. In monte Oliveti (de Lasso). Incipit oratio Jeremiae (Palestrina). Adoramus te (Aichinger). Christus factus est (Anerio). Ecce quomodo moritur (Gallus). Selections from the Missa Papae Marcelli (Palestrina). Surrexit pastor bonus (Haller).

8.50 p.m.—Pianoforte Recital from the Works of Mozart. Sonata in B Flat Major. Fantasia in D Minor. Minuet in D Major. Rondo alla Turca.

9.15 p.m.—News, followed by Concert of Light Music.

10.30 p.m. (approx.)—Close Down.

**LJUBLJANA (Yugoslavia)**  
Radio-Ljubljana. 522 kc/s (574.7 m.); 2.8 kW.

Transmits at intervals from 11.15 a.m.

4.30 p.m.—Orchestral Concert.

5.30 p.m.—Italian Lesson.

6.0 p.m.—Polish Lesson.

6.30 p.m.—Talk on Hygiene.

7.0 p.m.—Orchestral Concert.

9.0 p.m.—Weather and News.

**MADRID (Spain)**  
Union Radio (EAJ7). 707 kc/s (424 m.); 2 kW.

Transmits at intervals from 11.45 a.m.

2.0 p.m.—Chimes, Time Signal, Weather Report and Concert. Pasodoble, La cava (Francés). Intermezzo from "Cavalleria rusticana" (Mascagni). Hungarian Dance, No. 6 (Brahms). Selection from "La Juive" (Halévy). Selection from "Zwei Herzen in Dreiviertel Takt" (Stolz). Gavotte (Rodrigo). Marche militaire in E (Schubert).

3.25 p.m.—Theatre Notes.

3.30—7.0 p.m.—Interval.

7.0 p.m.—Chimes, Exchange Quotations, Market Prices and Topical Review of Sport.

7.30 p.m.—Dance Music.

8.25 p.m.—News Bulletin.

8.30 p.m. (approx.)—Close Down.

**MILAN (Italy)**  
Ente Italiano Audizioni Radiofoniche. 599 kc/s (501 m.); 8.5

kW. Programme relayed by Turin, 1,013 kc/s (296 m.); and Genoa, 958 kc/s (313.2 m.).

Transmits at intervals from 7.15 a.m. (Giornale Radio).

6.30 p.m.—Concert of Light Music. Marcietta gaia (Crisuolo). Malle gitana (Mariotti). Canzone solitaria (Ranzato). Fagottino, giullare di Corte (Camussi). A zozzo (de Micheli). Selection from "A Waltz Dream" (O. Straus). L'uomo e fumatore (Ranzato).

7.0 p.m.—Time, Announcements, Giornale Radio, and Weather.

7.45 p.m.—Scientific Talk.

8.0 p.m.—Concert of Chamber Music, organised by Ildebrando Pizzetti, with the collaboration of Maria Roka (Soprano) and Castelnovo Tedesco.

9.0 p.m.—Variety Programme.

10.0 p.m.—Giornale Radio, followed by Concert from the Cova Restaurant.

10.55 p.m.—News Bulletin.

**MOTALA (Sweden)**  
222.5 kc/s (1,348 m.); 40 kW. See Stockholm Programme.

**MÜHLACKER (Germany)**  
Süddeutscher Rundfunk. 833 kc/s (360 m.); 75 kW. Relayed by Freiburg, 527 kc/s (570 m.). Transmits at intervals from 5.15 a.m. (Time, Weather and Gymnastics).

3.30 p.m.—Orchestral Concert from Freiburg.

5.0 p.m.—Time, Weather and Agricultural Notes.

5.15 p.m.—(from Karlsruhe). Talk: Reading Invisible Writing by means of Optophotography.

5.45 p.m.—Talk from Frankfurt.

6.5 p.m.—Time Signal.

6.10—11.0 p.m.—See Frankfurt.

11.0 p.m. (approx.)—Close Down.

**MUNICH (Germany)**  
567 kc/s (533 m.); 1.7 kW. Relayed by Augsburg, 536 kc/s (560 m.); Kaiserslautern, 536 kc/s (560 m.); and Nürnberg, 1,256 kc/s (239 m.).

Transmits at intervals from 5.45 a.m. (Gymnastics).

12.20 p.m.—Gramophone Records of Modern Orchestral Works.

1.0 p.m.—Time Signal, Weather Report, Programme Announcements, News Bulletin, Exchange Quotations and Advertisements.

2.40 p.m.—Reading of a Sketch (F. Anstey).

3.5 p.m.—Time, Weather and Agricultural Notes.

3.20 p.m.—Pianoforte Recital from the Works of Munich Composers. Fantasia and Fugue (Thomassin). Landsommertage—Seven Variations on an Original Theme, Op. 22 (A. Reuss). Seven Mazurkas (H. Mainzer).

4.0 p.m.—Programme for Children.

4.20 p.m.—Orchestral Concert, conducted by Karl List. Overture "Czar and Carpenter" (Lortzing). Two Selections (Dvorák). Suite (Tchaikovsky). Slumber Song (Moszkovsky). Canzonetta (Schütt). Selection from "La Bohème" (Puccini). Ballet Intermezzo (Bayer-Zdenko).

5.20 p.m.—Time Signal, Weather Report and Agricultural Notes.

5.30 p.m.—Review of Books: Books in connection with the Week's Programmes.

5.45 p.m.—Dialogue: Gold-digging in Alaska.

6.5 p.m.—Talk for Workers.

6.30 p.m.—Orchestral Concert. Selection from "Tiefland" (d'Albert). Träume der Nacht (Schmalstich). Czardas (Monti). Selection from "The Geisha" (Jones). Interlude by Otto Willner. Murmuring Zephyr (Jensen). Harlequin and Columbine (Kaskel). March, Unterm Doppeladler (J. F. Wagner).

7.45 p.m.—Talk: Gregorian Music.

8.0 p.m.—Sacred Music relayed from Regensburg Cathedral. Holy Week Music by the Regensburg Cathedral Choir, conducted by Dr. Theobald Schrems. Organist: Professor Josef Renner. Organ Prelude. Six-Part Choir, In monte Oliveti (Orlando di Lasso). Six- to Eight-Part Choir, Oratio Jeremiae (Palestrina). Four-Part Choir, Three Boys' Voices and Tenor: Adoramus te (Aichberger). Four-Part Choir, Christus factus est (Anerio). Four-Part Choir, Ecce quomodo moritur (Handl). Kyrie and Sanctus from the "Missa Papae Marcelli" (Palestrina). Five-Part Choir, Surrexit pastor bonus (Haller).

8.50 p.m.—Monthly Review of World Politics.

9.20 p.m.—Taxation Notes, Time, Weather, News and Sports Notes.

**OSLO (Norway)**  
Kringkastingsselskapet. 280 kc/s (1,071 m.); 75 kW. Relayed by Fredrikstad, 815 kc/s (368 m.); Hamar, 511 kc/s (587 m.); Notodden, 671 kc/s (447.1 m.); Porsgrund, 662 kc/s (453 m.); and Rjukan, 671 kc/s (447.1 m.).

Transmits at intervals from 10.15 a.m.

4.30 p.m.—Chamber Music Concert.

5.30 p.m.—Review of Foreign Affairs.

6.0 p.m.—Announcements, Weather and News.

6.20 p.m.—Talk on the following Transmission.

6.30 p.m.—"The Marriage of Figaro"—Opera in Four Acts (Mozart), under the direction of A. Jarnfelt, relayed from the Royal Opera House, Stockholm. In the interval at 9.15 p.m.—Weather and News.

10.0 p.m. (approx.)—Close Down.

**PARIS (France)**  
Eiffel Tower (FLE). 207 kc/s (1,445 m.); 15 kW.

Time Signals (on 2,650 m., 113 kc/s); at 9.25 a.m. and 10.25 p.m. (preliminary and 6-dot signals).

5.45 p.m.—Le Journal Parlé.

7.10 p.m.—Meteorological Forecast.

7.30 p.m.—Symphony Concert conducted by M. Edouard Flament. Sicilienne, Gavotte and Bourrée (Bach-Gevaert). Overture, "Hansel and Gretel" (Humperdinck-Artok). Norwegian Dances (Grieg). In a Persian Market (Ketelbey). Romance for Cello (E. Flament). Rustle of Spring (Sinding). Waltz, Dolores (Waldteufel). Song of the Boatmen (Glazounoff). Violin Solo: In the Gardens of Murcia (Turina-Chapelier). Slavonic Dances (Dvorak). En yacht le soir (Fl. Schmitt). Selection from "Javotte" (Saint-Saëns-Alder). Souvenir de Hapsal (Tchaikovsky). La fille aux cheveux de lin (Debussy-Mouton). Waltz: Wine, Woman and Song (Strauss).

**PARIS (France)**  
Poste Parisien. 914 kc/s (329 m.); 1.2 kW.

9.0 a.m.—Transmission of Pictures.

8.25 p.m.—Gramophone Records, Talk and News Bulletin.

9.0 p.m.—Concert by the "Harmonie du Petit Parisien," conducted by Henri Coquart. March and Cortège from "Déjanire" (Saint-Saëns). Overture, "The Caliph of Baghdad" (Boieldieu). Polonaise No. 4 (Chopin). Ballet Music from "Faust" (Gounod). Persian Dance (Guiraud).

**PARIS (France)**  
Radio-Paris (CFR). 174 kc/s (1,725 m.); 17 kW.

Transmits at intervals from 6.45 a.m. (Physical Culture).

12.30 p.m.—Gramophone Records.

1.0 p.m.—Exchange and News.

1.5 p.m.—Symphony Concert on Gramophone Records. Finlandia (Sibelius). Concerto for Pianoforte in B Flat Major (Liszt). Suite in F (Roussel). Song: La Forêt (Caplet). Prelude to "The Tempest" (Honegger). In the intervals at 1.30 p.m.—Exchange and at 2.0 p.m.—Exchange and Market Prices.

3.30 p.m.—Exchange Quotations.

3.45 p.m.—Concert dedicated to the Oise District and especially to Noyon. Talk on Noyon. Readings: (a) Two Poems (Foulon de Vaux), (b) Pèlerinage ("Foultin"), (c) La rosière de Salency, (d) Aux morts de Noyon (Buffière). Two Pianoforte Solos (Carlier): (a) Le Clocher de Chaumont, (b) Mon Papa est Docteur. Two Songs (Carlier): (a) Chant de la Mer, (b) Je suis le ciment vivant. Serenade (Berton). Talk on the Sculptor Henri Greber. Readings: (a) Madrigals and Epigrams (Maucroix), (b) Epithalame (Rollaine), (c) La fontaine du pied du mont (Grevin), (d) La fête de Salency (de Genlis), (e) Calvin as a Writer (Faguet).

5.55 p.m.—Exchange and Market Prices.

6.0 p.m.—Agricultural Report and Racing Results.

6.30 p.m.—Modern Music on Gramophone Records. Petite Suite (Debussy). Selection from "La Korrigane" (Widor).

7.0 p.m.—Film Review.

7.10 p.m.—Talk.

7.30 p.m.—Spanish Lesson.

7.45 p.m.—Commercial Prices, Economic and Social Notes and News.

8.0 p.m.—"A Lost Ball"—Comedy (Achard).

8.30 p.m.—News and Sports Notes.

8.40 p.m.—Topical Review.

8.45 p.m.—Gramophone Records.

9.0 p.m.—"Enlevez-moi!" (Music by Gabaroché), relayed from the Théâtre de la Comédie Caumartin. In the interval, Press Review, News and Time Signal.

**POZNAŃ (Poland)**  
896 kc/s (335 m.); 1.9 kW.

Transmits at intervals from 6.15 a.m. (Radio Journal).

4.45 p.m.—Pianoforte and Vocal Recital. Baritone Solos from the Works of Leoncavallo, Zerkovitz, Tagliaferri and Schertzinger. Pianoforte Solos: (a) Know'st thou the Land? (Moniuszko), (b) The Legend (Rozycki), (c) Evening Song (Moniuszko), (d) Tango (Albéniz). Soprano Solos: (a) Aria from "Flis" (Moniuszko), (b) Aria from "Mazeppa" (Münchheimer), (c) Aria from "Beatrix Cenci" (Rozycki).

5.45 p.m.—Talk arranged by the Society for Physical Training and Military Preparation.

6.0 p.m.—Review of Art and Literature.

6.15 p.m.—Social Talk: A Brighter Future.

6.30 p.m.—Topical Talk.

6.45 p.m.—Literary Talk.

7.0 p.m.—Miscellaneous Items and News.

7.10 p.m.—Talk: The Poznań Fairs.

7.30 p.m.—See Warsaw.

9.0 p.m.—Time, News, Sports and Police Notes.

9.15 p.m.—Topical Talk.

9.30 p.m. (approx.)—Close Down.

**ROME (Italy)**  
Ente Italiano Audizioni Radiofoniche (IRO). 680 kc/s (441 m.); 75 kW. Relayed by Naples, 905 kc/s (332 m.), and 2RO, 11,810 kc/s (25.4 m.).

Transmits at intervals from 7.15 a.m. (Giornale Radio and Weather for Shipping).

4.0 p.m.—Reading of a Short Story.

4.20 p.m.—Talk on the following transmission.

4.30 p.m.—Concert by the Rome Quartet, relayed from the Royal Philharmonic Academy.

6.20 p.m.—Announcements and News.

6.50 p.m.—Gramophone Records.

7.10 p.m.—Giornale Radio and Miscellaneous Notes.

7.30 p.m.—Time and Announcements.

7.32 p.m. (approx.)—Talk: The Beatitudes.

8.0 p.m.—Vocal and Instrumental Concert. Overture, "Samson" (Händel). Choral Selections: (a) Ave verum (Mozart), (b) Hymn to Night (Beethoven), (c) Villotta (Azzaioli), (d) I Zolfanari (Banchieri). Announcements. Violin Solos: (a) Roxane's Song (Szymanovsky), (b) Tambourin chinois (Kreisler). Terra d'oro—Scene from Popular Abruzzian Life for Choir, Orchestra, Soprano, Tenor and Bass (Albanese). Violin Solos: (a) Lotus Land (Cyril Scott), (b) Zigeunerweisen (Sarasate). Interlude from "Pepe Jimenez" (Albéniz). Dance from "La Sacra rappresentazione di Abramo ed Isacco" (Pizzetti). Choral Selections: (a) Lu pianto de le foje and Vola, vola—Abruzzian Songs (Albanese), (b) Dammari un ricciolo dei tuoi capelli (Tosti), (c) Popular Song of Trieste: In mezzo al mar (Sadero). Rapsodia lombarda (Cerr).  
9.55 p.m. (approx.)—News.

**SCHENECTADY (U.S.A.)**  
General Electric Company (WGY). 790 kc/s (379.5 m.); 50 kW. Relayed at intervals by W2XAF on 9.530 kc/s (31.48 m.), and by W2XAD on 15.340 kc/s (19.56 m.).

Transmits at intervals from 1.45 a.m.

11.30 p.m.—Ivanhoe Programme.

11.45 p.m.—Musical Programme.

12. midnight.—Weather Report.

12.1 a.m.—(Tuesday)—Municipal Series.

12.14 a.m.—Time Signal.

12.15 a.m.—McAler Melodists.

12.30 a.m.—Baker Chocolate Programme.

12.45 a.m.—Rice String Quartet.

1.0 a.m.—Agricultural Programme.

1.30 a.m.—A and P Gypsies, from New York.

2.30 a.m.—General Motors Programme, from New York.

3.0 a.m.—Mixed Quartet Programme.

3.30—4.30 a.m.—Programme from New York.

3.30 a.m.—Symphonic Rhythm Makers.

4.0 a.m.—Hotel Paramount Orchestra.

4.30 a.m.—Organ Recital from the Proctor's Theatre, Albany, N.Y.

5.0 a.m.—Bill Houlthan's Cadets.

5.30 a.m.—Doc Peyton and the Hotel Kenmore Orchestra, Albany, N.Y.

6.0 a.m. (approx.)—Close Down.

**STOCKHOLM (Sweden)**  
Radiotjänst (SASA). 680 kc/s (436 m.); 75 kW. Relayed by Boden, 244 kc/s (1,220.5 m.); Göteborg, 932 kc/s (322 m.); Hörby, 1,166 kc/s (257 m.); Motala, 222.5 kc/s (1,348 m.); Östersund,

890 kc/s (335 m.); Sundsvall, 554 kc/s (542 m.).

Transmits at intervals from 6.15 a.m. (Gymnastics).

12 noon—12.30 p.m.—Talk for Schools.

4.0 p.m.—Reading.

4.20 p.m.—Gramophone Records.

5.20 p.m.—Elementary English Lesson, relayed from Jönköping, 1,490 kc/s (202 m.).

5.50 p.m.—Talk: Modern French Statesmen—Thiers.

6.20 p.m.—Introductory Talk to the following transmission.

6.30 p.m.—"The Marriage of Figaro"—Opera in Four Acts (Mozart), relayed from the Royal Opera House.

10.0 p.m. (approx.)—Close Down.

**STRASBOURG (France)**  
Radio-Strasbourg (PTT). 869 kc/s (345 m.); 15 kW.

Transmits at intervals from 11.30 a.m.

7.0 p.m.—Instrumental Concert.

7.30 p.m.—News in French and German.

7.45 p.m.—Gramophone Records.

8.30 p.m.—Concert relayed alternately from the Café de la Paix and the Odéon.

10.30 p.m. (approx.)—Close Down.

**TOULOUSE (France)**  
Radiophonie du Midi. 779 kc/s (385 m.); 8 kW.

Transmits at intervals from 12.45 p.m.

7.0 p.m.—Musical Programme.

7.30 p.m.—Exchange Quotations and News.

7.45 p.m.—Musical Programme.

8.55 p.m.—Fashion Review.

9.0 p.m.—Time Signal.

9.2 p.m.—Orchestral Concert. In the interval, News.

11.0 p.m.—Chansonnets.

11.15 p.m.—North African News.

11.30 p.m.—Musical Programme.

12 midnight (approx.)—Close Down.

**VIENNA (Austria)**  
Radio-Wien. 581 kc/s (517 m.); 20 kW. Relayed by Graz, 851 kc/s (352 m.); Innsbruck, 1,058 kc/s (283 m.); Klagenfurt, 662 kc/s (453.2 m.); Linz, 1,220 kc/s (246 m.); and Salzburg, 1,373 kc/s (218 m.).

Transmits at intervals from 8.20 a.m. (Market Prices).

6.30 p.m.—Vocal and Instrumental Concert.

7.0 p.m.—Concert arranged by the Burgenland Local Government to celebrate its Tenth Anniversary as an Austrian Possession, relayed from the Music Society's Hall.

9.5 p.m. (approx.)—News.

9.15 p.m. (approx.)—Dance Music.

**WARSAW (Poland)**  
Polskie Radio. 212 kc/s (1,411 m.); 158 kW.

Transmits at intervals from 10.40 a.m.

1.20 p.m.—Economic Notes.

1.40 p.m.—Talk: Political and Social Reforms in England.

2.0 p.m.—Talk: Silesia and Poland in History.

2.20—2.35 p.m.—Interval.

2.35 p.m.—Press Review.

2.50 p.m.—French Lesson.

3.10 p.m.—Marine Notes.

3.15 p.m.—Programme for Children.

3.45 p.m.—Gramophone Records.

4.15 p.m.—Talk: The Influence of Town and Country on the Length of Life, relayed from Luów, 788 kc/s (381 m.).

4.45 p.m.—Orchestral Concert.

5.45 p.m.—Miscellaneous Items.

6.10 p.m.—Agricultural Correspondence and Quotations.

6.25 p.m.—Technical Talk.

6.30 p.m.—Gramophone Records.

6.35 p.m.—Programme Announcements.

6.40 p.m.—Radio Journal.

6.55 p.m.—Gramophone Records.

7.0 p.m.—Talk (to be announced).

7.15 p.m.—Music Talk.

7.30 p.m.—Orchestral Concert with Mme. Olga Kalliwoda (Mezzo-Soprano) and L. Urstein (Pianoforte). In the interval, Theatre Review.

9.0 p.m.—Talk: Human Sentiments and Presentiments.

9.15 p.m.—Gramophone Records.

9.50 p.m.—Weather, Police and Sports Notes.

**WILO (Poland)**  
815 kc/s (368.1 m.); 0.5 kW.

Transmits at intervals from 10.58 a.m.

4.45 p.m.—See Warsaw.

5.45 p.m.—Sports Notes.

6.0 p.m.—Talk.

6.15 p.m.—Programme to be announced.

6.25 p.m.—See Warsaw.

6.30 p.m.—Programme Notes and Miscellaneous Announcements.

6.40—6.15 p.m.—See Warsaw.

9.15 p.m.—Gramophone Records.

9.50 p.m.—See Warsaw.

10.0 p.m. (approx.)—Close Down.

# PROGRAMMES FOR TUESDAY (March 31)

**NOTE: THE HOURS OF TRANSMISSION ARE REDUCED TO GREENWICH MEAN TIME**

**ALGIERS (N. Africa)**  
825.3 kc/s (363.4 m.); 13 kW.  
12.30 p.m.—Gramophone Records.  
7.0 p.m.—Exchange; Weather, Agricultural Report and Shipping Notes.  
7.15 p.m.—Gramophone Records of Accordion Music.  
7.30 p.m.—Songs from Talking Films.  
7.50 p.m.—News Bulletin.  
8.0 p.m.—Chamber Music.  
9.0 p.m.—Concert of Eastern Music.  
10.30 p.m.—Gramophone Records.  
11.0 p.m. (approx.)—Close Down.

**BARCELONA (Spain)**  
Radio-Barcelona (E.A.R.). 860 kc/s (349 m.); 8 kW.  
Transmits at intervals from 8.0 a.m. (Radio Journal).  
5.30 p.m.—Exchange and Concert. March, Kad-Dür (Lorenz). Gramophone Record: Death and the Maiden (Schubert). Interlude (Franco). Aubade, Chanson d'Arlotte (de Tavey). Minuet and Allegro ma non troppo from the Quartet in D Minor (Haydn). March of the Gnomes (von Blon).  
6.0 p.m.—Trio Music. Serenade, Amoroso (Donizetti). Japanese Festival (Palau). Selection from "Rigoletto" (Verdi). Butterflies (Leopold). Stadium March (Leopold). News after the Programme.  
7.0 p.m.—Gramophone Records.  
8.30 p.m.—English Lesson.  
9.0 p.m.—Chimes, Weather and Exchange.  
9.5 p.m.—Orchestral Concert. Overture, "Alceste" (Gluck). Romantic Song (Demaret). Illyrian Serenade and Romance (Widor). Gaillarde (Delibes). Pavane (Delibes). Petit Menuet (Dubois).

10.0 p.m.—News Bulletin.  
10.5 p.m.—"El Redil"—Comedy in Two Acts (José Ramos Martín).  
12 midnight (approx.)—Close Down.

**BERLIN (Germany)**  
Königs Wusterhausen. 183 kc/s (1,635 m.); 35 kW.  
Transmits at intervals from 5.20 a.m.; (Hamburg Relay).  
3.30 p.m.—Concert from Leipzig.  
4.30 p.m.—Talk: An Introduction to Modern Music.  
5.0 p.m.—Talk: The Dynamic Centre of German Politics.  
5.30 p.m.—Educational Talk: The Style of the Age.  
6.0 p.m.—Elementary French Lesson.  
6.30 p.m.—A Forecast of the April Programmes.  
6.50 p.m.—Weather for Farmers.  
7.0 p.m.—See Hamburg.  
9.20 p.m.—Political Press Review, Weather, News and Sports Notes, followed by Cabaret from Hamburg.  
11.0 p.m. (approx.)—Close Down.

**BERLIN (Germany)**  
Witzleben. 716 kc/s (418 m.); 2.7 kW.  
Transmits at intervals from 6.0 a.m. (Gymnastics).  
5.45 p.m.—Labour Market Report.  
5.50 p.m.—Concert of Light Music.  
7.0 p.m.—Topical Talk.  
7.30 p.m.—"L'Arlesienne"—Opera (Bizet).  
9.15 p.m.—Weather, News and Sports Notes.

**BERNE (Switzerland)**  
Radio-Bern. 743 kc/s (403 m.); 1.1 kW.  
Transmits at intervals from 11.27 a.m.  
5.15 p.m.—Gramophone Records.  
6.0 p.m.—English Lesson.  
6.28 p.m.—Time and Weather.  
6.30 p.m.—Concert by an Italian Orchestra.  
7.15 p.m.—Talk: The Dreyfus Case.  
7.35 p.m.—Symphony (Beethoven), relayed from Geneva, 395 kc/s (760 m.).  
9.15 p.m. (approx.)—News, Weather and Close Down.

**BORDEAUX-LAFAYETTE (France)**  
(P.T.T.) 986 kc/s (304 m.); 35 kW.  
Transmits at intervals from 12.0 noon.  
7.30 p.m.—News and Exchange.  
7.40 p.m.—Spanish Lesson.  
7.55 p.m.—Result of the Prize Draw.  
8.0 p.m.—Advanced Spanish Lesson.  
8.15 p.m.—Gramophone Records.  
8.30 p.m.—Chamber Music, After the Programme, Amusement Guide and Time Signal.

**BRUSSELS (Belgium)**  
Radio-Belgique. 590 kc/s (509 m.); 20 kW.  
5.0 p.m.—Orchestral Concert. Mili-

tary Symphony (Haydn). Passionnément (Messager). 1930 (Nicholls).  
5.45 p.m.—Programme arranged by the RESEF. Variety Items. Talk for Women. Notes. Cradle Songs: (a) Berceuse rose (Daneau), (b) Je sais chanter (Busser), (c) Ma poupée chérie (de Séverac), (d) Peasant Cradle Song (Moussorgsky). Popular Songs: (a) L'homme au sable (Doret), (b) Corsican Cradle Song, (c) Alsatian Cradle Song, (d) Le p'tit Quinquin (e) Breton Cradle Song.  
6.45 p.m.—Gramophone Records.  
7.15 p.m.—Talk: The Worker's Garden.  
7.30 p.m.—Le Journal Parlé.  
8.0 p.m.—Organ Recital from the Carmelite Church. Concerto grosso (Corelli). Aria (Bach).  
9.0 p.m.—Selections from "The Passion" (Bach), with Introductory Talk.  
10.0 p.m.—Le Journal Parlé.

**BRUSSELS No. 2 (Belgium)**  
887 kc/s (338.2 m.); 20 kW.  
Programme in Flemish.  
5.0 p.m.—Chamber Music. Quintet with Clarinet (Dubois). Children's Scenes for String Quartet and Clarinet.  
5.45 p.m.—Programme for Children.  
6.45 p.m.—Gramophone Records.  
7.15 p.m.—Economic Review.  
7.30 p.m.—Le Journal Parlé.  
7.55 p.m.—Talk for Women.  
8.0 p.m.—Concert. 1812 Overture (Tchaikovsky). Ballet Music from "Henry VIII" (Saint-Saëns). Song. Selection from "Mignon" (Thomas). In the Steppes of Central Asia (Borodin). Talk. Selection from "Les trois Sultanes" (Busser). Song. Joyous Youth (Coates). Divertissements (Lalo).  
10.0 p.m.—Le Journal Parlé.

**BUDAPEST (Hungary)**  
545 kc/s (550 m.); 23 kW.  
(Concert).  
Transmits at intervals from 8.15 a.m.  
6.0 p.m.—Talk by Julius Halász.  
6.30 p.m.—Recital of Songs.  
8.0 p.m.—Military Band Concert.  
9.30 p.m.—Talk in English; Agricultural Prices, followed by Tzigane Concert from the Café Bodo.

**COLOGNE (Germany)**  
Westdeutscher Rundfunk. 1,319 kc/s (227 m.); 1.7 kW.  
See Langenberg Programme.

**COPENHAGEN (Denmark)**  
1,067 kc/s (281 m.); 1 kW. Relayed by Kalundborg, 260 kc/s (1,153 m.).  
Transmits at intervals from 6.30 a.m. (Morning Gymnastics).  
2.0 p.m.—Instrumental Concert. March, Frühlingszug (Blon). Red Roses, Waltz from "The Man with Three Wives" (Lehár). Wiegenlied. (Mozart). Air with variations from the "Suite ancienne" (Halvorsen). Neapolitan Serenade (Bayer). Waltz. Weisst den Du, wie ich verliebt bin? (Jermann). Foxtrox, The Devil is playing (Plessow). Piano-forte Solos: (a) Oriental (Albéniz), (b) Serenade, Cordoba (Albéniz), (c) Valse romantique (Debussy), (d) Bergeronnette (Cyril Scott), (e) Sorgente misteriosa and (f) Burlesca (Mario Tarenghi). Pasodoble, Sevilla (Alfonso). Chanson de Pierrot (Drigo). Selection from "Victoria and her Hussar" (Abraham). Mustalain (Merikanto). Waltz from "A Waltz Dream" (O. Strauss). Si tu le voulais (Tosti). March, King Cotton (Sousa).  
4.0 p.m.—Programme for Children: Musical Selections and Reading.  
4.40 p.m.—Exchange Quotations and Fish Market Prices.  
4.50 p.m.—Talk: The Work of the Copenhagen Fire Brigade.  
5.20 p.m.—German Language Lesson.  
5.50 p.m.—Weather Report.  
6.0 p.m.—News, and Report of the Danish Radio Club.  
6.15 p.m.—Time Signal.  
6.30 p.m.—Review of Politics for the Month of March.  
7.0 p.m.—Town Hall Chimes.  
7.2 p.m.—"The Hansen Family"—Humorous Episode (Jens Locher).  
7.15 p.m.—Concert from the Works of Alfred Toft. Prelude and March from "Vifandaka." Two Songs from "Vifandaka." Dance from "Vifandaka." Romance for Violin and Orchestra in C Major. Three Songs. Pastoral and Scherzo for Oboe and Piano-forte. Three Songs for Male Voice Choir.

8.15 p.m.—Danish Provincial Programme. Talk and Songs.  
9.35 p.m.—News Bulletin.  
9.50 p.m.—Viola Recital. Hebrew Melodies, Op. 9 (Joachim).  
10.10 p.m. (approx.)—Close Down.

**CORK (Ireland)**  
(6CK). 1,337 kc/s (225 m.); 1.5 kW.  
1.30 p.m.—Weather Forecast and Gramophone Records.  
6.0 p.m.—Exchange, News Bulletin and Gramophone Records.  
6.15 p.m.—Programme from Dublin.

**CRACOW (Poland)**  
Polskie Radio. 959 kc/s (312.8 m.); 1.5 kW.  
Transmits at intervals from 10.40 a.m.  
4.15—5.45 p.m.—See Warsaw.  
5.45 p.m.—Miscellaneous Items, News Bulletin and Programme Announcements.  
6.10 p.m.—Talk: Easter Customs among the People of Cracow.  
6.20 p.m.—See Warsaw.  
6.30 p.m.—Gramophone Records.  
6.40 p.m.—Radio Journal.  
7.0—10.0 p.m.—See Warsaw.  
10.0 p.m. (approx.)—Close Down.

**DUBLIN (Ireland)**  
(2RN). 725 kc/s (413 m.); 1.5 kW.  
1.30—2.0 p.m.—Time Signal, Weather Report, Stock Report and Gramophone Concert.  
2.0—6.0 p.m.—Interval.  
6.0 p.m.—Gramophone Records.  
6.15 p.m.—Programme for Children.  
7.0 p.m.—Gramophone Records.  
7.15 p.m.—News Bulletin.  
7.30 p.m.—Time Signal.  
7.32 p.m.—Leighceacht Gaedhilige.  
7.40 p.m.—Talk by Maura Laverty: Spain's Way of the Cross.  
8.0 p.m.—Selections by the Station Sextet.  
8.30 p.m.—Recital by C. M. Ni Dhubhghaill with Gerard Crofts (Tenor).  
8.50 p.m.—Violin Duets by Mrs. Larcher and E. K. Lange.  
9.10 p.m.—Soprano Solos by Gertrude Mortimer.  
9.20 p.m.—Selections by the Station Sextet.  
9.30 p.m.—Sponsored Programme.  
10.0 p.m.—Time Signal, News Bulletin, Weather Report and Close Down.

**FRANKFURT-am-MAIN (Germany)**  
770 kc/s (390 m.); 1.7 kW. Relayed by Cassel, 1,220 kc/s (246 m.).  
Transmits at intervals from 5.15 a.m. (Mühlacker Relay).  
3.30 p.m.—"The Lindbergh Flight" (Words by Bert Brecht. Music by Kurt Weill).  
4.30 p.m.—Old Dance Music.  
5.0 p.m.—Economic Notes.  
5.15 p.m.—Talk: America as depicted in French Literature.  
5.45 p.m.—See Mühlacker.  
6.15 p.m.—Reading: Bismarck (M. Harden), on the Anniversary of his Birth.  
6.45 p.m.—Mandoline Concert.  
7.15—11.0 p.m.—See Mühlacker.  
9.45 p.m.—(In an interval), Time, Weather, News and Sports Notes.  
11.0 p.m. (approx.)—Close Down.

**HAMBURG (Germany)**  
Norag (na, in Morse). 806 kc/s (372 m.); 1.7 kW. Relayed by Bremen, 1,112 kc/s (270 m.); Bremen, 1,373 kc/s (218 m.); Hanover, 530 kc/s (566 m.); and Kiel, 1,202 kc/s (232.2 m.).  
Transmits at intervals from 5.20 a.m. (Time and Weather).  
11.30 a.m. (from Hanover)—Orchestral Concert from the Wireless Exhibition. Overture, "Zaida" (Mozart). Minuet (Mozart). Selection from "Lucia di Lammermoor" (Donizetti). Passepied from "Le roi s'amuse" (Delibes). Wolgastler (Leuschner). Negro Cradle Song (Clutnam). The Far West (Demaret). Boston, Wenn zwei träumen (de Bozi). Der Globetrotter-Record (Schneider-Bobby).  
11.55 a.m.—Time Signal.  
12.15 p.m.—Gramophone Concert.  
1.0 p.m.—Weather and Ice Report.  
1.15 p.m.—News Bulletin.  
1.15 p.m. (from Hanover)—Orchestral Concert (continued).  
1.45 p.m.—Cattle Market Report.  
1.50 p.m.—Exchange Quotations.  
2.25 p.m.—Shipping Forecast.  
2.40 p.m.—Exchange Quotations.  
3.15 p.m.—Reading from his own Works by E. M. Salzer.  
3.45 p.m. (from Hanover)—Talk: Easter in North German Folk Customs.  
4.10 p.m. (from Hanover)—Concert of Popular Melodies, relayed from

the Hanover Wireless Exhibition. Oriental Step, Solamah (Anton Profes). Songs: (a) Sag mir, du liebst mich (Bruno Uher), (b) Ich gehe mit der aller letzten Mode (Becke). Valse Boston, All mein Glück auf Erden (Stolz). Songs: (a) Sag mir etwas Liebes (Gold-Boelke), (b) Traumkönigin (Schmidt-Arioso with Violin (Gilbert). Song: Frühlingsnacht (Guttmann). One-step, Carambolina Carambolina (Kálmán).  
4.55 p.m.—Talk: The Stars and Weather, and their Influence on our Lives and Health.  
5.20 p.m.—Variety Programme.  
6.0 p.m. (from Bremen)—Agricultural Talk.  
6.25 p.m.—Talk: Inland Shipping in South America.  
6.50 p.m.—Exchange Quotations.  
6.55 p.m.—Weather Report.  
7.0 p.m. (from Bremen)—Military Band Concert. March, Adlerflug (Blankenburg). Overture, "William Tell" (Rossini). Aria and Ballet Music from "Rübezahl" (Flotow). Chronological Fantasia on Wagner's Stage Works: Erinnerungen an Bayreuth (Morena). Army March No. 7. March, Mit dem Halbmond (Voigt). Deutscher Glaube (Nagler). Hochgewitter (Hutter). Folk Song: Captain and Lieutenant (arr. Heinrichs). March, Herr, mach uns frei (Schulz). Overture, "The Merry Wives of Windsor" (Nicolai). Procession of the Women to the Minster, from "Lohengrin" (Wagner). Waltz, Immer oder nimmer (Waldeufel). March, Von der Lancken (Schultz). In the interval at 8.0 p.m.—First News.  
9.15 p.m.—News Bulletin.  
9.35 p.m.—Instrumental Cabaret.  
10.50 p.m.—Ice Report.

**HEILSBERG (Germany)**  
1,085 kc/s (276.5 m.); 75 kW. Relayed by Danzig, 662 kc/s (453 m.).  
Transmits at intervals from 5.30 a.m. (Gymnastics).  
6.30 p.m.—"Catastrophes of 1930." Riot, the Anna Mine, and Lyon.—A Radio Sequence (Heinz Lipmann, Music by Gerhard Brostig).  
7.30 p.m.—See Berlin (Witzleben). After the Programme, Weather, News and Sports Notes.  
10.0 p.m.—Orchestral Concert.  
11.0 p.m. (approx.)—Close Down.

**HILVERSUM (Holland)**  
160 kc/s (1,875 m.); 8.5 kW. (transmitted from Huizen).  
4.0 a.m. till Close Down. Programme of the Algemeene Vereeniging Radio Omroep (A.V.R.O.).  
7.45 a.m.—Time and Gramophone Records.  
9.40 a.m.—Daily Service.  
10.10 a.m.—Quintet Concert.  
11.40 p.m.—Time Signal.  
11.55 a.m.—Gramophone Records.  
12.40 p.m.—Organ Recital. Toccata (Dubois). Viennese Caprice (Kreisler). La Précieuse (Couperin-Kreisler). Entr'acte (Moszkovsky). Humoresque (Dvorák). Träumerei (Schumann). Largo (Händel).  
1.10 p.m.—Gramophone Records.  
1.40—2.10 p.m.—Interval.  
2.10 p.m.—Recitation.  
2.40 p.m.—Gramophone Records.  
2.55 p.m.—Chamber Music. Quartet on a popular Russian theme by six Russian composers. Quartet (Malipierro).  
3.40 p.m.—Gramophone Records.  
4.10 p.m.—Study Music for Piano-forte, with Introductory Talk.  
4.40 p.m.—Selections by a Children's Choir.  
5.10 p.m.—Violin and Piano-forte Recital. Concerto in E Major (Bach). Rondo (Mozart). Romance (Fried-Certler). Czardas Scene (Hubay).  
5.40 p.m.—Orchestral Concert. Lass mich einmal deine Carmen sein (Hollaender). Two Pieces from "Schön ist die Welt" (Lehár). Monastery Bells (Huntley). Waltz Potpourri (Robrecht). Crying myself to sleep (Wendling). Harmonica Harry (Baxter). Selection (Menicenti). Uns kennt jeder (Berchert). Selection from "Die drei von der Tankstelle" (Heymann).  
6.50 p.m.—Talk on Agriculture.  
7.40 p.m.—Time Signal.  
7.41 p.m.—Orchestral Concert. Overture, "Anacreon" (Cherubini). Piano-forte Concerto, No. 26, in D Major (Mozart). Symphony No. 11 in G Major (Haydn).  
8.40 p.m.—Weekly Book Talk.  
9.10 p.m.—Orchestral Concert, Over-

ture, "Les Saltimbanques" (Ganne). Waltz, Love Angel (Waldeufel). Napoli (Mezzacapo). Selection from "Eine Sängerfahrt nach Wien" (Silying). Glowworm Idyll from "Lysistrata" (Lincke). Martial Moments (Winter).  
9.55 p.m.—Weather and News.  
10.5 p.m.—Recitations.  
10.40 p.m.—Gramophone Records.  
11.40 p.m. (approx.)—Close Down.

**HUIZEN (Holland)**  
1,004 kc/s (298 m.); 8.5 kW. (transmitted from Hilversum).  
7.40 a.m. till Close Down. Programme of the Catholic Radio Society (K.R.O.).  
7.40 a.m.—8.55 a.m.—Gramophone Records.  
9.40 a.m.—Gramophone Records.  
11.10 a.m.—Religious Address by the Rev. Perquin.  
11.40 a.m.—Trio Concert.  
1.10 p.m.—Gramophone Records.  
1.40 p.m.—Programme for Women.  
2.40—3.10 p.m.—Dressmaking Lesson.  
3.40 p.m.—Gramophone Records.  
6.10 p.m.—Talk (to be announced).  
6.25 p.m.—Writing Lesson.  
6.55 p.m.—Talk by Dr. Gelissen.  
7.25 p.m.—Gramophone Records.  
7.40 p.m.—Choral and Organ Recital from the Church of St. Peter and Paul at Amsterdam. Address in the interval.  
9.10 p.m.—News Bulletin.  
9.20 p.m.—Second and Third Acts of the Passion Drama: "The Condemnation of Jesus Christ" (Vuysters).  
10.40 p.m.—Gramophone Records.  
11.40 p.m. (approx.)—Close Down.

**JUAN-LES-PINS (Nice, France)**  
1,205 kc/s (249 m.); 1.2 kW.  
12.30 p.m.—News, Amusement Guide and Concert. Selection from "La Fille de Madame Angot" (Lecocq). Nocturne in E Flat Major (Chopin). Prélude (Chopin). Selection from "The Queen of Sheba" (Gounod). Allegro (Fiocco). La Capriciosa (Ries). Souvenir de Capri (Becke). Réviens à Sorrente (de Curtis). Chant vosgien (Marchais). Les fleurs du passé (Lenoir). Chantez, Grand-mère (Garaboche). Kol Nidrei (Bruch). Selection from "Don Carlos" (Verdi). Polonaise brillante (Wieniawsky). Suite in A Major (Händel). Concertino for Clarinets (Weber). Selection from "The Daughter of the Regiment" (Donizetti).  
2.0 p.m.—The Marseillaise.  
2.10 (approx.)—8.30 p.m.—Interval.  
8.30 p.m.—News, Amusement Guide and Weather Report.  
8.45 p.m. (approx.)—"Faust"—Opera (Gounod), on Gramophone Records.  
10.0 p.m.—The Marseillaise and Close Down.

**KALUNDBORG (Denmark)**  
Kalundborg Radio. 260 kc/s (1,153 m.); 12 kW.  
See Copenhagen Programme.

**KÖNIGSBERG (Germany)**  
Ostmarken Rundfunk. 1,382 kc/s (217 m.); 1.7 kW.  
See Heilsberg Programme.

**LANGENBERG (Germany)**  
Westdeutscher Rundfunk. 655 kc/s (473 m.); 17 kW. Relayed by Aachen, Cologne and Münster, 1,310 kc/s (227 m.).  
Transmits at intervals from 5.45 a.m. (Lesson in Self-defence).  
12.5 p.m.—Orchestral Concert, conducted by Kühn. March, One, Two, Three (Dostal). Overture, "Der Waldmeister" (Joh. Strauss). Selections from "La Bohème" (Puccini). Ballet Music from "Sicilian Vespers" (Verdi). Selections from "The Indian Widow" (O. Strauss). Waltz, Badner Madeln (Komzák). Kontraste, a Short Cut through the World of Music (Robrecht). Reminiscences of Lucerne (Blon). March-Intermezzo, Frühlingsfest (Ailbott).  
2.30 p.m.—Tidal Report, Time Signal and Economic Notes.  
2.50 p.m.—Programme for Children.  
3.30 p.m.—Talk on Vocations: What shall I be? Hints for the Girl Student.  
4.0 p.m.—Scenes from the First and Second Acts of "Tannhäuser"—Opera (Wagner), on Gramophone Records by the Cast of the Bayreuth Festspielhaus.  
5.0 p.m.—Franz Johannes Weinrich reads from his own Works.  
5.20 p.m.—Agricultural Talk.

Programmes for Tuesday—(Cont.)

5.40 p.m.—French Language Lesson.
6.0 p.m.—Weather Report, Time Signal, Economic and Sports Notes.
6.15 p.m.—Wireless Notes.
6.25 p.m.—Talk on West German Industry.

LEIPZIG (Germany)
Mitteldeutscher Rundfunk. 1,157 kc/s (259 m.); 2.3 kW. Relayed by Dresden, 941 kc/s (319 m.).

5.30 p.m.—Orchestral Concert. Overture in Italian Style, in D Major (Schubert). Hersilia—Suite for Orchestra (Alfred d'Ambrosio). Romance for String Orchestra and Four Horns (Karl Thiessen). Third Norwegian Rhapsody in G Major (Svendsen).

LJUBLJANA (Yugoslavia)
Radio-Ljubljana. 522 kc/s (574.7 m.), 2.8 kW.
Transmits at intervals from 11.15 a.m. to 5.0 p.m.—Orchestral Concert.

MADRID (Spain)
Union Radio (EAJ7). 707 kc/s (424 m.); 2 kW.
Transmits at intervals from 8.0 a.m. (to local Review).

7.30 p.m.—Hunting and Fishing Notes, followed by Dance Music.
8.5 p.m.—English Language Lesson by the Linguaphone Method.
8.25 p.m.—News Bulletin.
8.30—9.30 p.m.—Interval.

MILAN (Italy)
Ente Italiano Audizioni Radiofoniche, 599 kc/s (501 m.); 8.5 kW. Programme relayed by Turin, 1,013 kc/s (296 m.); and Genoa, 958 kc/s (313.2 m.).

7.30 p.m.—Recital of Italian Operatic Duets.
8.0 p.m.—Talk by Gigi Michelotti.
8.10 p.m.—Symphony Concert. Overture, "Anacreon" (Cherubini). First Movement from the Second Concerto in D Minor for Violin and Orchestra (Max Bruch). Concerto in D for Violin and Orchestra, Op. 77 (Brahms). Ritorno da una festa Valdostana (Barbieri). Harlequin's Entrance from "Riflessi e Paesaggi" (Mancinelli). Overture, "Ruy Blas" (Mendelssohn). Theatre Notes in the interval.

MOTALA (Sweden)
222.5 kc/s (1,348 m.); 40 kW. See Stockholm Programme.

MÜHLACKER (Germany)
Süddeutscher Rundfunk. 833 kc/s (360 m.); 75 kW. Relayed by Freiburg, 527 kc/s (570 m.).

7.45 p.m.—(From Karlsruhe) "The May Queen"—Pastoral Play (Gluck).
8.45 p.m.—Vocal and Orchestral Concert of Operetta Music. Overture, "Gri-gri" (Lincke). Waltz, Unter der blühenden Linde (Fetrás). Soprano and Tenor Duet from "The Czardas Princess" (Kálmán). Tenor Solo from "Countess Maritzka" (Kálmán). Prinz-Eugen-Marsch (Jos. Strauss). Rhine-Waltz from "The Bird Fancier" (Zeller). Potpourri of Joh. Strauss' Operetta Music. (Schlögl).

MUNICH (Germany)
563 kc/s (533 m.); 1.7 kW. Relayed by Augsburg, 536 kc/s (560 m.); Kaiserslautern, 536 kc/s (560 m.); and Nürnberg, 1,256 kc/s (239 m.).

PARIS (France)
Poste Parisien. 914 kc/s (329 m.). 1.2 kW.
9.0 a.m.—Transmission of Pictures.
8.25 p.m.—Gramophone Records and News Bulletin.
8.45 p.m.—Talk on Sports, Gramophone Records and News Bulletin.

PARIS (France)
Radio-Paris (CFR). 174 kc/s (1,725 m.); 17 kW.
Transmits at intervals from 6.45 a.m. (Physical Culture).

5.20 p.m.—Time Signal, Weather Report, and Agricultural Notes.
5.30 p.m.—Review of Periodicals.
5.45 p.m.—French Language Lesson.
6.5 p.m.—Talk: The Psychological Problems of Age.
6.30 p.m.—Introductory Talk to the following Transmission.
6.35 p.m.—"Othello"—Tragic Opera in Four Acts (Verdi), relayed from the National Theatre.

Allmacht. Concerto in G Minor for Viola and Organ (Eccles). Sacred Songs for Soprano and Organ (Hugo Wolf): (a) Auf ein altes Bild, (b) Herr, was trägt der Boden hier, (c) Karwoche. Introduction and Fugue from the Sonata in D Minor, Op. 60 (Bach).
12.30 a.m. (Wednesday)—Close Down.

OSLO (Norway)
Kringkastingselskapet. 280 kc/s (1,071 m.); 75 kW. Relayed by Fredrikstad, 815 kc/s (358 m.); Hamar, 511 kc/s (587 m.); Notodden, 671 kc/s (447.1 m.); Porsgründ, 662 kc/s (453 m.); and Rjukan, 671 kc/s (447.1 m.).

PARIS (France)
Eiffel Tower (FLE). 207 kc/s (1,445 m.); 15 kW.
Time Signals (on 2,650 m.; 113 kc/s) at 9.25 a.m. and 10.25 p.m. (preliminary and 6-30 signals).
5.45 p.m.—Le Journal Parlé.
7.10 p.m.—Meteorological Forecast.
7.30 p.m.—Political Review, followed by Concert. Selections (Schumann): (a) Waldszene for Piano and Voice, (b) Song, Der arme Peter, (c) Sonata in A Minor for Violin and Piano, (d) Song, Das Ringlein, (e) Song, (f) Bilder aus dem Osten for Piano and Voice. Selections (Schubert): (a) Moment musical in A Flat Major, (b) Moment musical in F Minor, (c) Four Songs Geheimnis, Heidenröslein, Der Doppelgänger, and Die Forelle, (d) Two Impromptus in G Major and A Flat Minor.

PARIS (France)
Poste Parisien. 914 kc/s (329 m.). 1.2 kW.
9.0 a.m.—Transmission of Pictures.
8.25 p.m.—Gramophone Records and News Bulletin.
8.45 p.m.—Talk on Sports, Gramophone Records and News Bulletin.
9.0 p.m.—Concert with the collaboration of Artists from the Opéra and Opéra-Comique. Prelude to "Songs of Spain" (Albéniz). Humoresque (Dvorák). Symphonic Poem, Till Eulenspiegel (R. Strauss), conducted by M. Theodore Mathieu. Norwegian Rhapsody, Op. 17 (Svendsen). Eglogue (Rabaud). Russian Dance, Bourlák (Weksler). Ceremonial March (Suk).

PARIS (France)
Radio-Paris (CFR). 174 kc/s (1,725 m.); 17 kW.
Transmits at intervals from 6.45 a.m. (Physical Culture).

5.20 p.m.—Time Signal, Weather Report, and Agricultural Notes.
5.30 p.m.—Review of Periodicals.
5.45 p.m.—French Language Lesson.
6.5 p.m.—Talk: The Psychological Problems of Age.
6.30 p.m.—Introductory Talk to the following Transmission.
6.35 p.m.—"Othello"—Tragic Opera in Four Acts (Verdi), relayed from the National Theatre.
9.20 p.m.—Time Signal, Weather Report, News Bulletin, Sports Notes and Snow Report.
9.45 p.m.—Gramophone Concert.
11.30 p.m.—Night Concert (Munich and Zeesen, 31.38 m. only). Organ Concerto in F Major (Händel). Three Songs for Mezzo-Soprano (Schubert): (a) Im Abendrot, (b) Wanderers Nachtlied, (c) Der

nomie and Social Notes and News.
8.0 p.m.—"I Pagliacci"—Opera (Leoncavallo) and "Cavalleria Rusticana"—Opera (Mascagni). In the intervals at 8.30 p.m.—Sports Notes, Gastronomic Notes and Topical Review, and at 9.15 p.m.—Press Review, News and Time Signal.

POZNAŃ (Poland)
896 kc/s (335 m.); 1.9 kW. Also relayed on 9,830 kc/s (30.5 m.) from 12.5—1.0 p.m.
Transmits at intervals from 6.0 a.m. (Gymnastics).
4.30 p.m.—Debate on Principles.
4.45 p.m.—See Warsaw.
5.45 p.m.—Review of European Affairs.
6.0 p.m.—Reading: "The Crossroads" (Claudel).
6.15 p.m.—Elementary French Lesson.
6.30 p.m.—Talk: The Hygiene of Pronunciation.
6.40 p.m.—Miscellaneous Items and News.
7.0 p.m.—See Warsaw.
9.30 p.m.—Time, News, Sports and Police Notes.
9.45 p.m. (approx.)—Close Down.

ROME (Italy)
Ente Italiano Audizioni Radiofoniche (IRO). 680 kc/s (441 m.); 75 kW. Relayed by Naples, 905 kc/s (332 m.), and 2RO, 11,810 kc/s (25.4 m.).

SCHENECTADY (U.S.A.)
General Electric Company (WGY). 790 kc/s (379.5 m.); 50 kW. Relayed at intervals by W2XAF on 9,530 kc/s (31.48 m.) and by W2XAD on 15,340 kc/s (19.56 m.).

STOCKHOLM (Sweden)
Radiotjänst (SASA). 680 kc/s (436 m.); 75 kW. Relayed by Boden, 244 kc/s (1,227.5 m.); Göteborg, 932 kc/s (322 m.); Hörby, 1,166 kc/s (257 m.); Motala, 222.5 kc/s (1,348 m.); Östersund, 389 kc/s (770 m.); Sundsvall, 554 kc/s (542 m.).

STRASBOURG (France)
Radio-Strasbourg (PTT). 869 kc/s (345 m.); 15 kW.
Transmits at intervals from 11.30 a.m. to 6.0 p.m.—Operetta Music.
6.45 p.m.—Talk in German: The International Colonial Exhibition.
7.0 p.m.—Dance Music.
7.30 p.m.—News in French and German.
7.45 p.m.—Gramophone Records.
8.30 p.m.—Instrumental Concert.
10.30 p.m. (approx.)—Close Down.

TOULOUSE (France)
Radiophonie du Midi. 779 kc/s (385 m.); 8 kW.
Transmits at intervals from 12.45 p.m. to 7.0 p.m.—Russian Songs.
7.15 p.m.—Dance Music.
7.30 p.m.—Exchange Quotations and News.
7.45 p.m.—Musical Programme.
8.25 p.m.—Gramophone Records.
8.55 p.m.—Fashion Review.
9.0 p.m.—Time Signal.
9.2 p.m.—Sketch.
9.45 p.m.—Orchestral Music.
10.0 p.m.—Dance Music from the Café Sion. In the interval at 10.30 p.m.—News.
11.0 p.m.—Operetta Songs.
11.15 p.m.—North African News.
11.30 p.m.—Military Music.
11.45 p.m.—Vocal Tangos.
12 midnight (approx.)—Close Down.

VIENNA (Austria)
Radio-Wien. 581 kc/s (517 m.); 20 kW. Relayed by Graz, 851 kc/s (352 m.); Innsbruck, 1,058 kc/s (283 m.); Klagenfurt, 662 kc/s (453.2 m.); Linz, 1,220 kc/s (246 m.); and Salzburg, 1,373 kc/s (218 m.).

WARSAW (Poland)
Polskie Radio. 212 kc/s (1,411 m.); 158 kW.
Transmits at intervals from 10.40 a.m. to 1.20 p.m.—Economic Notes.
1.40 p.m.—Literary Talk: Jan Kochanowski.
2.0 p.m.—Talk: The Union of Lithuania and Poland.
2.20—2.35 p.m.—Interval.
2.35 p.m.—Talk on Aviation: By Aeroplane across Africa.
2.50 p.m.—Talk: Battles near Wawer and Dab Wielki.
3.10 p.m.—Marine Notes.
3.15 p.m.—Gramophone Records.
4.15 p.m.—Talk: The Scientific Organisation of Work.
4.45 p.m.—Concert by the Warsaw Philharmonic Orchestra. The Legend of St. George (Rytel). Italian Caprice (Tchaikovsky). Overture, "Tannhäuser" (Wagner).

# PROGRAMMES FOR WEDNESDAY (April 1)

**NOTE: THE HOURS OF TRANSMISSION ARE REDUCED TO GREENWICH MEAN TIME**

**ALGIERS (N. Africa)**  
825.3 kc/s (363.4 m.); 13 kW.  
12.30 p.m.—Gramophone Records.  
7.0 p.m.—Exchange; Market Prices, Weather, Agricultural Report and Shipping Notes.  
7.15 p.m.—Talk for Women.  
7.30 p.m.—Spanish Songs.  
7.50 p.m.—News Bulletin.  
8.0 p.m.—Orchestral Concert.  
8.30 p.m.—Review of New Books.  
8.45 p.m.—Concert of Russian Music.  
10.0 p.m.—Dance Music from the Hotel Aleitti.

**BARCELONA (Spain)**  
Radio-Barcelona (EA1). 860 kc/s (349 m.); 8 kW.  
Transmits at intervals from 8.0 a.m. (Radio Journal).  
4.30 p.m.—Exchange, Market Prices and Concert. March, Darcia (Terrés). Gramophone Record: Prelude in E Flat Minor (Bach). Barcarolle (Albeniz). Lamento de amor (Canals). Gramophone Record: Selection from "Il Re Pastore" (Mozart). Fest der Zwerge (Noack).  
6.0 p.m.—Trio Music and News.  
7.0 p.m.—Gramophone Records.  
8.30 p.m.—Elementary French Lesson.  
9.0 p.m.—Chimes, Weather and Exchange, followed by Fortnightly Report of the Municipal Institute of Hygiene.  
9.5 p.m.—Orchestral Concert. Overture, "L'enfance du Christ" (Berlioz). Autumn Song (Elgar). Erikning (Schubert). Le Matin (Chaminade). Près du berceau (Moszkovsky). Gavotte en rondeau (Lully). Meditation from "Thais" (Massenet).  
10.0 p.m.—News Bulletin.  
10.5 p.m.—Reading from the Works of Miguel Nieto.  
10.20 p.m.—Orchestral and Vocal Concert. Prelude to the First Act of "Lohengrin" (Wagner). Aria (Händel). Song (Fauré). Sara-bande for String Quintet (Saint-Saëns). Two Sacred Songs (Bach). Adagio from the Concerto in B Flat, Op. 4, No. 6, for Organ and Orchestra (Händel). Sacred Song and Aria No. 47 from "The Passion according to St. Matthew" (Bach). Adagio from the Concerto in D Minor, Op. 7, No. 4, for Pianoforte and Orchestra (Händel).  
12 midnight (approx.)—Close Down.

**BRUSSELS (Belgium)**  
Radio-Belgique. 590 kc/s (509 m.); 20 kW.  
5.0 p.m.—Dance Music.  
6.0 p.m.—Organ Recital from the Carmelite Church.  
6.45 p.m.—Gramophone Records.  
7.15 p.m.—Talk (to be announced).  
7.30 p.m.—Le Journal Parlé.  
8.0 p.m.—Gramophone Records (Gershwin): (a) Concerto in F, (b) Rhapsody in Blue.  
8.30 p.m.—Concert relayed from the Palais des Beaux-Arts. In the interval, Debate: Is it necessary to speak Esperanto?  
10.0 p.m.—Le Journal Parlé.

**BRUSSELS No. 2 (Belgium)**  
887 kc/s (338.2 m.); 20 kW.  
Programme in Flemish.  
5.0 p.m.—Gramophone Records.  
6.0 p.m.—Dance Music.  
6.30 p.m.—Selections from the Works of De Boeck.  
6.45 p.m.—Gramophone Records.  
7.15 p.m.—Talk: April Fool's Day.  
7.30 p.m.—Le Journal Parlé.  
7.55 p.m.—Theatre Talk.  
8.0 p.m.—Gramophone Records.  
8.45 p.m.—Review of Books.  
9.0 p.m.—Dance Music.  
10.0 p.m.—Le Journal Parlé.

**BERLIN (Germany)**  
Königs Wusterhausen. 183 kc/s (1,635 m.); 35 kW.  
Transmits at intervals from 5.20 a.m. (Hamburg Relay).  
3.30 p.m.—Concert from Hamburg.  
4.30 p.m.—Talk: Passion Poems and Passion Songs.  
5.0 p.m.—Shortland Lesson.  
5.30 p.m.—Educational Talk: The Conquest of the World.  
6.0 p.m.—Talk for Civil Servants.  
6.30 p.m.—Talk: The Drop in the Costs of Building.  
6.55 p.m.—Weather for Farmers.  
7.0 p.m. till Close Down.—See Berlin (Witzleben).

**BERLIN (Germany)**  
Witzleben. 716 kc/s (418 m.); 1.7 kW.  
Transmits at intervals from 6.0 a.m. (Gymnastics).  
5.10 p.m.—Concert of Light Music.  
7.0 p.m.—Review of Gramophone Records.  
7.30 p.m.—Ballads, Tales and Romances.  
9.0 p.m.—Weather, News and Sports Notes.  
9.30 p.m.—Concert of Light Music.  
11.30 p.m.—Mozart Concert. Overture, "Titus." Eine kleine Nachtmusik. Ballet Suite, Les petits riens. Overture, "The Marriage of Figaro."

**BERNE (Switzerland)**  
Radio-Bern. 743 kc/s (403 m.); 1.1 kW.  
Transmits at intervals from 9.45 a.m.  
5.15 p.m.—Gramophone Records.  
6.0 p.m.—Talk on Butter.  
6.28 p.m.—Time and Weather.  
6.30 p.m.—Talk: A Newspaper Reporter, relayed from Zürich, 653 kc/s (459 m.).  
7.0 p.m.—Programme of Orchestral Music, Songs and Recitations.  
8.55 p.m.—News and Weather.  
9.10 p.m.—Running Commentary on the Boxing Match, relayed from

the Kuchlintheater, Basle, 1,229 kc/s (244.1 m.).  
9.40 p.m. (approx.)—Close Down.

**BORDEAUX-LAFAYETTE (France)**  
(PTT). 986 kc/s (304 m.); 35 kW.  
Transmits at intervals from 12.45 p.m.  
7.30 p.m.—News and Market Prices.  
7.40 p.m.—Gramophone Records.  
7.55 p.m.—Results of the Prize Draw.  
8.0 p.m.—Agricultural Report.  
8.15 p.m.—Charades.  
8.30 p.m.—Orchestral Concert with Soprano and Tenor Solos. After the Programme, Amusement Guide and Time Signal.

**BRESLAU (Germany)**  
923 kc/s (325 m.); 1.7 kW.  
Relayed by Gleiwitz, 1,184 kc/s (253 m.).  
Transmits at intervals from 10.15 a.m.  
6.0 p.m.—Weather for Farmers, followed by Orchestral Concert.  
7.0 p.m. (from Gleiwitz).—Weather Report and Talk: Colonial Industries.  
7.30 p.m.—April! Humorous Programme of Music and Literature.  
8.20 p.m.—Orchestral Concert.  
9.10 p.m.—Time, Weather, News, Sports Notes and Programme Announcements.  
9.30 p.m.—See Berlin (Witzleben).  
11.30 p.m. (approx.)—Silent Night.

**BRUSSELS (Belgium)**  
Radio-Belgique. 590 kc/s (509 m.); 20 kW.  
5.0 p.m.—Dance Music.  
6.0 p.m.—Organ Recital from the Carmelite Church.  
6.45 p.m.—Gramophone Records.  
7.15 p.m.—Talk (to be announced).  
7.30 p.m.—Le Journal Parlé.  
8.0 p.m.—Gramophone Records (Gershwin): (a) Concerto in F, (b) Rhapsody in Blue.  
8.30 p.m.—Concert relayed from the Palais des Beaux-Arts. In the interval, Debate: Is it necessary to speak Esperanto?  
10.0 p.m.—Le Journal Parlé.

**BRUSSELS No. 2 (Belgium)**  
887 kc/s (338.2 m.); 20 kW.  
Programme in Flemish.  
5.0 p.m.—Gramophone Records.  
6.0 p.m.—Dance Music.  
6.30 p.m.—Selections from the Works of De Boeck.  
6.45 p.m.—Gramophone Records.  
7.15 p.m.—Talk: April Fool's Day.  
7.30 p.m.—Le Journal Parlé.  
7.55 p.m.—Theatre Talk.  
8.0 p.m.—Gramophone Records.  
8.45 p.m.—Review of Books.  
9.0 p.m.—Dance Music.  
10.0 p.m.—Le Journal Parlé.

**BUDAPEST (Hungary)**  
545 kc/s (550 m.); 23 kW.  
Transmits at intervals from 8.15 a.m. (Gramophone Records).  
6.15 p.m.—Answers to Correspondence.  
7.0 p.m.—Artists' Evening.  
9.15 p.m.—Pianoforte Recital, followed by Tzigane Concert from the Hotel Britannia.

**COLOGNE (Germany)**  
Westdeutscher Rundfunk. 1,319 kc/s (227 m.); 1.7 kW.  
See Langenberg Programme.

**COPENHAGEN (Denmark)**  
1,067 kc/s (281 m.); 1 kW. Relayed by Kalundborg, 260 kc/s (1,153 m.).  
Transmits at intervals from 6.30 a.m. (Gymnastics).  
2.30 p.m.—Orchestral Concert from the Wivel Restaurant.  
3.15 p.m. (in the interval).—Programme for Women.  
4.0 p.m.—Programme for Boys.  
4.40 p.m.—Exchange Quotations and Fish Market Prices.  
4.55 p.m.—Talk: Scandinavian Co-operation in Geneva, relayed from Geneva.  
5.20 p.m.—French Language Lesson.  
5.50 p.m.—Weather Report.  
6.0 p.m.—News and Report of the Non-Political Danish Radio Club.  
6.15 p.m.—Time Signal.  
6.30 p.m.—Agricultural Talk.  
6.30 p.m.—Town Hall Chimes.  
7.2 p.m.—Concert of German Folk Music. Torgauer Marsch. Fantasia on Carinthian Folk Melodies. Folk Songs: (a) Du, du liegst mir am Herzen, (b) Drünten im Unterland, (c) The Loreley, (d) Heimliche Liebe, (e) Ein Jäger aus Kurpfalz. Silesian Folk Songs to Violin accompaniment. Two Swabian Dances (Urbach). Folk Songs: (a) Untreu (Glück), (b) Warnung, (c) Freudvoll and leidvoll, from Goethe's "Egmont"

(Reichardt), (d) Freut euch des Lebens (Nägeli). Country Dance, Frohsinn auf den Bergen (arr. O. Fetras). Old Hunting March.  
8.0 p.m.—Recital of Modern Pianoforte Music. Dance Piece, No. 3 (Hindemith). Suite (Erwin Schulhoff). Bagatelle, Op. 6, No. 5 (Béla Bartok).  
8.15 p.m.—Humoresques (Deuschlöff).  
8.40 p.m.—Concert of Old Danish Songs.  
8.55 p.m.—News Bulletin.  
9.10 p.m.—Concert of Chamber Music. Quintet for Two Violins, Viola, Cello and Pianoforte in F Minor, Op. 34 (Brahms).  
9.50 p.m. (approx.)—Close Down.

**CORK (Ireland)**  
(6CK). 1,337 kc/s (225 m.); 1.5 kW.  
No Transmission.

**CRACOW (Poland)**  
Polskie Radio. 959 kc/s (312.8 m.); 1.5 kW.  
Transmits at intervals from 10.40 a.m.  
4.45 p.m.—See Warsaw.  
5.45 p.m.—Miscellaneous Items, News and Programme Announcements.  
6.10 p.m.—Agricultural Report.  
6.25 p.m.—See Warsaw.  
6.30 p.m.—Gramophone Records.  
6.40 p.m.—Radio Journal.  
7.0 p.m.—Answers to Correspondents.  
7.15 p.m.—See Warsaw.  
7.30 p.m.—See Poznań.  
8.45 p.m.—Literary Programme, relayed from Wilno, 215 kc/s (368.1 m.).  
9.15—10.0 p.m.—See Warsaw.  
10.0 p.m. (approx.)—Close Down.

**DUBLIN (Ireland)**  
(2 R.N.) 725 kc/s (413 m.); 1.5 kW.  
No Transmission.

**FRANKFURT-am-MAIN (Germany)**  
770 kc/s (390 m.); 1.7 kW.  
Relayed by Cassel, 1,220 kc/s (246 m.).  
Transmits at intervals from 5.15 a.m. (Mühlacker Relay).  
6.10 p.m.—Time, Weather and Economic Notes.  
6.15 p.m.—See Mühlacker.  
6.45 p.m.—Cello Recital.  
7.45 p.m.—See Mühlacker.  
8.15 p.m.—Time, Weather, News and Sports Notes.  
8.35 p.m.—Variety Programme.  
11.0 p.m. (approx.)—Close Down.

**HAMBURG (Germany)**  
Norb (ha, in Morse). 806 kc/s (372 m.); 1.7 kW. Relayed by Bremen, 1,112 kc/s (270 m.); Flensburg, 1,373 kc/s (218 m.); Hanover, 530 kc/s (566 m.); and Kiel, 1,292 kc/s (232.2 m.).  
Transmits at intervals from 5.20 a.m. (Time and Weather).  
11.30 a.m.—Orchestral Concert. Selection from "Die Bajadere" (Kálmán). Meioldy, La Cloche (Saint-Saëns). Little Serenade (Billi). Fantastic Waltz (Heinecke). Overture, "Egmont" (Beethoven). Selection from "Manon Lescaut" (Puccini).  
11.55 a.m.—Time Signal.  
1.0 p.m.—Weather and Ice Report.  
1.15 p.m.—Gramophone Records.  
1.45 p.m.—Hanover Cattle Market Prices.  
1.50 p.m.—Exchange Quotations.  
2.25 p.m.—Shipping Forecast.  
2.40 p.m.—Exchange Quotations.  
3.15 p.m.—Orchestral Concert of Dances. German Rocco—a Suite of Old Dances (Günther). Ballet Music from "The Demon" (Rubinstein). Symphonic Waltz, Olafs Hochzeitsreigen (Ritter). Austrian Dances (Bittner). Waltz, Liebesstunden (v. Briesen).  
4.30 p.m.—Talk: Hamburg Penal Law Questions.  
4.55 p.m. (from Bremen).—Talk on Employers' Insurance.  
5.15 p.m.—Variety Programme.  
6.0 p.m.—Talk: Mecklenburg as a North German Colony.  
6.25 p.m.—Exchange Quotations.  
6.30 p.m.—Talk on Topical Questions.  
6.55 p.m.—Weather Report.  
7.0 p.m.—"The Naked Truth"—A Grotesque Wireless Comedy (Carl Bretschneider).  
8.15 p.m.—News Bulletin.  
8.25 p.m.—Concert of Fantasias and Parodies. Fantasia-Overture, Romeo and Juliet (Tchaikovsky). L'apprenti sorcier (Dukas). Two Etudes from "Dr. Faust" (Busoni): (a) Sarabande and Cortège, (b) Church Scene. The Witch Scene

from "Walpurgisnacht" (Mendelssohn). Seltsamer Traum (Nicodé). Two Selections from the Fantastic Symphony (Berlioz). Songs: (a) Mephistopheles' Serenade from the Fourth Act of "Faust" (Gounod), (b) Rondo of the Golden Calf from the Second Act of "Faust" (Gounod). Dance of the Seven Veils from "Salome" (R. Strauss). Ride of the Witches from "Hansel and Gretel" (Humperdinck). Duet from "The Tales of Hoffmann" (Offenbach). Prelude to the Fifth Act of "Die versunkene Glocke" (Zöllner). Finale from "La belle Hélène" (Offenbach).  
10.25 p.m.—News Bulletin.  
10.50 p.m.—Ice Report.

**HEILSBURG (Germany)**  
1,085 kc/s (276.5 m.); 75 kW.  
Relayed by Danzig, 662 kc/s (453 m.).  
Transmits at intervals from 5.30 a.m. (Gymnastics).  
6.25 p.m.—Talk: Bismarck and Women.  
6.55 p.m.—Weather Report.  
7.0 p.m.—See Berlin (Witzleben).  
11.30 p.m. (approx.)—Close Down.

**HILVERSUM (Holland)**  
1,004 kc/s (298 m.); 8.5 kW.  
8.40—9.40 a.m.—Programme of the Workers' Radio Society (V.A.R.A.). Gramophone Records.  
9.40 a.m.—Programme of the Liberal Protestant Radio Society (V.P.R.O.). Religious Transmission.  
9.55 a.m. till Close Down.—Programme of the V.A.R.A.  
9.55 a.m.—Talk by Mr. Kers.  
10.40 a.m.—Gramophone Records.  
10.45 a.m.—Educational Talk.  
11.15 a.m.—Septet Concert, Variety Items and Gramophone Records.  
1.55 p.m.—Gramophone Records.  
2.5 p.m.—Programme for Women.  
3.0 p.m.—Talk (to be announced).  
3.15 p.m.—Dressmaking Lesson.  
4.5 p.m.—Gramophone Records.  
4.10 p.m.—Programme for Children.  
5.40 p.m.—Mandoline Concert.  
6.10 p.m.—Mandoline Lesson.  
6.40 p.m.—Educational Talk.  
7.10 p.m.—An Address.  
7.30 p.m.—Gramophone Records.  
7.50 p.m.—Orchestral Concert, conducted by Hugo de Groot, relayed from Zutphen.  
8.20 p.m.—"Warenar"—Wireless Play.  
10.20 p.m.—Gramophone Records.  
10.40 p.m.—News Bulletin.  
10.50 p.m.—Gramophone Records.  
11.40 p.m. (approx.)—Close Down.

**HUIZEN (Holland)**  
160 kc/s (1,875 m.); 8.5 kW  
7.40 a.m. till Close Down.—Programme of the Christian Radio Society (N.C.R.V.).  
7.40 a.m.—Time and Reading.  
7.55 a.m.—Gramophone Concert.  
10.10 a.m.—Service for Hospitals.  
10.40 a.m.—Harmonium Recital, with Contralto and Soprano Solos.  
11.40 a.m.—Police Notes.  
12.10 p.m.—Instrumental Concert. Song Cycle for Violin, Flute, Cello and Organ. Sonata for "Cello and Pianoforte (Birkenstock). Largo for Cello and Pianoforte (Eccles). Song without Words for Violin, Flute, Cello and Pianoforte (Mendelssohn). Cycle of Dutch Folk Songs for Flute, Violin, Cello and Pianoforte.  
1.40 p.m.—Concert of Classical Music on Gramophone Records.  
2.40 p.m.—Vocal and Instrumental Concert. Soprano Solo: Ich bin vernügt in meinem Leiden (J. S. Bach). Aria for Soprano from "Ottone" (Händel). Sonata for Violin and Pianoforte (Locatelli). Soprano Solo: S'io non vedo Alidoro—with Violin and Pianoforte accompaniment (Cesti). Aria for Soprano, Quoniam (Hasse). Soprano Solo: Più non ti voglio credere, with Violin and Pianoforte accompaniment (Bononcini). Scherzo for Pianoforte (Chopin). Two Songs for Soprano (Brahms): (a) O wüsst ich doch den Weg zurück, (b) Immer leiser wird mein Schlummer. Duet for Violin and Pianoforte (Schubert). Soprano Solo: Ich bin der Welt abhanden gekommen (Mahler).  
4.10 p.m.—Gramophone Concert.  
4.25 p.m.—Programme to be announced.  
4.40 p.m.—Talk by H. J. Steinvoort.  
5.10 p.m.—Agricultural Talk.  
5.55 p.m.—Gramophone Records.  
6.10 p.m.—A Visit from the Radio Doctor.

6.40 p.m.—Programme arranged by the Department of Buildings and Roads.  
7.10 p.m.—Police Notes.  
7.40 p.m.—Instrumental Concert and Talk: Along the Via Dolorosa at Jerusalem.  
9.40 p.m. (in an interval).—News.  
10.10 p.m.—Gramophone Records.  
11.10 p.m. (approx.)—Close Down.

**JUAN-LES-PINS (Nice) (France)**  
1,205 kc/s (249 m.); 1.2 kW  
12.30 p.m.—News, Amusement Guide and Concert. Selection from "Rosamunde" (Schubert). La Campanella (Paganini-Liszt). Staccato (Rubinstein). Selection from "Carmen" (Bizet). Selection from "Werther" (Massenet). Trümmererei (Schumann). Melody in F (Rubinstein). Selection from "Les cent vierges" (Leococq). Selection from "La mascotte" (Audran). Intermezzo from "L'arlesienne" (Bizet). Santissima! (Corelli). Chaconne (Durand). Berceuse from "Jocelyn" (Godard). Overture, "Mireille" (Gounod). Serenade (Moszkovsky). La Serenata (Braga). Serenade for Organ (Drigo). Serenade (Schubert). The Anchor's weigh (Zimmermann). All hands (Benter).  
2.0 p.m.—The Marseillaise.  
2.10 p.m. (approx.)—8.0 p.m.—Interval.  
8.0 p.m.—News, Amusement Guide, and Weather Report.  
8.30 p.m.—Agricultural Report, Astro-nomical Talk, and Talk by M. Anterieu Vons, Commissioner of Woods and Forests, followed by Radio Cabaret Programme with the assistance of the Singer Dominus Henri Yan, Mme. Zévaco and Tadiolo.  
10.0 p.m.—The Marseillaise and Close Down.

**KALUNDBORG (Denmark)**  
Kalundborg Radio. 260 kc/s (1,153 m.); 10 kW.  
See Copenhagen Programme.

**KÖNIGSBERG (Germany)**  
Ostmarken Rundfunk. 1,382 kc/s (217 m.); 1.7 kW.  
See Heilsberg Programme.

**LANGENBERG (Germany)**  
Westdeutscher Rundfunk. 635 kc/s (473 m.); 17 kW. Relayed by Aachen, Cologne and Münster, 1,319 kc/s (227 m.).  
Transmits at intervals from 5.45 a.m. (Lesson in Self-defence).  
12.5 p.m.—Orchestral Concert, conducted by Wolf. Hamlet Overture (Gade). Arabian Suite (Leopold). Adagio (Kodaly). Selections from "Eugen Onegin" (Tchaikovsky). Overture, "Giralda" (Adam). Scherzo, Sonnenkind und Wolken-mann (Clemus). Selection from "Die Puppe" (Bayer).  
2.30 p.m.—Tidal Report, Time Signal and Economic Notes.  
2.50 p.m.—Programme for Children.  
3.30 p.m.—Talk: Holidays from the Point of View of the Teacher and the Doctor.  
4.0 p.m.—Vocal and Instrumental Concert. Pianoforte Solo: Sonata in C Major (Mozart). Chiemsee-Terzette (Hermann Zilcher): (a) Fliege hin im Abendlicht, (b) Musikalisch bist du nicht, (c) Am Hügelraum kennst du den Mauerrand? (d) Intermezzo—Bavarian Scherzo, (e) Du meinst, du bist am Ende. Three Pianoforte Pieces from my Diary (Reger). Songs (Mendelssohn): (a) Schönheit, (b) Herbst, (c) Fernweh, (d) Immer wenn der Märzwind weht. Pianoforte Solo: Cuckoo Variations (Hermann Reutter).  
5.0 p.m.—Talk for Women: Legal Questions in Marriage—Maintenance.  
5.20 p.m.—Review of Books by Modern German Authors.  
5.40 p.m.—Talk on Unemployment.  
6.0 p.m.—Weather Report, Time Signal, Economic and Sports Notes.  
6.15 p.m.—Topical Talk.  
6.25 p.m.—Talk for Workers: The Health Insurance of the Unemployed.  
6.45 p.m.—Concert by the Little Station Orchestra, conducted by Eysoldt. Overture, "In the Spring-time of Life" (Mouton). Waltz Frühlingsstimmen (Joh. Strauss). Country Suite (Scassola). Japanese Lantern Dance (Yoshitomo). Descriptive Piece, Frühling am Mühlbach (Zimmer). Potpourri of

Programmes for Wednesday—(Cont.)

Popular Songs: Alles singt mit! (Recktenwald). 7.30 p.m.—An April Programme, followed by News, Sports Notes, Concert and Dance Music. 11.0 p.m. (approx.)—Close Down.

LEIPZIG (Germany)

Mitteldeutscher Rundfunk. 1,157 kc/s (259 m.); 2.3 kW. Relayed by Dresden, 941 kc/s (319 m.). Transmits at intervals from 9.0 a.m. (Economic Prices). 3.30 p.m.—Orchestral Concert. To Spring. 4.30 p.m.—Weather and Time. 4.55 p.m.—Economic Notes. 5.0 p.m.—Educational Talk: All Education is Self-Taught. 5.30 p.m.—Italian Language Lesson. 5.50 p.m.—Talk: To be announced. 6.0 p.m.—Talk: The Balances of the Great German Banks. 6.30 p.m.—Talk and Readings: Modern German Women's Literature.

7.0 p.m.—Concert of Mandoline and Guitar Music. Barcarolle, Return of the Fishermen (Marzuttini). Zither Selection: March, Old Munich (Reiter). Spanish Dance (Schmeling). Zither Selection: Potpourri, Alplers Traumbild (Bösch). Intermezzo, Murrning of the Sea (Salveti). Zither Selection: Miesbacher Schnackler (Bauer). 7.40 p.m.—Talk: The New Wireless House.

8.10 p.m.—Concert by the Leipzig Symphony Orchestra. Symphony in E Flat Major (K. F. Abel). Concerto for Trumpet and Orchestra in D Major (Leopold Mozart). Concerto grosso for Oboe, Violin, Cello, String Orchestra and Pianoforte, Op. 51 (Emborg). Irish Rhapsody in A Major. (Herbert.) 9.15 p.m.—News Bulletin, followed by Concert of Light Music. 10.30 p.m. (approx.)—Close Down.

LJUBLJANA (Yugoslavia)

Radio-Ljubljana. 522 kc/s (574.7 m.); 2.8 kW. Transmits at intervals from 11.15 a.m. 5.0 p.m.—Orchestral Concert. 6.0 p.m.—Journalistic Report. 6.30 p.m.—Russian Lesson.

7.0 p.m.—Sokol Programme. 7.30 p.m.—Violin Recital. 9.0 p.m.—Weather and News.

MADRID (Spain)

Union Radio (EAJ7). 707 kc/s (424 m.); 2 kW. Transmits at intervals from 8.0 a.m. (Topical Review). 2.0 p.m.—Chimes, Time Signal, Weather Report and Concert. Overture, Fingal's Cave (Mendelssohn). Song, Ich trage meine Minna (Strauss). Selection from "La Bejarana" (Serrano and Alonso). Selection from "The Puritans" (Bellini). Hindu Song (Rimsky-Korsakoff). Prelude to the Third Act of "Lohengrin" (Wagner).

3.20 p.m.—Theatre Notes and News. 3.30—7.0 p.m.—Interval. 7.0 p.m.—Chimes, Exchange Quotations, Market Prices and Topical Review—Special Section: Programme for Women.

7.30 p.m.—Dance Music. 8.5 p.m.—Talk: Fruit Trees. 8.25 p.m.—News Bulletin. 8.30—9.15 p.m.—Interval. 9.15 p.m.—Lesson in English Pronunciation by Mr. Philips. 9.30 p.m.—Chimes, Time Signal, Exchange Quotations and Organ Recital: Adaptation of an Easter Eclogue (Gil Vicente), followed by the Third Act of "Parsifal"—Opera (Wagner) and News Bulletin. 12 midnight.—Chimes and Close Down.

MILAN (Italy)

Ente Italiano Audizioni Radiofoniche. 599 kc/s (501 m.); 8.5 kW. Programme relayed by Turin, 1,013 kc/s (296 m.); and Genoa, 958 kc/s (313.2 m.). Transmits at intervals from 7.15 a.m. (Giornale radio).

6.30 p.m.—Concert of Light Music. Spain (Dreyer). Serenata patetica (Frontini). Selection from "Cloclo" (Lchár). Danza illyrica (Escobar). Waltz, The Butterfly (Friml). Turkish March (Mozart). Caccia (Magro). 7.0 p.m.—Time, Announcements, Giornale radio and Weather. 7.20 p.m.—Medical Talk.

7.35 p.m.—"Mario e Maria"—Comedy in One Act (Zorzi). 8.10 p.m.—"Donna Juanita"—Operetta (Suppé). In the intervals: Talk on the Scientific Organisation of Work and Giornale radio. After the Programme: Concert from the Sala Gay, Turin. 10.55 p.m. (approx.)—News.

MOTALA (Sweden)

222.5 kc/s (1,348 m.); 40 kW. See Stockholm Programme.

MÜHLACKER (Germany)

Süddeutscher Rundfunk. 833 kc/s (360 m.); 75 kW. Relayed by Freiburg, 527 kc/s (570 m.). Transmits at intervals from 5.15 a.m. (Time, Weather and Gymnastics).

3.30 p.m.—Orchestral Concert. 5.0 p.m.—Time, Weather and Agricultural Notes. 5.15 p.m.—Talk: Alsatians in the Mannheim Court Orchestra. 5.45 p.m.—Talk: From Andree to Nobile. 6.10 p.m.—Time Signal. 6.15 p.m.—Talk: The Agricultural Labour Pact. 6.45 p.m.—See Frankfurt. 7.45 p.m.—"Mixed Winter Salad"—Wireless Play of Sportsmen, Globe-trotters and Criminals (Curt Elwenspöck). 8.15 p.m.—Programme Announcements, News and Weather. 8.35 p.m.—See Frankfurt.

MUNICH (Germany)

563 kc/s (533 m.); 1.7 kW. Relayed by Augsburg, 536 kc/s (560 m.); Kaiserslautern, 536 kc/s (560 m.); and Nürnberg, 1,256 kc/s (239 m.). Transmits at intervals from 5.45 a.m. (Gymnastics).

1.0 p.m.—Time, Weather, Programme Announcements, News, Exchange Quotations and Advertisements. 2.45 p.m. (from Nürnberg).—Reading: Three Anecdotes (J. P. Hebel). 3.5 p.m.—Time, Weather and Agricultural Notes. 3.20 p.m.—Programme for Children. 4.20 p.m.—Chamber Music by the Zagreb String Quartet. 5.20 p.m.—Time, Weather and Agricultural Notes. 5.30 p.m. (from Nürnberg).—Lesson in Esperanto.

5.50 p.m.—Talk by Dr. Paul Rohrbach: Fifteen Minutes' World History. 6.5 p.m.—Herbert Eulenberg reads from his own Works.

6.30 p.m.—Military Music by the Johann Schwarz Orchestra. March of the First Battalion of the Guards, 1806. Overture, "Le postillon de Longjumeau" (Adam). Walter's Prize Song from "The Mastersingers" (Wagner). Waltz, Lotosblumen (Ohlsen). Selections from "Lilac Time" (Schubert-Berté). Wanderlieder-Marsch (J. Schwarz).

7.30 p.m.—"Hannibal and Scipio"—a Fragment (Franz Grillparzer).

7.45 p.m.—Orchestral Concert, conducted by Hans A. Winter. Overture, "Maritana" (Wallace). Prélude a l'après-midi d'un faune (Debussy). Danse macabre (Saint-Saëns). Suite from the Pantomime, "Glasbläser und Dozressa" (Reuss). Overture, "Tannhäuser" (Wagner). 8.50 p.m.—Tenor Song Recital by August Richter of Berlin. Richard Staab at the Pianoforte. 9.20 p.m.—Time Signal, Weather, News Bulletin and Sports Notes. 9.45 p.m.—Concert by the Georg Frank Orchestra, relayed from the Café Stadt Wien. 11.0 p.m. (approx.)—Close Down.

OSLO (Norway)

Kringkastingselskapet. 280 kc/s (1,071 m.); 75 kW. Relayed by Fredrikstad, 815 kc/s (368 m.); Hamar, 511 kc/s (587 m.); Notodden, 671 kc/s (447.1 m.); Porsgrund, 662 kc/s (453 m.); and Rjukan, 671 kc/s (447.1 m.). Transmits at intervals from 10.10 a.m.

4.0 p.m.—Orchestral Concert from the Cecil Restaurant. 5.0 p.m.—Cabaret Programme. 5.30 p.m.—Programme for Girls: Talk and Songs: Easter Melodies. 6.0 p.m.—Announcements, Weather and News. 6.30 p.m.—Song Recital. 7.0 p.m.—Talk. 7.30 p.m.—Orchestral Concert. Symphony in B Flat Major (Schumann). Symphonic Poem, Die Moldau (Smetana). 8.35 p.m.—Weather and News. 8.50 p.m.—Topical Talk.

9.5 p.m.—Gramophone Dance Music. 11.0 p.m. (approx.)—Close Down.

PARIS (France)

Eiffel Tower. (FLE). 207 kc/s (1,445 m.); 15 kW. Time Signals (on 2,650 m., 113 kc/s) at 9.25 a.m. and 10.25 p.m. (preliminary and 6-dot signals).

5.45 p.m.—Le Journal Parlé. 7.10 p.m.—Meteorological Forecast. 7.30 p.m.—Symphony Concert under the direction of M. Edouard Flament. Overture, "Piccolino" (Guiraud-Mouton). Minuet (Mozart-Woodhouse). Maitag for Violin (Ed. Flament). En révant (Fl. Schmitt). Campana a sera (Billi). Hungarian Dances (Brahms). 8.0 p.m.—Programme for Children.

PARIS (France)

Poste Parisien. 914 kc/s (329 m.); 1.2 kW.

9.0 a.m.—Picture Transmission. 8.25 p.m.—Gramophone Records, Talk and News Bulletin. 9.0 p.m.—Concert with the collaboration of Artists from the Opéra and Opéra-Comique. Overture, La belle meunière (Michiels). Songs: Le paon, Le grillon and Le cygne; from "Histoires naturelles" (Ravel). Pianoforte Solo: Variations, Interlude and Finale on a Theme by Rameau (Dukas). Irish Melodies (Myddleton). Night in the Bay of Palma (Turina). Rustic Scenes (Fletcher). Prelude, Recitative and Variations for Flute and Viola (Duruffé). First Suite from "Petites Musiques" (Florent Schmitt). La Belle au bois dormant (Debussy). Selection from "Boccaccio" (Suppé). Berceuse (Ravel). Waltz, Vision (Waldteufel).

PARIS (France)

Radio-Paris (CFR). 174 kc/s (1,725 m.); 17kW. Transmits at intervals from 6.45 a.m. (Physical Culture). 12.30 p.m.—Gramophone Records. 1.0 p.m.—Exchange Quotations and News. 1.5 p.m.—Gramophone Concert. Paraphrase on Verdi's "Il Trovatore" (arr. A. Lange). Pastiches musicaux (Bétove). Variations on a Popular Song for Pianoforte:

THE WORLD-RADIO BROADCASTING MAP OF EUROPE

You need to keep a map permanently at the side of your set. It is invaluable with a frame aerial, or any portable set. It is essential for the enthusiast who is working all out for long distance stations. This map, published by the British Broadcasting Corporation, was prepared under the advice of the Hydrographer to the Royal Navy. It is mounted on linen 36" x 34", printed in colour, and absolutely accurate. It costs three shillings post free, of the Publications Dept., B.B.C., Savoy Hill, W.C.2

The



D.C. to A.C.

ROTARY TRANSFORMER

SOLVES THE

D.C.

TO

A.C.

PROBLEM

D.C. Mains need not prevent your using an A.C. All Electric Receiver. Use an M-L D.C. to A.C. Rotary Transformer and operate your set from mains, private house plant or L.T. Accumulator. Can be supplied to run from any voltage 12-250 V.D.C. 40 watt model £13; 85 watt model £17. Send coupon today for "The Book of the M-L Rotary Transformer."

The M-L Magneto Synd. Ltd., Radio Dept. F., Coventry. Telephone: 5001.

Contractors to the Air Ministry, the B.B.C., the G.P.O., Marconiphone, The Gramophone Co. Ltd., etc. etc.

To The M-L Magneto Synd. Ltd., Radio Dept. F., Coventry.

Please send me free copy of "The Book of the M-L Rotary Transformer."

Name.....

Address.....



Programmes for Wednesday—(Cont.)

From Mozart to Hindemith (Lederer). Imitations. Potpourri of Wagner's Works for Piano and Violin. Duet: Bayreuth-Souvenirs (Faure-Messager). Chopiniana for Piano. Isoldina for Piano (Doucet). Parody on "Carmen" (Bizet, arr. Cole). In the intervals at 1.30 p.m.—Exchange Quotations, and at 2.0 p.m.—Exchange Quotations and Market Prices.  
 3.30 p.m.—Exchange Quotations.  
 5.55 p.m.—Agricultural Report and Racing Results.  
 6.30 p.m.—Gramophone Concert of Music Hall Items.  
 7.0 p.m.—Talk on Horticulture.  
 7.15 p.m.—Talk: French Archaeologists in Syria.  
 7.30 p.m.—Medical Talk: The Danger of Whooping Cough.  
 7.45 p.m.—Commercial Prices, Economic and Social Notes and News.  
 8.0 p.m.—Readings from the Works of Francois Villon on the Fifth Centenary of his Birth.  
 8.30 p.m.—Sports Results.  
 8.35 p.m.—Fashion Review.  
 8.40 p.m.—Announcements.  
 8.45 p.m.—Gramophone Records.  
 9.0 p.m.—"The Redemption"—Oratorio (Gounod) relayed from the Church of St. Nicolas-des-Champs. In the interval, Press Review, News and Time Signal.

POZNAŃ (Poland)

896 kc/s (335 m.); 1.9 kW. Also relayed on 9,830 kc/s (30.5 m.) from 7.30—9.15 p.m.  
 Transmits at intervals from 6.15 a.m. (Radio Journal).  
 4.0 p.m.—Programme for Children.  
 4.45 p.m.—See Warsaw.  
 5.45 p.m.—Review of New Books.  
 6.0 p.m.—Talk on Aviation.  
 6.10 p.m.—Bolshevist Report.  
 6.20 p.m.—Musical and Literary Programme for Soldiers.  
 7.0 p.m.—Topical Talk.  
 7.15 p.m.—Miscellaneous Items and News.  
 7.30 p.m.—Orchestral and Vocal Concert. Orchestral Selection. Two Duets for Mezzo-Soprano and Baritone: (a) Duet (Massenet),

(b) Duet from "Mignon" (Thomas). Orchestral Selection. Duets: (a) Les adieux (Donizetti), (b) Autumn Song (Mendelssohn). Orchestral Selection. Duet: Silano (Campana). Orchestral Selection.  
 8.30 p.m.—Song Recital by Mme. Olga Kalliwoda, Mezzo-Soprano, of Budapest. Finnish Melodies. Popular Hungarian Melodies. Modern Hungarian Songs. In the intervals, Theatre Notes and Programme Announcements.  
 9.15 p.m.—Time, News, Sports and Police Notes.  
 9.30 p.m. (approx.)—Close Down.

ROME (Italy)

Ente Italiano Audizioni Radiofoniche (IRO). 680 kc/s (441 m.); 75 kW. Relayed by Naples, 905 kc/s (332 m.); and 2RO, 11,810 kc/s (25.4 m.).  
 Transmits at intervals from 7.15 a.m. (Giornale Radio and Weather for Shipping).  
 4.0 p.m.—Instrumental Concert. Overture, "Anacreon" (Cherubini). Minuet from the Septet, Op. 20, and March from "The Ruins of Athens" (Beethoven). The Flight into Egypt from the Oratorio, "L'enfance du Christ" (Berlioz). Kamarinskaja—Fantasia on a Popular Russian Motive (Glinka). Selection from "Le donne curiose" (Usiglio). Tramonto (Pennati-Malvezzi). In gondola (Catalani). Suite, "Nächtliche Fest (Siede). Prelude to the Fourth Act of "La Traviata" (Verdi). Selection from "La Bohème" (Leoncavallo).  
 6.20 p.m.—Giornale Radio and Announcements.  
 6.50 p.m.—Gramophone Records.  
 7.10 p.m.—Giornale Radio and Report of the International Institute of Agriculture (in Italian, French, English, German and Spanish).  
 7.30 p.m.—Time Signal and Announcements.  
 7.32 p.m. (approx.)—Medical Talk.  
 7.45 p.m.—Gramophone Records.  
 8.0 p.m. (approx.)—Relay of an Opera from the Royal Theatre or the Teatro San Carlo, Naples.

In the intervals, Announcements and Topical Review.  
 9.55 p.m. (approx.)—News.

SCHENECTADY (U.S.A.)

General Electric Company (WGY). 790 kc/s (379.5 m.); 50 kW. Relayed at intervals by W2XAF on 9,530 kc/s (31.48 m.) and by W2XAD on 15,340 kc/s (19.56 m.).  
 Transmits at intervals from 11.45 a.m.  
 11.30 p.m.—Ivanhoe Programme.  
 11.45 p.m.—Uncle Abe and David from New York.  
 12 midnight.—Musical Programme.  
 12.15 a.m.—Thursday.—Dupont Blenders.  
 12.30 a.m.—Chevrolet Programme.  
 1.0 a.m.—Bobby Jones Golf Chat, from New York.  
 1.15 a.m.—Orchestral Programme.  
 1.30—4.0 a.m.—Programme from New York.  
 1.30 a.m.—Mobiloil Concert.  
 2.0 a.m.—Halsey Stewart Programme.  
 2.30 a.m.—Palmolive Hour.  
 3.30 a.m.—Coca Cola Programme.  
 4.0 a.m.—Sleepy Hall and Hotel DeWitt Clinton Orchestra, from Albany, N.Y.  
 4.30 a.m.—Vincent Lopez and the Hotel St. Regis Orchestra, from New York.  
 5.0 a.m.—Hotel Paramount Orchestra.  
 5.30 a.m.—Doc Peyton and the Hotel Kenmore Orchestra, from Albany, N.Y.  
 6.0 a.m. (approx.)—Close Down.

STOCKHOLM (Sweden)

Radiotjänst (SASA). 680 kc/s (436 m.); 75 kW. Relayed by Boden, 244 kc/s (1,229.5 m.); Göteborg, 932 kc/s (322 m.); Hörby, 1,166 kc/s (257 m.); Motala, 222.5 kc/s (1,348 m.); Östersund, 389 kc/s (770 m.); Sundsvall, 554 kc/s (542 m.).  
 Transmits at intervals from 6.15 a.m. (Gymnastics).  
 12 noon—12.30 p.m.—Educational Talk.  
 4.0 p.m.—Concert of Folk Music, relayed from Boden.  
 4.15 p.m.—The Children's Letter Box.  
 4.30 p.m.—Gramophone Records.  
 5.30 p.m.—Agricultural Talk.  
 6.0 p.m.—Song Recital.

6.15 p.m.—Talk on Social Questions.  
 6.45 p.m.—Military Band Concert. Venetian March (Fabiani). Selection from "Rigoletto" (Verdi). Waltzes: (a) La Sérénade (Métras), (b) Golden Hours (Ivanovici), (c) Münchner Kindl (Komzák), (d) Goldregen (Waldteufel). Selection from the Ballet "Sylvia" (Delibes). Overture (Spiellek). German March Pearls (arr. Blankenburg).  
 7.45 p.m.—Talk on Michael Faraday, relayed from Uppsala, 662 kc/s (453.2 m.).  
 8.40 p.m.—Play (Ernst Fastbom).  
 9.15 p.m.—Programme of Old Dance Music.  
 10.0 p.m. (approx.)—Close Down.

STRASBOURG (France)

Radio-Strasbourg (PTT). 869 kc/s (345 m.); 15 kW.  
 Transmits at intervals from 11.30 a.m.  
 6.0 p.m.—Instrumental Concert.  
 6.45 p.m.—Talk in French: A Trip through Lorraine.  
 7.0 p.m.—Operetta Music.  
 7.30 p.m.—News in French and German.  
 7.45 p.m.—Gramophone Records.  
 8.30 p.m.—Instrumental Concert.  
 10.30 p.m.—Gramophone Dance Records.  
 12 midnight.—Close Down.

TOULOUSE (France)

Radiophonie du Midi. 779 kc/s (385 m.); 8 kW.  
 Transmits at intervals from 12.45 p.m.  
 7.0 p.m.—Chansonnettes and Piano-forte Solos.  
 7.30 p.m.—Exchange and News.  
 7.45 p.m.—Musical Programme.  
 8.55 p.m.—Fashion Review.  
 9.0 p.m.—Time Signal.  
 9.2 p.m.—Vocal and Orchestral Concert. In the interval at 10.30 p.m.—News.  
 11.15 p.m.—North African News.  
 11.30 p.m.—Vocal Tangos.  
 11.45 p.m.—Dance Music.  
 12 midnight (approx.)—Close Down.

VIENNA (Austria)

Radio-Wien. 581 kc/s (517 m.); 20 kW. Relayed by Graz, 851 kc/s (352 m.); Innsbruck, 1,058 kc/s (283 m.); Klagenfurt, 662 kc/s

(453.2 m.); Linz, 1,220 kc/s (246 m.); and Salzburg, 1,373 kc/s (218 m.).  
 Transmits at intervals from 8.20 a.m. (Market Prices).  
 6.0 p.m.—Elementary French Lesson. (Marker Prices).  
 6.25 p.m.—Time, Weather and Programme Announcements.  
 6.30 p.m.—A Conversation with Joseph Delmont, followed by "The Language of Animals," by J. Delmont.  
 7.10 p.m.—"In the Musical Automatic Machine Hall"—A Jest with Orchestral Concert Pieces—Grave and Gay, Popular Songs and Alpine Songs (Edmund Skurawy). News in the interval.

WARSAW (Poland)

Polskie Radio. 212 kc/s (1,411 m.); 158 kW.  
 Transmits at intervals from 10.40 a.m.  
 1.20 p.m.—Economic Notes.  
 1.40 p.m.—Literary Talk: Jan Kockanovsky.  
 2.0 p.m.—Talk: The Causes of the French Revolution.  
 2.20—2.35 p.m.—No Transmission.  
 2.35 p.m.—Talk for Boys Scouts.  
 2.50 p.m.—Talk: Information Bureaus in England.  
 3.10 p.m.—Marine Notes.  
 3.15 p.m.—Programme for Children.  
 3.45 p.m.—Gramophone Records.  
 4.15 p.m.—Talk: Polish Horses, relayed from Cracow.  
 4.45 p.m.—Orchestral Concert. Part I from the Suite, Roma (Bizet). Pastoral (César Franck). Ernste Suite (Brahms). Elegy (Moniuszko). Adagio from the Fourth Symphony (Beethoven). Angelus (de Micheli).  
 5.45 p.m.—Miscellaneous Items.  
 6.10 p.m.—Agricultural Correspondence and Quotations.  
 6.25 p.m.—Gramophone Records.  
 6.35 p.m.—Programme Announcements.  
 6.40 p.m.—Radio Journal.  
 6.55 p.m.—Gramophone Records.  
 7.0 p.m.—Review of New Books.  
 7.15 p.m.—Talk (to be announced).  
 7.30 p.m.—See Poznań.  
 8.45 p.m.—"Manwantara," relayed from Wilno, 815 kc/s (368.1 m.).  
 9.15 p.m.—Musical Programme.  
 9.50 p.m.—Weather, Police and Sports Notes.

PROGRAMMES FOR THURSDAY (April 2)

NOTE: THE HOURS OF TRANSMISSION ARE REDUCED TO GREENWICH MEAN TIME

ALGIERS (N. Africa)  
 825.3 kc/s (363.4 m.); 13 kW.  
 12.30 p.m.—Orchestral Concert.  
 6.0 p.m.—Programme for Children.  
 7.0 p.m.—Physical Culture Lesson.  
 7.15 p.m.—Transmission of Pictures.  
 7.30 p.m.—Military Music.  
 7.45 p.m.—Variety Items.  
 8.0 p.m.—News Bulletin.  
 8.10 p.m.—Concert of Mandoline, Guitar and Accordion Solos.  
 9.0 p.m.—Sketch in Dialect.  
 9.15 p.m.—Songs from Various Districts of France.  
 10.0 p.m.—Gramophone Records.

BARCELONA (Spain)  
 Radio-Barcelona (EAJ). 860 (349 m.); 8 kW.  
 8.0—9.0 a.m.—Topical Review.  
 11.0 a.m.—Chimes and Weather.  
 7.0 p.m.—Relay of the Holy Week Procession from Seville.  
 9.0 p.m. (approx.)—Close Down.

BERLIN (Germany)  
 Königs Wusterhausen. 183 kc/s (1,635 m.); 35 kW.  
 Transmits at intervals from 5.20 a.m. (Hamburg Relay).  
 3.30 p.m.—Concert from Berlin (Witzleben).  
 4.45 p.m.—Talk: Genius and Sport.  
 5.0 p.m.—Talk: Symbols of the Passion—The Cross and the Crucifix.  
 5.30 p.m.—Educational Talk: Basic Questions of Modern Psychology.  
 6.0 p.m.—Advanced English Lesson.  
 6.25 p.m.—Talk: The Total Eclipse of the Moon on the Second of April.  
 6.35 p.m.—Agricultural Talk.  
 6.55 p.m.—Weather for Farmers.  
 7.0 p.m.—See Breslau.  
 9.30 p.m.—See Berlin (Witzleben).

BERLIN (Germany)  
 Witzleben. 716 kc/s (418 m.); 1.7 kW.  
 Transmits at intervals from 6.0 a.m. (Gymnastics).  
 5.10 p.m.—Concert by Blind Artists.

5.50 p.m.—Philosophical Dialogues: Dialogue with a Scientist—The Beginning of the World and the Origin of Life.  
 6.15 p.m.—Wind Instrument Concert. March and Pilgrim's Chorus from "Tannhäuser" (Wagner). Overture, "Maritana" (Wallace). Romance from "Mignon" (Thomas). Russian Folk Songs. Marche militaire (Schubert). Overture, "Poet and Peasant" (Suppé). Three Army Marches.  
 7.10 p.m.—"Passion"—a Religious Play, after Old Motives.  
 9.15 p.m.—Weather, News and Sports Notes.  
 9.20 p.m.—Third Act of the Opera "Parsifal" (Wagner).

BERNE (Switzerland)  
 Radio-Berne. 743 kc/s (403 m.); 1.1 kW.  
 Transmits at intervals from 11.27 a.m.  
 5.15 p.m.—Gramophone Records.  
 6.0 p.m.—English Lesson.  
 6.28 p.m.—Time and Weather.  
 6.30 p.m.—Talk: Music on the Wireless.  
 7.0 p.m.—Gramophone Records—Russian Choral Selections.  
 7.30 p.m.—Instrumental Concert relayed from Basle, 1,229 kc/s (244.1 m.).  
 8.15 p.m.—Orchestral Concert.  
 9.0 p.m.—News, Weather and Close Down.

BORDEAUX-LAFAYETTE (France)  
 (PTT). 986 kc/s (304 m.); 35 kW.  
 Transmits at intervals from 12.45 p.m.  
 7.30 p.m.—News and Exchange.  
 7.40 p.m.—Talk: Unemployment and Salaries in America.  
 7.55 p.m.—Result of the Prize Draw and Charade Competitions.  
 8.0 p.m.—Gramophone Records.  
 8.30 p.m.—"The Tomb beneath the Arc de Triomphe"—Play in Three Acts (Reynal). After the Programme, Amusement Guide and Time Signal.

BRESLAU (Germany)  
 923 kc/s (325 m.); 1.7 kW. Relayed by Gleiwitz, 1,184 kc/s (253 m.).  
 Transmits at intervals from 10.15 a.m.

6.0 p.m.—Talk: The Foundations of World Economics.  
 6.30 p.m.—Weather for Farmers and Orchestral Concert.  
 6.55 p.m.—Weather Report.  
 7.0 p.m.—"Die Judasspieler"—Play (Mirbt).  
 7.50 p.m.—News Bulletin.  
 8.0 p.m.—Symphony Concert.  
 9.20 p.m.—Time, Weather, News, Sports Notes and Programme Announcements.  
 9.30 p.m.—See Berlin (Witzleben).  
 11.0 p.m. (approx.)—Silent Night.

BRUSSELS (Belgium)  
 Radio-Belgique. 590 kc/s (509 m.); 20 kW.  
 5.0 p.m.—Gramophone Records.  
 6.0 p.m.—Programme for Children.  
 6.45 p.m.—Gramophone Records.  
 7.15 p.m.—Talk (to be announced).  
 7.30 p.m.—Le Journal Parlé.  
 8.0 p.m.—Concert. Overture, "The Thieving Magpie" (Rossini). Selection from "H.R.H." (Carvill). Song. Selection from "Oh Kay!" (Gershwin). Petite suite de concert (Coleridge-Taylor). Minuet (Sgambati). Au pays du lin (Vandermeulen). Prélude, Carême and Air de danse from "L'Enfant prodige" (Debussy). Talk. Waltz, Mon rêve (Waldteufel). Selection from "Faust" (Gounod). Song. Four Ways (Coates).  
 10.0 p.m.—Le Journal Parlé.

BRUSSELS No. 2 (Belgium)  
 887 kc/s (338.2 m.); 20 kW.  
 Programme in Flemish.  
 5.0 p.m.—Orchestral Concert. Prelude and Good Friday Magic from "Parsifal" (Wagner). Meditation (Bach-Gounod). Rédemption (César Franck).  
 6.0 p.m.—Programme for Children. Choral Selections.  
 6.45 p.m.—Gramophone Records.  
 7.15 p.m.—Talk: The Flemish Language.  
 7.30 p.m.—Le Journal Parlé.  
 7.55 p.m.—Sports Talk.  
 8.0 p.m.—Orchestral Concert conducted by M. A. Meulemans. Overture, "The Messiah" (Händel). Songs. Concerto grosso (Händel). Sacred Songs. Talk: How to bring about International

Peace. Organ Solos. Aria (Bach). Maundy Sunday in Seville (Turina). Largo (Handel). Choral Selections.  
 10.0 p.m.—Le Journal Parlé.  
 BUDAPEST (Hungary)  
 545 kc/s (550 m.); 23 kW.  
 Transmits at intervals from 8.15 a.m. (Concert).  
 5.30 p.m.—English Lesson.  
 6.0 p.m.—Talk: Easter in Rome.  
 6.30 p.m.—Third Act of "The Twilight of the Gods"—Opera (Wagner), followed by "Requiem" (Verdi), relayed from the Opera House.

COLOGNE (Germany)  
 Westdeutscher Rundfunk. 1,319 kc/s (227 m.); 1.7 kW.  
 See Langenberg Programme.

COPENHAGEN (Denmark)  
 1,067 kc/s (281 m.); 1 kW.  
 Relayed by Kalundborg, 260 kc/s (1,153 m.).  
 Transmits at intervals from 9.0 a.m. (Divine Service).  
 11.0 a.m.—Instrumental Concert. Overture, "Jean de Paris" (Boieldieu). Valse en sourdine (Aekermans). Selection from "The Mute of Portici" (Auber). Neapolitan Serenade (Bayer). Mazurka from "His Life for the Czar" (Glinka). Gavotte from "Iphigenia in Aulis" (Gluck). Slavonic Dance No. 16 (Dvorak). Amorretto (Bullerian).

1.30 p.m.—Instrumental Concert. Overture, "Pique Dame" (Suppé). Waltz, A Summer's Evening (Waldteufel). Selection from "Der Bittelstudent" (Millock). Serenade for Strings (Piémé). Litanei (Schubert). Punctinello (Herbert). Zigeuner-Laengesel (Niklass-Klemperer). Recital of Modern Danish Spring Songs. Selection from "Lilac Time" (Schubert). Cradle Song (Per Winge). Waltz, Hoffnungsstrahlen (Lanner). Canto d'amore (Thielemann). Parade i Børuehaven (Paul Bendix). Spanish March, Hispania (Dreyer).  
 3.30 p.m.—Programme for Children.  
 4.0 p.m.—Divine Service from Copenhagen Cathedral.  
 5.20 p.m.—Talk: The Constellations during the Month of April.

5.50 p.m.—Weather Report.  
 6.0 p.m.—News Bulletin.  
 6.15 p.m.—Time and Sports Notes.  
 6.30 p.m.—Talk: Young Handicraft Workers.  
 7.0 p.m.—Town Hall Chimes.  
 7.2 p.m.—Concert of Old English Melodies from Shakespeare's Time, for Wood Wind Instruments. It was a Lover and his Lass, from "As You Like It." To-morrow is St. Valentine's Day, from "Hamlet." Green Sleeves, from "The Merry Wives of Windsor." Light O' Love, from "Much ado about Nothing." When that I was and a little tiny boy, from "Twelfth Night."

7.15 p.m.—"The Merchant of Venice"—Play (William Shakespeare, translated Lembcke).  
 8.55 p.m.—Concert of Danish Folk Melodies for Vocal Quartet.  
 9.25 p.m.—News Bulletin.  
 9.30 p.m. (approx.)—Dances of the Seventeenth Century for String Orchestra. Intradas Nos. 1 and 2 from "Neue Musikalische Intruden auf allerhand Instrumenten" (Melchior Franck). Suite (Henry Purcell). Suite from "Studentemusik" (Rosenmüller). Suite II, from the "Banchetto-Musicale" (J. H. Schein).  
 10.10 p.m. (approx.)—Close Down.

CORK (Ireland)  
 (6CK). 1,337 kc/s (225 m.); 1.5 kW.  
 No Transmission.

CRACOW (Poland)  
 Polskie Radio. 959 kc/s (312.8 m.); 1.5 kW.  
 Transmits at intervals from 10.40 a.m.  
 4.15 p.m.—See Warsaw.  
 4.45 p.m.—"Samson"—Oratorio (Händel).  
 5.45 p.m.—Miscellaneous Items, News Bulletin and Programme Announcements.  
 5.55 p.m.—Recitation by M. Dorula.  
 6.10 p.m.—Agricultural Report.  
 6.25 p.m.—Gramophone Records.  
 6.30 p.m.—See Warsaw.  
 6.40 p.m.—Radio Journal.  
 7.0 p.m.—Talk and Concert from Warsaw, followed by News.

Programmes for Thursday—(Cont.)

DUBLIN (Ireland) (RULN). 725 kc/s (413 m.); 1.5 kW. No Transmission.

FRANKFURT-am-MAIN (Germany) 770 kc/s (390 m.); 1.7 kW. Relayed by Cassel, 1,220 kc/s (246 m.). Transmits at intervals from 5.15 a.m. (Mahlacker Relay).

HAMBURG (Germany) Norag (ha, in Morse). 806 kc/s (372 m.); 1.7 kW. Relayed by Bremen, 1,112 kc/s (270 m.); Flensburg, 1,373 kc/s (218 m.); Hanover, 530 kc/s (566 m.); and Kiel, 1,292 kc/s (232.2 m.).

6.30 p.m.—Orchestral Concert. 7.20 p.m.—Five Songs for Soprano (Wagner): (a) Engel, (b) Stehe still, (c) Schmerzen, (d) Treibhaus, (e) Träume.

6.10 p.m.—French Lesson. 6.15—9.30 p.m.—See Mühlacker. 9.35 p.m.—Time, Weather, News and Sports Notes, followed by Programme from Berlin (Witzleben).

11.30 a.m.—Orchestral Concert. Overture, "The Crown Diamonds" (Auber). Die Spieluhr (Blaauw). The Phantom Brigade (Myddleton). Spring Suite (Nevin-Artok). Selection from "Carmen" (Bizet). March, Freiheitsgöttin (Blankenburg).

11.55 a.m.—Time Signal. 12.15 p.m.—Gramophone Records. 1.0 p.m.—Weather and Ice Report.

5.5 p.m.—Talk: Problems of the Great City—Hamburg. 6.0 p.m.—See Königsberg Wusterhausen. 6.25 p.m.—Talk for Women: Sappho and other Immortals of Helios.

HEILSBURG (Germany) 1,085 kc/s (276.5 m.); 75 kW. Relayed by Danzig, 662 kc/s (453 m.). Transmits at intervals from 5.30 a.m. (Gymnastics).

6.30 p.m.—Orchestral Concert. 7.20 p.m.—Five Songs for Soprano (Wagner): (a) Engel, (b) Stehe still, (c) Schmerzen, (d) Treibhaus, (e) Träume.

HILVERSUM (Holland) 1,004 kc/s (298 m.); 8.5 kW. 7.40 a.m. till Close Down.—Programme of the Algemeene Vereeniging Radio Omroep (A.V.R.O.).

11.40 a.m.—Time Signal. 11.42 a.m.—Gramophone Records. 11.55 a.m.—Musical Programme. 1.40—2.10 p.m.—Interval.

HUIZEN (Holland) 160 kc/s (1,875 m.); 8.5 kW. 7.40—9.10 a.m.—Programme of the Catholic Radio Society (K.R.O.). Gramophone Records.

JUAN-LES-PINS (Nice, France) 1,205 kc/s (249 m.); 1.2 kW. 12.30 p.m.—News, Amusement Guide and Concert. Selection from "Le roi d'Ys" (Lalo). Minuet (Debussy). Gavotte tendre (Hillmacker). Storm on the Volga (Patschenka).

Weather Report and Concert. Selection (Schirmann). Selection from "Si j'étais roi" (Adam). Readings from "Les lettres de mon moulin" (Daudet).

KALUNDBORG (Denmark) Kalundborg Radio. 260 kc/s (1,153 m.); 10 kW. See Copenhagen Programme.

KATOWICE (Poland) Polskie Radio. 734 kc/s (408 m.); 16 kW. Transmits at intervals from 10.40 a.m.

KÖNIGSBERG (Germany) Ostmarken Rundfunk. 1,382 kc/s (217 m.); 1.7 kW. See Heilsberg Programme.

LANGENBERG (Germany) Westdeutscher Rundfunk. 635 kc/s (473 m.); 17 kW. Relayed by Aachen, Cologne and Münster, 1,319 kc/s (227 m.).

4.0 p.m.—Concert from Mühlacker. 5.0 p.m.—"Love in Music"—Human Love. A Gramophone Concert with Introductory and Explanatory Comments by Dr. Martin Friedland.

LEIPZIG (Germany) Mitteldeutscher Rundfunk. 1,157 kc/s (259 m.); 2.3 kW. Relayed by Dresden, 941 kc/s (319 m.). Transmits at intervals from 9.0 a.m. (Economic Prices).

"Sejungfrau." Soprano Solo from "The Wreckers" (Dame Ethel Smyth). "Der Einsame an Gott"—Cantata for Soprano, Baritone, Women's Voices, String Orchestra and Pianoforte (Philippine Schick-von Waltershausen).

LJUBLJANA (Yugoslavia) Radio Ljubljana. 522 kc/s (574.7 m.); 2.8 kW. Transmits at intervals from 11.15 a.m.

MADRID (Spain) Union Radio (EAJ7). 707 kc/s (424 m.); 2 kW. Transmits at intervals from 8.0 a.m. (Topical Review).

MILAN (Italy) Ente Italiano Audizioni Radiofoniche. 599 kc/s (503 m.); 8.5 kW. Programme relayed by Turin, 1,013 kc/s (296 m.); and Genoa, 958 kc/s (313.2 m.).

MOTALA (Sweden) 222.5 kc/s (1,348 m.); 40 kW. See Stockholm Programme.

MÜHLACKER (Germany) Süddeutscher Rundfunk. 833 kc/s (360 m.); 75 kW. Relayed by Freiburg, 527 kc/s (570 m.).

MUNICH (Germany) 563 kc/s (533 m.); 1.7 kW. Relayed by Augsburg, 536 kc/s (560 m.); Kaiserslautern, 536 kc/s (560 m.); and Nürnberg, 1,256 kc/s (239 m.).

Transmits at intervals from 5.45 a.m. (Gymnastics).

12.10 p.m.—Gramophone Records. 1.0 p.m.—Time Signal, Weather Report, Programme Announcements, News Bulletin and Advertisements.

2.40 p.m.—Reading from A Conversation with Eva (Leo Weismantel). 3.5 p.m.—Time Signal, Weather Report and Agricultural Notes.

3.20 p.m.—Zither Recital by Fritz Mühlhölzl. Concertino in B Flat Major (Reigerberg). Impromptu and Rondo (Grünwald). Romance in D Major (Mühlhölzl). Im Märchenschloss (Mühlhölzl).

5.45 p.m.—Agricultural Talk. 6.5 p.m.—Talk: The Idea of the Redemption.

6.30 p.m.—Symphony Concert by the Station Orchestra, conducted by Hans Winter. Pianoforte Soloist: Lore Winter. Concerto grosso in B Minor (Händel). Concerto in F Minor for Pianoforte and String Orchestra (J. S. Bach). Symphony in G Minor (Mozart).

7.35 p.m.—"Everyman"—The Play of the Death of the Rich Man (Hugo von Hofmannsthal). Music by Einar Nielsen.

8.55 p.m.—Gramophone Records of Music of the Pre-Classical Period—Arcadelt, Lasso, Palestrina, Sartorius, Hessler and Hammerschmidt.

9.20 p.m.—Time, Weather, News, Sports Notes and Snow Report.

OSLO (Norway) Kringkastingsselskapet. 280 kc/s (1,071 m.); 75 kW. Relayed by Fredrikstad, 815 kc/s (368 m.); Hamar, 511 kc/s (587 m.); Notalden, 671 kc/s (447.1 m.); Postgrund, 662 kc/s (453 m.); and Rjukan, 671 kc/s (447.1 m.).

PARIS (France) Eiffel Tower. (FLE). 207 kc/s (1,445 m.); 15 kW. Time Signals on 113 kc/s (2,650 m.) at 9.25 a.m. and 10.25 p.m. (preliminary and 6-dot signals).

PARIS (France) Poste Parisien. 914 kc/s (329 m.); 1.2 kW. 9.0 a.m.—Picture Transmission.

8.45 p.m.—Talk on Films, Gramophone Records and News Bulletin. 9.0 p.m.—Concert with the collaboration of Artists of the Opéra and Opéra-Comique. Overture, "Titus" (Mozart). Romance in F for Violin and Orchestra (Beethoven). Brandenburg Concerto, No. 2 (Bach). Trumpet Soloist: M. Vignal. Symphonic Poem, La jeunesse d'Hercule (Saint-Saëns), M. Théodore Mathieu conducting.

Programmes for Thursday—(Cont.)

Larghetto for the Quintet for Clarinet and Orchestra (Mozart). Largo for English Horn and Orchestra (Händel). Soloist: M. Gobert. Turkish March from "The Ruins of Athens (Beethoven)
PARIS (France)
Radio-Paris (CFR). 174 kc/s (1,725 m.); 17 kW. Transmits at intervals from 6.45 a.m. (Physical Culture).
12 noon.—Protestant Address: St. Paul, by the Reverend André Bertrand.
12.30 p.m.—Gramophone Records
1.0 p.m.—Exchange Quotations and News.
1.5 p.m.—Gramophone Concert for Young People. In the intervals at 1.30 p.m.—Exchange Quotations, and at 2.0 p.m.—Exchange Quotations and Market Prices.
3.30 p.m.—Exchange Quotations.
5.55 p.m.—Exchange and Market Prices.
6.0 p.m.—Agricultural Report and Racing Results.
6.30 p.m.—Gramophone Dance Records.
7.0 p.m.—Talk by M. Mac Orlan.
7.30 p.m.—Advanced Book-keeping Lesson.
7.45 p.m.—Commercial Prices, Economic and Social Notes and News.
8.0 p.m.—Talk with Illustrations on Gramophone Records: Music and Religion.
8.30 p.m.—News and Sports Results.
8.45 p.m.—Concert. Concerto in D Minor for Pianoforte and Orchestra (Brahms). Songs (César Franck): (a) Two Arias from "Rédemption," (b) Mater Dolorosa—Eighth Beatitude. Prelude and Good Friday Magic from "Parsifal" (Wagner). Symphony in C Minor (Beethoven). In the interval at 9.15 p.m.—Press Review, News and Time Signal.
POZNAN (Poland)
806 kc/s (335 m.); 1.0 kW. Also relayed on 830 kc/s (30.5 m.) from 7.30—8.30 p.m. Transmits at intervals from 6.0 a.m. (Gymnastics).
4.45 p.m.—See Cracow.
5.45 p.m.—Talk on Economics.
6.0 p.m.—Humorous Programme.

6.15 p.m.—Agricultural Report.
6.30 p.m.—Agricultural Correspondence.
6.45 p.m.—Educational Talk.
7.5 p.m.—Elementary English Lesson.
7.20 p.m.—Miscellaneous Items and News.
7.30 p.m.—Choral Concert from the Works of Montusako. Ecce lignum Crucis. Chorus of the Righteous. In the intervals, Theatre Notes and Programme Announcements.
8.30 p.m.—Programme to be announced.
9.15 p.m.—Time, News, Sports and Police Notes.
9.30 p.m. (approx.)—Close Down.
ROME (Italy)
Ente Italiano Audizioni Radiofoniche (I.RO). 680 kc/s (441 m.); 75 kW. Relayed by Naples, 903 kc/s (332 m.), and 2RO, 11.8 to kc/s (25.4 m.). Transmits at intervals from 7.15 a.m. (Giornale Radio and Weather for Shipping).
4.0 p.m.—Vocal and Instrumental Concert of Sacred Music. "Cello Solos: (a) Aria di chiesa (Stradella), (b) Gebet (J. S. Bach). Baritone Solos: (a) Aria from "The Passion of Christ" (Perosi), (b) Agnus Dei (Bizet). Mezzo-Soprano Solo: Salve Maria (Mercadante). Tenor Solo from "Les Sept paroles du Christ" (Dubois). Sonata in G Minor for Cello (Benedetto Marcello). Talk: Holy Week Rites in Rome. Selections from "Stabat Mater" (Rossini): (a) Cujus animam, for Tenor, (b) Fac ut portem, for Mezzo-Soprano, (c) Qui est homo—Duet for Soprano and Mezzo-Soprano, (d) Sancta Mater—for Soprano, Mezzo-Soprano, Tenor and Bass.
6.20 p.m.—Giornale Radio, Announcements and News.
6.50 p.m.—Gramophone Records.
7.10 p.m.—Giornale radio and Announcements.
7.30 p.m.—Time Signal and Announcements.
7.32 p.m. (approx.)—Talk: The Beatitudes.
7.45 p.m. (approx.)—Instrumental Concert from the Works of Ildebrando Pizzetti, conducted by the Composer. Three Preludes for

Orchestra to Sophocles' "Oedipus Rex" (Pizzetti). Announcements. Trio in A for Pianoforte, Violin and Cello (Pizzetti). "Sister Beatrice"—Mystery in Three Acts (Mauricé Maeterlinck). Rondo veneziano (Pizzetti). 9.55 p.m. (approx.)—News.
SCHENECTADY (U.S.A.)
General Electric Company (WGY). 700 kc/s (379.5 m.); 50 kW. Relayed at intervals by W2XAF on 9.530 kc/s (31.48 m.), and by W2XAD on 15.340 kc/s (19.56 m.). Transmits at intervals from 11.45 a.m.
11.44 p.m.—Time Signal.
11.45 p.m.—Uncle Abe and David, from New York.
12 midnight.—Fro Joy Dinner Dance Orchestra.
12.30 a.m. (Friday)—4.0 a.m.—Programme from New York.
12.30 a.m.—Niagara Hudson Programme.
1.0 a.m.—Fleischmann Programme.
2.0 a.m.—Arco Birthday Programme.
2.30 a.m.—Jack Frost Melody Moments.
3.0 a.m.—Lucky Strike Hour.
4.0 a.m.—Organ Recital from the Ritz Theatre, Albany, N.Y.
4.30 a.m.—Cotton Club Orchestra, from New York.
5.0 a.m.—Gordie Randall and Orchestra.
5.30 a.m.—Doc Peyton and the Hotel Kenmore Orchestra, from Albany, N.Y.
6.0 a.m. (approx.)—Close Down.

STOCKHOLM (Sweden)
Radiotjänst (SASA). 680 kc/s (436 m.); 75 kW. Relayed by Boden, 244 kc/s (1,229.5 m.); Göteborg, 932 kc/s (322 m.); Hörby, 1,166 kc/s (257 m.); Motala, 222.5 kc/s (1,348 m.); Östersund, 380 kc/s (770 m.); Sundsvall, 554 kc/s (542 m.). Transmits at intervals from 6.15 a.m. (Gymnastics).
4.0 p.m.—Service relayed from Jönköping, 1,490 kc/s (202 m.).
4.30 p.m.—Programme for Children, relayed from Sundsvall.
5.0 p.m.—Gramophone Records.
5.45 p.m.—Agricultural Talk.
6.0 p.m.—Elementary German Lesson relayed from Göteborg.

6.30 p.m.—Talk on Foreign Politics.
6.50 p.m.—Concert. Overture, "Princess Rosina" (Lincke). Suite No. 1 on Johann Strauss' Melodies (Morena). Rustle of Spring (Sinding). Waltz from "A Ball Night" (O. Strauss). Negro Melody, Deep River (Coleridge-Taylor). Furiant (Grün). Selection from "By Jingo!" (Finck).
7.45 p.m.—Talk on Dietetics.
8.40 p.m.—Talk by Dr. Sven Hedin: My Last Voyage of Exploration.
9.10 p.m.—Concert of Light Music.
10.0 p.m. (approx.)—Close Down.

STRASBOURG (France)
Radio-Strasbourg (PTT). 869 kc/s (345 m.); 15 kW. Transmits at intervals from 11.30 a.m.
6.0 p.m.—Instrumental Concert.
6.45 p.m.—Medical Talk in German: Parasites.
7.0 p.m.—Orchestral Concert. Overture, Anacraon (Cherubini). Réverie du soir (Saint-Saëns). Selection from "Don Carlos" (Verdi). March from "The Fair Maid of Perth" (Bizet).
7.30 p.m.—News in French and German.
7.45 p.m.—Gramophone Records.
10.30 p.m. (approx.)—Close Down.

TOULOUSE (France)
Radiophonie du Midi. 779 kc/s (385 m.); 8 kW. Transmits at intervals from 12.45 p.m.
7.0 p.m.—Musical Programme.
7.30 p.m.—Exchange and News.
7.45 p.m.—Musical Programme.
8.55 p.m.—Fashion Review.
9.0 p.m.—Time Signal.
9.2 p.m.—Concert of Opera Music.
9.45 p.m.—Light Music.
10.30 p.m.—News Bulletin.
10.45 p.m.—Military Music.
11.0 p.m.—Russian Songs.
11.15 p.m.—North African News.
11.30 p.m.—Accordion Recital.
11.45 p.m.—Dance Music.
12 midnight (approx.)—Close Down.

VIENNA (Austria)
Radio-Wien. 581 kc/s (517 m.); 20 kW. Relayed by Graz, 851 kc/s (352 m.); Innsbruck, 1,058 kc/s (283 m.); Klagenfurt, 662 kc/s (453.2 m.); Linz, 1,220 kc/s (246

m.); and Salzburg, 1,373 kc/s (218 m.). Transmits at intervals from 8.20 a.m. (Market Prices).
6.20 p.m.—Time, Weather, Alpine Weather Report and Programme Announcements.
6.30 p.m.—Talk: Friedrich von Spee—Man and Priest.
6.55 p.m.—"Das Trauergespräch Christi am Kreuze" (F. von Spee), from the Time of the Thirty Years' War, re-arranged by E. L. Stahl.
7.30 p.m.—"Requiem" (Verdi), on Gramophone Records.
9.5 p.m. (approx.)—News Bulletin.

WARSAW (Poland)
Polskie Radio. 212 kc/s (1,411 m.); 158 kW. Transmits at intervals from 10.40 a.m.
1.20 p.m.—Economic Notes.
1.40 p.m.—Literary Talk: Peter Skarga.
2.0 p.m.—Talk: The French Revolution.
2.20—2.35 p.m.—No Transmission.
2.35 p.m.—Report of the Aerial Defence League.
2.50 p.m.—Sports Talk.
3.10 p.m.—Marine Notes.
3.15 p.m.—Gramophone Records.
4.15 p.m.—Talk: Holy Week—its Customs and Ceremonies.
4.45 p.m.—See Cracow.
5.45 p.m.—Miscellaneous Items.
6.10 p.m.—Agricultural Report.
6.25 p.m.—Gramophone Records.
6.30 p.m.—Talk on Sports and Physical Training.
6.35 p.m.—Programme Announcements.
6.40 p.m.—Radio Journal.
6.55 p.m.—Gramophone Records.
7.0 p.m.—Talk: Cain and Abel.
7.15 p.m.—Concert by the Warsaw Philharmonic Orchestra.
7.50 p.m.—Weather, Police and Sports Notes.

WILNO (Poland)
815 kc/s (368.1 m.); 0.5 kW. Transmits at intervals from 10.58 a.m.
5.45 p.m.—Social Report.
6.0 p.m.—Reading of a Story by the Author, Tante Hala.
6.30 p.m.—See Warsaw.
6.35 p.m.—Programme Announcements.
6.40 p.m.—See Warsaw.

PROGRAMMES FOR FRIDAY (April 3)

NOTE: THE HOURS OF TRANSMISSION ARE REDUCED TO GREENWICH MEAN TIME

ALGIERS (N. Africa)
825.3 kc/s (363.4 m.); 13 kW.
12.30 p.m.—Gramophone Records.
7.0 p.m.—Exchange Quotations, Weather, Agricultural Report and Shipping Notes.
7.15 p.m.—Agricultural Talk.
7.30 p.m.—Variety Items.
7.50 p.m.—News Bulletin.
8.0 p.m.—Talk: Nature in Music, with Illustrations.
9.0 p.m.—Orchestral Concert.
10.0 p.m.—Vocal Tangos.
10.15 p.m.—Solo Selections.
10.30 p.m.—Gramophone Records.
11.0 p.m. (approx.)—Close Down.

BARCELONA (Spain)
Radio-Barcelona (RAJ). 860 kc/s (349 m.); 8 kW.
9.30 p.m.—Religious Programme. Reading of Religious Poems. Concert of Sacred Music. Talk in Catalan: "The Seven Words from the Cross. Sacred Music.
10.30 p.m. (approx.)—Close Down.

BERLIN (Germany)
Königs Wusterhausen. 183 kc/s (1,635 m.); 35 kW. Transmits at intervals from 7.50 a.m. (Witzleben Relay).
3.0 p.m.—Talk: Eternal Man.
3.30 p.m.—Orchestral Concert relayed from Heilsberg.
5.0 p.m.—Talk: Leaves from the Diary of a Tour on the Western Front.
5.40 p.m.—Talk: Albrecht Schaeffer's "Parsifal".
6.5 p.m.—Talk: Occultism and Religious Experience.
6.35 p.m.—See Frankfurt.
9.0 p.m.—News from Berlin (Witzleben).

BERLIN (Germany)
Witzleben. 716 kc/s (413 m.); 1.7 kW. Transmits at intervals from 7.50 a.m. (Service).
3.0 p.m.—String Quintet in C Major

for Two Violins, Two Cellos and Viola (Schubert).
4.0 p.m.—"Everyman"—a Play, renewed by Hugo von Hofmannsthal.
5.0 p.m.—See Leipzig.
9.0 p.m.—Weather, News and Sports Notes.

BERNE (Switzerland)
Radio-Bern. 743 kc/s (403 m.); 1.1 kW. Transmits at intervals from 9.30 a.m.
5.15 p.m.—Gramophone Records.
6.0 p.m.—Topical Talk.
6.15 p.m.—Sports Notes.
6.22 p.m.—Tourist Report.
6.28 p.m.—Time and Weather.
6.30 p.m.—Reading.
7.0 p.m.—Concert for Tenor, Violin and Orchestra.
9.0 p.m.—News and Weather.
9.15 p.m.—Special Weather Forecast.
9.20 p.m.—Programme Announcements in Esperanto.
9.25 p.m. (approx.)—Close Down.

BORDEAUX-LAFAYETTE (France)
(PTT). 986 kc/s (304 m.); 35 kW. Transmits at intervals from 12 noon.
6.0 p.m.—Literary Talk.
7.30 p.m.—News Bulletin.
7.40 p.m.—Gramophone Records.
8.10 p.m.—Result of the Prize Draw.
8.15 p.m.—Charades.
8.30 p.m.—Orchestral Concert with Soprano and Baritone Solos. After the Programme, Amusement Guide and Time Signal.

BRUSSELS (Belgium)
Radio-Belgique. 590 kc/s (509 m.); 20 kW.
5.0 p.m.—Gramophone Records of Sacred Music. Selection from "The Crucifixion" (Stainer). Selection from "The St. John Passion" (Bach).
5.45 p.m.—Concert. Piedigrotto (Bonincontro). My Baby (Bosc). Réverie (Barzanie). Laissez-moi rêver (Barbirolli). Rizaudon (Chamérande). Talk, Badingue (d'Agreves). Zampognari (d'Indy). Défilé tartare (Delmas). Selection from "The Pink Lady" (Caryll). Slavonic

Dance (Dvorák). March, Phono (Bades).
6.45 p.m.—Gramophone Records.
7.15 p.m.—Technical Talk.
7.30 p.m.—Le Journal Parlé.
8.0 p.m.—Concert. Selection from "Le Cheval de bronze" (Auber). Selection from "Zaza" (Leoncavallo). A Night in St. Petersburg (Meyer-Helmund). Song. Petite Suite No. 2 (de Micheli). Talk. Ballet Suite from "La Juive" (Halévy). Song. Hopak (Moussorgsky). Sérénade à Lisette (Caludi). Waltz, Abandon (Waldteufel).
10.0 p.m.—Le Journal Parlé.

BRUSSELS No. 2 (Belgium)
887 kc/s (338.2 m.); 20 kW. Programme in Flemish.
5.0 p.m.—Orchestral Concert. Selection from "Il Re pastore" (Mozart). The Unfinished Symphony (Schubert). Marche écosais and Dance (Debussy). Pieces for Organ (César Franck).
6.0 p.m.—Concert of Passion Music. Vere languoros nostros (Lotti). Selections (Palestrina): (a) Eram quasi agnus, (b) Omnes amici mei, (c) Improperia, (d) O Domine Jesu Christe. Talk by the Reverend Father Van Gestel. Ne derelinquas me (Williaert). O Crux benedicta (de Rori). Selections (Da Vittoria): (a) Judas Mercator, (b) Quomodo obscuratum. Vexilla regis (Palestrina).
6.45 p.m.—Gramophone Records.
7.15 p.m.—Talk: Easter Eggs.
7.30 p.m.—Le Journal Parlé.
7.55 p.m.—Wireless Review.
8.0 p.m.—Concert, conducted by M. F. Quinet. Selections (Beethoven): (a) Overture, Leonora, (b) Symphony No. 6. Talk by M. Herman Vos. Spring Sonata for Violin and Pianoforte (Beethoven). Selections (Wagner): (a) Prelude to the Third Act of "Lohengrin," (b) Funeral March from "The Twilight of the Gods," (c) Siegfried's Rhine Journey. Selections (Beethoven): (a) Romance in G for Violin and Orchestra, (b) Romance in F for Violin and Orchestra. Overture, "The Flying

Dutchman" (Wagner). After the Programme, Gramophone Record: Psalm (van Hoof).
10.0 p.m.—Le Journal Parlé.
BUDAPEST (Hungary)
545 kc/s (550 m.); 23 kW. Transmits at intervals from 8.0 a.m. (Service).
5.0 p.m.—Choral and Orchestral Concert.
COLOGNE (Germany)
Westdeutscher Rundfunk. 1,319 kc/s (227 m.); 1.7 kW. See Langenberg Programme.
COPENHAGEN (Denmark)
1,067 kc/s (281 m.); 1 kW. Relayed by Kalundborg, 260 kc/s (1,153 m.). Transmits at intervals from 9.0 a.m. (Divine Service).
11.0 a.m.—Instrumental Concert. March from the Music to "Ein Ritterballet" (Beethoven). Selection from "Orpheus and Eurydice" (Gluck). Gavotte from "Idomeneus" (Mozart). Prelude, Ritornelle and Chaconne for Strings (Lully). Chanson Louis XIII et Pavane (Couperin). Adagio and Allegro (Corelli).
2.0 p.m.—Orchestral Concert. Festival Overture (Nicolai). Introduction to the Fifth Act and Prayer from "Rienzi" (Wagner). Air for Strings (J. S. Bach). Selection from "Iphigenia in Aulis" (Gluck). Overture, "Coriolanus" (Beethoven). Reading (Kierkegaard). Overture, "Rosamunde" (Schubert). Selection for Strings: Frühlingsglaube (Schubert). Andante from the Violin Concerto in E Minor (Mendelssohn-Bartholdy). Selection from "The Damnation of Faust" (Berlioz). Coronation March from "The Prophet" (Meyerbeer).
4.0 p.m.—Divine Service from the Elias Church.
5.50 p.m.—Weather Report.
6.0 p.m.—News Bulletin.
6.15 p.m.—Time Signal.
6.30 p.m.—Talk: The Icelandic Hymn-Writer Hallgrímur Pjetursson.

7.0 p.m.—Town Hall Chimes.
7.2 p.m.—Good Friday Concert relayed from the Nikolaj kirkesal. Ricercare for Organ (Froberger). Selection for Quartet A-cappella (Goudimel). Litany on Old Church Motives for Baritone and A-cappella Quartet (Th. Laub). O, du Guds Lam—Quartet with Organ (Th. Laub). Organ Chorale: O, Hoved højt forhaenet (Frungk). Christ Jesus, Motet a Capella (Th. Laub). Paduane for Six String Instruments (Schein). "The Seven Words from the Cross"—for Soloists, Strings and Organ (Scheitz). Sacred Concerto for Soloists, Strings and Organ (Hammerschmidt).
8.15 p.m.—Reading (S. Lagerlöf).
8.45 p.m.—Suite No. 17 for Cembalo (Scarlatti).
9.0 p.m.—News Bulletin.
9.5 p.m. (approx.)—Concert from the Works of Händel. Overture, "Agrippina." Recitative: So spricht der Herr, and Aria: Wer mag den Tag from "The Messiah." Larghetto for Violin and String Orchestra. Aria from "The Messiah." Concerto grosso No. 7 in C Major.
10.0 p.m. (approx.)—Close Down.

7.0 p.m.—Town Hall Chimes.
7.2 p.m.—Good Friday Concert relayed from the Nikolaj kirkesal. Ricercare for Organ (Froberger). Selection for Quartet A-cappella (Goudimel). Litany on Old Church Motives for Baritone and A-cappella Quartet (Th. Laub). O, du Guds Lam—Quartet with Organ (Th. Laub). Organ Chorale: O, Hoved højt forhaenet (Frungk). Christ Jesus, Motet a Capella (Th. Laub). Paduane for Six String Instruments (Schein). "The Seven Words from the Cross"—for Soloists, Strings and Organ (Scheitz). Sacred Concerto for Soloists, Strings and Organ (Hammerschmidt).
8.15 p.m.—Reading (S. Lagerlöf).
8.45 p.m.—Suite No. 17 for Cembalo (Scarlatti).
9.0 p.m.—News Bulletin.
9.5 p.m. (approx.)—Concert from the Works of Händel. Overture, "Agrippina." Recitative: So spricht der Herr, and Aria: Wer mag den Tag from "The Messiah." Larghetto for Violin and String Orchestra. Aria from "The Messiah." Concerto grosso No. 7 in C Major.
10.0 p.m. (approx.)—Close Down.

7.0 p.m.—Town Hall Chimes.
7.2 p.m.—Good Friday Concert relayed from the Nikolaj kirkesal. Ricercare for Organ (Froberger). Selection for Quartet A-cappella (Goudimel). Litany on Old Church Motives for Baritone and A-cappella Quartet (Th. Laub). O, du Guds Lam—Quartet with Organ (Th. Laub). Organ Chorale: O, Hoved højt forhaenet (Frungk). Christ Jesus, Motet a Capella (Th. Laub). Paduane for Six String Instruments (Schein). "The Seven Words from the Cross"—for Soloists, Strings and Organ (Scheitz). Sacred Concerto for Soloists, Strings and Organ (Hammerschmidt).
8.15 p.m.—Reading (S. Lagerlöf).
8.45 p.m.—Suite No. 17 for Cembalo (Scarlatti).
9.0 p.m.—News Bulletin.
9.5 p.m. (approx.)—Concert from the Works of Händel. Overture, "Agrippina." Recitative: So spricht der Herr, and Aria: Wer mag den Tag from "The Messiah." Larghetto for Violin and String Orchestra. Aria from "The Messiah." Concerto grosso No. 7 in C Major.
10.0 p.m. (approx.)—Close Down.

7.0 p.m.—Town Hall Chimes.
7.2 p.m.—Good Friday Concert relayed from the Nikolaj kirkesal. Ricercare for Organ (Froberger). Selection for Quartet A-cappella (Goudimel). Litany on Old Church Motives for Baritone and A-cappella Quartet (Th. Laub). O, du Guds Lam—Quartet with Organ (Th. Laub). Organ Chorale: O, Hoved højt forhaenet (Frungk). Christ Jesus, Motet a Capella (Th. Laub). Paduane for Six String Instruments (Schein). "The Seven Words from the Cross"—for Soloists, Strings and Organ (Scheitz). Sacred Concerto for Soloists, Strings and Organ (Hammerschmidt).
8.15 p.m.—Reading (S. Lagerlöf).
8.45 p.m.—Suite No. 17 for Cembalo (Scarlatti).
9.0 p.m.—News Bulletin.
9.5 p.m. (approx.)—Concert from the Works of Händel. Overture, "Agrippina." Recitative: So spricht der Herr, and Aria: Wer mag den Tag from "The Messiah." Larghetto for Violin and String Orchestra. Aria from "The Messiah." Concerto grosso No. 7 in C Major.
10.0 p.m. (approx.)—Close Down.

7.0 p.m.—Town Hall Chimes.
7.2 p.m.—Good Friday Concert relayed from the Nikolaj kirkesal. Ricercare for Organ (Froberger). Selection for Quartet A-cappella (Goudimel). Litany on Old Church Motives for Baritone and A-cappella Quartet (Th. Laub). O, du Guds Lam—Quartet with Organ (Th. Laub). Organ Chorale: O, Hoved højt forhaenet (Frungk). Christ Jesus, Motet a Capella (Th. Laub). Paduane for Six String Instruments (Schein). "The Seven Words from the Cross"—for Soloists, Strings and Organ (Scheitz). Sacred Concerto for Soloists, Strings and Organ (Hammerschmidt).
8.15 p.m.—Reading (S. Lagerlöf).
8.45 p.m.—Suite No. 17 for Cembalo (Scarlatti).
9.0 p.m.—News Bulletin.
9.5 p.m. (approx.)—Concert from the Works of Händel. Overture, "Agrippina." Recitative: So spricht der Herr, and Aria: Wer mag den Tag from "The Messiah." Larghetto for Violin and String Orchestra. Aria from "The Messiah." Concerto grosso No. 7 in C Major.
10.0 p.m. (approx.)—Close Down.

7.0 p.m.—Town Hall Chimes.
7.2 p.m.—Good Friday Concert relayed from the Nikolaj kirkesal. Ricercare for Organ (Froberger). Selection for Quartet A-cappella (Goudimel). Litany on Old Church Motives for Baritone and A-cappella Quartet (Th. Laub). O, du Guds Lam—Quartet with Organ (Th. Laub). Organ Chorale: O, Hoved højt forhaenet (Frungk). Christ Jesus, Motet a Capella (Th. Laub). Paduane for Six String Instruments (Schein). "The Seven Words from the Cross"—for Soloists, Strings and Organ (Scheitz). Sacred Concerto for Soloists, Strings and Organ (Hammerschmidt).
8.15 p.m.—Reading (S. Lagerlöf).
8.45 p.m.—Suite No. 17 for Cembalo (Scarlatti).
9.0 p.m.—News Bulletin.
9.5 p.m. (approx.)—Concert from the Works of Händel. Overture, "Agrippina." Recitative: So spricht der Herr, and Aria: Wer mag den Tag from "The Messiah." Larghetto for Violin and String Orchestra. Aria from "The Messiah." Concerto grosso No. 7 in C Major.
10.0 p.m. (approx.)—Close Down.

7.0 p.m.—Town Hall Chimes.
7.2 p.m.—Good Friday Concert relayed from the Nikolaj kirkesal. Ricercare for Organ (Froberger). Selection for Quartet A-cappella (Goudimel). Litany on Old Church Motives for Baritone and A-cappella Quartet (Th. Laub). O, du Guds Lam—Quartet with Organ (Th. Laub). Organ Chorale: O, Hoved højt forhaenet (Frungk). Christ Jesus, Motet a Capella (Th. Laub). Paduane for Six String Instruments (Schein). "The Seven Words from the Cross"—for Soloists, Strings and Organ (Scheitz). Sacred Concerto for Soloists, Strings and Organ (Hammerschmidt).
8.15 p.m.—Reading (S. Lagerlöf).
8.45 p.m.—Suite No. 17 for Cembalo (Scarlatti).
9.0 p.m.—News Bulletin.
9.5 p.m. (approx.)—Concert from the Works of Händel. Overture, "Agrippina." Recitative: So spricht der Herr, and Aria: Wer mag den Tag from "The Messiah." Larghetto for Violin and String Orchestra. Aria from "The Messiah." Concerto grosso No. 7 in C Major.
10.0 p.m. (approx.)—Close Down.

7.0 p.m.—Town Hall Chimes.
7.2 p.m.—Good Friday Concert relayed from the Nikolaj kirkesal. Ricercare for Organ (Froberger). Selection for Quartet A-cappella (Goudimel). Litany on Old Church Motives for Baritone and A-cappella Quartet (Th. Laub). O, du Guds Lam—Quartet with Organ (Th. Laub). Organ Chorale: O, Hoved højt forhaenet (Frungk). Christ Jesus, Motet a Capella (Th. Laub). Paduane for Six String Instruments (Schein). "The Seven Words from the Cross"—for Soloists, Strings and Organ (Scheitz). Sacred Concerto for Soloists, Strings and Organ (Hammerschmidt).
8.15 p.m.—Reading (S. Lagerlöf).
8.45 p.m.—Suite No. 17 for Cembalo (Scarlatti).
9.0 p.m.—News Bulletin.
9.5 p.m. (approx.)—Concert from the Works of Händel. Overture, "Agrippina." Recitative: So spricht der Herr, and Aria: Wer mag den Tag from "The Messiah." Larghetto for Violin and String Orchestra. Aria from "The Messiah." Concerto grosso No. 7 in C Major.
10.0 p.m. (approx.)—Close Down.

7.0 p.m.—Town Hall Chimes.
7.2 p.m.—Good Friday Concert relayed from the Nikolaj kirkesal. Ricercare for Organ (Froberger). Selection for Quartet A-cappella (Goudimel). Litany on Old Church Motives for Baritone and A-cappella Quartet (Th. Laub). O, du Guds Lam—Quartet with Organ (Th. Laub). Organ Chorale: O, Hoved højt forhaenet (Frungk). Christ Jesus, Motet a Capella (Th. Laub). Paduane for Six String Instruments (Schein). "The Seven Words from the Cross"—for Soloists, Strings and Organ (Scheitz). Sacred Concerto for Soloists, Strings and Organ (Hammerschmidt).
8.15 p.m.—Reading (S. Lagerlöf).
8.45 p.m.—Suite No. 17 for Cembalo (Scarlatti).
9.0 p.m.—News Bulletin.
9.5 p.m. (approx.)—Concert from the Works of Händel. Overture, "Agrippina." Recitative: So spricht der Herr, and Aria: Wer mag den Tag from "The Messiah." Larghetto for Violin and String Orchestra. Aria from "The Messiah." Concerto grosso No. 7 in C Major.
10.0 p.m. (approx.)—Close Down.



Programmes for Friday—(Cont.)

FRANKFURT-am-MAIN

(Germany) 770 kc/s (300 m.); 1.7 kW. Relayed by Cassel, 1,220 kc/s (246 m.). Transmits at intervals from 7.0 a.m. (Organ Recital). 3.0 p.m.—"The Messiah"—Oratorio (Händel), on Gramophone Records. 5.0 p.m.—See Mühlacker. 6.0 p.m.—Good Friday Programme. Address. 6.35 p.m.—"Mass in A flat Major" (Schubert), on Gramophone Records. 7.30 p.m.—Reading: "A Legend of Christ" (Selma Lagerlöf). 8.0 p.m.—Chamber Music. Sonatas from "The Seven Words from the Cross"—String Quartet, Op. 51 (Haydn). 9.0 p.m.—Time, Weather, News and Sports Notes.

HAMBURG (Germany)

Norag (ha, in Morse). 806 kc/s (372 m.); 1.7 kW. Relayed by Bremen, 1,112 kc/s (270 m.); Flensburg, 1,373 kc/s (218 m.); Hanover, 530 kc/s (566 m.); and Kiel, 1,292 kc/s (232.2 m.). Transmits at intervals from 5.20 a.m. (Time and Weather). 11.0 a.m. (from Bremen).—Piano-forte Recital. Two Organ Choral Preludes for Piano-forte (Bach, arr. Busoni). Eroica Variations Op. 35 (Beethoven). Intermezzo Op. 116 No. 4 (Brahms). Intermezzo Op. 119 No. 3 (Brahms). 11.45 a.m.—Weather Report. 11.50 a.m.—Good Friday Concert. Adagio in C minor for Piano-forte from the Sonate pathétique (Beethoven). Song: Litanei (Schubert). Prelude and Fugue on the Name BACH for Organ (Liszt). Two Choral Selections. The Death of Aase (Grieg). Organ Choral: Herzlich tut mich verlangen (J. S. Bach). Good Friday Magic from "Parsifal" (Wagner). Overture to the Oratorio "Athalie" (Mendelssohn). 12.45 p.m. (from Kiel).—Concert of Old Chamber Music for Violin and Piano-forte. Sonata No. 1 in D Major (J. E. Bach). Sonata No. 1 in D Major (J. C. Bach). Sonata No. 2 in G Major (J. W. Hässler). 1.30 p.m.—The Final of the Municipal

Gymnastics Competition—Hamburg, Berlin and Leipzig. 2.0 p.m. (from Bremen).—Concert of Bach Chorales and Sacred Folk Songs. Befehl du deine Wege (Hässler). Ein Lämmlein geht (Strasbourg, 1525). Gib dich zufrieden (Bach). Gott ist und bleibt getreu (Melody of 1628). Harre meine Seele (Malan). Ich bete an die Macht der Liebe (Bortniansky). Unter Lilien jener Freuden (Voigtländer). Wo findet die Seele die Heimat. die Kuh' (Tübingen 1834). So nimm denn meine Hände (Slicher). 3.0 p.m. (from Kiel).—"The Seven Words from the Cross"—String Quartet Op. 51 (Haydn). 3.45 p.m.—Concert of Sacred Music from the Oberrealschule, Eppendorf. Two Selections for Male Voice Choir and Organ: (a) Dem Gedanken der Gefallenen (G. Wohlgenuth), (b) Trösterin Musik (Bruckner). Andante from the Concerto for Violin in G Minor (Max Bruch). Male Voice Choir Selections: (a) Sturmbeschwörung (Dürmer), (b) Gottes ist der Orient (Franz Liszt), (c) Hoch empor (Curti). Soprano Solos: (a) In dieser Abendstunde (Haas), (b) Wenn einst die Türen der Himmel aufgehen (Haas). Selections for Mixed Choir: (a) Passion Song (J. S. Bach), (b) Liebe, die für mich gestorben (Mozart), (c) In dieser österlichen Zeit (Kecard). 4.30 p.m.—Talk: Famous Conductors. 4.55 p.m.—Concert from the Works of Old Composers on Old Instruments. Sonata in D Major for Viola da gamba and Cembalo (Guarini). Sonata in A Major for Viola d'amore and Cembalo (Aristosti). Suite for Viola da gamba and Cembalo (Forguery). Minuets Nos. 1 and 2 for Viola d'amore and Cembalo (Milandre). Sonata for Viola d'amore, Viola da gamba and Cembalo (Erlbach). 5.55 p.m.—Organ Recital from the Works of Heinrich Kaminsky. Choral Prelude, Psalm 130 Op. 1a for Mixed a capella Choir—"Aus der Tiefe rufe ich." Toccata on the Choral "Wie schön leuchtet der Morgenstern". Three Chorales for Mixed a capella Choir: (a) Ihr Gestirn, ihr hohen Luft, (b)

Die liebe Sonne, (c) Der Tag ist hin, die Sonne gehet nieder. Choral Sonata in Four Movements. 6.45 p.m.—Sports Notes. 6.55 p.m.—Weather Report. 7.0 p.m.—"Cain"—A Mystery (Lord Byron), arranged for the Wireless by Hans Bodenstedt. Music by Horst Platen. 8.40 p.m.—News Bulletin. 9.0 p.m.—Organ Recital from the Works of Händel. Concerto Op. 4 No. 1 in G Minor. Three Pieces for Organ: (a) Passacaglia, (b) Sarabande, (c) Selection from the Oratorio "Saul" Concerto Op. 4 No. 4 in F Major. 10.0 p.m. (approx.).—Close Down.

HEILSBURG (Germany)

1,085 kc/s (276.5 m.); 75 kW. Relayed by Danzig, 662 kc/s (453 m.). Transmits at intervals from 9.0 a.m. 6.10 p.m.—Talk: Impressions of a Journey in the Wilno District and a Sight of the Old East Front once again. 7.0 p.m. (from Danzig).—"The Trojan Women"—after the Tragedy by Euripides (Franz Werfel). 8.15 p.m.—"The Königsberg Passion 1672" (Joh. Sebastiani), relayed from the Neurosgärtner Kirche, Königsberg.

HILVERSUM (Holland)

1,004 kc/s (298 m.); 8.5 kW. 8.40—9.40 a.m.—Programme of the Workers' Radio Society (V.A.R.A.). Gramophone Records. 9.40 a.m.—Programme of the Liberal Protestant Radio Society (V.P.R.O.). Religious Transmission. 9.55—11.40 a.m.—Programme of the V.A.R.A. 9.55 a.m.—Recitations. 10.10 a.m.—Programme for Hospitals. 11.10 a.m.—Gramophone Records. 11.40 a.m.—3.40 p.m.—Programme of the Algemeene Vereeniging Radio Omroep (A.V.R.O.). 11.40 a.m.—Orchestral Concert. Festival Overture (Leutner). Suite Saharienne (Ackermans). Berceuse from "Jocelyn" (Godard). Serenade (Grünfeld). Prelude (Rachmaninoff). Organ Solos. Selection from "The Pearl Fishers" (Bizet). Le pas des fleurs (Delibes). Organ Solos. Scottish Dances (Beethoven). Extravaganzen (Morena). Red Roses Waltz

(Lehar). Love Dream (Bece). March, Return to France (Mezzacapo). 1.40 p.m.—Quartet in A Minor for Strings (Schubert). 2.10 p.m.—Daily Service. 2.25 p.m.—Choral Concert. Selection from "The St. Matthew Passion" (Heinrich Schutz). Two Sacred Songs (Heinrich Schutz). Selection from "Kruisbergh" (Padbruë). 3.40 till 7.55 p.m.—Programme of the V.A.R.A. 3.40 p.m.—Organ Recital. 4.10 p.m.—Programme for Children. 4.55 p.m.—Songs, Piano-forte Solos and Gramophone Records. 5.40 p.m.—Orchestral Concert, conducted by Hugo de Groot. Topical Talk in the interval. 7.55—10.40 p.m.—Programme of the V.P.R.O. 7.55 p.m.—Divine Service. 8.55 p.m. (approx.).—Vocal and Instrumental Concert. 10.40—11.40 p.m.—Programme of the Workers' Radio Society (V.A.R.A.). Gramophone Records. 11.40 p.m. (approx.).—Close Down

HUIZEN (Holland)

160 kc/s (1,875 m.); 8.5 kW. 8.10 a.m. till Close Down.—Programme of the Christian Radio Society (N.C.R.V.). 8.10—9.20 a.m.—Morning Recital. 10.10 a.m.—Programme for Hospitals. 10.40 a.m.—Gramophone Records. 11.40 a.m.—Police Notes. 12.10 p.m.—Instrumental Concert. Selections from "Christ on the Mount of Olives" for Violin, Cello and Piano-forte (Beethoven). Sonata in E Major for Violin and Piano-forte (Mozart). Clarinet and Piano-forte Selections: (a) Pastoral (Busser), (b) Romance (Spohr). Allegro animosamente for Violin and Piano-forte (Tartini-Elman). Chant élégiaque for Cello and Piano-forte (Schmitt). Fantastic Pieces for Clarinet (Gade). Theme with Variations from the Trio, Op. 50, for Violin, Cello and Piano-forte (Tchalkovsky). 1.40 p.m.—Gramophone Records. 2.10 p.m.—Reading. 2.40 p.m.—Vocal and Instrumental Concert. Prelude and Fugue in F for Organ (J. S. Bach). Soprano Solo from "The St. Matthew Passion" (J. S. Bach). Violin

Solos: (a) Moderato tranquillo (J. S. Bach), (b) Adagio (Corelli). Recitative and Aria from the Cantata No. 89, for Soprano, Violin and Organ (J. S. Bach). Grave, Op. 16, for Organ (Bach). Sonata in D for Violin (Händel). Soprano Solos: (a) Am Karfreitag (J. S. Bach), (b) Passionslied (C. P. E. Bach). Violin Solos: (a) Larghetto (Nardini), (b) Air (J. S. Bach). Klaar bloed en louter wonden—for Soprano, Violin and Organ (v. d. Horst). Soprano Solo: Die mijns harten vrede zijt (v. Nieuwenhoven). Sonata for Organ Part II (Kloek). 4.10 p.m.—Programme for Children. 5.10 p.m.—Programme to be announced. 5.25 p.m.—Organ Recital from a Chapel in Amsterdam. Organ Choral: O, Mensch, bewein' dein' Sünde gross (J. S. Bach). Andante from the Fourth Sonata (J. S. Bach). Dumka (Novosjensky). Marche funèbre and Chant séraphique (Guilmant). Ave verum corpus (Mozart-Liszt). Preghiera (Ravanello). Wenn ich einmal soll scheiden (J. S. Bach). 6.10 p.m.—Gardening Talk. 6.40 p.m.—Gramophone Records. 6.55 p.m.—Police Notes. 7.10 p.m.—Divine Service from the Oude Kerk, Amsterdam. 8.40 p.m.—News Bulletin. 8.55 p.m.—Vocal and Instrumental Concert. 10.40 p.m.—Gramophone Records. 11.10 p.m. (approx.).—Close Down.

JUAN-LES-PINS (Nice, France)

1205 kc/s (249 m.); 1.2 kW. 12.30 p.m.—News Bulletin, Amusement Guide and Concert. Selection from "Il Trovatore" (Verdi). Selection from "Véronique" (Messager). Rhapsody (Debussy). Selection from "The Huguenots" (Meyerbeer). Selection from "Aida" (Verdi). Symphonic Poem, Finlandia (Sibelius). Selection from "Werther" (Massenet). Prelude (Rachmaninoff). Algerian Suite (Saint-Saëns). Arlequin (Popper). Romance (Fauré). Selection from "Rose Marie" (Friml). Selection from "The Love Parade" (Schertzing). 2.0 p.m.—The Marseillaise. 2.10—8.30 p.m.—Interval.

GO MOTOR BOATING

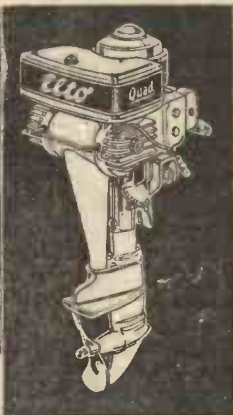

NO LONGER ARE YOU DENIED ITS THRILLS!

You may have thought of motor boating as costly, or restricted to people living close to water. Instead, its keenest thrills are yours for a remarkably small cost. No need to even own a boat. Just possess an Elto Outboard Motor—and go motor boating anywhere, in any boat.

An Elto Motor transforms the usual rowing-boat into a swift, easy-to-handle motor boat. Just clamp it on the stern. Carry it with you wherever you go. Elto are the world's finest Outboard Motors. Prices range upwards from only £26. Complete Elto Motor Boats range from £46. Possessing either an Elto Motor or Motor Boat means lifting your leisure out of everyday sameness.

14 Elto Motors range from the fastest, most powerful Outboards ever built, to the handiest and most compact. Prices from £26 upwards. Complete Motor Boats from £46.



Sent to-day for the Elto Catalogue No. WR.10., and for free advice on motor boating.

ELTO MOTOR SALES CO., LTD., 24, Harrison Street, London, W.C.1

FREE 9d BOX POST PAID

WILL YOU TRY THIS PROVED REMEDY FOR INDIGESTION

ACID STOMACH FLATULENCE HEARTBURN BILIOUSNESS PALPITATION GASTRITIS We offer to GIVE you your FIRST Box (put up for Free Trial only and not for sale), for we KNOW this NEW REMEDY is so ASTOUNDINGLY GOOD it will remain with you and your family as your ONLY Remedy for Indigestion and its attendant ailments. We KNOW it will give you instant relief. Our confidence in this PROVED Remedy is so great that we not only offer you a 9d. Box absolutely free, but will pay the cost of postage to you. All you need do is to send the coupon to-day in 3d. stamped unsealed envelope. Birley's Antacid Powder is tasteless and harmless.

IT WILL ONLY COST YOU 3d. STAMP TO SEND COUPON BELOW.



DON'T SUFFER THE MISERY OF DYSPEPSIA ANOTHER DAY!

BIRLEY'S ANTACID POWDER

A DOSE A DAY KEEPS ACID AWAY. Of all Chemists including all Branches of Boots Cash Chemists, Taylor's Drug Co., Timothy White, Hodders, etc. Sold only in 1/3, 3/- and 5/- tins.

FREE TRIAL COUPON No. 204

To BIRLEY'S ANTACID LTD., 16, Northdown St., King's Cross, London, N.1. Send FREE 9d. Box of Birley's Antacid Powder

Name ..... Address ..... Use stamped envelope with 3d. stamp. Enclose nothing else or postage will be more. Please write clearly.

Programmes for Friday—(Cont.)

8.30 p.m.—Concert by the Station Orchestra.
10.0 p.m.—The Marschallise and Close Down.

KALUNDBORG (Denmark)
Kalundborg Radio. 260 kc/s (1,153 m.); 10 kW.
See Copenhagen Programme.

KATOWICE (Poland)
Polskie Radio. 734 kc/s (408 m.); 16 kW.
Transmits at intervals from 10.40 a.m.
6.10 p.m.—Literary Programme.
6.25 p.m.—Announcements, Theatre Review, Programme Notes and Amusement Guide.
6.40 p.m.—News and Sports Notes.
7.0 p.m.—Talk (to be announced).
7.15 p.m.—Sacred Music.
8.15 p.m.—Literary Programme, Weather Report and Programme Announcements in French.
10.0 p.m.—The Letter Box in French.

KÖNIGSBERG (Germany)
Ostmarken Rundfunk. 1,382 kc/s (217 m.); 1.7 kW.
See Heilsberg Programme.

LANGENBERG (Germany)
Westdeutscher Rundfunk. 635 kc/s (473 m.); 17 kW. Relayed by Aachen, Cologne and Münster. 1,319 kc/s (227 m.).
Transmits at intervals from 5.40 a.m. (Lesson in Self-defence).

10.30 a.m.—Gramophone Records of Bronislav Huberman (Violinist) and Ignaz Friedman (Pianist): The Kreuzer Sonata in A Major, Op. 47 (Beethoven).
11.10 a.m.—Talk on Careers: Commercial Employees in Circuses.
11.35 a.m.—Review of Books dealing with Economics and Society.
12 noon.—Chamber Music by the Budapest String Quartet. String Quartet in A Minor, Op. 132 (Beethoven). Baritone Solo: St. John the Apostle (Loewe). String Quartet in A Major, Op. 18 (Beethoven). Baritone Solo: Selene Beter (Loewe). String Quartet in F Major, Op. 59 (Beethoven).

2.0 p.m.—Fairy Tales for Children.
2.20 p.m.—Talk for Women: Legal Questions in Marriage—Parental Control.
2.45 p.m.—Young People's Programme.

3.30 p.m.—Passion Music, relayed from the New Reformed Church at Elberfeld. Organ Solo: Fantasia in C Minor (Bach). Four Chorales: (a) O Mensch, bewein' dein' Sünde gross (Praetorius), (b) Ein Lämmlein geht und trägt die Schuld (Vulpinus), (c) Herzliebster Jesu, was hast du verbrochen (Krüger), (d) O Haupt voll Blut und Wunden (Hassler). Contralto Solos: Three Old Sacred Songs (Franck). Two Old Sacred Folk Songs: (a) Da Jesus in den Garten ging (arr. Thiel), (b) In stiller Nacht (arr. Brahms). Christ Todeskunde (Haydn). Organ Solo: Passacaglia in D (Buxtehude). O Lamm Gottes, Op. 138 (Regner). Agnus Dei, from the Mass in G (Förtner). Contralto Solos: Three Modern Sacred Songs (Courvoisier). Hier liegt der, welcher ist und war, from the German Choral Mass (Haas).

5.0 p.m.—Talk: A Visit to the Holy Land—In Jerusalem.
5.20 p.m.—Programme for Workers: Vagabonds' Tales.
5.40 p.m.—Love in Music—Human Love—a Concert on Gramophone Records, with Introductory and Explanatory Notes by Dr. Martin Friedland.

6.20 p.m.—Talk: Industrial Towns—News on the Rhine, a Town between Coal and Corn.
6.40 p.m.—Talk: The World of Animals.

7.10 p.m.—"A German Requiem" for Soloists, Choir and Orchestra (Brahms). Soloists: Wally Kirsamer (Soprano); Lothar Lessig (Baritone). The Station Choir and Orchestra. After the Programme, News, Sports Notes and Silent Night.

LBIPZIG (Germany)
Mitteldeutscher Rundfunk. 1,157 kc/s (259 m.); 2.3 kW. Relayed by Dresden, 941 kc/s (319 m.).
7.30 a.m.—Organ Recital from St. Thomas' Church.
8.0 a.m.—"Passional"—A Sequence of Sacred Literature and Music (Dietrich).
10.0 a.m.—Passion Thoughts in Modern German Literature from

Gerhart Hauptmann to Martin Behaim-Schwarzbach.

11.0 a.m.—Orchestral Concert. Overture, "Joseph in Egypt" (Méhul). Sollicitudo (Muffot). Symphony in D Major, No. 3 (Schubert). Gesang vom Reigen der Geister (Busoni). Two Selections (Grieg): (a) Abend im Hochgebirge, (b) An der Wiege. Legends (Dvorak). Prelude and Theme with Variations from the Symphonic Suite in B Minor, Op. 17 (Nicodé).
1.0 p.m.—Review of Scientific Books.
1.30 p.m.—Concert for Young People. Old German Songs: (a) Hildebrandslied, (b) Es taget in dem Osten, (c) Herzog Ulrichs von Württemberg Jagd- und Liebeslied, (d) Der Lindenschmied. Sonata for Flute and Piano in E Minor, No. 1 (G. F. Händel). Rondo in A Minor for Piano (Mozart). Old German Songs: (a) Zum Lobe der Musik (Voigtlaender), (b) Abendlied (Krieger), (c) Schäfers Totenlied (Dedekind).
2.0 p.m.—Talk: As a German Worker in Romania.
2.30 p.m.—Chamber Music by the Dresden String Quartet. String Quartet in F Minor, Op. 95 (Beethoven).
3.0 p.m.—"Torquato Tasso"—Drama (Goethe), arranged as a Wireless Play by Detlef Sierck.
4.30 p.m.—Talk on the following Transmission.
5.0 p.m.—"The St. Matthew Passion" (J. S. Bach) from St. Thomas' Church.
9.0 p.m.—News and Silent Night.

LJUBLJANA (Yugoslavia)
Radio-Ljubljana. 522 kc/s (574.7 m.); 2.8 kW.
Transmits at intervals from 11.15 a.m.
5.0 p.m.—Gramophone Records.
6.0 p.m.—Programme for Women. The Seven Words from the Cross (Haydn).
9.0 p.m.—Weather and News.

MADRID (Spain)
Union Radio (E.A.J.). 707 kc/s (424 m.); 2 kW.
8.0 a.m.—Topical Review of Sports, Literature and Art, Subjects of interest to Women and Children. Theatre and Cinematograph Notes.
12 noon.—Divine Service. Relay from the Church of San José—the Seven Words from the Cross.
3.0 p.m. (approx.)—Close Down.

MILAN (Italy)
Ente Italiano Audizioni Radiofoniche. 599 kc/s (501 m.); 8.5 kW. Programme relayed by Turin, 1,013 kc/s (296 m.); and Genoa, 958 kc/s (312.2 m.).
Transmits at intervals from 7.15 a.m. (Giornale radio).
6.20 p.m.—Announcements.
6.30 p.m.—Concert of Light Music. Morning (Grieg). Prayer from the Asiatic Suite (Preston). Moment Musical (Schubert). Largo (Veracini-Corti). Rondo a capriccio (Beethoven). Pasqua di Resurrezione (Zoboli).
7.0 p.m.—Time, Giornale radio, Announcements and Weather.
7.45 p.m.—Talk on Art.
8.0 p.m.—Variety Programme.
8.30 p.m.—Concert of Sacred Music. First and Second Preludes to "The Passion of Christ" (Perosi). Stabat Mater for Soloists and String Orchestra (Pergolesi). Good Friday Magic from "Parsifal" (Wagner). In an interval, Talk: From Near and Far.
10.0 p.m.—Giornale radio, followed by Concert from the Cova Restaurant.
10.55 p.m.—News Bulletin.

MOTALA (Sweden)
222.5 kc/s (1,348 m.); 40 kW.
See Stockholm Programme.

MÜHLACKER (Germany)
Süddeutscher Rundfunk. 833 kc/s (360 m.); 7.5 kW. Relayed by Freiburg, 527 kc/s (570 m.).
Transmits at intervals from 0.15 a.m.
3.0 p.m.—See Frankfurt.
4.15 p.m.—"Requiem" (Hugo Kaun), relayed from Heidelberg.
5.0 p.m.—"Passio Christi"—as performed at the Benedictine Monastery at Vienna (arr. Dr. G. E. Terramare).
6.0 p.m.—Talk: Ramadan, the Mohammedan Lent.
7.0 p.m.—Talk: Ramadan, the Mohammedan Lent.
7.30 p.m.—Elementary English Lesson.
7.45 p.m.—Commercial Prices, Economic and Social Notes and News.
8.0 p.m.—Dramatic Programme. In the interval at 8.30 p.m.—Sports Results, Amusement Guide and Announcements.

MUNICH (Germany)
563 kc/s (533 m.); 1.7 kW. Relayed by Augsburg, 536 kc/s (560 m.); Kaiserslautern, 536 kc/s (560 m.); and Nürnberg, 1,256 kc/s (239 m.).
9.0 a.m. (from Nürnberg).—Evangelical Service, with Address by Dr. Werner Ehlert, of Erlangen.
9.20 p.m.—News Bulletin.

OSLO (Norway)
Kringkastingselskapet. 280 kc/s (1,071 m.); 7.5 kW. Relayed by Fredrikstad, 815 kc/s (368 m.); Hamar, 511 kc/s (587 m.); Notodden, 671 kc/s (447.1 m.); Porsgrunn, 662 kc/s (453 m.); and Rjukan, 671 kc/s (447.1 m.).
Transmits at intervals from 9.0 a.m.
3.30 p.m.—"The Seven Words from the Cross" (Haydn), by the Norwegian String Quartet.
4.50 p.m.—Chimes and Divine Service from the Fagerborg Church.
6.30 p.m.—Talk.
7.0 p.m.—Time Signal.
7.2 p.m.—Concert from the St. Saviour's Church. Choral, Soloist and Organ Selections.
8.35 p.m.—Weather and News.
8.50 p.m.—Topical Talk.
9.5 p.m. (approx.)—Close Down.

PARIS (France)
Eiffel Tower (FLE). 207 kc/s (1,445 m.); 15 kW. Time Signals (on 2,650 m.); 113 kc/s at 9.25 a.m. and 10.25 p.m. (preliminary and 6-dot signals).
5.45 p.m.—Le Journal Parlé.
7.10 p.m.—Meteorological Forecast.
7.30 p.m.—Symphony Concert under the direction of M. Edouard Flament. Prologues to "Les Béatitudes" (C. Franck-Casadesus). Ave Maria (Schubert-Tavan). Fugue for Cello (de Bréville-Chapelier). Largo (Händel). Ave Maria (Gounod). Violin Solo. Nocturne (Chausson-Chapelier). Overture, "Joseph" (Méhul-Nardou). Adagio cantabile (Tartini-Salabert). Panis Angelicus (César Franck). Preludes for Piano (Bach), played by M. Ed. Flament. Consolation (Liszt-Flament). Lento ma non troppo for Viola (C. Franck-Rudd). Interlude (Chausson-Chapelier). Le dernier sommeil de la Vierge (Massenet). Andante religioso (E. Flament). Good Friday Magic from "Parsifal" (Wagner-Salabert).

PARIS (France)
Poste Parisien. 914 kc/s (329 m.); 1.2 kW.
9.0 a.m.—Transmission of Pictures.
8.25 p.m.—Gramophone Records, Talk and News Bulletin.
9.0 p.m.—Concert with the collaboration of Opéra and Opéra-Comique Artists. Overture, "St. Paul" (Mendelssohn). Suite in D (Bach). Midnight on Maundy Thursday (Turina). Procession, nocturne (Rabaud). Le Messie d'amour (Francis Casadesus), conducted by the Composer. Good Friday Magic from "Parsifal" (Wagner). Finale (Schumann).

PARIS (France)
Radio-Paris. (CFR). 174 kc/s (1,725 m.); 17 kW.
Transmits at intervals from 6.45 a.m. (Physical Culture).
12.30 p.m.—Gramophone Records.
1.0 p.m.—Exchange Quotations and News.
1.5 p.m.—Gramophone Concert of Chamber Music. Jota aragonesa for Violin (Sarasate). Andalusian Romance for Violin (Sarasate). Pianoforte Solos (Albeniz): (a) Oriental, (b) Seguidillas. Song: Cantares (Turina). Cello Solo: Goyescas (Granados). Spanish Dance for Cello (Granados). Seven Spanish Songs (de Falla). Guitar Solos (Torroba): (a) Preludio, (b) Fandanguillo. Song: Montañanarde (Nin). Violin Solo: Chant d'Espagne (Samazeuilh). In the intervals at 1.30 p.m.—Exchange Quotations and 2.0 p.m.—Exchange Quotations and Market Prices.
4.30 p.m.—Exchange Quotations and Market Prices.
5.55 p.m.—Exchange Quotations.
6.0 p.m.—Agricultural Report and Racing Results.
6.30 p.m.—Gramophone Records. Selections from (a) "Si j'étais Roi" (Adam), (b) "Le Roi d'Ys" (Lalo), (c) "Lohengrin" (Wagner).
7.0 p.m.—Talk: Ramadan, the Mohammedan Lent.
7.30 p.m.—Elementary English Lesson.
7.45 p.m.—Commercial Prices, Economic and Social Notes and News.
8.0 p.m.—Dramatic Programme. In the interval at 8.30 p.m.—Sports Results, Amusement Guide and Announcements.

9.15 p.m.—Press Review, News and Time Signal.

9.30 p.m.—Organ Recital by Mlle. Marthe Bracquemond, relayed from the Old Conservatoire.

POZNAŃ (Poland)
896 kc/s (335 m.); 1.9 kW.
Transmits at intervals from 6.15 a.m. (Radio Journal).
4.45 p.m.—Concert by a String Quartet.
5.45 p.m.—Topical Talk.
6.0 p.m.—French Lesson.
6.15 p.m.—Talk: Literature and Poetry.
6.30 p.m.—Advanced English Lesson.
6.45 p.m.—Slav Programme.
7.0 p.m.—Miscellaneous Items and News.
7.15 p.m.—See Warsaw.
9.30 p.m.—Time, News, Sports and Police Notes.
9.45 p.m. (approx.)—Close Down.

ROME (Italy)
Ente Italiano Audizioni Radiofoniche (IRO). 680 kc/s (441 m.); 7.5 kW. Relayed by Naples, 905 kc/s (332 m.); and 2RO, 11,810 kc/s (25.4 m.).
Transmits at intervals from 7.15 a.m. (Giornale radio and Weather for Shipping).
4.0 p.m.—Concert of Sacred Music. Andante religioso (Bottazzo). Ave Maria (Gounod). Presso l'altare (Sinigaglia). Harp Solo: Mestizia (Valenza). Elegy (Rachmaninoff). March, La Fede (Boschi). Melodia religiosa (Bolzoni). Selection for Violin, Cello, Harp and Harmonium: Tergi quelle lacrime (Del Riego). Selection from "The Transfiguration" (Perosi).
6.20 p.m.—Announcements and Giornale radio.
6.50 p.m.—Gramophone Records.
7.10 p.m.—Giornale radio and Announcements.
7.30 p.m.—Time Signal and Announcements, followed by Talk on Literature and Art.
8.0 p.m.—Concert of Sacred Music.—Symphonic Intermezzo, The Redemption (Franck). Duet for Soprano and Mezzo-Soprano—quando corpus (Pergolesi). Amen—for Women's Choir and Orchestra (Lazzari). The Resurrection of the Dead, from "Il Giudizio Universale" (Perosi). Inno dei beati—for Soprano, Choir and Orchestra (Perosi). Announcements. Three Selections (Verdi): (a) Recordare, Jesu pie—Duet for Soprano and Mezzo-Soprano, (b) Ingemisco—for Tenor, (c) Offertory—for Four Voices. Variations on the Prayer from Rossini's "Mosè" for Cello (Paganini-Silva). Second Part for Choir and Orchestra from "The Resurrection of Christ" (Perosi).
9.55 p.m. (approx.)—News.

SCHENECTADY (U.S.A.)
General Electric Company (WGY). 790 kc/s (379.5 m.); 50 kW. Relayed at intervals by W2XAF on 9,530 kc/s (31.48 m.) and by W2XAD on 15,340 kc/s (19.56 m.).
Transmits at intervals from 11.45 a.m.
11.44 p.m.—Weather Report.
11.45 p.m.—Uncle Abe and David from New York.
12 midnight.—Union College Speaker.
12.14 a.m. (Saturday).—Time Signal.
12.15 a.m.—Musical Programme.
12.30 a.m.—Baker Chocolate Programme.
1.0 a.m.—Latin-American Programme.
1.30 a.m.—Philco Programme.
2.0 a.m.—4.0 a.m.—Programme from New York.
2.0 a.m.—Cluquot Club Eskimos.
2.30 a.m.—Enna Jettick Songbird.
2.45 a.m.—Two Troupers.
3.0 a.m.—Eastman Kodak Programme.
3.30 a.m.—RKO Programme.
4.0 a.m.—Vincent Lopez and Hotel St. Regis Orchestra.
4.30 a.m.—Sleepy Hall and Hotel De Witt Clinton Orchestra, from Albany, N.Y.
5.0 a.m.—Johnnie Hamp and Orchestra.
5.30 a.m.—Doc Peyton and the Hotel Kenmore Orchestra from Albany, N.Y.
6.0 a.m. (approx.)—Close Down.

STOCKHOLM (Sweden)
Radiotjänst. (SASA). 689 kc/s (436 m.); 7.5 kW. Relayed by Boden, 244 kc/s (1,229.5 m.); Göteborg, 932 kc/s (322 m.); Hörby, 1,166 kc/s (257 m.); Motala, 222.5 kc/s (1,348 m.); Östersund, 389 kc/s (770 m.); Sundsvall, 554 kc/s (542 m.).
Transmits at intervals from 6.15 a.m. (Gymnastics).

9.0 a.m.—Divine Service from the Cathedral, Malmö, 1301 kc/s (231 m.).

11.45 a.m.—Weather Report.
11.55 a.m.—Time Signal.

2.0 p.m.—Gramophone Concert. Selections from "Parsifal" (Wagner).
3.0 p.m.—Reading (Selma Lagerlöf).
3.30 p.m.—Programme for Children.
4.0 p.m.—Orchestral Concert. Overture, "Athalie" (Mendelssohn). Panis Angelicus (César Franck). Andante religioso (Henriques). Ave Maria (Bach-Gounod). Serenade (Rachmaninoff). Chanson triste (Tchaikovsky). Träumerei (Schumann). Vid Frösö kryka (Peterson-Berger). Angelus (de Micheli). Four Indian Love Lyrics (Woodforde-Finden).

4.55 p.m.—Chimes from the Town Hall.
5.0 p.m.—Evensong.
6.15 p.m.—Introductory Talk to the following transmission.
6.30 p.m.—First Part of the "St. Matthew Passion" (Bach), relayed from the Engelbrekt Church.
8.40 p.m.—"Good Friday"—Play (John Masefield).
10.0 p.m. (approx.)—Close Down.

STRASBOURG (France)
Radio-Strasbourg (PTT). 869 kc/s (345 m.); 15 kW.
Transmits at intervals from 10.0 a.m.
6.0 p.m.—Instrumental Concert.
6.45 p.m.—Legal Talk in German.
7.0 p.m.—Instrumental Concert. Overture, "St. Paul" (Mendelssohn). Moi, j'ai pleuré (Pesce). The Death of Aase from "Peer Gynt" (Grieg) Andante from the Fifth Symphony (Beethoven).
7.30 p.m.—News in French and German.
7.45 p.m.—Gramophone Records.
8.30 p.m.—Chamber Music.
10.30 p.m. (approx.)—Close Down.

TOULOUSE (France)
Radiophonie du Midi. 779 kc/s (385 m.); 8 kW.
Transmits at intervals from 12.45 p.m.
7.0 p.m.—Spanish Songs and Piano-forte Solos.
7.30 p.m.—Exchange and News.
7.45 p.m.—Orchestral Music.
8.15 p.m.—Opera Songs.
8.30 p.m.—Cello Recital.
8.45 p.m.—Recitation.
8.55 p.m.—Fashion Review.
9.0 p.m.—Time Signal.
9.2 p.m.—Orchestral Concert. In the interval, News.
11.0 p.m.—Light Music.
11.15 p.m.—North African News.
11.30 p.m.—Hawaiian Guitar Selections.
11.45 p.m.—Dance Music.
12 midnight (approx.)—Close Down.

VIENNA (Austria)
Radio-Wien. 581 kc/s (517 m.); 20 kW. Relayed by Graz, 851 kc/s (352 m.); Innsbruck, 1,058 kc/s (283 m.); Klagenfurt, 662 kc/s (453.2 m.); Linz, 1,220 kc/s (246 m.); and Salzburg, 1,373 kc/s (218 m.).
No Transmission.

WARSAW (Poland)
Polskie Radio. 212 kc/s (1,411 m.); 158 kW.
Transmits at intervals from 10.40 a.m.
2.50 p.m.—French Lesson.
3.15—4.15 p.m.—No Transmission.
4.15 p.m.—Talk: The Worship of St. Casimir, relayed from Wilno, 815 kc/s (368.1 m.).
4.40 p.m.—See Poznań.
6.10 p.m.—Miscellaneous Items.
6.30 p.m.—Gramophone Records.
6.35 p.m.—Programme Announcements.
6.40 p.m.—Radio Journal.
6.55 p.m.—Gramophone Records.
7.0 p.m.—Talk on Easter.
7.15 p.m.—Concert of Sacred Music. Selection (Palestrina). Sacred Song (Bach-Cornelius). Te Deum (Haydn). Selections for Choir and Baritone (Montuszkó): (a) Choeur des justes, (b) Voici le bois de la Croix.
8.15 p.m.—"Judas"—Sketch (Casimir Tetmajer).
9.15 p.m.—Weather, Police and Sports Notes.

WILNO (Poland)
815 kc/s (368.1 m.); 0.5 kW.
Transmits at intervals from 10.58 a.m.
4.45 p.m.—See Poznań.
6.10 p.m.—Programme Notes and Miscellaneous Announcements.
6.25 p.m.—Programme to be announced.
6.40—9.30 p.m.—See Warsaw.
9.30 p.m. (approx.)—Close Down.

PROGRAMMES FOR SATURDAY (April 4)

NOTE: THE HOURS OF TRANSMISSION ARE REDUCED TO GREENWICH MEAN TIME

ALGIERS (N. Africa) 825.3 kc/s (303.4 m.); 13 kW. 12.30 p.m.—Instrumental Concert. 7.0 p.m.—Report from the Chamber of Commerce. 7.15 p.m.—Hebrew Songs. 7.30 p.m.—Waltzes and Foxtrots. 7.50 p.m.—News Bulletin. 8.0 p.m.—Military Music. 8.15 p.m.—Song Recital. 9.0 p.m.—Accordion Selections. 9.15 p.m.—Humorous Songs and Monologues. 9.30 p.m.—Solo Selections. 9.45 p.m.—Operetta Songs. 10.0 p.m.—Concert relayed alternately from the Municipal Casino and the Hotel Aletti.

BARCELONA (Spain) Radio-Barcelona (EAJ1). 860 kc/s (349 m.); 8 kW. Transmits at intervals from 8.0 a.m. (Radio Journal). 5.30 p.m.—Exchange, Market Prices and Concert, followed by News. 7.0 p.m.—Gramophone Records. 8.30 p.m.—Elementary German Lesson. 9.0 p.m.—Chimes, Weather, Exchange and Agricultural Report. 9.5 p.m.—Orchestral Concert. March (Mannfred). Schottische, Ay, L'adoro I (Secret). Waltz, Exquisite (Worsley). Arab Intermezzo, In the Oasis (Martí). Waltz in A (d'Ambrosio). Pavane (Chaminade). Overture, "Zampa" (Herold). 10.0 p.m.—News Bulletin. 10.5 p.m.—Easter Celebrations, relayed from the Plaza de San Jaime.

BERLIN (Germany) Königs Wusterhausen. 183 kc/s (1,635 m.); 35 kW. Transmits at intervals from 5.20 a.m. (Hamburg Relay). 3.30 p.m.—Concert from Hamburg. 4.0 p.m.—See Hamburg. 4.40 p.m.—Health Talk: The Value of Fine Extract Baths. 5.5 p.m.—Advanced French Lesson. 5.30 p.m.—Talk: Travel Impressions from Russia. 6.0 p.m.—Talk: Symbols of the Passion—The Veronica and Pieta. 6.30 p.m.—"The Quiet Hour"—The New Morning. 6.55 p.m.—Weather for Farmers. 7.0 p.m. till Close Down.—See Berlin (Witzleben).

BERLIN (Germany) Witzleben. 716 kc/s (418 m.); 1.7 kW. Transmits at intervals from 6.0 a.m. (Gymnastics). 6.0 p.m.—Organ Recital. 6.30 p.m.—Nikolaus Schwarzkopf reads from his own works. 7.0 p.m.—Orchestral Concert. Suite from "Le roi s'amuse" (Delibes). Poeme d'amour (Strauss). Norwegian Melodies for String Orchestra (Grieg). Violin Solos: (a) Prelude and Allegro (Pugnani-Kreisler). (b) Tarnourin chinois (Kreisler). Suite, As aller Huren Länder (Moszkovsky). Selection from "Pique Dame" (Tchaikovsky). Waltz from "Eine Ballnacht" (O. Strauss). Reading of Poems. Suite, Aus Holbergs Zeit (Grieg). Wo die Zitronen blühen (Strauss). 9.0 p.m.—Weather, News and Sports Notes. 9.30 p.m.—Symphony No. 2 in C Minor (Mahler).

BERNE (Switzerland) Radio-Bern. 743 kc/s (403 m.); 1.1 kW. Transmits at intervals from 6.0 a.m. 5.15 p.m.—Literary Programme. 5.45 p.m.—Gramophone Records. 6.28 p.m.—Time and Weather. 6.30 p.m.—Talk on Optimism, relayed from Basle, 1,229 kc/s (244.1 m.). 7.0 p.m.—Variety Programme: Yodel Selections, Orchestral Music and Reading. 8.10 p.m.—Concert for Piano, Soprano, Violin and Cello from the Works of Aeschbacher, relayed from Basle. 9.0 p.m.—News and Weather. 9.15 p.m.—Dance Music. 11.0 p.m. (approx.)—Close Down.

BORDEAUX-LAFAYETTE (France) (PTT). 986 kc/s (304 m.); 35 kW. Transmits at intervals from 12.45 p.m. 6.30 p.m.—Radio Journal. 8.0 p.m.—News, Exchange and Sports Notes. 8.10 p.m.—English Lesson

8.25 p.m.—Result of the Prize Draw. 8.30 p.m.—Gramophone Records. 8.45 p.m.—Sextet Concert. After the Programme Amusement Guide and Time Signal.

BRUSSELS (Belgium) Radio-Belgicue. 590 kc/s (509 m.) 20 kW. 5.0 p.m.—Dance Music from the Hotel Atlanta. 5.45 p.m.—Concert. Selection from "The Bohemian Girl" (Balfé). Selection from "The Nuremberg Doll" (Adam). Mazurka, No. 2 (Gondard). Cantilene (Gounod). Talk. Défilé sous un champignon (Gervais). Selection from "Robert the Pirate" (Romberg). L'étoile polaire (Waldeufel). 6.45 p.m.—Gramophone Records. 7.15 p.m.—Talk: Some Flemish Dramatists. 7.30 p.m.—Le Journal Parlé. 8.0 p.m.—Gramophone Records. 8.45 p.m.—Talk and Readings: The Belgian Writer Camille Lemonnier. 9.0 p.m.—Dance Music from the Hotel Atlanta. 10.0 p.m.—Le Journal Parlé.

BRUSSELS No. 2 (Belgium) 887 kc/s (338.2 m.); 20 kW. Programme in Flemish. 5.0 p.m.—Quintet Concert. Le Cabriolet enchanté (Ackermans). Nocturne (Borodin). Gothic Minuet (Boellmann). Selection from "The Daughter of the Regiment" (Donizetti). Sincerity (Byford). The Butterfly (Benaix). Ariette d'autrefois (Brusselmans). Waltz, Loin du Pays (Berger). Scarf Dance (Candioli). Cortège catalan (de Séverac). Selection from "Rigoletto" (Verdi). Neapolitan March (Baldi).

5.45 p.m.—Gramophone Records. 6.45 p.m.—Gramophone Records. 7.15 p.m.—Talk: The Age of the Child. 7.30 p.m.—Le Journal Parlé. 7.55 p.m.—Agricultural Report. 8.0 p.m.—Orchestral Concert, conducted by M. Meulemans. Selection from "Paragraph III" (Suppé). A Summer Night in Madrid (Glinka). Song. Czardas. Readings from "The Passion" (Verschaeva). Selection from "Un Bal costumé" (Rubinstein). Rhapsody (Lalo). Song. Selection from "The Geisha" (Jones). Salut d'amour (Elgar).

BUDAPEST (Hungary) 545 kc/s (550 m.); 23 kW. Transmits at intervals from 8.15 a.m. (Concert). 5.20 p.m.—Talk by Béla Bangha. 5.50 p.m.—Gramophone Records. 7.10 p.m.—Concert conducted by Ernst v. Dohnanyi, followed by Tzigane Concert from the Café Spolarich.

COLOGNE (Germany) Westdeutscher Rundfunk. 1,319 kc/s (227 m.); 1.7 kW. See Langenberg Programme.

COPENHAGEN (Denmark) 1,067 kc/s (281 m.); 1 kW. Relayed by Kalundborg, 260 kc/s (1,153 m.). Transmits at intervals from 6.30 a.m. (Gymnastics). 2.0 p.m.—Programme for Children. 2.30 p.m.—Instrumental Concert. Overture, "The Caliph of Bagdad" (Boieldieu). Styrian Dances (Lanner). Cradle Song (Danning). Czardas from "Die Fledermaus" (Joh. Strauss). Prelude to the Fourth Act of "Carmen" (Bizet). Spanish Dance in A Major (Moszkovsky). Recital of Scandinavian Songs. Slavonic Dance (Glazounoff). Shadow Dance from "Dinorah" (Meyerbeer). Toreador and Andalouse, from the Suite. "Bal costumé" (Rubinstein). Waltz, Morgenblätter (Joh. Strauss). Catalan Caprice (Albeniz). Badinage (Herbert). Serenade (Pierné). Crown Prince Frederick March (Borregaard).

4.40 p.m.—Exchange Quotations and Fish Market Prices. 4.50 p.m.—Programme to be announced. 5.20 p.m.—Talk: The Campaign against Tuberculosis in the Schools. 5.50 p.m.—Weather Report. 6.0 p.m.—News and Report of the Christian Listeners' Association. 6.15 p.m.—Time Signal. 6.30 p.m.—Talk on Randers (from the Randers Studio). 7.0 p.m.—Town Hall Chimes.

7.2 p.m.—Ten minutes by Per Knutzon. 7.10 p.m.—Concert from the Works of Danish Composers. 7.25 p.m.—Concert of Old Dance Music. Turkish Patrol (Michaelis). Pas de quatre (Michaelis). Valse Boston, Quand l'amour meurt (Crémieux). Polka, The Nigger's Birthday (Lincke). Quadrille, Les Lanciers (Mikel). Spanish Mazurka, Madrilena (Mikel). Schottische, Petite Tonkinoise (Scott). Waltz, Mondnacht auf der Alster (Fétras). Finale (Fétras). Gallop, En Traeffler (Kral). 8.25 p.m.—Reading (Bauditz). 8.50 p.m.—News Bulletin. 9.5 p.m.—Concert of Modern Dance Music, with Vocal Refrains. 11.30 p.m. (approx.)—Close Down.

CORK (Ireland) (6CK). 1,337 kc/s (225 m.); 1.5 kW. 1.30 p.m.—Weather Forecast and Gramophone Records. 7.20 p.m.—Programme from Dublin

CRACOW (Poland) Polskie Radio. 959 kc/s (312.8 m.); 1.5 kW. Transmits at intervals from 10.40 a.m. 4.15 p.m.—Talk: Civilisation in Silesia—Past and Present, relayed from Katowice, 734 kc/s (408 m.). 4.40 p.m.—Talk: The Sigismund Bell. 5.0 p.m.—Divine Service—The Resurrection. During the Service Relay of the Tolling of Sigismund—the Great Bell of the Old Kings of Poland. 6.0—7.30 p.m.—See Warsaw.

DUBLIN (Ireland) (2RN). 725 kc/s (413 m.); 1.5 kW. 7.20 p.m.—News Bulletin. 7.30 p.m.—Time Signal. 7.32 p.m.—Talk by Esme Biddle: Shakespearean Heroines. 7.45 p.m.—Irish Lesson by Seamus O'Duinn. 8.0 p.m.—Selections by the Augmented Station Orchestra. 8.30 p.m.—Piccolo Solos by Mollie Flynn. 8.40 p.m.—Selections by the Augmented Station Orchestra. 9.0 p.m.—Pianoforte Solos by Carmel Turner. 9.10 p.m.—Variety Programme by Mai Neville and Company. 9.40 p.m.—Easter Music by the Augmented Station Orchestra. 10.30 p.m.—Time Signal, News Bulletin, Weather Report and Close Down.

FRANKFURT-am-MAIN (Germany) 770 kc/s (390 m.); 1.7 kW. Relayed by Cassel, 1,220 kc/s (246 m.). Transmits at intervals from 5.15 a.m. (Mühlacker Relay). 3.30 p.m.—Concert from the Kurhaus, Wiesbaden. 4.0 p.m.—See Hamburg. 4.40 p.m.—Concert (continued). 5.0 p.m.—Economic Notes. 5.15 p.m.—Talk: The Greek Invasion. 5.40 p.m.—Time and Programme Announcements. 5.45 p.m.—(from Cassel).—Talk: An Introduction to "Faust." 6.5 p.m.—Time, Weather and Economic Notes. 6.10 p.m.—Spanish Lesson. 6.45—10.45 p.m.—See Mühlacker. 9.45 p.m. (in an interval).—Time, Weather, News and Sports Notes. 10.45 p.m. (approx.)—Close Down.

HAMBURG (Germany) Norag (ha, in Morse). 806 kc/s (372 m.); 1.7 kW. Relayed by Bremen, 1,112 kc/s (270 m.); Flensburg, 1,373 kc/s (218 m.); Hanover, 530 kc/s (566 m.); and Kiel, 1,292 kc/s (232.2 m.). Transmits at intervals from 5.20 a.m. (Time and Weather). 12.15 p.m.—Sponsored Gramophone Concert. 1.0 p.m.—Weather and Ice Report. 1.5 p.m.—News Bulletin. 1.15 p.m.—Shipping Forecast. 1.40 p.m.—Exchange Quotations. 2.15 p.m.—Market Prices. 2.30 p.m.—A Dialogue on German Books. 3.15 p.m.—Orchestral Concert from the Works of Lehár. Overture, "Wiener Frau'n." Waltz from Der Rastelbinder. Duet from "Pagani." Waltz from "Eva." Selection from "The Count of Euxembourg."

4.0 p.m.—Relay of the Second Half of the International Hockey Match, Germany v. England. 4.40 p.m. (from Bremen).—Literary Programme: Rudolf Alexander Schroeder. 5.5 p.m.—Concert of Wind Instrument Music. Overture, "The Merry Wives of Windsor" (Niccolai). Waltz, Wiener Bürger (Ziehrer). Selection from "La Traviata" (Verdi). Sei gegrüsst, du mein schönes Sorrent (Waldmann). Selection from "A Waltz Dream" (O. Strauss). Overture, "Light Cavalry" (Suppé). March, Deutschlands Ruhm (Schroeder). Kaiser-Friedrich-Marsch (Friedemann). Song, An der Weser (Pressel). March, Götterfunken (Rumohr). Björneborganes-Marsch, German March Pearls (Blankenburg). Helenen-Marsch (Lubbert). Mein deutsches Vaterland (Jessel). 6.55 p.m.—Weather Report. 7.0 p.m.—"Hans Dampf in allen Gassen"—a Wireless Play after the Story by Heinrich Zschokke (Felix Mendelssohn). 8.0 p.m.—Concert of Light Orchestral Music. Overture, "Undine" (Lortzing). Polonaise from "Eugen Onegin" (Tchaikovsky). Waltz Wiener Bonbons (Joh. Strauss). Song from "Frühlingsluft" (Strauss-Reiterer). Potpourri, Ein Melodienstraum (Urbach). Valse caprice (Rubinstein). March, Aller Ehren ist Oesterreich voll (Novotny). Wiener Jubel-Ouverture (Suppé). La lettre de Manon (Gillet). The Cuckoo (Billi). Selection from "Rose Marie" (Friml). March, Uncle Teddy (Fucik). Fantasia, Blue Shadows (Lange). Waltz, Flott durchs Leben (Translateur). Neapolitan Tarantella, La Danza (Rossini). Selection from "La donna perduta" (Pietri). Waltz, The Rose Queen (Leoncavallo). Alma de Dios (Serrano). 9.0 p.m. (in an interval).—News Bulletin. 10.50 p.m.—Ice Report. 11.0 p.m.—Dance Music by the Scarpa Orchestra.

HEILSBURG (Germany) 1,085 kc/s (276.5 m.); 75 kW Relayed by Danzig, 662 kc/s (453 m.). Transmits at intervals from 5.30 a.m. (Gymnastics). 6.0 p.m.—The New Organ in Königsberg Cathedral—a Report. 6.30 p.m.—Talk: The Struggle for Gold. 6.55 p.m.—Weather Report. 7.0 p.m.—Concert. Overture, Im Frühling (Goldmark). From the Fields and Groves of Bohemia (Smetana). Phaeton (Saint-Saëns). Norwegian Rhapsody, No. 3 (Svendens). Overture, Easter (Rimsky-Korsakoff). 8.20 p.m.—Peer Gynt Music (Grieg), with Text, arranged after Ibsen by A. Auerbach. 9.10 p.m.—Weather, News and Sports Notes. 9.30 p.m.—See Berlin (Witzleben).

HILVERSUM (Holland) 1,004 kc/s (298 m.); 8.5 kW. 8.40—9.40 a.m.—Programme of the Workers' Radio Society (V.A.R.A.). Gramophone Records. 9.40 a.m.—Programme of the Liberal Protestant Radio Society (V.P.R.O.). Religious Transmission. 9.55 a.m. till Close Down.—Programme of the V.A.R.A. Workers—Concert and Address. 11.40 a.m.—Septet Concert. 12.25 p.m.—Gramophone Records. 12.55—1.25 p.m.—Interval. 1.25 p.m.—Gramophone Records. 1.45 p.m.—Educational Talk. 2.0 p.m.—Gramophone Records. 2.25 p.m.—Concert. 3.55 p.m.—German Language Lesson. 4.25 p.m.—Esperanto Lesson. 4.45 p.m.—Educational Talk. 5.15 p.m.—Talk by Mr. Landré. 5.45 p.m.—Gramophone Records. 5.50 p.m.—Talk (to be announced). 6.5 p.m.—Gramophone Records. 6.10 p.m.—Literary Talk. 6.55 p.m.—Gramophone Records. 7.10 p.m.—Reading. 7.30 p.m.—Variety Items. 7.40 p.m.—Violin and Pianoforte Recital.

8.10 p.m.—Vocal and Orchestral Concert, conducted by Hugo de Groot. News and Gramophone Records after the Programme. 11.10 p.m.—Gramophone Records. 11.40 p.m. (approx.)—Close Down.

HUIZEN (Holland) 160 kc/s (1,875 m.); 8.5 kW. 7.40 a.m. till Close Down.—Programme of the Catholic Radio Society (K.R.O.). 7.40—8.55 a.m.—Gramophone Records. 9.40 a.m.—Gramophone Records. 11.10 a.m.—Religious Address by the Rev. Fr. Perquin. 11.40 a.m.—Police Notes. 11.55 a.m.—Sextet Concert. 1.25 p.m.—Gramophone Records. 2.10 p.m.—Programme for Young People. 2.40 p.m.—Programme for Children. 4.10 p.m.—Technical Talk. 4.40 p.m.—Gramophone Records. 5.40 p.m.—Sports Talk. 5.55 p.m.—Press Review. 6.15 p.m.—Gramophone Records. 6.25 p.m.—Esperanto Lesson. 6.55 p.m.—Talk by Dr. Meulemann. 7.25 p.m.—Police Notes. 7.40 p.m.—Concert of Light Vocal and Instrumental Music, with Cabaret Items. 10.40 p.m.—Gramophone Records. 11.40 p.m. (approx.)—Close Down.

JUAN-LES-PINS (Nice, France) 1,205 kc/s (249 m.); 1.2 kW. 12.30 p.m.—News, Amusement Guide and Concert. Bacchanale from "Samton and Delilah" (Saint-Saëns). Introduction and Chorus from "Samson and Delilah" (Saint-Saëns). The Carnival of Venice (Genin). Minuet from L'arlesienne (Bizet). Interlude from "Pelléas et Mélisande" (Debussy). Duet from Werther (Massenet). La ronde sous la cloche (Coppola). Selection from "Der Freischütz" (Weber). Selection from "Cavalleria rusticana" (Mascagni). Selection from "Le jongleur de Notre Dame" (Massenet). 2.0 p.m.—The Marseillaise. 2.10 p.m. (approx.)—8.30 p.m.—Interval. 8.30 p.m.—News, Amusement Guide, Weather Report and Concert by the Nizza Codolban Orchestra, relayed from the Hotel Negresco, Nice. Violin Soloist: Y. Bajac. 10.0 p.m.—The Marseillaise and Close Down.

KALUNDBORG (Denmark) Kalundborg Radio. 260 kc/s (1,153 m.); 10 kW. See Copenhagen Programme.

KÖNIGSBERG (Germany) Ostmarken Rundfunk. 1,382 kc/s (217 m.); 1.7 kW. See Heilsberg Programme.

LANGENBERG (Germany) Westdeutscher Rundfunk. 635 kc/s (473 m.); 17 kW. Relayed by Aachen, Cologne and Münster, 1,319 kc/s (227 m.). Transmits at intervals from 5.45 a.m. (Lesson in Self-defence). 12.5 p.m.—Orchestral Concert, conducted by Wolf. Overture, "Die vier Menschenalter" (Lachner). Two Melodies (Rubinstein). Selections from "The Mastersingers" (Wagner). Waltz, Frühlingstimmen (Joh. Strauss). Overture, "Fra Diavolo" (Auber). International Suite (Tchaikovsky). Song, Austria (R. Strauss). Selections from "Oberon" (Weber). 1.35 p.m.—Week-end Concert of the Latest Gramophone Records. 2.30 p.m.—Tidal Report, Time Signal and Economic Notes. 2.50 p.m.—Programme for Children. 3.20 p.m.—Talk: Excursions in the Rhineland and Westphalia—the Upper Mohne and Weser Valley. 3.40 p.m.—Talk: The Beginnings of Christianity in Westphalia. 4.0 p.m.—See Hamburg. 4.40 p.m.—Choral and Instrumental Concert. Maundy Thursday Graduale: Christus factus est. Popule meus. Duet for Tenor and Tenor Flute (Heurteur). Four Part Movement for Flutes and Lute with Contralto Solo. Old Sacred Folk-song for Choir. In stiller Nacht. (arr. Rein). Flute Chorales for Flutes and Lute: (a) O Traurigkeit (from the Würzburg Song Book, 1620) (b) O Lamb of God (Pratorius), (c) Brich entzwei mein armes Herze. Choral Selections: (a) Adoramus te Christe (Aichinger), (b) Wann kommen wird mein letzte Stund" (Lechner), (c) By the Waters of Babylon (Pratorius). Two Minuets for Solo with Lute and Tenor Flute (Rameau and Dowland). Entrée for Flutes

Programmes for Saturday—(Cont.)

and Lute (Lully). Maria zart, Contralto Solo with Flutes and Lute (Schlic). Choral Selection: Wer kann das Korn anschauen (Knab). Gregorian Chant: Alleluiah for the Saturday in Holy Week. Nun freut euch, liebe Christenheit (Ducis). 5.20 p.m.—Talk: A Visit to the Holy Land—Bethlehem, the Dead Sea, the Jordan, and Jericho. 5.40 p.m.—Economic Review. 6.0 p.m.—Weather Report, Time Signal, Economic and Sports Notes. 6.15 p.m.—Wireless Notes. 6.25 p.m.—English Language Lesson. 6.40 p.m.—Talk for the Business Woman: Continuation Classes for Saleswomen. 7.0 p.m.—Sacred Concert, relayed from the Reinoldikirche, Dortmund. A-cappella Choir: (a) Ecce quomodo moritur (Handl), (b) Tenebrae factae sunt (Haydn). Two Choral Preludes (Bach): (a) O Mensch, bewein' dein' Sünde gross, (b) Schmücke dich, o liebe Seele. Adagio from the Sonata in D major (Handel). Andante (Bach). A-cappella Choir: (a) Zions Stille (Becker), (b) Hoffe, Herz (Rust). Herr, was trägt der Boden hier (Wolf). Pocaata and Fugue in D minor and D major from Op. 59 (Reger). Choral Cantata: "Meinen Jesum lass ich nicht," for Soprano, Violin, Viola, Organ and Mixed Choir (Reger). Largo from the Suite in Old Style (Reger). Two Selections (Courvoisier). Easter Anthem—Sacred Folk Melody of Twelfth Century—Christ is risen (arr. Hasler). Organ Chorale: Christ is risen. After the Concert, News, Sports Notes and Silent Night.

LEIPZIG (Germany) Mitteldeutscher Rundfunk. 1,157 kc/s (259 m.); 2.3 kW. Relayed by Dresden, 941 kc/s (319 m.). Transmits at intervals from 9.0 a.m. (Economic Prices). 11.0 a.m.—Orchestral Concert. Overture, "Preciosa" (Weber). Two Selections (R. Schumann): (a) Träumerei, (b) Abendlied. Selection from "Le Postillon de Longjumeau" (Adam). Selection from "Tiefland" (d'Albert). Prelude in C Sharp Minor (Rachmaninoff). Overture, "La Part du Diable" (Auber). Torch Dance of the Brides, from "Feramors" (Rubinstein). Serenade, The Old Song (L'Ormanovsky). Suite from "Lakmé" (Delibes). 11.55 a.m. (in the interval).—Nauen Time Signal. 12 noon (in an interval).—Weather, News and Exchange Quotations. 1.0 p.m.—Dialogue for Young People. 1.30 p.m.—Handicrafts for Young People. 2.15 p.m.—Review of Periodicals. 2.45 p.m.—Economic Notes. 3.0 p.m.—Gramophone Concert. 4.0 p.m.—Second Half of the International Hockey Match, Germany v. England, relayed from Hamburg. 4.40 p.m.—Weather, Time and Wireless Notes. 5.0 p.m.—The Letter Box. 5.20 p.m.—German Language Lesson: Everyday Words. 5.40 p.m.—Sylvia von Harden reads from her own Works. 6.0 p.m.—Talk: The Commercial Traveller. 6.30 p.m.—Concert by the Leipzig Symphony Orchestra. Symphony, No. 94 in G Major (Haydn). Concerto for Clarinet and Orchestra in F minor (Weber). Music to "A Midsummer Night's Dream" (Mendelssohn). 8.0 p.m.—Topical Talk. 8.10 p.m.—"Verlorener Weg"—a Wireless Play (Gustav Herrmann). 9.0 p.m.—News, followed by Light Orchestral Concert. 11.0 p.m. (approx.).—Close Down.

LJUBLJANA (Yugoslavia) Radio-Ljubljana. 522 kc/s (574.7 m.) 2.8 kW. Transmits at intervals from 11.15 a.m. 5.0 p.m.—Solemn Cagillon. 6.0 p.m.—Universal Peace Programme 7.0 p.m.—Relay of an Opera from Belgrade, 697 kc/s (430.4 m.). 9.0 p.m.—Weather, News and Dance Music.

MADRID (Spain) Union Radio (EAJ7). 707 kc/s (424 m.); 2 kW. Transmits at intervals from 8.0 a.m. (Topical Review). 2.0 p.m.—Chimes, Time Signal, Weather Report, and Concert. Pasodoble, Gitanerias (Arúé). Waltz, Frühlingsstimmen (Joh. Strauss), Melody (Tchaikovsky). Jota from "La alegría dal

huerta" (Chueca). Gipsy Dance from "Carmen" (Bizet). Suite from "Alicia" (Händel): (a) Overture, (b) Minuet and Musette, (c) Gavotte and Sarabande, (d) Minuet, Gavotte and Tambourin. Interval: Review of Books by Isaac Pacheco. Selection from "The Force of Destiny" (Verdi). Turkish March (Mozart). 3.20 p.m.—Theatre Notes, News and Programme Announcements. 3.30—7.0 p.m.—Interval. 7.0 p.m.—Chimes, Exchange Quotations, Market Prices and Topical Review.—Film Section. 8 p.m.—Dance Music. 8 p.m.—English Language Lesson by the Linguaphone Method. 8.30—9.30 p.m.—Interval. 9.30 p.m.—Chimes, Time, Exchange Quotations and Musical Comedy Selection. 11.55 p.m.—News Bulletin. 12 midnight.—Chimes and Close Down.

MILAN (Italy) Ente Italiano Audizioni Radiofoniche, 599 kc/s (501 m.); 8.5 kW. Programme relayed by Turin, 1,013 kc/s (296 m.); and Genova, 958 kc/s (313.2 m.). Transmits at intervals from 7.15 a.m. (Giornale radio). 6.30 p.m.—Concert of Light Music. The Sacred Hour (Kettelbey). Country Sketch (Barbieri). Selection from "The Transfiguration" (Perosi). Humoresque (Dvorak). Le campane di San Petronio (Longo). Adagio from Sonata No. 27 (Beethoven). Minuet (Paderevsky). 7.0 p.m.—Time, Announcements, Giornale radio and Weather. 7.20 p.m.—"Mario e Maria"—Comedy in Three Acts (Sabatino Lopez). 9.0 p.m.—Operetta Selections. In the interval: Review of New Books. 10.0 p.m.—Giornale radio, followed by Concert from the Sala Gay, Turin. 10.55 p.m.—News Bulletin.

MOTALA (Sweden) 222.5 kc/s (1,348 m.); 40 kW. See Stockholm Programme.

MÜHLACKER (Germany) Süddeutscher Rundfunk. 833 kc/s (360 m.); 75 kW. Relayed by Freiburg, 527 kc/s (570 m.). Transmits at intervals from 5.15 a.m. (Time, Weather and Gymnastics). 3.30 p.m.—See Frankfurt. 4.0 p.m.—See Hamburg. 4.40 p.m.—See Frankfurt. 5.0 p.m.—Time and Weather. 5.15 p.m. (from Mannheim).—Talk by Prof. Wassermann. 5.45 p.m.—See Frankfurt. 6.5 p.m.—Time Signal. 6.10 p.m.—See Frankfurt. 6.45 p.m. (from Mannheim).—Wind Instrument Concert by the Mannheim National Theatre Orchestra. Serenade for Wind Quintet, Op. 12 (Gustav Kaleve). Sonata for Flute and Pianoforte (Jules Moquet). Quintet for Oboe, Clarinet, Horn, Bassoon and Pianoforte (W. Gieseking). 7.30 p.m.—Two Fairy Tales (Mansfred Kyber): (a) "The Wandering Soul"; (b) "Death and the Maiden." 8.30 p.m.—Bach Concert by the Stuttgart Philharmonic Orchestra, conducted by Emil Kahn. Prelude and Fugue in B Flat minor from "Das wohltemperierte Klavier," for Orchestra (arr. Emil Kahn). Concerto A in Minor for Violin, Flute and Pianoforte with String Orchestra. Ricercare from "Das musikalische Opfer." Choral Prelude, O Mensch bewein' dein Sünde gross (arranged for String Orchestra by Max Reger). 9.45 p.m.—Programme Announcements, News and Weather. 10.0 p.m.—Recital of Swiss Lyrics. Contralto Solos and Recitations. 10.45 p.m. (approx.).—Close Down.

MÜNICH (Germany) 563 kc/s (537 m.); 1.7 kW. Relayed by Augsburg, 536 kc/s (560 m.); and Nürnberg, 1,256 kc/s (239 m.). Transmits at intervals from 5.45 a.m. (Gymnastics). 1.0 p.m.—Time Signal, Weather Report, Programme Announcements, News and Exchange Quotations. 1.25 p.m.—A Study with Gramophone Illustrations: Music as an Expression of Feeling. 2.0 p.m.—Easter Bells from Our Lady's Church. 2.10 p.m.—"At the Tomb of Jesus." 2.55 p.m.—Time, Weather and Agricultural Notes. 3.10 p.m.—Labour Market Report.

3.20 p.m.—Talk: Ludwig Richter.—A Picture of an Artist. 3.35 p.m.—Orchestral Concert, conducted by Karl List. Overture, "Das Glöckchen des Eremiten" (Maillart). Ave Maria (Bach-Gounod). Minuet in G Major (Beethoven). Suite pastorale (Scassola). Gavotte (Gossec). 4.30 p.m.—"The Cathedral at Cologne"—a Cycle of Poems (Juga Krannhals-Russel). 4.45 p.m.—Talk for Girls. 5.15 p.m.—Wireless Notes. 5.30 p.m.—Orchestral Concert, conducted by Karl List. Overture, "The Golden Cross" (Brüll). Soirées de Vienne (Schubert-Liszt). Cantique d'amour (Schürt). Canzonetta (Schürt). Potpourri of German Folk Songs (Rhode). Pas de fleurs (Delibes). Maria Wiegand (Reger). Hungarian Dances (Brahms). 6.30 p.m.—Talk: An Earthly Paradise—the Malabar Coast. 7.0 p.m.—Orchestral Concert, conducted by Karl List. Part I. Overture, "Iphigenia in Aulis" (Glück). Choral Cantata for Seven Instruments and Solo Voice, Op. 22 (H. Lang). Concerto grosso in A Minor (Vivaldi). Easter Chorus from Goethe's "Faust" (Unger). Part II. "Die Weise von Liebe und Tod des Cornets Christoph Rilke" (Rainer Maria Rilke, Music by C. v. Paszthory). Albert Lipper (Recitations). Gisela von Paszthory (Pianist). Part III. Overture, "The Water Carrier" (Cherubini). Nocturne from "A Midsummer Night's Dream" (Mendelssohn). Selection from "Il Trovatore" (Verdi). Intermezzo and Barcarolle from "The Tales of Hoffmann" (Offenbach). Selections from the "Peer Gynt" Suite (Grieg): (a) Morning, (b) In the Hall of the Mountain King. Shepherd Life in the Alps (Kling). 9.0 p.m.—Concert by the Karl Greiner Orchestra, relayed from the Neue Börse. 9.20 p.m. (in an interval).—Time, Weather, News and Sports Notes. 11.0 p.m. (approx.).—Close Down.

OSLO (Norway) Kringkastingslaget. 280 kc/s (1,071 m.); 75 kW. Relayed by Fredrikstad, 815 kc/s (368 m.); Hamar, 511 kc/s (587 m.); Notodden, 671 kc/s (447.1 m.); Porsgründ, 662 kc/s (453 m.); and Risør, 671 kc/s (447.1 m.). Transmits at intervals from 10.10 a.m. 4.45 p.m.—Programme for Children: "The Green Knight"—a Play after the Tales of Asbjørnsen. 5.45 p.m.—Concert of National Music. Selections on the Hardanger Fiddle and Songs. 6.15 p.m.—Weather and News. 6.30 p.m.—Talk by Lars Eskeland. 7.0 p.m.—Time Signal. 7.2 p.m.—"The Father"—Play (August Strindberg). 9.0 p.m.—Weather, News and Topical Talk. 9.30 p.m.—Evening Concert. 10.30 p.m. (approx.).—Close Down.

PARIS (France) Eiffel Tower (FLE). 207 kc/s (1,445 m.); 15 kW. Time Signals (on 2,650 m., 113 kc/s) at 9.25 a.m. and 10.25 p.m. (preliminary and 6-dot signals). 5.45 p.m.—The Journal Parlé. 7.10 p.m.—Meteorological Forecast. 7.30 p.m.—Dramatic Programme. 7.30 p.m.—Variety Concert, with the Tenor, Maurice Cloquet, in his Repertoire, the Singer Monty and the Accordionists Radon and Savoye. 9.0 p.m.—Transmission of Pictures. 8.25 p.m.—Gramophone Records and News Bulletin. 8.45 p.m.—Theatre Talk, Gramophone Records and News Bulletin. 9.0 p.m.—Concert with the collaboration of Artists from the Opera and Opéra-Comique. Prelude, "Les noces corinthiennes" (Büsser). Czech Polka (Balling). Concerto for Small Orchestra (Roussel). Spanish Caprice (Rimsky-Korsakoff), conducted by M. Francis Casadesu. Symphonie Sketch, Au village (Mouquet). Valses nobles et sentimentales Nos. 1, 2 and 3 (Ravel). Danse de Salomé (Glazounoff).

PARIS (France) Poste Parisien. 914 kc/s (329 m.); 1.2 kW. 9.0 a.m.—Transmission of Pictures. 8.25 p.m.—Gramophone Records and News Bulletin. 8.45 p.m.—Theatre Talk, Gramophone Records and News Bulletin. 9.0 p.m.—Concert with the collaboration of Artists from the Opera and Opéra-Comique. Prelude, "Les noces corinthiennes" (Büsser). Czech Polka (Balling). Concerto for Small Orchestra (Roussel). Spanish Caprice (Rimsky-Korsakoff), conducted by M. Francis Casadesu. Symphonie Sketch, Au village (Mouquet). Valses nobles et sentimentales Nos. 1, 2 and 3 (Ravel). Danse de Salomé (Glazounoff).

PARIS (France) Radio-Paris (CFR). 174 kc/s (1,725 m.); 17 kW. Transmits at intervals from 6.45 a.m. (Physical Culture). 12.30 p.m.—Gramophone Concert. In the intervals at 1.0 p.m.—Exchange Quotations and News and at 1.30 p.m.—Exchange Quotations. 2.0 p.m.—Exchange; Market Prices. 3.30 p.m.—Exchange Quotations. 3.45 p.m.—Programme for Children. 4.30 p.m.—Dance Music. 4.55 p.m.—News Bulletin. 6.0 p.m.—Agricultural Report and Racing Results. 6.30 p.m.—Gramophone Records: Suite carnavalesque (Thomé). Songs. 7.0 p.m.—Talk, arranged by the Union des Grandes Associations Françaises. 7.5 p.m.—Talk on Science. 7.30 p.m.—Advanced English Lesson. 7.45 p.m.—Commercial Prices, Economic and Social Notes and News. 8.0 p.m.—Literary Readings: Easter Stories. 8.30 p.m.—News and Sports Results. 8.45 p.m.—A Comedy. 9.15 p.m.—Press Review, News and Time Signal. 9.30 p.m.—Chamber Music.

PARIS (France) Radio-Paris (CFR). 174 kc/s (1,725 m.); 17 kW. Transmits at intervals from 6.45 a.m. (Physical Culture). 12.30 p.m.—Gramophone Concert. In the intervals at 1.0 p.m.—Exchange Quotations and News and at 1.30 p.m.—Exchange Quotations.

2.0 p.m.—Exchange; Market Prices. 3.30 p.m.—Exchange Quotations. 3.45 p.m.—Programme for Children. 4.30 p.m.—Dance Music. 4.55 p.m.—News Bulletin. 6.0 p.m.—Agricultural Report and Racing Results. 6.30 p.m.—Gramophone Records: Suite carnavalesque (Thomé). Songs. 7.0 p.m.—Talk, arranged by the Union des Grandes Associations Françaises. 7.5 p.m.—Talk on Science. 7.30 p.m.—Advanced English Lesson. 7.45 p.m.—Commercial Prices, Economic and Social Notes and News. 8.0 p.m.—Literary Readings: Easter Stories. 8.30 p.m.—News and Sports Results. 8.45 p.m.—A Comedy. 9.15 p.m.—Press Review, News and Time Signal. 9.30 p.m.—Chamber Music.

POZNAŃ (Poland) 896 kc/s (335 m.) 1.0 kW. Transmits at intervals from 6.0 a.m. (Gymnastics). 4.0 p.m.—Religious Programme from Wilno. 5.0 p.m.—See Cracow. 6.0 p.m.—Concert of Sacred Music. Choral Selections. Sonata for Violin and Pianoforte (Corelli). Choral Selections. 6.45 p.m.—Talk: Alexander Brückner and his Activities in the Realm of Science. 7.5 p.m.—Talk on the East. 7.15 p.m.—Miscellaneous Items and News. 7.30 p.m.—Concert from Warsaw. 9.0 p.m.—Time, News, Sports and Police Notes. 9.15 p.m. (approx.).—Close Down.

ROME (Italy) Ente Italiano Audizioni Radiofoniche (IRO). 680 kc/s (441 m.); 75 kW. Relayed by Naples, 905 kc/s (332 m.); and 2 RO 11,810 kc/s (25.4 m.). Transmits at intervals from 7.15 a.m. (Giornale radio and Weather for Shipping). 4.0 p.m.—Concert. Overture, "Poet and Peasant" (Suppé). Canzone d'amore (Leoncavallo). Selection (Gade). Selection from "Coppélia" (Delibes). Dances from "Prince Igor" (Borodin). Selection from "Othello" (Verdi). March of the Mongolian Emperors, from "The Crown of India" (Elgar). Selection from "Asrael" (Franchetti). Selection (Chaminade). Spanish Serenade (Glazounoff). Overture, "Le preziose ridicole" (Lattuada). 6.0 p.m.—Atmospheric Signals and Wireless Technical Lesson. 6.20 p.m.—Giornale radio and Announcements. 6.5 p.m.—Gramophone Records. 7.10 p.m.—Giornale radio and Announcements. 7.30 p.m.—Time Signal and Announcements. 7.45 p.m.—Gramophone Records. 8.0 p.m. (approx.).—Relay of an Opera from the Royal Theatre of the Teatro San Carlo, Naples. In the intervals: News and Theatre Notes. 9.55 p.m. (approx.).—Close Down.

ROME (Italy) Ente Italiano Audizioni Radiofoniche (IRO). 680 kc/s (441 m.); 75 kW. Relayed by Naples, 905 kc/s (332 m.); and 2 RO 11,810 kc/s (25.4 m.). Transmits at intervals from 7.15 a.m. (Giornale radio and Weather for Shipping). 4.0 p.m.—Concert. Overture, "Poet and Peasant" (Suppé). Canzone d'amore (Leoncavallo). Selection (Gade). Selection from "Coppélia" (Delibes). Dances from "Prince Igor" (Borodin). Selection from "Othello" (Verdi). March of the Mongolian Emperors, from "The Crown of India" (Elgar). Selection from "Asrael" (Franchetti). Selection (Chaminade). Spanish Serenade (Glazounoff). Overture, "Le preziose ridicole" (Lattuada). 6.0 p.m.—Atmospheric Signals and Wireless Technical Lesson. 6.20 p.m.—Giornale radio and Announcements. 6.5 p.m.—Gramophone Records. 7.10 p.m.—Giornale radio and Announcements. 7.30 p.m.—Time Signal and Announcements. 7.45 p.m.—Gramophone Records. 8.0 p.m. (approx.).—Relay of an Opera from the Royal Theatre of the Teatro San Carlo, Naples. In the intervals: News and Theatre Notes. 9.55 p.m. (approx.).—Close Down.

SCHENECTADY (U.S.A.) General Electric Company (WGY). 790 kc/s (379.5 m.); 50 kW. Relayed at intervals by W2XAF on 9,530 kc/s (31.48 m.), and by W2XAD on 15,342 kc/s (19.56 m.). Transmits at intervals from 11.45 a.m. 11.44 p.m.—Weather Report. 11.45 p.m.—Uncle Abe and David, from New York. 12 midnight.—Time Signal. 12.1 a.m. (Sunday).—Jeannette Getz (Pianist). 12.15 a.m.—Programme from New York. 12.30 a.m.—WGY Players—Frank Oliver Director. 1.0 a.m.—5.0 a.m.—Programme from New York. 1.0 a.m.—Weber and Fields. 1.15 a.m.—Radiotron Varieties. 1.30 a.m.—Silver Flute. 2.0 a.m.—General Electric Concert. 3.0 a.m.—Lucky Strike Hour. 4.0 a.m.—Troubadour of the Moon. 4.15 a.m.—Henry Busse and Hotel New Yorker Orchestra. 4.45 a.m.—Little Jack Little. 5.0 a.m.—Sleepy Hall and the Hotel DeWitt Clinton Orchestra, Albany, N. Y. 5.30 a.m.—Doc Peyton and the Hotel Kenmore Orchestra, Albany, N. Y. 6.0 a.m. (approx.).—Close Down. STOCKHOLM (Sweden) Radiotjänst. (SASA). 680 kc/s (436 m.); 75 kW. Relayed by Boden, 244 kc/s (1,229.5 m.); Göte-

borg, 932 kc/s (322 m.); Hörby, 1,166 kc/s (257 m.); Motala, 222.5 kc/s (1,348 m.); Östersund, 389 kc/s (770 m.); Sundsvall, 554 kc/s (542 m.). Transmits at intervals from 6.15 a.m. (Gymnastics). 3.0 p.m.—Orchestral Concert, relayed from Göteborg. Selection from "Il Seraglio" (Mozart). Dröschwalben aus Österreich (Strauss). Un peu d'amour (Silésu). Il Natale di Pierrot (Monti). Mazurka de Salon (Tchaikovsky). Selection from "Oberon" (Weber). 4.0 p.m.—Programme for Children. 4.30 p.m.—Gramophone Records. 5.30 p.m.—Talk: Easter Eggs, the Maypole and the Christmas Tree, relayed from Uppsala, 662 kc/s (453.2 m.). 6.0 p.m.—Easter Programme—Song Recital, a Play, Orchestral Music, Accordion Solos, Reading and Selections by a Whistling Trio. 8.40 p.m.—Old Dance Music, relayed from Göteborg. 9.30 p.m.—Modern Dance Music. 11.0 p.m. (approx.).—Close Down.

STRASBOURG (France) Radio-Strasbourg (PTT). 869 kc/s (345 m.); 15 kW. Transmits at intervals from 11.30 a.m. 6.0 p.m.—Instrumental Concert. Overture, "Martha" (Flotow). Selection from "The Daughter of the Regiment" (Donizetti). Selection from "Romeo and Juliet" (Gounod). Overture, "The Bohemian Girl" (Balfe). Selection from "Jocelyn" (Godard). 6.45 p.m.—French Lesson in German. 7.0 p.m.—Orchestral Concert. 7.30 p.m.—News in French and German. 7.45 p.m.—Gramophone Records. 8.30 p.m.—Orchestral Concert. 10.30 p.m.—Gramophone Dance Records. 12 midnight.—Close Down.

TOULOUSE (France) Radiophonie du Midi. 779 kc/s (385 m.); 8 kW. Transmits at intervals from 12.45 p.m. 7.0 p.m.—Chansonnettes. 7.15 p.m.—Dance Music. 7.30 p.m.—Exchange and News. 7.45 p.m.—Musical Programme. 8.55 p.m.—Fashion Review. 9.0 p.m.—Time Signal. 9.2 p.m.—Concert of Opera Music. 10.0 p.m.—Military Music. 10.15 p.m.—Chansonnettes. 10.30 p.m.—News Bulletin. 10.45 p.m.—Musical Programme. In the interval at 11.15 p.m.—North African News. 12 midnight (approx.).—Close Down.

VIENNA (Austria) Radio-Wien. 581 kc/s (517 m.); 20 kW. Relayed by Graz, 851 kc/s (352 m.); Innsbruck, 1,058 kc/s (283 m.); Klagenfurt, 662 kc/s (453.2 m.); Linz, 1,220 kc/s (246 m.); and Salzburg, 1,373 kc/s (218 m.). Transmits at intervals from 8.20 a.m. (Market Prices). 6.30 p.m.—Aria and Song Recital by Richard May of the State Opera House. 7.10 p.m.—"Serene Week"—Drama in One Act (Saulescu) from the Romanian. 7.50 p.m.—"The Naughty Boys" Play (Nestroy). 9.0 p.m.—News Bulletin. 9.10 p.m.—Orchestral Concert.

WARSAW (Poland) Polskie Radio. 212 kc/s (1,411 m.); 158 kW. Transmits at intervals from 10.40 a.m. 1.30 p.m.—Review of Recent Publications. 1.55—2.50 p.m.—No Transmission. 2.50 p.m.—Technical Correspondence and Hints. 3.10 p.m.—Programme for Children. 4.15 p.m.—Talk: Ancient and Modern Civilisation in Silesia, relayed from Katowice, 734 kc/s (408 m.). 4.40 p.m.—See Cracow. 6.0 p.m.—Musical Programme: "The Nazarene" (W. Hausmann) relayed from Lwów, 788 kc/s (381 m.), followed by Selections for Vocal Quartet (Bach). In the interval, Theatre Review. After the Programme, Weather, Police and Sports Notes.

WILNO (Poland) 815 kc/s (368.1 m.); 0.5 kW. Transmits at intervals from 10.58 a.m. 4.40 p.m.—See Cracow. 6.0 p.m.—Literary Programme and Concert from Lwów, 788 kc/s (381 m.). 6.30 p.m. (approx.).—Close Down.

# Stations in Order of Frequencies and Wavelengths

Corrected in accordance with the latest official information available at the time of going to press

The figures in black type represent the power according to the Hague power-rating scheme

| Kc/s   | M.     | Station  | Dial Readings | Kc/s  | M.    | Station  | Dial Readings | Kc/s   | M.    | Station   | Dial Readings |
|--|--------|--|---------------|-------|-------|--|---------------|--------|-------|---|---------------|
| <b>EUROPEAN</b>  |        |  |               |       |       |  |               |        |       |   |               |
| (Including Stations connected with the European System.) |        |  |               |       |       |  |               |        |       |   |               |
| 155  | 1935   | Kaunas (Lithuania), 7 kW.  |               | 815   | 370.4 | Radio LL (France).   |               | 1220   | 246   | Eskilstuna (Sweden) (relays Stockholm), 0.25 kW.              |               |
| 160  | 1875   | Huizen (Holland), 8.5 kW. (Hilversum programme and announcements.) |               | 824   | 368.1 | Fredriksstad (Norway), 0.8 kW. (relays Oslo).                      |               | 1229   | 244.1 | Pietersaari (Jacobstad) (Finland) (relays Helsinki), 0.25 kW. |               |
| 167  | 1796   | Lahti (Finland) (relays Helsinki), 54 kW.                          |               | 825.3 | 364.1 | Seville (Union Radio) (EAJ1) (Spain), 1.5 kW.                      |               | 1238   | 242   | Linz (Austria) (relays Vienna), 0.6 kW.                       |               |
| 174  | 1725   | Radio Paris (CFR), 17 kW.  |               | 833   | 360   | Wilno (Poland), 0.5 kW.  |               | 1240.6 | 240.6 | Cassel (Germany) (relays Frankfurt), 0.3 kW.                  |               |
| 183.5  | 1635   | Königs Wusterhausen (Zeeseen) (Germany), 35 kW. Relays Berlin.     |               | 842   | 356.3 | Bergen (Norway), 1.13 kW.  |               | 1256   | 239   | Kiruna (Sweden) (relays Boden), 0.25 kW.                      |               |
| 193  | 1554.4 | Daventry National Station (Gt. Britain), 35 kW.                    |               | 851   | 352   | Algiers (N. Africa), 13 kW.  |               |        |       | Cartagena (Spain), 0.4 kW.                                    |               |
| 195  | 1538   | Ankara (Turkey), 7 kW.   |               | 855.5 | 351   | Mühlacker (Germany), 75 kW.  |               | 1229   | 244.1 | Basle (Switzerland) 0.65 kW.                                  |               |
| 202.5  | 1481   | Moscow (Old Komintern) (RA) (Russia), 40 kW.                       |               | 860   | 349   | London Regional Stn., 70 kW.                                       |               | 1238   | 242   | Belfast (2BE) (Ireland), 1.2 kW.                              |               |
| 207.5  | 1445.7 | Eiffel Tower (FLE), 15 kW.   |               | 867   | 345   | Graz (Austria) (usually relays Vienna), 9.5 kW.                    |               | 1247   | 240.6 | Stavanger (Norway), 0.5 kW.                                   |               |
| 212.5  | 1411   | Warsaw (Poland), 158 kW.   |               | 878   | 342   | Barcelona (Radio Barcelona) (EAJ1) (Spain), 8 kW.                  |               | 1256   | 239   | Nürnberg (Germany) (relays Munich), 2.3 kW.                   |               |
| 222.2  | 1350   | Kasbah (Tunis), 0.5 kW.  |               | 887   | 342   | Strasbourg-Brumath (France), 15 kW.                                |               |        |       | Bordeaux Sud - Ouest (France) 3 kW.                           |               |
| 222.5  | 1348   | Motala (Sweden) (relays Stockholm), 40 kW.                         |               | 896   | 338.2 | Brno (Czechoslovakia), 3 kW.                                       |               | 1265   | 237.2 | Radio - Nimes (France), 1 kW.                                 |               |
| 230.6  | 1304   | Moscow (Trades Unions), 75 kW.                                     |               | 905   | 335   | Brussels No. 2 (Belgium), 20 kW. (Flemish programme)               |               | 1265   | 237   | Örebro (relays Stockholm) (Sweden), 0.25 kW.                  |               |
| 244  | 1229.5 | Boden (Sweden), 0.75 kW.   |               | 914   | 332   | Cadiz (Spain), 0.5 kW.   |               | 1274   | 235.5 | Kristianssand (Norway) 0.5 kW.                                |               |
| 250  | 1200   | Istanbul (Turkey), 5 kW. }<br>Reykjavik (Iceland), 21 kW. }        |               | 923   | 328.2 | Poznan (Poland), 1.9 kW.   |               | 1283   | 234   | Lodz (Poland), 2.2 kW. Exp.                                   |               |
| 260  | 1153   | Kalundborg (Denmark) (relays Copenhagen), 10 kW.                   |               | 932   | 325   | Naples (INA) (Italy), 1.7 kW.                                      |               | 1292   | 232.2 | Kiel (Germany) (relays Hamburg), 0.3 kW.                      |               |
| 268.6  | 1116   | Novosibirsk (Russia) R.A., 4 kW.                                   |               | 941   | 322   | Grenoble (PTT) (France) 1.2 kW.                                    |               | 1301   | 231   | Norrköping (Sweden), 0.25 kW.                                 |               |
| 272  | 1103   | Moscow Popoff (Russia), 40 kW.                                     |               | 941   | 319   | Paris - Poste Parisien (France), 1.2 kW.                           |               | 1310   | 229   | Malmö (Sweden) (relays Stockholm), 0.75 kW.                   |               |
| 279.6  | 1073   | Rostov-Don (Russia), 4 kW.   |               | 950   | 316   | Breslau (Germany), 1.7 kW.   |               | 1319   | 227   | Helsingborg (Sweden), 0.25 kW.                                |               |
| 280  | 1071   | Oslo (Norway), 75 kW.  |               | 959   | 312.6 | Göteborg (Sweden), (relays Stockholm), 15 kW.                      |               | 1337   | 224.4 | Uddevala (Sweden), 0.1 kW.                                    |               |
| 283  | 1060   | Tiflis (Russia), 10 kW.  |               | 968   | 309.9 | Dresden (Germany) (relays Leipzig), 0.3 kW.                        |               | 1346   | 222.9 | Cologne (Germany), 1.7 kW.                                    |               |
| 300  | 1000   | Leningrad (Russia), 20 kW.   |               | 977   | 307   | Sofia Rodno - Radio, (Bulgaria), 1 kW.                             |               | 1355   | 221   | Aachen (Germany), 0.3 kW.                                     |               |
| 320  | 937.5  | Kharkov (Russia), 20 kW.   |               | 986   | 304   | Marseilles (PTT) (France), 1.5 kW.                                 |               | 1373   | 218   | Münster (Germany) 0.6 kW.                                     |               |
| 357  | 840    | Nijni Novgorod (Russia), 1.8 kW.                                   |               | 995   | 301   | Genoa (IGE) (Italy), 1.5 kW.                                       |               | 1382   | 217   | Cork (6CK) (Ireland), 1.5 kW.                                 |               |
| 375  | 800    | Kiev (Russia), 20 kW.  |               | 1004  | 298.8 | Radio-Vitus (France).  |               | 1391   | 216   | Fécamp (France).  |               |
| 385  | 778    | Petrozavodsk (Russia), 2 kW.                                       |               | 1013  | 296.1 | Cracow (Poland), 1.5 kW.   |               | 1400   | 214.2 | Helsinki (Finland), 15 kW.                                    |               |
| 389  | 770    | Ostersund (Sweden), 0.75 kW. (relays Sundsvall).                   |               | 1022  | 293   | Cardiff (5WA), 1.2 kW.   |               | 1450   | 207   | Flensburg (Germany) (relays Hamburg), 0.6 kW.                 |               |
| 395  | 760    | Geneva (Switzerland), 1.5 kW.                                      |               | 1031  | 291   | Zagreb (Yugoslavia), 0.7 kW.                                       |               | 1470   | 204   | Salzburg 0.6 kW. Relays Vienna.                               |               |
| 416.6  | 720    | Moscow (Experimental), 20 kW.                                      |               | 1040  | 288.5 | Bordeaux-Lafayette (PTT) (France), 35 kW.                          |               | 1480   | 203   | Königsberg (Germany), 1.7 kW.                                 |               |
| 428  | 700    | Minsk (Russia), 4 kW.  |               | 1049  | 286   | Falun (Sweden), 0.65 kW.   |               | 1490   | 202   | Halmstad (Sweden), 0.25 kW.                                   |               |
| 442  | 680    | Lausanne (Switzerland), HBz, 0.6 kW.                               |               | 1058  | 283   | Aberdeen (2BD), 1.2 kW.  |               | 1500   | 200   | Radio Chatelineau (Belgium).                                  |               |
| 511  | 587.1  | Hamar (Norway) (relays Oslo), 0.8 kW.                              |               | 1067  | 281   | Hilversum (Holland), 8.5 kW. (Huizen programme and announcements). |               | 1530   | 196   | Warsaw, No. 2 (Poland), 1.9 kW. Experimental.                 |               |
| 522  | 574.7  | Ljubljana (Yugoslavia), 2.8 kW.                                    |               | 1085  | 279.5 | Tallinn (Estonia), 0.7 kW.   |               | 1530   | 196   | Boris (Sweden), 0.12 kW.                                      |               |
| 527  | 570    | Freiburg-im-Breisgau (Germany) (relays Stuttgart), 0.3 kW.         |               | 1094  | 277   | Kosice (Czechoslovakia) 2.5 kW.                                    |               | 1530   | 196   | Gävle (Sweden) (relays Stockholm), 0.2 kW.                    |               |
| 530  | 566    | Hanover (Germany), 0.3 kW. (relays Hamburg).                       |               | 1103  | 276.5 | Limoges, PTT (France), 0.08 kW.                                    |               | 1530   | 196   | Kristinehamn (Sweden), 0.25 kW.                               |               |
| 531  | 565    | Smolensk (Russia), 2 kW.   |               | 1112  | 275   | Tampere (Tammerfors) (Finland) (relays Helsinki) 1 kW.             |               | 1530   | 196   | Jonköping (Sweden), 0.25 kW. (relays Stockholm).              |               |
| 536  | 560    | Augsburg (Germany) (relays Munich), 0.3 kW.                        |               | 1121  | 273.2 | Viipuri (Viiborg) (Finland), relays Helsinki, 15 kW.               |               | 1530   | 196   | Leeds (2LS) (Gt. Britain), 0.16 kW.                           |               |
| 545  | 550    | Kaiserslautern (Germany) (relays Munich), 0.3 kW.                  |               | 1121  | 272   | <b>British Relay Stations</b>                                      |               | 1530   | 196   | Karlskrona (relays Stockholm) (Sweden), 0.25 kW.              |               |
| 554  | 542    | Budapest (Hungary), 23 kW.   |               | 1121  | 270   | Bournemouth (6BM), 1.2 kW.   |               | 1714   | 175   | St. Quentin (France).   |               |
| 563  | 533    | Sundsvall (Sweden), 15 kW.   |               | 1121  | 268   | Bradford (2LS), 0.16 kW.   |               |        |       |   |               |
| 572  | 525    | Munich (Germany), 1.7 kW.  |               | 1121  | 268   | Dundee (2DE), 0.16 kW.   |               |        |       |   |               |
| 581  | 517    | Riga (Latvia), 13 kW.  |               | 1121  | 268   | Edinburgh (2EH), 0.4 kW.   |               |        |       |   |               |
| 585  | 511    | Vienna (Rosenhügel) (Austria), 20 kW.                              |               | 1121  | 268   | Hull (6KH), 0.16 kW.   |               |        |       |   |               |
| 590  | 509    | Archangel (Russia), 1.2 kW.  |               | 1121  | 268   | Liverpool (6LV), 0.16 kW.  |               |        |       |   |               |
| 599  | 501    | Brussels No. 1 (Belgium), 20 kW.                                   |               | 1121  | 268   | Newcastle (5NO), 1.2 kW.   |               |        |       |   |               |
| 603.5  | 497    | Milan (Italy), 8.5 kW.   |               | 1121  | 268   | Plymouth (5PY), 0.16 kW.   |               |        |       |   |               |
| 608  | 493.4  | Moscow (Russia), 1.2 kW.   |               | 1121  | 268   | Sheffield (6FL), 0.16 kW.  |               |        |       |   |               |
| 617  | 487    | Nidaros (Trondhjem) (Norway), 1.3 kW.                              |               | 1121  | 268   | Stoke-on-Trent (6ST), 0.16 kW.                                     |               |        |       |   |               |
| 626  | 479.2  | Prague (Czechoslovakia), 5.5 kW.                                   |               | 1121  | 268   | Swansea (5SX), 0.16 kW.  |               |        |       |   |               |
| 630  | 476    | Midland Regional Station (Gt. Britain), 38 kW.                     |               | 1121  | 268   | Lyons (Radio) (France), 0.8 kW.                                    |               |        |       |   |               |
| 635  | 473    | Simferopol (Russia), 1.2 kW.                                       |               | 1121  | 268   | Montpellier (France), 1.2 kW.                                      |               |        |       |   |               |
| 644  | 466    | Langenberg (Germany), 17 kW.                                       |               | 1121  | 268   | Berlin Relay (Germany), 0.6 kW.                                    |               |        |       |   |               |
| 644  | 466    | Lyons (La Doua), France (relays Ecole Supérieure), 2.3 kW.         |               | 1121  | 268   | Magdeburg (Germany), 0.6 kW.                                       |               |        |       |   |               |
| 653  | 465.8  | Tartu (Estonia).   |               | 1121  | 268   | Stettin (Germany) (relays Berlin), 0.6 kW.                         |               |        |       |   |               |
| 653  | 459    | Zürich (Switzerland), 0.75 kW.                                     |               | 1121  | 268   | Innsbruck (Austria) (relays Vienna), 0.6 kW.                       |               |        |       |   |               |
| 662  | 453.2  | Porsgrund (Norway) (relays Oslo), 1.5 kW.                          |               | 1121  | 268   | Varberg (Sweden), 0.3 kW.  |               |        |       |   |               |
| 666.5  | 450    | Salamanca (Spain), EAJ22, 1 kW.                                    |               | 1121  | 268   | Copenhagen (Denmark), 1 kW.  |               |        |       |   |               |
| 671  | 447.1  | Bolzano (Italy) BZ, 0.2 kW.  |               | 1121  | 268   | Radio Liège (Belgium).   |               |        |       |   |               |
| 680  | 441    | Danzig (Free City), 0.25 kW. (relays Königsberg).                  |               | 1121  | 268   | Bratislava (Czechoslovakia), 14 kW.                                |               |        |       |   |               |
| 689  | 436    | Klagenfurt (Austria), 0.6 kW. (relays Vienna).                     |               | 1121  | 268   | Heilsberg (Germany), 75 kW. (relays Königsberg).                   |               |        |       |   |               |
| 697  | 430.4  | San Sebastian (Spain), 0.6 kW.                                     |               | 1121  | 268   | Turin (Italy), 8.5 kW.   |               |        |       |   |               |
| 702.5  | 427    | Bodø (Norway), 0.6 kW.   |               | 1121  | 268   | Rennes (France), 1.2 kW.   |               |        |       |   |               |
| 707  | 424    | Tromsø (Norway), 0.11 kW.  |               | 1121  | 268   | Bremen (Germany) (relays Hamburg), 0.3 kW.                         |               |        |       |   |               |
| 716  | 418    | Uppsala (Sweden), 0.2 kW. (relays Stockholm).                      |               | 1121  | 268   | Barcelona (EAJ13), Radio Catalana (Spain), 10 kW.                  |               |        |       |   |               |
| 721.1  | 416    | Moscow (Russia), RA2, 1 kW.  |               | 1121  | 268   | Ovideo (Spain), 0.7 kW.  |               |        |       |   |               |
| 725  | 413    | Paris (PTT) (Ecole Supérieure) (France), 1 kW.                     |               | 1121  | 268   | Lille (PTT) (France), 1 kW.  |               |        |       |   |               |
| 734  | 408    | Notodden (Norway), 0.9 kW.   |               | 1121  | 268   | Moravská-Ostrava (Czechoslovakia), 11 kW.                          |               |        |       |   |               |
| 743  | 403    | Rjukan (relays Oslo) (Norway), 0.17 kW.                            |               | 1121  | 268   | London National Stn., 68 kW.                                       |               |        |       |   |               |
| 752  | 398.9  | Aalesund (Norway), 0.4 kW.   |               | 1121  | 268   | Leipzig (Germany), 2.3 kW.   |               |        |       |   |               |
| 761  | 394    | Rome (IRO) (Italy), 75 kW.   |               | 1121  | 268   | Hörby (Sweden), (relays Stockholm), 15 kW.                         |               |        |       |   |               |
| 770  | 390    | Stockholm (Sweden) 75 kW.  |               | 1121  | 268   | Toulouse (PTT) (France), 1 kW.                                     |               |        |       |   |               |
| 779  | 385    | Malmö (Sweden) (relays Boden) (Sweden), 0.25 kW.                   |               | 1121  | 268   | Gleitwitz (Germany), (relays Breslau), 5.6 kW.                     |               |        |       |   |               |
| 788  | 381    | Belgrade (Yugoslavia), 3 kW.                                       |               | 1121  | 268   | Almeria (Spain) (EAJ18), 1 kW.                                     |               |        |       |   |               |
| 797  | 376.4  | Kharkov (Russia), RA4, 25 kW.                                      |               | 1121  | 268   | Barcelona (Asociacion Nacional) EAJ15, 1 kW.                       |               |        |       |   |               |
| 806  | 372    | Madrid (Union Radio) (EAJ7) (Spain), 2 kW.                         |               | 1121  | 268   | Trollhatten, (Sweden) 0.3 kW.                                      |               |        |       |   |               |
|  |        | Berlin (Witzleben), 1.7 kW.  |               | 1205  | 249   | Juan-les-Pins (Nice) (France).                                     |               |        |       |   |               |
|  |        | Rabat (Morocco), 2.5 kW.   |               | 1211  | 247.7 | Kalmar (relays Stockholm), 0.25 kW.                                |               |        |       |   |               |
|  |        | Dublin (2RN) (Ireland), 1.5 kW.                                    |               | 1220  | 245.9 | Schaerbeck (Brussels) (Belgium) 0.1 kW.                            |               |        |       |   |               |
|  |        | Katowice (Poland), 16 kW.  |               |       |       | Turku (Åbo) (Finland) (relays Helsinki), 0.6 kW.                   |               |        |       |   |               |
|  |        | Berne (Switzerland), 1.1 kW.                                       |               |       |       | Saffle (Sweden) (relays Stockholm), 0.4 kW.                        |               |        |       |   |               |
|  |        | Glasgow (5SC), 1.2 kW.   |               |       |       |  |               |        |       |   |               |
|  |        | Ducharest (Romania), 16 kW.  |               |       |       |  |               |        |       |   |               |
|  |        | Frankfurt (Germany), 1.7 kW.                                       |               |       |       |  |               |        |       |   |               |
|  |        | Toulouse (Radio) (France) 8 kW.                                    |               |       |       |  |               |        |       |   |               |
|  |        | Lwów (Poland), 21 kW.  |               |       |       |  |               |        |       |   |               |
|  |        | Manchester (2ZY), 1.2 kW.  |               |       |       |  |               |        |       |   |               |
|  |        | Hamburg (Germany), 1.7 kW.   |               |       |       |  |               |        |       |   |               |

### DEVIATIONS

The following are the actual deviations from the official frequencies, as noted during measurements made at the Tatsfield Checking Station. All differences of 1.0 kc/s and over are shown.

|        |        |                      |
|--------|--------|----------------------|
| 220.4  | 1361   | Motala (Sweden)      |
| 241.2  | 1243.7 | Boden (Sweden)       |
| 246.6  | 1216.2 | Istanbul (Turkey)    |
| 258.1  | 1162.1 | Kalundborg (Denmark) |
| 270    | 1111   | Oslo (Norway)        |
| 508.8  | 589.6  | Hamar (Norway)       |
| 801    | 374.5  | Seville (Spain)      |
| 1013.5 | 295.9  | Turin (Italy)        |
| 1045.1 | 287.1  | Lyons (France)       |
| 1060.1 | 283.9  | Innsbruck (Austria)  |
| 1214.1 | 247.1  | Kalmar (Sweden)      |
| 1452.7 | 206.5  | Boris (Sweden)       |
| 1492.6 | 201    | Jonköping (Sweden)   |

### BRITISH DOMINIONS AND COLONIES

#### AUSTRALIA

|     |     |                        |
|-----|-----|------------------------|
| 560 | 517 | Perth (7ZL), 3 kW.     |
| 620 | 484 | Melbourne (3AR), 5 kW. |
| 665 | 451 | Sydney (2FC), 5 kW.    |
| 690 | 435 | Perth (6WF), 5 kW.     |
| 734 | 409 | Adelaide (5CL), 5 kW.  |
| 779 | 385 | Brisbane (4QG), 5 kW.  |
| 808 | 371 | Melbourne (3LO), 5 kW. |
| 838 | 358 | Sydney (2BL), 5 kW.    |

#### CANADA

|     |     |                             |
|-----|-----|-----------------------------|
| 680 | 435 | Toronto (CKGW), 5 kW.       |
| 730 | 411 | St. Hyacinthe (CKAC), 5 kW. |
| 780 | 385 | Winnipeg (CKNR), 5 kW.      |

#### EAST AFRICA

|     |     |                      |
|-----|-----|----------------------|
| 750 | 400 | Nairobi, Kenya (7LO) |
|-----|-----|----------------------|

#### INDIA

|     |       |                       |
|-----|-------|-----------------------|
| 810 | 370.4 | Calcutta (VUC), 3 kW. |
| 840 | 357.1 | Bombay (VUB), 3 kW    |

## NORFOLK BROADS HOLIDAYS

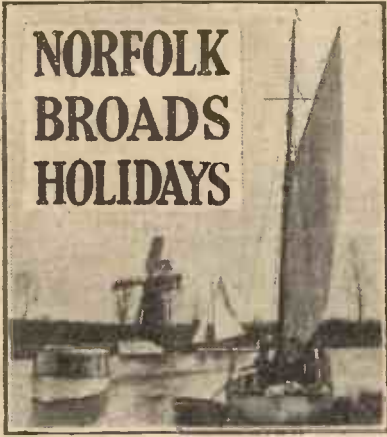

**T**HE NORFOLK BROADS, with their natural beauties and quiet old-world villages will enchant you. They are 120 miles from London, and consist of 200 miles of safe inland rivers and lakes, situated between Cromer, Lowestoft and the fine old city of Norwich, with its Cathedral and Castle. The cost, including boat, food, etc., averages £4 per head per week.

Send 6d. in stamps or P.O. for "NORFOLK BROADS HOLIDAYS AFLOAT," 300 pages. Contains details of 600 Yachts, Motor-Cruisers, etc., we have for hire. "How to Enjoy a Broads Holiday," "How to Run a Motor-Cruiser," "The Origin of the Inland Waterways of East Anglia." Map, Views in colours, etc.

Also obtainable through all W. H. Smith & Son's Bookstalls.

Train Service, Fares, and other information from any L.N.E.R. & L.M.S. Enquiry Office.

BLAKE'S LTD., 26, Broadland House, 22, Newgate St., London, E.C.1

## HIGH BLOOD PRESSURE

WORLD'S BEST PRESCRIPTIONS FOR HEART AND ARTERIES..

Don't be alarmed at heart attacks. Live your normal span; palpitation, tremblings, heart attacks, depression, nervousness, insomnia, hardening of the arteries are only serious when neglected. Shadforth Blood Pressure Reducing Tablets (No. 1,129) quickly restore the arteries to their youthful vigour. They cost only 2/6 and 4/6. In addition you take the Shadforth Heart Tonic Pills (No. 632). These quickly steady the heart, strengthen the nerves, and provide the tonic you need. They cost only 2/6 and 4/6. Full directions supplied. Two or three weeks of this treatment will make you feel 20 years younger. The Shadforth reputation for supplying the world's best prescriptions is your guarantee.

Privately packed and post free at these prices from

**Shadforth Prescription Service, Ltd.,**  
Dispensing Chemists,

(Dept. W.R. 32), 49, King William St., London Bridge, E.C.4, and branches. Boots, Taylors, Squires, Timothy Whites, and all the best chemists hold stock or obtain to order at short notice when requested to do so.

## THE WORLD-RADIO IDENTIFICATION PANELS BOOKLET

A new edition is ready of this famous B.B.C. log-book. It is really worth buying and keeping. It contains wavelengths, frequencies, power, call signs, interval signals, and closing signals of every important European station, and some American short wave stations. This new edition contains several new panels, and details of new European power ratings. Buy it together with the World-Radio map! It costs one shilling post free, of the Publications Dept., B.B.C., Savoy Hill, W.C.2

# UNDY MULTIPOLE Super Dynamic "8"

FAR IN ADVANCE OF ANYTHING EVER  
PREVIOUSLY ATTAINED IN LOUD SPEAKERS

There is nothing to equal it in the world of radio—an advance in design and capacity which denotes the pinnacle of loud-speaker production. Equally suitable for all from "All Mains" to the smallest "battery" receivers.

Not only is the "Undy" SUPER DYNAMIC fitted with a magnet of unequalled power, but the three tapings on the incorporated auto-transformer enable the perfect adaptation of the A.C. resistance of the speaker to any type of valve, and consequently 100 per cent. result in all cases. This means that whether a low, medium, or high resistance valve is employed in the final stages, the "Undy" Super Dynamic '8' can be adapted to work in complete unison. No other speaker can claim this.

The provision of the volume switch enables the loud-speaker to stand a constant anode current of 200 milliamperes and anode voltages of over 500 volts without injury.

On Sale Everywhere

**Greater Volume!**

**Greater Strength!**

**Greater Sensitivity!**

British  
Patent  
No.  
336,930

PRICE:

**70/-**

COMPLETE.

# Startling Pronouncement of Vital Concern to the Invalid and the Athlete, the Old and the Young.

The new Health Method described in this announcement increases Vital Energy, Strengthens Weak Constitutions, Builds up the Muscular Tissues, Tones Up the Vital Organs, Softens Hardened Arteries, Normalises the Circulation, Restores Youthful Vim and Vivacity, and Gives the elderly a New Lease of Life.

## SCIENTIST'S AMAZING HEALTH DISCOVERY

### ASTOUNDING TRIUMPH OVER OLD AGE INFIRMITIES

Remarkable New Method of Drugless Healing Promises Better Health for All and Longer Life

## VALUABLE FREE BOOK FOR EVERY READER

Medical Men, the Press and the general public cannot fail to be deeply interested in the news that Mr. O. Overbeck, F.R.S.A., F.P.C. (Lond.), has discovered a new health method entirely independent of drugs, and of equal benefit to the invalid and the athlete, the old and the young.

his eyesight improved to such an extent that he was soon able to give up the spectacles he had worn for years; and before long he was able to resume a normal life of active work.

World patents were taken out. A name had to be chosen for the instrument. "It has rejuvenated me. It will rejuvenate others. I will call it

#### WHAT THE PRESS SAYS

The Press, not only of the Empire but of many foreign countries, has drawn attention to Mr. Overbeck's remarkable invention for prolonging life and banishing disease.

"Health and Efficiency," one of the leading health journals, says: "The Overbeck Rejuvenator is well so called because the extraordinary difference in his own and other people's appearances, palpable to everybody, has been so marked after using the process."

#### ENDORSED BY MEDICAL MEN

In a lengthy report about Overbeck's Rejuvenator Dr. Brucker, Director of the Etablissements Aero-therapique, Paris, and a Chevalier of the Legion of Honour, says:—"By its graduated current of galvanisation this apparatus acts powerfully on the tissues, the organs, nervous centres, and consequently on the nutrition, circulation and disin-toxication."

#### STRIKING REPORTS FROM USERS

##### RHEUMATIC GOUT ROUTED.

Case No. 109. I have just cured a patient of rheumatic gout, severe form, and surprised three doctors.

##### CRIPPLED WITH NEURITIS. Now Able to Walk.

Case No. 108.—With reference to my mother, who, as you know, six months ago, was a cripple by neuritis. We have been using your machine six months and find great improvements, as now she can walk and do most things herself.

##### ASTHMA OVERCOME.

Case No. 261.—I have not had an attack of asthma since receiving the instrument.

##### BLOOD PRESSURE LOWERED.

Case No. 2/93.—The doctor says that my blood pressure test last week was lower than any previous test. I am going on fine, feeling well, sleeping well, and eating well. Again great praise for your electrical machine.

Hundreds of similar reports concerning the amazing health-restoring powers of Overbeck's Rejuvenator are reproduced in the Free Book which readers of "World-Radio" may obtain by simply completing and forwarding the form below.

Few men are better entitled to a hearing when they speak on the subject of health and well-being.

#### ROMANCE OF OLD MAN'S RECOVERY OF HEALTH AND VIGOUR

Eight years ago, prematurely worn out by a life devoted to scientific research, Mr. Overbeck was the picture of a decrepit old man on the verge of the grave.

It was at this time that, concerned at the rapid thinning and whitening of his hair, Mr. Overbeck's thoughts turned to electrical stimulation. He began experimenting. His first efforts were not very successful. Then the idea came to him that if electricity is to be of real lasting benefit, it must be absorbed without sensation, just as it is absorbed from the food we eat. The cells must, in very truth, be fed with the electric current.

#### AN EXPERIMENT—AND ITS MAGICAL RESULT.

The upshot was the invention of an electrical instrument constructed on entirely new lines. He tried it first on his hair. The result was magical. Not only did his hair rapidly grow thicker and darker in colour, but his mental faculties became greatly invigorated; every day he found himself getting stronger; the rheumatism that had plagued him for some time disappeared, as well as the kidney trouble, from which he had been a chronic sufferer;

Inset. Mr. O. Overbeck, F.R.S.A., F.P.C. Lond. Below, Reduced facsimile of the Diploma of Merit, awarded to Mr. Overbeck for his exhibit of Overbeck Rejuvenator at the International Exhibition of Inventions 1929.

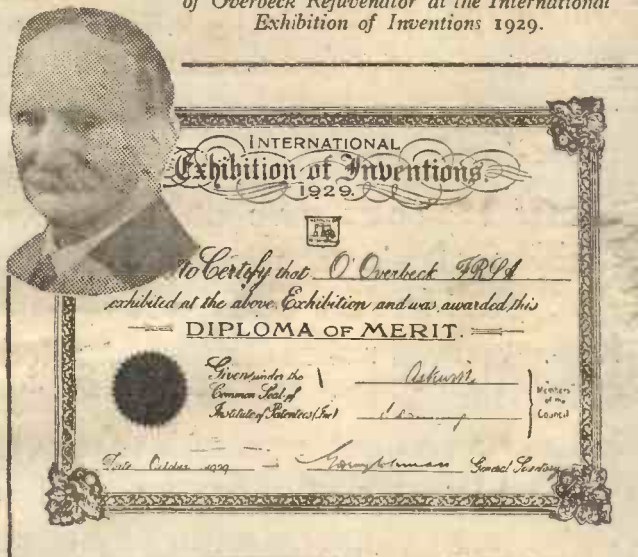

This picture of Mr. Overbeck skating at the Ice Dome Hammersmith is a typical presentation of the man as he is to-day—untiringly energetic, physically as well as mentally, and full of the joy of life, though past seventy years of age.

Overbeck's Rejuvenator," was a happy thought, and under this aptly chosen name it has gone forth on its mission of healing to all parts of the Globe.

#### JUSTIFIED BY RESULTS.

It is strengthening weak constitutions. It is steadying shaky nerves. It is building up wasted muscles. It is bringing down high blood pressure to normal. It is increasing the capacity to resist disease. It is banishing constitutional disorders in young and old alike.

### FREE BOOK

FILL IN & POST IMMEDIATELY THIS "WORLD-RADIO" FORM entitling you to a copy of the Fully Illustrated Book about the remarkable health-restoring method described in this announcement.

THE NEW HEALTH METHOD DESCRIBED ON THIS PAGE HAS ACHIEVED WONDERFUL SUCCESS IN THE FOLLOWING CASES:—

- ASTHMA
- BLOOD PRESSURE
- CATARRH
- CRAMP
- CONSTIPATION
- DEAFNESS
- EYESIGHT DEFECTS
- GENERAL WEAKNESS
- GOUT
- GOITRE
- HEADACHE
- HEART AFFECTIONS
- HAIR FALLING OUT and COLOUR LOSS

- INSOMNIA
- INDIGESTION
- LUMBAGO
- LOSS OF VIGOUR
- NERVOUS DEBILITY
- NEURASTHENIA
- PARAPLEGIA
- RHEUMATISM
- RHEUMATOID
- ARTHRITIS
- SCIATICA
- STAMMERING
- VOICE PRODUCTION
- WRINKLES

### To O. OVERBECK, F.R.S.A., CHANTRY HOUSE, GRIMSBY

Please send me Free Book about Overbeck's Rejuvenator, containing plates illustrating self-treatment and testimony to its power of increasing Vital Energy, Strengthening Weak Constitution; Building Up the Muscular Tissues, Toning Up the Vital Organs, Softening Hardened Arteries, Normalising the Circulation, Restoring Youthful Vim and Vivacity, and Giving the Elderly a New Lease of Life. I enclose 3d. in stamps to cover postage.

NAME .....  
ADDRESS .....  
(Please write clearly) .....

Simple facts for Valve Users No. 1.

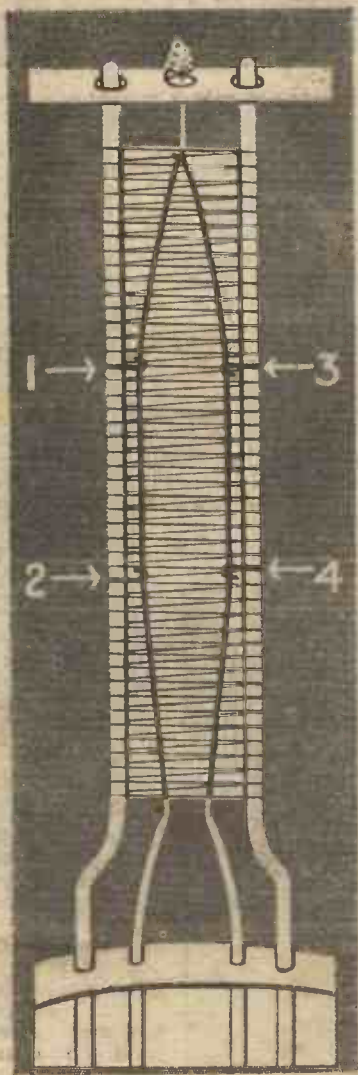

# Why Cossor Valves are non-microphonic

**M**ICROPHONIC (or ringing) noises in a valve are usually due to filament vibrations. It is normal practice to suspend the filament in an inverted V formation with a spring hook at its upper extremity to counteract expansion due to heat. Naturally—because it is taut—such a filament is very prone to vibrate.

Cossor engineers have definitely solved the problem of microphonic noises by evolving the 7-point filament suspension system shown here. You will notice the four insulated hooks which secure the filament in position and instantly damp out any tendency to vibration. Incidentally, the Cossor Insulated Bridge Construction ensures a much higher standard of accuracy in assembly—thereby permitting greater uniformity of characteristics and a finer all-round performance.

**Over 50 types of Cossor Valves are available from any Wireless Shop to suit all 2, 4, and 6 volt Battery operated and A.C. Mains Receivers**

| Battery Valves                             | Price each | A.C. Mains Valves         | Price each |
|--|------------|---------------------------|------------|
| H.F., H.L., L.F., R.C., and Defector types | 8/6        | H.F., L.F. and R.C. types | 15/-       |
| Power Valves                               | 10/6       | Power Valves              | 17/6       |
| Extra Power Valves                         | 13/6       | Extra Power Valves        | 22/6       |
| Screened Grids                             | 20/-       | Screened Grids            | 25/-       |
| Pentodes                                   | 22/6       |                           |            |

# COSSOR

A. C. Cossor, Ltd., Highbury Grove, London, N.5.

**Cossor Insulated Bridge Construction guarantees better performance**

7 806g