

Wireless Weekly

and The Wireless Constructor

Vol. 2.
No. 21.

CONTENTS

A Universal Two-Valve Receiver.

100-Metres C.W. Transmission.

Valve Notes.

Aperiodic Aerial Coils.

Atmospherics.

Constructional - Notes Broadcasting News, American Broadcast Reception, Jottings by the Way, Random Technicalities, Correspondence, Information Department, etc., etc.

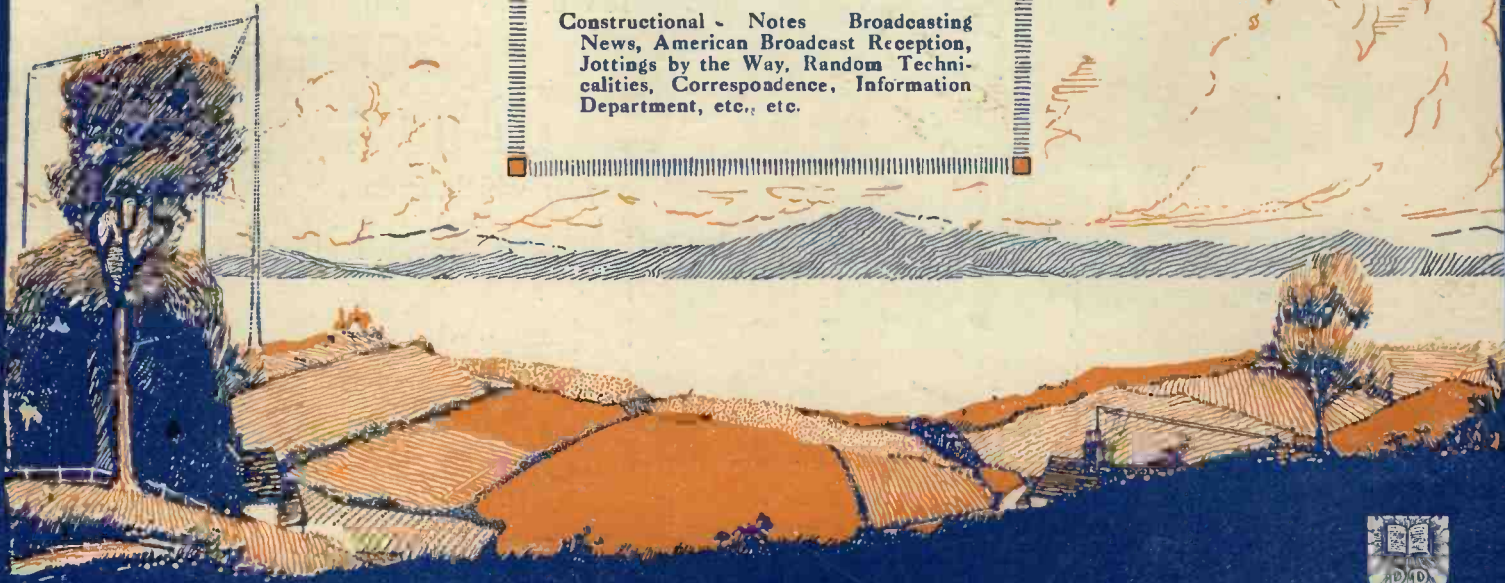

More about the Cowper Circuit



Cosmos Radio Sets for Xmas Presents

YOU could make a gift of nothing more acceptable this Christmas than a well-made and efficient Radio Receiving Set.

The Sets illustrated here represent a few of the series of

COSMOS RADIOPHONES

any of which, from the Crystal Set at £3 10s. to the Six-Valve Jacobean Cabinet at £125, would form a splendid gift.

“Cosmos” Radiophones are obtainable from all Retailers of Wireless Apparatus.

Have you obtained your copy yet of 'Building with Radiobrix'? 1/- everywhere (post free 1/5).

Send for our Catalogue and Handbook 7117/1 L.W. Post Free 1/- from the Manufacturers—

**METROPOLITAN
Vickers**
ELECTRICAL CO. LTD
TRAFFORD PARK WORKS :: MANCHESTER

Wireless Weekly

Vol. 2, No. 21
Dec. 5, 1923.

CONTENTS

	Page
Editorial	706
100-Metres C.W. Transmission	707
Atmospherics	709
"Aperiodic Aerial" Coils	711
Jottings by the Way	713
Some Good Earths	714
Super-Heterodyne Receivers (Conclusion)	715
Broadcasting News	717
Inductances for the Cowper Circuit	720
American Broadcast Reception	721
Super Regenerative Circuits—Are they Worth While?	722
Winder for Tubular Coils	723
A Use for Burnt-Out Transformers	723
News of the Week	724
Improving Cheap Telephones	725
An H. T. Battery Connector for Flash-lamp Cells	725
Random Technicalities	726
Phones in Every Room	727
A Universal Two-Valve Receiver	728
Apparatus We Have Tested	731
R.S.G.B. (Transmitters' Section)	732
Valve Notes	733
Correspondence	734
Radio Press Information Department	735

Editor: JOHN SCOTT-TAGGART, F.Inst.P.

Assistant Editors { E. REDPATH.
P. W. HARRIS.

Radio Press, Ltd.

Publishers of Authoritative Wireless Literature
DEVEREUX COURT, STRAND, W.C.2

Tel.—Central 3763.

Advertisement } SCHEFF PUBLICITY ORGANIZATION,
Managers: { LTR., 125, Pall Mall, London, S.W. 1
Tel.—Regent 2440.

Scientific Adviser:
Prof. G. W. O. HOWE,
D.Sc., M.I.E.E.
Advisory Editors:
Prof. R. WHIDDINGTON,
M.A., D.Sc.
Prof. C. L. FORTESCUE,
M.A., M.I.E.E.

Staff Editors
E. H. CHAPMAN, M.A., D.Sc.
A. D. COWPER, M.Sc.
G. P. KENDALL, B.Sc.
R. W. HALLOWS, M.A.
S. G. RATTEE.



All correspondence relating to contributions is to be addressed to the Editor of "Wireless Weekly."

Nothing contained herein is to be regarded as permission or encouragement to infringe any patent rights.

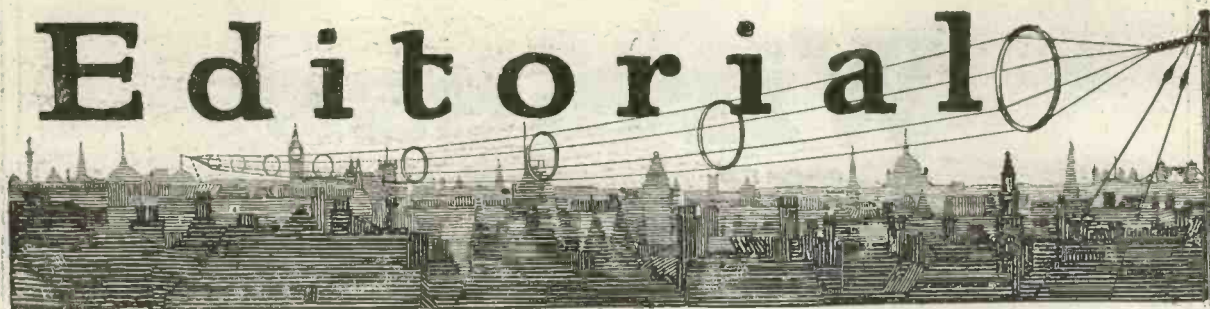

American Broadcast Reception.

WE congratulate the B.B.C. and the organisers of the recent Transatlantic broadcasting tests upon the measure of success attained and, more particularly, upon the amount of public and press interest evoked. It is all good publicity in the cause of wireless. It is, perhaps, rather amusing to notice in some of the daily papers, that the reception of American broadcasting is considered quite a recent achievement, whereas it has been quite a regular performance with scores of experimenters for some months.

As we mentioned last week, favourable periods for reception appear to occur in cycles and, judging by the number of reports received at this office, atmospheric conditions appear to have been particularly favourable during the past fortnight.

In this connection there is a splendid opportunity for the B.B.C. to accomplish some relay work on an extensive scale, following their recent successful wireless relaying from the "Old Vic," and, just as we go to press, we learn that Capt. Eckersley, chief engineer to the B.B.C., is to conduct experiments with the object of receiving the American transmissions, relaying them to London by land-line and re-transmitting from 2 LO.

We can imagine a certain amount of disappointment being felt by owners of multi-valve sets who perhaps regarded such long distance reception as their own special accomplishment, but think whatever disadvantages there are in this direction are easily outweighed by the pleasure which hundreds of thousands of listeners will feel at thus having New York programmes brought within easy range of their single-valve and crystal sets.

There remains, of course, the great difficulty of the difference in time between England and America. Listening in at 3 a.m. may be all very well once in a way, but cannot be

indulged in as a regular thing. We have recently had reports however of Sunday afternoon transmission in America being received, and we suggest that the B.B.C. makes tests to discover whether reception at 7 or 8 o'clock in the evening can be relied upon. If so, it would seem to afford a solution of this last-named difficulty.

Our New Scheme.

Elsewhere in this issue will be found full details of our free gift scheme for readers, referred to upon this page last week. We take this opportunity of impressing upon all our readers who have not already placed a standing order with their newsagent, the desirability of doing so for the six special issues, commencing with Vol. 3—No. 1, which will be on sale on Wednesday next. This advice is given in all seriousness, as next week's issue, and, in fact, each of the six special numbers, is certain to be in great demand.

We remember that similar advice was given in announcing the publication of the first number of *Modern Wireless*, the first edition of which, as many readers will no doubt recollect, was sold out within a few hours of publication. Thousands of would-be readers, who had failed to place a definite order, were obliged to await a reprint edition. *There will be no reprint in this case.*

This new gift scheme of ours is planned to offer a special inducement to all who are more than superficially interested in wireless, to become acquainted with *the* quality weekly wireless journal.

We have every confidence that, recognising our policy of having the real technical value in the journal itself, they will become regular readers. Our present readers will, of course, be fully entitled to benefit under the scheme and, by recommending *Wireless Weekly* and our special scheme, to their friends, they will benefit both them and us.

100-METRES C.W. TRANSMISSION

By S. R. WINTERS.

An account of the experiments carried out at the Bureau of Standards, Washington, U.S.A.

RESEMBLING a suspended latticework, an aerial designed and installed by F. W. Dunmore and F. H. Engle, of the Radio Laboratory of the Bureau of Standards, United States Department of Commerce, has made possible the transmission of radio-telegraph signals, on a wave-length of 105 metres, to a distance of 300 miles. Continuous-wave transmission at wave-lengths exceeding 150 metres has

graph, the aerial used in this instance is at variance with the type elevated above the roofs of residences and apartments and the frame aerial. This semblance of latticework, suspended above a house on the grounds of the Bureau of Standards, a structure usually reserved for tests with radio direction finders is a combination of the capacity and coil types of aerial. The coil design, as previous experiments have determined, effectively radi-

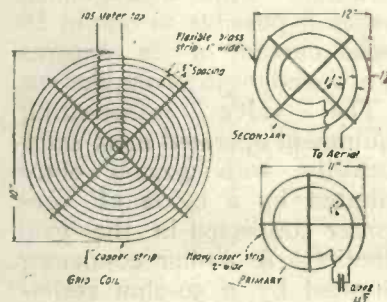
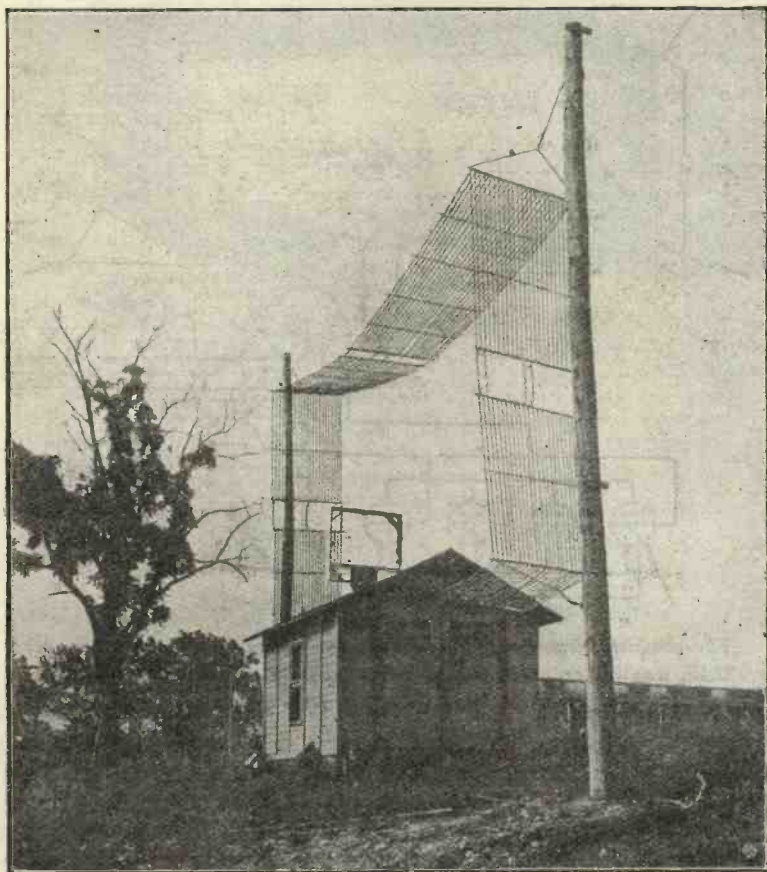

Our photograph shows the hut containing the apparatus, and the special aerial used by the Bureau of Standards during the 100 metres transmission tests. Inside the main aerial is a small frame aerial for reception.

For those who may be interested our smaller illustration gives constructional data of the three inductances employed. Large copper stripping is used so as to minimise high-frequency resistance.

been a subject of frequent experiments, but the sending of wireless signals of 105 metres wave-length is a departure in radio communication.

Novel experiments demand unusual equipment. As seen in the accompanying photo-

ates electric energy at abbreviated wave-lengths and has directional characteristics.

As the illustration reproduced with this article shows, this aerial is comprised of a number of wires in parallel in the form of a rectangle, with a gap in it. It includes a

single-turn inductance coil and a condenser. The latter is formed by covering the two wooden spreaders with copper foil. The glass rods between the spreaders function as insulators. The parallel wires in this wave-radiating system are bare copper strands, connected in parallel and spaced 3 in. apart. Light wooden spreaders are placed at 4-ft. intervals as a means of ensuring the separation of the wires. The complete aerial is 18 ft. high and 40 ft. long.

The source of electric power is coupled at a point about the centre of the lower horizontal section of the aerial. This combination type of aerial, with a 3-turn secondary coil connected in series, constitutes a circuit which operates on a wave-length of 105 metres. The valve circuit bears similarity to the Meissner circuit. The type G, 50 watt, transmitting valve, manufactured by the Western Electric Company, is employed, four of these being operated in parallel. This arrangement makes it possible to obtain an aerial current of six amperes at a wave-length of 105 metres.

The valve transmitting equipment operated most satisfactorily with 32,000 ohms shunted by a 0.002 μ F condenser connected in the grid circuits. A similar condenser shunted by a 50-ohm resistance in the high voltage supply circuit proved to be a stabilising agent in the operation of the valves. The primary or plate coil was composed of two turns of heavy copper strip, 2 in. wide, shunted by a 0.002 μ F transmitting condenser.

A 14-turn helix was employed for the grid coil. A tapping at $5\frac{1}{2}$ turns from the centre was most satisfactory. The coupling between the grid and plate coils is described as somewhat critical. A secondary coupling coil was employed for the purpose of transferring the energy to the aerial. This coil, connected in series with the aerial, was comprised of three turns of brass strip, 1 in. wide. A "chopper" was used when interrupted continuous wave transmission was resorted to, the "chopper" being connected in series with the lead from the filament to the radio-frequency circuits.

Tests have been conducted with this transmitting outfit, a detector and one stage of

audio-frequency amplification being used for reception, the signals being very clearly received at East Pittsburgh. Two-way communication was maintained between the latter point and Washington, while a report indicates that the signals during these tests were heard as far distant as Boston.

The gratifying success of the evening transmission tests prompted an investigation into the effects of short-wave signalling during daylight. Continuous transmission, therefore, was conducted at two periods, beginning at noon and continuing until 10 o'clock at night. Thus a relative comparison was made between the intensity of the wireless signals sent during the day and those transmitted after nightfall. Quite logically, it was anticipated that the signals would be weaker during the day than at night, but the actual results showed that the strength of the signals during the day and evening was the same,

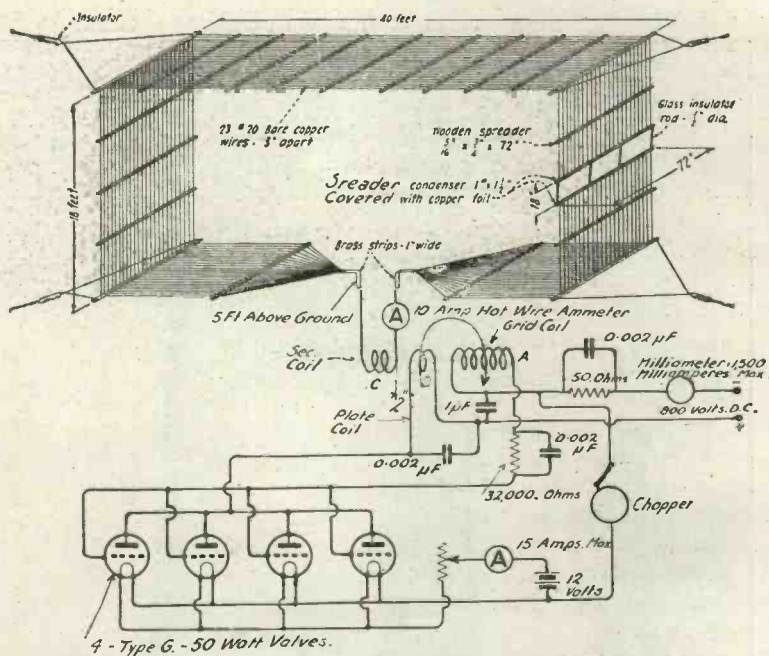

The complete circuit diagram of the 100-metres C.W. and interrupted C.W. transmitter, using four 50-watt valves. Details of the aerial together with condenser, resistance and other values are given.

irrespective of the period of time at which messages were sent. This surprising result apparently explodes the theory that the absorption of wireless signals on short wave-lengths is greater during daylight than after nightfall. The Radio Laboratory of the Bureau of Standards, however, withholds conclusions on this point until further experiments are conducted. The lack of fading, too, was a gratifying observation, although conclusive evidence has not been obtained on this point. (To be continued.)

ATMOSPHERICS

By Lt.-Col. Chetwode Crawley, R.M.A., M.I.E.E., Deputy Inspector of Wireless Telegraphy, G.P.O.

A few notes of particular interest now that long distance reception is being so much attempted.

TWENTY years ago the problems of the future seemed far different from those which confront the vast army of wireless experimenters of to-day, but the greatest problem of 1903 remains, unfortunately, the greatest problem of 1923, viz., the elimination of the effect of atmospherics on the reception of wireless signals. This problem has been attacked unceasingly throughout these twenty years, and every improvement made in transmitting and receiving circuits has helped in its solution. No one can deny the fact that great progress has been made, but most of this progress has resulted, not from direct assault but from, as it were, an enveloping attack produced by the solution of other problems.

The first really notable advance was made when reception by sound supplanted reception by sight, that is, when the telephone receiver ousted the morse inker. This change brought into prominence the fact that atmospherics produced a low pitched note, through which signals could be read when the pitch of the note produced by them was higher than that produced by the atmospherics, even when the sound of the atmospherics was as loud as the sound of the signals. This was a very great advance, in fact by far the greatest advance made by any one change, in the solution of this problem, and it is the irony of fate that this great advance has paved the way for the possibility of its suicide, and the use, once more, of the printed record with all its potential advantages for high-speed reception. But the printed record, which is a necessity if a point to point wireless service is to be a commercial proposition, has, as before, shown that the reduction of the effect of atmospherics is still of vital importance, especially in long range working where the unavoidable use of long waves makes the problem more difficult than ever.

For the first ten years of the period under review there was little time to collect sufficient data on the subject, and no properly organised effort was made to do so until the matter was taken up by the British Association in this country in 1912, when a definite plan was drawn up for obtaining data from ship and shore stations all over the world. By the end of the following year some very useful data

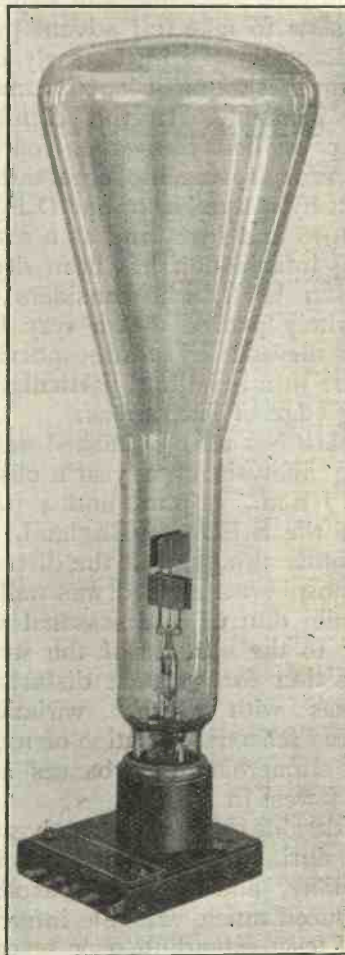

Photo by Western Electric.

The Cathode-ray Oscillagraph. An instrument used for determining the wave-forms of atmospherics.

had been collected, but in 1914 these stations had very different work to perform, and the whole scheme was abandoned. It must not be thought, however, that in those early days, before 1913, no data was collected, in fact the present writer published in 1921 data which he had obtained some years before when engaged on wireless work in the Mediterranean, and a considerable amount of far more important data had been published from time to time, even indeed before wireless signalling was invented. But the fact remains that no effort, properly organised on a large scale, was made to collect data from the available world-wide sources until 1912. Since then, a

great mass of information has been obtained by systematic observation, and although there is still much to learn about the nature of atmospherics, and how best to combat their effects, it is no longer a matter of haphazard groping in the dark.

Organised investigations, so far as Europe is concerned, were interrupted to a great extent by the war, but American experimenters were not slow to take full advantage of their happier circumstances in the early days, and it is to them that we must look for much of the data now available. In this country, however, after we had recovered from the first shock of War, systematic observations were carried out by a number of our D.F. stations, between 1916 and 1918, and as a result much interesting information has been deduced by Mr. Watson Watt, who considers that it is now definitely proved that a very high proportion of the sources of atmospherics are in areas where rain is falling, particularly on the advancing edge of such areas.

Mr. Watt has also published recently an interesting analysis of a year's observations made at 7 a.m., 1 p.m. and 4 p.m., at a station in the S.E. of England, showing, amongst other things, that the direction from which atmospherics arrived was well marked, with definite diurnal and seasonal variations according to the altitude of the sun. The mean direction for greatest disturbance was 153 degrees with diurnal variation of 60 degrees, and seasonal variation of 100 degrees. The most numerous disturbances arrived in June, the fewest in March.

A considerable amount of data has also been published during the last few years in France and Germany, and American experimenters have produced much valuable information as a result of tests extending over several years, especially in regard to the directions from which atmospherics may be expected in various localities. It is now agreed that the most troublesome atmospherics originate in mountainous districts, a fact which the writer has had the misfortune to prove, to his own complete dissatisfaction, in the highlands of Central Africa, Jamaica, and the Azores. In America, for instance, it has been found that the worst atmospherics received at stations on the Atlantic seaboard originate in the Allegheny and Mexican mountainous districts, whilst those on the Pacific seaboard originate

in the nearby chain of mountains, and similar reports have been received in respect of the great mountainous districts in Africa. Dr. Eccles, in his presidential address to the Radio Society of Great Britain last January, laid stress on the influence of the position of the sun on the display of atmospherics. He suggested that "as the sun moves round the equator and warms the air on the land, the consequent meteorological phenomena produce atmospherics in England," and he went on to show how this theory seemed to apply, in a general way, to the facts established regarding the directions from which, and the time at which, atmospherics are received all over the world.

Recently a paper was read before the Royal Society by Messrs. Watt and Appleton, who are working under the auspices of the Radio Research Board, giving results of observations on the wave form of atmospherics. These experiments, which are still continuing, are of great importance, as they consist of inquiries into the very nature of atmospherics, that is, their wave forms, more than into their special origin and into their effects, fields of investigation which have already received considerable attention.

As regards the actual origin of atmospherics very little is known, in fact M. Chauvaux in Part I of his "Electricité Atmospherique," says that no single theory for explaining the interchange of electricity between the earth's surface and the lower atmosphere can be seriously maintained.

But, after all, judging from electricity itself, so much can be done without understanding "origin" that there is no need to be disheartened, and even the much abused atmospheric has its silver lining, as its systematic pursuit leads inevitably to international co-operation. This is now fully recognised, and the "International Union of Scientific Radiotelegraphy," which came into being in 1919, has taken the matter under its wing. This Union embraces Great Britain, the United States, France, Italy, Norway, Belgium, and will shortly include Australia, Japan, Spain and Holland. Most of what has been done so far has been the result of rather isolated investigations. How much more, therefore, can we not hope for when the International Union is firmly and widely established?

BINDING CASES FOR VOL. II.

This issue concludes Vol. II., and binding prices are as follows:—The prices of the cases only are 2/6 for the cloth (2/10 post free), and 4/6 for the half leather (4/10 post free). The charge for binding readers back numbers, including the necessary case and index, is 4/6 (5/6 post free), and 7/6 (8/6 post free), in the two styles. The prices given for cases only do not include the cost of the index, which can be supplied separately at 1/- (1/1 post free).

"APERIODIC AERIAL" COILS

By G. P. KENDALL, B.Sc., Staff Editor.

Some useful notes on one of the latest developments.

READERS of *Wireless Weekly* will have noticed that a number of interesting developments are taking place along the lines of the "aperiodic aerial" method of tuning. This system of tuning consists, essentially, of an aerial circuit which is probably almost aperiodic, and which is very tightly coupled to a secondary circuit, which is tuned accu-

ritically equals that of a good loose-coupler, so that it is exceedingly helpful in reducing interference. Nevertheless, it is no more difficult to operate than a single-circuit tuner, and has none of the complication of the loose-coupled type. Further, if the coil is properly designed, there is little or no loss of signal strength, and the calibration of the circuit remains constant whatever the size of aerial with which it is used. This latter point is particularly advantageous where portable sets are concerned.

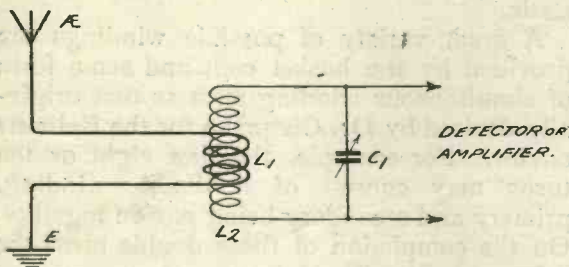

Fig. 1.—A typical circuit employing the aperiodic aerial system.

rately to the received wavelength. The aerial circuit usually consists of the aerial itself, a few turns of wire on a coil, and the earth connection, as shown in Fig. 1. Provided that the number of turns is small and the resistance low, this circuit responds fairly uniformly over the entire band of wavelengths covered by the secondary.

Since the aerial circuit is required to function aperiodically, it might be expected that resistance in series would be beneficial rather than harmful, but the reverse is found in practice, and it is essential that the aerial coil be wound with quite thick wire. It is necessary, also, to keep down the resistance of the secondary circuit, and here also thick wire must be used if really good results are to be obtained. The essential features of this system of tuning, then, are these:—Low resistance in both primary and secondary circuits, a relatively small number of turns in the aerial circuit, and extremely "tight" coupling between the circuits.

Granted these conditions, the method possesses several great virtues. First, its sharpness of tuning is very much superior to that of the ordinary single-circuit tuner, and prac-

tically equals that of a good loose-coupler, so that it is exceedingly helpful in reducing interference. Nevertheless, it is no more difficult to operate than a single-circuit tuner, and has none of the complication of the loose-coupled type. Further, if the coil is properly designed, there is little or no loss of signal strength, and the calibration of the circuit remains constant whatever the size of aerial with which it is used. This latter point is particularly advantageous where portable sets are concerned.

Since the tuning is independent of the size of the aerial, coils of the type which we are considering are especially useful upon the shorter waves (600 metres and below), as they remove any limitation upon the dimensions of the aerial which would otherwise be imposed by the exigencies of tuning. When a "Ducon" is employed, for example, it is often necessary to use a very small series condenser to bring the system down to the shorter waves, with consequent loss of efficiency in the case of an ordinary tuner. If the "aperiodic aerial" method is substituted,

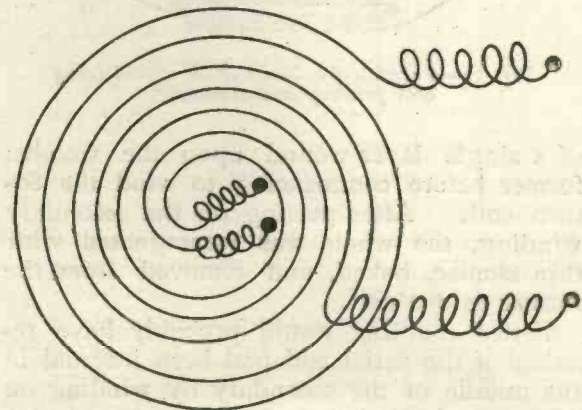

Fig. 2.—Illustrating the simultaneous winding of primary and secondary in a spiral coil such as a basket.

no series condenser is required, and signals are therefore much improved.

The original type of coil consisted of a single-layer secondary winding upon a tube, the aerial coil comprising about ten turns wound directly on top of the secondary at a

point near its centre. (Several experimenters confirm that it is best to place the primary fairly accurately in the centre.) The larger the number of turns in the aerial coil, the less sharp the tuning, while if their number is reduced beyond a certain point, signal strength suffers.

A coil suitable for broadcast reception consists of a secondary winding of 70 turns upon a 3½-in. tube, and an aerial coil of 8 turns, No. 22 double-cotton covered wire being used for the secondary and No. 20 double-cotton covered for the primary. This coil will cover a range of about 200 to 500 metres with a variable condenser of 0.0003 μF.

Since extreme tightness of coupling with the minimum number of aerial turns is required, it is obvious that some form of multi-layer coil should give better results than the type which has just been described, and this expectation is borne out in practice. A number of experimenters, the writer among them, have obtained remarkably good signals and selectivity by the use of a variety of multi-layer coils in which the aerial turns are interwoven with the secondary. The first successful coil made by the writer was a duo-lateral having 80 turns of No. 20 d.c.c. constituting the secondary winding and 10 turns of No. 18 d.c.c. the primary. The latter took the form

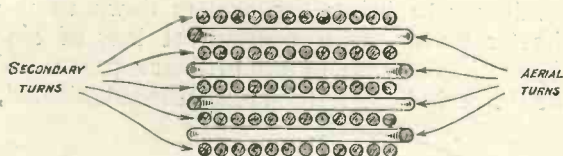

Fig. 3.—A section of a lattice winding containing both primary and secondary.

of a single layer wound upon the wooden former before commencing to wind the 80-turn coil. After putting on the secondary winding, the whole was impregnated with thin shellac, baked, and removed from the former as one coil.

Better coupling would probably have resulted if the aerial coil had been inserted in the middle of the secondary by winding on 40 turns of the latter, then the ten primary turns, and over these the remaining 40 of the secondary.

A particularly effective coil recently wound by the writer consists of what is really a modification of the lattice ("Burndept") coil. It will be remembered that the lattice coil (see *Modern Wireless*, Vol. I, No. 4) is composed of alternate layers of wire and zig-zag spacing turns, and it is a simple matter to adapt

it to the requirements of the "aperiodic aerial" tuning system by winding the layers from one bobbin of wire and the zig-zag turns from another. The result is two separate windings, of which the zig-zag turns form the aerial coil, extremely tightly coupled to the other winding, which constitutes the secondary. A good coil for broadcast reception has ten layers of seven turns each, wound with No. 22 d.c.c., the nine spacing turns of No. 20 d.c.c. being connected in the aerial circuit. A section of part of such a coil is shown in Fig. 3, its inner diameter being 2 in.

Since the spacing turns in this type of coil cross those composing the secondary winding at angles, it would seem that the magnetic coupling between primary and secondary must be poor. However, the coil gives excellent results, and it is suggested that the effective coupling is to some extent electrostatic.

A great variety of possible windings are provided by the basket coil, and some form of simultaneous winding such as that originally devised by Dr. Chapman for the Reinartz circuit. For example, the first eight or ten turns may consist of a double winding, primary and secondary being put on together. On the completion of these double turns the primary is cut off and the secondary continued for a further 60 or 70 turns.

The simultaneous turns may be inserted at any point in the coil, a good form being that included in the crystal set described by Dr. Chapman in the current issue of *Modern Wireless*, in which the double turns are placed at the midway point in the winding of the coil.

A better method, in the writer's experience, is to wind on first eight turns of the secondary, then one turn of the primary, another eight of the secondary, one primary, and so on until the coil is complete.

Honeycomb and duolateral coils also provide a convenient basis for simultaneously-wound aerial and secondary coils. The primary can be inserted at any convenient point during the winding, an example having been quoted above. The most effective way of doing this appears to be by winding simultaneously from two bobbins of wire, so that both primary and secondary are wound with the correct honeycomb formation where they lie side by side.

The impregnation of the finished winding is a more critical matter than in the case of coils of ordinary type, and it seems that it is essential to use the absolute minimum of good quality shellac or paraffin wax.



Noble Resolves.

THE path to a certain very undesirable abode is stated on the best authority to be paved with good resolutions. If this be so, and I have no reason to doubt it, then that path must be something very different from the easy and inviting way that some would have us believe it to be. For nothing is more slippery than a good resolution, and any path paved therewith must offer a foothold as insecure as the butter slide booby trap of our boyhood days. You may make as many good resolutions as you will, but you simply cannot keep the blessed things. Though you do your best, they elude you and are promptly grabbed by Old Nick to be added to his collection of paving stones, which must be a fairly extensive one.

You will gather from all this that I have lately been resolving. You are right. I have. Not long ago I decided that it was about time that I put into practice some of the excellent maxims that I had long been instilling into others. My log should be written up in a fair book, instead of on odd scraps of paper scattered like the Sibylline Leaves over tables and chairs, and even at times upon the floor. No longer would I beseech the partner of my joys and sorrows to tell me what her handmaiden had done with the condenser which I had certainly left upon the mantelpiece, only to find after a soul-shattering search that it was nestling all the while in the coal scuttle, into which I then remembered having dropped it. The wireless bench should become a thing of orderliness and beauty instead of being a horrid scene of chaos that cried aloud to gods and men for the touch of a tidying hand.

More Paving Stones for the Old Man.

Everything should be put away. In this drawer you would find valves and their appurtenances, in that condensers, in that inductances, in that odd bits and pieces. Every wire should have its ends properly made off. The soldering iron should be busy about the work of making proper connections where previously things had just been twisted haphazard round other things.

So far, you will admit, my conduct was laudable in the extreme. And it went even further than this, for I duly carried many good resolutions into effect. Beyond this I cannot claim merit, for order has once more given place to disorder; there are bits here and pieces there. Everything, in fact, is anyhow. Like a partially reformed criminal, I have suffered a relapse. But do not seek for signs of repentance, for there is no sorrow in my heart.

How it worked out.

When you place your valves in their particular drawer you are probably unmindful of the ancient adage about the folly of putting all your eggs into one basket. I never gave it a thought until one day that miserable drawer stuck and I pulled until it came out by the roots, scattering my cherished valves upon the cold, unyielding boards. You may imagine that dreadful moment; you may picture my anguish, calculate the number of bad marks that my naughty words scored in the ledger of the Recording Angel, even with the 50 per cent. discount that I am sure he allows to us sorely tried wireless men in moments of great stress.

However, it is no good crying over spilt valves. Consoling myself with the thought that they had all seen a great deal of ser-

vice and were probably consuming so much juice that it would actually pay to invest in a new lot, I went forth and did in several hard-earned Fishers. When I got back I wanted the ammeter and its cousin Milli to test their performances. Were they in their appointed place? No. It was not until every drawer had been turned upside down that they came to light. Those soldered connections, too, are a bore: you can't just hook things on here or there in a moment.

The Reason Why.

As for the log book, what's the good of keeping it if you can never find it? Tidiness may look nice, but it isn't comfortable. I remember hearing a subaltern of much experience say in the early days of the war on learning that yet another brass hat visit was to be expected: "No sooner does the camp get decently dirty and comfortable than six blanky generals must needs come and inspect it and we've got to tidy the whole blinking place into discomfort."

There's a world of truth in that. Woman loves tidiness, or, rather, she pretends that she does, because men think that she ought to; but man is never so happy as when his den is littered with promiscuous odds and ends. Then he can work with an untroubled mind, and usually he can find things when he wants them. That is the reason, Sirs, why I have broken my good resolution, the reason why my wireless table looks like a haystack that has been buffeted by a gale. At least I try to persuade myself that this is so, and I would like you to think so. In my heart of hearts I have a kind of feeling that sheer laziness is the real cause of my backsliding from the paths of virtue.

A Noble Work.

Some day I am going to write a book for the benefit of stricken wireless men whose sets play up just when they are least wanted to do so. It will contain the fruits of ripe experience . . . this sentence is not going well somehow: the fruits should be ripe, I think, and the experience bitter. Anyhow, it will set forth in the simplest and clearest of language all the calamities that may befall the enthusiast, how they are caused and what to do when they happen.

Some day I hope to write it, and then you will fall, metaphorically, of course, upon my neck and weep salt tears of gratitude, whilst I, pocketing as my

royalty 10 per cent., or even 15 if the publisher is kind, of the purchase price paid by you and all the brotherhood, will go upon my way rejoicing in a Rolls-Royce car.

The Little Rift.

But, as Tennyson might have said.

It is the little snag that cropping up,
Makes writers realise they've bought a pup,
And so not write the blessed thing at all.

Many a time have I started upon that noble work. My pen flew lightly and, if I am to believe the common plaint of editors, illegally, over the paper as I

described some little waywardness and showed precisely how it might be tracked down and cured.

And when I turned on my own set to enjoy an hour or so of musical relaxation, that selfsame fault occurred, and all the little demons that live around the wireless set held their sides as they watched me tracing it by my cunning methods and applying the remedies that could not fail—but did. Then I tore out handfuls of hair and tore up handfuls of fair written pages. Only one chapter has ever survived. It is headed "Faults that Defy Detection," and it contains but three words, "Try the coke hammer."

WIRELESS WAYFARER.

DWELLERS in flats, unless they live upon the ground floor, are almost forced to use an indoor earth. Gas pipes should be entirely eschewed, since the packing of their joints offers a high resistance. The choice lies between the radiator system, if there is one, and the water mains. The former may answer fairly well, but the latter will usually be found better, though it is essential to make use of an ascending main. A descending pipe may come from a cistern, and so make no proper contact with earth at all.

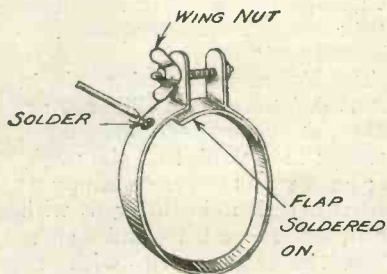

Fig. 1.—A suggestion for an earth clip.

If the pipe is of lead, the earth lead should preferably be soldered to it; this, however, is a job to be undertaken only by the skilled amateur. Those who are not real experts with the soldering iron will do better to use a clip for attaching the earth to a pipe, whether it is of iron or of lead. One such as that shown in Fig. 1 can be made and fitted in a quarter of an hour.

SOME GOOD EARTHS.

Measure the distance round the pipe with an inch tape. Deduct a quarter of it, and add three-quarters of an inch for each of the upturned ends. This gives the length of the strip to be cut out. Thus, if a pipe measures 3 in. in circumference, the length is $3 - \frac{1}{4} + 1\frac{1}{2} = 3\frac{3}{4}$ in. Cut a strip of sheet copper of the right length and $1\frac{1}{2}$ in. wide. Drill a 2B.A. clearance hole in each end, and turn them up at right-angles, as shown. Below one of them solder on a flap 1 in. in length. This is not a difficult job, since copper is very easy to solder.

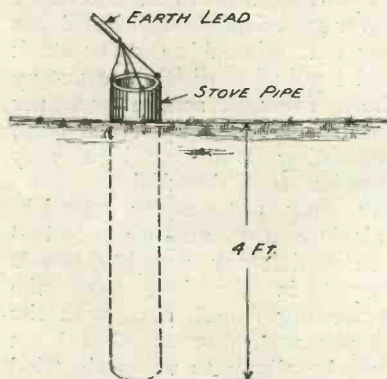

Fig. 2.—The "Stove-pipe" earth.

Now place the clip on a well-scraped part of the pipe, pass a 2B.A. bolt through the holes and screw hard down. Lastly, solder

the earth lead to the clip. A coat of shellac varnish over the junction between clip and pipe will keep both from corroding, and so will preserve a good connection.

An excellent outdoor earth is shown in Fig. 2. This is a 4 ft. 6 in. length of stove pipe, or, better still, galvanised iron piping sunk 4 ft. into the ground.

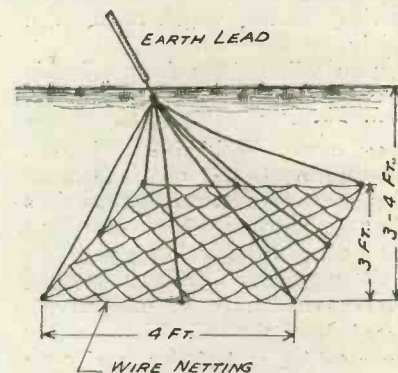

Fig. 3.—An earth mat of wire netting.

Fill the pipe with powdered coke. This will retain moisture and will keep the earth at the foot of the pipe wet. An occasional bucketful of water should be poured into the pipe.

Another good earth can be made from a piece of wire netting measuring about 8 ft. by 3 ft. This is folded double so as to make a mat 4 ft. long. The earth wire is unstranded and soldered to various points; this will not be found difficult, as the wire is galvanised.

R. W. H.

unit is carefully shielded as well as the cabinet itself, in order to prevent reaction and inductive effects between the various circuits.

For convenience, since it was not possible to use storage batteries, dull emitter valves were employed throughout with dry cells as filament supply: In order to obtain more strength in the heterodyne circuit, two valves were connected in parallel, but with individual rheostats, so that one may be employed if desired. For ordinary purposes, only one valve is required, but two were necessary in some experiments which were carried out. The tuner consists of honeycomb coils connected in a standard circuit, and a jack is provided so that a frame aerial may be substituted for the secondary coil when necessary.

The radio-frequency amplifier consists of four stages with transformer coupling, and detector, the tuned circuits being connected as shown in Fig. 3, between the last amplifying valve and the detector. The audio-frequency amplifier used with the set does not present any departure. It is composed of three

stages, with the necessary jacks, rheostats and grid biasing batteries. It is only necessary when desired to operate the loud-speaker, because when headphones are used, they are generally plugged directly in the detector circuit.

When using an outside aerial with the honeycomb coil tuner, a regenerative action may be obtained by means of the reaction coil connected in the plate circuit of the frequency changer; but in this case the strength of the local oscillations must be reduced by either filament control of the oscillating valve, or by variation of the coupling between the coil L₄ and the heterodyne. The constants for the oscillator circuit are the same as those given previously.

With this receiver, using an indoor aerial or the house lighting system through a condenser plug, distant stations were heard, in spite of heavy interference. The selectivity is such that by moving only the vernier control of the oscillator condenser, the nearer broadcasting station can be entirely eliminated.

OUR NEW SCHEME.

FULL PARTICULARS OF THE FREE GIFT SCHEME
FOR READERS OF "WIRELESS WEEKLY."

On Wednesday next, December 12, will appear the first of six especially attractive issues of *Wireless Weekly*. Incidentally the first of these commences a new volume. Not only will each of these special numbers, with the usual number of editorial pages, contain articles which no real wireless enthusiast—whether experienced or a mere beginner—can afford to miss, but in each will appear a special coupon, in connection with a scheme whereby Radio Press, Limited, offer free gifts, up to 5s. in value, to all readers who comply with certain simple conditions.

THE CONDITIONS.

The coupon should be cut from each issue and kept until six coupons are obtained. (For the benefit of readers who, through not placing an advance order, are unable to secure the first special issue, a *seventh* coupon will appear and will be accepted in lieu of Coupon No. 1.)

The six coupons, together with an order for any one of the Radio Press Series of

handbooks, are to be sent, in an envelope marked "Coupon," to:—

RADIO PRESS, LTD.,
Devereux Court,
Strand, W.C., 2,

accompanied by a postal order for ONE HALF OF THE LIST PRICE OF THE BOOK CHOSEN, plus 2d. for postage.

For example, if a half-a-crown book is chosen, the six coupons and a postal order for 1s. 5d. will ensure its dispatch. If a 10s. book is selected, the six coupons, together with a postal order for 5s. 2d., buys the book.

We invite all our readers to place an order *immediately*—a special order form will be found amongst our advertisement pages—in order to avoid disappointment, as there is certain to be a great demand for the first of the special issues.

If our regular readers will kindly bring this scheme to the notice of their wireless acquaintances, the courtesy will be greatly appreciated.

Broadcasting News



LONDON.—By far the most interesting experiment that has been undertaken for some time by the Engineers of the B.B.C. was one which met with complete success in connection with the transmission of the first Act of "La Traviata" on the evening of Saturday, November 24. This part of the performance at the "Old Vic" was sent by wireless from the theatre on a specially allotted wavelength to the British broadcasting station, where it was picked up on a special receiving set, amplified, and simultaneously broadcast from the London, Manchester and Glasgow stations. Whilst there was practically no theoretical difficulties in the way of achieving this, it had never before been attempted in the history of British broadcasting, and its success reflects great credit upon the technical skill of the engineers who achieved it. The success of this experiment may be very far reaching, and all listeners, who yet possess a sense of the magic of wireless telephony, will await with eagerness further developments.

"Russian Night," at 2LO, was one of exceptional interest, affording us, as it did, an opportunity of hearing Slavonic music (with its strange blending of the tender and barbaric), rendered by two Russian singers, both the possessors of remarkably fine voices and a full appreciation of the artistic, whilst the guitar accompaniment gave us the atmosphere that is peculiarly gipsy.

On this night, too, we had another budget of humour, clear and clever, from Mr. Ronald Gourley, the blind entertainer and siffleur. How unobtrusively he

"comes over." We always have a "good quarter of an hour" when he is broadcasting.

It is said that one can have too much of a good thing, but the grand old compositions are repeated again and again, and their charm never seems to wane. For instance, just to mention a few, we had Rossini's "William Tell," Lincke's valse "Venus on Earth," Ketelby's "In a Monastery Garden," "Zampa" by Herold, a good sprinkling of Grieg's during the week, and we enjoyed them all; then on the light side we recently heard selections from that good old favourite "The Geisha." This is much better than being forced to listen to some of the plagiarised patchwork efforts that are served up to us by stunt jazz bands, such as, for instance, a fox-trot consisting of several bars of terribly, aye aggressively, negroid syncopated stuff, then of all things, a passage or two from Gounod's divine garden scene music from "Faust," anon more stunts and syncopation, and, by way of a change, another fox-trot! When we do hear a good waltz we can, thanks to the stuff that has gone before, appreciate it the more.

We thoroughly enjoyed Capt. Eckersley's little address, and marvelled at his speed of delivery, and our sympathies went out to his unfortunate stenographer, but perhaps he puts the brake on sometimes. At any rate, we always like to hear his cheery voice so brimful of good humour and happiness, and we hope it will not be long ere he and his staff accomplish relaying wireless transmissions through the air for long distances.

Our friends in Belgium must have been very pleased to hear the little message of good luck transmitted in French from 2 LO. We understand that the new Belgian Company is transmitting on a wavelength of 410 metres.

Forthcoming Events DECEMBER.

- 5th (WED.).—Miss Florence Jenkins, soprano. Mr. Pollard Crowther, "Reminiscences of Japanese Customs and Folklore." Canterbury Tales. by Mr. Leonard Badman. Wireless Orchestra. Syncopated Songs, by Miss Margot D'Arvis and Mr. Fred Spencer as "Mrs. 'Arris."
- 6th (THURS.).—Musical Programme. "Maritana," from the "Old Vic." Savoy Orpheans Dance Music. Savoy Havanna Band.
- 7th (FRI.).—Orchestra. Signor Silvio Sideli, baritone. Mr. Ronald Gourley, blind entertainer, pianist and siffleur.
- 8th (SAT.).—The Elite Concert Party. Capt. Peter Cheyney, entertainer.
- 9th (SUN.).—Organ Recital. Miss Beatrice Eveline, 'cellist. Mr. George Parker, baritone. Miss Dorothy Cowper, soprano. Religious Address by the Rev. J. H. Ritson, M.A., D.D., of the British and Foreign Bible Society. Mr. William Anderson, the principal Bass to the B.N.O.C. Royal Air Force Band. Mr. Anderson, singer. Band Selection.
- 10th (MON.).—"Uncle Rex." Symphony Concert conducted by Mr. Percy Pitt. Miss Thelma Petersen, soprano. Mr. John Pauer, concerto.
- 11th (TUES.).—"Aunt Priscilla" on "How to Organise a Picnic." "Uncle John's" Railway Talk. Meredyll Pianoforte Quartette. Mr. George Howe and Mrs. Elizabeth Pollock, entertainers. Mr. Phillip Wilson, tenor.

A BERDEEN.—Listeners to Aberdeen broadcasting station had the unique—so far as 2 BD is concerned—experience on

November 24 of hearing an encore. To such fine effect did Mr. George W. L. Rae, one of the city's foremost tenors, render "O Sole Mio" (Capua) that scarcely had his concluding top note died away than the studio telephone bell rang and a request came over from an enthusiast that the item might be repeated. From then until closing time—25 minutes later—the station director was literally bombarded with similar requests by 'phone, wire and messenger, and at 10.30 Mr. R. E. Jeffrey was able to announce something new in radio transmission from his station—an encore. Mr. Rae responded in his best vein.

BIRMINGHAM.—During the last few weeks there has been noticeable improvement in 5 IT's transmissions of the Sunday afternoon S.B. concert from London. Much of the old heavy "mush" has disappeared, and music and speech are clearer and sweeter in tone. May the improvements continue, for these concerts have become very popular in the Midlands.

Many people in the Birmingham district are wondering what will be the effect upon broadcasting of the proposed new Post Office wireless station at Rugby. This, it is said, will be one of the largest stations in the world, and as Rugby is only some thirty miles from Birmingham, it is feared that there may be some interference with the broadcasting of the local station. Everyone is hoping that the Post Office authorities will do their best to remove this possibility.

Forthcoming Events
DECEMBER.

5th (WED.)—3.30-4.30, Lozells Picture House Orchestra. 7.45, Miss Carmen Hill, soprano. 8, Mr. William W. Allen, in a Dramatic Recital. 9, Station Orchestra. 10.15, Mr. Walter Badham, humorous items.
6th (THURS.)—3.30-4.30, Miss Winifred Morris, contralto; Lozells Picture House Orchestra. 7.45, Station Repertory Company. 8, Miss Alice Couchman, solo pianist. 8.45, Miss Ethel Malpas, recital. 9, Special performance of "The Persian Garden" (Lehmann). 9.45, Mr. Jack Venables,

humorous pianisms. 10, Dance Music.
7th (FRI.)—3.30-4.30, Lozells Picture House Orchestra. 7.30, Station Orchestra. 7.45, The Rev. C. T. Fry, Dean of Lincoln, on "The History of Lincoln Cathedral." 8.45, Major Vernon Brook. 9.45, Mr. David Hamilton, Dramatic Recital. 10, Station Orchestra.
8th (SAT.)—3.30-4.30, Special Children's Concert. 7.15-10.30, Station Orchestra; Lieut. Arthur Spry, Talk on the Battle of the Falklands; and Miss Norah Leslie Pigott, humorous songs at the piano.
9th (SUN.)—8.30-10.15, Programme by the Station Orchestra; Station Repertory Choir and Miss Nellie Dempster, soprano. 8.40, Address by the Rev. D. F. Crick, of Wednesbury.
10th (MON.)—3.30-4.30, Mr. Harold Casey, baritone. 5, Ladies' Corner.

BROADCAST TRANSMISSIONS

	Call-Sign	Wavelength.
CARDIFF.....	5WA.....	353 metres.
LONDON.....	2LO.....	363 ..
MANCHESTER.....	2ZY.....	370 ..
BOURNEMOUTH.....	6BM.....	385 ..
NEWCASTLE.....	5NO.....	400 ..
GLASGOW.....	5SE.....	415 ..
BIRMINGHAM.....	5IT.....	425 ..
ABERDEEN.....	6BD.....	485 ..

TIMES OF WORKING.

Weekdays.....3.20 to 4.20 p.m. and 5.0 to 10.50 p.m. G.M.T.

London: 11.30 a.m. to 12.30 p.m.

Sundays.....10 p.m. to 5.0 p.m. and 8.20 to 10.50 p.m. G.M.T.

NOTE—The wavelengths given above are allocated temporarily and other alterations are pending.

11th (TUES.)—3.30-4.30, Lozells Picture House Orchestra; Mr. Ronald Pearson, pianist. 7.15, Mr. Joseph Farrington; Miss Beatrice Miranda, soprano. 9, The Kalamazoo Players in a Humorous Play. 9.45, Mr. Leigh Phillips, solo violin. 10, Dance Music.
12th (WED.)—7.30, Special performance of Benedict's Opera, "The Lily of Killarney."

CARDIFF.—The Transatlantic tests from all the B.B.C. stations on Monday morning, 3 a.m., proved of interest to amateurs in this district, a great number keeping an all night vigil at their sets. Bournemouth came in here—on two valves—with a terrific roar, and it was easily apparent that

the engineers at this station were doing their utmost to reach Uncle Sam. Birmingham and Manchester, as usual, were most elusive, Glasgow and Aberdeen coming through with about twice their volume.

GLASGOW.—Scottish listeners were recently entertained by operatic singers, members of the British National Opera Company. On Thursday, November 22, Miss Beatrice Miranda (soprano) and Mr. Wm. Michael (bass) contributed several items from their repertoire. As a duet they rendered "Nedda and Sylvio" (Pagliacci), in which they were heard to advantage. The following evening Miss May Blyth (soprano), and Mr. Robert Parker (baritone) were the star artistes, the former contributing several items from Weber and Mascagni and the latter from Wagner. The wireless public appreciated very highly this delightful change from the ordinary programme routine.

Forthcoming Events
DECEMBER.

9th (SUN.)—The Rev. James McMillan, M.A., of Newlands United Free Church, Religious Address.
11th (TUES.)—Professor Lindsay, of Glasgow University, on "The Effect of Mechanical Invention on Industry." Miss Constance Willis, of the B.N.O.C., contralto.
12th (WED.)—Classical Night. Overture, "William Tell" (Rossini). Mr. William Michael, of the B.N.O.C., bass. "Credo," "Othello." Miss Doris Lemon, of the B.N.O.C., soprano.

MANCHESTER.—In this column recently we reported on the reception in Manchester of the distant stations of the B.B.C., but omitted Aberdeen, which was not then regularly transmitting. It may now be said, however, that this station comes through very satisfactorily, signals being stronger, in fact, than some of the nearer stations, such as Newcastle.

The operatic transmission "Pagliacci" was unquestionably

the finest we have heard from 2 ZY. The technical part was perfect, whilst singers and orchestra united in an exceptionally brilliant production, securing the true "atmosphere," which almost compensated for the absence of vision.

Forthcoming Events

DECEMBER.

- 5th (WED.).—3.30, 2ZY Trio. 6.30, Organ Recital, Piccadilly Picture House. 7.45, Eighth Symphony Concert by 2ZY Augmented Orchestra, conducted by Mr. Dan Godfrey, Jun., A.R.A.M.; "A Night with the Old Masters." Miss Jo. Lamb, Solo Violin.
- 6th (THURS.).—11.30, 2ZY Trio. 6.30, Girl Guides' and Boy Scouts' Bulletins. 6.40, German Talk. 7.45, Concert s.b. from Glasgow. 9.45, Talk on "A Trip to the Moon," by Mr. W. R. Stokes, F.R.A.S.
- 7th (FRI.).—3.30, Concert by Mme. V. Whitworth, soprano. Mme. J. Shea, elocutionist. Mr. H. Read, solo violin. Mr. H. J. Davies, bass baritone. 6.30, 2ZY Orchestra. 7.45, 2ZY Opera Company in "Faust" (Gounod).
- 8th (SAT.).—3.30, Oxford Picture House Orchestra. 6.30, Organ Rachael Hunt, contralto. 10.10, 7.45, Keyboard Kitty. 8, Miss Madge Taylor, soprano. Miss Rachael Hunt, contralto. 10.10, Football results.
- 9th (SUN.).—8, Talk to Young People, by Mr. S. G. Honey. 8.30, Talk by Canon Shimwell on "The Coming Conference on Christian Politics and Economics of Citizenship." 8.45, Mr. Sidney Wright, solo violincello. Miss Beatrice Miranda, of British National Opera Company. Mr. Joseph Farrington, bass.
- 10th (MON.).—3.30, 2ZY Orchestra. 5, Mainly Feminine. Mr. C. P. Crowther will speak on "Things Japanese." 6.30, Boys' Brigade Bulletin. 6.35, French Talk.
- 11th (TUES.).—Concert by Mme. Ella Goodfellow, mezzo-soprano. Mr. A. Davies, tenor. Mr. A. G. Yates, bass. Mr. J. Bowden, dialect entertainer. 6.30, 2ZY Orchestra. Mr. Klinton Shepherd. 8.45, Percy Phlage. 9.40, Spanish Talk.

NEWCASTLE.—A considerable improvement in the reception of simultaneous broadcasting has been noted recently, a great deal of unpleasant noises having been eliminated. There is incidentally a curious error current locally as to the manner in which telephony is relayed and radiated. The view held by a large majority of the uninitiated appears to be that it is received from 2 LO in a telephone receiver or loud-speaker which is placed in front of 5 NO's microphone.

We believe we are correct in stating that many would like to see a little more variety in the Monday evening concerts transmitted from 2 LO. Is there any definite reason that it should be a symphony concert each week? We have heard no regrets at the omission of the men's hour from recent programmes.

Forthcoming Events

DECEMBER.

- 5th (WED.).—3.45, Mr. J. W. Smith, tenor. Mr. W. A. Crosse, clarionet. 7.30, Spencer Steel Works Band. Miss Hilda Rood, contralto. Mr. Norman Curry, baritone.
- 6th (THURS.).—3.45, Miss Florence Farrar, piano. Osram Quartette Party.
- 7th (FRI.).—3.45, Mr. Ralph Elliott, piano. Miss Norah Allinson, soprano. Mr. A. Seabridge, violin. 7.30, Schubert Evening. Mr. Lambert Harvey, tenor. Mr. Joseph Farrington, London, bass. Miss Beatrice Miranda, British National Opera Company, soprano; Messrs. H. Yeaman and Geo. Dodds, duets with two pianos.
- 8th (SAT.).—3.45, Mr. and Miss Golightly, duets. Miss Robbins, 'cello. 7.30, 5NO Orchestra. Mr. Hudson Barnsley, baritone. Electric Sparks Concert Party. Miss Evelyn Wilson, soprano.

- 9th (SUN.).—8.30, Rev. A. Thomas, Address. Miss Constance Willis, British National Opera Company, contralto. Mr. Lambert Harvey, tenor. Mr. G. Van Hee, 'cello.
- 10th (MON.).—3.45, Miss Eva Smith, soprano. Mr. W. J. Starkey, banjo.
- 11th (TUES.).—3.45, Miss A. Armstrong, pianist. Mr. J. Kelley, baritone. 7.30, 5NO Orchestra. Mr. G. Hodgson, tenor. Miss Elsie Downing, soprano.

SHEFFIELD.—The remarkable strides which have been made in the science of wireless telephony were testified when this, the first wireless relay station, finally became a recognised and official fact by the ceremony of declaring it open, performed by the Lord Mayor.

The relay station, together with a compact studio for the once-a-week broadcasting programme, is in Corporation Street, near the city's centre, but the actual opening ceremony took place away up on the western heights of the city, in the beautiful Mappin Hall of Sheffield University.

Simultaneous Broadcasting Events.

DECEMBER.

- 7th (FRI.).—7.10, Film Critique.
- 9th (SUN.).—Organ Recital.
- 10th (MON.).—7.10, Literary Critique. 9.10, Lieut.-Col. Mummary.
- 11th (TUES.).—Savoy Orpheans.
- 12th (WED.).—7.10, Dramatic Critique.
- 13th (THURS.).—7.10, Music Critique. 7.25, Radio Society. 8.30-9.30, "Little Nellie Kelly," Act I, from the New Oxford Theatre. 9.45, Sir William Bull.
- 14th (FRI.).—9.40-11, "Little Nellie Kelly," Act II.
- 15th (SAT.).—7.30, "Pagliacci." 8.50-9.30, Roosters Concert Party. 10-11, Savoy Orpheans.

THE CHRISTMAS NUMBER OF "MODERN WIRELESS"

This issue contains, together with other interesting contributions, the following:— "A Cabinet 2-valve magnifier," by Percy W. Harris. "What to do with three Valves," by John Scott-Taggart. "Loud-speakers and How they Work," by E. Alexander. "Some new American Single-valve Circuits," by A. D. Cowper.

INDUCTANCES FOR THE COWPER CIRCUIT

By A. D. COWPER, M.Sc., Staff Editor.

Constructional details of a novel type of variometer and choke coil for use with this circuit.

IN the stable series-tuned anode method of H.F. amplification on the shorter waves described by the writer in *Wireless Weekly*, Vol. 2, No. 19, a tuning-coil or variometer of unusually high inductance value, together with low H.F. resistance and mineral distributed capacity is required.

Those who try this circuit will be apt to meet with disappointment as regards degree of amplification, if they are tempted to use the ordinary type of plug-in coil of the requisite inductance value (No. 100 or 150), or variometers wound with a great deal of crowded fine wire. The utmost freedom of oscillation is required for good amplification; the relative high H.F. resistance of such inductances, which were, of course, designed rather for longer-wave reception, militates greatly against this.

In the original article there was described a form of 3-pile-wound variometer suitable for this purpose, with about 180 turns in all of No. 22 S.W.G. d.c.c. wire. Experiment has shown that excellent results are obtained with a variometer made up with both rotor and stator in the form of the multiple miniature frame-aerial introduced by Mr. P. W. Harris, to which reference was made in that article.

As shown in the figure, the former for both rotor and stator consists of a frame constructed of two bent strips of ebonite and two No. 2 B.A. screwed brass rods. The ends of the ebonite strips are cut into a comb by hack-saw slots, and are then bent through 45 degrees by immersing them in boiling water for a minute, bending them with the fingers and pliers, and holding them in cold water until cold to retain their shape. The (wider) centre tooth is left unbent in the case of the stator and carries the brass rods.

Short stub axles pass through centre holes in the ebonite, and make electrical connection with the rotor-coils as usual.

When wound with 64 turns of No. 22 S.W.G. d.c.c. wire in the 8 stator slots, and 60 turns of the same wire in the 6 rotor slots, this tunes from below 300 to

This form of variometer is particularly handy for trial adjustments of numbers of turns, etc., and forms incidentally a useful low-resistance variometer for general use. With rotor and stator windings connected in parallel, it gives excellent results on the short waves as an A.T.I.

The other alternative is a fixed coil of high inductance value and low H.F. resistance and capacity, tuned by the minimum possible proportion of a 0.0001 μF variable condenser in parallel with it. This gives a slightly lower degree of amplification than the variometer described above, but many may prefer it, as the 0.0001 μF low-minimum air-dielectric variable condenser is a standard component, and it is easy to arrange for two stages of H.F. amplification to be tuned by a single control, by winding two similar anode coils and tuning these by two coupled (but wholly insulated) 0.0001 μF variable condensers.

A high-minimum mica-dielectric condenser is unsuitable for use here.

A suitable fixed inductance is readily made by winding 72 turns of No. 22 S.W.G. d.c.c. wire, 12 turns in each of 6 slots, each $\frac{3}{4}$ in. deep, of a frame-aerial type of former similar to that illustrated in the first article in *Wireless Weekly*, Vol. 2, No. 19, with sides $1\frac{3}{4}$ in. wide and 6 in. long, of three-ply wood, $\frac{3}{16}$ in. ebonite, or fibre. This will tune as an anode inductance with a low-minimum 0.0001 μF variable condenser (7-plate) in parallel with it from 300 to about 550 metres wave-length and has the requisite low H.F. resistance and low capacity.

The radio-chokes necessary for this mode of H.F. coupling can be wound on similar formers with 6 slots $\frac{3}{4}$ in. deep and about $\frac{1}{4}$ lb. of No. 26 S.W.G. d.c.c. wire suffices for each choke.

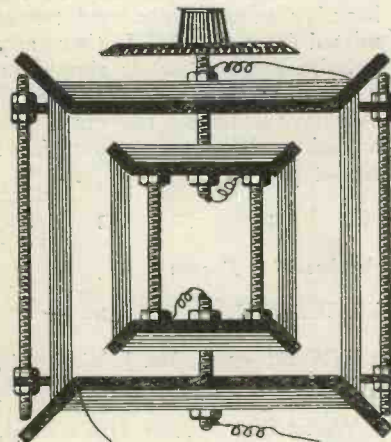

The Complete Variometer.

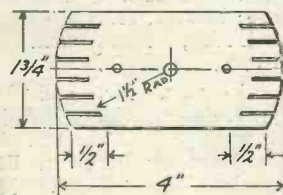
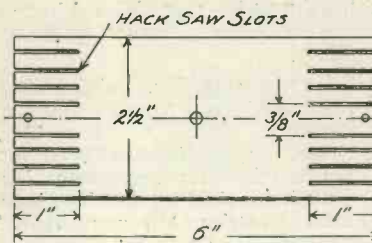

Constructional details of the Stator and Rotor formers.

about 400 metres wave-length in the series-tuned-anode position alone, or from below 300 to 460 metres with a low-minimum 0.0001 μF variable condenser in parallel. The wave-length range can readily be extended by putting on a few more turns of wire.

AMERICAN BROADCAST RECEPTION.

Further reports received from readers.

Date.	Call Sign.	Wave-length in metres	Name.	Town.	Receiver.	G.M.T.
21-10-23	WGY	380	J.G.W.	Kirkpatrick ..	Marconiphone V.2.A. ..	1.30—2.30
23-10-23	WMAF	360	"	"	"	1.30—2.0
26-10-23	"	"	"	"	"	1.0 —2.30
"	WGY	400	"	"	"	2.0 —2.50
11-11-23	—	360	E.T.R.	Bristol ..	1 H.F.—Detector—2 L.F. ..	1.0 —4.10
14-11-23	WGY	380	M.V.R.	Kew Gardens, Surrey.	"	2.30—3.35
16-11-23	"	"	J.G.W.	Kirkpatrick ..	Marconiphone V.2.A. ..	11.0 — —
"	"	"	H.J.V.	Walsall ..	1 H.F.—Detector—1 L.F. ..	11.0 —12.0
18-11-23	"	"	J.C.	Liverpool ..	1 H.F.—Detector—2 L.F. (Dual.) ..	12.45—1.45
"	"	"	J.G.W.	Kirkpatrick ..	Marconiphone V.2.A. ..	7 0 —7.50
"	"	400	H.J.V.	Walsall ..	1 H.F.—Detector—1 L.F. ..	1.15—2.15
19-11-23	"	380	"	"	Detector—1 L.F. ..	11.0 — —
"	"	380	G.S.	Manchester ..	Detector—1 L.F. ..	12.30—1.45
"	"	400	E.J.R.	Okehampton, Devon.	1 H.F.—Detector ..	12.35—1.46
"	"	380	T.G.H.	Grantham, Lincs.	Detector ..	11.05—11.25
* "	"	"	L.V.McN.	South Shields ..	Detector—1 L.F. ..	11.0 —1.20
"	"	"	A.D.C.	Norwich ..	1 H.F.—Detector—1 L.F. ..	11.05—11.25
"	"	"	F.L.	Stalybridge ..	W.W. Circuit No. 16 ..	—
"	—	—	J.N.D.	Redcar ..	Modified " All Concert Receiver." ..	12.40—1.55
"	—	—	"	"	"	11.02— —
19-11-23	—	—	"	"	"	—
24-11-23	KDKA	360	L.V.McN.	South Shields ..	1 H.F.—Detector—2L.F. ..	11.34—12.08

* In this case reception was carried on by the use of a frame aerial only.

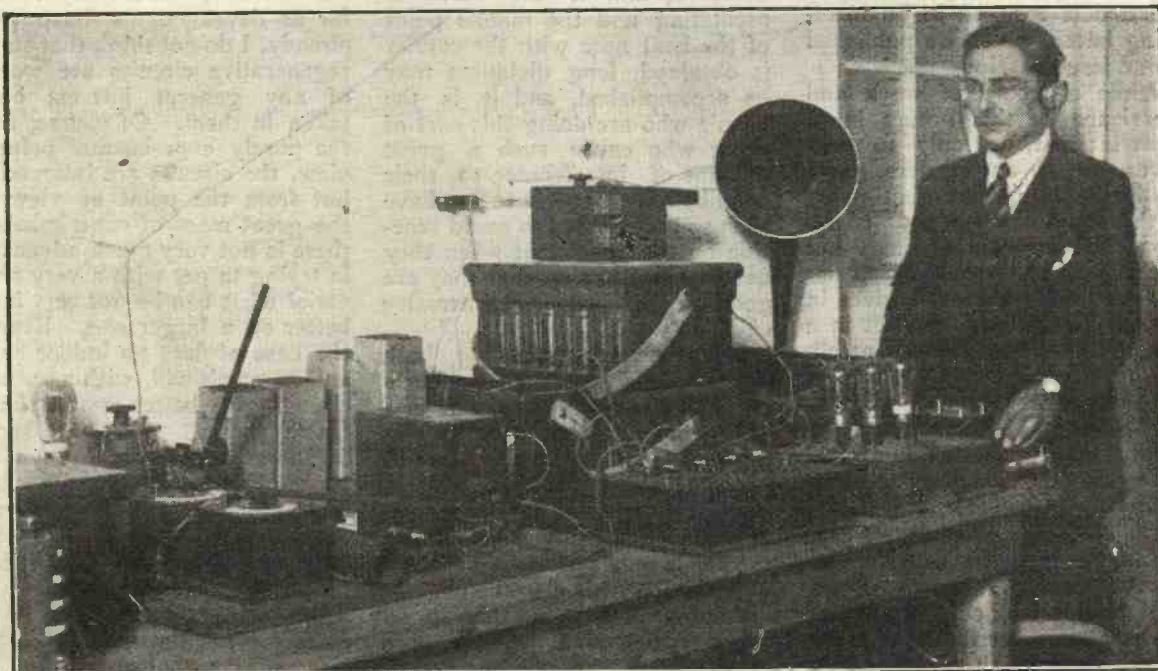

Our photograph shows Mr. West of the B.B.C. with the receiving apparatus at 2LO on which the opera from the "Old Vic" was received on Nov. 24th, thus eliminating the usual land-line.

SUPER-REGENERATIVE CIRCUITS; ARE THEY WORTH WHILE?

By JOHN SCOTT-TAGGART, F.Inst.P., Editor.

Some critical remarks regarding super-regenerative circuits and circuits which are supposed to be super-regenerative.

SUPERLATIVES are becoming popular—much too popular. We have a super this, and a super that, and in 75 per cent. of the cases the imagined effect is not obtained.

Personally, I have become very suspicious of many circuits which claim super-regenerative properties. One in point is the autoplex circuit, an American arrangement for which characteristic claims have been made. This circuit was reproduced in our issue of Nov. 14, together with our statement that, so far as we were concerned, this was an untried circuit. This, of course, is in accordance with our recognised policy not to advocate anything which has not been fully tested out by ourselves. The article resulted in an interesting letter, which we published in our issue of Nov. 28.

While a record of work and experience of this nature is of great interest, not only to ourselves, but to our readers, yet I am inclined to think that many of the conclusions of our correspondent are not only hasty but inaccurate. I do not myself see how the final circuit he gives in Fig. 5 on page 676 can act in a super-regenerative manner at all. The autoplex circuit, as published in the American periodicals, might readily be explained by simply regarding the duolateral coil in the grid circuit as an alternative to a gridleak, the actual aerial circuit consisting of the variometer and the grid to filament capacity. A circuit of this kind using a leak across grid and filament was used in the Air Force during the war. The arrangement of our correspondent in Fig. 5 on page 676

seems to be more or less an ordinary arrangement in which the aerial is connected to the intermediate point between the Burndept S4 and the variometer in the grid circuit.

I have come to the conclusion that a very large proportion of those who have been experimenting with super-regeneration are merely obtaining good results because of ordinary regeneration or reaction. The high-pitched whistle is a clue as to whether super-regeneration is being obtained or not. The absence of the high-pitched whistle may in general be taken as an indication that super-regeneration is absent and that the ordinary reaction effect is being obtained. This reaction effect will certainly result in very good signals being obtained, and if the valve is oscillating and the middle point of the beat note with the carrier is obtained, long distances may be accomplished, and it is the people who are doing this sort of thing who cause such a great amount of interference to their neighbours. Experimenters have been so accustomed to avoid reaction on the aerial that when they use it they imagine that they are getting a super-regenerative effect.

These remarks apply to both Armstrong's and Flewelling's circuits. In both circuits it is a very simple matter to be obtaining only ordinary reaction and to be imagining that a super-regenerative effect is being obtained. In reality the experimenter is only making a nuisance of himself to his neighbours.

Another fallacy is that good super-regenerative effects are obtainable on an outdoor aerial. Even if such effects are obtainable, which is very doubtful, the

results are bound to be very poor, and for this reason super-regenerative and Flewelling circuits are inevitably bound up with frame aerials or small indoor aerials three or four feet long. On an outdoor aerial a dual amplification circuit is unquestionably the ideal thing to use, although here the type of circuit to be employed depends upon whether loud signals or long ranges are desired.

If we take it that frame aerials are essential to super-regeneration and if super-regenerative circuits are used on outdoor aerials, no better results are obtained than with ordinary reaction, we are faced with the obvious question "Is super-regeneration worth while?"

At the risk of being regarded as a heretic, I must say that as far as developments have gone already, I do not think that super-regenerative circuits are worthy of any general interest being taken in them. Of course, from the purely experimental point of view, the circuits are interesting, but from the point of view of the great mass of experimenters, there is not very much advantage in trying to get with a very small aerial what can be got very much better on a larger one. Even in the case of flats an indoor aerial and an earth will, with a suitable circuit, give better results than a frame aerial with a super-regenerative circuit. In my view, super-regenerative circuits have their application in portable sets for detectives, perhaps for motor-cars, and for similar very special purposes. In the case of the average experimenter who is out more for results than for certain interesting technical effects, the super-regenerative circuit is a will-o'-the-wisp.

A WINDER FOR TUBULAR COILS.

EVERYONE who has tried has found by experience how difficult it is to get windings evenly and tightly on to a tubular former. If one is making up a single layer inductance wound with enamelled wire for use with a sliding contact it is essential that the turns should be touching one another, and that they should be so tight that there is no chance for the contact points of the slider to cause them to ruck up.

Winding low-frequency transformers is such a tedious job without a machine of some kind that no one who is not endowed

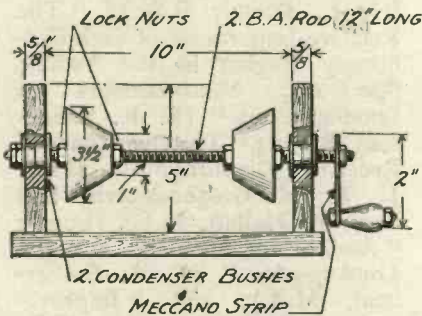

Fig. 1. Constructional details of the winder.

with the patience of a saint and a Chinaman's genius for taking pains can possibly tackle the job successfully. It is, for example, quite a usual task to have to put from 2,000 to 3,000 turns on the primary and from three to five times that number on to the secondary.

The little device to be described can be made up from such odds and ends as are to be found in every wireless man's workshop with the exception of a 12-in. length of 2B.A. screwed rod, which is not an expensive item. It is so arranged that tubes of any size from 1 in. to 3 1/2 in. in diameter and of any length up to 9 in. can be wound with the greatest ease. If it is desired to make up coils with a smaller diameter than 1 in. a second pair of cones tapered from, say 1/2 in. to 1 in., should be provided.

The foundation of the winder is a piece of any wood 1/2 in.

thick, 12 in. long and 5 in. wide. On this are mounted two end-pieces also of 5/8 in. wood and 5 in. square.

Diagonal lines are ruled across these, and at the point of intersection a 3/8 in. hole is drilled. A slot 3/8 in. wide is then cut from the top edge of the end-piece into which are inserted two standard condenser spindle bushes from opposite sides, as shown in the drawing. On either face of each end-piece a little swing hook fastening is mounted. This serves to keep bush and spindle in place when winding is in progress, but allows the work to be inserted or taken out of the machine very quickly.

Two cones of hard wood are now turned up tapering from 1 in. to 3 1/2 in. If the workshop does not contain a lathe this is a job that any joiner will undertake at very small cost. Through the centre of each is drilled a 2B.A. clearance hole.

The spindle is now placed in position, as shown in the drawing. At the left hand end is a nut secured by a lock-nut. Inside the left end-piece is a third nut between which and the bush a spring washer may be inserted if found necessary. Another nut comes against the smaller face of the left cone, and is tightened hard down so that this cone is immovable. The right cone is free to travel up and down the spindle, the limit of its movement towards the right being set by another nut.

When an inductance is to be wound the spindle with its bushes is removed *en bloc*. The crank and the right cone are taken off and the tube is forced lightly on to the left cone. The right cone is then slipped on to the spindle and tightened firmly into the tube by means of its nut. The crank is then replaced and the spindle with the tube mounted upon it is reinserted into the slots in the end pieces.

The crank itself is made from a meccano strip of any convenient

length. For the handle nothing is better than one obtained either from an old sewing machine, or even from some disused kitchen utensil, such as a mincing machine or a knife cleaner.

When using the device it is usually most convenient to place it quite close to the left hand edge of a table and to fix it in place by means of an ordinary clamp. If, however, coil winding is frequently undertaken, it may be made into a permanent workshop fixture, being screwed to the end of the bench.

R. W. H.

A USE FOR BURNT-OUT TRANSFORMERS.

WHEN L.F. transformers burn out they are generally thrown at one side and left to rust. Usually one winding is burned out only—the primary. The secondary forms a powerful choke, and as such may be used for impedance coupled L.F. amplification.

The circuit is similar to that of the tuned-anode H.F. coupling,

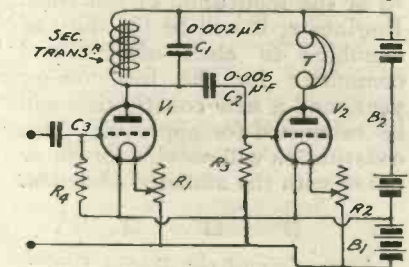

Fig. 1. Circuit illustrating position of transformer.

except that the coil is replaced by the secondary of the transformer. A fixed condenser of 0.002 μF should be connected across the choke, to by-pass H.F. currents.

It is necessary to use a grid condenser of about 0.005 μF capacity, and a grid leak of about 2 megohms, connected between grid and L.T. negative.

The amplification is not quite so great as with the usual transformer, but quite a useful amount of amplification per valve is obtainable. An advantage over resistance coupled amplification, in which the choke is replaced by a 50,000 ohm resistance, is that only the normal H.T. voltage is required.

E. L. S.



News of the Week

WE are asked to announce that members of the Radio Society of Great Britain, who desire to attend the lecture which will be given by Mr. John Gray, B.Sc., of the Institute of Aeronautical Engineers on "Leader Cable System for Electrical Steering of Aeroplanes," at the Royal Society of Arts, at 7.30 p.m., on December 14, should send a post-card to the Hon. Secretary of the Radio Society, Mr. L. McMichael, 32, Quex Road, West Hampstead.

At an annual general meeting of the Radio Society of Great Britain, to be held on December 19 at the Institution of Electrical Engineers, it will be the duty of members to elect officers and committee for the forthcoming year, and a new constitution will be submitted for approval. This constitution will provide for closer union with the affiliated societies.

A meeting of the Radio Transmitters' Society will take place on Friday, December 7, at 6.30 p.m., at the London School of Economics, Room 58B, when a discussion on "Aerial Design for 200 Metres Transmission" will be opened by Mr. George Leslie Morrow (6UV). All members of the Radio Transmitters' Society are asked to make an effort to attend this meeting, to bring their friends and join in the informal discussion which will follow Mr. Morrow's opening remarks.

One of the outstanding publicity features at the recent Wireless Exhibition at the White City was the large illuminated model of the R.I. transformer. The interest taken in this model

has induced the manufacturers, Radio Instruments, Ltd., to have a number of similar models built, and these will be available to prominent dealers in various parts of the country for window display during the Christmas season.

The following is an extract from a report by the Operator-in-Charge of s.s. *Monica Seed*, which is fitted with a crystal receiver by the Radio Communication Co. :—

"When trading to Hamburg, I was able to hear the broadcasting from London, Newcastle, Glasgow, at distances to 400 miles; I have also heard Newcastle as far away as Stettin, about 600 miles. We are at present at Cadiz, Spain, about 1,000 miles from England, and I can hear Bournemouth, and also London when they send their simultaneous broadcast, music being exceptionally clear."

We are asked by the British Battery Supply Service to announce that their advertisement appearing in Vol. 2, No. 16, in connection with the supplying of charged accumulators should read: . . . For 15s. a quarter only 1s. 3d. a week inclusive.

On Thursday, November 29, a joint meeting of the Physical Society of London and the Institution of Electrical Engineers was held at the latter body's headquarters in Savoy Place, Victoria Embankment. The object of the meeting was a discussion on "Loud Speakers for Wireless and Other Purposes," and the popular interest of the subject was attested by the remarkably large attendance, the main hall of the Institute being

filled to overflowing. A series of Papers was read, among which were included the following :— "General Principles Involved in the Accurate Reproduction of Sound by Means of a Loud-speaker" (Prof. A. O. Rankine, D.Sc.); "Theory of Loud-speaker Design" (L. C. Pocock, B.Sc.); "The Sources of Distortion in the Amplifier" (Prof. C. L. Fortescue); "The Acoustic Problems of the Gramophone" (H. L. Porter, B.Sc.); "The Relative Importance of each Frequency Region in the Audible Spectrum; Measurements on Loud-speakers" (E. K. Sandeman, B.Sc.); "The Over-tones of Receiver Diaphragms" (Prof. J. T. MacGregor-Morris and Prof. E. Mallett, M.Sc. (Eng.)); "Auditorium Acoustics and the Loud-speaker" (G. A. Sutherland, M.A.); and "Improvements in the Loud-speaking Telephone" (S. G. Brown, F.R.S.).

Various interesting points in the Papers were illustrated by demonstrations. By means of an apparatus resembling the Western Electric public address system the actual effect on speech of suppressing certain frequencies was shown, the existence of stationary waves in the air was demonstrated, and a very striking experiment was performed to show by means of Chladni's figures the mode of vibration of a telephone diaphragm at various frequencies. Mr. S. G. Brown demonstrated and explained the Frenophone, and a speech from Capt. Eckersley describing a new loud-speaker having a diaphragm approximately 12 ins. in diameter, composed of radially pleated paper concluded the proceedings. This latter instrument, also, was demonstrated on 2LO's transmission.

IMPROVING CHEAP TELEPHONES.

NOTHING that one can do will convert really bad headphones into good ones, but one can do a good deal to make badly-designed ones a great deal more comfortable for the head than they are when first purchased. There is perhaps nothing more irksome in wireless than to have to wear for any length of time a heavy headset which presses on one's crown and whose earpieces squeeze the ears until one feels almost as if caught between the jaws of a rat-trap.

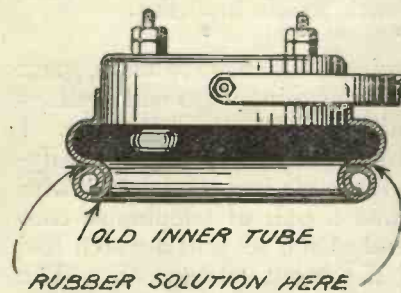

Fig. 1.—The ear-pad fitted to the 'phone.

The first part of the process of improving uncomfortable 'phones is to bend the bands gently until they are a fit for the head. This can be done without any risk of breaking them if they are held between the forefinger and thumb of the left hand and shaped very gradually with the right. Be careful not to make them gape too large, otherwise the receivers will not fit closely enough to the ears, and faint signals may pass undetected.

Here is a simple tip which provides both an ear protector and a soundproof connection between 'phones and ears. Obtain a 6-in. length of an old motor-cycle inner tube with a diameter of about 2 in. Roll it up as one does a rubber handle of a cricket bat preparatory to putting it on. Leave about 1½ in. unrolled and force this end over one of the receiver caps, as shown in Fig. 1. If necessary, it may be retained in place by means of a binding of rubber tape. Force the rolled up part tightly against the cap, and apply a little rubber solution to its turns. Hold it until the solution

is set. The pad will then be ready for use.

If the weight of the 'phones is such that pressure on top of the head becomes objectionable when they are worn for any length of time, a little pad should be made and attached to the underside of each of the metal bands. The best way of fixing it is to drill a few small holes in the band and to stitch through these.

One of the most objectionable features of some makes of 'phones is their propensity for tearing out tufts of the hair just above the ears every time that they are taken off. This is caused by the pincer-like action of the bands at the point of junction. A simple tip for remedying this nuisance is to make a triangular sleeve of linen or canvas long enough to cover the joint and to extend about 1½ in. up the bands. When this is done hairs cannot possibly get into the V between the bands, and one is safe from being plucked.

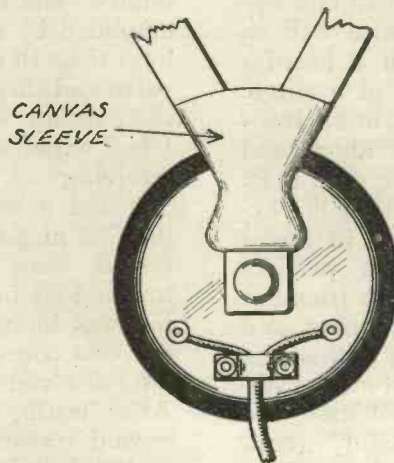

Fig. 2.—The 'phone cushion in position.

Though, as we have said, bad 'phones cannot be made good, something can be done in many cases to improve their performances to a certain extent. In the first place, if the caps are removed it will often be found that the diaphragms are thick and heavy. Light stallo diaphragms can be purchased for about 6d. a pair from many firms of telephone

manufacturers. The substitution of these will often be found to work wonders. Should they be rather too large when purchased they can easily be cut to size with a strong pair of scissors. Care must, however, be taken to see that they are not buckled in the process.

Another common fault is that the diaphragms are placed too far away from the poles of the magnets. The only way to remedy this is to rub down the case very carefully on a piece of smooth carborundum stone, taking great care that the edge is kept absolutely level all round.

R. W. H.

AN H.T. BATTERY CONNECTOR FOR FLASH-LAMP CELLS.

MANY amateurs are availing themselves of the excellent economical H.T. battery made up of flash-lamp cells obtainable at from 2s. 6d. to 4s. a dozen, which give good service for months if bridged by a 2 microfarad condenser and renewed when they test below 3 volts. The difficulty with these cells is the provision of a reliable and easily-replaced connection between the cells. Bending the brass strips over and soldering together, often recommended, is a troublesome, precarious job, and makes replacement difficult, whilst the soldering of short connecting wires is similarly objectionable. The small spring clips illustrated in Fig. 1, cut out of, say, No. 22 sheet brass with an old pair of strong scissors, are easily made, give firm contact, and allow of replacement of a cell in a few seconds. The two side pieces are bent at right angles, as shown at the dotted lines; the strip is then folded in the centre and pinched down at the bend so as to press the ends together with considerable spring. Slight bell-mouthing (with the end of narrow pliers) renders application easier. The long connecting strip on the battery is doubled down and bent as shown, and the clip is simply pushed down on to the

(Continued on page 727).

RANDOM TECHNICALITIES

By PERCY W. HARRIS, Assistant Editor.

A few notes of general interest to the experimenter and home constructor.

SEVERAL readers of *Wireless Weekly* have asked me to give them an idea of what would normally be the receiving range of the Pea-nut Reinartz receiver recently described in this journal. At the time of writing the article I did not make many statements, as, although the set had been tested on broadcasting from several stations, I preferred to wait a little and give the instrument more exhaustive test before publishing the results. I have now had many opportunities of trying it out, and have no hesitation in stating that on the average aerial and in normal conditions all the British broadcasting stations can be easily received. Recently I took the instrument to Woking, a distance of 20 or more miles from 2LO. At this distance it was just possible to hear London on a "Ducon," although signals were very faint, but with an indoor aerial consisting of a few yards of wire taken out of the room and upstairs we could hear London quite well in two pairs of telephones. With a hastily-rigged outdoor aerial, consisting of a single wire taken out of the window up to an insulator suspended from the window above and thence to a clothes-prop not more than 8 ft. high, all of the B.B.C. stations, with the exception of Aberdeen, were heard in broad daylight, Bournemouth coming in particularly well. I have just heard that a friend at Letchworth has built up the receiver and obtained even better results, using in this case "bright" and not "dull" emitters. Considering that high-frequency is not used, the results with this circuit are certainly good, and, unlike the usual Reinartz, there seems to be no loss whatever from using this particular form of aerial coupling.

I was sorry to see that crystal sets were being sold in Woking for broadcast reception. At 20 miles from a broadcasting station signals on a crystal receiver, save in skilled hands with abnormally good aerials, are far too weak to satisfy the average broadcast listener. We are no longer in the times when the reception of any wireless signals

whatever was counted a success, and when a few faint sounds of telephony, so weak that the utmost concentration was necessary to hear them, would satisfy the ardent devotee. The new public which is taking up broadcasting, not as a scientific hobby, but as a means of availing itself of the excellent programmes now provided, is likely to feel itself cheated if it is sold sets which give signals of such feeble intensity.

A rather rare fault which gave me a great deal of worry a few evenings ago will perhaps interest the readers of *Wireless Weekly*. I had been building a two-valve note magnifying unit, and on completion tried it out with my usual test, *i.e.*, a pair of telephones connected to each end of the set and a watch laid on the face of the input telephones. The ticking of the watch vibrates the diaphragm, the movement of the diaphragm sets up minute electric currents, and these, being amplified by the magnifying unit, give very loud ticks in the telephones. I tried the first valve and then the second, and obtained good clear results with the degree of magnification I had expected. I then connected it up to a receiving set (2 H.F. and 1 detector), and adjusted it on amateur wave-lengths. With the first magnifying valve in circuit, excellent results were obtained. With the second, tremendous howling was set up. The howling was immediately remedied by connecting the two cores together, but there remained the most violent distortion I have ever heard. After testing every part, I found that the second transformer was faulty, whereupon I replaced it by a brand new transformer of another make. Result, no howling, but again the same violent distortion! The chance that this transformer also was faulty was remote, and a thorough test of the rest of the set showed that everything else was apparently in good order. Tests of the transformer showed that this, too, was perfect. After some hours of testing it occurred to me to replace the second valve socket. This immediately remedied the trouble. Tests on the socket showed that it was thoroughly bad in insulation.

'PHONES IN EVERY ROOM.

SEVERAL enthusiasts of the writer's acquaintance have so wired their houses that though the receiving set itself is not moved, telephones or loud-speaker may be plugged in instantly in any room. This is perhaps further than most of us

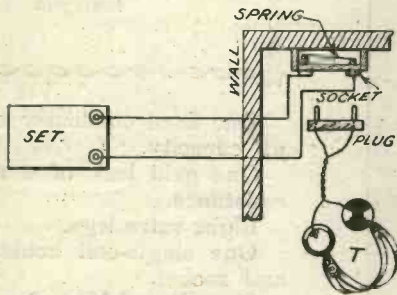

Fig. 1.—Illustrating the 'phone connection.

would wish to go. It is, however, a great advantage to instal a certain number of wall plugs so that the reception of broadcasting is not confined to the wireless den.

The ordinary jack is not quite suited for the purpose owing to its comparatively great length.

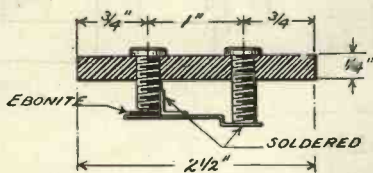

Fig. 2.—Details of the socket.

We need something of the same kind, however, so that the circuit shall be automatically remade when the plug is removed from the socket. Fig. 1 gives a general idea of what is required.

A very neat little fitting can be made up in the way shown in Fig. 2. Into a piece of $\frac{1}{4}$ -in. ebonite $1\frac{1}{2}$ in. wide by $2\frac{1}{2}$ in. long are fixed two standard sockets. They should be of the screw in type; but if these are not obtainable, plain ones should be bought. The handyman at your local garage will put a thread on to them and will also tap the

holes in the ebonite into which they are screwed at very small expense should your tool outfit not contain suitable taps and dies.

One of the sockets is cut off quite short, so that when a plug is pushed home its tip protrudes for a quarter of an inch or so. The other is left full length.

A strip of sheet brass $\frac{5}{8}$ in. wide and $1\frac{1}{2}$ in. long is now cut out. To one end of it is pinned a square of $\frac{1}{8}$ in. thick ebonite, the pins being short lengths of brass wire riveted over lightly. To the short socket is soldered an L-shaped piece of sheet brass $\frac{1}{2}$ in. wide whose horizontal portion comes about 3-32 in. below the bottom of the socket.

The long ebonite tipped blade is soldered to the uncut socket and is bent so that it springs hard against the L-shaped piece fixed

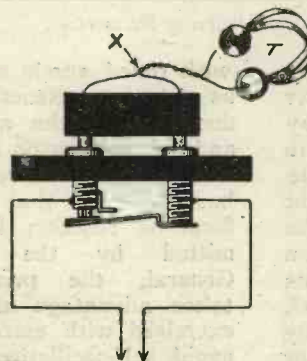

Fig. 3.—The plug in use.

to the short socket. A glance at Fig. 3 will show that when the plug is pushed in, the pin engaging in the short socket bears on the ebonite square and forces the brass strip away from the L-piece. Direct contact between the sockets is thus broken so that current must flow round the telephones attached to the plug. As soon as the plug is removed the strip springs up and re-establishes contact.

The ebonite with its sockets is mounted on a small box made of varnished wood, which is fixed to the wall with rawlplugs. Wiring is done with good quality bell wire with a good inner layer of rubber insulation.

Fig. 4 shows how the plug is made. Two pieces of $\frac{1}{4}$ -in. ebonite 2 in. by 1 are fixed together by three 4 B.A. screws.

They are then clamped tightly in a vice and two $\frac{1}{4}$ -in. holes 1 in. apart are drilled as shown right through from edge to edge.

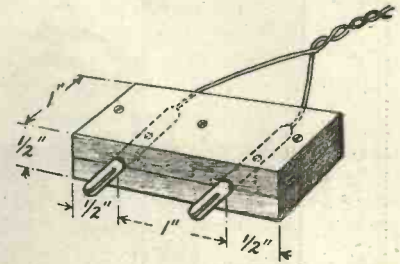

Fig. 4.—Constructional details of the plug.

The flex leads of the phones are passed through these holes. They are soldered to the tops of standard De Forest coil pins, which are a driving fit for the $\frac{1}{4}$ -in. holes. The pins are secured by drilling and tapping 4 or 6 B.A. holes through them from the surface of the ebonite and inserting screws.

To make the leads perfectly secure they should be bound with narrow tape at the point X in Fig. 3, the tape being taken twice round the ebonite and tied. A pull on the leads will thus not throw such a heavy strain upon the soldered joints as might cause them to give way.

R. W. H.

An H.T. Battery Connector for Flash-lamp Cells.

(Continued from page 725.)

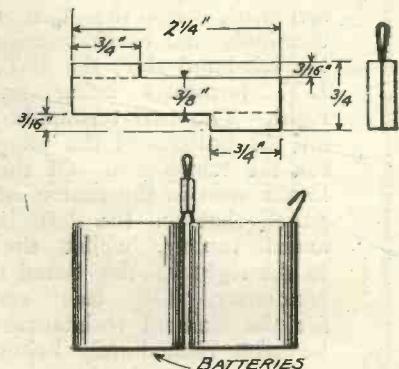

Fig. 1.—The H.T. Battery connector.

pair of connections. A large clip made $1\frac{3}{4}$ in. wide provides for bridging two rows at the end of a compactly arranged battery, whilst clips with short pieces of flex soldered on make excellent wander-plugs.

A. D. C.

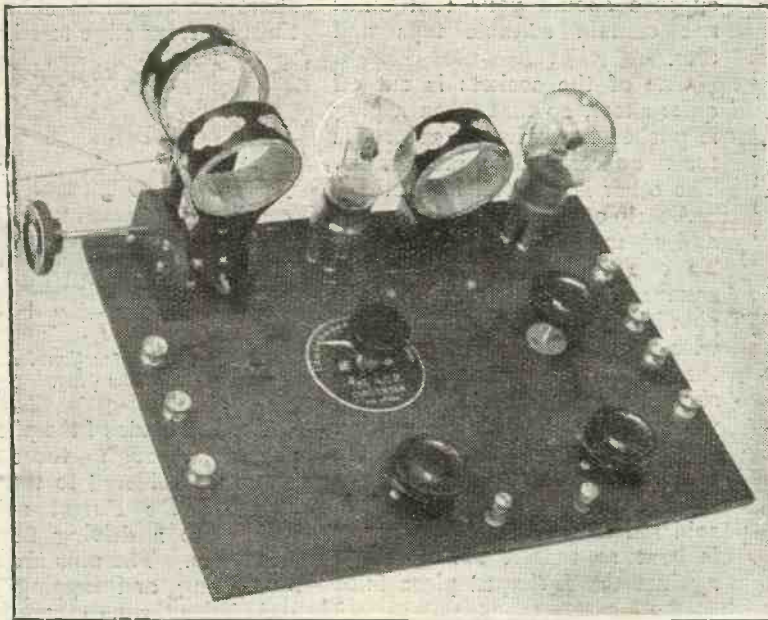

Fig. 1.—A front of panel view of the receiver.

THE receiver described hereunder was designed in order that long-wave telephony and telegraphy, in addition to British broadcasting, could be received on a single instrument of simple construction. The apparatus is used in conjunction with plug-in coils, and, by means of an extra "aerial" terminal, the aerial tuning condenser may be connected either in series or in parallel.

The photograph, Fig. 1, shows a front view of the complete instrument, with the two aerial terminals and earth terminal on the left-hand side, the H.T. and L.T. terminals being on the right. The two terminals seen on the bottom of the panel are for the telephones. Of the two knobs seen in the centre of the panel, that on the left is for aerial tuning, whilst the one to the right is the tuned anode condenser. The two controls for the filament resistances may be seen immediately below the two condenser knobs previously referred to. The coil situated between the two valves is the tuned anode coil, whilst those on the left are the aerial and reaction coils respectively.

The circuit employed is a simple two-valve arrangement using one high-frequency valve

with tuned anode and the other as detector. Reaction is introduced on to the aerial circuit, and for this reason those readers who construct this receiver should bear in mind that though this form of reaction is now permitted by the Postmaster-General, the privilege when taken advantage of should be exercised with extreme care to avoid self-oscillation and consequent interference. The theoretical circuit is illustrated in Fig. 2.

Materials Required.

The components and materials necessary for the construction of a receiver of the type herein described are as follows:—

One ebonite panel, 12 in. by 9 in. by 1/4 in.

One 0.001 μ F variable condenser (that fitted to the original set is an A.C.H. condenser).

One 0.0003 μ F variable condenser, or, as fitted in the original set, a two-plate "Baty" condenser.

Set of coils to cover the wavelengths required (those shown in the photograph are made by the Igranic Co.);

Nine terminals.

Two filament resistances.

One "Polar" cam-vernier two-coil holder or other make.

A UNIVERSAL RECEIVER

By STANLEY G. R.

A complete receiver embodying tuning-in both broadcasting

One fixed condenser of 0.0003 μ F capacity.

One grid leak of 2 megohms resistance.

Eight valve legs.

One single-coil holder or pin and socket.

Quantity of No. 18 or No. 20 tinned-copper wire for connecting purposes, and systoflex.

The Panel.

This is made from ebonite, 9 in. by 12 in. by 1/4 in., drilled to take the various spindles and

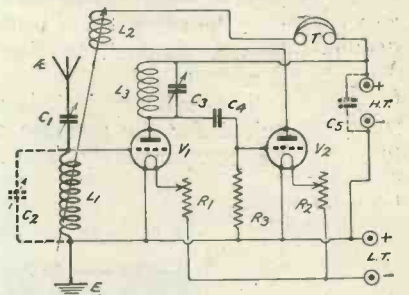

Fig. 2.—Theoretical circuit diagram of the instrument. It will be noted that the positive side of the L.T. battery is earthed instead of the more usual method of earthing the negative side. Fig. 3.—Showing position of drill holes and dimensions of panel. A blue print of this figure is obtainable from the offices of this journal.



screws. The positions for these holes should be determined by means of intersecting lines drawn with a sharp-pointed tool, and

TWO-VALVE RECEIVER

ATTEE, Staff Editor.

ing reaction, and capable of
and long-wave stations.

with the holes drilled, the panel should be treated on both sides to a thorough rubbing with fine emery paper in order to remove the glossy finish; this latter, though effective in appearance, being undesirable from an insulation point of view. The positions of the holes will be gathered from Fig. 3, whilst the disposition of the actual components will be understood from the photographs Figs. 1 and 6.

Should any difficulty be experienced in drilling holes for the valve legs, a template for such drilling may be found in *Modern Wireless*, Vol. 1, No. 6, or, as an alternative, a complete valve-holder may be purchased, thus calling for less accuracy in the drilling operations.

Assembling the Components.

As a thorough understanding of the circuit is desirable before

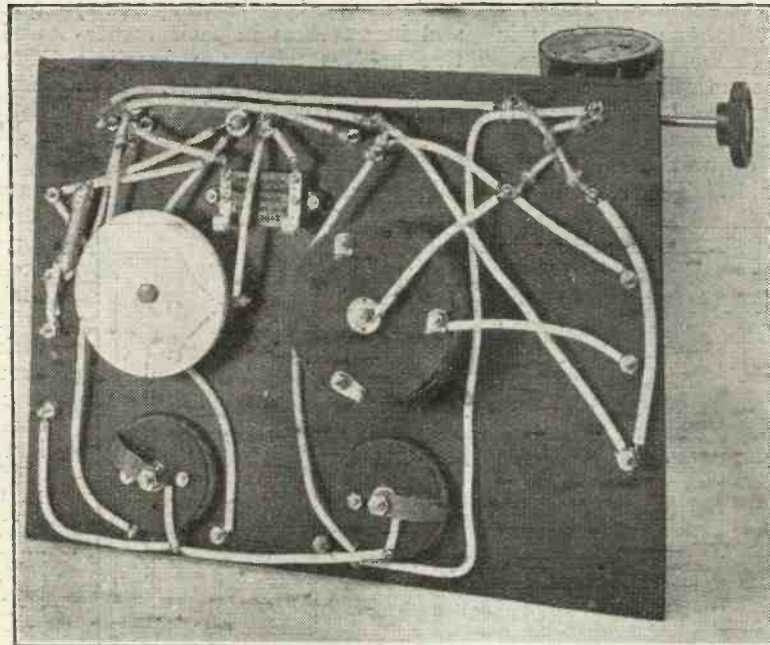

Fig. 6.—The back of the receiver, showing disposition of the components.

nects his parts on a temporary base-board in accordance with the circuit diagram, Fig. 2. This method, though perhaps delaying the completion of the finished instrument, enables the constructor to familiarise himself with the circuit requirements, and, most important of all, any misunderstanding of the arrangement will manifest itself in negative results before the work of mounting the components and soldering them together has been done.

With satisfactory results obtained, the components should then be mounted upon the panel and connected as shown in the theoretical circuit, Fig. 2, and in accordance with the wiring diagram, Fig. 4. The arrangement of the components when mounted is such that every connecting point is accessible for easy soldering, and for simplicity and quickness of work the best method to use in conjunction with a careful study of Figs. 2 and 4 is as follows:—

From the L.T. negative terminal make connection with the switch arms of both rheostats. From the ends of each of the two resistances make individual connections to the filament legs nearest to the base of the panel.

From the L.T. positive terminal connection is made to the remaining filament leg of the detector valve, the remaining filament leg of the H.F. valve and the earth terminal. From the middle terminal marked A in Fig. 4 connection is made to one side of the aerial tuning condenser, the other side of which is connected to one side of the aerial inductance, and thence to the grid leg of the high-frequency valve.

From the other side of the aerial coil, connection is made to the earth terminal. The anode leg of the high-frequency valve is connected to one side of the tuned anode coil and to one side of the 0.0003 μ F or two-plate "Baty" condenser and to one side of the fixed condenser. From the remaining side of the variable condenser connection is made to the other end of the tuned anode coil and H.T. positive. From the other side of the fixed condenser connection is made to the grid of the detector valve and one side of the grid leak. Connection is now made from the remaining end of the grid leak to the positive L.T. terminal and H.T. negative. From the plate leg of the detector valve make connection to one side of

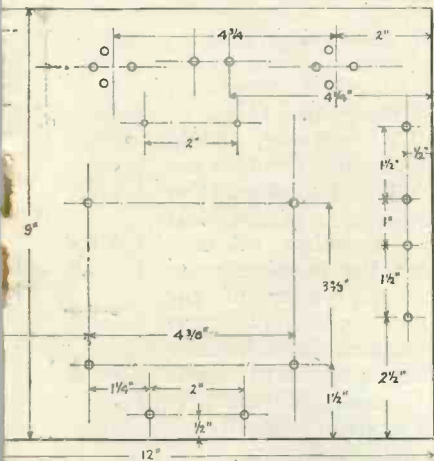

the different components are mounted, and the many connections soldered, it is suggested that the reader lays out and con-

the reaction coil, the other end of which is connected to one of the telephone terminals. The remaining telephone terminal is connected to the H.T. positive.

It will be noticed that the positive side of the L.T. battery is connected to earth, instead of the usual connection from the negative side. The reason for

(for wavelengths other than broadcasting, if the test is to be made during broadcasting hours) and insert them in their respective holders with the smallest coil in the aerial socket. Turn the reaction coil at right angles to the aerial coil, switch on the filament current, and by turning the adjusting handle of the

in relation to the fixed coil, in a very slow movement, the required signals are easily found, and will be strongest when the anode circuit is in-resonance with the aerial circuit.

Parallel Capacity.

To connect the condenser in parallel, the aerial connection should be removed from A to A₁, which actually brings the aerial in direct connection with the fixed coil of the two-coil holder, and one side of the condenser. The terminals A and E should be short circuited by a piece of wire, thus placing the condenser *across* the aerial coil instead of in series.

General Remarks.

When complete the instrument may be fitted in a cabinet made to the dimensions given in Fig. 5, or if the reader prefers, a box with sloping front may be used.

For the convenience of those readers who prefer to work from full-size drawings, blue prints of Figs. 3 and 4 are being prepared and may be obtained from the offices of this journal at a cost of 1s. 6d. each.

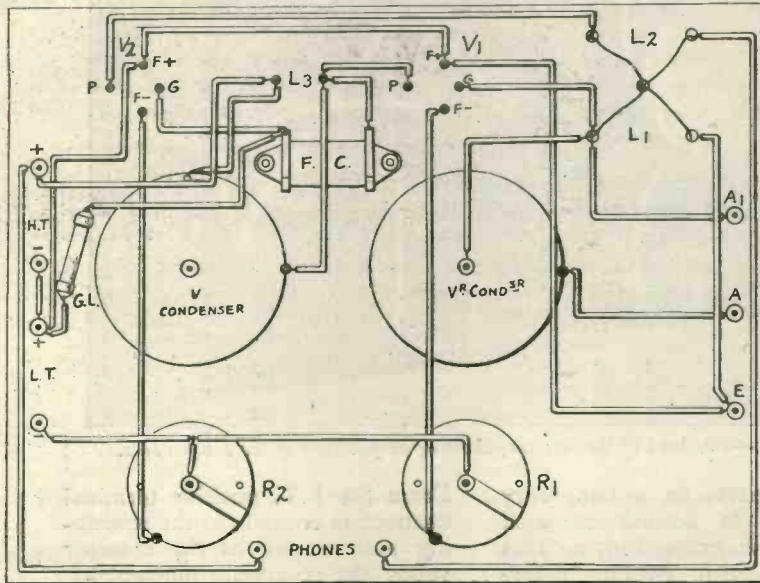

Fig. 4.—Wiring diagram, of which a blue print may be obtained from the offices of this paper.

doing this is in order to overcome any tendency to self-oscillation when the aerial and tuned anode circuits are in resonance. Though perhaps some small losses may result from this arrangement, all such losses may be adequately overcome by the judicious use of the reaction coil. Those readers who prefer to use the negative connection may, of course, do so without hesitation.

This last connection completes the wiring of the receiver and subject to the instructions of both text and Fig. 4 having been carried out in the correct manner, the instrument is now ready for testing.

This is done as follows: Connect the accumulator to the L.T. terminals, taking care before so doing that the filament resistances are in the "off" position, and test each valve. Subject to the filament brilliancy being consistent with the movement of the switch arm, the H.T. battery may now be connected.

Attach the aerial, earth and telephones; select suitable coils

moving coil towards the fixed, a relatively loud "plonk" will be heard in the telephones. If there is no evidence of this plonk, it indicates that the set is not oscillating, in which case the connections to either the aerial or the reaction coil should be reversed.

Operating the Receiver.

As previously stated, the tuning arrangements are such as to be efficient on both short and long wavelengths in that by altering the condenser from the series to the parallel arrangement a receiver of this type will permit tuning over a multiplicity of wavelengths, according to the coils inserted in the sockets, and for those readers who are not familiar with which coils to use for certain required wavelengths, reference to the chart given in *Modern Wireless No. 6* will help considerably. To tune to any given wavelength, the aerial and reaction coils should be placed at right angles to each other and by slowly turning the condensers, at the same time bringing nearer the moving coil

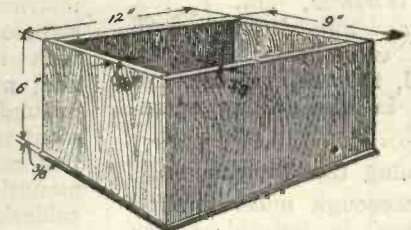

Fig. 5.—The containing box.

It will be observed in Fig. 3 that a fixed condenser is shown dotted across the H.T. terminals, and though the writer found no need for this condenser, should battery noises be troublesome readers are advised to connect as shown a condenser of not less than 0.02 μ F capacity. A condenser across the telephones, to overcome the impedance of the high-resistance windings, was also tried, but since no difference in reception was apparent it was omitted. If used, however, it should be of 0.002 μ F capacity.

As to results, using 54 volts H.T. and a very indifferent aerial (the writer being a flat-dweller), all the B.B.C. stations were received with remarkable strength and clarity, their tuning presenting no difficulty.



Conducted by A. D. COWPER, M.Sc., Staff Editor.

A Battery Tester.

The Radio Communication Co., Ltd., have sent for our inspection a battery tester. This consists of a test-lamp mounted in the end of the ebonite handle of a long brass plug, with which connection is made to one pole of the battery-cell to be tested. The circuit is completed by connecting to the other pole a pivoted leg, which swings out compass-leg fashion to a radius of a couple of inches. This is a neat, well-finished, and useful little accessory.

High-Frequency Coupling Unit.

The Armac Co. have submitted for practical trial a novel unit intended to plug-in in place of an ordinary high-frequency amplifying valve, thereby effecting economy of current.

It has often been noticed—in fact it appears to be rediscovered about once a week—that a multi-valve receiver will sometimes give signals, on loud transmissions, when one high-frequency valve is turned off, or even with the valve removed from its socket. The reason being that the small capacity coupling through the valve or wiring of the panel is sufficient to pass on the oscillations from one tuned circuit to the other. The Armac Co. have utilised this fact in their unit, which gives more efficient and adequate capacity coupling, a coupling condenser being mounted in a neat ebonite case fitted with two pins to plug into grid and plate sockets respectively.

On actual trial on a set with H.F. valve, the latter could be withdrawn and replaced by this unit, when after slight retuning, signals came in quite well, rather more selectively than without the extra tuned circuit, though of

course without the amplification of the valve it replaced.

Telephone Head Set.

Messrs. S. G. Brown, Ltd., have sent for test a sample of their light 2,000 ohm head-sets, type A. These have the well-known Brown reed-and-aluminium-cone mechanism, with magnets adjustable by milled-head screws at the back of the receivers. These telephones are light and for comfort have an elaborate universal-joint mounting, with a double head-band capable also of a wide range of setting. A generous length of cord is supplied with them. We would like to see the positive terminal marked a little more clearly, if the makers consider it necessary to connect up the 'phones always in the one way.

On actual trial, on crystal and valve, the 'phones were found to be light and easy on the head, and readily adjusted to a sensitiveness that left nothing to be desired.

Hellesens Dry Cells.

Samples of the well-known Hellesens dry cells, type VIII No. 2, have been submitted for test by Messrs. A. H. Hunt, Ltd. These are 3 in. square by 6 in. high and give when new an E.M.F. of about 1.5 volts, showing a very large current on momentary short-circuit, indicating that they possess extremely low internal-resistance. Accordingly, it was to be expected that they would prove suitable for the supply of filament current for dull-emitter valves. On actual trial, over an extended period of continuous

use, two (in series) were found to run an ordinary type of English dull-emitter valve without the least sign of distress, or requiring adjustment of the filament resistance at frequent intervals to compensate for polarisation. There was entire absence of noise, and there was no fall in open-circuit volts after a fairly long test run. These cells can be recommended, therefore, for supplying current for dull-emitter valves (best in series-parallel arrangement if for a two or three-valve set), for use in remote country places where accumulators are not available on account of the re-charging problem. A single cell would run a "pea-nut" type of valve for a period extending to months of occasional listening-in.

A Vario-Coupler.

Messrs. Gaston E. Marbaix have sent for test a sample of a very handsome vario-coupler, for panel-mounting or table use, with primary tapped at 16 points. This is built up on red-mottled bakelite formers and is extremely well made and finished. The moulded base allows the instrument to stand securely on the table, while two small screws in the spindle boss afford convenient means of mounting behind a panel. The instrument is of fairly large size.

On test, the instrument tuned from 300 to above 700 metres on a P.M.G. aerial with the tapped primary, and with a 0.0005 μ F variable condenser across the secondary; the desired degree of loose-coupling could be readily obtained by adjusting the rotor position, giving good selectivity. The signal strength on crystal reception was excellent.

A High-Frequency Transformer.

The Formo Co. have submitted for test a high-frequency transformer of the semi-aperiodic high-resistance type to plug into the standard four-socket valve-holder, and covering a range of from 1,000 to 3,600 metres without tuning condenser.

This is a neat little instrument, substantially made, with the windings in a groove in an ebonite former. On actual trial in an ordinary two-valve receiver it covered the range specified quite well, giving good amplification at all points (best above 1,700 metres), being everywhere markedly superior to resistance-capacity coupling. There was no instability displayed when using this H.F. coupling. It can be recommended for use when it is desired to avoid the trouble of tuning a low-resistance tuned transformer or tuned anode, especially in view of the tendency towards self-oscillation of the latter. The Radiola concert was received comfortably on two valves, with 100 volts on the plates, without any sign of incipient oscillation.

"Ferrix" Transformer.

Messrs. Rose, Lloyd and Co., Ltd., have sent for trial a sample of their "Ferrix" transformers, for use on alternating-current house-mains, giving several amperes of alternating current at a low voltage, and taking about as much power as a small electric lamp. It is suggested that these may be useful as a source of filament-current supply for radio reception.

The instrument submitted was wound for 110 volts A.C., of 50 cycles and had two secondary coils, giving nominally three volts each, or six volts together.

On testing (necessarily it was actually tested on a 240 volt main with a lamp resistance in series) it was found to give several amperes at well over 6 volts under these circumstances, but warmed up considerably. A smaller pattern, which has been in the possession of the writer for some time, and has given every satisfaction, wound for 200-250 volts A.C., keeps considerably cooler in operation. The present sample was tested more particularly with a view to filament lighting.

Evidently there are encourag-

ing possibilities in this direction for the application of these handy little transformers.

A Variometer.

Messrs. Gaston E. Marbaix have submitted a variometer for test. This is uniform with their vario-coupler, and is of similar fine finish and appearance, but with larger rotor, giving small clearance and large inductance-ratio. On test, this gave excellent signal-strength, and a similar large wavelength range.

A Loose-Coupler for Panel-Mounting.

There has been submitted for test by Messrs. E. J. Baty a novel and exceedingly compact type of loose-coupler for mounting behind the panel, consisting of two small spider-coils on ebonite formers, each of about 100 turns of thin wire, mounted on a screw-operated slide fitting which is fixed behind the panel by two small screws, only the control knob showing outside. These coils form the primary and secondary respectively and have a range of around one inch of movement for varying the coupling.

On practical trial on local broadcasting good signals were obtained, using a small series condenser with the primary and nearly the minimum of a low-minimum 0.0005 μ F variable condenser in parallel with the secondary.

The wavelength range available on a P.M.G. aerial was found to be from 360 metres to 800 metres, the last with 0.0005 parallel condenser.

While lightly made, the compactness of these inductances offers advantages for use in, e.g., portable sets.

A Low-Minimum Variable Condenser.

An interesting and extremely simple compact type of variable condenser comes also from Messrs. E. J. Baty, consisting of two 3-in. diam. metal plates, one mica-faced, mounted on a screw-operated fitting which fixes by two screws behind the panel, the operating knob being, as usual, all that is visible outside. Small terminal screws are provided for connections. The screw-spindle passes through an ebonite boss provided with a brass nut. On test the insulation

was remarkably good, even with the one (moving) plate screwed solid up against the fixed plate. In the latter position the maximum capacity was 0.0005 μ F the maximum readily available being about 0.0004 μ F. The minimum capacity with the moving plate well out was the extremely low figure of 0.0002 μ F. The greater part of the range was, of course, in the first turn of two, thus with an ordinary No. 50 plug-in coil the condenser tuned from 350 to 425 metres on half a turn.

Tested in crystal-reception in careful comparison with the standard type of air-dielectric moving-vane condenser, no difference in signal-strength was detected, and the tuning was quite convenient.

There are many occasions where an extremely low-minimum variable condenser is required and where this simple type would be extremely effective.

Radio Society of Great Britain.

T. & R. Section.

DURING the week ending Nov. 25 many members of the T. & R. Section were endeavouring to work relays. This was the first attempt at forming organised chains of communication. Acting on experience gained in the preceding tests, the chains were formed when possible of members resident within 50 miles of each other. The results show that it is not easy to establish perfect relay communication. It is a striking fact that several of the stations which are received well at considerable distances—e.g., in France, Holland and even Switzerland—cannot always be heard for certain at distances of only 50 or 100 miles.

Concurrently with the Franco-British tests arrangements have been made with the Cercle Vervietoise d'Etudes Radio-electriques to listen-in for signals on about 440 metres, which will be sent out by members of the T. & R. Section early in December.

Reports regarding the reception of the French amateur signals are being received, and the substance of these will be published after the conclusion of the tests.

Valve Notes

By John Scott-Taggart, F. Inst P.

I RECEIVED an interesting suggestion from a well-known manufacturer of intervalve transformers. I pass it on as a suggestion which is well worth trying out. It consists in supplementing the coupling of an intervalve transformer by means of a small condenser of about $0.0005 \mu F$ capacity.

The accompanying figure shows a three-valve receiver which will be found to give excellent results with a loud-speaker, or over long ranges with telephone receivers. The circuit has the advantage that it is particularly useful for the reception of continuous waves, spark signals, or telephony at will, by simply varying the reaction coupling between L_2 and L_1 . The circuit, of course, is of the ordinary type, except that this hint about a coupling condenser has been applied to it. This circuit is only one example, but it will indicate where the coupling condenser should be connected. It will be seen that a condenser C_4 , which has a capacity of about $0.0005 \mu F$, is connected between the anode of the second valve and the grid of the third. It will be found that in many cases this condenser will improve the quality of speech and music, although, of course, there is no point in having this condenser if spark or C.W. signals are to be received. A similar condenser, C_5 , shown in dotted line, may be tried in the corresponding position between the first and second valves, although it is not likely to make much difference here owing to the masking effect of the condenser C_3 , which will usually have a value of $0.002 \mu F$. This latter condenser, however, might be omitted in most cases as the self-capacity of T_1 is sufficient to allow the passage of the high-

frequency currents in the anode circuit of the first valve.

The New Valves.

The new valves are certainly creating an immense amount of interest, and for a very good reason. As is customary in the case of this journal, I arranged for the new valves to be tested, both by means of measuring instruments and on actual sets.

popularity of the peanut valves will compare with that of the new 0.06 valve is a matter of conjecture. Both types have valuable properties and the protagonists of one type of valve will explain how only one cell is needed, while the supporter of the other valve will point out that although three cells are necessary, yet smaller ones may be used and they may be used

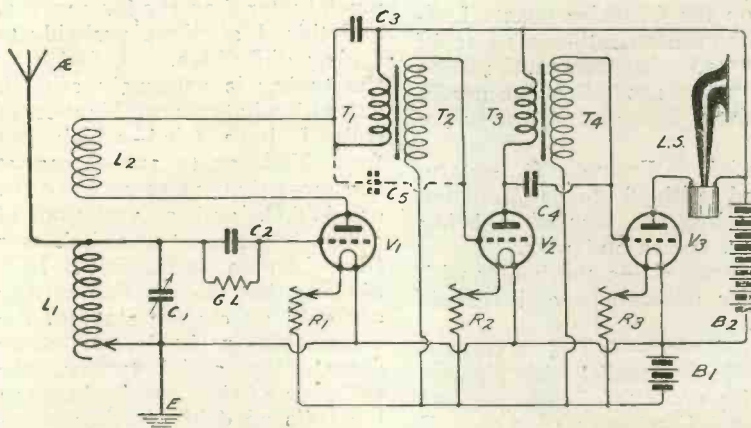

Illustrating method of connecting condensers to obtain additional transformer coupling.

The results of the 0.06 amp. filament valves were really excellent, although it was noticeable that different makes differed somewhat. In one case the valve submitted for test gave an emission only one-third of that of the other valves. This, of course, is detrimental to the use of a valve for loud-speaker purposes, but does not materially affect it as regards general reception. The complete results of our tests were summarised in our issue of November 21.

The filaments are certainly very fine and the valves will probably require a little more careful handling. How the

for long periods without polarisation. All the manufacturers, of course, will talk about watts.

The price of the valves, of course, seems much too high, but nevertheless, even at this price they represent good value because of their long life, and the saving in cost of accumulators and the charging thereof will balance the extra cost of the valve. Incidentally, I note that the Exide Company have produced a very nice little accumulator cell giving two volts which may be used with dull emitter valves. The accumulators, they state, may be left for six months without charge.

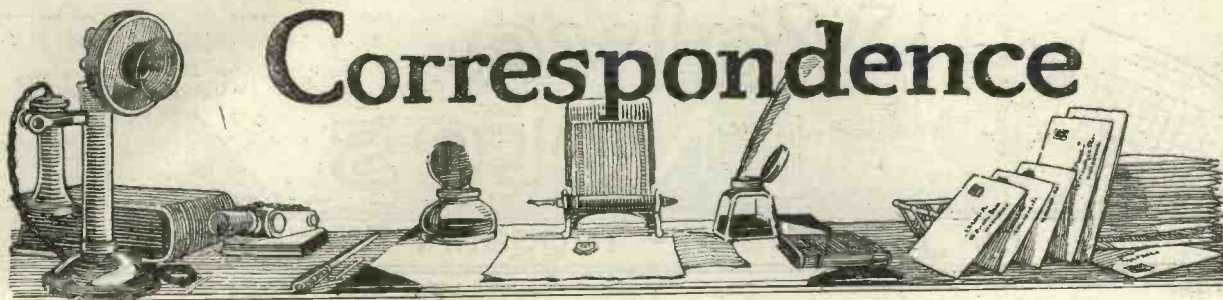

Correspondence

THE FLEWELLING CIRCUIT

SIR,—The following notes on some experiments, which I have carried out with this circuit, may be of interest to your readers, and also may obtain for me some assistance or information, either from your technical staff or from some of your readers regarding any particular difficulties.

The details of the installation are as follows—

Situation of Station.—At sea level, about 100 yds. from the sea on the Cheshire coast, London 200 miles south-east; Cardiff about 150 miles due south; Glasgow about 175 miles due north, the latter being mainly over the sea.

Aerial.—Frame 3 ft. square, wound with 8 turns insulated bell wire, the insulation being rubber, cotton and wax.

Inductance.—3 coil-holder with Vernier adjustment and Igranic coils.

Condenser.—A.T.C. $0.0005\mu\text{F}$ variable, in parallel with 5 plates Vernier cross terminals.

Fixed Condenser of $0.0002\mu\text{F}$ in the grid circuit, with $0.006\mu\text{F}$ as bye-pass.

Wattmel variable grid leak.

Valve.—Xtraudion and non-descript French "R."

Plate Voltage.—Varying 80/120.

The original "Flewelling" circuit, with the arrangement of three condensers did not work at all well. I found great difficulty in finding any station, and the signals were very faint. I therefore adopted the modified circuit, published by you in your issue of August 1, modifying it however, by using a variable grid-leak and fixed condenser, instead of the arrangement shown, which has a variable condenser and fixed grid-leak. The variable leak is carried to L.T. positive.

With this circuit I have had very remarkable results. Cardiff and London come in clearly in the headphones, with a strength approximately that of a good crystal circuit 15/20 miles from broadcasting station. Newcastle comes in excellently, but faintly. Manchester comes in strongly, but very difficult to tune in. Glasgow and Birmingham, however, have not been heard.

You will notice from this that the short wave stations come in much better than the long waves, and this, I attribute probably to tuning difficulties. I find that the tuning is extremely critical, as, with whatever combination of coils I have tried—which run from Nos. 25 to 250—I cannot use more than 15 to 20 per cent. of A.T.C. and a variation of 3 deg. is sufficient to switch over from London to Cardiff. It is obvious that the reaction setting not only affects the state of the valve, but probably, to some extent, the aerial tuning, the variation of the capacity between the coils no doubt having something to do with this.

It is emphatically not a set to interest the ordinary broadcasting listener, as, when giving the best results, it bursts into violent oscillation at the slightest provocation, and body capacity effects are strongly noticeable. I find that when critically tuned, with the signals coming in clearly and strongly, if I move about the table, the note varies and the whole set tends to burst into oscillation. The setting of the variable grid-leak is extremely critical, and although I have tried several types on the market, the one I am now using appears to be most satisfactory, but still leaves a lot to be desired, particularly at the higher resistances. I suggest, for those of an inventive turn of mind, that

they might do worse than apply themselves to the problem of designing a really variable grid-leak which is steady in its action.

I have adapted a low-frequency amplifier to this set, with excellent results, it being possible to get speech and music sufficiently loud in the 'phones from all the stations mentioned, without the critical tuning and high whistle, necessary to ensure results when working on a single-valve, and the set under these conditions is infinitely more stable than when a single-valve is used.

This circuit is of fascinating interest, I think, to any experimenter, providing it gives the maximum results with the minimum apparatus and complication, and while I am experimenting with various values of condenser and grid-leak, I should welcome the assistance of others who have been experimenting with this circuit or of your technical staff, if they can help me to overcome some of my difficulties, which are:—

Firstly.—Some means of tuning accurately the long wave stations.

Secondly.—Some method of screening apparatus from body capacity effects.

With regard to the first problem, I am considering using "Gimbal" coils, as by the use of these, a vario-coupler effect can be obtained, which may assist in fine tuning.

In conclusion, may I ask you to use your influence to advise experimenters to avoid using a circuit of this type on an outside aerial during broadcasting hours, the extremely unstable nature of the circuit makes it highly probable that it would interfere very considerably with the pleasure of many people in the neighbourhood. — Yours faithfully,
SIX DEE BEE.

Information Department



W. C. J. (BISHOP'S STORTFORD) asks if it is possible to make use of reaction without fear of causing interference.

It is possible to ensure that any radiation which may occur is extremely slight by utilising the arrangement shown in the accompanying figure, in which reaction is applied to the closed oscillatory circuit, namely, the tuned anode circuit of the preceding valve.

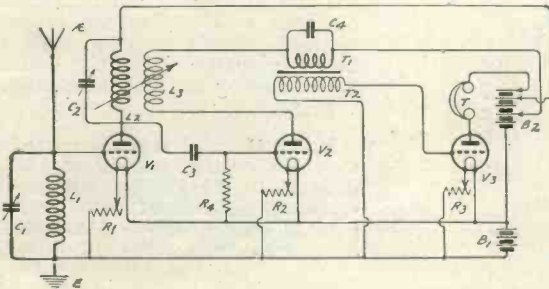

L. T. M. (LEEDS) asks how he can test a pair of telephones which he suspects of being defective.

Place their tags across a single dry cell or two of the adjacent sockets of an H.T. battery and note whether a click is produced at the "make" and "break" of the circuit. No click indicates a break in either cords or winding. Replace the cords with temporary leads and try again. If there is still no click the fault is in one or both of the earpieces. Short circuit first one and then the other with a piece of wire and repeat the test. If shorting one earpiece enables clicks to be heard in the other, the shorted one is at fault. If no result is obtained by shorting either, both are faulty.

D. S. C. (BIRMINGHAM) asks whether an increase in the size of a tuning coil will result in reception from greater distances.

The distance over which signals can be received depends primarily upon the power of the transmitting station and the sensitiveness of the receiving apparatus. Increasing the size of the tuning coil does not in any way affect either of these essential conditions, but merely increases the range of wavelengths to which the receiving set can be adjusted. Incidentally, the high-power long-distance stations usually employ long wavelengths, so that for reception of their signals a large tuning coil would be required, and although reception of signals from this class of station may

be obtained over great distances, it is entirely due to the high power employed.

P. J. P. (CLAPHAM) asks how it is possible to adjust a valve to various points upon its characteristic curve.

The actual adjustment consists in giving a potential to the grid so that the anode current is maintained at the desired average value. By including a number of dry-cell batteries in the grid circuit, it is possible to give to the grid any desired positive or negative potential. The diagram herewith shows these cells introduced so as to put a negative potential of from $1\frac{1}{2}$ to $4\frac{1}{2}$ volts upon the grid, an adjustment which is of particular value when using the valve as a low-frequency amplifier. Another method of effecting the desired grid control is to connect a potentiometer across the filament lighting battery and connect the potentiometer slider to the grid, via the tuning inductance. By this means the grid condenser can be controlled from zero (the potential of the negative leg of the filament) to either 4 or 6 volts positive, according to the voltage of the filament lighting battery.

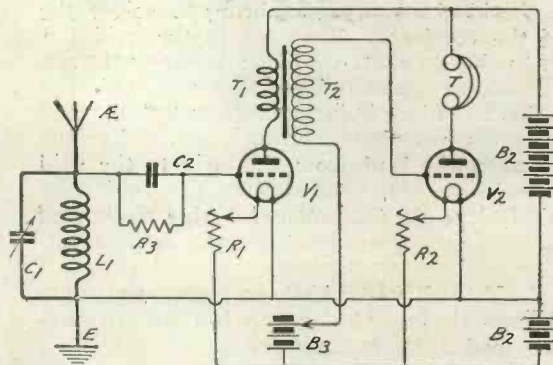

L. M. G. (WANDSWORTH) inquires as to the function of a telephone condenser.

In the simple case of a crystal receiver, the telephone condenser acts as a reservoir for the unidirectional radio-frequency impulses which come from the crystal, storing them and discharging them through the telephones in the form of audio-frequency impulses. This is a somewhat complex point, and for a full explanation reference should be made to a good text-book of wireless theory. In valve sets this condenser is often provided to perform a second function of by-passing radio-frequency impulses, the passage of which would

otherwise be blocked by the high impedance of the phones. This is the case when the phones are connected to the plate circuit of a detector valve, which is used for reaction purposes. When low-frequency amplifying valves are used a condenser to perform this duty is necessary across the primary of the first intervalve transformer. In either case a good value for this condenser is $0.002 \mu\text{F}$.

N. M. D. (SYDENHAM) inquires how many valves must be used to work a loud-speaker efficiently.

The number varies with the efficiency of the receiving aerial and its distance from the broadcasting station. The following figures, however, assume an average-size outdoor aerial, and should give a general idea of the required amount of amplification:—

Up to 10 miles—crystal and two low-frequency valves.

Up to 10 to 40 miles—H.F., detector with reaction and L.F.

Up to 40 to 50 miles—H.F., detector with reaction and 2 L.F.

Over 80 miles—2 H.F., detector with reaction, 2 L.F.

These are the minimum number of valves for consistent reception and without much skill in manipulation.

D. N. G. (WOOD GREEN) inquires whether there is any special point to be observed when making the connections to grid condensers and grid leaks.

The primary object should be to keep these connections as short as possible. It is particularly important to keep the connections between the grid of the valve and the grid condenser extremely short, the ideal arrangement being to solder the tag of the condenser direct on to the grid pin of the valve socket. This arrangement not merely reduces undesired reaction effects, but it also helps to reduce inductance from lighting and power mains, near-by generators, etc. For the same reason the lead from the grid to the grid leak should also be kept short. The lead from the grid leak to the filament (when this method of connecting is used) need not necessarily be short.

A. C. H. (LEWISHAM) is constructing a frame aerial for the reception of broadcasting and asks for particulars.

The winding should consist of 12 turns of bell wire or No. 20 S.W.G.-d.c.c. copper wire in the form of a square, 36- to 40-inch size, the turns of wire being spaced about half an inch apart.

BOOKS.

From the number of queries we receive from readers it would seem that it is not known how adequately do Radio Press Books deal with the subject of Wireless. A full list of our publications may be found in our advertisement pages.

JUST OUT!

—but I don't understand Circuit diagrams

WHEN a wireless enthusiast decides to build his own Set, his first job is to study the necessary wiring diagram. And that is where quite a number meet their Waterloo.

Those of us who can read circuit diagrams as easily as we can our morning paper are apt to show but little sympathy for the extreme novice making his first flounders into Wireless.

Radio Press, however, appreciate that the correct reading of circuit diagrams is the first essential to the successful building of a Set, and are publishing an entirely new Book which completely cuts out this difficulty.

Every circuit diagram in "Pictorial

Wireless Circuits" is shown pictorially—that is to say, the actual components used are drawn instead of conventional signs for them. Thus there will be no excuse, for example, for any enthusiast not knowing the correct position for his filament rheostat.

Altogether over 70 circuits are shown, ranging from simple Crystal Receivers to more elaborate Multi-valve Sets.

If difficulty in reading Circuit diagrams has hitherto prevented you from building or improving your Set—get a copy of this Book to-day. It will be eighteenpence well spent.

Pictorial Wireless Circuits

by

OSWALD J. RANKIN

From
all
Book-
sellers

1/6

1/7½
post
free

Published by

RADIO PRESS, LTD.

Devereux Court, Strand, W.C.2

Radio Press Series No. 8.

WECONOMY SETS

incorporating the
WECOVALVE.

The WECOVALVE (Pea-nut type) is the most economical valve existing, requiring only 0.25 of an ampere at 0.8 to 1.1 volts, and having more than twice the life of tungsten and other dull-emitter valves.

It can be used either as a Detector or Amplifier, and operates off a single dry cell.

Filament current 0.25 amp.

Filament Voltage 0.8 to 1.1 volts.

Detector Plate Voltage 17-22 volts.

Amplifier Plate Voltage 22-45 volts.

Dimensions $\frac{1}{2}$ in. diameter by $2\frac{3}{4}$ in. long.

Price £1 10s.



No. 44215-A.

Patent Nos. 1750 (1915), 1,0990 (6641-1921).

The WECOVALVE (Pea-nut type) can be used with your existing receiving sets by the use of the Weco Valve Adaptor (No. 44092), which has contact springs faced with gold and silver alloy, to ensure perfect contact with the base of the valve.

Dimensions $1\frac{1}{2}$ in. by $1\frac{1}{2}$ in.

Price 3s. 6d.

The Weco Valve Socket is a small type bayonet socket arranged for four soldered connections. The contact points are faced with a special gold and silver alloy, to ensure perfect contact with the base of the valve.

Dimensions $1\frac{1}{2}$ in. by $\frac{3}{4}$ in.

Price 1s. 6d.



No. 44060.

Crystal Set with Double Amplification.

The WECONOMY CRYSTAL RECEIVING SET No. 44080 is a combined crystal pattern receiving set and two-stage Valve Amplifier. The Set, used for the reception of local Broadcasting Stations, will operate a Loud Speaker direct, or if desired the crystal set portion may be used alone with Head Receivers.

The excellent qualities of the Western Electric Crystal Set are well known, and the addition of the Amplifier, containing special distortionless transformers, and the particularly silent operation of the Weco valves, render this combination almost perfect in its reproduction.

Dimensions $8\frac{1}{2}$ in. by $8\frac{1}{2}$ in. by 7 in.

Weight 7 lbs.

COLUMBIA RADIO "A" CELLS
ARE RECOMMENDED
FOR USE WITH WECOVALVES.

The WECONOMY AMPLIFIER No. 44010 is designed primarily to fit into the receiver compartment of the Western Electric Crystal Pattern Receiving Set. Two Weco valves are used and no accumulators are therefore necessary. Terminals are provided for two dry cells for filament heating and for a H.T. battery of 45 volts for the plate circuit.

Complete with Western Electric high efficiency transformers, condensers, etc., and clearly marked terminals, this Amplifier when used with a Crystal Set will reproduce speech or music from a local Broadcasting Station in sufficient power to operate a Loud Speaker successfully. If desired, it can be used to secure at least double the range of the Crystal Set by retaining the Head Receivers.

Dimensions $6\frac{1}{2}$ in. by $5\frac{1}{2}$ in. by $3\frac{1}{2}$ in.

Weight 7 lbs.



No. 44010.

Small Two-Stage L.P. Amplifier
for use with Crystal Set.

WRITE FOR BOOKLETS—W.E.Co. 132/W. 528 and W. 529.

Western Electric Company Limited,

(WHOLESALE ONLY)

Connaught House, Aldwych, London, W.C.2.

Telephone: Central 7345 (9 lines).

Branches:—

Glasgow, Leeds, Birmingham, Manchester, Newcastle, Cardiff, Southampton, Dublin.

You CANNOT be out of WIRELESS WEEKLY because it brings BIG Business.

A Valve for every Wireless Circuit.

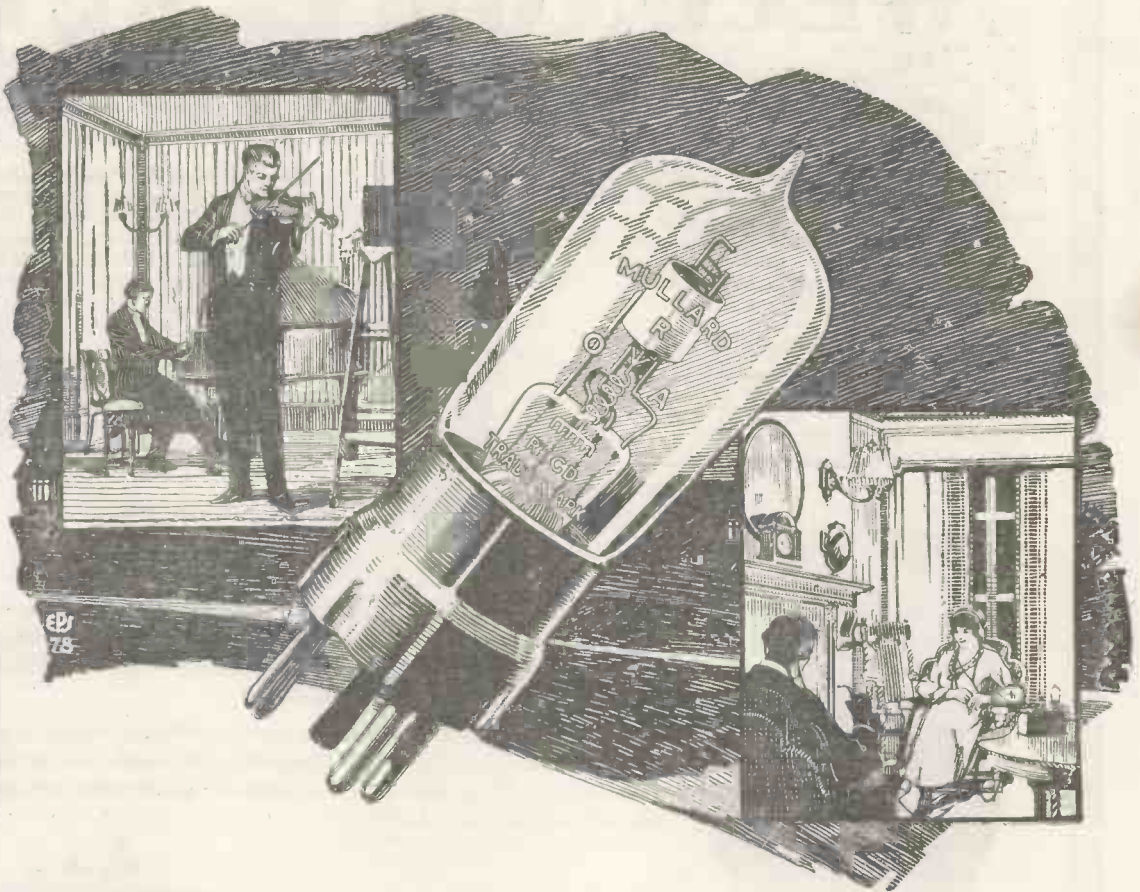
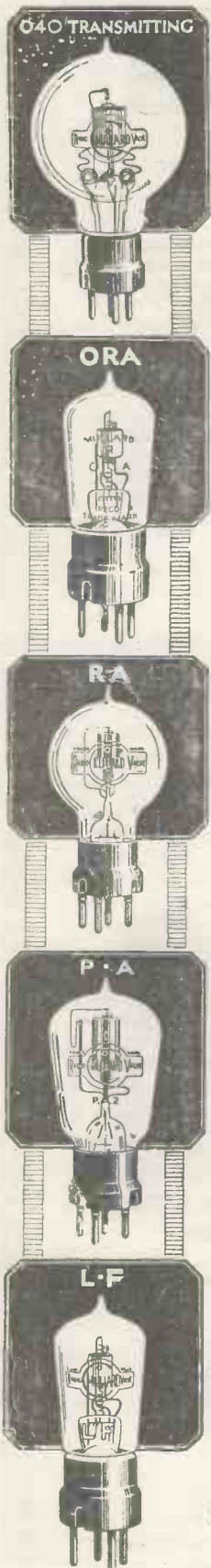

“The Indispensable Link.”

The artiste at the Broadcasting Station makes use of his utmost skill to provide you with a first-class entertainment.

Do you enjoy the light and shade of his playing, does your receiver reproduce his exact tones and words, or do you get muffled and indistinct sounds? The quality of received signals depends so largely upon the valves used in the receiver that Mullard Valves have come to be regarded as the indispensable link between good transmission and good reception.

There is a Mullard Valve specially suited to your set; ask your dealer for booklet M3, or drop a line to us.

Mullard

Advert. : The Mullard Radio Valve Co., Ltd., Balham, London, S.W.12.

You CANNOT be out of WIRELESS WEEKLY because it brings BIG Business.

Increased Sales
make
PRICE REDUCTION
possible in



**SPRING
TERMINALS & CUP**

All prices are reduced as follows:

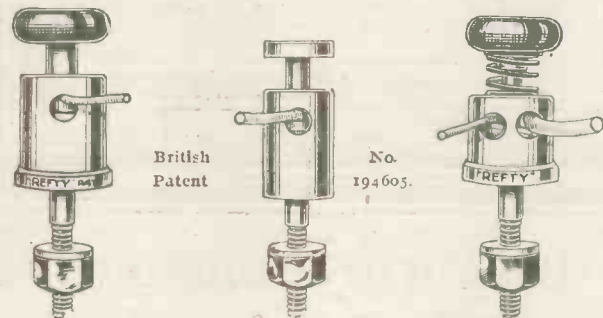

No. 1, Lacquered. 9d. each. Ebonite Top. Will hold a hair without harm. Full capacity No. 10 S.W.G.

British Patent

No. 2, Lacquered. 4½d. each. All Brass.

No. 4, Lacquered. 10d. each. Ebonite Top. Grips different size wires.

DEPRESS KNOB! INSERT WIRE! LET GO!

All 1d. each extra, Nickel Finish.

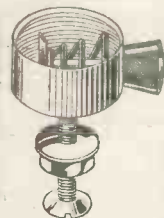

4½d. each.
Lacquered.
4 B.A. x ½ in.
Prov. Patent
No. 20606.

The New
Super-sensitive
**"REFTONE"
CRYSTAL.**

Prices
6d., 9d., 1/-

PULL KNOB! INSERT CRYSTAL! LET GO!

Obtainable
from all Wireless Dealers.

REFTY ELECTRICAL LTD
APPLIANCES LTD

2, Featherstone Buildings, Holborn, London, W.C.1.

Phone: Chancery 8264.

Buy British Goods Only

EDISWAN

THE LATEST
**DULL EMITTER
VALVE**



**TYPE AR'06
30/-**

This valve can be run off dry cells, thus banishing accumulator troubles and reducing the upkeep cost to a minimum. The current consumption at a filament voltage of 2.5 volts is only .06 of an ampere. Another feature of this valve is the special safety cap. (Prov. Pat.) The filament pins are shorter in length than the plate and grid pins. It is therefore impossible for the filament pins to make surface contacts on the wrong sockets. This, however, does not prevent the valve being used in a standard holder.

SPECIFICATION:

Filament voltage	...	2.5 volts.
Filament current06 amps.
Plate voltage	...	20-50 volts.
Bulb diameter	...	31 m/m.
Overall length	...	110 m/m.
Cap (Prov. Pat.)	...	4-pin safety

Write to-day for leaflets fully describing our range of Sets and Parts. If your dealer does not stock, send us his name and address. We'll see that you get what you want.

Free on request. Just send a postcard for our Illustrated Booklet "The Thermionic Valve."

The EDISON SWAN ELECTRIC Co., Ltd.
123/125, Queen Victoria St., E.C.4 & 71, Victoria St., S.W.1

Branches in all
principal Towns.
Works: Ponders
End, Middlesex.

Contractors to
H.M. Admiralty,
— War Office, —
Royal Air Force.



You CANNOT be out of WIRELESS WEEKLY because it brings BIG Business,

A Revolution in B.B.C. Receiver Design!

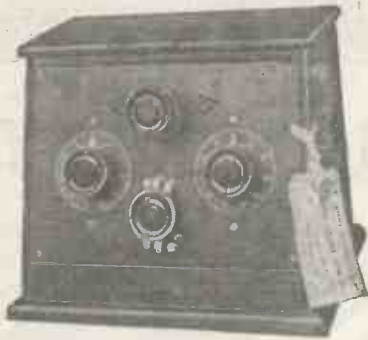

The Marvellous

MÉCOPHONE

One Valve Receiver

It embodies a new and patented circuit with all the efficiency of a "super-regenerative" circuit without its drawbacks:—complication, instability, hand-capacity effects and difficult tuning. No crystal to adjust. No low-frequency transformer to distort. Like Samsón's riddle, it combines "Strength with Sweetness."

Both in volume and purity of tone it is definitely better than the best two-valve B.B.C. model on the market, and equal to most three-valve models. It will receive, on a good P.M.G. aerial, all the B.B.C. stations at "phones-on-table" strength or work a loud speaker within "crystal range" of a station.

It is perfectly stable—no whistling or howling.

It is extremely simple to tune—no hand-capacity effect.

Two tuning controls only—coarse and fine.

The tone is absolutely pure—no self-oscillating or "dual amplification" to cause distortion.

It is compact (9" x 8" high), and the valve is enclosed.

It is beautifully made and finished in polished mahogany and nickel plate.

And the price is only £8 15 0

B.B.C. Tariff 10 0

Valve, Batteries and 'Phones £4 10 0

Order early to avoid delay in delivery. Trade enquiries invited.

MANN EGERTON & CO., LTD.,
Manufacturers and Patentees,

LONDON: 156, New Bond St. NORWICH: 21/3, King St. IPSWICH: 39, Prince St.

BEWARE OF WORTHLESS IMITATIONS, SEE THE TRADE MARK **WatMel** ON EVERY GRID LEAK.

WATMEL VARIABLE GRID LEAK

(Patent No. 206098).

The Resistance is steadily Variable between 1/4 to 5 megohms. Only requires a 3/16 hole in panel for fitting.



Suitable for use in any circuit, and improves the working of any valve detector. (50,000 to 100,000 ohms for the S.T.100 Circuit.

PRICE 2/6 each.

The best Variable Grid Leak made.

Price 3/6.)

WATMEL WIRELESS CO., Connaught House, 1a, Edgware Road Marble Arch, W.2. Tel. 4575 Paddington.

ECONOMIC ELECTRIC LTD.



The "EEC" "XTRAUDION" VALVE

is being used by the leading Radio Experimenters for detection, high and low frequency amplification, power amplifiers and low power transmission. Price 15/-

USE "RECTARITE," the synthetic crystal that makes Loud speakers talk. 1/6 Large Specimen.



Write to-day for 40 page Radio Catalogue mailed post free, 4d.

Head Office: 10, FITZROY SQUARE, LONDON, W.1.

Showrooms: 303, EUSTON RD., N.W.1.

Branch and Works: TWICKENHAM.

Trustworthy Components on a New Principle

EVERY BOWYER-LOWE COMPONENT is mounted on a circular flanged ebonite panel which fits flush in a hole bored to receive it on the Experimenter's own base-board. This may be of wood.

In a short time excellent receiving sets can be assembled without any tools except that required for cutting the circular holes. We supply such a tool for 2/-.

Every component is thoroughly well made and carries our complete guarantee. Prices, too, are thoroughly reasonable.

No. 56. Valve Holder	...	1/8
" 59. Valve Panel, with plain Rheostat	...	8/6
" 60. Valve Panel, with Vernier Rheostat	...	11/-
" 53. Series Parallel Switch	...	5/3
" 42. Two way Switch	...	2/9
" 3d. extra for each way up to Twelve way	...	5/3
" 32. Graduated Shielding Dial	...	2/6

Drop us a line to-night for illustrated descriptive list of these trustworthy parts of protected design.



SALES-DEPT.

The Bowyer-Lowe Co., Ltd., LETCHWORTH

Wholesale Distributors. SCOTLAND: Messrs. Robb Bros., Ltd., 69, West Nile Street, Glasgow, and North Street, Dundee. NORTH OF ENGLAND: Messrs. Wadsworth Sellers & Co., Standard Buildings, Leeds. MIDLANDS: Messrs. Robb Bros., Ltd., 9, Barnstone Road, Nottingham.

You CANNOT be out of WIRELESS WEEKLY because it brings BIG Business.

ANOTHER WONDERFUL SELLING LINE

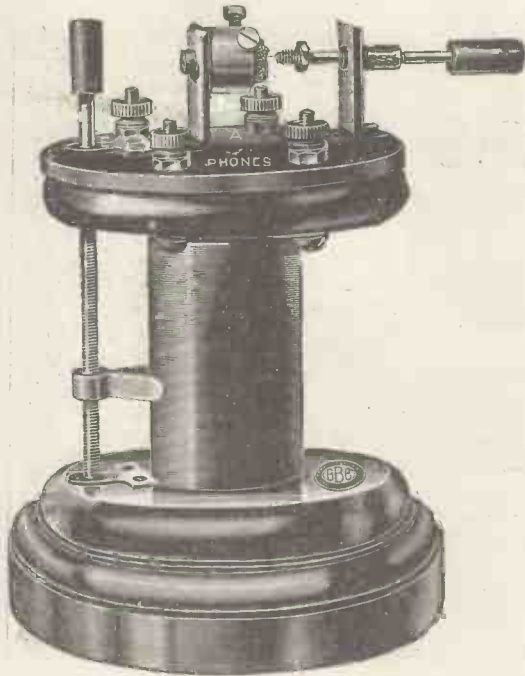

No. B. 12.

R.E.C. 'RAQUIP' CRYSTAL SET

R.E.C. "RAQUIP" Complete Crystal Receiving Outfit ... Listed at **30/-** Including B.B.C. Fee

The Outfit includes:—

- CRYSTAL SET AERIAL EQUIPMENT.
- 1 PAIR R.E.C. 4,000 OHMS TELEPHONES.

This Outfit, constructed ready for use, provides fine tuning over entire Broadcasting Range. For volume and purity of sound is equal to Crystal Sets sold at many times the price.

The whole Outfit packed and boxed ready for mail, 30/- subject.

Illustrated Price List on application to—

The Radio Equipment Co., Ltd.
329, HIGH HOLBORN, W.C.1

Reductions in Price

THE prices of the famous Fuller "Block" Batteries have been reduced generally and the sizes considerably extended. If you want better results with far less trouble and expense—specify Fuller's. Not only is the output double that of ordinary plate type batteries of the same rating, but the charge is retained for months when not in use, internal "shorting" is impossible, and the solid ebonite cases avoid fire risks and acid leakage.



BLOCK
ACCUMULATORS • SOLID • NO PLATES
BATTERIES

We invite you to visit our London Depot, 58, High Street, W.C.2, and inspect them for yourself. Write to-day for Catalogue No. 315—it PROVES the superiority of the "Block" Battery, and contains full particulars of a range of wireless parts which especially appeal to constructors.

6 VOLT L.T.

B.W.X. 6/24 ...	£1 9 3
B.W.X. 6/30 ...	1 14 0
B.W.X. 6/45 ...	2 0 0
B.W.X. 6/60 ...	2 8 6
B.W.X. 6/90 ...	3 8 9
B.W.X. 6/120 ...	4 7 6
B.W.X. 6/160 ...	5 7 0
B.W.X. 6/220 ...	6 11 0

30 VOLT H.T.

H.T. 1 ...	£1 10 0
------------	---------

You can obtain these batteries from any of our Service Agents throughout the Country. Additional Agents are required in districts not yet covered. Dealers should write to-day.

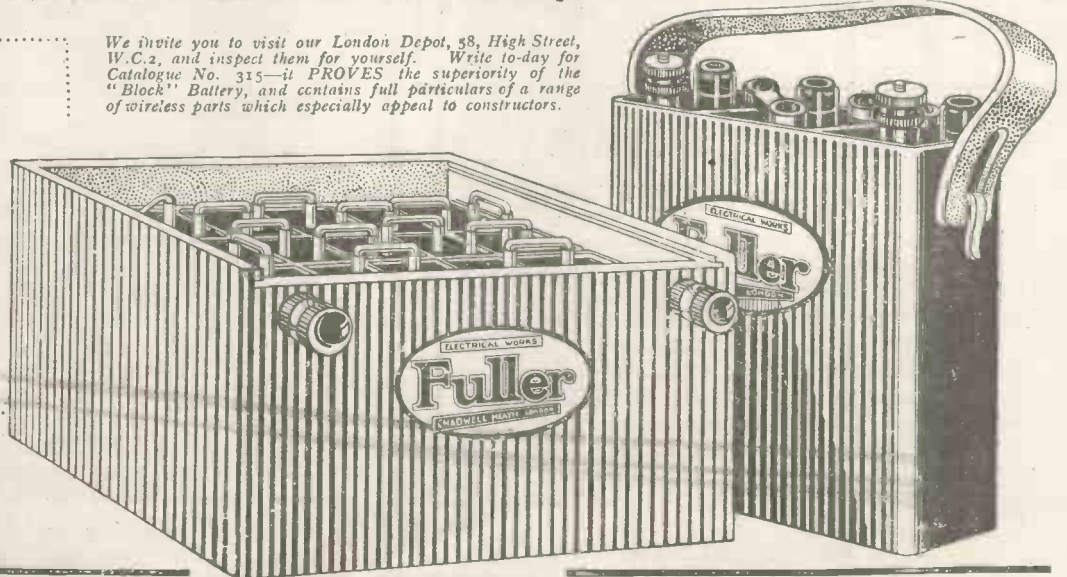

Telephone: Hford 1200 (6 lines).

FULLER'S UNITED ELECTRIC WORKS Ltd.
Woodland Works, Chadwell Heath, Essex.

Telegrams: "Fuller, Chadwell Heath."

You CANNOT be out of WIRELESS WEEKLY because it brings BIG Business.

DUBILIER ANODE RESISTANCES

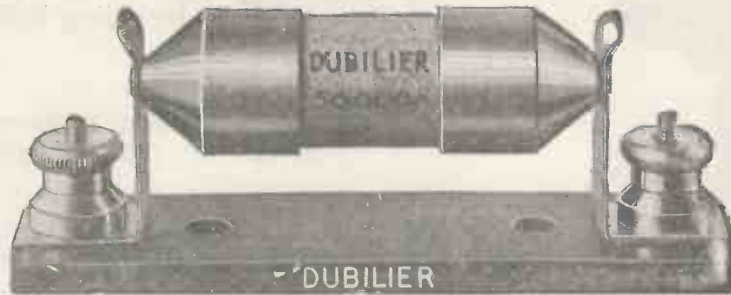

Actual size.

These resistances are the result of careful research and experiment. They are submitted to a test of 200 volts D.C. and are

GUARANTEED TO REMAIN CONSTANT

Price, complete with holder as illustrated . . . 5/8
Made in resistances of from 20,000 to 100,000 ohms.

**THE DUBILIER CONDENSER CO. (1921) Ltd., Dept. G,
Ducon Works, Goldhawk Road, London, W.12**

Telegrams : "Hivolcon, 'Phone, London."

Telephone : Hammersmith 1084.

E.P.S.19

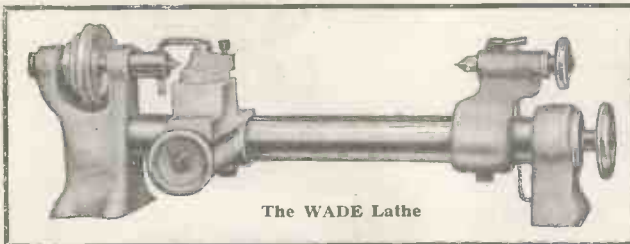

The WADE Lathe

You Know the parts are right if you make them yourself

You can make all your Wire-
less parts on the Wade Lathe,
easily and cheaply. It's the
handiest tool for turning,
boring, facing and drilling.
Turns material up to 12 inches
by 4. British made, strong and
inexpensive. The slide rest
travels whole length of bed and
is fitted with cross feed as well.

Sold by leading Tool Dealers.

The
WADE
Lathe
as

illustrated
£2 - 10 - 0

Send for Illustrated Leaflet W.12.

**C.A.V. SMALL TOOLS LTD.,
181, Queen Victoria Street, LONDON, E.C 4**

THE "ATLAS" SUPER COIL.

P.P. No.
2250/23.

All
Wave-lengths
Covered.

MAXIMUM
AIR-SPACE

MINIMUM
SELF-
CAPACITY

ONCE
TRIED

ALWAYS
USED.

Prices on
Application.



Ask for Catalogue of
Radio Components.

Manufactured only by

H. CLARKE & Co. (M/cr.) Ltd.

**Radio Engineers, ATLAS WORKS,
OLD TRAFFORD, MANCHESTER.**

Telephone Nos. :
683 & 793 Trafford Park.

Telegrams :
PIRTOID, Manchester.

You CANNOT be out of WIRELESS WEEKLY because it brings BIG Business.

"IGRANIC" RADIO DEVICES SATISFY

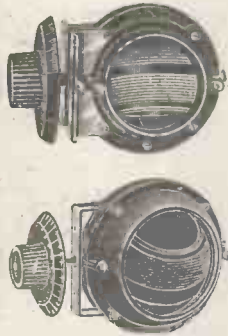

VARIOMETERS.
 Type "H." For use with crystal and valve sets. Wave length range approx. 150/600 metres with P.M.G. Standard Aerial ... Price **15/-**
 Type "S.R." Designed for secondary and tuned anode circuits. Wave length approx. 150/600 metres ... Price **18/-**

149, Queen Victoria Street, LONDON.



BATTERY POTENTIOMETERS.
 (Patent applied for.)

"Igranic" Battery Potentiometer furnishes the precise control of the plate potential so necessary for the successful operation of the sensitive detector valve. Resistance 300 ohms. Adjustable contact fingers. Nickel finish ... Price **7/-**

Works: Elstow Road, BEDFORD.



Write for Lists Y 15.

GAMAGES

Now that Christmas is almost upon us, look to your set—it must be in perfect condition for the festive season. Here are some offers to ensure its efficiency. If unable to call, write for catalogue and send your order by post.

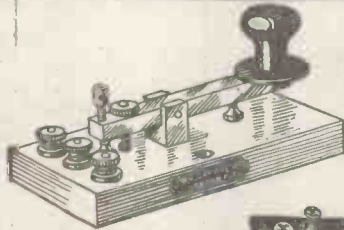

TAPPING KEYS.

Well finished and accurate working. Mounted on polished wooden base. Length of tapping key base 3 1/2 in. x 2 1/2 in. ... Price **3/6**
 Post 6d.
 Larger key, similar type to illustration. Mounted on polished walnut base 4 1/2 in. x 2 in. x 1/2 in. with two terminals ... Price **4/6**
 Post 6d.

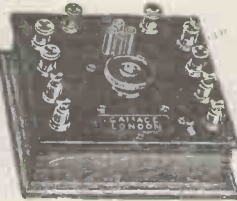

The "SONUS" UTILITY PANEL.

For use in adding Valves to Crystal Sets. This panel, finished in polished mahogany box with ebony top, lacquered terminals engraved, makes the adding of low frequency or high frequency valve to your B.B.C. or any other crystal set a very simple matter. Size 8 in. x 8 in. x 2 1/2 in., supplied complete with wiring diagrams and instructions. Price **20/-**

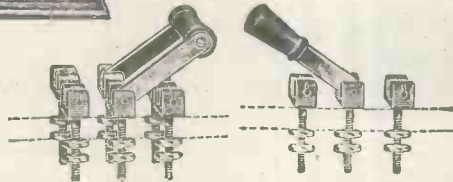

UNMOUNTED SWITCHES.

These switch parts are nickel-plated and consist of double switch arm with small black handle, together with the necessary contact parts complete with fixing nuts.
 Single Pole, change-over ... **1/6**
 Double Pole ... **2/3**
 Post free.

Customers are invited to consult us on any problems with their sets. Our assistants are always ready to help and advise. Come along to Gamages and see the wonderful Bazaar.



THE "KOOBEE" MULTIPLE CRYSTAL DETECTOR.

A whisker for every Crystal. The detector with many good points. Gives you the choice of six different whiskers. Solid Gold, Brass, Solid Silver, Copper, Phosphor Bronze, special Alloy. Price with three crystal cups **4/9**
 Arm only with six whiskers ... **2/3**
 Post free.



FULLER'S BLOCK WIRELESS ACCUMULATORS.

Special offer of ex-Government Stock, but absolutely unused.
 2 volt, **10/6** Post
 4 amp. 1/6.
 4 volt, **21/-** Post
 40 amp. 1/6.
 6 volt, **31/6** Post
 40 amp. 1/6.
 Boxes to hold 5 of these, fitted with lid and carrying strap, each 1/6. Postage extra. Five Accumulators and box sent post free.

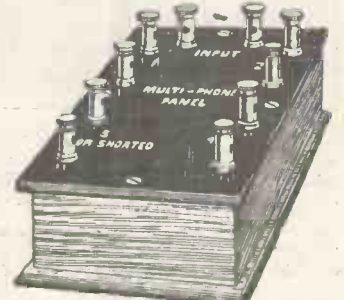

THE MULTI 'PHONE PANEL.

This is the perfect addition for any Wireless Set when it is required to use several pairs of phones. Price **7/6**
 Post 6d.

PERMANITE CRYSTAL

For best results use Regd. No. 438341
 always get the best results wherever the transmitting station. Gamages "Permanite" is the only crystal that can guarantee this efficiency. Clear powerful results. Highly sensitive and remains in adjustment longest. Price per large specimen **1/6**
 Post free.

A. W. GAMAGE, Ltd., HOLBORN, LONDON, E.C.1. Cheapside Branch: BENETFINKS.

"EL-BE" ANTI-CAPACITY HANDLES.

No Screws. No Clamps.

Fixed by Suction—Removed in a second.
 A Type for Horizontal working. Price **2/2** each
 C Type for Vertical working. Post free.
 A perfect combination with the "EL-BE" Coil Holder. Ask your DEALER for them.

"EL-BE" INSULATING PANEL BUSHES.

Experimenters save cost of EBONITE.
 4 B.A. Pillar-Terminals with one BUSH, 2/- doz.
 2 " " " " " " 3/- " " (with nut and washer).
 Extra BUSHES Tenpence per doz.
 Bushes tested for insulation to 25,000 volts.
YOUR DEALER WILL SUPPLY YOU.
LEIGH BROS.



37, Sidmouth Street, Gray's Inn Road, LONDON, W.C.1. Telephone: Museum 4547.

NEW IDEAS.



KEEN PRICES.

"QUALITY" WIRELESS COMPONENTS

Our New List which was in such demand at the Wireless Exhibition can now be obtained. Write or call for free copy.

EAGLE ENGINEERING CO., LTD., WARWICK.

LONDON SHOWROOMS: 8, GREAT RUSSELL STREET, W.C.1

You CANNOT be out of WIRELESS WEEKLY because it brings BIG Business.

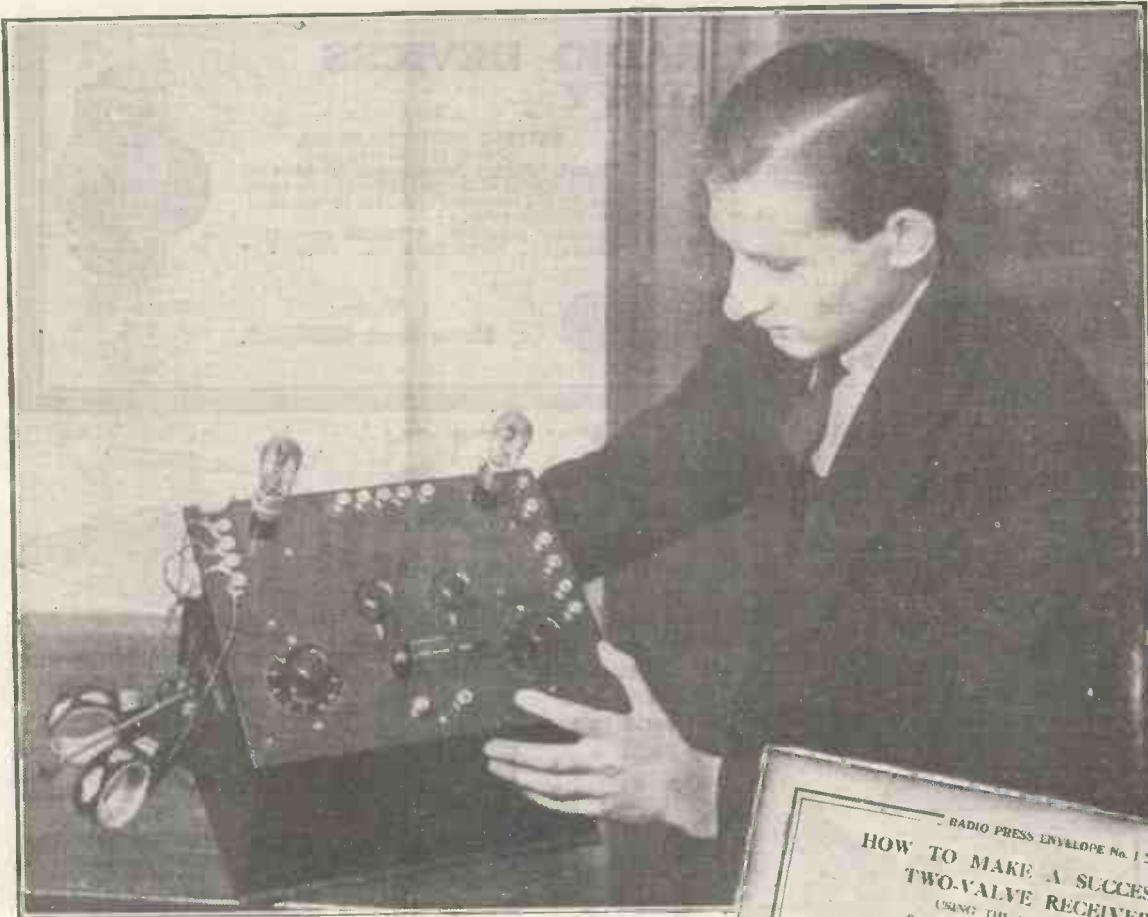

Full instructions for building this fine S.T. 100 Set:

THE tremendous success which followed the publication of constructional articles dealing with the S.T. 100 Circuit and the heavy demand from our readers for further articles on the same subject, has led us to place on the market an Envelope containing the fullest details about it.

This Envelope can be bought by anyone in full confidence that with the least amount of mechanical ability he can build a really first-class Receiver—similar in every respect to the one illustrated above.

But even more important, this Envelope contains working hints and instructions which will prove invaluable to anyone operating a Reflex Set for the first time.

We have aimed, in fact, to make the material contained in this Envelope as comprehensive as possible. Why not get one to-day and start building this most fascinating of Receiving Sets?

From all Booksellers

1/6



SIMPLEX RADIO CHARTS.

WE have just published a further series of envelopes, each of which contains a full size chart for building a Valve Receiver (see below) together with a booklet which explains exactly the components which are required for the construction of the Set.

- No. 1.—A Two-Valve Receiver 1/-
- No. 2.—A Three-Valve Receiver 1/-
- No. 3.—A Four-Valve Receiver 1/-

From all booksellers or direct (postage 2d. extra.)

RADIO PRESS Ltd.—Devereux Court, STRAND, W.C. 2.

Cossor

Everybody's Valve

ALTHOUGH the COSSOR—with its hood-shaped Anode and Grid—can always be depended upon to render a good account of itself during critical scientific tests, yet it is as everyone's work-a-day Valve that it gives the most gratifying results.

If the Aerial is poor and badly screened, the extra amplification produced by the COSSOR will save the day. If the Set is not too efficient and the user possesses more enthusiasm than skill, then the COSSOR can be relied upon to pick up distant stations clearly and distinctly.

Or, if the Loud-Speaker is to be called upon to deliver extra volume for dancing the COSSOR Valves can be given additional H.T. voltage without creating the slightest trace of distortion.

In short, although the discriminating select it for its technical superiority, we are more proud of it as being Britain's choice for the best Valve for everyday use.

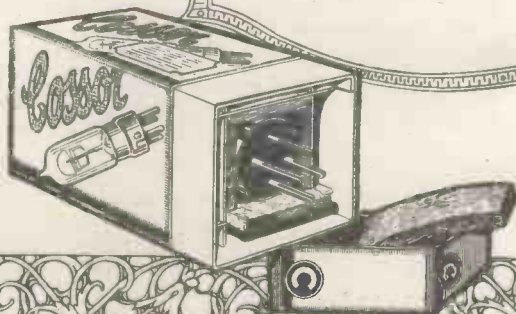

Advertisement issued by
Cossor Valve Co., Ltd.,
Highbury Grove, N.5.

Gilbert Ad.

You CANNOT be out of WIRELESS WEEKLY because it brings BIG Business.

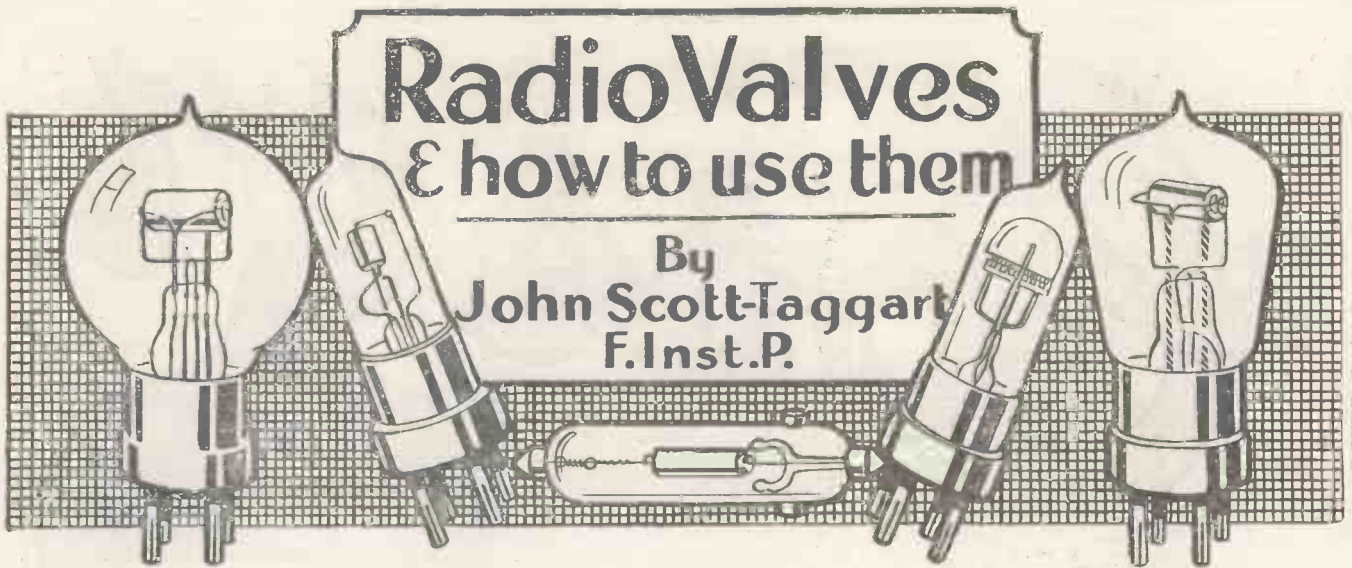

JUST
PUBLISHED!

—a complete course of
instruction on the Valve

Can you answer
these questions fully ?

What is meant by Reactance-capacity coupling ?

Which is more selective—
"Tuned Anode" or "Reactance capacity" for H.F. use ?

What is Reaction ?

What is meant by "Dual Amplification" ?

How is self-oscillation caused ?

What is an aperiodic transformer and its advantages ?

2/6

from all Booksellers, or
2/8 post free direct from
publishers.

RADIO PRESS, LTD.,
Devereux Court, Strand,
W.C. 2.

TO make real progress in Wireless you must be able to understand the principles of the Radio Valve. The importance of this cannot be emphasised too strongly.

While there are several Books on the Valve by the same author, none of them covers quite the same field as "*Radio Valves and how to use them.*"

This Book is rather more elementary in its appeal and should be extremely useful to those who are beginning to take a more serious interest in Wireless.

Its explanations are most lucid and graphically illustrated by a very large number of diagrams. It is a Book which, although dealing with a difficult subject, is most fascinating and intriguing in its appeal. A Book which ought, in fact, to be on every wireless enthusiast's book-shelf.

It is written from the point of view of the man who is going to *use* valves.

Radio Press Series No. 12.

You CANNOT be out of WIRELESS WEEKLY because it brings BIG Business.



W. G. PYE & CO.,



Manufacturers of Physical and Electrical Instruments,

**Granta Works,
CAMBRIDGE.**

If you are building your own set, and want the best components, you must use our :—

**Tuning Coils,
Coil Holders,
Switches,
Condensers,
Panels, etc.**

TWO-VALVE RECEIVING SET (No. 520.)
 Price, including all royalties (less Valves) .. £12 11 0
 Price, including Headphones, Valves, Batteries, etc., and all Royalties .. £18 10 0
 Two Valve-Power Amplifier of similar design. Price .. £10 10 0

Complete Receiving Sets of 2, 3, and 4 Valves also supplied.



RESULTS!

WIRELESS WEEKLY

will bring you
BUSINESS

It is as good an advertising medium as
MODERN WIRELESS.

Rates for both publications on application to—

Scheff Publicity Organisation

Ltd.

125, Pall Mall, London, S.W.1.

No. 2.

Phone: Regent 2440.

CHANGE OF ADDRESS.

J. FRANCIS

147/149, Newington Causeway,
Elephant and Castle, S.E.1.

HOP 57.4

VERNIER AIR
DIELECTRIC CONDENSER

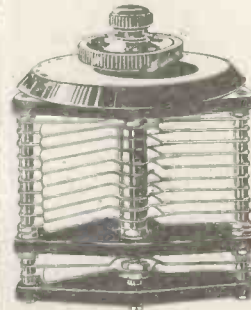

.0003, 10/- .0005, 12/- .001, 15/-

FIXED VANES are Adjustable to MAIN CONDENSER.

Liberal Discount to Dealers.

Wholesale Factors
OF

EDISON BELL

SPECIALITIES

VARIOMETERS.
TWIN DETECTORS.
FIXED CONDENSERS,
from .0001 to .005.
GRID LEAKS, .5, 1, 2 & 3 megs.
AUTOMATIC EARTH PLUG.
JACK SWITCHES.

"E.B." CRYSTAL SETS.
DIALS, KNOBS, ETC.

Lists sent on application.

DEALERS ONLY

You CANNOT be out of WIRELESS WEEKLY because it brings BIG Business,

WIRELESS WEEKLY SMALL ADVERTISEMENTS.

PREPAID Advertisements are accepted under this heading for Wireless Apparatus and Parts WANTED or FOR SALE, etc., at the rate of 1s. 6d. per line, MINIMUM THREE LINES, Advertisements should reach Scheff Publicity Organisation, 125 Pall Mall, London, S.W.1, LATEST by first post FRIDAY preceding date of publication. The publishers are not responsible for clerical or printers' errors, but every care is taken to avoid mistakes.

4 VALVE ASHLEY SET, reaction, B.B.C. stamped, including 2 accumulators, 1 H.T. battery, 1 full-size amplifier. Insured for £75, Sale £35.—HHH, 383, Kentish Town Rd., N.W.5.

3 VALVE SET, tuned anode, plug in coils, mahogany case, ebonite top, receives American broadcast, professionally made, £10; Peto Scott panel and box, wired as 2 valve receiver, 10/-; variometer, coils and condensers for above, 10/-; ten Discol transformers (50 to 400), two sets, 10/- each; Oajah transformers (1 to 4), 2/- each; 1 pair Brown "A" patt. phones, 300 ohms, £1; 1 pair army ditto, 10/-; exchange entertained.—Knowles, 55, Denmark Villas, Hove.

2 VALVE WIRELESS set for sale on stand complete with 2 valves, 3 pairs ear 'phones, low and high tension batteries, wireless pole and aerial, £10. Seen Weybridge.—Box 342, Review Press, Ltd., 13, Little Trinity Lane, E.C.4.

AT LAST! A really genuine Crystal, loudest yet produced, sensitive all over, 1/8 post free; money returned if not satisfied.—C. Hatton, 55, Eglinton Hill, London, S.E.18.

SPECIAL CHRISTMAS OFFER.—The neatest, most compact and efficient LF transformer ever marketed, original price, 15/-; Special Offer (one week only), 10/6 each, post paid.—Bain, 20, Waghorn St., London, S.E.15.

HOME CONSTRUCTORS! Send for our lists of parts; lowest prices, best value. Save pounds by dealing with Webb and Goward, Caxton St., Market Harborough.

B.B.C. Crystal Sets (stamped).—Agents wanted for districts within 25 to 30 miles of any broadcasting station. Prices from 7/9 to 13/9 each; every set guaranteed.—Simons, 100, Houndsditch, London, E.1.

2 VALVE SET, HF and Det, all broadcasting clearly received at Brighton; price, £2 40s, carriage paid (no accessories).—Phillips, 64, Ewart St., Brighton.

FOR the Experimenter.—1/8 in. square copper rod, tinned, fine for wiring panels, 2 ft. lengths, 3/- doz.; ribbon aerial, 100 ft. 3/-. Mark III* tuners, army condensers. Send for list.—Spark's Radio Supplies (Dept. W.), 43, Gt. Portland St., W.1. Trade supplied.

5-VALVE experimental cabinet with coil holder and coils, £20. Complete with D.E.R. valves, batteries and 'phones, £30.—Goodwin, Chemist, Spondon, Derby.

A BARGAIN.—New Magnavox 3-power valve amplifier with 3-power valves and 300 volts H.T., cost £30, sell £20. New Sterling intervalve transformer, cost 30s. sell £1.—May, 220 Clarence Road, Kentish Town, N.W.1.

SELECTONE.

Fit your wireless set with Selectone Super Radio L.F. Transformers.

A most gruelling test has lately been carried out by the National Physical Laboratory, and results are such that we will send *complete* copy on request.

BRITISH ELECTRIC & TRANSFORMER CO.,
Brent Green, Hendon, N.W.4.

See page xv.



CABINETS YOU WANT

PICKETT'S Cabinets—they're good value, from 1/6 each, highly polished. Cabinet Works, Albion Rd., Bexley Heath, S.E. Write for Lists W.L.

RESULTS!
WIRELESS WEEKLY

will bring you
BUSINESS

It is as good an advertising medium as
MODERN WIRELESS.

Rates for both publications on application to—
SCHEFF PUBLICITY ORGANISATION, LTD.,
No. 2, 125, Pall Mall, London, S.W.1.

Phone Regent 2440.

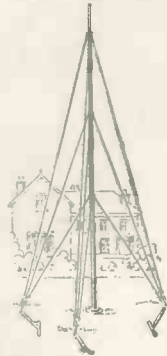

Ex-Government Steel Masts

Large diameter steel tubing (2 1/2 inches), very strong, extremely light, socket joints, 11-ft. lengths, non-rusting finish. Cannot be repeated at double the price.

Complete with pulley, guy wires, anchors, cleat, and wire tensioners—

27 1/2 feet	25/-	38 1/2 feet	38/-
33 "	33/-	44 "	44/-

Carriage paid.

TUBULAR GATE CO., Ltd.,
Lord Street, SOUTHPORT.

Radio Press Information Dept.

2/6 QUERY COUPON 2/6

WIRELESS WEEKLY. Vol. 2. No. 21. December 5, 1923.

(This coupon must be accompanied by a postal order of 2/6 for each question, and a stamped addressed envelope.)

AMATEURS—HAVE YOUR PANEL NEATLY ENGRAVED.

It is permanent and far superior to scales and tablets, Panels drilled and engraved, delivery by return of post.

ESTIMATES FREE.

We also make steel and brass dies for marking panels, dials, etc. in quantities.

T. R. FRANCIS, 28, GLOUCESTER ST., CLERKENWELL, LONDON, E.C.1

Fix your Crystal in—GOLD SEAL PLASTIC METAL

It is positively the best contact possible, and results in **LOUDER AND CLEARER SIGNALS.**

Guaranteed to contain no mercury. Price 6d. per packet, sufficient for 3 to 4 crystal cups. Of all Wireless Stores.

Wholesale Enquiries (or sample 6d.) to

SAMUEL LEVY, 53, Ben Jonson Road, Stepney, London, E.1.

EBONITE

Sheet rod and tubing in all sizes kept in stock and cut to any required size while you wait, or sent by post on receipt of cash.

WE CAN TURN ANYTHING IN EBONITE.

BURGE, WARREN & RIDGLEY, LTD.,

91/92, GREAT SAFFRON HILL, LONDON, E.C.1. Phone 8572 Central.

You CANNOT be out of WIRELESS WEEKLY because it brings BIG Business.



R.P.

Home - built Wireless Components

—a new Book giving
complete constructional
details and drawings

EVERY time the wireless enthusiast wants to build *every* part of his Set. Not only does he save money, but he is able to appreciate better how each individual component works.

It is not uncommon to find that the man who is sufficiently painstaking to make his own components will get better results from a 1-Valve Receiver than many will get from 3-Valve Sets. This is merely because he has the patience to experiment and to be continually making adjustments for the improvement of his reception.

If you are contemplating making additions to your Receiving Set, why not get a copy of **Home-built Wireless Components** and start making some of the parts yourself? With the technical data given and the very clear diagrammatic sketches, you can't possibly go wrong.

Remember, every article described has been actually built up and subjected to thorough tests.

Published by
RADIO PRESS, LTD.,
Devereux Court,
Strand, W.C. 2.

2/6

From all Booksellers or
2/8 post free direct.

R.P.

Radio Press Series No. 16

R.P.

You CANNOT be out of WIRELESS WEEKLY because it brings BIG Business.

NEW BOOKS.

JUST PUBLISHED.

ARE YOU GOING TO STAGNATE THIS WINTER? CHOOSE YOUR NEW BOOKS FROM THIS LIST.

Radio Valves and How to Use Them. By John Scott-Taggart, F.Inst.P.

This volume constitutes a complete course in the theory and operation of the thermionic valve, commencing with such elementary considerations of its working as will enable the absolute beginner to tackle the subject easily and leading right on to the theory of such recent developments as the Flewelling circuit. The text of the book takes the form of question and answer, the questions having been carefully framed to bring up the difficulties which perplex beginner and advanced experimenter alike in such a way as to settle the problem once and for all in the mind of the reader. A special feature of the book is the plentiful use of pictorial diagrams, which have been specially drawn to show the relation between a theoretical circuit diagram and the actual wiring of the corresponding receiving set.

2s. 6d. NET.

Twelve Tested Wireless Sets and How to Build them. By Percy W. Harris.

As one of the most popular writers of constructional articles, Mr. Harris has described in *Modern Wireless* and *Wireless Weekly* a large number of extremely practical and useful

receiving sets, and certain of these designs are brought together for the first time in this book, together with information and description not previously published. A new set of special interest is a three-valve Reinartz receiver of original design, incorporating a stage of high-frequency amplification in such a way that the original virtues of the Reinartz circuit are preserved.

Every set has been constructed by the author himself and exhaustively tested, and therefore the reader may feel confident that each one is a thoroughly practical design. The earlier designs have been amplified and several additions suggested by the experience of readers have been made.

2s. 6d. NET.

More Practical Valve Circuits. By John Scott-Taggart, F.Inst.P.

Another book on the general lines of the perennially-useful "Practical wireless valve circuits." Besides a great variety of standard circuits of all sorts, the volume contains all the latest developments in super-regenerative, Flewelling and reflex circuits, including ST75, ST76, ST100, and a number of original and hitherto unpublished circuits. Each circuit is accompanied by a short description and some useful

notes on its working. Correct values of all the components in each circuit are given. The book is attractively bound in cloth.

3s. 6d. NET.

500 Wireless Questions Answered. By E. Redpath and G. P. Kendall, B.Sc.

One of the first things that the beginner in wireless discovers is that there is an amazing difference between understanding the general principles as expounded in an elementary text-book and possessing the really practical and detailed knowledge required to construct and operate wireless sets successfully. "500 Wireless Questions Answered" has been compiled for the express purpose of bridging the gap and solving all the problems which confront the beginner when he turns to the practical side of wireless, explaining the "why" of many things which even the more experienced experimenter often does not understand.

The volume is broken up into sections covering all the principal branches of the science and is provided with a very full index, so that any required piece of information may be readily found.

2s. 6d. NET.

Pictorial Wireless Circuits. By Oswald J. Rankin.

The ideal book for the beginner who finds it difficult to wire up a set from a circuit diagram. Each component is represented pictorially and the actual wiring is shown, so that no technical knowledge is required to assemble a set. A variety of good standard valve and crystal circuits are given, each accompanied by useful notes and the values of the components, besides a miscellaneous section of switching arrangements, etc., and a useful data section.

1s. 6d. NET.

ORDER FORM.

Make sure of obtaining your SIX SPECIAL ISSUES by completing this form and handing it to your news-agent *without delay*.

PLEASE SUPPLY ME WITH WIRELESS WEEKLY FOR SIX WEEKS COMMENCING WITH THE DECEMBER 12TH ISSUE, VOL. 3, No. 1, AND UNTIL FURTHER NOTICE.

Signature.....

Address.....

You CANNOT be out of WIRELESS WEEKLY because it brings BIG Business.

200,000 MAGNET LETTERS have been supplied by us to WONDERSIGNS of HOBORN. Each letter is a perfect Magnet. Hence our knowledge of what a Magnet should be, and our ability to produce the BONTONE PHONE under mass production.



Points to Consider.

Every Phone is sold under guarantee. Every Phone is tested before leaving Factory. We are Old-Established British Manufacturers, whose object is to give complete satisfaction. Why saddle yourself with unscrupulous Importers, with small offices and elaborate note-paper, and NO GUARANTEE or hope of redress if found faulty. Original of upwards of 100 unsolicited testimonials and letters of appreciation can be seen at our offices. **GUARANTEE.**—We agree to replace or return cash if Phones do not give complete satisfaction, subject to Phones being returned to us within 7 days of purchase undamaged.

BONTONE PHONES (4,000 ohms) BRITAIN'S BEST.

14/6 per pair. Carriage paid United Kingdom.

SENSITIVE, DURABLE, COMFORTABLE, AND BEAUTIFULLY FINISHED.

Manufactured entirely by **BRITISH labour.**
LIBERAL TERMS TO THE TRADE.

B. D. & CO. (Edward A. Boynton).

WORKS: GOSWELL ROAD AND CITY ROAD.
OFFICES: 167-173, GOSWELL ROAD.

ADMIRALTY, WAR OFFICE, AND INDIA OFFICE CONTRACTORS.

SELECTONE

Super Radio

L.F. TRANSFORMER



Extract from report of National Physical Laboratory:

AMPLIFICATION.
Frequencies, 1,000. 2,000.

Ratio: (5 to 1) 8.0 18.0
(2.2 to 1) 14.5 17.0

Breakdown Test.

Ratio: (5 to 1) 2,100 volt.
Mean square root value.

PRICE (5 to 1) 27/6
(2.2 to 1) 31/8

N.B. Our new pattern embodies improved type pin terminals.

British Transformer & Electric Co. Brent Green, Hendon, N.W.

Following the reduction in the B. B. C. tariff we are by increased output able to announce the following

REDUCTIONS IN PRICE

OF ALL **MH** PRODUCTS

When you see M. H., The Mark of Merit, on any piece of wireless apparatus, you know that it is efficient, well made and reasonable in price, and British.

M. H. COMPLETE SETS FOR BROADCAST AND GENERAL RECEPTION STAMPED B.B.C.

M.H.B.R.2. Two Valve Receiver ..	£15 0 0 plus 17/8	M.H.B.R.4. Four Valve Receiver ..	£22 10 0 plus 27/6
M.H.B.R.2A. Two Valve Amplifier ..	10 0 0 ,, 10/0	M.H. Crystal Set. Everset Crystal ..	1 14 0 ,, 1/-
M.H.B.R.3. Three Valve Receiver ..	18 0 0 ,, 22/8		

M. H. ACCESSORIES AND COMPONENTS.

Condenser Variable .0007 mF ..	18/-	Variable Plug Adapter, split grid ..	3/8
Fixed Condenser and clips ..	16/-	Valve Adapter, V 24 ..	3/6
Grid Leak, all values ..	1/4	Valve Holder ..	2/3
Grid Leak and Condenser Mounted ..	1/-	for flat mounting ..	1/6
Coil Holder Capstan ..	2/8	Duo lateral Coil Holder Valve Adapter ..	2/-
" Polished, 2 coil ..	12/6	Plug and Socket Terminal Adapter ..	1/6
" " 3 coil ..	12/6	Filament Resistance Standard with knob and dial ..	5/8
" " Side Fixing, 2 coil ..	15/-	" Flat Mounting ..	4/8
" " " 3 coil ..	7/6	" With Knob and Pointer only ..	4/-
Coil Mount with tags and screws ..	1/8	" Second quality ditto ..	2/8
for flat mounting ..	1/8	Adapter, plug-in type ..	12/8
Transformers H.F. Variable, mounted 150/600 metres ..	22/6	Knobs and Extension Handles ..	1/8
" " 600 metres up ..	22/6	Potentiometer, mounted ..	21/-
" " plug-in 150/600 metres ..	20/-	for panel mounting ..	7/6
" " 600 metres up ..	20/-	Reactance Capacity Coupling, mounted, low range ..	27/8
Transformers H.F. Plug-in No. 0 150/300 metres ..	7/-	" " high range ..	27/6
" " 1 300/600 ..	7/-	" " low range ..	25/-
" " 2 550/1200 ..	7/-	" " high range ..	25/-
" " 3 1100/3000 ..	7/-	Crystal Detector, 5 crystal ..	7/6
" " 4 2000 upwards ..	7/-	Anode Resistance, including resistance ..	4/-
" " The complete set of 5 ..	32/6	" without ..	3/-
Transformer, intervalve ..	18/6	Resistances for ditto ..	1/3
telephone ..	17/6	Anode Resistance, all values ..	1/3
Another type, on mahogany case with ebonite top ..	15/-	" Everset " Crystal Detector ..	4/-

VISIT STAND No. 83, AT THE ALL-BRITISH WIRELESS EXHIBITION, WHITE CITY.

Buy British Goods Only.

L.M. MICHAEL LTD

Buy British Goods Only.

LONDON: HASTINGS HOUSE,
(Head Office) Norfolk Street, Strand, W.C.2

IN CONJUNCTION WITH **B. HESKETH LTD**

Radio Corner (Retail Showrooms), 179, Strand,
Barnardiston, 5, Yelverton Road. W.C.2

You CANNOT be out of WIRELESS WEEKLY because it brings BIG Business.

OVER A MILLION SATISFIED CUSTOMERS ELKAY WIRELESS CO.

GREAT BRITAIN'S LARGEST EXCLUSIVE WIRELESS STORES.
Quality, Quantity and Consistency Our Motto. See Our Six-Window Display of Bargains.

PIONEERS OF CHEAP PRICES. WIRELESS & EVERYTHING FOR IT.

ELKAY Lightweight Headphones, 4,000 ohms. All guaranteed. per pair **12/9**
FELLOW'S New Lightweight phones 4,000 ohms. Stamped B.B.C. **18/6**

Super-'Phones, Light, easy adjustment, 4,000 ohms, Guaranteed ... **13/9**
N & K (The genuine article) 4,000 ohms. All guaranteed. per pair **12/9**

ALSO BROWNS, BRUNET, THOMSON-HOUSTON (French), etc., AT SPECIAL REDUCED PRICES.

VALVES MARCONI R EDISWAN MULLARD ORA COSSOR (Red or Plain Top) **ALL ONE PRICE** } each **11/10**
Special Packing and Postage 1/- extra. Bankrupt Stock and of limited quantity.

DULL EMITTER VALVES: Marconi, Ediswan, Mullard. All One Price. Packing and Postage, 1/- extra. Bankrupt Stock and of limited quantity **24/9**

LOUD SPEAKERS. Say What Make You Require. 10% Reduction of STANDARD PRICES.

DUTCH VALVES 6/11 & 7/11	FILAMENT RESISTANCES, smooth 1/9	H.F. PLUG TYPE TRANSFORMER:
L.F. TRANSFORMERS Ratio 5 to 1. All guaranteed (postage 1/-) each 11/3	With engraved dials 2/6	1 .. 250 to 600 metres .. 3/9
CRYSTAL DETECTORS 1/9, 1/3, and 10/4d.	FILAMENT COMPLETE CIRCLE RESISTANCE SCALES, 0 to 300 each 6d.	2 .. 350 to 710 .. 4/3
CRYSTAL DETECTORS , enclosed in glass case 2/6, 2/3, 1/6	BELL WIRE, tinned copper, 12 yds. 6d.	3 .. 100 to 900 .. 4/6
AERIAL WIRE, 7/22, guaranteed hard-drawn copper, 100 ft. (postage 1/-) 1/10d.	VALVE LEGS, nut and washer .. each 1d.	4 .. 800 to 1350 .. 4/9
CONDENSER VANES, fixed or moving, per doz. 3/4d.	VALVE PINS, nut and washer .. each 1d.	5 .. 1600 to 3200 .. 5/-
REAL GOLD CAT'S WHISKERS each 2d.	PLUNGER SPRINGS, complete .. each 1d.	VARIABLE CONDENSERS of high quality. With aluminium top and bottom plates: Complete with knob and dial, guaranteed accurate:
SILVER CAT'S WHISKERS per doz. 1/5	SLIDER ROD, brass, 13 ins. long, 3/4 in. square, drilled .. each 3/4d.	Vernier .. 3/-
SILVER CAT'S WHISKERS per doz. 7d.	SLIDER KNOB .. each 2d.	.002 .. 4/6
CONDENSER SCALES, 0 to 180 each 3/4d.	SWITCHES ON EBONITE, S.P.S.T. (quality the best) .. each 1/6	.003 .. 5/6
IVORINE LABEL SET, 12 different titles, the set 6/4d.	SWITCHES ON EBONITE, S.P.D.T. (quality the best) .. each 1/11	.005 .. 6/-
BASKET COILS, set of 6, up to 3,000 metres 2/4	SWITCHES ON EBONITE, D.P.D.T. (quality the best) .. each 2/9	.0075 .. 7/-
SLEEVING, 3 yds., assorted colours, for 11/4d.	CONDENSER SPINDLES, all sizes in stock, from .. each 1/4d.	.001 .. 8/-
NUTS, 2 B.A. .. per doz. 2/4d.	SCREWED ROD, 2 B.A., 12 ins. long from .. each 1/4d.	SUPER-QUALITY 2-WAY COIL HOLDER 5/3
NUTS, 4, 5, 6, and 8 B.A. .. per doz. 2d.	SCREWED ROD, 4 B.A., 12 ins. long .. each 2/4d.	REAL EBONITE 3-WAY COIL HOLDER 7/9
WASHERS, 4 B.A. .. per doz. 1/4d.	RUBBER INSULATED LEADING-IN WIRE .. per yd. 1/4d.	O.B.A. NUTS .. per doz. 4d.
WASHERS, 2 B.A. .. per doz. 1/4d.	VARIABLE GRID LEAK, Pencil type, 1/11	DETECTOR ARMS, Ball Joints, Ebonite Handle and Whisker Holder .. 3/4d.
CONTACT STUDS, with nuts and washers, per doz. 4d.	INSULATORS, white reel, 2 in., each 1d.	WOOD SCREW TERMINALS .. each 1/4d.
TERMINALS, with nut and washers, each, 1d., 1/4d., & 2d.	INSULATORS, white egg, each 2d.	SHELLAC per bot., 10/4d. & 6d.
EBONITE KNOBS, 2 B.A. .. each 2d. & 3d.	WOUND INDUCTION COILS (postage 9d):	AERIAL PULLEYS ea. 10/4d., 8/4d., 6d., & 4/4d.
SPACING WASHERS, large .. per doz. 2/4d.	12x4 9x4 8x2 6x3 6x2	TINFOIL large sheet 4d.
SPACING WASHERS, small .. per doz. 1/4d.	2/5 2/3 1/11 1/8 1/5	COPPER FOIL, 6 in. wide .. per ft. 5d.
CRYSTAL CUPS, 2 screw .. each 1d.	TAPPED INDUCTION COILS, 20 tappings wound to 1,600 metres .. each 2/6	GRID LEAKS, 2 1/2 and 2 meg. each 10/4d.
CRYSTAL CUPS, 4 screw .. each 2d.	VARIOMETERS (Tube type), complete with knob 3/11 & 2/11	FLEX (Twin), various colours per yd. 2d.
FIXED CONDENSERS, all capacities each 10/4d.	DOUBLE 'PHONE CORDS, full length 11/4d.	CONNECTING WIRE, tinned copper, 20 gauge .. 3 yds. 2d.
EBONITE, cut to any size by machinery while you wait .. per lb. 3/6	HERTZITE, genuine, in box .. 8d.	ENAMEL WIRE in 1/2, 1, and 1 1/2 lb. reels: per lb. 22 24 26 28 2/4 2/8 3/2 3/6
TELEPHONE TERMINALS, nuts, and washer, each 1/4d. .. per doz. 1/3	TALITE, genuine, in box .. 8d.	Note.—Bobbins 2d. each extra.
W. O. TERMINALS, nuts and washers each 2d. .. per doz. 1/7	PERMANITE, genuine, in box .. 8d.	POTENTIOMETERS, guaranteed up to 900 metres, superior make, compact size 7/3
PANEL BUSHES, drilled .. each 1/4d.	ZINCITE, genuine, in box .. 8d.	CRYSTAL DETECTOR, glass enclosed, fitted on 4x2 ebonite panel with terminals for aerial, earth, and 'phones, already wired and beautifully finished 4/9
TOP CONDENSER bushes .. each 1d.	BORNITE, genuine, in box .. 6d.	VALVE HOLDERS each 10/4d. & 1/3
BOTTOM CONDENSER bushes .. each 1d.	MIXED CRYSTALS (6 kinds) .. 5/4d.	BATTERIES, H.T., dry:
SWITCH ARMS, 4 laminations, ebonite knob, complete with panel, bush, nuts, and spring washer .. 8/4d.	CARBORUNDUM .. 5/4d.	30 volts, including Wander Plugs .. 5/9
STOPS with nuts .. per doz. 6d.	ZINCITE and BORNITE, both in box .. 1/-	60 volts, including Wander Plugs .. 9/6
	COIL PLUGS, real ebonite 1/3, 10/4d., & 9/4d.	AMALGO-PLASTIC METAL, for fixing Crystals. No Wood's metal necessary 6d.
	EBONITE CONDENSER KNOB AND DIAL .. 1/6	GOLD SEAL PLASTIC METAL, for fixing crystals 6d.
	FILAMENT RESISTANCE DIALS .. 8/4d.	IVORINE NAME PLATES, all readings, each 1d. per doz. 9d.
		EARTH CLIPS, Copper, adjustable, each 5/4d.

IMPORTANT: Mail Order Dept.: Orders Despatched Same Day as Received—NO WAITING. Goods Sent to all Parts of the World. Don't Pay More and Get Junk. Pay LESS and get the GOODS AT

"ELKAY" WIRELESS CO., 225 & 227, BISHOPSGATE, LONDON, E.C.2.

Open Saturday all day. (To the Trade—New Trade Counter now open.) We open Sundays 11 to 2-30.
Special Terms to Radio Clubs. Note our Telephone Nos.: Wholesale, Bishopsgate 2313 Retail, Central 8544.
PLEASE REMIT AMPLE POSTAGE. Telegrams: "ELKAYWIRY, AVE."

SAVE MONEY BY STUDYING OUR ADVERTS.

MAKE NO MISTAKE
When calling SEE THAT YOU ARE AT ELKAY'S

You CANNOT be out of WIRELESS WEEKLY because it brings BIG Business.

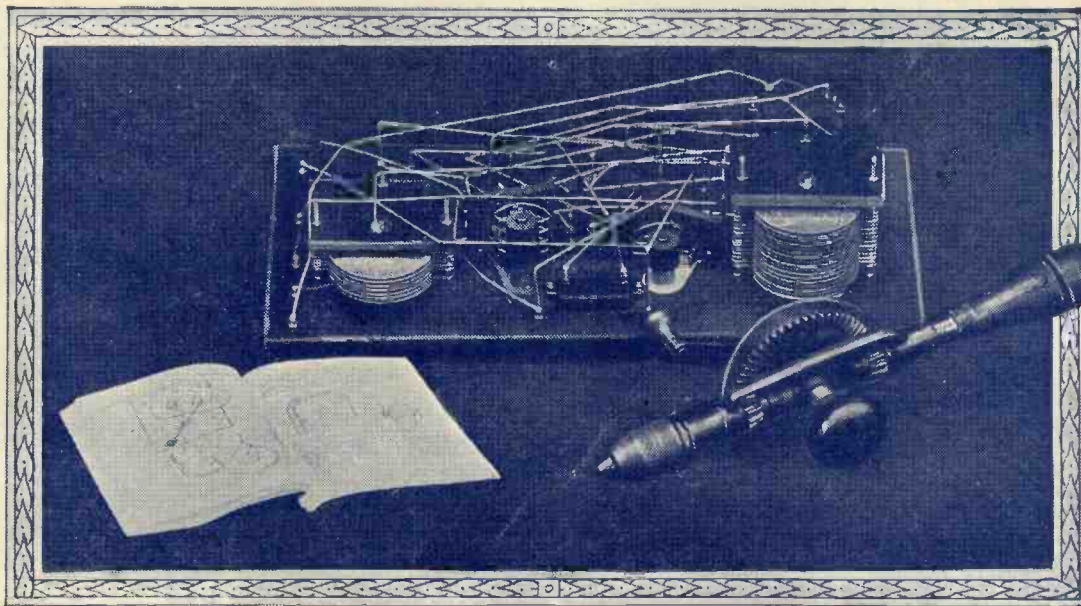

Good Books and a few simple household tools —

Choose your Books from this List:

	Price
1. Wireless for All By JOHN SCOTT-TAGGART, F.Inst.P.	6d.
2. Simplified Wireless By JOHN SCOTT-TAGGART, F.Inst.P.	1/-
3. How to Make Your Broadcast Receiver By JOHN SCOTT-TAGGART, F.Inst.P.	1/6
4. How to Erect Your Wireless Aerial By B. MITTELL, A.M.I.E.E.	1/-
5. The Construction of Wireless Receiving Apparatus By P. D. TYERS.	1/6
6. The Construction of Crystal Receivers By ALAN L. M. DOUGLAS.	1/6
7. How to Make a "Unit" Wireless Receiver By E. REDPATH.	2/6
8. Pictorial Wireless Circuits By OSWALD J. RANKIN.	1/6
9. Wireless Valves Simply Explained By JOHN SCOTT-TAGGART, F.Inst.P.	2/6
10. Practical Wireless Valve Circuits By JOHN SCOTT-TAGGART, F.Inst.P.	2/6
12. Radio Valves and How to Use Them By JOHN SCOTT-TAGGART, F.Inst.P.	2/6
13. 500 Wireless Questions Answered By G. P. KENDALL & E. REDPATH.	2/6
14. 12 Tested Wireless Sets By P. W. HARRIS.	2/6
15. More Practical Valve Circuits By JOHN SCOTT-TAGGART, F.Inst.P.	3/6
16. Home-Built Wireless Components Elementary Text-book on Wireless Vacuum Tubes By JOHN SCOTT-TAGGART, F.Inst.P.	10/- (post free.)

Published by
Radio Press, Ltd.,
Devereux Court,
Strand W.C.2.

ONE of the great charms of Wireless lies in its appeal to our national character. We possess in a far greater degree than any other nation the faculty of teaching ourselves the use of tools and the ability to devise home-made substitutes for the more elaborate factory-made article.

Thousands of enthusiasts have made their own Sets not with the idea of saving money, but because they are intrigued with the fascination of being able to make something which will really work.

And a very large number of these Wireless experimenters have obtained their information from Radio Press Books

If you, too, have decided to enter the ranks of the Home Constructors, look down the list of books on this page and make your selection. Any of them can be obtained from your local Bookseller or we will send them direct at an extra cost of 2d. per book for postage.

Radio Press Books
— a complete wireless library

The Ideal Christmas Present

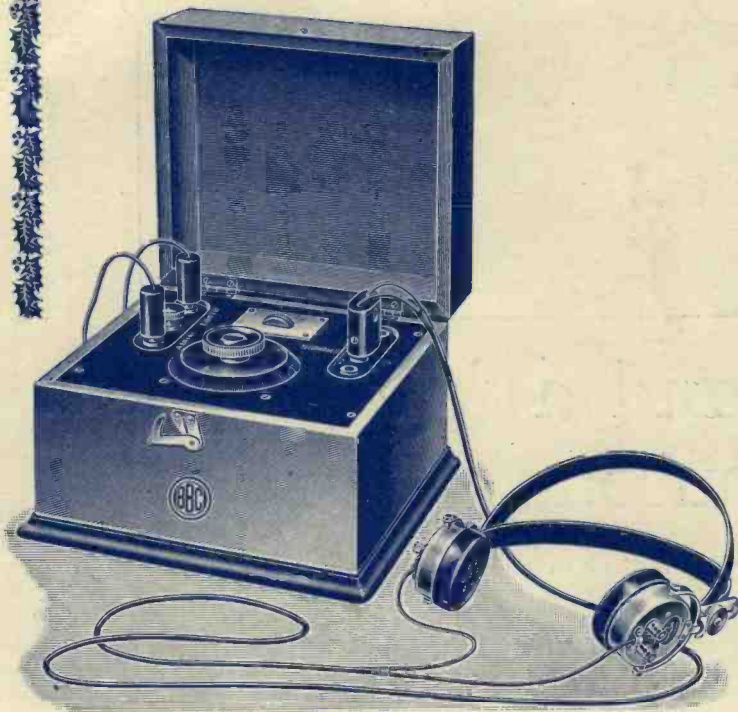

No R 1552.

PRICE £4 - 10 - 0

B.C.C. Tariff is. extra net.

STERLING

No. 2

CRYSTAL RECEIVING SET VARIOMETER TUNED

An entirely new departure in Crystal Set construction, at a moderate price.

FITTED WITH "STERLING" PATENT SEMI-AUTOMATIC CRYSTAL DETECTOR. NO TEDIOUS PROBING FOR SENSITIVE SPOTS. EVERY TURN OF THE WHEEL FINDS A SPOT.

Complete in highly-finished Walnut Case, with one pair of "STERLING" High Grade Head Telephones, cord and plug, and with cord, plug and socket connections for earth and aerial

**APPROXIMATE RANGE FOR
BRITISH BROADCAST
30 MILES.**

An extra aerial inductance is mounted internally and can be switched into the circuit for

PARIS TIME SIGNALS.

Obtainable from all Electrical Dealers and Stores.

STERLING TELEPHONE & ELECTRIC CO., LTD.,

Manufacturers of Telephones and Radio Apparatus, etc.

(WHOLESALE ONLY).

Telephone House, 210-212, TOTTENHAM COURT ROAD, LONDON, W.1.

Telephone: Museum 4144 (7 lines).

Telegrams: "Cucumis, Wesdo, London."

BIRMINGHAM: 150, Edmund Street. CARDIFF: 10, Park Place. GLASGOW: 33, Robertson Street. MANCHESTER: 14, St. Peter's Square. NEWCASTLE-ON-TYNE: 9, Clavering Place. WORKS: Dagenham, Essex.

Wireless Weekly

and The Wireless Constructor

Vol. 3.
No. 1.

CONTENTS

OUR
FREE GIFT
SCHEME

FULL PARTICULARS
INSIDE

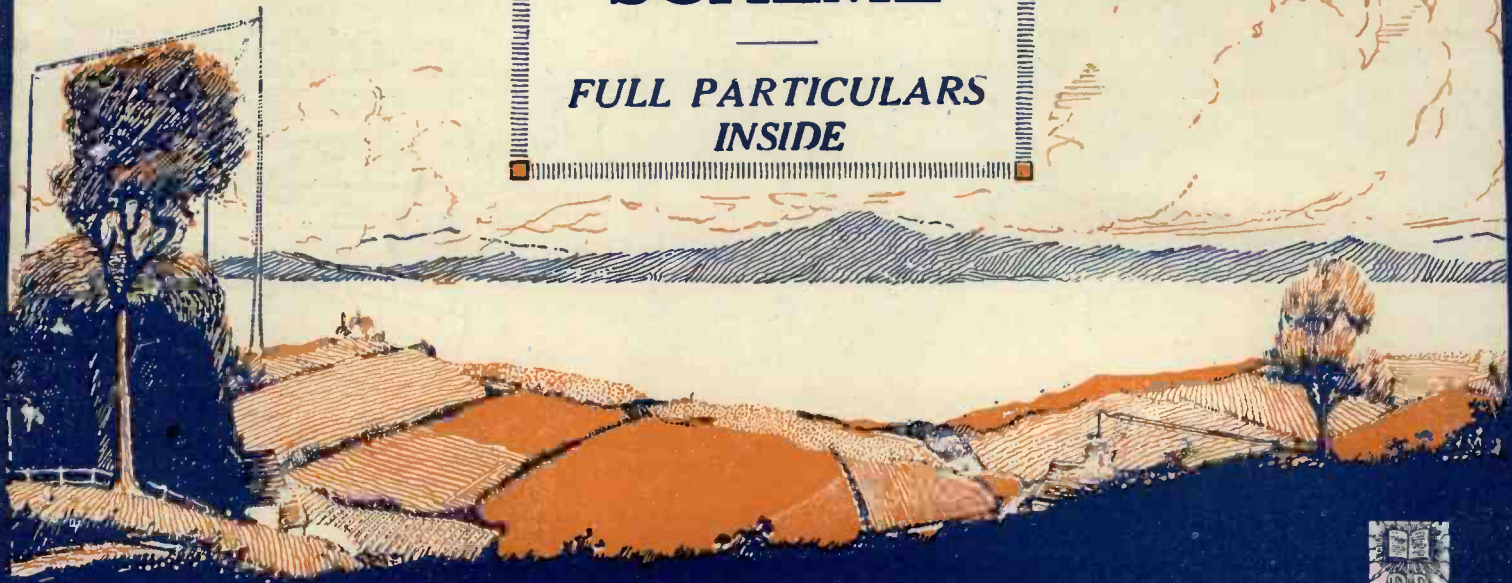

Number One of Six Special Issues.



Cosmos Radio Sets for Xmas Presents



YOU could make a gift of nothing more acceptable this Christmas than a well-made and efficient Radio Receiving Set.

The Sets illustrated here represent a few of the series of

COSMOS RADIOPHONES

any of which, from the Crystal Set at £3 10s. to the Six-Valve Jacobean Cabinet at £125, would form a splendid gift.

"Cosmos" Radiophones are obtainable from all Retailers of Wireless Apparatus.

Send for our Catalogue and Handbook L.W. 7117/1 Post Free 1/- from the Manufacturers—

METROPOLITAN Vickers

ELECTRICAL CO. LTD
TRAFFORD PARK WORKS :: MANCHESTER

For those who are interested in Wireless Experiments give **RADIOBRIX** from 24/- to 50/- each.

The Book of Circuits shown here contains much valuable wireless information. Obtainable from all Newsagents & Radio Dealers 1/- (Post Free 1/5.)



R
Z43A

Wireless Weekly

Vol. 3, No. 1
Dec. 12, 1923.

CONTENTS

	Page No.
Editorial	2
Six Lectures on Dual Amplification, No. 1 .. .	3
A Broadcast Crystal Receiver	7
How to Adjust the Variable Grid-Leak	8
Jottings by the Way	9
A Positive Selector Switch	10
Broadcasting News	11
A Cabinet ST100 Receiver	14
Loud Speakers for Wireless Purposes	19
"Wireless Weekly" Universal Valve Panel	20
How to Design your Own Set	25
The Simplest Super Set	27
Valve Notes	29
Apparatus Tested	30
An Adaptor for Basket Coils	31
A Holder for Nuts and Washers	31
Correspondence	32
Radio Press Information Dept.	33

Editor: JOHN SCOTT-TAGGART, F.Inst.P.

Assistant Editors: E. REDPATH.
P. W. HARRIS.

Radio Press, Ltd.

Publishers of Authoritative Wireless Literature
DEVEREUX COURT, STRAND, W.C.2

Tel.—Central 3763.

Advertisement Managers: } SCHEFF PUBLICITY ORGANIZATION,
LTD., 125, Pall Mall, London, S.W.1
Tel.—Regent 2440.

Staff Editors:

E. H. CHAPMAN, M.A., D.Sc.
A. D. COWPER, M.Sc.
G. P. KENDALL, B.Sc.
R. W. HALLOWS, M.A.
S. G. RATTEE.

Scientific Adviser:
Prof. G. W. O. HOWE,
D.Sc., M.I.E.E.
Advisory Editors:
Prof. R. WHIDDINGTON,
M.A., D.Sc.
Prof. C. L. FORTESCUE,
M.A., M.I.E.E.



All correspondence relating to contributions is to be addressed to the Editor of "Wireless Weekly."

Nothing contained herein is to be regarded as permission or encouragement to infringe any patent rights.



Milestones.

THE close of one volume, and the beginning of another, marks one of the lesser graduations on the scale of our career. It is not as important perhaps as a "birthday," but, nevertheless, is worthy of notice as being an occasion affording opportunity for effecting such modifications in the journal as experience and the friendly and much-valued criticisms of our readers indicate, coupled with a determination to make the journal "better and better."

It will be appreciated that our policy of publishing the latest wireless circuits, and only the best and thoroughly reliable literary matter, is expensive, necessitating as it does the retention of a fully qualified technical staff; and only by the hearty support of all our readers can such a policy be maintained. The larger the circle of readers, the better can the journal be made, so that, by recommending *Wireless Weekly* to their friends and acquaintances, readers are not only starting those friends upon the high road to success in wireless, but are helping us to make the journal still more valuable, with consequent benefit to themselves.

Our Scheme.

With the especial object of inducing all enthusiasts who have already passed, or who desire to pass, the first "broadcast listener" stage, to make our closer acquaintance we have inaugurated a Free Gift Scheme, full particulars of which will be found elsewhere in this issue. Notice particularly that under this scheme the gift offered has a definite and readily ascertainable cash value. In addition, the selection lies with the recipient who is afforded a chance of obtaining one of our "standard lines," the success of which has already been amply proved by the sales records. Think this over, and if you have a friend to whom a reliable wireless book at half

price would be an assistance (apart from the valuable help obtainable from this journal alone), advise him to order copies of the next six issues, *immediately*.

Wireless Publicity.

According to all reports, the recent Transatlantic tests, although not recordable as an unqualified success, appear to have done a great deal towards furthering interest in matters wireless. We are also pleased to note that the magnificent opportunities afforded in connection with the recent election were by no means neglected, and feel sure that many thousands throughout the country would realise, perhaps for the first time, that in not possessing a wireless receiving set they were at a considerable disadvantage. This is certainly as it should be, and we trust that this point will be made the most of in wireless advertising, and that those members of the public who have not wireless sets may be convinced that they are really missing something, and take steps accordingly to remedy the deficiency.

We are now looking forward to the interesting experiment, which, if successful, will enable practically every owner of a crystal receiving set in this country to hear concerts broadcast from one of the American stations. This of course necessitates excellent and reliable long-distance reception, in addition to high efficiency in connection with the land-line and re-transmission. We understand that the B.B.C. engineers are engaged upon the problem, but up to the time of going to press no definite announcement can be made.

In connection with the recent Transatlantic tests, we think there is a certain amount of humour in the situation in which the B.B.C. engineers beseech all listeners to stop their sets oscillating, and then subsequently report that several *carrier waves* were picked up by them on their apparatus.

SIX LECTURES ON DUAL AMPLIFICATION

By JOHN SCOTT-TAGGART, F.Inst.P., Editor.

No. 1.

Introduction.

At a time when one hears so much of dual-amplification circuits, it is only appropriate that a full investigation should be made of the possibilities of this type of circuit, and

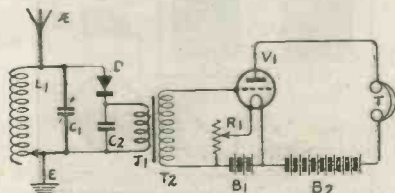

Fig. 1.—Crystal followed by a single valve amplifier.

it is proposed in the following six instalments to cover shortly the chief principles of dual amplification. There is so much to say about this very important subject, which has become almost a branch in itself of valve work, that it will not be possible for the author to deal with the subject, except in a brief manner. Nevertheless, it is hoped that the information given will prove of value to those who are interested in obtaining the maximum results with a minimum number of valves.

Definition.

The words "dual amplification" imply that a valve is being used to amplify twice, and that the two amplifications are taking place at the same time. The three-electrode valve will act as an amplifier of currents of all frequencies; alternating currents of the lowest possible frequencies will be faithfully amplified by a three-electrode valve, and so will oscillations having a frequency of 30,000,000 per second. In this respect the valve is very different from amplifiers of the microphone type which will only amplify low-frequency currents.

Not only will the valve amplify

currents of any frequency, from the lowest to the highest, but it will amplify currents of differing frequencies at the same time, the two amplifications going on simultaneously, but independently of each other.

It will simplify the explanation of dual amplification if we first consider the valve acting as a simple amplifier of low-frequency currents and then as an amplifier of the high-frequency currents obtained in a wireless receiver.

The Valve as a Low-Frequency Amplifier.

The three-electrode valve was undoubtedly a distinct advance over other low-frequency amplifying devices, and at a very early date it was applied to the

connected the crystal detector D and the primary T1 of a step-up transformer T1 T2, the usual blocking condenser C2, having a capacity of 0.002 μ F. (microfarad), is connected across T1, the primary of the transformer, but in many cases this condenser may be omitted. The secondary T2 of the transformer, which has more turns than T1, is connected across the grid of the valve V1 and the negative terminal of the filament battery B1. In the anode circuit of the valve V1 we have the telephones T and the high-tension battery B2.

The operation of this simple low-frequency amplifier circuit is as follows: In the aerial circuit we have high-frequency oscillations, which, in the case of

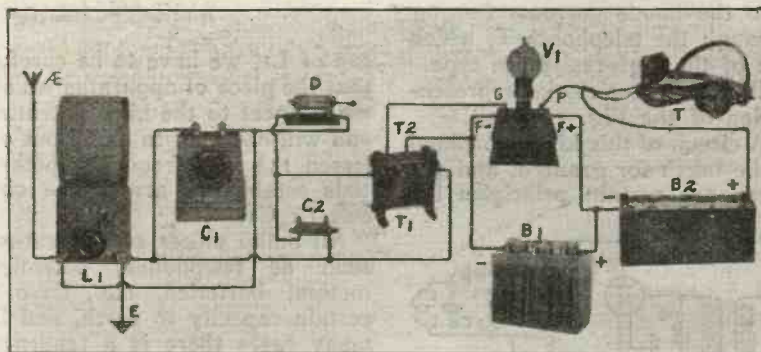

Fig. 2.—Pictorial form of Fig. 1.

amplification of signals from existing wireless receivers.

Fig. 1 shows how a valve may be added to a simple crystal receiver in order to amplify the low-frequency currents supplied by the left-hand portion of the circuit. The aerial circuit is shown tuned by an inductance L1 and a variable condenser C1, although, of course, any other method of tuning the aerial circuit might be adopted. For example, a slider inductance might be used, or a variometer. Across the aerial circuit we have

broadcast signals, have a frequency of something of the order of 1,000,000 per second. These high-frequency currents are not capable of operating telephones direct, and we therefore have to change the high-frequency currents into those of low frequency. The high-frequency oscillations, if due to broadcast signals, are continually varying in strength, or amplitude, according to the speech or music being transmitted. These variations of the strength of the high-frequency oscillations are of low frequency,

even though the currents they "modulate" are of high frequency. The object of the crystal detector is to eliminate the high-frequency currents, which really serve simply as carriers of the low-frequency currents.

In Fig. 1 the crystal detector D has the effect of sifting out the high-frequency currents, and the low-frequency currents which are obtained by this process pass through the primary T₁ of the step-up transformer T₁ T₂. The varying currents in T₁ induce exactly similar currents in T₂, but at the same time the voltage of these currents is increased because of the step-up effect of the transformer, which in this case acts somewhat in the same way as an induction coil which enables us to obtain high voltages from simply a 6-volt accumulator. The voltage changes across the secondary T₂ are communicated to the grid of the valve, one end of T₂ being connected to the grid and the other being connected to the filament. The low-frequency potential variations on the grid of the valve vary the number of electrons flowing between the filament and the anode, and therefore the anode currents flowing through the telephones T, which are of the high-resistance type.

Fig. 2 is a pictorial representation of the Fig. 1 circuit.

A circuit of this kind is inclined to be taken for granted, and yet there are certain principles in-

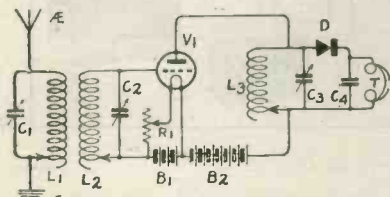

Fig. 3.—Simple high-frequency amplifier circuit.

involved which will also apply to dual amplification circuits. Although the principles are quite simple, yet when a new circuit is evolved in which the different components are used in a different manner, standard principles are not adopted, with the result that in many cases failure results.

In the case of Fig. 1, it will be seen that the crystal detector has one terminal connected directly to the top end of the in-

ductance L₁. This is called the high potential end of the aerial circuit; the potential at the top end of L₁ is continually varying with respect to the bottom end of the aerial circuit, which is directly connected to earth, and therefore remains at a steady potential, which we may call zero. We can connect anything we like to earth without affecting the operation of the high-frequency circuit, but if a connection is to be taken from a point at high-frequency potential to earth, such as the

but they have a capacity to other parts of the circuit, and this "stray capacity" is undesirable and leads to complications.

It is for this reason that the crystal detector is connected to the high potential end of the aerial circuit, while the relatively bulky transformer T₁ T₂ has its primary connected on one side directly to earth.

Another Point.

Another point to notice is that the secondary T₂ of the trans-

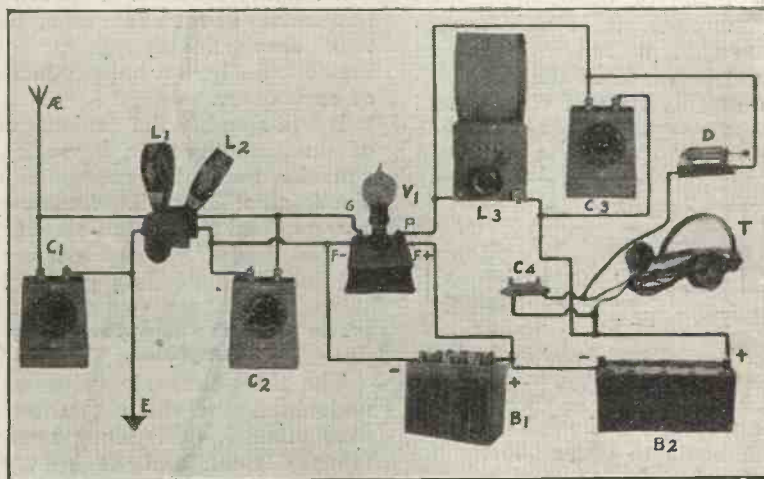

Fig. 4.—Pictorial form of Fig. 3.

top of L₁, we have to be careful that the piece of apparatus which we connect to the high potential end will not tend to damp out or lessen the high-frequency potentials established across the circuit L₁ C₁.

All bulky pieces of apparatus, such as telephones, potentiometers, batteries, etc., have a certain capacity to earth, and in many cases there is a tendency for a leakage to earth. Telephone receivers, for example, when on the head of the operator, have a distinct capacity to earth, since the human body may be taken as being practically at earth potential. By a capacity effect to earth, we mean that the earth acts as one plate of a condenser, while the piece of apparatus acts as the other plate. The effect of this capacity will be to alter the tuning of an oscillatory circuit in some cases, and to lessen the potential variations across that circuit. Not only have such pieces of apparatus as telephones, loud-speakers, batteries, etc., a capacity to earth,

former T₁ T₂ has one end connected to the negative terminal of the filament battery B₁, while the rheostat R₁ is connected in the position shown. When the rheostat is in this position, there is normally a drop of potential across the rheostat, due to the filament current flowing through it, and this drop of potential may amount to about 1 volt. This means that the left-hand side of the filament in Fig. 1 is at a different potential than the negative terminal of B₁, the latter being at a potential of 1 volt with respect to the left-hand side of the filament. Since the grid is connected through T₂ to the negative terminal of B₁, the grid will have a potential of 1 volt with respect to the left-hand side of the filament; with respect to other points of the filament, it will be still more negative. The result of this is that, under ordinary conditions, the grid will not be made sufficiently positive to draw electrons to itself. The moment the grid is made too positive, it will begin to attract elec-

trons, and these flowing round the grid circuit will have the effect of introducing damping on to the positive half-cycles of current supplied from the secondary of the transformer. This damping effect will prevent the full degree of amplification being obtained, and it will also introduce a certain amount of distortion.

Another point to notice is that the negative terminal of the high-tension battery B₂ is connected to the positive terminal of B₁. For the sake of simplicity, this convention should be observed in all valve circuits where possible, especially when two or more valves are used. There are arguments in favour of connecting the telephones next to the filament battery in the case of single-valve circuits, but if good-quality telephone receivers are used, there is no point in departing from the regular convention.

High-Frequency Amplification Circuits.

To those who are doubtful whether to use low-frequency or high-frequency amplification, dual amplification provides the answer, because in this case both high and low-frequency amplification are employed. In general, we can say that low-frequency amplification gives volume of signal and that high-frequency amplification gives range. To the beginner, this fact seems strange, because he would imagine that if stronger signals are obtained, signals from further distances could be received. This is, however, only partially true. One can state the principle in a rather different manner by saying that low-frequency amplification will strengthen signals which are already there, even though only faintly heard, but will not bring in signals which are ordinarily inaudible. High-frequency amplification, on the other hand, will strengthen any kind of a signal, and will bring in signals which, without high-frequency amplification, are inaudible. On the other hand, high-frequency amplification is not a good means of increasing the volume of an existing fairly strong signal.

The reason for this is not far to seek. A crystal detector, or a valve detector, requires a certain strength of oscillation before

it will effectively respond. A very weak oscillation will not have any effect on a crystal detector; consequently, there will be no low-frequency currents produced through rectification, and there will therefore be nothing to amplify. Beyond a certain signal strength, however, a crystal detector begins to respond, and the low-frequency currents may be strengthened by low-frequency amplification. The signals, however, may still be too weak to be appreciated, and some means, other than low-frequency amplification, must be found to bring the signal strength up to that required. It is now that we employ high-frequency amplification. By using a valve to amplify the high-frequency oscillations, we increase their amplitude, and therefore the voltage changes across the crystal detector—due to the high-frequency currents—are increased in magnitude. It is important to point out here that the rectified current supplied by

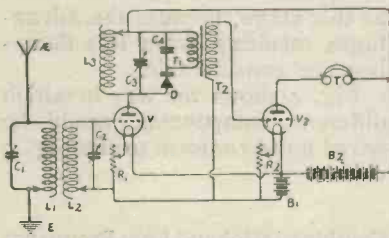

Fig. 5.—Receiver involving a stage of H.F. and one of L.F. amplification.

the crystal detector varies as the square of the strength of signals applied to it. This means that, if we have a very weak high-frequency signal and double its strength, we will get, not twice the rectified current, but four times the amount. Similarly, if we increase the high-frequency current to three times its original value, we will get nine times the response from the crystal detector. It is therefore very important to see that the high-frequency oscillations are strong enough to work the crystal detector. High-frequency amplification is therefore ideal if our object is to strengthen weak signals or to bring in stations which could not otherwise be heard.

On the other hand, low-frequency amplification is the best method of strengthening the signal which is already fairly

strong and which may, for example, have been made strong by a preceding stage of high-frequency amplification.

Example of High-Frequency Amplification.

In Fig. 3 is represented a typical high-frequency amplifier circuit in which a valve amplifies the incoming oscillations and a crystal detector serves to rectify them.

It will be seen that the aerial circuit consists of an inductance L₁ shunted by a variable condenser C₁. The inductance L₁ is coupled to a secondary inductance L₂, which is shunted by a variable condenser C₂. Both the aerial circuit and the circuit L₂ C₂ are tuned to the incoming wave-length. This method of loose-coupling will, of course, be familiar to readers, and it is given in this case as an alternative to the direct coupling illustrated in Fig. 1. In the anode circuit of the valve we have the inductance L₃ shunted by a variable condenser C₃. When the circuit L₃ C₃ is tuned to the incoming wave-length, much stronger oscillations will appear in this anode oscillatory circuit than in the case of the oscillations in the circuit L₂ C₂. We now treat the circuit L₃ C₃ just as we would treat a secondary circuit or aerial circuit, and we therefore connect a crystal detector D and telephones T across the circuit L₃ C₃. The usual telephone condenser C₄ is connected across T, although in many cases this condenser may be omitted.

A circuit of this kind has the advantage that longer ranges may be accomplished with it. It is interesting to compare the results obtainable with the Fig. 3 circuit with those obtained with the Fig. 1 arrangement. On very short distances the Fig. 1 arrangement is probably best. At about 10 miles from a broadcasting station, there is nothing to choose between the Fig. 1 and the Fig. 3 arrangements. As the set is taken further and further away from a transmitting station, the Fig. 3 high-frequency amplifying circuit begins to show a superiority over the Fig. 1 arrangement.

There are two points of interest in connection with the Fig. 3 cir-

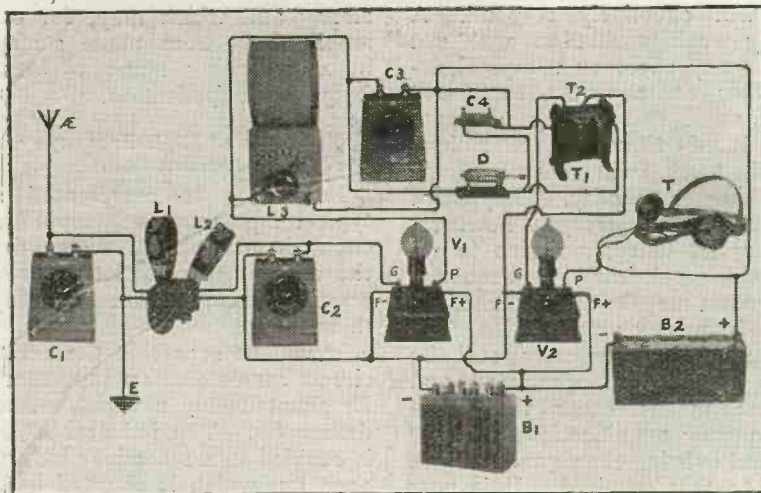

Fig. 6.—Pictorial form of Fig. 5.

cuit; one is that the crystal detector must have one side connected directly to the high potential end of the circuit L3 C3; the reason for this has already been explained in connection with Fig. 1, but here in Fig. 3 we have similar conditions in the anode circuit of the valve; in this case it is the anode that is at the high-frequency potential, and the bottom end of the circuit L3 C3 is taken as being at earth potential. Signals would still be obtained by reversing the position of the crystal detector D and the telephones T, but the results would not be as good, nor as stable.

The other point is that the crystal detector D, being a partial conductor, adds considerably to the damping of the circuit L3 C3. When a circuit has no parallel resistance across it, any oscillation which is set up in it will tend to be perpetuated. If we add damping to the circuit, by connecting a resistance across it, or by connecting a crystal detector across it in the manner of Fig. 3, we add to the damping and at

the same time prevent the valve from oscillating, as it might otherwise do if no crystal detector were connected in the position shown. Since crystal detectors are very commonly employed in dual-amplification circuits, this damping effect of a crystal detector should be noticed at this stage, because the advantages resulting from this damping are considerable.

Fig. 4 shows the way in which different components would be wired up to conform to the Fig. 3 circuit.

Combined High and Low-Frequency Amplification Circuit.

Since there are advantages both in high and low-frequency amplification, a straightforward compromise is frequently made in order to obtain the benefits of both methods. Such a compromise is illustrated in Fig. 5. This circuit is really a combination of the Fig. 3 arrangement and that illustrated in Fig. 1. Instead of connecting the telephones in the position shown in

Fig. 3, we now connect the primary of a step-up intervalve transformer T1 T2, which serves to pass the currents which would have gone through the telephones to the grid of the second valve after the voltage has been stepped-up by means of the transformer T1 T2. In the Fig. 5 arrangement we therefore have one stage of high-frequency amplification, a crystal detector and one stage of low-frequency amplification. It will not be necessary to explain how the Fig. 5 circuit works; it will be obvious from the preceding explanation that the first valve acts as a high-frequency amplifier, the amplified oscillations flowing in the circuit L3 C3. These oscillations are rectified by the crystal detector D, the rectified currents passing through the primary T1 of the transformer T1 T2. The stepped-up low-frequency currents are now applied to the grid of the second valve, which amplifies them at low-frequency. The amplified low-frequency currents are now made to operate the telephone receivers T.

Such a circuit may be termed a "straight" circuit, because each valve carries out only one function. Both valves act as amplifiers, but the first functions as a high-frequency and the second as a low-frequency amplifier. It is the purpose of a dual-amplification circuit to combine the two grades of amplification in one valve, and the next consideration, therefore, is how we can dispense with one of these valves and obtain the three operations of high-frequency amplification, detection and low-frequency amplification by the aid of one valve and a crystal detector.

Fig. 6 is simply a pictorial representation of the Fig. 5 circuit.

Next week: No. 2 of these lectures, dealing with single valve dual circuits.

Radio Society of Great Britain.

At the Annual General Meeting of the Radio Society of Great Britain, which is to be held on December the 19th, at the Institution of Electrical Engineers, Mr. E. J. Hobbs will read a paper on "Simplified Radio Calculation." This will be illustrated by lantern slides, and will be of special interest to experimenters.

A BROADCAST CRYSTAL RECEIVER

By J. STIRLING, Jr.

The following article should appeal to the home constructor whose interest lies in the building of crystal receivers.

THE outer or stator winding of the variometer should be wound upon a 2½-in. cardboard tube, though in the set under description, part of a "Permagrip" motor cycle repair outfit tube is used as the former. The tube was given two coats of shellac varnish, and when dry two small holes were bored ¼ of an inch from the edge to secure the wire. The winding on the stator consists of 40 turns of

the stator coil. The winding is now given a coat of thin shellac and baked gently until hard.

The inner coil or rotor is next wound. A stout cardboard tube of 1½ in. outside diameter is procured and 30 turns of No. 36 S.W.G.-d.c.c. are wound. The winding of the rotor turns is carried out in exactly the same way as was done with the stator, with the exception that there are 15 turns on each half instead of 20. The winding is treated with shellac varnish, as before. When the shellac is dry the coils are mounted on their spindle, which consists of a 2 B.A. threaded brass rod 2 11/16ths long. Fig. 3 gives all the necessary constructional details, which are as follows:—

Main spindle, 2 B.A. threaded brass rod, 2 11/16ths long, fitted with five hexagonal 2 B.A. nuts. The inner washers are of cardboard, 1/16th of an inch thick, ¼ in. diameter, whilst the outer washers are also of cardboard 1/32nd of an inch thick, ⅜ of an inch diameter. The washer, situated under the panel, is of the same material and dimensions as the outer washers. The washer on the top of the panel is of brass, 1/32nd of an inch thick (2 B.A. washer). The aluminium or thin fibre band, for securing the variometer to the panel, is held in

held in position on the panel by means of a thin fibre or aluminium band, clearly shown in the photograph, Fig. 4. Before this band is fixed, however, several layers of thick brown paper should be placed between the windings and the band to protect the stator turns.

The Panel.

This is made of ebonite, 2 9/16ths in. by 2 15/16ths in. by

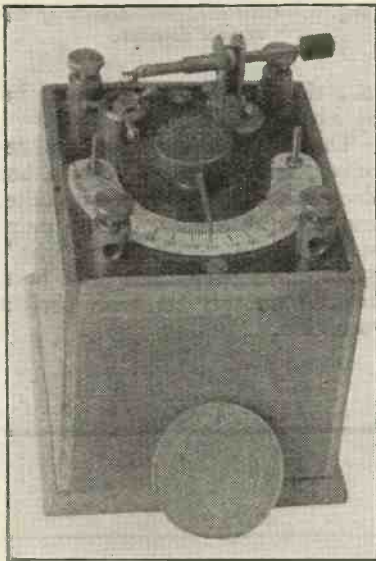

Fig. 1.—A general view of the receiver.

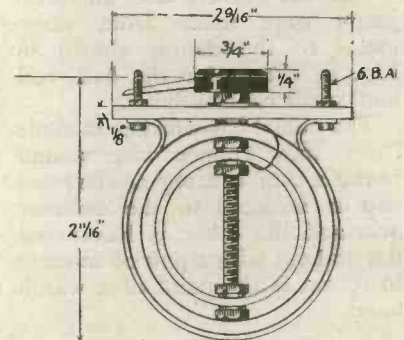

Fig. 3.—Constructional details of the variometer.

¼ in., drilled to the dimensions shown in Fig. 5. The terminal holes are drilled 5/16ths of an in. from each edge and in each of the four corners. An engraved ivory scale reading 0 to 180 degs. may be fitted, thus adding greatly to the appearance of the receiver.

No. 36 S.W.G.-d.c.c. copper wire, and after 20 turns have been wound, two small holes, as close to the 20th turn as possible, should be bored. At this point the wire should be cut, leaving approximately 3 in. spare, which is to be soldered to the other half of the stator. Now bore two small holes 3/16ths of an inch further along the tube, so that there is a 3/16ths gap in the middle of the winding. Thread the 3-in. lead through these two holes and then solder it to the coil of wire. Having soldered the joint, 20 more turns are wound, and at the 20th turn of the second half or the 40th turn of the whole winding, two more small holes are bored, as shown in Fig. 2, opposite the first two, to fix the end of

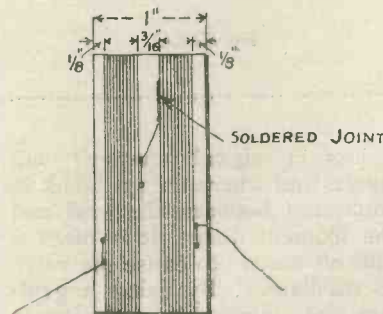

Fig. 2.—Illustrating the stator winding.

place by means of 6 B.A. brass cheese-headed screws fitted with hexagonal nuts, the screws being ¾ of an inch long.

One end of the outer winding is soldered to one end of the inner coil, and the whole variometer

Connecting Up.

The wiring of the receiver is as follows:—The lead from the beginning of the outer coil is fixed to the aerial terminal and another short wire connects the aerial to the cat-whisker. From the crystal cup a lead is taken to one of the telephone terminals, whilst from the other a lead is connected to the earth terminal. Connection to the earth terminal is also made from the inner coil winding. Across the telephone terminals a small Dubilier 0.001 µF fixed condenser is shunted. This condenser is suspended from the actual telephone terminals by means of two stiff copper wires, so that it hangs vertically and clear of the rotating coil.



Fig. 4.—An underside view of the receiver.

The cat-whisker and universal joints were made from scrap metal to the details shown in Fig. 6, except for the ball, rod and small ebonite knob.

The actual cat-whisker is made from thin copper wire wound round a thin knitting needle; one end is soldered to the detector arm and the other is hammered flat and cut with a pair of scissors to resemble the point of a watch hand.

The knob and pointer for the coil control were made from pieces of ebonite and copper respectively. The knob is $\frac{1}{4}$ in. thick, roughly filed to a $\frac{3}{4}$ -in. circle, with a tapped 2B.A. hole drilled in its centre. The pointer was filed out of some old scrap brass, $\frac{1}{16}$ th of an inch thick.

The box containing the instrument was roughly knocked together out of $\frac{1}{2}$ -inch cigar-box wood, the dimensions being: Base, same as panel, $2 \frac{9}{16}$ ths

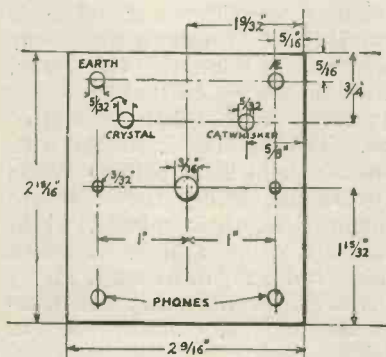

Fig. 5.—Dimensions and positions of drill holes of panel.

in. by $2 \frac{15}{16}$ ths in.; the two sides, $3 \frac{3}{16}$ ths in. by $2 \frac{9}{16}$ ths

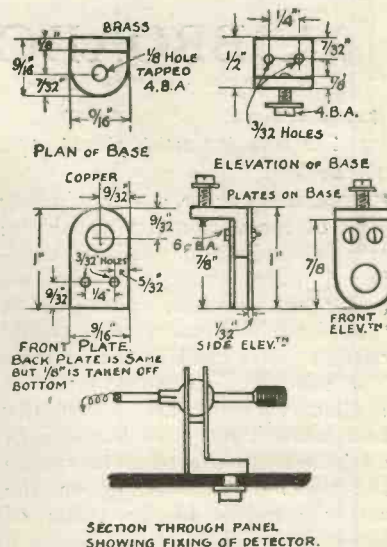

Fig. 6.—Constructional details of the crystal detector.

in.; the two ends $2 \frac{9}{16}$ ths in. by $2 \frac{9}{16}$ ths in.

The crystals used in this receiver, with excellent results, are electronite, permanite, hertzite, and several others. Four pairs of Brown's "Featherweight" 4,000 ohms telephones have been worked on this set with perfect reception.

HOW TO ADJUST THE VARIABLE GRID-LEAK

By H.A.C.

PROBABLY many experimenters have grid-leaks of variable resistance but do not know how to regulate them. Much depends upon the value of the leak, and many faults are often due to this source.

If its resistance be too high the grid of the valve will have an excess negative charge owing to the accumulation of electrons, and, in consequence, any attempt to use reaction will cause "howling." If, on the other hand, the resistance is too low,

a loss in signal strength will result, and where the grid-leak is connected between the grid and the filament direct, it is often a difficult matter to cause the valve to oscillate. By using a grid-leak of fairly high resistance stronger signals may often be obtained than when the resistance is of a lower value.

Perhaps the following method of adjusting the leak is one of the most satisfactory. The leak is first adjusted to a high value, so that when the reaction coupling

is increased the valve "howls." The resistance is then gradually lowered until the howl is entirely eliminated when using fairly tight coupling of the reaction coil. In this position the valve will work well, and maximum signal strength may still be obtained. This adjustment may vary slightly with different values of filament current and high-tension voltage, so to try different values until the best results are obtained is the best course to adopt.



Spooneritis.

Do you ever suffer from the embarrassing attacks of the malady spooneritis, which causes your tongue to become temporarily unruly and to turn words inside out? Occasionally I fall a victim to it, babbling during a brilliant explanation of the mysteries of wireless, of casket boils, meat voltors, plattery bugs and things of that kind. I once perpetrated, completely by misadventure, the most appalling one in a foreign tongue. Whilst trying without marked success to show my complete mastery of the language in a Swedish drawing-room I was abashed to find the three ladies who were there suddenly turn red and all begin talking hard at once. What I said I never knew, since no one would say more than that I had spoonerised not wisely but too well. But it must have been a pretty meaty one, for they were obviously electrified, and it requires something with a fairly high potential to electrify the charming Swedes.

Little Puddleton was the scene of a beauty the other week, when a considerable star in the radio firmament was billed to lecture at the wireless club. Under the able chairmanship of Sir Ponderby Bunch, after whose receipt of his present title Little Puddleton was for some time known as The Village of the Dreadful Knight, everything passed off well, until the lecturer was warming to his work in a fine peroration. "Such," he declaimed, "was the tiny station that stood upon this site but ten short years ago. To-day we have a wondrous installation flinging far and wide a hundred willow cats. . . ." "wallow kits," whispered the chairman, in a hoarse semi-shout; doing his bit to help a man in dire straits. "Er, er, I should say callow wits. Oh, damnit! a hundred thousand watts," bleated the much-tried star, and sat down mopping a fevered brow.

The Cussedness of Things.

Funny how perverse things can be at times. I have, as I mentioned recently, a broken arm, whose bits, with the aid of medical tinkering, are slowly re-establishing contact. In the ordinary way the terminals on my set don't work loose. At the present time every single one of them shows a marked disposition to come unscrewed all on its little own. I've one hand left, of course, which is also one left hand, and that should be enough for any wretched terminal. Unfortunately, you can't make twisting motions with the unaccustomed left without doing the same with the right. Any turning of a broken arm is—well, it is things that can be expressed only by asterisks. Hence, as I tighten those infernal terminals, I pile up quite a score in the Recording Angel's log.

But the worst instance of the general cussedness of things that I ever came across was that of the Reverend Stephanns Chittermole (pronounced Chimmle, to rhyme with Scamperholme), who was presented with a wireless set by the ladies of the parish in order that he might have a leetle recreation amidst his all too arduous duties. The Reverend Stephanns was not measured for the set as he should certainly have been. It was so built that the reaction terminals were directly in line between the operator and the aerial tuning condenser. The ghostly man (this is to show you that I know my Tennyson) combined abnormal shortness of sight with an almost freakish length of proboscis. Whenever he leaned forward to peer at the reading on the condenser scale he short-circuited the terminals with his nose, whose consequent redness after each wireless séance gave rise to some very unkind rumours.

Tracked to his Lair.

The new commandment "thou shalt not energise thy neighbour's aerial," which has replaced the old ordinance limiting the use of reaction, seems to be broken in some parts with a consistency that is worthy of a better cause. My own was so enthusiastically energised a few days, or rather nights, ago that the howls of Radiating Rupert were audible in rooms on the floor above my wireless den. If you have an ammeter in series with your H.T. supply one of these howls will make it give a kick like that of a mule.

I tracked one of the squealers to his lair quite by accident last week. He was by no means a beginner, and he wanted to show off his set. As he sat atuning there came an eerie screech which died away to nothing and then gradually rose again to its fullest power. I expostulated promptly. "Oh, *that's* nothing," quoth he, with a cheerful grin, "that's only the carrier." Only the carrier, ye gods! And there are thousands of similar cheerful criminals who believe that they are doing no wrong if they pick up their favourite broadcasting station in this way. They do not realise, I think, that while they are gaily flirting with those carriers strong men in neighbouring houses are tearing out handfuls of locks that they can ill spare and calling upon all the furies and demons to arise instantly and smite the author of the ear-destroying squeals that are making the night hideous.

The Radiowoman.

I have met the superwoman. Twice have I come across charming beings whose friends held them in awe as real authorities on wireless. The first was a hollow fraud, but so pretty a fraud withal that no one probably had the heart to show her up. Even her little habit of mixing

up volts and amperes passed with no more comment than a slight raising of the eyebrows on the part of the less impressionable of her masculine hearers.

The second is a sheer wonder. She really does know the business, and I am ready to wager six to four in "peanuts" that she could give you points at reading Morse. Would that more of her sisters would follow her excellent example; but I am afraid that there is little chance of women taking seriously to wireless, or, at any rate, of their admitting that they possess an intimate knowledge of its workings. If they did so they could not assume that appealing look of pathetic helplessness whereby they entice mere men to do for them awkward little jobs that they are really perfectly capable of doing for themselves. Woman is not so foolish as to surrender one of the most effective weapons in her armoury like that.

Look Before you Leap.

In time I suppose we shall find devotion to wireless on the part of the husband cited as a valid reason for divorce. "Then," as a correspondent, whom I deduce to be a married man, remarks in a breezy letter, "then we shall be able to do some really serious work!" There are times, of course, when it is difficult to reconcile marriage with a whole-hearted devotion to wireless. Some time ago I warned any ladies who were thinking of committing matrimony with radiomaniacs to think twice before they took the plunge. But there is also the man's side of the question to be considered.

Two little hints I would give. If you discover that the object of your attentions is addicted to the terrible habit of knitting jumpers, break it off at once. Never mind if she sues you for breach of promise. Care not at all if

you have to make an ass of yourself in the witness-box whilst counsel rends you metaphorically limb from limb. Do not be downhearted as the court rocks with glee over the sloppiest passages of your letters when they are read out. You have done the right thing, for nothing is more searing to the soul than the click of knitting needles when you are straining your ears to catch a faint signal. The second hint concerns those whom it is too late to save from Hymen's clutches. Never bring home the evening paper. Leave it in the train, give it to the ticket collector, do what you will with it, but don't bring it home. If you are so misguided to do so, your better half will sit reading it and rustling it until you, with the 'phones about your ears, are driven to the verge of conjugical insanity.

WIRELESS WAYFARER.

A POSITIVE SELECTOR SWITCH

THE selector switch is one of the most useful of those that find a place upon the wireless set, but the ordinary pattern has one rather serious drawback, which becomes particularly obvious when the switch is employed either in the aerial-tuning circuit or in the grid circuit of a valve. One of its contacts, that made by the laminated arm, is positive; but the other, which occurs between the panel and the bush in which it revolves, is of rather a changeable kind, and it is apt to become less and less reliable as the switch becomes worn with constant use. When a switch of the ordinary type is used so as to enable the gridleak to be connected in various ways at will, in the manner which was described not long ago in this journal, or as a simple means of varying the grid biasing potential of low-frequency valves (see *Wireless Weekly*, Vol. 2, No. 19, page 662), a faulty or poor contact between the spindle and its bush may give rise to a certain amount of parasitic noises.

Having traced one case of crackling to a selector switch (which he is proud to say was *not* home-made!), the writer has

converted all such switches in his possession to the positive contact pattern, now to be described, with excellent results. It is such a simple business that anyone can make the improvement in a very short time.

The existing laminated arm is removed and replaced by a double-ended one of the shape shown in Fig. 1. This can be made from three layers of thin springy sheet metal. The arm intended to make contact with the studs is made to the same dimensions as the original one.

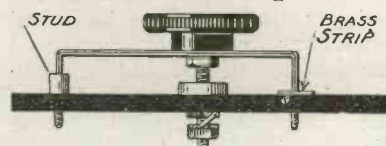

Fig. 1.—The Selector Switch.

The other should be $\frac{1}{2}$ in. or so shorter, and its end should be bent so that it makes contact with the ebonite. The arm is now mounted and the switch turned once or twice so that the short arm scratches a segment of a circle upon the ebonite corresponding to the travel of the long arm. Near the ends of this line, and in the middle of it, are drilled three 4B.A. clearance

holes. A curved brass strip $\frac{1}{4}$ in. wide is now cut out, and in it are drilled three very slightly countersunk 4B.A. holes. The heads of three 4B.A. countersunk screws are now filed almost away. These are inserted into the holes in the strip on the panel, and are tightened by means of nuts. The heads are then trimmed off with a file and with emery paper, until they are absolutely flush with the strip.

Tap connections are made as before to the studs, and the fixed connection is made by a wire soldered to one of the screws which retain the strip in position. If the ends of the arm have been bent well down, contact will now be quite positive, and the arms will automatically clean and keep bright their paths over the studs and the brass strip.

The reason why one arm is made shorter than the other is to allow this form of connection to be used with switches the studs of which are so numerous that they occupy more than a semi-circle. Since the radius of the brass strip is less than that of the studs, the device can be used even when the studs stand upon the circumference of a complete circle.

R. W. H.

Broadcasting News

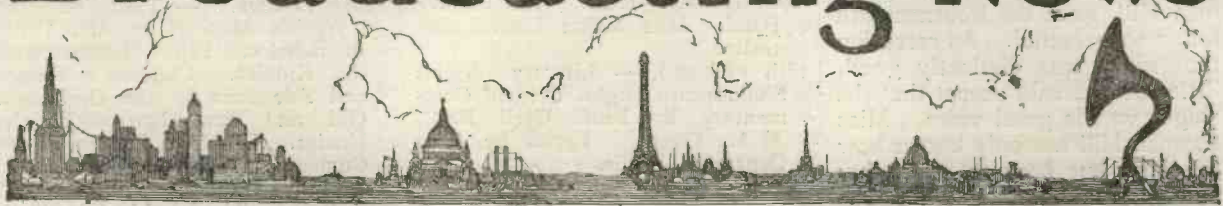

LONDON.—It remains to be seen what the recent wireless telephony tests between America and Great Britain will bring to the listener on each side of the Atlantic. Whilst the attempt to get into conversation in the early hours of the morning of December 2nd was unsuccessful, the engineers of the B.B.C. are optimistic regarding the future. This failure was due to four main causes :—bad atmospheric conditions at the time when the test was taking place, interference from oscillating sets in London, interference by the unexpected transmission of l'Ecole Supérieur des Postes et Telegraphies, which was also attempting to call up America, and apparently a weaker transmission than usual. Three of these causes can be remedied by human agency, the other is outside that.

Both Capt. Eckersley and Capt. West when discussing with the writer the possibilities of these transmissions expressed their conviction that conversation will undoubtedly take place with America, and at no distant date; furthermore, they are seriously considering the possibility of a test which, if successful, would enable even the owner of a crystal set in this country to listen to a transmission of an American programme. One need not be too fanciful in one's imaginings to visualise the time when by agreement international concerts will be received in palaces and cottages in most parts of the world. That is the outstanding fact remaining from the excitement created by these tests.

"Operatic Night"—Monday, December 3—was one of supreme excellence. The artistes were all stars of the first magnitude, but whether it was the opportunities

of the "Tales of Hoffmann" or not, we thought that Miss Gertrude Johnson's singing was the outstanding feature, particularly in the closing scene of the third act. Then came the grand, solemn, requiem-like music before the epilogue, and personally, we cannot conceive why the composer (Offenbach) did not end his opera at this point instead of bringing us back once again to the wine room to hear Hoffmann's recitative telling us that his tales were now told.

Generally speaking, the Opera was a great success, although it did suffer somewhat from the fact that it was produced in a studio insufficiently roomy for such a large company and augmented orchestra, giving rise at times to somewhat "dead" or "fading" effects, but we understand 2LO are well on the way with experiments to produce these operas in a larger studio, and let us have a little of the echo effect that we associate with Opera Houses and large halls.

Forthcoming Events

DECEMBER.

- 12th (WED.).—5.30, "Uncle Jeff" will talk to the children. 7.30, London Wireless Orchestra. Miss Marjory Phillips, contralto. Miss Edith James, pianist. John Henry's account of "What happened to me at the General Election."
- 13th (THURS.).—"Auntie Hilda" and "Uncle Humpty Dumpty" musical talk. Dance Band. Musical Comedy, "Little Nellie Kelly," Act I. The Rt. Hon. Sir William Bull, Bart., M.P., P.C., will give a talk on "Inventions of this Country."
- 14th (FRI.).—Orchestra. Lecture by Mrs. May on "Housekeeping." Mr. Stanley Holt, pianist.

Acts II and III of "Little Nellie Kelly."
 15th (SAT.).—"Pagliacci" from the "Old Vic." Roosters' Concert Party. W. J. Bassett-Lowke, M.Inst., Loco.E., will talk on "Models and Model Railways." Dance music from the Savoy Hotel.

ABERDEEN. — Whatever doubts there may have been as to the wisdom of having a real Scotch nicht broadcast from 2BD were completely set at rest by the result. Probably no programme since the inauguration ceremony has evoked such enthusiasm, and it is commented that a repetition should not long be delayed. Aberdeen listeners had another new experience last week when the performance of the opera "Carmen" at the "Old Vic" Theatre, London, was relayed to the farthest North station with excellent results.

BOURNEMOUTH. — During the past week, we have had an exceedingly interesting series of transmissions from the Bournemouth station. On Wednesday, November 28, a new play by Thomas Hardy, the Wessex novelist, was performed at Dorchester by the Hardy players. This was transmitted by land line to Bournemouth, and broadcast from that station to an eager and expectant audience. Unfortunately, owing partly to the fact that the hall in which the play was produced was poorly suited for the purpose, and partly to the hissing noise, caused apparently by the microphone, reception was somewhat indistinct, even on a crystal set 2 miles from the station.

On Friday, Nov. 30, Mr. G. K. Chesterton, speaking at the

Bournemouth Rotarian banquet, gave his unseen listeners a thoroughly enjoyable time. On Sunday, December 2, Miss Carmen Hill gave the Bournemouth folk a song recital. As reception that night was distinctly good, little need be said except that the singer was in good voice. Miss Carmen Hill not only knows how to sing, but how to make her audience understand what she sings. Her enunciation was excellent, every word she sang being clearly heard.

□ □ □

CARDIFF.—Cardiff and district amateurs are overjoyed at an early possibility of their local station's wavelength being increased to over 400 metres. On the present wavelength — 353 metres — London, working on 363 metres was practically a dead letter, as being only 10 metres between the two, it was almost impossible to get the latter. When Cardiff was transmitting, Bournemouth, too, was subject to serious interruptions for the same reason, if one happened to be within 10 miles of the Cardiff station.

□ □ □

It appears to be the general opinion in the district, both by users of valve and crystal sets, that simultaneous broadcasting has been rather overdone and, in view of the very fine programmes given from Cardiff in the past, listeners have shown by numerous letters to the Station Director that a reversion to the old régime will be appreciated, and that special events only should be simultaneously broadcast.

□ □ □

Forthcoming Events

DECEMBER.

- 12th (WED.). — Popular Night. Vocalist, Mr. Joseph Farrington. Miss Beatrice Miranda, soprano. Chat on British Mammals by Dr. Jas. J. Simpson, M.D., D.Sc.
- 14th (FRI.).—The Cardiff Musical Society's Small Choir. Mr. Frank Taylor, baritone. Mr. R. J. Pugsley, Chat on "Individuality in Business."
- 15th (SAT.).—Mr. Willie C. Clissitt on "Sport of the Week." Mr. Owen Gane, baritone. Mr. Alec John, tenor. Mr. Charlie Chipmunk in "A Restaurant Episode."

- Major E. H. Gunn (the well-known Dog Judge).
- 16th (SUN.).—Beethoven Night. Mr. David Thomas, vocalist.
- 17th (MON.).—H.M. Air Force Band. Miss Lillian Lewis, contralto.
- 18th (TUES.). — Literary Night. Shakespeare Night. Critical Commentary by Prof. Cyril Brett, M.A., Oxon. Lyrics by Miss Constance Willis.

□ □ □

GLASGOW.—The Officials of 5SC are at present arranging for a series of short talks on educational and other subjects of universal interest. It is proposed that a Committee representative of the various educational bodies in the city will be set up in an advisory capacity. Already the Glasgow Education Authorities

BROADCAST TRANSMISSIONS

	Call-Sign	Wavelength.
CARDIFF.....	5WA.....	353 metres.
LONDON.....	2LO.....	363 "
MANCHESTER.....	2ZY.....	370 "
BOURNEMOUTH.....	6BM.....	385 "
NEWCASTLE.....	3NO.....	400 "
GLASGOW.....	5SC.....	415 "
BIRMINGHAM.....	5IT.....	425 "
ABERDEEN.....	6BD.....	495 "

TIMES OF WORKING.

Weekdays..... 3.30 to 4.30 p.m. and 5.0 to 10.20 p.m. G.M.T.

London : 11.30 a.m. to 12.30 p.m.

Sundays..... 2.0 p.m. to 5.0 p.m. and 8.30 to 10.30 p.m. G.M.T.

NOTE:—The wavelengths given above are allocated temporarily and further alterations are pending.



have appointed a representative in connection with the scheme.

□ □ □

The simultaneous broadcasting from London of "Five Birds in a Cage" by Miss Gertrude Jennings, was one of the finest things ever listened to by a Glasgow wireless audience. Everywhere people have expressed their appreciation of this class of entertainment and desire that material after this light comedy type should be introduced more frequently into Scottish programmes, in place of the preponderance of "highbrow" items.

□ □ □

Forthcoming Events

DECEMBER.

- 12th (WED.).—Mixed classical music by the Wireless Orchestra. Miss

- Doris Lemon, soprano. Mr. William Michael, baritone. A Chat on "Shorthand," by Mr. James H. Baird, A.F.I.
- 13th (THURS.). — Talk on the "Week's Music" by Mr. Percy A. Scholes. Fifty Minutes with the Kiddies. Children's Games and Selections by the Orchestra. Old and new choruses by the Uncles. S.B. from London of the Comedy, "Little Nellie Kelly." Old-time Dances.
- 14th (FRI.).—The Weekly Film Talk by Mr. G. A. Atkinson. A short talk on "Football," by Mr. John Leggat, Secretary of the N.W. Lanark Referees' Association. Mr. William MacDowell, baritone. Miss Catherine Paterson, contralto. Dance music. S.B. from London of the Comedy, "Little Nellie Kelly."
- 15th (SAT.).—The Possilpark and District Prize Pipe Band. Mr. R. A. Cunningham, baritone. Mr. George Hewson, banjoist. A chat on "Joseph Conrad and his Books," by Mr. J. R. Peddie, M.A., of Glasgow University.

□ □ □

MANCHESTER. — The Sunday evening talks to young people, given by Mr. S. G. Honey, Assistant Director of the Manchester station, are becoming very popular with the younger listeners, and it is good to find that they appreciate serious talks as well as the more jovial weekday chats.

□ □ □

The transmissions from the Piccadilly Picture Theatre, which have been suspended for some time, have now been resumed, and although considerable improvements have been made, it is doubtful whether the organ music will ever equal the transmissions we had from the Steinway Hall. The "full organ" comes out well, but the small stops, though of good quality, transmit weakly and require considerable amplification to bring them up to suitable strength. The structure of the building makes it a most difficult matter to find a suitable position for the microphone.

□ □ □

Forthcoming Events

DECEMBER.

- 12th (WED.).—3.30, Concert by Mme. V. Whitworth, soprano. Mme. J. Shea, elocutionist. Mr. H. Read, solo piano. Mr. H. J.

- Davies, bass baritone. 6.30, 2ZY Orchestra. 7.45, 2ZY Operatic Company in "Faust" (Gounod).
- 13th (THURS.).—11.30, 2ZY Trio. 6.30, Girl Guides and Boy Scouts' Bulletins. 6.40, German Talk. 7.45, Oxford Picture House Orchestra.
- 14th (FRI.).—Concert by Miss N. Riley, contralto. Mr. A. Schofield, comedian. Mr. O. Collet, baritone. Mr. T. O. Snawfield, solo piano. 6.40, 2ZY Orchestra, Children's Music. 7.45, Popular and Light Music by 2ZY Orchestra. Mr. T. Sherlock, baritone. Miss C. Willis, soprano. Talk on "A Winter Walk by the Mere," by Mr. T. A. Coward, M.Sc.
- 15th (SAT.).—3.30, Oxford Picture House Orchestra. 6.30, Organ Recital, Piccadilly Picture House. 7.45, Heywood Co-operative Glee and Madrigal Society.
- 16th (SUN.).—3, 2ZY Orchestra. 8, Talk to Young People, by Mr. S. G. Honey. 8.30, Rev. L. J. Shields, Director of the Industrial Christian Fellowship. 8.45, Mr. Pat Ryan, solo clarinet. Miss Doris Lemon, soprano. Mr. Wm. Michael, baritone.
- 17th (MON.).—3.30, 2ZY Orchestra. 6.35, Boys' Brigade Bulletin.
- 18th (TUES.).—3.30, Concert by Miss Eugenie Crompton, soprano. Mr. R. Bagat, elocutionist. Mr. H. Thorpe, baritone. Mme. A. Sampson, contralto. 6.30, H.M. Royal Air Force Band. 8.15, Mr. Harry Hopewell, baritone. 8.45, Talk by Mr. J. E. Phythian, M.A., on Burne-Jones' "Star of Bethlehem." 9.40, Spanish Talk.

□ □ □

NEWCASTLE.—Owing to the unfortunate indisposition of one of the artistes last week, it

was found necessary to engage a substitute at short notice, with the result that an entertainer filled the gap under the name of "Quip and Jest." He appears to have given universal satisfaction and great curiosity has been expressed as to his identity. Many have also expressed the hope that he will frequently figure in the programmes. We are given to understand that his re-appearance is very probable, but that the desire for anonymity of the very well-known gentleman who thus conceals his light under a bushel will be respected.

Forthcoming Events

DECEMBER.

- 12th (WED.).—3.45, Wardle's Highland Pipers' Band. Mr. A. Robins, cornet. Mme. Jennie Forster, soprano. 7.30, Orchestra. Mme. Dorothy Forster's Quartette Party. Mme. Edna Sheard, contralto.
- 13th (THURS.).—3.45, Miss Dorothy Sanderson, soprano. Mr. S. Coulson, violin.
- 14th (FRI.).—3.45.—Miss Florence Farrar, pianist. Mr. M. Henderson, concertina. Miss Ella Dent, soprano. 7.30, Operatic Night. Orchestra. Mr. J. Clinto, tenor. Miss Doris Lemon, soprano. Mr. Wm. Michael, bass.
- 15th (SAT.).—3.45, Clay-Page Trio. 7.30, Mme. Mabel Herbert, contralto. Mr. Stuart McKintosh, baritone.
- 16th (SUN.).—8.30, Rev. R. Robertson, address. Wallsend Male Voice Choir. Miss Ida Cowey, soprano.
- 17th (MON.).—Mr. J. Phillips, tenor. Mr. E. Forster, cornet.

18th (TUES.).—Miss Florence Farrar, piano. Mr. T. Brennan, euphonium. Miss Natalie Crear, soprano. Orchestra. Domino Set Concert Party.

□ □ □

SHEFFIELD.—In response to his appeal to the Sheffield wireless public to write to the relay station stating whether they desired Sunday afternoon transmissions, Mr. F. Lloyd received a huge post showing a substantial majority for this. The result is that relayed matter will be sent out on Sunday afternoons, commencing on Sunday, December 2. Many objections contending that the wavelength of 350 metres was not suitable have been made, and in consequence it has been altered to 300 metres.

□ □ □

Simultaneous Broadcasting Events
DECEMBER

- 12th (WED.).—7.30, "The Lily of Killarney" (Benedict). 8, Dance Programme.
- 13th (THURS.).—8.20, "Little Nellie Kelly," Act I, relayed from the New Oxford Theatre. 9.56, Sir William Bull.
- 14th (FRI.).—7.25, Shakespeare Programme. 7.30, "The Lily of Killarney." 9.40, "Little Nellie Kelly," Act II.
- 15th (SAT.).—"Pagliacci" (Leoncavallo). 8.50, The Roosters' Concert Party.

Scientific Supply Stores.—We have received a copy of this firm's latest catalogue of wireless and electrical apparatus. It contains copious illustrations and describes a wide range of apparatus in its 48 pages.

The Bowyer-Lowe Co., Ltd.—Publication No. 20 of this firm describes a series of components specially designed for mounting on wood panels. The advantages of this method will at once be apparent to the experimenter.

Sterling Telephone & Electric Co., Ltd.—This firm has sent us copies of publications Nos. 371, 376, 379 describing two crystal sets and variable air condensers

TRADE NOTES

respectively. These condensers will be of interest in that they are so designed as to have a straight line characteristic. A report upon their working is given in Vol. 2, No. 20, p. 699.

Darimont Electric Batteries, Ltd.—Wireless enthusiasts should obtain a copy of List No. 1, published by this firm, which describes the new Darimont cell. This is a primary cell capable of supplying filament heating cur-

rent either for low- or high-temperature valves.

Messrs. Alfred Graham & Co.—We have received booklets giving particulars of the latest models of Amplion loudspeakers, of which the prices of certain models have been reduced. These incorporate special features, notably the wooden trumpets.

Tingey Wireless, Ltd.—We are in receipt of an attractive pamphlet describing the Tingey "Superfine" Cabinet Receiver. This model is fitted with variable reaction, and it is claimed that under reasonably good conditions all the British and Continental Broadcasting may be received.

A CABINET ST100

By G. P. KENDALL, B.Sc., Staff Editor.

This instrument has been specially designed for use in situations where reflex circuits suffer from interference by lighting and power mains. It completely eliminates such induction effects and does not require an earth connection.

INTERFERENCE by induction from power and lighting mains carrying alternating current is one of the erratic and incalculable factors affecting reception conditions; in some (perhaps the majority) of cases one may have a house full of wiring and hear no more than a faint humming which is barely noticeable. In others there may be no mains within fifty yards or more, and yet the induction effects are so pronounced as to produce an overpowering roar if anything but the simplest receiver is used.

In view of certain experiences of the writer during the War when using amplifiers for picking up earth-borne buzzer signals, it seems probable that stray currents in the earth may explain, in part at least, the erratic nature of the phenomena observed, and this suggestion is strengthened by the fact that removing the earth connection from the receiver very often stops the interference completely. A partial cure may also be effected in many cases by the use of a counter-poise earth.

Most reflex circuits are particularly prone to trouble of this nature, since they usually embody a valve carrying L.F. currents, whose grid and filament are connected directly to aerial and earth, and any audio frequency impulses therein are therefore picked up and amplified. ST100 is no exception to the rule, and its well-known great advantages are somewhat offset in some situations by the fact.

The ST100 receiver illustrated in the accompanying photographs represents an attempt to overcome the difficulty in a simple way, without departing far from the original form of the circuit. The obvious line to adopt is to separate the first valve from the aerial-earth circuit by means of some type of coupling which will transfer the H.F. impulses of the signals but not the audio frequency ones of the interference. An ordinary loose-coupled tuner is fairly successful, but reduces

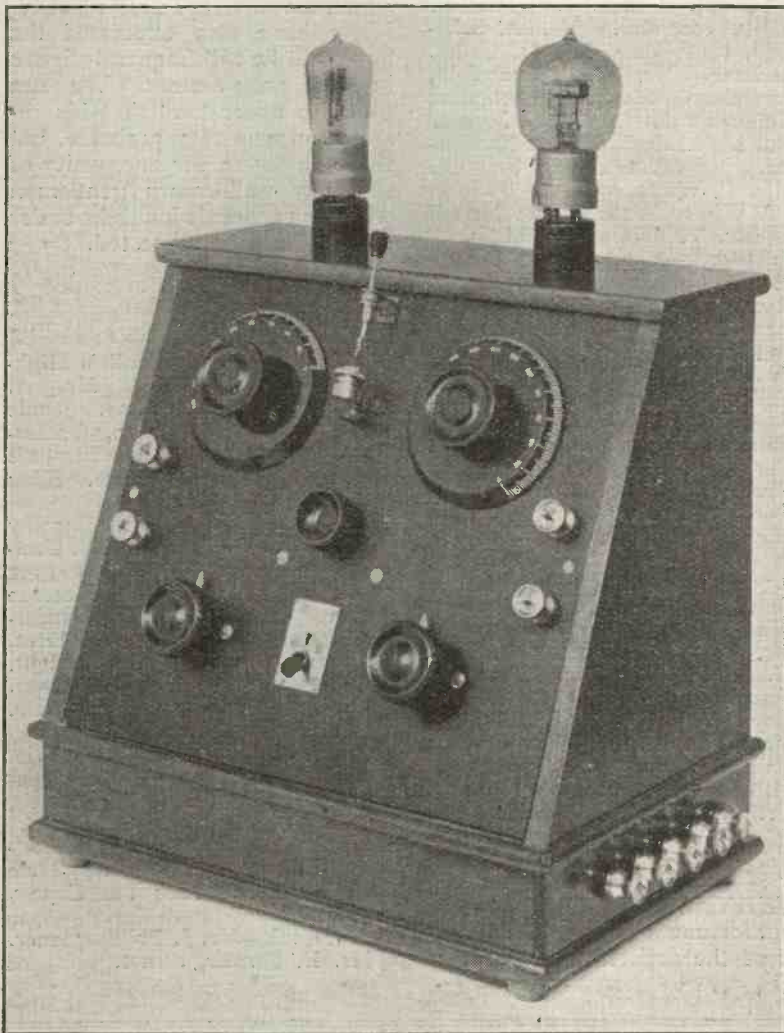

Fig. 1.—The finished instrument. A good combination of valves is suggested by this photograph, namely, an ordinary receiving valve in the first socket and a small power valve in the second.

the stability of the circuit and adds to the complication of its operation. The latter objection can be removed by employing one of the "aperiodic aerial" coils described last week; but the instability is still very great, and the method finally adopted is to use the same type of centre-tapped coil as that described by the present writer under the title of "A New Single-Valve Circuit" recently (*Wireless Weekly*, Vol. 2, No. 19). The circuit thus modified is fairly stable, practically free from induction effects, and does not require an earth

connection. There is, however, a slight reduction in signal strength, which was not observed in the case of the single-valve circuit; the ST100 usually has an ample "reserve of power," and the reduction is not serious. In any case, the price is worth paying to be free from A.C. interference in those positions where it is serious.

The general arrangement of the set can be seen from the photographs, and we will now proceed to consider its construction in detail.

The following parts are necessary:—

- One sloping front cabinet.
- One ebonite panel to fit (10 in. by 9 in. is a convenient size).
- Two valve holders.
- Two variable condensers of $0.0003 \mu\text{F}$.
- Two filament resistances.
- One on-and-off switch for panel mounting.
- One crystal detector for panel mounting. (Burndept or other screw-adjustment type recommended.)
- One Igranite L.F. transformer.
- One Radio Instruments L.F. transformer.
- One fixed condenser of $.0001 \mu\text{F}$.
- One fixed condenser of $.0003 \mu\text{F}$.
- One fixed condenser of $.0003 \mu\text{F}$.
- One fixed condenser of $.002 \mu\text{F}$.
- One grid leak of 0.5 megohm.
- Nine terminals. (Five of these to be provided with ebonite bushes, since they are mounted on the side of the cabinet.

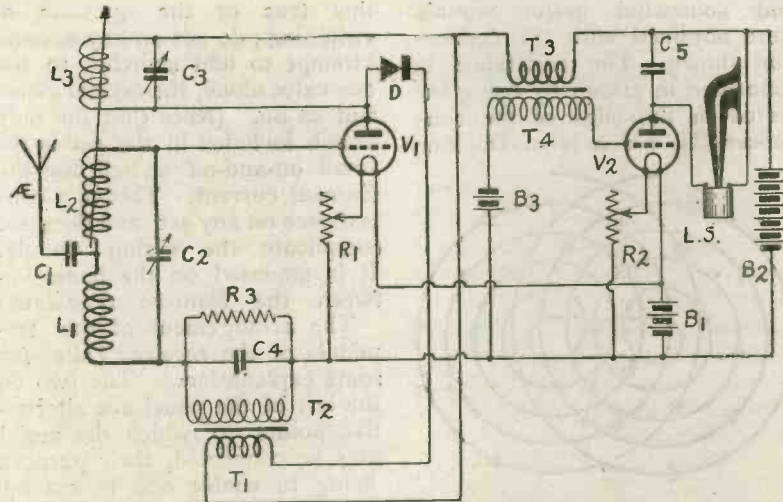

Fig. 3.—The circuit of the receiver.

Messrs. Bowyer-Lowe supply these.) The circuit is shown in Fig. 3, and it may be helpful to identify the various components therein. C1 is the condenser of $0.0001 \mu\text{F}$, C2 and C3 are the variable condensers, C4 is of $0.0003 \mu\text{F}$, and

C5 is of $0.002 \mu\text{F}$ capacity. T1 T2 is the Igranite transformer, and T3 T4 the R.I., this arrangement having been found to give particularly good results.

The inductances L1, L2, are basket coils of 40 turns each, wound with No. 20 S.W.G. double cotton-covered wire and joined in series. They are placed together side by side in such a manner that a current flowing through them travels the same way round in each, i.e., so that their magnetic fields are added. This is shown in Fig. 4. The coils are bound with adhesive tape to each other and to a strip of ebonite in the manner shown in Fig. 6, this ebonite arm being mounted on a spindle (see the photograph of the interior of the set), so that the coils may be swung across the coil L3 to produce reaction. (If no reaction effect is obtainable, reverse the connections to L3.)

The coil L3 is another basket, having 80 turns of No. 22 S.W.G. d.c.c., and mounted by means of a small bridge-piece of ebonite on the ebonite end-plate of the condenser C3, as shown in Fig. 5.

The resistance R3 is the half megohm grid leak, and serves the purpose of improving the quality of the reproduction of speech and music. If any difficulty is experienced in controlling the set, i.e., if it shows a tendency to instability, this resistance should be connected directly between the grid and filament of the first valve. This was not found necessary with the set illustrated,

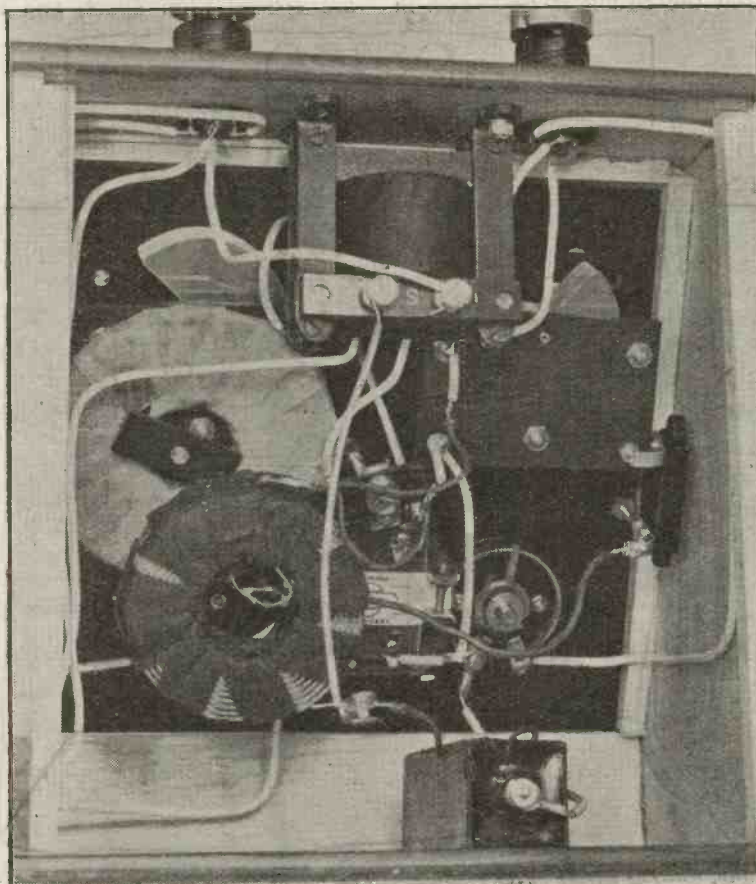

Fig. 2.—The interior of the cabinet. Note position of first intervalve transformer (T1 T2). This is situated midway between the filament resistances, and has the condenser C4 across its secondary terminals. (See the wiring diagram.)

and somewhat better signals were obtained with the connection shown. The resistance is connected in circuit by being inserted in the clips of the condenser C₄, which is of Dubilier

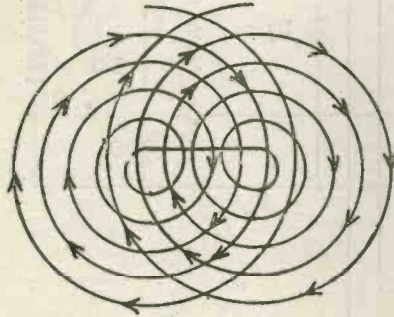

Fig. 4.—Connect the basket coils L₁ and L₂ in series, so that the currents travel in the same direction in each. This diagram shows the coils separated a little to make the point clearer.

make. It is most important, by the way, that both the leak and the condensers should be of thoroughly reliable make. Their values are somewhat critical within certain limits, and should not be departed from.

In passing, it should be mentioned at this point that the success of a set of this sort depends

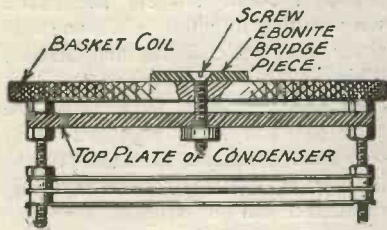

Fig. 5.—How to mount the coil L₃ on the ebonite end-plate of the condenser C₃. The screw shown is displaced from the centre of the condenser to clear the spindle of the latter.

very largely upon the use of particular valves for the components, a suitable lay-out of the parts, suitable valves, and H.T. voltage, and so on. Therefore, adhere closely to the data given, since it should be realised that the real purpose of an article of this sort is to provide a set of values and a method of arrangement which has been found by experiment (often laborious) to work satisfactorily. Any departure in the important parts of the design from the instructions given is liable to upset the whole circuit and make it necessary to do the whole of the experimental work over again. Especially is

this true of the question of switching; do not on any account attempt to add switches to use one valve alone, the crystal alone, and so on. (Note that the only switch included in the set is the small on-and-off switch for the filament current. This is a convenience on any set, and does not complicate the wiring unduly. It is mounted on the panel between the filament rheostats.)

The arrangement of the terminals of the receiver calls for some explanation. The two on the left of the panel are alternative points to which the aerial may be connected, their purpose being to enable one to cut out the condenser C₁, if desired. If the aerial is connected to the lower terminal the effect is to cut this condenser out of circuit and join the aerial directly to the centre point of the coils, L₁, L₂. This is desirable in the case of small indoor aerials.

When a large aerial, a Ducon or a gas-pipe, is used, it should be connected to the upper terminal, when the circuit is as shown in

Fig. 3. Incidentally, quite good signals can be obtained at moderate distances by connecting this terminal to earth and dispensing with the aerial.

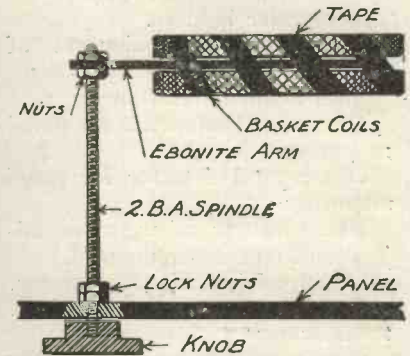

Fig. 6.—The spindle carrying the coils L₁ and L₂. The knob is that seen near the centre of the panel.

The pair of terminals on the right of the panel are for the loud-speaker, and the 0.002 μF condenser is connected across these.

On the side of the cabinet on the right is a row of terminals for the external connections to the batteries. These terminals are spaced 1 in. apart, and are

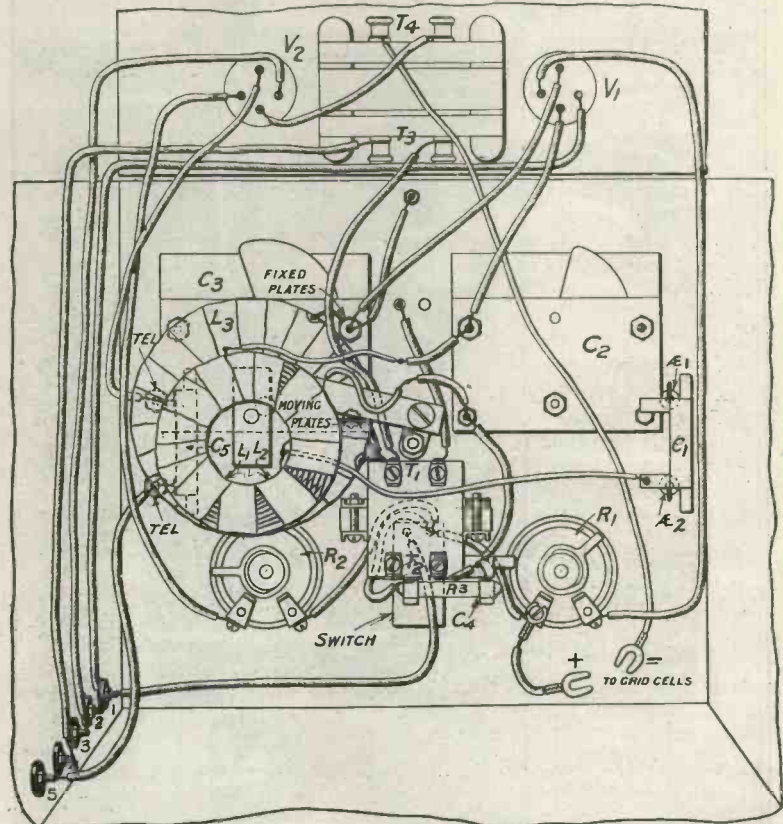

Fig. 7.—The wiring of the receiver. The top of the cabinet is shown turned back. Note the connection between Æ2 and the centre point of coils L₁ and L₂. The actual I.P., O.P., etc., connections of the transformers are best found by experiment, but primary and secondary are shown by the letters T₁, T₂, etc., respectively.

bushed with cbonite. Their purpose is to enable different filament and anode supplies to be provided for each valve, so that different types of valve can be used in the first and second sockets. They are five in number, and we will refer to them as Nos. 1, 2, 3, 4 and 5. No. 1 (at the front) is the common negative terminal to which the negative poles of all the batteries are connected; No. 2 is the L.T. positive of the first valve; No. 3 is ditto of the second; No. 4 is the H.T. positive of the first valve; and No. 5 (at the rear) is ditto of the second.

It is therefore possible to use separate accumulators for the two valves and apply a different voltage to their anodes. This is an advantage where economy of upkeep is important, since a dull emitter can be used for the first valve and run from dry batteries, while the second may be a special power valve. This last is desirable if the best results are to be obtained, since the smaller dull-emitters do not seem able to carry the necessary power in a circuit of this sort. One of the large dull-emitters, specially designed for loud-speaker work,

may, of course, be used, and, in any case, a high anode voltage (between 100 and 300 volts) should be applied and provision made for putting a negative bias on the grid of this second valve. A single grid cell is shown in the photograph, and its connections are given in Fig. 7.

The best results yet obtained by the writer have been with a Cossor "Red Top," as No. 1, with 100 volts on the anode and a small power valve as No. 2, with 140 volts H.T., and -5 volts on its grid. Both were run from the same 6-volt accumulator.

"Wireless Weekly" Free Gift Scheme

This present issue is of particular importance, for three reasons:—

Firstly, it commences a new volume, Vol. 3.

Secondly, it is the first of a series of six special issues.

Thirdly, it contains the first coupon in connection with our Free Gift Scheme, whereby we offer free gifts, up to 5s. in value, to all readers who comply with certain simple conditions.

THE CONDITIONS.

At the foot of this page will be found a coupon (Free Gift Coupon No. 1), which should be

cut out and kept until six coupons are obtained. For the benefit of new readers, a seventh coupon will appear, and will be accepted in lieu of Coupon No. 1. The six coupons, together with an order for any one of the Radio Press series of handbooks named below, are to be sent in an envelope marked "Coupon" to: Radio Press, Ltd., Devereux Court, Strand, W.C.2, accompanied by a postal order for ONE HALF OF THE LIST PRICE OF THE BOOK CHOSEN, plus 2d. for postage.

Here is an opportunity to obtain, at half price, any one of the most authoritative and practical wire-

less handbooks published. We strongly advise all readers to place an order for the next six issues with their newsagent immediately—for their convenience an order form is given below—in order to avoid disappointment, as there is every indication of the demand exceeding the supply, and there can be no reprint.

If our regular readers will kindly bring this scheme to the notice of their wireless acquaintances, pointing out especially that there is still time for them to participate in the scheme by ordering next week's issue, the courtesy will be much appreciated.

Choose your Books from this List:

	Price 6d.		Price		Price
1. Wireless for All By JOHN SCOTT-TAGGART, F.Inst.P.		7. How to Make a "Unit" Wire- less Receiver	2/6	13. 500 Wireless Questions Answered	2/6
2. Simplified Wireless By JOHN SCOTT-TAGGART, F.Inst.P.	1/-	8. Pictorial Wireless Circuits ..	1/6	14. 12 Tested Wireless Sets ..	2/6
3. How to Make Your Own Broad- cast Receiver	1/6	9. Wireless Valves Simply Explained	2/6	15. More Practical Valve Circuits By JOHN SCOTT-TAGGART, F.Inst.P.	3/6
4. How to Erect Your Wireless Aerial	1/-	10. Practical Wireless Valve Circuits	2/6	16. Home-Built Wireless Compo- nents	2/6
5. The Construction of Wireless Receiving Apparatus ..	1/6	By JOHN SCOTT-TAGGART, F.Inst.P.		Elementary Text-book on Wireless Vacuum Tubes	10/-
6. The Construction of Crystal Receivers	1/6	12. Radio Valves and How to Use Them	2/6	By JOHN SCOTT-TAGGART, F.Inst.P.	
By ALAN L. M. DOUGLAS.		By JOHN SCOTT-TAGGART, F.Inst.P.		Radio Press Envelope No. 1 (an ST100 Receiver)	1/6
				Radio Press Envelope No. 2 (a 4-Valve Receiver)	2/6

ORDER FORM.

Make sure of benefiting under our FREE GIFT SCHEME by completing this form and handing it to your newsagent *without delay*.

PLEASE SUPPLY ME WITH WIRELESS WEEKLY FOR SIX WEEKS COMMENCING WITH THE DECEMBER 19TH ISSUE, VOL. 3, NO. 2, AND UNTIL FURTHER NOTICE.

Signature

Address

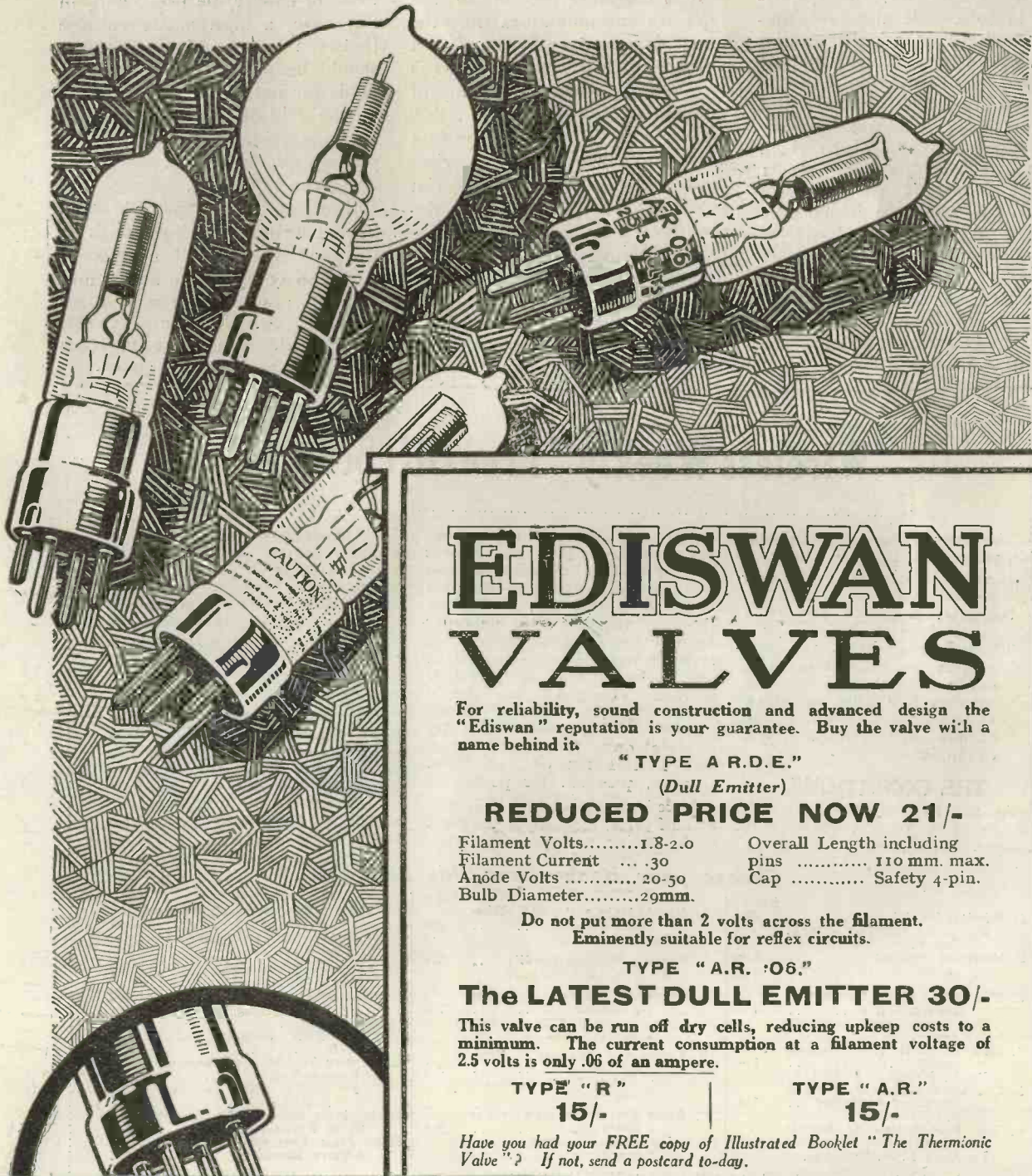

EDISWAN VALVES

For reliability, sound construction and advanced design the "Ediswan" reputation is your guarantee. Buy the valve with a name behind it.

"TYPE A R.D.E."
(Dull Emitter)

REDUCED PRICE NOW 21/-

Filament Volts.....1.8-2.0	Overall Length including pins	110 mm. max.
Filament Current30	Cap	Safety 4-pin.
Anode Volts	20-50	
Bulb Diameter.....	29mm.	

Do not put more than 2 volts across the filament.
Eminently suitable for reflex circuits.

TYPE "A.R. .06."

The LATEST DULL EMITTER 30/-

This valve can be run off dry cells, reducing upkeep costs to a minimum. The current consumption at a filament voltage of 2.5 volts is only .06 of an ampere.

TYPE "R"
15/-

TYPE "A.R."
15/-

Have you had your FREE copy of Illustrated Booklet "The Thermionic Valve"? If not, send a postcard to-day.

Your dealer holds stocks to supply you. If not, write us direct, giving his name and address.

EDISON SWAN ELECTRIC CO., Ltd.,
Queen Victoria St., E.C.4, & 71, Victoria St., S.W.1.

Principal
London
Middlesex.

Contractors to
H.M. Admiralty,
War Office, Royal
Air Force.



Everything for Wireless.

...ly. ... because it brings BIG Business.

LOUD SPEAKERS FOR WIRELESS PURPOSES

Below are given summaries of a series of interesting papers recently delivered before the Institution of Electrical Engineers and the Physical Society of London.

ON Thursday, November 29, a joint meeting of the Physical Society of London and the Institution of Electrical Engineers was held at the headquarters of the Institution for the purpose of discussing "Loud Speakers for Wireless and Other Purposes." The discussion was opened by a paper from Professor A. O. Rankine, D.Sc., on "The General Principles Involved in the Accurate Reproduction of Sound by Means of a Loud Speaker." Professor Rankine gave a general outline of the problem, and indicated the important factors which were to be covered by the speakers who followed. He emphasised the fact that the subject was one in which practice had far out-stripped theory, and urged the need of more research work, the practical side having been forced into unduly rapid growth by a sudden demand. He further considered that absolutely faithful reproduction would never be possible, partly because of varying absorption and resonance effects in the auditorium, and, moreover, that it was not necessary. The human ear is really accustomed to various forms of distortion, and makes unconscious allowance for them.

Professor Rankine went on to show that to obtain good reproduction it is necessary to eliminate resonance effects in the mechanism, but that this can only be done at the expense of sensitivity, and a compromise is required. Three principal methods of reducing resonance may be used: the diaphragm or other sound-producer can be heavily damped, its natural frequency can be made lower than the lowest audible note, or raised above that of the highest. Whatever method is used the essential condition to success is that the mechanism should not be asked to produce more than a certain volume of

sound: over-loading accentuates every defect.

The speaker deprecated the use of horns to obtain large sound volume, and considered that they inevitably led to distortion. Dealing with "room effect," he urged that reverberation or echo should not be introduced into the transmission, since when a loud-speaker is used a second set of echoes may be produced in the listening room, with objectionable results. He disliked, personally, the admixture of any echo effect, but explained that the habit of listening to music in resonant halls led many to prefer it. If used at all, echoes should be pro-

duced at *either* transmitting or receiving station, but *not* at both.

duced at *either* transmitting or receiving station, but *not* at both.

L. C. Pocock, B.Sc., A.M.I.E.E., followed with a paper on "The Theory of Loud Speaker Design." He dealt in detail with the question of balancing the sensitiveness gained by resonance against the distortion resulting from its undue use, and showed that reproduction cannot be perfect in any resonant system, or in any system containing mass and stiffness, even

though the damping be such as to prevent any natural oscillation.

Practical loud-speakers consist of a rather sharply resonant system working into an acoustical load, namely, a horn. It is not quite accurate to describe the horn as a load, because the useful work is the energy transmitted *through* it. The horn is operating in a capacity-analogous both to an electrical transformer and to an electrical transmission line. The likeness to a transformer is seen in the passage of energy from the high mechanical impedance of the diaphragm to the low impedance of the open end through a coupling device, which reduces energy reflection to a minimum and aims at obtaining the greatest possible transfer of energy.

The acoustical impedance of a horn at its small end depends a good deal on the cross-section and also varies with the solid angle and the form of the horn, but the total impedance is also a function of the impedance into which energy is delivered, *i.e.*, the open end. In general, the horn impedance varies with frequency, and, though horns of uniform impedance can be made, they are not necessarily the best. The acoustical impedance is virtually coupled to the diaphragm, and has a considerable effect upon its mode of vibration.

The resonance of a diaphragm without horn may be such that it vibrates with more than 50 per cent. of additional amplitude at resonance over a frequency region perhaps 100 periods wide. When the horn is put in place the diaphragm is made to do more work and the resonance is made much less sharp. Thus, the horn may actually improve the reproduction besides increasing the volume of sound.

(To be concluded).



A typical Loud-Speaker for wireless.

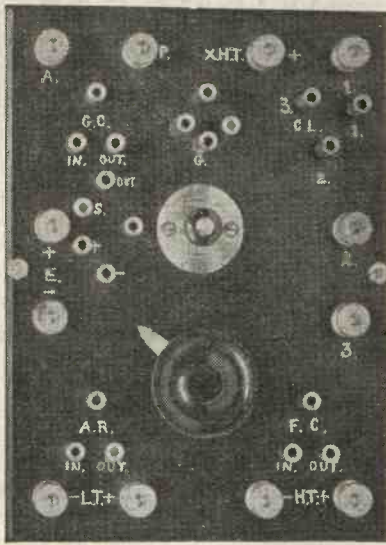

Fig. 1.—Front view of the Panel.

IN this and the following articles of the series full constructional details will be given so that a beginner will find no difficulty in completing the panel, or the various coils and other small components to be used with it.

Each of the series of articles will be essentially practical. Readers who desire to obtain a thorough knowledge of the theory involved are referred to the various handbooks published by Radio Press, Ltd.

The photographs, Figs. 1 and 2, show the front and back respectively of the completed panel.

Materials Required.

- 1 ebonite panel, 7½ in. by 5½ in. by 3-16 in. or ¼ in. thick.
- 1 piece of ebonite 2½ in. by 1½ in. by 3-16 in. for plugs.
- 2 No. 4 B.A. screws, each 1 in. long, and 4 nuts.
- 12 terminals.
- 21 valve legs, with 2 nuts each.
- 10 valve pins, with 2 nuts each.
- 1 piece of thin sheet brass 6 in. by 3 in.
- 3 yards No. 18 S.W.G. tinned copper wire.
- 2 yards No. 32 S.W.G. enamelled Eureka resistance wire.
- 1 piece ebonite rod ¾ in. diameter by 1½ in. long.
- 1 variable grid leak.

- 1 grid condenser 0.0003 µF.
- 1 telephone condenser 0.002 µF.
- 1 filament rheostat, 5 to 7 ohms resistance.
- 1 crystal detector on a small ebonite base.

Drilling the Panel.

The first procedure is to mark out and drill the ebonite panel, and, to facilitate this work, a full-sized plan of the front of the panel, with the positions of all holes clearly shown, is given in Fig. 5 (see page 23).

When the ebonite panel has been cut to size and squared up, the drilling plan should be carefully placed upon it and the positions of the holes marked by means of a spring centre-punch or other sharp-pointed instrument. The actual sizes of the various holes are not specified, as the dimensions of terminals, etc., will vary somewhat, but the following are usual sizes :—

- Terminals No. 2 B.A.
- Valve legs No. 4 B.A.

The diameters of the holes for the spindle of the filament rheostat, and for the variable grid leak, should be drilled to suit the actual components which it is proposed to fit.

Having carefully marked the positions of the holes, it is a good plan to enlarge the marks slightly, with a countersunk drill, for instance, in order to prevent the twist drill from wandering. Drill slowly, and take care to keep the drill at right angles to the panel. Having completed the drilling, remove all the original surface polish of the ebonite, both back and front, by the use of a little pumice powder and oil, rubbing energetically with a piece of soft flannel wrapped round a flat piece of wood, which should result in a fine matt finish.

Engraving.

If preferred the constructor can have this portion of the work done by one of the better class wireless dealers at a cost of approximately 3s. With a little care, however, quite a satisfactory result can be obtained by using a small diamond-pointed

“ WIRELESS UNIVERSE VALVE ”

This panel has been specially designed for trying numerous circuits, ranging from advanced dual-amplification circuit and a which the following is the first article, about 2

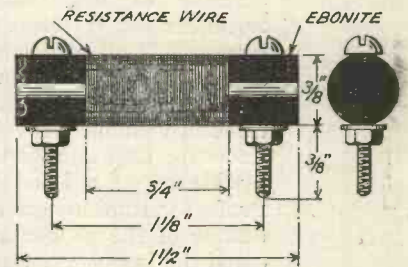

Fig. A.

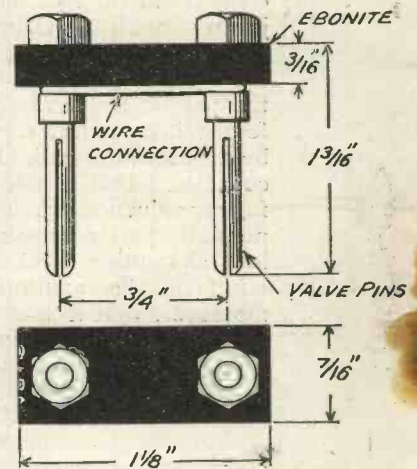

Fig. C.

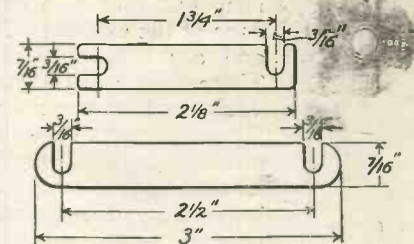

Fig. E.

WEEKLY "CRYSTAL PANEL"

Provide the home constructor facilities for a simple crystal circuit to the more complete valve transmitter. In the series, of 5 different circuits will be fully explained.

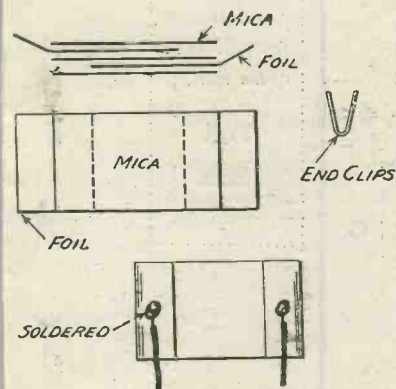

Fig. B.

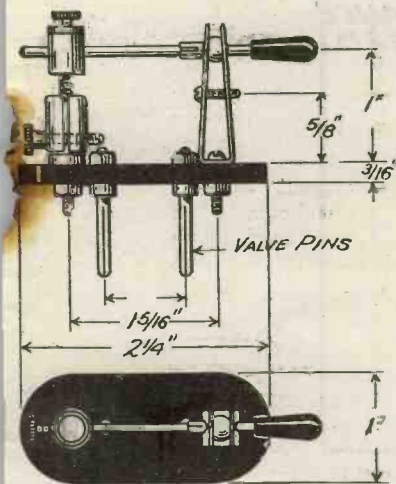

Fig. D.

Fig. 3.—A, B, C, D, E, showing constructional details of the resistance, bridges, connecting bars, condenser and crystal detector.

graver—similar to a scribe but with an oblique diamond-shaped point—a little practice being obtained first of all upon a scrap piece of ebonite. After the letters and figures have been cut, they should be filled in with white lead, any surplus being subsequently cleaned off with turpentine.

Assembling and Wiring.

The various terminals and valve legs may now be secured to the panel, as may also the grid leak and filament rheostat. The wiring is to be done with the tinned copper wire, in accordance with the full-sized wiring diagram (Fig. 4). All connections should be carefully soldered and, if care is taken to preserve the straightness of the various wires, a good appearance is obtained, as will be seen on reference to the photograph (Fig. 2), which shows a back view of the completed panel. As the wiring proceeds cross off the items one by one upon the full-sized plan, and when all is completed, carefully check.

The Auxiliary Resistance.

This is incorporated in the panel, to enable a dull emitter valve to be used. It is made by closely winding the two yards of enamelled Eureka wire upon a piece of ebonite rod, as illustrated in Fig. 3 (a). First drill a No. 4 B.A. clear hole, 3/16th inch from each end of the rod, and secure the two screws in position. Remove the enamel from each end of the Eureka wire, solder one end to one of the screws, and wind the whole of the wire upon the rod, soldering the remaining end to the second screw. This resistance, which has a value of about 10 ohms, is then to be secured, where shown on the practical wireless plan, Fig. 4. (Constructional details of an extra resistance for Pea-nut valves will be found in *Wireless Weekly*, Vol. 2, No. 19.)

The Grid Condenser.

This item may be either bought complete or made up in accordance with the details given in Fig. 3 (b). It comprises two pieces of copper foil, with an overlap of 1 1/8 ins. by 3/8 in.,

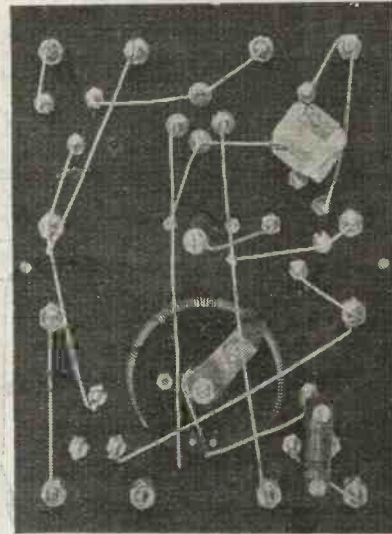

Fig. 2.—Back of Panel view.

separated by a piece of thin mica, say 0.002 inch thick, with two extra pieces of mica placed on the outside, the ends of the foils being soldered over and secured with clips of soft brass, to which the connections are subsequently to be soldered. When completed this condenser is to be soldered in position, as shown in the wiring diagram (Fig. 4).

As other condensers of this type will be required for use in some of the circuits later, the constructor may at this stage make these up as per table given on next page.

A small label should be placed beneath one of the outer pieces of mica, to indicate the value of the condenser.

Connecting Plugs.

From the piece of ebonite, 2 1/2 in. by 1 1/8 in. by 3/16th in., cut four pieces, each 1/2 in. wide by 1 1/8 in. long. 3/16th in. from each end of these strips, drill a hole to take the screws of the valve pins, clean off the original polished surface as in the case of the panel itself, bevel the edges of the strip, and secure the two valve legs in position, connecting together by means of a piece of the No. 18 S.W.G. tinned wire (or a narrow brass strip if preferred), as shown in Fig. 3 (c). One of the pins in each case may be cut short, to enable the con-

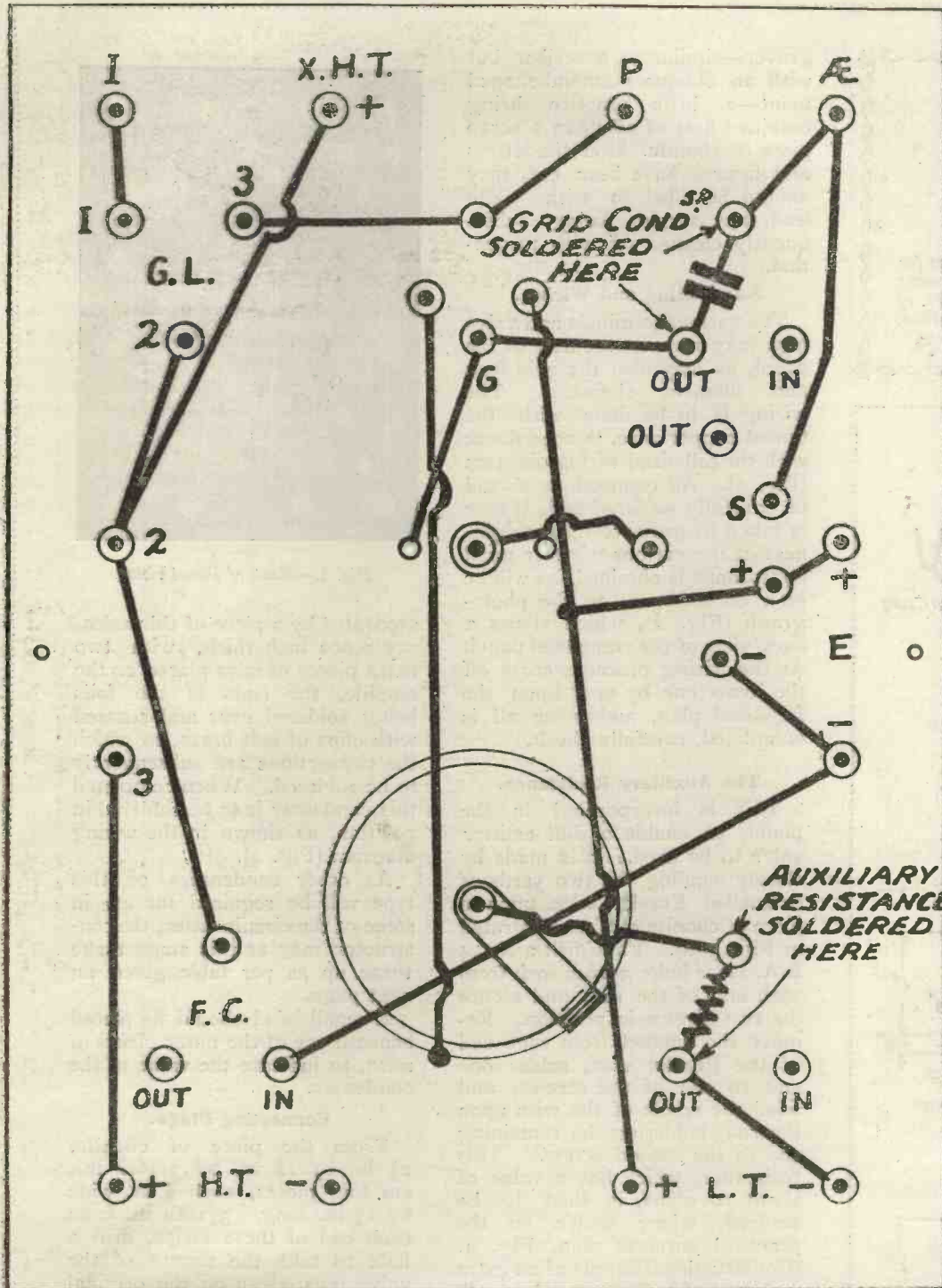

Fig. 4.—
Wiring of the
panel as seen
from the back
of the unit.

Full
Size

necter to be pivoted upon the remaining pin when changing connections, thus obviating the necessity for withdrawing the plug entirely. Four of these plugs should be made and numbered.

The Crystal Detector.

This item also can either be bought complete, or may be made up in accordance with the details

given in Fig. 3 (d). If a detector is bought, it merely requires the addition of the two valve pins $11/16$ th in. apart, to be connected to the pillar and cup of the detector respectively.

Connecting Straps.

Four of these straps are required, as shown in Fig. 3 (e); two of the shape shown in the upper sketch ($1\frac{1}{2}$ in. centres), one to the shape shown in the lower

Size of Condenser.	No. of Plates.	Overlap Area.	} Allow $\frac{1}{4}$ in. extra on length of foil for brass clips.
0.0003 μ F.	2	$1\frac{1}{2} \times \frac{3}{8}$ inches	
0.001 μ F.	5	$1\frac{1}{2} \times \frac{3}{8}$ "	
0.002 μ F.	6	$1\frac{1}{2} \times \frac{3}{8}$ "	
0.004 μ F.	6	$1\frac{1}{2} \times \frac{3}{8}$ "	
0.006 μ F.	8	$1\frac{1}{2} \times \frac{3}{8}$ "	

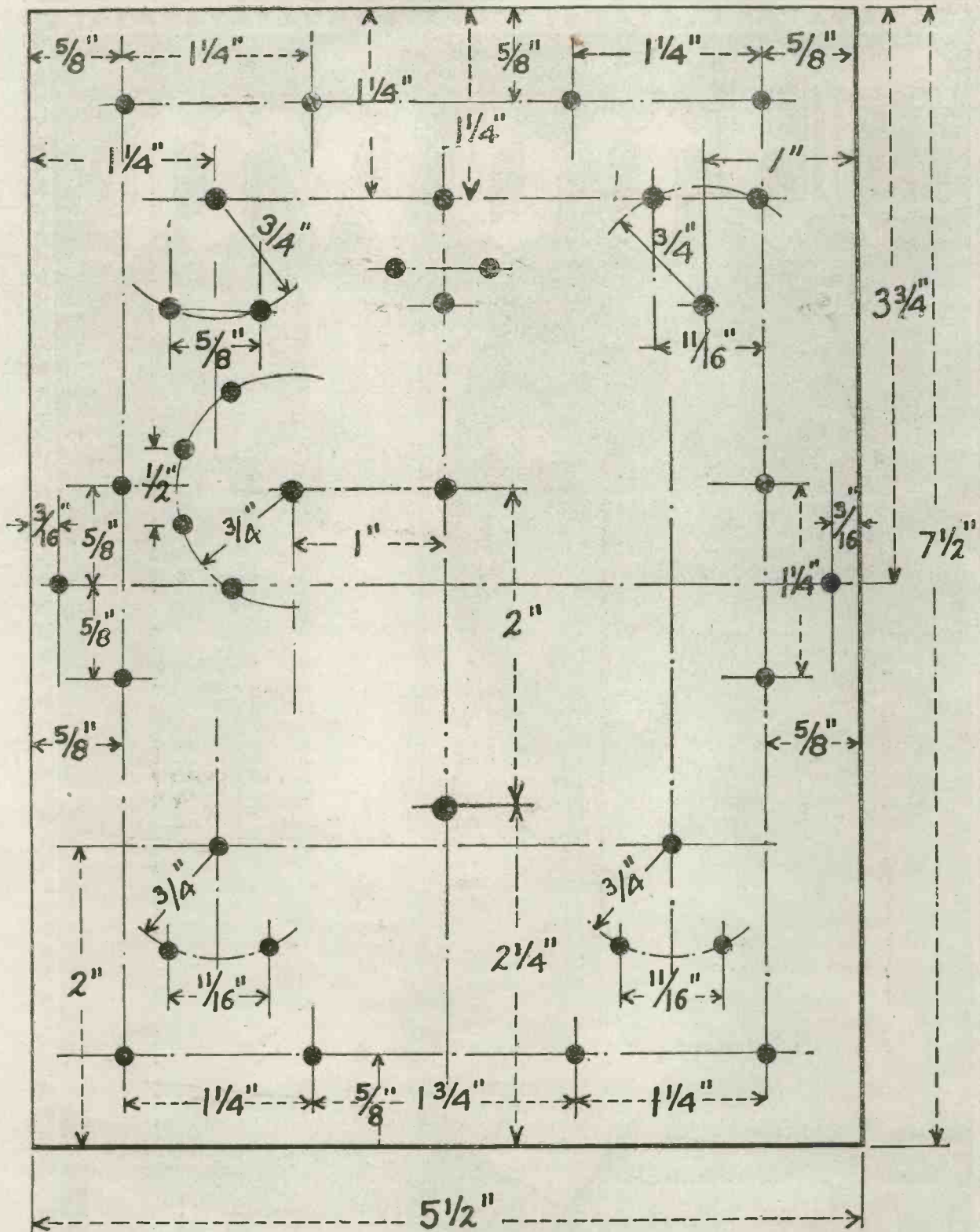

Fig. 5.—Drilling Plan.—Full Size.

sketch ($2\frac{1}{2}$ in. centres), and a fourth strap similar to this latter, but with slots at $1\frac{1}{4}$ in. centres.

The Containing Box.

This may be made of mahogany, oak or other hard wood. The

dimensions are $7\frac{1}{2}$ in. long by $5\frac{1}{2}$ in. wide by 3 in. deep. The panel is secured by means of two No. 4 B.A. screws, with one No. 4 B.A. nut screwed lightly upon each.

In our next issue will be given particulars of coils, variometer, etc., together with diagrams and instructions for connecting up the first group of circuits.

Brown

The best gift of all
— a Brown Loud Speaker

Gilbert Ad.

You CANNOT be out of WIRELESS WEEKLY because it brings BIG Business.

HOW TO DESIGN YOUR OWN SET

By PERCY W. HARRIS, Assistant Editor.

In the following article, the first of a special series, the essential principles of successful design are dealt with in a simple and practical manner.

SOONER or later every home constructor arrives at the stage when the mere reproduction of other people's designs no longer satisfies him. He has perhaps built several sets, starting with a simple crystal receiver and proceeding from this to a valve magnifier, a two-valve set with reaction, and, finally, to a multi-valve set in the most elaborate style. In building them he has acquired experience with the drill, pliers and soldering iron, so that these tools, once handled so gingerly and clumsily, are now ready servants of his will. The operation of the set has shown him just what he should expect on his own aerial from a crystal, one-, two- and three-valves and he is naturally longing to express his own individuality in a special design. Here generally he "sticks," for there is a great gap between the fully-detailed description of a set with its complete wiring diagram and the conventionalised drawing, which goes under the name of a "circuit diagram." The lack of information on how to bridge this gap has impelled me to write this series of articles, not with any idea that they are representing new information, but only to make accessible to the general reader such data as is generally acquired by painful and expensive experience.

Let us see first of all what a circuit diagram really is and what it can and cannot do. Unfortunately there are too many people who confine their "experimenting" to paper circuits, and fondly imagine they have solved their difficulties by producing some new form of diagram which ought to produce the results they desire. Every reader of wireless literature is acquainted with circuits so freely given of three, four, and even more stages of high-frequency amplification, with switches to cut out each or all of the valves. The beginner is liable to gain the impression that with such a circuit diagram before him and a

little experience he can build up a good set which will give the results he desires. The experienced man knows that such is far from being the case, as the technical difficulties of working several stages of high-frequency make such instruments so unstable as to be practically unworkable. This brings us to the first point I wish to emphasise--*a circuit which looks all right on paper may be quite useless in practice.*

frequency amplification is used. Then again, a circuit diagram, unless it is specially lettered, rarely gives such data as the number of turns of wire, the capacity of condensers, etc. We may know that a certain combination of capacity and inductance should have a frequency corresponding with a wavelength of, say, 400 metres, yet this is not sufficient. In obtaining this frequency we may have either large inductance with small capa-

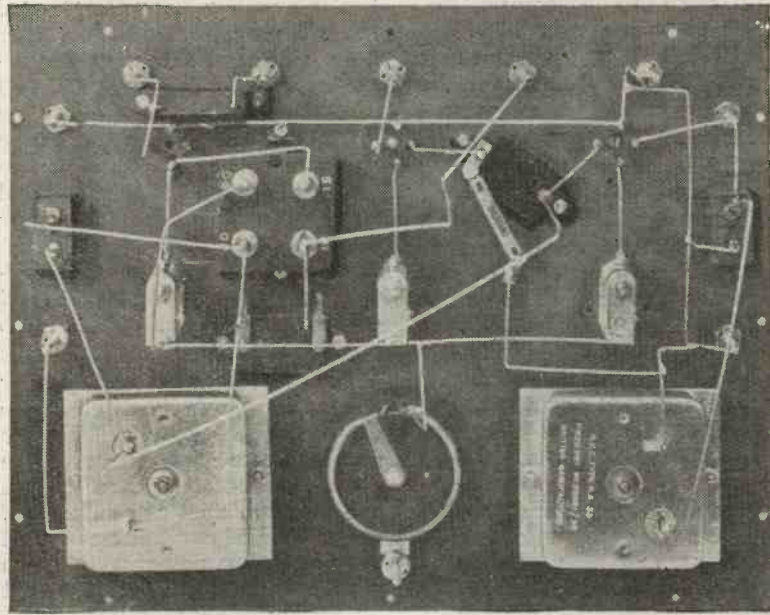

An example of neat design. Note the workmanlike appearance of the connections.

A circuit diagram shows, first of all, how the various parts are connected electrically, without giving any indication of how the components can best be arranged to give the most efficient results. For this reason it is quite possible to have a dozen different receivers all constructed from the same circuit diagram, yet all working at a different efficiency. One of them may be practically a perfect instrument, whilst another may be so inefficient as to give with three valves results which would be obtained on a properly-designed single valve set. This remark particularly applies to sets in which high-

city or large capacity with small inductance. The proportion of capacity to inductance is often of the highest importance, and may be quite sufficient to determine whether a set is efficient or not.

Still another point is of importance in our preliminary consideration. A circuit diagram, valuable as it is to the more advanced reader, can never incorporate much vital information that we must have before starting on our instrument designing. You might, for example, write to me and send me a circuit diagram with the question, "will this circuit enable me to hear Radiola in Wigan?" First of all I have

never been to Wigan, and am therefore unacquainted with the local conditions, which may be vastly different from those which pertain at my home. Secondly, I do not know what your aerial is like, and mere physical dimensions will give me very little indication of its receiving qualities, unless maybe I have a contour map of the district showing every house and building. Thirdly, I do not know the conditions under which you will work your apparatus, and how far the set will be from the leading-in point. Other questions having bearing on the set are your earth connection and the way it is made, the nature of the soil in which the earth plate or pipe is buried, and whether or not you are sufficiently close to a transmitting station to be seriously interfered with by it. So you will see that we must not rely too much on the circuit diagram.

You may think I am overstressing these preliminary points, but I should not do so if they had not been the subject matter of a vast amount of correspondence with readers of my books and articles. Bad as are the effects of "switchitis," they pale before the devastating results of "circuit-diagramitis," which has caused more waste of ebonite and wireless material than any other disease with which we enthusiasts are afflicted.

The choice of a circuit naturally precedes the design of an instrument, and here, of course, there are many pitfalls to be avoided. A very large number of experimenters attempt to jump from a crystal or a single-valve set to a five or seven-valve instrument of very elaborate design. This is the very worst possible way of acting. Yet, however bad the step may be from a technical viewpoint, one at least has sympathy with the experimenter who acts in this way. His reasons are easy to understand, for with his simple set he gets neither distance nor volume. Knowing that high-frequency amplification increases the range of a set and note magnification the volume, he very naturally desires to include two or three stages of high-frequency to bring in "practically anything," a detecting valve, and two or three

stages of note magnification to work a loud-speaker

In choosing a circuit we must therefore have clearly before us the purpose for which the set is to be designed. We must also be clear in our minds as to whether we are prepared to have a number of controls and to put up with a good deal of trouble in adjustments to get the results. Simplicity of manipulation is only too often obtained by a sacrifice of sensitivity and efficiency, whilst conversely the utmost efficiency is frequently paid for by a most exasperating complication of adjustment. A further point of importance and one too frequently ignored by those who prepare catalogues of commercial sets is that *no matter how complicated the set may be, and no matter how many valves may be included in it, the reception of distant broadcasting (such as Aberdeen in London) can never be so successful as the reception of the local station.* I know this will surprise many readers, and may possibly bring forth an indignant protest from certain manufacturers; for this reason I will explain why the statement is so boldly made..

In listening to broadcasting or telegraph signals by wireless, we desire to hear only the signals sent out from one station. If the ether were but the bearer of this one particular set of oscillations, nine-tenths of our troubles would disappear, but unfortunately this great medium has to carry a vast number of other vibrations varying in strength and character. By utilising the principle of resonance we can filter out a large proportion of the unwanted signals, but there will always be a residue of impulses we do not want.

Certain wireless transmitters (some are much greater offenders than others) radiate not only signals of the wavelength they are designed to give out, but also sub-multiples of these waves. The major portion of the power is radiated on the fundamental wavelength, but a certain proportion is wasted in these harmonic radiations which may be so numerous as to be found right down on to the shortest adjustment of our tuners. If a

harmonic happens to fall on a wavelength very close to that we are listening to, then it will cause interference by producing what we call a heterodyne note with the carrier wave of the broadcasting station. Lastly, but by no means the least trouble, there are the noises created by what are termed "atmospherics." These atmospheric are natural electrical discharges originating in storm centres, and even in calm spots in certain conditions. Atmospheric disturbances can rarely be tuned out, for they have not any particular wavelength as have ordinary wireless signals.

In case you may think I am wandering away from the subject, I now want to explain how the points mentioned in these preceding paragraphs have an important bearing upon our choice of a circuit. The ideal in wireless reception is to get a *good volume of signals from the station we want to hear with a minimum of interference from unwanted signals.* When we are listening to the near-by station, the strength of signals is such that with no magnification whatever, we can obtain very considerable strength, and thus we can say that the *ratio of wanted signals to unwanted signals* is very high. In these circumstances we shall hear practically nothing from atmospheric troubles, harmonics or weak interference from other stations.

Contrast this with the conditions pertaining when we endeavour to listen to very distant broadcasting such as that from the other end of the country or even from America. What is this ratio now? The distant signals will be so weak that without considerable amplification or magnification (it does not matter which term we use) they will not satisfy us. Magnification with valves seems a simple matter, but unfortunately it is frequently overlooked that the magnification of the *wanted* signals is also accompanied by a magnification of those we *do not want*, so that no matter how loud we may make the distant signals, that very important point, the *ratio of wanted to unwanted signals*, remains practically the same.

A further article of this series will appear next week.

THE SIMPLEST SUPER

By A. D. COWPER, M.Sc., Staff Editor.

Those readers who are familiar with "Super" circuits, together with those who have not yet experimented with them, will find the following article by the inventor of the "Cowper" circuit of particular interest.

EXPERIMENT shows that the right place for the frame aerial in a "Super" is in the plate-circuit, where there is power directly available to overcome radiation and ohmic resistances. It is then much easier to build up violent oscillations in the very brief time available in the manner that is characteristic of all super-regenerative circuits.

In the well-known De Forest "Ultraudion" circuit it will be remembered that the tuning inductance (a variometer) is connected directly between the plate and the grid-condenser. It seemed of interest, therefore, to see if this could be adapted for use in a super circuit, as we have here the most direct possible energising of the tuning inductance.

As will be seen from the circuit diagram (Fig. 1), the small condenser represented by the grid-to-anode capacity of the valve is practically the whole tuning-condenser capacity across this inductance. Any potential difference set up along the inductance will, by charging the grid and plate with opposite signs, accentuate the P.D. by the familiar "valve" effect of the grid controlling the electron stream, so giving rise to violent oscillations.

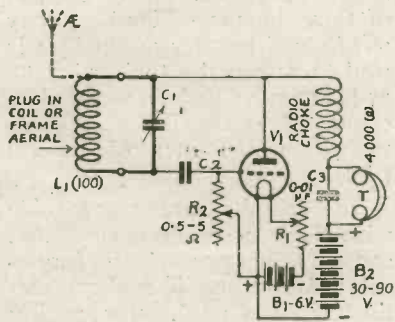

Fig. 1.—The circuit arrangement.

If the oscillating circuit has extremely low H.F. resistance and capacity (this is absolutely essential), with proper value of

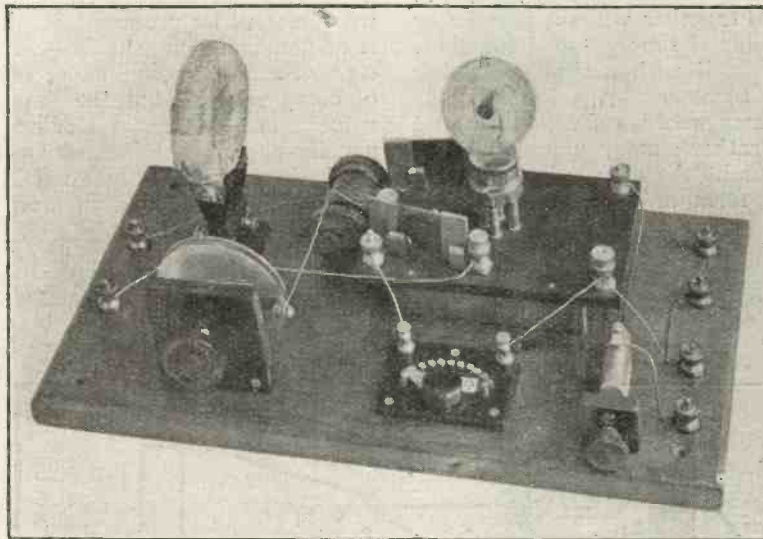

Fig. 2.—The Complete Receiver.

grid-leak, a loud howl will be produced, which can be tuned up into a high-audio-frequency quenching whistle by adjustment of grid-leak value in the usual way. The Ultraudion circuit is an essentially unstable one, which is, in ordinary practice, held down at a point just below oscillation by a variable condenser across the plate and filament (original De Forest), or across grid and filament (Albright and May modifications). The latter is omitted here, of course.

A little experimenting along these lines resulted in the super circuit shown, which can fairly claim to be the simplest, at least, of any published hitherto.

It has one-hand control, one tuning inductance (or frame aerial), and variable grid-leak—which latter does not need to be continuously variable. Tuning is effected by a small two-plate tuning condenser. As any capacity above about .0001 μ F in the plate-circuit is found to prevent entirely the "super" action, an extremely low minimum-capacity variable condenser with this maximum value is required, so that even the ordinary three-plate "vernier" is unsuitable here.

Fortunately, however, several firms have recently put on the market a form of two-plate mica-and-air condenser, with the movable plate moved to-and-fro from the fixed plate by a screw action, thus giving the desired very low minimum capacity. That illustrated in the figure, with two plates, 3 in. diam., was supplied by E. J. Baty

The fixed tuning inductance, if used (with small vertical aerial, or merely "capacity" aerial), must be wound with thick wire; the ordinary tuning inductances of the plug-in type are designed for longer wave work, and their high-frequency resistance is so high for the short waves that they render this circuit inoperative. For wavelengths from 350 to about 450 metres a coil of some 100 turns of No. 20 d.c.c. is required in any one of the familiar low-capacity windings. That used by the writer in this and other super receivers is wound on a $1\frac{1}{4}$ in. diameter former $\frac{3}{8}$ in. wide, with two rows of 6 pins each; those in the one row being opposite the spaces in the other, alternate layers being wound honeycomb and lattice fashion.

Starting round No. 1, the wire is taken round No. 3 pin of the opposite row, then back round No. 6; and so on, for one layer; then a layer of ten turns wound side by side, lattice-coil fashion, etc. This makes a fairly compact coil, only 3 in. diameter, even with 100 turns of this thick wire. The wire is stiff enough to hold together without paraffin or shellac if simply taped together.

A coil with a similar number of turns on a 3 in. diameter former would suffice, but would be rather clumsy unless two-pile wound. An alternative offers in the form of two 50-turn basket

paraffined paper, each layer consisting of a roughly-piled winding several wires deep. It was equal, roughly, to a 250-turn coil in effective impedance.

The grid-condenser is preferably of small size— $0.0001 \mu F$; while the 'phone blocking condenser, which is quite essential in this circuit in order that the whistle shall be produced at all, is of unusually large value—viz., $0.01 \mu F$. If unobtainable, one of 0.005 will do, but the larger value is better. Ordinary paraffin-paper and foil condensers rarely have sufficiently good insulation for this kind of work.

$\frac{3}{8}$ in. ebonite screwed to the base, on which also the coil-holder and terminals are mounted. A suitable frame-aerial has 24 turns of No. 20 or 22 D.C.C. wire spaced at $\frac{1}{4}$ in. by fibre (or ebonite) combs attached to the arms of a wooden cross 2 ft. square. It should be noted that the number of turns required is unusually high, to tune over the range 350 to 450 metres or thereabouts, on account of the extremely small tuning capacity available. If a plain vertical aerial is used, it should not be more than about 4-5 ft. high, as a longer one brings in more "mush," which actually drowns the less powerful signals. It is attached to the plate terminal, the tuning-coil being left in position. No "earth" is needed.

The operation of the circuit is similar to that of other grid-leak-howl supers, of the Flewelling type, or that described by the writer in the September 26 issue of *Wireless Weekly*. The account given on p. 416 of the issue mentioned, and the note on p. 540 of Vol. 2, No. 15 (October 24), should be referred to in this connection.

The first thing is to get a loud howl. One may start with 30 to 90 volts applied on the plate of a hard R valve with the filament as bright as possible, and with minimum condenser across the inductance, the grid-leak being set to its maximum value. Then this howl must be brought to a shrill whistle by adjusting the grid-leak, and the station tuned in by finding the array of heterodyne "bumps" which announce its vicinity, and getting into the silent region between the loudest of these bumps. Hand capacity effects will be very marked; it is well to screen the tuning handle as far as possible by a metal plate connected to the L.T.+ . Fine-tuning is a matter of several trials.

The results are comparable with those of other supers, and can actually approach the single-valve Armstrong if a short vertical aerial is used. The quality of speech, however, was found by the writer to be rather poorer than in more elaborate supers; probably this can be eliminated by more careful tuning and adjustment of H.T., filament temperature, and grid-leak.

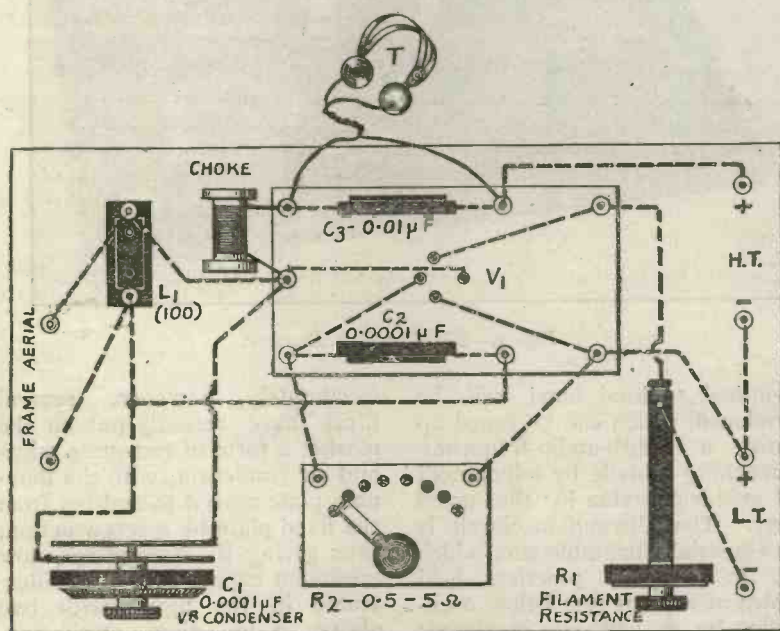

Fig. 3.—Practical wiring diagram.

coils connected in series and fastened close together with paraffined paper between. As pointed out, the ordinary thin-wire inductances marketed are useless for this purpose.

The radio-choke, which prevents the high-frequency energy from shorting to the filament via the 'phones and H.T. battery, can be any coil of over 200 turns of usual dimensions; the size and type of covering of wire are largely immaterial. A No. 250 plug-in coil suffices admirably. For the sake of compactness, a special small choke was used in the receiver illustrated; this consists of about 4 oz. of No. 32 enamel-covered wire wound on a spool 1 in. diameter by $1\frac{1}{2}$ in. long, in three multiple layers separated by several layers of

Those shown are of an extremely convenient type, allowing of instant changing for experimental purposes, and were supplied by the Grafton Electric Co., who also supplied the coil-holder. The grid-leak is of the multi-tapped variety, supplied by Messrs. Peto-Scott; the filament resistance, which should have a smooth, silent action for proper fine-regulation of the whistle, is the handy compact form marketed by T. C. Ball.

The components are conveniently mounted on a wooden base-board, as illustrated in the photograph, Fig 2, a small ebonite panel, 6 in. by 4 in., carrying the valve-holder and fixed condensers; adjustable condenser and filament resistance being mounted on small pieces of

Valve Notes

By John Scott-Taggart, F. Inst P.

Choke Coils for Low-Frequency Amplification.

I HAVE been carrying out some interesting experiments with choke coils and resistances in low-frequency amplifiers. The idea that iron introduces distortion is a very prevalent one, but one which is not founded on

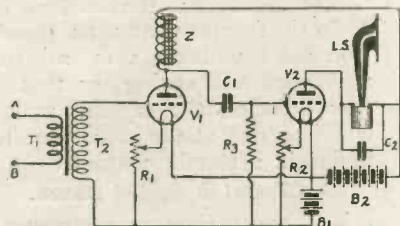

Fig. 1.—Choke-coupled L.F. amplifier.

practical experience. While it is true that a poorly designed intervalve transformer will introduce distortion, yet that most useful of metals—iron—must not be blamed as a result.

The natural tendency is to turn towards resistance coupled low-frequency amplifiers. A good deal has been written in the past with regard to resistance coupled low-frequency amplifiers, but it would be idle to suggest that a resistance coupled amplifier is any improvement upon a transformer coupled arrangement. It is just as easy to obtain distortion with a resistance coupled amplifier as with one using a transformer. When using a resistance, a value of from 50,000 to 100,000 ohms is required, and a variable anode resistance is very suitable for this purpose. The coupling condensers may have a capacity of 0.002 μ F, a gridleak of 2 megohms being employed. One of the biggest disadvantages of the resistance coupled amplifier is that a much larger high-tension voltage is required. The anode resistance cuts down the voltage on the anode of the valve by about a half, which means that to obtain proper results the anode voltage requires to be about twice as much. This is a

very serious bar to the general use of resistance coupling, but when we take into consideration the fact that the results are considerably inferior to those obtained with a transformer, we are bound to regard this form of coupling with a considerable amount of suspicion.

I have, however, recently been making some comparative tests with iron-core choke coupling, and the results are surprisingly good. The choke-coupling method has two big advantages over the resistance coupled arrangement. In the first place, ordinary high-tension voltages may be employed, and in the second place the signals obtained are much stronger. In preliminary experiments, I have found that when the iron-core choke is used, the results are just as good as those obtainable with the average, well-designed intervalve transformer. Anyone can readily make an iron-core choke, and the cost of manufacture is very much less than that of intervalve transformers. I therefore certainly recommend readers who are using two stages of low-frequency amplification to try the choke method of coupling. I first tried using the secondary of an intervalve transformer as a choke and got perfectly good results. There seems to be an opening here for intervalve transformers with burnt-out primaries. Good results are also obtainable with the primaries of intervalve transformers. Wondering if a closed-core choke was essential for good results, I tried the secondary winding of a microphone transformer, consisting simply of a straight, open-ended, iron wire core wound with a primary and secondary. Excellent results were obtainable. I then used a special choke made for the purpose; this is illustrated in Fig. 2. It simply consists of a bundle of iron wires measuring 4 in. and $\frac{1}{2}$ in. in diameter; a bobbin is slipped

over this core and is wound with 14,000 turns of No. 44 silk-covered wire. As a matter of fact, the actual amount of wire used does not seem to be at all critical, and all kinds of different chokes were tried with success.

Fig. 1 shows the type of circuit employed. It will be seen that the input to the valve V_1 is the usual intervalve transformer T_1 T_2 , but in the anode circuit of the valve V_1 , a choke Z is connected instead of the primary of a second intervalve transformer. The anode of the first valve is connected through the grid condenser C_1 to the grid of the second valve. This condenser C_1 , I find, should have a capacity of 0.002 μ F. I tried different capacities up to 4 microfarads, but found that 0.002 μ F gave as good results as any other value. I thought I detected a slight increase in signal strength when using $\frac{1}{4}$ microfarad, but if there was any improvement, it was so slight as to be almost imperceptible. The gridleak R_3 may be of practically any value, and an ordinary gridleak of 2 megohms resistance will do perfectly well, and no advantage is to be gained by having a variable grid-

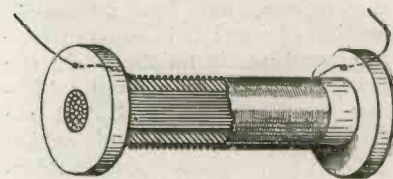

Fig. 2.—Construction of choke-coil.

leak. The condenser C_2 across the loud-speaker is optional; it may have any value from 0.002 μ F to 0.05 μ F, according to the winding and type of loud-speaker and the impedance of the valve used.

A concluding point is that for purity of reproduction the simple choke coil gives remarkably effective results. I shall be glad to hear from any readers who try out this arrangement.



Conducted by A. D. COWPER, M.Sc., Staff Editor.

L.F. Interval Transformers.

Burndept, Ltd. have submitted for test samples of their low-frequency interval transformers, No. 226 (high ratio) and No. 333 (low ratio). These are designed for use directly after the detector valve and for the second step of L.F. amplification and power amplification, respectively.

On test, the No. 226 showed excellent insulation resistance, as was to be expected from the drastic factory tests to which the transformers are, we learn, subjected. The capacity "O.P." to "I.S." was unusually low ($0.000058 \mu\text{F}$ in the sample submitted); the primary winding had obviously a high impedance, and showed a fairly high D.C. resistance. The amplification in actual reception of broadcast speech on a two-valve set without reaction was excellent, comparing favourably with the standard, and there was an absence of distortion, when using 90 volts on the plate of an R valve, and proper grid bias.

The transformer is of small dimensions, but has an ample section of iron; it is substantially built and neatly finished. In the present pattern only small soldering tags are provided, but we understand that terminals which permit, however, of soldering, if desired, will be fitted in future models.

The No. 333 (which should not be used *directly* after an ordinary rectifying valve) showed a high-resistance and high-impedance primary, but the secondary has not so high a value in proportion as in the No. 226. The insulation resistance was good, and in general appearance and finish it is similar to the transformer previously mentioned. Tested in actual reception as the second L.F. transformer in a two-valve

amplifier using L.S.1 and L.S.2 power amplifying valves, with high plate voltage and the proper high negative grid bias, very good amplification resulted, sufficient, in fact, to overload a small loud-speaker.

Polar Condenser.

The Radio Communication Co., Ltd., have sent for examination a sample of their "Polar" variable condenser, for panel mounting, in which, by the use of mica dielectric an exceedingly compact form is given to a condenser of fairly high capacity. This instrument takes the form of a brass box, some 3 in. square by only $\frac{3}{4}$ in. deep, which is arranged for mounting behind the panel by means of two small screws and ebonite distance-pieces. A black metal scale, knob and pointer, the last secured by a substantial set-screw, are also provided. Small terminal screws project at the back of the brass case.

On test, the sample was found to have the rather high minimum capacity of nearly $0.0001 \mu\text{F}$, the maximum being around $0.0012 \mu\text{F}$, thus giving an available range of $0.0011 \mu\text{F}$. On trial in actual reception, no sensible difference in signal strength could be detected in critical comparison with an ordinary air-dielectric condenser, both tuning-in various transmissions, including the Dutch concert, on a single-valve and the same tuning inductances, at similar signal-strength. The Polar condenser was found easy to adjust, the long open scale (practically 340° degrees) being appreciated in this connection.

A Hertzite Crystal Sold under Seal.

The Amax Crystal Co. have sent for test a sample of their Hertzite crystal, which is

marketed in sealed containers, together with a cat's whisker for use with it.

This crystal proved on trial to be excellent, being sensitive practically all over; the surface of a fresh fracture was as good. The cat's whisker was of the right size and spring, so that it was light on the crystal, whilst enabling one at the same time to maintain a steady contact.

A Crystal in Sealed Boxes.

The North-Eastern Instrument Co. have drawn our attention to the fact that they have been marketing their "Cymosite" crystal for some time in sealed boxes, as had been suggested as a desirable practice in the Editorial columns of *Wireless Weekly*.

On examining a sample of this sealed crystal, we found it to be of the finely granular variety, with an ample number of sensitive spots. It gave good results on test in actual reception.

Headset.

Canadian Brandes, Ltd., have sent in for test a set of headphones, the Brandes "Matched Tone," of 4,000 ohms resistance. These are of moderate weight, and are fitted with a comfortable type of head-band, which is easily adjusted and does not catch in the hair.

The pair submitted had a generous length of cord, with the positive end clearly marked; the interior finish and workmanship were of the best, in keeping with the external appearance. The nickel-plated magnets were particularly noticed.

On practical trial in valve and crystal reception they proved to be exceedingly sensitive, comparing favourably with the best English and Continental types of phones.

AN ADAPTOR FOR BASKET COILS

By R. W. HALLOWS, M.A., Staff Editor.
A constructional note for the home worker.

THERE are literally dozens of methods of mounting basket coils, most of which are satisfactory in their own way. There is, however, one great drawback from which all of those ordinarily used seem to suffer. If the coils are to be mounted so that they are interchangeable with honeycomb or duolateral coils upon a standard holder with plug and socket fixing

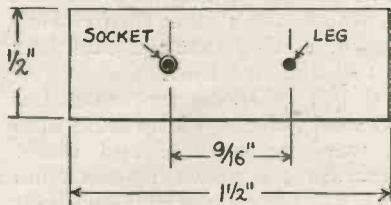

Fig. 1.—The mounting for coil.

arrangement, each must be mounted upon its own piece of thick ebonite provided with contacts of the kind mentioned. This is rather an expensive business, since each coil requires a fairly large piece of ebonite, and it also entails a good deal of work if a dozen or so coils have to be dealt with. The writer, who uses coils of very many types, puzzled over the problem for some time before a method was found of mounting all of them so that they could be used upon the same tuning stand and were quickly and easily interchangeable.

For each coil two pieces of 3-16 in. thick ebonite, 1 1/2 in. long and 1/2 in. wide, were cut out. The pair were then clamped together in a lead-jawed vice and drilled as shown in Fig. 1. The size of the two holes, the centres

of which are 9-16 in. apart, will depend upon the diameter of the plugs and sockets to be used. If possible, plugs and sockets with threaded shanks should be obtained, otherwise the more commonly seen type with plain shanks should be procured, a suitable male thread being put on to each. If dies of the right size are not in the workshop outfit, this is a job that any garage or cycle shop will undertake at very small cost. The size of the holes in the ebonite should be such that threaded shanks will just pass comfortably through them.

Now take a basket coil and place one of the ebonite strips on either side of it. Pass a plug through one pair of holes and secure it by means of two nuts. Into the other pair of holes insert a socket and secure in the same way. Tighten the nuts sufficiently to clamp the coil firmly between the strips, but not so as to crush it. Now trim off the ends of the shanks and solder to them the end of the coil windings. If a rule is made to attach the "In" end to the plug and the "Out" end to the socket in all cases, then the windings will always run in the same direction when the coil is mounted.

The next step is to make the attachments which fit the tuning stand. Of these, only two or three are required, according to whether the stand is of the two- or three-coil type. For these we require a piece of 1/2-in. ebonite 2 1/4 in. long and 1 1/4 in. wide. In one face of this, quite close to the top, two 1/4-in. holes 9-16 in.

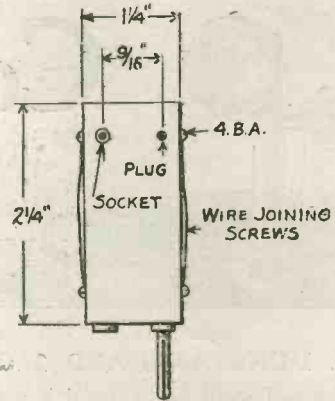

Fig. 2.—The plug-in arrangement.

apart are drilled, as shown in Fig. 2. Into these are inserted one plug and one socket, the two being held in place by 4B.A. screws driven in from the edge.

In the lower edge of the holder a second plug and socket are mounted in a similar way. Systoflex-covered wires are then used to join the screws holding the two plugs in place and retaining the two sockets.

When it is desired to use basket coils on the tuning stand, the ebonite pieces just described are fixed into it in the ordinary way. Any basket coils provided in the manner described with a plug and socket can then be slipped on in a moment.

It might be thought at first sight that when mounted in this way the coils would not be capable of the close coupling that is required at times owing to the length of the plugs and sockets. As a matter of fact, this difficulty does not arise. The writer uses a tuning stand with which coils have a straightaway movement. It is never found that they require to be less than 1 1/2 in. apart, and the usual distance between primary and secondary is considerably greater than this.

HOLDER FOR NUTS AND WASHERS

SMALL nuts and washers usually find their way to the bottom of the junk box and are found only after an exhaustive search.

Even if the constructor keeps a separate box for such parts much time is wasted in finding a nut of the size required. Probably the following idea is new to readers, but in any case will save considerable time and trouble, as any re-

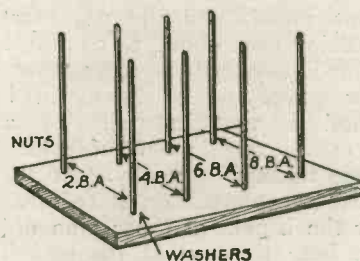

The holder illustrated

quired size of nut or washer is at once to be found.

Into a wooden base of convenient size, say 6 in. by 3 in. by 1/2 in., drive 8 short thin knitting needles. Nuts and washers may then be threaded on these needles in sizes 2, 4, 6 and 8B.A., washers being placed on, say, the front row of needles and nuts at the back.

W. B.

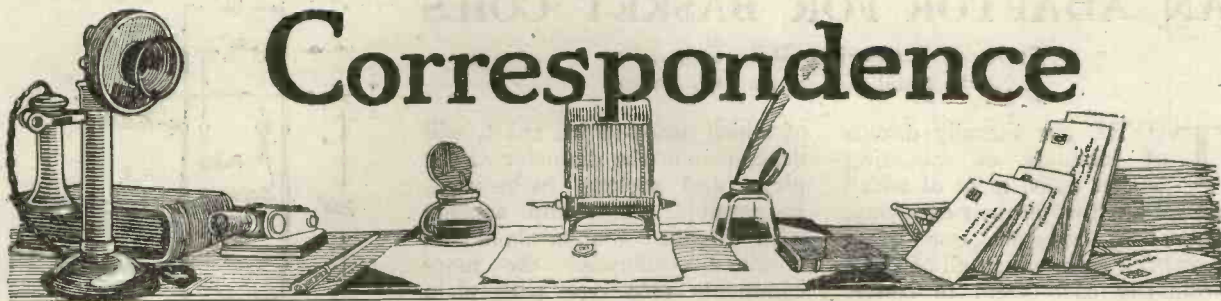

Correspondence

ST. DUNSTAN'S AND 2LO.

SIR,—I shall be grateful if you will give me space in your columns to tell your readers of an event which has been arranged for the evening of December 23, in which I hope all "listeners-in" will find interest.

In connection with the St. Dunstan's Carol League, which labours devotedly to raise funds for the furtherance of St. Dunstan's work, a selection of Christmas carols will be simultaneously broadcast from 2LO between 8.30 and 9.0 p.m. by four gentlemen from St. Paul's Cathedral choir, who have been chosen by Dr. Charles Macpherson, the choirmaster.

I want to ask your readers if they will arrange for this occasion, "listening-in" parties amongst their friends, and will make during the evening, a collection on behalf of the funds which St. Dunstan's so badly needs. I hope, before or after the singing of the carols, to be able to tell all "listeners-in" something of the work St. Dunstan's has done, is doing, and must do in the future for the men who made the great sacrifice of their sight in defence of King and Empire.

May I add that I shall be only too happy to send special collecting envelopes to those of your readers who will write me at St. Dunstan's headquarters, Inner Circle, Regent's Park, London, N.W.1. With many thanks for your help in this matter.—I am, etc.,

IAN FRASER.
(Chairman).

A NEW SINGLE-VALVE CIRCUIT.

SIR,—I write to thank you for the splendid single-valve circuit which was described by Mr. G. P. Kendall in *Wireless Weekly* of November 21st. I

have constructed this circuit and had marvellous results. Unfortunately I could not procure the ebonite former; however as an experiment I wound on a $3\frac{1}{2}$ in. cardboard former, 80 turns of No. 24 double silk-covered wire, and in all other details the set is exactly as you describe.

The following components were used:—

- J.B. variable condenser.
- Dubilier fixed condensers.
- Lissen variable grid leak.
- D.E. 3-valve and Igranic aerial circuit type variometer.

The following is a report of my first experiments, which I think are nothing short of marvellous. Glasgow came in (20 miles) with great strength on gas pipe aerial. I then tried for other stations with the same energy collector and was thunderstruck to find that I could tune in *all* other B.B.C. stations, Bournemouth (400 miles) being next best to Glasgow. Most wonderful of all, I was able to tune Glasgow (415 metres) out, and tune in the new Belgian station on 410 metres, this station being quite as loud as the English ones. This was all on the gas pipe aerial, admittedly the tuning was very critical, especially as I have no anti-capacity handles or screening of any description.

I was so delighted with results that I decided to be one of the many listeners to America at 3 a.m. Unfortunately I overslept myself and did not start listening until about 3.15 a.m. I immediately got a strong carrier wave, and on tuning in I found I was listening to a speech, every word of which came through perfectly. At the finish the announcer stated that for the benefit of those who did not hear the first of the speech he would again state the speaker, which he then did, the name being

Owen Young, Chairman of the General Electric Company. He then announced that the Wireless Orchestra would play "God Save The King," which they did and repeated, the station then closing down, stating that the time was 8-18½ standard time.

I got other carrier waves but was not able to pick up more than a word or so here and there, whereas the above results from WGY were perfect without fading or disturbance of any kind, and I think it marvellous.

The following are the details of how I received the above. I did not risk the gas pipe aerial for this reception, so moved my set to another room and attached my outdoor aerial (no earth of course). I was using the D.E. 3-valve run with 3 volts off a high tension battery and with 36 volts on the anode.

I will not weary you with further remarks, but must thank you for this circuit and hope you think the above really good results for it. I am again using the gas pipe to-night and I am listening to Glasgow as I write. Again thanking you. I am, etc.,

J. KERR.

Beith, Ayrshire.

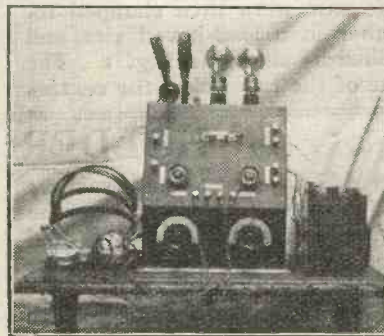

The number of ST100 sets that have been made by experimenters is legion. Our photograph shows an arrangement made by Mr. W. Barber, who states: "No amateur could wish for a more perfect instrument."

Information Department

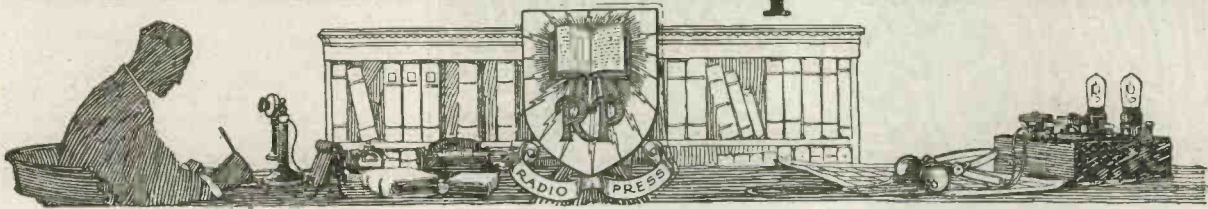

W. H. (NEWCASTLE-ON-TYNE) enquires with regard to the use of a wavetrap.

You do not state whether the condenser in your receiver is in series or in parallel with the tuning inductance. If it is in series, the type "C" wavetrap will not be very successful, but if it is in parallel you should get good results with only a slight reduction of signal strength. If the condenser is in series, the type "A" trap is generally the most successful, but in this case you will require to increase the size of the aerial tuning inductance in order to get the best results. If your present plug-in coil is a No. 50, try a No. 100 or even a No. 150 instead, when using the series wavetrap.

A. R. P. (BARROW-IN-FURNESS) asks for particulars of American broadcasting stations frequently heard in this country.

CALL SIGN.	WAVE-LENGTH	STATION.
KDKA.	360.	Westinghouse Electric & Manufacturing Co., East Pittsburgh, P.A.
WDAF.	400. } 485. }	Kansas City Star, Kansas City, M.O.
WEAF.	400.	
WFI.	400. }	Strawbridge & Clothier, Philadelphia, P.A.
WGY.	380.	
WHAZ.	400.	Rensselaer Polytechnic Inst., Troy, N.Y.
WIP.	485.	Gimbel Bros., Philadelphia, P.A.
WJZ.	360.	Westinghouse Electric & Manfg. Co., Newark, N.J.
WLAF.	360.	Johnson Radio Co., Lincoln, Nebr.
WMAF.	360.	Round Hills Radio Corp., Dartmouth, Mass.
WMAL.	360.	Trenton Hardware Co., Trenton, N.J.

A. J. R. (EDINBURGH) enquires regarding the receiving range of the "unit" set.

There are many factors which determine the actual receiving range, but, with any given set situated at a given distance from a transmitting station of known power, successful reception

depends principally upon the efficiency of the receiving aerial and the skilful manipulation of the apparatus.

With the set in question, Glasgow is received here in London without difficulty, but for satisfactory operation of a loud-speaker, it will probably be found necessary to construct and add a further L.F. unit, similar to unit No. 2. In order to obtain the best results, it is essential that the tuned-anode circuit should be in resonance with the aerial circuit, and to ensure this the compensating condenser should be added, as explained in the handbook.

P. M. (HUDDERSFIELD) wishes to make a receiver employing a crystal detector, one valve and a transformer.

For simplicity of construction and ease of operation, the single-valve *Wireless Weekly* Reflex receiver, as described in Vol. 2, No. 9 of this journal, and which requires just the components you mention, should meet your requirement. At distances up to about 15 miles from the broadcasting station the set referred to will operate a small loud-speaker fairly satisfactorily.

L. D. (PORT GLASGOW) asks several questions, the nature of which will be gathered from the following replies.

Your trouble in connection with the addition of one stage of high-frequency amplification to your existing crystal receiver may be due to several causes, such as:—

(1) The new aerial tuning variometer may be faulty. Test this by connecting the crystal detector and telephones across its terminals and using it as a variometer tuned crystal receiver.

(2) Without the aerial connection, the second variometer may not tune to the desired wavelength. Connect across the input terminals of this variometer a compensating condenser having a capacity of 0.0002 μ F or 0.0003 μ F.

(3) The valve itself may be faulty, and if this is suspected and you are unable to test it properly yourself, we advise that you call upon your wireless dealer and ask him to try the valve for you in a receiving set.

(4) The crystals in the detector may be insensitive. This point can be tested as indicated in No. 1 above.



Albert Ad.

To users of COSSOR Valves
 throughout the British Isles:
 The Compliments of the Season
 and may you get as much en-
 joyment from Broadcasting
 during the coming year as
 you have during 1923.

Advt. of Cossor Valve Co. Ltd.
 Highbury Grove, N.5

You CANNOT be out of WIRELESS WEEKLY because it brings BIG Business.

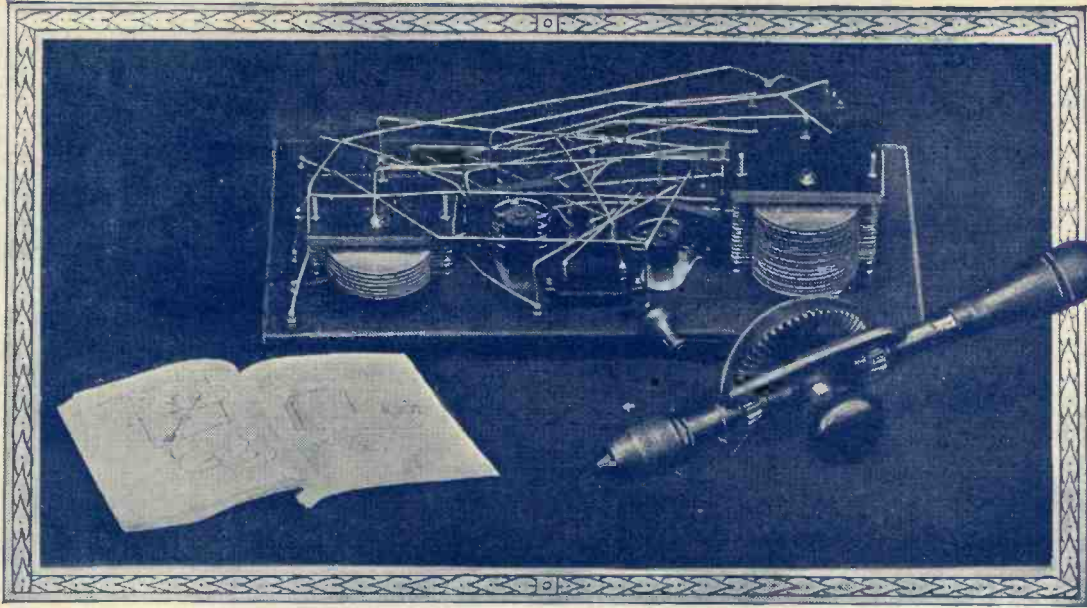

Good Books and a few simple household tools —

Choose your Books from this List:

	Price
1. Wireless for All By JOHN SCOTT-TAGGART, F.Inst.P.	6d.
2. Simplified Wireless By JOHN SCOTT-TAGGART, F.Inst.P.	1/-
3. How to Make Your Broadcast Receiver By JOHN SCOTT-TAGGART, F.Inst.P.	1/6
4. How to Erect Your Wireless Aerial By B. MITTELL, A.M.I.E.E.	1/-
5. The Construction of Wireless Receiving Apparatus By P. D. TYERS.	1/6
6. The Construction of Crystal Receivers By ALAN L. M. DOUGLAS.	1/6
7. How to Make a "Unit" Wireless Receiver By E. REDPATH.	2/6
8. Pictorial Wireless Circuits By OSWALD J. RANKIN.	1/6
9. Wireless Valves Simply Explained By JOHN SCOTT-TAGGART, F.Inst.P.	2/6
10. Practical Wireless Valve Circuits By JOHN SCOTT-TAGGART, F.Inst.P.	2/6
12. Radio Valves and How to Use Them By JOHN SCOTT-TAGGART, F.Inst.P.	2/6
13. 500 Wireless Questions Answered By G. P. KENDALL & E. REDPATH.	2/6
14. 12 Tested Wireless Sets By P. W. HARRIS.	2/6
15. More Practical Valve Circuits By JOHN SCOTT-TAGGART, F.Inst.P.	3/6
16. Home-Built Wireless Components Elementary Text-book on Wireless Vacuum Tubes By JOHN SCOTT-TAGGART, F.Inst.P.	2/6 10/- (post free.)

New Books

Published by
Radio Press, Ltd.,
Devereux Court,
Strand, W.C.2.

ONE of the great charms of Wireless lies in its appeal to our national character. We possess in a far greater degree than any other nation the faculty of teaching ourselves the use of tools and the ability to devise home-made substitutes for the more elaborate factory-made article.

Thousands of enthusiasts have made their own Sets not with the idea of saving money, but because they are intrigued with the fascination of being able to make something which will really work.

And a very large number of these Wireless experimenters have obtained their information from Radio Press Books

If you, too, have decided to enter the ranks of the Home Constructors, look down the list of books on this page and make your selection. Any of them can be obtained from your local Bookseller or we will send them direct at an extra cost of 2d. per book for postage.

Radio Press Books
— a complete wireless library

STERLING

FOUR VALVE LONG RANGE RECEIVING SET

WHOLLY BRITISH
MANUFACTURE.

THIS instrument is of highest grade finish and will meet all the requirements of those desiring perfect reception of Broadcast music and speech, either from local or distant stations, when operated on a standard P.M.G. aerial. The design of the instrument is such that excellent loud speaking can be obtained when operated on distant stations.

Complete with all valves, one pair of "Sterling" Super Quality Head Telephones with cord and plug, High Tension Battery, Grid Battery, all fitted in highly finished walnut cabinet. Price **£40 : 0 : 0**

B.B.C. Tariff 25/- extra net. LOW TENSION ACCUMULATOR £3 : 7 : 9.

Obtainable from all Electrical Dealers and Stores.

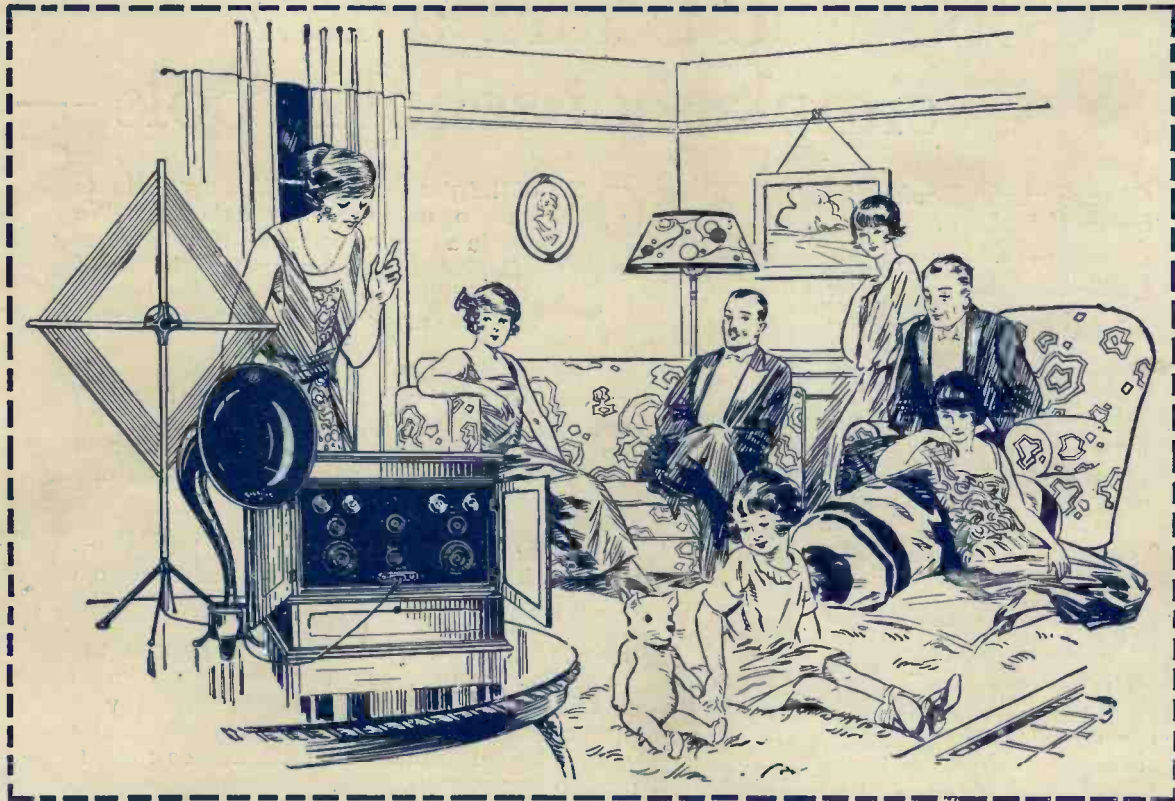

Equipment showing "Sterling" Four Valve Long Range Set as above, operating a "Sterling" Standard Loud Speaker on a "Sterling" Portable Frame Aerial.

Advertisement of **STERLING TELEPHONE & ELECTRIC CO., LTD.**, Manufacturers of Telephone and Radio Apparatus, &c, 210, Tottenham Court Road, London, W.1. Branches: Birmingham, Cardiff, Glasgow, Manchester, Newcastle. Works: Dagenham, Essex.

Printed for the Proprietors, **RADIO PRESS, LTD.**, Devereux Court, Strand, W.C.2, by **THE AVENUE PRESS (L. Upcott Gill & Son, Ltd.)**, 55-57, Drury Lane, London, W.C.2. Published on Wednesday of each week at 3, Bolt Court, Fleet Street, London, E.C.4. Address for Subscriptions and Editorial Communications:—Devereux Court, Strand, London, W.C.2. Advertisement Managers:—**THE SCHEFF PUBLICITY ORGANISATION, LTD.**, 125, Pall Mall, London, S.W.1. Registered as a newspaper and for transmission by Canadian Magazine Post. Subscription rates:—32/6 per annum, 16/3 for six months, post free. Sole Agents for Australasia:—**GORDON & GORCH (Australasia), LTD.** For Canada:—**IMPERIAL NEWS, LTD.** For South Africa:—**CENTRAL NEWS AGENCY, LTD.**

Wireless Weekly

and The Wireless Constructor

Vol. 3.
No. 2.

CONTENTS

- Dual Amplification—
Lecture No. 2.
- A Simple C.W. and Telephone Transmitter.
- A Two-Valve Power Amplifier.
- A Variometer Crystal Receiver.
- How to Design Your Own Set.
- Constructional Notes, Broadcasting News, Jottings by the Way, Basket Coils of Low Capacity, Random Technicalities, Valve Notes, Correspondence, Information Department, etc., etc.

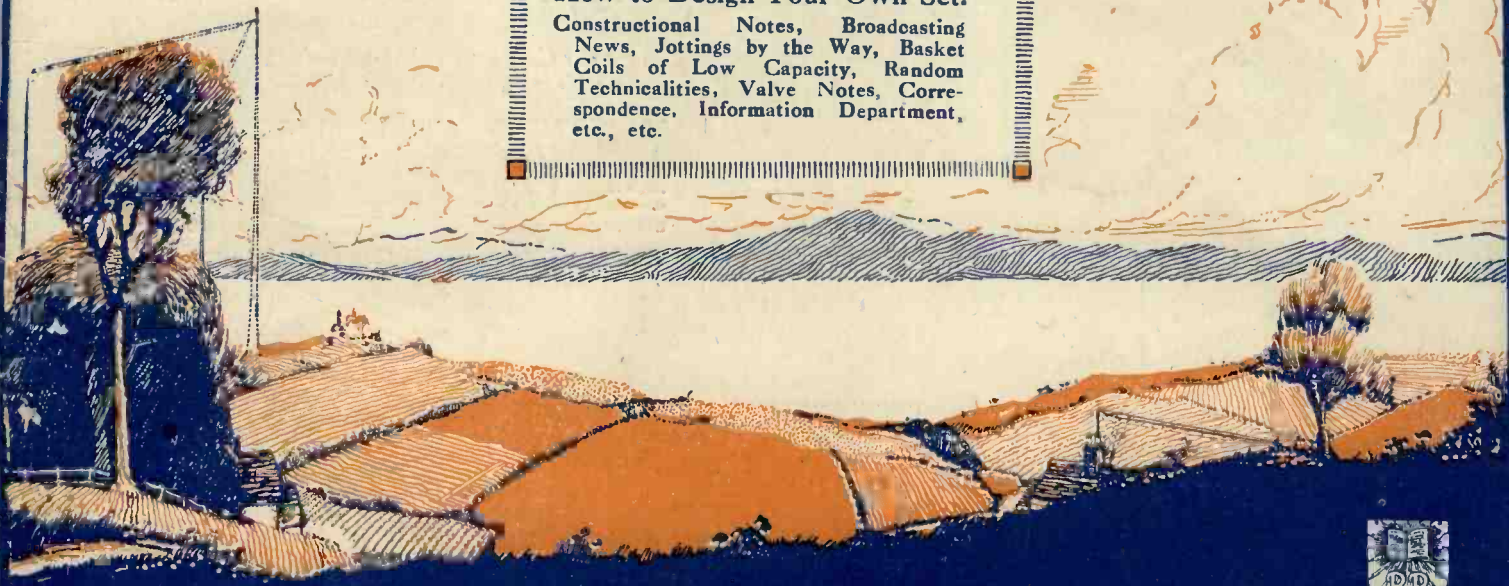

A Stable Two-Valve Dual Circuit—by A. D. Cowper, M.Sc.



Cosmos Radio Sets for Xmas Presents

YOU could make a gift of nothing more acceptable this Christmas than a well-made and efficient Radio Receiving Set.

The Sets illustrated here represent a few of the series of

COSMOS RADIOPHONES

any of which, from the Crystal Set at £3 10s. to the Six-Valve Jacobean Cabinet at £125. would form a splendid gift.

"Cosmos" Radiophones are obtainable from all Retailers of Wireless Apparatus.

Send for our Catalogue and Handbook L.W 7117/1 Post Free 1/- from the Manufacturers—

METROPOLITAN Vickers

ELECTRICAL

CO. LTD

TRAFFORD PARK WORKS :: MANCHESTER

For those who are interested in Wireless Experiments give **RADIOBRIX** from 24/- to 50/- each.

The Book of Circuits shown here contains much valuable wireless information. Obtainable from all Newsagents & Radio Dealers. 1/- (Post Free 1/5.)



Wireless Weekly

Vol. 3, No. 2
Dec. 19, 1923.

CONTENTS

	Page No.
Editorial	34
Dual Amplification Lecture—No. 2	35
A Simple C.W. and Telephony Transmitter ..	37
Jottings by the Way	41
A Stable Two-Valve Dual Circuit	43
Radio Society of Great Britain—Election of Officers	44
A Two-Valve Power Amplifier	45
Basket Coils of Low-Capacity	47
How to Design Your Own Set—No. 2	49
“Wireless Weekly” Universal Valve Panel ..	51
Multi-connection Terminals	55
A Detachable Extension Handle }	
A Vernier Filament Resistance	56
Broadcasting News	57
A Variometer Crystal Receiver	60
Valve Notes	62
Correspondence	63
Information Department	65

Editor: JOHN SCOTT-TAGGART, F.Inst.P.

Assistant Editors { E. REDPATH.
P. W. HARRIS.

Radio Press, Ltd.

Publishers of Authoritative Wireless Literature
DEVEREUX COURT, STRAND, W.C.2

Tel.—Central 3763.

Advertisement Managers: { SCHEFF PUBLICITY ORGANIZATION,
LTD., 125, Pall Mall, London, S.W.1
Tel.—Regent 2440.

Staff Editors:
F. H. CHAPMAN, M.A., D.Sc.
A. D. COWPER, M.Sc.
G. P. KENDALL, B.Sc.
R. W. HALLOWS, M.A.
S. G. RATTEE.

Scientific Adviser:
Prof. G. W. O. HOWE,
D.Sc., M.I.E.E.
Advisory Editors:
Prof. R. WHIDDINGTON,
M.A., D.Sc.
Prof. C. I. FORTESCUE,
M.A., M.I.E.E.

All correspondence relating to contributions is to be addressed to the Editor of “Wireless Weekly.”



Nothing contained herein is to be regarded as permission or encouragement to infringe any patent rights.

Editorial

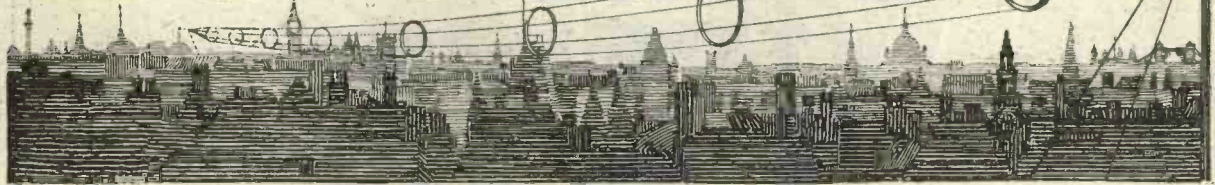

The Radio Society Again.

THE Radio Society is truly in the melting pot. Those whom we had regarded as permanent pillars supporting the fabric of the society have resigned. A new committee has been proposed, and the new officers will be elected to-day. Decisions will also be taken regarding the new constitution of the Radio Society of Great Britain.

So much for the facts. Such far-reaching changes cannot be allowed to pass without comment. We cannot regard it as anything else but intolerable that an entirely new constitution should be forced on the members of the Radio Society of Great Britain without any opportunity for them to consider it in detail. The temper of experimenters in the country, and of provincial societies, is not such that these rush tactics can be practised.

At the time of going to press we have no indication as to the nature of the new constitution, and that it should be brought forward in such a way as to prevent any criticism is reprehensible in the last degree and will do nothing to increase the confidence of the country in the Radio Society.

The committee members are apparently blind to the general state of feeling, but we remind them of the secession of most of the best transmitters in the country, the formation of a league of Southern Radio Societies which openly declares that it neither wants affiliation nor any other connection with the Radio Society, and the attitude of over 50 wireless societies, which out of a total of about 53 declared themselves entirely in sympathy with our remarks regarding the attitude towards the Wireless Relay League; are not these facts sufficient to indicate that the old committee had lost the confidence of the great mass of experimenters? A fitting climax to the career of the retiring members of the committee is the attempt to make alterations in the constitution by methods which cause the recent rush General Election to fade into insignificance.

We have good reason to believe that there is more in the committee changes than meets the eye, but all will agree that a change was necessary. The fact is that the Society had

outgrown its committee, some members of which thought that the old pompous and bullying methods could be perpetuated, whereas the whole progress of the Society depends upon the goodwill of all. The Society must keep the widest publicity possible, and must not be satisfied with reaching only about 10 per cent. of those interested in wireless.

As regards the secretarial appointment of Mr. Philip R. Coursey, we cannot but think that this is a blunder of the first order. Much as we esteem Mr. Coursey, and great as have been his services in the past (it will be recalled that we presented Mr. Coursey with a silver watch earlier in the year), we think he is entirely unsuited to the class of work which must be carried out by a secretary of such a society. His talents lie more on the scientific than the business side, and he is far from being the man to carry out a fighting programme for the rights of experimenters and for the support of experimenters. We repeat, no one has done more for certain sections of the amateur movement than Mr. Coursey, and his assistance and advice will be well worth retaining, but not as secretary of the Society. A disadvantage, moreover, of his appointment is that he is intimately associated with a wireless journal, the Editor of which is already a member of the committee. At times such as these the secretary of the Radio Society of Great Britain should be an entirely impartial and independent person, acceptable to all sections of the movement.

We believe that Dr. Eccles, as President, is clearing away the obstacles in the way of establishing a really strong national Radio Society, but nevertheless, the secretaryship is an appointment of importance and a man with political instincts and marked business ability should receive the appointment. Mr. Coursey is a busy man, and we have reason to believe that the position has been more or less thrust upon him. His valuable services should be retained, but we do not consider that he is qualified for the particular class of work which the secretary is called upon to perform.

SIX LECTURES ON DUAL AMPLIFICATION

By JOHN SCOTT-TAGGART, F.Inst.P., Editor.

No. II.

SUMMARY OF PREVIOUS LECTURE.

High and Low-Frequency Amplification were explained, and Fig. 6 was a two-valve receiver in which the first valve acted as a high-frequency amplifier, followed by a crystal detector, and a valve acting as a low-frequency amplifier.

A Simple Dual Circuit.

THE advantage of the dual-amplification circuit will be at once apparent when it is pointed out that the Fig. 6 two-valve receiver gives no better results than a single-valve dual circuit, such as that illustrated in Fig. 7. What we have now done is to use the valve not

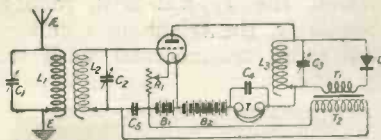

Fig. 7.—A single valve dual circuit.

only as the high-frequency amplifying valve, but also as a low-frequency amplifier. Let us examine for a moment how the Fig. 7 circuit works.

We have the aerial circuit L_1 , C_1 tuned to the incoming wavelength. To L_1 a coil L_2 is coupled, and the circuit L_2 , C_2 is also tuned to the incoming wavelength; this circuit is connected across the grid and filament of the valve. The fact that the secondary T_2 of an intervalve transformer T_1 , T_2 is included in the grid circuit does not affect the high-frequency currents because the secondary T_2 is shunted by the condenser C_2 of, say, $0.001 \mu\text{F}$ or $0.002 \mu\text{F}$ capacity. In the anode circuit of the valve there is the tuned circuit L_3 , C_3 , which is adjusted so as to be in resonance with the incoming signals.

The valve is now acting as a high-frequency amplifier, and magnified oscillations appear in the circuit L_3 , C_3 , when the latter is correctly tuned. The crystal detector D and primary T_1 of the step-up transformer T_1 , T_2 are

connected across the circuit L_3 , C_3 , with the result that the rectified currents pass through T_1 and induce varying currents in the secondary T_2 , of higher voltage.

In the Fig. 6 circuit we connected the secondary T_2 across the grid and filament of a second valve which acted as an amplifier of the low-frequency currents. In the dual-amplification circuit, however, we convey these low-frequency currents, not to the grid circuit of a second valve, but to the grid circuit of the same valve that has been used for amplifying the high-frequency oscillations. In the present case we include the secondary T_2 in the grid circuit of the valve, as shown in Fig. 7.

It will be seen that the poten-

tial across T_2 will now be applied to the grid of the valve, the potential of this grid varying at a low frequency with respect to the filament. The condenser C_2 does not act as a short circuit to the low-frequency currents, for the simple reason that its capacity is too small; the low-frequency potentials are communicated through the inductance coil L_2 to the grid. The grid itself is kept at a normal potential which is slightly negative owing to the presence of the rheostat R_1 in the negative lead to the filament, as has already been explained in connection with the "straight" circuits previously described.

The low-frequency potential variations of the grid cause low-frequency anode current variations, and these pass through L_3 and through the telephone receivers T , which are included in the position shown. We have therefore amplified the low-frequency currents.

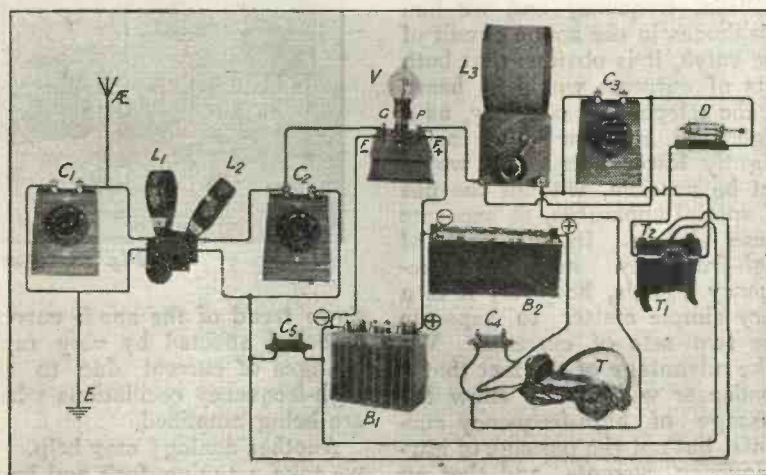

Fig. 8.—Pictorial form of Fig. 7.

It will thus be seen that the high- and low-frequency currents each take separate paths which do not interfere with each other. The high-frequency currents in the grid circuit pass through the

condenser C_3 and are unaffected by the secondary T_2 . The high-frequency currents in the anode circuit energise the oscillatory circuit $L_2 C_2$, but are unaffected by the telephones T , which are shunted by a condenser C_4 of,

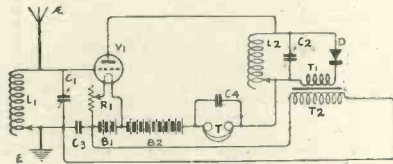

Fig. 9.—Direct-couple dual circuit.

say, $0.002 \mu F$ capacity. The low-frequency currents do not interfere with the operation of the crystal detector and the detector circuit because these circuits, as regards low-frequency currents, are virtually short-circuited by the inductance L_2 .

Fig. 7 is shown pictorially in Fig. 8.

Why a Valve can Act as a Dual Amplifier.

To many it will be a strange thing that a valve can carry out two functions simultaneously without any mutual interference. The reason is that the two sets of currents are sufficiently different in frequency to enable us to separate them by means of inductance coils and condensers. If a valve were amplifying two low-frequency currents of slightly different frequency and we had telephones in the anode circuit of the valve, it is obvious that both sets of currents would be heard in the telephones, one, say, as a high note, and the other as a slightly lower note. It would not be possible, without the use of special apparatus, to separate these signals. In the case of high-frequency and low-frequency signals, however, it is a very simple matter to separate the two sets of currents. We take advantage of the fact that a condenser will readily allow the passage of high-frequency currents, but not the passage of low-frequency currents, and that an ordinary inductance coil, as used for tuning purposes, acts as a virtual short-circuit for low-frequency currents.

The idea of one piece of apparatus carrying out two duties at once is not really new at all. There are numerous analogies;

for example, in the case we have just considered, the telephone diaphragm responds simultaneously to the two different notes.

Let us consider for a moment the state of affairs when a person is walking due east along a road. To those of us on the earth, his motion is a very simple one, but to anyone who could stand away from this earth and watch the man walking, there would be two distinct motions. If, for example, he were walking backwards and forwards along a road, not only would this motion be seen, but also the rapid motion of the earth through space. One moment the man would be going forward rapidly and the next he would be going forward more slowly, but those of us on earth would think that he was simply going backwards and forwards.

So it is in the case of a valve amplifier. We can consider that the chief anode current variations are those due to the low-frequency currents, but that at any given instant the general up and

the latter will have two distinct motions; it will be carrying out a slow to and fro swing, and it will also be vibrating at a high frequency, which will give forth the distinctive note. In the case of the valve acting as a dual amplifier, not only is the anode current varying up and down at a comparatively slow rate, but it is also trembling, as it were, all the time. As far as a person with a musical ear is concerned, the swinging of the tuning fork would not matter; it would be the high-frequency vibration which would count, because it would send out a musical note.

So, in the same way, the crystal detector of a circuit of the kind shown in Fig. 7 is not at all worried or concerned about the low-frequency current variations in the anode circuit. What it is interested in is the trembling, or high-frequency variations, of this anode current, because these are the variations which the crystal is to rectify. Similarly, the telephone receivers are quite unconcerned with the

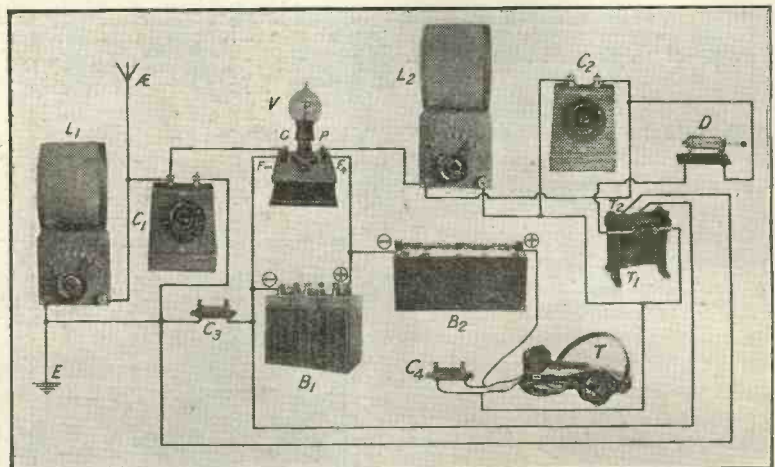

Fig. 10.—Pictorial form of Fig. 9.

down trend of the anode current is being affected by very rapid changes of current due to the high-frequency oscillations which are being amplified.

Another analogy may help. If we take a tuning fork and hang it up by a piece of string and then give it a sharp knock so that it gives out a note, the tuning fork will be moving in one manner only; it will be vibrating at a certain frequency. If now we give the string a pull so that it sets the tuning fork swinging,

high-frequency part, or component, of the anode current variations, because they cannot respond to them; they only take notice of the low-frequency current variations.

A Direct-Coupled Single Valve Dual Circuit.

The use of a tuned oscillation transformer or loose-coupler, as it is sometimes called, involves extra apparatus and greater skill in manipulation. Many, therefore, prefer to use a direct-

coupled arrangement in which the aerial circuit includes an inductance coil and a variable condenser, this circuit, or a portion of it, being connected across the grid and filament of the amplifying valve. Such a circuit is illustrated in Fig. 9. Fig. 10 is the pictorial equivalent of Fig. 9.

The aerial circuit is tuned by means of the inductance L_1 and

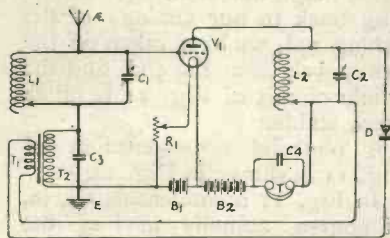

Fig. 11.—Showing position of transformer.

a variable condenser C_1 . This circuit is connected across the grid and filament of the valve V_1 , a condenser C_3 of $0.001 \mu\text{F}$ capacity being connected across the secondary T_2 of the step-up transformer T_1 . In the anode circuit of the valve we have the tuned circuit $L_2 C_2$, the telephones T shunted by the condenser C_4 of $0.002 \mu\text{F}$ capacity and the high-tension battery B_2 , having a value of from 40 to 100 volts, according to the type of valve used and the strength of signal desired. The amplified oscillations in $L_2 C_2$ are rectified by the crystal detector D , the low-frequency currents passing through T_1 and inducing currents of higher voltage in the secondary T_2 .

This secondary is included in the grid circuit of the valve, and as a result, the grid potential will vary at low frequency.

It may be asked, "But how can the grid potential of the valve vary at low frequency when the grid is connected to the coil L_1 to earth? If it is connected through L_1 to earth and L_1 acts towards the low-frequency potentials just as an ordinary wire connection would, how can the grid potential be anything but zero?" This point has worried many students in the past, but it is due to a misunderstanding of the meaning of grid potential.

Grid potential is nothing absolute. It is always relative to the potential of the filament, and for the sake of convenience and for

other reasons we always consider the grid potential with reference to the negative side of the filament. We do not worry very much what the potential of the grid is with respect to earth. In nearly all cases the filament battery is connected to earth in the circuit employed, but in the case of the Fig. 9 circuit it is by no means at earth potential, and when the circuit is operating the low-frequency potentials across T_2 will cause the filament battery B_1 and the filament to vary at a low-frequency potential to earth. For example, at one moment the filament battery and filament may be at a potential of + 3 volts with respect to the earth, and the next moment it may be at a potential of - 3 volts with respect to the earth.

Since the grid is connected through L_1 to earth and to the right-hand side of T_2 , we can say that in one case the grid is at a

From what has just been said, it will be clear that the right-hand side of the secondary T_2 being connected to earth will always be at a fixed potential, and that it will be the left-hand side of T_2 which will be the point of varying potential. This means that the left-hand side of T_2 and the apparatus connected to it, namely, the filament battery B_1 , the high-tension battery B_2 , etc., will always be at a varying potential to earth when signals are being received.

We can consider, with advantage, an analogy to this. If we have an ordinary oscillatory circuit, consisting of an inductance and a condenser in which oscillations are flowing, this is comparable to a see-saw; one end goes down and the other up, and then vice versa. If, however, one end of the oscillatory circuit is connected to earth, then the potential of that end is fixed, and it is

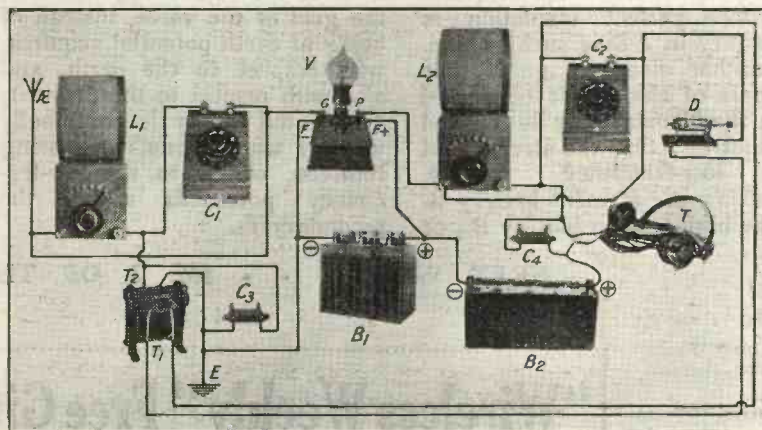

Fig. 12.—Pictorial form of Fig. 11.

potential of - 3 volts with respect to the filament, and at the next moment at a potential of + 3 volts. Thus, although the grid potential with respect to earth may remain constant, its potential with respect to the filament is varying all the time when the circuit is operating and signals are being received.

Some Disadvantages.

The circuit of Fig. 9 has a serious disadvantage which few have appeared to realise. The author has got over the difficulty by the arrangement in Fig. 11, but before discussing this figure it will be as well to point out the disadvantages of the Fig. 9 circuit.

the potential of the other end which must vary with respect to earth. This effect may be compared to that obtained when a fisherman with a long, slender fishing rod causes the tip of the rod to swing up and down by a sharp, but almost imperceptible, wrist movement at the thick end of the rod which is in his hand. One end of the rod is anchored, as it were, while the other end swings freely up and down.

In the case of the Fig. 9 circuit, it is the right-hand side of T_2 which is anchored, as it were, to earth, while the potential of the other end swings up and down. Unfortunately, it also has to cause the potential of large masses of apparatus, such as fila-

ment accumulators and high-tension batteries also to swing up and down, and they do not like it. It is like adding a weight to the tip of the fishing rod; the immediate effect would be to prevent the tip of the fishing rod from moving only to a small extent, and if the weight were heavy enough, the movement would be prevented altogether.

Coming back to the Fig. 9 circuit, it will be seen that the accumulator and high-tension battery, instead of being at earth potential, have to adapt themselves to the low-frequency current variations. The batteries have an appreciable capacity to earth themselves, and this capacity will therefore act in parallel with the secondary T_2 and help to lessen the low-frequency potentials applied across grid and filament. If there is any leakage between either of the batteries and the earth, the signal results will be seriously impaired, and therefore perfect insulation is necessary in a case such as this.

Another disadvantage is that no part of the circuit connected with the filament may be touched without affecting the strength of the low-frequency signals. Touching the filament battery B_1 , or the high-tension battery B_2 , or

the telephone receiver T , will not only weaken the low-frequency currents, but will probably set up undesirable howling noises. Touching these parts is like tying a weight on the end of the fishing rod.

Overcoming the Difficulty.

To overcome the difficulty of the batteries, etc., being at what we can call a low-frequency potential to earth, the author devised the idea of connecting the secondary of the step-up transformer in the position shown in Fig. 11. It will be seen that the filament accumulator B_1 , the high-tension battery B_2 , and the left-hand side of the telephones T , are all at earth potential, and therefore may be touched with impunity. The top end of the secondary T_2 , however, which corresponded to the right-hand side of T_2 in Fig. 9, is connected through the inductance L_1 to the grid of the valve, and this time the grid of the valve, instead of being at earth potential acquires, with respect to the earth, and also with respect to the filament, a potential which is continually varying when signals are being received, owing to the low-frequency potentials across the secondary T_2 .

The only way of affecting the low-frequency potentials across T_2 would be to touch the grid of the valve or the top end of T_2 , and this, in practice, would never be done. Moreover, the advantage of this arrangement is that the low-frequency potentials across T_2 have only to change the potential of the very small structure of the grid which has a negligible capacity. Referring back to our analogy of the fishing rod, we have taken off the heavy weight at the end, and the whole circuit of Fig. 11 is much more stable.

A pictorial representation of Fig. 11 is shown in Fig. 12.

In Fig. 11 a condenser, C_3 , is, of course, actually part of the aerial circuit, and the high-frequency oscillations in the aerial circuit pass through C_3 , which consequently affects somewhat the tuning of the aerial circuit. The best capacity for C_3 is 0.001 μF or 0.0015 μF . The secondary T_2 does not in any way affect the flow of oscillations in the aerial circuit. It has been suggested that the use of the transformer in this position would lead to more interference from electric light mains, but in practice this does not, as a rule, seem to be borne out.

NEXT WEEK - - - No. 3 OF THIS SERIES

“Wireless Weekly” Free Gift Scheme

On one of the advertisement pages will be found a coupon (Free Gift Coupon No. 2), which should be cut out and kept until six coupons are obtained. For the benefit of new readers, a seventh coupon will appear, and will be accepted in lieu of Coupon No. 1. The six coupons, together with an order for any one of the Radio Press series of handbooks named below, are to be sent in an envelope marked “Coupon” to: Radio

Press, Ltd., Devereux Court, Strand, W.C.2, accompanied by a postal order for ONE HALF OF THE LIST PRICE OF THE BOOK CHOSEN, plus 2d. for postage.

Here is an opportunity to obtain, at half price, any one of the most authoritative and practical wireless handbooks published. We strongly advise all readers to place an order for six issues with their newsagent immediately—for their convenience an order form is

given alongside the coupon—in order to avoid disappointment, as there is every indication of the demand exceeding the supply, and there can be no reprint.

If our regular readers will kindly bring this scheme to the notice of their wireless acquaintances, pointing out especially that there is still time for them to participate in the scheme, the courtesy will be much appreciated.

Choose your Book from this List:

	Price		Price
1. Wireless for All	6d.	7. How to Make a “Unit” Wireless Receiver	2/6
2. Simplified Wireless	1/-	8. Pictorial Wireless Circuits	1/6
3. How to Make Your Own Broadcast Receiver	1/6	9. Wireless Valves Simply Explained	2/6
4. How to Erect Your Wireless Aerial	1/-	10. Practical Wireless Valve Circuits	2/6
5. The Construction of Wireless Receiving Apparatus	1/6	12. Radio Valves and How to Use Them	2/6
6. The Construction of Crystal Receivers	1/6	13. 500 Wireless Questions Answered	2/6
		14. 12 Tested Wireless Sets	2/6
		15. More Practical Valve Circuits	3/6
		16. Home-Built Wireless Components	2/3
		Elementary Text-book on Wireless Vacuum Tubes	10/-
		Radio Press Envelope No. 1 (an ST100 Receiver)	1/6
		Radio Press Envelope No. 2 (a 4-Valve Receiver)	2/6

A SIMPLE C.W. AND TELEPHONY TRANSMITTER

By E. REDPATH, Assistant Editor.

The instrument described in the following article is simple to construct, and affords the experimenter a starting point in transmission work.

MANY experimenters are deterred from taking up experimental transmission work for two reasons. Firstly, the necessity of qualifying for a full experimental licence which, of course, is necessary before transmitting apparatus may be installed and worked, and, secondly, the cost or difficulty in construction of the necessary apparatus.

In order to qualify for such a licence, the applicant should comply with the following conditions:—

(1) He should have a good

theoretical and practical knowledge of wireless transmitting and receiving apparatus.

(2) He must be able to transmit and receive messages in Morse code at a speed not less than twelve words per minute. (As an alternative, a qualified operator may be engaged.)

(3) He must have a letter from at least one licensed experimenter who is agreeable to co-operate.

(4) He must indicate the nature of the proposed experimental work which he intends to carry out.

To the enthusiast, the foregoing conditions scarcely present an insuperable difficulty. The practical knowledge required in accordance with the first condition above mentioned may be obtained by constructing transmitting apparatus and using it in connection with an artificial aerial consisting of a small inductance coil, condenser and resistance. Permission to experiment with transmitting apparatus on an artificial or "non-radiating" aerial may be obtained upon application to the Secretary, G.P.O., London, and at present no charge is made.

Before authority can be granted to operate a transmitting set upon a regular aerial, the remaining conditions must be complied with and it must be clearly shown that the nature of the proposed experimental work necessitates actual radiation.

With regard to the question of cost of apparatus. Provided that it is not desired to transmit over considerable distances, which, of course, would require the use of a high voltage supply with attendant generator, or transformer and rectifiers, quite interesting and useful experimental work may be carried out by means of apparatus costing no more than the average receiving set, and deriving its power from the usual type of dry-cell high-tension battery.

A low-power transmitter of this description is shown in the photograph, Fig. 1. The instrument is arranged to give any one of three kinds of transmission, namely, continuous wave Morse, "buzzer - interrupted" C.W. Morse, or radio telephony, and, as will be seen from the photograph, only a single valve is employed, which, together with its filament rheostat, is mounted upon the top of the cabinet.

Upon the sloping front of the

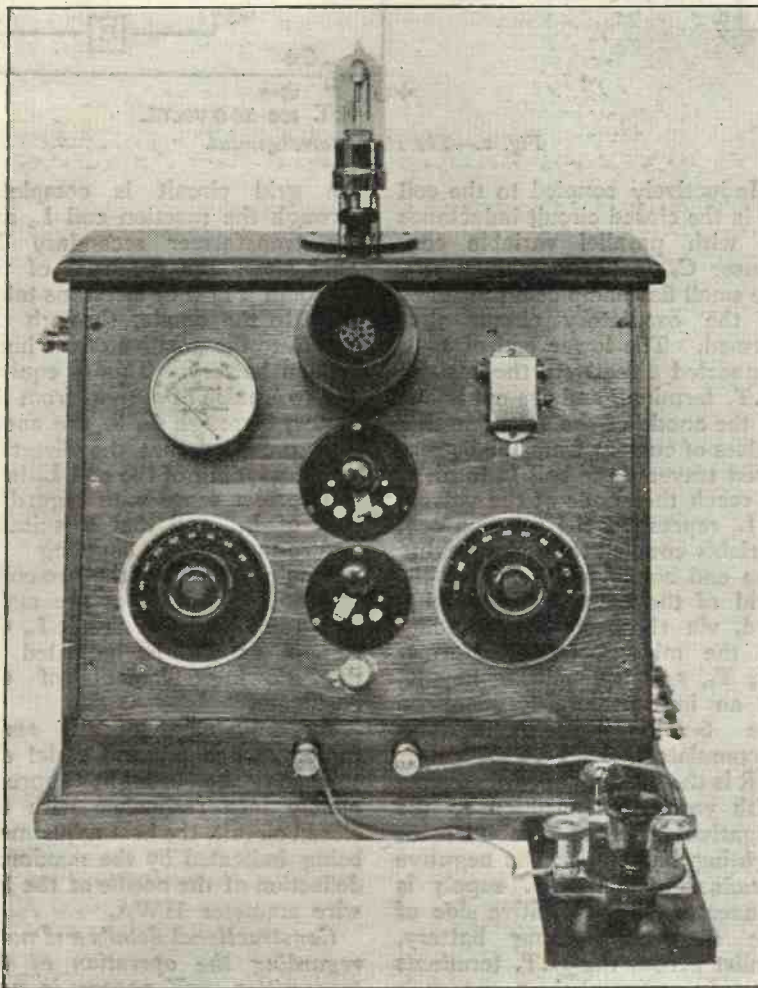

Fig. 1.—The completed transmitter.

cabinet, immediately beneath the valve, is the microphone. This is of the standard "solid-back" type. If preferred, of course, a hand microphone may be employed, in which case two terminals should be provided. Upon the left of the microphone is the aerial, hot-wire ammeter, reading up to 0.5 ampere. For such a low-power set, an ammeter reading up to 0.25 ampere only would be preferable. To the right of the microphone is the buzzer, fitted upon the front of the cabinet so as to be easily accessible.

The five-point selector switch tunes the aerial circuit approximately, fine adjustments being carried out by means of the knob and dial upon the left, which actuates the variable condenser in the closed oscillatory circuit. The knob and dial to the right of the cabinet, varies the reaction coupling, the adjustment for most efficient operation being indicated by the glow of the small flashlamp bulb fitted immediately below the three-point switch.

The nature of the transmission is varied by means of this switch. When in the position shown in the photograph, and with the transmitting key either held down or screwed down, the microphone is brought into circuit for radio telephony. With the switch arm upon the centre stud, continuous-wave Morse signals may be sent by means of the key shown connected to the two terminals in the lower front of the cabinet, and, with the switch arm upon the right-hand stud, the same transmitting key operates the buzzer, and interrupted C.W. or "buzzer-modulated" Morse signals may be transmitted.

The aerial and earth terminals are fitted upon the left-hand side of the cabinet, and the battery terminals, five in number, at the foot of the right-hand side. These terminals are just visible in the photograph.

The circuit arrangement adopted is shown in the diagram, Fig. 2. It will be seen that the general tuning arrangements are similar to those of an inductively coupled single valve receiver, but that the positions of the closed circuit and the reaction coil are reversed; the former being now connected to the anode, and the latter to the grid of the valve.

The aerial circuit includes the aerial itself, \mathcal{A} ; a fixed condenser C_1 , having a value of $0.003 \mu\text{F}$; the five-point selector switch, S_1 , the aerial tuning inductance L_1 , the hot-wire ammeter, HWA, and the earth connection E.

(say 0.05 to $0.3 \mu\text{F}$). This is optional with a good battery.

The Action of the Set.

When the valve is glowing at its correct brilliancy, the high-tension supply connected, and the transmitting key K depressed,

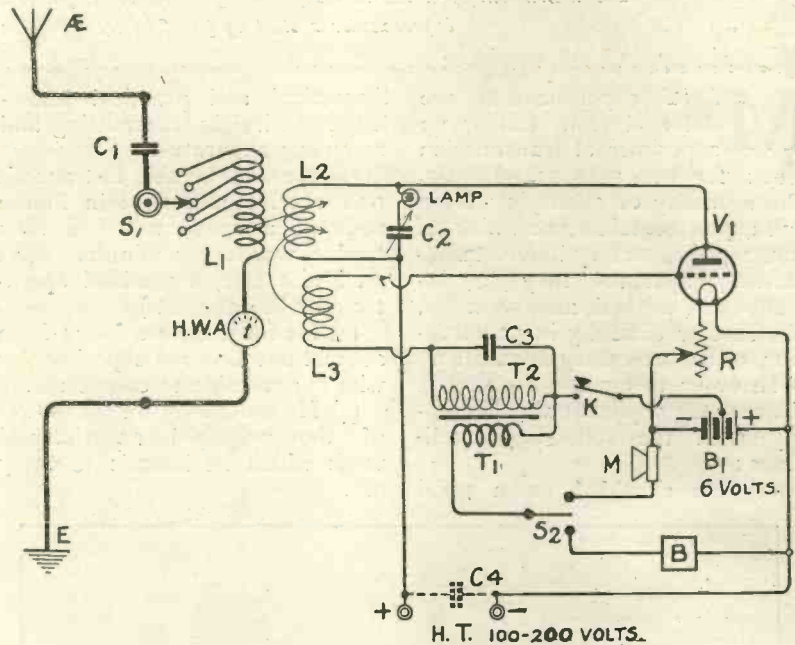

Fig. 2.—The circuit arrangement.

Inductively coupled to the coil L_1 is the closed circuit inductance L_2 with parallel variable condenser C_2 (capacity $0.0005 \mu\text{F}$), the small flashlamp being included in the oscillatory circuit thus formed. The lower end of L_2 is connected directly to the positive H.T. terminal, and the upper end to the anode of the valve, so that pulses of current from the battery must traverse the coil L_2 in order to reach the anode of the valve.

L_3 represents the reaction coil, variably coupled to L_2 , and having one end connected direct to the grid of the valve and the other end, via the secondary winding of the microphone transformer T_1 , T_2 , and transmitting key K, to an intermediate terminal on the 6-volt filament lighting accumulator.

R is the usual filament rheostat, with variable connection to the negative side of the filament lighting battery. The negative terminal of the H.T. supply is connected to the positive side of the filament lighting battery, whilst across the H.T. terminals may be connected a reservoir condenser C_4 of large capacity

the grid circuit is completed through the reaction coil L_3 and the transformer secondary T_2 . This alters the potential of the grid and a flow of electrons takes place to the anode, through the coil L_2 to the positive of the high-tension battery. This is equivalent to a pulse of current from the battery through L_2 to the anode and, provided that the direction of the winding of the coil L_3 is in the correct sense with regard to that of L_2 , and that a suitable electro-magnetic coupling is maintained between the two coils, continuous oscillations are maintained in the closed circuit $L_2 C_2$, Fig. 2, as will be indicated by the glowing filament of the flashlamp.

By adjustment of the aerial tuning switch S_1 , the aerial circuit may be brought approximately into resonance with the closed circuit, the best adjustment being indicated by the maximum deflection of the needle of the hot wire ammeter HWA.

Constructional details and notes regarding the operation of the transmitter, will appear in next week's issue.



Relief.

LAST week I told you that once in a Swedish home my tongue twisted itself into the uttering of a Spoonerism which caused consternation. I thought at the time that I had unwittingly committed some terrible blunder, and for years I have known the murmurings of an uneasy conscience on this account. Only the other day I came across a Swede and besought him to tell me what my unintentional jumbling of words meant. You may picture my relief when I found that it was only some perfectly harmless swear words of quite drawing-room calibre. Other countries, other customs! A relief, yes. But I have not forgiven my conscience for treating me thus. I will get even with it somehow.

What a Life!

There can be no doubt about it that we wireless folk are a hardy, much-enduring crew, and that we are fired by a devotion for our art and mystery that surpasses even the sighing swain's passion for the ladye fair to whose eyebrow he composes odes of well-nigh incredible badness. His, we will admit, is a thorny path beset by many a pitfall, for woman is as unstable and as difficult to handle as a set provided with half a dozen tuned anodes, and in her case no one has discovered any effective method of silencing. But what of ours? Ah, what?

When we begin we hastily marshal such scraps of electrical knowledge as remain to us from our schooldays, patting ourselves on the backs on the score that now at last we have found a use for them. Positive and negative have, we feel, no mysteries for us. Positive is where the juice starts from, and negative is the haven where it brings up after

making its eventful journey through the mazy convolutions of myriad wires. So far so good. The first shock to the system occurs when we read that no matter how they may have behaved in the days of such highly respected persons as Ampere and Volta, the up-to-date currents of to-day have decided to flow in the opposite direction, completely messing up the ideas to acquire which we suffered the martyrdom of the cane. Nor is that all. The way in which the valve plays hanky panky with his law is enough to make poor old Ohm of pious memory turn in his grave, and give birth to a new one:

progress = $\frac{\text{head.}}{\text{heels.}}$

We Never Sleep.

In our early wireless days we apply the wet towel and burn the midnight oil laboriously, unlearning what we learnt so painfully, and making ourselves familiar with a host of forbidding words. In the next stage we are found also at hours when we should have sought our couches long ago, tinkling with pliers and soldering irons and screwdrivers at refractory sets which refuse to behave themselves properly. The third stage finds us burning the midnight amp as we sit with bated breath waiting for the sound of nasal accents that will tell us that we really are listening to WMAF or WJZ.

All the stages, as you will notice, have one factor in common: we never go to bed till daylight gilds the skies. The unenlightened, who have not yet been converted to wireless, sleep sound o' nights, wallowing disgustingly in quite unnecessary slumber whilst we toil and moil without so much as winking an eyelid. Wireless, I firmly believe, is hastening the coming of the superman, who will require neither food nor rest. You have

probably reached the stage already at which it is necessary for your good wife to drag you semi-forcibly from your wireless den to the dining table, when experiments are in progress.

Daylight Losing.

If only one could find the perfect wireless wife one could organise things properly so as not to interfere with one's activities. Breakfast after the night's vigil would be at noon, lunch at 4 p.m. Tea could be fitted quite nicely into the broadcasting interval at seven o'clock in the evening, whilst dinner would just fill the otherwise almost dead period that occurs between midnight and half-past one in the morning. I fear, though, that the radio cook sufficiently enthusiastic to make this delectable programme possible might be even harder to find than the wireless wife.

Alternatively the requirements of the age may produce the super-Willett who will introduce no mere trifling change like Summer Time, which is worse than useless to the wangers of condensers. He will do something really useful by persuading Parliament to adopt Radio Time. That will indeed be a masterstroke. On a given day we shall all put our clocks back five hours and keep them there. The Daylight Losing Act will rid us of as much as possible of this wretched sunshine and will enable us really to get down to serious wireless work. The super-Willett will, of course, be made a duke, receiving as his coat of arms *sable* between a chevron of aerials *argent* three condensers *or*: crest, a gridleak rampant *gules*: motto, "This Freed 'em."

Christmas Horrors.

In years gone by Christmas used to be a season looked forward to with a certain amount of foreboding by husbands and wives

as well as by those who, having plighted their troth, were, so to speak, under sentence of matrimony. The trouble, if you remember, was that wives would give husbands cigars of the genuine Flor de Cabbagio brand, which could be smoked with impunity only by those with the stoutest hearts. Husbands retaliated by presenting their spouses with hats which to the feminine mind seemed worse offences against decency than did the cigars to the masculine. Young Strephon laid a huge bunch of hyacinths at the feet of Amaryllis, and she, poor girl, though she loathed their scent, had to keep them near her for fear of hurting his feelings. Her counterstroke was the necktie. You must have had one in your young and gallant years: a fearsome thing of motley colours knitted with her own fair hands, which had to be worn though it made even the cab horses shy.

Of late there has been an improvement, for people seemed to be becoming more sensible and

less susceptible. I know one couple who work it excellently. His Christmas present to her is usually a case of briar pipes, whilst she gives him a vanity bag and a year's supply of face powder. Thus, each in the end gets what is needed. But wireless, I fear, has rather torn things, and there are signs that the irrepressible feminine is breaking out again. Only yesterday I beheld one selecting a cheap and exceedingly nasty little transformer, which she told the salesman was to be a Christmas present for her husband.

What to do with Wireless Presents.

The great problem is to know what to do with such appalling gifts when they come along. If you consign them to the junk box, the giver is sure to find them there. You can't give them away, for you may be sure that the recipient will take the first opportunity of getting rid of them by passing them on. Thus describing what is known as a vicious circle they may eventually find their way back to the original

giver, who will be anything but pleased when such ill-favoured chickens come home to roost. It is a very difficult problem, and one which requires a little tact for its solution.

Suppose, now, that A—it is always poor old A who is getting into trouble—suppose that A is presented by an ancient aunt, from whom he has expectations, with the world's worst receiving set. It is certain that she will always be coming round to hear it. What should A do? Answer adjudged correct: A should take it at once to the local power station. He should make friends with the engineer and should induce him to attach the terminals marked AE and E to the largest possible source of power. He should then show the remains to his aunt, explaining to her how terrible the results of atmospherics can be. A can then instal a respectable set with the certainty that she will be far too nervous of it to wish to have anything to do with it.

WIRELESS WAYFARER.

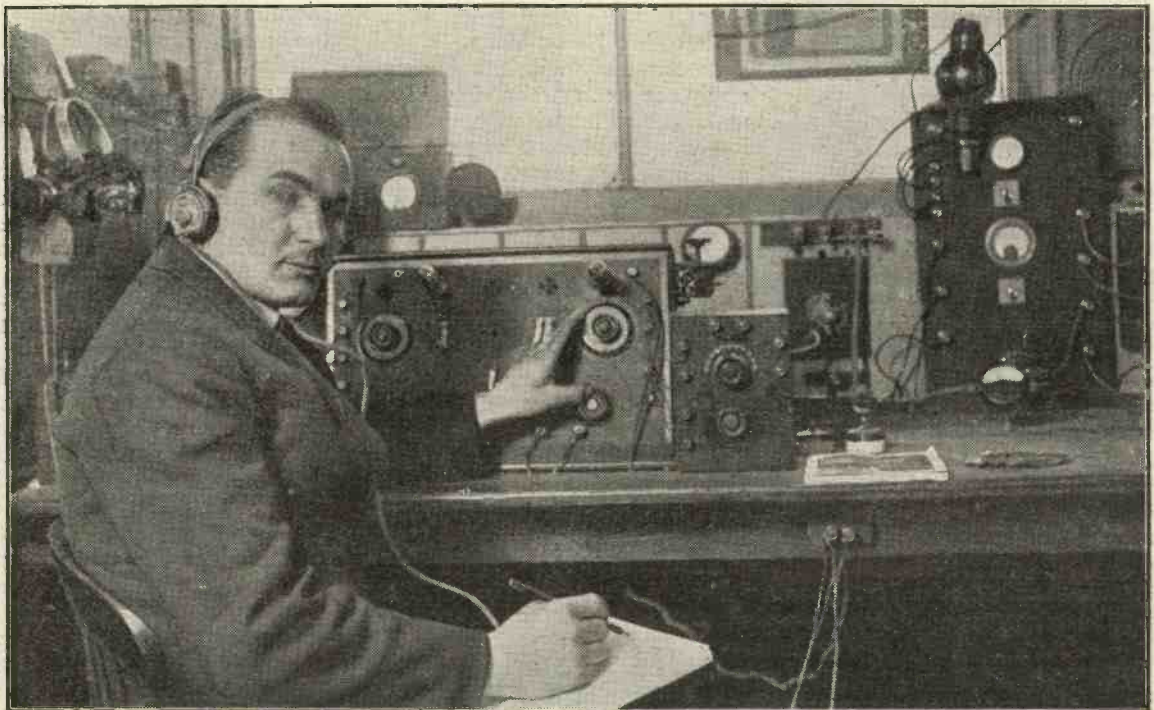

Our photograph shows Mr. J. A. Partridge of Wimbledon, a British amateur who has succeeded in getting into touch with Mr. Warner, the Secretary of the American Radio Relay League. Mr. Warner transmitted several messages from America, one of which was addressed by Mr. Hiram Percy Maxim, President of the American Radio Relay League, to Admiral of the Fleet Sir Henry Jackson, who, last year, was President of the Radio Society of Great Britain. The message reads as follows:—"Sir Henry Jackson, London, A.R.R.L.—Have great pleasure in transmitting to R.S.G.B. greetings by direct amateur contact across Atlantic (stop) Expect visit you in London, February. Hiram Percy Maxim. from 1M.O. to 2K.F. The President of the Radio Society of Great Britain has asked Mr. Partridge to transmit the following message to Mr. Maxim at the first opportunity:—"The President and Past-President of the Radio Society of Great Britain have received your greetings and join with you in tendering felicitations to the amateurs of America and of Britain now united by this triumph."

A STABLE TWO-VALVE DUAL CIRCUIT

By A. D. COWPER, M.Sc., Staff Editor.

A novel circuit employing the series-tuned anode H.F. coupling invented by the Author.

The writer has recently described (*Wireless Weekly*, Vol. 2, No. 19) a modification of the conventional tuned-anode high-frequency coupling, which possesses the useful property of

cariously. In a dual circuit using valves only this damping is not available and there is an added danger of L.F. energy reaching the detector, being amplified there as well as rectified, and

handed back via the L.F. transformer to build up the characteristic howl.

With this stable series-tuned anode coupling the first trouble can be almost entirely avoided, so that there remains only the second, which implies a complete isolation of the detector-valve from L.F. impulses, and the usual danger of casual capacity couplings, etc.

The circuit shown in Fig. 1 has accordingly been developed. It follows the Marconiphone dual circuit in the mode of introducing the L.F. energy into the grid-circuit of the first valve, behind a grid-condenser and through a radio-choke, and in the use of a radio-choke on the plate of the first H.F. valve, for connection to the 'phones and H.T., but has the series-tuned anode coupling referred to, the anode-tuning variometer being connected in series with the plate and the second grid-condenser. This gives a stable and effective H.F. coupling, if the variometer is wound with the right amount of

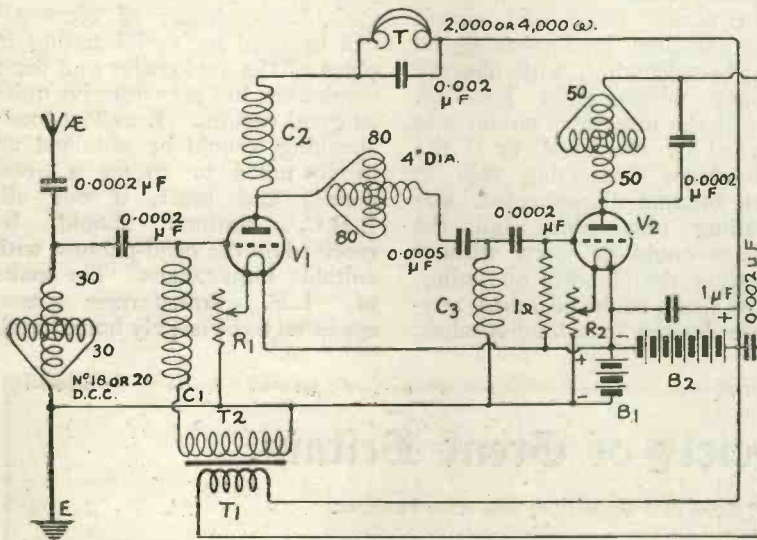

C₁, C₂, C₃ : RADIO CHOKES 200-250 TURNS

Fig. 1.—The circuit arrangement.

inherent stability, without the additional complication of any external stabilising devices.

The effect of stabilising resistances, positive grid-bias applied by potentiometer, etc., as is well known, is to flatten the tuning and lower the amplifying power of the circuit; but such devices are generally necessary in H.F. amplifying circuits where tuned low-resistance transformers or anode inductances in general are used to stop the persistent self-oscillation.

In dual-amplification circuits this difficulty is often aggravated and is the prime cause of that terrible howling frequently associated with such circuits. When crystal-rectification is used, the considerable damping effect of this on the plate circuit of the last H.F. valve will sometimes hold the circuit down, even if pre-

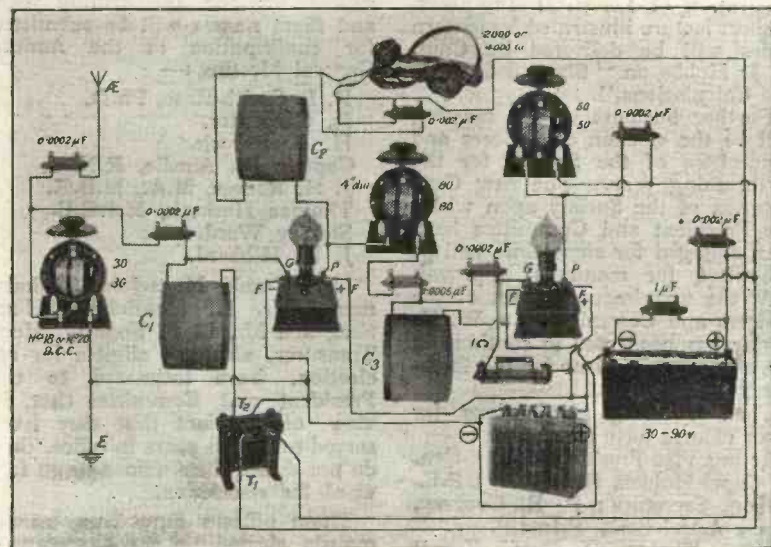

Fig. 2.—A pictorial representation of Fig. 1.

fairly thick wire, and has reasonably small distributed capacity.

For radio-chokes, good low-capacity coils of not too thin wire are indicated. Nos. 200 and 250 Igranic, and similar coils, are effective here, or a choke consisting of $\frac{1}{4}$ lb. No. 26 S.W.G.-d.c.c. wire wound in a multi-grooved former of the type described by Mr. P. W. Harris in No. 10 of *Wireless Weekly*, giving about 250 turns. A barrel-type of single-layer inductance of the same number of turns on a 4 in. diam. former will also suffice.

The detector valve is effectively isolated as far as low-frequency impulses are concerned by yet another radio-choke (which, for audio-frequencies, is a dead short-circuit), connected just in front of the usual grid-condenser. A plate variometer on the detector valve, consisting of about 50 turns of No. 26 S.W.G.-d.c.c. wire on a 3-in. diam. stator and corresponding rotor, bridged by a fixed condenser of $0.0002 \mu\text{F}$, provides reaction, without danger of howling.

The first plate variometer must have a larger inductance, as the available tuning capacities with which it is associated are small. A large Igranic variometer served admirably for the broadcast range. There are required about 80 turns each on rotor and stator of 4 in. diam., or rather more than the customary amount on smaller variometers. An extra loading capacity of an appreciable size (above $0.0001 \mu\text{F}$) cannot be used across this variometer, as it interferes with the correct functioning. Other details will be gathered from the circuit-diagram, which gives the necessary values.

On actual trial, this circuit gave excellent loud-speaking on local broadcasting, with absence of any whistling or howling. Only if the intervalve circuit was touched by the hand, or if the radio-choke connecting this to earth became disconnected, was whistling observable, and the 'phones could be worn without upsetting the stability or tuning, whilst leads could be taken anywhere desired to a loud-speaker.

Naturally, another note-magnifier could be added if desired.

For searching, a little electrostatic reaction by means of a three-plate variable condenser connecting the grids of the two valves generally gives quiet and controllable oscillation. It is best to arrange to switch out the last (L.F.) stage when searching, putting the 'phones temporarily in the plate-circuit of the second valve, between the reaction variometer and H.T.+ It was not found essential to use grid-bias on the first valve. The tuning-range, as shown, was from 320 to 420 metres on a P.M.G. aerial.

A No. 50 coil and series variable condenser of $0.001 \mu\text{F}$ can be used for aerial tuning in place of the variometer and fixed condenser, but may not give quite as good results. Excellent loud-speaking should be obtained up to 30 miles or so on a good aerial; and most, if not all, B.B.C. stations should be received on the head-phones, with suitable inductances. The make of L.F. transformer used appeared to be largely immaterial.

Radio Society of Great Britain.

Election of Officers and Committee, and other business.

The Annual General Meeting of this Society will take place this evening (Dec. 19) at 6 p.m., at the Institution of Electrical Engineers. A short lecture illustrated by lantern slides will be delivered by Capt. E. J. Hobbs on "Simplified Wireless Calculations."

Further business of the meeting will be the election of Officers and Committee of the Society for the forthcoming year. The new Constitution of the Society upon which the President and Committee have been engaged for some time will be submitted for members' approval.

At the unanimous request of the Officers and Committee Dr. W. H. Eccles has consented to continue in the office of President for the forthcoming year.

The following nominations for other officers have been made:—

Acting Vice-President: Brig.-Gen. Sir Capel Holden, K.C.B., M.I.E.E.

Hon. Secretary: P. R. Coursey, B.Sc., A.M.I.E.E., F.Inst.P.

Hon. Treasurer: Prof. Ernest Wilson, M.I.E.E.

From amongst a large number of

names considered, the Committee have selected the following for nomination to serve on the Committee for the forthcoming year, and these names will be submitted for confirmation at the Annual General Meeting:—

R. L. Smith-Rose, Ph.D.

R. Carpenter.

H. S. Pocock.

Captain M. Ainslie, R.N.

J. H. Reeves, M.A., M.B.E.

Thomas Hesketh, M.I.E.E.

Stanley Ward.

J. H. Hibberd.

Mr. Frank Hope-Jones, Chairman, Mr. L. McMichael, Hon. Sec., and Mr. L. F. Fogarty, Hon. Treasurer, although eligible for re-election, have intimated to the President and Committee that, in view of the fact that they have served some ten years in office, they do not desire their names to go forward for re-election.

These officers have been unanimously elected by the Committee. Vice-Presidents of the Society.

Mr. R. H. Klein, founder of the

Society, vacates his office as Vice-President.

It will be found in the new constitution of the Society, which is being submitted to members, that it is not proposed to continue the offices of Chairman or Vice-chairman, and consequently no nominations for these offices are put forward.

On account of the very large increase in the clerical work connected with the conduct of the affairs of the Society and Affiliated Societies, the Committee recommend that the appointment shall be made of a salaried assistant and that office accommodation shall be provided.

TRANSATLANTIC TESTS.

The Radio Society's transmitting station has been allotted the call sign 6XX. Mr. Coursey, who is arranging these tests, is busy fixing a schedule for the 60 experimenters who are entering.

These tests will take place between December 22 and January 10 from 1 a.m.—6 a.m.

A TWO-VALVE POWER AMPLIFIER

By STANLEY G. RATTEE, Staff Editor.

Herein is described an instrument which may be added to any crystal or single valve receiver, permitting thereby the use of a loud-speaker.

Introduction.

A power amplifier is not in itself a radio receiver, but an instrument employing one or more valves in order to amplify whatever may be applied across its "input" terminals, whether it be connected to the usual broadcast receiver or whether it be connected to a microphone circuit for amplifying the direct voice of a speaker. Each stage of amplification comprises a valve and low-frequency transformer of good manufacture, guaranteed to stand high voltages, the subsequent result, such as absence of distortion, depending very considerably upon the merits of the transformers chosen.

As the output of the amplifier is a considerably magnified repetition of the input, the speech or music must be free from distortion before being applied to the power amplifier, otherwise all such distortion will be considerably accentuated. For this reason the input signals should, where possible, be received without the use of reaction, or if used the valves should be worked well below the point of oscillation.

General Remarks.

The instrument to be described, and illustrated in Fig. 1, was designed to fulfil the conditions that it may be permanently connected to a wireless receiver, yet at the same time permit the user to receive direct from his original set without disturbing connections. In order to do this in the shortest possible time, a system of plug and jacks is employed. The plug and jacks, there being three of the latter, may be seen in the photograph, Fig. 1; that on the left connecting the telephones direct to the receiver, the middle one introducing one stage of power amplification, and the third jack putting both power valves in the circuit.

The terminals seen to the left of Fig. 1 are, reading from the top:—First pair, the two "in-

The two knobs seen in the centre of the instrument are the filament resistances, whilst the



Fig. 1. A front view of the instrument.

put" terminals; third, a dummy terminal put there merely to balance out the number seen to the right of the photograph; last pair, the L.T. positive and L.T. negative.

Those terminals shown on the right, reading in the same order as before, are:—First pair, telephone terminals permitting the use of extra telephones when the plug is in the first position, or, in other words, when the power valves are not in circuit; third terminal, H.T. positive. The fourth terminal from the top is a common terminal for both H.T. negative and L.T. positive, whilst the fifth or bottom terminal is the L.T. negative:

sockets seen above them are for varying the grid potential. The centre socket connects the two secondaries of the low-frequency transformers (I.S.) and the other four, reading from the bottom and clockwise, are zero volts, $1\frac{1}{2}$, 3, and $4\frac{1}{2}$ volts negative. The grid potential is varied therefore by connecting the centre socket with any one of the remaining four, according to the number of cells required.

Materials.

In order to construct a power amplifier to the specification given herein the following materials and components are necessary:—

BASKET COILS OF LOW CAPACITY

THE importance of having coils of low self-capacity is well known to those who experiment in short-wave reception. The ordinary basket coil is fairly satisfactory up to a point, but it has its limitations. Its weak points are these. Coils of the ordinary commercial variety are wound upon formers shaped like a wheel minus its rim. When completed, the coil is immersed in shellac or paraffin

the same former, you can never be certain that two ordinary baskets wound to exactly the same dimensions will be perfectly matched.

The method of winding to be described is believed to be quite novel, though, as in wireless, one is always finding that one's own ideas have been thought of some time previously by someone else, it is quite possible that it has already been worked out independently by other experimenters. The chief point in its favour is that the turns make no contact whatever with one another; hence single cotton covered or a single silk covered wire may be used, or even bare wire if the winding is carefully done. The former remains in position when the coil has been wound, which makes it unnecessary to apply any wax or varnish stiffener. Lastly, this method of winding makes it possible to duplicate coils exactly. The self-capacity of the finished inductances is so low that they are most suitable for short-wave work.

Fig. 1 shows the way in which the former and coil-holder are made. The former consists of a disc of hard wood 2 in. in diameter and $\frac{1}{2}$ in. in width. Round the circumference of this is fixed an odd number of wooden pegs—seven or nine will do very well—in which saw-cuts are made in the way to be described presently. The pegs are secured by being glued into holes drilled in the circumference. The best way to obtain the correct positions for the holes is to use a circular or semi-circular protractor. If there are to be seven pegs, the angular distance between them will be $51\frac{1}{2}^\circ$; with nine the angular distance is 40° .

The length of the pegs will depend, of course, on the number of turns to be wound. It may be calculated very easily in inches as one-sixteenth of the number of turns plus $\frac{3}{8}$ in. Thus for a 20-turn coil the length of each peg, excluding the portion glued into the former, would be $1\frac{3}{8}$ in.

Fig. 1 shows the way in which the saw-cuts are made in the sides of the pegs. For peg No. 1 the cuts on the left will begin $\frac{3}{16}$ in. from the bottom and will be $\frac{1}{8}$ in. apart. On the right the cuts will have the same spacing, but will start $\frac{1}{4}$ in. from the bottom. We may call this a left-handed peg. Peg No. 2 will be right-handed—that is to say, on the right side its cuts will start $\frac{3}{16}$ in. from the bottom, and on the left $\frac{1}{4}$ in. from the bottom. No. 3 will again be a left-handed peg, and No. 4 a right-handed, and so on, until we reach No. 7, which, like No. 1, will be left-handed.

If the pegs are made of seasoned hard wood, such as mahogany, oak or teak, single cotton-covered wire may be used. Should it be desired to make up coils with bare wire, the pegs should be of ebonite.

The method of winding is quite simple. In the bottom cut of peg No. 1 a small hole is pierced with a bradawl, and the end of the No. 26 S.W.G. wire is pushed through it. The loose end can be secured if the

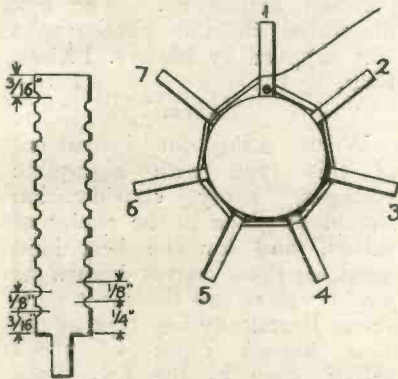

Fig. 1.—Details of former and coil-holder.

wax, the "spokes" being withdrawn when it has set hard. In order to make the coil anything like robust a great deal of wax or shellac must be allowed to remain upon it. Since both of these materials have a high dielectric co-efficient, that of shellac being 3 and that of wax rather more than 2 as compared with air, their presence between the turns of the windings increase the self-capacity of the coil to a considerable extent. Secondly, the spacing between layers is provided merely by the wire itself—that is to say, turn No. 2, spaces No. 1 and No. 3, and so on. The turns, therefore, touch each other at numerous points. For this reason well-insulated wire must be used, which again increases the self-capacity of the coils. Last, but most important of all, the particular method of winding generally used makes it a matter of the utmost difficulty to duplicate coils exactly. Though you use wire of the same size and employ

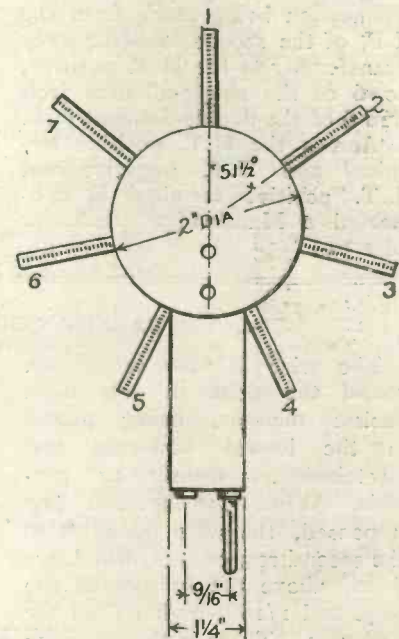

Fig. 2.—Illustrating method of mounting coil.

hole does not grip it sufficiently tight by taking a turn with it round a small screw driven into the wooden disc.

(Concluded on page 48.)

A TWO-VALVE POWER AMPLIFIER.—(Continued from page 46).

From the top "input" terminal connection is made to the I.P. of the first low-frequency transformer, to one of the extra telephone terminals and to 6 of the single-circuit jack. From the O.P. of the low-frequency transformer connection is made to 5 of the single-circuit jack, whilst the remaining "input" terminal is connected to the other terminal for extra telephones and to 4 of the same jack. The I.S. of the first transformer is connected to the socket marked A in Fig. 2, whilst the O.S. is connected to the grid leg of the valve V_1 . To the plate of the first valve connect 4 of the double-filament jack, and from 5 of the same jack connect to the O.P. of the second transformer.

A lead is now taken from the grid of the valve V_2 to the O.S. terminal of the second low-frequency transformer, whilst the I.S. is connected to the centre socket marked A in Fig. 2. The plate of the second valve is now connected to 4 of the single-filament jack; the next connection being made from the I.P. of the second low-frequency transformer to the H.T. positive, to 6 of the single-filament jack and 6 of the double-filament jack.

Across the H.T. positive terminal and H.T. negative and L.T. positive terminal is connected a Mansbridge condenser of $1 \mu F$.

Grid Cells.

These cells are connected to the four sockets marked B, C, D, E in Fig. 2, with the positive end of the battery connected to the L.T. negative. From the same end of the battery connection is made to the socket

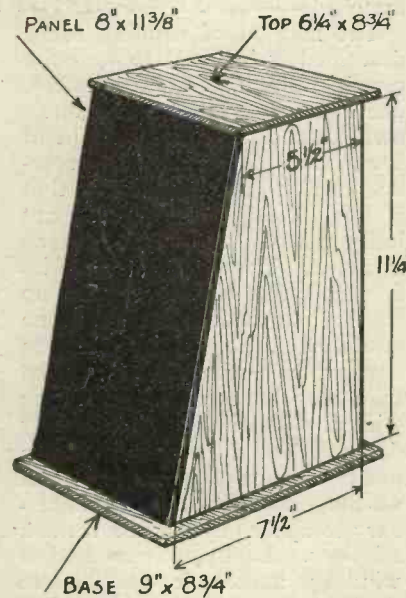

Fig. 4. The Containing Box.

marked B; from the negative side of the first cell connection is made to the socket marked C; from the negative side of the second cell connection is made to D, and from the negative side of the third cell connection is made to E.

At this point a flexible wire is taken through the socket and soldered to the point A on the under side of the panel; to the end of the wire is fitted a suitable plug, by means of which all or none of the cells may be connected in the circuit.

The Containing Box.

The dimensions and shape of this may, of course, be left for the constructor to exercise his discretion, but for the guidance of those who wish to construct an instrument strictly in accordance with that seen in Fig. 1, the dimensions of the actual box are given in Fig. 4, the wood being polished mahogany. The box illustrated in the photographs was supplied by Messrs. Pickett Bros.

Valves.

When using an instrument of this type with high-plate voltages, every consideration should be given to the choice of valves, and for the best loud speaking those valves known as power valves are the most suitable. Practically any type of the most known types of these valves, such as the LS_1 , LS_2 , Mullard P.A., etc., will give satisfactory results, though with voltages up to, say, 100 volts, the ordinary receiving valve may be used.

Note.—In next week's issue will be given a wiring diagram together with details of results obtained.

BASKET COILS OF LOW CAPACITY.—(Concluded from page 47).

The wire is now woven round the pegs in the usual basket manner, being placed in the lowest saw-cuts and stretched as tightly as possible. When the seventh peg is passed, the wire goes on to the second row of cuts, which are $\frac{1}{2}$ in. above the bottom of the pegs and $\frac{1}{16}$ th higher than the first row. There is thus a space of $\frac{1}{16}$ in. between the turns of successive layers measuring from centre to centre of the wire. Winding now continues until the required number of turns has been put on, when the end is made fast in the same way as the beginning by being passed

through a small hole pierced in one of the spokes.

The holder, provided with plug and socket or with any other form of mounting that may appeal to the constructor, is seen in Fig. 2. It consists of a piece of $\frac{1}{4}$ -in. ebonite $2\frac{1}{2}$ in. in length and $1\frac{1}{4}$ in. wide. It is secured to the disc of the former by a couple of screws. The wires from the coil may conveniently be taken to either side of the holder and secured to the screws which hold the plug and socket in place.

The number of turns of wire required for short wavelengths is not very large. The exact figure for the primary will depend, of

course, upon the constants of the user's aerial, but for the standard amateur type, with a capacity of about $0.0003 \mu F$, fifteen to eighteen turns will usually be about right for short-wave reception up to 300 metres, if a $0.001 \mu F$ condenser is used in series. The secondary coil in this case, if a $0.0005 \mu F$ condenser is used, will require about twenty to twenty-four turns. It is impossible to give the number of turns that will suit every set exactly, since condensers are not always what they seem, and a great deal depends upon the capacity which exists within the set itself.

R. W. H.

HOW TO DESIGN YOUR OWN SET

No. II.

By PERCY W. HARRIS, Assistant Editor.

The second article of a series of six which began in our last issue.

WE can divide the wireless apparatus we use into three main divisions. Firstly, we have the tuning apparatus, which brings us into resonance with the signals we want to hear; secondly, we have the detecting apparatus which changes the high-frequency oscillation into currents

amplifying apparatus, we can choose either a crystal or a valve. Although one frequently sees it stated otherwise, a single valve without reaction is considerably more efficient than a crystal, but we must not forget that a valve requires the expensive accessories of high and low-tension batteries. Thousands of

A single valve receiver with reaction used on a good aerial will, when conditions are favourable, bring in all the broadcasting stations, but when the set is adjusted to this degree of sensitivity there is a great risk of radiation and causing interference to one's neighbours. Such a set with note magnifiers added

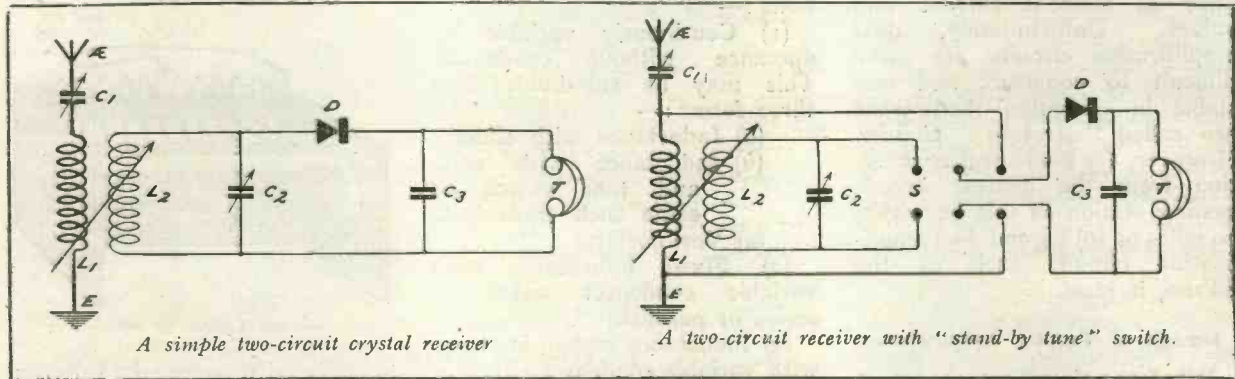

A simple two-circuit crystal receiver

A two-circuit receiver with "stand-by tune" switch.

which will operate a telephone earpiece or a loud-speaker; and thirdly, we have the magnifying apparatus used when the intensity of the signals is not sufficient to give strength to our reception. The important sub-division is that of the amplification apparatus into two main parts, high-frequency amplifiers and low-frequency amplifiers. The purpose of high and low-frequency magnification has been dealt with so many times before that I do not intend to discuss its merits and demerits here. It is assumed that the reader who wishes to design his own set is sufficiently acquainted with these principles.

Although there are numerous devices capable of changing high-frequency oscillation into currents which will operate the telephones, in practice only two are used to any degree, the crystal and the valve. If we decide upon a circuit which has a detector alone without any

listeners are situated in spots so close to a broadcasting station that a crystal receiver on a good aerial will give them all the strength they require for telephone reception. Three or four miles from a broadcasting station a well-designed crystal receiver on a good outdoor aerial will operate half a dozen pairs of telephones quite comfortably. A single valve magnifier added to a crystal used at this distance will work a loud-speaker for an ordinary living room, and a two-valve note magnifier of efficient design will be ample for the largest room. But save in very exceptional circumstances (which very rarely occur) a crystal set with note magnifier will bring in nothing whatever from a broadcasting station in another part of the country. The design of crystal receivers will be dealt with in a further article, wherein I hope to show why some home-made crystal sets are so inefficient.

will work a loud-speaker and can frequently be made to give loud-speaker results from several broadcasting stations. The method, however, is not recommended for distant reception owing to the distortion which is produced when a single valve is used at its maximum sensitivity. The introduction of one stage of high-frequency magnification to precede the detector (whether this be crystal or valve) will enable us to get the distant stations without the need of pressing our apparatus to the last limit. Naturally the addition of a further stage of high-frequency magnification would appear to be most desirable, but as will be seen from the article of this series which will deal with the design of high-frequency amplifiers, the disadvantages of multi-stage high-frequency amplification frequently outweigh the advantages. For this reason three-valve sets with one stage of high-frequency, a detector and

note magnifier, and four-valve sets with one stage of high-frequency, a detector and two note magnifiers are highly popular. With such sets the sensitivity is sufficient to hear the distant broadcasting stations whilst the note magnifying stages are sufficient to give the necessary "body."

So far we have dealt with what are commonly called "straight" circuits. Within the last few months, however, we have been introduced to numerous circuits known as "dual amplification" or "reflex" circuits with many peculiarities of their own. In a dual amplification circuit one or more valves are made to serve both as high-frequency and low-frequency amplifiers, and thus we can economise in filament current and valves. Unfortunately, dual amplification circuits are more difficult to construct and less stable in operation than what are called "straight" circuits. However, for loud-speaker reception from the nearest broadcasting station (if this be within 20 miles or so) a good dual amplification circuit, such as the ST100, is ideal.

Design of Tuning Apparatus.

Whatever circuit we choose, it is bound to include apparatus for tuning, so that our first consideration will be how best to design

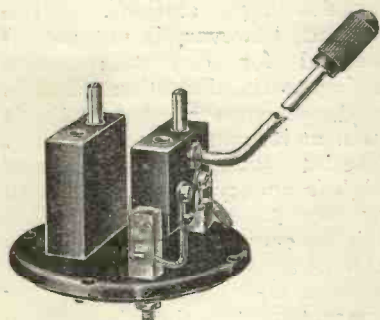

A typical two-coil holder.

this portion of the apparatus. Our tuner may be what is called a "single circuit" or "two circuit," and we must decide first of all which of these two kinds to use.

So far as signal strength is concerned, there is little to choose between the two methods, although on short waves with a crystal detector slightly louder

signals can be obtained with a well-designed loose-coupled apparatus. In selectivity, however, we can gain very considerably by using a loose-coupled set, although we must pay the price in complication and difficulty of tuning. Furthermore, when reaction is used, the handling may become so complicated that the improvement in selectivity may not be worth while, and, still further, if we use tuned high-frequency amplification with two or three stages, the use of loose coupling will add greatly to the general instability characterising such highly sensitive circuits.

Design of Single-circuit Tuners.

A single-circuit tuner consists of one of the following combinations:—

- (1) Continuously variable inductance without condenser. This may be sub-divided into three forms:—
 - (a) Inductance with slider.
 - (b) Inductance with units and tens switch or some such equivalent.
 - (c) Variometer.
- (2) Fixed inductance with variable condenser either in series or parallel.
- (3) Inductance tapped in steps, with variable condenser either in series or parallel.

Method No. 1 has the great advantage of simplicity and cheapness. In the sub-divisions (a) and (b) have the disadvantage, when a large inductance is used to cover a considerable range of wavelength, of possessing "dead-end" losses. These can be somewhat reduced by (a) short-circuiting the turns not used, (b) short-circuiting a portion of the turns not used, just ahead of the tapings (this method is used in America to some degree); and may be entirely avoided by sub-dividing the inductance so that portions not used are entirely cut out. The introduction of dead-end switches, however, makes for complication, and cannot generally be recommended, as the same effects can be obtained in a simpler way. Method No. 2 has much to recommend it, as we can entirely avoid dead-end losses, and, if we choose an efficient inductance of suitable value and a variable condenser

which just covers the range of wavelength required with this particular inductance, we can attain very high efficiency. Method No. 3, whilst possessing the disadvantage of the dead-end effects which, as we have said, in very large inductances may be highly detrimental, yet enables us to attain fine tuning with a minimum amount of switching over a very considerable band of wavelengths without changing the inductance.

Let us assume for the minute that we want to design a receiver

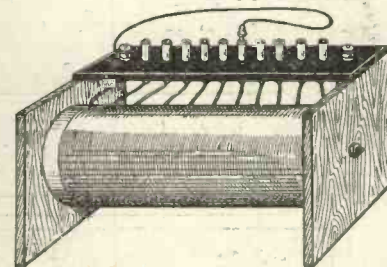
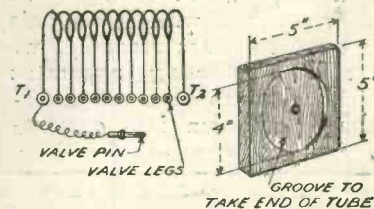

A novel form of tuner.

to cover all wavelengths between 300 and 3,000 metres. It is probable that our choice will fall on methods 2 or 3. The most general way of applying method 2 is to utilise the very popular multi-layer plug-in coils such as Igranic, Burndept, Gambrell, Atlas, etc. We may also use basket coils or slab coils. On short wavelengths, well-made basket coils of fairly thick wire with a minimum of wax or shellac are highly efficient, and probably would be more used if this were realised. Multi-layer coils for short wavelengths are less efficient than single-layer, for which reason the leading makers are now making their short wave plug-in coils of one or two layers at most.

Method No. 3 can be put into practice by using a suitably proportioned single-layer coil or by making what is known as a bank-wound inductance.

Next Week.—No. 3 of this Series.

"WIRELESS WEEKLY" UNIVERSAL VALVE PANEL

The following article is the second of a series dealing with the construction of the panel and the arrangement of the numerous circuits in which it forms the principal unit.

THE panel and its component parts having been satisfactorily completed in accordance with the particulars given in our last issue, it is necessary to decide what type of tuning coils are to be employed.

Those readers who do not wish to wind their own coils are advised to obtain a set of the honeycomb, duolateral or lattice-type coils, No. 35, 50, 75 and 100. These coils will satisfactorily cover the broadcast band

Tuning Coils.

A full description of the winding of various types of multi-layer coils will be found in *Modern Wireless*, No. 4 (May, 1923). Basket coils may be used if preferred, a useful set being made up quite easily upon 4-in. diameter formers (of stout cardboard or thin fibre), having either 7 or 9 slots, and 1-in. diameter centres, the windings consisting of 35, 50, 75 and 90 turns of No. 24, 26, 28, and 30 S.W.G.-d.c.c. wire.

Basket Coil Variometer.

An easily-made variometer for aerial tuning (which enables a variable condenser to be dispensed with), consists of two formers as above, each wound with 40 turns of No. 26 S.W.G.-d.c.c. wire, the windings being connected in series and the two coils arranged so as to slide over one another, or to open out like the leaves of a book.

For a tuned-anode circuit, two similar formers, but 5 in. in diameter, will be required, each wound with 80 turns of No. 26 or No. 28 S.W.G.-d.c.c. wire. Basket coils may also be used as high-frequency transformers, for which purpose two formers, each 2½ in. in diameter, with ¾-in. centres and having nine slots wound with 110 turns of No. 42 or No. 40 S.W.G.-d.c.c. wire, will be required.

With the above-described coils to select from, together with the coil-holder, variable condensers and fixed condensers made in accordance with the instructions given in the preceding article, the reader will be in a position to try out most of the circuit arrangements, four of which are given in this issue.

Solenoid or Tubular Variometer.

This, when used for aerial tuning, should consist of a 3 in. dia. tube 2 in. long for the rotor

wound with 40 turns of No. 26 S.W.G.-d.c.c., leaving a space after the 20th turn sufficiently wide to permit the fitting of the 2" B.A. spindle.

The stator is 4 in. dia. and 2 in. long, wound with 40 turns of the same wire, leaving space midway along its length for the spindle.

For a tuned-anode circuit the same sized tubes may be used, but each tube should be wound with 70 turns of No. 32 S.W.G.-d.c.c. wire.

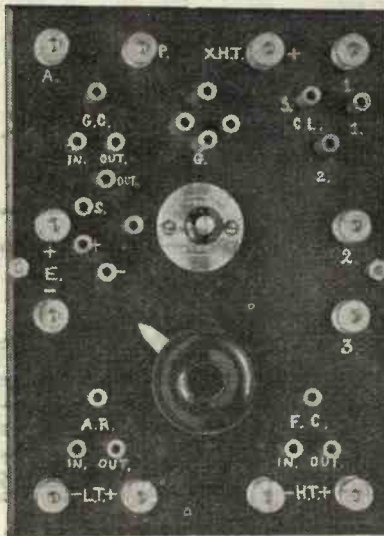

Front view of the Panel.

of wavelengths, and larger coils may be added later as desired, for longer waves.

A standard type of 3-coil holder will also be required, and this again may either be purchased or constructed in accordance with particulars given under the heading of "Constructional Notes" in previous issues. There will also be required a 0.001 μ F and a 0.0005 μ F variable condensers, and, as these are obtainable at very reasonable prices, it is perhaps scarcely worth while building them.

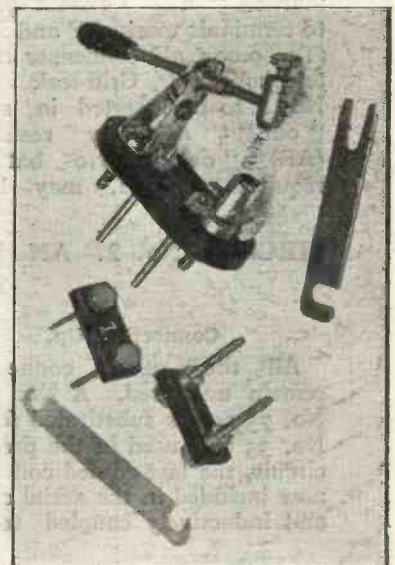

The crystal detector and bridges for use with the panel.

With a view to facilitating the work of connecting up the various circuits, the reader is advised to make up a number of flexible connections, each consisting of a length of single electric-lighting flex, 6 in., 9 in., 12 in., or 15 in. long, provided with a "spade" or "tag" terminal at each end. A neater appearance is maintained if the outer covering of cotton is stripped off, leaving the wire simply rubber covered.

CIRCUIT No. 1.—A SIMPLE CRYSTAL RECEIVER.

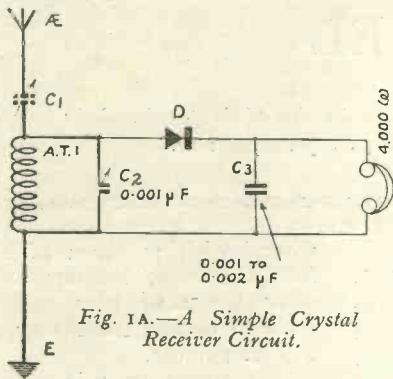

Fig. 1A.—A Simple Crystal Receiver Circuit.

Connecting Up.

Connect tuning coil (A.T.I.) to AE and -E terminals. Plug the crystal detector into grid and plate sockets of valve holder. Short-circuit grid condenser by placing Plug No. 1 into socket marked "out." Place Plug No. 4 in socket of Flewelling circuit marked "in." Connect phones to terminals marked P and XHT. (Try 0.002 μF condenser across telephones.) Grid-leak Plug No. 2 to be inserted in socket "out." Auxiliary resistance (AR) "out." No batteries required. A.T.I. may be a

slider coil, basket, honeycomb or duolateral coil or a variometer. The variable condenser (0.001 μF) is shown in parallel across the A.T.I., but it may be used in series as indicated by the dotted lines. Telephones should have a total resistance of 4,000 ohms (2,000 ohms each earpiece).

General Notes.

Carefully adjust the point of contact and the mechanical pressure of the wire upon the crystal in the detector (or, of course, the pressure between the two crystals if a combination detector is used). With an average aerial, 2LO should be tuned in at about 10 deg. on the condenser scale. Quite good speech and music can be received in two pairs of telephone receivers at distances up to 10 or 15 miles from the broadcasting station.

Excellent results will be obtained by using the basket-coil variometers, but actually this will depend to a large extent upon the crystal detector and its adjustment, as well as

CIRCUIT No. 2.—AN INDUCTIVELY-COUPLED CRYSTAL RECEIVER.

Connecting Up.

All the panel connections remain unaltered. A No. 50 or No. 75 coil is substituted for the No. 35 coil used in the previous circuit, the last-named coil being now included in the aerial circuit and inductively coupled to the

secondary coil, which has a 0.0005 μF condenser in parallel with it. In this circuit, also, the variable condenser may be used either in series or in parallel with the A.T.I. Improved results are sometimes obtained by earthing the telephones as indicated by the dotted line.

General Notes.

This circuit is much more selective than circuit No. 1, and, if the secondary or closed circuit condenser is kept at a low value, more turns (i.e., a larger coil) can be used, thus giving an increased potential to operate the crystal and accordingly an increase in signal strength. If used in conjunction with a really good aerial and earth system, the British broadcasting stations should be clearly received up to a distance of 15 to 20 miles.

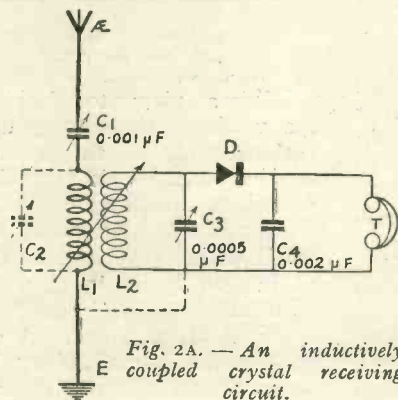

Fig. 2A.—An inductively coupled crystal receiving circuit.

"WIRELESS UNIVERSE VALVE"

Below appears the first four circuits of this panel as they

upon careful tuning and the general efficiency of the receiving aerial-earth system.

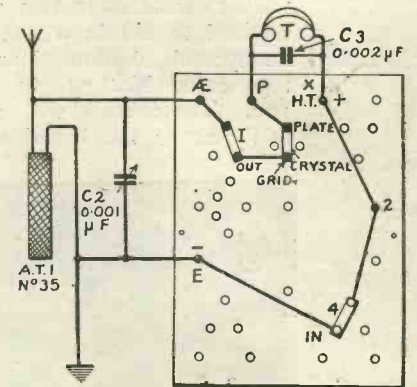

Fig. 1B.—The panel connections of Figure 1A.

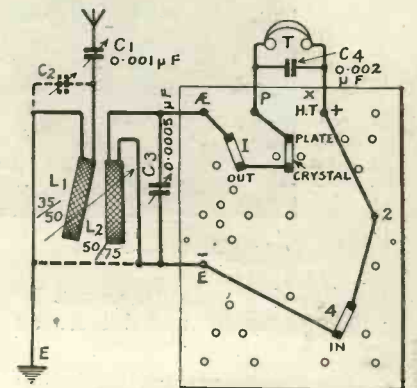

Fig. 2B.—The panel connections of Figure 2A.

Preliminary searching for signals with this arrangement should be carried out with the coils L₁ and L₂ tightly coupled. With signals obtained the coupling should be loosened and the set retuned by means of the condensers C₁ and C₃.

WEEKLY" RSAL PANEL

twenty possible arrangements using
rain unit.

Connecting Up.

Plug in the grid condenser by placing Plug No. 1 into socket

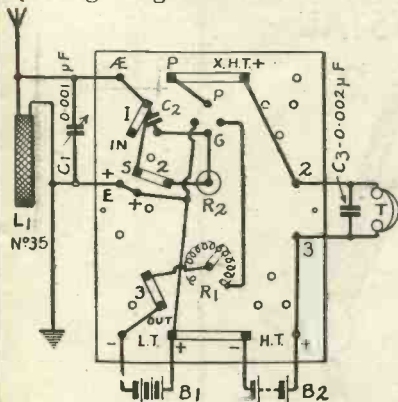

Fig. 3B.—The panel connections of Figure 3A.

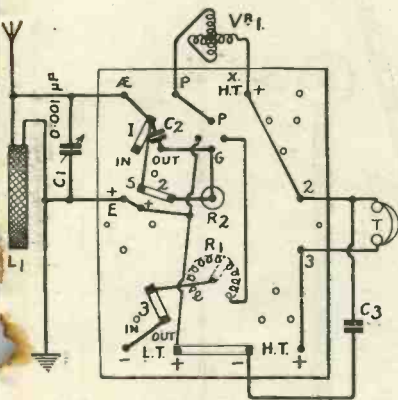

Fig. 4B.—The panel connections of Figure 4A.

Connecting Up.

Grid condenser Plug No. 1 "in." Grid leak Plug No. 2 shunted (S). Connect variometer to terminals P and XHT+. Connect telephones to terminals 2 and 3. Place strap across terminals HT - and LT +. Large

CIRCUIT No. 3.—A SINGLE-VALVE RECEIVER.

marked "in." Place grid leak Plug No. 2 into socket marked "shunt" (S). Connect brass strap across terminals P and XHT positive. Connect telephone receivers to terminals 2 and 3, place battery strap across terminals HT - and LT +. Connect up LT battery, test the valve filament, and then connect HT battery to correct terminals. Connect ATI to terminals AE and + E. A.R. Plug No. 3 "out" if using ordinary valves, but "in" for a dull emitter valve.

Note.—The telephones may be connected to the negative HT and the positive LT and terminals 2 and 3, short-circuited with the brass strap. In all further circuits the LT and HT batteries will be omitted from the practical wiring diagram.

General Notes.

This is a simple valve receiver in which the valve acts as a rectifier. A 4- or 6-volt accumulator (preferably 30 to 40 actual ampere hour capacity) will be required to light the valve. A modification can be introduced

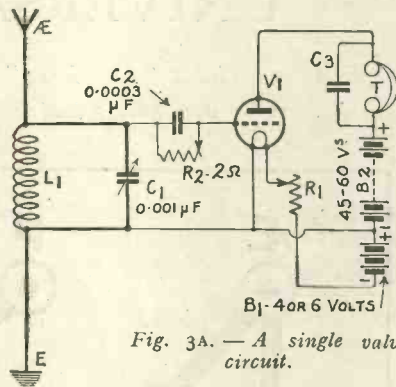

Fig. 3A.—A single valve circuit.

if desired by using the inductively coupled tuner of circuit No. 2 in lieu of the direct coupling as shown above. Care should be taken in the adjustment of both filament current and anode voltage if the best results are to be obtained. Low-resistance telephones may be used in conjunction with a step-down telephone transformer, the fine wire winding of the transformer being connected to the terminals 2 and 3 and the telephones being connected to the ends of the thick wire winding of the transformer.

CIRCUIT No. 4.—A SINGLE-VALVE RECEIVER WITH VARIOMETER TUNED PLATE CIRCUIT.

fixed condenser (0.01 to 0.1 μF) connected across terminals 2 and - HT. A.R. plug No. 3 "out" for ordinary valve. Connect ATI to parallel variable condenser (0.001 μF), and to terminals AE and + E. Connect LT and HT battery to proper terminals.

General Notes.

This is a single-valve regenerative circuit. The variometer in the anode circuit, when tuned to the same frequency as the aerial circuit, will cause the valve to oscillate provided that the correct values of filament current and anode voltage are employed. If excessive reaction is used, not only will received speech and music be greatly distorted, but the incoming carrier wave will be heterodyned and will be heard as a continuous whistle or musical note,

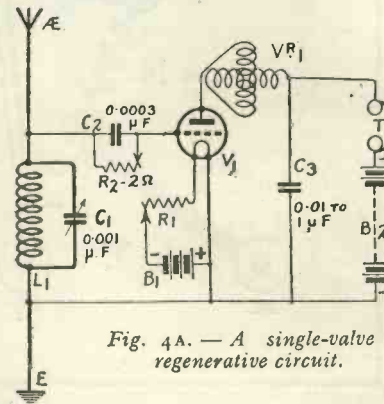
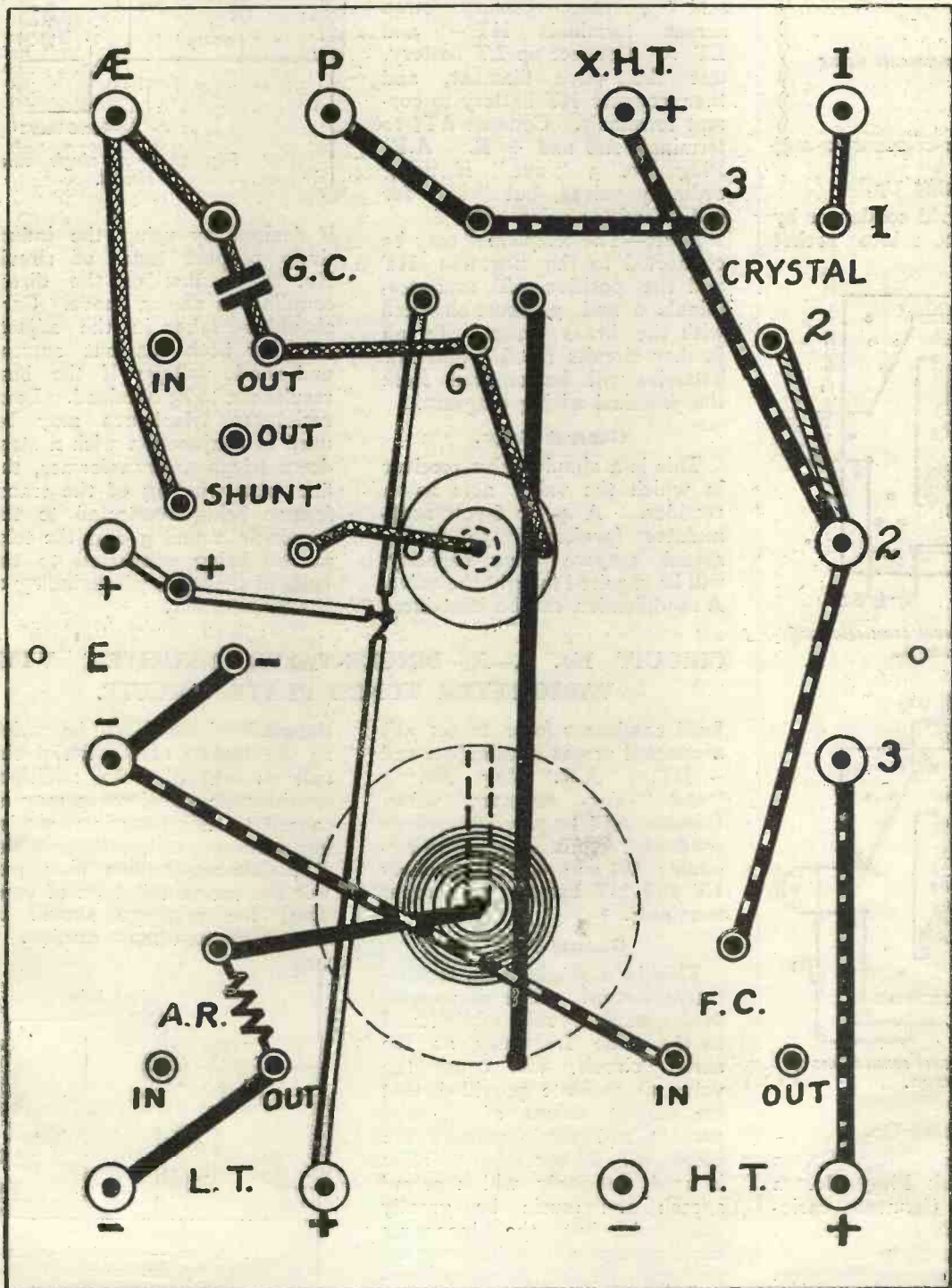

Fig. 4A.—A single-valve regenerative circuit.

KEY PLAN OF "WIRELESS WEEKLY" UNIVERSAL VALVE PANEL.

Below we give a "Key Plan" of the completed panel, with all wiring clearly shown, and advise that this be carefully retained for future reference.



FULL SIZE.

MULTI-CONNECTION TERMINALS

EVERY experimenter will appreciate the utility of a device which makes it possible for a number of leads to be attached easily and quickly to one terminal. When working with experimental layouts one frequently has to fasten two or more leads to terminals, and it is not at all an easy matter in the ordinary way to ensure that all make a really good contact. A further point is that if one wire has to be removed, all the rest are apt to come adrift. In any case, if ordinary terminals are used, the process of making or unmaking a number of connections to one of them is time-wasting and occasionally rather exasperating.

Quite a good adaptor for use with standard single terminals

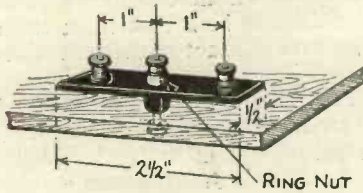

Fig. 1.—A simple multi-terminal or bus-bar arrangement.

can be made as shown in Fig. 1 from a strip of fairly stout sheet brass $2\frac{1}{2}$ in. in length and $\frac{1}{2}$ in. wide. A 4 B.A. clearance hole is drilled in the middle of it and two others are made, one on either side of it, a distance of 1 in. from centre to centre. In the outer holes are mounted small 4 B.A. terminals. The middle hole is passed over the shank of the existing terminal, the strip being firmly secured by a ring nut, which is turned hard down on to it.

For terminals of the telephone or "push in" type an adaptor can be made on the same lines. A 4 B.A. terminal with a long shank is inserted into the middle hole and its shank is secured to the terminal by means of the binding screw.

The writer has found most useful the multiple binding post shown in Fig. 2, which is very easily made. Take a $2\frac{1}{4}$ -in. length of round brass rod $\frac{3}{8}$ in. in diameter, and drill through it four 4 B.A. clearance holes $\frac{1}{2}$ in. apart. Drill and tap a 4 B.A. hole in either end. That at the upper end must run into the

4 B.A. clearance hole already made $\frac{1}{4}$ in. from the top. Now drill and tap three other 4 B.A. holes at right angles to the remaining clearance holes and running into them. Fit milled-headed screws as shown. Into the tapped hole at the lower end screw a $\frac{3}{4}$ -in. length of 4 B.A.

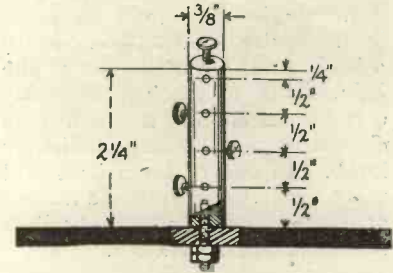

Fig. 2.—A multi-connection binding post or terminal.

studding, fixing it in place with a little solder. This serves as a shank for the post and enables it to be mounted in the ordinary way upon the panel with a nut and a lock nut.

The post shown in the drawing allows four connections to be made. If it is desired others may be made on the same lines for any number of connections from two upwards. They do not take long to make and their usefulness well repays one's trouble.

R. W. H.

MOST of us feel the want of extension handles for our variable condensers at times, especially when we are engaged in trying to receive very weak transmissions from great distances. Nothing is more annoying than to find that just as one has got the correct tuning with one circuit and wishes to make

its condenser. Again, it may be that one can tune in the signal quite well so long as the hand is kept upon the knob of the con-

A DETACHABLE EXTENSION HANDLE

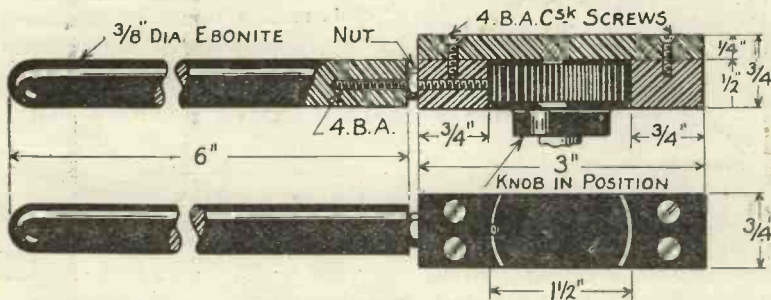

Fig. 1.—Constructional details of the extension handle.

final adjustments to the second, signals vanish entirely as soon as the hand approaches the knob of

denser, but that it becomes inaudible directly the hand is withdrawn.

The most satisfactory way of eliminating capacity effects is to fit extension handles, which enable the knobs to be moved without any part of the body being brought within 6 in. or so of condensers. It may also be desirable to fit them to inductance stands, for the additional capacity introduced, when the hand is brought near to make a variation in the coupling, is often sufficient to upset the tuning.

Permanent extension handles have distinct drawbacks. They take up a great deal of room and they are simply a nuisance at times when they are not actually required. Here is a simple way of making a handle which can be slipped on to a knob or removed

from it in a moment. If it is used a single handle will as a rule be sufficient for the whole set, since it can be employed to make one adjustment after another, in the manner of a spanner.

Cut out a piece of $\frac{1}{4}$ in. ebonite $2\frac{1}{2}$ in. long by $\frac{3}{4}$ in. wide. Drill and countersink a 4B.A. clearance hole quite close to each corner. Now obtain two small pieces of $\frac{1}{2}$ in. ebonite $\frac{3}{4}$ in. square. With a half round file make one of the $\frac{1}{2}$ in. faces of each sufficiently concave to enable it to fit the circumference of a condenser knob. In one of them drill and tap a 4B.A. hole from the middle of the face opposite to that which has been made concave.

Drill and tap two 4B.A. holes in each block to correspond with the clearance holes made in the $2\frac{1}{2}$ in. strip. Mount the two blocks upon the strip so that a knob will slip easily in between them.

Now take a 6 in. length of $\frac{3}{8}$ in. ebonite rod and make a tapped 4B.A. hole about $\frac{1}{2}$ in. deep at one end of it. Screw a $1\frac{3}{4}$ in. length of 4B.A. screwed rod into it and secure by putting on a nut and turning it hard down against the ebonite.

Insert the end of the rod into the tapped hole made in one of the blocks, screwing in until the point just protrudes from the concave

surface. The handle can now be placed over any knob and firmly fixed by a slight twist of the rod. A twist in the opposite direction loosens it without in any way interfering with the condenser's adjustment and allows it to be removed at once.

Even if capacity effects are unknown in the set, a handle of this type will be found a great boon for making fine adjustments, since owing to its great length it has to be moved through a considerable distance to make the pointer of the condenser travel through one division of its scale.

R. W. H.

THOUGH the word vernier really refers to a pair of sliding scales so arranged that they will allow very small measurements to be made, it seems to have been adopted by wireless people as a designation for any kind of apparatus which permits minute adjustments to be made. Hence the term is used in this note for an auxiliary rheostat, the purpose of which is to make it possible to obtain very small variations of the filament current.

Such a rheostat is particularly needed when one is using either soft or dull-emitter valves as rectifiers. The Wecovalve, for instance, requires very careful adjustment of its filament potential to give the best results. With the ordinary 6-ohm rheostat even of the best type, one cannot throw in less than one complete turn of resistance wire by moving the knob. The auxiliary rheostat is designed to bridge the gap between one turn of the main rheostat and the next; hence very small fractional changes in the current may be effected. For the former a disc of ebonite $2\frac{1}{2}$ in. in diameter is required. A shallow groove is cut in this to hold a 4-in. length of No. 26 Eureka resistance wire, whose total resistance will be about .3 ohm. The wire is stretched round the circumference between two screws, as shown in the figure.

The remainder of the make-up of the rheostat calls for very little comment since it follows the general lines previously described

A VERNIER FILAMENT RESISTANCE

in these notes. The design given has, however, one or two good points. It will be noticed that the spindle is held semi-rigidly by means of the nuts and spring washer, and that the distance

The arm itself should be of the shape shown in the figure, and should be so bent that it makes a very firm contact with the resistance wire.

The auxiliary rheostat is wired in series with the main rheostat. In actual operation it should be set at first so that the arm is midway along the piece of resistance wire. One then obtains the best adjustment possible with the main rheostat, making final exact adjustments by turning the knob of the auxiliary rheostat to right or left, and so throwing either a little more or a little less resistance into the circuit.

Beside this application to detector valves, the rheostat will be found most useful with high-frequency amplifiers of any kind, for here the filament potential is often very critical, and especially good results may be obtained when it is adjusted to precisely the right point.

R. W. H.

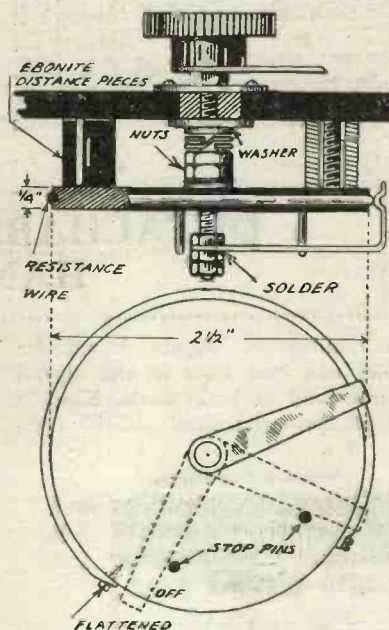

Details and section of the vernier filament resistance.

pieces enable the rheostat to be fixed very firmly to the panel. As the arm is fixed by means of nuts to the end of the spindle there is no chance of its working loose.

TRADE NOTES.

The title of the advertisement on page xii in our issue of the 5th inst., given as "The British Electric and Transformer Co.," should have read, "The British Transformer and Electric Co."

Broadcasting News

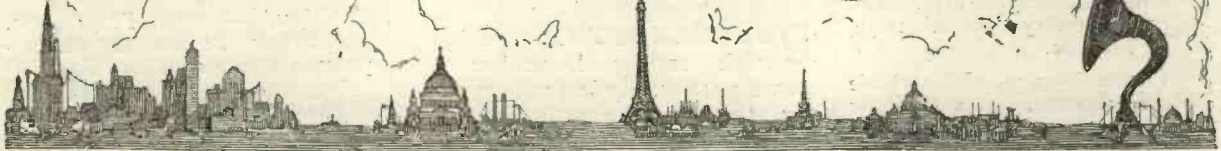

LONDON.—The sound of the tradesman's hammer is heard all day at 2LO these days. The offices are being considerably enlarged, and the new studio is nearing completion. So far as cubic capacity is concerned it will be about three times the size of the old studio, and will be big enough to contain the largest orchestras and bands in the country.

The various station directors met together last week when an interesting interchange of ideas took place. Steps will be taken to cull the best ideas of each director for the benefit of all stations. The women's and children's hours were the subject of special consideration, and steps are being taken to bring all the provincial stations more into line with London. There will be special children's programmes for the days round about Christmas. It is recognised that the kiddies are allowed to sit up a little later on festive nights, and the entertainments for the children will be somewhat later than usual.

It is good to learn that when the British National Opera Co. begins its season early in the new year excerpts from the performances will continue to be broadcast as before. There will be some new works never before given, and listeners will look forward to these with special interest.

Forthcoming Events

DECEMBER.

20th (THURS.).—Uncle Leslie's Zoo Talks to the Children. Band of H.M. Grenadier Guards. Orchestra. Mr. Foden Williams and Miss Helena Millais, entertainers.

21st (FRI.).—Orchestra. Mr. Charles Stainer, solo banjoist. Mr. Lyell Johnston, singer. The Elliotts.

22nd (SAT.).—Dance Music. Mr. Hector Gordon, Scottish entertainer. Capt. Grierson: Extracts of articles which have appeared in *Punch*. Old-time Dance Music.

23rd (SUN.).—Band of H.M. Irish Guards. Talk on St. Dunstan's by Capt. Ian Fraser, C.B. Choir of St. Paul's Cathedral.

24th (MON.).—Uncle Rex and Mr. E. W. Lewis will entertain the children. 2LO Wireless Waits, assisted by the Mayfair Singers. Mr. R. I. Stephenson, entertainer. Savoy Band.

25th (TUES.).—A Fairy Play by Auntie Phyllis and Uncle Carac-

when the uncles and the aunties entertained eighteen juvenile listeners at tea in the studio—the outcome of a competition organised by the director.

The variety of the Aberdeen programme is exciting favourable comment from a wide range of listeners. Correspondents go as far as to say that of all the programmes that broadcast by 2BD is the most acceptable, largely because of the efforts made to please every type of listener. It is tribute enough to say that Aberdonians are satisfied, for a more critical audience does not exist.

Forthcoming Events

DECEMBER.

19th (WED.).—Pupils of Miss Nellie Donaldson. Rendering of "A Christmas Carol," by Mr. R. E. Jeffrey.

20th (THURS.).—Band of H.M. Royal Air Force.

21st (FRI.).—Scottish Music, assisted by the Pipers of the British Legion.

22nd (SAT.).—General Popular Concert.

25th (TUES.).—Popular Concert.

BIRMINGHAM.—The recent transmission by land-line of a concert at the Birmingham Town Hall was a welcome variation from the usual run of programmes, and, having regard to the difficulties involved, was a success. In Bach's "Sleepers Awake" nothing of the original volume of sound of the City Orchestra was lost, and the various parts seemed excellently balanced. This was perhaps the best rendered piece (from the wireless point of view) of the evening. Many very enjoyable concerts are given in the Birmingham Town Hall, and it is hoped that they may be broadcast more frequently by 5IT.

BROADCAST TRANSMISSIONS		
	Call-Sign	Wavelength.
LONDON	2LO	365 metres.
ABERDEEN	2BD	495 "
BIRMINGHAM	5IT	475 "
BOURNEMOUTH	6EM	385 "
CARDIFF	5WA	435 "
GLASGOW	5SC	420 "
MANCHESTER	5ZY	460 "
NEWCASTLE	5NO	350 "

TIMES OF WORKING.	
Weekdays	3.20 to 4.20 p.m. and 5.6 to 10.10 p.m. G.M.T.
Sundays	3.0 p.m. to 5.0 p.m. and 8.50 to 10.30 p.m. G.M.T.

tacus. Rev. J. A. Mayo, Rector of Whitechapel. Orchestra. John Henry, entertainer. Miss Helena Millais, Mr. Ronald Gourley and Mr. Jay Kaye, humorists. Dance Music. The Rev. G. W. Kerr, B.A., LL.B., on "Wit and Humour." Dance Music.

ABERDEEN.—That the children's half hour has become one of the most interesting of the 2BD features is attributable mainly to the humanity and knowledge of the wants of the kiddies displayed by the central characters. An exemplification of this was forthcoming last week (December 10)

Forthcoming Events

DECEMBER.

- 19th (WED.).—3.30-4.30, Paul Rimmer's Orchestra playing at the Lozells Picture House. 7.30, Station Orchestra. 8.45, The Station Repertory Chorus. 10.30, Morse Practice.
- 20th (THURS.).—3.30, Miss Elsie Wilson, soprano. 7.30 Operatic Night. Performance of Balfe's Opera, "The Bohemian Girl," by the Station Repertory Co. and an Augmented Orchestra, conducted by Mr. Joseph Lewis, Musical Director; Station Orchestra, Suite, "Three Dances from Nell Gwynne."
- 21st (FRI.).—3.30, Paul Rimmer's

- 25th (TUES.).—6.30, Special Concert for Kiddies. 8, Concert as given at the London Studio.
- 26th (WED.).—7.30, The First Radio Panto-Revue, "Singbad the Wailer."

□ □ □

BOURNEMOUTH. — The week ending December 8 was a particularly interesting one for the Bournemouth station. The two simultaneous broadcasts of "Trilby" from Glasgow, and "Tales of Hoffman" from London were the star features, and the engineering staff of the B.B.C. is to be complimented on the excellence of these transmissions.

Religious Address by Rev. A. P. Annand, Rev. S. W. Allen and Father Triggs. Miss Jennie Malkin, contralto. Mr. Charles Leeson, solo pianoforte. The Messiah (S.B. from London).

- 24th (MON.).—London Programme. Sir Frank Benson in Shakespearean Recitals. Savoy Bands.
- 25th (TUES.).—Mr. George Dale, solo cornet. De Vekey's Juvenile Serenaders. Mr. J. C. B. Carter, B.A., on "Christmas Customs." Christmas Night Programme. The Rev. G. W. Kerr. Savoy Bands.
- 26th (WED.).—London Programme. Major L. R. Tosswill. The Savoy Bands.

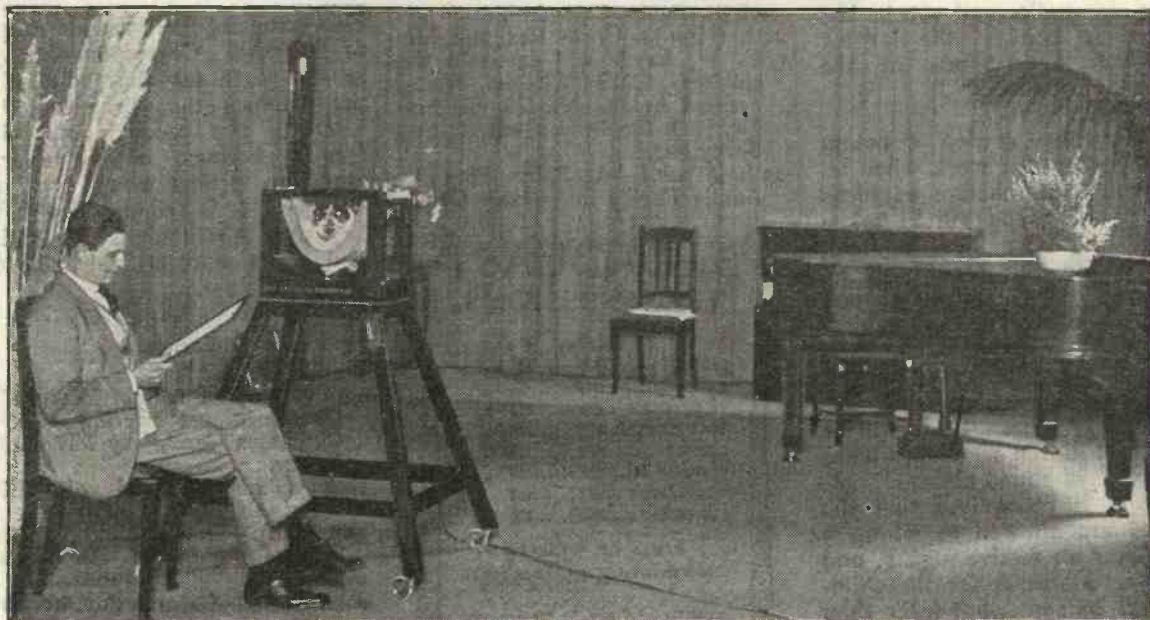

The Studio at the Bournemouth Station, with Bertram Fryer, the Station Director, announcing.

- Orchestra playing at the Lozells Picture House. Evening Programme by Miss Doris Lemon, soprano; Mr. William Michael, bass; Miss Alice Couchman, solo pianist; Mr. G. J. Jeffcock, baritone, and Major Vernon Brooke.
- 22nd (SAT.).—3.30, Kiddies' Concert. Evening Programme by the Band of H.M. Royal Air Force; Mr. Percy Edgar in Recitals, "Scenes from the Christmas Carol" and "The Carol Singers"; Mr. John Hingeley, Talk on "Some Ghost Stories of the Midlands."
- 23rd (SUN.).—8.30, Performance of the Oratorio, "The Messiah," S.B. from London.
- 24th (MON.).—3.30, Paul Rimmer's Orchestra. 7.30, Sir Frank Benson in Dramatic Recitals; Carols and Waits as played at the London Studio.

Forthcoming Events

DECEMBER.

- 19th (WED.).—Popular Night. Orchestra. Miss Edith Thomas, soprano. Miss Gladys Seymour, solo pianist. Mr. Robert Sturivant, baritone. Miss Constance Willis, of the B.N.O.C. Mr. Harold Stroud, tenor.
- 20th (THURS.).—Instrumental Night. The Bournemouth Wireless Orchestra. Mr. Reginald S. Mouat, solo violin. Mr. Thomas E. Illingworth, solo 'cello. Mr. Ben Huhn, solo violin.
- 21st (FRI.).—Eighty Years Ago—Old-time Programme.
- 22nd (SAT.).—Wireless Orchestra. The Elliotts, Mr. W. H. Lester and Mr. Lincoln Wright.
- 23rd (SUN.).—Irish Guards Band.

CARDIFF.—The "Tales of Hoffman," simultaneously broadcast from London on December 3, was considered by Cardiff listeners as one of the finest items that has yet been simultaneously broadcast from the London station. Every word came through as clear as a bell, and it was difficult to realise that the transmission was being sent over 150 miles of land-line. Praise is, indeed, due to the B.B.C. engineers for the excellent transmission of this opera, as well as to the artistes for their excellent rendering.

Forthcoming Events

DECEMBER.

- 19th (WED.).—Falkman and his Orchestra from the Capitol Cinema. Miss Doris Lemon and Mr. William Michael in Selections of Operatic Scenes. Talk by Mr. C. T. Hutchinson on "Producing a Pantomime."
 20th (THURS.).—London Programme. "Memories." Prof. A. J. Ireland.
 21st (FRI.).—Choral Night. Medical Officers for Cardiff on Slums.
 22nd (SAT.).—Popular Orchestral Night. Mr. W. C. Clissitt on "Sport of the Week." Miss Bella Redford, soprano. Mr. G. F. Jeffcock, baritone. Talk by Mr. Howard Coath on "Income Tax."
 23rd (SUN.).—Band of H.M. Irish Guards. "The Messiah," S.B. from London.
 24th (MON.).—"A Christmas Carol" (Dickens). Carols. Sir Frank Benson S.B. from Newcastle. Savoy Bands.
 25th (TUES.).—London Programme. Rev. G. W. Kerr. Savoy Bands.

GLASGOW.—In the broadcasting of George du Maurier's "Trilby" another venture of an ambitious nature was carried through successfully at 5SC. The production was in the hands of Mr. George Ross, who took the rôle of Svengali and gave a brilliant interpretation. The speaker in the part of "Trilby" was Miss Gladys MacDonald, while Miss G. Simpson rendered with fine effect the "Trilby" solos. The other members of the cast were equally successful. The play was relayed to all stations, and judging by the letters which have been received at the Glasgow station the effort was very highly appreciated throughout the country.

Forthcoming Events

DECEMBER.

- 19th (WED.).—Band of H.M. Royal Air Force. Mr. Joseph Farrington, of the B.N.O.C., bass.
 20th (THURS.).—Wireless Quartette. "Memories" Programmes S.B. from London.
 21st (FRI.).—Dance Music. Mr. Bertram Griffith, bass. Mr. Jan Wien, zither-banjoist. Talk on "Physical Exercise for Health," by Mr. William Carswell.
 22nd (SAT.).—"Pudding and Pie." Orchestral Selections.
 23rd (SUN.).—Band of H.M. Irish Guards. Capt. Ian Fraser. Lord Bishop of Southwark. "The Messiah" S.B. from London.

- 24th (MON.).—Sir Frank Benson in Shakespearean Recitals, S.B. from Newcastle. Savoy Orpheans and Savoy Havanna Bands.
 25th (TUES.).—Wireless Quartette. Games. Boys' Choir of Woodside Parish Church singing Carols. "A Christmas Carol" (Dickens). Mr. Robert Murray, entertainer. Wireless Orchestra. Savoy Bands.

MANCHESTER.—The versatility of Mr. Victor Smythe, of the Manchester station, was fully demonstrated last Saturday week. He confesses to three distinct voices, but we credit him with four, viz.: (1) his natural conversational voice, (2) his amusing "dandy" voice as typified in Algy, (3) the aged professorial voice, and (4) the radio or announcing voice, redundant in consonants. How many smiles have been raised by his delightful and oft-repeated "millibarrrrs"?

Forthcoming Events

DECEMBER.

- 19th (WED.).—3.30, 2ZY Trio. Mr. T. Taylor, baritone. Miss Helena Wheelhouse, soprano. Miss Gladys Woodward, contralto. Mr. R. Hunter, entertainer. 6.30, Organ Recital. Piccadilly Picture House. 7.45, 9th Symphony Concert by 2ZY Augmented Orchestra. 8.25, Miss Amy Buxton Nowell, elocutionist.
 20th (THURS.).—11.30, 2ZY Trio. 6.30, Girl Guides' and Boy Scouts' Bulletins. 6.40, German Talk. 7.45, Concert relayed from Birmingham. 9.45, Percy Phlage.
 21st (FRI.).—3.30, Concert by Mr. E. Sidebottom, baritone. Miss B. Blackburn, soprano. Mr. F. Carleton, tenor. Miss A. Calvert, contralto. 6.40, French Talk. 7.45, 2ZY Dramatic Company will present "A Butterfly on the Wheel," adapted and produced by Mr. Victor Smythe. Incidental Music by the 2ZY Trio. 10.20, Morse Practice.
 22nd (SAT.).—3.30, Oxford Picture House Orchestra. 6.30, Organ Recital, Piccadilly Picture House. 7.45, Garner-Schofield Dance Band. 8.20, Miss Lilian Gibson. 9, Mr. Victor. Smythe.
 23rd (SUN.).—3.30, H.M. Irish Guards Band (S.B. from 2LO). 8, Talk to Young People by Mr. S. G. Honey. 8.30, Handel's "Messiah" (S.B. from 2LO).
 24th (MON.).—3.30, 2ZY Orchestra. 5.30, Carols by the Abbott Street

Wireless Weekly

- Schoolboys. 7.30, Sir Frank Benson, Shakespearean Recitals (S.B. from Newcastle). 9.40, Christmas Greetings. 10, Savoy Orpheans. 11, Carols and Waits.
 25th (TUES.).—4, Dickens' "Christmas Carol," recited by Mr. R. J. Hever. Incidental Music by Mr. Eric Fogg. 5.15, Children's Hour, including a few words from Father Christmas. 6.30, Children's Talk from London. 3, Concert. 9.45, Savoy Orpheans.

NEWCASTLE.

Forthcoming Events.

DECEMBER.

- 19th (WED.).—Wireless Orchestra. Miss Mayn Grant, contralto. Mr. J. Wilson Beveridge, tenor. Mr. Tom Sherlock, baritone.
 20th (THURS.).—Boy Scouts' and Girl Guides' News. London Programme. "Memories."
 21st (FRI.).—"The Butterfly on the Wheel" (S.B. from Manchester).
 22nd (SAT.).—Lee Dixon and Party, "A Christmas Carol." Wireless Jazz Orchestra.
 23rd (SUN.).—H.M. Irish Guards Band. Miss Godfrey, soprano. Miss Beatrice Eveline, solo cello. Mr. John Collinson, tenor. London Programme. The Lord Bishop of Southwark, "The Messiah."
 24th (MON.).—Sir Frank Benson, Shakespearean Recitals. Newcastle Wireless Orchestra. Miss Ethel M. Stanley, mezzo-soprano.
 25th (TUES.).—London Christmas Night Programme. Rev. G. W. Kerr. The Savoy Orpheans and Savoy Havanna Bands.

Simultaneous Broadcasting Events.

DECEMBER.

- 23rd (SUN.).—3, Irish Guards Band. 9.10, "The Messiah."
 24th (MON.).—Sir Frank Benson, Shakespearean Recitals, etc.
 25th (TUES.).—Children's Hour.
 26th (WED.).—5.30, Children's Party. 7.30, Children's Concert; "Singbad the Wailer," the first Radio Panto-Revue.

"HOW-TO ADJUST A VARIABLE GRIDLEAK."

Referring to the note under this heading in last week's issue, it is to be observed that the adjustment described should be made once only, preferably out of broadcasting hours. Apart from the probability of causing interference, there is no need whatever for frequent re-adjustment of the gridleak.

A VARIOMETER CRYSTAL RECEIVER

By H. A. C.

A description of a simple crystal set for the beginner.

THIS receiver may be easily constructed by those readers who have as yet not attempted to construct their own apparatus, and will provide some experience to aid them in the building of the more complicated valve sets at some future date.

Standard components may be used, or, if preferred, the constructor may make each separate part himself from easily-acquired materials. The cost of this little set should certainly not be more than about ten shillings, exclusive of the containing box, even if bought components are used.

(6) A crystal detector or materials for making same, together with a 3-screw cup.

(7) Two pieces of brass tube screwed 5/16 Whitworth with a central 2 B.A. clearance hole and nuts or tapped washers to fit; alternatively, a screwed condenser bush and nuts.

(8) One ebonite knob tapped 2 B.A.

(9) Four 4 B.A. terminals.

(10) About $\frac{1}{2}$ lb. of No. 20 S.W.G. d.c.c. copper wire.

(11) Two ordinary contact studs, with nuts.

each side of the panel so that the tube is flush with the nut on the upper side. To accommodate these pieces of brass tube, which serve as bearings, two holes are drilled in the cardboard tube, care being taken that these are exactly opposite and at the mid-point along its length. The cardboard tube or former should then be coated with a thin layer of shellac varnish and wound tightly and evenly with No. 20 S.W.G. d.c.c. wire, leaving a space of $\frac{3}{8}$ in. wide to allow for the clamping nuts, as shown in Fig. 5. Fourteen turns should be

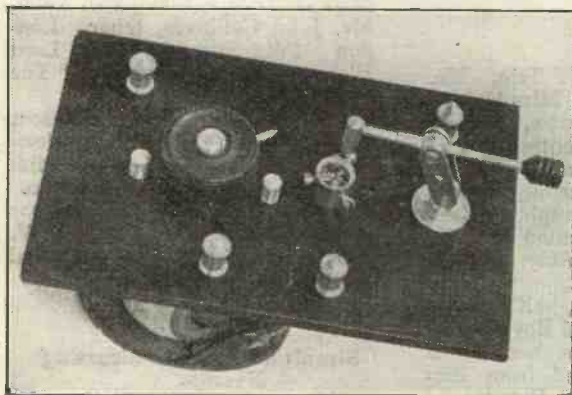

Figs. 1 and 2.—Photographs showing front and back views of the receiver.

Components and Materials.

In order to build a receiver of the type under description the following materials and components are necessary:—

(1) An ebonite panel measuring 6 ins. by 4 ins. by $\frac{3}{16}$ in.

(2) A containing box $3\frac{1}{2}$ ins. in depth to take the panel, or alternatively the wood necessary to make same.

(3) A cardboard tube 2 ins. long and having an internal diameter of $2\frac{1}{2}$ ins.

(4) A wooden variometer rotor $2\frac{1}{2}$ ins. overall diameter.

(5) A piece of 2 B.A. threaded rod 4 ins. long.

(12) A pointer or piece of plain 5 B.A. brass rod.

The ebonite panel should be squared up to the dimensions given in Fig. 4 and drilled as shown. After drilling it is advisable to rub the surface of the panel with coarse and then fine emery paper, after which it may be polished with a soft rag and a few drops of oil. This treatment will give the panel a good appearance whilst reducing surface leakage to a minimum.

One of the two pieces of screwed brass tube is inserted in the large hole in the panel and secured by means of a nut on

wound on each side of the centre spindle, with a further six turns on each side wound over them, the ends being secured by passing them through holes pierced in the ends of the former, which is itself clamped to the panel over the bearing tube by means of another nut.

The rotor should contain from thirty to thirty-five turns of wire, and by means of a 2 B.A. screwed rod passing through holes drilled and tapped in its walls it is supported within the outer tube or former. The second bearing consists, as may be seen from the diagrams, of a

piece of threaded brass tube similar to the first piece, with two nuts screwed up tightly against the cardboard tube. The tube should then be flush with the nut on the outside, whilst it will project slightly on the inside.

The rotor is secured on its

place by means of two lock nuts, will give the rotor a smooth movement. The pointer is secured under the knob by means of a nut, but a better job can be made by screwing a small piece of pointed brass rod into a brass bush drilled and tapped

through this tube carrying a small ebonite knob at one end and the cat's whisker at the other. Any of the treated or synthetic galenas may be used with a cat's whisker of gold, silver, or even copper in a 3-screw cup.

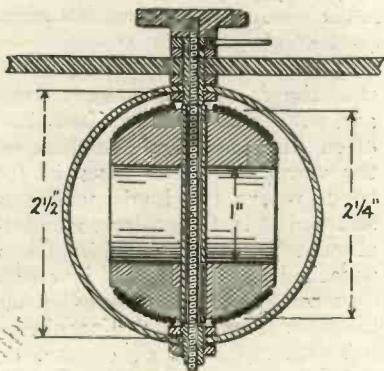

Fig. 3.

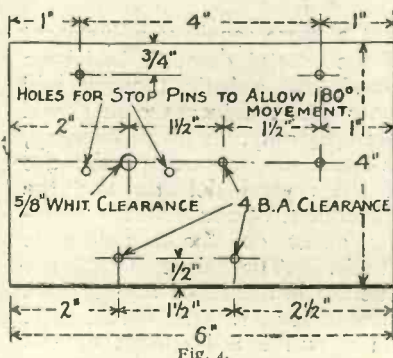

Fig. 4.

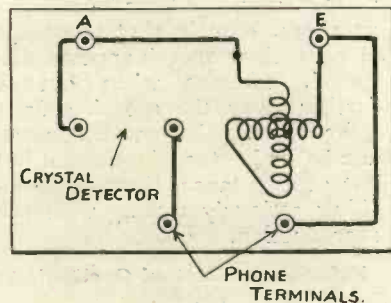

Fig. 6.

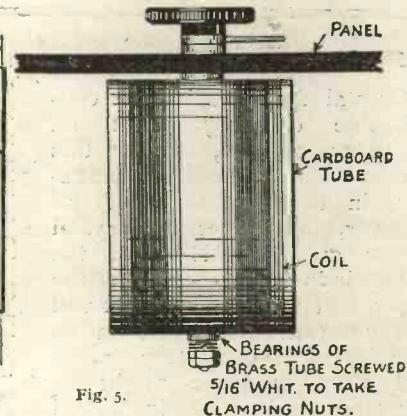

Fig. 5.

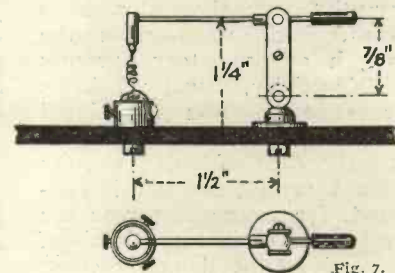

Fig. 7.

Figs. 3, 4, 5, 6 and 7, showing constructional details of the variometer, panel and crystal detector, together with a wiring diagram of the instrument.

shaft by a large terminal nut, which is tightened against the wooden rotor on the inside, whilst the ends of the rotor winding are passed through two small holes drilled at its two ends towards the central hole in the rotor. A channel is cut in the thick part of the rotor, and the two inner ends of its coil are joined and soldered within it. The outer ends, after passing through the two holes, are soldered to two pieces of thin rubber-covered flexible wire, which allow of free movement of the rotor whilst giving a good electrical connection.

The ebonite knob is fitted to the 2 B.A. rod, the free end of which is cut or filed off 1/2 in. from the bearing tube. A spring washer, slipped over the projecting end and secured in

5 B.A., which is in turn screwed up against the knob. Two contact studs serve as stop pins, the excess of thread being filed down flush with the nut to make room for the variometer tube.

A neat and effective crystal detector is made, as shown in Fig. 7 from two brass balls with two retaining side plates and the usual knob, rod, and cat's whisker. One ball is drilled and tapped 4 B.A., and fastened down to the panel by means of a screw, the ball itself resting on a small brass bush, as may be seen from the diagram. The side plates are held together by means of a 4 B.A. screw, and large holes are drilled in their ends to clamp over the balls. A piece of split tube is soldered into a hole drilled in the upper ball, and a brass rod slides

The terminals are inserted in their holes, and secured by means of the back nuts, whilst the wiring may be completed with tinned copper wire, the connections being soldered in place. Should the constructor wish to avoid soldering, the wires may be held firmly beneath the terminal nuts and screws, which in this case should have lock nuts.

At a distance of six miles from the London Broadcasting Station results are remarkably loud when using three pairs of phones and a rather badly-screened aerial. If it is required to receive Aberdeen on a small aerial, a few more turns will probably be required. Ten to fifteen extra turns wound on the former should, in this case, prove sufficient to give efficient results.

Referring to our report on dull-emitter valves (Vol. 2—No. 19), it has been pointed out to us that our remarks regarding the General Electric Co.'s D.E.3 valve may be interpreted as meaning that this valve is a copy of the British Thomson-Houston Co.'s B5 valve. No such meaning was intended, and, although the characteristics of the valves in question were very similar, we would never suggest that such well-known makers as the G.E.C. have any need to copy another valve.

Valve Notes

By John Scott-Taggart, F. Inst P

Damping Effect of Crystals.

Crystal detectors have a considerable damping effect on oscillatory circuits, and for this reason it is sometimes advantageous, in the case of a crystal receiver, to connect the crystal across only a portion of the aerial inductance — across the lower half for example. It will be found that this will lessen the damping of the oscillatory circuit, and although there might be expected a decrease in signal strength, yet the advantages gained, both as regards the strength of oscillatory currents and selectivity, usually balance any expected loss of signal strength.

In the case of valve circuits where a crystal detector is connected, for example, across the tuned-anode oscillatory circuit of the receiver, the damping effect on the circuit of the crystal detector is very marked. One beneficial effect is that the circuit is made much more stable and when a crystal detector is used, two stages of high-frequency amplification are much more readily handled.

As would be expected, any adjustment of the crystal will vary its resistance and the damping effect on the circuit will vary. This will vary the reaction, and quite misleading results may often be obtained. For example, with tight pressure, the crystal detector may be working at its best as a detector, but the damping effect will be very considerable, and this will lessen the strength of the high-frequency oscillations in the oscillatory circuit which, we will assume, is a tuned-anode circuit coupled so as to produce reaction on to the grid circuit, as in the case of the ST100 circuit.

If we now lessen the pressure of the cats-whisker on the crystal, the signal strength may increase, and it might at first be thought

that a more sensitive adjustment of the crystal detector had been found, but a little thought will show that the increase in signal strength may, in all probability, be due to the increased resistance of the crystal detector and the consequent decrease of its damping effect on the tuned-anode circuit. The result is that the reaction is increased and signals become louder. In actual fact, the sensitive adjustment of the crystal detector may be altered for the worse, but the increased



BURNT OUT!

A correspondent's loud-speaker after use on the S.T.100 at 10 miles from 2ZY. We publish this photograph with all reserve!

reaction may more than make up for this.

The moral is, that whenever the crystal detector is adjusted, a readjustment of the reaction is desirable if the full benefits are to be obtained. In the case of dual amplification circuits, the crystal detector is usually a boom in that it introduces sufficient damping into the circuit with which it is connected to prevent undesirable oscillation.

Testing Quality of Modulation.

When working with a loud-speaker, experimenters frequently get a wrong idea of the quality of the reproduction by remaining too close to the instrument. It is a good plan to go into another room of a house and to listen carefully to what is being said from a loud-speaker. At a

suitable distance it will be found that the ear is far more critical and will, in the case of distortion, often find it difficult to pick up the words, whereas when in the room where the loud-speaker is situated it is far easier to understand what is being said. Clear speech, however, should be easily discernible even at a considerable distance from the loud-speaker.

These remarks, of course, do not in any way affect what is often observed in the case of loud-speakers, namely that when too close to them speech appears distorted, whereas when one is further away the speech sounds quite clear. When the speech can be understood in a room but not at a distance, there is something seriously wrong with the reproduction.

Polarising Effect of Oscillating Valves.

Many experimenters who with special circuits imagine they are getting super-regenerative effects, are really only obtaining either ordinary efficient reaction results, or else their valves are oscillating, and the local oscillations of the valves serve to strengthen the incoming signals, although the latter may appear somewhat distorted. The usual procedure is to tune in the carrier wave of the distant broadcasting station and then to adjust the condenser until the squeal is no longer heard. It must not be imagined that because the squeal is not heard that the valve has stopped oscillating; it is probably still oscillating, but does not produce beats with the incoming signals.

The increased signal strength is chiefly due to what is known as the polarising effect of the continuous oscillations. The efficiency of a detector valve or of any other form of rectifier, such as a crystal detector, is greatly enhanced when there is a local continuous oscillation to be applied to the receiving circuit.

Correspondence

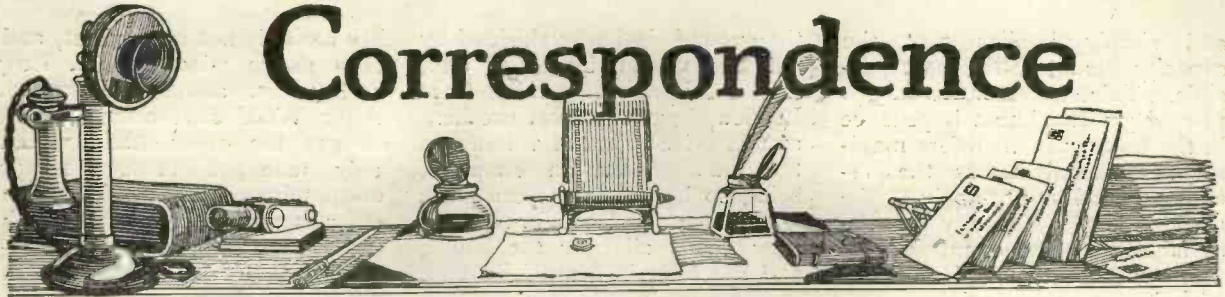

SINGLE OR TWIN WIRES ?

SIR,—In your article "Single or Double Wire Aerial" (*Wireless Weekly*, Vol. 2, No. 9), the writer states that if the two wires of a double aerial have different values it is almost impossible to tune the receiver critically. I cannot see any reason why this should be so. The writer does not offer any explanation, but I have seen it stated elsewhere that such an aerial responds to two wavelengths which are the fundamental wavelengths of the separate wires. This, I believe, is entirely untrue.

The values of the two wires, when connected in parallel, combine to form a single fundamental value, the capacities being added and the inductance reduced. This

being so, a double wire aerial in which the two wires are of widely different lengths does not receive simultaneously on two different wavelengths (a property which might be very useful in some cases).

Actually I have not tried such an aerial, but imagine that its behaviour would be perfectly normal.

It would be a very good thing if someone with sufficient aerial facilities would conduct exhaustive experiments on various types of aerials, including unorthodox arrangements, and publish the results.

The theory of aerials seems to be somewhat obscure (at any rate, to the average amateur), and in practice we are led by traditional superstitions which

can seldom be traced to any reliable source.

The writer also raises another point, when he says that a tuner "will be at efficiency at the one point on the condenser where the inductance and capacity are in agreement, and at that point only." This implies that for a particular wavelength there is an optimum ratio of inductance to capacity.

Reference to a text-book on wireless theory elucidates the fact that, where the capacity is in parallel with the inductance, the impedance of a tuned circuit to currents of the frequency to which it is tuned is inductance, capacity, resistance, so that the optimum ratio of inductance to capacity is infinity. This, of course, is an unattainable ideal,

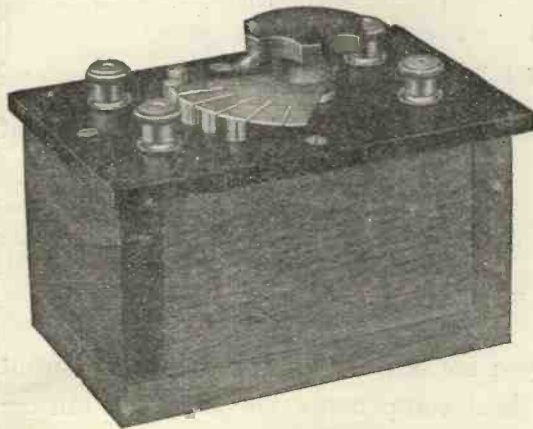

Tone Selector.

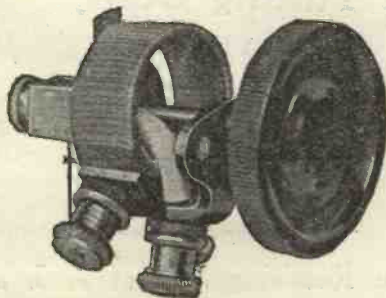

Potentiometer.

Perfect Reproduction with the New "FULLER" TONE SELECTOR.

After long months of patient research this marvellous tone control has been perfected, with the result that music can now be reproduced so faithfully as to be indistinguishable from the actual performance. The secret behind the success of this wonderful device is its ability to filter the sound, eliminating all those parasitic noises which result in the reproduction being harsh and distorted, allowing only the pure natural tones of the music to reach the Loud Speaker or Telephone. Another distinctive feature worthy of special mention is the 6-position switch enabling the volume of sound to be controlled to a degree hitherto impossible. It is supplied in a polished wood case with terminals marked "input" and "phones" and is for use with either low resistance Loud Speaker or Headphones.

Overall size $4\frac{1}{2}'' \times 3'' \times 3\frac{3}{8}''$ high. Code SELKE. Price £1 5 0

TWO SILENT TUNING DEVICES.

The "Fuller" Filament Resistance and Potentiometers are of the same pattern and have been specially designed to operate noiselessly and efficiently. Exceptionally neat and compact, they can be fitted into the same space as that occupied by the valve Holder. All resistances are fitted with an "off" position so that no separate switch is required.

FILAMENT RESISTANCES.

1 Valve Resistance 4/3. 2 Valve Res. 4/6. 3 Valve Res. 4/9.

POTENTIOMETERS.

The Resistance Value is approximately 400 ohms. Price 7/.

We shall be pleased if you will come to our London Depot, 58, High Street, W.C.2, and inspect our complete range of components, appealing particularly to experimenters. Anyway, make certain of having our Catalogue No. 315 by sending a postcard NOW.

FULLER'S UNITED ELECTRIC WORKS, Ltd.

Woodland Works :: :: Chadwell Heath, ESSEX

Telephone :
Ilford 1200 (6 lines).

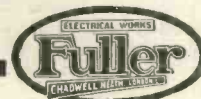

Telegrams :
"Fuller, Chadwell Heath."

and simply implies that the capacity should be the least possible. This, however, is only a rule to get maximum impedance in the tuner, and therefore maximum potential across the receiver, and does not apply to the aerial itself. Capacity in the aerial is not a disadvantage.

When the condenser is in series with the aerial, maximum efficiency is obtained with an infinitely large capacity, and minimum efficiency with infinitely small capacity, i.e., the more capacity the better.—Yours, etc.,

R. ST. Q. LENG.

[We disagreed with most of the views in the original article, which we published to make discussion. Differences in length of the twin wires makes no difference, nor is it necessary to take the lead-in from the exact end or the exact middle. These are hoary superstitions which it is sacrilege to expose!—Ed.]

ST 76

SIR,—In spite of the fact that, owing to force of circumstances, my aerial has almost every conceivable fault, faces the wrong direction, is only a few feet from

the ground, is badly shielded by hill, trees and buildings, etc., and also is about 35 miles from London, I get the most excellent results on ST76, the volume on the loud-speaker, an Amplion, being so loud that one can place it at the far end of one room to hear easily all over the house, and the tone is beautifully pure and free from distortion.

Now comes the more interesting feature. Using one's body as the aerial, i.e., by placing one finger on the aerial terminal, and re-tuning, one can still hear 2LO on the loud-speaker.—Yours, etc.,

EXPERIMENTER.

[Will correspondents please note that there is no reason why they should desire their real names to be withheld in such cases?—Ed.]

AMERICAN RECEPTION.

SIR,—I have to inform you that I received WGY, General Electric Co., New York, on a home-made ST100 so loud and clear that I eventually switched on my Brown loud-speaker and microphone amplifier and heard every word of Owen B. Young's speech in any part of the room.

My aerial is not of the best, and is a single wire, 100 ft. long and 30 ft. above the ground. After WGY shut down I tried to get the other stations, but only managed to get scraps of speech and jazz music. The ether seemed to be all upset with countless waves, and my instrument would not keep stable 10 seconds at a time.

The results I got were, however, wonderful, and say a great deal for your ST100 circuit. I get better results from it on broadcasting than from all my other sets put together.—Yours, etc.,

LAURENCE BELL.

Edinburgh.

ERRATUM.

We are informed that in our issue of "Wireless Weekly" for December 5 under the heading "American Broadcast Reception," wherein it is stated that L. V. McN. of South Shields received WGY on a frame aerial with Det.—1 L.F., this should read 1 H.F.—Det.—2 L.F.



W. G. PYE & CO.,



Manufacturers of Physical and Electrical Instruments,

Granta Works,
CAMBRIDGE.



TWO-VALVE RECEIVING SET (No. 529.)

Price, including all royalties (less Valves) .. £12 10 0
 Price, including Headphones, Valves, Batteries, etc., and all Royalties .. £18 10 0
 Two Valve-Power Amplifier of similar design. Price .. £10 10 0

If you are building your own set, and want the best components, you must use our:—

- Tuning Coils,**
- Coil Holders,**
- Switches,**
- Condensers,**
- Panels, etc.**

Complete Receiving Sets of 2, 3, and 4 Valves also supplied.



Information Department



T. D. C. (MANCHESTER) asks what is meant by double reaction.

In simple circuits reaction is applied at any one point, but it is possible to react into two or more of the circuits in a receiver with beneficial effects on the signal strength. Some receivers are apt to be difficult to handle, however. The accompanying diagram illustrates a double reaction circuit.

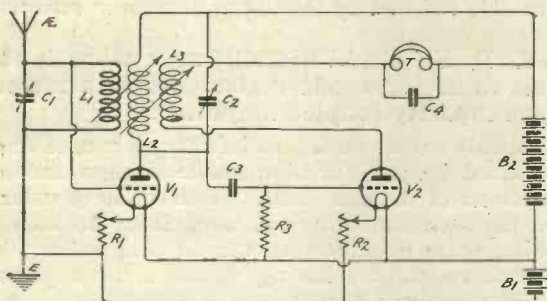

B. J. (NORTHAMPTON) requests particulars regarding the issue of transmitting licences.

This matter is referred to briefly in an article appearing elsewhere in this issue. Further particulars are given in the Radio Press Handbook, "Wireless Licences and How to Obtain Them."

T. R. R. (GLASGOW) asks what is the difference in sound between spark and continuous-wave signals.

Spark signals do not, as a rule, possess a very musical sound, but may range between a harsh buzzing sound and a clear note, the pitch of which is not altered in any way by varying the tuning of the receiving set. If the receiving set is allowed to oscillate, spark signals will be heard with a harsh, scratchy sound. Continuous-wave signals, on the other hand, cannot be received properly until the set oscillates, or, as an alternative, a local heterodyne is used. Such

DUBILIER CONDENSERS

When you buy a Vanicon, you pay slightly more ; but when you consider the improvement which it will make to the results from your set, you agree with thousands of other users of Dubilier Condensers, that it is **WORTH IT.**

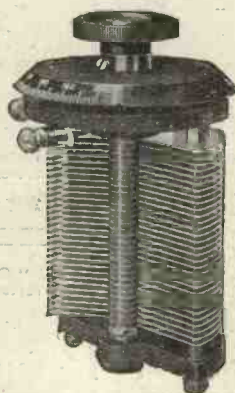

THE VANICON

Prices.

Capacity	Price	Extra for Ebonite Box
·0003 MFD	17/6	7/6
·0005 "	£1 0 0	7/6
·0007 "	£1 2 6	10/-
·001 "	£1 5 0	12/6

Each Condenser can be supplied with a calibration chart at an extra charge of 10/6.

Write to us to-day for our Trade Terms and Descriptive Leaflets.

THE DUBILIER CONDENSER CO. (1921) LTD. Dept. G.
 DUCON WORKS, GOLDHAWK ROAD, LONDON, W.12.
 Telepl. one : Hammersmith 1084. Telegrams : "Hivolteon, Phone, London."

signals have clear musical notes, the pitch of which can be varied between the highest and lowest audible frequencies, by altering the tuning of the receiver or separate heterodyne, if the latter is used.

J. T. W. (SHREWSBURY) asks if we can identify the source of certain telephony transmissions, on a wavelength of 1,000 or 1,100 metres.

We cannot positively identify the station from the particulars given, but suggest that it was probably one of the following:—

	Metres.	
Amsterdam (PA5)	1,100	Occasional concerts from 8 to 9 p.m.
Brussels (BAV)	1,100	Concerts on Tuesday evenings.
The Hague (PCUU)	1,070	Concerts on Thursday evenings.
The Hague (PCKK)	1,070	Concerts on Friday evenings.
Ijmuiden (PCMM)	1,050	Occasional concerts at 8.30 p.m.

J. T. M. (TORQUAY) asks what advantage is gained by using thick wire windings upon aerial tuning inductances.

The object of using thick wire is to keep down the high-frequency resistance of the aerial circuit, thereby decreasing the damping and improving the efficiency and selectivity of the aerial circuit. The higher the frequency of the incom-

ing waves the greater the advantage in using thick wire.

J. K. (ABERDEEN) asks whether it is necessary to have more than one insulator at each end of the aerial.

Although a single insulator at each end of the aerial will probably give quite satisfactory results, especially when the aerial is newly erected, two connected in series are much to be preferred. Insulation may be regarded as being a question of extremely high resistance. If two equal resistances are connected in series, the total resistance will be double. By using two or three insulators in series, therefore, the insulation resistance of the aerial at that point will be two or three times greater than if only one insulator was used. Three small insulators in series will probably give an equal or better insulation than a single large one, at less cost and with probably only about half the weight. The dielectric losses in the "condenser" formed by the insulator are also reduced by the use of several in series.

R. D. F. (GRAVESEND) asks what is the best value for anode resistances in a resistance capacity coupled amplifier.

Probably the most satisfactory results are obtained by using a high anode voltage and resistances of 100,000 ohms. With ordinary values of high-tension, ranging, say, from 80 to 100 volts, quite good results can be obtained by the use of resistances having values of from 50,000 to 80,000 ohms.

Good Crystals for Good Music



The Mark of Merit on any Wireless Set or Component is a guarantee of efficiency, reasonable price and sound British manufacture.

We are exhibiting in the Electrical and Allied Engineering Section of the British Empire Exhibition, 1924.

Complete Catalogue Post Free 1/8

To receive good clear music on a crystal set it is essential that a good crystal be used. An additional advantage obtained by the use of a good crystal is that adjustment to the best and most sensitive spot is facilitated.

Hertzite	per piece	1/6
Carborundum	"	6d.
Copper Pyrites	"	3d.
Zincite	"	9d.
Silicon	"	3d.
Galena	"	3d.
Permanite	"	1/3
Bornite	"	1/3
Talite	"	1/6
Radiocite and cats whisker	"	1/6
Electronite	"	1/6
Tellurium	"	1/6
Lionite	"	1/-
Molybdenite	"	1/6

We have a large stock of brand new Sullivan low resistance head telephones (no cords) which we are disposing of at exceedingly low rates, namely 8/- per pair. Send at once to avoid disappointment.

L.M. MICHAEL LTD

IN CONJUNCTION WITH **B. HESKETH LTD**

All correspondence to Head Offices:

HASTINGS HOUSE, NORFOLK STREET, STRAND, LONDON, W.C.2

Shewrooms: 5, Yelverton Road, Bournemouth

Radio Corner, 179, Strand, W.C.2.

"OOJAH" BASKET INDUCTANCES



Wavelength range 320-4,500 m. 5/- per set.
Wavelength range 300-2,000 m. 2/6 per set.
Descriptive Leaflet free upon Application.

LIBERAL DISCOUNT TO FACTORS

All "OOJAH" Inductances are wrapped in a transparent covering and sealed with the Registered Trade Mark

— OOJAH —

"OOJAH" Basket and Slab Inductances are being extensively copied, as most good things are, and purchasers are advised to not only specify "OOJAH" Brand in their order, but to see that the seal is intact.

It is not sufficient to say "I want a set of Basket Coils." Demand "OOJAH" Basket Coils.

GREENSLADE & BROWN

LANSDOWNE ROAD, CLAPHAM, S.W.9

Telephone—BRIXTON 639 & 3251.

A LINE OF *Western Electric* LOUD SPEAKERS

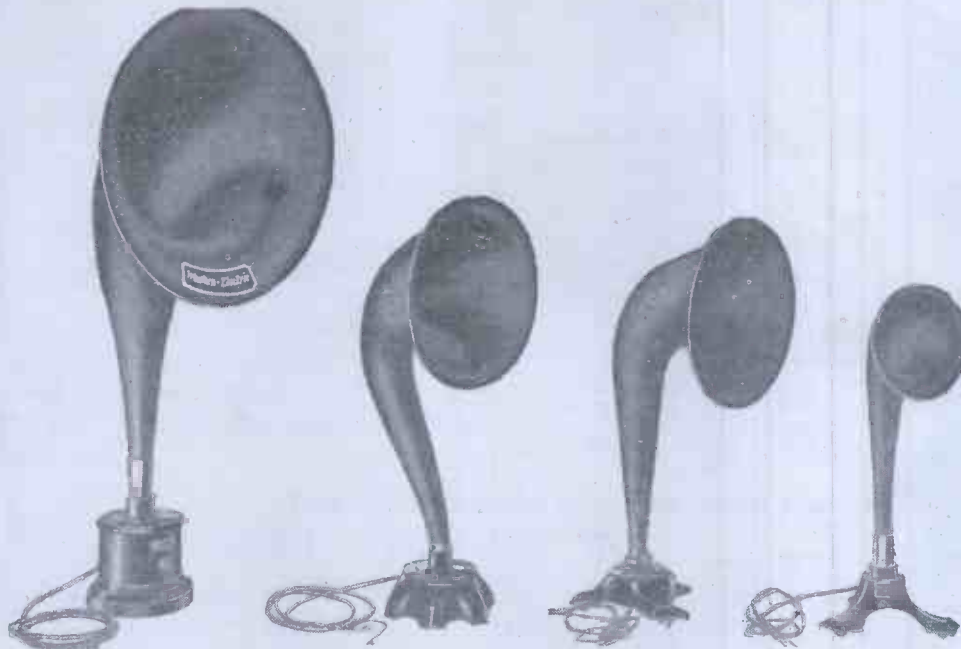

No. 44002.

No. 44005.

No. 44004.

No. 44003.

A complete line of four Loud Speakers are now available, all of which have been most carefully designed and constructed in consideration of the needs of the public.

No. 44003.—A small Loud Speaker operating on an ordinary magnetic diaphragm principle. The trumpet is of a non-metallic material with adequate acoustical properties. This model gives sufficient volume to enable a small audience to hear well in a quiet room.

No. 44004.—A Loud Speaker of medium size operating on the standard receiver principle, but having a large diaphragm and an adjustable air-gap which enables the utmost efficiency to be obtained upon any particular current strength. This Loud Speaker gives most excellent reproduction.

No. 44005.—This model is of medium size and operates on the balanced armature principle as so successfully applied in the case of the now famous Loud Speaking equipment. More powerful than the No. 44004 model, this Loud Speaker gives adequate volume without distortion.

No. 44002.—The now familiar Loud Speaker, known universally as part of the Western Electric Loud Speaking Equipment. Operating on the balanced armature principle, this powerful model gives most faithful reproduction and purity of tone and is free from distortion.

MADE BY THE MAKERS OF OVER HALF THE WORLD'S TELEPHONES.

Western Electric Company Limited.

CONNAUGHT HOUSE, ALDWYCH, LONDON, W.C.2.

Telephone : Central 7345 (9 lines).

Leeds, Manchester, Newcastle, Cardiff, Birmingham, Southampton, Glasgow, Dublin.
Also Singapore, Johannesburg, Buenos Ayres, Sydney, etc., etc.

A Valve for every wireless circuit

Mullard Valves for use with dry cells.

From the earliest days of the industry we have given our undivided attention to one subject — **Radio Valves.**

To-day our unique position enables us to take immediate advantage of developments in Radio science, while our concentration ensures that each Mullard valve is the best of its kind obtainable.

Whether you require valves for transmission or reception, for rectifying or amplifying, for dry batteries or accumulators, there is a Mullard valve specially designed to meet your needs.

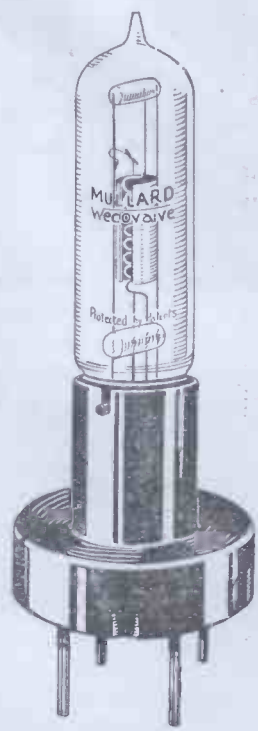

The latest additions to the Mullard range are:—

THE D.F. ORA. PRICE 30/-

This valve has all the characteristics of the celebrated ORA, it will Oscillate, Rectify and Amplify. It is particularly suitable where extreme economy of filament current is desired.

Filament volts 2 to 3, Filament current .06 of an amp., Anode voltage 20 to 100.

AND THE MULLARD WECOVALVE. PRICE 30/-

This valve is suitable for Oscillating, Rectifying and Amplifying. It has an extremely long life, is practically unbreakable, and is specially recommended where a low value of impedance in the Plate circuit is desired. Its filament operates from ONE dry cell.

Filament volts 0.8 to 1.1, Filament current .25 of an Ampere, Anode voltage 27 to 45.

NOTE.—The L.F. ORA Types B and C are now reduced to 21/-, and the Mullard Patented Fixed Resistances (30,000 ohms to 4 megohms) are reduced to 2/6.

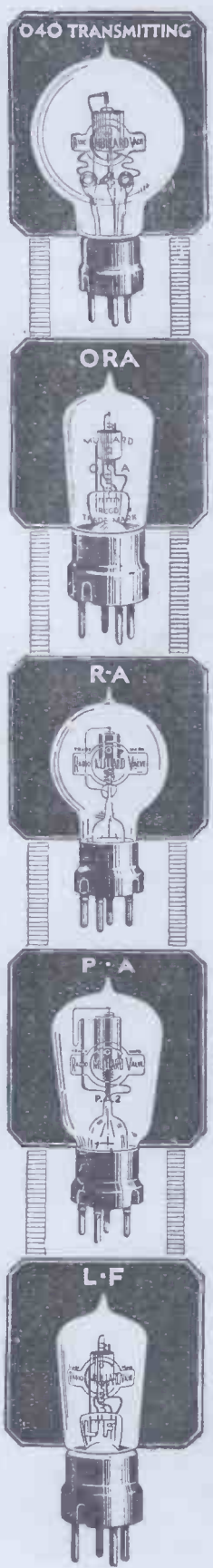

Mullard

Adv. : The Mullard Radio Valve Co., Ltd., Balham, London, S.W.12.

[E.P.S. 90.]

You CANNOT be out of WIRELESS WEEKLY because it brings BIG Business.

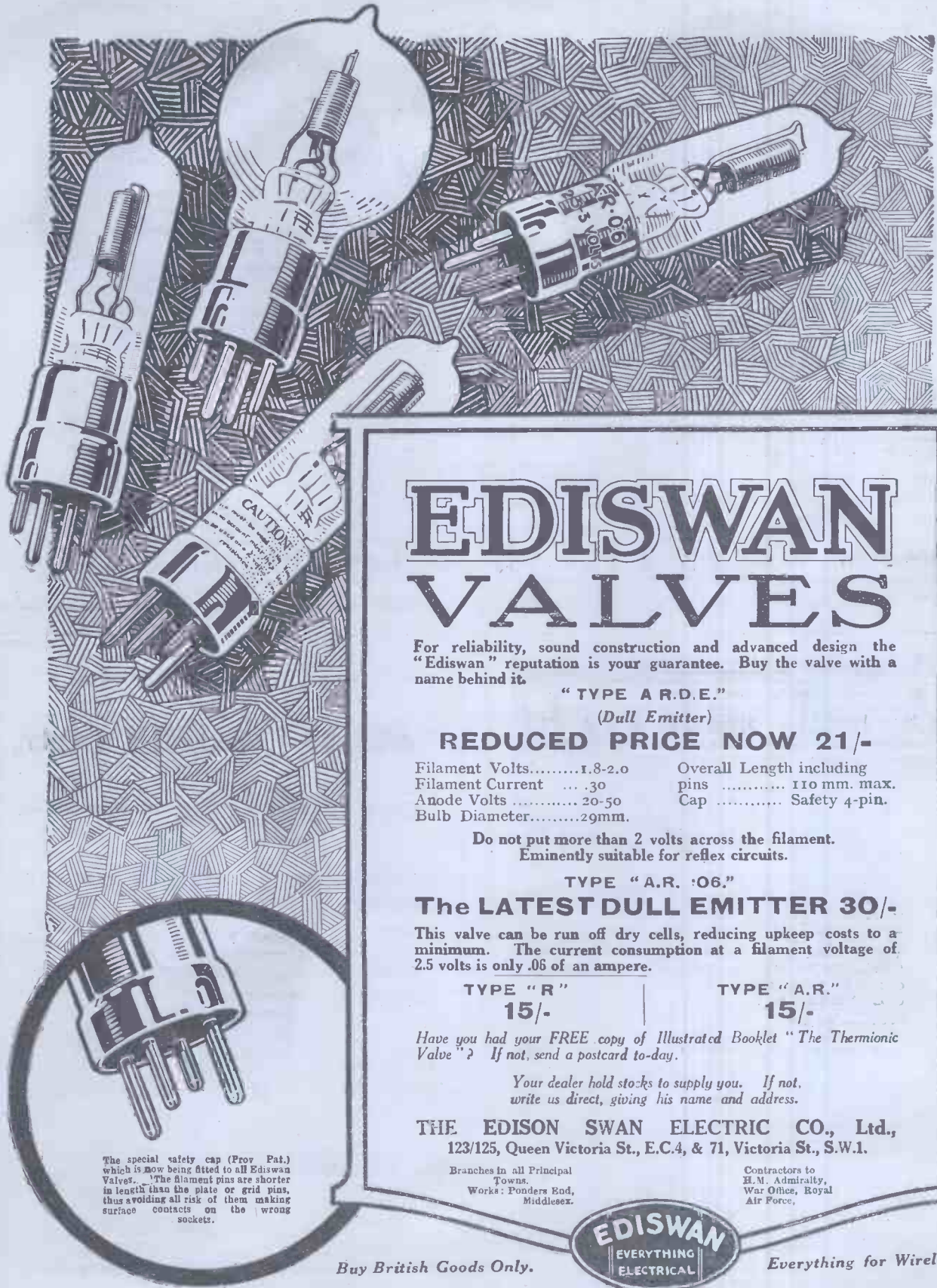

EDISWAN VALVES

For reliability, sound construction and advanced design the "Ediswan" reputation is your guarantee. Buy the valve with a name behind it.

"TYPE A.R.D.E."

(Dull Emitter)

REDUCED PRICE NOW 21/-

Filament Volts.....1.8-2.0	Overall Length including pins	110 mm. max.
Filament Current30	Cap	Safety 4-pin.
Anode Volts	20-50	
Bulb Diameter.....	29mm.	

Do not put more than 2 volts across the filament.
Eminently suitable for reflex circuits.

TYPE "A.R. .06."

The LATEST DULL EMITTER 30/-

This valve can be run off dry cells, reducing upkeep costs to a minimum. The current consumption at a filament voltage of 2.5 volts is only .06 of an ampere.

TYPE "R"
15/-

TYPE "A.R."
15/-

Have you had your FREE copy of Illustrated Booklet "The Thermionic Valve"? If not, send a postcard to-day.

Your dealer hold stocks to supply you. If not,
write us direct, giving his name and address.

THE EDISON SWAN ELECTRIC CO., Ltd.,
123/125, Queen Victoria St., E.C.4, & 71, Victoria St., S.W.1.

Branches in all Principal
Towns.
Works: Ponders End,
Middlesex.

Contractors to
H.M. Admiralty,
War Office, Royal
Air Force.

The special safety cap (Prov. Pat.) which is now being fitted to all Ediswan Valves. The filament pins are shorter in length than the plate or grid pins, thus avoiding all risk of them making surface contacts on the wrong sockets.



Buy British Goods Only.

Everything for Wireless

You CANNOT be out of WIRELESS WEEKLY because it brings BIG Business.



The O.T.B. Crystal Set



TYPE B. (As illustrated)

is fitted with special plug-in terminals on the sides, also internal lightning arrester enabling the set to be worked with cover on and no disconnection is required.

30/-

Plus 1/- for B.B.C. Stamp.

**Absolutely the Finest
on the Market.**

These instruments, both in finish and efficiency, are unsurpassed. B.B.C. stamped and each set guaranteed. In choice and selected wood.

TYPE A.

A similar instrument, is fitted with outside ordinary nickel-plated terminals, but with no lightning arrester.

25/-

Plus 1/- for B.B.C. Stamp.

If unable to obtain from your dealer, apply direct to the Sole Selling Agents:

HARDING, HOLLAND & FRY, LTD., 27, Garlick Hill, LONDON, E.C.4

Telephone: CITY 591-2146.

Telegrams: "SEEDTIME, CANNON, LONDON."

Made well, made right

BOWYER-LOWE TESTED COMPONENTS

TEST any Bowyer-Lowe Component in any way you like and the result will amply convince you that each one is made thoroughly from sound materials, and, what is more important, each is scientifically RIGHT.



Every worker who seeks to obtain the utmost of which his skill is capable should use these trustworthy parts of registered design.

In view of the strictures, upon the capacities of Variable Condensers, mentioned by P.W. Harris in "Wireless Weekly" of Nov. 14th, we wish to point out that every condenser we sell is guaranteed of stated capacity.

The following prices are selected from our list:

No. 39. Variable Condenser .0003 M.F.	15/-
No. 40. Variable Condenser .0005 M.F.	16/-
No. 42. Two Way Switch	2/3
3d. extra for each way to 12 Way (No. 52)	5/3
No. 53. Series Parallel Switch	5/3
No. 76. Double Two Way Switch	5/3
No. 77. Double Three Way Switch	6/3

Our complete lists of Components on our new "Flange" System will be posted to you on receipt of your enquiry. Drop a line tonight to Sales Dept.

**The Bowyer-Lowe Co., Ltd.,
LETCHWORTH**

Wholesale Distributors: SCOTLAND: Messrs. Robb Bros., Ltd., 69, West Nile Street, Glasgow, and North Street, Dundee. NORTH OF ENGLAND: Messrs. Wadsworth Sellers & Co., Standard Buildings, Leeds. MIDLANDS: Messrs. Robb Bros., Ltd., 9, Barnstone Road, Nottingham.

THE

"ATLAS" SUPER COIL.

P.P. No.
2250/23

All
Wave-lengths
Covered.

MAXIMUM
AIR-SPACE

MINIMUM
SELF-
CAPACITY

ONCE
TRIED

ALWAYS
USED.



Prices on
Application.

Ask for Catalogue of
Radio Components.

Manufactured only by

H. CLARKE & Co. (M/cr.) Ltd.
Radio Engineers, ATLAS WORKS,
OLD TRAFFORD, MANCHESTER.

Telephone Nos.:
683 & 793 Trafford Park.

Telegrams:
PIRTOID, Manchester.

You CANNOT be out of WIRELESS WEEKLY because it brings BIG Business.

BEWARE OF WORTHLESS IMITATIONS, SEE THE TRADE MARK **WATMEL** ON EVERY GRID LEAK.

WATMEL VARIABLE GRID LEAK
(Patent No. 206098).

The Resistance is steadily Variable between $\frac{1}{2}$ to 5 megohms. Only requires a $\frac{1}{8}$ in. hole in panel for fitting.



PRICE 2/6 each.
The best Variable Grid Leak made.

Suitable for use in any circuit, and improves the working of any valve detector. (50,000 to 100,000 ohms for the S.T.100 Circuit. Price 3/6.)

WATMEL WIRELESS CO., Connaught House, 1a, Edgware Road
Marble Arch, W.2. Tel. 4575 Paddington.

Genuine 4,000 Ohms Continental

ERICSSON

HEADPHONES with GUARANTEE.

THE Ericsson "Continental" is the best-known and most efficient Continental phone. Its qualities are loud, clear, and full articulation, capacity for receiving the most subtle variations of tone, comfort, lightness, and high finish. It equals the highest-priced phones on the market to-day.



PRICES:
14/- 4,000 ohms.
13/- 2,000 ohms.
ABOVE POST FREE.

No extra charges. Cheques and postal orders should be crossed and made payable to Wireless Distributing Co. Immediate delivery.

GUARANTEE.—We agree to replace or return cash if Phones do not give satisfaction, subject to their being returned within seven days undamaged.

WIRELESS DISTRIBUTING CO.,
(Dept. W), 2, Dorset Street, Salisbury Sq., London, E.C.

A Revolution in B.B.C. Receiver Design!

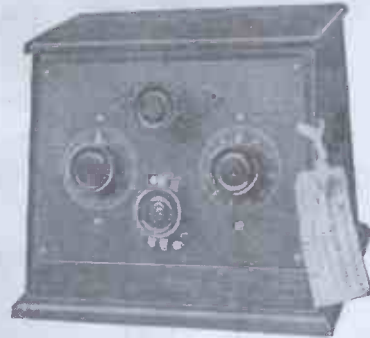

The Marvellous

MĒCOPHONE

One Valve Receiver

It embodies a new and patented circuit with all the efficiency of a "super-regenerative" circuit without its drawbacks:—complication, instability, hand-capacity effects and difficult tuning. No crystal to adjust. No low-frequency transformer to distort. Like Samson's riddle, it combines "Strength with Sweetness."

Both in volume and purity of tone it is definitely better than the best two-valve B.B.C. model on the market, and equal to most three-valve models. It will receive, on a good P.M.G. aerial, all the B.B.C. stations at "phones-on-table" strength or work a loud speaker within "crystal range" of a station.

It is perfectly stable—no whistling or howling.

It is extremely simple to tune—no hand-capacity effect.

Two tuning controls only—coarse and fine.

The tone is absolutely pure—no self-oscillating or "dual amplification" to cause distortion.

It is compact (9" x 8" high), and the valve is enclosed.

It is beautifully made and finished in polished mahogany and nickel plate.

And the price is only **£8 15 0**

B.B.C. Tariff 10 0

Valve, Batteries and Phones **£4 10 0**

Order early to avoid delay in delivery. Trade enquiries invited.

MANN EGERTON & CO., LTD.,
Manufacturers and Patentees,

LONDON: 156, New Bond St. NORWICH: 21/3, King St. IPSWICH: 39, Prince St.

ECONOMIC ELECTRIC LTD.



The "EEC" "XTRAUDION" VALVE

is being used by the leading Radio Experimenters for detection, high and low frequency amplification, power amplifiers and low power transmission. Price 15/-

USE "RECTARITE," the synthetic crystal that makes Loud speakers talk. 1/6 Large Specimen.



Write to-day for 40 page Radio Catalogue mailed post free, 4d.

Head Office: 10, FITZROY SQUARE, LONDON, W.1.

Showrooms: 303, EUSTON RD., N.W.1.

Branch and Works: TWICKENHAM.

You CANNOT be out of WIRELESS WEEKLY because it brings BIG Business.

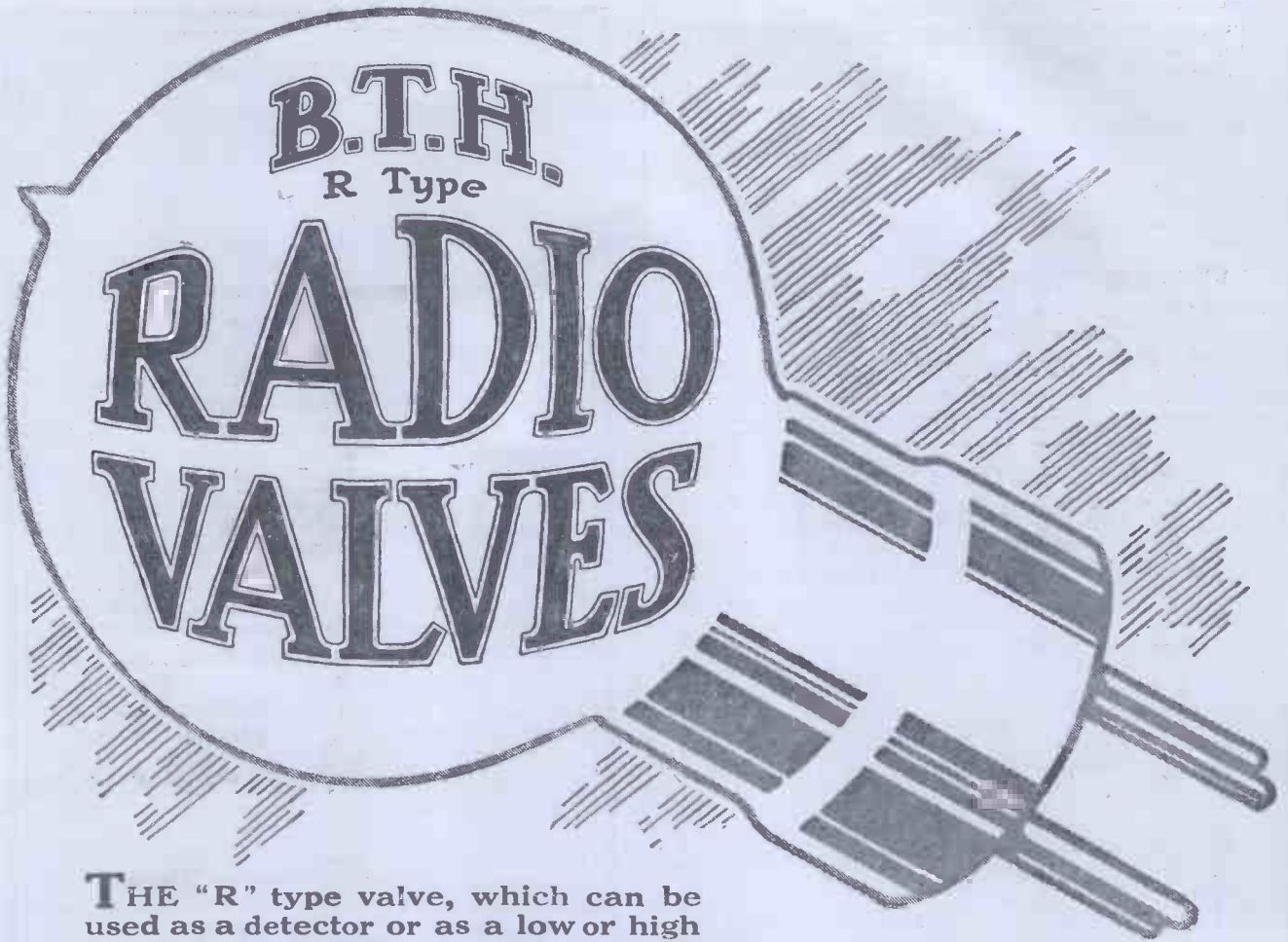

THE "R" type valve, which can be used as a detector or as a low or high frequency amplifier, is still, and will remain, the most generally popular valve on the market. And of the several available makes of "R" valves there is none better than the amber-tinted valve bearing the B.T.H. monogram.

For smooth detection and amplification, without valve distortion, the B.T.H. "R" type valve is unsurpassed; while the amber tinting referred to above entirely eliminates the glare which is such an objectionable feature of the clear glass valve.



See that your valves are amber-tinted and bear the B.T.H. monogram—the sign of good reception

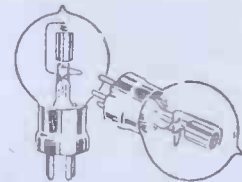

Price **15/-** each

The British Thomson-Houston Co Ltd

Works: RUGBY.

London Office: CROWN HOUSE, ALDWYCH, W.C.2

Sole Agents for the Music and Gramophone Trades:

THE MURDOCH TRADING COMPANY, 59 & 61 Clerkenwell Road, LONDON, E.C.1.

PLUGS and JACKS

PLUG & JACK COMPLETE
2/6 Post Free.

A. ROBERTS & CO.
42 Bedford Hill,
Ealing, S.W.12.

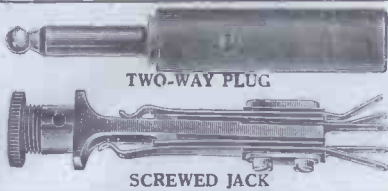

TWO-WAY PLUG

SCREWED JACK

Turn your Wireless knowledge into cash



We are always pleased to receive interesting articles for our various publications, and those accepted will be purchased at good rates. Articles can be submitted with or without diagrams or photographs. Where constructional articles are submitted, evidence of the actual working of the apparatus described must be forwarded if required.

RADIO PRESS, LTD., Devereux Court, STRAND, W.C.

A Super Crystal Set at very little extra cost. Gives best possible results and is really ornamental as well. Has accommodation for 2 pairs of headphones. Write for specification. Price £4 0 0 complete including B.B.C. Royalty, 1 pair 4,000 ohm phones, 100 feet 7/22 Copper Aerial Wire, Leading in Tube and 2 Insulators.

The EAGLE

Engineering Co. Ltd.,
London Showrooms:
8, GT. RUSSELL ST.,
LONDON, W.C.1.

Works:
EAGLEWORKS, WARY 1 K.



Chakophone
REGD.

CRYSTAL RECEIVER IN ANTIQUE CABINET.

"EL-BE" ANTI-CAPACITY HANDLES.

No Screws.



No Clamps.

Fixed by Suction—Removed in a second.
A Type for Horizontal working. Price 2/2 each
C Type for Vertical working. Post 3/- free.
A perfect combination with the "EL-BE" Coil Holder.
Ask your DEALER for them.

"EL-BE" INSULATING PANEL BUSHES.

Experiments save cost of EBONITE.
4 B.A. Pillar-Terminals with one BUSH, 2/- doz.
2 " " " " " " 3/- "
" " (with nut and washer).
Extra BUSHES Tenpence per doz.
Bushes tested for insulation to 25,000 volts.
YOUR DEALER WILL SUPPLY YOU.
LEIGH BROS.

37, Sidmouth Street, Gray's Inn Road, LONDON, W.C.1.
Telephone: Museum 4547.

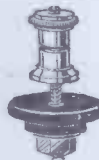

VARIABLE CONDENSER PARTS FOR HOME CONSTRUCTORS.

Complete sets of parts for building, including full ebonite ends, engraved dial, knob and terminals. With these parts you can build a high-class instrument, and condenser-making becomes a pleasure. Only the best materials are used throughout, and thus the exact fit so necessary in condensers is assured.

'001 8/3	'0005 6/6	'0003 5/9	'0002 5/3	'0001 5/-	'00005 4/6
-------------	--------------	--------------	--------------	--------------	---------------

Complete in stout box with full instructions for assembly. Postage and packing 1/- extra. Can also be supplied assembled.

Trade buyers write for terms.

CHARLES DAVIS,
WATER LANE, LEEDS.
TEL. 28317.

Also parts for variometers and other apparatus.

THE "ASTRA" VALVE AMPLIFIER

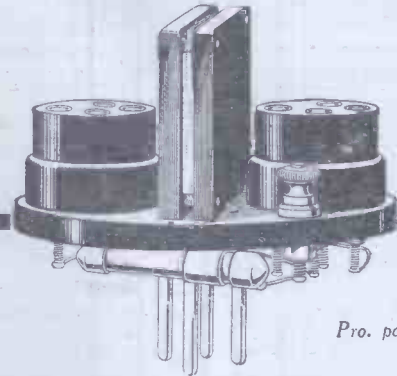

Pro. pat.

Amplification without Transformer!

The new "ASTRA" Valve Amplifier is indeed revolutionary, and the immediate result of its introduction has been a sheaf of gratifying testimonials from delighted users throughout the whole country.

A self-contained unit, it saves endless trouble and expense, and literally adds a hundred miles or five volumes to your valve set without extra wiring, or enables you to add a loud speaker to your one-valve outfit.

Used on a single valve set it adds volume to the extent of no less than five to one, and its simplicity is such that, to obtain its equivalent in power and efficiency, it would be necessary to employ separate valve holder, grid leak, intervalve transformer, filament resistance, panel, terminals, etc.—all of which are faithfully embodied in the "ASTRA" Amplifier.

No "construction" is necessary. The "ASTRA" is completely wired with valve holders, special resistance and a dual condenser; can be plugged in to any valve holder, either on the L.F. side (increasing the volume five times) or on the H.F. side (bringing in that distant Station, and greatly increasing the range and clarity of your set.)

In polished Ebonite

Complete **21/6** Post Free.

WRITE FOR LIST

of "Astra" Speciality Components—Now!

In addition to the "Astra" Valve Amplifier, there are many other remarkable "Astra" components in which you would immediately be interested—Variometers, Variocouplers (for tuning); Vernier Condensers (for cutting out interference); Wave Traps (for cutting out Spark Stations and interferences); Filstats (the perfect filament control, needing no wires and giving perfect graduation from zero to maximum); Permanent Crystal Detectors (specially constructed for dual amplification circuits); and—of course—the famous "ASTRAPHONE," the self-contained Headphones that actually embody their own crystal set in the earpiece of one 'phone and form a complete receiving station by merely attaching to earth and aerial.

GEORGE MANUFACTURING CO.

Wireless Specialists, Dept. 9,

Nelson Chambers, 52, High St., BIRMINGHAM

You CANNOT be out of WIRELESS WEEKLY because it brings BIG Business.

VALVES

GUARANTEED NEW

EDISWAN A.R. B.T.H. R. COSSOR P2.
MARCONI R. MULLARD ORA. COSSOR P1.

COIL HOLDERS, EBONITE, MATT FINISH,

With Extension Handles.

SPECIAL LINE

2 Way 4/6; Usual Price 7/-
3 Way 7/6; " " 10/6

FILAMENT RESISTANCES (5 ohms),
Smooth and Silent, Wonderful Value **1/9**

L.F. TRANSFORMERS, RATIO 1-4,
No Distortion or Howling **12/=**

Primary 5,000, Secondary 20,000 Turns, wound with Silk-Covered Wire.

ALL GOODS CARRIAGE PAID UNITED KINGDOM.

Save
Money

ALL COMPONENTS
CAN BE SUPPLIED
FROM STOCK.

Write for Price List.

Satisfaction
Guaranteed

DIRECT RADIO SUPPLIES

40/41, WINDSOR HOUSE,

WESTMINSTER, S.W.1.

All Cheques & P.O.'s to be
crossed Barclay's Bank, Ltd.

RESULTS!

WIRELESS WEEKLY

will bring you
BUSINESS

It is as good an ad-
vertising medium as
MODERN WIRELESS.

Rates for both publications on application to—

Scheff Publicity Organisation

Ltd.

125, Pall Mall, London, S.W.1.

No. 2.

Phone: Regent 2440.



Radio Press Diaries for 1924

FOR your appointments—to chronicle your doings—for the thousand and one things connected with your life, you need a Diary.

This year, purchase a Wireless Diary and get some useful information without extra cost.

These two Radio Press Diaries are both extremely neat and well-produced little Books. They do everything that a Diary should do—they are convenient in size and shape—do not bulge the pocket—strongly bound to give a whole year's service, and more besides, if needed. Just the Diary, in fact, to suit the most critical. From all Booksellers or direct (postage 2d. extra) from Radio Press, Ltd.

Radio Press Handbook and Diary for 1924.

Size 5½ in. by 3½ in., solidly bound in grained leather cloth, fitted with pencil. Diary portion shows a whole week at an opening. Large number of pages of technical data, including several pages of electrical formulae which will prove invaluable to the serious worker **2/6**

Radio Press Popular Wireless Diary for 1924.

Size 2½ in. by 4½ in. Strongly bound in leather cloth with rounded corners. One complete week shown at each opening. Wireless pages include information on call signs, circuit diagrams, Morse Code, electrical data, full instructions for building a complete Receiving Set, etc., etc. **1/-**

In Leather, with pencil **1/6**

You CANNOT be out of WIRELESS WEEKLY because it brings BIG Business.



101 processes —39 inspections

From start to finish there are actually 101 separate processes in the manufacture of **Cossor Valves**, and during its journey through the factory every Valve is subjected to no less than 39 different examinations by keen-eyed inspectors.

Obviously, therefore, the chances of any variation in manufacture ever escaping the scrutiny of these trained workers is exceedingly remote.

Our effort to maintain the highest possible standard of quality is reflected in the appreciatory letters which we receive from **Cossor Valve** users. Realising that we have the keen support of hundreds of thousands of wireless enthusiasts, will spur us on to even greater efforts.

Advertisement
issued by
**Cossor Valve
Co., Ltd.,
Highbury
Grove, N.5.**

Gilbr. Ad.

You CANNOT be out of WIRELESS WEEKLY because it brings BIG Business.

WIRELESS WEEKLY SMALL ADVERTISEMENTS

PREPAID Advertisements are accepted under this heading for Wireless Apparatus and Parts WANTED or FOR SALE, etc., at the rate of 1s. 6d. per line, MINIMUM THREE LINES, Advertisements should reach Scheff Publicity Organisation, 125 Pall Mall, London, S.W.1, LATEST by first post FRIDAY preceding date of publication.

The publishers are not responsible for clerical or printers' errors, but every care is taken to avoid mistakes.

"RADIOHM," No. 1. Crystal Receiving Outfit, the same quality and good reception you can pay 6 Guineas for. We charge 52s. 6d., and return your money if not satisfied. We've never had to do it yet.—Sparks' Radio Supplies, 43, Great Portland Street, W.1. 'Phone Langham 2463.

NOT A SUPER SET, but distinctly Superior—"Radiohm" C.-V. Type 1. A Crystal-Valve set "hooked up" to give better results than many 2 or 3-valve sets. Makes you forget a gramophone, £10 17s. 6d. complete.—Sparks' Radio Supplies, 43, Gt. Portland Street, W.1. 'Phone: Langham 2463.

A GOOD AERIAL means good reception. "Radiohm" Strip Ribbon Aerial, 25 per cent. better than wire. *Fact!* 100 ft., 3s., plus post. Trade supplied.—Sparks' Radio Supplies, 43, Gt. Portland Street, W.1. 'Phone: Langham 2463.

THE YANK KNOWS! Look behind the panel of the best American sets. They use square tinned copper rod for wiring—? We sell it. 2 ft. lengths, 3s. doz. Trade supplied.—Sparks' Radio Supplies, 43, Gt. Portland Street, W.1. 'Phone: Langham 2463.

WE HAVE ONE OR TWO "SNIPS"—the kind the Radio enthusiast likes to keep to himself. Write for particulars.—Sparks' Radio Supplies, 43, Gt. Portland Street, W.1. 'Phone: Langham 2463.

"RADIOHM" is our trade mark—It stands for Good Goods plus Good Service. We want Agents. A chance for real live men. Write now.—Sparks' Radio Supplies, 43, Gt. Portland Street, W.1. 'Phone: Langham 2463.

"ALL CONCERT" SET (Des. "Modern Wireless," Sept.), Ebonite Panel, 3 Dull Emitter Valves Accum. H.T. Bat., £10 10s. With "Music Master," L.S., £15.—Grant, 9, Gt. Newport Street, W.C.2.

3 VALVE TUNED ANODE, with React Set, slop. cabinet, with coils and switches. Brand new, £8 10s. Crystal Set, variometer tuned in sloping cabinet, £1.—348, Chester Road, Old Trafford, Manchester.

CELLULOID.—Thin transparent sheets, 1/6 sq. ft. Post free. Trade supplied.—Michell, Palmer St., S.W.1.

300,000 INSULATORS (7 kinds), egg shell reel, from 42/6 per 1,000; 10,000 knife switches, 90,000 nameplates, 600 lead in tubes, 400 variometers.—J. J. Eastick & Sons, 2, St. Dunstan Hill, E.C.3. Phone, Central 7571. Works, 3, Belfast Road, Stoke Newington, N.16. Phone: Dafton 1912.

BATY'S Variable Condensers, .0005, 5/3, post free. See "Wireless Weekly" Dec. 5th, "An interesting and extremely simple compact type of variable condenser."—Ernest J. Baty, B.Sc., 157, Dunstable Rd., Luton.

LOOK! 1/6 only, a miniature Wireless Vest Pocket Receiving Set. Tested and guaranteed to receive broadcasting concerts within a radius of 20 miles. Full instructions with each set. Money returned if not satisfied. Post free.—Send P.O. 1/6 to T. E. P. Gibbs, 21a, Northwold Road, Stoke Newington, London, N.16. Write also for the wonderful new Crystal Exelite (Regd. Trade Mark). Post free 1/—

AT LAST! A really genuine Crystal, loudest yet produced, sensitive all over, 1/8 post free; money returned if not satisfied.—C. Hatton, 65, Edlington Hill, London, S.E.18.

B.C.C. Crystal Sets (stamped).—Agents wanted for districts within B. 25 to 30 miles of any broadcasting station. Prices from 7/9 to 13/9 each; every set guaranteed.—Simons, 100, Houndsditch, London, E.1.

WANTED, STUDENTS, for Wireless Appointments; we find berth when qualified; situations waiting now; prospectus free. Wireless Training College, Lansdowne Rd., Bournemouth.

V2A "MARCONIPHONE."—Long range model in walnut cabinet (new), complete with two 4,000 ohms Western Electric Headphones, one 2 volt, 40 amp. acc. in case, earth, aerial, battery, phones, all plug connections; £12; worth double; perfect reception of all stations.—R. E. Price, 20, Thomas Street, Holyhead.

"EIFFEL TOWER" TRANSFORMERS.—L.F. 5/1, wonderful value. 12/6, carriage paid. Each Transformer guaranteed perfect and tested.—Wilkinson, Lonsdale Road, Queen's Park, N.W.6. Est. 1900.

ACCUMULATORS.—We repair and recharge any make of cell. Trade or Private.—Wilkinson, Lonsdale Road, Queen's Park, N.W.6. Est. 1900. Makers of the "Eiffel Tower" Wireless Mast.

HEADPHONE REPAIRS.—Re-wound, re-magnetised and re-adjusted, lowest prices quoted on receipt of telephones, delivery three days.—The Varley Magnet Co., London, S.E.18.

FREE XMAS OFFER OF HEADPHONES. To every purchaser of our well-known Etherwave Variometer Crystal Receiver, usually 25s., we will present free a Brandes "Matched Tone" Headphone, thus making a complete receiving station for 20s., carriage paid. Established 1899.—The Electric Laboratory, Enfield Wash, London, N.

MAGNORA

LOUD-SPEAKER

No. 1 Model.	Actual size 3½ in. high	£2 2 0
No. 2	Mounted	£3 3 0
No. 3	Shell	£4 4 0

WHAT SATISFIED CLIENTS SAY.

"The little instrument is a real marvel, the volume of sound coming from it can scarcely be believed."

"I think the 'Magnora' is truly wonderful."

"I have asked two local dealers in this town to apply for Agency terms."

"I am writing to say how pleased I am with my 'Magnora.'"

"I am telling my friends about it, as I do not know anything like it."

"We think your loud-speaker is wonderfully efficient."

CONDUIT WIRELESS CO., 47, CONDUIT STREET, LONDON, W.1.
'Phone: Regent 5475.

Branch for Scotland, 93, Waterloo St., Glasgow. Central 1478.

CABINETS YOU WANT

PICKETT'S Cabinets—they're good value, from 1/6 each, highly polished. Cabinet Works, Albion Rd., Bexley Heath, S.E. Write for Lists W.L.

EBONITE

Sheet rod and tubing in all sizes kept in stock and cut to any required size while you wait, or sent by post on receipt of cash.

WE CAN TURN ANYTHING IN EBONITE.

BURGE, WARREN & RIDGLEY, LTD.,

91/92, GREAT SAFFRON HILL, LONDON, E.C.1. 'Phone 8572 Central.

Radio Press Information Dept.

2/6 QUERY COUPON 2/6

WIRELESS WEEKLY. Vol. 3. No. 2, December 19, 1923.

(This coupon must be accompanied by a postal order of 2/6 for each question, and a stamped addressed envelope.)

ORDER FORM.

Make sure of benefiting under our FREE GIFT SCHEME by completing this form and handing it to your newsagent *without delay*.

PLEASE SUPPLY ME WITH WIRELESS WEEKLY FOR SIX WEEKS COMMENCING WITH THE DECEMBER 19TH ISSUE, VOL. 3, No. 2, AND UNTIL FURTHER NOTICE.

Signature

Address.....

"WIRELESS WEEKLY" FREE GIFT COUPON

No. 2

This coupon has a cash value. It should be retained until six coupons have appeared. The six coupons will be accepted by Radio Press, Ltd., as one half of the purchase price of any one of their hand-books in the above list.

You CANNOT be out of WIRELESS WEEKLY because it brings BIG Business.

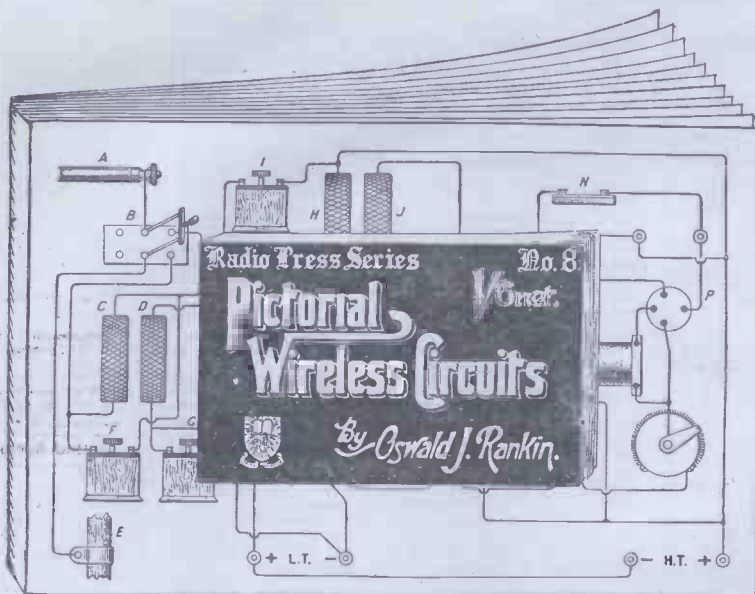

Just
published

Is reading a Circuit Diagram your Waterloo?

Pictorial Wireless Circuits

- Simple Crystal Circuits.
- Variometer Crystal Circuits.
- L.F. Amplifying Circuits.
- Power Valve Amplifying Circuits.
- Single Valve Circuits.
- Two and Three-Valve Circuits.
- Crystal-and-Valve Circuits.
- Flewelling Circuit.
- Four-Valve Circuits.
- Switching, etc., Circuits.

1/6

From all Booksellers
or post free direct 1/8.

WHEN a Wireless enthusiast decides to build his own Set, his first job is to study the necessary wiring diagram. And that is where quite a number meet their Waterloo.

Those of us who can read circuit diagrams as easily as we can our morning paper, are apt to show but little sympathy for the extreme novice making his first flounders into Wireless.

Radio Press, however, appreciate that the correct reading of circuit diagrams is the first essential to the successful building of a Set, and are publishing an entirely new book which completely cuts out this difficulty.

Every circuit diagram in "Pictorial Wireless Circuits" is shown pictorially—that is to say, the actual components used are drawn instead of conventional signs for them. Thus there will be no excuse, for example, for any enthusiast not knowing the correct position for his filament rheostat.

Altogether over 70 circuits are shown, ranging from Simple Crystal Receivers to more elaborate Multivalve Sets.

If difficulty in reading circuit diagrams has hitherto prevented you from building or improving your Set—get a copy of this book to-day. It will be eightpence well spent.

Radio Press Series No. 8.

You CANNOT be out of WIRELESS WEEKLY because it brings BIG Business.

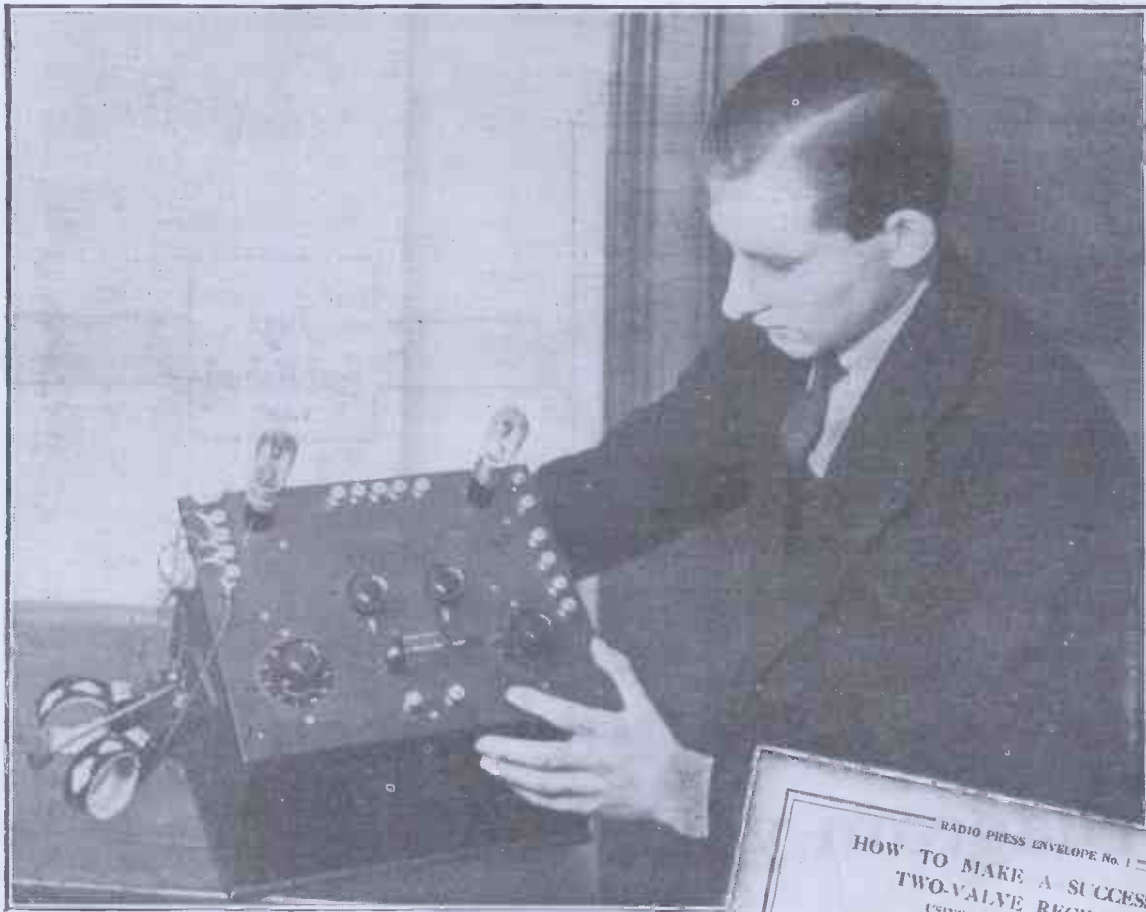

Full instructions for building this fine S.T. 100 Set:

THE tremendous success which followed the publication of constructional articles dealing with the S.T. 100 Circuit and the heavy demand from our readers for further articles on the same subject, has lead us to place on the market an Envelope containing the fullest details about it.

This Envelope can be bought by anyone in full confidence that with the least amount of mechanical ability he can build a really first-class Receiver—similar in every respect to the one illustrated above.

But even more important, this Envelope contains working hints and instructions which will prove invaluable to anyone operating a Reflex Set for the first time.

We have aimed, in fact, to make the material contained in this Envelope as comprehensive as possible. Why not get one to-day and start building this most fascinating of Receiving Sets?

From all Booksellers

1/6

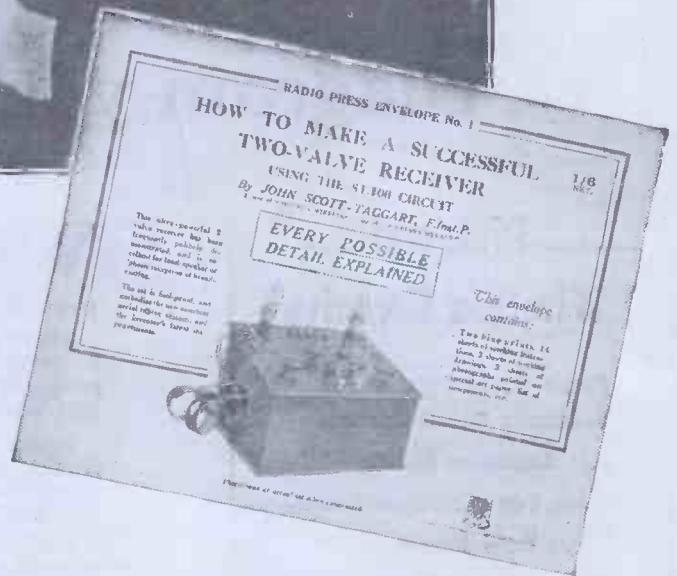

SIMPLEX RADIO CHARTS.

WE have just published a further series of envelopes, each of which contains a full size chart for building a Valve Receiver (see below) together with a booklet which explains exactly the components which are required for the construction of the Set.

- No. 1.—A Two-Valve Receiver 1/-
- No. 2.—A Three-Valve Receiver 1/-
- No. 3.—A Four-Valve Receiver 1/-

From all booksellers or direct (postage 2d. extra.)

RADIO PRESS Ltd.—Devereux Court, STRAND, W.C. 2.

Gilbert Ad.

You CANNOT be out of WIRELESS WEEKLY because it brings BIG Business.

High Class Components at Lowest Prices

We are neither Factors nor Retailers, but
THE ACTUAL MANUFACTURERS

RESISTANCES SUPER SMOOTH

The only Single Hole Panel

- fixing on the market - 3/-
 Do. S type - - - 2/6
 Standard - - - - 2/-
 W.T.S. type - - - - 1/6

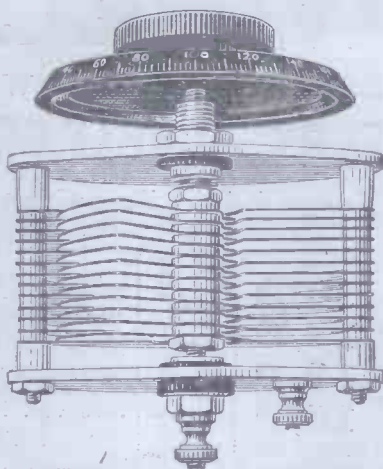

PHONES

The W. & S., a First Class Job, Limited
 Quantity. 4,000 ohms resistance.
 Light and comfortable to wear.

Makes a wonderful Xmas Gift.
10/6 per pair
 Every pair guaranteed.

N. & K., 12/6 per pair. W. & S.
 Lightweight, 21/- per pair.
 Browns, Brunets, etc., at standard
 prices.

VARIABLE CONDENSERS.

PRICES.

L.F. TRANSFORMERS. Postage 9d.	
W.S.	11/6
W.S. super	18/-
H.P. TRANSFORMERS :	
300-600 metres	4/-
600-1,000 "	4/3
900-1,900 "	5/8
1,800-2,500 "	6/-
DUTCH VALVES, hard and soft	6/9 and 7/9
All other makes of valves supplied.	
AERIAL WIRE, 7/22, hard-drawn copper,	
100 ft. (postage 1/-)	1/-
CRYSTAL DETECTORS	10d., 1/2, 1/6
CRYSTAL DETECTORS, enclosed in	
glass	1 3, 2/-, 2/8
CONDENSER VANES, fixed or moving,	
per doz.	3 1/2d.
IVORINE LABEL SETS, 12 different titles,	
per set	6d.
SLEEVING, 3 yds. assorted colours	11d.
EBONITE KNOBS, 2 B.A. each 2d. and 3d.	
CRYSTAL CUPS	each 1 1/2d. and 2d.
EBONITE, cut to any size by machinery,	
per lb.	3/3
SWITCH ARMS, with ebonite knob, com-	
plete with panel, bush, nuts or spring	
washer	8d.
RUBBER-INSULATED LEAD-IN WIRE	
per yd.	1 1/2d.
INSULATORS, white reel, each 1d., per	
doz.	10d.
INSULATORS, egg type, each 2d., per	
doz.	1/6
WOUND INDUCTANCE COILS :	
12x4 9x4 8x2 1/2 6x3 6x2	
2/6 2/2 1/9 1/6 1/2	
TAPPED INDUCTANCE COILS, 20	
tappings	2/3
VARIOMETERS (Tube type), complete	
with knob and dial	4/- and 2/9
TWO-WAY COIL-HOLDERS	5/-
THREE-WAY COIL-HOLDERS	7/-
VALVE HOLDERS	8d. and 1/-

FILAMENT RESISTANCE DIALS	6d.
Vernier	2/3
.0001	2/9
.0002	3/3
.0003	4/3
.0005	4/9
.00075	5/9
.001	6/9
Ebonite Dial and Knob, 9d. extra.	

POSTAGE FREE IN U.K.

GRID LEAKS, 2 1/2 and 2 meg.	each	8d.
VARIABLE GRID LEAKS, 0-5 meg. with		
guarantee for two years		3/-
GOLD CAT'S WHISKERS		2d.
SILVER CAT'S WHISKERS		1d.
CONDENSER SCALES, 0-180		3 1/2d.
BASKET COILS, set of 4 up to 2,000		
metres	2/3	
BELL WIRE, tinned copper, 12 yds.		6d.
SLIDER KNOBS		2d.
DOUBLE PHONE CORDS		11d.
GENUINE HERTZITE		6d.
TALITE		7d.
ZINCITE		8d.
BORNITE		5d.
MIXED, six kinds		9d.
CARBORUNDUM		6d.
PERMANITE		7d.
EBONITE CONDENSER KNOB AND		
DIAL	1/3	
HIGH-TENSION BATTERIES :		
30 volts, 5/8; 60 volts, 9/-		
SHELLAC	per bottle,	4 1/2d. and 9d.
NUTS, 2 B.A.	per doz.	2d.
NUTS, 4, 5, 6 and 8 B.A.	per doz.	1 1/2d.
WASHERS, 4 B.A.	per doz.	1 1/2d.

WASHERS, 2 B.A.	per doz.	1d.
CONTACT STUDS, with nuts and washers	per doz.	3d.
TERMINALS, with nuts and washers,		
each 1d., 1d. and 1 1/2d.		
LARGE SPACER WASHERS	per doz.	2d.
SMALL SPACER WASHERS	per doz.	1 1/2d.
TELEPHONE TERMINALS, with nuts		
and washers	each 1d.,	per doz. 1/-
W.O. TERMINALS, with nuts and		
washers	each 2d.,	per doz. 1/6
PANEL BUSHES, drilled		
each 1 1/2d., per doz.		1/2
CONDENSER BUSHES, each 1d., per doz.		8d.
CONDENSER BUSHES, bottom		
each 1d., per doz.		7d.
STOPS, with nuts	per doz.	6d.
VALVE LEGS, with nuts and washers,		
each 1d., per doz.		9d.
VALVE PINS, with nuts and washers,		
each 1d., per doz.		8d.
SLIDER ROD, brass, 18 in. long, 1/2 in.		
square drilled	each	3d.
CONDENSER SPINDLES, vernier		1d.
CONDENSER SPINDLES, 001		3d.
SCREWED ROD, 2 B.A., 12-in. lengths		2d.
SCREWED ROD, 4 B.A., 12-in. lengths		2d.
KNIFE SWITCHES, on polished ebonite		
base :		
S.P.S.T.		1/4
S.P.D.T.		1/8
D.P.S.T.		2/6
D.P.D.T.		2/8
FIXED CONDENSERS, any capacity		9d.
GRID LEAK AND CONDENSER		2/-
EBONITE COIL PLUGS, each 1/2, 6 for		
COIL CONTAINERS FOR BASKET		
COILS		3/-
AERIAL PULLEYS		6d.

**HEADPHONES, ALL MAKERS,
 AT STANDARD PRICES.**

All Mail Orders executed in strict rotation. Goods sent to all parts of the world. Please
 remit sufficient to cover postage. All goods are of reliable quality. Write for our full list.

WHOLESALE AND RETAIL

THE WIRELESS TRADERS' SUPPLY Co.,

80, Hampstead Road, London, N.W.1.

TELE. NO. MUS. 3483.

Three Minutes from Warren Street (Hampstead Tube). Right opposite Oetzmann's.

You CANNOT be out of WIRELESS WEEKLY because it brings BIG Business.

APPROACHING ONE MILLION & HALF SATISFIED
CUSTOMERS STUDY OUR ADVERTISEMENTS.
ELKAY WIRELESS CO.

BRITAIN'S LARGEST EXCLUSIVE WIRELESS STORES

QUALITY, QUANTITY AND
CONSISTENCY OUR MOTTO

PIONEERS of CHEAP PRICES

SEE OUR SIX-WINDOW
DISPLAY OF BARGAINS

You may require apparatus not detailed below. Be confident—we sell everything for wireless.
WRITE TO ELKAYS—WE STOCK IT.

ELKAY Lightweight Headphones, 4,000 ohms, all guaranteed ... per pair **12/9**
FELLOWS' New Lightweight Phones, 4,000 ohms, stamped B.B.C. ... **18/6**
SUPER PHONES, Light, Easy Adjustment, 4,000 ohms, guaranteed ... **13/9**
N & K (The genuine article), 4,000 ohms, all guaranteed ... Per Pair **12/9**
ALSO BROWNS, BRUNET, THOMSON-HOUSTON (French), ETC.

ALL MAKES of VALVES in STOCK
MARCONI R. EDISWAN, MULLARD and COSSOR (Red & plain top)
DULL EMITTERS, Ediswan & Marconi 21/-
Special packing and post 1/- each extra EACH
State what Make of **LOUD SPEAKER** you Require
EVERY TYPE IN STOCK

DUTCH VALVES ... 6/11 & 7/11	With engraved dial	2/6	VARIABLE CONDENSERS of high quality. With aluminium top and bottom plates. Complete with knob and dial, guaranteed accurate:
L.F. TRANSFORMERS. Ratio 5 to 1. All guaranteed (postage 1/-) ... each 11/3	FILAMENT COMPLETE CIRCLE RESISTANCE	6d.	Vernier ... 4/- .0005 ... 6/-
CRYSTAL DETECTORS ... 1/9, 1/3, and 10/4d.	SCALES, 0 to 300	1d.	.0001 ... 4/- .00075 ... 7/-
CRYSTAL DETECTORS, enclosed in glass case 2/6, 2/3, 1/6	BELL WIRE, tinned copper, 12 yds. ... each 6d.	10d.	.0002 ... 4/8 .001 ... 8/-
AERIAL WIRE, 7/22, guaranteed hard-drawn copper, 100 ft (postage 1/-) ... 1/10	VALVE LEGS, nut and washer ... per doz. 10d.	1d.	.0008 ... 5/8
CONDENSER VANS, fixed or moving ... per doz. 3/4d.	VALVE PINS, nut and washer ... per doz. 10d.	1d.	SUPER-QUALITY 2-WAY COIL HOLDER ... 6/3
REAL GOLD CAT'S WHISKERS ... per doz. 2d.	PLUNGER SPRINGS, complete ... each 3/4d.	2d.	REAL EBONITE 3-WAY COIL HOLDER ... 7/9
REAL GOLD CAT'S WHISKERS ... per doz. 1/5	SLIDER ROD, brass, 13 ins. long, 1/2 in. square, drilled ... each 2d.	1/8	O.B.A. NUTS ... per doz. 4d.
SILVER CAT'S WHISKERS ... per doz. 1d.	SLIDER KNOB ... each 2d.	1/8	DETECTOR ARMS, Ball Joints, Ebonite Handle and Whisker Holder ... 3/4d.
SILVER CAT'S WHISKERS ... per doz. 7d.	SWITCHES ON EBONITE S.P.S.T. ... each 1/8	2/9	WOOD SCREW TERMINALS ... each 1d.
CONDENSER SCALES, 0 to 130 ... each 6/4d.	B.P.D.T., each 1/11, D.P.D.T. ... each 3/4d.	1d.	SHELLAC ... per bot. 10/4d. & 6d.
IVORINE LABEL SET, 12 different titles the set ... 2/4	CONDENSER SPINDLES, all sizes in stock, from each 2/4	3d.	AERIAL FULLEYS ... each 10/4d., 8/4d., 6d. & 4/4d.
BASKET COILS, set of 6, up to 3,000 metres ... 11/4d.	SCREWED ROD, 2 B.A., 12 ins. long ... each 2/4d.	2/4d.	TINFOIL ... large sheet 4d.
SLEEVING, 3 yds., assorted colours, for NUTS, 2 B.A. ... per doz. 2/4d.	SCREWED ROD, 4 B.A., 12 ins. long ... each 2/4d.	1/11	GRID LEAKS, 24 and 2 meg. ... each 10/4d.
NUTS, 4, 5, 6, and 8 B.A. ... per doz. 2/4d.	RUBBER INSULATED LEADING-IN WIRE ... per yd. 1/11	1/8	FLEX (Twin), various colours ... per yd. 2/4d.
WASHERS, 2 B.A. ... per doz. 1/5	INSULATORS, white reel, 2 in., each 1d.; per doz. 10d.	1/8	CONNECTING WIRE, tinned copper, 20 gauge 3 yds. 2d.
CONTACT STUDS, with nuts and washers ... per doz. 2/4d.	INSULATORS, white egg, each 2d.; per doz. 2/4d.	2/4d.	ENAMEL WIRE in 1/2, 1, and 1 1/2 lbs. reels per lb. Note.—Robbins 2d. each extra.
TERMINALS, with nut and washers each 1d., 1 1/2d., & 2d.	WOUND INDUCTION COILS (postage 9d.): 12x4 9x4 8x2 6x2 2/5 2/3 1/11 1/8 1/5	2/6	POTENTIOMETERS, guaranteed up to 500 ohms, superior make, compact size ... 7/3
EBONITE KNOBS, 2 B.A. ... each 2d. & 3d.	TAPPED INDUCTION COILS, 20 tappings wound to 1,600 metres ... each 1/4d.	1/4d.	CRYSTAL DETECTOR, glass enclosed, fitted on 4x2 ebonite panel with terminals for aerial, earth, and phone, already wired and beautifully finished ... 4/9
SPACING WASHERS, large ... per doz. 2/4d.	DOUBLE 'PHONE CORDS, full length ... 11/4d.	8d.	VALVE HOLDERS ... each 10/4d. & 1/3
SPACING WASHERS, small ... per doz. 1/4d.	HERTZITE, genuine, in box ... 8d.	8d.	BATTERIES, H. T., dry: 30 volts, including Wander Plugs ... 5/9
CRYSTAL CUPS, 2 screw ... each 1d.	TALITE, genuine, in box ... 8d.	9d.	60 volts, including Wander Plugs ... 9/6
FIXED CONDENSERS, all capacities ... each 10/4d.	FERMANITE, genuine, in box ... 8d.	1/8	AMALGO PLASTIC METAL, for fixing crystals. No Wood's metal necessary ... 6d.
EBONITE, cut to any size by machinery while you wait ... per lb. 3/6	ZINCITE, genuine, in box ... 8d.	8/4d.	GOLD SEAL PLASTIC METAL, for fixing crystals ... 6d.
TELEPHONE TERMINALS, nuts and washers, each 1/4d. ... per doz. 2/4d.	BORNITE, genuine, in box ... 8d.	1/8	IVORINE NAME PLATES, all readings each 1d. per doz. 9d.
W. O. TERMINALS, nuts and washers ... each 1/3	MIXED CRYSTALS (6 kinds) ... 9d.	8/4d.	EARTH CLIPS, Copper, adjustable ... each 5/4d.
PANEL BUSHES, drilled ... per doz. 1/3	CARBORUNDUM ... 5/4d.	4/8	THE WONDERFUL TITANIC CRYSTAL SET , stamped B.B.C., including 1 pair of 4,000 ohms headphones, aerial wire, insulators, leading-in wire, lead-in tube, earth clip, etc. Maker's price 3 guineas. Our price 33/9
TOP CONDENSER, bushes ... each 1d.	ZINCITE and BORNITE, both in box ... 1/3, 10/4d., & 9/4d.	4/8	
BOTTOM CONDENSER bushes ... per doz. 2/4d.	COIL PLUGS, real ebonite ... 1/3, 10/4d., & 9/4d.	4/8	
SWITCH ARMS, 4 laminations, ebonite knob, complete with panel, bush, nuts, and spring washer ... per doz. 2/4d.	EBONITE CONDENSER KNOB AND DIAL ... 1/8	4/8	
STOPS, with nuts ... per doz. 2/4d.	FILAMENT RESISTANCE DIALS ... 8/4d.	4/8	
FILAMENT RESISTANCES, smooth action, marvellous value ... 1/9	H.F. PLUG TYPE TRANSFORMER: 1. 150 to 450 metres 3/9 4. 900 to 2000 metres 4/8 2. 250 to 700 " 4/- 5. 1600 to 3200 " 4/9 3. 450 to 1200 " 4/3 6. 2200 to 5900 " 5/-	5/-	

MAIL ORDERS DISPATCHED SAME DAY AS RECEIVED. NO WAITING.

Goods Sent to all Parts of the World.

"DON'T PAY MORE" AND GET JUNK.
BUY FROM ELKAYS WHERE YOU
"PAY LESS" AND GET THE GOODS.

PLEASE REMIT AMPLE POSTAGE.

"Elkay" Wireless Co. present the
Compliments of the Season
to their prodigious circle of customers
—actual and prospective.

MAKE NO
MISTAKE
When calling see
that you ARE at
ELKAY

"ELKAY" WIRELESS CO.

225 and 227, BISHOPSGATE, LONDON, E.C.2.

OPEN SATURDAY ALL DAY.

SUNDAYS 11—2.39.

TRADE COUNTER NOW OPEN.

Special terms to Radio Clubs. Telegrams: ELKAYWIRY AVE., LONDON. Telephone: { CENTRAL 8544, RETAIL. BISHOPSGATE 2313, WHOLESALE.

REMEMBER—DON'T PAY MORE!

You CANNOT be out of WIRELESS WEEKLY because it brings BIG Business.

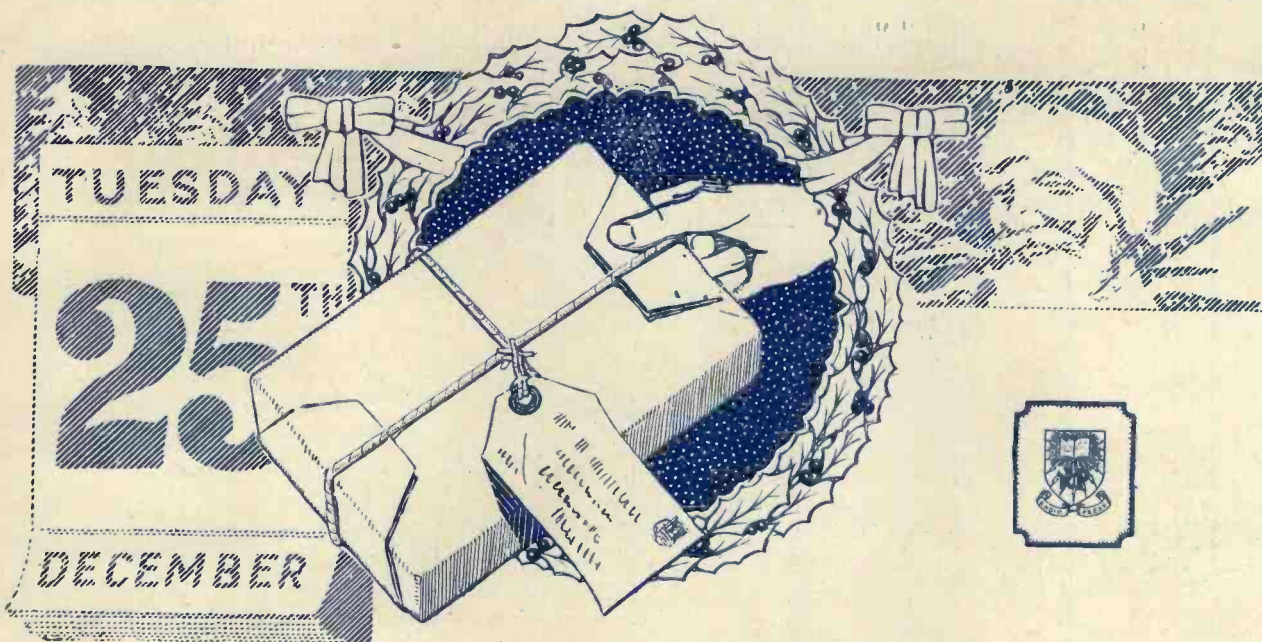

Four typical Books
from the extensive
Radio Press Series.

This year give a Radio Press Book

Elementary Text-Book on Wireless Vacuum Tubes

By JOHN SCOTT-TAGGART, F.Inst.P.

Recognised as the standard work on the Valve. Contains a vast amount of material which every experimenter needs to help him to obtain better results from his work. For the student it is a veritable stepping-stone to improved knowledge. Bound in full cloth.

10/-
post free

More Practical Valve Circuits

By JOHN SCOTT-TAGGART, F.Inst.P.

A handsome cloth bound book giving details of nearly 100 different circuits, together with a complete explanation of each, showing the values of the various components used. The circuits are so carefully drawn and the information is so complete that set building is considerably simplified.

3/6
Postage 2d. extra

500 Wireless Questions answered

By G. P. KENDALL and E. REDPATH

A perfect mine of information is contained in this Book. The experimenter, student or novice, will find that there is no one Book published which can be so helpful to him. All information is readily obtainable by means of a comprehensive index.

2/6
Postage 2d. extra

Radio Valves and how to use them

By JOHN SCOTT-TAGGART, F.Inst.P.

This Book is written in the form of questions and answers on the Valve—and provides a simple method of explaining exactly what goes on inside the Valve when your Set is working. It is illustrated with a large number of diagrams which are of considerable assistance to the reader.

2/6
Postage 2d. extra

YOUR wireless friend will appreciate the practical help and assistance derived from the gift of a Radio Press Book. It is certain that you cannot give anything which will be more appreciated.

And because all Radio Press Books are so essentially practical and dependable your selection is greatly simplified.

Any of the four Books described here are eminently suitable, but there are thirteen others to select from and your Bookseller has them all in stock. Why not call and examine them to-day?

Published by
Radio Press, Ltd.,
Devereux Court,
Strand, W.C.2.

Radio Press Books
— a complete Wireless Library

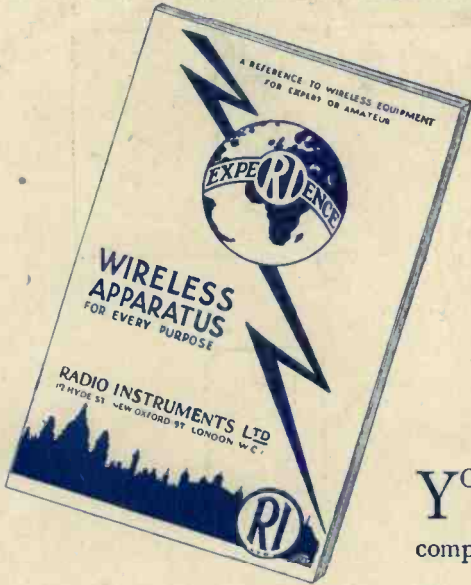

The **R.I.** Xmas Catalogue

YOUR friends who are interested in Wireless will appreciate an R.I. component as an Xmas Greeting.

A catalogue, overflowing with illustrations and accurate descriptions of all our apparatus will be sent free on application.

It provides a new field in seasonable gifts always appreciated and always unique.

These illustrations show a few R.I. products designed on 25 years experience, and built throughout in our factory and by the best British Labour.

R.I. components and sets are the accepted British Standards of to-day. No other components equal them in efficiency or finish.



Latest Improved Anode Choke Coil **10/-**

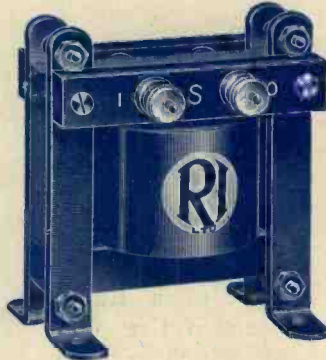

The famous R.I.I.F. intervalve transformer. One price, one quality. **25/-**



Combined Variable Intervalve Re-action and Anode Reactance. Wavelength range 200-4,000 metres. **45/-**

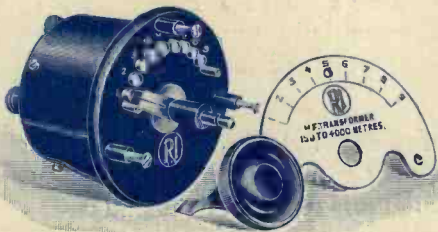

H.F. Transformer with 9 point switch, 150-4,000 metres, designed for easy panel mounting, scale may be used as template. **35/-**

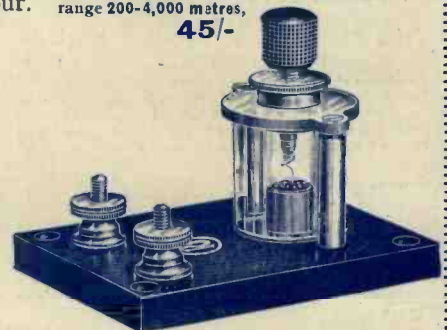

Crystal Detector, Micrometer Adjustment. **8/6**

RADIO INSTRUMENTS LTD.,

Managing Director: J. JOSEPH, M.I.E.E.
Chief Designer: W. A. APPLETON, M.B.E., M.I.R.E., late Admiralty Technical Research Officer.

Works, Offices and Showrooms:

12, HYDE STREET, NEW OXFORD STREET, W.C.1.

Telephone: Regent 6214-6215-6216.

Telegrams: "Instradio, London."

NORTHERN DEPOTS: 19, Hopwood Avenue, MANCHESTER, and Trinity House, Commercial Street, LEEDS.

Wireless Weekly

and The Wireless Constructor

Vol. 3.
No. 3.

CONTENTS

A Short Wave Receiver.
By A. D. Cowper.

Dual Amplification. — Lecture
No. 3.

Circuits for "Wireless Weekly"
Valve Panel.

Construction of a Telephony
Transmitter.

Constructional Notes, Broadcasting News,
How to Design Your Own Set, Valve
Notes, Correspondence, Information
Department, etc., etc.

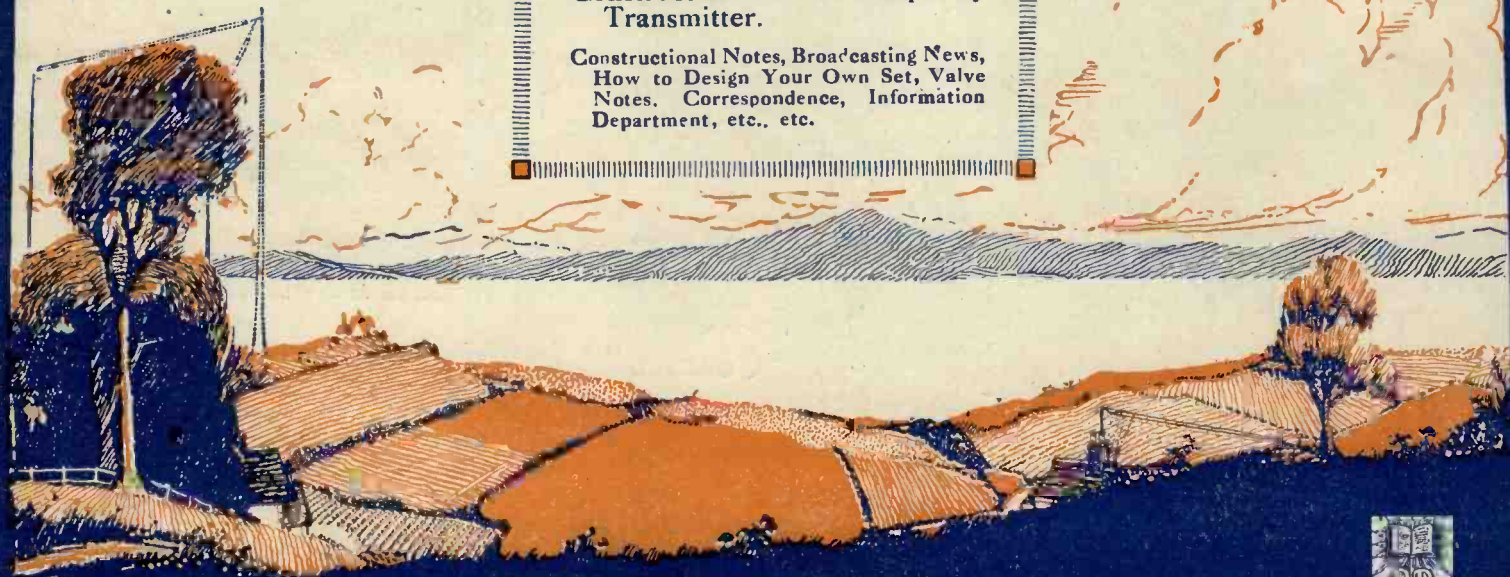

A Single Valve and Crystal Receiver.

RADIOBRIX

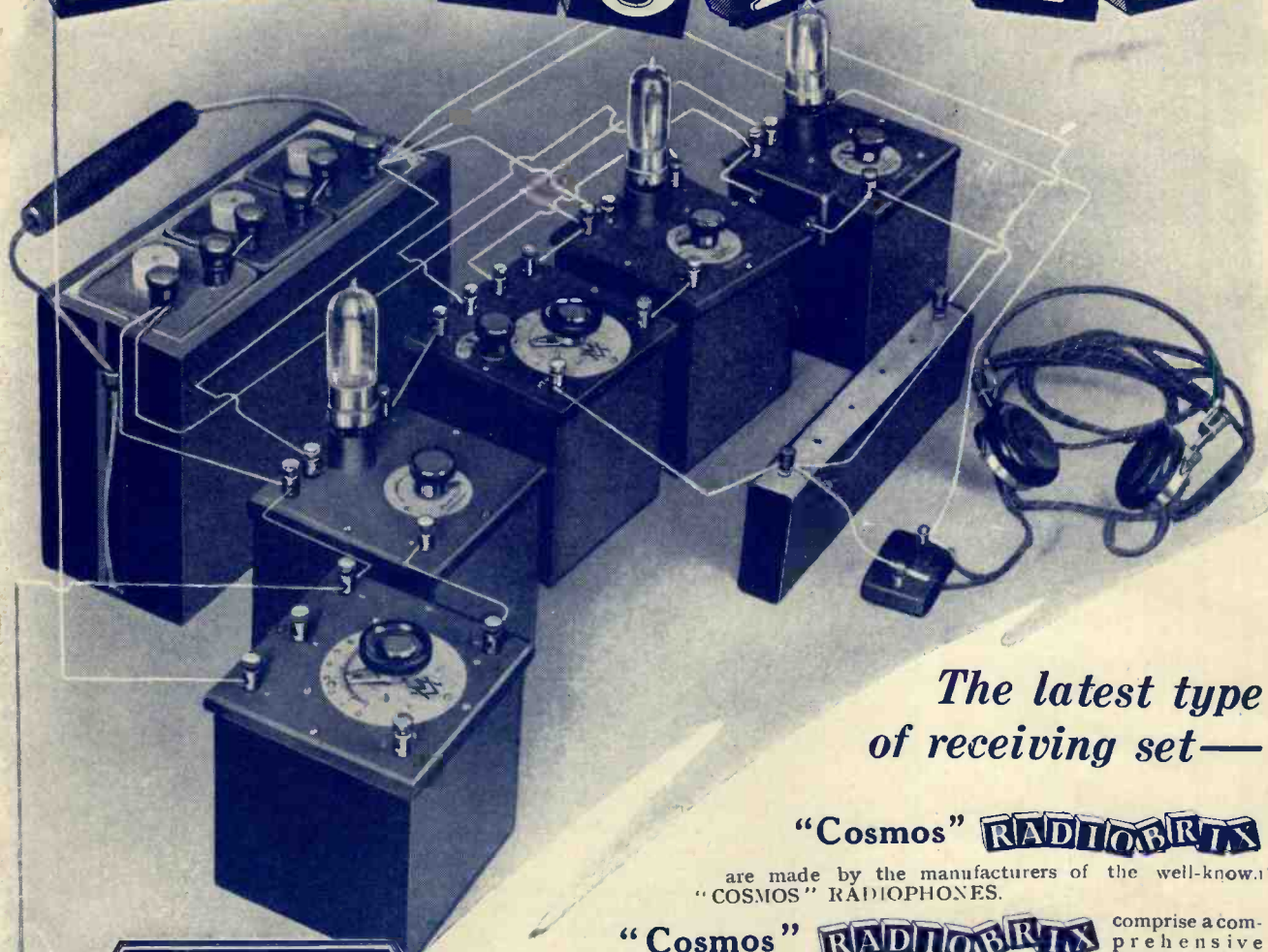

*The latest type
of receiving set—*

"Cosmos" RADIOBRIX

are made by the manufacturers of the well-known "COSMOS" RADIOPHONES.

"Cosmos" RADIOBRIX

comprise a comprehensive range of units by various combinations of which the radio experimenter or amateur can build up any type of receiving set or circuit.

"Cosmos" RADIOBRIX have been designed to secure the utmost flexibility. They enable the "listener" to build up his set gradually as his means allow, yet the bricks obtained at first never become useless but can be utilized as part of a more elaborate set.

"Cosmos" RADIOBRIX are thoroughly well-made and moderate in price.

ASK YOUR REGULAR WIRELESS DEALER TO SHOW YOU

"Cosmos" RADIOBRIX If he has not yet obtained his stock write

sending his name to the manufacturers—

METROPOLITAN Vickers

ELECTRICAL CO. LTD
WORKS: TRAFFORD PARK, MANCHESTER

BUILD YOUR RADIO SET WITH RADIOBRIX

**BUY
BRITISH
GOODS
ONLY**

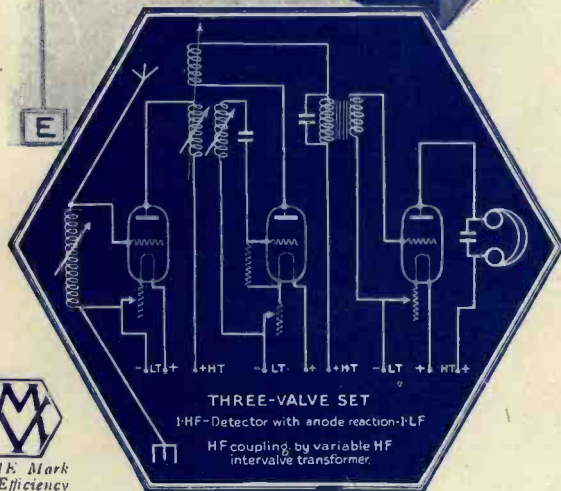

The above illustration and diagram shows a three-valve set made up with RADIOBRIX. Get a copy of the new book "BUILDING WITH RADIOBRIX," full of useful circuits with theoretical and wiring diagrams. OBTAINABLE EVERYWHERE, ONE SHILLING, OR POST FREE, ONE AND FIVEPENCE.

R
XO2A

Wireless Weekly

Vol. 3, No. 3
Dec. 26, 1923.

CONTENTS

	Page No.
Editorial	68
Six Lectures on Dual Amplification—No. 3	69
Relaying American Broadcasting	72
Jottings by the Way	73
A Rack-and-Pinion Operated Loose Coupler	74
How to Design Your Own Set—No. 3	75
"Wireless Weekly" Valve Panel	77
A Novel Extra Resistance for Dull Emitters	79
A Simple Morse Key	80
A Selector Switch for Peanut Dry Cells	81
A Short Wave Receiver	82
Tuned-Anode or Resistance Capacity Coupling	82
A Simple C.W. and Telephony Transmitter	83
(continued)	
A Crystal-Testing Holder	85
A Safety Valve Holder	86
A Single Valve and Crystal Receiver	89
Loud-Speakers for Wireless Purposes	91
Broadcasting News	94
A Two-Valve Power Amplifier (concluded)	96
Valve Notes	97
Correspondence	99
Information Department	99

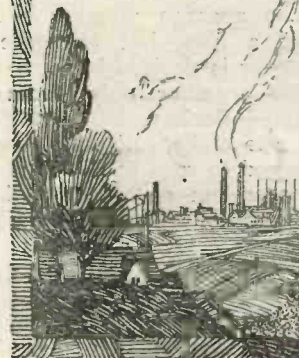

Scientific Adviser
Prof. G. W. O. HOWE,
D.Sc., M.I.E.E.
Advisory Editors:
Prof. R. WHIDDINGTON,
M.A., D.Sc.
Prof. C. L. FORTESCUE,
M.A., M.I.E.E.

Editor: JOHN SCOTT-TAGGART, F.Inst.P.
Assistant Editors: E. REDPATH,
P. W. HARRIS.

Radio Press, Ltd.

Publishers of Authoritative Wireless Literature
DEVEREUX COURT, STRAND, W.C.2

Tel.—Central 3763.

Advertisement Managers: SCHEFF PUBLICITY ORGANIZATION,
LTD., 125, Pall Mall, London, S.W.1
Tel.—Rezen: 2440.

Staff Editors:
E. H. CHAPMAN, M.A., D.Sc.
A. D. COWPER, M.Sc.
G. P. KENDALL, B.Sc.
R. W. HALLOWS, M.A.
S. G. RATTEE.



All correspondence relating to contributions is to be addressed to the Editor of "Wireless Weekly."

Nothing contained herein is to be regarded as permission or encouragement to infringe any patent rights.

Editorial

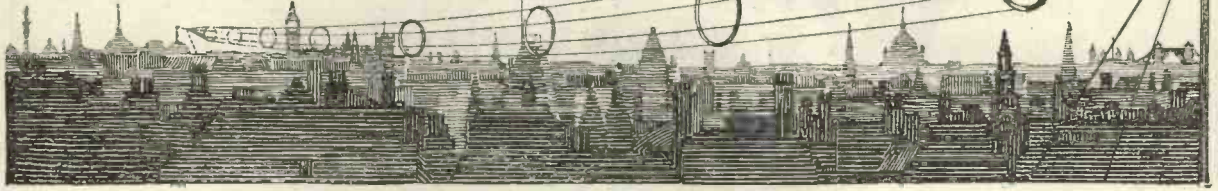

The Eight per cent. Vote:

LAST Wednesday a meeting of the Radio Society of Great Britain was held to make the most important decision in the history of this body. This vital matter was decided at an annual general meeting which was attended by 72 persons, which included officers, ex-officers and visitors.

These gentlemen solemnly approved in principle the new constitution, a document of seven long pages of small type, which was distributed on the spot.

That such a state of affairs should exist is, perhaps, one reason why the influence of the Radio Society has declined during the past year. Arbitrary methods are persisted in up to the last, and the Committee obviously has built on the natural instincts of the average member not to make a fuss, but to agree to whatever is decided by it.

One member only, from an affiliated Society, had any comments to make, although how he managed to read sufficient of the memorandum on which to base any questions is still a mystery to us.

Mr. Percy W. Harris remarked on the impossibility of forming any decision regarding a matter which was only raised at the last minute. He, and hundreds of others, including those at the meeting, had not even seen the memorandum of association until he reached the building in which the meeting was held. Even a momentary glance at the memorandum was impossible, and yet it was thought fit by the committee to put a motion of approval to the Society, or the remnant which represented the Society.

As regards the memorandum, we desire to say nothing, for the simple reason that we have not yet had time to read it ourselves, far less to consider it with the

full attention which is essential to a very important matter of this kind.

Our one and only objection so far has been the precipitate way in which this matter has been dealt with. The papers were sent out to members by the Wednesday morning post, and the great majority of the 800 members of the Society would only receive their copies on Thursday, long after a decision would have taken place! A most remarkable state of affairs for a Society which claims to represent the whole experimental movement in this country!

Mr. Harris's protest was, of course, unconnected with the contents of the memorandum of association, which he had in his hand, but had had no time to read. When it came to the motion regarding approval of the memorandum there were five dissentients, not with regard to the memorandum itself, but as an indication that there were at least some who were not ready to vote *en bloc* on a motion which they had not had time to consider.

We believe that this is the first time in the history of the Radio Society of Great Britain that the Committee has put forward any proposition which has not been swallowed whole without a gulp, by the meeting. We congratulate them on having a sufficient interest to produce even one dissentient. The incident must be mentioned in the Society's Year Book.

This, the last act of the old committee, is both a fitting and a typical one. The lack of consideration to the members, however, is not likely to be forgotten. The vote on the memorandum, of course, could hardly have resulted in any other decision in the form in which it was put forward. Whether or not it had been

watered down at the last minute, we do not know, but it was certainly of an unnecessarily vague character. Mr. Harris desired to move the adjournment of the meeting to enable members to consider the question of the new constitution which had been sprung upon them, but this was not permitted. It was pointed out that there was nothing really new and that the whole question had been discussed *ad nauseam* in the technical Press. The only thing we have noticed is the expressed desire in the Press for a new constitution, together, of course, with a certain amount of *nausea* regarding the present state of affairs.

It is regrettable that important decisions should be taken by 8 per cent. of the total membership of the Radio Society when the great majority, 92 per cent., do not even know the proposition to be decided. We can readily imagine the indignation of provincial members and provincial societies.

The members of the retiring Committee have, no doubt, been so comfortably ensconced in their positions that they resent any criticism. We hope the new committee will take a broader view and its members realise that they are trustees for a national society and not the Wireless Society of London.

The Radio Society cannot be run like a village social club. This apathy must be dispelled. We cannot have a society with 800 members having at their Annual General Meeting an audience which many a provincial radio Society would be ashamed of at one of their ordinary meetings. There is something wrong, and the position of the Committee is much too weak to justify any childish indignation at honest straightforward criticism of their methods.

SIX LECTURES ON DUAL AMPLIFICATION

By JOHN SCOTT-TAGGART, F.Inst.P., Editor.

No. III.

Dual Amplification and Reaction.

In the single circuits we have so far considered, plain high-frequency amplification has been the first step in obtaining loud signals. We can, however, improve matters still further by using reaction. In

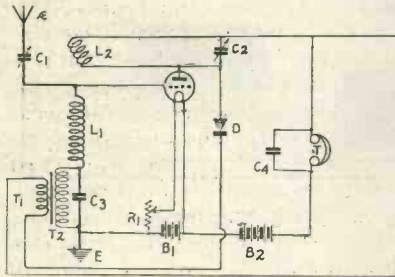

Fig. 13.—Single valve dual circuit using reaction.

the case of a single valve circuit, the reaction has to be applied to the aerial circuit or to a closed receiving circuit, and fortunately in many ways this is now permitted by the Postmaster-General provided the experimenter does not use the reaction carelessly and so cause self-oscillation of the valve, which in turn will result in continuous waves being radiated from the receiving aerial, thereby interfering with the reception of neighbours.

Fig. 13 shows a single valve dual amplification circuit, which has many features to recommend it. It will be noticed that the circuit is the same as a preceding figure, but that the anode inductance coil L_2 is now coupled to the aerial inductance L_1 . The secondary T_2 of the intervalve transformer T_1 T_2 is connected in the aerial circuit for the reasons already explained. It seems rather strange that this idea was not previously thought of because it increases the stability of any dual amplification circuit very considerably.

Fig. 14 is a pictorial representation of the Fig. 13 circuit, and may prove of value to those who are not fully conversant with the intricacies of some circuit diagrams.

The action of the circuit is as follows: The aerial circuit consists of the variable condenser C_1 , the inductance L_1 , the fixed condenser C_3 of about $0.001 \mu F$ capacity and the earth. This circuit is tuned by means of the variable condenser C_1 , which might, however, be connected in parallel with L_1 without altering the operation of the circuit. The anode circuit contains the inductance L_2 tuned by means of the variable condenser C_2 to the incoming wavelength. The crystal detector D and the primary T_1 of the intervalve transformer T_1 T_2 are connected across the oscillatory circuit L_2 C_2 . The high frequency oscillations,

varying the potential of the grid of V_1 at an audible frequency. These audio-frequency, or low-frequency, potentials applied to the grid cause amplified low-frequency currents to flow in the anode circuit of the valve, these passing through the inductance L_2 and round through the telephones T , which are shunted by the condenser C_4 of about $0.002 \mu F$ capacity to allow the high-frequency currents to pass.

The condenser C_4 may sometimes be omitted, and the experimenter may care to try connecting a fixed condenser of about $0.002 \mu F$ capacity across T_1 .

Operation of the Circuit.

A circuit of this kind needs rather careful adjustment. In the first place the reaction coil L_2 should be kept well away from L_1 , and, having set the crystal

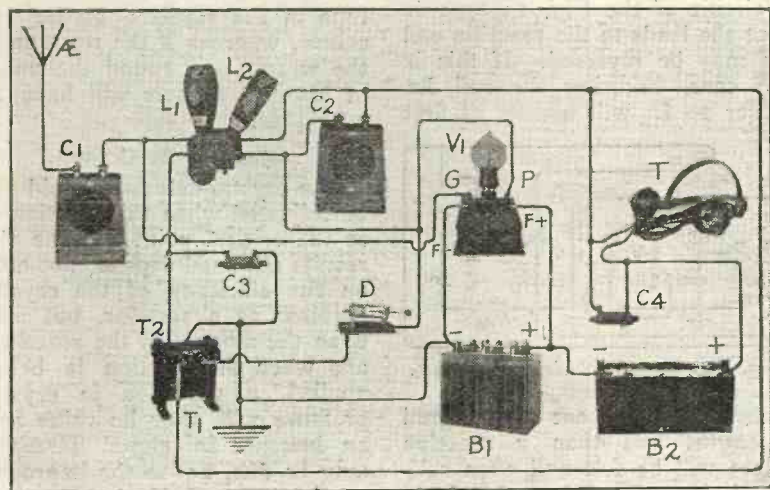

Fig. 14.—Pictorial form of Fig. 13

being amplified by the valve V_1 , appear in the circuit L_2 C_2 and are rectified by the crystal detector D . The rectified pulses passing through T_1 , produce varying currents in T_2 , these

detector; the condensers C_1 and C_2 should be carefully adjusted until the loudest signals are obtained. The next step is to adjust the crystal detector very carefully until the maximum re-

sponse indicates that the best adjustment has been made. Now bring the reaction coil a little closer to L_1 and retune on the condensers C_1 C_2 . It will be found that as the reaction is increased, the selectivity of the aerial and tuned anode circuits becomes greater and a more accurate adjustment of the condensers is required. The next step is to increase the reaction a little more and retune the condensers. This process should be continued until the fullest amplification effect is obtained. If the coupling is too tight it will be found that as one of the condensers is adjusted, the set will oscillate and perhaps produce a buzzing noise. If this happens the reaction coil should immediately be moved a little away from the other coil, and a cautious adjustment of the reaction again made.

The reaction may be varied by altering the tuning of one of the condensers, while keeping the coils fairly tightly coupled. This, however, is undesirable, partly because the results obtained are usually not as good as by slackening off the coupling, but also the chance of oscillating is increased and more interference from outside stations may occur.

Reverse Reaction.

A danger when connecting up a circuit of the Fig. 13 type is that the leads to the reaction coil L_2 may be reversed. If this is the case, bringing the coil L_2 closer to L_1 will usually at first

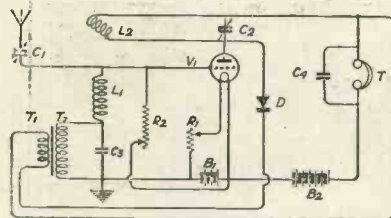

Fig. 15. Use of stabilising resistance.

cause no increase in signal strength, and then a reaction effect will be felt and even self-oscillation may be produced, in spite of the reverse inductive coupling. This is due to capacity coupling and is undesirable. The experimenter should always try reversing the leads to his reaction coil. If the reaction is the right way round, an improvement in signal

strength should be obtained as the reaction coil is brought near to the aerial coil, provided, of course, the condensers are retuned. It must not be expected that an increase in the reaction coupling should increase the signal strength without a retuning of the condensers; this latter operation is absolutely essential. As the reaction is

with the reaction coil well away from the aerial inductance coil.

Reaction and Instability.

Troubles with dual amplification circuits begin when reaction is used. When a good circuit is employed and the various precautions, which will be outlined in these lectures, are adopted, no trouble regarding instability

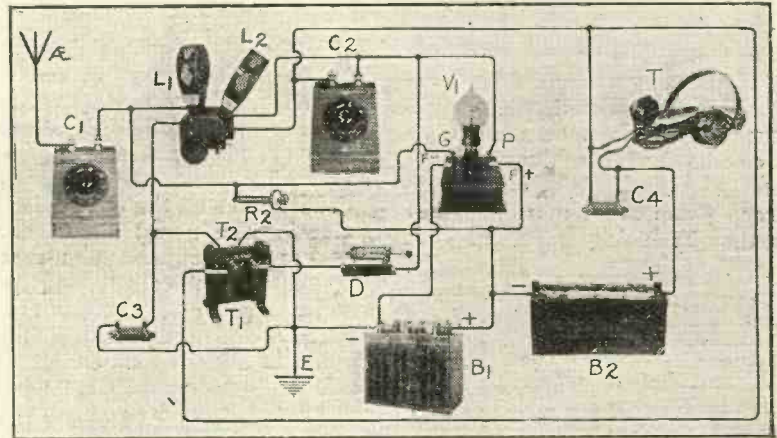

Fig. 16. Pictorial form of Fig. 15.

tightened, the wavelength of both circuits should be increased if the reaction is the right way round. It will be found that if the reaction is the right way round, a lower value on both the condensers C_1 and C_2 will be necessary to tune in the stations to be received, whereas if the reaction is the wrong way round the value of both condensers will have to be higher.

Adjusting the Crystal.

The crystal detector should not be adjusted when the reaction is at the critical point because the results obtained depend, not only on the efficiency of the crystal detector as a rectifier, but also upon the amount of the reaction, and when the reaction is being applied, a variation in crystal pressure will alter its value and an increase in signal strength may be due, not to the improved sensitiveness of the detector as a result of adjustment, but to the increased amount of reaction due to the crystal detector introducing less damping into the anode oscillatory circuit L_2 C_2 . The experimenter should therefore always adjust his crystal detector with weak signals and

should be experienced when reaction is not employed. It is, however, very rarely that a receiver will not start buzzing at audible frequency when the reaction is increased to too great an extent.

This is due to the fact that there is always a certain amount of inherent low-frequency reaction even though this is not deliberate. The valve does not need very much provocation to increase this inherent low-frequency reaction to such an extent that self-oscillation at audible frequencies occurs. The frequency is audible because the transformer windings and the capacities across them form low-frequency oscillatory circuits. If the reaction on a dual amplification circuit is increased too far, the valve will first oscillate at high frequency and will then oscillate at an audible frequency in most cases. The setting up of continuous oscillations due to too tight a coupling acts like a trigger and starts the valve oscillating at a low frequency. This sometimes only happens when the high-frequency oscillations are made sufficiently strong by tightening the reaction coil past the oscillation point, but

more frequently the low-frequency buzz starts the moment the high-frequency reaction is made sufficiently tight to cause the valve to oscillate at a high frequency.

Experiments prove that the valve rarely oscillates at both frequencies simultaneously, and the suggestion that dual amplification circuits cause a great deal of interference is not founded on fact. It will be found that in nearly all cases, as the reaction

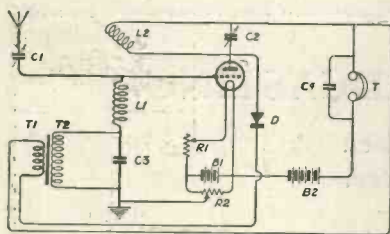

Fig. 17. Stabilising a dual circuit with a potentiometer.

is increased a point is reached where the valve will begin to oscillate at high frequencies, but this seems to be only a state of affairs lasting for a fraction of a second; the instant the valve begins to oscillate at a high frequency, the general working conditions are altered and the valve changes its mind and begins to oscillate only at a low frequency which, of course, does not in any way interfere with the reception of neighbours.

Under certain conditions, however, both high and low-frequency oscillations may be generated by the valve, in which case serious interference will be caused to nearby stations. The idea that a dual amplification circuit when it is oscillating at audible frequencies is causing a great deal of interference to neighbours, is probably believed in because such a loud, unpleasant noise is heard in one's own telephones, but in most cases this is quite innocuous. In nine cases out of ten the experimenter using a dual amplification circuit experiences a loud, low-frequency buzz the moment he gets too near the high-frequency oscillating point of the valve; this audible warning is followed by an immediate loosening of the inductive reaction coupling, whereas the inexperienced experimenter using an ordinary circuit often has his valve oscillating without knowing it.

Methods of Stopping Buzzing.

The design of a good dual amplification circuit involves the stopping of the unpleasant buzzing noises which so readily come in when an unsuitable circuit is in use. These buzzing noises are due to the reasons stated above, and the way to avoid them is to lessen the low-frequency reaction and also the tendency of the valve to oscillate at high frequencies, because in most cases it is the initial high-frequency oscillation which starts off the low-frequency buzzing.

The first thing to do to obtain a stable dual amplification circuit is to see that the connections to the low-frequency transformer are the right way round. A good rule is to connect O S (out secondary) terminal of the interval transformer so that it comes nearest the grid of the valve. One side of the crystal will usually be connected to the O P terminal of the primary winding of the transformer. These rules are not inflexible, and the experimenter should try juggling with the leads to the transformer to see

resistance such as that marketed by wireless dealers.

Fig. 15 shows the Fig. 13 circuit rendered more stable by connecting this variable 100,000 ohm resistance across the grid of the valve and one side of the filament battery. This resistance will have a great stabilising effect without weakening signal strength to any appreciable extent. The stabilising resistance R2 of Fig. 15 serves three purposes:—

1. It introduces damping into the low-frequency circuit and lessens the tendency for low-frequency reaction.
2. It lessens the tendency for high-frequency oscillation, and therefore the tendency for buzzing.
3. It improves the purity of the music or speech in the case of broadcast reception. This is a common result of connecting a resistance across the secondary of a transformer.

The resistance R2 may be fixed and have a value of 100,000 ohms, but a variable resistance is preferable and will also serve as a

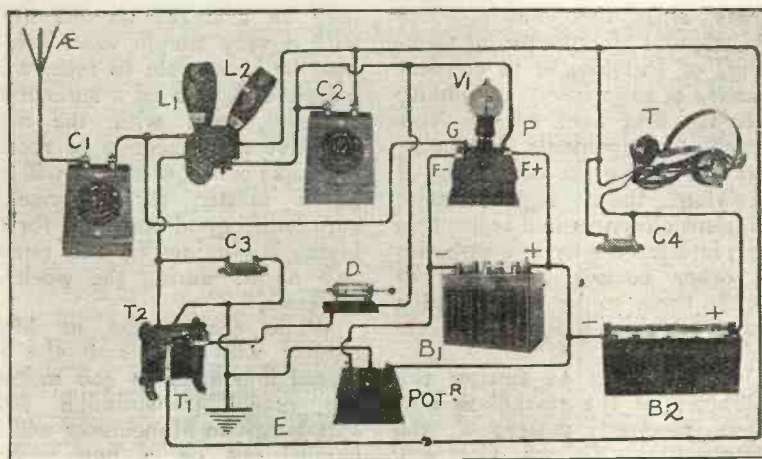

Fig. 18. Pictorial form of Fig. 17.

which form of connection gives the most stable and effective results.

Use of Stabilising Resistance.

The author has found that one of the best methods of stabilising a dual amplification circuit, apart from the method of connecting the secondary of the transformer in the aerial circuit, is to use a resistance of about 100,000 ohms, which is preferably a variable

means of obtaining extremely fine reaction.

The remarks regarding the desirability of having the condenser C4 which were made in connection with Fig. 13 also apply here. It is, unfortunately, very largely a matter of individual experiment to find out the best value of the fixed condensers, or even if they are required at all.

Fig. 16 is a pictorial representation of the Fig. 15 circuit.

Another Method.

Fig. 17 shows another method of arriving at somewhat the same result, although the author does not favour this to the same extent.

In this case, damping is introduced into the grid circuit of the valve by connecting the moving contact on the potentiometer R2 to earth. A somewhat similar

effect could be obtained by taking tapings off the filament accumulator B1. The value of the potentiometer resistance R2 is not important and any of the standard makes will do quite well.

The author does not like this method because he believes that it introduces a certain amount of distortion and also decreases the

degree of amplification obtainable with the valve. Moreover, owing to the characteristic curves of the valves in use to-day, a large high-tension voltage cannot be effectively employed with a circuit of the Fig. 17 type, and therefore the loudest results are not obtainable.

Fig. 18 shows the circuit Fig. 17 redrawn pictorially.

Next Week: Another Instalment of this Series.

RELAYING AMERICAN BROADCASTING.

An interesting experiment in which the co-operation of Amateurs is invited.

We learn that the Metropolitan-Vickers Electrical Company have for some time past been carrying out experiments with a view to ascertaining the best methods for picking up broadcasting from long distances, and, with this end in view, have made arrangements with the Westinghouse Electric and Manufacturing Company, of Pittsburgh, to conduct a series of experiments extending over the first week of the New Year. Arrangements are being made to gauge the possibility of receiving these signals with sufficient clearness and separation from interference by atmospherics or other outside influences to enable them to be relayed to a broadcasting station and re-radiated.

With a view to testing the character of the re-radiation of these received messages, the Metropolitan-Vickers Company will use a transmitting power of $1\frac{1}{2}$ kilowatts on 400 metres, with the call sign "2AC." The transmissions will be carried out from the special experimental plant of the Company's Research Laboratories at Trafford Park. The signals will be picked up from the Westinghouse Company's broadcasting station at Pittsburgh, known to amateurs as "KDKA," this station being opened in December, 1920, and the first to transmit a regular broadcasting service.

Experiments so far conducted between the Westinghouse Com-

pany and the Metropolitan-Vickers Company demonstrate that the chief trouble arises from static or atmospheric disturbances. Conditions vary enormously from day to day, and even from hour to hour, so that while reception of the American signals may be achieved on one night with a very simple valve set, it may be impossible to receive intelligible signals on a succeeding occasion, even with the most sensitive and selective of receiving sets; consequently, it will not be a matter for surprise if sufficiently good reception for relaying is obtained on only one or two nights during the week of the tests.

While the station at Manchester will re-transmit the received messages on 400 metres, the actual transmission from Pittsburgh to Manchester will be carried out on a new system which this series of experiments is intended to test.

It is specially requested that between the hours given below amateurs in this country will avoid oscillation, and listen rather to the re-transmitted messages with a view to reporting to the Metropolitan-Vickers Company the success of the experiment. The first attempt will be made on New Year's Eve, and, if reception is successful, re-transmission will probably commence shortly after midnight, but, in any case, as soon as possible after the British Broadcasting Company's

stations have closed down. During the remainder of the week it is hoped that it will be possible to radiate a message at 11.30 each night, or immediately after the B.B.C. stations shut down (should they continue after this hour), whether or not relaying is likely to take place that night, and at what time. In all probability relaying on favourable nights will commence at 11.30 p.m. to midnight. Special messages will be sent from America at 1.00 a.m., and it is hoped that Mr. Sidney J. Nightingale, of the Metropolitan-Vickers staff, who is at present in America, will contribute one or two vocal items to the programme sent out by "KDKA."

For the purpose of collecting experimental data, the Metropolitan-Vickers Company will be interested to receive reports from those who are able to listen to the re-radiation (anyone who is able to pick up the Manchester Broadcasting Station of the British Broadcasting Company should be able to hear this re-transmission). Such reports should be addressed to:—

Mr. A. P. M. Fleming,
Manager of Research and Educational Departments,
Metropolitan-Vickers Electrical
Co., Ltd.,
Trafford Park, Manchester.

N.B.—All the times mentioned are British time.



Christmas Cheer.

IF anything can ever bring back to us the good old-fashioned Christmas when all were as merry and as bright as could be, and when even the staidest of men laid aside their dignity for the nonce and skipped like young rams, wireless will do the trick. Thanks to it there will be music in hundreds of thousands of home. Under the inspiring influence of the Uncles the kiddies will fling off that tired feeling induced by too steady application earlier in the day to turkey and plum pudding. Their elders will forget gouty toes, and hobnailed livers when the orchestra strikes up. All will be joy and jollity. So tolerant will they be of everything that they will not even switch off as usual when the egregious "entertainer" prepares to make the microphone shudder. The young folk will dance their heels off, and will look deeply into one another's eyes when the contralto and the tenor oblige with particularly sloppy items. A tendency to high frequency osculation will be noticed where mistletoe is present.

Some wonderful programmes are in preparation, I hear. From London, Captain Eckersley is arranging to relay from the Restaurant Magnificent the suggestive noises emitted by profiteers as they ingurgitate their Christmas dinner. Not to be outdone, Bournemouth will endeavour to transmit the postprandial groans of its distinguished invalids. Glasgow hopes, by means of the new Popoff-Yuvadenuff naso-frequency method, to broadcast the smell of a cooking haggis. Listeners are urgently warned not to use reaction for this item.

Adding to the Gaiety.

The prospects of a really cheery Christmas, then, are of the brightest. There will be little contretemps, of course. Poddle-

flat's accumulator will conk out just when things are at their best. Snooksby will be unable to tune in anything, and will have disembowelled his set before he discovers that he has not remembered to attach the aerial. Prognapp will be horrified to see that a valve has burnt out, and will run about the city grinning like a dog in search of a spare, only to find later that he had omitted to turn the rheostat from the "off" position.

But these little things will only add to the general gaiety of the nation. The only households that I have any doubts about are those of fellows like Gubbleby and Potsworthy, who are more than likely to sit up all night on Christmas Eve listening for America, and thus to be feeling far from hilarious when the time of jollity draws on. So strongly do I feel about it that I am constrained to invoke the muse and burst into song.

A Song of Christmas Morn.

'Tis Christmas morn. Two hours ago
The bells rang out their midnight chime,

Two hours and more.
And in the homes of high and low
Folk slumber, recking naught of time

They simply snore.

The night is cold and black; a gale
Is screaming, shrieking, blustering,
A reg'lar snorter.

In fact with rain and sleet and hail

The weather's doing everything
It didn't orter.

But all is peace, for anyhow
When you're asleep you do not care

If it snows ink.
And all the world is slumbering now.

If a light's burning anywhere,
Then strike me pink.

But stay! What's that? I spy
a gleam
From yonder casement. Let
us peep,
There's one awake.
Whilst others snore and grunt
and dream,
Here's one who robs himself of
sleep.
It takes the cake.

With chattering teeth and shivering
hands
In his chill den he sits alode*
And sniffs and sneezes.
Before him, see, a table stands
Decked with the most unholy load
Of bits and pieces.

To his blue ears the 'phones are
clamped;
Silence enfolds them like a pall.
KDKA,
Is what he's after. Never
damped
He yearns to hear a nasal drawl
From U.S.A.

And thus he'll sit and twiddle
knobs,
Inventing whackers without end,
Such tales! But hush,
He's galvanised. He thrills.
He throbs. . . .
Ah! what a gay deceiver, friend,
Is Northolt's mush!

But when the world to Christmas
wakes
He'll be as grumpy as a bear
With a sore head.
'Tis sad that radiomania makes
This erstwhile cheery father
swear,
Even see red.

And so take warning ere you
wreck
Your Christmas cheer by burn-
ing, rapt,
The midnight amp.
Keep your devotion well in check
For Mistress Radio, for She's
apt
To be a vamp.

*He has a cold.

Treating Father Gently.

And now let Uncle Wayfarer broadcast a word to the kiddies. Be especially kind to your fathers, all you boys and girls, at this jolly season. You have thrown all cares aside. "Impots" and punishment drills no longer hang over you like the sword of the unfortunate Damocles. You can frisk as you will with never a worry in the world. But what of him? Ah, what? He is what the vulgar call "going through it." Though he may preserve a smiling exterior, awful fears and doubts are preying upon his grey cells.

For it falls to him to look after the wireless set, and he is jolly well certain that something will go wrong with it in a minute. Wireless sets are the shyest things in the world, and they are very apt to become dumb in the presence of a crowd. Therefore treat your fathers gently, remembering that they have much to bear. Stifle your mirth if three valves go up in a blue flame; do not chuckle when he gets a shock from the loudspeaker terminals; condole with him if the brightness of the filaments growing small by degrees and beautifully less heralds the accumulator's dying gasp. If he can get nothing but

crackles and splutters, talk loudly to your friends about atmospherics.

A Merry Christmas.

May I be permitted to wish each and everyone of those readers who have the fortitude to read through these random notes the best and happiest of Christmasses? May our sets behave perfectly, may your neighbours refrain from oscillating! May your high-tension batteries be purged of crackles! May your crystals become miraculously supersensitive!

WIRELESS WAYFARER.

A RACK-AND-PINION OPERATED LOOSE COUPLER

Though the rack-and-pinion system to be described can be applied without difficulty to any kind of loose coupler, the writer has found that one of its best uses is for working a reaction coil coupled to the inductance of a tuned-anode. In this case the primary or outer coil forms the anode inductance, and the inner sliding coil that of the reaction. Where an anode inductance is made to cover a fairly narrow band of wavelengths, such, for example, as that of the home broadcasting stations, no tapings are necessary for either this coil or the reaction. A 0.0002μF condenser shunted across each will be all that is necessary to tune them. In this case the coils made up into a small loose coupler can be mounted beneath the panel, nothing but a knob attached to the spindle of the pinion appearing above it.

This kind of small loose coupler makes one of the most satisfactory arrangements for working with. It does not occupy a great deal of space, and it allows reaction coupling to be adjusted to a nicety. It is important, by the way, that there should be sufficient length for the secondary coil to be able to slide right out of the primary, for with a mode-

ately strong signal only the loosest coupling will be needed.

The dimensions are not given in the drawing, since they will depend naturally upon the size of the coils used and of the kind of rack and pinion that the constructor is able to obtain. It is thought, however, that the drawing will make things sufficiently plain to anyone who desires to fit up this kind of adjustment.

The rack and pinion will in many cases be found in the lumber room as parts of an ancient and discarded stand camera or microscope. They are often to be picked up at second-hand shops which deal in odds and ends, or at those shops which supply photographic accessories.

A suitable pinion can always be obtained from a clockmaker, even if a rack is not forthcoming, and anyone who is fairly handy with a file will be able to cut quite a good rack for himself. An easy way of doing this is as follows: Mount the pinion upon a spindle of 2B.A. studding and run it over the surface of a piece of paper pressing it hard down. The teeth will make depressions in the paper which will enable the pitch to be measured without difficulty. Now take a piece of 3/8-in. square brass rod and with ruler and setsquare

transfer the marks upon the paper to it. Measure the depth of the teeth and make a hacksaw cut to correspond with each mark. It will not now be a difficult task to trim the teeth up with a fine file until they mesh perfectly with those of pinion.

The rack is mounted upon the ebonite disc of the sliding coil simply by drilling and tapping two 6 B.A. holes in it and inserting a pair of screws from the inside of the disc. It passes through a square hole cut in the bracket which supports the bearings of the pinion spindle. This supports it and prevents it

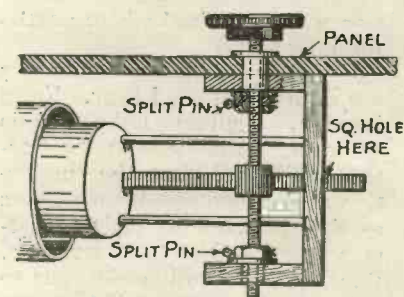

Illustrating the arrangement of the rack and pinion.

from being thrust away from the pinion. The pinion's bearings are formed as shown by three standard bushes. The spindle is secured by two nuts placed on the inside, these nuts being secured by small split pins passed through holes drilled through both nut and spindle.

R. W. H.

HOW TO DESIGN YOUR OWN SET

No. III.

By PERCY W. HARRIS, Assistant Editor.

The third article of a series of six which began in Vol. 3, No. 1.

Design of Single-layer Tuning Coils.

Whether we use method No. 2 or 3, we shall require to wind a single-layer inductance. The reader is strongly advised to use a fairly heavy wire for his inductance, such as No. 22, or, if the inductance has to be very large, No. 24 or 26. While it is sometimes convenient to use fine wire to enable the inductance to be wound in a small space, signal strength is undoubtedly sacrificed in this way. Particularly when using crystal detectors it is advisable to have as thick wire as possible, so as to reduce the high-frequency losses. In valve sets where reaction on to the tuning coil is used, the importance of thick wire is not so great, although even here careful test will show that thick wire gives better results than thin wire.

A whole book could well be written on the design and construction of inductance coils, and in a series of articles which attempts to embrace the general principles of the design of wireless apparatus we cannot do more than indicate a few leading points. It should naturally be our aim in designing a tuning coil to get the maximum inductance for the amount of wire used, for which reason the length of a coil should not greatly exceed its diameter. By this we mean that a given number of yards of wire wound on a long former of small diameter will not give so much inductance as the same amount of wire wound on a shorter former of much greater diameter. In general practice for broadcast wavelengths, a 3- or 3½-in. former will be found very suitable.

Choice of Kind of Wire.

The man who makes his own apparatus has a wide choice of wire, not only in the sizes, but

also in the method of insulation. Thus he may use enamelled wire, single-cotton covered, double-cotton covered, single-silk covered or double-silk covered. These are known as enamelled s.c.c., d.c.c., s.s.c., and d.s.c.

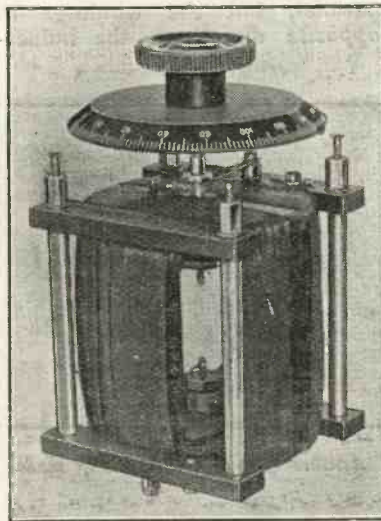

A typical commercial variometer.

respectively. It is also possible to obtain (although it is not generally sold yet by dealers) wire which is not only enamel insulated, but also double-cotton covered as well. Such wire has many advantages, and I would like it to be more generally obtainable.

As in many other wireless matters, we must compromise when designing tuning coils. In order to get a maximum efficiency, the self-capacity of our tuning coil (that is to say the capacity between turns and between various parts of the coil) must be reduced to a minimum; further, we must avoid dielectric losses in the insulating material. Enamel insulation has the advantage that it does not absorb moisture from the air, but this advantage is outweighed by the fact that the insulation

is exceedingly thin, and thus turns wound close to one another are separated by a very tiny film of insulating material. The fact that adjacent conductors are so close to one another means that the capacity between turns is high, and in many cases this will rule out the use of enamel-insulated wire. When we come to cotton-covered wire, we find that these have the distinct advantage of a fairly thick insulating covering, which enables the turns to be better spaced, the double-cotton covered wire naturally giving a wider spacing than the single-cotton covered, but here again we have a disadvantage of importance. Cotton is particularly susceptible to atmospheric conditions, and will absorb a very considerable quantity of moisture from the air. This moisture gravely affects the insulation of the coil, its self-capacity and general losses. For this reason it is sometimes advisable to bake the coil and impregnate the cotton insulation with a material such as paraffin wax or shellac. We do not overcome all disadvantages by so doing, for although we make the coil more or less immune to the presence of moisture in the air, we introduce into the space between turns a material of very high dielectric value, which therefore greatly increases the self-capacity. If we should impregnate a coil with paraffin wax or shellac, only the barest minimum should be used.

Silk insulation possesses the disadvantage of being affected as least as much as cotton by the presence of moisture, and its insulation is thin. A silk-covered wire coil thus has a greater self-capacity than a cotton-covered. It is possible that a coil wound with double-silk covered wire and not impregnated with any insulating material such as paraffin or shellac, is preferable

to a coil wound of double-cotton covered wire and impregnated, but there seems to be no agreement among experts on these points. Certain makes of multi-layer coils are impregnated with a synthetic resin compound, the coils first of all being dipped into a solution and then rapidly whirled so that the surplus insulating material is removed by centrifugal force. The coils are then baked. Another make of coil is wound with double-cotton covered wire not impregnated, absorption of moisture being largely prevented by wrapping the whole coil very carefully in "Empire" cloth, a kind of varnished fabric.

Tappings on Coils.

There are many methods of tapping coils, perhaps the simplest being to wind up to the point where tapping is required, hold the wire down with the thumb, taking a loop of the wire and twisting it up, continuing the winding once again until the next tapping is reached. When the whole coil is wound, the end of the loop may be scraped and the wire soldered to this and taken to the switch point. Another simple method is to wind up the point where the tapping is required, bend the wire back and make a complete turn over the wire already wound, and then carry on back again on the former until the next tapping point is reached. After the whole coil is wound and impregnated (this method is best when impregnating the coil), the loop is cut and the two ends twisted together up to the point where the winding continues on the former. Still a further method is to take a strip of ebonite and, when the tapping point is reached, carry one turn over the strip. When the next tapping point is reached, the ebonite strip is pushed forward, and the same procedure adopted until, at the end of the coil, one has a strip of ebonite the whole length with a wire running over it at each point where a tapping is required. This is probably the neatest and most efficient way of all, although the beginner may find it a little difficult to apply.

Variometers.

Many beginners seem to think that the variometer is a mysteri-

ous and wonderfully efficient piece of apparatus, enabling much better signals to be received with crystal apparatus than by any other method. Whilst a good variometer is very efficient, even the best of them can be equalled in signal strength by the other methods if these are suitably carried out. A variometer is simply a pair of inductance windings arranged so that one may rotate within the other. When the two windings are parallel with one another and in the same direction, a maximum inductive action will be obtained. If now one winding be rotated through 180 deg., so that the two inductances are once more parallel, but the windings in *opposite* directions, the induct-

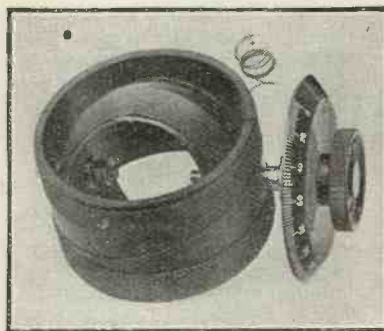

Another type of commercially made variometer.

ance of one winding will tend to neutralise that of the other. We now have a minimum inductance. By varying the angular displacement of the coils, we can pass from a minimum to a maximum inductance in even progression.

The simplest variometer of all is probably two coils of wire wound on two cardboard tubes or formers, the smaller being of such a size that it can just be rotated inside the larger. A spindle can be passed through the two formers, the inner former being rigidly attached to the spindle so that a knob will enable a turning movement to be given. In making variometers one should use as large wire as possible. Such a variometer, however, will not enable a very large range of inductance to be obtained, for the inductive effects at its maximum between the two coils will not be particularly great. The construction of a variometer of maximum efficiency

is rather beyond the abilities of the experimenter, as will be seen by examination of a highly-efficient variometer. In America the design of variometers has been carried to a wonderful degree of efficiency. The best form of variometer for obtaining the widest range of inductance is that in which the stationary winding is wound on the inner side of a globular former, the moving winding being wound on the outside of a ball of such a diameter that when the wire is wound on both formers there is the barest clearance between them. Quite efficient spherical variometers can be wound by the method described in Mr. E. Redpath's book, "The Construction of a Unit Receiver." In the best commercially manufactured variometers, the amount of dielectric material in the formers has been reduced to a minimum, thus avoiding losses.

Efficiency of Variometers.

A variometer is working at its maximum efficiency when the two windings are parallel and in the same direction, that is to say, when it is giving its maximum inductance. The whole of the wire in the variometer is then used at high efficiency. A variometer is least efficient when it is set for minimum inductance, for in this case a great deal of wire is used to obtain an inductance which could otherwise be had with perhaps a quarter of the amount. The high-frequency losses are thus larger than need be for the particular inductance. However, few variometers are used at the minimum point, and therefore you are not likely to find serious losses in variometer tuning. The range of variometer can, of course, be greatly increased by shunting its windings with a fixed condenser of such a value that when the variometer is set at the minimum the fixed condenser will bring the wavelength up to just below the wavelength the variometer would give at its maximum without this condenser. It is easy to arrange the tuner with a fixed 0.0003 μ F condenser across a variometer, so that one can obtain the first range of wavelength from minimum to maximum on the variometer alone, and then the second range from minimum to maximum with condenser.

CIRCUIT No. 5.
A SINGLE-VALVE
RECEIVER
WITH REACTION.

Connecting Up.

GRID condenser Plug No. 1 "in." Grid leak Plug No. 2, shunted (S). A.T.I.

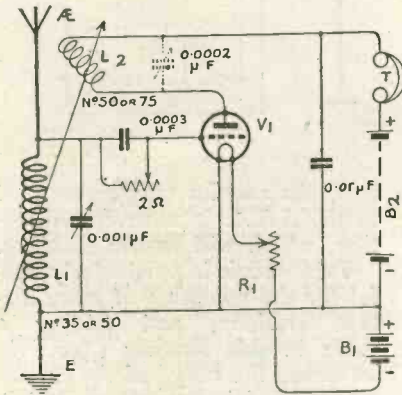

Fig. 5A.

connected to $\mathcal{A}E$ and $-E$. Reaction coil connected to P and XHT+. Telephones connected to terminals 2 and 3. Battery and $-LT$ straps in position. Fixed condenser ($0.01 \mu F$) between terminals 2 and $-HT$.

Connecting Up.

Plug the crystal detector into sockets 1 and 2. Grid condenser Plug No. 1 "out." Grid leak Plug No. 2 "out." One end of A.T.I. to terminal 2, and the other end to earth and to O.P. terminal of L.F. transformer. I.P. terminal of transformer to terminal 1. I.S. of transformer to $-E$ and O.S. of transformer to $\mathcal{A}E$ terminal. Telephones connected to terminals P and 3. Both of the short-circuiting straps in position. FC Plug No. 4 "out." AR Plug No. 3 "out" for ordinary valve.

Note.—Try the effect of reversing the connections of the L.F. transformer to see which arrangement gives the best result. Also, try earthing the negative side of the LT battery, as shown by dotted line.

General Notes.

This circuit represents a complete crystal receiving set with a low-frequency amplifier (or note-amplifier) added. It is probably

" WIRELESS WEEKLY "
UNIVERSAL VALVE PANEL

Below appear four further circuits of the twenty possible arrangements, using this panel as the main unit.
Constructional details were given in Vol. 3, Nos. 1 & 2.

General Notes.

In this circuit electro-magnetic reaction is employed. The reaction coupling must be adjusted very carefully as the circuit oscillates readily, and is therefore liable to cause interference with adjacent receiving stations. The presence of oscillations can be detected by the peculiar "cluck" which occurs as the reaction coupling is increased or as the aerial terminal of the set is touched with the moistened finger tip. Modifications which may be tried include connecting the telephones between the $-HT$ and $+LT$, with a short-circuiting plug between terminals 2 and 3; and connecting the earth end of the A.T.I. and aerial condenser to the positive side of the LT battery instead of to the negative.

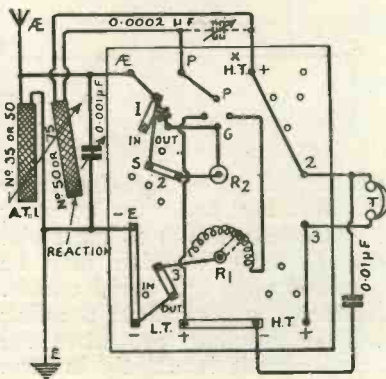

Fig. 5B.

FC Plug No. 4 "out." AR Plug No. 3 "out" for ordinary valve. The reaction coil may be tuned by means of a small capacity variable condenser, indicated by dotted lines.

CIRCUIT No. 6.—A CRYSTAL RECEIVER WITH L.F. AMPLIFYING VALVE.

the most effective way of amplifying signals which are sufficiently strong to actuate the crystal detector, and, with care-

The operation of this circuit is precisely the same as that when using a crystal receiver, the only additional requirement

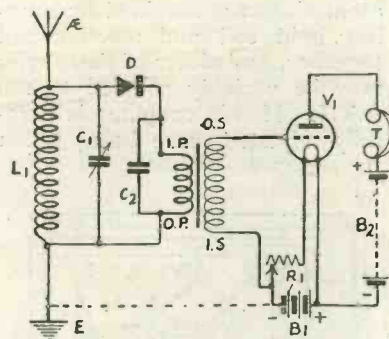

Fig. 6A.

ful adjustment, should enable a small loud-speaker to be operated at distances of 8 or 10 miles from a broadcasting station. It is a very simple circuit to operate and cannot cause any interference with adjacent receiving stations.

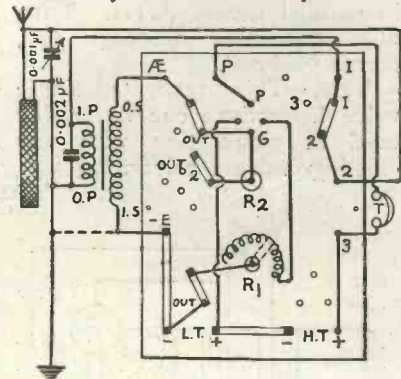

Fig. 6B.

being the adjustment of the filament rheostat. The effect of connecting a fixed condenser (say, $0.0005 \mu F$) across the IP and OS terminals of the L.F. transformer, as described in recent "Valve Notes," should also be tried.

**CIRCUIT No. 7.
HIGH FREQUENCY
AMPLIFICATION (WITH
REACTION) AND CRYSTAL
RECTIFICATION.**

Connecting Up.

Grid condenser Plug No. 1 "out." Grid leak Plug No. 2 "out." A.T.I. connected to $\mathcal{A}\mathcal{E}$ and $-E$ terminals. Tune the tuned anode coil (L_2) connected to terminals P and 3, with $0.0002 \mu F$ variable condenser in parallel across the coil. Crystal detector plugged into sockets 2 and 3. Telephones connected to terminals 2 and 3. Both battery straps in position. Plug No. 3 AR "out" for ordinary valve. FC Plug No. 4 "out." Variable condenser $0.001 \mu F$, in parallel across A.T.I. Fixed condenser ($0.002 \mu F$), shunted across telephone receivers.

General Notes.

This circuit employs the tuned

Connecting Up.

Grid condenser "in." Grid leak, shunted (S.). Place crystal detector in sockets Nos. 1 and 2. Connect one telephone lead to terminal No. 2, and the other to the earth lead and the earth end of A.T.I. Both battery straps "in." Connect grid coil to $\mathcal{A}\mathcal{E}$ and $-E$ terminals. Connect reaction coil to terminals P and 3. Variable condenser ($0.001 \mu F$), in parallel across A.T.I. Variable condenser ($0.0005 \mu F$), across grid coil.

Note.—This separate single valve heterodyne can be readily used in conjunction with any existing valve receiver.

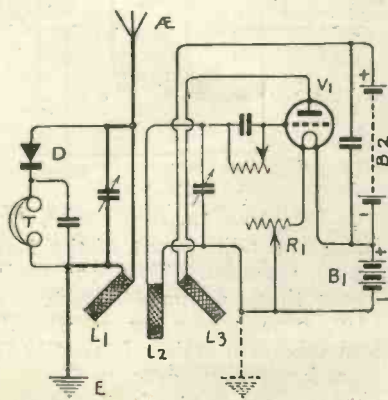

Fig. 8A.

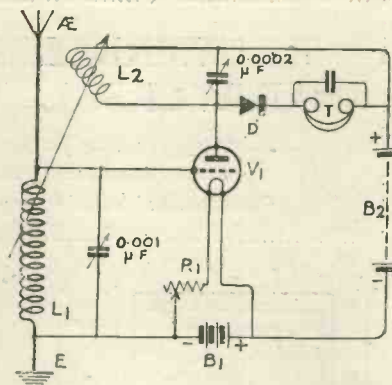

Fig. 7A.

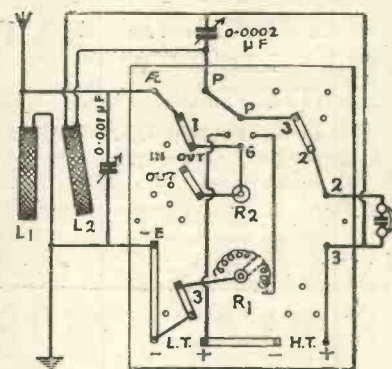

Fig. 7B.

anode method of high-frequency amplification, and, by coupling the anode coil (L_2) to the aerial coil (A.T.I.), reaction may be obtained upon the aerial circuit. Normally, a very slight coupling will be required, as, when the anode circuit is exactly in tune with the aerial circuit, there is an inherent tendency to oscillate. If trouble is experienced due to

this, the coil L_2 may be coupled to the A.T.I. in a reverse direction, which will ensure stability.

This circuit is particularly useful for the reception of more distant stations, and adding a valve in this manner effectively increases the range of the crystal set, but a fair amount of skill in adjustment is required to obtain the best possible results.

**CIRCUIT No. 8.—A CRYSTAL RECEIVER WITH
SEPARATE SINGLE-VALVE HETERODYNE,**

General Notes.

The employment of a separate heterodyne is particularly useful in the reception of long waves, where, owing to the amount of detuning necessary with a self-oscillating or autodyne receiver, there is a considerable loss of signal strength. The local oscillations are obtained by coupling grid coil and reaction coil together, and either of these coils may be variably coupled to the A.T.I. If this coupling is carefully adjusted, care being taken

to avoid too tight a coupling and consequent radiation from the aerial, signals from fairly distant stations can be received, including continuous wave transmissions, which would otherwise be inaudible on an ordinary crystal set. For the reception of short-waves the $0.001 \mu F$ variable condenser may be connected in series in the aerial circuit, between the aerial end of the A.T.I. and the aerial itself, the coils L_1 L_2 and L_3 consisting of suitably wound basket coils.

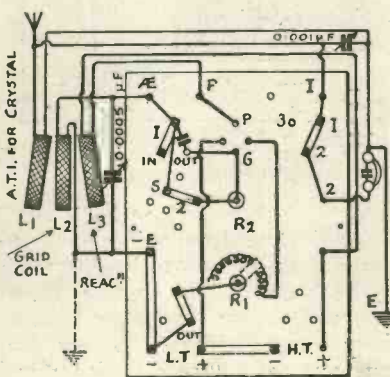

Fig. 8B.

TO OUR NEW READERS.

Why not get the back numbers and have a complete set? We have them all from No. 1. 7½d. per copy, post free from

RADIO PRESS, LTD.
Devereux Street, W.C.2.

A NOVEL EXTRA RESISTANCE FOR DULL-EMITTERS

NOW that the experimenter is dealing from time to time with valves which require filament voltages so widely different as the Wecovalve (.8—1.1 volts), the Mullard L.-F. Ora and M.O. D.E.R. (1.8 volts), D.E.V. and D.E.Q. (3 volts), Ora and R. (4 volts), V24 (just over 5 volts), and the various patterns of power amplifying

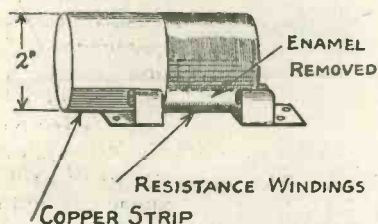

Fig. 1.—The Resistance.

valves, most of which take about 6 volts, the ordinary 5 or 6 ohm rheostat does not enable him to control the output of a 6-volt accumulator, so that it can be used with any of these types.

There are various ways of overcoming the difficulty. Special batteries may be used for low temperature valves, or the accumulator may be split up into separate cells and a switch arranged so that the E.M.F. can be made at will 2, 4 or 6 volts. The most satisfactory arrangement, however, is to provide some form of auxiliary resistance which may be varied from about 30 ohms to zero. This, wired in

series with the existing rheostat, will enable one and the same battery to be used for all types of valves that require filament potentials between about .75 volts to 6 volts.

A very convenient form of extra resistance is shown in Fig. 1. The former is a piece of $\frac{1}{4}$ in. ebonite $4\frac{1}{2}$ in. long by 2 in. wide. The corners are bevelled off, as shown, to make the winding of the wire evenly and tightly, an easier matter. Two strips of thin sheet copper or brass $2\frac{1}{4}$ in. long and $\frac{3}{4}$ in. wide are cut out and fixed to the lower edges at each side of the former by means of countersunk 6 or 8 B.A. screws. The windings consist of about 120 turns of No. 28 gauge enamelled Eureka resistance wire. As this wire makes sixty-one turns to the inch, the windings will occupy about 2 in. if wound closely, thus leaving space $\frac{1}{4}$ in. or so at the end of the former. The starting end of the wire is passed through a hole drilled right through the copper strips and the former, and is soldered to both strips. The other end is anchored in the usual way.

The clips, the shape of which is shown in Fig. 2, are easily made from springy sheet brass, T-shaped pieces measuring $4\frac{1}{4}$ in. across the arms and $1\frac{1}{4}$ in. from top to bottom of the upright, are cut out and bent into shape with pliers.

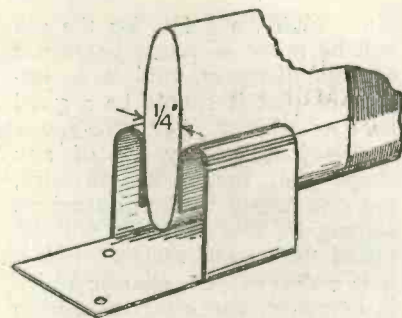

Fig. 2.—One of the Clips.

The clips are mounted 2 in. apart either on the valve-holder or on a small base of their own. The enamel is now carefully removed from the wire along a band about $\frac{3}{4}$ in. wide at the lower edge of the windings on each side of the former, in order to ensure good contact with the clips. This is easily done with fine glass paper.

It will be seen that when the resistance is placed as shown in Fig. 1, practically the whole of the windings are in play. As it is moved towards the right, less and less extra resistance is brought in, and when the copper strip makes contact with both clips, it is altogether out of action. The extra resistance and the rheostat can thus be worked one against the other until exactly the right voltage for any particular valve is found. As the current carrying capacity of No. 28 Eureka wire is 1 ampere, the resistance can be used for controlling any ordinary type of "high temperature" valve, and may be employed in connection with two or more dull emitters, according to their current requirements.

R. W. H.

A REALLY satisfactory transmitting key is rather expensive to buy, but one that will be found most convenient to use, either for actual transmission or for morse practice with a buzzer, can be constructed very easily in the workshop. As most of its parts can be made from odds and ends from the scrap box, its cost will be very small indeed.

Fig. 1 shows the finished key. It will be seen that the travel can be adjusted by means of the

A SIMPLE MORSE KEY

milled headed screw provided with a lock nut, seen at the right hand end of the bar, and that as the return spring is also adjustable, the user can set the key to suit both his speed and touch.

The bar should be preferably of 5/16-in. square brass rod, but if a four-inch length of this is not

to be found in the scrap box, either $\frac{1}{4}$ -in. or $\frac{3}{8}$ -in. rod will do quite well. Drill the rod as shown in Fig. 2, tapping the hole for the adjusting screw 4B.A. and drilling the other two between the horizontal faces 4B.A. clearance. The hole made from side to side, which is for the pivot

pin, should be $\frac{3}{8}$ in., for the pin will be made of round brass rod of this diameter, and it is important that it should be a good fit.

The handle may be of any shape that the maker favours, but one turned to the dimensions shown in the drawing will be found very comfortable. Below it is a disc of $\frac{1}{2}$ -in. ebonite $1\frac{1}{2}$ in. in diameter, which serves to keep the hand from coming into contact with the bar.

The upper contact, a little piece of platinoid, is fixed into the middle of the underside of the

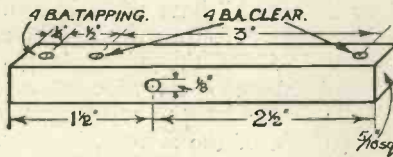

Fig. 2.

bar, 1 in. from its end. The lower contact is made by drilling a suitable hole in the top of an ordinary contact stud and inserting a piece of the same inexpensive, but quite efficient, material.

The bridge should be filed out of a piece of brass measuring $\frac{3}{4}$ in.

by $\frac{3}{4}$ in. by $\frac{1}{2}$ in. The slot cut in it should be a close fit for the bar, and it should be deep enough to allow the key to be fully depressed without coming into contact with its lower edge. The ends of the pivot pin should be spread over slightly by tapping

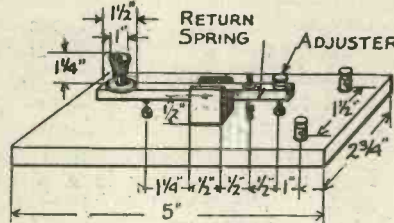

Fig. 1.

Figs. 1, 2, 3, showing key and constructional details, together with wiring diagram.

clearance holes should be drilled are seen in Fig. 1. There are, of course, two others as well for the screws securing the bridge.

The adjuster is a 1-in. 4B.A. screw with a milled head. A milled ring nut put on below its head serves to lock it once the best setting has been found. Below the point of the screw is a second stud.

The return spring is a short piece of coil spring, each end of which is bent into a small, almost closed hook. The lower fits into a hole in a small piece of 4B.A. studding screwed into the ebonite

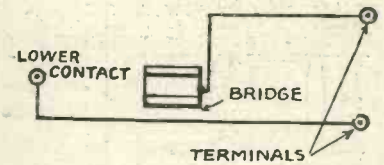

Fig. 3.

with a hammer. Two 4B.A. tapped holes are drilled in the lower side of the bridge for the screws which secure it to the ebonite base.

This base measures 5 in. by $2\frac{3}{4}$. The points at which 4B.A.

base. The upper is attached to a $\frac{3}{8}$ -in. length of 4B.A. studding which passes through the bar and has a milled, adjusting ring nut.

The wiring of the key is shown in Fig. 3.

R. W. H.

ONE has to "nurse" ordinary dry cells a little when they are used for heating the filaments of Wecovalves or other dull emitters in order to get the best out of them. Handled with reasonable care they will work satisfactorily and will have a respectably long life, provided that they are of ample proportions, otherwise they will soon become noisy and useless.

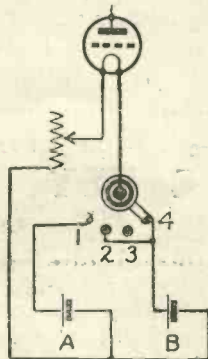

Fig. 1.—The wiring of the switch.

It should be noted that if two dry cells of equal size are wired in parallel their life is from two and a half to three times that of one cell.

A SELECTOR SWITCH FOR PEANUT DRY CELLS

Normally, then, it is best to use two cells in parallel; but it is also desirable to give them a complete rest from time to time. Fig. 1 shows the wiring diagram of a switch which enables this to be done without difficulty.

When the arm is placed upon stud No. 1, cell A only is in circuit. Stud No. 4 brings in cell B by itself. No. 3 is a dead stud, which acts as an "off" point for the switch. If the arm is turned so that it rests upon both stud No. 1 and stud No. 2, then both cells are brought in connected in parallel.

To make this switch (Fig. 2) obtain a selector arm with knob spindle and bush such as is sold by advertisers in this journal for about 1s., four studs $\frac{1}{4}$ in. in diameter and a pair of stop pins. Drill the holes for the studs with centres $\frac{5}{16}$ in. apart on the circumference of an arc of a circle

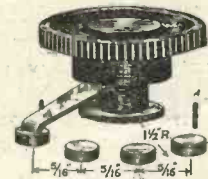

Fig. 2.—The completed switch.

whose radius is the same as that of the switch arm; this will usually be $1\frac{1}{4}$ in. or $1\frac{1}{2}$ in. Place the stop pins so that the arm cannot travel beyond the end studs.

The switch is best mounted directly on the battery box. A piece of hard wood $2\frac{1}{2}$ in. by 2 by $\frac{3}{8}$ in. thick makes an excellent base for it. It is unnecessary to use ebonite owing to the low voltages that it is called upon to deal with, but soft or unseasoned wood should be avoided.

R. W. H.

A SHORT-WAVE RECEIVER

By A. D. Couper, M.Sc.,
Staff Editor.

Some notes on a circuit of especial interest to those who are experimenting in short-wave reception.

THOSE who served with the Wireless Section of the Royal Air Force during the late unpleasantness, may recognise the type of short-wave receiving circuit illustrated here; but it does not appear to be very well-known amongst amateurs.

It is a commonplace that with extremely high-frequency waves the grid-to-filament capacity of the ordinary valve is responsible for a serious loss of signal-strength. This is accentuated if further capacity is introduced by the tuning device, as, for instance, a tuning condenser in parallel with the A.T.I. For this reason, special types of valves in which the filament connections are kept as remote as possible from the grid (and

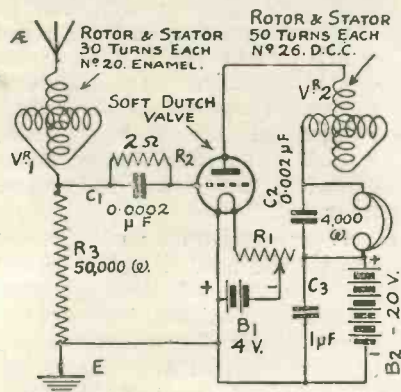

Fig. 1.—The circuit arrangement.

plate) have been developed, such as the Marconi tubular type of valve, which is particularly suitable for short-wave reception.

A good deal can be done, however, to minimise this loss by using a series condenser of fairly small value. In the circuit here described, this principle has been taken to the logical limit by using the grid-to-filament capacity of the valve itself as the small

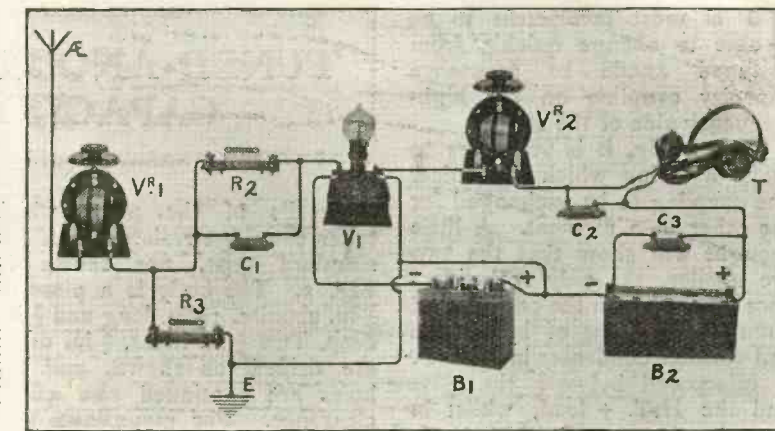

Fig. 2.—A pictorial representation of the circuit shown in Fig. 1.

series condenser, and tuning by means of a variometer placed in series in the aerial circuit.

By this ingenious device the ordinary type of bulbous valve can be used quite successfully in reception down to about 100 metres wave-length. Reaction must almost necessarily be obtained by means of a tuned-anode. With low-resistance variometers, and particularly by the use of easily oscillating "soft" valves, no difficulty is experienced in bringing up reaction to the oscillating point, if necessary for autodyne reception of C. W. Morse.

An extra advantage, from the point of view of the amateur with limited resources in the way of apparatus, is that by this arrangement of a series variometer, the ordinary tuning units provided for broadcast reception can be used, without modification, for occasionally listening to the numerous transmissions on about 180 to 230 metres nightly committed to the ether by experimental 10-watters. Even with a P.M.G. type of double-wire aerial, of 0.0003 μ F capacity, there is no difficulty in picking up, e.g., South-East London transmitters at a point in outer N.W. London, on a single Dutch valve with 20 volts on the plate, at comfortable strength in the 'phones—after broadcasting has finished for the evening. This does not represent exactly any record in reception, but merely indicates what can be done at any time on a fairly "heavy" aerial and without any special short-wave equipment.

A particular point to notice is the extraordinarily low value of

the second grid-leak type of resistance right across the grid and filament. Experiment shows that this is necessary. The value does not appear to be critical but it must be much lower than one would expect and the ordinary anode resistance of around 50,000 ohms suffices. With soft valves, the regular grid-leak can often be omitted altogether, although the writer found that, with a soft Dutch valve, a 2-megohm Dubilier leak slightly improved clarity of reception.

The aerial variometer *must* be of low H.F. resistance, as otherwise the set will not oscillate at all. A large variometer wound with No. 22 d.s.c., about 60 turns each, on rotor and stator, offered far too much H.F. resistance. A Bowyer-Lowe variometer, of the ebonite tube type, stator about 4 in. diameter, wound with No. 20 enamel-covered wire, was very successful. The plate variometer was of the small moulded composition type with internally-wound stator (about 3 in. diameter) and ball rotor, rewound with No. 26 d.c.c. about 50 turns each.

With the soft Dutch valve, both filament temperature and plate voltage were, as usual, rather critical, but the results were well worth a little trouble in adjusting these. The filament volts were less than 3.5, for best reception and easy oscillation.

The wave-length range of the set as described, with a P.M.G. double aerial, was from below 100 to about 250 metres, and it oscillated readily within this range with 20 volts H.T., and proper setting of the plate variometer.

IT is most convenient to be able to change quickly from tuned anode to resistance capacity coupling on the high-frequency side of the set.

Fortunately, it is very easy to make a fitting which will allow one coupling to be exchanged for the other in a moment. A little thought will show that the two are similar, the only real difference being that in the one a tuned circuit, consisting of inductance and variable condenser in parallel, is interposed between the plate and the H.T. + lead, whilst in the other its place in this circuit is taken by a fixed non-inductive resistance with a value of about 80,000-100,000 ohms.

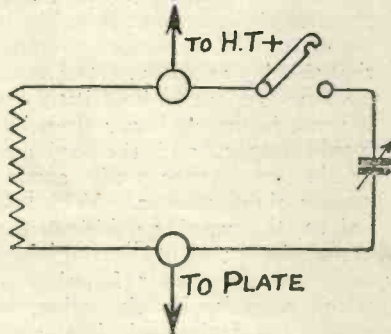

Fig. 1.—Showing switching method for cutting out condenser.

All that we have to do then to solve the problem of interchangeability is to design a resistance that can be plugged in in place of the usual anode coil, and to find some way of removing capacity due to the tuning condenser. This latter we need not worry about, if the condenser is specially designed to have a very low minimum value; it will be sufficient to set it at zero. In most condensers, however, the minimum is at least ten per cent. of the maximum. With a condenser of the ordinary type, therefore, it is best to provide a simple switch to enable the capacity to be cut out, as shown in Fig. 1.

TUNED-ANODE OR RESISTANCE CAPACITY COUPLING

Details of the plug, which takes cartridge resistances of the standard type, are shown in Fig. 2. The body is a piece of 1/2-in. ebonite, 1 1/2 in. long and 3/4 in. deep. Two 1/4-in. holes, 1/2 in. deep, are drilled, as shown, and the holes are continued size 4 B.A. clearance. For mountings that take standard De Forest coils the holes will be 9/16 in. apart.

Insert a plug into one and a socket into the other; they will be found to be a good driving fit for the 1/4-in. holes. Fix them in place by 4 B.A. screws driven through from the sides, as shown. Now, through the holes at the top, drill and tap a 4 B.A. hole in the top of both plug and socket.

Cut out two little L-shaped pieces of sheet brass, drilling a 4 B.A. clearance hole in one arm and a 3/16-in. hole in the other. The clips should be of such a length that when they are mounted by means of 4 B.A. screws, driven through them into

plug and socket, their upright arms are about 2 1/8 in. apart. A cartridge resistance can now be slipped into place, its pointed ends fitting into the 3/16-in. holes. When this is done the device is ready for use (Fig. 3).

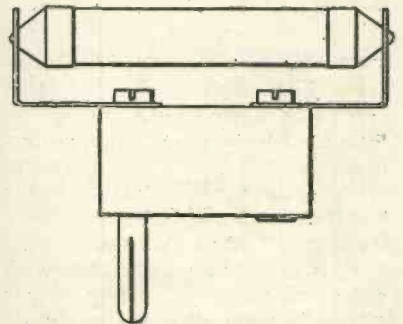

Fig. 3.—The finished plug.

It must be remembered that a higher anode voltage will now be needed for the high-frequency valves, in order to compensate for the drop that occurs across the large resistance introduced.

Should the constructor not desire to go to the expense of cartridge resistances, he will find that very good results can be obtained by using in their stead match sticks that have been dipped in Indian ink and allowed to dry. These should be slightly pointed at the ends, 3/32-in. instead of 3/16-in. holes being drilled in the brass to receive them.

Where resistances of different lengths are used, it is best to cut slots instead of drilling plain holes in the horizontal arms of the clips. Their distance apart can then be adjusted to a nicety.

R. W. H.

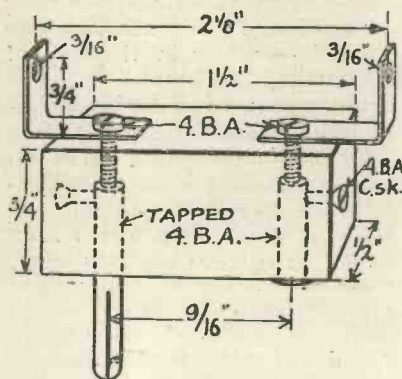

Fig. 2.—Constructional details of the plug.

“PICTORIAL WIRELESS CIRCUITS.”

Will our readers kindly note that as a result of the unexpectedly large demand for “PICTORIAL WIRELESS CIRCUITS,” by Oswald J. Rankin, the first edition is now out of print, and owing to the disorganisation produced by the Christmas holidays there will be some delay in the preparation of a second edition.

Prospective purchasers are therefore requested to withhold their orders until January 14th.

A SIMPLE C.W. AND TELEPHONY TRANSMITTER

By E. REDPATH, Assistant Editor.

Constructional details of the instrument illustrated and described in our last issue.

LAST week was given a brief description of the action which occurs when the transmitting key is depressed and with the arm of the 3-point switch S_2 , upon the centre stud, as shown in Fig. 2. If this switch is now moved to the upper stud and the key is depressed, the microphone M and the primary T_1 of the microphone transformer are connected across two cells of the 6-volt battery, that is to say, 4 volts are applied to the microphone, which, if spoken into, causes a variation in the current flowing through the primary T_1 , sets up induced currents (of higher voltage) in the secondary T_2 , and so varies the grid potential in accordance with the original speech. This is known as modulation, and this particular application as "grid modulation." The object of the fixed condenser C_3 (capacity 0.001 μ F), shunted across the secondary of the transformer, is to bye-pass the high-frequency currents induced into the reaction coil from L_2 .

If the arm of the 3-point switch S_2 is moved over on to the lowest stud, the buzzer, represented at B in Fig. 2, in series with the primary T_1 of the microphone transformer and the transmitting key K , is connected across one cell of the filament battery, so that when the key is depressed, the buzzer operates, causing varying voltages to be applied to the grid via the microphone transformer, thus producing what is known as "buzzer-modulated" C.W.

The Tuning and Reaction Coils

These items, which, together with a variable condenser (0.0005 μ F), form the complete tuning arrangements, should be constructed first as, when completed, they may be temporarily connected up and tested. This will

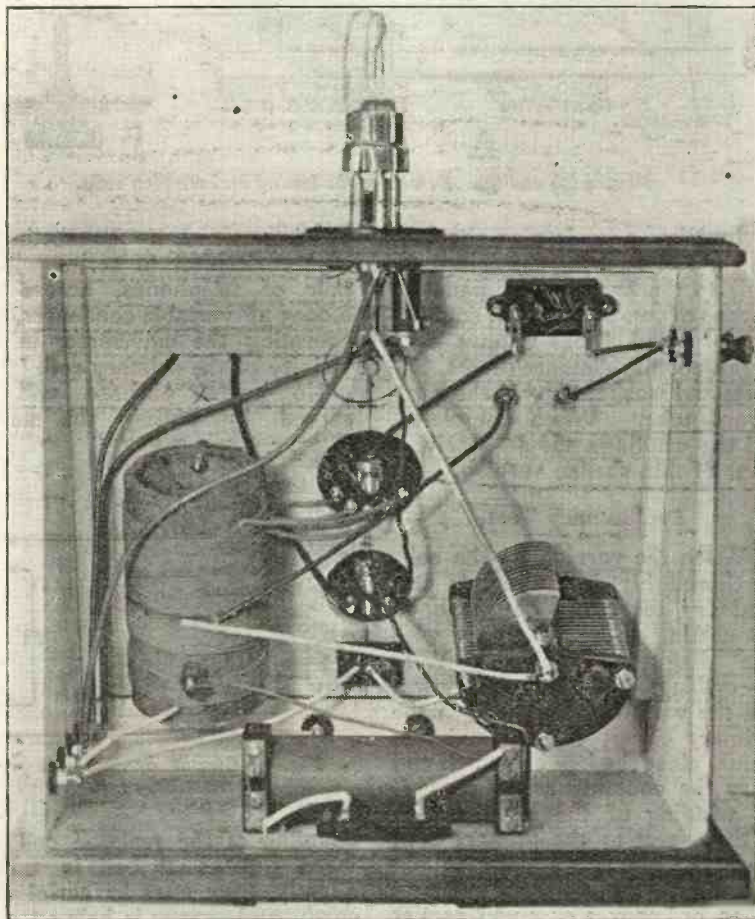

Fig. 3. Showing the arrangement of components inside the cabinet.

ensure that they are quite satisfactory, both as regards the generation of oscillations and, provided a wavemeter is available, the range of wavelengths covered, before they are fitted in place in the transmitting set.

The materials required are as follow:—

1 ebonite or wax impregnated cardboard tube, $4\frac{1}{2}$ ins. long by $2\frac{1}{2}$ ins. diameter; about 4 ozs. of No. 20 S.W.G.-d.c.c. copper wire; 1 wooden ball former to the dimensions given in Fig. 4 (b), complete with No. 2 B.A. brass spindles, nuts, washers, ebonite

knob and dial, and about 1 oz. of No. 31 or 32 S.W.G.-d.c.c. copper wire.

Full particulars of the windings of the aerial coil, the closed circuit or primary coil and the reaction coil (which is to be fitted so as to rotate through 180 deg. inside the primary coil at the position indicated by the dotted centre line) are given in Fig 4 (a) and (b). The actual procedure to be adopted in winding, securing and tapping coils of this description has been given so frequently that it is not necessary to repeat the details here.

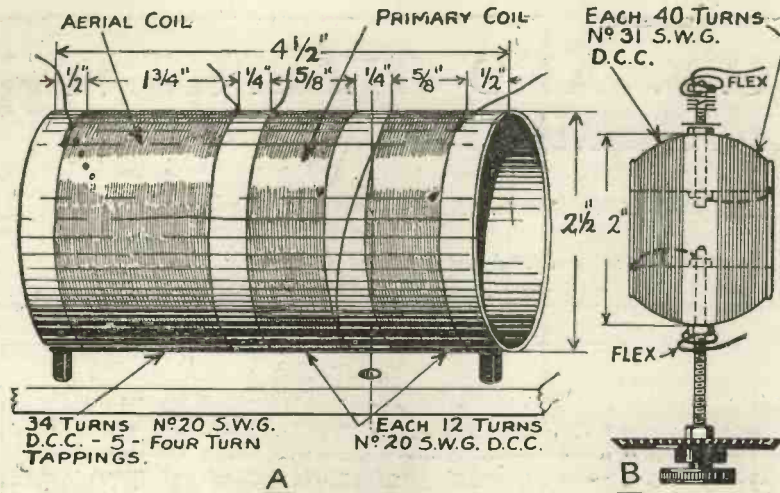

Fig. 4 (a) and (b). Details of the tuning and reaction coils.

In Fig. 4 (a) is also shown a method of securing the completed coil to the back of the panel by means of two No. 4 B.A. counter-sunk-headed brass screws with small ebonite distance pieces, and nuts and washers inside the cardboard tube. When completed, all the windings should receive a coat of thin shellac varnish.

Preliminary Test.

When the varnish on the coils is thoroughly dry, a simple preliminary test may be made by connecting up in accordance with the diagram, Fig. 5. With everything connected as shown, set the variable condenser in the primary circuit to its maximum value, close the key or switch and vary the coupling and "sense" of winding of the reaction coil with respect to the primary coil, until the maximum glow is obtained in the lamp, which should be an ordinary 2 or 4-volt pocket flashlamp bulb.

With a high-tension supply of 100 volts only, the lamp will not flash brightly, but quite a good glow should be obtained. Keeping the key or switch closed, reduce the capacity of the variable condenser gradually, adjusting the coupling of the reaction coil simultaneously and note where the set ceases to oscillate, which indicates the minimum wavelength obtainable. The coils and variable condenser may now be disconnected from the valve panel, batteries, etc., and, if a suitable wavemeter is available, the range of wavelengths over which oscillations were obtained, may readily

be determined by connecting a crystal detector in series with a pair of telephones, across the 0.0005 μ F variable condenser, and operating the wavemeter in the vicinity of the primary coil.

No useful purpose will be served by noting the actual

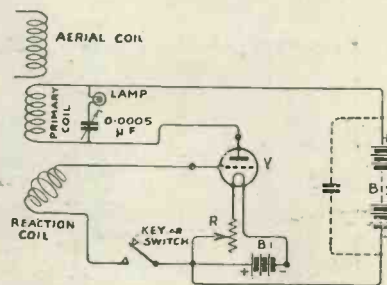

Fig. 5. Circuit arrangement for preliminary test.

coupling of the reaction coil as, when the aerial coil is subsequently connected to aerial and earth, and energy is being transferred from the primary coil to the aerial, a considerably tighter reaction coupling will be required. The sense or direction of the reaction coil winding may be noted, however.

The Microphone Transformer.

The transformer fitted in the original set and clearly visible in the photograph Fig. 3, is one of the ex-Army type. Similar transformers are obtainable from dealers in Disposal Board materials, or, if preferred, a very suitable one may be made in accordance with the details given in Fig. 6, in which case the following materials will be required:—

2 ebonite end-pieces, 1 1/2 ins. square by 3/8 in. thick, having a 7-16th in. centre hole in each. An iron core, assembled so as to be a tight fit into the 7-16th in. hole in the ebonite end-pieces, and consisting of soft iron wire (No. 22 or No. 24 S.W.G.); about 2 ozs. No. 26 S.W.G.-d.s.c. or No. 28 S.W.G.-d.c.c. copper wire for the primary winding; about 4 ozs. No. 38 S.W.G.-d.s.c. copper wire, for the secondary winding, and a supply of thin silk insulating tape and (to finish off the transformer) some Empire tape or Empire cloth.

The iron core is first to be carefully insulated by being tightly bound with the thin silk tape. The primary winding is to consist of 150 to 200 turns of the wire specified, wound closely and evenly over the tape upon the core, after which the complete core should be immersed in molten paraffin wax, removed, and all surplus wax drained off.

Over the primary winding is to be wound another layer of silk tape, and, the two ebonite end-pieces having been tightly secured in position, the whole should be mounted in a winding device of some kind and the secondary winding of from 6,000 to 8,000 turns of the wire specified should be put on as smoothly and evenly as possible over the insulated primary winding.

[To be concluded next week.]

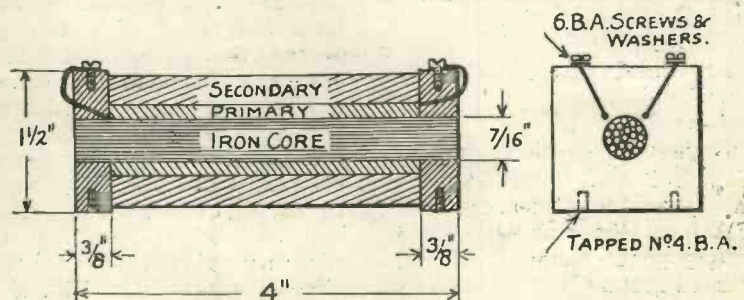

Fig. 6. Construction of the microphone transformer.

A CRYSTAL TESTING HOLDER

WHEN testing the merits of rival crystals one requires a simple holder of some kind which will allow them to be changed as easily and as rapidly as possible. One certainly could not set each in Wood's metal, and even the type of cup in which the crystal is retained in place by means of three screws does not allow changes to be made quickly enough for the purpose.

A very simple holder can be made, as shown in the drawing, from a short piece of wire of about No. 16 gauge. The wire should be as springy as possible, and it is desirable that it should be tinned in order that the contact may not be spoiled by a coating of oxide. The stiff wire sold for making connections beneath

the surface of panels will be found to answer admirably.

Take a piece about 8 in. in length. With the aid of a 2B.A. drill or some piece of round metal of about the same size form a loop as shown at A in the drawing. Now separate the ends for

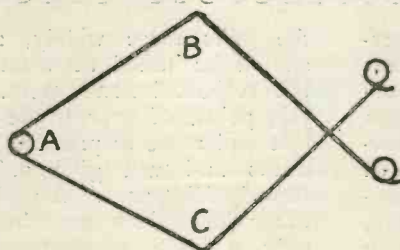

The crystal holder.

a short distance, afterwards bringing them back and across each other. Quite close to each

end form a loop about $\frac{1}{4}$ in. in diameter.

The holder is fixed to the panel of the detector by a screw driven through the loop A. To insert a fresh crystal simply press the points B and C with the finger and thumb. The jaws will then open and the crystal can be slipped into the loop, which will grip it firmly.

It is important that the crystal should not be handled, for even the cleanest fingers have a thin coating of grease, which is deposited upon the crystal and may detract greatly from its sensitiveness. Insert the crystal in this way. Pick it up with a pair of tweezers and dip it into rectified spirit. Do not use n. ethylated spirit or petrol, since both of these contain solid impurities which will be deposited upon the crystal. Wave it about in the air for a moment until it is dry, then, still grasping it in the tweezers, place it in the clip.

R. W. H.

ALMOST every experimenter has the unwelcome experience of burning out a valve sooner or later through carelessness in inserting it into the holder. We all of course know the very sound rule that the H.T. battery should be switched off when a valve is being changed, but when we are in a hurry most of us honour it more in the breach than in the observance. Safety fuses protect the valves to a great extent from such ill-treatment, but the difficulty about them is that their current carrying capacity does not suit every type of valve. If, for example, one fits a fuse which will burn out at .75 ampere, it will protect Ora and similar valves admirably, but it will not be of any use with such dull emitters as the D.E.3 or the Ediswan A.R.O.6, which are designed for a maximum current of .06 ampere. Nor would such a fuse allow "R" valves to be used on the set, for these, even when new, pass $\frac{1}{2}$ ampere, and when they have aged a little their requirements are considerably greater.

The best way is to design one's valve holders so that a short circuit is practically impossible. A simple way of doing this is

A SAFETY VALVE HOLDER

shown in the drawing. Standard valve legs are used, those for the grid and the two filament connections being inserted in the ordinary way into 4B.A. clearance holes and secured with nuts. The plate leg, however, is treated

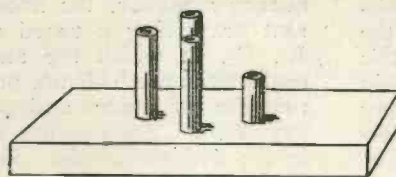

Safety valve pins.

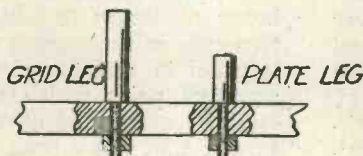

The safety valve holder.

quite differently. Its socket is cut off quite short and it is passed through a suitable die so that a male thread is put on to its lower half. As valve legs vary in ex-

ternal diameter, one cannot give a size of thread that will suit all. A hole tapped with the same thread is then made in the ebonite panel in the proper place and the leg is screwed home so that its top is $\frac{1}{4}$ in. or so below those of the other three.

An alternative and perhaps a simpler method in which no screwing is required, is shown in the accompanying drawings.

It will be seen that so long as the valve is not tilted right over whilst being inserted into the holder it is now impossible to apply H.T. to the filament, for the other three prongs must be pushed well home before the plate pin can make any contact at all with its socket. Care must of course be taken to arrange the height of the plate leg so that its prong makes good contact when the valve is pushed home. A holder of this type may at first sound rather elaborate, but it is nevertheless a very useful and precautionary device.

R. W. H.

A SINGLE VALVE AND CRYSTAL RECEIVER

By G. P. KENDALL, B.Sc., Staff Editor.

NOW that the Postmaster-General has to some extent relaxed his regulations regarding the use of reaction upon broadcast wavelengths, interesting new fields for experiment become available. The relaxation in the regulations, of course, does not entitle one to make a set a nuisance to one's wireless neighbours, but it does enable circuits to be used which were previously forbidden, but which may now be employed provided that "all reasonable care is taken to prevent radiation." The careful experimenter may therefore use circuits which employ reaction on the aerial circuit, but it is most important that he should familiarise himself with the methods of assuring that no radiation is taking place. Certainly, no one should use such circuits until he feels confident that he knows how to ascertain when a circuit is oscillating, and how to adjust it so that any self-oscillation which may occur shall be only momentary.

One of the surest tests for self-oscillation is that known as the wet finger test, since by this means one is enabled to ascertain whether oscillation is taking place actually in the aerial circuit, and not merely in one of the intervalve circuits. A moistened finger is applied to the aerial terminal with the receiver in the operating condition, and the sound thereby produced in the phones is noted. If a strong, distinct click results upon touching the terminal and upon removing the finger, you can feel fairly certain that oscillations are flowing in the aerial, and that radiation is taking place. The reaction coupling should be immediately loosened by separating

the coils more widely, and it should be noted at what point the self-oscillation ceases. At this point, of course, the finger test will cease to produce strong clicks and will give only extremely faint ones. A variety of other indications may be used, only a little experience being necessary to recognise them. For example, in a receiver in the oscillating condition, there will usually be heard a slight rustling noise as a result of the partial heterodyning of the continuous stream of small atmospherics, battery noises, etc.

In receiving telephony, moreover, if the receiver oscillates, speech will almost certainly be heard in a somewhat distorted fashion, and upon varying the tuning some sound of the carrier wave will be heard.

One of the earliest, and still one of the most efficient, single-valve circuits employing reaction is that shown in the accompanying circuit diagram, Fig. 3. The valve functions as a high-frequency amplifier, the anode current traversing a tuned circuit, L_2, C_2 , in which the amplified oscillations are built up, provided that the inductance and capacity are of the correct values to tune in the desired signals. Reaction is provided by coupling the anode coil L_2 to the aerial coil L_1 , it being necessary to couple these two coils in the correct sense, as is usual in reaction circuits. A practical point which may perhaps be mentioned at this juncture is that this circuit is one in which it is sometimes a little difficult to ascertain if the coils are connected correctly. It is often found that the set will oscillate, whichever way the coils are connected, but much more

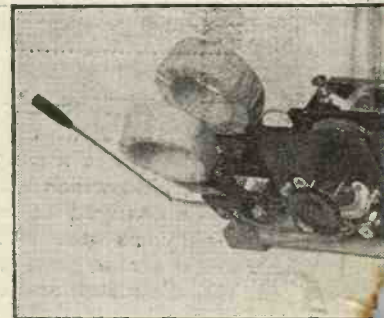

Fig. 1.—The

freely and controllably when they are connected in one particular sense. The reason, of course, is that there is considerable capacity between the two coils, and that this serves to make the set oscillate in the ordinary manner of a reaction condenser. The experiment should, of course, be tried of reversing the connections to one of the coils, and ascertaining in this way which is the correct connection to obtain both capacity and magnetic reaction. Connected across the tuned-anode circuit are the crystal detector and telephones. No telephone condenser is shown, since the writer has not found it of any benefit in this circuit.

As in all simple circuits, to obtain the very best results it is necessary to acquire a certain amount of skill in the handling of the receiver; but given this, remarkably good results can be obtained. Upon a reasonably good outside aerial, and given fairly favourable conditions, it is

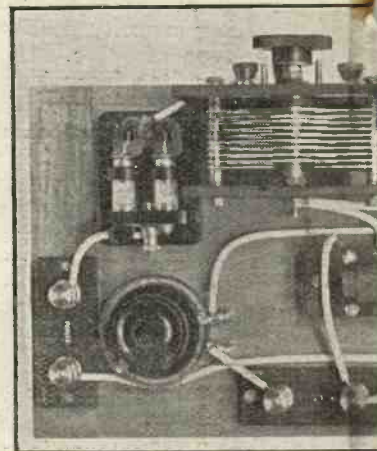
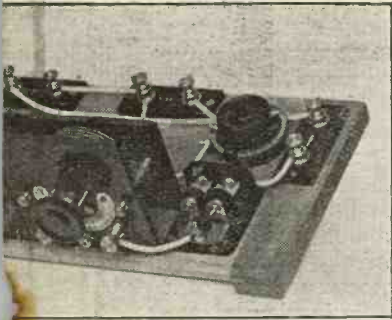

Fig. 2.—Plan view



Completed receiver.

possible to receive all the broadcasting stations, not very loudly, but at readable strength. As an example of its powers may be quoted the fact that it was with the aid of this circuit that the writer first succeeded in picking up the Dutch concerts in the North of England soon after the Hague station commenced work upon its early very low power. Actually, such long-distance reception demands an exceedingly critical setting of the reaction, a good valve, suitable values of high-tension and low-tension supply, a good crystal detector, and so on.

The receiver illustrated in the photographs, Figs. 1 and 2, was designed to incorporate this circuit in such a way as to simplify the construction as much as possible. The assembly takes the usual experimental form of an arrangement of bought components upon a baseboard, and the wiring is all of the "above board" type. The whole of the

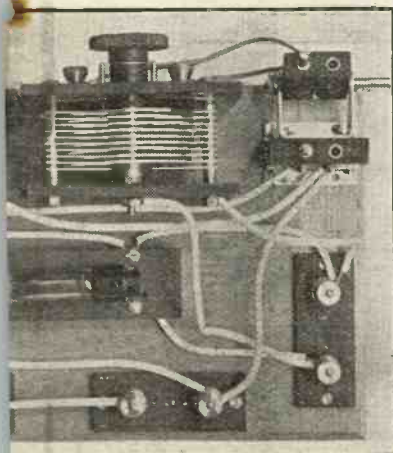

Detail of the instrument.

Constructional details are given in this article of a very simple receiver employing the newly introduced Myers Valve.

components, with one exception, were purchased, and the actual construction and wiring of the set occupied rather less than one afternoon. The only component which actually required to be made was the holder for the valve, and this was necessitated by the fact that one of the newly-introduced Myers valves was used. These valves are of the tubular pattern, and are held between four clips, which make connection with four contacts in the composition ends of the valve. Clips for the purpose are supplied with these valves, and the making of the holder merely consists in cutting a strip of ebonite 6 in. long, $1\frac{1}{2}$ in. wide and $\frac{1}{4}$ of an inch thick. The holes for the clips were drilled by means of a template, and the ebonite strip was mounted upon the baseboard by means of two wood screws. The strip is spaced above the surface of the wood to a height of about $\frac{1}{4}$ of an inch to allow room for the wires to pass beneath for the connections, by inserting two thick washers through which the wood screws are passed. If any difficulty is experienced in obtaining suitable washers, two brass nuts of 2 B.A. size will serve perfectly well. The construction and method of mounting of these valves is such that the capacity between electrodes is very much less than that of the four-pin type, and it may therefore be expected that they would give better results as high-frequency amplifiers. The one used in this set certainly gave very good results in this capacity.

The wooden base upon which the set is assembled is of polished mahogany $\frac{3}{4}$ of an inch in thickness, 14 in. long, and

7 in. wide. Two cross-pieces are fitted to its ends, 7 in. long, $1\frac{1}{2}$ in. wide, and $\frac{1}{2}$ an inch thick. These serve the purpose of lifting the baseboard itself clear of the table upon which the set may stand, in order to make room for various projecting nuts, screw-heads and connecting wires, etc., upon the underside.

The terminals of the receiver must, of course, be mounted in some way upon this baseboard, and it is worth a little consideration to see how this may best be done to procure good insulation. If the constructor feels quite confident that his sample of mahogany has good insulating properties—that is, that it is well seasoned and thoroughly dry—it may be simply varnished, well dried, and then the terminals can be mounted directly in the wood. This, however, is a somewhat risky proceeding, since it is very difficult to tell without the aid of measuring instruments whether any given sample of wood is satisfactory from the insulation point of view. A cheap method of ensuring that the insulation is fairly good is to drill all the holes for the terminals perhaps a thirty-second of an inch larger than is necessary to insert the terminal, and then, before screwing up the nut and washer, fill the hole surrounding the shank with very hot liquid paraffin wax. The wax will thoroughly impregnate the wood and provide quite good insulation.

A neater and more workmanlike method which is slightly more expensive is to use the ebonite bushes sold by a number of firms for the purpose of separating each terminal from the wood. When using these bushes it is necessary to drill for

LOUD SPEAKERS FOR WIRELESS PURPOSES

Below are given further summaries of a series of several interesting papers recently delivered before the Institution of Electrical Engineers and the Physical Society of London
(Concluded from Vol 3, No. 1, page 19.)

The next paper was delivered by Professor C. L. Fortescue, M.A., M.I.E.E. on the subject of "Sources of Distortion in the Amplifier." Professor Fortescue showed very clearly how distortion may be produced in the process of amplification by the following causes:

(a) Curvature in the valve characteristics.

(b) The use of intermediate circuits having more or less clearly defined natural frequencies.

(c) The unavoidable reaction effects present in most note magnifiers.

(d) Unsatisfactory reproduction in the last (output) transformer.

Taking these causes individually, it was demonstrated that to reduce the first it is necessary to use valves possessing a long, straight portion upon their characteristic curves, to adjust the mean grid potential to near the centre of this part, and to prevent grid current. The effect of the latter in cutting off the tops of the positive half-cycles was very clearly illustrated by means of oscillograph records.

Trouble (b) arises in the case of transformer coupled amplifiers, and leads to the over-emphasising of such frequencies as correspond nearly to the natural period of the windings. The trouble is naturally more pronounced the larger the number of stages of amplification that are used.

Reaction effects are greatest in transformer-coupled amplifiers, and are attributable to the capacity between the valve electrodes. The effect of this reaction is that with sustained waves the frequency which renders the system most nearly unstable attain to a higher amplitude than waves of other frequencies.

The pure resistance amplifier is not entirely immune from the effects of reaction unless the condenser across the H.T. supply is

very large indeed. Under certain circumstances, also, if the capacity across the anode resistance is appreciable a resistance amplifier will howl, owing to self oscillation being set up in the same way as in the "Kallitron."



The
Magnavox
Loud Speaker

Distortion in the last stage is not infrequently a source of serious trouble for two reasons:

(a) The amplitudes are large.

(b) The "load" on the output transformer, viz., the winding of the loud speaker, is inductive, and this inductance is not constant.

In his concluding remarks the speaker stated that with properly designed valves and circuits it does not appear that any serious distortion can be charged against the amplifier. Valves giving considerable power output must, however, be used in the last stage.

Some resonance effect seems unavoidable in the transformers,

and may be accentuated by reaction. The presence of this effect, however, may be an advantage owing to the fact that it can be used to some extent to compensate for defects in other parts of the equipment.

The next speaker was H. L. Porter, B.Sc., whose paper was entitled, "The Acoustical Problems of the Gramophone." Exigencies of time prevented the reading of more than a small part of this, and after an interval the discussion was continued by a paper on "The Relative Importance of Each Frequency Region in the Audible Spectrum — Measurements on Loud-Speakers," by E. K. Sandeman, B.Sc.

This paper included a series of curves showing the relative importance of the different frequencies composing speech when considered from the view point of:

(a) Intelligibility.

(b) Naturalness of reproduction.

(c) Reproduction at correct volume.

The curves showed that the frequencies between about 200 and 2,000 per second are the crucial ones which carry the greater part of both the energy and the "intelligibility" of speech. The actual meaning of the curves was demonstrated in a very interesting manner by means of the Western Electric public address system. The speaker gave a part of his discourse from an adjacent room, his voice being made audible from two large loud-speakers. Certain filter arrangements were connected in circuit which had the effect of suppressing certain definite and calculable frequencies, and the effect was clear to the whole audience. When all frequencies below 500 cycles per second were suppressed the speech lost a certain amount of naturalness, but the intelligibility

was still good and the articulation sounded quite clear. On cutting off all above 2,000 the speech became muffled and nasal but was still intelligible. All frequencies below 1,500 were next suppressed, and the result was almost unintelligible, with much distortion and ringing. In the last experiment all above 500 were cut off, and the speech was then found to be practically destroyed.

The second part of the paper was concerned with the measurement of the energy output of loud-speakers, and showed how this may be done by placing in front of the horn at a fixed distance an electro-static microphone whose output has been calibrated. An interesting point which arises with this method is in connection with the production of "standing waves" in the air. This was demonstrated, the audience being instructed to close one ear and listen to a note emitted by a loud-speaker. It was found easy to find a position in which no sound could be heard in the ear remaining open, although on moving the head a few inches the note was heard loudly.

The next contribution to the discussion was a paper on "The Overtones of the Diaphragm of a Telephone Receiver," by Professors J. T. MacGregor-Morris, M.I.E.E., and E. Mallett, M.Sc. (Eng.), M.I.E.E. This paper demonstrated that the diaphragm

very commonly vibrates in a complicated manner, rather than in the assumed simple up and down motion. Experiments were performed with sand scattered upon a vibrating diaphragm, which assumed the geometrical arrangements known to physicists as Chladni's figures, and indicated the particular system of over-

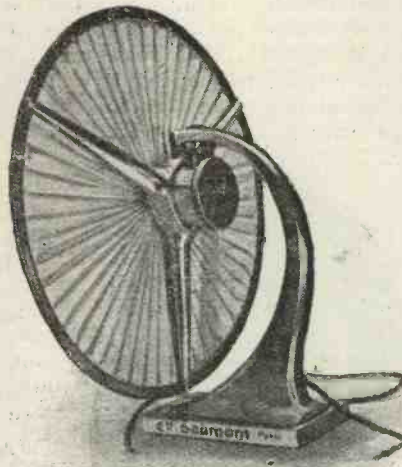

The Gaumont Loud Speaker.

tones to which the diaphragm was responding.

A paper entitled "Auditorium Acoustics and the Loud-Speaker" was then read by G. A. Sutherland, M.A.

The effects of reverberation and sound-absorption or decay

were considered in detail by this speaker, and he showed that these effects are of great importance in satisfactory reproduction of speech and music. If the auditorium is exceedingly resonant the reverberation effects will be so pronounced that successive notes and syllables will be prolonged and interfere with each other, whereas if the absorbing power of the room is too great there will be a lack of continuity in speech, and there will be no blending of the sounds in music. The actual amount of sound absorption in any given room depends upon a variety of factors, chief among which are the size and shape of the room and the nature of its lining. A lining of porous material increases the absorption and therefore reduces reverberation, whereas a hard glazed lining has the contrary effect. Further, different sound frequencies are absorbed to a different extent, and therefore what we are accustomed to call distortion in a loud-speaker must always be present to some extent in a concert hall.

The meeting closed with a demonstration by S. G. Brown, F.R.S., of the Frenophone loud-speaker, and by Captain P. P. Eckersley of the new Gaumont loud-speaker. The latter had not previously been publicly demonstrated, and aroused considerable interest. It is illustrated in this report.

A SINGLE VALVE AND CRYSTAL RECEIVER.

(Concluded from page 88).

The variable condensers are held with quite sufficient rigidity in this way. The advantages of this method in a board-mounted component set are simply those of cheapness and ease of construction. The condensers actually used by the writer cost only 6s. each, which is, of course, a considerable economy over the usual price for condensers mounted in boxes. If difficulty is experienced in obtaining suitable condensers, how-

ever, the boxed type may be used, whereupon it will be necessary to use a wooden base some 3 ins. wider than the one specified.

The wiring of the set is exceedingly simple, and probably no difficulty will be experienced in following it from the wiring diagram, Fig. 4, without detailed explanation. The simplicity of the wiring is such that bare wire might quite well be used, that

upon the set illustrated having been sleeved with white systoflex for the simple reason that it was desired to make the wiring as prominent as possible in the illustrations. The only part of the wiring which cannot be done with ordinary stiff wire, either bare or sleeved, are the connections to the moving socket of the coil-holder. These must be made as usual with flexible rubber-covered wire.

Broadcasting News



LONDON.—If ever the B.B.C. were to advertise, a development which is not in contemplation, some idea how to charge would be provided by a letter sent by Lord Knutsford, the champion beggar of London, if not of all the world. Lord Knutsford some months ago made an appeal for the London Hospital, and in response he received over £5,000 in the course of a few days.

Lord Knutsford now offers the B.B.C. £5 a minute for a twenty-minute talk, but this offer has not been accepted. Lord Knutsford has been informed that the idea of payment for a talk on behalf of a charity cannot be considered for one moment, and no offer, however great, will influence the B.B.C.'s decision to maintain a strict rota for charitable appeals.

The Archbishop of Canterbury has kindly consented to broadcast a message to the nation on New Year's Eve at 6.30. The address will be transmitted simultaneously from all the stations of the B.B.C. This is the first occasion on which His Grace will have spoken, and it is to be hoped that others who have the right to speak to the nation as a whole will avail themselves of the opportunity afforded by wireless of doing so.

Sunday, December 9.—A most excellent afternoon concert, and the listeners who did not hesitate to forego their siesta were well rewarded by such items as Liza Lehmann's "The Cuckoo," most melodiously rendered by Miss Dorothy Cowper; Foulds' "Celtic Lament," as interpreted by Miss Beatrice Eveline on her 'cello, the warmth and roundness of tone and excellent technique all combining to give us a true

conception of this effective little composition. Mr. George Parker seemed at his best, and we were particularly enamoured of his singing of "The Pibroch," by C. V. Stanford.

On Saturday, December 15, "The Roosters" once again flapped their wings at 2LO and gave us a lively time. They certainly do keep the ball rolling, and we trust we may have the pleasure of hearing them from time to time to stir things up a bit and make us forget for a

30th (SUN.).—Sacred Concert. Mr. Keighley Dunn, tenor. 2LO Light Orchestra.

31st (MON.).—The Lord Archbishop of Canterbury (6.30). Popular Concert. Miss Ethel Kemish, soprano. Mr. Tom Copeland and Miss Suzette Tarri, entertainers. Savoy Orpheans and Havana Bands.

JANUARY.

1st (TUES.).—The Band of His Majesty's Grenadier Guards. Mr. Frederick Lake, tenor. Mr. Wilfred Clissold, entertainer.

ABERDEEN.—Many listeners in this district are in doubt as to whether they should be content with the local programmes or run the risk of a ruined "simultaneous" from London. That risk is, of course, at its maximum during the winter months, when the vagaries of the weather put the long land wire to a severe strain. And so the demand of one day for more simultaneous broadcasting is countered the following day by requests to let well alone, in other words, to stick to the admirable Aberdeen programmes. Tests are being undertaken almost nightly in an endeavour to eliminate the risk, and it is hoped that the progress which has already been made will be expedited.

A plebiscite of Northern listeners shows that Scotch songs and music are greatly in demand, and it is noticeable that national airs are more and more taking their rightful place in the programmes. There is also a demand for the more popular type of song.

Forthcoming Events

DECEMBER.

26th (WED.).—An old-time Christmas night with reminiscences of Darby and Joan (specially written

BROADCAST TRANSMISSIONS		
	Call-Sign	Wavelength.
LONDON	2LO	365 metres.
AERDEEN	2BD	465
BIRMINGHAM	5IT	475
FOURNEMOUTH	6BN	395
CARDIFF	5WA	360
GLASGOW	5SC	420
MANCHESTER	2ZY	460
NEWCASTLE	5NO	485

TIMES OF WORKING.	
Weekdays	3.20 to 4.20 p.m. and 5.0 to 10.20 p.m. G.M.T.
Sundays	8.0 p.m. to 5.0 p.m. and 8.30 to 10.30 p.m. G.M.T.

while that there are such outstanding questions as "Reparations," and the like.

Forthcoming Events

DECEMBER.

27th (THURS.).—Mr. Rowley on "Bathing at Christmas." "The Mariners of England." Savoy Orpheans and Havana Bands.
 28th (FRI.).—Miss H. M. Boulnois on "The Buddhist Monasteries of Little Thibet." Savoy Bands.
 29th (SAT.).—1st and 2nd Acts of "The Magic Flute," from the "Old Vic" Theatre. Talks by Prof. Cheshire and Mr. R. D. McMillan. Savoy Bands.

by Mr. R. E. Jeffrey, Station Director).
 27th (THURS.).—Auld Scotch Airs. Talk by Dr. John Levaack, M.B., on Mountaineering.
 29th (SAT.).—Dance Music.
 30th (SUN.).—A Short Address by the Rev. W. Mair, M.A., Ferryhill U.F. Church, Aberdeen.
 31st (MON.).—One-act Play, "Hogmanay," produced by Mr. R. E. Jeffrey. Jazz Music by Orchestra. Programme concluding at 12.30 a.m.

JANUARY.

1st (TUES.).—Oakbank Industrial School Pipe Band. Aberdeen Wireless Jazz Orchestra. Band of the British Legion.

quent intervals towards the end of the programme, but it was explained afterwards that this exasperating trouble was not the fault of the transmitting station. Still, it did add emphasis to the growing feeling on the part of many listeners-in that something ought to be attempted in the way of simultaneous broadcasting with wireless itself as the medium, instead of trunk lines, after the manner of the recent experiment at the Old Vic. This would, of course, do away with the distortion due to the land lines.

30th (SUN.).—6.30, Station Orchestra. Address by the Rev. Ronald H. Royle, of the Birmingham Branch of "Toc H." Station Repertory Choir. Orchestra. Mr. George Dillon and Mr. Harvey Smallwood in a Duet.
 31st (MON.).—3.30, Paul Rimmer's Orchestra. Mr. Sidney Rogers, F.R.H.S., on "Horticultural Hints." Talk by the Rev. Dr. Fleming. Hymn and "Auld Lang Syne."

JANUARY.

1st (TUES.).—3.30, Mr. Ingram Benning (song recital). Station Orchestra. Mr. Brampton Hawkins in Humorous Recitals. Mr. William Clarke, bassoon solos.

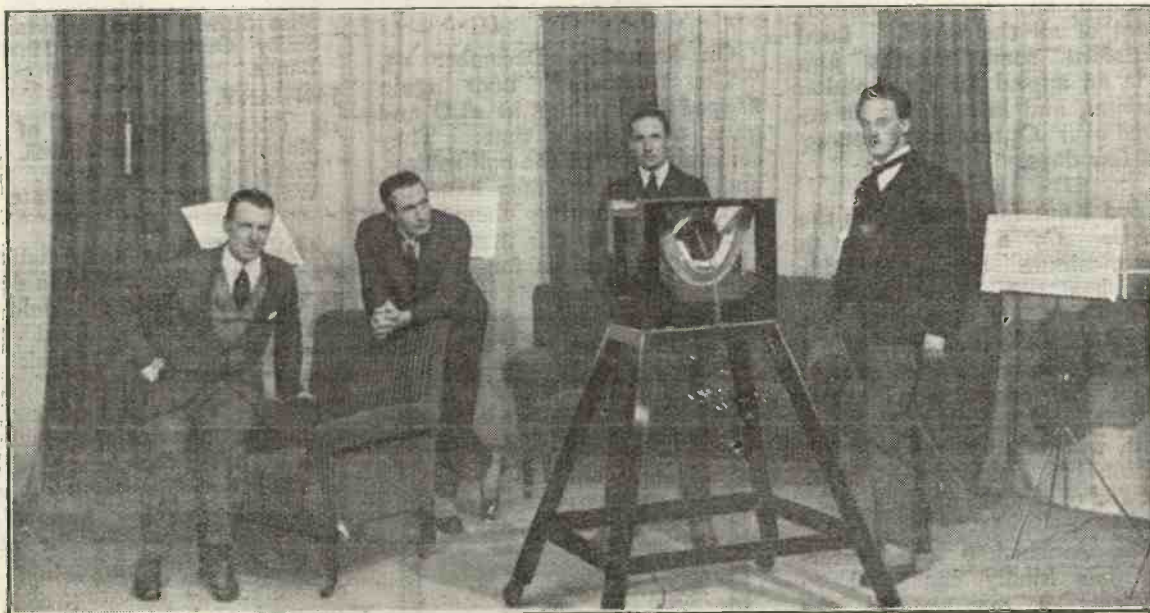

The Studio and Staff at Aberdeen.

BIRMINGHAM.—The change in 5IT's wavelength caused not a little inconvenience to many listeners-in, particularly those with crystal sets of limited capacity. Happily, those who did not know how to adapt their sets had the guidance of members of the technical staff of 5IT, who broadcast their instructions on the first few evenings on which the change came into operation.

□ □ □
 The link-up with Manchester two Sundays ago, when an orchestral concert was transmitted from 2ZY, was not so successful as it might have been on account of induction effects in the trunk lines. Reception was, in fact, cut off completely at fre-

Forthcoming Events

DECEMBER.

27th (THURS.).—3.30, Paul Rimmer's Orchestra. Evening programme by the Station Orchestra and the Greys Concert Party, followed by an hour's Dance Music.

28th (FRI.).—3.30, Lozells Picture House Orchestra. Station Orchestra in special request items. Major Vernon Brook, Talk, Motors and Motoring Review. Station Repertory Co. Mr. Percy Edgar, impersonations of old favourite music hall artistes. Orchestra.

29th (SAT.).—3.30, Special Concert by the Kiddies. Orchestra. Humorous Items by Mr. Walter Badham. Lecture Recital from the various musical comedies, by Mr. Sidney Russell and Miss Doris Lemon.

BOURNEMOUTH.—The outstanding feature at the Bournemouth Station during the past week was the broadcasting of Sir Julius Benedict's "Lily of Killarney" on Friday, December 14. This was the first opera transmitted from Bournemouth, and all concerned in its production deserve congratulations. Dr. Rowland Thurnam, M.D., gave an exceedingly happy talk on the opera, and its composer. The principals and chorus all did extremely well.

□ □ □
 Having heard the "Lily of Killarney," Bournemouth folk are suffering from Oliver Twist's complaint, and the Station Director will do well to see that

his listeners do not have to wait too long for another opera.

Another item, worthy of mention, was the dramatic sketch "The Bishop's Candlesticks," played by Madame Owen and Mr. Edward James, of Manchester. On Sunday, December 16, the Royal Air Force band, under Lieut. Amers, rendered some excellent music, the "Merry Wives of Windsor" and "In a Monastery Garden" being especially good.

Forthcoming Events

DECEMBER.

- 26th (WED.).—Mr. Arthur S. Tetlow, L.R.A.M., pianoforte recital. Women's and Kiddies' Corners. Mr. H. J. Harding will talk to the Scholars on "Further Rambles of an Entomologist."
- 27th (THURS.).—Mr. H. J. Sherring, solo banjo. Miss Jennie Malkin, contralto, and Mr. A. S. Tetlow, piano. Women's and Kiddies' Corners. Girl Guides' and Boy Scouts' Bulletins. "Dickens and Christmas," by Mr. Hubert Hill. Orchestra. Miss Amy Cockburn, mezzo, and Mr. Harold Stroud, tenor. Violin solos by Miss Nellie Fulcher, with orchestral accompaniment.
- 28th (FRI.).—Mr. J. T. Thompson, L.R.A.M., A.R.C.M., pianoforte recital. Talk to the Scholars by Mr. W. J. Woodhouse, A.C.P., on "The Wizard Jack Frost." Orchestra. Mr. Lyell Johnstone, baritone.
- 30th (SUN.).—Addresses by the Rev. C. R. Stewart, the Rev. J. Courtenay James and Father Triggs. Concert by the Æolian Quintette.
- 31st (MON.).—Concert mainly relayed from London.

JANUARY.

- 1st (TUES.).—Popular Orchestral Night.

CARDIFF.—The band of the Glamorgan Royal Garrison Artillery (T.A.) was one of the most enjoyed "turns" at the Cardiff station last week. The transmission of their items was perfect. The Cardiff Musical Society's Small Choir, which gave several selections on December 14, was also greatly appreciated by Cardiff listeners, and on December 15, "Charlie Chipmunk in a Restaurant Episode" was the feature of the evening—"Charlie Chipmunk" being impersonated by the Station Director, Mr. A. Corbett Smith.

Forthcoming Events

DECEMBER.

- 26th (WED.).—Popular Night—Vocalists: Ramsay Clarke, baritone; Miss Clovia Giles, soprano. Dr. Jas. J. Simpson, M.A., D.Sc., Comedy, "Feed the Brute," repeated by special request.
- 27th (THURS.).—"The Mariners of England." Special Sea Programme.
- 28th (FRI.).—The Cardiff Musical Society's Male Voice Choir in Old Folk Carols of the English Counties.
- 29th (SAT.).—Vocalist, Lyell Johnstone, baritone. Violin Solo, Mr. Hubert Isaacs.
- 30th (SUN.).—Station Symphony Orchestra. Carols. An Address by the Rev. S. C. Edwards.
- 31st (MON.).—Popular Night. The Cory Workman's Silver Band.

JANUARY.

- 1st (TUES.).—Shakespeare Night. Critical Commentary by Prof. Brett.

MANCHESTER.—The change in wavelength to 400 metres seems to be a mixed blessing. Whilst many listeners have reported an improvement in transmission, others—chiefly crystal set users—state that it is the reverse, and some go so far as to suspect the station engineers of playing pranks with the transmission to the advantage of valve users and to the disadvantage of crystal sets. Such a contention is obviously absurd.

Forthcoming Events

DECEMBER.

- 26th (WED.).—No afternoon transmission. Kiddies' Talk. 7.45. Mr. J. Proctor, baritone. Mr. Mikel Arenstein, solo 'cellist. Miss Molly Gray, soprano. Mr. James Worsley, dialect entertainer. Keyboard Kitty. Mr. Victor Smythe. Savoy Orpheans.
- 27th (THURS.).—2ZY Trio. Children's Party. Father Christmas will tell a story and all the Aunties and Uncles will combine to entertain the youngsters. Dance Music. Savoy Orpheans.
- 28th (FRI.).—2ZY Trio. Concert. Christmas Party at 2ZY. Miss Madge Taylor, Miss Helena Taylor, Miss Rachael Hunt, Miss Nellie Davis, Mr. Lee Thistlethwaite, Mr. Wilfred Hindle and Mr. Harold Marsden will sing. Savoy Orpheans and Dance Band of the 2ZY Orchestra until midnight.
- 29th (SAT.).—Oxford Picture House Orchestra. Children's Hour.

- Keyboard Kitty. Miss Bella Redford, mezzo-soprano. Mr. T. H. Morrison, solo violin. Miss Mabel May, contralto. Mr. L. T. Whipp, dialect entertainer. Mr. Tom Case, baritone. Mr. Victor Smythe. Savoy Orpheans.
- 30th (SUN.).—Young People's Talk, by Mr. S. G. Honey. Rev. K. L. Parry, B.Sc. Cambria Male Voice Choir. Mr. Pat Ryan, solo clarinet.
- 31st (MON.).—2ZY Trio. Talk by Rev. Dr. Temple (S.B. from London). New Year's Greetings.

JANUARY.

- 1st (TUES.).—Mme. Alice Wragg, soprano. Mme. Lizzie Pickles, contralto. Mr. C. Turner, tenor. Mr. D. Lewis, baritone. Dance Music. Percy Phlage. Spanish Talk. Savoy Orpheans.

NEWCASTLE.

Forthcoming Events.

DECEMBER.

- 27th (THURS.).—3.45, Mme. Alec. Thompson's Quartette Party. 7.30, As afternoon, and 5NO Orchestra.
- 28th (FRI.).—3.45, Miss Gwladys Edmonson, piano. Mr. and Miss Golightly, duets. 7.30, Waverley Orchestra. Miss Phyllis Rickard, contralto. Mr. Geo. Harris, tenor.
- 29th (SAT.).—3.45, Mr. Mackintosh, cornet. Mr. Rowell, tenor. 7.30, Harton Colliery Band. Mr. W. A. Bates, entertainer. Mr. Kemp Jordan, baritone. Mme. Phyllis Howe, soprano.
- 30th (SUN.).—8.30, Rev. F. W. Beal, address. Band of the Sunderland Constabulary. Miss Madge Raine, contralto.
- 31st (MON.).—3.45, Mr. Wm. Laws' Trio. Mr. Yates, baritone.

JANUARY.

- 1st (TUES.).—3.45, Mme. Leonara Nicholson's Quartette Party. 7.30, 5NO Orchestra. Mr. Harold Brown, baritone. Mr. Catcheside Warrington, entertainer. Mr. Babbs, violin.

Simultaneous Forthcoming Events.

DECEMBER.

- 27th (THURS.).—"The Mariners of England." Children's Party.
- 28th (FRI.).—Christmas Party.
- 29th (SAT.).—"The Magic Flute," Acts 1 and 2 (Mozart), relayed from the "Old Vic" Theatre.
- 30th (SUN.).—Organ Recital relayed from the Armitage Hall.
- 31st (MON.).—The Archbishop of Canterbury. Popular Concert. M. Poincaré relayed from Paris. The Rev. Dr. Archibald Fleming.

JANUARY.

- 1st (TUES.).—Band of H.M. Grenadier Guards.

A TWO-VALVE POWER AMPLIFIER

By STANLEY G. RATTEE, Staff Editor.

The following is the conclusion of a constructional article which began in our last issue describing an instrument which may be added to any crystal or single valve receiver, permitting thereby the use of a loud-speaker.

Wiring Diagram.

With the connecting-up of the instrument carried out as given in last week's issue, the final result will be as shown in Fig. 4, from which photograph may also be seen the disposition of the various components.

For those readers who have not yet made this amplifier and yet intend to do so, Fig. 5 shows

the actual wiring diagram, and should be used in conjunction with Fig. 2, at the same time observing the instructions given in last week's issue, with regard to connecting-up, when no difficulty will be experienced in the assembly. For the guidance of those constructors who prefer to work from full-size drawings, a blue print wiring diagram of

this amplifier may be obtained from the Offices of this Journal, price 1s. 6d.

All connections should be soldered, rather than locked, between nuts, as one bad connection in the instrument will cause hissing or crackling sounds to be present in the loud-speaker, especially when both power valves are in circuit; the reason being that not only will the reception be amplified very considerably, but any extraneous noises due to faulty connections must of necessity be similarly amplified.

General Considerations.

With the amplifier just described, made up with components as given, loud-speaking of uncomfortable volume was received the same evening as the completion of the instrument by means of a crystal receiver and an Amplion loud-speaker some 10 miles from 2LO, using 100 volts on the plates of two R valves. Other results indicate that very little strength of signals is required across the "input" terminals to make the amplifier give satisfactory volume; a point which is not common to all power amplifiers, in that certain designs of the same type of instrument fail to give any results unless a relatively loud signal is applied to them.

It may be found with certain makes of low-frequency transformers, results may be improved by the addition of high resistances connected across the secondary windings, though with the two enumerated in this article it is by no means necessary. Should the constructor choose makes other than these, and his results have a scratchy sound in spite of the adjustment of the grid voltage, then resistances of not less than 100,000 ohms should be connected

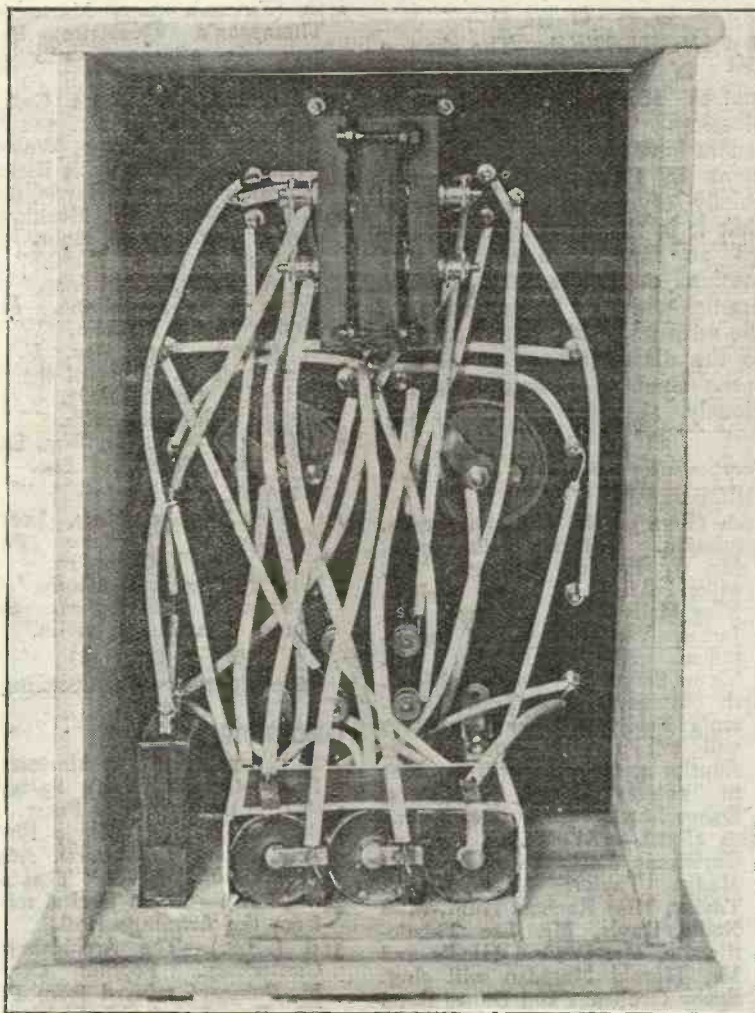

Fig. 4.—A close-up of the back of the instrument with cover opened to show disposition of components and wiring.

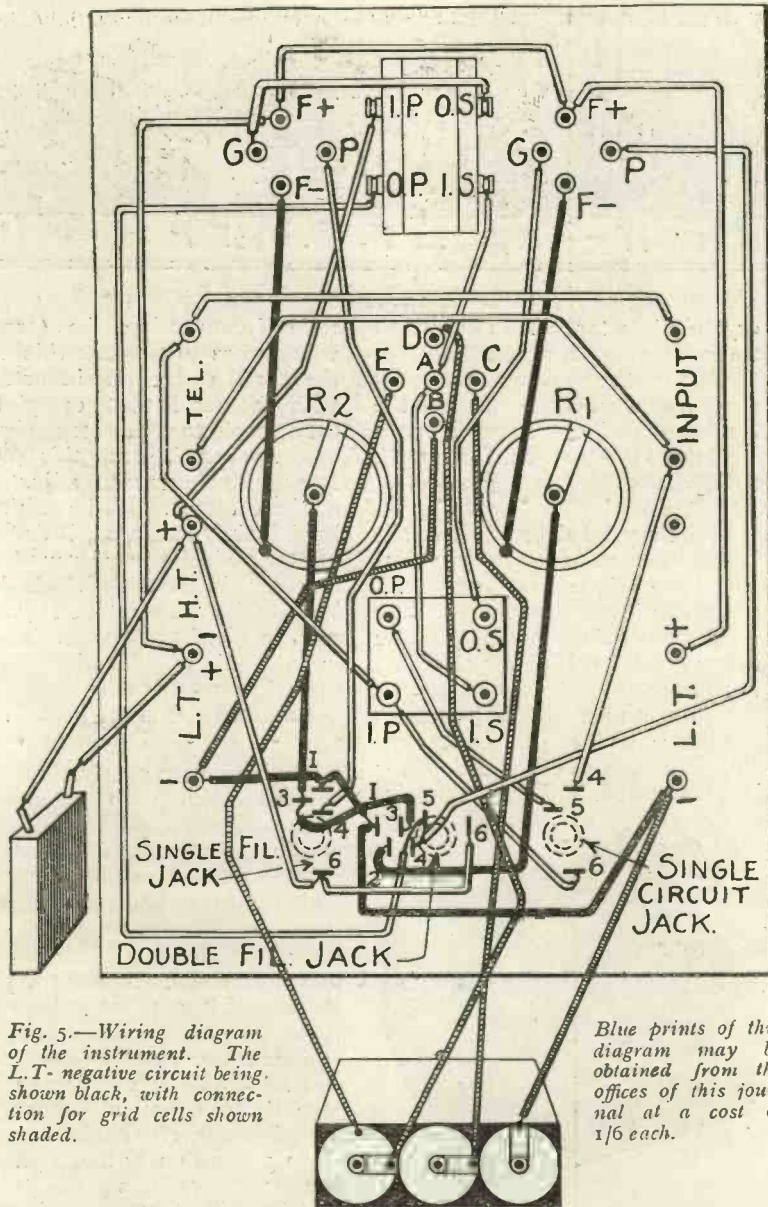

Fig. 5.—Wiring diagram of the instrument. The L.T. negative circuit being shown black, with connection for grid cells shown shaded.

Blue prints of this diagram may be obtained from the offices of this journal at a cost of 1/6 each.

directly across the secondary windings.

The purpose served by these resistances is to stabilise the response of the transformers to various frequencies. In the majority of transformers of the low-frequency type there is what may be termed a "peak" reson-

ance frequency which causes the accentuation of high-pitch notes in some transformers and low-pitch notes in others.

Many interesting experiments may be carried out in this direction by testing a number of roughly-wired-up low-frequency circuits of the same type

using different transformers, connecting them to the receiver one after the other. It will be readily observed that certain makes of these components accentuate the high notes, others give a mellowness throughout the musical scale, whilst others produce a "blurry" sound, in spite of the fact that the same transmission is being received.

To obtain clear, yet powerful, loud-speaking in such circumstances, resistances across the secondary windings are introduced, and though a certain amount of volume may be lost, such losses may be adequately recovered by the judicious adjustment of the H.T. voltage.

Dependent upon the type of loud-speaker used, a fixed condenser of any value between 0.005 μ F and 0.008 μ F connected across the loud-speaker terminals may also improve results, the necessity of such condenser being decided by the characteristic of the loud-speaker connected to the amplifier, the presence of "woolly" speech advocating its use.

The reason for this is that similar to low-frequency transformers, most loud-speakers respond more readily to certain audio-frequencies than to others.

Parallel Loud-Speakers.

Should the object of the reception be to fill a small hall for dancing or other purposes, then rather than load one loud-speaker to its maximum volume, it is recommended that a number of loud-speakers be distributed about the hall (one in each corner, for instance), and connected in parallel with the "output" terminals of the amplifier. By this method each individual loud-speaker is giving a good clear result, free from overloading, and since there are a number of such instruments, the volume of sound is evenly distributed throughout.

"WIRELESS WEEKLY" BINDING CASES.

To make the best use of such a work of reference as is provided by the second volume of "WIRELESS WEEKLY," it is essential to possess it in a compact form with a comprehensive index, and that our readers realise the fact is evident from the flow of orders for the bound volume.

Cases only 2s. 10d. (post free), and 4s. 10d. (post free), for the cloth and leather cases respectively. The cost of binding where readers provide their own back numbers is 5s. 6d. post free and 8s. 6d. post free. These latter prices include the index, obtainable separately at 1s. 1d. (post free), and the necessary case. To new readers who do not possess the necessary back numbers, the price of the complete bound volume is 16s. in the cloth style, and 19s. in the half leather (post free).

Valve Notes

By John Scott-Taggart, F. Inst P

Crystals and Valves.

THERE are many, and I must number myself among them, who are partial to the judicious use of a good crystal detector in conjunction with one or more valves.

A point to notice in connection with the use of crystal detectors is that if too high potentials are applied to the detector, the sensitive spot will be impaired. It is quite possible for signals, after two stages of high-frequency amplification, to injure seriously a crystal detector. The effect is rather curious, but many have noticed it when working with dual amplification circuits; if the signals are too strong after two stages of high-frequency amplification, the sensitive point rapidly loses its sensitiveness, and so different points on a crystal may lose their freshness and effectiveness.

Another point to remember is that there is a limit to the output obtainable from a crystal detector. Unlike a two-electrode valve, a crystal detector has a characteristic curve both above and below the horizontal line on which the E.M.F. applied to a detector is indicated. The characteristic curve is somewhat like the letter S, and, while the crystal acts as an excellent rectifier for currents of medium strength, for strong oscillations it is not so ideal.

As, however, loud signals may be obtained by stages of low-frequency amplification, this peculiarity of the crystals need not worry us very much.

I have been told that clearer signals may sometimes be obtained by connecting a very small condenser in parallel with a

crystal detector. This is stated to do away with a good deal of the "mush" experienced by some listeners. The effect of the condenser, of course, will be to weaken the signal strength somewhat.

If the crystal detector is of the home-made variety, it may possibly not have an insulated adjusting knob for varying the pressure of the catswhisker or upper crystal. If this is the case, the lower crystal cup should be the side connected to the high-frequency end of the oscillatory circuit across which the detector is connected. For example,



A valve-crystal receiver (ST100) by Radio Instruments, Ltd.

when a tuned anode circuit is used and it is desired to connect across it a crystal and a primary of an intervalve transformer, as in the ST100 circuit, the lower crystal cup should be connected to the anode side of the anode inductance, and the other side of the transformer winding should go to the other end of the inductance nearest the positive terminal of the high-tension battery. Crystal users often make the mis-

take of connecting the terminal which goes to the catswhisker to the aerial end of the inductance, with the result that every time they touch the detector signals are weakened, and this interferes with the correct adjustment of the detector. If the adjusting knob is duly insulated, it does not matter which way round the detector is arranged. I have been told by some that they find a reversal of the crystal detector in a dual amplification circuit often improves results, but I have not noticed the effect myself.

Beginners are nearly always inclined to jump to conclusions regarding the importance of a certain effect they have noticed in their own particular set and which is due to some special peculiar circumstances. It is not often that an effect is obtained in practice which is contrary to theory; if it appears to be, then there is probably some special circumstance or possibly some fault in the set. For example, I was recently told that a reader obtained better results by connecting a 5-megohm gridleak across the 100,000-ohms resistance! Another—in fact several—state that since a certain broadcasting station has changed its wavelength by a few metres signals are very much weaker. This is coupled with a statement that tuning is perfect and no fault lies there. Many a beginner will blame everything except his high-tension battery, which has run down or some other simple fault. Nevertheless, he will stoutly affirm that a certain circuit he has tried is no good at all, even though all his neighbours may be getting excellent results with it.

NEXT WEEK

A Complete Single-Valve Broadcast Receiver.
A Simple Three-Valve Receiver.

Correspondence



ST76.

SIR,—Again I wish to thank you for that excellent circuit ST76. At 12.53 a.m. recently I received some station on about 300 metres, words not readable. At 12.57 I got WGY and held them till 1.57 when they signed off. I received their call letters, WGY, seven times, and heard the announcer very clearly.

At 2.8 a.m. I picked up another station talking and heard a violin solo. This went on until 2.41 a.m., band music and voices being sometimes loud, but no call letters audible. At 2.43 a.m. I heard another station on about 400 metres. At 2.57 a.m. another station came in on

about 500 metres, some words being audible. At 3.1 a.m. I got WGY and heard almost every word till 3.17 a.m.

I then got WHAZ, and held them till 4.2 a.m. This circuit is certainly a good one.—Yours, etc.,

J. D. ACLAND.

Allerford.

ST100.

SIR,—Owing to various circumstances I have been unable to try out the ST100 until the last few days.

At the moment the aerial is of a temporary nature, and will be replaced by an outside one at an early date. It is composed of six

wires 15 ft. 6 in. long spaced 4-6 ins. under the roof. The lead-in is brought down the stairs and along one side of the room.

The results are: Cardiff (loud speaker), Birmingham, Glasgow, and Newcastle. The set is of the "Hook-up" type.

Recently I tried FL, Paris, and got great results upon the headphones, one whole transmission being perfectly clear and distinct.

The outfit was as follows:—

Coils L1 Burndept 300, parallel capacity.

Coils L2 Burndept 400.

Condensers C1 0.001 μ F, set at 65°.

Condensers C2 0.0005 μ F, set at 40°.



TrueMusic Loud Speakers

Clear as Crystal Headphones

TMC
Wireless

If unable to obtain locally, write to us direct.

THE TELEPHONE MANUFACTURING CO., LTD., HOLLINGSWORTH WORKS, DULWICH, LONDON.
BRITISH EMPIRE EXHIBITION, WEMBLEY, 1924.

(P.P.S.
171)

Condensers C3 0.001 μ F, set at 75°.

Valves Ora, now about 12 months old, and fairly well used. Transformers, Igranic.

H.T. battery 100 volts, T.E.C. Crystal, Hertzite and gold wire.

Resistance, 100,000 ohms, Mullard.

Reaction coil was out as far as the coil holder would permit, about 95°.

Now reading the above suggests a very good performance, but in no circumstances can I get 2LO. Of course, the aerial is not good, but seeing the way other stations come in it seems strange.

Using my 7-valve set, 3 H.F., R., and 3 L.F. I have had all stations, but only after considerable trouble did I get London, once. Later I shall report results upon the outside aerial.

Might I also suggest when reports are furnished as to trials of circuits, details of the outfit be given as above for the assistance of others?—Yours, etc.,

J. C. H. HOWELL.
Bristol.

" WIRELESS WEEKLY "
REFLEX RECEIVER.

SIR,—I am writing in praise of the *Wireless Weekly* Reflex Receiver, as described in No. 9, Vol. 2, of *Wireless Weekly*. I am only a beginner with valves, so no doubt you will be pleased to hear that I have received Paris, School of Posts and Telegraphs with this receiver. The singing, accompaniments and announcements were clear, distinct, and quite loud, and the reception of the speeches at the Hotel Victoria dinner were marvellous.

Previous to this I was able to get all the B.B.C. stations quite loud.

It is an excellent circuit. I was using home-made variometers and condenser across the secondary of the transformers.

Wishing you all success.—Yours, etc.,

M. H. OXBV.
Swinton, nr. Rotherham.

INTERFERENCE.

SIR,—I do not think that X-ray apparatus can be accused of being the cause of interference with broadcasting. I am the possessor of a powerful X-ray

outfit, which happens to be situated in a house about 300 yards from my private residence, where I have a 5-valve wireless set.

Some months ago, with the help of a friend, I carried out some tests to try and discover if a spark discharge from my large 16-inch coil could be heard on the broadcasting wave band with the aforementioned apparatus. Most careful tests were made, and it was not found possible for me to hear the results of the intense discharge which my friend was creating at so short a distance.—Yours, etc.,

" X-RAY."

Torquay.

**AMATEUR TRANSMISSION
IN THREE LANGUAGES.**

It will be of interest to readers to know that the well-known French amateur, Dr. Pierre Corret, of Paris, has lately been sending out Morse transmissions under the call sign of 8AEz. He works at 11 p.m. on Monday, Tuesday, Thursday, and Friday of each week, and sends out messages in French, English and Esperanto on a wave-length of 200 metres.

**—TINGEY SUPERFIVE—
CABINET RECEIVER**

The last word in PERFECT REPRODUCTION, SELECTIVITY and STRENGTH OF SIGNALS.

Enclosed in Lock-up Oak Cabinets, complete with High Tension Battery of 120 volts.

Composed of TWO HIGH FREQUENCY, one H.F. Rect. and two L.F. Power Valves. By means of two simple wander plugs any combination or number of valves may be employed.

Each set is supplied with a set of Coils covering the wavelengths of British Broadcasting Stations. Other sets of Coils may be supplied at extra charge.

We manufacture Valve Sets—1, 2, 3, 4 and 5 Valves, also an excellent Crystal Set.
Send for our new Components List—free on request.

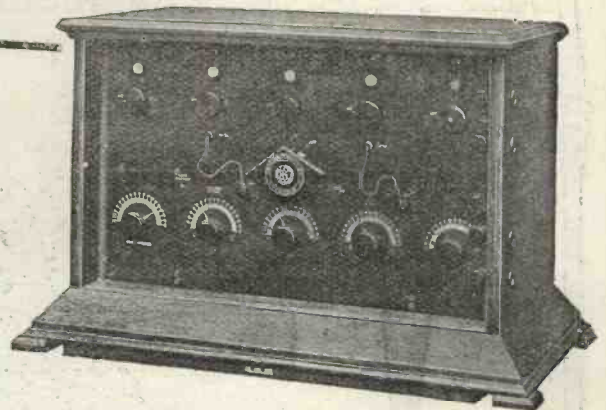

PRICE, as illustrated, including Special Valves and High Tension Battery - - - £56 : 5 : 0

Ask for Superfive pamphlet.



(FEW AGENCIES STILL OPEN.)

Offices and Showrooms :

(OPEN 8 to 7. SATURDAYS 8 to 1.)

92, Queen St., Hammersmith, London, W.6.

Phone : Hammersmith 1916.

Grams : "Tingoidar, London."

Information Department



W. W. (DALTON) requests constructional details of a low-frequency intervalve transformer suitable for use with power valves.

The necessary details of a suitable transformer would occupy more space than can be spared in these columns, and we hope to be able to publish a special article upon the subject in the near future.

C. A. T. (NEWCASTLE-ON-TYNE) asks several questions regarding the "All Concert" Receiver.

Provided that you are using a reasonably efficient aerial, the results so far obtained by you do not appear to be satisfactory. It would certainly be an advantage to apply different anode potentials to the high-frequency, rectifying and low-frequency amplifying valves. It will be necessary to fit additional terminals to the set for this purpose, and connect each one to the anode circuit

of the respective valves, when, by using a high-tension battery provided with wander plugs, the desired effect can be obtained.

W. J. M. (MANSFIELD) desires to improve the tone of his loud-speaker.

To improve the clarity of the reproduction of your loud-speaker upon strong signals, try shunting across its terminals a fixed condenser having a capacity of 0.005 μ F to 0.05 μ F.

J. T. T. (NOTTINGHAM) submits a diagram of his receiver from which he has so far failed to obtain results.

The wiring diagram submitted and the values of components indicated thereon appear quite in order and should give you excellent results at the distance named. We observe, however, that you are using type V 24 valves, and as many of the loose valve clips sold have been lacquered with

M. H. The Mark of Merit on any Wireless Set or component is a guarantee of efficiency, reasonable price and sound British manufacture.

We are exhibiting in the Electrical and Allied Engineering Section of the British Empire Exhibition, 1924.

Complete Catalogue Post Free 1/8.

CONDENSERS

Moderately Priced and Efficient

With Dial and Knob as illustrated.

0'0001 with Vernier	17/6
0'0005 " " "	15/-
0'0003 " " "	14/-
0'0002 " " "	12/6
0'0001 without " "	10/6
0'0005 " " "	9/-
0'0003 " " "	7/6
0'00005 " " "	5/6



We have a large stock of brand new Sullivan low resistance head telephones (no cords) which we are disposing of at exceedingly low rates namely 8/- per pair. Send at once to avoid disappointment.

L.M. MICHAEL LTD

IN CONJUNCTION WITH B. HESKETH LTD
SHOWROOMS: Radio Corner, 179, Strand, W.C.2.

All correspondence to Head Office,
HASTINGS HOUSE, NORFOLK STREET, STRAND, LONDON, W.C.2.
Bournemouth Depot: 5, Yelverton Road.

BEWARE OF WORTHLESS IMITATIONS, SEE THE TRADE MARK **Watmel** ON EVERY GRID LEAK.

WATMEL VARIABLE GRID LEAK

(Patent No. 206008).

The Resistance is steadily Variable between $\frac{1}{2}$ to 5 megohms. Only requires a $\frac{1}{8}$ in. hole in panel for fitting.



Suitable for use in any circuit, and improves the working of any valve detector. (50,000 to 150,000 ohms for the S.T.100 C. circuit.

PRICE 2/6 each. The best Variable Grid Leak made. Price 3/6.)

WATMEL WIRELESS CO., Connaught House, 1a, Edgware Road Marble Arch, W.2. Tel. 4575 Paddington.

ECONOMIC ELECTRIC LTD.



The "EEC" "XTRAUDION" VALVE

is being used by the leading Radio Experimenters for detection, high and low frequency amplification, power amplifiers and low power transmission. Price 15/-

USE "RECTARITE," the synthetic crystal that makes Loud speakers talk. 1/6 Large Specimen.



Write to-day for 40 page Radio Catalogue mailed post free, 4d.

Head Office: 10, FITZROY SQUARE, LONDON, W.1.

Showrooms: 303, EUSTON RD., N.W.1.

Branch and Works: TWICKENHAM.

Glowing Testimony

to the D.E.3.

The opinion
of an expert

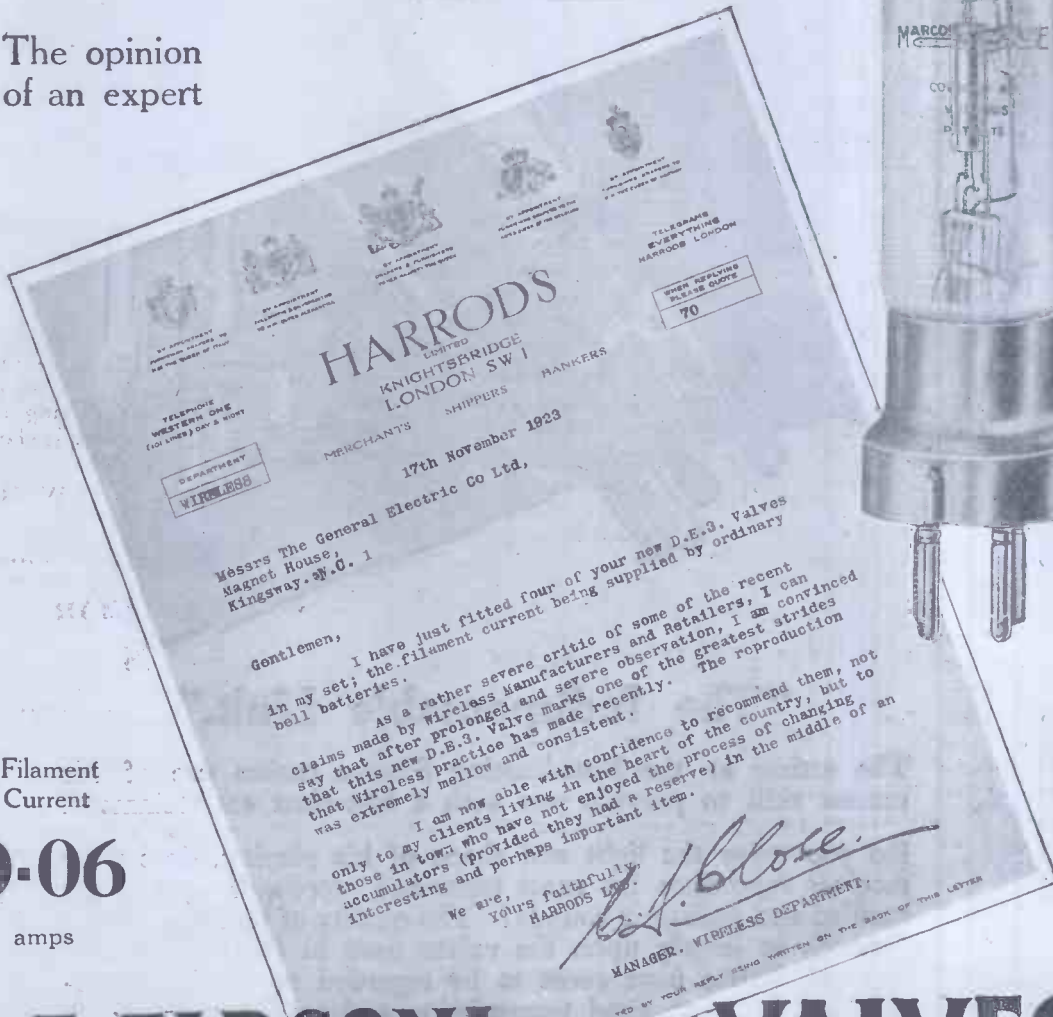
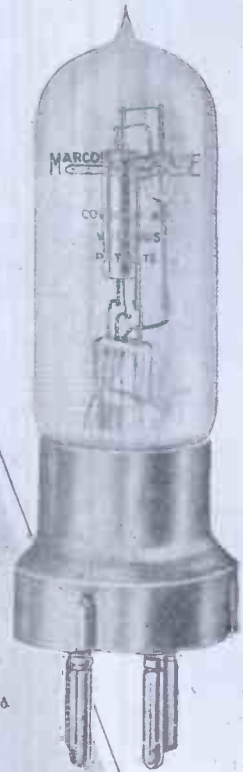

BY APPOINTMENT
TO HER MAJESTY THE QUEEN

BY APPOINTMENT
TO HIS MAJESTY THE KING

BY APPOINTMENT
TO HIS ROYAL HIGHNESS THE DUKE OF BRUNSWICK

BY APPOINTMENT
TO HIS ROYAL HIGHNESS THE DUKE OF Saxe-Coburg and Gotha

BY APPOINTMENT
TO HIS ROYAL HIGHNESS THE DUKE OF SAXE-MEININGEN

TELEGRAMS
EVERYTHING
HARRODS LONDON

WHEN REPLYING
PLEASE QUOTE
70

HARRODS
LIMITED
KNIGHTSBRIDGE
LONDON SW 1

MERCHANTS SHIPPERS BANKERS

17th November 1923

Messrs The General Electric Co Ltd,
Magnet House,
Kingsway. W.C. 1

DEPARTMENT
WIRELESS

TELEPHONE
WESTERN ONE
(10 LINES) DAY & NIGHT

Filament
Current

0.06

amps

Gentlemen,

I have just fitted four of your new D.E.3. Valves in my set; the filament current being supplied by ordinary bell batteries.

As a rather severe critic of some of the recent claims made by Wireless Manufacturers and Retailers, I can say that after prolonged and severe observation, I am convinced that this new D.E.3. Valve marks one of the greatest strides that Wireless practice has made recently. The reproduction was extremely mellow and consistent.

I am now able with confidence to recommend them, not only to my clients living in the heart of the country, but to those in town who have not enjoyed the process of changing accumulators (provided they had a reserve) in the middle of an interesting and perhaps important item.

We are,
Yours faithfully,
HARRODS LTD.

W. K. Blose

MANAGER, WIRELESS DEPARTMENT.

READ BY YOUR REPLY (BEING WRITTEN ON THE BACK OF THIS LETTER)

MARCONI VALVES

MADE AT THE OSRAM LAMP WORKS

D.E.3. TYPE
For use with dry batteries. No adaptor required

PRICE 30/- each

SOLD BY ALL GECOPHONE SERVICE DEPOTS & WIRELESS DEALERS

(Manufacturer & Wholesale only) The General Electric Co., Ltd. Head Office: Magnet House, Kingsway, London, W.C.2.

WIRELESS WEEKLY is the best weekly wireless advertisement medium.

A Valve for every Wireless Circuit.

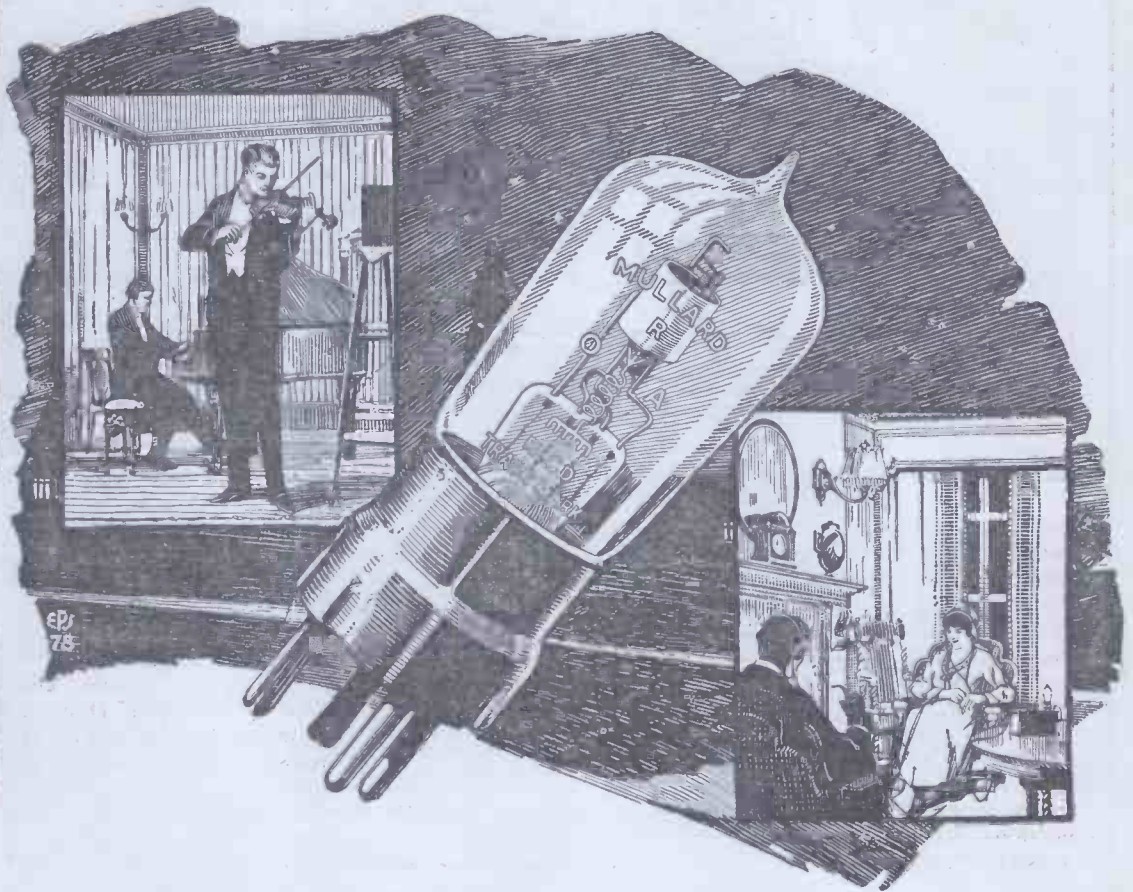
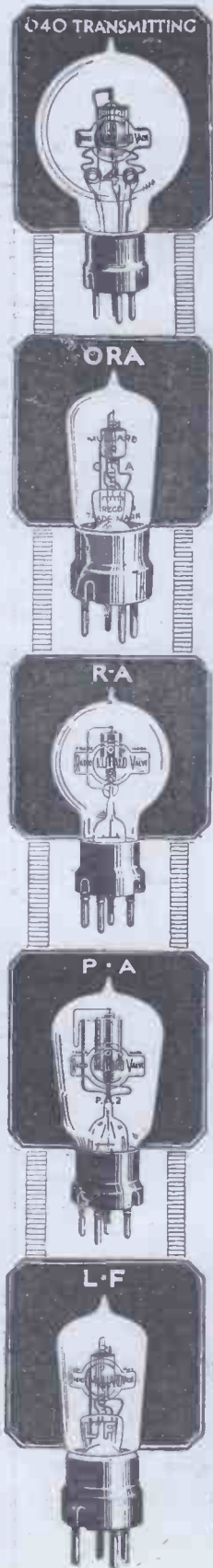

“The Indispensable Link.”

The artiste at the Broadcasting Station makes use of his utmost skill to provide you with a first-class entertainment.

Do you enjoy the light and shade of his playing, does your receiver reproduce his exact tones and words, or do you get muffled and indistinct sounds? The quality of received signals depends so largely upon the valves used in the receiver that Mullard Valves have come to be regarded as the indispensable link between good transmission and good reception.

There is a Mullard Valve specially suited to your set ; ask your dealer for booklet M 3, or drop a line to us.

Mullard

Advert. : The Mullard Radio Valve Co., Ltd., Balham, London, S.W.12.

Keep advertising and advertising will keep you.

That Set you're making— make it GOOD



TURN over back numbers of this paper. You will hardly find one which does not contain independent, highly enthusiastic comments upon one or another of our products.

Ample evidence that all Bowyer-Lowe products are completely reliable in construction and use.

If you're making a Wireless Set, use these tested components which you can trust. They cost no more.

Selected from our List of TESTED COMPONENTS

No. 39. Variable Condenser .0003 M.F.	15/-
No. 40. Variable Condenser .0005 M.F.	16/-
No. 42. Two Way Switch	2/9
3d. extra for each way to 12 Way (No. 52)	5/3
No. 53. Series Parallel Switch	5/3
No. 76. Double Two Way Switch	5/3
No. 77. Double Three Way Switch	6/3

SQUARE TINNED COPPER WIRE 2d. per 4 ft. length.

Our complete lists of Components on our new "Flange" System will be posted to you on receipt of your enquiry. Drop a line to night to Sales Dept.

The Bowyer-Lowe Co., Ltd., LETCHWORTH

Wholesale Distributors: SCOTLAND: Messrs. Robb Bros. Ltd., 69, West Nile Street, Glasgow, and North Street, Dundee. NORTH OF ENGLAND: Messrs. Wadsworth Sellers & Co., Standard Buildings, Leeds. MIDLANDS: Messrs. Robb Bros., Ltd., 9, Barnstone Road, Nottingham.

MODEL ENGINEER EXHIBITION, JANUARY 4 to 11, STAND 28

SIMPLEST A BARGAIN YOU CHEAPEST SHOULD NOT MISS EASIEST AND BEST AERIAL IN THE WORLD

WE are offering 100 feet of the finest insulated aerial, VULCANIZED, for 1/8, carr. paid. Experts and enthusiasts all over the country write in praise of it. NO INSULATORS REQUIRED. WIRELESS MASTS UNNECESSARY.

Read this one of many UNSOLICITED TESTIMONIALS:
18, Dunham Rd., Manchester.

Dear Sirs,
The 100 feet of your excellent cable arrived quite safely, for which many thanks. I might add that I removed my original aerial of 7/22's hard copper, and re-erected it with your cable, and the results are much better.

and more stable. Will you please forward me a further 100 feet of the same, for which I enclose P.O. for 1/8, as before. Yours faithfully—(signed) R. W. EVANS.

Originals can be seen at our offices.

Send your order NOW.

Larger quantities.			
500 feet	500 feet	1,000 feet	1/2 mile coil
4/3	6/3	10/3	17/6
CARRIAGE PAID.			
Cash with Order.			

NEW LONDON ELECTRON WORKS, LTD.,
65, Regents Dock
London, E.14

100 ft.
1/8
Carriage Paid

A Ribbon Aerial



Complete with Insulators and Clips 2/3
Adaptable also for indoor Aerial.

Please order from your usual Dealer. We cannot supply direct.

The Amplifytone Aerial Outfit

consists of a new ribbon type aerial (with minimum high-frequency resistance), 4 insulators and clips, and a new design lead-in tube, which obviates the drilling of holes. Quickly rigged up, this outfit will appeal to all. List No. 17440. COMPLETE 6/8

Are you building your own set?
If you are, the B.B.L. Booklet of Wireless Diagrams will be a decided help. Get a copy from your Dealer. PRICE 1/-

Brown Brothers

with which is amalgamated Thomson & Brown Brothers Ltd.

Wholesale only. Head Offices & Warehouses. GREAT EASTERN ST., LONDON, E.C.2
118, George St., Edinburgh, and Branches.

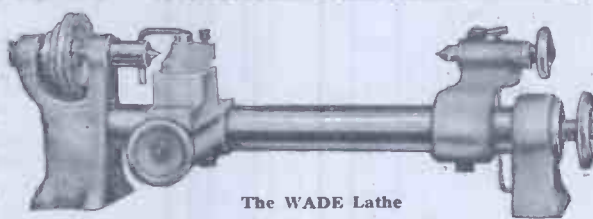

The WADE Lathe

Make your own parts and assure good results

The WADE Lathe as illustrated £2 - 10 - 0

The best parts are those you make yourself, on the Wade Lathe. Turns material up to 12 in. by 4 in. Suitable for boring, facing and drilling. Just the thing for Wireless work. British made, inexpensive and takes up very little space. Slide rest travels whole length of bed and is fitted with cross-feed as well. Sold by leading tool dealers.

Send for List W12

C.A.V. SMALL TOOLS LTD.,
181, Queen Victoria Street, LONDON, E.C.4

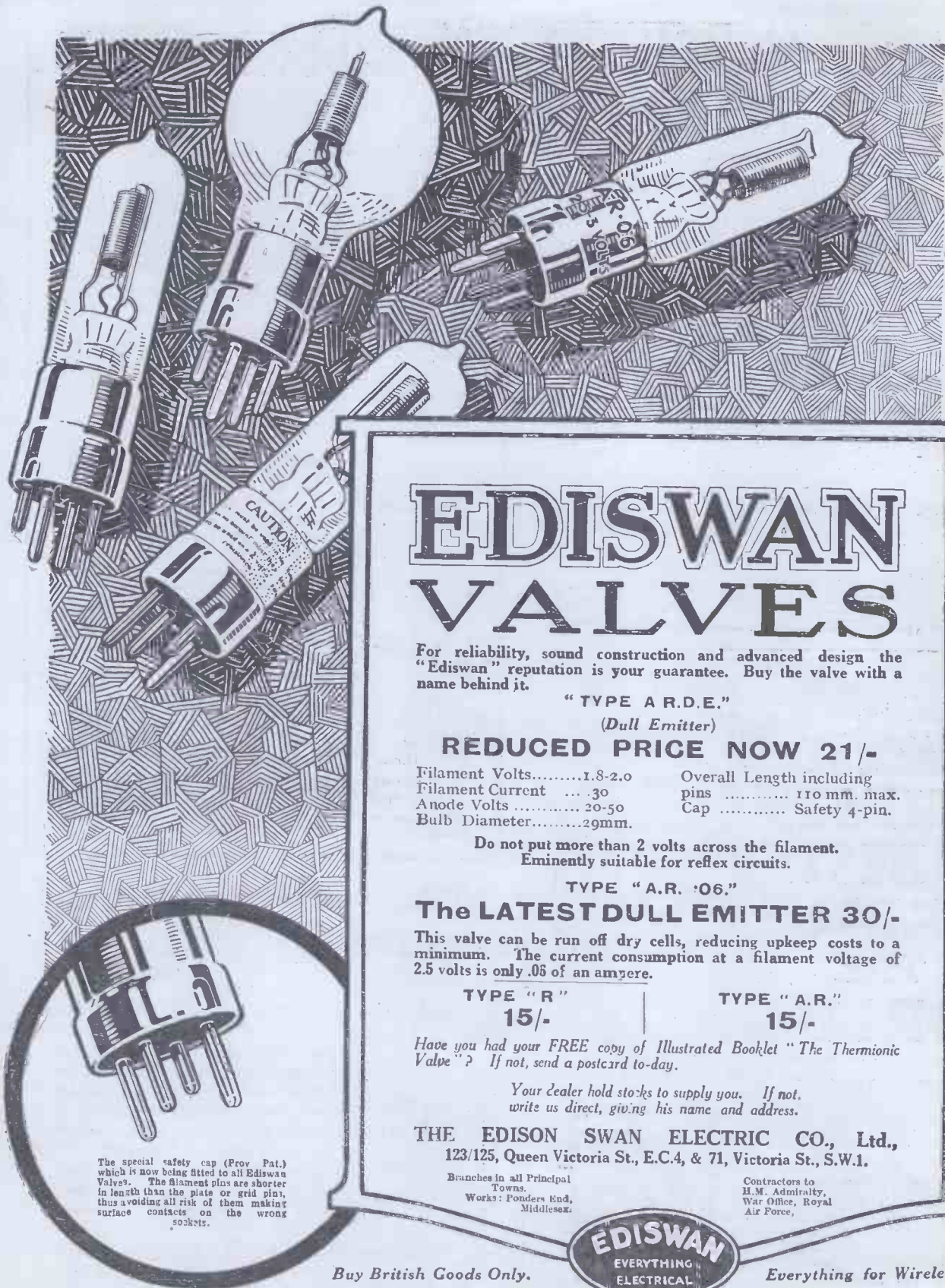

EDISWAN VALVES

For reliability, sound construction and advanced design the "Ediswan" reputation is your guarantee. Buy the valve with a name behind it.

"TYPE A.R.D.E."

(Dull Emitter)

REDUCED PRICE NOW 21/-

Filament Volts.....1.8-2.0	Overall Length including pins	110 mm. max.
Filament Current30	Anode Volts	20-50
Bulb Diameter.....29mm.	Cap	Safety 4-pin.

Do not put more than 2 volts across the filament.
Eminently suitable for reflex circuits.

TYPE "A.R. .06."

The LATEST DULL EMITTER 30/-

This valve can be run off dry cells, reducing upkeep costs to a minimum. The current consumption at a filament voltage of 2.5 volts is only .06 of an ampere.

TYPE "R"
15/-

TYPE "A.R."
15/-

Have you had your FREE copy of Illustrated Booklet "The Thermionic Valve"? If not, send a postcard to-day.

Your Dealer hold stocks to supply you. If not, write us direct, giving his name and address.

THE EDISON SWAN ELECTRIC CO., Ltd.,
123/125, Queen Victoria St., E.C.4, & 71, Victoria St., S.W.1.

Branches in all Principal Towns.
Works: Fonders End, Middlesex.

Contractors to H.M. Admiralty, War Office, Royal Air Force.

The special safety cap (Prov. Pat.) which is now being fitted to all Ediswan Valves. The filament pins are shorter in length than the plate or grid pins, thus avoiding all risk of them making surface contacts on the wrong sockets.



Buy British Goods Only.

Everything for Wireless.

Keep advertising and advertising will keep you.

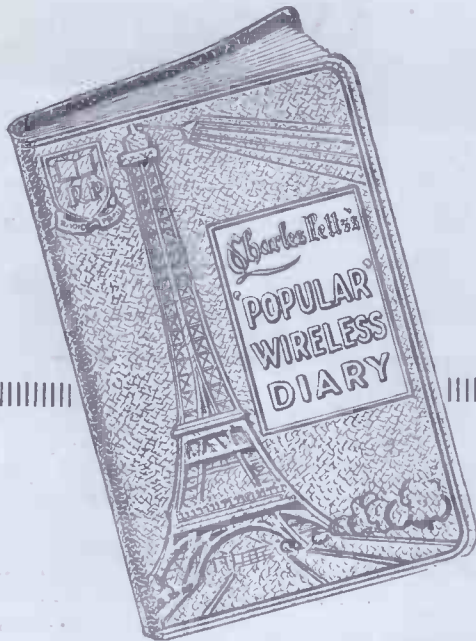

Radio Press Diaries for 1924

FOR your appointments—to chronicle your doings—for the thousand and one things connected with your life, you need a Diary.

This year, purchase a Wireless Diary and get some useful information without extra cost.

These two Radio Press Diaries are both extremely neat and well-produced little Books. They do everything that a Diary should do—they are convenient in size and shape—do not bulge the pocket—strongly bound to give a whole year's service, and more besides, if needed. Just the Diary, in fact, to suit the most critical. From all Booksellers or direct (postage 2d. extra) from Radio Press, Ltd.

Radio Press Handbook and Diary for 1924.

Size 5½ in. by 3½ in., solidly bound in grained leather cloth, fitted with pencil. Diary portion shows a whole week at an opening. Large number of pages of technical data, including several pages of electrical formulae which will prove invaluable to the serious worker **2/6**

Radio Press Popular Wireless Diary for 1924.

Size 2½ in. by 4½ in. Strongly bound in leather cloth with rounded corners. One complete week shown at each opening. Wireless pages include information on call signs, circuit diagrams, Morse Code, electrical data, full instructions for building a complete Receiving Set, etc., etc. **1/-**

In Leather, with-pencil **1/6**

BUY BRITISH GOODS ONLY

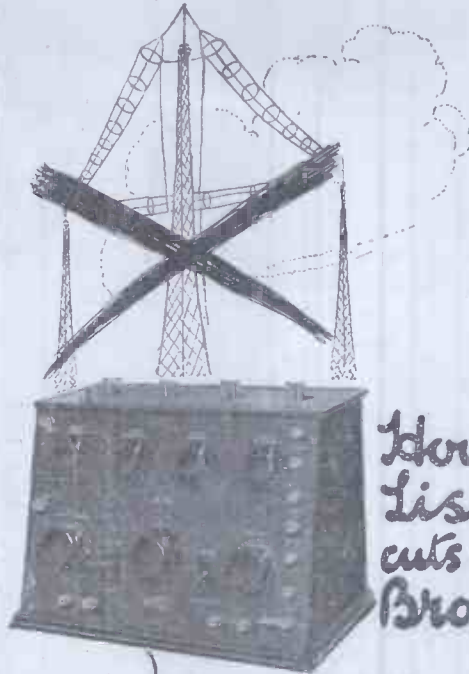

How one Listener cuts out local Broadcast

ARE you a "local listener" — tied down to one station by powerful local broadcast?

If so, the experience of the writer of the accompanying letter suggests a way out for you.



Glasgow:
Monday, 3rd Dec., 1923.
The British L.M. Ericsson
Mfg. Co., Ltd., London.
Dear Sirs,—It may be of interest to you to know that last night on my indoor aerial with one of your new 4-Valve Sets I tuned out Glasgow within 4 miles from the Broadcasting Station, and got on direct to Bournemouth and London with such strength as to enable me to switch through to Loud Speaker. I consider this a very good performance as it was practically clear from any interruption from the local station.
Yours faithfully,
A. B.

The striking success of this listener is due to the incorporation in Ericsson Multivalve Receivers of the utmost reactance permitted by regulation aided by highly selective loose coupled circuits.

Nothing is spared or scamped in Ericsson Multivalve Receiver. Every detail is perfect — transformers, condensers, wiring, woodwork, etc.

Write us to-day, stating your needs. Ask for our splendid lists or apply to your nearest Ericsson Agent.

The British L.M. Ericsson Mfg. Co., Ltd.,
International Buildings,
Kingsway, W.C.2.

SELLING AGENTS:
Manchester — 19, Bridge Street.
Deansgate; Nottingham — W. J. Furse & Co., Traffic Street; Birmingham — 14/15, Snow Hill; Colchester — 121, High Street; Scotland — Malcolm Breingan, 57, Robertson Street, Glasgow; N.E. England — Milburn House, New-castle-upon-Tyne.

Ericsson
VALVE RECEIVERS



Super 3 Set.

Price
£12

Complete with H.T. Battery, Accumulator, 100 ft. Aerial and Insulators, and 1 pair 4,000 ohms Headphones.

A 2-valve amplifying unit, as illustrated, is specially constructed for use with the Super 3 Set.

Price
£6

B.B.C. and Marconi taxes and valves extra.



Super 3 Amplifier.

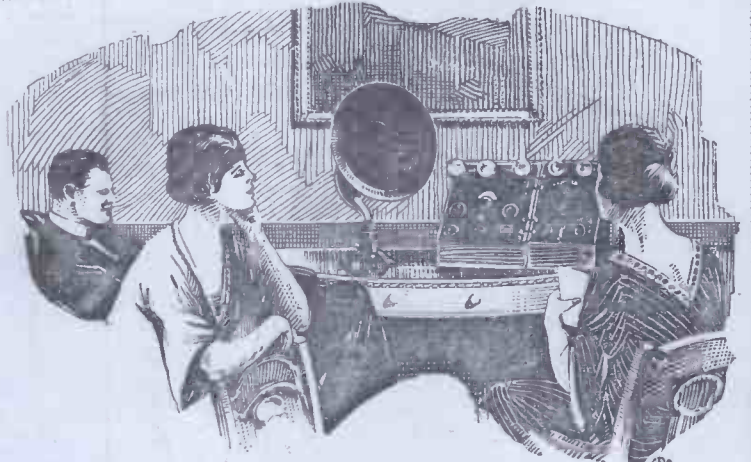

30

THOSE LONG WINTER EVENINGS

will soon pass if you have a really good Wireless Set with which you can entertain your friends. The FELLOPHONE SUPER 3-Valve Set, as illustrated, is mounted in a well-finished mahogany case, and comprises 1 H.F. Valve, 1 Detector, and 1 L.F. Valve. The circuit is the most selective known at present, and contains the maximum reaction allowed by the P.M.G. First-class reception of any British and Western Continental Telephony is assured, even though the nearest Broadcasting Station is working.

FELLOWS

Advt. of the Fellows Magneto Co., London, N.W.10.

RESULTS!

WIRELESS WEEKLY

will bring you
BUSINESS

It is as good an advertising medium as
MODERN WIRELESS.

Rates for both publications on application to—

Scheff Publicity Organisation

125, Pall Mall, London, S.W.1.

No. 2.

'Phone: Regent 2440.

THE
"ATLAS" SUPER COIL.

P.P. No.
2250/23.

All
Wave-lengths
Covered.

MAXIMUM
AIR-SPACE

MINIMUM
SELF
CAPACITY

ONCE
TRIED

ALWAYS
USED.

Prices on
Application.

Ask for Catalogue of
Radio Components.



Manufactured only by

H. CLARKE & Co. (M/cr.) Ltd.

Radio Engineers, **ATLAS WORKS,**
OLD TRAFFORD, MANCHESTER.

Telephone Nos.:
683 & 793 Trafford Park.

Telegrams:
PIRTOID. Manchester.

Keep advertising and advertising will keep you.

Enormous Success

**PENTON
LOW CONSUMPTION
VALVE**

Type H.E.4. for 6 volt accu.

„ H.E.6. „ 4 „ „

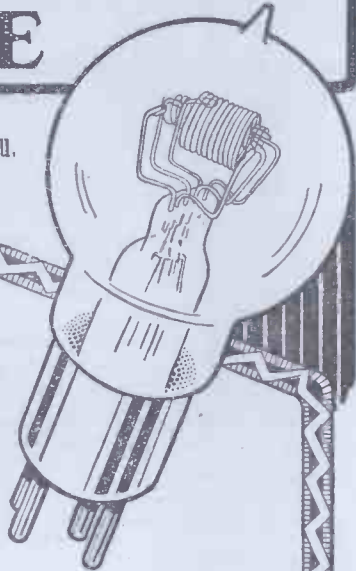

	H.E.4	H.E.6
Fil. Amps.	15	15
„ Volts	5	3.5
Plate	60	60

Every Valve Tested and Fully Guaranteed.

Half the price
and consumes
Less current
than most of the Dull Emitters.

DISTORTION entirely eliminated as this Valve incorporates the patent SPIRAL ANODE.

PRICE **15/-** EACH

Postage 6d. extra.

Your Accumulators will last 4-5 times longer than when using the ordinary R type Valve. Will operate satisfactorily using PRIMARY or DRY CELLS as filament lighting supply.

As we have greatly increased our production we are now able to offer immediate delivery from Stock.

WRITE FOR LEAFLET.

The
PENTON ENGINEERING CO.,

15, Cromer Street, King's Cross, W.C.1

'Phone : Museum 4681.

Grams : "ERPENTOBAL, KINCROSS."

Genuine 4,000 Ohms Continental
ERICSSON
HEADPHONES with GUARANTEE.

THE Ericsson "Continental" is the best-known and most efficient Continental phone. Its qualities are loud, clear, and full articulation, capacity for receiving the most subtle variations of tone, comfort, lightness, and high finish. It equals the highest-priced phones on the market to-day.



Post your order to-day.

PRICES:

14/- 4,000 ohms.

13/- 2,000 ohms.

ABOVE POST FREE.

No extra charges. Cheques and postal orders should be crossed and made payable to Wireless Distributing Co. Immediate delivery.

GUARANTEE.—We agree to replace or return cash if Phones do not give satisfaction, subject to their being returned within seven days undamaged.

WIRELESS DISTRIBUTING CO.,
(Dept. W), 2, Dorset Street, Salisbury Sq., London, E.C.

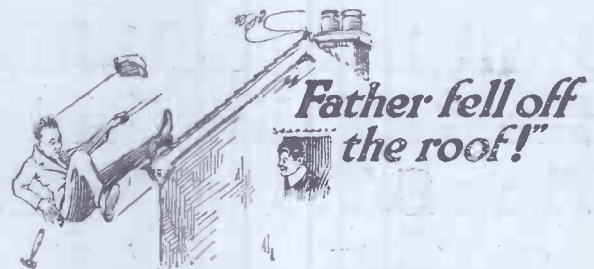

"Father fell off the roof!"

Oh dear! But what was he doing on the roof? Fixing up an aerial! Well I'm dashed he ought to have known better and bought a

CLIMAX
MONOVALVE

No outside aerial. No earth. Portable as a gramophone. No installation cost.

It gives loud and clear reception on local stations up to about 50 miles, while quite a pleasant Volume can be obtained at distances of 100 miles and over.

The set on which "Popular Wireless" got all British stations at 3 miles from 2LO. Climax Monovalve with Climax patented folding frame aerial... **£10** (if used with B.B.C. Licence—Tax 11/- extra.)

Accessories required: Headphones, valve and batteries. Approx. cost... **£4** (Any standard accessories can be used.)

Write for full particulars: (Dept. WW)
CLIMAX PATENTS LTD.,
182, Church St., Kensington, London, W.3.
(Phone: Park 2023.)

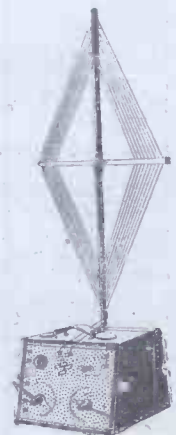

(E.P.S. 12.)

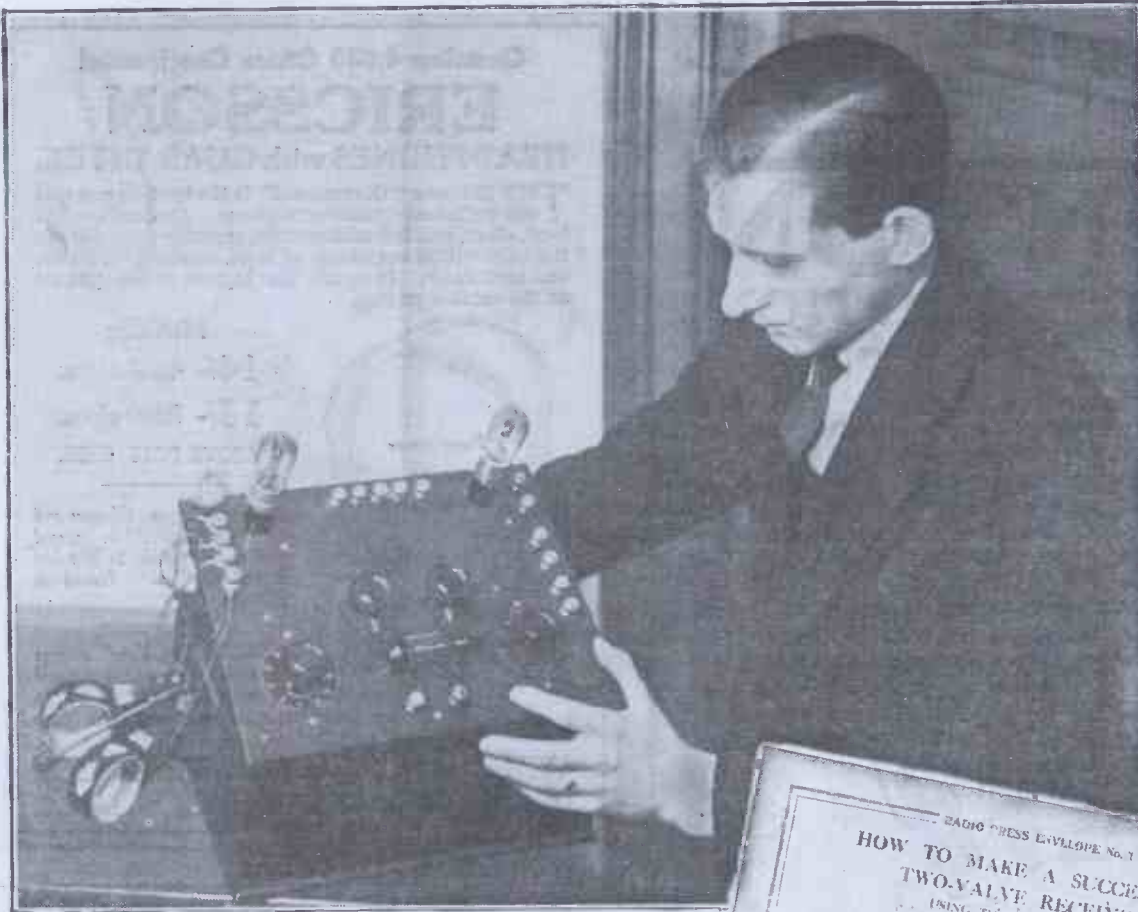

Full instructions for building this fine S.T. 100 Set:

THE tremendous success which followed the publication of constructional articles dealing with the S.T. 100 Circuit and the heavy demand from our readers for further articles on the same subject, has lead us to place on the market an Envelope containing the fullest details about it.

This Envelope can be bought by anyone in full confidence that with the least amount of mechanical ability he can build a really first-class Receiver—similar in every respect to the one illustrated above.

But even more important, this Envelope contains working hints and instructions which will prove invaluable to anyone operating a Reflex Set for the first time.

We have aimed, in fact, to make the material contained in this Envelope as comprehensive as possible. Why not get one to-day and start building this most fascinating of Receiving Sets?

From all Booksellers

1/6

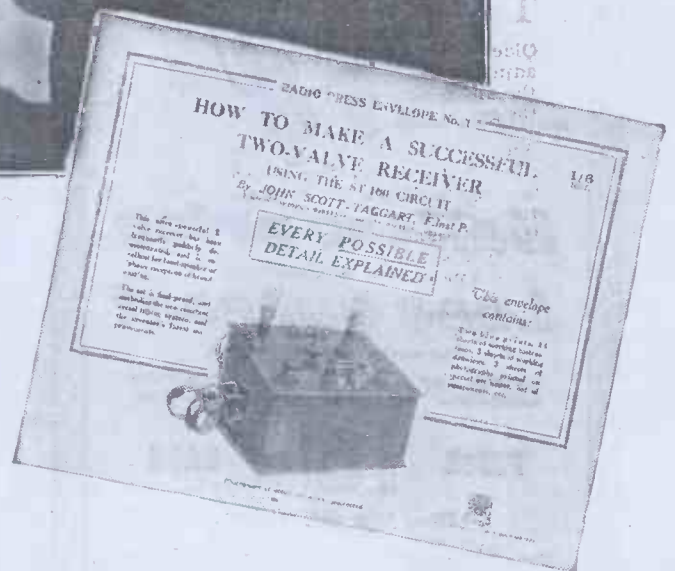

SIMPLEX RADIO CHARTS.

WE have just published a further series of envelopes, each of which contains a full size chart for building a Valve Receiver (see below) together with a booklet which explains exactly the components which are required for the construction of the Set.

- No. 1.—A Two-Valve Receiver 1/-
- No. 2.—A Three-Valve Receiver 1/-
- No. 3.—A Four-Valve Receiver - - 1/-

From all booksellers or direct (postage 2d; extra.)

RADIO PRESS Ltd.—Devereux Court, STRAND, W.C. 2.

Cossor

—makes happy faces

THE extreme dependability of Cossor Valves has been no small factor in popularising Radio.

Older Wireless enthusiasts will recall the days of critical rheostat adjustment—the necessity for having the H.T. supply just right—the uncertainty as to whether the results will be good or bad—and the general falling off in efficiency throughout the life of the Valve.

With the advent of improved manufacturing facilities coupled to a higher standard of accuracy from the workers themselves, all this has changed and the modern Valve is as nearly perfect as any human product ever can be.

The Cossor Valve—with its hood-shaped Anode and Grid and its curved filament—represents a distinct advance in design over all other types of Valves. And the reason can be understood by all.

Every Valve depends on the fullest use being made of the stream of electrons given off by the filament. In the Cossor the curved filament is quite out of sight and almost totally enclosed by the

hood-shaped Grid and Anode. Therefore practically the whole of the electron stream is caught either by the Grid or by the Anode.

In a Valve with a straight filament, on the other hand, a big proportion of the electron stream escapes out of each end of the tubular Anode and travels wastefully to the sides of the glass.

Cossor users know that this vast improvement in design gives them a higher amplification factor, greater sensitiveness, absolute reliability and a longer life.

And all these advantages are procurable at the same cost as for an ordinary valve.

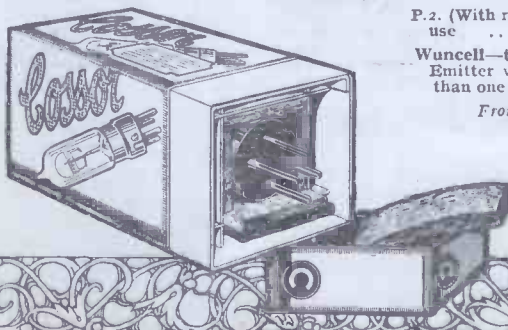

Types: P.1. For Detector and L.F. use 15/-

P.2. (With red top) For H.F. use .. 15/-

Wuncell—the improved Dull Emitter working from less than one volt .. 30/6

From all Dealers.

Manufactured solely by—
COSSOR VALVE CO. LTD.,
Highbury Grove—N.5.

Gilbert Ad.

WIRELESS WEEKLY SMALL ADVERTISEMENTS

PREPAID Advertisements are accepted under this heading for Wireless Apparatus and Parts WANTED or FOR SALE, etc., at the rate of 1s. 6d. per line, MINIMUM THREE LINES, Advertisements should reach Scheff Publicity Organisation, 125 Pall Mall, London, S.W.1, LATEST by first post FRIDAY preceding date of publication.

The publishers are not responsible for clerical or printers' errors, but every care is taken to avoid mistakes.

"RADIOHM," No. 1. Crystal Receiving Outfit, the same quality and good reception you can pay 6 Guineas for. We charge 52s. 6d., and return your money if not satisfied. We've never had to do it yet.—Sparks' Radio Supplies, 43, Great Portland Street, W.1. 'Phone Langham 2463.

NOT A SUPER SET, but distinctly Superior—"Radiohm" C.-V. Type 1. A Crystal-Valve set "hooked up" to give better results than many 2 or 3-valve sets. Makes you forget a gramophone, £10 17s. 6d. complete.—Sparks' Radio Supplies, 43, Gt. Portland Street, W.1. 'Phone: Langham 2463.

A GOOD AERIAL means good reception. "Radiohm" Strip Ribbon Aerial, 25 per cent. better than wire. Fact! 100 ft., 3s., plus post. Trade supplied.—Sparks' Radio Supplies, 43, Gt. Portland Street, W.1. 'Phone: Langham 2463.

THE YANK KNOWS! Look behind the panel of the best American sets. They use square tinned copper rod for wiring? We sell it. 2 ft. lengths, 3s. doz. Trade supplied.—Sparks' Radio Supplies, 43, Gt. Portland Street, W.1. 'Phone: Langham 2463.

WE HAVE ONE OR TWO "SNIPS"—the kind the Radio enthusiast likes to keep to himself. Write for particulars.—Sparks' Radio Supplies, 43, Gt. Portland Street, W.1. 'Phone: Langham 2463.

"RADIOHM" is our trade mark—it stands for Good Goods plus Good Service. We want Agents. A chance for real live men. Write now.—Sparks' Radio Supplies, 43, Gt. Portland Street, W.1. 'Phone: Langham 2463.

HEADPHONE REPAIRS.—Re-wound, re-magnetised and re-adjusted, lowest prices quoted on receipt of telephones, delivery three days.—The Varley Magnet Co., London, S.E.18.

WANTED, STUDENTS, for Wireless Appointments; we find berth when qualified; situations waiting now; prospectus free. Wireless Training College, Lansdowne Rd., Bournemouth.

LOOK! 1/6 only, a miniature Wireless Vest Pocket Receiving Set. Tested and guaranteed to receive broadcasting concerts within a radius of 20 miles. Full instructions with each set. Money returned if not satisfied. Post free.—Send P.O. 1/6 to T. E. P. Gibbs, 21a, Northwold Road, Stoke Newington, London, N.16. Write also for the wonderful new Crystal Exeliter (Regd. Trade Mark). Post free 1/-

B.C. Crystal Sets (stamped).—Agents wanted for districts within 25 to 30 miles of any broadcasting station. Prices from 7/9 to 13/9 each; every set guaranteed.—Simons, 100, Houndsditch, London, E.1.

WIRELESS SLEEVING for Sale, cheap; excellent material, in yard lengths. 12 lengths 2s. 6d., post free.—Martin Evans, South Dock, Swansea.

WIRELESS RECEIVERS OF TO-DAY.—A Book giving a full description of how to use, erect and choose a Wireless Set, fully illustrated; send for a copy now, post free, 1/3.—Ed. J. Burrow and Co., Ltd., 93, Kingsway, W.C.2.

2-VALVE GECOPHONE CABINET SET, with valves, H.T., 1 pair phones, 2 10-foot plugged leads. Absolutely as new. £15.—Particulars J. Shepherd, 123, Wellgate, Rotherham.



CABINETS YOU WANT

PICKETT'S Cabinets—they're good value, from 1/6 each, highly polished. Cabinet Works, Albion Rd., Bexley Heath, S.E. Write for Lists W.L.

EBONITE

Sheet rod and tubing in all sizes kept in stock and cut to any required size while you wait, or sent by post on receipt of cash.

WE CAN TURN ANYTHING IN EBONITE.

BURGE, WARREN & RIDGLEY, LTD.

91/92, GREAT SAFFRON HILL, LONDON, E.C.1. 'Phone 8572 Central.

Don't buy accumulators for your valves

Unskilled chargers will only ruin them. For 15/- a quarter ONLY 1/3 A WEEK INCLUSIVE we will supply you continuously with reliable charged L.T. Batteries, replaced at time of collection by motor anywhere in London. 'Phone: East 5655. British Battery Supply Service, Write NOW for Pamphlet C Free. Carr St., London, E.11 (Originators of the Battery Supply Service.)

Radio Press Information Dept.

2/6 QUERY COUPON 2/6

WIRELESS WEEKLY. Vol. 3. No. 3. December 26, 1923.

(This coupon must be accompanied by a postal order of 2/6 for each question, and a stamped addressed envelope.)

ORDER FORM.

Make sure of benefiting under our FREE GIFT SCHEME by completing this form and handing it to your newsagent without delay.

PLEASE SUPPLY ME WITH WIRELESS WEEKLY FOR SIX WEEKS COMMENCING WITH THE DECEMBER 19TH ISSUE, VOL. 3, No. 2, AND UNTIL FURTHER NOTICE.

Signature

Address

FINEST WORK & PROMPTITUDE. INCOMPARABLE WHITE FILLING. HAND AND MACHINE ENGRAVING ON ANY MATERIAL.

Phone Central 1137. CLIFFT & GOSKLE, 51, Arcade Chambers, St. Mary's Gate, MANCHESTER.

PLUGS and JACKS

PLUG & JACK COMPLETE 2/6 Post Free. TWO-WAY PLUG. A. ROBERTS & CO. 42, Bedford Hill, Balham, S.W.12. SCREWED JACK

ELBE COIL HOLDERS

USE SINGLE COIL HOLDERS FOR MAXIMUM EFFICIENCY. HIGHLY RECOMMENDED. Ebonite Basket-Coil Mounts to plug in above, 2/- each. Ask your Dealer for them. LEIGH BROS., Tel.: Mus. 4792 37, Sidmouth Street & 1a, Prospect Terrace, Gray's Inn Road, LONDON, W.C.1. Price 1/9 each. Post 5/- Set of three. Free.

"EL-BE" ANTI-CAPACITY HANDLES.

No Screws. No Clamps. Fixed by Suction—Removed in a second. A Type for Horizontal working. Price 2/2 each. C Type for Vertical working. Post 2/2 free. A perfect combination with the "EL-BE" Coil Holder. Ask your DEALER for them.

"WIRELESS WEEKLY" FREE GIFT COUPON

No. 3

This coupon has a cash value. It should be retained until six coupons have appeared. The six coupons will be accepted by Radio Press, Ltd., as one half of the purchase price of any one of their handbooks.

Keep advertising and advertising will keep you.



R.P.

Home - built Wireless Components

—a new Book giving
complete constructional
details and drawings

EVERY time the wireless enthusiast wants to build *every* part of his Set. Not only does he save money, but he is able to appreciate better how each individual component works.

It is not uncommon to find that the man who is sufficiently painstaking to make his own components will get better results from a 1-Valve Receiver than many will get from 3-Valve Sets. This is merely because he has the patience to experiment and to be continually making adjustments for the improvement of his reception.

If you are contemplating making additions to your Receiving Set, why not get a copy of *Home-built Wireless Components* and start making some of the parts yourself? With the technical data given and the very clear diagrammatic sketches, you can't possibly go wrong.

Remember, every article described has been actually built up and subjected to thorough tests.

Published by
RADIO PRESS, LTD.,
Devereux Court,
Strand, W.C. 2.

2/6

From all Booksellers or
2/8 post free direct.

R.P.

Radio Press Series No. 16

R.P.

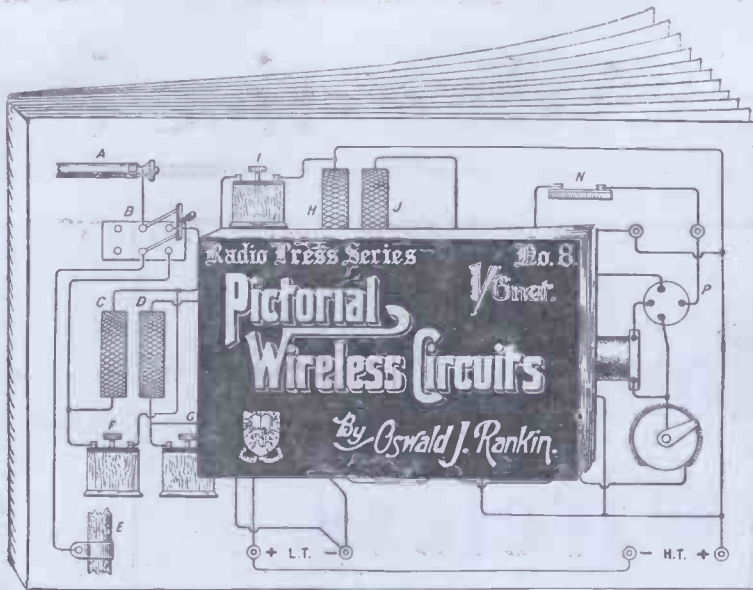

Just published

Is reading a Circuit Diagram your Waterloo?

Pictorial

Wireless Circuits

- Simple Crystal Circuits.
- Variometer Crystal Circuits.
- L.F. Amplifying Circuits.
- Power Valve Amplifying Circuits.
- Single Valve Circuits.
- Two and Three-Valve Circuits.
- Crystal-and-Valve Circuits.
- Flewelling Circuit.
- Four-Valve Circuits.
- Switching, etc., Circuits.

1/6

From all Booksellers or post free direct 1/8.

WHEN a Wireless enthusiast decides to build his own Set, his first job is to study the necessary wiring diagram. And that is where quite a number meet their Waterloo.

Those of us who can read circuit diagrams as easily as we can our morning paper, are apt to show but little sympathy for the extreme novice making his first flounders into Wireless.

Radio Press, however, appreciate that the correct reading of circuit diagrams is the first essential to the successful building of a Set, and are publishing an entirely new book which completely cuts out this difficulty.

Every circuit diagram in "Pictorial Wireless Circuits" is shown pictorially—that is to say, the actual components used are drawn instead of conventional signs for them. Thus there will be no excuse, for example, for any enthusiast not knowing the correct position for his filament rheostat.

Altogether over 70 circuits are shown, ranging from Simple Crystal Receivers to more elaborate Multivalve Sets.

If difficulty in reading circuit diagrams has hitherto prevented you from building or improving your Set—get a copy of this book to-day. It will be eighteenthpence well spent,

Radio Press Series No. 8.

Keep advertising and advertising will keep you.

Why Not Advertise?

Let some of the satisfied advertisers in "MODERN WIRELESS" and "WIRELESS WEEKLY" give their reasons for using these two wonderful media.

The George Manufacturing Co. & Production Service,
Nelson Chambers,
52, High Street, Birmingham.

Messrs. The Wireless Weekly,
Scheff Publicity Organisation, Ltd.,
125, Pall Mall, S.W.1. 18th December, 1923.

Dear Sirs,

In reply to your letter of yesterday's date we are pleased to inform you that the "Astra" Amplifier ordered by Mr. _____ was duly despatched to him yesterday, so that it should be in his hands this morning.

We quite appreciate how unsatisfactory this delay with deliveries is, but thanks to the publicity obtained through your publication, demands completely exceeded our available supplies, which is, of course, receiving our immediate attention.

Yours faithfully,
A. W.
p.p. THE GEORGE MANUFACTURING CO.

Autoveyors Ltd.,
84, Victoria Street,
London, S.W.1. 16th January, 1923.

The Advertisement Manager,
Modern Wireless,
125, Pall Mall, S.W.1.

Dear Sirs,

We thank you for your letter of the 18th instant and we are pleased to find that the advert. inserted in your publication has resulted in so many enquiries.

We are answering each enquiry individually and we are hoping that substantial results will ensue.

Thanking you,

Yours faithfully,
For and on behalf of AUTOVEYORS, LTD.,
C. Valley, Secretary.

General Radio Co.,
Twyford Abbey Works,
Acton Lane, Harlesden N.W.10.
24th February, 1923.

Modern Wireless,
The Scheff Publicity Organisation, Ltd.
125, Pall Mall, S.W.1.

Dear Sirs,

We beg to thank you for your further list of enquiries for our sets as received by you and same will have our prompt attention.

You might be interested to learn that we have received 1,261 enquiries from our advertisement in the first issue of "MODERN WIRELESS."

Yours very truly,
GENERAL RADIO CO.
By W. Stephenson.

The Peto-Scott Co., Ltd.,
Featherstone House,
64, High Holborn, W.C.1.

11th July, 1923.

Messrs. The Scheff Publicity Organisation Ltd.,
125, Pall Mall, S.W.

Dear Sirs,

We understand from our Agents that our contract for 13 full page insertions has expired with the current issue. Because we are so pleased with the results obtained from advertising in "WIRELESS WEEKLY" we have instructed them to place with you a further series order of full pages.

In our opinion the reader of "WIRELESS WEEKLY" is just the class of customer we desire to do business with, and we have been able to trace a very considerable portion of our business directly to our advertising in that magazine.

Permit us to congratulate Messrs. The Radio Press, Ltd., on the production of such a magnificent weekly wireless magazine.

Yours faithfully,
PETO-SCOTT CO., LTD.
W. Scott Worthington, Managing Director.

The Bowyer-Lowe Co., Ltd.,
Commerce Avenue,
Letchworth, Herts.
6th July, 1923.

Radio Press, Ltd.,
Devereux Court,
Strand, W.C.2.

Dear Sirs,

With reference to our Wavemeter advertisements we have now carefully gone into the results of these and have much pleasure in informing you that our advertisement in "WIRELESS WEEKLY" has been productive of excellent results, and taking the next best result as indicating 1, the results from "WIRELESS WEEKLY" are 4½.

As a result of this we shall be booking a series of advertisements with your periodical.

Yours faithfully,
THE BOWYER-LOWE CO., LTD.
(Signed) A. C. Bowyer-Lowe, Director.

NOW may we book your order!

Advertisement Managers for BOTH Publications—

SCHEFF PUBLICITY ORGANISATION LTD.

125, Pall Mall, LONDON, S.W.1.

'Phone: Regent 2440 (2 lines).

Keep advertising and advertising will keep you.

APPROACHING ONE MILLION & HALF SATISFIED CUSTOMERS STUDY OUR ADVERTISEMENTS.

ELKAY WIRELESS CO.

BRITAIN'S LARGEST EXCLUSIVE WIRELESS STORES

QUALITY, QUANTITY AND CONSISTENCY OUR MOTTO

PIONEERS of CHEAP PRICES

SEE OUR SIX-WINDOW DISPLAY OF BARGAINS

You may require apparatus not detailed below. Be confident—we sell everything for wireless. WRITE TO ELKAYS—WE STOCK IT.

- ELKAY Lightweight Headphones, 4,000 ohms, all guaranteed ... per pair 12/9
FELLOWS' New Lightweight Phones, 4,000 ohms, stamped B.B.C. ... 18/6
SUPER PHONES, Light, Easy Adjustment, 4,000 ohms, guaranteed ... 13/9
N & K (The genuine article), 4,000 ohms, all guaranteed ... Per Pair 12/9
ALSO BROWNS, BRUNET, THOMSON-HOUSTON (French), ETC.

ALL MAKES of VALVES in STOCK
MARCONI R. EDISWAN, MULLARD and COSSOR (Red & plain top)
DULL EMITTERS, Ediswan & Marconi 21/-
Special packing and post 1/- each extra EACH
State what Make of LOUD SPEAKER you Require
EVERY TYPE IN STOCK

Table listing various electronic components such as valves, transformers, wires, and condensers with their respective prices and specifications.

OUR NEW BRANCH NOW OPEN
159, BISHOPSGATE, E.C. 2.
(12 DOORS FROM LIVERPOOL STREET STATION—ON SAME SIDE)

Table listing various electronic components such as terminals, knobs, washers, cups, condensers, and coils with their respective prices and specifications.

Please address Post Orders to:

Please send ample postage.

MAIL ORDERS DESPATCHED SAME DAY AS RECEIVED. Goods sent to all parts of the World.

“ELKAY” WIRELESS CO.
225 and 227, BISHOPSGATE, LONDON, E.C.2.
OPEN SATURDAY ALL DAY. SUNDAYS 11—2.30. TRADE COUNTER NOW OPEN.
Special terms to Radio Clubs. Telegrams: ELKAYWIRY AVE., LONDON. Telephones: CENTRAL 8544, RETAIL. BISHOPSGATE 2313, WHOLESALE.
REMEMBER—DON'T PAY MORE!

Keep advertising and advertising will keep you.

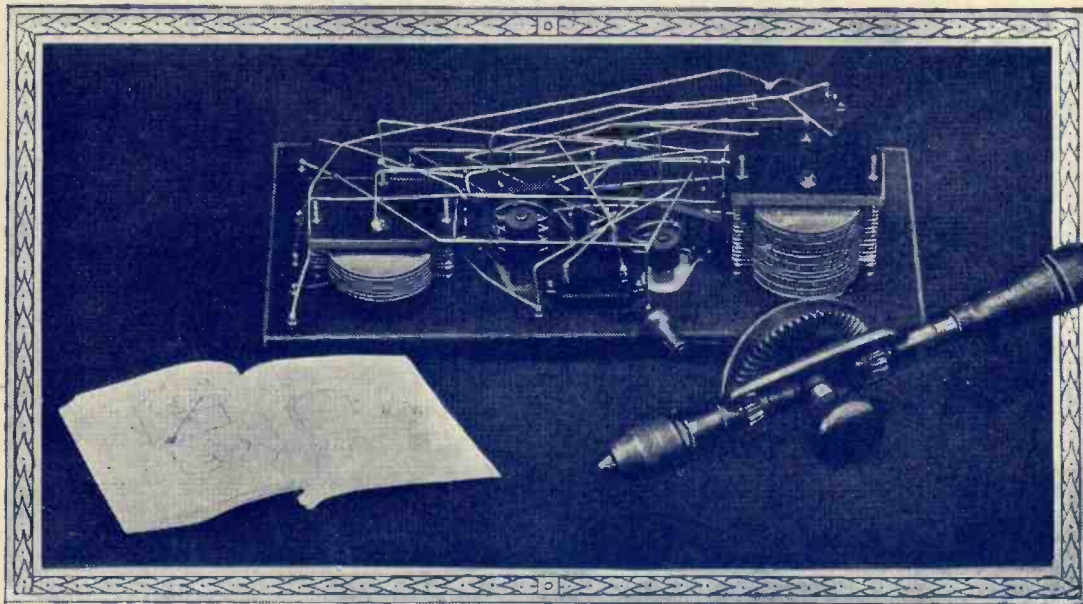

Good Books and a few simple household tools —

Choose your Books from this List:

	Price
1. Wireless for All By JOHN SCOTT-TAGGART, F.Inst.P.	6d.
2. Simplified Wireless By JOHN SCOTT-TAGGART, F.Inst.P.	1/-
3. How to Make Your Broadcast Receiver By JOHN SCOTT-TAGGART, F.Inst.P.	1/6
4. How to Erect Your Wireless Aerial By B. MITTELL, A.M.I.E.E.	1/-
5. The Construction of Wireless Receiving Apparatus By P. D. TYERS.	1/6
6. The Construction of Crystal Receivers By ALAN L. M. DOUGLAS.	1/6
7. How to Make a "Unit" Wireless Receiver By E. REDPATH.	2/6
8. Pictorial Wireless Circuits By OSWALD J. RANKIN.	1/6
9. Wireless Valves Simply Explained By JOHN SCOTT-TAGGART, F.Inst.P.	2/6
10. Practical Wireless Valve Circuits By JOHN SCOTT-TAGGART, F.Inst.P.	2/6
11. Radio Valves and How to Use Them By JOHN SCOTT-TAGGART, F.Inst.P.	2/6
12. 500 Wireless Questions Answered By G. F. KENDALL & E. REDPATH.	2/6
13. 12 Tested Wireless Sets By P. W. HARRIS.	2/6
14. More Practical Valve Circuits By JOHN SCOTT-TAGGART, F.Inst.P.	3/6
15. Home-Built Wireless Components Elementary Text-book on Wireless Vacuum Tubes	2/6
16. Home-Built Wireless Components Elementary Text-book on Wireless Vacuum Tubes By JOHN SCOTT-TAGGART, F.Inst.P.	10/- (post free.)

New Books

Published by
Radio Press, Ltd.,
Devereux Court,
Strand W.C.2

ONE of the great charms of Wireless lies in its appeal to our national character. We possess in a far greater degree than any other nation the faculty of teaching ourselves the use of tools and the ability to devise home-made substitutes for the more elaborate factory-made article.

Thousands of enthusiasts have made their own Sets not with the idea of saving money, but because they are intrigued with the fascination of being able to make something which will really work.

And a very large number of these Wireless experimenters have obtained their information from Radio Press Books

If you, too, have decided to enter the ranks of the Home Constructors, look down the list of books on this page and make your selection. Any of them can be obtained from your local Bookseller or we will send them direct at an extra cost of 2d. per book for postage.

Radio Press Books
— a complete wireless library

STERLING

"DOME" LOUD SPEAKER



No. R 1287.

Height 12 ins. Diameter of Deflector 8½ ins.

THIS instrument marks a distinct departure in the design of Loud Speakers. It reproduces with a beautiful, mellow tone of ample volume for the home and all ordinary purposes. Its compact and pleasing lines will appeal specially to those who object to the usual large horn. The decorative treatment in black and gold floral design will harmonise with and enhance the furnishings of any room.

£4 : 15 : 0

Wound to resistance of 120 or 2,000 ohms.

Obtainable from all Electrical Dealers and Stores.

STERLING TELEPHONE & ELECTRIC CO., LTD.,

Manufacturers of Telephones and Radio Apparatus, etc.

TELEPHONE HOUSE, 210—212, TOTTENHAM COURT ROAD, LONDON, W.1.

Telegrams: "Cucumis, Wesdo, London."

Telephone: Museum 4144 (7 lines)

BIRMINGHAM: 150, Edmund Street. CARDIFF: 10, Park Place. GLASGOW: 33, Robertson Street. MANCHESTER: 14, St. Peter's Square. NEWCASTLE-ON-TYNE: 21, Mosley Street.

Works: DAGENHAM, ESSEX.

Wholly British
Manufacture.

Write for
Publication
No. 387.