

Wireless Weekly

and The Wireless Constructor

Vol. 2.
No. 12.

CONTENTS

“Wireless Weekly” Three Valve Receiver.

Short Wave Transmission.

Construction of Variable Condensers from Standard Parts.

How Wireless Solves the Problem of the Navigator.

A Four Weeks' Holiday with a Portable Set.

Jottings by the Way, Constructional Notes, Mainly about Valves, Random Technicalities, Apparatus we have Tested, Information Dept., Correspondence, etc., etc.

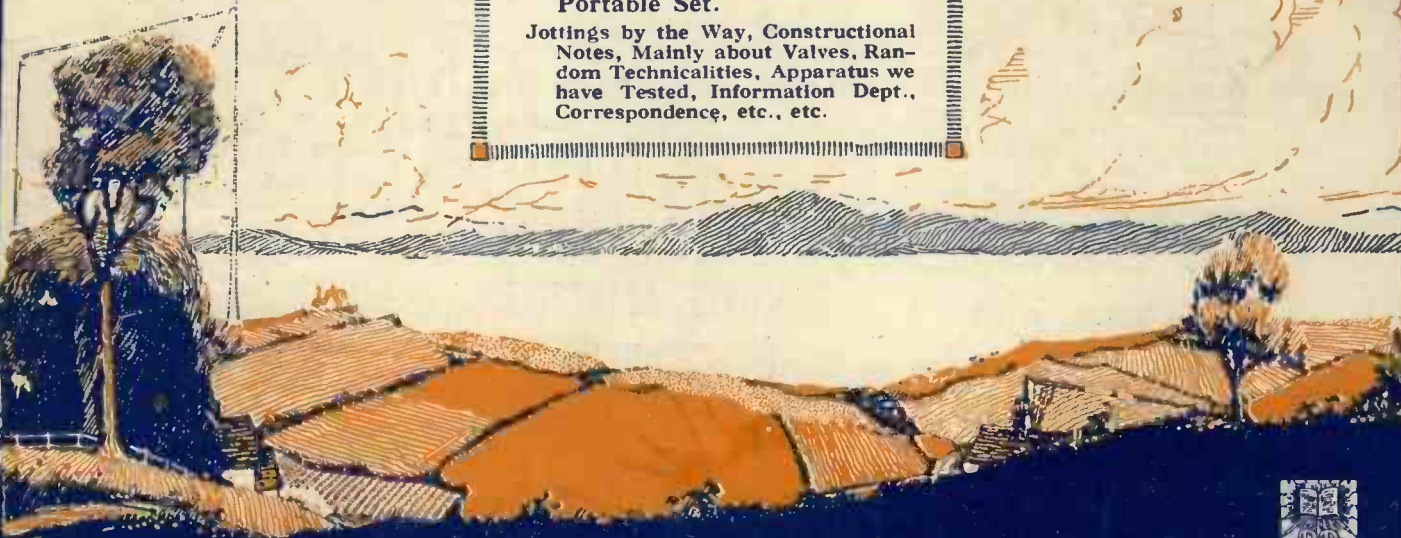

Operating Crystal Receivers.

Crystal Reception



We do not claim

that Cosmos Crystal Type Radiophones will receive over distances like these. The circumstances of the reception forming the subject of the letter here produced are undoubtedly abnormal. We do claim, however, that Crystal Type

COSMOS RADIOPHONES

are well-made and efficient sets, and will give your customers thorough satisfaction.

NOTE AMPLIFIERS & LOUD SPEAKER

Attachments are also supplied for working with the "Cosmos" Crystal Set.

Send for Booklets 4670/1 overprinted with your own name and address.

METROPOLITAN Vickers

ELECTRICAL CO. LTD

Head Office & Works : TRAFFORD PARK, MANCHESTER.
London Address : 232-233, HIGH HOLBORN, W.C.1.

£
A07

Dear Sirs,

You will be pleased to hear that one of our clients managed to receive your station 2ZY (200 miles) and Cardiff Station 5WA (over 350 miles) on a Cosmos Radiophone Crystal Set purchased through us. The musical items were quite clear and it was possible to make out the speech of the announcers. This was our client's first experience of operating a Wireless set, and this performance speaks highly for the efficiency and simplicity of operation of your instruments.

Considerable interest has been aroused in the district by this performance, and we hope to dispose of more of your excellent products.

Yours faithfully,
pp. FERGUSON & TURNBULL.

THE Marks of Efficiency & Approval.



"COSMOS" Crystal sets reduced in price.

BELFAST
BIRMINGHAM
BRISTOL
CARDIFF
DUNDEE
EDINBURGH
GLASGOW

LEEDS
MANCHESTER
NEWCASTLE-
ON-TYNE
SHEFFIELD
SOUTHAMPTON
SWANSEA

Wireless Weekly

Vol. 2, No. 12
Oct. 3, 1923.

CONTENTS

	Page
Editorial - - - - -	430
How Wireless Solves the Problems of the Navigator - - - - -	431
"Wireless Weekly" Circuits.—No. 25 - - - - -	433
A Four Weeks' Holiday with a Portable Set - - - - -	434
Construction of Variable Condensers from Standard Parts - - - - -	436
Jottings by the Way - - - - -	439
Short-Wave Transmission - - - - -	441
News of the Week - - - - -	443
Operating a Crystal Set - - - - -	444
"Wireless Weekly" Three-valve Receiver - - - - -	446
Constructional Notes - - - - -	449
Broadcasting News - - - - -	452
Random Technicalities - - - - -	454
Apparatus We Have Tested - - - - -	455
Correspondence - - - - -	456
Radio Press Information Department - - - - -	457



Editor: JOHN SCOTT-TAGGART, F.Inst.P.

Assistant Editor { E. REDPATH.
P. W. HARRIS.

Radio Press, Ltd.

Publishers of Authoritative Wireless Literature
DEVEREUX COURT, STRAND, W.C.2
Tel.—Central 3763.

Advertisement { SCHEFF PUBLICITY ORGANIZATION,
Managers: LTD., 125, Pall Mall, London, S.W.1.
Tel.—Regent 2440.

Staff Editors:

E. H. CHAPMAN, M.A., D.Sc.
A. D. COWPER, M.Sc.
G. P. KENDALL, B.Sc.
R. W. HALLOWS, M.A.
S. G. RATTEE.

Scientific Adviser:
Prof. G. W. O. HOWE,
D.Sc., M.I.E.E.
Advisory Editors:
Prof. R. WHIDDINGTON,
M.A., D.Sc.
Prof. C. L. FORTESCUE,
M.A., M.I.E.E.



All correspondence relating to contributions is to be addressed to the Editor of "Wireless Weekly."

Nothing contained herein is to be regarded as permission or encouragement to infringe any patent rights.



Is the Radio Society Disintegrating?

THE first meeting of the session of the Radio Society of Great Britain was held last Wednesday, when Dr. Eccles, the President, pointed out the importance of the experimenter and the value of organisation.

Simultaneously, we hear of two more examples of separate societies springing up independently of the Radio Society of Great Britain. There can be no doubt that the time has come when an honest stocktaking must be taken of the value of the leading society in the country. Does it really represent experimental interests throughout the country, or is it only a glorified form of the Wireless Society of London? Is it really a live society which has done great things for the experimenter and intends to do more in the future? Is it really ready to take up cudgels on behalf of the wireless transmitter, or must some other society be formed?

These are the sort of questions which are being asked on every hand, and the reply is to be found in the attempt to form a separate radio transmitter society, quite apart from the Radio Society of Great Britain, and a league of southern wireless societies.

There are those who think that the society, or rather its executive, is played out, that new blood is required; that there are self-complacent members engaged on work which requires enthusiasm devoid of officiousness and a *clique-y* atmosphere. These criticisms are, in a large measure, unwarranted, but they are being made, not only by club secretaries who come to these offices, but in many other quarters.

Our own view is that the Radio Society has failed, utterly and ignominiously, to get a constructor's licence or an adequate supply of experimental licences. True, they sent a deputation to the Post Office last year and

were deluded by the usual official promises. Why have they not since then used every possible means to improve the licence position? Why do they not enlist the help of some members of Parliament who can urge their case in the House of Commons? Another move in the right direction would be to give up their narrow-minded attitude with regard to press publicity. A new committee should adopt a friendlier attitude towards those who are capable of helping them. A national view should be taken and petty jealousies eliminated.

The most important thing is that the Radio Society should cultivate a fighting spirit. Docile ineffectiveness must give place to a vigorous fighting campaign against the Post Office, and if necessary the B.B.C., to obtain new protection and privileges for the experimenter. We are tired of the mutual admiration talk which has obtained in the past. The Radio Society must fight, and if the existing members of the executive will not fight, new ones will have to be chosen.

As for the new Radio Transmitters Society which is in competition with the Radio Society of Great Britain, it is foredoomed to failure. It will follow the long, long trail made by the Wireless Relay League. The new section of the Radio Society devoted to transmitters deserves every support, and it is absorbing the Wireless Relay League. The old policy of patting sectional societies on the back is apparently to cease.

The Radio Society is fortunate in having Dr. Eccles as its President. We trust he will turn the Radio Society into a powerful, and yet sympathetic, fighting force. Its political functions are ten times as important as its technical work.

HOW WIRELESS SOLVES THE PROBLEMS OF THE NAVIGATOR

(1) The Air, (2) The Sea, and (3) Hydrographical Surveying

By Lt.-Col. H. F. TOWLER.

The first instalment of an interesting series of articles upon the application of wireless to navigation.

THE technical side of directional wireless has already been described by Dr. J. Robinson in the pages of *Modern Wireless*, and my purpose is to deal only with the manner in which, in my opinion, it is more and more affecting not only the speed of transport by sea and air but also the safety of life.

There are, of course, two well-known methods in which directional wireless is used. (1) From coast stations which, acting together (two stations or in some cases three stations), take bearings of the ship's or aeroplane's wireless signal; and later signal the position obtained as a result of the observations to the navigator.

(2) From a directional wireless coil which is carried in the aeroplane or ship, and which can possibly, from the seaman's point of view, be best described by the American term "radio compass." In this article Dr. Robinson's method, as used by the Royal Air Force and many merchant steamers, is discussed.

The first method is not likely, in my opinion, to develop much beyond its present state for the following reasons.

(a) In the last war it was found of great value to use coast stations to plot the position of enemy aircraft, surface craft and submarines. This was so fully appreciated that when in the vicinity of the enemy our own vessels refrained from using wireless as much as possible, so as not to inform the enemy of their position and movements. Therefore, any use of coast stations is likely to inform both friend and foe of position.

(b) The commander of a ship

is responsible for the safe navigation of his ship and is disinclined to rely to any great extent on a position given to him by a shore station. If that position happened to be incorrect and his ship went ashore, the court of enquiry would only consider *his* actions. The evidence of the wireless stations might never be called, and, in any case, the finding of the court, of "neglect," or "error of judgment," would only affect his certificate.



Fig. 1.—Illustrating the elementary principles of navigation.

ment," would only affect his certificate.

(c) If the above conservative attitude were overcome the number of ships which would simultaneously require a position in any crowded waters in foggy weather would very rapidly lead to a choking point. Directly the shore stations had difficulty in dealing with the volume of traffic, faith in the shore stations must again break down.

The difficulty of selecting the ship in a dangerous position, and giving her preference over all others, can be imagined; and in practice she would have to wait her turn

under the rules of ordinary wireless procedure.

Again, from the navigator's point of view one "fix," whilst being of value, is not conclusive, since it is only by frequent observations that the track of a ship or aeroplane can be plotted and the effect of winds and currents allowed for. This need complicates the question as regards jamming.

It is in consideration of these points that I have decided, more particularly, to describe the second method of directional wireless, in which the ship or aeroplane can take bearings as often as desired of any wireless station which is operating, without the necessity of transmitting any signal or interfering with other traffic.

I have selected Dr. Robinson's method as, owing to its "maximum" method, it is suitable for use in either an aeroplane or ship, where extraneous noise may be expected. The instantaneous nature of the reading helps to avoid incorporating error, from the swinging of the compass, into the reading, and the rigid nature of the coil avoids errors which might be occasioned in any method requiring aials—due to the pressure of the wind or the rolling of the ship deflecting the aerial from its correct position in relation to the fore and aft line of the vessel.

The Elements of Navigation.

The navigator, wishing to take his ship from any place A to any place B, can, as shown in Fig. 1, find the angle which the required track makes with the geographical meridian by measuring the angle from the chart or from calculation.

The compass, after allowance is made for the difference in geogra-

phical position of the magnetic and true poles of the earth, and for any iron or steel in the ship's construction which may be near enough to deflect it, provides a method of steering in such a way that the ship is always pointing in the required direction.

If this were all, navigation would be simple; but in flying, the aero-

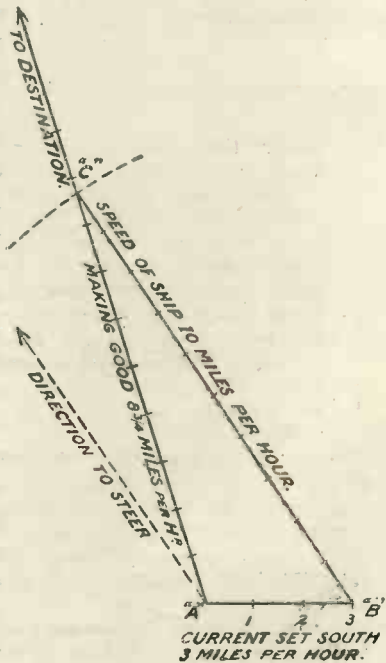

Fig. 2.—Method of allowing for "lee-way" in the case of a ship, or "drift" in an aeroplane.

plane is always being carried in the direction in which the wind is blowing and at its speed. A ship is being carried in the direction towards which the current is setting and at its speed, with the additional complication that the ship is only partly immersed in the water, and may be further driven from her required direction through the pressure of wind on her upper works causing her to make "lee-way."

If the force and direction of the wind or the set and speed of the current are known, provision can

easily be made for these conflicting forces by the triangle of forces, as shown in Fig. 2, where AC is a portion of the track it is required to follow, AB is the direction towards which the wind is blowing or the current setting and is proportional to the speed for any given time, say, one hour. Then BC, being proportional to the speed of the ship or aeroplane for the same period of time, represents the direction in which she must be steered to make good the required track and AC, to the same scale, represents the distance which will actually be made good in that time.

In practice, of course, the aeroplane, being entirely supported in air, has the current of air caused by its own speed always passing in the fore and aft line of the machine, and has no method of telling how the force and direction of the wind may alter when in flight.

The sea navigator has information on his chart and sailing directions, etc., as to the set of tide and current likely to be experienced, but as this may be influenced by weather conditions many hundreds of miles away it is never claimed that this information is absolutely accurate.

Therefore, in practice the navigator requires frequent checks on his position to make sure that the required track is being followed, and with the information obtained from a series of such positions and a knowledge of the course steered, together with the speed of his craft, he can calculate the force and direction of the actual wind or current experienced and make any necessary correction to his course in order that the required track may be followed.

In the Air

Aerial navigation, whilst in some ways having greater difficulties than sea navigation, does not require the same degree of accuracy. There are no submerged shoals or rocks for an aeroplane to strike, but, as flying in fog develops, trees and hills will become very definite dangers to navigation, and greater

accuracy will be necessary whilst flying at a low altitude approaching or leaving an aerodrome.

The difficulties of aerial navigation are comprised in the great speed of aircraft, and the variability and high speed of the wind as compared with surface currents at sea. In my own experience it has not been unusual to set a course allowing for a wind of 20 miles an hour in one direction and within half an hour to find that the wind has changed and is blowing at the same speed from almost the opposite direction. In other words, at the end of an hour, under such circumstances, the aeroplane would have been 40 miles from her estimated position if the change had not been detected.

Methods of Navigation in use in Aircraft, apart from Wireless

The earliest form of navigation used in aircraft was to have an idea of the compass direction in which it was proposed to fly and by carefully watching the ground and comparing it with a map to follow the route intended. In clear weather this can be satisfactory if the map is good, but it frequently results in the pilot getting off the desired track, being unable to locate his position on the map, and having either to land in a field to ask where he is, or to fly round and round some country railway station at a low altitude whilst he tries to read the name from the notice board.

The next step in aerial navigation was the introduction of the drift bearing plate. In this case the pilot or observer had a small grid of three parallel wires which he could twist slightly in a horizontal plane until the passage of any object on the ground was right along the wires. This instrument gives the angle at which the aeroplane is drifting to the right or left of the direction in which she is pointing, and by applying this angle to the required track it is possible to steer fairly accurately for the destination, provided clouds do not hide the ground.

(To be concluded.)

"WIRELESS WEEKLY" BINDING CASES

To make the best use of such a work of reference as is provided by the first volume of "Wireless Weekly" it is essential to possess it in a compact form with a comprehensive index, and that our readers realise the fact is evident from the flow of orders for the bound volume.

Cases only 2s. 10d. (post free) and 4s. 10d. (post free) respectively. Cost of binding 5s. 6d. (post free) and 8s. 6d. (post free). These latter prices include the index, obtainable separately 1s. 1d. (post free). The volume bound complete 12s. 6d. (cloth) or 15s. 6d. (half-leather) post free.

“ WIRELESS WEEKLY ” CIRCUITS—No. 25

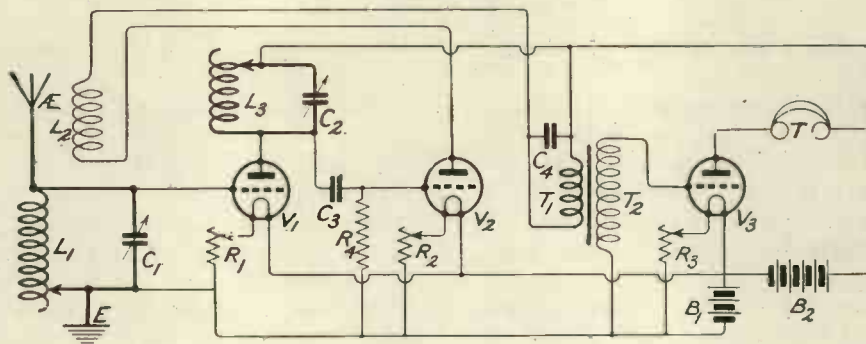

COMPONENTS REQUIRED

- L₁ : A variable inductance.
- C₁ : A variable condenser of capacity 0.001 μ F.
- L₂ : A fixed reaction coil.
- C₂ : A variable condenser of 0.001 μ F capacity.
- L₃ : A variable inductance.
- T₁ } Step-up intervalve trans-
- T₂ } former

GENERAL NOTE

This circuit, although not permissible for the reception of British Broadcasting, is an excellent circuit for the reception of telephony and spark signals, and may be used for receiving Continental broadcasting. Reaction is introduced from the anode circuit of the second

valve to the grid circuit of the first valve. The last valve acts as a low-frequency amplifier. The reaction coil may be smaller than would be the case in an ordinary single - valve circuit. The tuned anode circuit, as well as the aerial circuit, will require careful retuning as the reaction is increased.

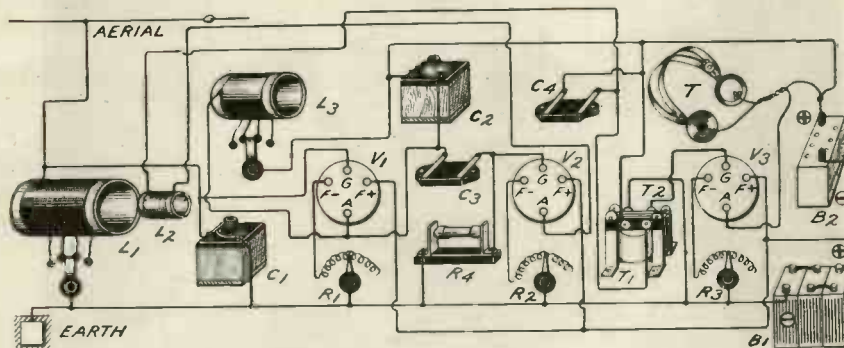

PRACTICAL WIRELESS NOTES—No. 7

VARIABLE GRIDLEAKS

of many types are now available at reasonable prices. Probably the most satisfactory type is that in which the variation in resistance is effected by the rotation of a screw which compresses the material within the

device and so increases its conductivity.

Those experimenters who have up to now used only a fixed-value leak will appreciate the increased efficiency obtainable by the careful adjustment of a variable gridleak. The most useful range of resistance for use in the grid circuit of a de-

detector valve is from 1 to about 3 megohms, whilst variable units having much lower resistances, varying from 40,000 to about 100,000 ohms, may advantageously be used in shunt across transformers or telephones, or may form the anode resistance of a resistance-capacity coupled amplifier

A FOUR WEEKS' HOLIDAY WITH A PORTABLE SET

By P. G. A. H. VOIGT, B.Sc.

Describing a series of interesting and unusual tests with a novel pattern of crystal-valve amplifier.

ALTHOUGH I had plenty of warning that I was to be on holiday at Brighton for four weeks, it was not until twelve days before I was due to leave home that I was able to start making the portable set which I intended to take with me.

It was decided to use three valves, with switches, so that one, two or three could be used as desired. In order to get the maximum amplification out of the set, valves number 1 and 2 were to be dual amplifiers. For convenience it was decided to use an aperiodic H.F. coupling. The only adjustments on the set were, therefore, the aerial tuning, reaction and grid voltages. With the particular valves and H.T. used, it was found that the best results were obtained with grids at zero volts.

Fig. 1 is a photo of the set, while Fig. 2 gives the circuit diagram. Switches marked with the same letter are mechanically connected together. The switch AA puts one variable condenser in series or in parallel with the ATI. BB cuts out the second valve (dual), while CC cuts out the third valve (note-magnifier). The intervalve transformers were taken from a Disposals Board TB amplifier. The intervalve H.F. coupling has 700 turns on each basket coil choke and the valve to crystal coupling has 600 turns on the chokes.

The H.T. used consisted of two 30 volt groups of accumulators of a new type. The use of accumulators as H.T. eliminated high-tension battery noises of any sort, and thus helped to make the set sensitive. The weight of the set was 12 lb.; H.T. 9 lb.; L.T. 8 lb., 'phones, aerial, tuning coils and wire 3 or 4 lb. Total weight about 32 lb. and sensitiveness equal to a 6 valve set.

Many people think that the crystal detector must have been a source of continual trouble. This, however, was not the case. As will be seen from the diagram Fig. 2, two detectors were used with a switch to change from one to the other. With this switch, the detectors could be quickly set by comparison with one another. If one detector was suspected of insensitiveness it was compared

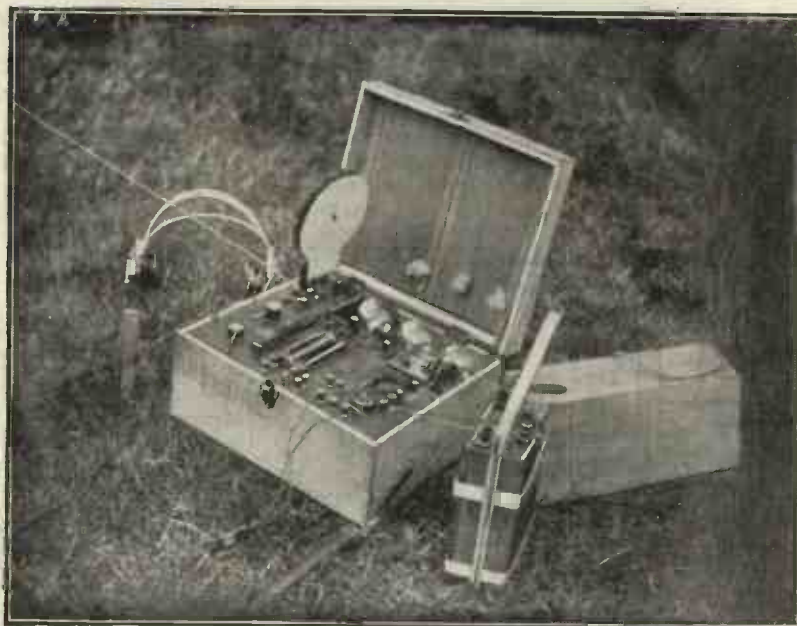

Fig. 1.—The portable receiver ready for working.

with the other (without being disturbed), and generally found to be quite O.K. It could stand almost any amount of vibration and knocking, and I think that a knock which would throw out both detectors would also break one of the valve filaments. I may mention that on returning home after the holiday, a detector of a similar type which had been left alone for a month was still sensitive.

At Stratheden Mansions Hotel, Regency Square, Brighton, where I spent my holiday, the management very kindly gave me a free

hand, providing that I did not set the place on fire. On arriving in my proper room, the first questions that cropped up were about aerial and earth connections. My room was on the fourth floor, the ceiling being 50 ft.

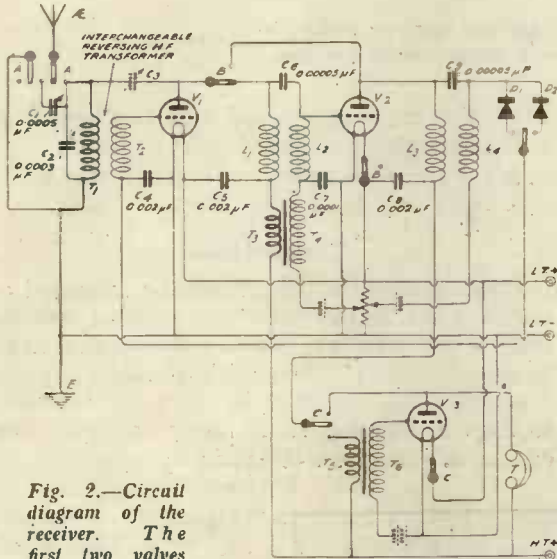

Fig. 2.—Circuit diagram of the receiver. The first two valves are dual amplifiers, while the third valve acts as a low-frequency amplifier.

from ground level. The ceiling, which was 7 ft. above the floor, was square, and measured 8ft. each way. The first aerial used was an inverted L, the horizontal part being 8 ft. long and the down lead 3 ft. long.

As earth connection, one of the 20 S.W.G. wires running to the electric bell push in the room was used. The other wire was tried, but signals were only of three-quarter strength. I do not know if the electric bell system is earthed or not, but it is a better earth than a 40ft. connection of 22 S.W.G. wire to a 2in. iron main gas pipe. As soon as possible I put up an aerial which consisted of an 8ft. square loop round the ceiling. The down lead was taken from that part of the square which was nearest the set. A series of experiments was made with this aerial, which is shown in plan in Fig. 3. The dot marks the position of the down lead. First the aerial was cut at A to open the loop. This made no difference in strength, and the difference in wavelength was not noticeable on 600 ms. spark.

Second, the section AB was cut out. About 5% decrease in strength was noticed.

Third, with AC cut out the decrease was about 20%, and with AD cut out there was a decrease of 40%.

These tests were all made on 600 ms. spark. Next the opposite sides of the square were joined up as shown in Fig. 4. The joining wires were at first inverted L's not connected to the loop, but connecting them to the square made no difference, and elimination of the two extra down leads did not weaken the signals.

The use of the two extra wires gave about 25% improvement, but they could not be left on permanently as they got in the way.

The writer thinks that if a sheet or wire net had been used, signals would have been 50% louder. The next series of experiments was made to find out how the strength decreased as the aerial system was put down lower. In order to make sure that the earth-aerial system remained constant, a counter capacity was used instead of an earth. The aerial was 5ft. long and went vertically upwards, the counter capacity used was a 5ft. wire running out horizontally.

This was first tried in my room, with the set 43ft. from ground level. The only station which could be relied upon for a continuous transmission was PCGG. Using the 5ft. aerial and counter capacity and the 3 valves PCGG'S carrier wave was easily audible with the 'phones off. The whole set, with aerial and counter capacity, was then moved *en bloc* to another place 23ft. lower down, i.e., 20ft. above ground level. The carrier wave was somewhat weaker, but I could not judge how much. The whole set was then



Fig. 3.—Plan of the first aerial experimented with.



Fig. 4.—Another arrangement of aerial which added considerably to the strength of signals.

moved to ground level and the carrier wave could not be heard at all, unless the counter capacity was connected to earth. These experiments were repeated with a 4ft. frame aerial with 5 turns. With the three valve set upstairs PCGG'S music was just nicely audible. With only two valves it was too faint to experiment with.

(To be concluded.)

THE CONSTRUCTION OF VARIABLE CONDENSERS FROM STANDARD PARTS

By W. H. FULLER.

Experimenters who have difficulty in building their own condensers from standard parts will find this article of considerable assistance.

EVERYTHING used in the construction of a variable condenser must be exactly true to size in every respect. The spacing washers made by some manufacturers are $\frac{1}{16}$ in. thick, but this size is not adhered to by all, and it is advisable to purchase all the parts required from the same dealer.

Capacities

Although it is not possible to give exact figures, the following table will be found very useful. If the rotating plates are $2\frac{1}{2}$ in. in diameter and spacing washers $\frac{3}{32}$ in. thick the undermentioned capacities and numbers of plates will be found approximately correct:

Capacity μ F.	Total Number of Plates.
0.001	55
0.0005	27
0.0003	13
0.00005 (vernier)	3

The remaining parts necessary to complete a variable condenser are as follows:—

Top and bottom plates of ebonite.

A centre spindle to hold the moving vanes.

Approximately three times as many small spacing washers as there are fixed vanes.

One large spacing washer for each moving plate and two extra washers.

Eighteen No. 2B.A. nuts, one dozen No. 2B.A. flat washers, three pieces of screwed brass rod, No. 2B.A., length, according to the number of rotating vanes.

One bush (brass) to fit the top ebonite plate.

One centre screw for bottom ebonite plate.

One ebonite engraved dial or alternatively a knob, pointer and scale. A small piece of copper foil for making connections. If it is desired to fit the completed condenser into a

case, the necessary wood and two terminals will be required in addition.

All of the above-mentioned parts are obtainable from any reputable wireless dealer.

Construction

It is advised that the vanes be mounted on the rods before the latter are screwed into the top plates. This helps to prevent the vanes being distorted when being fitted to the screwed rods. It will be seen on reference to Fig. 2 that the whole block of fixed vanes can be adjusted on the rods by means of the nuts. This is very helpful when making the final adjustment of the instrument, the greatest trouble to the amateur constructor. The main thing to bear in mind is that great care must be taken to avoid any distortion of the vanes.

If the vane should become bent, the best method of straightening it is to lay it upon a flat surface such as a lathe bed or the under-side of a

domestic flat iron and *slap* the vane with the flat face of a steel rule. Do not hammer it.

If the condenser is required for panel mounting, special top and bottom plates may be obtained for the purpose. If it is to be mounted in a wooden case, then a piece of ebonite about $4\frac{1}{2}$ in. \times $4\frac{1}{2}$ in. \times $\frac{1}{4}$ in. thick is necessary to form the top of the case, and your dealer will probably drill and tap it for a small charge.

The No. 2B.A. brass rod should now be cut into the required lengths, and any "burr" that may be left at the cut should be removed. At one end slip on a flat washer and screw on two nuts, leaving about $\frac{3}{8}$ of an inch of rod

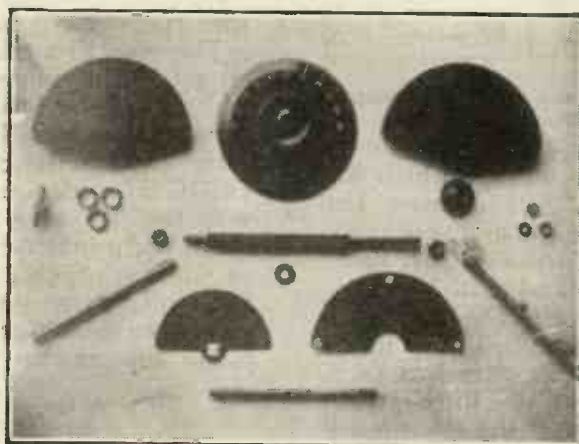

Fig. 1.—Component parts of a variable condenser.

clear. Next, slip on the large vane from the other end, followed by a spacing washer,

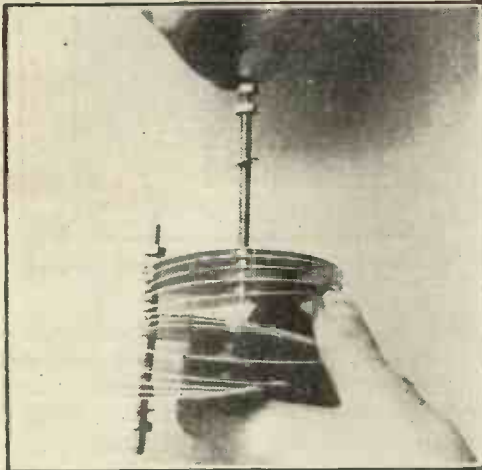

Fig. 2.—Fixing the rods into position.

and continue this assembly until the required number of plates is in position. Do not tighten up the nuts yet.

Proceed in a similar manner with the remaining two brass rods. We now have the large vanes mounted on the rods and the complete assembly will be referred to as the "block." Press the brass bush into the hole

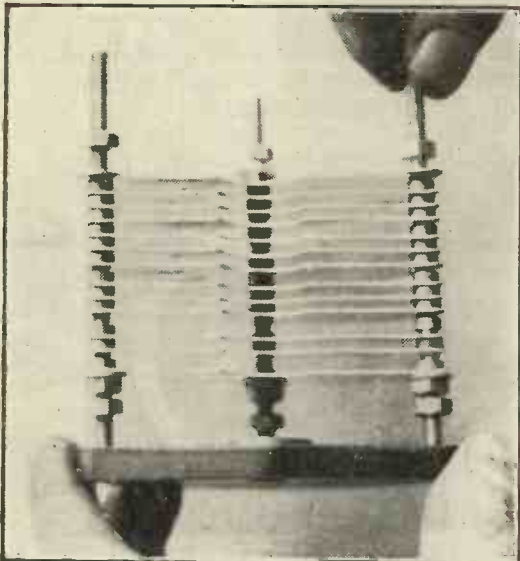

Fig. 3.—Method of fixing the vanes, showing the adjusting nuts.

provided for it in the top plate and secure it there. Place the vane-block over the holes

in the top plate and, with the fingers, carefully screw in the rods. Then screw on and tighten the nuts, which will hold the complete block rigid. Next proceed to mount the rotating vanes upon the centre spindle by placing the vanes and washers upon it in the following order: First, a large spacing washer, then a vane, and so on until the required number of vanes is mounted upon the spindle. Complete the assembly with a large spacing washer and one flat washer, and secure the whole by screwing up the nuts; then insert the longer end of the centre spindle through the bush in the top plate. Fit the brass centre screw to

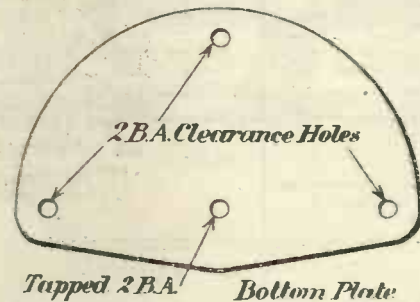
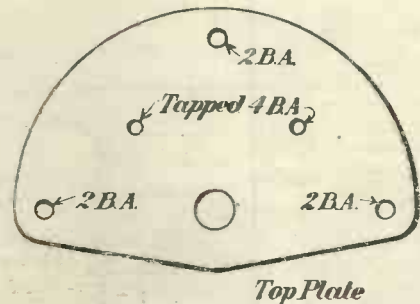

Fig. 4.—The top and bottom plates showing holes.

the bottom plate and fit and secure the bottom plate in position, observing that the centre spindle carrying the rotating vane revolves freely

Adjustments

This is where the beginner experiences the greatest difficulty. Holding the instrument in the left hand, tighten up the nuts next to the plates by means of a small pair of pliers or, better still, a No. 2B.A. spanner, so that the fixed plates are clear of the moving plates. Tighten up the nuts at the other end of the block, namely, the bottom end, and turn the spindle round, when the moving vanes should move between the fixed vanes

without touching them. Should they be found to touch, a slight adjustment of the nuts will probably put this right. If this is done and the instrument does not work satisfactorily, then the spacing washers should be carefully examined and care should be taken to see that they are perfectly true. A slightly thinner washer in one place will put that side out of alignment. If the builder is lucky enough to possess a micrometer, the spacing washers should be tested before they are used in the instrument. This saves much time and labour.

All that is now required to finish the instru-

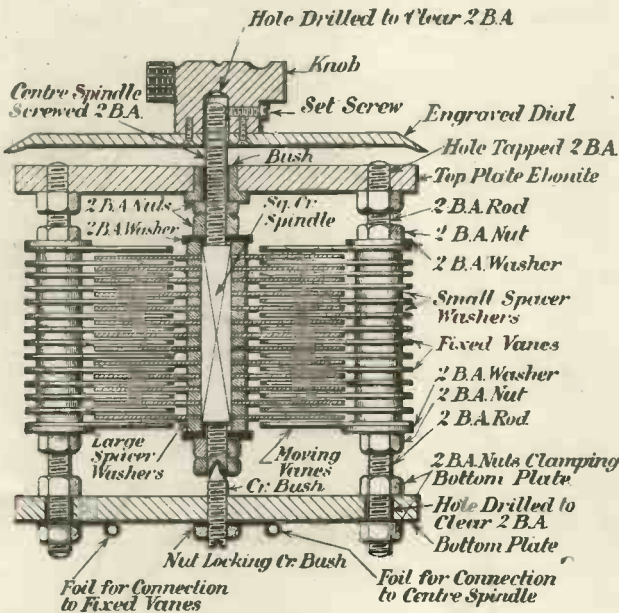

Fig. 5.—A cross-section of the condenser, showing details.

ment is a dial and suitable connections from the centre spindle nut and one of the nuts locking the side rods in position.

If the condenser is to be fitted to the back of a panel, drill two holes through the panel to coincide with the two 4B.A. tapped holes in the top plate. Pass screws through the panel and screw into the top plate; counter-sunk screws are advisable, as they will not be so liable to foul the dial when it is placed in position.

Should it be necessary to fit the instrument into a wooden case, which should preferably be made from 3/4 in. mahogany as shown in



Fig. 6.—Case for containing the plates of the condenser

the sketch, the top plate is then fitted with two terminals; and connecting strips of copper foil run between these terminals and the respective points with which they make connection on the condenser. Again, should it be required to mount the condenser on a baseboard, circular top and bottom plates are to be used. A strip of celluloid or similar transparent material might be wrapped round the outside of the condenser to prevent dust getting between the vanes and so impairing the efficiency of the instrument.

A neat job may be made if a piece of cardboard of the correct diameter is slipped over the outside. This may be either black enamelled or French polished. As a last word, remember to make sure that all your parts are correct in all respects and very little trouble should then arise. It is not possible to rush at this job and make a good condenser, and detailed attention to these little things will result in lasting satisfaction.

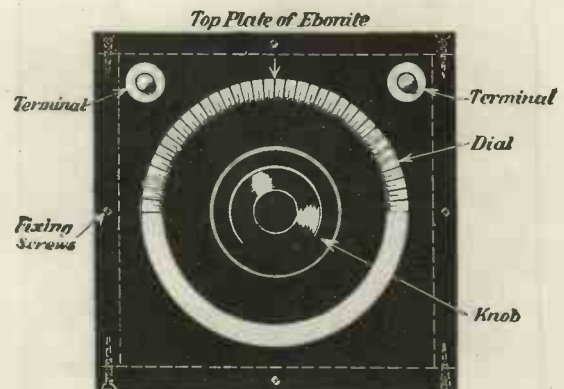

Fig. 7.—The ebonite top, together with engraved dial ready for mounting on the wooden case.

OCTOBER "MODERN WIRELESS"

ON SALE EVERYWHERE

PRICE ONE SHILLING



What's in a Name?

SOME people are very appropriately named. I have known a Bald who rivalled any coot in the polished whiteness of his cranium, a Breadsell who baked, a Matchett who was a draper. There was, too, the case of an elderly charwoman whose proud parents, desiring ardently to do their best for their first-born in the matter of names, had had her christened Rosabelle. She did not prove a beauty, but her addiction to little drops of comfort produced so finely coloured a proboscis that nothing could have been more appropriate than her cognomen as transformed by the vagaries of local pronunciation into Rosybill.

But even these examples fade into insignificance when we come to the man Steele who was launched upon his career of crime by a fatal passion for wireless coupled with a balance at the bank whose equilibrium was so unstable that the smallest cheque usually sufficed to convert Cr. into Dr.

Born of poor but dishonest parents towards the closing years of Queen Victoria's reign, young Steele quickly set himself to carve out a career on original lines. His guiding principle was that work was a thing to be avoided. "Since there are so many unemployed," he nobly put it, "is it right that I should do some other fellow out of a job by working?" During his earlier years no trace of criminal propensities manifested itself. He lived as the lilies of the field without toiling or moiling. His *modus vivendi* was simplicity itself; having a wide circle of relatives and

friends he billeted himself upon all of them in turn in a regular rota. He had in fact a time-table which exactly covered the twelve months. And so charming was the man, so joyous his company, that he was always sure of a welcome.

Led Astray by a Chee-ild

It was at the end of the year 1921 that the first indications that he might be about to stray from the paths of virtue showed themselves. The small son at the house where he was temporarily installed at the time had come back from school with a craze for some new-fangled invention which enabled you with the aid of a battery, a sparking coil, and a tapping key to make a thing in the house say "buzz," whereupon another thing at the end of the garden also said "buzz," though there was no connection of any material kind between the two of them.

Always fond of children, Steele threw himself heart and soul into the little fellow's new interest, and soon the pair of them might be found at all hours of the day (save at meal times, for Steele, if otherwise casual, always obeyed with alacrity the summons of the gong) one in a top bedroom, the other in the summer-house, buzzing away like the most industrious and praiseworthy of bees. At first he did it merely to amuse the lad; presently the lad was doing it to amuse him.

In a very short time the man was a confirmed wireless maniac. He revised his visiting list so that it included chiefly those who had been bitten by the same bug. If he were forced to stay at a house

whose owner had not yet seen the light he set himself the task of initiating his host into the mysteries, and would not leave until he felt assured that the seeds sown had fallen upon fertile ground. The result was that he moved round the country like a tse-tse fly among the herds, infecting all and sundry with whom he came into contact with the disease that he carried. He became a wireless missionary, seeking and making converts not only in previously happy and contented homes, but in trams, omnibuses, and trains.

The Radio Missionary

Now a missionary cannot travel successfully without a stock in trade. If after expatiating at length upon the charms, the joys, the wonders of wireless, he had to confess that he himself possessed no set, the praises that he so constantly sang were apt to fall a little flat. His case was as bad as that of a Mr. Doan who suffered from perpetual stabbing pains in the back, a sea-sick Mothersill, or a chronically bilious Beecham. He was, in fact, in the same lamentable position as a bald-headed purveyor of infallible hair restorers.

To remedy this manifestly unsound condition of affairs was a necessity so obvious that something had to be done forthwith, if not sooner. The obvious solution was to make use of his fellow men as radio suppliers, even as he had previously used them as providers of free board, lodging and entertainment.

At first his intentions and his practices were strictly honourable. He could borrow a valve from A

and use it for demonstration to B. Then when he had induced B to invest in two or three, he would beg the loan of one of them, returning A's valve with a warm letter of gratitude. By this means he was able always to have a fairly respectable set to take about with him at no expense at all. There was the question of post-ages, it is true, but that can always be solved by the ingenious, especially if they have a reputation for absent-mindedness.

The Looter

His real descent into evil ways occurred when a wealthy aunt died and left him a sum that would just enable him to have a small house of his own. He might, of course, have continued his previous nomadic existence, but the desire to possess an aerial of his own determined him to settle down, which, being now able to settle up, he promptly did.

The pride of ownership was now strong upon him. A noble set he must have, but his means did not run to the necessary array of components. He borrowed them as of old, but he no longer returned them to their rightful owners. In fact, if he now comes round in quest of a valve holder you may feel quite sure that if you are so foolish as to part with it—and you will do so, for as I said he is a charming fellow—it

will never again adorn your wireless bench or aid you to bring in distant signals about whose strength you would subsequently lie with a conscience made clear by the knowledge that everybody else was doing it.

Steele, in a word, lives up to his name. It has been calculated that the total capacity of the condensers that he has pinched exceeds a kilofarad, and that if all the inductances that had found their way into his possession were unwound and their wires (with neatly soldered joints) stretched out in one long straight line they would reach from the Town Hall of Little Puddleton to the top of the great crater Copernicus on the Moon.

Water off a Duck's Back

Yes, Steele was my friend. I regret that I must say "was," for one can ill spare an entertaining companion, a prince of story-tellers, a sympathetic listener to one's woes such as he. But he was too expensive a luxury to have about the house. To make up for the losses suffered during his periodic looting of my wireless room I was forced into an expenditure so heavy that ruin stared me in the face. Still, I did not wish to break with the man, and I strove to postpone as long as possible the inevitable rupture of diplomatic relations.

The climax came when in my

absence he persuaded my wife to let him into the house and bamboozled her into believing that I had promised to lend him the brand new wavemeter that was the joy of my life. I asked him to return it; he promised to do so, but invariably kicked himself for having forgotten to bring it with him when he called round to see me. I reasoned with him; he agreed with my every point. I spoke sharply; he smiled and promised not to forget again. Finally, in desperation, I wrote to him; it was a biting little note, indited with a pen steeped in gall. "In future," I said, "do not ask whether you may borrow this or that. Be straightforward, and say, 'do you mind if I Steele your variometer?' Then we shall know."

This you might think would crush the man. But did it? Only yesterday he wrote to me: "Dear old man, thanks for your hint. An excellent jest! May I Steele a couple of your low temperature valves?" What can one do with such a man? There is only one way of dealing with a creature so lost to all sense of decency, and that is to drop him. I have informed him that we are no longer friends, but I feel somehow that before long he will have succeeded in worming his costly way once more into my affections.

WIRELESS WAYFARER.

The Sorbo Rubber Sponge Products, Ltd., have forwarded an example of their work in the shape of a pair of rubber pads which when fitted over the ear-pieces of a pair of telephones considerably lessen the discomfort usually experienced, without in any way affecting reception. We can fully recommend these pads to listeners-in who are in the habit of using telephones for the purpose of listening to broadcasting during several hours.

Canadian Brandes, Ltd.—We have received booklets describing the well-known Brandes

CATALOGUES RECEIVED

"Matched tone" head 'phones. It is claimed that the diaphragms of these 'phones are exactly matched as regards tone, and are not damaged by an accidental fall, advantages which will be at once apparent.

Forno Company.—This firm brings to our notice the fact that inferior imitations of "Forno" radio components

are being offered on a fairly extensive scale, as such goods have been sent to them for replacement. Every genuine "Forno" part is clearly marked with the name "Forno," which implies that they are fully guaranteed.

Burndept, Ltd.—A booklet of instructions and diagrams relating to a set of components for the use of students has been sent to us for inspection. Persons interested in wireless from an educational viewpoint should obtain a copy of this pamphlet, for which a small charge of 6d. is made.

SHORT-WAVE TRANSMISSION

By E. H. ROBINSON.

An article of especial interest and value to all who are contemplating experimental transmission work.

SINCE the advent of broadcasting and the agreement amongst experimenters holding transmitting licences to confine their activities during broadcasting hours as far as possible to the shorter wavelengths, the question of effecting efficient short-wave transmission has come very much to the fore. The trans-Atlantic tests have also afforded a great stimulus to short-wave work, both on the reception and transmission sides. The object of the present article is to draw attention to one or two points in connection with low-power short-wave valve transmitters which are worth attending to if the best results are to be obtained.

Aerial

The shorter wavelengths at present allowed for experimental use lie in the band between 150 and 200 metres, and experimenters sometimes find that the aerial currents obtainable on these short wavelengths are poor compared with those obtainable on 440 metres. Sometimes the effect is the other way about, better

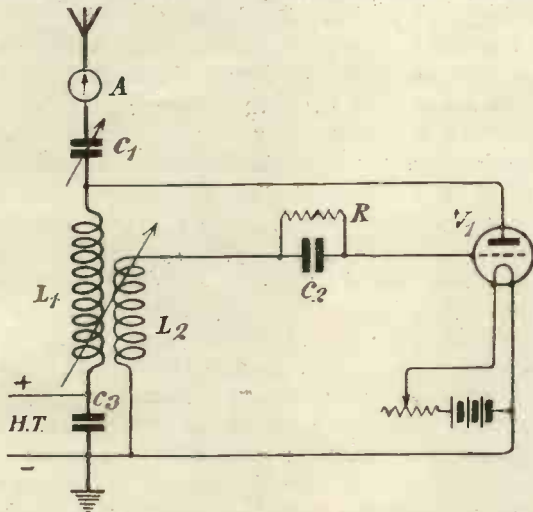

Fig. 1.—A simple transmitting circuit with series condenser for reducing the effective capacity of the aerial circuit.

radiation being obtained on a particular aerial on 200 metres than on 440 metres. The aerial and earth systems are chiefly responsible for these differences.

For shorter wavelengths, that is for higher

oscillation frequencies, the high-frequency losses in the aerial and earth systems become greater. The causes of these losses are threefold: first, high-frequency resistance in the aerial, earth leads and tuning coils due to the well-known "skin effect"; secondly, absorp-

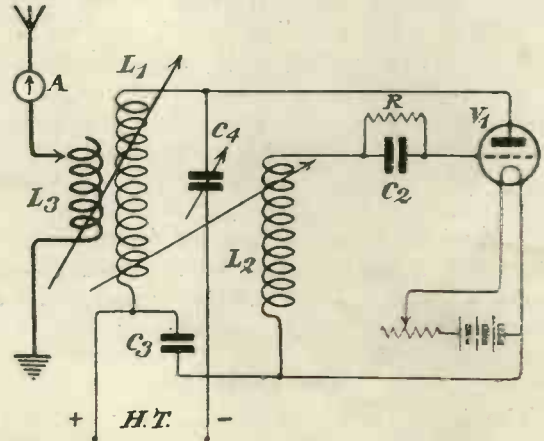

Fig. 2.—Showing the more efficient method of reducing the effective aerial capacity by means of loose-coupled circuits.

tion by neighbouring conductors and partial conductors in which currents are induced and dissipated; and, thirdly, di-electric losses due to the presence of non-conducting or partially non-conducting substances in the electrostatic field of the aerial.

To these may be added a fourth loss known as "radiation resistance," which represents the loss of energy from the aerial circuit due to radiation into space, and not due to the ordinary dissipation of electrical energy into heat. It should always be remembered that a high radiation resistance is desirable, while all other resistances should be reduced to an absolute minimum. The radiation resistance of any given aerial is greater the higher the oscillation frequency, which means that for short wavelengths a greater portion of the power in the aerial is sent out as useful radiation into the surrounding space. This is a strong point in favour of the use of short wavelengths.

The most efficient aerials for short-wave transmission are high but comparatively short ones with several parallel wires. For

example, a good aerial would be one of the T or inverted L type, 60ft. high, with a horizontal top portion 40ft. long comprised of three or four parallel wires at least 2ft. apart. A good height is necessary in order to secure a high radiation resistance, while the use of several wires in parallel reduces the H.F. resistance and gives the aerial sufficient capacity.

The aerial ammeter does not necessarily give an exact measure of the radiation into space; only a small fraction of the aerial current is actually radiated, and it is this portion alone that is effective in establishing communication. On doubling the height of your aerial you may possibly reduce your aerial ammeter reading for the same power, but your radiation, and therefore your signal strength, would probably be increased.

Instead of being supported from straight spreaders the wires may be disposed round wooden hoops or bicycle wheel rims to form a "sausage" or "cage" aerial.

The Earth

The ideal thing, of course, is a counterpoise. This consists of a number of parallel wires insulated from and raised a few feet above the ground beneath the aerial. The counterpoise forms a kind of screen, which should preferably extend well beyond the longitudinal and lateral limits of the aerial itself. The wires of the counterpoise are all connected together at one end and used in place of, or in conjunction with, the usual earth connection.

It is highly important that all conductors in the field of the aerial should be either completely insulated or definitely connected to earth. Thus, if the aerial passes over or near any lead or zinc roofing, the roofing should be carefully connected to the earth terminal of the set. Attention to such points as this will make the set oscillate more easily in the case of a valve transmitter and make the tuning sharper in the case of a spark transmitter. Indifferent contacts between conductors near H.F. circuits may cause bad losses.

Adapting Apparatus to Existing Aerials

It is often inconvenient, if not impossible, for the experimenter to alter the aerial he already has, and the best has to be made of, say, a single wire about 100ft. long. As the natural wavelength of such an aerial is usually

not far short of 150 metres, only a very few turns of aerial tuning inductance are necessary to bring the wavelength to, say, 200 metres if the inductance is connected directly between aerial and earth. Owing to the small number of turns it is difficult to make the transmitting valve oscillate properly if this aerial inductance also constitutes the anode inductance.

This difficulty may be overcome in various ways. The commonest thing amongst amateurs with small power sets is to insert a series condenser in the aerial, as shown in Fig. 1. The condenser C_1 may be variable with a maximum capacity of $0.0005 \mu\text{F}$. The function of this condenser is to reduce the effective capacity of the aerial system so that the inductance L_1 may be increased to a reasonable number of turns without making the wavelength too high. Although quite good results are obtained by the simple inclusion of a series condenser, this in itself is not the most efficient procedure, for by reducing the capacity of the aerial we also reduce the current which we should theoretically be able to get into it for a given power.

An obvious way of doing away with the series condenser and yet making the set oscillate properly is to use a loose-coupled aerial circuit, as shown in Fig. 2, in which the aerial tuning coil L_3 has just enough turns to tune to the desired wavelength, say, 200 metres, in conjunction with the aerial. Coupled to L_3 is the anode coil L_1 of the valve V_1 , L_1 being tuned to the same wavelength as the aerial circuit by means of a small variable condenser C_4 . This arrangement is very sound, has the advantage that the frequency of the oscillations is mainly determined by the circuit L_1C_4 , and the wavelength will not fluctuate so badly if the aerial happens to sway, as it would in the case of transmitters where the valve is directly connected to the aerial circuit.

The chief disadvantage from the experimenter's point of view is the multiplicity of adjustments which are necessary in order to obtain maximum aerial current. First the valve circuit L_1C_4 must be tuned to the desired wavelength, and then the aerial circuit must be tuned to the valve circuit by means of tapings on the inductance L_3 . The coupling between L_1 and L_3 will affect the tuning somewhat; and again adjustment of reaction coupling from L_2 will upset the tuning of the whole system.

(To be continued.)



News of the Week

REFERRING to the application made by the Relay League to the Radio Society of Great Britain to the effect that the former be taken over as a part of the organisation of the latter, we understand from the Secretary of the Radio Society that discussions are now taking place with a view to determining the best, possible means of doing this.

Rules are being drafted where-by the Relay League will obtain the same advantages they have hitherto enjoyed.

The G.P.O. has been asked that Transatlantic tests may take place this year as previously, and those private stations and affiliated societies desirous of taking part should make application to the G.P.O. for the necessary permission.

Details of the preliminary tests will be given in due course. Mr. Philip R. Coursey, B.Sc., has been appointed Chairman of the Sub-committee of the Radio Society of Great Britain to deal with this matter.

Wireless enthusiasts of the Yoker and Clyde Bank district have formed an organisation designated the Western District Radio Club. Mr. W. Wylie, North Avenue, Yoker, has been appointed President, and Mr. J. Smith, Drumchapel, and Mr. J. Turner, Vice-President and Secretary respectively. The Club is to run on similar lines to the Glasgow Radio Club, and affiliation will be sought with the Radio Society of Great Britain.

We learn with interest that the L.C.C. has opened at the Peckham Rye Institute, Wharlton Road, S.E., classes of instruction in wireless and instrument making, under the tuition of Mr. Bennett. The fee for these classes is 3s. per quarter.

We are given to understand that a Radio Society has been formed at the new London County Council Housing Estate, Bellingham.

According to *The Times*, wireless receiving sets have been installed on a number of vessels, and ship carriers, running between Billingsgate and the North Sea Fleet, and the fishermen, who are sometimes absent from land many weeks at a time, can thus listen in to concerts.

We note from *The Westminster Gazette* that there are indications of wireless concerts on licensed premises in Birmingham losing their popularity, in that only six of the thirteen persons who had held licences applied yesterday for their renewals. The Chairman of the Session said that he thought that people were getting tired of these concerts.

A meeting will be held on Thursday, October 4th, at 78A, High Street, Poole, Dorset, with the object of forming a Radio Society for Poole and district. Persons interested in wireless are cordially invited to attend this meeting, which commences at 7.30 p.m.

Our readers will no doubt be interested to hear that the Leeds and District Amateur Wireless

Society has changed its title to "The Leeds Radio Society."

At present most, if not all, of the radio apparatus required in Chile is being supplied by American and French manufacturers. It is from America that a high-power transmitter is shortly being shipped for Santiago, where a station is to be erected.

An interesting feature which is broadcast each Saturday evening from Manchester is an interview with the leading actress or actor appearing at the Manchester theatres. These interviews show the celebrities in a new light and are as entertaining to the persons interviewed as to the listeners-in. Manchester is very enterprising in this respect, as we understand that all persons of note visiting the city who are likely to be of interest to the radio community are invited to "come and be interviewed."

Aberdeen station is to have as call letters 2BD, and a wavelength of 360 metres. Bournemouth is to be 6BM, with a wavelength of 410 metres. It may be taken for granted that these wavelengths are only temporary, as it is hoped shortly to secure a considerable extension of the broadcasting wave-band.

Some interest has been created amongst valve users by the announcement appearing in our advertisement columns of a firm which undertakes to supply fully-charged 4-volt 40 a.h. or 6-volt 30 a.h. accumulators, replacing them at regular intervals, for 12s. a quarter.

OPERATING A CRYSTAL SET

By G. P. KENDALL, B.Sc., Staff Editor.

A further article explaining the actual procedure to be followed in adjusting a crystal detector to yield the best possible results.

ONE of the first things which a beginner discovers when he commences to use some sort of wireless receiver and to compare notes with his friends is that different people get extraordinarily varying results with very similar types of sets. He finds that with, say, a two-valve set he can only hear the local broadcasting station, and perhaps one other, while the man across the way, whose aerial is no better and who uses the same circuit, hears all the B.B.C. stations and has even on occasion received from America.

The reason, of course, is not far to seek;

Tuning has already been dealt with in previous articles in sufficient detail for crystal set purposes, and we will now proceed to consider the other adjustment. Before attempting to secure a sensitive adjustment of the crystal detector we must obviously first see that it is capable of being so adjusted, and I would strongly advise the use of one of the synthetic galena crystals and a gold cat-whisker. Experiment with various other crystals by all means when you have learnt what to expect, but at first when you are finding out how to set the detector, make sure that the crystal is one which gives you a

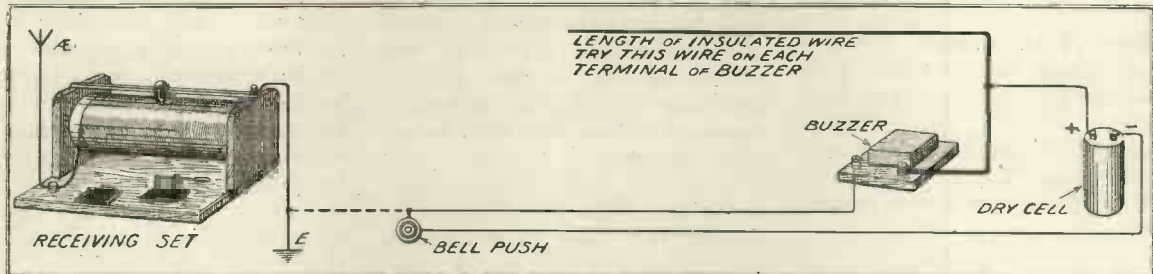

Fig. 1.—A suitable arrangement for a testing buzzer set. The connection shown dotted may be desirable for a beginner, to produce stronger indications, and can be removed when a little experience has been gained.

one knows how to adjust his set to its most sensitive condition and to keep it in perfect order, whereas the other, being a novice, lacks that useful knowledge. In this article I propose to give some hints on adjusting a crystal set to its maximum sensitivity, and to deal with the question of its maintenance at a later date.

The most important points in getting the best from a crystal set are accurate tuning and the setting of the crystal, and of the two I am inclined to think that the latter is the more important, since tuning is usually somewhat flat, whereas delicate adjustment of the crystal will often make a very great difference where weak signals are concerned.

chance, such as Hertzite, Electronite, or one of the other reputable types.

The cat-whisker should be thin and springy in order that quite a light pressure may be put upon the crystal, and it is a great advantage to have some means of regulating the pressure with exactness, since a little experience will show that the precise degree of pressure applied has almost as much to do with results as the selection of a sensitive spot, and many a good crystal is condemned simply because the user fails to get the right pressure. Some sort of screw motion for advancing the contact point is a great advantage, and it is surprising that more crystal users do not avail themselves of

the many excellent types now on the market which possess this refinement.

There is, decidedly, a right and a wrong way to search the surface of a crystal for the most sensitive spot, and the aim should be to lower the point of the cat-whisker upon each place, try various degrees of pressure, and if satisfactory results are not obtained raise it, move it horizontally, and lower it upon another spot. Avoid scratching and scraping at the surface, because that is the way that good crystals are worn out.

The method of deciding whether a good spot has been found must depend upon circumstances. At moderate distances from a broadcasting station the adjustment can be made upon the signals themselves, especially if the tuning adjustments are known, but when the signals to be picked up are weak, even with the crystal set to its greatest sensitiveness, it is a help to have a buzzer for testing purposes.

The connections of a testing buzzer are shown in Fig. 1, and it will be seen that it consists of a dry cell, a small switch, press-button or key, a buzzer and a yard or two of insulated wire elevated in any convenient manner (attached to a picture hook, for example) to serve as an aerial. The whole arrangement constitutes a transmitter of very feeble waves which can be heard on the crystal set when the detector is properly adjusted. The buzzer should preferably be enclosed in some sort of sound-deadening box, in order that the indications in the 'phones may not be confused with sounds made by the buzzer itself and heard directly.

Press the buzzer key or switch in a series of dashes and adjust the crystal until the buzzes are heard at maximum strength and clearness in the 'phones. This may be done at any adjustment of the tuning, since the waves emitted by the buzzer circuit have no definite wavelength. When the crystal has been properly set, the buzzer can be switched off and the desired signals searched for by variations of tuning, taking care not to disturb the detector, and checking its adjustment by pressing the buzzer key at intervals.

When signals are strong and the crystal is adjusted without the aid of a buzzer it is sometimes desirable to adopt the expedient which follows to make certain that the very

best possible setting has been found: adjust the crystal roughly to its best, then alter the tuning so that the signals become almost inaudible and re-adjust the detector until they can be heard clearly once more. De-tune yet again, and if possible improve the crystal setting still further, after which if the tuning is restored to its correct value the maximum signal strength is assured.

An incidental advantage of this method is that it furnishes a rough and ready way of comparing the relative sensitiveness of different crystals, by noting how far the de-tuning process can be carried before the signals are so weakened as to be inaudible with the most careful setting of the detector.

We have considered up to this point, of course, only the cat-whisker type of detector, but the adjustment of the only other type in common use, namely, the Perikon, is practically the same. The Perikon detector, it will be remembered, consists of two crystals, commonly zincite and bornite, so mounted that they may be pressed into contact with each other. The method of adjustment is identical with that of the cat-whisker type, save that a somewhat heavier pressure is usually required, and that even greater care should be exercised to avoid scratching the crystals against each other.

The importance of a gold, silver, or nickel-silver cat-whisker is difficult to over-estimate, and the use of such unsatisfactory material as copper or brass wire explains a good deal of the popular belief that crystal sets are necessarily unreliable and troublesome. Such wires are commonly too stiff for a delicate adjustment to be made, and their points tarnish in air and cease to make the sharp and definite point-contact necessary for good rectification. The first-named metals, on the other hand, do not tarnish readily, and may be used indefinitely. Moreover, they give a much more permanent adjustment of the detector. Gold, in particular, is good, since with many crystals it improves signal strength noticeably. Should a cat-whisker appear to have lost its efficiency, it is worth noting, a cure can be effected by cutting a fragment off its end with a pair of scissors, thus exposing a fresh surface. If the cut is made on the slant a sharp point will result, and further sharpening will be unnecessary.

◆ “WIRELESS WEEKLY” ◆
 ◆ THREE-VALVE RECEIVER ◆

◆ By E. REDPATH, Assistant Editor. ◆

THIS article is written primarily to interest and benefit those readers who have neither time nor facilities for making individual components, yet are very desirous that the completed receiving set should be in part their own handiwork

The regular home-mechanic may perhaps prefer to make some, if not all, of the required components himself, but there is considerable satisfaction to be obtained in the correct assembly, wiring up, and testing of such a set as herein described.

There is also a distinct advantage in that by using professionally made and therefore reliable components almost all risk of failure is eliminated and the final appearance and the *actual* results, upon which, of course, one's pride in the set depends, are assured

The General Arrangement

The photographs, Figs. 1 and 2, show a plan and elevation respectively of the completed receiver. The circuit arrangement is quite a straightforward one; the left-hand valve in Fig. 1 functioning as a high-frequency amplifier, the centre valve as a rectifier, and the right-hand valve as a low-frequency amplifier. The aerial circuit is effectively tuned over a range of wavelengths from 250 to 500 metres by means of the variometer shown on the lower left of Fig. 1, whilst the provision of the coil mounting, fitted on the left of the first valve, enables this range to be increased by plugging in a suitable coil.

The anode circuit of the first

valve is tuned by means of the variable condenser in the centre of the baseboard and the plug-in coil immediately on its right, whilst H.F. intervalve coupling is effected by means of the small fixed condenser, secured to the upper edge of the baseboard. The position occupied by this component enables the connecting wires to be kept very short.

The gridleak of the rectifying valve, fitted upon the baseboard between the first and second valve and connected between the grid of the valve and the positive side of the filament, is variable, and affords exact control of the rectifying valve.

The low-frequency valve is coupled to the detector valve by means of the iron-core intervalve transformer, shown a little above the two-coil holder. The right-hand coil in this holder is the reaction coil, and together with the primary winding of the iron-core transformer, it is included in the anode circuit of the detector valve. The output side of the transformer is connected to the grid-filament circuit of the L.F. valve, and the telephone receivers are in the anode circuit of this valve.

The remaining items upon the baseboard are the terminals, suitably fitted upon ebonite strips, the aerial and earth terminals being upon the left, telephone terminals at the front (or lower edge in the photograph, Fig. 1), and the L.T. and H.T. battery terminals, four in all, are upon the right.

Components Required

The components required for the

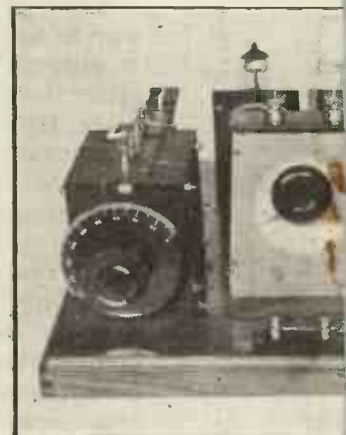

Fig. 2.—An elevation

complete assembly of this three-valve receiver are as follows:—

- 1 wooden base (electric light distribution board) 13 or 14 in. square.

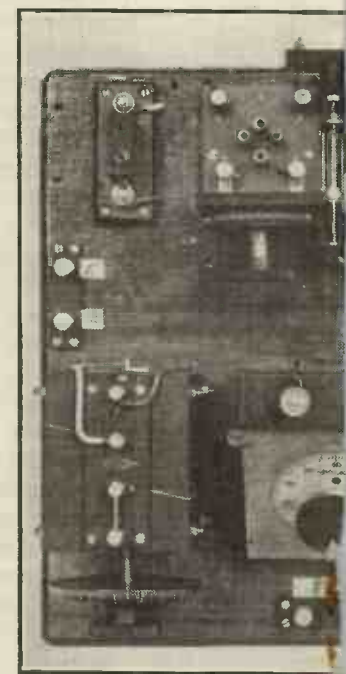

Fig. 1.—A plan of the receiver components may be

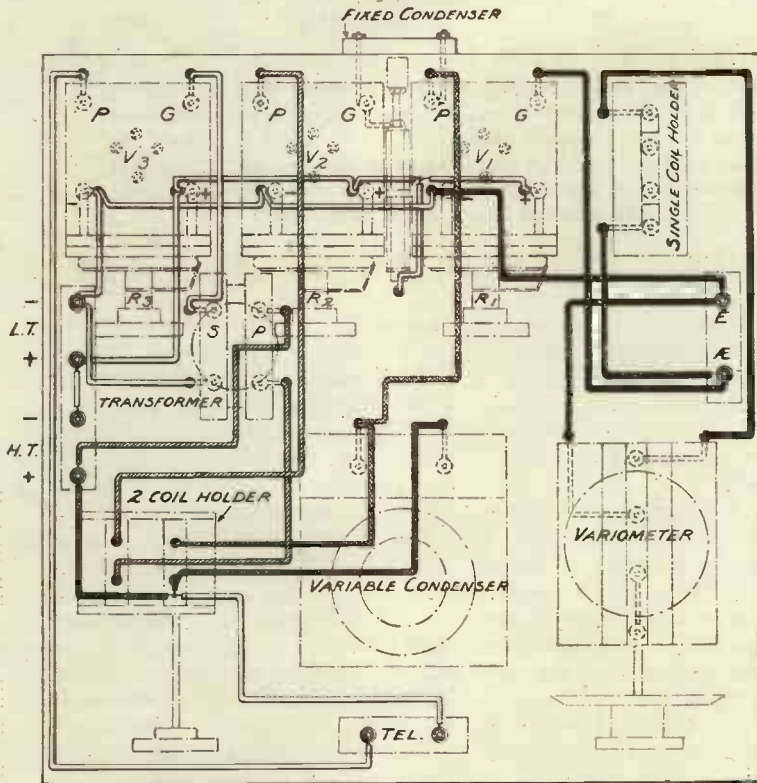

Fig. 3.—Wiring diagram.

with the set, one P₂ (with red top) for H.F. amplification, and two P₁ type. These are shown, though not very clearly, in the photograph Fig. 2.

Assembling the Components

Although there is no particular difficulty in the assembly and connecting up of the components forming the set, there is, nevertheless, a proper and methodical method of setting about the work. First, set out all the components upon the baseboard, along the lines indicated in the photographs, Figs. 1 and 2, and, when all are satisfactorily in position and accessible, mark the position of all securing holes by means of a scribe or small bradawl. Before actually screwing any components in position, mark carefully the points at which holes have to be drilled through the panel for the connecting wires. The positions for most of these will be gathered on reference to the photograph, Fig.

1, and the wiring diagram shown in Fig. 3. Care should be taken to avoid drilling unnecessary holes. The actual baseboard shown had been used for previous experiments, hence the additional holes in this case.

First fit into position the three valve panels with rheostats, aerial and earth terminals, telephone terminals, and battery terminals, and carry out the complete wiring of the filament lighting circuit as shown in the wiring diagram, Fig. 3.

Next fit the single-coil holder and variometer into place and wire up the aerial circuit with its connection to the grid and negative side of filament of the first valve panel. Now fit into position the variable condenser and the two-coil holder and complete the anode circuit of the high-frequency valve; also fit and connect up the grid condenser and gridleak.

The remaining item, the intervalve transformer, should next be fitted into position. The anode

circuit of the detector valve includes the reaction coil and the primary of this transformer. Contrary to expectation, the primary did not appear to require a parallel fixed condenser. The transformer secondary is to be connected to the grid and negative of filament of the third valve. Many readers appear to experience some difficulty in determining which is the correct way to connect up an L.F. intervalve transformer. In order to make certain that the best results are being obtained, connect the primary winding, and with the filament lead from the secondary disconnected, connect the grid to each of the secondary terminals in turn. The correct terminal for the grid connection will enable signals to be heard although the filament is not connected. Follow this by reversing the primary connection and again try both secondary terminals for grid connection. Notice whether the results in this case are an improvement upon the previous one.

Reference to Fig. 3, the wiring diagram, and Fig. 4, the theoretical circuit diagram, in conjunction with the foregoing, should enable all connections to be correctly made. To facilitate the identification of the different circuits in the wiring diagram, it will be noticed that different kinds of lines are employed for the different circuits.

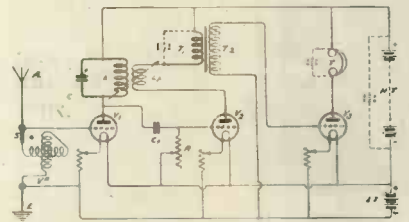
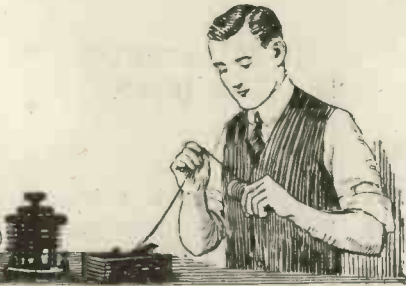
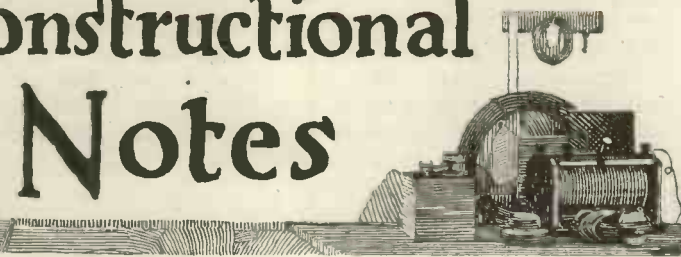

Fig. 4.—Theoretical circuit diagram.

Those readers who prefer it may obtain a full-size blue print wiring diagram by forwarding to this office a postal order for 1s. 6d. Notes on the operation and details of results obtained with this receiver will be given in our next issue.

Constructional Notes



Conducted by R. W. HALLOWS, M.A., Staff Editor.

A LONG-WAVE TUNER

A VERY successful tuner for longer waves, between, say, 2,000 and 20,000 metres, can be made by the use of "pile" winding upon a fair-sized cardboard tube, tappings being taken at appropriate points to switch studs. Pile winding is a little difficult to do at first, but a little practice will give the small amount of skill necessary, and a very efficient coil can be readily wound. A very full explanation of this method of winding was given in an article upon "Multi-layer Coils" in *Modern Wireless*, No. 3, and the reader is referred thereto for the actual details.

A very useful tuner made on these lines some years ago by the writer consisted of a cardboard tube eight inches in length and four in diameter, wound with three layers of pile winding with No. 32 double cotton covered wire, giving rather over 1,000 turns. Tappings were taken at equal intervals along the winding from ten points, and the required wave-length range was easily covered with the aid of a variable condenser of 0.001 μ F capacity.

The tube was mounted between wooden end-pieces, such as that whose details are given in Fig. 1, and the whole firmly clamped together by means of a threaded brass rod passing through the centre of the tube and out through

the end-pieces. A length of about a quarter of an inch projected at each end, and upon these were screwed a pair of nuts to hold the assembly together.

A strip of ebonite 8 in. long, 1 in. wide and $\frac{3}{8}$ in. thick was

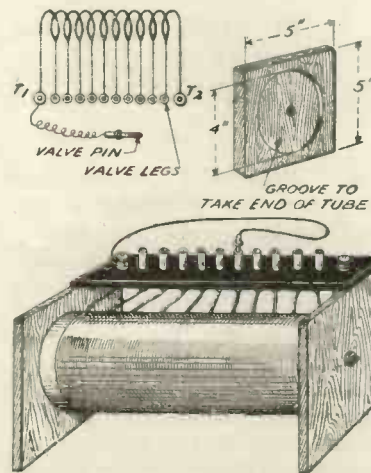

Fig. 1.—The complete details of the tuner and wooden end-pieces.

attached to the wooden ends by means of two round-headed brass wood-screws, and carried two terminals and ten valve socket legs. Wires connecting the valve legs to the tapping points on the coil were soldered in after the ebonite strip had been screwed in position, and the variation of the inductance was

done by a wander-plug consisting of a valve-pin connected by means of a six-inch length of single flex to one of the terminals. Insertion of this pin in any desired socket then short-circuited part of the coil, since its two ends were connected to the terminals.

The ebonite strip shown was screwed on *at one side* of the coil, and not exactly over its centre, in order to make room for the projecting shanks of the valve legs beneath, and to facilitate the soldering of the tappings.

The method of making tappings calls for some explanation, since it is not very easy to make them in a pile-wound coil; as a rule it is not worth while to attempt to make them as winding proceeds, but to wait until the coil is finished. On completion of the winding, soak the coil in *dilute* shellac varnish (thinned down with methylated spirit) and bake it in an oven of moderate warmth until thoroughly dry. Then take a pair of sharp-pointed scissors and cut one of the turns at each of the tapping points, turn back the two cut ends of each severed turn and scrape them bare with a knife. Solder these ends in pairs to their respective tapping wires.

This tuner was used as a loading coil pure and simple, reaction being otherwise provided for; but it could easily be modified to include a reaction coil. For example, one end could be left open like a loose-coupler and a coil consisting of a tube 3 in. in diameter and 5 in. long wound full with No. 36 enamelled wire arranged to slide inside. G. P. K.

HOME-MADE LOUD-SPEAKER HORNS

THE following is a description of an easily constructed loud-speaker horn.

The curved portion of the horn is moulded with "Necol" plastic wood; this is a thick paste before use, and can be worked like Plasticine.

After exposure to the air for several hours, the paste becomes

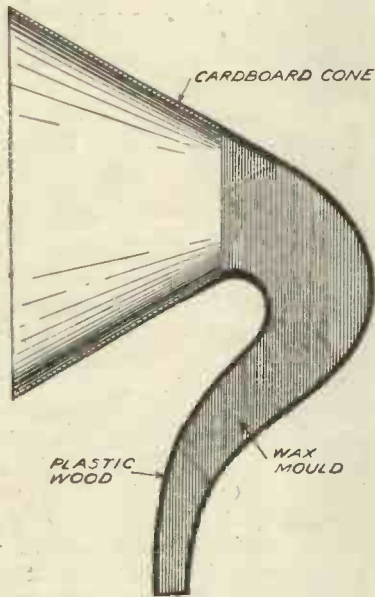

Fig. 2.—Illustrating method of moulding the plastic wood to the required shape.

as hard as wood, and can be planed, sawn, etc.

"Necol" is sold in various size tins, the ½ lb. size being 1s. 9d.

The mouth of the horn is made from two or three thicknesses of cardboard glued together. The wax mould on which the plastic wood is moulded is made from a long cone of stiff paper, the diameter at the top being 3 inches and at the bottom about ½ of an inch; the length for the cone shown in Fig. 2 will be about 12 inches to 14 inches. When made, the cone is closed at the bottom and filled

with melted wax, about 1¼ lb. being needed, which is then allowed to set. When the wax is hard, the paper is removed and the resultant solid cone of wax is carefully warmed and bent to the required shape. The mouth of the horn is next made from cardboard and fixed in position on the end of the wax mould by means of pins. The plastic wood is now moulded as evenly as possible round the mould, and also for about 1 inch up the cardboard, gradually thinning it so as to make a neat join with the cardboard. After this the horn is set aside to harden, after which the wood can be smoothed up with glasspaper and the wax slowly melted out. It will be found that when the horn has become heated, most of the wax can be pulled out of the large end of the horn. For a horn about 14 inches high the total cost, including wax, is about 2s. 6d.

F. H.

FINDING THE POLARITY OF TELEPHONES

A FRENCH experimenter uses the following simple method of determining the polarity of telephone head-gear. A central zero milliammeter is placed across the leads going to a single earpiece. The polarity of the milliammeter must be known. The diaphragm of the earpiece is removed and a piece of steel is brought near to the poles of the magnets. This causes a movement of the milliammeter needle

If this movement is in such a direction that the milliammeter needle moves towards the negative side, then the negative terminal of the milliammeter is connected to the positive of the telephones.

If on the other hand the movement is such that the needle goes towards the positive side, then the negative terminal of the milliammeter is connected to the negative of the telephones.

In the case of two receivers in series one proceeds in the same manner, but one of the telephones must be short-circuited. After carrying out this test, the respective leads to the telephone terminals should be marked in some way.

X. Y. Z.

AN EFFICIENT LEAD-IN TUBE

OBTAIn an 18in. length of micanite or paxolin tube which has an external diameter of 1¼ in. and an inside diameter of 1 in. This can be purchased from any reliable dealer in insulating materials and should not cost more than a shilling or so. This may seem to be a somewhat heavy cost for such a tube, but it should be remembered that faulty insulation of the aerial lead-in may bring about a very consider-

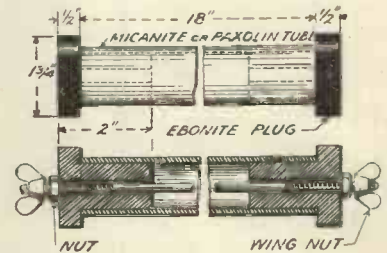

Fig. 3.—Details of the lead-in tube, together with dimensions.

able signal strength reduction. Next turn up two ebonite end plugs as shown in Fig. 3, place these in the positions indicated in the drawing, and through them thread a ¼ in. brass rod, 24 in. long, tapped at each end to take a hexagonal nut and a thumb screw.

The two hexagonal nuts should be screwed up tight by means of pliers against the ebonite end plugs, thus securing the whole unit. The tube may then be mounted in the window frame or wall as the case may be.

R. W. H.

DOUBLE-BASKET WINDING

THE conventional type of basket coil, wound by passing the wire alternately under and over the pins of a spider, is probably one of the most efficient concentrated inductances at present used, but it has certain defects from the practical



Fig. 4.—The conventional winding.

point of view. The principal one, of course, is its mechanical weakness, while the next most serious is its large size for a given inductance value, which is undesirable, not merely from considerations of compactness, but because it means that the stray field from such coils, when they are used as H.F. intervalve couplings, is extensive and troublesome.

The simple modification known as the double-basket method of winding to those who are acquainted with it removes these drawbacks to a very great extent, and would appear to deserve general adoption wherever a flat coil of high efficiency and moderate bulk is required. It



Fig. 5.—The suggested method of winding.

enables one to put approximately twice the number of turns in a given space, and comparative tests indicate that its efficiency remains very high.

The method of winding is extremely simple: The usual type of basket-coil spider with an odd number of spokes is used, and the wire is carried round *two* pins at a time instead of one, as shown in Fig. 5, which results in the formation represented in Fig. 6.

The points of adhesion between the turns are much increased in number in this winding, and, consequently, when it has been waxed, or alternatively, shellacked and



Fig. 6.—The resulting formation of double-basket winding.

baked, it is sufficiently strong for most purposes. An incidental advantage is that less wax or shellac can now be used in the impregnation, and so the internal capacity of the coil can be kept down.

This modified winding is also decidedly beneficial in the case of coils wound upon cardboard discs, since it reduces their inherent flabbiness. G. P. K.

A CABINET FOR SMALL PARTS

MANY wireless constructors have no doubt experienced considerable inconvenience in storing small parts and accessories in such a way as to enable them to find whatever they require without loss of time.

It is well worth while to construct a small cabinet for these



Fig. 7.—A completed match box cabinet.

articles, and so save both time and labour in searching.

A very simple, cheap and quick method of storing parts is shown in Fig. 7. When a number of

empty match boxes have been saved, the outer cases are neatly glued together and a supporting piece of cardboard is glued to the back. The whole is covered with coloured art paper and carefully trimmed. To the front of each inner case, or the matchbox itself, is fixed a small boot button to act as a handle, and above this is gummed a small label upon which is written a list of the contents.

H. B.

A VERNIER ADJUSTMENT

IT is sometimes found that a vernier adjustment is required for a small experiment of such a nature that its permanent fixing is not justified.

In some cases the writer finds

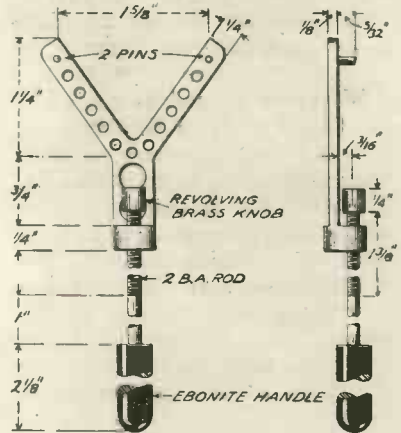

Fig. 8.—Details and dimensions of the vernier adjustment handle.

the gadget illustrated in detail in Fig. 8 of considerable convenience on account of its variable adjustment in relation to different knobs, and the ease with which it is removed.

The clip is made from brass, drilled to reduce capacity, whilst the handle of ebonite may be cut to any length the constructor may desire. J. P. C.

Broadcasting News



LONDON.—There was some perturbation at 2LO the other evening. An invitation was extended to a party of Swedes to visit the studio, but the request contained no reference to the fact that a member of the Swedish Royal household was to be one of the party.

The Royal visitor was exceedingly interested in all that he saw, and asked several pertinent questions of Captain Eckersley who was in charge of the party. He had been listening to the programmes from a motor car equipped with wireless, and thought that he would like also to see the place where the music came from.

We are interested to learn that the Old Vic. is to be linked up with 2LO, and that excerpts from Shakespeare are to be broadcast. The Old Vic is evidently more enterprising than many of its more youthful contemporaries. The B.B.C. seem very confident that the people want to hear Shakespeare, but if rumour is to be relied upon, many experimenters use that night for taking their sets to pieces.

"Rob Roy" is to be relayed from Glasgow to London on October 6th. What would "ma worthy faither the Deacon" say to that? A cynic has suggested that this particular transmission should be considered one of the language tests which are being sent out periodically.

We very much enjoyed Monsieur Ciaroff's rendering of Verdi's "De Miel Bollenti Spiriti," for in this he showed us more feeling

and finish than were evident in any of his other selections. We hope to hear him again in more mellow and less belligerent form. If the writer were asked to compress his opinion into terse form he would feel inclined to coin the following aphorism: "Monsieur Ciaroff's singing shows great art but little heart."

The "Talk on French," by Monsieur Audra, was most unique and instructive, although, of course, not new. We think the arrangement might be improved by delivering a talk of about 400 words in English; then take the same address, and divide it into convenient phrases, giving first the English phrase followed by its French equivalent, and at the end of this English-French alternating address, let us have the translation of the whole 400 words delivered in French.

Forthcoming Events

OCTOBER.

3rd (WED.).—7.15, Dramatic Criticism. 7.30, 2LO Orchestra; John Henry. 9.45, Dance music by the Savoy Band.

4th (THURS.).—7.15, Musical Criticism. 7.30 to 9, 2LO Dance Band.

5th (FRI.).—7.15, Cinema Criticism. 7.30, Orchestral and Vocal items. 9.15, Professor A. J. Ireland on "History."

6th (SAT.).—7.15, Mr. E. Kay Robinson on "A Wild Rabbit's Life." 7.30 (simultaneous), "Rob Roy," played at the Glasgow Station.

7th (SUN.).—(Simultaneous) Steinway Hall Organ Recital at 3.30.

8th (MON.).—7.15, Mr. John Strachey on "Books." 9.15, Mr. H. E. Haslam on "Hockey."

9th (TUES.).—7.15, Lord Shaftesbury

on the Shaftesbury Society. 9.15, Mr. F. Bligh Bond on "Old Buildings." 10, Talk on "Motor-ing."

BIRMINGHAM.—It is not always fair to single out individuals or companies for praise where 5IT's programmes are concerned, but commendation has undoubtedly been earned by the "Kalamazoo Company" whose recent visit was marked by a contribution on distinctly original lines. It was a burlesque rendering of a typical evening in a Somerset country inn, and the players succeeded in conveying in a remarkably successful way the rustic joviality which would prevail in such a place.

The station Military Band is, in common parlance, "doing fine." Mr. Applebey Matthews has soon shaped the embryo into a very artistic whole, and his concerts are keenly looked forward to. One wishes they could be given more often.

Forthcoming Events

OCTOBER.

3rd (WED.).—Song Recital by Principals of the Station Repertoire Co.

5th (FRI.).—Special Tschairowsky programme.

6th (SAT.).—Station Military Band.

11th (THURS.).—Opera, "Il Trovatore."

GLASGOW.—Mr. R. E. Jeffrey, a prominent figure in Glasgow amateur theatrical circles, has been appointed Director of the new Aberdeen broadcasting station, which is to be opened on October 10th. Lord Gainsford, Chairman of the B.B.C.; Mr. Reith, the Managing Director;

and other members of the company are expected to be present at the opening ceremony in connection with the Aberdeen establishment. The Glasgow station will transmit the opening speeches.

Band music is a most popular item on the Glasgow programme. Within the space of a few days we are hearing the Glasgow Amateur Concertina Band, the Royal Air Force Band, and the Band of the 1st Royal Scots Fusiliers.

Forthcoming Events

OCTOBER.

- 3rd (WED.).—The Royal Air Force Band. Miss Crue Davidson, contralto.
- 4th (THURS.).—Classical Night of the Wireless Orchestra. Mr. Alex. McGregor, baritone, and Miss Josephine MacPherson, L.R.A.M., mezzo-soprano.
- 5th (FRI.).—Signor Sylvio Sideli, bass. Miss Tina McIntyre, soprano.
- 6th (SAT.).—Repeat performance of "Rob Roy." On this occasion "Rob Roy" will be simultaneously broadcast from all stations.
- 9th (TUES.).—Mr. William Michael, of the British National Opera Company.

MANCHESTER.—There is a morning transmission from 2ZY at 11.30 every Thursday, usually given by the 2ZY trio, which consists of Mr. Leonard Hirsch, Mr. Sydney Wright, and Miss Jessie Cormack. In consequence of this, no afternoon programme is provided on that day.

The 2ZY Operatic Company's first performance, Verdi's "Il Trovatore," was an entire success; the principals' voices came out to advantage, whilst the orchestra was not too obtrusive and the chorus maintained a suitable degree of reserve. Both principals and chorus were provided out of local talent, the former consisting of Miss Madge Taylor, Miss Olive Mackay, Mr. Lee Thistlethwaite and Mr. Wilfred Hindle, and the chorus was composed of 16 members of the Beecham Opera chorus. The orchestral music was by the

2ZY orchestra, conducted by Mr. Dan Godfrey, jun., A.R.A.M., to whom great credit is due for such an excellent production. Mr. Moses Baritz gave an outline of the opera in his usual lucid style and filled in the gaps necessarily caused by the condensation of the piece into a performance of under two hours.

Sunday afternoon transmissions are expected to commence on October 7th, and will take the form of organ recitals relayed from 2LO.

Forthcoming Events

OCTOBER.

- 3rd (WED.).—3.30, Mme. Sinkinson, soprano, 2ZY orchestra. Miss Catherine Aulsebrook, contralto.

BROADCAST TRANSMISSIONS

	<i>Call-Sign</i>	<i>Wavelength</i>
CARDIFF	SWA	353 metres.
*LONDON	2LO	369 "
MANCHESTER	2ZY	385 "
NEWCASTLE	5NO	400 "
GLASGOW	5SC	415 "
BIRMINGHAM	5IT	420 "

TIMES OF WORKING.

Weekdays ... 3.30 to 4.30 p.m. and 5.0 to 10.30 p.m. G.M.T.

*London 11.30 a.m. to 12.30 instead of 3.30 to 4.30 p.m.

Sundays... 8.30 to 10.30 p.m. G.M.T.
2LO 3.0 p.m. to 5.0 p.m.

SILENT PERIODS.

CARDIFF	8.0	to 8.30
LONDON	6.15	" 7.0
MANCHESTER	7.15	" 7.46
NEWCASTLE	9.0	" 9.30
GLASGOW	9.0	" 9.30
BIRMINGHAM	8.0	" 8.45

- Signor Sylvio Sideli, bass. Mr. James Worsley, dialect entertainer. 9.45, German talk.
- 4th (THURS.).—11.30 a.m., Concert by 2ZY trio. 6.15, Girl Guides and Boy Scouts pow-wow. Classical concert by members of Manchester College of Music; Miss Elsie Leggott, contralto; Crossland Moor United Handbell Ringers. 9.45, Spanish talk.
- 5th (FRI.).—3.30, Oxford Picture House-orchestra; 2ZY orchestra; Miss Olga Telba, soprano. 9.45, French talk.
- 6th (SAT.).—3.30, Oxford Picture House orchestra. 6.15, Dance programme by O'Brien Dance orchestra. 7.30, Scottish play, "Rob Roy," as recently played from Glasgow.
- 7th (SUN.).—Radio Military Band, conductor Mr. H. Mortimer.

8th (MON.).—3.30, 2ZY trio. Vocalists, Miss Eva Farris, soprano; Mr. Wm. Higgins, baritone; Mme. Evans-Gregory, contralto. 6.45, Spanish talk. 7.30, Gounod's Opera, "Romeo & Juliet," with augmented orchestra conducted by Mr. Percy Pitt, and star artists, relayed from 2LO.

9th (TUES.).—3.30, Oxford Picture House orchestra. 6.30, Miss Elizabeth Henson, soprano. 7.45, Symphony concert, augmented orchestra conducted by Mr. Dan Godfrey, jun., A.R.A.M. Lecturer: Mr. J. F. Russell, subject, "Evolution of the Symphony from Mozart to Glazounov."

NEWCASTLE.—With the ending of summer time and the alteration of the time of 5NO's evening concerts, there is every sign of greatly increasing interest in wireless on Tyneside. One can scarcely travel by any train or tram without hearing discussions on wireless. Great satisfaction is expressed on all hands at the recent regular introduction of simultaneous broadcasting.

A welcome recruit to the 5NO programme has recently appeared in the person of Mr. Norman Wright, one of the most popular members of the Newcastle Amateur Operatic Society. At the society's annual Gilbert and Sullivan performances Mr. Wright plays those parts upon which Mr. Lytton, of the D'Oyly Carte Company, has built his reputation.

Forthcoming Events

OCTOBER.

- 3rd (WED.).—Band of Northumberland Fusiliers.
- 4th (THURS.).—Scenes from "Romeo & Juliet," "Othello," and "Hamlet" by the Lee Dixon Co. Signor Sylvio Sideli, London, bass.
- 5th (FRI.).—Central Band of the R.A.F.
- 6th (SAT.).—Simultaneous broadcasting of "Rob Roy" from Glasgow.
- 7th (SUN.).—Address by the Bishop of Edinburgh.
- 8th (MON.).—Simultaneous broadcasting of "Romeo & Juliet" from London.
- 9th (TUES.).—John Henry, the well-known London entertainer.

RANDOM TECHNICALITIES

By PERCY W. HARRIS, Assistant Editor.

Untuned aertals—The Cockaday four-circuit receiver—Braided copper wire.

I AM delighted to find that the notes on untuned aerial circuits have aroused so much interest. The success obtainable with the method described certainly confirms the view which I have held for a long time, that our knowledge of receiving aerials and their action is very incomplete.

Of course, I do not claim to have originated this form of circuit, for it is an integral part of the well-known Reinartz tuner, although in this case there is a conductive connection as well as an inductive one between the aerial and the closed circuit. M. B. Sleeper in his own publication, "Radio and Model Engineering," has also described a fixed coupler much on the lines of that indicated in my article, and L. M. Cockaday has used something of the kind in his "Four-Circuit" Receiver.

This latter, by the way, has a circuit of considerable interest. There is a semi-aperiodic aerial circuit of one turn, a secondary of 65 turns of No. 18 wire on a 3½ in. tube and an absorption circuit, the winding of which consists of 34 turns of No. 18 on the other end of the tube carrying the secondary. The secondary is shunted by a variable condenser as is the absorption circuit. The connection of the valve to the secondary circuit is of the De Forest Ultraudion type, a circuit which oscillates very readily.

The circuit diagram (Fig. 1) will explain the general arrangement. The action is as follows—The absorption circuit is "impacted" by the aerial, and the secondary circuit coupled to it will not be affected unless it is set to the same wavelength. Normally the set will oscillate, but if the

variable condenser is turned, a point will be reached, very close to the wavelength of the secondary circuit, when this absorption circuit will withdraw a considerable amount of energy and tend to stop the set oscillating. The circuit is thus an Ultraudion circuit very loosely coupled to the aerial and provided with means to stop the set oscillating. Critical setting of the absorption circuit enables the user to keep the set just off oscillation point, when good signals

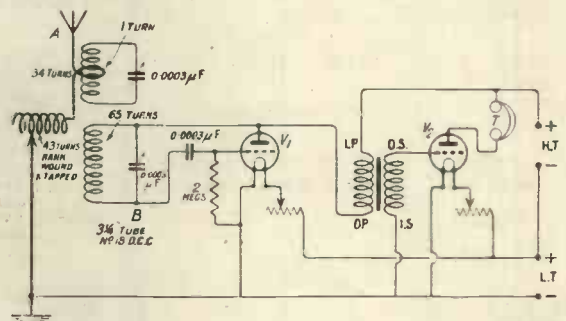

Fig. 1.—The Cockaday four-circuit receiver. The aerial loading coil is not coupled to the other two coils. Note the absorption circuit coupled to the aerial by one turn of wire.

will be received, and at the same time a great degree of selectivity obtained.

I am afraid a mistake crept into "Random Technicalities" for the week before last. In referring to the braided copper which I have found so useful for experimental purposes I gave the price as 5s. 6d. per hundred yards. This should have been 8s. 6d. per hundred yards. The London Electric Wire Co. ask me to point out that they do not execute retail orders, but only supply through the trade. Experimenters should, therefore, order this material from their ordinary dealer who will be able to obtain it from the manufacturing firm in the usual way.



Conducted by A. D. COWPER, M.Sc., Staff Editor.

A Lightning Arrester

A NEAT little lightning arrester fitting has been sent to us for test by M. E. Peake, consisting of a multiple narrow spark-gap between points of two brass plates mounted on an ebonite base, with terminals for connecting to aerial and earth. This supplies an easy and ample path for discharges direct to earth, while not interfering with ordinary reception when installed as a permanent safeguard. It is well finished, and the insulation on test proved excellent.

A Filament Rheostat Adapter

Messrs. L. McMichael, Ltd., have produced a plug-in valve-filament adjustable resistance for use with the ordinary valve-socket, which also carries in turn the valve itself in a holder on the top of the fitting. The regulating handle is at the side, and permits of adjustment from minimum (with a definite "off" position) to maximum with a movement of a little under 180 degrees. This is particularly suited for use with their M.H.B.R.2 valve set (already noticed in No. 3, Vol. 1 of this journal), wherein, for the sake of simplicity of control, no filament resistances are fitted, a four-volt battery being used.

Adding only about 2in. to the height of a panel set, it is suitable for use in any case where a filament resistance is needed.

The sample submitted had an

unusually high maximum resistance in the neighbourhood of 10 ohms, and is the more useful on this account alone in experimental work; on trial in practical reception the adjustment was noticeably smooth, a somewhat tricky soft valve being readily controlled as a detector on a six-volt battery. The finish and workmanship in the unit are beyond exception.



The rheostat adapter.

High-frequency Plug-in Transformers

In Vol. 2, No. 7, p. 297, we reviewed the plug-in type of H.F. transformers marketed by Messrs. L. McMichael, Ltd. We learn that the three submitted for test were three members, Nos. 1, 2, and 3, of a set of five, of which the first, No. 0, tunes from 150 to 300 metres; and the last, No. 4, from 2,000 metres upwards, those tested covering from 300 to 3,000 metres.

A Tuning Unit

N. V. Webber has sent for inspection and test a tuning unit consisting of a small panel, 5in.

by 4in., mounted on a polished wood box, with four terminals for aerial, earth, grid and low-tension, and carrying a coil plug-and-socket for plug-in coils. Included in the unit are a compact variable condenser of 0.0005 μ F capacity, a series-parallel switch of neat form, and a fixed condenser of 0.0009 μ F capacity which can be switched across the variable condenser by a swinging connector-bar to increase the effective range.

On actual trial it was found to be a handy and efficient unit, good signal strength being obtained with standard plug-in coils. The insulation also was good and the tuning sharp. The interior construction was sound, workmanship and finish being quite adequate.

The "Mystic" Aerial

Messrs. Hollingdick and Son have submitted for test their "Mystic" aerial, for which it is claimed better reception is obtained than with the conventional aerial wire. This consists of a hard-drawn strip of thin and light copper or silicon-bronze, to be erected in the same manner as the customary "7/22's." This certainly offers a minimum high-frequency resistance (it is well known that high-frequency currents are only skin-deep), and on practical trial quite good results were obtained with a short indoor aerial on the ground floor a dozen miles from 2LO, using a single-valve set.

Our readers will be interested in the announcements regarding the new dull-emitter valve—the Wecovalve. Before definitely recommending these valves we are awaiting the receipt of samples which we can actually test and report upon on this page.



Correspondence

THE RELAY LEAGUE

SIR,—The British Wireless Relay League in July last became absorbed into the Radio Society of Great Britain under conditions which will ensure the continuance of its activities and give it the advantage of the financial and administrative support of the larger body.

The Committee of the Society have now decided to make preparations for the organisation of an attractive programme of relay work for the winter, and for this purpose have arranged to establish a special section of the Society called the "Transmitters and Relay Section." The work of this Section will be guided by a Committee democratically elected from within the Section, and will have several grades of membership.

As an outline of what may be arranged, Corporate members of the Radio Society and its Affiliated Societies may become members of the Transmitter and Relay Section on payment of an annual subscription of 5s. if they hold transmitting licences, and 3s. 6d. if they hold only receiving licences; persons who are not members of the Radio Society or its Affiliated Societies may become members of the Section upon payment of a subscription of 10s. per annum if they hold transmitting licences, and 7s. if they hold only receiving licences.

These suggested rates of subscriptions are provisional, and, besides, are not intended to apply to those original members of the Relay League who have already paid a subscription which has not

yet expired, and for whom special terms will be arranged.

All classes of members will receive the circulars giving details of the programmes of work organised by the Committee of the Section.

The Radio Society will be liable for any excess of expenditure over income which may arise in operating the Section in accordance with the Rules which are being drawn up. Prospective members of the Section, whether members of the Radio Society of Great Britain and the Affiliated Societies or not, should send their names to Mr. L. H. McMichael, 32, Quex Road, West Hampstead, London, N.W.6, who will send them a copy of the rules as soon as they are ready.

The present epoch is critical in the history of the amateur movement in this country. The advent of broadcasting, and the possibility of the rapid growth in the number of broadcasting stations, each of which will require a special band in the already crowded spectrum of wavelengths, calls for a united and definite statement by the amateurs of their own claim to an adequate waveband.

There is at the moment some danger that the needs of the amateur will be overlooked, unless by union they bring to bear upon the Departments of State concerned an influence equal to that of any other interest.

It will be realised that if, through lack of cohesion, British experimenters are ultimately barred from the use of transmitting apparatus, the progress of

wireless discovery and invention in this country will be crippled, and many of the honours of pioneer work in the still unexplored regions of our wonderful subject will be left to other nations.

I am, etc.,

W. H. ECCLES, President.

Radio Society of Great Britain.
[This matter is referred to in our Editorial.—ED.]

ST36

SIR,—On the morning of September 9th, between 2.15 and 3.45 a.m., using circuit ST36, I received WMAF, Round Hill Radio Corp., Dartmouth, Mass., and WGY, General Electric Co., Shenectady, N.Y. The dance music from the last station was so loud for 10 minutes that it could be heard 2ft. from the 'phones.

I am, etc.,

N.W.10. FRANK GOULDEN.

FLEWELLING

SIR,—I have been experimenting with the simplified Flewelling circuit as described by Mr. Cowper recently, and have so far succeeded in receiving Newcastle and Glasgow B.B.C. stations on a frame measuring 8in. by 14in., using a D.E.R. valve with 66 volts H.T. 2 mg. gridleak across a 0.0003 μ F, grid condenser shunted by a vernier variable condenser for fine adjustment.

I am, etc.,

E.11. J. J. JACKSON.

We shall be pleased to hear from readers who receive American broadcast transmissions.

Information Department



W. T. H. (HAVERFORDWEST) asks for a circuit for applying an additional valve and low-frequency transformer to the one described in "MODERN WIRELESS" of May, 1923, page 293. He further asks what is the tuned anode method of reaction and can it be used in conjunction with the high-frequency transformer.

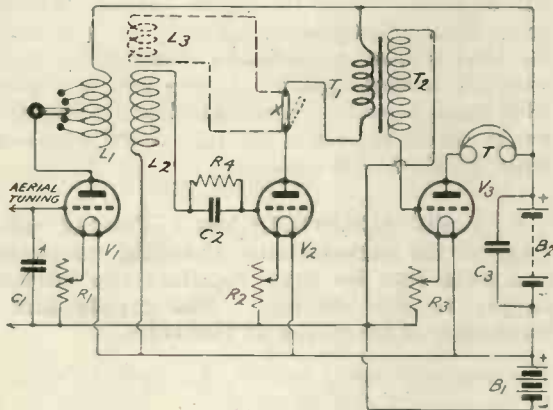

We reproduce herewith a suitable circuit arrangement for an additional low-frequency valve to be added to the receiver you mention. The tuned anode method of reaction can be employed satisfactorily with a high-frequency transformer. It is quite a feasible plan to adopt reaction operating in the manner you suggest; but for constructional details of a suitable arrangement we would refer you to the article entitled "A Three-valve Regenerative Receiver," by E. Redpath, appearing in *Wireless Weekly*, Vol. 1, No. 11.

D. R. (BATTERSEA) asks how to make a gridleak having a value of 10,000 ohms, suitable for a small C.W. transmitter.

It is advisable to use a wire-wound resistance for this purpose, as the graphite type frequently breaks down. A suitable leak could be made by winding 100 feet of No. 44 single silk-covered Eureka resistance wire on an ebonite rod half an inch in diameter and about 6in. long. This might be

wound in small sections, and tapings taken from the last four sections, which should each consist of about 20 turns. This will allow the value of the leak to be varied.

C. R. K. (BRADFORD) wishes to add two low-frequency amplifying valves to his crystal receiver, employing only one transformer.

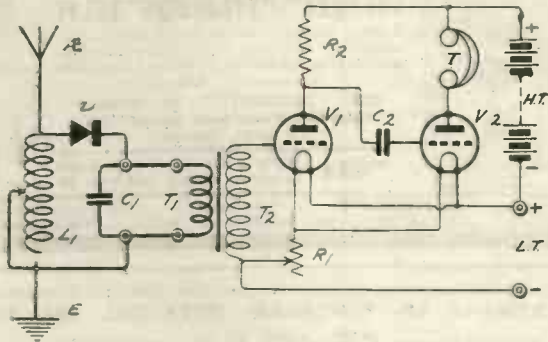

Although the best effect would be obtained by the use of two intervalve transformers, we give above a circuit diagram which will meet your requirements. The anode resistance R_2 should have a value of 50,000 ohms; the capacity of the coupling condenser C_2 should be $0.01 \mu F$, and the high-tension voltage should be 50 to 80 volts.

B. L. T. (LLANELLY) experiences difficulty in obtaining a critical adjustment of reaction.

Your set appears to be suffering from a trouble known as overlap, for which you should apply the usual remedies. These are as follows:—Try different makes of valves for the rectifier, and vary the plate voltage and filament current of the high-frequency and rectifying valves separately. You might also try varying the value of the gridleak. The "howls" which you have heard are, of course, quite normal in such a receiver, but yours appears to be somewhat uncontrollable. We think that when you have corrected this difficulty you will be able to tune in other broadcasting stations.

GOOD TOOLS MEAN EFFICIENT WIRELESS SETS

We give you Best Quality Tools with lowest prices by supplying the user direct. Send us your Postal Order or enquiries to-day; you'll get our best immediate attention.

None too small or too large.

WE PAY CARRIAGE ON ALL ORDERS.

HAND DRILL, capacity 0-4". Gears cut from full metal. Complete with three-Jaw Chuck and Set of Drills, 10/6

ADJUSTABLE STEEL HACKSAW FRAMES, 8-12", Nickel Plated, complete with 1 Blade 2/-

SUPERIOR PARALLEL TABLE VICES, with clamp, 2 1/2" steel jaws, accurate finish 6/6

STOCKS & DIES, B.A. (Dies 1/8" dia.), cutting 2, 4, 6 and taps. London made. 10/- per set.

On card with Taper Taps 12/6

with Taper and Plug Taps

THE BILLING TOOL CO., 303, HIGH HOLBORN, Phone LONDON, W.C.1. Holborn 898.

ECONOMIC ELECTRIC

THE "EEC" "XTRAUDION" VALVE

is being used by the leading Radio Experimenters for detection, high and low frequency amplification, power amplifiers and low power transmission. Price 15/-

USE "RECTARITE," the synthetic crystal that makes Loud speakers talk! 1/6 Large Specimen.

Write to-day for 40 page Radio Catalogue mailed post free, 4d.

Head Office: 10, FITZROY SQUARE, LONDON, W.1. Showrooms: 303, EUSTON RD., N.W.1. Branch and Works: TWICKENHAM.

BEWARE OF WORTHLESS IMITATIONS, SEE THE TRADE MARK *WatMel* ON EVERY GRID LEAK.

WATMEL VARIABLE GRID LEAK
(Patent applied for.)

The Resistance is steadily Variable between 1/2 to 5 megohms. Only requires a 1/8 in. hole in panel for fitting.

PRICE 2/6 EACH
The best Variable Grid Leak made.

Suitable for use in any circuit, and improves the working of any valve detector. (50,000 to 100,000 ohms for the S.T.100 Circuit. Price 3/6.)

WATMEL WIRELESS CO., Connaught House, 1a, Edgware Road, Marble Arch, W.1. Tel. 4575 Paddington.

Reduced Advertisement Rates

NEXT MATTER (In columns only).

13 insertions consecutive £20 6 insertions consecutive £20 plus 5%

1 to 5 insertions consecutive £20 plus 10%

ORDINARY POSITIONS.

13 insertions consecutive £15 6 insertions consecutive £15 plus 5%

1 to 5 insertions consecutive £15 plus 10%

All per page and pro rata.

SCHEFF PUBLICITY ORGANISATION, LTD., 125, Pall Mall, London, S.W.1. Phone—Regent 2440 (2 lines).

D. R. P. (DURHAM) asks one or two questions relating to the "WIRELESS WEEKLY" Reflex Receiver.

You proposed scheme of building this receiver into a panel set is quite satisfactory, and you will be able to add a low-frequency valve if desired, so converting the complete set into an ST100 receiver. An article describing a similar conversion appears in *Modern Wireless* for October. Adding a high-frequency valve is not quite such an easy matter, however, and we recommend you to read the article by Mr. A. D. Cowper in *Modern Wireless* No. 7.

J. J. R. (PORTSMOUTH) asks several questions relative to his ST100 receiver.

The howl which you experience with ST100 seems to indicate that your gridleak resistance is too high or that you are not controlling the reaction of the set correctly. Weakening the coupling, that is, separating the coils, should stop this noise and enable you to receive the signals clearly. The reaction should be tightened up to the point at which the howl is about to commence to enable you to receive the loudest signals. If you require a somewhat more powerful circuit we should recommend you to try ST76, which has been described several times in *Wireless Weekly*.

E. V. (BLACKPOOL) has a Tungar valve rectifier for accumulator charging purposes, and asks how he may regulate the current supply to this device. His supply has a frequency of 60 cycles at 100 volts.

The most economical method of adjusting the input to the primary side of an A.C. transformer is to use an iron core choke inserted in one of the supply leads. A suitable choke for your apparatus may be constructed as follows:—Obtain a thin brass tube about 10in. long and 1in. internal diameter. Two brass end pieces about 2in. in diameter should be soldered on to the ends of the tube so as to form a spool. The exterior of the tube and the inner faces of the discs are to be insulated with mica, and 2 lb. of No. 18 d.c.c. copper wire are to be wound upon it. An iron core consisting of a bundle of wires 10in. long is to slide inside the tube, and regulation is effected by moving the core in or out. When the core is right out, the current is at its maximum. Such an arrangement permits of about 25 per cent. regulation.

G. A. (GLOUCESTER) requests particulars of the best arrangement of a single valve and crystal to receive broadcasting at a distance of 35 to 40 miles.

A single valve reflex receiver will give you excellent results at this distance. We can recommend either the receiver described by Mr. G. P. Kendall in *Modern Wireless* No. 6, or the *Wireless Weekly* Reflex Receiver, which appeared in Vol. 2, No. 9, of this journal.

WECOVALVES (PEA-NUT TYPE).



Patent Nos. 17580 (1915),
180090 (6641-1921).

Dimensions: $2\frac{1}{2}$ in. \times $\frac{5}{8}$ in.

Price:

£1 : 10 : 0

No. 44215-A.

THE WECOVALVE.

THE New Wireless Valve which is to revolutionise wireless reception. Only $2\frac{1}{2}$ in. high and $\frac{5}{8}$ in. in diameter, this small size valve can be used equally well either as a detector or amplifier, and operates off a single dry cell, no accumulators being necessary.

The WECOVALVE is the most economical valve existent, requiring only 0.25 of an ampere at 0.8 to 1.1 volts, and its life is more than twice that of tungsten and other dull-emitter valves.

The WECOVALVE has a special Bayonet Cap which prevents the possibility of destruction through careless insertion in the valve socket.

Operating characteristics:—

Filament Current 0.25 amps.

Detector Plate Voltage 17.22 volts.

Filament Voltage 0.8-1.1 volts.

Amplifier Plate Voltage 22.45 volts.

THE SOCKET.

This WECOVALVE Socket is arranged for four soldered connections and has contact points faced with a gold and silver alloy which ensure perfect contact with the base of the valve.



No. 44092.

Dimensions: $1\frac{1}{2}$ in. \times $1\frac{1}{4}$ in.

Price: 3s. 6d.

THE ADAPTOR.



No. 44090.

Dimensions: $1\frac{1}{2}$ in. \times $\frac{3}{4}$ in.

Price: 1s. 6d.

The WECOVALVE adaptor makes it possible to use the WECOVALVE in your existing sets. Designed to fit into valve sockets which carry the ordinary four-pin type valves, this adaptor enables everyone to take advantage of the *great economy in current consumption* which the use of the Weco valve effects.

WRITE FOR BOOKLETS

W.E.Co./32/W. 528 and W.E.Co./32/W. 529.

Western Electric Company Limited.

(WHOLESALE ONLY)

CONNAUGHT HOUSE, ALDWYCH, LONDON, W.C.2.

Telephone: Central 7345 (9 lines).

Branches:—Glasgow, Leeds, Birmingham, Manchester, Newcastle, Cardiff, Southampton, Dublin

The Valve for perfect reception

The holiday season is over and your thoughts are turning to the pleasures of the longer nights.

Broadcasting has improved by great strides since last winter, both in quantity and quality. To enjoy it to the full, you must use Mullard Valves.

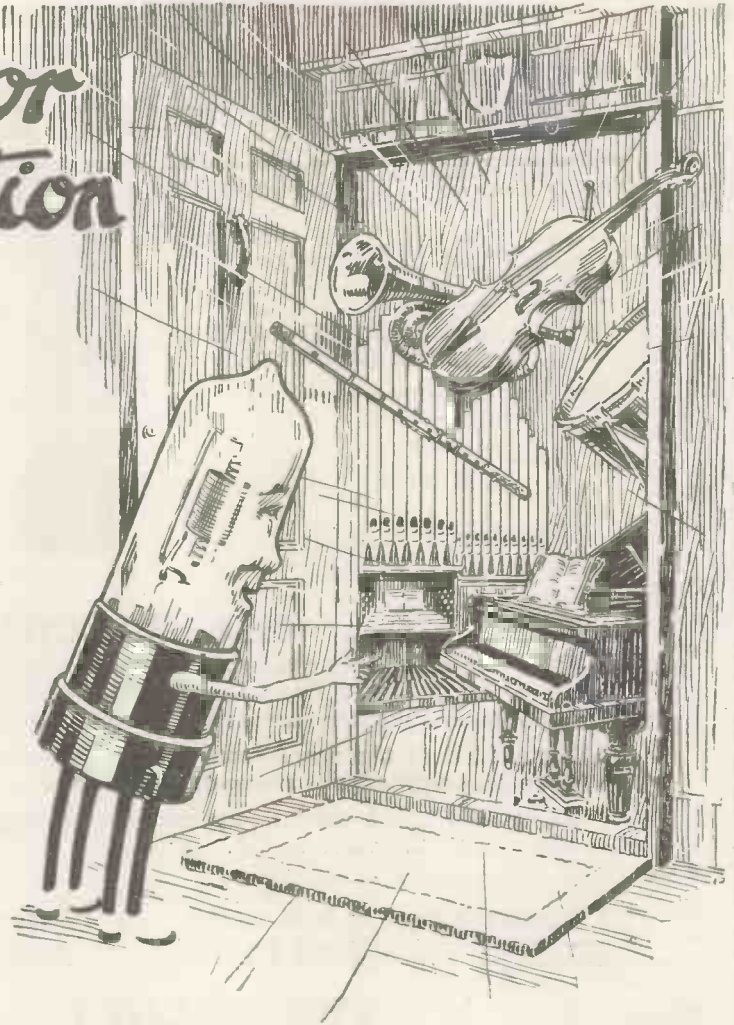

E.P.S. 58

The Mullard Wecovalve for use with a single dry cell. Twice the life of any other type of valve - - - -	£1 10 0
Type "Ora" and "R" for general reception with 4-volt accumulators -	15 0
Type L.F. (low filament current) for general reception with 2-volt accumulators or suitable primary batteries - - - -	£1 7 6
Type P.A. for loud speakers, giving good volume without distortion -	£1 2 6 to £1 15 0

Ask your usual dealer for them and for particulars of other Mullard products.

Mullard

Obtainable from all high-class electricians, wireless dealers, etc.

You CANNOT be out of WIRELESS WEEKLY because it brings BIG Business.



CARBON - GALENA LOUD SPEAKER

See "Wireless Weekly," Sept. 26th, 1923.

Finest quality Carbon Shot. Accurately ground and true to size, 1/- per packet, post 1d.

WE HAVE THE LARGEST STOCK IN THE COUNTRY.

NOTE.—A Free Packet will be given to anyone who can estimate correctly how long we took to set them up as illustrated. No adhesive used.

2½" dia. selected Mica Diaphragms, 1/6 each, post 1d.
Galena Crystals, best 6d. packet, post 1d.

The above are only a few items from our large illustrated 100 page Catalogue, 3d. post free.

GRAFTON ELECTRIC COMPANY,
54, GRAFTON STREET, TOTTENHAM COURT RD., LONDON, W.1.
Telephone: Museum 241. Works: Slough.

EQUIPMENT FOR EXPERIMENTERS

SUPERIOR SELECTION

YOUR possibilities of accurate reception are summed up in your method of tuning.

Perfect selection demands the careful choice of the tuning unit.

The WEBBER AERIAL TUNING UNIT is the result of keen research with the best Radio components on the market, and is designed and finished with the usual high standard of WEBBER PRODUCTIONS.

It possesses the advantage of a small fixed condenser for accurate tuning and of a large POLAR Variable Condenser for searching and long wave lengths.

The double pole throwover switch places the coil in series or parallel with the variable condenser, and a shorting strap across the fixed condenser enables it to be cut out of circuit when required.

Price as above 30/-
Without fixed condenser 27/6

Approved by the Radio Communication Co., Ltd., and on view at 35, Norfolk Street, W.C.2.

Write for descriptive list, post free.

N. V. WEBBER & CO., Radio Engineers,
WALTON-on-THAMES, SURREY. ARKS 3

FILTRON-COMBINATION (Patd.) 7/6 each.

Consists of a combined:—

VARIABLE GRID LEAK (Zero-7 Megohms).
VARIABLE GRID CONDENSER (Zero-0005 M/F).

Efficient in every Radio application.

FILTRON—VARIABLE GRID LEAK. 4/- each.
(Zero-7 Megohms.)

Approx. Calibration with H Graphite.

Degrees Rotation	0°	90°	180°	270°	360°	540°	720°	1080°	1170°
Megohms Resistance	∞01	∞4	∞8	∞1.2	∞1.6	∞3.2	∞4.1	∞7.6	∞10.7

Harder Graphites increase and Softer decrease these readings proportionally.
Available High Ohmic resistance of precision.

STATIC-MASTER 2/9 each. Lengthens the life of Coils, Condensers and Head-phones and insures Perfect Safety to your Set. Fitted to any Set in two minutes and needs no further attention.

RADIO SPECIALITIES, 57a, Denbigh Street, Pimlico, S.W.1.
(Phone: Victoria 6483. (Generous Trade Terms.)

Trapping

Your Choice

In the Wireless Weekly of Aug. 15 and Sept. 5 Mr. P. W. Harris gave details concerning the construction of a Wave-trap.

The Bowyer-Lowe Type C Wave-trap

is made on the lines indicated, and is a most efficient instrument for receivers in which the tuning condenser is in parallel with the tuning coil. The principle of operation is simplicity itself: two connections only, which are permanent, having to be made to the receiver, a switch being provided on the trap for cutting it in or out of the circuit. No difference whatever is made to the tuning of the receiver, this being carried out in the ordinary way. The tuning of the B.L. Type C Wave-trap is very selective; stations five metres different from that being received can be successfully cut out. Mounted on polished 35/- Postage ebonite plate and fitted in a mahogany case. Price 9d. extra.

This instrument is obtainable at all wireless dealers; if any difficulty in obtaining it is experienced send direct to



The Bowyer-Lowe Co., Ltd.,
Manufacturers of Wireless Instruments,
Radio Works, Commerce Avenue,
Letchworth, Herts.

Wholesale Distributor for Scotland:
F. M. MILLIGAN, 23-25, Renfrew Street, GLASGOW.

WIRELESS

A SET OF

6 BOOKS

FOR

10/6

ALL ABOUT RECEIVERS
IN A DELIGHTFULLY
UNDERSTANDABLE WAY

*Send 2d. postage for First
Book on approval.*

HOWARD T. WRIGHT
10, NEW BOND ST., LONDON, W.1.

The Ethophone Popular

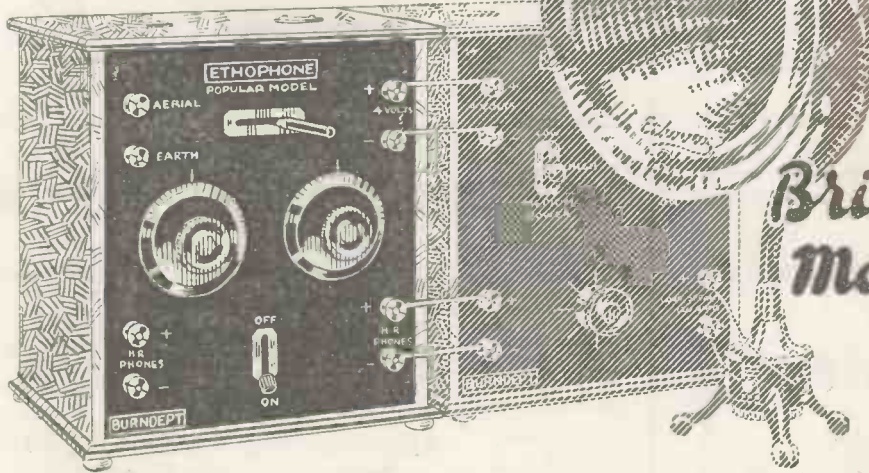

**British
Made**



Burndept Safety Switch. See description and purpose below.

A LONG range set—capable of receiving British Broadcast in any part of the country on headphones. A set in which simplicity of control is an outstanding feature. A set having Burndept finish, and covered by the famous Burndept Guarantee label with Burndept service to fall back upon if you require advice. Such is the Ethophone Popular Broadcast Receiver. When Loud Speaker reception is required, the Ethophone Speech Amplifier and the Ethovox Loud Speaker should be coupled to the Receiver, when a really large volume of clear undistorted music and speech will be obtained.

The Burndept Safety Switch has been specially designed to safeguard the windings of your set from strong atmospheric disturbances such as lightning, whether the set is switched to aerial or not.

It should be used by everybody, is convenient, and serves a double purpose in enabling you to "earth" your set when not receiving.

No. 510.	Ethophone Popular Model with self-contained H.T. battery	..	£13	10	0
	Broadcast Tariff	..	1	15	0
.. 510 WA.	As 510, complete with valves, battery, accumulator, telephones and aerial equipment	..	18	10	0
	Broadcast Tariff	..	1	15	0
.. 525.	Ethophone Speech Amplifier, complete with two special valves and self-contained High-tension battery..	..	20	0	0
	Broadcast Tariff	..	1	0	0
.. 233.	Burndept Safety Switch	..	12	6	0
.. 203.	Standard table pattern. Ethovox Loud Speaker	..	5	10	0
.. 213.	Junior Model	..	2	15	0

Burndept, Ltd., Aldine House, Bedford St., Strand, W.C.2
Phone: Gerrard 7794.

BURNDEPT
WIRELESS APPARATUS

We are showing at the Exhibition being held at the White City from November 8th-21st, under the auspices of the National Association of Radio Manufacturers.

BRANCHES

- LEEDS: The London Assurance House, Bond Place.
- NEWCASTLE-ON-TYNE: 7 St. Andrew's Buildings West, Callowgate.
- CARDIFF: 67 Queen Street.
- HEAD DISTRIBUTING SERVICE DEPOTS. ENGLAND.
- BIRMINGHAM: C. S. Bayliss, 133 New Street.
- MANCHESTER: W. C. Barraclough, 61 Bridge Street.
- BRIGHTON: H. J. Gallers, 32 St. James's Street.
- NOTTINGHAM: Pearson Bros., 54 Long Row.
- YEovil: Western Counties Electrical & Engineering Co., Electricity House, Process Works.
- BRISTOL: King & Co., Western Electric Works, Park Row.
- SCOTLAND.
- GLASGOW: W. A. C. Smith Ltd., 93 Halm Street, 236 Argyle Street.
- IRELAND.
- BELFAST: R. & S. Scott, Kingscourt, Wellington Place.
- DUBLIN: Dixon & Hempstead, 17 South St.
- CANADIAN OFFICES.
- 172 King Street West, Toronto.
- SERVICE DEPOTS. IN ALL LOCALITIES.

If for any reason you do not buy BURNDEPT apparatus, at any rate buy BRITISH apparatus.

No more Wireless Masts

UTILITY ENDORSED
BY THE EDITOR
OF "WIRELESS
WEEKLY."



OUR HIGH GRADE RUBBER COVERED TELEPHONE CABLE GIVES WONDERFUL RESULTS AS AN AERIAL INDOORS AND OUT

WIRELESS MASTS AND INSULATORS ABOLISHED.

The simplicity in erection is beyond the dreams of all wireless enthusiasts, as the troublesome insulators are absolutely unnecessary. Suspend this wire where you will, lead in, and your result is there.

It is a simple matter to make a portable aerial from this wire or to run a lead-in from the house to the garden, whether it is a few yards or half a mile. Ideal for telephone work all over the world.

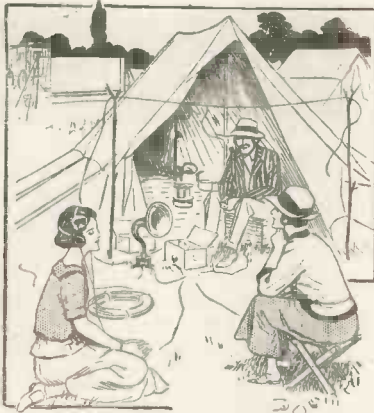

READ THIS CONVINCING UNSOLICITED TESTIMONIAL.

32, Alverstone Road,
Waddiscombe, 2nd Sept, 1923.

The Manager,
New London Electron Works.

Dear Sir,
I am pleased to inform you that the wire arrived safely yesterday, for which many thanks.

I should like to mention that I have taken my ordinary aerial down, and erected one with your thin wire, and with 80 feet I obtain results much better in every way than I had before.

Yours faithfully,
(Signed) GEO. FURMINGER.

Supplied in 3 Thicknesses on original drums.

Special terms to the Trade.

Class 0	1/4 mile drums (Thin for light work)	15/-	} Per drum Carriage forward.
Class 1	1 mile drums (medium for most jobs)	35/-	
Class 2	2 mile drums (Thickest for heavier work)	70/-	

Orders for 6 miles assorted (if required) carriage paid.

Smaller Quantities of Class 1 (medium) sent carriage paid.

100 feet 1/8 500 feet 6/3 1,000 feet 10/3

(Sufficient for the finest AERIAL.) Carriage Paid.

NEW LONDON ELECTRON WORKS LTD.,

65, REGENT'S DOCK, LIMEHOUSE, E.14.

Telephone: East 1821.

Telegrams: "Stannum, Step, London."

AERIAL.

1/8

100 feet.

POST PAID ANYWHERE.

They're Ediswans

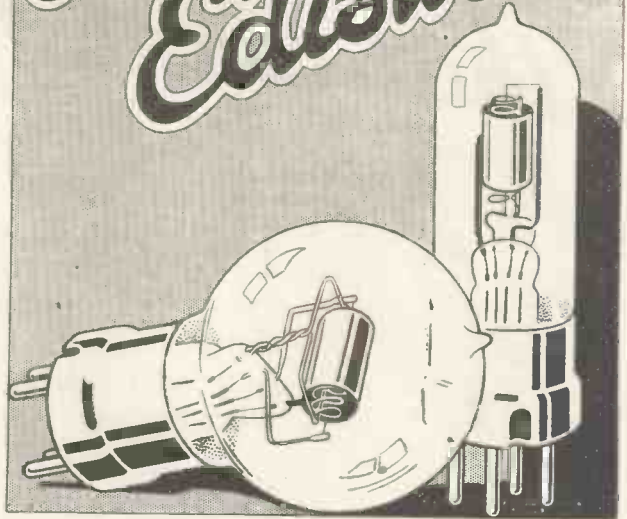

Buy the valve with
a name behind it.

The Ediswan reputation—firmly established on the judgment of satisfied users—is your protection.

Read this record of actual results:—

Birmingham, 20/8/23.

'Using one of your A.R. Valves I have received clear music and speech from London, Cardiff, Manchester, Newcastle and Glasgow—Glasgow strong enough for comfortable reception with one earpiece only. Not wishing to invest in more than one valve at the time of purchase, I decided on one with a name behind it and must say I am more than satisfied.'

(Original letter available for inspection.)

EDISWAN
Type "R." 15/-

EDISWAN
Type "A.R." 15/-

LOW TEMPERATURE (DULL EMITTER) EDISWAN VALVE

Type "A.R.D.E." 27/6

(Requires only 2 volts across the filament.)



Type A.R.D.E.

We manufacture Complete Receiving Sets and Accessories, also H.T. and L.T. Batteries. Ask or write for leaflets. If your Dealer does not stock, send a p.c. with his name and address. FREE ON REQUEST. Write now for our Illustrated Booklet, "The Thermionic Valve" — a postcard will do.

The EDISON SWAN ELECTRIC CO., LTD.,

Contractors to H.M. Admiralty, War Office, Royal Air Force,

123/125, Queen Victoria Street, E.C.4,
and 71, Victoria Street, S.W.1.

Works:
Ponder's End, Middlesex.



Branches in all
Principal Towns.

It's the valve that counts!

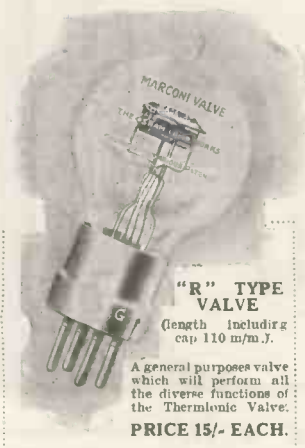

"R" TYPE VALVE

(Length including cap 110 m/m.)

A general purpose valve which will perform all the diverse functions of the Thermionic Valve.
PRICE 15/- EACH.



"D.E.R." TYPE VALVE

(Length including cap 115 m/m.)

The special feature of this Valve is that the filament current and voltage—i.e., the working filament voltage—is very small, being in some cases less than ONE QUARTER of that required by ordinary valves having similar operating characteristics. The filament runs at a dull red temperature, thus ensuring a very long life, as well as freedom from crackling, etc.

PRICE 27/6 EACH.

If you use a Valve receiving set you will do well to realise that the efficiency of your outfit is largely dependent upon your choice of Valves. It's the Valve that counts. You will positively ensure the best reception of vocal and musical items by using



which are made—and made to last—with the same scrupulous care that has always characterised the manufacturing operations of the famous OSRAM Factory.

You use OSRAM Lamps at home—use the Valves with the "OSRAM MADE" reputation.

MARCONI VALVES

MADE AT THE OSRAM LAMP WORKS

Sold by all leading Wireless Dealers, Electrical Contractors, Stores, etc.

(Wholesale only)

THE GENERAL ELECTRIC Co. Ltd., Magnet House, Kingsway, London, W.C.2.

Britain's Best Broadcasting Set



GECOPHONE

The Gecophone "Listening in" set has well earned its title of "Britain's Best Broadcasting Set." Its remarkable efficiency has amazed both the amateur and wireless expert alike. A Gecophone gives the best possible results always—frequently where other sets fail. No matter where you live you can ensure full enjoyment of the daily broadcasted programmes by installing a Gecophone.

Gecophone "Listening in" sets are manufactured by the G.E.C. and are the outcome of long experience in the manufacture of both wireless and telephone equipment.

GECOPHONE TWO-VALVE SET (as illustrated). A mahogany set complete with valves, all batteries and one set double head-phones. Approx. range 100 miles. Price complete, £25 0 0

GECOPHONE CRYSTAL SET NO. 2. Complete with one set double head-phones and aerial equipment. Approx. range 30 miles. Price complete - £9 15 0

GECOPHONE CRYSTAL SET NO. 1. Complete with one set double head-phones and aerial equipment. Approx. range 25 miles. Price complete - £5 10 0

Sold by principal Electricians, Stores, Musical and Wireless Dealers.

Sole Selling Agents for the Music Trades in Great Britain and Ireland: Columbia Graphophone Co., Ltd., 102-108, Clerkenwell Road, London, E.C.1.

Manufacturers and Wholesale only:—
The GENERAL ELECTRIC CO., LTD., Magnet House, London, W.C.2.

Reduced

Prices



FELLOCRYST SUPER.



FELLOPHONE SUPER 2.

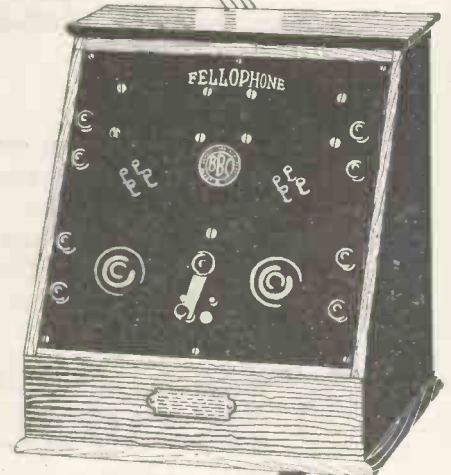

SUPER 2 AMPLIFIER.

Oct. 1st.

On and after this date, new and reduced prices will be operative for Fellows Wireless Sets and accessories. These reductions are accompanied by increased value, for example:—The New FELLOWS HEADPHONES, which are very sensitive, extremely comfortable, have duralumin head bands, stalloy diaphragms, etc., and are 4,000 ohms each earpiece, weight under 6 ozs.

The New Price is 18/6

Other prices are:		£ s. d.
LADIES' HEADPHONES	0 12 6
FELLOCRYST SUPER SET	3 7 6
FELLOPHONE "SUPER 2" VALVE SET	9 0 0
"SUPER 2" AMPLIFIER	5 10 0
FELLOPHONE "SUPER 3" VALVE SET	12 0 0
"SUPER 3" AMPLIFIER	6 0 0
FELLOPHONE "SUPER 5" VALVE SET	35 0 0
JACOBAN 5 VALVE SET	75 0 0

All sets are complete with aerial, headphones, and batteries.

Valves, Marconi and B.B.C. taxes extra.

FELLOWS

MAGNETO CO., Ltd., London, N.W. 10.



(P) 23

"The Race for Supremacy"

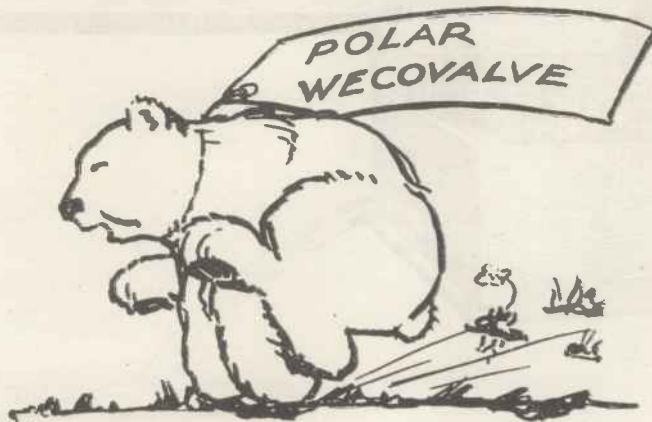

He eats less and stays twice the distance!

HE's a sure winner—we can tip him as an absolute cert. It stand to reason that all those other valves, consuming six times the current and lasting out only half as long, are going to be "also rans" now that the POLAR WECOVALVE has taken the field. Glance at his form and general capabilities :

The life of the Polar Wecovalve is **GUARANTEED** at 1,000 hours minimum—twice the average life of the ordinary tungson or dull emitter valve.

Its current consumption is only 0.25 of an amp. at 0.8 to 1.1 volts—or one-sixth of the current required by ordinary valves.

The special bayonet cap on the Polar Wecovalve prevents accidental breakage when you are carelessly inserting the valve in its socket.

The Polar Wecovalve is of low self capacity, and remarkably efficient as a Detector, Low Frequency Amplifier, or High Frequency Amplifier, and is adaptable for fitment into ordinary valve socket. (See Adaptor illustrated.)

NO ACCUMULATORS ARE NEEDED.

YOU can obtain the POLAR WECOVALVE through your local POLAR STOCKIST—look for his name in the list on the page facing. If you have no local stockist, write direct to :



POLAR WECOVALVE

Dimensions :
2½" x ⅜"

Filament Current :
0.25 at 1.1 volts.

Plate Voltage :
21 to 45 volts.

PRICE
30/-

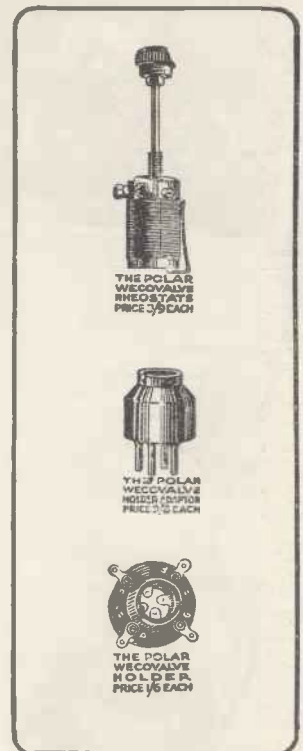

RADIO COMMUNICATION Co., Ltd.,

Telephone:
CENTRAL 8480
(3 lines).

34/35, NORFOLK STRAND,
STRAND, W.C.2.

Telegrams:
RADIOCOMM, ESTRAND,
LONDON.

NEWCASTLE :
17, Sandhill, and
23, Collingwood St

CARDIFF :
Atlas Chhrs., James St.

WARRINGTON :
106, Bridge St.

BRANCHES—
GLASGOW :
125, Hope St.

ABERDEEN :
9, Hadden St.

LIVERPOOL :
67, Dale Street.

SOUTHAMPTON :
19, Queen's Terrace.

FLEET AD.



Where you see the
'POLAR'
SIGN
you can buy
POLAR
ACCESSORIES

WHOLESALE STOCKIST DISTRIBUTORS.

BELFAST.—Messrs. The Electrical Installation & Repairing Co., 40, Berry St. **BRETFORD.**—London Radio College, Ltd., Suffolk House, 82 1/2, High St. **LONDON.**—Messrs. Auto Soundings, Ltd., 101, Lower Grosvenor Place, S.W.1. Messrs. Brown Bros. Ltd., 40/44, Great Eastern St., E.C.2. Messrs. C. F. Elwell, Ltd., 128, Gordon Rd., Peckham, S.E.15. Messrs. L. McMichael, Ltd., Hastings House, Norfolk St., Strand, W.C.2. **MANCHESTER.**—W. E. Beavall & Co., Ltd., 14, Causton St. E. M. Evans & Son, Ltd., 1 & 5, Lever St. R. O'Brien & Co., 66, Mosley St. **STOCKPORT.**—Messrs. Henry Hollingdale & Son, Ltd., 65, Prince St.

POLAR STOCKISTS.

ACCINGTON.—G. V. Stephenson & Sons, 31, Blackburn Rd. **AIRDRIE.**—T. Neil Rose, Esq., 14, Graham St. **ALBINGTON (Northumberland).**—L. W. Shearer, Esq., 51, Station Rd. **ARBROATH, N.B.**—Messrs. Ponsford & MacHardy, Ltd., 165, High St. M. D. Munro, Esq., 21, Dalnair St. **AYR.**—M. Meldrum, Esq., 27, Burns Street. **BATH.**—Messrs. Lawson, Esq., Imperial Buildings, Peel Square. **BARRY DOCK.**—Messrs. Lewis & Mayer, Seaboard Rd. **BARRROW-IN-FURNES.**—Messrs. Corrie & Banks, 25, 27 & 29, Cavendish St. J. Dall, Esq., 76/78, Dalton Rd. **BATH.**—J. A. Smith, Esq., 18, Northumberland Place. Messrs. J. Lambert & Sons, 16, Broad St. **BECLES.**—Messrs. C. F. N. Engineering Co., 5, Smalgrave. **BELOTT.**—A. S. Simpson, Esq., The Elms, Elms Wood, 177, Old Lodge Rd. J. Patton, Esq., East End Supplies Stores, 63, Belvoir St. Messrs. John Robertson (B), Ltd., 46, May St. The Phoenix Radio Co., 5, Dosegate Square East. **BERWICK-ON-TWEED.**—Messrs. Knox Bros., 25, Bridge St. **BEVERLY.**—Ernest E. Foster, Esq., Wireless Supplies, Swinemore Lane. **BIRKENHEAD.**—Messrs. Hughes & Wats, Ltd., Woodchurch Rd. **BLACKBURN.**—Messrs. E. Peacock & Co., 42, Grande Rd. West. Messrs. Racoc Motor Co., Ltd., 18, Chester St. **BIRMINGHAM.**—Messrs. A. E. Parsons, 42, Park Road, Aston. Midland Counties Elec. Co., Ltd., 136, Sandon Rd. **BISHOP AUCKLAND.**—D. Latham, Esq., The Electric Shop, Market Place. **BLACKBELL (Co. Durham).**—Messrs. Oliver & Courtney, St. Aidan's Place. **BLYTH.**—G. W. Smith, Esq., 9, Croft Rd. **BOLTON.**—Messrs. A. Fittis, Ltd., 90, Bradshawgate. **BOLTON.**—Messrs. T. J. Whittaker, Esq., The Wireless Depot, Tenancy Bldg., Parkstone. Messrs. British Radio Supplies Corp., 25, Poole Rd. Westbourne. Messrs. Laurence Fish & Co., 10, Palmerston Rd., Boscombe. Messrs. Goddard, Lawrence & Co., Ltd., 28, Palmerston Rd., Boscombe. **BURNHAM (Somerset).**—Messrs. Hatchin & Son, 43, High St. **BURY.**—The Manchester District Wireless Co., 21, Agar St. **BURY (Herts).**—Messrs. C. Pratt & Sons, Ltd., North Parade. Messrs. The Gramophone Stores, 150, Bowling Old Lane. Super Radio Co., 4, Thornton Rd. **BRANDON (Suffolk).**—Thos. A. Green, Esq., High St. **BIDWATER.**—F. A. Pine, Esq., Electrical Engineer. **BRIGHTON.**—Ronald S. Mann, Esq., "Radio Supplies," 87, York Place. E. B. Paine, Esq., "Sports Shop," 86, Preston Drive. **BRIGHTON.**—Messrs. Electric Accessories Co., 44, Park St. Messrs. White's Emporium, 38/40, North St. Messrs. G. F. Wats & Son, 131, Gloucester Rd. Bishopton. Messrs. The Colton Electrical Co., 9, Denmark St. The Ashley Elec. & Mech. Eng. Works, 4, Ashley Down Rd., Horfield. H. Salansen, Ltd., 20, High St. **BROMLEY (Kent).**—Dainton-Stephens Co., 73, Mason's Hill. **BROUGHTY FERRY, N.B.**—Messrs. Ponsford & McHardy Ltd., 58, Gray St. **BRYNAMORE.**—Messrs. South Wales Radio & Scientific Company. **CAMBRIDGE.**—Messrs. Betty Grandy & Barrett, Ltd., 8, St. Mary's Passage. The Nega Electrical Co., 22, Regent St. **CAMPELTOWN (Argyll).**—A. P. MacGrovy, Esq., 16 & 18, Main St. **CARDIFF.**—Messrs. South Wales Wireless Installation Limited, 18, West Bute St. Messrs. R. Woodruff & Son, 79, City Rd. Messrs. H. Salansen, Ltd., 4, High St. R. W. Braisington, Esq., 33, Morgan Arcade. The Cardiff Elec. Wireless Supply Co., 43, Bute St. S. Goodyear, Esq., Manager, Radio Club, 29, Cathedral Rd. Messrs. Robins Wireless Co., Ltd., Park Place. J. Howell & Co., Ltd. **CATWICH.**—Messrs. Geo. Rowatt & Co., Station Buildings. **CARLISLE (Cumberland).**—James Hodgson, Esq., 42, Lowther St. **CHELTENHAM.**—Messrs. Pound Bros., 4, St. Anne's Prom. Albion St. **CHERTSON.**—Messrs. Coles & Shirley, St. Mary's Garage. **CHESTERFIELD.**—Messrs. Wireless Electrical Co., 35, West Bar & Park Rd. Messrs. Cavendish Motors, Ltd., Cavendish St. **CHIFFENHAM (Wills).**—A. R. Fox, Esq., High St. **CHRISTCHURCH.**—The Excelsior Motor Works, 24, High St. **CHRISTCHURCH.**—Messrs. A. H. Buncombe & Co., 169a, Cricklade St. **CIRECHEATON.**—Messrs. Butler & Horn, 15, Northgate. **COLWYN BAY.**—Messrs. Ellis, Hands & Dean, Ltd., Aberglow Rd. **CONYER (Co. Durham).**—Messrs. Wireless Electrical Co., The Crescent. **COVENTRY.**—A. Salmon, Esq., F.S.M.C., F.I.O., Drinkwater Arcade. Messrs. The Reid Radio Co., 1, Chester St. **CROYDON (Surrey).**—Messrs. W. J. Bishop & Co., 1, King's Parade, High St. Harold's Stores, 71, South End. A. Stevenson, 191, Lower Addiccombe Rd. Store, 95a, George St. **COLLEDOONERS.**—Norman Laws, Esq., Front St. **DARLINGTON.**—Messrs. The Chase Motors Co., Ltd., 36, Northgate. Messrs. E. Sutcliffe & Sons, Northgate. **DARWEN.**—W. V. Fairhurst, Esq., Wellington Fold, Market St.

DEVIZES.—Messrs. Cole & Son, 153, Market Place. **DONCASTER.**—Messrs. Smith & Son, Ltd., Central Garage, Halifax-Gate. M. E. Goddard, Esq., 25, Silver St. **DUMFRIES.**—The Magneto Accum. & Electro-Plating Co., 72, Broome Rd. **DUNDEE.**—Messrs. Ponsford & McHardy, Ltd., 13, Reform St. Messrs. Struock & Allen, Radio Specialists, 19, Nehergate. **DUMFRIES.**—Messrs. James Scott & Co., Inglis St. **DURHAM.**—Messrs. Devereux Wood & Co., 25, Elvet Bridge. **ELEBOROUGH.**—David Gardner & Wainwright, Ltd., 25, High St. Messrs. Robertson & Hogg, 29, Nicholson St. Messrs. Spensers (Scotland), Ltd., 119, George St. **BORAM (Surrey).**—The Radio Supply Stores, 147, High St. **EOREMONT (Cumberland).**—Messrs. Egremont Radio Stores, 31, Market Place. **FARNHAM (Hants).**—Messrs. See & Burgess, 147A, West St. **FERRYHILL (Wales).**—J. F. H. Banner, Esq., "The Chemical." **FOLETTON.**—Messrs. T. C. Gilbert & Co., Ltd., 26, Guildhall St. **FRASERBURGH.**—William J. Reid, Esq., "Home of the Wireless," High St. **FROME (Somerset).**—G. F. Thick, Esq., The Bridge. **GLASGOW.**—Robert Ballantyne, Esq., 103 1/2 St. Vincent St. A. S. Birrell, Esq., 11, Nieldale Rd., Strathbungo. Messrs. Craig & Osborne, 84, Woodlands Rd., Charing Cross. Messrs. Hunters Wireless Dept., 75, West Nile St. Messrs. Arch. Loth & Sons, Ltd., 28A, Ransfield St. Messrs. R. McHugh & Son, 423, Govan Rd. Messrs. Milligan Wireless Co., Ltd., 23/25, Renfrew St. Messrs. Pressie Radio Supplies, 11, Beth St. Messrs. Rice & Sons, 22, Waterloo St. The Rex Import Co., Ltd., Rax House, 202, Bath St. **GLASGOW (Somerset).**—Messrs. Bartlett & Company, Magdalene St. **GOOLE.—The Little Wireless Shop, Boothferry Rd.** **GLONCESTER.**—Messrs. James Archer, Loth & Sons, Ltd., 28, Ransfield St. **GULDFORD (Surrey).**—Messrs. Tilly & Brown, 25, 187 1/2, High St. **GRANTHAM.**—Messrs. White & Senance, St. Peter's Hill. **GREENOCK.**—Messrs. J. A. Kinnaird & Co., Ltd., 40, Cathcart St. Rae, 38, Hamilton St. **HALIFAX.**—Messrs. The Equitable Electrical Co., 36, St. Paul's Rd. Messrs. Electrical Supply Stores, 11, Fountain St. **HARROGATE.**—Messrs. Topham Bros., Ltd., 26, Oxford St. **HARLOW.**—Messrs. E. W. Brice & Sons, 49, High St. **HARTLEPOOL.**—Messrs. Edgar Phillips, Ltd., 41, Northgate. **HELLENBURGH.**—Messrs. Youdall & Spott, West Princes St. **HELWORTH (Holland).**—Goolische Footballd, Kerkerstraat 106. **HESTER.**—C. A. Brooks, Esq., 22, South View, Heavere. **HODDERFIELD.**—Messrs. J. H. Taylor & Co., Macaulay St. **HILL.**—Messrs. B. Cooke & Son, Kingston Observatory, Paragon Square. **HITCHIN.**—The Electrical Co., 2, Porter St. Messrs. Clark & Graham, 73, Prospect St. E. M. Parsons, Esq., 38A, Brook St. Messrs. Morrell, Jameson St. J. C. Scarborough, Esq., 21, George St. **IPSWICH (Essex).**—Messrs. Cranbrook Spars Co., 91, Cranbrook Rd. **IPSWICH.**—Messrs. Cook's Wireless Co., 37, St. Matthew's St. **KETERINGO.**—Paul Taylor, Esq., 147, Stamford Rd., Montagu St. **KILMARNOCK.**—Messrs. Aird, Walker & Ralston, Hill Lane. **KLONINGTON.**—Adas Wireless Co., Ltd., 78, Richmond Rd. Messrs. The Thames Electric Co., Ltd., 16, Market Place. Messrs. Sittings, Ltd., 17, Clarence St. **LARNE (Ulster).**—William Law, Esq., Electrical Engineer, Bay Road. **LEDS.—A. I. Greenwood, Esq., Motor Engineer, 39/41, Guildford St.** **LEICESTER.**—H. T. Griffiths, Esq., 61, London Rd. Messrs. Fittings Maintenance Co., 103, Harborough Rd. **LEITH.**—Messrs. Randolph & Co., 46, Henderson St. **LIVERPOOL.**—Messrs. B.N.B. Wireless Ltd., Renshaw St. Messrs. John Banks & Sons, 14-18, Dale St. The British Radio Manufacturing Co., South Castle St. Messrs. Lewis, Ltd., Ransleigh St. Messrs. Fulford Bros., Ltd., 106-110, Whitechapel. Messrs. C. A. Sutton & Co., 110, Dale St. Messrs. Taylor, 46, Tiseburn St. Messrs. Western Wireless Telephones, Ltd., 15, Chesapeake. **LLANELLY (S. Wales).**—H. S. Lloyd, Esq., Garage House, Prospect Place. **LONDON.**—Nelson Arnold, Esq., 5, Ranelagh Gardens, Barnes, S.W.13. J. H. Bennett, Station Rd., Willesden Junction, N.W.10. Messrs. Bonds of Euston Road, Ltd., 245-247, Euston Rd., N.W.1. Messrs. R. Ball & Co., 287, Upper St., Ilford, N.E.1. Messrs. Bannock & Co., Ltd., Chesapeake, E.C. Messrs. Brompton Engineering Co., 169, Fulham Rd., South Kensington, S.W.10. Messrs. W. Bird & Sons, 33, Fulham Palace Rd., Hammersmith, W.6. Messrs. City Fittings Co., 66, Harbison, 'E.C.1. E. W. Chamberlain, Esq., 196, King St. Messrs. Hammich, W.6. Messrs. Cunningham, Ltd., 169-171, Edgware Rd., W.2. Messrs. Granley Garages, Ltd., 161, Gloucester Rd., S.W.7. Messrs. The Diamond Wireless Equipment Co., 82A, Oxford St. W. Messrs. C. O. Danham & Sons, 232-8, Brixton Hill, S.W.2. Messrs. Freeman's Filling Station & Motor Stores, 92-94, Camberwell Rd., S.E.7. Messrs. A. W. Garage, Ltd., Holborn, E.C.1. Messrs. Griffin Wireless Supplies Co., 80, Newtoning Causeway, S.E.1. Messrs. Grafton Elec. Co., Ltd., 54, Grafton St., Tottenham Court Rd., W.1. Messrs. W. J. Henderson & Co., 351, Fulham Rd., South Kensington, S.W.10. Highbury Eng. Works, 61, Holloway Rd., N.7. Messrs. Jones & Noyes, 164A, Railway Approach, Shepherd's Bush, W. Messrs. Keen Wireless Co., 11, Dan Rd., West Ealing, H. Lafferty, Esq., 208, King's Rd., Chelsea, S.W.8. Messrs. Richard Methuish, Ltd., 84, Fetter Lane, E.C. Messrs. The Metron Electrical Co., 141 & 143, High St., Collier's Wood, S.W.1. Messrs. Mann, Egerton & Co., Ltd., 175/177, Cleveland St., W.1. Messrs. H. Orman & Co., Ltd., 165/6, Aldergate St., E.C. Messrs. Pugh Bros., 101, Holloway Rd., N. Messrs. Penrose Cycle Co., 16, Borough High St., S.E.1. Messrs. T. Poore & Son, 232, High St., Acton, W.3. The Ruby Wireless & Electrical Stores, 86, Hoe Street, Walthamstow, E.17. Messrs. Radio Appliance, Ltd., 185, High Rd., Streatham, S.W.16. Secrecan & Mallett, Ltd., Barnes, S.W. Messrs. Shove, Porter & Co., 36, Mortimer St., W.1. Messrs. H. J. Shearn, Ltd., 30, High St., Putney, S.W.15. H. B. Timpon, Esq., 29 & 30, High St., Ealing, W.5. H. Walker, 714, Holloway Rd., N.19. W. E. Wilson, 158, Finchley Rd., N.W.3. General Wireless Ltd., 21, Garrick St., W.C.2. Messrs. R. Woodruff & Co., 550, Streatham High Rd., S.W.16. Woolwich Radio Supplies, 22, New Road, Woolwich, S.E.18. Messrs. V. Zeitlin & Sons, 144, Theobalds Rd., W.C.1. **LOUGHBOROUGH.**—Messrs. W. W. Leslie & Co., 43, Nottingham Rd. **LUTVHAM.**—Messrs. Frank Kay & Co., 40, Clifton Street. **MANCHESTER.**—Messrs. A. Franks, Ltd., 95/97, Deansgate. Messrs. A. Franks, Ltd., 444, Market St. Messrs. A. Franks, Ltd., 73, Oxford St. Messrs. A. Franks, Ltd., 12, Victoria St. J. Nodding, Esq., Central Station, Levenshulme. Messrs. Trojan Electrical Co., 141, Upper Moss Lane, Alexandra Rd. The Universal Electrical Supply Co., Ltd., 4, Brown St. **MARKET HARBOUR.**—Messrs. Harboro Motor Co., 79/80, Station Rd. **MARKENSBROOK.**—Messrs. Baker Bros., Electrical Engineers, Corporation Rd. Messrs. Harrison Bros. (Elec. Engrs.), Ltd., Orange Chambers, 6, Grange Road West. Messrs. P. F. Perry & Co., 26A, Newport Rd. **MINERAD (Somerset).**—The Margaret Edgar Studios, Ltd., Park St. **MONTROSE, N.B.**—James A. Marnie, Esq., Montrose Wireless Depot, 107, High St. **MORPETH.**—John H. Woodhead, Esq., 22, Newgate St. **NEW BRIDGE (Cheshire).**—Messrs. Jenson & McNicol, Wireless Corner, 149a, Seabank Rd. **NEWARK.**—Messrs. Harrison & Co., Beaumont Cross. **NEWCASTLE-ON-TYNE.**—Messrs. The Chase Motors Co., Ltd., 21, New Bridge St. Messrs. Chase Motors Co., Ltd., 43, Great Market. Messrs. G. S. Douthwaite & Co., 25, Dean Street. Messrs. Electrical Devices, Ltd., 18, Collingwood St. Messrs. James Corson & Co., Ltd., Market St. Messrs. J. C. Jones & Co., 239, Westgate Rd. Messrs. The Macco Parents Mig. Co., 36, Grey St. Messrs. John Mills & Sons, Northumberland Rd. Messrs. Payne & Hornby, 6, St. Andrew's Buildings, Gallowgate. Messrs. Thomson & Brown Bros., Ltd., Carlisle St. Messrs. Walker's Wireless Supply Co., 31, Westgate Rd. Messrs. Wilson & Ridley, 161, Northumberland Rd. **NEWPORT (Mon.).**—The Newport Electrical Co., Ltd., 3, Dock St. Messrs. Newport, Ltd., 31, Bridge St. Messrs. South Wales Wireless Installation Co., Ltd., 37, Cardiff Rd. **NEWTOWN PARKESTONE (Dorsetshire).**—E. T. Chapman, Esq., A.M.I.E.E. **NORTHALLERTON.**—Herbert E. Lightfoot, Esq., Market Place. **NORTHAMPTON.**—Fred G. Cave, Esq., 22, Horsemarket. **NEWINGTON-BY-SEA (Northumberland).**—Messrs. E. Watson & Sons, 23, Gibson St. **NETHERMOUTH.**—Netherm. Electrical Equipment Co. Messrs. Kennedy & Son, 78, Bedford St. **OLDHAM.**—The Oldham Wireless Stores, 141, King St. **OXFORD.**—The Oxford Wireless Telephone Co., Ltd., 22, Queen St. Messrs. F. E. Woodton, Ltd., 56, High St. **PEBBLES.**—T. W. Bracewell, Esq., Ironmonger, 60, High St. **PERNARTH (Glam.).**—C. W. Davies, Esq., B. Eng., 98, Glebe St. **PETER.—W. B. McCallum, Esq., 8, Scott St.** **PLYMOUTH (Devon).**—W. N. Brice, Esq., Bedford Row, Tavistock Rd. **POOLE (Dorset).**—C. H. Gould, Esq., Poole Amature Radio Supply, Tram Terminus. **PRESTON.—A. Lotus, Esq., 2, Mill Bank, Church St. Messrs. Richard Marsden & Son, Ltd., 115, Church St. Geo. Wilkinson, Esq., 152, Church St.** **READING.**—Messrs. Reading Radio Installation, 17, King's Rd. The Reading Radio Supplies, 32, Castle St. W. R. Thomson & Son (The Universal Electrical Co.), 100, Reading Rd. **REDBRITH.**—Alfred G. Tonkin, Esq., Bannock Terrace, Illogan Highway. **RICHMOND (Surrey).**—Richard Hammond, Esq., The Arcade. **RICHMOND (Lancs.).**—Messrs. R. W. Aerial & Co., Radio House, 98, Yorkshire St. **SALISBURY.**—Messrs. Clayton Bros., 4, Winchester St. Messrs. Wessex Motors, Ltd., 3, Winchester St. Messrs. Western Wireless & Elec. Co., 98A, Fishers St. **SCARBOROUGH.**—F. Greenhead, Esq., 9, Hunters Row. **SHAFTESBURY (Dorset).**—W. Holder, Esq., 65, High St. **SHEFFIELD.**—Messrs. Thos. A. Ashton, Ltd., Norfolk St. Messrs. Dewhurst's Engineering Co., Ltd., Attercliffe Rd., Messrs. Wallace Heaton, Ltd., 17/27, Change Alley, Kitching, Ltd., 4, Charles St. Messrs. Sheffield Wireless Dept., Ltd., 178, Norfolk St. Messrs. Sparks & Co., 45/47, Fitzwilliam St. **SEDERBERG (York).**—J. W. Shepherd, Esq., Bainbridge Rd. **SOUTHAMPTON.**—Messrs. A. Smethurst & Sons, Ltd., 16, Bernard St. Messrs. A. Smethurst & Sons, Ltd., 49, Shirley Rd. **SOUTHEND.**—Barnes Bros., Radios House. E. D. Macgregor, 160, Central Avenue. Messrs. The Radio Equipment Co., Queen's Arcade, Queen's Rd. **SOUTHSEA.**—Messrs. Wadhams Bros., 89, Palmerston Rd. **SOUTH SHIELDS.**—Messrs. Law & Barnes, Dean St. Messrs. Payne & Hornby, Grand Electric Buildings, Ocean Rd. **SPENYMOOR (Co. Durham).**—R. S. Bakewell, Esq., 38, King St. **STIRLING.**—Messrs. W. & T. Marshall, 12, Upper Cairg. Messies Bros., Dumbarton Rd. **ST. MARGARETS-ON-THEMERE.**—W. F. Santon, Esq., 4, The Broadway. **ST. MARY CHAY (Kent).**—The Radio & Electrical Supply Co., Reynolds Cross. **ST. ALBANS.—B. & A. Wireless Co., Verulam Rd. W. J. Elliott, Ltd., Chequer.** **STOCKTON-ON-TREE.**—Messrs. T. B. Watson & Son, Ltd., Central Buildings. **STOKE-ON-TRENT.—T. A. D. Lawton, Esq., Brown Edge.** **STORBRIDGE (Worcestershire).**—Messrs. Saunders & Bowkley, Ltd., 41, High St. **STRANRAER.**—T. W. Maccready, Esq., 39, George St. **SUNDERLAND.**—Messrs. H. Binns, Son & Co., Ltd., 38, Fawcett St. Messrs. Bransfom Bros., Holmside, Thomas Hudson, Esq., 314, High St. West. Messrs. Payne & Hornby, Roker Theatre Buildings, Roker Avenue. Young & Lower, 2, Victoria Chambers, Laura St. **SURBITON.**—Messrs. Lankester Eng. Co., 82, Victoria Rd. **SWANSEA.—Dan Morgan, Esq., The Wireless Centre, 28, Oxford St. J. H. Symons, Esq., The Wireless Depot, 228, Oxford St.** **SWINDON (Wills).**—L. Howell, Esq., 10, Victoria Rd. W. J. Moran, Esq., 153, Victoria Rd. **TAMWORTH.—P. Harold Lawrence, Esq., Aldergate.** **TAUNTON (Somerset).**—F. J. Setle, Esq., 10, East Rectory. **TOWNBRIDGE (Wills).**—E. Powell, Ltd., 41, High St. **ULVERSTON (Lancs.).**—J. J. Downward, Esq., M.P.S., 5, Market St. **WALTON-ON-THAMES (Surrey).**—N. V. Webber, Esq., Walton House. **WARRINGTON.**—Messrs. C. H. & J. Dawson, Ltd., 59 & 65, Sankey St. Messrs. Economic Electric Co., 64, Sankey St. Messrs. Hill & Co. (Chemists) Ltd., 62, Butchermarket St. **WATFORD.—J. I. Ve, 7, Cleverdon Corner.** **WELLINGTON (Surrey).**—Messrs. H. J. Jones & Co., Market St. **WEMLEY (Middlesex).**—Messrs. Turner, Radford & Co., 64, High Rd. **WEXHOUT.**—Messrs. Brooking & Co., 73; St. Thomas St. Messrs. W. Smith & Son, Esplanade. **WESTON-SUPER-MARE.**—Messrs. W. J. Badman & Co., 9, Orchard St. S. Betts, Esq., 4, Hopkins Ln. **WEST HARTLEPOOL.**—Messrs. P. F. Perry & Co., 11, Church St. Messrs. Edge Parfums, Ltd., 67, Church St. **WHITBY (Surrey).**—Oates, Esq., 77, Rowlands Rd. **WHITLEY BAY (Northumberland).**—A. O. Hunter, Esq., 15, Queen's Drive. **WICKFORD (Essex).**—Messrs. The Radio Equipment Co., Sileman's Works. **YOBB.—H. P. Jackson, Esq., 70, Hicklegate. Messrs. Smiths, 172, Walmgate.**

If there is a "Polar" stockist near you, make a friend of him. With our assistance he can give you any advice or technical information you require—gratis.

RADIO COMMUNICATION CO. LTD.

Telephones: Central 8490 (3 lines) **34-35 Norfolk Street, Strand, London, W.C.2.** Telegrams: Radiocomco, Strand, London.

You CANNOT be out of WIRELESS WEEKLY because it brings BIG Business. A39



Brown A-type

—they speak when others are dumb.

FOR Brown A-type Headphones to be selected by practically every merchant service in the world is a unique compliment to their outstanding qualities. But then Brown A-type phones are *unique* Headphones.

Their principle of construction embodies laminated pole pieces—an adjustable vibratory reed—and an aluminium diaphragm.

Here, then, is the secret of their wonderful sensitiveness. Whereas every other phone uses a comparatively thick iron diaphragm, the aluminium diaphragm used in the A-type is as thin as paper, yet, due to its cone shape, it is even more robust than the iron type.

Obviously, the thinner the diaphragm the more sensitive it will be to the slightest fluctuations of current in the magnet coils. This is why Brown phones speak when others are dumb.

When choosing your Headphones, let your natural pride in wanting the world's best persuade you to select Brown A-type. You are then assured of phones which will greatly improve the efficiency of your Set—which will be a continual pleasure to wear—and which, above all, will give you years and years of faithful service.

PRICE LIST OF HEADPHONES

A-type: 120 ohms	..	56/-	per pair.
2000 & 4000 ohms	..	62/-	" "
8000 ohms	..	66/-	" "
D-type: 120 ohms	..	48/-	" "
2000 & 4000 ohms	..	52/-	" "
F-type: 120 ohms	..	22/6	" "
4000 ohms	..	25/-	" "

Manufactured only by
S. G. Brown Ltd.
 at VICTORIA ROAD,
 N. ACTON, W.3.

Retail:
 19, Mortimer Street,
 London, W.1.

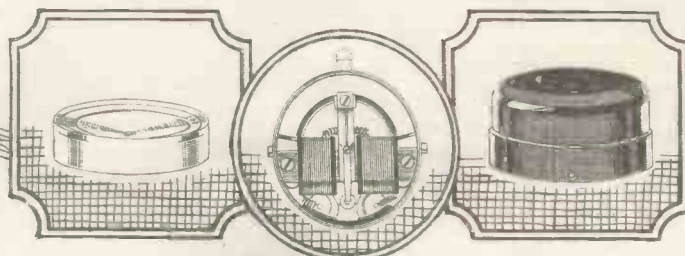

Gilbert Ad.

MICA

CONDENSER
PLATES

&

INSULATING MATERIALS
OF EVERY DESCRIPTION.

MICA & MICANITE SUPPLIES, Ltd.,
MICA HOUSE, OFFORD STREET, 'Phone North 805.
CALEDONIAN RD., LONDON, N.1

GRIFFIN'S

80, NEWINGTON CAUSEWAY.
(Corner of Lancaster St.),
Elephant & Castle, London, S.E.1.

Est. 1896.

AGENTS for all the Leading Manufacturers.
"Polar" STOCKISTS. Genuine Radio Experts.

SPECIALS.

No. 2 "GRIFPHONES," 4,000 ohms. Adj. Pole Pieces 15/11
The best value on the market. Sent on "appro."

V 24 Valves, Guaranteed New. Bargain 15/-
Basket Coil Holders 2-way, 4/6. 3-way, 5/6
"GRIFFIN" Hedgehog L.F. Transformers, Ratio 4-7 to 1 20/-

We claim these have no equal. Distortionless.

CALL AT OUR SHOWROOMS AND INSPECT THE LARGEST
RANGE OF COMPONENTS IN SOUTH LONDON.

Advice Free. New List Free on Application, also Trade List.

"ATLAS" THE COIL SUPREME.

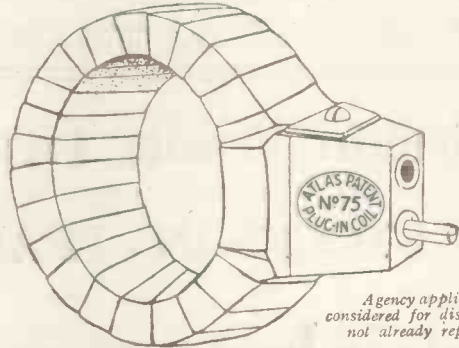

Agency applications considered for districts where not already represented.

The last word in efficiency.

Maximum Inductance. Minimum Self-capacity.
All Wave-Lengths covered.

Prices on application. Radio Components Catalogue on request.

Manufactured only by

H. CLARKE & CO. (M/cr.), LTD.,
Radio Engineers,
ATLAS WORKS,
OLD TRAFFORD, MANCHESTER.

Telephone Nos. :
683 & 793 Trafford Park.

Telegrams :
PIRTOID, Manchester.

Don't buy accumulators
for your valves

Unskilled chargers will only ruin them. For 12/- a quarter
ONLY 1/- A WEEK INCLUSIVE
we will supply you continuously with reliable charged L.T.
Batteries, replaced at time of collection by motor anywhere
in London.
Phone: East 5655. British Battery Supply Service.
Write NOW for pamphlet C Free. Carr St., London. E.14

ELBE COIL HOLDERS

USE SINGLE COIL HOLDERS FOR MAXIMUM
EFFICIENCY. HIGHLY RECOMMENDED.

Ebonite Basket Coil Mounts to plug in above
2/- each.

Ask your Dealer for them.

LEIGH BROS., Tel: Mrs. 4547.
87 Sidmouth Street & 1a Prospect Terrace,
Gray's Inn Road, LONDON, W.C.1.



Price 1/9 each. Post
5/- Set of three. Free.

FINEST WORK & PROMPTITUDE.

INCOMPARABLE
WHITE
FILLING.

HAND & MACHINE
ENGRAVING
ON ANY MATERIAL

'Phone
Central 1137.

CLIFFT & COCKLE,
51, Arcade Chambers,
St. Mary's Gate,
MANCHESTER.

Radio Press Information Dept.

QUERY COUPON

WIRELESS WEEKLY. Vol. 2. No. 12. October 3, 1923.

(This coupon must be accompanied by a postal order of 1/- for each
question, and a stamped addressed envelope.)

WHY BUY JUNK

when you can obtain precision instruments
AT THE SAME PRICE?

Our STANDARD VARIABLE CONDENSERS
are better than the majority at twice the price.

POINTS OF NOTE.

CIRCULAR EBONITE END PLATES.
UNIFORM CLEARANCE BETWEEN FIXED AND MOVING VANES
SPECIAL SPRING WASHERS, ENSURING PERFECTLY SWEET
MOVEMENT AND RELIABLE CONTACT.
DIAL EASILY FIXED AND REVOLVING WITHOUT "WOBBLE."
NO SLACK BEARINGS.

MAKE TUNING A PLEASURE.

ASSEMBLED COMPLETE WITH DIAL AND KNOB.

'001 M.F. ..	11/-	'0003 M.F. ..	7/-
'0005 M.F. ..	8/-	'0001 M.F. ..	5/6

2 COIL STANDS—GEARED	10/6	each
—PLAIN	8/6	..

DUSTPROOF CRYSTAL DETECTORS	3/-	..
EBONITE DIALS	1/-	..
VALVE HOLDERS	9d.	..
SWITCH ARMS	1/3	..
FILAMENT RESISTANCES	2/-	..
4,000 Ω PHONES, STAMPED B.B.C. ..	16/-	per pair
CANADIAN BRANDES PHONES	25/-	..

PLEASE SEND SUFFICIENT TO COVER POSTAGE.

All our Accessories of highest possible quality.

MANUFACTURERS:

KERR & THOMAS, Barr Hill Works, DALBEATTIE, Scot.

To Makers of Wireless Instruments,
Factors and Dealers only.

Re WILKINS & JACKSON, LIMITED,
Foster's Buildings, 22, High St., SHEFFIELD

(BY ORDER of the Receiver for the Debenture Holders, Mr. ERNEST WESTON, Chartered Accountant, Hartshead, Sheffield.)

For Sale by Private Treaty

(IN ONE OR SEVERAL LOTS)

THE STOCK - IN - TRADE

OF

Wireless Instruments
and Accessories

COMPRISING IN PART:

- | | | |
|----|------------------|--|
| 16 | WESTERN ELECTRIC | LOUD SPEAKING EQUIPMENT. |
| 18 | " " | LOW FREQUENCY AMPLIFIERS, 1s and 2s type. |
| 32 | " " | CRYSTAL PATTERN RECEIVING SETS, with Headpieces. |
| 67 | " " | LOUD SPEAKERS, 4,000 ohms. |
| 5 | " " | HIGH FREQUENCY AMPLIFIER DETECTORS. |
| 24 | " " | WAVE WIRELESS HEADPHONES (2,000+2,000). |

- | | | |
|----|--------------------------------|--|
| 29 | BROWN'S MICROPHONE AMPLIFIERS. | 2,000+120. |
| 17 | " do. | do. 2,000+2,000. |
| 30 | " LOUD SPEAKERS. | H.1. 2,000 ohms. |
| 15 | " do. | do. H.1. 120 ohms. |
| 15 | " do. | do. H.2. 120 ohms. |
| 60 | " HEADPHONES. | TYPE F. A. & D. (120, 4,000 and 8,000 ohms.) |

- | | |
|----|--------------------------------------|
| 1 | BURNDIPT "ETHOPHONE" V. 4 VALVE SET. |
| 1 | do. 2 VALVE. No. 2. STATION SET. |
| 1 | do. ULTRA 4 VALVE SET. |
| 10 | do. CRYSTAL RECEIVING SETS. |

- | | | |
|---|--|---------------------------|
| 3 | GECOPHONE WIRELESS RECEIVING SETS. | 2 Valve type. |
| 2 | (RADIO INSTRUMENTS LTD.) AMPLIFYING RECEIVERS. | Type V., Va. |
| 2 | do. | do. TYPE V. 4a SETS. |
| 1 | do. | do. TYPE V. 3a SET. |
| 2 | do. | do. TYPE V. 2a SETS. |
| 1 | do. | do. TYPE V. 1a SET. |
| 1 | do. | do. NOTE MAGNIFIER V. 8m. |

Also

300 GRANIC HONEYCOMB COILS 25s to 1,500s. ATLAS COILS, 25s to 300s. 200 lbs. "KENT BROS." WIRE. ACCUMULATORS. BATTERIES, MULLARD "ORA" and other VALVES, etc.

THE WHOLE STOCK WILL BE EXPOSED TO VIEW at 22, HIGH STREET, SHEFFIELD, from OCTOBER 4th to 13th inclusive, and may be inspected any time during those days by appointment.

FOR FURTHER PARTICULARS apply to

FRANK LYTE, Auctioneer,

Tel. No. 1,104.

St. James Row, SHEFFIELD.

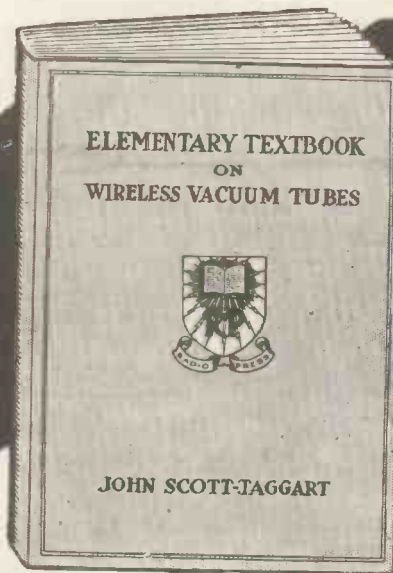

Not the cost
of a Valve

WHETHER you are taking up Radio for a livelihood or only as a hobby, you must have this standard Book on the Thermionic Valve. Beautifully bound in full cloth, this 250-page book represents many years of patient research work by a recognised authority on the subject. Master the theory of Wireless and you are certain to make rapid progress.

From all Booksellers or direct from Publishers.

Post free 10/-

Radio Press, Ltd
PUBLISHERS OF AUTHORITY TATIVE WIRELESS LITERATURE
DEVEREUX COURT, STRAND, W.C.2.

Wireless
Vacuum Tubes
By John Scott-Taggart, F.Inst.P.

THE "CLARITONE" ABROAD



REPORTING a North American Boxing Contest, round by round, before a vast crowd assembled in front of a newspaper office in one of the

LIST PRICE **£6:0:0**

world's largest cities, the "Claritone" was so natural and clear that some hundreds were sold in a few days.

OUR local foreign agents immediately cabled Liverpool for further shipments. The British reputation "That the 'CLARITONE' has no superior" is thus confirmed.

OUR agents' subsequent reports continue to affirm that the quality of the "Claritone" is now recognised by Trade and Public alike as superior to that of any other Loud-Speakers in their market.

The thousands in use are selling thousands more.

— BUY THE PROVED BEST —



Manufacturers:—

AUTOMATIC TELEPHONE MANUFACTURING Co., Ltd.,
Milton Road, Edge Lane, Liverpool.

Sole Distributing Agents:—

Ashley Wireless Telephone Co., Ltd., 69, Renshaw St.,
Liverpool.

THE CUP WHICH CHEERS, BUT NOT A CRYSTAL BREAKS.

All "Old Hands" know the misery which screw cups have caused.

All "New Hands" will be wise to avoid it. Both can—by spending sixpence.

Here are two pictures of the Cup (exact size). A lot of explanation is not necessary.

THE PICTURES TELL THE STORY.

The screws are No. 4 B.A. x 1/2" and can be used either way up.

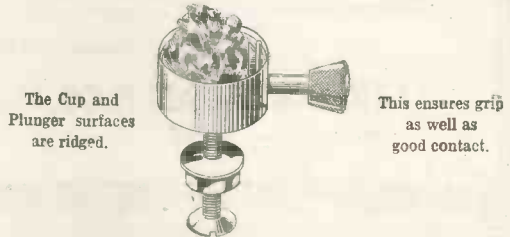

PULL KNOB! INSERT CRYSTAL! LET GO!

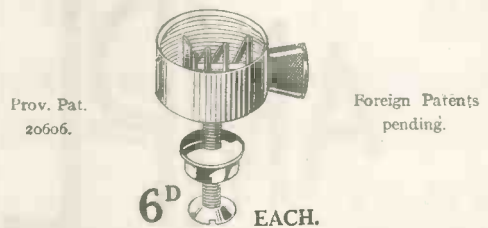

MORE REFTY TIME-SAVERS

No. 1. Lacq. 10 1/2d. each. Ebonite top. No. 2. Lacq. 6d. each. All brass. No. 4. Lacq. 1/- each. Ebonite top.

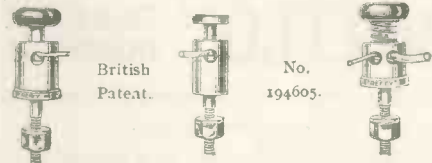

No. 1a. N. Plate. 11 1/2d. each. No. 2a. N.P. 7d. each. No. 4a. N.P. 1/1 each.

Depress the Knob! INSERT THE WIRE! LET GO!
THE TERMINAL WHICH IS AS GOOD AS A SOLDERED JOINT
yet which is connected or disconnected in an instant
AND CANNOT POSSIBLY SHAKE LOOSE.

Hundreds of Dealers Stock REFTY Products. Here are some of them. If your dealer doesn't—send cost plus postage for direct delivery.

- | | |
|---|--|
| St. Albans. B. & A. Wireless Co., Verulam St. | Luton. P. T. King & Co., 17a, Manchester St. |
| Barnet. G. F. Saul & Son. | Oxford. W. Ambrose, 42, High St. |
| Bristol. Salanson & Co., 20, High St. | Portsmouth. Percy Kilm, Ltd., Elm Grove, Southsea. |
| Cardiff. Friend Wintle & Co., Electric House. | Redhill. T. G. Bailey, 7 & 34, London Rd. |
| Croydon. J. Bridger, Ltd., Poplar Walk. | Salisbury. Clayton Bros., 4, Winchester St. |
| Guildford. H. Fentum Phillips & Co. | Shrewsbury. A. T. Doody, 78, Castle Foregate. |
| Halesowen. Midland Hardware Co., New Rd. | Southampton. Pratt & Co., 69, London Rd. |
| Ilford & Romford. Ajax Elec. Co., 291, High Rd. | Teddington. F. Stockwell, 45, Broad St. |
| Kingston. Atlas Wireless Co., 78, Richmond Rd. | Warminster. Walter M. Monk, 13, High St. |
| Littlehampton. H. Smart, 52, High St. | Watford. Messrs. Darley's, St. Albans Rd. |

REFTY ELECTRICAL APPLIANCES LTD.,

2, FEATHERSTONE BUILDINGS, HOLBORN, LONDON, W.C.2
Telephone: Chancery 8264. Telegrams: "Retinal," Holb, London.

AMPLION RECEIVERS are designed and produced by the world's original and largest manufacturers of Loud-speaking Telephones. First demonstrated in 1887, commercially introduced in 1893, adopted by the British Admiralty in 1894, and by Foreign Governments and the leading Steamship Lines in the following years, no less than 12,000 vessels were fitted with Graham's instruments by the end of the year 1919, besides installations in numerous power stations and for other purposes. To-day the number of Graham Loud-speakers in use exceeds that of all other makes combined.

More Loud-speakers than ever are now produced in the Graham Factories or under licence, and in the Wireless field the Graham Amplion represents the utmost technical efficiency and unequalled commercial value.

Ask for Folder "W.W."

ALFRED GRAHAM & CO. ST. ANDREW'S WORKS.
Crofton Park, LONDON, S.E.4

'Phone : Sydenham 2820-1-2. 'Grams : "Navahada, Catgreen, London."

Demonstrations at our Showroom
The Algraphone Salon,
25-26, Savile Row,
Regent Street,
London, W.1
'Phone : Regent 1075.



AMPLION

The World's *Standard*

"BUTTLO" GUARANTEED COMPONENTS.
Sent postage free, for cash with order, in United Kingdom.

◆◆◆◆◆

SOLID MAHOGANY CABINET, 12" x 12" x 4½" deep with plinth base, complete with ebonite panel, 12" x 12" x ¼"	19/6
COILSTAND (Fig. 12) for 3 Coils.	11/6
VALVE HOLDERS (Turned Ebonite)	1/4
VARIABLE CONDENSERS for panel mounting:—	
0'001	0'0005
0'002	0'001
0'003	0'0015
0'004	0'002
0'005	0'0025
Fig. 37	15/-
	10/6
	8/-
LOW FREQUENCY TRANSFORMERS	22/6
Filament Rheostats (Fig. 24a)	3/6
Crystal Detectors (Fig. 38)	3/6
HIGH FREQUENCY TRANSFORMERS:—	
4-pin type to fit valve socket	4/- to 10/6
Range 175 to 24,000.	
4 stage tapped primary 120/2600.	18/-
9 " " tapped primary 120/4600	27/6

FULLY ILLUSTRATED LISTS, POSTAGE FREE 6d.

◆◆◆◆◆

H. D. BUTLER & CO., Ltd.,
Showroom: BARCLAY'S BANK BUILDINGS,
222, GT. DOVER STREET, BOROUGH, S.E.1.
Telephone: Hop 3029. Three minutes from London Bridge Station

Wireless Weekly SMALL ADVERTISEMENTS.

PREPAID Advertisements are accepted under this heading for Wireless Apparatus and Parts WANTED or FOR SALE, etc., at the rate of 1s. 6d. per line, MINIMUM THREE LINES. Advertisements should reach Scheff Publicity Organisation, 125 Pall Mall, London, S.W.1, LATEST by first post FRIDAY preceding date of publication. The publishers are not responsible for clerical or printer's errors, but every care is taken to avoid mistakes.

AMATEUR selling up 3 valve sloping panel mahogany cabinet, H.F. det. and L.F. 2 tuning condensers, etc. As new with valves, Brown 'A' phones, loud speaker, £13 10s. Various other gear, must sell. Stamp, list. 21 Willow Avenue, Edgbaston, Birmingham.

"A" TYPE Brown's 120 ohm new ex Govt. headphones, 25 - post paid. Send for free complete price list of all post paid unequalled radio values. J. H. Taylor & Company, Macaulay Street, Huddersfield.

DON'T throw away your old dry batteries. I have a genuine and lasting method of recharging same. Send P/O 6d. for full particulars to W. E. Wood, 39, Kirkgate, Birstall.

GO to Mica & Micanite Supplies Ltd., Mica House, Offord Street, Caledonian Road, N.1, for mica and all insulating materials.

MARCONI multi-valve R.B. 7, complete, £55. Marconi N.B. 2 amplifier, 12 gns. The above shop-sold only, condition as new, less than cost. Bridges Ltd., Electrical Engineers, Cirencester.

NOTES on Wireless. This little book will save you money and trouble. Originally published at 1/-, our price 7d. post free. Roebuck, 121 Kingsway, London.

ULTRA phones, genuine super-sensitive 4000 ohms 13/11. Adjustable magnets 17/11. Limited stock. Postage free. Stanley, 1, Maze Road, Kew.

AMPLYING crystal detector, requires no adjustment. A long-felt want supplied. The latest and greatest boon to radio enthusiasts. Resists all vibration. Neat. Compact. Reliable. Always set. Fool proof. Obtains louder and clearer reception. Also functions admirably with valves. The detector you must use on your set. By post 3/3. Trade supplied. Mayfield Wireless Stores. Mayfield Avenue, Ealing, W.13.

THEY'RE Good Value. Pickett's Cabinets, highly polished, 1/6 each. Write for lists (W.L.). Works: Albion Road, Bexley-heath, S.E.

BETTER BARGAINS and MORE OF THEM at GAMAGES GREAT SALE

Be sure to visit our Wireless Dept. during October, where there is a special display of all the best makes of sets and parts. Every offer a genuine bargain. Send your order now.

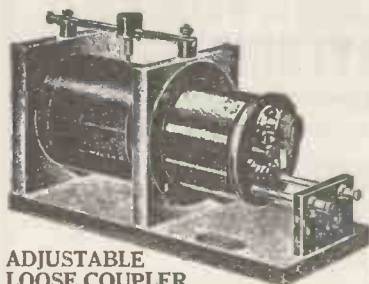

ADJUSTABLE LOOSE COUPLER

Tapped on Secondary, covering band of wave-lengths 300 to 1,000 metres. The most efficient for short wave-lengths, especially with crystal receivers. Ten per cent. better results than the ordinary "tight" type. Especially effective when used with a variable Condenser, either in shunt or series. **SALE PRICE 27/6**

Post 1/-
List Price 37/6.

THREE-COIL HOLDERS.

Beautifully finished throughout. Suitable for Honeycomb and Burn-dept Coils. Simple in construction and most practical in use. **SALE PRICE 12/6**

Best quality Geared Type. **SALE PRICE 20/-**
Postage 6d.



The "Multiplex" Special Receiving Inductance Units.

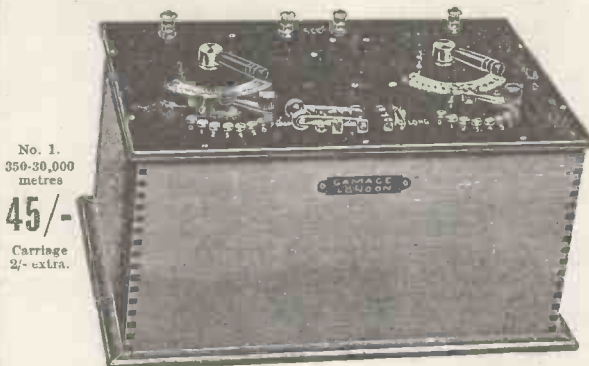

No. 1. 350-30,000 metres

45/-

Carriage 2/- extra.

No. 2. 350-4,500 metres

30/-

Carriage 1/6 extra.

Designed for use with all classes of valve receivers. They offer many distinct advantages over the complete receiving sets, as with a few accessories, a complete receiver of almost any type can easily be assembled.

Two types are made covering the following range of wave-lengths.

No. 1. 350-30,000 metres. No. 2. 350-4,500 metres. These wave-lengths are covered with use of variable condenser of '00045 mfd. Price 7/-. Postage 6d. No. 1 Unit is arranged in short (350-4,500 metres) and long wave-lengths (3,500-30,000 metres), each having a separate primary and secondary, ensuring the maximum efficiency. No. 2 Unit is for the convenience of those who wish to confine their experiments to the particular limits specified.

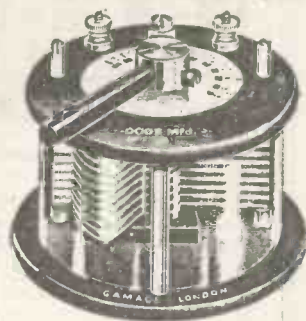

VARIABLE CONDENSERS of our well-known design.

	Sale Price	List Price
'0005	7/6	16/6
'00045	7/-	14/9
'0003	6/9	13/-

Postage 6d. extra.

BROWN'S PHONES (Type A) (W.D.)



Every pair tested. Resistance 120 ohms. Usual price 30/- **21/-**
SALE PRICE
Post 6d. Cords 2/9 per pair extra.

GAMAGES, HOLBORN, LONDON, E.C. 1.

TINGEY SUPERFIVE CABINET RECEIVER

The last word in PERFECT REPRODUCTION, SELECTIVITY and STRENGTH OF SIGNALS.

Enclosed in Lock-up Oak Cabinets, complete with High Tension Battery of 120 volts.

Composed of TWO HIGH FREQUENCY, one H.F. Rect., and two L.F. Power Valves. By means of two simple wander plugs any combination or number of valves may be employed.

Each set is supplied with a set of Coils covering the wavelengths of British Broadcasting Stations. Other sets of Coils may be supplied at extra charge.

We manufacture Valve Sets—1, 2, 3, 4 and 5 Valves, also an excellent Crystal Set.

Send for our new Components LIST—free on request.

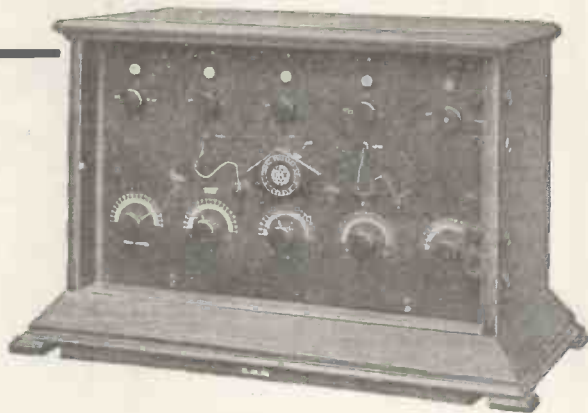

PRICE, as illustrated, including Special Valves and High Tension Battery **£56 : 5 : 0**

Ask for Superfive pamphlet.



(FEW AGENCIES STILL OPEN.)

Offices and Showrooms :

(OPEN 8 to 7. SATURDAYS 8 to 1.)

92, Queen St., Hammersmith, London, W.6.

'Phone: Hammersmith 1916.

'Grams: "Tingoidar, London."

Chiswick Agents:—The Askew Motor Works, Ltd., 72, High Road, W.4.

OVER HALF A MILLION SATISFIED CUSTOMERS WIRELESS! WIRELESS! WIRELESS! and EVERYTHING for it. DON'T PAY MORE! PIONEERS OF Great Britain's largest CHEAP PRICES. exclusive Wireless Stores.

NOTE. We are exclusively WIRELESS — NOT DABLERS!
QUALITY, QUANTITY, AND CONSISTENCY OUR MOTTO.
See Our Six-Window Display of Popular Bargains.

BRUNET 'Phones. The genuine article **13/11**
We offer for the first time the new "FELLOWS" Lightweight Headphones, 4,000 ohms. A masterpiece of workmanship. A guarantee with every pair. **18/6** per pair. Honestly worth 30/-
Special offer—BROWN'S Featherweight Headphones. Stamped B.B.C. 4,000 ohms. Our Price... .. **19/6**

ELKAY Lightweight Headphones, 4,000 ohms	12/9	MULLARD "ORA" Valves	12/3
EDISWAN Valves	12/3	MARCONI "R" Valves	12/3
COSSOR Valves	12/3	EDISWAN DULI EMITTER. Onr price	25/9

Bankrupt Stock and of Limited Quantity. Guaranteed all New.

N. & K. 'PHONES, the genuine article. Our Price	12/9	FILAMENT RESISTANCES, smooth action, marvellous value	1/10	VARIABLE CONDENSERS of high quality. Vanes and Spacers of aluminium. Complete with knob and dial, guaranteed accurate:			
DUTCH VALVES	8/3	With engraved dials	2/9	Vernier	4/9		
L.F. TRANSFORMERS Ratio 5 to 1. All guaranteed (postage 1/-)	11/3	PLUNGER SPRINGS, complete	each	'0002	5/9		
CRYSTAL DETECTORS	1/9, 1/3 and 10/d	SLIDER ROD, brass, 13ins. long, 1/4in. square, drilled	3/d	'0003	6/3		
CRYSTAL DETECTORS, enclosed in glass case,	2/6, 2/3, 1/6	SLIDER KNOB	each	'0005	7/-		
AERIAL WIRE, 7/22, guaranteed hard-drawn copper, 100 ft. (postage 1/-)	1/10	SWITCHES ON EBONITE, S.P.S.T. (quality the best)	each	'00075	8/6		
CONDENSER VANES, fixed or moving, per doz.	3/d	SWITCHES ON EBONITE, S.P.D.T. (quality the best)	1/6	'001	9/9		
REAL GOLD CAT'S WHISKERS	2d.	SWITCHES ON EBONITE, D.P.D.T. (quality the best)	1/11	O.B.A. NUTS	per doz. 4d.		
REAL GOLD CAT'S WHISKERS	per doz. 1/5	CONDENSER SPINDLES, all sizes in stock, from	2/9	DETECTOR ARMS, Ball Joints, Ebonite Handle and Whisker Holder	3/d.		
SILVER CAT'S WHISKERS	per doz. 7d.	SCREWED ROD, 2 B.A., 12ins. long	1/d	WOOD SCREW TERMINALS	each 1/d.		
SILVER CAT'S WHISKERS	per doz. 7d.	SCREWED ROD, 4 B.A., 12ins. long	3d.	SHELLAC	per bot. 10/d. and 6d.		
CONDENSER SCALES, 0 to 180	each 3/d.	RUBBER-INSULATED LEADING-IN WIRE	2/d.	AERIAL PULLEYS	each 10/d., 8/d., 6d. and 4/d.		
IVORINE LABEL SET, 12 different titles,	the set 6/d.	CHINA INSULATED SPRING CONNECTORS	1/d.	TINFOIL	large sheet 4d.		
BATTERIES, 4 1/2 volts, best quality	each 3/4	1 way	3/d.	COPPER FOIL, 6in. wide	per ft. 5d.		
BASKET COILS, set of 6, up to 3,000 metres	2/4	2 way	4d.	GRID LEAKS, 2 1/2 and 2 meg.	each 10/d.		
SLEEVING, 3 yds. assorted colours, for	11/d.	3 way	6d.	FLEX (Twin), various colours	per yd. 2d.		
NUTS, 2 B.A.	per doz. 2/d.	INSULATORS, white reel, 2in. each	1d. per doz. 11d.	CONNECTING WIRE, tinned copper, 20 gauge	3 yds. 2d.		
NUTS, 4, 5, 6 and 8 B.A.	per doz. 1d.	INSULATORS, white egg, each 2d.	per doz. 1/8	ENAMEL WIRE, in 1/2, 3/4 and 1 lb. reels:			
WASHERS, 4 B.A.	per doz. 2d.	WOUND INDUCTION COILS (postage 9d.):		22	24	26	28
WASHERS, 2 B.A.	per doz. 1/d.	12 x 4	9 x 4	8 x 2 1/2	6 x 3	6 x 2	
CONTACT STUDS, with nuts and washers,	per doz. 4d.	2/5	2/3	1/11	1/8	1/5	
TERMINALS, with nut and washers, each 1d., 1 1/2d. & 2d.		TAPPED INDUCTANCE COILS, 20 tappings, wound to 1,000 metres	each 2/6	VARIOMETERS (Tube type), complete with knob	3/11 and 2/11		
EBONITE KNOBS, 2 B.A.	each 1/d., 3d. & 4d.	DOUBLE 'PHONE CORDS, full length	11/d.	DOUBLE 'PHONE CORDS, full length	11/d.	Note: Bobbins 2d. each extra.	
SPACING WASHERS, large	per doz. 2/d.	HERTZITE, Genuine Large Piece	9/d.	TALITE, Genuine Large Piece	9/d.	POTENTIOMETERS, guaranteed up to 900 metres, superior make, compact size	7/3
SPACING WASHERS, small	per doz. 1/d.	PERMANITE, Genuine Large Piece	9/d.	VALVE HOLDERS	each 11/d., 10/d. and 9/d.	CRYSTAL DETECTOR, glass enclosed, fitted on 4x2 ebonite panel with terminals for aerial, earth and 'phones, already wired and beautifully finished	4/9
CRYSTAL CUPS, 2 screw	each 1d.	ZINCITE, Genuine Large Piece	9/d.	BATTERIES, H.T., dry:		36 volts, including Wander Plugs	5/9
CRYSTAL CUPS, 4 screw	each 2d.	BORNITE, Genuine Large Piece	9/d.	36 volts, including Wander Plugs	9/6	60 volts, including Wander Plugs	9/6
FIXED CONDENSERS, all capacities	10/d.	MIXED CRYSTALS (6 kinds)	9/d.	FILAMENT RESISTANCE DIALS	9/d.	AMALGO-PLASTIC METAL, for fixing crystals. No Woods metal necessary	6d.
EBONITE, cut to any size by machinery while you wait	per lb. 3/6	CARBORUNDUM	5/d.	GOLD SEAL PLASTIC METAL, for fixing crystals	6d.	IVORINE NAME-PLATES, all readings each 1d. per doz. 9d.	
TELEPHONE TERMINALS, nuts and washer, each 1d.	per doz. 1/3	ZINCITE and BORNITE, both in box	1/-	EARTH CLIPS, Copper, adjustable	per doz. 5/d.	RADIONETTE CRYSTAL SET, complete, stamped B.B.C. and including one pair 4,000 ohms 'phones, 100ft. 7/22 aerial wire, 4 insulators, lead-in tube, 6 yds. lead-in insulated wire and adjustable earth clip. Ready to listen-in. Honestly worth 3 gns.	36/6
W.O. TERMINALS, nuts and washers	per doz. 2d.	COIL PLUGS, real ebonite	1/3, 10/d., and 9/d.	RADIONETTE ONE-VALVE L.F. AMPLIFIER for above	34/6	CABINETS, all shapes and sizes in stock	from 1/3 each
PANEL BUSHES, drilled	each 1/d.	H.F. PLUG TYPE TRANSFORMER:					
TOP CONDENSER, bushes	each 1/d.	1. 250 to 600 metres	3/9				
BOTTOM CONDENSER, bushes	each 1d.	2. 350 to 700	4/-				
BELL WIRE, tinned copper, 12 yds.	6d.	3. 500 to 900	4/3				
SWITCH ARMS, 4 laminations, ebonite knob, complete with panel, bush, nuts, and spring washer	8/d.	4. 800 to 1350	5/6				
STOPS, with nuts	per doz. 6d.	5. 1600 to 3200	4/9				
VALVE LEGS, nut and washer	each 10.	6. 2200 to 5600	5/-				
VALVE PINS, nut and washer	per doz. 10d.	FILAMENT COMPLETE CIRCLE RESISTANCE SCALES, 0 to 800	each 6d.				
	per doz. 13.	EBONITE CONDENSER KNOB AND DIAL	1/9				
	per doz. 9d.	SUPER QUALITY 2-WAY COIL HOLDER	5/3				
		REAL FRONITE 3-WAY COIL HOLDER	7/6				

IMPORTANT NOTICE. In view of the enormous increase in our Mail Order business, we wish to inform our customers that all post orders are dealt with in strict rotation and at the earliest possible moment.

"ELKAY" WIRELESS CO.,
225 & 227, BISHOPSGATE, LONDON, E.C.2.
Open Saturday all day. (To the Trade—New Trade Counter now open. Send for NEW LIST.)
We open Sundays 11 to 2.30. Special Terms to Radio Clubs. Note new Telephone No.: Central 8544
PLEASE REMIT AMPLE POSTAGE.

SAVE MONEY BY STUDYING OUR ADVERTS.

200,000 MAGNET LETTERS have been supplied by us to WONDERSIGNS of HOLBORN. Each letter is a perfect Magnet. Hence our knowledge of what a Magnet should be, and our ability to produce the **BONTONE PHONE** under mass production.



Points to Consider.

Every Phone is sold under guarantee. Every Phone is tested before leaving Factory.

We are Old - Established British Manufacturers, whose object is to give complete satisfaction.

Why saddle yourself with Continental Phones distributed by unscrupulous Importers, with small offices and elaborate note paper, and **NO GUARANTEE** or hope of redress if found faulty.

Originals of upwards of 100 unsolicited testimonials and letters of appreciation can be seen at our offices.

GUARANTEE.—We agree to replace or return cash if Phones do not give complete satisfaction, subject to Phones being returned to us within 7 days of purchase, undamaged.

BONTONE PHONES (4,000 ohms) BRITAIN'S BEST.

14/6 per pair. Carriage paid United Kingdom. **SENSITIVE, DURABLE, COMFORTABLE, AND BEAUTIFULLY FINISHED.**

Manufactured entirely by **BRITISH labour.**
LIBERAL TERMS TO THE TRADE.

B. D. & CO. (Edward A. Boynton).

WORKS: GOSWELL ROAD AND CITY ROAD.
OFFICES: 167-173, GOSWELL ROAD.

ADMIRALTY, WAR OFFICE, AND INDIA OFFICE CONTRACTORS.

FREE

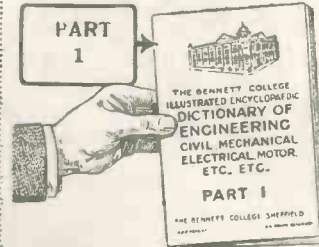

To extend the name of the Bennett College to everyone engaged in the different branches of Engineering, we are publishing an **Illustrated Dictionary of Engineering**, in about 24 **MONTHLY PARTS** (16 pages each part). You can have each monthly part as it comes out, **FREE**.

1/- Postage only to pay

The Dictionary is free to those engaged in any of the following trades: *Engineering, Civil, Mechanical, Electrical, Structural, Motor, Sanitary, Boiler, Internal Combustion, Draughtsmanship, Marine, Shipbuilding, Naval Architecture, Building, Architecture, Quantity Surveying, Aviation, Chemistry, Foundry Work, Metallurgy, Matriulation, Mining, Surveying and Levelling, Telegraphy, Telephony, Wireless*, and the conditions are that you send your name and address, your age and occupation, with one shilling (to cover postage on the 24 parts), writing your name and address very clearly. We shall then place your name on our Free List and send you part 1 at once. The others will be forwarded as issued.

We teach above trades by Post; particulars Free.

Department D 133,
The Bennett College,
Sheffield.

This handsome 2 valve "PELMERSET" complete with H.T Battery, 6 volt 40 amp. Accumulator, 100 feet stranded Copper Wire, 2 insulators, 1 pair 4,000 ohms Headphones

Only **£9** complete

B.B.C. and Marconi taxes extra.

Valves 15/- each extra.



Telephone: Museum 3134.

Enjoy the Broadcasting of Paris, The Hague, as well as all **BRITISH Stations.**

The "PELMERSET" will give you all the joys of wireless for £9 complete. The only additional expense is the aerial poles.

Distant stations come in clear and distinct, even though your nearest Broadcasting station is in operation.

The "PELMERSET" is a perfect instrument of expert manufacture—nothing to go wrong—easily understood—no technical knowledge required.

No mechanical knowledge is required in operating—booklet given with each set gives full instructions.

A special voucher relating to Broadcasting fees supplied with every set.

PERONET LTD.,
38, BLOOMSBURY SQ., LONDON, W.C.1.

Cossor Spirals Springs!

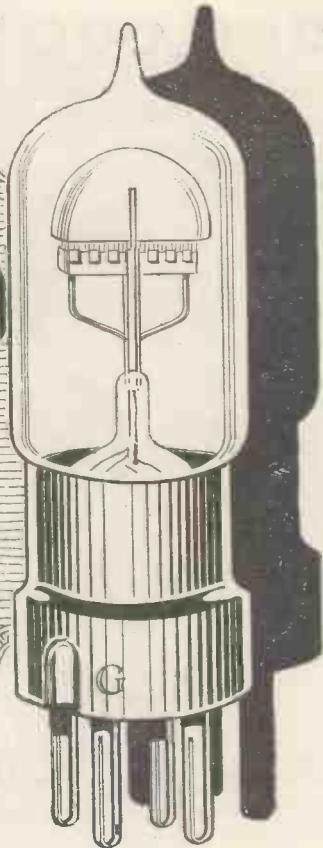

— a prolific cause of
valve breakdown.

HOW can a spring shorten the life of a Valve. Let us explain.

Everyone knows that metal—when heated—expands. Now the filament of a Valve is no exception. The moment the current is switched on, the filament glows and lengthens.

Now in every Valve—except the Cossor—some device is necessary to take up this slack, otherwise the filament will quickly sag, and touching the Grid, put the Valve out of action.

And the usual device is a spring—not necessarily a coiled spring (though some Valves even use these), but the same result is obtained by springing

apart the supporting electrodes so that the filament is carried always *under tension*.

This is why on any other Valve but a Cossor—it is dangerous to switch the current on or off suddenly. Any sudden expansion or contraction quickly finds the weak spots in a filament and causes a fracture.

There are no springs in the Cossor Valve. On the contrary its Filament is supported—like the arch of a bridge—by stout electrodes. This unique principle is responsible for a remarkably long life with complete freedom from the risk of breakdown due to the filament touching the grid. Remember that—for all these exclusive features the Cossor costs no more than ordinary Valves.

TYPES :

P.1 (for Detector or L.F. use) **15/-**
P.2 (with red top for H.F. use)

Sold by all Dealers and
manufactured only by
COSSOR VALVE CO., LTD.,
HIGHBURY GROVE, N.5.

"Business Bringers"

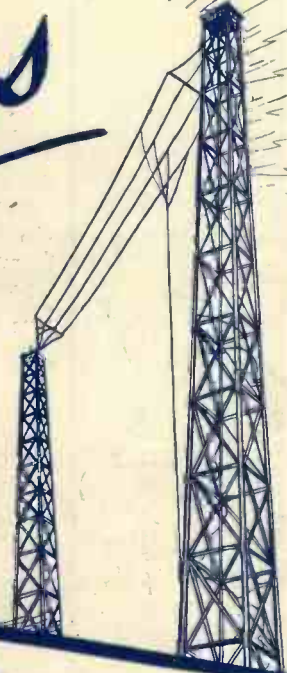

**YOU
MUST
ADVERTISE
IN BOTH**

**MODERN
WIRELESS**
Edited by JOHN SCOTT TAGGART, F.Inst.P.
Vol. 1, No. 6

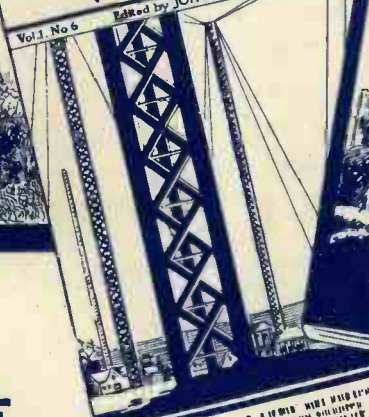

No. 6

Principal Agents for the Home Counties
Messrs. H. W. & A. G. ...

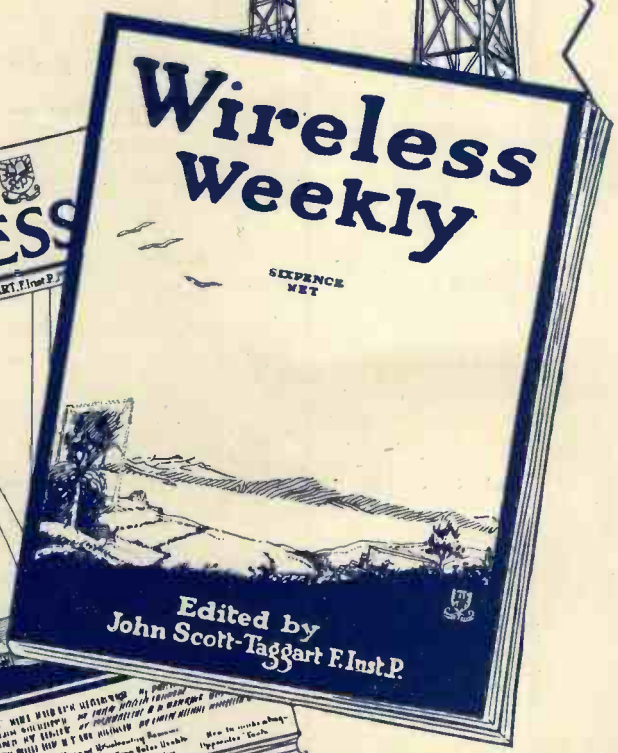

Scheff Publicity Organisation, Ltd.
125, Pall Mall, London, S.W. 1.
Advertisement Managers for both papers.
Phone: Regent 2440.

STERLING

WHOLLY BRITISH
MANUFACTURE.

RADIO INSTRUMENTS The Hall Mark of Quality.



BABY STANDARD LOUD SPEAKER LOUD SPEAKER

(Patent applied for.)

A MARVEL OF VALUE.

The most efficient instrument of its class. Constructed on novel lines. Reproduces high and low notes with equal fidelity, and preserves the natural timbre of the original tones.

PRICE - - (120 or 2,000 ohms)

£2 : 15 : 0

Reproduces Radio music and speech faithfully and without distortion. Its Volume is limited only by the amount of low frequency amplification employed.

Ideal for the home, and suitable for public purposes when used with a power amplifier.

PRICE - - (120 or 2,000 ohms)

£6 : 0 : 0



No. R. 1283

SIZE:—

Height 19 in., Diameter of Flare 10½ in., Diameter of Base 5½ in.



No. R. 1284

SIZE:—

Height 27½ in., Diameter of Flare 14 in., Diameter of Base 8 in.

"STERLING" LOW FREQUENCY AMPLIFIER UNITS.

(One and two valves.)

These Units, when added to a receiving set (one or two valves as required), will amplify Radio Speech and music without distortion. The two-valve Unit, with a crystal or Detector Valve Set, will give ample loud speaker volume within 15 to 20 miles of a Broadcasting Station.

No. R. 1533. "STERLING" SINGLE VALVE AMPLIFIER UNIT in highly finished metal case.

PRICE including B.B.C. Royalty (without valve) - £4 : 10 : 0

No. R. 1537. "STERLING" TWO-VALVE AMPLIFIER UNIT.

PRICE including B.B.C. Royalty (without valves) - £8 : 2 : 0
"R" Valves 15/- each extra.

"STERLING" STANDARD LOW FREQUENCY POWER AMPLIFIERS.

Efficient instruments, which give perfect reproduction with large volume and without distortion. Ideal for use with "Sterling" standard or "Magnavox" Loud Speakers.

No. R. 1334. "STERLING" STANDARD TWO-VALVE POWER AMPLIFIER in highly finished Walnut cabinet as shown.
PRICE including B.B.C. Royalty (without Valves) - £16 : 16 : 0

No. R. 1345. "STERLING" STANDARD THREE-VALVE POWER AMPLIFIER as above, but with valves vertically arranged.
PRICE including B.B.C. Royalty (without Valves) - £22 : 0 : 0

L.S.2 Valves for above, PRICE each £1 : 15 : 0 extra

Obtainable from all Electrical Dealers and Stores.



No. R. 1334.

"STERLING" STANDARD
TWO-VALVE POWER AMPLIFIER.

STERLING TELEPHONE & ELECTRIC Co., Ltd.,

Manufacturers of Telephones and Radio Apparatus, etc.

(WHOLESALE ONLY)

Telephone House, 210-212, TOTTENHAM COURT ROAD, LONDON, W.1.

Telephone: Museum 4144 (7 lines.)

Telegrams: "Cucumis, Weedo, London."

BIRMINGHAM: 150, Edmund Street.

CARDIFF: 10, Park Place.

MANCHESTER: 14, St. Peter's Square.

NEWCASTLE-ON-TYNE: 21, Mosley Street

WORKS: Dagenham, Essex.

Wireless Weekly

and The Wireless Constructor

Vol. 2.
No. 13.

CONTENTS

A Simple Crystal Receiver.
Direction Finding in Navigation.
Notes on a Long Distance Receiver.
C. W. Transmission.
Makeshift Aerials.

"Wireless Weekly" 3-Valve Receiver,
Jottings by the Way, News of the Week, Constructional Notes, An Emergency Apparatus for Ship-board Use, Broadcasting News, Random Technicalities, Apparatus we have Tested, Mainly about Valves, Correspondence, etc., etc.

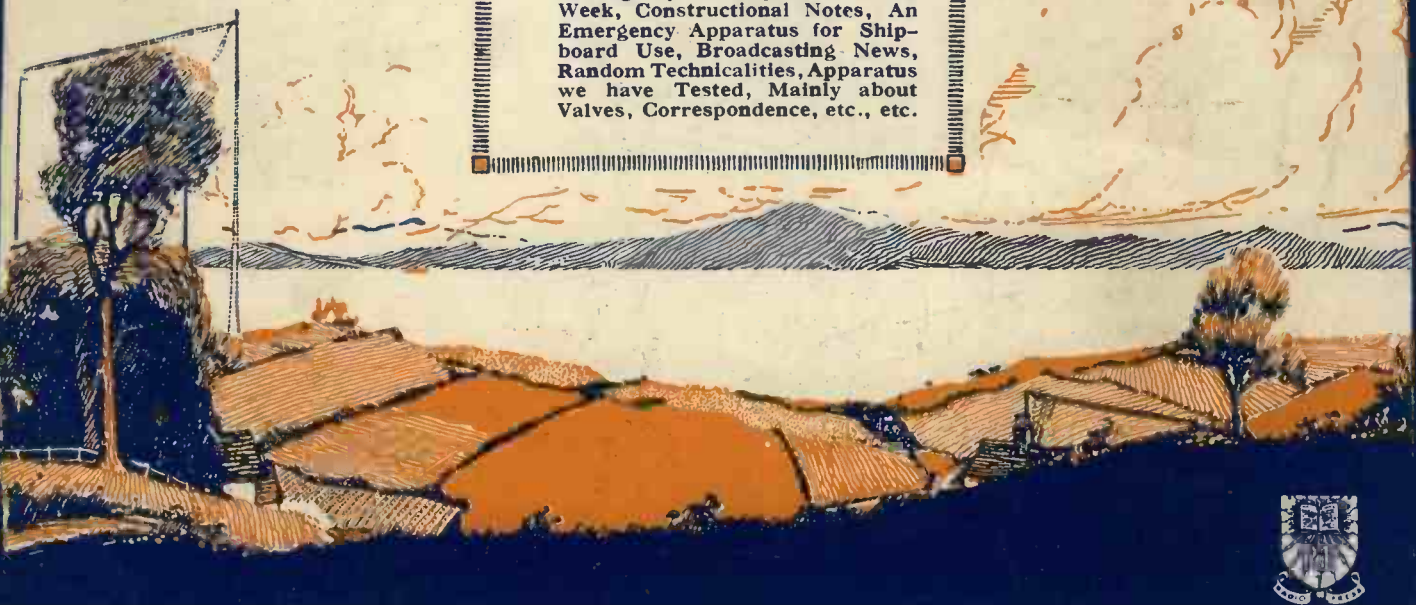

Committee's Decision—Constructor's Licence—

Full Details

NOW!

With the issue of the P.M.G.'s Report, you can go ahead and **ADVERTISE.**

The very **BEST** Media are represented below. You will need to be in both to secure *your* share of the business.

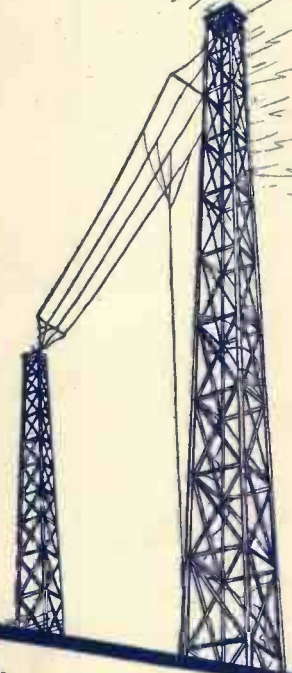

NOVEMBER SPECIAL EXHIBITION NUMBER OF MODERN WIRELESS AT PRESS OCTOBER 15th Send YOUR COPY NOW

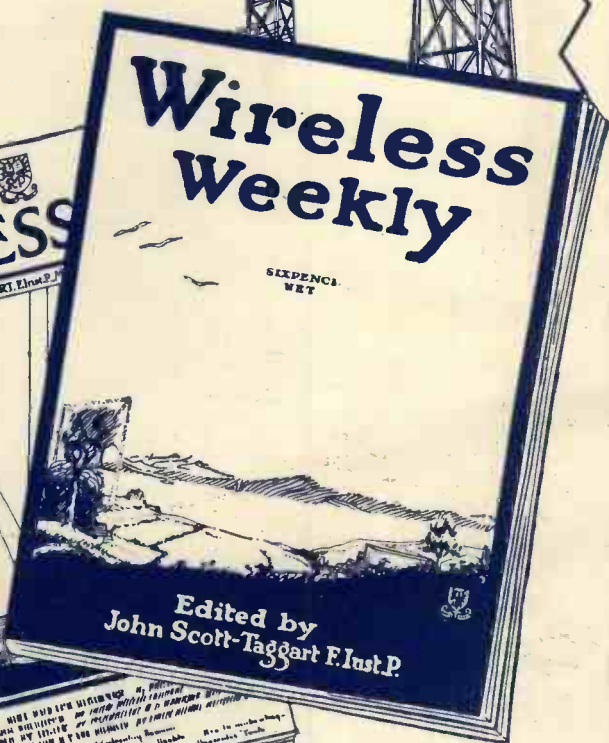
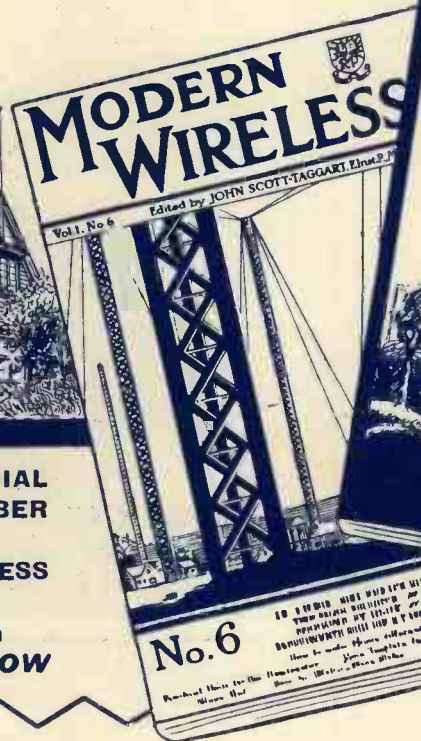

Scheff Publicity Organisation, Ltd.
125, Pall Mall, London, S.W.1.
Advertisement Managers for both papers.
Phone: Regent 2440.

Wireless Weekly

Vol. 2, No. 13
Oct. 10, 1923

CONTENTS

	Page
Editorial - - - - -	460
Makeshift Aerials - - - - -	461
"Wireless Weekly" Circuits—No. 26 - - - - -	463
Notes on a Long-distance Receiver - - - - -	464
Jottings by the Way - - - - -	466
Direction Finding in Navigation - - - - -	468
The Broadcasting Committee's Decisions - - - - -	470
News of the Week - - - - -	472
C.W. Transmission - - - - -	473
"Wireless Weekly" Three-valve Receiver (con- clusion) - - - - -	475
A Simple Crystal Receiver - - - - -	476
Constructional Notes - - - - -	478
Broadcasting News - - - - -	481
Apparatus We Have Tested - - - - -	483
Mainly About Valves - - - - -	484
Radio Press Information Department - - - - -	485

Editor: JOHN SCOTT-TAGGART, F.Inst.P.

Assistant Editors { E. REDPATH.
P. W. HARRIS.



Scientific Adviser:
Prof. G. W. O. HOWE,
D.Sc., M.I.E.E.
Advisory Editors:
Prof. R. WHIDDINGTON,
M.A., D.Sc.
Prof. C. L. FORTESCUE,
M.A., M.I.E.E.

Radio Press, Ltd.

Publishers of Authoritative Wireless Literature
DEVEREUX COURT, STRAND, W.C.2

Tel.—Central 3763.

Advertisement Managers: { SCHEFF PUBLICITY ORGANIZATION,
LTD., 125, Pall Mall, London, S.W.1.
Tel.—Regent 2440.

Staff Editors:

E. H. CHAPMAN, M.A., D.Sc.
A. D. COWPER, M.Sc.
G. P. KENDALL, B.Sc.
R. W. HALLOWS, M.A.
S. G. RATTEE.



All correspondence relating to contributions is to be addressed to the Editor of "Wireless Weekly."

Nothing contained herein is to be regarded as permission or encouragement to infringe any patent rights.

Editorial



A Settlement at Last

ELSEWHERE in this issue we publish a summary of the Broadcasting Committee's decisions, together with the modified regulations regarding licences which are to be put into force by the P.M.G. Having carefully examined the report, we fail to discover any justification for the long delay which has occurred, or, as a matter of fact, for the existence of the Broadcasting Committee, except that, we suppose, a Committee had to be appointed to satisfy the demands of the daily Press.

The very first thing that strikes us is that, whereas the Committee recommend one thing, the Postmaster-General deliberately decides upon another. This is particularly noticeable in regard to the recommendation concerning licences, and we contend that there was no reason why the interim report for which we continually pressed could not have recommended the issue of an interim constructor's licence at 15s., exactly as is now provided.

If the Radio Society of Great Britain had taken an active interest in the licensing problem before the appointment of the Broadcasting Committee, we feel sure that some settlement of that problem might have been arrived at. After the regrettable delay in the publication of the report, the action of the P.M.G. in publishing the report and his decisions thereon simultaneously, with consequent absence of any further delay, is duly appreciated.

At all events we now have a settlement, and, in general, a

very satisfactory settlement, of the broadcasting controversy, so, without further recrimination, we can take careful stock of the new regulations. Upon examination, there appeared to be two or three items which were somewhat obscure, and, with the object of avoiding any further delay or confusion in the minds of our readers, we have made careful enquiries and have succeeded in clearing up the points in question.

Existing experimental receiving licences are not to be interfered with in any way.

They will be renewed periodically upon payment of the regular fee, without any requirements in connection with a declaration regarding the use of broadcast transmissions for experimental purposes only.

Existing experimental transmitting licences also will not be interfered with in any way, and new licences of this type will be issued upon compliance with the usual conditions and upon payment of the existing fee of 20s. per annum.

Owners of unlicensed receiving apparatus of any type are required to take out before October 15th next, a special interim licence at a fee of 15s.

Those who desire to construct their own receiving apparatus, but are not qualified for an experimental licence, can obtain a constructor's licence (fee 15s.) upon application at any head or branch Post Office in the Kingdom. Both the interim and constructor's licences will remain in force until the end of 1924. Under the terms of these licences, foreign-made components may not knowingly be used in the construction of apparatus.

Experimental receiving licences (fee 10s.) will continue to be

issued, but, in addition to the present condition, applicants will be required to sign a declaration to the effect that they will not use the broadcast programmes except for experimental purposes.

In connection with this, there arises a point of considerable importance to would-be experimenters, which has either been entirely overlooked or inadvertently omitted from the published details. *Holders of experimental receiving licences issued after October 4th* may enjoy all the usual privileges of the experimenter, including that of purchasing whatever foreign-made components or sets may be required in the course of their work, but *will be prohibited from listening, however occasionally, to the broadcast transmissions for the purpose of entertainment.*

On the other hand, the constructor's licence permits this, and, at first sight, might appear to afford better facilities than the experimental licence, but it does not permit the use of foreign components or sets other than those marked B.B.C. Therefore, a serious worker who took out a constructor's licence because he could not honestly declare that he would never listen to broadcasting merely for pleasure, would be debarred from carrying out any test with foreign-made apparatus, such as the soft valves, for example, which are not manufactured in this country.

We feel certain that there is some misunderstanding in this matter, for, as the regulations stand, *the genuine experimenter* (Continued on p. 469.)

MAKESHIFT AERIALS

By G. P. KENDALL, B.Sc., Staff Editor.

An article of special interest to flat dwellers and others who have difficulty in arranging an efficient outdoor aerial.

WOULD-BE wireless enthusiasts are often deterred, it seems, by the difficulty or impossibility of erecting an outdoor aerial in such situations as



Fig. 1.—The "Ducon" adapter.

flats or boarding houses, and are apt to regard themselves as debarred from the joys of wireless in consequence.

It is the object of this contribution to show that no one need despair of obtaining some sort of results in almost any position, since the popularisation of wireless has led to the collection of much useful information as to the properties and efficiency of various sorts of makeshift aerials: from the knowledge gained it is a simple matter to choose a suitable type for any particular set of conditions.

It is as well to realise at the outset, however, that makeshift aerials, in general, pick up considerably less energy than the normal outdoor type, and must not be expected to give as loud signals with a given set. To compensate for the loss of signal strength resulting from the use of a makeshift type of aerial, it is as well to allow one additional high-frequency valve, although this may not be necessary when using a particularly good specimen of the first variety in the list which follows.

The most useful types of makeshift aerials are here set out, arranged roughly in the order of

the amounts of energy picked up by average specimens of each type.

1. Lighting main aerials.
2. Indoor aerials.
3. Bell wiring aerials.
4. Frame aerials.

We will now consider each type separately, in order to show the characteristics and relative advantages of each, so that a choice of a suitable one may be made for any given situation.

Lighting Main Aerials

The use of the lighting main as an aerial was very completely dealt with in No. 1 of *Modern Wireless* in an article commencing upon page 6. To use the mains safely it is necessary to employ one of the special attachments sold for the purpose, such as that illustrated in Fig. 1. This type of makeshift aerial generally gives the best signals of any of those con-

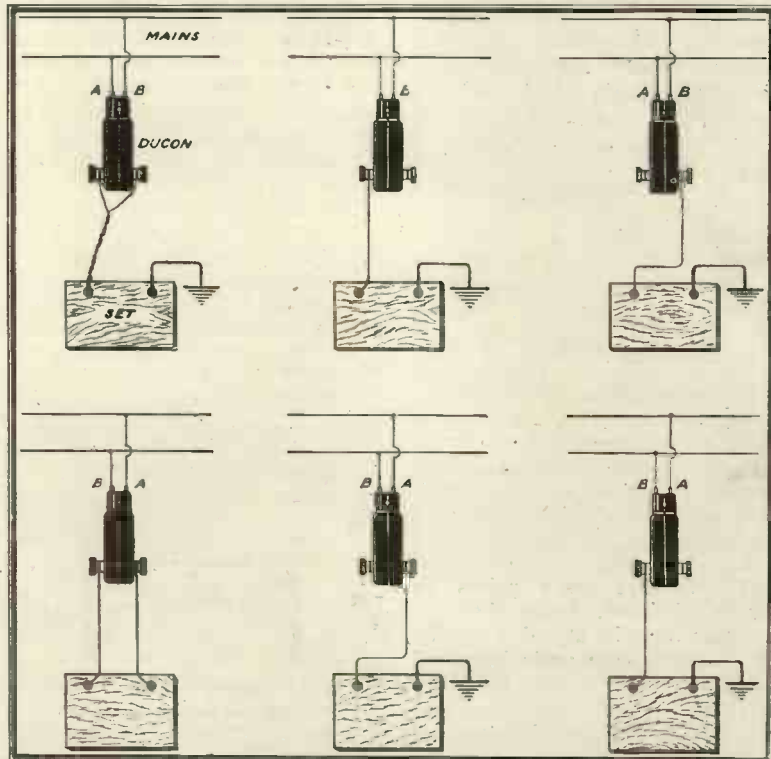

Fig. 2.—A few of the possible ways of connecting a "Ducon" adapter to the receiving set. It should be noted that some of these ways depend for their distinction from each other upon the fact that the two halves of a "Ducon" are different. The number of connections given above can be doubled by trying each with the lamp switch on or off.

sidered in this contribution, though, of course, it should be realised that the actual results obtained depend in a large measure upon the arrangement of the wiring in the building. This, no doubt, explains how it is that such varied reports are heard of the performance of lighting main aeri- als. In some cases, perhaps one should say in the majority of cases, there is a good deal of wiring arranged about the upper parts of the building which acts as a moderately efficient aerial and picks up a fairly adequate amount of energy. In other and much rarer cases there may be only quite a small amount of wiring available which only picks up a trifling amount of energy. In the majority of cases lighting main aeri- als may be expected to give results something like 75% as good as those of an average outdoor aerial.

Remember when using one of the special attachments illustrated that there are a great number of different ways of connecting it to the set and to the lighting mains. There are at least a dozen different ways of making the connection (Fig. 2). These attachments, by the way, are perfectly safe and cannot possibly lead to injury of either apparatus, user or lighting main; also, they do not consume any current. These facts should be borne in mind by those living in flats who may have difficulty with a landlord who objects to the use of any sort of wireless apparatus.

Indoor Aerials

Probably the most popular type of makeshift aerial is that which consists of one or more wires strung across the ceiling of a room or in the roof of a building to form a miniature indoor aerial. Such small aeri- als can be made to give fair results if put up with due regard to the principles of aerial operation. The main points to bear in mind are, firstly, that the insulation must be attended to with just as much care as is bestowed upon an outdoor aerial; secondly, that care must be taken to avoid bending the aerial back upon itself at an angle, such, for example, as results from running it backwards and forwards on a wall instead of straight across the ceiling; and

thirdly, it must be kept well away from walls and all other objects which would tend to increase its capacity abnormally.

A common mistake which is made in installing indoor aeri- als is to imagine that the full permitted roof- of wire must be employed somehow, even if it is done by coiling the wire round and round a small room. Such an arrangement, of course, may merely lead to a large increase in the capacity of the aerial without yielding any greater signal strength, since the waves crossing one side of the coiled aerial simply annul the result which they produce in passing

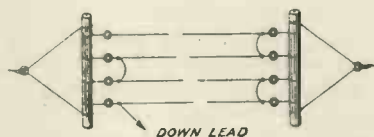

Fig. 3.—The wrong way to arrange the wire in an indoor aerial of small size.

the other side. Better results would be obtained by the use of a shorter aerial, kept straight and brought up to the desired wave-length by the addition of inductance in series. It is better practice, in general, to increase the wavelength of these very small aeri- als by the use of a number of wires, say three or four, spaced two or three feet apart and all joined together at one end and brought down in a single down-lead to the set.

The results obtainable with such aeri- als, of course, depend entirely upon the size of aerial which it is possible to construct; its height above the set and above ground level; the nature of the surrounding building, that is, whether it is of brick or whether it is a con-

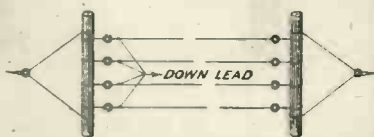

Fig. 4.—The right way to arrange the wire in an indoor aerial.

crete building with a steel frame, and a number of other factors. With a fairly good indoor aerial, it is generally possible to receive

broadcasting with a crystal set up to a distance of about 10 miles, and, of course, at proportionally greater distances with valve receiving sets. With valve receivers, by the way, trouble may be experienced with very small indoor aeri- als, resulting from the instability of the valve circuits caused by the small size of the aerial. This instability can generally be removed by the use of a moderately large tuning condenser in parallel with the tuning inductance, though, of course, at the expense of signal strength.

Bell Wiring Aerials

The use of the bell wiring as an aerial is an expedient that meets with extremely varying success, since the efficiency of such an aerial depends upon a number of variable factors very similar to those governing the efficiency or otherwise of lighting main aeri- als. Bell wiring circuits, of course, differ one from another, even more than do lighting main circuits, and consequently it is impossible to generalise as to their effectiveness. The matter can only be settled in any given case by experiment.

One advantage of this type of makeshift aerial is that no form of adapter or attachment is needed. The aerial terminal of the set is simply connected with a piece of wire to one of the wires of the bell circuit at any convenient point, such as one of the bell pushes. On the other hand, this system has a drawback which in some cases may be serious, namely, that every time a bell is rung, loud noises are produced in the receiver, which may be a serious nuisance in the case of flats which have a number of bells all run from a common battery.

A word of warning as to this sort of makeshift aerial. It is sometimes found that the bells of a large building are run by means of a small transformer from the lighting mains, and in this case it is not safe to use the wiring as an aerial without some form of adapter, such as that referred to when dealing with the use of lighting mains as an aerial, since connecting the bell wiring to earth through the receiving set may cause serious damage.

(To be concluded.)

" WIRELESS WEEKLY " CIRCUITS—No. 26

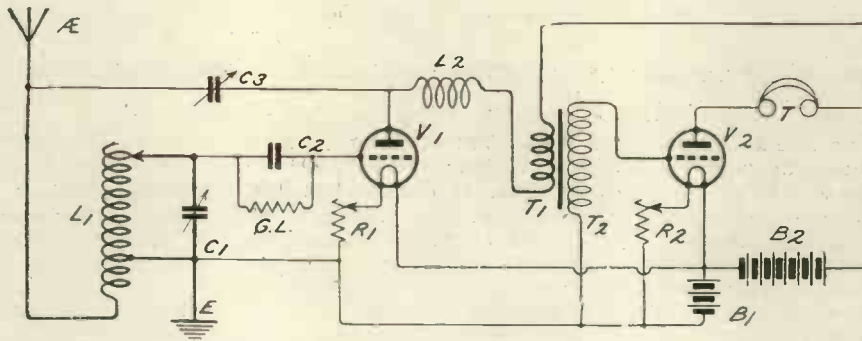

COMPONENTS REQUIRED

- L₁: A variable inductance tapped.
- C₁ { Variable condensers having a maximum capacity of 0.0005 μF or 0.001 μF.
- C₂: Grid condenser of 0.0003 μF capacity.
- L₂: Air-core choke coil.

- T₁ } Step-up intervalve trans-
- T₂ } former.
- T: High-resistance telephone receivers.
- B₁: Six-volt accumulator.
- B₂: High-tension battery.

GENERAL NOTES

This is a Reinartz receiver in which the second valve acts as a low-frequency amplifier. The

choke coil L₂ is an air-core choke, the value of which will depend upon the range of wavelength to be covered. In some cases the choke coil may be omitted; this depends chiefly on the capacity of the winding T₁ of the intervalve transformer. The circuit may not be used for the reception of British broadcasting.

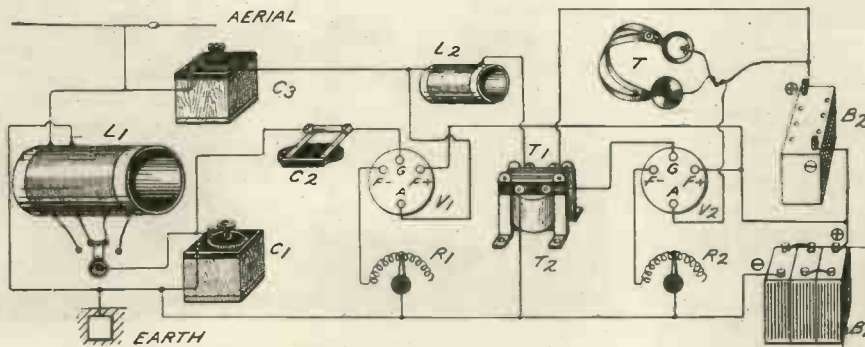

PRACTICAL WIRELESS NOTES—No. 8

WIRING DIAGRAMS

may sometimes appear very complicated. Especially is this so in the case of a three- or four-valve circuit in which reaction and possibly dual amplification is provided for.

Facility in reading such diagrams can only be gained with practice, but a mere beginner

will find the following plan very helpful.

Keep in mind the fact that each valve of the set to which the diagram refers has three essential circuits:—(a) The filament lighting circuit; (b) the input or grid-filament circuit; and (c) the output or anode-filament circuit.

Having checked the filament lighting connections of all the

valves shown, deal with each valve separately, following its input and output circuits and noting the relation of the latter to the subsequent valve.

A little practice along these lines will soon enable the most complicated diagram to be resolved into its separate circuit and the function of the individual components in those circuits to be understood.

NOTES ON A LONG-DISTANCE RECEIVER

By E. S. TAIT.

An interesting description of a sensitive experimental valve receiver with some practical details.

IN writing this article and giving a few constructional guides, it is with the object, rather than to present anything new, apart perhaps from a few switching devices, to give an opportunity to other experimenters of comparing their own experiences and results with those given here and to encourage the beginner to construct as many of his own components as possible.

I will endeavour, therefore, to give as concise a description as possible of an amateur-constructed universal receiver. The unit system was adopted in order to facilitate the changing of circuits for experimental purposes, and also to allow of part of the apparatus being altered without disturbing the remainder. Switching devices are incorporated to allow of rapid changes being made without interrupting the reception to any extent.

The Units.

The set comprises three units:—

- (1) A high-frequency and tuner combined unit.
- (2) A second high-frequency and detector unit.
- (3) A two-valve note magnifier.

The first unit contains a three-coil holder of standard pattern, a tuning condenser, a series-parallel switch, another switch to effect rapid change from a direct coupled aerial circuit to loose coupling, a valve switch, and a small tuning condenser for the first tuned anode coil, which plugs in from the outside.

The second unit is a high-frequency and detector combined because this station is too far from any of the telephony stations for a single valve to be of any value without the excessive use of reaction. This unit contains all that is necessary for a complete receiver without the tuning apparatus. A second grid condenser and leak are provided on the high-frequency valve with a switch so that either high-frequency transformers or tuned anode coils can be used as desired when both stages of high-frequency

are in use. All three units are made from mahogany boxes, with $\frac{1}{4}$ in. ebonite lids, of equal dimensions, namely, $10\frac{1}{2}$ in. by $7\frac{1}{2}$ in. by $3\frac{1}{2}$ in. As will be seen from the diagram, the following combinations are possible:—

- (1) Detector and one high frequency.
- (2) Detector and two high frequency.
- (3) Detector and one high and one low frequency.
- (4) Detector and two high and one low frequency.

the solenoid variety and with great labour, the introduction of an automatic winder was very welcome. All my coils now in use are of fixed wavelength, and are tuned with a variable condenser. They have all been constructed on a "Lokap" winder. This winder produces a unilateral type of coil with a very low self-capacity, and I have found them compare very favourably with other more expensive types. For the low wavelengths No. 22 wire was used and for the higher No. 32. With a good

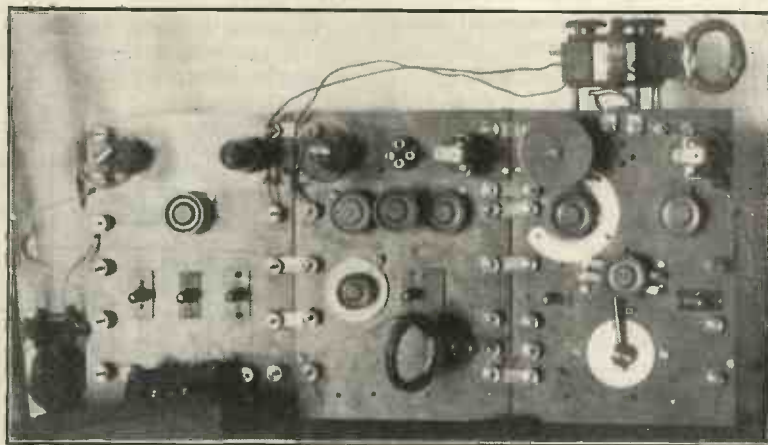

The complete receiver.

- (5) Detector and two high and two low frequency.

The circuit that is now in use embodies reactance-capacity coupling or tuned anode coils, and this was adopted after many experiments with other circuits and with high-frequency transformers, and it certainly gives better results than any other method that I have tried. In addition, tuned anode coils are much simpler to construct than transformers and lend themselves admirably to the application of reaction.

As regards the construction, I had better now give a few details. Having made many inductances of

full-size aerial about 20ft. of No. 22 d.c.c. makes an inductance that, with the use of a series-parallel switch, will tune between 300 and 450 metres with a condenser of $0.0003 \mu\text{F}$ capacity. In other words, it covers the whole band of wavelengths employed by the Broadcasting Company. These coils are very quickly constructed, but the correct size has to be determined by experiment.

The tuned anode coils were constructed in exactly the same manner and then mounted between two circular pieces of ebonite and bolted to yet another piece containing four valve pins. The tuned anode coils

are thus able to be plugged in from the outside, and by connecting together the two valve pins that lead respectively to the plate and grid one can plug in either H.F. transformers or tuned anode provided that the internal wiring is arranged for the use of transformers.

With the use of the winder before-mentioned, the following turns of the handle produce tuned anode coils of the values as indicated below:—

Turns of handle.	Gauge of wire.	Wave-length.
180	32 d.s.c.	350—450
400	32	900—1200
500	32	1200—1500
800	44	2600 approx.

These values naturally can only be approximate, as the capacity of the wiring of the set will vary, and so a few turns more or less may be required, but they are sufficiently accurate for a working basis.

When winding the very thin wire such as No. 44, it is advisable to fasten it occasionally with a little paraffin wax in order to prevent slipping. A variable condenser of the value 0.0002 μ F, or rather smaller, is used with all these coils.

High-frequency transformers wound in a slot and with both windings in the same direction, diameter of the core $1\frac{1}{2}$ in., require turns as follows:—

Number of turns on Former.	Gauge of wire.	Wave-length.
80	44 d.s.c.	360—500
165	44	900—1100
400	44	2600.

The same number of turns being wound on the secondary as the primary, and the second winding being placed directly on the top of the first, or with one layer of insulating material in between.

The formers themselves were cut out of $\frac{1}{8}$ in. ebonite about 2 in. in diameter and the core $1\frac{1}{2}$ in. A cen-

tral hole is then drilled through all three pieces, and the whole secured in position by a brass bolt and lock-nut. If the bolt is left a little long to begin with, it can then be held in the jaws of an American twist drill for winding. This method will be found very useful, as, by carefully noting the ratio of turns between the handle of the drill and the former held in the jaws, several transformers of almost identical value can be very quickly and evenly wound. It is of great utility for tuning multiple circuits. The same condenser of 0.0002 μ F is required for these transformers, and is arranged in the panel to tune the primary. The same remark applies to these as to the tuned anode coils as regards internal capacity

high- or one of low-frequency is sufficient to give loud signals with careful tuning.

American broadcasting stations have also been picked up on three occasions, twice with the use of three valves only, and on the last occasion, which was the transmission by WOR (Newark, New Jersey), two high-frequency stages were used, and every word could distinctly be heard and understood at some distance from the telephones, as there was an entire absence of atmospheric disturbance or jamming. Not less than thirty British amateurs are easily picked up on the three-valve combination, and several of them are capable of producing moderate signals on the loud-speaker with the same number

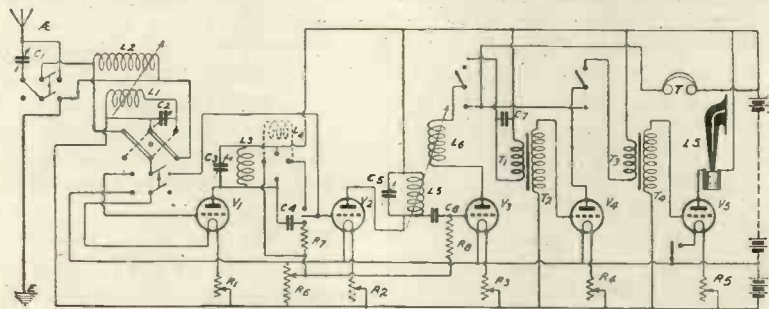

Circuit diagram of the receiver.

of the unit, and a few turns more or less might be found advisable, in order to obtain the most critical value.

The best results are obtained when the finishing ends of the transformers wound in this fashion are taken to the plate and grid respectively.

Now as to the possibilities of reception with a receiver of this description. The London station of the British Broadcasting Company is perfectly received on a loud-speaker without the use of any reaction with one H.F., detector and one L.F. (in Kent). All the other stations of the Broadcasting Company have also been received on the loud-speaker with the same three-valve combination, but with the use of reaction on the tuned anode coil. The addition of either one stage of

of valves. Such stations are 2FQ, 2OM, 2IF, 2PQ, 2ON, 2LZ. The nearest of these stations is situated at twenty miles from this receiving station. A small two-foot frame aerial is sufficient to work the loud-speaker with the London Broadcasting Station when all the valves are in use, and it is audible on the telephones with three.

I hope that these results will be sufficient to fire the ardour of others, or perhaps of those who are contemplating building up a set of their own. The components that I have dealt with are easily and efficiently made by anyone with the smallest mechanical knowledge, but the construction of low-frequency transformers and telephone transformers requires considerable skill, and in my opinion these are best purchased from a reliable firm.

CONSTRUCTIONAL BOOKS.

Now that the Constructors' Licence is available, why not make your own receiver or extend your existing apparatus? Radio Press "How-to-Make" Handbooks give you reliable information, and are obtainable at all bookstalls or direct from: Radio Press, Ltd., Devereux Court, Strand, W.C.2.



Woman

WOMAN, as I think you must admit, is all very well in her way, but I think somehow that when a component part, a rib to wit, was borrowed from Adam in order to make a loud-speaker a better job might have been made of it. Charming as she is, woman has ever been a sore trial to the serious-minded male. Years ago when we were bold enough to ply the terrible cut-throat razor upon the stubble of our chins, she had a little way of borrowing our keenest and best beloved for the sharpening of pencils or the ripping of seams that she wished to rend asunder. The coming of the safety razor rather cramped her style in this direction, for its two edged blade is apt to cut not only the work in hand, but the fingers that ply it. She never tires of the age-old plot of placing our fruitiest pipes mouthpiece downward in their rack after she has tidied up the room, thus providing her lord and master with a noxious and totally unexpected free drink of nicotine when he seeks solace in smoke after his labours.

For a time it seemed that there was nothing much that she could do to the wireless man; knowing her little ways most of us printed notices bearing such words as DANGER, 5,000,000 VOLTS, and placed them in conspicuous positions upon our wireless tables, what time we issued dark warnings of the shocks that might come the way of any who were rash enough to meddle with our gear.

Familiarity Breeds Contempt

This worked very well for a time. We had peace; our dens

grew comfortably dirty, undisturbed by the ravages of mop and duster. A feeling of serenity crept over us and we thought that now we had managed to obtain security from feminine assaults. Woman said nothing, she watched and waited. She noticed that we, when in the throes of radio rapture, touched any old thing in sight without raising a death dealing shock. Our hands strayed here, there, and everywhere, but no sparks flew, one's hair did not suddenly stand on end, and if we used mighty words beneath our breath they were torn from us by causes quite other than the sudden passage through our bodies of the mighty voltages of which we had spoken to her.

She watched the kitten playing unharmed amidst the gadgets that she had been led to believe were as deadly as trinitrotoluol. And then she saw through the whole thing. The result? She began to wonder whether she could not make use of any of our bits and pieces. My friend Cappsworth tells me that when he returned home unexpectedly early the other evening he found the joy of his life placidly darning a sock with his most cherished Ora valve pushed up into its toe to act as a stretcher; when he remonstrated the lady merely requested him to purchase "R" valves in future as they were of a shape much more suited to her purpose. That, I think, is about the limit.

A Fly in the Ointment

Referring to the patched-up friendship of our friends Bilsford and Brogson, there is, however, one large fat fly in the ointment of Brogson's con-

tent, and that is that he can seldom induce anyone to climb the hill that leads to his eyrie in order to hear his receptions. Bilsford, on the other hand, has always a crowd around his loud-speaker in the evenings listening in admiration to its stentorian tones.

The battle therefore appears to be ending in a draw. We, none of us, like to admit that adiposity or slackness has prevented us from scaling the giddy heights upon which Brogson's home reposes. We therefore talk glibly of his wonderful receptions as though we often heard them. But we are on surer ground when talking of Bilsford's, and they form a more frequent topic in our conversation. At the same time Brogson has scored a distinct point in the matter of apparatus. He will always offer to lend you things if you will call for them, but as he knows that you will not do so he need not buy them. Still Bilsford, being the more accessible, now monopolises the major part of the queries, for Brogson can be questioned only when he strolls down the High Street or makes his appearance at the club.

A Ray of Hope

Honours would thus appear to be easy, and there are signs that the daggers of rivalry so long drawn may eventually be sheathed. Bilsford is becoming very curious about Brogson's new circuit; he will question you minutely about it should you meet him. His rival is beginning to think that there must be something after all in the wondrous receptions of which he boasts. Each has been heard to admit that the other knows something of

wireless, and if you, reader, have heard radio experts discussing one another, you will realise that this is a compliment indeed. As a rule if you mention one authority's name to another he will say "Ah, yes, a clever chap in his way, but, of course, he knows nothing at all about wireless." If you don't believe me, try it and see!

Atmospheric Troubles

I am delighted to read in the Czecko-Slovakian technical paper *Yeswe Avenoban Anas*, whose title may be translated roughly as "The Contented Wireless Man," that radio telegraphy and telephony are making gratifying progress in Central Europe. Quite a good set, it appears, can now be bought for 1,000,000,000 bonanzas, the local standard coin. Considerable trouble, however, has been experienced with atmospherics.

It seems that the loud tearing crackles which herald the approach of a thunderstorm are so exactly like the vernacular phrase meaning "Votes for Women" or "Down with Everything" or something of that kind that many owners of receiving sets who have invited the Mayor or the Chief Justice round to listen-in have

been forthwith hurled into prison as spreaders of some vile propaganda subversive to the Constitution. Is it not sad to think how even Nature can be misunderstood and lead her children into trouble?

His Master's Voice

Speaking of languages the sounds of which closely resemble the explosion of a soda water syphon, the efforts of a person endeavouring to swallow a red hot potato, the gasps of a drowning baker who is coming to the surface for the third time, reminds me that several correspondents have written in recently to say that they are getting weird results from their home-made sets constructed from cheap components. They complain that clear reception cannot be obtained. Speech is always either guttural or spluttering and they are utterly at a loss to understand why.

The explanation is simple. Most of this job lot stuff is made in Germany or Austria. Detectors, 'phones, and so on manufactured in countries where they say quite regularly such things as "Ach, potztausend" or "Donner und Blitzen" or "Gottesdämmerung" have become so used to the weird noises of the land of their birth that they cannot reproduce the

clear tones of Uncle Arthur when 2LO is coming in. It is really a fact that the first American loudspeakers brought over to this country had a distinctly American accent!

Perplexing Morse

Ever found Morse signals coming in in the most incomprehensible and unreadable manner so that no matter how expert you are you can't make head or tail of them? This happens sometimes when a harmonic of some long wave station is being heterodyned. The signals come in "inside out"! That is, you get dots and dashes where there should be spaces, and spaces where there should be iddies and umpties.

'Tis a curious effect that may lead to no small perplexity till you tumble to what is going on. It happened to three of us who sat up till the "wee small hours" of the morning a few days ago to listen for American amateurs transmitting C.W. Quaint signals came in without the characteristic U.S.A. amateur note, and when we came to analyse them afterwards we found that they were undoubtedly harmonics of Northolt that had got twisted out of all recognition.

WIRELESS WAYFARER.

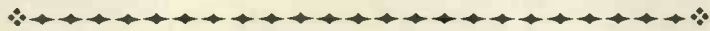

RADIO PRESS INFORMATION DEPARTMENT

THERE would appear to be some misapprehension on the part of our readers as to the exact functions of this department, and the following statement is issued for their guidance. If readers will comply with the conditions laid down they may be assured of more prompt attention.

All queries are replied to by post, and those which are published in *Wireless Weekly* are merely selected for their general interest, having already been answered by post. In every case,

therefore, the following regulations must be complied with.

(1) A Postal Order to the value of 2/6 for each question must be enclosed, together with the Coupon from the current issue, and a stamped addressed envelope.

(2) Not more than three questions will be answered at once.

(3) Complete designs for sets and complicated wiring diagrams are outside the scope of the department and cannot be supplied.

(4) Free answers to queries can only be supplied to those sub-

scribers who registered in the period during which our offer remained open, and were allotted a subscriber's number. The period in question extended from July 4th to August 16th, and was terminated when it was found that the arrangement re-acted unfairly upon readers who placed their orders through newsagents.

(5) Queries should be addressed to Information Department, Radio Press Ltd., Devereux Court, Strand, London, W.C.2, marking the envelope "Query."

DIRECTION-FINDING IN NAVIGATION

The following is the conclusion of an article "How Wireless Solves the Problems of the Navigator."

(Continued from Vol. 2., No. 12, page 432.)

ASTRONOMICAL observations are not of very great value for flying, particularly in daylight, when only the sun is available. Briefly, an astronomical observation gives the navigator the angular distance from the point vertically over his head, known as the zenith, to the sun or other body observed. As the point on the earth at which the sun is vertically over is known, this information tells him that he is somewhere on the arc of a circle with the point the sun is exactly over as centre and the zenith distance as radius. The direction in which the sun is bearing gives him a rough approximation of the position of this circle on which he is, but it is only by two or more observations, with an interval of time between them to allow the sun to materially alter its bearing from the observer, that any exact position can be determined.

As some hours must necessarily elapse for this to happen, and the course and speed of the observer in the interval must be known fairly accurately, the fact that it is almost impossible to use the method satisfactorily in the air can easily be appreciated.

In fact, the only occasion on which I consider it might be useful would be in conjunction with directional wireless, when only one wireless station is within range of the aeroplane and this astronomical position line can be used to cut the wireless bearing and thus obtain a fix.

Directional Wireless for Aircraft

In cases where no navigator is carried, directional wireless comes to the rescue in this way. Wing coils are fitted to the aeroplane as shown in Fig. 3. With the switch in the position of "one coil only" the pilot turns the aeroplane slightly until very roughly he receives the loudest

signal; the aeroplane is then heading within about 10° of her destination. The switch is then put over to the position marked "both coils," and the reversing switch is rocked backwards and

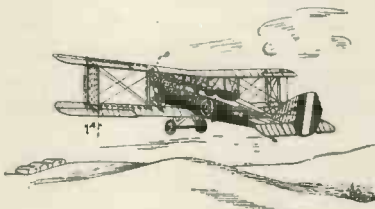

Fig. 3.—Illustrating position of direction-finding wing-coils.

forwards, thus alternately adding and opposing any energy in the coil marked B to that in the main coil marked A. The aeroplane is again turned slightly until the intensity of the signals is equal in whichever position the reversing switch is placed. At this instant



Fig. 4—Showing how the position of a ship or aeroplane is determined by cross bearings of coast stations.

the aeroplane must be heading directly towards her destination and the compass reading is observed. The aeroplane can in this way be kept pointing towards her destination by occasional checks.

If the wind were blowing from either side the machine would, of course, travel along a spiral path, but in practice the pilot makes allowance for the wind experienced; for example, supposing the Wireless Station at Croydon were found to be right ahead of the machine when she was heading 345° by compass, and ten minutes later, when the directional wireless coil proved Croydon to be again dead ahead, the compass reading was 342° , it would be obvious that there was a wind blowing from his left and he would head up towards it for from 10° to 15° ; in other words, he would steer between 327° and 332° . He thus finds the compass course to steer in a very short time by trial and error, without the slightest worry about the variation and deviation of the compass and with the comfortable feeling that however inexperienced he may be, he cannot fail to pass right over his destination, as long as the wireless direction is checked periodically.

Navigation of the larger type of aeroplanes can be carried out by fitting a rigid coil just over 3 ft. square in the body of the aeroplane. This consists of two coils, the main and auxiliary, as described in the case of wing coils. The whole coil is revolved on its axis in the machine until, by operating the reversing switch, it is found that it is pointing at the wireless station. The compass direction of the aeroplane's head is noted at that instant, and at the same time the pointer on the coil shows the angle that the coil is making with the fore and aft line of the aeroplane. It is therefore a simple calculation to determine the bearing of the wireless station. For example, with the aeroplane heading 15° Mag. and the coil making an angle of 30° with the aeroplane (this angle is marked 0° to

360° clockwise) the bearing of the wireless station must be 15° plus 30°, or 45°, with the ambiguity which is easily determined in practice that it may be 45° plus 180°, or 225°. The position of the aeroplane is then plotted on the chart, as shown in Fig. 4, the position of the machine being, of course, at the intersection of the three lines of bearing.

Navigating in this way the position of the aeroplane can be obtained at short intervals, and the line drawn on the chart from one fix to the next indicating the track the aeroplane has followed. Whilst the distance between the two together with the interval of time provide the data to ascertain the speed which is being made good over the ground.

Many successful long distance flights have been made in this way, in which the navigator has never seen the ground from the start to the finish of the flight.

Sea Navigation

At sea, of course, there are many more methods of navigation available than there are in the air, but even at sea every now and then accidents occur which show how far a ship can get off her course in a few days during which the sky has been cloudy and no observations possible. The stranding of a battleship some few years ago at the entrance to the Bristol Channel when she was supposed to be entering the English Channel is an example which occurs to me as indicating what may happen to capable navigators with the best of instruments. In addition to the accidents which are heard of, there are, of course, thousands of cases each year,

when ships have to reduce their speed and go a long way out of their direct route to avoid the risk of passing too close to a dangerous coast, when uncertain of their position in thick weather.

The steamer fitted with a directional wireless coil has now a big advantage over her competitors. I heard only a few days ago of a steamer beating another, which must have been capable of steaming more than two miles an hour faster than her, by over a day in a trans-Atlantic voyage—and wireless was given the credit.

The method of use is just the same as that described for large aircraft. A rigid coil between 3 ft. and 4 ft. square is placed near the navigating bridge of the steamer; the direction of the wireless stations from the ship is found with this and converted into a geographical bearing by reference to the standard compass, and the position of the ship plotted on the chart by cross bearings, thus enabling the navigator to be certain of his position in all weathers.

A development which I think may come later is the additional use of directional wireless for avoiding collision in fog. If when the fog horn of an approaching steamer is heard, she is called up by wireless and a bearing taken of her by the directional coil and the process repeated a minute or so later it can easily be seen if there is danger of collision. If both ships are steering a steady course and maintaining a fixed speed and there is no change in their relative bearing they must meet, but if the relative bearing is altering they will pass clear of each other in the direction indicated by the change.

A further development worth

trying is to ask the other vessel to give a signal by wireless and a blast of her fog horn at the same instant. The difference in the time of receiving the two signals will then give her distance as well as the bearing to be obtained by wireless. The sound can in this case be assumed to travel at about 1,130 ft. per second, which is near enough for practical purposes. The argument sometimes advanced against this method is the possibility of a silent zone preventing the fog signal being audible, but after all, at the present moment, audibility is the only thing to rely on, and the danger of a silent zone, if worthy of serious consideration, is another argument in favour of a wireless fog signal.

Radio Acoustics for Surveying

The results of some very remarkable experiments in determining position in this way have recently been published by Dr. A. B. Wood and Captain H. E. Browne, R.N. They have used a method whereby they fired a small charge of explosive under the water, making at the same instant a wireless signal. The signals are received at a shore station, the explosion being heard, of course, through a hydrophone, the difference in the time of the receipt of the signals being recorded mechanically and with very great accuracy, and giving the distance very simply. One of the most interesting results of their experiments was to prove that several lightships in the North Sea were nearly a mile out of their correct position.

It can be imagined how valuable such a method may be for hydrographic surveyors in certain parts of the world.

A SETTLEMENT AT LAST.

(Continued from page 460.)

who wishes to enjoy an occasional Sunday afternoon concert is required to take out a constructor's licence at 15s., in addition to his experimental licence at 10s., an arrangement which is obviously very unfair to the experimenter.

Whether due to an actual oversight or merely to a clerical inadvertence, the matter can be put right speedily and need cause no delay in the issuing of licences.

All that is required to overcome the difficulty is that the experi-

menter who desires to derive occasional entertainment from the broadcast transmissions should, upon payment of an additional sum of 5s., be exempt from signing the declaration regarding listening to broadcasting.

Believing in a certain amount of initiative in these matters, we have already communicated with both the Post Office Authorities and the British Broadcasting Co. We learn that the B.B.C. will be perfectly satisfied by such an arrangement as we suggest, and are con-

fident that the Postmaster-General will make the necessary modification, which will settle the matter.

And now that the "All Clear" signal has at last been given, and the constructor can obtain his licence and construct to his heart's content, we believe our sustained optimism regarding the development and popularity of broadcasting, and the revival of the wireless industry as a whole, will be amply justified in the winter season which is now commencing.

THE BROADCASTING COMMITTEE'S DECISIONS

The Committee was appointed on the 24th April, 1923, by Sir William Joynson-Hicks, then Postmaster-General, to consider: (a) broadcasting in all its aspects; (b) the contracts and licences which have been or may be granted; (c) the action which should be taken upon the determination of the existing licence of the Broadcasting Company; (d) uses to which broadcasting may be put; (e) the restrictions which may need to be placed upon its use or development.

(The following official statement has been issued by the G.P.O.)

IN giving instructions for the issue of the Report of the Broadcasting Committee, the Postmaster-General desires to express publicly—as he has already done privately—his warmest thanks to the Committee for the great care which they have given to the consideration of the novel and difficult questions referred to them by his predecessor.

The Report makes the following main recommendations:

That a Broadcasting Board should be established by Statute.

That the broadcasting service should not be operated by a Government Department, and that the existing service of the British Broadcasting Co. should be continued and extended for two years upon modified terms.

That one form of licence at a fee of 10s. a year (of which the Broadcasting Co. should receive 7s. 6d. and the Government 2s. 6d.) should be issued and placed on sale at Post Offices.

That no protection should be given to the British manufacturers by the licence.

Sir Laming Worthington-Evans finds that it is not possible for the scheme recommended by the Committee to be brought fully into operation immediately. As the Committee themselves point out, it has been necessary to have regard to the existing Agreement with the British Broadcasting Co., which does not expire until December 31st, 1924. Under this Agreement, and in accordance with the statements made in the House of Commons at the time, the manufacturers are entitled to protection, and no licences were intended

to be granted to any persons not using sets marked "B.B.C." and manufactured by members of the Company.

The immediate cause of the appointment of the Committee was the deadlock which had arisen between the Post Office and the Company in regard to the proposed introduction of another form of licence, viz., a "constructor's licence," to persons who make their own sets or assemble them from ready-made parts, but who do not desire to carry on experiments. These receiving sets were being used contrary to the terms of the agreement. Large numbers of such persons had applied to the Post Office for licences, and probably many others, realising that no licence was in existence appropriate to their case, have been using their apparatus without making application.

The continuance of the present situation would be bad for all parties, the Broadcasting Co. because it is losing a revenue upon which it has counted, and the Post Office because, as the Department entrusted with the administration of the law regarding the licensing of wireless apparatus, it is unable to enforce the contemplated restriction.

In these circumstances a compromise has had to be sought. In order to recognise the Company's rights under its Agreement and at the same time to meet the views of the Committee as far as immediately practicable, the Postmaster-General has agreed with the Broadcasting Co. that a constructor's licence should be issued for a limited period at an annual fee of 15s. (as compared with the fee of 10s. charged for the B.B.C.

licence). The additional 5s. for the constructor's licence is justified because otherwise the constructors would be obtaining the benefit of the Broadcasting Co.'s programme without making a proportionate contribution to the expense.

The company have agreed to this arrangement on condition that the licensee gives an undertaking that, in constructing his apparatus, he will not knowingly use parts manufactured elsewhere than in Great Britain or Northern Ireland. In all the circumstances, and especially having regard to the unemployment which at present exists, and which would be accentuated by the importation on any considerable scale of wireless receiving apparatus from abroad, the Postmaster-General has accepted this condition.

There are, however, probably 200,000 persons already in possession of unlicensed receiving apparatus, and, as the Committee point out, these persons are paying nothing towards the cost of the programme, because in the past there has been no licence applicable to them. A special interim licence will be issued at a fee of 15s., covering their present apparatus, whether made or purchased and wherever made or purchased, which will be granted to them provided that they apply for licences before October 15th. No charge will be made for past user, and no proceedings will be taken in respect of past user if the licence is taken out before October 15th.

Constructors' and interim licences as above will be placed on sale at all head and branch post offices and certain sub-offices on and from October 4th. Applicants

for such licences, as well as for the existing B.B.C. licence, will be required to fill up and sign a simple form. Copies of these application forms may be obtained not only at head and branch offices, but at all sub-offices at which money orders are issued.

This system of licensing will be continued for an interim period expiring on December 31st, 1924, after which it will be possible for the single form of licence recommended by the Committee to be introduced, without any condition as to the marking or origin of the licensed apparatus, if it should be then thought desirable.

Out of the fees of 15s. for the constructor's licence and 10s. for the B.B.C. licences, the Company will, if the House of Commons agrees, receive 12s. 6d. and 7s. 6d. respectively, instead of 5s. per licence which they receive under the existing scheme.

The Postmaster-General is not satisfied that, even with the increased contribution from licence fees, the revenue of the Company will, for some time to come, be sufficient to provide adequate programmes without a substantial contribution in the form of royalties on the sale of sets by the manufacturers who form the Company. Hence he has stipulated for the continued payment of such a contribution, but on a reduced scale. The reduction will be approximately 50 per cent., except in the case of crystal receiving sets, where it will be considerably more. This reduction should enable a cut to be made in the cost of receiving sets. The proportion of the licence fees receivable by the Company will, after December 31st, 1924, be placed on a sliding scale based on the number of licences on the one hand, and the cost of maintaining an adequate broadcasting service on the other hand. Any surplus profit accruing to the Company over and above 7½ per cent. on its capital and a necessary reserve for depreciation, etc., of plant and machinery will be surrendered to the Post Office; in other words, the profits of the Company are limited to 7½ per cent.

The existing experimental licence, at an annual fee of 10s., will continue to be issued from the General Post Office to persons who are able to satisfy the Postmaster-General that they desire the licence for *bona fide* experimental purposes, and are qualified to conduct experiments, and who sign a declaration to the effect that they will not use the broadcast programmes except for experimental purpose.

Each new licence (as distinct from renewed licences) will cover a period of twelve months from the first day of the month of issue. Renewed licences will cover twelve months from the date of expiration of the old licence.

The basis of membership of the Broadcasting Company will be extended so as to include dealers, with suitable representation on the Board of Directors for the new membership if it becomes at all substantial; and the deposit of £50 now required from members will be abolished. The licence held by the Company will be prolonged, on suitable conditions, to the end of 1926, as recommended by the Committee.

If the Company supply a satisfactory service and are willing to erect additional stations where the Postmaster-General may consider them necessary, he will not license any other broadcasting service during the interim period up to December 31st, 1924.

After that date, if the Postmaster-General should consider it desirable that additional stations should be established in any town or district where the Company's service is not adequate, and if the Company are not prepared to provide such stations, the Postmaster-General reserves the right not only to license other organisations to do so, but also to give them an appropriate share of the revenue arising from new receiving licences in the district in question. He also reserves the right to license other services (without regard to geographical area) without withdrawing from the Company any part of the licence fees to which they may be entitled. In either case, he re-

serves the right to allot suitable wavelengths to the new organisation, while taking all reasonable steps to avoid creating interference with the Company's services.

The Postmaster-General proposes at an early date to appoint an Advisory Board, as recommended by the Committee, to assist him in all important questions relating to broadcasting. He has noted with pleasure the Committee's commendation of the present broadcasting service; and he trusts that the service will give increasing satisfaction under the new conditions, and that a great impetus will be given to the sale of British-made receiving apparatus.

In the enforcement of the new scheme of licensing, much will depend upon the willing co-operation of the public. So long as there has been no licence to fit the case of the many thousands of "listeners" who are using home-made apparatus, it would have been unreasonable for the Post Office to attempt to enforce the law with any strictness; but now that such a licence is available, there will no longer be any excuse for the use of receiving apparatus without licence. The Postmaster-General believes, however, that the "listening" public will require no pressure in this respect. He is confident that they will be not only willing, but anxious, to put themselves right as regards the law, and at the same time to contribute their quota towards the cost of a service which is affording them so much enjoyment.

Copies of the Broadcasting Committee's Report may be purchased through any bookseller or directly from H.M. Stationery Office at the following addresses: Imperial House, Kingsway, London, W.C.2, and 28, Abingdon Street, London, S.W.1; York Street, Manchester; 1, St. Andrew's Crescent, Cardiff; and 120, George Street, Edinburgh. Its price is 9d. or, if ordered by post, 1d. extra for postage.

G.P.O., October, 1923.

[This matter is also referred to in our Editorial.]



News of the Week

WE are informed by the Radio Society of Great Britain that arrangements with regard to the transmitter section are progressing favourably, and it is hoped to make an announcement shortly.

At a Committee meeting of the Schools Radio Society, of which Mr. Hibberd, of the Haslemere School, is Hon. Secretary, it was resolved to ask the Radio Society of Great Britain to take the Schools Society within their organisation. The Committee of the Radio Society of Great Britain have agreed, and arrangements are now being made.

The next meeting of the Radio Society of Great Britain will take place on Oct. 17th at 6 p.m. at the Institute of Electrical Engineers, when an informal meeting will be held. A general meeting of the same Society will take place on October 24th at 6 p.m. at the Institute of Electrical Engineers.

It may interest our readers to learn that the Radio Society of Great Britain have made arrangements with the B.B.C. whereby they will broadcast a news bulletin relative to the work of the Society. These bulletins will be broadcast on Thursdays as from October 11th.

At the forthcoming exhibition at the White City, the Radio Society of Great Britain will be represented. Thanks to the organisers, Messrs. Bertram Day & Co. and the National Society of Radio Manufacturers, a stand has been placed at the disposal of the

Society for the benefit of its own members, as well as those of affiliated Societies.

We learn from *The Times* that a movement has been begun on the initiative of M. Homburg, a Paris barrister, for the promotion of an international committee to protect authors and artistes whose interests are affected by broadcasting entertainments. It is contended that new laws are necessary to safeguard artistic and literary rights. As to authors' royalties it is held that the broadcasting companies, rather than the public, should pay, and a more binding financial contract than now exists is suggested between the companies and the proprietors of places of public entertainment.

We understand from the *Freeman's Journal* that negotiations between representatives of several wireless manufacturing companies and the Post Office officials of the Free State of Ireland have reached a stage when it is safe to assume that an Irish Broadcasting Company will be formed in the near future.

The proposed station is to be in or near Dublin. One important result of the formation of a broadcasting company will be that all restrictions on the use of private wireless sets at present obtaining will be removed.

Many Northern experimenters are desirous that a wireless exhibition be held in Newcastle, on similar lines to those which have taken place in London, Cardiff, and elsewhere.

Still further evidence of the far-reaching abilities of wireless is forthcoming in the fact that Miss Kennedy, sister of the ill-fated Col. Kennedy, who was recently murdered in an Indian railway train, first heard the news of her brother's fate while listening-in, with some friends at Dungannon, to the news bulletin broadcast from Glasgow.

We are given to understand by a Belfast correspondent that the local police are now making a house-to-house inspection of wireless licences. It is understood that the chief reason for this vigilance is that by insisting upon all listeners taking out a licence promptly the Ministry of Commerce will have a basis on which to conduct negotiations with the B.B.C. relative to their co-operation in a Northern Ireland station.

Considerable sensation has been caused in South African circles by the announcement in the Press of this country that a deadlock has arisen in regard to the establishment of an Imperial Wireless Chain.

The *Cape Times*, in stating that the construction of the South African station by the Marconi Co. will begin immediately, also adds: "For communication between Great Britain and South Africa a high-power station in England is essential. If its erection is to be obstructed any longer by officials of the British Post Office, General Smuts will certainly express his opinion of their tactics in no mild terms."

C. W. TRANSMISSION

By E. H. ROBINSON.

The following is the continuation of an article in which the author deals with anode-taps, reaction, and a popular American arrangement.

(Continued from Vol. 2, No. 12, page 442).

The Anode Tap

THE most efficient way of getting the best out of one's transmitter is to use an "anode tap." This is shown in Fig. 3. The anode circuit contains an inductance, L_1 , of a greater number of turns than is necessary

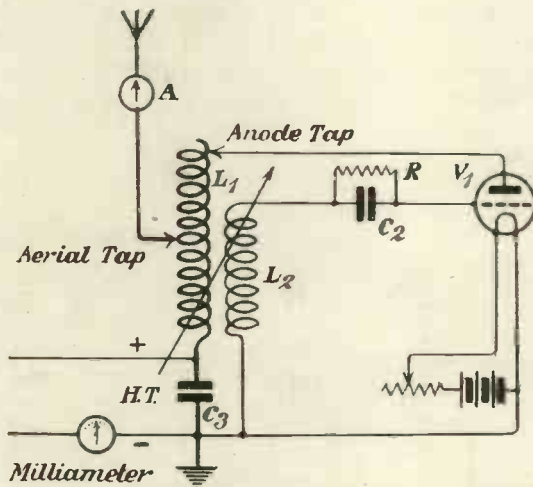

Fig. 3.—Method of using an anode tap for regulating impedances.

to tune the aerial, and by means of a separate aerial tapping just enough turns are included between aerial and earth to tune to the desired wavelength. The anode tap is adjusted until a maximum reading is obtained on the aerial ammeter A. The reaction coil L_2 is coupled to L_1 in the usual way, but the actual amount of coupling will be found to be rather critical for maximum aerial current.

The object of the separate anode tap is to make the impedance of the inductance included in the anode circuit of the valve V_1 equal to the impedance of the valve itself for the particular oscillation frequency being generated. In other words, the comparatively large inductance in the anode circuit forms an oscillatory circuit with the comparatively small internal capacity of the valve, this oscillatory circuit forming a kind of primary circuit tuned and auto-coupled to the aerial

circuit made up of the comparatively large capacity of the aerial itself and the few turns included between the aerial tap and earth.

A maximum transference of energy from the valve to the aerial circuit is thus ensured. No matter how few turns are included between aerial and earth (provided, of course, that there are at least one or two), the set can hardly help oscillating if the anode tap is correctly adjusted. This adjustment is usually rather critical, but a little patience expended in this respect will be amply repaid by results. The best position of the tap varies with different valves, for a given wavelength, and also varies to some extent with the power used.

Sometimes it may be necessary for the anode tap to be taken nearly coincidentally with the aerial tap or even below it—especially if the aerial is a very small one. As a rule, however, the anode tap must be well above the aerial tap. In a typical 200-metre C.W. transmitter the inductance L_1 was wound with 16-gauge d.c.c. copper wire on a cylindrical former 4in. in diameter, the turns being wound close. The anode circuit included 50 turns, while only 20 of these turns were included in the aerial circuit. This example must only be taken as a rough indication of the size of inductance to be used for 200 metres; the capacity and inductance of different experimenters' aerials differ considerably, and the exact values can only be found by trial in individual cases.

A correctly adjusted anode tap reduces the heating up of the plate of the power valve. When more than 300 volts H.T. is being used on the plate of a small transmitting valve, the plate may become bright red hot owing to excessive electronic bombardment. Careful adjustment of the anode tap will often not only increase the plate current, as registered by the milliammeter in the H.T. supply leads, and the aerial current, but will also reduce the heating effect on the plate sufficiently to keep it below red heat.

Another very good circuit, which is a

slight modification of Fig. 3, is shown in Fig. 4. Here the connection to filament and earth is taken from a point P on the inductance L_1 , intermediate between the anode tap S and the aerial tap Q, the turns

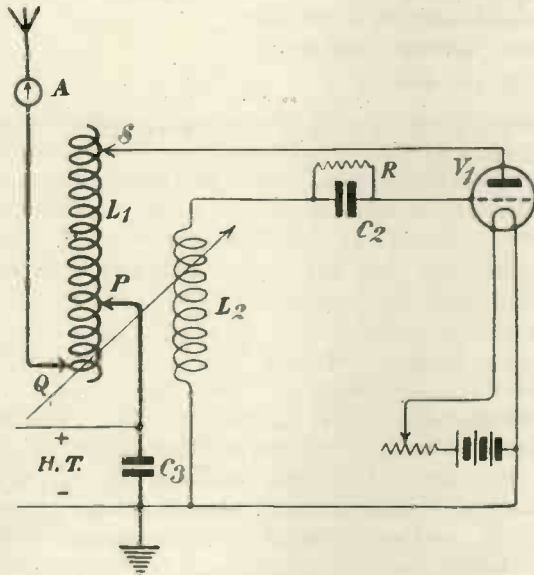

Fig. 4.—A modification of the circuit given in fig. 3.

between P and Q comprising the aerial inductance and those between P and S, comprising the anode inductance. For best results the anode and aerial circuits are brought into resonance in the usual manner by adjustment of the anode tap S. The writer has found it best to couple the reaction coil L_2 into the end Q of the inductance L_1 and not into the end S.

Reaction

Not much has been said yet about the reaction coupling coil L_2 . The size of this does not seem to be a very critical factor, and may vary between quite wide limits without materially affecting the radiation. As a general rule the fewer the turns on L_2 the

tighter must be its coupling to L_1 . A useful value for L_2 is something a little larger than the aerial inductance (i.e., the portion of L_1 included between aerial and earth). L_2 may be made to slide either outside L_1 or within it; the latter is preferable, however, from a practical point of view, as an external coupling coil is liable to get muddled with the various tappings and connection clips projecting from the anode coil L_1 .

Circuits of the type shown in Fig. 5 seem to be rather popular amongst American experimenters. There is only the one inductance coil L_1 , the separate reaction coil, or "tickler coil," to use the phraseology of our expressive cousins, being dispensed with. Nevertheless, it will be seen that the elimination of the separate grid coil is amply compensated by the wealth of adjustable clips that becomes necessary. However, this arrange-

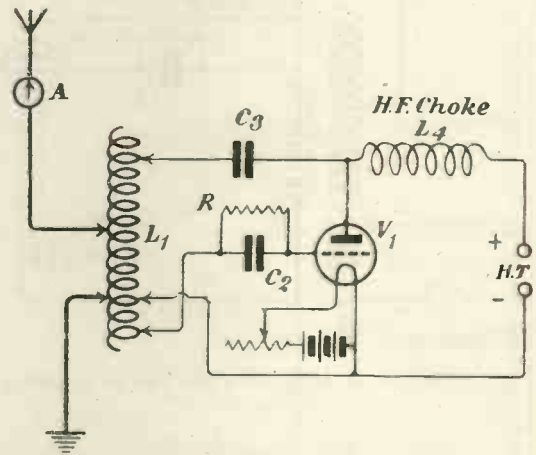

Fig. 5.—A popular American circuit for C.W. transmission.

ment has the advantage of compactness, and does away with the trouble of mounting a separate coil with variable coupling. Reaction coupling is controlled by adjustment of the position of the grid tap.

"MODERN WIRELESS" BINDING CASES

"MODERN WIRELESS" has now completed its first volume, the October issue being the first number of Vol. II. The publishers are preparing binding cases and these, together with the necessary index, will be ready on October 17th.

The covers are in two attractive styles, one being a cloth-backed case and the other leather-backed, both lettered in gold. The prices of the cases are 2s. 6d. and 4s. 6d. (post 4d.), while if readers supply the necessary back numbers, they can be returned bound for 4s. 6d. or 7s. 6d. (post 1s.).

"WIRELESS WEEKLY" THREE-VALVE RECEIVER

By E REDPATH, Assistant Editor.

Some practical notes concerning the manipulation of the receiving set described in our last issue.

Operating the Set

THE actual procedure to be adopted when using the set for the first time after completion or, indeed, at any time until considerable experience is gained, is as follows. Connect the aerial and earth, telephone receivers, and accumulator battery to appropriate terminals as marked. Insert the three valves carefully and tightly into their respective sockets, and move the rheostat knobs to see that the valves light up correctly. Switch off the valves again and connect the high-tension battery to the correct terminals, and light up the valves to proper brilliancy.

By making a rule never to connect the high-tension battery until the accumulator has been connected and the valves inserted in their holders *and tested*, the risk of damaging valves, due to a mistake in wiring or to using the wrong terminals, is obviated.

Short-circuit the single-coil holder in the aerial circuit, and (for broadcast reception) insert a No. 50 honeycomb, duolateral or lattice, coil in the left-hand side of the two-coil holder and a No. 50 coil in the right-hand side.

Reaction

It will be remembered that reaction is obtained between a coil in the anode circuit of the second or rectifying valve, and the tuned anode circuit of the first, or high-frequency valve.

This method of applying reaction to the circuit being permissible under the Post Office Regulations, bring the reaction coil fairly close to the anode

tuning coil and rotate the variable condenser until the "cluck" and continued breathing sounds indicate that the set is oscillating. Loosen the reaction coupling until the set stops oscillating, and rotate the aerial tuning variometer until a point is reached where the set recommences to oscillate.

The more definite the oscillation point, that is to say, the smaller the amount of variometer movement during which the set continues to oscillate, the greater will be the sensitivity of the receiver as a whole.

When endeavouring to pick up signals from distant stations, loosen the reaction coupling and proceed to rotate the variometer and move the condenser knob simultaneously so as to search the complete wavelength range of the variometer with the receiver in a sensitive condition.

When signals are received loosen the reaction coupling until the set is not oscillating, and try the effects of varying the filament brilliancy of each valve in turn, also readjustment of the variable gridleak, until best results are obtained. It will be found that a slight variation of the gridleak varies the reaction effect and, if a difficulty is found in setting the coil to the correct position, the variable gridleak may be used instead.

Aerial Tuning Condenser

The efficiency of the set for reception of the shorter broadcasting and experimental wavelengths, especially when used in conjunction with a fairly large aerial, is considerably improved by the ad-

dition of an aerial tuning condenser.

This condenser was not included in the original specification, as the set (exactly as described) gave excellent results, but subsequent trial of a $0.0005\mu\text{F}$ fixed condenser in the aerial lead proved such addition to be advantageous upon the shorter waves.

Results Obtained

In conclusion, a few words regarding the results obtained immediately after the set was completed will no doubt prove useful to readers who contemplate its construction.

With any receiving set having several adjustments improved efficiency is almost certain to be gained as the operator's familiarity with the set increases. Used in conjunction with a good aerial, about 60ft. long and 40ft. high, situated 15 miles south-east of London, all the British broadcasting stations were satisfactorily received on a loud-speaker. 2LO interfered to some extent with reception from Cardiff and from Manchester. L'Ecole Supérieure (Paris) wavelength, 450 metres, was also clearly received.

With suitable "plug-in" coils inserted in the single coil-holder (aerial circuit) and in the two-coil holder (tuned anode and reaction circuits), the Hague (1,085 metres) and Radiola (1,780 metres) were also tuned in at good strength.

Further tests, commencing at midnight and ending about 5 a.m., resulted in good, clear speech and music being received from several American broadcasting stations, although at times atmospherics were fairly bad.

MANY would-be listeners to the broadcast concerts who live within the range for crystal reception will welcome the following description of another simple form of crystal receiver, which does not require a great amount of mechanical skill for its construction.

The general appearance of the complete set can be seen from the photograph Fig. 1. It consists of a baseboard on which are mounted aerial, earth and telephone terminals, a crystal detector, and two basket coils, the lower one being fixed and the upper one being pivoted to slide across it for tuning purposes.

The baseboard is 7 in. long, 5 in. wide, and $\frac{1}{4}$ in. thick, preferably of hardwood, such as teak or mahogany, which has been well dried and then given a coat of French polish or shellac varnish to exclude moisture. The positions of the four terminals are shown in Fig. 1. The base is stiffened by the addition of two cross pieces of wood, each $5\frac{1}{2}$ in. by 1 in. by $\frac{3}{4}$ in. It will be necessary to bore two holes in the front piece with a $\frac{3}{4}$ in. centre-bit, in order to make a clearance below the telephone terminals.

The basket coils each consist of 40 turns of No. 26 S.W.G. d.c.c. wire, wound on flat discs of stiff cardboard each $3\frac{1}{2}$ in. diameter, well dried, and having nine slots, cut as shown in Fig. 2. The winding is commenced by passing the wire through a pin-hole midway between two slots, then back

A SIMPLE CRYSTAL RECEIVER

By E. M.

A constructional article describing an easily made and inexpensive receiver, simple to operate and capable of good broadcast reception at distances up to about 20 miles.

through the first slot, out through the second in a clockwise direction, and so until the required number of turns have been completed. The end of the wire then passes through another pinhole on the outside of the card (see Fig. 2). Six inches of wire should be left at each end for making connections, and it is important that both coils should be wound in the same direction.

Two small circular pieces of wood $\frac{7}{8}$ in. diameter and $\frac{1}{4}$ in. thick should be glued in the centre of each coil, and both coils should be given a coat of shellac varnish and allowed to dry.

When dry, the fixed coil should be screwed to the baseboard and the moving coil should be fixed to a strip of wood, 5 in. long, $\frac{3}{4}$ in. wide, and $\frac{1}{4}$ in. thick, pivoted upon a small wooden block 1 in. high, as shown in Fig. 3.

The loose ends of wire from each coil are passed to the underside of the base through small holes, the wires from the moving coil being coiled, as shown in the photograph, to allow of movement. If the dimensions given have been followed, the top coil will now slide across the bottom one without touching it when the pivoted arm is moved (Fig. 3).

If desired, a complete set of parts for a crystal detector may be purchased for about one shilling. That shown in Fig. 4 is a modification of one which appeared in *Wireless Weekly* of April 11th, 1923.

A piece of 2B.A. threaded brass rod $2\frac{1}{2}$ in. long is fitted with two nuts and washers and secured to the base as shown. A strip of springy brass about $\frac{1}{16}$ in. thick, $4\frac{1}{2}$ in. long and $\frac{1}{2}$ in. wide is cut and filed to shape as in Fig. 5. Two holes are drilled so that it moves freely on the brass upright. The narrow end is given a half twist for about $\frac{3}{4}$ in. and the broad end bent to a semi-circular shape, so that the two holes are

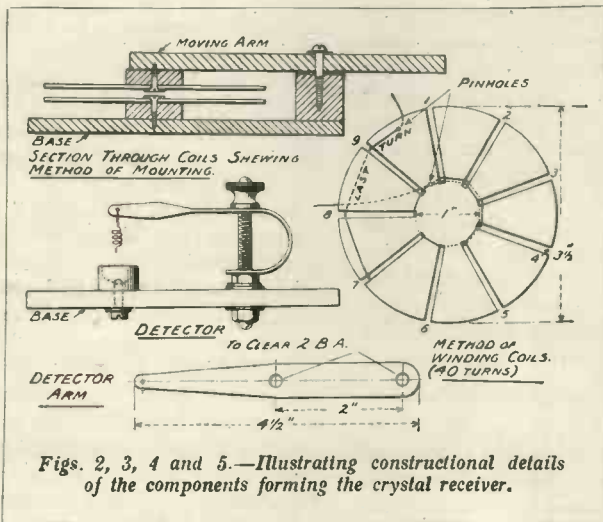

CRYSTAL RECEIVER

KNIGHT.



Fig. 1.—Photograph of the receiver.

above one another. A small hole is drilled at the narrow end, through which a 2 in. length of fine copper wire is passed twice and soldered to make secure. The loose end can be twisted round a French nail to form a spiral "catwhisker." The complete arm is slipped on the brass upright and a 2 B.A. terminal head screwed on the top. The crystal cup is fixed immediately below the whisker, and this completes the detector.

The final operation is to make the connections underneath the baseboard. The aerial terminal is to be connected to the centre of the fixed coil and the crystal cup; the left-hand telephone terminal to the detector upright; the earth terminal to the outer end of the moving coil and the right-hand telephone terminal. The outer end of the fixed coil and the inner end of the moving coil are to be connected by twisting the wires together and soldering. The complete assembly and connections are shown in Fig. 6. The addition of three ivoryine labels to mark aerial, earth

and telephone terminals completes the receiver as shown in the photograph Fig. 1.

High-resistance telephones should be used. To tune the receiver, a contact is first made on the crystal. If a sensitive spot is found, a weak signal will probably be heard. The top coil is now moved slowly across the bottom one until the loudest signals are heard, a final adjustment of the crystal detector completing the operation.

The writer is situated about $4\frac{1}{2}$ miles from 2LO. The crystal used is Hertzite and the telephones are of 4,000 ohms total resistance. On an indoor aerial consisting of three parallel wires, 19 ft. long, immediately under the roof tiles and about 25 ft. high, 2LO can be heard clearly, and the music recognised, with the telephones held at arm's length. With the telephones on, music and speech are perfect, and nothing better could be desired.

Readers who make the set should have no difficulty in obtaining equally satisfactory results. There are no sliding contacts to cause trouble, as in many types of crystal receiver, whilst the work involved takes comparatively little time, and the total cost, excluding telephones and aerial, should not exceed half a crown or three shillings.

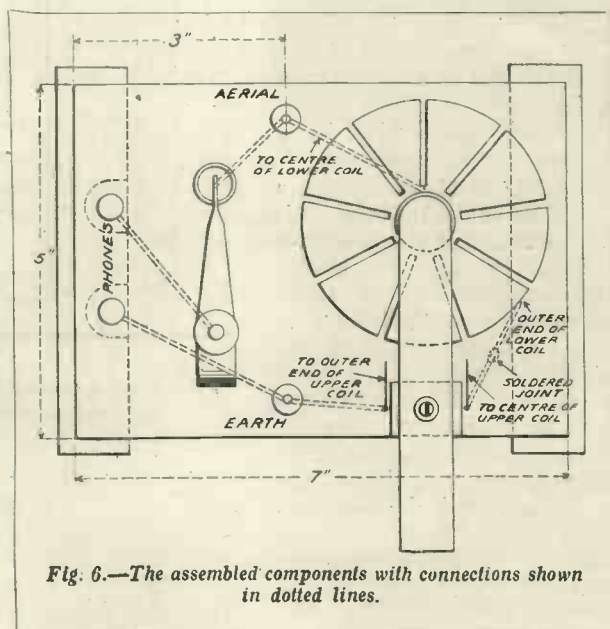
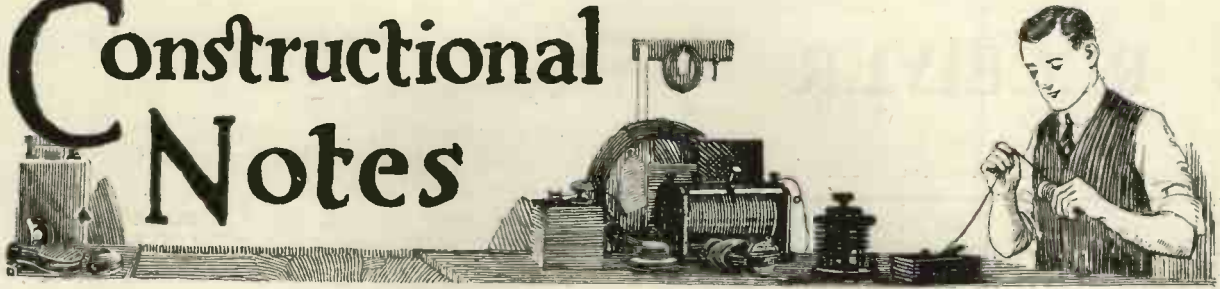

Fig. 6.—The assembled components with connections shown in dotted lines.

Constructional Notes



Conducted by R. W. HALLOWS, M.A., Staff Editor.

READERS of *Wireless Weekly* have frequently been advised to make use of separate components, with which any circuit can be wired up very quickly, rather than of boxed-in sets mounted in cabinets, whose wiring is neither readily accessible nor easy to alter. There is no doubt that this is the only satisfactory method for those who are engaged in serious experiments. One of its great advantages is that if several low-frequency transformers are used, as when making up reflex circuits, they can be kept far enough apart to make sure that distortion and howling are not caused by the inter-action of stray fields.

The amateur who adopts this method of wiring up his circuits will find that a great deal of time is saved and that he has more room at his disposal if he fits up a wireless bench (or adapts his existing one) in the way to be described.

The table itself should be a solid, steady affair, made of stout deal. Its minimum size should be 2ft. wide by 4ft. in length. Twelve inches below is a shelf, strong enough to support the accumulator and the high-tension battery, which, besides giving house room to these rather cumbersome parts of the wireless set, also provides an excellent place in which to keep spare coils, condensers, valve holders, and the thousand and one odd components that go to make up the enthusiast's stock-in-trade.

Placed at one end of the table, and measuring its whole width, a long, narrow box with ten ter-

AN EXPERIMENTER'S BENCH

minals fitted upon an ebonite strip, as shown in Fig. 1, should be secured. This is the connection panel, the wiring diagram of which is seen in Fig. 2.

At the upper end is a large

terminal and those for the A.T.C. is a small series parallel switch, whose usefulness is at once apparent. A single pole knife switch is situated between the earth terminal and L.T. negative. This makes it possible to wire up single-circuit layouts without difficulty, as well as enabling one to earth the secondary at will if a closed circuit is in use. Cut-out switches for both high- and low-tension batteries are also provided.

For aerial and earth leads heavy ex-army terminals may be used. The remainder are 4B.A., but all should be of the double type which facilitates the attachment of several leads to one terminal.

The panel is a sheet of $\frac{1}{4}$ in. ebonite measuring 24 inches by 2 or $2\frac{1}{2}$, which is marked out and drilled as shown in Fig. 1. The holes for the various switches are not shown, since the positions of these are governed by the patterns in hand. If he desires to make the switches himself, he will find constructional details amongst these notes in earlier issues of this journal.

Wiring should be done on the bridge method. Use stiff tinned copper wire of No. 18 or 20 gauge without systoflex or any other insulating covering. Keep the leads well away from each other, and when they must cross let them

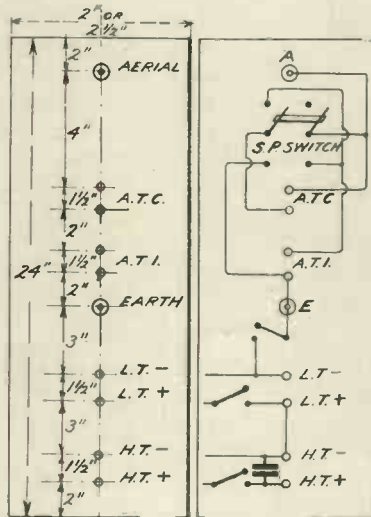

Figs. 1 and 2.—Details of the connection panel.

terminal for the aerial lead. A little lower down come two pairs of smaller terminals for A.T.C. and A.T.I. respectively, which are followed by a second large terminal for the earth lead. The remaining two pairs are connected to low- and high-tension batteries.

do so at some little distance and as nearly as possible at right angles. If all leads are kept at least $\frac{1}{2}$ in. apart there will be very little capacity between them, since air spacing only is used. The high-tension battery condenser is to be mounted on the underside of the panel. Leads long enough to reach the high- and low-tension batteries are secured to the shanks of their respective terminals. All connections, whether between wire and wire or wire and terminal, are soldered so that there may be nothing to work loose.

A wooden box 24 in. by 2 (or $2\frac{1}{2}$) and three inches in depth is now made, being fixed to the table, when finished, by screws. Holes are drilled right through the bottom of the box and the top of the table for the battery leads. These are passed through the holes made for them, and the panel is screwed down to its box.

As dilute sulphuric acid has a very rapid action upon soft wood, a tray made of well beeswaxed teak should be provided upon the shelf for the accumulator to rest upon.

The table is now ready for use, though various improvements can be made from time to time. One of these is to place a beading right round the top of the table so that small components may be prevented from rolling off on to the floor. Another that may suggest itself is to fit a drawer between the shelf and the table top at the end opposite to that occupied by the batteries.

R. W. H.

A NOVEL FILAMENT SWITCH

FOR a multi-valve set employing separate filament rheostats it is a great convenience to have a switch for the accumulator, so that the rheostats may be left in their best position. Unfortunately, this plan has its

disadvantages, in that at the moment of switching on the full working current is applied to the filaments in their cold condition, thereby shortening their life.

This difficulty may be overcome by using the switch described here-

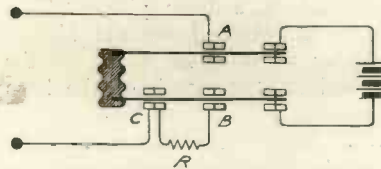

Fig. 3.—Details and circuit of the filament switch.

in. When the contact arm is depressed the valves light up and the current passes through an extra resistance, which is cut out by a further movement of the arm.

The switch is made from the parts of an ordinary double-pole double-throw knife switch. The contact points are remounted as shown in the diagram so as to form a single-throw switch with two contacts on one of the arms. Only three of the four contacts are needed. Between B and C is connected a coil of resistance wire, such as is used for filament resistances, of about 1 or 2 ohms resistance. The knife arms are connected to the accumulator, and contacts A and C to the L.T. terminals of the set.

As the switch is pushed down from the "off" position, contacts A and B are engaged first, and the L.T. circuit is completed through the resistance R. Contact is then made with point C, and the resistance is short-circuited.

E. L. S.

DRILLING CONDENSER END PIECES

WHEN drilling holes for the supporting rods and the spindle of condensers of the rotary vane type either in ebonite end pieces or in the panel itself

one is very apt to make an error, which, small though it may be, is quite sufficient to spoil the working of the instrument. If either the supports or the spindle are at all out of the true, fixed and moving plates will not be quite in the same plane. If the error is bad they may actually touch at some points, but even if it is only slight the condenser will be most unsatisfactory to use for anything like fine tuning, since owing to the varying air space between the plates there will not be a regular increase or decrease in capacity as the knob is turned.

One can make use of the fixed plates themselves as templates for drilling the holes for the supports, but the difficulty is to find the centre which lies outside the plate altogether.

Here is a simple tip that will save trouble. Paste a piece of thin white paper over the place on the ebonite to be occupied by the condenser. Lay one of the rotary plates upon it, adjusting it carefully until it is exactly in the right position. Then take a sharp-pointed pencil and mark out the outline of the plate on the paper. Run the point also round the insides of each of the three holes. Now remove the plate and proceed in the way shown in the drawing.

Find the centre of the rings representing the support holes by

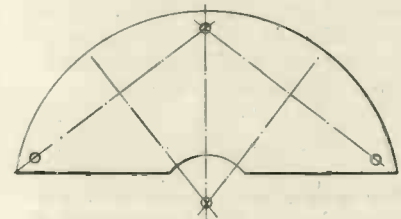

Fig. 4.—Illustrating the suggested method for finding the radius of condenser vanes.

eye. Make a dot at each and join the three by straight lines. Bisect each line, and from its middle point draw a line at right angles. Where the two lines cross is the exact centre required.

Punch marks should now be made for the centres of each of

the four holes, after which they may be drilled with perfect confidence.

If plates of the same size are always used it will pay to make a template in this way from sheet metal. When this is done the holes in the template should be just large enough to allow the point of the centre punch to pass.

R. W. H.

SAWING EBONITE

THE sawing of fairly large pieces of ebonite often seems to the novice a matter of some difficulty; when the saw cut is more than, say, six inches long he finds a considerable tendency to irregularity, and cannot keep the saw from straying off the line ruled upon the ebonite.

A simple expedient for overcoming the difficulty is to clamp upon the ebonite sheet a piece of hard wood having a fairly straight edge, so that the latter is exactly parallel to the line upon which the cut is to be made, and perhaps $\frac{1}{2}$ in. away from it. Clamp the whole firmly to the work-bench and use the edge of the piece of wood as a guide. Keep the saw up against it as you go, and the cut will automatically be kept straight and true.

G. P. K.

USING AN ELECTRIC RADIATOR AS A LOUD-SPEAKER

MANY wireless experimenters possess in their homes an electric radiator which has a parabolic copper reflector. This device can be very easily changed into a loud-speaker, giving good results, in the following manner:—

First of all the porcelain carrying the heating element is removed and a diaphragm, of some elastic substance for preference, is attached to the wide end of a little horn, which can be easily made from soft cardboard with the aid of a little glue. This horn is attached by the aid of copper wires in the place of the porcelain, the mouth of the horn pointing into the interior.

To obtain the best tone it is necessary to experiment with the position of the horn a little, the most effective point being where the sound waves are sent out parallel with the central axis of the reflector, but this does not present any great difficulty.

A telephone earpiece must, of course, be fixed to the narrow end of the horn.

X. Y. Z.

AN IMPROVEMENT FOR CRYSTAL CUPS

OWING to their constructional shortcomings crystal cups are often found to be very inconvenient for quick fixing of crystals. A small gadget

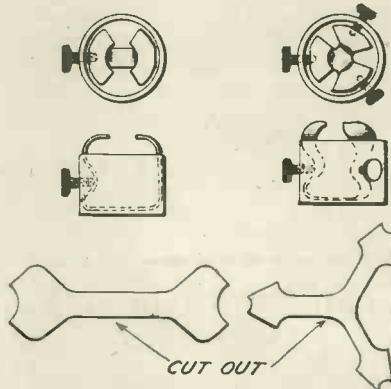

Figs. 5 and 6.—Illustrating details of the crystal cup attachments.

which effectually simplifies the operation of inserting the crystal in the cup is easily made as shown

in the diagram. A suitable design for single screw cups is shown in Fig. 5, whilst one for a triple screw cup is shown in Fig. 6. For single screw cups a piece of springy brass of appropriate dimensions is cut out as shown, and bent to form the curve indicated. This is slipped into the cup when the screw is out. On replacing the screw, pressure is brought to bear on the clip by turning the screw towards the indent. This operation holds the clip and at the same time actuates the jaws above the surface of the cup. For triple screw cups cut from springy brass a shape as shown in Fig. 6, bend over in the manner indicated, and insert same in the cup in a manner similar to that adopted in the case of the single screw cup.

H. B.

ADJUSTABLE BITS

PERHAPS the most useful bit of all for wireless constructors is the washer cutter by means of which thin brass or ebonite washers may be cut to any size complete in one operation. This bit, which is adjustable to any desired diameter, is well worth purchasing, in view of the fact that in a few moments a dozen ebonite washers can be cut, which would cost at least 2d. each.

The bit is adjusted to the desired external and internal diameters of the washer to be cut by means of thumb screws which actuate the positions of four sliding cutting points. The two external points are first fixed to the desired external diameter of the washer and then tightened. The two internal points are fixed in a similar way to correspond with the internal diameter of the washer. The bit is then used in the ordinary way with either a brace or a breast drill. H. B.

Broadcasting News

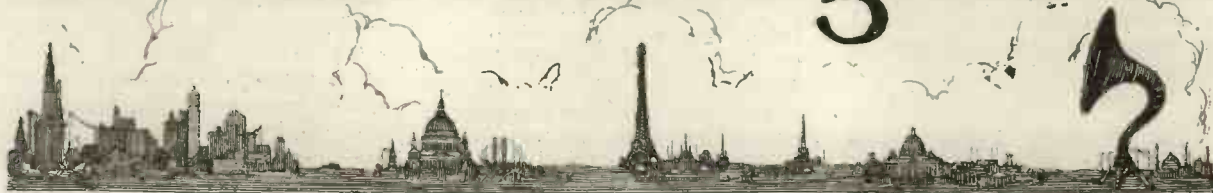

By OUR SPECIAL CORRESPONDENTS.

LONDON.—It was unfortunate that the first Symphony Concert which was broadcast simultaneously from 2LO fell on the night of the publication of the report, with the result that it did not get as good a press as it might have done. It was generally agreed, however, that the transmission was very creditable to everyone concerned.

The musical critics were quick to observe that the balance of the orchestra for wireless transmission must differ from that for an ordinary concert. It was taken for granted that it is the desire of the B.B.C. to give as much of the best as the public will stand, but they recognised also that Symphony Concerts are not always the most popular musical performances, and they will not forget that the main function of the B.B.C. is to cater for everybody in turn.

We are usually averse to listening to automatically produced "music," and our aversion was intensified one Sunday afternoon recently when the B.B.C. gave us several items on the "Reproducing Organ" at Steinway Hall.

The only bright spots in the afternoon's performance were the several vocal items by Mr. Farrington.

However, the Sunday evening concert made ample amends for the shortcomings of the earlier transmission, and the inclusion in the programme of H.M. Royal Air Force Band of such popular items

as "Poet and Peasant" and "Samson and Delilah," with the long and difficult cornet solo, "Softly Awakes the Heart," faultlessly executed, must have given infinite enjoyment to thousands of music lovers.

Earlier in the week we also enjoyed listening to the "Ensemble Singers," correctly named, for they worked all together, their voices being well balanced and blending harmoniously.

Then the selection of Squire's popular songs made very good hearing, for one has far to seek to find more tuneful or better orchestrated songs than these favourites.

Forthcoming Events

- OCTOBER.**
 10th (WED.).—Popular selections by the Orchestra. Mr. Haddon.
 11th (THURS.).—Music critic. Mr. E. Fagg on "Modern Painting." Ballad concert.
 12th (FRI.).—Musical comedy programme. Film critic.
 13th (SAT.).—Advice on Photography," by Mr. J. H. Gear, F.R.P.S. Dance music by the 2LO Dance Band.
 14th (SUN.).—The Dean of Manchester will give an address.

BIRMINGHAM.—During the past few weeks 5IT has been received several times in America, and letters have been received by the Station Director specifying the items and testifying to their clearness, so that there could have been no imagination about it on the part of the "fans" over there.

The simultaneous transmissions of Mr. Percy Scholes' musical talks from 2LO have been keenly appreciated in the Midlands, and, allied to the splendid programmes now being provided by 5IT, they have done much to increase the artistic value and enjoyment of broadcast music.

The Station Repertoire Company have been putting in some enthusiastic rehearsal work for the opera "Il Trovatore," and it will be their aim, together with the orchestra, to achieve an even greater measure of success than has been reached in the past with performances of this kind. The opera will in all probability be transmitted to the other stations.

Forthcoming Events

- OCTOBER.**
 10th (WED.).—Lozell's Picture House Orchestra.
 11th (THURS.).—"Il Trovatore" (simultaneous). John Henry.
 12th (FRI.).—Mr. William Michael, bass, of the British National Opera Co. Mr. Wilfred Ridgeway on "The Appreciation of Music." Selections by the English Trio.
 13th (SAT.).—Station Military Band.
 14th (SUN.).—8.30-9.45, Land-line transmission of the "Hymn of Praise" from the Newcastle Station.

GLASGOW.—One of the most popular features broadcast by the Glasgow Station is the "All Scotch Nights." On Saturday, September 29th, there was another brilliant programme devoted to Scotch music, including songs by Miss Flora Blythman, contralto, and Mr. Alexander Morrison,

baritone; 'cello, piano, clarionette and flute solos by members of the wireless orchestra. It is believed that, so far as Glasgow district is concerned, more people listen-in to this class of music than to any other.

The Company which recently performed "Rob Roy" at the Glasgow Station is now engaged at the Glasgow Coliseum Theatre. Two of the cast, Mr. Fred Borthwick (who plays the part of "Major Galbraith") and Miss Ella Lorraine ("Helen" of "Rob Roy"), returned to the Station to delight a Sunday audience with their beautiful renditions.

Forthcoming Events

OCTOBER.

- 10th (WED.).—Mr. T. C. Gregory, pianist (the first blind pianist to broadcast from 5SC); Miss Christine Macfarlane, contralto; Mr. Stanley Field on "Industrial Training of Disabled ex-Service Men."
- 11th (THURS.).—Mr. W. R. Ferguson, of the St. Andrew's Ambulance Association. Orchestra.
- 12th (FRI.).—Miss Gertrude Johnson, soprano, of the British National Opera Co.; Mr. J. Bland Bruce, baritone; the Pipe Band of the 139th Glasgow Company of the Boys' Brigade; Mr. Arthur Murray on "Football."
- 13th (SAT.).—The Band of H.M. 1st Bttn. Royal Scots Fusiliers; Mr. Alexander Hope, bass-baritone.

MANCHESTER.—If listeners could see the production of an operatic performance, such as "Carmen," which was rendered from 2ZY last week, they would appreciate what a bargain they get for the licence fee. After half an hour's vigorous rehearsal, the orchestra, soloists and choir were packed inside the studio and the doors closed. For two hours the opera proceeded, the musical items being interspersed with brief explanations from Mr. Moses Baritz, who sat in a corner with a microphone to himself, the other microphone for recording the

music being placed on the studio clock near the top of the studio.

The conductor, Mr. Dan Godfrey, jun., sans coat, vest, collar and tie, and with sleeves rolled up, prepared for his "physical jerks," and soon the perspiration was rolling down his face. The opera was delightful to hear, the clarity of the instruments and the rich tones of the vocal music testifying to the remarkable improvement made in radio transmission during the last few months, and great praise is due to the B.B.C. for presenting us with such music in the quiet comfort of our own homes.

Forthcoming Events

OCTOBER.

- 10th (WED.).—3.30, Miss Lyndi Partington, contralto; Mr. Frank Perrin, tenor; Miss Phyllis Kebble, soprano. 6.15, 2ZY Orchestra; Miss Gertrude Johnson, soprano, of the British National Opera Co.
- 11th (THURS.).—11.30, 2ZY Trio. 6.30, Miss Elsie Tippet, contralto; Mr. T. H. Morrison, solo violin. 7.45, St. John's Wesleyan Prize Choir. 9.45, Spanish talk.
- 12th (FRI.).—3.30, Oxford Picture House Orchestra. 6.15, 2ZY Orchestra; Miss Nellie Walsh, contralto; Mr. Harold Brown, baritone. 8.45, Talk on "Morocco and Algeria," by Rev. G. W. Kerr. 9.45, French talk.
- 13th (SAT.).—3.30, Oxford Picture House Orchestra. 7.45, Rag-a-Jazz Monarchs Dance Orchestra. 8.45, Talk on "Winter Sport," by Mr. J. Boardman. 8.55, Miss Henry, soprano.
- 14th (SUN.).—8.30, Concert by members of the British National Opera Co. 9, Rev. J. Adamson, M.A., B.Sc.
- 15th (MON.).—3.30, 2ZY Trio; Cliff Weston, baritone. 5.30, Children's music. 6.45, Spanish talk.
- 16th (TUES.).—3.30, Oxford Picture House Orchestra. 7.45, Ashton-under-Lyne Concertina Prize Band; Mr. Lambert Harvey, tenor. 8.45, Talk on "Mythological Pictures," by Mr. J. C. Phythian. 9.40, Talk on "Northumbrian Legends," by Capt. H. G. Bell

NEWCASTLE-ON-TYNE.—It was announced in the official programme that Earl Haig's speech on the occasion of the unveiling of the Newcastle War Memorial would be broadcast from 5NO, whose studio looks on to the Memorial, and a special microphone for use out of doors had been secured for the event. On the eve of the ceremony it was notified that representations had been made to the B.B.C. to the effect that this was in the nature of a transmission of news, and was therefore not permissible before 7 p.m. according to the terms of the company's licence.

In view of the alleged imminence of the publication of the Broadcasting Committee's report, the company decided to cancel the arrangements without offering any opinion as to the merits of the point raised.

Forthcoming Events

OCTOBER.

- 10th (WED.).—Mr. William Michael. Corporation Tramways Band.
- 11th (THURS.).—A night with Grand Opera. "Maritana," Acts I. and II.
- 12th (FRI.).—Semi-classical concert.
- 13th (SAT.).—Popular music.
- 14th (SUN.).—Handel's "Hymn of Praise," with Miss Gertrude Johnson, London.
- 16th (TUES.).—Mr. Robert Gourley, entertainer, London.

Simultaneous Broadcasting Events

OCTOBER.

- 10th (WED.).—Opening Aberdeen Station. Mr. Archibald Haddon, dramatic critic.
- 11th (THURS.).—"Il Trovatore" from 5IT to 5WA and 5SC. Savoy Orpheus Dance Band to all stations. My Percy Scholes, musical critic.
- 12th (FRI.).—Mr. J. A. Atkinson, film critic.
- 14th (SUN.).—3.5 p.m., Transmission from Steinway Hall. "Hymn of Praise" from 5NO to 5IT and 5SC.
- 15th (MON.).—"Composer Evening," conducted by Sir Alexander Mackenzie. Savoy Orpheus Dance Band. Mr. John Strachey, literary critic.



Apparatus we have tested

Conducted by A. D. COWPER, M.Sc., Staff Editor.

Plug-in Coil-holder

ARATHER more than usually pretentious coil-holder for plug-in coils for use on the experimenter's table is produced by N. V. Webber, a sample of which we have examined. The ordinary plug-and-socket fitting are mounted on a small panel which in turn is mounted on a wooden base, terminals of handy size being provided on the panel. With two of these fittings, coils can be placed close enough for magnetic coupling whilst standing on the table. The holder should prove a useful accessory in experimental work on new circuits, etc.

An Extension Handle

An exceedingly useful and ingenious gadget for use in fine tuning and careful experimental work generally is the "El-Be" anti-capacity extension handle submitted by Messrs. Leigh Bros. In each of the three types offered, the plain type, the telescopic type, and the vertical handle, a soft rubber cup or sucker is mounted on the end of the handle. By simply moistening the rubber and pushing down in place the handle is firmly and instantaneously held on to any standard ebonite knob. On trial it was found to adhere firmly enough to move any but the tighter spindles, and to provide fine adjustment in a most convenient manner, as e.g. in a "super" circuit with capa-

city aerial alone, where body capacities are most irksome. It is quite an invaluable accessory for the serious experimenter, of the widest application, and is, incidentally, of neat and workman-like appearance, besides being modest in price.



The Elwell tuning unit.

"Receptite" Crystal

Yet another of the sensitised galena type of crystals is the "Receptite," marketed by Messrs. Cook and Co., a sample of which we have been able to put to extensive practical trial. The sample submitted was found to be sensitive, practically everywhere on its bright surface.

A Universal Tuning Unit

Messrs. C. F. Elwell Co., Ltd., have submitted a miniature desk-type of unit which comprises a coil-holder, 0.001 μ F "Polar" variable condenser, and series-parallel switching device with the aid of which many different arrangements involving tunable circuits can be conveniently set up. This has the "Polar" condenser Xa control knob and scale in a handy position on the sloping front of the small desk. Two terminals are provided at the top and two pairs of plug-and-sockets are arranged in a square, by which means, with the help of a loose plug with terminal, the series-parallel alternative is available. The maker's special coils plug in conveniently and provide for aerial tuning, tuned coupled and anode circuits, rejector circuits, etc. by various simple modifications. It was noticed on trial that the ordinary type of plug-in coil could not be accommodated in the holder when this loose plug was inserted, thus indicating that coils with narrow mountings would have to be used.

In practical tests, both in experimental circuits and in straight broadcast reception as an ordinary tuner, quite satisfactory results were obtained, whilst the convenience of this self-contained unit was manifest. The general finish and workmanship were good, the construction being sound and substantial.

Owing to the demands upon our space we regret that the conclusion of "Four Weeks' Holiday with a Portable Set" and "Correspondence" have been unavoidably held over.



Mainly about Valves

Our weekly causerie written by the Editor.

Testing Gridleaks

A METHOD of testing gridleaks which is very rarely used by the experimenter consists in arranging a valve so that it oscillates intermittently, producing a buzzing note, the frequency of the buzz depending upon the value of the condenser and leak.

An arrangement of this kind was used during the war and was called a "squegger," this hybrid name being derived from the words "squeak" and "megger," the latter, of course, being the name of the well-known instrument for measuring resistances.

Fig. 1 shows a squegger circuit which, as will be seen, consists simply of an oscillating valve in which an anode coil is coupled to a grid coil; the reaction is made very tight, and the ordinary coupling between honeycomb coils will not usually be sufficient. If the coupling is made tight, it will be found that the valve will produce a buzzing sound in the telephone receivers. The pitch of this note will depend upon the value of the high-resistance connected across the terminals A B. The greater this resistance the lower will be the note, and clicks at the rate of one per second are readily obtainable.

The principle on which the apparatus works is quite simple. Owing to the tight coupling, self-oscillation is set up in the valve, and the oscillating currents applied to the grid will cause the latter to become positive with respect to the filament at every half-cycle. As the grid reaches a potential at which it begins to draw electrons to itself these latter accumulate on the grid and on the right-hand side of the grid condenser. After a number of oscillations have taken place, an appreciable negative grid potential is built up, and this potential finally becomes so negative that the anode current is appreciably reduced, and the valve no longer produces oscillations. In other words, the rapidly accumulating nega-

tive charge on the grid causes the representative point on the characteristic curve of the valve to move down towards the bottom bend, and when it reaches this point the valve may stop oscillating. When the valve stops oscillating there is no further piling up of electrons on the grid, but, on the other hand, the electrons on the grid and on the right-hand side of the grid condenser leak away through the gridleak. This will take some time, and may

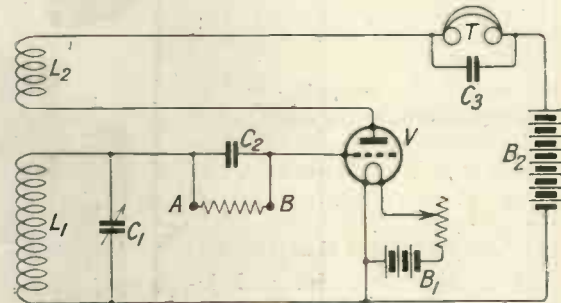

Fig. 1.—A "Squegger" circuit for testing gridleaks.

even take a second. As the charge on the grid is leaking away, the grid potential is becoming less negative and the valve ultimately becomes normal when oscillations recommence and the process is repeated. The device, therefore, becomes a self-acting oscillator which is interrupted at regular intervals.

The groups of high-frequency oscillations generated are detected by the valve, and each produces a click in the telephone receivers. The rapid sequence of clicks produces the musical note, and the more rapidly the leak carries off the electrons from the grid the higher will be the pitch of the note heard.

An excellent means of testing the efficiency and reliability of a variable gridleak is to connect it across the terminals of a squegger circuit. The variation of note heard in the telephone receivers should be perfectly smooth.

Information Department



J. W. R. (LIVERPOOL) has constructed a 3-valve receiver using ST45 circuit, and now wishes to add an additional high-frequency valve.

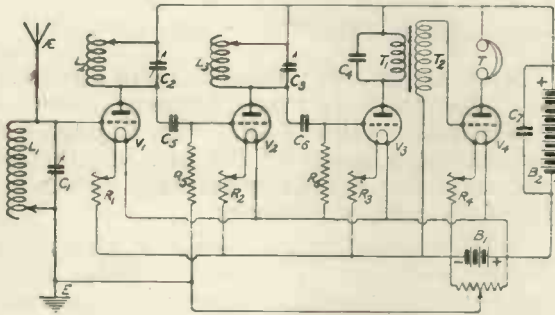

We reproduce herewith a circuit diagram explaining how an additional valve may be employed. You will find this circuit rather difficult to handle, as it is necessary to tune both the high-frequency circuits simultaneously. There will be a general tendency to self-oscillation, but this can be largely checked by careful adjustment of the potentiometer.

B. M. D. (LEVENSHULME) asks if basket coils may be used instead of honeycomb coils in the ST100 circuit, and also for details of number of turns, etc.

Basket coils may be substituted for honeycomb coils in practically every case save where considerations of space have to be taken into account. We would

point out that for larger inductances basket coils are particularly unwieldy unless wound with extremely fine wire which will lower their efficiency. You will find eighty turns of No. 26 wound on a 5-in. former a suitable number for the anode coil for broadcast wavelengths, and thirty-five turns for the aerial coil if the variable condenser is to be used in parallel. Should you use the condenser in series, then fifty turns would be more suitable.

J. S. I. (N.W.1) has constructed an ST76 receiver and wishes to add a further high-frequency valve.

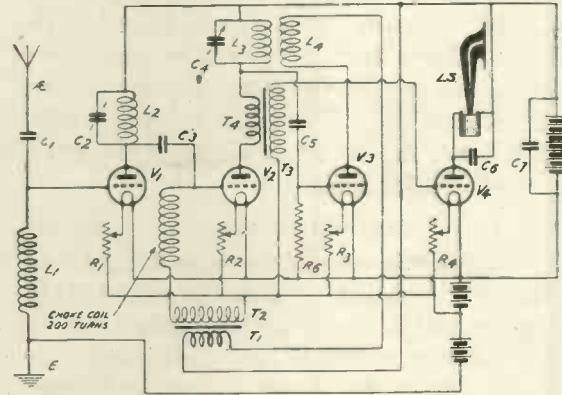

We reproduce herewith a suitable circuit which, though capable of giving good results, will probably require a little experimenting with regard to plate voltages to obtain stability of action.

E CONOMIC ELECTRIC LD.

THE "EEC" "XTRAUDION" VALVE

is being used by the leading Radio Experimenters for detection, high and low frequency amplification, power amplifiers and low power transmission. Price 15/-

USE "RECTARITE," the synthetic crystal that makes Loud speakers talk!
1/8 Large Specimen.

Write to-day for 40 page Radio Catalogue mailed post free, 4d.

Head Office: 10, FITZROY SQUARE, LONDON, W.1.

Showrooms: 303, EUSTON RD., N.W.1.

Branch and Works: TWICKENHAM.

BEWARE OF WORTHLESS IMITATIONS, SEE THE TRADE MARK *WatMel* ON EVERY GRID LEAK.

WATMEL VARIABLE GRID LEAK

(Patent applied for.)

The Resistance is steadily Variable between $\frac{1}{2}$ to 5 megohms. Only requires a $\frac{3}{8}$ in. hole in panel for fitting.

Suitable for use in any circuit, and improves the working of any valve detector. (50,000 to 100,000 ohms for the S.T.100 Circuit. Price 3/6.)

PRICE 2/6 EACH
The best Variable Grid Leak made.

WATMEL WIRELESS CO. Connaught House, 1a, Edgware Road, Marble Arch, W.1. Tel. 4575 Paddington.

POST OFFICE

:: NOTICE ::

USE OF UNLICENSED WIRELESS RECEIVING SETS

THE Postmaster General calls attention to the new arrangements announced in the Press for the issue of wireless licences.

Many persons are known to be using wireless receiving sets without a licence, owing to the fact that no licence has hitherto been available for home-made sets. A new form of licence known as an "Interim Licence" has now been introduced to meet the case of persons *who are already in possession of unlicensed sets*. It imposes no condition as to the make of existing apparatus.

This licence will be issued at an annual fee of 15/- to persons who apply *before the 15th October*. No charge will be made for past user, and no proceedings will be taken in respect of past user if the licence is applied for before the 15th October. *Any person who uses unlicensed apparatus after that date will render himself liable to heavy penalties under the Wireless Telegraphy Act 1904.*

The "B.B.C." Licence at 10/- still remains on sale, and a second new form of licence, known as a "Constructor's Licence," which will meet the case of persons who intend to make their own sets but have not yet done so, is also issued at 15/-.

The new licences are on sale at all Head and Branch Post Offices and certain Sub-Offices. Forms of application can be obtained at any of these offices and also at any Sub-Office at which Money Orders are issued.

E. A. (NEWPORT, MON.) asks for constructional data to enable him to assemble the Flewelling receiver, and also particulars regarding frame aerials.

The following will enable you to arrange the Flewelling circuit shown in Fig. 8, *Modern Wireless* for September, page 568. The variable condenser in parallel with the loop should have a capacity of $0.0005 \mu\text{F}$. The grid condenser should be of $0.0003 \mu\text{F}$, and the gridleak should be variable, as shown in the diagram. The high-tension battery should have a voltage of about 80 to 100 volts. It is not possible to introduce low-frequency amplification into this circuit without the addition of a second valve. A suitable frame may be 2 ft. square and be wound with twelve turns of No. 20 d.c.c. wire. Suitable designs for such frames have been given in *Wireless Weekly* and *Modern Wireless*, Vol. 1, No. 9, and Vol. 1, No. 5 respectively.

N. J. D. (N. 15) wishes to build a receiver as described in the August issue of "MODERN WIRELESS," Fig. 4, page 528, but having a range of 300 to 2,600 metres, and asks for details regarding number of turns for each variometer.

It is not possible to wind variometers capable of covering this range. You could, of course, replace each of the variometers by a plug-in coil of a standard make shunted by a suitable variable condenser. Suitable sizes of coils can be chosen from a chart given in *Modern Wireless*, No. 6. This chart will also enable you to decide upon suitable number of turns for home-made coils. If you decide to construct variometers they should have the following numbers of turns for the broadcasting wavelengths: Aerial circuit variometer, forty turns on both stator and rotor; plate circuit variometer, sixty turns on both stator and rotor.

The No. 200 choke coil is a coil having 200 turns. The dimensions of the variometers can be as follows: Diameter of rotor, 3 in.; diameter of stator, 4 in.; length of both stator and rotor tubes, 2 in.

J. B. (ANTRIM) intends making a receiver using circuit ST44 and requests particulars regarding the inductances.

L_1 , L_2 , and L_3 can all be wound on a $3\frac{1}{4}$ in. former. L_1 should have 30 turns, L_2 70 turns, and L_3 40 turns. So long as the condenser C_1 is of $0.0005 \mu\text{F}$ capacity and condenser C_2 0.0002 or $0.0003 \mu\text{F}$ capacity, the whole of the tuning for lower wavelengths can be carried out without alteration of coils, and for this reason no tappings are necessary. Your attention is drawn to the fact that ST44 must not be used for British broadcasting. ST45 could be used in its stead, in which case the same values will suit. If Igranic coils are used, L_1 should be 25; L_2 , 50 or 75; and L_3 , 50 or 75. For the reception of the French Radiola concerts L_1 should be a 150 coil, L_2 a 200 coil, and L_3 a 100 or 150 coil. The wire used for winding your coils, if wound as single layer inductances, should be No. 24 d.c.c. or enamelled wire.

WECONOMY SETS

incorporating the

WECOVALVE.

The **WECOVALVE** (pea-nut type) is the most economical valve existent, requiring only 0.25 of an ampere at 0.8 to 1.1 volts and having more than twice the life of tungsten and other dull-emitter valves.

It can be used either as a Detector or Amplifier and operates off a single dry cell.

Filament Current 0.25 amps.
 Filament Voltage 0.8 to 1.1 volts.
 Detector Plate Voltage 17—22 volts.
 Amplifier Plate Voltage 22—45 volts.
 Dimensions $\frac{3}{8}$ " diam. \times $2\frac{1}{8}$ " long.

Price: £1 10s. 0d.



No. 44215-A.

Patent Nos. 17580 (1915), 180090 (6641-1921).

The **WECOVALVE** (pea-nut type) can be used with your existing receiving sets by the use of the Weco Valve Adaptor (No. 44092), which has contact springs faced with gold and silver alloy to ensure a perfect contact with the base of the valve.

Dimensions $1\frac{1}{2}$ " \times $1\frac{1}{4}$ "

Price: 3s. 6d.

The Weco Valve Socket is specially designed to mount Weco Valves and is arranged for your soldered connections.

Dimensions: $1\frac{1}{2}$ " \times $\frac{3}{4}$ "

Price: 1s. 6d.

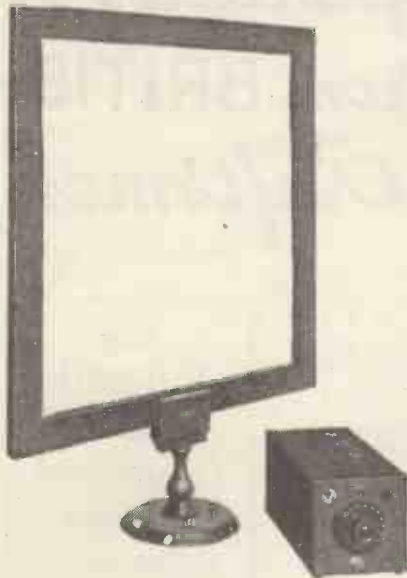

No. 44085.

A Frame Aerial Receiving Set and a Frame Aerial.

This Frame Aerial Set consists of a special three-valve set designed to tune within the B.B.C. band of wave-lengths (300—500 metres) when used with the Western Electric Frame Aerial. Three Weco Valves are used, hence accumulators are unnecessary—three dry cells suffice for the filaments and a 45-volt high-tension battery is required for the plate circuit.

As is usual with frame aerial sets, the range is somewhat limited, but increased freedom from interference is secured, apart from the actual fact that no external connection whatever, either aerial or earth, is necessary with this type of Set.

Code No. 44083 Frame Aerial Receiving Set only - **£17 17s. 6d.**
 Code No. 44084 Frame Aerial only - **£2 17s. 6d.**
 Code No. 44085 Receiving Set complete with aerial - **£20 15s. 0d.**
 (Prices includes Valves)

A Detector Set having two stages of high-frequency amplification and detection; containing three Weco Valves and operating without reaction. Designed primarily for use as a detector where Amplifiers and Loud Speakers are required and for other cases where extreme purity of tone is essential. Suitable for use within the B.B.C. band of wave-lengths, i.e., 300 to 500 metres.

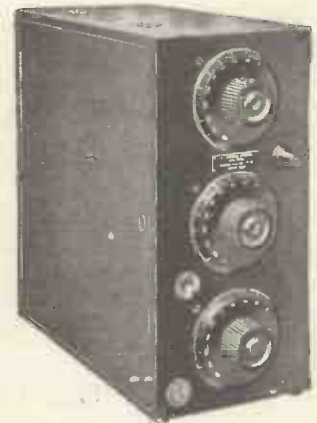

No. 44082.

A Three-Valve Receiving Set

WRITE FOR BOOKLETS

W.E.Co./32/W. 528 and W. 529.

Western Electric Company Limited

(WHOLESALE ONLY)

Connaught House, Aldwych, London, W.C.2.

Telephone: Central 7345 (9 lines).

Branches:—Glasgow, Leeds, Birmingham, Manchester, Newcastle, Cardiff, Southampton, Dublin.

Ethophone Broadcast Receivers



BURNDEPT *Wireless Apparatus is wholly BRITISH made from BRITISH materials by BRITISH Craftsmen.*

AS a result of the New Post Office Regulations, we have been able to amend the prices of our Broadcast Receivers as below:—

No. 500. Ethophone Junior, Crystal Receiver	£3 0 0
Extra Broadcast Tariff	£0 1 0
No. 501. Ethophone No. 1 Crystal Receiver	£5 0 0
Extra Broadcast Tariff	£0 1 0
No. 510. Ethophone Popular Model, complete with self-contained H.T. Battery	£13 10 0
Extra Broadcast Tariff	£0 17 6
No. 510 WA As No. 510, complete with Valves, Battery, Accumulator, Telephones and Aerial Equipment	£18 10 0
Extra Broadcast Tariff	£0 17 6
No. 525. Ethophone Speech Amplifier, complete with two special Valves and self-contained 120-volt Battery	£20 0 0
Extra Broadcast Tariff	£0 10 0
No. 506. Ethophone IV., inclusive of 3 M.O. Valves and High Voltage Battery	£30 0 0
Extra Broadcast Tariff	£1 2 6
No. 507. Ethophone V., inclusive of 4 M.O. Valves and High Voltage Battery	£35 0 0
Extra Broadcast Tariff	£1 7 6
No. 520. Ethophone Power Amplifier, inclusive of 2 M.O. L.S.2. Valves and 150-volt High Tension Battery	£27 0 0
Extra Broadcast Tariff	£0 10 0

BURNDEPT Ltd., Head Office: ALDINE HOUSE, BEDFORD STREET, STRAND, W.C.2.

Phone: Gerrard 7794. Also at Leeds, Cardiff and Newcastle.

BURNDEPT
WIRELESS APPARATUS

Buy
BRITISH
Made
Guaranteed
Wireless
Apparatus.

WE are showing at the Exhibition being held at the White City from November 8th - 21st, under the auspices of the National Association of Radio Manufacturers.

Build your own Set

The Ethophone Home Constructor No III

MANY people receive much more satisfaction in building their own wireless receiver than in purchasing one already made. Here is an opportunity for every one to build their own 3-valve set out of British guaranteed components. The set can be assembled quickly with a screwdriver, soldering iron and pliers only. When completed it has the appearance and performance of a factory-made product of Burndept standard. The set will receive British Broadcast anywhere in the country. American reception is quite usual, but cannot be guaranteed. Continental Broadcast is almost a certainty. Will operate a loud speaker up to 80 miles from a Broadcast centre under normal conditions, but much greater distances have been obtained.

Write for descriptive
Pamphlet No. 234.

No. 532. Complete set of components from which to build a 3-valve receiver as illustrated (1 stage Radio Frequency, detector and note magnifier). Inclusive of Marconi Licence. Price £12 0 0

BURNDEPT LTD. *Head Office: Aldine House, Bedford Street, Strand, W.C.2.*

BURNDEPT

WIRELESS APPARATUS

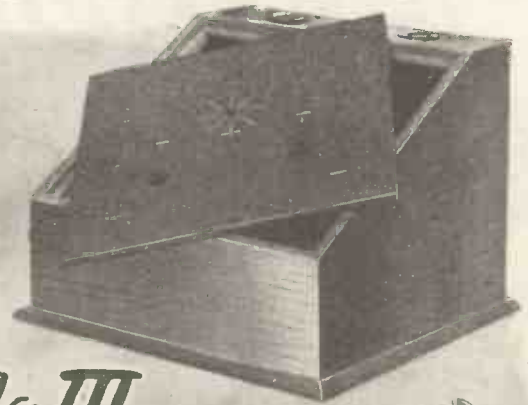

BRANCHES

- LEEDS: The London Assurance House, Broad Place, Gallowgate.
- NEWCASTLE-ON-TYNE: 7 St. Andrew's Buildings West, Queen's Street.
- CARDIFF: 27 Queen's Street.
- HEAD DISTRIBUTING SERVICE DEPOTS. ENGLAND.
- BIRMINGHAM: C. S. Baynton, 133 New Street.
- MANCHESTER: W. C. Barracough, 61 Bridge Street.
- BRIGHTON: H. J. Callers, 32 St. James's Street.
- NOTTINGHAM: Pearson Bros., 54 Long Row.
- YEOVIL: Western Counties Electrical & Engineering Co., Electricity House, Princeps Street.
- BRISTOL: King & Co., Western Electric Works, Park Row.
- SCOTLAND.
- GLASGOW: W. A. C. Smith, Ltd., 93 Holm Street, 236 Argyle Street.
- IRELAND.
- BELFAST: R. & S. Scott, Kingscourt, Wellington Place.
- DUBLIN: Dixon & Hempstead, 17 Suffolk St.
- CANADIAN OFFICES.
- 172 King Street West, Toronto.
- SERVICE DEPOTS IN ALL LOCALITIES

The New Arrival

Mr. "ORA" welcomes the baby "Wecovalve" to the Mullard family. Like most fathers he looks to his son to uphold the traditions of the house and, indeed, to go one better.

The baby "Wecovalve" shows every evidence of living up to these expectations. It consumes very little current, lasts twice as long as other valves, and needs no accumulators.

If you are buying or making a new set Wecovalves will save you money as they cut out accumulators.

If you have a valve set Wecovalves will pay for themselves in a few weeks.

In any case write to the manufacturers or ask your dealer for List M.W.I. It tells you all about this wonderful new valve.

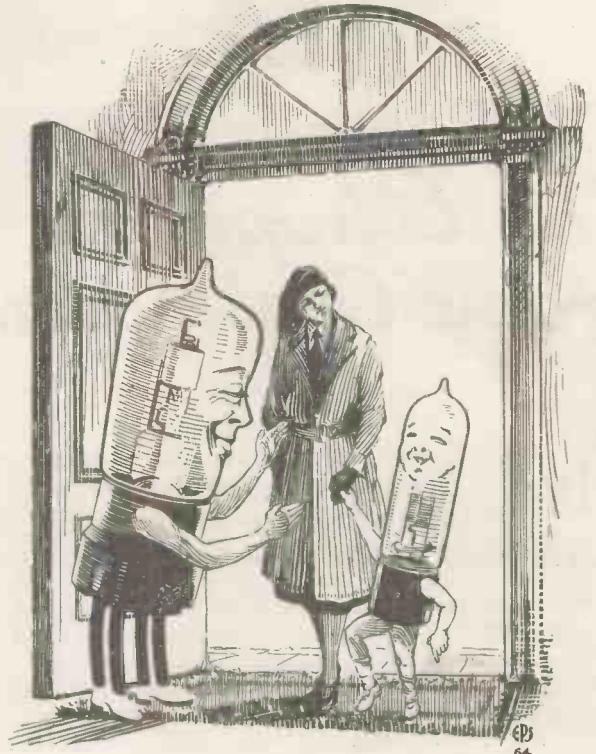

MULLARD WECOVALVE . . .	30/-
SOCKETS	1/6
4-PIN ADAPTORS	3/6
FILAMENT RESISTANCE FOR WECOVALVES	3/9
MULLARD RADIO "A" CELL SPECIALLY DEVELOPED FOR USE WITH THE WECO- VALVE	2/6

Mullard

Advt. The Mullard Radio Valve Co., Ltd., Balham, S.W.12.

You CANNOT be out of WIRELESS WEEKLY because it brings BIG Business.

Lower Prices for the popular Bowyer-Lowe Tuners

We are pleased to announce that we are now able to reduce the prices of the Bowyer-Lowe Standard Variometers. These instruments are well known and are used by many of the best experimenters. The new prices are:

- No. 1. Variometer for Aerial Tuning, 15/-, post 6d.
- No. 2. Variometer for Tuned Anode Coupling, 15/-, post 6d.

A New Tuner

Our latest Tuner is quite new in principle and is a two-circuit arrangement in which the aerial or primary circuit is untuned. The secondary, when tuned with one of our 0.0005mf. variable condensers, covers the range of 250 to 650 metres. The efficiency, selectivity, and sharpness of tuning of this coupler will surprise many who have hitherto thought that the aerial circuit must of necessity be tuned. Constructed on ebonite former with supports and screws for panel mounting.

- Price, Fixed Coupler, 250 to 650 metres, 7/6, post 6d.
- Price, Tapped Variocoupler, 300-800 metres, 19/-, post 9d.

Each of the above instruments can be obtained of all wireless dealers, or in case of difficulty will be sent direct.

The Bowyer-Lowe Co., Ltd.,
Manufacturers of Wireless Instruments,
Radio Works, Commerce Avenue,
Letchworth, Herts.

Wholesale Distributor for Scotland:
F. M. MILLIGAN, 23-25, Renfrew Street, GLASGOW.



EDISWAN

for preference.

Experimenters—the men who know—always specify Ediswan, because experience has taught them that Ediswan means “the best possible results”

Model 1923B.

P.O. Regd.

No. 433.

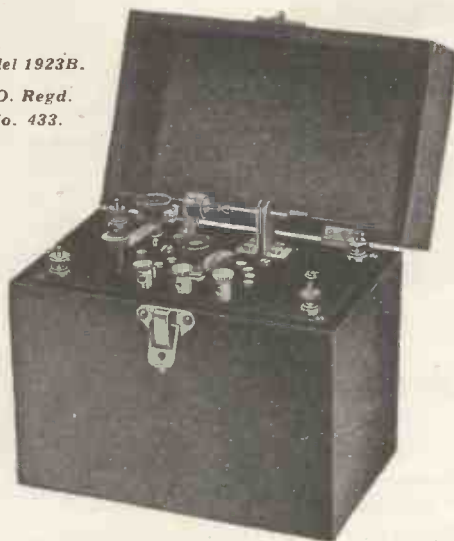

THE EDISWAN CRYSTAL SET.

Clear and loud reception is readily obtained over a range of 25 miles, under favourable conditions. Receives on wave-lengths between 200 and 500 metres. Special type Cat's whisker detector and super-sensitive crystal, special provision made for the addition of a Valve Note Magnifier. Including headphones and all accessories ready for immediate use. Price **£3 : 7 : 6**

B.B.C. Tax 7/6 extra.



EDISWAN HEADPHONES.

Total Resistance 4,000 ohms. Adjustable Double Headbands, polished Pressed Aluminium Cases, Moulded Ear-pieces and six feet of flexible cord. Price **24/- per pair.**

We manufacture Complete Valve Sets and Accessories, also H.T. and L.T. Batteries. Ask or write for leaflets.

If your dealer does not stock, send us a P.C. with his name and address.

FREE ON REQUEST. Write now for our Illustrated Booklet, "The Thermionic Valve"—a postcard will do.

THE EDISON SWAN ELECTRIC CO., LTD.,

Contractors to H.M. Admiralty, War Office, Royal Air Force,
123/125, Queen Victoria St., E.C.4, and 71, Victoria St., S.W.1.

Works: Ponder's End, Middlesex.

Branches in all Principal Towns.



The "Chello" LOUD SPEAKER Cabinet

Overall
13½" sq. by 24" high
Compartment
12½" sq. by 9½" high
In rich dark oak,
£3 0 0
Carr. fd. Packing 2/6 ret.
Or fitted with
Standard Amplifier
£6 5 0

The MASTER COMPONENT

Just the thing for building up a worth while amplifier or a complete receiving set. An elegant and distinctive cabinet ingeniously combined with a mellow toned wood sound box of unique design and proved efficiency. Replaces the ugly horn type loud speaker and provides an excellent wireless compartment with panelled doors.

For new wireless ideas; write or 'phone

CHELLIS

(Chambers & Ellis)

6 & 7, CRAVEN HOUSE, KINGSWAY, LONDON, W.C.2.

Phone: Regent 1130.

(E.P.S.S.)

EVERYTHING for the Radio Constructor



—even to Explanatory Wiring Diagrams. Showing all the components required, and their relative positions for wiring up, these diagrams are in booklet form and are obtainable from your dealer at 1/- each.

Woodhall Paxolin Variometer. Constructed of Paxolin tubing (not cardboard) the $\frac{1}{4}$ walls allow close coupling. The bearings are accurate and robust. Wound to 300-450 metres and attached to panel by drilling one hole only. Complete with Terminals (less knob and dial).
List No. 15341. 6/9 each.

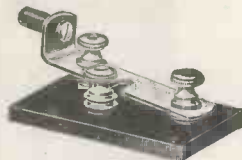

"Security" Earthing Switch. A neat and effective cut-out and a positive protection against lightning.
List No. 17032. 2/3 each

Brown Brothers

with which is amalgamated Thomson & Brown Brothers Limited.

Wholesale only. Head Offices and Warehouses:
Great Eastern St., London, E.C.2.
118, George St., Edinburgh, and branches.

TRADE ONLY SUPPLIED. Kindly order from your usual dealer.



HOME ASSEMBLY SET



M.H.3.
One High Frequency Valve
—One Detector Valve—One
Low Frequency Magnifier
Price £7 : 7 : 0

Complete, clear and concise instructions for assembling are supplied with each set.

Illustrates Completely Assembled Set.

Within twenty miles of a station of the British Broadcasting Company with the aerial allowed by the Postmaster-General this set will work a loud-speaker. Our **Home Assembly Sets** are made up from the actual components used in our well-known M.H. Sets. Select your needs from these:—

- | | |
|--|---|
| M.H.1.—One Detector Valve,
Price £3 7s. 6d. | Two stages of Magnification.
Price £11 0s. 0d. |
| M.H.2.—One High Frequency Amplifying Valve—One Detector Valve.
Price £4 10s. 0d. | M.H.4.R.T.—As M.H.4.R., but with telephone transformer and change over switch. Price £11 11s. 0d. |
| M.H.4.—One High Frequency Valve — One Detector Valve — Two stages Low Frequency Magnification. Price £10 0s. 0d. | M.H./L.C.—Tuner. Price £4 17s. 6d. |
| M.H.4.R.—One High Frequency Valve—One Detector Valve— | M.H.2.A.—One Note Magnifier. Price £3 7s. 6d. |
| | M.H.2.B.—Two Note Magnifier. Price £1 15s. 0d. |

L.M. MICHAEL LTD

IN CONJUNCTION WITH B. HESKETH LTD

Showrooms: **RADIO CORNER, 179, STRAND, W.C.2.**

All correspondence to Head Offices:

HASTINGS HOUSE, NORFOLK STREET, STRAND, LONDON, W.C.2.

SIEMENS

DRY CELLS

FOR OPERATING

LOW TEMPERATURE VALVES

1.1 volt. 0.25 ampere.

Any of our standard sizes above 2½ ins. diameter or 2½ ins. square will give perfectly satisfactory results with this type of valve.

A few of the sizes which we recommend are illustrated below



Size No. 640
Weight 2 lbs. 3 ozs. Dimensions
2½ ins. dia. x 6½ ins. high overall.
1.5 volts.
PRICE RETAIL 2s. 8d.



Size '0'
Weight 3 lbs. Dimensions
2½ ins. x 2½ ins. x 6½ ins. high overall.
1.5 volts.
PRICE RETAIL 3s. 11d



Size No. 948
Weight 5½ lbs. Dimensions
3½ x 3½ x 7½ ins. high overall.
1.5 volts.
PRICE RETAIL 6s. 9d.



Size No. 884
Weight 12 lbs. Dimensions
4½ x 4½ x 8½ ins. high overall.
1.5 volts.
PRICE RETAIL 12s. 0d.

Nos. 948 and 884 sizes have been specially designed for this work, and when used for periods of 3 hours per day will give satisfactory service for at least 4 to 6 and 12 to 18 months respectively, assuming one valve only is used. They will operate two or even three valves connected in parallel, but the length of service will be reduced thereby

SIEMENS BROTHERS & CO., LTD.

WOOLWICH, LONDON, S.E. 18

Stocks held at

BELFAST—36, Mill St. BIRMINGHAM—111, New St. BRISTOL—30, Bridge St. CARDIFF—57-59, St. Mary St. DUBLIN (Irish Free State)—52, William St. GLASGOW—40, Wellington St. & 144, St. Vincent St. LEEDS—129, Park Lane. LIVERPOOL—81, Dale St. LONDON—38-39, Upper Thames St. MANCHESTER—196, Deansgate. NEWCASTLE-ON-TYNE—64-68, Collingwood Bldgs., & Exchange Bldgs., Quayside. SHEFFIELD—22, High St. SOUTHAMPTON—46, High Street.

BUY BRITISH GOODS ONLY!

POLAR CONDENSER

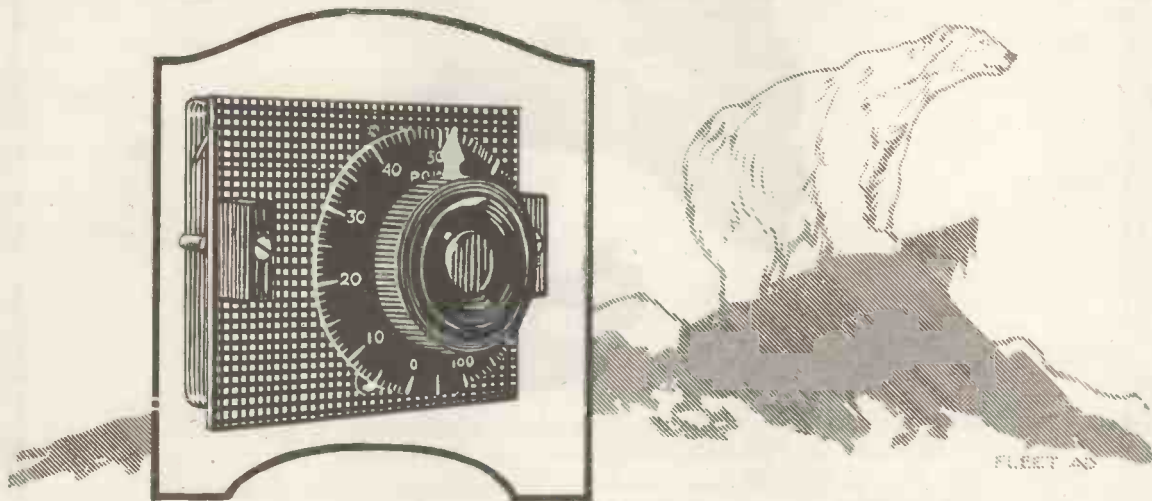

Why you should use it—

Every wireless man knows that when using a tuned circuit the condenser capacity should be as small as possible and the inductance as large as possible.

In the ordinary vane condensers half the capacity is contained in the first $\frac{1}{4}$ th of the scale, so that in the actual operation the section of the condenser mainly used is very cramped and limited.

In the case of the "Polar" Condenser the reverse applies—the first $\frac{1}{4}$ of scale contains only $\frac{1}{10}$ th of the capacity, so that an absolute vernier is provided over the section mainly used.

No "Polar" Condenser is sold without the "Polar" Guarantee to replace if not satisfied.

SPECIAL NOTE.

Amateurs who experiment with various circuits frequently require condensers having different maximum capacities. "Polar" condensers are so constructed that they may readily be adjusted to any of the following maximum capacities:—

'001. '0005. '0003. '0002.

Should the purchaser of a "Polar" condenser of any of these capacities desire to have it changed to an alternative capacity, he may forward it to our Head Office together with a remittance of one shilling to cover the cost of readjustment and return postage. We will then have the condenser adjusted to the desired capacity and returned. We do not recommend amateurs to attempt readjustment of the condensers themselves unless they have ready means for ascertaining the actual readjusted capacities.

PRICES: Unmounted, 14/-; Mounted, 20/-. Postage 6d.

Obtainable at all "Polar" stockists or direct.

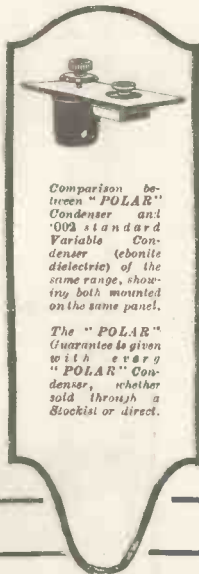

Comparison between "POLAR" Condenser and '002 standard Variable Condenser (ebonite dielectric) of the same range, showing both mounted on the same panel.

The "POLAR" Guarantee is given with every "POLAR" Condenser, whether sold through a Stockist or direct.

We are exhibiting at the N.A.R.M. Exhibition, White City, Nov. 8 to 21

RADIO COMMUNICATION Co., Ltd.

34/35 Norfolk Street, London, W.C.2.

Telephone: Central 8480 (3 lines).

Telegrams: "Radiocomco, Estrand, London."

Fleet Ad.

You CANNOT be out of WIRELESS WEEKLY because it brings BIG Business

The "Amplion" again



Better reproduction of Radio Broadcast Music, whether vocal or instrumental, is afforded by the 1924 AMPLION Models now introduced.

The New AMPLION Series render all ordinary loud speakers obsolete, yet with the latest improvements the AMPLION is one of the least expensive loud speakers on the market.

Having a world-wide sale the AMPLION is produced upon a scale so large that it is possible to offer greatly increased value at the strictly moderate prices of the original types.

Folder W.D.8 describes the AMPLION range for 1924. Prices from £2 2 0.

The Portable AMPLION is fully detailed in Booklet W.D.3.

These Catalogues will be forwarded with the greatest pleasure.

AMPLION Loud Speakers are standardised by the leading producers of Radio Receiving Sets and stocked by all Wireless Dealers of repute.

Patentees and Manufacturers:

ALFRED GRAHAM & COMPANY

(E. A. GRAHAM)

St. Andrew's Works, Crofton Park, London, S.E.4.

Telephone Nos.: Sydenham 2820-1-2. Telegrams: Navalhada, Catgreen, London.

West End Showrooms:

The Algraphone Salon,

25-26, Savile Row, Regent Street, W.1.

Telephone: Regent 1075.

Telegrams: Sonalagra, Piccu, London.

AMPLION

Leads the way!

All New Models of The AMPLION

have non-resonating acoustic amplifiers and wood trumpets.



Swan-neck or "Music Master" style, £6 0 0
List Nos. AR 13 & 15.

Curved Horn or "Dragon" pattern, £5 5 0
List Nos. AR 17 & 19



The Junior-de-Luxe design at £3 5 0

List Nos. AR 41 & 43.

Catalogue Nos.—
The first No. refers to 120 ohm windings, and the second to 2,000 ohm coils.



Universal style for Wall or Table, £8 5 0.
List Nos. AR 5 & 7.



The Portable "All Purpose" model - £6 6 0
List Nos. AR 60 & 61.



Wall or Table Type, £4 15 0
List Nos. AR 1 & 3.

Buy British Goods only.

AMPLION

You CANNOT be out of WIRELESS WEEKLY because it brings BIG Business.

Worth waiting for!



**Cosson
Dull Emitter**

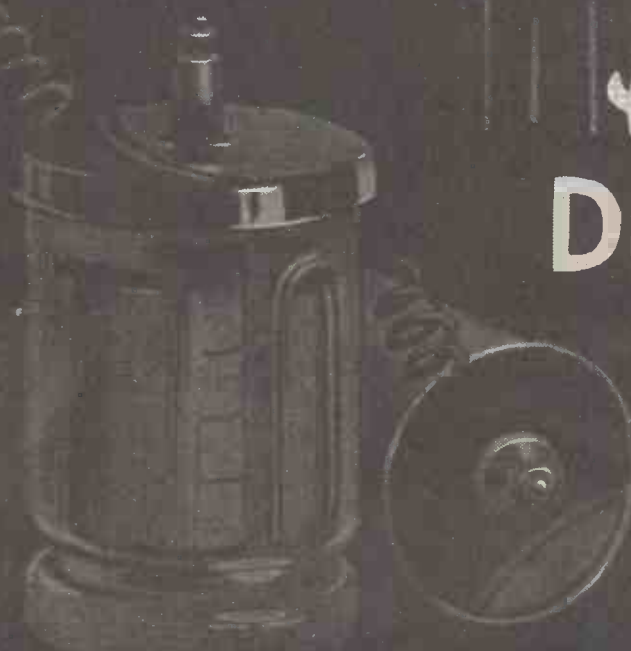

Renders the
accumulator
obsolete

MICA CONDENSER PLATES

&
INSULATING MATERIALS
OF EVERY DESCRIPTION.

MICA & MICANITE SUPPLIES, Ltd.,
MICA HOUSE, OFFORD STREET, 'Phone
CALEDONIAN RD., LONDON, N.1. North 805.

TELEFUNKEN E.V.N. 171 VALVES AT 6/9 POST FREE FOR LONG DISTANCE.

Filament 2-3.5 v. Plate 50-150 v.
WHAT DID WE TELL YOU? READ THIS:
"All British Stations, Christiania, and even American Broadcast received on ONE E.V.N. 171."
(AN EXTRACT FROM A RECENT CUSTOMER'S LETTER, LANGS.)
A few K.T.D. Valves now in stock at 3/9 each. NEW TELEFUNKEN:
Variable Fixed Condensers 1001 at 2/- ea. Post Free. BALL-BEARING
TRANSMITTING GENERATORS by A.E.G. 12 v.D.C. Input 400 v.D.C.
Output. £12 10 0 Carr. Free. TRANSMITTING "BOTTLES" 10 W. &
20 W. at £3 3 0 Post Free. Crystal Detectors, with Crystal at 3/6 ea. Post
Free. Wavemeters, with charts 50-7,500 metres. £10 10 0 Carr. Free.
Transmitting Set, Mod. Control. £10 10 0 Carr. Free. 2-V. Amplifiers,
with double grid valves. £7 10 0 Carr. Free. Moving Coil Volt and OHM
Meters (comb.) from 12/6 Post Free. Roller Switches (various), 12/6 each,
Post Free. H.T. Batteries, 60 v.—3v. Tappings, 9/- each, Post Free.
H.T. " " 36 v.—3v. 6/- " " "

ELEFACTORS, LTD. 86, Granville Rd., Child's Hill,
LONDON, N.W.2.

Just issued—

Wireless Map

of Great Britain

THIS new map has been prepared under expert supervision, and gives the following useful information—
All places with transmitting apparatus are shown in black. Call signs applying to these in red. Broadcasting, Commercial, Aviation, and Amateur and Experimental Transmitting Stations are all indicated by special symbols, also in red. Admiralty, Naval and Trinity House Stations specially shown in blue. A Complete Index to all Amateurs and Experimental Stations appears on the map, the origin of a call-sign being at once located by means of numbered squares. Diagrams with Compass bearings show the direction of important Overseas Stations in relation to different portions of the map. London and District: An inset map on an enlarged scale (1 1/2 miles to 1 in.) clearly shows the stations within this area.

PRICES

On Paper folded in Cover 2/6 net, postage 2d.
Mounted on cloth, folded in Case. . . . 5/6 net, postage 4d.
Mounted on Cloth and Varnished, with Rollers. . . 7/6 net, postage 0d.

2/6

We are only accepting direct orders

RADIO PRESS, Ltd., Devereux Court
STRAND, W.C.2

THE CUP WHICH CHEERS, BUT NOT A CRYSTAL BREAKS.

All "Old Hands" know the misery which screw cups have caused.

All "New Hands" will be wise to avoid it. Both can—by spending sixpence.

Here are two pictures of the Cup (exact size). A lot of explanation is not necessary.

THE PICTURES TELL THE STORY.

The screws are No. 4 B.A. and can be used either way up.

The Cup and Plunger surfaces are ridged.

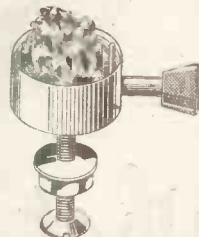

This ensures grip as well as good contact.

PULL KNOB! INSERT CRYSTAL! LET GO!

Prov. Pat. 20606.

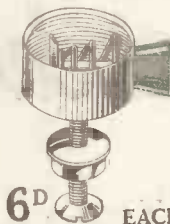

Foreign Patents pending.

6D EACH.

MORE REFTY TIME-SAVERS

No. 1. Lacq. 10 1/2d. each. Ebonite top.

No. 2. Lacq. 6d. each. All brass.

No. 4. Lacq. 1/- each. Ebonite top.



British Patent.



No. 194605.



No. 1a. N. Plate. 11 1/2d. each.

No. 2a. N.P. 7d. each.

No. 4a. N.P. 1/1 each.

Depress the Knob! INSERT the WIRE! LET GO! THE TERMINAL WHICH IS AS GOOD AS A SOLDERED JOINT yet which is connected or disconnected in an instant AND CANNOT POSSIBLY SHAKE LOOSE.

Hundreds of Dealers Stock REFTY Products. Here are some of them. If your dealer doesn't—send cost plus postage for direct delivery.

- N.W.1.—M. Coles, 70, Park Road, Baker Street.
- N.W.3.—S. Porter, 173a, Finchley Road, S. Hampstead.
- N.W.3.—J. Richardson, 32, Heath Street, Hampstead.
- N.12.—North Finchley Motor & Wireless Co., 15, Woodhouse Park.
- S.W.1.—The Haymarket Stores, 28, Haymarket.
- S.W.1.—T. L. Collins, 178, Vauxhall Bridge Road.
- S.W.17.—Brown & Russell, 45, Mitcham Road, Tooting.
- S.E.27.—Lynton Trading Co., 67, Knights Hill, W. Norwood.
- E.C.2.—Messrs. Varato, Ltd., 6, Eldon Street.
- E.C.4.—Fleet Radio Stores, 142, Fleet Street.
- E.C.4.—Mather Bros., 36, Farringdon Street.
- E.C.4.—Richford & Co., 153, Fleet Street.
- W.1.—Radio Stocks, Ltd., 89, Newman Street.
- W.C.2.—Neophone Wireless Co., Little Andrews Street.
- W.C.2.—E. Shipton & Co., King Street, Covent Garden.
- W.11.—H. Nash, 1, High Street, Notting Hill.

REFTY ELECTRICAL LTD., APPLIANCES

2, FEATHERSTONE BUILDINGS, HOLBORN, LONDON, W.C.2
Telephone: Chancery 8264. Telegrams: "Refitinal," Holb, London.

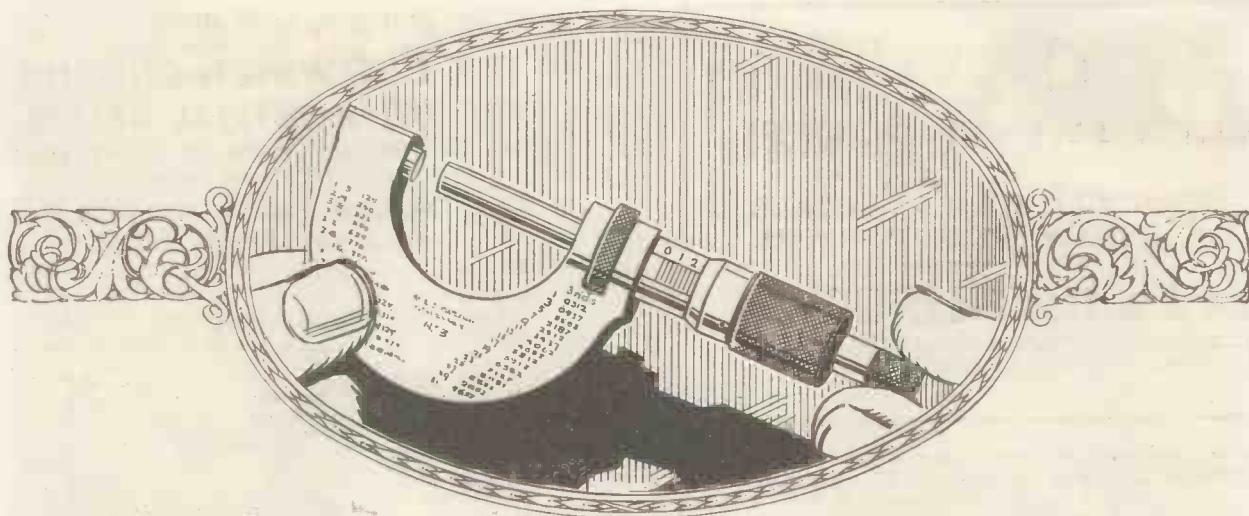

What does diaphragm thickness mean to you?

Prices:

	Model H.1. 21" high.		
120 ohms	£5	5 0
2000 ohms	£5	8 0
4000 ohms	£5	10 0
	Model H.2. 12" high.		
120 ohms	£2	5 0
2000 ohms	£2	8 0
4000 ohms	£2	10 0

HAVE you ever stopped to consider the immense importance of a really thin diaphragm in a Loud Speaker?

Sound waves are created by the rapid vibrations of the diaphragm—these in turn are caused by fluctuations of current in the coils around the magnet poles.

It will be obvious to you if you have been able to compare its aluminium diaphragm with the ordinary flat iron type, why the Brown is so much more sensitive.

Actually the Brown aluminium diaphragm is only 1/500 of an inch thick and about one-quarter of the thickness of the ordinary iron type of diaphragm.

This ensures the Brown being sensitive to a very much greater range of sounds than the ordinary

Loud Speaker—in fact, we say without fear of contradiction, that it is the only Loud Speaker able to reproduce correctly every inflexion of the human voice without distortion.

Its ability to single out instruments in an orchestra, to reproduce them with life-like fidelity is positively uncanny. And it is all due to this wonderful aluminium diaphragm and the principle of the vibratory reed which are Brown master patents.

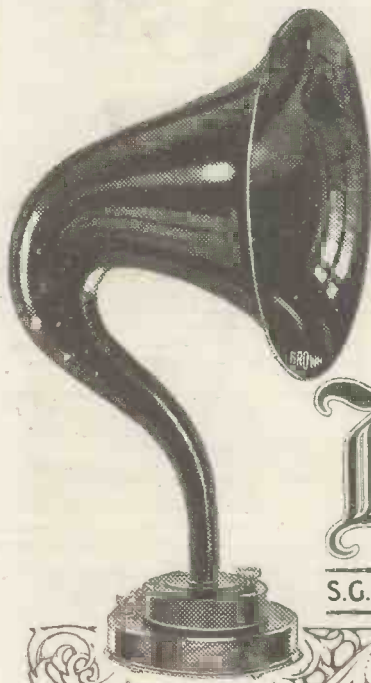

Brown

S.G. BROWN LTD. RETAIL: 19 MORTIMER STREET, W.1. WHOLESALE: VICTORIA ROAD, N. ACTON, W.3.

In fairness to your own judgment, you should certainly hear the Brown before you select your Loud Speaker—your Dealer has one in stock or will get one for you.

"ATLAS" THE COIL SUPREME.

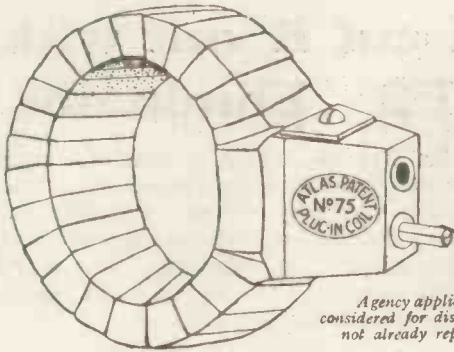

Agency applications considered for districts where not already represented.

The last word in efficiency.
Maximum Inductance. Minimum Self-capacity.
All Wave-Lengths covered.

Prices on application. Radio Components Catalogue on request.

Manufactured only by

H. CLARKE & CO. (M/cr.), LTD.,

Radio Engineers,

ATLAS WORKS,

OLD TRAFFORD, MANCHESTER.

Telephone Nos. :

683 & 793 Trafford Park.

Telegrams :

PIRTOID, Manchester.

FREE

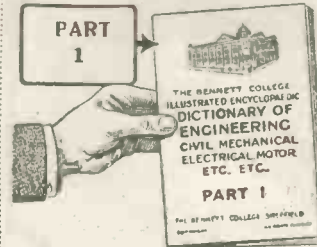

To extend the name of the Bennett College to everyone engaged in the different branches of Engineering, we are publishing an **Illustrated Dictionary of Engineering**, in about 24 MONTHLY PARTS (16 pages each part). You can have each monthly part as it comes out, FREE.

1/- Postage only to pay

The Dictionary is free to those engaged in any of the following trades: *Engineering, Civil, Mechanical, Electrical, Structural, Motor, Sanitary, Boiler, Internal Combustion, Draughtsmanship, Marine, Shipbuilding, Naval Architecture, Building, Architecture, Quantity Surveying, Aviation, Chemistry, Foundry Work, Metallurgy, Matriculation, Mining, Surveying and Levelling, Telegraphy, Telephony, Wireless*, and the conditions are that you send your name and address, your age and occupation, with one shilling (to cover postage on the 24 parts), writing your name and address very clearly. We shall then place your name on our Free List and send you part 1 at once. The others will be forwarded as issued.

Department D 133,

The Bennett College,
Sheffield.

We teach above trades by Post; particulars Free.

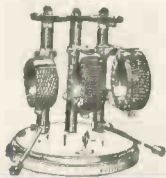

"IGRANIC" RADIO DEVICES

assure absolute accuracy and dependability of operation.
HONEYCOMB INDUCTANCES.
(De Forest Patent No. 141344).

"IGRANIC" Honeycomb Inductances are world famous and recognised to be the most efficient and satisfactory coil obtainable. Supplied in two types of mounting, Gimbal and Plug. The Gimbal type of mounting enables extremely fine and critical adjustments to be made. Low absorption factor and minimum high-frequency resistance. Each turn surrounded by an air pocket. Wavelength approximately 100/25,000 metres. The only coils that uphold their claim for negligible losses.

GIMBOLDER COIL HOLDER
for Gimbal Type Coils.

TRIPLUG COIL HOLDER
for Plug Type Coils.

Write for Lists Y10.

IGRANIC 149, Queen Victoria Street,
ELECTRIC Co. Ltd. LONDON.

Works: BEDFORD.

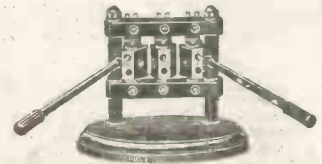

Don't buy accumulators for your valves

Unskilled chargers with only ruin them. For 12/- a quarter **ONLY 1/- A WEEK INCLUSIVE** we will supply you continuously with reliable charged L.T. Batteries, replaced at time of collection by motor anywhere in London.

Phone: East 5655. British Battery Supply Service, Write NOW for pamphlet C Free. Carr St., London, E.14

"ELBE" INSULATING PANEL BUSHES.
Experimenters save cost of EBONITE.

4 B.A. Pillar Terminals with one BUSH, 2/- doz.
2 " (with nut and washer), " 3/- "

Extra BUSHES Tenpence per doz.
Bushes tested for insulation to 25,000 volts.
YOUR DEALER WILL SUPPLY YOU,
LEIGH BROS.,
37, Sidmouth Street, Gray's Inn Road, LONDON, W.C.1.
Telephone: Museum 4547.

ELECTRADIX RADIOMETERS.
WAVEMETERS from 100 to 10,000 metres. From £2 10 0. New Ex W.D. MILLIAMMETERS for Fine Tuning, 17/6 to 35/-. **VOLTMETERS** Panel & Portable 2 volts to 2,500 volts, 5/- to £5. **RECORDERS.** Wireless Morse Inkers make long wave reception interesting, £6 10 0. **MOTOR ALTERNATORS.** Wonderful £30 machines for £3. Ex Aircraft. **POTENTIOMETERS.** Army 350 ohm 3 6.

For details see "Wireless World" or our 3d. Catalogue.
We have many thousand pounds worth of the pick of Gort. Wireless gear displayed at our showrooms at 9, Colonial Avenue, Miracles (near Aldgate Station).
LESLIE DIXON & CO. Ave. 4166.

Radio Press Information Dept.
QUERY COUPON

WIRELESS WEEKLY. Vol. 2. No. 13. October 10, 1923.
(This coupon must be accompanied by a postal order of 1/- for each question, and a stamped addressed envelope.)

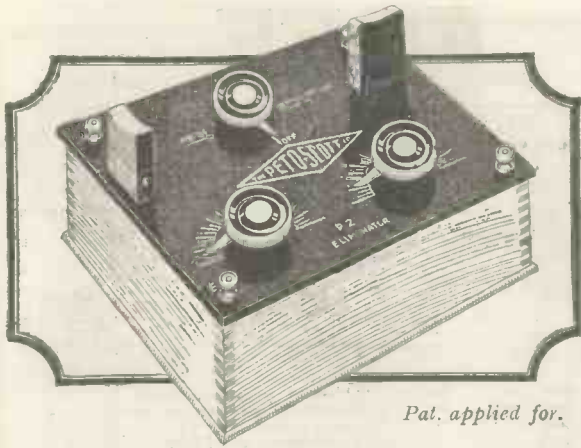

Pat. applied for.

What the P2 Eliminator will actually do.

At our Demonstration Lounge at 99 High Holborn we can easily tune out 2LO and receive Blrmingham on the Loud Speaker. This is with a simple, non-selective Receiving Set employing no reaction. Our Demonstration Lounge is approximately 600 yards from 2LO.

To many this performance may seem incredible, but really it is thoroughly typical of the P2 Eliminator—the instrument which will enable the full pleasures of Radio to be enjoyed by all.

Think how its possession would vastly increase the utility of your own Set, for example, and send for one to-day.

Tired of your Local B.B.C. Station?

—then cut it out with this P2 Eliminator.

Even if your Set has two, three, or four Valves, it does not follow that you can enjoy Broadcasting from any other Station you may choose. Probably you will have to wait for an interval during your own Station's transmission. The man who owns a P2 Eliminator, however, can tune out his Local Station at any time with the greatest of ease.

Further, he hardly ever suffers from interference from ships or high power stations because the P2 Eliminator operates on *all* wavelengths.

Remember this, the P2 Eliminator can be used with any Receiving Set—it will be sent on 3 days trial, and if found unsatisfactory the money will be refunded in full if seal is unbroken. We make this offer because we are confident that the Instrument will do all that we claim and more besides. Carriage paid **63/-**

More British Components from our new 40 page Catalogue.

A copy of this new Catalogue should be in the hands of every wireless enthusiast. Send for one to-day and start saving money. Post free **3d.**



H.T. BATTERIES.
The SPHINX. Made specially for us and to our own specification.

15 volts	3/-
36 volts	7/-
45 volts	8/9
60 volts	12/6



GRID LEAKS.
Made in our own factory. Each one tested and guaranteed accurate. 1, 2, 3, 4, and 5 megohms. 1/6 each.
Brass clips, per pair .. 3d.

PANEL SWITCHES.

The neatest nickel-plated miniature switch yet designed. Takes up little room, and adds a finishing touch which is most distinguishing.
Single pole, double throw .. 1/9
Double pole ditto .. 2/6

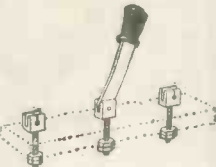

MULTI-WAVE AMPLIFIER.

Gives wonderful H.F. amplification on all wavelengths over 1,000 metres. No variable condenser required.
No. 1 .. 8/6 No. 2 .. 12/6
Use No. 1 for one stage of H.F.
For two stages of H.F., use No. 2 after first Valve and No. 1 after second Valve.



RESISTANCE UNITS.
Best quality, permanent, and guaranteed accurate. 50,000, 60,000, 80,000, and 100,000 ohms, each .. 2/-
Brass clips 3d. per pair extra.

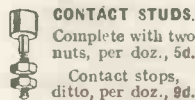

CONTACT STUDS.
Complete with two nuts, per doz., 5d.
Contact stops, ditto, per doz., 8d.

FILAMENT WINDOWS.
Real opal glass with brass fitting. For any thickness of panel .. 9d.



The latest Peto-Scott idea! Build your own Peto-Pan



A complete set of parts ready for the home assembly of the well-known Peto-Pan Loud Speaker. All coils ready wound to 4,000 ohms, metal parts, etc., machined enamelled and polished. Only a screwdriver needed to complete. Full instructions supplied with each set of parts .. 35/-
If stamped BBC, extra 3/-
Crate (returnable) and carriage 2/6 extra.



ANTI-CAPACITY DIALS.
A beautiful dial in real ebonite with long handle of same material to match. Standard fitting engraved 0°—100°, 4/-

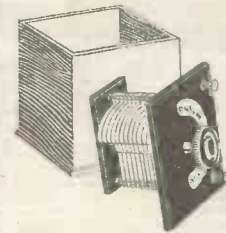

CONDENSERS.

For panel mounting in sets of parts.		Finished.
*001 ..	7/6 ..	9/-
*00075 ..	6/6 ..	7/6
*0005 ..	5/6 ..	6/11
*0003 ..	4/3 ..	5/11
*0002 ..	3/6 ..	4/11
*0001 ..	3/2 ..	4/6
*0005 ..	— ..	2/6

CONDENSERS IN CABINETS.

*001 ..	15/6	*0003 ..	10/6	*0005 ..	5/6
*00075 ..	13/-	*0002 ..	9/6		
*0005 ..	12/6	*0001 ..	8/-		

Peto-Scott Co. Ltd. Pioneers of the Unit System.

Head Office: 64, High Holborn, W.C.1.
Branches: 99, High Holborn, W.C.1.
3, Wellington St., Strand, W.C.2.
4, Manchester St., Liverpool.
94, Queen St., Cardiff.

The GREAT SALE at GAMAGES

Everything from a complete set to the smallest accessory to be cleared regardless of cost prices. During the Sale there is a SPECIAL DISPLAY of Apparatus by all the leading makers which should be seen by everyone interested in Wireless.

WRITE FOR SALE LIST.

The Best Crystals
PERMANITE
(Regd. No. 498341).
Clear, Powerful Results.
Price per large Specimen 1/6
Postage free

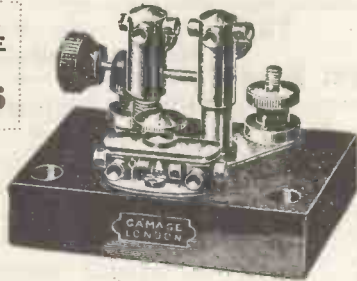

"CAPSTAN" TYPE CRYSTAL DETECTOR

The finest perikon detector made With two spare capstan heads.
Ebonite base 3x2 x 7/8 ins. Sale Price **15/3**
Usual Price 21/-
Postage 6d. extra.
Many other models in stock.

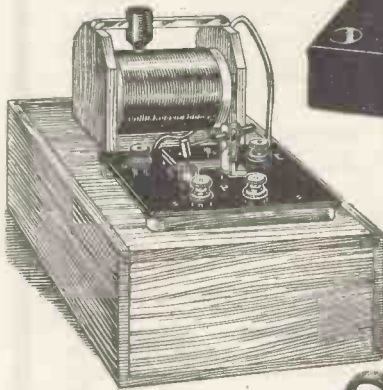

CRYSTAL SETS IN PARTS

Special Offer of these fine Crystal Sets in Parts. The illustration above shows the set made up ready for use. All parts are beautifully made and finished. Size of Box 10 1/2" x 8" x 4". Complete instructions—quite simple to carry out—are given with every box.

Sale Price **15/-**
Usual Price 21/-

Post 9d. extra.
Early buying is advised for this really remarkable value.



SCOUT'S TELEGRAPH SET

Limited number only. A self-contained set comprising Sounder 10 ohms; Galvanoscope 10 ohms; single current Key with gold-silver contacts, and 4 terminals. Mounted on polished wood base as illustrated. Can be used for direct working between two stations, or as a learner's set. When coupled up as a learner's set for total working, clear signals are obtainable with two dry cells in series. Usual Price 35/- Sale Price **25/-**

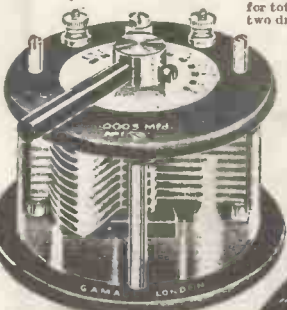

VARIABLE CONDENSERS

of our usual well-known design.

	Sale Price	List Price
0005	7/6	16/6
00045	7/-	14/9
0003	6/9	13/-

Postage on each of above 6d. extra.

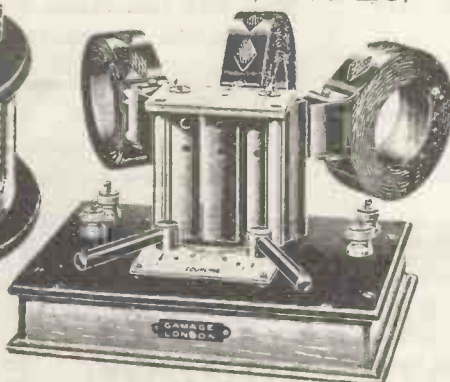

Special Offer of our usual best quality Coil Holders. Size of base, 8" x 6" x 5". Sale Price **20/-**
Usual Price, 30/- Post 9d.

GAMAGES, HOLBORN, LONDON, E.C.1

ACCESSORY MAKERS



H. A. H. "Clutch" Insulating Tape tins
PRICE 6d. small, 9d. larg.



SAFETY FUSE

H. A. H. WIRES and CABLES
Twinw/shop 37/6
Single 20/-
Twin Cotton 29/6
per gross yards.

Leading-in WIRE
Fig. 207 Rubber covered 46/- per 100 yds.
Write for full details.



Fig. 828. "SAVEIT" VALVE PROTECTOR
PRICE 2/6 each with bulb.



Fig. 1,100. Variable grid leak, 1/2 to 5 megohm 7/6
Anti Capacity Handle Extra 1/-

Code word.	Volts.	Details.	Size.	Price Each.
"WIRON"	15	Three Screw Terminals	8" x 1" x 3"	3/6
"WIRUS"	15	Two Insulated Wander Plugs	8" x 1" x 3"	3/6
"WIRIT"	36	Two Insulated Wander Plugs	6 1/2" x 2 1/2" x 3"	8/6
"WIRIN"	60	Two Insulated Wander Plugs	6" x 5" x 3"	14/-
"WIRUP"	100	Two Insulated Wander Plugs	9" x 5" x 3"	23/-

TWO Wander Plugs one red and one black are included in the price as above and are not extra. **MAY WE QUOTE YOU?**
For any Special Size, Voltage, or Capacity; made to your own Special Requirements.
Croydon "Keyage";
2225 A. H. HUNT, LTD. (Department W.E.) Croydon.
H. A. H. WORKS, TUNSTALL ROAD, CROYDON, SURREY.

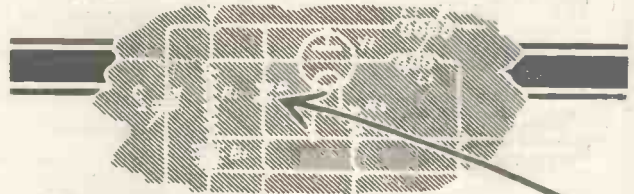

Put **CYMOSITE** here

For your Crystal Detector you want the finest possible Crystal—one which is super-sensitive and thoroughly reliable. In other words, you want **CYMOSITE**.

This *exclusive* Crystal is not produced in huge quantities, but its output is purposely restricted in favour of a small supply of only the finest possible quality.

Further, each piece is carefully packed so that it reaches you in the finest possible condition.

CYMOSITE users write most enthusiastic letters about its phenomenal rectifying properties—we are confident that you, too, will become equally enthusiastic.

Norman Hall, A.I.R.E.,
North Eastern Instrument Co.,
Durham Road, Low Fell,
GATESHEAD.

Sold only in Sealed Boxes

2/6

If unable to obtain from your dealer send to:

CYMOSITE
Sold only in Sealed Boxes

OVER HALF A MILLION SATISFIED CUSTOMERS WIRELESS! WIRELESS! WIRELESS! and EVERYTHING for it. DON'T PAY MORE!

PIONEERS OF Great Britain's largest CHEAP PRICES. exclusive Wireless Stores.

NOTE. We are exclusively WIRELESS — NOT DABLERS!
QUALITY, QUANTITY, AND CONSISTENCY OUR MOTTO.
 See Our Six-Window Display of Popular Bargains.

N. & K. Phones. The genuine article. Our Price ... **12/9**

Special offer—**BROWN'S Feather-weight Headphones.** Stamped B.B.C. 4,000 ohms. Our Price... **19/6**

We offer for the first time the new "**FELLOWS**" Lightweight Headphones, 4,000 ohms. A masterpiece of workmanship. A guarantee with every pair. **18/6** per pair. Honestly worth 30/-

ELKAY Lightweight Headphones, 4,000 ohms... **12/9**

EDISWAN Valves	12/3	MULLARD "ORA" Valves	12/3
COSSOR Valves	12/3	MARCONI "R" Valves	12/3
		EDISWAN DULL EMITTER. Our price	25/9

Bankrupt Stock and of Limited Quantity. Guaranteed all New.

BRUNET 'PHONES, the genuine article	13/11	STOPS, with nuts	per doz.	6d.	VARIABLE CONDENSERS of high quality. Vanes and Spacers of aluminium. Complete with knob and dial, guaranteed accurate:								
DUTCH VALVES	8/3	FILAMENT RESISTANCES, smooth action, marvellous value	1/10	2/9	Vernier	4/8							
L.F. TRANSFORMERS Ratio 5 to 1. All guaranteed (postage 1/-)	11/3	With engraved dials	1d.	1d.	'0002	5/9							
CRYSTAL DETECTORS 1/9, 1/3 and CRYSTAL DETECTORS, enclosed in glass case, 2/6, 2/3, 1/6	10/d.	PLUNGER SPRINGS, complete	each	3/d.	'0003	6/3							
AERIAL WIRE, 7/22, guaranteed hard-drawn copper, 100 ft. (postage 1/-)	1/10	SLIDER ROD, brass, 13ins. long, 1/4in. square, drilled	each	2d.	'0005	7/-							
CONDENSER VANES, fixed or moving, per doz.	3/d.	SLIDER KNOB	each	2d.	'00075	8/6							
REAL GOLD CAT'S WHISKERS ... each	2/d.	SWITCHES ON EBONITE, S.P.S.T. (quality the best)	each	1/8	'001	9/9							
REAL GOLD CAT'S WHISKERS ... per doz.	1/5	SWITCHES ON EBONITE, S.P.D.T. (quality the best)	each	1/11		4d.							
SILVER CAT'S WHISKERS ... each	1d.	SWITCHES ON EBONITE, D.P.D.T. (quality the best)	each	2/9	O.B.A. NUTS ... per doz.	4d.							
SILVER CAT'S WHISKERS ... per doz.	7/d.	CONDENSER SPINDLES, all sizes in stock, from	each	1/d.	DETECTOR ARMS, Ball Joints, Ebonite Handle and Whisker Holder	3/d.							
CONDENSER SCALES, 0 to 180	3/d.	SCREWED ROD, 2 B.A., 12ins. long	each	3d.	WOOD SCREW TERMINALS ... each	1/d.							
IVORINE LABEL SET, 12 different titles,	6/d.	SCREWED ROD, 4 B.A., 12ins. long	each	2/d.	SHELLAC ... per bot.	10/d. and 6d.							
BASKET COILS, set of 6, up to 3,000 metres	2/4	RUBBER-INSULATED LEADING-IN WIRE per yd.	1/d. and 2d.	11d.	AERIAL PULLEYS ... from	4/d.							
SLEEVING, 3 yds. assorted colours, for	11/d.	INSULATORS, white reel, 2in., each 1d. per doz.	11d.	1/8	TINFOIL ... large sheet	4d.							
NUTS, 2 B.A.	2/d.	INSULATORS, white egg, each 2d.	per doz.	1/8	COPPER FOIL, 6in. wide	5d.							
NUTS, 4, 5, 6 and 8 B.A.	per doz.	WOUND INDUCTION COILS (postage 9d.):			GRID LEAKS, 2 1/2 and 2 meg.	each 10/d.							
WASHERS, 2 B.A.	per doz.	12 x 4	2/5	9 x 4	1/11	8 x 2 1/2	1/8	6 x 2	1/5	FLEX (Twin), various colours	per yd.	2d.	
WASHERS, 4 B.A.	per doz.	2 1/2	1/11	1/8	1/5	CONNECTING WIRE, tinned copper, 20 gauge	3 yds.	2d.	ENAMEL WIRE, in 1/4, 1/2 and 1 lb. reels:				
CONTACT STUDS, with nuts and washers,	per doz.	2 1/2	1/11	1/8	1/5	22	24	28	per lb.	2/4	2/8	3/8	
TERMINALS, with nut and washers, each 1d.	11/d. & 2d.	TAPPED INDUCTION COILS, 20 tappings, wound to 1,600 metres	each	1/11 and 2/8	VARIOMETERS (Tube type), complete with knob	3/11 and 2/11	POTENTIOMETERS, guaranteed up to 900 metres, superior make, compact size	7/3	CRYSTAL DETECTOR, glass enclosed, fitted on 4 x 2 ebonite panel with terminals for aerial, earth and phones, already wired and beautifully finished	4/9	BATTERIES, H.T., dry:		
EBONITE KNOBS, 2 B.A.	each 2 1/2 & 3d.	DOUBLE 'PHONE CORDS, full length	11/d.	HERTZITE, Genuine Large Piece	9/d.	BORNITE, Genuine Large Piece	9/d.	ZINCITE, Genuine Large Piece	9/d.	PERMANITE, Genuine Large Piece	9/d.	36 volts, including Wander Plugs	5/9
SPACING WASHERS, large	per doz.	TALITE, Genuine Large Piece	9/d.	BORNITE, Genuine Large Piece	9/d.	ZINCITE, Genuine Large Piece	9/d.	BORNITE, Genuine Large Piece	9/d.	MIXED CRYSTALS (6 kinds)	9/d.	60 volts, including Wander Plugs	9/6
SPACING WASHERS, small	per doz.	PERMANITE, Genuine Large Piece	9/d.	MIXED CRYSTALS (6 kinds)	9/d.	CARBORUNDUM	5/d.	ZINCITE and BORNITE, both in box	1/-	COIL PLUGS, real ebonite	1/3, 10/d., and 9/d.	FILAMENT RESISTANCE DIALS	9/d.
CRYSTAL CUPS, 2 screw	each 2d.	ZINCITE and BORNITE, both in box	1/-	COIL PLUGS, real ebonite	1/3, 10/d., and 9/d.	H.F. PLUG TYPE TRANSFORMER:		1. 250 to 600 metres	3/9	AMALGO-PLASTIC METAL, for fixing crystals. No Woods metal necessary	6d.	GOLD SEAL PLASTIC METAL, for fixing crystals	6d.
CRYSTAL CUPS, 4 screw	each 2d.	H.F. PLUG TYPE TRANSFORMER:		2. 350 to 700 "	4/-	3. 500 to 900 "	4/3	4. 800 to 1350 "	5/8	IVORINE NAME-PLATES, all readings each	1d.	EARTH CLIPS, Copper, adjustable	each 5 1/2d.
FIXED CONDENSERS, all capacities	each 10/d.	5. 1600 to 3200 "	4/9	6. 2200 to 5600 "	5/6	FILAMENT COMPLETE CIRCLE RESISTANCE SCALES, 0 to 300	each 6d.	EBONITE CONDENSER KNOB AND DIAL	1/9	RADIONETTE CRYSTAL SET, complete, stamped B.B.C. and including one pair 4,000 ohms phones, 100ft. 7/22 aerial wire, 4 insulators, lead-in tube, 6 yds. lead-in insulated wire and adjustable earth clip. Ready to listen-in. Honestly worth 3 gns.	36/6	RADIONETTE ONE-VALVE L.F. AMPLIFIER for above	34/6
EBONITE, cut to any size by machinery while you wait	per lb.	VALVE LEGS, nut and washer	each 10d.	VALVE PINS, nut and washer	each 10d.	VALVE HOLDERS ... each 1/3, 1/- and 9/d.				CABINETS, all sizes in stock.			

IMPORTANT NOTICE.

that all post orders are dealt with in strict rotation and at the earliest possible moment.

In view of the enormous increase in our Mail Order business, we wish to inform our customers at the earliest possible moment.

Follow the crowd to Elkay Corner.

"ELKAY" WIRELESS CO.,

225 & 227, BISHOPSGATE, LONDON, E.C.2.
 Open Saturday all day. (To the Trade—New Trade Counter now open. Send for NEW LIST.)
 We open Sundays 11 to 2.30. Special Terms to Radio Clubs. Note new Telephone No.: Central 8544

PLEASE REMIT AMPL POSTAGE.

SAVE MONEY BY STUDYING OUR ADVERTS.

DUBILIER CONDENSERS

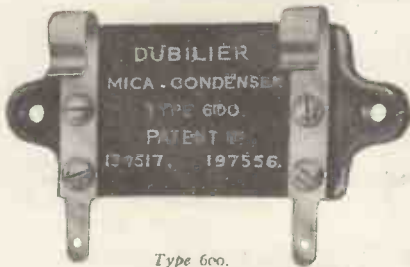

Type 600.

DUBILIER CONDENSERS FOR RECEPTION ONLY.

- *Type 600 Capacities between 0.0001 and 0.0009 mfd. - 2/6
- Type 600. Capacities between 0.001 and 0.006 mfd. - 3/-
- Type 600a. Capacities below 0.001 mfd. - 2/6
- Type 600a. Capacities between 0.001 and 0.006 mfd. - 3/-

*Supplied with or without grid-leak clips as desired.

It all depends on the Condenser—

Capacity plays such an important part in your Wireless circuit that you dare not leave your Condenser equipment to chance. For over 11 years our Laboratories have been testing and perfecting our products. You receive the benefit of this experience whenever you specify Dubilier, and the Condenser or Resistance which you buy is better than any other by just that margin which makes it worth your while to insist on having our products.

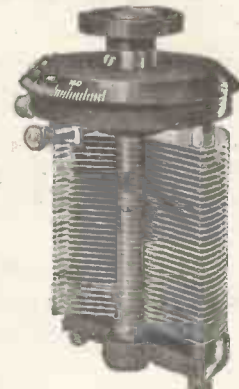

VANICON VARIABLE CONDENSERS.

0.001 mfd.	-	£1:5:0
0.0007 ..	-	1:2:6
0.0005 ..	-	1:0:0
0.0003 ..	-	0:17:6

THE DUBILIER CONDENSER CO. (1921) LTD. DEPT. G.
DUCON WORKS - GOLDHAWK ROAD - LONDON, W.12

Telegrams—"Hwoltcon, Phone, London."

Telephone—Hammersmith 1084. (E.P.S. 21)



W. G. PYE & Co.

Scientific Instrument Makers,
CAMBRIDGE, ENG.



2 VALVE RECEIVING SET No. 520.

Wireless Receiving Apparatus of the
Highest Possible Efficiency,
Greatest Selectivity,
Easiest Tuning,
Best Quality Workmanship,
Moderate Price.

Our Wireless Apparatus is of the same high quality as our general Scientific Apparatus, and WE INVITE COMPARISON ON ANY AERIAL with Receiving Apparatus of any make. Let us send you details of our 2, 3 and 4 Valve Sets

All our Receiving Sets are approved by the Postmaster General.



You CANNOT be out of WIRELESS WEEKLY because it brings BIG Business.

RADIONS LTD.

beg to announce that in consequence of their ever increasing business in

REPAIRING WIRELESS VALVES

they have now taken extensive works, and equipped them with the most modern plant. This plant is operated by a highly skilled staff, and they are now in a position to give the utmost satisfaction combined with

PROMPT DELIVERY.

Write for prices and particulars:

RADIONS LTD., Church Street, Bollington, nr. Macclesfield.

Telegrams: "Radions, Bollington."

200,000 MAGNET LETTERS

have been supplied by us to WONDERSIGNS of HOLBORN. Each letter is a perfect Magnet. Hence our knowledge of what a Magnet should be, and our ability to produce the BONTONE PHONE under mass production.



Points to Consider.

Every Phone is sold under guarantee. Every Phone is tested before leaving Factory.

We are Old-Established British Manufacturers, whose object is to give complete satisfaction.

Why saddle yourself with Continental Phones distributed by unscrupulous Importers, with small offices and elaborate note paper, and NO GUARANTEE or hope of redress if found faulty.

Originals of upwards of 100 unsolicited testimonials and letters of appreciation can be seen at our offices.

GUARANTEE.—We agree to replace or return cash if Phones do not give complete satisfaction, subject to Phones being returned to us within 7 days of purchase, undamaged.

BONTONE PHONES (4,000 ohms) BRITAIN'S BEST.

14/6 per pair. Carriage paid United Kingdom. SENSITIVE, DURABLE, COMFORTABLE, AND BEAUTIFULLY FINISHED.

Manufactured entirely by BRITISH labour. LIBERAL TERMS TO THE TRADE.

B. D. & CO. (Edward A. Boynton).

WORKS: GOSWELL ROAD AND CITY ROAD. OFFICES: 167-173, GOSWELL ROAD.

ADMIRALTY, WAR OFFICE, AND INDIA OFFICE CONTRACTORS.

Wireless Weekly

SMALL ADVERTISEMENTS.

PREPAID Advertisements are accepted under this heading for Wireless Apparatus and Parts WANTED or FOR SALE, etc., at the rate of 1s. 6d. per line, MINIMUM THREE LINES.

Advertisements should reach Scheff Publicity Organisation, 125 Pall Mall, London, S.W.1, LATEST by first post FRIDAY preceding date of publication.

The publishers are not responsible for clerical or printer's errors, but every care is taken to avoid mistakes.

ALL post paid. 60 volt H.T. battery and plugs 8/-; 400 ohm phones 12/-. Complete list of similar values free. J. H. Taylor & Co., Macaulay St., Huddersfield.

EXCHANGE three valve set complete with acc., valves, coils, loud speaker, as new, for motor cycle of reliable make. Value of set, £35. Lovell, 46 Kent Road, Grays.

HANDSOME B.B.C. four-valve set universal tuner British and Continental Broadcasting, £15. Two-valve B.B.C. set, £6 10s. Brown microphone amplifier, £4 10s. Loud-speaker, 10/6. Headphones, 10/6. Bean, "Inglewood," Coatbridge.

MARGONIPHONE, long range V2, dull emitter valves, all accessories, list price £22 10 0. Sacrifice £16 as new. 52 Maudslay Rd. Eltham. S.E.

THEY'RE Good Value. Pickett's Cabinets, highly polished, 1/6 each. Write for lists (W.L.). Works: Albion Road, Bexley-heath, S.E.

WIRELESS agency, Holland: Dutchman, at present in London, desires to represent a first-class manufacturing wireless firm. Write:—Box A.6, Radio Press, Ltd., Devereux Court, STRAND, W.C.2.

SCHEFF PUBLICITY ORGANISATION

125, PALL MALL, LONDON, S.W.1

are Advertisement Managers for

WIRELESS AND MODERN WEEKLY WIRELESS

Particulars on application of RATES for both publications.

'Phone: Regent 2440 (Two Lines).

FRENCH THOMSON-HOUSTON PHONES

The Headphone with the Two Years' Guarantee.

All GENUINE French Thomson-Houston Headphones are now Guaranteed against Defective Workmanship for 2 Years. A guarantee is given with each Headphone sold. What more do you want?—This speaks for itself.

If your local Dealer cannot supply you send direct to us.

DELIVERY AT ONCE FROM LONDON STOCK.

Revised list post free.

List No.	Specification.	Total Resistance.	PRICE.	Post.
250	Nickel-plated or polished aluminium detachable receivers. Double-nickel plated or horn headbands, fully adjustable. Long flexible cords. Beautifully finished and perfect workmanship throughout. Undoubtedly the very best value for money obtainable.	4,000	19/-	6d.
210	As above, but fitted with double imitation tortoiseshell headbands. Particularly suitable for ladies.	4,000	22/-	6d.
212	As No. 250, but wound to a total resistance of 8,000 ohms.	8,000	24/-	6d.



The French Thomson-Houston Phone.

READ THIS.—Have you a Crystal Set? If so, you cannot afford to be without one of our "Eccentro" Detectors. A real novelty in Detectors (*Vide "Amateur Wireless"*). It is Semi-automatic, Dust-proof, Shock-proof and a temper saver. **IT NEVER FAILS!**

NOTE.—This is not the "Hit and Miss" Type; it is a real piece of Mechanism and something to give entire satisfaction **Our Price 8/- Post free.**



TRADE SUPPLIED AT RIGHT PRICES.

W. JOANES FOR PHONES.

42, JENNER ROAD, STOKE NEWINGTON, LONDON, N.16.

Phone: Dalston 474L.

Telegrams: "Joanes, Stoke Newington, London."

Employing a circuit approved by the P.M.G.

"HOME CONSTRUCTORS"

Simplicity itself to assemble

Complete Sets of Parts

FOR MAKING WIRELESS RECEIVING SETS.

Chakophone REGD.

Chakophone REGD.

TUNER No. 1a.

TUNER No. 1.

1st STAGE H.F. AMP. No. 2.

2nd STAGE H.F. AMP. No. 3.

DETECTOR No. 4.

2 I.F. AMPLIFIER No. 6.

CRYSTAL SET No. 7.

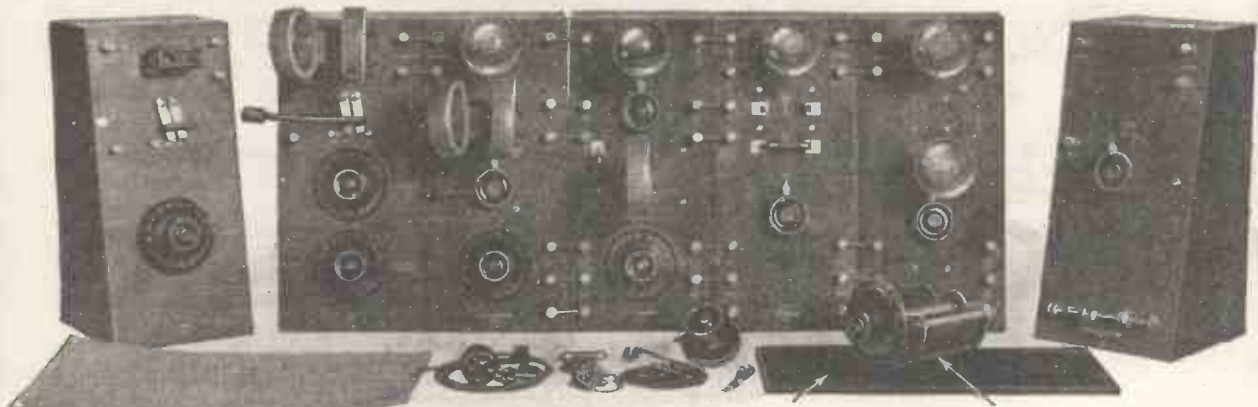

INSTRUCTION SHEET.

PARTS

PANEL DRILLED AND ENGRAVED.

BEST ASSEMBLED CONDENSER.

"YOU CANNOT BUY A BETTER SET OF PARTS."

Send for free list.

Delivery from stock from our London Showrooms: The Eagle Wireless Supply Co., Ltd., 8, Great Russell St., W.C.1, OR FROM THE MANUFACTURERS:—

THE EAGLE ENGINEERING CO., LTD., WARWICK.

FRENCH THOMSON-HOUSTON HEADPHONES REDUCED to 19/- PER PAIR!

(Postage (registered) which must be prepaid, 1/- extra).



THE ONLY HEADPHONE
THAT IS FULLY
GUARANTEED
FOR TWO YEARS



4,000 ohms, per pair 19/-

Our Paris office has been successful in obtaining the distribution of these Headphones for the whole of Great Britain. Moreover, having taken timely advantage of the rate of exchange, we can offer them at a price very much below that asked elsewhere.

WE CAN CONFIDENTLY RECOMMEND THESE HEADPHONES AS BEING THE MOST SENSITIVE ON THE MARKET, AND THE MOST PERFECT FOR REPRODUCTION OF MUSIC AND SPEECH.

GUARANTEE.

The Headphone contained in this box is guaranteed to have been manufactured by

COMPAGNIE FRANCAISE THOMSON-HOUSTON
(S.A. au Capital de 250,000,000 de francs),
254 & 256, Rue de Vaugirard, PARIS (15).

Should any fault in manufacture be discovered within two years from the date of purchase the Phones will be replaced **FREE OF CHARGE** if returned together with this band of guarantee, bearing the number, date of purchase, and signature of the Retailer.



BANDE DE GARANTIE.

Le receveur serre-tête contenu dans cette boîte est garanti fabriqué par la

COMPAGNIE FRANCAISE THOMSON-HOUSTON
(S.A. au Capital de 250,000,000 de francs),
254 & 256, Rue de Vaugirard, PARIS (15).

En cas de défaut de fabrication, signalé dans l'intervalle de 2 ans à compter de la date d'achat, le casque sera remplacé gratuitement s'il nous est retourné accompagné de la présente bande de garantie, portant le numero, date d'achat et le Signature du détaillant.

IMPORTANT.

The public are asked, in their own interests, to see that all phones offered to them as French Thomson-Houston manufacture bear the above guarantee.

Any phones not carrying this guarantee should be refused.

The CITY ACCUMULATOR Co

79, MARK LANE, LONDON, E.C.3.

'Phone: AVENUE 1316.

10, RUPERT STREET, COVENTRY STREET, W.1.

'Phone: GERRARD 3063.

Agents:

LANCASHIRE & CHESHIRE:

Henry Hollingdrake & Son, Ltd., Princes Street, Stockport.

S. WALES: South Wales Wireless Installation Co., Ltd., 18, West Bute Street, Cardiff, and at Cambrian Road, Newport.

YORKSHIRE (West Riding): Messrs. H. Wadsworth

FRANCE: 33, Rue d'Hautville, Paris.

GLOUCESTERSHIRE, SOMERSET & WILTS

Bristol Wireless Co., 52, Cotham Hill, Bristol.

LEICESTERSHIRE:

Walter Rowe, Ltd., Eldon House, 97, London Road, Leicester.

Sellers & Co., Standard Buildings, Leeds.

AUSTRALIA: 4, Teakle Street, Summer Hill, Sydney.



Radio Press Books give him all the information he needs

Complete List

	Price.	Post Free
1. Wireless for All John Scott-Taggart, F.Inst.P.	1/6	1/7 1/2
2. Simplified Wireless... John Scott-Taggart, F.Inst.P.	1/-	1/1 1/2
3. How to Make Your Broadcast Receiver... John Scott-Taggart, F.Inst.P.	1/6	1/7 1/2
4. How to Erect Your Wireless Aerial B. Mittell, A.M.I.E.E.	1/-	1/1 1/2
5. The Construction of Wireless Receiving Apparatus P. D. Tyers.	1/6	1/7 1/2
7. How to Make a "Unit" Wireless Receiver E. Redpath.	2/6	2/8
9. Wireless Valves Simply Explained... John Scott-Taggart, F.Inst.P.	2/6	2/8
10. Practical Wireless Valve Circuits..... John Scott-Taggart, F.Inst.P.	2/6	2/8
11. Wireless Licences and How to Obtain Them E. Redpath.	1/-	1/1 1/2
Elementary Text-book on Wireless Vacuum Tubes		10/- (Post free)
John Scott-Taggart, F.Inst.P.		

☐ Those printed in heavy type have been published recently.

HOW many turns for a Coil to reach the Paris Wavelength—the type of circuit to operate a Loud Speaker using only an indoor Aerial—Crystal or Valve rectification in a multi-valve Set? These are a few of the questions which confront the amateur constructor.

Some will find out the correct answers by expensive experiment—others, more wisely, will benefit by the experience of those who have trodden the thorny paths of Radio before them.

The concentrated experience of some of the best known Wireless engineers and experimenters is available for all readers of Radio Press Books. You cannot do better than purchase the complete Library—one Book at a time. Each Book covers a different phase of Wireless and none overlap. Get one or two to-day and keep them by you for ready reference—they are sure to save their cost many times over. From all Booksellers.

RADIO PRESS LTD.,
Devereux Court, STRAND, W.C.2.

Radio Press Books
— a complete Wireless Library

Gilbert Ad.

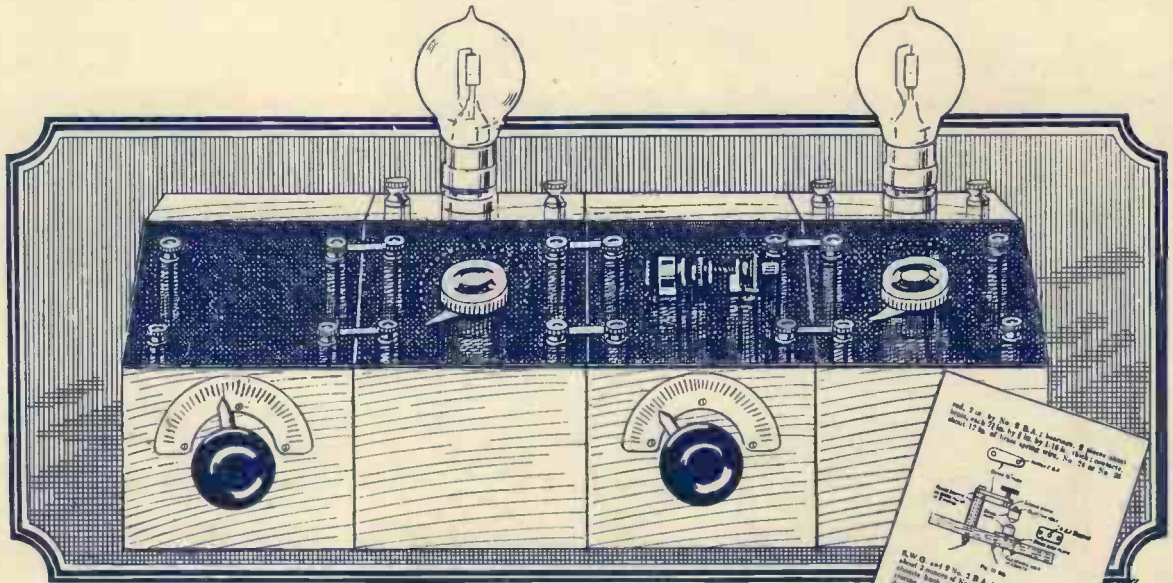

Such clear instructions enable anyone to build this excellent 4-Unit Set

ONE special feature of this new Book is that it does not presume any knowledge of Wireless at all on the part of the purchaser.

Constructional articles in "Wireless Weekly" and "Modern Wireless" necessarily anticipate that the reader has some knowledge of Wireless—if only of the most elementary kind.

Even if you don't know one end of the Receiving Set from the other, and have never even "listened in," you can buy this Book confident that you can build your own Set—one which will give you particularly good results over long distances.

The Receiving Set described in this Book is quite different from any yet placed on the market. It is particularly neat and efficient, and as an economical Set it is certainly without parallel. For, at an original outlay of a few shillings, it is possible to construct the Detector Unit (which uses a crystal) and to enjoy the pleasures of "listening in" right from the very beginning. Later on—and at your convenience—you can add valves which will enable you to pick up Broadcasting stations further away or to use a Loud Speaker instead of head-phones.

The whole Instrument has been carefully designed and tested for reception over long distances.

Get a copy Now—and start Wireless economically.

Radio Press Ltd., Devereux Court, Strand W.C.2

How to make a "Unit" Wireless Receiver

by E. REDPATH (Assistant Editor of "Wireless Weekly.")

RADIO PRESS
Wireless Library
No. 7.

2/6

or 2/8 post free

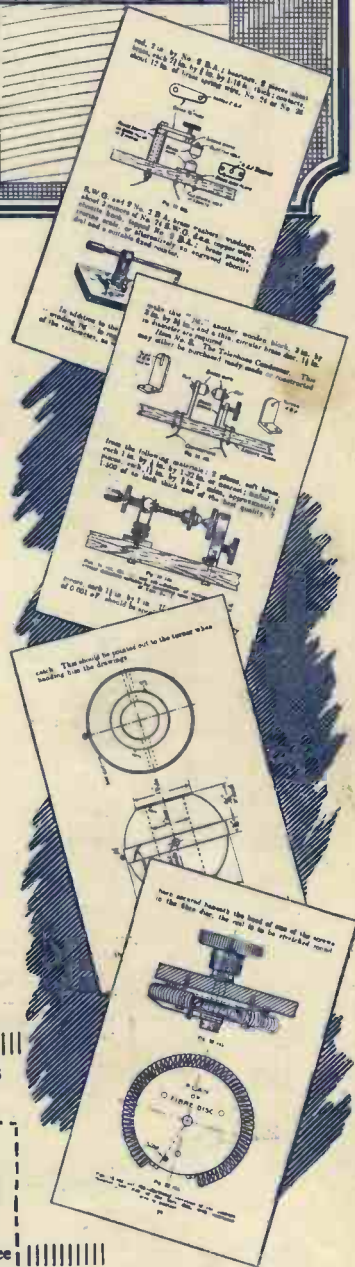

Gilbert Ad.

Wireless Weekly

and The Wireless Constructor

Vol. 2.
No. 14.

CONTENTS

A Simple H.F. Amplifier.
Some Developments in Short
Wave Research.

The Construction of High-Fre-
quency Transformers.

Practical Short-Wave Trans-
mission.

Wireless Reception in South
Lancashire.

Jottings by the Way, Constructional
Notes, Broadcasting News, Ran-
dom Technicalities, News of the
Week, Apparatus we have Tested,
Radio Press Information Dept.,
Correspondence, etc., etc.

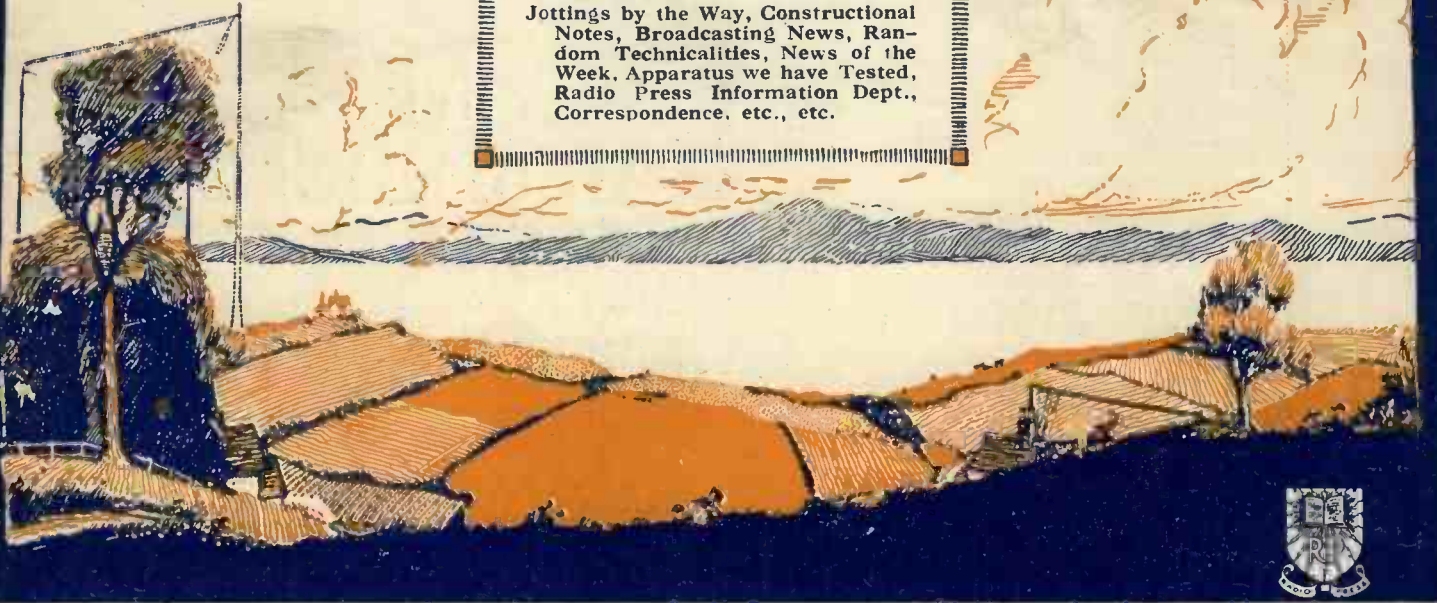

A Three-Valve Receiver for all Wavelengths.

Crystal Reception

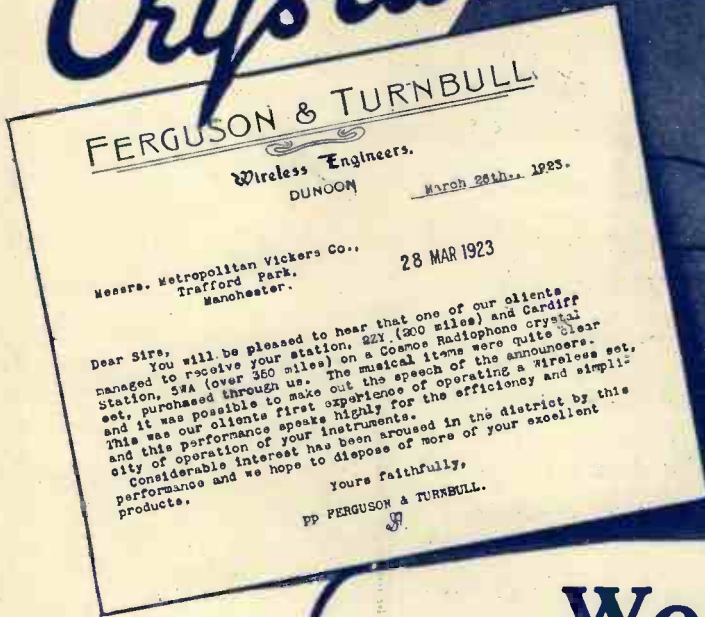

Dear Sirs,
 You will be pleased to hear that one of our clients managed to receive your station, 22Y (200 miles) and Cardiff Station, 5WA (over 350 miles) on a Cosmos Radiophono Crystal Set, purchased through us. The musical items were quite clear and it was possible to make out the speech of the announcers. This was our clients first experience of operating a wireless set, and this performance speaks highly for the efficiency and simplicity of your instruments.
 Considerable interest has been aroused in the district by this performance and we hope to dispose of more of your excellent products.

Yours faithfully,
 P. FERGUSON & TURNBULL.

We do not claim

that Cosmos Crystal Type Radiophones will receive over distances like these. The circumstances of the reception forming the subject of the letter here produced are undoubtedly abnormal. We do claim, however, that Crystal Type

COSMOS RADIOPHONES

are well-made and efficient sets, and will give your customers thorough satisfaction.

NOTE AMPLIFIERS & LOUD SPEAKER

Attachments are also supplied for working with the "Cosmos" Crystal Set.

Send for Booklets 4670/1 overprinted with your own name and address.

METROPOLITAN Vickers

ELECTRICAL CO. LTD

Head Office & Works: TRAFFORD PARK, MANCHESTER.
 London Address: 232-233, HIGH HOLBORN, W.C.1.

R
 A07

Dear Sirs,

You will be pleased to hear that one of our clients managed to receive your station 22Y (200 miles) and Cardiff Station 5WA (over 350 miles) on a Cosmos Radiophone Crystal Set purchased through us. The musical items were quite clear and it was possible to make out the speech of the announcers. This was our client's first experience of operating a Wireless set, and this performance speaks highly for the efficiency and simplicity of operation of your instruments.

Considerable interest has been aroused in the district by this performance, and we hope to dispose of more of your excellent products.

Yours faithfully,
 pp. FERGUSON & TURNBULL.

THE Marks of Efficiency & Approval.



"COSMOS" Crystal sets reduced in price.

BELFAST
 BIRMINGHAM
 BRISTOL
 CARDIFF
 DUNDEE
 EDINBURGH
 GLASGOW

LEEDS
 MANCHESTER
 NEWCASTLE-
 ON-TYNE
 SHEFFIELD
 SOUTHAMPTON
 SWANSEA

Wireless Weekly

Vol. 2, No. 14
Oct. 17, 1923

CONTENTS

	Page
Editorial - - - - -	488
Some Developments in Short-wave Research - - - - -	489
Wireless Reception in South Lancashire - - - - -	490
"Wireless Weekly" Circuits—No. 27 - - - - -	492
A Three-valve Receiver for all Wavelengths - - - - -	493
Jottings by the Way - - - - -	495
The British Broadcasting Company - - - - -	496
The Construction of High-frequency Trans- formers - - - - -	497
Practical Short-wave Transmission - - - - -	498
News of the Week - - - - -	500
A Four Weeks' Holiday with a Portable Set - - - - -	501
Makeshift Aerials - - - - -	503
A Simple H.F. Amplifier - - - - -	504
The Amateur's Part in Wireless Development - - - - -	506
Constructional Notes - - - - -	508
The R.S.G.B. (Transmitting Section) - - - - -	511
Broadcasting News - - - - -	512
Random Technicalities - - - - -	514
Apparatus We Have Tested - - - - -	515
Correspondence - - - - -	516
Radio Press Information Department - - - - -	517

Editor: JOHN SCOTT-TAGGART, F.Inst.P.

Assistant Editors: E. REDPATH,
P. W. HARRIS.

Radio Press, Ltd.

Publishers of Authoritative Wireless Literature
DEVEREUX COURT, STRAND, W.C.2

Tel.—Central 3763.

Advertisement Managers: SCHEFF PUBLICITY ORGANIZATION,
LTD., 125, Pall Mall, London, S.W.1.
Tel.—Regent 2440.

Staff Editors:

E. H. CHAPMAN, M.A., D.Sc.
A. D. COWPER, M.Sc.
G. P. KENDALL, B.Sc.
R. W. HALLOWS, M.A.
S. G. RATTEE.

Scientific Adviser:
Prof. G. W. O. HOWE,
D.Sc., M.I.E.E.
Advisory Editors:
Prof. R. WHIDDINGTON,
M.A., D.Sc.
Prof. C. L. FORTESCUE,
M.A., M.I.E.E.



All correspondence relating to contributions is to be addressed to the Editor of "Wireless Weekly."

Nothing contained herein is to be regarded as permission or encouragement to infringe any patent rights.

Editorial



The Settlement

WE have come to the conclusion that, in general, a satisfactory settlement of the broadcasting problem has been arrived at, and consider that the Postmaster-General and the British Broadcasting Co. are to be congratulated. Naturally, there remain a few minor points to be disposed of, but these are chiefly in reference to matters which affect the B.B.C. and its individual members rather than users of wireless apparatus.

Whilst the policy of inviting wireless dealers to become members of the B.B.C. is an excellent one in many respects, there will be, no doubt, many reputable dealers who will desire to preserve their independence, though at the same time being fully determined not to act in any manner contrary to the best interests of British trade.

Licences

That the new licensing regulations are considered satisfactory by users, and would-be users, of home-constructed apparatus is evident by the number of Interim and Constructor's Licences which have been taken out. These licences became available on October 4th, and, up to the end of last week, the total number issued, of both kinds of licences, was 75,000. As the number of licences issued daily is increasing progressively, no doubt this figure will be greatly exceeded when the final returns are available.

Adding to the above figure the number of Experimental Licences issued up to September 30th last, namely, 58,000, and Broadcast Licences, 122,000, there are already over a quarter of a million licences issued. We hope to see this number doubled before the New Year.

Possibly some readers, in the absence of a licence to fit their case, took out a Broadcast Licence, although their apparatus was made, or was being made, at home. All who did

so and have since obtained an Interim or Constructor's Licence, should forward their Broadcast Licence to the Secretary, G.P.O., London, quoting the serial number and office of origin of their new licence, when a refund for the unexpired period of their Broadcast Licence will be made to them as promptly as possible.

Freedom for Experiment

Elsewhere in this issue we publish details of the new scheme introduced by the Radio Society of Great Britain with a view to providing for experimental transmitting and relay work. This scheme, an outcome of the absorption by the Society of the British Wireless Relay League, makes provision for all holders of experimental licences, whether at present members of the Society or not.

If the principle of "freedom for experiment" is actively maintained, the new section will probably fully justify its existence, and, apart from the purely technical aspect of the matter, its political significance is commended to all experimenters. There are occasions when the spirit of independence should not be allowed to prevent adequate support being given to a movement intended to protect and improve the status of all experimenters, and we suggest that this effort on the part of the Radio Society of Great Britain is such an occasion.

The sterling value of the work done by amateur experimenters in the past, and the surprising developments which have followed discoveries made whilst experimenting "just for fun," are attested by Dr. Eccles, F.R.S., in his Presidential address to the Society, as given upon another page.

Such evidence warrants the greatest consideration on the part of the authorities when dealing with the experimenters of this country.

SOME DEVELOPMENTS IN SHORT WAVE RESEARCH

How the use of short waves may solve the problem of interference.

UNTIL recently wavelengths varying from 10,000 metres down to about 600 metres have been used for commercial work. Broadcasting, inaugurated about one year ago, witnessed a reduction of this wavelength down to about 360 metres. Long before that time, experimenters had been transmitting on a wavelength of 200 metres, and although radio experts stated that very long wavelengths, such as 10,000 metres and over, were absolutely necessary for long-distance work, such as trans-oceanic, the transmitting amateur proved that he could span the ocean with facility with his puny wavelength.

About a year ago Marconi made the announcement that he could send wireless waves in any direction by means of parabolic wave reflectors. The wavelengths he used were about 10 metres or thereabouts. This was a great step in advance. Recently Dr. E. F. Nichols, Director of the Nela Research Laboratories, and his associate, Mr. J. D. Tear, went further, and actually produced a wavelength of a little less than 1-100th of an inch. This is most extraordinary, because for the first time wireless waves have been made to overlap heat waves. Heat waves of 1-175th of an inch have been obtained in the laboratory, so that we have now actually merged wireless waves into heat waves.

Just what this statement means to the future of radio seems impossible to discern, even dimly, to-day. If we say that the future radio generator may be an ordinary burning candle, this may sound like a wild dream, nevertheless the results of Nichols and Tear might make such a thing possible. If the radio waves can be converted into heat waves, or rather intermingled with them, there is no reason why the flame of an ordinary candle cannot be made to give out radio waves by some sort of transformation which as yet we can only see dimly in the future.

On the practical side, the era of short waves is yet dawning. Recent experiments of Dunmore and Engel, of the Bureau of Standards, have shown that an entirely new

field may be opened by short wavelengths of about 10 metres or less. Such wavelengths can and will be used for house-to-house communications in low-power radio telephony. These waves can be directed in a beam so that they will only go in one direction. In other words, they can be directed just as a light ray is directed by a searchlight, with the advantage that the concentrated wireless beams go much further than light rays.

Hertz, in his famous researches years ago, has shown that electromagnetic waves—wireless waves, in other words—can be refracted exactly as light rays. By means of a huge lens made of pitch Hertz actually focussed a beam of wireless waves upon a chosen spot. By means of the pitch prism he refracted his waves much as we refract light rays through a crystal prism. Indeed, Nichols and Tear used similar appliances; for instance, they used a focussing lens made of paraffin where Hertz used a lens made of pitch.

There is a tremendous field for research open to amateurs on wavelengths between 10 metres and 1 metre, and entirely new fields will be opening up once we avail ourselves of these new wavelengths. For one thing, interference is practically done away with. Static vanishes when such a wavelength as 10 metres is used. For communication between friends and for short distances up to a few miles a 10-metre wavelength is ideal and likely to bring out new and unsuspected phenomena. Unless all indications are wrong, great use will be made of these short waves during the next few years. This will be accompanied by new types of instruments which we probably cannot even conceive of clearly to-day. This is certain, mainly because the frequencies for the low wavelengths become truly enormous. Thus, for instance, the frequency corresponding to a wavelength of 350 metres is 856,628. For 200 metres the frequency has already become 1,499,100 vibrations per second, while for wavelengths of 10 metres the frequency has gone up to the tremendous value of 29,982,000 oscillations per second.

WIRELESS RECEPTION IN SOUTH LANCASHIRE

By H. CHADWICK.

Our readers in the North will find many points of interest in the following account of amateur reception.

WHEN anyone contemplates the erection of a radio receiving set, be it experimental or broadcast, the first thing of any consequence to be considered is the range it will cover, unless it is desired in the first instance to receive certain transmissions, and then it becomes a question of what type of set must be installed for this purpose.

Therefore, as a guide to anyone so placed, at least so far as this district is concerned, I will attempt to give some idea of reception conditions and prospects. Broadcasting, predominating as it does in the ether, naturally strikes one as the first consideration, and in this respect we are fairly well placed. I am, of course, excepting the controversy as to which station gives the best—or worst—programme, for with true British spirit we are all inclined to give the "booby" to our own station.

Interest primarily centres round the Manchester station 2ZY, which is twelve to fifteen miles away. This station is very conveniently placed, as it is quite easy to bring the telephony up to any desired strength, and, on the other hand, it is just possible to tune it out when desired, for the reception of any of the other stations. This did not always hold good as, some time ago, it was useless to attempt reception of any other station within the Broadcast band, and a considerable improvement has recently been made in the tuning.

Now, reception of this station may be accomplished on crystal and, providing the aerial is of fair proportions, the strength is just sufficient to enable one to appreciate the quality of the transmission. Very little more may be said about the crystal, for its usefulness practically ends here. We do hear occasionally of some wonderful distances being covered by its aid, such as reception of London, Birmingham, and Glasgow, using crystal

only, but this may be considered a "freak." A certain amount of shipping certainly may be heard; notably the Liverpool traffic, and, perhaps, Cullercoats, but a very good aerial is essential to make shipping reception of any interest. On longer waves a few spark stations, such as Eiffel Tower, Nantes, Nauen, and, under favourable circumstances, even Warsaw, are to be picked up, but as these stations only give occasional spark transmissions there are some very big gaps during which silence reigns supreme!

The same applies to single-valve reception without reaction, for this is very little—if any—better than crystal, as the valve is a notoriously poor rectifier. Could reaction be added, however, the sensitivity of the single valve would be increased enormously. With its aid it would be possible to hear all the broadcasting stations, but, unfortunately, its use is only permissible on one of the approved circuits, the simplest of which necessitates the use of two valves (and even then with discretion), during those hours which are devoted to broadcasting.

In stating that all the stations could be heard on one valve, it must not be expected that the telephony would be audible yards from the 'phones.

On the contrary, only under the best circumstances would it be heard at all, and no hard and fast rule can be laid down, as individual cases vary so considerably. Manchester is, of course, perfect on the one valve, without reaction, and is at the maximum strength recommended for head 'phones.

With reaction, London is loud, and quite easy to pick up, especially now that the peculiar fading characteristic of this station seems to have been reduced. Birmingham comes a good second to London, but is too near the shipping wavelength, chiefly D.F. work, and is usually so badly jammed that very

little pleasure is obtained from the programme. Now, I think, Glasgow comes next on the list of relative strengths, with Newcastle and Cardiff very similar, perhaps slightly weaker, but neither of them deafening on one valve.

Probably the best type of receiver for broadcast reception is the two-valve (one H.F. and one detector) with reaction on the valve coupling. This set will give all stations quite comfortably, with no fear of radiation due to use of the reaction. The relative strength will naturally remain the same. However, the two-valve set is hardly enough for loud-speaker operation, and a note-magnifier is required for this purpose, making three valves in all. Manchester is quite loud enough for any ordinary purposes, though for a very large room at least another valve is desirable. The other stations are only just audible on a loud-speaker, and five valves, or say two-valve receiver with two-valve power amplifier are required to make them of any decent strength.

Here, again, I wish to emphasise the fact that the foregoing is subject to considerable variation due to locality, etc., but I have attempted to put my own observations, both on my own and on other enthusiasts' sets, into words, and no doubt many will consider results poor or underestimated, while some may consider them even exaggerated. There is, however, one peculiar thing I have noticed; whether it be due to the atmosphere or the surroundings, I cannot say. On practically all sets in this district signal strength appears to be about one-valve strength weaker than the stated strength of reception in other towns. I have had visitors from different parts of the country, and always the same remark, "how weak," is made when they commence to listen-in. But on distance results compare very favour-

ably with other districts, and is well up the lists in the "Transatlantics," including broadcasting reception from the U.S.A.

One particular receiver employing four valves, namely, one H.F. (aperiodic transformer coupled), one detector and two L.F. with single wire aerial 30ft. high, has been highly successful in reception of U.S. broadcasting, and has frequently picked up the station WGY, Schenectady.

Regarding amateur transmissions we are not quite so fortunate as the surrounding districts, and are very badly supplied in this respect. Within about forty miles radius, however, we have a considerable number, notably on the Manchester side, and it is very rarely that one fails to find at least one amateur station working. Several of them may be heard on telephony with one valve, chief amongst them being 5AJ, 2FZ, 2WK, 5OW, and one or two others who come in exceptionally strong, but all at least ten miles away. A three-valve receiver of the one H.F., detector, and one L.F. type, is usually required for reception of most amateurs' in comfort, though, of course, if Morse only is desired a single valve is extremely useful.

Of the foreign telephony stations perhaps the Hague is the most sought after, but reception of this station is hardly a great success owing to the considerable amount of jamming. To receive the station with anything like strength, at least three valves are required, though under favourable circumstances it can be heard with two. Five will operate a loud-speaker such as the "Brown," for a small

room. FL telephony is considerably easier to receive and is very nice on four valves, while the German station LP (though I seldom hear of its reception) may be heard with the four-valve set. This set should also be suitable for reception of the various French broadcasting stations.

The British Airway telephony stations are, strangely enough, rather conspicuous by their absence, but this is mainly due to the fact that Manchester, GEM, seldom operates his radiophone, and those down south (Croydon, Pulham, Lympe, etc.) are so erratic in their transmissions that no opportunity is given for tuning in. However, once tuned in a three-valve set will give nice clear speech, at any rate from Croydon, and, occasionally, the aircraft. Owing to lack of observation on these stations I cannot give definitely the number of valves required to work a loud-speaker, but as the power used by these stations approximates to that used by the B.B.C. stations, the reception should be very similar.

For reception of Morse from any part of the Continent or even the U.S. a single valve is practically all that is necessary, and with autodyne reception for C.W. it forms a simple and very effective receiver. One conclusion which may be drawn from recent tests is that for reception of C.W. with outdoor aerial, the addition of valves does not increase the effective reception from any particular station. I attribute this to the fact that the limiting factor in C.W. work is the relation between signal and atmospheric strength, including, of course, interfering noises

such as the continuous rustle from spark and battery irregularity. Now, on adding more valves these noises are amplified to the same extent as the signal, with the result that the weak signals are as unreadable as before, in spite of the fact that the noise from the receivers may be deafening. Therefore, a signal almost unreadable with even two or three stages of high-frequency amplification, may, providing the operator's ears are trained to the weaker sounds, be readable on a single valve.

As the foregoing only applies to the oscillating valve, conditions are different for reception of spark, and, to some extent, telephony. Here, an oscillating valve is useless on shipping; except for the loud signals, due to the continuous drumming from dozens of ships, and to stop oscillation brings silence only broken by the nearer stations such as GLV and GCC and the ships working with them. One stage of H.F., however, makes a wonderful difference, and is sufficient to bring in all the British and French coast stations, those on the other side of the North Sea (KAV, OST, etc.), and also Mediterranean stations. As the addition of more H.F. will only increase jamming it is useless to apply it, and therefore if louder signals are wanted the addition of L.F. valves will suit just as well. Three valves will operate a loud-speaker satisfactorily, on the near stations, though should something really deafening be required the addition of, say, another two valves will give all the results desired.

"MODERN WIRELESS" BINDING CASES

"MODERN WIRELESS" has now completed its first volume, the October issue being the first number of Vol. II. The publishers are preparing binding cases and these, together with the necessary index, will be ready on October 17th.

The covers are in two attractive styles, one being a cloth-backed case and the other leather-backed, both lettered in gold. The prices of the cases are 2s. 6d. and 4s. 6d. (post 4d.), while if readers supply the necessary back numbers, they can be returned bound for 4s. 6d. or 7s. 6d. (post 1s.). The Index can be supplied separately at 1/- (post 1d.)

“ WIRELESS WEEKLY ” CIRCUITS—No. 27

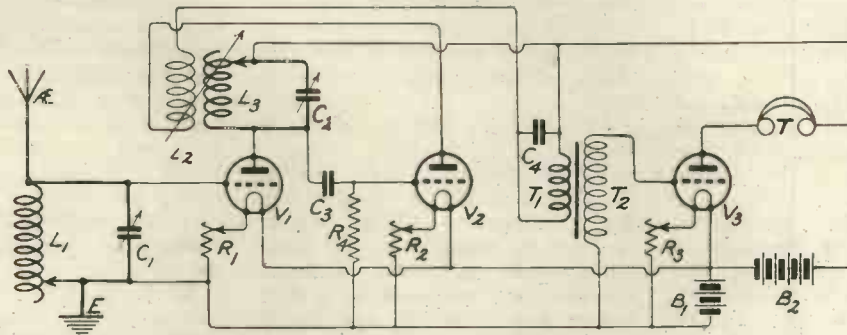

COMPONENTS REQUIRED

- L₁: A variable inductance.
- C₁: A variable condenser, capacity 0.001 μF.
- L₂: A fixed reaction coil.
- C₂: A variable condenser, capacity 0.001 μF.
- L₃: A variable inductance.
- T₁, T₂: A step-up inter-valve transformer.

GENERAL NOTES

This circuit is an excellent

three-valve circuit for the reception of broadcasting from distant stations. Owing to the fact that reaction is introduced from the anode circuit of the second valve on to the tuned anode coil of the first, no appreciable radiation takes place from the aerial. Accordingly the circuit complies with the requirements of the Post Office in this respect, and may be used for the reception of British Broadcasting.

VALUES OF COMPONENTS

The inductance L₁ may consist of 50 turns of No. 26 S.W.G. d.c.c. copper wire upon a 3in. diameter cardboard tube with tapings at the 20th, 30th, 40th, and 50th. L₃ may be similar to L₁, whilst the reaction coil L₂ should consist of 40 to 50 turns of No. 26 or 28 S.W.G. d.c.c. copper wire upon a 2½in. diameter former.

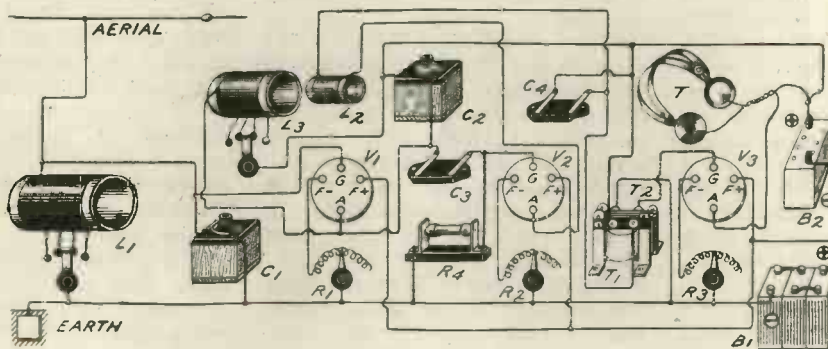

PRACTICAL WIRELESS NOTES—No. 9

L.F. TRANSFORMERS

usually have their terminals marked I.P., O.P. (representing inner and outer ends of the primary winding respectively), and I.S., O.S. (inner and outer ends of the secondary winding). In some cases, however, the two primary terminals are merely marked P, and the secondary terminals S.

There is really no standard

method of connecting this type of transformer in circuit, and, if any difficulty is experienced, the following hint will be found useful. Connect the two primary terminals in the most convenient manner and connect each of the secondary terminals in turn to the grid of the succeeding valve, leaving the remaining secondary terminal unconnected.

With the correct secondary terminal connected to the grid,

quite good signals will be received. Next, reverse the primary connections and again try each secondary terminal in turn. Note which arrangement gives best results, and make permanent connections accordingly. Finally try the effect of adding a fixed condenser across the transformer primary. Some transformers do not require this, whilst with others results are considerably improved.

A THREE-VALVE RECEIVER FOR ALL WAVELENGTHS

By HAROLD E. DYSON.

A full description, with constructional details, of a simple but effective all-wave receiver.

IT is proposed in the following article to describe a three-valve set of universal wavelength range which may be easily made by the experimenter. Whenever possible, a simple method of making each component without expensive tools or material

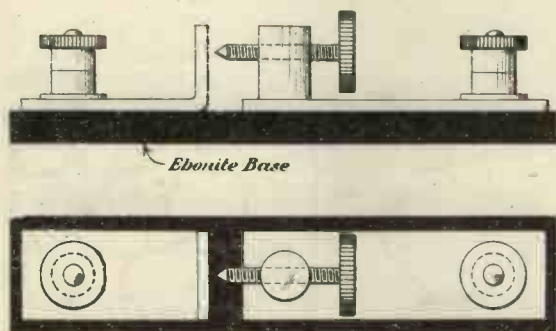

Fig. 1.—Details of the lightning arrester.

will be given. This, while not preventing the experimenter from using any purchased article, will enable him to build a receiver for an unusually small outlay.

Three is generally the most useful number of valves to adopt. The first should be a high-frequency amplifier to obtain sufficient energy for efficient rectification when receiving distant stations. It also increases selectivity, and enables reaction to be used with safety.

The second valve is, of course, the rectifier. These two may be used alone, or the third, a low-frequency valve, may be switched in for use when receiving distant stations or when using a loud-speaker. With a standard P.O. aerial, reception of the broadcast stations should be excellent in the telephones up to 100 miles, and with a loud-speaker up to 40 miles.

Commencing at the aerial end the first piece of apparatus to demand attention is the lightning arrester.

An arrester is to be preferred to a switch, because the latter is more or less frequently forgotten and left open when reception is

finished. It must be remembered, however, that many types of arrester in use on line telephones possess too much self-capacity to render them suitable for wireless use. The type shown in Fig. 1 is suitable and easily made. The screw is turned until it almost touches the brass strip. The dimensions are not important. It is better to place it at the point of leading in than on the set itself, using a separate outside earth.

The next consideration is the aerial tuning inductance. This should be an interchangeable inductance of a concentrated form, in order that the set may have universal wavelength range. It will also be found that from the range of coils required for aerial tuning, coils not in use at the moment in the aerial circuit may be selected for use as tuned anode and reaction coils.

Honeycomb coils are fairly easily made and are efficient. Obtain a piece of round wooden rod about 2 inches in diameter and 2 inches long. Put two rings of wire nails round this, leaving one inch between the two rings. (Fig. 2.)

For the small coils ten nails should be used in each ring, but this number should be in-

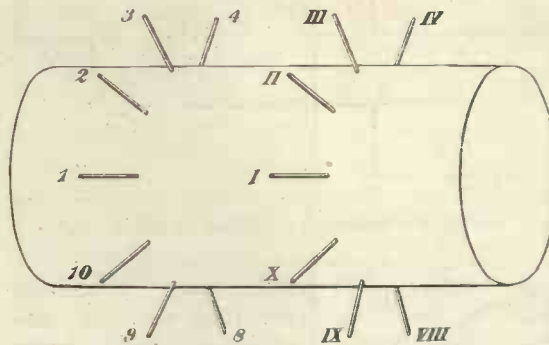

Fig. 2.—The former for winding the coils.

creased in steps up to about thirty for the large sizes. The small number gives the small coils a very low distributed capacity, but would be found to make the larger sizes very clumsy. Paper cut to a width of one

inch must be wound round the wood former between the nails before the wire is put on.

Commencing with the smallest coil, number one ring 1 to 10, and the other I. to X. Passing the wire round 1, go to VI., then

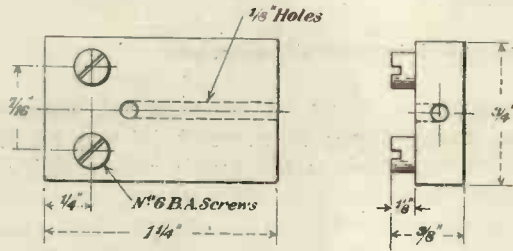

Fig. 3.—Details of plugs.

to 2, then VII., then 3, and so on until sufficient turns have been put on.

The coil will soon be found to take on a honeycomb formation, very similar to that of the commercial article. It should be varnished at intervals during winding with thin shellac varnish. Thick varnish would increase the self-capacity. When the coil is finished, it will be found that the nails can be withdrawn and the coil will slide off the

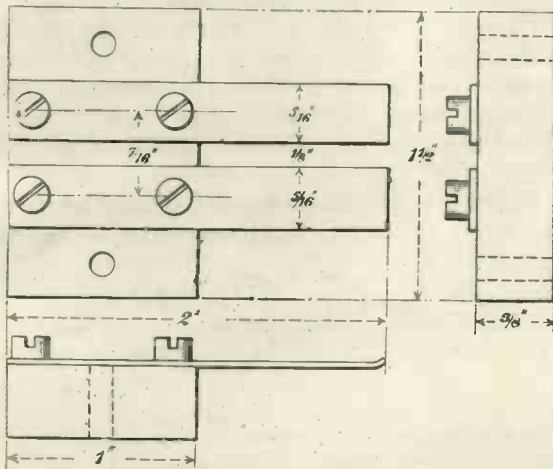

Fig. 4.—Showing dimensions of jacks.

wood former. A good range of coils should be used, in order that a small condenser capacity may be introduced, especially when using the smaller sizes. A suitable range is obtained by using the following

number of turns: 25, 35, 45, 60, 75, 100, 150, 200, 350, 600, 1,000 and 1,500. The last two or three sizes will take some considerable time to wind.

Wire may be No. 24 for the small coils, No. 32 for the larger ones. Silk or cotton covered wire may be used.

The easiest and cheapest method of connecting these in circuit is to solder a length of, say, 10 inches of twin silk covered bell flex to the coil ends, binding these to the coil with thread, so that no mechanical strain comes on the soldered joint. The other end of this flex is passed through the hole shown in Fig. 3 and fastened under the two screws in the little ebonite plug block.

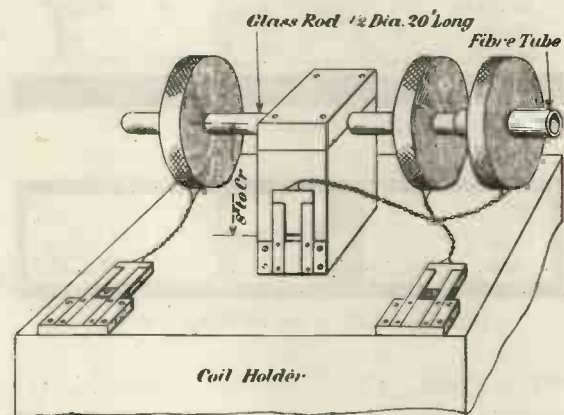

Fig. 5.—Showing jacks and plugs, together with coils in position.

Three flat jacks are made, as in Fig. 4. The flat springs are German silver strips about 3/2 of an inch thick. When these are screwed down, it is only necessary to slip the plugs under to get a good sound connection.

A 1/2-inch wood rod or glass tube is arranged on the top of the case containing the set, with a supporting block in the centre (see Fig. 5). On one side is slipped the aerial coil and on the other the tuned anode coil. The reaction coil may then be slipped on to either side, but should always be used on the tuned anode side for the reception of broadcast. To prevent capacity effects from the hands, a piece of fibre tubing (an easy fit on the rod) is used to move the reaction coil.

(To be concluded.)

HAVE YOU SENT IN YOUR BACK NUMBERS FOR BINDING?



Jottings by the way

The Surrender of the Desperadoes
THERE have been moving scenes these last few days during the playing of the sensational drama "The Capitulation of the Pirates or Hauling down the Skull and Crossbones" as staged by the Postmaster-General. Stirred to its nethermost depths by the moving appeals of the Powers that Be, and possibly by the dread threats that all who did not don the white sheet of penitence should suffer penalties too awful to be set down in cold print, the great British conscience awoke. The outlaws, the bandits, the other pariahs emerged from the shadow of their lawless aerials and hastened armed with good silver coins (or the nearest that we can do to them in these days) to the post office to make their peace while there was yet time.

Many of them shrank from laying bare their secret crimes to the maidens of their local post offices. These fared far afield and crept into distant offices where they were unknown. But when they had at last persuaded some young thing to interrupt for a moment her conversation about chiffons and face powder with a companion and to give ear to their tale they received no sympathy. Cold, haughty tones informed them that the post offices laid on at their own doors were the only places where confession might be made.

Men Once More

And so, choosing times when they thought that all their friends would be out of the way they slunk round to the place of restitution, glanced round furtively to see that no acquaintance was within, then hastily pushed a half

Fisher and two silver coins across the counter, asking in low tones for the cleansing licence that should make them once more into self-respecting citizens, able to hold up their heads amongst their fellows.

When the transaction was over and they were purified from crime, you saw a vast change in their demeanour. They might have entered meekly, weighed down by the sense of unpurged guilt, but when they left the meekness had vanished. They were men, strong, aggressive men, once more ready to look with scorn and loathing upon any who were still so case-hardened as to continue in their wicked ways.

Would You Believe It?

'Tis extraordinary to see what an unholy mess some fellows can make of wiring up even the simplest and most straightforward circuit. I received an S.O.S. the other day from a friend, a new recruit to the ranks of wireless enthusiasts, who could not make his set work no matter what he did to it.

He had bought a selection of parts and put the thing together most carefully (so he averred) with the help of diagrams of unimpeachable correctness. Yet it had no voice. Can you wonder when I tell you that he had reversed the H.T. connections, and that his grid condenser occupied the place designed for the leak, the latter being in series with grid and I.T. negative.

Pull Together

The future of wireless has been seriously jeopardised in many ways during the last year. There

have been aggravating delays of all kinds; there have been quite unjustified attacks on the quality of the broadcast entertainments made by a certain section of the Press.

All this has led to a certain falling off in keenness. People who would have purchased sets in the ordinary way held back till they could see how the cat was going to jump. Now their ardour has partly evaporated and they will not join the brotherhood of wireless men unless efforts are made to rope them in. It is to the interest of all of us to see that wireless does go ahead, and it can do so only if the number of listeners-increases and multiplies exceedingly.

All wireless clubs should start a regular propaganda by holding meetings, preferably with demonstrations, at which members and non-members alike are welcomed. If good lecturers are chosen many conversions are sure to be made. He is a poor secretary who does not enrol at once his man whose new-found enthusiasm is red hot. Much can be done, too, by the individual wireless man, who can interest his friends in the greatest of hobbies and so help to further the spread of the movement. It is worth while to make the effort that may mean so much.

A Reformed Character

I am just re-rigging my aerial. Friends and neighbours have so taunted me about it that, stung at length into action, I have decided that something must be done. For years I have been telling others that aerial masts must be stayed, that the free end of the aerial should be higher

than t'other, that numerous insulators are essential, and things of that kind. But, to let you into a grim secret, mine own has always been rather of the fearful example type.

I was too busy (which, of course, means too lazy) to attend to the thing properly, and as it did all that was necessary, even to the bringing in, when asked to do so, of the nasal accents of Uncle Sam's broadcasting stations, I simply let it continue in its wickedness as an eyesore and an offence to all good wireless men.

What Will Happen?

Now the mast is to be raised by ten good feet. Comely stays are to secure its stability in the gales of winter. Insulators will be strung upon the suspended wires as prodigally as pearls in a chorus girl's two-thousand-pound necklace. Stout 7/18's are to replace the bell wire that constitutes the present lead-in. Everything in a word is to be slap up so that I

may no longer incur the reproaches of my fellows.

The result should, of course, be a marked improvement in reception, an increase in range, an addition to signal strength. But will it? If you have had much experience of the little ways of wireless you will forecast as I do that the new contraption will not work half as well as the old. Anyone who has set himself the task of improving his already excellent set will know what I mean. 'Tis often a case of love's labour lost.

Came to Pieces in Me 'And

It is really terrible how things come adrift, or fly asunder, or peter out of their own accord. One used to laugh heartily at the ancient joke about the housemaid who said that cups, tumblers, dishes, and other fragile bits and pieces "came to pieces in me 'and." But the wireless set's little way of coming unstuck all on its own teaches one that she was probably not without sound reason

for her remark. You have no doubt had experience of it; certainly you have if you are an old hand, whilst if you are more or less new to the game you will know it to your cost sooner or later.

When I came back from a few weeks' holiday the wireless room was naturally the first part of the house that I visited. The set hadn't been touched since I left, and all was well with it then. But the first glance disclosed unhealthy-looking slimy patches on the wax of the high tension battery. No less than four cells had given up the ghost. Now if this happens when the set is working every day one does not mind so much, for the cells die in harness, so to speak; but when they work perfectly well up to the last moment that they are in use and then go and snuff out when they are doing nothing, one somehow feels that they are not quite playing the game.

WIRELESS WAYFARER.

THE BRITISH BROADCASTING COMPANY, LIMITED

Extraordinary General Meeting.

WE were privileged to attend an Extraordinary General Meeting of the above-mentioned Company in the Cannon Street Hotel, E.C.4, on Tuesday, October 9th. The purposes of the meeting were to receive a report on the terms of an Agreement arrived at between the Postmaster-General and the Directors of the Company, and, if thought fit, to approve the terms of such Agreement, also to consider and pass the necessary resolution modifying the Articles of Association of the Company.

In the course of his opening speech Lord Gainford, Chairman of the Company, recounted the considerable difficulties which had now been overcome. He made reference to the technical progress which had been made, and, alluding to the programmes, sug-

gested that those who are critics keep fairly in mind the fact that, whereas a theatre entertains different audiences with the same play, the broadcasters' problem was to entertain the same audience by a different programme every night in the week.

Lord Gainford also outlined the progress of negotiations with the P.M.G. and the modifications in the licensing regulations.

During the meeting, Major Binyon, a Director of the Company, gave brief particulars of the modified conditions now to be complied with by B.B.C. sets in order to be approved by the Post Office Engineering Department. Such sets are to be tested for wavelength range only, the inclusion of reaction being permissible, subject to the manufacturer

supplying adequate instructions with each set to permit of its being operated without risk of causing interference.

Opportunity was given to shareholders to voice their opinions or to enquire upon any obscure points, and, as was only to be expected, several questions were raised. One gentleman raised a question that gave promise of developing into a lively interlude when he criticised the insertion of the word "knowingly" in the constructor's licence.

Altogether, however, the meeting was extremely harmonious, the proposed resolution was carried unanimously, and there appeared to be general satisfaction at the settlement of the long-drawn-out broadcasting controversy and a strong desire to get down to business forthwith.

THE CONSTRUCTION OF HIGH-FREQUENCY TRANSFORMERS

By G. P. K.

The following short article gives a few practical hints concerning H.F. transformers, together with constructional details of the one illustrated.

A METHOD of high-frequency amplification which, in the writer's opinion, is being most unjustly neglected at the present time is that which employs the high-frequency transformer as a method of inter-valve coupling.

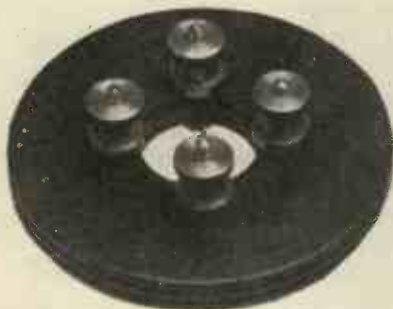

Fig. 1.—A simple form of H.F. transformer.

Where only one high-frequency valve is employed the tuned anode method is, no doubt, the most efficient form of coupling, but where more than one high-frequency stage is used the tuned or semi-tuned transformer has much to commend it.

It is very cheap, since it requires no gridleaks and condensers between the successive high-frequency valves, and it is quite easy to stabilise to any desired degree by a suitable design of the windings. The construction of such transformers is a job of which the average experimenter is usually rather shy, since there are popular ideas that it is very difficult.

Actually, however, so long as one does not attempt any of the more complicated types, such as those with switching devices, the

matter is really very simple and does not even require the possession of a lathe. All that is wanted is a little definite information from someone who has done the necessary experimental work as to the correct numbers of turns to put on the windings. This information is given upon this page, together with some hints for the actual construction of the transformers.

It must be understood at the outset that there are two distinct types of high-frequency transformers, namely, the semi-a-periodic type, which is wound with moderately fine resistance wire so that the peak upon the resonance curve of its windings is very much flattened out so that it will work over quite a wide range of wavelengths, and the "tuned" type.

This latter is wound with fairly low resistance copper wire and has either one or both of its windings accurately tuned to the received wavelength by means of a small variable condenser.

Upon the shorter wavelengths it is more usual to employ the tuned type of transformer, and a specimen of this variety is shown in the photograph (Fig. 1). This is a very simple type, consisting of a disc of ebonite 2½ in. in diameter and ¾ in. thick, in the edge of which two grooves have been turned of the dimensions shown in Fig. 2. The example in the photograph is provided with four terminals for the connections to the primary and secondary windings, since it was intended to be connected permanently in circuit. It is a simple matter, however, to replace these four terminals by

four valve pins, so that the transformer will plug into a valve socket, thereby enabling one to use a set of interchangeable transformers to cover the whole wavelength range.

The primary and secondary windings are wound separately in the two grooves, and each consists of 80 turns for broadcast reception, either of No. 40 single silk-covered resistance wire if it is desired that the transformer shall function without a tuning condenser, or No. 36 d.s.c. copper wire if it is proposed to tune it. It will be noted that two separate grooves are specified for the winding, since the writer is not an advocate of the type in which only one groove is used, with both primary and secondary wound simultaneously or one above the other, having found that equally good results are obtainable with the two slots, and it is very much easier to secure efficient insulation

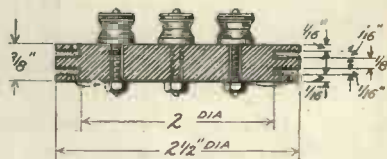

Fig. 2.—A section view of the transformer showing constructional details.

between the two windings. The constructional details of this transformer are clearly indicated in Fig. 2. A further constructional article dealing with high-frequency transformers will be given in next week's issue under "Constructional Notes."

PRACTICAL SHORT-WAVE TRANSMISSION

By E. H. ROBINSON.

The following is the conclusion of an article in which the author explains a practical short-wave C.W. transmitting circuit.

(Continued from Vol. 2, No. 13, page 474).

Position of High Tension Supply

IN Figs. 1, 2, 3 and 4 the H.T. supply is shown connected between the anode inductance and the junction of earth and filament leads, a fixed condenser C_3 of at least $0.001 \mu\text{F}$ capacity being shunted across the H.T. leads as an H.F. by-pass.

This method of supply is simple and direct, and gives as good results as any; but the alternative method of supply shown in Fig. 5 has certain advantages to recommend it. In the latter system the negative pole of the H.T. supply is connected to the filament while the positive is connected through a high-frequency choke L_4 to the plate of the transmitting valve V_1 . The plate is also connected to the inductance L_1 through a condenser C_3 , sometimes called the "anode stopping condenser," the value of which is best found by trial, but which may usually have a capacity of $0.001 \mu\text{F}$.

The function of the choke L_4 is to pass D.C. currents from the H.T. supply while keeping out H.F. oscillations. It may consist of a cylindrical coil or a basket coil which would normally tune to about 1,000 metres or more. This "shunt supply" has the advantage that the plate of the valve is the only part of the apparatus at H.T. potential, so that there is no danger of a severe shock should the aerial or inductance be accidentally touched when the transmitter is running. Slight H.F. burns may result, but these are not serious as compared with an H.T. shock.

The frequent practice of inserting the H.T. battery or generator straight between the plate terminal and the inductance is not to be recommended, as this puts the battery or generator at full H.F. potential and its capacity effect, as well as any faulty insulation from earth, may seriously hamper the efficient working of the set.

Grid Condenser and Leak

The grid condenser and leak, shown as C_2 and R respectively in all the figures, form

an important item which is frequently neglected. In very low power transmitters using 2 watts or less, it is perhaps not absolutely essential, but in a transmitter using 10 watts or more on the plate it is usually very important. A valve transmitter without any grid condenser and leak at all is apt to work near the upper saturation bend on the characteristic curve of the valve in use, and consequently use an unduly large anode current and give a poor aerial current.

The action of the grid condenser and leak in a transmitter is to put a large negative potential on the grid of the power valve, thus making the valve oscillate about the lower part of its characteristic curve, with the result that the grid-current damping is reduced and the same, or greater, aerial current is obtained with considerably less current consumption in the anode circuit of the valve. The latter point is of material importance to those using small dry cells as a source of H.T., as the life of such cells is short and their use is expensive unless the very best is made of the current taken from them.

In experimenting, it is well to have the grid-leak continuously variable. The condenser may also be variable, but this is not so important; it may be of the fixed type with mica or glass dielectric and a capacity of about $0.0005 \mu\text{F}$. Starting with the resistance of the grid-leak at minimum and increasing its resistance gradually, a certain point will be reached where the aerial current has a distinct maximum, and any further increase in the resistance of the grid-leak results in a rapid falling off of the aerial current. As this optimum value is rather critical, it is absurd to buy fixed grid-leaks; some form of variable liquid resistance is recommended for preliminary experiments. The actual value of the leak required may be anything between a few thousand ohms and several hundred thousand, depending on the type of valve used, power, etc.

For serious work an aerial ammeter of the

hot-wire type is absolutely essential, and a D.C. milliammeter is highly desirable in one of the leads from the H.T. supply. The usual place for the aerial ammeter is in the aerial lead as shown at A in the various figures.

A Practical Short-wave Transmitter

Nothing has been said so far in this article about keying for Morse transmission or modulation for radio-telephony as the primary object has been to give hints on how to obtain the best radiation on short-wave valve transmission. Any of the well-known methods of keying and modulation may, however, be applied to any of the circuits described. Fig. 6 shows a practical transmitter which is efficient and convenient for all-round work on wavelengths between 150 and 200 metres. V_1 is the main oscillator valve, while V_2 is a choke control modulator used only when speech is to be transmitted.

The valves V_1 and V_2 should preferably be of a similar type. L_5 is an audio-frequency choke which may be the secondary of a small spark-coil, one winding of an inter-valve transformer or any similar inductive coil with a large number of turns and a laminated iron core. The H.F. choke L_4 confines the H.F. oscillations to the valve V_1 , and is of the dimensions referred to in the description of Fig. 5. The Morse key K , for C.W. transmission, is inserted in series with the grid-leak R . For telephony the key is closed or shorted by a switch. It will be noticed that the grid condenser and leak have been transferred to the earth side of the grid coil L_2 , as they work just as well in this position, but are not at the H.F. grid potential, and may be handled without fear of H.F. burns.

Results to be Expected

Very good work may be accomplished on short wavelengths. The aerial currents to be expected for any given power depend very largely on the aerial and the earthing. A good counterpoise below the aerial usually makes an enormous difference to the aerial currents obtainable. For an average amateur aerial, however, about 0.2 amp. may be expected for a plate power input of 2 watts, and for 10 watts 0.5 amp. may be obtained with luck. These, however, are conservative estimates; some experimenters claim to get over 1.0 amp. into their aerials on 10 watts, though such feats require good aerials and earths and careful adjustment of apparatus.

Ranges covered in short-wave transmission are very much characterised by freak effects. As a rule powerful signals are obtainable over short distances, but they become very attenuated and faint over long ranges (over 50 miles). At times, however, especially during the night, the barrier of distance seems to be broken down for intervals of varying duration, and signals may be exchanged on low power over remarkable distances. Thus one night the writer exchanged signals on 200 metres with another station in Geneva (over 400 miles from London), both stations using a power of 10 watts. French and Dutch amateur stations can be raised almost any

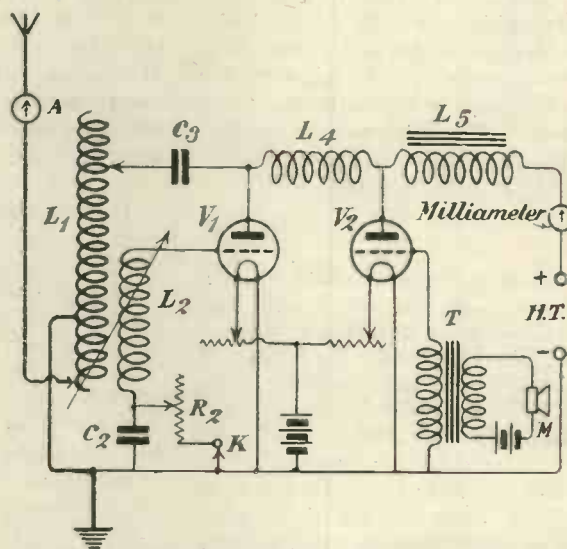

Fig. 6.—A practical transmitting circuit for wavelengths between 150 and 400 metres.

night after dark (and, of course, after the broadcasting).

The most remarkable feature about short-wave transmission over distances exceeding 150 miles is the alternate swelling and fading of the received signals. At times the signals will become surprisingly strong, and one wonders whether their source can really be more than a few miles distant; but this illusion is dispelled after a short time by the signals fading away to complete inaudibility. The fading effect is no fault of the transmitter or receiver; it is characteristic of short-wave transmission, and seems to be due to some irregularity in the intervening medium.

Perhaps it is the element of sporting chance that makes short-wave work so fascinating for the experimenter.



News of the Week

AT the informal meeting of the Radio Society of Great Britain to be held on October 17th at 6 p.m. at the Institute of Electrical Engineers, Mr. Phillip R. Coursey, B.Sc., will open a discussion on short-wave reception. In view of the forthcoming Transatlantic tests, this discussion should be of particular interest to those experimenters who anticipate taking an active part in them.

With reference to the arrangements made for the White City Exhibition, a competition is being organised by the Radio Society of Great Britain for the best specimens of amateur-made apparatus. Affiliated Societies have been asked to select by competition or otherwise their best efforts and to submit them for exhibition purposes. Exhibits will be on view, and we are given to understand that some three or four prizes are offered by the President and Committee of the Radio Society of Great Britain.

We are informed that the organisation of the transmitters and relay section is progressing favourably. It will be remembered that the President, Dr. Eccles, F.R.S., addressed a letter to all transmitters throughout the country inviting them to join this section, irrespective of whether they were members of the Radio Society of Great Britain or not. There was to this appeal a ready response, and the British Wireless Relay League that was, is now embodied in this section. Full particulars of the rules of this new section,

together with particulars of the first series of tests, will be found on page 511 of this issue.

From the Government wireless station at Calgary, wireless conversation is being held with the Macmillan Arctic exploration party on the ship "Bowdoin," two thousand miles north of civilisation, in the Arctic circle.

The operator on the "Bowdoin," said that the Calgary signals were coming in clearly. A Calgary dance programme has been sent by wireless to the explorers in the far North.

Professor J. A. Fleming, F.R.S., is to deliver at University College, commencing on October 24th at 5 p.m., a series of six lectures entitled "Ionic and Thermionic Valves." We understand that the course is open to a limited number, and a syllabus of the lectures and particulars as to fees can be obtained on application to the Secretary, University College, Gower Street, London, W.1.

We learn from Autoveyors, Ltd., that the General Electric Co. are now licensed to manufacture and sell the 3-E.V.C., and that their model of this instrument will be on the market in a week or two.

The Liverpool Marine & General Insurance Co., Ltd., are issuing policies to protect the landlord fully against all and every damage that may be done to his property, or the property of adjoining landlords, directly due to the erection, maintenance, or

dismantling of a wireless set and its aerial equipment, the property of his tenant.

The cover is most comprehensive so far as the landlord is concerned, and meets every possible contingency that is likely to run him into expense in connection with the tenant's wireless apparatus. The advantages of the scheme from the tenant's point of view are that it relieves him entirely of all legal obligations to his landlord in respect of his set, and yet enables him to indulge in his hobby without interference.

An interesting and original club has been formed near Paddington Station for wireless experimenters, where, for a small fee, members have the use of a small engineers' workshop during the day and evenings for the construction of any set. Free expert advice is at the members' disposal at any time, and an aerial is available for testing sets. Readers interested should apply to the Secretary, "Home Radio Construction Club," 31, Upper Brook Mews, W.2.

We understand from the Western Electric Co., that arrangements have been made whereby on October 25th they will transmit by means of their loud-speaking equipment, the Premier's speech to the annual Conference of the National Unionist Association, in the new Palladium, at Plymouth, to another meeting in the Guildhall. It is estimated that in this way 10,000 people will hear the address clearly and under comfortable conditions.

A FOUR WEEKS' HOLIDAY WITH A PORTABLE SET

By P. G. A. H. VOIGT, B.Sc.

The following is the conclusion of an article describing a series of interesting experiments with a novel design of valve-crystal receiver.

(Concluded from Vol. 2, No. 12, page 435.)

THE set was then moved down to 20ft. above ground level, next to 3ft. above ground level, and lastly into the coal cellar under the pavement, *i.e.*, 7ft. below ground level, the frame standing on the floor. PCGG's music and speech, which had become slightly weaker at every move, was still audible, the speech being quite readable. To

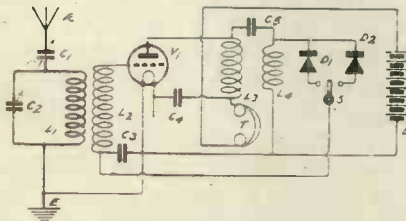

Fig. 5.—A simplified illustration of the circuit for the first valve. Filament batteries, potentiometers, etc., are omitted.

get a direct comparison, the set was then taken upstairs again, and I found that PCGG was certainly not more than three times as loud as down in the cellar.

One day another experiment was tried. The set was used downstairs and a 40ft. down lead was taken from the 32ft. aerial in my room. Many signals and telephony, including 2OM, 2ON, and 2KT were received. The down lead was then connected to earth, cut 20ft. higher up, and the set was inserted there. Signals were slightly weaker. This was repeated higher up with only a 7ft. down lead. Signals again were weaker, but not less than half as strong as downstairs.

If the 33ft. of wire which were earth lead instead of down lead could have been used to increase the size of the aerial, I am sure results would have been better with the big aerial, short down lead, and long earth lead than with the small aerial, long down lead, and short earth lead. The total length of wire in the aerial and down lead being the same in each case.

Those amateurs who have their sets at the top of the house, and practically the whole

of their 100ft. of wire acting as an efficient aerial can therefore expect better results than those amateurs who have short aerials, long down leads, and short earth. If, however, the aerial span is fixed, it is better to have the set as low as possible in order to get more wire on the aerial side of the set, even though the additional wire is a very poor sort of aerial.

When experimenting with earth connections, the DC light mains were tried. As the voltage was only 115 here, there was no danger from shocks. With the switch closed either of the wires made as good an earth as the bells; if the switch was open, the wire leading to the switch was only about half as good, because then it acted partly as a counter capacity and partly as one plate of a small condenser of which the other wire was the other plate, so that the earth was partly a counter capacity and partly a real earth with a small series condenser. It is interesting to note that the lighting wires went through the ceiling over the aerial, and then downstairs. In every case where the mains were used as a direct earth connection, generator hum was audible and drowned the

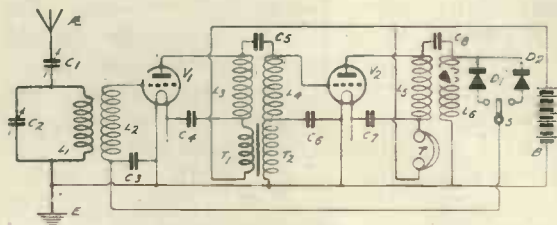

Fig. 6.—The two-valve circuit in simplified form, batteries, etc., being omitted.

very weak signals. By putting a 0.0003 μ F fixed condenser in series, this hum was absolutely cut out.

Reception using two earths was also tried and compared with normal reception on the small indoor aerial. The bells and the mains were the two earths used; it was found that some stations were slightly louder like this.

and others were weaker, thus proving that reception on two earths is exactly the same as frame aerial reception except that only a single turn of unknown size is used. A blocking condenser was left in the lead to the mains for safety.

About 100 yards from the hotel there is a jeweller who has an electric clock that makes and breaks its circuit once per second. On the ordinary aerial it becomes audible on about 900 ms, is a great nuisance on 1,050 ms, and gets weaker as the wavelength increases. It was noticed that whenever the electric light mains were used as earth, this clock was jamming on a wider band of wavelengths, being comparatively loud on 600 ms. When the frame aerial was used upstairs on 1,050 ms the clock could not be received, but with the frame set 20ft. lower down, it became audible, and with the set in the coal cellar, where the mains came into the house, it was very loud. This seems to be a case of wired wireless, the electric mains acting as the guide wires.

Another kind of jamming was sometimes experienced. It was a continual buzz lasting sometimes for half an hour and broke through on all wavelengths, but was louder on some bands than on others. It must have been nearly all electrostatic, because it could not be received on a frame. It was loud enough to jam all but the loudest coast stations, but it could not be received when using the frame; everything was much weaker, of course, but the jamming did not come through at all.

The Paris concert received on the 4ft. 5-turn frame with 3 valves and crystal could be heard in the loud-speaker. Using the 1,900-metre tuning coil as frame (diam. 8in., about 120 turns) it could just be received with very careful adjustment. On returning home, I found on my full-size aerial I needed one note-magnifier less than on the small indoor aerial at Brighton to get the same strength. The circuit diagram, Fig. 2, looks rather complicated, so Figs. 5 and 6 give the equivalent single and two valve circuits with grid potentiometer and other refinements and reaction omitted. Filament batteries are not shown.

On the outward and return railway journeys I tried to listen in. On the outward journey I went in a coach which was illuminated by electric light. The commutator must have been in a very bad condition, be-

cause the crackling from it drowned any signal I might have heard. On the return journey, profiting by my previous experience, I chose a compartment which was illuminated by coal gas. The aerial (single wire) went just under the luggage rack and the counter capacity was another single wire at the back of the seat. A proper earth to the heating system would probably have been better.

While in Brighton station (glass roof on metal framework), signals on this aerial and counter capacity were very weak. On joining the free ends of the aerial and counter capacity to make a single turn loop, there was a marked improvement. Before leaving the station the joint was opened so as to get back to the ordinary open aerial. The moment the train left the station, signals came in quite well, some being audible with only 2 valves and crystal. I expected to get a great deal of valve clang, but it was not audible above the noise of the train itself.

Passing under telegraph wires, signal posts, stay wires, foot bridges, or any other earthed conductor caused a drop in signal strength. When the conductor was very high up, the drop was not very great (say to $\frac{1}{3}$ normal), but when the conductor was low, the change was very great, sometimes wiping out the signal altogether. The decrease in strength was not noticeable when the angle between the direction of the conductor and the vertical exceeded 30 or 45 degrees. Overhead conductors were not the only causes of screening. Wireless "shadows" were quite marked. In one case a gasometer was passed, but there was no change in strength opposite it. The decrease occurred between 20 and 30 yards farther on.

Going through country stations with waiting rooms on each side of the main line always decreased the strength. Going down a cutting decreased the strength. In tunnels I could not hear any wireless signals, but interference from the lighting dynamos on the other coaches increased in some tunnels. Coming out of a cutting increased the strength. The more exposed we were, the better the results. In fact, I could tell how the contour was changing simply by listening-in.

Before the end of the journey the free ends of aerial and counter capacity were joined to get back to the loop aerial, but signals were much weaker, and I did not have time to make a proper test.

RADIO PRESS "HOW TO MAKE" HANDBOOKS ARE OBTAINABLE AT ALL BOOKSTALLS.

MAKESHIFT AERIALS

By G. P. KENDALL, B.Sc., Staff Editor.

The conclusion of an article which commenced in our last issue, of special interest to experimenters not possessing an outdoor aerial.

Frame Aerials

ALTHOUGH the frame aerial is placed at the bottom of the list when makeshift aerials are arranged in order of the amounts of energy which they pick up, it should be explained that frame aerials have certain very valuable properties which none of the others possess. Their principal advantages are, firstly, their extremely sharp tuning which in itself makes them very selective and valuable in cases where much jamming is experienced, and secondly, their very marked directional property (which means that they receive signals most strongly from a certain direction, that is, signals passing in a direction parallel to the plane of the frame produce relatively strong effects upon it, whereas those passing in a direction at right angles to it produce little or no effect). A minor advantage of the frame is that it does not require an earth connection.

The directional property of the frame aerial is, of course, made use of for a great variety of wireless purposes. That of greatest value to the amateur is probably the selection of the desired station and the elimination of undesired ones by arranging the frame so that its plane is parallel to the line of travel of the desired signal.

It must be emphasised that frame aerials are only capable of picking up quite small amounts of energy, very much smaller than those picked up by any of the types previously considered. The reason for this will be grasped from Fig. 5, which shows the direction of the induced electrical impulses in the two vertical sides of a frame

when acted upon by a wave passing in the direction shown by the arrows. As will be seen, the induced pulses tend to pass upwards at each side of the frame and would annul one another but for the fact that there

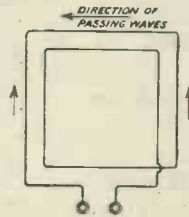

Fig. 5.—The direction of the impulses generated in a frame by a given half-wave is indicated by the small arrows.

is a slight difference in time between the impulse generated on one side of the frame and that generated on the other, this being due to the fact that the waves take a very minute but nevertheless de-

upon its size and the number of turns of wire with which it is wound; the larger the frame and the greater the number of turns, the greater the amount of energy received. At first sight, it would seem that to get the best results one should make the frame as large as is conveniently possible, and to wind it with a very large number of turns of wire. Unfortunately, the matter is not so simple and one must remember that the frame must be capable of being tuned to the received wavelength, and when this wavelength is short the size and number of turns of the frame must be limited to such values as will give the desired resonance. The actual design of a frame to receive upon any given wavelength is a somewhat complex matter and cannot be treated fully here. It will probably be much more useful to the experimenter to give in the accompanying table particulars of suitable dimensions of frames for various wavelengths.

Wavelength range.	Size of frame (square).	No. of turns.	Tappings at.	Wire (S.W.G.)	Spacing between turns.
300—600m.	3 feet	7	—	18	1/8"
1,000—5,000m.	6 feet	40	10, 15, 25 turns	20	1/4"
5,000—15,000m.	8 feet	60	15, 25, 40 turns	20	1/2"

finite time to cross the frame. But for this slight time interval between the two induced impulses, of course, the frame aerial would be useless. The existence of the very slight phase difference, however, enables small oscillatory currents to be built up in the frame circuit.

The amount of energy picked up by a frame aerial depends chiefly

Note: In the case of frames having tappings it is very desirable to use some sort of dead-end switch to cut off the unused turns, since objectionable absorption effects are very prone to manifest themselves in frame aerials. It is assumed that a variable condenser of 0.001 μF will be used with the above frames.

HAVE YOU READ THE CURRENT NUMBER OF "MODERN WIRELESS" ?

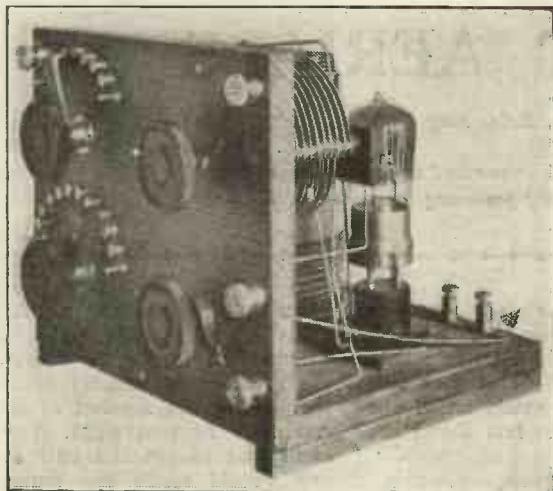

Fig. 1.—The instrument as seen from the front.

UNDER this heading is described an instrument which may be used in conjunction with the crystal receiver and note-magnifier described in *Wireless Weekly*, Vol. 2, Nos. 9 and 10, or, if desired, in conjunction with any crystal receiver possessing variable tuning arrangements.

Its construction is simple and its design so thought out that little expenditure is demanded of the constructor.

The Panel and Base

That part of the unit calling for most attention is perhaps the panel upon which are mounted the tappings and adjusting switches. This panel is made from hard wood, and, as in the case of all wood panels when used in high-frequency units, all moisture must be removed from the wood before satisfactory results may be expected.

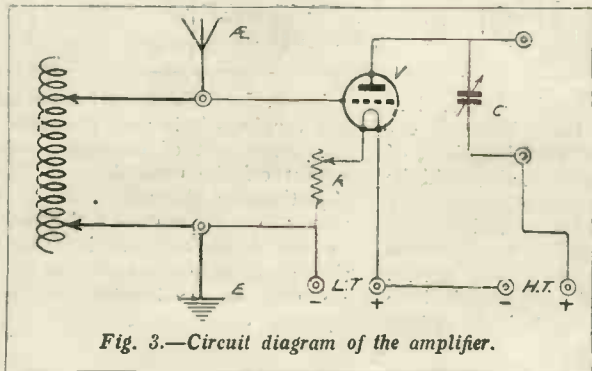

Fig. 3.—Circuit diagram of the amplifier.

A SIMPLE H.F.

By STANLEY G. R.

A useful unit which may be added to any broadcast

Should the instrument be intended for use with the crystal receiver and note-magnifier previously referred to, then the height of the panel and depth of the base should conform with the previous dimensions, otherwise the reader is not held to any specified sizes.

With the panel and base cut and bracketed together, and all holes for terminals, contact studs and switch-arms drilled, the whole should be gently baked until completely dry, when it should be thoroughly soaked in molten paraffin wax and after removal allowed to cool; the superfluous wax may then be scraped off. This process will render the panel free from absorption.

An alternative suggestion is that the contact studs, together with switch-arms, be mounted on an ebonite strip, thereby calling for less care in the preparation of the panel.

Components Required

The components and materials necessary for the construction of an H.F. amplifier as described herein are as follows:—

- 1 valve socket.
- 1 filament resistance.
- 1 cardboard tube, 4in. diam. by 5in. long,
- $\frac{1}{2}$ lb. No. 24 or No. 26 S.W.G., d.c.c.
- 8 terminals.
- 1 variable condenser of 0.0003 μ F capacity (or standard parts to make).

Quantity of No. 18 or No. 20 tinned copper wire for connecting purposes.

Figs. 1 and 2 are photographs of the front and back of the panel respectively, and, as will be noticed, the instrument bears a striking resemblance to the crystal receiver referred to in the opening paragraph.

The arrangement of the components is such that soldering is an easy matter, and at the same time permits the leads to be consistently short.

AMPLIFIER

STEE, Staff Editor.

crystal receiver where increased range is desired.

The aerial and earth terminals may be seen at the top of Fig. 1, whilst the "output" terminals, for connecting to the crystal receiver, may be seen on the bottom right. The L.T. and H.T. terminals are arranged in a similar manner to those of the note-magnifier, that is to say, at the back of the base, (Fig. 2).

The Inductance

This is wound on a cardboard former 4in. by 5in., and consists of 69 turns of the No. 24 or No. 26 d.c.c. wire and tapped in the manner indicated in *Wireless Weekly*, Vol. 2, No. 9, and as illustrated in Fig. 4. When this unit is connected to the crystal receiver the inductance of the last-named becomes the tuned anode coil.

Connecting the Components

The connecting of the components is carried out as indicated in the circuit diagram Fig. 3, and is best executed in the following order.

Before mounting the inductance coil in position, complete the filament lighting circuit by connecting the L.T. negative terminal to the blade of the filament resistance, and the end of the resistance to one of the filament legs of the valve socket. The remaining filament leg is connected to the L.T. positive.

Now fix the inductance coil in position by means of a wooden crosspiece, as in Fig. 2, and solder the various tappings to the studs in the same way as was done for the crystal receiver. From the switch-arm controlling the single turn tappings, connection is now made to the aerial terminal and to the grid leg of the valve socket; the anode leg being connected to one of the "output" terminals.

From the switch-arm controlling the 10-turn tappings, connection is made to the earth terminal and L.T. negative terminal.

The H.T. positive terminal is now connected to the remaining "output" terminal

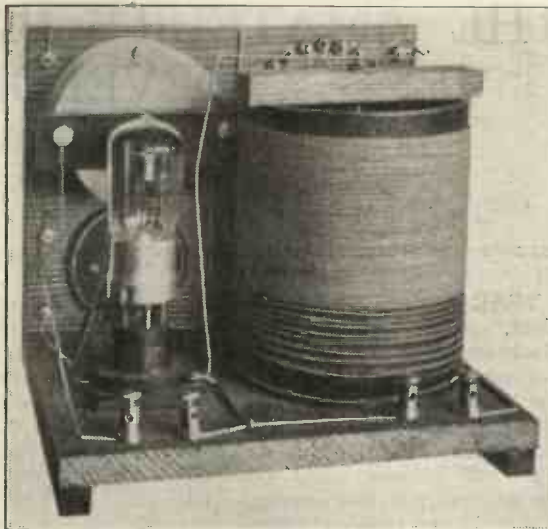

Fig. 2.—The back of the unit.

and from thence to one side of the 0.0003 μ F condenser; from the other side of the condenser connection is made to the remaining "output" terminal, the condenser thus being directly across the "output."

The final connection is made from the H.T. negative to the L.T. positive. In high-frequency amplifiers all connections should be soldered.

If preferred, the reader may use a 0.0003 μ F fixed condenser across the "output" terminal instead of a variable type, but the fact that the variable arrangement adds considerably to the selectivity of the unit when used with a broadcast crystal receiver justifies the small additional expense involved.

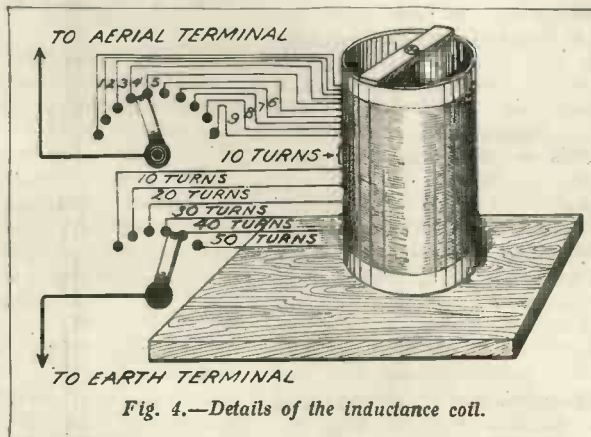

Fig. 4.—Details of the inductance coil.

THE AMATEUR'S PART IN WIRELESS DEVELOPMENT

By W. H. ECCLES, F.R.S., D.Sc.

*Autumn Session Presidential Address to the Radio Society of Great Britain.**

A YEAR ago our then President, Admiral Sir Henry Jackson, set up the custom of an autumn address on what might be called the politics of amateur wireless, and therefore, in accordance with custom, which we cannot yet call immemorial, I am going to address you this evening on the amateur and things of interest to the amateur, especially in the light of what is happening in the development of broadcasting in this country and other countries. An amateur, I take it, is a person who is fond of the subject for its own sake, and not for what he gets out of it. An amateur cultivates his subject, perhaps as a serious study, or perhaps as a pastime, but the subject is never his main business. Within the scope of this definition, especially as applied to wireless, there are all sorts of persons. On the one hand we find people who are not learned in the physical sciences, and on the other hand we find mathematicians, physicists, and electrical engineers, each very deeply versed in his own particular subject, and it is very strange, it seems to me, that to all these types wireless makes an irresistible appeal. Perhaps at first its attraction springs from the sense of mystery, the feeling of eeriness with which one picks up and listens to the sound of signals that have come thousands of miles from the great stations, or perhaps its attraction lies in the glow of achievement which follows an exploration into the regions beyond the perception of the unaided human senses. The first time the amateur listens in to any distant signals he must feel that he has entered a new world, a world of which the people around him are quite ignorant, and which could not be entered except by making the special preparations he may have

been making for weeks before. In addition to these very unusual elements of fascination, wireless offers nearly all the other distractions, difficulties and delights that any other hobby ever did offer.

We may say that when following any study or hobby, any amateur in any subject is obeying an impulse towards making something; he is answering the call of the creative instinct. The boy who does fretwork, or the man who does ornamental turning, is employing simultane-



Dr. W. H. Eccles, F.R.S., D.Sc.

ously his mechanical and artistic gifts in the production of something useful or decorative; and the strictly mechanical devotee who makes elaborate working models of steam engines and other machines, as well as the man with electrical leanings who makes dynamos and model motors, is obeying the same instinct, the joy of making something. But these older forms of hobby have a great difference from the type of hobby that we follow, because when they make model engines they make mere copies of real things, which are usually extremely inefficient and incapable of practical application. I remember very well the first steam locomotive model that I made, and

the great difficulty that it experienced in dragging its slow length along. These things are admittedly things to be put into glass cases for admiration and not for use. Therein is a great contrast with wireless. The apparatus of the wireless amateur is practical apparatus. It is as good as, and sometimes better than, the apparatus supplied by commercial firms, supplied, in fact, to ships employing commercial operators and doing commercial business, especially as regards receiving apparatus. As regards transmitting apparatus, the difference between the plant of the amateur and that of the professional is usually one of size merely and not one of quality. The efficiency, in the strict quantitative sense, of the amateur's apparatus may in fact be greater than that of many a commercial station, and it is one of the problems of the large power wireless engineer to try to get big plants working as efficiently as the small plant of the amateur can work. In consequence of this difference between wireless as a hobby and any other hobby I have ever experienced, I can say that the wireless amateur tastes more completely than do any of the other scientific amateurs the joys of having accomplished something really usable in every sense of the word.

From the instant the wireless amateur first tunes up his receiving apparatus and listens in to all the world's telegraphic traffic crossing sea and land and the boundaries of different countries, he comes into close contact with the practical telegraphic world. This fact, taken together with the circumstances that he is using full scale apparatus, ensures that there is a perpetual flow of improvements and suggestions from the amateur fraternity into the practical world as regards wireless methods and apparatus. It seems probable that if we could estimate the minor improvements of appara-

* Delivered on September 26th, 1923.

tus and conveniences attached to modern commercial apparatus, it would be found that the contributions of the amateur would outweigh those of the commercial designer.

We would go further, and say that many of the great advances in wireless have been initiated by the amateur, and that most of the early steps in the inception of the subject were taken under the stimulus and guidance of men who were neither telegraphists nor engineers, but merely lovers of the infant science. Perhaps it is in the nature of a platitude to state that before wireless became commercial all the workers in it were amateurs; they were experimenting in ignorance of the vast commercial future before it, and were studying it without thought of gain. Sir Oliver Lodge's work with the short aerial, on waves a few metres long, using the filings coherer with the tapper, back in 1894, constituted the first complete wireless receiving set ever assembled, and was certainly done "for fun." It was an aside from his laborious scientific work in the laboratory and in the study; in fact, he probably set it up to amuse people, and it is rather a curious reflection that this early piece of apparatus is regarded, and must be regarded, as more important in the practical world than those studies which Sir Oliver Lodge preferred to follow at that date. One may say also that until about 1897 Marconi was an amateur making experiments with Hertzian waves, as were a great many people in the various physical laboratories and lecture rooms throughout the world, and Rutherford's open-air experiments with his own magnetic detector in 1896, when he received signals across Cambridge, a distance of a mile and a half, were done without thought of pecuniary recompense. On that occasion we may say that, as Rutherford stayed only about two months with wireless, we had too little Rutherford.

Later, Duddell, whilst still a student, discovered the singing arc, which, in the hands of Poulsen and other practical engineers, has become one of the most important elements in high power wireless telegraphy. At a later date, when wireless was in full swing as an industry, the work of innumerable amateurs brought forth a great miscellany of detectors. The various

contact detectors ranged from Walter's tantalum mercury instrument, in which a fine wire of tantalum dipped into a cup of mercury, to Pickard's perikon detector, with its crystals in contact, through all sorts of combinations of crystals and other things, metals and liquids, which were tried in every country in the world by a legion of amateurs. It was the amateur who brought forward the crystal detector, who found out the best combinations, who introduced it into our subject. It was some time after this work by the amateur that the crystal detector came gradually into practical commercial telegraphy.

Again, it is notable that the earliest frame aerials were employed for directive reception by amateurs, especially in America and Germany. It was some years after these early trials by the American amateurs that the frame aerial was introduced into practical work. Again, in 1913, a young American student, E. H. Armstrong, working with wireless circuits because he loved them, produced the first auto-heterodyne receiver using the audion, and staggered all the professionals and commercial experts of the world by demonstrating in New York the reception of trans-Atlantic signals, inaudible otherwise. Finally, when the war came, the amateurs penetrated in their hosts into the armies, and turned their wireless experience and their talents to the design, construction, operation and improvement of apparatus for use in war. Of the countless gadgets invented by the transformed amateurs a great many survive to this day, and may be seen by the observant eye in much of the apparatus now manufactured in various countries. It is very interesting to note that a great many of the different ways of winding inductance coils now practised are due to the experimenter; and it is well to notice, in passing, that the numerous elegant and simple methods of calculating inductances by means of abacs have emanated from the amateur world under the stimulus of the desire for accurate scientific design. These and numerous other small improvements all contribute to the general advance in the technique of wireless construction and operation.

The above survey of the influence of the amateur on wireless progress encourages one to declare that if

wireless investigation, invention and design had been confined strictly to commercial firms, the development of wireless would have been slower, and the subject would have been in a position less advanced than it is to-day. For one thing, the people permanently engaged in the industry are few in number compared with the amateurs, and therefore they could not have thought of so many things to try nor have made so many trials. Again, it is a tenet of some commercial firms to resist improvements in standardised apparatus until as much business as possible has been done with the standardised apparatus, or until some other firm threatens their position. This is always, in all industries, a well-known clog on the progress that the employees could make if they were unhampered.

It is inevitable that the prominently successful amateur should often be drawn into the wireless industry in a professional or commercial capacity when that industry expands. That happens in every walk of life—literature, music, art, and connoisseurship, sports and games—and therefore, why not in science? That this is so does not detract from the beneficent influence that amateurship has exerted and still exerts in every branch of human activity. And that not only the prominent personages whom I have mentioned, but also many of those who make minor improvements, tend to cross the boundary and become technicians. This is also of great advantage to the community, for it is in my opinion certain that no new technique, no novel industry, can possibly develop rapidly unless this transmutation takes place freely. We have seen this happen during the war, and again, quite recently, during the rise of broadcasting to popularity.

This recalls the fact that broadcasting as it is to-day is indebted to the amateur for its existence. In America the broadcasting movement was started by amateurs and their clubs and societies giving gramophone concerts and other entertainments to their fellow amateurs. In this country a similar movement took place, but was limited to smaller dimensions by the restrictions which were an aftermath of the war.

(To be continued.)

Constructional Notes

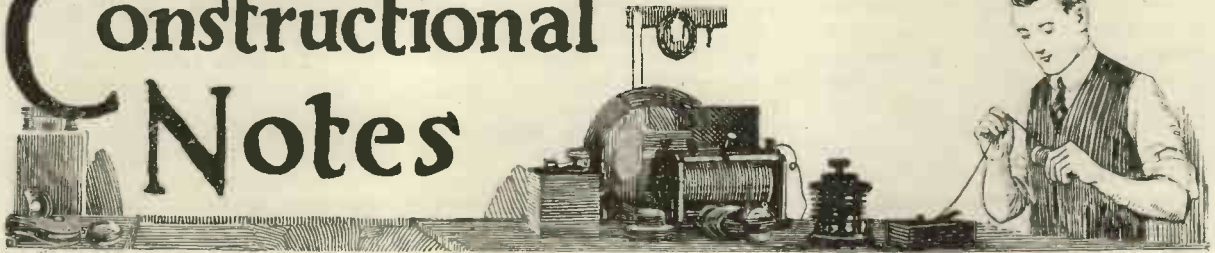

Conducted by R. W. HALLOWS, M.A., Staff Editor.

A SIMPLE VARIOMETER

A VARIOMETER is such a useful component of the modern receiver, apart from the economy in variable condensers that its introduction into the circuit brings about, that it is felt the following description of

variometer is destined to perform.

Referring to Fig. 1, it will be seen that the variometer consists of a tubular or spherical former rotating inside a tubular coil.

Taking the rotor first, this should be a hard wood ball $3\frac{1}{2}$ in. in diameter, turned as shown in Fig. 2, so that there is a raised section at each side to hold the winding in place. If this is not done it will be impossible to wind the coils without their collapsing. Drill two holes $\frac{1}{8}$ in. in diameter in the centre of the grooved portion, each penetrating about a quarter of the way through but not meeting in the centre, into which brass stems may be inserted to mount the ball in the tube.

Alternatively, the wooden ball may be replaced by a cardboard tube of the same external diameter and short enough to permit its rotation within the outer coil.

The tubular former should next be made of several layers of stout cartridge paper well glued together, or, better still, a good tube of cardboard should be obtained. It should be about 4 in. long and have an inside diameter of $3\frac{3}{4}$ in.

In this tubular former drill two holes in the centre, diametrically opposite, to take the spindles of the spherical former.

Now make the wooden stand, which can be cut from good hard wood of $\frac{3}{8}$ in. thickness.

We shall require two pieces for the end supports, each 5 in.

square, with holes in the centre of each to fit over the end of the tube, one piece for the base 5 in. by 4 in., and two pieces for the sphere supports—one piece 4 in. by $1\frac{1}{4}$ in. placed along the top of the tube from end to end—and a small block 1 in. square for the bottom spindle.

Before winding the formers assemble the whole unit so that any necessary mechanical adjustments can be made without fear of damaging the windings.

First of all fit the tube into the

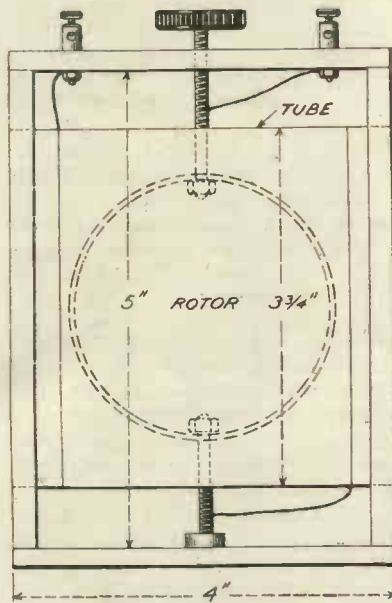

Fig. 1.—Cross section showing stator and rotor.

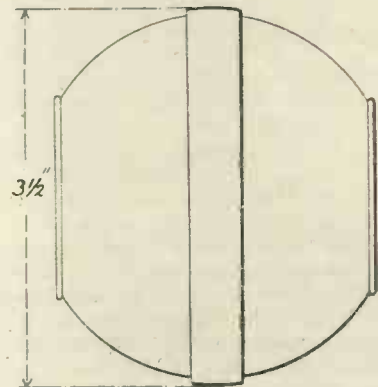

Fig. 2.—The rotor.

end pieces and place the spherical former in its position inside the tube, screwing the spindles through the holes in the tube into the spherical former. The top spindle should be $2\frac{3}{4}$ in. long, and the bottom $1\frac{1}{2}$ in., both being of $\frac{1}{4}$ -in. brass rod. Then mount the end pieces and tube on to the base, having previously placed in position the small block with the hole through it which is to act as a pedestal bearing for the ball

a simply made instrument will prove useful to a large number of readers.

Since a variometer can be used in so many parts of a circuit, no details of the actual windings are given, as this will obviously depend on the particular function the

spindle. After this put on the top spindle bearing, which is the piece of wood 4in. by 1½in. The position of the hole in this piece should be very carefully found by measurement. Lastly provide the knob, pointer, and scale; the knob can be obtained ready-made complete with pointer, the scale being an ordinary small protractor fixed to the cross-piece, or here again a bought component can be used. If the mounting of this unit is accomplished with a little care on the part of the builder, a very useful piece of apparatus will result.

R. W. H.

MOUNTINGS FOR BASKET COILS

BASKET coils have their drawbacks, but they have one enormous advantage, which is that they are cheap. For short-wave reception they are very efficient, owing to their low self-capacity, and, as a set that will tune from 200 to 3,000 metres can be bought for a few shillings, they are deservedly popular. The main objections to them are that they are rather fragile and that it is most difficult to get two with precisely similar electrical properties.

The coils are sold unmounted, and many amateurs find difficulty in designing a mounting that is really satisfactory. Perhaps the best way is to provide them with plug and socket fitted bases, which will suit tuning stands designed for de Forest and other similar coils. One can then use the same stand for both honeycomb or duolateral inductances and baskets.

A simple way of doing this is shown in Fig. 3. Little ebonite blocks fitted with a plug and a socket spaced the right distance apart can be purchased from advertisers in this journal quite cheaply or else can be made at home without much difficulty. Take a block of ebonite ½in. thick and measuring 1in. in width by 1¼in. in length, and in its lower

edge drill two ¼in. holes ¾in. deep with their centres ½in. apart. Insert a plug and a socket into these and drive them home by gentle tapping. Drill and tap a 4B.A. hole from either long edge right into the brass of the plug and socket, and put in a 4B.A. screw with a round head, placing a washer under the head.

Now take some ½in. sheet ebonite and cut out two strips ½in. wide with a length 1½in. greater than the diameter of the coil to be

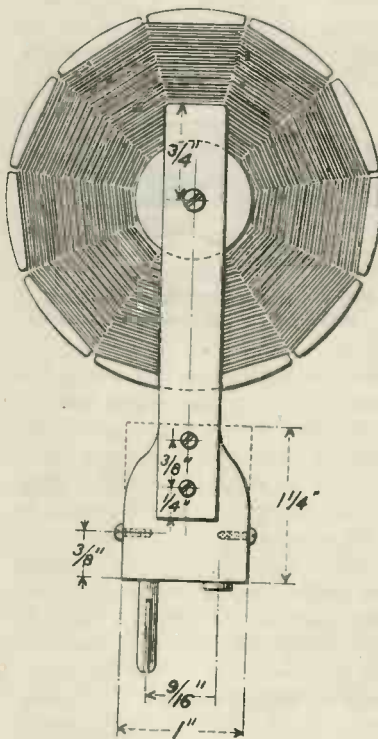

Fig. 3.—Dimensions for basket coil mountings.

mounted. Drill a 4B.A. clearance hole ¾in. from the top of each, and two others ¾in. apart at the other end. Fix one of these to either face of the holder by drilling two B.A. clearance holes and inserting a pair of inch-long bolts.

Next cut out two discs of wood or stout cardboard and make a hole through the centre of each. Pass a 4B.A. bolt through both strips and the coil, placing one of the discs on either side of the coil. Put on a nut and tighten down sufficiently to hold the coil firmly but not to crush it.

Now bring the wires from the coil to the screws which secure the plug and socket, and the job is complete. It is important, by the way, that coils should be so mounted that their windings run in the same direction, otherwise you may have trouble if they are used in the reaction circuit. It is not at first sight easy to see which wire is which, but if you look carefully you will see that one of them passes from the circumference to the central hole *via* one of the spoke holes. This is the "out" wire. If one makes a practice of connecting in-leads to sockets and out-leads to plugs the coils will all be properly mounted.

An improvement on the mounting described can be made by using discs of thin ebonite, celluloid, or even cardboard cut with a diameter ½in. bigger than that of the coil to be mounted. Such discs act as protectors for the windings and prevent them from being crushed or displaced by accidental knocks.

R. W. H.

A SIMPLE ANODE RESISTANCE

WHEN experimenting with resistance-capacity coupled high- or low-frequency amplifiers, it often happens that the commercially manufactured resistances are of either too low or too high values to give the best results.

In such cases a simple home-made resistance as described below is very often invaluable.

An ordinary slate pencil is sawn in halves, leaving two portions each about 2 in. long. One of these halves is taken and painted with Indian ink carefully applied with a camel-hair brush so that a band 2in. long is coated at each end.

Round each of these end pieces is wrapped a piece of thin sheet copper pulled tight to make contact and secured by running a *little* solder along the joint. When fitting these contacts, care should

be taken to see that their length is just *under* $\frac{1}{2}$ in., so that a little of the Indian ink protrudes.

Using the camel-hair brush, join the two end coatings of Indian ink by another ink line about $\frac{1}{8}$ in. wide.

If the component is now placed in the set in use, its resistance will in all probability be found to be too low. If this is the case the ink line is reduced in width by scraping with a knife.

R. W. H.

DULL-EMITTER VALVES

THE dull-emitter valve has been principally developed in the laboratories of the General Electric Company in America, especially by Dr. Irving Langmuir. Some very interesting special applications have been developed, amongst which may be mentioned a simple form of the magnetron which is suitable for high-power transmitting valves. The essential feature is a large straight filament arranged along the axis of a cylindrical anode. The magnetic field produced by the current flowing through the filament, if the latter is d.c., is sufficient to prevent the electronic emission from the cathode from reaching the anode. If, however, the filament be heated by alternating current, the electronic current passes across to the anode whenever the heating current sinks to a low value, and consequently the valve gives oscillations which may be used for radio transmission. A tube of this kind, rated at 1,000 kilowatts, is in the course of development.

J. H. T. R.

The Sterling Telephone Co., Ltd. have just placed on the market a range of variable condensers designed to have a straight line characteristic and provided with vernier attachment.

CUTTING GROOVES IN WOOD

FOR grooving wood for wireless cabinets, a chisel may be used, in lieu of a special "grooving" plane, as follows. The cutting line is marked upon the face of the wood, at the correct distance from the edge, and a cut to the desired depth is made with a tenon saw. Another line is marked down the centre of the thickness of the wood, and short sharp jabs are made in a

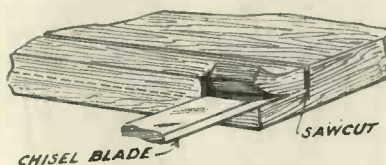

Fig. 4.—Illustrating the method suggested for cutting grooves in wood.

horizontal direction all along the centre line, on the upper side of it to allow for cleaning up. Care must be taken to see that the tenon saw cut is made sufficiently deep before doing this, which results in a clean square cut. To finish, the chisel is run lightly straight across the grain, and the groove is finally sand-papered. To keep a chisel in good condition, which is essential for easy work, it should be sharpened in similar manner to a plane-iron, as described on page 322 of Vol. 2, No. 8.

H. B.

SOLDERING THE LEAD-IN

THE aerial and the down-lead should, whenever possible, be all of one piece, the wire being simply taken through the insulator, turned back upon itself, and whipped with fine wire. The bare down-lead may reach to within a few feet of the building, but at this point it is usually desirable to join it to a length of heavily insulated cable, the

gauge and number of wires of which should not be less than those of the down-lead itself. It is essential that this joint should be soldered, for if the wires are merely twisted together perfect contact will not be obtained. Further, when the action of damp has formed a thin skin of oxide over the surface of the wires a very high resistance may be set up at the joint, which is just the place where it is least wanted.

As the making of a soldered joint between a pair of thick cabled wires is a job which many people find difficult, the following hints may be found useful. If they are carefully carried into practice the result will be a neat, solid joint of low resistance and quite immune from corrosive action of moisture or soot.

The first step is to bare about three inches of insulated wire, which we will suppose consists, like the down-lead, of 7/22's—that is, seven strands of No. 22 gauge wire. The strands are each scraped bright with an old knife. Two of them are left pointing forward; the other five are bent back till they stand out like the arms of a starfish. The down-lead is treated in the same way.

The next process is to twist the two straight wires of each cable as tightly together as possible with fingers and flat-nosed pliers. The other wires are now taken singly, and from each end alternately, and twisted tightly round these.

When all are in place and the joint has been flattened well down with the pliers, soldering may be done. Give it a good dressing of fluxite, and hitch up the wires so that you may have both hands free for the job. In the left hand hold a pad of rag well saturated with tallow; with the right wield the soldering-iron, which should be of large size. Take up as much solder as you can with the iron, running it into the joint, and wipe it smooth with the rag. Continue until the joint is completely covered with a neat, smooth sleeve of solder.

R. W. H.

Referring to "Wireless Weekly" three-valve receiver, the coils shown in Fig. 2 are Atlas coils made by H. Clarke & Co., of Manchester. These coils have very low resistance and self-capacity.

The Radio Society of Great Britain.

The following are the Rules governing the newly formed Transmitter and Relay Section.

THIS new section has been formed because the British Wireless Relay League has been merged in the Radio Society of Great Britain. The objects of the Section are (1) to promote intercommunication between experimenters and thus assist them to improve their apparatus; (2) to join hands with similar organisations overseas; (3) to investigate the quality of the transmissions in various directions at different hours; (4) to establish a collection of wave-meters and other useful apparatus for loan within the Section. In supporting the Section the Radio Society will protect the principle of "Freedom for Experiment."

Rules of the Section

1. All persons holding experimental licences are eligible for election to the Section in one of the following classes:—

	<i>Annual Subscription.</i>
Members of the Radio Society and its Affiliated Societies	Class TM 5s. od. " RM 3s. 6d.
Non-members	" TN 10s. od. " RN 7s. od.

Persons in classes TM and TN must be holders of transmitting licences, and in classes RM and RN must be holders of receiving licences. The annual rates of subscription may be amended at any time by the Council of the Radio Society.

2. All persons within the Section will obtain the programmes of work and may vote for the election of the Committee.

3. The work of the Section will be directed by a Committee, who shall have power to co-opt members. The Committee will be responsible for the election of candidates to the Section.

4. The Committee shall consist of the President of the Radio Society, the Treasurer of the Radio Society, and three members elected by ballot from classes TM and TN, of whom not more than one shall be from class TN.

5. During the coming Session the organiser of the trans-Atlantic tests will serve as a special member of the Committee.

6. The first election of the Committee will be conducted as follows:—

Any person belonging to any of the four

classes may send to the President between the 25th and the 30th November, 1923, a sheet of paper bearing three names of eligible persons arranged in order of preference and signed by the proposer. The President will count the votes and arrange the names in order of aggregate preference, and will announce the names of those three persons with the largest number of votes who are eligible and willing to serve.

7. An account of the expenditure of the Section shall be rendered to the Council of the Radio Society monthly, and the Council shall have power to restrict expenditure at any time.

8. It must be clearly understood that persons joining the Section do not thereby become members of any grade of the Radio Society of Great Britain.

Members of the British Wireless Relay League are admitted to the full privileges of the Section. At the termination of the period covered by their subscription they should join one of the classes of the Section.

First Series of Tests

These tests are chiefly for the purpose of estimating the ranges of stations, and for selecting transmitters for the trans-Atlantic tests.

From the lists of transmitters batches of ten or more will be selected and different nights assigned to each batch. For each night a table will be prepared showing the time at which each transmitter will commence work, and this time-table will be circulated to all the Section. Each observer should keep a log of what he hears, and should send an abstract of the log, with notes on the strength of each station, to the Secretary of the Transmitter and Relay Section.

During these first tests the procedure on each test night will be as follows:—

Part 1—Outgoing Transmissions.

Each transmitter on duty will transmit certain selected matter in Morse at a rate not exceeding 12 words per minute, commencing precisely at the scheduled time and following the usual rules with regard to call signs.

(Continued on page 514.)

Broadcasting News

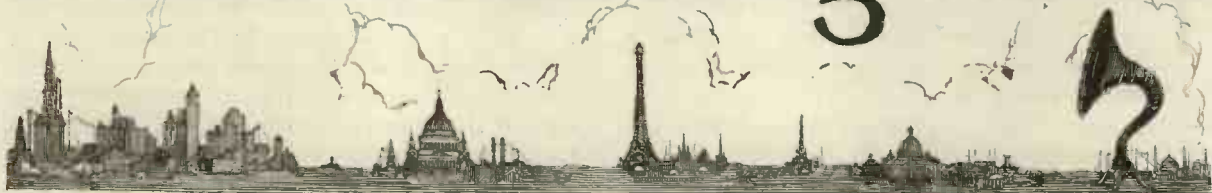

By OUR SPECIAL CORRESPONDENTS.

LONDON.—The past week has been full of good things in the way of music and singing, for we have been afforded another opportunity of hearing some exceptional violin numbers by that splendid artiste, Miss Daisy Kennedy.

Schubert's "Shepherd on the Rock," sung by Miss Winifred Fisher, gave us great pleasure, and it was a pity that the selection had to be sung in French, for the singer's diction suffered, ever so slightly. We should like to hear this little gem of Schubert again, but rendered in Miss Fisher's clear English diction.

The B.B.C. are very satisfied with the excellent reception that the Postmaster General's recommendation obtained in the Press. There is no doubt that on the whole, the Press, the public and the trade have accepted the compromise as being the best possible in the circumstances. The fact that component parts are to be of British manufacture and not marked B.B.C. has gone down well with the public, especially in these critical days of unemployment.

Forthcoming Events OCTOBER.

17th (WED.).—Children's hour. Uncle Jeff will talk on "The Families of Instruments in the Orchestra." 7.30, Orchestra. 8.45, Landline transmission of the opening of the Bournemouth Station (6BM, 410 metres).

18th (THURS.).—Miss Hilda Dederich, Pianist, "The Adventures

of Pip." 7.30, Shakespeare's "Macbeth." Principals: Mr. Norman V. Norman (*Macbeth*), Miss Beatrice Wilson (*Lady Macbeth*), Mr. J. H. Barnes (*Banquo*). Incidental music to "Macbeth." Savoy Orpheans.

19th (FRI.).—Orchestra.

20th (SAT.).—Dance Band. Roosters' Concert Party.

21st (SUN.).—3.0 p.m., Transmitted from Steinway Hall. Miss Catherine Aulsbrook, Mr. William Anderson, Miss Adela Hamaton. Evening, Trafalgar Day programme. "Songs of the Sea," by William Michael, with Chorus and Orchestra.

22nd (MON.).—Wagner evening. Mr. Robert Parker, Miss May Blyth and Mr. John Perry, conducted by Aylmer Buest.

ABERDEEN.—It is interesting, on the occasion of the opening of the new station of the British Broadcasting Co. at Aberdeen, to realise that the general manager, Mr. J. C. W. Reith, has very close associations with the town.

One of the first fruits of the Broadcasting Committee's labours has been the extension of the wave band for broadcasting purposes. It was originally intended that Aberdeen should have a wavelength of 360 metres, but it has now been allotted 495 metres.

BELFAST.—While the Glasgow station, with its cheery-voiced announcer is always first favourite with Northern Ireland listeners-in, London has recently established itself very high in

their popularity. Strangely enough 2LO, though about 325 miles from Belfast, is distinctly heard on a three-valve receiver, while Birmingham, only 220 miles away, is very often indistinct.

BIRMINGHAM.—5IT is following the gratifying policy of "capturing" any well-known individuals who come to the city and persuading him or her to broadcast a short address. Thus, the Chief Scout, Sir Robert Baden-Powell, who was in Birmingham for an evening recently, was enticed from his Rover Scout Conference to the New Street Studio, whence he gave a cheery message to listeners-in.

The weekly request programmes continue to be extremely popular, so much so, in fact, that it is quite impossible to respond at once to all the requests. It may be taken for granted, however, that every endeavour is made to meet all reasonable ones in due course, and it is hoped that requests will continue to flow in, for they form a valuable criterion of what the wireless public likes.

Forthcoming Events OCTOBER.

17th (WED.).—7.30, Performance of "Elijah."

18th (THURS.).—9.30, Special programme of Beethoven Music with explanatory talks.

19th (FRI.).—7.15, Mr. Sydney Russell Dramatic Company, Trial Scene from "The Merchant of Venice."

23rd (TUES.).—7.15, Greys Concert Party.

GLASGOW. — After receiving the freedom of his native city, Sir Thomas Lipton paid a visit to 5SC and broadcast a brief address. For thousands of Glasgow wireless users, it was the first time that they heard the voice of this most illustrious son of Glasgow.

Mr. Jeffrey, the new station director at Aberdeen, visited Glasgow recently for the purpose of broadcasting a repeat performance of "Rob Roy" (in which he takes the part of the famous Highland chieftain). The production was again strikingly successful, the narration of the stirring deeds of yore, the sound of the pibroch, and the clash of sword being graphically portrayed.

Forthcoming Events

OCTOBER.

- 17th (WED.).—Mr. F. D. Lynn, baritone; Miss Edith Caird, soprano. A Talk on "The City and the Child," by Councillor Matthew Armstrong, of Glasgow. Classical Russian music.
- 19th (FRI.).—Talk by Dr. Gunn, of Edinburgh, on "Practical Education as affecting the Cottage Industry." Mr. Robert Murray, entertainer; Miss Rhoda Graham, contralto; Orchestra (dance music).
- 20th (SAT.).—Victoria Male Voice Quartette. Miss Winifred Scott, soprano. Orchestral selections.

MANCHESTER. — It is a great pity that the operas now being performed in Manchester are not permitted to be broadcast, especially when it is known that the performers themselves are in favour of it. It is certain they are missing the best advertisement they could possibly have, and it is to be regretted that the management adhere to such a short-sighted policy. Only last week, after allowing a person who had not previously heard wireless music, to listen to "Romeo and Juliet," he declared it was the finest musical treat he had had in his life, and that if the opera were performed at any of the theatres

within his reach he would certainly go to hear it again—and this was from a person who is entirely ignorant of the controversy on this subject.

Forthcoming Events

OCTOBER.

- 17th (WED.).—3.30, "The Limits" Concert Party. 6.30, Piccadilly Picture House, Organ. 7.45, Mr. Eli Spivak, Miss Bella Redford, Mr. Ronald Gourlay. 8.45, Talk on "World Peace," by Rt. Hon. J. R. Clynes, M.P. 9.40, German talk.
- 18th (THURS.).—11.30, 2ZY trio. 6.20, Mr. Laurence Smith. 6.30, Spanish talk. 6.45, Guides and Scouts pow-wow. 9.20, Music Criticism.

- Kloet, soprano. 6.45, Spanish talk.
- 23rd (TUES.).—3.30, Oxford Picture House Orchestra. 6.30, Piccadilly Picture House, Organ. 7.45, Recital, violin and piano, by Miss Jo Lamb and Mr. Eric Fogg. 8.15, Miss Madge Taylor. 9.15, Mr. John Wright.

NEWCASTLE. — All seem unanimous in acclaiming the simultaneous broadcasting of the speeches of H.R.H. the Duke of Connaught and the Colonial Premiers at the Royal Colonial Institute Dinner as the most interesting transmission so far attempted. We hope to have more items of this kind in the future, if only to cater to some extent for the many listeners-in who are not musical.

Forthcoming Events

OCTOBER.

- 17th (WED.).—Mendelssohn Night, Miss J. Wyatt and Miss Beatrice Paramoor.
- 18th (THURS.).—Mr. E. A. Crosse's Jazz Orchestra. Mme. Lilian Coburn, soprano.
- 19th (FRI.).—The Apollo Male Quartette. Mr. A. Leycock, cornet.
- 20th (SAT.).—Newcastle Wireless Orchestra. Mr. Crosse's Trio.
- 21st (SUN.).—Mr. Herbert Jennings's Trio. Mme. May Grant.
- 22nd (MON.).—Wagner Night.
- 23rd (TUES.).—Lecture by Mr. Philip Wilson on the Music of the period 1225-1558. Messrs. Pitt and Marks, entertainers.

Simultaneous Broadcasting Events

OCTOBER.

- 17th (WED.).—Dramatic Criticism by Mr. Archibald Haddon. Opening of Bournemouth Station by His Worship the Mayor of Bournemouth. Speech by Viscount Burnham.
- 18th (THURS.).—Mr. Percy Scholes, Musical Critic. Savoy Orpheans.
- 19th (FRI.).—Mr. G. A. Atkinson, Film Critic.
- 20th (SAT.).—Lt.-Col. Crisp on the Humours of Football. Mayor-elect of Lewes.

BROADCAST TRANSMISSIONS		
	Call-Sign	Wavelength
CARDIFF	5WA	353 metres.
*LONDON	2LO	369 "
ABERDEEN	2BD	495 "
MANCHESTER	2ZY	385 "
NEWCASTLE	5NO	400 "
GLASGOW	5SC	415 "
BIRMINGHAM	5IT	420 "
TIMES OF WORKING.		
Weekdays	3.30 to 4.30 p.m. and 5.0 to 10.30 p.m. G.M.T.	
*London	11.30 a.m. to 12.30 instead of 3.30 to 4.30 p.m.	
Sundays	8.30 to 10.30 p.m. G.M.T. 2LO 3.0 p.m. to 5.0 p.m.	
SILENT PERIODS.		
CARDIFF	8.0	to 8.30
LONDON	6.15	" 7.0
MANCHESTER	7.15	" 7.45
NEWCASTLE	9.0	" 9.30
GLASGOW	9.0	" 9.30
BIRMINGHAM	8.0	" 8.45

- 19th (FRI.).—3.30, Oxford Picture House Orchestra. 6.30, Mr. Joseph Clegg, Mr. Leonard Barry, Miss Jean Gordon, Mr. Frank Taylor 8.15, Piccadilly Picture House Orchestra. 8.45, "Romanesque Buildings," by Mr. G. W. Thompson. 9.0, Miss Oliva McKay. 9.40, French talk.
- 20th (SAT.).—3.30, Piccadilly Picture House Orchestra. 6.30, Piccadilly Picture House, Organ. 7.45, Dance Music by Garner-Schofield Dance Band. 8.45, Talk on "Old Buildings," by Mr. F. Bligh Bond.
- 21st (SUN.).—8.30, Armstrong-Whitworth Orchestra. Mr. Hugh Spencer. 9.0, Rev. R. G. Parsons.
- 22nd (MON.).—3.30, Miss Doris

RANDOM TECHNICALITIES

By *PERCY W. HARRIS, Assistant Editor.*

A few notes on the uses of fret saws and wood panels for the wireless constructor.

IN previous notes I have mentioned one or two useful tools recently added to my equipment; I now have one more to mention, the fret-saw. Strangely enough, although many articles have been written on wireless workshops and their equipment, few writers have mentioned this particular tool and its application. Only those experimenters who have fitted Dewar switches to ebonite panels can realise the difficulty of so doing and of cutting the hole to take the switch neat and square. Four holes drilled at the corners of the rectangle it is desired to cut out and a few minutes with a fret-saw, completely dispose of the problem, these saws cutting ebonite exceedingly easily and neatly. The blades are very cheap and replaceable in a moment, and the frame of the fret-saw is big enough to enable one to cut holes of any size in practically any kind of panel. Few experimenters have a set of drills for the larger size holes necessitated by switches and other fittings, and indeed it is difficult to bore large holes in ebonite with twist drills in the ordinary type of hand or breast drill when the holes exceed about $\frac{1}{4}$ in. in diameter. With wooden panels, fret-saws are very useful to cut the holes around the terminals of ebonite strips. A lever frame fret-saw is the best kind to buy, and the blades should be fairly strong.

Speaking of wood panels reminds me that one firm manufacturing components is just marketing an excellent line enabling every part to be mounted with ease on a wooden panel. The principle adopted is to place each component (valve-holder, plug sockets, even condenser) on a disc of ebonite flanged so that when a hole is cut the projecting flange covers the rough edge. Terminal bushes are provided with a $\frac{3}{8}$ in. bush, also flanged, so that when this size hole has been cut the bush can be pushed through, the terminal pushed in place, and a small disc secured on the other side underneath the lock nut of the terminal itself. In this way ample insulation is provided around each terminal. The condensers so mounted are particularly convenient, as it is not necessary to remove the knob and dial when mounting them, and, furthermore, the ebonite flange is provided with a neat white line to show the setting. Perhaps the most useful components are the switches, which are supplied ready mounted on ebonite discs. Anyone who has tried to mount, say, a 12-point switch on a nice new piece of ebonite so that the switch arm runs smoothly and evenly will appreciate that any component which will do away with the necessity of such careful marking out, drilling, and fitting is a veritable godsend to the amateur.

THE RADIO SOCIETY OF GREAT BRITAIN

(Continued from page 511.)

The receiving stations will have no other information than the call sign and the scheduled time of each transmitter.

Part 2—Return Transmissions.

Immediately the last transmitter on the programme has finished his task, he will address to the station immediately preceding him in the schedule a return relay acknowledgment in a prescribed form. This acknowledgment should be handed on from each station to the next preceding one as quickly as possible. At the close of the return transmission, if time allows, a brief forward signal of prescribed form may be started along the

chain and returned, and so on, in order to gain practice in relay work.

The tests will be arranged to take place between 11 p.m. and 1 a.m.

Those experimenters wishing to participate in these tests should send:

- (1) Name and address.
- (2) Call letters.
- (3) Licensed power of station.
- (4) Normal working wavelength nearest 200 m. to the Secretary, Transmitter and Relay Section, Finsbury Technical College, Leonard Street, London, E.C.2.



Conducted by A. D. COWPER, M.Sc., Staff Editor.

Note Magnifier

MESSRS. C. F. ELLWELL have submitted a small panel with two note-magnifying units and blocking condenser. Each unit consists of a metal-cased low-frequency transformer, with terminal-panel and valve-holder on the top of the case, the whole being only about 2 in. x 3 in. An earthing-screw is provided for the metal case. No filament resistance is fitted, the unit being intended for use with a 4-volt accumulator directly connected.

On trial with their crystal set, with 130 volts on the plate, an R valve, and minus 4 volts grid-bias, with one unit, quite good loud-speaking was obtained on 2LO, sufficient for comfort in a small room, or for two or three listeners. With both units and Mullard R valves, same plate voltage and grid-bias, after a slight whistle had been stopped by simply earthing the L.T. minus, a really remarkable exhibition of clear, loud, undistorted loud-speaking was obtained. We have heard louder, on four valves, but never so clear and distinct. With the loud-speaker at an upper window, every word was readable all over a large garden, and loud music was audible 100 yards away, being scarcely drowned by the noise of passing motor lorries.

For those who wish to get local broadcasting really loud and can put up a good aerial, this combination of efficient crystal-tuner and two note-magnifiers can be heartily recommended.

The A.C.H. Variable Condenser

A compact variable condenser, of the solid dielectric type, and arranged for panel mounting, has been submitted for test by Messrs. A. Knapton and Co. We understand that this is made in two capacities, 0.001 and 0.0005 μ F maximum. The condenser tested was the 0.001 μ F, which measures only $3\frac{1}{16}$ in. diameter by $1\frac{1}{4}$ in. thick. This is mounted behind the panel by means of two small screws, and is provided with a knob, pointer, and scale reading from 0 to 180 degrees. The actual capacity on measurement proved to be precisely that claimed, namely, 0.001 μ F. The minimum being quite low—0.00015 μ F; giving a large available tuning range. In operation during actual reception it compared quite well with a standard air-dielectric type, and was silent and smooth in action. It was noted that contact to the moving vanes was taken through a spiral spring. Substantial stops are provided, and it is difficult to imagine how any accidental short-circuits between the plates could happen, and the insulation resistance also proved excellent on trial. Soldering tags are provided in lieu of terminals on the bottom for electrical connections. Stray capacity effects are minimised by a metal band around the condenser.

Double Crystal Detector

The Formo Co. have sent us for trial a neat double crystal detector, fitted with twin crystal-cups and a single cat-whisker mounted on a

circular composition base, provided with two terminals. This proved on trial to be a serviceable unit, the adjustment being smooth and firm, either crystal being brought into use with great ease. The insulation was good, on test, and the cat-whisker reasonably fine and springy. It is a useful fitting for crystal sets, providing an alternative crystal in case one becomes insensitive in use or for easy comparison of the efficiency of two different crystals.

Inductance Coil Mount

A useful fitting for those who prefer to wind their own coils is the coil mount produced by the Athol Engineering Co., a sample of which has been submitted to us. These are nicely finished, substantial fittings with turned split plugs and sockets, and the usual clamping plates and screws for securing the coil. The insulation resistance was high. The unit plugs into the standard fitting, making good electrical contact.

A Lightning Arrester

Messrs. Sidney Jones, Ltd., have sent for inspection a sample of their "Thor" lightning arrester, consisting of a circular fitting carrying a narrow spark-gap, mica-covered, across which, when connected across the aerial and earth, any high-potential discharges can pass harmlessly to earth. This is well finished, with a nickle-plated ring and serrated circular central electrode, giving ample path for any discharge.

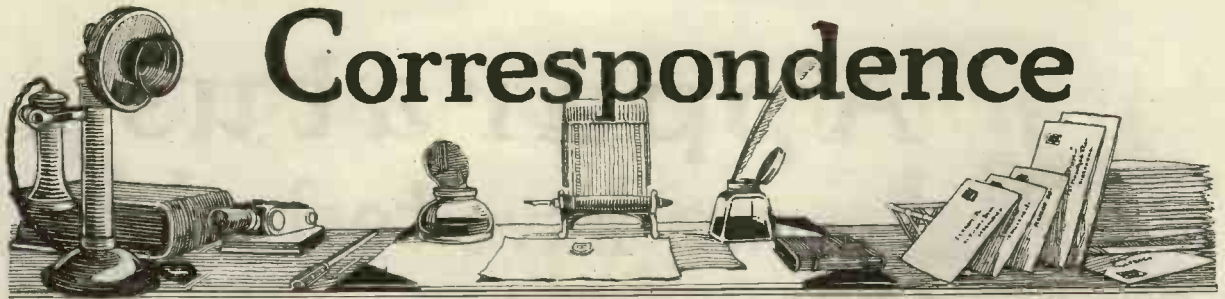

Correspondence

RE LICENCES

On October 1st we wrote to the Post Office Authorities pointing out that the new regulations operated unfairly against the holder of a new experimental licence inasmuch as he is prohibited from enjoying even a Sunday afternoon concert, unless a constructor's licence (15s.) is obtained in addition to his experimental licence (10s.).

We suggested that future applicants for experimental licences should, upon payment of an additional sum of 5s., be exempt from signing the declaration regarding listening-in to broadcasting.

We also mentioned that we had communicated with the British Broadcasting Co. in this matter, and understood that such an arrangement as suggested above would be perfectly satisfactory from their point of view.

We have received the following reply to our letter:—

General Post Office,
London, E.C.1.

Sir,— October 5, 1923.

I am directed by the Postmaster-General to acknowledge receipt of your letter of the 4th inst., and to thank you for the suggestion contained therein.

The Postmaster-General has communicated with the British Broadcasting Co. concerning the point you raise and the best means of meeting it, and a further communication will be sent to you as soon as a decision is reached.

I am, Sir,
Your obedient servant,
(Signed) S. W. PHILLIP.
For the Secretary.

2LO

SIR,—With reference to your Editorial in *Wireless Weekly*,

No. 6, concerning the erection of a Central Broadcasting Studio, although this suggestion has certain advantages, I think that general satisfaction would be given if the following points were to receive consideration by the B.B.C.:—

(a) The power of 2LO should be increased.

(b) Twice a week concerts should be arranged at this station to include the very finest artistes procurable. These concerts should be relayed to the other stations by land-line.

(c) On two nights a week it would therefore not be necessary for the remaining stations to give concerts, the expense saved to be credited to 2LO.

Under this scheme the provincial stations would enjoy bi-weekly concerts given by the best London artistes, their own local artistes could still be employed, and we could still amuse ourselves by trying to eliminate other stations.

Regarding the announcers at 2LO. I quite agree that youth should be on this side. A lot of us miss the witty "*sub voce*" asides of Mr. Rex Palmer and Captain Lewis. The announcer should be an artiste himself, with perfect self-assurance combined with a breezy and confidential manner; and we don't mind if we occasionally hear him enjoying a well-deserved drink!

I am, etc.,

London, S.E.1. R. F. B.

[We ourselves are not intrigued by asides, self-applause or inaudible jokes which the staff apparently perpetrate amongst themselves occasionally.—ED.]

OPEN-AIR RECEPTION

SIR,—The enclosed cutting may interest some of "Wireless Wayfarer's" admirers. The genial landlord seems to have discovered a means of overcoming one of the difficulties to which users of loud-speakers are subject, but I am undecided whether the absence of distortion is due to the special radio equipment, the powerful loud-speaker, the presence of the hon. gentleman or some special method of manipulation adopted by "mine host."

I am, etc.,

H. W. COOK.

London, S.W.16.

Shenfield Wireless Entertainment.

The fine lawn adjoining "The Green Dragon," Shenfield, was the setting for a private wireless entertainment on Saturday evening, when there were about 70 people present at the special invitation of Mr. S. Platt, the popular landlord. The apparatus used was a three-valve instrument *with special radio equipment*. Those assembled had the pleasure of listening to quite three and a half hours' programme of music and other items broadcast from 2LO, the London broadcasting station of *Marconi's*. The entire programme was heard without any distortion, a powerful loud-speaker being used *to clarify the reception*.

[The italics are ours.—ED.]

[Owing to the demand upon our space the Editor regrets that a number of communications are unavoidably held over.—ED.]

Information Department



C. W. (E. DULWICH) requests advice regarding the best method of switching H.F. and L.F. valves.

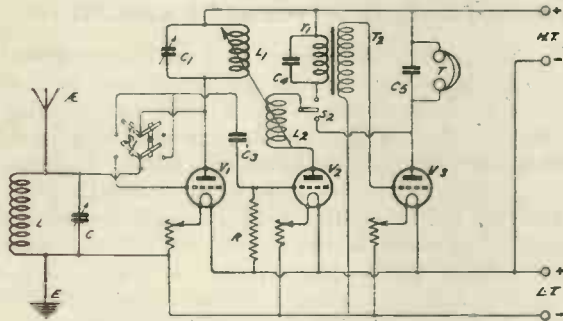

The circuit diagram herewith shows a three-valve receiver in which the first valve is a high-frequency amplifier, the second the rectifier, and the third valve the L.F. amplifier. The anode circuit of the first valve is tuned by means of the inductance L_1 and variable condenser C_1 , the intervalve coupling being effected by means of the fixed condenser C_3 , value $0.0005 \mu F$.

By means of the double-pole change-over switch the aerial end of the inductance L may be connected to the grid of V_1 (via condenser C_3) to the grid of V_2 . In the latter circumstance the upper arm of the switch disconnects the condenser C_3 from the anode of the first valve.

A single-pole switch S_2 , introduced in the anode circuit of the rectifying valve, permits the anode current to flow either through the primary winding of the iron-core transformer T_1 , T_2 , or direct through the telephone receivers.

V. B. (GRAVESEND) experiences difficulty in adjusting his receiving set which includes two tuned anode high-frequency valves.

Such a set as you describe will always be found very difficult to handle, calling for considerable experience. It is quite usual for the tuning to be exceedingly sharp so that a movement of either condenser, merely one or two degrees, is quite sufficient to cut out the London station. It is a difficulty which is met with everywhere, and our Staff Editors are busily engaged on the problem.

We hope to publish the first result of our researches in the November issue of *Modern Wireless*.

L. S. M. (BRIGHTON) complains of interference from a near-by generator.

We suggest that you should adopt a loose-coupled circuit. An alternative method well worth trying would be to adopt the arrangement of tuning used in the crystal set described by Mr. P. W. Harris in *Wireless Weekly*, No. 10. If you decide to make a coil exactly in accordance with his description and substitute it for your present arrangement by placing the condenser in parallel, we think you will find the interference considerably reduced.

R. R. (WHITEHEAD) asks for particulars and a circuit diagram of a simple telephony transmitter to operate on low voltage.

The arrangement shown in the circuit diagram herewith has proved quite useful. The aerial circuit comprises the variable condenser C_1 (capacity $0.0005 \mu F$ to $0.001 \mu F$) and the plug-in inductance coil L_1 , the aerial end of the coil being connected direct to the anode of the valve. The high-tension battery, which may be made of dry cells to give the total voltage indicated, has its positive side earthed and its negative side connected to the positive side of the filament. L_2 is the reaction coil, connected directly between the grid and negative side of the filament lighting battery. It may be found necessary to reverse this coil in order to generate oscillations. The plug-in coil L_3 , shunted by the microphone M , forms an absorption circuit, by means of which the energy in the aerial circuit

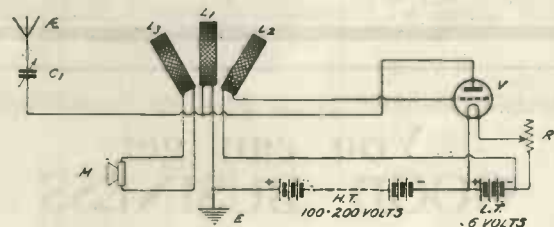

can be controlled. For short-wave working (in the neighbourhood of 200 metres) each of the coils shown may be a No. 25 honeycomb or duolateral coil, though it may be found advantageous to use a No. 35 as the reaction coil.

A Good Drill means efficiency



HAND DRILL complete with three-jaw chuck and set of Drills. Capacity 0— $\frac{1}{2}$ in. Price **10/6**

BREAST DRILL, 2 Speed, Ball Thrust, three-jaw chuck, complete with set of Drills, 0— $\frac{1}{2}$ in. Price **22/6**

DRILLING MACHINE, Chuck capacity 0— $\frac{1}{2}$ in., exposed gears, auto-matic feed. Price **55/-**

WE PAY CARRIAGE
Send P.O. and Order. Money returned if not satisfied.

THE BILLING TOOL CO. (Dept. W.),
303, HIGH HOLBORN, LONDON, W.C.1.

BEWARE OF WORTHLESS IMITATIONS, SEE THE TRADE MARK *Watmel* ON EVERY GRID LEAK.

WATMEL VARIABLE GRID LEAK
(Patent applied for.)

The Resistance is steadily Variable between $\frac{1}{2}$ to 5 megohms. Only requires a $\frac{1}{2}$ in. hole in panel for fitting.



Suitable for use in any circuit, and improves the working of any valve detector. (50,000 to 100,000 ohms for the S.T.100 Circuit. Price 3/6.)

PRICE 2/6 EACH
The best Variable Grid Leak made.

WATMEL WIRELESS CO., Connaught House, 1a, Edgware Road, Marble Arch, W.1. Tel. 4575 Paddington.

ECONOMIC ELECTRIC CO. LD.

THE "EEC" "XTRAUDION" VALVE
is being used by the leading Radio Experimenters for detection, high and low frequency amplification, power amplifiers and low power transmission. Price 15/-

USE "RECTARITE," the synthetic crystal that makes Loud speakers talk!
1/6 Large Specimen.



Write-to-day for 40 page Radio Catalogue mailed post free, 4d

Head Office: 10, FITZROY SQUARE, LONDON, W.1. Showrooms: 303, EUSTON RD., N.W.1. Branch and Works: TWICKENHAM.

You can get GOOD BUSINESS
by advertising in this section of **WIRELESS WEEKLY**

SPECIAL RATES.
A space this size costs £2-10-0 per insertion for 13 insertions, £2-10-0 plus 5% per insertion for 6 insertions, £2-10-0 plus 10% per insertion for less than 6 insertions.

SEND YOUR ORDER TO
SCHEFF PUBLICITY ORGANISATION LTD.,
125, Pall Mall, LONDON, S.W.1.
Phone: REGENT 2440

A. W. (SURBITON) enquires regarding the possibility of obtaining good loud signals upon a single valve set, 30 miles from a broadcasting station.

A single-valve set alone will not give you the results desired, which could only be obtained by the use of reaction in a manner contrary to the Post Office regulation.

If you are prepared to use a crystal detector in addition to your valve, we recommend you to try the *Wireless Weekly* reflex receiver (one valve and a crystal), as described by Mr. E. Redpath in Vol. 2, No. 9.

A. W. B. (CHELMSFORD) writes regarding the comparative results to be obtained from an ST100 and a Reinartz set.

If you have already built and successfully operated the ST100 set, we would not advise you to construct a Reinartz set with a view to obtaining better results. The particular virtue of this latter set is the simplicity and ease of control of tuning and reaction on short wavelengths. The coil described by the author of the article in the current issue of *Modern Wireless*, will cover wavelengths from about 300 to 700 metres. For wavelengths from 150 metres upwards it will be advisable to wind a special coil with 80 turns in the first portion and, say, 30 in the second.

The size of wire is very important on these short wavelengths and we do not recommend you to use wire finer than No. 20 s.w.g. d.c.c.

D. S. (EAST CROYDON) asks how to apply a negative voltage to the grids of his valves.

A method of obtaining exact adjustment of grid potential was explained under the title "Mainly About Valves" in our issue of August 8th (Vol. 2, No. 4). Under the same heading in our issue of Sept. 12th (Vol. 2, No. 9) a novel method of obtaining negative grid bias was also explained. In the ordinary way grid cells may be added by breaking the connection between the transformer secondary and the filament and inserting the required number of cells, with their negative end connected to the transformer, and thence to the grid, and the positive end to the filament.

M. L. (PRESTON) asks values of the components required for the ST50 circuit.

The following are suitable values:— C_1 —0.0005 μ F, C_2 —0.0003 μ F, C_3 —0.0003 μ F, C_4 —0.0003 μ F, C_5 —0.002 μ F.

L_1 and L_2 should be Igranic coils or Burndepet coils chosen by means of the chart given in *Modern Wireless*, No. 6.

R_1 , R_2 , R_3 , and R_4 are the usual filament resistances. R_5 should be of 3 megohms resistance.

B_1 is a 6-volt accumulator, and B_2 a 60-volt high-tension battery.

WECONOMY SETS

incorporating the
WECOVALVE.

The **WECOVALVE** (Pea-nut Type) is the most economical valve existent, requiring only 0.25 of an ampere at 0.8 to 1.1 volts and having more than twice the life of tungsten and other dull-emitter valves.

It can be used either as a Detector or Amplifier and operates off a single dry cell.

Filament Current 0.25 amps.
Filament Voltage 0.8 to 1.1 volts.
Detector Plate Voltage 17—22 volts.
Amplifier Plate Voltage 22—45 volts.
Dimensions $\frac{3}{8}$ " diam. \times $2\frac{1}{4}$ " long.

Price: £1 10s. 0d.



No. 44215-A.

Patent Nos. 17580 (1915), 180030 (6641-1921).

The **WECOVALVE** (Pea-nut type) can be used with your existing receiving sets by the use of the Weco Valve Adaptor (No. 44092) which has contact springs faced with gold and silver alloy to ensure perfect contact with the base of the valve.

Dimensions $1\frac{3}{4}$ " \times $1\frac{1}{4}$ ". **Price: 3s. 6d.**

The Weco Valve Socket is arranged for four soldered connections. These connections have contact points faced with a special gold and silver alloy to ensure perfect contact with the base of the valve.

Dimensions $1\frac{1}{2}$ " \times $\frac{3}{4}$ ". **Price: 1s. 6d.**

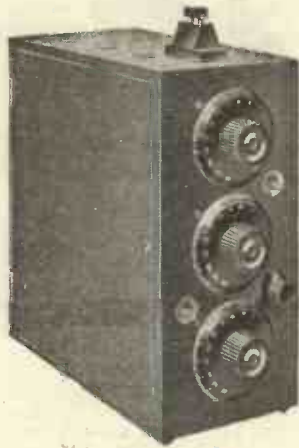

No. 44081.

Two Valve Receiving Set with
Coil Attachment.

two dry cells are sufficient for the filaments, whilst a High Tension Battery of 45 volts is recommended for the plate. The characteristics of both the valves and transformers are such that almost perfect amplification is secured, and consequently this instrument can be used with confidence wherever high grade reproduction is desired. The power output of this Amplifier is comparable with ordinary low frequency amplifiers, and will be found sufficient for operating Loud Speaking Receivers of the small variety. The No. 44011 Weconomy Amplifier is a single stage Amplifier which, like the two stage Amplifier, contains Western Electric special distortionless transformers, whilst the silent operation of the Weco valves ensures the most perfect reception.

THIS TWO VALVE WECONOMY SET (No. 44081), fitted with Weco valves, is arranged for high frequency amplification and detection, and is complete with tuning inductance, filament resistance, &c., to cover the Broadcast wave length band of 300 to 500 metres. That is, it will tune to any of the B.B.C. Stations without additional coils. By adding Igranic Coils, for which two holders are provided, the tuning can be increased up to 3,000 metres. The power of this Set is such that with a standard aerial it will receive B.B.C. Stations within a wide radius. This is accomplished by using a tuned anode circuit and a certain degree of reaction. The Set gives a purity of tone better than that of other reaction sets on the market, and is therefore suitable for use with Loud Speakers. Two dry cells are required for the filaments, and a 45-volt battery for the plate circuit.

THIS TWO VALVE, TWO STAGE AMPLIFIER (No. 44012) has a key or switch which gives a "one valve" circuit or the "two valve" circuit. Being fitted with Weco valves, accumulators are unnecessary, and



No. 44012.

One or Two Stage Low Frequency
Amplifier.

WRITE FOR BOOKLETS W.E.Co. /32, W. 528 and W. 529.

Western Electric Company Limited.

(WHOLESALE ONLY)

Connaught House, Aldwych, London, W.C.2.

Telephone: Central 7345 (9 lines).

Branches:—

Glasgow, Leeds, Birmingham, Manchester, Newcastle, Cardiff, Southampton, Dublin

COLUMBIA
RADIO "A"
CELLS for
WECOVALVES

COLUMBIA
RADIO "A"
CELLS for
WECOVALVES

Hello Everybody !!

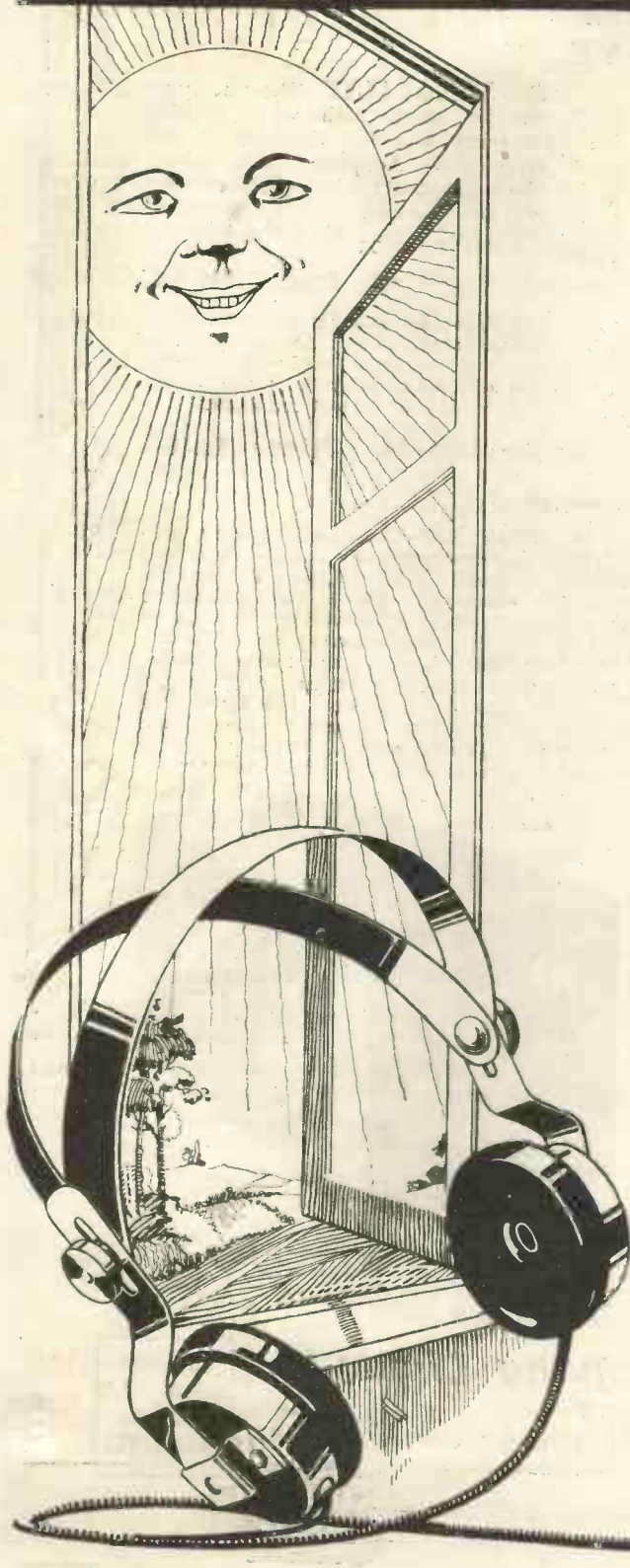

*Did you
listen-in
last night
on*

TMC Headphones

You missed a treat if you didn't. They give such clear and pure reproduction. Comfortable to wear. Do not pinch the ears. Without them you do not know what your set can do.

25/-

THE TELEPHONE MANUFACTURING CO., LTD.

LONDON SHOWROOMS:
68, NEWMAN ST., OXFORD ST., W.1



You CANNOT be out of WIRELESS WEEKLY because it brings BIG Business.

TRADE **Greco** MARK

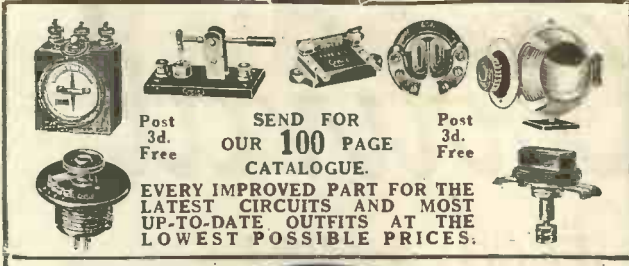

Post 3d. Free SEND FOR OUR 100 PAGE CATALOGUE. Post 3d. Free

EVERY IMPROVED PART FOR THE LATEST CIRCUITS AND MOST UP-TO-DATE OUTFITS AT THE LOWEST POSSIBLE PRICES.

Telephone: MUSEUM 241

Works: ELOUGH.

ELECTRIC GRAFTON COMPANY

84, GRAFTON STREET,

LONDON, W.C.

TOTTENHAM COURT ROAD,

"OOJAH" BASKET INDUCTANCES



Wavelength range 320-4,500 m. 5/- per set.
Wavelength range 300-2,000 m. 2/6 per set.

Descriptive Leaflet free upon Application.

LIBERAL DISCOUNT TO FACTORS

All "OOJAH" Inductances are wrapped in a transparent covering and sealed with the Registered Trade Mark

— OOJAH —

"OOJAH" Basket and Slab Inductances are being extensively copied, as most good things are, and purchasers are advised to not only specify "OOJAH" Brand in their order, but to see that the seal is intact.

It is not sufficient to say "I want a set of Basket Coils." Demand "OOJAH" Basket Coils.

GREENSLADE & BROWN
LANSDOWNE ROAD, CLAPHAM, S.W. 9

Telephone—BRIXTON 639 & 3451.

Remarkable Results are being obtained with Sets using HAWKERS LTD. DISC FIXED CONDENSERS

The fact that every Disc Condenser offered for sale has been tested on an oscillating valve set under actual working conditions, and that the scientific method of manufacture employed absolutely precludes the possibility of variation in capacity under any climatic conditions after leaving our Works, enables us to recommend it with unbounded confidence. We deal only with the wholesaler but if you are unable to obtain supplies in your particular district, we shall have pleasure in supplying you direct upon receipt of Postal Order and address of your local dealer.

Made in Six Capacities: .0002 .0003 .0005 @ 1/3 each. .001 .0015 .002 @ 1/3 "

HAWKERS Ltd., Hockley, Birmingham.

Telegrams: "Hypatia," Birmingham. Telephone: Northern 889.

Telegrams: "Hypatia," Birmingham.

Telephone: Northern 889.

Buy British Goods Only



Buy the valve with the name behind it.

Ediswan Lamps have been world-famous since 1880. These valves are the product of the same experience, research and extensive manufacturing organisation. That they are used by H.M. Admiralty, War Office, and Air Force is conclusive proof of their superiority. The name is your guarantee.

EDISWAN TYPE "A.R." 15/-

EDISWAN TYPE "R" 15/-

EDISWAN TYPE A.R.D.E. (Du!! Emitter), 27/6.

Filament Volts 1.8—2.0
Filament Current30
Anode Volts 20—50
Bulb Diameter 29 mm.
Overall Length { 110 mm. max.
including pins } Standard 4-pin.
Cap. Standard 4-pin.
Do not put more than 2 volts across the filament. Eminently suitable for reflex circuits.

Have you had your FREE copy of Illustrated Booklet, "The Thermionic Valve"? If not, write us at once.

Manufacturers of Complete Receiving Sets and Accessories, also H.T. and L.T. Batteries. Ask or write for leaflets.

Your Dealer holds stocks to supply you. If not, write us direct and give his name and address—a post card will do.

We are exhibiting at the N.A.R.M. EXHIBITION, WHITE CITY, NOVEMBER 8th—21st. STAND No. 87.

The EDISON SWAN ELECTRIC Co., Ltd.
123/125, Queen Victoria Street, E.C.4,
and 71, Victoria Street, S.W.1.

Branches in all Principal Towns. Works: Ponders End, Middlesex.



Contractors to H.M. Admiralty, War Office, Royal Air Force.

The New Arrival

THE MULLARD "WECOVALVE."

Mr. "ORA" welcomes the baby "Wecovalve" to the Mullard family. Like most fathers he looks to his son to uphold the traditions of the house and, indeed, to go one better.

The baby "Wecovalve" shows every evidence of living up to these expectations. It consumes very little current, lasts twice as long as other valves, and needs no accumulators.

If you are buying or making a new set Wecovalves will save you money as they cut out accumulators.

If you have a valve set Wecovalves will pay for themselves in a few weeks.

In any case write to the manufacturers or ask your dealer for List M.W.I. It tells you all about this wonderful new valve.

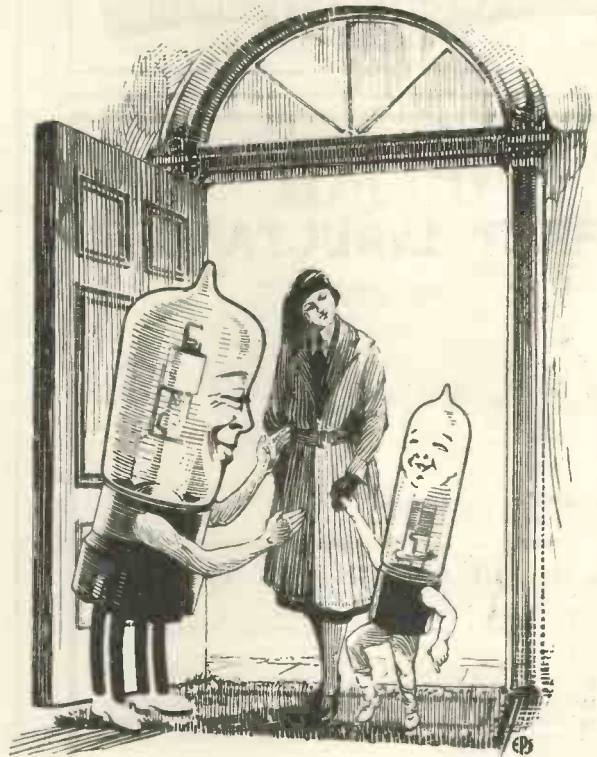

MULLARD WECOVALVE . . .	30 -
SOCKETS	1/6
4-PIN ADAPTORS	3/6
FILAMENT RESISTANCE FOR WECOVALVES	3/9

Full Manufacturing license under British Patents Nos. 17580, 123126, 180090.

Mullard

Advt. The Mullard Radio Valve Co., Ltd., Balham, S.W.12.

You CANNOT be out of WIRELESS WEEKLY because it brings BIG Business.

*Get this Form and fill it up —
Whether you are buying a complete set, or
building your own; Rely on BURNDDEPT*

REGULATION FOR BROADCAST LICENCES.

I _____ (Name in full)
of _____ (Address in full)
apply for _____ licence for a wireless receiving station.
Strike out the words not required.
a Broadcast
a Constructor's
an Interim

at _____ (Address at which receiving set is to be used)

I declare that —
A. (BROADCAST LICENCE, 10/-)
My receiving set, and any valve amplifier, head-telephone, or loud-speaker used therewith will bear the official trade-mark of the British Broadcasting Company.

B. (CONSTRUCTOR'S LICENCE, 15/-)
My receiving set will be made or put together by myself and in its construction I will not knowingly use parts manufactured elsewhere than in Great Britain or Northern Ireland.

C. (INTERIM LICENCE, 15/-)
My receiving set will only be accepted from person who applies for licences before October 15th, 1923. All others must sign A or B.
My receiving set was made or purchased by me before the 30th September, 1923.

(Note—This declaration will only be accepted from person who applies for licences before October 15th, 1923. All others must sign A or B.)
The following is a brief description of it —

Here give brief description of set, saying whether aerial or valve set, with number of valves, and whether with or without loud speaker or separate amplifier.

I undertake that in making any alteration in or addition to the set I will not knowingly use parts manufactured elsewhere than in Great Britain or Northern Ireland.

Signature _____
Date _____



No. 532. — Ethophone Home Constructor No. III. Complete set of parts, together with polished cabinet, panel drilled and engraved, capable of being built into a highly efficient 3 valve receiver.

Price - £12.



No. 510 W.A.—Ethophone Popular Model. A 2-valve highly efficient long distance receiver, complete with self-contained High Tension Battery, Accumulator, Telephones and Aerial Equipment. Price £18 10 0 To which must be added Broadcast Tax £ 17s. 6d.

BURNDDEPT Apparatus is entirely BRITISH made.

AMATEURS, Experimenters, and others interested in wireless and Broadcast reception, will welcome the new Post Office Regulations governing the issue of the various licences. It is now perfectly clear, you can buy what you like so long as it is British. For your own sake, see that the apparatus you buy, whether a complete receiver, or a component part, carries with it a written guarantee. Every piece of Burnddept Apparatus carries such a document attached, thus safeguarding their customers.

Our new catalogue consisting of 88 fully illustrated pages will be ready on November 1st. We have no hesitation in saying that this will be the finest wireless catalogue yet produced in this country. It must be on the bookshelf of every wireless enthusiast as a work of reference. It will be sent entirely free of charge to all those who apply before November 1st. The published price of the catalogue is one shilling.

BURNDDEPT LTD. Head Office: Aldine House, Bedford Street, Strand, W.C.2.
PHONE: GERRARD 7794.



GECOPHONE

Important Announcement

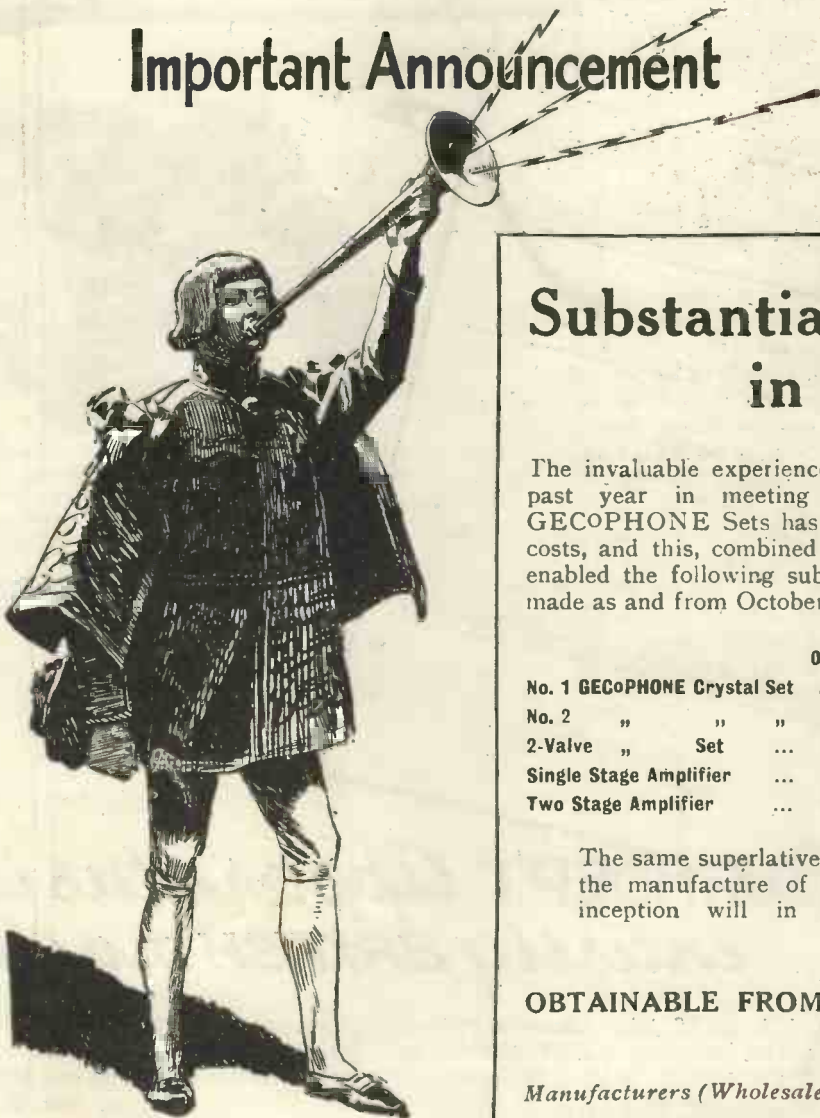

Substantial Reductions in Price

The invaluable experience gained by the G.E.C. during the past year in meeting the unprecedented demand for GECOPHONE Sets has resulted in reduced manufacturing costs, and this, combined with the lower B.B.C. tariffs, has enabled the following substantial reductions in prices to be made as and from October 1st, 1923.

	OLD PRICE	NEW PRICE
No. 1 GECOPHONE Crystal Set	£5 10 0	£4 10 0 + 1/- B.B.C. Tariff
No. 2 " " "	9 15 0	7 10 0 + 1/- " "
2-Valve " Set	25 0 0	20 0 0 + 17/6 " "
Single Stage Amplifier	7 0 0	5 10 6 + 5/- " "
Two Stage Amplifier	13 10 0	11 10 0 + 10/- " "

The same superlative quality that has characterised the manufacture of GECOPHONES since their inception will in every way be maintained.

OBTAINABLE FROM ALL WIRELESS DEALERS

Manufacturers (Wholesale only):

The GENERAL ELECTRIC Co., Ltd.

MAGNET HOUSE, KINGSWAY,
LONDON, W.C. 2



Branches in all the principal towns throughout Great Britain and in all important markets of the world.



We are exhibiting at the N.A.R.M. Exhibition at the White City, Nov. 8 to 21.

BUY BRITISH GOODS ONLY

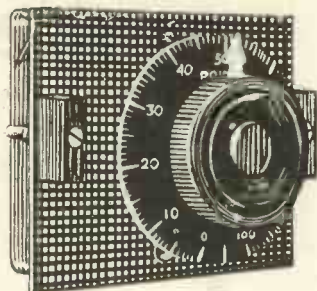

THE POLAR CONDENSER

(BRITISH MADE.)

World-wide approval has built its sales higher than these of any other type of condenser.

Unlike the ordinary vane condenser—in which half the capacity is cramped and limited to the first 1/5th of the scale—the Polar Condenser offers an open scale, the first 1/4 of which contains only 1/10th of the capacity, thus producing an absolute vernier over the section chiefly used. The recognised best Marine and Broadcasting Receivers use Polar Condensers.

Polar Condensers are supplied, **GUARANTEED**, by all Polar Stockists in the following capacities:—'001; '0003; and '0005.

Unmounted, Price 14/-. Mounted, Price 20/-.

The Polar Guarantee, insuring the buyer of every Polar Condenser against disappointment, was the **FIRST** guarantee given with any condenser.

We are exhibiting at the N.A.R.M. Exhibition, White City, Nov. 8th—21st.

RADIO COMMUNICATION CO. LTD.,

34/35, NORFOLK STREET, LONDON, W.C.2.

POLAR

HYER
PLANT

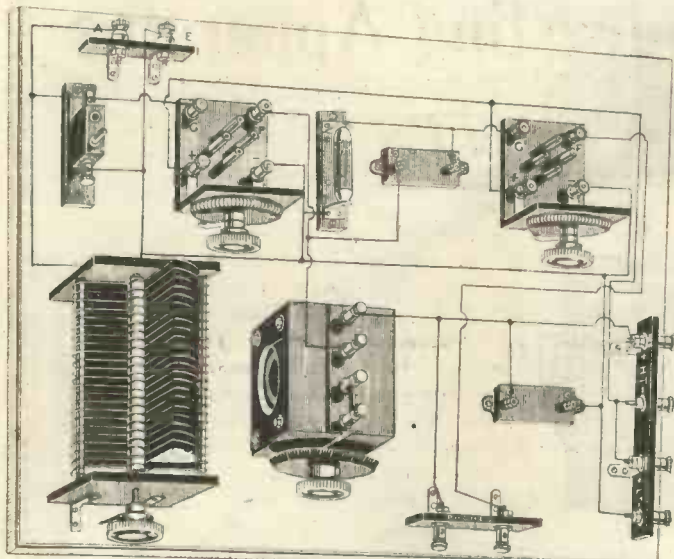

A typical 2-Valve Set.

A brilliant idea in Receiving Sets

1. Build up any Circuit in an hour.
2. Use any Combination of Valves.
3. No component is ever superseded.

IT is certain that nothing gives the true Radio enthusiast more pleasure than testing out new Circuits. But if the Set has to be built into an elaborate Cabinet, half the pleasure will have evaporated before the Set can be completed. Or, if it has got to be rigged up in a ramshackle way, the results are sure to be disappointing. Here at last is a perfected System—every component you can possibly need can be mounted on a board and wired up in the ordinary way, without even being

soldered. You can change your Circuit as often as you like, you can compare the relative advantages of the Flewelling, the S.T. 100, the Reinartz, etc., at practically no expense.

Once you have bought sufficient components, you can carry on with your experiments at no extra cost. A selection of suitable components are given below but we have all you need in stock at most moderate prices.

(Postage extra, but paid on orders over £2).

Use these P-S Board Components

Send to-day for a copy of our big 40-page Catalogue—the largest in the Trade. Fully illustrated, post free. 3d.

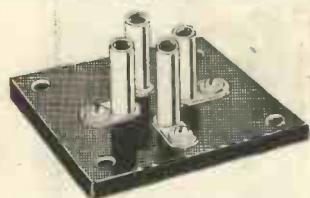

Socket for Valve or Transformer
Mounted on real ebonite, no fear of leakage. 1/3

Socostat

Combined filament resistance and Valve holder. A most convenient and economical method—all wiring concealed in base. 6/6

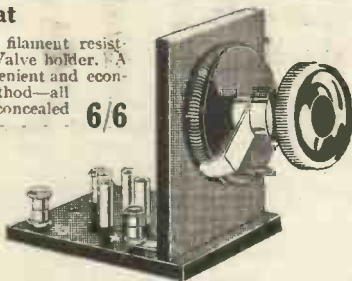

2-Coil Holder

Beautifully made from real hand-cut ebonite and hand polished. Very strongly made. 7/6

Coil Holder

Very economical method of carrying any type of coil. 1/9

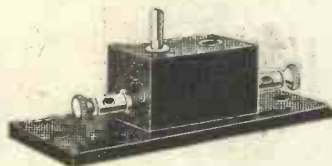

Swinging Coil Holder
Enables coil to be moved through an angle to give coupling effects. 2/3

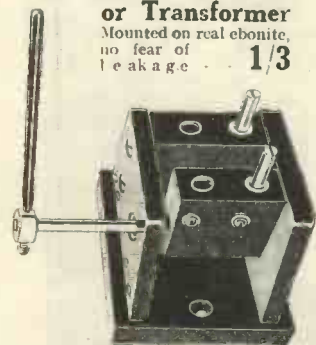

Variobloc Variometer

Best quality Variometer, internally wound, guaranteed to give the closest coupling of any Variometer on the market. High inductance ratio and sharp tuning. Permanent contact, can be used either as Variometer or Variocoupler.
No. 1 250-720 metres } 17/6
No. 2 250-840 metres }

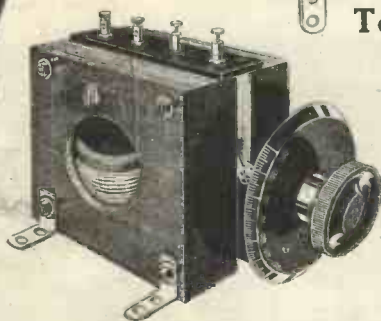

Fixed Condensers

Every one tested and guaranteed. Why risk making your own and shorting your H.T. Battery when you can buy these for so little! Capacity: .001, .002 and 1/6 .004 mfd. 1/6



Terminal Strip

Peto-Scott Co., Ltd.,

Pioneers of the Unit System.

HEAD OFFICE:

64, High Holborn, W.C.1.

Branches:

99, High Holborn, W.C.1.
3, Wellington St., Strand, W.C.2.
4, Manchester St., Liverpool.
94, Queen St., Cardiff.

Manufacture of Broadcasting Apparatus

USE OF PATENTS

The pioneer work of the Marconi Company in connection with wireless telegraphy and telephony is well known, and as the result of many years of research work and considerable expenditure, the Company controls numerous patents relating to the manufacture or use of wireless telegraph and telephone apparatus.

The Company is prepared to grant a license for the use of its patents in connection with the manufacture of broadcasting apparatus to any member of the British Broadcasting Company Limited.

A large number of firms (including the principal manufacturers) are already so licensed and pay

royalty for the use of these patents, and all apparatus manufactured under license is so marked. Any persons or firms manufacturing or offering for sale valve apparatus embodying patents controlled by Marconi's Wireless Telegraph Company Ltd. without its permission render themselves liable to legal proceedings for infringement.

Whilst hoping that it will not be forced to take legal proceedings the Marconi Company wishes to give notice of its intention to protect its own interests and those of its licensees, and in cases of infringement the Company will be reluctantly compelled to take such steps as may be necessary to defend its patent rights.

Marconi's Wireless Telegraph Co., Ltd.

Marconi House, Strand, London, W.C.2.



FELLOWS

Lovers of Music.

Wherever you live, stay at home in comfort and enjoy all the best concerts brought to your music room by the Fellows Super Two Set.

A 2-Valve Set of superior quality mounted in a highly finished case, that will receive any British or continental telephony even though the nearest Broadcasting Station is working.

PRICE: COMPLETE WITH H.T. BATTERY ACCUMULATOR, 100 ft. 7/22 STRANDED COPPER WIRE, 2 INSULATORS, 1 pr. 4,000 ohms HEAD-PHONES.

£9

plus B.B.C. Tax, 17/6, Marconi Tax, £1 5s., and 2 valves. A new 2-valve amplifier mounted in cabinet uniform with super 2 set £5 10s., plus B.B.C. tax, £1, plus 2 valves.

FELLOWS MAGNETO CO., LTD., LONDON, N.W.10

Telephone Willesden 1560-1. Telegrams: "Quiamag," Phone, London.



You CANNOT be out of WIRELESS WEEKLY because it brings BIG Business.

*The Amplion
again leads the way*

by the introduction of 1924 Models embodying numerous advantageous features ensuring **BETTER REPRODUCTION** of Radio Broadcast Music whether Vocal or Instrumental.

The New AMPLION Series render all ordinary loud speakers obsolete, yet the AMPLION, with all the latest improvements, is one of the least expensive Loud Speakers on the market.

Having a world-wide sale the AMPLION is produced upon a scale so large that it is possible to offer greatly increased value at the previous strictly moderate prices.

The 1924 Swan-neck or "Music Master" Style with non-resonating sound conduit and wood trumpet, as illustrated, costs only **£6 0 0**, with the option of 120 ohm. or 2,000 ohm. windings.

AMPLION Loud Speakers are standardised by the leading producers of Radio Receiving Sets and stocked by all Wireless Dealers of repute.

"Buy British Goods Only."

AMPLION

Patentees and Manufacturers:

ALFRED GRAHAM & COMPANY
(E. A. Graham)

St. Andrew's Works, Crofton Park, London, S.E.4.
Telephone Nos.: Sydenham 2820-1-2. Telegrams: Navalhada, Catgreen, London.

West End Showrooms:

The Algraphone Salon,
25-26, Saville Row, Regent Street, W.1.

Telephone: Regent 1075.

Telegrams: Sonalyra, Piccy, London.

We are exhibiting at the
National Association of
Radio Manufacturers
Exhibition, White City,
November 8-21.

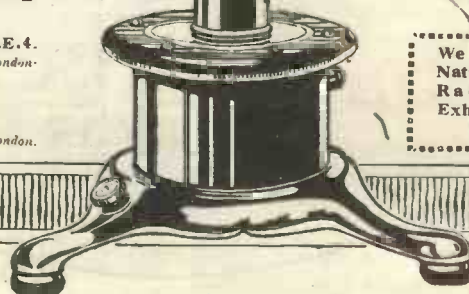

GAMAGES SALE

EX-ARMY SIGNAL LAMPS

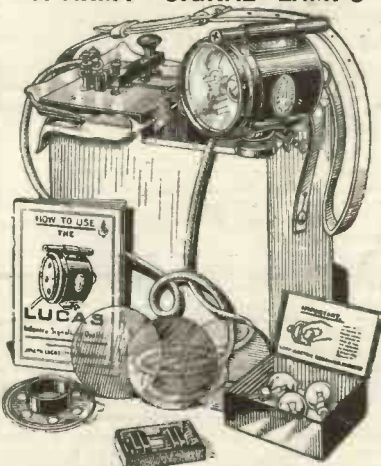

SPECIAL OFFER.

For day or night signalling. The Lamp projects a very powerful, straight beam of light that makes signals readable at a distance of three miles in daylight. Three colour discs, Ruby, Green and Yellow, and reducing screen supplied for night use. Outfit consists of wooden carrying case with leather shoulder strap, containing lamp fitted with cable and two-pin plug, ball-jointed helio, tripod adapter tube sight, steel earth spike, three spare bulbs, box of spare parts, tapping key and instruction book.

7/6

Special Siemens Battery for same 12/-
Or Three 4-volt Box Batteries in series at 1/8 each battery.

Try Gamages Famous 'PERMANITE'

Regd. No. 438341.
In your Crystal Detector. It will amaze you by the wonderfully clear reception and sensitivity.
Per large specimen. Post free

1/6

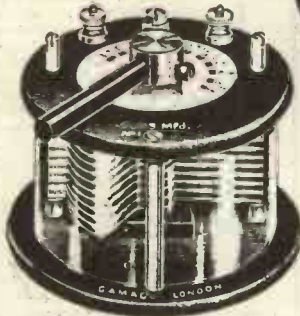

VARIABLE CONDENSERS

of our usual well-known design.

	Sale Price	List Price
00045	7/-	14/9
0003	6/9	13/-

Postage on each of above 6d. extra.

THE 'SONUS' UTILITY PANEL

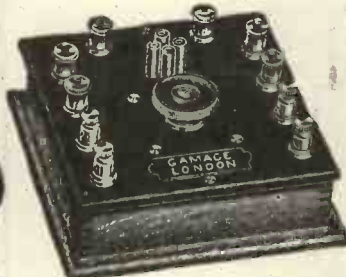

For use in adding Valves to Crystal Sets. This panel, finished in polished mahogany box with ebonite top, lacquered terminals engraved, makes the adding of low frequency or high frequency valve and your B.B.C. or any other crystal set a very simple matter. Size 8in. X 8in. X 4in., supplied complete with wiring diagrams and instructions. Price **20/-** Post 6d.

A really remarkable bargain of which early advantage should be taken.

Be sure to visit Gamages Wireless Department during the Sale, where there is a

SPECIAL DISPLAY

of apparatus by all the leading makers—a display that should be seen by all.

BROWN'S PHONES



Type A. Every pair tested. Resistance 120 ohms. Usual price 30/-
Sale Price **21/-**
Post 6d. Cords 2/9 per pair extra

GAMAGES, HOLBORN, LONDON, E.C.1

EQUIPMENT FOR EXPERIMENTERS

SIMPLIFIED TUNING

Many methods of coupling coils for Anode and Aerial Tuning have been designed with the purpose of giving fine adjustment, but with each development the apparatus has become more and more complicated and expensive. To achieve equal results in a simple and neat manner at low cost is the purpose of the WEBBER COIL HOLDER, W.70.



There is no loose wiring or trouble of fraying flex, and any degree of close or open coupling can be easily obtained by moving the coil holder to or from the back of the tuning unit.

Price 3/9; with double terminals, 4/-

Write for illustrated lists of all WEBBER EQUIPMENT.

N. V. WEBBER & CO., Radio Engineers,
Walton House, WALTON-on-THAMES, SURREY. ARKS 4

WELCOME NEWS

—for the Experimenter

TOTALLY NEW EQUIPMENT FOR SET-BUILDERS.

- FOR some time past much of our time has been concentrated on the production of a complete series of component parts with the help of which the assembly of the latest receivers, embodying the ideas set forth week by week in "Wireless Weekly," can be made with the minimum of time, and with the certainty of first-class results.
- The designs of these components are entirely new, and constitute further examples of the efficiency and robustness of Bowyer-Lowe productions.
- Equipped with a selection of these components, the experimenter will be able to assemble a receiver of pleasing appearance in an extremely short time, while the expense incurred in changing from one circuit to another is trifling.
- An illustrated descriptive pamphlet is now ready and a copy will be sent on application. send a postcard now.
- Supplies of the components can be obtained from any wireless dealer, or, in case of difficulty, we shall be pleased to supply direct.



The Bowyer-Lowe Co., Ltd.,
Manufacturers of Wireless Instruments,
Radio Works, Commerce Avenue,
Letchworth, Herts.

Wholesale Distributor for Scotland:
F. M. MILLIGAN, 23-25, Renfrew Street, GLASGOW.

"ATLAS" THE COIL SUPREME.

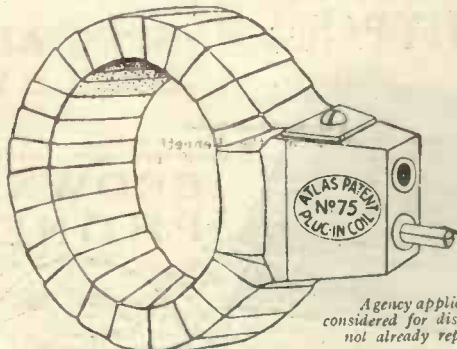

Agency applications considered for districts where not already represented.

The last word in efficiency.
Maximum Inductance. Minimum Self-capacity.
All Wave-Lengths covered.

Prices on application. Radio Components Catalogue on request.

Manufactured only by

H. CLARKE & CO. (M/cr.), LTD.,

Radio Engineers,

ATLAS WORKS,

OLD TRAFFORD, MANCHESTER.

Telephone Nos. :
683 & 793 Trafford Park.

Telegrams :
PIRTOID, Manchester.

ELBE COIL HOLDERS

USE SINGLE COIL HOLDERS FOR MAXIMUM EFFICIENCY. HIGHLY RECOMMENDED.

Ebonite Basket Coil Mounts to plug in above 2/- each.

Ask your Dealer for them.

LEIGH BROS., Tel: Mus. 4517.
37 Sidmouth Street & 1a Prospect Terraces,
Gray's Inn Road, LONDON, W.C.1.

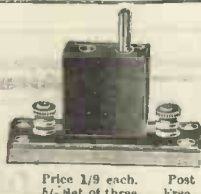

Price 1/9 each. Post 1/- Set of three. Free.

Turn your wireless knowledge
into cash

£

We are always pleased to receive interesting articles for our various publications, and those accepted will be purchased at good rates. Articles can be submitted with or without diagrams or photographs. Where constructional articles are submitted, evidence of the actual working of the apparatus described must be forwarded if required.

RADIO PRESS, Ltd. Devereux Cour', STRAND, W.C.

RESULTS! WIRELESS WEEKLY

will bring you
BUSINESS

It is as good an advertising medium as
MODERN WIRELESS.

Rates for both publications on application to—

SCHEFF PUBLICITY ORGANISATION, Ltd.,

No. 2, 125, Pall Mall, London, S.W.1.

Phone : Regent 24.0.

Wireless Weekly

SMALL ADVERTISEMENTS.

PREPAID Advertisements are accepted under this heading for Wireless Apparatus and Parts WANTED or FOR SALE, etc., at the rate of 1s. 6d. per line, MINIMUM THREE LINES. Advertisements should reach Scheff Publicity Organisation, 125 Pall Mall, London, S.W.1, LATEST by first post FRIDAY preceding date of publication. The publishers are not responsible for clerical or printer's errors but every care is taken to avoid mistakes.

LOOK! 1/6 only, a miniature wireless vest pocket receiving set. Tested and guaranteed to receive broadcasting concerts within a radius of 20 miles. Full instructions with each set. Money returned if not satisfied. Post free. Send P.O. 1/6 to T.E.P. Gibbs-21a, Northwold Road, Stoke Newington, London, N.16.

ALL post paid. 60 volt H.T. battery and plugs 8/-; 400 ohm phones 12/-. Complete list of similar values free. J. H. Taylor & Co., Macaulay St., Huddersfield.

BROWN'S microphone amplifier, new; £5 or nearest. Handsome set of 7 books. Cyclopedia of Applied Electricity, £3. A few experimental accessories, including V 24 valves 15/-, 1 pr. Brown's 120-ohm phones, odd condensers, transformers, and other components cheap. W. McCoy, 11, Goldsmith Rd., New Southgate, N.11.

EDISON-BELL, condensers, variometers, transformers, bobbins, knobs, earcups, dials, etc. Stocked British goods with a name, at foreign junk prices. Nos. 2a, 12b & 75 Buses pass the door.—Below.

LISSEN & Fernet components stocked; call or write for price list; special quick reply to all first enquiries. We want your business and will serve you well.—Below.

CLARITONE speakers, on hire. Accumulators charged on the premises, valves repaired. Stockists for Britannia sand-blasted ebonite. B.B.C. H.T. wireless cells. R.B. accumulators.—Below.

EXPERIMENTERS' assorted box of screws, nuts, bolts, terminals, contact blades, etc., 4 doz. articles, many alone worth 6d. each, 2/6 post free. Write now, Bell Wireless Co., opposite Gas Works, Sydenham, S.E.

FIVE valve Peto-Scott unit set. 2 H.F. det. 2 L.F. £12 10s. Complete with aerial, valves, 6-v. accumulator, 60 a.h. act. cap. 66-v. H.T. batt., pr. Brown's F. type 'phones; £20. Bowick, c/o Miller, 4, Gillespie Cres., Edinburgh.

GO to Mica & Micanite Supplies Ltd., Mica House, Offord Street, Caledonian Road, N.1, for mica and all insulating materials.

MARCONI multi-valve R.B. 7, complete, £55. Marconi N.B. 2 amplifier, 12 gns. The above shop-sold only, condition as new, less than cost. Bridges Ltd., Electrical Engineers, Cirencester.

PICKETT cabinets. They're good value, 1/6 each, highly polished. Write for lists (W.L.) Works: Albion Road, Bexley-heath.

WHY pay more? Special offer of phones, 4000 ohms, very sensitive, guaranteed accurate, 11/6; extra special 13/-; carriage extra. Cash with order. Trade supplied.—Lee, 58, Woodville Rd., Golders Green.

3 VALVE set. I.D.T. 2 L.F. 6 v. 60 A accumulator, loud-speaker. 2 prs. phones, valves complete, splendid bargain, £15; seen working after 7.—197, Green Lanes, N.16.

MAGNORA LOUD-SPEAKER



The loud-speaker WITHOUT DISTORTION, looking like a towtoiseshell vase. Only 4 1/2" high. 42/- post free. Demonstrations in the evening and during the morning hour.

Sole Manufacturers:

CONDUIT WIRELESS CO.,

'Phone: Regent 5475. 47, Conduit St., London, W.1.

200,000 MAGNET LETTERS have been supplied by us to **WONDERSIGNS** of **HOLBORN**. Each letter is a perfect Magnet. Hence our knowledge of what a Magnet should be, and our ability to produce the **BONTONE PHONE** under mass production.



Points to Consider.

Every Phone is sold under guarantee. Every Phone is tested before leaving Factory.

We are Old-Established British Manufacturers, whose object is to give complete satisfaction.

Why saddle yourself with Continental Phones distributed by unscrupulous importers, with small offices and elaborate note paper, and **NO GUARANTEE** or hope of redress if found faulty.

Originals of upwards of 100 unsolicited testimonials and letters of appreciation can be seen at our offices.

GUARANTEE.—We agree to replace or return cash if Phones do not give complete satisfaction, subject to Phones being returned to us within 7 days of purchase, undamaged.

BONTONE PHONES (4,000 ohms) BRITAIN'S BEST.

14/6 per pair. Carriage paid United Kingdom.

SENSITIVE, DURABLE, COMFORTABLE, AND BEAUTIFULLY FINISHED.

Manufactured entirely by **BRITISH** labour. **LIBERAL TERMS TO THE TRADE.**

B. D. & CO. (Edward A. Boynton).

WORKS: GOSWELL ROAD AND CITY ROAD. OFFICES: 167-173, GOSWELL ROAD.

ADMIRALTY, WAR OFFICE, AND INDIA OFFICE CONTRACTORS.

FREE

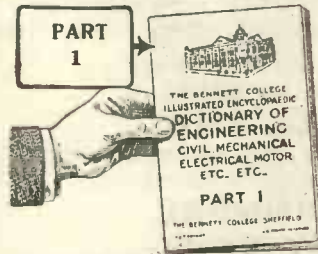

To extend the name of the Bennett College to everyone engaged in the different branches of Engineering, we are publishing an **Illustrated Dictionary of Engineering**, in about **24 MONTHLY PARTS** (16 pages each part). You can have each monthly part as it comes out, **FREE**.

1/- Postage only to pay

The Dictionary is free to those engaged in any of the following trades: **Engineering, Civil, Mechanical, Electrical, Structural, Motor, Sanitary, Boiler, Internal Combustion, Draughtsmanship, Marine, Shipbuilding, Naval Architecture, Building, Architecture, Quantity Surveying, Aviation, Chemistry, Foundry Work, Metallurgy, Matriculation, Mining, Surveying and Levelling, Telegraphy, Telephony, Wireless**, and the conditions are that you send your name and address, your age and occupation, with one shilling (to cover postage on the 24 parts), writing your name and address very clearly. We shall then place your name on our Free List and send you part 1 at once. The others will be forwarded as issued.

Department D 133,
The Bennett College,
Sheffield.

We teach above trades by Post; particulars Free.

**—TINGEY SUPERFIVE—
CABINET RECEIVER**

The last word in **PERFECT REPRODUCTION, SELECTIVITY** and **STRENGTH OF SIGNALS.**

Enclosed in Lock-up Oak Cabinets, complete with High Tension Battery of 120 volts.

Composed of **TWO HIGH FREQUENCY**, one H.F. Rect., and two L.F. Power Valves. By means of two simple wander plugs any combination or number of valves may be employed.

Each set is supplied with a set of Coils covering the wavelengths of British Broadcasting Stations. Other sets of Coils may be supplied at extra charge.

We manufacture Valve Sets—1, 2, 3, 4 and 5 Valves, also an excellent Crystal Set.

Send for our new Components LIST—free on request.

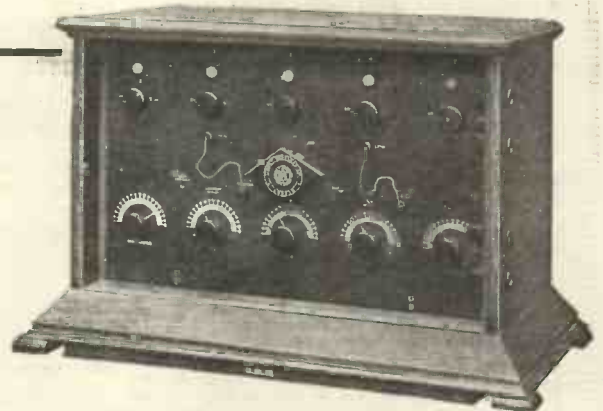

PRICE, as illustrated, including Special Valves and High Tension Battery **£56 : 5 : 0**

Ask for Superfive pamphlet.



(FEW AGENCIES STILL OPEN.)

Offices and Showrooms :

(OPEN 8 to 7. SATURDAYS 8 to 1.)

92, Queen St., Hammersmith, London, W.6.

Phone: Hammersmith 1916.

Grams: "Tingoidar, London."

Chiswick Agents:—The Askew Motor Works, Ltd., 72, High Road, W.4.

THE REFTY CRYSTAL CUP is UNDOUBTEDLY THE MOST SATISFACTORY AND THE **FINAL SOLUTION OF ALL THE TROUBLES OF THE CRYSTAL USER.** IT IS ONE OF A SERIES OF **WINNERS PRODUCED BY REFTY ELECTRICAL APPLIANCES LTD.**

THE PICTURES TELL THE STORY.
The screws are No. 4 B.A. x 1" and can be used either way up.



The Cup and Plunger surfaces are ridged.

This ensures grip as well as good contact.

PULL KNOB! INSERT CRYSTAL! LET GO!



Prov. Pat. 20606.

Foreign Patents pending.

6D EACH.

MORE REFTY TIME-SAVERS

- No. 1. Lacq. 10jd. each. Ebonite top.
- No. 2. Lacq. 6d. each. All brass.
- No. 4. Lacq. 1/- each. Ebonite top.

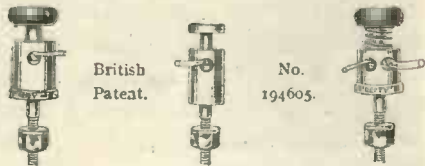

- No. 1a. N. Plate. 11jd. each.
- No. 2a. N.P. 7d. each.
- No. 4a. N.P. 1/1 each.

Depress Knob! INSERT WIRE! LET GO!
THE TERMINAL WHICH IS AS GOOD AS A SOLDERED JOINT yet which is connected or disconnected in an instant **AND CANNOT POSSIBLY SHAKE LOOSE.**

Hundreds of Dealers Stock REFTY Products. Here are some of them. If your dealer doesn't—send cost plus postage for direct delivery.

- Barrow-in-Furness. J. Dall, 76/8, Dalton Road.
- Bradford. The Gramophone Stores, 150, Bowling Old Lane.
- Croydon. C. W. Brown, 78, Church Street.
- Coventry. Coventry Wireless Supply, Clay Lane.
- Edinburgh. Robertson & Hogg, 29, Nicholson Street.
- Felixstowe. S. M. Douthwaite, 4, Constable Road.
- Glasgow. W. A. C. Smith Ltd., 236, Argyle Street.
- Grays. M. A. Flint Ltd., Orsett Road.
- Guildford. Bowden Higgitt & Co., Onslow Street.
- Norwich. E. & C. Gates Ltd., Arcade Street.
- Tunbridge Wells. Premier Electrical, 60, High Street.
- Romford. C. A. Paterson, Hornchurch Road.

REFTY ELECTRICAL APPLIANCES LTD.,

2, FEATHERSTONE BUILDINGS, HOLBORN, LONDON, W.C.2
Telephone: Chancery 8264. Telegrams: "Reftival," Holb, London.

MICA CONDENSER PLATES

& INSULATING MATERIALS OF EVERY DESCRIPTION.

MICA & MICANITE SUPPLIES, Ltd.,
MICA HOUSE, OFFORD STREET, CALEDONIAN RD., LONDON, N.1
Phone North 805.



FILTRON-COMBINATION (Patd.) 7/6 each.

Consists of a combined:—
VARIABLE GRID LEAK (Zero-7 Megohms).
VARIABLE GRID CONDENSER (Zero-0005 M/F).

Efficient in every Radio application.
FILTRON—VARIABLE GRID LEAK. 4/- each. (Zero-7 Megohms.)

Approx. Calibration with H Graphite.

Harder Graphites increase and softer decrease these readings proportionally. Available High Ohmic resistance of precision.

Degree Rotation	0°	90°	180°	270°	360°	540°	720°	1080°	1170°
Megohms Resistance	001	01	04	08	12	16	32	41	76
									107

STATIC-MASTER 2/9 each. Lengthens the life of Coils, Condensers and Head-phones and insures Perfect Safety to your Set. Fitted to any Set in two minutes and needs no further attention.

RADIO SPECIALITIES, 57a, Denbigh Street, Pimlico, S.W.1.
Phone: Victoria 8463. (Generous Trade Terms.)

ELECTRADIX RADIOMETERS.

WAVEMETERS from 100 to 10,000 metres. From £2 10 0. New Ex W.D. **MILLIAMMETERS** for Fine Tuning, 17/6 to 35/-. **VOLTMETERS** Panel & Portable 2 volts to 2,500 volts, 5/- to £5. **RECORDERS.** Wireless Morse Inkers make long wave reception interesting, £6 10 0. **MOTOR ALTERNATORS.** Wonderful £30 machines for £3. Ex Aircraft. **POTENTIOMETERS.** Army 350-ohm 3/6.

For details see "Wireless World" or our 3d. Catalogue.

We have many thousand pounds worth of the pick of Govt. Wireless gear displayed at our showrooms at 9, Colonial Avenue, Minories (near Aldgate Station).

LESLIE DIXON & CO. Ave. 4166.

FINEST WORK & PROMPTITUDE.

INCOMPARABLE WHITE FILLING.

HAND & MACHINE ENGRAVING ON ANY MATERIAL

Phone Central 1137.

CLIFFT & COCKLE,
51, Arcade Chambers, St. Mary's Gate, MANCHESTER.

Don't buy accumulators for your valves



Unskilled chargers will only ruin them. For 12/- a quarter **ONLY 1/- A WEEK INCLUSIVE** we will supply you continuously with reliable charged L.T. Batteries, replaced at time of collection by motor anywhere in London.

Phone: East 5655. **British Battery Supply Service.** Write NOW for pamphlet C Free. Carr St., London, E.14

Radio Press Information Dept.

QUERY COUPON

WIRELESS WEEKLY. Vol. 2. No. 14. October 17, 1923.
(This coupon must be accompanied by a postal order of 7/- for each question, and a stamped addressed envelope.)

No more Wireless Masts

UTILITY ENDORSED BY THE EDITOR OF "WIRELESS WEEKLY."



OUR HIGH GRADE RUBBER COVERED TELEPHONE CABLE GIVES WONDERFUL RESULTS AS AN AERIAL INDOORS AND OUT. IDEAL FOR ALL TRAINING PURPOSES IN THE GARDEN.

WIRELESS MASTS AND INSULATORS ABOLISHED.

The simplicity in erection is beyond the dreams of all wireless enthusiasts, as the troublesome insulators are absolutely unnecessary. Suspend this wire where you will, lead in, and your result is there.

It is a simple matter to make a portable aerial from this wire or to run a lead-in from the house to the garden, whether it is a few yards or half a mile. Ideal for telephone work all over the world.



READ THIS CONVINCING UNSOLICITED TESTIMONIAL.

32, Alverstone Road, Waddiscombe, 2nd Sept. 1923.

The Manager, New London Electron Works.

Dear Sir, I am pleased to inform you that the wire arrived safely yesterday, for which many thanks. I should like to mention that I have taken my ordinary aerial down, and erected one with your thin wire, and with 80 feet I obtain results much better in every way than I had before.

Yours faithfully, (Signed) GEO. FURMINGER.

Supplied in 3 thicknesses on original drums.

AERIAL.

1/8

100 feet.

POST PAID ANYWHERE.

Special terms to the Trade.

Class 0	1/4 mile drums (Thin for light work)	15/-	Per drum Carriage forward.
Class 1	1/2 mile drums (medium for most jobs)	35/-	
Class 2	2 mile drums (Thickest for heavier work)	70/-	

Orders for 6 miles assorted (if required) carriage paid.

Smaller Quantities of Class 1 (medium) sent carriage paid.

100 feet **1/8** 500 feet **6/3** 1,000 feet **10/3**

(Sufficient for the finest AERIAL.) Carriage Paid.

NEW LONDON ELECTRON WORKS LTD.,
65, REGENT'S DOCK, LIMEHOUSE, E.14.

Telephone: East 185L.

Telegrams: "Stannum, Step, London."

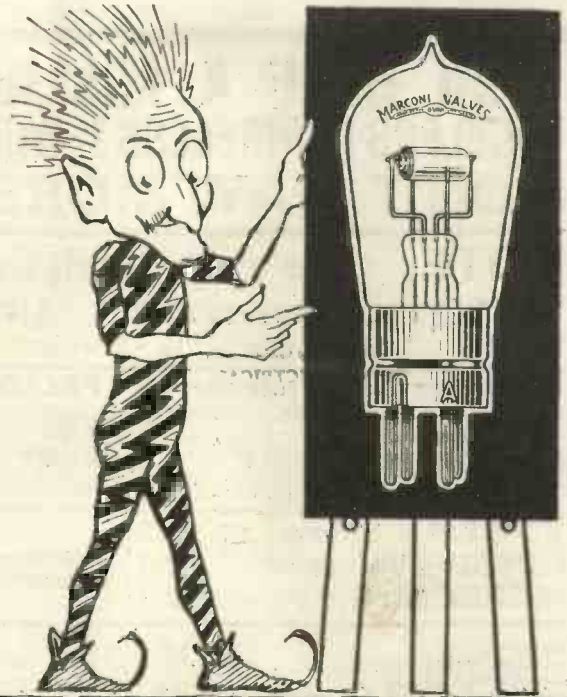

This is what really counts

YOUR set may contain all the latest 'gadgets'—it may be of the most beautiful design and finish—it may be the last word in appearance; but unless you've got the best **valves** your outfit is going to be like a house built on the sand.

MARCONI VALVES have the "OSRAM MADE" reputation behind them. They are made at the famous Osram Works at Hammersmith—and they are **MADE TO LAST.**

Put first things first, by insisting on

MARCONI VALVES

MADE AT THE OSRAM LAMP WORKS

BUY BRITISH GOODS ONLY.
Manufactured by the GENERAL ELECTRIC CO., LTD., and sold by all Trading Wireless Dealers, Electrical Contractors, Stores, etc.

OVER HALF A MILLION SATISFIED CUSTOMERS WIRELESS! WIRELESS! WIRELESS! and EVERYTHING for it. DON'T PAY MORE!

PIONEERS OF Great Britain's largest CHEAP PRICES. exclusive Wireless Stores.

NOTE. We are exclusively WIRELESS — NOT DABBLERS! QUALITY, QUANTITY, AND CONSISTENCY OUR MOTTO. See Our Six-Window Display of Popular Bargains.

We offer for the first time the new "FELLOWS" Lightweight Headphones, 4,000 ohm. A masterpiece of workmanship. A guarantee with every pair. Honestly worth 30/- Per pair. **18/6** Special offer—**BROWN'S** Featherweight Headphones. **19/6** Stamped B.B.C., 4,000 ohms. Our Price.

ELKAY LIGHTWEIGHT HEADPHONES. 4,000 ohms **12/9** **BRUNET 'Phones.** The genuine article **13/11** **N. & K. 'PHONES.** The Genuine article. Our Price **12/9**

EDISWAN Valves 12/3 } **Bankrupt Stock and of Limited Quantity. Guaranteed all New** } **MULLARD "ORA" Valves** 12/3
COSSOR Valves 12/3 } **EDISWAN DULL EMITTER.** }
MARCONI "R" Valves 12/3 } Our price 25/9

DUTCH VALVES	6/11	STOPS, with nuts	per doz.	6d.	VARIABLE CONDENSERS of high quality. Valves and Spacers of aluminium. Complete with knob and dial, guaranteed accurate:	
PHILLIPS DUTCH VALVES	7/11	FILAMENT RESISTANCES, smooth action, marvellous value		1/10	Vernier	4/9
L.F. TRANSFORMERS Ratio 5 to 1. All guaranteed (postage 1/-)	each 11/3	With engraved dials	each	2/9	'0002	5/9
CRYSTAL DETECTORS	1/9, 1/3 and 10/1d.	PLUNGER SPRINGS, complete	each	1d.	'0003	6/3
CRYSTAL DETECTORS, enclosed in glass case, 2/8, 2/3, 1/6		SLIDER ROD, brass, 13ins. long, 1/4in. square, drilled	each	3/1d.	'0005	7/-
AERIAL WIRE, 7/22, guaranteed hard-drawn copper, 100 ft. (postage 1/-)	1/10 1/2	SLIDER KNOB	each	2d.	'0007 1/2	8/6
CONDENSER VANES, fixed or moving, per doz.	3/1d.	SWITCHES ON EBONITE, S.P.S.T. (quality the best)	each	1/6	'001	9/9
REAL GOLD CAT'S WHISKERS	each 2d.	SWITCHES ON EBONITE, S.P.D.T. (quality the best)	each	1/11	O.B.A. NUTS	per doz. 4d.
REAL GOLD CAT'S WHISKERS	per doz. 1/5	SWITCHES ON EBONITE, D.P.D.T. (quality the best)	each	2/9	DETECTOR ARMS, Ball Joints, Ebonite Handle and Whisker Holder	3/1d.
SILVER CAT'S WHISKERS	each 1d.	CONDENSER SPINDLES, all sizes in stock, from	each	1/1d.	WOOD SCREW TERMINALS	each 1/1d.
SILVER CAT'S WHISKERS	per doz. 7d.	SCREWED ROD, 2 B.A., 12ins. long	each	3d.	SHELLAC	per bot. 10 1/2d. and 6d.
CONDENSER SCALES, 0 to 180	each 3/1d.	SCREWED ROD, 4 B.A., 12ins. long	each	2 1/2d.	AERIAL PULLEYS	from 4 1/2d.
IVORINE LABEL SET, 12 different titles, the set	6 1/2d.	RUBBER-INSULATED LEADING-IN WIRE	per yd. 1/1d. and 2d.	TINFOIL	large sheet 4d.	
BASKET COILS, set of 6, up to 3,000 metres	2/4	INSULATORS, white reel, 2in., each 1d. per doz.	11d.	COPPER FOIL, 6in. wide	per ft. 5d.	
SLEEVEING, 3 yds. assorted colours, for	11 1/2d.	INSULATORS, white egg, each 2d. ... per doz.	1/8	GRID LEAKS, 2 1/2 and 2 meg.	each 10 1/2d.	
NUTS, 2 B.A.	per doz. 2d.	WOUND INDUCTION COILS (postage 9d.):		FLEX (Twin), various colours	per yd. 2d.	
NUTS, 4, 5, 6 and 8 B.A.	per doz. 2 1/2d.	12x4 9x4 8x2 1/2 6x3 6x2		CONNECTING WIRE, tinned copper, 20 gauge	3 yds. 2d.	
WASHERS, 3 B.A.	per doz. 7d.	2/5 2/3 1/11 1/8 1/5		ENAMEL WIRE, in 1, 1 1/2 and 1 lb. reels:		
WASHERS, 2 B.A.	per doz. 1 1/2d.			22 24 26 28		
CONTACT STUDS, with nuts and washers, per doz.	4d.	TAPPED INDUCTION COILS, 20 tappings, wound to 1,600 metres	each 1/11 and 2/8	per lb. 2/4 2/8 3/2 3/6		
TERMINALS, with nut and washers, each 1d., 1 1/2d. & 2d.		VARIOMETERS (Tube type), complete with knob	3/11 and 2/11	Note: Bobbins 2d. each extra.		
EBONITE KNOBS, 2 B.A.	each 2 1/2d. & 3d.	DOUBLE 'PHONE CORDS, full length	11 1/2d.	POTENTIOMETERS, guaranteed up to 900 metres, superior make, compact size.	7/3	
SPACING WASHERS, large	per doz. 2 1/2d.	HERTZITE, Genuine Large Piece	9 1/2d.	CRYSTAL DETECTOR, glass enclosed, fitted on 4x2 ebonite panel with terminals for aerial, earth and phones, already wired and beautifully finished	4/9	
SPACING WASHERS, small	per doz. 1 1/2d.	TALITE, Genuine Large Piece	9 1/2d.	BATTERIES, H.T., dry:		
CRYSTAL CUPS, 2 screw	each 11d.	PERMANITE, Genuine Large Piece	9 1/2d.	36 volts, including Wander Plugs	5/9	
CRYSTAL CUPS, 4 screw	each 2d.	ZINCITE, Genuine Large Piece	9d.	60 volts, including Wander Plugs	9/6	
FIXED CONDENSERS, all capacities	10 1/2d.	BORNITE, Genuine Large Piece	6d.	FILAMENT RESISTANCE DIALS	9 1/2d.	
EBONITE, cut to any size by machinery while you wait	per lb. 3/6	MIXED CRYSTALS (6 kinds)	9d.	AMALGO-PLASTIC METAL, for fixing crystals. No Woods metal necessary	6d.	
TELEPHONE TERMINALS, nuts and washer, each 1 1/2d.	per doz. 1/3	CARBORUNDUM	5 1/2d.	GOLD SEAL PLASTIC METAL, for fixing crystals	6d.	
W.O. TERMINALS, nuts and washers	per doz. 1/7	ZINCITE and BORNITE, both in box	1/-	IVORINE NAME-PLATES, all readings each	1d.	
PANEL BUSHES, drilled	each 1 1/2d.	COIL PLUGS, real ebonite	1/3, 10 1/2d., and 9 1/2d.	per doz.	9d.	
TOP CONDENSER, bushes	each 1/3	H.F. PLUG TYPE TRANSFORMER:		EARTH CLIPS, Copper, adjustable	each 5 1/2d.	
BOTTOM CONDENSER, bushes	each 1d.	1. 250 to 600 metres	3/9	RADIONETTE CRYSTAL SET, complete, stamped B.B.C. and including one pair 4,000 ohms 'phones, 100ft. 7/22 aerial wire, 4 insulators, lead-in tube, 6 yds. lead-in insulated wire and adjustable earth clip. Ready to listen-in. Honestly worth 3 gns. ...	36/6	
BELL WIRE, tinned copper, 12 yds.	6d.	2. 350 to 700 "	4/-	RADIONETTE ONE-VALVE L.F. AMPLIFIER for above	34/6	
SWITCH ARMS, 4 laminations, ebonite knob, complete with panel, bush, nuts, and spring washer.	8 1/2d.	3. 500 to 900 "	4/3	CABINETS, all sizes in stock.		
VALVE LEGS, nut and washer	each 1d.	4. 800 to 1350 "	5/6			
VALVE PINS, nut and washer	each 1d.	5. 1600 to 3200 "	5/9			
" " " " " " "	per doz. 10d.	6. 2200 to 5600 "	5/-			
" " " " " " "	per doz. 9d.	FILAMENT COMPLETE CIRCLE RESISTANCE SCALES, 0 to 300	each 6d.			
" " " " " " "	per doz. 9d.	EBONITE CONDENSER KNOB AND DIAL	1/9			
" " " " " " "	per doz. 9d.	SUPER QUALITY 2-WAY COIL HOLDER	5/3			
" " " " " " "	per doz. 9d.	REAL EBONITE 3-WAY COIL HOLDER	7/9			
" " " " " " "	per doz. 9d.	VALVE HOLDERS	each 1/3, 1/- and 9 1/2d.			

IMPORTANT NOTICE. In view of the enormous increase in our Mail Order business, we wish to inform our customers that all post orders are dealt with in strict rotation and at the earliest possible moment. Follow the crowd to Elkay Corner.

"ELKAY" WIRELESS CO.,

225 & 227, BISHOPSGATE, LONDON, E.C.2.
Open Saturday all day. (To the Trade—New Trade Counter now open. Send for NEW LIST.)
We open Sundays 11 to 2.30. Special Terms to Radio Clubs. Note new Telephone No.: Central 8544
PLEASE REMIT AMPLE POSTAGE.
SAVE MONEY BY STUDYING OUR ADVERTS.

AT YOUR SERVICE

By Test
The Best
Wireless
Advertising
Media

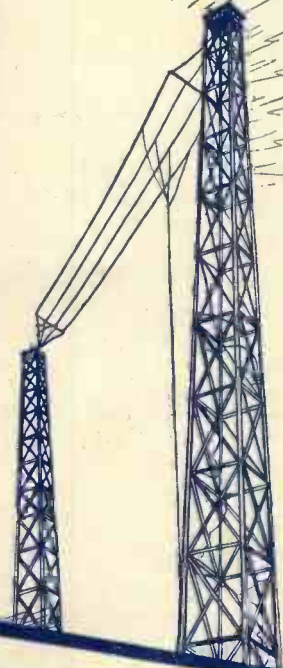

You
Must
Advertise
To Get Sales

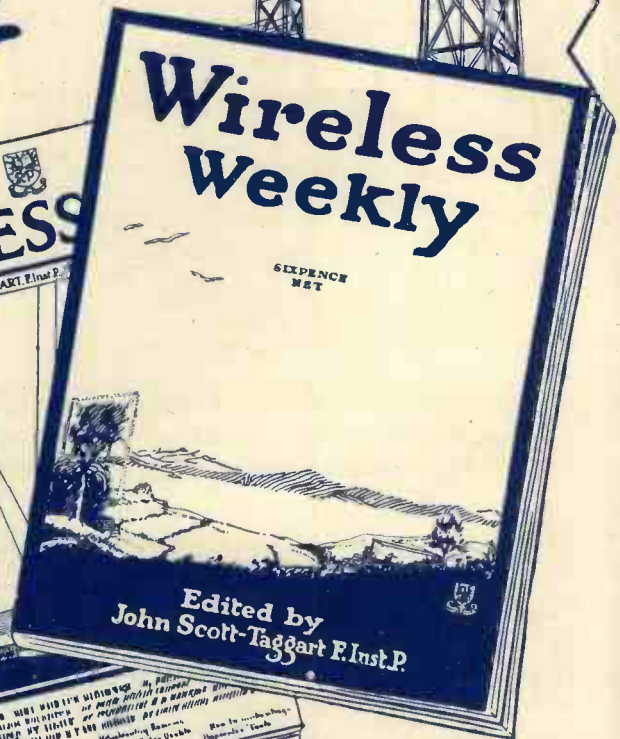
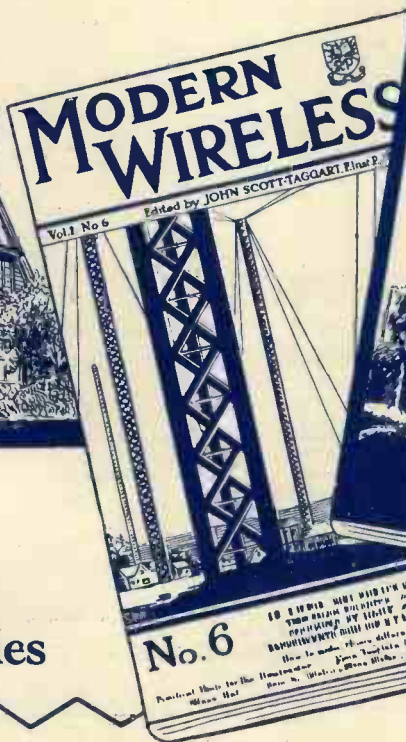

Seheff Publicity Organisation, Ltd.
125, Pall Mall, London, S.W.1.
Advertisement Managers for both papers.
Phone: Regent 2440.

STERLING

WHOLLY BRITISH
MANUFACTURE.

RADIO RECEIVING SETS

The Hall Mark of Quality.

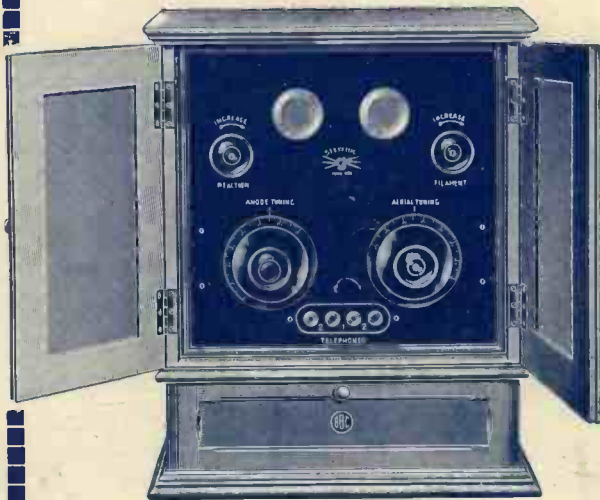

No. R 1588

“STERLING”

TWO-VALVE LONG RANGE RECEIVING SET.

With Anode Tuning and Reaction.

Although a range of only 100 miles is claimed, we possess evidence that this can be easily doubled, and under favourable conditions all British Broadcasting can be received.

Certain localities exist, termed “Blind Spots,” where reception of distant stations is very difficult; this Set, however, has been found to give good results even in such localities.

The first valve is a high frequency amplifier, and the second a detector; the Anode Circuits being coupled with a “Sterling” Anode Reaction Unit. Aerial tuning is accomplished with the “Sterling” Variometer provided; and anode tuning, with the “Sterling” Variable Air Condenser.

In highly finished Walnut Cabinet complete with two “D.E.R.” valves, one pair of No. R 1238 “Sterling” super quality Head Telephones (2,000 ohms), H.T. Battery in base and all connecting leads.

PRICE £22 : 0 : 0

B. B. C. TARIFF - - 17/6 extra.

No. R 2908 ACCUMULATOR, 2 volts, 40 amp. hours (actual) - - £1 : 6 : 0

Obtainable from all Electrical Dealers and Stores.

STERLING TELEPHONE & ELECTRIC Co., Ltd.,

Manufacturers of Telephones and Radio Apparatus, etc.

(WHOLESALE ONLY)

Telephone House, 210-212, TOTTENHAM COURT ROAD, LONDON, W.1.

Telephone : Museum 4144 (7 lines.)

Telegrams : “Cucunia, Wsdo, London.”

BIRMINGHAM :
150, Edmund Street.

CARDIFF :
10, Park Place.

MANCHESTER :
14, St. Peter's Square.

NEWCASTLE-ON-TYNE :
21, Mosley Street

WORKS :
Dagenham, Essex.

Wireless Weekly

and The Wireless Constructor

Vol. 2.
No. 15.

CONTENTS

Some Common Aerial
Faults.

A 3-Valve Receiver for all
Wavelengths.

The Dry Cell.

Radio Opera.

The Amateur's Part in Wireless
Development.

Jottings by the Way, Random
Technicalities, Broadcasting
News, Apparatus we have Tested,
Mainly about Valves, Corres-
pondence, Information Dept., etc.

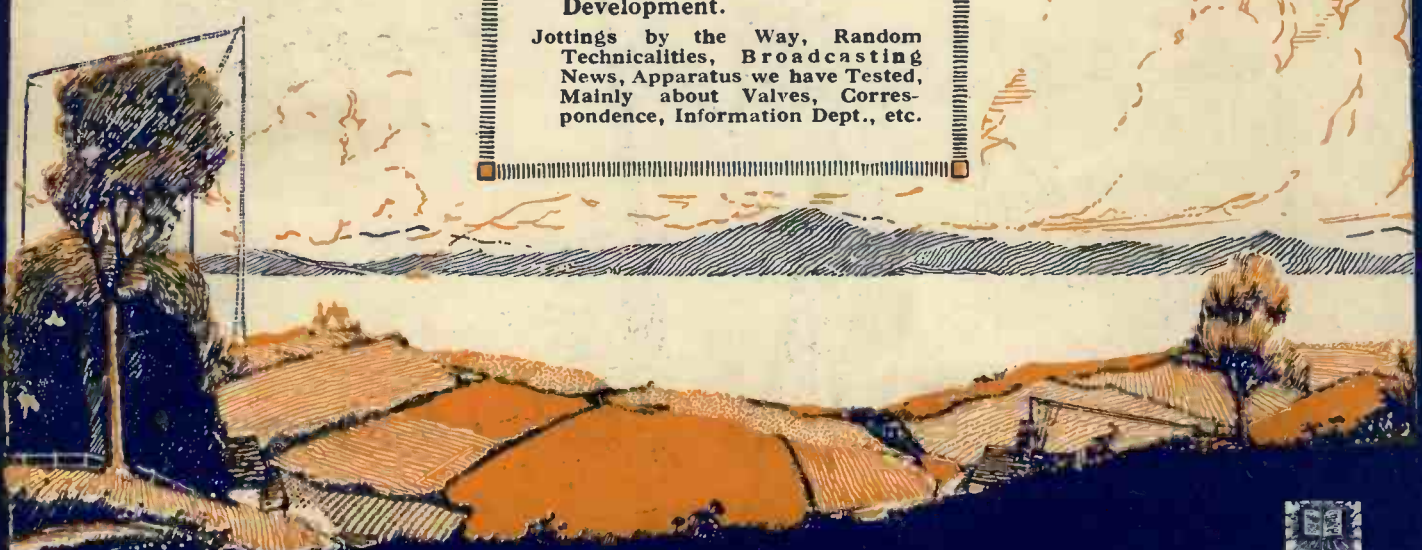

A Variometer-Crystal Unit.

AT YOUR SERVICE

By Test
The Best
Wireless
Advertising
Media

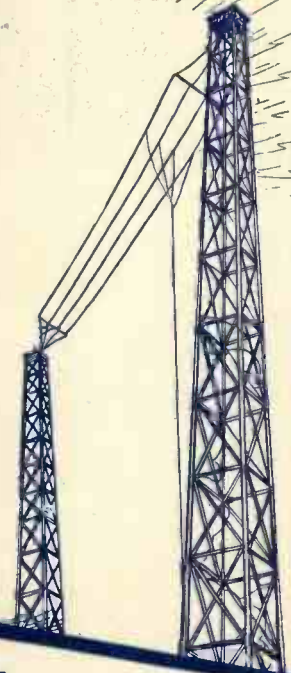

**YOU
MUST
ADVERTISE
IN BOTH**

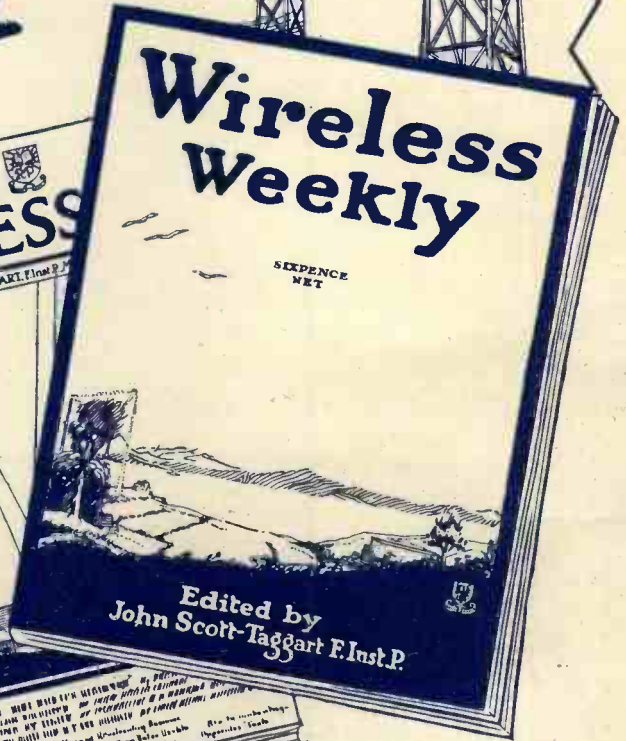
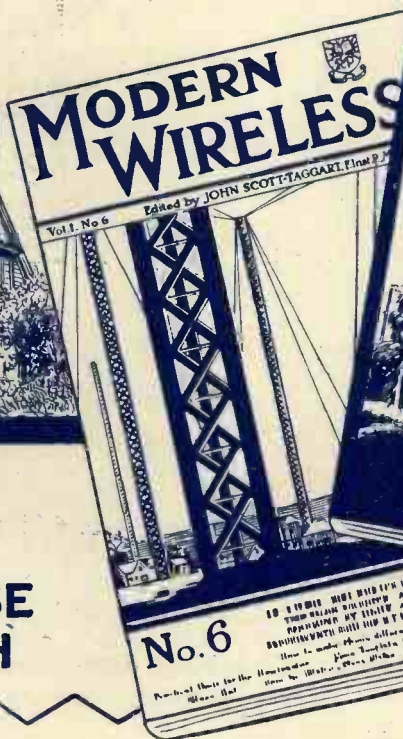

Scheff Publicity Organisation, Ltd.
125, Pall Mall, London, S.W.1.
Advertisement Managers for both papers.
Phone: Regent 2440.

Wireless Weekly

Vol. 2, No. 15
Oct. 24, 1923

CONTENTS

	Page
Editorial - - - - -	520
"Some Common Aerial Faults" - - - - -	521
"Wireless Weekly" Circuits—No. 28 - - - - -	524
A 3-Valve Receiver for all Wavelengths - - - - -	525
Jottings by the Way - - - - -	527
5IT - - - - -	528
The Amateur's Part in Wireless Development - - - - -	529
News of the Week - - - - -	532
Radio-opera - - - - -	533
The Dry Cell - - - - -	534
A Variometer-crystal Unit - - - - -	536
A Modern Marine Direction-finder - - - - -	538
Constructional Notes - - - - -	539
Broadcasting News - - - - -	542
Random Technicalities- - - - -	544
Mainly About Valves - - - - -	545
An Emergency Apparatus for Shipboard Use - - - - -	546
Apparatus We Have Tested - - - - -	547
Correspondence - - - - -	548
Radio Press Information Department - - - - -	549

Editor: JOHN SCOTT-TAGGART, F.Inst.P.
Assistant Editors { E. REDPATH.
P. W. HARRIS.

Radio Press, Ltd.

Publishers of Authoritative Wireless Literature
DEVEREUX COURT, STRAND, W.C.2
Tel.—Central 3763.

Advertisement Managers: { SCHEFF PUBLICITY ORGANIZATION,
LTD., 125, Pall Mall, London, S.W.1.
Tel.—Regent 2440.

Staff Editors:

E. H. CHAPMAN, M.A., D.Sc.
A. D. COWPER, M.Sc.
G. P. KENDALL, B.Sc.
R. W. HALLOWS, M.A.
S. G. RATTEE.

Scientific Adviser:
Prof. G. W. O. HOWE,
D.Sc., M.I.E.E.
Advisory Editors:
Prof. R. WHIDDINGTON,
M.A., D.Sc.
Prof. C. L. FORTESCUE,
M.A., N.I.E.E.

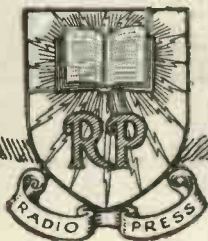

All correspondence relating to contributions is to be addressed to the Editor of "Wireless Weekly."

Nothing contained herein is to be regarded as permission or encouragement to infringe any patent rights.



The Radio Society and the Transmitters

IN our last issue we commended the action of the Radio Society of Great Britain in establishing a Transmitting and Relay section. This appeared to us a most desirable feature, and one which would make for the unity of control which we have consistently advocated.

Our independent and impartial attitude has obvious advantages in the consideration of these matters, and, during the past week, we have been looking carefully into this question, particularly with regard to the new section of the R.S.G.B. and the Radio Transmitters' Society, which, at present, are in direct competition.

We have taken steps to ascertain the views of both sides, and in the course of a visit which Captain Fraser, Chairman of the R.T.S., paid us, we learned that he, together with two other delegates from his Society, met representatives of the R.S.G.B. with a view to further discussion of the situation, but that their overtures were rejected. As a result, this Society, with a membership of about 100, feels that the door has been slammed in its face, and consequently that amalgamation with the parent Society is out of the question.

Discussing the matter with Mr. Hope-Jones, Chairman of the Radio Society of

Great Britain, who called upon us in response to our invitation, it appears that his Society, whilst deprecating the formation of a separate transmitting Society at a time when proposals were afoot to modify the constitution of the parent Society so as to make proper provision for transmitters, had, and still has, no intention of antagonising the members of the new Transmitters' Society, many of whom were already members of the parent Society.

Whatever the intention, the fact remains that a deadlock has arisen and, unless overcome, the new Society will lose the influence of the parent Society, whilst the latter will lose some advantage in not being able to speak with a single voice for *all* experimenters. We have sympathy with the members of the R.T.S. in their dissatisfaction with the parent Society as regards past interest, but the Radio Society is at present in the throes of reconstitution, and will emerge a very much stronger and more representative body.

A way out of the present difficulty should be found, and found immediately, in the best interests of experimental wireless, and we suggest that the discussion, which, it seems to us, was terminated too abruptly, should be reopened with a view to arranging an amalgamation, or, at least, an affiliation.

EXPERIMENTAL LICENCES

(Copy of letter received by us from the G.P.O.)

With further reference to your letter of the 4th inst., I am directed to inform you that the Postmaster-General has decided to adopt your suggestion concerning the conditions attached to new Experimental Receiving Licences.

As recently announced, any person who applies in future for an Experimental Receiving Licence will be asked to sign a declaration that he will not use his set for the reception of broadcast programmes except for experimental purposes. In accordance with the present decision, however, provision will be made on the new application forms for this declaration to be dispensed with, if the applicant prefers instead to pay a fee of 15s. a year in place of the normal fee of 10s. He will then be entitled to receive broadcast programmes for entertainment purposes.

Experimental Receiving Licences will, of course, only be issued to *bona fide* experimenters.

I am, Sir, Your obedient Servant,

(Signed) J. F. BROWN.

15th October, 1923.

"SOME COMMON AERIAL FAULTS"

By A. D. COWPER, M.Sc., A.I.C., Staff Editor.

How to erect the most efficient aerial in any given situation is a matter of prime importance to any experimenter.

IT is an interesting and instructive study to compare the probable efficiency of the many types of aerials, good, bad, and mainly indifferent, that are rapidly changing the skyline of the suburbs of any broadcasting centre—like the outgrowth of some epidemic, a kind of radio measles.

In the good old days, before broadcasting commenced, when "wireless was a pleasure" (I have the word of the worthy hon. secretary of a radio society for this), the erection of an aerial was a job for some fine week-end, to be approached with elaborate preparations and much figuring and silent prayer; now they spring up, like weeds in a tropical clearing, overnight. This is all to the good; even if only by supplying, for all the world to observe and learn, dreadful examples of how *not* to put up your aerial—i.e., if you are really going to use it for reception of reasonably loud signals, and not merely to be in the fashion!

Aerial faults can be roughly classified, for the practical purposes of the average town-dweller who has no choice of position, nor even of direction, generally under the heads of Material, Height, Isolation (including Spacing), Insulation, Lead-in, and Screening (where some choice of position is possible). Geographic position, directional effects (and even length of earth-lead), are generally outside the power of the amateur to control, so will not be discussed here.

Material

It is seldom, except for surreptitious and toy sets, that sufficiently stout and good-conducting wire is not used for the aerials; the 7/22's stranded wire that is almost standardised now is cheap and plentiful, and is scarcely worth improving on for ordinary reception. Iron wire, of course, is barred, and heavily insulated wire is out of place, not only on account of weight, but of possible electrical losses in the insulation. Certain specially insulated wire has been successfully used; and so long as

one resists the temptation to overlook *isolation* through over-confidence in good *insulation*, there is no reason to expect poor results with such wire.

If plain wire is used with a crystal receiver it should be of the heaviest gauge available, as there is no means of introducing negative reaction to wipe out its high-frequency resistance—which is a very different thing to the continuous-current resistance, being often four or five times as high, for short wavelengths. The American yarn about gold-plating the aerial wire to decrease the H.F. resistance is *a propos* here—and not so very unsound electrically, if it be so financially!

Height

There's the rub. Height is everything in an aerial. Hence the enormous and expensive mast-systems one sees in commercial stations. The amateur is generally very limited as to height, but he can at least make the best of whatever height he can get by reasonable pains and outlay; nevertheless, this very obvious point is the one most usually and most conspicuously neglected. By height is meant "effective height"—i.e., the height clear above the underlying surface of roofs, etc., which can, at any rate in wet weather, act effectively as an "earth." Thus a ten-foot pole above a lead roof or wet slates at the top of a four-storey building may give an effective height electrically of little over 10ft.; though, of course, it is very much better situated than a ten-foot high aerial in the backyard of that building.

Yet one sees many cases where the most magnificent possibilities in the way of effective height are apparently blindly ignored—e.g., where there is a lofty private house standing in its own grounds, with a beautiful high tree (with sturdy branches made for climbing) at the bottom of the garden, a convenient 60ft. or so away; and the aerial is a miserable narrow twin

affair of some 30ft. slung at a slope to a first-storey window. There may be some family history behind that aerial; electrically, it is a tragedy in one act.

Where some kind of a pole costs a mere nominal sum—and some guineas' worth of apparatus is tied to the other end of that wire—it seems absurd to limit the possibilities of effective reception to that kind of feeble scratching that passes muster for "wireless" in some suburban circles by deliberately sacrificing height, in securing the aerial to a nail in the window-frame and a fence-post in the garden, instead of throwing a weighted string over the roof-ridge, or, better still, between the chimney-pots; hauling up a light pulley to the highest point possible, and erecting a cheap pole in the garden for the further end. A long stick lashed to the top branch of a handy tree will give good height above most of the foliage, which, of course, is "earth."

In many cases a short pole has been erected on the roof; but then the height gained has been sacrificed by forgetting this "relative earth" difficulty—running the wire too close to the roof itself instead of away from the roof altogether, even at the sacrifice of some height for the further end. Often, too, where there is a stout pole available, the idea of a top-mast does not seem to have occurred to the owner, and one seldom sees the steeply slanting bowsprit or flag-pole kind of mast, which can be very simply fixed in an upstairs window, so as to gain several feet in height.

Isolation

A somewhat elusive principle, seldom given much consideration in the text-books. In ordinary electrical work, and in the elementary physics we may have learnt at school; it practically does not come in; and yet with these extraordinarily high-frequency radio currents it is of immense importance. Few people, unless they have worked with valves and small

frame aerials for weak telephany reception; have any idea of the most remarkable way in which these oscillations, at a frequency of some three-quarters of a million per second, seem to reach out, as it were, to surrounding objects—particularly conductors—over almost incredible distances, and include them effectively in their own sphere of action.

One has to be extremely respectful to high-frequency oscillations—to give them plenty of liberty and

well, accordingly, not to use more of that power than we can help in trying to warm up the rain-water gutters, stand-pipes, and other miscellaneous conductors about the roof and walls of our house by inducing currents in them with the tiny little bit of energy we have been able to pick up. Yet one of the commonest faults noticeable in aerials is just this point of poor isolation; no effort has been made, it seems, to treat the aerial, and particularly the lead-in, as if it had

of view of harmful capacity, much further away.

The ideal, of course, is a single high wire over a clear field, with lead-in straight down to a low wooden cabin. But we cannot all have this in the cities; there would not be any room for the operators.

Similar considerations show that in the case of double aerials, which for amateur reception are at best a poor compromise, the widest possible spacing is called for—not the miserable two or three feet very

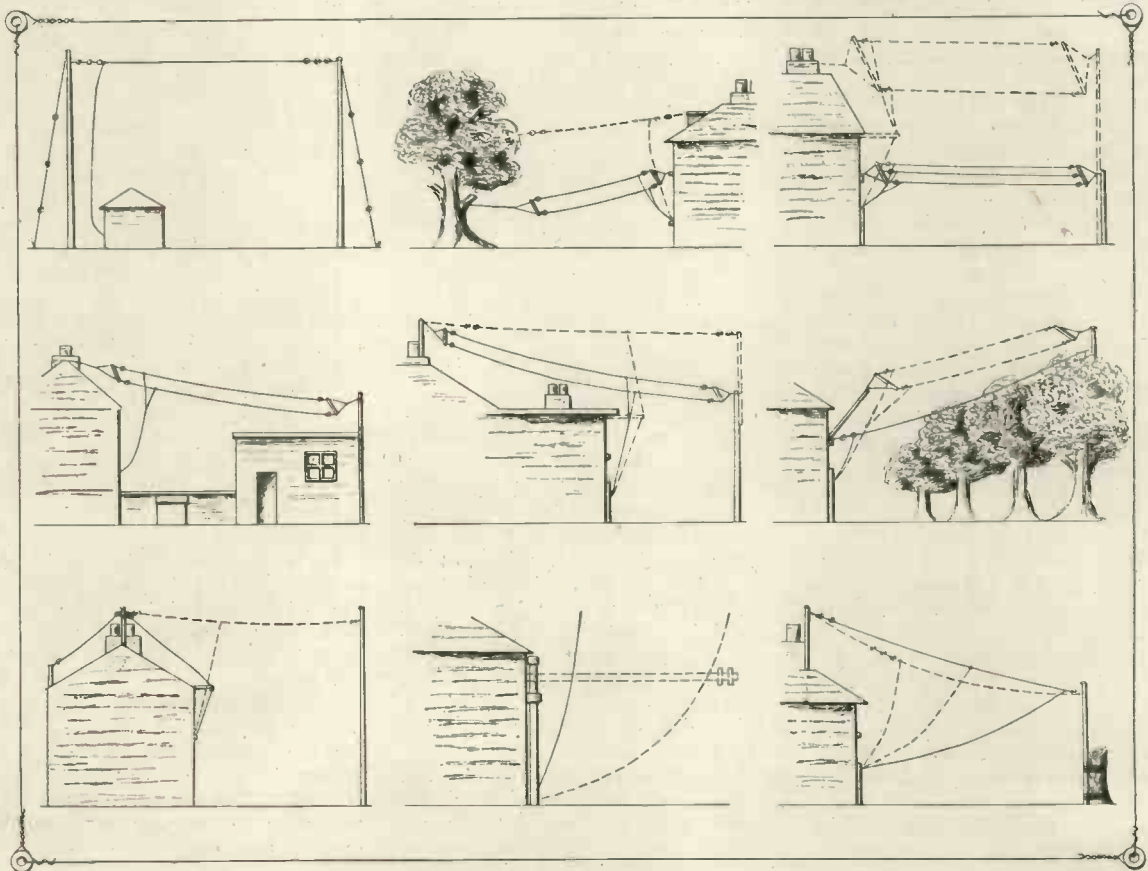

Some suggested aerial arrangements and improvements.

elbow-room, or trouble ensues. The classic instance of this is the case of an isolated brass terminal in a panel on a transmitting plant, which, although entirely disconnected and isolated, was found to have charred the ebonite in which it was seated simply by the heat developed through the high-frequency currents induced in it.

We have in radio reception, even when sitting, as it were, in the backyard of a very powerful transmitting station, an extremely small amount of power to draw on; it is

anything but some feeble telephonic low-frequency current in it. Hundreds of cases of this sort can be observed in a large town.

The best way to avoid this very certain source of poverty of signal-strength is to imagine that the wire has swollen to the size of a very large barrel, and to arrange room for it accordingly. Certainly no conductors or surfaces that can become conducting in rainy weather should be within at least a yard of most of the length of the aerial and lead-in; preferably, from the point

often seen. Two wires so close have, of course, less electrical resistance than one—even if another peculiarity of high-frequency currents is that they are so jealous, as it were, of any rival that they push themselves over uncomfortably to one side of the conductor, as various experiments show, and thereby increase the resistance of the wire carrying them—but two crowded wires do not pick up much more energy than one, and bring in more capacity, which should be avoided. The longest bamboo or

light hollow spar is none too long for spacers; one does not see 4ft. wide double aerials on ships that have to receive over hundreds of miles.

Insulation

This is a thing that is often overdone, if anything. One sees enormous strings of porcelain insulators, evidently purchased at a cut-price by the dozen, loading down the wires and sacrificing precious height. False analogy with elaborately insulated transmitting stations, employing thousands of volts electrical pressure in the aerials; is probably responsible for such cases. Two or three ordinary insulators in series—most in the halliard end in the case of a double aerial, with, say, one between the wires and spreader at each end—are ample. Since absolutely faultless reception in all weathers is not aimed at, the kind of insulators is of little moment.

Lead-in

This is the grave of most of that lost signal-strength. A lofty aerial of 7/22's wire. A lead-in of some mongrel flex draped over most of the available capacities and conductors, run in through a fancy insulator set in damp wood. A long wire run over small insulators and paralleled by the earth-lead for much of its path, close to a damp, conducting, earthed wall. For the earth-lead itself any odd scrap of thin wire, uninsulated, and just twisted round a distant tap. This is the kind of thing that is much too common. Yet it is bound to prevail unless it is at once realised that we are not dealing here with ordinary modest, well-behaved low-frequency or continuous currents; and that the aerial, lead-in, tuning inductance, and earth-lead are all parts of one electrical circuit.

As the strength of a chain is that of its weakest link, so the efficiency of this circuit may be dictated by the poorest portion of it—which is often the humble earth-lead. The barrel analogy is helpful here. If one imagines that the lead-in has swollen to at least 6ft. diameter, and as an extra help in carrying about 20 amperes of current at an electrical pressure of some thousands of volts (instead of a few

micro-amperes at a tenth of a volt or so), we may be inspired to handle it with that proper respect due to the peculiar nature of very high-frequency currents.

The thick wire lead-in, accordingly, should be brought, by the very shortest and most direct route, at as large an angle from the aerial as possible (up to 90 degrees, of course), either from the exact centre or exact end of the aerial; be kept at least a yard away from the wall down parallel to which it has to be brought—jutting spars fixed into the brickwork, with a couple of insulators at the end, ensure this in some very difficult cases of long leads-in; then brought squarely in through fair insulation (look out for rain here) through the thinnest part of the window or frame possible; and connected by the shortest possible thick cable suspended in mid-air well away from walls and ceiling, and especially any earth-lead and earthed metal, to the receiver. It is worth sacrificing much comfort to locate the receiver *near* the point of lead-in; long leads without special precautions can be taken for telephones or loud-speaker in a distant room from the receiver. Similarly, the earth-lead should be a thick cable (several No. 22's twisted together is good), as short as possible, at least lightly insulated, and going to as good as possible an electrical connection with the best earthing point available. A well-clamped, or, better still, soldered joint is called for. Most of the high resistance of many amateurs' aerials is found to be just here: at the earth connection. The earth should be a definite single point, hence the light insulation up to the actual earthing point; this gives sharper tuning. Most readers will have the usual water-pipe earth, so little remains to be said about this. Not many will attempt at this date to get a good "earth" in a flower-pot indoors, as in the story.

A few actual observations as to the effects of the common faults on actual signal strength will be relevant. With a fair double 40ft. P.M.G. aerial in a north-west suburb of London, with lead-in some 15ft. long within the house of twin lighting flex, passing through one partition and suspended a few inches

from wall and ceiling from small insulators—so there was no question of direct leakage, 2LO came in on an old-fashioned single-slider-tuner very weak; with good crystal, carefully set by a buzzer, ships were not heard at all; and only a murmur of one very noisy amateur well-known to all North Londoners. Eiffel was just audible. By simply moving the same receiver to the foot of the lead-in 2LO became easy to hear and enjoyable; ships were simply chatty; and the ether in general became a little alive. Eiffel wanted 30 degrees more condenser (0.001), but was much clearer.

By raising the same aerial a few feet, re-arranging the lead-in so as to avoid the gutter it paralleled (at 2ft.) for a little distance before, making the lead-in of nine strands of No. 28 (in default of 7/22's), with good short earth-lead soldered to a lead water-pipe—with a very hot iron and some patience—on a good tuner, 2LO fairly sings to one at the eat-dry-biscuits-and-still-hear-what-he-says stage on crystal alone.

The effect of size and height is well shown in some actual measurements of signal strength made on this improved aerial, and one erected, for comparison, roughly parallel to it, two-thirds of its height (and therefore much more badly screened), and only 30ft. long—a fair imitation of many new aerials seen. The actual measured signal-strength on a very uniform transmission (Press Bulletin, speech) from the local broadcasting station with a particularly efficient crystal tuner of exceedingly low resistance and self-capacity was nearly one-sixth (actually $41/230$) with the 30ft. low aerial, compared with the 40ft. double one. With a less efficient tuner, using parallel condenser to cover the range, the ratio was almost incredibly greater: $3/200$! This was due to the high value of condenser necessary to tune up to 369 metres with the small aerial and fixed tuning-coil. With a very good variometer the ratio was $14/210$: a sufficiently striking result. This illustrates very well, incidentally, some of the difficulties the maker of broadcast receivers has to face. He gets blamed for all the poor aerials his instrument is tried on, and it is not really always his fault that signals are poor.

The Period for Issue of Interim Licences has been Extended until October 31st.

"WIRELESS WEEKLY" CIRCUITS—No. 28

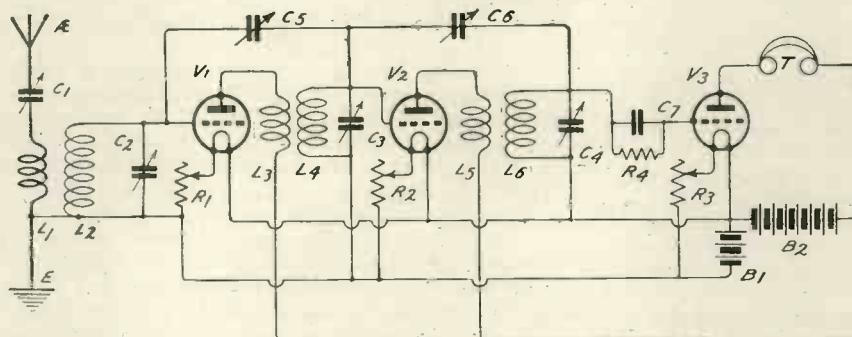

COMPONENTS REQUIRED

- L_1, L_2 } Fixed inductances.
- C_1 : Variable condenser of 0.001 μF .
- C_2, C_3, C_4 } Variable condensers of 0.0005 μF .
- C_5, C_6 } Vernier condensers.

- L_3, L_4, L_5, L_6 } H.F. intervalve transformers.

GENERAL NOTES

This is the neutrodyne circuit in which the capacities of the valves are balanced by the condensers C_5 and C_6 .

Sometimes the inductance L_1 consists of about 10 turns wound right over the coil L_2 , in which case the aerial condenser C_1 is omitted. The condensers C_5 and C_6 when once adjusted need not be varied. Usually, the coils L_3 and L_5 consist of fewer turns than their secondary coils, L_4 and L_6 .

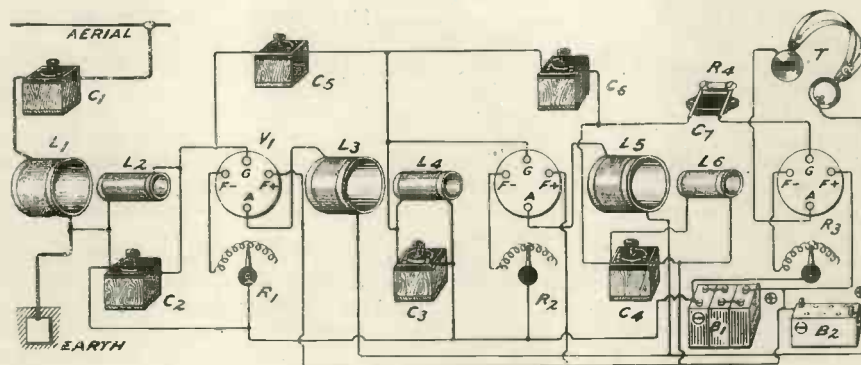

PRACTICAL WIRELESS NOTES—No. 10

VALVE HOLDERS

form such an essential part of the specification for most receiving sets that they are, in many cases, taken very much for granted. Some of the cheaper types of holder are made of poor material having a low insulation resistance. With a detecting valve mounted in a "leaky" holder, it

is of little use to introduce a grid-leak having a resistance of, say, 2 megohms, in an endeavour to control accurately the operation of a valve.

Of the two general types of valve holder, one having the brass sockets embedded in ebonite (or similar insulating material), and the other in which the sockets stand out, the former has the advantage of affording

protection against accidental short-circuit which is liable to occur in the case of the exposed socket.

In the case of a high-frequency valve, however, there is an appreciable capacity between the sockets of the former type of holder, due to the presence of the ebonite dielectric, and this is an undesirable feature, especially in short-wave reception.

A THREE-VALVE RECEIVER FOR ALL WAVELENGTHS

By H. E. DYSON.

The conclusion of a constructional article which began in our last issue.

(Concluded from Vol. 2, No. 14, page 494.)

THE aerial condenser now claims attention. The parts for this are now so cheap that few will care to make them. All parts required should be purchased at one time as a complete set. The capacity should be $0.001 \mu\text{F}$.

A similar but smaller condenser will be needed across the anode tuning coil; fifteen

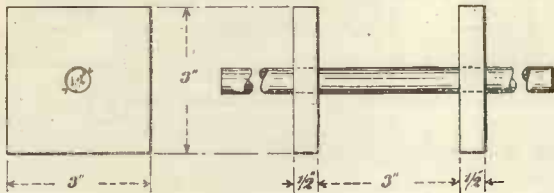

Fig. 6.—The bobbin for L.F. transformer.

plates will be sufficient for this. Several fixed condensers are needed. One of about $2 \mu\text{F}$ is useful across the high-tension battery.

The grid condenser and the condensers across the low-frequency transformer primary and the telephones have a mica dielectric 2 mils thick. The plates should be of thin copper foil, each one being 4 cms. long by 2 cms. wide. If they are assembled with mica between them so that the copper plates overlap 3 cms., the copper plates will project 1 cm. alternately at each end. These ends may be soldered together, which is almost impossible if tinfoil is used. The assembled condensers are to be clamped between $\frac{1}{8}$ in. ebonite plates. Three copper plates will be required for the grid condenser, and seven for the other two.

The gridleak will have to be adjusted to the best value on signals. It is formed by pencil lines on ebonite, in the following manner:—

Two terminals are mounted on a piece of ebonite one inch apart. Before screwing

these down a circle of lead is rubbed on the ebonite of a slightly larger diameter than the terminals chosen. Tinfoil washers are then put under the terminals so that they may make contact with the leaded surface without injuring it. After the set is otherwise completed these two circles of lead may be connected by pencil lines, lead being rubbed on or off until the best effect is obtained.

In making the low-frequency transformer no attempt should be made to make it as small as the commercial article. The coils of these are usually wound by special machinery which interwind a cross pattern of silk thread with the wire.

A bobbin is first constructed. Two hard wood ends are made (Fig. 6) and soaked in hot paraffin wax. They are then mounted on a core made of iron wire. About $1\frac{1}{2}$ lbs. of iron wire in 10 in. lengths will be required. It will be found possible to pack these with core wire until they are quite tight. The core wires are wrapped between the end pieces with five layers of either empire cloth

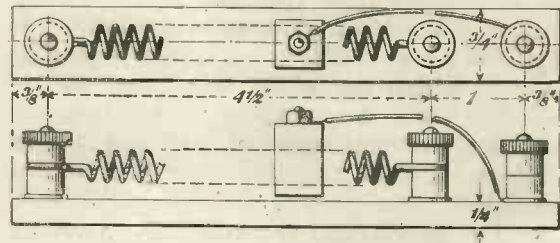

Fig. 7.—Details of the filament resistances.

or waxed paper. It is extremely important that this insulation should press right up against the wooden ends so that the windings cannot slip down and touch the core wires. The primary is wound with 4 oz. of No. 42 s.s.c. and the secondary with 4 oz. of No. 46 s.s.c.

Another five or six layers of waxed paper or empire cloth are put on between the primary and secondary windings, the same care being taken as in the first case that the insulation shall come to the ends. A few layers may be put on over the top of the secondary as a protection. The four ends of

minerals are mounted on a block of ebonite and the spirals are held by two of these. A springy brass or German silver clip is made to fit the spiral and attached by a flexible wire to the third terminal. Thus the resistance between the end terminals can be varied by moving the clip.

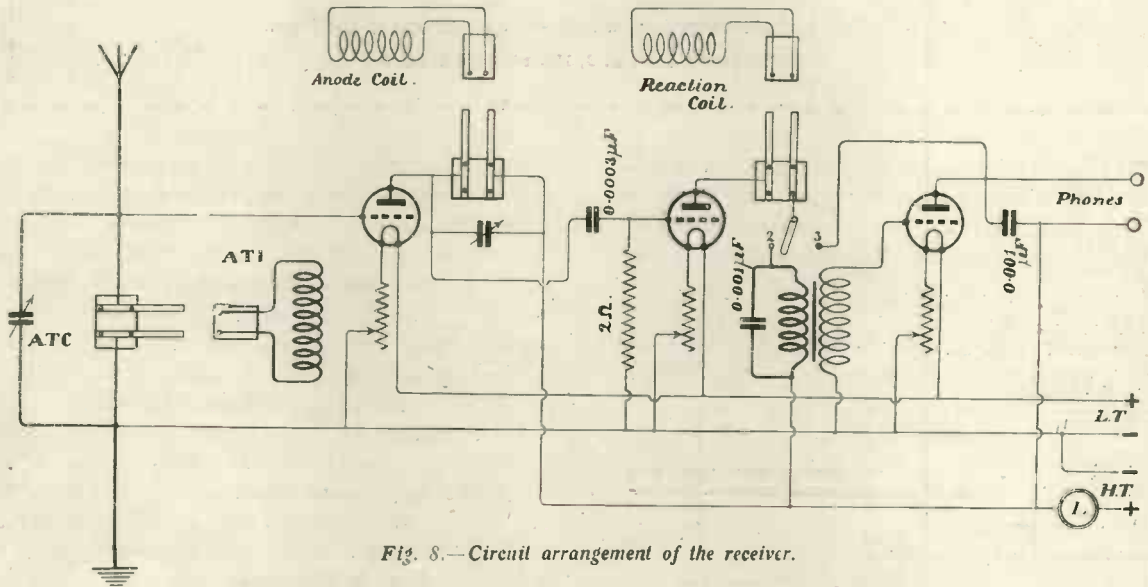

Fig. 8.—Circuit arrangement of the receiver.

the windings must be brought out through four separate holes in the wooden ends. It is advisable to solder together three or four strands to make the lead that comes through the end.

If the winding is done in a lathe care should be taken that the wire is not pulled tight during winding. It is best to wind rather slowly. Pieces of metal or fibre tube can be slipped over the core wires to keep them together when gripped in the lathe. If a lathe is not available wood supports may be made in which the whole thing may be revolved. After the winding is finished the core wires are bent round at each end so that they can be made to intermingle and form a closed iron circuit.

A filament rheostat for each valve is to be preferred. A very simple type may be made when it is once realised that continual adjustment is not required. Three spirals of 22 gauge bare resistance wire are made by winding tightly round a slate pencil for a distance of four inches. These are the separately mounted as shown in Fig. 7. When mounted they are stretched slightly, thus preventing adjacent turns from touching. Three ter-

If a 4 volt accumulator is used care should be taken that the whole of the filament resistance can be cut out when necessary.

A small flash lamp bulb should always

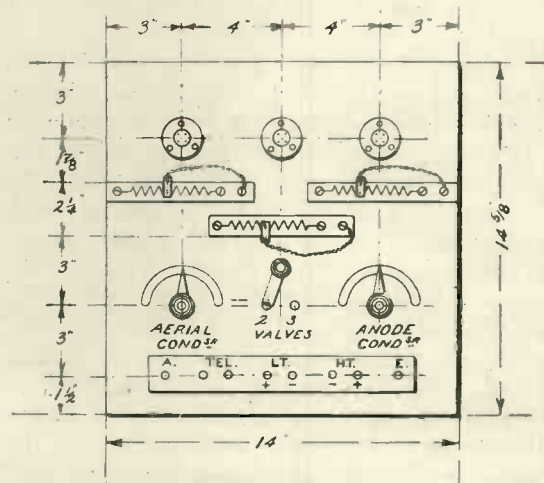

Fig. 9.—Details and dimensions of panel.

be placed at L (Fig. 8), as this will effectively prevent the high tension battery from burning out the valves in the event of an accidental short circuit and also save the battery.



The Radiolar Again

WE have already discussed the longbow-drawing propensities of the radiolar; in fact, we have had so much to say of the prevalence of the radiological inexactitude that I am almost afraid to preface the story I have to relate by telling you that it is a true one. Yet so it is, and even though your eyebrows automatically raise themselves on reading these words, I must ask you to believe me. What I have to tell is the true tale of a really beautiful lie—no mere fib, but a downright whacker of the first and purest water.

The story concerns my friend Borrow, whose name is one of those instances of perfect fits that one sometimes comes across. For Borrow has prehensile hands and an acquisitive nature, a combination that usually results, as it has done in his case, in the possession of a fine collection of wireless gear. A month or two ago he decided that the time was ripe for him to add his contribution to an already overloaded ether. In other words he made up his mind to join the band of those who criticise each other's gramophone records from the closing down of the broadcasting stations until midnight. The P.M.G. duly authorised his activities, allotting him a call-sign of which he was so intensely proud that he had it inscribed upon his visiting-cards. Borrowing on all sides with a freedom and a measure of success that easily beat all previous records, he soon assembled sufficient gadgets to make up a spark transmitter. This was merely a beginning. Higher flights were to follow later.

Wondrous Transmissions

He decided to start operations upon the following Wednesday. On the Sunday he wrote to friends in various parts of the country asking them to listen for him and to report. When the great evening came he started operations, in the presence of one or two of us, tapping out various inane messages. The aerial ammeter showed such a wondrous reading that his hopes ran high of being heard at vast distances. His only regret was that he had not written to a friend living at Stornoway. As his receiving set was not working, he could not obtain reports at once; but the next day he met one of the listeners at lunch in town.

"Well, how was it?" he queried anxiously, "did you get me all right?" "Rather," replied the friend; "you came in with an absolute roar. Don't quite like your note, though; sounds something like tearing calico." Borrow promised to see to this, and went off to 'phone to other friends. All reported perfect reception. One dwelling five score miles away declared that so strong were the signals that he had received them on a loud-speaker with three valves.

Sinful Pride

Borrow's happiness was complete. Nightly he transmitted and daily he had glowing encomiums of his strength and his clearness. He was in the seventh heaven of delight. But Nemesis, who ever lies in wait for those that are puffed up with unseemly pride, was preparing her bludgeon for the blow. She is a lady with a muscular arm, and when she

smites she usually does the thing in style.

It was on the Saturday of this eventful week that, finding a per condenser missing, I went up to Borrow's house in order to cast an eye round his den. This time he was guiltless, or, at any rate, the strayed gadget was not visible upon his crowded shelves. I sat therefore puffing at my pipe whilst he jiggled away with his tapping key. My eye chanced to fall upon a switch beneath the table which, though tightly closed, should obviously have been open. "Hello," I said; "what's this? Wouldn't it be better if you flicked this fellow up?"

Nemesis

He looked; he gasped. At first words failed him. Then in a small, strained voice he told me that that switch must have been in the same position the whole week, for he remembered putting it so whilst rigging the set up and he had not touched it since. His whole gear was directly shorted. Nothing that he had sent could have been audible a quarter of a mile away!

And what of the enthusiastic and obliging friends who had heard him at distances little short of miraculous? Ah, what? I would like to see their faces when Borrow meets them and tells them all about it. But it shows you, does it not, what wireless men *can* do when they want to help a pal?

Smiffkins Minds the Baby

Though it is admittedly a noble and uplifting pursuit, wireless may at times cause a fellow to stray from the narrow paths of virtue and so produce trouble. Such any-

how has been the experience of Smiffkins. The other evening the partner of his joys and sorrows announced her intention of faring forth to the cinema, and Smiffkins was left in sole charge of the baby with strict injunctions to listen for its faintest cry. The lady instructed him exactly how to thump its back, or turn it upside down, or whatever one does do to babies when an excess of high-tension in their tummies produces howling. With Smiffkins's stout assurances that he would sit with every sense on the alert, still ringing in her ears, she departed.

With no thought of evil Smiffkins straightway placed the 'phones upon his head and tuned in 2I.O. In a moment he was

sitting enraptured. A fluty tenor warbled about his lady love's locks; a baritone announced that he was a bold, bad fellow who preferred an outlaw's life to all others; the orchestra played a piece which bemoaned a lamentable scarcity of bananas. And so the evening passed in peace, harmony, and blue clouds of tobacco smoke.

The Sequel

At 10 p.m. Mrs. Smiffkins, on entering Acacia Terrace, was aware of shrieks and yells whose wavelength told her mother's heart that they could proceed from no other throat than that of her babe. A fine sprint, which had it been timed would probably have

broken the feminine record for the 80 yards, brought her to her door. Entering with a latch key she fled upstairs to find the child black in the face and broadcasting its woes with at least fifty horse-power in the airy yell. Having eventually induced it to close down, she descended to interview her spouse.

The light of battle burned in her eyes, but Smiffkins could not see it since he was bending over the set to make an adjustment. "Did you hear the baby?" she queried with suspicious sweetness. "Not a sound, m' dear. Slept like a lamb all the evening," said Smiffkins, still wearing the 'phones. And then the fur began to fly.

WIRELESS WAYFARER.



5IT

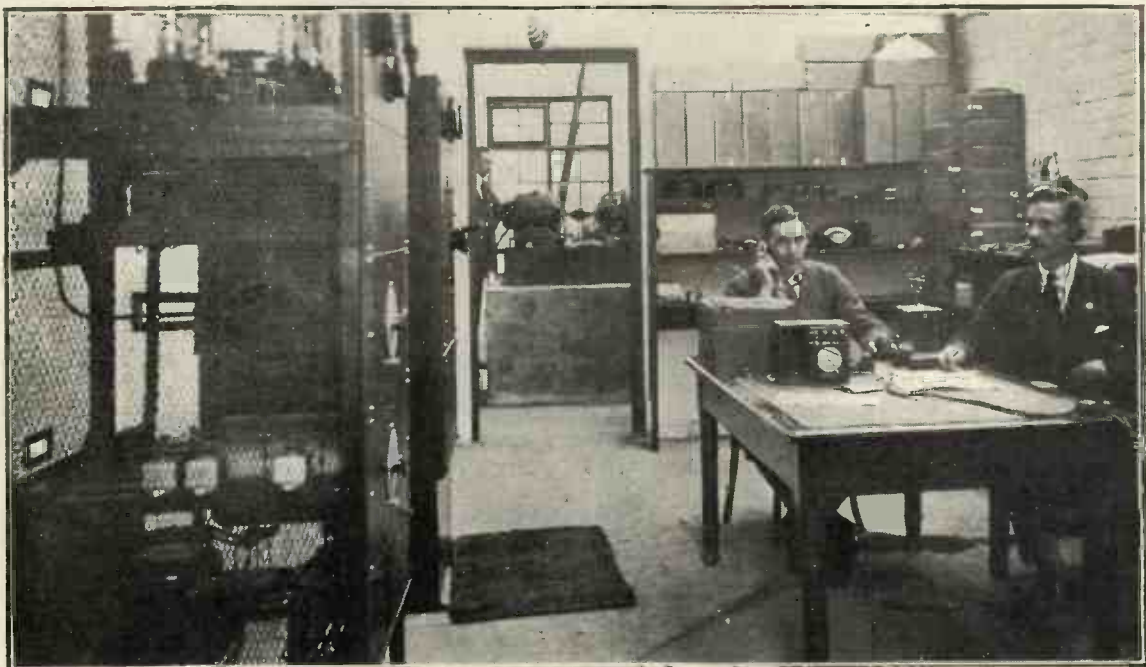

Our photograph shows the transmitting plant of the Birmingham Broadcasting station at the Summer Lane Power station of the Birmingham Corporation. The generator room is seen in the background.

THE AMATEUR'S PART IN WIRELESS DEVELOPMENT

By W. H. ECCLES, F.R.S., D.Sc.

The continuation of the Autumn Session Presidential Address to the Radio Society of Gt. Britain.

(Concluded from Vol. 2, No. 14, page 507.)

IT will be remembered that during the greater part of the year 1921 this Society was occupied with negotiations which extended into the various Government Departments using wireless, in the endeavour to obtain official sanction for the broadcasting of music and speech for half an hour on one evening a week, with an output of $\frac{1}{4}$ -kilowatt. This year of struggle culminated in the Wireless Society of London and its Affiliated Societies presenting to the Postmaster-General a formal petition on the subject, and, as a result, the small station at Writtle was permitted to start a limited programme. A few months later, broadcasting on a large scale was proposed by the commercial companies, and sympathetically considered by the Postmaster-General. It is not unreasonable, however, for the amateurs to claim that their previous presentation of the case smoothed the way for the inauguration of the British Broadcasting Company and its large scheme of eight powerful stations.

The incidence of broadcasting on the amateur world compels us to stop and take thought for the morrow. From what I have already said, we shall have to adopt as the policy of this Society the cry of "Freedom for experiment," for the patriotic reasons I have stated. To pass from the general to the particular, the change of the amateur position can be reviewed better this year than last, because now we have the experience of nearly a whole season's working, and can make some definite statement about the reactions which the broadcasting industry is sure to make on the amateur field. There are, of course, advantages and disadvantages. The advantages of broadcasting to amateurs include these: he can now test apparatus by listening-in to the broadcasting stations for long periods of each day, and can trust to their reliable wavelengths in a way that helps him in his calibrations very considerably; he can test telephones and other apparatus of that kind involving speech currents, because he can rely on the high

quality of the articulation which is present in the broadcasting waves, if they are properly received; and he can conclude quite safely that if speech or music is mangled by a piece of new apparatus it is his own fault, or perhaps I should say the fault of his apparatus. Leaving out the æsthetic benefits which the amateur or any other listener receives from broadcast matter, there are other advantages, social advantages, which I think we ought to admit. I think it is not an exaggeration to say that many a father who studied Morse in a laboratory has brought his apparatus down into the drawing-room, and is in a sense restored to the bosom of his family. (Laughter.) We may say that broadcasting has brought harmony into the home in more senses than one, and that many an errant spouse has been restored to the wireless widow, of whom we heard so much some years ago. Then there are other advantages, either social or national. There is, for instance, the fact that listeners who buy apparatus because they wish to hear concerts become lovers of their sets and soon become amateurs. The story of the motor cycle and the motor car is being repeated. I think most young men who bought motor cycles did not rest satisfied with riding them, but usually spent a little time, either willingly or unwillingly, taking them to pieces. In that way many a person who did not intend it became an accomplished motor mechanic. These are the advantages.

There are also disadvantages disclosed by the last season's working of the broadcasting stations, and I think I may quote from a letter which is typical of other letters that our Secretary receives, showing some of these disadvantages rather strongly. For instance, this letter says that the experimental-licence holder is now faced with the following problems. First, he can work only after broadcasting hours; next, he has a fixed wavelength to transmit on only; next, his letter says that the experimental transmitter

has to carry out experiments during the hours when other people are sleeping; next, he is open to be shot at by any possessor of a crystal set who tunes on to him by accident instead of tuning on to the broadcasting station; and next, he gets the full disadvantage of the spark transmission at 450 metres from ships, etc., which is entirely stopped during broadcasting hours, and, as a result, when the time for work comes this spark sending starts with terrific volume, and spoils at least a portion of the time the experimental-licence holder can devote to the work.

There are many other grievances. There is the one that Sunday also is barred to the amateur transmitter, and that therefore the only day on which the real amateur, who has to work on other things during the week, can use his apparatus is thus taken away from him. Still another disadvantage, which one experiences when close up to broadcasting stations, is that receiving sets intended for other work than listening to concerts become jammed; and, in fact, if you are near enough to a broadcasting station and are endeavouring to do laboratory experiments, you may find that near the wavelength of the station the calibration of a piece of apparatus for scientific purposes is almost impossible.

There is another side to this picture, which is the fact that the unskilled and inconsiderate experimenter often spoils the sport of those people around him who are anxious to listen to the concerts. The only thing one can say about that is that in wireless, as in all things, the injunction should be followed that "thou shalt love thy neighbour as thyself." This Society is doing all it can to help the authorities in curbing the inconsiderate and unreasonable experimenter.

The question which we have to face is "Will these disadvantages increase or diminish in the future?" If we try and see what the future contains, by looking at America, France, Germany, the Argentine

and other countries where broadcasting is in operation, we find that, sometimes in one country, and sometimes in another, there are commercial exchange prices being broadcast, Stock quotations, in some cases sporting and general news and racing results, and in other cases political orations in addition to entertainments. If broadcasting develops in this country from the entertainment or instructional side which it exhibits at the present time, and takes up all these items, it is quite possible that it will become as necessary to the community as the Press. If that is so, it may become even more influential than the Press, because hearing is very much easier to most people than reading, and because the voice carries personality. I have spoken to people in the United States who have listened to some of their great political orators over the broadcast, some of whom have had good voices and some of whom have had bad voices, and it is the fact that those with good voices made many converts and provoked much admiration, whilst those with bad voices had better have stayed away, for the sake of their political reputation. It seems that it is not so much what you say, but how you say it, that counts in politics; and for that reason wireless broadcasting will exert quite a different influence from what the Press does, if it is carried so far as to enable the politicians to harangue us in our own homes. It may come, therefore—it probably will come—that every large city and town will possess its own broadcasting station; it may have it in the town hall, and may rent it with the hall, and candidates and Members of Parliament could take it in their turns and all their speeches would be broadcast; and, for that matter, municipal elections may come to be conducted in the same way.

The idea that every large city and town may have its own broadcasting station some day is not so fantastic as would have been the suggestion in Caxton's days that some time or other every large city would have one printing press in it; and it is not so fantastic, by any means, as would have been the suggestion that at some day to come every person in a country, or nearly every person, would be able to read the printed word. Therefore we have to contemplate—we, as amateurs—this

possible expansion, and to think how we shall fare under it. If it is to come it will come quickly, because ten years of technical progress nowadays is really more than a century in Caxton's time. In future, too, the kind of programme may be very different, and the kind of programme will have a considerable effect upon relations between broadcasting as an industry or as part of social life, and the amateur. Up to the present the Broadcasting Company has maintained a very high standard, and has broadcast the highest class of music and very interesting and instructive litera-

ture. Perhaps the only interesting and instructive literature not yet broadcast is the Report of the Broadcasting Committee. The items are greatly appreciated by the present *clientèle*, but the future *clientèle* may be very different. It may be more numerous; if it is more numerous it will be more humble on the average. A foretaste of the kind of comment that will come when things too good for average life are put on the broadcast was given us the other day, when the British Association Presidential address was sent forth all over the country. According to some of the newspapers, the complaint in nearly every home was that there was too much Rutherford; but it is a fact, and we must admit it, that you cannot run a daily paper on choice extracts from the poets and essayists. Bach and Beethoven will not suit everybody. In fact, I can imagine that, rather than hear Bach and Beethoven, many people will prefer constant repetitions, with strong affirmation, of the fact that we have no bananas. King Demos may become less and less sympathetic with the experimenter the more and more broadcasting becomes like a popular daily paper, and it may be that in a few years we may find that the majority of users of the broadcast will be, we will say, something like that famous verse-maker

The experimental station of Mr. L. McMichael, Secretary to the Radio Society of Gl. Britain. Call-sign 2FG.

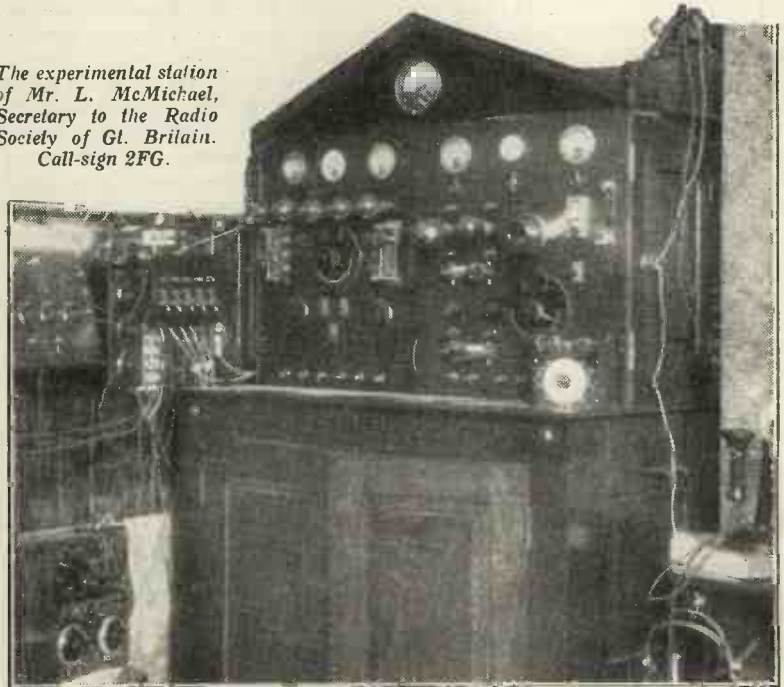

of about half a century ago, who said, if I may modify it a little—

“Let laws and learning, art and science die,
But give us jokes and jazz and lullaby.”

But the immediate future is more interesting than the remote future of ten years hence, and the prime interest we have is wrapped up with the Broadcasting Committee's Report. I had hoped that by this evening that Report would have been published and that I could have spoken freely about it—in support of it. It has been half published, and you will have seen that there are three main principles which have been suggested in it and which have been discussed pretty freely by

of about half a century ago, who said, if I may modify it a little—

“Let laws and learning, art and science die,
But give us jokes and jazz and lullaby.”

But the immediate future is more interesting than the remote future of ten years hence, and the prime interest we have is wrapped up with the Broadcasting Committee's Report. I had hoped that by this evening that Report would have been published and that I could have spoken freely about it—in support of it. It has been half published, and you will have seen that there are three main principles which have been suggested in it and which have been discussed pretty freely by

all the newspapers. The first main principle is, perhaps, that the licence fees collected from the listeners must pay for everything—for administration and for the concerts. The second principle, which has been disclosed already in the newspapers, is that the licence fee must be adjusted to support the authorities giving the broadcast services. And the third main principle which has been discussed in the papers is that there should be one licence for receiving apparatus of all kinds, and it has been suggested that it shall be ten shillings per annum. Now, I am not in a position to say that these are accurate forecasts or inaccurate, and besides that, we do not know that any of these will be adopted by the Postmaster-General, who is responsible, but I should like to say that if we assume that one licence has been recommended, and that the Postmaster-General accepts that recommendation, it is not fair for some amateurs to object, as they do, to the payment of the ten shillings. I have heard it stated by some vehement amateurs that it is wrong that they should be called upon to pay anything towards the authority that does the broadcasting when, in fact, they do not receive anything, being interested in quite different affairs; but I should like to point out to them that in the first place broadcast transmissions are useful for experiment. In the second place, an occasional concert will not do an amateur any harm; and in the third place 2d. per week is worth paying for the sake of peace and for the good of the cause in general. I hope that the suggestion, if the Postmaster-General adopts it, of a ten shilling licence fee per annum, will not cause any real trouble in amateur ranks.

There have been various newspaper forecasts of the Report, and I saw one in the *Times Engineering Supplement* for August 25th, which foreshadowed provisions for the multiplication of stations working as relays, so that it does seem imminent that more stations will be erected and more wavelengths will have to be allotted to these stations, and the question will arise before very long, what will become of the amateur transmitter; will he become extinct? I think it will depend on the record he can show of the services rendered, directly or indirectly, but probably indirectly, to the whole community; and it will depend also

upon the influence he can bring to bear on public opinion. At present his numbers are very small compared with the estimates of the numbers of those who listen in. He is in the proportion, perhaps, of only 1 in 2,000, and in a democratic country noses must be counted, and an insignificant number may come to be ignored, even though they may be the salt of the earth. Now, it cannot be for the good of wireless in general that non-commercial wireless experimenters should be barred from the study of any branch whatever of wireless. Therefore I think it is the duty of all amateurs—it ought to be part of the whole amateur movement—to work together so as to get a fair hearing when the freedom of experiment is endangered in any section whatever. If we take things on that basis, if we suppose that the whole of the amateurs will stand by their brothers who happen to be in the section that is threatened at any particular juncture, then we can say that we have a much greater claim for consideration than if the transmitters try to act alone. The ratio of amateurs to broadcast listeners is probably something like 1 in 5. It may increase if, as I have suggested, men with broadcasting sets become interested in their apparatus, but that is a substantial minority. We live, too, not in a hard and fast democracy where the only way of settling the question is by the counting of votes, but we live in what one might call a mitigated democracy where the rights of minorities are studied and protected by statesmen and administrators, and where great weight is given to minority views if they are shown to be important to the progress of the nation. This has happened in the past in other things than wireless, and it has happened now and again in wireless. The Post Office have always listened sympathetically to every case made out before them, even when that case affected only a small minority of the users of wireless, and have taken into account every consideration put before them.

Probably the most immediate problem that the amateurs have to think about is the allocation of the wave bands. The increase in the number of broadcasting stations will demand that an increased wave band shall be set aside for broadcasting. It follows that there will be less space left in the spectrum for the amateur, and we, as ama-

teurs, ought to take on the whole problem of preparing a case to be put before the authorities, whenever they require to hear us, in order that we may set forth our views and put them in proper form for exerting due weight. It is conceivable that in default of some such preparation on the part of the amateur fraternity, the allocation of wavelengths to them for their use in transmission experiments may be too narrow or even nil.

In what I said earlier I pointed out that wireless telegraphy was originated by amateurs who were neither engineers nor telegraphists, and that wireless development since then has owed as much at least to the amateur experimenter as to the trained technician. But it is not alone on these rather obvious grounds that I would base the argument that the pursuit of wireless as a hobby and a study is a national weal, for there are two important national aspects not yet alluded to which must not be forgotten. There is, firstly, the direct educational benefit to the individual; of which no more need be said than that wireless, I think, is the best gateway to many branches of physical science, for it touches upon some of the more advanced regions of electricity and magnetism, upon acoustics and radiation, and it teaches skill in the manipulation of a great variety of apparatus as well as in a special technique. The second and less obvious national advantage arises from the fact that the cultivation of any branch of learning, artistic or scientific, and the universal practice of any technique as a hobby, has a profound influence upon the development of the corresponding industry.

Moreover, the presence of a large amateur wireless section in a population ensures that that community will be receptive to new ideas in wireless and produces an environment in which the highest form of technician can flourish. As a consequence, men of special ability are afforded adequate scope, and genius is discovered and given its opportunity. When it is remembered that one inventor or genius, like James Watt, may be worth untold millions to the world, we feel the importance of encouraging to the utmost the spread of the amateur spirit in wireless as in other branches of our modern electrical civilisation.



READERS will be interested to hear that a Radio Society has been formed in Dublin calling itself the Radio Association of Ireland. Professor W. J. Lyons has been elected President, whilst Messrs. A. Callan and H. Hodgens are Hon. Treasurer and Hon. Sec. respectively. Readers interested in this Association should address their enquiries to the Secretary, Wireless Department, Technical Institute, Kevin Street, Dublin.

We learn with interest that Dr. B. Hodgson, O.B.E., M.Sc., Ph.D., F.Inst.P., late of H.M. Signal Experimental Establishment, is now engaged in the Research Laboratory of the Mullard Radio Valve Co., Ltd.

We are given to understand from Reuter's News Agency that the Ministry of Posts, Berlin, will during this month inaugurate broadcasting from the wireless station at Koenigs-Wusterhausen. Concerts, lectures and stories will be broadcast daily to subscribers, who will pay a fee of twenty-five gold marks annually.

Mr. H. W. Soase, of Darlington, reports that he heard from a distance of six thousand miles on the night of September 2nd a broadcasting service at the Grace Presbyterian Church, Calgary. This is believed to be a record for Canadian long-distance broadcasting. Readers will perhaps remember that a full description of the Calgary broadcasting station was given in this journal in the issue of July 25th.

We read in the *Hull Daily News* that loud-speakers are to be installed in every drawing-room of a block of flats which it is proposed to build a few miles outside London.

From the same source we learn that when the escape of two American convicts was broadcast two amateurs receiving the news relayed it to the police two hours before the last-named were informed of the escape officially.

In order to continue the various experiments recently undertaken to determine the exact value of radio communication in mine operation and rescue work, the United States Department of the Interior is making extensive preparations at the Government Experimental coal mine at Bruceton, Pennsylvania. Experiments so far prove that transmitting can be carried on using short wavelengths through fifty feet of coal strata, and it is believed that with a longer wavelength than has so far been used the signals can be transmitted to even greater depths.

Among the engagements of M. Masaryk, President of the Czechoslovakian Republic, in Paris recently, was a visit, in company with M. Millerand, the French President, to the powerful wireless station at Saint Assise. To mark the occasion, M. Millerand radiated a message of greeting to French Allies and friends throughout the world in the following terms:—

"In visiting, with His Excellency the President of the Czechoslovakian Republic, the great wireless centre of Saint Assise, the

President of the French Republic is happy to address to all Allied nations and friends of France, and in particular to the noble Czechoslovakian nation, an expression of the profound sympathy and unshakable friendship of the French Government and people.

"The wireless centre of Saint Assise places France in direct radiotelegraphic communication with all parts of the world, and the President of the French Republic expresses the hope that the waves radiated by Saint Assise may always be messages of peace and a medium for fraternal collaboration between all peoples."

Still another Radio Society has been formed, the latest bearing the name of the Abertillery County School Radio Society. Those readers who are interested should make application to the Hon. Sec., Mr. Benjamin H. Jones, Bryn Brith, Aberbeeg, Mon.

A B.B.C. correspondent states in the following words how wireless usefully serves the farmer:—

"Owing to the wet weather recently it has been very difficult to get the crops harvested in good condition. I had some valuable crops of garden seed peas, and mangold and wurzel seed, which I had decided to leave in the field one more day before carting them, but upon hearing from the broadcasting station that rain was expected in the evening of the following day, I arranged to start harvesting these crops at 7 a.m. on the following morning, and just managed doing so when the rain came on in the evening.

"I think in the near future a receiving set will be part of the stock-in-trade of every progressive farmer, as well as the telephone and other aids to business."

RADIO-OPERA

By H. E. ADSHEAD, B.A.

The following notes are of particular interest to those readers who wish to enjoy fully the broadcasting of opera.

WITH the advent of Radio-opera it is safe to say that this class of music will reach a large audience at present unfamiliar with it.

Many books attempt to set out a synopsis of the plots and chief arias (in opera one does not say "songs"), but the English books are mostly poor. Those who can read German have a much better field open to them. Perhaps the best English one is the H.M.V. "Opera at Home," but as this confines itself to the company's own gramophone records, the Wagner operas and some others are inadequately done.

Another small book is "Opera Synopses" (by McSpadden; Harrap & Co.). This is well got up and gives the stories of sixty-four operas, but there is not the slightest reference to the music. A much better book than these is the German "Führer durch die Opern" (Melitz; Globus Verlag, Berlin). In each description of the 220 operas the names of the chief arias, duets, trios, etc., are given as they occur. Biographical notes, etc., complete the pocket volume. A companion volume, "Führer durch die Opern Musik" (Chopin), specialises in the music and gives 450 short examples in music type, in the text.

Books of the words, usually called librettos, can be obtained from the various publishers, such as Ricordi. Some are issued in two languages, English translation on one page and the original language opposite. In Wagner's operas the music is built up from a number of "motives," each reserved to express a certain idea, such as Sword motive, Curse motive, Valhalla motive, etc. These are not printed in the English librettos, but in Germany both Schott & Co. and Breitkopf and Härtel have librettos with the names of the motives (Ausgabe mit Motiven) printed all down the margin and, at the end, the same set up in music type. The former edition is in German letters, the latter in English (Latin) characters.

Single pianoforte selections from the scores of many operas with words, motives, and comments are issued in a cheap edition called "Musik für Alle" (Ullstein Verlag, Berlin).

Before very long the listener-in will catch the disease; every opera-goer gets it eventually; he will become a Wagnerite. Perhaps he will even write threatening letters to 2LO about those interpellations—though personally I do not think they do any harm. When that time comes there are four excellent little volumes awaiting him by Alice Cleather and Basil Crump (publishers, Methuen), entitled "The Ring of the Niebelung," "Tannhäuser and the Meistersingers," "Lohengrin and Parsifal," "Tristan and Isolde," which contain the stories of the operas, the leading motives, and other comments.

The Radio-listener has one advantage over his Covent Garden brother—he can spread out on the table an array of music, words, and motives before him which he can follow and so make a good study of the opera.

There is a demand in England to have the operas rendered in English, and this may do very well for a start, but an opera should be sung in its own language. It is impossible to make a cultivated translation and fit the meaning and accents on to the right words. A Continental friend of mine says English is an impossible language anyway. Further, he advised me not to buy operatic arias recorded by concert singers, as, never having acted in the opera, they have not the atmosphere and they don't sing them properly. I pass this tip on for what it is worth.

For those readers who are interested in concert hall programmes, I will conclude by mentioning another German volume in the above series: "Führer durch die Konzert Musik" (Burkhardt), which deals with 1,500 works by 114 composers on analogous lines to "Führer durch die Opern Musik," and is an excellent little work with, I believe, no counterpart in English.

THE DRY CELL

By GEORGE SUTTON, A.M.I.E.E.

An interesting article describing the manufacture of dry cells for high-tension supply and other purposes.

WE had occasion recently to point out that wireless practice could not exist without wire, and now we propose to consider the second great requirement, which, if not quite so indispensable, would at least entail very great difficulty to do without. We mean the dry cell, which we use on the high-tension side of our valve apparatus. The crystal set may also often be enormously improved by a good dry cell and a potentiometer.

Manufacturers of the modern dry cell have spent considerable time and money in experimental work with a view to producing a really reliable cell. It has been found that the secret lies in the use of ingredients of the highest quality, and in a modern works all materials used in the process of manufacture are subjected to the most rigorous mechanical, chemical, and electrical tests by experts.

All materials which fail to come

in quality between samples but a very big difference over the range. Every package of this material entering the works has some of its contents tested by qualified chemists, and should this fail to come up to the standard the whole consignment is rejected.

Beginning at the middle of the dry cell. The centre element is a carbon rod. The best carbon for this purpose is that which clings round the sides of the gas retorts



Fig. 1.—A view of the general assembling room at Messrs. Siemens, Ltd.

The writer has had an opportunity of visiting one of the largest dry battery factories in this country, and one whose productions are known all over the world. His own experience of dry cells, extending over some thirty years of their use, since they first began to threaten, and then eventually to supersede to a great extent, the wet Leclanché pattern, has enabled him to compare every well-known dry cell on the market. There is no doubt that the modern product is a great advance upon the earlier type of cell.

up to the required standard are rejected.

We should perhaps be more popular with the Editor if we started off by describing how dry cells can be made at home with the contents of the dustbin and a few odds and ends of roofing zinc, but our counsel to those who contemplate making their own dry cells is like that of *Punch*, namely, *Don't do it*.

To give one reason alone: The peroxide of manganese, the active "depolarising" material, is mined and marketed in innumerable grades, with very slight differences

when coal is coked, and this is also a particularly hard variety. This carbon is fed into a machine with heavy iron champing jaws and is literally "chewed up" into smaller pieces, round about walnut size. These are then shovelled into the pan of a rolling mill such as one may often see mixing mortar for house-building. From there it is ground up even finer between polished steel horizontal rollers, and as the ingredients for "binding" the material are now beginning to be incorporated, the rollers are kept hot by steam circulating inside

them. Liquid as well as solid binders are used, and the whole black mass is kneaded into a paste, which paste is made up into cylinders about five inches in diameter and nine inches long. These are put into the container of a hydraulic press, and, still hot, the material is squirted through dies, which give it the shape of section in which it is eventually used.

After extrusion, the rods or plates are bricked up in a kiln, where they are baked for a week or ten days, and upon taking out they are nearly as hard as the original gas retort carbon, but of a shape which the battery maker requires. Before baking, however, the thicker rods are drilled up the centre for the insertion of the brass screw which forms part of the positive terminal. This drilled hole is "undercut," so that when the brass screw is inserted and the type metal mixture is poured in round it, this mixture swells as it cools and tightens in the hole, and then a tapped washer is screwed down on to the top of the carbon, making assurance doubly sure as regards a firm electrical contact.

The manganese dioxide is supplied in powdered form to a specified fineness of grain and oxygen content, and after being tested and approved by the chemist is mixed with some of the powdered carbon or graphite, and forms the depolarising compound of the cell.

At another part of the factory the zinc containers are being made, and a comparison of the thickness of the zinc sheet used by various cell makers will give one method of comparison; a thin zinc will soon be eaten through.

The quality of the zinc is also a matter of great importance, and the chemist is very vigilant to see that no foreign matter is likely to cause minute "local couples" in the cell and run its energy to waste. In the early days of dry cells a piece of crock or glass was placed at the bottom of the zinc container to prevent the carbon rod accidentally short-circuiting to the zinc, but nowadays the matter is handled much more scientifically.

Into the prepared zinc container a block of the depolariser is placed, and about one-eighth of an inch is left all round into which is poured

the exciting paste, the active ingredient of which is sal-ammoniac. This paste never dries hard, but sets to a cheesy consistency, and rises all round the block to a little below the level of the top. Into the space thus left is run a little ring of melted ozokerite, which seals in the paste. Now, a cotton gauze disc or diaphragm is dropped on to the top of the cell. Next a thin layer of rice husks to form an air space for the gases to collect in, then a diaphragm of paper, and last of all a complete sealing-in between the edge of the zinc container and the terminal, with melted pitch having two little vent holes left to allow any gas formed to escape.

We have described the construction of the dry cell in some detail, and the varying sizes and shapes only differ in that way and not in quality of material or care in manufacture. The skilled testing does not cease upon the material enter-

ing athlete gives out, not only through primary muscular fatigue and the general distress of imperfect oxygenating of the blood, but by the poison he himself secretes at too great a rate to dissipate as he goes along. Like the athlete, too, the cell will recuperate after a rest. As a rough and ready figure of the safe available current which may be taken without the cell polarising, one milliampere per cubic inch of depolarising compound is suggested.

The cell will put out this current contentedly day and night without ceasing till it has used up all its energy in the least internally wasteful way. A great deal more current than this may be demanded of the cell if it is called for intermittently.

It is well known that the E.M.F. which a new dry cell will give is 1.5 volt, and nearly all calculations are based upon this figure. A glance at the diagram in Fig. 2 will indicate the fallacy of taking such a figure as a basis upon which to calculate the total output of a cell. If we plot out the life of a cell at a normal output in days, on a horizontal line, and the voltages indicated during that life in vertical lines, we shall get a characteristic curve like that at the top of the figure.

The area enclosed by the figure A.O.H. may be considered to represent the amount of energy the cell has delivered, if we assume that the intermittent current output is a normal one, and could be replaced for the purposes of this chart by a smaller continuously delivered one.

In the first ten days the voltage has dropped to 1.2, but the figure A.O.B.C. is only about one-seventh of the whole figure A.O.H. We cannot, however, get much useful work out of the battery after it has fallen below 0.6 of a volt, so if we discard it at the point G we shall have about 100 units of work on the scale which we have adopted, of which the figure A.O.B.C. has enclosed fifteen units.

From the shape of the curve in Fig. 2 it will be clear that if a battery is required to give a certain specific voltage, the number of cells to be employed should be calculated on the basis of one volt per cell, and not 1.5 volt per cell.

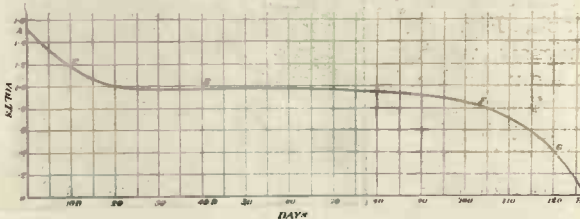

Fig. 2.—Curve showing fall in voltage of a Siemens dry cell in relation to time.

ing the factory. Every stage has its test, and every cell, however small, is given an electrical test so stringent as to find out any weak ones, which are ruthlessly scrapped. High-tension batteries are mounted in a solid block of paraffin wax, the cardboard cases, also impregnated with wax, serving as a mould for the wax rather than as a container for so many dry cells.

This ensures a maximum of insulation between the units of the battery as well as insulating the whole battery from earth leakage and the telephone noises which would inevitably result from such leakage. The sawdust packing between the cells of some makers has not nearly so good an effect as paraffin wax.

If any dry cell is compelled to put out an amount of current in excess of what is known to be its safe rating, it soon gets exhausted, much in the same way as a perspir-

THE instrument described in this article is the result of an attempt to design an appliance which should combine the functions of a number of separate instruments. First and foremost, it is a crystal receiver of neat appearance and good performance, with an efficient but simple variometer for tuning. Its other uses are these: by connecting two of its terminals in the plate circuit of a high-frequency valve it becomes an anode tuning unit with a crystal detector, while by adding an external buzzer and dry cell it is converted into a simple wavemeter for the broadcast wavelengths. Incidentally, it can be connected into any circuit so that its variometer will provide the tuning for that circuit, and hence it may be regarded as a makeshift tuner.

These alternatives are made possible by the use of the six terminals visible in the photograph, Fig. 1, and the Dubilier condenser which can be seen attached to the underside of the panel, Fig. 2. The actual methods of using the unit in the various ways mentioned will be considered later, and we will now proceed to its construction.

The variometer must claim our attention first. It consists of two concentric basket coils, one attached to the panel and the other (the inner one) carried upon a spindle so that it can be revolved. Each coil has 40 turns of No. 28 double cotton-covered wire, and is wound upon the double-basket principal described recently in *Constructional Notes*. Since the spindle has to pass through the holes in the coils which were occupied by the spokes of the spider during winding, it is important that spokes of a suitable size be employed, so that the spindle may be of a fairly substantial diameter. If the spokes are cut from $\frac{3}{16}$ in. round brass rod a convenient pair of coils can be made.

After winding on the first 40 turns representing the inner coil, the wire should be cut and the end tied with thread to the turns beneath. Then wind on a further 15 or 20 turns



Fig. 1.—The complete receiver.

(actually about $\frac{1}{16}$ of an inch of winding is required), and cut the wire once more, but do not secure the end. Over this wind the 40 turns forming the outer coil, and tie in its two ends as before.

The coils can now be shellacked and baked, after which the spokes are to be pulled out and the coils separated from each other. If this operation proves difficult, find the outer and inner ends of the 20-turn winding and pull out a few turns. The intermediate winding, by the way, is intended solely for the purpose of ensuring that the inner diameter of the outside coil shall be larger than the outer diameter of the inside coil by an amount sufficient to enable the inner coil to revolve freely. A clearance of about $\frac{3}{16}$ in. is necessary, since the mounting of the inner coil on its spindle is slightly

A VARIOMETER

By G. P. KENDA

In the following article are given... being a crystal receiver, may also...

eccentric as a result of the fact that a basket coil spider necessarily has an odd number of spokes.

After baking, the coils should be bound with adhesive insulating tape, taking care, however, to leave exposed a hole at either side of each for the spindle.

The larger coil is attached to the underside of the panel by two small angle brackets of strip brass. The base of each bracket is screwed to the panel, and the coil is attached by binding firmly with waxed thread to the upright part of the bracket. The brackets should be made from strip $\frac{1}{4}$ in. wide and $\frac{1}{32}$ in. thick, and they should stand up about 2 in.

The larger coil being attached, with the holes for the spindle ex-

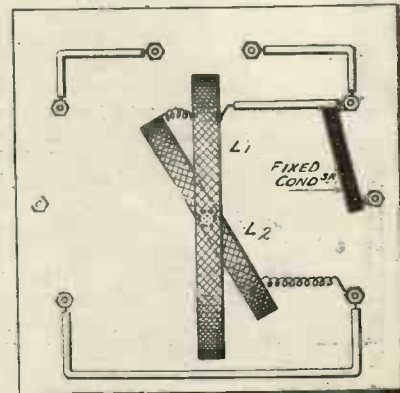

Fig. 3.—Wiring as carried out on the underside of the panel.

actly over the centre hole in the panel, the spindle may be passed through, and the inner (revolving) coil can be mounted. This is done by passing the spindle through two

CRYSTAL UNIT

L. B. Sc., Staff Editor.

Instructional data of a unit, which, besides
can be used as a tuned-anode unit or wavemeter.

roughly opposite holes in the coil and locking it by means of the two nuts visible in the photograph, Fig. 2. The nuts should be provided with washers so that tightening them against the coil does not injure the wire.

The spindle is to be cut to length from screwed brass rod, either 3 or 4BA, according to the size of the spaces in the basket coil windings, through which it must pass freely. Its upper end carries either a knob and pointer or a dial of any preferred pattern. If the type shown in the photograph, Fig. 1, is used there will be no need to provide the usual nuts and spring washer under

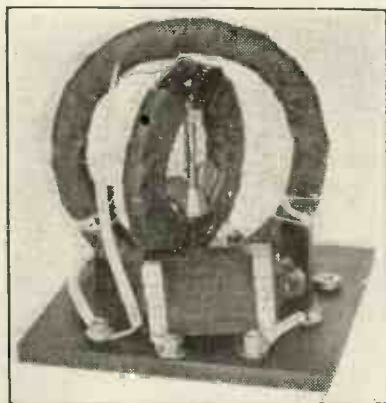

Fig. 2.—The receiver with box removed.

of this type of knob and dial (supplied by C. F. Elwell, Ltd.) is that it possesses a vernier slow-motion through about 30 degrees at any desired point on the scale. This slow-motion comes into action automatically, and is operated from the same knob as the rough adjustment.

The connections of the coils are made as follows: the outer end of the fixed coil is taken to the rear terminal of the three on the left in the photograph, and its inner end is connected with a short piece of very light flex to the outer end of the revolving coil. The inner end of the latter coil is connected through a few inches of very light and slender flex to the end of a stiff piece of wire attached to the earth terminal. The flex, it should be noted, is carried through one of the spaces in the winding so that it appears on the edge of the coil in the photograph. This is done to enable the coil to revolve without fouling it.

The other connections of the set

will be clear from the wiring diagram, including the connections of the fixed condenser of 0.0003 μ F capacity, which are so arranged that it may be placed in series or in parallel with the variometer or cut out altogether.

Fig. 4 shows the position of the holes in the panel, and the latter's dimensions, so that a suitable box can be made or purchased. The only requirement in the box is that it should have a depth of about 5 in.

When the unit is used as a crystal receiver the earth lead is connected to the front terminal of the three on the left (Fig. 1), and the aerial is taken to either the centre or the rear terminal of the same group. If it is connected to the centre terminal, the fixed condenser is placed in series with the variometer in the aerial circuit, and this will be found advantageous with large aerials. With an aerial of moderate size, however, results will usually be better without the series condenser, and it should be cut out by connecting the aerial to the rear terminal.

The condenser can be placed in parallel for use with small indoor aerials (up to about 6 miles from a broadcasting station) by connecting the aerial to the rear terminal and joining together the front and centre terminals with a piece of wire.

The telephones are connected to the group of terminals seen on the right in Fig. 1, the actual method of doing so depending upon whether one or two pairs are in use. When only one pair is required, the tags are connected to the front and rear terminals, since the centre one is not connected into the circuit and was put there chiefly to match the one on the other side of the panel. Two pairs can be used in series by screwing one tag of each under the "dead" centre terminal and connecting the other tags to the front and rear terminals respectively. No telephone condenser is included in the set, because I have found it unnecessary in the great majority of crystal receivers, though possibly with different makes of telephones it may be desirable.

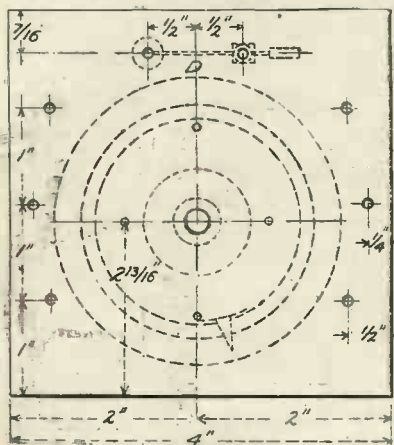

Fig. 4.—Details and dimensions of panel.

the panel, since the dial is screwed to the panel and the knob contains a chuck which grips the spindle firmly when the knurled nut in the centre is screwed down. A further advantage

A MODERN MARINE DIRECTION-FINDER

The following is a description of the compact D.F. apparatus as manufactured by the Marconi's Wireless Telegraph Co., Ltd.

IN addition to their normal wireless telegraph installations, many vessels of the Mercantile Marine are now being fitted with suitable apparatus for direction-finding, amongst which is that designed by the Marconi's Wireless Telegraph Co., Ltd.

The apparatus is so designed that no movement of the aerial is required, hence the special aerial may be such a size as to ensure good directional reception. Being an entirely separate piece of apparatus, the direction-finder should be regarded as an assistance to navigation rather than a part of the general wireless installation. It is practically independent of the remainder of the equipment, and so can be added to installations of any type.

By means of the instrument the direction of the source of origin of a wireless signal can be determined relative to the keel line of the vessel with considerable accuracy.

The purely electrical errors are not likely to exceed 1°, whilst the accuracy when translated into bearings suitable for navigation should not exceed 2°. Under unfavourable conditions, say at about sunset and sunrise, or if the line of bearing runs along the foreshore, the error is not likely to exceed 5°.



The Marconi Type 11 B marine direction-finder, which was exhibited recently at The Shipping and Engineering Exhibition.

Our photograph shows the Marconi wireless direction-finder Type 11 B, which is extensively used on shipboard, the compact appearance of which leaves little to be desired.

OCTOBER "MODERN WIRELESS"

The current issue of "MODERN WIRELESS" contains the following articles of outstanding interest to experimenters and constructors:

A New Invention for Selective Reception.
Dull-emitters and How to Use Them.
Wave-traps Explained.
How to Make a Two-valve Set

A Loud-speaker Set with One Control.
How to Measure Gridleaks.
How to Make Two Crystal Sets.
A Visit to the Eiffel Tower Station.

Useful Circuits for Long Wave Reception.

ON SALE EVERYWHERE - - - - - PRICE ONE SHILLING

Constructional Notes

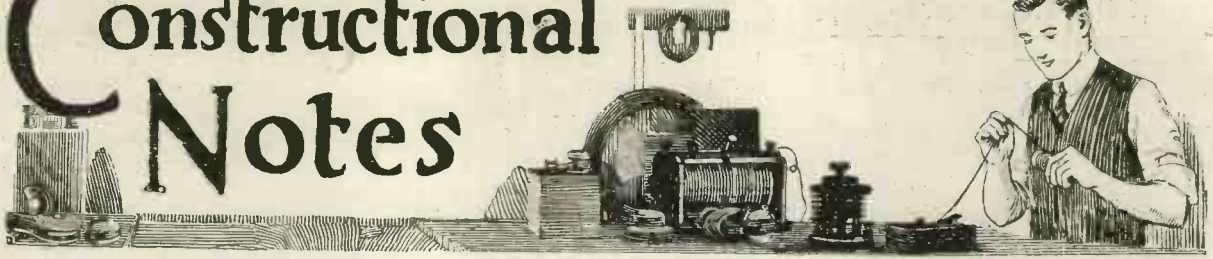

Conducted by R. W. HALLOWS, M.A., Staff Editor.

H.F. TRANSFORMERS

A TRANSFORMER for 200-metre reception may be made by using a bobbin of the same dimensions as that given in the drawing, and winding both primary and secondary with 50 turns of the same gauge of wire, while for the longer wavelengths the diameter of the bobbin must be increased to 3 in. and the depth of each groove to $\frac{1}{2}$ in. The following numbers of turns will be suitable for the longer waves up to about 3,000 metres: 100, 150, 200, 250, 450, and 600 turns, on both primary and secondary. The wire used should be either No. 42 single silk covered copper wire, or No. 42 single silk covered resistance wire, according to whether the transformer is to be tuned or not.

A particularly successful transformer which the writer has used a great deal for broadcast reception is one of the type whose secondary winding is tuned. This transformer was wound upon a bobbin of the same dimensions as that given on page 497 last week, and had the same number of turns of wire on both primary and secondary as has already been given, but the primary was wound with No. 40 single silk covered resistance wire, and the secondary with the same gauge of copper wire, the latter winding being tuned by means of a 0.002 μ F capacity variable condenser.

Using two high-frequency valves coupled by transformers of this type, an extremely stable receiver was constructed, giving very good results upon the broadcast wavelength, whilst its tendency to oscillate was easily controlled by means of a potentiometer.

Those constructors to whom lathe work is out of the question will find the suggestion contained

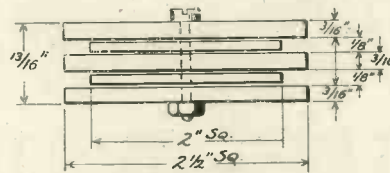

Fig. 1.—Dimensions of the transformer bobbin.

in Fig. 1 helpful. This shows the construction of a high-frequency transformer bobbin of the type shown in Fig. 2 page 497, No. 14, from five separate square pieces of sheet ebonite clamped together by means of a single 4 B.A. screw through their centres. This makes a perfectly satisfactory former upon which to wind the transformer, since there is no reason why square windings should not be employed. It will be found an advantage to round off the corners of the inner ebonite squares.

The "tuned" type of transformer gives the greatest amplification per stage, and is recom-

mended when only one or two high-frequency valves are used. When as many as three high-frequency stages are to be employed it is desirable to use the semi-aperiodic type, since it is very much more stable in operation, *i.e.*, it does not produce a receiver having so strong a tendency to self-oscillation, and it eliminates the additional adjustment in the form of a tuning condenser.

Probably the best known example of the semi-aperiodic pattern is the barrel type used in some of the Army receivers. This consists of an ebonite barrel 3 in. long and 2 in. in diameter in which are turned a series of slots or grooves, each $\frac{1}{2}$ in. wide and $\frac{1}{2}$ in. deep, these being usually eight in number. These grooves are wound full with No. 40 single silk-covered resistance wire, each section being wound in the same direction. The alternate sections are then connected together in series to form the primary and secondary windings respectively. Thus, four sections joined in series provide the primary and four sections form the secondary.

Such a transformer is quite satisfactory for long wave work and will cover a wavelength range of perhaps 1,000 to 8,000 metres without the use of a variable condenser across either of the windings. If a $\frac{3}{8}$ in. hole is drilled through the centre of the cylinder along its axis, the transformer can be made to serve upon the longest wavelength by inserting a bundle of iron wires to serve as a core.

G. P. K.

MOUNTING HOME-MADE COILS

BEFORE home-made coils of the duo-lateral type can be used in the standard coil holders some form of plug is necessary.

These can be very easily made if a little care is taken in marking out accurately and in drilling perpendicularly.

Obtain some $\frac{3}{4}$ -in. thick ebonite and cut out as many blocks as there are plugs required, each block

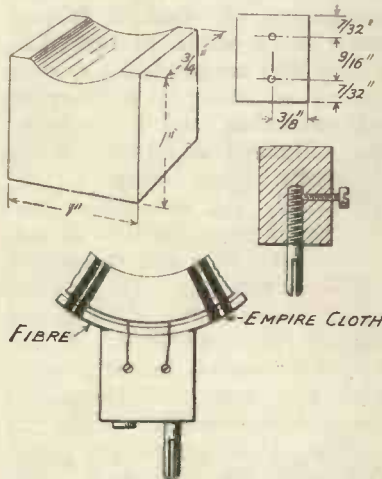

Fig. 2.—Illustrating details of the coil mounting.

being filed smoothly until it is rim square by $\frac{3}{4}$ in. deep. By means of a large half-round file, form a hollow in the top of each block to fit the coils it is desired to mount (see Fig. 2).

The plug and socket required to fit into the standard holder can be obtained from almost any dealer, the sockets usually being smooth and of approximately $\frac{3}{16}$ in. outside diameter, and the plugs tapped 3 or 2 B.A.; both will need to be inserted into the ebonite to a depth of about $\frac{3}{4}$ in.

To prepare the block, clamp it in a vice, taking care to use lead jaws to prevent the surface of the ebonite from being damaged, and carefully mark off the bottom edge as shown.

Having done this, and while the ebonite is still in the vice, drill carefully two holes for the plug and socket to a depth of $\frac{3}{4}$ in.

It is impossible to give the exact diameter of these holes, as the sizes of plugs vary according to where they are obtained, but that for the socket should be about 1-64 in. less in diameter, in order that the socket can be driven in tightly. The hole for the plug should, of course, be tapped either 3 or 2 B.A., whichever is the size of the plug.

Having secured the plug and socket, two 6 B.A. holes should be drilled and tapped from the face of the ebonite in such a way that when screws are inserted they project through into the metal portion of the plugs, as shown in the section.

Lastly, a strip of fibre about 3 in. long should be cut and bolted by means of a couple of small screws to the hollow of the holder. The coil can now be lashed to this by means of tape, or, better still, Empire cloth, as illustrated; the two ends of the coil leads should now be secured under the two 6 B.A. screws and the coil is complete.

R. W. H.

SPRING TERMINALS

ANY experimenter who is continually wiring up new circuits or making changes in his existing sets must often feel the need for some improvement upon the usual type of screw-down terminal. It is excellent for semi-permanent leads, for if properly tightened it provides a firm and secure contact, but it wastes a great deal of time when numbers of leads have to be changed.

Below are illustrated four good types of spring terminal, all of which have been used by the writer with excellent results. They are quite easy to make, and if they are fitted to such components as

variable condensers, gridleaks, valveholders, transformers, coil stands, and measuring instruments they will save both time and temper.

The first (Fig. 3) can be fitted to any existing terminal. The milled headed nut is removed and a small hole (6 B.A. will do very well) is drilled in the threaded rod about a quarter of an inch from the top. An oval hole is then made near one end of a $\frac{1}{4}$ in. wide strip of springy phosphor-bronze, and a 4 B.A. clearance hole at the other. The strip is bent as shown in the drawing and fixed in position by a nut. To connect a lead one simply presses down the end of the strip and inserts the wire into

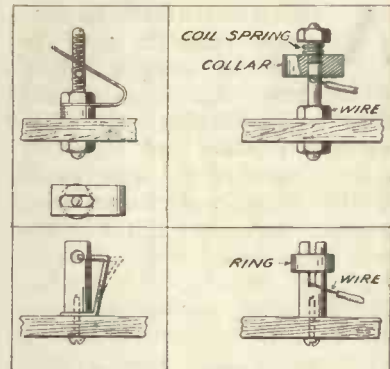

Figs. 3, 4, 5 and 6.—Illustrating suggestions for spring terminals.

the small hole. On being released the spring rises against the wire and holds it firmly.

A similar type of terminal is also shown in Fig. 4. A hole is bored in the rod, but this time quite near the base of the terminal. Over the screwed rod is passed a brass collar—a thick washer will answer quite well—followed by a stiffish spiral spring and a retaining nut. A connection is made in this case by lifting the collar and pushing the wire into the hole. The spring thrusts the collar tightly down on to the wire and jams it. Provided that the coil spring is stiff enough to exert sufficient pressure, this terminal makes as good a connection as could be desired.

In Fig. 5 a terminal of quite a different kind is seen. That

shown in Fig. 5 is made from a short piece of $\frac{1}{4}$ in. round brass rod, through which a hole is drilled quite close to the top. A second hole, just large enough to take comfortably the wire used for the spring, is drilled at right angles to the first and running into it. A 4 B.A. hole is drilled and tapped in the base of the terminal to take the screw which secures it to the panel. The spring is made of stiff silicon-bronze or phosphor-bronze wire of No. 16 or 18 gauge. At its lower end a loop is made and is sandwiched between the pillar and the panel to keep the spring in position.

Fig. 6 shows a good terminal which works on the principle of the point protector of a pocket pencil. It consists of a short piece of $\frac{1}{16}$ in. round brass rod which is "split" for part of its length by a cut made with a jeweller's or dentist's hacksaw. These, by the way, are two splendid little tools for fine work in brass or ebonite, and one of them should find a place in every wireless constructor's workshop. The former takes blades 6 in. long by about $\frac{1}{4}$ in. wide, which are much finer than those of the ordinary hacksaw. The blades of the latter are like those used in a fretsaw, save that they are stouter and adapted for cutting metal.

Over the rod is slipped a ring made from a $\frac{1}{4}$ in. length of brass tubing. A hole whose diameter is rather less than that of the wire ordinarily used is made at the lower end of the hacksaw cut. The writer has found this the most satisfactory of all forms of spring terminal, for, thanks to the great force exerted by the ring on the split rod, wires can be jammed tightly with no great effort.

R. W. H.

TO OUR NEW READERS.

Why not get the back numbers and have a complete set? We have them all from No. 1. 7½d. per copy, post free from *Raito Press, Ltd.*, Devereux St., W.C.2.

CALCULATING RESISTANCE WINDINGS

IN the following table all the necessary data for making calculations are given. The resistances stated refer to Eureka wire, which is the brand most commonly offered at wireless shops.

The column headed "Turns per inch" refers to enamelled wire with the turns wound so as to touch each other.

It must be understood that the figures in columns 2, 3 and 5 are

a resistance of 400 ohms; hence the resistance per yard is $\frac{400}{210}$, or 1.9 ohm. Three yards will give a total resistance of 5.7 ohms, and will occupy rather under 4 in. of the rod; a winding $4\frac{1}{4}$ in. in length will give the required 6 ohms.

Next take the case of a 300-ohm potentiometer suitable for grid control use. Here the current passed (20 milliamps. with a 6-volt battery) is so small that we need take no account of it. We wish to use a rectangular former 1 in. wide and $\frac{1}{4}$ in. thick. In this case

1. S.W.G.	2. Yards per lb.	3. Resistance per lb. Ohms.	4. Turns per Inch (Enamelled).	5. Carrying Capacity. Amps.
16	26	5.6	15	6.0
18	46	17	20	4.0
20	83	56	26	3.0
22	130	150	33	2.3
24	210	400	42	1.5
26	320	900	50	1.0
28	475	1,970	61	0.75
30	680	4,000	73	0.60
32	900	6,900	83	0.50
34	1,250	13,200	98	0.40
36	1,800	28,000	116	0.30
38	2,950	72,800	143	0.20
40	4,590	180,000	180	0.15
42	6,200	368,000	211	0.13
44	10,100	900,000	253	0.10
46	18,900	2,845,000	307	0.07

approximate, since there are slight variations in any kind of wire. Those valves with large current consumption, such as the "R," Ediswan, or ORA, are all rated at .75 ampere, but as they grow old their demands increase; we must, therefore, allow 1.5 amp. to be well on the safe side and to ensure that the rheostat does not heat up.

For this carrying capacity, No. 24 S.W.G. is suitable. This wire makes 42 turns to the inch or 31 when spaced with string. The $\frac{1}{4}$ in. diameter former will give each turn a total length of $\frac{3}{4}$ in.; we shall be quite near enough if we take the circumference as three times the diameter, and do not bother about π . Forty-two turns will thus go to a yard of wire.

Now 210 yards of No. 24 have

unspaced enamelled wire will be the most suitable.

The distance round the former is $1 + 1 + \frac{1}{4} + \frac{1}{4}$, or $2\frac{1}{2}$ in., which gives approximately $14\frac{1}{2}$ turns to the yard. If we use No. 32 wire the resistance per yard will be

$$\frac{6,900}{900}$$

or 7.6 ohms; thus to obtain 300 ohms we shall need roughly 40 yards or 580 turns, which means that the windings will be 7 in. long at 83 turns to the inch.

As this is too long to be convenient, we select No. 36, which works out as follows:—

Ohms per yard, 15.5.

Yards for 300 ohms (approx.), 20.

Yards per inch of windings, 8.

Length of windings, $2\frac{1}{2}$ in.

R. W. H.

Broadcasting News



By OUR SPECIAL CORRESPONDENTS.

LONDON.—The B.B.C. are making a commendable effort to do as much as possible for British music and musicians. There are about 2,000 artistes on the books at 2L.O., and a greater number in the combined books of the provincial stations. More than 90 per cent. of these are British musicians, and some who have foreign names were born not very far from Bow Bells. The orchestra at 2L.O. is British to a man, and the same is true of the provincial stations.

Wireless juggling does not appear to be confined to simultaneous broadcasting. Reference to our list will show that there has been some manœuvring with the wavelengths of the various stations. We understand that the present allocation of wavelengths is by no means final.

All wireless experimenters should listen-in at 7.25 on Thursdays when news items and announcements are broadcast from all stations regarding the activities of the Radio Society of Great Britain.

Forthcoming Events OCTOBER.

25th (THURS.).—Musical programme by the band of H.M. Grenadier Guards. The Garden Scene from "Faust," at the "Old Vic."

26th (FRI.).—Wireless orchestra and Shaftesbury Male Voice Quartette.

27th (SAT.).—Orchestral music.

29th (MON.).—Symphony programme.

30th (TUES.).—Music programme. The works of the late Sir Hubert Parry, preceded by a talk by Sir

Hugh P. Allen, Director of the Royal College of Music. Vocal items by Miss D. Robson, Mr. M. Davies, and a mixed quartette from the Royal College of Music. Miss C. Izard, violinist; Miss W. Gardiner, pianist; and Mr. R. P. Jones, cellist.

31st (WED.).—Instrumental and concert programme. Misses M. Bourn and N. Dale, duettists; Miss M. Cooper, elocutionist; and Miss G. Braddick, pianist.

ABERDEEN.—The station was formally opened by the Marquis of Aberdeen and Temair. In his speech, which was relayed to all stations, the Marquis referred to the benefits which the station would confer on the North of Scotland. The musical programme included songs by Miss May Lymburn, contralto; bagpipe selections by the Gordon Highlanders; and the band of the 2nd Gordon Highlanders. We wish 6BD the best of luck. By the way, how many noticed the impatient telephone subscriber trying to get through?

During the recent transmission from 6BD of a concert at 2L.O., the land-lines were broken down by the storm. Mr. R. E. Jeffrey had a busy time organising an emergency concert, but his efforts proved quite successful.

BIRMINGHAM.—A few weeks ago we urged the desirability of considering carefully the arrangements at provincial stations when simultaneous transmissions are to be given. The recent performance of "Il Trovatore" had to be hurried through in order that

the London land-line arrangement should be adhered to.

Birmingham listeners very naturally resent such treatment, and, when they have the opportunity of listening to a good opera, well performed at their own station, they do not wish to have it curtailed. Further, if land-line transmissions occupy so much time, local artistes will, of necessity, be crowded out.

Forthcoming Events OCTOBER.

26th (FRI.).—Operatic night. "The Magic Flute" (Mozart), at 7.15.

27th (SAT.).—Station orchestra and local artistes.

28th (SUN.).—An address by the Rev. G. H. Moore.

30th (TUES.).—Mr. Pitcairn Shearer on "Water Power," at 7.30.

BOURNEMOUTH.—The new station was opened on Wednesday evening last. Amongst those taking part in the proceedings were Viscount Burnham, Lord Gainford, the Mayor of Bournemouth, and Mr. J. C. W. Reith, General Manager of the B.B.C.

In his opening remarks Lord Gainford said that, although glad to have a spell of peace and prosperity, the Company realises that, with the establishment of this eighth and last main station, it is not at the end, but only at the beginning, of its labours.

In a short but interesting address, Lord Burnham referred to the effect of broadcasting upon journalism, and in concluding expressed the hope that this fine station may be a radiating centre of information and refinement, a remark which we heartily endorse.

GLASGOW.—There were many football fans listening-in on the evening of Mr. A. Murray's address on "Football." Mr. Murray has for many years been associated with the premier Scottish amateur football club. Mr. Edwards, the well-known Scottish football referee, is to give an address in November.

A special All-Scots Night has been arranged for Hallowe'en. Folk-songs and Scots and Gaelic songs will be interspersed with instrumental selections. The old-fashioned customs connected with Hallowe'en are, of course, difficult to broadcast, but we understand there will be sounds like the dookin' for apples and the cracking of nuts in the broadcasting studio.

Forthcoming Events
OCTOBER.

- 24th (WED.).—Miss C. Mawer, soprano; Mr. T. R. Brechin, bass.
- 26th (FRI.).—Miss E. Brass, soprano; Mr. Geo. Hutchinson, humorist.
- 27th (SAT.).—Miss J. Forrester, soprano; Mr. John Hosie, baritone. A talk by Mr. A. F. Wright on "The Alsatian Wolfhound."

MANCHESTER.—The delightful selection of glees and sacred music, rendered by the St. John's (Weaste) Wesleyan Prize Choir, provided a welcome change of programme. The tone and balance were excellent, the precision particularly good throughout, and the pianissimo passages most effective.

Many valve users are disappointed that the half-hour close-down, so valuable for listening to distant stations, either for entertainment or experimental purposes, has been encroached upon recently, with the result that there is frequently a break of only a few minutes, chiefly due to the relayed talks from 2LO which are often long drawn out.

Forthcoming Events
OCTOBER.

- 24th (WED.).—3.30, Miss D. Crooks, solo violin; Mr. D. Hargreaves, pianist; Miss D. Patterson, soprano; Messrs. Pitt and Marks, entertainers. 7.45, Sixth Symphony concert, Mr. Edward Isaacs, pianist.
- 25th (THURS.).—11.30, Miss A. Pickering, soprano; Miss Leah Jackson, soprano; Mr. H. Deveney, baritone. 6.45, Spanish talk. 7.15, Grenadier Guards Band.
- 26th (FRI.).—3.45, Miss C. Payne, contralto; Oxford Picture House Orchestra. 6.30, 2ZY Orchestra; Mr. H. Hopewell, baritone; Miss Betty Wheatley, soprano.
- 27th (SAT.).—3.30, Oxford Picture House Orchestra. 6.30, Organ

BROADCAST TRANSMISSIONS

Call-Sign.	Wavelength
CARDIFF 5WA ... 353 metres.	
*LONDON 2LO ... 363 ..	
MANCHESTER 2ZY ... 370 ..	
BOURNEMOUTH 6BM ... 385 ..	
NEWCASTLE 5NO ... 400 ..	
GLASGOW 5SC ... 415 ..	
BIRMINGHAM 5IT ... 420 ..	
ABERDEEN 6BD ... 495 ..	

TIMES OF WORKING.

Weekdays 3.30 to 4.30 p.m. and 5.0 to 10.30 p.m. G.M.T.

*London 11.30 a.m. to 12.30 instead of 3.30 to 4.30 p.m.

Sundays: ... 3.0 p.m. to 5.0 p.m. and 8.30 to 10.30 p.m. G.M.T.

NOTE:—The wavelengths given above are allocated temporarily and further alterations are pending.



recital from Piccadilly Picture House. 7.45, Bolton Dance Band. 9, "Algy." 9.10, Keyboard Kitty.

- 28th (SUN.).—8.30, Concert by Stephens Military Band. 9, Talk by Rev. Principal Brewis, B.A., B.D., of the United Methodist College.
- 29th (MON.).—3.30, 2ZY Trio. 6.35, Boys' Brigade bulletin. 6.45, Spanish talk. 7.10, Mr. John Strachey on "Books of the Week."
- 30th (TUES.).—3.30, Oxford Picture House Orchestra. 6.30, Mr. and Mrs. A. C. Hawthorn, duets. 6.45, Capt. H. G. Bell, M.Sc., on "Hallowe'en." 7.45, 2ZY Orchestra. 8.20, Mr. Tom Case, baritone; Mr. Percy Phlage will "Persiflage."

NEWCASTLE.—The simultaneous broadcasting of dance music by the Savoy Orpheans is proving a very popular feature, and it does not appear to suffer by reason of its land-line transmission. Even those who profess a dislike for jazz music make an exception in this case.

Forthcoming Events
OCTOBER.

- 24th (WED.).—3.30, Miss Farra, pianist. 7.30, An evening with British composers. Miss B. Paramore, soprano, and Mr. William Hendry, baritone.
- 25th (THURS.).—3.30, Mme. May Grant; Miss Greta Fottrill.
- 26th (FRI.).—3.30, Mr. W. A. Crosse's Bijou Orchestra. 7.30, Electric Sparks Concert Party.
- 27th (SAT.).—3.30, Mr. Adam Nockles, tenor. 7.30, Mr. Carl Fuchs, 'cello soloist; Mme. Betty Humble, soprano.
- 28th (SUN.).—8.30, Durham Road Baptist Church Choir.
- 29th (MON.).—3.30, Miss Farra, pianist; Miss Alice F. Nicholson.
- 30th (TUES.).—3.30, Mme. Nicholson's Quartette 7.30, Mme. May Grant's Quartette.

SHEFFIELD.—Apart from the work of the new relay station, a weekly programme of direct broadcasting has been inaugurated. The first of the transmissions, which are to take place each Wednesday evening, proved quite successful, and very good reception of all the items is reported.

Simultaneous Broadcasting Events

OCTOBER.

- 24th (WED.).—7.15, Dr. F. Nansen on "The Plight of Europe."
- 25th (THURS.).—7.15, Band of H.M. Grenadier Guards, followed by the Garden Scene from "Faust" at the "Old Vic."
- 28th (SUN.).—Organ recital from the Steinway Hall, London.
- 29th (MON.).—7.10, Mr. John Strachey, B.B.C. music critic. 9.30, Lord Curzon's speech on the occasion of the unveiling of the bust of Abraham Lincoln at the Savoy Hotel.
- 30th (TUES.).—10-11, Savoy Orpheans Band.
- 31st (WED.).—7.10, Mr. Arch. Had- don, B.B.C. dramatic critic.

RANDOM TECHNICALITIES

By PERCY W. HARRIS, Assistant Editor.

A few remarks relative to dull-emitter valves—dry cells—wave-traps.

WHEN so much is being written about dull emitter valves, it is well to clear up a slight misconception that exists regarding their current consumption compared with the ordinary "bright emitters." Whether or not we can conveniently run valves from dry batteries depends not upon the voltage (which is easily obtained by putting the cells in series) but upon the amperage or current taken.

There are several dull emitters which have a current consumption of about .3 to .4 ampere (a little more than half of the current consumption of the ordinary valve). This means that if a two-valve set with dull emitters can be run from dry cells, the same cells would serve to light a single valve of the ordinary type equally satisfactorily.

Personally, I am inclined to think that in all circumstances where it is possible to get the accumulators re-charged, these should be used for the dull emitter type of valve, as the dry cells necessary to give so large an amperage are very expensive. Of course, in the country districts where facilities for charging accumulators are non-existent, dry cells must of necessity be used. Perhaps the best solution for the country dwellers' difficulty will turn out to be the use of large wet batteries of the primary type.

I have just heard of a new battery which would seem to serve admirably for all purposes with valves. The cost for a three-volt unit (two single cells in series) capable of giving enough current to run three dull emitters continuously will be under £2. These will have a capacity of about 350 ampere hours on continuous discharge, and a new charge will cost about 10s.

The discharge curve of this new battery is practically a straight line for the best part

of the discharge, and the internal resistance is very low. Only by adopting an entirely new principle has it been possible to evolve a primary cell of this kind, and full particulars will no doubt be published shortly.

I am glad to see that several firms are now supplying wave-traps. Among such firms are Messrs. Tingey, Radio Instruments, Peto-Scott, and the Bowyer-Lowe Co. This latter firm is putting up the "type C" trap described in my recent article in a very convenient form so that it can be permanently wired to the set and cut off by means of a switch when not required.

Writing on the subject of ebonite and the production of a matt surface, a correspondent tells me that he finds that by rubbing a rag dipped in acetone over the surface of an old gramophone record he can produce a splendid matt finish. He adds, "This makes sand-papering pre-historic." I would like to think so, but my correspondent falls into the error of assuming that gramophone records are made of ebonite. I know that they can serve quite usefully as insulating panels when suitably cut and treated, but the fact remains that there is not an atom of ebonite or rubber in any form in their composition. Having seen them made I am able to state that the composition consists of cotton flock, baryta, lampblack and shellac, this last being the important component, the others being used to give "body" and strength. The ground baryta, lampblack and shellac are all mixed up with the cotton flock and subjected to pressure under heat. The heat melts the mixture, which on cooling becomes the black substance of which our records are made. Although the insulating properties of this substance are inferior to those of good quality ebonite, they are certainly better than many of the imitation "ebonites" now sold.

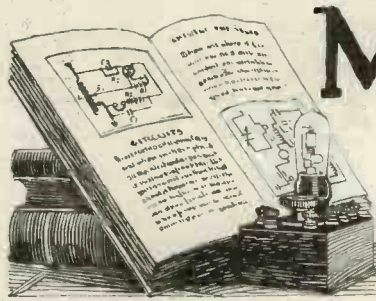

Mainly about Valves

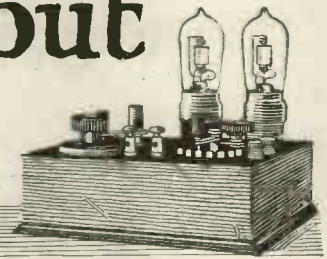

Our weekly causerie written by the Editor.

FIG. 1 is a reproduction of the ST75 circuit, which has proved almost as popular as the ST100. As has been previously explained, the ST75 is a two-valve

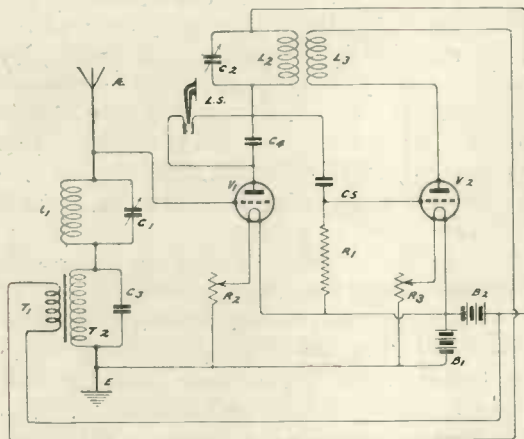

Fig. 1.—The ST75 circuit.

receiver in which the first valve acts as a high-frequency amplifier.

The position of the loud-speaker is such that any low-frequency potentials set up across its terminals are not communicated to the grid of the second valve, and therefore the arrangement does not establish a chain of low-frequency reaction.

With certain transformers, any tendency to low-frequency oscillation may be stopped by connecting a 100,000 ohm resistance across the grid of V_1 and the positive terminal of the filament accumulator B_1 . I have not, however, found that this is necessary in ordinary circumstances. The condenser C_3 might be a variable one of 0.001 μF capacity.

A disadvantage of this circuit is that when telephone receivers are connected in place of a loud-speaker, they require to be particularly

well insulated. It will not be possible, usually, to adjust the reaction quite as tightly, owing to the fact that the telephones will have a certain capacity to earth through the human body, and this will vary slightly, thereby disturbing the amount of reaction introduced into $L_2 C_2$.

These troubles are not experienced when a loud-speaker is used.

To overcome the effect entirely, the circuit of Fig. 2 was produced. Here it will be seen that there are three windings, L_5 , L_4 and L_2 , all wound on a single tube. In practice, it was found that for British broadcasting purposes, each of the coils could consist of 30 turns of No. 26 gauge d.c.c. wire, wound on a $3\frac{1}{2}$ in. diameter cardboard tube. L_4 is wound directly over L_2 and L_5 directly over L_4 . With this arrangement it is possible to touch

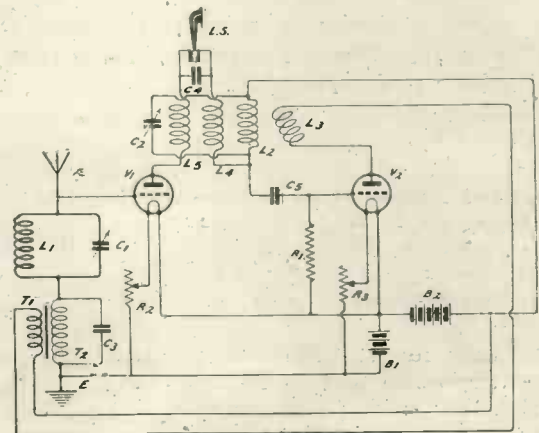

Fig. 2.—Illustrating the stabilising refinements.

the loud-speaker terminals with the hand without in any way affecting the signal strength, because the loud-speaker is artificially brought to earth potential.

AN EMERGENCY APPARATUS FOR SHIPBOARD USE

The following is a brief description of the emergency apparatus now being fitted to ships by the Marconi's Wireless Telegraph Co., Ltd.

MANY of our readers are no doubt aware that vessels of the Mercantile Marine carrying wireless are also fitted, in addition to the main installation, with



The Marconi emergency break for use on shipboard.

emergency apparatus to permit of communication during times of distress, independent of the ship's power supply.

In the early days of wireless this was done

by means of a 10in. sparking coil, supplied with power by an accumulator battery, being used as a "plain-aerial" transmitter. For many years this arrangement served its purpose until a more efficient method was devised introducing a transmitting condenser and jigger primary across the electrodes of the coil. Coupled to the jigger primary was the aerial-earth circuit by means of a secondary winding, thus affording a tuned arrangement. Subsequent improvements to this were made in that the secondary of the 10in. coil was connected direct to the condenser of the main transmitter, thus utilising the bulk of the main installation.

The modern version of emergency apparatus is somewhat different, though the principle is the same. An electrically operated vibrator is connected in series with the primary of the main transformer, accumulator battery and key. The purpose of the vibrator is to interrupt regularly the D.C. supply, which in passing through the transformer primary induces alternating current in the secondary, thus permitting the main transmitter to be operated at reduced power.

Industrial Applications of X-Rays. By P. H. S. Kempton. Price 2s. 6d. (Sir Isaac Pitman & Sons, Ltd., 39-41, Parker Street, Kingsway, W.C.2.) Pp. 112.

In many respects there is a close relationship between X-rays and wireless, and the apparatus and methods used in the two sciences frequently bear a close resemblance. For this reason a little handbook on the industrial applications of X-rays should be interesting to the wireless experimenter. X-rays have been applied to a considerable variety of useful purposes in connection with the

BOOK NOTES

examination of wood and metal parts intended for use in manufacture. The book describes the apparatus used and gives plates showing the results of X-ray examination of materials.

Directive Wireless Telegraphy.

By L. H. Walter. (Sir Isaac Pitman & Sons Ltd., 39-41, Parker Street, Kingsway, London, W.C.2.) Pp. 124. 57 Illustrations and 5 tables. 2s. 6d. net.

The subject of directional wireless is one which is of considerable importance in the Services and in commercial working, and, whilst of great interest to the more advanced wireless experimenter, it is a subject on which connected information is difficult to obtain. The present volume, however, gives an accurate and well-illustrated *résumé* of the subject, with many useful references to original papers and more advanced treatises. The author is stated to have introduced into England, a matter of a dozen years ago, the well-known Bellini-Tosi system of directional wireless.



Apparatus we have tested

Conducted by A. D. COWPER, M.Sc., Staff Editor.

A Folding Frame Aerial

WITH the increasing interest in sensitive reflex and "super" circuits of various types for the reception of broadcasting at comparatively moderate distances, a frame aerial has become almost a necessity for both the serious experimenter and flat-dweller alike; it is, however, apt to be rather cumbersome and unstable when not in actual use. Messrs. Webb Bros. have mastered this objection in a very effective way in their folding frame aerial, a sample of which we have recently had an opportunity of putting to extensive tests. This opens out into a frame of a little over two feet square with eleven turns of wire liberally spaced in solenoid formation, the frame being quite rigid and the wires taut. By means of an ingenious arrangement of four hinges it can be made to fold up in a moment into a package little larger than two folded umbrellas would make. A hinged base is incorporated in the design.

On test it tuned from below 200 metres up to 600 metres with a $0.0005 \mu\text{F}$ parallel condenser and valve-capacity; with a No. 35 coil in series (for reaction coupling) from 280 metres to 700 metres. With various super-regenerative circuits all the B.B.C. stations could be tuned-in in succession without much difficulty. With a single valve and low plate voltage the local station was easily read at 13 miles on conventional circuits; enjoyable loud reproduction being

obtained on the loud-speaker at the same distance with two valves and with 120 volts H.T.

As to general criticism which may be offered, it is suggested that the folding base should be made with stronger hinges.

A Variable Gridleak and Grid-condenser

Radio Specialities are marketing a component in which both variable gridleak and variable grid-condenser are incorporated, a sample of which has been submitted for practical test. This resembles the well-known "Filtron" variable gridleak, but has in addition a variable condenser operated by a co-axial spindle with smaller knob fitted above the variable leak-resistance control. Good in finish and appearance, as well as in the mode of regulating the leak-resistance (of the graphite-line variety, in a long spiral groove), it is identical with the former unit.

On test, the convenience of having the two variable components in one unit was noticeable, so that fine adjustment of the rectifying valve became easy. Unfortunately in the sample submitted, the gridleak was disconnected at one terminal; on remedying this, the gridleak operated satisfactorily, giving a good range of adjustment over the ordinary useful values. On measurement, the variable grid-condenser showed a capacity variable from 0.00002 to $0.00011 \mu\text{F}$. The upper value might perhaps be raised, with advantage.

A Variometer

Messrs. Peto-Scott, Ltd., have submitted a variometer of the ball-rotor and internally wound block stator type. The unit is equipped with four terminals for convenience in connecting up the two windings, either in parallel or series; or it may be used as a vario-coupler—a very valuable feature. The instrument is nicely finished, and is suitable for use in experimental circuits on the table, or for panel mounting. A knob and pointer are provided in addition to substantial stops. While quite compact (about $3\frac{1}{2}$ in. cube) the unit submitted for test tuned a P.M.G. aerial from 340 to 860 metres with series connections, and about 140 to 410 metres with rotor and stator in parallel. With the latter connection the signal-strength on crystal reception was excellent. The small clearance between the windings accounts for the large inductance-ratio shown.

In all, a workman-like and extremely useful tuning unit.

Panel Coil Receptacle

The Athol Engineering Co. have submitted for inspection a coil receptacle for mounting on the front of a panel, taking the ordinary plug-in type of coil. This has the standard plug-and-socket fitting on the top of an insulating block. Screwed pins are provided with two nuts each, suitable for fitting to panels up to $\frac{1}{2}$ in. thick. The finish, insulation resistance, and accuracy of fit for standard coils call for favourable comment.

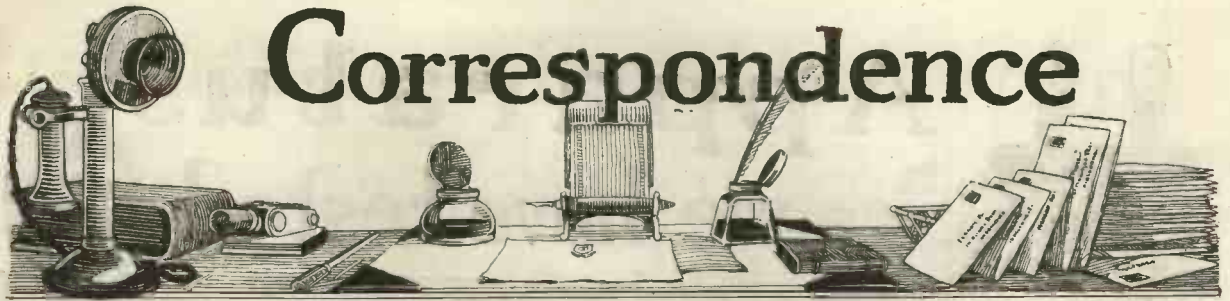

Correspondence

ST100

SIR,—Some time ago you published a letter from me (in *Modern Wireless*) re ST100.

Several people in this district seem to doubt the statements I then made, simply because they cannot get the same results themselves. I shall be glad, therefore, if you will publish the enclosed diagram of connections, as it seems rather a pity that some people should need three- or four-valve sets when ST100 is all that is necessary.

The fixed condensers are Dubilier; transformers, Elwell; valves, Ediswan A.R.; leak 100,000 ohms. Mullard; crystal, Zincite - bornite; loud speaker, Browns H2, small H.R.; variable condensers, Polar.

With the aerial used results seem better with a series condenser though in the majority of cases a parallel condenser is better.

It is absolutely necessary to have a good aerial and earth, of course, since I am about 70 miles from the nearest station. In the country I can get Paris on a loud-speaker, Radiola and PCGG on 'phones. Glasgow is very good, of course, and Newcastle comes in excellently

I need no grid potential when using Ediswan A.R.'s, but when using Mullard valves, 6 volts help considerably.

I am, etc.,

Alyth WEMYSS.

CRYSTAL RECEPTION

SIR,—I thought that it might interest you to know that I have received the following amateur stations on my home-made crystal set. It is variometer tuned, similar to the one described in *Wireless*

Weekly—Vol. 1., No. 8, page 476, with the exception that it has a 0.0003 μ F fixed condenser in series with the variometer and also a 0.001 μ F fixed condenser across the 'phones. The stations are as follow:—

2AJ, 2OM, 2KZ, 2PB, 2VR, 2XB, 2YR, 5BB, 5BD, 5BR,

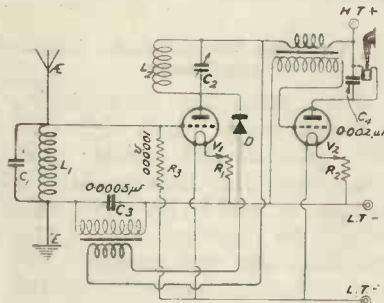

5CB, 5CP, 5DB, 5DK, 5FK, 5FR, 5IO, 5IS, 5PU, 5OF, 5XB, 5YR, 6HD, 6IM.

Wishing your magazine every success.

I am, etc.,

R. CROXTON.

W. Kensington, W.14.

WAVE-TRAPS

SIR,—In your article on "Wave Traps," which appeared in Vol. 2, No. 5, you invited readers to submit their experiences. I took it into my head recently to try "type B" to see whether 2LO could be cut out. At the time I was not experiencing any interference from Morse, etc., but tuned in to about 410 metres with 2LO coming in very loudly on 'phones. I then put a 0.0005 μ F condenser in parallel with the "trap" coil, which was formerly the primary of a loose-coupler (oojah basket coils on a two-coil

holder). As I brought more of the condenser into use 2LO died away, until at 120° (presumably 369 metres) not a sound of it could be heard. But I then heard an amateur sending Morse with the ATI tuned to about 410.

The slightest loosening of the coupling brought in 2LO very loudly, and 2 degrees of the trap condenser either way made it audible.

This seems to me to be a more severe test than that carried out by the author of the article when Birmingham and London were both coming in on a loud-speaker. For in his case he brought in signals which could be heard when London was operating and which might conceivably wash out the 2LO signals when the latter were partially detuned.

But the complete success of the "type B" trap is surely demonstrated when signals are brought in on 410 metres which were not previously audible.

Thank you very much for these articles, which will prove of great practical value to me in the course of the winter. I may say that I was using the wave-trap with a crystal set.

Incidentally, on three consecutive occasions I heard a B.B.C. station other than London. On the third occasion (12th inst., 10.30-11 p.m.), I recognised the Grand March from "Tannhauser" which was followed at 11 p.m. by "God Save the King." A letter to the Glasgow station has brought me confirmation that these items were transmitted from 5SC on the date and at the times stated.

I am, etc.,

F. W. FORSTER.

London, S.W.18.

Information Department



H. R. H. N. (N. 16) asks what is meant by an "artificial" aerial. He also wishes suggestions for experimental transmission work.

An "artificial aerial" is a combination of inductance, capacity, and resistance, giving the same general electrical effects as an ordinary aerial, but so disposed that it does not appreciably radiate energy. Such arrangements are useful in experimenting with transmitting circuits, but it must be understood when using them that it is impossible to estimate such values as range of the set, quality of modulation, etc. The following are lines of research suitable for experiment in transmission. (1) The best arrangement of wiring and earth connections. (2) Methods of reducing loss at the leading-in insulator. (3) Various forms of counterpoise with and without an earth connection at the same time. (4) Circuits which are not effected in their oscillation frequency by variation in aerial resistance, height, etc., due to swaying in the wind. (5) Short wave transmission below 200 metres with a view to finding best radiation methods.

R. S. (N. 15) has constructed the "All Concert Receiver" described in "MODERN WIRELESS" for September, but suffers from interference.

To eliminate interference with this receiver shunt the following arrangement across the aerial and earth terminals. On a $3\frac{1}{4}$ in. former wind 60 turns of No. 24 d.c.c. wire, leaving sufficient lengths at each end of this coil for further connections. In the middle of this coil and immediately on it, wind 5 turns of the same wire, bringing out the ends for further connections. The small coil should now be connected directly across the aerial and earth terminals of the set, the leads going to the aerial terminal being connected through an "on" and "off" switch. The ends of the wire from the larger coil should be taken to a $0.0005 \mu\text{F}$ variable condenser.

With the lead from the short coil to the aerial disconnected, tune your set to the signals you wish to receive irrespective of interference. Close the switch so that the coil is connected across the aerial and earth and vary the $0.0005 \mu\text{F}$ condenser connected across the larger coil until the signals are once more heard, but without interference. You will

find that the setting of this trap or eliminator condenser is very critical, a couple of degrees either side of the correct point losing everything. When correctly set this condenser will enable you to receive signals with very little reduction in signal strength.

F. P. W. (Catford); F. H. R. (S.W.1); C. N. W. (Sanderstead) and others; ask various questions relative to the Super Receiver described in Vol. 2, No. 11, p. 414.

Since it is not recommended for those who have not already had some experience in construction work to commence on the somewhat tricky business of building a new "super" receiver, the constructional details in this article were given merely in a brief and technical form, easily interpreted by the experienced. Several successful receivers have, in fact, been constructed from these.

Two-pile winding is described and figured fully in *Modern Wireless*, Vol. I, No. 3, p. 185, and No. 5, p. 321. Briefly, two single layers of wire are wound on the same former, the second lying in the depressions between the wires of the first, and consisting actually of the same wire carried back a turn or two after each turn on the former, this wire being given one turn on top of the first layer, and then carried forward for the next turn on the former, and so on alternately. A row of four or five pins or thin nails driven temporarily into the cardboard former obviates side-slipping of the lower end turns whilst winding on the upper end turn or two: these are subsequently removed after shellac-varnishing the finished coil. The necessary sharp bends or kinks in the wire where it is carried back and forth from the one to the other layer are arranged to lie spirally round the former. In this way one obtains twice as much wire in a given length, without serious increase in self-capacity, if d.c.c. wire be used.

The No. 75 loading-coil is the plug-in coil of that number of turns in the usual series of purchased coils, such as Igranic, Burndep, etc., or can be a basket-coil of about that number of turns of No. 22 or 24 d.c.c. and of usual size. Actual experiment with the help of some form of wavemeter is essential to fix these values.

A fixed grid-condenser, e.g., Dubilier $0.0002 \mu\text{F}$, can be used, if preferred, with reliable make of variable gridleak, and gives excellent results.

ECONOMIC ELECTRIC



THE "EEC" "XTRAUDION" VALVE
 is being used by the leading Radio Experimenters for detection, high and low frequency amplification, power amplifiers and low power transmission. Price 15/-

USE "RECTARITE," the synthetic crystal that makes Loud speakers talk! 1/6 Large Specimen.



Write to-day for 40 page Radio Catalogue mailed post free, 4d

Head Office: 10, FITZROY SQUARE, LONDON, W.1.

Showrooms: 303, EUSTON RD., N.W.1.

Branch and Works: TWICKENHAM.

Tappings are made in the usual way by twisting a small loop in the wire every tenth turn whilst winding, leaving these loops projecting and subsequently cleaning off insulation and soldering short leads to switch-points.

For details of variometer-rotor mounting, see any one of several recent constructional articles embodying variometers.

When tuning-in, look for the array of heterodyne "bumps" described in the article. The station will be found between the loudest two; then raise the whistle frequency as high as desired.

W. H. H. (BIRMINGHAM) asks how he may increase the wavelength range of the three-valve regenerative receiver described in "WIRELESS WEEKLY," Vol. 1, No. 11.

To increase the wavelength range of the three-valve regenerative receiver, it will be necessary to include a fixed coil socket in the aerial circuit and another similar arrangement in the plate circuit. Into each of these plug a suitable size of coil for the longer wavelengths, replacing it by a short circuiting plug when working on the short waves. For suitable sizes of coils see the table in *Modern Wireless* No. 6. The coil-holders referred to should be two separate holders, and not the conventional two-coil holder.

H. M. U. (BIRMINGHAM) asks how he may add two low-frequency valves to the Flewelling circuit.

You may add two low-frequency valves to the Flewelling circuit by constructing the low-frequency amplifier described by Mr. E. Redpath in *Wireless Weekly*, Vol. 1, No. 3. The two input terminals of this amplifier should be connected to the present telephone terminals of the Flewelling circuit, and separate high- and low-tension batteries should be used.

J. P. (HENDON) asks if he may reasonably expect to operate a loud-speaker using the "All Concert Receiver" described in the September issue of "MODERN WIRELESS," to receive London at a distance of 100 miles.

With careful tuning it should be possible to receive 2LO on a loud-speaker at moderate strength with this receiver, though the strength obtained in this fashion would not usually be termed "loud-speaker" strength. In the November issue of *Modern Wireless* there will be described an additional note-magnifying panel to add to the "All Concert Receiver," which should then give the strength you require. An easily constructed note-magnifier which may be made pending the publication of that to be described in *Modern Wireless* is given in *Wireless Weekly*, Vol. 2, No. 10.

The New Bowyer-Lowe Components Set the Standard :: ::

WHICHEVER set you build you want it to be efficient. Indeed that set you are now going to build may be only one of several you intend to build. (There's pleasure in experimenting in wireless.) But you won't want to buy fresh parts for each set—that's too expensive. This is one reason why we got down to designing a really reliable set of components—components that can be used in any set you wish to try out. These components are beautiful in design, robust, durable and efficient—as you expect from Bowyer-Lowe products. They facilitate assembling, too. All prices are reasonable. We have prepared a special leaflet about these components and would like to send you one. May we? Just send a p.c. asking for Leaflet No. 20.

Our Stand at the Wireless Exhibition at the White City
—from November 8 to 25 will be—

No. 6.

The Bowyer-Lowe Co., Ltd.
Manufacturers of Wireless Instruments,
**Radio Works, Commerce Avenue,
 Letchworth, Herts.**

Wholesale Distributor for Scotland:
F. M. MILLIGAN, 23-25, Renfrew Street, GLASGOW.



**BWARE OF WORTHLESS IMITATIONS, SEE THE
 TRADE MARK *WatMel* ON EVERY GRID LEAK.**

WATMEL VARIABLE GRID LEAK
 (Patent applied for.)

The Resistance is steadily Variable between 1/2 to 5 megohms. Only requires a 3/8 in. hole in panel for fitting.



PRICE 2/6 EACH
 The best Variable Grid Leak made.

Suitable for use in any circuit, and improves the working of any valve detector. (50,000 to 100,000 ohms for the S.T.100 Circuit. Price 3/6.)

WATMEL WIRELESS CO., Connaught House, 1a, Edgware Road,
 Marble Arch, W.1. Tel. 4575 Paddington.

WECONOMY SETS

incorporating the WECOVALVE.

The WECOVALVE (Pea-nut type) is the most economical valve existent, requiring only 0.25 of an ampere at 0.8 to 1.1 volts, and having more than twice the life of tungsten and other dull-emitter valves.

It can be used either as a Detector or Amplifier, and operates off a single dry cell.

Filament current 0.25 amps.

Filament Voltage 0.8 to 1.1 volts.

Detector Plate Voltage 17-22 volts.

Amplifier Plate Voltage 22-45 volts.

Dimensions $\frac{5}{8}$ in. diameter by $2\frac{1}{2}$ in. long.

Price £1 10s.



No. 44215-A.

Patent Nos. 17580 (1915), 180090 (6641-1921).

The WECOVALVE (Pea-nut type) can be used with your existing receiving sets by the use of the Weco Valve Adaptor (No. 44092), which has contact springs faced with gold and silver alloy, to ensure perfect contact with the base of the valve.

Dimensions $1\frac{1}{2}$ in. by $1\frac{1}{2}$ in.

Price 3s. 6d.

The Weco Valve Socket is a small type bayonet socket arranged for four soldered connections. The contact points are faced with a special gold and silver alloy to ensure perfect contact with the base of the valve.

Dimensions $1\frac{1}{2}$ in. by $\frac{1}{2}$ in.

Price 1s. 6d.



No. 44080.
Crystal Set with Double Amplification.

The WECONOMY CRYSTAL RECEIVING SET No. 44080 is a combined crystal pattern receiving set and two-stage Valve Amplifier. The Set, used for the reception of local Broadcasting Stations, will operate a Loud Speaker direct, or if desired the crystal set portion may be used alone with Head Receivers.

The excellent qualities of the Western Electric Crystal Set are well known, and the addition of the Amplifier, containing special distortionless transformers, and the particularly silent operation of the Weco valves, render this combination almost perfect in its reproduction.

Dimensions $8\frac{1}{2}$ in. by $8\frac{1}{2}$ in. by 7 in.

Weight 7 lbs.

COLUMBIA RADIO "A" CELLS
ARE RECOMMENDED
FOR USE WITH WECOVALVES.



No. 44010.

Small Two Stage L.F. Amplifier
for use with Crystal Set.

The WECONOMY AMPLIFIER No. 44010 is designed primarily to fit into the receiver compartment of the Western Electric Crystal Pattern Receiving Set. Two Weco valves are used and no accumulators are therefore necessary. Terminals are provided for two dry cells for filament heating and for a H.T. battery of 45 volts for the plate circuit.

Complete with Western Electric high efficiency transformers, condensers, etc., and clearly marked terminals, this Amplifier when used with a Crystal Set will reproduce speech or music from a local Broadcasting Station in sufficient power to operate a Loud Speaker successfully. If desired, it can be used to secure at least double the range of the Crystal Set by retaining the Head Receivers.

Dimensions $6\frac{1}{2}$ in. by $5\frac{1}{2}$ in. by $3\frac{1}{2}$ in.

Weight 7 lbs.

WRITE FOR BOOKLETS—W.E.Co. /32/W. 528 and W. 529.

Western Electric Company Limited.

(WHOLESALE ONLY)

Connaught House, Aldwych, London, W.C.2.

Telephone: Central 7345 (9 lines).

Branches:—

Glasgow, Leeds, Birmingham, Manchester, Newcastle, Cardiff, Southampton, Dublin.



The New ETHOPHONE V. Mk. II. Broadcast Receiver.

All Ethophones are primarily designed for Broadcast reception, and the design calls for the highest efficiency combined with simplicity of control, and can be used successfully by any member of the family. The Tuner and Receiver are incorporated, the Valves and High Voltage Batteries are enclosed out of harms way but are instantly accessible, the whole forming a complete unit.

The new Ethophone V. Mark II. is a Tuner Receiver, and Power Amplifier combined, while the price is only that of a receiver of premier quality. The last valve is a power stage, which allows an enormous volume absolutely undistorted, whether it be speech, music or song, the tone produced is sweet and mellow over the whole range of the musical scale.

There are many people who are dubious about the purity of tone obtainable from a Loud Speaker. We would like them to call at any of our showrooms, and to demonstrate to them, when we feel confident that what they hear would be in the nature of a revelation to them. The most conservative musical critic could find no cause

for complaint. To obtain these results, we would use the Ethovox Loud Speaker.

The Ethophone V. Mark II. when used on a moderately good aerial, and with a little practice in handling, will bring the programmes of all the British Broadcast stations to your home, most of them on a Loud Speaker. Further, there are very few places where French and Dutch concerts cannot also be heard on a Loud Speaker.

Regularly we hear from customers that they have received American Broadcast on this instrument, but this we cannot guarantee.

The Ethophone V. was taken into the Arctic by the Merton College Arctic Expedition, and the members were able at times to listen to British Broadcasted Concerts.

No. 508. Ethophone V. Mk. II. complete with valves and High Voltage Battery Price £37 10 0
To which must be added the Broadcast Tariff £1 7 6

All BURNDEPT Products carry a written Guarantee.

EXHIBITION.

We are showing a complete range of Wireless Apparatus, together with Components and Accessories, at the All-British Wireless Exhibition being held at the White City under the auspices of the National Association of Radio Manufacturers, from Nov. 8th to 21st.

Stand Nos. 112 and 75.

Our new catalogue consisting of 88 fully illustrated pages will be received from the printers on November 1st. We are confident that this will be the finest descriptive wireless catalogue yet produced in this country. Everybody interested in wireless should have it on his bookshelf for reference. Fill in the coupon to obtain your copy.

BURNDEPT Ltd., Head Office:
Aldine House, Bedford Street, Strand, W.C.2.
Phone: Gerrard 7794.



COUPON.

Sales Manager,
Burndept Ltd.,
Aldine House,
Bedford Street,
Strand, W.C.2.

Please send me your new Illustrated Catalogue.

Name

Address

(Wireless Weekly.)



The Mullard
Weco valve

Price **30/-**
(actual size)



4-pin
adaptor
for fitting
the
Mullard
Weco valve
to your set.

Have you thought—
of the saving you will be able to effect by means
of the MULLARD WECO VALVE?

*If you are building your own set see that you fit it with "Weco valves."
If you already possess a valve set "Weco valves" will pay for themselves in a few weeks.
In any case write to us or ask your dealer for list M.W.I — it tells you all about this
wonderful new valve which in economy is far in advance of any valve of the dull emitter type.*

Do not let to-day go by without writing for full particulars.

Full Manufacturing Licence under British Patents, Nos. 17580, 123126, 180090.

We are exhibiting at the N.A.R.M. Exhibition, White City, November 8—21. Stand 90.

Mullard

Obtainable from the Leading Electricians, Wireless Dealers, etc.

Advt. of the Mullard Radio Valve Co., Ltd., Balham, S.W.12.

(E.P.S. 69.)

WIRELESS WEEKLY will be at the White City Exhibition.

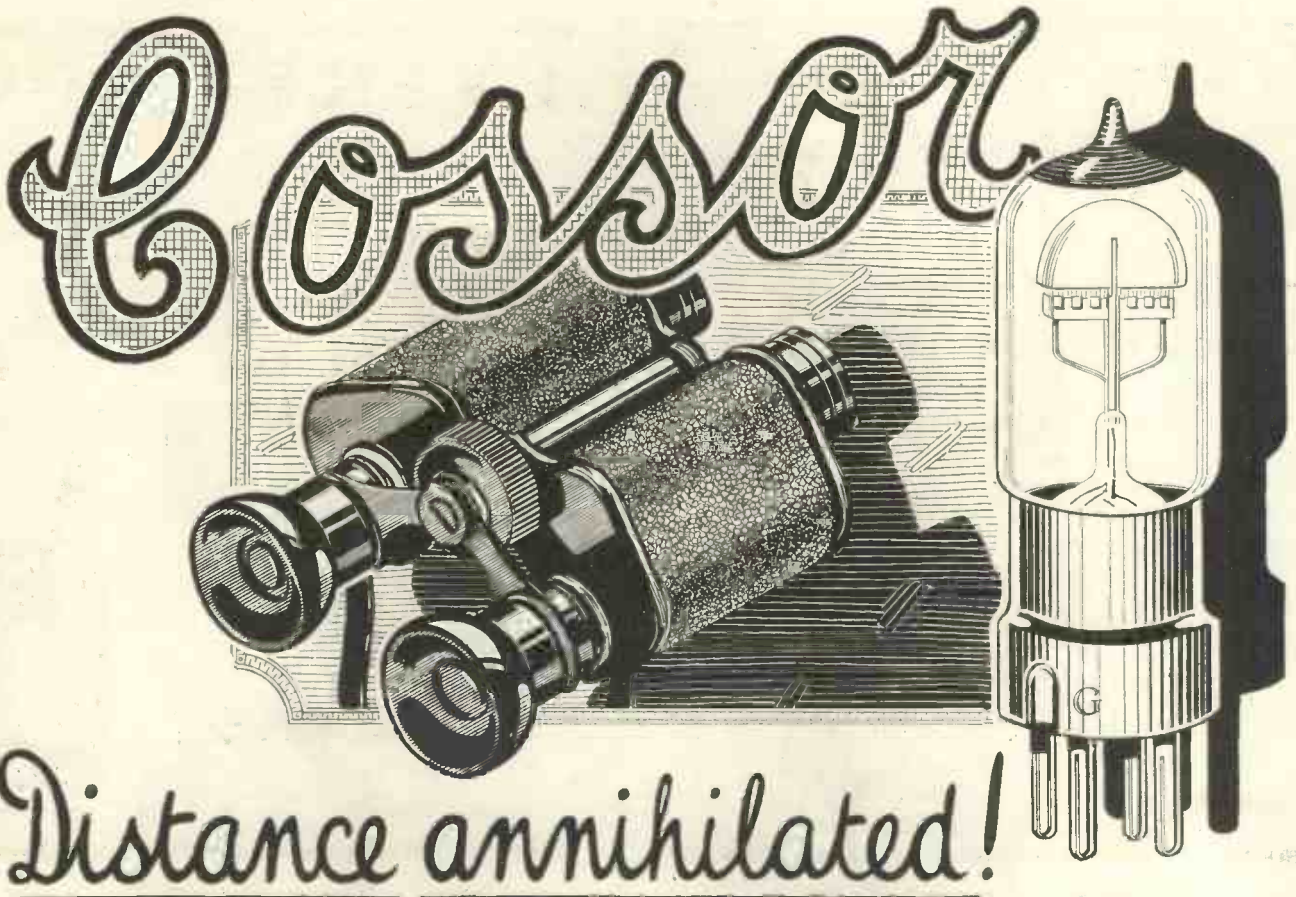

Distance annihilated!

THE man who buys his first motor cycle only wants to "potter" along the lanes; speed has no attraction for him. Similarly the enthusiast taking up Wireless for the first time merely wants to listen to his nearest B.B.C. Station.

But human nature being what it is, the motor cyclist soon begins to dream of fire-eating monsters capable of 60 m.p.h., and the wireless enthusiast of sitting up at night listening to half the American Broadcasting Stations.

Which Valves should be used for long distance work?

Obviously, the Brooklands racer is a very different machine to the more prosaic

motor-bike we see upon the roads—so the Valve for long distance reception should be different to the one used for Loud Speaker Work.

The COSSOR P.2 (with red top)—although following Standard COSSOR practice with hood shaped Anode and curved filament—has been designed specifically for high frequency amplification.

Its popularity among those who search the ether in the small hours of the morning for WJZ and other American Stations is most marked.

If your efforts to pick up distant Stations have been disappointing, insert a COSSOR P.2 as an H.F. Amplifier; we know that the results will agreeably surprise you.

TYPES:

P.1 (for Detector or L.F. use)

P.2 (with red top for H.F. use)

15/-

From all Dealers.

COSSOR VALVE CO., Ltd., Highbury Grove, London, N.5.

Gilbert Ad.

WIRELESS WEEKLY will be at the White City Exhibition

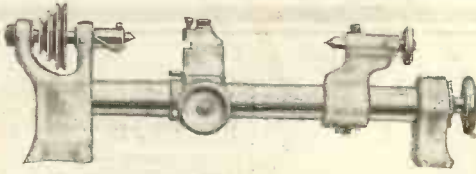

The WADE Lathe

Well made parts are half the battle

The WADE Lathe as illustrated £2 10 0

You can make all your own parts with the Wade Lathe; its so much better than buying them. Suitable for turning, boring, facing and drilling. Turns material up to 12 ins. by 1/4. Slide rest travels whole length of bed and is fitted with cross feed as well. British made, takes up very little space and the price is low. The handiest tool for Wireless workers. Sold by leading tool dealers.

Send for List W 12.

C.A.V. SMALL TOOLS, Ltd.,
181 Queen Victoria Street, LONDON, E.C.4.

EVERYTHING for the Radio Constructor

USE ONLY GUARANTEED COMPONENTS.



"Woodhall" Moulded Variometers.

Internal winding firmly fixed by special process. W.L. with 100 ft. aerial, 250/750 metres. With terminals as shown. Brackets movable for panel or table mounting.

List No. 15342.

Price, less knob, 15/9

Trade only supplied. Kindly order from your usual dealer.

Anti-Capacity Switch for panel mounting. Specially adapted for use in Radio receivers, the capacity between contacts being so low that it may be used in conjunction with H.F. as well as L.F. circuits.

- | | | |
|-----------------|------------|------|
| List No. 17034a | 2-way each | 9/- |
| 17034b | 3-way .. | 10/- |
| 17034c | 4-way .. | 11/- |
| 17034d | 5-way .. | 12/- |



Brown Brothers

with which is amalgamated Thomson & Brown Brothers Limited.

Wholesale only. Head Offices and Warehouses: Great Eastern St., London, E.C.2. 118, George St., Edinburgh, and Branches.

DUBILIER ANODE RESISTANCES



Actual size.

These resistances are the result of careful research and experiment. They are submitted to a test of 200 volts D.C. and are

GUARANTEED TO REMAIN CONSTANT

Price, complete with holder as illustrated . . . 5/6
Made in resistances of from 20,000 to 100,000 ohms.

**THE DUBILIER CONDENSER Co. (1921) Ltd., Dept. G,
Ducon Works, Goldhawk Road, London, W.12.**

Telegrams: "Hivoltcon, 'Phone, London."

Telephone: Hammersmith 1084.

E.P.S.19



We are showing at the White City Exhibition, November 8-21, under the auspices of the National Association of Radio Manufacturers.

Wireless VALVES

BRITISH MADE

B.T.-H. HEADPHONES.

have become famous for their wonderful sensitiveness and tonal quality. They perfectly reproduce speech and music, and, moreover, give maximum amplitude of sound. Comfortable and readily adjusted, they are a worthwhile addition to any wireless set.

Since the invention of the Thermionic Valve our research chemists and laboratory engineers have been working continuously for its improvement. As a result the B.T.-H. Valve is the *perfect* receiving valve and is unsurpassed for amplifying and detecting.

The valve is as strong mechanically as is consistent with efficient operation. The risk of the filament "sagging" is almost nil.

Price **15/-** Each



The British Thomson-Houston Co. Ltd.

Electrical Engineers and Manufacturers.

Works: RUGBY.

London Office: CROWN HOUSE, ALDWYCH, W.C.2

Sole Agents for the Music and Gramophone Trades:—

THE MURDOCH TRADING COMPANY, 59 & 61, Clerkenwell Road, LONDON

1926

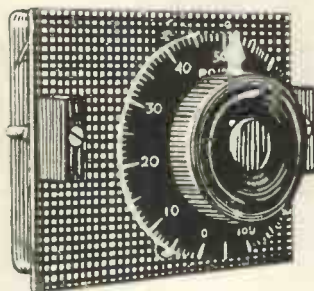

THE Polar Guarantee—the first ever given with any wireless apparatus—ensures the complete satisfaction of every buyer of a Polar Condenser.

The chief reason why the accepted best Marine and Broadcast Receivers are exclusively POLAR-Equipped is that this Condenser offers better operating principle. It works on an open scale, the first $\frac{1}{4}$ of which contains only $\frac{1}{10}$ th of the condenser's capacity, thus permitting an absolute vernier over the section scale mainly used.

Compared with the ordinary vane type of condenser, therefore, in which HALF the capacity is cramped and crowded into the first $\frac{1}{5}$ th of the scale, the superiority of the POLAR is obvious to every thoughtful amateur.

POLAR Condensers are supplied by all POLAR STOCKISTS in the following capacities:—·001; ·0002; ·0003; and ·0005.

Unmounted, price 14/- Mounted, Price 20/-

We are exhibiting at the N.A.R.M. Exhibition, White City, Nov. 8th—21st.

RADIO COMMUNICATION CO. LTD.,
34/35, NORFOLK STREET, LONDON, W.C.2.

POLAR

DYER
FLEET

The new
AMPLION

*Renders all other
Loud Speakers obsolete*

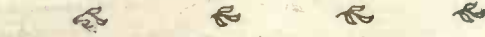

BY reason of the advanced electro-magnetic system and the improved non-resonating sound conduit with wood trumpet standardised throughout the 1924 Models of the AMPLION now introduced, are "head and shoulders" above other makes. Yet an AMPLION costs no more although the value is incomparably greater.

The association of a 1924 AMPLION and a suitable Wireless Receiving Set means better reproduction—increased volume with greater clarity and truly natural tone.

New AMPLIONS at popular prices are:—

The Junior-de-Luxe design at	£3 5 0
Curved Horn or "Dragon" pattern	£5 5 0
Swan-neck or "Music Master" style	£6 0 0
The Portable "All-Purpose" model	£6 6 0

AMPLION Loud Speakers are standardised by the leading producers of Radio Receiving Sets and stocked by all Wireless Dealers of repute.

The Portable Amplion is fully detailed in Booklet W.D. 3, and Folder W.D. 8 describes the Amplion range for 1924.

Prices from £2-2-0

These catalogues will be forwarded with the greatest pleasure

"Buy British Goods Only."

We are Exhibiting at the
National Association of Radio
Manufacturers Exhibition,
White City, Stand 113, Nov-
ember 8-21.

Patentees and Manufacturers:
ALFRED GRAHAM & COMPANY
(E. A. GRAHAM).
St. Andrew's Works, Crofton Park, London, S.E.4.
Telephone Nos. Sydenham 2820-1-2
Telegrams: Navalhada, Catgreen, London.
West End Showrooms:
The Algraphone Salon,
25-26 Savile Row, Regent Street. W.1.
Telephone: Regent 1075.
Telegrams: Sonalera, Pccy, London.



THE REFTY CRYSTAL CUP is UNDOUBTEDLY THE MOST SATISFACTORY AND THE FINAL SOLUTION OF ALL THE TROUBLES OF THE CRYSTAL USER. IT IS ONE OF A SERIES OF WINNERS PRODUCED BY **REFTY ELECTRICAL APPLIANCES LTD.**

THE PICTURES TELL THE STORY. The screws are No. 4 B.A. x 1/4" and can be used either way up.

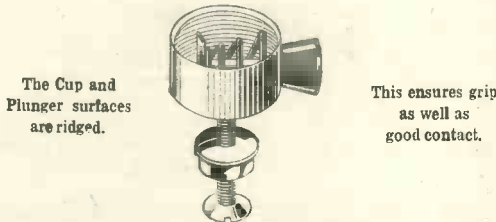

PULL KNOB! INSERT CRYSTAL! LET GO!

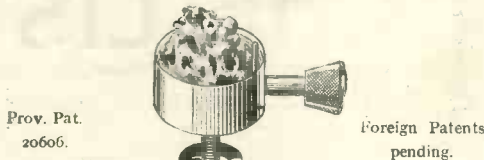

6^D EACH.

MORE REFTY TIME-SAVERS

- No. 1. Lacq. 10 1/2d. each. Ebonite top.
- No. 2. Lacq. 6d. each. All brass.
- No. 4. Lacq. 1/- each. Ebonite top.

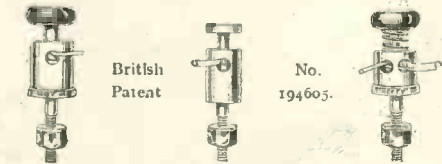

- No. 1a. N. Plate. 11 1/2d. each.
- No. 2a. N.P. 7d. each.
- No. 4a. N.P. 1/1 each.

Depress Knob! INSERT WIRE! LET GO!
THE TERMINAL WHICH IS AS GOOD AS A SOLDERED JOINT
 yet which is connected or disconnected in an instant AND CANNOT POSSIBLY SHAKE LOOSE.

Hundreds of Dealers Stock REFTY Products. Here are some of them. If your dealer doesn't—send cost plus postage for direct delivery.

- N.22. Goodchild, Chapman & Co., 357, High Rd., Wood Green.
- N.W.3. G. Richardson, 32, Heath Street, Hampstead.
- N.W.4. W. E. Wilson, 138, Finchley Road.
- S.W.2. Victor F. Lyon, 182, Tulse Hill.
- S.W.4. C. A. Walker, 37, Old Town, Clapham.
- S.W.15. R. Russell, 173, Upper Richmond Road.
- E.C.2. Piggott Bros., 220, Bishopsgate.
- E.C.4. S. E. Bland, 82a, Queen Street, Cheapside.
- S.E.1. E. Griffin & Co., 80, Newington Causeway.
- S.E.5. Freeman's Garage, 92, Camberwell Road.
- S.E.23. W. L. Andrewartha, 61, Dartmouth Road, Forest Hill.
- W. Lucas & Co., 390, High Road, Chiswick.

REFTY ELECTRICAL APPLIANCES LTD.

2, FEATHERSTONE BUILDINGS, HOLBORN, LONDON, W.C.2
 Telephone: Chancery 8264. Telegrams: "Reftinal," Holb. London.

"Buy British Goods Only"

NEW!
THE

EDISWAN

Toovee



This 2-Valve Set is astonishing the radio world by the remarkable results obtained. 2 L.O. 10 miles away is clearly received on the telephones, without using an aerial or earth. A novel circuit is used, employing dual-amplification combined with reaction (passed P.M.C.), and there are many constructional refinements including a switch which allows either one or two valves to be used and the H.T. and L.T. to be switched off without disconnecting any wires. The controls are easy to learn and it is a simple matter to receive any Broadcasting Station.

Complete with all accessories, Price **£18 0 0** Instrument only, including batteries. **£16 0 0**
 (B.B.C. Tax 17/6) (B.B.C. Tax 17/6)

Write to-day for leaflets fully describing our range of Sets and Parts. If your dealer does not stock send us his name and address. We'll see that you get what you want. Free on request. Just send a postcard for our Illustrated Booklet "The Thermionic Valve."

We are exhibiting at the
 N.A.R.M. Exhibition, White City, November 8th—21st.
 STAND No. 87.

The EDISON SWAN ELECTRIC Co., Ltd.

123/125, QUEEN VICTORIA STREET, E.C.4, and 71, VICTORIA ST., S.W.1

Branches in all Principal Towns.
 Works: Ponders End, Middlesex.



Contractors to H.M. Admiralty, War Office, Royal Air Force.

E. J. GALPIN,

16, Loampit Hill, Lewisham, S.E.13.

Lee Green 1531.

GOVERNMENT SURPLUS STORES.

D III. Buzzers with screws, less contacts, 1/- each.
Fullerphone Buzzers complete, in working order, 3/- each.

2 Volt 15 Amp. Accumulators, new, 5/- each.
Highly Sensitive Microphones, new condition, for transmission work, 2/- each.

M II. Portable Telephones, complete and perfect, containing Earphone, Microphone, Telephone transformer, Bell Set, Generator, etc. Telephone 150 ohms. Polished teak case. 12/6 each.

2 MF Condensers, Mansbridge, each tested to 1,000 volts, 2/6 each.

.025 Condensers, Mansbridge, every one tested, 6d. each.

R.A.F. Transmitting Sets, all complete and perfect, will transmit 10 miles on four volts. No licence required to buy. 15/6 each, post 1/-. Worth four times as much to break up.

Tapping Keys, small and compact, complete with contacts, 2/6 each.

500-ohm Choke Coils, 1/- each.

Telephone Transformers, 2/6 each.

Plug and Jack, complete, 2/-.

1" Wireless Spark Coils, new, every one tested; useful as modulation transformers, etc. Nickel fittings, ebonite panels. 6/6 each, post 9d.

Telephone Generators, as new, for generating HT current, or, if rewound, make good dynamos, 4/- each.

2 Volt 10 Amp. Accumulators in ebonite cases, 3/- each.

Lucas Long Range Daylight Signalling Lamps, new, complete with 4 bulbs, Morse key, long flexible leads, coloured glasses, earth pin and book of instructions, strong waterproof case with leather carrying strap, 15/- each.

Leading in Wire, 30-foot lengths, rubber covered, 1/- per coil.

P.O. Type Galvanometers, by General Electric, Silvertown, Walters, etc., 15/- each.

Mirror Reflecting Voltmeters, 0-24 volts, fine reading dead beat. Makers: Everetts. £2 each.

ETC. ETC. ETC.

SPECIAL LINE.

Brown's Featherweight Phones, 4,000 ohms, new " " " Pair **22/6**

Write for fully detailed price list of all ex-Government Stock and new Wireless Goods of every description at very low prices

150-ohm Earphones for Wireless work each 4/-

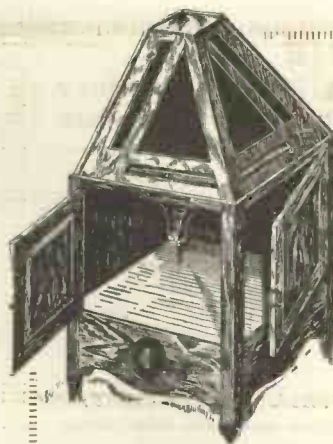

The "Chello" LOUD SPEAKER Cabinet

Overall 13½" sq. by 24" high
Compartment 12½" sq. by 9½" high
In rich dark oak,
£3 0 0
Carr. fd. Packing 2/6 ret.
Or fitted with Standard Amplion,
£6 5 0

The MASTER COMPONENT

Just the thing for building up a *worth while* amplifier or a complete receiving set. An elegant and distinctive cabinet ingeniously combined with a mellow toned wood sound box of unique design and proved efficiency. Replaces the ugly horn type loud speaker and provides an excellent wireless compartment with panelled doors.

For new wireless ideas, write or 'phone

CHELLIS

(Chambers & Ellis)

6 & 7, CRAVEN HOUSE, KINGSWAY, LONDON, W.C.2.

Phone: Regent 1130.

(F.P.S.5.)

Wickens' Wireless Message Recorder

A new book for the Experimenter. It contains a large number of blank leaves with such printed headings as:—Inventory of Receiving Set, Wireless Library, Inventory of Workshop, Material and parts in stock, Memo of Circuits, etc., Wireless Message Records, Technical classified pages for press cuttings, etc., together with a copy of the Morse Code on fold-over sheet. An exceedingly useful Book for any Wireless enthusiast.

Postage 3d. extra.

2/6

RADIO PRESS, Ltd., Devereux Court, STRAND, W.C.2

Direct orders only accepted.

Radio Press Information Department

QUERY COUPON

WIRELESS WEEKLY. Vol. 2. No. 15. Oct. 24, 1923

(This coupon must be accompanied by a postal order of **2/6** for each question, and a stamped addressed envelope.)

"IGRANIC" RADIO DEVICES

Insist on

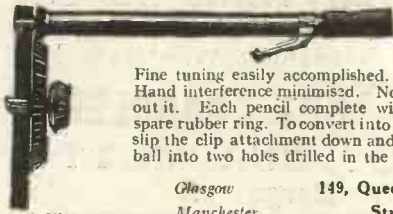

**VERNIER
FRICTION
PENCIL**

Fine tuning easily accomplished. Positive friction drive. Hand interference minimised. No radio set complete without it. Each pencil complete with three bushes and one spare rubber ring. To convert into an anti-capacity adjuster, slip the clip attachment down and insert the brass pin and ball into two holes drilled in the knob - Price 2/-

Glasgow
Manchester
Bradford.

149, Queen Victoria
Street,
LONDON.



INTERVALVE TRANSFORMERS.

Designed for the distortionless reproduction of speech and music. The steel shroud effectively shields from external interference. Recent improvements in design render it the finest amplifying transformer obtainable.

Prices: Shrouded, 21/-; Open, 20/-



Shrouded Type
INTERVALVE
TRANSFORMER.

Works:
Elstow Road,
BEDFORD.

Newcastle
Cardiff
Birmingham.

Write for
Lists Y 11

Last Few Days—Final Bargains from

**GAMAGES
GREAT Wireless SALE**

It is not given to Wireless Enthusiasts the opportunity every day to purchase Equipment of the very highest quality at "Bargain Prices." Order at once to secure them. Special Display of Apparatus by leading Makers.

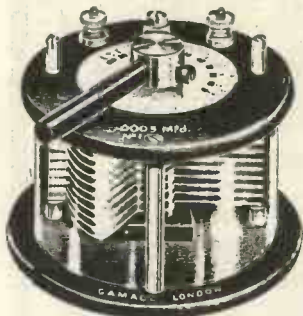

VARIABLE CONDENSERS

of our usual well-known design.
Sale Price List Price
'00045 7/- 14/9
'0003 6/9 13/-
Postage on each of above 6d. extra.

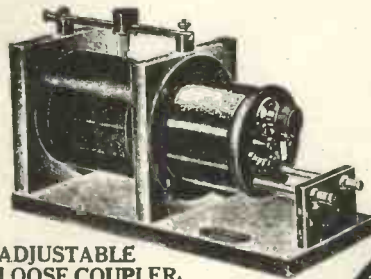

**ADJUSTABLE
LOOSE COUPLER.**

Tapped on Secondary, covering band of wave-lengths 300 to 1,000 metres. The most efficient for shorter wave-lengths, especially with crystal receivers. Ten per cent. better results than the ordinary "tight" type. Especially effective when used with a variable Condenser, either in shunt or series. SALE PRICE

27/6

Post free. List Price 37/6.

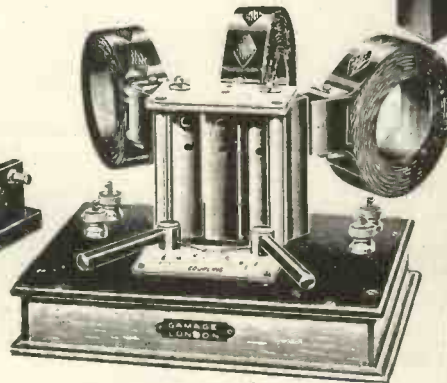

COIL HOLDERS.

Special offer of our usual best quality Coil Holders. Size of base 8" x 6" x 5". SALE PRICE 20/- Usual Price 30/- Post 9d.

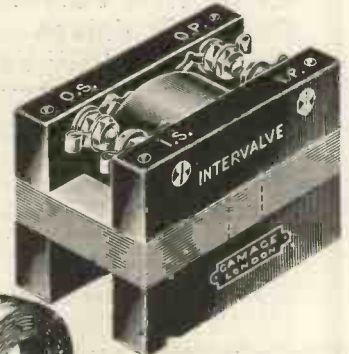

L.F. TRANSFORMER
for Panel Mounting. Low frequency type, highly efficient, small and compact. Ratio 5 to 1. Post 6d. SALE PRICE 12/6

SUNDRIES.
Terminals, 1/-, 1/6 and 2/- per doz.
Paraffin Wax. Per lb. 9d
Shellac Varnish. Per bot. 6d.
Contact Studs. Per doz. 1/3
Telephone Plugs. Each 1/6
Special Line of Telephone Jacks offered to clear at 6d. each
Postage extra on all the above items

The best crystal is
"PERMANITE"
(Regd. No. 43341)
CRYSTAL.

Highly sensitive and remains in adjustment longest. Clear powerful results. Price per large specimen 1/6 Post free.

A. W. GAMAGE, LTD., HOLBORN, LONDON, E.C.1.

WIRELESS AUCTION Sets & Accessories.

Complete Crystal Receiving Sets, Variable Condensers, China Insulators, Loud Speakers, Brown's Reed Type Headphones, Three Valve Amplifiers.

Complete shop soiled Receiving Sets of well-known makes.

Complete Ex-Government Transmitting and Receiving Sets, B.M.II. Short Wave Tuners, Sullivan's Ex-Government Headphones, also Ex-Government and New Miscellaneous Wireless Material.

OUTHWAITE & LITHERLAND,
AUCTIONEERS AND APPRAISERS.
49/51, SOUTH CASTLE STREET, LIVERPOOL.

TUESDAY, OCTOBER 30th, 1923, at 12.30 o'clock.
On view Monday, October 29th, from 10 a.m. to 6 p.m. Catalogues on application.

MICA CONDENSER PLATES

&
INSULATING MATERIALS OF EVERY DESCRIPTION.

MICA & MICANITE SUPPLIES, Ltd.,

MICA HOUSE, OFFORD STREET, CALEDONIAN RD., LONDON, N.1 'Phone North 805.

OVER HALF A MILLION SATISFIED CUSTOMERS WIRELESS! WIRELESS! WIRELESS! and EVERYTHING for it. DON'T PAY MORE!

PIONEERS OF Great Britain's largest
CHEAP PRICES. exclusive Wireless Stores.

NOTE. We are exclusively WIRELESS — NOT DABLERS!
QUALITY, QUANTITY, AND CONSISTENCY OUR MOTTO.
See Our Six - Window Display of Popular Bargains.

We offer for the first time the new "FELLOWS" **18/6** Special offer — Sterling
Lightweight Headphones, 4,000 ohms. A masterpiece of workman-
ship. A guarantee with every pair. Honestly worth 30/- Per pair. New Lightweight Headphones. **19/3**
Stamped B.B.C., 4,000 ohms. Our Price.

ELKAY LIGHTWEIGHT BRUNET 'Phones. The N. & K. 'PHONES. The
Headphones. 4,000 ohms 12/9 genuine article .. 13/11 Genuine article. Our Price 12/9

EDISWAN Valves .. 12/3 }
COSSOR Valves .. 12/3 } Bankrupt Stock and of Limited
MARCONI "R" Valves 12/3 } Quantity. Guaranteed all New

MULLARD "ORA" Valves 12/3
EDISWAN DULL EMITTER.
Our price .. 25/9

DUTCH VALVES .. 6/11	STOPS, with nuts .. per doz. 6d.	VARIABLE CONDENSERS of high quality. With aluminium top and bottom plates: Complete with knob and dial, guaranteed accurate: Vernier .. 3/-
PHILLIPS DUTCH VALVES .. 7/11	FILAMENT RESISTANCES, smooth action, marvellous value .. 1/10	'0002 .. 4/6
L.F. TRANSFORMERS Ratio 5 to 1. All guaranteed (postage 1/-) .. 11/3	With engraved dials .. 2/9	'0003 .. 5/8
CRYSTAL DETECTORS .. 1/9, 1/3 and 10/d.	SLINGER SPRINGS, complete .. each 1d.	'0005 .. 6/-
CRYSTAL DETECTORS, enclosed in glass case, 2/6, 2/3, 1/6	SLIDER ROD, brass, 13ins. long, 1/4in. square, drilled .. 3/d.	'00075 .. 7/-
AERIAL WIRE, 7/22, guaranteed hard-drawn copper, 100 ft. (postage 1/-) .. 1/10 1/2	SLIDER KNOB .. each 2d.	'001 .. 8/-
CONDENSER VANES, fixed or moving, per doz. 3/d.	SWITCHES ON EBONITE, S.P.S.T. (quality the best) .. each 1/6	O.B.A. NUTS .. per doz. 4d.
REAL GOLD CAT'S WHISKERS .. each 2d.	SWITCHES ON EBONITE, S.P.D.T. (quality the best) .. each 1/11	DETECTOR ARMS, Ball Joints, Ebonite Handle and Whisker Holder .. 3/d.
REAL GOLD CAT'S WHISKERS .. per doz. 1/5	SWITCHES ON EBONITE, D.P.D.T. (quality the best) .. each 2/9	WOOD SCREW TERMINALS .. each 1/d.
SILVER CAT'S WHISKERS .. each 1d.	CONDENSER SPINDLES, all sizes in stock, from .. 1/d.	SHELLAC .. per bot. 10/d. and 6d.
SILVER CAT'S WHISKERS .. per doz. 7d.	SCREWED ROD, 2 B.A., 12ins. long .. each 3d.	AERIAL PULLEYS .. from 4/d.
CONDENSER SCALES, 0 to 180 .. each 3/d.	SCREWED ROD, 4 B.A., 12ins. long .. each 2/d.	TIN FOIL .. large sheet 4d.
IVORINE LABEL SET, 12 different titles, the set 6/d.	RUBBER-INSULATED LEADING-IN WIRE .. per yd. 1 1/2d. and 2d.	COPPER FOIL, 6in. wide .. per ft. 5d.
BASKET COILS, set of 6, up to 3,000 metres ... 2/4	INSULATORS, white reel, 2in. each 1d. per doz. 11d.	GRID LEAKS, 2 1/2 and 2 meg. .. each 10/d.
SLEEVING, 3 yds. assorted colours, for .. 11/d.	INSULATORS, white egg, each 2d. ... per doz. 1/8	FLEX (Twin), various colours .. per yd. 2d.
NUTS, 2 B.A. .. per doz. 2/d.	WOUND INDUCTION COILS (postage 9d.): 12x4 9x4 8x2 1/11 6x3 6x2 2/5 2/3 1/8 1/5	CONNECTING WIRE, tinned copper, 20 gauge 3 yds. 2d.
NUTS, 4, 5, 6 and 8 B.A. .. per doz. 2d.	TAPPED INDUCTANCE COILS, 20 tappings, wound to 1,000 metres .. each 1/11 and 2/3	ENAMEL WIRE, in 1/2, 1/4 and 1 lb. reels: 22 24 20 28 per lb. 2/4 2/8 3/2 3/8
WASHERS, 2 B.A. .. per doz. 1d.	VARIOMETERS (Tube type), complete with knob .. 3/11 and 2/11	Note: Bobbins 2d. each extra.
WASHERS, 2 B.A. .. per doz. 1/d.	DOUBLE 'PHONE CORDS, full length .. 11/d.	POTENTIOMETERS, guaranteed up to 900 metres, superior make, compact size .. 7/3
CONTACT STUDS, with nuts and washers, per doz. 4d.	HERTZITE, Genuine Large Piece .. 9/d.	CRYSTAL DETECTOR, glass enclosed, fitted on 4x2 ebonite panel with terminals for aerial, earth and 'phones, already wired and beautifully finished .. 4/9
TERMINALS, with nut and washers, each 1d., 1 1/2d. & 2d.	TALITE, Genuine Large Piece .. 9/d.	BATTERIES, H.T., dry: 36 volts, including Wander Plugs .. 5/9
EBONITE KNOBS, 2 B.A. .. each 2 1/2 & 3d.	PERMANITE, Genuine Large Piece .. 9/d.	60 volts, including Wander Plugs .. 9/8
SPACING WASHERS, large .. per doz. 2/d.	ZINCITE, Genuine Large Piece .. 8d.	FILAMENT RESISTANCE DIALS .. 9/d.
SPACING WASHERS, small .. per doz. 1/d.	BORNITE, Genuine Large Piece .. 6d.	AMALGO-PLASTIC METAL, for fixing crystals. No Woods metal necessary .. 6d.
CRYSTAL CUPS, 2 screw .. each 1d.	MIXED CRYSTALS (6 kinds) .. 9d.	GOLD SEAL PLASTIC METAL, for fixing crystals .. 6d.
CRYSTAL CUPS, 4 screw .. each 2d.	CARBORUNDUM .. 5/d.	IVORINE NAME-PLATES, all readings each 1d. per doz. 9d.
FIXED CONDENSERS, all capacities. .. each 10/d.	ZINCITE and BORNITE, both in box .. 1/-	EARTH CLIPS, Copper, adjustable .. each 5 1/2d.
EBONITE, cut to any size by machinery while you wait .. per lb. 3/6	COIL PLUGS, real ebonite .. 1/3, 10/d., and 9/d.	RADIONETTE CRYSTAL SET, complete, stamped B.B.C. and including one pair 4,000 ohms 'phones, 100ft. 7/22 aerial wire, 4 insulators, lead-in tube, 6 yds. lead-in insulated wire and adjustable earth clip. Ready to listen-in. Honestly worth 3 gns. .. 36/6
TELEPHONE TERMINALS, nuts and washer, each 1/d. .. per doz. 1/3	H.F. PLUG TYPE TRANSFORMER: 1. 250 to 600 metres .. 3/9	RADIONETTE ONE-VALVE L.F. AMPLIFIER for above .. 34/6
W.O. TERMINALS, nuts and washers .. each 2d.	2. 350 to 700 .. 4/-	GABINETS, all sizes in stock.
PAÑEL BUSHES, drilled .. each 1 1/2d.	3. 500 to 900 .. 4/3	
TOP CONDENSER bushes .. per doz. 1/d.	4. 800 to 1350 .. 5/6	
EOTTOM CONDENSER bushes .. each 1d.	5. 1600 to 3200 .. 4/9	
BELL WIRE, tinned copper, 12 yds. .. 6d.	6. 2200 to 5600 .. 5/-	
SWITCH ARMS, 4 laminations, ebonite knob, complete with panel, bush, nuts, and spring washer .. 8 1/2d.	FILAMENT COMPLETE CIRCLE RESISTANCE SCALES, 0 to 300 .. each 6d.	
VALVE LEGS, nut and washer .. each 1d.	EBONITE CONDENSER KNOB AND DIAL .. 1/9	
VALVE PINS, nut and washer .. per doz. 10d.	SUPER QUALITY 2-WAY COIL HOLDER .. 5/3	
" " " .. each 1d.	REAL EBONITE 3-WAY COIL HOLDER .. 7/9	
" " " .. per doz. 9d.	VALVE HOLDERS .. each 1/3, 1/- and 9 1/2d.	

IMPORTANT NOTICE. In view of the enormous increase in our Mail Order business, we wish to inform our customers that all post orders are dealt with in strict rotation and at the earliest possible moment.

Follow the crowd to Elkay Corner.

Make no mistake when you call on us.
SEE THAT YOU ARE AT ELKAY'S

"ELKAY" WIRELESS CO.,
225 & 227, BISHOPSGATE, LONDON, E.C.2.
Open Saturday all day. (To the Trade—New Trade Counter now open.) Wholesale, Bishopsgate 2313.
We open Sundays 11 to 2.30. Special Terms to Radio Clubs. Note our Telephone Nos: Retail, Central 8544.
PLEASE REMIT AMPLE POSTAGE.
SAVE MONEY BY STUDYING OUR ADVERTS.



HOME ASSEMBLY SET



M.H.3.
 One High Frequency Valve—
 One Detector Valve—One
 Low Frequency Magnifier
Price £7 : 7 : 0

Complete, clear and concise instructions for assembling are supplied with each set.

Illustrates Completely Assembled Set.

Within twenty miles of a station of the British Broadcasting Company with the aerial allowed by the Postmaster-General this set will work a loud-speaker. Our **Home Assembly Sets** are made up from the actual components used in our well-known M.H. Sets. Select your needs from these:—

- M.H.1.—One Detector Valve, Price £3 7s. 6d.
- M.H.2.—One High Frequency Amplifying Valve—One Detector Valve. Price £4 10s. 0d.
- M.H.4.—One High Frequency Valve—One Detector Valve—Two stages Low Frequency Magnification. Price £10 0s. 0d.
- M.H.4.R.—One High Frequency Valve—One Detector Valve—Two stages of Magnification. Price £11 0s. 0d.
- M.H.4.R.T.—As M.H.4.R., but with telephone transformer and change over switch. Price £11 11s. 0d.
- M.H./L.C.—Tuner. Price £4 17s. 6d.
- M.H.2.A.—One Note Magnifier. Price £3 7s. 6d.
- M.H.2.B.—Two Note Magnifier. Price £4 15s. 0d.

L.M. MICHAEL LTD Buy British Goods Only
 Visit our STAND No. 83 at the All British Wireless Exhibition, White City, Nov. 8th—21st.

IN CONJUNCTION WITH **B. HESKETH LTD**
 Showrooms: **RADIO CORNER, 179, STRAND, W.C. 2.**
 All correspondence to Head Offices:
HASTINGS HOUSE, NORFOLK STREET, STRAND, LONDON, W.C. 2.

FREE

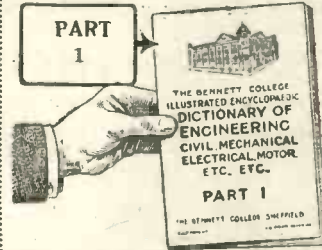

To extend the name of the Bennett College to everyone engaged in the different branches of Engineering, we are publishing an **Illustrated Dictionary of Engineering**, in about 24 MONTHLY PARTS (16 pages each part). You can have each monthly part as it comes out, FREE.

1/- Postage only to pay

The Dictionary is free to those engaged in any of the following trades: *Engineering, Civil, Mechanical, Electrical, Structural, Motor, Sanitary, Boiler, Internal Combustion, Draughtsmanship, Marine, Shipbuilding, Naval Architecture, Building, Architecture, Quantity Surveying, Aviation, Chemistry, Foundry Work, Metallurgy, Matriculation, Mining, Surveying and Levelling, Telegraphy, Telephony, Wireless*, and the conditions are that you send your name and address, your age and occupation, with one shilling (to cover postage on the 24 parts), writing your name and address very clearly. We shall then place your name on our Free List and send you part 1 at once. The others will be forwarded as issued.

We teach above trades by Post: particulars Free.

Department D 133,
The Bennett College,
Sheffield.

READ!!

Dear Sirs, Taunton, Som.
 The other day I wrote you stating that I had been receiving Newcastle and Manchester on your Super Crystal Set.
 It may interest you further to know that yesterday evening I got Glasgow very well indeed on two pairs of phones.
 This astounds me, and furthermore I found I could pick up at my pleasure Newcastle 275 miles, Manchester 175 miles, London 150 miles, and Cardiff 35 miles, also of course, as I have stated, Glasgow at a distance of 350 miles.
 All I had to do was to tune in to their respective wavelengths and I immediately got what was going on. This is corroborated by my wife, who was listening in with me, for, as I have said, this extraordinary reception was with two pairs of phones, which makes it all the more astounding, but nevertheless a fact.
 I am, Yours faithfully, E. S. S.

We have plenty of testimonials like the above and are selling over 500 specimens of our

"NATIONAL"

Super Crystal Combination

which is Used on Above Set and to which We Attribute the Wonderful Results.

"There is nothing to approach it."

TESTED SPECIMENS IN SEALED BOXES:
 1/9 Half Size. 3/- Full Size.

THE "NATIONAL" SUPER CRYSTAL SET is the one and only which receives broadcast telephony up to 110 miles.

Price £1-17-6 (Regd. G.P.O. Design. No. 441.)
 If stamped B.E.C. 1/- extra.

WRITE FOR FULLER PARTICULARS.

NATIONAL WIRELESS & ELECTRIC Co.
 7a, Church Rd., Acton, W. 3, and 79, Cannon St., London, E. C.

Telephone: Chiswick 2266.

Come and See Our Testimonials.

"ATLAS" THE COIL SUPREME.

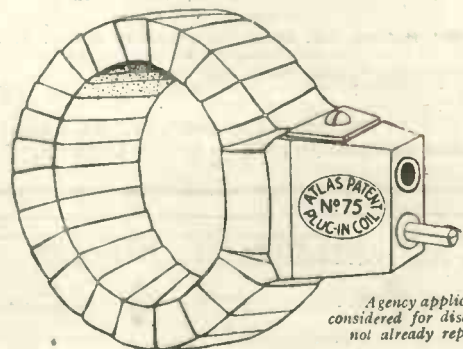

Agency applications considered for districts where not already represented.

The last word in efficiency. Maximum Inductance. Minimum Self-capacity. All Wave-Lengths covered.

Prices on application. Radio Components Catalogue on request.

Manufactured only by

H. CLARKE & CO. (M/cr.), LTD.,
 Radio Engineers,
ATLAS WORKS,
OLD TRAFFORD, MANCHESTER.

Telephone Nos.: 683 & 793 Trafford Park.

Telegrams: PIRTOID, Manchester.



2-VALVE RECEIVING SET No. 520.

W. G. PYE & Co.

Scientific Instrument Makers,
CAMBRIDGE, ENG.

Wireless Receiving Apparatus of the
Highest Possible Efficiency,
Greatest Selectivity,
Easiest Tuning,
Best Quality Workmanship,
Moderate Price.

Our Wireless Apparatus is of the same high quality as our general Scientific Apparatus, and **WE INVITE COMPARISON ON ANY AERIAL** with Receiving Apparatus of any make. Let us send you details of our 2, 3 and 4 Valve Sets.

All our Receiving Sets are approved by the Postmaster General.



First Quality Goods Only.

Postage Free.

- | | |
|---|--|
| HEADPHONES : | SWITCH ARMS, one quality |
| Brunet, Genuine, 4,000 ohms. 17/6 | only, beautiful finish 1/- |
| N. & K., 16/- | |
| Fellows, latest "type," weight 6 ozs., 4,000 ohms. 18/6 | DUBILIER FIXED CONDENSERS : |
| Ericsson, Continental, 4,000 ohms. 15/- | .0001 to .0005 2/6 |
| | .001 to .005 3/- |
| TRANSFORMERS : | Grid Leaks 2/6 |
| Power, guaranteed 12/6 | |
| Forno, shrouded type, guaranteed 18/6 | VARIOMETERS, our very special |
| Igranic, highly efficient 21/- | type, complete knob and dial, 250-600 metres 4/6 |
| Radio Instruments 25/- | |
| ACCUMULATORS : | VARIABLE CONDENSERS. Another of our special lines, with round top and bottom ebonite plates, fully assembled complete with knob and dial, as follows— |
| Rotax, 4 v. 40 amps. } Post- 17/- | .0001 8/6 |
| C.A.V., 6 v. 40 amps. } age 26/- | .00075 8/- |
| C.A.V., 6 v. 60 amps. } extra 36/- | .0005 7/6 |
| Oldham, 6 v. 60 amps. } 35/- | .0003 7/- |
| | .0002 6/6 |
| FILAMENT RESISTANCES : | .0001 5/6 |
| Forno, silk action 2/6 | Vernier 4/9 |
| COIL HOLDERS : | |
| 3-way, very fine value 5/9 | |
| 2-way, very fine value 4/6 | |
| Single (for panel mounting) .. 1/- | |

AERIAL WIRE (Pirelli) hard drawn, 7/22 (Postage extra), 2/6

All types of Valves in Stock at Standard Prices.

Huge Stocks of Terminals and all Brass parts.

FOWLER & BRIGDEN,
130, Euston Road, King's Cross, N.W.1.
Telephone: Museum 4827.

Wireless Telephone & Telegraph Accessories (ex. Govt. Surplus.)

THE AUCTION ROOMS,
13, HIGH HOLBORN, W.C.1.

HENRY BUTCHER & COMPANY

Have been instructed to SELL by AUCTION as above on
THURSDAY, NOVEMBER 8th, 1923,
at 10.45 a.m. precisely,

LARGE QUANTITIES OF WIRELESS ACCESSORIES ELECTRICAL & MISCELLANEOUS STORES,

comprising approximately
700 PORTABLE TELEPHONES. 750 HAND PHONES.
100 SIMPLEX TELEGRAPH SETS. 1,000 PRS. HEADPHONES. 900
Single Earphones. 6 Telephone Exchanges. Aerial Wire, Aerial Poles,
Black Enamelled Wire. 20 MILES TWIN ELECTRIC CABLE. 16 3-Valve
Amplifiers. 1,200 Resistance Coils. 250 Buzzers. 200 CRYSTAL SETS,
fitted with best Crystal and ready for use. 2,000 sheets thin Ebonite
5 cwt. Ebonite Rod. 250 NEW ACCUMULATORS. 20 Transmitters
6,000 Insulators. 100 sheets Red Fibre. 150 Battery Boxes. 1,200
Resistance Coils. 150 Indicators. 40 NEW BELL SETS. 100 lbs. COPPER
STRIP. 350 DAYLIGHT SIGNALLING LAMPS, etc., etc.

On View NOV. 5th, 6th and 7th, and MORNING OF SALE.

Catalogues (when ready) may be obtained from
HENRY BUTCHER & CO., Auctioneers, Valuers and Surveyors,
Telephone: Holborn 741 & 742. 63 & 64, Chancery Lane, London, W.C.2.
Telegrams: Penetrancy, Holb, London.

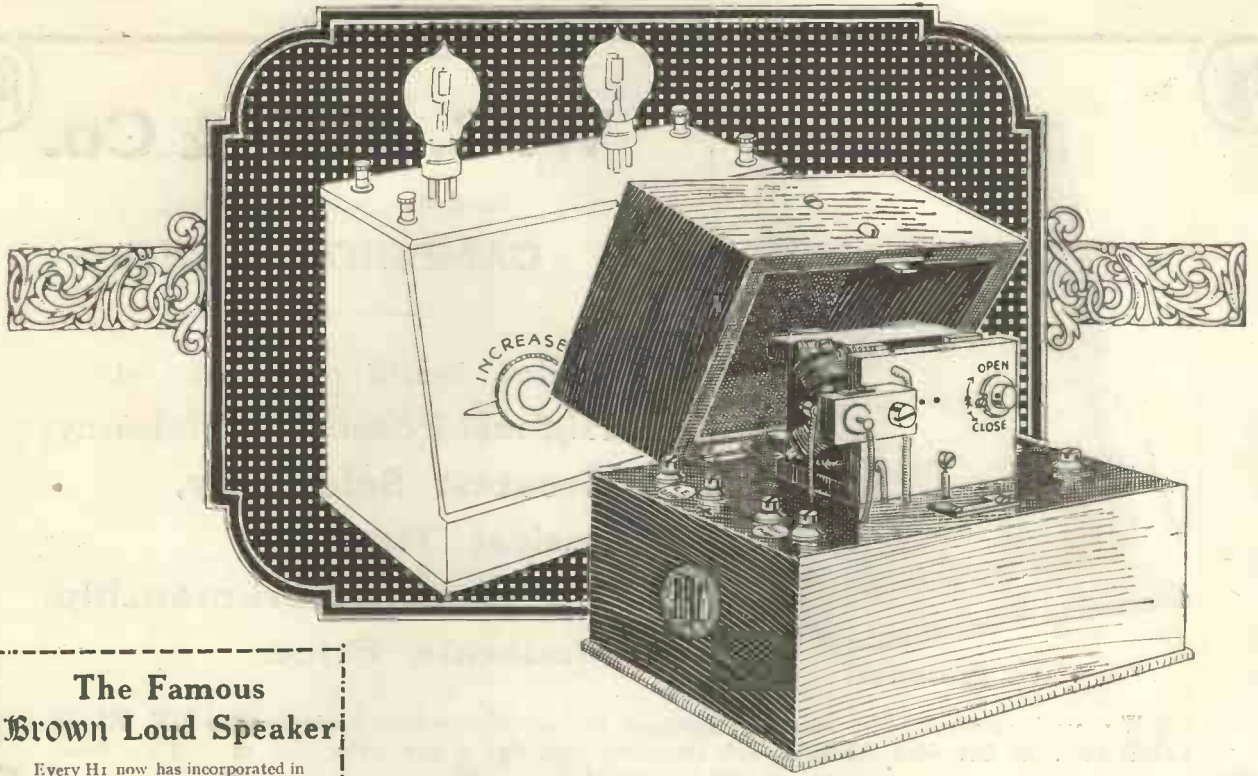

**The Famous
Brown Loud Speaker**

Every H1 now has incorporated in its base a Tone Filter—the latest development of the Brown Research Dept. Faults in transmission and other harsh sounds are now mellowed and purified automatically during actual reproduction. Hear one of these world-famed Loud Speakers at your Dealers—the purity of its tone will surprise you.

MODEL H1.		MODEL H2.	
120 ohms.	£5 5 0	120 ohms.	£2 5 0
2000 ohms.	£5 8 0	2000 ohms.	£2 8 0
4000 ohms.	£5 10 0	4000 ohms.	£2 10 0

From
all Dealers.



**Better and cheaper than
any 2-Valve Amplifier.**

If your Receiving Set gives good results in the Headphones and you want to use a Loud Speaker, there are two alternatives open to you.

You can add a 2-Valve Low Frequency Amplifier or you can use a Brown Microphone Amplifier.

The first method means the purchase and upkeep expenses of 2 Valves with a further drain upon your accumulator, together with the distortion and noises which are inseparable from the use of L.F. Transformers.

The Brown Microphone Amplifier, on the other hand, gives a pure and undistorted volume of sound greater even than two Valves, and the only running cost is a small 6-volt. dry battery, which lasts for months without replacement.

And its operation is simplicity itself. A vernier magnetic tuning device in the lid regulates the volume, and, once set, need not be altered for months.

If you would appreciate really loud and clear telephony, free from distortion, then you must certainly use a Brown Microphone Amplifier.

Brown

S.G. BROWN LTD. RETAIL: 19 MORTIMER STREET, W.1. WHOLESALE: VICTORIA ROAD, N. ACTON, W.3.

**Brown
Microphone Amplifier**

Input — 120 ohms }	£5 10 0
Output — 120 ohms. }	
Input — 2000 ohms. }	£5 13 6
Output — 120 ohms. }	
Input — 2000 ohms. }	£5 18 6
Output — 2000 ohms. }	



Radio Press Books give him all the information he needs

Complete List

	Price.	Post Free
1. Wireless for All John Scott-Taggart, F.Inst.P.	-/6	-/7½
2. Simplified Wireless John Scott-Taggart, F.Inst.P.	1/-	1/1½
3. How to Make Your Broadcast Receiver John Scott-Taggart, F.Inst.P.	1/6	1/7½
4. How to Erect Your Wireless Aerial B. Mitchell, A.M.I.E.E.	2/-	1/1½
5. The Construction of Wireless Receiving Apparatus P. D. Tyers.	1/6	1/9½
7. How to Make a "Unit" Wireless Receiver E. Redpath.	2/6	2/8
9. Wireless Valves Simply Explained John Scott-Taggart, F.Inst.P.	2/6	2/8
10. Practical Wireless Valve Circuits John Scott-Taggart, F.Inst.P.	2/6	2/8
11. Wireless Licences and How to Obtain Them E. Redpath.	1/-	1/6½
Elementary Text-book on Wireless Vacuum Tubes John Scott-Taggart, F.Inst.P.		10/- (Post free)

Those printed in heavy type have been published recently.

HOW many turns for a Coil to reach the Paris Wavelength—the type of circuit to operate a Loud Speaker using only an indoor Aerial—Crystal or Valve rectification in a multi-valve Set? These are a few of the questions which confront the amateur constructor.

Some will find out the correct answers by expensive experiment—others, more wisely, will benefit by the experience of those who have trodden the thorny paths of Radio before them.

The concentrated experience of some of the best known Wireless engineers and experimenters is available for all readers of Radio Press Books. You cannot do better than purchase the complete Library—one Book at a time. Each Book covers a different phase of Wireless and none overlap. Get one or two to-day and keep them by you for ready reference—they are sure to save their cost many times over. From all Booksellers.

RADIO PRESS LTD.,
Devereux Court, STRAND, W.C.2.

Radio Press Books
— a complete wireless library

Gilbert Ad.

A BRITISH STANDARD



The anniversary of the Broadcasting is now approaching, and even after a period of twelve months it has become a permanent British institution to render service to the public.

The great success of this Service has been largely due to the number of R.I. sets that have been used; these instruments have proved in practice that they are superior to all others.

In design, in finish, and in the positive knowledge there is nothing better in the British Wireless Industry, R.I. Sets stand absolutely alone.

They are scientifically designed.

They are easy to operate.

They are made by the best British labour.

They are the results of a quarter century's radio experience.

They have the confidence of the British public.

The illustrations show one of our latest models, all of which are now fitted with polished mahogany covers which can be closed without removing valves or leads.

We are confident these instruments are as perfect as modern radio science can make them.

All new models and components can be seen at our stand at the White City, and will be illustrated and described in a new catalogue which will be sent free on application.

Our showrooms are open till 7 p.m.



5 Valve set, new model. 300—4,000 metres.



4 Valve set, new model. 300—4,000 metres.



4 Valve set closed.

RADIO INSTRUMENTS LIMITED.

Managing Director: J. JOSEPH, M.I.E.E.

Chief Designer: W. A. APPLETON, M.B.E., M.I.R.E., Late Admiralty Technical Research Officer.

Only Address, Works, Offices, and Showrooms:

12, HYDE STREET, NEW OXFORD STREET, W.C.1.

Telephone: Regent 6214-6215-6216.

Telegrams: 'Instradio, London.'

Northern Depots: 19, HOPWOOD AVENUE, MANCHESTER, and TRINITY HOUSE, COMMERCIAL STREET, LEEDS.

Wireless Weekly

and The Wireless Constructor

Vol. 2.
No. 16.

CONTENTS

Some Modern Receiving Circuits.

A Crystal Receiver as a Wave-meter.

Broadcasting Problems.

A New High-Efficiency Coil.

American Broadcast Reception.

Ebonite.

Short Wave Reception, Wireless Reception in Northern Ireland, Random Technicalities, Jottings by the Way, Constructional Notes, Broadcasting News, Mainly about Valves, Correspondence, etc., etc.

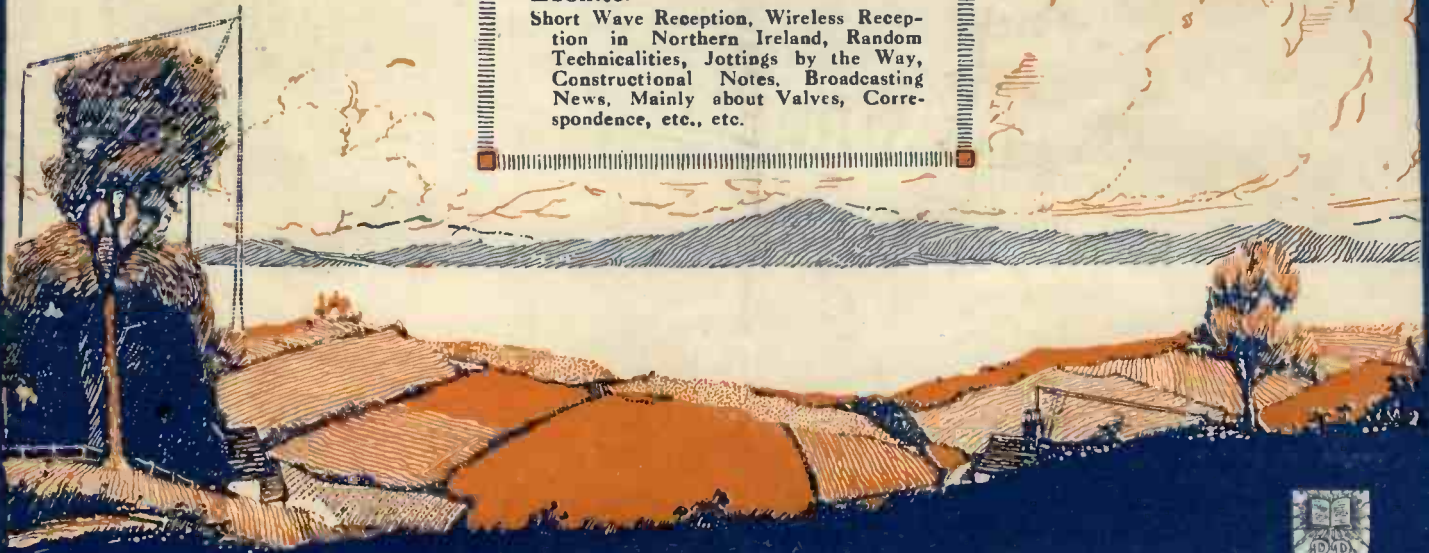

All Stations on a Frame Aerial.

NOW!

ADVERTISE!

The Best
Wireless
Advertising
Media.

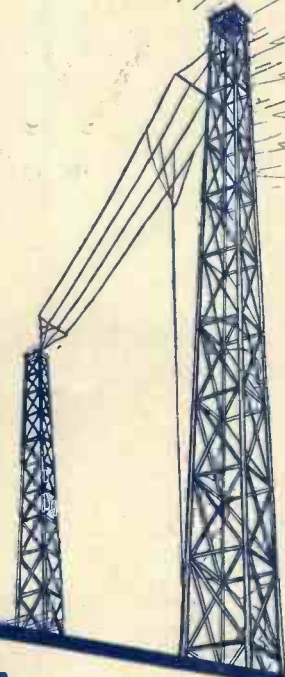

**YOU
MUST
BE
IN BOTH**

MODERN WIRELESS

Edited by JOHN SCOTT-TAGGART, F.Inst.P.

Vol. I, No 6



No. 6

TO BE OBTAINED FROM THE PUBLISHERS...
THE GREAT BRITAIN...
PUBLISHED BY THE...
LONDON: THE...
1923.

Wireless Weekly

SILVER
NET



Edited by
John Scott-Taggart F.Inst.P.

Scheff Publicity Organisation, Ltd.
125, Pall Mall, London, S.W.1.
Advertisement Managers for both papers.
Phone: Regent 2440.



Wireless Weekly

Vol. 2, No 16
Oct. 31, 1923.

CONTENTS

	<i>Page</i>
Editorial	552
Tuning Inductances of High-Efficiency ..	553
"Wireless Weekly" Circuits—No. 29 ..	554
Jottings by the Way	555
Trade Notes	556
A Crystal Receiver as a Wavemeter ..	557
Broadcasting Problems	558
Wireless Reception in Northern Ireland ..	559
American Broadcast Reception	561
Ebonite	562
Short Wave Reception	564
All Stations on a Frame Aerial	565
Random Technicalities	567
Some Modern Receiving Circuits ..	568
Constructional Notes	571
Broadcasting News	574
Mainly about Valves	576
Radio Press Information Department ..	577



Editor: JOHN SCOTT-TAGGART, F.Inst.P.

Assistant Editors { E. REDPATH.
P. W. HARRIS.

Radio Press, Ltd.

Publishers of Authoritative Wireless Literature
DEVEREUX COURT, STRAND, W.C.2

Tel.—Central 3763.

Advertisement { SCHEFF PUBLICITY ORGANIZATION,
Managers: { LTD., 125, Pall Mall, London, S.W. 1
Tel.—Regent 2440.

Staff Editors:

E. H. CHAPMAN, M.A., D.Sc.
A. D. COWPER, M.Sc.
G. P. KENDALL, B.Sc.
R. W. HALLOWS, M.A.
S. G. RATTEE.

Scientific Adviser:
Prof. G. W. O. HOWE,
D.Sc., M.I.E.E.
Advisory Editors:
Prof. R. WHIDDINGTON,
M.A., D.Sc.
Prof. C. L. FORTESCUE,
M.A., M.I.E.E.



All correspondence relating to contributions is to be addressed to the Editor of "Wireless Weekly."

Nothing contained herein is to be regarded as permission or encouragement to infringe any patent rights.

Editorial

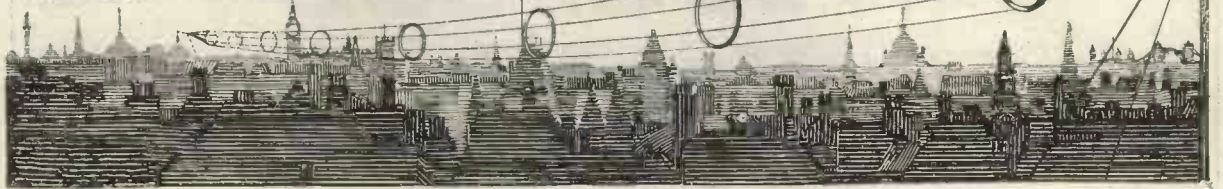

The Need for Joint Publicity.

THE time has now come when the wireless industry, as a whole, should endeavour to increase the popularity of broadcast listening.

Other sections of industry, such as lamp-makers, radiator manufacturers, and others, advertise their products in general to the British public. Why should not wireless manufacturers and traders combine to popularise wireless as wireless? It is much cheaper than individual firms advertising their products. Why should not organisations of manufacturers take space in the daily Press to persuade people to take up wireless? The British Broadcasting Company have themselves done nothing to popularise wireless telephony, except to produce programmes of a suitable character. This large organisation is receiving tens of thousands of pounds from the public. Why do not they devote some of this money to increasing the popularity of their wares? The results will be more licences and more money for themselves. Incidentally they will be greatly helping British industry at a time when it needs the fullest encouragement.

Trade organisations, such as the National Association of Radio Manufacturers, might well consider at this stage the advisability of launching a national scheme of propaganda which would benefit themselves. True, it might also benefit other trades who pay nothing towards the propaganda, but on the other hand, no such scheme is without its beneficial effects in often undesired directions.

The Wireless Exhibition, which commences on November 8, might well be the starting point of a strong publicity campaign.

Lunch-Hour Programmes.

When we first heard the lunch-hour programmes being sent out by the aid of a gramophone, we thought that it was merely a temporary arrangement due to incomplete

organisation. We said nothing, but a time has now come to draw attention to a very undesirable practice. The lunch-hour programme is treated as the "Cinderella," and apparently is given an absolute minimum of attention. We often hear it said that wireless is "like a gramophone"—and often that it is "like a cheap gramophone." These comments are usually made when loud-speakers are improperly employed. If a gramophone is used in the first place, under the most ideal conditions the results will not sound any better than a gramophone. When one considers all the intermediate stages in transmission and reception where distortion may occur, it seems grotesque that the British Broadcasting Company should go on deliberately grinding out gramophone records with the idea of pleasing the public.

Another point is, that during this lunch-hour programme wireless sets are being demonstrated with the object of selling them. What have the traders' association got to say about this? Are they willing to stand by and do nothing while the B.B.C. complacently send out mutilated music, which may be still further mutilated in the receiver? Do they not wish to have the best possible ether energy to work their receivers?

Moreover, the transmission of gramophone records is entirely unworthy of the B.B.C. It seems to be simply a question of slackness. Is it necessary to point out that in the agreement between the Postmaster-General and the B.B.C. it was implied that the latter were not to use this cheap and undignified method of entertaining, or annoying, the public? What is the Postmaster-General doing about the matter? We hope he will look into it.

More might be said about the Steinway Hall Sunday afternoon programme. A mechanical organ is all very well in its way, but are we not getting rather tired of the mechanical nature of this entertainment?

TUNING INDUCTANCES OF HIGH EFFICIENCY

By PERCY W. HARRIS, Assistant Editor.

A number of coils, as described, may be used in series for long-wave reception.

I HAVE been seeking for some time to find a simply wound inductance which would combine compactness with high efficiency. The form of coil about to be described is the most efficient I have yet been able to make, and it possesses the following highly desirable characteristics:—

- (1) The winding can be a uniform single layer;
- (2) There is no necessity to use shellac, paraffin wax or other stiffening material;

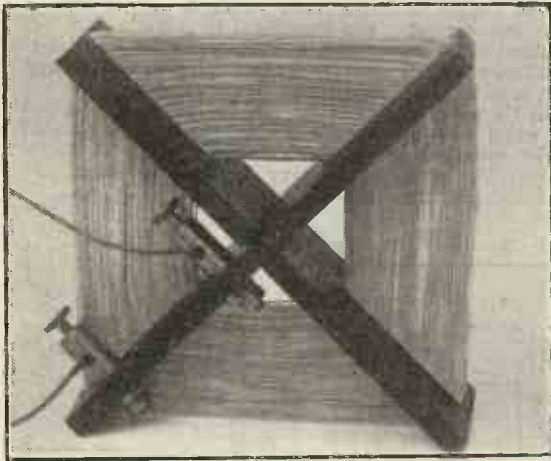

Fig. 1.—A completed coil as used to receive PCGG.

- (3) There is a minimum of insulating material used to support the coil;
 - (4) The coil is exceedingly simple to wind, being far easier to construct even than a single layer winding on a tube;
 - (5) It is so constructed that it will stand conveniently on the table without any special support;
 - (6) Terminals can be fitted very simply;
 - (7) Exceedingly compact long wave inductances can be wound in a similar fashion just as easily and without sacrificing any efficiency;
 - (8) The coils need no special stand and can be coupled conveniently.
- A long wave inductance wound in this way

is possibly the most efficient form of coil that can be constructed for the size of wire used.

To make the coil it is only necessary to take two pieces of wood or ebonite and cut them so that they will fit together after the style of the cardboard partitions in an egg box. The two pieces which are so joined have saw cuts made in each end and after the two pieces have been put together the wire is wound into the saw cuts. It is easily arranged that the width of the slot so cut with the saw is just equal to that of the wire it is desired to use. For example, an ordinary hacksaw blade will make a cut which will just take No. 22 d.c.c. wire. The coil illustrated is wound with No. 26, and for this reason is not strictly a single layer coil as two turns fall side by side.

Obviously the former for such a coil can be made of any convenient size, but as an illustration I will give the figures used in the coil shown in the photograph. The two ebonite strips are $\frac{1}{4}$ inch thick, 6 inches long, and $1\frac{1}{2}$ inches wide. The depth of the saw cuts in the four ends is exactly 2 inches. Two holes are drilled in one side of the ebonite strip just by the bottom of the saw cut, and

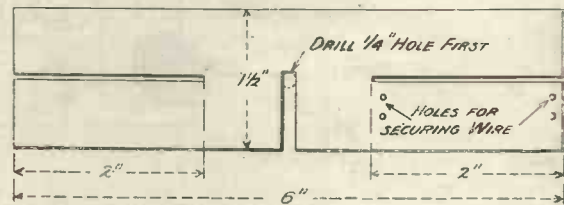
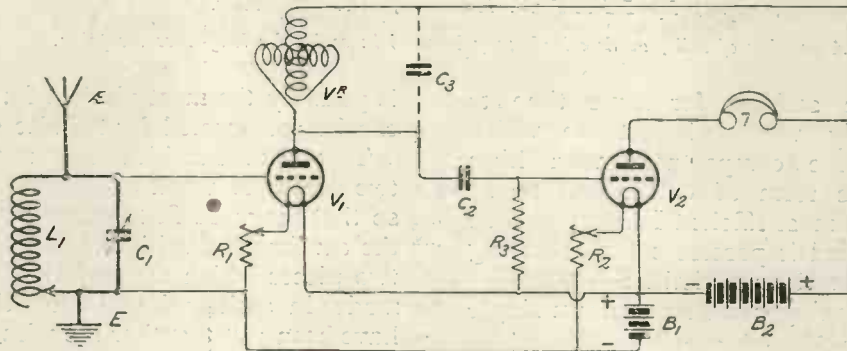

Fig. 2.—Details of the supports.

two more at the top. Two terminals are also attached as shown. To wind the coil, the wire is first attached to the lock nuts of one of the terminals, after having been passed through the two lower holes to secure it. The coil is then wound in until the slots are filled, whereupon the end of the wire is passed through two holes at the top and secured to the second terminal. The coil shown corresponds to a number 100 Igranic coil, and was used for tuning in to the Dutch concerts.

“WIRELESS WEEKLY” CIRCUITS—No. 29



COMPONENTS REQUIRED

- L₁: Variable inductance.
- C₁: Variable condenser (0.0005 μF).
- V_R: Variometer.
- C₂: Grid condenser (0.0003 μF).
- C₃: Variable condenser (0.0003 μF).
- R₁ } Filament rheostats.
- R₂ }
- R₃: Gridleak, 2 megohms.
- B₁: Filament lighting battery.
- B₂: High-tension battery.

GENERAL REMARKS

This two-valve receiver will be found to give very good results if the variometer is of the correct size. It should have about twice as many turns as an ordinary aerial tuning variometer, in which case the condenser shown at C₃ will not be necessary. If the usual size of variometer employed in aerial circuits is used, the variable condenser or a fixed condenser having

a capacity of 0.0003 μ F. should be connected across it as shown in the theoretical circuit diagram.

The circuit, when no fixed condenser C₂ is employed, is not very selective.

As an alternative to the tapped inductance coil L₁ and its parallel variable condenser C₁, a variometer may be used to tune the aerial circuit.

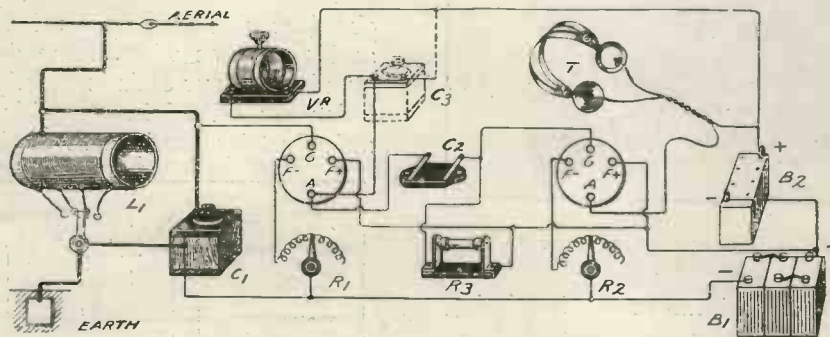

PRACTICAL WIRELESS NOTES—No. 11

TELEPHONE TRANSFORMERS

are necessary when it is desired to use low-resistance telephone receivers with almost every crystal and with all valve-receiving sets.

A little confusion sometimes arises when speaking of the primary and secondary windings of telephone transformers, owing to the fact that the primary winding is of very fine wire, and the

secondary of thick wire. In all cases, the *input* should be regarded as the primary, and the *output* as the secondary.

The fine wire-winding of the transformer should be connected to the telephone terminals of the receiving set, the telephones themselves being connected across the thick wire winding. By this means a step down in voltage and an increase in current is obtained so

that the telephones, depending for their operation upon ampere-turns, work more efficiently.

A telephone transformer, not necessarily of the step-down type, should be used with all receivers comprising more than three valves, as otherwise the continued flow of current through the telephones in the anode circuit of the last valve puts a considerable strain upon their windings.



Jottings by the way

Cherished Washouts

I SUPPOSE that, like my unworthy self, you have a shelf, or it may be even an array of shelves, upon which reposes a miscellaneous collection of wireless odds and ends. Some of them are things that you bought in the gay irresponsibility of your wireless youth and have since discarded because you have come to know better. Others have been acquired at different times in different ways—for discretion's sake we will not be more precise about the "ways"—but one and all of them lie wasting their sweetness (or the reverse) on the cupboard air. You don't use them; there is not the slightest likelihood that you will ever do so.

Yet when your better half makes "insinuendoes" that a clearance might be effected without your feeling any loss you are up in arms at once. Like the White Knight in *Alice*, who carried a mousetrap so that he should not be at a loss if mice did get into the joints of his harness, you want to be prepared for all eventualities. You cannot bear to part with even the most useless things because of a lurking feeling that a day may arrive when they will come in handy. You, being a fellow radiomaniac, know the pride that one takes in such an array of "hasbeens" or even of "neverwasers."

The Sacrilege

You will appreciate my feelings, therefore, when I tell you that the sanctity of my shelves has been violated. They have been looted, pillaged, and some of my most cherished "duds" have disappeared. Requiring

the other day a stout fixed condenser to put a check on the clamour of a high-tension battery that was tottering into senile decay, I bethought me that there was one somewhere on the junk shelves that might possibly justify its long residence there by doing something useful at last. Like Old Mother Hubbard I went to the cupboard, and just as she cried "Yes, we have no bones," so I lifted up my voice to lament the disappearance not only of that condenser but of quite a number of other things.

Where was the world's worst transformer? Where were the filament resistances that wouldn't resist, and the valve of dread appetite that ate a solid ampere and a half and then asked for more? Where were all those horrible (but nevertheless cherished) little terminals that used to make one's thumb and forefinger so sore? Where were the tuft-tearing telephones with the rat trap grip? Where, oh where? I searched high, I searched low, I used the bitter words of a strong man brought nigh to the breaking point; but none of these things availed.

The Young Looter

By lunch time I was calmer, though still pained. I mentioned my loss and noticed a blush mantling the countenance of my firstborn. You who have been a boy can guess what that meant. You are perfectly right; he had. Later he conducted me upstairs to show me what he had contrived. It was, I confess, a proud moment, for the lad had put together quite a respectable set with those fearsome parts. Even with the bell-wire aerial

that was attached to a handy tree and came in naked but quite unashamed through the open window he was able to pick up a number of transmissions.

My anger subsided at once. I complimented him; I believe that I even went so far as to promise a better selection of gadgets. But all these pleasant feelings were of a sudden nipped in the bud by a horrid realisation. I who pride myself upon my respectability, I whose pen courses o'er the fair paper for this journal of unimpeachable morality that you now hold in your hand, I am (can I say it?), *I am the father of a pirate!*

A Bitter Moment

Most unkindest cut of all, I shall have to go to the Post Office of Little Puddleton to take out the penitent's certificate, for the boy being under age 'tis I that must do it. The place will be crowded with my friends. They will hear me asked for my full name. They will see me shamefacedly pushing fifteen bob beneath the rail. They will nudge one another and smile. They will hear my explanation—and they will not believe a word of it. Would you?

Ah me; as one, William Shakespeare, might have said had he been living in this hectic age, "'Tis sharper than a serpent's fangs to have a wireless child."

Oh, Never!

There is amongst us a fellow whose name might be Brown, though actually it isn't, who affects never to use the programmes of a certain broadcast-

ing station, possibly, I think, because they can be received without undue difficulty on all but the duddest of sets even with one lone valve. The rest of us rather like them. We were discussing the question at the club the other night, when Brown (let us call him that) entered and joined the circle.

"Oh!" quoth he, "you're actually saying that you like that wretched station. Why the announcer's got a voice like a cracked foghorn suffering from asthma, the orchestra's always out of tune and they never play anything decent. Three nights ago they went on for three-quarters of an hour with some beastly symphony. The evening before last signal strength faded badly for exactly 48 minutes, and last night they were nearly three

metres off their wave for the first hour and a half. That station! No, I *never* listen to its transmissions." And he wondered why we found it hard to restrain our mirth.

The Post Office Man

Poor little Podsnap had rather a blow to his dignity the other day. The maid announced that a man from the post office wanted to see him. Podsnap went out forthwith to meet the visitor, for he had heard that wireless inspectors were abroad in the district. He is a little man who never stops talking, in fact when you're with him it takes you all your time to squeeze even a syllable in edgeways.

"Ah yes," he said cheerily. "come along and I'll show you my set." Talking nineteen to

the dozen, he led the man to his wireless den.

There he displayed the light of his eyes, the darling of his soul, explaining the circuit, showing how it was utterly impossible for him to radiate so much as a single bleat even if he tried to. He took a heap of trouble over everything, and went so far as to give a prolonged practical demonstration. After about an hour he said gaily, "Well, I suppose you'll pass *this* set as all right, anyhow." "It's a wonderful thing this wireless, sir," replied the other, now at last able to make a remark, "and I thank you kindly for letting me hear it. What I came to ask was whether you'd buy a ticket for the postmen's ball!" And that was precisely that.

WIRELESS WAYFARER

Messrs. S. A. Lamplugh, Ltd., have forwarded a leaflet describing Regent wireless sets and components. This leaflet is well illustrated and informative from an experimental point of view.

The Peto-Scott Co., Ltd.—We have received from the above-named a copy of their latest catalogue of wireless components, for which a small charge of 4d. is made. The booklet is fully illustrated, contains particulars of components, complete sets and numerous sundries, and should appeal to every wireless enthusiast. Experimenters residing in the Liverpool district should note that this firm has opened a branch at 4, Manchester Street, Liverpool.

Sterling Telephone and Electric Co., Ltd., have sent for our inspection their publication No. 374, describing Sterling hand and hand phones. Readers should note that the prices of these instruments are now reduced.

Messrs. Ward and Goldstone, Ltd., have forwarded a copy of their new and well illustrated

TRADE NOTES

booklet of radio sets, accessories and components. Experimenters can obtain copies of this list by applying to the above firm.

The Cossor Valve Co., Ltd.—We have received a photograph of a new showcard produced on behalf of the Cossor Valve Co., Ltd. The showcard is produced in ten colours and is most attractive.

Midland Radiotelephone Manufacturers, Ltd.—We are in receipt of a booklet describing "Mellowtone" wireless sets and components. Amongst other refinements provided on the five-valve sets are grid bias, approved reaction, a tone modulator, and power amplification.

The Metropolitan-Vickers Electrical Co., Ltd.—This firm has sent us one of its new trade showcards for reference in these columns. We are of the

opinion that it cannot fail to attract attention, being a fine piece of colour work.

Mullard Radio Valve Co., Ltd.—Particulars of the new Mullard Wecovalve are given in List MW1, a copy of which has been sent to us. This list deals also with holders, resistances and cells suitable for use with this valve, and points out the advantages which are obtained.

Siemens Brothers and Co., Ltd.—This firm has sent us a copy of catalogue 595 describing and illustrating various wireless accessories, including lightning protectors, loud speakers, etc.

J. H. Taylor & Co.—This firm has forwarded a copy of its catalogue and price list of wireless component parts. The booklet contains particulars and prices of numerous items.

The Armax Crystal Co.—Our readers will remember a note in the Editorial columns of *Wireless Weekly*, Vol. 2, No. 9, relating to the sale of boxed crystals, and will no doubt be interested to hear that the above firm supplies boxed crystals which are free from dust and untouched by fingers.

A CRYSTAL RECEIVER AS A WAVEMETER

By G. P. KENDALL, B.Sc., Staff Editor.

This article explains how the Variometer-Crystal Unit described in our last issue can be made to serve other very useful purposes.

A BRIEF explanation was given in my article last week of the use of this little unit as a crystal receiver, and it now remains to show how it may be employed in other ways. It is particularly adapted to conversion into a simple valve amplifying and crystal rectifying receiver, with variometer tuning in the plate circuit of the valve, which functions as a high-frequency amplifier. All that is necessary to effect the conversion is a valve panel and an additional variometer or

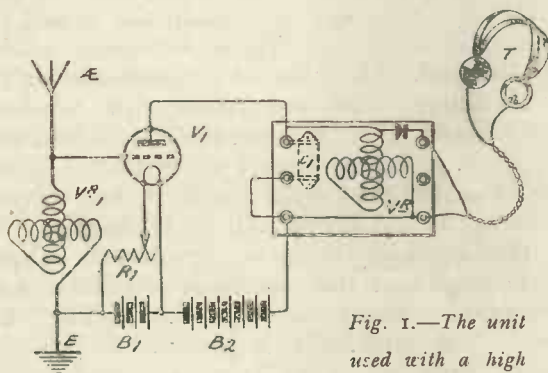

Fig. 1.—The unit used with a high frequency amplifying valve.

other tuning device for the aerial circuit, the connections of the components being as shown in Fig. 1. As is indicated in this diagram, the fixed condenser in the variometer unit is to be connected in the parallel position.

Since no intentional reaction is used in a set assembled in this way the tuning is not very sharp, and it is very easy to operate. It will give signals of moderate strength up to quite considerable distances from a broadcasting station, and it is interesting to note that this is a method of conversion applicable to almost any type of crystal set, the only actual alteration necessary in a given set being the provision of the small fixed condenser in parallel with the tuner.

Fig. 2 shows how the unit may be used as a wavemeter for rough work, the external additions necessary being a buzzer, a dry cell, and a small switch, key or press-button. As before, the condenser is connected in parallel with the variometer by bridging two of the terminals with a piece of wire, and it is essential that the cat whisker should be lifted off the crystal and that the telephones should be removed from their terminals. So arranged, the apparatus constitutes a transmitter of weak waves of any length between about 250 and 500 metres, depending upon the setting of the variometer.

The set can be easily calibrated with the aid of a borrowed wavemeter, or failing this, with any reasonably sensitive valve set. The procedure in the latter case is as follows: Tune in any given broadcasting station upon the valve set, and then start the buzzer of the wavemeter (which should be placed near by),

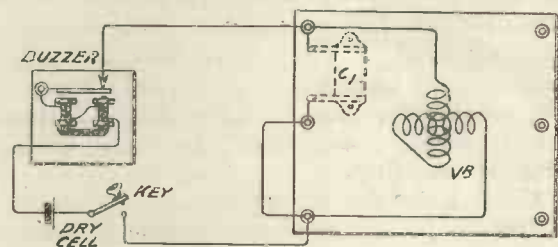

Fig. 2.—Showing method of using the unit as a wavemeter or "tuning-tester."

and note the reading of the variometer dial which brings the buzz in on top of the speech in the valve set. Record this reading for each broadcasting station and you will be in possession of a set of figures enabling you to tune in any of the stations quickly on any receiver, and from which a graph could be drawn for easy reference.

BROADCASTING PROBLEMS

By P. P. ECKERSLEY (Chief Engineer of the B.B.C.).

The following is a report of a lecture given on October 13th at the Weymouth Secondary School, under the auspices of the South Dorset Radio Club.

IN opening his address the speaker explained that he would deal mainly with the technical side of broadcasting, and without further delay plunged at once into his subject, commencing with a very elementary and clear explanation of the principles of wireless telephony.

Capt. Eckersley explained how the Broadcasting Company had to face the fundamental problem of arranging things in order that anyone would be able to instal a receiver, turn the variometer, tune in and hear broadcasting. The man who got Australia on half a valve seemed to be the beau ideal of the average Radio Society. (Laughter.) If the B.B.C. used high power stations people would be complaining that they wanted to listen to some other station and "can only hear your beastly broadcasting." In the second place they would not be allowed to do it as the Services would come down upon them for interference with the naval and military signalling. They were only allowed a power of $1\frac{1}{2}$ kilowatts, and the only thing to do, obviously, was to have relay stations which would repeat what the main station was transmitting.

Capt. Eckersley then proceeded to take his hearers right through the various phases of work in a broadcasting station, explaining the requirements and the difficulties in a humorous way which kept them continually laughing. One of the greatest difficulties in the studio was to get a microphone which was absolutely perfect and which would reproduce all the sounds. In music the vibrations ranged from 8,000 per second down to approximately 30. In the London studio 4 tons of material were used to deaden the sound of the echo, and the effect was very curious when one heard one's voice for the

first time. "Some of the artistes heard theirs for the first time and received terrible shocks," added Capt. Eckersley, amidst laughter.

The lecturer next paid attention to the thermionic valve, which he said was the greatest invention of the century. By giving electrons personality and speaking of them as little people hurrying along the wire carrying little parcels of electricity, Capt. Eckersley was able to explain the action of the valve in a way which everyone could understand. He spoke of the phenomenon of "shielding" as the casting of wireless shadows by hills, between the station and the receiver. Some places 8 miles from Cardiff could not get the Cardiff station on two valves, whereas it was heard well in Madeira.

Dealing with reception problems, Capt. Eckersley said that the most important was reception without interruption. "This," he said, "is practically impossible if you are more than 30 miles from a broadcasting station. Further afield you cannot get super quality." Above all the difficulties, there was the silly foolishness of certain amateurs in the method of using reaction. By its careless use the receiver was made so sensitive that it became a transmitter and was heard very strongly by other listeners. It was done not through malice, but through ignorance. In this connection he advised everyone interested to join their local radio club.

Capt. Eckersley then went to the piano and caused roars of laughter by giving a splendidly realistic expression of an operatic solo sung by an Italian tenor as received to the accompaniment of sundry "reaction fiends" and Morse signals from ships in the Channel. This little diversion literally "brought down the house."

WIRELESS RECEPTION IN NORTHERN IRELAND

By R. V. MACRORY, M.I.E.E.

Some interesting notes upon the problems of broadcast reception at long distance.

AFTER making a careful study of some reliable modern text-books, I decided to assemble a multi-valve receiving set, and purchase only those components which I considered could not be efficiently home-constructed.

I will not weary my readers by describing my early experiments. It will be sufficient to say that I assembled two compact 5-valve sets, which I afterwards dismantled, being dissatisfied with their arrangement and having found certain cheap components most inefficient. I then determined to model a set with all the apparatus exposed and arranged so that alterations could be effected conveniently, and the set now described has thus been gradually evolved.

Having come to the conclusion that for really effective consistent results over a range of 400 miles, not less than two high-frequency and a detector valve would be necessary for head-phone reception, with the addition of two low-frequency valves for the loud-speaker, and having also decided to "play the game" by not using aerial reaction so as to cause interference I laid out my plans accordingly. Being also anxious to try out the merits of the various H.F. valve couplings and other combinations, the set, as will be seen from the diagram and photograph, is so designed that alternative couplings can be plugged in or out without interfering with the wiring.

The following apparatus was home-constructed: A set of honeycomb inductances, wound on a Drummond lathe on a $1\frac{3}{4}$ in. mandrel with a proper

wave form by means of a home-made adaptation causing the wire to reciprocate when being led on. The coils up to 100 turns were wound with No. 22 s.w.g. d. c.c. wire, and over this with No. 24 similar wire, the width of coils being $\frac{3}{8}$ in. Two sets of coils having 35, 50, 75, 100, 200, and 300 turns were made. A number

of coils swing horizontally and the tuned-anode holders vertically. The potentiometer controlling the grids of the two H.F. valves and also that controlling the grid of the detector valve were made with two H.B. lead pencils split, the lead forming a most effective non-inductive resistance, the two ends of these being con-

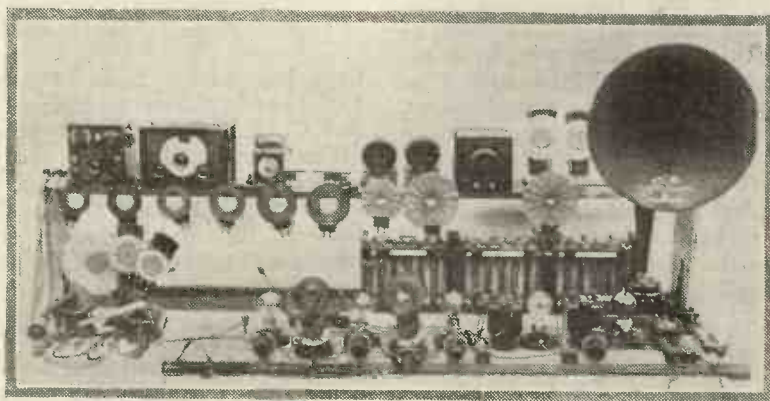

A general view of the apparatus. The variometer-reaction unit with its plug-in coils may be seen between the first and second valves.

of basket coils were also made, from 50 to 120 turns. Each coil was mounted on an ebonite block, having two split connecting pins of the same size and pitch as the ordinary 5-ampere electric lighting plugs. One three-coil holder for one fixed and two moving coils was made for the aerial tuning inductances and reaction; one for the first tuned anode coupling (here two act as a variometer and one as a reactance), and a two coil-holder or variometer for the second tuned-anode coupling. All coil-holders are arranged so that coils swing in the same plane as the coil (not like the leaves of a book), the aerial tuning holders being mounted so

nected across the L.T. battery, and a sliding brush to the valve grids.

The following apparatus was purchased:—Two 0.001 μ F variable condensers, two Sullivan L.F. iron-cased transformers, one variable gridleak for the detector valve, one grid-condenser, two 0.0002 μ F fixed condensers for tuned-anode couplings, two 2-megohm leaks, two 50,000 ohm leaks for resistance capacity couplings, two Discol transformers, two 0.0001 μ F variable condensers for tuning same, two Sullivan aperiodic tapped transformers, three telephone jacks and plug for connecting in and out the L.F. valves, three

D.P. change-over switches for (1) parallel or series connection of A.T.C., (2) connecting receiver to aerial or closed circuit, (3) changing from telephone to loud-speaker.

The tuning apparatus was mounted on a small flat board, and the receiver on a mahogany panel 4 ft. by 10 in., and arranged in proper sequence so as to shorten connecting wires as much as possible. The various H.F. couplings, consisting of tuned anode coupling, resistance capacity, Sullivan aperiodic transformer, and disc-tuned transformer, are each provided with connecting pins to plug into the two valve holders mounted between the first and second valves respectively, the tuned anode coupling consisting of coil-holder, 0.0002 μ F condenser and two-megohm leak, being mounted on a sheet of ebonite measuring 3 in. by 4 in.; two series connected coils (one swinging) forming a variometer, can be employed as a tuned anode coupling, all the coils both for aerial and anode circuit being interchangeable; various wavelengths can thus be conveniently tuned. For resistance capacity coupling a 50,000 ohm resistance

cient, and that variometer anode tuning, although more critical, gives louder signals than a coil tuned with a variable condenser.

Because of their greater compactness I employ honeycomb coils for the tuned anode coup-

Connections are made so that a higher H.T. voltage can be impressed on the plates of the L.F. than on the H.F. valves, which I find a great advantage, since it permits the use of the power valves which are now strongly

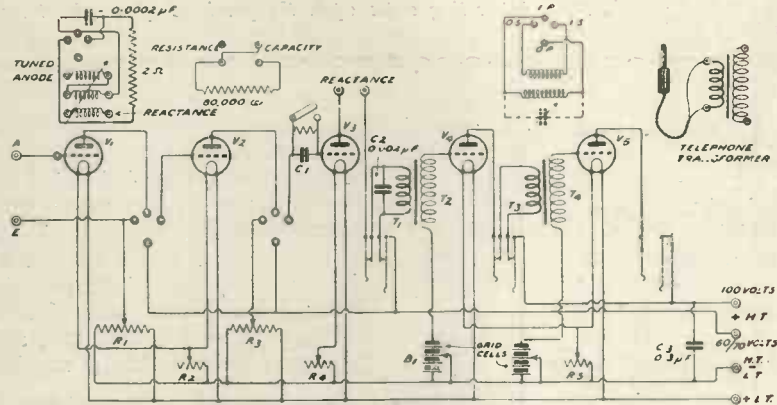

Theoretical circuit showing plug and jack connections.

ling, but basket coils both for aerial and closed circuit; the A.T.C. for short waves being series connected. For longer waves, such as The Hague or Eiffel Tower, I use at present the Sullivan tapped transformer and tune the detector anode circuit by means of a variometer, which I find increases signal strength to a degree equivalent to aerial reaction. This method is of American origin, I believe, and seldom described here, but is most effective.

It will be noticed that the method of using jacks for connecting in and out the L.F. valves, disconnects all unused parts of the circuit, and is consequently most efficient. To eliminate losses I purposely omitted jacks or switches on the H.F. side, but the H.F. valves can also be readily cut in or out by means of the flexible lead connected to the aerial terminal of the tuner, which terminates in a wander plug, the grid terminal of the first valve being provided with a suitable socket for the same, and by detaching either H.F. valve coupling, this wander plug can also be connected into the socket leading to the succeeding valve grid.

recommended for loud speakers. With "R" type receiving valves I find about 60 volts for H.F. and 70 volts for L.F. valves give the best results.

All controls are provided with long extension handles, to obviate body capacity effects.

Having described the apparatus, readers will doubtless be interested to hear something of results. 2LO, the most distant British broadcasting station, comes in very strong and clear with two H.F. and one L.F. valve with head phones, and the addition of one or two L.F. valves operates the Magnavox loud speaker most effectively. When conditions are favourable the music and speech are loud enough to fill a hall or large room, but Morse interference (principally from ships) in this area is most trying, and it is seldom that the ether is quite clear of it.

Glasgow is very strong and the quality is little short of London. Newcastle and Birmingham are also quite effective on many occasions. Manchester is strong, but curiously enough is seldom free from distortion even when reaction is cut out. Cardiff is rather weaker than the others.

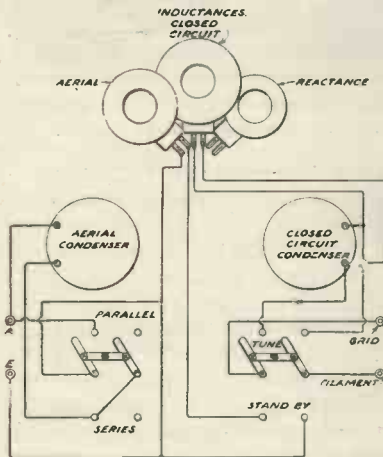

Details of the tuning arrangement.

mounted on ebonite with pin connections is plugged into the anode coil-holder instead of coils.

For short wavelengths such as the British Broadcasting, my experiments prove that the tuned anode coupling is the most effi-

AMERICAN BROADCAST RECEPTION.

We shall be pleased to hear from readers who have received American Broadcasting, giving details as enumerated below.

Date.	Call-Sign.	Wave-Length in metres	Name.	Town.	Receiver.	G.M.T.
16-9-23	WGY	400,485	D.C.W.H.	Sutton, Surrey	—	—
19-9-23	"	"	J.G.R.	Glasgow	<i>Wireless Weekly</i> Circuit No. 16	—
20-9-23	"	"	"	"	"	—
"	WDAF	400,485	D.J.	Rochdale	Detector	—
"	WLAJ	360	R.G.B.	Loughborough	—	1.30—2.30
21-9-23	"	"	"	"	—	—
"	WGY	400,485	"	"	1 H.F.—Detector	—
"	"	"	S.F.B.	Tufnell Park, N.W.8.	September <i>Modern Wireless</i> All Concert Receiver.	1.45—2.30
"	"	"	J.G.R.	Glasgow	<i>Wireless Weekly</i> Circuit No. 16	—
22-9-23	"	"	W.S.W.	Shepherds Bush, W.12.	<i>Wireless Weekly</i> —Vol. 2, No. 2. Flewelling Circuit and 1 L.F.	1.30—4.30
"	"	"	D.J.	Rochdale	Detector	—
"	"	"	C.B.	Islington, N.1	Detector	1.55—4.40
"	"	"	W.K.I.	Cambridge	ST75 Circuit	3.40—4.40
"	"	"	F.R.N.	Belfast, Ireland	2 H.F.—Detector—1 L.F.	3.40—4.40
"	"	"	D.C.W.H.	Sutton, Surrey	—	—
"	"	"	H.C.C.	Bolton	1 H.F.—Detector	—
"	"	"	N.	Birkdale, Southport	2 H.F.—Detector—1 L.F.	1.45
"	WFAM	360	D.J.	Rochdale	1 H.F.—Detector—1 L.F.	—
"	WAH	485	"	"	"	—
"	WLAS	360	"	"	"	—
"	WDAP	"	"	"	"	—
"	WEAF	400	"	"	"	—
"	WIP	485	"	"	"	—
"	WMAF	360	J.G.R.	Glasgow	<i>Wireless Weekly</i> Circuit No. 16	—
23-9-23	"	"	A.T.	Ashton	1 H.F.—Detector—2 L.F.	—
"	"	"	M.V.P.	Kew Gardens, Surrey	1 H.F.—Detector—1 L.F.	—
"	"	"	D.C.W.H.	Sutton, Surrey	—	—
"	"	"	J.G.R.	Glasgow	<i>Wireless Weekly</i> Circuit No. 16	—
"	WHAZ	400	E.R.	Crayford, Kent	<i>Wireless Weekly</i> Three-Valve Receiver.	0.30
"	WFI	400,485	N.	Birkdale, Southport.	2 H.F.—Detector—1 L.F.	1.15
"	KDKA	360	D.C.W.H.	Sutton, Surrey	—	—
"	WJZ	360	M.V.P.	Kew Gardens, Surrey.	1 H.F.—Detector—1 L.F.	—
"	WGY	400,485	"	"	"	—
"	WMAL	360	A.C.C.	Pewsey, Marlborough, Wilts	Detector	1.30—3.0
"	WGY.	400,485	D.J.	Rochdale	1 H.F.—Detector—1 L.F.	—
"	WMAF	360	"	"	"	—
24-9-23	WGY	400,485	M.V.P.	Kew Gardens, Surrey.	1 H.F.—Detector—1 L.F.	—
"	"	"	J.G.R.	Glasgow	<i>Wireless Weekly</i> Circuit No. 16	—
"	"	"	N.	Birkdale, Southport.	2 H.F.—Detector—1 L.F.	0.05

EBONITE

By R. EARDLEY BESWICK.

An article which gives the reader an insight into the manufacture of that commodity used by every wireless constructor and experimenter.

OF the numerous materials which serve the needs of the wireless constructor ebonite or vulcanite is easily the most interesting. Its sober appearance as it reaches us in the form of rod, sheet, or moulding hides a past of great subtlety, though, as a rule, the amateur who upbraids it for blunted tools and tried temper realises little of the mystery that has gone to its making. For ebonite, like all rubber products, is but dimly understood, and so far the most brilliant chemists have had to content themselves with complex and more or less plausible explanations of the way in which a mixture of raw rubber and flowers of sulphur becomes, when duly heated, the familiar hard black solid.

The essential constituents of black ebonite are those given above, and its only difference from commercial manufactured rubber is in its far greater sulphur content and longer period of vulcanisation. It is not very generally known that ebonite may be produced in colours varying from bright red through salmon to a soft fawn, by substituting varying amounts of antimony sulphide for the sulphur constituent. An appearance similar to that of red-grained black marble can be produced by roughly mixing raw red ebonite with the raw black material before calendering it out into sheet for curing.

Although, as stated, raw rubber and sulphur are the essentials, there may always be present to a greater or less degree other constituents known as "fillers" and "accelerators," whose objects respectively are to reduce

the material cost by diluting the mixture with some inert harmless powder, and to decrease the length of time required for vulcanisation or "curing." Besides these ebonite must, to be controllable in manufacturing processes, be diluted with ebonite. The paradox is due to the fact that the material shrinks and warps during the "curing" process, and to reduce this defect to controllable dimensions a large percentage of ground ebonite dust that has had its "nerve" or "life" destroyed by curing to brittleness has to be added to each mixing. Grinding ebonite dust is a special process involving difficulties all its own, for the heat generated by ordinary grinding methods would render the material soft, sticky, and essentially ungrindable. Many manufacturers buy their dust, and there are several busy factories to-day which specialise in the supply of this ingredient. After grinding, the fine dust is separated by an air current and the coarser particles returned for further grinding.

Most of the defects of ebonite are due to impurities in the dust used. Some dusts contain considerable grit, to which the cutting edge of our drills and taps bear subsequent witness, others metallic particles which reduce the insulation value of the finished article.

The proportions and constitution of their mixings are generally a closely-guarded secret of the manufacturers, each having his own specification. Although all these are no doubt very similar, the slightest difference in the mixings will need some sort of

allowance in curing, and most formulæ contain small percentages of special constituents, such as oils, waxes and gums, which are added to effect some particular property desirable in the finished article. Different mixings are, as a rule, employed for sheet, rod, and mouldings respectively. Each change in the grade of the rubber obtainable has also to be studied for its effect on the product, and all "drugs" must conform to a standard, samples being analysed before the bulk is passed for use.

The various constituents are weighed out in the "drug room," a closely-guarded sanctum, and passed out to the mixing department where they are amalgamated by passing between steam-heated rolls. The rubber is softened first with the rolls fairly wide apart, and then the drugs are shovelled on and the rolls closed-up. One roll turns more slowly than the other, and the effect is for the material to form itself into a sheet about this roll. This is counteracted by the attendant, who from time to time slashes the mixing diagonally with a knife, while with the other hand he peels it off the roll, finally flinging it on to the top to be fed through again. When completely mixed the material is known as "dough," and is cut off the rolls and stacked in rough sheets for the next operation.

Ebonite dough is a sticky, semi-plastic, dark grey material, capable of many surprising changes. For the purpose of making sheet it is fed through heavily-weighted rolls which calender it into a continuous thin sheet. This is "plied up" layer

on layer by another roll until the right thickness for the final sheet is reached. Thin plates of pure tin are pressed on each side of the raw sheet, air, the tiniest bubble of which between the material and the tin would cause a blister, being carefully rolled out.

The tin-covered sheets proceed to the vulcanising department, where they are stacked on trolleys which run them into the "pans." These pans are more like large cylindrical steam boilers, with massive hinged doors at their ends, capable of being locked by a multitude of heavy bolts. Steam is now

off them and appear as the ordinary "tin-polished" sheets of commerce.

A point of special interest to radio workers may be mentioned in passing. Tin-polished sheet usually contains small particles of pure tin, derived from the foil, embedded in its surface. These may often be seen by the naked eye, and if they are numerous the surface insulation will be poor, and the sheet should be rejected, or surfaced down with emery to a matt finish. It is to these tin particles rather than to hygroscopy that the comparatively low surface resistance of some

superficial appearance marketable.

Owing to the high cost of the tin-foil required many substitute methods are adopted for producing matt sheets, and also for polished, surfaces of paper, glass, stainless steel, aluminium, etc., being all employed to some extent.

For ebonite rod or tube the "dough" does not need calendaring. It is forced through steam-heated dies in a kind of sausage machine. The correct temperature is important, and the die has to be dimensioned to allow for the expansion of the



By courtesy of Messrs. Fullers United Electric Works, Ltd.
Ebonite making-up shop. Note the raw dough in sheets and in rolls with linen to prevent the surfaces from sticking.

turned on in the pans and the pressure allowed to rise slowly to that demanded by the cure, probably between 50 lbs. and 60 lbs. per square inch, held steady at this for a number of hours and finally blown off. Recording pressure gauges testify to the watchfulness of the attendants and the diligence of the stokers, as material worth hundreds of pounds may be spoiled by a chance variation of the pressure.

When cured and cool again the sheets have their tin-foil stripped

polished sheet is due, but for ordinary use on panels the matter is of far less importance than is sometimes assumed, very high voltages indeed being required to cause any harmful leakage.

Polished sheets are to-day produced by other processes not involving the use of tin, but such processes may not be made public. Matt sheets are generally and probably best made by sand-blasting ordinary tin-foil sheet, and this forms a good way of rendering sheet with a poor

material as it emerges from the high pressure of the interior, as well as for the shrinkage that subsequently takes place in the cure. In spite of this many manufacturers will guarantee their rod to .001 in. diameter. As the material emerges in the form of plastic rod, it is cut into convenient lengths by the attendant. Almost any section of rod or tube can be "squirted." Rod and tube are cured on similar lines to sheet, the greatest care being necessary to keep them straight.

SHORT WAVE RECEPTION

An Interesting Discussion at the Radio Society Meeting.

AT an informal meeting of the Radio Society of Great Britain, held on Wednesday evening, October 17, Mr. Philip R. Coursey delivered a paper on "Short Wave Reception" to a highly interested audience. Every available chair was soon occupied, and at least a couple of dozen members were left standing.

In his opening remarks Mr. Coursey said that we must first of all define what we mean by short wave reception. A few years ago 600 metres would have been considered a short wave, but at the present time, when we are preparing for the forthcoming Transatlantic tests, chief interest centres around the band of 150 to 200 metres, which he would call short waves for the purpose of the paper.

He then outlined the chief methods of receiving short waves, and pointed out that whereas on longer waves it was comparatively easy to employ radio frequency amplification, on wavelengths of 200 metres and under it was exceedingly difficult to get effective amplification by any of the existing methods. His own experience led him to think that perhaps the best way of receiving American amateurs was on a single valve using reaction. If radio frequency amplification preceded the detector valve, we must not forget that the inter-electrode capacity of the valve enabled the signals to be by-passed straight through to the detector, and it was frequently found in a set employing radio frequency amplification, that no appreciable diminution of signal strength resulted by turning off the filament of the first valve. Mr. Coursey then spoke of the Armstrong super-heterodyne as very effective means of amplifying short wavelength signals and recommended it to the attention of experimenters for the coming tests.

In the discussion which followed a number of members took part, and divergent views were expressed on the subject of the super-heterodyne. Mr. Child expressed the opinion that the super-heterodyne was a disappointing instrument, as it had a nasty habit of ampli-

fying not only the signals one wished to receive, but numerous harmonics as well. Mr. Reeves expressed the opinion that a solution to short-wave amplification would probably be found in the use of aperiodic transformers, and gave some details of experiments he was conducting at the present time with that end in view. Another speaker detailed his experience in building a super-heterodyne set, and said that although he had not brought it to the stage of perfection he desired, he was quite convinced that it offered an excellent solution of radio frequency amplification difficulties on short waves. He explained, however, that much care was necessary in constructing the instrument, particularly in regard to the coupling between the first part of the instrument and the long wave amplifier. He also remarked that it was almost impossible to ascertain when the transformer was properly tuned, and had found the best way to proceed was to wind two coils which would give the wavelength desired without the need of any tuning condensers across them. By selecting a wavelength just above that of Leafield's first harmonic he has found that he is fairly free from interference.

He also pointed out that the separate oscillator used in the super-heterodyne needed to be very powerful to give good results, and he used high voltage on the plates. Mr. Harris pointed out the losses which may occur in short-wave tuners through inefficient variable-condensers. Mr. Hale gave an interesting description of a method he had found very satisfactory for neutralising the tendency to self-oscillation. Several other members also spoke.

In replying to the points raised, Mr. Coursey indicated that practically all of the trouble in the super-heterodyne from harmonics of high power station could be guarded against by carefully screening the radio frequency amplifier with sheathing of both iron and copper. The Radio Society is to be congratulated upon the success of this meeting, which is a good augury of the future success of the Society.

ALL STATIONS ON A FRAME AERIAL

By A. D. COWPER, M.Sc., Staff Editor.

An article of particular interest to experimenters whose aerial accommodation is limited.

IT is not generally realised how readily the powerful transmissions of the B.B.C. stations (i.e., powerful relative to the comparatively short distances involved) can be picked up on ridiculously small aeri-als and a single valve receiver, by careful and patient tuning, and without calling into play any super-regenerative principle.

It has been repeatedly confirmed by independent experi-

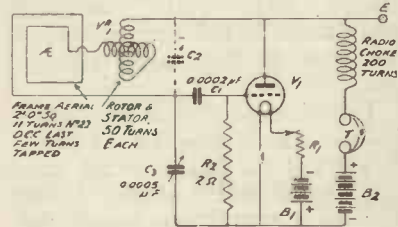

Fig. 1.—A single valve, variometer tuned, frame aerial circuit.

menters that the waves at least of stations at two hundred miles or more can be detected by a single valve with critical reaction, on a two-foot square frame, or even smaller. Newcastle has been heard speaking (in a jumbled, hardly intelligible way, of course) on an isolated two-foot frame; and Glasgow's wave was quite marked, though not resolved, in London. Probably the signals are brought in to some extent by "casual" aeri-als in the form of electric-light mains, etc., in most cases; thus a tuned aerial in the same room will give quite audible crystal reception of 2LO on a frame some distance away.

The writer has long been of the opinion that the best results with frame reception (without super-regeneration) would be obtained by following more closely the

methods of the transmitter, and putting the load of the frame aerial directly in the plate-circuit (rather than in the grid-circuit), trusting to the close reaction coupling essential for successful reception on a small frame with minimum number of valves, to hand back to the latter the energy received in the form of signals.

Some work with forms of the De Forest Ultra-audion circuit, with its aerial tuning inductance connected between anode and grid, and with simple capacity reaction, suggested the modifications shown in the accompanying diagrams, which many will probably recognise as bearing the strongest resemblance to simple C.W. transmitter circuits. It will be noticed that the telephones and H.T. are isolated by a radio-choke, arranged in a shunt circuit, as is the H.T. supply in many transmission circuits. The anode is connected directly to the aerial inductance, and the reaction condenser, which at the same time assists to tune the A.T.I. with which it is in series, is connected between the grid and "local earth." The grid is isolated by its condenser, the grid-leak being taken to L.T. plus.

In Fig. 1 it will be noticed that variometer tuning is used, with the variometer in series with a roughly-tapped frame aerial; and in Fig. 2 tuning condensers only are used. A three-plate "vernier" condenser (shown dotted in Fig. 1) is a refinement, hand-capacity effects being very prominent in such circuits.

On practical trial of the circuit shown in Fig. 1, with a 2-foot frame and a small internally-

wound variometer of some 100 total turns (No. 26 d.c.c.); with other values of components as indicated, and a No. 200 plug-in Igranic coil (i.e., 200 turns duolateral wound on 2-in. former), as radio-choke, without an earth connection, it was found to be quite controllable. The set oscillated easily with 30 volts on an R valve, and showed none of that troublesome "back-lash" in going into and out of oscillation. London came in strongly

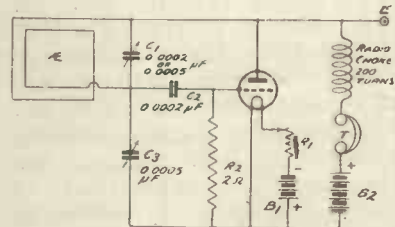

Fig. 2.—Frame aerial circuit, using condenser in lieu of variometer.

in the outer suburbs, and Birmingham was distinctly readable with extremely fine tuning. Several other carrier-waves were heard, and a local amateur could be read. With the arrangement shown in Fig. 2 similar results were obtained, but it was easier to handle, and the fine tuning not being so complicated by hand-capacity effects, a vernier adjustment was not necessary.

Upon adding an earth connection, with a 15-ft. lead connected to the anode (point E), a remarkable improvement was noticed, both in signal-strength and ease of operation. In quick order every B.B.C. station was tuned in, including the new Aberdeen station (495 metres). Speech, etc., was quite audible, though not comparable with the steadier and louder signals given by a

“super” under such circumstances. A relayed transmission from Glasgow to Aberdeen was perfectly distinct, as also were the words of the announcer: It was noticed, though, that directional effects on e.g. Glasgow were markedly small; rotating the frame did not tune him quite out, though he was weaker with the frame E and W. On substituting a No. 50 plug-in coil for the 2-ft. frame, and tuning again with the wave-meter, the distant stations were obtained every bit as easily, and London came in at moderate loud-speaker strength. Evidently the frame merely supplied a tuning-inductance; the major part of the “pick-up” was on the earth-lead alone.

Accordingly the circuit shown in Fig. 3 was developed. It is a slight modification of the receiver, arranged for grid-leak-howl super-regeneration, shown in *Wireless Weekly*, No. 11, September 26, p. 414. The only alterations are the substitution of a fixed grid-condenser (0.0002 μ F. of Grafton Electric Co.'s make), retaining the 2 megohm Dubilier grid-leak to L.T. positive; and changing over connections so that the variable grid-condenser of 0.0002 μ F. is now used across grid and L.T. positive for reaction-condenser; whilst the variometer is connected in the plate circuit, as in the diagram. The magnetic reaction winding of the super is merely disconnected. The radio-choke was $\frac{3}{4}$ oz. No. 32 s.w.g. enamel covered wire, wound on a 1 in. diameter bobbin, $1\frac{1}{2}$ in. long, in three layers, separated by several thicknesses of waxed paper, each

layer consisting of a roughly piled winding several turns deep, so as to give large inductance and fairly low distributed capacity.

The tapped variometer was retained:— $3\frac{1}{2}$ in. former, wound with 80 turns No. 22 d.c.c.; wooden ball rotor $2\frac{3}{4}$ in. diam. wound full of No. 22, about 54 turns; five tappings on stator. The plug connection for loading-coils was also retained.

On trial, only 20 volts H.T. were required with a good French R-valve to oscillate strongly but controllably over the whole range. London required only the variometer inductance, whilst longer-wave stations came in best with a No. 50 plug-in coil as loading-coil.

On the 15 ft. lead-in alone (the regular aerial being disconnected—if earthed no difference was noticed) every British station and the Ecole Supérieure in Paris

Aberdeen readable, the first easily so in daylight. London, of course, at 13 miles, came in at moderate loud-speaker strength. Another valve, as note magnifier, would have given all the loud-speaking one would want in a private house.

The tuning is a little peculiar until one gets used to it. By simultaneous adjustment of the variometer and reaction-tuning condenser the wave is kept “in sight” until maximum condenser value is reached, when the heterodyne note is just on the point of vanishing. Then a touch on the condenser, allowing for hand-capacities, which are always troublesome, brings it exactly into tune, the receiver really oscillating very slightly, but in step with the received wave. Of course, it is of little avail to try for the distant stations without some experience in handling the circuit, and a fairly accurate wave-meter is quite necessary, in any case, as there is so little to guide one in tuning.

Experiments with a very short indoor aerial attached at point E showed no improvement over the earth-lead alone. The P.M.G.'s regulations would not prohibit the use of this circuit on an earth lead or with a frame aerial. It is not suggested here that this circuit has any extraordinary superiority over the more customary type with magnetic reaction, or that any “super” action is taking place. It is simply an unusually convenient and finely adjustable type of single-valve-with-reaction circuit, adapted for use with a small frame or earth connection alone.

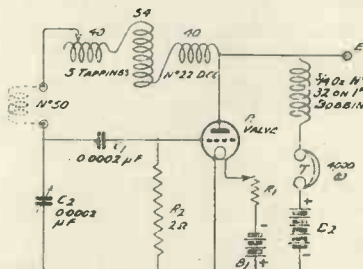

Fig. 3.—A modified circuit for reception upon earth lead.

were tuned in, the simultaneous transmissions from one station being picked up readily at other stations, Cardiff being readable while London was working. Newcastle was particularly strong, and both Glasgow and

R.S.G.B. TRANSATLANTIC TESTS, 1923.

Will all those Transmitters wishing to participate in this year's Tests please communicate at once with Mr. P. R. Coursey, Stamford House, Marchmont Road, Richmond, Surrey.

This year the main efforts will be directed to Transmission rather than to Reception. The following information should be supplied:—1. Call letters. 2. Location of Station. 3. Licensed power (has application been made to the G.P.O. for increased power during these tests?). 4. Normal working wavelength near 200 metres. 5. Can you Transmit every night, or do you prefer one night a week (if the latter, please state which night)? 6. If you do not wish to Transmit, do you wish to participate in Reception Tests?

RANDOM TECHNICALITIES

By PERCY W. HARRIS, Assistant Editor.

A few notes relative to high-frequency amplification.

EVERY morning I receive a batch of letters from wireless enthusiasts in all parts of the country telling me of their successes, failures, troubles and ambitions. Among these letters are quite a number from people who want to know how to add further stages of high-frequency amplification to receivers they have built. Most of these people seem to think that it is as easy to hitch a high-frequency amplifier to the front of the set as it is to tie a note-magnifier to the end. I wish this were so, but unfortunately it isn't! I am not at all surprised that this impression has gained currency, and I think I can trace the cause to the ease with which certain writers fire off circuit drawings showing any number of high-frequency stages. My wish is that these "experts" could be locked up in a room and made to build the receivers of which they so freely furnish circuit diagrams. Those who succeed in building them should be taken to another room, given an aerial and earth connection, and be forced to work them. I cannot imagine any worse punishment.

We all know the wonderful success attained last winter by British experimenters in the reception of American amateur signals. Seeing that the successful experimenters represented what might be termed the "cream" of the experimental world, it is to be supposed that they know something about high-frequency amplification and its value in such tests. Further, if it were so easy to add high-frequency stages one would expect that several would be used in each case. What did we find? Practically all of the successful reception was carried out with only one high-frequency valve preceding the detector.

The fact is that if we use more than one stage of tuned high-frequency the separately tuned circuits interact and, unless one takes great precautions to prevent it, self oscillation

is set up. These precautions usually reduce the sensitivity of the set. As a further worry we are faced with extremely critical tuning, necessitating the handling of several variable condensers simultaneously. We can, of course, use untuned transformers, which are fairly sensitive over a narrow band of wavelengths, but these attain simplicity at the sacrifice of magnification, so that we need several stages before we get really satisfactory results.

* * *

The neutrodyne is, of course, an attempt to get over the difficulty from self-oscillation by utilising special neutralising capacities and windings. The idea is ingenious, but we find that if more than two stages of high-frequency amplification are used the set becomes unmanageable. In view of the exaggerated claims sometimes made for the neutrodyne by enthusiasts I would like to point out that Mr. Wheeler, a co-worker with Professor Hazeltine, the inventor, has stated in print that the best set for 150 to 220-metre work is a super heterodyne, so that we have yet to find the simple solution of radio frequency amplification for very short wavelengths.

* * *

I have just succeeded in constructing a fairly simple three-valve set in which the first two valves are high frequency amplifiers, both stages being tuned. By using V 24 and QX valves, very careful wiring, and by connecting both high-frequency tuning condensers to the same shaft I have been able to produce quite a stable instrument which brings in the distant broadcasting stations comfortably without the need of pressing the set to the last limits of reaction. Six miles away London is as loud as one needs it to be in the telephones (two or three pairs), without any aerial or earth connection whatever.

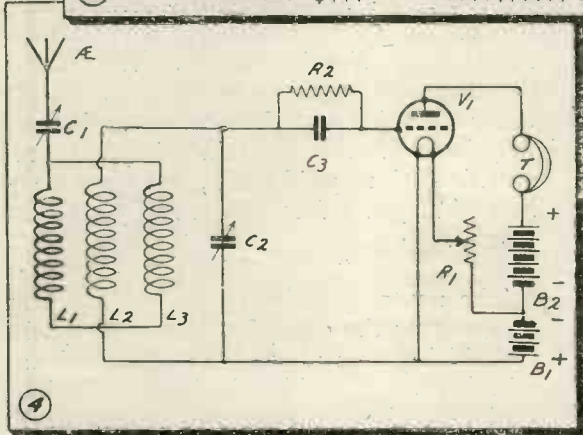
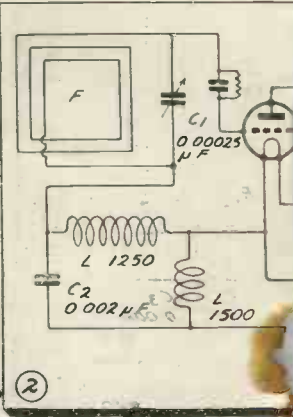
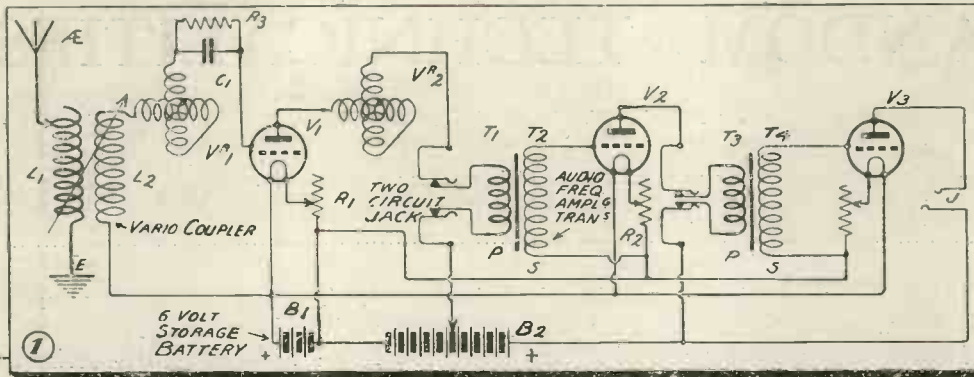

SOME MODERN RE

Upon this page we present a con-
receiving circuits embodying nov-
our readers a fairly extensive p-

Figure 1.—The Armstrong Three-Circuit Regenerative Receiver, with two stages of low-frequency amplification.

Figure 2.—The Armstrong Super-Regenerative One-Valve Receiver, used with a frame aerial.

Figure 3.—The Cockaday Four-Circuit Receiver, employing two stages of low-frequency amplification.

Figure 4.—The Satterlee Single-Valve Receiving Circuit.

Figure 5.—The Flewelling "Flivver" or Super-Circuit.

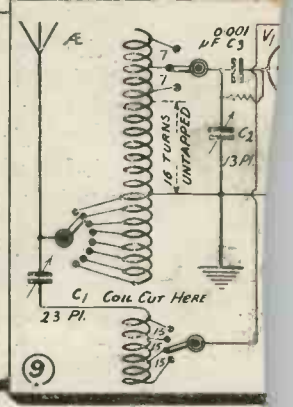
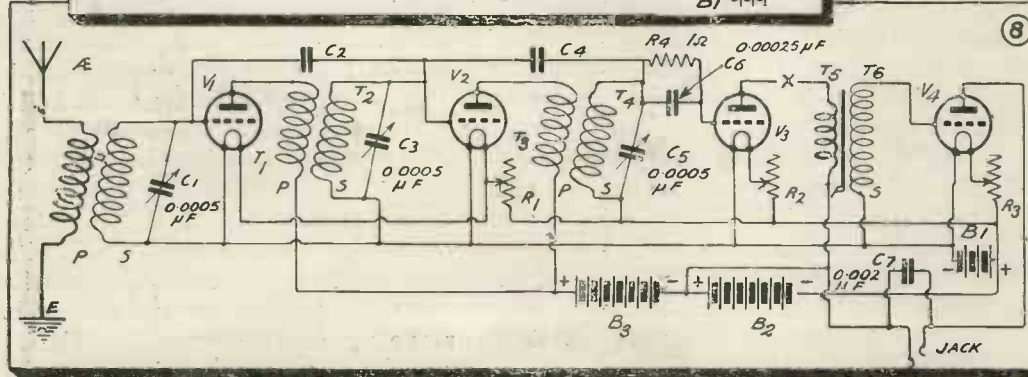
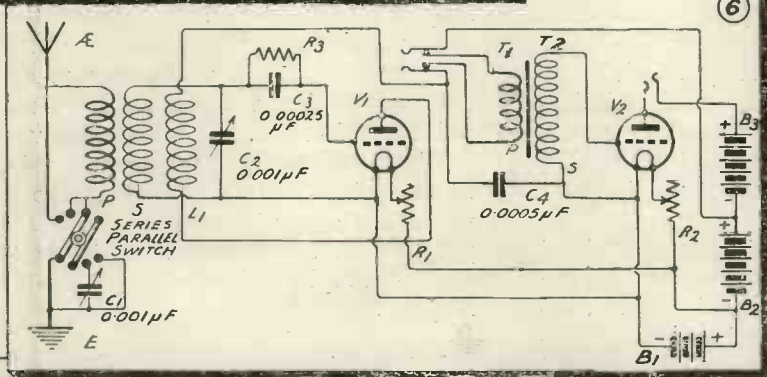

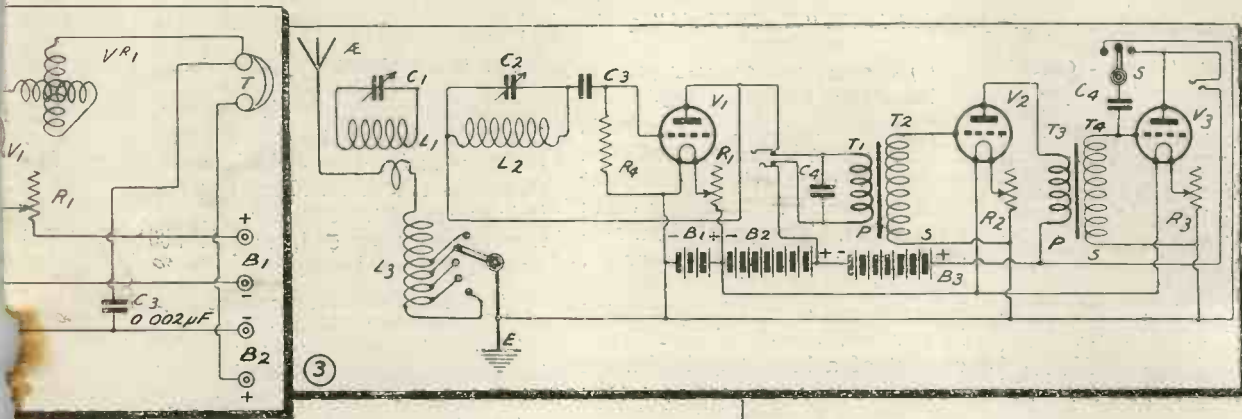

RECEIVING CIRCUITS.

comprehensive collection of American electrical principles, thus providing for a programme of experimental work.

Figure 6.—The Armstrong Regenerative "Feedback" Circuit, with one stage of low-frequency amplification.

Figure 7.—The Stockleburg Pup Circuit, with one low-frequency amplifying valve.

Figure 8.—The Hazeltine Neutrodyne Three-Valve Circuit, including one stage of low-frequency amplification.

Figure 9.—The Reinartz Receiver, with one low-frequency amplifying valve added.

Figure 10.—The Grimes Inverse Duplex Circuit for three valves.

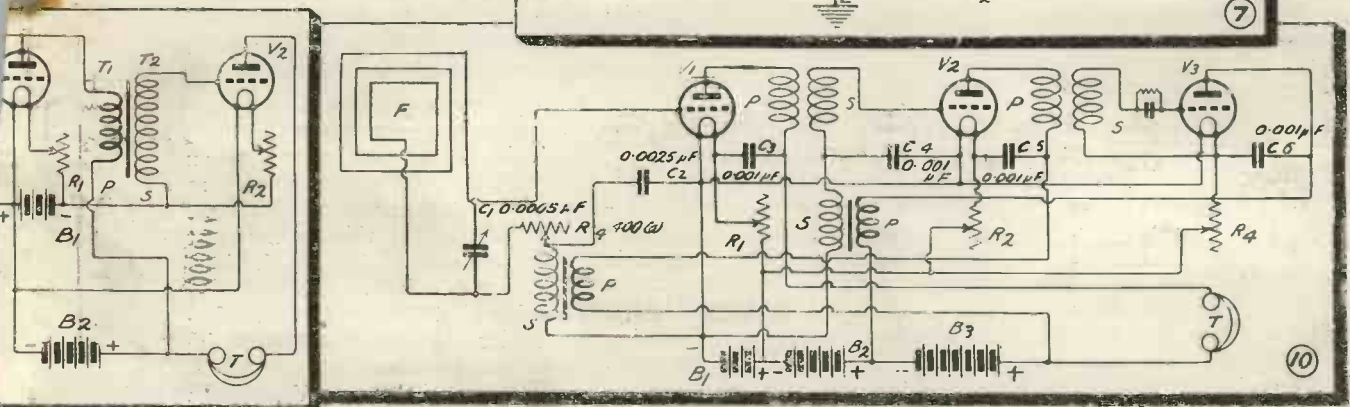
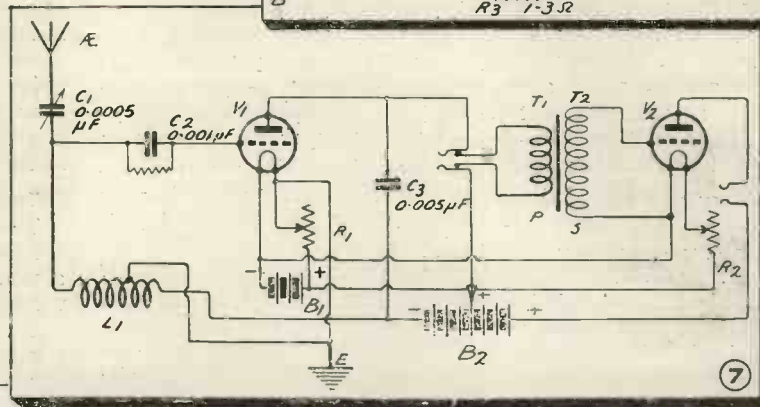
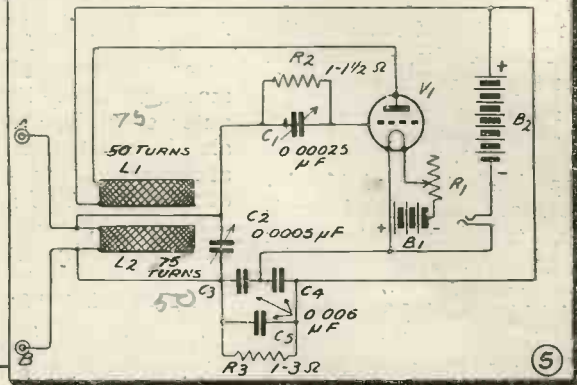

DETAILS OF THE MODERN RECEIVING CIRCUITS

(As published in the "Radio World" of America.)

The Armstrong Three - Circuit Regenerative Receiver. (Fig. 1.)

This circuit is highly selective and critical in tuning, calling for considerable skill in manipulation. Tuning is effected by means of the vario-coupler and the two variometers shown, which should be capable of adjustment to cover wavelengths from 200 to about 600 metres. An ordinary type of loose-coupler will no doubt prove effective in lieu of the vario-coupler. In this, as in all the following circuits, the voltages of the batteries B_1 and B_2 , also the values of grid leaks, will depend upon the type of valves employed.

The Armstrong Single - Valve Super-Regenerative Receiver. (Fig. 2.)

The special features of this circuit are sharp tuning and sensitiveness, together with great signal strength from the one valve employed. This circuit should be used only with a frame aerial as, if not skilfully operated, it readily generates oscillations which give rise to all kinds of howls and squeaks. The two coils, $L_{1,250}$ and $L_{1,500}$ are honeycomb coils arranged at right angles to one another. Reaction effects are produced by the variometer, which tunes the plate circuit.

The Cockaday Four-Circuit Receiver. (Fig. 3.)

It is claimed that this circuit is very selective, that the tuning is not too critical, that it does not produce howls, and cannot cause interference by radiation. The aerial circuit comprises the inductance L_3 , which consists of 43 turns, bank wound, upon a $3\frac{1}{2}$ -in. diameter tube, with tapings at the 3rd, 7th, 13th, 21st, 31st, and last turns, placed at right angles and close to coils L_1 and L_2 . The inductances L_1 and L_2 consist of 34 and 65 turns, respectively, wound side by side upon the same tube with a small gap between the windings. The single turn of wire in the aerial circuit is wound around the coil L_1 .

The Satterlee Single-Valve Receiving Circuit. (Fig. 4.)

The main point about this circuit is that it can be used with an earth connection alone, or with an aerial without any earth connection. The aerial circuit includes the variable condenser C_1 , capacity $0.0005 \mu F$ and the two inductances L_1 and L_3 connected in parallel. Each of these coils consist of a basket coil of some 60 to 80 turns, and the two coils are hinged to open like a book. The secondary coil, L_2 , is also a basket coil of from 50 to 70 turns, so arranged that it can be moved vertically between the two outer coils, L_1 and L_3 , and can also be rotated until its plane is at right angles to the plane of the other coils. The secondary condenser, C_2 , should preferably have a capacity of $0.001 \mu F$.

The Flewelling "Super" Circuit. (Fig. 5.)

This circuit may also be used with either an aerial or earth connection. The terminals A or B should be connected to one side of a frame aerial, or to a regular aerial or earth connection, or both if desired. The "whistle" produced by this receiver resembles the variation frequency of the Armstrong Super-Circuit, and, if it is not present, the set is not operating correctly. If used upon a regular aerial, this circuit is capable of causing considerable interference in near-by receivers. Constructional details have been given in a previous issue.

The Armstrong Regenerative Three - Circuit "Feed - Back" Receiver. (Fig. 6.)

This circuit has gained considerable popularity amongst experimenters who desire flexibility and selectivity. This is not a "super" circuit, but an ordinary reaction circuit with one stage of low-frequency amplification added. By means of the telephone jacks shown, one or two valves may be used at will.

The Stockleburg Pup Circuit. (Fig. 7.)

This is a single circuit receiver having only one tuning adjustment, namely, the variable condenser in the aerial circuit. The inductance L_1 , consists of a honeycomb type coil, tapped at one-third of its turns.

The Hazeltine Neutrodyne Receiver. (Fig. 8.)

The coils shown at an angle in the diagram are oscillation transformers with tuned secondaries. They are identical in construction, having a primary winding of 16 turns of No. 26 S.W.G.-d.c.c. copper wire upon a 3-inch diameter tube, and a secondary winding consisting of 65 turns of similar wire wound upon another and slightly larger tube, directly over the first. These three transformers should be mounted at an angle of 55 degrees from the vertical. The Neutrodyne or neutralising condensers, C_2 and C_3 , should have a very small capacity, about 1 micro-microfarad, the exact value depending upon the particular valves in use. Reaction effects may be obtained by the introduction of a suitable variometer at the point marked X.

The Reinartz Circuit. (Fig. 9.)

This is really a particularly efficient C.W. receiver, but is also a good broadcast receiver when properly constructed and operated. It is selective, and good for long distance reception. Constructional details of a Reinartz receiver have already been given in a previous issue.

The Grimes Inverse Duplex Receiver. (Fig. 10.)

This is a multi-valve reflex receiver in which three valves are made to do the work of five. It is claimed that this is the best reflex circuit yet developed. The first two valves, V_1 and V_2 , amplify both high and low-frequencies, due to the action of the iron core reflex transformers, whilst the third valve, V_3 , acts as a rectifier.

Constructional Notes

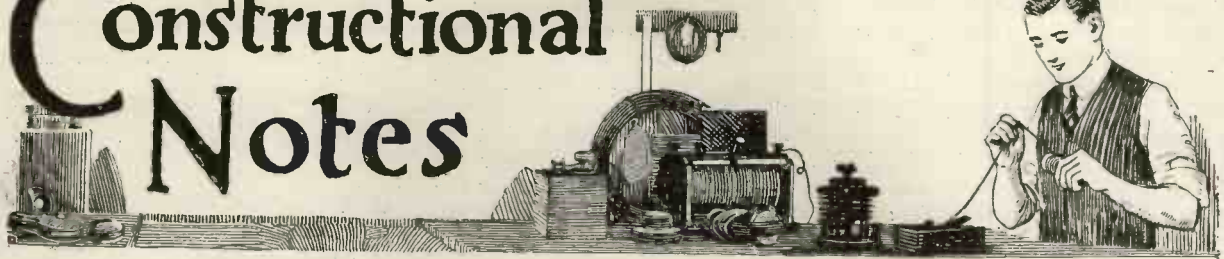

Conducted by R. W. HALLOWS, M.A., Staff Editor.

CRYSTAL ADJUSTMENT INDICATOR AND DUST CAP

An extremely useful* device for crystal detectors may be made from an ordinary pill box. In operation it has two very useful functions; firstly, it acts as an effective dust cap, and thus protects and prolongs the life of the crystal; secondly, it registers a permanent sensitive point on the crystal. The cat-whisker may be removed from the crystal and again placed in identically the same spot, giving the same results simply by remembering the marking numbers on the gauge. Having obtained a pill box, remove the lid and mark round the top edge of the box a number of equal divisions, numbering them in rotation. Next make a mark on the rim of the lid, to act as a pointer. On the top of the lid prick a series of small holes with a needle and number them, as shown in Fig 1. To assemble, screw the crystal cup into position inside the pill box and insert the crystal; now place the lid in its rightful position so covering the crystal within the box. To operate, the cat-whisker is passed through one of the holes in the lid and placed on the crystal. If the spot is not suitable the lid is slowly turned round until a suitable contact is found. If then the adjustment is favourable, the position can be permanently remembered by noting the rela-

tive positions of the pointer on the lid and the scale on the box. For example, if the pointer is opposite the division marked 20 on the box and the cat-whisker is inserted through hole No. 2 in the lid, all that is required is to remember these numbers, and place the lid in a similar position for further use, or leave it so placed when the cat-whisker is removed. Further, a series of good spots on the crystal may be found and remembered by pass-

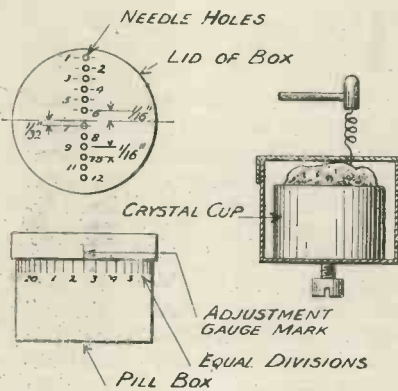

Fig. 1.—Illustrating details of the pill-box dust cap.

ing the cat-whisker through any one of the holes in the lid, each of which it will be seen has a different circumferential movement, when the lid of the pill box is turned round. So long as care is taken in making the various markings and pinholes, quite a neat-looking job may be made of this little "gadget."

H. B.

NEW DESIGN OF TRIPLE COIL HOLDER

SINCE many experimenters experience difficulty in making the orthodox type of plug and socket coil holder, this constructional article is specially written to overcome that difficulty by replacing the usual sockets by commercial fuse clips, and the plugs by strips of brass.

Figs. 2 and 3 illustrate the general arrangement of the coil holder, together with full working details. Both figures are self-explanatory, and if care is taken to construct according to details the experimenter will be in possession of a first-class component.

For the sake of those who wish to make a cheaper article, the following alterations could be made:—

1. The baseboard (A, Fig. 3) could be made of hard wood with a strip of ebonite on top for terminals.
2. The brass bearing bushes (E, Fig. 3) of the bearing bracket (B, Fig. 3) could be omitted and 3/16in. holes drilled in the ebonite to take the spindle. This detail could also be made of hard wood.
3. If difficulty is experienced in threading the 2B.A. brass rods to sizes given, these could be substituted by commercial 2B.A. threaded rods cut to size. These are sold by

wireless dealers in 12in. lengths.

The fuse clips can be bought from any electrical shop. Strong clips (about 10 amp.) should be purchased, when there will be no fear of even the largest coil falling out of holder.

In Fig. 3, showing details, is also drawn an adaptor (J) for use with this holder, and each coil

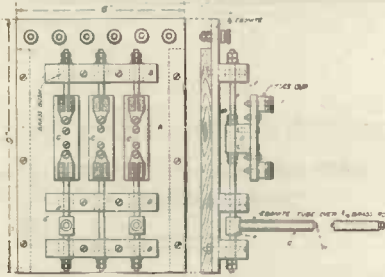

Fig. 2.—Plan and elevation of the coil holder.

requires to be fitted with one of these. The adaptor is easily attached to the coil by means of insulating tape or waterproof silk.

Wood battens are fitted (as shown in Fig. 2) on the back of the main ebonite panel; the dimensions of these are left to the reader's discretion.

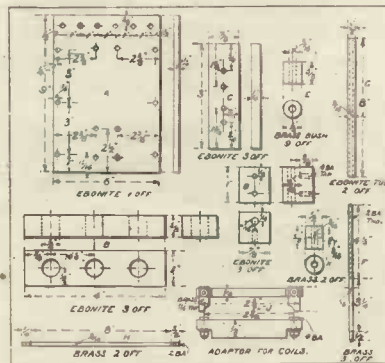

Fig. 3.—Constructional details of the various parts of the coil holder.

The wiring of this component is best carried out by first drilling three 3/16in. diameter holes in the ebonite, one immediately below each fuse clip. Connect pieces of flexible cable to a nut on each of the three fuse clips; lead each cable through

the hole below each clip and attach the other end to a terminal below the ebonite. Sufficient loose cable must be left to enable the two outer holders free movement for tuning purposes.

It may be thought that in using this type of coil-holder the coils may be put in the holder the wrong way round; this is not so, as it must be remembered that if the coils are placed, say, upside down their connections will also be reversed. If the coils are connected to their adaptors in the proper manner to start with no further trouble will be experienced.

Modifications of this type of coil-holder can easily be made for panel mounting to take the coils for a tuned anode circuit with or without reaction.

I. L. R.



THE most convenient way of supplying the necessary potential to a carborundum or similar detector is by means of pocket flash-lamp batteries; their cells, however, are so small that they cannot be called upon to give more than the tiniest current if they are to last for any time. The usual 300-ohm potentiometer is useless for the purpose, as a moment's thought will show. If such a potentiometer is placed across two 4 1/2 volt flash-lamp batteries in series, as shown in Fig. 4, the current flowing will be $\frac{9 \times 1000}{300}$ or 30 milliamperes,

which is a far greater load than the small cells will stand up to for economical use.

What we require is a potentiometer with a resistance of about 900 ohms, which will pass only 10 milliamperes of current, a discharge rate that is well within the powers of the cells. We can reduce the current to less than 7 milliamperes by using 3-volt

lamp batteries, which are obtainable at most electrical shops.

A 900-ohm potentiometer is an expensive gadget to buy, but it can be made without difficulty and at very small cost.

Obtain a piece of 1/2-in. ebonite measuring 4 1/2 by 2 3/4 in. Round

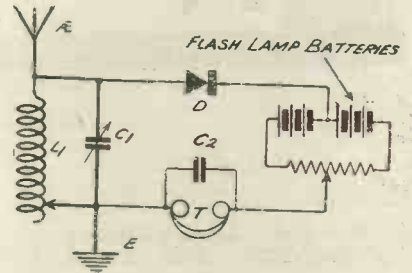

Fig. 4.—Showing a crystal circuit using potentiometer.

off the long edges with a file, as shown in Fig. 5 a and b, so as to make the former roughly oval in shape. This will greatly facilitate winding, and will enable the turns to be put on quite tightly. Half an inch from either end drill two very small holes through the former, as shown in Fig. 5 a. These are to serve as anchorages for the ends of the wire.

The wire used will be No. 36 Eureka, which has a resistance of 14.5 ohms per yard. We shall therefore need 62 yards, which

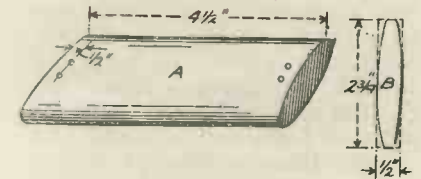

Fig. 5.—Details of the former to take the winding.

works out at 410 turns, or 3 1/2 in. of close even winding. Enamelled wire is used so that there need be no spacing between turns. When the former has been wound give the turns a good coating of shellac or enamel to fix them firmly, and allow to dry hard.

We require next a 5-in. length of 1/4-in. square brass rod, a spring-contact slider which is a

good fit upon it and two small strips of $\frac{1}{4}$ -in. ebonite or wood to act as end-pieces (A, A Fig. 6). The last will be $3\frac{1}{2}$ in. wide. Their height will depend upon the size of the slider; it must be such that the point of the slider makes firm contact with the turns when the former is mounted.

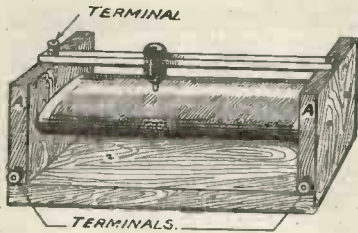

Fig. 6.—The finished instrument.

Secure the end pieces to the former by means of 4B.A. countersunk screws. Its lower edge should be $\frac{1}{4}$ in. from the bottom of each end piece. Now mount the apparatus on a polished wood base board measuring 5 in. in length by $3\frac{1}{2}$ in. in width by $\frac{1}{2}$ in. thick by means of countersunk 4B.A. screws driven through the wood.

Fix the square rod in place on top of the ebonite by means of a 4B.A. screw at one end and a terminal at the other. Screw a terminal into each end piece, attach the ends of the windings to these, and the potentiometer is ready for use as soon as a bare path for the slider's point has been scraped with a piece of glass paper. A reference to Fig. 4 will show how it is wired up.

If it is desired to have the potentiometer out of the way on the set, the former can be mounted beneath the panel. A slot wide enough to take the point of the slider and $3\frac{1}{2}$ in. long is cut in the panel, and the square rod is mounted on two small ebonite supports.

Care must always be taken to disconnect the batteries when the detector is not in use, otherwise even the 900 ohm resistance will not prevent them from running down in a comparatively short time.

R. W. H.

A HOME-MADE
BATTERY TESTER

THERE is only one real way of knowing how your battery is being treated by the charging station to whom you entrust it periodically, and that is to test the electrolyte by means of a hydrometer. This is a most useful little instrument, for it tells you at any time the condition of the cells as regards the charge remaining in them.

A simple hydrometer that will give excellent service can be made at home for a few pence. The only thing that need be bought is a pipette—that is, a glass tube brought to a fine end and fitted with a rubber pinch bulb. The pipette should be about 6 in. long with a diameter of $\frac{5}{16}$ or $\frac{3}{8}$ in.

Obtain the loan of a scaled hydrometer, and with its aid mix two test-tubefuls of dilute sulphuric acid solution, using the



Fig. 7.—The pipette cell tester

best brimstone acid and distilled water. The first must have a specific gravity of 1.22, the second of 1.17. A specific gravity of 1.22 is the usual figure for a fully-charged accumulator. Some makes, however, are designed for a higher gravity. If this is so in the case of yours you will find the correct figure indicated on the label. Make the first solution equal to this, and increase the gravity of the second in proportion.

Now roll between the finger and thumb a little ball of paraffin wax that will fit easily into the tube of the pipette. Press lead filings into it until it floats just touching the surface in the first test tube.

Place the ball in the pipette and draw up about 4 in. of the

solution from the first test tube. Make a mark with a diamond on the glass opposite the top of the liquid. Empty the pipette and draw up solution from the second tube until the scratch on the glass is reached.

The wax ball will now be found to be floating some distance from the top of the column of liquid. Make a second mark to indicate the spot reached by it.

When testing accumulators the pipette must always be filled up to the top mark. The position of the ball will then indicate their condition. If it just touches the surface the cell under test is fully charged. When it reaches the lower mark the cell is right down and should be charged without delay.

R. W. H.

STARTING AWKWARD
SCREWS

A VERY useful little tool for starting screws in awkward places where the task is most difficult with a screw-driver can be made from a piece of iron wire of fairly stout gauge. Bend the wire as shown in the drawing and fit it with a slider.

To use the tool place the head of the screw between the looped ends and grip it firmly by pushing the slider hard down. The screw can then be inserted with-



Fig. 8.—Screw-holder with slider.

out difficulty into the most awkwardly placed hole.

Another use for the tool is when a small screw slips and falls into some part of the work in hand where it cannot be reached with fingers or pliers. If the little wire device is used as a pair of tweezers it can be picked out quite easily.

R. W. H.

Broadcasting News



LONDON.—The question of simultaneous broadcasting is discussed freely amongst the listening public, and there seems to be a diversity of opinion as to whether or not the simultaneous transmission of music is a complete success. Capt. Eckersley gave a characteristically humorous talk on the subject, with a view to finding out what the listeners thought about it, and a mass of correspondence reached the B.B.C., of which 95 per cent. was in favour of its continuance.

On another evening Capt. Eckersley announced that in view of its undoubted popularity simultaneous broadcasting would be continued with few curtailments.

Trafalgar Day, October 21, was very appropriately celebrated by the London broadcasting station. The 2LO orchestra was in good form, the solo and chorus singing by a portion of the British National Opera Company were likewise inspiring and enjoyable. The capable singing of the hymn after his remarks rather "toned up" the observations of the good Rector from Lambeth, whose oration regarding Nelson and his greatness seemed strangely mild and lacking in patriotic fire and enthusiasm. However, one can't have everything in this world of ours.

"The Roosters Concert Party" were indeed a lively lot of "birds" on Trafalgar Eve; they seemed to "hold the stage" continuously and kept the listener interested all the time. As a matter of fact, they reminded us somewhat of that

galaxy of talent, the "Co-optimists," which we seem to have had "radioed" but once. We have heard somewhere, however, that they are coming again.

There has been some talk of late about the desirability of broadcasting Eiffel Tower programmes from the British Broadcasting stations; a kind of wireless "entente cordiale." It is very difficult to arrange this satisfactorily, but it is quite possible that M. Poincaré and other distinguished Frenchmen may broadcast messages of goodwill to the British people.

Forthcoming Events

NOVEMBER.

1st (THURS.).—6.30, Organ Recital at Westminster Cathedral by Mr. Herbert Carruthers. 8.15, Band of H.M. Guards; Mr. Foden Williams, entertainer; Miss Ethel Tuck, pianist.

2nd (FRI.).—Wireless Orchestra. Miss Nora Delmarr, soprano; Mr. Lewis Hertel, entertainer.

3rd (SAT.).—Orchestra. Mr. J. Kaye, entertainer; Miss Violet Norman, soprano. "Other Things I Know," by Mr. William Le Queux. Capt. Twelvetrees on Motoring.

4th (SUN.).—3 p.m., Mr. Joseph Farrington, baritone; Mr. Frederick J. Thurston, clarinet solos. 8.30 p.m., Royal Engineers String Band; M. Romano Ciaroff, tenor.

6th (TUES.).—Classical evening. Miss Bessie Rawlins, violinist; Miss Ethel Hobday, pianist; Mr. Bertram Binyon, singer. Mr. Harry Lyttler, flute and piccolo.

7th (WED.).—Mr. Lee Thistlethwaite and Orchestra. Miss Irene Morris, soprano. Miss Amy Buxton Nowell will recite "Bergliot," with orchestral accompaniment.

9th (FRI.).—7.30, Mr. Maurice Cole, pianist; Mr. Lyell Johnston singer; Hawaiian Players. 8.45. Transmission of speeches from the Lord Mayor's Banquet. 10th (SAT.).—Orchestral and Dance Music. Miss Nora Lynn and Mr. James Bolden, vocalists; John Henry.

BIRMINGHAM.—In the last few months, 5IT's orchestra has attained a high standard of perfection, and it has been encouraging to notice how consistently their playing has improved with the increase in the number of players. The playing shows a mastery of technique which is extremely pleasing, and gives a fine volume. Haydn's "Oxford Symphony," which they gave the other evening, was a notable example. It is a work which makes an unusual demand upon the precision and uniformity of the players, and the orchestra responded to it in a way wholly delightful.

Forthcoming Events

OCTOBER.

31st (WED.).—7.30, Station Répertoire Choir. 9 p.m., Mr. Sidney Grew (recital).

NOVEMBER.

2nd (FRI.).—Request Night. 8.45-9.30 p.m., the "Toc H." Party will render selections.

3rd (SAT.).—7.30 p.m., Station Orchestra.

5th (MON.).—3.30-4.30 p.m., Mr. Joseph Lewis (pianoforte recital).

6th (TUES.).—3.30-4.30 p.m., Lozell's Picture House Orchestra. 7.30-10.30 p.m., the Greys Concert Party.

GLASGOW.—In view of the popularity of "All-Scots Night," programmes have likewise been arranged for broad-

casting "All-Irish," "All-Welsh" and "All-English" items, when the favourite national songs of these countries will be sent out by selected singers, as well as by the members of the wireless orchestras. Music will also be a more conspicuous feature in the programmes of the future, and listeners-in will soon be able to hear such popular old dances as the Circassian Circle and the Polka.

Forthcoming Events

OCTOBER.

31st (WED.).—Hallowe'en Night. Miss Margaret F. Stewart, soprano; Mr. Laurence Macaulay, baritone; Miss Annie Hamilton, solo-violinist. Scotch Selection by the Wireless Orchestra.

NOVEMBER.

1st (THURS.).—Les Cloches de Corneville specially adapted for wireless transmission by Mr. R. E. Jeffrey.

2nd (FRI.).—Miss Jessie Millar, soprano; Mr. Harry Ritchie, baritone. Wireless Orchestra. Mr. William Carswell on "Physical Exercise for Health."

3rd (SAT.).—Mr. Dave Thompson, baritone, with orchestral accompaniments; Miss Josephine MacPherson, L.R.A.M., mezzo-soprano.

MANCHESTER. — Transmissions from the different stations of the B.B.C. are coming through much stronger than during the summer months, which is, of course, to be expected. Cardiff seems to be the most elusive, with Newcastle next in order of difficulty, whilst Birmingham, London and Glasgow come through quite strongly. The new Bournemouth station too is received surprisingly well. Before this station was opened residents in Bournemouth told us that the Manchester transmissions came through much better than London or Birmingham, so doubtless the conditions are reciprocal.

Forthcoming Events

OCTOBER.

31st (WED.).—3.30, Piccadilly Picture House Orchestra. 6.30, Piccadilly Picture House, Organ Recital. 7.45, 2 ZY Operatic

Company in Verdi's "Rigoletto": Augmented Orchestra conducted by Mr. Dan Godfrey, Jun.

NOVEMBER.

1st (THURS.).—11.30, 2 ZY Trio: Miss Alice Hill, contralto. 6.40, Spanish Talk. 7.10, Music of the Week, by Mr. Percy Scholes, from 2 LO. 7.35, H.M. Irish Guards Band, from 2 LO. 9.45, Savoy Orpheans.

2nd (FRI.).—3.30, Miss Frances Roland, contralto; Mr. G. Taylor, baritone; Miss Elene Shepherd, soprano. 6.30, Oxford Picture House Orchestra. 7.45, 2 ZY Orchestra. 8.15, Piccadilly Picture House Orchestra. 8.45, French Talk. 9.0, Mr. Joseph Markham, tenor.

BROADCAST TRANSMISSIONS

Call-Sign	Wavelength.
CARDIFF.....5WA.....	353 metres.
LONDON.....2LO.....	383 "
MANCHESTER.....2ZY.....	370 "
BOURNEMOUTH.....6BM.....	385 "
NEWCASTLE.....5NO.....	400 "
GLASGOW.....58C.....	415 "
BIRMINGHAM.....5IT.....	420 "
ABERDEEN.....6BD.....	465 "

TIMES OF WORKING.

Weekdays.....3.30 to 4.30 p.m. and 5.0 to 10.30 p.m. G.M.T.

* London 11.30 a.m. to 12.30 instead of 3.30 to 4.30 p.m.

Sundays.....3.0 p.m. to 5.0 p.m. and 8.30 to 10.30 p.m. G.M.T.

NOTE:—The wavelengths given above are allocated temporarily and further alterations are pending.



3rd (SAT.).—3.30, Oxford Picture House Orchestra. 6.30, Piccadilly Picture House, Organ Recital. 7.45, Mr. T. H. Morrison, solo violin; Miss Helena Taylor, soprano; Miss Emmie Lord, elocutionist; Mr. Klinton Shepherd, baritone. 9.0, Mr. Victor Smythe. 9.15, Keyboard Kitty will.purr.

4th (SUN.).—8.30, Wesley Male Voice Choir; Mr. Carl Fuchs, solo 'cellist. 9.0, Talk by Mr. A. B. Turner, Chairman of the Manchester City Mission.

5th (MON.).—3.30, 2 ZY Orchestra; Mr. William Ibbotson, baritone; Mrs. Florence Eaves, soprano. 6.40, Boys' Brigade Bulletins. Spanish Talk.

6th (TUES.).—3.30, 2 ZY Trio. 6.30, Organ Recital from Piccadilly Picture House. 9.15, Mr. Percy Phlage.

NEWCASTLE.—We regret to learn of a recurrence of radiation in a certain district in the North of Newcastle. The surprising thing is that on each occasion it happened during the simultaneous broadcasting. It is difficult to see why it should be necessary to use reaction at all during such transmissions.

We see an announcement has been made from headquarters to the effect that special attention is to be devoted to lightening the programme somewhat by the inclusion of more items of a humorous nature. From criticisms we have heard, we feel sure that more artistes of the type of Messrs. Robert Gourlay and John Henry, of London, or of our own inimitable Mr. Bates, would be welcome.

Forthcoming Events

OCTOBER.

31st (WED.).—3.45, Miss Florence Farrar, piano; Miss Ella Dodds, soprano. 7.30, Operatic Night; Mr. John Wyatt, lecturer; Messrs. Ernest Sharp and Robert Strangways; Miss Beatrice Paramor.

NOVEMBER.

1st (THURS.).—3.45, Mr. J. Martin, baritone; Miss Ida Cowey, soprano; Miss Ella Scott, elocutionist.

2nd (FRI.).—3.45, Mme. F. Hicks, soprano; Master McKeown, boy baritone. 7.30, Mr. Tom Sherlock, baritone; Miss Elsie Macdermid, soprano.

□ □ □
Simultaneous Broadcasting Events

OCTOBER.

31st (WED.).—9-9.30, Hon. W. R. Warren, Prime Minister of Newfoundland (all stations).

NOVEMBER.

1st (THURS.).—6.30-7.45, Organ Recital in Westminster Cathedral by Carruthers (all stations except Newcastle). 8.20-9.10, 9.45-10.45, Irish Guards Band (to Manchester and Birmingham only). 8.20-10.30, Glasgow, Les Cloches de Corneville (to Aberdeen only).

4th (SUN.).—3-5, Concert (all stations).

5th (MON.). 7.30-9.30, 9.45-10.45, Newcastle, Mozart Programme (to all stations).

6th (TUES.).—10-11, Savoy Orpheans (to all stations).

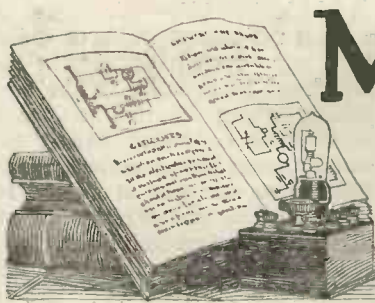

Mainly about Valves

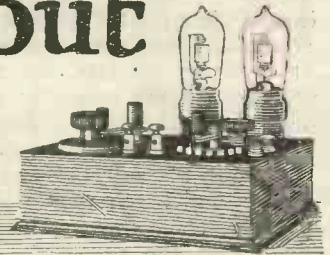

Our weekly causerie written by the Editor.

Some More Remarks About Reaction.

IT is remarkable the little that the average experimenter knows about reaction. In theory, reaction seems simple, but when we come down to the practical use of it, all sorts of peculiar effects are produced, and there are various ways of obviating the troubles which are likely to arise.

In the first place, let me warn the experimenter against the idea that reaction is produced when a coil is coupled one way round to another and not in the reverse case. It is all very well to say that the anode coil should be connected one way round for reaction and that if it is connected the other way round, reverse reaction will be obtained. It will not, however, be long before the experienced experimenter will find that he can get it to oscillate, and even to give the increased signal strength due to reaction, and yet have the reaction coil the wrong way round.

There are two principal ways in which reaction is obtainable; one is by inductive coupling between an anode coil and a grid coil, and the other is by a capacitive coupling, this being accomplished either by means of a condenser, or simply by the condenser formed by the grid and anode inside the valve. Capacity coupling is generally the cause of self-oscillation in a circuit using a tuned anode circuit. When this anode circuit is tuned to the same wavelength as the grid circuit, it needs very little capacity to couple the two circuits in such a way as to produce self-oscillation. The same effect will be obtained if the anode circuit contains, say, a variometer, or a tapped inductance which, with its own self-capacity and the capacity of the anode to filament and stray

capacities, corresponds to the same wavelength as the grid circuit.

This capacity coupling will remain even when the reaction coil is reversed, and the capacity coupling may be greater than the reverse inductive coupling, and so there may still be self-oscillation. In fact, by tightening the coupling the capacity between the two coils will increase, and this capacity will supplement the capacity inside the valve and so increase the capacity reaction, even though the reverse reaction has been increased. It is possible to increase the capacity reaction to a greater extent than the reverse inductive reaction, and in this case, bringing the two coils closer together will result in self-oscillation.

This phenomena will be particularly noticed when a tuned anode circuit is coupled to a tuned grid circuit. It very rarely happens when a simple reaction coil, which is untuned, is coupled to the grid circuit; in the latter case, increasing the coupling between the two coils will cause an increase in signal strength if the coupling is the right way round, and a decrease in signal strength if the reaction is the wrong way round.

Be careful, then, when using a tuned anode circuit coupled to a tuned grid circuit, to make absolutely sure that you have the reaction the right way round. Do not be deceived by the fact that as you bring the coils together you get an increase in signal strength, or self-oscillation. Always try connecting one of the coils the other way round. If you are using the ST 100 circuit, you will often find that the reaction effect is obtained whichever way round you have the connections to the tuned anode coil. Nevertheless, one way will be very much better than the other.

DO NOT MISS NEXT WEEK'S ISSUE—OUR FIRST EXHIBITION NUMBER

Information Department

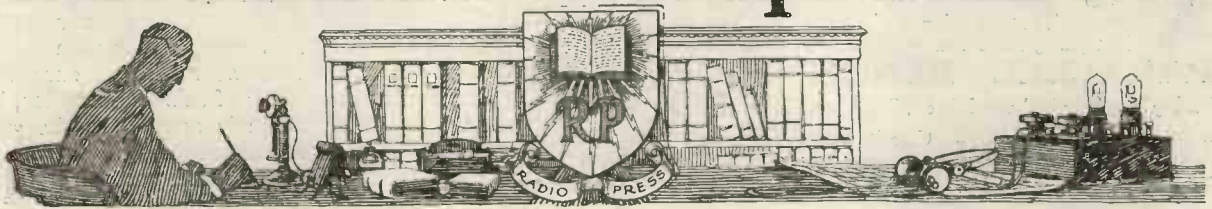

J. F. F. (DUMBARTONSHIRE) asks for a diagram showing how to switch in and out the last valve of an ST 76 set, by means of a plug and jack system.

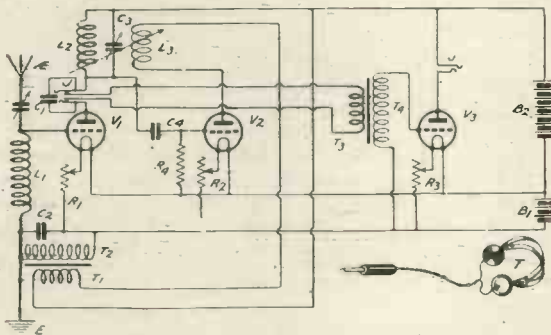

We reproduce herewith a suitable circuit.

K. A. (BANWELL) asks why the valve in the reflex circuit illustrated in "WIRELESS WEEKLY" for May 23rd, page 425, should act as a detector without the condenser and leak.

You are wrong in assuming that a valve will not rectify without a grid condenser and leak, since it is quite easy to make it do so by means of a potentiometer or other method of adjusting the grid potential to one of the bends of the characteristic curve. This can also be done by adjustment of plate voltage. It is therefore quite possible that a reflex circuit may fail to amplify satisfactorily because the valve chances to be rectifying as the result of an unsuitable plate voltage. The remedy is to increase the latter, and it is also desirable to try varying the filament current.

A. M. F. (AVIEMORE) wishes to use a pair of 4,000-ohm telephones in the ST 75 circuit.

We think that you can overcome your telephone difficulty by connecting the two earpieces of your receivers in parallel instead of in series and using a telephone transformer of the ordinary pattern. The condenser across the telephones in ST 75 is

optional, and should be a matter of experiment to see whether it suits the particular receiver. With some valves and certain plate voltages, the addition of the condenser sometimes results in self-oscillation. In any case, the set should be tried both with and without it.

E. A. E. (KILBURN) is using a loose-coupled crystal receiver in conjunction with a low-frequency valve, and now wishes to add a high-frequency unit.

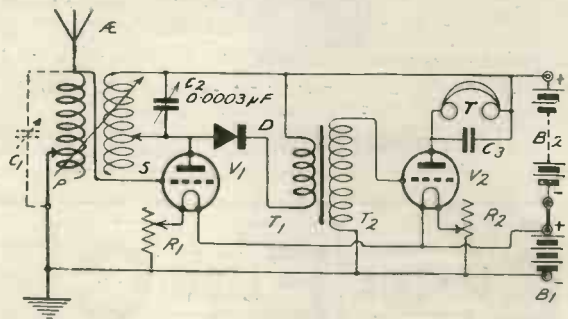

We reproduce herewith a circuit diagram showing how this may be done.

C. J. E. (MARGATE) asks several questions regarding modified ST 100 circuit in "MODERN WIRELESS" No. 7, page 528, fig. 4.

If you substitute plug-in coils for the variometers in your circuit, it will be necessary to shunt each one with a variable condenser of the following values:—

- Aerial circuit ... 0.0005 μ F.
- Plate circuits ... 0.0003 μ F.

The following coils should be used for the Dutch concerts:—

- Aerial circuit ... No. 100.
- Plate circuits ... No. 200.

For Radiola, the values should be as follows:—

- Aerial circuit ... No. 150. (If your aerial is a large one No. 100 will serve for this station also.)
- Plate circuits ... No. 200.

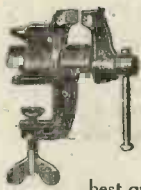

Good Tools — Good Temper and Good Work

The three things are inseparable. Have the best quality and cut out middle costs by buying direct.

PARALLEL BENCH VICE

Quality guaranteed, Covered Screw, Steel Jaws, Price 5/6

HAND DRILL Capacity 0- $\frac{1}{4}$ in. Complete with three-jaw Chuck and Set of drills $\frac{1}{16}$ in., $\frac{3}{32}$ in., $\frac{1}{8}$ in., $\frac{3}{16}$ in., $\frac{1}{4}$ in. **10/6**

Money returned if not satisfied. We pay carriage.

THE BILLING TOOL CO. (Dept. W), 303, High Holborn, LONDON, W.C.1.



BEWARE OF WORTHLESS IMITATIONS, SEE THE TRADE MARK **WatMel** ON EVERY GRID LEAK.

WATMEL VARIABLE GRID LEAK

(Patent applied for.)

The Resistance is steadily Variable between $\frac{1}{2}$ to 5 megohms. Only requires a $\frac{3}{8}$ in. hole in panel for fitting.



Suitable for use in any circuit, and improves the working of any valve detector. (50,000 to 100,000 ohms for the S.T.100 Circuit. Price 3/6.)

PRICE 2/6 each.

The best Variable Grid Leak made.

WATMEL WIRELESS CO., Connaught House, 1a, Edgware Road, Marble Arch, W.1. Tel. 4575 Paddington.

E

ELECTRIC

C

THE "EEC" "XTRAUDION" VALVE

is being used by the leading Radio Experimenters for detection, high and low frequency amplification, power amplifiers and low power transmission. Price 15/-

USE "RECTARITE," the synthetic crystal that makes Loud speakers talk. 1.6 Large Specimen.

Write to-day for 40 page Radio Catalogue mailed post free, 4d.

Head Office : 10, FITZROY SQUARE, LONDON, W.1.

Showrooms : 303, EUSTON RD., N.W.1.

Branch and Works : TWICKENHAM.

RESULTS! WIRELESS WEEKLY

will bring you
BUSINESS

It is as good an advertising medium as
MODERN WIRELESS.

Rates for both publications on application to—

SCHEFF PUBLICITY ORGANISATION, LTD.,

No. 2, 125, Pall Mall, London, S.W. 1.

Phone : Regent 2440.

J. W. (SOLIHULL) asks various questions, the nature of which may be gathered from the following answers :—

(1) The phenomena which you report, of getting signals with the secondary of the low-frequency transformer disconnected from the filament of the low-frequency valve, is one of common occurrence. You should remember that no current is drawn from the secondary of this transformer, but merely a potential which is applied to the grid. This being so, it is often unnecessary to connect the other end of the transformer secondary to the filament. Leaving it free results in a building up of a negative potential upon the grid, which serves to ensure that the valves will work at a suitable point on its characteristic curve, thereby producing quite satisfactory amplification.

(2) The fact that you can still receive signals with the filaments of your high-frequency valves switched off is explained by the amount of capacity coupling between the grid and plates of the valves, which is sufficient to pass the energy to the detector valve.

(3) The gridleak to the second high-frequency valve which you mention is necessary to prevent the building up of very excessive negative potentials upon the grid which would result if no leak were provided. A suitable value for this leak is 2 megohms.

W. P. (BRIDGWORTH) asks particulars about the ST51 circuit.

This circuit is a slightly complex one for the beginner, and a little difficulty may be experienced at first in getting it to function. Insert suitable high-frequency transformers and adjust the potentiometer to keep the set in an oscillating condition. Then try varying the condenser C₁ (assuming that a suitable coil has been plugged-in in the socket for L₁, which can be done by consulting the chart in *Modern Wireless*, No. 6) until signals are heard. Then adjust the potentiometer so that the set is either oscillating for reception of continuous waves or not oscillating if telephony is required.

W. A. (MANCHESTER) asks particulars concerning transformer connections in the ST100 circuit.

The connections to the transformers in the ST100 circuit are certainly of considerable importance, but unfortunately it is not possible to give you the information you require, since the actual connections differ with different makes of transformers. Experiment by reversing the connections to the primaries of the two transformers. You will soon ascertain the correct connections in this manner. We should warn you that it is of great importance to obtain suitable transformers for this circuit, some of the cheap patterns being not altogether satisfactory.

WECONOMY SETS

incorporating the
WECOVALVE.

The **WECOVALVE** (Pea-nut Type) is the most economical valve existent, requiring only 0.25 of an ampere at 0.8 to 1.1 volts and having more than twice the life of tungsten and other dull-emitter valves.

It can be used either as a Detector or Amplifier and operates off a single dry cell.

Filament Current 0.25 amps.
Filament Voltage 0.8 to 1.1 volts.
Detector Plate Voltage 17—22 volts.
Amplifier Plate Voltage 22—45 volts.
Dimensions $\frac{3}{8}$ " diam. \times $2\frac{1}{8}$ " long.

Price: £1 10s. 0d.



The **WECOVALVE** (Pea-nut Type) can be used with your existing receiving sets by the use of the Weco Valve Adapter (No. 44092) which has contact springs faced with gold and silver alloy to ensure perfect contact with the base of the valve.

Dimensions $1\frac{1}{2}$ " \times $1\frac{1}{4}$ ". Price: 3s. 6d.

The Weco Valve Socket is arranged for four soldered connections. These connections have contact points faced with a special gold and silver alloy to ensure perfect contact with the base of the valve.

Dimensions $1\frac{1}{2}$ " \times $\frac{3}{4}$ ". Price: 1s. 6d.

No. 44215-A.
Patent Nos. 17580 (1915), 18090 (6641-1921).

THIS TWO VALVE WECONOMY SET (No. 44081), fitted with Weco Valves, is arranged for high frequency amplification and detection, and is complete with tuning inductance, filament resistance, etc., to cover the Broadcast wave length band of 300 to 500 metres. That is, it will tune to any of the B.B.C. Stations without additional coils. By adding Igranic Coils, for which two holders are provided, the tuning can be increased up to 3,000 metres. The power of this Set is such that with a standard aerial it will receive B.B.C. Stations within a wide radius. This is accomplished by using a tuned anode circuit and a certain degree of reaction. The Set gives a purity of tone better than that of other reaction sets on the market, and is therefore suitable for use with Loud Speakers. Two dry cells are required for the filaments, and a 45-volt battery for the plate circuit.



No. 44081.
Two Valve Receiving Set with
Coil Attachments.

THIS TWO VALVE, TWO STAGE AMPLIFIER (No. 44012) has a key or switch which gives a "one valve" circuit or the "two valve" circuit. Being fitted with Weco Valves, accumulators are unnecessary, and

two dry cells are sufficient for the filaments, whilst a High Tension Battery of 45 volts is recommended for the plate. The characteristics of both the valves and transformers are such that almost perfect amplification is secured, and consequently this instrument can be used with confidence wherever high grade reproduction is desired. The power output of this Amplifier is comparable with ordinary low frequency amplifiers, and will be found sufficient for operating Loud Speaking Receivers of the small variety. The No. 44011 Weconomy Amplifier is a single stage Amplifier which, like the two stage Amplifier, contains Western Electric special distortionless transformers, whilst the silent operation of the Weco Valves ensures the most perfect reception.

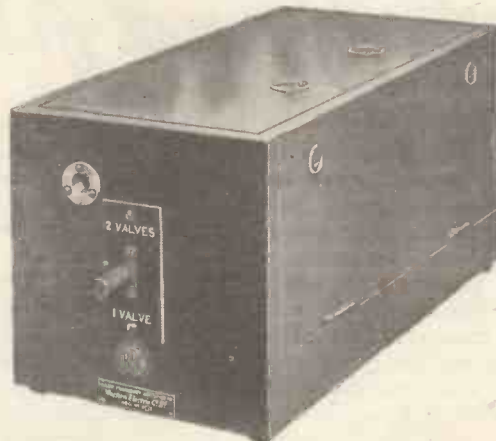

No. 44012.
One or Two Stage Low Frequency
Amplifier.

WRITE FOR BOOKLETS W.E.Co. 32/W. 528 and W. 529.

Western Electric Company Limited

(WHOLESALE ONLY)

Connaught House, Aldwych, London, W.C.2.

Telephone: Central 7345 (9 lines).

Branches:—

Glasgow, Leeds, Birmingham, Manchester, Newcastle, Cardiff, Southampton, Dublin.

COLUMBIA
RADIO "A"
CELLS for
WECOVALVES.

COLUMBIA
RADIO "A"
CELLS for
WECOVALVES

You CANNOT be out of WIRELESS WEEKLY because it brings BIG Business.

You can rely on your Wireless Apparatus if it bears the name **BURNDEPT**

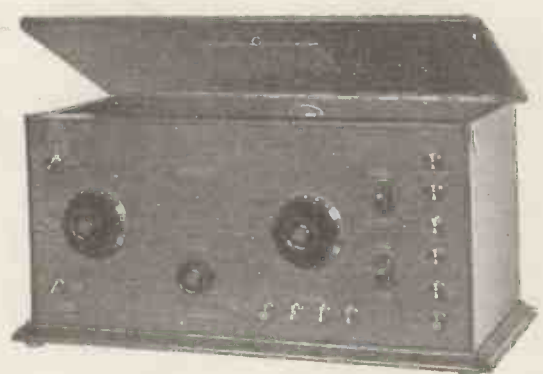
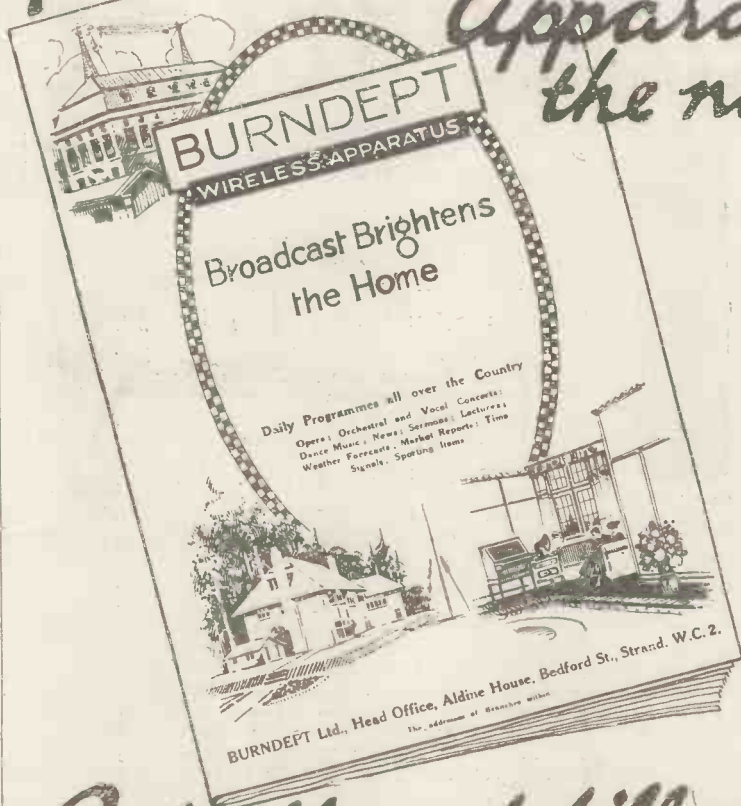

The New Ethophone V MK II (with the Power Valve)

Cut off and fill up this coupon

OUR new catalogue, consisting of 88 pages is now ready. It fully describes and illustrates all the high-class receiving sets, etc. manufactured by us, and should be on the bookshelf of every wireless enthusiast as a work of reference. This publication is priced at 1/-, but a **free copy** will be sent to all who cut off and fill in the coupon on this page.

Burndept goods can be obtained from our Branches—head distribution depots and at any of our 380 service agents throughout the country. Burndept goods are a little higher priced than most—but compare the quality, workmanship and appearance inside and outside.

Visit our **STANDS Nos. 75 and 112**, at the wonderful wireless exhibition being held at the White City, November 8th—21st. This exhibition is promoted by the National Association of Radio Manufacturers and is

ALL BRITISH.

BURNDEPT, Ltd. Head Office: Aldine House, Bedford St., Strand, W.C.2
Phone: GERRARD 7794.



Messrs. **BURNDEPT, LTD.**
ALDINE HOUSE,
Bedford St., STRAND, W.C.2.

Please send me your latest Catalogue.

Name

Address

.....
.....

(Wireless Weekly).

You CANNOT be out of WIRELESS WEEKLY because it brings BIG Business.

The New Arrival

THE "MULLARD WECOVALVE."

Mr. "ORA" welcomes the baby "Mullard Wecovalve" to the family. Like most fathers he looks to his son to uphold the traditions of the house and, indeed, to go one better.

The baby "Mullard Wecovalve" shows every evidence of living up to these expectations. It consumes very little current, lasts twice as long as other valves, and needs no accumulators.

If you are buying or making a new set "Mullard Wecovalues" will save you money as they cut out accumulators.

If you have a valve set Wecovalues will pay for themselves in a few weeks.

In any case write to the manufacturers or ask your dealer for List M.W.1. It tells you all about this wonderful new valve.

Full Manufacturing Licence under British Patents Nos. 17580, 123126, 180090.



MULLARD WECOVALVE . . .	30/-
SOCKETS	1/6
4-PIN ADAPTORS	3/6
FILAMENT RESISTANCE FOR WECOVALVES	2/6

*We are exhibiting at the N.A.R.M.
Exhibition, White City, Nov. 8-21,
Stand 90.*

Mullard

Advt. The Mullard Radio Valve Co., Ltd., Balham, S.W.12.

You CANNOT be out of WIRELESS WEEKLY because it brings BIG Business.

The last word— in Loud Speakers



If Amplion is not the first word in the Wireless vocabulary, it is a very good second, and is certainly the first as well as the last word in Loud Speakers. The manufacturers of the Amplion have a wider experience in Loud Speaker production than all the rest put together, and this accounts in a large measure for Amplion efficiency.

One Wireless Receiving Set may be better than another, but Amplion Supremacy—the supremacy of actual performance—with specially designed models for every purpose and exceptional "value for money" in all types, is without challenge.

Amplion Loud Speakers are standardised by the leading manufacturers of Wireless Instruments and stocked by all Radio dealers of repute.

The popularity of the Amplion is not confined to Great Britain, but is in evidence in every quarter of the globe.

THE
WORLD'S
STANDARD

AMPLION

WIRELESS
LOUD
SPEAKER

STAND III, HALL C.
WHITE CITY.

"BUY BRITISH GOODS ONLY."

Send for Folder W.D.8 describing in detail the new 1924 "AMPLION" MODELS.

ALFRED GRAHAM & COMPANY,
ST. ANDREW'S WORKS, CROFTON PARK, LONDON, S.E.4.

Telephone: Sydenham 2820, 2821, 2822. Telegrams: "Navalhada, Catgreen, London."
Cables: "Navalhada, London." W.14.

ADVERTISEMENT RATES

"MODERN WIRELESS"

RATES PER INSERTION

Ordinary position per page and pro rata	£40	Outside back cover per page (when available)	£50
Facing matter per page and pro rata (Limited number only)	£42	Junior Wireless Section per col. (next matter)	£14
Inside front and back covers per page (when available)	£45	Half-inch s. col. per insertion (prepaid)	15/-

SCHEFF PUBLICITY ORGANISATION, Ltd.

(Advertisement Managers, *Wireless Weekly* and *Modern Wireless*).

125 PALL MALL, LONDON S.W.1

'Phone—Regent 2440 (2 lines).

You CANNOT be out of WIRELESS WEEKLY because it brings BIG Business.

TRADE **Grelco** MARK



CONDENSERS WITH VERNIER.

A BRITISH-MADE INSTRUMENT AT MOST COMPETITIVE PRICES. BUILT ON SOLID EBONITE END PLATES. CAREFULLY ADJUSTED AND TESTED. EACH CONDENSER CONTAINS A THREE PLATE VERNIER OPERATED INDEPENDENTLY BY SMALL KNOB AT TOP.

'001 MFD ... 16/- '0005 MFD ... 13/8 Postage
'00075 MFD ... 15/- '0003 MFD ... 13/- Extra.

3d. POST FREE, OUR 100 PAGE CATALOGUE

Tottenham: MUSEUM 241 Works: BLOUGH.

ELECTRIC GRAFTON COMPANY

54, GRAFTON STREET, TOTTENHAM COURT ROAD,
LONDON, W.C.



CONDENSER PLATES

&

INSULATING MATERIALS OF EVERY DESCRIPTION.

MICA & MICANITE SUPPLIES, Ltd.,

MICA HOUSE, OFFORD STREET
CALEDONIAN RD., LONDON, N.1

Phone: North 805.

Are you constructing your own Set?



Type H. R. Variometer.
Stator and rotor of hard moulded insulation. Wave lengths from approx. 150 to 600 metres when used in secondary circuits. With Knob and Dial. List No. 13345 ... 18/- each.



The "DUCO" Crystal Detector.
A new and approved type in nickel-plated finish. List No. 15416 ... 1/6 each.

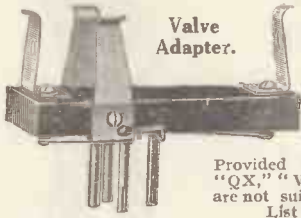

Valve Adapter.

The "DUCO" Crystal Detector.
A new and approved type in nickel-plated finish. List No. 15416 ... 1/6 each.

Provided with clips for carrying the "Q," "QX," "V24," and other special valves which are not suitable for the ordinary type holder. List No. 17312 ... 5/6 each.

Wholesale only.
Head Offices and Warehouses:
Brown Brothers GREAT EASTERN STREET
LONDON, E.C.2
with which is amalgamated Thomson 118, George Street, Edinburgh,
& Brown Brothers, Limited.

Trade only supplied.
KINDLY ORDER FROM YOUR USUAL DEALER.

Following the reduction in the B. B. C. tariff we are by increased output able to announce the following

REDUCTIONS IN PRICE

OF ALL  PRODUCTS

When you see M. H., The Mark of Merit, on any piece of wireless apparatus, you know that it is efficient, well made and reasonable in price, and British.

M. H. COMPLETE SETS FOR BROADCAST AND GENERAL RECEPTION STAMPED B.B.C.	
M.H.B.R.2. Two Valve Receiver ...	£15 0 0 plus 17/6
M.H.B.R.2A. Two Valve Amplifier ...	10 0 0 " 10/0
M.H.B.R.3. Three Valve Receiver ...	18 0 0 " 22/6
M. H. ACCESSORIES AND COMPONENTS.	
Condenser Variable .0007 mF	18/-
".00035 mF	16/-
Fixed Condenser and clips	1/4
Grid Leak, all values	1/-
Grid Leak and Condenser Mounted	2/8
Coil Holder Capstan	12/6
" Polished, 2 coil	12/6
" " 3 coil	15/-
" Side Fixing, 2 coil	7/6
" " 3 coil	9/6
Coil Mount with tags and screws	1/6
" for flat mounting	1/8
Transformers H.F. Variable, mounted 150/600 metres	22/6
" " " 600 metres up	22/6
" " " plug-in 150/600 metres	20/-
" " " 600 metres up	20/-
Transformers H.F. Plug-in No. 0 150/300 metres	7/-
" " " 1 300/600 "	7/-
" " " 2 550/1200 "	7/-
" " " 3 1100/3000 "	7/-
" " " 4 2000 upwards	7/-
" The complete set of 5	32/6
Transformer, intervalve	18/6
" telephone	17/6
Another type, on mahogany case with ebonite top	15/-
Variable Plug Adapter, split grid	3/6
Valve Adapter, V24 " plate	2/3
Valve Holder	1/6
" for flat mounting	2/-
Duolateral Coil Holder Valve Adapter	2/-
Plug and Socket Terminal Adapter	1/6
Filament Resistance Standard with knob and dial	5/6
" Flat Mounting	4/6
" With Knob and Pointer only	6/-
" Second quality ditto	2/6
" Adapter, plug-in type	12/0
Knobs and Extension Handles	1/6
Potentiometer, mounted	21/-
" for panel mounting	7/6
Reactance Capacity Coupling, mounted, low range	27/6
" " " high range	27/6
" " " plug-in low range	25/-
" " " high range	25/-
Crystal Detector, 5 crystal	7/6
Anode Resistance, including resistance	4/-
" without	3/-
Resistances " ditto	1/3
Anode Resistance, all values	1/3
" Everset " Crystal Detector	4/-

VISIT STAND No. 83, AT THE ALL-BRITISH WIRELESS EXHIBITION, WHITE CITY.

Buy British Goods Only.

L.M. MICHAEL LTD

LONDON: HASTINGS HOUSE,
(Head Office) Norfolk Street, Strand, W.C.2

IN CONJUNCTION WITH

B. HESKETH LTD

Buy British Goods Only.

Radio Corner (Retail Showrooms), 179, Strand,
Bournemouth: 5, Yelverton Road. W.C.2

You CANNOT be out of WIRELESS WEEKLY because it brings BIG Business.

Valve Troubles

You've finished with valve troubles when you've plugged in  — the valves with the "OSRAM MADE" reputation behind them. They are made at the famous Osram works at Hammer-smith — and they are made to last.



After all—it's the valve that really counts; that can make or mar your reception, so that it's just as well to get the best *now*.

Put first things first and insist on

MARCONI VALVES

MADE AT THE OSRAM LAMP WORKS

BUY BRITISH GOODS ONLY.

Manufactured by

THE GENERAL ELECTRIC Co. Ltd.
and sold by all leading Wireless Dealers, Electrical Contractors, Stores, etc.

We are exhibiting at the
N.A.R.M. Exhibition,
White City, Nov. 8—21,
STAND No. 103.

You CANNOT be out of WIRELESS WEEKLY because it brings BIG Business.

GECOPHONE

BRITAIN'S BEST BROADCASTING SET

Clear Reception

If you want full enjoyment of the broadcasted programmes, then a Gecophone cannot fail to please you.

Efficient reception is the primary idea in its construction, and it can be installed and operated with the utmost ease.

Vocal and instrumental music, speeches, news, weather reports—every broadcasted item—may be received with wonderful clarity, whether you live in a remote corner of the country, or close to any broadcasting station.

An Enniskillen user writes :

" I can get ALL Broadcasting Stations in Great Britain on your 2-Valve Gecophone Set at Enniskillen. There is nothing freakish about these results, as I can rely on getting a satisfactory show every night."—Colin T. Methuen, Enniskillen

GECOPHONE

Single Circuit Crystal Receiving Set, complete with one set double head-phones. Approximate range (with Standard P.O. Aerial) 25 miles.
Price . . . £4 10 0
Plus B.B.C. Tariff.

GECOPHONE

Crystal Set No. 2, complete with one set double head-phones. Approximate range (with Standard P.O. Aerial) 30 miles.
Price . . . £7 10 0
Plus B.B.C. Tariff.

GECOPHONE

Two-Valve Set (as illustrated) complete with valves, batteries and one set double head-phones. Approximate range (with Standard P.O. Aerial) 100 miles.
Price . . . £20 0 0
Plus B.B.C. Tariff.

We are exhibiting at the N. A. R. M. Exhibition, White City, Nov. 8—21.



Sold by Principal Wireless Dealers.

Sole Selling Agents for the Music Trades in Great Britain and Ireland
Columbia Graphophone Co., Ltd., 102-108, Clerkenwell Rd., London, E.C.1

BUY BRITISH GOODS ONLY.

Manufacturers and Wholesale only.—The General Electric Co., Ltd.,
Head Office : Magnet House, Kingsway, London, W.C.2.

SIEMENS

WIRELESS ACCESSORIES



LOUD SPEAKER (Illustrated above), an instrument of the highest class. For use in place of the ordinary telephone head-sets in all cases where speech or music is received in sufficient volume.

Gives clear and pure reproduction, free from distortion.

INTERVALVE & TELEPHONE TRANSFORMERS, CRYSTAL DETECTORS, UNMOUNTED FILAMENT RESISTANCES, TELEPHONE TRANSFORMERS.

AERIAL WIRES & INSULATORS, EARTHING DEVICES, SWITCHES, EBONITE, JACKS & PLUGS, L.T. & H.T. BATTERIES, FUSES, ETC.

ALSO MANUFACTURERS OF
BROADCASTING WIRELESS RECEIVING SETS.

"BUY BRITISH GOODS ONLY."

We are exhibiting at **STAND No. 76, HALL C,**
at the **ALL-BRITISH WIRELESS EXHIBITION,**
White City, November 8th—21st.

Descriptive pamphlet obtainable from your local wireless dealer or stores.

SIEMENS BROTHERS & Co., LTD.
WOOLWICH, LONDON, S.E.18.

AND AT

BELFAST—36, Mill St. BIRMINGHAM—111, New St. BRISTOL—
30, Bridge St. CARDIFF—57-59, St. Mary St. DUBLIN (Irish Free
State)—52, William St. GLASGOW—40, Wellington St. & 144, St.
Vincent St. LEEDS—129, Park Lane. LIVERPOOL—81, Dale St.
LONDON—38-39, Upper Thames St. MANCHESTER—196, Deansgate.
NEWCASTLE-ON-TYNE—64-68, Collingwood Bldgs., & Exchange
Bldgs., Quayside. SHEFFIELD—22, High St. SOUTHAMPTON—
46, High St.

"Buy British Goods Only"
Months ahead
of present wireless
practice

THE EDISWAN

Toovee

That is what radio engineers are saying about the "Toovee." We on our part, are proud of this 2-Valve Set as a worthy addition to the splendid range of "Ediswan" Wireless products. The results obtained have been remarkable. One example of the extraordinary sensitivity of the set is the reception of 2L.O. 10 miles away, at good telephone strength, without using an aerial or earth. The controls are easy to learn, and you will find it extremely simple to "tune-in" any Broadcasting Station you desire. There is no glare from the valves as these are placed inside the cabinet. The H.T. and L.T. current can be disconnected by one switch.

Complete with all accessories, excluding valves

Price £18 : 0 : 0 (B.B.C. Tax 17/6).

Price of instrument only £16 : 0 : 0 (B.B.C. Tax 17/6).

Write to-day for leaflets fully describing our range of Sets and Parts. If your dealer does not stock send us his name and address. We'll see that you get what you want.
Free on Request. Just send a postcard for our Illustrated Booklet "The Thermionic Valve."

We are showing at the
N.A.R.M. Exhibition, White City, Nov. 8th—21st. STAND No. 87

Special switch which allows either one or two valves to be used at will.

Highly sensitive, Reaction control of advanced design. (Passed P.M.G.)

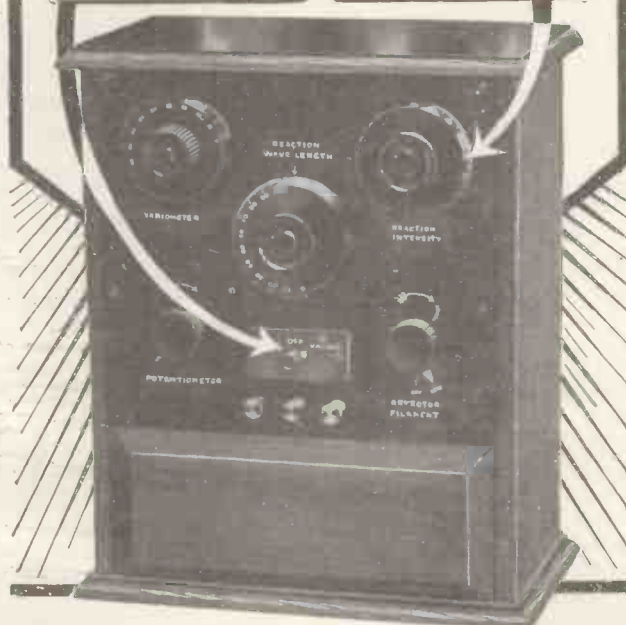

EDISON SWAN ELECTRIC CO., LTD.,
123/125 Queen Victoria Street, E.C.4. 71 Victoria Street, S.W.1.
Contractors to H.M. Admiralty, War Office, Royal Air Force.
Branches in all Principal Towns. Works: Ponders End, Middlesex.

You CANNOT be out of WIRELESS WEEKLY because it brings BIG Business.

My home-assembled Set

—the interesting experiences of an Amateur's first steps in Wireless

ALWAYS being fond of mechanics—in a mild sort of way—I fell an easy victim to the fascination of wireless. After reading one or two little books on the subject, I made up my mind to build up my own set. A timely article in a wireless paper describing a simple crystal set seemed to me to show just the instrument which would fill the bill.

A Crystal Set.

It was simple and consisted of few parts—a great advantage to a novice—and could be constructed for a few shillings. I well remember the thrill experienced when I heard my first telephony on it—the excitement of other members of the household at hearing this “music through the air.” But this set, good though it was, later on began to pall. My interest seemed to wane; I wanted to hear more than the nearest broadcasting station and the few amateurs in my neighbourhood. In short, I had tired of this crystal set and wanted a more ambitious valve receiver.

After looking around I found that to buy a ready-made instrument was far beyond my means, and constructional articles in the wireless papers seemed hard to understand, and to require rather more skill in the use of tools than I possessed.

A Unit Valve Receiver in sets of parts.

There seemed no alternative until by chance I discovered just the type of receiving set I had in mind. It was in units—that is to say, it could be made to expand and more valves could be added just as often as one's purse permitted, until eventually a super-sensitive multi-valve receiver is obtained. Just like a certain expanding blockcase, in fact, “always complete, yet never finished.” And the greatest advantage of all, perhaps, was that it was supplied

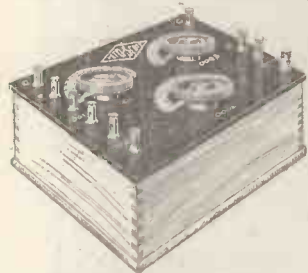

The Condenser Unit.

in complete sets of parts all ready to assemble at home.

The manufacturers and designers of this clever set were the Peto-Scott Co., Ltd., of 64, High Holborn, London, W.C.1, and having obtained a copy of their catalogue, I lost no time in studying it.

Making a start with one Valve.

I found that I could make an excellent start—using the tuning coils from my old crystal set—with the Detector Unit (No. 4) alone. Having bought the complete

set of parts for the modest sum of 19s. and followed the directions contained in a six-page illustrated instruction folder, a couple of hours' work gave me a complete valve unit. There were no holes to drill; all I had to do was to insert the parts as shown.

Although my valve now gave me much better results than I had ever been able to obtain with my crystal set, I found that my primitive tuning arrangements had very serious drawbacks, therefore I decided that my next step would be to invest in a proper tuner.

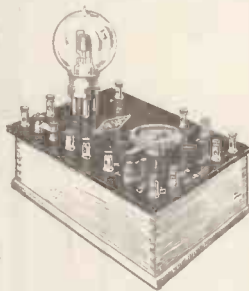

The Detector Unit.

A Tuner for all Wavelengths.

An outlay of £2 19s. 3d., therefore, procured for me all the requisite parts for a really first-class tuner in two units suitable for all wavelengths. The tuner unit itself is most ingenious. Besides a three-coil holder it has two rotary switches; one is for putting the condenser in series or in parallel with the primary coil, and the other is for “Stand by” or “Tune.” The advantages of the former are probably very well known to you, but the latter may be as new to you as it was to me.

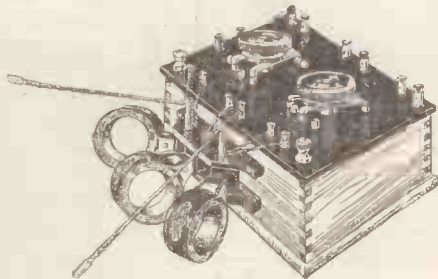

Tuner Unit.

It operates like this: When the switch is at “Stand by” the tuning is done on one coil only—the other one for the time being is not in use at all. The result is that the tuning is quite “broad” and non-selective. This has advantages; for instance, if you are searching for a station you can find it so much quicker on a non-selective circuit. Also, if you are listening to a couple of amateurs talking to one another, you can hear them both without having to re-tune each time, supposing they are not exactly on the same wavelength.

When the switch is at “Tune,” you are operating two circuits at once and are able—by separating the coils and adjusting the condensers—to cut out all interference from near-by stations.

Every Broadcasting Station heard on this set.

I was now on the high road to success. These three units enabled me to pick up all the broadcasting stations with ease from London to Newcastle, as well as the splendid Eiffel Tower concerts from Paris.

In due course—and as funds permitted—I added a high frequency amplifying unit (at the moderate cost of but 14s. 9d.)

enabling me to pick up the Hague, and a low frequency unit which gave me the necessary strength to use my headphones attached to an old gramophone horn as a loud speaker.

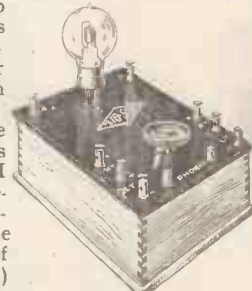

L.F. Unit.

Building the Set into an old Bureau.

You will observe that I have said nothing about cabinets. Although I could have purchased suitable mahogany ones from Peto-Scott, Ltd., for as little as 3s. 6d. each, I did not do so; instead I bought at a local auction

sale a fine old bureau which I am now converting as a suitable receptacle for all these five units. The result of my efforts, I am convinced, will be a three-valve set worthy of any home, H.F. Unit, and one which would have cost me probably three times as much had I bought it ready made. It will certainly be an investment I shall never regret.

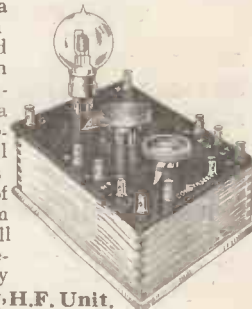

E. R. G.

PRICE LIST OF SETS OF PARTS.

Complete for Home Assembling.	
No. 1 Tuner Unit	24/9
No. 2 Condenser Unit	34/6
No. 3 H.F. Amplifying Unit	14/9
No. 4 Detector Unit	19/-
No. 5 L.F. Amplifying Unit	34/6
No. 6 Crystal Detector Unit	15/6
No. 7 Rectode Unit	28/6
All Royalties paid.	
Catalogue of Radio Components, 40 pages fully illustrated, 3d.	
Postage 9d. per Unit extra, but paid on all orders of £2 and over.	

Advertisement issued by:

PETO-SCOTT CO., LTD.,

Head Office: 64, High Holborn, W.C.1.
 Branches: 99, High Holborn, W.C.1.
 3, Wellington Street, Strand, W.C.2.
 4, Manchester Street, Liverpool.
 94, Queen Street, Cardiff.



Always awarded FIRST—

in the race for supremacy, it is significant and appropriate that Polar Guaranteed Accessories should be allotted Stand No.

111

at the NARM Exhibition, White City.

Every visitor to the Exhibition, between November 8th and 20th, should make a special note of seeing the Polar Units, particularly the Polar Variable Condenser, which have done so much to better Wireless reception, and none should fail to see POLAR BLOK—the greatest system of set building ever put on the market.

BUY BRITISH GOODS ONLY.

**RADIO COMMUNICATION CO., LTD.,
34/35, Norfolk Street, London, W.C.2.**

Telephone :
Central 8480 (3 lines).

Telegrams :
" Radiocomco, Estrand, London."

FLEET AD. CO.

POLAR

FLEET

You CANNOT be out of WIRELESS WEEKLY because it brings BIG Business.

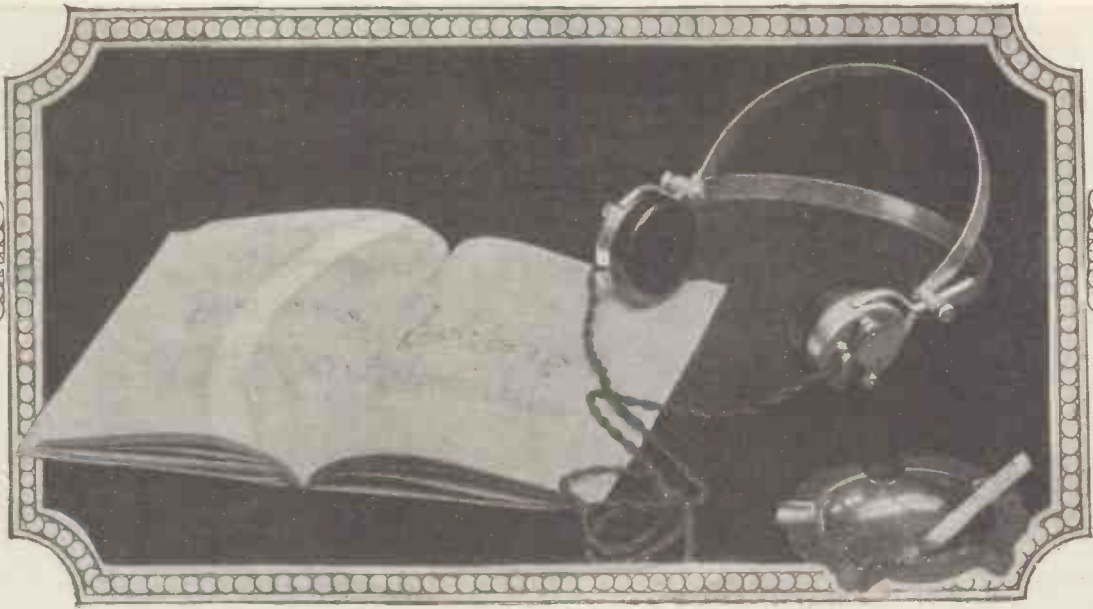

Dependable Books —your greatest aid

Choose your Books
from this List:

	Price.
1. Wireless for All	6d.
By JOHN SCOTT-TAGGART, F.Inst.P.	
2. Simplified Wireless	1/-
By JOHN SCOTT-TAGGART, F.Inst.P.	
3. How to Make Your Broadcast Receiver	1/6
By JOHN SCOTT-TAGGART, F.Inst.P.	
4. How to Erect Your Wireless Aerial	1/-
By MITCHELL, A.M.I.E.E.	
5. The Construction of Wireless Receiving Apparatus	1/6
By P. D. TYERS.	
6. The Construction of Crystal Receivers	1/6
By ALAN L. M. DOUGLAS.	
7. How to Make a "Unit" Wireless Receiver	2/6
By E. REDPATH.	
8. Pictorial Wireless Circuits	1/6
By OSWALD J. RANKIN.	
9. Wireless Valves Simply Explained	2/6
By JOHN SCOTT-TAGGART, F.Inst.P.	
10. Practical Wireless Valve Circuits	2/6
By JOHN SCOTT-TAGGART, F.Inst.P.	
11. Wireless Licences and How to Obtain Them	1/-
By E. REDPATH.	
12. Radio Valves and How to Use them	2/6
By JOHN SCOTT-TAGGART, F.Inst.P.	
13. 500 Wireless Questions Answered	2/6
By G. P. KENDALL and E. REDPATH.	
14. 12 Tested Wireless Sets	2/6
By P. W. HARRIS.	
15. More Practical Wireless Circuits	3/6
By JOHN SCOTT-TAGGART, F.Inst.P.	
16. Home Built Wireless Components	2/6
17. Wireless Sets for Home Construction	2/6
By E. REDPATH.	
Elementary Text-book on Wireless Vacuum Tubes	10/-
By JOHN SCOTT-TAGGART, F.Inst.P.	
(post free)	

TO attempt to understand Wireless without the aid of good books, is both foolish and shortsighted. True, you can make a certain amount of progress by your own endeavours—just as you can learn to swim without the assistance of an instructor—but in each case progress is much more rapid and pleasant if you have a helping hand to guide you.

The list of books given here comprises a complete library, dealing with every phase of Wireless. Each book is written in a masterly fashion by an authority. The fact that Radio Press, Ltd., are publishers exclusively of Wireless Books is a guarantee of their accuracy and dependability.

These books can be obtained from all booksellers or direct from publishers (postage 2d. per volume extra).

RADIO PRESS, LTD.
Devereux Court, Strand, W.C.2.

Radio Press Series.

"NATIONAL" VALUE! SERVICE!! AND ATTENTION!!!

WE ARE SOLELY WIRELESS AND KNOW OUR JOB THOROUGHLY. VISIT OUR STAND AT WHITE CITY AND BOURNEMOUTH EXHIBITIONS AND DO NOT SELL RUBBISH. WE SHALL HAVE "THE GOODS."

WE ARE SOLE MANUFACTURERS OF THE ONE AND ONLY CRYSTAL SET WITH A GUARANTEED RANGE (BROADCAST) OF 110 MILES, VIZ.:

THE "GNAT" SUPER CRYSTAL SET.

TRY THE FAMOUS CRYSTAL USED IN IT

"National" Super Crystal Combination. 3/- and 1/9

OVER 500 SOLD BY US WEEKLY!

SPECIAL OFFERS:

- TAPPED COILS, 10 taps, silk wound on fibre former, broadcast wavelength, each 2/-
- WOUND COILS, enamel wire, wound on fibre former, broadcast wavelength, each 1/6
- FLEX, standard lighting, various colours per yard 2d. per doz. 1/9
- KNOBS, small moulded, large 2BA bush. Worth double, each 1 1/4d. per doz. 1/4
- LOUD SPEAKERS, highly efficient, 4000 Ohms. Only each 18/6
- AERIAL PULLEY CORD, very strong, best quality jute. 36 ft. hanks each 1/-
- BATTERIES, 4.5V pocket lamp type. Best quality, each 4 1/2d. per doz. 4/-
- VARIABLE CONDENSERS, .001 Mica dielectric. Very neat. Usual price, 12/6. Our price each 3/8
- AERIAL WIRE, Bare, 7/22 100 ft. Coil, best quality British make each 2/3
- AERIAL WIRE, Enamelled, same as above, best quality Enamel each 3/6
- AERIAL INSULATORS, Reel type, 2 in. diam., best Porcelain or China, each 1 1/2d. per doz. 1/5
- AERIAL INSULATORS, Shell type, Small each 2 1/4d.
- AERIAL STAY WIRE, Best British stranded, very strong, 50 ft. each 1/6
- AERIAL PULLEYS, Ex-Navy, beautiful finish, aluminium each 1/8, 1/- and 10d.
- AERIAL OR EARTH LEAD IN WIRE, Very special double H.T. insulated, per yard 3d. per doz. 2/6
- AERIAL OR EARTH LEAD IN WIRE, Ex-Govt., rubber covered, all copper, each 1 1/4d. per doz. 1/4
- AERIAL LEAD IN TUBES, fine finish each 12 in., 1/3; 9 in., 1/-; and 6 in., 9d.
- ACCUMULATORS, these are one of our specialties. Best quality only, each 6V.60A., 31/6; 6V.40A., 25/-; 4V.60A., 21/6; 4V.40A., 17/6
- BATTERIES, H.T., Hellesen's best in the long run, each 60V., 14/-; 36V., 8/6; 15V. 4/0
- BASKET COILS, Set of 7. Oojah best make, as sold at 5/-; our price each 3/6
- BASKET COILS, Set of 6. Just as well made as above; our price each 2/4
- BASKET COIL HOLDERS, very useful. Well made each 2/-
- BUSHES, for panel mounting. 2BA, clearance with two screw holes, each 1 1/4d. per doz. 1/4
- CATWHISKERS, each National special, 4d.; gold, best quality, 2d.; silver, 1d.
- CRYSTAL CUPS, best finish only, each 3 screw type, 2d.; and 1 screw type 1 1/4d.
- CRYSTAL DETECTORS, on ebonite base, all nickel plated, fine finish each 1/9
- CRYSTAL DETECTORS, Glass enclosed. Best qualities each 3/-, 2/6, and 1/11

- COLLARS, BRASS, best qualities turned. Tapped 2BA, diam. 1/2 in., each 1d. Per doz. 11d.
- CONDENSERS, VARIABLE, beautifully made, ebonite top and bottom, complete with dial and knob, each .001, 9/-; .0005, 7/-; .0003 6/3
- CONDENSERS, FIXED, Dubilier pattern. Guaranteed, .001-.0003-.0005 each 1/-
- CONDENSERS, MANSBRIDGE, each, 3 Mfd., 2/6; 2 Mfd. 2/-
- CONDENSER SCALES, each 0-180, engraved on ebonite, 4d.; ditto on ivory 2d.
- COIL PLUGS, best quality, wedge shaped, ebonite each 1/6 and 1/3
- COIL HOLDERS, best quality solid ebonite with or without extension handles. each 3 Way, 6/9; and 2 Way 5/3
- CONTACT STUDS, best quality, 4BA, complete with nut and washer per doz. 6d.
- CHOKE COILS, ex-Govt., 750 Ohms, enclosed in metal cases N.P. each 2/6
- DEWAR SWITCHES, ex-Govt., worth double, limited number 2/6
- DIALS, EBONITE, 0-180, engraved and filled white, fine finish each 1/3
- DIALS AND KNOBS, COMPLETE, best quality, engraved 0-180 each 1/9
- EBONITE, very best quality. Polished one side, matt. other. Any size cut on premises 3/6
- EARPIECES, ex-Govt., made by Siemens. Low resistance. Fine value each 3/6
- FILAMENT RESISTANCES, well made, quite reliable, 5 Ohms each 1/9
- FILAMENT RESISTANCES, Superior quality, wire on former, 7 Ohms each 3/-
- FILAMENT SCALES, circular ivory, best quality, engraved each 4d.
- GRID LEAKS. Best to use a reliable make. 2 and 3 Meg each 1/-
- HYDROMETERS, very best quality, as sold elsewhere at 7/6 each 3/9
- KNOBS, all qualities, brass bushed 2BA each 4d., 3d., and 2d. 2d.
- NUTS, best quality brass, per doz. 2BA, 2 1/4d.; 4, 6, and 8BA 2d.
- POINTERS, brass, best quality, for condensers, etc., each 1/4d. per doz. 5d.
- POTENTIOMETERS, ex-Govt., beautiful finish, 700 Ohms, on slate each 9/6
- ROD, SCREWED, best quality, 12 in. lengths each 2BA, 3d.; and 4BA 2 1/2d.
- ROD, SQUARE SLIDER, best quality, 1/2 in. square. Drilled. 1 ft. len. each 4d.
- SLIDER AND PLUNGER, complete, good fit, 1/2 in. square hole each 3d.
- SLEEVEING INSULATED, takes 18 gauge wire. Finest quality. Various colours per yard 5d.

- SWITCH ARMS, very special quality, self adjusting. Unbeatable. each 1/6 and 9d.
- SWITCHES, change over, copper poles each D.P.D.T., 2/6; D.P.S.T. 1/6
- SWITCHES, TUMBLER type, for panel mounting. Very neat appearance each 2/6
- SPADE TERMINALS, special type, heavy brass with special screw each 2d.
- SPADE TERMINALS, ordinary brass type. Fit them to your wires, each 1 1/4d. per doz. 5d.
- SCREWS, assorted lengths and heads, 4BA and 6BA. Best quality per doz. 3d.
- TERMINALS, standard W.O. pattern, 4BA, best quality, with nut and washer, each 1 1/4d. per doz. 1/5
- TERMINALS, telephone type, 4BA, best quality only with nut and washer, each 1 1/4d. per doz. 1/4
- TERMINALS, small barred type, and fancy type 4BA, with nut and washer, each 1d. per doz. 1/-
- TELEPHONES, Brown's F type, 4000 Ohms. Not bankrupt junk B.B.C. each 25/-
- TELEPHONES, Ericsson, 4000 Ohms. As good as anything on the market each 15/3
- TELEPHONES, T.M.C., 4000 Ohms. Excellent value, beautifully made. Our price each 22/6
- TELEPHONES, Continental, 4000 Ohms. Quite reliable each 14/9
- TELEPHONE CORDS, ex-Govt. Super value, 7 ft. long, very strong Pt. each 2/-
- TRANSFORMERS INTERVALVE, L.F., absolutely reliable. Ratio 4-1. Our price each 11/3
- TABLETS, IVORINE, best quality engraved, AERIAL, EARTH, etc., each 1d. per doz. 11d.
- TAPPING KEYS, ex-Govt., best quality. Adjustable highly efficient each 4/-
- TAPE INSULATING, best quality, highly adhesive. 2 oz. rolls each 5d.
- VALVES, Mullard, Cossar, Ediswan, etc. Not old bankrupt stock each 15/-
- VALVES, Phillip's best each 9/6
- VALVES, Dutch, best type, with N.P. bases. Highly efficient. Hard each 8/-
- VALVE HOLDERS, best quality turned and polished ebonite. The best each 1/-
- VALVE LEGS, best quality, 4BA, with nuts and washer, each 1d. per doz. 11d.
- VALVE PINS, best quality, 6BA, with solid shoulder per doz. 7d.
- VALVE HOLDERS, moulded ebonite, quite reliable, with nuts and washer each 10d.
- VARIOMETERS, for panel mounting. Ebonite broadcast wave length. Usual price 10/6, ours each 6/6
- VARIOMETERS, same as above, but not ebonite, very neat each 3/6

PLEASE REMIT AMPLE POSTAGE.

THE NATIONAL WIRELESS & ELECTRIC CO.

77/79, CANNON STREET, LONDON, E.C.

WORKS—7A, CHURCH ROAD, ACTON, LONDON, W.3.

Telephone: Chiswick 2266.

You CANNOT be out of WIRELESS WEEKLY because it brings BIG Business.

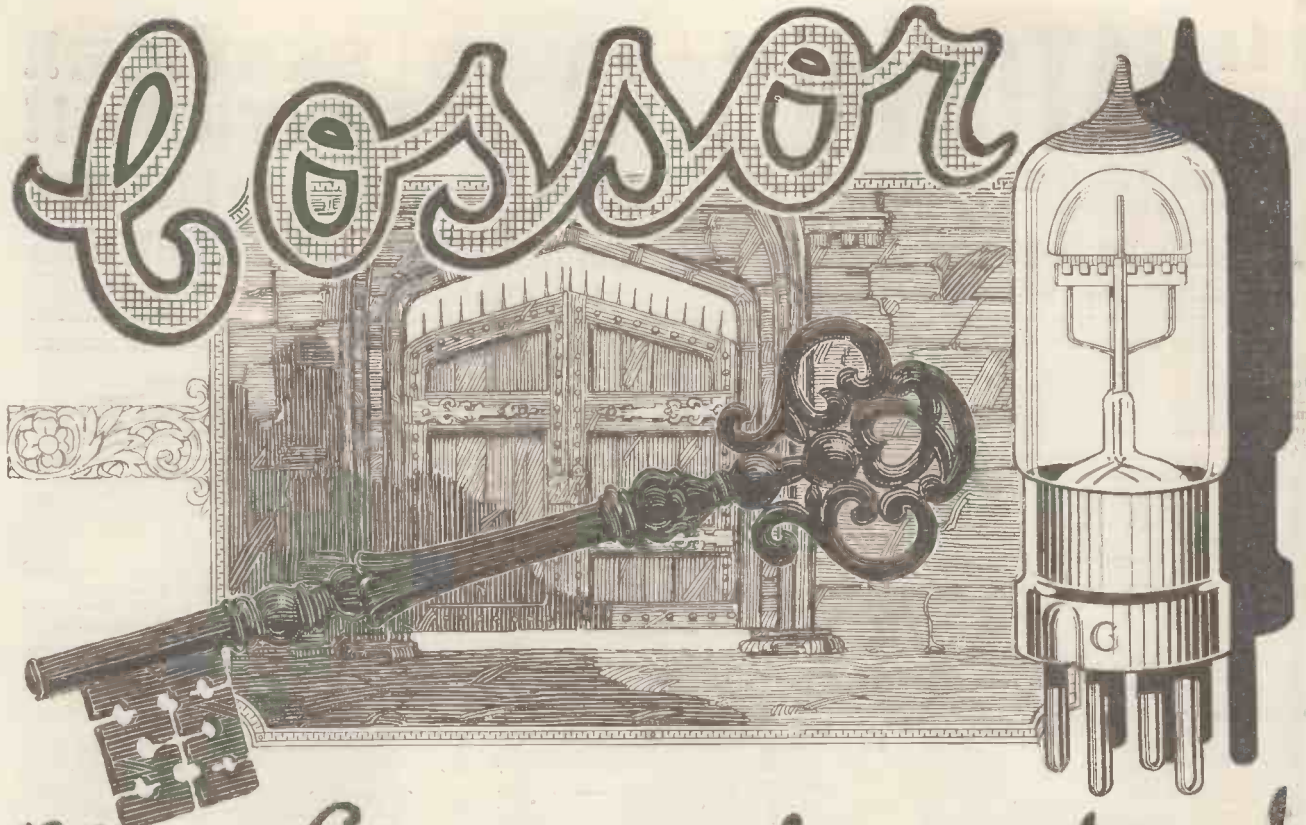

The Key to the ether!

THE Cossor Valve, with its hood-shaped Grid and Anode and curved filament, is a veritable key to the ether.

When conditions are poor, when atmospheric seem to be much in evidence, when "fading" is most noticeable; this is the time when Cossor users appreciate their sense of discrimination.

Why is the Cossor so much better than ordinary Valves? In as few words as possible we will tell you.

When the filament of any Wireless Valve is heated a constant stream of electrons is given off. The efficiency of the Valve, whether as a Rectifier or an Amplifier, depends upon this electron stream being put to the best possible use. Now here is one vital difference—between the Cossor and ordinary

Valves. In the Cossor the filament is curved and is almost entirely enclosed by the hood-shaped Grid and Anode—therefore practically the whole of the electron stream is usefully employed. But in the ordinary type of Valve a large portion of the electron stream escapes out of each end of the tubular Anode and is wasted against the sides of the glass.

This, then, is one of the factors which have made the Cossor the most talked-of Valve in the country.

We know—without a shadow of a doubt—that it is the most efficient Valve, but don't accept our word for it, ask your wireless friends about them—or better still—try one yourself.

TYPES :

P 1. For Detector and Low Frequency use.	15/- EACH.
P 2. With red top, for H.F. use only.	
Dull Emitter (released Nov. 8th)	27/6

COSSOR VALVE Co., Ltd. ————— **Highbury Grove, N.5.**

Gilbert Ad.

You CANNOT be out of WIRELESS WEEKLY because it brings BIG Business.

GAMAGES

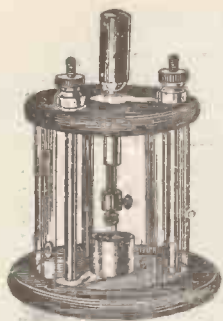

Although we have such a very efficient post service, it is always better to shop in person, as there is always so much in the Wireless Dept. to interest the enthusiast—listening-in at various times of the day and always large stocks of the best instruments at London's lowest prices.

Visit us **White City, Hall 2, Stand 81.**

You may order by post with every confidence of obtaining genuine worth and complete satisfaction.



THE "SONUS" UTILITY PANEL

For use in adding Valves to Crystal Sets. This panel, finished in polished mahogany box with ebonite top, lacquered terminals engraved, makes the adding of low frequency or high frequency valve and your B.B.C. or any other crystal set a very simple matter. Size 8 in. X 8 in. X 4 in., supplied complete with wiring diagrams and instructions. Price **20/-**

Stand No.

81

Write for new illustrated Wireless List—post free on request.

Single Valve Panel.



The ideal accessory for amateur experimenters. This single valve panel consist of valve holder and filament resistance mounted on ebonite panel on polished box. Size, 4 1/2 ins. by 5 1/2 ins. Post 6d. Price **12/6**

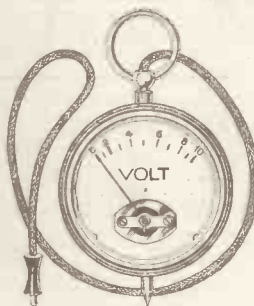

SUPERIOR QUALITY VOLTMETERS.

A most useful instrument to the wireless experimentalist. These are all tested before being put on sale. 0-6 volts. 0-15 volts. 0-12 " 0-20 " **4/6** Post 6d.

CRYSTAL DETECTOR.

New Dustproof Detector with Permanite Crystal. A beautifully made piece of apparatus, and very efficient in use. Transparent covers protect the Permanite Crystal from dust. Price complete with Crystal **6/6** Post 6d.

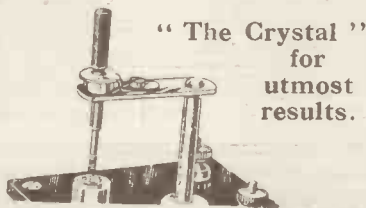

PERMANITE

Regd. Trade Mark No. 438341. Users of "Permanite" as supplied by Gamages (and there is a difference) always get the maximum results, wherever the broadcasting station. It is the only crystal that can guarantee this efficiency—but it must be GAMAGES Permanite—the one with the Regd. Trade Mark. Highly sensitive and remains in adjustment longest. Clean, powerful results. Price per large specimen, post free **1/6**

SIEMAN'S BATTERIES.

15 volts H.T. Batteries, Sieman's each **3/6**
36 volts H.T. Batteries, Sieman's each **8/-**
60 volts H.T. Batteries, Sieman's each **13/6**
100 volts H.T. Batteries, Sieman's each **21/6**

A. W. GAMAGE, LTD., HOLBORN, LONDON, E.C.1.

SUNDRIES.

Filament Resistances **2 6/3- & 3/6**
Earth Clips **5d.**
100 ft. Best Copper stranded aerial wire **2/9**
100 ft. ditto enamelled **4/6**
150 ft. ditto enamelled **6/9**
Postage extra on all above items.

TINGEY SUPERFIVE CABINET RECEIVER

The last word in PERFECT REPRODUCTION, SELECTIVITY and STRENGTH OF SIGNALS.

Enclosed in Lock-up Oak Cabinets, complete with High Tension Battery of 120 volts.

Composed of TWO HIGH FREQUENCY, one H.F. Rect. and two L.F. Power Valves. By means of two simple wander plugs any combination or number of valves may be employed.

Each set is supplied with a set of Coils covering the wavelengths of British Broadcasting Stations. Other sets of Coils may be supplied at extra charge.

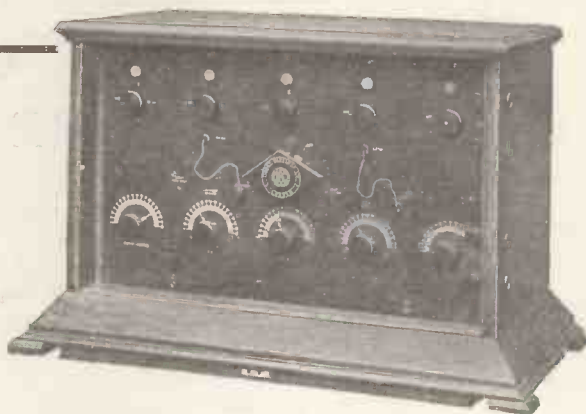

PRICE, as illustrated, including Special Valves and High Tension Battery - - **£56:5:0**

Ask for Superfive pamphlet.

We manufacture Valve Sets—1, 2, 3, 4 and 5 Valves, also an excellent Crystal Set.

Send for our new Components LIST—free on request.

(FEW AGENCIES STILL OPEN.) Offices and Showrooms: (OPEN 8 to 7. SATURDAYS 8 to 1.)
92, Queen St., Hammersmith, London, W.6.

Phone: Hammersmith 1916.

'Grams: "Tingoidar, London."

Chiswick Agents:—The Askew Motor Works, Ltd., 72, High Road, W.4.



You CANNOT be out of WIRELESS WEEKLY because it brings BIG Business.

WIRELESS WEEKLY SMALL ADVERTISEMENTS.

BRO-CAST VISIBLE WIRELESS SETS.—Fitted with patent detector terminal abolishes the old-fashioned detector, carries signals direct from crystal to phones. Post Free, 6s. 6d. Super quality Head Phones, 15s.—Holmes, 8, Donisthorpe Street, Bradford.

PICKETT Cabinets.—They're good value, 1/6 each, highly polished.—Write for lists (W.L.). Works : Albion Road, Bexley-heath.

ALL post paid, 60 volt. H.T. battery and plugs 8s.—4,000 ohm phones, 12s.; filament resistances, 1s. 9d.; Igranite, 4s. 6d. Complete list of similar values free.—J. H. Taylor & Co., Macaulay Street, Huddersfield.

MARCONI multi-valve R.B. 7, complete, £55. Marconi N.B. 2 amplifier, 12 gns. The above shop-soiled only, condition as new, less than cost. Bridges Ltd., Electrical Engineers, Cirencester.

ELLA Battery Chargers for home use.—A.C. full wave rectifier, £6 6s., carr. pd. from your dealer or direct, Lionel Robinson & Co., 3, Staple Inn, London, W.C.1. Order now for delivery early November.

GO to Mica & Micanite Supplies, Ltd., Mica House, Offord Street, Caledonian Road, N.1, for mica and all insulating materials.

"SUPREME" EBONITE PANELS.—High grade, finest matt finish. Send stamp for Sample and list standard sizes. Working instructions accompany each panel.—Ebonite Accessories Co., 211, Albert Road, London, N.22.

3-VALVE UNIT SET.—1 H.F., 1 L.F. and accessories—valves, transformers, H.T. battery, &c. Perfect order. Receives Brit. & Cont. Telephony. £12. Trial by appointment.—D. 48, Onslow Gardens, N.10

CONSTRUCTORS.—Parcels of British components made up to suit your requirements. Mail order only.—Dee Bee Electrical Co., Belvedere, Kent.

LOOK! 1/6 only, a miniature wireless vest pocket receiving set. Tested and guaranteed to receive broadcasting concerts within a radius of 20 miles. Full instructions with each set. Money returned if not satisfied. Post free. Send P.O. 1/6 to T.E.P. Gibbs-21a, Northwold Road, Stoke Newington, London, N.16.

MAKE YOUR OWN
"TURRET"
WIRELESS MASTS.

Steel Clamps and Belts, 2/6 pair.

Unbreakable tapering Columbian pine poles, painted 3 coats with truck, octagonal poles.



13 ft., 2-in. base, 5/9; 16 ft., 2½-in. base, 7/9; 28 ft., 2 pairs steel clamps, 17/9; 42 ft., 4 pairs steel clamps, 29/9.

SIMPSON & BLYTHE, 8 and 9, Sherwood Street, Piccadilly, W. Phone: 2656 Gerrard.

FINEST WORK & PROMPTITUDE.
INCOMPARABLE
WHITE
FILLING.

HAND & MACHINE
ENGRAVING
ON ANY MATERIAL

Phone
Central 1137.
CLIFFT & COCKLE,
51, Arcade Chambers, St. Mary's Gate,
MANCHESTER.

Don't buy accumulators
for your valves

Unskilled chargers will only ruin them. For 12/- a quarter
ONLY 1/- A WEEK INCLUSIVE
we will supply you continuously with reliable charged L.T. Batteries, replaced at time of collection by motor anywhere in London.
Phone: East 5655. **British Battery Supply Service,**
Write NOW for Pamphlet C Free. Carr St., London, E.14

"ATLAS"
THE COIL SUPREME

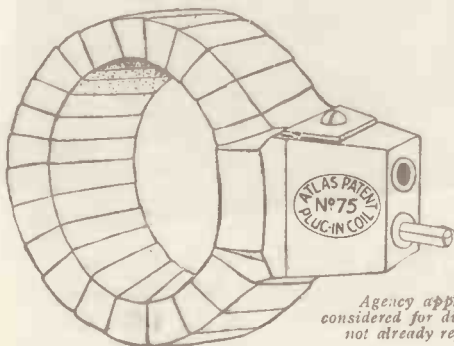

Agency applications considered for districts where not already represented.

The last word in efficiency.

Maximum Inductance. Minimum Self-capacity.
All Wave-Lengths covered.

Prices on application—Radio Components Catalogue on request.

Manufactured only by

H. CLARKE & CO. (M/cr.), LTD.,
Radio Engineers,
ATLAS WORKS,
OLD TRAFFORD, MANCHESTER.

Telephone Nos. : 683 & 793 Trafford Park. Telegrams : PIRTOLD, Manchester.

EX-GOVERNMENT STEEL MASTS.

Large diameter Steel Tubing (2½ inches). Very strong, extremely light, socket joints, eleven-foot lengths, non-rusting finish. Cannot be repeated at double the price. Complete with pulley, guy wires, anchors, cleat, and wire tensioners.

27½-feet .. 28/- 33-feet ... 37/- 38½-feet ... 44/-

TUBULAR GATE CO., LTD., Lord Street, SOUTHPORT.

"EL-BE" ANTI-CAPACITY HANDLES.

No Screws.



No Clamps.

Fixed by Suction—Removed in a second.
A Type for Horizontal working. Price 2/2 each
C Type for Vertical working. Post free.
A perfect combination with the "EL-BE" Coil Holder.
Ask your DEALER for them.

ELBE COIL HOLDERS

USE SINGLE COIL HOLDERS FOR MAXIMUM EFFICIENCY. HIGHLY RECOMMENDED.

Ebonite Basket Coil Mounts to plug in above, 2/- each.

Ask your Dealer for them.

LEIGH BROS., Tel. : Mus. 4547.
37, Sidmouth Street & 1a, Prospect Terrace,
Gray's Inn Road, LONDON, W.C.1.

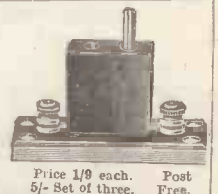

Price 1/9 each. Post 5/- Set of three. Free.

Radio Press Information Dept.

QUERY COUPON.

WIRELESS WEEKLY. Vol. 2. No. 16. October 31, 1923.

(This coupon must be accompanied by a postal order of 5/- for each question, and a stamped addressed envelope.)

You CANNOT be out of WIRELESS WEEKLY because it brings BIG Business.

LADIES AND GENTLEMEN AT HOME & ON THE HIGH SEAS! THE CUP!

HERE IT IS—

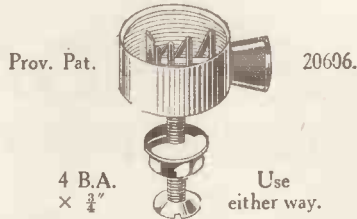

Pull Knob! Insert Crystal! Let Go!
DOES WORK WORTH POUNDS.
COSTS 6d. ONLY

THEN THE REFTY TERMINALS. JUST AS GOOD AS THE CUPS

No. 1 Lacq. ^{each} 10 1/2 d. Ebonite Top.
No. 2 Lacq. ^{each} 6d. All Brass.
No. 4 Lacq. ^{each} 1/- Ebonite Top.

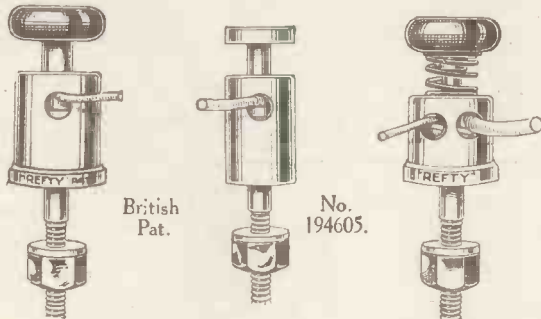

Will hold a hair without harm. Full capacity No. 10 S.W.
Grips different size wires.

No. 1A Nickel ^{each} 11 1/2 d.
No. 2A Nickel ^{each} 7d.
No. 4A Nickel ^{each} 1/1

Depress Knob! Insert Wire! Let Go!
*Your Dealer should have them.
In case not, send cost plus postage,
for direct delivery.*

IS YOUR DEALER HERE?

- BARROW-IN-FURNESS.—J. Dall, 76, Dalton Road.
- BOURNEMOUTH.—M. Hooper, 7, Windsor Road, Boscombe.
- CROYDON.—MacCleaster & Holmes, 14, Surrey Street.
- FELIXSTOWE.—S. M. Douthwaite, 4, Constable Road.
- GUILDFORD.—Cole, Ltd., 4, Market Street.
- KINGSTON.—W. F. Landon, 24, Richmond Road.
- MANCHESTER.—Eurlington Wireless Co., 313, Oxford Street.
- “ Tutills, Ltd., 7/9, Swan Street.
- OLDHAM.—Putterfeld Bros., 48, Yorkshire Street.
- TEDDINGTON.—Jenkins & Dickinson, 10, High Street.

REFTY ELECTRICAL APPLIANCES LTD.,
2, FEATHERSTONE BUILDINGS,
HOLBORN, LONDON, W.C.1.

Telephone: Chancery 8264. Telegrams: "Retinal," Holb, London.

No More Wireless Masts

UTILITY ENDORSED
BY THE EDITOR
OF "WIRELESS
WEEKLY."



OUR HIGH GRADE RUBBER COVERED TELEPHONE CABLE GIVES
WONDERFUL RESULTS AS AN AERIAL INDOORS AND OUT.

WIRELESS MASTS AND INSULATORS ABOLISHED.

The simplicity in erection is beyond the dreams of all wireless enthusiasts, as the troublesome insulators are absolutely unnecessary. Suspend this wire where you will, lead in, and your result is there.

It is a simple matter to make a portable aerial from this wire or to run a lead-in from the house to the garden, whether it is a few yards or half a mile. Ideal for telephone work all over the world.



READ THIS CONVINCING UNSOLICITED TESTIMONIAL.

Darnall, Sheffield.

Dear Sirs,
No doubt you remember me purchasing 100 ft. of your rubber covered telephone cable three weeks back.
I must say that the said wire gives splendid results as an aerial, and friends who have listened in are surprised at the results, and the ease with which the wire is put up, that two of them have asked me to purchase them a 100 ft. length from you.
So would you kindly forward me 200 ft. of the same wire; I enclose P.O. for 3/4 for same.
Thanking you in anticipation,
I remain, yours faithfully,
T. ELLIOTT.

P.S.—Would you kindly enclose the wire in two 100-ft. lengths, and oblige.

Supplied in 3 Thicknesses on original drums.

Class 0	1/2 mile drums (Thin for light work)	15/-	Per drum Carriage forward
Class 1	1 mile drums (Medium for most jobs)	35/-	
Class 2	2 mile drums (Thickest for heavier work)	70/-	

Orders for 6 miles assorted (if required) carriage paid.

Smaller Quantities of Class 1 (Medium) sent carriage paid.

300 feet 4/3 500 feet 6/3 1,000 feet 10/3
(Sufficient for the finest AERIAL.) Carriage Paid.

IDEAL FOR ALL TRAINING PURPOSES IN THE GARDEN, FOR
FRUIT TREES, PEAS, BEANS, &c.

NEW LONDON ELECTRON WORKS, LTD.,
65, REGENT'S DOCK, LIMEHOUSE, E.14.

Telephone: East 1821.

Telegrams: "Stannum, Step, London."

You CANNOT be out of WIRELESS WEEKLY because it brings BIG Business.

GREAT RADIO SENSATION

NO OUTSIDE AERIAL.
 NO EARTH.
 PORTABLE AS A
 GRAMOPHONE.
 COSTS LITTLE.
 GETS ALL STATIONS
 ON ITS
 FOLDING FRAME AERIAL.

*The Set for the
 Broadcaster,
 Constructor
 and
 Experimenter.*

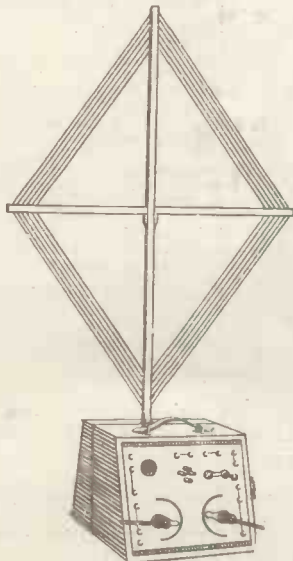
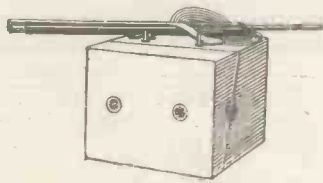
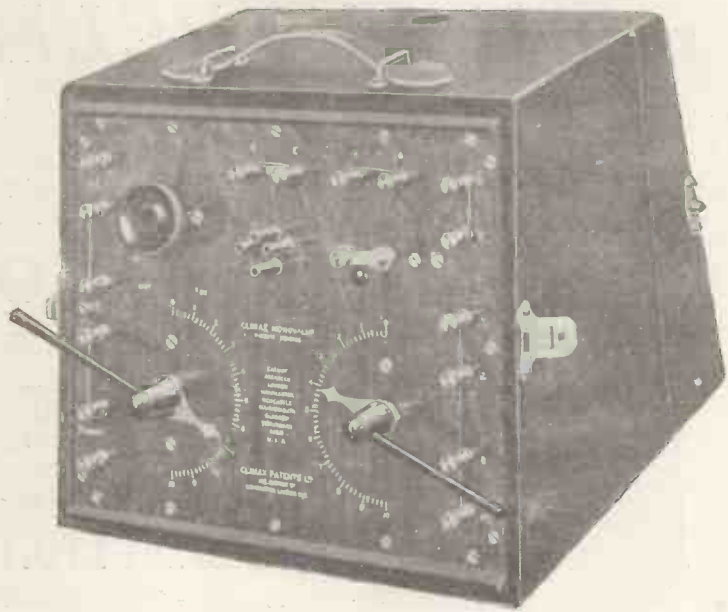

A WIRELESS SET that *doesn't* want a water-pipe and doesn't want you to go on to the roof to put up an aerial in the garden you may not have.

A wireless set that is self-contained and as portable as a small gramophone. A wireless set that cuts all the nuisance out of wireless and gives you all the pleasures.

Its efficiency gives you all the broadcasting stations.

Its selectivity cuts out those you don't want.

Its simplicity gives you ease of operation.

Its one valve gives you economy.

Its design enables you to construct and experiment.

It's British made of British materials by skilled British workmen.

Its workmanship makes it a pleasure to have in the home.

It is called the

CLIMAX

MONOVALE

And now look at the Price :

THE CLIMAX MONOVALE, WITH CLIMAX COLLAPSIBLE FRAME AERIAL **£10**
 If used with BBC Licence, BBC Tax 11/- extra.

Accessories required :—Head Telephones, Valve and Batteries. Approx. cost, 24, according to choice.

This advertisement will be seen by thousands.

If you want early delivery, place your order now, either direct or with your usual dealer.

CLIMAX PATENTS Ltd., 182, CHURCH ST., KENSINGTON, LONDON, W.8.

Telephone : Park 2023.

Wireless Exhibition, White City, Stand 25, November 8—21

(E.P.S.I.)

You CANNOT be out of WIRELESS WEEKLY because it brings BIG Business.

Get the RIGHT Set, the wonderful "PELMERSET"

Test it for yourself at
STAND 20
WHITE CITY



Enjoy wireless and enjoy it thoroughly with the PELMERSET. Let PARIS and the HAGUE entertain you—have all the British Programmes at your beck and call. The PELMERSET will give you near and distant calls clear and distinct. Its price is £9 without valves or:

£10 : 10s.

COMPLETE WITH TWO SELECTIVE VALVES

—one high frequency and one detector—the high frequency valve being of the tuned anode type—H.T. Battery, 6 volts 40 amp. accumulator, 100 feet stranded copper wire, two insulators, one pair 4,000 ohms Headphones. (B.B.C. and Marconi Taxes extra).

PERONET LTD. (W1) 38, BLOOMSBURY SQUARE,
LONDON - - - W.C.1

To Dealers :—Write for liberal TRADE TERMS. We only deal through you.



What is NEW and what is GOOD in the WIRELESS WORLD ?

HERE at the Service Co. Store there is a Wireless Department in which you can see, select or merely chat about all that is new and good in Wireless. Comfortable—Pleasantly—you can get an Expert Manager who will 'understand' and advise as to your ideas and needs.

To understand the Lowest Prices compatible with first-class instruments—the Help which is offered to buy what you want, on Easy Payments if desired—and the Pleasant Spirit of Service—which makes our Store a friendly place—call in if you can—or write as to any wish or requirement.

Write for Catalogue 'C' today if you cannot call!



273-4, HIGH HOLBORN, LONDON, W.C.1

R. H.

200,000 MAGNET LETTERS have been supplied by us to WONDERSIGNS of HOLBORN. Each letter is a perfect Magnet. Hence our knowledge of what a Magnet should be, and our ability to produce the BONTONE PHONE under mass production



Points to Consider.

Every Phone is sold under guarantee. Every Phone is tested before leaving Factory. We are Old-Established British Manufacturers, whose object is to give complete satisfaction. Why saddle yourself with Continental Phones distributed by unscrupulous Importers, with small offices and elaborate note-paper, and NO GUARANTEE or hope of redress if found faulty. Originals of upwards of 100 unsolicited testimonials and letters of appreciation can be seen at our offices. **GUARANTEE.**—We agree to replace or return cash if Phones do not give complete satisfaction, subject to Phones being returned to us within 7 days of purchase undamaged.

BONTONE PHONES (4,000 ohms)
BRITAIN'S BEST.

14/6 per pair. Carriage paid United Kingdom.
SENSITIVE, DURABLE, COMFORTABLE, AND BEAUTIFULLY FINISHED.

Manufactured entirely by **BRITISH labour.**
LIBERAL TERMS TO THE TRADE.

B. D. & CO. (Edward A. Boynton).

WORKS: GOSWELL ROAD AND CITY ROAD.
OFFICES: 167-173, GOSWELL ROAD.
ADMIRALTY, WAR OFFICE, AND INDIA OFFICE CONTRACTORS.

You CANNOT be out of WIRELESS WEEKLY because it brings BIG Business.

This Wavetrap

gives you
the Station
you want



Price **35/-** Postage **6d.**

Full descriptive leaflet sent on receipt of p.c.

We are looking forward to meeting you at our

Stand 6

at the
Wireless Exhibition,
White City, Nov. 8—21.

The Bowyer-Lowe Type C Wavetrap enables you to take your choice of all the Broadcasting Stations. It successfully eliminates all others. The demand for this instrument has been remarkable; its success was instantaneous; repeat orders are arriving by almost every post. *Verb. sap.*

The Bowyer-Lowe Type C Wavetrap is obtainable at all wireless dealers, or will be sent direct from our works.



THE BOWYER-LOWE CO., LTD.
MANUFACTURERS OF WIRELESS INSTRUMENTS,
Radio Works, Commerce Avenue, LETCHWORTH, Herts.

Wholesale Distributors:
Milligan's Wireless, Ltd., 23-25, Renfrew St., Glasgow.
H. Wadsworth Sellers & Co., Standard Buildings, Leeds.

FREE

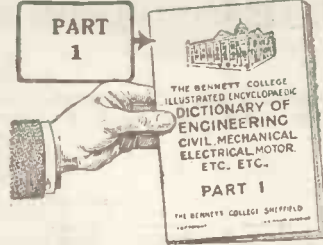

To extend the name of the Bennett College to everyone engaged in the different branches of Engineering, we are publishing an Illustrated Dictionary of Engineering, in about 24 MONTHLY PARTS (16 pages each part). You can have each monthly part as it comes out, FREE.

1/- Postage only to pay

The Dictionary is free to those engaged in any of the following trades: *Engineering, Civil, Mechanical, Electrical, Structural, Motor, Sanitary, Boiler, Internal Combustion, Draughtsmanship, Marine, Shipbuilding, Naval Architecture, Building, Architecture, Quantity Surveying, Aviation, Chemistry, Foundry Work, Metallurgy, Matriculation, Mining, Surveying and Levelling, Telegraphy, Telephony, Wireless, and the conditions are that you send your name and address, your age and occupation, with one shilling (to cover postage on the 24 parts), writing your name and address very clearly. We shall then place your name on our Free List and send you part 1 at once. The others will be forwarded as issued.*

We teach above trades by Post; particulars Free.

Department D 133,
The Bennett College,
Sheffield.

FELLOWS

The "Fellocryst" Super receiving set is a simple and reliable crystal set for broadcasting reception between 300 and 500 metres, up to a range of from 15 to 20 miles.

It comprises an ebonite panel mounted in an oak cabinet, tuning coil, silicon crystal detector, variable condenser; 4,000 ohms double headphones, 100 ft. aerial, 2 insulators.

Price **£3 7 6** plus B.B.C. tax 1/-.

The "Lightweight" Headphones weigh under 6 ozs., and are extremely comfortable. With the special spring adjustment the earpieces may be moved into any desired position or separated without the use of adjusting nuts. This fitting is specially designed not to break the hair. Wound to 4,000 ohms, they are very sensitive and are well made with duraluminium head bands. Stalloy diaphragms, etc.

Price **18/6.**

Adv.: *Fellows Magneto Co.-Ltd., London, N.W.10.*

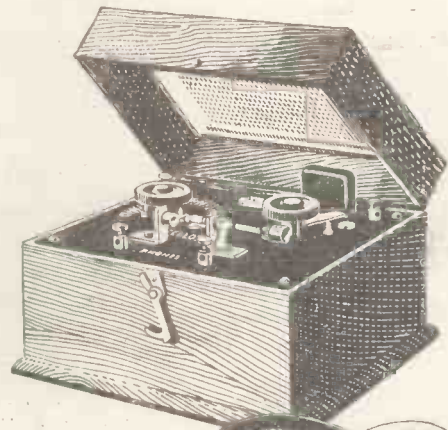

You CANNOT be out of WIRELESS WEEKLY because it brings BIG Business.

OVER HALF A MILLION SATISFIED CUSTOMERS

WIRELESS! WIRELESS! WIRELESS! and EVERYTHING for it.

DON'T PAY MORE!

PIONEERS OF Great Britain's Largest
CHEAP PRICES. exclusive Wireless Stores.

NOTE. We are exclusively **WIRELESS—NOT DABLERS!**
QUALITY, QUANTITY, AND CONSISTENCY OUR MOTTO.
See Our Six-Window Display of Popular Bargains.

"FELLOW'S" LIGHTWEIGHT HEADPHONES 4,000 ohms. A masterpiece of workmanship. A guarantee with every pair. Honestly worth 30/- **18/6** **SPECIAL OFFER—Sterling New Lightweight Headphones.** Stamped B.B.C., 4,000 ohms. Our Price **19/3**

ELKAY LIGHTWEIGHT HEADPHONES. 4,000 ohms... 12/9 **FRENCH THOMSON-HOUSTON HEADPHONES.** Each pair guaranteed... 15/11 **N. & K. 'PHONES.** The genuine article Our price... 12/9

EDISWAN Valves ... 12/3 } **Bankrupt Stock and of Limited Quantity. Guaranteed all New.** **MULLARD "ORA" VALVES** 12/3
COSSOR Valves ... 12/3 }
MARCONI "R" Valves 12/3 } **EDISWAN DULL EMITTER.** Our price ... 25/9

DUTCH VALVES	6/11	STOPS, with nuts	per doz.	6d.	VARIABLE CONDENSERS of high quality. With aluminium top and bottom plates. Complete with knob and dial, guaranteed accurate:	
PHILLIPS DUTCH VALVES	7/11	FILAMENT RESISTANCES, action, marvellous value	smooth	1/10	Vener	3/-
L.F. TRANSFORMERS Ratio 5 to 1. All guaranteed (postage 1/-) each	11/3	With engraved dials		2/9	.0002	4/8
CRYSTAL DETECTORS 1/9, 1/3, and 10/3d.		PLUNGER SPRINGS, complete	each	1d.	.0005	5/6
CRYSTAL DETECTORS, enclosed in glass case 2/6, 2/3, 1/6		SLIDER ROD, brass, 13 ins. long, 1/2 in. square, drilled		3/3d.	.0005	6/-
AERIAL WIRE, 7/22, guaranteed hard-drawn copper, 100 ft. (postage 1/-)	1/10 1/2	SLIDER NOB	each	2d.	.00075	7/-
CONDENSER VANES, fixed or moving,	per doz.	SWITCHES ON EBONITE, S.P.S.T. (quality the best)	each	1/6	.001	8/-
REAL GOLD CAT'S WHISKERS each	2d.	SWITCHES ON EBONITE, S.P.D.T. (quality the best)	each	1/11		
REAL GOLD CAT'S WHISKERS per doz.	1/5	SWITCHES ON EBONITE, D.P.D.T. (quality the best)	each	2/9	O.B.A. NUTS	per doz. 4d.
SILVER CAT'S WHISKERS each	1d.	CONDENSER SPINDLES, all sizes in stock, from	each	1 1/2d.	DETECTOR ARMS, Ball Joints, Ebonite Handle and Whisker Holder	3/3d.
SILVER CAT'S WHISKERS per doz.	7d.	SCREWED ROD, 2 B.A., 12 ins. long each	each	3d.	WOOD SCREW TERMINALS	each 1 1/2d.
CONDENSER SCALES, 0 to 180 each	3 1/2d.	SCREWED ROD, 4 B.A., 12 ins. long each	each	2 1/2d.	SHELLAC per bot., 10 1/2d. & 6d.	
IVORINE LABEL SET, 12 different titles, the set	6 1/2d.	RUBBER INSULATED LEADING-IN WIRE per yd., 1 1/2d. & 2d.		11d.	AERIAL PULLEYS	from 4 1/2d.
BASKET COILS, set of 6, up to 3,000 metres	2/4	INSULATORS, white reel, 2 in., each 1d.		11d.	TINFOIL	large sheet 4d.
SLEEVING, 3 yds., assorted colours, for	1 1/2d.	INSULATORS, white egg, each 2d.		1/8	COPPER FOIL, 6 in. wide	per ft. 5d.
NUTS, 2 B.A.	per doz. 2 1/2d.	WOUND INDUCTION COILS (postage 9d.): 12x4 9x4 8x2 1/2 6x3 6x2 2/5 2/3 1/11 1/8 1/5		2/6	GRID LEAKS, 2 1/2 and 2 meg. each	10 1/2d.
NUTS, 4, 5, 6, and 8 B.A.	per doz. 2d.	TAPPED INDUCTANCE COILS, 20 tappings wound to 1,600 metres, each	1/11 & 2/6		FLEX (Twin), various colours per yd.	2d.
WASHERS, 4 B.A.	per doz. 1d.	VARIOMETERS (Tube type), complete with knob	3/11 & 2/11		CONNECTING WIRE, tinned-copper, 20 gauge	3 yds. 2d.
WASHERS, 2 B.A.	per doz. 1 1/2d.	DOUBLE 'PHONE CORDS, full length	11 1/2d.		ENAMEL WIRE in 1/4, 1/2, and 1 1/2b. reels: 22 24 26 28 2/4- 2/8 3/2 3/6	
CONTACT STUDS, with nuts and washers, per doz.	4d.	HERTZITE, Genuine Large Piece	9 1/2d.		Note.—Bobbins 2d. each extra.	
TERMINALS, with nut and washers, each, 1d., 1 1/2d., & 2d.		TALITE, Genuine Large Piece	9 1/2d.		POTENTIOMETERS, guaranteed up to 500 ohms, superior make, compact size	7/3
EBONITE KNOBS, 2 B.A.	each 2d. & 3d.	PERMANITE, Genuine Large Piece	9d.		CRYSTAL DETECTOR, glass enclosed, fitted on 4x2 ebonite panel with terminals for aerial, earth, and 'phones, already wired and beautifully finished	4/9
SPACING WASHERS, large	per doz. 2 1/2d.	ZINCITE, Genuine Large Piece	9d.		BATTERIES, H.T., dry: 36 volts, including Wander Plugs	5/9
SPACING WASHERS, small	per doz. 1 1/2d.	BORNITE, Genuine Large Piece	6d.		60 volts, including Wander Plugs	9/6
CRYSTAL CUPS, 2 screw	each 2d.	MIXED CRYSTALS (6 kinds)	9d.		FILAMENT RESISTANCE DIALS	9 1/2d.
CRYSTAL CUPS, 4 screw	each 1d.	CARBORUNDUM	5 1/2d.		AMALGO-PLASTIC METAL, for fixing Crystals. No Woods metal necessary	6d.
FIXED CONDENSERS, all capacities	each 10 1/2d.	ZINCITE and BORNITE, both in box	1/-		GOLD SEAL PLASTIC METAL, for fixing crystals	6d.
EBONITE, cut to any size by machinery while you wait	per lb. 3/6	COIL PLUGS, real ebonite 1/3, 10 1/2d., & 9 1/2d.			IVORINE NAME PLATES, all readings, each	1d.
TELEPHONE TERMINALS, nuts and washers, each 1 1/2d.	per doz. 1/3	H.F. PLUG TYPE TRANSFORMER: 1 150 to 450	3/9		per doz.	9d.
W. O. TERMINALS, nuts and washers each	2d.	2 250 to 700	4/3		EARTH CLIPS, Copper, adjustable, each	5 1/2d.
PANEL BUSHES, drilled	per doz. 1/7	3 450 to 1200	4/3		RADIONETTE CRYSTAL SET, complete, stamped B.B.C. and including one pair 4,000 ohms 'phones, 100 ft. 7/22 aerial wire, 4 insulators, lead-in tube, 6 yds. lead-in insulated wire and adjustable earth clip. Ready to listen-in. Honestly worth 3 gns.	36/6
TOP CONDENSER bushes	each 1d.	4 900 to 2000	5/8		RADIONETTE ONE-VALVE L.F. AMPLIFIER for above	34/6
BOTTOM CONDENSER bushes	per doz. 1d.	5 2200 to 3200 metres	4/9		CABINETS, all sizes in stock.	
BELL WIRE, tinned copper, 12 yds.	6d.	6 2200 to 3600 metres	5/-			
SWITCH ARMS, 4 laminations, ebonite knob, complete with panel, bush, nuts, and spring washer	8 1/2d.	FILAMENT COMPLETE CIRCLE RESISTANCE SCALES, 0 to 300 each	6d.			
VALVE LEGS, nut and washer	each 1d.	EBONITE CONDENSER KNOB AND DIAL	1/9			
VALVE PINS, nut and washer	per doz. 10d.	SUPER-QUALITY 2-WAY COIL HOLDER	5/3			
" " " " " " " "	each 1d.	REAL EBONITE 3-WAY COIL HOLDER	7/9			
" " " " " " " "	per doz. 9d.	VALVE HOLDERS each 1/3, 1/- & 9 1/2d.				

IMPORTANT NOTICE. In view of the enormous increase in our Mail Order business, we wish to inform our customers that all post orders are dealt with in strict rotation and at the earliest possible moment. **Follow the Crowd to Elkay Corner.**

Make no mistake when you call on us. SEE THAT YOU ARE AT **ELKAY'S**

"ELKAY" WIRELESS CO.,
225 & 227, BISHOPSGATE, LONDON, E.C.2.
Open Saturday all day. (To the Trade—New Trade Counter now open.) We open Sundays 11 to 2-30.
Special Terms to Radio Clubs.
Note our Telephone Nos.: Wholesale, Bishopsgate 2313. Retail, Central 8544.
PLEASE REMIT AMPLE POSTAGE.
SAVE MONEY BY STUDYING OUR ADVERTS.

You CANNOT be out of WIRELESS WEEKLY because it brings BIG Business.

Radio Press Books give him all the information he needs

Complete List

	Price.	Post Free
1. Wireless for All... John Scott- Taggart, F.Inst.P.	1/6	7/4
2. Simplified Wireless John Scott- Taggart, F.Inst.P.	1/-	1/1 1/2
3. How to Make Your Broadcast Receiver John Scott- Taggart, F.Inst.P.	1/6	1/7 1/2
4. How to erect your Wireless Aerial.... B. Mittell, A.M.I.E.E.....	1/-	1/1 1/2
5. The Construction of Wireless Receiving Apparatus..... P. D. Tyers.	1/6	1/7 1/2
7. How to Make a "Unit" Wireless Receiver..... E. Redpath.	2/6	2/8
9. Wireless Valves Simply Explained. John Scott- Taggart, F.Inst.P.	2/6	2/8
10. Practical Wireless Valve Circuits.... John Scott- Taggart, F.Inst.P.	2/6	2/8
11. Wireless Licences and How to Obtain Them..... E. Redpath.	1/-	1/1 1/2
Elementary Text-book on Wireless Vacuum Tubes..... John Scott- Taggart, F.Inst.P.	10/-	(Post free)

☐ Those printed in heavy type have been published recently.

HOW many turns for a Coil to reach the Paris Wavelength—the type of circuit to operate a Loud Speaker using only an indoor Aerial—Crystal or Valve rectification in a multi-valve Set? These are a few of the questions which confront the amateur constructor.

Some will find out the correct answers by expensive experiment—others, more wisely, will benefit by the experience of those who have trodden the thorny paths of Radio before them.

The concentrated experience of some of the best known Wireless engineers and experimenters is available for all readers of Radio Press Books. You cannot do better than purchase the complete Library—one Book at a time. Each Book covers a different phase of Wireless and none overlap. Get one or two to-day and keep them by you for ready reference—they are sure to save their cost many times over. From all Booksellers.

RADIO PRESS LTD.,

DEVEREUX COURT, STRAND, W.C.2.

**WHOLLY BRITISH
MANUFACTURE**

STERLING

**WE ARE EXHIBITING AT THE ALL-BRITISH WIRELESS EXHIBITION,
WHITE CITY, SHEPHERD'S BUSH,
NOV. 8th to 21st, Stand No. 108/9.**

RADIO COMPONENTS



No. R 273.

**"STERLING" BROADCAST
VARIOMETER.**

Inexpensive; very efficient; extremely fine tuning on broadcast wave-lengths. With reversible brackets for mounting in horizontal or vertical position. Rotor wound on bakelite former, and stator on a paxolin cylinder. Complete with dial and knob .. **Price 13/-**



No. R 2710.

**"STERLING" ANODE REACTION
UNIT (Patent applied for).**

Constructed on novel lines; an effective method of coupling valve anode circuits and of introducing reaction. Gives extremely fine adjustment. The adapter may be permanently fixed to the instrument, horizontally or vertically, and reaction units clipped on for various wave ranges.

No. R 2710—Complete with adapter. For broadcast wave-range (280 to 500 metres) .. **Price £1**

Without Adapter.

No. R 2711—For British Broadcast (280 to 500 metres) .. **Price 12/-**

No. R 2712—For Aircraft Telephony and Dutch Concerts (800 metres to 1600 metres) .. **Price 12/-**

No. R 2713—For high wave Continental Telephony (1400 metres to 3000 metres) .. **Price 12/-**

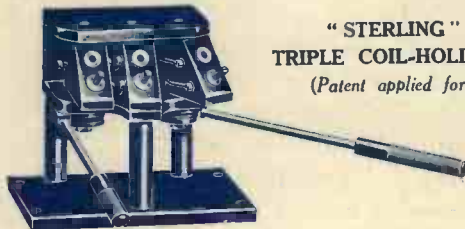

**"STERLING"
TRIPLE COIL-HOLDERS
(Patent applied for).**

No. R 2718—(Horizontal Type) on base, for mounting on the top of instrument (as illustrated) .. **Price £1 2 6**

No. R 2715—(Vertical Type) for mounting on side of a receiving set .. **Price £1 0 0**

Obtainable from all Electrical Dealers and Stores.

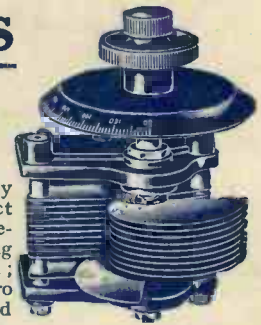

**"STERLING"
SQUARE-LAW VARIABLE
AIR CONDENSERS.**

These Condensers have specially shaped vanes; permit of exact tuning; have a straight wave-length curve, thereby giving uniform wave-length variation; and possess practically zero minimum capacity. The end plates are arranged for either horizontal or vertical mounting.

With Vernier Adjustment (as illustrated). The auxiliary knob controls the Vernier vane.

No.	Capacity	Price
No. R 2724,	.00025 mfd.	£1 3 0
No. R 2725,	.0005 mfd.	£1 5 6
No. R 2726,	.001 mfd.	£1 10 6

Do. do. mounted in metal case with white ivory dial.

No. R 2733,	.00025 mfd.	£2 2 6
No. R 2734,	.0005 mfd.	£2 5 0
No. R 2735,	.001 mfd.	£2 10 0

Without Vernier Adjustment, otherwise as illustration.

No. R 2729,	.00025 mfd.	£1 0 0
No. R 2730,	.0005 mfd.	£1 2 6
No. R 2731,	.001 mfd.	£1 7 6

"STERLING" UNIVERSAL MULTIPLE SWITCHES.

A Switch of universal application and almost unlimited possibilities. Innumerable combination contacts can be arranged by moving the screws on the drum into various holes. The end-plates are drilled for mounting as desired.

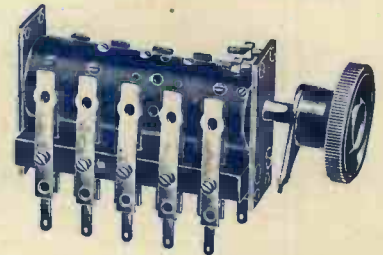

No. R 2837—(5 way),	40 screw positions and 10 contacts, as illustrated	Price 14/-
No. R 2833—(3 way)	24 screw positions and 6 contacts,	Price 10/-

These coil-holders give the best tuning results with any standard plug-in coils. The extended handles provide the usual lateral adjustment, and also control the new patented "Sterling" Vernier adjustment. The sloping face of the coil-holders allows the coils, when inserted, to be inclined at an angle upwards, thus minimising hand capacity effects.

**WRITE FOR CATALOGUE
OF RADIO COMPONENTS.**

STERLING TELEPHONE & ELECTRIC Co. Ltd.

Manufacturers of Telephones and Radio Apparatus, etc. (Wholesale Only.)

Telephone House, 210-212, TOTTENHAM COURT ROAD, LONDON, W.1.

Telephone: MUSEUM 4144 (7 lines).

Telegrams: "CUCUMIS, WESDO, LONDON."

BIRMINGHAM:
150, Edmund Street.

CARDIFF:
10, Park Place.

MANCHESTER:
14, St. Peter's Square.

NEWCASTLE-ON-TYNE:
21, Mosley Street.

WORKS:
Dagenham, Essex.