

WIRELESS, incorporating 'Wireless Weekly,' NOVEMBER 13, 1926.

# WIRELESS



INCORPORATING  
WIRELESS WEEKLY

2<sup>D</sup>  
WEEKLY

1926 2.50



Vol. VI] NOVEMBER 13, 1926 [No. 1

## THE MONODIAL ON THE LONG WAVES

WHAT DO WE GAIN  
BY LOW-LOSS?

By Captain H. J. ROUND, M.C., M.I.E.E.

KEEPING LISTENERS' INTEREST

By Dame CLARA BUTT

[Registered at the G.P.O. as a Newspaper]



# Two interesting receivers published in Issue Now on Sale

**THE "DRAWING ROOM FIVE."** The set described by John Underdown has been designed with the object of giving good all-round results. It will give excellent reproduction from the local station and very good loud-speaker signals on many British and Continental stations. As will be seen from the accompanying illustration, the L.F. Coupling is by the resistance-capacity method. A volume control is provided which enables very loud signals to be adjusted to the strength required.

**A "PUSH-PULL THREE."** This receiver, incorporating the push-pull method of amplification, has been specially designed for those home constructors who, possessing a number of general purpose valves, desire to obtain power valve results without purchasing special L.F. Power Valves. Mr. Stanley G. Rattee is the author.

**BUY YOUR COPY TO-DAY**

**1/-**  
MONTHLY

**MODERN WIRELESS**

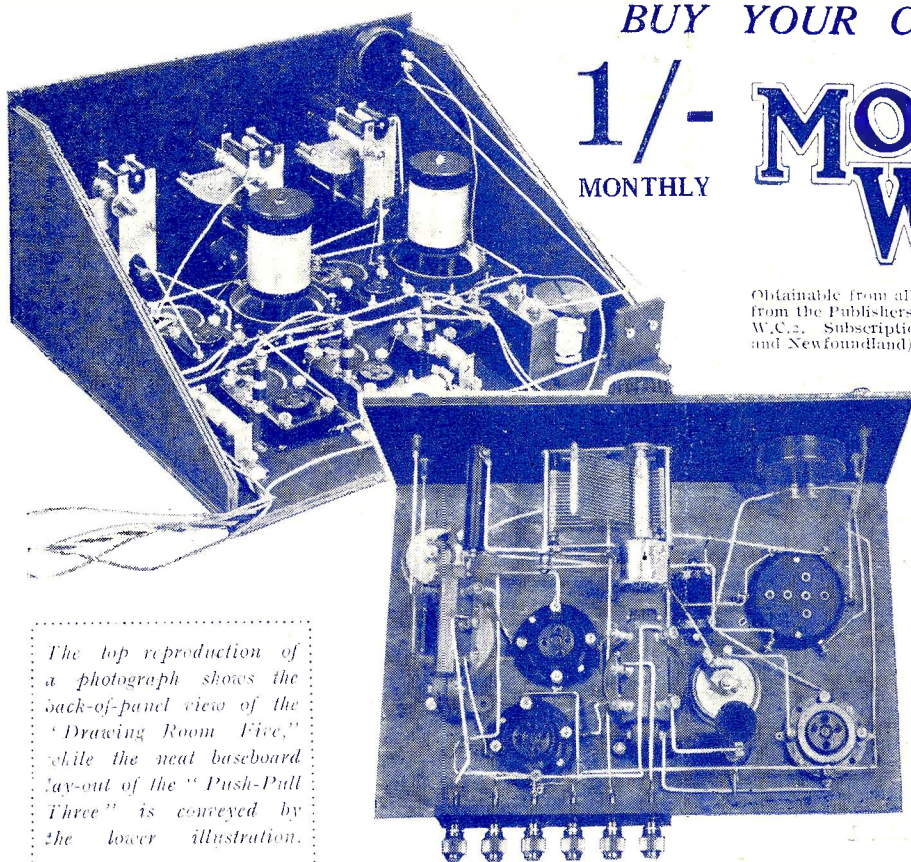

The top reproduction of a photograph shows the back-of-panel view of the "Drawing Room Five," while the neat baseboard lay-out of the "Push-Pull Three" is conveyed by the lower illustration.

Obtainable from all Newsagents, Booksellers or Book-stalls, or direct from the Publishers, Radio Press, Ltd., Bush House, Strand, London, W.C.2. Subscription Rates 15/- per annum (13/6 per annum Canada and Newfoundland). Lesser periods *pro rata*.

*Contents of this issue also include:*

**Some Further Notes on the "Solodyne"**  
**The "Elstree Six" (Further Hints on Operation, etc.)**

**Day and Night Effects**  
*By G. P. Kendall, B.Sc.*

**What Jack Shall I Need?**  
*By A. V. D. Hort, B.A.*

**Neatness and Efficiency (A Crystal Set)**  
*By H. Bramford.*

**Hints for the Short-Wave Novice**  
*By L. H. Thomas (6 QB.)*

**Points about Battery Eliminators**  
*By J. H. Reyner, B.Sc. (Hons.), A.M.I.E.E.*

*This Magazine published "The Elstree Six"*

**Igranic  
Triple Gang  
Condenser**

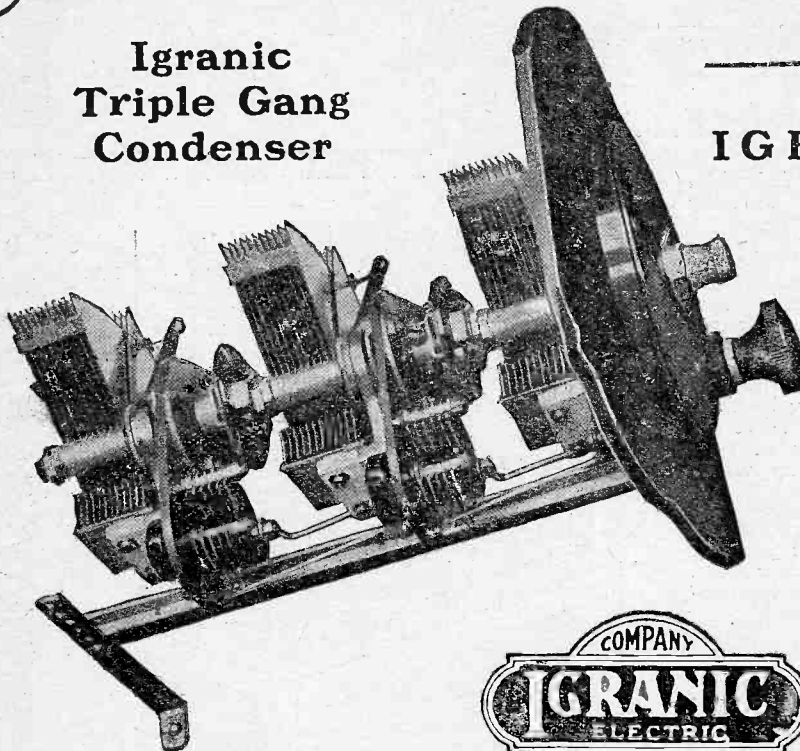

— *and now the*  
**IGRANIC Twin**

**I**GRANIC GANG CONDENSERS successfully solve the problem of single knob control.

Small compensating condensers connected in parallel with the main condensers enable each section to be exactly equalised without the necessity of altering the relative settings of the main condensers.

The Igranic method is simple and practical and preserves the accurate square law tuning of the condensers as a whole.

Twin Gang Pattern... £2 10 0  
Triple Gang Pattern .. £3 15 0

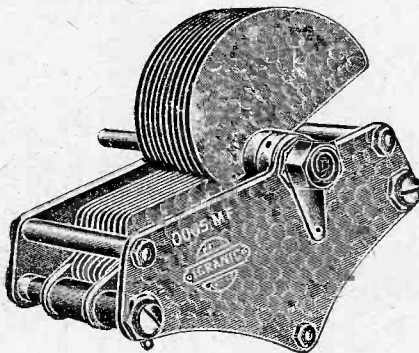

**Low Loss Square Law  
VARIABLE CONDENSERS**

**I**GRANIC VARIABLE CONDENSERS have earned the reputation of being the "choice of experts — and amateurs." Accurate square law tuning, extremely low losses, negligible minimum capacity, smooth ball-bearing movement. Ask your dealer to show you one so that you may see the beautiful workmanship.

Single Pattern.	.00015 mfd.	....	17/-
	.0003	..	18/6
	.0005	..	21/6
	.001	..	25/-

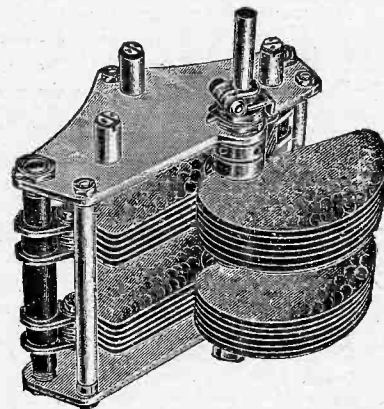

**Low Loss Dual  
VARIABLE CONDENSER**

**I**GRANIC DUAL VARIABLE CONDENSERS are similar in design to the single pattern. The whole construction is particularly rigid, so that there is no risk of the plates getting out of alignment or of the accuracy of tuning being affected.

	.0003 mfd. (Dual)	22/6
	.0005	27/-

SEND FOR  
LIST No. S.38

**IGRANIC ELECTRIC CO LTD**

149 Queen Victoria St., London. Works: Bedford.

Always use the Igranic Indigraph Knob and Dial. Gives smooth slow motion control, entirely free from backlash. Price 7/6



## Ten Reasons why you'll prefer S.T.'s

- (1)—Because they are designed and made by John Scott-Taggart, the best known authority on the valve in this country.
- (2)—Because they have been designed on the only rational basis, namely, that of dynamic characteristic curves, which represent working conditions with an impedance in the anode circuit.
- (3)—Because the performance of a valve (as distinguished from its life) is disclosed entirely by its characteristic curves, and S.T.'s are widely publishing theirs because of their obvious superiority over ordinary valves. *It's their curves that count.*
- (4)—Because S.T.'s are built, like the Pyramids, to last. The torodium filament takes, in practically all types, only 0.1 amp., and gives a copious emission at so low a temperature that no glow can be seen.
- (5)—Because the special alloy of which the filament is made is not brittle, but even after long use remains as flexible and strong as a steel cable.
- (6)—Because the long life and maintained performance is also obtained by the use of the Barget process, which produces in the bulb the highest vacuum which science has yet achieved.
- (7)—Because you save money in upkeep, as the life of the valve is very long and the filament current is exceptionally small. You have only to charge your small accumulator once or twice a year and this also saves you a lot of trouble.
- (8)—Because S.T.'s are not critical to work. Many valves are very critical on filament voltage, but S.T.'s do not need rheostats or even resistors, although both can be used.
- (9)—Because the designer has used every invention (under patent licence) which has advanced the valve and has used the best features of existing valves to obtain the ideal. Every valve is non-microphonic and exceptionally strongly made, though built with the accuracy of a chronometer.
- (10)—Because the valve you are going to buy has a test certificate (see illustration) on its carton, personally initialled by John Scott-Taggart with his own pen to state that he is thoroughly satisfied with that particular valve, which has been rigidly tested electrically and on actual signals under his direct supervision.

**BUY ONE TO-DAY!**

Send for details. If you cannot buy your valve at one of our local dealers, write to us:

Head Office: S.T. Limited, 2, Melburne Place, London, W.C.2.

Works: London. W.1.

## TYPES and PRICES

2 Volt.		4 Volt.		6 Volt.	
H.F. S.T.21	0.1 amp. 14/-	H.F. S.T.41	0.1 amp. 14/-	H.F. S.T.61	0.1 amp. 18/6
L.F. S.T.22	0.1 amp. 14/-	Power S.T.42	0.1 amp. 18/6	Power S.T.62	0.1 amp. 18/6
Power S.T.23	0.15 amp. 18/6	Super Power S.T.43	0.25 amp. 22/6	Super Power S.T.63	0.25 amp. 22/6

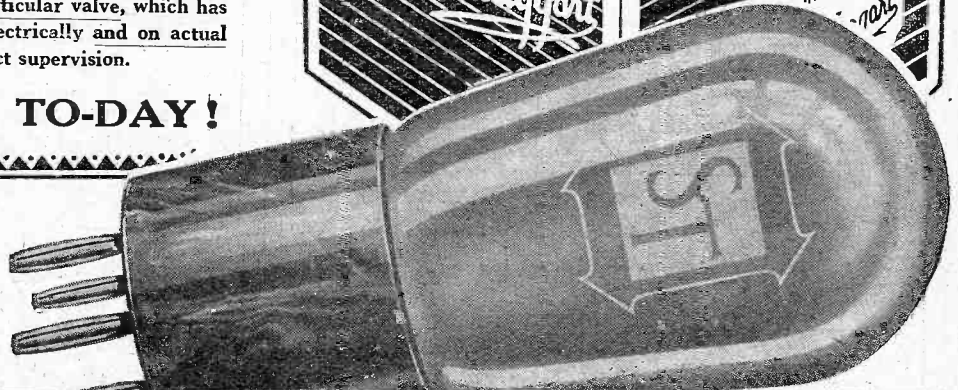
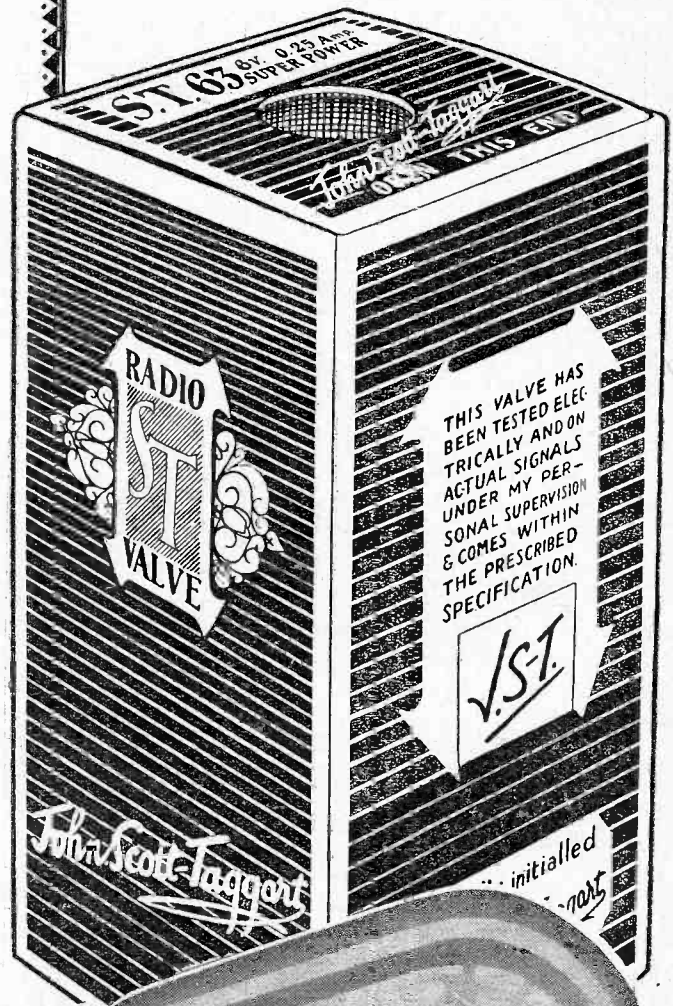



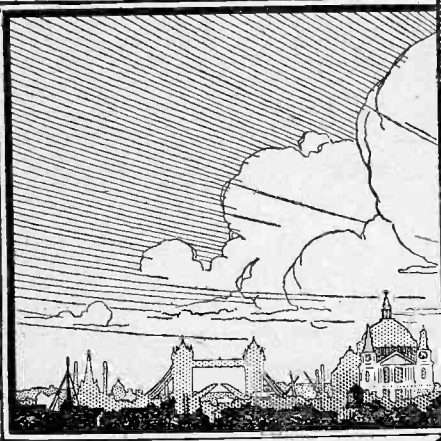

# WIRELESS

INCORPORATING

## WIRELESS WEEKLY

Published by

**RADIO PRESS, LTD.,**  
Bush House, Strand, London, W.C.2.

All communications concerning contributions should be addressed to the Editor and must be accompanied by a stamped addressed envelope if the return of MSS. is desired.

Nothing contained herein is to be regarded as encouragement or permission to infringe any patent rights.

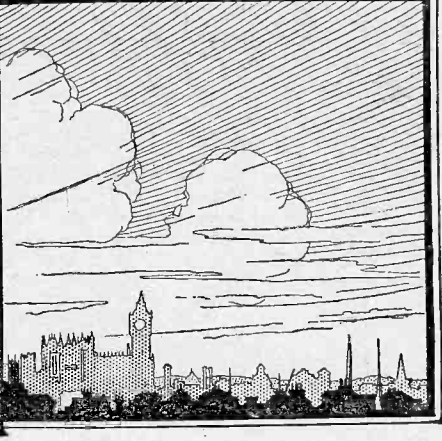

## THIS WEEK'S NOTES AND NEWS

### Manchester's Escape

**2ZY** had quite a narrow escape on October 20. A fire broke out in the offices of an electric lamp firm, just beneath the offices of First National Pictures, Ltd., in Orme Building (also the home of 2ZY). Luckily, it was discovered in good time by a fifteen-year-old office boy, otherwise Manchester listeners might have had to listen to Daventry for some time to come!

### Snobbish!

"**M**AKE your set more select" is the headline of a "Wireless Corner" of one of the provincial papers. How is it done?

### Worse Offenders Still

**M**UCH as some people grumble at the number of talks from 2LO and, in fact, all the B.B.C. stations, I am beginning to think that we are not so badly off as we might be. Personally, my almost infallible method of picking out German stations is to tune in those which have interminable talks going on! The German announcers must have very well-developed tonsils!

### No Wavelength Tests

**I** UNDERSTAND that it has now been decided not to hold a general test of the new wavelengths, when they are brought into use. The relay stations have already carried out several tests, and the B.B.C. state that no trouble is expected in this direction.

### A "Crackling" Tip

**S**EVERAL of my acquaintances have mentioned to me at one time or another that, with the modern valves

which show little sign of glow, they have experienced peculiar cracklings which have been put to the credit of the high-tension battery and subsequently found to be coming from the low-tension accumulator. In the days of bright-emitters, of course, it was generally sufficient to watch the valve filament and see whether any fluctuation took place, but now it is a good plan to keep a filament voltmeter connected across the filament legs of, say,

coloured pansies, elongated caterpillars, attenuated worms are all connected in some mysterious way with the aerial belonging to "the chap next door." We are living in a world of wonders, but I am afraid a good many of them are imaginary!

### Mars

**O**NCE more the experts have failed to produce any convincing signals from the Red Planet. Their efforts have, however, produced many interesting phenomena. I was particularly pleased to note that while a certain gentleman was listening for Mars on 30,000 metres, "the G.P.O. station at Rugby, using a wavelength of 18,740 metres, cut in and drowned the signals!"

### Mass Singing

**O**N November 20 the B.B.C. will probably have to deal with a greater volume of sound than it has ever done before. The date is the occasion of the concert to inaugurate the *Daily Express* National Community Singing Movement, which will be held at the Albert Hall. The broadcast will take place from 9 till 9.30 p.m. and 10.15 to 10.30 p.m. Listeners will also hear the Royal Albert Hall Orchestra and items by Mr. John

Goss and Mr. Norman Allin.

### A Record

**S**HORT-WAVE communication has been responsible for the putting up of a remarkable record for "ship-to-shore" telegraphy. The steamship *Jervis Bay* recently established contact with Sydney from a point off Portugal, (Continued on next page.)

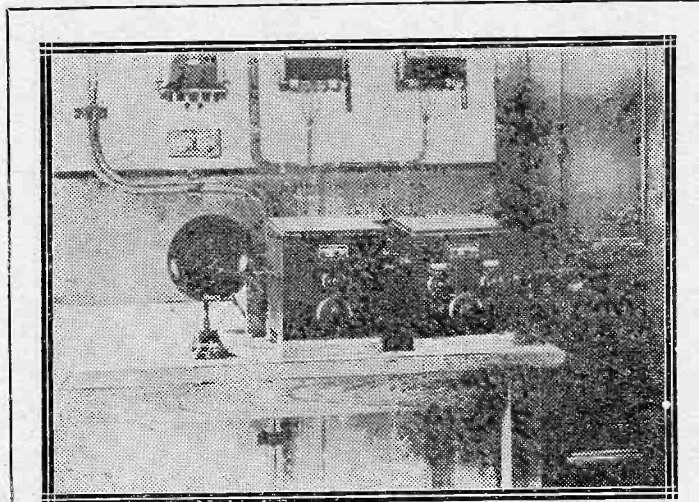

According to reports, the opening day of the new "Beam" service between Bodmin and Canada was marred by an interruption of service, due, it was stated, to "fading." Our picture shows the apparatus which produces an audible note for checking up the constancy of the transmission.

the detector valve. Any "jumps" in the voltage, due to bad connections on the accumulator, are then easily spotted.

### Old Wives' Tales

**T**HERE are still some who believe that wireless has some sort of effect upon their gardens. Giant marrows, shrivelled-up beans, dis-



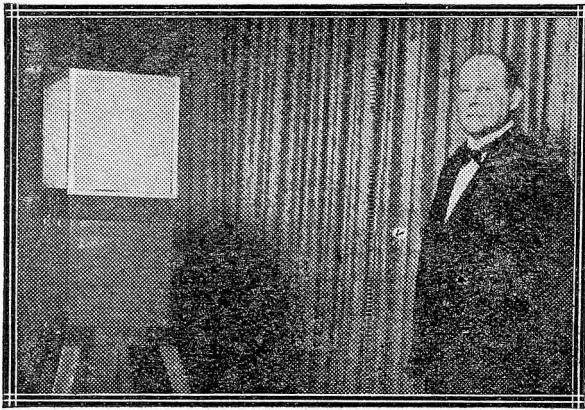

The Editor of "Punch," Sir Owen Seaman, recently gave a broadcast talk from 2LO. Sir Owen is here seen before the microphone at the London station.

over 10,000 miles distant. This is the first time that a ship on this side of Colombo has connected up with Sydney. Using the same power on the usual 600-metre wave, it would have been considered quite creditable to communicate over a distance of about 600 miles!

#### The New Wavemeter

A WEEK or so ago I was shown the new standard wavemeter to be used at 2LO. The wavemeter itself is rigidly made and beautifully finished, and so constructed as to be capable of measuring 2LO's correct wave and the wave of either of 2LO's neighbours—Breslau and Graz. Each European station will have a similar wavemeter adjusted to its own wavelength. Further details of the wavemeter will be found elsewhere in this issue.

#### Radio Week

I AM asked by the Hon. Secretary of the Maidstone and District Radio Society to announce that the Maidstone Radio Week, held under the auspices of the Society, will be held from November 16 to 20 inclusive. The fourth annual Wireless Exhibition is to be held during the week, in the Concert Hall, Corn Exchange, Maidstone. An open competition is also being held. Roll up, Maidstonians, in your thousands!

#### New Dutch Station

THE Dutch Government Telegraph and Telephone authorities are contemplating the erection of a new station to be placed at the disposal of business firms who wish to make announcements at a moderate "advertising rate." From tests that have already been carried out it appears that with 3 kw. in the aerial station at Scheveningen Haven can make itself heard all over Holland. The wavelength used will probably be 1,950 metres.

## THIS WEEK'S NOTES AND NEWS

Continued

#### On Armistice Day

ON Armistice Day special programmes are being broadcast from the Canadian National Railways' fine chain of "CNR" stations, on a wavelength of 434.5 metres. On the following day CNRA will broadcast a special

Armistice Day service from the Central United Church, Moncton.

#### Hands Off!

SIR ARTHUR STANLEY and Professor Low have addressed a letter to Members of Parliament pointing out that the £900,000 accu-

tion is interested in broadcasting, and has made several substantial grants towards the purchase of apparatus.

#### Atmospherics and the Beam

I REMARKED a few weeks ago that no trouble had been experienced by the "Beam" stations on account of atmospherics. Shortly after reports appeared stating that communication had been held up by static disturbances, and, needless to say, I was gently but firmly corrected by some of my readers. I have emerged triumphant, however, since the official report states distinctly that the cause of the delay was *not* atmospherics but fading.

At about the same time as the above occurrence a severe electric storm played havoc with the Transatlantic cables, and very fine displays of the Aurora were seen in America and Scotland.

#### The Birthday Week

WE have some excellent programmes to look forward to during the B.B.C.'s birthday week, mostly of a light nature. The informal "rags" usually forming a feature of the birthday celebrations, providing they are not overdone, are really excellent fun, and always remind me of "P.P.'s" solo efforts, from Writtle—now more than four years ago. This feature will, needless to say, be made the most of this year, since it is the last birthday that the B.B.C. will hold.

#### Welsh Dissatisfaction

WALES is again complaining that it is sadly neglected in radio matters, not only in the matters of language and music, but also as far as the stations themselves are concerned. Cardiff and Swansea are, after all, in the extreme south of Wales, which is a very mountainous country.

#### Do You Agree?

THE following words of wisdom dropped from the lips of Mr. Edison last month: "There isn't 10 per cent. of the interest in radio that there was last year. It's a highly complicated machine in the hands of people who know nothing about it. No dealers have made any money out of it."

CALL-SIGN.

### AT THE SCIENCE MUSEUM

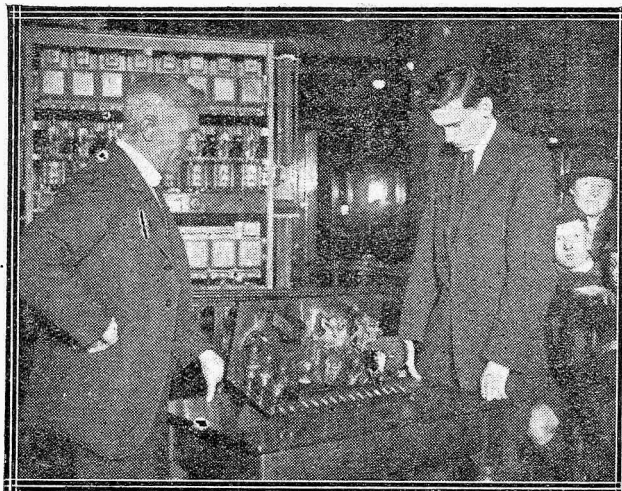

The Government standard seven-valve wireless receiver which is now on view at the South Kensington Science Museum. On certain days of the week this receiver can be heard by visitors to the Exhibition.

mulated by the G.P.O. from licences should not be claimed by the Treasury when the B.B.C. is "handed over," as it is needed for the advance of wireless throughout the Empire.

#### In Czecho-Slovakia

RADIO seems to be in a very flourishing state in the majority of countries which possess a broadcasting service. In Czecho-Slovakia, for instance, a 700 per cent. increase in the number of listeners is reported since the beginning of this year. Several training schools in that country have installed stations, the use of which is shared by other establishments. The Ministry of Educa-



# The "MINIWIRE" SUPERHETERODYNE

By Stanley G. Rattee, M.I.R.E.



Here is a really simple, easy-to-build, easy-to-work "super" using only six valves, which gives very good results on a frame aerial



ANY people who are anxious to build for themselves a multi-valve receiver which will within a reasonable distance of a local station permit them to receive other British or foreign stations will find a ready solution in the superheterodyne. In my own case, though a straight multi-valve set can be made sufficiently selective to cut out the local station for the reception of Bournemouth, local conditions are such that the set will not receive Manchester, though there is no audible interference when the set is adjusted to that station's wavelength.

The reason for this peculiarity is, to my mind, attributed to the close proximity of the Crystal Palace, for not only is Manchester inaudible, but similarly Aberdeen, Glasgow and Newcastle are affected. The aerial used in these circumstances is somewhere about a quarter of a mile from the North Tower of the Crystal Palace, so

placed that the Tower lies between it and the stations given above.

### "Superhet" Advantages

For the reasons given a superheterodyne receiver was tried about a year ago—more out of curiosity to see

tions could be received on a straight set in the circumstances mentioned six valves were needed, three of them being high-frequency amplifiers.

The thought of building a superheterodyne receiver perhaps conjures up in the minds of many home constructors pictures of complicated wiring schemes with possible disappointment following upon several evenings' work with the soldering iron.

To some extent the building of a receiver of the superheterodyne type calls for a certain amount of ability, and in the case of many already published designs the wiring diagram is somewhat awesome, but, notwithstanding these facts, the superheterodyne receiver is not by any means as difficult to build as the average man persuades himself into believing.

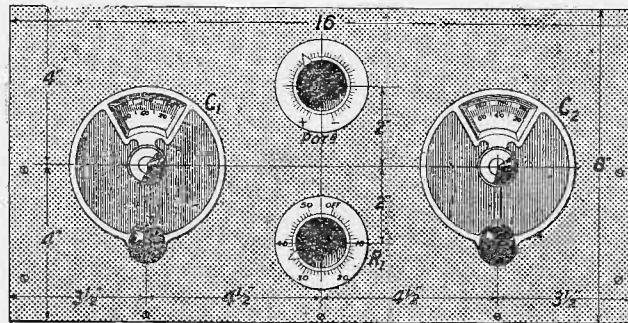

Fig. 1.—Note the simple panel arrangement of the "Miniwire," all dimensions for which can be transferred from this drawing to your panel.

### Simple to Wire

In the case of the "Miniwire" the

### STATIONS RECEIVED

The following list of stations will serve to give some idea of the capabilities of the set, and though numerous others have been heard their origin at the time of writing is somewhat obscure. The stations given were not only identified by the items in their programmes, but confirmation was obtained by actually receiving the announcers' remarks.

The locality where the reception was made was in the Crystal Palace district, S.E. London, and those stations marked with an asterisk were received on the loud-speaker at adequate strength.

- |                     |                 |
|---------------------|-----------------|
| Breslau             | Glasgow         |
| Bournemouth*        | Radio-Milan*    |
| Frankfurt-am-Main*  | Oslo*           |
| Leipzig*            | Newcastle*      |
| Radio-Barcelona*    | Hamburg*        |
| San Sebastian*      | Stuttgart       |
| Cadiz*              | Manchester      |
| Birmingham*         | Radio-Toulouse* |
| Aberdeen (daylight) | Radio-Belgique* |

whether it would receive what the other set could not than anything else—and though the set used was not the one shortly to be described, it is interesting to note that all the main B.B.C. stations could be received in daylight, as against only a few with a straight set. In both cases five valves were used, the straight set being made up of two neutralised H.F. stages, detector, and two note magnifiers, while the superheterodyne was the "Tropadyne" arrangement without any low-frequency amplification.

Further experiment along these lines showed that before all the main B.B.C. sta-

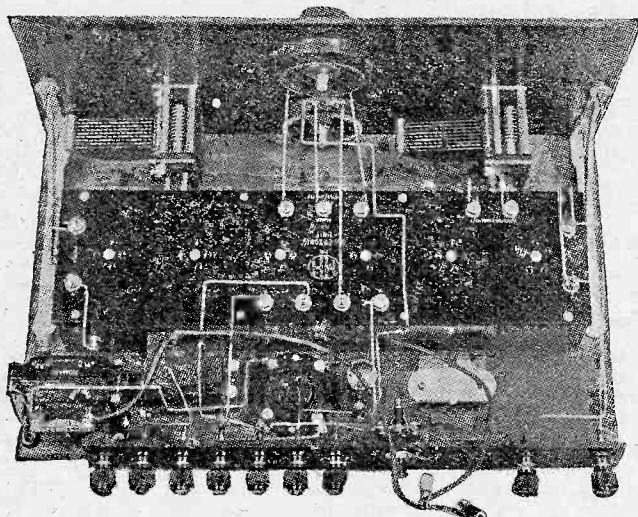

As its name suggests, the great feature of this receiver is the absence of complicated wiring.

work involved is little more than that called for in the construction of, say, (Continued on next page.)



# The "Miniwire" Superheterodyne

- Continued

a three-valve receiver, the reason being that the majority of the instrument is already assembled in the form of a unit which may be purchased complete. The various components, such as tuning condensers, potentiometer, and filament resistance, are connected to this unit by means of the terminals provided, while the valves are mounted in holders situated on an ebonite panel forming a lid or covering for the unit itself.

Normally the unit provides for five valves, but in order that a loud-speaker may be used with satisfactory results an extra valve has been added in the form of a transformer-coupled low-frequency amplifier.

## Lay-out

The panel of the receiver carries two variable condensers, a potentiometer and a filament rheostat; the "on-off" switch and all terminals being

fitted to a terminal strip situated at the back of the baseboard. The unit, the low-frequency transformer, the extra valve holder, a fixed resistor and clips for the grid battery are fitted to the baseboard in the conventional manner, and the whole arranged to slide into an American type of cabinet.

## The Circuit

From the circuit diagram which accompanies this article it will be seen that the "Tropadyne" arrangement is employed, which, as has already been pointed out to readers of this journal, utilises a combined oscillator and detector valve, thus economising in the total number of valves used.

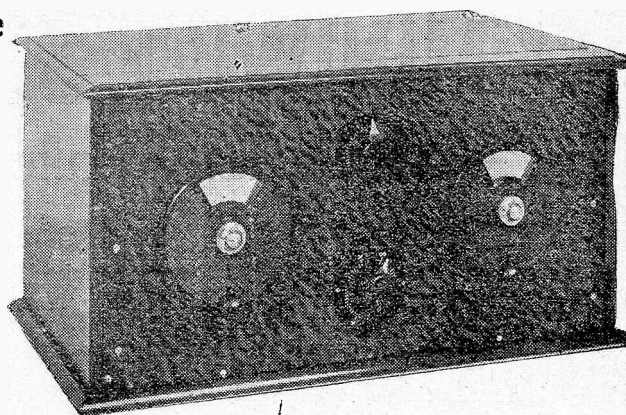

For a receiver employing six valves, the "Miniwire" is remarkably compact.

Since the majority of the circuit is already wired in the unit, the circuit diagram calls for no special discussion, but is given merely from the point of interest to the more advanced reader. The note-magnifier which has been added is, it will be seen, of quite conventional design, and is accommodated with a separate high-tension terminal for, applying voltages higher than that used for the rest of the circuit, to the anode of this last valve.

The two variable condensers, each of .0005 capacity, form the tuning controls, while the potentiometer serves

## WIRING INSTRUCTIONS

Join loop terminals of set to loop terminals of superonic unit and thence, to moving and fixed plates of C1.

Join "Autodyne Condenser" terminals of superonic unit to moving and fixed plates of C2.

Join potentiometer - terminal of unit to one side of potentiometer.

Join potentiometer + terminal of unit to other side of potentiometer.

Join centre potentiometer terminal of unit to slider of potentiometer.

Join phones + terminal of unit to "H.T. +" terminal of transformer T9, T10.

Join phones - terminal of unit to "plate" of T9, T10.

Join "grid" of T9, T10 to G of V6.

Join "grid bias" of T9, T10 to G.B. - wander plug (flex lead).

Join A of V6 to left-hand L.S. terminal.

Join L.S. + terminal to H.T. + 2 and thence to one side of C4.

Join H.T. + of unit to H.T. + 1 of set and to one side of C3.

Join H.T. - of set to remaining sides of C3 and C4, and thence to H.T. - of unit.

Join L.T. - of set to one side of R2 and thence to one side of R1. Join G.B. + flex lead to point on latter wire.

Join other side of R2 to F- of V6.

Join other side of R1 to L.T. - of unit.

Join L.T. + of set to one side of switch S.

Join other side of S to F + of V6 and to L.T. + of unit.

as a stabilising device after the filament resistance has been satisfactorily adjusted.

## Materials

As to components required for building a set to these specifications, these are given in a special manner for quick and easy reference. With regard to the superheterodyne unit, there is, of course, so far as the present set is concerned, no choice but to use the make given, but so far as the

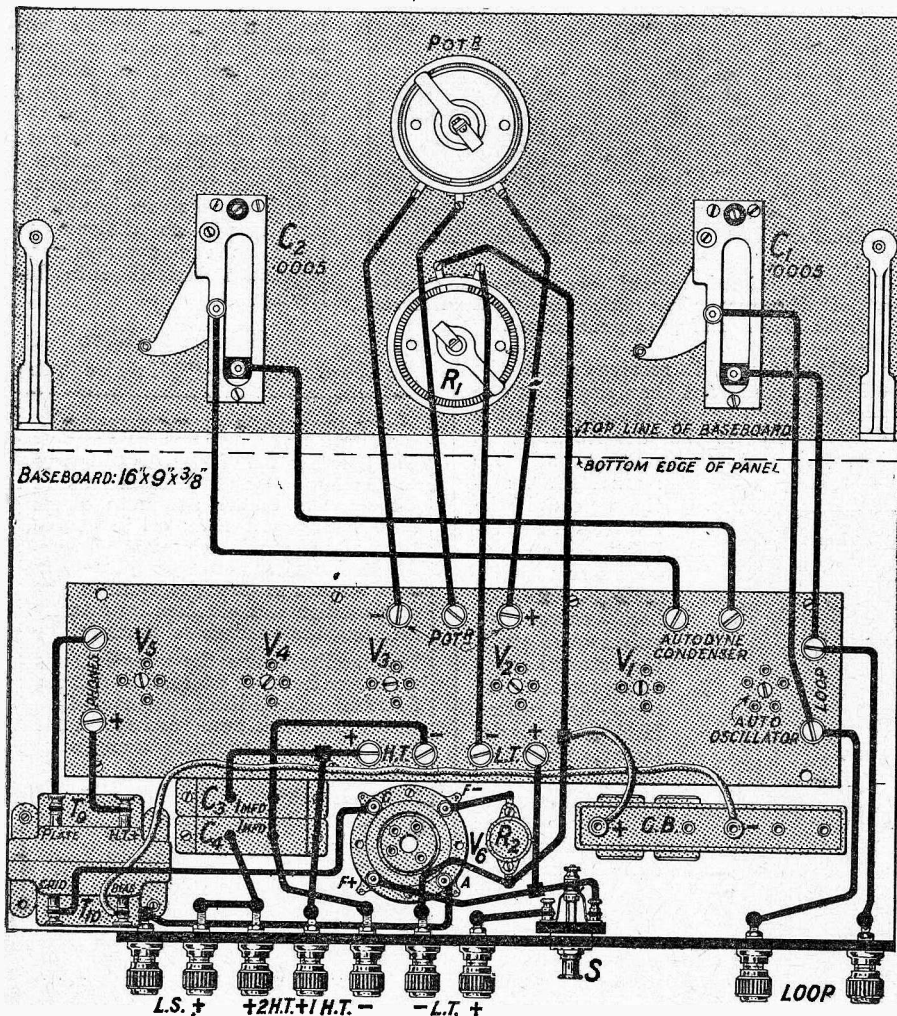
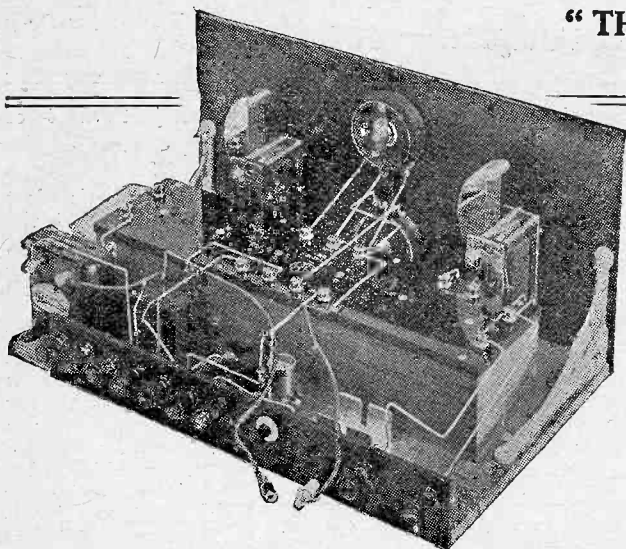

Fig. 2.—The switch marked "S" is brought into use when it is desired to light the filaments.



## "THE SIX-VALVE SET WITH ONE-VALVE WIRING"



The two plugs seen below the switch on the terminal strip make connection to a grid-bias battery.

approaching success though a host of "chirps" may be picked up.

Another point which should be borne in mind is that the filament rheostat should be sufficiently robust and of such a value as to give satisfactory control of the first five valves. This value will, of course, be dependent upon the type of valves it is intended to use, and care therefore must be exercised when buying this component in order

to avoid trouble at some subsequent period.

board by means of the brackets, and before proceeding further, secure the two small flat brackets to the sides of the superheterodyne unit.

Before screwing this latter to the baseboard make the necessary connections with the two condensers on the panel, the unit being in position but by virtue of its not being secured to the baseboard allowing the connections to be more easily made.

Next screw the unit to the baseboard and connect in circuit, that is, to the appropriate terminals on the unit, the filament rheostat and the potentiometer. Place the L.F. transformer, the valve holder, fixed resistor base, and battery clips in position, making sure that sufficient clearance is allowed for the valve and grid battery when these are inserted in the respective positions.

remaining components are concerned, it may be understood that other suitable makes will be found among the many listed in the advertisement

to avoid trouble at some subsequent period.

### WHAT YOU WILL NEED

- "Trolite" panel, 16 in. by 8 in. by 1/4 in. (F. A. Hughes & Co., Ltd.)
- Panel brackets. (Burne-Jones & Co., Ltd.)
- Cabinet and baseboard 9 in. deep. ("Camco.")
- Potentiometer. (Ericsson Telephones, Ltd.)
- Filament rheostat. (Ericsson Telephones, Ltd.)
- Two .0005 S. L. F. Condensers. (Beard & Fitch, Ltd.)

- Two vernier dials. (The Formo Co.)
- Superheterodyne unit, with plug-in Autodyne coil unit. (L. McMichael, Ltd.)
- L. F. Transformer, Type A.F.4. (Ferranti, Ltd.)
- Fixed resistor and base. (Burndept Wireless, Ltd.)
- On-off switch. (A. F. Bulgin & Co.)
- Two 1 mfd. Mansbridge condensers. (T.C.C.)
- Grid battery clip. (A. F. Bulgin & Co.)

- Valve-holder. (Garnett, Whiteley & Co., Ltd.)
- Two Wander plugs.
- Short length rubber covered flexible wire.
- "Glazite" connecting wire.
- Nine terminals marked as per wiring diagram. (Belling & Lee, Ltd.)
- Ebonite strip, 14 in. by 2 in. by 1/4 in. (Burne-Jones & Co., Ltd.)
- Two small flat right-angle brackets.

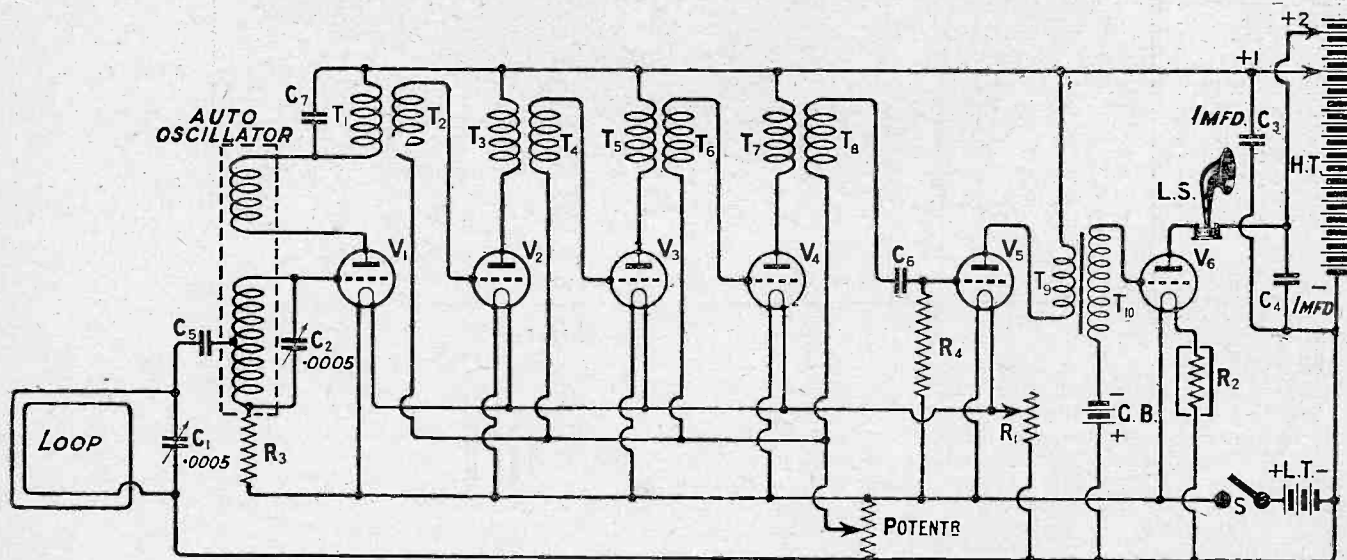

Fig. 3.—For the L.F. amplifying valve a fixed resistor (R2) is used to limit the filament current. The remaining valve filaments are controlled by a variable resistance seen at R1.

pages. In any case, it is recommended that slow-motion dials be used, otherwise it will be found an extremely difficult business to operate the receiver with anything

### Constructional Work

After the panel has been prepared in accordance with the details given in the drawing of the panel layout, this should be secured to the base-

whether or not sufficient room has been allowed for accommodating the stems of the terminals, whereupon all the components, including the terminal strip, may be permanently fixed.

## The "Miniwire" Superheterodyne—continued

### Wiring

The wiring of the receiver will not be found any more complicated than that of an average small receiving set, further, as many of the connections are screwed under terminals, those readers who fight shy of soldering will feel particularly favoured.

Where possible, the general directions for wiring should be followed, as though the connections are clearly given in the wiring diagram, and shown, the constructor is warned against accepting his own interpretation of the arrangement immediately the set is finished, for a single mistake at a point may quite conceivably mean the burning out of all the valves.

Discretion is the better part of valour in these matters, and before connecting any batteries the whole of the wiring should be checked against the diagram. Following upon this, connect the accumulator across the appropriate terminals, place the switch in the off position, turn the filament rheostat to zero and insert the valves. On switching on, the valve situated upon the baseboard should light while the remaining five should show no light until the filament rheostat is turned, whereupon all five will light up together.

### A Safety Test

The negative lead of the H.T. battery can now be connected, and using, say, 3 volts of the H.T. battery, touch the first H.T.+ of the instrument, noting whether or not the valves show any tendency to brighten up, and if nothing untoward happens it may be assumed that so far the circuit is correctly wired. Still using, say, 3 volts H.T., touch the H.T.+2 terminal, making the same observation as before, when if all appears to be correct, connect, say, 60 volts across H.T.— and H.T.+1 and a voltage suitable to the valve chosen for the

last stage to H.T.+2, not forgetting to use suitable grid bias also.

If this last valve is of the power type, then 120 volts will prove a suitable value, while the grid bias voltage may be taken as being somewhere between 6 and 12 volts, according to the make of valve chosen.

### Operating

So far as operating the receiver is concerned, this will be dealt with at some length in next week's issue, but in order that readers may in the meantime learn the preliminary handling of the set the following points should

adjusted to a point just *short* of oscillation.

### Searching

For the reception of signals first adjust the potentiometer so that the intermediate stages *just* oscillate, whereupon turn the Autodyne condenser (right-hand side of panel) either one way or the other until a powerful "chirp" is heard. Assuming that no chirp is heard throughout the operation, move the condenser on the left of the panel slightly and try again, whereupon sooner or later a chirp will be heard.

Slowly settle down on this chirp by adjusting both the Autodyne and frame aerial condenser together until the signals, though distorted, are at their loudest, when a slight adjustment of the potentiometer in order to stop oscillation will render the signals clear of distortion.

Further adjustments should now be made to both condensers until the best results are obtained, both with regard to volume and clearness, not forgetting to alter the angle of the frame aerial for possible betterment.

If any difficulty is experienced in finding stations in

this way a rough and ready method may be adopted by first searching on the Autodyne condenser and then adjusting the aerial condenser, keeping the intermediate stages well below self-oscillation the whole time by adjusting the potentiometer to a safe value. The receiver in this way loses much of its sensitiveness, though the method has much to commend it until the operator is proficient in making his adjustments quickly.

Those readers who have never handled a superheterodyne before should bear in mind that signals from a given station can be generally heard at two readings of the Autodyne condenser dial.

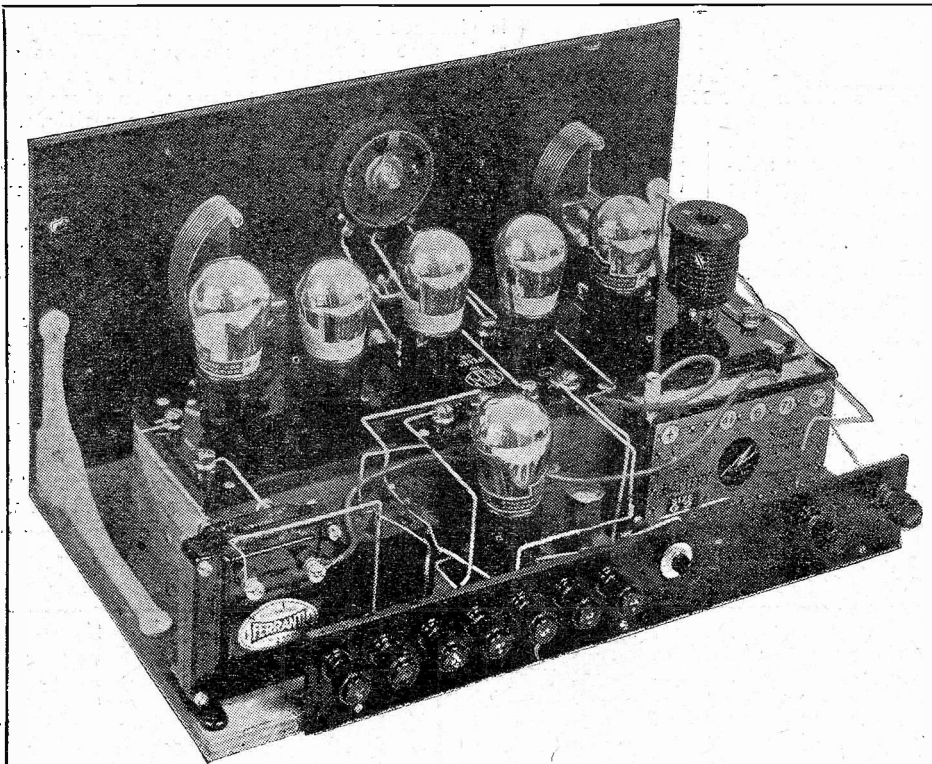

The finished six-valve receiver with coils and valves in position. Note that room is left on the baseboard for the grid-bias battery.

be observed. First connect the frame aerial and loud-speaker (or 'phones) across the appropriate terminals, assuming that the batteries are already connected, insert the Autodyne unit in its five-socket position on the main unit, turn the potentiometer to a mid-scale reading, and light the valves.

By turning the potentiometer either one way or the other a certain point will be reached where a distinct rushing sound is heard. This condition denotes that the intermediate frequency system is oscillating, a condition which is controlled by the potentiometer adjustments; for normal reception the potentiometer should be



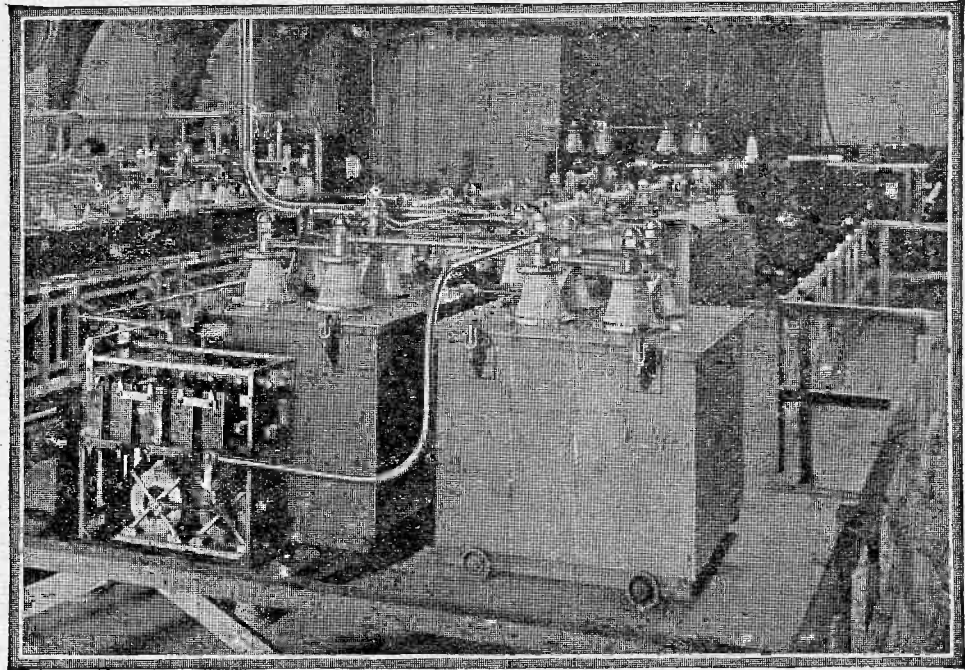

## Specify Dobilier!

Sixteen years ago we commenced manufacturing wireless condensers. In those days, electrical condensers certainly existed but they were totally unsuitable for wireless purposes. Accordingly we made a minute study of the subject and, as a result of careful observations over long periods, we were enabled to design condensers in which hysteresis losses, insulation leakage and numerous other factors opposed to condenser efficiency were either reduced to the minimum or eliminated completely. The small, meticulously sealed groups of mica and metal plates which form the essential units of the familiar 600 Type condensers are the direct outcome of these observations.

They represent the very high standard of electrical efficiency to which modern science has brought the condenser, and it is interesting to note that the identical units grouped in their tens of thousands, make up the Condenser Banks of the world's principal wireless stations.

In the Condenser equipment of the Government Radio Station at Rugby, of which we show a view above, there

are in each of the large "tanks" over half a million of such mica and metal plates grouped into hundreds of condenser units.

Each of the many millions of plates are individually selected and tested before being collected into groups, and each group was again subjected to frequent and stringent tests during the successive stages of assembly.

This ritual of tests, tests, and more tests is observed in the case of every single product bearing the Dobilier name. Our long experience has taught us that if we are to make condensers which will be satisfactory in service, whether they are designed for High Power Stations or for Broadcast Receivers, we must take precautions to eliminate every possible cause of failure. As Condenser Specialists we know these precautions to be not only desirable but essential. Governments and Manufacturers of Broadcast Receivers all over the world, agreeing with us in this matter, specify Dobilier.

Are there Dobilier Condensers in your set?

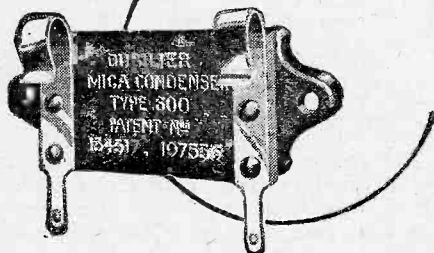

Specify—



ADVERT. OF THE DUBILIER CONDENSER CO. (1925) LTD.,  
DUCON WORKS, VICTORIA ROAD, NORTH ACTON, W.3.  
TELEPHONE: CHISWICK 2341-2-3.

E.P.5:234

# A.C. FOR VALVE FILAMENTS

## Results of Some Practical Tests

By L. I. LESLIE

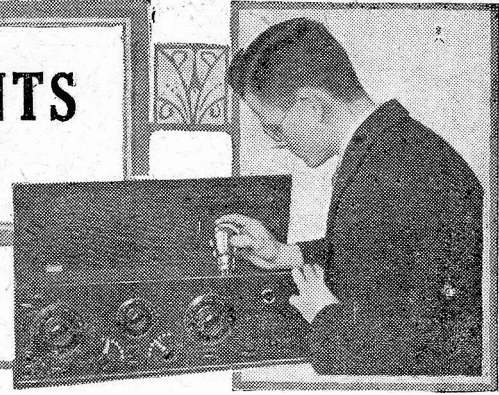

In our last issue Mr. Reyner described the possibility of using A.C. mains for filament lighting, and below our contributor describes the results of some actual practical tests at Elstree.



As indicated by Mr. Reyner in his article in last week's *Wireless*, tests have been carried out at the Elstree laboratories with the object of finding out the effects produced when using A.C. for valve filaments. It was shown in the previous article that it was necessary to connect the earth return of the grid circuit to the centre of the secondary of the input transformer, or to the centre point of a potentiometer connected across the filament of the valve in use. By employing this method a large part of the hum caused by the alternating current can be eliminated.

### Another Difficulty

In actual practice, however, there is a further difficulty to be overcome; this is due to the fact that the current passing through the filament is alternating, so that the heating effect is continually varying.

It is well known that two currents, opposite in direction, but of the same magnitude, will each cause the same heating effects in a conductor. With an alternating supply the current changes its direction continuously, starting at a positive value and falling to zero before it becomes negative: this will occur, perhaps, 100 times a second. Although the heating effect on the filament depends on an average value of the current, it is evident that the variations will be perceptible, if the filament is very sensitive to any change of current.

### The Only Remedy

The eye cannot detect fluctuations

in the light produced by an electric lamp working off alternating current: but the ear is much more sensitive in this respect. If the temperature of the valve filament changes with each current fluctuation, the emission will vary, and a hum will be produced in the 'phones connected in the anode circuit of the valve. Therefore the only method of getting over this difficulty is to design a filament which is very insensitive to sudden changes of

power applied to it is to remain constant, the shorter it is the thicker it can be made, and the more desirable it will be for working off alternating current. Finally the co-efficient of heat conductivity of the filament should be as low in value as possible, so that it will not tend to take in or give up its heat too readily. This points to the use of a low-temperature filament, such as is used in modern dull-emitters.

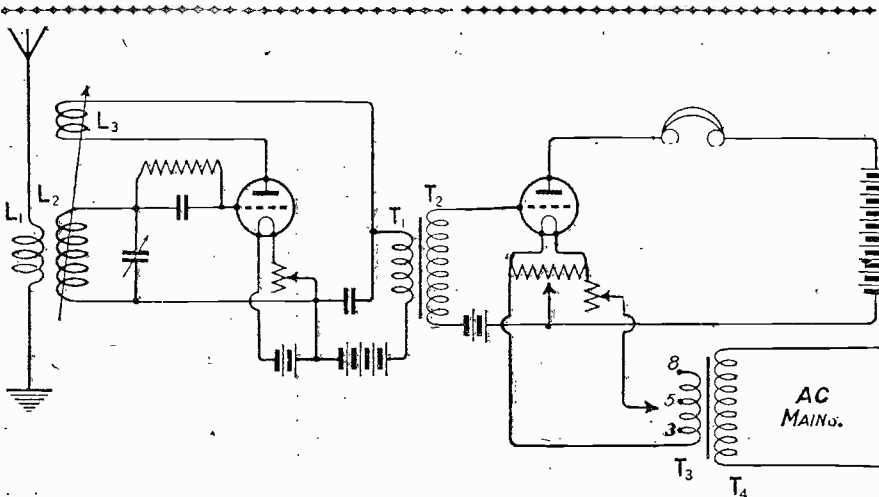

Fig. 1.—The leads from the A.C. mains (240 volts) were taken to the primary of a step-down transformer having a ratio of 30 to 1 for the tests described this week.

current; or, in other words, will always remain at a constant temperature.

The question naturally arises as to what properties such a filament should possess. Length, thickness and co-efficient of heat conductivity must all play an important part in the design. Now, a thin wire will lose its heat much quicker than a thick one; therefore our filament must be thicker than is normally the case. In order to obtain the required emission from a thick filament, a larger current will be necessary, although the voltage may be cut down by a corresponding amount.

It is also evident that, if the emission from the filament and the

### Summarised Requirements

Making a summary of these points, we should expect to get the best results with a filament which is short and thick. This would require a large current at a small voltage. When working off A.C., however, we are mostly concerned with the wattage consumed; therefore we need not worry about the magnitude of the current required provided the voltage is correspondingly reduced.

### Practical Tests

In order to find out if these reasonings were approximately correct, tests were carried out on a large selection of dull-emitter valves. The circuit used is shown in Fig. 1. The leads from the A.C. mains were taken to the primary of a step down transformer, having a turn ratio of 30 to 1. 240 volts were put on the primary, and by means of a tapping from the secondary winding voltages of 8, 5 or 3 could be obtained as desired.

The hum is principally noticeable on L.F. stages, and the actual tests were made on a single-valve amplifier. It was found that grid bias had a noticeable effect on the amount of



## A.C. FOR VALVE FILAMENTS

(Continued from previous page)

hum present, and this was adjusted to the correct operating point for each test. In order to ensure this the amplifier in question was coupled to a simple valve detector, and all the tests were made whilst signals from 2LO were actually being received.

In some cases, using short, heavy-current filaments, the hum was sufficiently reduced to permit the reception of distant stations; but, in any case, the signals from the local station enabled the grid bias to be adjusted to the correct operating point so that no distortion was present.

### Excessive Grid Bias

This precaution proved necessary, because in many instances the hum could be cut down considerably by increasing the grid bias, but in such cases it was found that distortion was being introduced indicating that the grid bias was excessive. The presence of the signals thus acted as a check and ensured the validity of the observations.

In view of the influence of grid bias, it was decided not to run the detector valve off A.C., as if this were done there would be too many variable factors contributing to the final result. Accordingly the detector valve was provided with an accumulator and a separate H.T. battery to confine the observations to the L.F. valve entirely.

### Change-over Arrangements

In order to facilitate the comparison in the hum obtained with various valves, a second valve holder was connected in parallel to the one in use, and by means of a single-pole double-throw knife switch, one valve could be switched on and the other off in a single movement of the switch. It was found necessary to connect the potentiometer across the valve legs (not across the secondary terminals of the transformer), so that its centre point should not be disturbed by alterations of the filament resistance.

A selection of 2-volt valves was first tested; the results obtained were fully in accordance with the theory put forward in this article, the quietest valves being those which took the greatest current. The Marconi Osram D.E.R., which takes a current of 0.35 amps. at 2 volts, gave very little hum, and when listening to the local station, tuned in at moderate strength, it was easy to forget that there was any hum present. The Mullard double green ring, taking 0.3 amps., and the Ediswan A.R.D.E., taking 0.25 amps., were also fairly silent in operation, but the Cossor Point One and the Mullard P.M.1,

taking 0.1 amp., gave a noticeably louder hum.

### Four-Volt Valves

Some 4-volt valves were then tested. As one would expect, the type of valve, taking 0.06 amps. was in general the noisiest, and those taking 0.12 amps. were quieter. A Mullard D.F.A.0 taking 0.35 amps. at 4 volts was then tested and proved to give the loudest hum of any 4-volt valve. Considering its high current consumption, this might appear at first to be in direct contradiction to our theory, but it will be noticed that the filament of this valve is of the loop variety, and therefore about twice the length of those previously tested.

### Tests on Six-Volt Valves

A selection of 6-volt valves were then tried. Most of them, such as the Marconi D.E.5 and D.E. 5B, and the B.T.H. B4 and B7, had long filaments, and all gave a very loud hum. The amount of current taken by these 6-volt valves did not appear to affect the hum produced to any noticeable extent, the length of the filament appearing to over-rule the current factor in this case.

The results quoted are a few selected out of a large number of tests or as indicating the general tendency observed in the experiments. It will be clear that they bear out the theory put forward at the beginning of the article to a large extent, and they serve to emphasise the relative importance of the several factors.

### Importance of Length

Thus the most important factor of all seems to be that of filament length. The 6-volt valves tried, all of which had long filaments, were uniformly unsuitable, and a wide difference in filament current, ranging from 100 milliamperes to .25 amperes, produced no appreciable alteration in the hum. The first essential, therefore, appears to be a short filament.

Here, in order to obtain the necessary emission, a heavy current is required, but this, fortunately, is also the requirement for silent working, the hum becoming appreciably less as the current is increased. In fact, some of the 2-volt valves tried were almost silent in operation. This again bears out the theory.

Two-volt valves are at present limited by the attempt to keep the current within reasonable limits. As has been stated, this objection does not hold in A.C. working, and possibly it is in this direction that future developments may occur.

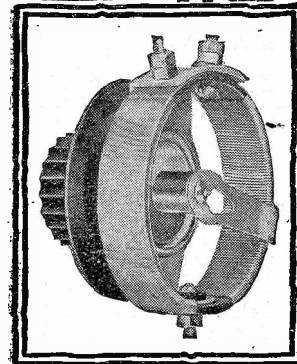

## bright & dull emitter valves

There are two windings on this one Rheostat—one of a resistance of 6 ohms and a combination of this on to a 30 ohm strip winding. This has been specially made to meet the demand for a thoroughly reliable Rheostat covering needs of both bright and dull emitter valves. The resistance wire is wound on hard fibre strip under great tension and is immune from damage. The popular one-hole fixing method is provided and the terminals are conveniently placed. Contact arm has a smooth, silky action. All metal parts nickel-plated. Complete with ebonite combined knob and dial.

**The NATIONAL WIRELESS WEEK**

NOV 7<sup>th</sup> - 13<sup>th</sup>

*Let your Friends Listen*

The  
**'PEERLESS'**  
DUAL RHEOSTAT

PRICE **3/9** EACH.

From all dealers or direct from  
**THE BEDFORD ELECTRICAL & RADIO CO., LTD.,**  
22, CAMPBELL ROAD, BEDFORD.

# KEEPING LISTENERS' INTEREST

## WHY GREAT ARTISTS CANNOT BROADCAST

By

DAME CLARA BUTT



FROM the point of view of broadcaster and listener alike, wireless has entered a new era. No longer is it a scientific novelty with which to while away an hour. Probably the vast majority of people in this country have handled wireless sets, and, except for a comparatively small number of enthusiastic experimenters, it no longer holds the same attraction from a mechanical point of view. Even the keenest distant station seeker likes to listen to a good programme from his local station occasionally.

From the listener's point of view broadcasting is beginning to be looked upon primarily as a means of entertainment, and the B.B.C., as the entertainers, will have to see that they keep the interest of their vast audience. Novelties will sooner or later cease to amuse, and entertainment equal in quality to that of the theatres and concert halls will have to be provided.

### The Broadcaster's Viewpoint

The point of view of the broadcaster, too, is changing. Broadcasting was at first treated as a form of privilege, and many famous people were willing to accept it as such. But now that the novelty of singing or playing before a vast unseen audience has worn off, they are no longer willing to broadcast for nothing.

I am not complaining of the present wireless programmes. In their way they are excellent, but I think that, unless concerts by the best artists are given at least once a week, there will shortly be a decrease in the number of licence holders. Music lovers were content to listen to a second-rate violinist or singer when the sound was brought to them by the mysterious ether, but the ether is no longer mysterious, and they are taking broadcasting for granted. Unless it can give them entertainment at least as good as that of the concert halls they will not renew their licences.



*In view of the split between Mr. de Groot and the B.B.C., this article, from the pen of a famous artist, is of special interest.*

ally famous. Six nights out of seven they provide excellent music, but on the seventh night a large section of listeners will want serious music by a famous musician. They will want the music of someone with a magnetic personality—a Kreisler or a Caruso.

At the moment very few of the world's great instrumentalists or singers will broadcast. It is not that they are not willing, or even anxious, to broadcast, but simply that they cannot afford to do so. Some artists, it is true, still look unfavourably on broadcasting, because they think that it is imperfect. Perhaps they have been unfortunate enough to hear a distorting loud-speaker making music into cacophony. I know that there are distorting receivers—but so are there distorting gramophones, and no artist refuses to make records. Perfect wireless reproduction is not only possible, but the general rule. No musical person would listen to a bad loud-speaker, and I am sure that artists need not fear that faulty apparatus will injure their reputations if they broadcast.

### Broadcasting Beneficial

Unlike other types of broadcaster, the musician does not have his material spoilt when it is distributed to several million people at once. I can sympathise with the comedian who complains that, once he has used a joke on the wireless, it becomes a chestnut. But music improves on a second or third hearing, and I am sure that a great artist, with a magnetic personality, will draw people who have heard him to see him.

The difficulty is, I am aware, almost entirely a question of money. Famous artists cannot afford to broadcast at the fees paid by the B.B.C., and the B.B.C. cannot afford to pay adequate fees, because their income is limited. The matter lies in other hands than those responsible for arranging the programmes, but it is only right that attention should be called to it, and that the money paid by licence holders should be used entirely in providing entertainment for them.

### What We Want

Most B.B.C. artists are good, but few have won their spurs on the concert platform, or become internation-

(Continued on page 14.)



*Who earns your money?  
Who spends it? Who  
chooses your parts for you?*

No set published by any periodical could use only one make of parts or could use the same make of transformer, for instance—it would not be fair to advertisers if they did not all have a share in this kind of mention. **BUT YOU ARE FREE TO CHOOSE YOUR OWN PARTS.**

Your transformer, for instance. Never again pay a high price for your transformer no matter what may be specified—the new LISSEN has revolutionised all previous ideas of transformer price and performance.

So good is it, that all our own high priced models, which have been on the market and largely sold for several years past, have been unhesitatingly withdrawn in favour of this new LISSEN.

*The fine tone and great power of this new LISSEN Transformer have been proved by the trade—they are largely using it for their own built-up sets.*

It Fully Amplifies Every Note—Every Harmonic—Every Overtone.

Choose the New LISSEN. First for its Performance. Secondly for its Price. **ACTUALLY TEST IT FOR 7 DAYS—IF NOT SATISFIED THEN TAKE IT BACK TO YOUR DEALERS OR SEND IT BACK TO US.**

Our new direct to dealer policy of distribution (which cuts out all wholesale profits), aided by our huge production programme and the special plant installed to turn it out have enabled us to sell this new LISSEN Transformer at an unheard-of low price.



**8/6**

AND GUARANTEED FOR 12 MONTHS.

TEST IT FOR 7 DAYS

Turns ratio 3 to 1  
Resistance ratio 4 to 1

Use it for 1, 2 or 3 stages L.F.

*It will suit every circuit and every valve you will want to use.*

**LISSEN LTD., 18-22, FRIARS LANE, RICHMOND, SURREY.**

Managing Director: T. N. Cole.

*Many are using LISSEN Transformers in "N" Circuits.*

**USE LISSEN FIXED CONDENSERS, TOO, Mica and Mansbridge Type**

**LISSEN Mica Type CONDENSERS**

Small energy-conserving condensers—note the new case which enables the condenser to be used upright or flat. At present the new case is available only in the most used capacities, but will quickly become a LISSEN standard.



Capacities—  
.0001 to .001 1/- each (much reduced).  
.002 to .006 1/6 each (much reduced).  
Accurate to 5 per cent.—they never leak—they never vary.

**ADD 10% MORE LIFE TO YOUR H.T. BATTERY**

merely by using a LISSEN 2 mfd. or 1 mfd. (Mansbridge type) condenser across your H.T. battery. It cuts out all the noise from your H.T. battery when the battery is old, and keeps the energy flow steady and quiet in the meantime. One LISSEN condenser will outlast many batteries, and the lengthened life you get out of your battery will pay for the cost of the LISSEN condenser over and over again. Your dealer will tell you how you can easily connect the condenser when buying it. Use either 2 mfd. or 1 mfd. capacity—the larger condenser is more effective.

**LISSEN (Mansbridge Type) CONDENSER**

2 mfd.	.. .. .	4/8
1 mfd.	.. .. .	3/10
Other capacities made are:		
.01	.. .. .	2/4
.025	.. .. .	2/4
.05	.. .. .	2/4
.1	.. .. .	2/6
.25	.. .. .	3/-
.5	.. .. .	3/4
1.0	.. .. .	3/10
2.0	.. .. .	4/8

Instead of a tin case, the LISSEN CONDENSER, unlike all other condensers of the Mansbridge type, has a specially moulded case which in itself is a SOLID INSULATOR. That is why it is impossible for the LISSEN Condenser to short circuit on to its case, an important protection for you when you are using the condensers in any circuit which is connected straight on to the electric light mains.

And due to our new direct-to-dealer policy of distribution THESE LISSEN CONDENSERS COST YOU NO MORE THAN THE ORDINARY KIND.

**LISSEN FIXED GRID LEAKS**

A case of these was left on our factory roof during the summer of 1925, soaked in rain, baked by sun and the resistance value of these leaks never altered.

All capacities, previously 1/8, Now 1/- each.



Improve every circuit by using LISSEN parts wherever you can—save money too—for now you get keen prices as well as fine quality.

## Keeping Listeners' Interest—continued from page 12

Because their income is fixed, regardless of the number of licence holders over about 1,000,000, the B.B.C. do not, perhaps, take the same trouble to keep alive the interest of listeners as they would if they received the whole of the licence fees. Concerts are one of the surest ways of keeping the interest of listeners. If a great artist can pack the Albert Hall to overflowing, surely, when he broadcasts, thousands of listeners will renew their licences simply to hear him.

### What Must Come

Sooner or later the B.B.C. will, I think, have to make contracts with big artists, guaranteeing them a reasonable sum for a certain number of concerts, to be given over a period of, say, two or three years. Sir Harry Lauder and Chaliapino both received large fees for their broadcasts, I believe, but these are but two instances in the course of four or five years!

The broadcasting authorities will have to spend more money when this change takes place. This may mean raising the licence fee (although I think more careful collection of the ordinary fee would meet the case). A pound licence fee would, I know, raise a storm of protest, but, after all, it is not a great sum to pay for the privilege of listening to first-class entertainment every night of the year.

### A Difference

It is sometimes suggested that great artists will no longer be needed on the wireless, because broadcasting will, like the cinema, create its own stars. While it is true that film producers soon gave up looking for talent on the stage, and started training their own stars, I do not think that the same development will take place on the wireless. The arts of the stage and screen are very different, but those of the platform and studio are not dissimilar. A girl with a voice which would not make her world-famous on

the concert platform is hardly likely to become a star because she has learnt the art of broadcasting. On the other hand, I think that the established artist is likely to succeed in the studio, for she has developed personality, and can express it in her voice. I think, also, that listeners will

it is easier for a singer than for a lecturer or comedian to visualise a vast unseen audience. The knowledge that there were millions listening always urged me to give my best.

In addition, I find a certain sentimental enjoyment in broadcasting. It may be true, as Ruskin said, that, if anyone really wants anything, they will find the money to buy it, but I do not doubt that there are many people who never go to big concerts because they cannot afford to do so. It made me very happy to think that there were, perhaps, thousands of these people listening-in.

### Broadcasting and its Opportunities

Often, when I am on tour, a note is slipped into my hand as I go on to the platform. It tells a tale of suffering or bereavement, and begs me to sing "Abide with Me" or "The Lost Chord." Of course, I comply if it is possible, and it makes me very happy to think that my art can help. Broadcasting enables me to reach men and women such as the writers of these notes, and possibly make their troubles easier to bear.

I like singing into a microphone because it is able to "take" my big voice. When I have made gramophone records I have had to stand a long way from the recording apparatus to ensure pure reproduction. But wireless reproduces the "bigness" of my voice without difficulty.

### National Possibilities

Lastly, I am interested in broadcasting because of the wonderful opportunity it is offering to music lovers. It is often said that the English are unmusical, but I think that Englishmen would be as musical as the French, the Germans, or the Italians if they were given the opportunity. Men and women on the Continent are musical because they can hear first-class music for next to nothing.

In England we have no state-aided music, but broadcasting, if it provides first-class concerts, will go a long way to making the Englishman interested in good music.



Top.—Sir William Noble, fourth from left in front row, declaring open the Third Manchester Wireless Exhibition, which was held in the City Exhibition Hall at Deansgate. Capt. P. P. Eckersley, Chief Engineer of the B.B.C., is fourth from the right in the front row. Our picture below shows one of the exhibits—a demonstration showing how wireless is used by an army in the field.

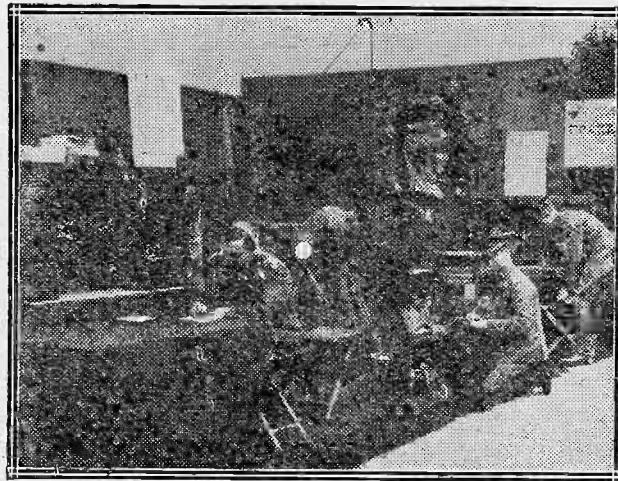

want to hear and see those who broadcast.

### Personal Experiences

This article sounds very commercial, but I hope I have not conveyed the idea that I am interested in broadcasting simply from a financial point of view. On the rare occasions I have appeared before the microphone I have enjoyed myself, and never suffered from "stage fright." Probably



# From my Armchair

BY EARL RUSSELL

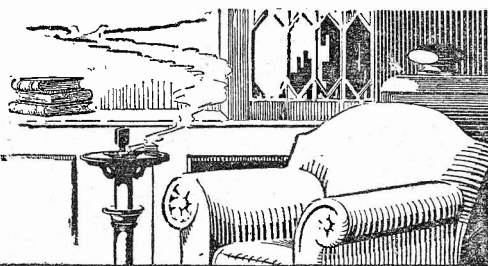

In these columns Lord Russell expresses each week his own personal views on matters of interest to "Wireless" readers.

## How Many Valves?

It is not much more than a year ago that I ventured to commit myself to the view that three valves would probably be the normal limit for receivers. On three valves with the 'phones any station could be audibly picked up with proper tuning; a detector followed by two L.F. amplifiers would give all the loud-speaking required from a local station or Daventry. The use of more valves involved impossible demands for both L.T. and H.T. current. How shortsighted I was in my prophecy! The super-heterodyne came in with its six valves and manufacturers rose to the occasion and produced valves to meet the demand. The dull emitter, which had been an expensive toy, became an article of commerce, not cheap it is true, except in comparison with valve prices of two years ago, but soon earning its keep in accumulator saving.

I am at present running a set with five valves, which together take .6 ampere at 2 volts, as against .7 for each bright emitter at 6 volts. Put into watts it means 1.2 against 21. Moreover, the general public's demand now is for loud-speaking; so, usurping the privileges of Delphi, I now interpret my prophecy to mean that no one in future will use less than five valves.

## Some Curious Views

I have been reading an article lately from a quite competent hand, containing one or two statements which are to say the least open to challenge. For example, it is stated that 12 milliamperes are necessary for ample volume in a loud-speaker. I have a five-valve set which works two loud-speakers quite satisfactorily with  $3\frac{1}{2}$  milliamperes. Crystals are brushed aside as being impossible in sets for the general public. Considering the

vast number of crystal users who have patiently learnt to fiddle with a cat's whisker, and the large number of stable crystal detectors on the market, which will stay put, I do not see why my old friend the crystal should be considered such a hopeless proposition. As a matter of fact, there are two or three reflexing circuits in the air at the present time using crystals which give quite remarkable results.

## Some Construction Points

Amateurs who construct their sets at home will do well to remember that tags are tinned commercially by an acid process which is apt to leave a film of oxide on the tin. This has to be scraped off with a knife or the tag re-tinned if an easy joint is to be made. It is wise to do this in advance rather than to wait until one is about to solder in an inaccessible position.

I have for a long time been in doubt about the best size of wire to use. There was a time when square 16 was the rage, and I still have a preference for that size, but round. I am not at all sure, however, that for a multivalve set on broadcast wavelengths 18 is not quite as good. The use of these modern coil bases and screens make easy leads difficult to find, and 18 Glazite is often the best solution. It would be interesting to have authoritative and quantitative comparisons from Elstree on the point.

# SIEMENS

# "FLUID" LEGLANCHE CELLS

for H.T. purposes

## A novel Feature

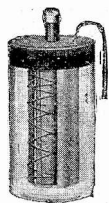

H.T. 1 Size.

The new form of excitant which we supply with these cells renders them as clean and convenient to use as the so-called "dry" cell. "Creeping" of the salts is entirely eliminated and NOISELESS RECEPTION ENSURED.

*It is more economical to purchase the larger size, having regard to the ratio of output in comparison with the price.*

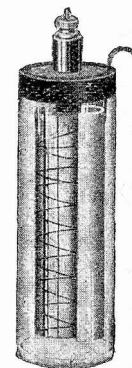

H.T. 3 Size.

Size No.	Nominal E.M.F.	Dimensions overall approximate	Maximum Economical Discharge Rate.	Weight without electrolyte approximate	Ratio of output.	Price per cell complete.
	Volts.	Inches.	Milli-Amps.	ozs.		s. d.
H.T.1	1.55	1 1/4 dia x 3 1/4 high	5	3	1	1 0
H.T.2	1.55	1 1/4 " x 5 "	10	4	2	1 3
H.T.3	1.55	1 1/2 " x 5 1/2 "	20	6	5	1 6

Complete batteries in wood boxes can be supplied for 50 volts (36 cells); 60 volts (44 cells); and 100 volts (72 cells).

Our new catalogue, No. 650, of "Siemens" Radio Batteries contains a large amount of useful information on the CARE, MAINTENANCE and SELECTION of batteries for all radio purposes. It also shows how to obtain the most efficient service at the lowest operating cost. A copy will be sent post free on request.

**SIEMENS BROTHERS & CO., LTD., WOOLWICH, LONDON, S.E.18**

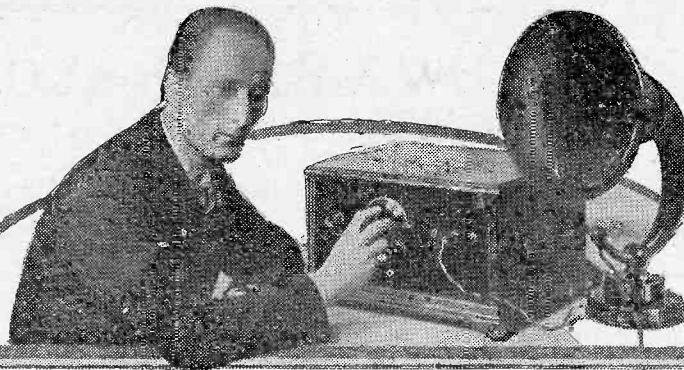

## THE MONODIAL ON LONG WAVES

Some Further Results with our Latest Star Receiver



It has always been the fashion to say "High-frequency amplification on the long waves is easy enough; it is the shorter waves that are so difficult." In the case of the Monodial the reverse has been the case. Little difficulty of any serious nature was found in getting the set to function satisfactorily on the shorter waves, and such troubles as there were did not include parasitic oscillations, or uncontrollable oscillation of any kind.

### A Difficulty

When I first started on the long-wave experiments, however, I found myself up against a serious difficulty. The set went into violent oscillation, which nothing apparently would stop. It was soon found that the trouble did not actually lie in the high-frequency circuit—the trouble was only affecting the detector. On examination, indeed, this almost appeared to be oscillating at several different frequencies.

The detector circuit will be seen in Fig. 2 in the October 30th issue of WIRELESS, in which the constructional details regarding the Monodial were given. As will be noticed, the detector grid circuit consists of an inductance which is tuned by a variable condenser. One side of this circuit is connected to the grid of the valve, while the other goes to the anode through a small variable condenser which is used for reaction. A high-frequency choke is connected in the plate circuit of the detector so as to enable capacity reaction control of

this description to be used, while the L.T. return goes to a point at the centre of the inductance.

### The Reason

It will readily be seen that if it should chance that the choke in the plate circuit were self tuned to the same frequency as that of each half of the coil, each in turn tuned by its self-capacity, the circuit would go into self-oscillation, which nothing would stop—and it does! This is what occurred with several chokes that were

tried, and those with a very small self-capacity were specially found to have this effect owing to the low wavelength to which they are naturally tuned on account of this point.

When at last reaction was induced to behave normally it was found to be extremely fierce, and the expedient of shifting the filament tap further away from the grid end of the inductance had to be resorted to, and although this was a cure for fierce reaction, it might then occur that the choke which was suitable on account of its not giving rise to parasitics with a centre tap would do so with the tapping point shifted down to inductance. A spot had therefore to be chosen which would enable stability to be obtained with the largest number of high-frequency chokes, so that the circuit should not become critical as regards this component.

### Windings

Other points that required investigation were chiefly as regarded the primaries of the two H.F. transformers used, one for the aerial coupling, and one for the intervalve H.F. coupling. The correct proportions of the windings had to be determined, the number of turns and the degree of coupling with the secondary, while, if possible, it was intended that both these inductances should be made the same, so that both coils would be interchangeable.

It was also necessary that the primary winding be connected the right way round, otherwise the receiver would not neutralise correctly, and though the H.F. valve in the Monodial was found to be almost stable on the long waves without being neu-

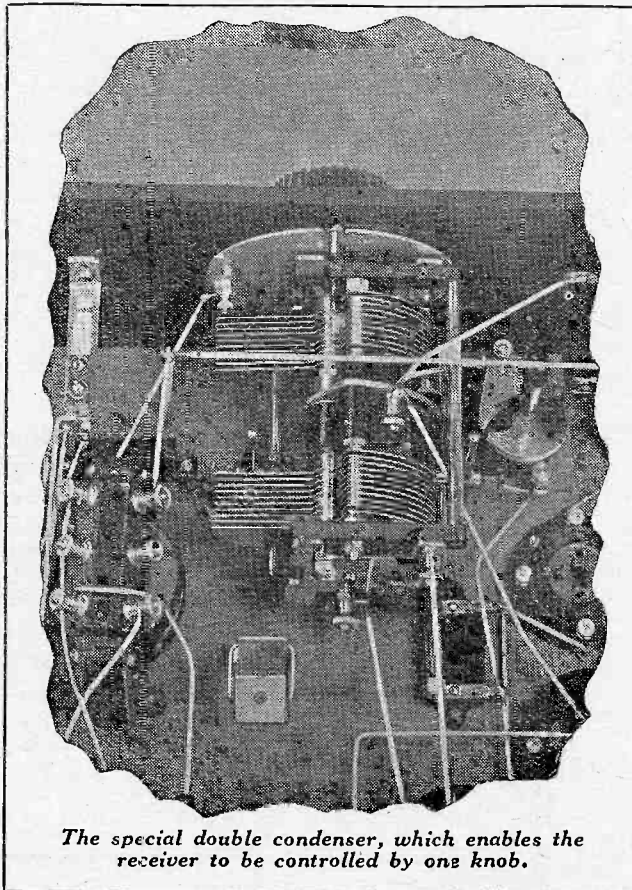

The special double condenser, which enables the receiver to be controlled by one knob.



**THE MONODIAL ON LONG WAVES**

(Continued)

tralised, yet it was necessary to bear in mind that with different valves and under different circumstances this would quite probably not always be the case.

**Results**

Once an indication had been obtained as to the direction in which the solution of the various problems lay, progress was rapidly made, and I soon had the pleasure of listening to a special concert which was being broadcasted from Daventry, unmarred by any form of oscillation from within the set itself. On turning the tuning control and advancing the reaction slightly

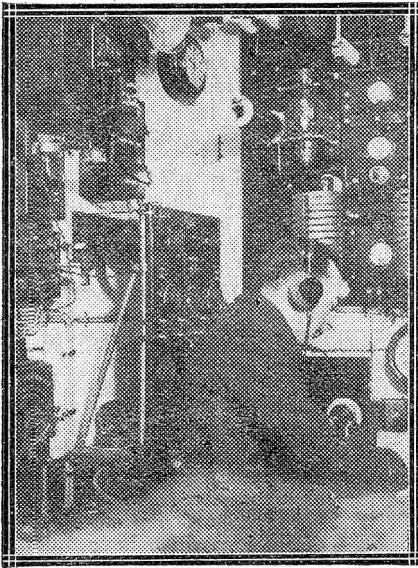

*The wireless cabin of the "Jervis Bay," the chief wireless officer of which vessel is reported to have been in daily communication with Sydney throughout the whole voyage from Australia to Plymouth.*

Radio-Paris was received at medium strength in the loud-speaker.

In view of the fact that a short sercened aerial almost in the heart of town was being used I considered the signal strength to be well up to normal, and, indeed, highly satisfactory for a one-knob control set.

The next station to be picked up in the loud-speaker was Hilversum, who came in at decidedly better strength than did Radio-Paris, while one or two other transmissions round the 1,400-metre mark were heard.

Next week, for the benefit of those who may wish to make their own coils, I will give full details as to the long-wave inductances, together with one or two operating notes specially applicable to long-wave work on the Monodial, and a full test report, since the above results are intended only as a general guide.

C. P. A.

**NOW A Brandes CONDENSER**

**STRAIGHT LINE FREQUENCY SLOW MOTION LOW LOSS.**

It will be obvious from the table given below of new B.B.C. wave-lengths, that a condenser in which the dial reading varies directly as the frequency will give a more uniform separation of stations than one in which the dial reading varies directly as the wave-length. This is particularly apparent in the lower wave-lengths. Brandes Straight Line Frequency Slow

Motion Low Loss Condenser has been specially designed to provide a Straight Line Frequency tuning characteristic and to bring in the B.B.C. Stations well spaced out over the major portion of the dial, whilst, at the same time maintaining the compact form which is so very essential in a back-of-panel instrument.

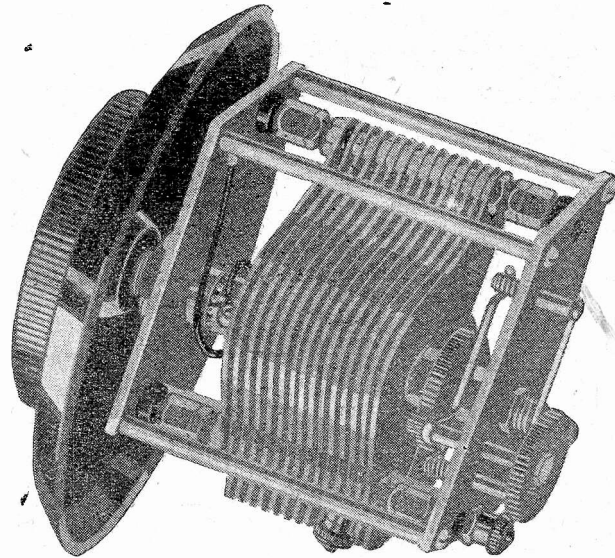

The following table shows the new wave-lengths of the B.B.C. stations with their corresponding frequencies:—

Call Sign.	Station.	Wavelength.	Frequency.
2 BD	Aberdeen	491.8 metres.	610 kc
5 IT	Birmingham		
5 SC	Glasgow	405.4	740 "
2 ZY	Manchester	384.6	780 "
2 LO	London	361.4	830 "
5 WA	Cardiff	353	850 "
2 BE	Belfast	326.1	920 "
5 NO	Newcastle	312.5	960 "
6 BM	Bournemouth	306.1	980 "
2 LS	Leeds	297	1,010 "
	Bradford	294.1	1,020 "
	Other Relays	288.5	1,040 "

With this condenser a positive movement for approximate setting is obtained by turning the 4in. diameter dial which is provided with finger grips for this purpose. The final critical setting is obtained by turning the 2½ in. knob which actuates the slow motion mechanism. Low dielectric losses and the complete absence of backlash are ensured.

**PRICE : ·0005 ... 18/6 ; ·0003 ... 18/-**

(From any good dealer.)

**Numerous Advantages:—**

1. A handsome 4in. dial engraved with clearly marked divisions and provided with finger grip for the approximate setting of the condenser.
2. The large knurled knob 2½ in. diameter operates the patent vernier mechanism for fine or critical tuning.
3. A minimum quantity of highest quality ebonite ensures low dielectric losses.
4. The single hole fixing bush has a knurled face to ensure a firm grip on the panel. Ball bearings fitting into cone-shaped races prevent shake and backlash.
5. A pigtail flexible connection ensures perfect contact between the frame and the moving vane system.
6. Brass vanes and spacing collars chemically cleaned ensure perfect contact.
7. Conical bearings at base prevent shake and backlash.
8. The Slow Motion is transmitted to the moving vanes through a carefully designed friction clutch by means of a train of wheels having a finely knurled surface which ensures a very smooth reduction movement without 'jump or slip.
9. Specially designed spring bearings keep the train of wheels in intimate contact and by exerting a gentle pressure on all the moving parts entirely eliminate backlash. This condenser will provide a Straight-Line-Frequency tuning characteristic with the stations within the B.B.C. frequency range well spaced over the dial. The shape of the moving vane is designed to provide a small compact condenser having a straight-line-frequency tuning characteristic without taking up a large back-of-panel space. Most other S.L.F. Condensers have a long, narrow vane with a very wide swing, taking up a lot of valuable space at the back of the panel.

**BRANDES, Ltd., 296, Regent St., W.1. Works : Slough, Bucks.**

# Secrets of the Low-Frequency Transformer

By J. H. REYNER, B.Sc. (Hons.),  
A.M.I.E.E.

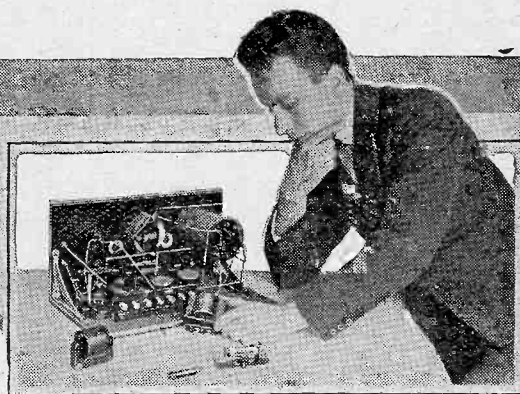

Many people are apt to regard the low-frequency transformer as "a box with four terminals" without paying any attention to its functions and position in circuit. In this special article Mr. Reyner gives some interesting details about this highly-specialised instrument which you should not miss.

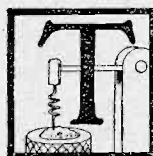

THE modern low-frequency transformer is a highly-specialised instrument. The accumulated results of years of research applied to the problem by some of the best brains in this country have made possible the production of instruments which achieve a high standard of efficiency. It is, indeed, a field of research in which this country is unquestionably the leader, and the methods adopted by British engineers are studied and often copied all over the world.

## The Differences

The average reader must at times wonder what difference there can be between various makes of instruments. The purpose of the low-frequency transformer is to receive the energy from one valve and to pass it on to the succeeding valve, so that it shall be increased in volume, if possible, but at any rate an accurate copy of the signals originally supplied on the input side.

Rival manufacturers claim for their own particular articles various peculiar attributes which assist one or other, or, if possible, both of these two functions. The most important is unquestionably that of faithful reproduction, and the amplification obtained over the whole stage, although of importance, is usually relegated to a second place in the design.

## Strength and Quality

Now there is no doubt that there is a difference between various makes of transformers. Some instruments give markedly better results than others. Two instruments may give an equal amplification, but one may give more natural reproduction than the other. Alternatively, we may have two instruments between which there is little to choose as far as purity is concerned,

and yet one of which will give a quite definite and appreciably greater signal strength than the other. It is proposed in this series of articles to discuss in simple terms the multitude of factors which affect the design

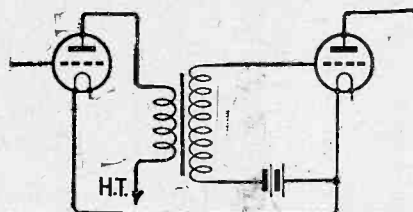

Fig. 1.—A typical low-frequency transformer circuit in its simplest form.

of a low-frequency intervalve transformer.

It is hoped that this will prove of service not only in appreciating the

by which improvements may be effected with existing patterns of transformer which may perhaps have been purchased at a time when the science was not so fully understood as it is to-day. Moreover, as will be seen later, naturalness of reproduction depends to no small extent on the personal factor, and an instrument can often be altered to suit different tastes.

## Fundamentals

Let us consider a low-frequency transformer circuit in its simplest form. In Fig. 1 we have a valve, the anode circuit of which carries the primary of a low-frequency transformer. One end of the secondary winding of this transformer is connected to the grid of the succeeding valve, and the other end to the filament through appropriate grid-bias, in order that the second valve may operate on a suitable part of its characteristic. This latter point is one of considerable importance, and must be assumed to be fulfilled throughout the whole of the discussion which is to follow.

The modern valve, designed for low-frequency work, is so arranged that when it is operating with a suitable transformer in its anode circuit, the variation of current produced in the anode circuit follows faithfully the variation of voltage applied to the grid circuit. In order that this may be the case two effects are necessary. In the first case the grid must never be allowed to become positive, for if this is done grid current will flow, and this immediately absorbs energy from the grid circuit and produces distortion. The second point is that the characteristic must be such as to permit a sufficient grid swing.

As the grid voltage is increased so the anode current increases and vice versa. We therefore have a limiting grid swing. The maximum positive grid voltage is that which, in association with the grid bias provided, (Continued on page 20.)

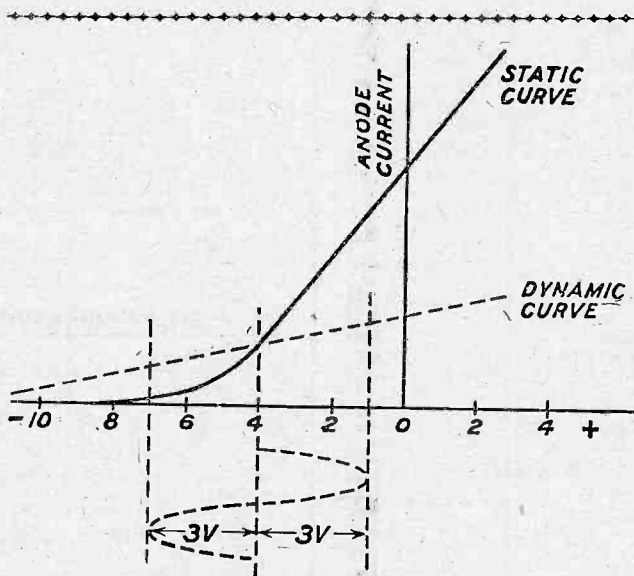



Fig. 2 (a).—This curve is suitable for a grid voltage swing which reaches a maximum of three volts in either direction.

connection between high-quality construction and satisfactory results, but arising out of the discussion of the subject, in indicating possible methods





**REDFERN'S**  
**Ebonart**  
NON-METALLIC SURFACE  
**RADIO PANELS**

are the accepted made-in-England high-grade radio panels with a beautiful surface, making the set de luxe. EBONART is ebonite—the finest; but not all ebonite is Ebonart, which is distinguished by its leak-free surface, brilliantly polished by non-metallic means. *Because of this it needs no scraping.*

3

TAKE no risk in buying the very foundation of your set. You buy your valves on a merited reputation. For the same reason insist on EBONART panels, on which the reputation of Redfern's is staked.

3

MACHINING and tooling qualities of EBONART ensure both ease and accuracy of construction work.

3

EVERY EBONART panel of standard size is sold in a carton, artistic in design, protecting the brilliant surface which is one distinguishing feature of this high-grade ebonite. EBONART is a trade mark, registered for your protection.

3

*Stocked by all reputable radio dealers in the 21 standard sizes in black and mahogany (polished surface) and in fine S.B. matt (black).  
Discriminating buyers of complete radio units always look for the Ebonart tag.*

WRITE FOR FOLDER A 262.

**REDFERN RUBBER WORKS, LTD.**  
HYDE, CHESHIRE.

*London: 75, NEWMAN STREET, W. 1.*

# Louden Valves



The Town Hall ROYTON

*"I have been running two Loudon Dull Emitters over 18 months . . . at a recent test . . . there was nothing to touch them."*

So writes Mr. O'Neill from Royton, and every post swells the number, now amounting to many thousands, of people who agree with his opinion. Loudon Valves cost less, they last longer, they consume less current, they are famous for "Silver Clear" reception, and they give greater volume. We could write you a treatise on the scientific reasons for all these qualities, but it's Results you want—not Reasons. Write to us for your Loudens to-night. This is Mr. O'Neill's letter:

*"Gentlemen,  
"It might interest you to know that I have been running two Loudon Dull Emitters for over 18 months and they were second-hand when I got them. They also are still going strong."  
"At a recent test of various valves there was none to touch them."  
"Please furnish me with a catalogue."  
"Yours sincerely,  
"W. O'NEILL (Royton, Nr. Oldham)."*

Louden Valves are made by British labour in a British factory with British capital and can be depended upon for the finest volume, range and silver clearness. They can only be offered at such low prices because of our well-known policy of selling direct to the public and cutting out the middleman's profit. The list below gives prices and full particulars. Order your Loudon Valves from us by post.

<p><b>4/6</b> Bright Emitters. L.F. Amplifier. F.1. H.F. Amplifier. F.2. Detector. F.3. <b>5.5 volts 0.4 amps.</b></p>	<p><b>8/-</b> Dull Emitters. L.F. Amplifier. L.E.R.1. H.F. Amplifier. L.E.R.2. Detector. L.E.R.3. <b>2 volts 0.2 amps.</b></p>	<p><b>8/-</b> Dull Emitters. L.F. Amplifier. F.E.R.1. H.F. Amplifier. F.E.R.2. Detector. F.E.R.3. <b>4 volts 0.1 amps.</b></p>
<p><b>9/-</b> Dull Emitters. L.F. Amplifier. F.E.R.1. H.F. Amplifier. F.E.R.2. Detector. F.E.R.3. <b>6 volts 0.1 amps.</b></p>	<p><b>11/-</b> D.E. Power Valves. Trans. Amplifiers P.E.R.1. Resist. Amplifiers P.E.R.2. <b>4 volts 0.2 amps.</b></p>	<p><b>12/-</b> D.E. Power Valves. Trans. Amplifiers P.E.R.1. Resist. Amplifiers P.E.R.2. <b>6 volts 0.2 amps.</b></p>

Postage and packing: 1 Valve, 4d. 2 or 3 Valves, 6d. 4, 5 or 6 Valves, 9d.

**FELLOWS, PARK ROYAL, N.W.10.**

*Branches:*

**WRITE FOR 48 pp. ILLUSTRATED CATALOGUE No. 34 FREE**

LONDON: 20, Store St., Tottenham Court Rd., W.C. (Museum 9200).  
BIRMINGHAM: 248, Corporation Street (Central 435).  
BRIGHTON: 31, Queen's Road (Brighton 899).  
CARDIFF: Dominions Arcade, Queen St. (Cardiff 7685).  
LEEDS: 65, Park Lane (Leeds 21479).  
NOTTINGHAM: 30, Bridlesmith Gate (Nottingham 5551).  
TONBRIDGE: 34, Quarry Hill (Tonbridge 172).

**BUY DIRECT AND SAVE MONEY**

# Secrets of the Low-Frequency Transformer—con. from page 18

makes the grid just positive, while the maximum in the opposite direction is that which takes the value down to the lower bend in its curve. If the available voltage range in between these two extremes is less than the signal applied, then we shall get distortion. This point will be clear from the diagram shown in Fig. 2a.

### Dynamic Curves

The actual operating or "dynamic" characteristic of a valve depends on the value of the impedance in the anode circuit. For each particular value of grid bias it is possible therefore to draw a dynamic characteristic. Let us assume that we have a voltage swing which reaches a maximum of three volts in either direction. In Fig. 2 (a) we have a characteristic which is ample to handle such a grid swing. In Fig. 2 (b), however, we have a case where the valve is not adequate for the purpose. We must utilise at least 3 volts grid bias in order to avoid running into grid current, and if we do so we find that we cannot obtain a swing of 3 volts in the opposite direction before the current drops to zero.

This point has been discussed in a fair amount of detail because it is one of paramount importance in the discussion of low-frequency amplifier design. With modern valves it is quite possible to handle a very large volume without running into grid current or "blasting," and we may, therefore, consider the valve as being a faithful reproducing device, the sole purpose of which is to produce an amplification of the signals.

### What We Need

Our problem, therefore, is how to make the fullest possible use of this amplification which is provided by the

practically entirely on this desirable end.

Now the difficulties to be encountered are enormous. The more the problem is examined the more impossible does its achievement appear to be. It has already been mentioned that the characteristics of the valve with which the transformer is associated depend upon the impedance in the anode circuit, and this has a definite effect upon the operation of the whole arrangement in that the amplification over the whole stage is dependent upon the impedance of the transformer primary.

### Variation of Impedance

Now the impedance of the primary winding of a transformer is not a constant property. It depends not only upon the resistance of the winding, but also upon the inductance. This latter property is a measure of the magnetic field produced by the winding, and it is indeed by virtue of this magnetic field that the energy is transferred to the secondary circuit. Unfortunately the effect produced in the anode circuit by the inductance of the transformer is dependent upon the frequency of the current flowing through it.

We are accustomed to speak of choke

an iron core, which tends to oppose the passage of varying currents, although it will have little effect on a direct current. Such choke coils are utilised, for instance, in smoothing out the ripple produced when the electric light mains are used for high-tension supply. They obtain their effect from the

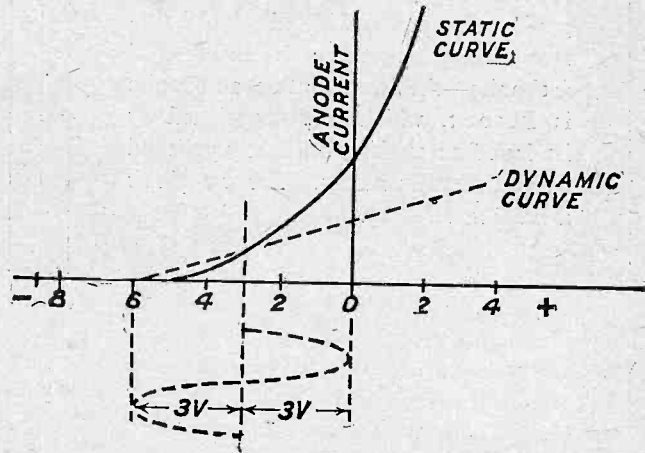

Fig. 2 (b).—At least three volts grid-bias is required in this example to avoid running into grid current, and if this is done, it is not possible to obtain a swing of three volts without distortion.

fact that they oppose any such change in the current, although they do not interfere with any steady flow of current through them. Without going into mathematics in the problem, it will be appreciated that the more rapid the change in current, the greater the choking effect. In other words, the greater the frequency, the more efficient does the choke become, always provided that other effects such as self-capacity do not come into play.

### Effect of Frequency

The primary winding of the transformer, therefore, acts as a choke coil in this manner, and its choking effect or impedance varies as the frequency. For very low frequencies its impedance is quite small, while for higher frequencies of the order of 3,000 or 4,000 its impedance rises to a very high value. Since the amplification of the previous valve depends upon the impedance in the anode circuit it will be clear that the overall amplification, therefore, will vary rapidly with the frequency, which is the exact opposite of the conditions of affairs required.

### The Remedy

To mitigate this disadvantage, therefore, it is necessary to design the transformer so that the primary winding has a high inductance. When the impedance of the anode circuit is about three times that of the valve

(Continued on page 33.)

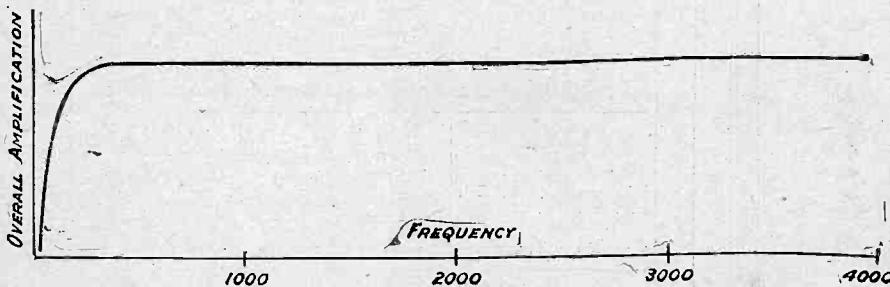

Fig. 3.—When a certain critical point is reached the curve of an L.F. transformer flattens out, and the amplification is practically uniform over the remaining range.

valve without introducing distortion into the circuit, and in order to achieve this result our intervalve coupling should be of such a nature that its response is the same at all frequencies. The research work of the transformer designer is concentrated

coils both in low-frequency and high-frequency circuits, and it should be remembered that the function of such coils is to prevent the passage of varying currents through them. A low-frequency choke is a coil having a large number of turns, often provided with



## SHORT-WAVE NOTES AND NEWS



THROUGHOUT last week all the "G" stations were to be heard working between midnight and 6 a.m. with very fine D.C. notes and rather weaker, but steadier, signals than usual. The explanation of this phenomenon was fairly simple—the T. and R. Section's Low-Power Tests were in progress. Members could be heard repeating five-letter code words and calling stations at distances that instantly branded them as confirmed optimists. Needless to say, much very fine work was done, and a notable feature of the tests was the way in which those who had good aerials scored over the others. A really good aerial makes much more difference to low-power work than it does to communications carried out with 500 watts at each end. The maximum power used in these tests was, of course, 5 watts. One well-known transmitter told the writer that his favourite song was "All Through the Night"!

### WIZ

WIZ has actually been heard in communication with other stations, instead of calling the eternal ABC. When the writer heard him he was working GLKY, the s.s. "Carinthia," and saying, in the usual "ham" manner, "Sri, gess n d o.m.!" Obviously an American amateur transmitter had got hold of the key. WIZ, by the way, continues to be a model of steadiness and purity of note. Most of the German commercial stations also leave very little to be desired in this way. Of our own stations,

however, the less said the better. At least two of them sound as if they are working on Ford coils, and a third is a passable imitation of an atmospheric.

### 2XAF

WGY'S transmission under the call

### SEND ALL YOUR QRA QUERIES TO US!

sign of 2XAF, on 32.79 metres, is becoming stronger almost nightly. More than one reader has been moved to write and comment on the obvious

least one person has received this transmission on a crystal and one or two note-magnifiers during the summer, so that it should be quite easy to repeat the feat now.

### Plug-in Coils

The use of standard plug-in coils for short-wave work appears to be on the increase, chiefly on account of the convenience of using one set for all wavelengths. The writer tested out one of these "universal" receivers against a special short-wave receiver a short time ago, and as regards signal-strength there was nothing to choose between them. As far as selectivity went, however, the short-wave set possibly gained a few points. There was certainly very little in it; not enough to justify the use of two separate sets in place of one.

### Short-wave Broadcasting

The possibility of a British broadcasting station on short waves is not so remote, as might be imagined. Such a station would serve the Dominions extremely well, and at the same time would not interfere to any great extent with the amateur enthusiasts in this country, since the "kilocycle accommodation" is so much greater on these waves.

### Expeditions Wanted

There is at present a great dearth of the Expeditions that used to liven up short-wave work. Last winter it seemed that every other day, an amateur in some country effected contact with an unknown expedition with a strange call-sign. This year there does not seem to be nearly so much excitement.

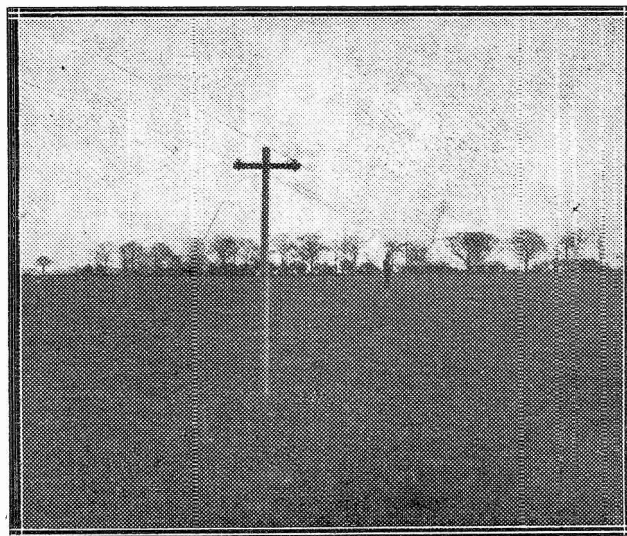

An unusual type of aerial (known as the "Beverage") which is used by B.B.C. engineers at Keston for receiving Hilversum and other long-wave stations, consists of two wires nine feet high and six hundred yards long.

veracity of those who affirm that they received him at loud-speaker strength on two valves, when they had previously been inclined to doubt it. At

# SELLING IN

Everywhere, people are buying S.T. v  
At the Manchester Wireless Ex  
enthusiasm, and some proof of t  
that they were used in an  
the broadcast music

BUY YOUR

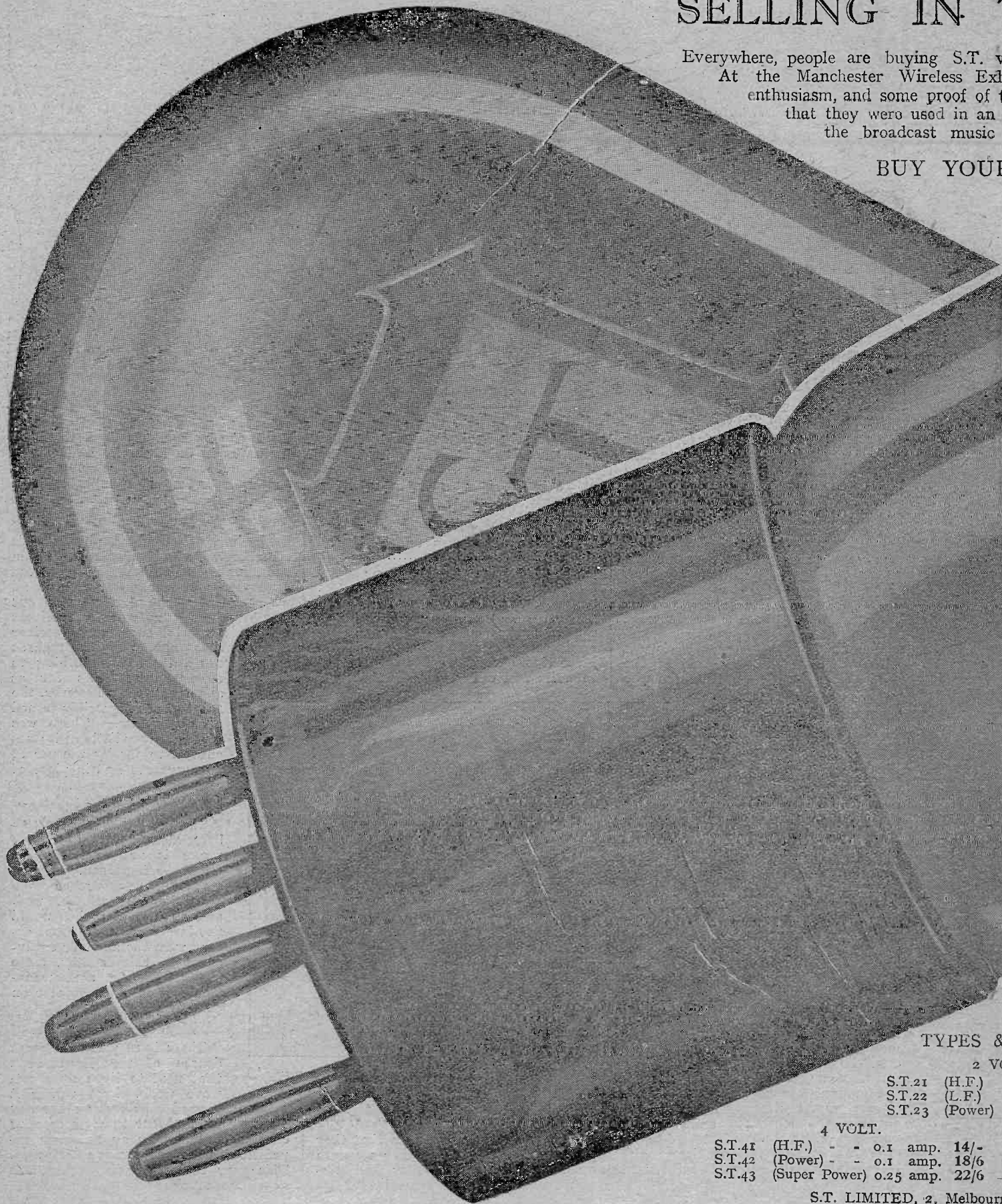

TYPES &

2 VOLT.

S.T.21 (H.F.)  
S.T.22 (L.F.)  
S.T.23 (Power)

4 VOLT.

S.T.41 (H.F.) - - 0.1 amp. 14/-  
S.T.42 (Power) - - 0.1 amp. 18/6  
S.T.43 (Super Power) 0.25 amp. 22/6

S.T. LIMITED, 2, Melbourn



# THOUSANDS!

valves and are delighted with them.  
hibition they were received with  
their efficiency lies in the fact  
official receiver supplying  
to the Exhibition.

RS NOW!

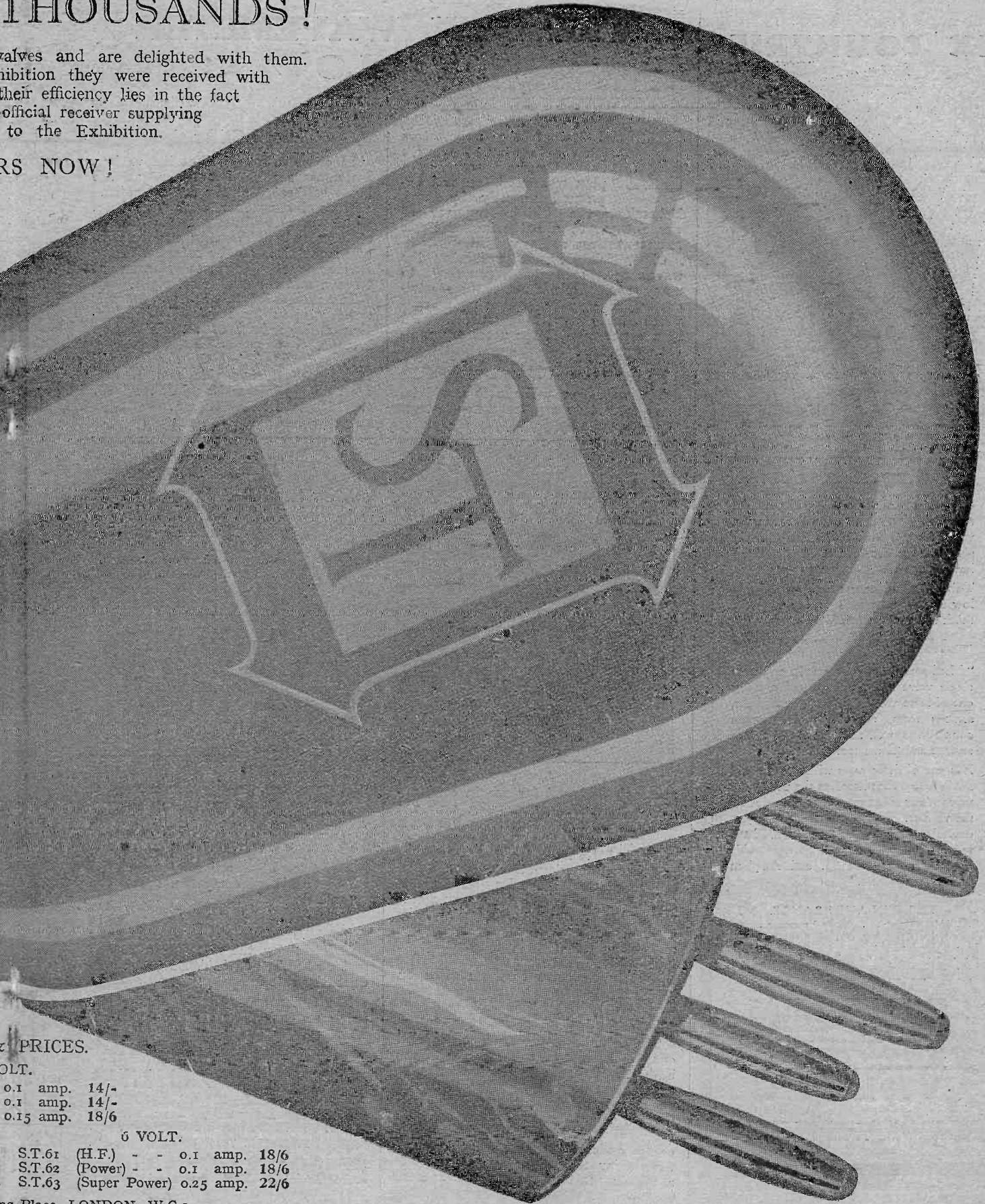

## PRICES.

OLT.

- 0.1 amp. 14/-
- 0.1 amp. 14/-
- 0.15 amp. 18/6

6 VOLT.

- S.T.61 (H.F.) - - 0.1 amp. 18/6
- S.T.62 (Power) - - 0.1 amp. 18/6
- S.T.63 (Super Power) 0.25 amp. 22/6

ne Place, LONDON, W.C.2.

# SIX COUNTRIES

## IN DAYLIGHT

We have received the following testimonial:—

"I do not know whether you know that this particular valve is the finest in the world for use in a reflex set, it easily gives double the volume of any other I have ever used.

This is due of course to the remarkably low impedance, which is the lowest I think of any valve made."

### —AND ON ONE VALVE

"I had some wonderful results on a new single valve reflex unit yesterday, using one of these valves, tuning in, in daylight, stations from six different European countries, as well as a number of British stations and 22 amateur transmitters.

It is one of those cases where one would not believe unless heard, as the use of this valve in any reflex set will at once double the volume. I may add that I am just over three miles from 2 Z.Y. and I have to detune to bring the volume reasonable on a large Brown H.Q. and Amplion Radiolux Speakers."

#### THE BENJAMIN RANGE.

S.P. 18 RED 14/- Fil. Volts 1.6 Amps .3  
 S.P. 18 GREEN 14/- Fil. Volts 1.6 Amps .3  
 S.P. 18 BLUE 14/- Fil. Volts 1.6 Amps .09  
 D.E. 55 18/6. Fil. Volts 5.5 Amps .09  
 S.P. 55 BLUE 18/6. Fil. Volts 5.5 Amps .09  
 S.P. 55 RED 22/6. Fil. Volts 5.5 Amps .25

# BENJAMIN SHORTPATH VALVES

THE BENJAMIN ELECTRIC LIMITED,  
 Brantwood Works, Tottenham, London, N.17.

# THE NEW WAVEMETER AT 2LO

**T**HE first of the wavemeters for use in connection with the Geneva wavelength plan was exhibited and explained recently by Capt. Eckersley, the Chief Engineer of the B.B.C., to a gathering of Press representatives at Savoy Hill.

Capt. Eckersley, in explaining the wavemeter, said that, contrary to many reports, it was not of the crystal-controlled variety, but simply consisted of the usual inductance shunted by a capacity with the necessary indicating devices.

### Small Ranges

The wave-, or perhaps it would be more correct to say frequency-meters,

### Central Calibration

In order to ensure that the various instruments shall not differ, all are being calibrated at one central point.

With instruments such as these, which can be used for checking stations on neighbouring wavelengths, any complaints can be referred to the International Broadcast Bureau at Geneva and the matter set right.

The success of this scheme depends entirely upon the spirit of co-ordination and goodwill of all stations in Europe.

It is expected that the changes will take place during this month, and according to information just received, the 14th is the day chosen.



Representatives of the Press inspecting the new wavemeter, which has just arrived for use at the London station. Captain Eckersley, Chief Engineer of the B.B.C., is fourth from the left.

are each designed for use in conjunction with one station only, and the range covered is 20 k.c. Thus London's new wavemeter, the central reading of which is 361.4 metres or 830,000 cycles, can record any deviation up to 840,000 or down to 820,000 cycles.

Each station will have its own wavemeter permanently secured near the transmitter, explained Capt. Eckersley, and in addition to the checking of their own position stations will be able to check the wave of the station on either side.

### The Indicators

The actual measurements are carried out by means of a small flash-lamp bulb, or, where a greater degree of accuracy is desired, by a device known as a "thermo-couple" which acts upon a galvanometer. The setting on the wavemeter at which the lamp glows corresponds to the frequency at which the station is transmitting, thus it is a simple matter to keep to a fixed wavelength.

## NEWS IN ADVERTISEMENTS

Messrs. County Electrical and Wireless Stores, Ltd., are announcing the complete kit of components for the Monodial Receiver.

Readers are invited to apply to Dept. W.5, Messrs. Hart Accumulator Co., Ltd., for the full details of the series of H.T. and L.T. Batteries produced by this company.

The full range of their products is being advertised by Messrs. Neutron, Ltd.

## GLASS JARS AND ZINGS FOR MAKING WET H.T. BATTERY.

PARTICULARS AND SAMPLES — 3d. STAMPS. FINISH WITH WORRY AND EXPENSE OF DRY H.T. PAPER DIAPHRAGM TYPE SPEAKER PARTS.

**SPENCERS STORES LTD.**  
 4/5, MASON'S AVENUE, COLEMAN STREET,  
 Phone: London Wall 2292. LOTHBURY, E.C.2. (nr. Bank)





## Your Transformer must be right!

**Y**OUR valves may be of the right impedance, your condensers low in loss, your plate voltage right, but if you have a poor transformer you *must* have distortion, poor volume, and worse reproduction.

Put an Ericsson Tested Transformer on your baseboard and the difference will astonish you. Distortion disappears, volume swells and clarity and purity takes the place of discordant muffling and harshness.

Ericsson Tested Transformers are designed along careful tone value lines and are guaranteed distortion free. Replace your present Transformers with Ericsson Tested—you'll transform your set.

Two ratios, one price. 1:2, 1:4

# 17/6

On Sale at all good dealers.  
Write to-day for full particulars.

ERICSSON TELEPHONES LTD.,  
67/73, Kingsway, London, W.C.2.

**Ericsson**  
TESTED  
TRANSFORMERS

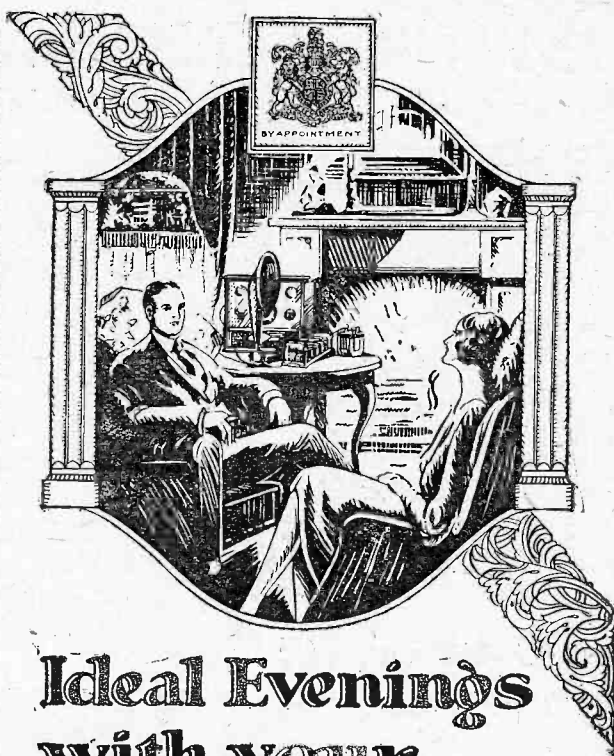

## Ideal Evenings with your Wireless Set

**F**OR real wireless enjoyment—purity of reproduction, freedom from distortion and ample volume of tone are, of course, essential.

Use "HART" BATTERIES with your set for both Low and High Tension supply and "wireless" will reveal new charms to you; their steady voltage, low resistance and exceptional reserve of power ensuring reception at its best.

Discard your dry batteries to-day and substitute the "HART" "RAY" type of High Tension Accumulator (20 volts 14/8, 30 volts 22/-, 60 volts 44/-). The marked improvement in reception will certainly surprise you.

# HART

THE BATTERY OF QUALITY

There are models of "HART" Batteries for all Low and High Tension Circuits. Write to Dept. "W.5" to-day for illustrated lists and full particulars.

HART ACCUMULATOR CO., LTD.,  
STRATFORD, LONDON, E.15

# S.T. VALVES GET 51 STATIONS ON THE MONODIAL

(See WIRELESS, October 30th and November 6th)

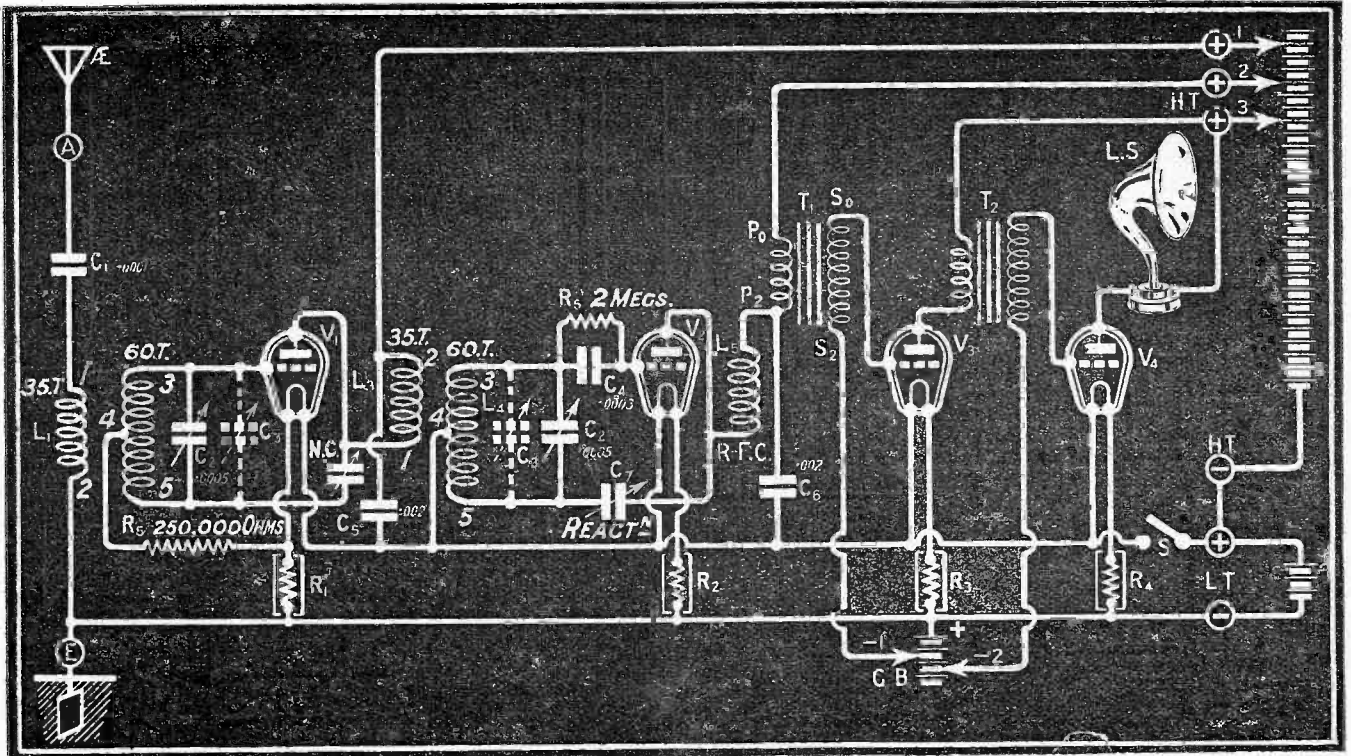

S.T. 21 (1st & 2nd valves).

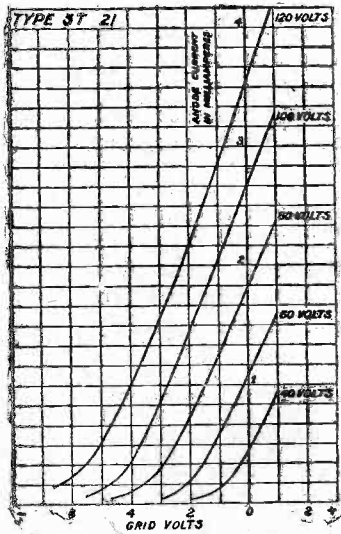

S.T. 21  
H.F.

Filament 1.8 volts.  
0.1 amp.  
Anode 40-120 volts.  
Impedance 26,000 ohms.  
Amplification 16.

An excellent valve for H.F. amplification and resistance capacity coupling. It is also to be recommended as a detector valve.

Price 14/-

S.T. 22 (3rd valve).

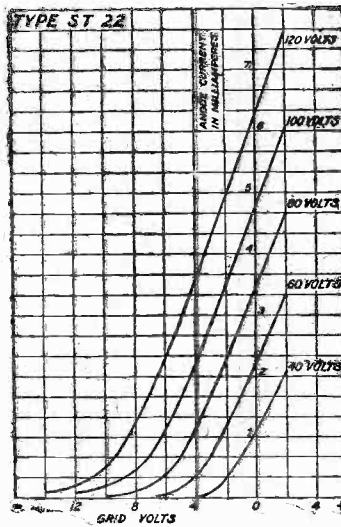

S.T. 22  
L.F.

Filament 1.8 volts.  
0.1 amp.  
Anode 40-120 volts.  
Impedance 16,000 ohms.  
Amplification 10.

This valve is for the first stage of a low frequency amplifier and will give undistorted reproduction. It may also be used for H.F. amplification, especially in neutrodyne circuits, and for detection.

Price 14/-

S.T. 23 (last valve).

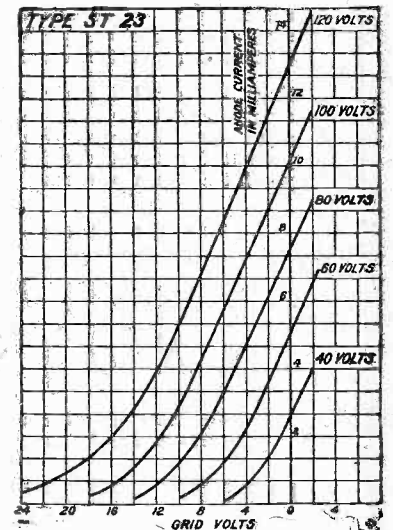

S.T. 23  
POWER

Filament 1.8 volts.  
0.15 amp.  
Anode 80-120 volts.  
Impedance 6,000 ohms.  
Amplification 6.

A magnificent 2 volt. power valve giving superb reproduction when used as the last valve of a set when a loudspeaker is employed. Note its low impedance and the high amplification factor for such a valve.

Price 18/6

Adv. of S. T. Ltd., 2, Melbourne Place, W.C.2.



## Inventions and Developments



**A** PATENT which is of interest principally on account of the possibilities which it suggests is that taken out by the Société d'Etudes pour Liaisons, Telephoniques et Telegraphiques (251,588). It relates to the suppression of certain frequencies or bands of frequencies in a valve amplifier.

### Feed-back Effects

It is well known that the inherent capacity between the anode and grid of a valve produces a feed-back of energy, which may be either positive or negative in character, either producing a tendency to oscillate, or else introducing extra damping into the circuit. In the normal form of amplifier the reaction is positive, and steps have to be taken to check the tendency to oscillation by some suitable means.

### Phase Relations

The question of the sign of the regeneration (i.e., whether the feed-back is positive or negative), depends on the phase of the currents in the various circuits. The currents flowing from anode to grid

of the valve itself, through the inter-electrode capacity, need not pulsate in unison with those in the tuned circuits of the receiver. They may quite conceivably be out of step, or out of phase, as it is called.

For example, we can have two men walking side by side, and both taking equal steps at the same rate, but they can, nevertheless, be out of step. Similarly, we can have currents in different circuits of a valve amplifier out of phase with each other.

If the feed-back current is in phase with the current in the grid circuits, then positive reaction is obtained. If the feed-back is directly opposite in phase we obtain a damping effect. In between the two extremes we have a neutral position, at which no effect is produced.

### The Essential Feature

In the invention in question an additional circuit is connected between the anode and grid, in parallel with the internal capacity. By a suitable

choice of this "network" it is possible to control the phase of the feed-back current so that the reaction effect is either positive, negative, or zero.

With a simple circuit this control is dependent on the frequency. It is possible to arrange for a heavy damping effect to come into play at a certain point so that an almost complete suppression of a given frequency is obtained.

### Possibilities

By the employment of more complex networks, however, similar to band filters, it would be possible to arrange for a circuit to remain stable over the whole working range. It is even conceivable that by some such method a correction could be introduced to allow for the increasing liveliness of the average receiver towards the bottom of the scale.

An aspect of the question which is probably worth investigating is the application to low-frequency work, where the suppression of certain frequencies may be desirable. Possibly also the suppression of certain bands of frequency might assist in the reduction of the effect produced by atmospheric disturbances.

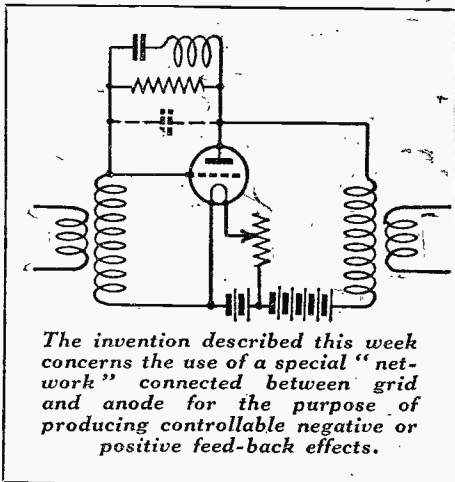

### LATE NEWS

The new B.B.C. wavelengths will come into operation, we are informed, on November 14 and are as follows:—

- Aberdeen and Birmingham, 491.8 metres.
- Glasgow, 405.4 metres.
- Belfast, 326.1 metres.
- London, 361.4 metres.
- Newcastle, 312.5 metres.
- Manchester, 384.6 metres.
- Bournemouth, 306.1 metres.
- Cardiff, 353 metres.
- Leeds, 297 metres.
- Bradford, 294.1 metres.
- Other relays, 288.5 metres.

Listeners are asked not to send in criticisms until the scheme has been in operation for a fortnight or more.

Ashley  
Radio

## JACKS

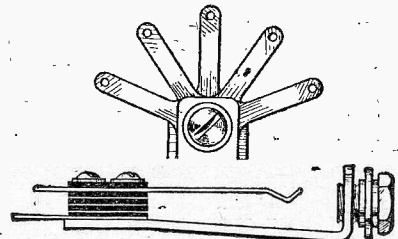

—are made of nickel silver springs, with pure silver contact, and Bakelite insulation throughout. Tags are tinned and spread fan-wise for easy soldering.

JACK No. 1 Single Circuit (open) <b>1/3</b>	JACK No. 2 Single Circuit (closed) <b>1/6</b>
JACK No. 3 Double Circuit <b>1/9</b>	JACK No. 4 Filament Single Control <b>1/9</b>
JACK No. 5 Filament Double Control <b>2/3</b>	

TELEPHONE PLUG, 1/6

### CLARITONE LOUD SPEAKERS

Senior Model, 2,000 ohms, } £5 0 0  
W.265, 120 ohms, W.266 }  
Junior Model, 2,000 ohms, } £2 15 0  
W.267, 120 ohms, W.268 }

### CLARITONE HEADPHONES

W.216 ... 20/-

### ASHLEY WIRELESS TELEPHONE CO., LTD.

17, Finch Place,  
London Road,  
LIVERPOOL



Pat. No. 256833  
Pro. Pat. No. 20339



The Grid Leak is not discernible, being totally enclosed in Bakelite Valve Holder Base.

## Something new and good in component design

The latest LOTUS triumph is a Combination Grid Leak and Valve Holder which eliminates unnecessary wiring and soldering and makes for economy in cost and space.

Guaranteed efficient in construction and design.

From all Radio Dealers

- Combination Grid Leak and Terminal Valve Holder . . . . . 3/9
- Terminal Valve Holder . . . . . 2/6
- Valve Holder without Terminals . . . . . 2/3

All Anti-Microphonic Type.

# LOTUS

Combination

GRID LEAK AND BUOYANCY VALVE HOLDER  
Anti-Microphonic

Garnett, Whiteley & Co., Ltd.  
Lotus Works, Broadgreen Road, Liverpool.

Makers of the famous "Lotus" Vernier Coil Holders

## ACCUMULATOR CHARGING SETS

for Home Service  
NO TECHNICAL KNOWLEDGE OR ATTENTION REQUIRED.

CLEAN, ECONOMICAL, SIMPLE AND EFFICIENT.

Simply plug-in to any Convenient Lampholder. Supplied complete with Adaptor, Flexible Cords and full instructions.

The "ALTERNO." (As illustrated.)

Alternating Current.

Charges the High Tension Accumulator at negligible cost. Price 21/-

The "INDISPENSO." Direct Current.

Charges the High Tension Accumulator at no extra cost when light is in use. Price 6/-

GOLSTONE "PENDLETON." Patent App.

Alternating Current.

Charges the Low Tension 2, 4 or 6 volt Accumulator economically and effectively. No Valves or renewals. Charging Rate approx. 2 Amps. Price £2:12:6

Fitted with Ammeter for ascertaining rate of charge. Price £3:7:6

Please state voltage and frequency of Lighting Mains when ordering.

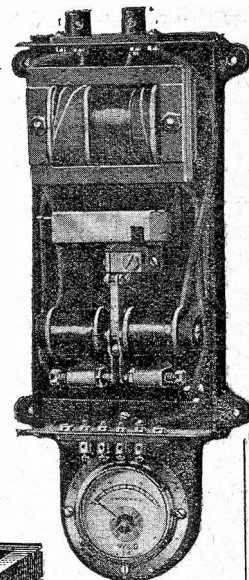

"PENDLETON" CHARGER with Cover Removed.

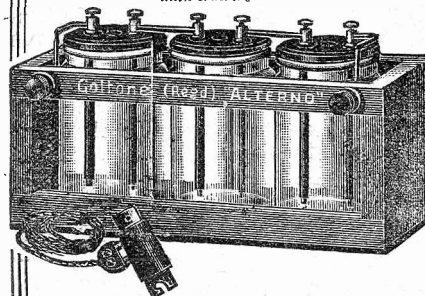

Large fully illustrated Radio Catalogue, No. E/116, on request. Dealers should enclose Business Card for Trade Terms. "Golstone" Products are stocked by the Leading Stores. Refuse substitutes.

J.W.D., Ormskirk Road, Aintree, writes: "I bought an 'Alterno' and was surprised at the results. I think it the most wonderful and simple arrangement I ever saw for so little money."

**Ward & Goldstone**  
PENDLETON. MANCHESTER

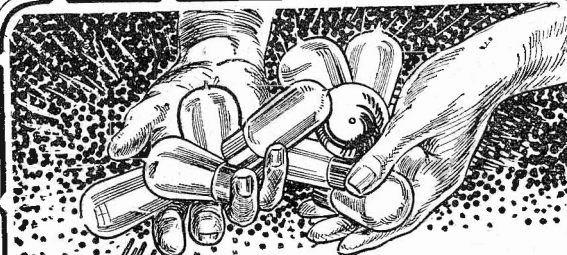

### THE BEST DULL EMITTER MONEY CAN BUY.

Frelat D.E. Valves cost only 4s. 11d. for Detector or Amplifier and they are costed low so that they meet the need of millions in purse and performance. A new addition to the range is the 2-volt power Valve at 8s. 6d., which ensures results that cannot be excelled.

Valves will be sent C.O.D. Type "K" 5/3 post free "D.K.P." 8/10 (New 2-volt power Valve)

4/11 Type K—2 volt .3 amp. 4/11

If your Dealer cannot supply, write to the: CONTINENTAL RADIO IMPORT CO., LTD., SPITAL SQUARE, LONDON, E.1

Frelat



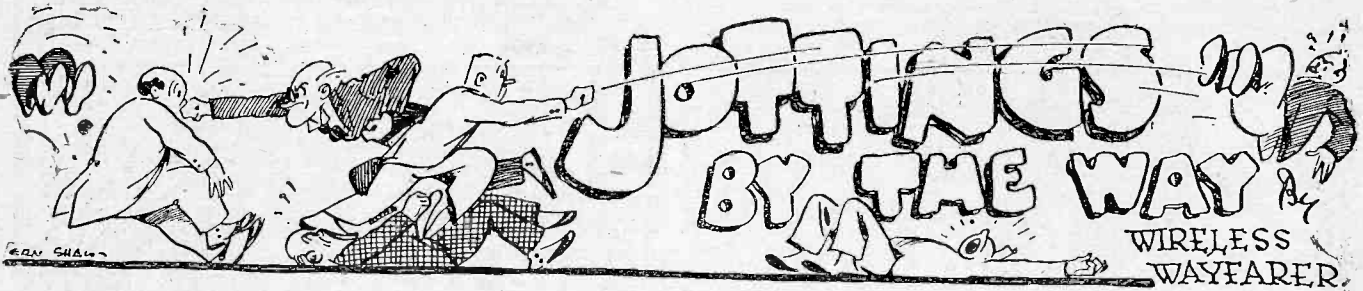

I AM afraid I am a little late," said the General cheerily as he ran into the wireless club the other night. "The fact is I was half the afternoon trying to find why my new set would not work, and I only discovered ten minutes ago that I had forgotten to switch on. Well, as everybody seems to be here let us open the meeting without further delay." We all moved to the table to take our seats. The General sank into his chair with a sigh and a loud pop, only to leap immediately ceiling-wards, the sigh turning into a queer gurgling noise which was apparently an expression of mingled pain and despair. "Encore, encore!" I cried, banging the table like anything. "There is nobody like our chairman for brightening up dull meetings. Encore! Bravo!! Bis!!!"

**Misunderstood**

The General flung me one soul-searing glance and proceeded to turn the fragments of a defunct valve out of his coat-tail pocket into the wastepaper basket. Meantime Poddleby, who is always minding somebody else's business, asked me in a nasty, sneering kind of way to be good enough to behave myself. "Oh, shut up!" I said, "I thought that the General was doing a little comic turn and naturally I applauded." "Your manners," remarked Snaggsby, butting in as usual,

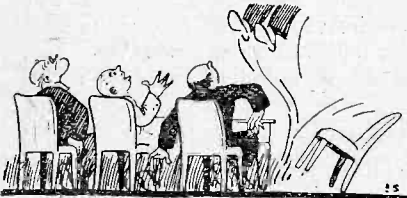

"... Only to leap immediately ceiling-wards ..."

"are simply beyond words." "Then why use words about them," I inquired sweetly. "Because ..." Snaggsby began. "Of all the ...!" shouted Poddleby. They got no further, for if there is one thing I cannot stand it is a display of ill-breeding of this kind. Poddleby was on my right, Snaggsby on my left. Rising suddenly from my chair I seized each

of them by the scruff of his neck and banged their faces together.

**The Fat in the Fire**

"Order!" called the General, looking round from the wastepaper basket. "Order! Order!" shouted Admiral Whiskerton Cuttle, digging his elbow

**A disorderly meeting of the Little Puddleton Wireless Club, followed by a very practical lecture.**

hard into Poddleby's ribs. "Behave, behave," chirped Bumbleby-Brown, applying his elbow to Snaggsby. Some people seem to have no control of themselves. Poddleby simply flew at Admiral Whiskerton Cuttle, whilst Snaggsby turned round and delivered an exceedingly neat left hook on Bumbleby-Brown's third waistcoat button. As Poddleby took the Admiral by surprise he thrust him rather hard against Gubbworthy, nearly knocking him off his chair. Gubbworthy naturally retaliated, but in turning round to do so he trod on Dippleswade's toe. In endeavouring to move his feet to a safe place Dippleswade kicked the Editor of the Gazette hard upon the shins, which caused him to start so violently that he upset an inkpot over Breadsnapp's waistcoat.

**Hostilities Spread**

Leaping to his feet Breadsnapp sent a shower of ink all over Professor Goop, who, in a flash, removed one of his elastic-sided boots and smote him with it shrewdly over the head. Unfortunately, the boot slipped from the Professor's grasp, cannoned off Breadsnapp's head and made a bee-line for Winklesworth's left eye. By this time the train of oscillations had travelled right round the table, for Winklesworth, always a bad shot with a boot, missed the Professor clean, but caught Bumbleby-Brown squarely on the brisケット. Seldom have I witnessed such a disgraceful scene. As the only two non-combatants, the General and I endeavoured to restore order, but the battle raged for a considerable time, lasting, in fact, until everyone was too exhausted to continue.

**A Point of Order**

"And now," I said, when at last they had desisted from their efforts of annihilating one another, "and now that this exhibition of brotherly love is con-

cluded perhaps we can get on with the meeting." The General, first feeling carefully in his other coat-tail pocket, again took the chair, and at last we got down to real business. What would happen to the club if I were not there to keep them in order I shuddered to think. "I would like ... " said the chairman. "I rise to a point of order," said Professor Goop. "Has anybody seen my boot?" The boot was at this moment brought in by young Edward Bugsnip, who had found it in the High Street, whither it had travelled through one of the windows which was not open at the time. The Professor put it absently into his pocket, and the General continued. "I would like," quoth he, "to say that it is high time that the club had an increase in its membership. There are, I know, quite a number of Little Puddletonians who are not members, though they possess wireless sets. An intensive campaign is indicated. Has any member any suggestions to offer?"

**A Brain-wave**

When one or two of the others had given vent to their usual tosh I rose to my feet, but was immediately forced to sit down again by my neighbours, both of whom had some stupid remarks to get off their chests. At the conclusion of these I rose once more, and this time I was not interrupted. "It seems to me," I said, "that what we must do is to get some eminent man down to give a lecture; that we must



"... Through one of the windows which was not open ..."

thoroughly advertise his coming, and that we must invite every Little Puddletonian to attend whether he is a member or not. They will come in their thousands. They will be thrilled. They will enroll as one man. I will stand at the door and collect their subscriptions as they go out." Though my suggestion was accepted with

(Continued on page 31.)

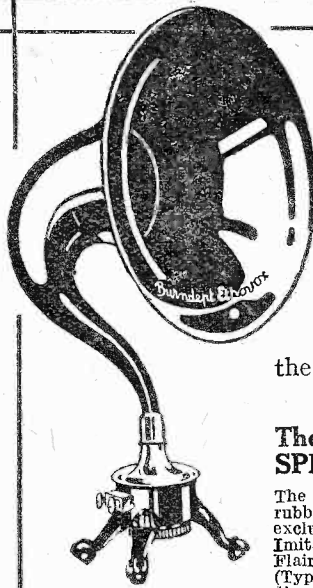

## The Public and the Trade alike acclaim "The ETHOVOX" LOUD-SPEAKERS

They say the results are simply amazing and that our claims have been too modest. They write us to this effect. Have you heard broadcast via the "Ethovox." It has to be heard to be believed. Ask your local dealer.

### The "ETHOVOX" LOUD-SPEAKER with Metal Horn.

The standard full-size "Ethovox," with rubber-covered feet. Finished in Burndept exclusive dust-proof rich mahogany colour. Imitated but unequalled. Height 26 ins. Flair diam. 15 ins. No. 963 "Ethovox" (Type 750), with Metal Horn; for use direct in the plate circuit. Price **£4:10:0**

### The "ETHOVOX" LOUD-SPEAKER with Mahogany Horn

Similar to above, but the flair is of dark coloured polished mahogany and constructed by a special process which gives it great strength and is particularly neat in appearance. No vibration is possible. No. 966 "Ethovox" (Type 750), with Mahogany Horn; for use **£5:5:0** direct in the plate circuit. Price

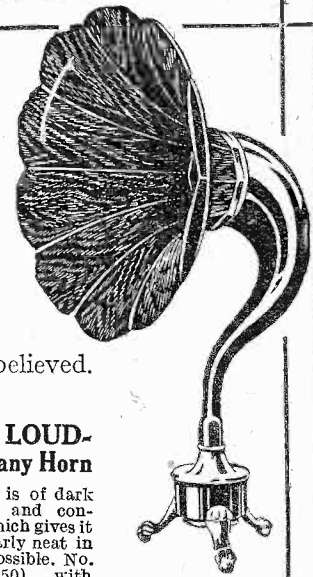

Also a "Junior" Model at £2-2-0

**BURNDEPT**

WIRELESS UNIT

Head Office and Factory:  
BLACKHEATH, LONDON, S.E.3.  
Telephone: Lee Green 2100.  
'Grams: Burndept, Phone, London.  
London Office & Showrooms:  
15, BEDFORD ST., STRAND, W.C.2.  
Telephone: Gerrard 9072.  
'Grams: Burndept, Strand, London.  
Agents and Branches everywhere.

National Wireless Week—Nov. 7-13.  
"Let your friends listen."

RH

# THIS IS THE VERNI-NOB!

PRICE  
**6d.**

The Verni-Nob does all the work of a Vernier attachment or Vernier dial and increases the selectivity of your set.

Positive drive—No back-lash, 10 to 1 reduction with 3" dial, 16 to 1 reduction with 4" dial.

Over 8,000 were sold during the Wireless Exhibition at Olympia!

From all dealers.  
By post 7½d.

Fitted in a few moments.

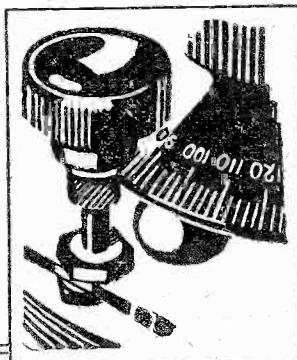

THE  
**M·A·P**  
Company  
246, Great Lister Street,  
BIRMINGHAM

## REDUCED PRICES of LEWCOS Inductance Coils

Coil No.	25	35	40	50	60	75	100	150	200	250	300
Old Price	4/6	4/6	4/6	5/-	5/6	5/6	6/9	7/6	8/6	9/-	10/-
NEW PRICE	4/-	4/-	4/-	4/6	4/9	4/9	5/9	6/3	6/9	7/-	7/6

INCREASED DEMAND and new methods of production have made it possible to lower the cost of manufacturing LEWCOS Coils. We have decided to give the public the benefit of this saving immediately.

All enquiries for LEWCOS Radio Products should be made to your local dealer. Descriptive leaflet gladly sent on request to:

The  
**LONDON ELECTRIC WIRE COMPANY & SMITHS, LTD.**  
Playhouse Yard, Golden Lane, London, E.C.1



## Jottings by the Way—continued from page 29

acclamation, it was for some reason decided that the collection of subscriptions should be entrusted to someone with more time on his hands.

### Without a Doubt

The question now arose as to which eminent man should be invited to Little Puddleton. On this point I explained to the assembly there could be no manner of doubt. Positively the only man was Professor S. O.

High, the eminent expert in every subject under the sun. Professor High's name is practically a household word. If a walrus arrives in the Thames, Professor High is promptly interviewed by representatives of the entire popular Press, to whom he demonstrates his idea for harpooning walruses from aeroplanes. If somebody invents a new wireless circuit, Professor High is again interviewed and explains exactly why his own is so very much better.

It was Professor High who invented, as I announced exclusively some time ago, a self-rocking cradle with three speeds forward and reverse and a silencer; Professor High has recently described in several acres of print how he makes his alarm clock remove the bedclothes at the right moment by operating a relay, whilst another relay sees to the provision of his early morning tea; it was Professor High who solved the problem of squeaking boots by producing his soleless footwear, and is it not Professor High who keeps on assuring us that wireless is still in its infancy? Need I say more?

### The Subject

My suggestion was agreed to with acclamation, Poddleby being instructed to write forthwith a letter of invitation to Professor High. The Professor accepted by return of post, stating that he would be happy to lecture upon either Paraphlogistic Submodulation, in Brachycymatic Oscillators, or the Ideal Diet for D.X. Enthusiasts. We chose the former subject. Nobody had the slightest idea what it meant, so we all looked wise and pretended that it was just *the* point upon which we had been desiring information for years.

I was fearfully enthusiastic about it, for I suffer at times tortures from day-time and early evening insomnia, and I felt that I should be able to make up for at least a couple of hours of lost sleep. It was arranged that the lecture should take place upon the following Saturday, and since I was

the most presentable of the club's members, being the only one, with the exception of the General, who had escaped unscathed from the scandalous *mêlée* which took place at the meeting at which the suggestion was first made, I was deputed to go to the station to meet the Professor as the club's representative.

### The Arrival

On the great evening I was conveyed

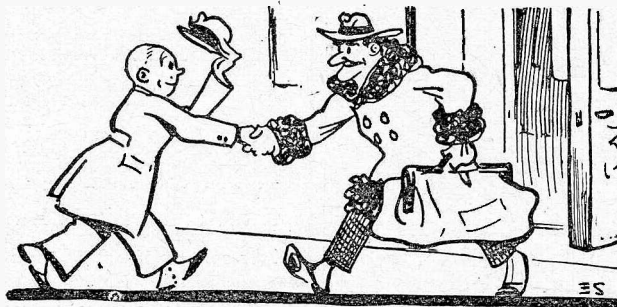

“ . . . Good evening, Professor . . . ”

in state to the station in the *Gazette's* Lizzie, driven by the sub-editor-compositor-reporter-office-boy-chauffeur. As the train came to a standstill a tall figure clad in a fur coat and carrying a gigantic bag stepped from a carriage. “Good-evening, Professor,” I said, advancing and holding out my hand. “I have been deputed by the club to welcome you to Little Puddleton.” “Very kind, I am sure,” answered the Professor, “but I was 'ardly expectin' . . .” “Not a word, not a word, I beg you,” cried I, “you must rest

once. Rising to his feet, he remarked that he would not keep the audience from the feast in store for them by making a speech, and sat down, bowing to the Professor.

### The Demonstration

“Friends,” said the Professor, beaming on his audience, “I scarcely expected to 'ave such a welcome as this on the hoccasion of my first visit to Little Puddleton. (Loud and prolonged applause.) Bein' a man of few words, I would like to give you a himmediate demonstration. Will any gentleman kindly step up on to the platform? Or perhaps the chairman 'ere will kindly hobble.” Here he stooped down, opened his bag, and took something from it. Moving over to the smiling General, he pressed his head backwards and opened his mouth. His right hand moved so quickly that no eye could follow it.

Next instant the General was stamping round the platform screaming and holding his hand to his face whilst the Professor was displaying to the enraptured audience a gigantic tooth gripped in a pair of forceps. “Instantaneous and completely painless,” he bawled. “You 'ave now seen what Professor Bungo can do for any man, woman or child in this 'ere audience as is sufferin' from a haching tooth.” At this moment a telegraph boy elbowed his way through the throng and handed an orange-coloured envelope to Poddleby. Glancing over his shoulder, I read:—

“Very much regret laid up by sudden attack of influenza.—HIGH.”

It struck me suddenly that I had forgotten to lock the pantry window in my house. I think I can claim on that evening to have broken all records for the distance between the clubhouse and my own. Several people seemed to be inquiring for me, but I could see no point in remaining. After all, I had done my job by meeting the Professor, and the meeting itself was no affair of mine.

WIRELESS WAYFARER.

### A Correction

We are asked by Messrs. S.T. Valves, Ltd., to draw our readers' attention to the fact that a printer's error occurred in their advertisement on page 439. The figures “0.2 to 0.35 amp.” should read “0.2 to 0.25 amp.”

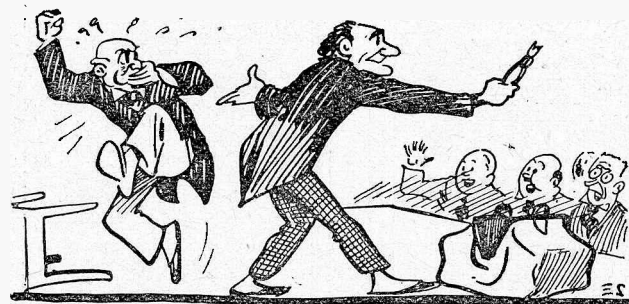

“ . . . The General was stamping round the platform . . . ”

your voice, so that you may be in your very best form.” As we were a little late, I ran him along the platform and through the doors into the *Lizzie*, which, after a succession of back-fires, rattled off to the clubhouse. The meeting was packed to the doors; in fact, I had quite a business to force a way for the Professor to the platform. When I had introduced him to the General, the chairman said that the proceedings might as well start at



*You will—*  
when you buy  
**NEUTRON**  
**PRODUCTS**

NEUTRON PRODUCTS are constructed with but one purpose in mind—to give to the user really dependable and lasting service.

NEUTRON VALVES will make a decided improvement in your reception—they are built to give greater volume realistic reproduction of voice and music and to ELIMINATE VIBRATION AND OTHER CONDITIONS THAT IMPAIR RECEPTION. They are positively NON-MICROPHONIC.

Knowing how much vibration impairs the tone quality of reception, enthusiasts everywhere are equipping their sets with Neutron valves. Fit Neutron valves to your set and note the surprising softness and fullness of tone of reception that follows the elimination of vibration.

<i>RED SPOT.</i>	<b>12/6</b>	<i>GREEN SPOT.</i>
H.F. and Detector.	<b>EACH</b>	V.L.F.
4 volt .06 amps.		4 volt .06 amps.
2 volt 0.2 amps.		2 volt 0.2 amps.

**NEUTRON PERMANENT DETECTORS**  
Each Detector is tested on actual Broadcast 130 miles from 5XX  
DE LUXE 5/6; CRYSTASTAT 4/6; PANECTOR 3/5

**NEUTRON**  
H.T. Battery  
Full 60 volt  
**10s. 6d.**

**NEUTRON**  
4.5 volt  
Battery  
Suitable for H.T.  
**5d. each.**

*Advt. of Neutron, Ltd., London.*

**NEUTRON CRYSTAL**  
*The powers of this wonderful crystal are known the world over—no better crystal is or has been made. Of all Radio dealers. Complete with cat's whisker. Price*

**1/6**



Sole Distributors for U.K. and Ireland—  
Neutron Distributors, 144, Theobald's Rd., London, W.C.1.  
All Export enquiries for Continent and Australasia to—  
Fettigrow and Merriman (1925), Ltd.,  
2 and 4, Buckle Street, London.

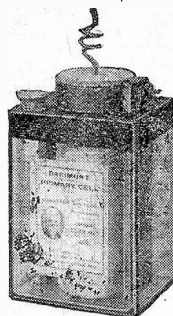

**Comfort**

**DO YOU KNOW HOW**

you can enjoy your Wireless this winter without the discomfort of carrying heavy accumulators to be charged?

If you use Dull Emitter Valves we can show you how to charge and recharge the

**DARIMONT**  
**"HOME-SERVICE"**  
**BATTERY**

in ten minutes without any electrical connections, and without leaving your home.

*The cost—quite moderate The current—quite steady*

*ASK YOUR DEALER for particulars of this comfort service, or write for a copy of our Valve Guide and Service Chart to Dept. C,*

**Darimont Electric Batteries Ltd.**

ABBEY ROAD, PARK ROYAL, LONDON, N.W.10

Telephone: Wembley 2807.

**The "BULLPHONE" Nightingale**

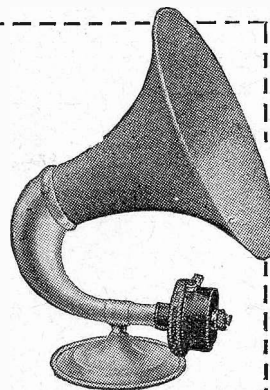

**Will not overload**  
**from 2 to 10 valves**

**ACCLAIMED THE WONDER**  
**SPEAKER OF THE WORLD**

The pure rich tone of the Bullphone is true to its name—the "Nightingale."

**5/-** deposit and  
**12 monthly**  
**payments of**  
**5/- or 60/-**  
**cash.**

**CLEAR TONE**  
**GREAT VOLUME**

*Specification.*

Height 21 ins. Bell Mouth 14 ins. Nickel Arm and Stand. Black crystal bell head, as photo. Also de luxe model, mahogany finish bell, same size, 65/- cash or 10/- deposit. List free.

Individually tested and guaranteed to be superior to any other Loud Speaker, regardless of price, for finish, purity and strength of tone and value. Cash Price 60/-, post free United Kingdom.

*Apply through your local dealer or send direct to us. Deposit returned if not highly satisfactory.*

**W. BULLEN**  
*(Dept. W3.)*

**38, HOLYWELL LANE,**  
**LONDON — E.C. 2.**



**SECRETS OF  
THE LOW-FREQUENCY  
TRANSFORMER**

(Continued from page 20)

itself, the amplification obtained from the valve is very nearly equal to that expected from the voltage amplification factor as determined by the characteristics. Any further increase in the impedance beyond this value therefore does not produce any appreciable increase in the amplification obtained over the whole stage.

The obvious method of combating the difficulty which has just been stated, therefore, is to arrange the inductance of the transformer so that its impedance is two or three times that of the valve at a very low frequency. This means that the amplification over the whole stage above this point should remain practically constant, although below his critical frequency it will fall away somewhat rapidly.

**Modern Practice**

Now with a good modern transformer it is possible to arrange that this critical frequency is reached somewhere in the neighbourhood of 200 cycles per second. Since the upper limit of the frequency which has to be handled in the transmission of ordinary speech or music is in the neighbourhood of 4,000 to 6,000, this would appear to be a low frequency. On the other hand, one has only to remember that middle C on the piano corresponds to a frequency of only 256 vibrations per second to realise that the whole of the bass tones in music fall below 200 cycles per second, and that even with the arrangement thus described we amplify these tones to a less extent than the rest of the music. While this will not produce any distortion as such, it will result in a loss of naturalness, and the transformer designer is continually endeavouring to reduce the critical frequency as far as is consistent with the other problems in design.

**Apparent Simplicity**

Now on this simple theory the problem does not appear to be very complicated. We make the impedance of the transformer large compared with that of the valve in use. The effect of this is that for all frequencies below a certain critical point the amplification obtained rises more or less progressively with the frequency. As the critical point is approached, however, the curve flattens out, and beyond this the amplification is practically uniform over the whole range as in Fig. 3.

Unfortunately, however, there are all sorts of other effects which occur, most of the evils being due to the two causes, one the presence of the secondary winding, and the other the magnetic leakage which takes place between the primary and secondary winding. These points will be discussed in the next article of the series.

**High Recommendation by  
"Popular Wireless."**

**TUNGSTONE**  
Pure Lead Grid  
**Accumulator**

Entirely of British Origin and Workmanship.

Editor writes in issue of June 12th, 1926:—

**A**MATEURS who are fortunate enough to own motor-cars need not worry about accumulator charging during the summer. Current can be tapped off from the dashboard to supply portable sets, while, if a "Tungstone" accumulator is used, a cell or two can be removed for running a "household" receiver when the car is in the garage. Better still, extra cells can be purchased and interchanged with those on the "auto." During summer months the car accumulator is not called upon to do much work, so the foregoing is an economical proposition. The "Tungstone" is eminently suitable for the purpose, as its cells can be detached with the greatest of ease. As a matter of fact, the plates themselves can be removed from an individual cell in a few minutes. And this is but one of the many unique features of the Tungstone Accumulator. Its design throughout, from the construction and composition of its plates to its patent "Vislok" terminal locknuts, is a triumph of thoughtful attention to both details as well as essentials.

We have had a 6-volt "Tungstone" in use on a car for a period of about six-months, and six months, moreover, of mainly hard winter work. The self-starter must have been used thousands of times, frequently on very cold mornings, and on one occasion the car was driven a distance of over 100 yards on the starter motor. Additionally, the accumulator has been used for wireless work as well, and yet, when recently we examined its plates, no signs of deterioration were in evidence. Our previous accumulator accumulated a deposit of "mud" half an inch in thickness after a similar period of not quite such hard usage, but the "Tungstone" did not need washing out. It is still in commission, and no doubt will remain at work for many years.

We have not sufficient space at our disposal to describe these products in the detail they deserve.

TUNGSTONE High Tension 60 Volt Battery 3 a.h. is sold in the United Kingdom on monthly payments over extended period. Apply for particulars. Further interesting information on points of this advertisement are to be found on pages 58, 59, and 67 to 73 of the Illustrated Booklet "Photography tells the Story" which will be sent free on application to the—

TUNGSTONE ACCUMULATOR CO., LTD.

St. Bride's House, Salishury Square, Fleet Street, London E.C.4.

**ALL MANUFACTURERS  
GOODS ADVERTISED  
IN THIS PAPER**

Can be obtained C.O.D. or Cash  
with Order, per return, from

**YOUNG'S**

(GLASGOW), LIMITED,

40, STOCKWELL ST., GLASGOW.

Write To-day for Big Free Catalogue.

References: "Wireless."  
Bankers: "North of Scotland Bank," Glasgow.



# What do we gain by Low-Loss

By *Captain H.J. Round M.C., M.I.E.E.*

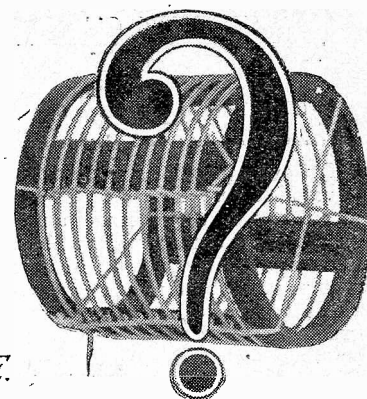

THE real difficulty to the amateur is not whether low-loss is an advantage, but to know when he has got low-loss apparatus.

Let us take a low-loss coil, one of about 200 microhenries is a very normal size. Now, the average old-fashioned coils of this size, wound of solid wire in one layer were of about 12 ohms resistance at 400 metres, and when they were wound in layers this resistance was considerably higher. A more modern coil, wound of stranded wire carefully spaced, can be obtained of 4 ohms resistance—a gain of three to one.

## Inter-action Requirements

Modern receivers, however, usually demand arrangements to prevent induction between the different coils of the receiver, and these arrangements have a habit of increasing this resistance considerably. For instance, an astatic coil system will be at least 6 ohms against the 4 ohms of the normal coil unless more space is allowable. And shielding will add a perfectly indefinite number of ohms, which can only be found by accurate measurement.

## Not Proportional

If these added ohms were proportional to the original ohms then the advantage would still be to the low-loss coil, but unfortunately they are only added. Thus a 4-ohm coil becomes, say, an 8-ohm coil when wound astatically and shielded, and an ordinary coil goes from 12 to 16 ohms, so that the gain of 3/1 becomes only 2/1.

Measurements of resistance are very difficult to do exactly, so that most experimenters will have to resort to trial to find the best arrangements. A few rules can be given which will help to maintain low-loss values in coils.

## Suggested Details

First of all, single-layer cylindrical coils of two to three inches diameter, with preferably a slight spacing be-

A stimulating article which should be read by everyone who takes an interest in modern tendencies in the design of radio circuits.

tween the turns, are as good as any, and if a wire such as enamelled 36/44's is used, with great care taken to connect every strand, no purchasable coil will be better.

Dry cardboard, I think, is as good as any material for winding coils on, but I always prefer to leave my coils

## Advantageous in Multi-Valve Sets

When every care is taken, I think we can assume that shielded astatic low-loss windings are at least as good as old-fashioned coils without the astatic and shielding arrangements, and in many cases can be taken as twice as good, so that from the point of view of multi-valve receivers we have gained considerably.

## On Long Waves

So far I have only spoken about coils of, say, 200 microhenries inductances, but low-loss windings made of stranded wire well spaced, particularly if in layers, are a great gain on the longer waves, the sizes I am referring to chiefly being from 1,500—5,000 microhenries, and it is quite possible now to make windings for these longer waves, which give too fine a tuning for good quality telephony, even without reaction being applied. The same astatic and shielding ideas, of course, apply on these wave-lengths also.

## On Short Waves

On the shorter wave-lengths under 150 metres it is doubtful whether anything will beat coils of solid wire wound rather openly. In this article I will not discuss further the short waves, because measurement of values is rather too difficult altogether for anywhere but a laboratory, and the building of receivers where low-loss matters has not progressed very far.

Low-loss condensers are now very common; in fact, one might say that practically all but the very cheap variety have very little loss.

## Where Do We Gain?

In the normal broadcasting band from 250-600 metres a low-loss coil in the aerial circuit will possibly give a gain of 15 per cent. with an average aerial, and with a very good aerial 30 per cent., by itself a gain hardly worth having, the reason being that the aerial resistance is already so high

(Continued on page 43.)

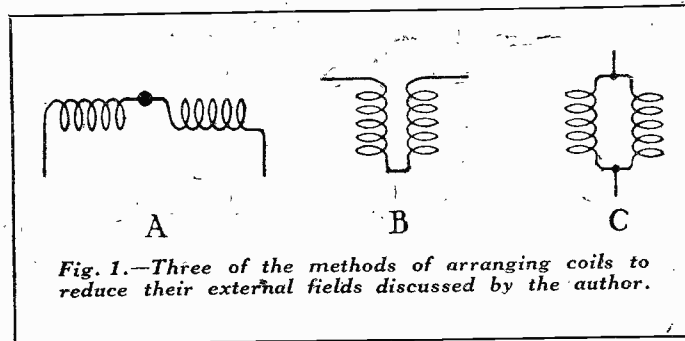

Fig. 1.—Three of the methods of arranging coils to reduce their external fields discussed by the author.

dry, because, unless tests are made of resistance afterwards, the influence of the varnish may be bad; and, of course, there is no simple indication of this.

Coils can be wound astatically in several ways, examples being given in A, B and C in Fig. 1. A has, I think, some advantage in that by making the two halves of the coil movable relatively to one another a small variometer action is possible, enabling circuits to be matched on their condensers.

## Shielding

Shielding is the latest fad, but a very useful one, and one very interesting point is to be noted here. An astatic coil having already a small magnetic external field, will induce smaller currents in the shielding case, so that the losses in the shielding will be less with the astatic coils than with ordinary coils. A series of tests indicate that the total losses on shielded astatic coils are less than in shielded non-astatic coils.



# Have you a gramophone?

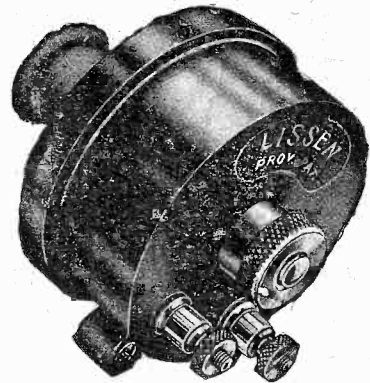

The LISSENOLA can be fitted to it in a second. Never again will you use telephones after hearing what can be done with the LISSENOLA Loud Speaking Unit and a horn made by yourself quickly and easily from materials purchasable anywhere for a few pence, or by fitting the LISSENOLA to your gramophone.

The LISSENOLA Loud Speaking Unit is the essential electro-magnetic sound reproducing mechanism of a loud speaker, concentrated in the most effective manner yet achieved, and produced by large production methods at **A RECORD IN LOW PRICE.** You cannot make it dither or resonate—it will carry high voltages without any sign of overloading—it is not to be confused with any imitations which lack its splendid

magnets, its non-resonant case, its fine tone qualities and tremendous power.

You add your own built horn to the LISSENOLA and you have a big, full-powered, senior-model loud speaker equal to the most expensive you can buy. With each LISSENOLA you are given full size diagrams and clear instructions showing you how to make a big horn. In addition you can also buy the LISSENOLA Reed which adapts the LISSENOLA to take any cone or other diaphragm working on the reed principle. You have in the LISSENOLA therefore the means of trying every known alternative of sound reproduction, an advantage which no other loud speaker gives you.

### 7 DAYS' TEST AT HOME.

Your dealer will demonstrate, but, better than all, take a LISSENOLA home—put it on your set—put it on your friend's set—try it with the horn of an expensive loud speaker fitted to it—then if you are not satisfied take it back to your dealer's or send it back to us.

## THE LISSENOLA

*Made Golden-Toned for your Enjoyment*

# 13/6

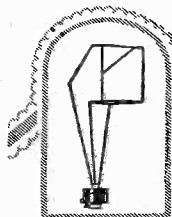

Full directions and full-sized patterns for making this horn are given with every 'LISSENOLA'

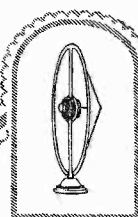

A cone diaphragm loud speaker can easily be constructed. The illustration shows one method of mounting.



The 'LISSENOLA' instantly converts any gramophone into a loud speaker.

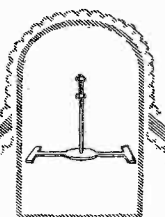

The 'LISSEN' Reed Attachment (pat. pending) for use with cone diaphragm loud speaker. Price 1/-.

**LISSEN Ltd.,**  
18-22, Friars Lane,  
Richmond,  
Surrey.

Managing Director:  
Thomas N. COLE.

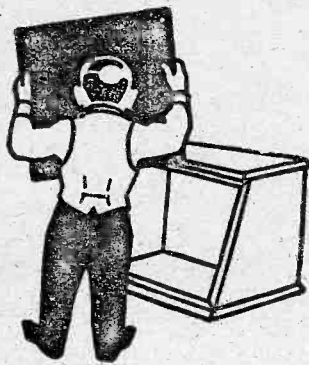

## Saving Space

TWO NEW ideas for saving back pane space—simplifying wiring and mounting, and doing away with all the troubles arising through faulty connections and spacing.

Remember, also, that the BENJAMIN Anti-Microphonic Valve Holder is not only infinitely superior to all its imitators in design and finish, but in actual performance too.

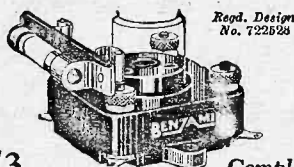

Regd. Design No. 722629

5/3

Complete

**VALVE HOLDER & GRID-LEAK**  
A Dubilier Dume ohm 2 meg. Grid-Leak is fixed on to a rigid insulating bar by means of nickel-plated copper clips.

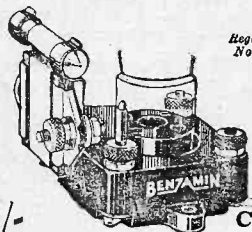

Regd. Design No. 722629

7/-

Complete

**VALVE HOLDER, GRID-LEAK & CONDENSER**

Nickel-plated copper clips carry a Dubilier fixed Condenser (1,0003) in addition to the Grid-Leak. Series or parallel.

**BENJAMIN VALVE HOLDER**

without Leak or Condenser.

Price 2/9

From all good Dealers

# BENJAMIN

BRITISH MADE

Clearer-Tone, Anti-Microphonic  
**VALVE HOLDER**

THE BENJAMIN ELECTRIC LIMITED  
Tottenham, Loncon, N.17.

## COMPONENTS WE HAVE TRIED

### A.C. Rectifier

WE have received from Messrs. Gent & Co. one of their Tangent A.C. rectifiers for H.T. supply. The unit is enclosed in an enamelled metal case. The lid, which is also of metal, completely screens the apparatus contained inside. The leads to and from the unit are brought out through insulated bushes. When the lid is opened the operating panel is exposed to view. Upon this panel is mounted a valve holder and an ebonite insulating strip carrying three terminals, and a knob for controlling one of the H.T. voltages.

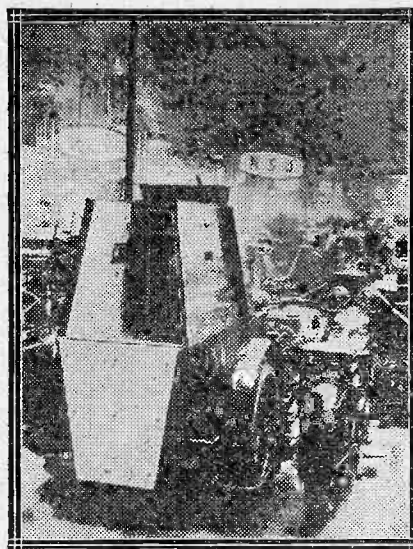

A novelty at the German Automobile Exhibition, a motor-cycle and "side-car" which consists of a complete wireless receiving and transmitting station.

The unit submitted is intended for use with a four-valve receiver, and it was tested upon a combination of two H.F., one rectifier, and one note magnifier. When in use the rectifier was found to be extremely efficient, and no hum could be noticed on the loud-speaker when it was tuned to its most sensitive condition, and even when telephones were used, only a very slight trace of hum was audible. It was found, however, necessary to use the correct grid-bias on the note magnifier valve to obtain the best results.

As previously mentioned, one of the H.T. voltages may be varied, this being done by rotating a small knob inside the cabinet. The three terminals are connected to the receiving set in the usual manner, no further apparatus being necessary. The only criticism we have to make is that the smoothing condensers are of the usual 300-volt type, which hardly gives an adequate factor of safety if the unit is to be used on 240-volt mains.

(Continued on page 41.)

# The latest in Jacks & Plugs

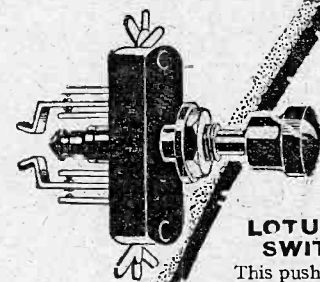

### LOTUS JACK SWITCHES

This push-pull switch is designed to occupy the minimum space, being only 1½ in. deep. Of the finest Bakelite, it has nickel silver springs and contacts of pure silver. Soldering contacts can be made to suit any wiring.

#### PRICES:

No. 9, as illustrated... 4/-  
Others from - 2/9

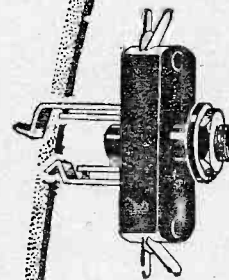

### LOTUS JACK

Designed to take up the least space, the depth back of panel being 1½ in. Made from best Bakelite mouldings with nickel silver springs and pure silver contacts. One-hole fixing. Soldering contacts can be brought into any position.

#### PRICES:

No. 3, as illustrated... 2/6  
Others from 2/- to 3/-

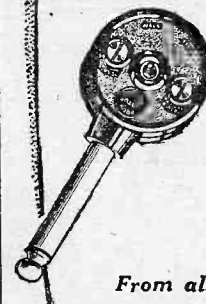

### LOTUS JACK PLUGS

Designed for use with Lotus Jacks. Made from best Bakelite mouldings and nickel-plated brass. To fix, the wires are placed in slots and gripped in position by a turn of the screw cams.

PRICE 2/-

From all Radio Dealers.

# LOTUS

## JACKS·SWITCHES·PLUGS

Garnett, Whiteley & Co., Ltd.

Lotus Works, Broadgreen Road, Liverpool.



**Bowyer-Lowe**  
*This Mark on Wireless Components is your Guarantee*

# PIONEERS of WIRELESS RECEPTION

**B**OWYER-LOWE are amongst the first manufacturers of Wireless Components. Since the days when wireless and its possibilities were but vaguely realised, Bowyer-Lowe have experimented unceasingly, and the components bearing the Bowyer-Lowe nameplate are backed by unlimited knowledge and research.

The "Popular" Condenser has proved the significance of this experience—hundreds of amateurs and experts write their appreciation of its excellent performance.

Design! without freaks or frills the Bowyer-Lowe Popular Condenser is, by its designing, inexpensive to produce, and you may secure the razor-edge tuning this instrument provides, at a trifling cost.

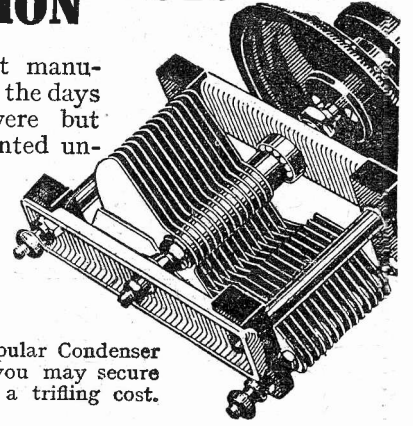

**GUARANTEED for TWELVE MONTHS**

Buy a **POPULAR** To-day—  
 Send your **Congratulations** To-morrow!

0003 M.F. }  
**10'**  
 0005 M.F. }  
**10 6**



ANNOUNCEMENT BY THE BOWYER-LOWE CO. LTD. LEITCHWORTH HERTS

**DON'T** USE A POWER VALVE IN ANY STAGE BUT THE LAST

**BUT**



BRITISH MADE

**TRANSFORMERS**

ARE SUITABLE FOR ALL L.F. STAGES

**TYPE AF3 - 25/-**  
 The "nearly perfect" transformer.

**TYPE AF4 - 17/6**  
 The best transformer at the price.

**FERRANTI LTD.,**  
 HOLLINWOOD,  
 LANCASHIRE.

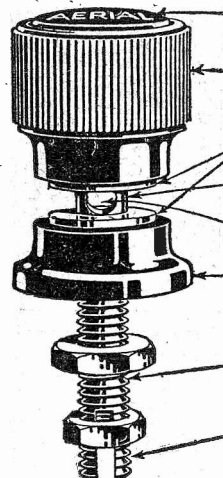
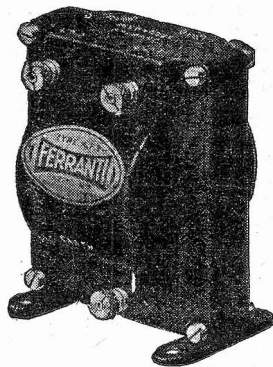

- Non-rotating insulated engraved top.
- Highly-finished screw-action Bakelite-insulated head.
- Shielded metal clamping faces
- Smooth stem, ensuring that strands of connecting wire will not bind up with thread.
- Cross-hole for connections, flush with clamping face.
- Highly-finished Bakelite-insulated collar.
- Standard 2.B.A. stem with nut.
- Transverse slot with clamping nut, eliminating soldering.

Patent No. 248921.  
 Registered Design No. 715424.

The Belling-Lee Terminal, made with 28 different engravings.

STANDARD MODEL (Bakelite-insulated) (Type B) 9d. each.  
 POPULAR MODEL (non-insulated) (Type M) 8d. each.

If you cannot get these at your dealers, send your order to us, enclosing his name and address.  
 Illustrated Catalogue free on request.

**BELLING-LEE**  
 PANEL FITTINGS

BELLING & LEE, Ltd., Queensway Works Ponders End, Middlesex. E.P.S. 13

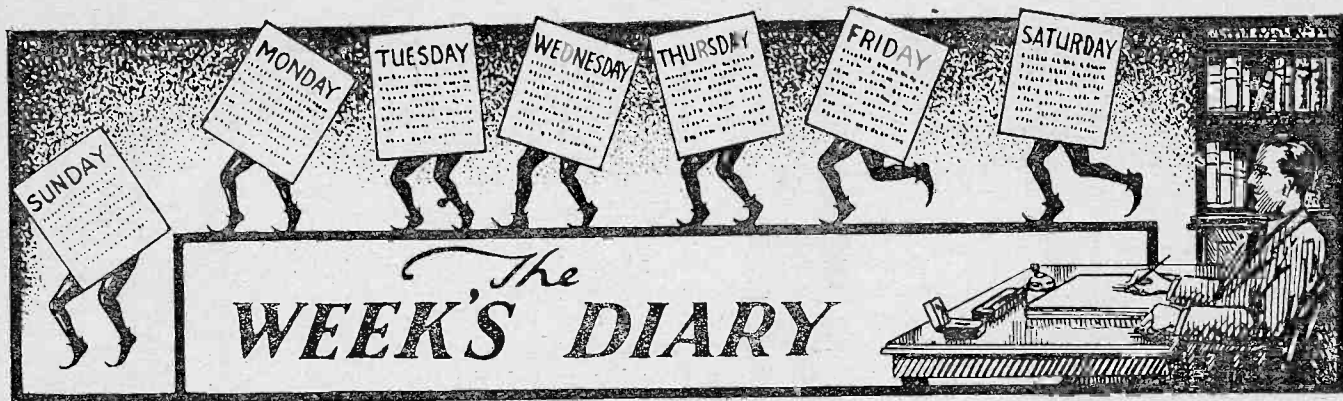

**T**HIS is National Wireless Week. Its slogan is, "Let Your Friends Listen." Perhaps I may be accused of quoting the obvious, but I am doing it for this reason: If you have a set that will not work a loud-speaker without occasioning insulting remarks from your friends, or which is at all prone to burst into oscillation, or to break down, for Heaven's sake *don't* let your friends listen! The object of the week's activities is to increase the numbers of regular listeners, not to repel those who are just on the point of enlisting.

If the week's possibilities are properly exploited it will do a vast amount of good to the progress of wireless in this country. If they are abused they will certainly be harmful.

**A** CONTEMPORARY hints that the sole result of all the recent agitation about listening for signals from Mars is that one worthy gentleman is 4s. 6d. out of pocket. That, perhaps, is the only good that has been done on this earth. But think of the way in which the Martians themselves have been entertained. They have by now a much truer knowledge of the "Earthians" than they ever had before!

**A** PARENTLY not everyone wishes the £900,000 accumulated by the G.P.O. from licences to be devoted to the improvement of the broadcast programmes. One gentleman in Manchester suggests that it would be much better employed by improving the postal service!

**T**HE number of prospective performers rejected by the B.B.C. after auditions have been granted is growing so large that in future it will be necessary to produce specially good recommendations before an audition will be granted. At the Newcastle station, for example, 700 successful artists have been secured as a result of 3,000 auditions.

**I**T is extremely likely now that the new wavelengths for European stations will come into force in the middle of November. The first of the new wavemeters having been delivered safely at 2LO, it really seems that the powers that be intend to "get a move on." Personally, I anticipate very little trouble when the new scheme commences. It seems to me to have been so well worked out that there can be hardly any hitches. Time will prove.

Goldschmidt at Sololo, is now working quite regularly with Belgium, and has maintained perfectly reliable communication for more than a month. The inception of this station was due to the fine performance put up by amateurs at both ends, and when the cable broke down valuable service was rendered by them. Thus there are now two regular links between Belgium and the Congo.

**NOT FROM A 'PLANE**

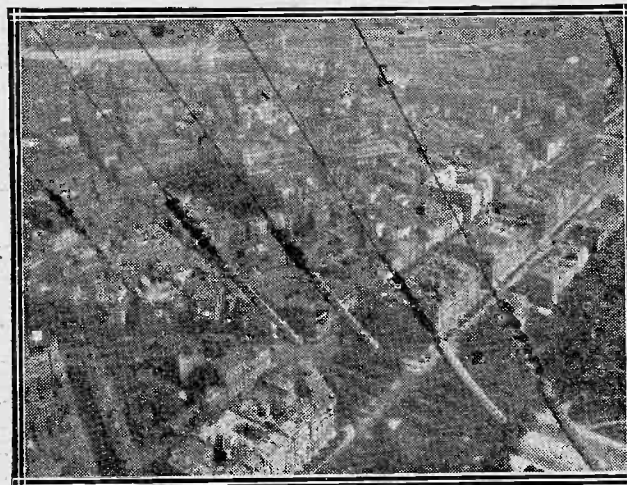

*This rather unusual view from the air was taken from the famous Eiffel Tower in Paris. The insulators, 132 in number, are those supporting the top end of the aerial from which transmissions are well received in this country.*

**T**HE B.B.C. are "going through the mill" generally at the present time on the count of underpaying their artists. Several hitherto well-known performers have made known their intention of refusing to broadcast again, and Mr. C. B. Cochran has now accused the B.B.C. of "buying an artist like a pound of tea." I shall be extremely interested to see their 1927 method of dealing with these little problems.

**T**HERE seem to be several supporters of the idea that the new State B.B.C. is too old. One correspondent says that in his opinion retirement from such a board as this should be compulsory at 50. There are many who agree with him, but I am afraid they are mostly the young ones! Those who are over 50 might very well consider that as a *minimum* age!

**T**HE programme of the Fourth National Concert at the Albert Hall on November 25 strikes me as being even nearer the ideal for such an occasion. Sir Edward Elgar is to conduct the entire concert, which consists of his own compositions. "Call Sign" recently predicted that we might possibly hear an all-British programme from 2LO, and his dream has apparently come true. In addition to this, we are to hear Albert Sammons.

**I**T struck me as rather significant that, on November 2, when the all-Italian Chamber concert was broadcast from 5XX and the provincial stations, there was no transmission from the Rome station. Probably this was nothing more than a coincidence, but at first it might appear that the Italians were rather anxious to see what we were doing to their music!

**NEXT WEEK.  
A SET FOR KDKA.**

**T**HE private station in the Belgian Congo, operated by Mr. Robert



IMPROVED 1927 MODEL  
H.T. ACCUMULATOR

100  
Guineas  
for a  
Name!

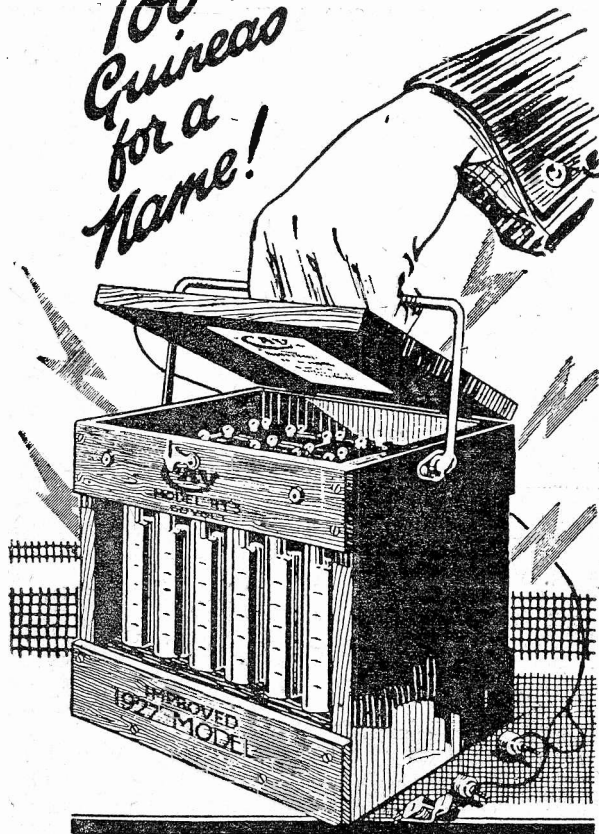

MODEL  
H.T. 3  
(160 VOLTS)

60

SUPPLIED  
READY FOR USE  
NO FILLING,  
WITH ACID.  
NO CHARGING

Dimensions 8 1/2" x 7" x 7 1/2" High  
Weight Charged 16 1/2 lbs Dru 13 1/2 lbs.

Also supplied in 30 or 90 Volts at proportionate prices.

COMPETITION OPEN TO USERS OF THIS ACCUMULATOR.

Full particulars, including conditions of competition, will be forwarded on application. Owing to the various special features of our H.T. Accumulator we desire to give it a distinctive name, and invite suggestions. Prizes will be awarded as follows:—

**FIRST PRIZE - 75 GUINEAS**  
to the entrant of name adjudged the best.  
**SECOND PRIZE - 25 GUINEAS**  
to the trader from whom the First Prize  
winner purchased his Accumulator.

**C.A.V. Vandervell & Co., Ltd.**  
ACTON, LONDON, W. 3.

Telephone: Chiswick 3801  
(Private Branch Exchange)

Telegrams:  
"Vanteria-Act-London."

**The NATIONAL WIRELESS WEEK**  
NOV. 7th—13th  
'Let your Friends Listen'

<b>COIL SCREEN &amp; BASE</b>  ONLY 9/-	<b>S.L.F. CONDENSER</b>  4-in. dial. .0003 7/- .0005 7/3	<b>RELIABILITY CONDENSERS</b>  Mansbridge Type. Mids. 1/6 1, 2/6 .25, 1/8 1, 2/6 .5, 1/8 2, 3/6	<b>WIRELESS CABINETS</b>  For Panels 7 in. high Width 8in. Hinged Lid Oak 12 in. 17/- 14 in., 17/6; 18 in., 18/6. Mahogany, 1/- extra.	<b>DEWAR SWITCH</b>  12-Contact. 2/6
---	--	--	--	---

READ THIS LIST AND SAVE MONEY ON COMPONENTS

**ACCUMULATORS**.—Exide, D.T.G., 4/6; D.F.G., 8/6; W.J., 20 v. H.T. type, 15/-; Oldham H.T. 16d. per volt, complete; Duros 20 v., 11/-; 10 v., 5/6; Resisting Outfit, 2/6.  
**AERIALS**.—200 ft. in copper tape, 1/6; 7/822s Bright, 2/3; Enamelled, 3/3; Electron, 1/8; Superial, 2/6; Mars, 9/6; Ashton Spreaders, 12/- per pair; O.V., complete, 2/6.  
**INSULATORS**.—Large Shell, 3d.; Reel or Egg, 1d.; Climax, 6d.; Ditto, with shock absorbers, 3/- pair; Gal. Pulleys, 4d.; 100 ft. Gal. Straining Wire, 1/6; Straining Bolts, 6d.  
**EBONITE**.—Any cut. Cleitor brand, 4 in., 1d. sq. in.; 9 in. by 5 in., 2/2; 12 in. by 9 in., 4/6; 15 in. by 9 in., 5/6; 3/16 in., 25 per cent. less. Paragon and Radon, 1d. per sq. in.  
**CONDENSERS**.—Low Loss, Square Law, with knob and dial, .0005, 5/-; .0003, 4/6; with Vernier Blade, 1/4 extra; Twin .0005, for Elstree Six, unequalled value, 9/6; Cylon Twin for ditto, 27/6; Ormond, J.B. Utility, Sterling, Polar, Formo, Igranite, G.E.C., Variable in all capacities. Neutrodyne types, Ormond, 2/-; Colvern, 3/6; Gambriel, 5/6.  
**FIXED CONDENSERS**.—Dubbler, Edison Bell, Lissen, Watmel, Mullard, McMichael, at advertised prices. Special Reliability Fallon, .0003 mfd., 2 mes. Leak, 1/3; Cases only 4d.  
**TERMINALS AND ACCESSORIES**.—Single W. Office N.P. or Pol. Brass with nut and washer, 1d.; Phone and Castle type, 1d.; Double Mark, 3, 2d.; 4-way Phone Connector, 6d.; Pole-binding paper, 3d.; Fluxite, 8d.; Black Tape, 6d. coil; in. Empire Tape, 6d. dozen yards; Insulating tube, 3d. yd.; Glazite, 1/2 10 ft. coil; Shellac Varnish, 6d.; Mica 2" x 1 1/2", 4d. doz.  
**VALVE HOLDERS**.—Anti-Phonic Benjamin, 2/3; Lotus, 2/3; with terminals, 2/6; Burndept, 2/9; Harlie, 1/6; Reliability, unequalled, 2/-; all baseboard types, ordinary ditto, 6d.; N.P. Valve Sockets, flush fitting, 1d.; Superior Panel Type, 6d.; All Ebonite, 10/6.  
**HEADPHONES**.—B.T.H., 15/-; Brown's "F" Type, 20/-; Reliability, 7/6; Adjustable, 8/-; Dr. Nesper, 12/11; T.M.C., 17/6; Western Electric, 20/-; all 4,000 ohms: Sullivan, 120 ohm Double, Ex-Govt., New, 4/-; 120 ohm Single Phone, 2/6; Long Phone Cord, 1/-.  
**BATTERIES**.—Reliability, 90 v., 11/-; 60 v., 7/6; 36 v., 4/6; 15 v., 1/10; Ever Ready, Baby Grand, 18/-; Ormond, 15/-; Royal, 20/-; Success, All Black, 21/-; Silvertown, 21/-; Siemens, Hollesen, 100 v., 21/-; 66 v., 12/8; 36 v., 7/6; Flashlight Battery Cases for 14 Batteries 3/6, 4 v. Batteries, 4d. 60 v., Unequalled, 8/6; Wander Plugs, 1d.; Clix Type, 2d.  
**L.F. TRANSFORMERS**.—R.I. Multi-Ratio, 25/-; Marconi Ideal, 25/-; Junior, 18/6; Ferranti A.F.3, 25/-; A.F.4, 17/6; Formo, 10/6; H.T.C. Empire, 7/6; Croix 5 to 1 5/-; Lissen new type, 8/6; Igranite, 10/-; Eureka Concert Grand, 25/-; No. 2, 21/-; Baby Grand, 18/-; Ormond, 15/-; Royal, 20/-; Success, All Black, 21/-; Silvertown, 21/-; G.R.C., 15/-; Brandes, 17/6; Burndept, 16/6; Special Valve, 7/6; Modulation, 7/6.  
**RECENT REDUCTIONS**.—Sterling .0005 Square Law Condensers with Vernier, 9/6; Geared 12/-; Miniloss 15/-; .00025, 8/6; Geared, 10/6; Miniloss, 14/-; Marconi Automatic Detector, 2/6; Series Parallel Variometer, 10/6; Eddystone Absorbos feet, set of four, 2/3; Benjamin S.P. Switch, 1/3; N.P. Clix Plug and insulator, 2d.; Adaptor, 1d.; Socket, 2d.  
**LATEST COMPONENTS**.—6-Way Coil Stand, 2/9; Colvern Low Loss Inductance Former, 5/6; Formo Straight Line .0005 Condenser, 10/6; Success, 18/6; Eureka, 15/6; Cylon, 15/6; Lissen 60 volt H.T. New Process Battery, 10/6; Valve Vibrating Springs, 6d. set of four.  
**EXPERIMENTERS' PARCELS**. Accessories of Various Types, worth 20/-, post paid, 5/6.

Send for RELIABILITY WIRELESS GUIDE No. 2, Free on Request Trade Supplied

**J.H. TAYLOR & CO.**  
11, RADIO HOUSE,  
MACAULAY ST., HUDDERSFIELD.  
Tel. 341. Grams: THOROUGH HUDDERSFIELD.

Orders 5/6 Value Carriage Paid, Under 5/6 2d. per lb. for Packing, etc.

If coils were this size the Lotus would hold them securely

The Moving Block Cannot Fall

The vernier movement comprises three sets of enclosed precision machine-cut gears, and reduces the speed of the moving block by eight times.

Side plates, coil blocks, and knobs in artistic bakelite mouldings. All metal parts heavily nickel plated. Made for left as well as right hand.

Patent No. 244,251

**LOTUS**  
VERNIER  
COIL HOLDERS

PRICES:  
Two Types:  
For outside panel mounting:  
Two-way ... 7/-  
Three-way ... 10/6  
For inside baseboard mounting, with 6-in. handle:  
Two-way ... 8/-  
Three-way ... 12/6

Made by the makers of the famous Lotus Buoyancy Valve Holder.

GARNETT, WHITELEY & CO., Ltd.  
Lotus Works, Broadgreen Rd., LIVERPOOL.



# JUST LIKE JACK-IN-A-BOX

Dutchman, Frenchman, Yank, Spaniard, German . . . . one after another up they come. They can all be tuned into a loud speaker with hardly more trouble than releasing the catch on the jack-in-a-box. They can be—but how often are they?—how often is the experimenter let down just at this point by inferior variable condensers?

Fit "Ormond"—the new Ormond S.L.F. "Slow-Motion Condenser" that the "Geneva Plan" has all but rendered imperative. The marking of the ORMOND dial enables listeners to pick up any station with the minimum of trouble and without any unnecessary calculations. The famous ORMOND SLOW-MOTION FRICTION DRIVE (RATIO 55-1) is incorporated and special ball-bearings give liquid-like movement to every turn of the knob. Easy to mount, having one and three hole fixings with both terminals and soldering tags for connections. Note the extraordinarily low retail prices:—

With 4" Bakelite Knob.  
 .0005 microfarad...20/-  
 .00035 " ...19/6  
 .00025 " ...19/-

**NATIONAL WIRELESS WEEK**  
 November 7th to 13th.  
*"Let your friends listen."*

With Dual Indicator Dial.  
 .0005 microfarad...21/6  
 .00035 " ...21/-  
 .00025 " ...20/6

NEW 1927 Catalogue (42 illustrated pages) gladly sent on request.



199-205 Pentonville Road, King's Cross, London, N.1.  
 Telephone: Clerkenwell 9344-5-6.      Telegrams: "Ormondengl, Kincross."  
 Factories: Whiskin Street and Hardwick Street, Clerkenwell, E.C.1.  
 Continental Agents: Messrs. Pettigrew & Merriman, Ltd., "Phonos House,"  
 2 and 4 Bucknall Street, New Oxford Street, W.C.1.

**DECKOREM**  
BRITISH MADE

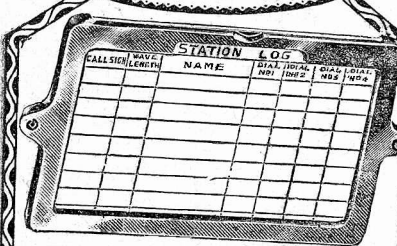

**STATION LOGS**

Make a permanent note of stations received! This handsome accessory is fitted with replaceable cards suitably printed. NICKEL PLATED, OXYDISED COPPER, or OXYDISED SILVER FINISH. Complete with cards.

Price **2/-** each.

**RUBY VALVE REFLECTORS**

A sure indication when set is switched "on" or "off," brilliant ruby lens reflects least glow from valves.

Price **9d.** each.

New Catalogues upon application.  
OBTAINABLE FROM ALL DEALERS OR

**A. F. BULGIN & CO.**  
9-10-11, CURSITOR STREET,  
CHANCERY LANE, E.C. 4.



**AERMONIC**  
VALVE HOLDER.

Don't pay more. You can't buy more. New design eliminates losses. New springing system gives better results. List of Aermonic Parts Free

**J. CHRISTIE & SONS, LTD.,**  
246, West Street, Sheffield.

London Agents: A. F. Bulgin & Co., 10, Cursitor St., London, E.C. 4



**BUILD A LOUDSPEAKER**

WITH OUR NEW  
**SEAMLESS MOULDED CONE**  
(Prov. Patent 25089/26)

and a BROWN A. or LISSENO LA. You will obtain PERFECT RESULTS. Successful construction for a minimum outlay is ensured with our Specialties. Illustrated Lists and full particulars for Stamp.

**GOODMAN'S, 27 Farringdon St. E.C. 4**

Also obtainable from Spencer's Stores, 4-5, Mason's Avenue, E.C. 2

**A HOME FOR YOUR WIRELESS SET**

OUR STANDARD  
CABINETS

are DUSTPROOF and house the whole apparatus, leaving no parts to be interfered with. All you do is **UNLOCK and TUNE IN** Made on mass production lines, hence the low price. Provision is made to take panels from 16x7 up to 30x18 in.



From **£4 15 0** Write for descriptive pamphlet and suggestions for adapting your receiver or panel in our Standard Cabinets. Immediate Delivery.

Dept. 4, Maxwell Chambers,  
60a, Lord St. LIVERPOOL.

Carriage paid and packed free England and Wales.

Thousand supplied with full satisfaction.

**MAKERIMPORT Co.**

**COMPONENTS WE HAVE TRIED**  
(Continued from page 36)

This unit is extremely simple to work, and we can recommend it to our readers for use with receivers not employing more than four valves.

**"O.C." Transformer**

**WE** have received from Messrs. Peto-Scott & Co., Ltd.; an improved type of high-frequency transformer, suitable for use with the standard six-pin base. It may be used either in the standard screened coils, or on a six-pin base without the screens.

On actual test we certainly found that the circuit remained stable over a wide band of the neutralising condenser, and that certain circuits which could not be stabilised at all under normal circumstances were quite under control when this new type of transformer was utilised. When tested on the "Solydyne" and the "Mewflex" receivers the stabilising was found to be considerably simplified, and the overall amplification was somewhat increased.

The tuning properties of the circuits remain unimpaired, and the coils are interchangeable with the normal types of H.F. transformer.

We can recommend this interesting unit to our readers.

**EVERY LOUDSPEAKER**

**DESERVES**  
**MULLARD**  
**MASTER**  
**VALVES**

— Ask for —  
**Mullard P. M. Power Valves.**

**VALVES!**

Radio Micro Power	Fama D.E.	
3v 1 amp. - - 10/9	2v 2 amp. - - 4/-	
3v 3 amp. - - 9/6	M.R., D.E.	
Radio Micro D.E.	3v .06 amp. - - 5/6	
3v .06 amp. - - 7/-	Folo 60-volt Batteries	
Fama D.E.	3-volt Tappings	
4v .06 amp. - - 5/9	Guaranteed - - 7/6	
Fama Power		
4v 2 amp. - - 8/8	All goods sent post free.	

Trade Enquiries Invited. Write for Lists —  
Kindly note change of address —

**W. SEGAL,** 58, RUSSELL ST., LONDON, E.C. 1.

**"WET" H.T. BATTERIES**

COMPLETE SACK LECLANCHE CELLS. WAXED JAR (1½ by 1½ by 2½). DOUBLE CAPACITY SACK with insulating rings and waxed carbon. ZINC with connecting wire.

PRICE 6/- per doz. CARRIAGE FREE.  
TRADE SUPPLIED.

**S. E. JONES & CO.,** Elsecar, Barnsley.

**2-VALVE AMPLIFIER, 35/-**

1-Valve Amplifier, 20/-, as new; Valves, D.E. .06, 7/-; Headphones, 8/6 pair; new 4-Volt Accumulator, 13/-; new 60-Volt H.T., guaranteed, 7/-; 2-Valve All-Station Set, 24/. Approval willingly. Write for free bargain list.

**R. Taylor,** 57, Studley Rd., Stockwell, London.

**ELECTRADIX**  
**BARGAINS. No. 107**

**ULTRA ONE-METERS.** The famous 58 range Radio Star Instrument 50s. Multipliers 6s. 6d. each.

**SPARK SETS** Sterling Coil, with Contacts. Oscill. adj. Spark Gap. Tapped Helix 25 to 600 metres. H.T. Mica Condenser, Terminals and attachments on ebonite, fine panelled case. These Sets cost £15, and are given away at 15s. 6d. each. Post 1s. 6d.

**700 G.P.O. 2-RANGE DETECTORS.** Ediswan G.E.C., 750 m/a and 2½ v. etc. Brand new, 5s. 6d. each.

**CELL CHARGERS OFF A.C.** 220 volts 50 cycles to D.C. 6 volts, 6 amps. Fully guaranteed, 70s.

**1,000 ACCUMULATOR FILLERS,** with suction bulb, celluloid acid chamber and nozzle. For Changing acid and testing Sp. Gr., 1s. 6d.

**WAVEMETER BARGAINS.** Bought from the Admiralty. Gambrell and Heterodyne Wavemeters; neat, but need recalibration. Last few clearing at 10s. each. Post 1s.

**SHORT-WAVE HELIX.** Copper strip on ebonite, with tapping clip, 5s.

**L. F. AMPLIFIERS,** 2-valve in mahogany case, 32s. 6d.

**PORTABLE FRAME AERIALS,** 21s. Indoor Wire 100 ft. 1s.

**DUCONETTE.** Plug in anywhere in lighting circuit, indoor aerial for 2s. 6d.

**110-v. ELECTRIC IMMERSION HEATERS,** brand new, nickel-plated, with flex and plug. Boils water, eggs, milk, etc., in a few minutes. Two in series for 220 v. Sale price, 5s.

**220 v. ELECTRIC TOASTERS,** nickelled, brand new, with flex and plug. List 35s. Sale, 7s. 6d.

**HOTPLATES, 100 v. LARGE, 200 v. SMALL SIZE.** Aluminium frame. List, 45s. Sale, 7s. 6d.

**110-v. ELECTRIC BLOWERS,** or Hair Dryers. Work off 220 v. in series with lamp. Nickel-plated, lightweight, with control switch for hot or cold. Brand new, with flex cord and plug. List 45s. Sale, 12s. 6d.

**110-v. ELECTRIC MASSAGE VIBRATOR SETS.** Work off 220 v. in series with lamp. Nickel finish with 5 applicators for muscular treatment. In padded case. Brand new. List, £4 5s. Sale 21s. 6d. 110 v. or 220 v.

**ELECTRIC IRONS,** List 21s. Sale 10s. All the above guaranteed for A.C. or D.C., and brand new.

**300 SURPLUS MARCONI 1-VALVE AND CRYSTAL DET. SETS,** in closed leather pattern case. Straight from the factory of a Leading Wireless Manufacturer, contain ebonite panel with nickel fittings for detector, valve holder, L. and S. wave switch, double spade tuning, two 1,000-w. 200/4,000-metre H.F. chokes, T.C.C. condenser, terminal and plug sockets. All new, fixed and partly wired, with wiring diagram and Osram valve. List price, £7. Sale, 10s. Finished complete, £7 10s. Sets with valve and tested on aerial, 30s.

**MK. III CRYSTAL SET AND TUNER.** Complete with Tapped Tuning Coils and Coupler Combination and Carborundum Detectors, Buzzer, Potentiometer, .001 and .0005 variable Condenser, Tune Stand-by Switch, Crystal or Valve Switch, in mahogany case. Panel engraved. Price 45s.

**EARTH MATS.**—Galv. wave-plate, with Electron wire riveted on, 2s. 6d.; post 9d. Copper Mesh Earth for short waves, 5s. 6d. each. Earth spikes, 1s. 3d.

**G.P.O. PORTABLE TELEPHONES.** Magneto ringing, containing Hand Combination, Phone, Microphone, Receiver, Condenser, Magneto, Bell, Transformer, etc., leather case. Worth £4 each. Price to clear, 22s. 6d.

**TWIN DOUGLAS PETROL ENGINES FOR ELECTRIC COUPLED GENERATION.** In good running order. To clear, £12.

**LABORATORY BRIDGE CONDENSERS,** 5,000 volt mica dielectric, and contain 7 separate condensers. Any condenser can be plugged in separate, and any combination of capacities can be obtained. Condensers all in 3½ in. £2 each.

**M.III SINGLE VALVE TRANSMITTERS,** range 300-1,450 metres, containing Tuning Coil, with Stud Tapping, 2 Variometers, Variometer Reaction and Variometer Tuning, with Ratchet. Low Loss wound on tubular ebonite. Condenser .01. Wound Leak and Condenser. Multiple Switch, Lamp, Heavy Key, Aerial Ammeter, etc., etc., ½ in. Ebonite Panel. Cost £25. Price to clear 30s. each. With slight alteration these can be used for receiving. Carriage, 2s. 6d.

**SKINDERVIKEN CRYSTAL LOUD SPEAKER TRANSFORMERS** for Crystal Amplification. List price, 20s. To clear, 10s. each, post 6d.

**LOUD SPEAKERS**—Western Electric, 17s. 6d.; T.M.C., 12s. 6d.; Fuller's Sparta 4 guin., 50s.; Serenada, 30s. Texas Cone, 40s. Magnavox 55s.

All parts for Paper Loud Speakers. Brown's A. Reed Receivers 12s. 6d. Plated 12 in. Twin Rings, 5s. pair. Stays, 2 for 1s. 9d. Machine Pleat, Parch. Paper for Diaphragms, 2s. 3d.

Personal inspection will convince you of our claim to hold the finest stock of perfect and accurate apparatus for immediate delivery in the City, and your call will be welcomed.

Our 4d. Catalogue containing 600 unique illustrations will save you pounds.

Have you bought your ONE-METER yet?

**ELECTRADIX RADIOS,**  
218, UPPER THAMES STREET.  
Blackfriars Stn., Met. Rly. Tel.: City 0191.

## Critical Tuning needs Critical Registration.

The more responsive your set the more critical your tuning.

Can you afford to be without our new **ILLUMINATED TUNING DIAL?** Lights up when in use. Positive hairline tuning.

## ARE YOU BUILDING A MONODIAL OUTFIT?

Once again we are first in the field and have in stock all the components necessary for building the MONODIAL Set (full list on application). Total Cost - £12 13 0.

Also Lewcos Coils, Coluenn Coils, Screened Coils, and all components for ALL RADIO PRESS OUTFITS.

OUR INTERNATIONAL RADIO CATALOGUE (3rd Edition) will be sent to all enthusiasts sending 6d. to cover cost of postage and packing.

# WILL DAY, LTD.,

(DEPT. S),

19, Lisle St., Leicester Sq., London, W.C.2.  
Telephone: Regent 4577. Telegrams: "Titles, Westrand, London."

### HIGH & LOW TENSION ACCUMULATOR HIRE SERVICE

Here's a way of improving reception, saving money, time and trouble for all valve set users who live within 12 miles of Charing Cross. Write now for particulars of this unique service.

**RADIO SERVICE CO.,**  
106, Torrington Avenue, N.W.5.  
\*Phone: North 0623 (3 lines).

ROTAX High Tension Accumulators greatly improve Loud-Speaker reception, eliminating the uncanny noises caused by partly run-down dry batteries and may be hired ready for use.

If you add the depreciation in value to the cost of having your own accumulators unskilfully recharged, our Hire Service effects a considerable saving.

## SAXON GUIDE TO WIRELESS

This book enables any beginner to construct Wireless Sets which are unequalled in price, quality or efficiency, and the cost is only one-fourth the price charged for a ready-made instrument not half so good. The exact cost of each set is clearly stated.

### FULL INSTRUCTIONS WITH CLEAR WIRING DIAGRAMS

are given for making Super Efficient Crystal Sets, Dual Amplification Receivers, Single Valve Sets, One and Two Valve Amplifiers; Two, Three and Four-Valve Tuned Anode All-Wave Receivers, and the Very Latest Type of Five-Valve Resistance Capacity Receiver.

**NO SOLDERING, NO SPECIAL TOOLS NO KNOWLEDGE REQUIRED.**

The chapter on testing wireless components is alone worth the price charged. 176 PAGES. **PRICE 1/3 POST FREE**

**SPECIAL OFFER.**  
This book will be sent on approval on receipt of your promise to return same post paid or to remit 1/3 within seven days.

**SAXON RADIO CO. (Dept. 32), Henry St. Works, BLACKPOOL**

## FORMO

### ULTRA LOW LOSS

#### Straight Line Frequency Condenser.

Cone bearings. Braced Vanes. Positive Collector. A real precision job.

Condenser only—  
0003 μF, 0005 μF ... **9/-**  
Condenser with plain dial. Standard 1/2" dia. Shaft ... **10/6**  
New Vernier Dial ... **6/-**

Reduction Ratio 16-1. No Backlash.

**THE FORMO COMPANY,**  
CROWN WORKS, CRICKLEWOOD, N.W.2.  
Phone: Hamp. 1787.  
Manchester: Mr. J. E. Leary, 29, Hartley Street, Levenshulme.  
Phone: Heaton Moor 475.

## WIRELESS Advertisement Rates

Per page and pro rata

	£	s.	d.
52 consecutive insertions ..	36	0	0
26 consecutive insertions ..	37	0	0
26 alternate insertions ..	38	0	0
13 consecutive insertions ..	38	0	0
13 alternate insertions ..	39	0	0
1 insertion ..	40	0	0

Single column space 30/- per inch

Communications should be addressed to  
The Advertisement Manager,  
WIRELESS, Bush House, Strand, London, W.C.2

**SPECIAL ADVERTISING OFFER** during Wireless Week and SEVEN DAYS following.

## LOUD SPEAKER GRATIS

to every purchaser of a Three or Four Valve Radiax Receiver.

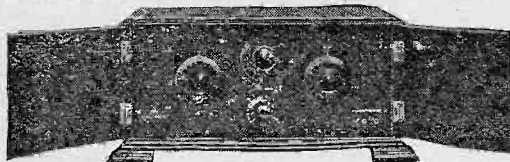

This offer closes on **NOVEMBER 20th.**

3 Valve Set (as illustrated) **£10.5.0** (plus 37/6 Royalty).  
4 Valve Set **£13.10.0** (plus 50/- Royalty).

Sets of parts for home assembly from £3.13.0 (2 Valves.)  
Order or enquire now to avoid disappointment.

**RADIAX LTD., 14, Accessory House, Palmer Place, London, N.7**

Parrs Ad.

## NATIONAL WIRELESS WEEK

**Nov. 6th — 13th**

### LET YOUR FRIENDS LISTEN!

## COUPON

**QUESTIONS & ANSWERS**

"WIRELESS," Vol. VI. - No. 1

This coupon must be accompanied by a P.O. for 2/6 for each question, and a stamped addressed envelope when sending queries to the Radio Press information Dept. for a postal reply.



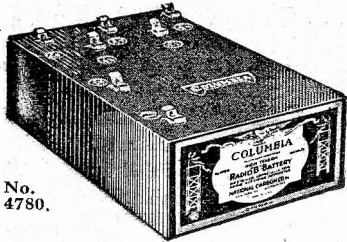

No. 4780.

**"They still read 55-56 volts after 12 months"**

Amateur Experimental Station: G6YR.  
Near Harrogate, Yorks.

DEAR SIRS,  
Perhaps the following account of the life of some of your batteries may be of interest to you.

In September, 1925, I purchased 4 of your 4780 dry batteries, totalling, of course, 240 volts. These were obtained because in my present location I have absolutely no other method of obtaining High Tension for my low-power transmitter. I have kept a watchful eye on them and was quite prepared to have another set to buy after about say six months, but I have been amazed at their remarkable life, which so far is 12 months. Each battery still reads about 55 to 56 volts.

They have survived two serious shorts, which would have ruined any ordinary battery; and still continue to give service. My DX may be of interest as, obviously, the h.t. supply plays a big part in results. I have been in two-way communication with Finland, France, Belgium, Holland, Italy, Germany, Denmark, Sweden, Ireland, and Brazil, with an input of 2 (two) Watts, except for Brazil, when I added some more batteries and used 4.8 watts (four point eight). I have also been heard in New York when using 3 1/2 watts, and my telephony signals got out reliably to about 300 miles.

The transmitting circuits are normal ones, a wavelength of 45 metres is used and a Hertz radiator, badly screened, serves as antenna.

—a letter received from a user of Columbia Batteries.

## Columbia Dry Batteries

Ask any good dealer for full particulars or write to us for Columbia literature.

**J. R. MORRIS,**  
15, 19, KINGSWAY, LONDON, W.C.2.

Telegrams: Colcarprod, London. Telephone: Gerrard 3038.

Scottish Representative:  
John T. Cartwright, 3, Cadogan Street, GLASGOW.

### WHAT DO WE GAIN BY LOW-LOSS?

(Continued from page 34)

that a little more makes very little difference.

On the longer waves a low-loss coil in conjunction with an aerial kept very well away from trees and buildings all along its length will sometimes give a gain of 3 or 4 to 11. On short waves I doubt if there is any marked difference between any ordinary sized coils that can be wound.

#### A Really Low-Loss Circuit

By the way, almost the best low-loss circuit I know of is a frame aerial wound of solid wire, each turn spaced from the next one and the framework kept to a minimum. On the Daventry wavelength I find such a frame often requires the insertion of a resistance in series to maintain good quality.

#### In Intervale Circuits

Intervale circuits are the places where "low losses" will tell if they are used correctly. A coil of half the loss of another one can give double the magnification if the valves are altered to suit, or 1.4 times the magnification if the transformer ratio is altered, and if we have several such circuits in cascade the total gain can be made large.

#### Another Aspect

All the time I have, of course, only considered the resistance as controlling the signal. This is the "in tune" position, but away from this position the reactance takes charge, and as that remains nearly the same, we can say our tuning is improved because we obtain a greater ratio of "in tune" to "out of tune" signals.

#### Sometimes Not Desirable

There are one or two cases where low-loss is a disadvantage, chiefly in cascade H.F. amplification. In crudely constructed receivers insufficiently shielded and balanced the tendency to oscillate is greater with such coils, and may be uncontrollable. Then if care is not taken to obtain the right ratio of transformation the tuning curve of each circuit may be too low, with the result of far too sharp a resonance curve, and muffled signals unless mistuning is applied. This muffling is particularly easy to produce on Daventry's wavelength.

#### LET US KNOW YOUR RESULTS

How many stations have you heard on the loud-speaker with your Monodial? How near to the wave of the local station can you tune without interference? Remember that the Editor is interested to hear of readers' results in different localities.

IN six Mahogany Cabinets, best components and workmanship, SUPERHET, Convertible One to Three H.F. (Anode or Trans.), and One to Three Stages L.F. (Trans. or Resistance). Too large to take abroad. Accessories as required, cheap. Exceptional opportunity acquiring remarkably efficient set. Trial. Parts alone cost abt. £75. Accept half or near offer. HERBERT DUNK, "The Myrtles," Hawkinge, near Folkestone, Kent.

### EASY PAYMENTS

LOUD-SPEAKERS, HEADPHONES, H.T. ACCUMULATORS. Anything Wireless.

Send a list of the parts you are requiring, and we will send you a quotation on monthly payments.

H. W. HOLMES, 29, FOLEY STREET, Phone: Museum 1414. Gt. Portland St., W.1

### PICKETTS CABINETS

FOR EVERY CONSTRUCTOR.

"Monodial"	.. . . .	from 25/- to 40/-
"Davlow"	.. . . .	.. 35/- to 75/-
"Elstree" Solodyne	.. . . .	.. 45/- to 85/-
"Night Hawk"	.. . . .	.. 25/- to 45/-
"Midget Reflex"	.. . . .	.. 10/6 to 18/6
"Four Valves One Dial"	.. . . .	.. 17/6 to 30/-

GUARANTEED AND SENT ON APPROVAL. Estimates to your own sizes and LISTS FREE.

Picketts—Cabinet (W.L.) Works, Bexleyheath.

### From SCHOOL to PROFESSION via WIRELESS.

No long expensive apprenticeship; just RADIO MARITIME TRAINING, and your son will be placed in a responsible position. Within twelve months the capital invested is returned in his salary as a Wireless Operator. But it must be the TRAINING WITH THE WIRELESS SERVICE BEHIND IT. Write to Radio Maritime, Ltd., 15, Broadway Chambers, Hammersmith, W.6, or to 26-27, St. Mary Street, Cardiff.

#### PHONE REPAIR SERVICE

Headphones rewound and Remagnetised 4/6. Loud Speaker rewound 4/6. Transformers rewound 5/-. Remagnetising only 2/-. All work guaranteed. Postage extra. Write for trade terms.—H. R. P. Co., 1, Cottrill Road, Spurstow Terrace, Hackney, E.8.

#### LISSENOLA & BROWN "A" USERS.

#### Get the wonderful 14-inch CINCINNATI CONE, 1 1/6

Complete with bronze base and support, ready to have Brown reed phone screwed on making it into complete cone speaker, post 1/6. Attachment for Lissenola, 1/6 fully guaranteed.

J. W. MILLER, 68, Farringdon Street, E.C.4. Sole British Distributor. Phone, Central 1950

### EBONITE PANELS

or Strips, etc., described in this issue (or any other) can be obtained immediately through any trader from

TRELLEBORGS EBONITE WORKS, LTD. Audrey House, Ely Place London, E.C.1

### Valves Repaired

AS GOOD AS NEW!!

(Except Weeco, S.P.'s and low capacity types.) Minimum D.E. Current 0.15 amps when repaired. ALL BRIGHT & DULL EMITTERS Listed at less than 10/-. Minimum charge 5/-. VALCO LTD. Dept. W, Tabor Grove, Wimbledon, S.W.

## REPAIRS

By specialists skilled in every form of accurate and intricate coil winding.

Headphones, Loud Speakers and Transformers rewound, remagnetised, and reconditioned EQUAL TO NEW.

Owing to the rapid growth of business in our REPAIRS Department, we regret that we find it temporarily impossible to maintain our 24 hours service. Pending extension and re-organisation, a delay of a few days may be unavoidable.

VARLEY Magnet Co. Replacements Dept. Woolwich, S.E.18



Proprietors: Oliver Pell Control Ltd.





5/6

THE  
SAFETY SWITCH

Prov. Pat. 20022/26.

Comprises Switch, Lightning Arrestor. Lead-in Tube and weather-proof cover. When off, the set is entirely disconnected from the Aerial and Lightning Conductance is attained *Outside* the house. Safety is ensured should you forget to switch off—by the Permanent Spark Gap provided.

**Price - 6-inch Tube - 5/6**  
 " 12-inch Tube - 6/6  
 " 18-inch Tube - 7/6

Write for List No. W.4, giving full particulars of the Eelex Standardised Plugs and Sockets System, recommended and used by all leading Wireless Journals.



Eelex House, 118, Bunhill Row, London, E.C.1.  
 \*Phone: Clerkenwell 9282-9283.

AMATEUR  
TRANSMITTING NOTES

QRA's Wanted

SK-2NAX, SPR, SPM, PT5, SOU, BXY, GC-2WL, LGN, OHK, G-5WK, G-6MO, G-6GA, G-6TR, G-6RT.

QRA's Found

G-2CB (ex 2BJK): C. A. J. Brookes, 7, Merivale Road, Putney, S.W.15.  
 I-1BS: F. Luise, Piazza Manzi 10, Piacenza, Italy.  
 I-1BF: O. Santini, Viale Cavour, 48, Ferrara, Italy.  
 CVPE: A. Gariso (Div. Hon. Sec., Div. 10), B. M. R. Telegraphs, Villa Pery, Portuguese East Africa.  
 BZ-1AO: F. N. A. Costa, Caixa Postal N. 1587, Rio de Janeiro, Brazil.  
 BZ-1BK: J. C. Roos, 139, Rua Paysandu, Rio de Janeiro, Brazil.  
 D-7AT: A. Lykstoff, 37 Julius Blomsgade, Copenhagen.  
 D-7NR: J. Nissen Rahn, 15, Bispegade, Haderslev, Denmark.

---

WIRELESS.—Capable trustworthy men with spare time who wish to substantially increase income required where we are not fully represented. Applicants must have practical knowledge of installation of Set and Aerial, be a householder or live with parents, and be able to give references; state age and experience. Address: Dept. 38, GENERAL RADIO COMPANY, LIMITED, Radio House, Regent Street, London, W.1.

MICROMAIN

A PERFECT SUBSTITUTE FOR THE H.T. BATTERY, WHERE DIRECT ELECTRIC CURRENT IS AVAILABLE, AT A COST OF A FEW PENCE A YEAR.

SMALLEST

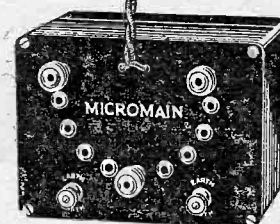

CHEAPEST

Size 3 1/4 x 4 1/4 x 3 1/4 ins.

THESE UNITS ARE SILENT, SAFE AND GUARANTEED FINISHED IN SOLID ALUMINIUM CASES COMPLETE WITH 6 YARDS OF FLEX AND LIGHT ADAPTER.

Model	Tappings	Finish	Price
SUPER	Ten 15-150	Polished	£2- 8-6
SPECIAL	" " " "	Dull Black	£2- 5-0
MARK II	Two 60 and 120	" "	£1-17-6
MARK I	One 90 or 120	" "	£1-10-0

Postage and Packing 1/- per unit extra.

MICROMAIN UNIT SERVICE,  
46, ARTILLERY LANE,  
LONDON, E.1.

Or Your Wireless Dealer.

---

"ARJA" Guaranteed 2-Valve Receivers £6:10:0

You must not miss this great opportunity of securing a guaranteed two-valve, all-station receiver complete with every accessory. Send at once for your copy of our Ultra Cat., Booklet No. 9 describing this instrument and many others. It is Post Free. You only have to get this book to be convinced. SEND NOW.

R. C. JONES, 75, HARGWYNE STREET, STOCKWELL, S.W.9

THE REMARKABLE  
MONODIAL RECEIVER

Order all, or any, of these Components NOW!  
IMMEDIATE DELIVERY.

	£ s. d.		£ s. d.
Cabinet (Camco.) ..	1 15 0	4 Burndept Fixed Resistors and Holders ..	0 10 8
Ormond Double Condenser ..	1 12 0	2 Baseboard Neutralising Condensers ..	0 10 0
4 Anti Phonic Valve Holders (with terminals) ..	0 10 0	1 P.M. Midget Condenser ..	0 7 6
1 R1 Transformer (multi) ..	1 5 0	1 Varley 250,000 ohm Resistance ..	0 9 6
1 Igranic-Pacent Transformer ..	1 4 6	2 Dubilier .002 Condensers ..	0 6 0
1 H.F. Varley Choke ..	0 9 6	Grid Battery Clips ..	0 0 6
1 Bulgin "On" and "Off" Switch ..	0 1 6	Battery Leads ..	0 8 6
2 Igranic-Pacent Jacks ..	0 6 0	3 Pilot Lamps and holders for H.T. Fuses ..	0 4 6
1 Dubilier Condenser and Leak ..	0 5 0		
Ebonart 14in. x 7in. Panel ..	0 7 9		
2 H.F. Transformers and 6-pin Eases ..	1 2 0	Total ..	£11 15 5

Prompt delivery of all parts for "Elstree Six," "Solodyne," etc., etc. Send Cash with Order. Carriage paid on orders value £2 or more.

County Electrical & Wireless Stores, Ltd.

2 & 3, Norfolk Street, Strand, London, W.C.2.

AND AT

1, South Street, Deal.  
124, Sandgate Road, Folkestone.

5, Yelverton Road, Bournemouth.  
86, Southgate Street, Gloucester.

TRADE ALSO SUPPLIED. FULL DISCOUNT TERMS.

VACANCIES

APPLICATIONS ARE INVITED FOR TECHNICAL ASSISTANTS WHO HAVE A THOROUGHLY SOUND KNOWLEDGE OF MODERN SETS AND THE RECTIFICATION OF FAULTS. ONLY MEN OF SOUND EDUCATION AND TECHNICAL ABILITIES NEED APPLY.

APPLICATIONS *MUST* BE BY LETTER AND SHOULD GIVE FULLEST DETAILS OF EXPERIENCE AND SHOULD STATE SALARY REQUIRED.

S.T. LTD., 2, Melbourne Place,  
London, W.C.2.





## Sources of supply

"THE WIRELESS DEALER and Radio Trade Journal" contains two important guides to sources of supply—Index to Advertisers and The Buyer's Guide. The first will refer to advertisements in the issue, while the second will direct you to the manufacturers of any particular product which you may require to order. These two guides compose an important fund of information.

Commence your subscription with the current issue—it is rather an important one for the retail section of the Trade. It contains a detailed "Stand to Stand Review" of the Great Exhibition at Olympia, a comprehensive résumé of the Shows at Belfast, Berlin, New York, and all available information of the Radio Show in one of England's greatest industrial centres—Manchester.

#### SUBSCRIPTION RATES:

7/6 per annum (abroad 10/-). Available to the Trade only. Trade card or business heading should accompany every subscription to the SALES MANAGER, Radio Press, Ltd., Bush House, Strand, London, W.C.2.

**The Wireless Dealer**  
AND  
Radio Trade Journal



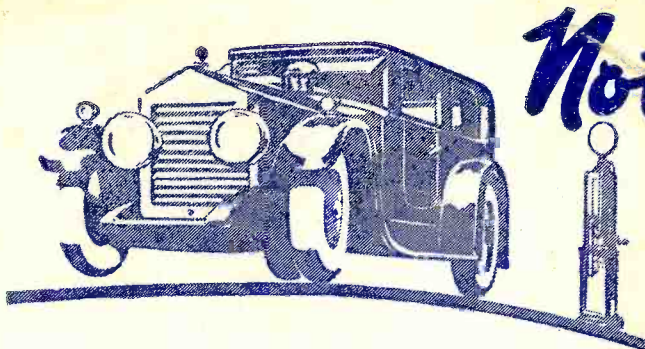

*Not*  
**M.P.G.**

*But*  
**H.P.C.**

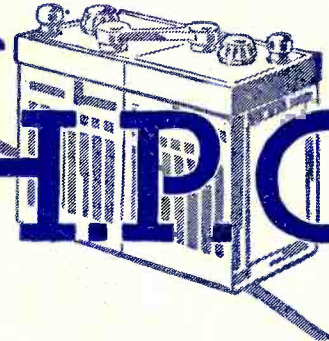

THE history of the radio valve industry is remarkably similar in outline to that of the motor industry. In both cases the first endeavour was to secure reliable operation. For years the design of cars and valves was improved stage by stage, giving better results and longer service. Then came the question of perfecting that achievement by giving in the case of cars more

**M.P.G.**  
(miles per gallon)

In 1925 Mullard placed on the market the first of a series of valves with qualities far in advance of the old standards and consuming only one-tenth ampere, with the result that the broadcasting public were enabled to secure up to seven times more

**H.P.C.**  
(hours per charge)

from their accumulators. At the same time these special valves gave them better, purer reception and the danger of loss due to accidents was reduced to a minimum owing to the extreme toughness of the unique Mullard P.M. Filament these valves embodied. In one short year over £200,000 has been saved in reduced upkeep costs by the users of Mullard P.M. Valves, apart from the renewal expenses that have been obviated by the vastly increased life of these valves.

Consider greater economy and greater results when you select your radio valves. Ask Your Dealer for Mullard P.M. Valves with the Wonderful P.M. Filament.

**Mullard P.M.**  
**Valves will**  
**improve**  
**any receiver.**

- For 4-volt accumulator or 3 dry cells
  - THE P.M. 3 (General Purpose) 0'1 amp. 14/-
  - THE P.M. 4 (Power) 0'1 amp. 18/6
  - For 6-volt accumulator or 4 dry cells
  - THE P.M. 5 (General Purpose) 0'1 amp. 18/6
  - THE P.M. 6 (Power) 0'1 amp. 18/6
  - For 2-volt accumulator
  - THE P.M. 1 H.F. 0'1 amp. 14/-
  - THE P.M. 1 L.F. 0'1 amp. 14/-
  - THE P.M. 2 (Power) 0'15 amp. 18/6
- These prices do not apply in Irish Free State.*

**British Made**  
**in a**  
**British Factory**

# Mullard

## THE MASTER VALVE

ADVT. THE MULLARD WIRELESS SERVICE CO. LTD., MULLARD HOUSE, DENMARK STREET, LONDON, W.C.2

Published by RADIO PRESS, LIMITED, Rush House, Strand, London, W.C.2, on Tuesday of each week, and printed for them by THE AVENUE PRESS (L. Upcott Gill & Son, Ltd.), 55-57, Drury Lane, London, W.C.2. Address for subscriptions and Editorial Communications:—Bush House, Strand, London, W.C.2. Address for Advertisements:—Advertisement Manager, WIRELESS, Bush House, Strand, London, W.C.2. Phone: City 9911. Registered as a newspaper and for transmission by Canadian Magazine Post. Subscription rates U.K. and abroad:—13s. per annum, 6s. 6d. for six months, post free. Sole Agents for Australasia:—GORDON & GOTCH (Australasia), LTD. For South Africa:—CENTRAL NEWS AGENCY, LTD. American Agents:—INTERNATIONAL NEWS Co., New York. Canadian Agents:—THE AMERICAN NEWS Co., LTD., also IMPERIAL NEWS Co., LTD.