

Wireless

VOL. 2
JULY

NO. 8
1935

AND TELEVISION REVIEW

PRICE

6^D

This Year's
**MIDGET
PORTABLE**



*The best and most Inexpensive
Set of its Kind ever designed*

Special Midsummer Number



GOOD GARDENING is a magazine written by people with gardens of their own—gardens such as you possess. It tells of the soil and its constituents, of the things which some plants love and others loathe. It plans your garden for you, and teaches you how to improve it. No gardening journal has ever before been able to illustrate its pages so beautifully or so lavishly as "GOOD GARDENING." Many varieties of blooms are shown in natural colours: the detail of many of the photographic illustrations is little short of marvellous.

GOOD GARDENING

SPECIAL MIDSUMMER NUMBER **6^d**

Now on Sale at all Newsagents and Bookstalls

*Here are some of the Contents of the
Special Midsummer Number :*

ENGLAND'S LOVELIEST ROSES.

A Beautiful Full-Colour Supplement.

THE SUMMER GLORY OF THE
HERBACEOUS BORDER,
by LADY MARTINEAU.

A WATERSIDE GARDEN,
by ELEANOR SINCLAIR ROHDE.

THE GARDENS OF CANADA.

THE RIGHT WAY WITH PAEONIES,
by MARION CRAN.

A GARDEN BY THE AVON, continu-
ing MURIEL MARSTON'S serial story.

CAPTAIN KINGDON WARD'S further
adventures in search of the Blue Poppy.

CONTENTS



	Page
The Editor's Chat	47
Radio To The Rescue	48
This Year's Midget Portable	49
From My Armchair	53
Improving the Ends of the Scale	55
"Mixing" the Microphones	56
With the B.B.C.'s Covered	57
Wagon	58
Short-Wave Notes	58
B.B.C. News	59
Touring Europe With a Portable	60

	Page
Radio In the Navy	61
Questions I Am Asked	63
Miliu : the Invisible	64
The "Hexoverter"	65
Practical Hints For All	75
As We Find Them	76
New Uses for Micro-Waves	77
In Lighter Vein	79
America Calling	81
S.G. Transmitting Valves	83

SPECIAL TELEVISION SECTION

	Page
General Notes by Dr. Roberts	67
"Hard" and "Soft" Scanning Circuits	69

	Page
Television Magnifiers]	71
Television Layouts	73
Safeguarding the Tube	74

As some of the arrangements and specialities described in this Journal may be the subjects of Letters Patent the amateur and trader would be well advised to obtain permission of the patentees to use the patents before doing so.



**PUBLISHED BY THE
AMALGAMATED PRESS LTD.
THE FLEETWAY HOUSE
FARRINGDON ST., LONDON, E.C.4**



Your Second
**Five Volumes of
THE MASTERPIECE
LIBRARY
OF SHORT STORIES**
Are Now Ready

SEND FOR THEM WITHOUT DELAY

Token No. 3, to complete your second Gift Voucher, appears in WIRELESS AND TELEVISION REVIEW to-day. Send in this completed Voucher AT ONCE, together with the first if you have not already done so. Follow the instructions given on the Gift Voucher carefully and do not forget to indicate which type of binding you have selected—

BLUE ART. LEATHER or SUPER DE LUXE

Your volumes are waiting. Complete Gift Vouchers and remittances should be sent to:

*The Amalgamated Press Book Dept.,
(G.P.O. Box 184a), Cobb's Court,
Broadway, London, E.C.4.*

Enclose P.O. for 10s. 6d. for each set of five volumes in the Art. Leather binding or £1 for each set of the Super De Luxe edition.

All applications will be dealt with in strict rotation; the sooner you apply, the sooner will you receive these magnificent volumes, of which you will be justly proud.

A Great Paper for the Boy of To-day!

Every boy is interested in adventure yarns, in the latest inventions and engineering marvels, railways, aeroplanes and motor cars. Then you will revel in MODERN BOY, for this splendid paper for the boy of to-day grips with a big budget of features that provide hours of absorbing and informative reading. Each week there are healthy and exciting stories by the best boys' authors, and articles that are just about the finest to be found anywhere. This is the paper for the boy who knows a good thing! Buy it regularly

MODERN BOY

Every Saturday, at all Newsagents and Bookstalls. 2d.

For
**OBVIOUS
REASONS**

For obvious reasons this is the time for you to invest in a new radio. There are weeks of unique broadcast programmes ahead, and during the next few years superheterodyne radio of the modern type is going to be more and more necessary for perfect separation and reproduction of Europe's elaborate network of programmes.

For obvious reasons also, a Marconiphone is the instrument you should have. *It is the only radio which needs no introduction, no explanation and*

no justification. Its unique superiority in home entertainment, with 25 years lead of all others, is obvious the moment you compare it with any other instrument. You will never be really satisfied until you have a Marconiphone. Why not use the coupon below and secure your instrument in time for the many brilliant programmes? Post it now and we will send you a fully descriptive leaflet and place you in touch with your 'Local Marconi-men' upon whom you can rely for prompt and experienced service.

L **MARCONIPHONE**



The model illustrated is the
**Jubilee Year
Superhet Radiogram**

A 5-valve 7-stage instrument of very latest design and the keenest possible performance.
(Model 287 for A.C. mains).

22 GNS OR **5/-** PER WEEK

APPLY NOW for an illustrated descriptive list of the Marconi Jubilee Year Models and the address of your local Marconi-men.

Name.....

Address.....

W. JULY.

To the MARCONIPHONE COMPANY LIMITED, RADIO HOUSE, TOTTENHAM COURT ROAD, LONDON, W.1.



The
Editor's
Chat

Wireless

& TELEVISION REVIEW

Portable Sets—Our New "Midget"—Car Radio Next Month

WHILE there are still many portable sets bought and built, it is an undeniable fact that they are not now so popular as they used to be. Three or four years ago there must have been at least a million in use.

But we would hazard the opinion that although most of them were acquired for employment as portable sets, the great majority were seldom if ever moved from their places in kitchens, parlours and drawing-rooms. In short, the theory of portability was fine, but in practice it was found to present physical difficulties!

And so, when the time came for those listeners to buy or assemble new sets, a large proportion went over to ordinary ones, for there seemed to be no purpose in adhering to the pseudo-portable type.

The question may then well be asked, "When is a portable portable?" and the answer is when it can be carried about easily without the assistance of a porter's trolley or a wheelbarrow, and when its current consumption is low enough for the batteries to give normal service.

Really Portable

And, perhaps, we should add, when it is a real equivalent to the ordinary outfit in so far as quality is concerned.

After all, if a so-called portable typewriter weighed rather more than a normal one and wrote with crooked characters, you wouldn't expect it to be popular, would you?

We are convinced that if an effort were made on the part of the radio industry to develop the portable to the

same extent as other radio devices have been developed, a considerable public demand would be re-created.

In the meantime, we are glad to be able to say that the home constructor has the opportunity of assembling a portable having all the desirable features to which we have referred. "This Year's Midget," which is described in this issue, really is a grand little portable. It is a trifle deeper, but its other dimensions are no greater than that of a small attaché case.

Well Worth Building

In fact, it really is a portable and can be carried in comfort the while it reproduces speech or music with a fidelity which shames many ordinary sets.

And yet the cost of its parts is not much more than 50s.! We believe it is a set constructors by the thousand will want to possess as an addition to their present receivers.

Not only can it be carried to any-

where in the house or the garden, but it is always ready to take its part in a day's outing in the country or to provide solace and diversion for a sick relative or friend in a nursing home or in their own bed. We hope a very large number of readers will build it.

From portable sets it is no great jump to car radio. Until recently there had been a certain amount of hesitation on the part of car owners to instal radio on their cars because of the uncertainty of possible legislation.

But now the matter has been clarified by the Minister of Transport, who has stated that he has no objection to car radio, and that should it ever become necessary to introduce laws and restrictions there will be a long period of notice given.

So the way is wide open for this newest branch of radio. Already one firm announces that its sales of car radio equipment have leapt up by one hundred and fifty per cent owing to the removal of uncertainties regarding official action.

FOR ULTRA-SHORT-WAVE TELEVISION

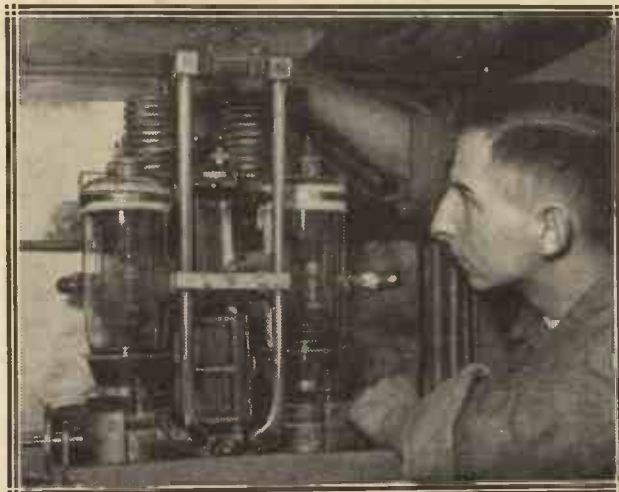

The water-cooled output stage of the Telefunken ultra-short wave television transmitter at Witzleben.

Special Articles

At this year's motor show it is anticipated that radio will be optional on practically all models, while those not having at least built-in aerial systems will be exceptions.

In view of this we have decided to prepare some special articles on the subject of car radio which will give all the latest information regarding the apparatus available and how it can be fitted to cars. These articles will appear next month and will cover the ground more completely than has hitherto been done by any journal.

RADIO TO THE RESCUE

A vivid pen-picture of life in the Frozen North and of the part wireless is playing in dispensing medical aid, promoting business and preventing crime.

RADIO has broken down the barrier of isolation for the Arctic.

On a fishing vessel sailing along under wintry blasts in the North Atlantic Ocean a seaman was injured. The extent of his injuries was such as to necessitate the low-powered wireless set on board to be called into action. A call for a radio doctor went out.

The call was answered by the nearest coast station. This was the isolated station on bleak and barren Resolution Island, at the entrance to the Hudson Straits. The SOS came as a break in the monotony of the weather reports which go from this station daily to Ottawa, more than 1,500 miles distant over uninhabited bush and windswept sub-Arctic mountains.

Rapid Advice

Here it was learned that the seaman's injuries were serious. He had fallen from a mast, and it was thought he had fractured his skull. What should the ship's captain, as the doctor, do in this case?

Resolution Island called Cape Hope's Advance along the Straits, explained

AN ARCTIC POLICE STATION



the situation as reported to it, and waited. V A Y, which is Cape Hope's Advance, dropped from the ship channel wavelengths to the short waves, and was immediately in touch with Ottawa. Its message received in the distant city, it was told to stand by while the operator telephoned for a doctor. That took but a few

moments. The doctor issued instructions for treatment and referred the Arctic radio operators to their first-aid manual, giving them the necessary pages where information on this case would be found.

The word went north to Hope's Advance, to Resolution Island, and then to the fishing vessel. The seaman was treated and a course set for Reykjavik, Iceland, where medical attention could be had. The radio doctor had functioned

.....
On the right is the radio station at a Hudson Bay mining camp. These lonely outposts keep in regular touch by short waves with civilisation further South.

* * *
A member of the mounted police (left) operating a short-wave station in a remote Arctic post in Northern Canada. News, medical advice, and criminal intelligence are all received by radio.

.....
 once more to save life in the distant Arctic.

Every now and then such messages filter in to the radio central maintained by the Canadian Government's marine department at Ottawa. They ask for medical aid

which cannot be had in the sub-Arctic and Arctic without travelling hundreds of miles, facing blizzards and hardships, to reach the few doctors which have been scattered throughout that vast northland by the Government. The radio stations, which are increased in the north-west territories every year, carry the more serious of

those cases which come to the attention of the radio operators. Colds and other lesser sicknesses are taken care of by the police and the radio men.

The Wounded Trapper

A trapper, wounded through one of his traps, decided to face the winter's blizzards to reach the radio station and possible assistance, rather than to die of his wounds in his isolated cabin. He harnessed his dogs and, with the greatest pain, managed to get into the sled and start his team for the radio station at Hope's Advance, fifty miles distant. How he arrived despite his wounds is still a mystery in the Arctic, but arrive he did, and at once the radio short waves became extra busy. Traffic to Ottawa

ON THE SHORES OF HUDSON BAY



was side-tracked for this medical case, and within a few minutes of the arrival of the trapper a doctor was at the other end of the invisible wire directing the radio man how to operate and treat the wound so that the much-feared blood poisoning, which had made the trapper leave his lonely cabin, would not set in.

But it is not only as a medical carrier that the radio has broken the Arctic's isolation. It has come to the relief of explorers and police as well as to the private citizen who lives in the Arctic as fur trader, trapper, missionary or mining engineer.

An Explorer Reports

After spending an entire winter making scientific investigations around the North Magnetic Pole, a Canadian Government explorer set out to reach civilisation while the ice was still strong enough to carry him and his dogs. He reached the first trading post along the Arctic coast and found a schooner frozen in for the winter, equipped with radio transmitter. Here was an opportunity to let his colleagues at Ottawa hear from him and report his findings. The radio sped the news

(Please turn to page 87.)

This Year's Midget Portable



LIGHT—COMPACT—EFFICIENT

An ideal summer companion that can be easily carried and which will give you first-class results in places all over the country.

Described by G. V. DOWDING, Associate I.E.E.

If some of those radio sets which are styled portables really have anything of a right to that description, then all I can say is that their only justification can be their handles. It would be just as fair to call a piano a portable simply because a handle had been fitted to it!

No, I fear the average so-called portable has no real portability, unless

you went and not merely strident squeaks or muffled grunts.

Our ambitions went even farther than that. We wanted our perfect portable to be one which could be made by anyone from standard and easily obtainable parts at a cost below that of its elephantine equivalents.

We believe that all our readers will agree that we have succeeded in every respect, and that "This Year's Midget Portable" is a quite extraordinary achievement.

small attaché case; with those items, the total weight is still only about half of that of the majority of portables.

Convenient Shape

But what you cannot appreciate, unless you actually handle the set itself, is the very convenient and easy manner in which it hangs from the hand, and this makes it feel even lighter than it is. This is due to the careful and rather unorthodox shaping of the case which allows the set to swing clear of the body without there being any need for you to strain your arm outwards. It is this which makes the average portable, which is already heavy enough in all conscience, feel such a "ton-weight" to carry, and you rapidly tire, though you only stand still, let alone when you try to hike it across a ploughed field!

Half the Usual Weight

The photographs will enable you to see how small it is, and its weight is largely made up of the weight of the standard H.T. battery, accumulator, and the miniature and quite light loud-speaker. Without these items the weight is hardly greater than that of a

THE FEW PARTS REQUIRED

- 2 Graham Farish Mid-Log-Line .0005-mfd. solid dielectric tuning condensers.
- 2 Polar 3-in. plain black dials, 0-100°.
- 1 Polar .0003-mfd. solid dielectric differential reaction condenser.
- 1 Formo "Sensity" iron-cored coil, type P.P.I.
- 1 Bulgin toggle on/off switch, type S.80.
- 1 Bulgin toggle 4-pt. shorting switch, type S.87A.
- 1 W.B. Universal valveholder.
- 1 Benjamin 4-pin "Vibroder" valveholder.
- 1 Benjamin 5-pin valveholder.
- 1 Varley "Nictet" L.F. transformer, 1:3:5.
- 1 T.M.C.-Hydra 2-mid. fixed condenser, type 30.
- 1 T.M.C.-Hydra .25-mfd. tubular fixed condenser.
- 1 Dubilier .0005-mfd. fixed condenser, type 820.
- 1 Dubilier .0002-mfd. fixed condenser, type 820.
- 1 Erie 2-meg. 1-watt grid leak.
- 1 Erie 20,000-ohm 1-watt resistance.
- 1 Bulgin screened H.F. choke, type H.F.S.
- 1 Wearite screened H.F. choke, type H.F.P.A.
- 1 Piece copper foil, 14 in. x 8½ in.
- 1 Piece copper foil, 9½ in. x 4½ in.
- 1 Piece 24-gauge aluminium, 7 in. x 8½ in.
- 1 Piece 24-gauge aluminium, 15 in. x 1 in.
- 2 Pieces 2 B.A. screwed brass rod, 3½ in. long.
- 8 2 B.A. nuts.
- 1 Coil B.R.G. "Quikon" connecting wire.
- 4 Belling & Lee wander plugs.
- 1 Belling & Lee wander-fuse.
- 2 Clix accumulator spades.
- Wood for chassis and case, etc. (see text).
- 1 Handle for case.
- 1 W.B. Baby Stentorian loudspeaker.
- Screws, flex, etc.
- 2 oz. 32 gauge D.C.C. wire.

SIMPLE DESIGN

The chassis of the Midget Portable removed from its case. The frame aerial and battery tray have been taken off so that as many of the components and as much of the wiring as possible can be seen.

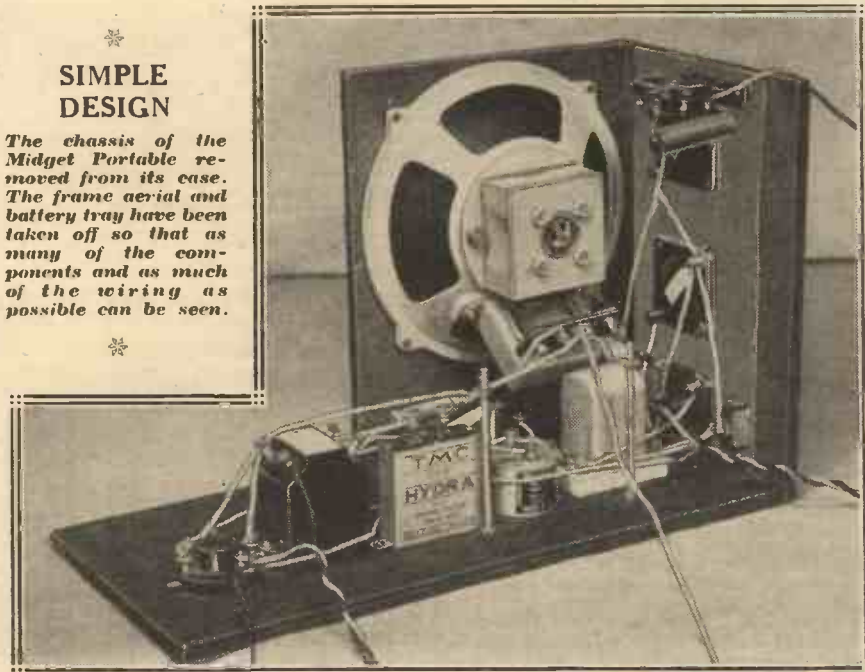

one possesses a car to carry it about. With this thought in mind, we decided to see if we could design a real portable, an efficient all-in loudspeaker outfit which was lighter and more compact, something which could be carried about with ease and which would, nevertheless, enable you to have good speech and music wherever

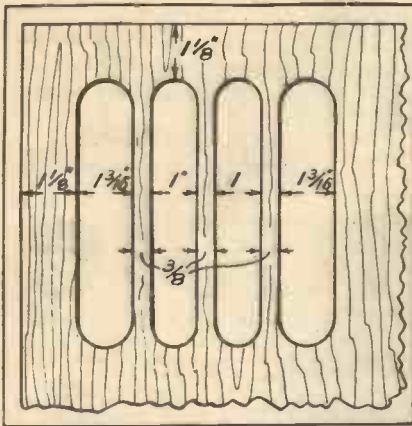

AN ARTISTIC LOUDSPEAKER FRET is cut in one side of the cabinet in accordance with the dimensions given above. As the loudspeaker is mounted on its own baffle, this fret can be modified to suit one's own ideas.

The moment you pick up the "Midget Portable" you are aware that here you have a portable which can be carried without distress to wind and limb.

And what of the cost of this notable little set? About 50/-! Or, with everything included, batteries, valves, loudspeaker, etc., less than £6!

And, let me repeat, its reproduction is first-rate, every bit as good as the average high-class domestic set, and about two thousand per cent better than the average portable. Clear and loud, with plenty of bass and crisp, clean high notes. I know all this must appear a pretty tall story, but it is absolutely factual.

It is a quite remarkable set, and is immensely superior in its reproduction and in its general qualities to anything—I was nearly going to say "of its own weight or size" but that would be an unnecessary restriction.

ACCESSORIES EMPLOYED

VALVES
S.G. Det. Output
Cosor 210 S.P.T. Osram H.L.2K. Hivac Y22D
(Metallised) (Metallised)

BATTERIES
H.T.—120 volts (Vidor).
G.B.—4½ volts (Drydex).
L.T.—2 volts (Exide), type P.O.—2.

I hope it will be appreciated that I do not usually eulogise about our sets in this manner, but on this occasion I

feel we have something which deserves just as much enthusiasm in its presentation as can reasonably be given to it.

Four or five months ago the following words appeared in WIRELESS: "With care and skill, and with the assistance of a well-equipped laboratory, it is not difficult for experienced designers to produce first-class designs for home-constructors. All these things are necessary in combination, however, . . . Our standard is a high one, and we believe we successfully maintain it; but at intervals the unceasing efforts of our Research and Design Dept. bear what we can only term as 'spectacular' results."

"Robust Results"

On that occasion we were discussing the "Ferrogang" Four, and we went on to describe how, although we knew that that set would be

surprised even us with its robust results. I think it might reasonably be called "The Dwarf with the Giant's Voice," or "The Mighty Atom"!

However, it will speak plainly

THE WIRING IN PLAN VIEW

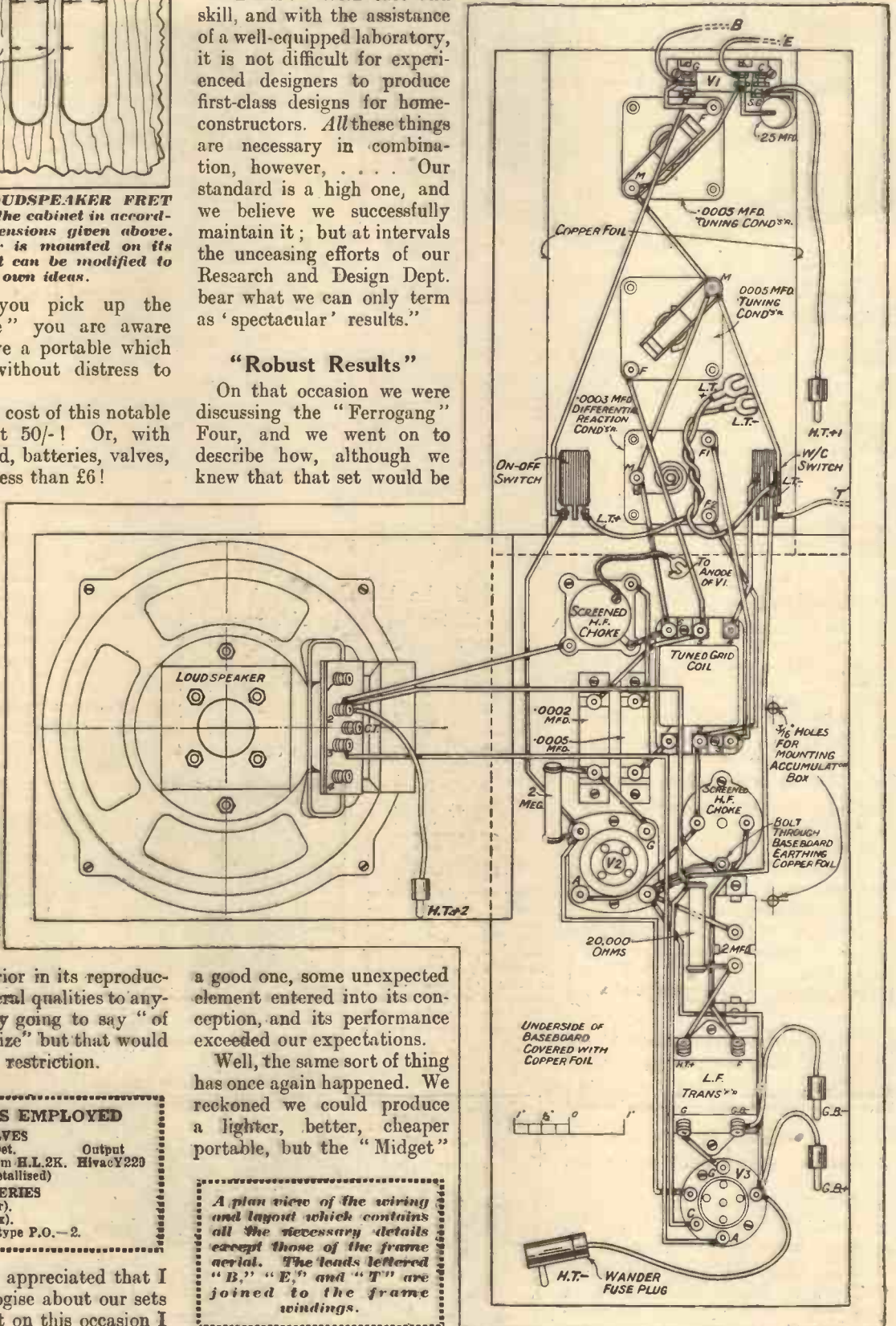

a good one, some unexpected element entered into its conception, and its performance exceeded our expectations.

Well, the same sort of thing has once again happened. We reckoned we could produce a lighter, better, cheaper portable, but the "Midget"

A plan view of the wiring and layout which contains all the necessary details except those of the frame aerial. The leads lettered "B," "E," and "T" are joined to the frame windings.

enough for itself to all those who decide to build it, and we all hope that that will be a very large number indeed.

While the "This Year's Midget" is a set which can easily be built by anyone able to handle a few simple tools such as a screwdriver, hack-saw, and so on, it would be wrong to say it could be built in, say, a couple of hours. The very nature of the set forbids that it should be capable of assembly in as short a time as a simple panel and baseboard table set.

You will probably have to spend more than one evening on its construction; perhaps several. It all depends upon your own ability to do the various little jobs required. But you will find the time has been very well spent when you have got the set working.

The inexpensive parts are widely obtainable, and you should encounter no difficulty at all in getting them. Of course, this is a set in which it is physically impossible to use any old equivalent to the various components. And that is in itself not a drawback, but a very good thing.

Making a Start

Undoubtedly the outstanding results given by the set are due in no small measure to the happy working together of the selected parts, and it is an advantage that the constructor cannot be tempted to employ alternatives that might in fact be unsatisfactory, though at first sight they appear to be suitable.

Another point which I am sure readers will appreciate is that the various sections of the set have to be built in a definite order. The chassis should be tackled first. Use 3/8-inch plywood for this, making the baseboard 14 in. by 6 1/2 in. and the panel 9 1/2 in. by 6 1/2 in. The size of the baffle is 7 in. by 8 1/2 in., and this has to have a circle of 5 1/2 in.

A DUAL PENTODE THREE-VALVER

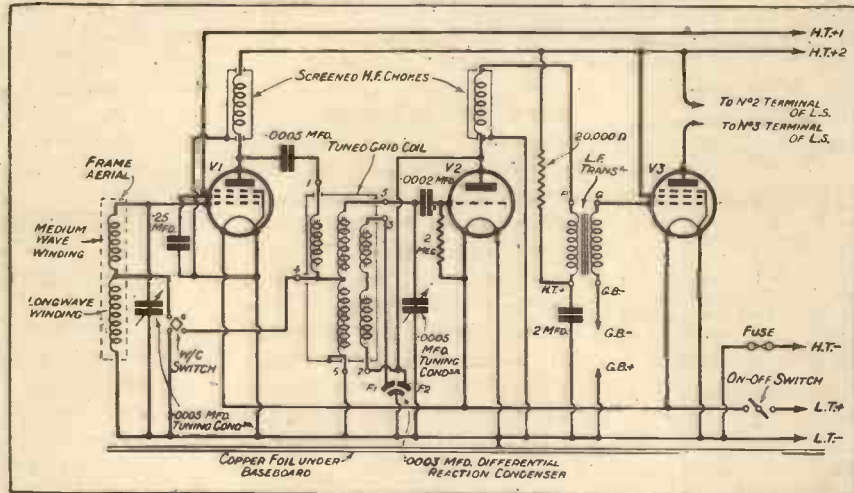

The highly efficient circuit employed incorporates both H.F. and L.F. pentodes, these ensuring great sensitivity and good power output.

diameter cut out of it, this hole being 3/8 in. in from the top and sides.

The control panel and baffle are mounted to the baseboard by means of 1-inch veneer pins. The under side of the baseboard should be surfaced with copper foil, and this can be held

tor carrier, and frame aerial are fixed in. A piece of card (cut from an ordinary postcard) must be placed behind the reaction condenser.

The valveholder for V1 is held out by about a quarter of an inch from the panel with nuts, in order to provide the required spacing. Keep closely to the positions of the baseboard components, as shown in the diagram, because there will be only just sufficient room for the 120-volt H.T. battery. Obviously, in a tiny portable like this, there cannot be lots of space to play with.

COMPLETELY WIRED



Fixing the Speaker

It is a good plan to place the H.T. battery in position before the parts are finally screwed down, to make sure that you have everything quite correctly placed.

Needless to say, the wiring ought to be carried out carefully for a portable generally has to withstand rougher handling than an ordinary set.

Subsequently to the completion of the wiring the loud-speaker can be fixed in place. It is held in position by means of four round-headed 1/8-in. No. 4 wood screws.

The connections to the loud-speaker, which are shown in the diagram, are suitable for the output valve we have specified, and it should be noted that if another make of output pentode of a similar type is used it may be necessary to employ different

L.T. AND H.T. BATTERIES

The L.T. battery tray is supported by two lengths of threaded brass rod, and prevents any possibility of the battery breaking loose. The H.T. battery stands on end in the space visible in the left foreground.

SLIDES IN AS ONE UNIT

The set can be tested before it is placed in its cabinet, and after test can be slid straight into the case without any connections having to be undone or altered.

tappings in order to obtain correct matching.

And now for the accumulator carrier. This also is constructed with $\frac{3}{8}$ -in. plywood, and a piece measuring $4\frac{1}{2}$ in. \times $2\frac{3}{8}$ in. will be needed. In addition, a 1-inch-wide aluminium

PANEL CONTROLS

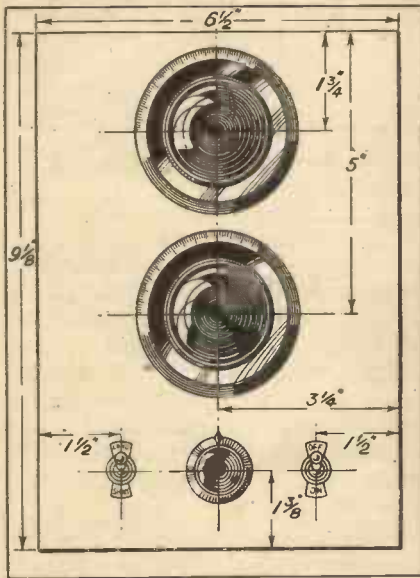

There are only two tuning dials the top being the frame aerial tuning control, and below it the detector tuning condenser. At the bottom of the panel are, left, the wave-change switch, centre, the reaction control, and right, the L.T. "on-off" switch.

strip approximately $14\frac{1}{2}$ in. in length, will be required.

Two holes should be drilled in the wood to take 2B.A. screwed rod for mounting the carrier to the baseboard. These holes are centred between the two sides and $\frac{1}{2}$ inch from their respective ends. They should be recessed on the top side in order to accommodate 2B.A. nuts.

The aluminium strip is bent round the sides of the wood and held in position with brads. It is advisable to insulate it along that part of it which runs close to the terminals of the loudspeaker and this can easily be done by sticking on some adhesive tape.

Height of the Tray

When in position the carrier should be raised $2\frac{5}{8}$ in. from the baseboard by means of the screwed rod "legs" and it will be found that these will hold it quite securely.

There is a clear diagram of the frame aerial, but some additional explanatory notes are needed. The same kind of plywood is used for it as has been employed for the other sections so far dealt with ($\frac{3}{8}$ -in. six- or seven-ply).

The four pieces can be tacked together with 1-inch veneer pins, one

being used in each corner in the centre of the frame. Then $\frac{3}{8}$ -in. square blocks are glued in each corner, these being pinned by means of $\frac{3}{8}$ -in. veneer pins.

Tape the Winding

Wind the wire in the direction indicated in the diagram and bind the centre of each side of the frame with adhesive tape so as to prevent any rattling of the windings.

Take the ends of the windings through small securing holes.

Three-quarter-inch No. 4 wood-screws are suitable for fixing the frame aerial to the baseboard, and two of these will suffice. But it is important to note that the frame should be raised $\frac{1}{8}$ in. by means of washers.

And now for the case. For this you will need the following timber :

TAKE IT ON YOUR HOLIDAY



The compact size of the Midget Portable can be judged from this photograph, while its weight is commensurate with its dimensions.

Two pieces of $14\frac{3}{8}$ in. \times $6\frac{1}{2}$ in. (full) \times $\frac{3}{8}$ in. for the top and bottom.

Two pieces $14\frac{3}{8}$ \times $9\frac{7}{8}$ \times $\frac{3}{16}$ (this will be 3-ply) for the sides.

One piece $9\frac{7}{8}$ in. \times $6\frac{1}{2}$ in. (full) \times $\frac{3}{8}$ in. for the back.

THE AERIAL
The frame aerial should be constructed according to the diagram on the right, and the sheet of aluminium screening affixed as shown.

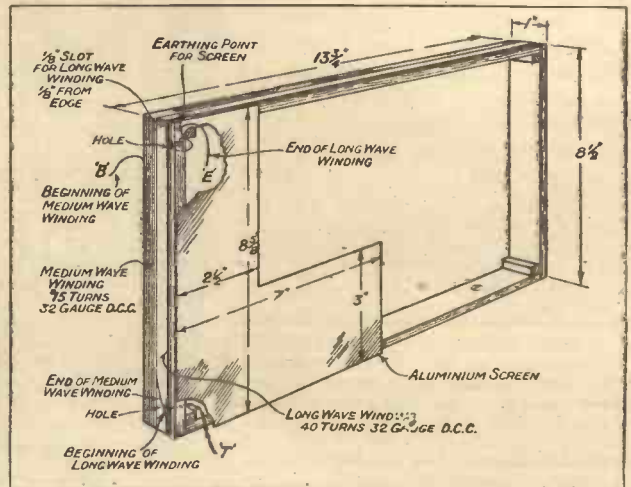

The top and bottom are fixed inside the back piece and the sides are fixed over all.

There is a diagram to show you how the fret is cut. You will find it quite easy to do this with a keyhole saw or with a fretsaw. Slight flaws can quickly be sandpapered out afterwards. The case should be both glued and pinned together, and those who desire to do so can, of course, polish it or cover it with leatherette.

For Easy Carrying

Now, while the handle is exactly equidistant from the front and back it is not centrally placed between the sides. You should fit it so that it lies 3 in. in from that side in which the fret appears. The purpose of this is so that a good balance is obtained, and so that the portable becomes particularly easy to carry.

There remains only the metal turn button for keeping the chassis securely locked into the case. This you make of $\frac{1}{16}$ -inch brass. It measures $\frac{1}{2}$ in. \times $\frac{5}{16}$ in., and it is drilled at one end and screwed to the centre of the edge of the bottom of the case at the panel end.

We would strongly advise you to use the particular detector valve which we have specified, because it is absolutely non-microphonic and needless to say, any microphony in a portable is likely to be very troublesome.

The bias for the output valve specified is normally 3 volts at 120 volts H.T., but it is desirable to use $4\frac{1}{2}$ in order to keep the H.T. current down to a low level. You will find that there

(Please turn to page 88.)

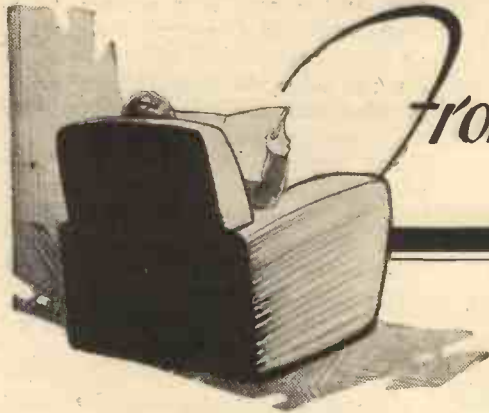

From My Armchair



Mr. Scott-Taggart, who recently went on a brief visit to Holland, has some amusing remarks to make about his trip.

THIS is Amsterdam—a place that conjures up visions of diamonds, cheese, clogs, bulbs, and the grandfather of all plus fours.

I found none of these, but I discovered a delicious lobster at the hostelry where I am staying, which for no readily ascertainable reason styles itself the American Hotel. Never have I tasted a lobster so delicious, so tender, so anxious that I should relish every shred of its meat.

The aftermath last night was equally delightful. After lobster I usually spend the night being hounded down the main streets of innumerable towns by shrieking home constructors with foam-flecked muzzles, from which issue blood-curdling cries. Just as their fangs fasten on my throat I waken up. I hope I always shall. No, lobster is not worth it.

"A Huge Resistor"

But here I felt it would be different. With the North Sea—not to mention the Zuyder variety—between us, I would surely be at peace and lo, it was so. I lay happily on my back, a gentle smile playing on my soft, innocent lips, when I suddenly realised I was sitting on a golden throne holding a diamond-encrusted sceptre. This was pretty good, so far—although some may regard it as symptomatic of delusions of grandeur, of which I am occasionally accused. Or it may just have been the onset of jubititis from which I am beginning to convalesce. Now I come to think of it, the sceptre was in the form of a huge resistor, 600 ohms I believe it was. (This number is known amongst some recent constructors as the Sign of the Beast.)

I then proceeded to receive delegations from all over the country, each delegation

crying out blessings on my head, declaring they had followed every line of every blue print of every set I had designed. No component had been shifted, no set had been housed in a coal-scuttle, no tobacco-ash had been dropped into differentials. What glorious results they had all had! What quality! What razor-like selectivity! How amazing was the performance! Even Chorlton-cum-Hardy could scarce forbear to cheer!

Hillegom Again

A Welsh choir then sang "For he's a jolly good fellow," and a delegation from Papplewick brought in on a golden salver a beautiful ruby jewel fashioned in the shape of a huge, resplendent raspberry.

It was all very good value from a lobster. But why am I in Holland at all? Carrying out researches into the life history of Dr. Aloysius Eddy—the discoverer of eddy currents? No; although yesterday I visited Leyden, where the jars come from, and where

Eddy received his Ph.D. What happy days he must have spent there gazing on the fields of tulips which grow in such profusion around those resorts, and on Cook's tourist pamphlets.

I even visited Hillegom, which figures almost weekly in the small advertisements in the weekly radio journals. Surely you have seen those adverts: 500 GLADIOLI, 5 vars., etc.? Well, Hillegom is their home town.

Perhaps I have come to escape the after-effects of my bound-to-be-notorious article on the short waves. I shall antagonise life-long friends and make life-long enemies. But what a relief to speak my heart and to debunk the sacred ballyhoo of the short-wave ramp!

What vandalism, though! What audacity to enter the mystic temples of the fashioners of short-wave adaptors, to desecrate the shrines of the short-wave merchant princes!

Sometimes, I wonder whether this linen-washing process is a good thing. It produces personal enemies, ruffles

the self-esteem of hundreds, cracks reputations, and what good does it do? Well, my view is that it puts things on a healthier footing. My article was anything but destructive, although it was robustly scornful of the fiddling fugitive fading fascination business.

Hilversum—Huizen

Almost every short-wave fan, ham, or whatever you may call him, is only scratching the surface of the Art, tackling a task with tools inadequate for their object. It is like using a spoon when a steam excavator is called for.

Returning to the lobster, I decided last night to find out the low-down about this Hilversum-Huizen business. As you know, there are the

"OLD MAMMY MINE"



Belle Baker, the well-known American star, looking very pleased over her record, "Old Mammy Mine." Miss Baker records for "H.M.V."

two Dutch broadcasting stations, and for six months of the year Huizen works on Hilversum's wavelength or Hilversum takes Huizen's programme and calls itself Huizen, or something like that.

While eating the lobster, I called over the Dutch waiter and the following edifying colloquy ensued—conducted in a mixture of Dutch, English and German, of each of which I know a few words.

Which is Which?

S.-T.: By the way, while I'm here could you explain, please, how Huizen and Hilversum work?

1st Waiter: Ah, Huizen and Hilversum?

S.-T.: Yes, Hilversum and Huizen.

1st Waiter: The radio?

S.-T.: Yes, the broadcasting stations.

1st Waiter (smiling and waving hand deprecatingly): Ah, I know nothing of the radio workings.

S.-T.: I don't want to know how radio works, but whether Huizen and Hilversum just exchange programmes, and Hilversum calls itself Huizen but really remains Hilversum while Huizen remains Huizen but calls itself Hilversum because it takes Hilversum's programme while Hilversum takes Huizen's programme, or whether Huizen actually changes its wavelength to Hilversum's while Hilversum takes Huizen's wavelength, and if this is so does Huizen then give a Huizen programme or does it take the programme from Hilversum's studio since it has taken Hilversum's wavelength, and does Hilversum take its programme from the Huizen studio since it has taken Huizen's wavelength and calls itself not Hilversum but Huizen. If so, does—"

"Ah!"

1st Waiter: You talk about Huizen and Hilversum?

S.-T.: Ja.

1st Waiter: The radio?

S.-T.: Ja.

1st Waiter (stroking chin) Ah!

"S.T." AND THE DUTCH WAITER

S.-T.: You listen to the radio, yes?

1st Waiter: Oh, ya. Huizen and Hilversum.

S.-T. (trying to simplify problem): Well, which is which?

1st Waiter: Which is Huizen?

S.-T.: Ya, or which is Hilversum?

1st Waiter (rubbing chin again): Ah!

S.-T. (helping him): They change about, don't they?

1st Waiter: Huizen and Hilversum, my sir?

S.-T.: Yes. The radio. Which is on the long waves?

Studios and Wavelengths

1st Waiter: It is Hilversum just now, my sir. Hilversum is now where Huizen was and Huizen is where Hilversum was. But wait, one minute, I am mistook; it is Huizen that is on the long wavelength now, but one month ago Huizen was Hilversum and Hilversum was Huizen, but is now Hilversum once more.

S.-T.: But I thought Hilversum always was Hilversum and Huizen was always Huizen and that Huizen for some reason simply took Hilversum's wavelength while Hilversum took Huizen's wavelength. If this is so, does Hilversum take Huizen's studio's programme as well as Huizen's

wavelength, and does Huizen take Hilversum studio's programme as well as Hilversum's wavelength? Or does Huizen keep to the Huizen programme and Hilversum to the Hilversum programme?

1st Waiter: Hilversum? You mean Huizen?

S.-T.: I said Hilversum and I mean Hilversum.

1st Waiter: But Hilversum is now Huizen, my sir.

S.-T.: A minute ago you said it wasn't.

"It is All the Same"

1st Waiter: Wasn't what, my sir?

S.-T.: Hilversum wasn't Huizen.

1st Waiter: That was a month ago.

S.-T.: It was only a minute ago, but I agree it feels like a month. Could I have some more mayonnaise, please?

1st Waiter (smiling): I am very sorry I cannot explain. It is all very simple. We in Holland are much used to it. Hilversum is Huizen sometime and Huizen is sometime Hilversum, but it is all the same. I go fetch my friend. He know all about the radio.

(Exit 1st Waiter. Enter 2nd Waiter.)

The reader is advised to go for a walk before continuing.

S.-T. (to 2nd Waiter): You know Huizen?

2nd Waiter: Oh, yes, sir, my mother was born there.

S.-T.: Well, Huizen and Hilversum change round, don't they?

2nd Waiter: The radio?

S.-T.: Yes. They change over?

2nd Waiter: Yes, it is every six months. At present it is Hilversum, I think.

S.-T.: What is Hilversum? Is Hilversum Hilversum or is Hilversum Huizen?

No Clearer

2nd Waiter: Huizen is Hilversum just now, I think, but they changed a month or two ago, I think.

S.-T.: The other waiter said Huizen was always Huizen and Hilversum Hilversum.

(Please turn to page 87)

TRYING OUT THEIR LATEST RECORD



Alfredo and members of his orchestra about to try out one of their latest records on an "H.M.V." Autoradiogram.

Improving the Ends of the Scale

HOW TO GET BETTER REPRODUCTION

by
K. D. Rogers

I WONDER how many sets there are that do not give quite the desired results in regard to their musical reproduction? Otherwise good sets, I mean, that are in perfect order, except for a lack of bass or a fall-off in the high notes. Or perhaps a little of both. Not enough to worry about very much but just sufficient to annoy enthusiastic owners once they have realised the fact.

And that last remark is important. Every set, all broadcast reception, is faulty in various ways, certain limits

we may find that the best thing to do is to fit a tone-controlling transformer, though this will tend to give us one thing at the expense of the other; top at the expense of bass, and vice versa. A high note "lift" transformer may increase the top but it will cut the bass, and if we are suffering from lack of both top and bass we shall find things a bit awkward unless we redesign the L.F. side of the set.

circuits and insert one or two components, a perfectly easy matter.

In the first place let us study Fig. 1A. This shows a resistance-coupled anode circuit using a 30,000 ohms resistance and a .25-mfd. coupling condenser. This latter value should be used if possible in order to get a good bass response through the coupling.

A SIMPLE CIRCUIT ADDITION

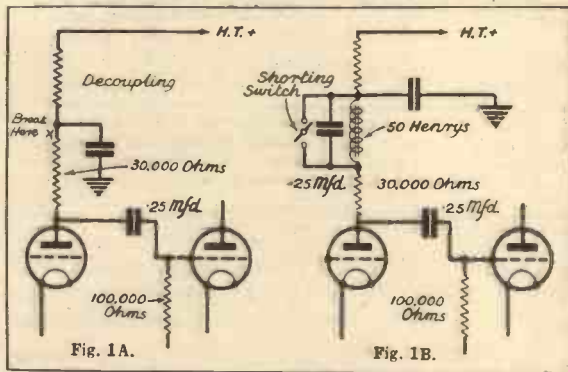

Figs. 1A and 1B. In the first figure the position for inserting the choke is shown. The circuit should be broken below the junction of the decoupling condenser and its resistance. Fig. 1B indicates the choke in position with the shorting switch attached.

of transmission and reception make it so, but while we are not aurally cognisant of the fact we do not worry about it, and we regard our reception as perfectly good enough. In other words we are quite satisfied.

Accurate Reproduction

But sometimes we realise that in spite of the necessary limits, we are not doing all we could to make our set fulfil its real purpose, that of reproducing sound as accurately as possible. We begin to notice a lack of bass, or a thinness of top. Not just a reedy sound but a definite removal of the top notes of the violin and a dullness in the percussion instruments, especially the cymbal.

What can we do about it? The answer to that depends largely upon the circuits employed in the set. If it is of the transformer-coupled variety

band-pass circuits.

What I am going to suggest to you to try if you are one of these set sufferers with out "ends" of the musical scale is to change your sets to at least one stage of resistance coupling (unless you already have one such stage) and to try the circuits shown in the diagrams.

I do not say the circuits will give a complete cure, but they will certainly help matters, and if you have two R.C. stages you can use two of the circuits.

Those who have R.C. already will only have to break into their anode

Increasing the Bass

But for some reason or other we will suppose that the bass is not good enough. What can we do?

What we require is something that will cause the valve to amplify the bass more than the top, but without reducing the amount of top amplification that we are now getting. Luckily, such a device is easy to arrange. It is merely the insertion of an L.F. choke, tuned to give a peak resonance at about 50 cycles, and inserted in series with the anode resistance at the point X. If you like, two chokes can be used one in each of two stages.

The tuning of the choke is done with a .25-mfd. condenser, and in Fig. 1B and the sketch Fig. 2 I have shown the choke with a shorting switch arranged on it so that it can be readily cut out if too much bass is obtained at any time.

This sounds peculiar, I know, but

HOW THE SWITCH IS FIXED

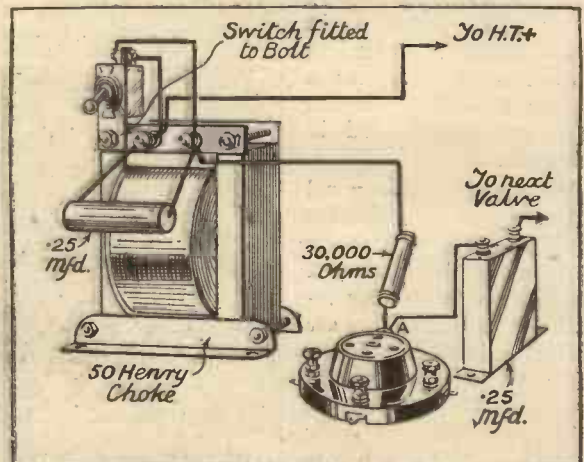

Fig. 2. Any good choke can be used and the switch is mounted on the bolt holding the laminations. The connections are clearly shown in the above diagram but it must be remembered that when the switch is "on" the choke is "out."

often with pick-up work too much bass is provided by the base lifting characteristic of the pick-up, and the choke can be cut out at such moments.

The results of such a choke will not be startling, but they will be audible and, if two are used, in cases where the bass drop is very bad, the results will certainly be well worth the trouble and expense. Provided always, of course, that the loudspeaker is good enough to reproduce the bass when you have obtained it.

Improving the Top

And now for the loss of high notes. Obviously something of the same type is required. We are dealing with resistance coupling again, and here again it is easy to arrange a "note lift" without loss of any other frequencies.

Still keeping the Fig. 1A circuit, we find we can insert at X another type of choke, one that will not have any effect on the amplification of the valve until the frequency is of the order of 5,000 cycles. Such a choke is the Bulgin Superhet H.F. choke, which has an inductance of round about 500,000 microhenries. This will give a resistance or reactance of about 15,000 ohms at 5000 cycles, and this

LIFTING BOTH ENDS

will increase as the frequency goes up (Fig. 3A).

If you want to work it out for yourself remember that the formula is Inductive Reactance (which is looked upon in such a circuit as resistance), equals $2\pi fL$, where L is the inductance of the choke in henries and f is the frequency of the notes concerned, in this case 5,000. So we have this choke giving $2\pi \times 5,000 \times .5$, which equals approximately 15,000 ohms, or half the anode resistance of the valve circuit. $2\pi = 6$ approximately, of course.

Thus we see that such a choke will give quite a noticeable amplification at 5,000 cycles, and as the frequency goes higher it will give more. Below 5,000, of course, it drops, and soon becomes negligible. Which is what we want.

Thus at 1,000, which is in the lower middle of the musical register, we have only $6(2\pi)$ times 1,000 times .5, or 3,000 ohms approximately, quite a negligible percentage of the 30,000 ohms used in the valve circuit. At 8,000 cycles, where most sets fall off badly, we find the choke gives us 24,000 ohms, or nearly doubles the value of the anode resistance. Thus a very good "lift" is obtained here.

Finally we can use both the low and the high note lifts together (Fig. 3B)

HIGH AND LOW NOTES

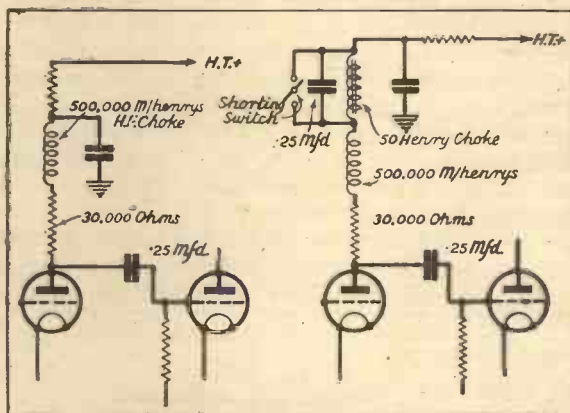

Fig. 3A and B. The first shows how an H.F. choke can be used as a high note "lift" while Fig 3B indicates the use of both the low and high note "lifts," correcting the musical scale reproduction at both ends.

"MIXING" THE MICROPHONES

Details of a unique control panel which has been installed at the H.M.V. Recording Studios.

ONE of the most interesting control panels in the world has recently been installed in the H. M. V. recording studios in London. As a matter of fact, it is the only one of its kind in existence.

The purpose of the panel is to allow a large number of microphones or pick-ups to be mixed and balanced for the making of any individual record. There are eleven connections from the panel to eleven separate microphones or transfer pick-ups, each line being controlled by a separate volume control.

Ten of these inputs are divided into groups of five each, and each bank of

five is controlled by a group mixing potentiometer. The output from the mixer is then connected to the remaining (eleventh) input.

Arrangements are made whereby the producer may speak from the control panel position to all artists in the studios, via loudspeakers, and facilities are provided for the wax playback to be heard in studios, operating room and control room simultaneously.

ONLY ONE IN THE WORLD



THE SPECIAL CONTROL PANEL in operation. It can mix and balance sound effects, music, and artists recording in eleven different studios for the making of a single record. It cost over £1,000.

A row of keys on the panel controls the potentiometers, each key being light-signalled in the studios or at the transfer pick-up.

Green and Red Signals

Thus, when the key is thrown up, a green light signals the "ready," and when the key is thrown down a red light appears, to signal that that portion of the panel is in operation and is "alive."

In complicated productions, where several pick-ups and several microphones may be in use, the producer may not always have time to operate the potentiometers and at the same time give the necessary warning and start signals to the studios.

To provide for this contingency the warning and start keys are duplicated on one side of the panel in such a position that they can be operated by a second man, either following the script or by the verbal instructions of the producer.

WITH THE B.B.C.'s COVERED WAGON

The Story of an Unusual Day spent near the Border of Norfolk

By ALAN HUNTER

BEFORE I try to tell you about one of my most unusual days please allow me to ask a geographical question. Ever heard of March? It is right up in the north-eastern corner of Cambridgeshire, within a few miles of Norfolk's border. I motored up there because the B.B.C.'s "covered wagon" had gone before me.

Mobile recording is not a new thing, especially for a certain gramophone company. It is quite an adventure for the B.B.C. engineers, all the same. A happy gang of "the boys" now travel around the most unheard-of spots of this green and pleasant land recording the oddest noises.

You understand that the covered wagon, as one of my fellow scribes facetiously describes it, is the mobile recording unit. It is destined, one imagines, to play an important rôle in the compilation of future special feature programmes.

There are critics who contend the B.B.C. has stayed at home too much up to the present. That it has concentrated on studio technique to the detriment of the infinitely more exciting exploration of the wandering microphone.

Mobile Recording

The criticism is not entirely just, but there is something in it. The B.B.C. itself recognises this, and recent programmes have proved that it has no intention of letting Germany and America beat it at the gentle game of "rapportage."

The mobile recording unit is the first move. It arrives after the B.B.C. has made certain of having found a form of recording suitable for this type of work.

With the idea of seeing exactly how this system worked—and with the added excitement of watching it being applied to an actual programme—I

turned my little sports car's nose northwards. I was to join in with the B.B.C. party at March, where, in case you don't know, they have an extraordinarily interesting goods marshalling yard.

This yard, or rather its incidental noises, were to play a star part in a railway feature which many of you will have heard by the time you read this description. Never mind that, though.

At the Goods Yard

The B.B.C. must have had its tongue in its cheek when it suggested March as a suitable place for me to see the unit in action. I mean, it is a long way, and it was perishingly cold. In fact, when I had found my way to that delectable playground of the L.N.E.R., it was snowing hard. Not a very warm welcome!

Max Kester, the producer and gag-writer of the B.B.C., was in the buffet with Claude Hulbert. Both had an appearance of wondrous contentment. I knew why only when I, too, had sampled the steak pudding and the treacle tart. Claude says he will return to March if only for another lunch like that.

The mobile recording unit was hoisted on a truck outside. We followed it down the line later in the "B.B.C. Limited"—one engine and one cattle truck!

And so to the Whitemoor Hump. A remarkable business. A humped line branches out into forty-two "roads"—we should call them railway lines, of course. The engine pushes its assortment of uncoupled trucks up to the hump, after which they run down into their correct roads with only the force of gravity to help them on their way.

When the trucks are heavily laden, or running into a nearly full road, their momentum would assume disastrous proportions if they were not slowed down. So just before they branch off a set of retarders come into action, smoothing out the downward slope for long enough to slow down the trucks. This is done by hydraulic means—and, what with the punching of the electrically operated point-switching, it all combines to make a rare old racket.

A Patient Official

The mobile unit's job was to record as much of the noise as possible, interleaved with Max's gags as uttered by Claude Hulbert in an interview with an extremely patient railway official—who, incidentally, rose to his unaccustomed part with great élan. He had almost the perfect microphone manner.

(Please turn to page 85.)

BY SHORT WAVES TO JAPAN



BEHIND THE PANEL of the short-wave receiver used for the Berlin-Tokio telephone service. Beam short-wave transmission and reception is used, the former from Nauen and the latter from Beelitz.

Short Wave Notes

This month W.L.S. has something to say about amateur transmitters and the wave-bands on which they work

READERS have been reminding me that I promised, many months back, to devote some space to the interests of those who like to listen to the amateur transmitters. As these same amateurs form quite a considerable percentage of the stations that one hears with a short-wave receiver, I am going to say a little about them this month.

Many "Professional" Amateurs

First of all, why "amateurs"? Many of them are professional men in the radio trade, and have gear that would not disgrace a fully-fledged commercial station. But that doesn't alter the fact that they are amateur transmitters; they transmit for the love of their hobby; they reap no financial reward whatever from anything that they do; and their stations may only be used for their own experimental purposes.

As a matter of cold fact, the ranks of the "amateur" transmitters have provided the radio industry, not to mention the B.B.C., with some of its best-known men.

But, you may ask, is there anything an amateur transmitter can do that has not already been done (or is being done) by the commercial concerns? Yes, there is. The amateur goes on tinkering with some little gadget of his, just in the hope of finding something out.

The commercial concern can't afford to waste time playing about with something in the faint hope of making something useful out of it some day; the amateur can and does.

Achieving the Impossible

A well-known amateur once said, "It will always be an amateur that will achieve the impossible—just because he doesn't know that it is impossible." A mathematician or scientist would know that (theoretically) it was impossible, and wouldn't waste time trying!

Listen, then, to the amateurs. You will find them congregated on narrow wave-bands in the regions of 80, 40, 20, and 10 metres. If your short-wave receiver will stretch nearly up

to the broadcast waves, you will also hear them on 160; if it's also an ultra-short-wave set, you may hear some of them on 5. Yes, it's very difficult to dodge the amateurs.

Now for the kind of work they do on each of these bands. Let us take them in order. The 160-metre band is "shared"; that is to say, it is not the exclusive property of the amateur, as are some of the others. Strangely enough, though, all the good transmissions you hear on 160 metres come from amateurs, and all the bad ones from commercials—trawlers, light-ships, etc.!



A typical group of "QSL" cards, as sent from one amateur to another as confirmation of a contact "on the air." Those in the group are from U.S.A., Australia, New Zealand, and Canada.

You will probably hear several British amateurs on telephony if you listen any night after 11 p.m., or any Sunday morning or evening. The work done seems to be chiefly concerned with getting the maximum number of watts into the aerial with the 10-watt input to which the stations are limited for that band. Work on modulation systems and microphones is also carried out; and the band serves as a useful place to discuss, with others, what one is doing on the other bands, where they probably cannot be heard.

An Increased Range

Eighty metres gives a little more "DX" reception than 160. Amateur 'phones from all over Europe may be

heard, since the range, for a given power, is considerably greater than on 160. In the early mornings, between 75 and 80 metres, several U.S.A. amateurs on 'phone may usually be heard, and C.W. signals from all parts of the world come in when conditions are good.

The Ether "Pirates"

Forty metres takes us a step further in the world of "DX" and no U.S.A. telephony is allowed on this band. You will, therefore, stand more chance of hearing amateur 'phone from more distant parts. Unfortunately, some of the European countries are overrun with "pirates" putting out so-called telephony of the most foul quality imaginable, and it is sometimes difficult to penetrate this ghastly barrage.

The best times for real "DX" on "40" are the early hours of the evening and most of the hours of darkness. The mornings, too, up till an hour or so after sunrise, are usually interesting.

Now we come to "20," which is easily the most intriguing of the amateur bands. Each band, as we go down, shows a tendency to give better "DX," but to be less reliable, than its upper neighbour, and "20" is no exception.

When conditions are good, the "DX" on this band can be tremendous; when they are bad it is possible to listen for an hour without hearing a signal of any kind. By the time this appears in print, 20 metres will probably be the most interesting band of them all, for conditions are usually extremely good during June and July.

Australia and New Zealand

American amateurs on telephony are confined to one quarter of the band, which they succeed in filling pretty well! New Zealand and Australia may be heard in the early mornings and again at mid-day; South America comes in for parts of the year late at night; Asia and Africa are heard during the afternoon and early evening.

On a good day it is possible to hear all continents within 10 minutes, and I believe this has actually been done by a reader.

Ten metres, at the moment of writing, is "dead" in this country, but the Australians have been obtaining spectacular results with it, having worked with Japan and U.S.A.—a feat which has not been possible since about 1929. As soon as it wakes up over here I will chronicle the news. Regarding 5 metres, that comes in the category of ultra-short waves, and is a story all to itself.



B.B.C. News

The Holiday Muddle—A Carpet Disappears—Good News for Torquay—Mr. Fisher Looks Round—Those Empire Programmes—Mr. Graves in Newfoundland.

By Our Special Commissioner

having been made in the balance arrangements, acoustics were thrown out badly, and the transmission suffered.

Later in the same day, the Variety Orchestra had a show in the same studio with similar unfortunate results, there still being no carpet. I have not heard whether the B.B.C. is offering a reward for the discovery of the carpet, but I saw a definitely sleuth-like glint in the eyes of the gallant Admiral Carpendale and his assiduous

Gielgud has encountered nothing but encouragement in framing schemes of extension in Shakespearean country. There is to be done next year a whole series of the minor plays as well as most of the big ones.

One programme builder was remarking to me that by the adroit use of the minor plays of Shakespeare and some of the books of the Old Testament, it is possible to circumvent many of the censorship rules of the B.B.C. microphone. I hope this is not the only reason for the threatening new epidemic of minor Shakespeare plays!

Chief of "Gags"

THE B.B.C. has appointed a full-time official to look after "gags."

All the producers, artists, and particularly the comedians now have to bring their gags to Mr. Anthony Hall, who, by the way, is no relation to his namesake Henry. Now, Mr. Anthony Hall is a very busy man these days. He has to use a lot of tact. Some of the most successful comedians are not the most anxious to drop or modify their gags but it is Mr. Anthony's job to see that they do. He stands for a clean ether.

Holidays for Orchestras

There is great bother this year in deciding on the holidays for the busiest of the orchestral players. Last summer the Theatre Orchestra sneaked a rest in August; the Variety Orchestra in July. It was all fixed that the order this year should be reversed. Arrangements were actually made for the Theatre Orchestra to go in July and the Variety to go in August.

But, alas, it all came to nothing. The big chiefs would not have it, so the players must go, if they go at all, the same as last year, which is bad luck on those members of the Variety Orchestra who have families of school age.

A Mysterious Carpet

When I was in the "Big House" the other morning, there was great commotion about the mysterious disappearance of a carpet from Studio 8A. First of all, the Theatre Orchestra had been pushed into the Studio for an important programme and no one on the programme or engineering side seems to have known in advance that the carpet had gone. No compensation

"SWEET MUSIC"



ALBERT HARRIS, the guitarist who is often heard in the Croom-Johnson "Soft Lights and Sweet Music" programmes.

assistant Captain Chilman as they flitted from corridor to corridor on the trail of the carpet!

More Shakespeare

The B.B.C. has "got" Shakespeare badly. Since the success of the Henry V production as the curtain raiser for the big Jubilee programmes, Mr.

Torquay Promoted

Good news for Torquay! Its Orchestra is very popular among the listeners; it also happens to be a good orchestra. So now it has been put under fresh grading by the musical authorities round in Portland Place. And there is more in it than glory. This orchestra, which in the past has been receiving fifteen guineas a performance, is now to get twenty guineas. And well earned, too!

"Love on the Dole"

The Talks officials of the B.B.C. are anxious to include in their autumn and winter programmes a series in which Mr. Walter Greenwood, the author of "Love on the Dole," will bring to the microphone typically destitute families of hard hit industrial areas. If it is desirable to reveal cameos of utter wretchedness and misery then this probably is the best way to do it. But there is a revolt coming against the sort of broadcasting which reveals only the reverse side of the state of the country, and is of doubtful value anyway.

Armistice Day Programme

There is great discussion at the B.B.C. about this year's Armistice Day Programme. There is a strong

(Please turn to page 86.)

A SHORT time ago I set out for a short European trip. When I packed a four-valve midget superhet in my suit-case, I foresaw endless difficulties. Customs, summer reception conditions, possible breakage of the set by a clumsy porter dropping my bag—all these things seemed to make it hardly worth while taking the set.

On our way through France and Switzerland the customs authorities made no difficulties. When we entered Austria we were only visitors, so our luggage was never opened. I first unpacked my set in Vienna.

There were as many as sixteen stations to be heard in Vienna, but none of them was English. Vienna itself gave news in German, at the end of which was an advertisement for a paper, "Radio Wien," the official organ of the Ravag.

This was to be my programme guide. Munich, Nuremberg and Stuttgart gave more news in German, so I was in touch with current events. The Italian stations were quite strong, and so was Zagreb in Yugoslavia; but as I do not know Yugoslavian, this was not one of my favourite stations.

In Budapest

After a week we moved on to Budapest. Here the current in the hotel was 100 volts D.C., but as my set was universal I was soon listening to the inevitable gipsy orchestra. But the reception of Radio Budapest being better than it is in England, I was amazed at the wonderful voice of the singer in the orchestra. Hitherto I had never noticed its timbre. I decided to listen more attentively to this station on my return home.

Then I heard the news. It was given in German from Prague. But most of the stations audible in Vienna could be also heard in Budapest; while Munich gave a louder signal than in Vienna. There followed several news bulletins from German stations.

A few days later I was listening in

Salzburg. It was here that I heard a language that puzzled me greatly, until I realised that it was Welsh from the Western Regional. The London Regional was jammed by a German station, which, like all German stations that day, was giving a relay of a Nazi rally in Nuremberg. Salzburg, being high up, reception was good all round. In addition to the German and Italian stations there was Strasbourg and Toulouse.

English from France

Two days later I unpacked my set in Munich. Here the German stations

in towns. From Hanover I went thirty-five miles out towards Minden, into the little principality of Schaumburg Lippe. Here in Bad Eilsen, the reception was excellent. By a quarter to six every evening the London National was easily audible. The London Regional was another good signal.

The Midland Regional was jammed by Leipzig, but the Northern Regional could be heard without interference. There was not the slightest "wipe out" from any local station, because the nearest station, Hanover, is a small relay. Sometimes the most powerful station of all would be the London National, sometimes Beromünster, sometimes Cologne, according to the condition of the ether. But all stations from Danzig to Barcelona came in well.

In this little village, with only three shops, listening was a welcome evening's distraction. Moreover, an English newspaper took at least three days to penetrate to these remote parts, so the wireless news was invaluable. For nowadays the German press does not give all that most of us want to know.

TOURING EUROPE WITH A PORTABLE



Salzburg, where our correspondent picked up the West Regional and where reception was particularly good.

An interesting account of radio experiences during a tour through a large area of Central Europe with a compact four-valve superhet.

By A SPECIAL CORRESPONDENT

were overpowering. But the Italians were easily audible. There was one programme in English, and that was coming from a French station and was sponsored. Can you guess who it was?

London News Every Night

When I went on to Hanover, I found that I could get the London National well enough to be sure of the news. The London Regional was often interrupted by Poznan. Though the German stations were loud, Prague gave as strong a signal as anywhere.

So far on my trip I had listened only

Always Mains Supply

Throughout the trip there had always been a wall socket or lamp holder for me to plug into, and I invariably had a radiator in my room with which to make an earth connection.

On the return journey home, there was no customs difficulty, and I decided I would always take my wireless with me in future.

The whole experience was one on which I could look back with complete enjoyment. And with the right sort of set the whole procedure of taking a portable abroad is a very simple one. Naturally it must not be a heavy or bulky receiver and the commercial all-mains type of midget is ideal for those who do not wish to build their own. Home constructors would do well with the battery midget portable described this month.



RADIO IN THE NAVY

By **Dr. J. H. T. ROBERTS** F. Inst. P.

WE grumble about the reception conditions at home often enough, but I wonder if we ever stop to think what they must be like on board ship, especially when that ship happens to be a man-of-war!

It takes a naval expert to tell you all about radio on board a battleship, and I have before me a most interesting paper read before the Institution of Electrical Engineers by my old friend Dr. W. F. Rawlinson, who is one of the leading naval radio experts at H.M. Signal School, Portsmouth.

He describes, first of all, how limited is the choice of receiving aerials in a man-of-war. There is usually a large, fairly high mast and either a second smaller mast or some form of control structure, to which all the aerials (for both transmitting and receiving) must be attached. The down-leads must keep fairly close to the mast or super-structure in order to avoid fouling guns, boats or derricks.

A Wide Variety

A "receiving aerial" may, therefore, be anything from the ship's main aerial, with a capacity of 0.003 mfd., to a single short wire with a capacity of 0.0001 mfd. In large ships the central receiving-room is placed well down below armour, and the distance between the central receiving-room and the foot of the aerials may be as much as 100 ft.

The aerial itself, therefore, terminates in a deck insulator and junction box, from which a special paper-and-air insulated cable is run to the receiver in the office. The electrical

properties of this aerial and cable system have, as you can imagine, a very important influence on the design of the input circuits for naval receivers, and consequently a great deal of work has been carried out on this subject.

Preventing Interference

The ship's main wireless office consists of a single room which is completely sound proof and surrounded by a steel shell. So far as screening from disturbances external to the ship or direct pick-up of unwanted

is well known, any lead which penetrates a "Faraday cage" is liable to bring in interference, especially on high frequencies.

Although this interference can often be considerably reduced by fitting radio-frequency filter circuits into the output leads of small machines and into buzzer and control leads just before they enter the office, it is still necessary to screen each receiver separately. The receivers are, therefore, built up in the form of an aluminium face-plate, carrying all components, fitting into a sheet-metal box, which is earthed.

Robustness of design is one of the most important features of all naval receivers. They must continue to work for years with the minimum of attention, under tempera-

tures varying from tropical heat to arctic cold, and in a salt-water-laden atmosphere; hence the insistence on the use of best quality components.

Always in Use

Further, the receivers must work for twenty-four hours per day, during which time control handles are being continually adjusted. Again, the whole office, including the receivers, is subjected at times to tremendous vibration if the ship is travelling at full

This article by our popular contributor describes the very interesting features of radio in a man-of-war. Dr. Roberts was at one time Senior Experimental Officer, Submarine Sound Telegraphy Section, H.M. Signal School, Portsmouth, and this article is based on a report by one of his former colleagues there.

signals on the receivers is concerned, the office may be said to be virtually perfect.

But this must not be taken to mean that interference within the office is negligible. In actual practice the noise level is usually high, owing to sparking and radiation from ventilating fans, light wiring and electrical machinery in the ship.

Light wiring, control leads for transmitters, buzzer leads, etc., must of necessity enter the office; and, as

WIRELESS OPERATORS OF THE FUTURE

One of the instructors on H.M.S. Ganges is putting his pupils through a stiff test in Morse by tapping out code messages which they receive in their headphones.



speed, whilst in action the apparatus must stand up to the concussion from the ship's guns or from shell-bursts on the ship.

This presents nasty problems due to microphony of the valves, and the detector valves of all naval receivers have to be separately sprung. It also brings into prominence the question of the mounting of the receivers.

Receivers were for many years screwed to the bulkheads; but this never gave entire satisfaction, for in the smaller classes of ships they were always liable to be torn down by the concussion from gunfire. In modern ships, therefore, a system of rack mounting has been adopted.

impossible to scrap or even modify receivers every few years, and it is equally impossible to design receivers so that they can be used with valves of entirely different characteristics.

Ease of Replacement

Apart from this difficulty in maintaining supplies of valves, the standardisation of only a few types puts a limit to the circuits that can be used, and the details of all naval receivers have to be considered from this standpoint.

It is obvious that on board a naval ship the valves are very liable to damage, and consequently all receivers are designed so that the valves can easily be taken out and replaced from

sense—in naval practice. Naval receivers are designed primarily for the reception of Morse signals, either continuous-wave (C.W.) or interrupted-continuous-wave (I.C.W.), and such matters as sideband cutting, tone correction and quality of reproduction are of minor importance. For the problem of selectivity in ships at sea is something entirely different.

It is, in fact, the problem of receiving a very weak C.W. or I.C.W. signal in the presence of a much more powerful signal transmitted by the receiving ship or by a nearby ship or some powerful coastal station, the two signals being in general fairly well separated in frequency. For this type of interference the so-called highly selective receiver, embodying a single tuned circuit of very low decrement, does not prove in naval practice to be the receiver of greatest selectivity.

THE AERIAL PROBLEM AT ITS WORST

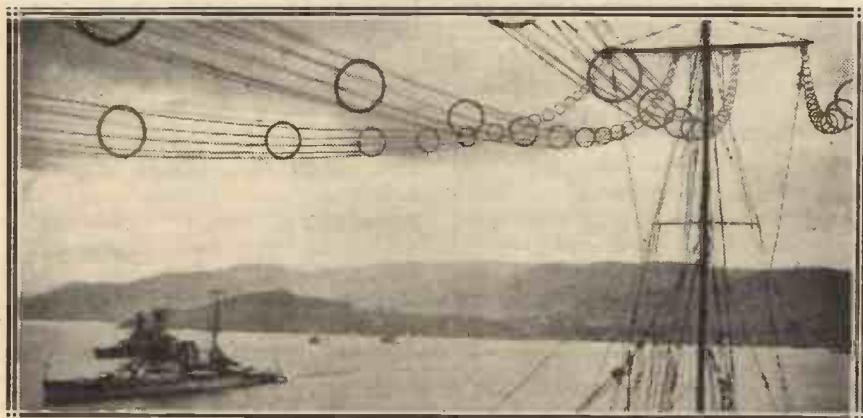

Part of H.M.S. Renown's aerial system as seen from the gun-directing turret. Note how insulators have to be inserted in the steel rigging to prevent the wires from affecting radio too badly—a serious problem on all ships of war.

The racks are made of aluminium alloy castings bolted together, and are themselves bolted to the deck, connections to the bulkhead or roof of the office being made only by means of flexible cables. The castings are designed to withstand the strains imposed upon them owing to "whip" in the deck.

The Valve Problem

The question of valves is also a very important one in Service conditions. The use of a large number of special types of valves is not possible, since ships must operate in all parts of the world and depend for their spares and replacements on the valves which they themselves carry or on stocks held at various dockyards.

Three types of valve have been adopted for naval use: the screen-grid valve for high-frequency amplification, a general-purpose valve for detection and low-frequency amplification, and a power valve for use as an oscillator and for certain other purposes.

The question of valve replacements is a very serious one, for it is obviously

the front of the set. The design of receivers for naval ships is greatly influenced by technical requirements not generally met with in shore receiving sets.

In service at sea it is necessary to receive several signals simultaneously within the frequency range 15–23,000 kilocycles per second. The frequencies of these signals may have to be changed at any time to allow for local conditions or jamming.

Again, the number of receivers which can be fitted is limited by considerations of weight and space and the number of operators available. Also it is essential that, as far as possible, the same types of receivers shall be used in all classes of ships.

This means that very wide frequency ranges must be covered by each receiver, the least being 10 to 1 and the greatest 30 to 1 for normal models, whilst for one particular receiver it is about 1,300 to 1. You can imagine that such wide ranges involve many serious technical difficulties.

As regards selectivity, this has little meaning—at any rate, in the ordinary

The "Adapto" Three

A Constructor's Experiences.

Dear Sir,—Some time in November, 1934, I wrote you and asked if you could assist me, as I had bought the fittings of your "Adapto" Three, to try and work it with my suit-case set. At that particular moment I was in the depth of despair, seeing that I had spent over £6 and could not even get a squeak.

Well, seeing that I was in want of a good short-wave set, I spent about £18 and bought a good one, at least a good make, from one of the best firms in the country. Well, I still had the £6 10s. on my mind and persevered with the "Adapto" Three, and now it is working on my set, and to be quite fair and frank, I am getting better results with it than the set I paid £18 for.

All Speak in Praise

At the moment I am listening to an organ recital from Tooting on 16·85 metres, and if it is possible for reception to be better I would go a long way to hear it. I have had all my ship-mates in to hear it, and all speak in great praise of the "Adapto" Three.

We are about to leave for Havre, France, and I will give the "Adapto" Three a good try-out on our passage home, but I have no fear but what it will come up to all that is claimed of it.

Yours faithfully,

ALEX MADDEN,

1st Engineer.

c/o British Oil Shipping Co.,
120, Fenchurch Street, E.C.4.

Questions I am Asked

Q. 137. Why are universal mains valves all rated at different voltages?

A. All the valves of a given manufacturer's range have, obviously, to be rated at the same current, since all the heater filaments are in series with each other, the whole, together with a resistor, being connected across the mains supply (whether D.C. or A.C.). Since the electron emissions of different kinds of valves, and their general design, vary with the purpose of the valve, it is not surprising that different designs of heater filaments are required; and when the standard current is passed through them, the voltage drop will vary with each type.

Q. 138. Why does the insertion of a high resistance in the grid circuit of, say, an L.F. amplifier valve not cut down the steady bias applied to the grid? Surely a million ohms must reduce it, since the voltage must be forced through this enormous resistance?

A. Since the grid is given a negative potential, the only grid current possible would be due to positive ions due to gas in the valve. Assuming the valve to be perfectly "hard," there will be no ions, because of the "perfect" vacuum. Since there is no grid current, there will be no voltage drop across the grid resistance, and therefore no back voltage to reduce that applied by the grid-bias battery. We therefore get the full voltage of the bias battery applied to the grid.

Q. 139. I have been told that electrons travel at the same speed as light. Is this so?

A. Not so. The speed of the electron is governed by the forces acting on it, while light is a wave-motion in ether. The speed of the electrons passing from filament to anode may be high, but nothing like as fast as 186,000 miles per second, which is the velocity of light.

The greater the anode voltage the faster will the electrons travel. The passage of individual electrons in a wire is very slow, but the "response" is almost instantaneous.



A wide range of subjects is covered this month by the questions Mr. Scott-Taggart has chosen, and he deals with some particularly interesting points.

Q. 140. I have been studying the operation of the cathode-ray tube in television, but do not understand how the deflecting plates move the electron beam. Is the beam curved after it leaves the influence of the plates?

A. The beam after leaving the deflecting plates is straight. We may conveniently regard the electric field of the two plates as extending solely between the plates, in which case the electron beam is straight until it reaches the plates. It is then bent in a parabolic curved path, but after emerging from between the plates it proceeds in a straight line in the direction it finally took up. The deflecting process occurs, of course, because the stream of electrons is negative, each electron being negative. If the two plates are given positive and negative potentials respectively, the electron stream will be deflected away from the negative plate towards the positive plate.

Q. 141. What is the screen made of in a cathode-ray television receiver? Why does light and shade appear on the screen?

A. The "screen" of a cathode-ray tube is at the big circular end and is a coating of chemical material on the inside of this "big end." The light and shade of the picture formed on this is not, of course, due to light shining on it, as in the case of the screen at a talkie theatre. The lighting which you see—i.e. the light and shade—is certainly light, but it is produced indirectly by electrons inside the tube impinging on and bombarding the chemical substance mentioned. When bombarded with electrons the substance gives off light at the particular point bombarded, but at no other.

This phenomenon of chemicals giving off light under the influence of electrons (or certain "rays") is known as *fluorescence*. The chemical coating is usually calcium tungstate or zinc sulphide in certain forms. There is, incidentally, much scope for research into fluorescent materials, as there is not much known as to what is likely to give the required fluorescent effects needed for television.

Different colours are obtainable with screens of different kinds, and no doubt tastes will vary somewhat as to what makes the best picture. This is so in the case of photographs, of course, where toning is an important art.

Must Be Kept Moving

You cannot, by the way, bombard a given spot on the screen indefinitely. The stream of electrons must be kept on the move all the time, otherwise the screen would be burnt. Of course, a television picture is made by the electron spot travelling very rapidly over the screen, but there may be occasions—e.g. when first switching on the mains receiver—when the spot tends to be stationary. If the spot cannot be kept on the move it may be necessary to remove it to prevent damage to the screen.

The brightness of the spot is controlled by the strength of the incoming signal which is varying all the time in accordance with the picture being transmitted. It is customary to apply these modulating potentials to the screen of the tube and so to vary the intensity of the electron beam. Some television systems, however, keep the

(Please turn to page 86.)

MILIU: THE INVISIBLE

The Story of the Mystery Announcer of Radio Barcelona

By Our Special Correspondent.

THE first things of the Catalonian capital I saw when arriving by airplane from Marseilles were a big broadcasting transmitter on the top of the Monte Tibidado erected in the park of the Hôtel Florida, the funny looking twisted towers of the church "Sagrada Familia" and some houses with the most astonishing roofs I ever saw—with wavy roofs. These houses are the result of the experiments of creating a new style of architecture, but later on I learned that the architect passed the rest of his days in a lunatic asylum. It is only a pity that the physicians discovered his illness so late.

Another Peculiar Experience

But the story of the crazy architect is not the only amusing one I can tell you from Barcelona. There is another, too, which is a little more mysterious. That is the mystery of Miliu, the invisible announcer of E A J 1.

When I reached the Barcelona broadcasting building in the Caspe a soldier with fixed bayonet prevented me from entering. It cost some of those black Spanish cigarettes to demonstrate that I was not an anarchist, but a journalist who would not blow up the building.

There is not much to say about the studios—there are several rooms, of fair size—in which the walls are covered with cloth. There is also a very huge microphone and some smaller rooms for talks. Altogether, the studios of Radio Barcelona did not differ from those of other smaller stations.

But the mystery began when the station's director opened a door and said to me:

"This is the announcers' room."

Two or Three?

I saw a microphone, two chairs, a writing-table and two men without jackets smoking pipes and glancing at us with peevish faces—it seemed that these two gentlemen were finishing

their 'siesta. "May I introduce to you Señor Toresky and Señor Miret, our speakers."

"When I listen to your station I always hear three different voices; what's the name of your third announcer?" I asked.

"Yes, we have indeed three announcers, and the third is called Miliu; he is here—but you can't see him—he is invisible," the director answered, smiling.

The Third Voice

Suddenly—I don't know why—I remembered the story of the architect with the wavy roofs.

"O.K. I see. Very interesting indeed—an invisible announcer!" Were they making a fool of me? Suddenly a bell rang.

"Go ahead, Toresky—the news!" the director said.

We went into the other room, the director, Señor Miret and myself.

THE ANNOUNCERS AT E A J 1



The two announcers at Radio Barcelona together with the small messenger boy whom Spanish listeners believe to be Miliu.

From a loudspeaker we heard the evening news bulletin, interrupted by advertisements.

"What do you think is the best Spanish cheese?" Toresky asked. And another voice answered:

"The España cheese, folks!"

I did not trust my ears. The

speakers' room had only one door before which I was sitting, and I could swear that there was only one person in the studio: Toresky. Then I looked through a little window—I saw the writing-table, a microphone, and Toresky sitting before it—where did the second voice come from? Once again an advertisement:

"Did you ever eat Toreador chocolate, Miliu?" Toresky asked. And a child's voice answered:

"Oh yes, of course I did—and the Toreador chocolate is marvellous and just as cheap as other products."

Solution of the Mystery

The director and Señor Miret prevented me from entering the neighbouring room. Two minutes later the news bulletin was concluded, and I rushed into the room.

"Where is this Miliu?" I questioned Señor Toresky.

From a corner the answer came:

"Here I am!"

I had a strange feeling—was it the effect of the heat or the heavy storm we passed through in our aeroplane? Or perhaps the consequence of the strange drinks a smart boy in the Café de la Rambla mixed for me?

"Shall we tell him?" the director asked Toresky.

"Yee-es, but don't write about it in Spanish papers because it must be a deep mystery—I'm a ventriloquist!"

A ventriloquist—that was the solution. And a famous ventriloquist, for Toresky was a well-known variety star who had travelled all round the world. He knows London as well as Berlin or Stockholm. When starting his new job as announcer he created his second self which he called Miliu. Miliu is the "enfant gâté" of all Spanish listeners—Miliu gets big packets of presents; Miliu is familiar to all boys and girls in Spain.

Gifts from Listeners

They send him chocolate, cakes, books—they know his birthday and all details of his private life. But Miliu, the invisible, becomes visible,

too! For there exist many photos of the three speakers, but nobody in Spain knows that the nice boy whom the Spanish listeners call Miliu and who must have a ladder to reach the microphone is one of the station messenger-boys who only acts as Miliu in photographs.

The HEXOVERTER

OPERATING THE UNIQUE SHORT-WAVE ADAPTOR DESCRIBED LAST MONTH

by

JOHN SCOTT-TAGGART

M.I.E.E., F.Inst.P., Fel.I.R.E.

IT seems like taking money under false pretences to accede to the editorial request for an article on the operation of the "Hexoverter." For there is practically nothing I can say. The whole design and the circuit were planned to cut out fiddling and to make the operation fool-proof.

There are no elaborate hints to give, no sententious warnings to administer, no snags sugared with glib-tongued phrases to persuade the constructor that pitfalls are merely pot-holes.

The Aerial Coupler

My main article last month gives all the information you really require. There are two tuning controls and one volume control. It is true there is a preset style of aerial coupler on the terminal strip, but it is only intended as an adjunct to cover a wide range of aeri-als. In practice you will probably leave the aerial coupler half-way. It certainly forms no part of the ordinary tuning-in as it may do on ordinary broadcast receivers.

I.F. Stage

Although there is an extra stage of intermediate frequency amplification in the "Hexoverter," this is aperiodic and calls for no tuning whatever. It therefore does not complicate the outfit in the slightest. The volume control on the "Hexoverter" enables one to reduce or increase within limits the I.F. amplification. It is useful as a control of sensitivity, and prevents the second valve from needlessly acting as a drain on the H.T. current.

Obviously, since the second valve is a variable-mu H.F. pentode, a reduction in the volume adjustment will cut down the H.T. consumption. This is clearly the best way to reduce signal strength since it effects economy.

When first working the "Hexoverter," I suggest having the volume

preferred to give the constructor some latitude. The short-wave enthusiast is essentially experimentally minded, and he will appreciate facilities to try out various voltages, for example.

Very Easy to Handle

The output terminal of the "Hexoverter" is connected to the aerial terminal of the main set. The earth terminal of the main set is connected to earth in the ordinary way. The aerial itself is connected to one of the aerial terminals of the "Hexoverter," while the earth terminal of the "Hexoverter" may be taken to the earth terminal of the set. A separate short "earth" might, under certain circumstances, give better results.

The "Hexoverter" itself is tuned simply. The left-hand tuning control is the "aerial" circuit and an approximate adjustment is sufficient. The right-hand dial is that of the local oscillations, and the slow-motion adjustment is essential.

Two Readings

Some sample readings were given last month. The two-dial readings will not be alike, but their relative values will remain much the same. It is, however, important to notice that nearly all stations will be received at two points on the right-

hand condenser. You can choose which of these you use; one will often give better and clearer signals than the other.

The main set calls for a few words. It must, with its aerial disconnected, preferably tune to a wavelength at the top end of the long waves. This is a

THE CONTROLS

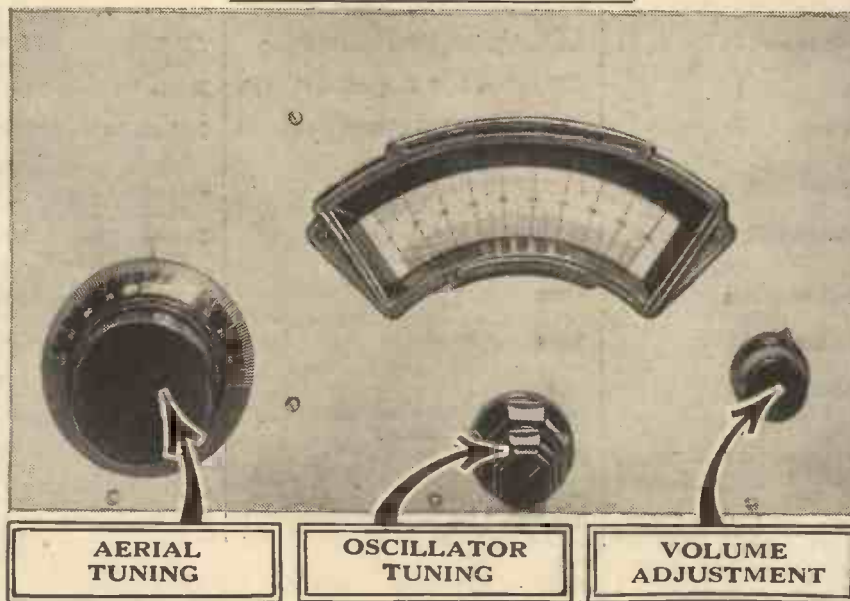

control about a quarter way from maximum. The connections and voltages to the adaptor were given last month and should be carefully adhered to, although the voltages are not critical, and some of the terminals could be joined together. Variations in samples of valves may occur, and so I have

simple matter in the case of a commercial or ganged set, but if you have a set with two tuned circuits, you must see that both circuits are tuned to a given wavelength. A good plan is to connect the set in the ordinary way to earth and aerial, and tune in to a station near the top end of the long waves, e.g. Huizen. You can use anode reaction with advantage, but not a critical amount. Then set each tuning condenser a few degrees to the same side of the Huizen settings. Now disconnect the aerial from the set and join up the "Hexoverter."

ADJUSTING THE MAIN RECEIVER

Once you receive a station at its best with the "Hexoverter," turn your attention once more to the main receiver and tune *that* to give the loudest results on the station being received. The tuning of the main receiver is exactly the same as if you were tuning an incoming signal on the long waves. You can use couplers, volume controls and reaction in ex-

actly the same way. Once you have obtained the best results, these will hold good on *any* short-wave station. There is no need to adjust the main set again. All your work will be done on the "Hexoverter." But unless your main set *is* working efficiently your "Hexoverter" will give poor or even no results. It makes no difference what short-wave station you use for your initial test, but it should be received at its best.

The wavelength chosen on the long
(Please turn to page 87.)

THE HEXOVERTER IS BUILT WITH THESE COMPONENTS

Component.	Make used by Designer.	Suitable Alternative Makes.
2 pairs 4-pin S.W. coils, 16 to 38 metres and 28 to 60 metres	B.T.S. type K	
1 .00015-mfd. Osc. tuning condenser	J.B. "Short-wave Special"	Polar reaction No. 4 .00015-mfd. with Polar micro-drive
1 Dual ratio arcuate drive	J.B.	J.B. Popular Log. slow-motion .00015-mfd.
1 .00015-mfd. aerial tuning condenser	Polar short-wave type "C"	Colvern S.T.5C/S with battery 3-pt. switch. (Insulating washers required)
1 25,000-ohm graded volume control with 3-pt. switch	BULGIN G.M. 25. (This is catalogued with insulating washers)	
1 Superhet screened choke	BULGIN H.F.10 (for anode circuit of heptode)	
1 Super H.F. screened choke	GOLSTONE type S.H.F. (for anode circuit of 210 V.P.T.)	
1 S.W. choke	WEARITE type H.F.3	
1 1-mfd. tubular condenser	T.M.C.-HYDRA	
2 0.5-mfd. condensers	DUBILIER type 9200	
1 .00005-mfd. condenser	DUBILIER type 670	Graham Farish, T.M.C.-Hydra, Ferranti, Bulgin, Polar-N.S.F., T.C.C.
1 .0003-mfd. condenser	LISSEN Mica L.N.11	Graham Farish, Dubilier, Ferranti, T.C.C.
1 .0003-mfd. tubular condenser	T.M.C.-Hydra	Polar-N.S.F., Bulgin, Ferranti, Graham Farish, Dubilier, T.C.C.
1 .0005-mfd. solid-dielectric variable condenser	GRAHAM FARISH "Litlos" log-mid-line	Polar, B.T.S., J.B.
3 1-mfd. tubular condensers	T.C.C., type 250,350v. D.C. working	T.M.C.-Hydra, Polar-N.S.F., Graham Farish, Bulgin, Ferranti, Dubilier
2 4-pin coil bases	EDDYSTONE "Frequentite" Cat. No. 949	Bulgin "Steatite" type S.W.21
2 5,000-ohms resistances	FERRANTI G.H.5 (½-watt baseboard mounting)	Graham Farish, with holders or following with terminal blocks — Erie, Dubilier, Polar-N.S.F., Bulgin
1 5,000-ohms 1-watt metallised resistance	DUBILIER	Graham Farish, Polar-N.S.F., Erie, Ferranti, Bulgin
1 10,000-ohms 1-watt metallised resistance	DUBILIER	Graham Farish, Polar-N.S.F., Erie, Ferranti, Bulgin
1 100,000-ohms 1-watt resistance	ERIE	Dubilier, Graham Farish, Polar-N.S.F., Ferranti, Bulgin
1 1-megohm 1-watt resistance	ERIE	Dubilier, Graham Farish, Polar-N.S.F., Ferranti, Bulgin
1 Universal valveholder	W.B.	Lissen L.N.739
1 7-pin valveholder	CLIX chassis mounting "Air sprung" with terminal screws	
Wander plugs (as required) G.B.—, G.B.+.	CLIX	Belling Lee
H.T.—, H.T.+1, H.T.+2, H.T.+3, H.T.+4	CLIX	Belling Lee
2 Accumulator Spade Tags	BELLING LEE type R	Clix, Bulgin, Goltone, Eelex
10 Terminals, A1, A2, E, L.T.—, L.T.+.	PETO-SCOTT	
H.T.+4, H.T.+3, H.T.+2, H.T.+1 Output	PETO-SCOTT	
1 Aluminium panel 12 × 7 ins. 16 S.W.G.	PETO-SCOTT	
1 Metaplex screen, 10 × 6½ × ⅜ in. (metallised on all surfaces)	PETO-SCOTT	
1 Metaplex baseboard, 12 × 10 × ⅜ in. (metallised one side)	PETO-SCOTT	
1 Terminal strip 12 × 3 × ⅜ in. ebonite	PETO-SCOTT	
1 Bracket for mounting 7-pin valveholder	PETO-SCOTT	
1 1-in. 6 B.A. round-head bolt (and terminal head) for screen	PETO-SCOTT	
1 Cabinet	PETO-SCOTT	
Wires and Screws		

VALVES—MARCONI, OSRAM HEPTODE X.21 metallised. COSSOR 210V.P.T. metallised.

Special TELEVISION Section



Conducted by
**Dr. JOSEPH HARRISON
 ROBERTS, F.Inst.P.**

I HEAR that rapid preparations are being made in Germany to put on the market a mass-produced television set at a price equivalent to about £30 in English money. It is proposed that there shall be no tax for the television service in Germany, the service being entirely free to purchasers of the receivers. Germany, in fact, claims to be ahead of any other country in the world in the matter of television development.

The wavelength used in recent German television transmissions was 7.059 metres for sound and 6.772 metres for vision. You will notice that these wavelengths are very nearly identical with those which it is believed will be used for ultra-short-wave sound and vision respectively in this country when the high-definition television service is inaugurated.

Nobody seems yet to have discovered the ideal term for a person who uses a television receiver, that is, a word corresponding to the term "listener" in the case of an ordinary radio receiving set. A writer in one of the leading papers lately gave a number of suggested terms, which included "televisa," "televist," and "televoyant."

The Final Terms

It is believed that the B.B.C. will adopt the term "televviewer" for a television receiving set, and either "looker" or "viewer" for the

operator of such a set, that is, for the television "audience," so to speak.

There are always plenty of busybodies about who want to interfere with things. You would hardly believe it, but many people have already suggested setting up a censorship of televised material and have gone to

Among the aspects of television discussed by Dr. Roberts this month are the preparations for mass-produced television set manufacture in Germany—Censorship—The Radio Exhibition—What the film stars think of television, etc.

great lengths to set out various features and details which ought to be included in such programmes and others which would be considered objectionable and which should be excluded.

All this kind of thing is bad enough in regard to transmission of ordinary sound programmes, but considering that television, in any real sense, is as yet unborn in this country, it seems rather early days for the fussy people to be getting busy. Still, I suppose Mrs. Grundy will always be with us, and the minority always makes the most noise.

In the Radio Exhibition in August I

understand that a combined television exhibit will be arranged by the Radio Manufacturers' Association, and that manufacturers of television sets will not show them on their own Stands. There are a number of reasons for this arrangement, one being that if they combine the television receivers together the Radio Manufacturers' Association will be able to give the public a big scale demonstration of high-definition television. There seems to be some difference of opinion in the trade as to how the public will regard television at this time.

Some of the trade say that the public will only be interested in seeing actual television reception and not very much in the purchase of receivers just yet; whilst, on the other hand, some

people think that there will be a lively demand for receivers, particularly if by that time a more definite date has been announced for the inauguration of the high-definition service by the B.B.C. In fact, there is actually a proposal that different existing television interests should get together and hold a separate Television Exhibition.

At the moment of writing we are still waiting for some official announcement as to whether the B.B.C. television service will be from the Crystal Palace, from Alexandra Park, or from elsewhere. Only two or three weeks ago the N. London site seemed to be a hot favourite, but I hear, during the

past day or so, that there is a change in the official view, and that there are good reasons for thinking that the choice will eventually fall on the Crystal Palace.

* * *

Since the activity in television preparations in this country, America is going ahead strongly in the same direction. The principal concern in this field is, of course, the Radio Corporation of America, of which Mr. David Sarnoff is the well-known president, and at a recent meeting of the company he announced that they had decided to spend some £200,000 on bringing television out of the laboratory stage and putting it on a practical basis.

Threefold Scheme

Apparently what they propose to do is first of all to construct a modern television plant in the U.S.A.; secondly, to manufacture a limited number of television sets to be used, first of all, semi-experimentally; and finally, to develop a programme service so as to get all the necessary experience in studio technique and to find out how various items go over, and what sort of entertainment is most popular with the general public.

It is anticipated that all this development work will take about a year to eighteen months. The headquarters for this television scheme will be at the Empire State Building in New York, where they have had an experimental transmitter in use for some considerable time past. As you

probably know, this is a very high building and the transmissions will be carried out from the hundredth floor.

As in this country, ultra-short-wave transmission will be used, having a range limited to, perhaps 20 to 25 miles, and this means that the television programmes will, at first, only be radiated in a few large towns where a considerable number of "viewers" can be served in relatively small areas.

AMERICA SPEEDS UP

Talking about television in America, it is interesting to have the views of some of the film people as to the effect television is likely to have on the moving picture business. As everyone knows, there has been no lack of dismal prophets to say that television is going to mean the end of talking pictures.

Personally, I think this is ridiculous, not only because the talking picture has reached such a very high state of perfection, whereas television is still in its infancy, but also because I think that even in years to come the two types of entertainment will be complementary and not to any extent competitive. Anyway, the moving picture people are not worrying at all about television having any adverse effect on their business—on the contrary.

In film circles in America it is be-

ment," declared Jolson. "It is human nature to want to go somewhere. If that hadn't been true, the talking machine and the radio would have done for the stage and screen years ago. Television will be an interesting novelty, but it will go along with pictures—not in place of them."

"The First to Buy"

Dick Powell admits that he will probably be among the first to buy a television outfit once they are on the market generally. "At the same time," he says, "every new medium of entertainment offers an additional opportunity for everybody connected with the amusement business. Why worry about it? Television is coming—it probably won't replace anything."

Ruby Keeler says, "I do not honestly see how it can affect motion pictures much one way or another. It will be a distinct type of entertainment, but it won't keep people away from horse races or motion pictures." So you see these players, at any rate, are not afraid of the television wolf;

in fact, they do not consider it a wolf at all.

* * *

I saw the other day a description of the cathode ray, which may be familiar to some of you but was new to me. It struck me as such an excellently illustrative description that I would like to repeat it, as I think it will help many of you to visualise more clearly what happens in a cathode-ray tube.

Here it is. The cathode ray paints a picture on the fluorescent screen in a series of single elements, differing

in shadings as in a newspaper halftone, as an artist with an air-brush might do it, by successive and varying pressures of his thumb. (Perhaps I should explain that the air-brush is a kind of scent-spray arrangement that you sometimes see used by decorators outside shop fronts. It sprays the paint in a mist of fine particles, the speed and volume of the particles being controllable by the pressure of the operator's thumb on a lever.)

PARIS BEGINS TELEVISION TRANSMISSIONS



Mlle. Beatrice Bretty, the French musical comedy artist facing the television transmitter in Paris during the first television transmission made to the public.

lieved that the present generation will see television perfected, but nobody thinks it will have any "devitalising effect" on screen and stage. These views are shared by such a veteran of the entertainment world as Al Jolson, and by such a comparatively newcomer as Dick Powell.

A Contemporary

"The people will never be content to stay home for all their entertain-

"HARD" & "Soft" Scanning Circuits

By G. Stevens

THE scanning circuit for moving the beam across the screen of the cathode-ray tube ranks equally in importance with the receiving circuit, since it is impossible to obtain good pictures unless the receiving screen is produced at the same speed and in perfect unison with the movement of the transmitting spot.

With low-definition television the problem of moving the beam across the screen uniformly in two directions is not difficult, since the movement is

FUNDAMENTAL CIRCUIT

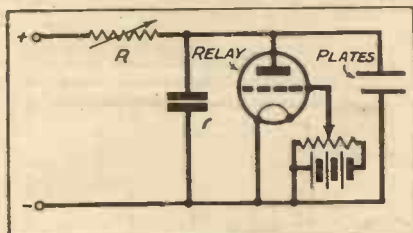

Fig. 1. The simplest scanning circuit, using a condenser and gas-filled relay to apply impulses to the tube deflector plates.

comparatively slow and slight irregularities in the scanning lines will not spoil the picture completely. As the definition increases, however, the need for accuracy in scanning becomes more important, and a modern 240-line picture will require a rhythmic movement of the beam 6,000 times per second in one direction without faltering or losing step.

Further, the scanning circuit must completely come into operation at the touch of the switch, and the speed must be attained without further adjustment. A great deal of research has been carried out recently to find the most satisfactory way of producing the scanning lines, and in this and subsequent articles the various suggested circuits will be discussed in detail.

Simplest Time Base

When the cathode-ray tube was originally introduced, its principal application was in the observation of waveforms which were drawn out to a horizontal time base. The simplest time base circuit was that employing a neon lamp and condenser, which was

★.....★
An extremely lucid and interesting description of the requirements for the scanning circuit of a cathode-ray television tube, and how those circuits operate.
 ★.....★

charged through a resistance and discharged periodically when its potential equalled the striking potential of the lamp.

This circuit has been described many times, and is still used with slight modifications for applying small regular impulses to the beam in special experiments. The disadvantage of this circuit so far as television scanning is concerned is twofold; it does not give a long enough travel to the beam, and the movement of the beam is not linear.

Gas-Filled Relays

An obvious way of lengthening the travel of the beam is to use a valve-amplifying stage between the condenser and the deflector plate circuit, but this is troublesome and requires a valve with a high anode voltage and long grid base.

A very important improvement was made by the substitution of the gas-

PICTURE PROPORTIONS

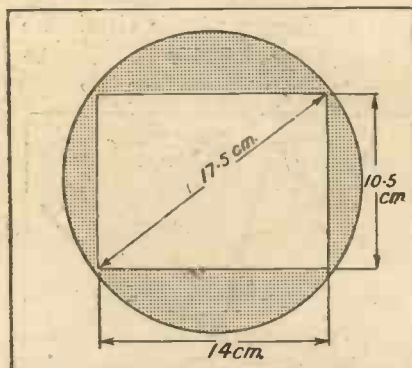

Fig. 2. The proportions of a picture on a 7-inch cathode-ray tube screen. The picture ratio is assumed to be 4:3, according to the P.M.C.'s Committee recommendations.

filled relay for the neon lamp (Fig. 1). This enabled a higher voltage to be applied to the deflector plates, and the length of travel of the beam, besides being increased became controllable

by alteration of the bias applied to the relay. The circuit of Fig. 1 can therefore be taken as the starting point of the scanning circuits for television, and since it uses a gas-filled valve it can be conveniently called a "soft" scanning circuit to distinguish it from the "hard" circuits using ordinary thermionic valves.

We can now develop this circuit further and see how it meets the requirements of a modern high-definition television screen. The speed

CONDENSER CHARGING

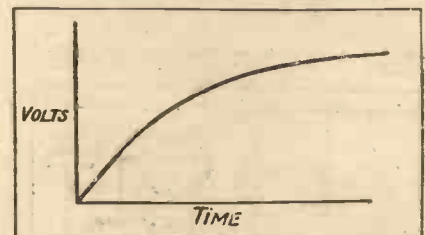

Fig. 3. The curve of charging potential of a condenser in series with a resistance. As the voltage rises the rate of increase becomes slower, giving a non-uniform deflecting force.

of travel of the beam need not concern us for the moment, since the circuit is capable of generating impulses up to 6,000 per second without difficulty, and it is only a question of choosing suitable constants.

If we assume a cathode-ray tube of 7 ins. diameter, between the big 10-in. tube and the baby 5-in., the area of picture on the screen will be 14 cms. by 10.5 cms. assuming a picture ratio of 4:3 (Fig. 2). These dimensions will therefore be the travel of the beam in the horizontal and vertical planes.

Deflecting Potentials

A high voltage tube is not very sensitive, so we can assume that a deflecting potential of 2 v. per mm. travel will be required. The voltage applied to the deflector plates will therefore have to be 140×2 and 105×2 , 280 and 210.

These figures must, of course, only be taken as illustrative, since the sensitivity of the tube varies with the operating voltage and the deflecting

potential must be capable of variation to meet a lower sensitivity. The voltage to be applied can, however, be taken to be 300, and this is therefore the potential to which the condenser must be charged.

If the overall H.T. voltage applied to the circuit of Fig. 1 is 300 the condenser will certainly be charged to this value, but the charging rate is non-linear, and the movement of the beam will follow the curve of Fig. 3. This will result in the cramping of the scanning lines at one end of the screen with a consequent distortion in the picture.

Constant Current

To overcome this difficulty there are two improvements which can be made in the circuit: The resistance can be replaced by a constant-current valve such as a pentode, or the overall voltage applied to the scanning circuit can be increased.

Dealing with the first alternative, the characteristic curve of the pentode

PENTODE-FED CONDENSER

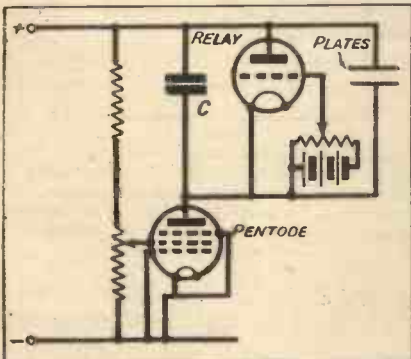

Fig. 4. The resistance of Fig. 1 has been replaced by a pentode to produce a linear charging rate of the condenser. This arrangement gives a true "saw-tooth" waveform.

is such that the current remains constant over a wide variation in anode voltage. If this valve is connected in the charging circuit, this will mean that the current flowing into the condenser will be unaffected by the rise in potential across it. The curve of charging potential is therefore straight, and the deflection of the beam is uniform with regard to time.

The rate at which the condenser charges is dependent on the value of the valve impedance, and it is therefore necessary to connect the screen of the pentode to a potentiometer across the H.T. supply. The altered circuit is shown in Fig. 4. This will require an applied H.T. of 400 volts to allow a margin of variation, and the current drain on the H.T. unit will be considerable, owing to the

potentiometer and the screen current.

The second alternative to the use of a pentode or screen-grid valve is the raising of the H.T. voltage of the scanning circuit. If the value of the final charging potential is made sufficiently high, say 1,000-2,000 v., the actual value of the voltage across the

THE LINEAR SECTION

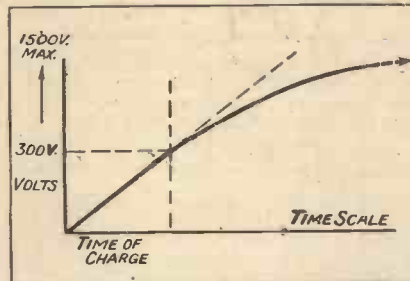

Fig. 5. A close-up of the curve of Fig. 3 showing how the initial part can be taken to be straight if the final voltage is sufficiently high.

condenser when the relay discharges it, is only a small proportion of this figure.

The curve of charging potential, shown in Fig. 3, will therefore still be in the straight portion and will not have started to curl over. This is shown more clearly in Fig. 5. The question is purely one of proportion between the condenser potential at the time of discharge and the final potential which it would reach if it were allowed to charge to the H.T. supply potential.

If this proportion is made high, say 4 or 5:1, it will be found that the curve is still very near linearity at the time of discharge. The charging resistances are of a high value, 1-2 megohms, owing to the high voltage used.

The advantages of this circuit are its simplicity and economy, requiring,

THE "SAW-TOOTH"

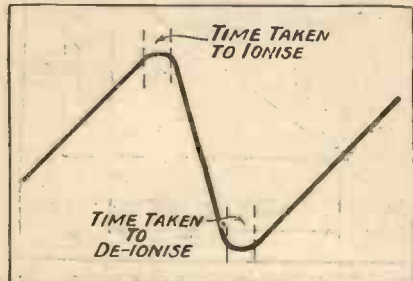

Fig. 6. A saw-tooth wave of voltage showing the pause at the top and bottom due to ionisation effects in the relay.

as it does, only the relay, condenser and high resistance. The obvious disadvantage is the high voltage required, which necessitates special precautions in the wiring and in the choice of components.

For example, should the relay not "strike" for any reason, the condenser will charge to the full H.T. potential, and it must therefore be capable of withstanding this without breakdown. Secondly, it is obvious that since the condenser charging curve is a curve it can never be truly said to be straight, and it therefore becomes a question of the degree of "non-linearity" permitted.

It should be remembered, however, that this non-linearity occurs at one end of the scanning where its effect is not so noticeable as in the middle of the picture. The high voltage must be provided for the tube itself, and there is no reason why this same supply should not be used for the scanning circuit.

The disadvantage of the high voltage is thus not so great as appears at first sight. Owing to its simplicity, this scanning circuit has proved very popular with experimenters and is capable of very good results with the correct values of components.

THE MULTI-VIBRATOR

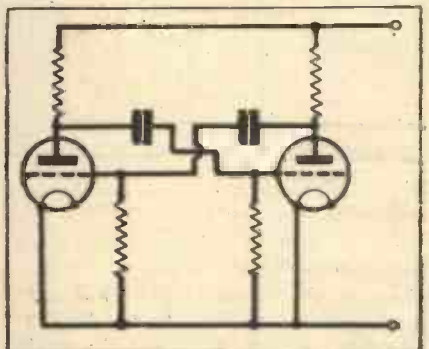

Fig. 7. Outline circuit of the "multi-vibrator," a hard valve oscillatory circuit which can be made to produce a saw-tooth wave.

The accurate working of "soft" scanning circuits depends mainly on the gas-filled relay, and herein lies the weak point. Any valve which operates by the ionisation of gas is liable to fluctuation, owing to variations in the pressure in the bulb. There is also a limitation to the speed of the discharge due to the time taken for the gas to become ionised.

Ionisation Lag

In practice this means that a small fraction of a second elapses between the time that the condenser reaches its full potential and the time that the discharge occurs.

A similar pause occurs at the end of the discharge when the voltage across the condenser has fallen to zero.

The ionisation in the relay takes a similar amount of time to disappear,

(Please turn to page 88.)

TELEVISION

MAGNIFIERS

by
*Victor
King*

Do we want large viewing screens for satisfactorily answered fully and clearly in the following article, which also deals with the latest type of electron camera used for high-

factory reception of television? This question is article, which also deals with the latest type of electron definition transmission.

THERE has been a great deal said about the projection of television pictures on to large screens, but I have been wondering (1) whether that is really what we want; and (2) if we would like it when we'd got it?

Those of you who have home cine's will know that the question of size of screen is very closely bound up with the viewing distance. If you were to project the pictures on to a screen the size of one of the walls you would not find them at all comfortable to look at. In order to be able to see what was going on you would have to wave your head about all the time.

In other words, the pictures would spread out far beyond the limits of your normal angle of view. Sometimes a newspaper will publish a picture occupying the whole of a page. To see it properly you have to spread the paper out and stand back a bit from it.

Supposing you were obliged to sit at a distance of three feet from the screen, then you would find a screen of eight by ten inches or so was about as large as you would want. Anything beyond that and your eyes would start to dart about restlessly as they tried to take in every part of the moving pictures.

Easy Viewing

Mind you, I am not going to try to convince you that eight by ten screens are big enough. They aren't. For several people to look-in together so that they can all obtain easy views a screen of about three feet by two feet six inches or so at a distance of some ten feet from the eyes is needed.

Another important point concerns the de-

tail of the pictures. The 30-line television which is at present being broadcast on an experimental basis will stand very little magnification before it disintegrates. A little while ago I attended a lecture during which a 30-line television picture was projected on to a screen several feet in height.

Improved by De-Focusing

Its crudeness was then so apparent that it lost all semblance of realism, though I am bound to say it didn't have much before! De-focusing the picture improved it a lot because, instead of seeing the harshly separate chunks which built it up, you saw the whole thing merge into the sort of picture you would see if you were looking through a fog and wore dark glasses.

Although in some cases it is an un-

fair comparison, in this particular instance you can get the trend of the idea very clearly if you examine a newspaper illustration. You will find that when looked at under a magnifying glass the picture breaks up into black dots. Well, looking at such a picture under those conditions is just about the same as viewing a low-definition television scene that has been enlarged to big screen size.

I have had a special picture prepared to illustrate the point, and in case you haven't quite got the drift let me add that I have now dealt with the number two reservation which questions whether or not we would like a big television screen.

Clearly, we would not if the pictures were low in definition and their crudeness became painfully apparent. It is much easier for our eyes to tolerate smallness and even dimness of lighting than crudeness of detail or flicker.

You see, the imagination can be stretched quite a long way but it has a breaking-point, though this, of course, varies with individuals and a very great deal with the subject of the pictures. Naturally, if the theme is uninteresting and does not by itself tend to hold the interest and attention of the looker then he will find his mind wandering — into critical channels.

Imagination Helps

Given a jolly good news reel or film drama, lookers will have no difficulty at all in forgetting the lack of brightness or the smallness of a television reception. Their imagination will help them to tolerate a small picture by removing their mental viewpoints back to

WHAT TOO LARGE A PICTURE SHOWS



LOW DEFINITION is illustrated by the portion of this photo in the magnifying glass. Look at it from a very short distance and you will see how really crude the picture elements are, and how widely they are spaced. Hold the picture well away and the form begins to improve. The picture illustrates the hopelessness of trying to enlarge low-definition television for close viewing on a big screen.

where they would have to be to make the actors and objects in the pictures appear natural at the size rendered.

And even on the poorer outfits the pictures won't be so dim that the eyes will be unable to adapt themselves to see them clearly, and imagination can do the rest by slipping a kind of subconscious fog or misty window between the pictures and the looker.

But poor detail, no. That, at least, is my opinion which has been arrived at after witnessing demonstrations of 30-line television on screens of all sizes from the area of a postage stamp to that of a large poster, and 180- and 400-line television also in a variety of screen sizes.

I hope the B.B.C. regards 240-line definition as the minimum for the new service, and keeps its mind very much on the real need for improvements even on that.

A number of readers have written to me asking for more details about that fascinating "Electron Camera" which I recently dealt with. Fortunately, I am able to add considerably to what I have already said without going beyond the bounds of the title of this article.

Insensitivity

The Electron Camera by itself is a rather insensitive device and it requires the aid of a "magnifier." But before I discuss this point, perhaps I had better briefly review the Camera itself for the benefit of those who may have missed my preceding article.

The Electron Camera is the invention of Farnsworth, an American, and its purpose is to act as the "eye" of a television transmitter. It comprises a kind of cathode-ray tube. The picture is focused on to a photo-electric cathode which emits electrons from its surface in direct proportion to the light which falls on it.

These emitted electrons leave the cathode and are made to maintain their relative positions by means of a magnetic field so that they pass across the tube like the rays of light leaving a cinema projector.

Deflecting coils are arranged to move the electron "rays" in a scanning

THE ELECTRON CAMERA

action so that each portion of the electron version of the pictures in its turn coincides with a tiny hole in the anode. The electrons which pass through this hole are led to an external circuit in which they comprise a current which fluctuates in accordance with the different degrees of light making up the picture.

Amplification Needed

But the current is extremely small and so needs considerable amplification. Valve amplification presents great difficulties. Farnsworth de-

THE FARNSWORTH MULTIPLIER

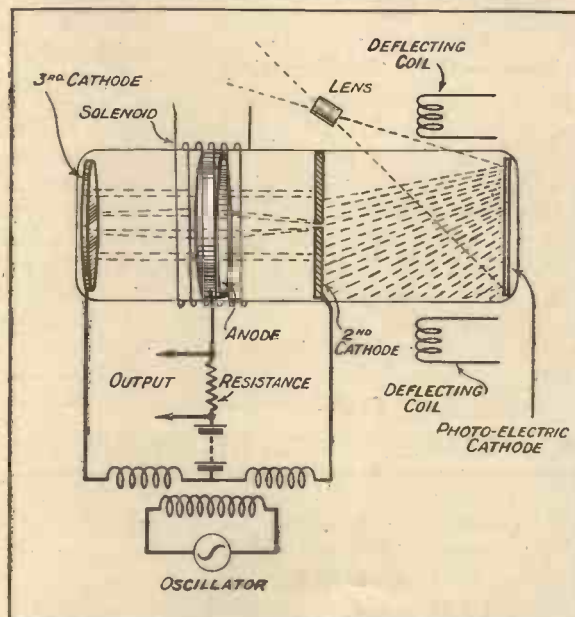

"CAMERA" AND MAGNIFIER in one is obtained by the ingenious arrangement shown here. The picture is focused on the photo-electric cathode, and the emission from this is scanned and made to pass through the hole in the second cathode. Hence it is made to generate a further series of electrons to provide a multiplied emission.

veloped his Electron Multiplier with the object of providing the necessary amplification and in the sketch you will see how it can be built into the one unit with the Electron Camera.

Secondary Emission

The anode of this latter is now replaced by a second cathode which, of course, has the small hole in it. The principle on which the Multiplier depends is that of secondary emission of electrons. Secondary emission is encountered in the thermionic valve.

When the electrons strike the anode of a valve they tend to knock some of the free electrons off it, and the number knocked off will depend upon the

nature of the metal of which the anode is composed and the speed of the electrons which strike it.

In the Farnsworth Multiplier the anode is for the purpose of adding velocity to the electrons which get through that tiny hole in the second cathode. It is fashioned in the shape of a ring and any tendency for the electrons to fly to it is eliminated by the provision round it of a solenoid which creates a strong magnetic field.

So the electrons fly through and strike the third cathode which is made of some such substance as caesium. A number of electrons is knocked off this and an alternating current being applied to the second and third cathodes makes these electrons fly backwards and forwards between them, knocking off more and more electrons, for the second cathode, too, is of caesium or something similar.

So the first few electrons which escaped into the Multiplier Section of the device through that tiny hole, build up into a comparatively large stream which bounces backwards and forwards between the second and third cathode growing bigger and bigger with each traverse of the Multiplier.

Millionfold Increases

I must admit to ignorance as to the limits of the operation. Presumably, the horde of electrons would continue to increase in size until the tube blew up unless something was done to stop the multiplication. It is, of course, necessary to do this in time for the next bit of picture to be dealt with, and I believe some external choking effect of a suitable frequency is applied for that purpose.

But what a mass of processes! It is said that a millionfold amplification without background is possible. I haven't yet seen one of these wonderful gadgets at work and I must say that, until I do, I feel inclined to reserve judgment, though I have heard that good results have been obtained.

Talking about magnification reminds me of a new "light valve" for mechanical reception which I recently heard of. It is a development of the Kerr Cell, and with it extremely bright pictures are said to be possible.

Apparently the control obtainable with the new device is exceptionally good and it has been tested with high-definition apparatus and large, bright projected pictures obtained.

I must say that this news, together with other I have gathered, inclines me to the opinion that the mechanical systems are going to give the cathode ray a very good run for its money.

TELEVISION



Special receivers for high-definition television will be required, and their design will necessitate a considerable practical knowledge of ultra-short-wave technique. Some useful information is given here by

L. H. THOMAS.

A RECEIVER designed expressly for high-definition television is a specialised product in several senses. For one thing, it must be designed by someone with a practical knowledge of the ultra-short waves and their eccentricities; and, once it is erected, it is of no use for anything but the reception of television.

In a way this is a good thing, for a receiver that has more than one job to do is invariably a compromise—and compromises seldom work well.

THE VISION RECEIVER

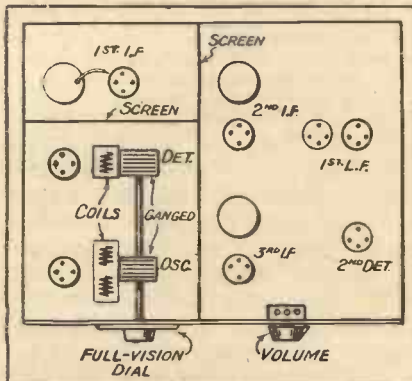

Fig. 1. A general idea of the layout of Mr. Thomas' ultra-short-wave receiver may be obtained from this sketch.

I have been doing a considerable amount of experimental work with ultra-short-wave superhets, and have found out several interesting facts about them. I even venture to suggest that no one who has not tried for himself can possibly foresee the little snags that appear to crop up.

Electron Coupling

Fig. 1 gives a general idea of the layout I used for my first attempt. The circuit consists of first detector (S.G.), with an electron-coupled oscillator (triode) feeding into its screen. Three I.F. stages (all H.F. pentodes) are followed by the second detector

(anode bend, triode) and one stage of L.F. (two triodes in push-pull, using a special form of direct-coupled circuit).

Note that the ultra-short-wave part of the set is all kept to the left of the vertical screen; on the right are the I.F.'s and the final part of the receiver. The I.F. couplings were of a rather special type giving high gain combined with a reasonably flat curve, but not by any means the "ultra-flat" affair suggested by some people. The tuning of each stage was carefully adjusted to give a band-pass effect, and a band-width not far short of a million cycles was obtained almost on the first test.

Ganged Tuning

The tuning controls of the first detector and oscillator were ganged, and it was found that by using coils of very small diameter one could do away with the necessity of screening them from each other—thanks, largely, to the extraordinary stability of the electron-coupled oscillator circuit.

All the wiring of the latter, by the way, had to be extremely direct and short before the oscillator could be made to oscillate really freely and smoothly throughout the whole range of the tuning condenser. But that is the sort of precaution that one would automatically take in any short- or ultra-short-wave receiver, and need not concern us here.

The I.F. stages, being so flatly tuned, did not show any tendency to be unstable; as a matter of fact one

of them did misbehave at the beginning, but it was a clear case of interaction with a neighbouring circuit, and a very half-hearted attempt at screening put things right at once.

Super-Regeneration

I am giving all my own experiences in this way just to show that the whole business is reasonably straightforward, and that the home constructor need not be worried. Given a ready-made circuit and layout (as you will be before very long) there is no reason why a copy of it should not work right away.

Fig. 2 shows the circuit used for the "sound" receiver. I have never seen why it should be necessary to use a large superhet for the reception of the sound that accompanies the vision. The modern super-regenerative receiver gives excellent quality on telephony transmissions, even if the latter are badly frequency-modulated, as in the case of many 5-metre amateur transmissions.

The circuit shown uses the "grid-blocking" scheme of super-regeneration, which has the merit of requiring no "quench" coils. An H.F. stage is

(Please turn to page 87.)

FOR "SOUND" BROADCASTS

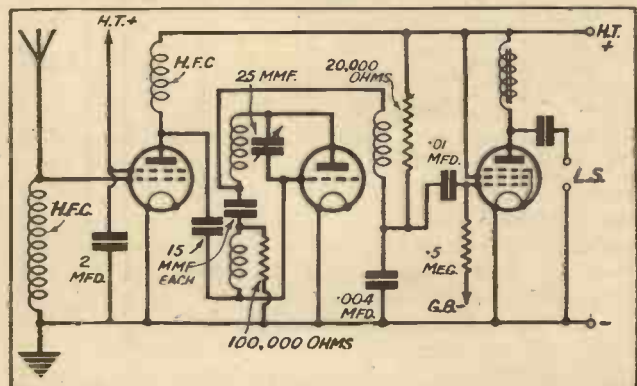

Fig. 2. For reception of sound a super-regenerative receiver circuit such as that shown above is quite satisfactory.

SPECIAL TELEVISION SECTION

SAFEGUARDING THE TUBE

The frailness of the cathode-ray tube, in its electrical, not mechanical, sense, is one of the drawbacks that have to be guarded against when one is using these devices. Some hints that may be of use to television experimenters are given below.

By K. D. ROGERS

THE cathode-ray tube is a vulnerable animal. Much more so than the valve—and, to make matters worse, it costs very much more, too.

The ordinary valve will stand over-running not only for a considerable time but at a considerable percentage above its rated anode current, to say nothing of the filament current.

Accelerator Current

In the case of the cathode-ray tube of the D.C. variety the filament can be slightly overrun for a short time without very serious things happening, but when it comes to the accelerator current things are not so happy. It is easy with the forces at work in a cathode-ray circuit to lose emission, and to lose it rapidly, for quite slight variations of component values may release voltages that will soon run the current up to several hundred per cent above its normal.

In a valve set the breakdown of a resistance, which may cause the removal of the grid bias from one of the valves, will certainly cause the

valve to be ruined in time, but at first nothing very much more serious occurs than the arrival of distortion in the results. Plenty of warning is thus given that something is wrong.

Remove the bias from the shield of the cathode-ray tube and see what happens. Yes, see it literally. There is a good hearty flash, and the cathode is blown to bits by a tremendous rush of electrons. The space-charge that is keeping the electrons in check has been removed and an electrical explosion of the cathode (which is only a small spot on the filament) occurs.

Tackling the Problem

That means a new tube, costing perhaps ten guineas. Not a very cheap pyrotechnic display.

How can we prevent this—or, rather, how can we safeguard ourselves? The answer is that there is no complete safeguard, though we can do a lot to make such an occurrence most unlikely.

Consider the circuit in Fig. 1. Here we have a skeleton exciter circuit for a cathode-ray tube, showing 2,000 volts maximum and the usual potentiometer scheme for the various voltage taps, including the bias for the shield.

Vital Points

Note the condenser "X" and the potentiometer "Y." If the former breaks down the bias is immediately short-circuited and bang goes the tube. If the potentiometer "Y" or the resistance below it shorts, the bias is reduced; but this will be shown by alteration in the spot brilliance

and focusing, and the tube can be saved by speedy action. If they both short, it is all up with the tube.

If the slider of "Y" makes no contact at any particular point—bang goes the tube again. A nasty outlook, isn't it?

We can mitigate the dangers somewhat. In the first case the resistance "R" in series with the cathode to exciter unit tap will militate against a very bad surge of electrons and will tend to hold up the disintegration of the cathode while the operator hurriedly switches off. The resistance should be as high as possible. But it is not a complete safeguard.

Fuses would not be any good for the currents are low and there is every likelihood of the cathode going before the fuses, so suddenly do things happen when anything goes wrong.

PREVENTS SCREEN BURNING

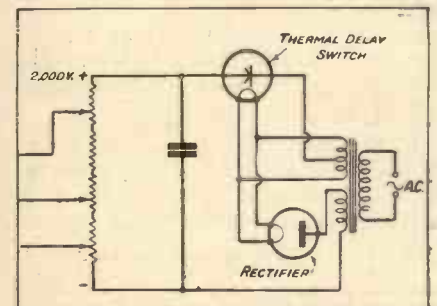

The use of a thermal delay switch, "lagged" so that the time base is working before the H.T. is applied to the tube, is an essential safeguard against a steady spot.

The best that can be done is to ensure that the condenser in question is of good make and that it is of a voltage that will certainly withstand any voltage that is likely to be imposed on it. You see, the earth of the exciter is at the positive end, so that the condenser "X" may have to withstand up to 2,000 volts or even more in cases where a larger voltage on the tube is required.

Condenser "Z" is also a danger spot, and this must for the same reason be of the high-voltage-plenty-of-margin type.

A Precaution

What about the resistance I have shown connected from the slider of "Y" to the end of that potentiometer? That is to safeguard the tube from bad contact between the slider of "Y" and the resistance element. In such a case, without the resistance, the bias would be immediately removed from the shield of the tube. The resistance prevents this happening, and, though the bias may be reduced, it is not

(Please turn to page 85.)

A SKELETON EXCITER CIRCUIT

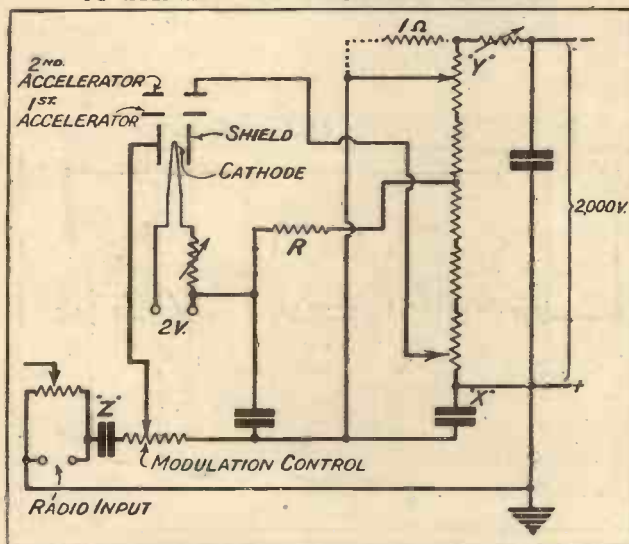

Vulnerable points in the exciter circuit which can prove fatal to the life of the cathode tube are indicated here.

READERS whose sets employ Class B output, Q. P. P., or push-pull arrangements, may sometimes be puzzled by the question of the correct way of running wires for an extension loudspeaker.

It is usual for modern loudspeakers to be provided with their own input transformers, the primaries being centre-tapped to accommodate the above-mentioned types of output. Therefore, at first sight, the employment of a speaker with its own transformer, for extension purposes, in the above cases would call for three wires—one going to the centre-tap terminal.

Easily Connected

Actually, however, two wires, as in the case of an ordinary loudspeaker extension are all that is required. The centre-tap on the extension speaker should be earthed via a condenser, while the two extension wires go to the two outer primary terminals of the input transformer.

CLASS B EXTENSION

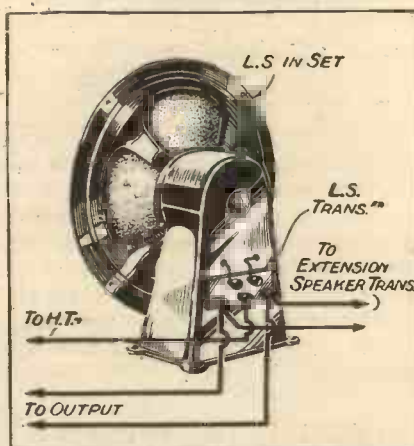

Wiring an extension speaker for Class B or push-pull is quite easy. The centre tap of the extension speaker need not go to H.T. +; it can be earthed via a large condenser to a convenient earthing point.

The reason for this is really quite simple. The object of the centre tap is merely to provide phase reversal in the anode circuits of the output valves.

The Voltage Variations

The fact that there are voltage differences across the ends of the primary of the extension loudspeaker ensures that pulsating currents will pass through the primary and thus

Practical HINTS FOR ALL



Some Topical Tips By A. S. CLARK

pass on the programme to the secondary and finally to the moving-coil of the speaker.

The correct connections to make for an extension speaker on a Class B or similarly arranged set are made quite clear by my first diagram this month.

The second diagram illustrates an ordinary sort of microphone, the suspension on which takes the form of four small coil-springs attached at intervals around the microphone case. Sometimes this form of mounting suffers from a definite disadvantage:

The "Sustained" Notes

The springs may produce a natural frequency of vibration which happens to fall somewhere within the range of musical frequencies. The result is that, suppose a strong note of this frequency is played say, on the piano, it is accentuated in the reproduction, and may even hang over with a sound very much like that produced when the finger-nail is run gently along the coils of one of the springs.

Replacing the springs by small rubber bands may often overcome the trouble, but rubber bands cannot be made to look so neat as the springs themselves. An alternative is suggested by the diagram.

Two of the springs have their natural frequencies made considerably different from those of the other two. This is achieved by shortening the springs a little and stretching them open further so that the microphone still hangs about central.

It is as well to "operate" on the top two, since the weight of the microphone will help to keep things even, because the shortened springs will give less than the other two.

And now to change the subject somewhat. Owners of good portable

sets often use them at home, when their portability is of no consequence, more than out of doors.

Quite frequently in such cases I have had complaints that the only drawback is

the frequent recharging of the accumulator which proves necessary.

It is quite natural that the accumulator in a portable set should be cut down to the smallest admissible dimensions, and it is quite usual to find that the type of accumulator employed does not hold its charge particularly well when left standing. So why not keep the small accumulator for portable purposes only?

External L.T. Supply

For a few shillings you can get a glass-cell two-volt accumulator with mass-type plates that will run your portable for weeks at a charge. It is as well to get one of about 50 ampere-hours' capacity, for this type of accumulator holds its charge for long periods even when not in use.

There will not be room inside the set for the large accumulator, so the L.T. leads must be brought outside and the battery stood beside the receiver. You may find it necessary to lengthen the leads a bit, in which case the joints should be covered with insulating tape for safety. There should be no need to remove the original spade tags as twisting the lengthening wires around them will suffice.

A USEFUL IDEA

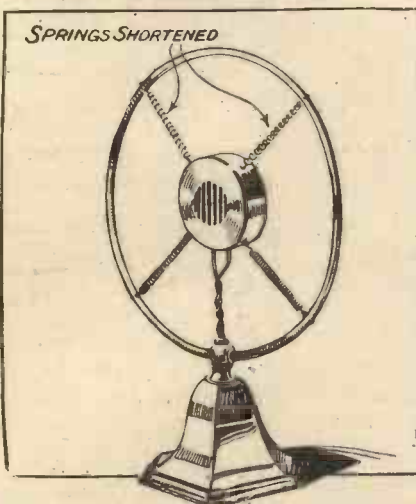

Preventing resonance due to the tension on the springs suspending a microphone.

Finally, don't forget the small portable accumulator entirely. Let it have an occasional charge.

AS WE FIND THEM

New apparatus tested

BY THE
"WIRELESS"
RESEARCH DEPT.

Interesting reviews of the latest products submitted by radio manufacturers and traders for examination and test in our laboratories.

For S.G. Valves

WHEN the screen-grid valve first came out, it had an ordinary screw terminal on the top of the bulb for the anode connection. Lately, however, the screw terminal has begun to disappear, its place being taken by a plain metal boss. The advantage of this boss is that one can utilise a simple push-on connector, which gives rapid connection and disconnection.

HANDY CONNECTORS



Three of the useful valve-top connectors marketed by A. F. Bulgin. On the left is a screened connector. Centre, an insulated model, and right, an adaptor for converting the plain boss type of valve to a terminal top.

So the position is that at the present time there are both types of valves, namely those with the screw top, and those with the plain boss.

We have recently had the opportunity of examining and trying out a number of very efficient connectors, marketed by Messrs. A. F. Bulgin & Co., Ltd., of Abbey Road, Barking, Essex, and especially designed for valves having contacts on the bulb.

Special Converter

There is, for instance, the special Bulgin adaptor, which screws on to the terminal type valves, enabling them to accommodate any of the new clip-on connectors. The adaptor has an internal thread, and you just screw it on to the terminal on the valve. This adaptor retails at 2d.

Alternatively you can convert the plain boss type of valve into a terminal top, the adaptor for this being shown on the extreme right of the photograph. It will be seen that this is a simple push-on device with an insu-

lated terminal top. This gadget is priced at 3d. In addition, there are two types of screened connector available. These are fitted with frosted aluminium cowls and have a soldering tag for the lead and a clamping lug for the shielding or braiding at the point where the lead is brought out.

The models differ as to their depth, one of them being of a shallow type, so that when it is placed in position it will not make contact with the metallising of the valve. This is desirable in certain cases, since if the metallising were earthed by the connector shield, the grid bias might be short-circuited.

A Multiple Coil Unit

We have also received from Messrs. Bulgin an ingenious coil unit which, with the aid of 5 interchangeable plug-in coils, covers short, medium and long waves. The unit is called the Multiple Short-Wave Coil Chassis, but it is actually a universal unit, the wave ranges available being as follow: 10-22 metres, 20-45 metres, 40-90 metres, 85-170 metres, 130-240 metres, 200-500 metres and 1,000-2,000 metres.

This complete range would, of course, entail seven separate coils, whereas the unit is designed to take five of them at any one time. But an examination of the wave-ranges available with the individual coils shows that all normal requirements are covered by a selected five of them. The two coils not in use in the unit can then be held in readiness for those occasions when they may be needed.

The chassis itself is fitted with a wave-change switch, which picks off the various wave ranges according to the position of the knob, the dial being engraved in the ranges corresponding to those which would normally be used.

The end plates are fitted for base-board mounting, or alternatively the unit can be mounted directly on the panel by means of a one-hole fixing if desired. Only four terminals are needed for connecting up.

The switch contacts are silver-plated and are self-cleaning, the springs being stiff and rigidly positioned. Moreover, the mechanism is of the low-capacity type, and strikes one as being very efficiently designed.

The price of the chassis complete with knob and dial is 15s. 6d., the coils, of course, being extra, the prices varying from 3s. 6d to 4s. 6d. according to the wave-ranges chosen.

Ganged Switch

Mention of switching reminds us of a very excellent ganged wave-change switch that has been produced by the Wright & Weaire factory. Constructors will agree that when the wave-changing of more than one circuit has to be carried out single knob wave-changing is a blessing.

This Wright & Weaire component consists of a pair of similar switches mounted on one framework, with a stout operating rod actuating both sets of contacts simultaneously. These contacts are of large area, are self-cleaning, and are arranged so that they possess low capacity.

The spindle is provided with a large flat so that once the knob is in position it cannot turn independently of the spindle. Nothing can be more annoying than to have a component, the knob of which works loose and rotates, without operating, the mechanism of which it is supposed to be part and parcel. The Wright & Weaire method overcomes this trouble.

UNIVERSAL WAVE-RANGE



The Bulgin multiple coil chassis and the coils which are used in conjunction with it. Only five of them are mounted at any one time.

New Uses for MICRO-WAVES

A great deal of research has recently been carried out in connection with ultra-short wavelengths of less than one metre. Such wavelengths require very special treatment, and, when satisfactorily harnessed, lend themselves to many valuable uses in medicine and chemistry. Ordinary aeriols are quite useless with these micro-waves and some very interesting facts concerning this aspect are given below.

By J. C. JEVONS

UP to the present the development of wireless has been chiefly confined to "action at a distance." The very latest "micro-wave" service, for instance, is on all fours with the older Beam system in this respect. Both are designed to send signals across so many miles of space.

Recently, however, a new line of research has been opened up in connection with the application of ultra-short-wave energy at close quarters—using it, one might say, after the fashion of a microscope, instead of a telescope.

No Coils

In certain cases this is found to throw new light upon the molecular structure of the body under test; in other cases the result of applying H.F. oscillations is to promote special kinds of chemical activity. Sometimes the effects are found to be beneficial in the treatment and cure of disease.

Most of the work in this direction has been carried out with waves less than one metre long, utilising circuits which differ in many respects from those used in ordinary broadcasting.

For instance, the valves used for generating "centimetre" waves are operated with a high positive voltage on the grid and none on the plate, so as to reduce the time taken by the electron stream to pass from one electrode to another inside the valve. Usually, too, the external circuits take the form of parallel Lecher-wires instead of the familiar tuning coils and condensers.

The Aerial

Then, again, one cannot use either an earthed-wire or a closed-loop aerial. The first has too much capacity, and the second too much inductance, to "tune down" to the wavelength required. For micro-wave working the only suitable aerial is the so-called "di-pole" type, which

is simply a straight piece of wire or rod—usually half a wavelength long—connected directly to the grid or anode of the valve.

Since the action of the di-pole aerial is closely bound up with the theory of the "close-range" effect of micro-waves, it will be described in some

USING A DI-POLE

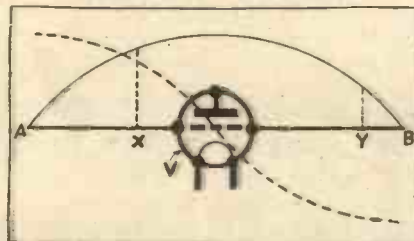

Fig. 1. How the current and voltage are distributed in a half-wave di-pole aerial system.

detail. In the first place, such an aerial possesses the minimum amount of distributed inductance and capacity, consistent with its primary duty of picking up short-wave energy from, or transferring it to, the ether.

When oscillating at its fundamental frequency, the built-up current and voltage are distributed as indicated in Fig. 1, where A.B. represents a half-

along the wire, though it has a different amplitude at each point, as shown, for instance, at x and y. This is true at any given time, though an instant later than that shown in the figure, the direction of the current will be reversed, so that it would be represented by a sine curve drawn below the line A.B.

Voltage and Current

The voltage, however, is always 90 deg. out of phase with the current, as shown by the dotted line curve. At the centre, for instance, the voltage (high frequency) is zero, whilst the current is at maximum. (The valve is feeding current into the di-pole.) On the other hand, the voltage is at a maximum at the two ends, where obviously no current can flow. As shown, the end A is charged positively, whilst the end B is negative, though an instant later the voltages will be reversed in sign.

In action, therefore, a di-pole aerial always develops charges (or poles) of opposite sign at the two ends—a fact which distinguishes it from the ordinary open wire, which is anchored at one end to earth potential, and from the closed loop which is usually connected to earth via the filament of the valve.

HOW THE MOLECULES BEHAVE

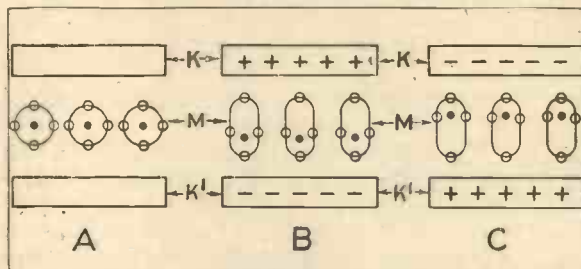

Fig. 2. A diagrammatic representation showing the response of the molecules of a condenser dielectric to different conditions of charge.

wave di-pole connected to the opposite ends of the grid of a Barkhausen-Kurz valve.

At any given instant the current in the aerial is "in phase" at all points

A New Theory

The new significance of the di-pole is largely due to the work of Professor Debye, of the Leipzig University, who has developed a theory that the molecules of certain non-conducting substances behave as small di-pole aeriols under the influence of high-frequency radiation.

Such di-pole molecules not only respond or "swing" to the action of applied high-frequency waves, but, what is more, they show a marked resonance at a certain definite frequency, which varies according to the substance.

For instance, chemical reactions can be promoted between substances which normally have little or no affinity to each other by subjecting the mixture to short-wave radiation of the proper frequency.

Also, one can determine the spatial arrangement of the atoms which go to form a given molecule. In water, for instance, there are two possible arrangements. In one, the two hydrogen atoms are placed at the two corners of a triangle with the oxygen atom at the third; in the second, all three atoms are strung out in line.

Molecular Di-poles

Experiments on the "di-pole moment" of water prove that the first or triangular setting is the true one.

Living substances, too, exhibit the di-pole effect, and can be set into internal resonance by short waves of the right frequency. The whole subject, though still in its infancy, has given rise to important developments in the diagnosis and cure of disease. The preservation of vegetable and animal food is another promising field of application.

The new line of research definitely shows that certain dielectrics and non-conducting bodies have a "static" polarisation not unlike the magnetic-polarity which we know to exist in ordinary iron. The process of magnetising a soft-iron bar, for instance, merely consists in setting the molecular magnets into definite alignment with each other.

Swinging the Atoms

Before the bar is magnetised, the molecules are higgledy-piggledy and their fields are neutralised. But by stroking the bar with a permanent magnet—or placing it inside a solenoid winding carrying a current—all the molecular magnets are "orientated" or brought into line, and the bar as a whole is transformed into a magnet.

In the same way the new high-frequency treatment is used to modify the physical or chemical properties of non-conducting substances by acting on the electrostatic "di-pole" molecules which they contain.

Every atom and molecule is made up of one or more positive ions in combination with a number of negative electrons. If these electric charges are not symmetrically arranged, the atom or molecule must possess a definite "polarity" along a certain axis, and

WEAPON AGAINST DISEASE?

will therefore behave as a miniature "di-pole," having a positive charge at one end and a negative charge at the other. Owing to this "di-pole moment" it can be swung or vibrated under the action of an applied field of the right frequency.

In the case of a complex molecule, such as those forming living tissues, the positive and negative poles are usually widely separated, so that a longer wavelength is required to vibrate it at resonant frequency than is the case with simpler inorganic substances such as hydrochloric acid and ammonia.

FOR ELECTRO-MEDICAL RESEARCH



A Marconi ultra-high-frequency therapy set. Apart from its uses in medical treatment, this apparatus is specially suitable for investigating the effect of high-frequency currents on bacteria cultures. The range of wavelengths available with this particular set range from 8.5 to 2.6 metres.

The di-pole theory as put forward by Professor Debye is found to explain the peculiar falling-off in the "dielectric constant" of certain insulators as they are subjected to an alternating potential of increasing frequency.

Fig. 2 shows diagrammatically what occurs to the molecules of the dielectric as an alternating E.M.F. is applied across the plates K, K1 of a condenser. At A neither of the condenser plates carries a charge, so that the molecules of the dielectric are at rest in their normal condition, with the electrons symmetrically arranged around a central nucleus.

At B the upper plate K is charged positively and the lower plate K1 negatively. Under these conditions

the molecule of the dielectric is distorted, because the negative electrons are strained towards the positive plate. The molecule is therefore no longer balanced electrically, but has become a "di-pole."

Inside the Condenser

At C the conditions are reversed; the lower condenser plate carries a positive and the upper plate a negative charge, so that the molecules of the dielectric are now distorted or strained in the opposite direction.

So long as the applied E.M.F. is kept below a certain frequency, the electrons in the dielectric are sufficiently "elastic" to keep pace with it. The resulting movement of the electrons, to and fro about the central nucleus, constitutes the charging current of the condenser—or, as it is sometimes called, the "displacement current"; though it does not, of course, pass completely through the condenser. It is merely a to-and-fro "drift" of the electrons about the central nucleus of the atoms forming the dielectric.

Hysteresis

As the frequency of the applied E.M.F. is gradually increased, certain effects are observed. In the first place the electron movements give rise to a certain amount of internal friction which in course of time may cause the condenser to heat-up quite appreciably. The effect is similar, though not so pronounced as the ohmic heat produced when a current flows through a conductor.

After a time the individual electron movements start to "lag" behind the frequency of the applied voltage. This produces what is known as condenser "hysteresis." Among other things it causes the "capacity" of the condenser to fall below its normal value.

Finally, a frequency is reached at which the molecules are set into pronounced vibration as a whole. They are then acting as "di-poles" swinging or vibrating in tune with the applied frequency. Here is the point at which curious things begin to happen. Where, for instance, chemical substances suddenly develop new activities, so that they enter into combination with other substances to which they were previously indifferent, and where, finally, it is possible that further research will discover a new weapon against disease.



IN LIGHTER VEIN

By
WIRELESS WAYFARER

THE FAMOUS PAIR ARRANGE TO GIVE "EVIDENCE" BEFORE THE BROADCASTING COMMITTEE

OBSERVING in the newspapers that the Committee on Broadcasting desired to hear evidence from persons representing important bodies, Professor Goop and I deemed it but our duty to apply forthwith for sanction to appear before it on behalf of the Mudbury Wallow Wireless Club, and of our millions of readers in WIRELESS. Official shows of this kind are usually fenced about by red tape entanglements, but on hearing from two such distinguished representatives of radio interests as the Professor and myself, the Committee laid aside all formalities and welcomed us with open arms.

I mean, there were none of those long delays about getting a reply that usually happen when you write to anybody connected with the Government. Believe me or not, less than three weeks after our letter had been despatched we received a printed postcard stating that it had been received, and that a reply would be sent to us in due course. And if that isn't hustling for a Government Committee, I'll be hanged, drawn and quartered if I know what is.

A Telephone Call

Some ten days later, as I was sitting with the Professor in his den at "The Microfarads," the telephone bell rang. As I happened to be nearest to the instrument, I tweaked off the receiver and cooed, "Hullo!" into the microphone.

"Is that Professor Goop?" inquired a culchahed voice.

"It all depends," I replied, "what you want. If you're the Income Tax man, he's departed for a world cruise; but if, on the contrary, you are of those who think it more blessed to give than to receive, I might be able to find him."

"This," said the voice, "is the Deputy Assistant Undah Secretary to the Deputy Assistant Undah Secretary to the Broadcasting Committee."

"Then speak freely," I cried, "for I am no other than Wayfarer, Professor Goop's friend and colleague. Or perhaps I might say the brains of the combination."

I ducked just in time to avoid the 60 ampere-hour accumulator the Professor hurled at my head, and this sailed gracefully through the French window, to land with a crash in Mrs. Goop's pet bed of begonias.

SPEAK FREELY



"I am no other than Wayfarer, Professor Goop's friend and colleague."

* * *

As Sir K. N. Pepper had just beaten Tootle by six and four, we found him in a most genial mood.

"Excuse me a moment," I murmured into the microphone, and dashed across the room to the cupboard in which the Professor was seeking further ammunition. Pushing him within, I locked the door and returned to the telephone. I gathered that the Committee was most anxious to hear two such eminent men as ourselves, but first of all some further particulars of our careers would be necessary. The necessary simple forms, I was told, were being sent to us that very evening. We had but to spend a moment or two in filling them in, and all would be well.

Having ended my talk to the satis-

faction of both the D.A.U.S. to the D.A.U.S. and myself, I released the Professor from his place of confinement and explained the whole position to him.

The Question of Expenses

He was still a trifle ruffled, and inclined at first to make scornful remarks about my intellect; but that is ever the way when one great mind is working with another. I soon calmed him down by pointing out the importance of the occasion, and its possibilities so far as we were concerned.

"The first thing to settle," I continued, "is the question of our expenses. Now I have" (and here I felt in various pockets) "fourpence in coppers, a doubtful sixpence and a postage stamp. How about you?"

The Professor produced a quaint coin which may have been a Zloty, though, on the other hand, it was possibly a Drachma, and a threepenny bit. It was clear that, however willing we might be to stand our own expenses, there were forces beyond our control in operation.

"The only thing," I said, "is to put the case quite frankly before the members of the Wireless Club. After all, it is but reasonable that as we are appearing on their

behalf, they should find the money for our goings, our comings and our meals."

Very "Touching"

The Professor agreed whole-heartedly and, being thorough believers in the policy of making hay while the iron is hot, we sailed forth straightway to interview Sir K. N. Pepper.

"I am sure," I remarked, "that we can tell him a touching little story."

"Touching," remarked the Professor, "is the operative word."



As Sir K. N. Pepper had just beaten Tootle by six and four, we found him in a most genial-mood. We listened with what we hoped were interested expressions to his long story of the way in which he had dealt with a stymie at the fourth, followed by his wonderful description of his baffly shot from a rabbit hole at the seventeenth. Then we told our little tale and departed with a perfectly good fiver and his blessing.

Captain Buckett, having a trace of Aberdonian blood in his veins, might have proved a trifle more difficult proposition; but I remembered that he was having a feud with Sir K. N. Pepper over the question whether casual lipsticks might or might not be removed from putting greens, and mentioned the amount of Sir K. N.'s contribution. Captain Buckett immediately produced a tanner.

The Net Result

Miss Worple we told that we intended to impress the Committee to recommend inclusion in the programmes of at least three hours a day of modern poetry. Almost without a murmur she coughed up a further fiver, and we began to feel that the going was indeed good.

Primplesom, Tootle and the others were tackled with equal tact and the net result of our efforts was a total of £72 14s. 9½d. The odd farthing was sent in a somewhat offensive anonymous letter which arrived on the following morning. We consigned the anonymous letter to the proper place for such things, the wastepaper

GOOD GOING

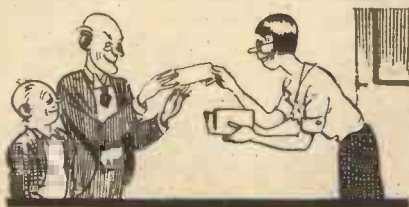

Almost without a murmur she coughed up a further fiver.

basket, but pocketed the farthing, since every little helps.

We found that we should be called to give evidence on a certain Tuesday morning. "Look here," I suggested to the Professor, "it is clearly up to us to arrive before the committee as fit and fresh as possible, and go up with our evidence thoroughly prepared. Is that so, or isn't it?"

"Most certainly it is," murmured the Professor.

"Then it is our positive duty to depart for a refreshing week-end at

"SILENCE IS GOLDEN"

Brighton. Those who have so generously contributed to the expense account had obviously something of the kind in mind. Surely it is up to us to carry out their wishes in this matter."

Perfect Relaxation

The Professor cordially agreed, but asked exactly what I meant by the term "week-end." On thinking the matter over, it seemed to me that anything that wasn't the beginning of the week must clearly be its end. We therefore packed up our traps and purchased two first-class tickets on the Monday evening, eight days before we were due to appear before the committee. This, we both felt, would give us comfortable time to get both ourselves and our evidence into form.

As neither of us had taken during the previous six months more than two hours four times a day for meals, or had had more than sixteen hours rest at nights, we were feeling the strain of over-work when we arrived at the Hotel Supersplendid. We decided, therefore, to lounge about on the beach for a day or two. One of the characteristics of really great brains is their ability to relax entirely when a rest is required. Day by day we went on relaxing like anything, but we were still feeling the strain of our previous efforts, and it was some little time before we began to feel the signs of returning vitality.

On the Friday evening the Professor settled down into a comfortable armchair after a remarkably good dinner, and inquired, with closed eyelids: "What about this—er—er—evidence of ours?"

Wayfarer Suddenly Remembers

From an equally comfortable chair, with my eyelids just as firmly closed, I made little soothing noises and endeavoured to impress upon him the inadvisability of tackling serious problems until both of us were completely rested. We were feeling distinctly better a couple of days later, but it still seemed that we were hardly strong enough to thrash out the evidence that we should give. The Monday and the Tuesday were glorious days, and we spent the whole of them in health-giving sun-bathing.

On Wednesday morning, as we lay in the nattiest of bathing suits upon the beach, the Professor once more

mentioned the subject of evidence. I awoke with a start.

"Did you say evidence?" I inquired.

The Professor confirmed my suspicion.

"Great Scott!" I cried, "that ought to have been yesterday. Well, anyhow, it's no good crying over spilt milk, and we are having a glorious time."

A LITTLE LATE



"Great Scott!" I cried, "that ought to have been yesterday."

There were certain black looks when we recounted to the Mudbury Wallow Wireless Club the evidence that we hadn't given, and there was some nasty talk amongst subscribers to the expenses fund about asking for their money back.

But a little oration of mine on the theme that "if speech is silver, silence is golden," worked wonders, and though we are at the moment not too popular with our fellow-townfolk, we feel that, whatever its decisions about the future of broadcasting may be, the Professor and I owe a debt of gratitude to the Broadcasting Committee.

A GREAT OCCASION

APPROXIMATELY one hundred and sixty men-of-war will be assembled at Spithead on July 16th when the great naval review by His Majesty the King takes place.

As the King, on board the Royal Yacht "Victoria and Albert," approaches the lines formed by the men-of-war he will be greeted by the Royal Salute fired from the ships' guns, music played by the ships' bands, and the cheers of the crews lined up on the decks.

To Be Broadcast

Listeners will be pleased to learn that arrangements have been made for the proceedings to be broadcast, the commentators being Commander Stride R.N., and Lieut.-Commander R. Woodroffe, R.N.

Microphones on the decks of the "Royal Sovereign" will pick up the sounds of the guns, music, and cheers.



America Calling!

Some details of the special short-wave receivers used by the B.B.C. at Tatsfield for the transatlantic relays.

Described by GORDON C. HAWKS.

CHANGES have taken place at Tatsfield, that lonely listening post of the B.B.C. on the Kent border, and Mr. Partridge and his associates who used to spend long sessions into the early hours searching the ether for American reception have moved on—some of them to other B.B.C. departments. But their wonderful pioneer work has had its reward, and the successful American relaying which has been done in the recent "Five Hours Back" programmes—foreshadowing what the B.B.C. hopes to do in American relays during the next few months—is largely the result that has been obtained by the Tatsfield pioneers.

Unlimited Aerial Space

In fact, one of the two special short-wave sets used by the B.B.C. was built way back in 1933, and was on the drawing-board even at the end of 1932. The second receiver is very much the same, and differs only in that it has waveband switching and does not incorporate a coil-changing arrangement as in the earlier set.

Unfortunately, neither the sets nor aerials are of the type which could be built by the average short-wave "fan," for at Tatsfield the B.B.C. has unlimited space for a spaced-aerial layout, and this is the latest addition to the bevy of aerial wires you see as you come up to the little brick building in the Tatsfield grounds. This means adding another two short-wave receivers to the list—but what is another receiver or two to the B.B.C.!

Wide Frequency Range

When I went down to the listening post the other day I was shown what changes had been made in the short-wave gear to cope with the "Five Hours Back" series, and this short-

wave plant can be used for practically any work on 22,600 to 3,900 kilocycles—even television reception! But I couldn't get any B.B.C. engineer—or "plumber," as the programme staff says—to agree that there was the necessity for short-wave television reception at Tatsfield. Not yet, at any rate.

The short-wavers are nothing much to look at from the outside. You see, they are mounted on the all-too-familiar grey steel racks in the main

apparatus room at Tatsfield. You need an expert guide to explain what is behind each panel. The knobs bear only very laconic instructions; not enough to show what circuits they control, unless you have seen the master circuit in the blue-print room.

In the first short-wave set—that is, the one which was working by the early part of 1933—the tuning coils were mounted in separate screening cases, and when the engineers wanted to change the waveband they had to undo the screening cases to get at the coils. This took too much time, and so a waveband switching device was incorporated in the later sets. This is arranged to cover four ranges, leaving no gaps between the limits of 22,600 and 3,900 kilocycles. The first position tunes from 3,900 k.c. to 6,100. The second from 6,000 to 9,100. The third from 9,100 to 14,700 and the fourth from 13,000 to 22,600 kilocycles.

AMONG THE TATSFIELD SETS

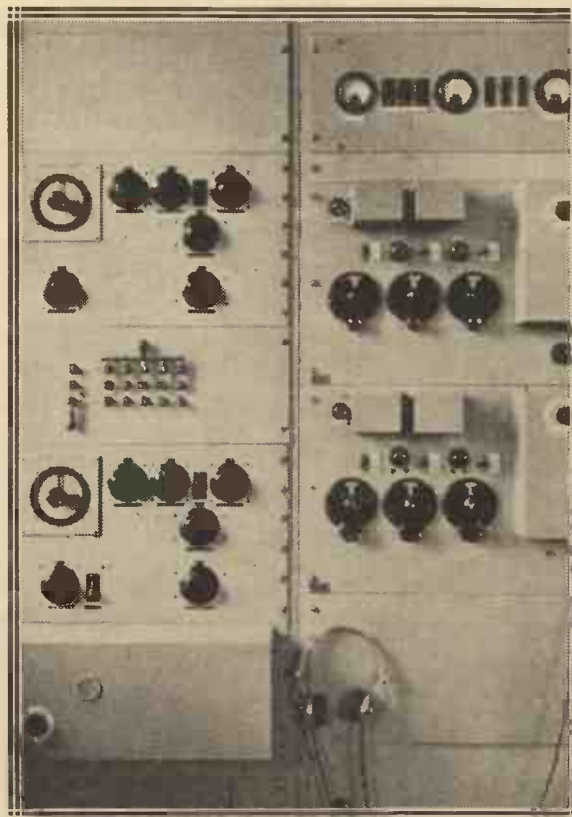

TWO RELAY RECEIVERS used by the B.B.C. One covers from 200 to 550 metres and the other 500 to 2,000 metres.

Future Series

When the "Five Hours Back" series was started the American officials co-operated by allowing W 3 X A L to come on the air at 4.45 p.m., and practically all the desired short-wave reception for any similar series in the future is covered by one of the four frequency ranges.

The grey cellulosed panels of the receivers have black engraved

vernier knobs to the main controls—some with small white ivorine dials. There are three meters in the main circuits, and switches, of course. I could not see how the wavelength switching was arranged, so my guide showed me the inside of one of the high-frequency units. These, and indeed each section of the receiver, are built up on a metal chassis. The valve holders are supported away from the metal base by a bracket standing about an inch and a half high.

Very Neat Wiring

Where the valves are mounted so that the tops project through a screen, the same brackets are used to keep the valve base away from the metal. This arrangement makes for very neat wiring, for the anode of one valve is connected through its appropriate circuits direct to the grid circuits of the next valve on the other side of the screen. It is all very straightforward, and I expect that has a great deal to do with the successful reception. The wiring is carried out for the most part with bare wire—all the high-frequency leads, anyway—and the high and low-tension circuits are taken out to terminals on a metal bracket strip at the back of each chassis section.

The wave-change arrangements are novel, and I am afraid rather above the capabilities of the average constructor who might want to copy them. The four coils for each wave-range section are mounted on a drum, and each coil is brought into circuit by rotating the drum (with a knob on the outside of the panel, of course) so that the contacts are completed through brass brushes bearing against the drum sides.

Ingenious

The B.B.C. engineer, in showing me this ingenious piece of mechanism, pointed out that there are a spring and four notches on the drum, so that the coils are definitely located in

AUTOMATIC GAIN CONTROL

each of the four wave positions. You can see which position each coil is in from the front of the panel, as there is a slot cut to show the number of the range.

"We use this arrangement of wave-changing as there is no dead-end loss caused by any part of a coil being still in circuit, although not used in that appropriate range," said the engineer. "Nor do we introduce any capacity loss or difficulties arising from the short-circuited turns which would probably be present in any other wave-changing system. And it works very well, indeed; so well, in fact, that the erection of two additional sets was contemplated to allow of spaced-aerial reception."

Enormous Amplification

I examined the rest of the receiver—the latest one—and saw that it had a rather unusual circuit, although one capable of immense high-frequency amplification. Each stage, needless to say, has its own grey metal-fronted cabinet, and each stage is coupled to

the next through easily-removable connectors.

There is an initial high-frequency amplifier to give the first detector a chance to work efficiently, and the first detector is an ordinary triode. I must tell that to my very technical friends who fancy a pentode in every position in their sets!

Three I.F. Stages

After the detector come three intermediate stages, and, following the practice of the latest short-wave superhets, the intermediate frequency can be changed. It can be varied between 1,400 and 500 kilocycles per second, and this flexibility is often of the greatest help in getting good reception. It is a tip which might be followed with greater advantage in ordinary short-wave reception.

Naturally, these B.B.C. sets have automatic gain control, and there are the usual two second detector stages, one for the automatic control and the other for the reception sequence. The ordinary second detector is a diode, which accounts for some of the purity of reception in recent B.B.C. short-wave relays; and a triode is used for the automatic gain control. This triode feeds right back to the grid of the first high-frequency stage (signal frequency, that is, and not intermediate frequency), and gives a very nice automatic control. It has done a lot to prevent that annoying fading out of signals which spoils American reception.

The "superheting" action is attended to by a separate oscillator—again a triode.

Minimising Fading

Direct coupling is also used between the diode detector and the first low-frequency stage. There is an ordinary iron-core transformer for connecting the receivers to the line amplifiers, and so very B.B.C.-ish is all this gear that there is a "mixing panel" *a la* Broadcasting House to put any one of the sets on to the line amplifier!

American reception is always very much in the hands of the gods—and the ionosphere—but by using a number of receivers simultaneously the B.B.C. experts at Tatsfield hope to minimise the effects of fading. They are keeping their aerials more than about a thousand feet apart, so that the fading noticed on one set is, with luck, not noticed on the other. They combine the outputs through the "mixer," and send the whole lot through the land lines to Broadcasting House.

FOR CHECKING WAVELENGTHS



A WAVEMETER used to check up reception on 10-100 metres. The receivers illustrated on the previous page can be seen in the background.



S.G. TRANSMITTING VALVES

THE prime essential in a satisfactory transmitting equipment is that it shall possess one source, and one source only, of high-frequency oscillations, the frequency of these oscillations being accurately maintained at a constant value—usually by some form of crystal control.

Unwanted Oscillations

It is therefore important to eliminate all the means whereby spurious oscillations may be introduced. A very obvious source of unwanted oscillation would be a triode valve used as frequency doubler, as high-frequency amplifier, or as high-frequency output valve, unless steps were taken to avoid retroaction caused by coupling between the anode and grid circuits through the inter-electrode capacity of the valve itself.

LOSS OF EFFICIENCY

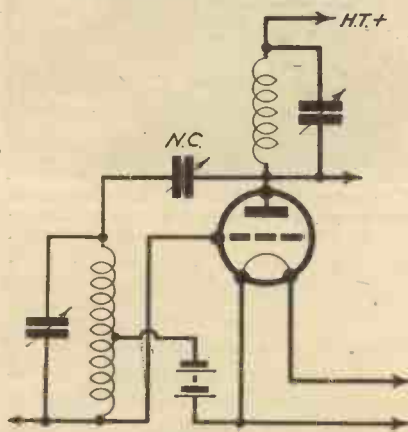

FIG. 1

To avoid self-oscillation with a triode valve the expedient of neutralising is often resorted to. If this is done by centre-tapping the grid coil the available input-voltage is halved.

The means adopted to reduce risk of such oscillation in the case of high-frequency triodes is the well-known device of "neutralising," wherein the inter-electrode feed-back within the valve is opposed and thus cancelled out by a controlled feed-back of equal amount but of opposite phase. The method is so familiar that no

extended description of it is necessary here. In transmitting practice, however, it presents certain difficulties and disadvantages.

In the first place, reasonably perfect neutralisation is not easy to achieve at the very high frequencies employed

Amateur transmitters sometimes experience trouble due to amplifying triode valves associated with their equipment falling into self-oscillation. Freedom from this unwanted oscillation is ensured by the use of a screened-grid transmitter valve as described

By C. PATTERSON.

by amateur transmitters, and especially if the valves used are modern high-slope valves, in spite of the fact that valve makers have been at great pains to reduce inter-electrode capacity to a minimum.

A Further Objection

An even more serious objection is that the neutralised circuit necessitates the use of split coils. Either the grid coil or the anode coil may be centre-tapped, as shown in Figs. 1 and 2, but in either case the efficiency of the stage suffers.

In the case of the tapped grid coil (Fig. 1) it is clear that only half the available excitation voltage is actually applied to the grid, so that the stage gain is reduced by at least 50 per cent. On the other hand, if the neutralising winding is placed in the output circuit, only one half of the effective resistance of the coil is available as the real load of the valve.

This loss is particularly serious because when working at short wavelengths (high frequency) the effective resistance is already low.

Obtaining Maximum Gain

Perhaps a more extended statement on this point may be of service to those amateurs who are not familiar with the quantitative aspect of radio problems. The power gain for a given valve depends upon the relation between the impedance of the load in

the anode circuit and the impedance of the valve itself.

It follows, therefore, that for maximum gain, the effective load resistance should be kept as high as possible. By effective resistance, of course, is meant the impedance,

which depends upon the ratio $\frac{L}{C R}$, where L is the inductance of the anode

A SUPER S.G. VALVE

The Mullard S.G. valve which has been developed in accordance with the principles discussed in the accompanying article.



coil, C is the capacity of the coil and R is its ohmic resistance.

It will be clear that, in order to achieve a high value of $\frac{L}{C R}$, L must

be large, and both C and R as small as possible. Now, in spite of all that can be done by way of coil design, various stray capacities will always occur; while at high frequency the ohmic resistance of the coil may be many times its resistance to direct current owing to the so-called "skin effect," whereby high-frequency currents reside chiefly on the outside of a conductor and do not penetrate into its core. There are also other phenomena which contribute to the high ohmic resistance of conductors to high-frequency currents.

With the best components and the most carefully designed circuits, therefore, there are inevitable losses which

tend to reduce the all important $\frac{L}{C R}$ ratio, so that the transmitter can ill afford to reduce the effective resistance by allotting fifty per cent of it to the neutralising circuit.

Following Receiving Practice

The disadvantages of neutralising were, of course, recognised long ago in receiving practice when the neutrodyne device was employed in conjunction with triodes used as high-frequency amplifiers. Not the least of these difficulties arises from the fact that even with the most carefully balanced circuits it is necessary to re-neutralise each valve every time the frequency of transmission is changed.

In receiving practice the need of neutralisation was ultimately eliminated by the introduction of the screened-grid valve (screened tetrode), which some few years ago revolutionised our ideas of radio frequency amplification and, in one form or another, remains standard receiving practice to-day.

For some time past, transmitting engineers have been conducting experiments in connection with the use of screened-grid valves in transmitting circuits, and considerable success has crowned their efforts.

Medium-Power Valves

Screened tetrodes for medium power equipment have been in existence for a considerable period, and amateurs will be interested to know that small power screened-grid transmitting valves are available from the Mullard Wireless Service Company who have developed two highly interesting types.

Such valves, while doing away at one fell swoop with the necessity of

THE COST OF STABILITY.

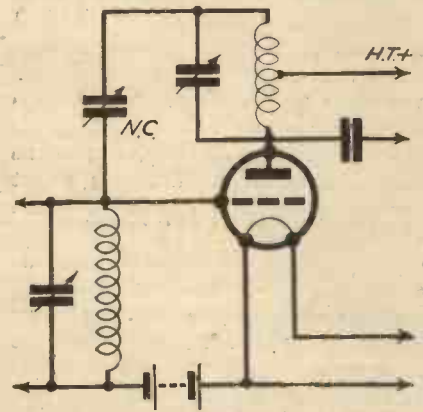

FIG 2
Neutralising by means of a tapped anode coil reduces stage-gain because the effective anode load is decreased.

INCREASED EFFICIENCY

neutralising, also have the effect of increasing the net gain per stage. This result is due to two main reasons.

In the first place, when coils of average efficiency are used in transmitting equipment, the stage gain is practically proportional to the working value of the mutual conductance of the valve.

Effect of the Screen

In the case of a three-electrode valve, the mutual conductance under working conditions—that is to say, with the grid excited—is substantially less than the “static” value taken from the published characteristic curves, but with a screened-grid valve, the work-

anode current characteristic where the behaviour of the valve is unstable.

This may, perhaps, be better understood if that portion of a tetrode, comprising the filament, control grid, and screen, be considered as a triode, of which the screen functions as the anode. In such an arrangement the operation is largely independent of variations in the voltage applied to an outer electrode—in this case the true anode of the tetrode.

Better Doubler Stage

Another important advantage of the screened-grid valve for transmission purposes is that the losses due to the flow of grid current are considerably less than in the case of a triode.

The improvements in stage efficiency described above not only affect the ordinary amplifying and output stages

IN THE BERLIN CONTROL ROOM



A corner of the control room in Berlin's "Broadcasting House." The indicator in the centre shows which studio is in use and whether for actual broadcasting or rehearsal. The engineer wearing headphones is standing by the checking receivers.

ing value is substantially identical with the nominal value.

This will be understood when it is realised that in a three-electrode valve the actual voltage applied to the anode varies with the variations in the anode current due to the grid excitation, because the varying current through the load causes a varying voltage drop across it.

Reduced Grid-Current Losses

In the case of a screened-grid valve, however, owing to the presence of the screen grid, which is maintained at a constant voltage, the value of the anode current, and hence of the mutual conductance, is practically independent of changes in anode voltage except over a small portion of the anode volts,

of a transmitter, but also apply to the frequency doubler stages. The efficiency of a doubler stage is, of course, inherently low, because, as the valve is biased down approximately to the bottom bend of the grid volts/anode current characteristic, impulses are only received during alternate half-cycles, although power is taken from the valve over a complete cycle.

It will thus be seen that the improvements resulting from the tetrode characteristic are particularly useful in frequency doubler stages.

**READ WIRELESS FOR ALL
THE LATEST
TELEVISION DEVELOPMENTS**

WITH THE B.B.C.'s COVERED WAGON

—continued from page 57.

For the first part of the affair Claude was located at the little checking office on the high side of the Hump. Somewhat lengthy leads from the van perched up on its truck down the line, were needed for the microphone.

The whole job took well over three hours. Max worked like a nigger getting the noises and the speaking of his gags just to his liking. All for one record of about six minutes.

Inside the Van

While the arduous part of this work was going on I poked my unwelcome nose into the van itself. I found the engineers using 12 in. or 13 in. blanks on very robust-looking recorders.

When they had a moment to spare they explained to me that the discs were of aluminium, sprayed with a cellulose compound. I watched the steel cutter at work. It churned out waste material that looked just like fine silken thread. When this process had been completed from the inside to the outside of the disc—a playing time of about 4½ minutes—another engineer carefully “doped” the thing.

The really interesting part of the business followed. Immediately the disc had been doped it was ready to be played back—to be used as an ordinary record with a pick-up. That, of course, is invaluable to the engineers, for they want to know while they are on the spot how the recording has “taken.”

This instant playing back can be done with the more orthodox wax recorder, of course, but the original is then useless. Whereas these aluminium discs will play at least a dozen times without any deterioration worth mentioning.

The Re-Recording Procedure

As one of the engineers explained to me afterwards, when we were trundling back to March station in the van-on-truck, the usual procedure is to take a re-recording of the best parts of the discs on the usual wax system. In doing this they can easily mix, cut, superimpose, and generally sub-edit the original recordings. The final result is a wax recording suitable for broadcasting.

I noted two recorders, both fitted with cutters and pick-ups for the dual function of the turntables. Four microphone inputs are possible, with two perfectly standard amplifiers.

Four sets of headphones can be plugged into these amplifiers, so that they can hear what sort of noise is being recorded—the noises made into the microphones at their distant points.

I wanted to know whether the van had been specially sprung for its unusual job. It seems not. The recorders are fixed on gimbals to make sure they are level, but apart from that everything seems quite simple.

Those Level Crossings

I left the gang at the station after we had all scoffed a gigantic tea in which crumpets played a leading part, Max and Claude going down by train, the engineers in their precious covered wagon, and yours truly by road.

Footnote.—If you are in a hurry, don't go to Peterborough from March. There are too many level crossings, all shut against you. I wished the mobile unit had been there to record my sentiments as I sat waiting in the freezingly cold night air. Perhaps that would have been a waste of time, though. They could not have broadcast the record.

SAFEGUARDING THE TUBE

—continued from page 74.

removed, and so the disaster that threatens the tube will not happen so speedily.

So much for the question of the cathode life of the tube, but there are other points that need consideration. Of these I intend to mention only one here, the fluorescent screen at the end of the cathode-ray tube.

Stationary Spots

This is fairly delicate and must be treated with circumspection. It will render good service provided it is not exposed to over-stimulation. This takes the form of too bright a spot or the resting of a spot on one point for any length of time.

The former is not likely to happen, for too bright a spot will also mean short life to the cathode, and the design of any good exciter unit will prevent this. So also should the design prevent the spot ever coming to rest on the screen.

No tube should be operated unless the accompanying scanning circuit, or time base, is also in operation. And this latter should be working before the tube begins to function.

In experimental circuits this merely means that the time base is switched on before the tube, but in a complete television receiver the whole mains-operated receiver has to be switched

on at the same time, and therefore to prevent the tube “lighting” before the time base begins its scanning-voltage sweeps a thermal delay switch should be used in the cathode tube exciter circuit.

Such a switch is shown in Fig. 2. and the time period of the switch should be set so that it will not make contact until the time base has warmed up and has started scanning. This will then ensure that the spot on the cathode-ray screen will be set in constant motion the moment it appears.

Two Switches Used

In most cases two thermal delay switches are used, one for the time base, and the other, with a definite lag, for the tube exciter circuit. It is not absolutely necessary to have a thermal delay switch in the time base circuit when hard valves are used, but where there are gas-filled discharge valves it is usually very advisable to avoid straining the valves.

Personally, I prefer to have the switch in, no matter what the method of obtaining the scanning voltage, for it prevents peaks in the H.T. voltage, and obviates the need for smoothing condensers with tremendous voltage-safety margins.

PILOT AUTHOR KITS HEXOVERTER

KIT "A" CASH or C.O.D. £4:14:6
Carriage Paid
Author's Kit of First Specified OR YOURS FOR parts, less Valves and Cabinet **8/6**
and 11 monthly payments of 8/6.

KIT "B" As for Kit "A," but including set of 2 specified Valves, less Cabinet. Cash or C.O.D. Carriage Paid, £8/5/6, or 12 monthly payments of 11/6.

KIT "C" As for Kit "A," but including set of 2 specified Valves and Peto-Scott specified Cabinet. Cash or C.O.D. Carriage Paid, £7/3/0, or 12 monthly payments of 13/.

FINISHED INSTRUMENT

Ready Assembled exactly to Mr. John Scott-Taggart's Specification. Including YOURS FOR Valves and Specified Peto-Scott Cabinet. With 4 Coils. Aerial tested on S.W. Tele. phony. Cash or C.O.D. Carriage Paid, £14/9, or 12 monthly payments of 14/9.

THIS YEAR'S MIDGET PORTABLE

KIT "A" CASH or C.O.D. £3:1:6
Carriage Paid
Author's Kit of First Specified Or Yours For parts, including STRUCTAKIT, less Valves, Cabinet and Speaker **5/9**
and 11 monthly payments of 5/9

PETO-SCOTT STRUCTAKIT. Com. CASH prising Baseboard, Ready-drilled Panel, Aluminium Screen, Aerial Framework, Accumulator Holder and Speaker Baffle-board. Every part made exactly to specification. **8/6** Postage 6d.

DETAILED PRICE LIST ON REQUEST

SEND FOR BARGAIN LISTS. Thousands of amazing Component, Speaker and Mains Unit offers up to 75% off List Prices. BARGAIN SETS from 5/- down. FREE GIFT WITH EVERY PURCHASE value 10/- and over.

PETO-SCOTT CO. LTD.
77 (W.8), CITY ROAD, LONDON, E.C.1.
West End Showrooms: 62 (W.8), High Holborn, W.C.1.

B.B.C. NEWS

—continued from page 59.

move to change the character of the celebration, which up to now has been of the conventional form of mourning the dead and conducting a general tirade against war.

There has been a complete change in the mood and spirit of our broadcasters. All this worked up to Mr. Kipling's broadcast, from the Royal Society of St. George's Dinner, on May 6th, which really hurled defiance at foreigners. So now the B.B.C. has got to decide whether its Armistice Day Programme resounds with martial music or subsides into a sort of nebulous negative sentimentalism. I back the bugles.

Mr. Fisher Looks Round

Mr. H. A. L. Fisher, the newly-appointed Governor of the B.B.C., has created a first-class sensation. Other Governors before him have been known to suggest that they would like to meet a few members of the staff; but then they just left it at that, and no more was heard of the rash idea.

But Mr. Fisher apparently is made of sterner stuff. He has a curious persistence. Anyway, he has actually been meeting people and has got down to within measurable distance of the people who really do the programmes. This has caused a profound sensation. I believe it is a good thing.

Those Empire Programmes

Now that the B.B.C. is constructing two new transmitters, and reconditioning a third, all for the short-wave services from Daventry, something should be done generally to raise the standard of the Empire Programmes. These are not bad, but they are much the same as they were two years ago, and meanwhile, foreign short-wave services have been rapidly improving.

It is a good thing that transmission six to Western and North America has survived the experimental stage, but it should be on every night in the week, or rather every morning, instead of the four occasions being planned for it. Then all the transmissions outside normal B.B.C. times should be lengthened and given more substantial material. My criticism is not aimed at the staff but at the money available. This at present is hopelessly inadequate for putting on programmes really worthy of Britain.

Mr. Graves in Newfoundland

Mr. Graves, of the B.B.C., now in Newfoundland, is advising the Govern-

ment there on the establishment of a broadcasting service modelled on the B.B.C. It is nearly a year now since the island was visited by a special mission of American broadcasters intent on bringing Newfoundland into their orbit.

But, of course, the Government of Newfoundland is now operated direct from Whitehall, so the move was countered until the B.B.C. could get busy. Newfoundland is intended to become an important B.B.C. outpost in North America.

QUESTIONS I AM ASKED

—continued from page 63.

beam at a constant strength but obtain light and shade effects by varying the speed of travel of the spot of "light" on the screen, slower travel giving brighter results.

Q. 142. I am told that a long

THE TRANSMITTING PANELS AT CAPE TOWN

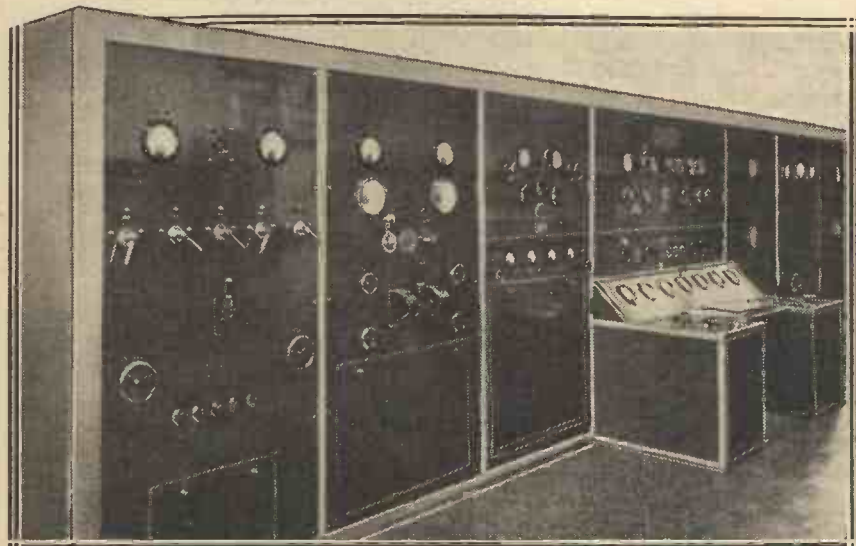

The transmitting panels and control desk of the Marconi 10 kw. broadcasting equipment installed at Cape Town. This station replaced the one erected in 1924.

earth lead is undesirable, but that if it is of insulated wire there is no objection to it. Is this correct?

A. No. The essential merit of insulating an earth lead (and I strongly recommend this procedure) is that this prevents leakages of an irregular and spasmodic type from the earth wire. Such leakages produce crackles or perhaps only rustling noises, depending on the kind of substance the bare earth lead is touching.

But insulating the earth lead, although stopping leakages, does not prevent the set from being at high-frequency potential to earth. The high-frequency currents in the aerial-to-earth system pass through a coil

(the "earthy" end of which is normally connected to the chassis of the set) and then "down" the earth lead.

The currents in the earth lead set up alternating voltages across it. Since the bottom end of the earth lead is electrically anchored to earth, the top end of the earth lead (which is connected to the earth terminal of the set) has a potential which is alternating (positive and negative with respect to earth) at a high frequency.

The whole set will thus normally be "alive" at H.F. and will form one "plate," so to speak, of a condenser with respect to other conductors in the room and with respect to the ground. The operator himself may form the other "plate," and as he handles different controls the set may become unstable and perhaps oscillate. For example, if the set is near the critical reaction point, altering the position of the hand may cause the receiver to go off tune sufficiently to cause a variation in signal strength,

or the action may considerably reduce reaction, or, in some cases, increase it and cause self-oscillation.

For the set to be at H.F. potential is generally undesirable, although the ill-effects in some cases are negligible, and a long earth lead (by providing more pick-up wire) may even increase signal strength when only a small aerial is possible.

If a set is susceptible to hand-capacity effects or is too lively and unstable, wet a finger and touch (pressing hard) the earth terminal. If this stabilises the set, the earth lead may well be at fault. The same applies if the earth connection is defective or the earth itself is poor.

RADIO TO THE RESCUE

—continued from page 48.

through Churchill, Manitoba, to Ottawa.

Since the explorer had left the previous summer, word had come to Ottawa of a projected mining rush that summer in the Coppermine district. The Government wanted an examination of the country before the prospectors arrived by plane. The explorer, who was also a mining engineer and geologist, was ordered by radio to go into that territory to see what was there before the prospectors arrived.

A few years ago a murder was committed in an Eskimo fishing village, remote from all police and trading posts. But word of the killing leaked out by way of some Eskimos selling their furs at a post. A police officer on his winter patrol heard the story from the trader, and immediately set out to find out the truth of it at the scene of the killing. The story was corroborated, and a month later he came back to his post, bringing the prisoner with him.

Unlike other murders committed in the distant north, the accused did not have to wait a year or more before instructions came through as to his trial. The police officer made use of a trading ship which was frozen in, and by radio received his instructions within three days.

FROM MY ARMCHAIR

—continued from page 54.

2nd Waiter: They do not change the names of the towns.

S.-T. (sarcastically and tiredly): Don't they really?

2nd Waiter: They change the programmes. Hilversum becomes where Huizen was on the radio and Huizen goes where Hilversum was.

S.-T. (getting warm): Yes, we all know that. But what puzzles me is whether the stations change wavelengths or programmes, or both or neither, or what the Huizen they do do.

2nd Waiter (smiling confidentially): Perhaps if you asked the other waiter he would know. You see, sir, I spent many years in America, and I have only been back in Holland six years.

J. S.-T.

CABINETS. Write for Free List
GILBERT (cabinet maker), SWINDON.

TELEVISION LAYOUTS

—continued from page 73.

used to avoid the annoying results of re-radiation; (5-metre amateurs can hear each other's receivers two or three miles away!)

This simple three-valver brings in low-power 5-metre telephony at really good loudspeaker strength, and there should not be the slightest need for anything more ambitious for receiving the high-power "sound" transmissions that will accompany the television.

No Interference

Incidentally, it has been carefully tested for interference with the "vision" superhet, and no trace of trouble can be found until its frequency is well within the band of frequencies that the "vision" station will be radiating. Obviously, the "sound" station will have to work outside this area, so there is no possibility of interaction between the two receivers.

Finality in receiver design, naturally, will never be reached; that much is obvious. But I think several developments will take place as soon as regular transmissions commence, and I imagine our present ideas on the subject will be out of date by this time next year.

Personally, I can quite believe that some form of single-frequency receiver will be satisfactory in many cases, particularly as H.F. amplification on 5 metres is quite practicable with some of the new low-capacity valves that have been developed in the U.S.A.

THE "HEXOVERTER"

—continued from page 66.

waveband does not matter very much, but keep off Huizen, Radio Paris and other wavelengths on which you might experience some direct pick-up of those stations.

A refinement for connoisseurs may be mentioned here. When searching for an extremely weak station, you can (if it is of the straight type) make the main set oscillate, e.g. by increasing the anode reaction. Proceed to search in the ordinary way; you will hear garbled whistles instead of pure music or speech; you can then "resolve" this into entertainment by reducing the anode reaction on the main set. This "wangle" is sometimes useful and corresponds to searching for "carriers" on a straight circuit by making it oscillate.

FOR BETTER RADIO

solder your contacts electrically

Plug in your Solon Electric Soldering Iron to the nearest lampholder and you know it'll be ready to make good jobs in three minutes.



**IT'S QUICKER
BETTER · MORE
ECONOMICAL
AND EFFICIENT**



W. T. HENLEY'S TELEGRAPH WORKS CO., LTD.
DEPT. 22Y.K., HOLBORN VIADUCT, LONDON, E.C.1

THE "NICLET" in the MIDGET PORTABLE



"NICLET"
L.F. Transformer
(DP21)
PRICE
7'6

This deservedly popular Varley "Niclet" L.F. Transformer, which has recently been featured by so many prominent set designers, is now chosen for the MIDGET PORTABLE, described in this issue. Follow the designer's advice and use Varley parts. Write now to Varley of Woolwich for free illustrated Catalogue.



Oliver Pell Control, Ltd., Bloomfield Road, Woolwich, S.E.18.
Telephone: Woolwich 2345.

THE BERLIN-TOKIO SHORT-WAVE TELEPHONE SERVICE

ANOTHER link has been added to the Inter-Continental telephone system by the recent opening of the Berlin-Tokio service, which enables anybody, not only from Berlin but from anywhere in Germany, to get a connection without even leaving his desk with any one of his Far Eastern friends in Tokio or elsewhere in Japan.

The Berlin-Tokio service, like the telephone connections between Berlin and South America, is operated on short waves, a new 50 kw. transmitter developed by Telefunken having been installed at Nauen. Conversations are transmitted from the Berlin trunk exchange through a cable line to the transmitter, and thence are radiated from a beam aerial.

20-Metre Wavelength

The transmitter aerial is suspended between two high iron masts. The wavelength is about 20 metres in the morning hours, but is changed to a slightly longer wave a little later, which is readily done by means of existing technical arrangements, the transmitter being quartz-controlled.

Telephone conversations from Tokio are likewise transmitted on short waves, and received in Beelitz, near Berlin. From the receivers, fitted with Telefunken beam-aerials which are installed there, microphone currents are taken across a cable to the trunk exchange, and thence to the subscriber. All the receivers, like any better-class broadcasting receiver, of course, employ automatic fading compensation, thus securing a satisfactory reception in spite of any such disturbances.

Clear Conversations

At the Japanese end the transmitting and receiving posts are likewise situated a considerable distance apart, the transmitter being installed at Nazaki, at about 80 kilometres, and the receiving post at Komuro, about 40 kilometres from Tokio. The Japanese transmitting station likewise uses a wavelength of 20-30 metres. Conversations are so clear as to give the illusion of a telephone talk over a distance of a couple of miles.

"HARD" AND "SOFT" SCANNING CIRCUITS

—continued from page 70.

with the result that if the condenser starts to charge again the relay is still conducting. The effect of the ionisation and de-ionisation time on the shape of the saw-tooth wave is shown in Fig. 6. If the condenser charging potential reaches 20 volts before the de-ionisation is complete the relay will continue to conduct and the time-base will stop working.

These disadvantages, which are inherent to gas-discharge relays, have led to the development of scanning circuits using thermionic valves throughout; the "hard" scanning circuits of our category. Most of these are based on the action of the multi-

vibrator, a very interesting and useful oscillatory circuit, which is shown in outline in Fig. 7.

The circuit is a form of R.C. coupled amplifier in which the anode of the second valve is connected to the grid of the first, thus feeding back sufficient energy to keep the system oscillating strongly. The wave-form of the voltage output is approximately that of a saw-tooth and can be adapted to produce a nearly perfect linear travel of the beam.

One of the notable points about this and similar circuits is the ease with which they can be synchronised to incoming signals, which enables the scanning circuit to be "locked" to the transmitting frequency. In the next article a typical "hard" scanning circuit will be described and compared with a "soft" one.

RADIO ON MOTOR CARS

At last it has been stated by the Minister of Transport that no objections will be raised to the use of radio on motor vehicles, and the way is clear for a general adoption of this admittedly fascinating and valuable accessory in the motor car. Car radio will rapidly grow in popularity during the next few years, and even during the remaining months of this summer we may expect sales of car sets to go up by leaps and bounds. What is your attitude towards car radio? It does not matter whether you are in favour of it, or against it, or whether you have already fitted it to your own car, you will be interested in the special series of articles in "Wireless" next month dealing with all aspects of the case and giving practical assistance to any who are desirous of fitting (or having fitted) radio sets to their cars.

READ ALL ABOUT CAR RADIO IN "WIRELESS" NEXT MONTH

THIS YEAR'S MIDGET PORTABLE

—continued from page 52.

is ample room for the bias battery to stand on the inside of the frame aerial.

The operation of the little set is quite simple. With 60 volts on the H.T.1 tap (the full 120 for H.T.2) you will discover that the reaction is smooth and effective.

The tuning of the top variable is moderately broad so you can do most of your searching with the other one, but remember to keep the top one roughly in step. Don't expect to find the dial readings exactly the same. However, a slight difference between them, or even a large one, is not going to affect the performance of the set in any way.

We don't claim that this portable will bring in hundreds of programmes, but we do say that it will give you a first-class result in almost any locality

in this country. Even in the worst of conditions there will be at least one of the B.B.C. stations to provide first-rate quality.

In fact, we believe that you will be delighted with our lusty midget, and find its performance quite amazing.

It should be remembered that any portable set will possess directional qualities, or, rather, we should say the frame aerial in it will be directional, though in practice it amounts to the same thing!

Pointing the Frame

Therefore, the position of the set must be varied in accordance with the direction of the stations you want to receive. If a station is situated to the north of you, then the set must be swung round so that it is in line with North and South.

It will then receive equally well from both of these points of the compass, and least efficiently from either direction at right angles to it—i.e. from West or East.

You cannot afford to miss this great opportunity

Sent to your Home FREE on approval for 7 days

Practical Knowledge For All

Six Volumes . . . Over 2000 Illustrations

TO-DAY, more than ever before, education is the surest, most effective weapon in the fight for success. With so many fully-trained young men and women in the labour market, all eager for success themselves, it is just courting failure to be without knowledge and education. Here is good news for all ambitious men and women. You can now educate yourself in your own home with "Practical Knowledge for All," the greatest home educational library ever offered to the public on such terms.

This work teaches twenty-nine vitally important subjects in the most fascinating and up-to-date manner, making learning a real pleasure. The courses are arranged in carefully graded and consecutive lessons, and have been prepared by recognised authorities, each course being the work not only of one, but of several experts.

With "Practical Knowledge for All" in your home, every member of your family will benefit. The child at school, the boy or girl at the threshold of a career, the ambitious man or woman, all will find practical help and inspiration in the pages of this wonderful work.



PRACTICAL KNOWLEDGE FOR ALL is available in two beautiful bindings, the Standard edition being bound in a terra cotta shade of art cloth over British boards, decorated in a most elegant fashion with real gold lettering on the spine.

The De Luxe edition, illustrated here, is bound in the well-known Roxburgh style, with green leather backs cut from specially selected paste grain skins, the sides being of fine quality art cloth in a shade to match. The spines are lettered in real gold leaf.

Are You Ambitious for Your Child, or Yourself? If so, Send for These Books NOW

POST THIS AT ONCE

Special FREE Examination Form.

To THE WAVERLEY BOOK CO., LTD.,
96-97, Farringdon Street, LONDON, E.C.4.

Sirs,—Please send me, carriage paid, for Seven Days' Free Examination, one complete set of PRACTICAL KNOWLEDGE FOR ALL in six volumes, in the binding indicated below. It is understood that I can examine the work for seven days from its receipt by me, and if I do not wish to keep it I may return it on the eighth day, and there the matter will end. If I decide to keep the work I will send you, on the eighth day, a first confirmatory payment, and commencing thirty days thereafter, I will send you further monthly payments, thus completing the purchase price as under.

Please strike out binding
NOT wanted

(A) The set in cloth binding (standard edition). First payment 2/6 eight days after delivery, and eight further monthly payments of 2/6, making a total in all of 22/6.

(B) The set in leather binding (de luxe edition). First payment 3/- eight days after delivery, and nine further monthly payments of 3/-, making a total in all of 30/-.

CASH PRICE WITHIN 8 DAYS 21/-

CASH PRICE WITHIN 8 DAYS 27/6

Name

Address

Occupation

Parent's signature required if under 21

State if Householder Date

W.1. 1935

PLEASE FILL IN ALL PARTICULARS ASKED

We will send you, carriage paid, the six volumes of PRACTICAL KNOWLEDGE FOR ALL, in whichever binding you select, for examination for 7 days without the slightest charge or obligation to purchase. You can either return the books to us, at our expense, within 8 days, or keep them on the very easy terms outlined on the Free Examination Form alongside.

SEND NO MONEY NOW
YOURS for 2/6 DOWN if kept after examination

Twenty - nine Vitally Important Subjects Taught in This Work For less than 9d. each subject

- ACCOUNTANCY
- AERONAUTICS
- ART & ARCHITECTURE
- ASTRONOMY
- BIOLOGY
- BOTANY
- BRITISH HISTORY
- CHEMISTRY
- DRAWING & DESIGN
- ECONOMIC GEOGRAPHY
- ECONOMICS
- ENGINEERING
- ENGLISH LANGUAGE
- ENGLISH LITERATURE
- FOREIGN LANGUAGES
Latin : French : German : Spanish
- GEOGRAPHY
- GEOLOGY
- HISTORY
(Ancient & Medieval)
- MATHEMATICS
- MODERN HISTORY
- PHILOSOPHY
- PHYSIOGRAPHY
- PHYSICS
- PHYSIOLOGY
- SHORTHAND
- ZOOLOGY

← SEND TO-DAY

The World's Greatest Short Stories

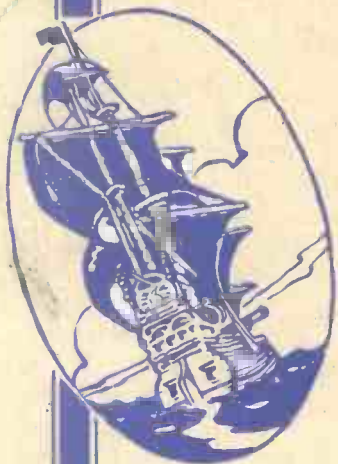

*World-famous
writers whose work
appears from time
to time in THE
ARGOSY*

W. SOMERSET MAUGHAM
A. T. QUILLER-COUCH
STEFAN ZWEIG
LEONARD MERRICK
FRANÇOIS COPPÉE
JOHN BUCHAN

GUY de MAUPASSANT
W. W. JACOBS
O. HENRY
THOMAS HARDY
JOSEPH HERGESHEIMER
SIGRID UNDSET

Etc.

Also regular monthly features including:

A literary ART SUPPLEMENT
A review of BOOKS OF MOMENT

You will never regret it, if you tell your Newsagent to deliver this excellent magazine regularly.

The ARGOSY

MAGAZINE

At All Newsagents and Bookstalls

ALL STORIES COMPLETE

Monthly 1/-

Buy YOUR Copy To-day