

# WIRELESS & TELEVISION REVIEW

EVERY MONTH

1½

VOL. 3 NO. 14  
JANUARY  
1936

SPECIAL PHOTOGRAVURE SECTION OFF THE BROADCAST TRACK  
THESE MODERN SETS. BY VICTOR KING  
THE "PRE-PLEX"—WITH A NEW CIRCUIT AND A NEW PERFORMANCE  
Fitting Extension Speakers :: :: Thrilling Short Story  
HOW TO MAKE AN ALL-WAVE BATTERY SET  
JOHN SCOTT-TAGGART'S INFORMAL CHAT TO READERS—  
FROM MY ARMCHAIR

EVERY MONTH

# **The Latest and Best** **Modern Fiction**

● The STORY-TELLER has been the leading fiction magazine for nearly thirty years. During this period taste in popular fiction has changed. The STORY-TELLER has always kept ahead of these changes, but its policy—that of publishing the best new fiction—has remained unchanged.

Its stories appeal to readers of all tastes. They are stories for men and women and reflect life as it is lived to-day. Many world-famous authors write for The STORY-TELLER, including :

**HUGH WALPOLE**  
**PHILIP GIBBS**  
**LOUIS GOLDING**  
**ALEC WAUGH**

**G. K. CHESTERTON**  
**L. A. G. STRONG**  
**I. A. R. WYLIE**  
**NEIL BELL**

In addition to publishing a selection of the best short stories each month the STORY-TELLER also publishes monthly a Long Complete Novel. These novels, too, are contributed by some of the leading authors of the day, including :

**Mrs. BELLOC LOWNDES**  
**LOUIS BROMFIELD**  
**ROBERT HICHENS**  
**VICKI BAUM**  
**HORACE ANNESLEY VACHELL**  
**ALAN SULLIVAN**

Why not get a copy of the current issue and see what excellent value it is for your money?

# The STORY-TELLER

*On Sale everywhere at all Newsagents and Bookstalls*

# Contents



	Page		Page
Editorial	71	Television To-day	101
Intensity Expansion	72	Short-Wave Crime	103
Modern Tuning	73	This Is Real Radio Service!	106
Women at the B.B.C.	76	Tour the World With This All-Wave Battery Set	107
From My Armchair	77	Changing the Frequency	113
The "Pre-Plex"	79	Broadcasting in Finland	116
Make Sure of Your Values	83	Short-Wave Developments	117
British Broadcasting News and Views	85	New Apparatus Tested	120
Fitting Extension Speakers	87	The Future of Radio Drama	121
Wireless in Denmark	91	Wireless Direction Finding	122
Questions and Answers	93	Two Tons of Music	123
Complete Tone Control	94	What I Saw—and Did—in Radio City	125
These Modern Sets	95	Photo-Cell Amplifiers	126
Famous Programmes—How They Began	100		

SPECIAL PHOTOGRAVURE SECTION "OFF THE BROADCAST TRACK" FOLLOWS PAGE 100.

As some of the arrangements and specialties described in this Journal may be the subjects of Letters Patent the amateur and trader would be well advised to obtain permission of the patentees to use the patents before doing so.

Published by the  
**AMALGAMATED PRESS LTD.**  
THE FLEETWAY HOUSE  
FARRINGTON ST., LONDON, E.C.4



## PIFCO TEST INSTRUMENTS ENSURE 100% EFFICIENCY FROM RADIO

Buy to-day one 42/- Pifco Rotameter-de-luxe (Moving-coil) or one 29/- Rotameter (Moving-iron) and you will receive a complete set of 3 Pifco Valve Adaptors costing 15/-, in velvet-lined case for 7/6. A Rotameter and set of Valve Adaptors will form a complete test set for your radio.



**PIFCO VALVE ADAPTORS**

Each adaptor has a 5-pin base with top sockets for "plug-in" testing of 5, 7 or 9-pin valves under working conditions without alteration to set wiring. Four nickel-plated terminals complete with strapping links are fitted, to connect meter in either grid or anode circuit of valve.



**ROTAMETER-DE-LUXE**

(9 Ranges including valve test) Every conceivable test, also valves, can be made with this amazing instrument (400 volts—500 ohms per volt). Black bakelite finish; complete with leads. In handsome velvet-lined case. Price 42/-, Horiz.

Ask your dealer to-day to show you Rotameters and Adaptors, or write for Pifco Testmeter Folder, post free, from PIFCO LTD., SHUDEHILL, MANCHESTER, or 150, Charing Cross Road, London, W.C.2.

**PIFCO ROTAMETERS and RADIOMETERS**  
PIFCO ON THE SPOT WILL TRACE YOUR TROUBLES LIKE A SHOT

# WEARITE

REGD. TRADE MARK



## UNIVERSAL COILS

Specified for the

### ★PRE-PLEX★

As illustrated—a modern tully screened coil which will bring any set up to date whatever the present circuit. Equally suitable for H.F., Aerial or Band Pass Tuning. Range 200-550 and 800-2,100 metres.

**TWO REQUIRED (each) 5/-**

Also specified for the

### Short-Wave Battery Set

To Messrs. Wright & Weaire, Ltd.

740, High Road, Tottenham, N.17

Please send me a copy of your NEW and Revised Book (No. 735) of Wearite Components and technical data, also black prints of NEW series of circuits.

Name .....

Address .....

W/186.

### THE H.F.P.J. CHOKE

A highly efficient H.F. Choke covering a wave-band of 100-2,000 metres.

Price 2/-

### THE H.F-3 Short-Wave (7.5 to 100 metres) CHOKE

Price 3/6



The H.F.P.J.

Why be content with  
REPRODUCTION

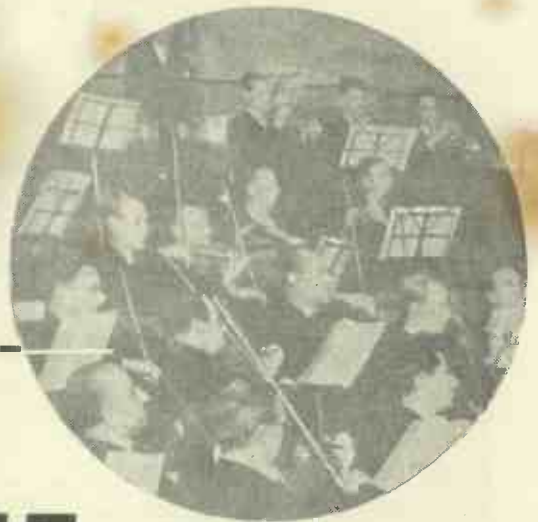

# MARCONIPHONE

*gives you*  
*the REAL thing*



There's no bluffing a connoisseur, he can detect in an instant the little flaws and imperfections that distinguish a reproduction from the Real thing. In radio, for instance, an absence of top notes and an accentuation of the bass are common flaws by which you can tell the difference. The Real thing in Radio is, of course, Marconiphone, Britain's most popular range, the only radio backed by 40 years' experience of electrical sound reproduction.

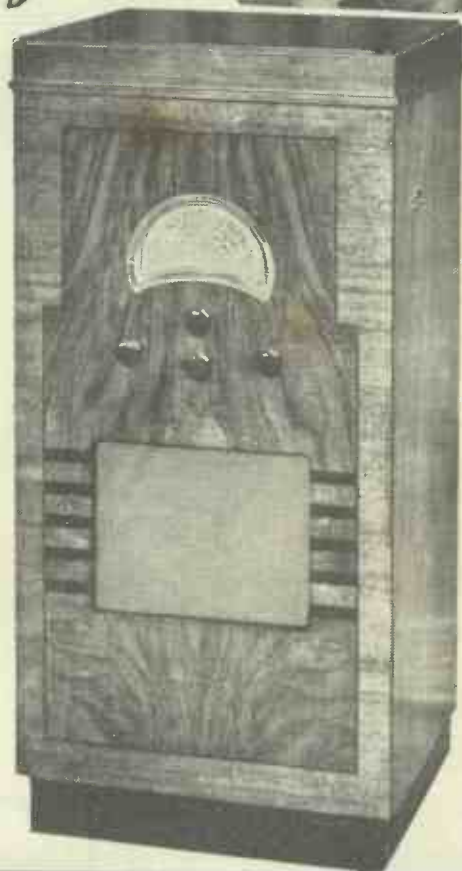

### MODEL 245

An entirely new radiogram with a highly sensitive radio chassis bringing in every worth-while station at ample volume. An equally fine performance on records is assured by the latest type pick up and silent running direct drive electric motor. In an inlaid and contrasted walnut cabinet—

# 16 GNS.

MODEL 235 is a handsome table receiver finished in black and chromium employing the same high efficiency chassis . . . 8½ GNS.

There are fifteen models in the Marconiphone list, all available on exceptionally easy terms. Fill this in and we will advise you which model is best for your home and where you can buy it from a recommended dealer.

NAME.....

ADDRESS.....

Have you electric supply?.....A.C. or D.C.....Voltage.....

Approximate amount you wish to spend.....

TO THE MARCONIPHONE COMPANY LIMITED,  
210 TOTTENHAM COURT ROAD, LONDON, W.1.

Wireless, Jan. 24/36.

# WIRELESS *and* TELEVISION REVIEW

Editor: G. V. DOWDING

Assistant Editor: A. S. CLARK

## Our Photogravure Section—Two Fine Sets—Coming Attractions

To you and I as listeners, broadcasting looms very large. But to you and I as radio enthusiasts, all other aspects of wireless are equally important. They are also vitally interesting.

Because of this, I hope all readers will enjoy reading "Off the Broadcast Track" as much as I did. "Off the Broadcast Track" is a singularly apt title for this month's eight-page photogravure supplement which parades before us in fine panorama the many other applications of radio.

But to return to broadcasting: Our older readers will remember how popular were reflex receivers in the days before we were introduced to pentode or S.G. valves. There was something fascinating about the idea of a reflex set, quite apart from its economy in valves and battery current. There still is.

Perhaps it is the thought of getting something for nothing by cleverly making a valve do double its normal work. Be that as it may, it certainly takes a clever designer to make the modern high-efficiency valve do double duty.

Many have tried. Many have given it up! But we know for a fact that a large number of constructors have watched hopefully for the design of a really modern dual-amplification receiver.

### Up-to-Date

They have no longer to wait. Once again WIRELESS proves itself "Britain's Leading Radio Magazine," by publishing the "Pre-Plex."

This is an absolutely up-to-date dual-amplification set. It uses a double-pentode valve in the dual stage, and this provides push-pull H.F. amplification. But you had best read about it in the designer's own words.

A second receiver which we present this month is for all-wave listening. Short, medium and long wavebands are covered. There is no

need for me to extol the advantages of short-wave listening as an adjunct to broadcast listening. They are too well appreciated by all keen enthusiasts. At the same time, I do want to advise you to look into the all-wave design on other pages—it has special merits.

And while on the subject of short-wave listening I must tell you about one of the fine features being prepared for next month. It will explain all about short-wave adaptors and converters for turning ordinary broadcast receivers into all-wave ones with a world-wide range. Types of circuits, types of units, how to connect up, how to operate instruments on the market—*everything* concerning the subject will be dealt with.

If you have any friends with broadcast receivers who have not yet sampled short waves, tell them about this item in the February WIRELESS. You will be doing them a good turn.

This feature next month will demonstrate once more that the aim of WIRELESS is to serve readers in just the way they desire, for we feel sure we are achieving this in helping you to make the most of your receivers, and to get the best results possible.

I have already mentioned one of the special attractions to appear next month. There are many others. For instance, an All-Mains Superhet for Short Waves, designed and described by W.L.S. Does that not whet your appetite?

### Don't Miss It

Then there is to be a number of bright and breezy articles concerning radio stars, full of entertaining incidents and authentic facts. And another radio story, to say nothing of the new features which are to brighten the pages of WIRELESS.

There is no need for me to tell you not to miss the February number. It's up to you to see that your friends do not miss it!

## MAKING AN H.M.V. RECORD



Hal Yates recording "Why Stars Come Out At Night," from the new film "The Big Broadcast of 1936," at the "His Master's Voice" Studios.

# Intensity Expansion

An explanation of a system which is receiving considerable attention at the present time, and a discussion of its possibilities and limitations.

By H. A. R. BAXTER

EVERY now and then the subject of intensity expansion comes to the fore. This has happened for some years now. The subject is far from being a new one. But it seems as though it might loom up rather more prominently in the very near future than it has done before. You will probably see a great deal of its technical aspects discussed. A number of both transmitting and receiving circuits have recently been patented, and there is at least one special expansion valve on the market.

## An Essential Control

Expansion is the offsetting of the contraction carried out by the B.B.C. As you all probably know already, very few of the things broadcast come over the air with their full ranges of intensity. The B.B.C. control engineers are busily at work the whole time broadcasting is being carried out, increasing the relative intensities of weak sounds and reducing those of loud ones.

This is very necessary in order that they shall be well encompassed by the transmitting apparatus. It is during outside broadcasts that this control is applied the most. When the crowd roars the volume control is applied to reduce the input to the transmitter; to catch some distant sound effect or a quiet one close at hand the "wick is turned up."

Therefore, the listener is not allowed to hear the full range of intensities as they arrive at the microphone; they are compressed within a limited com-

pass. But by means of special valves and circuits the range of volume of a set can be extended very considerably; quiet sounds made quieter, loud sounds made relatively louder.

But, as I see it, expansion at the receiving set is only of limited value while it is applied in this independent manner. If it could be made rigidly to keep in step with the controls carried out at the transmitter, then it would, of course, restore the original width of compass in the correct manner. But expansion independent of the transmitter must surely introduce further intensity distortion, not necessarily correct that which exists.

Take any loud sound—a bar of music, for instance. If expansion at the set makes that louder in comparison with a succeeding diminution of volume it

actors come nearer to or go farther away from the microphones, and their voices rise and fall in intensity, or would do so if the control engineer did not skilfully operate his volume control.

Surely expansion in such a case would be all wrong? The audience present in the theatre would not be aware of any marked alteration in the volume of an actor's voice because he walked along the footlights. I can visualise expansion playing tricks in such a case as this.

## Variation Difficult to Avoid

The control engineer would be hard at work trying to keep the intensity even, but whatever his skill there would surely be a certain amount of variation. Expansion at the set would emphasise this and create an effect of the actor walking farther away from and nearer to the microphone, whereas what might be happening was that the actor was not moving at all, but merely turning his head from side to side.

For myself, I would not pursue this argument any farther, nor would I feel inclined to pursue expansion itself, although there may be something in it which has passed me by.

But I feel that this question of intensity range is rather the province of the B.B.C. Unlike many other radio engineers, I have never felt that the contraction of intensity range which the B.B.C. has to impose is much of a disadvantage to the listener. Rather the other way about, in fact.

After all, there are artificial restrictions at the receiving end. A

full range of intensities is not possible unless there is the full maximum volume. At least, I can't see how there can be.

Supposing a war play with effects is being broadcast. The scene is a bombarded trench. There is a shattering explosion, one soldier whispers to

(Please turn to page 76).

## TWO STARS AND A RADIOGRAM



Diana Napier, the film star, tunes in some Viennese music on her Cossor Radiogram for Richard Tauber, the famous tenor.

may be that it is making it louder than it should be, for it is even chances that it is a sound that has not been subjected to a "turning down of the wick" at the transmitter.

## Theatre Broadcasts

Again, what of the broadcasting of an item from a stage? The actor or

# MODERN Tuning

In this review of modern methods in tuning, you are first introduced to the ideal in tuning schemes, then to some of the ideas incorporated in modern sets, and finally some comparisons with the older methods are made.

By A. S. CLARK.

THERE are so many aspects of modern tuning that I propose to divide this article into three sections. First of all, we will consider what are the requirements of a completely satisfactory tuning arrangement. That will give us a standard to keep in mind throughout the article.

Then we will have a look at some of the schemes adopted on modern receivers. This will refresh our minds nicely for the third section, in which we shall travel back a few years and compare modern tuning with the older systems and note the tremendous changes and advantages that have been made.

When considering the requirements of a completely satisfactory tuning arrangement, I do not intend to delve deeply into circuits, but rather to consider the mechanical aspects of the control operating the tuned circuits. Naturally, the circuits we are going to tune must be up to the standard required by modern conditions.

### Station Separation

Selectivity should come up to the 9-kc. separation requirements, and be able to differentiate completely between two stations on immediately adjacent channels. If variable selectivity is provided the degree of separation may even go to finer limits than this.

As regards the band width of the tuning circuits, this must be sufficiently wide over-all to take proper

care of the quality. A sufficiency of high notes to give proper harmonic response is necessary.

The question of what circuits will give the foregoing hardly concerns us here. That is a matter for one of the wireless circuit hounds to tackle at some other time.

The first requirement of a dial or indicator which shows the setting of the tuning is that it shall give only one indication for any given setting of the tuning. In other words, no matter how you look at it, if the tuning is set to 90° it

shown in (b). With stations as close together on the dial as they are these days, such variation could easily prevent one from tuning-in the right station by means of the dial.

One method which entirely avoids parallax is shadow tuning, with which we shall deal fully later.

Mention of shadow tuning brings up the fact that some form of illumination from behind is desirable for a dial. Accurate tuning cannot be carried out unless the dial is clearly visible.

Very often a set may be in a dull corner of the room, or so situated that the room's artificial lighting does not show up the dial very well. Again, it is sometimes nice to tune a receiver when sitting in the twilight or by the fire-glow without turning up the lights of the room.

### Dial-Light Switching

On a mains set the illumination can be left on the whole time the set is switched on, and thus act as an indicator which will prevent the receiver being left on unintentionally. But on a battery receiver this might prove uneconomical.

Battery sets can be provided with a dial-light switch. Or alternatively, an automatic device can be used which switches on the dial-light as soon as the tuning knob is gripped or turned.

Next, we come to calibration. Shall it be in degrees, frequency, wavelengths or station names? Frequency calibration can be ruled out, as, however theoretically desirable it may be, none of us seems to be able to train his mind to think in kilocycles.

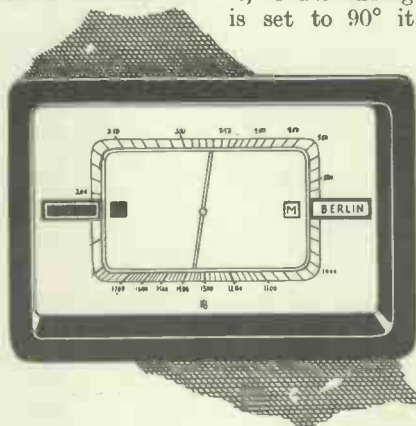
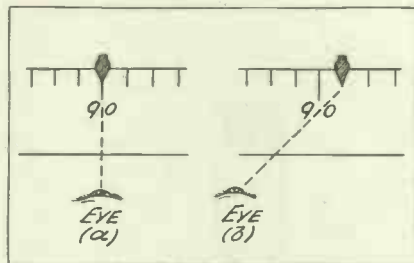

should always read as 90° on the dial.

At first this may sound a little obvious. Well, it certainly is obvious. But all the same there are a surprising number of dials in which what is known as parallax occurs.

There is a diagram on this page which illustrates well just what this parallax is. Imagine the pointer shown in the diagram mentioned to be an eighth of an inch or so away from the dial.

When looked at squarely from the front the reading would be 90° all right. But if you viewed the dial from the left it might easily read 91°, as

STUTTGART	440
SOTTENS	440
STOCKHOLM	420
ROME	420
MUNICH	400
SCOTTISH	400
LEIPZIG	380
WEST	380
MILAN	360
BERLIN	360
LONDON	340
HAMBURG	340
TOUR COISE	320
POSTE PARISIEN	320
HILVERSUM	300
MIDLAND	300
SCOTTISH NAT	280
NATIONALS	260
COPENHAGEN	260
TRIESTE	240
ARAD	240

The top diagram illustrates parallax, and shows how the position of the eye affects the reading obtained when this is present. In the middle is a sketch of the dial on the Kolster Brandes sets. It is described in the text. The bottom illustration is a close-up of the well-known Cossor thermometer tuning.

Choice between the other three is largely a matter of opinion. Personally I think dual calibration in station names and wavelengths is the best idea of all.

Back-lash between the tuning mechanism and the dial operation is to be avoided at all costs, for it means that the position of the condenser vanes, and therefore the tuning of the set, can be varied slightly without the dial indicating any change at all. This can produce a state of affairs very similar to the undesirable traits of parallax.

Back-lash in the vernier part of a control does not matter so long as the dial and condenser vanes move as one. Such gearing is desirable on all single-knob-tuning sets. And on short-wave receivers a fairly large step-down ratio should be used. A large open scale is also very desirable on receivers designed for use on the short waves.

**RECENT DEVELOPMENTS**

And that brings us to the second section, in which I hope to show how near the present-day tuning arrangements come to being perfect. First of all there is the question of appearance.

During the last two or three years the keenness of competition between set manufacturers has led to the adoption of all sorts of ideas to "catch the eye." And among these unique tuning dials and indicators have proved a popular line.

But in spite of the wide variety of designs which have been developed, efficiency certainly seems to have kept pace with novelty. The result is that the attractive tuning devices have simplified operation as well as improving appearance.

It would be impossible in this article to mention all the different ideas. For instance, there is "clock-face" tuning—really completely described by its title. A dial of this type is illustrated on this page.

**The "All-In" Dial**

Then there is the Ferranti "All-In" dial. Apart from showing the setting of the tuning, this dial also carries indicators which tell at a glance how all the other controls are set. This is quite a logical development, for, after all, why should not the operator know just where the tone control is set as much as where the tuning is?

The Ekco dial is an example of how easy tuning can be obtained with a large dial. It also employs a shadow for indicating the setting.

The cursor producing this shadow is situated between the dial-light and



*Clock-face tuning is becoming quite popular. Known as the Air Plane Dial, the one illustrated is made by Jackson Bros., Ltd.*

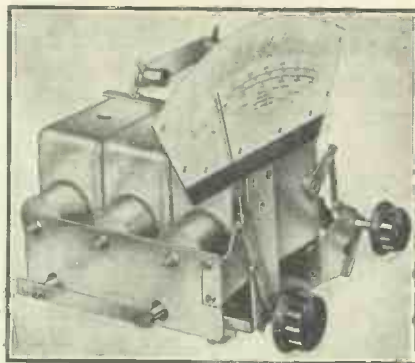

*The Varley permeability tuner in which tuning is achieved by sliding the iron cores in and out.*

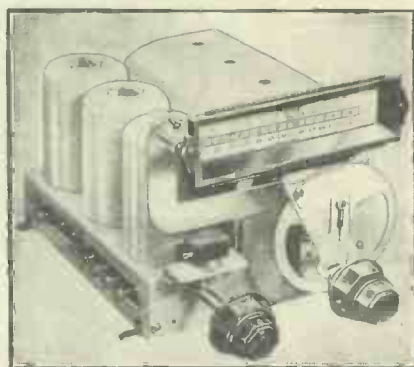

*A modern J.B. gang assembly. The three coils and condenser are all mounted on the same chassis.*

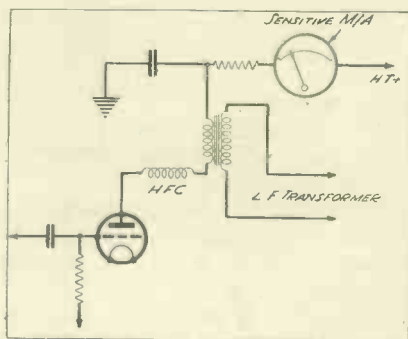

*A simple form of visual-tuning device, utilising a milliammeter in the anode circuit of the valve*

the translucent dial. Thus, no matter from what angle the dial is viewed the position of the shadow will not show any deviation at all, and parallax is thus impossible.

With the high selectivity of modern receivers, and the wide adoption of automatic volume control, it is not easy to tell just when a station is dead in tune even with the most accurate of dials. This is the reason for the appearance on modern receivers of tuning indicators.

The idea is not really new. A milliammeter connected in the anode circuit of a detector valve, as indicated in one of the diagrams, will tell when a station is properly in tune by giving the largest deflection at this setting.

**Using a Milliammeter**

The use of a milliammeter in this position, although quite old in radio technique, was formerly used for a different purpose. It was originally introduced to enable resonance curves to be drawn of tuned circuits, and for purposes of comparing the efficiency of one tuning arrangement with another.

Most tuning indicators are based on this principle of recording the anode-current charge as the station is tuned-in. It is usual these days, however, to work the indicator from the anode circuit of a variable-mu valve which is controlled for purposes of A.V.C.

All-wave tuning is one of the most recent attractions where commercial sets are concerned, although it was introduced years ago in certain wireless designs. It simply increases the necessity for accuracy in the tuning devices.

**Permeability Tuning**

And permeability is the most recent breakaway in tuning methods. Variable inductances of the iron-core type have their inductance varied by altering the positions of their cores. A tuner using this principle is included among the illustrations.

To a surprising degree people who are entirely non-technical seem to have considerable difficulty at times in differentiating between the medium and long waves. When both are marked on the same dial they sometimes get muddled between the two.

To avoid this many ingenious schemes have been invented, the simplest of which is to illuminate the calibration details of the waveband in use only. Often a different colour is adopted for each band.

One ingenious dial designed to avoid this confusion is illustrated. Not only



does a panel marked "medium" or "long" light up, but only the name of the station being tuned-in is visible.

Just one other modern tuning scheme before passing on to the third section. "Station suppression" and "inter-station silence" are two ways in which it is described.

Briefly the idea is completely to suppress all stations which do not reach a certain strength. This strength is sometimes a completely variable factor, and sometimes a pre-determined one.

With it in operation the set is much more pleasant to tune, as all the mush noises, heterodynes, and so forth between powerful stations of programme value are completely eliminated.

### TUNING PROGRESS

The efficiency of modern tuning arrangements is perhaps best appreciated by comparing them with some of the older ones. In this way the tremendous advances which have taken place become most noticeable.

Most outstanding of all the changes is the considerable increase which has been achieved in selectivity, although this has more or less been forced on designers by the greater congestion of the ether. It is true to say that modern technique would be capable of supplying a degree of selectivity far beyond the maximum permissible for even mediocre quality to be achieved unless considerable tone correction were employed.

#### Circuit Advances

The outward signs of advance, as I have already pointed out, are very marked. But it is in the circuits themselves that the changes which have called for more efficient control mechanism have actually taken place.

For instance, direct drive for condensers would be hopelessly out of place with the modern gang assembly of three or four tuned stages. As the old type tuners illustrated on this page show, no attempt was made to simplify tuning in the past years by means of ganging, although with the flatly-resonating circuits then employed it would have been a more straightforward job than it is to-day.

When gang tuning did put in an appearance it was simply "the

## SOME NEW AND OLD SCHEMES

exception" for many years. To-day it is expected on commercial designs as much as an on-off switch.

The idea of a separate tuning control for each tuned circuit is all very well when there are only two of them, and they have the advantage of ensuring that each circuit is dead in tune over the whole range of the receiver. Modern sets obtain their selectivity by means of many tuned stages—seven or eight in many superhets—

and separate controls for those which are variably tuned would be entirely out of the question.

Another feature concerning the tuning circuits is that peak resonance curves are avoided, band-passing being the order of the day so that

quality shall not suffer. In the old times great selectivity almost invariably meant a loss in high-note response.

#### Difference in Size

Another noticeable difference, between modern coils and those of a period a little later than the time we have just been considering, is their size. Modern coils are tiny compared with the large diameter coils of a few years ago, a difference well illustrated by one of the photographs.

This big difference in size is largely due to the use of iron-cored coils. Equal efficiency and selectivity are obtainable

when iron cores are used, with a fraction of the size necessary in the case of air-core inductances.

But tuning developments are by no means reaching a stationary state of development. Remote control is now a big feature of the tuning on one modern set.

No doubt before long we shall be able to push a few knobs in the right sequence to have any given station automatically tuned-in for us by the receiver.

Two of the latest developments in tuning aim at making it simply a matter of selecting the desired station. The set then automatically puts the final touches to the job.

The first of these two items is the automatic setting of the tuning to the correct point, thus removing the need for a visual tuning indicator.

The second scheme concerns quality and selectivity. Naturally it is impossible under modern conditions always to have the best quality (referring to frequency range), because of the varying degrees of selectivity required. Automatic selectivity control gives the best quality possible with the degrees of selectivity necessary.

It is impossible to explain how these arrangements work in this article, but it may be mentioned that there is a marked similarity in them to A.V.C. feed-back schemes.

### A STRIKING COMPARISON

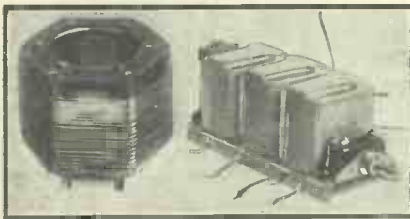

A good size-comparison is provided by these two components. One an old air-dielectric coil and on the right a Colvern three-stage iron-cored coil unit.

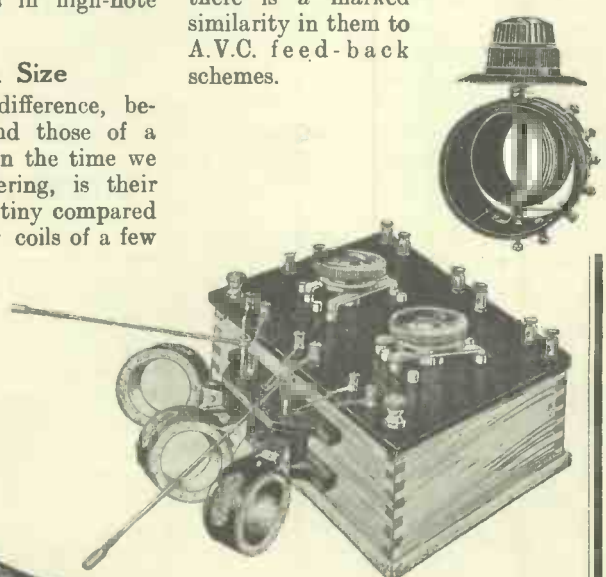

### TUNERS OF THE PAST

At the top is a once-popular tuner of the tapped variometer type, while the other two units represent the two parts of an early but well-made three-coil Peto-Scott tuner.

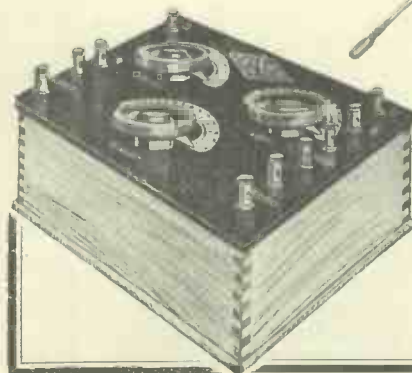

# WOMEN AT THE B.B.C.

Alan Hunter Interviews Jean Melville

"SHE'S over at St. George's Hall—rehearsing," they said. So I walked across from the "Big House" to its satellite establishment. But Jean Melville wasn't rehearsing. She was having a well-earned coffee in the little restaurant there. And she made me have one, too.

"My gory past?" she burbled, getting ready to be put on the spot, as she saw me take out my intimidating notebook.

## Came From Australia

"Well, the first thing you'd better know is that I hail from Australia—from Sydney, to be exact. Yes, where the aboriginals come from! How did I leave my home town? Oh, I won a scholarship, you know. A scholarship in music. It took me to the Royal Academy of Music.

"I studied there for some time. And then, well, I got fed up with studying. So I joined the Femina Quartet. For heaven's sake make it clear that it was the much later edition of this act I joined. Because, you see, the first Femina Quartet was started way back in 1908! My appearance was in 1919—I went all round the country with it.

"My first broadcasting date? Why, of course, the very first wireless revue. It was called 'Listening In'—and I did piano numbers with Herman Darewski.

"Then, let me see, what happened after that? Ah, yes, I went into Archie De Bear's shows—did a lot of work in 'R.S.V.P.' and 'Vaudeville Vanities'—and for that very successful show of his, 'Blue Skies.' I was tied up with all that for three or four years.

## The "Surprise Item"

"And then? I came to the B.B.C. And here I have been ever since! My job? Accompanying variety acts—all sorts of famous artists have come my way. Gloria Swanson, Evelyn Laye, Gracie Fields—she's a dear!—and Greta Keller.

"I seem to get on very well with foreigners. Well, this will show you: When I had finished accompanying Gretel Vernon, her manager came up to me in ecstasy and said, 'You are a great pianist, Miss Melville'—and pressed five shillings into my hand! I was so overcome I took it—and spent

it in a half-share of a sweepstake ticket. But I had no luck!

"That was not the first time I had been 'tipped' though. The first time the late Harry Weldon broadcast to my accompaniment his manager slipped me six shillings, saying: 'Buy yourself a box of chocolates.' I must admit that 'staggered' me. I turned to the announcer nearby and said: 'What do I do with this?' He laughed and replied: 'Keep it!' Apparently it is quite the custom on the music halls.

"Yes, it's an interesting job. I simply love it! The really big artists I have to accompany are always so nice. Burns and Allen, for example, were a delightful pair during the week I had to work with them. The bigger their reputations the nicer they seem to be!"

I turned to one of Jean's pupils, who was having coffee with us. "And what colour eyes would you say she has?"—pointing to 'teacher.' The seventeen-year-old aspirant to ether fame answered immediately: "Oh, smoky blue! And her hair is red-gold!"

Jean laughed. "You see, she knows it all!" There is absolutely no



Miss Jean Melville has met many famous artists in the course of her work as B.B.C. accompanist.

"side" in Jean's make-up—and that, perhaps, coupled with her ebullient nature, is what endears her to all the artists who come to her for their accompaniment. Very few people realise what a lot depends on the accompanist in broadcast turns.

Jean Melville is married to Maurice Brooke, the well-known dancer at Sadler's Wells.

## INTENSITY EXPANSION

—continued from page 72.

another. The difference in intensity between the sounds of an exploding shell and a whisper is enormous. Even if the B.B.C. could broadcast the original sounds in their correct perspective as it were, one or other would have to vanish in the set. You couldn't produce a sound as loud as an exploding shell from any normal outfit, and even if you could you wouldn't want to do so. But if you cut it down to a reasonable level for parlour listening then you would have to cut down the whisper to a similar extent (normal volume controlling methods would do that for you).

And the result would be that you would not hear the whisper at all. In a lesser degree the same would apply to a symphony orchestra broadcast, and to many other things which are subject to B.B.C. control. So in order that you should be able to hear all the

sounds you would have to apply not expansion at the set but contraction. You would have to do what the B.B.C. is already doing.

It is quite true that their intensity levels sometimes seem to provide curious contrasts, particularly when they change over from one item to another. A volume control setting which provides satisfactory listening to, say, a dance band may result in a speaker who follows being heard much too loud for comfort. But then, that can be adjusted easily enough by reference to the volume control.

But taking the question of relative sound intensities existing in any one particular item, it would seem to me that the B.B.C. in making contractions for their own purposes of transmission, are also fitting the sounds very comfortably into the kind of compass which suits the average set working in the average home. Further, it appears to me, that consciously or unconsciously the B.B.C. engineers are developing a technique of sound control which makes for an improvement on the original material rather than the reverse.

It so often happens in public performances, concerts, plays, speeches, and what not, that listening to the original on the spot is inferior to listening to it on the radio in one's own home. May it not be that this levelling of intensity which continually creates so much criticism is an unappreciated virtue? It would be very interesting to have the unbiassed views of others on the subject.

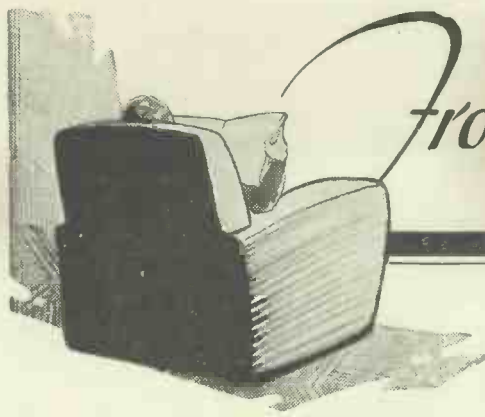

# From My Armchair

by 

Mr. Scott-Taggart writes about some B.B.C. policy matters, the standardisation of set performances and electron multipliers, in his popular feature this month.

THE B.B.C. has once more been pictured as a prude on the prowl. This time matters have gone so far that a committee of eminent men, including H. G. Wells, have remonstrated at the proposal (or is it now a fact?) that the B.B.C. should have a Director of Private Lives who will know all the gory details of each and every member of the B.B.C. staff.

### An Uncanny Knack

The idea certainly sounds fantastic. It is reminiscent of OGPU methods, and the group of clear thinkers, headed by Mr. Wells, bluntly ask the B.B.C. what does it matter how the staff conduct themselves if they do their job efficiently. A Recording Angel's department at Broadcasting House certainly sounds at first sight (or, rather, hearing) to be a colossal joke.

But Sir John Reith has a most uncanny knack of doing the right thing even when many people think it wrong. He certainly has made it clear that his Corporation—for, after all, it is his creation—must be *sans peur et sans reproche*.

This is no doubt partly due to personal idealism but also, I imagine, partly attributable to a shrewd outlook. There is no public body so much in the public eye as the B.B.C. (When television arrives, the B.B.C. will be even more in the public eye.) The B.B.C. has many enemies, some rampant, still more dormant but with one eye cocked expectantly on the armour of the B.B.C. waiting for a chink to reveal itself.

### Strictness is Better

The very people who now talk of the B.B.C. as a pack of prudish Mrs. Grundys would be the first to decry the slightest scandal. A reputation for strictness is much better than the

barest hint of laxity. The B.B.C. has to deal with a very queer motley of artistic people and as long as they do not apply to these the same strict standards of their own the public will not suffer.

I know a good many of the B.B.C. officials from Sir John Reith downwards and as individuals there is nothing prudish or humourless about them. We can therefore consider any edicts as being part of the "policy of the house."

I very much doubt whether the practical idealism of Sir John Reith has been widely enough appreciated. He could so easily have taken the easier course of bowing to the wishes of those

five per cent of the British public. Sir John Reith was an engineer, not an entertainment magnate. Thank heaven for that. If a frivolous epitaph were ever required for our chief of broadcasting, many a worse one could be found than: "He never made us sick of broadcasting." And yet if he had done what everyone wanted him to do—and what many to-day still want him to do—he would have degraded broadcasting to the level of a music-hall and we should have tired of it within a year.

### A Silent Tribute

As it is, there is not one of us who does not feel in his heart that should he develop ethically and culturally he will reap a richer harvest from the radio programmes.

This secret knowledge in the heart of every listener is the public's silent tribute to Sir John Reith.

\* \* \*

At an informal meeting of the Wireless Section of the Institution of Electrical Engineers recently, the subject of standardising the performance of commercial radio apparatus was aired to the point of draughtiness. Would it be "a good thing"? Certainly advertisements would be less glamorous.

### Uninteresting

The output volume would no longer be "a cataract of glorious sound," but just Grade A (or more likely B or C or D). Selectivity would cease to be razor-edged; it would merely conform to specification R.S./42A/H.F.375B. All-wave receivers that now bring (*sic*) Honolulu to your fireside, Timbuctoo to your doormat and make the wild cry of the Laughing Jackpot Bird seem as if it came from your own canary cage, will just be R.S.P./27A.W./427F.

### AN EARLY ELECTRON MULTIPLIER

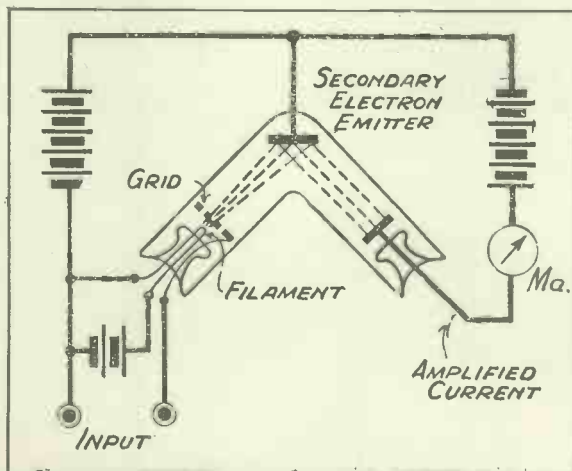

This electron multiplier was constructed by Mr. Scott-Taggart himself as long ago as 1919 in the works of The Edison Swan Electric Company.

who cry for entertainment. If it is true that those who kick the B.B.C. are apt to bruise their toes, it is not so much because the corporation is a powerful monopoly but that Sir John has made it an organisation that has the respect of the country.

His efforts in the direction of religion, uplift, education, "talks," serious music, are all efforts made in the face of the opposition of ninety-

I doubt if the public will be much the wiser or any the happier. They will probably go on buying sets because the one at Wilson's was "mellow," or because they like Mr. A's rugged, honest face, or because XYZ have a good name. Probably in the end they will buy a good set, even if the reason is not the best one, because good sets properly advertised and backed by a financially sound concern have a habit of surviving.

### Who Will Benefit?

As for retailers, well, they just sell the sets that "go." Although there are notable exceptions, most retailers are not greatly concerned over technical specifications. Who, then, will benefit from standardisation? I don't know.

Standardisation really benefits the technical people concerned. Specifications for components and valves may be useful, because manufacturers are technical people and will understand. In the electrical industry standardisation of specifications of switches, fuses, cables and the like is of great benefit to contractors, but the performance of radio sets comes into quite a different category. The retailer applies the "Sales" test while the public just applies the good old "pudding" test.

Frankly, I do not think the radio industry is at all "stabilised." Every year the ether conditions are utterly different. Vastly greater outputs from European stations must inevitably react on technique. A specification for performance might be either totally inadequate or grotesquely strict. Sensitivity necessary four years ago, may be excessive to-day.

As regards technique this has not altered very much in the last two or three years. The superhet with A.V.C. has come to stay and nearly all the manufacturers just copy each other or derive their circuits ready-made from obliging and competent valve manufacturers.

### Future Technique

But I am far from convinced that we have seen the end of progress. Television alone will rock the industry. Dropping to about 6 metres wavelength will, on sound broadcasting alone, revolutionise technique and even though ordinary broadcasting will continue simultaneously for a few years, we shall ultimately probably go down to these very short wavelengths for our domestic sound entertainment with television an optional addition. What will happen to foreign broadcasting is not quite clear.

## "PUDDING" AND "SALES" TESTS

At any rate, all that is some way off but I mention the possibility, nay the probability, to show that far from being stagnant the technical side of the radio industry is in for a spell of rough water—and probably not a little sea-sickness. I have not even much faith in the instruments whereby we achieve our technical results. The

### ANTI-FADING AERIAL

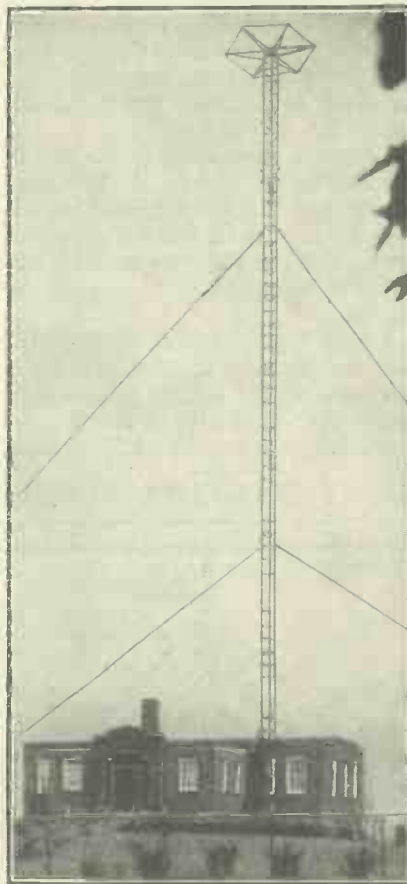

*A.V.C. has been developed for combating fading in receiving sets, and now engineers are tackling the trouble from the transmitting end. Here is the special anti-fading mast of WMAQ, the Chicago broadcasting station, which is the first to be thus equipped.*

valve is a pretty useful device as it is, but I am not at all sure that it is the only possible device. We vary the flow of electrons by a grid but we can vary it in other ways, e.g. by deflecting a beam of electrons on and off an anode plate or over two or more anodes.

And now we have much talk about electron multipliers which give enormous amplification. The idea is that

you vary an electron stream which strikes a special plate, which then gives off many secondary electrons. The electrons then all go on to another plate, knock out more electrons, and so on. Several stages of this in a single tube enable enormous amplification to be obtained.

### A Simple Affair

This scheme incidentally interests me particularly because in the winter of 1919 at the Edison Swan Electric Co.'s works I actually constructed an electron multiplier. Perhaps they could find it. It was a very simple affair consisting of a glass tube bent at right-angles and closed at each end. In one branch I mounted a filament and a grid (in the form of a wire mesh "plate") and an anode in the form of a flat-nickel plate situated crosswise in the bend of the glass tube. At the other end of the tube I had simply a nickel anode.

The principle was very simple. The electrons from the filament were drawn to the first anode which was made positive by a battery: this bombardment of primary electrons liberated electrons from the anode, and these secondary electrons were drawn to the second anode, which was made positive with respect to the first anode. The first anode was thus like a cathode supplying the second anode. Now, it is possible for a single primary electron to knock out as many as twenty secondary electrons.

### "Before Their Time"

Thus by varying the grid potential, the amount of bombardment could be varied and therefore the number of secondary electrons. One thus had an opportunity of multiplying the ordinary amplification a further twenty times. The accompanying drawing illustrates the tube I made. The scheme was very crude but it is another example of how ideas even sixteen years old can be "before their time."

J. S.-T.

## THE W.L.S. SUPER

*Full details of this sensitive short-wave A.C. superhet, designed by our S.W. expert, will appear in the next number of Wireless.*



condenser. This controls the volume and the selectivity. One end of the secondary of the aerial coil is connected via a .0001-mfd. condenser to one control grid of the double pentode, whilst the other end is connected to the other control grid in the same manner. These condensers prevent the secondary of the L.F. transformer being short-circuited by the tuning coil.

**Preventing a Short Circuit**

The amplified H.F. signals on the anodes of the double pentode are fed via .0001-mfd. condensers to the primary of the inter-valve H.F. transformer. These condensers prevent the L.F. output being short-circuited.

The secondary of the inter-valve H.F. transformer is tuned by a .0005-mfd. condenser, and feeds the H.F. signals to the grid of the triode detector of the leaky-grid type. Reaction is applied in the normal manner by means of a differential

reaction condenser from the detector anode back to the grid circuit. The anode of the detector is also connected via an H.F. choke to the primary of an L.F. transformer which has a centre-tapped secondary and a ratio of 1:9.

The secondary of this transformer feeds L.F. signals via 500,000-ohm resistances to the control grids of the double pentode valve. These resistances prevent short-circuiting of the H.F. circuit. The amplified L.F.

**HOW THE UNDERNEATH APPEARS**

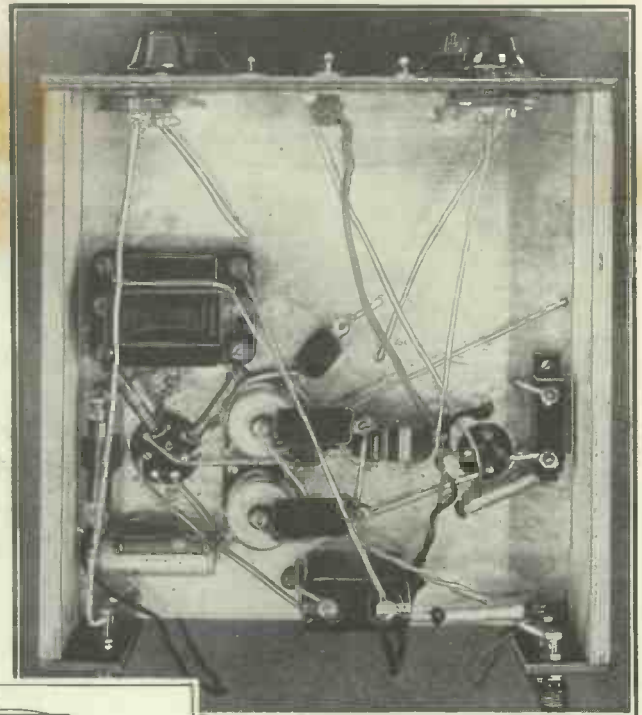

**THE ABOVE-CHASSIS WIRING**

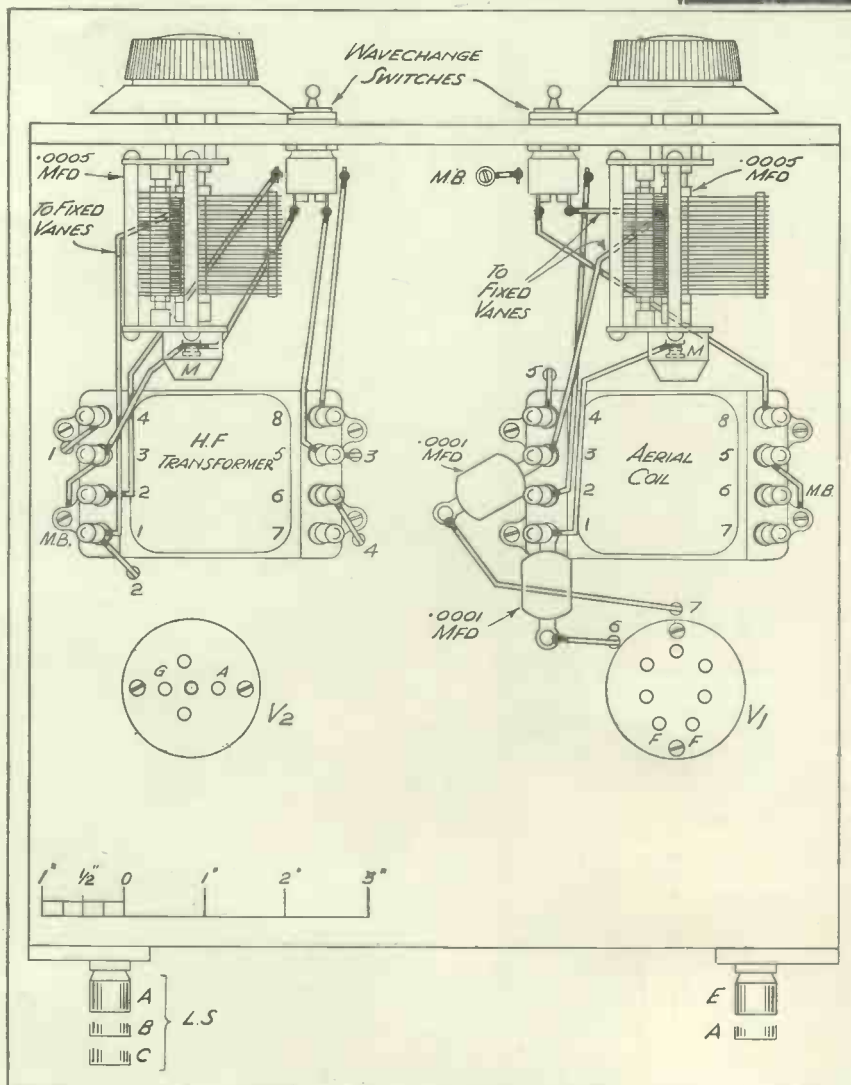

signals on the anodes of the double pentode are fed via H.F. chokes to the loudspeaker.

Automatic grid bias is used, and is obtained by inserting a 500-ohm resistance shunted by a 50-mfd. electrolytic condenser between the negative filament line and H.T. negative. The grid return of the double pentode is taken to H.T. negative. This gives the grids a negative bias of approximately four volts. The big advantage of using automatic bias is that the bias is automatically corrected as the H.T. battery runs down.

**Use the Specified Parts**

A separate double-pole shunting switch is used for wavechanging each coil. The on-off switch is a simple two-point toggle in the L.T. positive lead. So much for the theoretical arrangements of the circuit.

Before describing the construction of the "Pre-Plex," I will say a few words about the components: In many simple types of receiver it is possible to use components different from those specified by the designer, and still to obtain good results.

The "Pre-Plex" is not one of these receivers. I do not advise anybody in any instance to use components

*The diagram on the left shows how to carry out what wiring there is above the baseboard. The numbers, where leads pass through the baseboard, correspond with the numbers on the diagram on the opposite page.*

**THE COMPONENTS TO EMPLOY**

- 2 Polar No. 2 S.M. '0005-mfd. tuning condensers.
- 2 Wearite Universal type "A" screened coils.
- 2 Bulgin D.P.S.T. toggle switches, type S.126, with "Medium Long" plate.
- 1 Bulgin on-off toggle switch, type S.80.
- 1 Clx 7-pin chassis mounting valve holder with screw terminals.
- 1 Clx 4-pin chassis mounting valve holder with screw terminals.
- 1 Polar '0005-mfd. solid dielectric variable condenser.
- 1 B.T.S. '0031-mfd. differential reaction condenser.
- 1 Ferranti Q.P.P. L.F. transformer, type A.F.12 (C.).
- 2 Varley "Nicore" H.F. chokes.
- 1 B.T.S. disc type H.F. choke.
- 1 Dubilier 2-mfd. fixed condenser, type B.B.
- 1 Dubilier 50-mfd. dry electrolytic condenser, type 3013.
- 2 Dubilier '005-mfd. fixed condensers, type 670.
- 1 Dubilier '0003-mfd. fixed condenser, type 620.
- 4 Dubilier '0001-mfd. fixed condensers, type 665.
- 1 Erie 2-meg. 1-watt type grid leak.
- 2 Erie 500,000-ohm 1-watt type resistances.
- 1 Graham Farish 1/2-meg. 1/2-watt Ohmite resistance in horizontal holder.
- 1 Erie 30,000-ohm 1-watt type resistance.
- 1 Erie 500-ohm 1-watt type resistance.
- 1 Peto-Scott "Metaplex" (both sides) baseboard, 10 in. x 10 in., with 3-in. wood runners.
- 1 Peto-Scott ebonite panel, 10 in. x 9 in. x 1/8 in.
- 2 Peto-Scott terminal strips, 3 1/2 in. x 1 1/2 in. x 1/8 in.
- 5 Clx indicating terminals, type A.
- 1 Belling & Lee Wander fuse.
- 1 Belling & Lee Wander plug.
- 2 Belling & Lee Accumulator Spades.
- 2 Coils B.R.G. Quikon connecting wire.
- Screws, flex, etc.

other than those specified. There are definitely no other coils, to my knowledge, which are suitable for this receiver. Those used were chosen after I had tried many others. This does not necessarily mean that they are the best coils obtainable, but that they are the most suitable for this receiver.

The small tag type '0001-mfd. condensers are used because they can be mounted "in the air," and consequently their capacity to earth points is very low. Also their capacity to other components is low, and therefore there is less likelihood of undesirable stray couplings than there is with condensers of larger physical dimensions.

It will thus be seen that there are reasons for most things in the design of a radio receiver, and to change components or to alter the design in any way is very risky.

**A Good Plan**

By far the better plan is to obtain a complete kit of parts from one of the firms who make a speciality of supplying such kits. Then you will be sure that you have all the correct components and the necessary accessories.

We will now pass on to the construction. The receiver is built on a chassis which is composed of a 10 in. by 10 in. "Metaplex" (both sides) baseboard with 10 in. by 3 in. wood runners. This may be obtained ready made up from Messrs. Peto-Scott. Of course, copper foil may be used for covering the baseboard if desired, but "Metaplex" is much more convenient and easier to use.

If you make your own chassis, the holes for the valve holders must be cut in the baseboard before the

runners are fitted. These holes are cut preferably by means of an adjustable centre-cutter, but failing this a fret-saw or keyhole-saw can be used.

The hole for the seven-pin valve holder has a diameter of 1 1/4 in., whilst that for the five-pin holder has a diameter of 1 in. Having drilled the holes, fit the runners.

Now mount the terminals on the terminal strips, and fit the completed strips to the chassis. The next job is to mount all the sub-chassis components, including the wire-ended resistances and the 50-mfd. electrolytic condenser, all of which are supported by their wire ends.

**Points to Note**

A terminal at one end of each of the Dubilier '005-mfd. type 670 condensers is removed, so that their tags may be fitted direct to the top terminals of the H.F. chokes. Make sure that you connect the 50-mfd. electrolytic condenser the right way round, otherwise it will be destroyed when you switch on the receiver. The negative or

**BELOW THE CHASSIS**

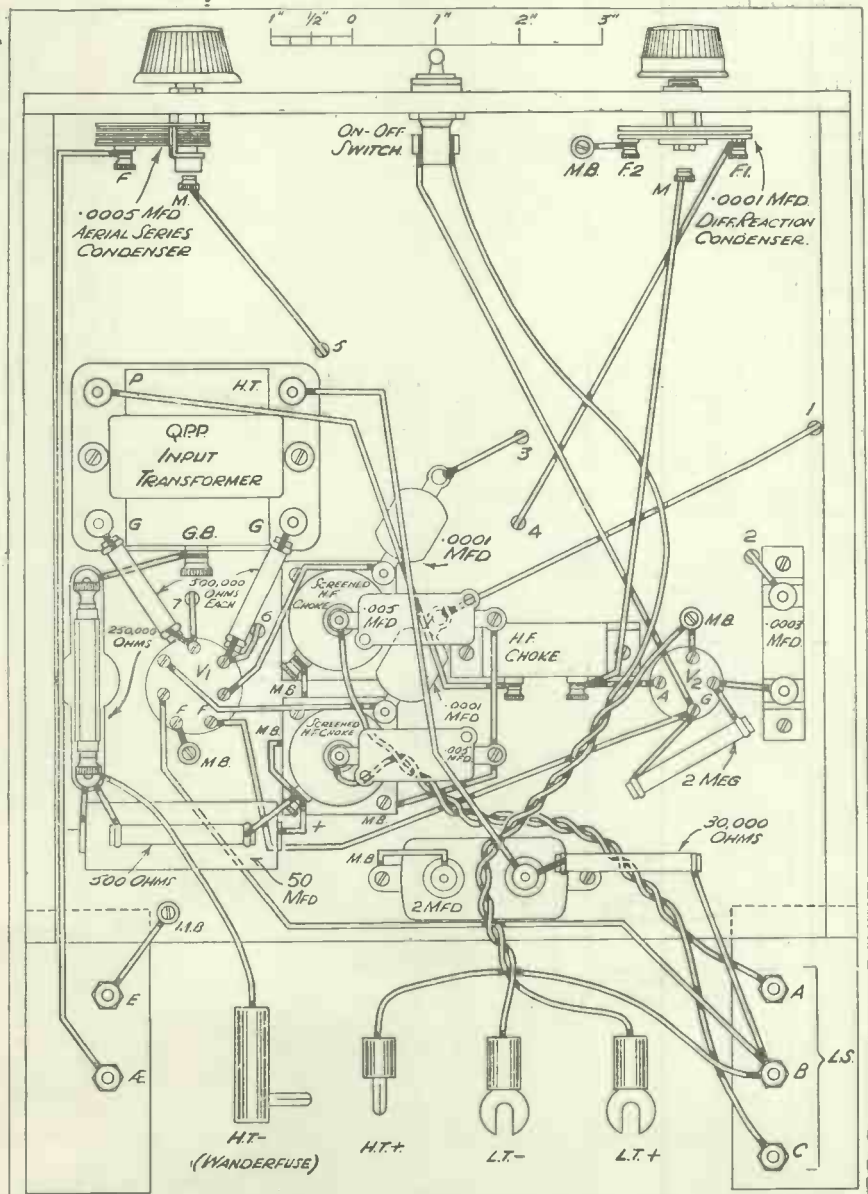

How the parts below the chassis are arranged and wired. This diagram should be used in conjunction with the "above-chassis" plan and "under-chassis" photograph on the preceding page.

black end must be connected to the terminal of the  $\frac{1}{4}$  meg. "Ohmite," to which the H.T. negative lead is joined.

The positive or red end must be connected to the earthing terminal of the H.F. choke. This is very important and must not be overlooked. It is quite easy to make a mistake here. I have done it myself, much to my annoyance!

### Completing the Chassis

When you have mounted all the components under the chassis, the next job is to mount those on top of the chassis. These are the coils, valve holders and the small tag-type condensers, which are fitted straight on to the terminals of the coils. That completes the mounting of the components on the chassis.

Next prepare the panel for drilling. I prefer to mark out and drill panels on the face side, when working from the front of a panel diagram. There is less likelihood of making a mistake. Provided that reasonable care is taken in marking out, the surface of the panel will not get scratched. There is less chance of this trouble when drilling, than there is when drilling from the back.

The hole sizes for the various controls are as follows. Tuning condensers,  $\frac{7}{16}$  in.; toggle switches,  $\frac{1}{2}$  in.; reaction condenser,  $\frac{3}{8}$  in.; aerial series condenser,  $\frac{5}{16}$  in. Their

### THE 7-PIN VALVE CONNECTIONS

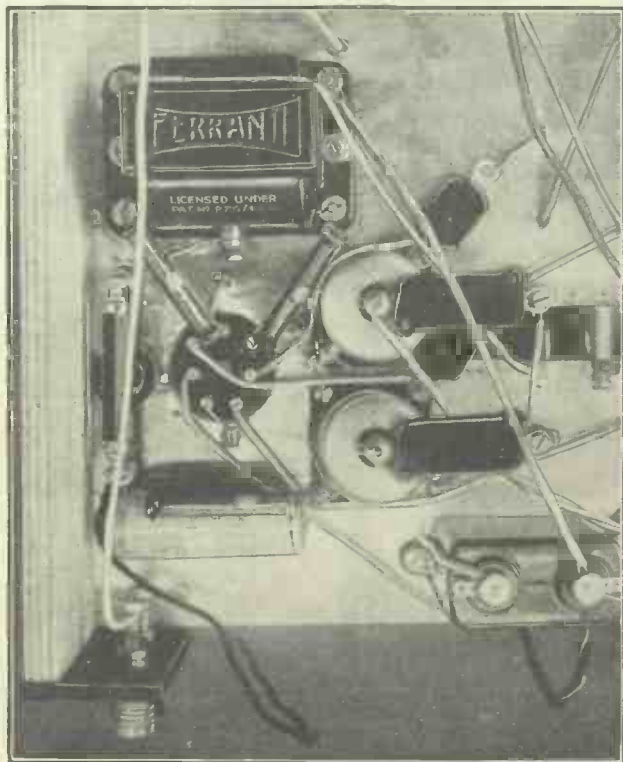

With the aid of this photograph there should be no difficulty in making the correct connections to the seven-pin valve holder.

SUITABLE ACCESSORIES	
BATTERIES	
H.T. 120 volts, Drydex.	
L.T. 2 volts, Exide.	
LOUDSPEAKER	
W.B. "Stentorian."	
VALVES	
H.F.—L.F.	Det.
Marconi Q.P.21 or Osram	Cossor 210 H.F.

positions are clearly indicated in the front of panel diagram.

Before fitting the panel to the chassis, leads should be fitted to the

### HOW THE PANEL IS DRILLED

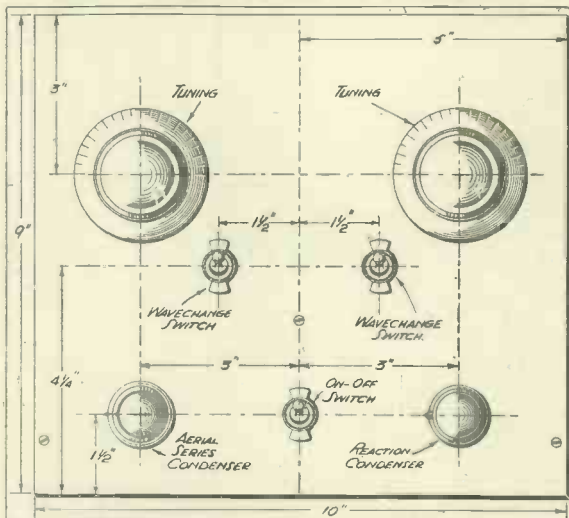

The operation of the set is similar to that of an ordinary straight two-valver, and has no complications at all.

switches and to the fixed vane terminals of the two tuning condensers. These leads may all be about 6 in. long, and can be cut to the correct length when the wiring is done. Unless these leads are fitted now difficulty will be found in doing same when the panel is in position.

Having fitted the panel to the chassis, now fit the control knobs to the two tuning condensers, the reaction condenser, and the series aerial condenser. With the tuning

condensers set at maximum, set the dials so that "100" is at the top. A small white arrow may be painted on the panel above the dial to act as an indicator.

The receiver is now ready for wiring. The holes in the baseboard, through which wires pass, are drilled as you do the wiring. It is extremely important that you wire this receiver strictly in accordance with the wiring diagram. Should a wire pass along one side of a component in the diagram, take it along that side, and not along the other side. Such deviations in the

wiring may cause undesirable couplings and cause trouble. Because I warn you about this, do not think that this receiver is "touchy" in that respect; it is not, but do not take any risks.

### Wiring Up

There is no particular order in which the wiring should be done, but it is advisable to attach first all the wires which go to terminals close to the baseboard, otherwise they will be awkward to get at when wires have been connected above them.

There are several soldered joints to be made, but nearly everybody can solder nowadays, so this should present no difficulties. The wavechange switches must be soldered, as a twisted wire joint is not good enough—it does not last. The .0001-mfd. fixed condensers may have small terminals fitted to them if desired. This will obviate the necessity for soldering here.

### Screws Must Be Tight

Where connections are made to the baseboard, washers should be used both under and over the wire, and round-headed screws used for screwing down. Make sure that these screws are really tight, or you may spend hours looking for the cause of crackles! When you have finished the wiring, fit the accumulator spades to the twin flex L.T. lead (I strongly advise the use of twin flex here, so that L.T. and H.T. leads do not get mixed up), the wander plug to the H.T.+ lead, and the wander fuse to H.T.—.

These wander fuses are very useful and convenient little things. They cost only a few coppers, but prevent any damage being done to the valves

(Please turn to page 128.)



# Make Sure of YOUR VALUES

RESISTANCES and condensers have an inconvenient habit of shedding their labels, so that when the value of any of these components is required an unwelcome strain is put on the memory or else the component is laid aside.

It would be extremely useful to be able, at a moment's notice, to measure a condenser or resistance with a high degree of accuracy. The experimenter often requires a resistance of a certain value which could be found at home if some means were readily available for adjusting it to the desired value.

It was with these and similar requirements in mind that work was undertaken to evolve a bridge which could be readily assembled from easily available component parts, and which would be simple and compact and yet reasonably accurate.

### Direct Reading

It was also considered essential that it should be direct reading, the resistance in ohms or capacity in microfarads being read from the scale at a glance, thus avoiding the necessity of a calculation at every measurement.

Such conditions are met in the bridge described here, and it will make an invaluable addition to the experimenter's laboratory.

The resistance range is from 1 ohm to 2 megohms, and the capacity range from 0.00005 to 10 mfd.

It will be seen from the circuit diagram that the unknown quantity is balanced against one of six standards, three resistances and three condensers, and the accuracy of the measurements depends on the degree of accuracy of these standards. If the experimenter is satisfied with a rough check only, ordinary units can be used.

### Guaranteed Units

It is, however, much more satisfactory to use units which are guaranteed within specific limits, as the additional cost is very small and well worth the assurance it gives that

any inaccuracy depends on the operator and not on an unknown quantity.

The standard condensers can be obtained specially selected to less than 2 per cent error from Dubilier at additional 10 per cent cost. The first, .0005 mfd., will cover an unknown capacity between .00005 mfd. and .001 mfd. The second, .01 mfd., gives a

range of .001 mfd. to .1 mfd.; while the third, 2 mfd., covers from .1 mfd. to 10.0 mfd.

The three standard resistances, which can be obtained from Bulgin at 50 per cent on list prices, adjusted to within 1.5 per cent error, are as follows: The first, 10 ohms, gives a range of 1.0 ohm to 100 ohms. The second, 1,500 ohms, covers from 100 ohms to

20,000 ohms; while the third, 150,000 ohms, extends from 20,000 ohms to 2.0 megohms. For this latter Bulgin will supply two in series. They are brought into circuit as desired by a single-pole six-way switch obtainable from Ferranti or made as single-pole stud switch.

The small size of the bridge and the convenient shape are brought about by the use, for the ratio arm, of an ordinary rotary wire-wound potentiometer. The actual resistance of this need not be known, as it is the ratio by linear measurement of one section to the other which is wanted.

### Must Not Be Logarithmic

Logarithmic variations will not do. The winding must be on a former which has the same width at all points.

The buzzer used to supply "A.C." to the bridge is connected to it in a special manner. The A.C. points of the bridge arms are connected across the armature and fixed contact. The action of the buzzer is not normally upset by this method of connection, as the resistance shunted across the contacts is fairly high except on the 10 ohm range, and a slight adjustment of the contact screw will usually put matters right here.

### Direct Current Also

The chief reason for this special connection is that the bridge can also be used on direct current, with a galvo, without any alteration. The battery will supply D.C. to the bridge and the buzzer armature can be prevented from vibrating by touching it once, or, if desired, can be left running; it makes no difference to results. A sensitive galvo such as the Weston Student Galvo is then connected in place of the phones.

★.....★

A component may be quite all right and yet prevent a set working properly, simply because it has the wrong value. That is just one of the cases in which the accurate measuring instrument described in this article can be of untold value.

★.....★

A SIMPLE CIRCUIT STANDARDS

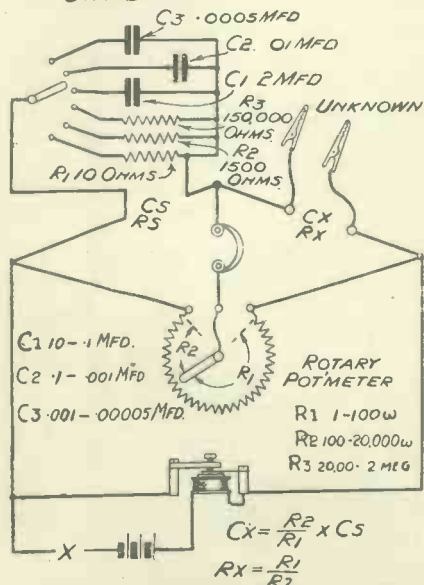

In spite of the accuracy and comprehensive range of the instrument, its conception is not complicated, as will be clear from this circuit of the internal connections.

The D.C. method of operation will be essential when attempting to measure the resistance of any component which has impedance instead of pure resistance, such as a transformer or even an H.F. choke. If the A.C. method is used in these cases the bridge will try to measure the impedance of the component instead of its D.C. resistance, and the null point will be flatly defined.

**A Very Sharp Point**

With the D.C. method the galvo indication of null point will be very sharp indeed, and will be an indication of the pure resistance of the component under test. The cursor type pointer is necessary in order to indicate pro-

**DETAILS OF THE SCALE**

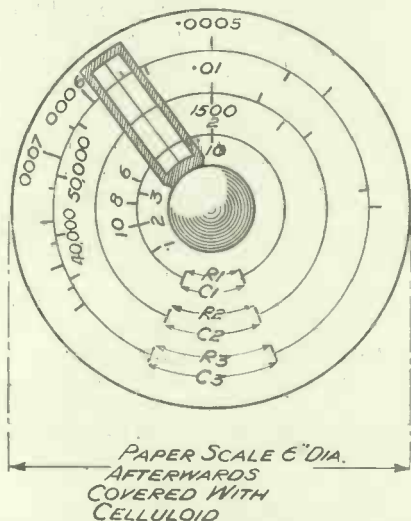

A feature of the scale is its property of providing direct readings for all values of capacity and resistance.

perly against the six scales, and should preferably be cut from 1/16-in. brass strip.

The window should be marked and small holes drilled all round, after which the centre can be punched out and the edges trimmed with a file. A coat of red enamel will impart an appearance of professional smartness to the pointer. The hair line is a piece of black cotton tied in place across the centre of the window. In wiring, 16-gauge copper should be used, especially in the bridge arms, and it should be done as symmetrically as possible.

**Only Done Once**

Calibration is carried out in a very simple manner, although perhaps it will prove tedious. The advantage is that it will all be done once only, and that future measurements will be read directly from the scale.

First, the paper scale should be temporarily fixed in place by its screws. Then the exact limits of the

**HOW TO CHECK YOUR COMPONENTS**

rotary resistance must be marked on the scale. If the moving arm does not travel as far as the last turn at either end, artificial limits should be marked on the scale by measuring with dividers some definite small amount, such as 1/4 in. from the end turn of the winding on both sides, setting a mark on the exact centre of the contact arm opposite this point and marking the scale at the corresponding setting taken up by the cursor.

It is important to note that if the cursor should have to be taken off for any purpose after calibration, it should be lined up exactly with the marks on reassembly. These artificial limits will be as accurate for calibration purposes, as the actual end turn of the winding, and should be marked very carefully.

**Marking the Divisions**

The paper scale should now be removed from the bridge, as the detailed calibration will be done on the drawing board. The outside edge of the scale must now be divided off between the marked limits into 100.0 divisions. These points should only be lightly marked in pencil, as they will not be wanted on the finished scale.

They must now be numbered from 0 to 100 both ways round, at every tenth point, the second set of figures being placed immediately over the first set.

Three equidistant lines should now be drawn round the scale to take the calibration figures, one in the centre of the window and the other two on either side at convenient distances as viewed through the window. The tedious part of the

**RELIABLE MAKES**

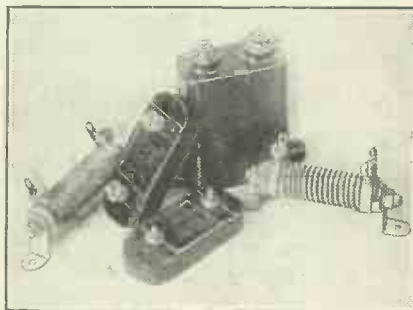

Condensers and resistances with very small percentage error can be obtained from Dubilier and Bulgin respectively for use in this bridge.

business now follows, and consists of working out the equation for either resistance or capacity at all the main points of the scale.

In accordance with the sharpness of indication and usefulness, the lowest capacity range and highest resistance range have been marked on the largest diameter line where more points can be indicated on account of the larger divisions.

**The Necessary Formulae**

In identifying R<sub>1</sub> and R<sub>2</sub>, care must be taken to see that they are on the correct sides. If the wiring has been carried out in accordance with the diagram, viewing the components from the back of the box, then the

**NEAT IN APPEARANCE**

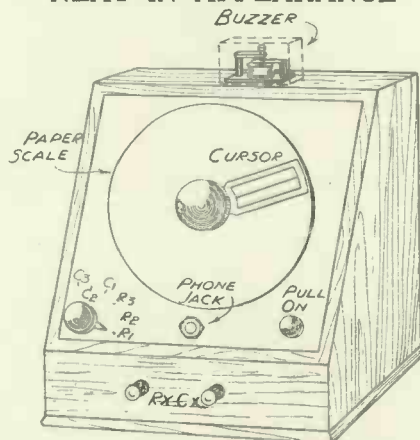

The "meter" is small, conveniently shaped and attractive in appearance. Note the buzzer mounted on top.

position of R<sub>1</sub> and R<sub>2</sub> will be reversed on the scale.

The bridge equation for capacity is:

$$C_x = \frac{R_2}{R_1} \times C_s$$

For resistance,  $R_x = \frac{R_1}{R_2} \times R_s$ .

As the ratio arm is a rotary potentiometer, and we want to find the points on our 100 division scale which correspond to the calibration quantities, the equations must be modified.

Let V = the variable quantity for which the ratio to the standard is required;

S = standard.

Then ratio for capacity:

$$\frac{R_2}{R_1} = \frac{100}{\frac{100 - \frac{V}{S} + 1}}{\frac{100}{\frac{V}{S} + 1}}$$

Ratio for resistance,

$$\frac{R_1}{R_2} = \frac{100}{\frac{\frac{V}{S} + 1}{100 - \frac{100}{\frac{V}{S} + 1}}}$$

{Please turn to page 94.}

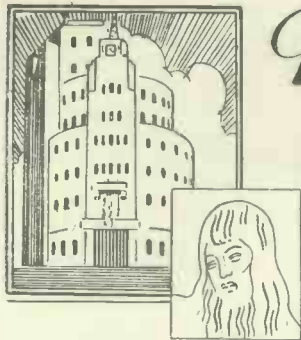

# British Broadcasting NEWS & VIEWS

By "Prospero"

Daily Bulletins for the Press—New Dance Music Post—An Amusing Incident—Manx Broadcasting Service—Brighter B.B.C. Talks—Big Programme Changes Coming.

## Entertainment Development

MR. ERIC MASCHWITZ is rapidly gaining ground in the ranks of those B.B.C. officials who count both with the listener and with the management. It is the "Variety drive" that Mr. Maschwitz has conducted in the past four years that is regarded as the chief factor in the rapid increase of licence revenue. And now it is to be developed further. Substantially more money is to be made available. More and brighter entertainment, more and better "stars" is the new motto.

## Listeners' Organisations

Now that it has been decided to wind up the Wireless League, there comes to an end the era of listeners' organisations. There were half a dozen of these eight or ten years ago. The Wireless League at one time enjoyed the active support of a national newspaper group; it had then more than 100,000 "live" members. It was, indeed, such a force that there were at one time thoughts that it might seek broadcasting facilities of its own in competition with the B.B.C. But any chance of this was lost when the monopoly was perpetuated on the advice of the Committee on Broadcasting presided over by Lord Crawford and Balcarres in 1925.

In the early days, too, the B.B.C. was much more friendly to listeners' organisations than it has been of recent years. There was a recognised Listeners' Organisations Advisory Committee, presided over by Sir Ian Fraser, M.P. This did a lot to bring B.B.C. policy in touch with listeners' requirements. In the end, however, the B.B.C. thought it could manage well enough on its own, so the day of the

listeners' organisations, except perhaps for group listening to adult talks, is gone.

## Sir Stephen Tallents' Plans

Sir Stephen Tallents has decided that the public is to know much more than it does about the inside working of the B.B.C. Applying the principles and methods which he found successful at the Empire Marketing Board, and later at the Post Office, Sir Stephen is about to "lift the lid" both at Broadcasting House and at regional centres.

I have not heard yet just how this will be done. Apparently, however, a preliminary step is the distribution of a daily bulletin of hot news to all Pressmen who want it. These items will serve to stimulate "stories" of a kind that the B.B.C. thinks would be of help.

I believe that next year we are likely to hear much more about the

personalities of the staff actually building programmes. For example, there is a fair prospect that Mr. Maschwitz and Mr. Gielgud will take listeners into their confidence regularly, explaining their various problems and how they are dealing with them.

## Mr. Ramsay MacDonald and the B.B.C.

There are strong rumours that Mr. MacDonald, the ex-Prime Minister, might be induced at the end of 1936 to accept the chairmanship of the B.B.C. As Lord President of the Council he will have to deal specially with B.B.C. matters in the House of Commons under the arrangement being recommended by Lord Ullswater's Committee. This will bring him even more closely in touch with broadcasting than he has been.

Then if he tires of Parliament it would be a natural and popular change to take over the B.B.C. Incidentally, Mr. MacDonald's admiration for and friendship with Sir John Reith would be a further recommendation for this appointment.

## Dance Music Reorganisation

After discussions lasting over several months, Mr. Roger Eckersley, the entertainment chief at the B.B.C., has about finished his plans for the reorganisation and development of broadcast dance music. There is to be a new appointment, corresponding for dance music to what Mr. Stanford Robinson means for theatre music: a sort of intermediate director who will not only relieve the dance conductor of administrative detail, but also take charge of the presentation of all dance programmes.

## SIR MALCOLM CAMPBELL



Sir Malcolm Campbell, the famous speed "ace" and holder of the world's land speed record, recording at the "His Master's Voice" studios. Sir Malcolm recently gave a talk on "Speed—Past, Present and Future" in the Midland programme.

It has not yet been decided who will be appointed to this important post. Mr. Henry Hall's name has been mentioned, and it is probable that he could have the job if he was prepared to give up most of his conducting.

### "Bunch" Keys in Studio "Scene"

Round at the "Big House" they are all laughing at an amusing incident in which Mr. Nelson Keys was the principal actor. Mr. Keys arrived for a rehearsal, and, by a mistake, was taken to the wrong studio—one then busily engaged in the rehearsal of a concert, with a staff conductor in charge. The latter, not recognising Mr. Keys, ordered him out rather curtly. There was a rapid unrehearsed exchange of views before the error was happily discovered. What is amusing the lads is the account of what "Bunch" said during the little quick-fire exchange. Needless to say, the debaters are now warm friends.

### Isle of Man Complains

The Isle of Man thinks it is badly treated by the B.B.C., and is attempting to get a broadcasting service of its own. The Manx complain that they should be treated as a Dominion, and included in the big Empire relays. They point out that there are Manxmen all over the Empire who would be glad to have some message by wireless from their homeland.

### ONE OF THE FAVOURITE BANDS



Jack Jackson and his orchestra listening to an H.M.V. Superhet Radiogram during an interval in a recording session at the His Master's Voice studios.

## TROUBLE IN MANXLAND

Also, the isle is deprived of all the advertising that other pleasure resorts seem to get from the broadcasting of their bands and entertainments. Direct representations to the B.B.C. not having availed, the Manx are to appeal to Parliament for a separate broadcasting licence.

### Brighter Talks

The B.B.C. has certainly lived up to its promise to provide brighter talks, with more human interest and less gloomy philosophy. The new series, "Men Talking," "Young Ideas," "Saturday Magazine," and the topical talks in the news, are vastly improved and are building up a new audience for the B.B.C. Mr. Moray Maclaren deserves the lion's share of the credit for this change.

### Better Day-Time Programmes

I am able to make the exclusive announcement that the next big programme change at the B.B.C. will affect day-time programmes, which, in the past, have been left much to themselves. They have consisted mostly of relays of restaurant and cinema music, light material, good of its kind but devoid of variety. Beginning next October the B.B.C.

will give "produced" programmes regularly during the day-time.

Also, the B.B.C. musical combinations will be heard at different times, not as now almost only at night. There will be music, light and gay, radio drama, and talks duly interspersed. Now if they will make sure of contrasts and alternatives, I shall welcome this as a really important forward step in British broadcasting.

### The "Portrait Gallery"

I was taken the other day into a room on the second floor of Broadcasting House which is used for meetings and conferences. On its walls are displayed the portraits of distinguished ex-members of the staff. The list makes interesting reading: Arthur Burrows, first Programme Director, now secretary of the Broadcasters Union; Colonel Dawnay, lately Programme Controller, now commanding a Guards regiment; the late Percy Pitt, first Director of Music; the late Walter Fuller, one-time Director London Station; the late J. C. Stobart, one-time Director of Education, Religion, and Children's Hour, Peter Eckersley, first Chief Engineer and father of Regional scheme, in private engineering practice; Rex Palmer, he of the "Golden Voice," former London Station Director, now of E.M.I.; Hilda Matheson, former Talks Director, made the B.B.C. worthy of recognition by the highbrows, now in journalism; Major Guy V. Rice, former Secretary of the Broadcasting Company, now in business; Cecil Lewis, former Programme Director, now in films and playwriting; R. E. Jeffrey, first Drama Director, now a "big shot" in films. There is lots of room for more portraits in this interesting gallery, and it is expected that there will be several additions before the end of the Charter next year.

### Radio Revue

One of the most popular of Martyn Webster's earlier productions at the Birmingham studios was the revue "Ye Olde Antique Shoppe." The idea was that the keeper of an antique shop shows some of his goods to customers, and the story of his principal treasures is revealed by means of flash-backs. This revue is to be revived (Midland, Jan. 4th), but with new matter to the extent of about fifty per cent—the framework lends itself to this treatment. The book and lyrics are by Charles Hatton, and the music is by Michael North, who was in Charlot's Hour.

# Fitting EXTENSION SPEAKERS

A special practical article by K. D. Rogers on a subject of interest to every set owner

**I**N these days of enlightened radio it is surprising that the extension speaker is not in more universal use. Not that I mean to infer that it is not employed widely; thousands and thousands of homes have such speakers, but they are not used in the almost universal manner that one would expect.

Why this should be so is difficult for the technically minded to appreciate, but it is probably largely due to lack of knowledge of the ease with which the speakers can be connected, and lack of experience in hearing really good speakers in operation.

### If You Have Doubts

Any qualms concerning the first reason I hope to banish in the course of this article. As regards the second, all I can do is to advise any reader who may be in doubt about the quality of reception which can be obtained with an extension speaker to get a demonstration at a reliable dealer's or from the makers of one of the types of speakers themselves.

Let me say here that the idea that an extension speaker takes so much power from the set, that volume seriously suffers, is totally wrong, provided that the speaker is properly connected and properly matched.

### MAKING A NEAT JOB



A very useful outfit for extension speakers can be obtained from Bulgfin. It includes the wire, plugs, jacks, and staples.

The power divided between the speaker in the set and one extension speaker must, of course, be halved, but that does not mean that the apparent volume is halved. That is definitely not the case, and if you can start with the set giving good loud-speaker strength the addition of a well-matched extension speaker will not have any deleterious effect upon reception.

### BLOCKING OFF THE H.T.

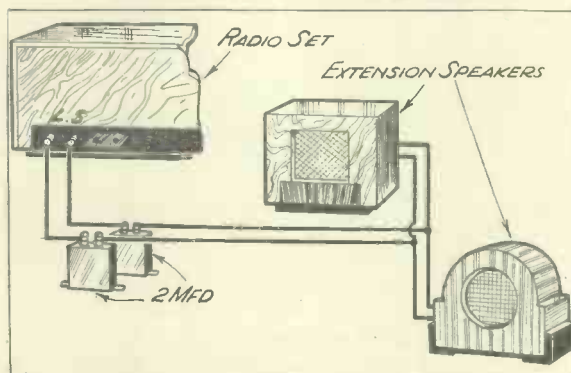

Where the extension leads are to be connected to the primary side of the set speaker (not shown in diagram), i.e. to the L.S. terminals of the set, it is a good plan to insert condensers in the leads to stop the H.T. from flowing through to the extension speakers.

Still dealing with the second of the two reasons for the doubts cast upon extension speakers by the uninitiated I must assert that the quality obtainable from a good extension speaker can be really first-class.

Probably the idea that I have found among certain people that the quality from the extension speaker is greatly inferior to that obtainable from the speaker in the set is due to the fact that so many in the past have used "any old thing" as the means of extending the programmes to points distant from the set.

And the "any old things" have included very cheap and nasty moving-coil speakers, poor moving-iron types, and even phone earpieces with horns on them. All of which are not only

atrocious in themselves, but are also incapable of being properly matched with the speaker in the set. The result, therefore, being twofold distortion.

But thanks to such firms as W.B., Rola, Amplion, Blue Spot, Wharfedale and many of the set makers, such as Marconiphone and H.M.V., the extension speaker of really good design has been brought right within the reach of everybody who can afford to run a set at all.

So the question of quality need not worry anyone. What about the matter of connecting the extension up to the main receiver?

### Not Difficult

That is not so difficult as it appears to be in many cases. Probably those who have simple home-made battery sets do not have any qualms about connecting a second speaker across the speaker terminals of their sets. It is very easy. But they may not take the trouble to see that the two speakers are matched.

### AN EXCELLENT MODEL



This is the 1936 Stentorian Junior, made by W.B. It costs 49s. 6d. and is provided with a special non-resonant acoustically balanced cabinet with an adiabatic volume control having an "off" position.

Yet those who possess mains sets and commercial receivers in particular seem to be a bit chary about carrying out the necessary connections. They need not be diffident about it.

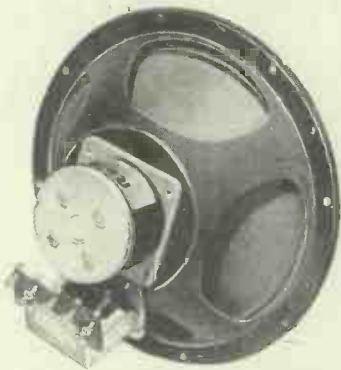

One of the inexpensive ranges of Rola P.M. speakers. This is the F.514, P.M.T. which costs 23s. 6d.

In the case of home-made mains sets the connecting points are all easily get-at-able, while in the cases of commercial sets there are usually extension speaker points provided somewhere at the back of the receiver.

The actual connections, therefore, are not difficult. What is more tricky at first sight is the choice of a suitable extension speaker and the question of matching.

**Four Ways**

Let us start at the connection end. There are four ways of connecting the extension speaker:

1. Across the primary of the main speaker, i.e. to the speaker terminals of the set.
2. In series with the primary of

the present speaker. This is not usually done in commercial sets, and only one manufacturer favours this method—Kolster-Brandes.

3. Across the secondary of the set speaker. That is, in parallel with the speech coil of this speaker. This is popular among commercial sets, especially of the E.M.I. group (Marconiphone, H.M.V. and Columbia).

4. In series with the speech coil of the set speaker. This is never used.

Let us take these methods one by one and discuss them:

Many commercial sets have the extension speaker terminals attached to the primary of the transformer feeding the speaker in the set, and this is a very convenient way of making the connection. It simply means (theoretically, at any rate) that the extension speaker is connected across the output

terminals of the set, in parallel with the speaker in the set.

In practice, however, unless the set has a filter circuit, the H.T. is fed through the extension wires to the extension speaker as well as to the speaker in the set. This objection holds, whether the set in question is a mains or a battery one (and is particularly undesirable in the case of a mains set), and whether or no the set is a home-made or a commercial one.

**The Solution**

There is one very simple way of overcoming the trouble, however, and that is to connect 2-mfd. condensers in series in the extension leads, one condenser in each lead. This does not in any way upset the operation of the extension speaker or the matching, but it does prevent any anode current and potential

passing down the extension leads.

In all cases where extension speakers are to be fitted to sets that need connections to the primary circuit of the set speaker I would recommend the condenser series method. This also holds in cases of Class B and Q.P.P., for two leads to the extension speaker can be run via the condensers and no third wire need be taken.

The reason no centre tap is required in the case of the extension speaker feed for Class B or Q.P.P. is that no

**THE EXTENSION CONNECTING WIRE**

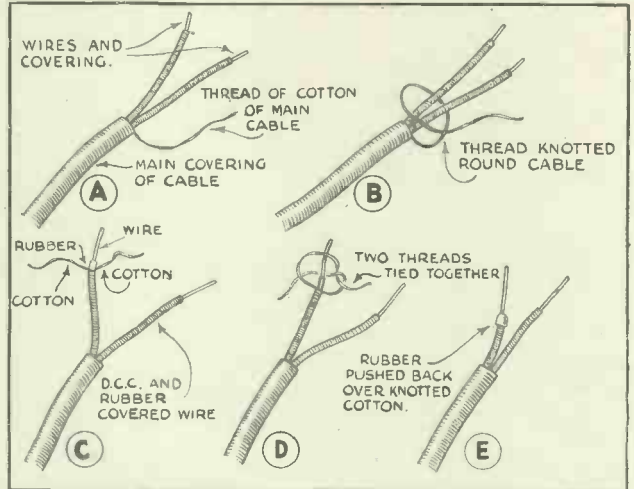

How the ends of the "Deekowire" are prepared for connection.

H.T. has to be passed into the circuit, while the A.C. potentials developed across the primary of the speaker belonging to the set is applied across the two ends of the primary of the extension speaker.

Now let us examine the second method of connection: This is rarely used, and I should say that it will

**INFORMATION AT A GLANCE**



At the back of the W. B. Stentorian cabinet speakers are tablets with the names of manufacturers' sets and the switching and terminal arrangements for matching the W. B. speaker.



Here is the Amplion Harmona which sells at 25s.

never be required in the case of a home-made set. If you have a Kolster-Brandes set requiring that method of connection you must state to the speaker manufacturers very clearly that such a set is used so that they may let you have the correct speaker for it. That is, unless you use a

**THE FIRST METHOD**

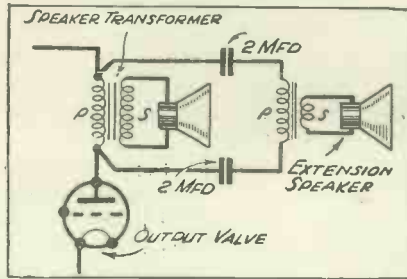

Connecting up the extension speaker in parallel with that in the set, using the "primary" method (No. 1).

specially tapped speaker such as the universal models marketed by W. B. But more of those later.

We can, I think, dismiss the series primary method of connection with the warning that if it is used then the H.T. and anode current must run through the extension speaker unless you go to the trouble of providing a choke output circuit to be placed in series with the speaker in the set. Careful choice of choke is necessary to keep the resistance down, and, of course, the matching of the speakers remains just as essential, for they are still in series.

**For Easy Matching**

When the extension leads are not to be very long I prefer the method of connection employed by the E.M.I. group and many other manufacturers, and outlined in No. 3. This obviates the H.T. bogey and allows easy matching of the speakers.

It must not be forgotten, though, that the currents flowing in the extension may reach a matter of amps. (A.C.) on powerful reproduction and that if the leads are very long quite an appreciable voltage drop may occur. This is especially bad in the case of one type of commercial

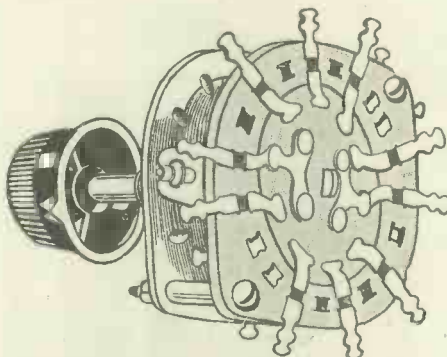

The "Truqual" specially compensated volume control, designed for the Wharfedale speakers.

**LOW-RESISTANCE WIRING**

set which requires a very low resistance extension speaker in conjunction with it, a matter of one to three ohms. Most of the E.M.I. sets need nine-ohm speakers, which, though unusual in value, is not bad from the point of view of voltage-drop danger.

Where the extension speaker is only one ohm the possibility of serious

many people use ordinary thin double-cotton-covered wire for their extension leads, and this is sheer folly. Not only



This is the Wharfedale "Coronet" cabinet speaker, which costs 52s. 6d. with transformer

does such wire tend to take up damp and cause leakage, and not only is it not up to the sort of wear and tear that extensions are sure to get from dusting activities and so forth, but it has too high a resistance, as a rule, for a lead of more than a very few feet.

It is best always to use some specially prepared wire, such as the flat twin wire made by Bulgin and sold under the name of "Deckowire." But I shall say more about that later when I deal with the actual laying of the extension leads.

**Not Recommended**

There remains the one other method of connecting the extension speaker, in series with the secondary of the set-speaker transformer. This is not a good method, and it is one that as far as I am aware is never used in commercial set designs. I have mentioned it because it is a possible way to do the connection and might occur to some people as needing some mention in this article. I do not recommend it, however.

Naturally, in all series methods, when a speaker is not to be used it must be shorted out. The parallel methods simply require the removal of the speaker in question or its disconnection by means of

a simple on-off switch.

So much for the four ways of connecting the speakers. Those mostly

**MATCHING THE RECEIVERS**

Make of Set	Model	Speaker Points	Wharfedale Type to Match
ACE	All	H.R.	Universal
AERODYNE	SNIFE	H.R.	Universal
	All others	L.R.	Type 32
ALBA	All	H.R.	Universal
ATLAS	All	L.R.	Type 32
BEETHOVEN	All	H.R.	Universal
BLUE SPOT	B3	L.R.	Type 64
	A.C. Sets	L.R.	Type 32
BURGOYNE	All	H.R.	Universal
BURNDEPT	All	H.R.	Universal
BURTON	All	H.R.	Universal
BUSH	D/ACI	L.R.	Type 32
	All others	H.R.	Universal
CLIMAX	All	H.R.	Universal
COLUMBIA	All	L.R.	Type 98
COSSOR	All	H.R.	Universal
DECCA	Portrola, Home and Cars and Rally Models	L.R.	Type 32
	All others	H.R.	Universal
DYNATRON	K116 & P86	L.R.	Type 32
	All others	L.R.	Type 32
EKCO	All	L.R.	Type 32
EVER-READY	All	L.R.	Type 32
FERRANTI	All	L.R.	Type 64
G.E.C.	D.C./A.C.	L.R.	Type 64
	All others	H.R.	Universal
HALCYON	B3	L.R.	Type 64
	All others	L.R.	Type 32
HEA'YBERD	All	L.R.	Type 32
H.M.V.	All	L.R.	Type 98
K.B.	All	L.R.	Type 32
LAMPEX	All	H.R.	Universal
LISSEN	All	L.R.	Type 32
MARCONI	223, 224, 235 } 236, 240, 245 } 257, 273, 282, 284 } 264, 279, Q286, 287 } 289, 292, 297, 298 }	L.R.	Type 32
	All	L.R.	Type 64
McMICHAEL	All	L.R.	Type 32
MILNES	All	L.R.	Type 32
MULLARD	All	H.R.	Universal
MURPHY	All	L.R.	Type 32
ORR	Battery Sets	H.R.	Universal
	Mains	L.R.	Type 32
PHILCO	255B, 98RG	L.R.	Type 31
	1280, 1280X, 280	L.R.	Type 32
PHILIPS	All	H.R.	Universal
PORTADYNE	Mains	L.R.	Type 32
	Battery	H.R.	Universal
PYE	All	L.R.	Type 32
R.A.P.	All	H.R.	Universal
R.G.D.	All	L.R.	Type 31
ULTRA	All	L.R.	Type 64
VIDOR	All	H.R.	Universal

voltage drop on the line can easily be seen. It does not take such a very long line of twin wires to reach an ohmage of one, and when this occurs the voltage across the extension speaker is halved. If each of the twin wires reaches one ohm then the voltage across the speaker is only a third of the total and the signal strength loss is considerable.

But in most cases the impedance of the speaker will not be anything like so low and the length of the extension wires can be correspondingly increased. I have stressed the matter of the resistance, however, because so

**LOW RESISTANCE**

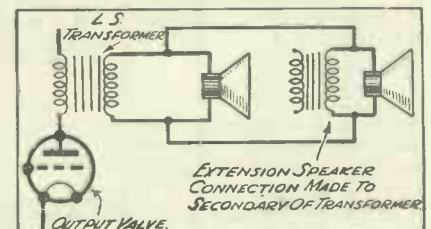

Here, No. 3 method of connection is used, the extension speaker being in the low-resistance circuit.

used are numbers one and three, and to these I shall confine myself for the rest of this article.

I do not propose to go into the vast lists of various speakers available for extension purposes. A line to any of

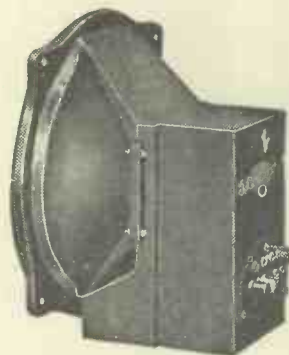

*The Blue Spot Senior has four low-impedance tapings for extension speaker matching. It is also available in cabinet type.*

the makers will be rewarded with the fullest details of the whole range of speakers made by that firm.

**Methods of Marketing**

The speaker manufacturers differ in their ideas as to the most suitable methods of marketing extension speakers. A few of them contend that the prospective purchaser should let them know exactly under what conditions he is going to use their speaker and allow them to send him an instrument that is correctly matched for the purpose. A very good plan this, but naturally open to the criticism that if the man changes his set he may have to change his extension speaker to suit it.

Others group their speakers in two classes (which we will call "A"): those tapped for high-resistance extensions and those for low resistance. Thus, if

you will need the low-resistance type.

This is quite good, for if you use a low-resistance system you can save money on the speaker transformer. Many makers, including Wharfedale and Rola, supply speakers without transformers, for L.R. connections.

Finally there is the method ("B") which, by tapings, allows the extension speaker to be converted into either high- or low-resistance type at will, and to be matched within reasonably close limits with any type of receiver. This method allows you to keep the

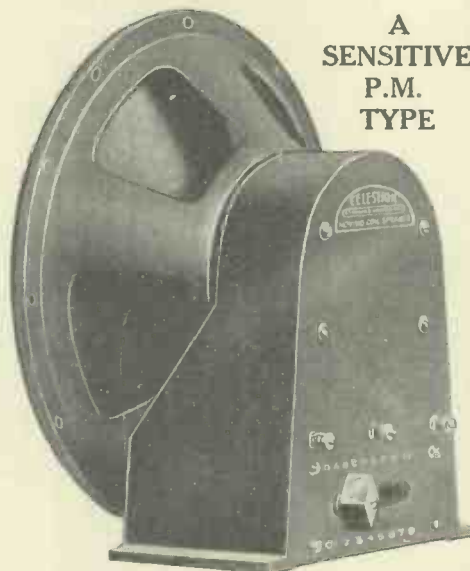

**A SENSITIVE P.M. TYPE**

*The Celestion Standard 8 which incorporates the New Universal Switch Control for impedance matching. The speaker costs 45s.*

same extension speaker or speakers no matter what set you employ.

The two categories of speakers are well exemplified by (a) Rola and Wharfedale, and (b) W.B. Celestion and Blue Spot. In addition, there is the Amplion range which allows matching against any high-resistance speaker in any set. In other words, they cover all cases of 1 and 2 methods of connection.

**In Cabinets**

Most, if not all, makes and types of extension speakers are obtainable in cabinets as well as in plain chassis form, and it is an easy matter to get one that will suit the furnishing of the room in which the speaker is to be housed.

So all you have to do if you want a speaker is to see what method of connection your set requires (a look at the table for Wharfedale speakers with this article will help you) and then choose the make of speaker you require.

And what about the connections themselves, the extension wiring? That is easily arranged if you use the special kits that have been prepared by people like Bulgin. Good quality insulated wire made flat so that it can be run under carpets if desired, and easily stapled, can be obtained at remarkably low cost, while special jacks or plugs and the corresponding neat wall sockets can be purchased so that the whole job is as neat as one could wish.

The actual laying of the wire is easy, and there should be no trouble so long as it is remembered that the wire must not be too long in cases of low-resistance speakers, and that it must be kept away from damp or excessive heat.

**Running the Wires**

All the connections are made in parallel, except where methods 2 and 4 of the types of connections are used, and the amount of wire used should be kept to a minimum in the cases of low-resistance speakers. Run the wire via any convenient channel, such as along the skirting board, but keep it inside the house unless you are prepared to use heavily rubbered cable where the wire has to go out into the open.

The "Deckowire," and other similar types, is easy to use, and very neat connections can be made with it. As in most things, there is a right and a wrong way of preparing the wire for connections to the plugs on the wall and any other necessary places. The sketch on page 88 shows pretty clearly what has to be done.

**FURTHER METHODS OF CONNECTION**

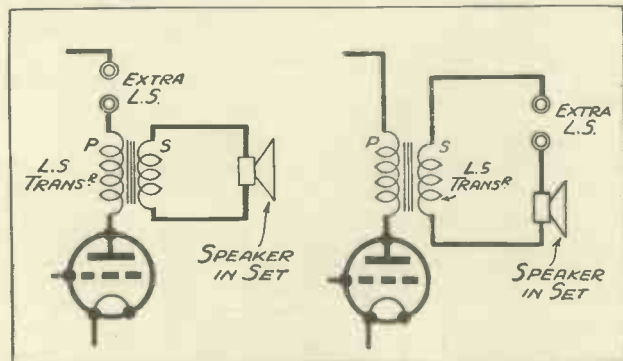

*The series method of connection is shown here. The one on the right is not recommended, while that on the left is used by Kolster-Brandes.*

you are going to use method 1 or 2 for connection you have to get a high-resistance extension speaker, and if you choose method 3 or 4



*A 32s.6d. Amplion Speaker — the M.C.22.*





# Wireless

in DENMARK

THE tiny country of Denmark, with its population of three and a half millions—less than half that of London—has proportionately the largest number of wireless receiving sets in the world, to wit, 553,000. If we reckon six persons to a family, it means that almost every Dane is a listener. The handful left over can be accounted for by seafarers and infants in arms. Television, however, has not yet made any progress, although Denmark's leading newspaper, "Politiken," carried out some interesting public experiments three years ago.

### A Humble Start

Danish wireless has developed, under the leadership of Mr. Emil Holm, from very humble beginnings. In October, 1922, radio telephony was demonstrated for the first time before an audience in the Copenhagen Technical School. A 250-watt transmitter was used, and was stationed no farther away than the docks. During the following two years several amateur wireless clubs sprang up, and they started their own little station in a building on the main street of Copenhagen, while the Army sent out experimental broadcasts from the military stations.

In April, 1925, the Danish Government took over experimental broadcasting, and a year later it passed the Wireless Act. The lesser stations were then discontinued, and Copenhagen sent out all transmissions, but was not

strong enough to cover the entire country. It was therefore decided to set up the station at Kalundborg, 62 miles due west of Copenhagen, on the opposite coast of the island Seeland.

The Kalundborg station was put into function on August, 29, 1927,

removed it from one post office building to another. Finally, in January, 1934, the new, powerful station was opened in the village of Herstedvester six miles outside Copenhagen. It has a power of 10 kw. and a wavelength of 255 metres.

### By G. Antoine Moller

Our contributor, a Belgian, is one of the few non-Danish subjects who have broadcast from the Copenhagen station in the Danish language. His knowledge of radio in that country is wide, and this account of the growth of broadcasting in Denmark is particularly interesting.

and in June, 1933, it was changed to 60 kw. The aerial system is composed of two tripod steel masts, 330 feet high, and 726 feet apart, with a double L aerial between them, and the station has a wavelength of 1,261 metres.

### From Pillar to Post

In the meantime the Copenhagen broadcasting station was being shifted literally from pillar to post, for they

A third station, Skamlebæk, is Denmark's commercial radio-telegraph and radio-broadcasting station, as well as its short-wave transmitter. The greater part of the Danish programme is sent over Skamlebæk for the benefit of Danes abroad.

### The Studios

The broadcasting studios also came in for a great deal of shifting about from one place to another. It was not until three years ago that they finally came to rest in a building of their own. It happened in this wise:

The Royal Theatre of Copenhagen is a government-subsidised institution for the diffusion of culture. This has repeatedly caused trouble in theatrical affairs, due to tactless politicians. Since the beginning of the present century Danes had been clamouring for a stage devoted to plays, and separated

from the operas, which were the predominating feature at the Royal Theatre. For thirty years they talked and planned.

Then in 1928, in a sudden whirlwind of activity, and in spite of the vociferous protests from Copenhagen's citizens, an Act was rushed through to build on some government property adjoining the Royal Theatre, a State wireless building which

### THE "BROADCASTING HOUSE" OF COPENHAGEN



On the left, behind and adjoining the Royal Theatre, is the famous "Starting Box," in which are housed the studios and offices of the Danish State Wireless organisation.

should also include the new stage. The new building was to be a continuation of the Theatre, and was therefore built right across the street between the buildings, with a low vaulted passage left open for pedestrians and traffic to pass.

To decrease the expenditure of the Royal Theatre, a law was passed in 1930 enabling two plays to be put on simultaneously—one in the Theatre, and the other in the Wireless Building, which by reason of its height and peculiar construction soon became popularly known as "The Starling Box" (all Danes have starling boxes in their gardens).

### The "Starling Box"

The Starling Box was first taken into use in 1931, but proved such a financial failure that the whole thing was given up two years later, and the Danish Wireless Studios—State Radiophone, as it is called—could then take over the entire building as their own.

There are also lesser studios, one in the building known as Axelborg, opposite the world-famous Tivoli Gardens, and another for the provinces at Esbjerg, in Jutland. But it was from the "Starling Box," the holy of holies, that I was engaged to lecture on Belgium.

To hear a foreigner talk to them over their wireless in their own language is not an everyday occurrence for the Danes. They, who are themselves such fluent linguists—practically every educated Dane speaks perfect English and German—are always delighted to find someone who has taken the trouble to learn their difficult language. Many foreigners have been on the air in Denmark, but I have heard only one speak in Danish—Mary Booth, who has been leader of the Salvation Army in Denmark since 1933.

### A Difficult Language

It is not an easy language, and the peculiar glottal catch, which gives it its hiccuppy pronunciation, forbids foreigners to speak it without a strong accent. I was therefore invited by the broadcasting manager, Mr. Emil Holm, to make a preliminary microphone test, and I had on that occasion the pleasure of coming into personal contact with that remarkable man, whose foresight and initiative, right from the very first days of wireless, have helped Denmark's Radiophone to attain the high standard it enjoys today.

Mr. Holm is an amiable, cultured man of 68. At the age of 25 he made his debut as a singer at a concert given

## FROM OPERA TO RADIO

by the venerable Musical Association, to which, by the irony of fate, wireless was later to give its death-blow. He later became an opera singer at the Royal Theatre, which, again by fate's strange whim, was to give him in after-life the remarkable building where he now reigns supreme.

According to the Danish Wireless Act, the Minister of Public Works is the highest authority in all matters relating to wireless, but the broadcasting department is headed by a radio council of fifteen, and Mr. Holm, as the broadcasting manager, is responsible for the daily programme.

### AT TATSFIELD



*The direction finding panels in the B.B.C. check station at Tatsfield. You probably heard the broadcast a short time ago from this room, when the wavelength of the London Regional was checked.*

He has under him 111 persons engaged in office and programme work, and he himself played the leading part in forming the famous Danish Wireless Orchestra, which is now composed of 61 permanently employed musicians. The rest of the items are furnished by "outsiders," like myself—the remuneration is generous and cash down. The technical side of the Danish wireless comes under the Postmaster-General, whose expenses are paid out of the Wireless Broadcasting Fund.

The licence fees paid by the listeners

costs about eight shillings and tenpence a year.

An atmosphere of friendliness, hospitality and good fellowship reigns over the Danish Broadcasting Studios. Everyone, from the doorkeeper up to the Chief himself, is polite and cheerful. On every floor of the high Starling Box one meets the happy smile that is so characteristic of these people.

### Fluent Linguist

The announcer (he is called "Speaker" in Danish) is Mr. Daniel Prior, a versatile and fluent linguist. His pronunciation and speech are the admiration of all listeners, who have come to regard him as the highest authority on the Danish language. Even the distinguishing signal of the Danish stations, which is a reproduction of the Copenhagen Town Hall chimes, has a blithe, merry tone all its own.

The actual broadcasting of lectures and other solo items takes place in a comfortable little room, furnished with a chair and a table, on which are placed a reading-lamp and the microphone. The overhead lights are extinguished and the lecturer is left strictly alone. On the wall before him hang a clock and two square lamps; one lights up red, with the words "GIV AGT" (Attention), the next shines green, "TAL" (Speak).

Should the lecturer speak too slowly or otherwise fail to make the desired effect, the Speaker sends in a written note with a friendly hint. When the green light on the wall goes out, the juice has been switched off and all Denmark is ready waiting for the next item on the programme.

### STORING ACCUMULATORS

THE accumulator is given a charge in the normal way and the acid emptied out. It is then thoroughly flushed out with tap water, after which it is filled with distilled water and allowed to stand for twenty-four hours.

Pour out the distilled water *all but an inch* at the bottom of the cell, replace the stopper, and seal the vent with sealing-wax so as to make the container airtight. The plates will then keep moist and active for long periods, without the hardening which takes place when they are allowed to dry out.

When the cell is to be put into commission again simply pour in acid of a few points higher specific gravity than that recommended by the makers. It will deliver current almost at once, and it will be in perfect condition.

W. N.

# Questions and Answers

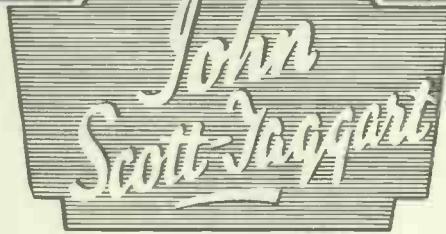

**Q. 162.** Why is it customary to increase the bias on a variable-mu high-frequency amplifier valve when greater selectivity is desired?

**A.** The reason is partly a practical and partly a technical one. Increasing the bias on the grid, *i.e.* making the grid more negative, reduces the amplification given by the valve. This reduces signal strength. Reaction is then applied and "brings up" the strength of the desired signal. The interfering signal of different wavelength is left behind, as reaction only strengthens signals to which the tuned circuit is tuned.

The first reason, therefore, for increasing the bias is to cut down all signals—desired and interfering—to such a low level that the interfering signals are submerged below the audibility level, *i.e.* so that they are no longer heard. Reaction is then applied until the desired signals are heard at the required strength.

These two adjustments, bias and reaction, call for some skill and many listeners do not apply sufficient bias, with the result that when reaction is applied signals become too loud and either distortion results or the amount of reaction is insufficient to give good selectivity. The amount of bias should always be too much rather than too little, so that when initial reaction is applied, signal strength from the speaker is somewhat below full loud-speaker strength. You then know you are getting maximum selectivity. If you desire still stronger signals you can decrease the negative bias, *i.e.* "increase" the volume control potentiometer which controls the bias voltage.

A more technical reason for increasing the negative bias to improve selectivity is that this process reduces the "damping" of the filament-to-anode path of the H.F. valve. This path acts in much the same way as a resistance would if connected across the tuned circuit which we connect directly or indirectly in the anode circuit. Such a resistance would increase the total losses of the tuned circuit, and the "tuning" would be "flatter," any given signal "spreading" more. The "losses" associated with the tuned circuit depend upon the design of the coil itself, the tuning

condenser and the apparatus to which the tuned circuit is connected. This "apparatus" is ordinarily the anode circuit of the H.F. amplifier and the grid and filament of the detector valve. We are for the moment only concerned with the former.

By making the grid more negative, we increase the A.C. resistance of the valve and throw less of a "load" on the following tuned circuit. If we cut the anode current down to zero there would be no resistance load and no damping resistance across the tuned

□.....□

*Our popular contributor gives you the benefit of his vast radio experience in his answers to these questions which are continually cropping up in readers' letters.*

□.....□

circuit. But also no high-frequency currents would be fed into the tuned circuit!

We, therefore, have to choose between strong signals and quite considerable damping, or else weaker signals and better selectivity. We are faced with exactly the same problem when we have a variable condenser feeding H.F. currents into the first circuit of a receiver. In practice we compromise—unfortunately. But by using a variable bias we can choose when to have signal strength and when to have maximum selectivity.

The damping introduced by the anode circuit may be largely wiped out by the application of reaction, but better results are obtained in practice with a lightly damped circuit to which a little reaction is applied, rather than with a heavily damped circuit to which much reaction is applied.

**Q. 163.** You have often insisted on the use of 120 volts H.T.; this seems a weakness of your sets as I rarely find any such insistence in the case of other designs. Our batteries will not stay at 120 volts for very long, anyway. Do you expect us to buy a new battery every week?

**A.** A good idea for millionaire readers. As for others, the fact that you get hungry around lunch-time is no reason why you should not have a good breakfast. Because a flash-lamp will, in any case, burn more dimly towards the end of its life, is no reason why you should start with a partly run-down battery.

As your H.T. battery runs down the set's sensitivity falls off somewhat, and its maximum output is reduced; the quality of reproduction also becomes poorer. The designer can do a good deal to mitigate some of these ills to which sets are prone. He can provide a separate screen-grid H.T. tapping so that when the H.T. battery begins to fall in voltage the intelligent user can put the screen-grid plug in the next socket higher up in nominal voltage. He can see to it that reaction does not "conk out" before the battery is really too low in voltage. He can avoid that falling-off in quality which is due to the resistance of the battery rising—as it does when the voltage drops; he does this by decoupling.

But even after taking all the precautions I and all others must say: "There is nothing like H.T." Speaking generally, you get out of the set what you put into it. Economy devices have an unpleasant habit of reducing the efficiency or quality of reproduction.

Thousands of battery set users struggle along on totally inadequate battery voltages. To use a set with, say, 80 volts H.T. is possible, but it is also criminal unless you are satisfied to put up with a small output and totally inadequate quality.

I was recently talking to a wireless dealer and asked him, "How do the old ladies know when the H.T. needs replacing on this commercial set?" The answer came swift and sure: "They telephone me when the set begins to whistle."

This was a pretty serious reflection  
(Please turn to page 127.)

# COMPLETE TONE CONTROL

*Some valuable suggestions for the quality enthusiast.*

By V. W. GREENHALGH

NOWADAYS some form of tone control is found in practically every receiver. Yet in very few, whether amateur or professional built, is full use made of tone-control. The high and low notes are well cared for, but the middle notes are entirely neglected.

## Effect of Reduced Volume

This is surprising, since it is becoming increasingly widely known that the middle notes can quite destroy that reality of reproduction for which we strive. In any item, speech or music, that is reproduced at a lower volume than the original sound, the strength of the middle notes is exaggerated, the amount of the exaggeration increasing as the difference between the original and the reproduced volumes increases.

Obviously, certain items, such as orchestral music, cannot be reproduced

## SIMPLE CHANGE-OVER

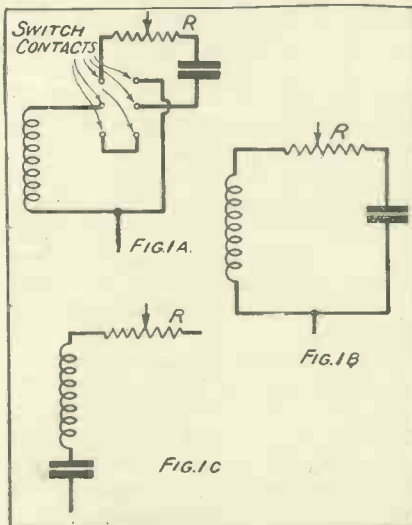

This diagram illustrates how either method of tone control can be made available at will by using an ordinary double-pole change-over switch.

in an ordinary room at their original volume. Some method of reducing the middle notes is, therefore, required.

This can easily be done by means of a condenser and inductance in series with a variable resistance, the whole being connected across an anode or grid resistance, or one winding of an L.F. transformer, as usual. The values of the inductance—which should preferably be an air-core one—and

condenser are not critical. In many cases those already incorporated in a set for the more usual form of tone correction can be made to serve the dual purpose, a double-pole change-over switch being employed to alter the connections.

The wiring for the switch is shown in Fig. 1a, and the theoretical circuit diagrams corresponding to the two positions of the switch in Figs. 1b and 1c. With the switch up (Fig. 1b) the ordinary form of tone correction—reduction of either high or low notes—is obtained. With the switch down (Fig. 1c) the middle notes only will be reduced, the amount of the reduction depending on the setting of the resistance, R.

The types of correction curves obtained are shown in Fig. 2. Curve (A) is obtained with a condenser of

.1 mfd. and inductance of .25 henry, these being good average values. Increasing the inductance reduces the amount of compensation and favours slightly the higher middle frequencies, as shown in curve (B). Increasing the condenser increases the amount of compensation and also the amount of attenuation of the lower middle frequencies.

It will probably be worth while experimenting with different values of condenser and inductance in order to find the best combination for an individual receiver. The value of the variable resistance, R, may be anything from 100,000 to 250,000 ohms.

## REDUCING THE MIDDLE FREQUENCIES

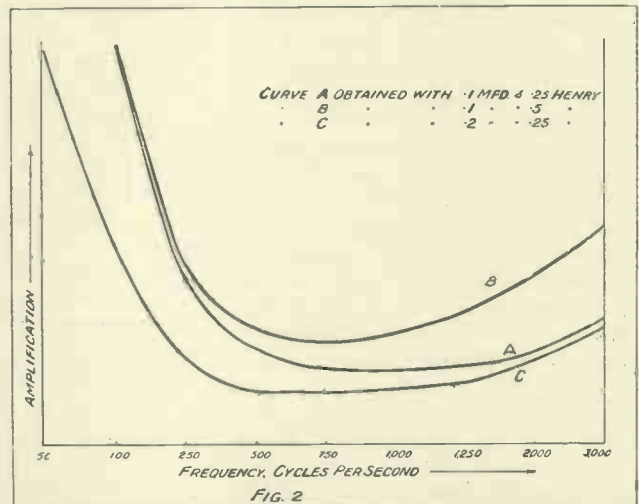

Three correctional curves that can be obtained with the Fig. 1c circuit, utilising the capacity and inductance values given above.

## MAKE SURE OF YOUR VALUES For 8.0 mfd.

—continued from page 84.

Suppose we want to find the point on the scale to mark 10.0 mfd. The standard will be 2.0 mfd.

$$\text{Then } \frac{R_2}{R_1} \text{ for } 10.0 \text{ mfd.} = \frac{100 - \frac{100}{\frac{10}{2} + 1}}{100}$$

$$= \frac{100 - 16.6}{16.6} = \frac{83.3}{16.6}$$

At this point on the ratio scale mark down 10.0 mfd.

$$\text{Similarly } \frac{R_2}{R_1} \text{ for } 9.0 \text{ mfd.} = \frac{100 - \frac{100}{\frac{9}{2} + 1}}{100}$$

$$= \frac{100 - 18.18}{18.18} = \frac{81.82}{18.18}$$

$$\frac{R_2}{R_1} = \frac{100 - \frac{100}{\frac{8}{2} + 1}}{100}$$

$$= \frac{100 - 20}{20} = \frac{80}{20}$$

and so on for all ranges of capacity.

For resistance the ratio is reversed:

$$\text{i.e. } \frac{R_1}{R_2}$$

When the calibration is complete a piece of celluloid should be cut to the same diameter as the paper scale and fixed in place with the scale screws as protection.

Providing the potentiometer limits have been marked accurately and the scale carefully calibrated, the accuracy of the bridge will be surprisingly good, and it will make an extremely useful addition to the experimenter's laboratory.

# THESE MODERN SETS

Many of you may not agree with everything Mr. King says in this article; we do not ourselves, but we think you will at least have to admit that every line he writes has punch and is interesting. If you have views of your own on the subjects he discusses, let's have them.

By VICTOR KING.

WHAT I am going to write on this particular occasion is going to be pretty outspoken, and maybe there will be many who will violently disagree with some of the things I say. However, I have the promise of our Editor that he will place space at the disposal of anyone who wants to register his own views on the subjects I shall discuss, so long as he can present them logically—and readably. Well, here goes for my onslaught:

I feel that the time has come when we should take stock, as it were. Here we are at the very beginning of 1936, and soon there will be upon us another Radio Show with television mixed up in it and causing a minor, perhaps even a major, upheaval.

Lots of experts glibly observe that radio has passed through its teething stage. That old tag "Radio is still in its infancy" has at last fallen into disuse. But when I look around the sets and circuits of this present day I sometimes find myself inclining to the view that radio has rushed into a premature second childhood.

## Radio Was Still Young

Ten years ago radio, in so far as broadcasting at least was concerned, was still young. There was fluidity in its technique. Engineers were arguing as to fundamentals. I myself was engaged in a controversy with the then chief engineer of the B.B.C. as to the relative merits of

the superhet and the straight circuit for short-wave reception. A very dignified and serious controversy. No, I am not going to say which of the two principles I was supporting! Anyway that little technical argument was symptomatic of the times. There was argument about almost everything from "grid leak" versus "anode bend" to "Is H.F. amplification worth while?"

## Not So Many Models

But were there more varieties of circuits in use? More different models of sets advertised and on show? Not at all. Far fewer. Perhaps some of you will at once leap in and say that it was because there weren't so many different circuits and arrangements of sets known, or not so many people engaged in their presentation

to the public. And not so many listeners and constructors to want different kinds of hook-ups.

One of those points is a good one. There were by no means so many listeners. But as against that there were very many more engaged in the struggle to produce novel circuits and sets which were so different as to qualify for the description "revolutionary." Some of you who know only the latter years of broadcasting would be astonished if I were to catalogue some of the "marvellous" circuits and principles which have fallen by the wayside.

And yet there were not so many different sets on the market as there are to-day. But are these many sets of to-day (wasn't it five thousand which were on show at the last Exhibition?) all that different? Or are they simply cuts off the same joints with merely different garnishings? Are their garnishings even all that different, except in so far as publicised specifications are concerned?

## The Other Extreme

If they are all in fact very different, then the radio industry needs a jolly good dose of rationalisation! But don't swing right over to the other extreme. Don't think that it ought to be possible to frame a set, circuit and specification so universally satisfactory that, like

## CHASSIS LAYOUT PROBLEMS



The extent to which the chassis layout of a set governs the positions of the controls is clearly indicated in this photo. It will be seen that the greatest difficulty in the way of any elasticity in arranging them is the ganging of condensers and coils, which is necessary in any modern design.

Hitler's National Set was presumably supposed to do, it would satisfy every listener in the country and with one clean sweep render that other four thousand nine hundred and ninety-nine models completely unnecessary.

That couldn't be done unless we lived in that Utopia where everyone had the same tastes and the same amount of money with which to gratify them. And if Utopia means a nice place to live in, I don't think I used the word correctly just now. Even if I am going to argue against some of the redundancies in our present set and circuit conditions, I hope I won't give the impression that I favour a grey, uninteresting uniformity!

### Experimental Tracks

Getting right down to the crux of the matter, this is what I think. The day of "revolutionary" development in radio is over. Before the invention of the screened-grid valve, the harnessing of the superhet principle and other such notable milestones in radio progress, the tracks being laid down by radio engineers were several and all very experimental. But gradually a broad, well-laid track, with an increasingly firm foundation of sound theoretical knowledge, began to take shape.

We are on it now, and it stretches ahead some little distance, though I am not going to say that there won't be discoveries which might cause it to deviate slightly, or even perhaps quite a bit, from the course that it would seem to us at present it will take.



This being the case—and it is not a merely personal opinion, but a fact—it should be and is possible to design a radio set which practically all radio engineers would agree to be the perfect instrument within the limits of our modern knowledge of the science. And those limits are pretty wide apart nowadays.

### A Given Performance

There might be slight discussions as to this or that detail. But the point to bear in mind is that the modern approach to such a task would be to design to a performance. Selectivity to such and such a degree, output of so many watts, response of this or that order of deviation from linearity between this or that pair of frequencies.

All this time remembering that there are arbitrary restrictions imposed by conditions on what a set, however good, can do in practice as opposed to theory. As a matter of fact, it is these restrictions which would render the proposition a practical one. We could not produce a set capable of rendering faithfully all the audio-frequencies. Or one having sufficient sensitivity to pick up any station in the world and sufficient selectivity to separate them all one from the other. Such are the ether conditions that even if we could those virtues would be valueless.

The nearer stations are so close together that your audio range is fixed and we are able to work up to it quite adequately. And when a station's strength sinks below the strength of the ever-present "mush," no

### CONVENIENT AND LOGICAL

*This is not one of the actual sets referred to by Mr. King, but it is an excellent example of the convenient, logical layout of a radio set, such as the author advocates. It is a Cossor Superhet, and with it you see Mr. Felix Mendelssohn, descendant of the famous composer, and himself a composer—of popular dance tunes.*

amount of sensitivity in a set will make it receivable. It must remain drowned beneath the sea of static.

Again, if all the American medium-

wave stations could be tuned-in on a super-super set during the evening above the mush (which they couldn't, anyway, let alone those of Australia, Argentine and the fifty-seven other varieties of nations) you couldn't sort them out with the keenest selectivity, for they would all lie higgledy-piggledy across the already crowded European ether map.

However, as I have already said in a different way, it would be possible to design a set just as good as the conditions would enable it to be.

Theoretical purists there would be to say that there could still be improvements in the instrument, but conceding that, they would be improvements such as would not be appreciable in practice to all but the most critical human observer.

But our "perfect" set would not be a commercial proposition. It would be too expensive.

### Suiting Different Pockets

So right away it must be admitted that there is a justification for a range of different sets to suit different pockets. But don't any of you leap in and say that there must also be sets which are different in appearance in order to satisfy lots of aesthetic tastes.

That is one of radio's oldest red herrings. And it was laid down by a decade of inartistic set designers. The pioneers didn't think a radio set ought to look nice, to be an attractive piece of furniture. They fashioned their sets as chassis and then, as a kind of afterthought, fitted them into any old kind of boxes to keep the dust out.

This was all right for the experimenter who soon scratched up his cabinets, anyway, but the ordinary listener didn't find it so good. He wasn't pleased that his broadcasting should be produced by a device which looked as though it had been made in a junior school laboratory. That was after he had got over the novelty-appeal stage of the business.

### Pseudo-Artistry

So he began to be discriminating and to choose the least evil-looking piece of apparatus for his parlour or drawing-room. Then the radio industry tumbled and there began an orgy of pseudo-artistry. Twentieth century invention put up in Queen Anne styles, in modernistic (save the word) forms, and so on. But the industry, if I may venture an opinion, tumbled the wrong way.

They realised that the listener was showing active choice in his selection

of sets. They heard him in large numbers say, "I like this one better than that," and so thought that it was a freedom of choice among things of diverse appearance that he was exercising in order to gratify individual taste. Whereas, as I have said, it was nothing of the sort. The poor listener was merely searching for something which looked the least revolting to him out of a rather grim selection of sinister-looking articles.

### Performance Counts

Had a nice clean form for a wireless set been adopted right at the beginning, then I do not think the majority of listeners would have sighed for a diversity of shapes and forms. Not the terrific diversity which, in fact, he has been given, anyway.

Do you know why I can say this with assurance? I'll tell you: During the course of the year about two thousand people ask me my opinion about radio sets. They want to buy a new one or to build one. It is exceptional for any to even mention the question of appearance.

"What set would you recommend? I can afford so much. So and so has told me that the new X Y Z sets are good. Do you think they are? If not, what would you recommend?" That is the kind of query that is shot at me. Mind you, I have said that there are exceptions. And what are they? Why, people who say that they don't like the appearance of this or that set. And invariably I agree because I, too, don't like the look of them and I wonder that anyone in the wide world does, either. Even so, I have known a hearty recommendation of the technical merits of a set to wash out completely any distaste for its appearance. And that doesn't contradict anything I have already said, for the simple reason that most of the sets on the market to-day do, at least, look fairly presentable.

### Importance of Colouring

The only really necessary difference which I will admit in this matter is that of colouring. It is not shape which matters so much to most people, but many do like a uniformity of colouring in their rooms in woods or their equivalent. Oak, mahogany and walnut—you know what I mean. You probably have the requirement yourself. That this must be so is proved by the fact that none of the big radio firms puts out a range of different styles of each of its models.

They almost without exception plump for the one design. However

## A WIDE VARIETY OF SHAPES

popular any set may be it is always seen in its same one style. If there were a wide demand for different styles, then that demand would be met. Therefore, there can be no logical reason why some semblance of law and order in the design of radio sets as a whole should not be brought about. Differences just for their own sake are worthless and are merely confusing.

### A SET THAT IS "DIFFERENT"



Harry Hemsley, the child impressionist, with a McMichael superhet. It will be agreed that this modern receiver is very different from the "device which looked as though it had been made in a junior school laboratory," of which Mr. King writes in the accompanying outspoken article.

I realise what a storm of criticism all this will bring down on my head. I shall get letters from the people who make and sell sets. They will say how nice their sets look and how much better than others they are. But I can agree right now that many of the sets on this present-day market do look very nice indeed. And I suppose when all is said and done it is no fault of the individual manufacturers that there should be such a wide variety of shapes and forms. It is the fault of our system—competition and all that. Which is verging too close to politics, so I had better head off in another direction!

However, we have passed the era of freak design in cabinets though not in circuits, but of the latter I shall have more to say later. But do you remem-

ber that craze for putting up a radio set so that it looked like anything but a radio set? Sets disguised as clocks, as desks, as books, as pianos even. One must admit that at least the radio set is developing something of an individual form. In the medley of different styles and forms one can discern just a trace of common sense!

And yet this is not a conscious development, at least it isn't deliberate. It is forced upon designers by the very nature of the apparatus. Just as the designers of pianos had a distinctive form forced upon them. It would be foolish to arrange the keyboard of a

piano vertically just to "get away from the conventional." No one would buy such a piano because it would be difficult to play.

### Sensible Design

Conventional design, which in this instance I interpret as "sensible" design, is developing very slowly in radio. And for the reason, I think, that designers are pursuing that red herring of appearance. And yet I'll wager anything that when the day arrives when all sets conform to general standards of design accepted by all as "sound convention" people will not criticise their appearance any more than they do those of bicycles or cottage or grand pianos.

But I suppose the crystallisation of

form is always a long process when there are many competitive concerns independently working towards the one end, for the simple reason that there are tendencies to arrive at the same end by different routes. Take the question of dials: The modern tuning dial, what is it? Does it exist as such? I don't think you can speak of it in the

### FROM GERMANY



A German set which exemplifies the universal tendency for a unified form of design to emerge from modern radio receivers.

singular at all. And there is no such thing as the *best* dial. There are many that are good and more that are not so good.

Among these last named I include those dials which are small, vertically placed and hard to see. And those having thick indicators standing away from the scales and giving large parallax error—by which I mean any one setting stands for any one of several stations or readings depending upon which angle you look at it.

### Calibration in Names

For the domestic set of 1936 I consider calibration in station names an essential. But the industry is not unanimous about that. Almost, but not quite. Without a station-name calibration a radio set is still a scientific experimental apparatus suitable for constructors and experimenters, of course, but not for listeners pure and simple.

There are quite sound arguments against station-name calibration, but if there is one thing certain it is that the domestic set of the future will be so equipped as a matter of course—even on the short waves, if it embraces these. In view of this certainty it is rather a pity some central body of the

industry does not exist to get down to the job of formulating specifications for approved designs; though if there were such a body there would be plenty of other rationalisation which they could get on with in addition.

I must point out in all fairness that a certain amount of standardisation has been carried out, and is being carried out still, in regard to the design of components by the Radio Component Manufacturers Federation.

### Control Standardisation

There ought also to be a standardisation of what is even more important to the public—the parts of sets which come within their view and their control. The operating controls, for example. Going from one set to another is much more confusing than changing motor-cars. A car may be more difficult to drive than a radio set is to handle (or it may be easier), but there is the advantage that the controls of all cars are in general similar. There will be a hand brake, a foot brake, a clutch and a throttle control on every car. And they will almost invariably operate in the same directions and be disposed more or less in the same order or pattern.

But one radio set may have just the same number of same-looking knobs as another and they may be arranged in a similar fashion, and yet the purposes of each of the knobs might be quite different from their equivalents on the other set.

I don't think there will be space on this occasion, but on some later occasion anyway I am going to question the value of many of the controls which appear on some modern sets. But just now I want to pursue this point about the arrangement of the controls.

Knobs may appear anywhere on a set. Sometimes they are grouped together on the front. Sometimes they are spread out over the "face" of the set. Sometimes there will be one or two on the sides as well, or even on the back.

### The "Best" Method

Well, there may be controls which are easier to handle if they are placed at the side. It may be better to distribute the controls over the various planes of a set, or it may be better to group them all together on the front. But surely out of all the "best" methods of disposing them there will emerge some day the best one which will be accepted as such by all with minor modifications to suit the needs of individual manufacturers and designers to express their individualism?

But first of all I think it is even more important to obtain some kind of standardisation of the functions of controls. They could then be plainly labelled on all sets. True, the controls of some sets are labelled, but not so many as was once the case. This for the reason that controls vary so much in their actions and functions.

### Uniformity Wanted

I really do not think that any but an extremely few listeners get the most out of some of these quite excellent modern sets, for the reason that they never get completely *au fait* with their controls. And it is made the more difficult for them to do so for the reason that the controls of different sets do not conform to anything to speak of in the way of uniformity.

Let me revert to the motor-car simile once again. When one has learned to drive on a certain make of motor-car one is equipped to handle adequately almost any other motor-car after only a little experience of its individual handling. The control known as the "accelerator" or the one styled "clutch" functions similarly on any motor-car.

Now, I have two commercial sets before me as I write. Both are current models of different makes. Both are

### UNUSUAL DESIGN



A continental portable which reveals a very interesting breakaway in layout.

superhets. Both are A.C. sets. They were not chosen from many in order to illustrate any points I wanted to make. They happen to be two sets which I have been testing under ordinary listening conditions.

They are the products of two of the most prominent firms in the country. You have seen both these sets advertised quite a bit in the newspapers?



during the past two or three months.

One has three knobs arranged in line, the other has three knobs not quite in line. In neither case are the knobs labelled. The right-hand knob on set No. 1 controls wave-changing. Wave-changing is accomplished by means of the centre knob on set No. 2. So far as set No. 1 is concerned there is a little control hidden away under the centre knob which regulates tone, while volume is controlled by the left-hand knob; the centre knob is a tuning control.

### Real Confusion

Set No. 2 possesses two other controls arranged concentrically with its right- and left-hand knobs to control selectivity and quiet tuning. Tuning is by the right-hand knob. Can you dig all this out? I know it is confusing, but the mere fact of this confusion proves my point completely. Would it not be a great improvement if there were a conventional placing for controls? And don't any of you say that the position of controls must be always dependent upon the layout of the chassis of the set. They are themselves part of the layout.

But even if the actual positioning of the modern unlabelled control could be passed over by the observation that listeners could quickly adapt themselves to changed positions on going to another set, there is still the problem of listeners being able to acquire a knowledge of using controls properly, and that is not made at all easy when the positions of controls vary from set to set.

And don't forget that the controls of different sets do different things. But every set must have certain fundamental controls. There must, of course, be a tuning control. A volume control is also essential, as is a wave-change switch and an on-off switch.

### A Suggestion

Well, being constructive, as always, in my criticisms, I suggest that a convention should be adopted by the radio industry always to place these fundamental controls on their sets in one unchanging pattern of relative positions. I don't mean that they should always appear in exactly and identically the same positions. We don't want anything as rigid as that. But surely it would not be difficult always to have them adopting similar relative positions.

Taking the three fundamental controls of tuning, switching and volume control. Couldn't the tuning always be central, the volume control to the

## "COMMON-SENSE CONVENTIONS"

left and the switching to the right, for example?

Then any further controls could be added in a more or less standardised manner. Selectivity control always tending to be above the volume control, and so on. There must be an awful lot of listeners who just fake about with their controls more or less haphazardly, and never know quite what are their real purposes.

### Recognised at a Glance

It is no argument at all to declare that a large number of listeners never go to other makes of sets than the one they begin with, or that as many more never buy a new set at all. The mere fact of widespread standardisation, or let us call it the widespread adoption of common-sense conventions, would, by the mere fact of its wide-

ones, and consciously or subconsciously gain something from seeing others handle them. At the present time even an expert has to ask, "What is that knob? And this?" when he approaches an unfamiliar set, though, of course, it doesn't take him long to learn what they do after handling them, for he has knowledge of the functionings behind them.

### Puzzling the User

Oh, yes, there are instruction books with modern sets. Listen to this passage from one of them: "The large knob on the right is the combined tone/selectivity control. The set is adjusted for maximum selectivity when this is turned fully round in an anti-clockwise direction. In the other direction the quality of reproduction is progressively improved and selectivity reduced." (I have altered the words very slightly.)

That is all, and I'll wager that the control leaves the average listener

## ONE OF HIS OWN RECORDS?



*Stanelli, famous for his Hornchestra, listening to his latest Cossor radiogram.*

spreadness, as it were, lead the listening public to a keener appreciation of the value of the intelligent understanding and use of controls.

Each listener would see a more or less exact duplication of the controls of his own set on each of the sets of his friends, although in cases there would be more or less of the knobs. But he'd recognise at a glance the primary

rather unhappy; aware that two desirable qualities (good tone and good selectivity) are hinted at, but that they lie at opposite ends of the same knob. Move towards one and you move away from the other! The onus of finding a compromise is handed over to him lock, stock and barrel! But that wouldn't be so bad perhaps if

*(Please turn to page 127.)*

# Famous Programmes

## —How They Began

*By a Special Correspondent*

WHAT goes on at the B.B.C. when a new programme is born? It must be a very serious business, you may think. But, actually, now-famous radio programmes have often been conceived in an impromptu, almost off-hand manner!

One day, nearly two years ago, Mr. Eric Maschwitz, B.B.C. Variety Director, decided to set aside half-an-hour on Saturdays for a surprise programme. Then he forgot about it. A few days before the first scheduled Saturday he rushed into his office crying: "There's that 'In Town Tonight'—we'll have to do something about it, and quickly!"

In a hectic rush London was combed for dustmen, flower-sellers, film stars. They were rushed to Broadcasting House on the Saturday morning and rehearsed. But twenty minutes before the programme was due on the air, Maschwitz again flew into his office:

"We've forgotten to choose a signature tune. Here, Munro! Fly to the gramophone library, get me every record you can of music about London!"

### "The Very Thing!"

Precious minutes passed. Munro, the assistant, returned with a pile of records. Maschwitz heard one after another. Then a stirring march tune shot forth, and everyone shouted: "That's it! The very thing! What is it?"

Somebody looked at the label. "'Knightsbridge Suite,' by Eric Coates," he read. Nobody had heard of it. It had never been broadcast. But Maschwitz immediately chose it as the signature tune.

Thousands of listeners have written to the B.B.C. asking for the name of that tune. It has made a fortune for its composer. And yet they have never played more than sixteen bars at a time!

Holidaying on the Riviera, in the summer of 1933, Eric Maschwitz sat listening to a café band. He liked the band. There was nothing like it in B.B.C. programmes, he thought. But he felt there ought to be. So he left

his table and went to the post office and sent off this cable:

"Walford Hyden,  
"Tavistock Square,  
"London.

"Would you form Continental orchestra to broadcast series of café music programmes?"—

"MASCHWITZ."

### ERIC MASCHWITZ



*The Variety Director of the B.B.C. whose lively imagination has been responsible for a large number of popular programmes.*

And Mr. Hyden replied that he would. But what would they call the new orchestra?

Mr. Maschwitz searched the Riviera for a title. There were a number of romantic-sounding Continental names, but most of them were unpronounceable to the Englishman. It was vitally important to have a title listeners could pronounce. Maschwitz knew that, from experience of his own name! After much hard thinking the word "Colette" came to him. It was pure imagination, but it was foreign-looking, picturesque—and simple to say.

So "Café Colette" came.

In 1931, musical comedy music on the wireless was confined to very ordinary "Musical Comedy Concerts," filled with rather tedious seventeen-minute selections. Leslie Woodgate, who was then in charge of the B.B.C. Theatre Orchestra, had to provide three of these concerts a week.

### Something Different

One morning he walked in to John Watt's office at Savoy Hill and sighed: "I wish these musical comedy selections anywhere!"

And then John Watt thought of it. "Why not be different?" he asked. "Take selections and songs from shows now running in London and New York, string 'em together with a compère—and call it 'Songs From the Shows.'"

Mr. Watt searched the music scores littering his desk and found a song out of a previous radio show called "The Stage Revolves."

"That'll be the signature tune," he announced.

"Compère?" asked Woodgate, rather hopelessly.

For there they were up against it. The B.B.C. was poor in those days, and the sum allowed for this programme would not run to the engagement of a compère.

"Oh, I'll do it!" said Watt desperately.

You know the rest! He's still doing it.

### Force of Circumstances

We owe to John Watt, also, another series of popular B.B.C. programmes—the "Guess Who It Is?" variety shows. But Mr. Watt says the credit for that lies with a series of very tiresome circumstances, rather than with himself.

He was trying to arrange an ordinary variety programme, but for one reason or another, every artist approached was unable to take part.

When the time came to publish advance details of the programme, still no artists had been booked.

Then said John Watt, "Call it a 'Guess Who It Is' show—then we shan't have to publish the names!"

And that's how that began!

MORE  
ENTERTAINING ARTICLES  
about  
RADIO PERSONALITIES  
AND STARS  
in the  
FEBRUARY "WIRELESS"

# Off the Broadcast Track

To the average person "Radio" means "Broadcasting"; the two terms are synonymous. But while broadcasting gets most of the publicity because of its domestic aspect, it is by no means the only interesting—and important—application of wireless.

Throughout the world, and throughout the twenty-four hours of each day, radio is serving humanity in hundreds of different ways. Messages controlling the destinies of whole nations are flashing through the ether, lives are being saved, routine jobs are being performed, criminals are being apprehended—it is impossible to estimate just how much civilisation owes to radio.

Let us forget broadcasting for once and explore the less familiar branches of radio. Let us look at some of the other achievements of the etheric science and get a glimpse of the romance often hidden behind a few electrical vibrations.

First of all we have the variety of ways in which radio is used in the service of the public. Consider travel: It is true to say that you cannot travel from Great Britain to any other country without radio playing its part in ensuring your complete safety. What a debt we owe to it in this connection!

The use of radio as an aid to shipping was one of its earliest applications. As soon as spark transmitters and suitable receivers proved the possibility of communication over large distances without wires, it was realised that here was the one thing that would make travel by sea really safe.

To-day, radio is one of the most important items in the equipment of a ship, particularly if it is a passenger liner. But its use is by no means confined to communication with other ships or with shore stations.

It is also a great aid to navigation by means of direction-finding apparatus. And in fog, radio beacons round the

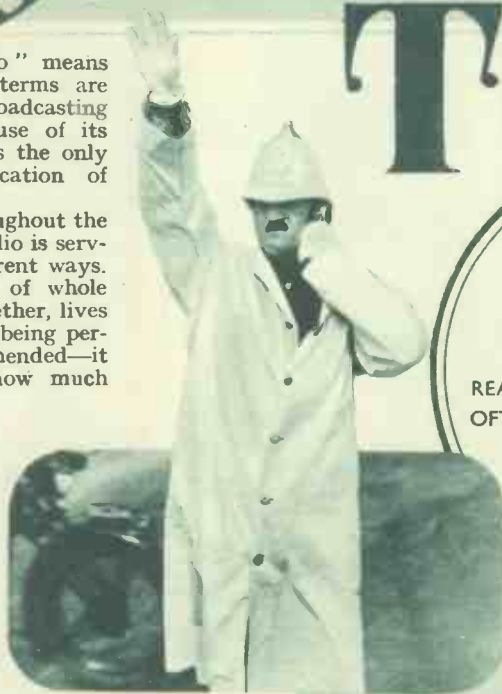

A Brighton policeman is seen above using his pocket radio set while on point duty.

By  
**A. S. CLARK.**

A SPECIAL  
ILLUSTRATED SUPPLEMENT  
WHICH INTRODUCES THE  
READER TO THE MANY AND  
OFTEN UNAPPRECIATED USES TO  
WHICH RADIO IS PUT OUT-  
SIDE ITS BROADCASTING  
ACTIVITIES.



The radio station of a mining camp in Northern Canada where radio is often the only link with the outside world.

coast warn shipping with as much reliability as lighthouses in conditions of good visibility.

A form of radio apparatus may also be used for sounding the depth of water in which a ship is travelling. Then there is Marconi's latest aid to navigation, which permits a ship to be steered right into harbour without a single thing being visible beyond its bows.

Even lifeboats. Both those which are carried on ships and those which go out from land to the aid of ships in distress have been fitted with radio, and this considerably increases the chances of successful rescues.

But as well as helping ships when in difficulties, radio also tends to prevent them getting into these difficulties by providing the means to send out regular weather forecasts. One section of this service is the shipping forecasts you have no doubt heard from Droitwich.

Finally, radio makes it possible for

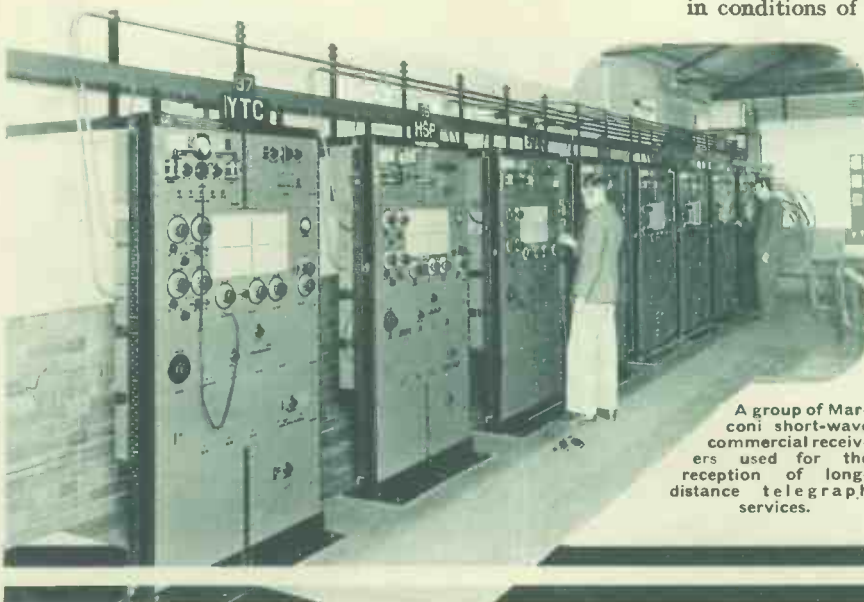

A group of Marconi short-wave commercial receivers used for the reception of long-distance telegraph services.



Controlling traffic from the air by means of radio has been adopted by the police in many countries. Airships and balloons were used in the first experiments, but the development of the Autogiro has brought the idea right within practical politics. A traffic-control Autogiro is seen in flight above.

makes this modern miracle possible. But a telephone service has even been experimented with in different countries between ordinary subscribers and people travelling in trains. And similar telephone links with aeroplanes have been achieved.

When we come to aircraft we are dealing with a form of travel whose very existence as a public service is largely due to the assistance rendered by radio. Without radio it would be impossible to visualise the development of giant air liners spanning the world with as much regularity as cross-Channel vessels.

Radio-telephony is used on most regular lines for communication between pilot and the control officer at the aerodrome. But on long-distance flights and in other special circumstances the help of telegraphy may be called in.

Radio proves of the greatest help to pilots when weather conditions are rough and visibility is bad. With the aid of his radio he can fly from one aerodrome to another without seeing the ground once during the whole journey.

This enables him to combat fog, or to rise above storm layers and fly in comparatively calm conditions at a higher altitude. Systems are also being developed which enable landings to be carried out with safety even when fog makes the ground totally invisible to the pilot.

As with shipping, direction-finding plays a large part in aircraft radio. It will enable the pilot to find and follow his route without aid from the ground, or two or three ground stations working together can ascertain an aeroplane's position and inform the pilot of it within a few minutes of receiving his request for the information.

Perhaps the public service to which the application of radio appeals most to our sense of the dramatic is the police force. Radio is now as much a part of crime detection and prevention as the plain-clothes detective.

The value of radio in this connection naturally shows up to best effect when used in conjunction with motor patrols. There are two systems that



The direction-finding aerial on the Pacific Coast, a large motor vessel. Radio D.F. apparatus is a great aid to the navigation of any ship.

passengers in mid-ocean to communicate with friends on shore, either by "Radio-telegram" or, in some cases, direct by telephone. In the latter instance the person on land uses his ordinary G.P.O. telephone.

This reference to the G.P.O. brings us to the question of long-distance phone calls in general. These calls to countries on the "other side of the world," are so common nowadays that many business men ring up, say, America from their offices without realising the part that radio is playing in their conversation.

It is beam radio, a development of the last few years, which

The ultra-short-wave aerial system at the G.P.O. station near Belfast, which is used for many of the ordinary telephone trunk calls between Northern Ireland and Scotland.



may be used, one in which a central station is able to speak to the patrol cars which carry receivers only, and the other in which the cars also carry transmitters and are therefore able to reply to the central station.

The latter system naturally has the greater value and will, no doubt, eventually be the only one used. A system has recently been introduced by the Bell Telephone Laboratories in America which is entirely automatic in operation.

The first sound of a policeman speaking into his microphone causes a relay to operate and to switch on the transmitter. When no more words follow one another for a considerable period, namely, when the policeman stops talking, the transmitter is automatically switched off and the receiver brought into operation ready to receive the reply from the central station.

A recent valve development has also made possible the provision of pocket receiving sets for policemen on ordinary duty. These have been used considerably in the Brighton district.

A use to which ultra-short waves have been put by the G.P.O. is as a link for certain telephone services instead of an ordinary sea cable. Such a service is now in operation between Ireland and Scotland.

Amongst the recent applications of radio is its use on fire-engines. A transmitter and receiver are installed on the engine or escape and enable touch to be kept with the station.

The value of such an installation is greatest in outlying districts where buildings are scattered over a wide area. Its chief value is in the event of a bad fire breaking out when all the firemen are attending a lesser, and possibly quite unimportant, outbreak.

But to turn to a much colder subject: In Northern Canada radio plays a big part in everyday life. It is the only link, very often for several months on end, between small villages and the big cities. And quite frequently it saves lives by enabling medical advice to be provided for some injured person.

Naturally, we have been dealing with the more spectacular applications of radio in the service of the public. But we must not entirely overlook the question of ordinary communication.

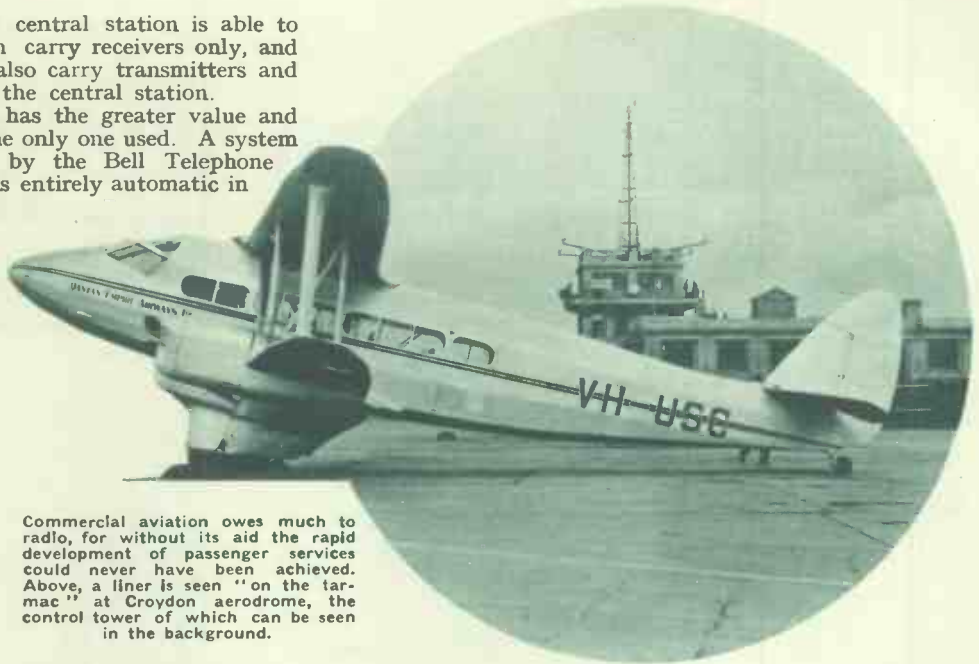

Commercial aviation owes much to radio, for without its aid the rapid development of passenger services could never have been achieved. Above, a liner is seen "on the tarmac" at Croydon aerodrome, the control tower of which can be seen in the background.



A special radio installation in a watertight case on the Hythe, Kent, lifeboat. Many of the lifeboats of large passenger liners are also equipped with radio.



This is in the hands of what are generally termed "commercial" stations. They work on telegraphy, use a variety of wavelengths, and carry a variety of messages.

Their two chief uses are the transmission of Press matter, and the sending of private and business "cables" from one part of the world to another. To facilitate the sending of many words in a short time, high-speed automatic working is used by quite a number of these stations.

Numerous as they are, however, public services by no means monopolise the "other" applications of radio, and we must pass on to some quite different purposes to which the world's greatest science is put.

The radio installation in the Northwood, Middlesex, Fire Station, one of the first to adopt radio for communication with fire-engines.

# WITH THE SERVICES



Testing out the radio apparatus of an R.A.F. machine prior to its departure on a flight.

**H**IGH above the enemy encampment an aeroplane circles. Watching through powerful glasses, an observer looks down from it, waiting for the upheaval which represents the arrival of a shell from behind his own lines.

Suddenly a shower of earth spurts from the side of a hill. "Too far to the right," murmurs the observer to himself, as his hand reaches out to a Morse key. A few cryptic code letters are tapped out, and appear on the blank pad in front of the radio operator away back behind the front lines.

Almost before the operator's pencil stops moving, the officer by his side has rapped out an order, and the up-pointed muzzles of the heavy guns swing imperceptibly to the left.

Another spurt of earth—right on the road alongside the encampment—and the observer in his plane sees ant-like figures running for their lives. He taps his key once more, and after a slight pause he is rewarded by a shell falling right into the middle of the encampment. "O.K. Carry on!" his next message signifies, and banking sharply he dives away for his aerodrome even as a number of black specks form up in the sun's glare.

"Spotting" for the artillery is a well-known military application of radio, but the little scene serves to illustrate how tremendously radio has altered warfare. No matter whether it is the Navy, the Army or the Air Force, radio plays an extremely important part in any manoeuvre which is carried out.

In the infantry, portable radio equipment has taken the place of the laboriously laid telephone line, and provides a much less vulnerable and reliable means of communication. When an advance takes place, each unit can be under the direct orders of the commanding officer, who in turn can be in communication with an aeroplane flying above the advancing troops.

This machine performs much the same duties as the "artillery-spotter" aeroplane. It guides the advance so that every advan-

tage is taken of weak spots in the enemy's defence.

At the same time he can pass on a warning to any unit which looks like being ambushed, or appears to be taking up a dangerous position. The infantry, always in the van of any advance, is probably helped by radio more than any other unit of an army.

And along with the infantry go the tanks. Each is equipped with radio, for this is an essential item in mechanised warfare.

Not only are the tanks able to keep in touch with one another in a way which would be impossible without radio, but, like the infantry, they are in direct communication with the commanding officer.

Apart from the straightforward use of radio for communication purposes, armies are likely, in the future, to use radio in other ways.

For instance there are innumerable possibilities in radio control of moving mechanical weapons, but more of this later on.

Simple radio control can be used to explode mines laid during a strategic retreat, and for similar purposes. But ordinary communication forms the main use of radio by armies, for with it enemy communication from field to headquarters, from headquarters to staff, and from staff to the leaders at "Home" can be conducted.

The uses to which radio is put in the Navy are very similar to those in the Army. Ships are

The "switchboard" for the Queen Bee, the radio-controlled machine of the R.A.F. which flies without any human beings at all on board.



able to keep in contact with one another and also with their base.

And the Fleet Air Arm is able to "spot" for the battleships and cruisers in the same way as the aeroplane described at the beginning of this article. But in the case of the Navy, the distances are likely to be much greater, and reconnaissance work is probably of even greater importance.

But to turn from radio uses by the Navy in time of war to times of peace: Here, again, it plays an important part, especially in connection with training and target practice.

For the latter purpose remote control by radio is sometimes employed. And a wonderful piece of engineering the target is.

Known as H.M.S. Centurion, an old battleship is provided with special radio apparatus and used as a moving and manoeuvrable target. Naturally no attempt is made to demolish the target com-

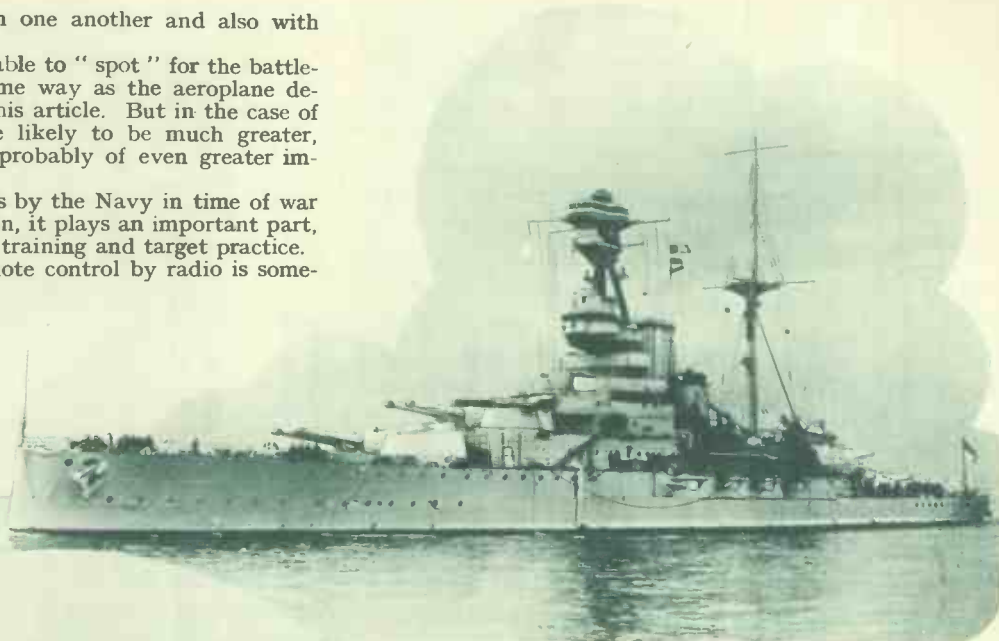

Radio could truly be described as the eyes and ears of the Navy, and is a vital item in the equipment of every man-of-war. Shown above is H.M.S. Royal Sovereign.

described, but it is used in other ways as well in the R.A.F.

Naturally it is put, among other things, to the same purposes

as in commercial flying, for communication with aerodromes, position finding and blind landings. Then there is one of the very latest developments, the Queen Bee.

This is a machine of quite ordinary type, which is controlled entirely by radio. It does not carry any human beings at all, and, like the Centurion is used as a "line" target for gun practice.

The pilot's cockpit is filled with the control apparatus, which consists essentially of a robot pilot, receiving apparatus and mechanical actuating devices. The robot pilot holds the machine in any manoeuvre dictated by the mechanical actuating device.

The latter, in its turn, is controlled by currents from the radio receiver, the form of these currents, and therefore the manoeuvres, being determined by the operator at the transmitter control-board. By simply pressing buttons on the control-board, the operator can make the machine take-off, climb, glide, turn, and so on. He can even bring it back to the aerodrome and land it again.

It has taken years to perfect the Queen Bee, and some of the most closely guarded of radio secrets are incorporated in its "works."

Without a doubt it represents the greatest advance ever made in aerial warfare.

Little imagination is required to picture the uses to which it could be put in wartime as a controlled projectile, or for the purpose of dropping bombs.

In the case, say, of a battleship, the aeroplane could be loaded with high explosives and directed by radio straight at the ship, no intention of saving the aeroplane being entertained. The value of the damage which could be done in this way would thoroughly justify the loss of an aeroplane which could be built on much cheaper lines than if it were to be used.

And the possibilities with a television transmitter installed on the aeroplane are, of course, innumerable.

But let us turn from the cruelties of war to some more humane aspects of radio "off the broadcast track."



pletely, and it is repaired after each practice.

The controls on a distant vessel enable the Centurion to be completely manageable. It can be stopped, or the speed can be altered, or its engines can be reversed. It can also be steered either to port or starboard.

Little imagination is required to visualise what a dance the officer controlling it can lead the harassed gunners who are doing their best to prove how proficient they are, and that they thoroughly deserve promotion.

But apart from special naval applications of radio, the Fleet naturally employs it for direction-finding and other navigational matters just as ordinary shipping, in the ways which have already been described in the previous article.

To the youngest Service, the Royal Air Force, the use of radio is no less important than it is to the Army and Navy. The way in which it is used by aeroplanes co-operating with both the Army and Navy has already been

As with the Air Force and the Navy, so it is with the Army. Radio is just as extensively used by our land forces. In the circle is seen General Sir John Burnett-Stuart in the gun-turret of one of the latest tanks.

**A**LTHOUGH not radio in the sense in which we usually use the term, there are many things which employ apparatus so closely allied to that of ordinary radio gear, that we cannot but include them in a section of this nature.

Valves, photo-electric cells, and similar apparatus find a use in quite a variety of applications. And chief among these is its use for medical purposes.

All sorts of curative treatments are made possible by high-frequency currents generated with the aid of valves. But perhaps the most amazing of all medical applications is the "radio knife."

This is used for operations in place of the normal lancet of the surgeon. With it the amount of bleeding is considerably reduced and the cut is cauterised as the knife moves along.

The actual cutting is achieved by a spark produced with high-frequency currents. This cuts through the tissues much more cleanly than an ordinary knife, and the heat produced automatically closes up the blood vessels as it goes along.

Closely allied to the curative use is the application of apparatus, closely allied to radio, to beauty treatment. And in this connection one of the most recent developments is a claim to performing plastic "surgery" without recourse to cutting the skin at all.

Even the permanent-wave has come in for its share of attention by the radio scientists. They have developed an apparatus which considerably increases the comfort of the person undergoing attention.

No longer do any connections have to be made to the waving apparatus placed on the head. It is thus possible for complete freedom of movement to be maintained throughout.

The deaf and dumb also benefit from radio science. It has been found that, with the aid of microphones and powerful amplifiers attached to earphones or special vibrators, deaf people are able to hear to a certain extent. This enables those born deaf to be taught more readily to speak.

Another application in which powerful amplification and microphones play a large part is the studying of heart-beats. Used in conjunction with oscillograph apparatus



The use of high-frequency and other electrical currents for medical purposes is quite common these days. This photograph shows a Marconi valve diathermy set which is suitable for both therapy and surgery.

# ALLIED APPLICATIONS

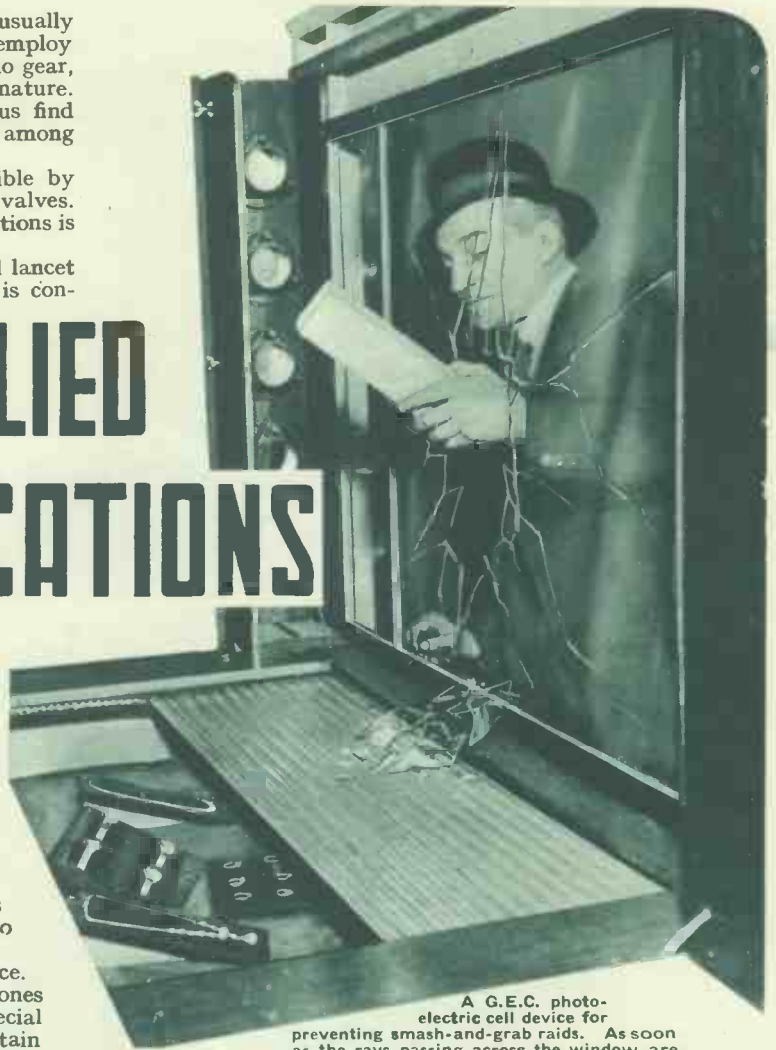

A G.E.C. photo-electric cell device for preventing smash-and-grab raids. As soon as the rays passing across the window are interrupted, an alarm rings and the goods are automatically covered.

thus the microphone and amplifier enable the doctor to study in detail the regularity and amplitude of the beats.

Another "allied application," perhaps more familiar to the ordinary person than the foregoing, is the radio organ. By means of oscillating valves coupled to loudspeakers, any note, and practically any timbre of note, may be produced.

The bare principle is very simple. A simple valve-oscillator circuit is coupled up to an amplifier, and by varying capacities or inductances in the circuit the frequency of the oscillations, and therefore the note, are varied.

The final scheme to which we will refer is the photo-electric-cell device illustrated on this page. Photo-electric cells can be made to operate from infra-red rays as well as from light rays normally visible to the eye.

Such infra-red rays are reflected backwards and forwards down behind the glass shop-window. Then, if any object such as a brick breaks the beam, the current through the photo-cell varies and thus actuates a relay. The latter then sounds an alarm, and at the same time automatically causes a shutter to cover the jewellery, or whatever may be on display.

The uses to which photo-electric cells are put are really multitudinous. The most common way in which they are employed is in the apparatus at cinemas for reproducing the sound from the films.

In industry it is applied to such purposes as counting articles as they pass by on an endless belt, or to the matching of colours. The photo-electric cell has also been applied to photography to act as an exposure meter.



# "THE THOUSAND AND ONE..."



The provision of a telephone service with express trains has claimed the attention of engineers in many countries. Above you see experiments in this connection in Japan. To the right is a radio-equipped racing car snapped while actually competing in last year's Belfast T.T. race. The driver is K. Evans.



prospecting for minerals and water-divining. Both of these jobs can be carried out by means of short-wave wireless.

The method employed is to direct a beam of radio waves down into the earth and to pick them up again if they are reflected off a conducting layer such as metal ore or water. If such a layer is present it is possible to calculate approximately its depth below the surface. This is done by comparing the difference in time taken for reflected and direct beams of radio waves to travel from the transmitter to the receiver. It is even possible to obtain some idea of the nature of the composition of the layer.

Transmission and reception over short distances by means of ultra-short waves have opened up a wide field of usefulness for small radio outfits. The advantages of these wavelengths is that the range of the apparatus is comparatively small normally, and therefore the chances of interference between one outfit and another is not likely to prove any obstacle.

Another advantage is the small power which is required to put a reliable signal over a reasonable distance. Such outfits have been adopted for all sorts of purposes, including their use by film companies when "on location."

Quite often the nearest telephone may be some distance from a rugged or back-country location, and in such circumstances the ultra-short-wave transmitter provides a convenient method of communication with the offices or main studios of the company.

A fairly recent application of radio is the regular use of it for transmitting Press and other photographs over very long distances. The process is very similar to that employed for sending

As a hobby, radio transmission and reception is one of the most useful and interesting. There are thousands of amateur transmitters throughout the world, and the picture below shows Mr. D. Walters, whose call sign is G5CV, speaking into the microphone during five-metre tests on Mount Snowdon.

**P**UBLIC services, the Army, Navy and Air Force, allied applications—we have considered them all, but there are still a thousand and one other uses of radio. So let's take a few of them at random, just to see how amazingly varied they are.

There is the question of food, for instance. Since bacteria can be killed by the application of strong "doses" of high-frequency currents, these form a convenient method of purifying certain foodstuffs.

Perhaps milk is the best example. By the application of high-frequency currents of the right intensity and wavelength it is possible to sterilise it in a very convenient manner.

The wavelength of the current is very short: in other words, extremely high frequencies are employed. And similar frequencies can be used to actually cook certain items.

Incidentally, in the case of eggs, it is possible to cook the yolk while leaving the white in its normal uncooked state. It is simply a matter of choosing the right wavelength.

And then, to turn to something very different indeed—





A picture of the Duke of Gloucester at a function in Australia, whence this photograph was transmitted by beam radio. It is reproduced without any retouching.

photographs over land line, the main difference being in the distances covered.

Beam radio is usually employed, and the picture is broken up into thousands of small sections, each section being transmitted separately as an "average density" of light or dark. These sections are picked up by the receiver one after the other and pieced together in the right sequence to form a complete picture.

During motor-car races, whether on the road or track, it is difficult for the driver to know his exact position in the race. It is therefore usual for signals to be given to him from the "pits" as he dashes past, telling him to go faster or slower according to requirements.

These signals are under the control of the pit manager, and some managers adopt radio for communicating with their drivers instead of signals. The advantages are many and obvious.

The first experiments used loudspeakers in the racing cars, but it was found that the large amount of noise ruled out this method as impracticable. Later installations have used headphones, which have proved quite satisfactory.

Perhaps the most surprising application of radio is to the study of the sun. In this case the idea is to apply television technique to obtaining useful views of the sun's corona.

Normally, due to the powerful steady light of the sun, it is only possible to study the corona satisfactorily during a complete eclipse. With the aid of television it should be possible to do this at any time.

Briefly, the scheme to be adopted is to use television principles to cut out the steady component of light and make use of the varying light of the corona only. This would be done in much the same way as an A.C. component may be separated from the D.C. component in the anode circuit of an amplifying valve.



But to turn to a more normal though adventurous use of radio—exploration. Radio has proved a most valuable aid to explorers, particularly near the poles where the chances of "feeding on the country" are so very slight in the event of a small party becoming lost or cut off from the main party.

Not only does radio enable explorers to keep in touch with one another, but it also enables them to keep in touch with the cities of civilisation many thousands of miles away. The occurrence of an exploring party perishing without the world knowing a thing about their plight is thus made almost an impossibility to-day.

Finally we come very close to broadcasting in the amateur-transmitter movement. With the amateurs, radio is first and foremost a hobby,

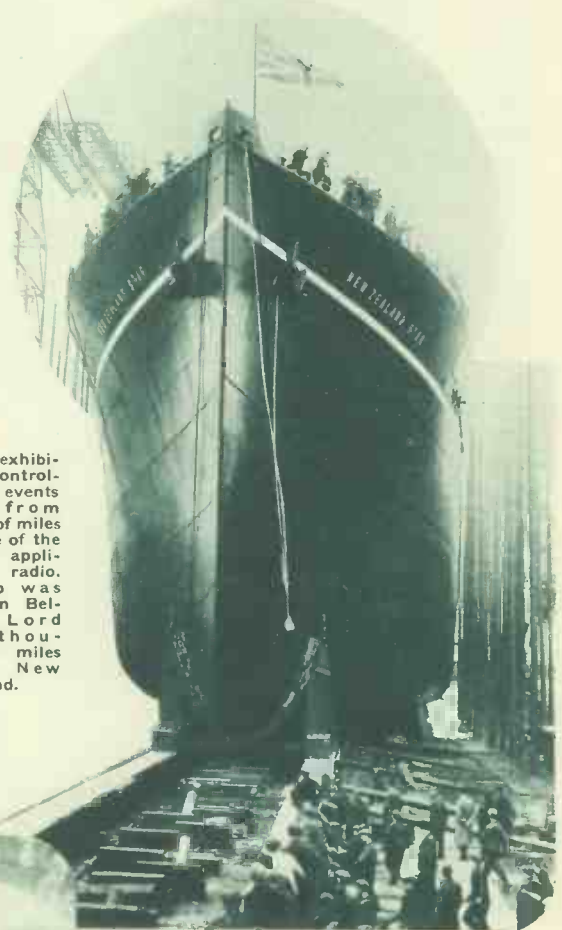

Opening exhibitions and controlling other events by radio from thousands of miles away is one of the spectacular applications of radio. This ship was launched in Belfast by Lord Bledisloe, thousands of miles away in New Zealand.

but at the same time they are often able to render valuable aid in relaying vital messages, or in getting into touch with places isolated perhaps by floods or other manifestations of Nature's power.

And so we see radio is as ubiquitous a science as any, and broadcasting is but a single bright facet on one of the most valuable jewels of modern civilisation. Broadcasting is bound to

become a greater and greater power in the world, but just as certainly the other uses of radio will become increasingly important to civilisation.

A novel use of radio is depicted on the left. It shows Warner Baxter taking the "phone" which controls a short-wave transmitter for communication between the "location" and the main studios.

# Television

## Go-day

Now that television is coming nearer and everybody is wondering what it is going to be like, all sorts of rumours are going about. Some people say that the two alternative systems, the Baird and the Marconi-E.M.I., will be transmitted at different times of the day, whilst others say that they will be sent out on alternative days of the week. As a matter of fact, I can tell you that they are both wrong, because the arrangements for changing over from one type of transmission to the other will necessitate a blank day on Sunday, with the result that we shall have Baird transmissions all one week, nothing on Sunday, then E.M.I. the next week, nothing on Sunday, and so on. In passing, it seems a great pity that the technical exigencies of the case necessitate the blank day on Sunday.

### Duller than Ever!

Goodness knows, it is bad enough with the ordinary sound programmes on Sunday, and many of us hoped that when television came along it would help to brighten up Sundays a bit. But now it seems that it is going to be like most things in England, "Closed on Sundays." However, there is perhaps one consolation that if the Sunday television programmes—if we had any—were going to be as exciting as the Sunday sound programmes, perhaps we shall be just as well off with a day's holiday!

Everyone hopes and expects that on weekdays, at any rate, something really good is to be looked for. I dare say you have heard that Mr. Gerald Cock, the new Director of Television, is looking for a beautiful young lady with what he calls a "photogenic face." It doesn't sound very complimentary at first, but it is really not so terrible as it seems.

### What It Means

The "photo" part of it means that her features must photograph well, and I don't know what the genic part

★.....★  
 How is the Alexandra Palace station getting on? Where will the television studios be? What is diffraction? These questions and other interesting subjects are discussed in this contribution

By Dr. J. H. T. ROBERTS, F.Inst.P.

★.....★

is, but the whole description taken together means that she must televise well. I expect you know that it is not necessarily the most beautiful faces that come out best on the cinema screen; a film director soon learns by experience the type of face to select and, in addition to this, a great deal depends upon the expert make-up man. The same kind of thing applies in television, except that the make-up art for television is different in many important respects from that required for films. The photogenic lady must also have a male partner; as they will presumably both be photogenic

they should get on very well together.

The present intention is that, in the early stages, programmes will be sent out for about three hours a day. Another important scheme is to establish in the West End of London a number of public demonstration rooms, so that all can have an opportunity of familiarising themselves with television before buying a receiver. It is expected that this will very soon be supplemented by demonstration rooms in the large stores and radio shops.

### Varied Programmes

The programmes will be made as varied as possible and, although film subjects will be included, it has now been decided that these shall not form the major part of the programmes. Some time ago everybody thought that the studio would be bound to rely largely on films, as it would be technically too difficult

to transmit actual subjects and scenes.

This has now been found not to be the case, and we shall see news items, fashion parades, demonstrations of all manner of merchandisè, and also orchestras and individual artists.

### Many Problems

There are plenty of technical problems still to be solved, and the transmissions in the early stages will still be more or less experimental in character. It is only fair to make all possible allowances for this, and if you cast your mind back to the first efforts of the B.B.C. in sound programmes in the very

### THE LONDON TELEVISION STATION

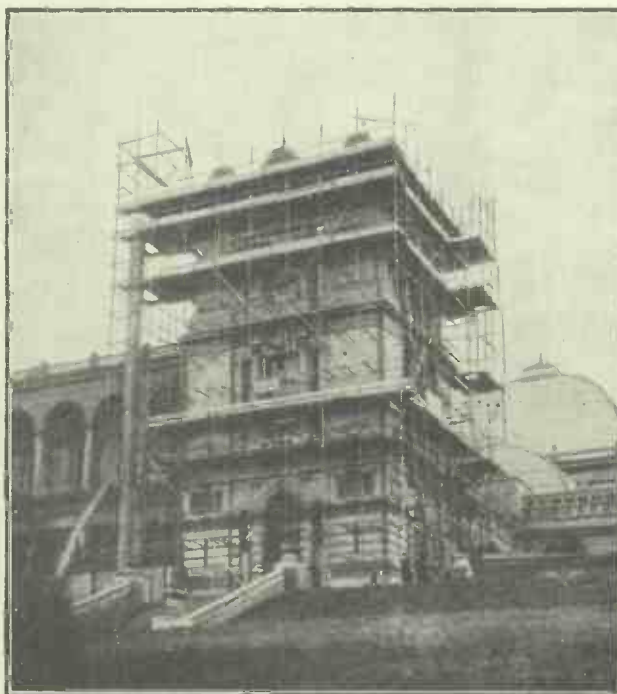

A mass of scaffolding surrounds the tower of Alexandra Palace on which the mast of the London television station is to be erected. Extensive alterations are being carried out.

first days and compare them with the present-day efforts (no matter how much you may criticise the latter), you will be bound to agree that the programmes and transmissions have improved out of all recognition. The same thing will undoubtedly happen with television, but every allowance must be made for it in the early stages.

\* \* \*

In connection with the starting of the television service, many people have the idea that, although the transmissions will be from the Alexandra Palace station, the studios will be in the West End of London. This is the sort of arrangement that is invariably made with sound broadcasting, and, of course, it is much more convenient for the artists to attend a studio in the West End than have to go somewhere outside London, or even to the suburbs.

### More Difficult Than Sound

With sound broadcasting, however, it is a very simple matter to transmit by land line from the studio to the transmitting station, but with television this is not so easy. In fact, transmission by land line presents a very serious problem. For this and other reasons the television studio will actually be at the Alexandra Palace also, and a wonderful studio is being erected there. Another important consideration is the fact that facilities are available at the Alexandra Palace for staging and televising outdoor scenes.

### Getting Ready

Many of the more important radio manufacturers are busy making preparations for the manufacture of television receivers, in readiness for the start of the service. One of the difficulties they have been up against for a long time, however, is that there is no high-definition transmission available on which to test out their instruments. Up to a few months ago we had the B.B.C. low-definition 30-line transmissions, but these have now stopped and the high-definition transmissions have not taken their place, so that there is a complete lack of any yardstick, as it were, by which to measure the performance of the new instruments. The companies preparing to engage in the manufacture of television sets have,

## DIFFRACTION ON ULTRA-SHORT WAVES

therefore, been obliged to set up their own transmitters for testing purposes, but this is really rather a makeshift way of doing things, especially in view of the fact that we are going to have two such different types of transmission as the Baird and the E.M.I. The P.M.G. has laid it down very definitely that the two types of transmission shall be such that any ordinary television receiver shall be capable of receiving them both without need for any serious adjustments.

How all this is going to work out in practice remains very much to be seen. Anyway, one of the difficulties, as I say, and one of the prevailing complaints in the trade, is that manufacturers cannot make such complete and efficient tests as they would like. I expect that some little time before transmissions start in earnest there will be "extra-experimental" ones given at stated times, to enable manufacturers to get things in order and to prevent a frightful scramble at the last minute.

\* \* \*

Everyone knows by now that the attenuation, or in more popular lan-

### FOR THE FRENCH SERVICE



One of the television receivers which are being installed in various parts of Paris, so that people can look-in to the pictures sent out from the Eiffel Tower.

guage the loss of strength, of ultra-short waves is relatively very rapid, with the result that the effective area of a broadcast transmitting station is somewhere about 25 to 30 miles, under ordinary conditions. Some important tests have been made lately by the

Baird Company on different wavelengths—8 metres, 5 metres and 3 metres. It has been found, as was expected, that the attenuation varies greatly with the wavelength, becoming greater as the wavelength is reduced.

There is also the phenomenon known as "diffraction" to be dealt with. Very roughly diffraction may be described as the breaking-up of waves (whether radio waves, sound waves or any other kind of waves) when they encounter objects the dimensions of which are of the same order as the wavelength of the waves themselves. Diffraction occurs with light waves, but in order to observe diffraction phenomena in this case, owing to the exceedingly short wavelength of light waves, it is necessary to use objects of extremely small dimensions. The well-known "diffraction grating," for example, has a number of parallel lines ruled on its surface, and these may run to many thousands of lines to the inch.

### Outside Interference

With radio waves, you would expect that when you got down to wavelengths of much less than 10 metres, diffraction effects would begin to come in, and this has been found to be the case. Seven metres wavelength was found to pass fairly well over large objects such as hills and mounds, and was a better carrier of the signals than wavelengths of 5 metres, 3 metres, or less.

Another important technical problem is concerned with the interference from motor-car engines and electrical machinery of all kinds. This problem we have always with us, even in the much longer wavelengths used for sound broadcasting. But they are liable to become serious when ultra-short waves are used.

One of the most interesting television events of recent weeks was the television dinner held at the Press Club, in London, in the early part of November. The demonstrations were arranged by the Baird Company with a view to showing the world the state of perfection which television had now reached. From this Press Club dinner the Chairman went to the Baird Studios at the Crystal Palace and was "transmitted" from there to the Club,

(Please turn to page 132.)



# Short-Wave Crime

**A**MONGST my friends I number one Black, a superintendent of police down in the New Forest. Popularly known as Smutty (I could give many reasons why, but won't), he is at once the entertainment and terror of the civilian population in those parts. People who don't know him are scared with his vicious scowl and apparent lack of all human feeling; people who do know him, look upon him as a magnificent leg-puller. And since I know him better than most people, I call him something of a rogue as well.

He is the most uncertain person. You never know what he might do next; and you never can tell whether he's talking nonsense, wild romance, or profound philosophy. I once wrote a book about a case of his, after which, on a visit to his town, he had me arrested by two plain-clothes men in the local cinema, and held all night in a cell. Next morning he arrived full of apology, saying that his men had mistaken me for a murderer, supposed to be fleeing through those parts.

And I never was able to say whether it was a mistake or not. It's only the connection which makes me suspicious.

He has a habit of smoking cheap green cigars, which, in moments of meditation, he pulls to pieces, leaf by leaf. One day last summer, on my way to Bournemouth, I called in on him and found him in his room, his feet on his desk, frowning as he pulled his cigar to pieces.

He looked up at me. "Hallo, run out of plots?" Then he laughed cynically.

"No, but I need some inside information on the niceties of graft."

He stopped pulling leaves off his cigar and fixed me with his glittering eye. "Would you care to repeat that before a witness?"

"Truth needs no witness." I sat down.

"Have a cigar."

"God forbid."

This ceremony being over, we began to talk about various things. Strangely enough, Smutty hadn't very much to talk about. I had nothing new—except a radio I'd just had fitted in my car.

It was an American set, and in place of our medium and

high wavebands, it had medium and short (the great American public derives some entertainment from picking up police calls, as perhaps you know).

"Short wave?" Smutty said, idly shedding tobacco leaves to the floor. "We've just had a bit of trouble with an old fool who's bought an all-wave set. Funny old chap. A hermit. Never sees a soul from one year's end to another, except when he rolls into town on his 1903 model bicycle to buy something. He's bought this set to keep him company, apparently, and now he's kicking up hell's delight because it won't get America. It's wonderful what some people expect from a six-guinea music-box."

"It should get it," I said. "My set gets it anywhere."

Smutty laughed. "Anglers, motorists, and radio fans..."

"But it does—after dark," I said. "I'll bet I'll take you out to-night and tune-in Pittsburg." Smutty makes me say things like that; he's provocative.

"I bet you don't go down near old Mingeing Marsh's house and tune-in Pittsburg," Smutty said, cunningly.

"Old who?"

"Old Mingeing Marsh. The hermit. The boy with the all-wave set. They call him Mingeing in the town. There's an idea about that he's got whole sacks full of gold hidden underneath his floorboards, and he wants a wireless to drown the tinkling as he counts out his sovereigns."

I laughed. I know Smutty's cock-and-bull stories too well.

"Anyhow, I'll bet you I'll take you anywhere you like and tune-in Pittsburg."

"And I'll bet you a fiver you don't," Smutty said, narrowing his eyes.

"All right. That's on." To me it was a bet as certain as a half-crown on the worst outsider of the afternoon, for though the set *had* picked up America, conditions had to be very, very favourable.

I'M afraid I've let radio get beyond me. In the old days, when valves were simple things with four legs, I was as good as the next man; but now they have become centipedes, I find it easier to buy a superhet which needs no more than a wall plug and the ability to read station names.

But certain things I do remember from my experimental days, and one is that thick woods and deep valleys are about the worst natural locations for good reception. Old Mingeing Marsh's house was in the deepest and most thickly wooded valley in the whole New Forest. Add to this the fact that it was summer time, and the uncertainty of short-waves anyway, and you'll see that my fiver rocked on a

□.....□

## Another Thrilling Mystery Story

by

John Newton Chance

□.....□

needle balance. In fact, when I saw the location Smutty selected, I counted the money as well on its way down the drain.

It was just after eleven when we stopped in the bottom of the valley. On each side of the road the forest trees grew thickly together.

"Old Marsh's house is in there," Smutty said, jerking his cigar in front of my face. "No, it's no good you looking. You can't see it. It's about two hundred yards from the road, and they say it's a real entertainment to see him bouncing up his cart track on his iron horse. There's the track."

He pointed ahead, and in the headlight beam I saw the lighter colour of clay where the track broke across the grass border and joined the road.

I switched off the headlights, and Smutty settled back to win his fiver. He puffed contentedly at his foul cigar and stared ahead into the darkness.

The look of the spot had already damped my hopes, but when I began to tune down from fifty-five metres, I felt I hadn't a hope left. In the ordinary way, Morse transmissions in that band fairly ring through the car, but in that spot it was difficult to pick them up at all.

I tuned down towards ten metres, and just above thirteen I picked up a disturbance. It sounded like a ragged sort of humming, and with the sound of it my hopes rose again. I took it to be a carrier-wave.

It *did* occur to me that the mush covered rather a broad spread on the dial, but I took no notice of that objection at the time.

"There's something here!" I said.

"Pick it out, boy," Smutty said, waving his cigar in a generous gesture. "I wait only to be convinced."

"It sounds like generators," I said.

"Generators!" he laughed. "Hell! don't listen for generators. The only chance you stand in is if they're putting over a brass band, Paul Whiteman, and a cinema organ all at once. You've probably picked up Marsh's refrigerator cutting-in," he added kindly.

But I was trying to pick something out of the mush. The needle hardly moved on the dial as I angled for Pittsburg and Smutty's fiver.

Then suddenly it happened. A hoarse, distorted voice—hardly recognisable as a voice at all—broke through the mush. It was broken, ragged, but I had been waiting for the sound of a voice, and my imagination fastened on to it immediately. The voice seemed to shout, then there was a sound like an explosion badly recorded on a film; a crumbling sound.

"And that's his vacuum cleaner," Smutty said, flicking a piece of cigar leaf out of the window.

"Nonsense. It's a play. The tail end. Somebody's been shot. That chap said, 'What do you want here?'"

Smutty roared with laughter and dropped his cigar. He bent to grope for it on the floor.

"My hat! What imagination!"

"I'll bet that's what it *was*. You wait a minute, and we'll hear an announcement."

"The National Broadcasting Company," Smutty said through his nose. "Be sure and tune-in at this hour to-morrow afternoon . . ."

We waited, but no more voices came. The mush still remained, but no recognisable sounds broke through.

"Hallo!" Smutty said, jerking his cigar across my face again. "Old Marsh is going up to complain about his set again."

I looked aside and saw the white headlights of a car shining through the trees.

## "A SOUND LIKE AN EXPLOSION!"

"What, at *this* time of night?"

"He went at four o'clock last night. Stood on the darned pavement and shouted about what a crowd of charlatans and swindlers the wireless

people were. We had to pinch him for disturbing the peace. Then he told *us* all about ourselves. Lord, but he was in a temper! Told us how he'd waited up half the night and lost his sleep trying to get America, when the cursed set couldn't get America—"

The car swung out of the track on to the road, and accelerated away from us. Smutty touched my arm.

"Go on, after him!" he barked. "We don't want him to get loose again. He'll probably break the shop window. Put your foot on it!"

He jammed his ragged cigar between his teeth, switched on the engine and pulled out the starter. I started off after Marsh, but he had a good lead, and he seemed to be in a hurry to get into town. We raced up the hill, out of the valley, and when we crested the rise the radio suddenly said:

G S G, G S L—L for liberty . . ."

"So it gets Daventry," Smutty said. "Now let's see this crate walk at seventy, otherwise I'll say you've been lying to me."

We went down the long slope into the town, with the road running under us like a strip of unwinding tape. The red tail-light gleamed ahead, then vanished round a bend. We took the bend with the tyres screaming, and the red light twinkled from the darkness beyond the headlight beam.

"How old is this bloke?" I said, keeping my eyes ahead.

"I don't know. He *was* sixty."

I didn't answer. Smutty is always talking utter nonsense and expecting you to search it for some semblance of wit.

The lights of the town appeared ahead, and the leading car slowed down to fifty. We gained on him quickly for a few seconds, until we, too, had to slow down. We followed him through the High Street at fifty-five, with street lamps flashing by in rhythmic flicks of light.

Marsh came to the end of the town, then forked right on to the London road.

"He's going to complain to the head office," Smutty said grimly.

We took the right fork and followed him up the long hill towards the plain. We gained considerably on the slope and shortened the lead to a hundred yards. I had to pay too much attention to the driving to remember anything that Smutty had said.

All I had in my mind was that we should overtake Marsh, and I was enjoying it. For I'm not often asked by the police to drive dangerously.

On the level of the plain he was eighty yards in front.

"Now you've got him!" Smutty said.

"I haven't," I said. "I can't wring another ounce out of it."

"Hoot! Flash your headlights!"

I hooted and, in answer, an arm appeared from the driver's window and signalled me to pass. Smutty laughed, and I began to switch the headlights up and down.

Marsh noticed this signal and began to slow down. We came level with him, then slowed down to his speed.

"Your rear light's out!" Smutty yelled through the window.

The driver nodded his head, then slowed down and stopped by the roadside.

"Park her right across the road!" Smutty barked. "Right across; don't give him an inch!"

## THE PART THAT RADIO PLAYED

I swung the car across and left it dead in the middle. Smutty got out and went towards the other car, as a man in a coat and felt hat got out.

"I'm a police officer," I heard Smutty say. "I'd like to see your licence."

The man said nothing, but put a hand into the breast-pocket of his coat. Then the astonishing thing happened.

Smutty hit him hard on the side of the jaw. The man staggered back against his car, and Smutty grabbed both his arms behind him. I ran round the car, not knowing what on earth was happening. I had gathered that Marsh was slightly mad, but I saw no reason for this peculiar treatment. Any man has the right to drive at seventy miles an hour at night if he wants to.

"Have a look at his inside pocket," Smutty snarled over the man's shoulder.

I put my hand in and pulled out an automatic pistol. I remember being more surprised at the weight of it than at the fact that it was there at all.

"Now go through the other pockets."

I did. It was difficult, since, not knowing the man from Adam, I didn't know what might be peculiar about his possessions. I'm afraid I behaved rather dumbly, quite unlike the usual type of man flung into a Secret Service trail of bloodshed. I felt that it was all rather ridiculous, and I've no doubt you would have felt the same in my position.

But I did find a bundle of notes and a very large bunch of keys. It was as I brought these out that the man suddenly twisted out of Smutty's grip, hit me in the mouth and ran.

Smutty picked up the gun I dropped and fired twice. The man fell headlong into the ditch. Smutty ran to the ditch and pulled him out.

"Thank God!" he said: "Only hit him in the leg."

The man looked up and gave out his opinion of Smutty in a most remarkable and varied series of expressions.

"I arrest you for the murder of Richard Marsh at his house, Denewood, at eleven-twenty to-night," Smutty said.

"How do you know he's d—"

The man stopped.

"So you *did* shoot him," Smutty smiled grimly. "We'll hold you till we know whether he's dead or not. You went to find his hoard and, by accident, you found him fiddling with a wireless set. It's all very simple."

WE went back into town, left the man there and went to Marsh's house with two policemen. Smutty had told us that we would find him shot in front of the new radio, which would be still switched on. We found just that.

I knew, then, that Smutty must have heard those blurred words just as surely as I did.

"No, I didn't," he said, lighting a cigar. "It was only after you'd told me that they began to seem like what you said."

"But I don't see how you connected——"

"Takes a detective to see these things," he sneered. "In the first place, the car that came out of the drive wasn't Marsh's. Marsh hasn't got a car. Would a man have a car and leave it in his forest retreat while he bumps about the countryside on an aged bicycle?"

"Then, if you knew it wasn't Marsh, why did you pretend it was?"

"Suspense value," he said, waving his cigar. "Besides, I look twice as clever that way."

"But it might have been a friend——"

"Didn't I say he was a hermit? Don't you know what a hermit is?"

"Both those things are inconclusive. And, anyhow, I didn't know Marsh had a short-wave transmitter."

"He hasn't."

"Then those words——"

"Do you remember me mentioning Marsh's six-guinea all-wave set? Well, if you read your advertisements like a good boy, you'll know you can't get an all-wave superhet for that price. You get a straight circuit with a reaction control. You know—you turn the knob and make it squeal."

"I know what reaction is, fool!"

Smutty laughed joyfully.

"And if you push a set to the edge of oscillation, it's possible—depending upon considerations of circuit—to radiate gruesome sounds over a very small area. Did you never hear of that before?"

"Yes, I have."

"Well, there was old Marsh, with the reaction pushed up tight, searching for carrier-waves down amongst the dead men. In comes this chap behind him. Marsh turns round and yells. The oscillating set puts out a violent distortion of the scream, and you, trying for Pittsburg same as Marsh was, pick up the noises."

He picked a leaf from his cigar.

"What put it into my head was, when you were searching for sounds, it reminded me of my early days of sitting up all night with headphones on. From there I remembered how two of us used to try to send out messages by pure oscillation. Just a chord in the memory."

"Very ingenious," I said, "but I wouldn't have acted on a few disjointed guesses like that. The sounds we picked up might have come from anywhere."



Smutty hit him hard on the side of the jaw. The man staggered back against his car.

"Disjointed guesses!" Smutty said fiercely. "Is that what you call it?" He laughed. "And you should take a few lessons in psychology. Those sounds couldn't have come from anywhere outside this valley."

"Couldn't?"

"Do you think I'd have betted you a fiver unless I was backing an absolute, cast-iron bonker?" Smutty said. "My dear, good fellow, the engineer came down here to-day to see what he could do for Marsh. He found that this is an absolute black spot for short waves. They just don't come down here, that's all. A freak of Nature." He shook his head. "No, my boy, I never back anything but dead certs."

Well, that's the sort of rogue he is.

**A**FTER one has seen what E.M.I. Service really means, a certain significant conclusion is inevitably reached. Simply that we must rid ourselves of "the set's gone wrong again" connotation of service, and in its place visualise radio service as that part of expert maintenance by qualified dealers without which no such highly intricate piece of apparatus as a receiver can be expected to give lasting pleasure.

That, anyway, is the general lesson I have learned from my chat with Mr. E. J. Emery, the Managing Director of E.M.I. Service, Ltd. He is in charge of an organisation unique in radio—and that is not a figure of speech. There is nothing quite like this organisation anywhere else.

### A Nation-Wide Organisation

Entirely self-contained, it looks after the products of four companies—The Gramophone Co. Ltd., H.M.V. Household Appliances Ltd., The Marconiphone Co. Ltd. and Columbia Graphophone Co. Ltd. A nation-wide service organisation has been built up, with charges that are the lowest possible compatible with a high standard of workmanship. A flat rate is charged for all service calls, but the charge is made only while the man is actually on the job. It is all the same if an engineer has to take train from Hayes to Land's End or John o' Groat's as if a local man were called in.

Normally, this service is intended to back up the local dealers, not in any way to supplant them. But let Mr. Emery, the live wire of this business, tell you about his organisation.

### Resident Engineers Employed

"The first point is that E.M.I. Service is a national organisation in every sense of the phrase. We have resident engineers throughout the country. Urgent calls for service can be dealt with in four hours, if necessary. Generally, we reckon on twenty-four hours, which I think you will agree is reasonable."

I did, bearing in mind some of the grisly tales of sets put "on the shelf" for weeks, even months, awaiting so-called service attention. Mr. Emery emphasised that, although occasions undoubtedly arose when it was advisable to send the set back to Hayes

# This Is Real Radio Service!

*Our Special Commissioner Interviews the Managing Director of E.M.I. Service, Ltd.*

for a thorough overhaul or repair, normally he aimed to make the local dealer competent to handle the job himself, with or without assistance from the local E.M.I. Service trained engineer.

"The first thing we try to teach the dealer is proper installation technique," went on Mr. Emery. "You know as well as I the value of so-called free installation. Often enough it means throwing up any old bit of wire round the picture rail.

### HEAD OF THE ORGANISATION



*Mr. E. J. Emery, Managing Director of E.M.I. Service, Ltd.*

"The modern set is so sensitive that it is quite possible to convince the ordinary listener nothing better is needed; stations roll in well enough, however poor the aerial. To make this possible, the volume control has to be pushed up to its limit. What is the result? A noisy background, and as often as not static picked up from the closeness of the aerial to various sources of electrical interference.

"With our modern anti-static type of lead-in cable, the aerial can be erected in its most efficient outdoor position, and lead along under the ground or floorboards to its most convenient set position in the room. Then for the modern luxury flats the aerial problem is equally well solved with this type of cable.

"It is possible to put up one good aerial on the roof and to tap off any number of individual leads for sets

installed in the flats. How much better than a lot of indoor aerial wires—all picking up internal sources of interference!

"We now have a new type of cable that will take care of the coming of television, too.

With this it is possible to erect communal aerials capable of dealing with all the wavelengths from 3 to 2,000 metres. I might mention, in passing, that we are now recommending dual points for flat aerials, one for sound and the other for the vision that will eventually be wanted.

### Household Appliances Too!

"To get back to the purely service aspects of my organisation, I should add that we deal not only with the radio gramophones, but with household appliances, such as refrigerators. Further, we guarantee to service any piece of E.M.I. apparatus up to five years from its withdrawal from the catalogue. We have in stock no fewer than three million parts to make this possible. That number of items represents 54,000 different types."

At that moment the telephone bell rang—an urgent call from Belgium for a highly skilled service engineer. Mr. Emery called in one of his divisional heads and said:

"Take this Belgian call and send one of your best engineers on this afternoon's plane." Within a few minutes a man was on his way. The whole incident, I must add, was treated as a matter of no more importance than just sending an engineer round the corner to the next street.

### Identical Treatment for All

"What I want you to understand," smiled Mr. Emery, apologising for the interruption, which I personally would not have missed for worlds, "is that we have brought service up to a basis of maintenance. It doesn't matter whether you buy a 12½ guinea machine or a 110 guinea radiogram, the service available is precisely the same.

"Radio, you know, has been going as a trade concern for a matter of only twelve or so years. Yet in

*(Please turn to page 128.)*



# Tour the World with This All-Wave Battery Set



THE advantages of a set which is able to tune-in short waves as well as the ordinary broadcast bands should be quite self-evident. But there has been so much loose thinking and writing about the subject that I feel a few special words are called for on this occasion.

Now this three-valver costs little, if anything, more to build than any ordinary arrangement of three valves. It is able to give very good service indeed on medium and long waves. It has ample reserves of power and selectivity within the limits of its specification. Judged from this point of view it is capable of satisfying the normal broadcast needs of a large percentage of listeners, if not all of them.

better than that to be found on the other bands. This set is designed to open up this, as yet, little used alternative. With its H.F. stage operative and giving amplification on the short waves, and with other features, it is able to tune them in very effectively.

These folk who keep on referring to the fading on short waves as though this washes out any possibility of achieving consistent entertaining reception unless very elaborate and expensive apparatus is used simply do not know what they are talking about.

bulletins and concerts which come over with great reliability. And then there is Zeesen also providing daily news bulletins in English and jolly good musical entertainment, not to mention French and other stations. Merely to add these is to gain a great deal, for

---

Why be confined to medium and long waves? Build this receiver which gives you all the advantages of an efficient "broadcast" receiver plus the varied entertainment to be derived from listening on the short waves. All this is obtained with little added expense and without extra complication of operation.

---

Designed and described by D. GLOVER.

---



The set is built on the chassis principle, but without the constructional complication often associated with chassis designs.

But, although the addition of the short waves to this fine little set does not increase to any great extent either its costs or the construction, I am not going to say that the short waves are thrown in, as it were, that you need not use them if you do not want to do so, and that at the least the set is a sound one for ordinary broadcast reception.

The short waves provide good entertainment, often as good as and

**Regular Programmes**  
There are some short-wave stations that provide regular and good programmes not available on other wavebands, which do not fade as much as medium wavers, and which can be heard just as loudly and clearly.

Rome, for example, gives war news

frequently you find them most attractive alternatives during the dead Sunday and other periods.

It is quite true that when you turn to the stations situated thousands of miles away fading does at times tend to interfere with reception. But what would you? Isn't the mere fact that you have the programmes of other continents opened up to you a tremendous asset? Wandering from one to the other of these extremely far-away entertainers you can nearly always light on some which are loud, clear, and not fading more than a trifle.

There is an idea widely current that you have to sit up to the small hours of the morning in order to hear such

DESIGNED  
FOR EASY  
BUILDING

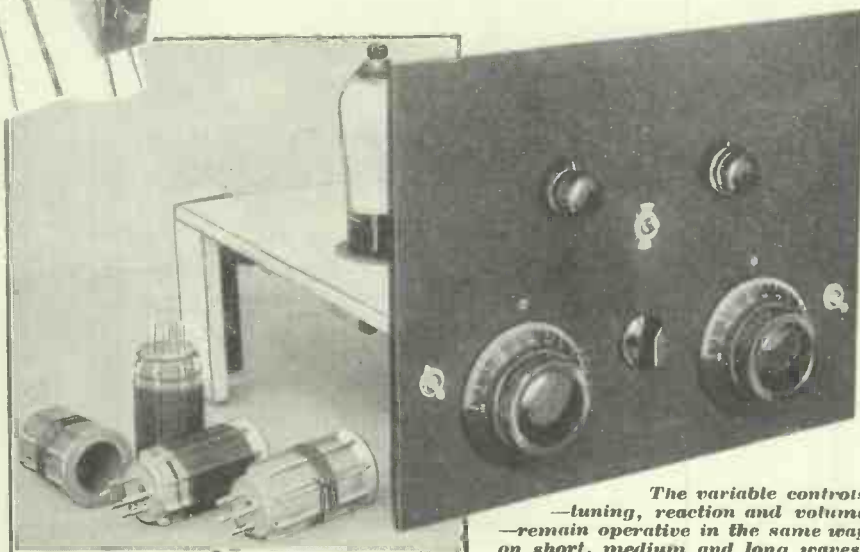

The variable controls—tuning, reaction and volume—remain operative in the same way on short, medium and long waves.



of the switches returns you to the original condition.

The same tuning condensers are employed throughout. But the switching which takes you over to short waves (and back again), and which rearranges the reaction circuit, also automatically adjusts the capacity ranges of the tuning condensers and makes them suitable for efficient short-wave working.

In some all-wave designs it is the practice to employ .0005-mfd. condensers for tuning the short waves as well as the medium and long waves. But this is not a particularly healthy practice as can readily be appreciated.

### Condenser Values

The condensers in the present set drop their value when you switch over. Series fixed condensers are brought into circuit. And it will be noted that these do not push the tuning condensers into "the air." They are on the high potential sides, and so the moving vanes of the tuning condensers are still earthed in order to eliminate hand-capacity.

The net result is that for all intents and purposes the tuning condensers become .00018's instead of .0005's, which is much more in line with the best short-wave practice.

### A First-Class Set

Although there is switching to take you over to the short waves, you are not fixed to the one arbitrary range of wavelengths. This is what often happens on all-wavers with switching—some of the best commercial ones, too.

But, of course, no one coil will cover all the short waves satisfactorily. It must be borne in mind that on, for example, the very short waves a matter of a few metres is equal to a whole broadcasting band higher up the spectrum. That is why thousands of stations can be accommodated "down there" as against the hundred or two on the medium waveband and only a dozen or so on the long waveband.

So to make this set really wide in its coverage, I have employed a plug-in

system so that you can change over the whole short-wave band for another one at any time you desire.

I have hinted that this set is particularly good as a short-waver. It is. So often the short-wave side of an all-wave outfit is merely an apology, an adaptation of unsuitable medium-wave technique, as it were. But I have gone all out to make this set as good on short waves as it is on the others.

When you switch over the outfit is a short-waver—and a first-class one at

coil windings are not sitting right on top of the short-wave coils and sucking energy away from them. By using separate coils and placing them on the other side of a baseboard, which is earthed, you have in effect entirely removed the ones not in use. In truth does the set become a short-waver and not a compromise.

### Scientifically Planned

I think I can safely say that the outfit has been scientifically planned, and I can bring this fact to the fore all the more readily because it has not been all my work. Each of the members of the Research Department of this journal has given the set a "once over" at various stages in its development, and has criticised it and offered suggestions. I do not think any previous three-valve set of any kind could have been subjected to more careful planning.

You will require to make several connections with the surfaces of the Metaplex. These can best be made by looping the ends of the leads, after having scraped them clean, and then screwing these loops down with small wood screws. Washers can usefully be used to hold the wire firmly in contact with the metallised surface.

The leads which pass through the baseboard must naturally have fair clearance. Don't tug them through undersized holes or their insulation may be damaged, and in that event short-circuits might occur.

### Important Points

Use flexible wire for the battery leads and do not have these over long. I do not mean by that that an inch or two here or there will make any difference at all, but have the

batteries reasonably close to the set. Not the other side of the room, for example.

It is always advisable to have a good earth when you are dealing with short waves, though the conventional water-pipe and so on will be quite O.K. so long as a sound connection is made at the point where the earth is joined.

The advantages of a high, outdoor aerial are more likely to be evident on

### PANEL PREPARATION DETAILS

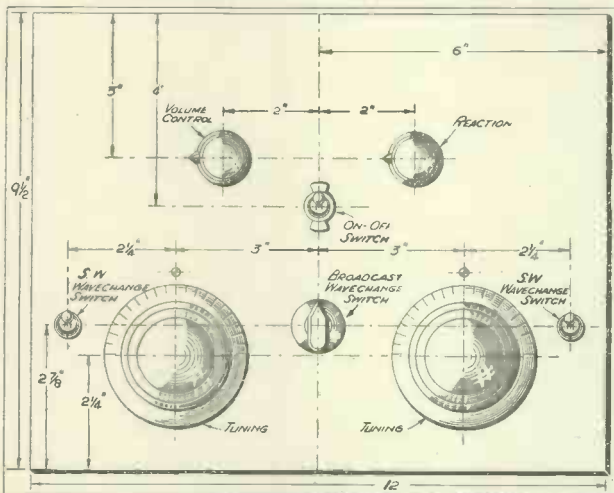

Information on the panel drilling and the positions of the panel-mounted components are contained in the above diagram.

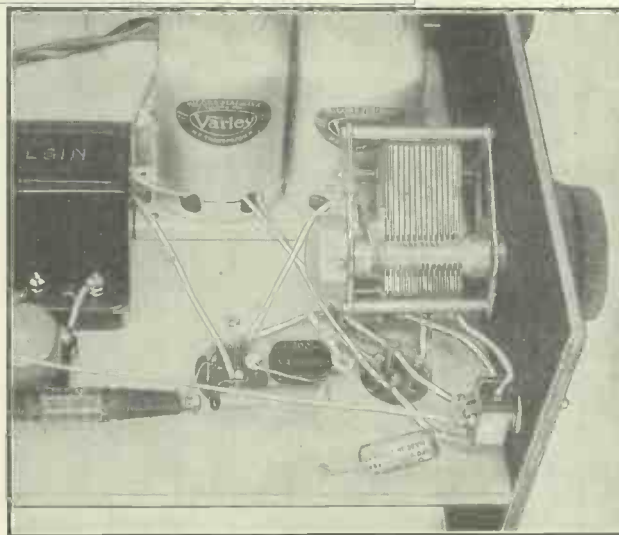

This photograph shows the detector section. The detector valve holder is on the left, the valve holder nearer the panel being for the detector-stage coil unit.

that. There is the best form of reaction, an H.F. stage which amplifies to a considerable extent, and does not merely act as a reaction smoother, a buffer between the aerial and the detector.

The tuning condensers have their capacities reduced to a correct value, and all the medium- and long-wave coils are earthed well and truly beneath the metallised baseboard. This is a point worth emphasising. The inactive

the medium and long waves than on the short waves, which have a habit of coming in just as well on a short indoor aerial as the best outdoor one. For that matter, you will hear plenty of the ordinary stations on an indoor aerial.

We have specified three sets of the short-wave coils to cover a range of from 13 to 94 metres. Actually, in this set we have found that these coils have a slightly wider range even than that.

### The Best Range

It is difficult, if not quite impossible, to say which of the coils is the most valuable. There are good stations to be found in all the ranges. If I had to choose only one pair out of them I might feel inclined to take the 22-47-metre ones, but then there would be times when I should want to hear the 19-metre stations and others when I wanted those around 50 metres!

Seventy-five volts H.T. will be about right for the screened grid (H.T.+1), and naturally the full 120 volts should be given to H.T.+3, for this feeds the output valve.

There is a separate H.T. tap for the detector valve (H.T.+2), and so you can play about with this until you get the results which fully satisfy you,

## NEATNESS CHARACTERISES THE RECEIVER

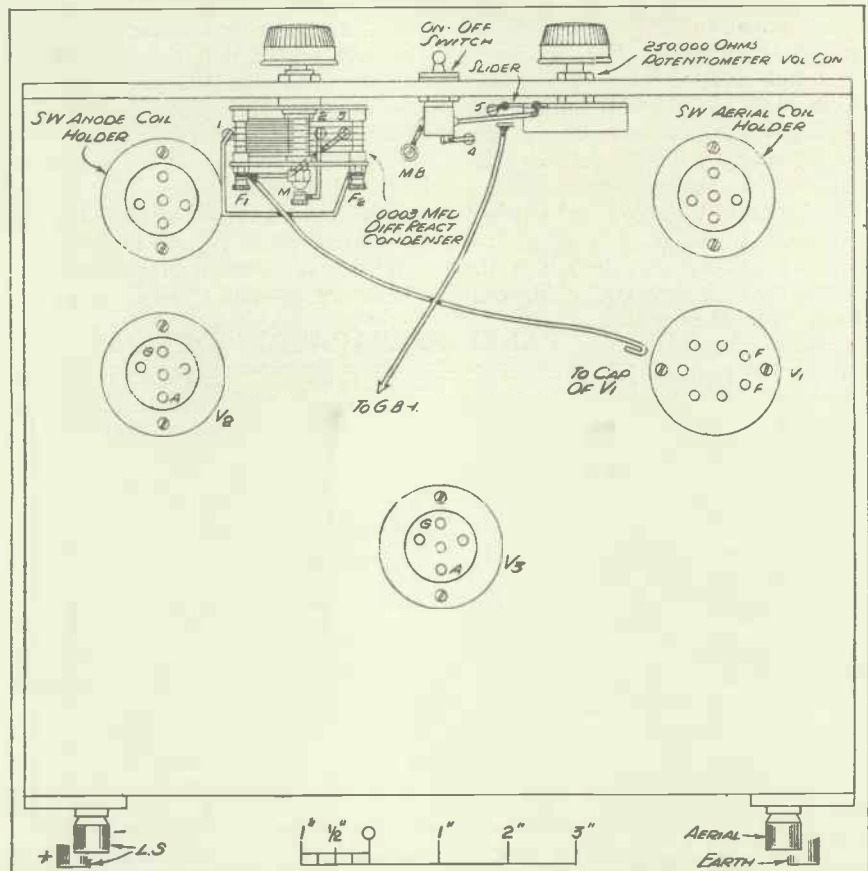

### FROM UNDERNEATH

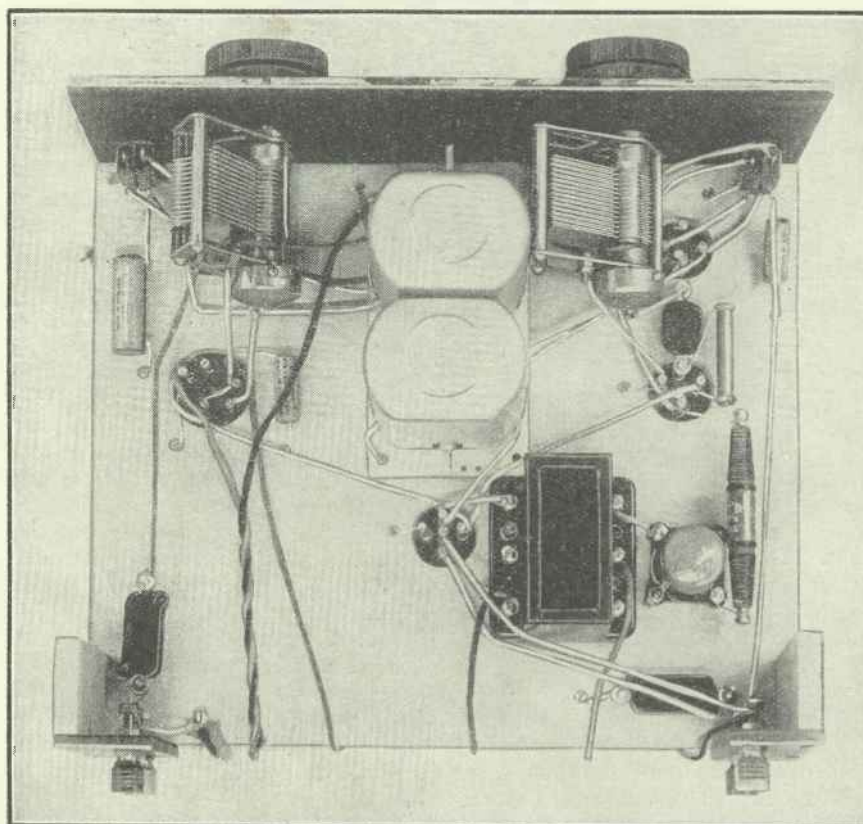

Comparison of this photograph when wiring-up with the diagram on page 112 should assist you in obtaining a good copy of the original.

The few leads visible above the base-board are illustrated in this wiring diagram. The numbers against holes in the baseboard correspond with the numbering on the wiring diagram on page 112.

although if you chance it at ninety volts you cannot be much out.

This detector H.T. voltage to some extent affects the smoothness of reaction. The reaction is normally very good and is not greatly affected by this voltage, that is, not within a few volts here or there.

But you may quite likely find that the set does not on occasions oscillate at the extremes of the ranges of the short-wave coils. But this need not worry you a scrap, for there is a wide margin. There is sufficient overlap for all the stations to be covered easily and with something to spare.

### Quite Easy Tuning

The tuning is not as critical as some might think. Of course, the short waves always need a little more coaxing than the ordinary ones. The tuning controls require to be handled appropriately. But although the tuning on the right-hand condenser (looking at the front of the set) will possess the normal short-wave keenness, the left-hand one is not sharper than, say, that of a condenser which is

# DUBILIER

## CONDENSERS & RESISTANCES



**DISCRIMINATING  
CONSTRUCTORS  
USE  
DUBILIER CONDENSERS  
AND RESISTANCES**

**DUBILIER  
stands for  
DEPENDABILITY**

and the use of a Dubilier  
Condenser or Resistance  
is an assurance of the  
utmost efficiency at a  
minimum of cost.

Write for a free copy of  
the Dubilier Illustrated  
Catalogue.

Dubilier Condenser Co. (1925) Ltd., Ducon Works, Victoria Road, North Acton, W.3



This is the  
De Luxe Edition.

Your Copy of the  
**BOOK OF  
PRACTICAL  
TELEVISION**  
is Now Ready

Send in Completed Gift  
Voucher and remittance at once.

Your volume is waiting. This month gift token No. 2 appears, and readers who have collected gift token No. 1 will be able to complete their Gift Vouchers, which, together with cash remittance, should be sent in immediately.

Do not delay! Volumes will be sent out in strict rotation, and if you want yours quickly you must send in your completed Gift Voucher the moment it is ready.



This is the  
Standard Edition.

Send Gift Voucher  
and Remittance to:

**WIRELESS & TELEVISION  
REVIEW** Presentation Book  
Dept. (G.P.O. Box No. 184a),  
Cobb's Court, Broadway,  
London, E.C.4.

# Wharfedale

## MOVING COIL SPEAKER

**does Justice to  
the best of sets**

It is little use building or buying a first-class set if the speaker lets it down. After all, what comes out of the speaker is the only real test of a receiver.

Wharfedale speakers are designed and built for quality reproduction. They have a well-balanced response range from below 50 to over 8,000 cycles, free from obtrusive resonance peaks. All models fitted with high-efficiency magnets of nickel-aluminium alloy and all gaps provided with 100% dust protection. Exponential cones (wide radiation) fitted to certain models.

Universal Transformers give perfect matching to all output valves. "CORONET" Cabinet illustrated is a worthy example of the Wharfedale range.

**UNIVERSAL - 52/6**  
Less Transformer, 45/-

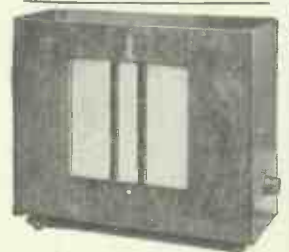

**GET A WHARFEDALE  
EXTENSION SPEAKER**

PRICES—UNIVERSAL	
Standard Chassis	- 32/6
Bronze Chassis	- 42/6
Golden Chassis	- 62/6

Bijou Cabinet	- 39/6
Coronet Cabinet	- 52/6
Bronzian Cabinet	- 65/6
De Luxe Cabinet	- 100/-

Send to-day for FREE  
Illustrated Catalogue.

**WHARFEDALE WIRELESS WORKS,  
62, LEEDS ROAD, BRADFORD, YORKS.**

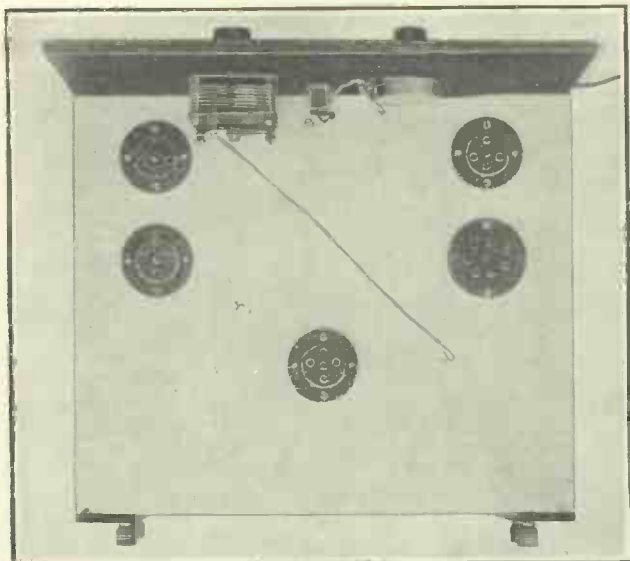

**STARK SIMPLICITY.**—An example of the efficiency which lies in the careful arrangement of the components employed.

tuning a long-wave station in conditions of average selectivity.

You will find that the set handles remarkably well, and will bring in the stations with considerable facility even after you have had only a short experience of its controls.

Although the layout of the set is of a very special character, it is not one that presents any difficulties to the constructor. I was careful not to lose the advantage of easy construction in all the other mass of attractive features.

### The Panel and Baseboard

There is a normal panel. I say normal, but it is normal only in so far as its simplicity is concerned. I am not going to press you to use ebonite for it. Five-ply wood serves the purpose admirably, and you will lose nothing electrical in employing it, and will save money if you do so.

The baseboard is Metaplex. The only alternative to this is ordinary plywood which you yourself cover with a layer of copper foil. The Metaplex is, on the other hand, all ready to use, costs no more in the long run, and presents no problems in preparation or use.

It will be noted that the baseboard is situated 4 in. up from the bottom of the panel, a semi-chassis scheme which permits of the merits of the chassis idea without its complications.

The two 4 x 1½ in. pieces of wood which support the baseboard at the back also retain the terminal strips, and these in their turn, by being screwed to the wooden strips (two ½-in.

wood screws), and to the baseboard by means of another screw, assist to render the whole construction strong and rigid.

The first task will be to drill the wooden panel and then to cut the holes for the valve holders in the baseboard. These holes will need to be 1 in. in diameter with the one exception of the hole for the seven-pin valve holder. That must be 1¼ in. in diameter. If you

haven't the tools to make these holes easily and quickly, you can get the baseboard supplied with them ready made at a trifling extra cost.

I would advise you to make the chassis completely before starting to mount the components. Some little care will have to be observed in lining up the coil unit correctly before it is screwed down, for you want its switch knob to lie properly. But this is merely a matter of common sense and hardly of technical ability!

Obviously you must wire up carefully, making sure that the leads run as straight as they can and do not crowd.

This is rather important in the case of the short-wave switches. Keep the leads to these well spread out without making them a scrap longer than they have to be.

### NOTHING TO WORRY YOU HERE

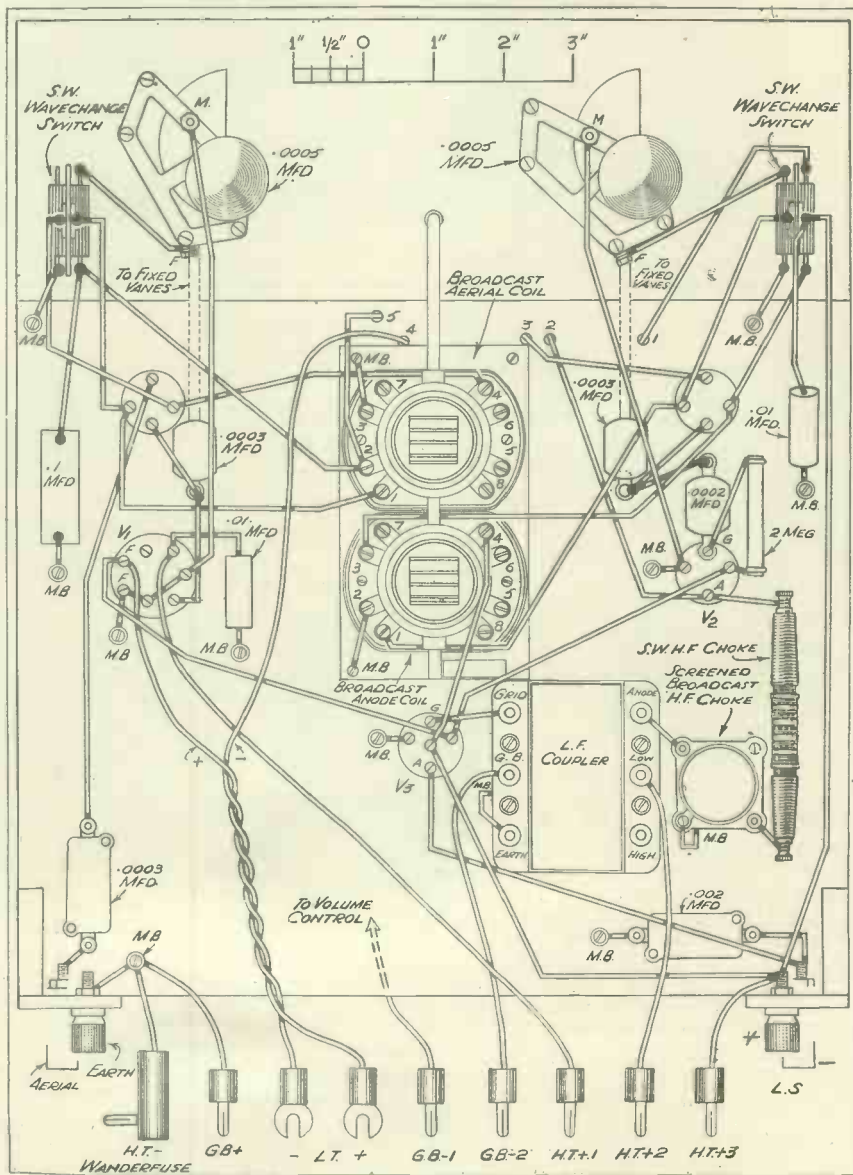

The wiring is even simpler than it appears in this diagram, a fact you will appreciate by comparing the diagram with the photograph on page 110.

# CHANGING the FREQUENCY

A review of the various mixer schemes for superhet receivers from the early separate triode oscillators and "First detectors" to the modern electron-coupled valves.

By E. H. GRIFFITHS.

**F**REQUENCY changing may be accomplished by means of two valves, one acting as the first detector and mixer valve and the other acting as the oscillator, or the two functions may be combined in one valve, a suitable coupling being made between the oscillating circuit and the signal frequency circuit.

As it is only recently that the two functions have been successfully combined in one valve for the purposes of telephony, it is proposed to deal with the two-valve method first.

The chief variations in these frequency changing circuits lies in the coupling between the first detector and the oscillator. The following methods are available for two valves :

- (a) Grid mixing.
- (b) Cathode mixing.
- (c) Anode circuit mixing.
- (d) Auxiliary grid mixing.

### Grid Mixing

This method was very often used in the early days of superheterodynes.

Two triodes are used as shown in Fig. 1, the first being the first detector and the second the oscillator. From the skeleton diagram it can be seen

### CATHODE COUPLING

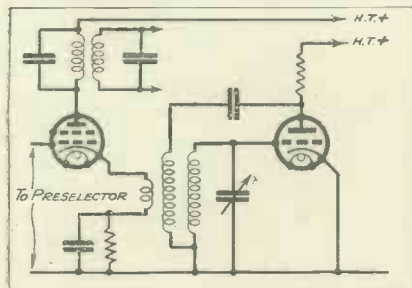

that the first detector is fed with signal frequencies from a centre-tapped frame aerial; the oscillator has a tuned anode coil coupled to an untuned grid coil. The coupling between the two circuits is effected by means of a small

coupling coil connected to the centre tap of the frame aerial.

The circuit is mainly of historical interest as the use of a frame aerial reduced the signal frequency pick-up to a very small amount.

With the advent of the screened-grid valve it was found possible to use an ordinary outdoor aerial with a superhet as it was possible to avoid re-radiation. If re-radiation is to be prevented it is not possible to use the control grid of the first detector in the coupling circuit and other methods have to be used. Cathode coupling is one of these.

Skeleton diagram 2 shows a method of cathode coupling. It will be seen that the coupling between the first detector is effected by means of a small

### USING A FRAME

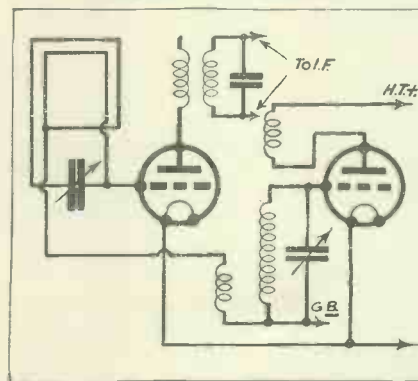

Fig. 1 (above) shows the early type of oscillator and mixer such as were used on frame aerials.

Fig. 2 (left) employs coupling provided by a coil in the cathode circuit of the mixer.

Fig. 3 (right) shows another form of cathode coupling via the condenser across the automatic-bias resistance.

coupling coil inserted in the cathode lead of the first detector. It is possible for this form of circuit to be used with battery valves where two coupling

coils are used, made of thick wire, one being inserted in each filament lead. The circuit shown, however, is for mains valves.

The oscillator has a tuned grid circuit coupled to an untuned anode coil, which is fed from the anode by a .0005-mfd. fixed condenser. A screened grid valve is shown, the input to which is through an ordinary preselector circuit. An H.F. pentode can, of course, be used, instead of the S.G. valve.

### A Third Method

Another method of cathode coupling is shown in skeleton diagram 3. The oscillator is of the conventional type and is coupled to the first detector by means of the reactance of a .0001-mfd. fixed condenser across the bias resistance common to the cathodes of both valves. This method of coupling has many advantages.

When the strength of the oscillations is at its maximum, i.e. at the highest frequency, the reactance (which controls the degree of coupling) of the

### REACTANCE FEED

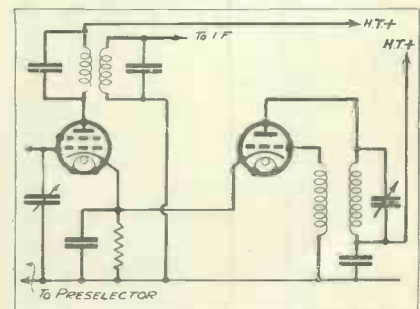

condenser is at its least. Thus there is a compensating action taking place which assures approximately that an equal amount of converted power is obtained at all settings of the oscillator dial.

The intermediate frequency may be produced in the anode circuit components of the first detector. This is termed anode mixing.

### Anode Mixing

A typical circuit is shown in diagram 4 of this particular kind of mixing. The mixing takes place in the primary of the first I.F. transformer. The H.T. supply for the first detector is fed through this transformer from the

#### ANODE MIXING

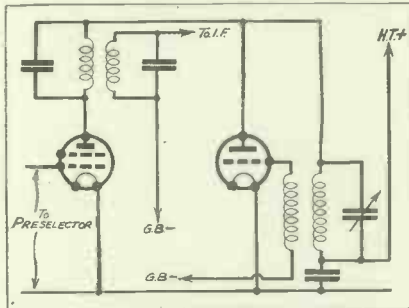

Fig. 4. A typical circuit for anode mixing. The oscillations are fed to the first I.F. primary.

anode of the oscillator which has a tuned anode circuit.

With the advent of multiple electrode valves of which the S.G. valve, the screened H.F. pentode and the bigrid valves are examples it was found possible to mix the oscillator and incoming frequencies by injecting the former into one of the auxiliary grids of the first detector.

### Auxiliary Grid Injection

Using a separate triode oscillator the following methods are possible:

- (1) *With S.G. Valve*: Injection into screening grid.
- (2) *H.F. Pentode*: (a) Injection into screening grid. (b) Injection into outer grid.
- (3) *Bigrig valve*: Injection into inner grid.

Methods (1) and (2a) have the disadvantage of having a rather high value of re-radiation, while (3) has never been very popular, probably owing to the same reason.

It is, however, possible to inject into the outer grid of an H.F. pentode from a separate oscillator in the manner shown in skeleton diagram 5, the circuit of which resembles very closely that of cathode injection. This method, however, does not appear to have found much approval in manufacturing or in wireless paper circles, cathode injection nearly always being used with H.F. pentodes.

The H.F. pentodes having separate outer or suppressor grid connections have found other uses in which a definite negative potential is applied

## THE USE OF PENTODES

to the outer grid. This action may be used to decrease the gain of the valve and to flatten the tuning so that better quality may be obtained where high selectivity is not essential.

### Single Valve Frequency Changers

A single valve may be used to perform the combined function of oscillator and first detector in a superheterodyne. Constructors have always grudged having to use a separate valve for the oscillator as it appeared not to add to the total gain of the set.

As valves constitute a very considerable portion of the cost of a receiver it is a welcome advantage to combine the oscillator and first

#### A PENTODE SCHEME

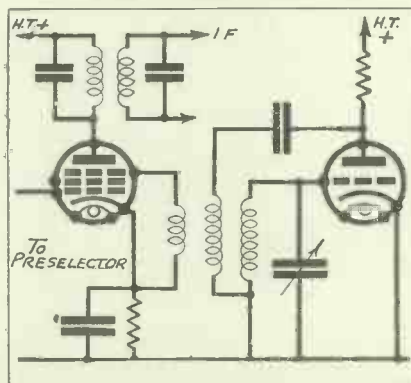

Fig. 5. In this arrangement the oscillator feeds a coil in the outer grid circuit of a pentode mixer.

detector in one valve. It is probably the same reason of cost which led one of our valve manufacturers to bring out a valve which is called the triode-pentode for frequency changing.

It consists of two distinct portions: one a triode, the other an H.F. pentode, which are entirely shielded from one another, the only part of the valve common to both being the cathode and the heater. The various electrodes of the two valves are brought out to separate pins beneath the glass envelope which contains them both, this necessitating a 9-pin base, and the circuit is wired exactly as if two separate valves were being used.

This valve cannot, of course, be considered as a single valve frequency-changer although only a single valve has to be used. The cost of the valve is considerably less than that of the two equivalent valves bought separately, and it may achieve some popularity for this reason alone, but

it has several very distinct disadvantages.

Turning to the single valve frequency-changer proper, the following methods are available for the job:

- (1) *With triode valve*: Ordinary autodyne method.
- (2) *With S. G. Valve*: Cathode mixing.
- (3) *With H.F. pentode*: (a) Cathode mixing; (b) Outer grid injection.
- (4) *With Bigrig Valve*: Inner grid injection.
- (5) *With hexode, heptode and octode valves*: Electronic coupling.

Method (1) using an autodyne triode arrangement is a circuit which is not used for receiving telephony, but is sometimes used to receive continuous wave telegraphy signals when the heterodyne is arranged to be of an audible not supersonic frequency note of variable pitch in the output circuit.

### Cathode Mixing

Method (2) is one which has been used successfully in quite a number of commercial superheterodynes. The circuit corresponds exactly with that for an H.F. pentode which is shown in Fig. 6. Nowadays H.F. pentodes are used almost exclusively in this type of circuit.

#### SINGLE-VALVE METHOD

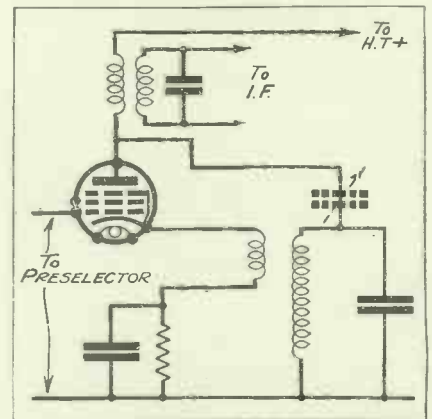

Fig. 6. How a pentode of the H.F. type is used in a self-oscillating mixer circuit.

Method (3 a) is that of using a self-oscillating frequency-changer of the H.F. pentode type, employing cathode mixing and is shown in Fig. 6. The conversion conductance of an H.F. pentode in this circuit arrangement is very high when used with intermediate frequency transformers having high dynamic resistance, iron-core transformers being very suitable.

The anode coil is fed through the intermediate frequency transformer tuning condenser. Coupled to this coil is the small cathode coupling coil in series with the cathode, the biasing resistance and by-pass condenser. The outer grid and the metal



coating of the valve are usually returned to earth direct instead of to the cathode, as shown in the diagram, as the former arrangement gives increased stability.

Care must be taken with this form of frequency changer to avoid adding to the control grid-cathode capacity by stray coupling in the wiring, as this causes re-radiation.

For other reasons, the control grid-anode circuits should be well screened from one another if the very best is to be got out of the circuit.

### Auxiliary Grid Mixing

Method 3 (b) may be employed, and the circuit used bears the same relationship to the two-valve method as does the single-valve cathode coupling method to the corresponding two-valve method.

### Bigrid Valve

The use of the Bigrid valve as a self-oscillating first detector is very interesting. Although the use of this valve for frequency-changing is undoubtedly out of date, it is of special interest, as it was the first real attempt to use a special valve for frequency changing.

As a matter of interest, a diagram of the circuit which may be employed in connection with an indirectly-heated bigrid is shown in Fig. 7. The inner grid is connected to tuned coil which is coupled to the coil which is connected between the anode and the primary of the first intermediate frequency transformer.

### Electronic Coupling

The methods enumerated in Fig. 5 are generally acknowledged to be the most successful of the many methods of single-valve frequency changing. The hexode is a valve which has been developed on the Continent for the especial purpose, and the heptode and octode valves first made their appearance in America.

### FIRST SPECIAL MIXER

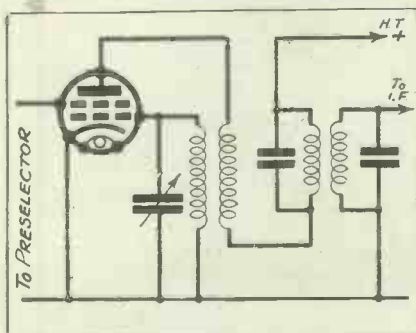

Fig. 7. Although not now used, the bigrid valve scheme is interesting as the first special mixer method.

## ELECTRON-COUPLING ARRANGEMENTS

These valves do not need to have any external coupling between the circuits connected to the oscillator section electrodes and those of the first detector. All the necessary coupling and mixing takes place with the valve itself.

Skeleton diagram No. 8 shows the use of a hexode valve converter. Grid No. 1 is the control grid, grid 2 is connected to a source of high potential and serves to screen grid 1. Grids 3 and 4 are the oscillator grid and anode grid respectively.

It can be seen from the diagram that the impulses from the detector portion of the valve will have to pass through grids 3 and 4 on their way to the anode. The circuits connected to these grids control the oscillating frequency, and therefore the two frequencies are very thoroughly mixed within the valve itself.

The heptode, or pentagrid as it is called in America, is one with which most of the readers of WIRELESS must be more or less familiar, and about which such a lot has been heard lately.

### HEXODE CONVERSION

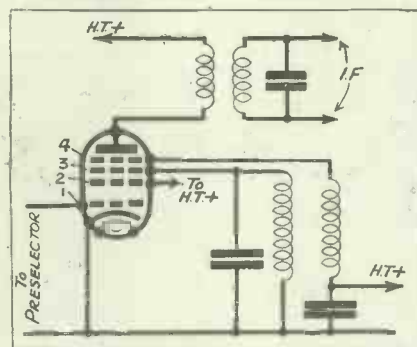

Fig. 8. How a hexode converter valve is employed in the superhet circuit.

The diagram No. 9 shows a typical circuit for use with this type of valve. The valve has five grids. Grid 1 is the oscillator grid, grid 2 is the oscillator anode grid, grid 3 is connected to grid 5, and is maintained at a suitable high potential and serve to screen the control grid, which is grid 4.

The control grid, cathode and anode act as an ordinary anode-bend detector, but instead of the electrons flowing from the cathode to the anode being controlled only by the control grid, grids 1 and 2, which are connected to the oscillator circuits, cause the flow to pulsate at a frequency determined by the constants of the oscillator tuning circuits.

This pulsation is superimposed on the ordinary action of an anode bend detector, and in this way the two frequencies are mixed in a very thorough manner without the need of external coupling.

It can be seen from the diagram the signal frequencies are applied between grid 4 and the cathode. The oscillator section consists of grids 1 and 2 and a suitable coupling between them. Grid 2 serves as an anode for

### THE HEPTODE

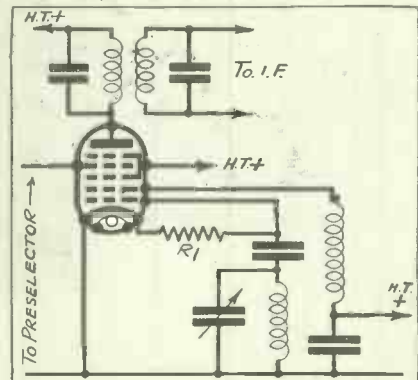

Fig. 9. One of the latest superhet advances, the special heptode mixer valve and its circuit.

the oscillator, and is connected to H.T. via the anode coil.

This coil is inductively coupled to the grid coil, connected to grid 1, which is tuned by the oscillator condenser. The oscillator grid is biased by the resistance R1.

The octode is different to the heptode in only one respect, and that is that the first detector portion is a pentode instead of a tetrode.

For the moment this valve and the triode hexode hold the record for the number of electrodes crammed round one cathode! I suppose that it would be possible to construct a valve of this type with a pentode portion both for oscillator and first detector, so keep your eye open for a decade!

The various ways of frequency changing have been dealt with rather briefly, but almost every method has been mentioned, and this should help those who have not read much about superhets to get a good general idea of how the most important part of this type of receiver functions.

A SPECIAL FEATURE

**NEXT MONTH**

Will tell you all about

**SHORT-WAVE CONVERTERS AND ADAPTERS**

and how to use them

# BROADCASTING IN FINLAND

*A page of pictures from Helsinki, where is to be found one of Finland's most powerful stations.*

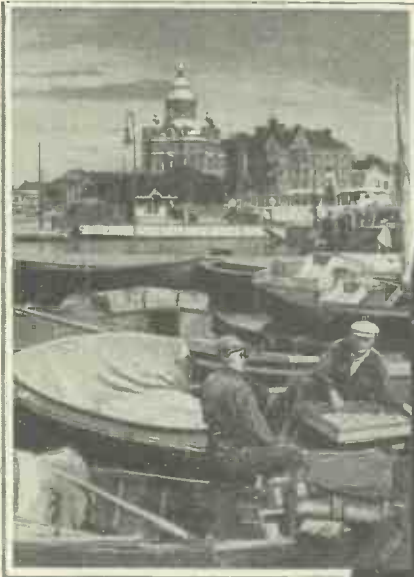

A typical view of the harbour at Helsinki, with the Russian church in the background.



The second photo is of Professor Ylostalo, the Deputy Director General of the Finnish Broadcasting service. The Broadcasting House at Helsinki, seen on the right, contains a number of modern studios, which compare favourably with British design.



Next to Broadcasting House, in the circle, we have a photograph of Markus Rautio, the chief announcer. He has been nine years at the microphone and is a popular "uncle" with the children. Below is seen the central control-room, which was completely fitted up by the technical staff of the Finnish Broadcasting Company.

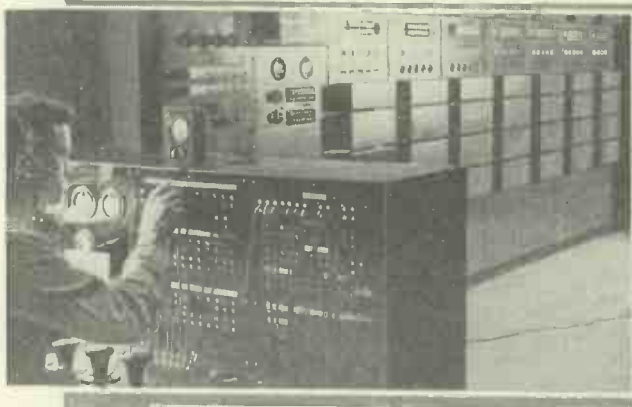

The lady on the right in the smaller picture is Miss Ulla Katajavuori, a well-known "Kantele" player. This is an instrument resembling the harp.



On the far right is Mrs. Jacobson-Silius, woman announcer of the Finnish stations. The remaining photo is of one of the producers at work. He has a clear view of the studio through the window.



# SHORT-WAVE DEVELOPMENTS

BY W.L.S.

No one can accuse me of upholding the "anti-British" attitude adopted by some short-wave writers and experimenters; but it is becoming increasingly difficult to talk of short-wave developments without referring to the U.S.A. ! This month's outstanding contribution to short-wave progress comes from the headquarters staff of the American Radio Relay League, that never-failing source of bright ideas.

## AN INGENIOUS SYSTEM

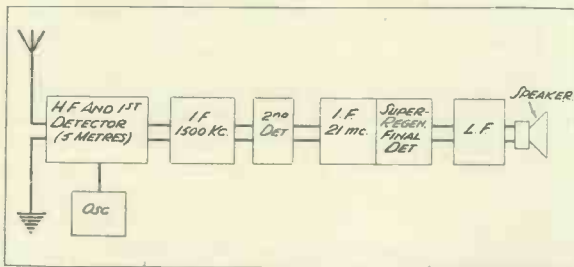

Fig. 1. The schematic arrangement of the latest American short-wave super-heterodyne development.

They have decided, at last, that the ultra-short-waves simply aren't getting a chance. The midget super-regenerative receivers that are so much in the fashion may be useful toys for the amateur transmitter who is content with a range of a few miles, but they simply aren't good enough for any serious work.

The superhet is the more logical receiver for the job, but suffers from several disadvantages—or, at any rate, lacks several of the very real advantages which are bestowed by the super-generator.

### Combining the Two

What could be more natural, then, than to combine the two, using a superhet with a super-regenerative second detector? One could then obtain reasonable selectivity by means of pre-selection and the tuned circuits at intermediate frequency, and, afterwards, make use of several valuable properties of the super-generator.

Among these latter are its ability to distinguish (favourably) between

★.....★  
 "THE STAGE IS ALL SET FOR THE RECEPTION OF REALLY LONG DISTANCES, EVEN ON WAVELENGTHS OF THE ORDER OF 5 METRES" SAYS OUR SHORT-WAVE EXPERT IN THIS PARTICULARLY INTERESTING ARTICLE.

★.....★  
 "man-made" static and signals, and its A.V.C. action—meaning its ability to adjust itself to the strength of the incoming signal. What we may call its "noise-discrimination" characteristic is the more important of these, and has been a very real advantage to users of this type of receiver.

Now for the snag. The super-regen. operates best at very high

## FIVE METRES

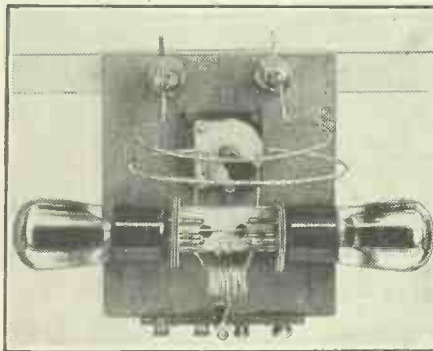

A compact 5-metre transmitter which is designed to be suspended from a tree or aerial pole.

frequencies, and a super-regenerative detector operating at the conversion frequency of the average short-wave superhet (say 465 kc.) is but a shadow of the lusty affair that we have been used to on 56 megacycles (the 5-metre band).

Accordingly our friends of the A. R. L. have developed what they call the "Super-Infragen"—in other words, a three-part receiver consisting of superhet, infradyne, and super-generator.

Incoming signals are first converted, along normal superhet lines, to

a fairly low frequency—round about 1,500 kc. (200 metres). The next step is to convert the 1,500 kc. signal to a much higher frequency—about 21,000 kc. (14 metres approx.), by the well-known infradyne method.

At this high frequency the full advantages of the super-regen. may be used, and the final detector, accordingly, is of this type. There is not much point in giving a full circuit diagram of this receiver, but Fig. 1 explains the scheme quite clearly, and Fig. 2 shows roughly the layout of the receiver, from which it will be seen that it is not terribly complicated in practice.

### Achieving Selectivity

All the necessary selectivity is obtained in the first conversion-stage of the superhet—at 1,500 kc. The second conversion, to 21,000 kc., is only for the purpose of obtaining much more effective "supering." The "second I.F." is fed directly into the final (super-regen.) detector without any attempt to obtain more selectivity by means of tuned circuits.

Thus the result really is a receiver with all the advantages of the super-regen. and none of the disadvantages—chief of which, of course, was its appalling lack of selectivity.

### THE "SUPER-INFRA GEN"

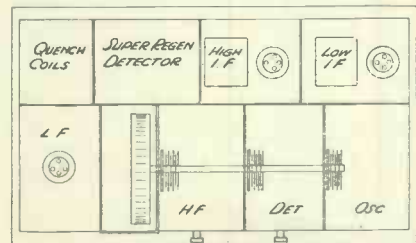

Fig. 2. How the new "Super-Infragen" is laid out on the chassis.

The designers claim that the result of their work is a receiver that handles exactly like an ordinary superhet, and with no more background noise. Furthermore, it started its working life by bringing in signals that an ordinary receiver simply wouldn't look at.

It appears that this particular short-wave development really will have a revolutionary effect upon ultra-short-wave working; and it could not have arrived at a more opportune time than the present, when the stage is all set for the reception of really long distances, even on wavelengths of the order of 5 metres.

By last month I was able to report that the amateur transmitters were covering most of the world on 10 metres, a thing which had never been done before in the history of radio. As I write this, things have improved still further. The position at the moment is simply this—that it is possible for an amateur with an input of 50 watts or so to work with the U. S. A. with greater reliability and signal-strength on 10 metres than on any of the other amateur wavelengths.

Day after day I have been receiving the Americans on "ten" at greater strength than I have ever heard them before on any wavelength — and this with a perfectly straight detector and L.F. receiver.

There are no particular receiving problems on 10 metres; any decently designed short-waver will get down there and behave perfectly normally.

### "Calling All Cars"

Now for the next stage. A few days ago, in the course of some band-spreading experiments down there, I listened casually between 8 and 9 metres, and what should I hear but a whole batch of American police stations, "Calling All Cars," "Missing from Home," and all the rest of it! And these comparatively low-powered stations were coming through at far greater strength than the 50-kw. broadcast stations on 19 metres.

As our dear old sunspot-cycle still has some years to go before the next peak is reached it is surely reasonable to assume that the "DX-band" will spread down as far as 5 metres. But those who pin their faith to crude super-regenerative receivers of the conventional type won't have much chance of hearing it.

## THE "TROMBONE" TUNER

Just to form some idea of the reliability of 10 metres at present, I am running a daily schedule with an amateur in New York. So far we haven't missed a day (it has been running about a fortnight). We haven't even a fixed time—we have simply agreed that I come on "after lunch" and he comes on "after breakfast." Signals are usually R8 both ways, and the least that they have been as yet is R6. How long we are going to keep this up I don't know—but I shall be disappointed if we don't get to the end of the year without missing a day.

### A New Principle

Does anybody know what "trombone" tuning means? No, it's nothing to do with Queen's Hall on the night of a symphony concert, but it is now an accepted radio term. This, again, hails from the U.S.A., and is a new form of resonant-line construction. Quite early 5-metre transmitters used a pair of parallel tubes instead of a tuning coil, with a shorting-strip (*a la* Lecher wire) for adjustment purposes.

Now we have the trombone! Fig. 3 shows the principle, and the appropriateness of the name will be seen at once. The total length of the "trombone," from A to B is a quarter of a wavelength, and Fig. 4 shows what a circuit diagram looks like when adapted to depict the new scheme. This, of course, is for transmitters only. We haven't sunk (yet) to receivers of this particular type of "push-pull."

### WEIRD!

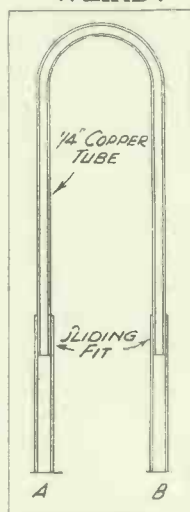

Fig. 3. The very latest method of tuning an ultra-short-wave transmitter is shown here.

### TWO "TROMBONES"

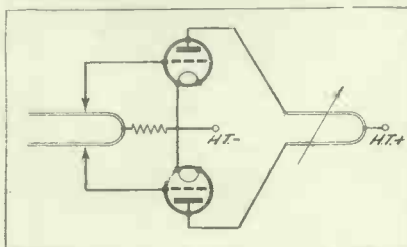

Fig. 4. A typical circuit using the peculiar "trombone" method of tuning.

One remarkable thing about the rapid growth in the popularity of short-wave reception is the way in which the short-wave converter has come back into its own once more. In the old days the building of a short-wave receiver that was "up-to-the-minute" in its design was a simple matter. Nowadays it's—well, not so easy.

Our modern broadcast receivers have automatic volume-control, inter-station noise-suppression, and a really high degree of selectivity; and no one who has used one would go back to the type of set that he thought quite a lot of five years ago.

When broadcast sets were simple there wasn't much point in making a short-wave converter. The H.F. gain in the broadcast set wasn't sufficient to warrant it. Instead, if we wanted to economise, we just built simple adapters that would utilise the L.F. end of the broadcast set.

### SUPERHET CONVERTER

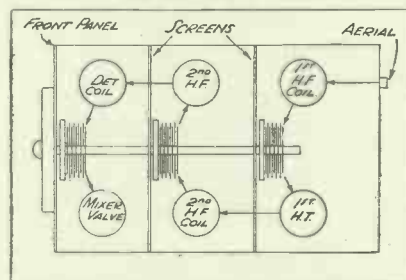

Fig. 5. How the "two H.F. and mixer" short-wave converter is laid out on its metal chassis.

Nowadays, when a man has a modern broadcast receiver at home, it just doesn't pay him to build a full-sized short-waver. He wants a really good converter, and all the advantages of the broadcast receiver are his for the asking, without any trouble.

I have recently been trying out a kind of "super-converter" with a really good commercial broadcast receiver, and the results one can obtain, from the entertainment point of view, are rather amazing. I left an American station on the speaker one evening, with the idea of seeing how long he would remain intelligible without touching any of the controls.

### A Powerful Set

After half an hour I started getting on with some work. After three hours I decided that his programme rather bored me, and went out. When I came back he was still there.

Such a receiver, I maintain, is no good for amateur DX listening—but for those who really want programme-value from the short waves it is absolutely untouchable. The converter, by the way, consists of two fully-tuned H.F. stages and a triode-hexode "mixer"—and the broadcast set is a six-valve superhet—so the combination ought to be good.

There's a certain amount of difficulty in ganging the four controls on the short-wave side, so I simply didn't try. I ganged the tuning of the two

H.F. stages and the detector, and left the oscillator control separate. All initial tuning is done on that, and the H.F. control simply brought into line until signal-strength reaches a maximum. Thanks to the triode-hexode and careful screening, there is absolutely no interlocking between the two controls, and a child could handle the set.

For the benefit of readers who like to give their broadcast receiver a truly world-wide range, I hope to describe this converter in detail early in the New Year, when I have done a little more experimental work with it. However good it may be, I always have a sneaking feeling that there's room for improvement.

### The Basic Layout

The simplicity of the layout for two H.F. stages and a frequency-changer is well illustrated in Fig. 5. This is the basic layout employed in the converter I have been talking about, although it makes it look a good deal tidier than it really is at present.

There seems to be every reason to suppose that conditions will be extremely good throughout this winter. Many new stations are coming on the air, and most of them seem to achieve a world-wide range within less than a week of their first transmission.

There are still "off" days, especially on the shorter waves, but six days out of seven are very good indeed. Colombia, that South American republic that was hardly heard of until the days of short-wave radio, seems to be establishing a monopoly. I, personally, have logged no fewer than 28 different Colombian stations within a few days, and there must be many more on the air.

By the time this appears in print we shall be well past the shortest day (for which many thanks!), and the time of "fade-out" should be getting perceptibly later every day. Round about December 22nd one finds that the 19-metre band tends to disappear completely by 5 p.m. or thereabouts. By now it should be good until 6 o'clock on a reasonably good day.

### A Common Problem

One of the problems of short-wave reception is to know what band to spend one's time on at a given time of day and a given part of the year. The daily and the seasonal variations become tied up with one another to such an extent that it becomes quite a complicated business to find out just what *should* be happening, say, on 23

## CHOOSING THE BEST TIMES

metres at 5.30 p.m. on January 19th!

Generally speaking, throughout January there is a rather annoying patch during the early evening, when 19 metres has faded out, 31-metre stations haven't started up, and 25 metres is monopolised, apparently, by Rome. It was very much the same in November.

The amateur bands supply a useful stop-gap, since they contain stations in every part of the world. Listening on 20 metres, one may find the Americans fading out at 5.30 p.m.—but that doesn't mean to say that all the others will go as well. On the contrary South Africa and Asia may be extremely good.

The fade-out doesn't occur by wavebands, but rather by continents. One

mind are W8XK with four wavelengths, Daventry and Zeesen, with goodness knows how many, and the great W2XAD-XAF partnership.

Listeners must be prepared to make the best use of things, too, and should study the published schedules of short-wave stations, where they are available, to make sure of getting the most out of their listening hours.

I often have people write to me complaining that they built such-and-such a set, but that "it seemed dead below 25 metres." Only after much correspondence does it sometimes transpire that they do all their listening after 10 p.m.—such a simple fact, but one that they don't think it worth their while to state. Of course it seems dead—it *is*!

### A Wonderful Broadcast

Readers who were fortunate enough to pick up that wonderful stratosphere broadcast in November will be pleased to hear that there is every likelihood of another during the early months of this year. It is to be hoped that some advance announcements will be made this time.

It seems a pity that such outstanding broadcasts are allowed to come upon the ether almost unheralded. That is the chief trouble with short waves, and with American programmes in particular. One *may* be rewarded for two hours of boredom by hearing a really exciting broadcast; on the other hand, one may not.

United States amateurs have pronounced ideas about making themselves useful. One of the latest results is the A.R.R.L. Emergency Corps, organised "for public service." Membership is confined to those amateurs who "possess equipment suitable for operation in an emergency when regular power and communication facilities are disrupted."

### Amateurs Valuable Work

Opportunities for this kind of work occur more frequently in the States than they do over here, and more than once the amateurs have been of real value to the community—in some cases they have been the means of saving nasty situations. In passing, it is interesting to note that there are now over 36,000 licensed amateur transmitters in the U.S.A. The total number here is considerably fewer than 2,000, and of those probably not more than 800 or so are active.

Wait till 5-metre operation is allowed without the necessity of entering for a test (Morse Code or otherwise), and see what happens!

### OFF TO THE STATES



Mr. Felix Greene, who has gone to America as the B.B.C. representative in that continent. He will keep a close watch on American broadcast developments, and will probably be the means of even closer co-operation between the B.B.C. and the U.S.A.

of these days, when I can get hold of a statistical expert with a sufficiently large head, I will dig out all my amateur band logs for the past twelve years, and see just what sort of a formula we *can* evolve from them.

All the commercial stations shift from one channel to another at various times during the day, and the more intelligent amateurs do the same. The broadcasting stations that can do so, however, are very much in the minority. Examples that come to



BY THE  
"WIRELESS"  
RESEARCH DEPT.

Interesting reviews of the latest products submitted by radio manufacturers and traders for examination and test in our laboratories.

THE elimination of interference picked up by the mains and passed via this source into the receiver has become a very important branch of radio. Electrical machinery and domestic appliances such as refrigerators, vacuum cleaners, and so forth, by reason of their method of working, cause all kinds of irritating troubles to the owner of a nearby wireless set. Switching on a vacuum cleaner may produce a terrific background of crackles, and the same applies to various other appliances.

Sometimes the effect is to produce a buzz or a hum, but no matter what form the noise takes, it is definitely undesirable, since it has the unhappy knack of spoiling one's reception—often of a much-desired programme.

### For Suppression

Messrs. Belling-Lee have carried out a considerable amount of research work on the elimination of this type of interference, with the result that they are able to provide listeners with special suppressors of various types. We have recently had one of these Belling-Lee suppressors sent in for test. The model in question has been designed for connecting in the supply leads of any electrical appliances using a 5 amp. 3-way plug with earth connection. The makers have chosen this type and size of plug in view of the possibility that in the near future this will be made standard on several classes of portable appliances. The suppressor is a choke and condenser filter, which is fitted between the appliance causing the interference and the plug point from which it derives its power.

The scheme used is that comprising two condensers, each connected to one pole of the mains supply, the common point being earthed.

lead to impede the passage of high-frequency interference from the frame of the machine down to earth.

The filter is attractively housed in a compact brown bakelite case, the three-pin socket being mounted flush on the front of the unit. At one end a length of three-core rubber covered flex, carrying the 5 amp. plug leaves the casing.

In use the unit is screwed to the wainscoting close to the mains point from which the appliance receives its power. In some cases where it is more convenient the suppressor can be screwed to the back of the electrical appliance, such as, for instance, in the case of a washing machine or earthed sewing machine.

Those who suffer from this type of

permanent-magnet types are available.

In the permanent-magnet range there are four models, and we illustrate one of them on this page.

This particular model is known as the "Senior 9." It is fitted with a universal switch control, a new Celestion feature which provides a ready means of rapidly matching up the speaker with any given output stage.

### As Additional Speaker

Moreover, the "Senior 9" is especially suitable for extension work, which means that it can be used satisfactorily as an additional speaker and installed in some room remote from the set. A loudspeaker used in this fashion must be so arranged that it can be matched up to the existing receiver, in spite of the fact that the

receiver already has a loudspeaker connected in its output stage (see the article on page 87).

### TWO COMPONENTS OF NOTE



The Belling-Lee suppressor (above) is designed for use with portable electric appliances and for three-pin power sockets. On the right is the Celestion "Senior 9" permanent magnet moving coil speaker which incorporates an attractive universal switching scheme.

interference should get into touch with Messrs. Belling-Lee, acquainting them with details of the interference. The address is Messrs. Belling & Lee, Ltd., Cambridge Arterial Road, Enfield, Middlesex.

### Celestion Loudspeakers

The makers of the well-known Celestion range of loudspeakers are marketing a number of attractive models for 1936. Both energised and

balance over a wide frequency range. This is not the same as joining the speaker directly in the output stage, and special matching is essential. The Celestion "Senior 9" provides for this. It is a very sensitive job and gives excellent results. There is full bass response and excellent tonal

In arranging the ingenious matching scheme the makers have thoughtfully used letters to denote the high-impedance range and numerals for denoting the low-impedance settings. A nine-inch cone is employed in this particular type instead of the usual eight-inch.

The price of this model is £2 15s. 0d. in chassis form, and it can also be obtained as a cabinet model for £4 10s. 0d.



# The Future of RADIO DRAMA

FOR ten years or more radio drama has been inchoate. Always beginning to evolve as an art form of its own, never actually doing so. There are several good reasons why drama has remained inviolate against the onslaughts of research writers—but probably the chief reason is the public's insatiable insistence on Simple Entertainment.

And that is just where so many of the early radio drama experiments failed. They did everything to show what a wonderful new medium the radio might become for the exploitation of dramatic feelings—but they did little to bring about the true radio drama synthesis.

Partly because, I imagine, there is no such separate entity as radio drama. Anyway, whether there is or not, the listening public's interest is guided very little by the mechanism of the broadcast play. It concerns itself—rightly so—with the ultimate entertainment value.

## Must Be Entertaining

Val Gielgud is acutely conscious of this axiom. Indeed, he himself summed up the trend of radio drama—which is under his control as Director of Drama—in this succinct aphorism:

"The future of radio drama does not lie in the production of futurist plays." No, it does not. One commentator, criticising the new play schedule for its dearth of experimental efforts, gave his case away completely by confessing that such efforts usually confused him.

Val Gielgud is much too much of a realist to want anyone to enjoy a play because of some abstruse theoretical thesis. The Drama Director wants broadcast plays to stand—or fall—on their ability to be entertaining. He does not even strenuously assert—as he must surely be tempted to do—that radio drama exists as such.

What he does say is that there is a vast audience for broadcast plays.

And he bases that contention on some very concrete evidence. On nothing less than the salutary experience of receiving 13,000 letters after a quite unheralded appeal over the air.

As he pointed out, allowing a modest four people listening to every letter received there is a minimum audience of 50,000. Even such a

at appealing to the biggest audience the world has ever known.

In passing, as Val Gielgud pointed out, the excuse for so many hours of broadcasting a day is that at no given time does the broadcast appeal to more than a fairly small percentage of the total listening public. That, incidentally, gives the Drama Chief a perfect alibi for the revival of plays during the summer months—but that's another story!

If, then, the Drama Direction as a whole is now against worrying listeners with futurist plays, where *does* the future of radio drama lie?

"As I see it," said Val Gielgud, "radio drama has reached the stage at which it must establish itself as good entertainment. We have taken nearly ten years to get to this stage—but that is the line along which further progress must be made.

"Now how are we going to ensure good entertainment? By appreciating what people in this country want. They want, I think, to hear an interesting story, told by interesting characters, in a way that is easy to follow, and represented by good actors and actresses. They are not, I feel sure, interested in the producers—or in the mechanism of production.

## A Knotty Problem

"We come up against the problem, immediately, of finding the sort of material that will fulfil the conditions I have laid down. Let me disabuse your mind once and for all that there is a wealth of really original material just waiting to be made use of. I can assure you that original plays simply are not there.

"You would not thank me, I imagine, for giving you most of the plays labelled 'original radio drama' that I have to read through. For some reason or other radio drama seems to have been regarded as a happy hunting ground for amateurs. Only a very few professional writers have given any attention to radio drama.

"Not that it is so very surprising.

(Please turn to page 130.)

Alan Hunter has a special interview with Val Gielgud, the B.B.C. Drama Director, who discusses his problems with characteristic candour.

meagre percentage of the total 30,000,000 listeners represented by 7,000,000 licences is not to be lightly dismissed.

For what dramatist in the past could ever have hoped for such an audience

## A FAMOUS PRODUCER

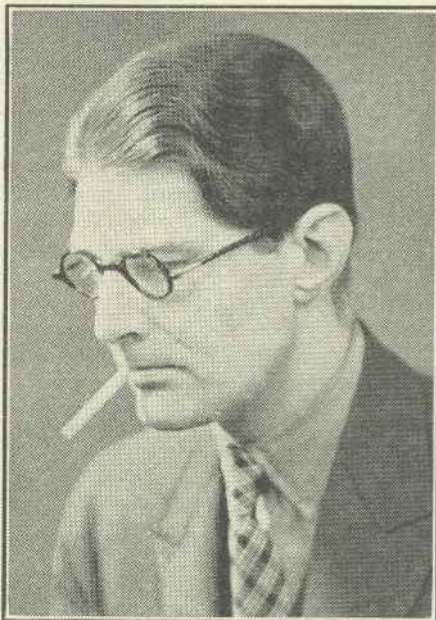

One of the B.B.C. drama producers—Mr. Lance Sieveking. He has been responsible for a number of play broadcasts and generally uses effects to a considerable extent.

as 50,000 people? It is a stupendous thought—and one that ought to have goaded more writers to try their hands

# WIRELESS DIRECTION FINDING

## AN INVALUABLE AID

By **CARDEN SHEILS**

**A** PART, perhaps, from television, the liveliest subject in radio to-day is what is known as direction-finding, or D.F. for short. It covers any use of the purely directional properties of wireless waves to indicate the position either of a fixed transmitter or beacon station on land, or of a moving receiver carried on a ship at sea or by an aeroplane.

### Urgently Required

The outstanding advantage of the wireless direction-finder is that it is just as reliable in the densest fog as it is in clear weather. Fog puts most ordinary "aids to navigation," such as the lighthouse and lightship, completely out of commission for the time being, and leaves the navigator practically helpless. This applies with particular force to the air pilot, who cannot cast anchor, or even cruise around indefinitely, once he is in flight. If he has strayed away from his course, he wants to be able to "locate" himself with the least possible delay. Also, he must face the risk of landing somehow.

Here, in fact, is the most promising field for future D.F. development. Civil aviation is expanding fast, and in our climate, particularly, it is

### REPLACES A FRAME

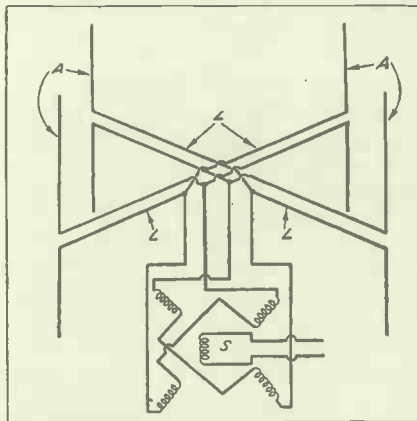

Fig. 3. How the Adcock aerial is arranged.

becoming more and more urgent to free the passenger service from the vicissitudes of fog.

The most practical way of solving this problem is to equip each aero-

drome with a complete radio outfit, including long-distance beacons to guide the pilot towards his destination, short-distance beams to tell him when he is over the aerodrome, and finally a "landing" beam which will bring him safely to ground—no matter how dense the fog may be.

Direction-finding is largely based on the use of the frame aerial. Unlike the ordinary vertical aerial, which does not discriminate between signals arriving from different directions, the frame aerial picks up maximum signal strength only when its plane is pointing

### ONE METHOD USED

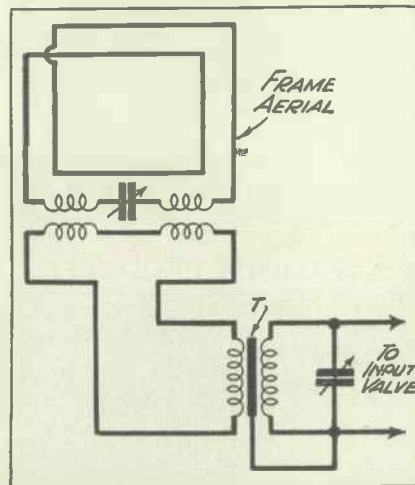

Fig. 2. One method of overcoming the trouble referred to in Fig. 1 is to use a shielded transformer (T).

directly towards the source of the signals. On the other hand, it gives no response when its plane is located at right-angles to the transmitter.

It should be explained that special precautions must be taken to secure this result. The frame aerial fitted to the ordinary broadcast receiving set does not usually show any pronounced directional effect because of the presence of "accidental" capacities to earth, such as are shown at C and C<sub>1</sub> in Fig. 1 (col. 3).

Under these conditions only part of the aerial current is confined to the true D.F. circuit across the frame windings. The rest passes up and down the windings and via the "accidental" capacities C, C<sub>1</sub> to earth. Since the latter current is really

flowing in an "earthed" or vertical aerial circuit it remains at constant strength, no matter how the frame is rotated. Its effect, therefore, is to obscure or "mask" the true direc-

### STRAY CAPACITIES

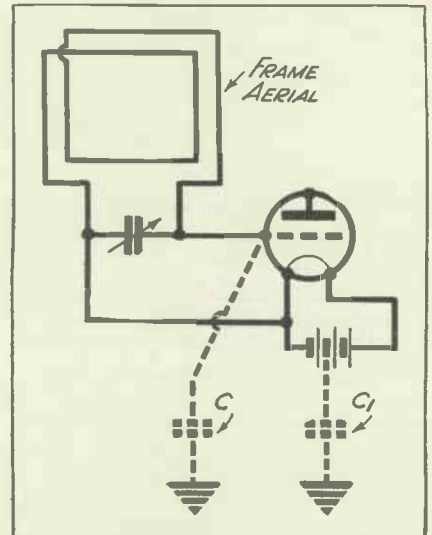

Fig. 1. A frame aerial fitted to an ordinary broadcast set often fails to show true directional effects, because of the presence of stray capacities (C and C<sub>1</sub>).

tional response of the frame windings alone.

There are various ways of getting rid of this unwanted "vertical" effect. For instance, the shielded transformer T, shown in Fig. 2, effectively prevents any electrostatic coupling to earth, and a frame aerial so fitted will indicate accurately the direction, say, of an aeroplane which is transmitting a "call" signal. Two such frames located at different land stations will provide cross-bearings, which when laid out on a map, are sufficient to identify the position of the "lost" machine. This information is transmitted back by wireless to the pilot.

### Land Observations

On land, where conditions are favourable, D.F. observations are usually taken on the minimum or "silent" position of the frame, because this gives the more accurate results. It is possible, however, to reverse the procedure, and allow the pilot to determine

(Please turn to page 129.)



"FOR the next half-hour our programme will be provided by Sydney Gustard on the organ of the Gaumont Palace, Chester." How often have you heard that announcement on a Saturday morning? And what has it conveyed to you?

A half-hour of tuneful music? Yes. But surely more than that? Whenever I hear a cinema organ I think of the tremendous conglomeration of rods and wires, pipes and gadgets that go to make up each one of these modern monsters.

Two tons of music. That is the average cinema organ, with its two, three or four manuals, its thousands of pipes, its percussion section and the drums, cymbals, piano and goodness knows what.

And everything—xylophone, vibraphone, piano, drums, cymbals, whistles, besides the pipes, are operated by air. This air has to be kept at a constant temperature so that the pipes do not go out of tune, and the control of the air is carried out solely by electro-magnetic devices operated by the keys and stops on the organ console.

### Ingenious!

The organist touches a stop tab. Up comes a long, thin rod in the mechanism in the organ loft. A note is touched on the keyboard. Immediately a small silver contact comes down, pulled magnetically by a bakelite strip. It touches the rod, and a current is passed to the required section of organ pipes or effects.

Immediately another electro-magnet is actuated. An air plunger is moved and air rushes from the reservoir to the pipe, or to operate a hammer on a xylophone, for instance.

The pressure on the key at the console ceases, and the little silver contact goes up again, pulled by a spring. Current is cut off from the magnet in the organ loft, and the pipe ceases to speak; the air flow has been stopped again by the little stopper.

And every key on the console has its corresponding bakelite strip with a number of silver contacts sticking out like pins. And every stop has a thin metal rod placed horizontally. Normally, unless any particular bar is raised by the lifting of its particular stop tab, the silver contacts do not make contact when they are pulled down by pressure of the key.

## Two Tons of Music

A glance at the works of one of our most popular broadcasters—the cinema organ.

But if the stop has been actuated, the bar is up, and when the note is played the silver contact on that particular bakelite strip will touch the rod, and the organ will speak.

You will understand this very much more easily if you have a look at the diagram on the next page, which shows the system in very simple form.

factory, while the pipes and even the metal for them and the electrical cables are made by them.

For the most part the pipes are made of spotted metal, an alloy of about 75 per cent tin and 25 per cent lead. The result is a mottled substance, which takes on its peculiar marking because the tin forms rings round the lead owing to the difference in solidifying temperatures of the two metals.

Wooden pipes are also made for certain organs, and a

special type of wood pipe was evolved for the B.B.C. organ at Broadcasting House. This was built by Compton, and the special pipe design for the bass notes was due to the restricted space available for housing the organ.

The pipe is wooden and is called a polyphone. It has a longish square-sectioned length going upwards from the mouth, and then it turns through two right-angles and comes down again almost to the bottom. The result is a pipe that is bent back on itself. This gives a good length with remarkably small height. But this is not all.

The whole pipe is divided into a series of pipes, eight in all, by cutting the total length into eight different lengths, which can be used at will.

### Saves Space

Thus for the deepest note you use the full length. For the next semitone up in pitch you cut off the last section of the pipe, and then the next section, and so on until you reach the octave above

the note you started with. Ingenious and effective. And it certainly does allow a good long pipe to be fitted into a restricted space.

Between the console of the organ and the organ loft, with its racks of electrical relays with the contacts and the rods I have already mentioned, is a long cable carrying the twelve-volt current from the keys and stops on the console to the contacts and relays on the racks.



Reginald New is one of our radio cinema organists. Here he is seen at the console of the organ at the Reigate New Cinema.

This is the method used by the John Compton Organ Company, which is the largest organ building concern in this country, and which makes its organs from the raw material at the works in Acton. Everything is done there with the exception of the ivory keys and tabs, and the construction of the percussion instruments and the "traps"—drums, and so forth. The mechanism that operates these gadgets is made by the Compton

This cable is itself a marvellous piece of work, for it has scores of wires, all of double cotton-covered 28-gauge copper, enclosed in a metal sheathing. These wires are not coloured, either, they are all white. And yet they can be connected up to the contacts on the console and the contacts on the racks in the organ loft without error.

The reason is that when the cables are made up by the engineers at the Compton works the wires are all cut to the right lengths, and when the ends of the cables are offered to the work in hand the whole of the wires, which stick out at right angles from the cable, come into the exact positions on the contact racks. All that has to be done is for the bottom one to be connected and the rest come exactly in position all the way up on each vertical "layer," or bank.

### Checking the Tuning

But that is not all. Consider that the organ has been installed in the cinema and is ready for tuning. All organs have to be tuned after installation, for though the pipes are tuned before the organ is passed at Acton, it will require checking up when it reaches its destination.

There is the organ, in two sections, say, in two lofts—one on either side of

## HOW THE ELECTRONE WORKS

note. Think what a job it would be shouting down to him or 'phoning him on a portable telephone after every adjustment was done.

But all that is not necessary. The organ builder has thought of that, and behind the racks of contacts in the organ loft, close to the pipes in question, are rows of metal staples.

### Quite Simple

A staple for each contact. Then all the tuner has to do is to fix crocodile clips on the requisite staples and the pipes will speak. He chooses his staples just as he would the keys and stops in the console down below, and his tuning troubles are almost over.

The tuning of non-reed pipes is done by means of the plugs in the tops of what are called stopped pipes, and

the same. The toning process is done at the works by the design of the pipes and does not have to be done again. Reed pipes sometimes have their reeds adjusted, for in the case of reed pipes the note is obtained by the vibration of a reed in the air passage and not by the column of air itself in

### BEHIND THE ORGAN

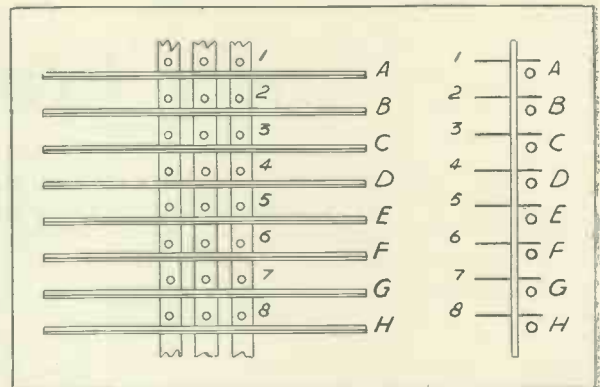

A simple diagram showing the arrangement of contacts that operate the various pipes. These are placed in the organ loft and operated by the console keys. Each lettered rod belongs to a stop, and each series of numbered silver wire contacts to a key, i.e. each bakelite strip means one note. Thus one note may be played on a number of stops.

the pipe. Thus, the length and pressure of the reed has to be adjusted in this case instead of the length of pipe by means of stoppers or collars.

The latest cinema organs made by Compton include the Electrone. This is a synthetic organ which has a completely new tone, and which is used to give further effects to the already amazing instrument.

The basis of the Electrone is the ordinary valve amplifier and speaker, and the cause of the sound is a sinusoidal variation of capacity across the grid of the first amplifier valve.

### Obtaining a Capacity Change

Just as a pick-up will impose musical voltages across the grid of an amplifying valve, so the Electrone input is applied from three discs, two of which revolve on opposite sides of a stationary one.

These discs are so constructed that the revolving provides a sine wave capacity change, the sine wave being preselected and mechanically fixed on the discs. Thus, if the sine wave of the fundamental note "A" is chosen and built up on the discs, then when they revolve, the note "A" is given out by virtue of the effect of the capacity change across the grid of the input valve of the amplifier.

All this is simply put here, of course. In practice it is much more complicated, for resistances come into the

(Please turn to page 131.)



This is an electronic organ of quite a different kind. It relies on tuned circuits for its notes and does not make use of any revolving discs.

the theatre—and the console is some fifty or more feet below in the proscenium. How is that organ to be tuned?

No joke to have a man at the console pressing keys and lifting stop tabs every time you want to check a

by collars at the tops of the open ones. Move the plug or collar upwards and the note becomes slightly deeper; move them downward and the pipe is shortened so that the note rises in pitch.

This holds whether there are metal or wooden pipes, the tuning process is

# WHAT I SAW -AND DID- IN RADIO CITY

*An exclusive account of his recent visit to the United States.*

*By AUSTEN CROOM-JOHNSON.\**

**B**ACK from New York and back with you all on the air again—but shortly to return to New York, and here's the story:

It was all started by Carroll Gibbons who asked me to meet one of the vice-presidents of the N.B. Company of New York and the European representative, Mr. Bate. I, in my turn, played them some records of "Soft Lights and Sweet Music"; they, in their turn, said that they liked them, and so, in a comparatively short time, I found myself being hustled aboard a transatlantic liner. The journey, of course, is a thrill in itself, and we had some good fun during the ship's concert.

## My First Act

The first thing I did on landing was to get married—I thought it was an excellent beginning. I then spent my first few days in New York studying American broadcasting methods; this is no simple matter.

Radio City is the most magnificent broadcasting edifice I have ever seen, and dozens of research men are always occupied in making extensive inquiries among listeners to ascertain the most popular programmes.

They make door-to-door investigations and will think nothing of ringing up every telephone subscriber in a town; with courteous apologies they proceed to rattle off the questions: "How many hours a day do you listen?"; "When do you first switch on your set?"; "Who are your favourite stars?"; "What type of programme do you like best—we are here to serve you?" And so on.

## "Slick" Programmes

The findings are computed, classified, and, by means of charts and graphs, reduced to facts and figures of the utmost statistical value.

It was then shown how the timing of American broadcasting is made

absolutely fool-proof. All the studios work on a relay system and are closed down automatically by the announcer when an item is scheduled to finish; the performer is allowed five seconds' "grace" and within this meagre latitude must round off his act without any sign of haste and confusion. He soon acquires the knack of working to such precise margins.

## Air is Never Dead

The next studio due to transmit automatically becomes "alive." And there is always an act ready to go over, a stand-by, in case of a breakdown. It is a principle of American broadcasting never to let the air go dead. Immediately there is a breakdown, the engineer in the control room presses a switch which sets twenty-four telephones ringing in various offices in the building. An executive somewhere is bound to respond and another studio takes its place on the air.

This system would also be employed in the event of an unpalatable subject or a questionable joke being put over. But one conspicuous feature of all American broadcasting is that the ether is remarkably free from "dirt"; no one ever takes the chance of introducing a suggestive gag.

I owe a good deal of my success in the American radio world to the kindness of Ray Noble and Bill Harty, his manager, who showed me the ropes and the shortest cuts, and put me on to the musicians I needed. Throughout the whole of my stay, however,

strange though it may seem, I didn't play a single note myself.

You see, the regulations of the American musicians' union forbid the professional exploitation of alien talent. But when I return to America and take out my naturalisation papers, the situation will, I hope, be different.

## Engaged on Productions

I was engaged solely on productions and was given a very free hand; I may say here that I found all the Americans with whom I worked to be the essence of hospitality and kindness, and I should like to qualify this acknowledgment—the like of which is so often made as a matter of form—by declaring it to be absolutely sincere.

One of the first acts I put over was "Two Friends in Harmony"; British listeners may recall hearing this done

*(Please turn to page 130.)*

## A B.B.C. FAVOURITE WHO IS LEAVING THIS COUNTRY



*Austen Croom-Johnson, who is going to become a naturalised American and make his home in the U.S.A.*

\*In an interview

# PHOTO-CELL AMPLIFIERS

## Why a Screen-Grid Valve is Best

BY G. STEVENS.

WITH the present interest in television, a number of experimenters are using photo-cells for the first time, and a great deal of useful work can be done with them on the investigation of light intensities, colour measurement, to say nothing of the many relay circuits which can be made up. The photo-cell, however, requires care in the design of the amplifier if the best results are to be obtained, and it is not possible to get the best out of it unless its behaviour is understood.

### A High Resistance

Since the interior of the cell contains only two electrodes, in its normal "dark" state it can be considered as a very high resistance with a small condenser in parallel with it, the capacity being due to the electrodes and their spacing. As the emission from the cathode starts when the cell is illuminated the resistance, of course, decreases. The usual way to amplify the photo-electric current is to connect the cell in the grid circuit of a valve, as shown in Fig. 1.

Since the cell resistance is high the value of the leak  $R$  should be high

### EFFECT OF CAPACITY

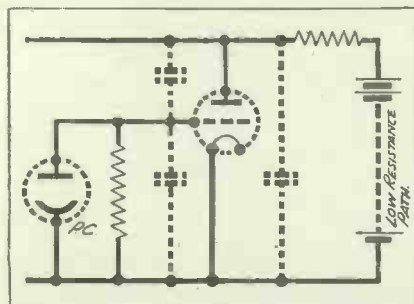

Fig. 2. The value of the grid leak should be as low as possible to counteract the effect of the valve capacities.

in order to obtain the maximum voltage change across the grid-cathode circuit. For example, assume the cell to have a resistance of 10 megohms. Then, if the grid leak is 5 megohms the total resistance in the circuit is 15, and the voltage developed between the grid and cathode will be  $5/15$  or  $\frac{1}{3}$  the total. If the resistance is only 1 megohm, the voltage change applied to the grid will be only  $1/11$ th of the total, and so on.

The conclusion that this leads to seems to be to use as high a leak as

possible. But this is where the effect of the cell capacity comes in. Inside the valve we have three capacities—grid filament, grid anode, and anode filament—represented in Fig. 2 by the three small dotted condensers.

The anode filament capacity can be disregarded, as it does not affect the

### THE FIRST STAGE

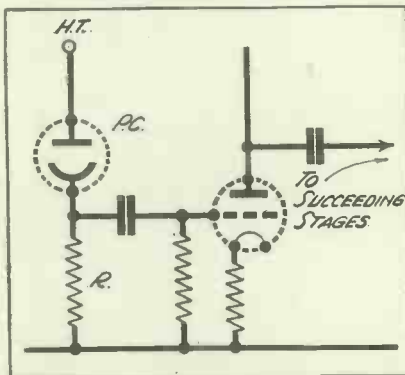

Fig. 1. The usual method of connecting a photo-cell to a valve for amplification purposes.

circuit to any extent. But the other two are acting as capacities in parallel with the capacity of the cell, and the effective capacity between grid and earth is proportional to all three—cell,  $C_{gr}$  and  $C_{ga}$ .

This means that at very high frequencies the grid leak will be shunted by a capacity which will have a decreasing impedance with increasing frequency. The amplification of the valve will, therefore, steadily fall off as the frequency of light fluctuation increases.

### Losses

The valve capacity will be equivalent to a resistance in parallel with the grid leak, and if we do not want this to affect the input resistance the grid leak itself should be kept to a low value. Some more examples may make this clearer: Suppose we have a grid leak of 10 megohms and at some value of frequency the valve capacity becomes equivalent to a resistance of

1 megohm. Then the valve input resistance is reduced to approximately 1 megohm, since the leak is very high in comparison. The voltage applied to the grid at this frequency will therefore be  $1/10$ th of what it was at normal frequencies, and the amplification will be reduced to correspond.

If, however, our grid leak is only 1 megohm, the input resistance is reduced to  $\frac{1}{2}$  megohm at the same frequency, and the voltage applied to the grid is only half of its original value.

On the other hand the voltage applied to the valve is less with a low value of grid leak, and this necessitates as high a magnification as possible if we are not to have too many stages. The screen-grid valve is therefore the best solution to the problem, since it combines a high magnification with a very low capacity between grid and anode.

### The Problem of Screening

There is a last and very important point to be remembered in the assembly of photo-cell amplifiers. The cell and its connections to the grid of the valve are very prone to pick up hum from external sources, and the leads should therefore be as short as possible and well shielded. This again introduces a difficulty, since the shielding of the leads introduces a shunting capacity across the cell which may be far greater than the valve capacities all put together. It is best, therefore, to use high insulation special anti-capacity shielded wire, although if at all possible the cell should be mounted right on top of the grid of the valve.

### AVOIDING PICK-UP OF HUM

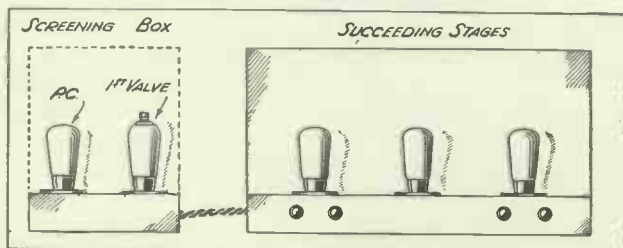

Fig. 3. It is best to enclose the photo-cell and the first amplifier valve in a separate screening box.

This is done by making the first amplifier stage in the same shielding box as the cell, and taking leads to the remainder of the amplifier. Fig. 3 shows an arrangement which ensures a minimum of pick-up.

## THESE MODERN SETS

—continued from page 99.

he were sure of the implications behind the instructions, remembered always to go to that knob every time he changed a station, knew how to decide quickly upon the compromise to make, knew, in fact, what he could do with that knob, and how and when to do it, and how to interpret the different reactions to its adjustment of the eye (visual tuning) and the ear (quality and volume).

### A General Criticism

Now, should any of you happen to identify the set which possesses this particular control, let me say I consider it to be one of the finest on the market. My criticism is a general one, and not levelled at any particular set. Take away any one of many of the sets being sold, and I'll willingly say it is a first-class piece of work; it is when modern sets are lumped together and surveyed in perspective that I feel there is something wanting, and that it is a conformity with standards, and that need not imply an uninteresting uniformity of detail. But, of course, each manufacturer sees in his own sets everything the listening public wants, and so competition creates numerous parallel sets of standards which time alone can cause to fuse together.

But it is when we come to the actual circuits and performances of sets that the real divergencies are found. And what is one manufacturer's meat is another's most unappetising standard. Here are varieties of conscience as well as of taste! Some sets are made to boom deliberately (did you know that?), others hum and crackle a lot because five pounds' worth of factory costing is put into them instead of five pounds ten shillings' worth. Some incorporate incomplete circuits, giving other undesirable effects. Others achieve inexpensiveness in less objectionable manners.

### Designing to a Price

Maybe it is all honest designing down to a price, but there are various ways of approaching the problem. But I cannot help feeling that there is too much striving to-day to try to give the buyer more for his money than it can economically be expected to give. And the trouble is that the average listener neither appreciates to the full the really marvellous value for money offered by the radio industry as a whole, nor possesses the ability

to discriminate between the marvellously wide specification thinly supported and the less ambitious specification very thoroughly rendered.

Both of such propositions may be wonderful value for money, and it is really for the listener, having a given amount of money to spend, to decide whether he wants a little that is very

good or a lot of that which is not so good. I feel it is rather the latter that is present in the greater numbers.

On some future occasion I must endeavour to apply a little analysis to this further aspect of modern sets.

## QUESTIONS AND ANSWERS

—continued from page 93.

on (a) the set, (b) the old ladies. A really well-decoupled set will not "whistle" even when the H.T. battery runs down. The whistle is caused by uncontrolled low-frequency reaction caused by the internal resistance of the battery rising as the voltage drops with use. Long before the whistle occurs there is probably some pretty horrid distortion. But it takes a whistle to wake up the old ladies. Perhaps the whistle is a good thing in its way, because if the set did not whistle, the battery would be run down more and more. The whistle is like that on some kettles which signifies that boiling point has been reached.

You may take it that whenever I recommend 120 volts, the advice applies equally to other sets, so no victimisation, please!

## NEXT MONTH

One of the finest numbers of "Wireless" ever published!

### THE SPECIAL FEATURES Include:

Inexpensive A.V.C. for any Set—  
The development of a remarkable invention

\* \* \*  
"The W.L.S. Super."  
An A.C. short-wave superhet

\* \* \*  
Entertaining articles on radio stars and personalities

\* \* \*  
All about Short-Wave Converters and Adaptors, etc., etc.

## GET THIS IMPROVED REPRODUCTION FROM YOUR SET!

### VOLUME 20% GREATER

The improved—and larger—"Mansfield" magnet brings a substantially higher sensitivity. The increased loudness not being obtained at the expense of "balance," is comfortably accommodated by the ear. It materially increases the "realism" of the performance.

### BASS RESPONSE—FULLER AND 15 C.P.S. LOWER

Measurable bass response goes 15 c.p.s. lower than previous models. Audible response—that part of the bass which is at audible frequency and reaches audible volume—is in these new models much more loudly reproduced. Thus the "bass background" is stronger and more colourful.

### HIGH NOTE RESPONSE—900 C.P.S. HIGHER

Due to the stronger magnet, new hand-made cone, and larger section-and-interleaved transformer, far brighter and cleaner reproduction of high notes and overtones has been achieved this year. This does not imply shrillness—in fact, objectional high resonances are conspicuous by their absence.

### ATTACK—CLEANER & CRISPER THAN EVER BEFORE

That "forwardness" of tone and the clean, instant response to transients which are so important to realism in reproduction, are, in this new speaker, present to a remarkable degree. Cone material, transformer, and the new accuracy of assembly are chiefly responsible.

The simple substitution of this advanced speaker for your present instrument will bring to your radio increased volume and a new amazingly colourful realism. Ask your dealer to demonstrate TO-DAY and hear for yourself.

EXCLUSIVELY SPECIFIED FOR BOTH THE "PRE-PLEX" AND THE "ALL WAVE BATTERY SET"



# 1936 STENTORIAN

Whiteley Electrical Radio Co. Ltd. (Electrical Dept.), Mansfield, Notts.



PRICES—	
<b>CABINET MODELS</b>	
36S Senior	63/-
36J Junior	49/6
36B Baby	29/6
<b>CHASSIS MODELS</b>	
Senior	42/-
Junior	32/6
Baby	23/6
Midget	17/6
Duplex	84/-
EM/W (Energised)	70/-

**THE "PRE-PLEX"**

—continued from page 82.

should the H.T. be inadvertently applied to the filaments, thus saving many shillings in valve replacements.

The receiver is now ready for its first try-out. However, before giving any hints on operation I should like to say a few words about accessories, i.e. loudspeaker and batteries: It is essential that the loudspeaker should be suitable for push-pull output, and that it can be matched to suit the Q.P.21, the optimum load of which, used as it is in this receiver, is approximately 12,000 ohms.

I can recommend the W.B. Stentorian specified, as this is the loudspeaker with which the "Pre-Plex" was tested, and gives really excellent results. It will be noted that the output terminals in the diagrams are marked to correspond with the markings on the Stentorian loudspeaker, and consequently it is obvious how to connect up.

The 120-volt H.T. battery is the ordinary standard capacity type. Of course, a higher capacity battery may be used, and will be found more economical in the long run, but the standard type is quite capable of supplying the current taken by the

receiver, which, as I have said before, is approximately 8 milliamps.

As the "Pre-Plex" is a battery receiver, I have tried it only with batteries, and I am unable to say whether or not H.T. eliminators will be satisfactory for supplying the H.T. current. I have no doubt, however, that an eliminator with a suitable output rating will be satisfactory. The total L.T. current taken is  $\frac{1}{2}$  amp., so that the accumulator should have a capacity of at least 20 amps. to be really serviceable.

**Valves to Use**

It is very important that the valves specified are used. No alternative types are given, because there are no alternatives, except possibly in the case of the detector. Here it may be possible to use other valves of the H.L. type, but if you have got to buy, buy the valve specified. If you use a different double pentode, I do not know what will happen, except that the grid bias will be all wrong, and the H.T. consumption will probably go up. So please do not attempt to use anything other than the Q.P.21 here.

I am afraid I have said "Don't do this" and "Don't do that" quite a lot, but I feel that it is better to warn readers not to do certain dangerous things, than to allow them to do these

things and tell them that they were wrong afterwards.

The operation of the "Pre-Plex" is perfectly simple. The two wave-change switches should be up for long waves, and down for medium waves. The two tuning dials keep pretty well in step, and should be rotated together, with the reaction control set just short of the oscillating point when searching for stations. The series aerial condenser should be set about half way in. Should the station be too loud when received, its volume may be reduced by turning the series aerial condenser anti-clockwise until the desired volume is obtained. This is a rather better method than reducing reaction, as the receiver is in a more selective condition, and there is less chance of interference from other stations.

**Using Reaction**

In order to make the receiver as selective as possible use plenty of reaction, and set the series aerial condenser to as low a value as is practicable without losing too much sensitivity. If you are fairly close to the local station no reaction will be required, and it will be necessary to keep the series aerial condenser well back to prevent overloading.

Provided that instructions have been carried out with reasonable care, I feel sure that you will be extremely satisfied with the results obtained from the "Pre-Plex."

No cabinet has been specified, as I feel that we all have our own ideas about housing a radio receiver. Consequently I am leaving it to my readers to decide the cabinet for themselves.

**THIS IS REAL RADIO SERVICE!**

—continued from page 106.

such a short time we have caught up with the thirty-year-old motor-car industry in interpreting service as maintenance.

"You accept your car service as a matter of course. You pull into any reputable garage and an expert mechanic will attend to your troubles. Before that was possible men had to be trained, organisations to be worked out. The public had to reach the point where it demanded quick, efficient and inexpensive attention to the dozens of little things needing periodical service. In E.M.I. we are aiming to give a similar service for radio.

(Please turn to next page.)

**THE UNIVERSAL LINACORE**



The J.B. Linacore has been designed to make possible the construction of really efficient receivers with the minimum of effort, on your part, and the maximum certainty of success. It is suitable for use with either battery or mains valves and costs 65/-. With the help of "Vivid Radio" (4d. post free) you can obtain brilliant performance, true reproduction, long range and freedom from interference. Thousands of listeners have built Linacore receivers and realised a new pleasure in radio.

POST THIS FOR  
**"VIVID RADIO"**



To Jackson Bros. (London) Ltd.,  
72, St. Thomas's Street, S.E.1.  
Please send me "Vivid Radio." I enclose  
4d. in stamps to cover postage, etc.

Name .....

Address .....

.....

## THIS IS REAL RADIO SERVICE!

—continued from previous page.

“The dealer himself must have some technical knowledge—or have associated with his organisation someone with this knowledge. At first sight the job of dealing in a modern set looks simple—because the set to-day is just a nice-looking piece of furniture with a few control knobs on the front. That is the external simplicity everyone aims at—but it does not mean the maintenance of the internal part is just as simple.

### Questions of Guarantees

“I might say a word here on guarantees. With the usual twelve months’ guarantee the maker undertakes to replace at the factory free of cost any part he considers is defective through either faulty material or poor workmanship. But the customer is expected to pay the freight and labour charges involved.

“With the new ninety-day guarantee—or the six months’ guarantee, for that matter—the same applies, except that the customer does not pay labour charges. He is still expected to pay the cost of the transport of the set or part from his home to the factory.

“It ought to be made clear that the amount of free service and the guarantee generally are limited not because the maker has only a limited confidence in his product, but because the price of the product is not built up to include an unlimited amount of free service. In other words, there is no really free service at all. The customer pays in the price of the set for his guarantee and his service within the period of that guarantee.

“We aim to serve the public through properly equipped dealers. The majority of faults can be attended to by the dealer, with the minimum of expense and delay to the customer. We have designed the necessary equipment for dealers to use—modern testing apparatus that includes measuring instruments, insulation testers and modulated oscillators.

### Helping the Dealers

“We help dealers to develop the efficiency of their service and show them how modern methods of costing and accounting enable them to reduce their charges to the lowest possible, consistent with a high standard of workmanship.”

It all sounded very impressive to me—and that was before I had been given a chance to look around. My rapid tour of the stores, the repair

shops, the index files in their fireproof room, the arrival and departure docks; all these aspects of E.M.I. Service brought home to me very vividly the backing that dealers are offered in their efforts to solve the “set gone wrong” problem in the most efficient way.

Down there at Hayes the redoubtable Mr. Emery sits at the head of an organisation he has built up with rare vision and energy from very small beginnings. Hayes is the central depot, but it must not be forgotten that there are depots in Glasgow and Dublin, linked with a team of engineers to whom service is the breath of life.

Most E.M.I. dealers can look after their own problems. But should they at any time baffle him he has the comforting knowledge that at the back of him is the Hayes organisation, ready to rush to his aid at a few hours’ notice.

## WIRELESS DIRECTION FINDING

—continued from page 122.

his own position, whilst in the air, by taking the bearings of two different land transmitters in succession.

Experience has shown that the frame aerial has certain drawbacks as a direction-finder when used over long distances at night, or when receiving from aeroplanes flying at a good height, and, in fact, on short waves generally. In all these cases there is a tendency for the wave-front of the received wave to be “bent” away from its original direction, due to reflection from the Heaviside layer.

Thanks to modern research, “false” readings due to this cause have now been eliminated, and the standard of D.F. accuracy correspondingly improved. One of the biggest advances in this direction is due to the use of what is known as the Adcock aerial in place of the frame, particularly for land observations.

As shown in Fig. 3, the Adcock aerial consists of two pairs of vertical unearthed aeriels, marked A, each pair being cross-coupled through horizontal connecting wires L, which feed a rotating search-coil S in an elevated observation hut.

The crossing-over of the horizontal wires L effectively balances-out any “false” vertical effect due to waves reflected downwards from the Heaviside layer, and gives amazingly accurate results on the direct or earth-bound wave from a distant transmitter.

## PILOT AUTHOR KITS

can only be obtained direct from Peto-Scott. We can supply any Kit for sets featured in this Journal during the past 3 years. Any item supplied separately. Orders over 10/- sent C.O.D. Carriage and post free.

### ALL-WAVE Battery 3

SEND FOR PRICED LIST OF PARTS

KIT “A” £5 : 12 : 6

Cash or C.O.D. Carriage Paid  
Author’s Kit of First Specified Parts  
less Valves and Speaker.

**10/-**  
DOWN

Balance in 11 monthly payments of 10/3

KIT “B.” Cash or C.O.D. Carriage Paid, £7/5/0.

Or 12 monthly payments of 13/3.

As for Kit “A.” but including set of 5 specified valves.

VARLEY 2-Gang Coil Unit and 2 J.B. Slow-motion

Tuning Condensers, £1/17/0.

Or 2/6 down and 10 monthly payments of 4/1.

Set of 3 Specified Valves, £1/12/6.

## PRE-PLEX

SEND FOR PRICED LIST OF PARTS

KIT “A” Cash or C.O.D. £4 : 12 : 6

Cash or C.O.D. Carriage Paid  
Author’s Kit of First Specified Parts Or yours for  
less Valves and Speaker.

**7/6**

Balance in 11 monthly payments of 8/6.

KIT “B.” Cash or C.O.D. Carriage Paid, £6/0/0.

Or 12 monthly payments of 11/-.

As for Kit “A.” but including set of 2 specified valves.

PETO-SCOTT ready-drilled Metaplex Chassis,

Ebonite Panel and Terminal Strips, 3/-. Postage 6d.

2 Specified Valves, £1/3/0.

## BRAND NEW P.M. SPEAKERS for 12/6 Carr. Paid

Manufacturers’ stock of BRAND NEW Permanent Magnet M.-C. Speakers at less than cost. 6-in. Cone, Large magnet and input transformer for Power, Super-Power, or Pentode. Cash or C.O.D. Carriage Paid, 12/6. Or 2/6 down and 5 monthly payments of 2/6.

ENERGISED MODELS, 2,500 and 5,000 Ohms. Cash or C.O.D., 5/6. Postage 5d.

SEND FOR COMPLETE BARGAIN LIST.

PETO-SCOTT Co. Ltd., 77, W7, CITY RD.

CLERKENWELL 94061/7. Hours of Business, 9-7. Sats., 9-1.

EST. 1919

## EASY WIRING

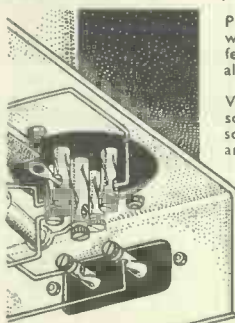

Perfect contact and ease in wiring are outstanding features in the design of all Clix components.

In Clix Chassis Mounting Valveholders the centre socket of the 5-pin and two sockets of the 7-pin type are made longer than the others: this reduces the possibility of short-circuits and adds to the ease of wiring.

The following Clix products are

Specified for the  
“PRE-PLEX”

and the

ALL-WAVE  
BATTERY SET

Valveholders

4-pin .. 8d.

5-pin .. 9d.

7-pin .. 1/-

(with terminals)

Terminals

Type B .. 4d.

Spade Terminals

Large 2d. Small 1½d.

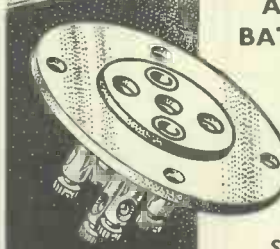

**CLIX**

Two New Illustrated Folders “C” Free on request.

LECTRO LINX LTD.

79a, Rochester Row, London, S.W.1.

# VITAL RELIABILITY

SPECIFIED for the  
"PRE-PLEX" and  
"ALL-WAVE BATTERY SET"

Use Erie Resistors and the Erie Volume Control, the choice of designers and manufacturers. They are the outcome of intensive research, and will not let you down.

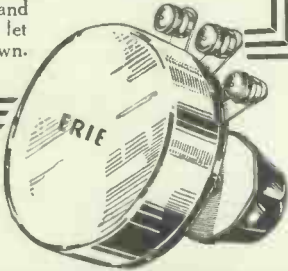

The Erie Volume Control. All sizes 2,500 ohms to 2 megohms.

**3/6** or with built-in mains switch, 5/-

Erie Impregnated Resistors.

**1/-** per watt in all values.

Send for the Free Erie Colour Code chart

The Radio Resistor Co., Ltd., 1, Golden Sq., London, W.1

# ERIE RESISTORS & VOLUME CONTROL

## CABINETS.

Write for Free List

GILBERT (cabinet maker), SWINDON.

## Engineers' Guide

containing the widest choice of engineering courses in the world

Outlines The T.I.G.B.'s up-to-date, home study Courses in Wireless, Electrical and Mechanical Engineering, etc. Shows how to become A.M.I.E.E., A.M.I.W.T., A.Rad.A., etc., and how to qualify for a well-paid post. Training until Successful Guaranteed. WRITE NOW for Free Guide.

THE TECHNOLOGICAL INSTITUTE OF GREAT BRITAIN, 21, Temple Bar House, London, E.C.4. (Founded 1917, 19,000 Successes).



## To Success

Please be sure to mention "WIRELESS AND TELEVISION REVIEW" when communicating with Advertisers. Thanks!

## WHAT I SAW AND DID IN RADIO CITY

—continued from page 125.

by Len Fillis and myself not so long ago. Over in America I had Andy Senella on the guitar and Frank Banta at the piano. Then, "The Band Goes to Town," a lively dance feature with Ella Logan—who is also known to British listeners—came next.

And I made a "talent discovery" for the N.B.C. While dining at a place called the Onyx Club, I was much impressed by the performance of the orchestra; what attracted me at first was their signature tune, "The Music Goes Down and Around," a highly original ditty, describing how the melody courses "down and around" the trumpet tubes—one of those catchy persistent tunes that you can't get out of your mind.

I introduced the band to American listeners; and don't be surprised if the Onyx Club Boys top the bill at the Palladium some day!

I also broadcast another selection of old tunes and ballads that came under a heading already familiar to listeners in this country—"Melodies Out of the Sky"—and, naturally, put over a few "Soft Lights" shows. When I go back I hope to have Connie Boswell with me in this series.

### Not All Sponsored

I think it is widely supposed in this country that everything transmitted on the American radio is commercially sponsored. This is by no means true.

To be sure, all American broadcasting is run on a commercial basis but, just as every newspaper proprietor aims to print the most attractive editorial matter in order to increase circulation and thereby getting more firms to advertise, so do all the competing radio stations endeavour to attract more advertisers by presenting *sustaining programmes*—that is, entertainment to fill the gaps between the sponsored broadcasts—which are likely to engage the attention of most listeners. I am to be engaged on the permanent N.B.C. staff to help provide these programmes.

Broadcast items do not drag on indefinitely; no single item exceeds three-quarters of an hour. There is, perhaps, five minutes of news at six-thirty and items lasting fifteen, thirty, or forty-five minutes follow on directly. It is not unusual to hear a full symphony orchestra playing light music.

Musical comedy and drama produced by the B.B.C. is to my mind

infinitely better than that attempted by American broadcasting organisations, the reason being that the commercial element governing the activities of the latter enforces a different treatment; but advertisers naturally cram as much as they can into their allotted time, which means that, artistically, American broadcasting suffers very seriously.

### "B.B.C. Takes More Trouble"

The B.B.C. here takes much more time and trouble and is not handicapped by the high-speed methods which commercial broadcasting necessarily compels.

I intend to return to England twice every year to see my people in Somerset and have a hectic reunion with that indefinite coterie of old pals, school-fellows and brother musicians known, collectively, as "the boys."

We shall live in New Jersey, forty-five minutes out of town. It is delightful there in the summer and the winter sports make the cold season equally enjoyable; later I may go over to Hollywood and have a shot at picture music.

Here's hoping you'll listen to me some time on short-wave broadcasting from Radio City, New York.

## THE FUTURE OF RADIO DRAMA

—continued from page 121.

Most professionals have their tie-ups with the theatre or the films, which, in the nature of things, can afford to remunerate them so much higher than we can.

"We have therefore to rely on both theatre and cinema for a good deal of our worth-while material. In the same way we depend on the theatre for our actors. There are very few real microphone actors, just as there are very few real microphone stars. The truth is, of course, that broadcasting is not and cannot be a full-time livelihood for a first-class artist or author.

"Some people seem to suggest that I am killing what they are pleased to call real radio drama by getting good plays and good actors for the microphone. Well, if by doing this I am raising the entertainment standard of broadcast drama I am quite willing to be pilloried as a murderer!

"Besides, it is not true, as you can see from the latest programme, that we have abandoned the play written specially for the microphone. But

(Continued on next page.)



## THE FUTURE OF RADIO DRAMA

—continued from previous page.

the insistence is not on the exploration of the medium but on the potential entertainment content of the product.

"The present policy, based on the entertainment criterion, has steadily improved the standard of material. Of that I am certain. If you quote 'Red Tabs' and 'The Squirrel's Cage' as examples of real radio drama I shall reply that our radio versions of 'The Constant Nymph' and of 'Bulldog Drummond' are by comparison better entertainment. In that sense radio adaptation needs no defence at all.

"Of course, any thoughtful surmise as to the future of radio drama must take television into account. For some time, it is true, the present type of radio play will run parallel with whatever is evolving through the television service.

### When Television Comes

"But people will not remain indefinitely content with reception through only one medium when they know they can get it through two. Talking films provide a classic example. When the talk was put into the silent film people preferred even bad talking films to good silent ones.

"What effect television will have on radio drama I cannot yet say, naturally. But in the end it will certainly have a decisive effect, even though, as I say, the present non-visual radio drama must run parallel with television drama for several years to come."

## TWO TONS OF MUSIC

—continued from page 124.

picture for determining the rate of die out or decrement of the note after the voltage impressed across the revolving condenser plates (the discs) has been removed by the lifting of pressure on the organ keyboard.

Every time the key of "A" is pressed the voltage is applied and the constantly revolving discs will cause the note to be produced in the loud-speaker. Harmonics and all sorts of other notes are built up on that fundamental "A" by means of fixed capacities and resistances which are added by the operation of certain stop tabs and keys on the Electrone manual.

The discs carry all the notes necessary for the operation of the full range of fundamentals on the Electrone key-

board, and the application of the desired voltage across the discs enables either or any group of notes to be played at will. And wonderful is the effect that can be obtained. The output power in watts of a very big Electrone amplifier such as is to be used shortly for carillon purposes in a church tower is round about 90 watts. That of a cinema would be less.

### Bells Particularly Effective

The speaker, of course, is situated in the organ loft so that the Electrone can be played with any part of the organ, or by itself if desired. It is particularly effective in bell work, either solo bells or carillons being reproduced by the correct choice of harmonics and partials.

One of the latest gadgets to be applied to the Electrone is the Hawaiian guitar effect. This is a scheme whereby at will the organist can make the Electrone note or chord of notes slide up to the correct pitch from about a semitone or more down, just like the Hawaiian guitar. And this occurs not every time he plays a note, whether he wants it or not, but, subject to the right stop tab being up, only when he has removed his hands completely from the organ keyboard for a fraction of a second and then played the note he wants to glide.

As you may know, an organist does not play his instrument like a piano, striking each note after completely removing pressure from the previous one. He slides from note to note so that the pressure only is transferred and no key is wholly without pressure during the playing of the piece unless he wants a staccato effect, or the glide I have mentioned.

### An Electrical Wonder

As long as he plays normally, with the pressure not ever wholly removed the Electrone will play clear notes with no glide. But on removal of the hands for a fraction of a second a mechanism is operated which changes through tapered pulleys the rate of revolution of the Electrone discs (slowing them down slightly). Then when the note is played on the manual the pulley band is slid along the tapered pulleys, and the discs revolve to the correct speed while the note is sounding, giving the glide effect.

All very ingenious, is it not? The cinema organ is undoubtedly one of the wonders of the electrical age, and I hope in this short article I have been able to convey to you something of that wonder which I mentally picture whenever I hear one of these marvellous instruments broadcast.

K.D.R.

**FOR A GOOD JOB  
WELL DONE**

---

  
**Cartridge Fuse** Length, 1 1/4"  
Ten distinguishing colours.  
All ratings same price, 6d.

---

  
**'Wanderfuse.'** 1028  
... In black or red.  
With 150 m/A fuse.  
Complete 1/-.

---

  
**Single Safety Fuseholder**  
1045. Complete with fuse 1/6.

---

**BELLING & LEE LTD**  
CAMBRIDGE, STERLING ROAD, HENFIELD, MIDDXX

Please send, free, your catalogue, "Radio Connections."

Name.....

Address.....

W. & T. R. Jan.'36.....

IT PAYS TO BUY  
THE BEST



INTERCHANGEABLE COILS.

New low loss formers of DL-9 high frequency insulation. Rigidly made and each coil matched. First-class results assured. 4-pin coils have two windings, 5-pin three windings. No. 959 6-pin Set of 4 1/2-170 metres Price 16/- No. 932 4-pin .. .. . Price 14/-



**Universal Valveholder**



**DL-9 H.F. Dielectric**

A low loss holder for above or below base-board use. The valve enters the contacts from either side. There is no measurable increase of self capacity to that already in the valve base. DL-9 H.F. dielectric one piece noiseless contacts.  
No. 1015 4-pin 1/3d. No. 1016 5-pin 1/5d.  
No. 1024 7-pin 1/8d.

**STRATTON & CO., LTD.**  
Bromsgrove Street, BIRMINGHAM.  
London Service Depot: Webb's Radio Stores,  
14 Soho Street, Oxford Street, W.1

EDDYSTONE

SHORT WAVE COMPONENTS

## TELEVISION TO-DAY

(Continued from page 102.)

where an excellent picture of him was seen, the size of the picture being roughly a foot square. The definition used was 240 lines. At the same time he spoke to the audience, the transmission of sound being on  $8\frac{1}{2}$  metres wavelength and the television on 7 metres.

If you are inclined to be a bit fed up at the B.B.C.'s delay in getting the television business going, remember that the B.B.C. sound broadcasting system is, by general consent, the finest in the world, and that, therefore, it is presumable that the B.B.C. will do the television job properly just the same.

### The Best Broadcasting

Americans can say what they like about their multitude of different stations and about the snappy items they put over, and we for our part can grumble just as much as we like about the B.B.C.—in fact, it seems to be a national habit—but we know perfectly well (and the Americans know too) that there is no broadcasting service in the world to come within streets of the B.B.C.

If they go to the television business with the same thoroughness—as indeed there is every evidence they intend to do—then I think we shall all feel satisfied in the knowledge that we are going to have the best television service in the world, and it will have been worth waiting for.

A new word comes to us from America. The "video frequency" band is the one which carries the

television signals, and is so called to distinguish it from the audio frequency band—"video" frequency and "audio" frequency. Strikes me as quite a good name and one that may catch on.

In America there are two principal systems of television in vogue: first the R.C.A. Victor system, which involves the iconoscope developed by Dr. Zworykin, and also his fixed field

it is retained only as an accurate means of sending out synchronising impulses. I hear from one of my correspondents in America that the following recommendations have been made there for the standardisation of television transmissions: The picture is to be of 343 lines, each picture containing 117,649 elements. In this way it is calculated that a picture will contain the same detail as you would

### RADIO ON A POLICE SIDE-CAR

Radio is playing an increasingly important part in police work, and in Vienna the motorcycle patrols have now been equipped with wireless. Our photograph shows the officer in the sidecar receiving instructions. Note the short mast for the aerial.



electron multiplier which he has more recently developed; and, second, the system developed by P. T. Farnsworth, using the electron image disector and his varying field electron multiplier. Both systems use electronic scanning at the transmitter and receiver. The original disc method of scanning appears to have been abandoned pretty generally in America;

get in a photograph of about  $2\frac{1}{2}$  feet square, assuming a 60-point half-tone were used.

### Free From Flicker

The picture is based on the provision of 360 scanning lines, but about 10 per cent of this is sacrificed in both directions for the sake of line and frame synchronising signals. The ratio of width to height of the picture is about 4 to 3 and the picture frequency is 30 frames per second. Owing to the use of interlacing, however, the field frequency is 60 per second. This is claimed to produce a flickerless picture, and one that it not influenced very much by hum in the amplifier.

The scanning spot covers the picture in  $\frac{1}{50}$ th of a second and then goes over it again, this time covering the spaces in between the lines it traced the first time.

It is reckoned that the channel required on the air will be about 4,000,000 cycles, which will accommodate the video signals and also the synchronising signals and sound.

## INDEX TO ADVERTISERS

	PAGE
Amalgamated Press Gift Books for Boys and Girls	Cover iv
Belling & Lee, Ltd.	131
Book of Practical Television	111
Dubilier Condenser Co. (1925) Ltd.	111
Gilbert Cabinets	130
Jackson Bros. (London), Ltd.	128
Lectro Linx, Ltd.	129
Marconiphone Co., Ltd.	70
Peto-Scott Co., Ltd.	129

	PAGE
Pifco, Ltd.	69
Radio Resistor Co., Ltd.	130
Storyteller	Cover ii
Stratton & Co., Ltd.	131
Technological Institute of Gt. Britain	130
Waverley Book Co., Ltd.	Cover iii
Wharfedale Wireless Works	III
Whiteley Electrical Radio Co., Ltd.	127
Wright & Weaire, Ltd.	69

All communications concerning advertising in "Wireless" must be made to Advertising Department, John Carpenter House, John Carpenter Street, London, E.C.4.

# Special FREE Offer to Electrical Engineers and Electrical Workers

Every reader of "Wireless" should take advantage of this opportunity. We invite you to examine in your own home, for one week, absolutely free of charge or obligation to purchase.

## The Electrical Encyclopedia

*THE FIRST AND ONLY BOOK OF ITS KIND*

**A Handbook of Modern Electrical Practice for the Working Electrician**

General Editor: S. G. Blaxland Stubbs.

Associate Editors: Arthur Arnold, A.M.I.E.E., A.M.I.Mech.E., Editor of "The Power Engineer." R. A. Baynton, B.Sc. (Eng.), A.C.G.I. Phillip Kemp, M.Sc. (Tech.), M.I.E.E., A.I.Mech.E., Mem. A.I.E.E., Head of the Polytechnic School of Engineering. S. O. Pearson, B.Sc., A.M.I.E.E. S. Austen Stigant, M.I.E.E., F.Am.I.E.E. G. W. Stubbings, B.Sc. (Lond.). F.Inst.P., A.M.I.E.E.

COMPREHENSIVE, sound, and up to date, THE ELECTRICAL ENCYCLOPEDIA is a book essential to all classes of electrical engineers and electrical workers. It contains authoritative information written by experts in every branch of the profession, and covers thousands of problems and questions of everyday work.

Whatever your particular subject or job you will find that this work will add to your efficiency, aid your advance in your profession and secure certain SUCCESS.

**New Opportunities Await You—Seize these Opportunities by the Aid of "The Electrical Encyclopedia"**

The electrical industry is developing faster than any other in the kingdom. The accelerated expansion of the use of electric power, due mainly to the organisation of the "grid" system, means an enormous increase of the opportunities for advancement, promotion, and new employment. To take proper advantage of these opportunities the electrical engineer must keep abreast of advancing knowledge and be able to acquire rapidly information on any branch of the subject. This great new work, THE ELECTRICAL ENCYCLOPEDIA, will help him at every turn.



**"THE ELECTRICAL TIMES" says:—**

*"The Electrical Encyclopedia" covers electrical science and technique literally from A-Z . . . it broadly covers the whole field presented by electricity and its widespread applications, both in industry and in the domestic sphere. The general practitioner and specialist alike can use it with advantage for everyday purposes."*

**A Few of the 2,000 Articles.**

- Alternating Current Circuit Calculations.
- Bells, Electric: Their Use and Installation.
- Bridges and their Practical Uses.
- Broadcasting: Complete Process in Outline.
- Cables for All Purposes.
- Cinema Plant: Modern Design and Organisation.
- Clocks, Electric: A Modern Development.
- Distribution of Electricity: Modern Methods.
- Electricity: its Nature and Action.
- Emergency Lighting.
- Factory Fittings.
- Faults and Fault Location
- "Grid" System.
- Heaters and Heating
- Lifts: Their Design and Maintenance.
- Mathematics for Electrical Engineers.
- Radio-Gramophone Electrical Equipment.
- Resistance in D.C. Circuits.
- Television: The Principles.
- Trolley-bus, The.
- Ultra-Violet Light Apparatus
- Vacuum Cleaners.
- Wiring and its Practical Applications.
- X-Ray Apparatus in Modern Work.

**SEND NO MONEY NOW**

**YOURS**  
for  
**2/6**  
DOWN  
if kept after  
examination

Just sign and post the form at right and we will send you these four volumes, carriage paid, to examine for one week free. You may either return them to us carriage forward, within 8 days, to end the matter, or you may keep them on the very easy terms outlined on the form. 

**"Wireless" FREE Examination Form.**

To the **WAVERLEY BOOK CO., LIMITED,**  
96 and 97, Farringdon Street, LONDON, E.C.4.

Please send me, carriage paid, for seven days' FREE Examination, "THE ELECTRICAL ENCYCLOPEDIA," complete in four volumes. It is understood that I may return the work on the eighth day after I receive it and that there the matter ends. If I decide to keep the books I will send you on the eighth day a First Payment of 2/6, and, beginning thirty days after, thirteen further monthly payments of 5/- each, and a final one of 6/-, thus completing the purchase price.

Price for Cash on the eighth day, 70/-.

Name .....

Address .....

Occupation .....

Parent's signature required under 21 .....

State if householder..... Date.....

**PLEASE FILL IN ALL PARTICULARS ASKED.**

W.T.R.Z.

# Ideal Gift-Books for Boys and Girls

Books are ideal gifts for children, and here are some of the best from which to choose. Make your selection from the popular Annuals shown here and be sure your gift will be a never-failing source of fascination and interest whatever age your boy or girl may be.

Some of these books are packed with lively fun in picture and story, others with the most fascinating of features. Most of them contain beautiful coloured plates and many pages printed in colours, and all are strongly bound. Your newsagent or bookseller will be glad to show them to you.

*At all Newsagents and Booksellers*

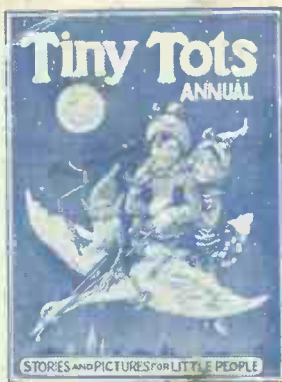

**Tiny Tots ANNUAL**  
STORES AND PICTURES FOR LITTLE PEOPLE  
For boys and girls up to nine years of age. Cheery stories, dainty verse, pretty and amusing pictures, and the ever-popular "Little Snowdrop" Picture Story  
**2/6** Net



**SUNBEAM ANNUAL**  
A big budget of jolly and exciting stories. Scores of funny pictures, tricks and puzzles. A Prize painting competition. Many fine coloured pictures  
**2/6** Net

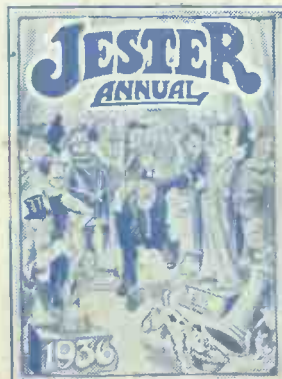

**JESTER ANNUAL**  
The big book with the big laughs in fun-pictures and stories for boys and girls of 8 to 13 years. Adventure stories, funniest pictures, &c.  
**2/6** Net



**JINGLES ANNUAL**  
A jolly fun-picture and story-book, packed with pictures, verses, puzzles, games, picture-stories and tales of fun and adventure.  
**2/6** Net

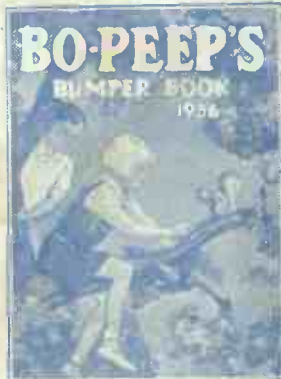

**BO-PEEP'S BUMPER BOOK**  
For boys and girls up to ten. Bright stories and dainty verse concerning humans and fairies, birds and bunnies, etc.  
**2/6** Net



**PLAYBOX 1936 ANNUAL 1936**  
The old favourite with all children between six and twelve years of age. Packed with pictures and stories, fairy tales, jokes and games.  
**3/6** Net



**THE NURSERY RHYME OMNIBUS**  
Nearly 700 rhymes, hundreds of pictures, specially drawn, and many pages of colour quite original in a book of this kind.  
**3/6** Net

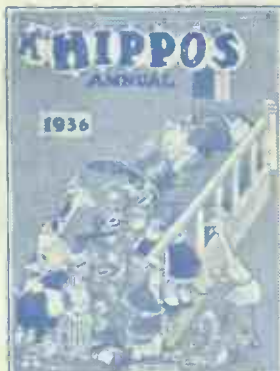

**CHIPPOS ANNUAL**  
For children up to ten. Packed with stories and pictures of the Hippo Girls, the Bumpy Boys, etc. Games, riddles and puzzles.  
**3/6** Net

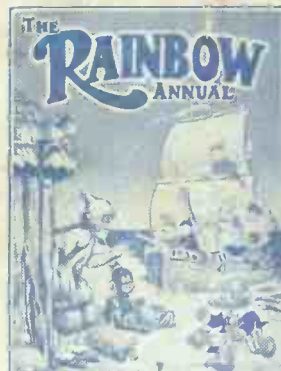

**THE RAINBOW ANNUAL**  
Packed with pictures and stories of the Bruin Boys, the Pickles, and other well-known characters.  
**3/6** Net



**THE MODERN BOY'S BOOK OF ADVENTURE STORIES**  
A 240-page volume of the finest fiction by the pick of present-day boys' authors. Flying, motor-racing, and adventures on land and sea.  
**5/-** Net

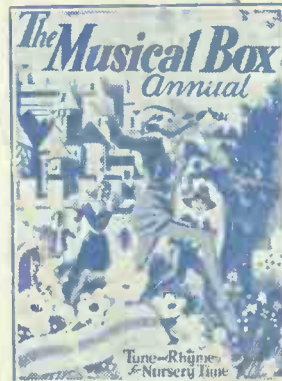

**The Musical Box Annual**  
Nursery rhymes with music, bedtime ballads, original pieces for children and famous lullabies. 52 pages in colour.  
**5/-** Net

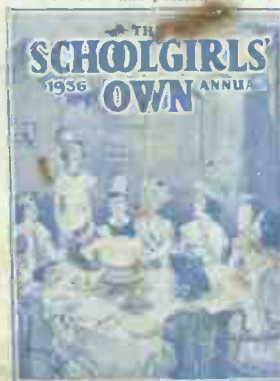

**THE SCHOOLGIRLS' OWN ANNUAL**  
The book for every school-girl from nine to fifteen years. Packed with school and adventure tales and articles. Lavishly illustrated.  
**6/-** Net

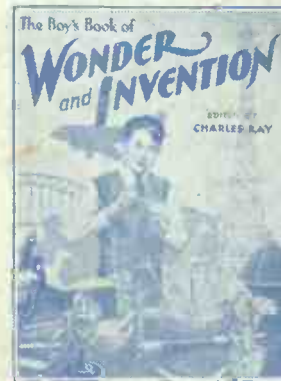

**The Boy's Book of WONDER and INVENTION**  
A splendid gift book for boys who find a thrill in science and the wonders of Nature. Safe experiments. Profusely illustrated.  
**6/-** Net

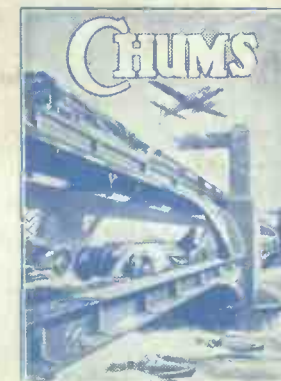

**CHUMS**  
416 PAGES of reading. Magnificent illustrations; colour plates. Book-length stories of adventure, mystery and school life; articles.  
**8/6** Net