

TELEVISION ENGINEERING
Principles and Practice

VOLUME FOUR

IN THIS SERIES

VOLUME ONE

Fundamentals, Camera Tubes, Television Optics, Electron Optics

VOLUME TWO

Video-Frequency Amplification

VOLUME THREE

Waveform Generation

BBC ENGINEERING TRAINING MANUALS

TELEVISION ENGINEERING
Principles and Practice

VOLUME FOUR
GENERAL CIRCUIT TECHNIQUES

S. W. AMOS, B.Sc. (Hons.), A.M.I.E.E.
and
D. C. BIRKINSHAW, M.B.E., M.A. M.I.E.E

LONDON : ILIFFE & SONS, LTD.

First published in this series, 1958

© British Broadcasting Corporation, 1958

*Published, by arrangement with the BBC, for "Wireless World" by
Hiffé & Sons, Ltd., Dorset House, Stamford Street, London, S.E.1*

Made and printed in England at The Chapel River Press, Andover, Hants

BK8 3178

ACKNOWLEDGMENTS

THE BBC wish to record their thanks to the Society of Motion Picture and Television Engineers for permission to reproduce one frame of the Television Test Film TV35, which was used in preparing Plates I, II and III.

Thanks are also due to the Editor of the *Proceedings of the Institution of Electrical Engineers* for permission to use material from the paper "Frame-scanning Output Circuits for Wide-angle Cathode-ray Tubes" by D. H. Covill published in Part IIIA *Convention on the British Contribution to Television*, Vol. 99, No. 19, April-May 1952.

Finally the authors would like to thank Mr. V. J. Cooper of Marconi's Wireless Telegraph Company for a most helpful discussion on shunt-regulated amplifiers and also for checking the manuscript of Chapters 13 and 14.

CONTENTS

<i>Chapter</i>		<i>Page</i>
	PREFACE	
1	COUNTER CIRCUITS	15
	Introduction—Distinction between Frequency Division and Counting—Bi-stable Dividers (Counters)—Step Counter—Ring Counter—Binary Counter—Binary Counter with Feedback	
2	FREQUENCY DIVIDERS	41
	Introduction — Monostable Dividers — Multivibrator — Phantastron — Astable Dividers — Multivibrator — Blocking Oscillator	
3	BASIC PRINCIPLES OF D.C. CLAMPING AND D.C. RESTORATION	58
	Introduction—Variation in Blanking Level and Sync Level due to A.C. Coupling—Variations in Blanking Level due to Other Causes—Action of D.C. Restorers and Clamps—Distinction between D.C. Restoration and D.C. Clamping	
4	D.C. RESTORER CIRCUITS	65
	Fundamental Circuit—D.C. Restorer with Provision for Adjusting Sync Level—D.C. Restorer Operating on Negative-going Picture Signal—D.C. Restorer Used for Picture-sync Separation	
5	D.C. CLAMP CIRCUITS	75
	Introduction—Typical Circuit—Alternative Circuit	
6	GAMMA-CONTROL AMPLIFIERS	81
	Introduction—Gamma—Point Gamma—Required Overall Value of Gamma—Effect of Incorrect Gamma Value—Gamma-control Circuits for Camera or Positive Film—Gamma-control Circuits for Negative Film	
7	DELAY LINES	106
	Introduction — Delay Cables — T- and π -Sections—Delay Networks—Networks with m -derived Sections—Termination of Delay Networks—Applications of Delay Networks—Appendix A: Iterative Impedance of Prototype T- and π -Sections—Appendix B: Group Delay of an m -derived Low-pass Section	

CONTENTS

<i>Chapter</i>	<i>Page</i>
<p>8 FIXED EQUALISERS</p> <p>Introduction — Constant-resistance Equaliser Networks — Simple Circuit—More Complex Circuit—Resonant Circuit —Appendix C: Frequency Response of Simple Constant-resistance Equaliser—Appendix D: Frequency Response of More Complex Constant-resistance Equaliser—Appendix E: Conditions for Resonant Equaliser to have Constant Resistance—Appendix F: Frequency Response of Resonant Constant-resistance Equaliser</p>	139
<p>9 VARIABLE (BODE-TYPE) EQUALISERS</p> <p>Introduction—Basic Circuit—Bode Condition—Frequency Response—Constant-resistance Bode-type Variable Equaliser —Appendix G: Input Impedance of a Four-terminal Network—Appendix H: Derivation of the Form of the Shunt Arm in a Constant-resistance Bode-type Variable Equaliser</p>	169
<p>10 ELECTRICAL CHARACTERISTICS OF SCANNING COILS</p> <p>Introduction—Fundamental Principles of Electromagnetic Scanning—Impedance of Scanning Coils—Basic Principles of Scanning Output Stages—Voltage Across Field-scanning Coils—Voltage across Line-scanning Coils</p>	188
<p>11 FIELD OUTPUT STAGES</p> <p>Introduction — Transformer-coupled Circuit — Effect of Primary Inductance—Practical Field-scanning Circuits—Using Curvature of Valve Characteristic—Using a Shaping Network—Using Negative Feedback—Blumlein Circuit—Appendix J: Determination of Feedback Components in Blumlein Circuit</p>	196
<p>12 LINE OUTPUT STAGES</p> <p>Introduction — Transformer-coupled Circuit — Effect of Resistance and Capacitance—Heavily-damped Circuit—Efficiency Diode—Booster Diode—Generation of E.H.T. Supply</p>	219
<p>13 SHUNT-REGULATED AMPLIFIERS</p> <p>Introduction—Basic Principles of Regulated Amplifiers—Output Resistance of Shunt-regulated Amplifier—Voltage Gain of Shunt-regulated Amplifier—Comparison with Conventional Amplifier—Compensation for Capacitive Load —Appendix K: Derivations of Expressions for the Output Resistance and Voltage Gain of a Shunt-regulated Amplifier —Appendix L: Compensation of Shunt-regulated Amplifier for Capacitive Load</p>	235

CONTENTS

<i>Chapter</i>	<i>Page</i>
14 SHUNT-REGULATED CATHODE FOLLOWERS	254
Introduction—Basic Circuit—Output Resistance of Shunt-regulated Cathode Follower—Voltage Gain of Shunt-regulated Cathode Follower—Comparison with Conventional Cathode Follower—Appendix M: Derivation of Expressions for the Output Resistance and Voltage Gain of a Shunt-regulated Cathode Follower	
BIBLIOGRAPHY	265
INDEX	267

PREFACE

THIS is the fourth and last volume of a textbook on television engineering written principally for the engineering staff of the British Broadcasting Corporation and intended to provide a comprehensive survey of modern television principles.

Earlier volumes have been concerned with such subjects as camera tubes (Volume 1), video amplifiers (Volume 2) and wave-form generation (Volume 3). This volume describes the principles of a number of circuit techniques which are extensively employed in television equipment but do not properly belong to the earlier volumes. Amongst the techniques treated are counter circuits, frequency dividers, d.c. clamps, d.c. restorers, gamma-control amplifiers, delay lines, fixed and variable equalisers, scanning output stages and shunt-regulated amplifiers. Some of these subjects, notably delay lines and equalisers, require a mathematical treatment but wherever possible self-contained derivations have been included in appendices at the ends of the chapters to avoid interruption to the flow of the argument.

The text of this volume was written by S. W. Amos, B.Sc., A.M.I.E.E., of the Engineering Training Department, in collaboration with D. C. Birkinshaw, M.B.E., M.A., M.I.E.E., Superintendent Engineer, Television, and is based on an internal BBC manual written by the same authors. Thanks are due to the Lines Department of the BBC for checking the technical accuracy of the chapters on equalisers and to G. G. Johnstone of the Engineering Training Department for a number of valuable suggestions.

PRINCIPAL SYMBOLS USED

<i>B</i>	Brightness
<i>C</i>	Capacitance in general
<i>C</i> ₁	Series capacitance in a network
<i>C</i> ₂	Shunt capacitance in a network
<i>D</i>	Density of a film
	Delay of a cable or network
<i>I</i>	Current in general
<i>I</i> _a	Anode current
<i>L</i>	Inductance in general
<i>L</i> ₁	Series inductance in a network
<i>L</i> ₂	Shunt inductance in a network
<i>L</i> _c	Inductance of a pair of scanning coils
<i>L</i> _l	Leakage inductance of a transformer
<i>L</i> _p	Inductance of the primary winding of a transformer
<i>M</i>	Mutual inductance
<i>R</i>	Resistance in general
<i>R</i> ₁	Series resistance in a network
<i>R</i> ₂	Shunt resistance in a network
<i>R</i> _a	Anode load resistance of a valve
<i>R</i> _c	Resistance of a pair of scanning coils
<i>R</i> _{in}	Input resistance
<i>R</i> _L	Load resistance
<i>R</i> _{out}	Output resistance
<i>R</i> _{opt}	Optimum value of load resistance
<i>R</i> _s	Resistance of the secondary winding of a transformer
<i>T</i>	Transparency of a film
	Period of a recurrent wave (= 1/ <i>f</i>)
<i>V</i>	Voltage in general
<i>V</i> _a	Anode voltage
<i>V</i> _g	Grid voltage
<i>V</i> _{in}	Input voltage
<i>V</i> ₀	Initial voltage
<i>V</i> _{out}	Output voltage
<i>V</i> _{<i>t</i>}	Voltage after a time <i>t</i>
<i>Z</i>	Impedance in general
<i>Z</i> _{in}	Input impedance
<i>Z</i> ₀	Characteristic Impedance
	Iterative Impedance
<i>Z</i> _{0π}	Iterative impedance of a π-section
<i>Z</i> _{0π_m}	Iterative impedance of an <i>m</i> -derived π-section
<i>Z</i> _{0T}	Iterative impedance of a T-section
<i>Z</i> _{0T_m}	Iterative impedance of an <i>m</i> -derived T-section

PRINCIPAL SYMBOLS USED

<i>a</i>	Network parameter used in Bode equalisers
<i>f</i>	Frequency in general
<i>f_c</i>	Cut-off frequency of a network
<i>g_m</i>	Mutual conductance of a valve
<i>i</i>	Current
<i>i_p</i>	Current in the primary winding of a transformer
<i>i_s</i>	Current in the secondary winding of a transformer
<i>l</i>	Length
<i>m</i>	Ratio of the series (or shunt) elements in an <i>m</i> -derived network relative to the corresponding elements in the prototype section
<i>n</i>	Number of sections in a delay line
	Turns ratio of a transformer
<i>p</i>	Ratio of shunt inductance to series inductance in a resonant equaliser (= L_2/L_1)
<i>r</i>	Ratio of series resistance to shunt resistance in an equaliser (= R_1/R_2)
<i>t</i>	Time
<i>x</i>	Variable directly proportional to frequency (= f/f_c)
<i>β</i>	Ratio of output voltage to input voltage of a network
<i>γ</i>	Slope of the log output-log input curve of an amplifier, camera or cathode-ray tube
	Slope of the density-log brightness curve for a photographic film
<i>θ</i>	Transfer constant of a network
<i>μ</i>	Amplification factor of a valve
<i>ω</i>	Angular frequency (= $2\pi \times$ frequency)

CHAPTER 1

COUNTER CIRCUITS

1.1 INTRODUCTION

IN a twin-interlaced television system the various pulses required in the sync signals or for camera operation have frequencies equal to the field frequency, line frequency or twice line frequency. The ratios between these frequencies must be kept constant and the phase relationship between them must also be maintained with precision. It is undesirable to obtain the line and twice line frequencies by frequency multiplication of the output of an oscillator operating at field frequency because any small variations in the phase of the field oscillator output would be exaggerated by the multiplier. It is better to obtain the required phase stability by use of a master oscillator at twice line frequency, the line and field frequencies being derived from it by frequency division. The next few pages describe the principles of a number of types of frequency divider suitable for use in television equipment.

1.2 DISTINCTION BETWEEN FREQUENCY DIVISION AND COUNTING

Before describing the various circuits which can be used for frequency division, we shall distinguish between frequency division and counting. These processes have much in common and certain circuits can be used for both, whereas other circuits are suitable for frequency division only. The distinction lies in the nature of the input signal: if this is repetitive at a frequency f the process of deriving an output from it at a frequency f/n , n being an integer, is known as *frequency division*; if the input is not repetitive but consists of signals such as pulses occurring at irregular intervals, the process of deriving one output pulse for every n input pulses is known as *counting*. If the input signals to a counter circuit are periodic, the output is also periodic and the circuit behaves as a frequency divider. It follows that all counter circuits, irrespective of their nature, can be used for frequency division. On the other hand all frequency dividers cannot be used for counting; many frequency dividers embody free-running relaxation oscillators and give an output even in the absence of an input signal. Perhaps the distinction is more obvious from the observation that a counter

circuit does not contain any timing circuits but a frequency divider may.

The intervals between the input pulses to a counter circuit can vary over wide limits without affecting the accuracy of counting, and such circuits are thus particularly useful as frequency dividers in applications where the frequency of the input may vary about its mean value. A field divider in a television system is such an example, for the input frequency is usually arranged to be so controlled from the mains frequency that it reproduces, to some extent, any phase fluctuations in the mains supply.

In this chapter we shall describe the circuits commonly used for bi-stable dividers or counters.

1.3 STEP COUNTER

1.3.1 Basic Circuit

Counters of this type are essentially energy-storage devices which accumulate the energy of input signals and, when a critical value is reached, return to the original state, generating an output pulse as they do so. The energy-storing device is usually a capacitor and the essential features of one type of step counter are shown in Fig. 1. C_2 is the storage capacitor and, when sufficient energy has been put into it, the voltage across it is enough to operate the

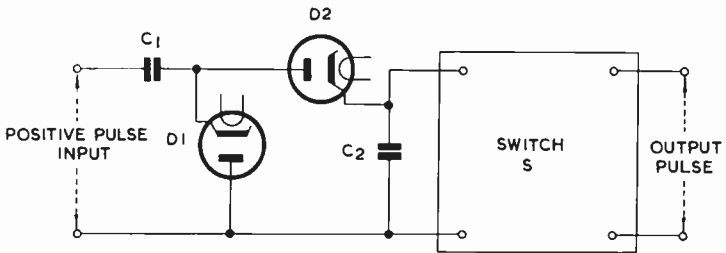

Fig. 1—Essential features of one type of step counter

switch S , which discharges C_2 and generates the output pulse. The capacitor C_1 is small compared with C_2 and determines the increment in energy (i.e. the rise in voltage) in C_2 for each input pulse. The purpose of the two diodes $D1$ and $D2$ is shown in the following description of the method of operation of the circuit.

Suppose initially C_1 and C_2 are uncharged and a source of positive-going pulses is applied to the input of the circuit. On receipt of the first pulse, $D2$ conducts and effectively connects the two

COUNTER CIRCUITS

capacitors C_1 and C_2 across the input terminals. The input potential is shared between the capacitors in inverse ratio to their capacitances and the voltage appearing across C_2 is given by

$$\frac{C_1}{C_1 + C_2} \cdot V_{in}$$

where V_{in} is the input-pulse amplitude. C_1 is small compared with C_2 and the voltage across C_2 is only a small fraction (e.g. 1/20th)

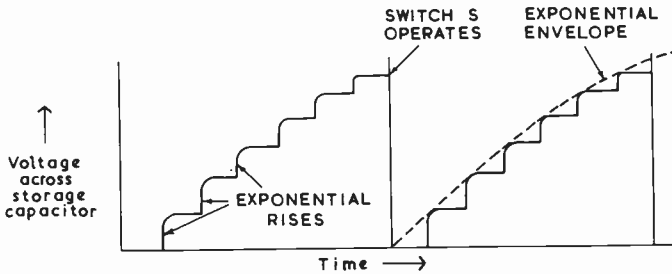

Fig. 2.—Waveform across storage capacitor in step counter

that of the input voltage. When the voltage across the input terminals falls to zero at the end of each input pulse, C_1 discharges through the resistance of the pulse source and the forward resistance of the diode D1. C_2 cannot discharge through D2, however, because the discharge current would have to flow through the reverse resistance of D2 which is virtually infinite. Thus, during the intervals between pulses, the charge on C_1 disappears but that on C_2 is preserved. The voltage across C_2 thus rises in steps as successive pulses are received, as pictured in Fig. 2. The appearance of this diagram accounts for the name "Staircase Generator" which is sometimes applied to this circuit. When the voltage across C_2 reaches a predetermined value, it operates the switch S. This has two effects; it generates an output pulse and it discharges C_2 , thus returning the circuit to its original state.

The switch S could take the form of a simple gas diode or triode which becomes conductive when the voltage across C_2 reaches a certain value, but it is more usual to employ a blocking oscillator or a multivibrator. Examples of both types of circuit are given later.

1.3.2 Methods of Controlling the Count Ratio

The number of input pulses required to give one output pulse (known as the count ratio) is determined by the initial voltage

across the storage capacitor (taken as zero in Fig. 2), the amplitude of the input pulses, the ratio of C_1 to C_2 and the voltage at which S operates. The input-pulse amplitude is usually maintained constant and any of the remaining factors can be made adjustable to enable the count ratio to be varied. For a given input-pulse amplitude and setting of S, if C_1 is increased more energy is fed to C_2 for each input pulse and the voltage steps are larger. The critical switch voltage is thus reached in a smaller number of steps than before and the count ratio is decreased. C_1 is sometimes composed of two capacitors in parallel, as shown in Fig. 3, one of which can be varied to adjust the count ratio. This method

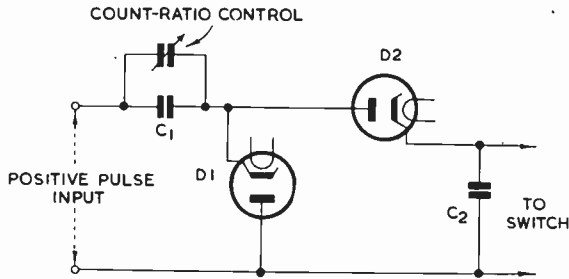

Fig. 3—One method of varying the count ratio in a step counter

is convenient when the capacitance of C_1 is small, say of the order of 20pF, but is hardly practicable when much larger values are required.

Alternatively the count ratio can be varied by adjustment of the voltage at which the switch S operates, the input-pulse amplitude and the capacitors C_1 and C_2 being fixed. This may be done directly by alteration of the grid bias of the valve following C_2 or indirectly by placing on C_2 a standing and predetermined voltage of controllable magnitude termed the initial voltage above. In the latter method the staircase waveform generated across C_2 starts, not from zero, but from the predetermined voltage level. The higher this initial level is made, the less is the number of steps required to reach the critical voltage at which the switch operates.

1.3.3 Limiting Value of Count Ratio for a Single Stage

The voltage steps across C_2 are not of constant amplitude; the initial step has maximum amplitude, subsequent steps having successively smaller amplitudes as shown in dotted lines in Fig. 2.

COUNTER CIRCUITS

The reason for this is that the voltage available to drive charging current through C_1 and C_2 becomes progressively smaller as the voltage builds up across C_2 . This can be illustrated by a numerical example: suppose the input-pulse amplitude is 100 volts and that C_2 is 9 times C_1 . At the first step 90 volts are developed across C_1 and 10 volts across C_2 . In the interval before the next step, C_1 is discharged but the 10 volts across C_2 are retained, and at the next step only 90 volts are available to charge C_1 and C_2 . This voltage is again divided in the ratio of the capacitances, 81 volts being developed across C_1 and 9 volts across C_2 (making 19 in all). The second step is thus 9 volts compared with a first step of 10 volts. Succeeding steps are progressively smaller as can be determined by continuing this calculation.

This fall-off in step amplitude sets an upper limit to the count ratio obtainable with reliability. If large steps are used, the reduction in step amplitude is very marked and it is difficult to assess at which step S will operate. The step amplitude can be made more constant by making it small compared with the input-pulse amplitude, but if the steps are small, the difficulty of determining which step will operate S still remains. In spite of this, it is usual to make the steps of small voltage by making C_1 small compared with C_2 .

To minimise the difficulty of obtaining a desired count ratio the latter is generally less than 10 and seldom exceeds 5. A ratio exceeding 10 can be obtained using two or more counters in cascade, feedback being used (as explained later) if the ratio cannot be factorised into two or more integers.

The ratio of C_1 to C_2 is determined by the required division ratio but the absolute values of capacitance are governed primarily by the frequency of the input to the divider. To obtain well-formed steps of potential across C_2 , the rise time of the input pulse must be short compared with the period of the input signal. Suppose it is decided that the rise time shall not be greater than $1/10$ th of the period ($1/f$). As shown in Volume 2, the rise time for a simple RC combination is given approximately by $2.2RC$ and, in this circuit, is equal to $2.2R_aC_1$ where R_a is the anode load resistance of the valve feeding C_1 . It is assumed that C_1 is small compared with C_2 and that the anode a.c. resistance of the previous valve is large compared with R_a . We thus have

$$2.2R_aC_1 \leq 1/10f$$

The valve is usually a pentode operating as a limiting amplifier and with a high-value anode load such as 50 k Ω . If $R_a = 50$ k Ω and

$f = 20$ kc/s (approximately twice line frequency for the British television system) we have

$$\begin{aligned} C_1 &\leq 1/(22R_a f) \\ &\leq 1/(22 \times 5 \times 10^4 \times 2 \times 10^4) \text{F} \\ &\leq 45 \text{ pF} \end{aligned}$$

Of this probably about 15 pF is contributed by the anode capacitance of the limiting amplifier and stray capacitance; a suitable value for C_1 is thus 30 pF. A value of 22 pF is commonly used in practice and C_2 is 10 or 20 times as great.

1.3.4 Step Divider with Multivibrator Switch

Fig. 4 gives a typical circuit of a step divider using a cathode-coupled multivibrator as a switch to discharge the capacitor C_2 . The potentiometer R_5 controls the division ratio and the variable resistor R_8 the duration of the output pulses.

The capacitors C_1 and C_2 are preceded by a valve V1 which functions as a limiting amplifier, the pulse amplitude developed at the anode being substantially independent of the input-signal amplitude. For full details of such circuits see Volume 3.

The diodes D1 and D2 constitute the step counter which is similar to that shown in Fig. 1 except that C_2 can be given an adjustable initial positive bias for count ratio control. This bias is obtained by returning the anode of D1 to the slider of the potentiometer R_5 which is connected in series with R_3 and R_4 across the h.t. supply. In the absence of signals from V1 anode this voltage causes D1 and D2 to conduct, thus charging C_2 to a voltage approximately equal to that on D1 anode.

V2 and V3 constitute a cathode-coupled multivibrator (switch S in Fig. 1) and in the absence of signals from C_2 , V3 is conductive because of the positive potential on its grid. By cathode-follower action, the common cathode potential is approximately equal to that at the junction of R_3 and R_4 . When the divider circuit is working, the staircase waveform developed across C_2 is applied to V2 grid. After a number of steps (determined by the setting of R_5) the potential at V2 grid approaches sufficiently near that of its cathode for V2 to take anode current. This initiates the regenerative action characteristic of multivibrators (described in Volume 3) which ends with V2 conductive and V3 cut off. The current in R_7 is now the cathode current of V2 instead of V3 current as formerly. V2 cathode current is, however, much smaller than that of V3 because the anode load resistor R_6 is greater than R_9 . Thus the cathode potential falls below V2 grid potential which is

COUNTER CIRCUITS

maintained by the charge on C_2 , causing V2 to take grid current from C_2 and discharge it. The potential across C_2 falls until it reaches the value at D1 anode at which it stabilises by conduction through D1 and D2 in series, V2 grid current being now supplied from C_6 via the two diodes in series.

The multivibrator is now in its unstable state, V3 being cut off by a negative potential on the control grid. This potential rises exponentially as C_7 discharges through R_8 until V3 begins to take current, when there is a further regenerative action which returns the circuit to its original, stable state. The duration of the unstable state and of the positive-going pulses generated at V3 anode can be controlled by variation of R_8 .

The operation of the divider circuit can be inspected (to check the division ratio) by an oscilloscope connected across a capacitor C_3 connected in series with C_2 as shown in dotted lines. If this

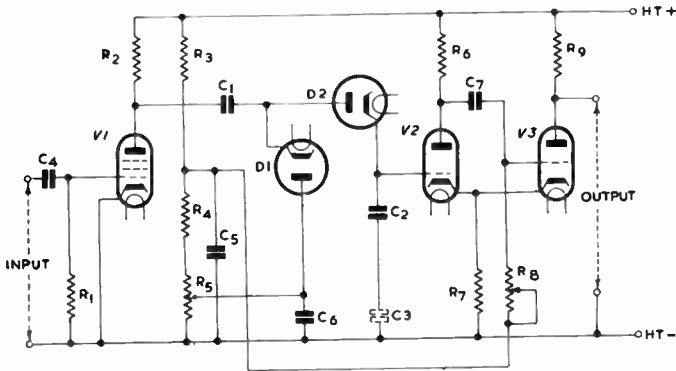

Fig. 4—Step divider using a multivibrator switch

capacitor is large compared with C_2 , its insertion in the circuit and the connection of the oscilloscope has negligible effect on the performance of the circuit.

1.3.5 Step Dividers in Cascade

The line divider, i.e. the divider deriving the line from the master-oscillator frequency, requires a factor of 2 which can readily be achieved in a single stage. The field divider, however, requires a factor equal to the number of lines per picture and this is normally too great to be achieved in a single stage. Thus the field divider contains a number of stages in cascade and the number of lines should be divisible into factors for which dividers can easily be

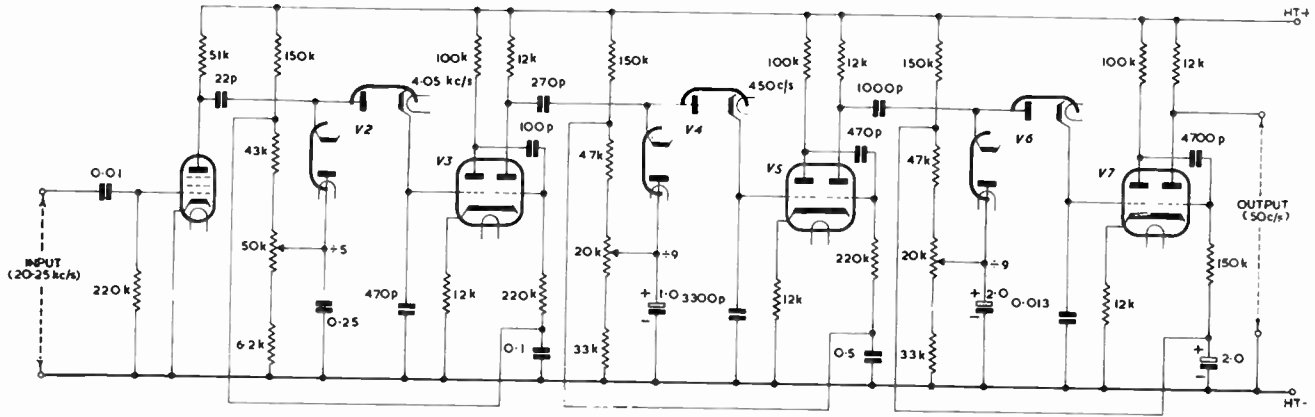

Fig. 5—Cascade step divider using multivibrator switches and dividing by 405

COUNTER CIRCUITS

designed. The principal requirement is that the factors should be fairly small and preferably less than 10. For the British system the number of lines is 405 and the field divider usually contains three stages with factors of 5, 9 and 9.

Each stage may have the form of Fig. 4 and the complete divider then has a circuit such as that shown in Fig. 5. The values of C_1 and C_2 are approximately in inverse ratio to the frequency of the pulse input. For example, the values are $C_1 = 22 \text{ pF}$ and $C_2 = 470 \text{ pF}$ for the first stage (input frequency approximately 20 kc/s), and for the succeeding stages are as follows:

C_1	C_2	<i>Approximate input frequency</i>
270 pF 0.001 μF	0.0033 μF 0.013 μF	4 kc/s 450 c/s

This is done to minimise effects of high-resistance leakage on the performance of the circuit. Consider the first stage which has an input at approximately 20 kc/s and $C_1 = 22 \text{ pF}$. For satisfactory operation the resistance in parallel with C_1 due to leakage should be so large that it gives with C_1 a time constant many times the periodic time of the input. The period is 50 μsec approximately and a suitable value for the time constant is 500 μsec . This gives the minimum leakage resistance tolerable as

$$\begin{aligned}
 R &= \frac{T}{C_1} \\
 &= \frac{500 \times 10^{-6}}{22 \times 10^{-12}} \Omega \\
 &= 25 \text{ M}\Omega \text{ approximately}
 \end{aligned}$$

Most practical circuits have a resistance greater than this. If the value of C_1 were kept unchanged in succeeding stages, the leakage resistance would need to be 125 M Ω for the second and over 1,000 M Ω for the third. By adopting the values of C_1 (and C_2) given in the above table, such high values of leakage are not necessary and satisfactory performance is possible with reasonably low values, such as 25 M Ω .

1.3.6 Step Divider using Blocking Oscillator Switch

A blocking oscillator can be used instead of a multivibrator as a switch and the circuit of a divider using a blocking oscillator is given in Fig. 6. V1 is the limiting amplifier which feeds the step

circuit as in the two previous diagrams and the staircase waveform generated across C_2 is applied to the blocking oscillator V2. The circuit of V2 differs from that of a conventional blocking oscillator in that it has cathode bias from the potential divider $R_3R_4R_5$ which, in the absence of a grid signal, biases V2 beyond cut off. It will be recalled that adjustment of the grid bias of the valve following the step counter is one of the methods which can be used to vary the division ratio. Thus R_5 is a division ratio control and is so set that V2 begins to take anode (and screen) current when the requisite number of voltage steps have been developed across C_2 . The start of screen current in V2 initiates a change of state, hastened by the regeneration characteristic of the blocking oscillator, which causes the anode and screen currents to increase rapidly to a high value. At the same time the valve takes grid current which discharges C_2 . Diodes D1 and D2 prevent C_2 being charged in the opposite direction by grid current and C_2 is effectively at zero potential at the start of the next staircase waveform.

After the screen current has reached saturation, there is a second change of state (described in Volume 3) in which the screen and anode currents are cut off very rapidly by regeneration in the transformer L_1L_2 . Thus V2 has one burst of conduction and gives a negative-going anode-potential pulse coinciding with the discharge of C_2 . The duration of this pulse is largely determined by the inductance and capacitance of the blocking-oscillator transformer and is thus not readily adjustable as in the previous circuits.

1.3.7 *Input Frequency Limits for Step Divider*

If the capacitors C_1 and C_2 were perfect and there were no leakage paths across them due to valves or other components in the divider, they would hold their charge indefinitely and the intervals between input pulses would have no effect on the accuracy of counting; in these idealised conditions the divider would maintain its division ratio in spite of decreased input frequency. In practice, leakage paths are present and set a lower limit to the input frequency.

There is also an upper limit to the input frequency for if the input pulses are of very brief duration, the series combination of C_1 and C_2 will have insufficient time in which to receive charge and the steps applied to C_2 will be abnormally small, thus upsetting the division ratio. The upper frequency limit depends on the charge time constant of the anode circuit of the limiting amplifier supplying the input pulses. C_2 is normally large compared with C_1 and the effective capacitance of the series combination is very

COUNTER CIRCUITS

nearly equal to C_1 . This capacitance together with the stray shunt capacitance at the anode of the limiting amplifier is in parallel with the anode load resistor, and this combination determines the charge time constant (the forward resistance of the diode D1 is neglected in this approximate calculation). Suppose C_1 is 20 pF, stray capacitance is 15 pF and the anode load 50 k Ω . The time constant is given by

$$35 \times 10^{-12} \times 50 \times 10^3 \text{ sec}$$

As shown in Volume 2, the rise time for a simple RC combination, i.e. the time taken for the voltage steps to rise from 10 per cent

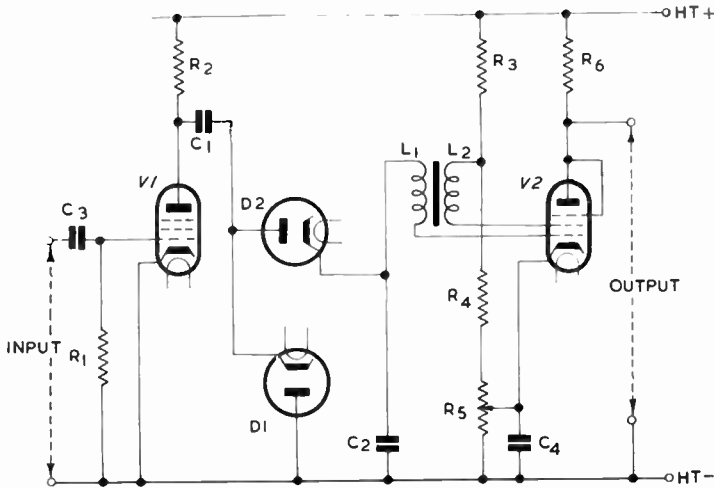

Fig. 6—A step divider using a blocking-oscillator switch

to 90 per cent of their final value, is approximately 2.2 times the time constant. For this circuit therefore the rise time is given by

$$\begin{aligned} &2.2 \times 35 \times 10^{-12} \times 50 \times 10^3 \text{ sec} \\ &= 3.85 \mu\text{sec} \end{aligned}$$

This is, however, not the only property of the circuit which limits the upper frequency at which the circuit will operate. After the requisite number of voltage steps have been developed across C_2 , this capacitor discharges through the grid-cathode resistance of the following valve. This process also takes a finite time which under ideal conditions is small compared with the periodic time of the input pulses. The discharge period is determined by the time

constant $R_g C_2$ (in which R_g is the input resistance of the valve) which sets an upper limit to the frequency at which the circuit will operate satisfactorily. For example, if R_g is 1 k Ω and C_2 is 500 pF, the time constant is given by

$$500 \times 10^{-12} \times 10^3 \text{ sec}$$

and the fall time, the time taken for the voltage across C_2 to fall from 90 per cent to 10 per cent of its original value, is equal to

$$\begin{aligned} &2.2 \times 500 \times 10^{-12} \times 10^3 \text{ sec} \\ &= 1.1 \mu\text{sec} \end{aligned}$$

This is less than the rise time of the voltage steps across C_2 and thus the upper frequency limit is determined primarily by the rise time.

The duration of the input pulses should not be less than the rise time in order to maintain the division ratio. If the minimum permissible duration is taken as 10 μsec , the period of the input is 20 μsec and the maximum input frequency 50 kc/s. This can be increased by decreasing the anode load resistance but this will necessitate redesign of the limiting amplifier.

Thus there are lower and upper limits to the frequency of the input to a step divider and provided these limits are not overstepped, the divider will maintain its division ratio in spite of variation in input frequency.

1.4 RING COUNTER

1.4.1 Introduction

Ring counters make use of principles quite different from those discussed above. The step counter is an energy-storage device but the ring (and binary) counter operates by arranging for input signals to alter the state of conduction or non-conduction of the valves employed. Since a valve can remain indefinitely in a given state, the intervals between the input signals can be increased to any extent without affecting the accuracy of the count; in other words the lower limit to the input frequency is zero. The upper limit is determined by time-constant considerations as in the step counter circuit.

The ring counter consists of a number of valves so connected that only one can be conductive at a time. The arrangement is such that every time an input pulse is applied to the circuit the state of conduction is handed on to the next valve in the ring. If there are n valves, after n input pulses the valve originally con-

COUNTER CIRCUITS

ductive is again conductive. Each valve thus becomes conductive once for each n input pulses.

A disadvantage of the circuit is that it is extravagant of valves, the number required per divider state being equal to the division ratio of the stage. Thus a circuit to divide by 9 requires 9 valves. This number can, however, be reduced to 6 by using two stages in cascade, each dividing by 3. However, to divide by 405 by this

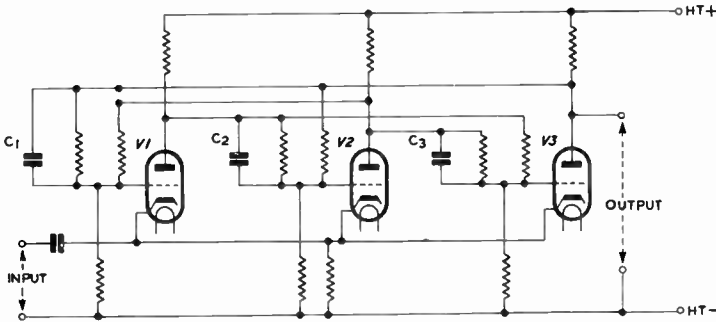

Fig. 7—Ring circuit for dividing by three

method, using factors of 3, 3, 3 and 5 requires 17 valves compared with the 7 valves employed in the step divider of Fig. 6. Moreover the input resistance of a ring counter is rather low and a fairly high-current valve may be necessary to drive it. Although the circuit is unlikely to be used for division by large numbers, it is mentioned here because, in its form for dividing by 2 it is identical with the binary counter which is the basis of a number of very successful counter circuits.

1.4.2 Ring Circuit for Division by Three

A ring circuit for dividing by 3 is illustrated in Figs. 7 and 8. It is shown in conventional form in Fig. 7 and in the form of a ring in Fig. 8. It consists of three amplifying stages with a common cathode circuit, the anode of each valve being directly coupled to the grids of the other two as in a bi-stable multivibrator circuit. This arrangement is such that if one valve is conductive, its anode potential is low enough to bias the remaining valves beyond cut off; only one valve can thus be conductive at a time. A positive pulse applied to the common cathode connection causes the conductive valve, whichever it is, to become non-conductive. Its

anode potential rises quickly to h.t. potential and this positive pulse is transferred to the grids of the other two valves.

Both valves thus tend to become conductive but it is essential for the proper operation of the circuit that only one should in fact become conductive, the other remaining non-conductive. This is achieved by arranging for the pulse at the anode (of V1, say) to be transferred immediately to the grid of one valve (say V2) but to be delayed in its transfer to the other valve (V3). By this means V2 anode potential falls before that of V3 anode and the negative pulse at V2 anode keeps V3 non-conductive by neutralising the

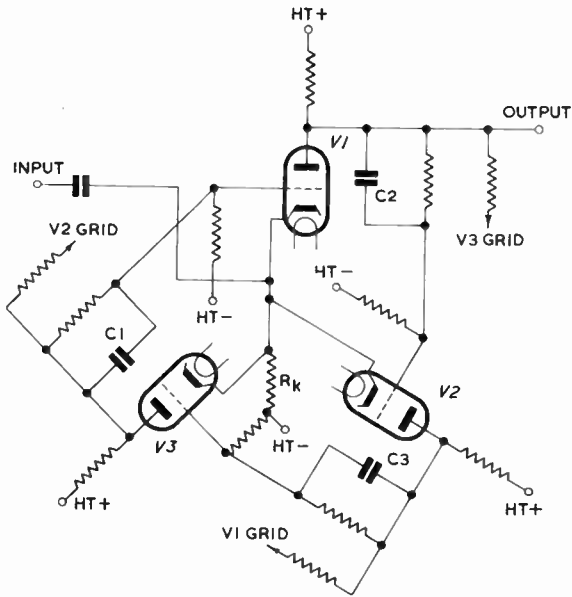

Fig. 8—Circuit of the previous diagram drawn in the form of a ring

positive pulse at V3 grid from V1 anode. This timing is achieved by use of speed-up capacitors C_1 , C_2 and C_3 . Each anode is connected to the grid of one of the other valves by a capacitor in addition to the resistive coupling. In Fig. 8, V1 is coupled by this method to V2, V2 to V3 and V3 to V1. This ensures that successive input pulses cause the state of conduction to be passed round the ring in the order V1, V2, V3, V1, etc. An output, at one-third the input frequency, can be taken from the anode of any of the three valves. The waveforms for the ring counter are illustrated

COUNTER CIRCUITS

in Fig. 9 in which the arrowed line shows how the state of conduction is passed round the ring as successive input pulses are received.

1.5 BINARY COUNTER

1.5.1 Introduction

The binary counter is a type of counter or frequency divider made up of units which are essentially bi-stable multivibrators. A multivibrator of this type consists of two valves so interconnected

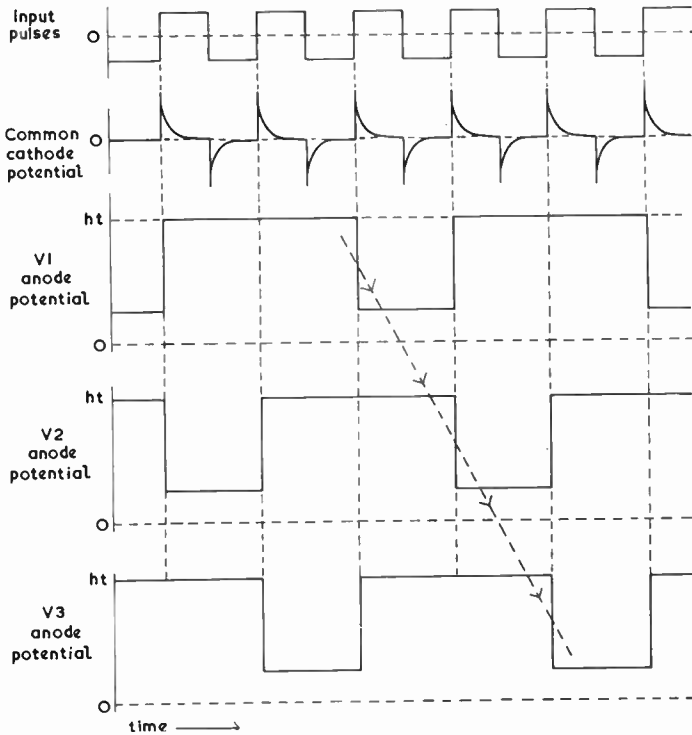

Fig. 9—Waveforms for ring counter of Figs. 7 and 8

that only one can be conductive at a time. Triggering pulses applied to the circuit have the effect of transferring the state of conduction from one valve to the other. Thus the pulses generated at the anode of each valve have half the frequency of the input pulses and the circuit can be used as a divider.

In this basic form, the circuit is capable of dividing by 2 only but, by connecting a number of such units in cascade, it is possible to

produce a circuit capable of dividing by 2^n where n is the number of stages. Thus a 2-unit circuit divides by 4 and a 3-unit by 8.

It is, however, often necessary to divide by numbers such as 3 or 15, which are not powers of 2. This can be achieved with binary counters by feeding pulses developed in one part of the circuit back to an earlier stage. By using a sufficient number of feedback loops

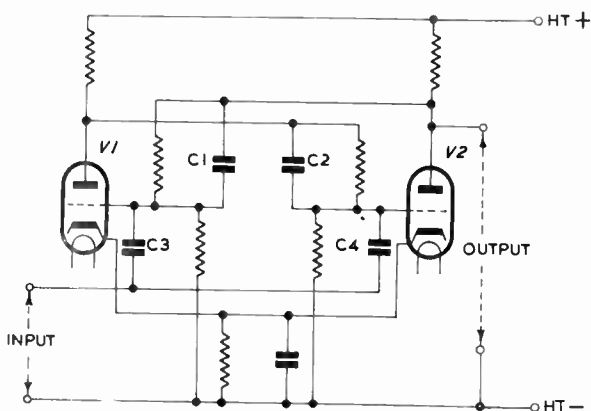

Fig. 10—Basic circuit for a binary counter

and by choosing their points of origin and return appropriately it is possible to produce a circuit which uses binary counters but is capable of dividing by any integer, whether it can be factorised or not. In fact such circuits can be used to divide by prime numbers such as 17 and 59, and if the field divider in a television system makes use of such circuits, the number of lines per picture can be chosen without regard to its possible factors.

1.5.2 Basic Circuit

The basic circuit can be a cathode-coupled multivibrator as suggested in the section on ring counters but is more usually anode-coupled with a circuit of the type shown in Fig. 10. This diagram is taken from Volume 3 to which reference should be made for complete details of the mode of operation of this circuit. Very briefly the circuit operates in the following manner.

Each valve is direct-coupled to the grid of the other, the component values being so chosen that if either valve is conductive, the anode potential is low enough to bias the other valve beyond cut off. If a negative-going pulse of sufficient amplitude is applied

COUNTER CIRCUITS

to the grid of the conductive valve, it becomes non-conductive and the positive-going pulse generated at its anode makes the other valve conductive. Because of the positive feedback inherent in the circuit, this interchange of conditions occurs very rapidly and the waves at the anodes are good approximations to rectangular form. The waveform is made even better by the inclusion of the speed-up capacitors C_1 and C_2 .

When such a circuit is used as a counter, the input signal may be applied to both grids via equal capacitors C_3 and C_4 as shown in Fig. 10 but, as will be shown, only one grid reacts to the input signal at any given moment. C_3 and C_4 have low values, and in conjunction with the resistance in the grid circuit, have a time

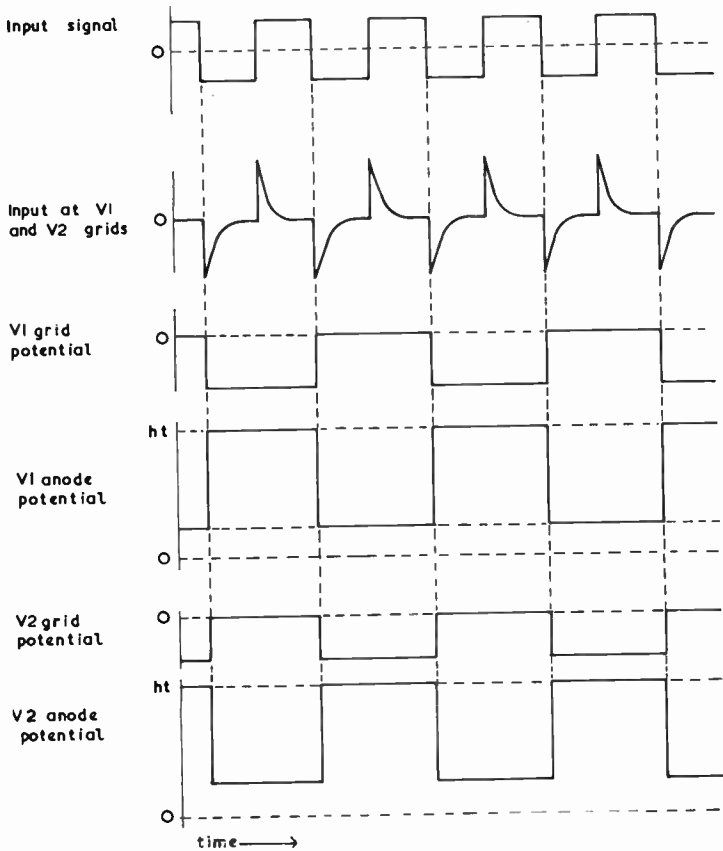

Fig. 11—Waveforms for the binary counter of Fig. 10

constant small compared with the duration of the input pulses. This is done to differentiate the input pulses before applying them to the grids but the small value of the capacitors also has the advantage that very little of the multivibrator output is transferred to the input-signal source, the latter having in general an impedance small compared with the reactance of the capacitors.

The signals at the grids have the form of positive-going spikes alternating with negative-going spikes as shown in Fig. 11. The positive-going spikes have no effect on the counter, their amplitude being insufficient to overcome the negative bias on the grid of the non-conductive valve. The negative-going spikes, on the other

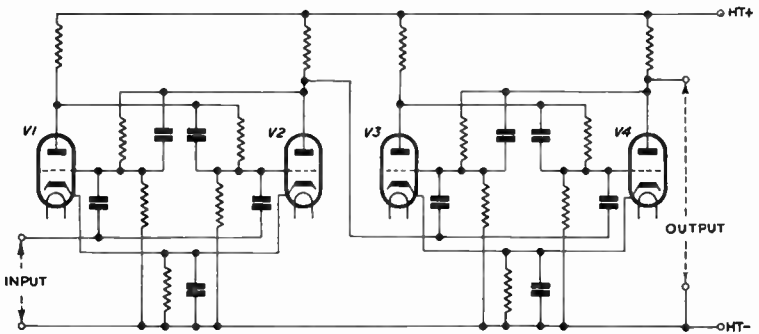

Fig. 12—Binary counter for dividing by four

hand, are amplified by the conducting valve and appear as magnified positive-going spikes at the grid of the non-conducting valve which they are able to trip, thus initiating a change of state. The negative-going spikes are able to do this because the potential at the grid of a conductive valve is very nearly equal to that of its cathode and a small negative step is sufficient to reduce anode current and start the regenerative action. Only the negative-going spikes are thus effective in switching the counter. If the first spike switches V1 to non-conduction, the next will switch V2 to non-conduction and the third will again switch V1 to non-conduction. The potentials at V1 and V2 anodes thus have the form shown in Fig. 11; it is a series of rectangular waves with one-half the frequency of the input signal.

1.5.3 Operation of Basic Binary Counter Circuit

To illustrate the operation of binary counters we shall first consider the circuit shown in Fig. 12. This contains two identical

COUNTER CIRCUITS

multivibrator stages, V1.V2 and V3.V4, and as a divider it has a factor of 4.

Assume the circuit is switched on in the absence of input pulses. Although each multivibrator circuit is perfectly symmetrical in the sense that corresponding components have equal values, one of the valves usually takes slightly more current than the other during the warming-up period. Any such difference causes the circuit to settle down with that particular valve conductive and the other non-conductive. In general however, it is not possible to predict which valve will become conductive when the circuit is switched on and, in the waveforms of Fig. 13, it was assumed that V2 and V3 are initially conductive. It follows that V1 and V4 are necessarily non-conductive. Thus the initial anode potentials of V2 and V3 are low and those of V1 and V4 are at h.t. potential.

We now assume that the rectangular input pulses (a) are applied to the circuit. At the grids of V1 and V2 these are differentiated and have the form shown at (b); this is the effect of the short time constant circuit coupling the input pulses to the grids. Only the negative-going edges of waveform (b) are effective in triggering the circuit. The first causes V1 to become conductive, the next V2, the third V1 again, and the waveforms generated at the grids and anodes of the first multivibrator are as shown in (c), (d), (e) and (f). These are rectangular waves (overshoots due to speed-up capacitors are omitted for simplicity) with a frequency equal to one-half that of the input pulses.

Waveform (g) illustrates the differentiating effect of the short time-constant circuit coupling the pulses at V2 anode to V3 and V4 grids. Again only the negative-going edges are effective in triggering the multivibrator V3.V4 and the waveforms at the grids and anodes have the form shown in curves (h), (i), (j) and (k). These rectangular waves have one-quarter the frequency of the input pulses and the circuit may thus be used for dividing by four.

Taken as a whole, the circuit has four possible states (equal to the division factor) and the negative edges of the input pulses cause the states to change in a certain order, the initial state being restored after each group of four edges. This is illustrated in the table on page 35. The initial state, as can be seen from Fig. 13, is with V1 non-conductive (off), V2 conductive (on), V3 conductive (on) and V4 non-conductive (off). The way in which the states change on receipt of successive pulses is illustrated in the table which shows that the fourth pulse restores the initial state. The table illustrates the fact that V1 is at all times in the opposite state to V2, and V3 is similarly in the opposite state to V4. This being

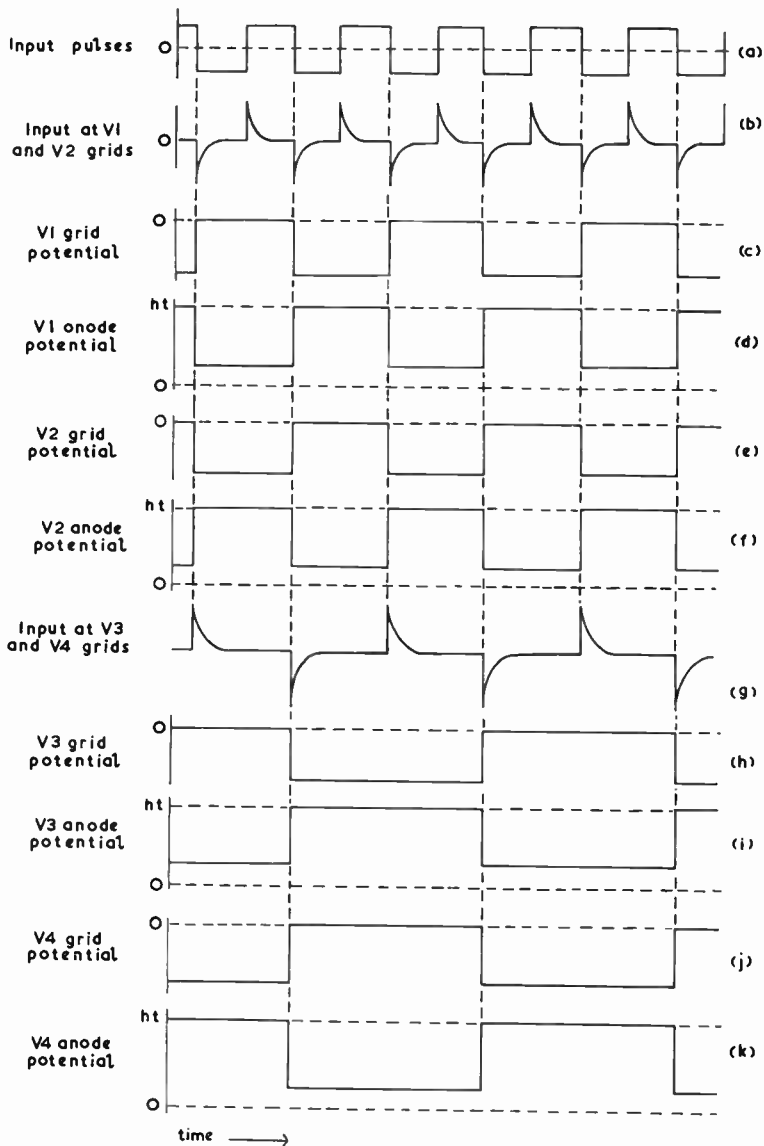

Fig. 13—Waveforms for the binary counter of Fig. 12

so, the four different states of the circuit listed in the table are the only ones possible.

A bi-stable multivibrator such as V1.V2 or V3.V4 is sometimes termed a *scale of two* and a divider of the type illustrated in Fig. 12 can be described as containing two scales of two.

The waveforms of Fig. 13 show the negative-going edges of V4 anode potential as coincident with negative-going edges of the input pulses. In fact the output pulses are slightly delayed with respect to the input pulses. The delay is due to the finite rise times

Sequence of Operations in a Basic Counter Circuit

State	V1	V2	V3	V4
initial	off	on	on	off
after pulse 1	on	off	on	off
after pulse 2	off	on	off	on
after pulse 3	on	off	off	on
after pulse 4	off	on	on	off

of the input pulses and those generated at various points in the divider. For example if the input pulses have a rise time of $0.1 \mu\text{sec}$ and the amplitude is five times that required to cut V1 or V2 off, the output of the first stage of the counter is delayed $0.02 \mu\text{sec}$ with respect to the input pulses. Such a delay occurs each time an anode-potential pulse is applied to a valve grid and the overall delay in a multi-stage counter can be appreciable.

1.6 BINARY COUNTER WITH FEEDBACK

1.6.1 Introduction

If in a counter of the type described in the previous paragraphs the output is connected to the input, the division ratio is changed from $n : 1$ to $(n - 1) : 1$. This is because the output pulse generated by n input pulses takes the place of one of the input pulses, and only $(n - 1)$ pulses are now required from the external source to produce one output pulse.

1.6.2 Operation of Counter with Feedback

Fig. 14 gives the circuit of a counter including such a feedback connection. It is basically the circuit of Fig. 12, which has a division ratio of 4, but the feedback connection reduces the division ratio to $3 : 1$. The feedback loop consists of an RC circuit between the anode of V4 and the grid of V2. The capacitor prevents direct

connection between input and output of the loop and also serves to differentiate the waveform (k) in Fig. 15) at V4 anode before application to V2 grid. The resistor is necessary for the following reason. The input pulses can reach V3 grid via a path including $C_2R_1C_1C_3R_3$ and R_2 , and R_1 is included and made large enough to attenuate these pulses to a value low enough to prevent V3 being

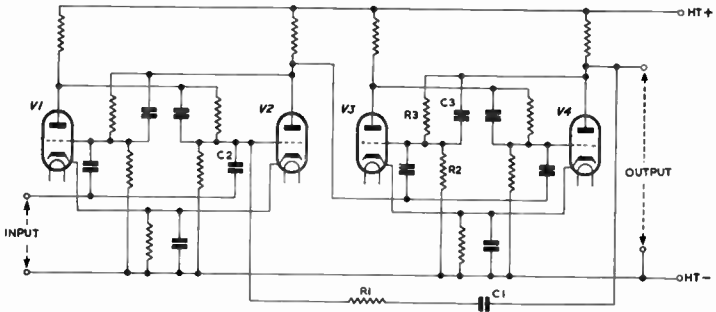

Fig. 14—Circuit of binary counter for dividing by three

triggered by them. The way in which this feedback loop affects the operation of the circuit is illustrated in the waveforms of Fig. 15 which should be compared with those of Fig. 13.

Initial conditions in the circuit are as assumed before and the waveforms are similar to those of Fig. 13 up to the first negative-going edge from V4 anode. This edge is applied, after differentiation, to V2 grid and is shown in Fig. 15 as coincident in time with a positive-going edge from V1 anode. In fact there is a slight delay between the two, V2 being first driven into conduction by the pulse from V1 anode and almost immediately cut off by the pulse from V4 anode. Thus the changes in the circuit which, in the absence of feedback, would have been brought about by the third negative-going edge in the input signal have been accomplished immediately after the second edge by the feedback signal. The third input pulse now produces the same changes in the circuit that the fourth did

Sequence of Operations in a Counter with Feedback

State	V1	V2	V3	V4
initial	off	on	on	off
after pulse 1	on	off	on	off
after pulse 2	off	on	off	on
after feedback pulse	on	off	off	on
after pulse 3	off	on	on	off

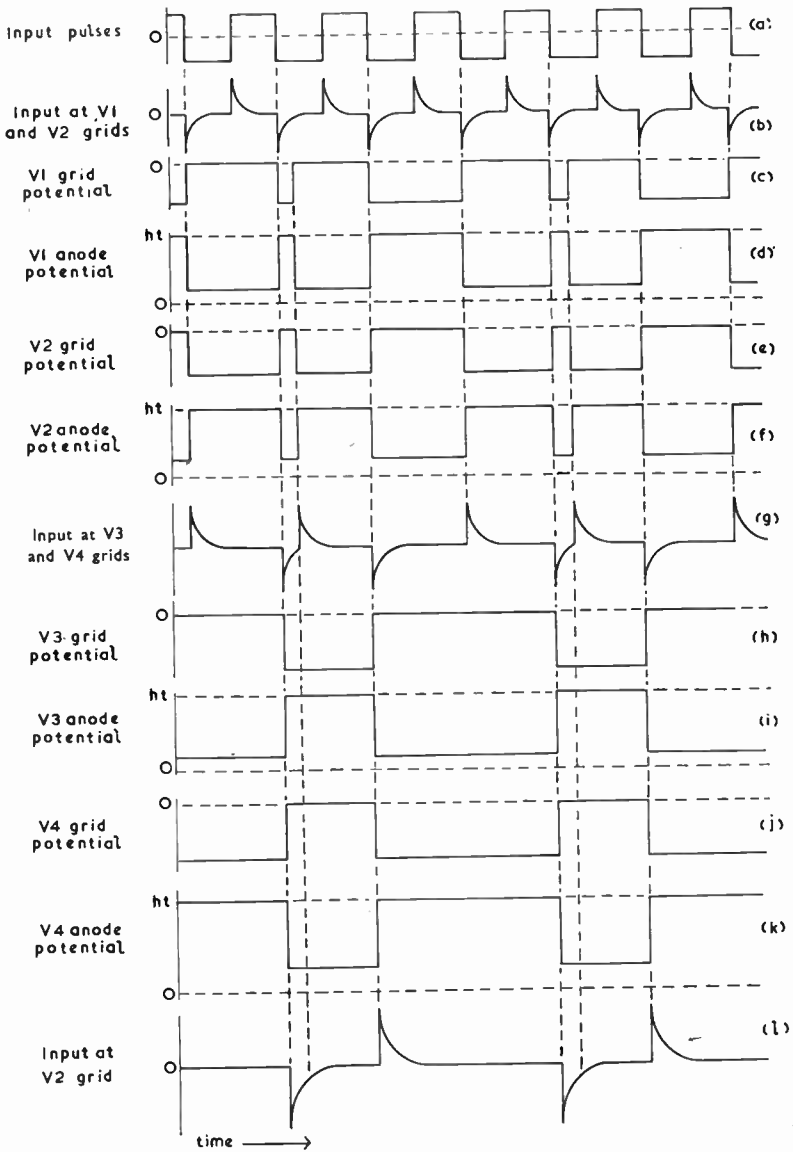

Fig. 15—Waveforms for the binary counter of Fig. 14

previously. Since the feedback pulse performs one of the operations formerly carried out by an input pulse, it follows that only three input pulses are now required to produce one output cycle and the divider now has a factor of three. This is illustrated in the waveforms of Fig. 15 and also in the table on page 36, both of which show that the initial state of the circuit is restored after every group of three input pulses.

1.6.3 *Alternative Methods of Feedback*

The feedback connection in the circuit of Fig. 14 is from the output to the input of the counter and has the effect of reducing the division ratio from 2^n to $(2^n - 1)$ where n is the total number of multivibrators. This is only one of a number of possible methods of applying feedback and the alternative circuits give division ratios not obtainable by other means. The most important of these feedback circuits will now be described.

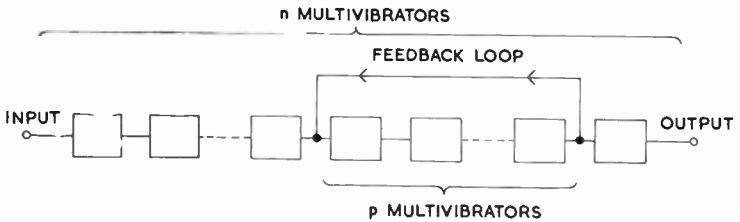

Fig. 16—General form of counter circuit with feedback

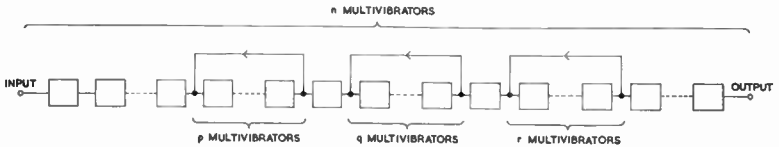

Fig. 17—General form of a feedback counter circuit suitable for certain division ratios which have factors

The counter of Fig. 14 may be regarded as a particular example of the general type of feedback counter shown in Fig. 16. This shows a feedback loop embracing p out of a total of n multivibrators. (In Fig. 14, $p = n$).

The division ratio of the $(n - p)$ multivibrators outside the feedback loop is 2^{n-p} and that of the multivibrators inside the loop is $(2^p - 1)$. Thus the overall ratio is $2^{n-p}(2^p - 1)$. For example if there are 5 multivibrators of which 3 are included within the

COUNTER CIRCUITS

feedback loop we have $n = 5$ and $p = 3$, giving the overall division ratio as $2^2 (2^3 - 1) = 4 \times 7 = 28$.

If the counter includes a number of feedback loops as shown in Fig. 17, the loops embracing p, q, r , etc. multivibrators, the overall division ratio is given by

$$2^{n-(p+q+r+\dots)} \cdot (2^p - 1)(2^q - 1)(2^r - 1)(\dots)$$

Such a feedback system is useful where the division ratio has factors which are equal to a power of 2 or one less than a power of 2.

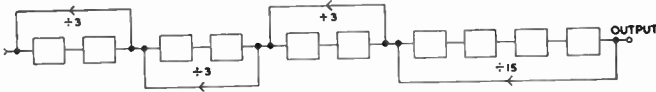

Fig. 18—Arrangement of a counter of the type shown in Fig. 17 to divide by 405

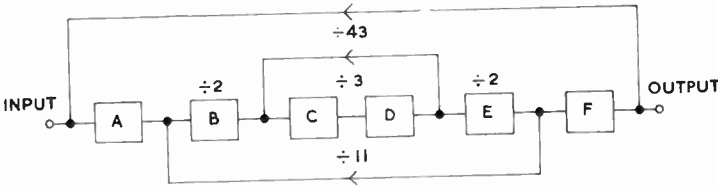

Fig. 19—General form of a counter with feedback suitable for prime division ratios

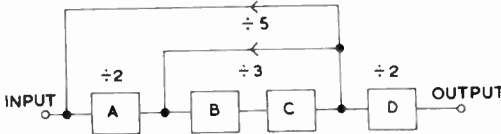

Fig. 20—A counter of the type of Fig. 19 designed for a division ratio of 10

For example, a division ratio of 405 ($= 3 \times 3 \times 3 \times 15$) can be achieved by a divider arranged as shown in Fig. 18. Such a divider includes a total of 10 multivibrators.

If the factors of the division ratio do not satisfy this condition, a feedback arrangement containing loops within loops as shown in Fig. 19 can be used. The division ratio for this circuit can be calculated as follows. Multivibrators C and D together have what could be termed an internal division ratio of 4 but because of the feedback loop around them, the external division ratio is 3. Multivibrators B and E have each a division ratio of 2 and thus the internal division ratio for BCDE is $2 \times 2 \times 3 = 12$ which is

reduced to 11 by the feedback loop surrounding BCDE. A and F have each a factor of 2 giving the internal gain of the entire counter as $2 \times 2 \times 11 = 44$. The feedback loop reduces this to 43, which is a prime number.

A particularly useful example of a divider of this type is illustrated in block form in Fig. 20. It has an overall ratio of 10 and is used in decade counters. The derivation of the overall division ratio is illustrated in the diagram.

CHAPTER 2

FREQUENCY DIVIDERS

2.1 FREQUENCY DIVIDERS USING MONOSTABLE CIRCUITS

2.1.1 *Introduction*

The types of frequency divider so far described are basically counter circuits. They contain no timing circuits and their performance is to a large extent unaffected by variations in frequency of the input signal. However, in many applications of frequency dividers the input signal is substantially constant in frequency and it is possible to use monostable or astable circuits (which contain timing networks) as the basic units of the divider. Amongst the circuits which are commonly used for frequency division are multi-vibrators, phantastrons and blocking oscillators and the next few pages describe frequency dividers using these circuits. Monostable circuits have certain advantages over astable circuits and are described first.

A monostable circuit has one stable and one unstable state. In the absence of triggering signals the circuit remains in its stable state. On receipt of a triggering signal the circuit goes into its unstable state which persists for a predetermined period after which, without external stimulus, the circuit reverts to its stable state. During the period of the unstable state the circuit is insensitive to input triggering signals and a number of these can be received without effect on the circuit. However, the first triggering signal received after the end of the unstable period will trip the circuit again. Thus the number of cycles performed by the circuit is less than the number of input triggering signals and the circuit can thus act as a divider.

The division ratio is determined by the ratio of the duration of the unstable state to the interval (assumed constant) between the input triggering signals. If a division ratio of $n : 1$ is required, the duration of the unstable state must be between that of $(n - 1)$ and n input signals as shown by the line AB in Fig. 21. The duration should not be slightly greater than that of $(n - 1)$ signals, as for line CD, otherwise a slight decrease in the duration of the unstable period or a decrease in the frequency of the input signals

will cause the circuit to be triggered by the $(n - 1)$ th pulse and the division ratio is reduced to $(n - 1) : 1$. On the other hand, the duration should not be just less than that of n signals, as for line EF, otherwise a slight increase in the duration of the unstable state or of the frequency of the input signals will cause the n th pulse to fall within the unstable period and the division ratio increases to $(n + 1) : 1$.

The highest division ratio obtainable per stage is thus dependent on the accuracy with which the frequency of the input signals and the duration of the unstable period can be maintained.

Although monostable frequency dividers are sensitive to changes in the frequency of the triggering signals they are relatively unaffected

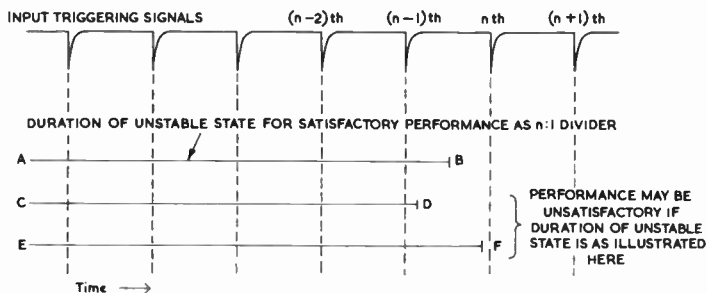

Fig. 21—Relationship between duration of unstable period and period of input triggering signals for a monostable or astable frequency divider

by variations in the amplitude of the input signal—provided this is greater than a certain value and that the signal has a steep negative-going edge.

2.1.2 Divider using Monostable Multivibrator

Any monostable circuit can be used as a frequency divider and Fig. 22 illustrates a monostable multivibrator suitable for the purpose. The circuit is similar to that shown in Volume 3 and is fully described there but a brief description of the operation of the circuit as a divider is given here.

The circuit is stable when V2 is conductive and V1 non-conductive. In this state the anode potential of V1 (and hence that of the diode V3) is very near h.t. positive value as indicated at $t = t_1$ in Fig. 23. Since the cathode of V3 is returned by R_1 to h.t. positive, the diode conducts on receipt of a negative-going signal which is thus able to reach the grid of V2 via C_g' . Such a signal causes V2 to become non-conductive and V1 conductive, the change of state being

FREQUENCY DIVIDERS

speeded by the regeneration characteristic of multivibrators. The circuit is now ($t = t_2$) in its unstable state, V2 being held non-conductive by a negative potential on its grid, this potential rising exponentially towards zero as C_g' discharges. During this state V1 and V3 anode potentials are low and V2 anode potential is high. V3 anode potential is thus strongly negative with respect to its cathode potential; triggering signals received during the unstable period are incapable of making the diode conduct and have no effect on the circuit. After an interval primarily determined by C_g' and R_g' , V2 begins to conduct ($t = t_3$). This initiates a

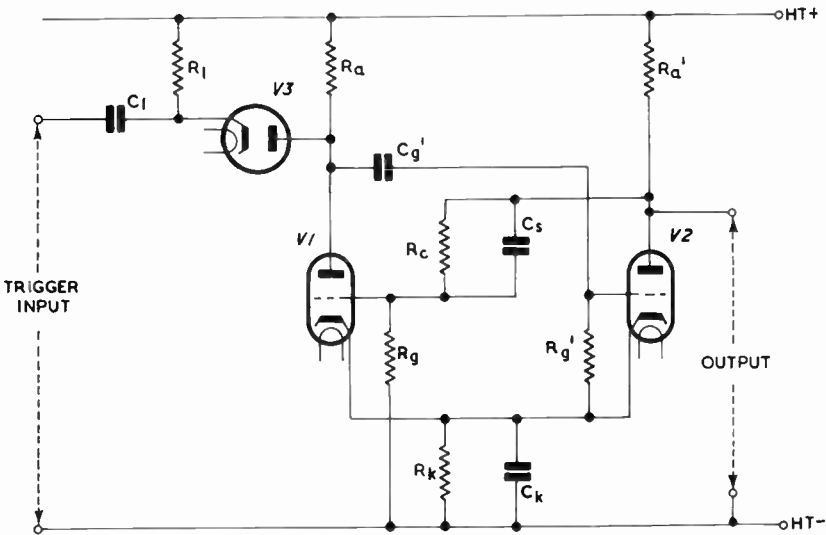

Fig. 22—A monostable multivibrator used as frequency divider

return to the original state, a change also accelerated by regeneration, and V1 anode potential rises to h.t. positive value again. The diode V3 is now able to conduct the next negative triggering signal to V2 grid to recommence the cycle just described. The division ratio can be controlled by variation of C_g' or R_g' and in Fig. 23 has a value of 4.

Provided the negative-going edge of the input pulses is large enough to trigger V2 with certainty, operation of the circuit is independent of the amplitude and duration of the input signals.

The output of the divider can be taken from the anode of V1 or V2 but to prevent any interference with multivibrator action

the output should preferably be taken from a tapping point on the anode resistors. Alternatively a cathode-coupled multivibrator could be used; this has a " free " anode from which an output can be taken without affecting multivibrator action. Fig. 24 gives the circuit of a cascade divider using two cathode-coupled monostable multivibrators.

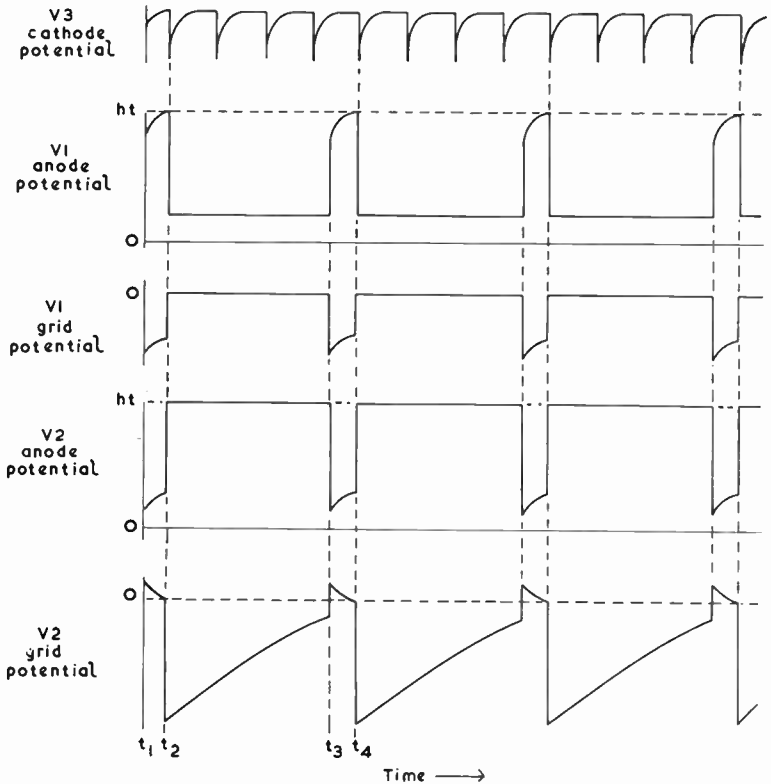

Fig. 23—Waveforms for the frequency divider of Fig. 22

2.1.3 Phantastron Dividers

The transitron equivalent of the cathode-coupled monostable multivibrator, namely the cathode-coupled phantastron, is often used in divider circuits and Fig. 25 gives the circuit of a single-stage divider of this type. The circuit is very similar to that given in Volume 3 and is fully described there but a brief account of the

FREQUENCY DIVIDERS

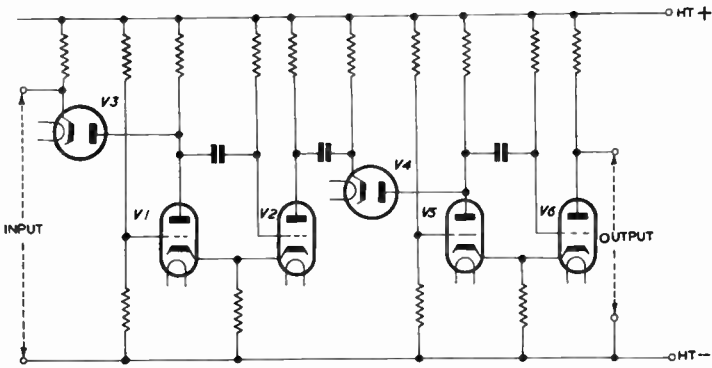

Fig. 24—A two-stage divider using cathode-coupled monostable multivibrators

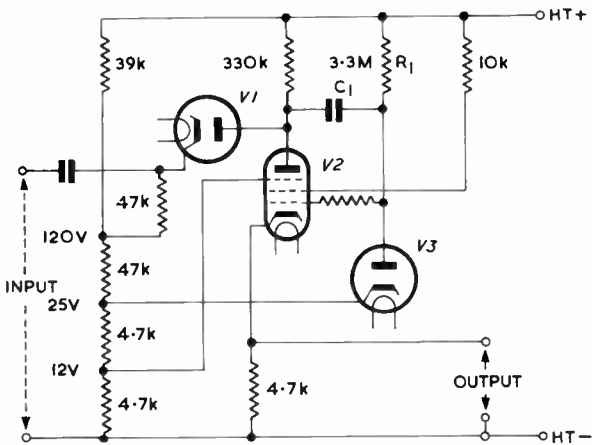

Fig. 25—Cathode-coupled phantastron frequency divider

operation of the circuit is given below. The waveforms developed at various points in the circuit are illustrated in Fig. 26.

The circuit belongs to the type known as a Miller integrator and, in its stable state, the control grid has the higher of its two possible potentials. Cathode current is therefore high and the cathode potential is well above that of the suppressor grid, cutting off anode current, the cathode current flowing wholly to the screen grid. The diode V3 is included to keep the control grid sufficiently negative in this state to prevent excessive screen-grid dissipation.

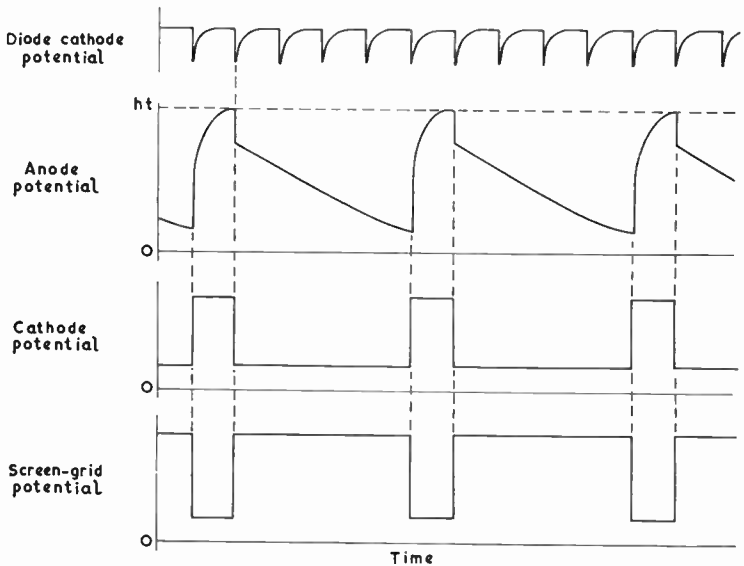

Fig. 26—Waveforms for the circuit of Fig. 25

Due to the absence of anode current the anode potential is high but the anode potential is stabilised by diode V1 at the potential of V1 cathode (approximately 120 volts in this circuit).

When a negative pulse is applied to the control grid via V1, the cathode current falls and the cathode potential drops relative to that of the suppressor grid. Thus anode current starts and its onset is regenerative as in all transitron circuits. The anode potential now falls and due to the feedback of anode potential via C_1 to the control grid, the fall is approximately linear as shown in the waveforms. The fall continues until the anode potential reaches a certain value, commonly 20 volts, at which there is another change of state, also hastened by regeneration, and the circuit reverts to its original state.

FREQUENCY DIVIDERS

During the unstable period, the anode potential falls from 120 volts to 20 volts and, for most of this period, the anode of V1 is negative with respect to its cathode, thus isolating the control grid from any triggering signals which occur during this period. At the end of the unstable period the anode potential returns to 120 volts and the diode V1 is again ready to conduct triggering pulses to the control grid.

Fig. 25 gives typical values for all components in the circuit, except C_1 . The value of this capacitance is determined by the frequency of the input triggering signals and the division ratio, and may be calculated in the following way.

Suppose the triggering pulses are at a nominal frequency of 20 kc/s (approximately twice line frequency for the British television system) and that a division ratio of 3 : 1 is required.

The intervals between the input pulses are equal to $1/20 \times 10^3$ sec, i.e. 50 μ sec, and to give the required division ratio the unstable period should exceed that of two pulses but be less than that of three pulses; it will be taken as 120 μ sec.

It is shown in Volume 3 that the duration of the unstable period is given by $V_a R_1 C_1 / V$ seconds where V_a is the change in anode potential and V is the voltage across R_1 . For this particular circuit $V_a = 100$ volts and $V = 200$ volts. We thus have

$$\begin{aligned} C_1 &= \frac{V}{V_a R_1} \times \text{duration} \\ &= \frac{200 \times 120 \times 10^{-6}}{100 \times 3 \cdot 3 \times 10^6} \text{ F} \\ &= 72 \cdot 7 \text{ pF} \end{aligned}$$

The value used in practice is 69 pF.

Dividers of this type can be cascaded to give large division ratios, outputs being taken from the cathode or screen grid through differentiating networks as shown in Fig. 27.

2.1.4 Monostable Dividers using Feedback

The range of numbers by which it is possible to divide can be extended, as for counter (bi-stable) circuits, by use of feedback. If a feedback loop of the type illustrated in Figs. 16–18 is established around a particular section of a monostable cascade divider it has the effect of *reducing* the division ratio from $n : 1$ to $(n - 1) : 1$ where n is the ratio without feedback.

There is, however, another type of feedback circuit used with monostable circuits such as the phantastron which has the effect of *increasing* the division ratio. The principle of this feedback system is illustrated in Fig. 28. B represents part of the divider

chain over which feedback is applied and another phantastron D is included in the feedback loop itself. D is triggered by the output of B and delivers rectangular waves to the input of B. This input has the effect of restoring B to its stable state for a predetermined period (which may be termed the gating period) during which it is insensitive to triggering signals. B is, however, triggered by the first input signal received after the end of this period. The number of input triggers which are "lost", i.e. ineffective, depends on the

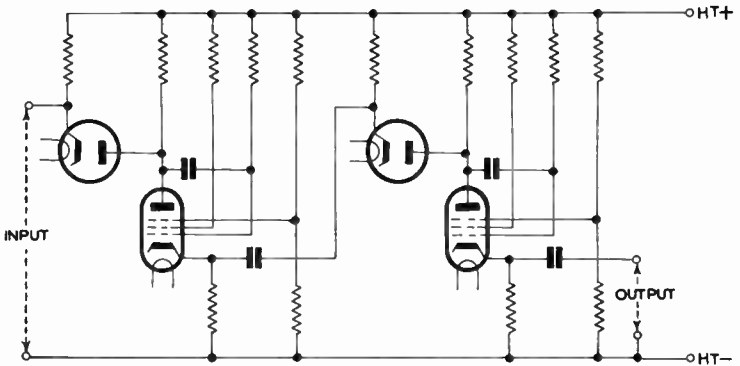

Fig. 27—A divider consisting of two cathode-coupled phantastrons in cascade

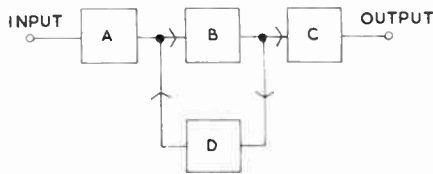

Fig. 28—A cascade divider of monostable circuits with a feedback circuit which increases the division ratio

ratio of the gating period to the interval between triggering pulses and can be varied within wide limits by suitable adjustment of D. Suppose m triggers are lost and that the divider, in the absence of feedback, has a division ratio of $n : 1$. When feedback is present the ratio becomes $(m + n) : 1$.

2.2 DIVIDERS USING ASTABLE CIRCUITS

2.2.1 Introduction

Astable circuits such as multivibrators and blocking oscillators can also be used as frequency dividers; in such applications they

FREQUENCY DIVIDERS

operate as oscillators synchronised at a submultiple of the frequency of the input signal. The chief disadvantage of such circuits is that the division ratio varies with the amplitude of the input signals, necessitating very close control of the latter to give satisfactory operation. On the other hand circuits of this type have the advantage that they can be designed to divide by numbers such as $2/3$, $3/4$, etc., which can be expressed as a ratio of two simple integers. Astable dividers differ from monostable and bi-stable (counter) dividers in that they deliver an output (generally at a lower frequency) when the input signal fails; this may or may not be an advantage depending on the circuit application.

2.2.2 Astable Multivibrator Divider

The behaviour of synchronised multivibrators was discussed in Volume 3 but the principal points are repeated below for the sake of completeness.

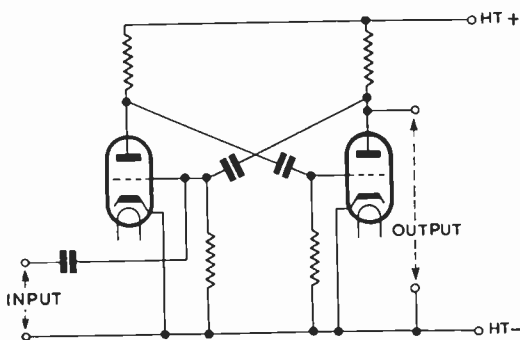

Fig. 29—Astable multivibrator frequency divider suitable for an odd or even division ratio

The circuits are synchronised by positive-going signals applied to the control grids (or negative-going signals applied to the cathodes) which have the effect of terminating the unstable periods earlier than would occur naturally; thus the synchronised frequency is higher than the natural frequency.

Fig. 29 gives the circuit of an astable anode-coupled multivibrator which is synchronised by signals applied to the control grid of V1. Fig. 30 shows the grid-potential waveforms for this circuit (a) when free-running and (b) when synchronised; it is assumed that the multivibrator is symmetrical. The change of state occurring immediately before the 3rd sync signal is brought about by V2 grid potential which reaches the critical value V_c'

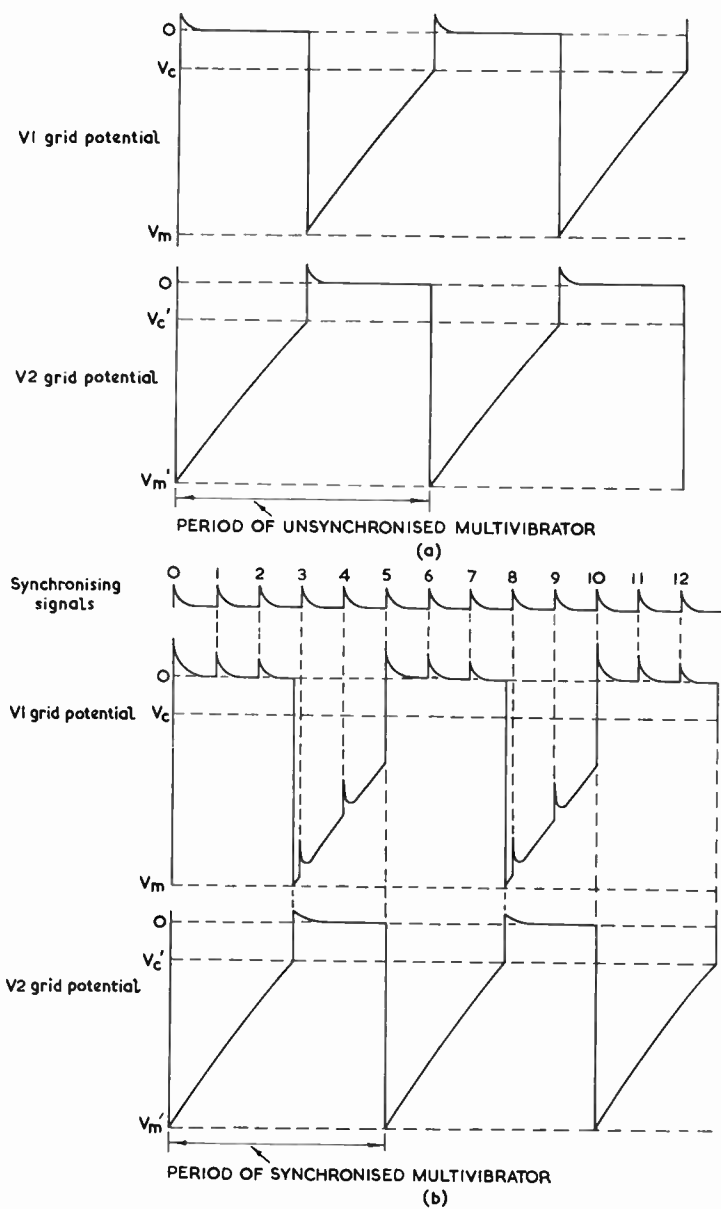

Fig. 30—Grid-potential waveforms for a symmetrical multivibrator (a) free-running and (b) with synchronising signals applied to one control grid

FREQUENCY DIVIDERS

at this instant; this is a natural action and occurs independently of the sync signals. The change of state occurring at the 5th sync signal is, however, brought about by this signal which, being applied to V1 control grid, causes the potential to reach the critical value V_c earlier than would occur naturally. This foreshortens the period during which V1 is non-conductive as shown in Fig. 30. A second natural change of state occurs just before the 8th sync signal and a second forced one at the 10th; so the cycle continues, the multivibrator being tripped by every 5th sync signal. The

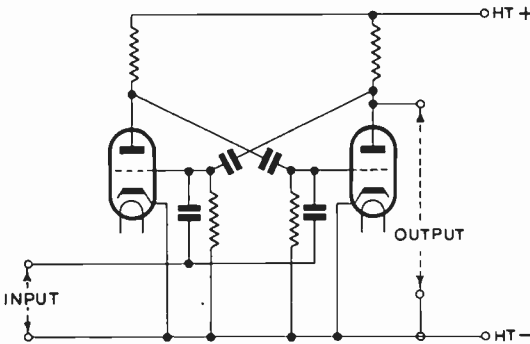

Fig. 31—Astable multivibrator frequency divider suitable for even division ratios

multivibrator produces one output cycle for every 5th sync signal and thus behaves as a frequency divider with a 5 : 1 ratio.

If the amplitude of the sync signals is increased until the 4th is sufficient to raise the potential at V1 grid to the value V_c , this signal will initiate a change of state. Similarly the 8th sync signal will also initiate a change of state and the multivibrator will continue to be tripped by every fourth signal. The circuit is now behaving as a 4 : 1 frequency divider.

Further increase in the sync-signal amplitude will cause the multivibrator to operate as a 3 : 1 frequency divider. Thus the division ratio is dependent on the sync-signal amplitude and, as the latter is increased, the frequency of the multivibrator increases in steps, the driven frequencies being integral submultiples of the sync-signal frequency. Thus if the sync-signal frequency is n times the natural frequency, as the sync-signal amplitude is increased from zero, the multivibrator frequency jumps from $1/n$ to $1/(n - 1)$ to $1/(n - 2)$, etc., of the sync-signal frequency.

In the circuit just described in which sync signals are applied to one grid only, every other change of state is brought about by

the sync signals, intervening changes of state being achieved by the natural action of the multivibrator itself. If the sync signals are applied to both grids of the multivibrator as shown in Fig. 31 the behaviour of the circuit is somewhat different because all changes of state are now brought about by the sync signals. This form of operation is illustrated by the waveforms of Fig. 32. As shown, every 3rd sync signal initiates a change of state; thus the circuit

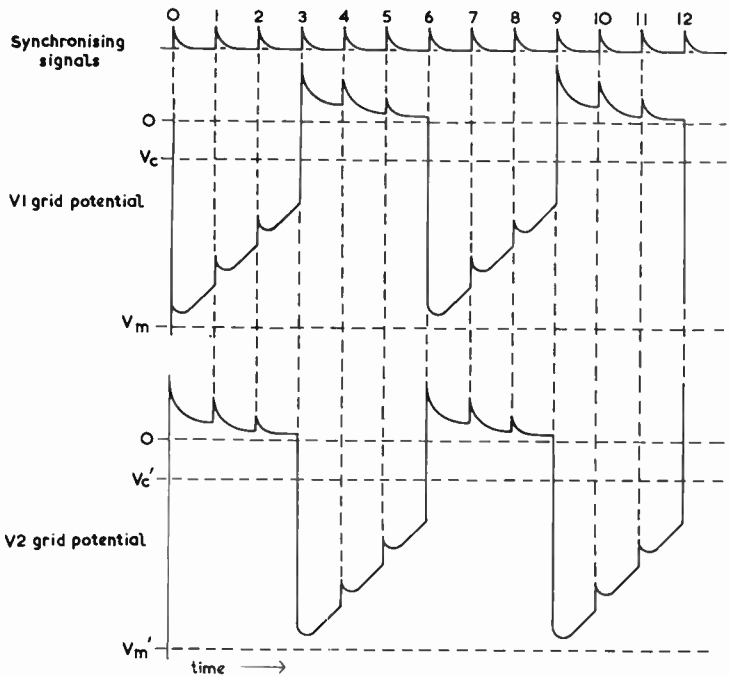

Fig. 32—Grid-potential waveforms for a symmetrical multivibrator with synchronising signals applied to both grids

produces one output cycle for every 6 input signals and behaves as a frequency divider with a division ratio of 6 : 1.

If the amplitude of the synchronising signals is increased until signal (2) is sufficient to bring V1 grid potential to the critical value V_c , the first change of state will occur coincidentally with signal (2) and the next with signal (4) and so on, the divider now having a division ratio of 4 : 1. Further increase in sync-signal amplitude will cause the multivibrator to be tripped by signals (1), (2), (3), etc., the circuit now having a division ratio of 2 : 1.

FREQUENCY DIVIDERS

In circuits of this type in which the sync signals are applied to both grids of a synchronised multivibrator, every n th sync signal initiates a change of state and since there are two changes of state per output cycle, the division factor is $2n$, an even number.

Thus if it is required to have a divider with an even division ratio the circuits of Figs. 29 or 31 can be used but if the factor is odd, the circuit of Fig. 31 is unsuitable and that of Fig. 29 should be used.

If the sync signals are applied in push-pull to the two grids as shown in Fig. 33, positive-going signals on one grid coincide with negative-going signals on the other and the multivibrator

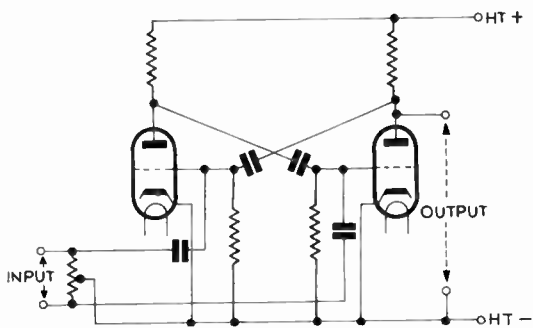

Fig. 33—Astable multivibrator with sync signals applied to the two grids in push-pull

tends to run at an odd submultiple ($1/3$ rd, $1/5$ th, $1/7$ th, etc.) of the sync-signal frequency. The reason for this can be seen from Fig. 34 in which, for simplicity, the sync signals are shown as spikes. The state in which V1 is non-conductive is terminated by a positive-going signal on V1 grid; the resulting state, in which V2 is non-conductive, is similarly terminated by a positive-going signal on V2 grid. This signal coincides with a negative-going signal on V1 grid which implies that the duration of V2 non-conduction period is equal to that of an integral number of sync-signal periods together with half a period. Thus the duration of one cycle of multivibrator action is equal to that of an odd number of sync-signal periods and the circuit, considered as a divider, has an odd division ratio. In Fig. 34 the division ratio is 3 : 1.

In the astable dividers so far discussed the division ratio is an integer. The ratio can, however, be less than unity provided it can be expressed as a fraction composed of simple numbers such as $2/3$, $3/4$, etc.

Fig. 35 illustrates the process of synchronising which gives such ratios. It is assumed that the sync signals are applied to one grid only and, as shown, sync signals (2) and (5) initiate a change of state, intervening changes occurring naturally. Every third

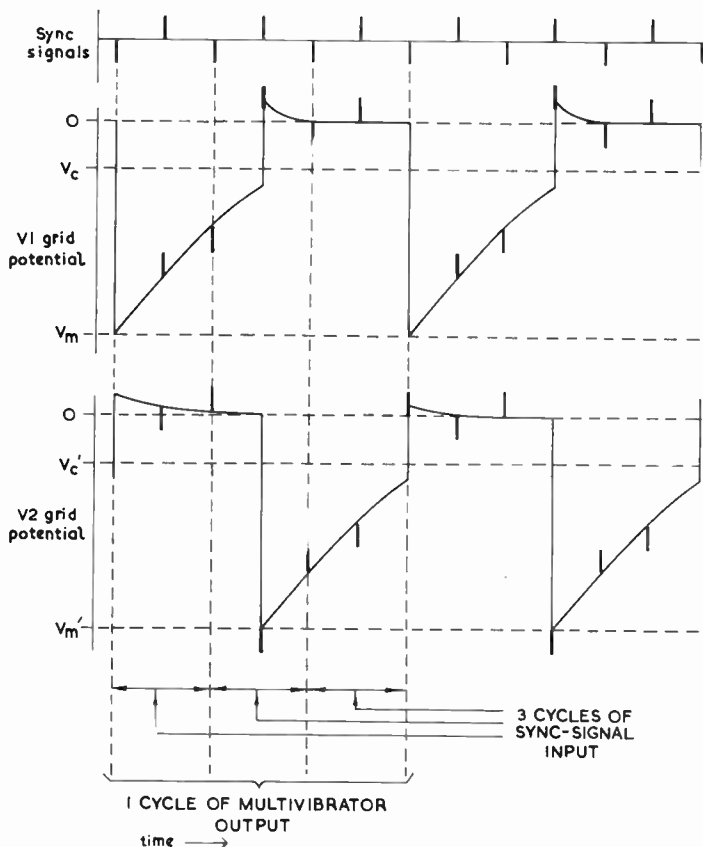

Fig. 34—Waveforms for a multivibrator in which sync signals are applied to the two grids in push-pull

sync signal causes a change of state and two cycles of multivibrator output occupy the same time as three sync signals; in other words the division ratio in Fig. 35 is $2/3$.

2.2.3 Frequency Dividers using Blocking Oscillators

Another astable circuit which can be used for frequency division is the blocking oscillator and a typical circuit is given in Fig. 36.

FREQUENCY DIVIDERS

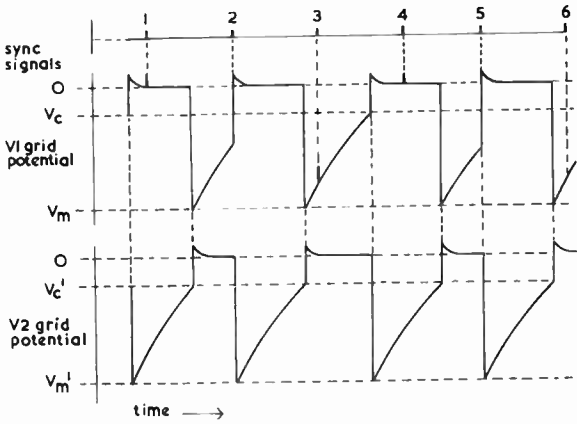

Fig. 35—Grid-potential waveforms for a multivibrator operating at a frequency which is a fraction of the sync-signal frequency

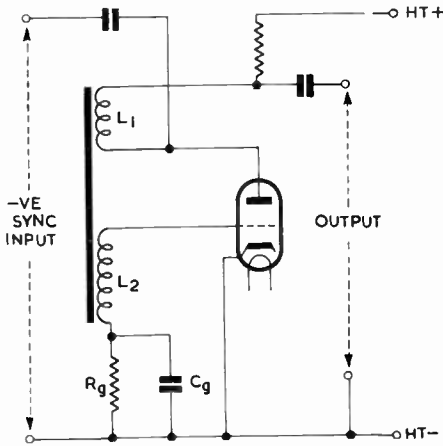

Fig. 36—Single-stage blocking-oscillator frequency divider

The operation of the blocking oscillator is described in detail in Volume 3 but a brief account is given here to explain the operation of the divider circuit. We shall assume initially that there are no sync pulses. Due to the coupling between anode and grid circuits provided by the transformer L_1L_2 , the circuit tends to oscillate at the resonance frequency of the transformer. The coupling is, however, very tight and the oscillation amplitude builds up very rapidly, causing the valve to take considerable anode and grid

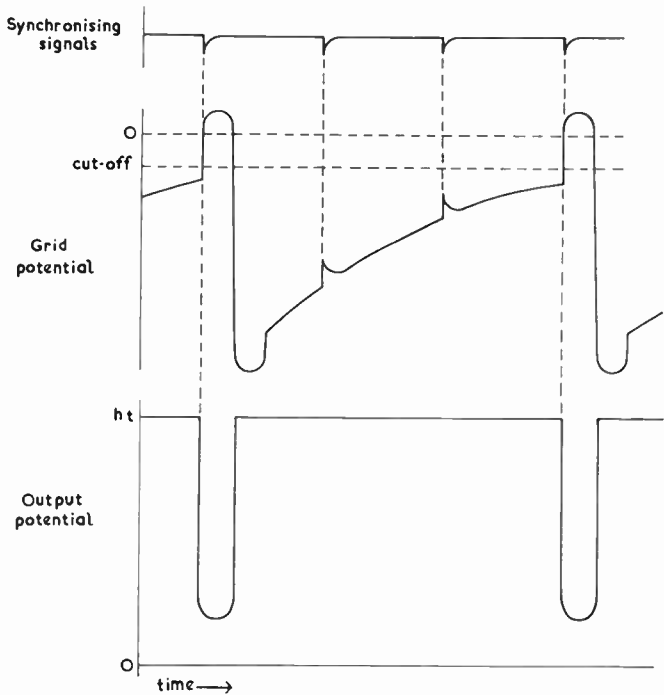

Fig. 37—Waveforms for the blocking-oscillator frequency divider of the previous diagram

current, the latter charging the capacitor C_g . The voltage developed across C_g is sufficient to bias the valve well beyond cut-off and only approximately one cycle of oscillation is in fact achieved. The circuit now relaxes whilst C_g discharges through R_g , the anode current being zero during this state. When the voltage across C_g has fallen sufficiently for the valve to become conductive, oscillation recommences and the cycle of events starts again.

Thus the circuit takes recurrent bursts of anode and grid current at a frequency dependent on the time constant R_gC_g . The leading

FREQUENCY DIVIDERS

and trailing edges of these current pulses are steep because of the positive feedback due to the coupling between L_1 and L_2 . The output thus consists of short-duration pulses, which are eminently suitable for synchronising subsequent blocking oscillators as in a cascade divider.

When sync signals are applied to the circuit (positive-going on the control grid or negative-going on the anode) they have the effect of initiating conduction in the valve earlier than would occur naturally. This is illustrated in the waveforms of Fig. 37, in which every fourth sync signal has sufficient amplitude to promote conduction; thus this diagram illustrates the performance of a blocking oscillator as a 4 : 1 frequency divider.

In the circuit of Fig. 36 the division ratio can be controlled by varying R_g or C_g . Alternatively the values of R_g and C_g can be fixed and R_g returned to the slider of a potentiometer across the h.t. supply, the potentiometer acting as a division ratio control.

Other astable circuits, such as Miller-transistrons, could also be used as frequency dividers but those described above are more usually employed.

CHAPTER 3

BASIC PRINCIPLES OF D.C. CLAMPING AND D.C. RESTORATION

3.1 INTRODUCTION

It is shown in earlier volumes that video signals have an asymmetrical waveform containing a d.c. component and a number of a.c. components. The distortionless amplification of such signals theoretically requires amplifiers capable of responding equally to all these components. This suggests that the video chain should consist of d.c.-coupled amplifiers with a response covering the entire video band. The design of such a sequence of amplifiers would be difficult but, fortunately, is not necessary because a.c.-coupled amplifiers can be used instead, in spite of the loss of the d.c. component. This loss necessarily implies distortion of the video waveform but this can be tolerated because the missing component can be artificially re-created and reintroduced, where necessary, by the circuit techniques of d.c. restoration and clamping.

There are a number of points in the chain where the d.c. component must be present; for example in early links in the chain when blanking and sync signals are inserted to form the video signal. It is also advisable to have the d.c. component at later points in the chain where the video waveform is monitored or displayed. In particular in high-power video stages of a television transmitter the presence of the d.c. component results in economy of operation by reducing the absolute excursion of the signal. This enables valves to be smaller or more efficient use to be made of existing valves than is possible in the absence of the d.c. component. Finally it is desirable that the d.c. component should be present in the signal which is displayed on a television receiver screen although some receiver manufacturers reduce the amplitude of the d.c. component at this point, claiming that this reduces the annoyance value of "aeroplane flutter" and vision-signal fading.

Clamping can be used to eliminate low-frequency ripple voltages such as those which might be present in the h.t. supply to an amplifier and which may be superimposed on the video signal, and, as shown later, the clamp must operate at a frequency higher than that of the unwanted signals, a convenient value being line frequency.

BASIC PRINCIPLES OF D.C. CLAMPING AND D.C. RESTORATION

Although d.c. restoration and clamping both reintroduce the d.c. component, there are differences between the two processes and in practice there are often good reasons for adopting one in preference to the other.

3.2 VARIATION IN BLANKING AND SYNC LEVELS DUE TO A.C. COUPLING

Before describing the techniques of d.c. restoration and clamping we shall examine the effects of removing the d.c. component from a video signal. Fig. 38 (a) shows a few lines of a video signal representing a scene with zero white content, the amplitude of the picture signal being small compared with that of the sync signals. For convenience the sync level is taken as zero volts. The d.c.

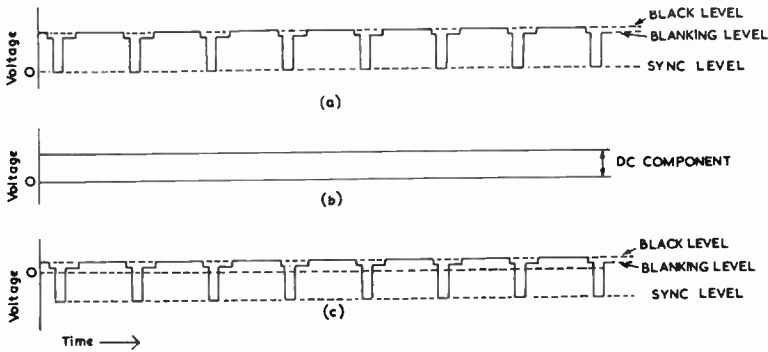

Fig. 38—A video signal for a dark scene is shown at (a); its d.c. and a.c. components are shown at (b) and (c)

component of waveform (a) is shown at (b) and the a.c. component at (c); (b) and (c) are the two components of (a) and thus addition of (b) and (c) gives (a).

Fig. 39 gives a similar set of diagrams for a video signal representing a scene with considerable white content. Comparison of Fig. 39 (b) with Fig. 38 (b) shows that the white scene gives a greater d.c. component.

When a video signal is passed through an a.c.-coupled amplifier, the d.c. component is lost; a signal such as that of Fig. 38 (a) thus emerges in the form of Fig. 38 (c) and a signal such as that of Fig. 39 (a) emerges in the form of Fig. 39 (c). The position of the zero-voltage datum line in these output waveforms is such that the area above the datum line and under the curve is equal to that below the line and above the curve. The two output signals

have different values of blanking level, that of Fig. 39 (c) being more negative than that of Fig. 38 (c).

The video signals chosen for Figs. 38 and 39 are extreme examples, one representing a dark and the other a white scene. In practice, video signals can, of course, represent any degree of brightness between these two limits and hence the blanking level in video signals at the output of an a.c.-coupled amplifier may have any value within a certain range. During a television programme the degree of brightness of the scenes may vary and there are corresponding changes in the blanking-level voltage at the output of the a.c.-coupled amplifier. If such an output signal is displayed as a picture on the screen of a cathode-ray tube, this variation in the blanking-level voltage will show up as changes in the background tone of the picture. On dark scenes the picture will tend to be too bright and on bright scenes it will tend to be too dark.

It is impossible to find a setting of the bias control which gives correct tonal rendering on scenes of widely different average brightnesses. This wandering of blanking level constitutes dis-

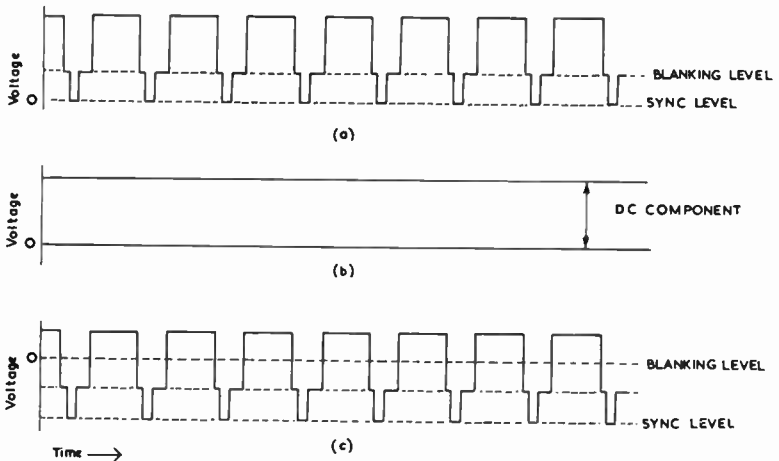

Fig. 39—A video signal for a white scene is shown at (a); its d.c. and a.c. components are shown at (b) and (c)

tortion of the video waveform, because in an ideal video waveform the blanking level remains constant in spite of variations in scene brightness and there is no need for continual adjustment of bias when such a signal is displayed on a cathode-ray tube. To obtain a constant blanking level, the d.c. component must be present in the signal.

3.3 VARIATION IN BLANKING LEVEL DUE TO OTHER CAUSES

The use of a.c.-coupled amplifiers is only one of a number of causes of variation in sync or blanking levels. A rhythmic rise and fall can be produced if an unwanted low-frequency signal is mixed with the video signal; the unwanted signal could arise as a result of induction from a circuit carrying mains current or from the ripple on the h.t. line in an amplifier. The appearance of a video signal subjected to such an effect is illustrated in Fig. 40.

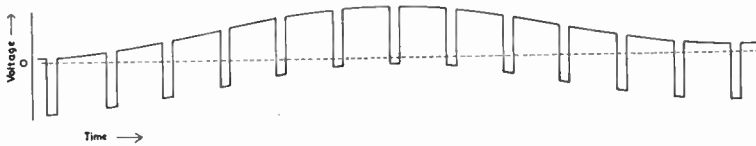

Fig. 40—A video waveform with a super-imposed low-frequency sinusoidal signal

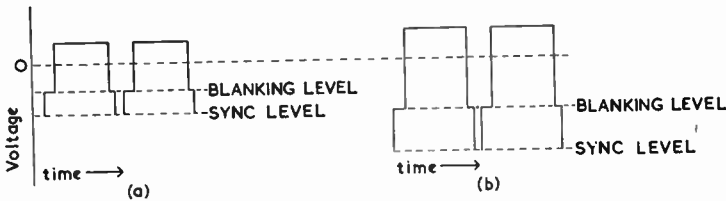

Fig. 41—The video output from an a.c.-coupled amplifier is shown at (a) and the effect of increasing the gain at (b)

Variations in blanking or sync level also occur as a result of gain adjustments in video amplifiers. As an example Fig. 41 (a) represents the output signal from a video amplifier at a particular setting of the gain control. We shall assume that the amplifier is a.c.-coupled and the output signal therefore has positive and negative excursions, the average value of the signal being zero as indicated. Now suppose the gain of the amplifier is increased; the output signal has the same form but is of larger amplitude as indicated in Fig. 41 (b). The average value of the signal is still zero, however, and hence the sync level and blanking levels now occur at voltages different from those which were obtained before the change of gain. Any change of gain affects the output voltages of both levels.

If the amplifier is d.c.-coupled, it can be designed to give an output signal with a sync level independent of the gain or the magnitude of the input signal. However, any increase in gain or input increases the voltage difference between sync and blanking levels at the output; thus blanking level must vary with the gain

setting. Therefore whether the video amplifier is a.c.- or d.c.-coupled, the blanking-level output voltage is likely to vary with the gain setting. For faithful reproduction of the picture on a cathode-ray tube screen the instants of blanking level in the input signal should always cause the electron beam to be just cut off; if the blanking level changes, this condition cannot be maintained and anomalies in tonal rendering are inevitable. This is a familiar effect to anyone who has adjusted a television receiver. Any adjustment of the contrast (gain) control alters the blanking-level voltage at the tube input and an adjustment of the brightness (tube bias) is necessary to restore the balance of the tonal values.

Summarising the previous few paragraphs, we may say that for a number of reasons a video signal may contain anomalies equivalent to the addition of spurious low-frequency components. These spurious signals make the signal unsuitable for displaying on the screen of a cathode-ray tube, because they cause the blanking and sync levels to wander; they also cause the excursion of the video signals to move up and down the valve characteristics during amplification. There are circumstances where these effects are unimportant, for example in amplifying a video signal the amplitude of which is small compared with the useful length of the valve characteristic. Where, however, a constant blanking or sync level is required, as when the signal is to be displayed, these spurious signals must be eliminated.

3.4 ACTION OF D.C. RESTORERS AND D.C. CLAMPS

These variations in sync and blanking levels can be overcome by circuit techniques which sample the waveform at regular intervals and automatically add a voltage to correct any errors; this is the basic principle of d.c. restoration and d.c. clamping. If these voltages were introduced at widely separated intervals, the spurious low-frequency components could perform several cycles between successive applications and the correcting voltage would be ineffective. To eliminate the unwanted signals the correcting voltages must be added at a frequency higher than that of the spurious signals. Moreover the voltages must not be introduced during line-scanning periods because they may cause unwanted changes in tonal values. Thus d.c. restoration and d.c. clamping of a video signal are usually carried out during the line or field blackout intervals, either during the sync or post-sync periods. In a picture signal (i.e. one without sync pulses or blanking periods) it may be necessary to introduce a repetitive period of blanking level at field or line frequency to permit d.c. restoration or d.c. clamping.

BASIC PRINCIPLES OF D.C. CLAMPING AND D.C. RESTORATION

A d.c. restorer adjusts the *most positive* (or *most negative*) excursion of the video waveform occurring in a given period to a predetermined value. Often the extreme excursion is the sync level in a video waveform or black level in a picture waveform. The operation is illustrated in Fig. 42 where waveform (a) represents a few lines of a video signal in which the sync level is creeping positively; (b) shows the waveform after d.c. restoration. The restorer has acted upon the intervals of sync level and has brought them all to a common potential which for simplicity is indicated as zero volts in Fig. 42 although it could have any desired value.

A d.c. clamp adjusts the potential of *any chosen part* of the video waveform to a predetermined value. To enable the clamp to operate upon the desired part of the waveform and to be inoperative during intervening periods it is supplied with pulses (termed

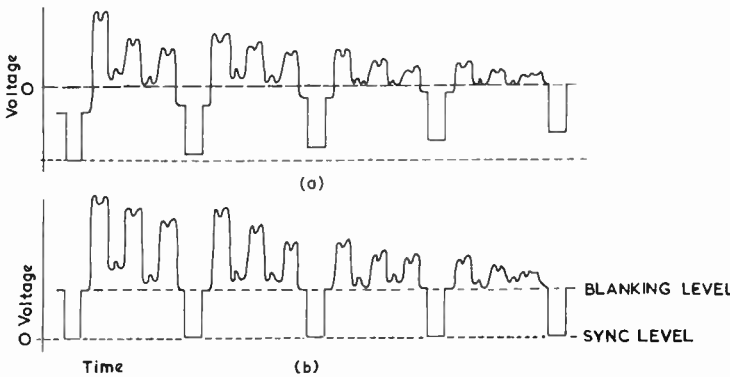

Fig. 42—A video signal with varying sync level is shown at (a) and the waveform after d.c. restoration at (b)

keying or *clamping* pulses) which must be at the frequency of the waveform and coincide in time with the chosen part of the waveform. The operation of a d.c. clamp is illustrated in Fig. 43 which shows at (a) a picture signal with intervals of black level between lines. The black level is wandering and the clamp is used to fix its potential. In effect the clamp adds a correcting voltage to the signal to bring the periods of black level to a common potential. To do this the clamp is supplied with pulses (c) which fall within the periods of black level.

3.5 DISTINCTION BETWEEN D.C. RESTORATION AND D.C. CLAMPING

Comparison of Figs. 42 and 43 shows one advantage of the clamp, that it does not require an extreme excursion of the signal

on which to operate, although it does, of course, require a repetitive "interval" in which the signal remains substantially steady. A d.c. restorer could not be used satisfactorily with a waveform such as that shown in Fig. 43 (a) because it would tend to operate on any negative-going spike occurring in the picture signal; that is to say it cannot distinguish between negative-going signals occurring *between* lines and those occurring *during* lines.

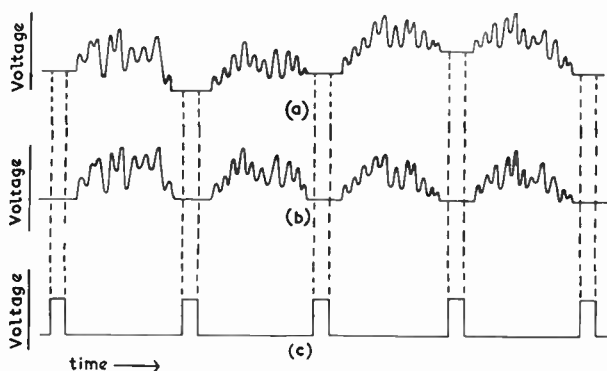

Fig. 43—A picture signal with a varying black level is shown at (a), the effect of d.c. clamping at (b) and the required clamping pulses at (c)

On the other hand a d.c. clamp could be used with a video signal such as that shown in Fig. 42 and often is so used, for example to maintain a constant blanking level at the output of a gain-adjusting stage. A d.c. restorer could not be used for this purpose because blanking level is neither the positive nor the negative extreme of the video signal.

CHAPTER 4

D.C. RESTORER CIRCUITS

4.1 FUNDAMENTAL CIRCUIT

THE circuit of the simplest d.c. restorer is given in Fig. 44. It is similar to that of a shunt-fed diode detector but is used in a manner somewhat different from that of a detector. In a detector it is the rectified d.c. output which is required and any signal-frequency components in the output circuit are deliberately attenuated, usually by an RC circuit. In a d.c. restorer, however, the output comprises the whole of the input signal as undistorted as possible, together with the d.c. output of the diode.

To illustrate the action of the circuit, suppose a video signal such as that illustrated in Fig. 45 (a) is applied to the input

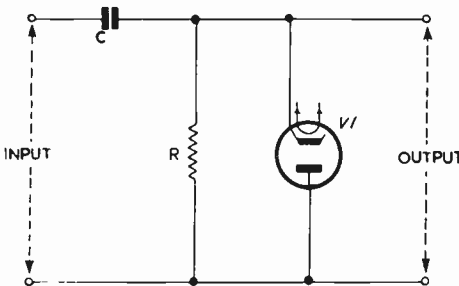

Fig. 44—Circuit of simplest type of d.c. restorer

terminals from a source assumed to have very low resistance. This signal is assumed to be the output of an a.c.-coupled amplifier having positive excursions OA and negative excursions OB. There is negligible attenuation due to R and C and this signal appears in full at the output terminals. The diode V_1 conducts on the negative excursions of the signal and charges C , making the plate connected to the valve cathode positive relative to the other. As in diode detector circuits, the capacitor discharges through the resistance during positive excursions of the input signal but, if the time constant RC is large compared with the period of the signal, C loses little of its charge during the signal period and, to

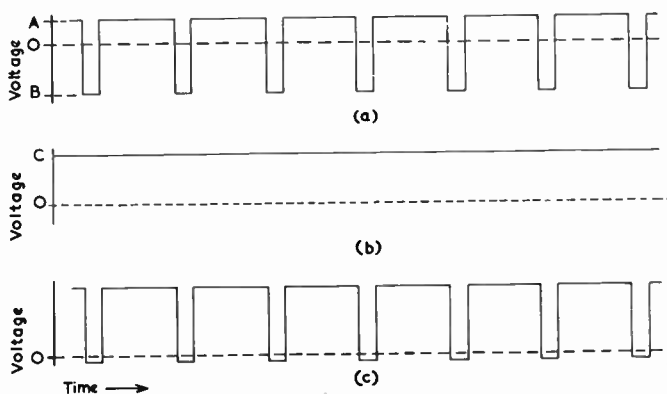

Fig. 45—A d.c. restorer with an infinite discharge time constant, fed with waveform (a), adds a signal of the form (b) to give an output of waveform (c)

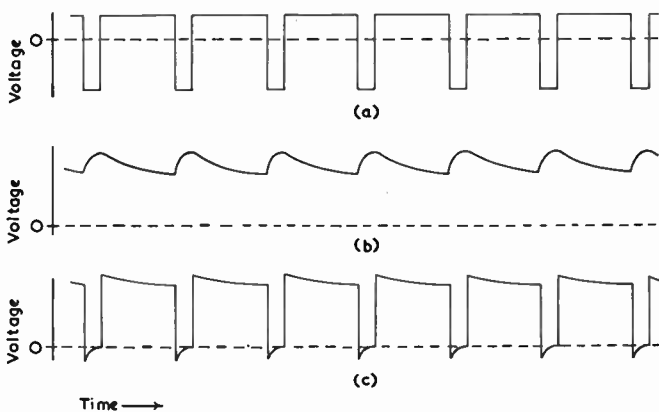

Fig. 46—A d.c. restorer with a finite discharge time constant, fed with waveform (a), adds a signal of the form (b) to give an output of form (c)

D.C. RESTORER CIRCUITS

a first degree of approximation the voltage across C can be regarded as constant and equal to the negative excursion OB.

This voltage biases the diode cathode positive relative to its anode and prevents the diode from conducting except at the instants when the input signal passes through its negative maximum, i.e. at the bottom of the sync pulses, this small period of conduction being all that is necessary to maintain the voltage across C at a steady value in the interval between successive sync signals.

The output signal thus consists of the input signal, Fig. 45 (a), together with a steady potential (b) approximately equal to OB. This gives a waveform of the type shown in (c) in which the excursions are positive for the interval between successive sync signals. The waveform becomes negative only during the period of the sync signals (when the diode conducts) and the amplitude of the negative excursion is extremely small.

In preparing Fig. 45 it was assumed, for simplicity, that the potential across the diode capacitor does not decay in the intervals between successive sync signals. It is shown as steady at (b), having an amplitude OC nearly equal to OB in (a). In practice the voltage across C falls exponentially after each charging period and the waveform generated across C has the form given in curve (b) of Fig. 46; thus the output waveform is as given in Fig. 46 (c). The extent of the voltage fall in the intervals between the input pulses is governed by the discharge time constant RC which should be long relative to the intervals between the pulses, to keep the extent of the fall small compared with the amplitude of the signal. This voltage fall is thus an imperfection in performance, but it also acts as a stimulus to more vigorous restoration because it causes the diode cathode potential to drift negatively, i.e. in the direction which causes diode conduction.

The d.c. restorer is primarily employed to reduce the amplitude of low-frequency spurious signals in say, a video signal, i.e. it has to check unwanted positive and negative drifts of video signal. Because of the exponential fall in voltage across the capacitor, the restorer is able to check drifts in one direction more speedily than drifts in the opposite direction. This can be shown in the following way.

Fig. 47 represents a video waveform on which is superimposed a spurious low-frequency signal shown as sinusoidal for convenience. This may be taken as an example of a type of waveform which requires d.c. restoration. During the periods t_0t_1 and t_3t_4 the signal drifts negatively and, because the signal is applied to the diode cathode, this tends to promote diode conduction; this drift is in

the same direction as that due to decay of the capacitor voltage and d.c. restoration occurs on every negative pulse in the signal, causing the foot of each pulse to be brought to a fixed potential and thus arresting the negative drift.

Consider now the behaviour of the restorer during intervals such as t_1/t_3 in which the signal drifts positively. Such drift carries

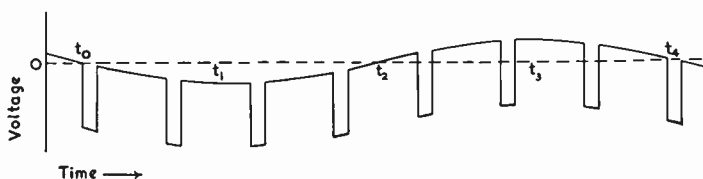

Fig. 47—Form of the signal of Fig. 45 (a) in the presence of a sinusoidal ripple

the diode cathode positively, i.e. in the direction opposite to that due to decay of the capacitor voltage. Whether the diode conducts during this interval depends on the sign of the resultant drift of the anode-cathode potential of the diode. If, during this interval, the positive signal drift exceeds the negative drift of capacitor voltage, the diode may fail to conduct and no restoration then occurs. Such intervals are inevitably of limited duration because of the steady decay of voltage across the capacitor and also because the sign of the signal drift ultimately reverses, both drifts then tending to produce conduction and d.c. restoration. Thus positive signal drifts are checked by the d.c. restorer but, if the decay time constant is long, there may be short periods within which fractions of a cycle of spurious signal are allowed through to the restorer output. The process of positive-drift elimination is thus not so speedy as that of negative-drift elimination.

The effectiveness of positive-drift elimination can be improved by reducing the decay time constant of the restorer but if this is made too small there is a danger that the repeated sequence of capacitor discharge curves may be impressed upon the output signal with an undesirably large amplitude. If the restorer operates at line frequency this may cause obvious shading effects across reproduced pictures, or if it operates at field frequency it may cause a change in background tone from top to bottom of the picture. The choice of time constant must hence be a compromise enabling signal drifts to be reduced but not causing obvious shading effects.

The operation of a d.c. restorer is illustrated in Fig. 48. The input waveform shown at (a) has a superimposed spurious sinusoidal signal. This causes the negative excursions of the sync signals to

D.C. RESTORER CIRCUITS

vary rhythmically, causing the peak potential generated across the diode capacitor to vary similarly. This potential decays exponentially between each charging period as shown at (b). Addition of waveforms (a) and (b) gives (c) which represents the output of the restorer. This shows how the output signal is restored periodically to a constant level thereby eliminating the sinusoidal ripple; there is, however, a fall in level between successive sync signals.

Fig. 48 is exaggerated in a number of respects, to illustrate more graphically the operation of the restorer. In practice the amplitude

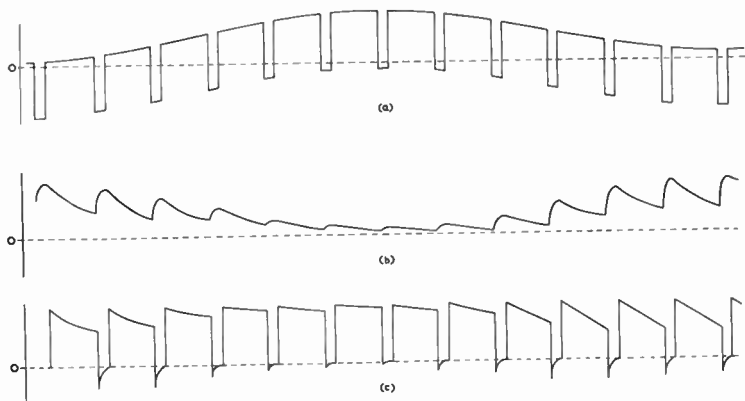

Fig. 48—Diagram (a) shows a video signal with a spurious sine wave superimposed, (b) shows the wave generated across the capacitor of a restorer and (c) the restorer output

of the spurious signals is likely to be much smaller than that of the wanted signal and their frequency is small compared with that of the sync signals. Thus the performance of the restorer is likely to be better than suggested in diagram (c).

4.1.1 Numerical Example on Restorer operating at Line Frequency

As a numerical example, consider a d.c. restorer to operate at line frequency (approximately 10 kc/s for a 405-line system). We will begin by considering the charge time constant. The resistance through which the capacitor is charged is composed chiefly of the forward resistance of the diode and the resistance of the signal source: it is doubtful if this can be made much less than 1,000 ohms. The duration of the charging period is that of the line-sync pulses, 10 μ sec. Ideally, charging should be completed within this period, but this may require a very small capacitor and a prohibitively large discharge resistor. We will therefore try to arrange for the capacitor

voltage to rise from 10 per cent to 90 per cent of its final value within the period of $10 \mu\text{sec}$. Such a rise time corresponds to a time constant of $10/2.2$, approximately $4.5 \mu\text{sec}$.* We thus have

$$rC = 4.5 \times 10^{-6} \text{ sec}$$

where r is the charge resistance. From this

$$C = \frac{4.5 \times 10^{-6}}{r}$$

If $r = 1,000$ ohms

$$\begin{aligned} C &= \frac{4.5 \times 10^{-6}}{10^3} \text{ F} \\ &= 0.0045 \mu\text{F} \end{aligned}$$

To avoid obvious change of background tone across the picture we will limit the fall in voltage across the capacitor to 2 per cent during the interval between charging pulses. For such a small fall in voltage the voltage-time relationship can be regarded as linear, having the equation

$$\frac{\text{fall in voltage}}{\text{initial voltage}} = \frac{t}{RC}$$

The voltage drop is $1/50$ th of the initial voltage and thus

$$RC = 50t$$

The interval between pulses is approximately $90 \mu\text{sec}$ and hence

$$\begin{aligned} RC &= 50 \times 90 \times 10^{-6} \text{ sec} \\ &= 4.5 \text{ msec} \end{aligned}$$

We have already calculated C as $0.0045 \mu\text{F}$ and hence R is given by

$$\begin{aligned} R &= \frac{4.5 \times 10^{-3}}{C} \\ &= \frac{4.5 \times 10^{-3}}{0.0045 \times 10^{-6}} \text{ ohms} \\ &= 1 \text{ megohm} \end{aligned}$$

* For a simple RC combination the rise time is equal to 2.2 times the time constant; this is deduced in Volume 2.

† This is deduced in Volume 2.

D.C. RESTORER CIRCUITS

4.1.2 Numerical Example on Restorer operating at Field Frequency

For a d.c. restorer operating at field frequency we can assume the rise time of the voltage across the capacitor to be equal to the duration of the field-sync signal, i.e. 400 μ sec. We then have

$$\begin{aligned} rC &= \frac{400 \times 10^{-6}}{2.2} \text{ sec} \\ &= 182 \times 10^{-6} \text{ sec} \\ \therefore C &= \frac{182 \times 10^{-6}}{r} \end{aligned}$$

Taking r as 1,000 ohms as before

$$\begin{aligned} C &= \frac{182 \times 10^{-6}}{10^3} \text{ F} \\ &= 0.2 \mu\text{F approximately} \end{aligned}$$

The interval between field-sync signals is 1/50th sec and for a 2 per cent fall in voltage during the field period we have

$$\begin{aligned} RC &= 50t \\ &= 50 \times 1/50 \text{ sec} \\ &= 1 \text{ sec} \\ \therefore C &= \frac{1}{R} \end{aligned}$$

But

$$\begin{aligned} C &= 0.2 \mu\text{F} \\ \therefore R &= \frac{1}{0.2 \times 10^{-6}} \text{ ohms} \\ &= 5 \text{ megohms} \end{aligned}$$

These two calculations were based on the assumption of a charging resistance as low as 1,000 ohms and larger values would require discharge resistors of many megohms. Thus a d.c. restorer requires a very low source resistance for satisfactory operation and in the circuit now to be described this is achieved by use of a preceding cathode follower.

4.2 D.C. RESTORER WITH PROVISION FOR ADJUSTING SYNC LEVEL

Fig. 49 gives the circuit diagram of a d.c. restorer based on the fundamental circuit of Fig. 44 but including provision for adjusting the sync level. V1 is a cathode follower a.c.-coupled to the d.c.-restoring diode V2 which is, in turn, direct-coupled to the amplifying stage V3. This differs from the fundamental circuit in that V2

anode is returned to the slider of a potentiometer R_1 connected in series with R_3 across the h.t. supply.

We shall assume that V1 is fed with a video signal in which picture white is positive. The output of V1 is in the same phase and is applied to V2 cathode. As described above, V2 conducts on negative peaks (i.e. the periods of sync level in the sync signals) and so charges C_1 that V2 cathode is for the most part positive with respect to the anode; only during conduction periods does the cathode go negative with respect to the anode and even then the negative excursion is very small. Thus, to a first degree of approximation it is possible to say that sync level of the video signal on V3 grid has the potential at R_1 slider. By adjustment of R_3 , sync level can be given any desired value within the range of the control. The process of increasing the positive bias on V2 anode is sometimes termed "lifting" the video signal.

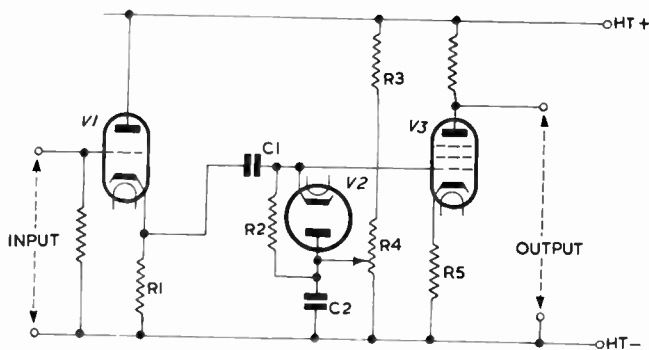

Fig. 49—Circuit diagram of a d.c. restorer with provision for adjusting sync level of output

The signals on V3 grid are always positive with respect to the potential at R_1 slider and the bias resistor R_5 must have a value higher than normal to give V3 the correct value of grid bias. R_5 is often undecoupled to give current feedback which extends the useful grid base and enables the valve to accept the video signal and also any variations in positive bias due to adjustment of R_5 .

4.3. D.C. RESTORER OPERATING ON NEGATIVE-GOING PICTURE SIGNALS

Up to this point it has been assumed that the video signal to be d.c. restored has a positive-going picture signal; accordingly the diodes have been arranged to conduct on the negative-going sync signals. If a signal requiring d.c. restoration has a negative-going

D.C. RESTORER CIRCUITS

picture signal, the circuit must be such that the diode conducts on the positive-going sync signals. A suitable circuit for d.c. restoration of such a signal is given in Fig. 50; it is similar to the circuit of the previous diagram with the diode inverted. In this circuit sync level in the signal at V3 grid is established near the potential of

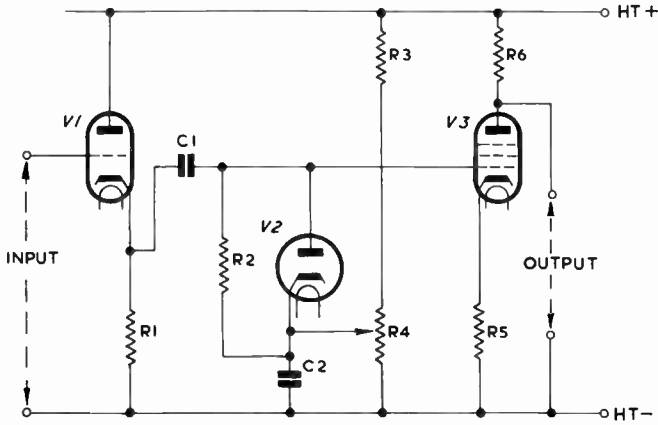

Fig. 50—Circuit for d.c. restoration of a video signal with negative-going picture signal with provision for adjusting sync level of output

R_4 slider and the excursions of the signal are almost wholly negative with respect to this potential.

4.4 D.C. RESTORER USED FOR PICTURE-SYNC SEPARATION

If, in d.c. restoration of a video signal in which the picture signal is negative-going, the sync level at V3 grid is required to be at or

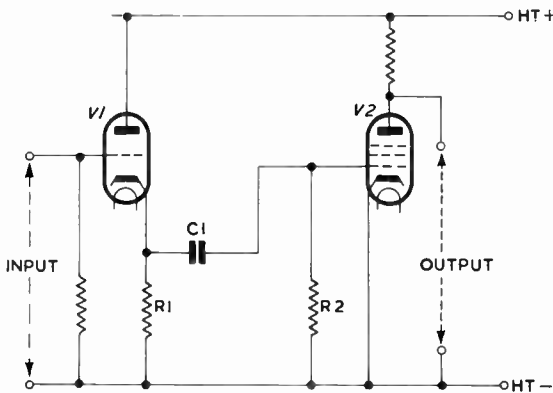

Fig. 51—Simplified circuit for d.c. restoration

near zero volts, it is possible to use a circuit simpler than that shown in Fig. 50. The diode can be omitted because its functions can be carried out by the grid and the cathode of the following amplifying stage. Thus the circuit has the simple form shown in Fig. 51; the valve does not require a cathode resistor because the d.c. restoration ensures that the signal at the grid is negative with

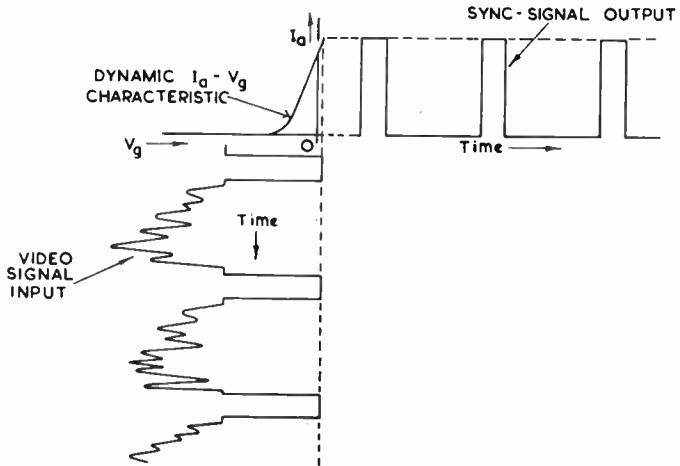

Fig. 52—Illustrating the operation of a simple d.c. restorer as sync separator

respect to zero volts. By correct choice of valve grid base and video-signal amplitude, the valve will operate as a linear amplifier.

A d.c. restorer of this type can be used for the separation of picture from sync signals in a video input by arranging that the amplitude of the sync-signal component at V_2 is greater than the valve grid base. The sync level at V_2 grid is established at zero volts by d.c. restoration and the picture signal thus corresponds to grid voltages well beyond anode-current cut-off as illustrated in Fig. 52. Thus the anode current contains only sync-signal components.

CHAPTER 5

D.C. CLAMP CIRCUITS

5.1 INTRODUCTION

WE shall now consider the circuits used for d.c. clamping. These are operated by clamping pulses which enable the clamp to act upon the chosen part of the signal in order to add the required correcting voltage to it, the design being such that the clamp is virtually disconnected from the signal source except at the instants of correction. Basically the circuit employed is of Wheatstone's bridge form which enables the pulses to operate the clamp without being impressed upon the signal waveform.

5.2 TYPICAL CIRCUIT

The circuit of one form of d.c. clamp is given in Fig. 53. The clamp proper consists of the four diodes V3 to V6 which are arranged in the form of a bridge. V_{in} represents the source of signal to be clamped and R_{10} is its internal resistance. Positive-going clamping pulses are applied to V1 grid and appear amplified and in push-pull at V1 and V2 anodes. The method of feeding the phase-inverter V2 indicated in this diagram (by means of R_1 , C_2 and R_3) is, of course, only one of many which could be employed.

The amplified pulses are applied to the bridge circuit via C_1 and C_3 , appearing at points A and C with a polarity such as to make all four diodes conduct, i.e. A is made more positive than C. During conduction the diode resistances are low and effectively connect together points B and D of the bridge so that, for the duration of the clamping pulse, the grid of V7 is connected to the source of reference potential. If, when a particular clamping pulse begins, the video signal V_{in} has a value differing from the reference potential, current flows through R_{10} to charge or discharge C_4 and the potential on V7 grid approaches that of the reference potential. The rate of change of potential on V7 grid during this period is governed by the constant $R_{10}C_4$, which is generally made small compared with the duration of the clamping pulses to enable the adjustment of V7 grid potential to be substantially completed within the pulse duration.

In the interval between the clamping pulses point C is made positive with respect to point A thus maintaining the diodes in a

state of non-conduction. Their resistance is very high indeed—almost infinite—and the charge placed on C_1 during the preceding clamping pulse is unable to leak away. It therefore persists, as a bias for V_7 , until the next pulses; there is no exponential fall of voltage across C_1 as in a d.c. restorer. To keep the diodes non-conductive during this interval the charges on C_1 and C_3 must also be preserved. This implies that the time constants R_6C_1 and R_5C_3

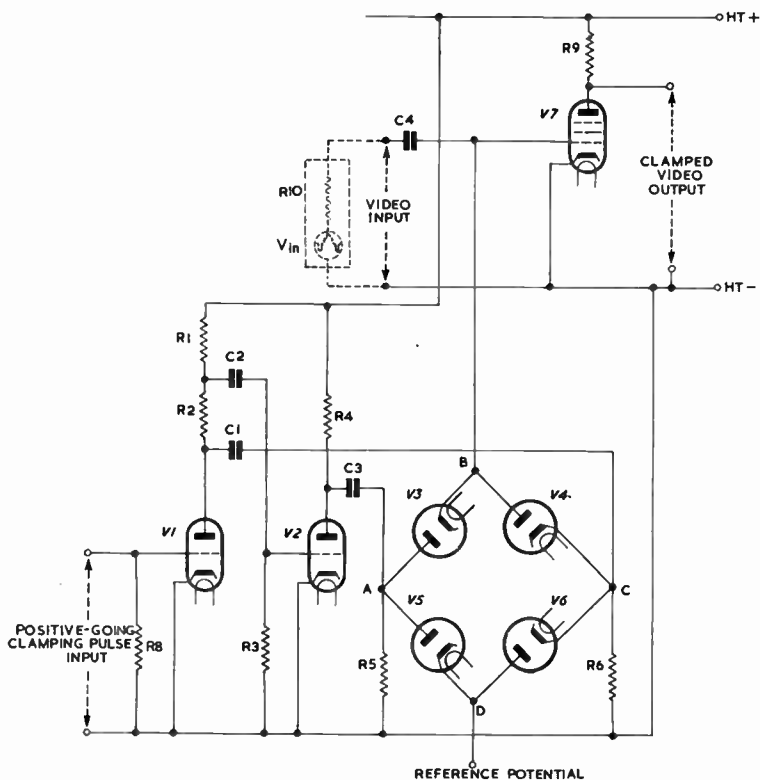

Fig. 53—One circuit for a d.c. clamp

must be large compared with the interval between the clamping pulses; this will be recognised as the condition for the clamping pulses at the diodes to be undistorted.

5.2.1 Numerical Example on a D.C. Clamp

If the clamp operates at line frequency the clamping pulses may be of, say, $5 \mu\text{sec}$ duration which is one-half the duration of the

D.C. CLAMP CIRCUITS

line-sync signals. The time constant $R_{10}C_1$ must be small compared with this and a value of $2 \mu\text{sec}$ will be assumed. If R_{10} is 2,000 ohms this gives C_1 as $0.001 \mu\text{F}$; the capacitance must not exceed this value and should preferably be smaller. From a knowledge of the time constant ($2 \mu\text{sec}$) and the period available for charging or discharging C_1 ($5 \mu\text{sec}$) we can calculate the effectiveness of the clamp in stabilising the sync level in the video signal.

This can be estimated by calculating the effective reduction in the amplitude of a spurious 100 c/s signal superimposed on the video waveform. Suppose this unwanted signal has an amplitude of 1 volt at the grid of V7 (Fig. 53). The performance of the clamp is most severely tested at the instants when this signal has its maximum rate of change, which occurs when the 100 c/s signal passes through zero, the slope of the sine curve at such points being given by $2A\pi f$ where A is the signal amplitude. In this example

$$\begin{aligned} 2A\pi f &= 2 \times 1 \times 3.142 \times 100 \text{ volts/sec} \\ &= 628.4 \text{ volts/sec} \end{aligned}$$

At this rate of change, in the interval between line-sync pulses ($90 \mu\text{sec}$ approximately), the extent of the signal drift is given by

$$\begin{aligned} 628.4 \times 90 \times 10^{-6} \text{ volts} \\ = 56.6 \text{ millivolts} \end{aligned}$$

and it is the task of the d.c. clamp to reduce this to as small a value as possible. The reduction achieved depends on the ratio of the time constant $R_{10}C_1$ to the $5\text{-}\mu\text{sec}$ clamping-pulse period and can be calculated from the relationship

$$V_t = V_0 e^{-t/RC}$$

where V_0 is the spurious signal voltage at the beginning of the clamping-pulse period and V_t is its voltage at the end of the period, t being the duration of the clamping pulse. In the example under discussion $t = 5 \times 10^{-6}$ sec and $RC = 2 \times 10^{-6}$ sec giving

$$\frac{V_t}{V_0} = e^{-2.5}$$

from which $\log_e V_0/V_t = 2.5$

giving $V_0/V_t = 12.2$

implying that voltage across C_1 can fall to approximately 1/12th of its initial value during the clamping period. Now the voltage placed on C_1 by the unwanted signal in a line period amounts to

57 millivolts and the clamp is able to reduce this, by charge or discharge of C_4 , to $57/12$, i.e. approximately 5 millivolts.

This occurs during the period when the 100 c/s signal is changing at its maximum rate and at other instants during the cycle the voltage appearing on C_4 due to the 100 c/s signal will be less than 57 millivolts and the residual voltage left on C_4 after the clamping pulse will be less than 5 millivolts. Thus the sync level of the signal at V7 grid is brought to within 5 millivolts of the reference potential at the end of each clamping period. At the beginning of the clamping periods the voltage on C_4 can differ from the reference

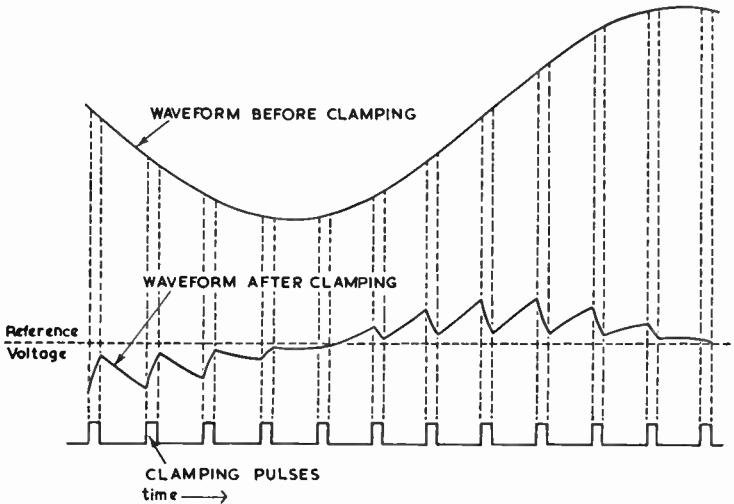

Fig. 54—Illustrating the action of a d.c. clamp

potential by a maximum extent of 57 millivolts and this is therefore the amplitude of the 100 c/s spurious signal in the output from the clamp. At the input of the clamp the amplitude is 1 volt.

This is illustrated in Fig. 54 in which the upper waveform represents the 100 c/s spurious waveform, the amplitude of which is required to be reduced by clamping. For simplicity the picture and sync waveforms are omitted and the spurious signal is represented as a sine wave. The bottom diagram represents the clamping pulses and from the leading and trailing edges of these, dotted lines are drawn to intersect the sine wave to indicate those sections of the spurious signal which are affected by the clamp. The waveform of the spurious signal after clamping is indicated by the centre diagram; this has the sinusoidal waveform of the

D.C. CLAMP CIRCUITS

original signal in the intervals between the clamping pulses but during each pulse the signal falls exponentially to a small fraction of its initial value. The diagram shows that the effect of the clamp is to convert the initial sine waveform into a rough sawtooth waveform of considerably smaller amplitude. In practice the difference between the ripple and clamp frequencies is greater than is indicated in Fig. 54 and the reduction of ripple amplitude is correspondingly greater.

The time constants R_6C_1 and R_5C_3 must be large compared with the interval between the clamping pulses in order to preserve on the capacitors the voltage which holds the diodes non-conductive. In the example chosen the interval is approximately 100 μ sec and the time constant should preferably not be less than 10 times this, i.e. 1 msec. Suitable values for the resistance and capacitance are 1 megohm and 0.001 μ F.

The diodes V3 to V6 should preferably be very similar in characteristics, otherwise there is a possibility that the clamping pulses may appear in the input to V7. For example, if the forward resistance of V3 is 1 per cent smaller than that of V4 to V6, the clamping-pulse voltage generated across V3 is approximately 0.5 per cent smaller than that generated across C_5 and the resultant voltage appearing at the terminals BD is also 0.5 per cent of the switching voltage. If the clamping pulses at V1 and V2 anodes are of 100 volts amplitude, the input to V7 contains a clamping-pulse signal of 0.5 volts amplitude in addition to the video signal to be clamped. The magnitude of this unwanted signal depends on how closely the diodes can be matched and a certain minimum amplitude is probably inevitable; its effect can however be minimised by arranging for the amplitude of the signal to be clamped to be large compared with the amplitude of the clamping pulses likely to be impressed on the signal.

5.3 ALTERNATIVE CIRCUIT

Fig. 55 shows another circuit diagram for a d.c. clamp. Only two diodes are employed and the bridge is completed by resistors R_5 , R_6 , R_7 . These behave as diode loads and develop between points A and C a steady voltage equal to the amplitude of the clamping pulses at V1 and V2 anodes. A fraction of this voltage is used as the reference potential and can be adjusted within limits by means of the potentiometer R_7 . If V3 and V4 are identical, point B is, in effect, connected to the mid-point of the resistance chain R_5 , R_6 and R_7 during the period of the clamping pulses, and it is to the potential at this mid-point that the grid of V5 is

restored by the clamp. If the slider of R_7 is set to the mid-point of R_7 as indicated in the diagram, the reference potential is zero. If, however, the slider of R_7 is moved, say to the junction of R_6 and R_7 , the reference potential is that of the mid-point of R_7 relative to its earthed end and is determined by the values of R_5 , R_6 and R_7 together with the clamping-pulse amplitude at V1 and V2 anodes. For example if $R_5 = R_6 = 470 \text{ k}\Omega$, $R_7 = 150 \text{ k}\Omega$ and the clamping

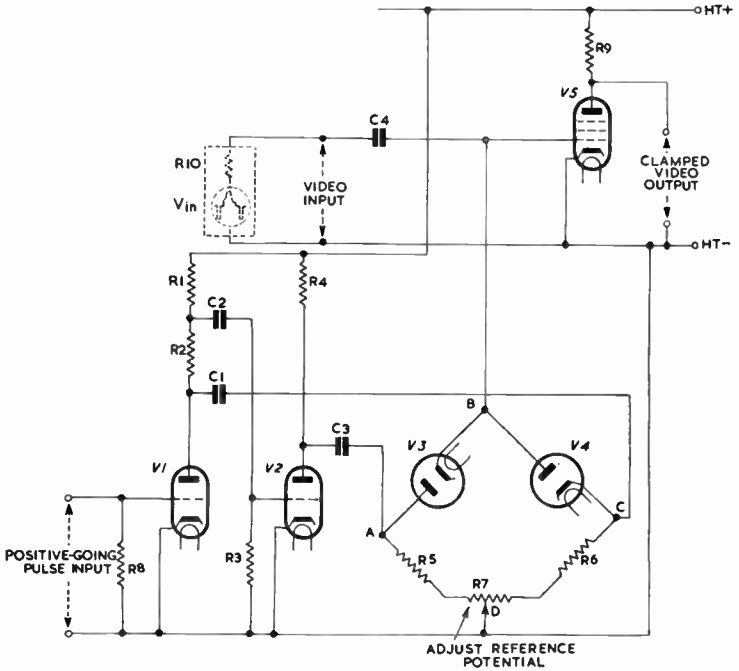

Fig. 55—An alternative circuit for a d.c. clamp

pulse amplitude is 100 volts, the reference potential when the slider is at the junction of R_5 and R_7 or R_7 and R_6 is given by

$$\begin{aligned}
 & 100 \times \frac{(150 \times 10^3)/2}{2 \times 470 \times 10^3 + 150 \times 10^3} \\
 &= 100 \times \frac{75}{1090} \\
 &= 7 \text{ volts approximately}
 \end{aligned}$$

the voltage being positive with respect to V5 cathode at the junction of R_6 and R_7 but negative at the junction of R_5 and R_7 .

CHAPTER 6

GAMMA-CONTROL AMPLIFIERS

6.1 INTRODUCTION

THE signal input—light output characteristic of a cathode-ray tube of the type used for picture reproduction in television is far from linear and, to obtain faithful reproduction of the tonal values in the original scene, the amplitude characteristic of the remainder of the chain must have approximately complementary curvature. High-velocity camera tubes such as iconoscopes and image-iconoscopes have a signal input—light output characteristic of approximately this shape and good pictures can therefore be obtained by using linear amplifiers throughout the chain. However c.p.s. Emitron camera tubes and image-orthicon tubes operated below the knee of the characteristic have a linear signal-light relationship and, in a television system employing such tubes, it is necessary to introduce a non-linear link to obtain satisfactory pictures. This is generally achieved by including in the chain a non-linear amplifier with an amplitude characteristic complementary to that of the reproducing cathode-ray tube.

A similar problem arises in the transmission of cinema film and here, too, it is necessary to employ a non-linear amplifier with a characteristic obeying a certain law in order to give good reproduction.

The problem is, in fact, more complicated than this, because facilities are also required for the transmission of *negative* film in addition to the *positive* film implied above. The shape of amplifier characteristic required for the transmission of negative film is quite different from that needed for positive film transmission.

Thus there is a need in television for amplifiers with input-output characteristics obeying certain laws. It is the purpose of this section to state these laws and to outline the principles which are employed in designing amplifiers to meet these requirements.

6.2 DEFINITION OF GAMMA

By analogy with photographic nomenclature, the form of input-output characteristics of television equipment is usually expressed in terms of gamma (γ). In general, with a suitable choice of origin,

the characteristics obey approximately an equation of the form

$$y = kx^\gamma \quad \dots \quad \dots \quad \dots \quad (1)$$

where x = input,
 y = output,
 and k, γ = constants.

If $k = 1$, gamma is the index of the power to which the input must be raised to obtain the output. A gamma value frequently required in television is 0.5; for an amplifier with this value of gamma the output is proportional to the square root of the input. If $\gamma = 1$, equation (1) reduces to the form

$$y = kx \quad \dots \quad \dots \quad \dots \quad (2)$$

The output being now proportional to the input. This describes a linear device and such devices therefore have a gamma value of unity.

Equation (1) may be written in the form

$$\log y = \gamma \log x + \log k \quad \dots \quad \dots \quad (3)$$

which is of the form $y = mx + c$ and, if $\log y$ is plotted against $\log x$, a straight line is obtained. The slope of the line is equal to gamma and the intercept on the $\log y$ axis is equal to $\log k$. Gamma may alternatively be defined as the slope of the line obtained when the logarithm of the output is plotted against the logarithm of the input.

As an illustration of the determination of a gamma value, Fig. 56 shows the form of curve obtained when the screen brightness of a picture tube is plotted against the control-grid voltage. This curve is of approximately the same form as the I_a-V_g characteristic of a valve, having an approximately linear section between values of V_g of -20 and -30 volts. However, operation of the cathode-ray tube is not confined to this region because the electron beam must be extinguished in black parts of the picture and is reduced to a small value in reproducing dark grey areas. The useful region of the characteristic extends from cut-off at approximately -45 volts to maximum brightness between -20 and -30 volts. Over this region the relationship between light output and signal input is far from linear and, in fact, the law connecting these quantities may be assumed to have the form of equation (1) which, for the tube, can be written

$$B = kV_g^\gamma \quad \dots \quad \dots \quad \dots \quad (4)$$

in which B is the brightness and V_g is the control grid-cathode

GAMMA-CONTROL AMPLIFIERS

voltage (measured with respect to the cut-off voltage, i.e. the voltage for zero screen brightness).

To obtain the gamma value we must plot $\log B$ against $\log V_g$ or alternatively plot B against V_g using logarithmic vertical and horizontal scales. The resulting curve, shown in Fig. 57 is not perfectly straight showing either that the tube characteristic is not exactly of the form of equation (1) or that the value assumed for

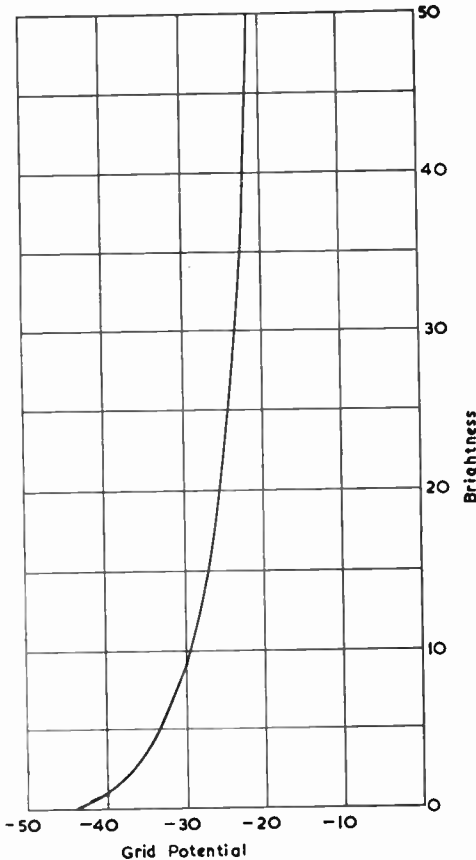

Fig. 56—Light output—signal input characteristic for a picture tube

the cut-off voltage is not exactly right but the curve approximates fairly closely to the dotted straight line AB. The slope of AB may be taken as representing an average value of gamma which applies over the entire range of operating voltages and the value

obtained from Fig. 57, when allowance is made for the difference in the vertical and horizontal scales, is approximately 2.5; this value will be assumed throughout this section.

The procedure which was adopted to obtain the gamma value can be applied generally; that is to say the gamma value averaged over a given range of an input-output characteristic (see Fig. 58) can be obtained from the relationship

$$\gamma = \frac{\log O_2 - \log O_1}{\log I_2 - \log I_1} \quad \dots \quad (5)$$

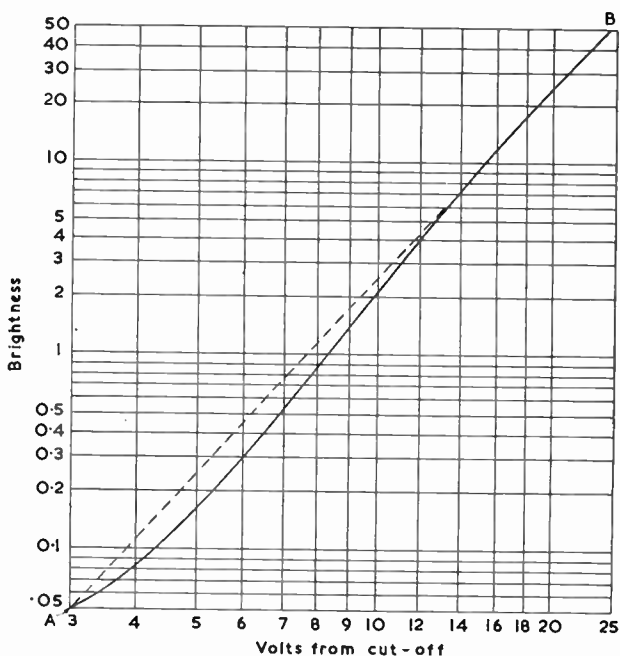

Fig. 57—The picture-tube characteristic of Fig. 56 plotted on logarithmic vertical and horizontal scales

where I_1 is the input corresponding to point P,
 O_1 is the output corresponding to point P,
 I_2 is the input corresponding to point Q,
 and O_2 is the output corresponding to point Q.

As shown in Fig. 58 the points P and Q mark the length of the characteristic employed in amplification and over which the average value of γ is required.

GAMMA-CONTROL AMPLIFIERS

6.3 DEFINITION OF POINT GAMMA

In practice small signals may not be subjected to the same gamma as large ones. This is illustrated in Fig. 59; the average gamma for signals occupying the region PQ is greater than that for small signals which occupy a limited extent of the characteristic centred

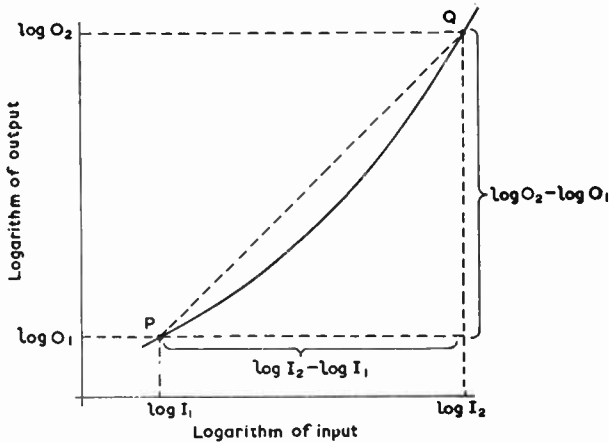

Fig. 58—Determination of an average gamma value from a given input-output characteristic

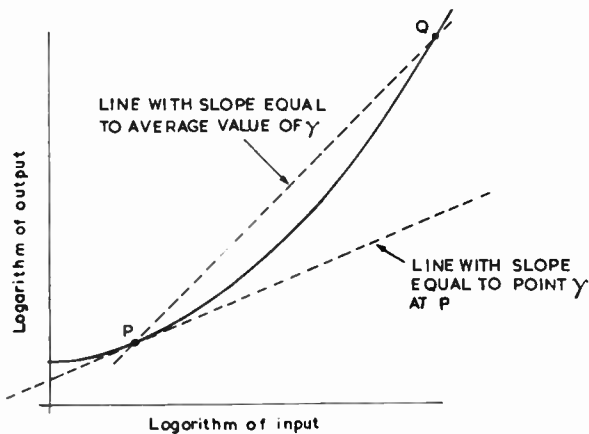

Fig. 59—Illustrating the meaning of point gamma

about the point P. The average gamma is measured by the slope of the chord PQ and the small-signal gamma (known as the point gamma and written γ) is measured by the slope of the tangent to the curve at P.

If a characteristic accurately obeys expression (1) the log-log relationship is straight and the point gamma is equal to the average gamma. If, however, the characteristic merely approximates to one obeying expression (1), values of point gamma differ from those of average gamma, the disagreement giving a measure of the extent to which the characteristic departs from one in accurate agreement with the expression. For example, in Fig 57 values of point gamma vary between approximately 2.0 measured near point A, to 2.75 measured near the mid-point of the characteristic, the average value of gamma being 2.5 as determined above.

6.4 REQUIRED OVERALL VALUE OF GAMMA

6.4.1 *In a Camera Channel*

To give faithful representation of the tonal range in the original scene it might be thought that a television system from original to reproduced scene should have an overall linear characteristic, i.e. an overall average gamma value of unity. This is true for a system required to transmit black and white scenes but when coloured scenes are reproduced in black and white, a linear characteristic tends to give rather flat, dull pictures because the contrast due to colours is missing. Results are better if the overall gamma is made slightly greater than unity say 1.1 or 1.2. The precise value of overall gamma is, however, of less importance than the maintenance of a reasonably constant value of point gamma over the range of signal amplitudes to be transmitted.

If we accept the gamma of the picture tube as 2.5 and the overall desirable value of gamma as 1.2, it follows that the chain of equipment preceding the picture tube should have a gamma of $1.2/2.5$, nearly 0.5. As shown in Volume 1, this is approximately the gamma value for iconoscope and image-iconoscope camera tubes. Thus where such tubes are in use the entire amplifying chain can be linear ($\gamma = 1$). Pictures are also satisfactory with linear amplifiers if the camera tube is an image-orthicon operated around the knee of the signal input—light output characteristic. When, however, the camera tube is a c.p.s. Emitron or an image-orthicon operated below the knee of the characteristic, it has a gamma of unity and to give correct tonal gradation the system requires a non-linear stage with a gamma of 0.5. The image-orthicon tubes originally used in television services had 3-in. diameter image sections and, if operated below the knee of the characteristic, tended to give a high noise output, the visibility of which was increased by the use of subsequent gamma-reducing circuits. However, these image-orthicons were operated above the knee and no gamma correction was necessary.

The larger image-orthicon tubes (with 4½-in. diameter image sections) of more recent introduction give less noise output and it is practicable to operate these below the knee and to follow them with gamma correctors.

6.4.2 *In a Positive Film Channel*

The value of gamma required in a television film channel depends on the method of film reproduction. In flying-spot scanners an unmodulated raster is generated on the screen of a cathode-ray tube and the film passes between this and a photo-electric cell. Light from the screen passes through the film and is focused on the cell by a lens system, the output from the cell constituting the required picture signal. One advantage of this method of reproduction is that, by suitably choosing the aspect ratio of the raster, it is possible to employ continuous motion of the film. This is, however, incidental to considerations of gamma.

When a photographic film is exposed to a range of subject brightness and developed, the density (or opacity) of the negative film so obtained is not linearly related to the subject brightness. If, however, the film is used to produce a positive print, this non-linearity is corrected by the approximately complementary characteristic of the printing process and the transparency of the resulting positive film is very nearly linearly related to the original subject brightness over a certain usable range of brightness. Thus the signal obtained from the photo-electric cell when a positive film is reproduced in a flying-spot scanner has a gamma of unity. The signal thus has the same nature as that from a c.p.s. Emitron camera tube and, to obtain satisfactory pictures, the chain of equipment between the photo-electric cell and the picture tube should have a gamma value of approximately 0.5.

6.4.3 *In a Negative Film Channel*

It saves time and money if negative films can be transmitted; this economy is a consideration of some importance in a news service. To determine what form of gamma correction is necessary in a negative film channel, the relationship between density and subject brightness must be known. Over a range of subject brightnesses the density D obtained by exposure to a subject brightness B is of the form

$$D = \gamma \log_{10} B/B_0 \quad \dots \quad \dots \quad \dots \quad (6)$$

Where γ is a constant depending on the photographic emulsion employed and the processing conditions, B_0 being another constant.

The transparency or transmission T of the film is related to the density according to the relationship

$$D = \log_{10} 1/T \quad \dots \quad \dots \quad \dots \quad (7)$$

Eliminating D between (6) and (7) we have

$$T = kB^{-\gamma} \quad \dots \quad \dots \quad \dots \quad (8)$$

where k is a constant. For normal cinematograph technique γ is approximately 0.6 and thus we have

$$T = kB^{-0.6} \quad \dots \quad \dots \quad \dots \quad (9)$$

and this equation expresses the relationship between the output of the photo-electric cell in a flying-spot scanner and the original subject brightness. The relationship required in order to give a good reproduction of the original scene is of the form

$$T = kB^{+0.5} \quad \dots \quad \dots \quad \dots \quad (10)$$

for this gives an overall gamma of just over unity for a cathode-ray tube having $\gamma = 2.5$. The problem then is to determine what form of characteristic is required in a non-linear amplifier to turn a characteristic having an equation (9) into one having an equation (10).

The required value of γ is defined in the equation

$$(B^{-0.6})^\gamma = B^{+0.5}$$

which gives

$$\begin{aligned} \gamma &= -\frac{0.5}{0.6} \\ &= -0.8 \text{ approximately} \end{aligned}$$

The required gamma-correcting amplifier thus requires a characteristic of the form

$$V_{out} = kV_{in}^{-0.8}$$

To summarise, the chain of equipment at the transmitting end of a television system should have a net gamma of approximately 0.5. This gamma value may be inherent in a camera tube or may be a property of a gamma-correcting amplifier. Such a value implies compression of the signal range; if the range of brightnesses in the original scene is 100 : 1 the range of the corresponding signal at the output of the transmitting equipment is 10 : 1.* Hence

* This follows because the output of a device with a gamma of 0.5 is proportional to the square root of the input.

GAMMA-CONTROL AMPLIFIERS

the minimum signal has 10 times the amplitude required in a linear transmitting system and the signal-noise ratio is correspondingly improved. The signal range is restored to just greater than in the original by the picture tube which acts as an expander by virtue of its gamma value of greater than unity.

The effect on a signal of gamma reduction followed by reciprocal expansion can be illustrated as shown in Fig. 60. Diagram (a) shows the way in which the brightness is distributed throughout

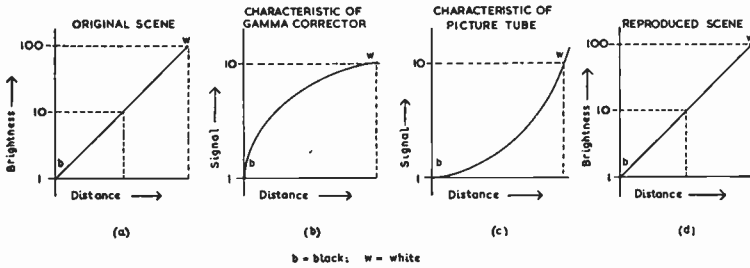

Fig. 60—Illustrating the stages in the gamma-reduction and gamma-expansion of a video signal

the original scene and, for convenience, it is assumed that the brightness increases uniformly over a range of 100 : 1 across the picture. When the signal corresponding to this scene is applied to the gamma-reducing device, the low-light signals are amplified more than the high-light signals (a process colloquially known as “black stretching”) with the result that the distribution of signal across the picture is now of the form shown at (b); the 100 : 1 variation in brightness has become a 10 : 1 change in signal amplitude. The signal is now applied to a picture tube which amplifies the low-light signals less than the high-light ones. Diagram (c) illustrates the way in which the gain of the tube varies in relation to the spatial distribution of signal across the picture. The gain varies in the ratio of 10 : 1 which together with the input-signal variation of 10 : 1 gives an overall variation of 100 : 1. Thus the output signal has the form shown in (d) which agrees with the original (a).

6.5 EFFECTS OF USING INCORRECT VALUE OF OVERALL GAMMA

Such a series of diagrams can be used to predict the effects of applying the wrong degree of gamma correction. For example, suppose a video signal is not subjected to gamma reduction before transmission. This means that a signal of the form shown in Fig. 60(a) is applied to a characteristic of the form shown

in Fig. 60 (c). The result will be a signal of the form shown in Fig. 61 (a); the characteristic is curved and covers a signal range of 1,000 : 1. The low slope of the curve for small signals means that there will be a lack of detail in the dark grey and black areas of the picture. The extended signal range means that white signals are reproduced at an unnaturally high level and in practice may cause overloading and consequent saturation in some link of the chain, resulting in a lack of detail in the white areas also. These are the consequences of reproducing a picture with too high a value of overall gamma. This is illustrated by Plates I and II (facing page 96). Plate I has a satisfactory value of overall gamma but Plate II illustrates the same scene as reproduced with an excessive value of gamma. Lack of detail in the dark areas of the scene known as "black crushing" is a significant feature of Plate II.

Consider now the effect of excessive gamma reduction in the gamma corrector; if the gamma of the corrector is 0.25 (as opposed to the correct value of 0.5) the output signal will have a range of only 3 : 1 approximately.* This is applied to the picture tube (which has a gain range of 10 : 1) to produce a brightness variation of 30 : 1, only 1/3rd of the original. Moreover the shape of the curve (Fig. 61 (b)) is such that the white signals are reproduced at less than their correct amplitude. There is thus a loss of detail in the white parts of the picture, an effect sometimes described as "white crushing." This is illustrated in Plate III (facing page 97) which is a reproduction of the scene of Plate I printed with a low value of overall gamma. The significant feature is the lack of detail in white areas.

6.6 EFFECT OF GAMMA CORRECTION ON SIGNAL-NOISE RATIO†

The light output—signal input characteristic of Figs. 56 and 57 give the picture-tube output in terms of the *objective brightness* of the screen, i.e. the brightness as measured by a light meter. The sensation of brightness as measured by the human eye, i.e. the *subjective brightness* is proportional to the logarithm of the objective brightness (Weber-Fechner law) and, in fact, the relationship is such that the curve relating subjective brightness with picture-tube input is, to a first degree of approximation, linear. This means that the eye may be regarded as having an effective gamma value of approximately 0.4 although the behaviour

* A gamma value of 0.25 means that the output signal is proportional to the fourth root of the input signal.

† Abstracted from R. D. A. Maurice, M. Gilbert, G. F. Newell and J. G. Spencer, "The Visibility of Noise in Television." B.B.C. Engineering Division Monograph No. 3, October 1955.

GAMMA-CONTROL AMPLIFIERS

of the eye is not so simple as that of a camera tube: for example, the sensitivity of the eye to a given brightness is affected by the ambient lighting.

Noise voltages in a television system are usually small compared with the picture signal and may be considered as "riding on" the picture signal. The subjective effect on the picture-tube screen of noise voltages at a picture-tube input is proportional to the noise-voltage amplitude and independent of the picture signal amplitude: in other words the noise is uniformly visible over the whole of the grey scale of reproduced images.

In a television system employing a high-velocity camera tube such as an iconoscope (with a gamma value of approximately 0.5)

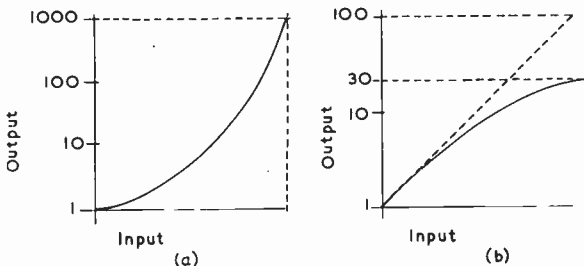

Fig. 61—Form of output signal obtained (a) when the overall gamma is too high and (b) when it is too low

no gamma-correcting circuits are normally required. Noise introduced by the camera head amplifier is amplified linearly by the subsequent chain and appears at the picture-tube input independent of the picture-signal amplitude. Such noise voltages give rise to noise uniformly distributed over the grey scale of reproduced images.

If, however, the camera tube is a low-velocity type such as a c.p.s. Emitron (having a gamma value of unity) and if the chain still contains no gamma-correcting circuits, the signal applied to the picture-tube input has too high a value of gamma and gives images characterised by accentuated detail in high-light areas and lack of detail (crushing) in low-light areas. Noise voltages now added to the system by the camera head amplifier cause a greater disturbance to low-light signals than to high-light signals. The noise would therefore be expected to be more visible in dark grey than in light grey areas but in practice is often masked by the black crushing. A gamma-reducing circuit inserted in the chain after the camera head amplifies low-light signals (and the associated noise) more than the high-light signals and causes the noise to

become more obvious in the low-light areas. For this reason gamma-correcting circuits are often said to impair the signal-noise ratio of video signals but, in fact, they may not add any noise; they make noise already present in the signal more obvious.

By an extension of this argument we can deduce that if the picture source has a gamma value of less than approximately 0.4, noise added to the chain subsequent to the picture source tends to be more obvious in high-light than in low-light areas of the image. Again the noise may not be obvious because of the effect of the white crushing which occurs in a system having an overall gamma of less than unity. To restore the grey scale, a gamma-increasing circuit must be included in the chain. This amplifies high-light signals and their associated noise more than low-light signals so making the noise more obvious in the high-light areas of the image. Here again it would appear that the gamma-correcting circuit has increased the noise although it has only made existing noise more obvious.

We shall now describe the basic principles of gamma-reducing amplifiers.

6.7 FUNDAMENTAL PRINCIPLES OF GAMMA-CORRECTING CIRCUITS FOR CAMERA OR POSITIVE FILM

6.7.1 Introduction

The form of input-output relationship required for gamma reduction is illustrated by the line OA in Fig. 62. The straight

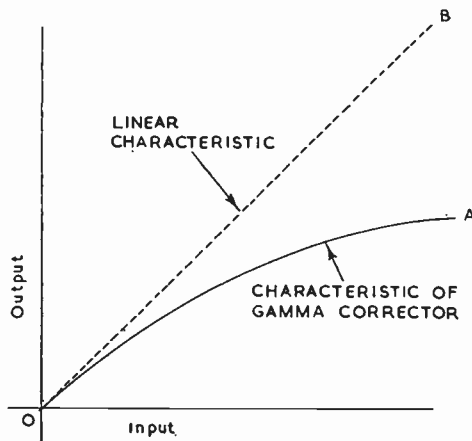

Fig. 62—OA shows the characteristic shape required for gamma reduction and OB is a linear characteristic

line OB represents the performance of a linear circuit, i.e. one with unity gamma.

Comparison of the two shows that the output of the gamma corrector falls more and more below that of the linear circuit as the input is increased. The performance of the gamma corrector is, in fact, similar to that of a simple potential divider (Fig. 63) in which the resistance of the lower arm R_2 is progressively reduced

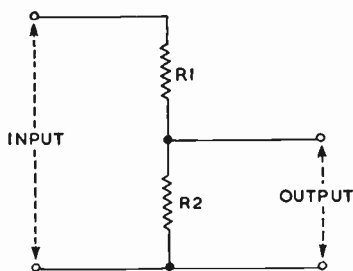

Fig. 63—A simple potential divider

as the input to the circuit increases. An approximation to the desired performance can be obtained if R_1 is a linear resistor and R_2 a non-linear resistor, the resistance of which decreases with increase in the current through it. Such a resistor is a diode valve and the resistance may be many thousands of ohms for very small currents falling to, say, 100 ohms for a current of 1 mA through the valve.

6.7.2 Simple Circuit using a Diode

A very simple gamma corrector could have the form shown in Fig. 64. To obtain maximum benefit from the non-linear characteristic of the diode the resistor R_1 should be large compared with the maximum value of R_2 ; the total resistance is then only slightly greater than R_1 and the current in the circuit is approximately equal to V/R_1 where V is the input voltage. Thus, if R_1 is large enough, the diode is effectively fed with a current directly proportional to the input signal. With such a value of R_1 , however, the output signal is small compared with the input signal. Great attenuation cannot normally be tolerated and the value of R_1 is therefore limited. This, in turn, limits the range of input signal over which the non-linear characteristic retains the desired shape.

Ideally the characteristic should conform to the required law over a wide range of input signal, say 100 : 1, but it is always difficult to find a characteristic which retains its shape over such a

wide range and it may be necessary to accept a smaller range of say 20 : 1. To make most effective use of the characteristic, the signals must operate over the chosen part of it and this implies that the operating point must be accurately placed on the characteristic. This contrasts with class A amplification where the

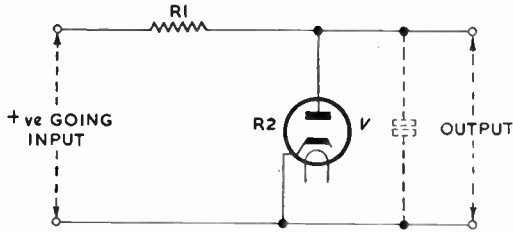

Fig. 64—Basic circuit for a gamma corrector using a diode

position of the operating point on the characteristic does not matter provided the signals occupy a linear region. In the gamma corrector, to obtain a precise operating point it is necessary that the input signal should have a fixed black level; this necessitates a black-level clamp at the input of the potential divider and for a simple circuit such as that of Fig. 64 the black-level voltage should be zero, the picture signal being positive-going on whites.

Such a simple circuit has a number of serious limitations; one is the attenuation already mentioned. Another is concerned with

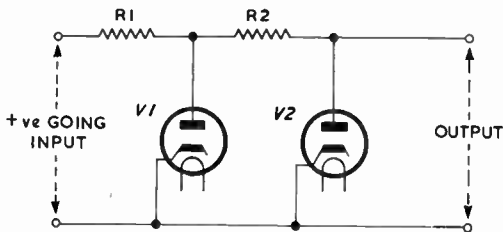

Fig. 65—Circuit of a gamma corrector using two diodes

the bandwidth of the circuit. In practice there is shunt capacitance across the output, contributed by the diode itself and also the input capacitance of the following amplifier. This capacitance (shown dotted in Fig. 64) causes a falling high-frequency response, that is to say a decreasing bandwidth. The bandwidth will be greater on large signals for which the diode resistance is small than on

GAMMA-CONTROL AMPLIFIERS

small signals for which the diode resistance is large. The bandwidth is thus greater for white details than for black ones; this is certainly preferable to the alternative in which the bandwidth is less for white details, but ideally the bandwidth should be independent of the signal level.

These limitations can both be overcome, at the expense of reducing the accuracy of gamma correction, by reducing R_1 to say 1 k Ω . The gamma correction can be restored to some extent by adding a second stage of correction. The circuit then takes the form illustrated in Fig. 65. To obtain a satisfactory performance the circuit must be so designed that, as the input signal is increased from zero, V1 conducts first and V2 later. This necessitates a

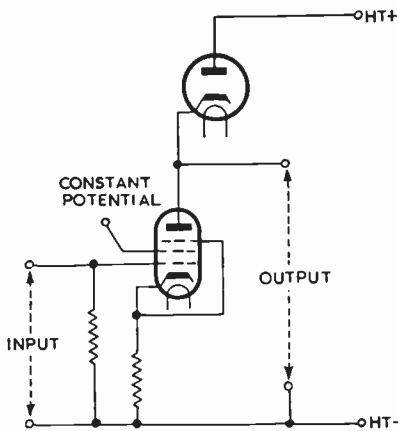

Fig. 66—Simple gamma corrector using a pentode as constant-current source

system of d.c. biasing which keeps V2 non-conductive until the input signal reaches a predetermined level.

6.7.3 Circuit employing a Pentode as Constant-current Source

To obtain full advantage of the simple gamma corrector of Fig. 64, the resistor R_1 must be large compared with the diode resistance. As pointed out earlier, with such a value of R_1 , the current supplied to the diode is nearly proportional to the input signal. Any form of constant-current generator could thus be used in place of R_1 and one possibility is to use a pentode valve as shown in Fig. 66. This shows a diode connected as the anode load of a pentode, the input signal being applied between the control grid and cathode of the pentode, the output signal being developed across the diode.

The diode resistance is unlikely to exceed a few tens of thousands of ohms and this is small compared with the anode a.c. resistance of the pentode which, by suitable choice of valve, can be as high as 1 megohm. Thus the pentode anode current is independent of the diode resistance, being determined almost entirely by the input signal.

A great advantage of this circuit over that of Figs. 64 and 65 is that there is no attenuation; instead there can be gain. The pentode may have a mutual conductance of 8 mA/V and, when the diode resistance is 1,000 ohms, there is a gain of 8. Circuits of this fundamental type are used in flying-spot film scanners; one example is illustrated in simplified form in Fig. 67. In this the non-linear resistor is a triode, the grid of which is effectively earthed.

The resistance of a triode valve so connected is approximately equal to $1/g_m$ and a typical triode may have a mutual conductance of 10 mA/V when the anode current is 10 mA; its resistance and hence the anode load for the pentode, is thus $1/(10 \times 10^{-3}) = 100$ ohms for this value of anode current. If, however, the anode current of the triode is reduced to a very low value, the mutual conductance will also fall. Near anode current cut-off, the mutual conductance may be 0.1 mA/V, making the triode resistance $1/(0.1 \times 10^{-3}) = 10,000$ ohms. Thus by swinging the anode current of the triode from 10 mA to nearly zero, the pentode anode load varies from 100 ohms to 10,000 ohms, a range of 100 : 1. The pentode gain is proportional to the anode load resistance and will also vary over the range 100 : 1 and by applying the picture signal to the pentode grid in the correct sense, the gain for small (black) signals can be made 100 times that for large (white) signals, this illustrating the "black stretching" referred to earlier.

The variation of mutual conductance of the triode is a method of expressing the non-linearity of the I_a-V_g characteristic of the valve and this form of gamma corrector puts this non-linearity to good use. The characteristic has a satisfactory value of gamma (i.e. approximately 0.5) provided that the correct operating point is chosen and that the full length of the characteristic is employed. Thus, for satisfactory performance, the current through the triode must be very nearly zero for black-level input signals and must vary over a wide range up to say 10 mA for signals at white level. Even though a considerable length of the characteristic is used, the gamma correction achieved can never be perfect. If a gamma corrector of this type accurately obeyed a law of the form of expression (1), the gain would be infinite for a triode anode current



Plate 1a. A photograph reproduced with a satisfactory value of overall gamma



Plate 1b. The photograph of Plate 1a reproduced with too high a value of overall gamma



Plate II. The photograph of Plate Ia reproduced with too low a value of overall gamma

GAMMA-CONTROL AMPLIFIERS

of zero; this is impossible because the pentode has a finite value of amplification factor and the gain cannot exceed this value.

The two valves in Fig. 67 are in series and the anode-current swing for the pentode must equal that for the triode, from zero to 10 mA. The anode current of the pentode should ideally be linearly related to the control-grid voltage but this cannot be maintained if the anode current is to swing to zero. To avoid this difficulty a linear resistor can be connected in parallel with the valve V2 as shown in the dotted lines in Fig. 67. If this is arranged to carry, say, 5 mA, the anode-current swing for the pentode becomes 5 to 15 mA, a range which can be achieved with linearity. Such a resistor necessarily has a "diluting" effect on the gamma correction because it is in parallel with the triode and therefore reduces the variations in resistance, but this can be made very small.

The circuit so far developed has two major weaknesses. One has already been mentioned, namely the variations in bandwidth

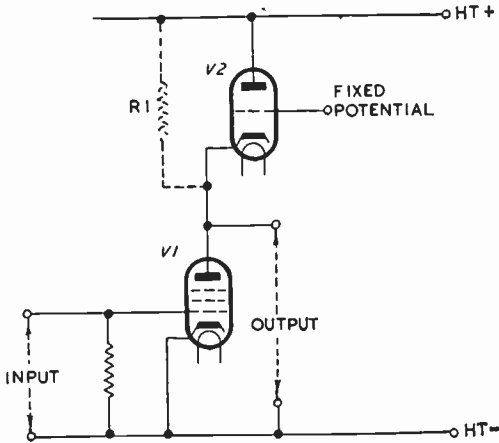

Fig. 67—Simplified circuit diagram of a gamma corrector employing the non-linearity of a triode I_a-V_g characteristic

with signal level. In a practical circuit there is inevitably some capacitance in shunt with the output terminals, the principal sources being the output capacitance of V1 and V2 and the input capacitance of the next stage. This capacitance has a time constant with the effective resistance of V2 which determines the turnover frequency, i.e. the bandwidth of the circuit. If the total capacitance is 30 pF, the cut-off frequency is 50 Mc/s when V2 is effectively 100 ohms but only 500 kc/s when V2 is 10 kΩ. A bandwidth as low as

500 kc/s implies that there will be some loss in detail in the dark parts of the picture.

This difficulty can be overcome by use of negative feedback and a suitable circuit is illustrated in Fig. 68. The output of the gamma corrector is developed at V1 anode and is applied to the grid of V3, the output of which is returned to the grid of V2 via R_3 and C_1 . The negative feedback so obtained has two major effects; firstly it decreases the output of the gamma corrector stage, but this is of little consequence because an amplified output is now obtainable from V3 anode. Secondly it reduces the effective resistance of V2 by a factor of, say, 10, which means that the bandwidth of the circuit, even for black signals, is better than the minimum acceptable value. Although the effective resistance of V2 is reduced by

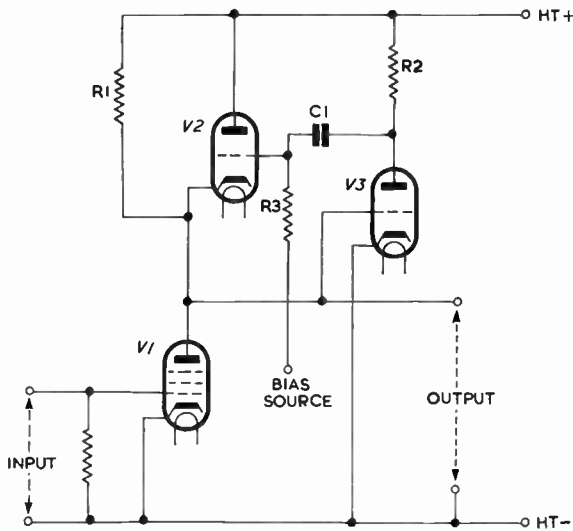

Fig. 68—One method of applying negative feedback to the gamma corrector of the previous diagram

feedback, the ratio by which it changes in response to input signals remains unaltered. For example the resistance of V2 may now alter from 10 ohms to 1,000 ohms, whereas without feedback the variation was from 100 ohms to 10 k Ω .

The effect of feedback on the resistance of valve V2 may be determined in the following way. To begin with suppose that V3 is removed and the circuit has the form shown in Fig. 67: there is now no feedback. V1 drives a current through V2 and variations in current (due to signals applied to V1 grid) can occur only if the

grid-cathode potential of V2 changes suitably. The grid potential of V2 is fixed and it follows that current variations occur as a result of changes in V2 cathode potential. For a current change of ΔI_a the cathode potential must change by ΔV_k where

$$\Delta I_a = g_m \Delta V_k$$

The resistance of the cathode circuit is thus given by

$$\frac{\Delta V_k}{\Delta I_a} = \frac{1}{g_m}$$

Consider now the behaviour of the circuit when V3 is restored and feedback is present (Fig. 68). The grid of V2 now receives signals from V3 anode which are amplified and in antiphase to those applied to V2 cathode. Let the change in cathode potential required to give a change ΔI_a in anode current be $\Delta V_k'$. The signal at V2 grid is thus $A \Delta V_k'$ where A is the voltage gain of V3. The grid-cathode signal of V2 is now $(A + 1) \Delta V_k'$ and we have

$$\Delta I_a = g_m (A + 1) \Delta V_k'$$

The resistance of the valve is still given by $\Delta V_k' / \Delta I_a$ and is hence

$$\frac{\Delta V_k'}{\Delta I_a} = \frac{1}{g_m (A + 1)}$$

which is still inversely proportional to the mutual conductance of V2 but is reduced by a factor of $(A + 1)$ due to feedback, A being the voltage gain of V3.

The second difficulty of the basic circuit of Fig. 67 is that of maintaining the required value of grid bias for V1. Variations in the value of bias can affect operation of the circuit because the bias value determines the current in the circuit and, for successful results, it is essential that the current in V2 should be a close approximation to zero for input signals corresponding to black. In other words the input signal must have a black level which is fixed with great accuracy. This can be achieved by use of a conventional clamp circuit at the input to V1, the reference voltage being manually adjusted to the correct value. Alternatively a circuit can be employed which produces the required reference voltage automatically by means of feedback.

6.8 FUNDAMENTAL PRINCIPLES OF GAMMA CORRECTOR FOR NEGATIVE FILM

6.8.1 Introduction

To obtain satisfactory pictures from negative film reproduced by a flying-spot scanner, a non-linear amplifier is required with

a gamma value of approximately -0.8 . The shape of the characteristic for an amplifier with this gamma value is illustrated in Fig. 69; this is, in fact, the curve of the equation

$$y = x^{-0.8}$$

This equation is similar in form to

$$y = x^{-1}$$

i.e.

$$xy = 1$$

which is the equation to a rectangular hyperbola; as shown in Fig. 69 the gamma-corrector curve is similar in shape to a rectangular hyperbola.

Examination of the curve of Fig. 69 shows that a positive-going input signal produces a negative-going output signal. The output is thus in the opposite phase to that produced by the gamma correctors considered earlier in this section. The difference in

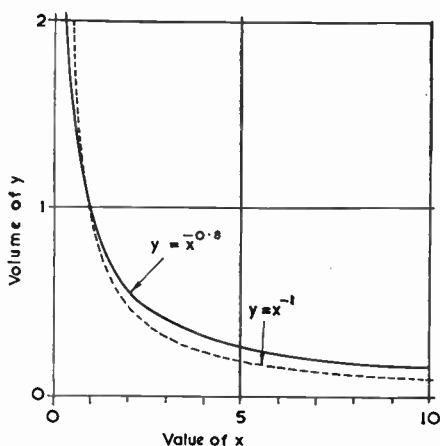

Fig. 69—Form of input-output characteristic required for gamma correction of negative film

polarity of output is, of course, due to the use of negative film; the photocell output is at a maximum when transparent areas of film are scanned. For negative film such areas correspond to picture black, whereas for positive film these areas correspond to picture white. The phase reversal inherent in Fig. 69 is thus necessary in order that the output of the gamma corrector shall be positive-going on whites. If the gamma corrector incorporates a linear phase-reversing stage, the characteristic of the non-linear

GAMMA-CONTROL AMPLIFIERS

section should be as shown in Fig. 70, which is a mirror image of the curve of Fig. 69 seen in the y -axis. This characteristic has the equation

$$y = (-x)^{-0.8}$$

The problem is now to find a device with a characteristic similar to that of Fig. 70. Two features of the characteristic are that y is infinite when x is zero and that x is minus infinity when y is zero.

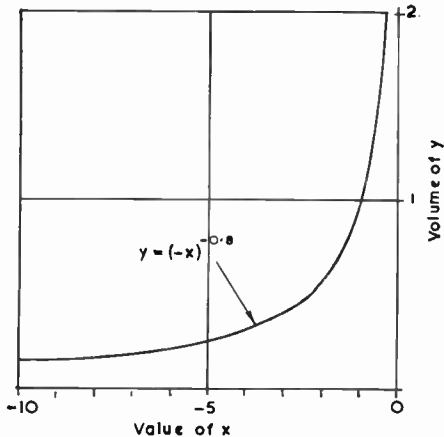

Fig. 70—Mirror image of the characteristic of the previous diagram

A curve which is similar to this over most of its length is the I_a-V_g characteristic of a variable- μ pentode. For such a valve, as V_g approaches zero, the anode current does increase very sharply and, if saturation and the onset of grid current did not exist, the anode current would reach infinity for a value of V_g approximately equal to +1 volt. Moreover the characteristic of the variable- μ valve has a long "tail," implying that a very large negative grid voltage is required to reduce the anode current to a low value, this, of course, being the chief feature of this type of valve. Thus the I_a-V_g characteristic of a variable- μ pentode gives a reasonable approximation over most of its length to the input-output relationship required in a negative film scanner.

There is, however, a disagreement between the two curves over the region between $V_g = -1$ volt and $V_g = +1$ volt; here in the ideal curve y goes to infinity but the anode current of the variable- μ valve remains finite because of saturation and the effects of grid current. Fortunately, however, this region of the variable- μ characteristic is unlikely to be used in a gamma corrector. It

corresponds to values of V_g around zero, i.e. a very low output from the photocell. Such an output implies that the film is practically opaque and it corresponds to a white intenser than any likely to be encountered in practice; this we can term "infinite white." Thus the region where the variable- μ characteristic

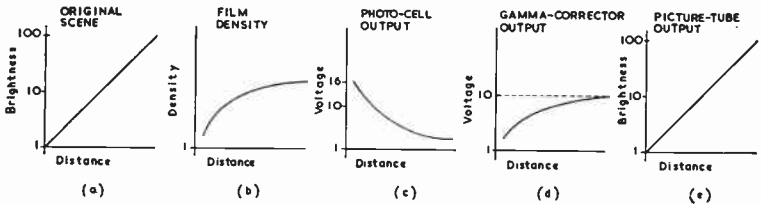

Fig. 71—Effects of the various non-linear links in a negative-film reproducing chain

departs from the ideal shape is never likely to be required in practice and a valve of this type can be quite successfully employed as the non-linear element in a negative-film gamma corrector.

The way in which the gamma corrector produces the desired overall characteristic is illustrated in Fig. 71 which shows the effect of the various links in the chain. Diagram (a) represents the original scene, the brightness of which is assumed to rise linearly with distance through a range of 100 : 1 across the scene. When this is photographed and the film developed, the density varies across the film in the manner shown at (b). When the film is reproduced in a flying-spot scanner, the output of the photocell varies across the scene in the manner illustrated at (c) and if the film is developed to a gamma of 0.6 the photocell output varies in the ratio 16 : 1 representing a considerable degree of compression compared with the 100 : 1 contrast ratio in the original scene. The corrector has a gamma of -0.8 , the effect of which is to produce a signal varying across the scene as shown in (d); the signal range has been further reduced to 10 : 1. Finally the full range of the original signal is restored in the picture tube as shown at (e).

6.8.2 Circuit employing a Variable- μ Pentode

Fig. 72 shows in simplified form the circuit diagram of a negative-film gamma corrector using the principles discussed above. V_1 is a phase-reversing stage which accepts the picture signals at the photocell output and applies them to the grid of the variable- μ pentode V_2 . We shall assume that the signals from the photocell are positive-going on black, zero voltage corresponding to infinite white; the signal at V_2 anode, having undergone two phase reversals is also of this form. In order to give a gamma-corrector output

GAMMA-CONTROL AMPLIFIERS

which is positive-going on whites, an additional phase-reversing stage V3 is introduced subsequent to the variable-mu valve.

One difficulty is to ensure that the picture signals operate on the desired part of the variable-mu characteristic. This is achieved in the following manner. The beam in the flying-spot scanner is cut off during the line and field flyback periods. The output of the photocell is thus zero during these periods and corresponds to infinite white. Infinite white signals at V2 grid should, theoretically, produce an infinite anode current. A variable-mu characteristic, if it followed the same law for the whole of its length, would reach such an anode current at a small positive grid voltage, say +1 volt. The circuit is so designed that the inter-line signals bias V2 grid to this voltage; this is achieved very simply by d.c. restoration at V2 grid by the grid-circuit components R_4C_1 . The inter-line pulses at V2 grid cause grid current in R_4 and develop across C_1 a voltage

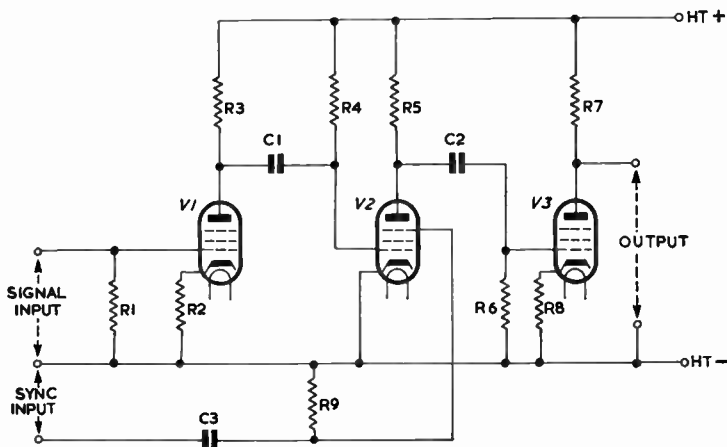

Fig. 72—Basic form of a negative-film gamma corrector employing a variable-mu valve as the non-linear device

such that the tips of these pulses are slightly positive with respect to V2 cathode potential.

Complete opacity of the film is never obtained in practice and the picture signal thus does not operate on the valve characteristic between say $V_g = -1$ volt and $V_g = +1$ volt. The signal lies wholly negative with respect to $V_g = -1$ volt, as shown in Fig. 73, signals corresponding to black being sufficiently negative to reduce anode current to zero.

The inter-line signals at V2 output correspond to infinite white but for correct operation of subsequent equipment it is frequently

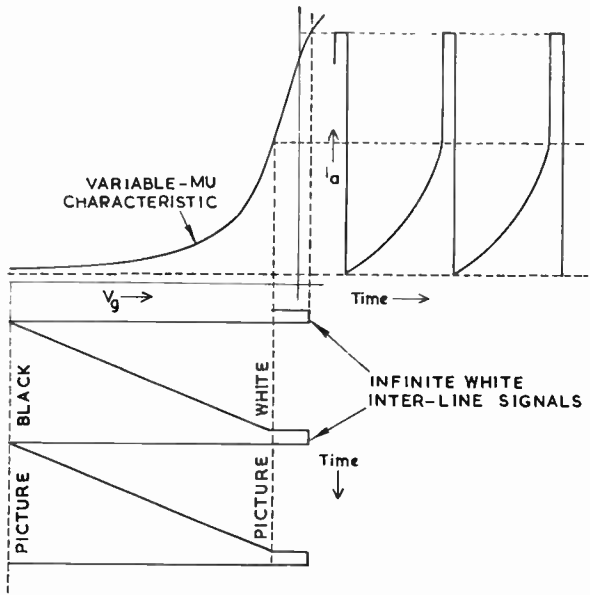

Fig. 73—Illustrating application of the picture waveform to the variable-mu grid

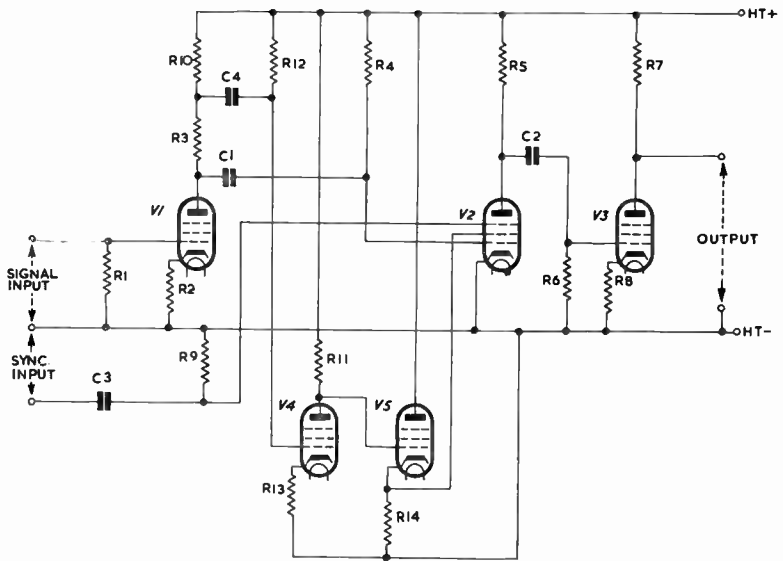

Fig. 74—Improved form of the gamma corrector of Fig. 72

GAMMA-CONTROL AMPLIFIERS

desirable that these signals should correspond to black. The necessary change can be effected by applying to the suppressor grid of V2 negative-going inter-line pulses sufficient to cut the valve off. These cause the anode current of V2 to be reduced to zero for the duration of these pulses and V2 output thus corresponds to black level during flyback periods. If desired the reduction of V2 anode current to zero may be achieved by applying the standard sync waveform to V2 suppressor grid at a suitable amplitude.

For gamma correctors of this type there is a limited range of input over which the necessary correction can be accurately applied. The range can, however, be extended and the gamma value of the circuit made a closer approximation to the ideal value by applying the input signal to the screen grid of V2 in antiphase with the signal applied to the control grid. This may be achieved as shown in Fig. 74. Two signals are derived from the anode circuit of V1; one is applied to V2 control grid as before and the other is applied via R_{10} , C_4 and R_{12} to the control grid of an amplifying stage V4, d.c. restoration occurring as in V2 grid circuit. The output of V4 is, in turn, applied to the screen grid of V2 via a cathode follower V5.

CHAPTER 7

DELAY LINES

7.1 INTRODUCTION

To generate a video signal a number of pulses are necessary and, to ensure constancy in the characteristics of the video signal, the timing of the pulses must be maintained with accuracy. The timing is usually achieved by use of delay circuits which deliver an output at a definite controllable interval after the application of the input. There are three commonly employed forms of delay circuit, namely:

- (a) Monostable valve circuits such as multivibrators and phantastrons.

The input signal initiates the leading edge of the multivibrator output pulse, the trailing edge of which is used as the delayed signal. The delay so obtained is equal to the output-pulse duration which can be controlled within wide limits as described in Volume 3. This method of obtaining a delay is applicable only to signals with steep edges, such as pulses.

- (b) Cables resembling co-axial lines.

The distributed inductance and capacitance of the line cause signals to be transmitted along it with a finite velocity and the delay of a given line depends on the construction of the line and on its length. Such cables have a falling high-frequency response but short lengths can be used to delay video signals.

- (c) Ladder networks of inductance and capacitors, usually arranged in the form of low-pass filters and known as *delay lines*.

The delay obtained is dependent on the L and C values and on the number of sections in the line. Such networks have a definite cut-off frequency and are generally used to delay pulses, but can be employed to delay any form of signal, provided its spectrum lies sufficiently below the cut-off frequency.

Each of these delay circuits has certain advantages and disadvantages. The valve circuit, sometimes known as an *active delay network* because it contains a source of power, can be used only with signals in the form of pulses but can readily be adjusted to provide

DELAY LINES

any desired value of delay within a wide range. The delay so obtained may, however, vary with changes in supply voltages and with ageing of the valve. Only a single value of delay can be obtained from such a circuit and one circuit is required for each value.

Passive networks such as lines and cables can be used to delay signals of any waveform without introducing appreciable distortion provided the passband is adequate but the delay obtainable is usually limited to less than, say, 50 μsec ; otherwise the networks become bulky physically. The delay is not continuously adjustable, as in a valve circuit, but the line can be provided with a number of tapping points and a rough adjustment is possible by selecting the tapping providing the nearest approximation to the desired value. The properties of the line depend only on its physical construction and the delays are more constant than those obtained from a valve circuit such as a phantastron.

This chapter describes the use of passive circuits to provide delays; the use of valve circuits for this purpose is covered in Volume 3.

7.2 DELAY CABLES

7.2.1 Introduction

One way of delaying a signal is to send it along a transmission line. The velocity of propagation of electromagnetic waves along a line is given in centimetres per second by

$$v = 1/\sqrt{LC} \quad \dots \quad (11)$$

where L and C are respectively the inductance (in Henrys) and the capacitance (in Farads) per unit length of line. The delay D is, of course, the time taken by the signal to travel from the input to the output of the line; for unit length of line it is given in seconds by the reciprocal of the velocity, i.e.

$$D = \sqrt{LC} \quad \dots \quad (12)$$

For a given line length, therefore, the delay can be increased by increasing L and/or C . The delay of a line of length l is hence given by

$$D = l\sqrt{LC} \quad \dots \quad (13)$$

where l is the length in any units (e.g. in cm)

L is the inductance per unit length (e.g. per cm)

and C is the capacitance per unit length (e.g. per cm).

There are two basic forms of transmission line, the twin-wire type (which is balanced) and the co-axial cable (which is unbalanced). For producing delays the co-axial form is preferred. Most forms of co-axial cable have small inductance and small capacitance per unit length and from (12) the delay per unit length is also small. Long lengths of cable may be necessary to give a wanted delay but the outer conductor screens the inner and the cable may be coiled up so as to occupy little space.

To reduce the length of cable required for a given delay, special cables have been constructed having large inductance and large capacitance per unit length. Fig. 75 illustrates the construction used in one cable of this type.

To increase inductance the inner conductor is wound on a dust-iron core. To minimise eddy-current losses the outer conductor consists of a braid of individually insulated conductors and, to

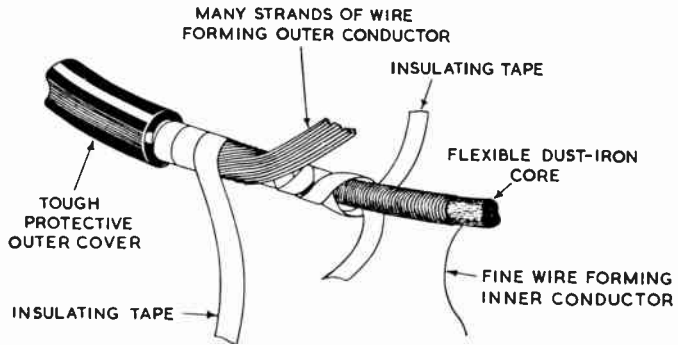

Fig. 75—Construction of a delay cable

increase capacitance, the di-electric separating the braid from the inner conductor consists of a number of layers of very thin insulating tape. The outer covering is of a tough material for mechanical protection of the cable.

The iron particles in the centre core are embedded in a plastic material which is sufficiently elastic to permit the cable to be bent into a circle of a few inches radius. The outer conductor does not behave as a screen and the cable should not be wound into a coil otherwise the close proximity of different sections of the cable may cause undesirable interaction.

A delay cable of this type may have an inductance of $160 \mu\text{H}$ per in. and a capacitance of 20 pF per in. The delay is given by

DELAY LINES

$$\begin{aligned}\sqrt{LC} &= \sqrt{(160 \times 10^{-6} \times 20 \times 10^{-12})} \text{ sec per in. length} \\ &= 56.6 \times 10^{-9} \text{ sec per in. length} \\ &= 0.057 \mu\text{sec per in. length}\end{aligned}$$

The length of cable required to give 1 μsec delay is thus $1/0.057 = 17.5$ in. approximately.

In circuits employing a delay cable, the cable must be so terminated at the receiving end that the video signal is completely absorbed at that end. If the termination is not correct signals may be reflected at the end of the line and travel back along it to the sending end. Reflection can occur again at the sending end and thus a second forward-travelling video signal of small amplitude is set up and delayed with respect to the wanted signal. Such delayed signals can cause second images in reproduced pictures, these unwanted images being usually fainter than the principal image and displaced to the right of it. To avoid the effect, cables carrying video signals must be terminated in a particular value of impedance known as the characteristic impedance. This may be defined in the following way.

7.2.2 Characteristic Impedance

Consider an infinitely long cable composed only of inductance and capacitance and therefore incapable of dissipating power. Signals applied to one end of this cable set up a travelling wave which moves along the cable at a finite velocity but never reaches the other end because this is an infinite distance away. In establishing this wave the cable absorbs power from the source and behaves as a resistive load even though it contains inductance and capacitance only. This value of resistance to which the input impedance of a cable or line tends as the length approaches infinity is termed the characteristic impedance of the cable.

If a short length of cable is removed from the sending end of an infinitely long cable the remainder is still infinitely long. The remainder has an input impedance equal to the characteristic impedance and may be replaced by a resistance of this value. It follows that the input impedance of a short length of cable, terminated in a resistance equal to the characteristic impedance, is equal to that of an infinitely long cable, i.e. to the characteristic impedance. Any power applied to the input of a short length of cable so terminated must be delivered to the load resistance because the cable cannot itself dissipate power. A resistive termination equal to the characteristic impedance thus absorbs all the power transmitted along the cable and is a perfect match or termination for the cable.

The characteristic impedance, Z_0 , is given by the expression

$$Z_0 = \sqrt{L/C} \quad \dots \quad (14)$$

where L and C are as defined above. For a co-axial or twin-wire line the characteristic impedance is independent of frequency.

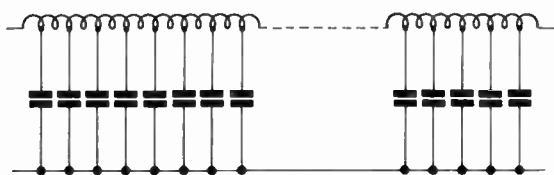

Fig. 76—The inductance and capacitance of a delay cable is distributed throughout its length

For the particular cable discussed above the characteristic impedance is given by

$$\begin{aligned} \sqrt{L/C} &= \sqrt{[(160 \times 10^{-6})/(20 \times 10^{-12})] \text{ ohms}} \\ &= \sqrt{8 \cdot 0 \times 10^6} \text{ ohms} \\ &= 2,830 \text{ ohms} \end{aligned}$$

An ideal transmission line has no losses and the signals received at the far end, though delayed, are without attenuation, irrespective of their frequency. Practical lines inevitably have resistance and this dissipates some of the energy in the signal, causing attenuation. Moreover the losses increase with increase in frequency causing a practical line to have a frequency response which falls with increasing

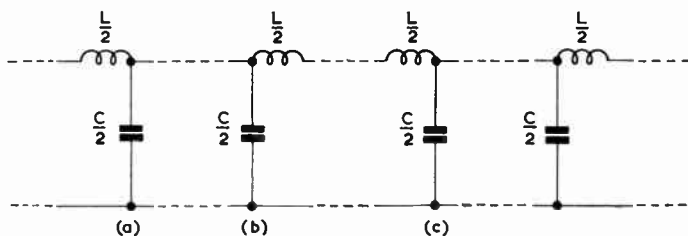

Fig. 77—Ladder network of inductance and capacitance with properties similar to those of a delay cable

frequency, although there is no cut-off as in a delay network of lumped inductance and capacitance.

Thus a delay cable has a falling high-frequency response and the loss at a particular high frequency increases with the length of

DELAY LINES

the cable. The maximum tolerable loss determines the delay obtainable with a given type of cable. For example, the measured frequency response of the cable of which details are given above shows 1 dB loss at 3 Mc/s for a 17.5-in. length of cable; the frequency response is usually specified for that length of cable which gives 1- μ sec delay. If 6 dB is the maximum loss which can be tolerated at 3 Mc/s, the maximum length of delay cable which can be used is 6×17.5 in., nearly 9 ft, and this gives a delay of 6 μ sec.

7.2.3 T- and π -sections

The capacitance of a delay cable is distributed throughout the length of the cable, as suggested in Fig. 76, but an approximation to this form of construction can be made with lumped components by arranging them as shown in Fig. 77 in the form of a series of small inductors each associated with a single shunt capacitor. Each

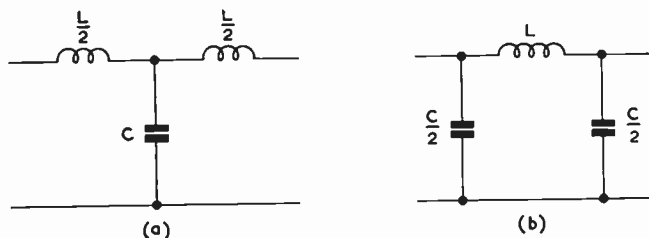

Fig. 78—Two basic forms of full filter section (a) T-section and (b) π -section

combination of inductor and capacitor constitutes what is known in network theory as a half-section.

By combining two neighbouring half-sections, a full section is obtained and there are two basic types of full section depending on the way in which the half-sections are chosen. By combining half-section (a) with half-section (b) we obtain the form of full section shown in Fig. 78 (a); this is known as a T-section. By combining half-section (b) with half-section (c) we obtain the form of full section shown in Fig. 78 (b); this is known as a π -section.

If a number of T-sections or a number of π -sections are connected in cascade, they form a ladder network of the type illustrated in Fig. 79. If this is regarded as a succession of T-sections, the full sections forming the structure are obtained by splitting the ladder at the centre points of the series inductors as by the dotted lines AB and CD: each full T-section so obtained has two series inductors, each of $L/2$, and a shunt capacitance of C . If, however, the ladder network is regarded as made up of π -sections, the full

sections forming the structure are obtained by splitting the ladder at the centre points of the capacitors as shown by the dotted lines EF and GH. Each full π -section has a series inductance of L and two shunt capacitors, each of $C/2$.

This ladder network constitutes a low-pass filter and is the basic form of artificial delay lines, usually termed "delay networks." Networks of this type are also used in filters to attenuate signals in certain frequency bands whilst allowing other signals to pass freely, but here we are interested in the use of such networks to introduce delays.

In a delay cable or transmission line, the series inductance and shunt capacitance are distributed; that is to say the line can be

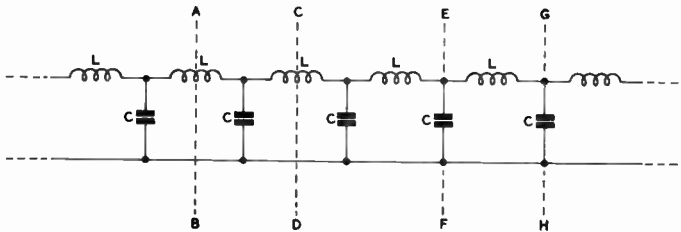

Fig. 79—A low-pass filter can be regarded as a succession of T-sections divided by lines such as AB and CD, or as a succession of π -sections when divided by lines such as EF and GH

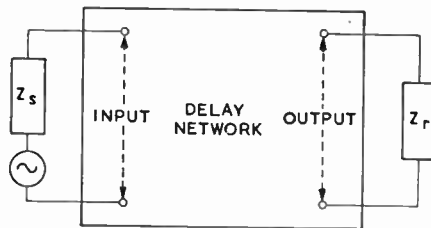

Fig. 80—A delay network fed from a source of impedance Z_s and supplying a load of impedance Z_r

regarded as a low-pass filter containing an infinite number of sections, each with an infinitely small inductance and capacitance. In making an artificial delay cable, i.e. a delay network, we must use finite values of inductance and capacitance, e.g. $100 \mu\text{H}$ and 100 pF . There is thus a marked disparity between the values of L and C in a delay cable and those used in a delay network; for this reason a delay network must not be taken as a perfect substitute for 112

a delay cable. In some respects the properties of the two are quite different as described in the following pages.

7.3 DELAY NETWORKS

7.3.1 Introduction

We shall now consider the fundamental properties of delay networks and the circuit with which we are concerned is that shown in Fig. 80 in which Z_s is the source impedance and Z_r the load impedance. As we shall see both Z_s and Z_r have an important bearing on the performance of the network. The delay of such a network could be explained, as for a delay cable, in terms of the finite velocity of propagation of waves through the network but frequently the distance between the input and output terminals is small and it is perhaps better to explain the propagation in terms of the charging of capacitors as follows:

The series inductance in a single π -section separates the two capacitances and a steep-sided signal applied to one capacitor cannot be transferred instantaneously to the other. The voltage across the output capacitance can be altered only by charging or discharging the capacitance and this takes a finite time.

7.3.2 Iterative Impedance

The input impedance of an infinite number of delay network sections is known as the *iterative impedance*; this corresponds with the *characteristic impedance* of a transmission line. As shown in Fig. 81 at low frequencies the iterative impedance of a network of π -sections is equal to $\sqrt{L/C}$ but as frequency is increased it increases, at first slowly and then more rapidly, becoming infinite at a particular frequency. This frequency is an important parameter of the π -section and is known as the *cut-off frequency*; it depends on the L and C values, being given by

$$f_c = \frac{1}{\pi\sqrt{LC}} \quad \dots \quad \dots \quad \dots \quad (15)$$

The variation of iterative impedance with frequency follows the relationship

$$Z_{0\pi} = \frac{\sqrt{L/C}}{\sqrt{1 - f^2/f_c^2}} \quad \dots \quad \dots \quad \dots \quad (16)$$

which is deduced in Appendix A.

For a network composed of T-sections, the iterative impedance is also equal to $\sqrt{L/C}$ at low frequencies but as frequency is increased

the impedance falls, reaching zero at the cut-off frequency as shown in Fig. 81. The cut-off frequency is given by expression (15) and the relationship between iterative impedance and frequency is

$$Z_{0T} = \sqrt{L/C} \cdot \sqrt{1 - f^2/f_c^2} \quad \dots \quad (17)$$

also deduced in Appendix A.

These variations in iterative impedance have important practical consequences. They make it difficult to terminate a delay line satisfactorily over a wide band of frequencies because ideally the terminating impedance should vary in the same way as the iterative

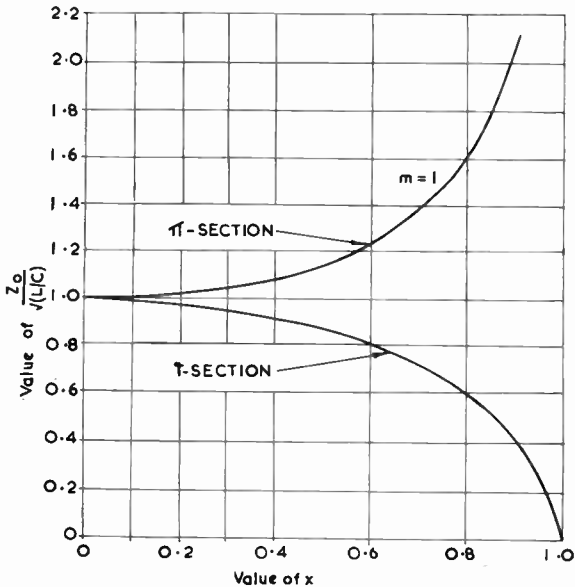

Fig. 81—Variations of iterative impedance with frequency for a delay network

impedance. A resistance equal to $\sqrt{L/C}$ is a good match at low frequencies but becomes less effective as frequency approaches the cut-off value. Some methods of minimising this difficulty are discussed later.

These variations of iterative impedance have, of course, no counterpart in transmission line theory, for the characteristic impedance of a transmission line is independent of frequency. This does not show that the above theory is inapplicable to networks with distributed constants. The theory is general but a transmission line has such small values of L and C that the cut-off

frequency (see expression 15) is infinite. Working frequencies are well below cut-off and the variations in characteristic impedance are negligible.

7.3.3 Frequency Response

It is essential that the waveform of a signal should not suffer distortion in its passage through a network. This distortion can be expressed, as for video amplifiers, by the frequency response and phase response curves of the network. We shall now consider the response curves for a low-pass filter to see to what extent they are satisfactory for the transmission of pulses.

One difficulty experienced in such considerations is that the frequency and phase response of any network are affected by the nature and magnitude of the source and load impedance. For example Fig. 82 shows in dotted lines the response curves for a single low-pass section in the form in which they are often shown in books on network theory. The frequency response is plotted in terms of the *insertion loss*, this being the loss in dB obtained in the load impedance when the filter section is inserted between generator and load, compared with the loss in dB experienced when the generator is connected directly to the load. The frequency response is level up to the cut-off frequency above which the response falls off rapidly. The frequency range below f_c is often termed the *pass-band* and that above cut-off the *attenuation band*. The phase response shows a rise, linear near the origin but increasing sharply to 180° at the cut-off frequency. These are the responses obtained when the filter is terminated *at both ends* by an impedance equal to the iterative impedance Z_0 ; that is to say by an impedance which varies with frequency as indicated in Fig. 81. The dotted curves therefore represent ideal responses which cannot be obtained in practice.

If a single low-pass section is terminated at both ends in a resistance equal to $\sqrt{L/C}$ the frequency and phase responses obtained are as shown in solid lines in Fig. 82. The frequency response agrees with the idealised curve at low frequencies but begins to show a slight loss in the passband as the cut-off frequency is approached; the loss is, however, only 3 dB at cut-off. The phase response, too, agrees with the idealised curve at low frequencies but shows divergencies as cut off is approached; both phase responses, however, show 180° phase shift at the cut-off frequency.

The condition for distortionless transmission of pulse signals is that the amplitude-frequency characteristic should be level and the phase-frequency characteristic linear over the spectrum occupied by

the pulse. Fig. 82 shows that the curves for a single low-pass section satisfy these requirements up to a frequency equal to approximately half the cut-off frequency and this result also holds for multi-section low-pass filters. It is therefore usual to design the delay network to have a cut-off frequency at least twice the highest frequency it is desired to pass.

Fig. 82 shows the responses of a single-low pass section; by adding further sections the fall in response above cut-off is made more pronounced and the passband becomes more sharply defined. This contrasts with the frequency response of a delay cable which shows a steady fall but no sharp cut-off as frequency is increased. The cut-off frequency for a delay cable is infinite and theoretically the cable should show a level frequency response. The slight fall found in practice is due to the resistance of the line.

7.3.4 Calculation of Delay and Number of Sections

The delay of a single π -section is given by expression (12) which applies equally to the delay cable

$$D = \sqrt{LC}$$

For example if $L = 100 \mu\text{H}$ and $C = 100 \text{ pF}$, the delay per section is given by

$$\begin{aligned} D &= \sqrt{100 \times 10^{-6} \times 100 \times 10^{-12}} \text{ sec} \\ &= \sqrt{10^{-14}} \text{ sec} \\ &= 10^{-7} \text{ sec} \\ &= 0.1 \mu\text{sec} \end{aligned}$$

For a delay line of n sections, the delay is given by

$$D = n\sqrt{LC} \quad \dots \quad \dots \quad \dots \quad \dots \quad \dots \quad (18)$$

where L and C are the inductance and capacitance in a single section.

From this calculation it would appear that any value of delay could be obtained by making L and C large enough. This would be true if the frequency and phase response of the network were unimportant but, as we have seen, the cut-off frequency must be at least twice the highest frequency it is required to pass. This sets an upper limit to the L and C values which can be used and thus determines the number of network sections required. Eliminating LC between (15) and (18) we have

$$n = \pi f_c D \quad \dots \quad \dots \quad \dots \quad \dots \quad \dots \quad (19)$$

which shows that for a given frequency response the number of sections is proportional to the required delay. Moreover for a given

DELAY LINES

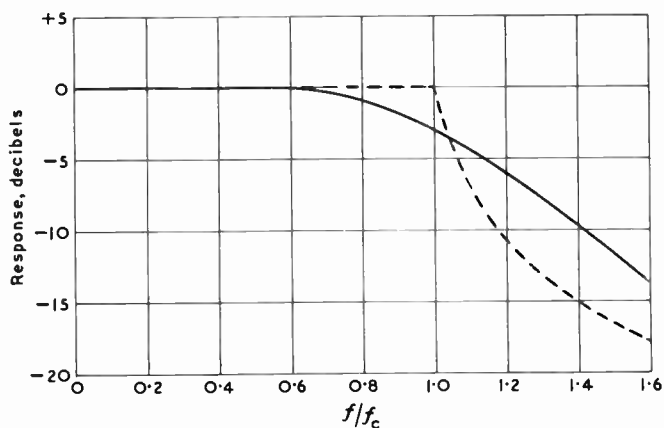

(a)

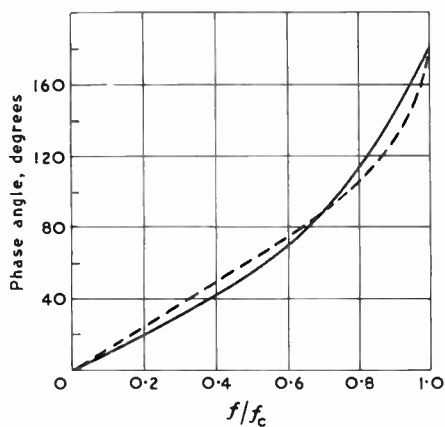

(b)

Fig. 82—The frequency response (a) and phase response (b) of a single low-pass section when terminated at both ends in an impedance Z_0 (dotted) and when terminated in a resistance equal to $\sqrt{L/C}$ (solid)

delay the number of sections required is proportional to the frequency response. Thus in practice a large number of sections with small L and C values is superior to a small number of sections with large L and C values.

As a numerical example suppose a pulse is to be delayed by $1 \mu\text{sec}$ and the rise time must not be more than $0.2 \mu\text{sec}$.

A rise time of $0.2 \mu\text{sec}$ implies a passband of at least $1/(2 \times 0.2 \times 10^{-6}) = 2.5 \text{ Mc/s}$. This requires a cut-off frequency of at least 5 Mc/s . Substituting for D and f_c in (19) we have

$$n = 3.142 \times 5 \times 10^6 \times 1 \times 10^{-6} \\ = 16 \text{ sections}$$

The values of L and C are determined by the iterative impedance required. Suppose this is required to be $3,000 \text{ ohms}$. From (14) we have

$$Z_0 = \sqrt{L/C}$$

From (15)

$$f_c = \frac{1}{\pi\sqrt{LC}}$$

Eliminating C between these equations we have

$$L = \frac{Z_0}{\pi f_c} \dots \dots \dots (20)$$

Eliminating L

$$C = \frac{1}{\pi f_c Z_0} \dots \dots \dots (21)$$

Substituting in (20)

$$L = \frac{3 \times 10^3}{3.142 \times 5 \times 10^6} \text{ H} \\ = 190.8 \mu\text{H}$$

Substituting in (21)

$$C = \frac{1}{3.142 \times 5 \times 10^6 \times 3 \times 10^3} \text{ F} \\ = 21.2 \text{ pF}$$

The delay of a network can be expressed in terms of its iterative impedance. From

$$Z_0 = \sqrt{L/C}$$

we have $\sqrt{L} = Z_0\sqrt{C}$

DELAY LINES

Substituting for \sqrt{L} in (18)

$$D = nZ_0C \quad \dots \quad (22)$$

= number of sections \times iterative impedance \times
capacitance of a full section

This relationship is useful because it often enables the delay of a network to be stated on inspection of a circuit.

Numerical Example

A delay line has 50 sections with series inductors of 1 mH and centre capacitors of 50 pF. Find the delay, cut-off frequency and iterative impedance

From (15)

$$f_0 = \frac{1}{\pi\sqrt{LC}}$$
$$= 3.142 \times \sqrt{\frac{1}{(10^{-3} \times 50 \times 10^{-12})}} \text{ c/s}$$
$$= 1.423 \text{ Mc/s}$$

From (14)

$$Z_0 = \sqrt{L/C}$$
$$= \sqrt{\left(\frac{10^{-3}}{50 \times 10^{-12}}\right)} \Omega$$
$$= 4,500 \Omega \text{ approximately}$$

From (18)

$$D = n\sqrt{LC}$$
$$= 50 \times \sqrt{(10^{-3} \times 50 \times 10^{-12})} \text{ sec}$$
$$= 50 \times 2.236 \times 10^{-7} \text{ sec}$$
$$= 11.2 \mu\text{sec}$$

Alternatively from (22)

$$D = nZ_0C$$
$$= 50 \times 4,500 \times 50 \times 10^{-12} \text{ sec}$$
$$= 11.2 \mu\text{sec}$$

7.4 DELAY NETWORKS WITH m -DERIVED SECTIONS

7.4.1 General

A delay network of simple T- or π -sections has a useful pulse response up to approximately half the cut-off frequency but by use

TELEVISION ENGINEERING PRINCIPLES AND PRACTICE

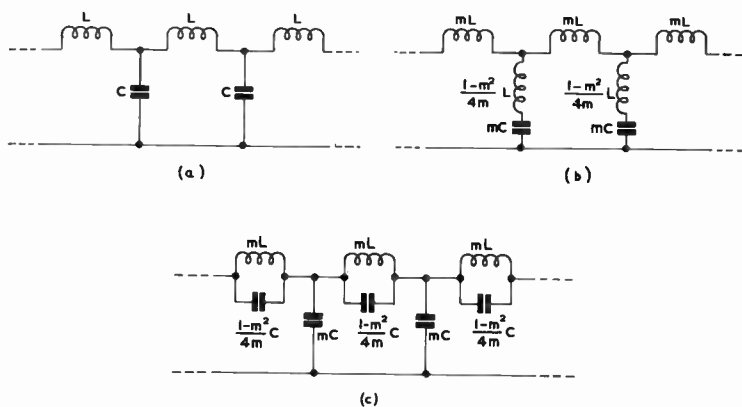

Fig. 83—Part of a recurrent network is shown at (a), one m -derived equivalent at (b) and a second m -derived equivalent at (c)

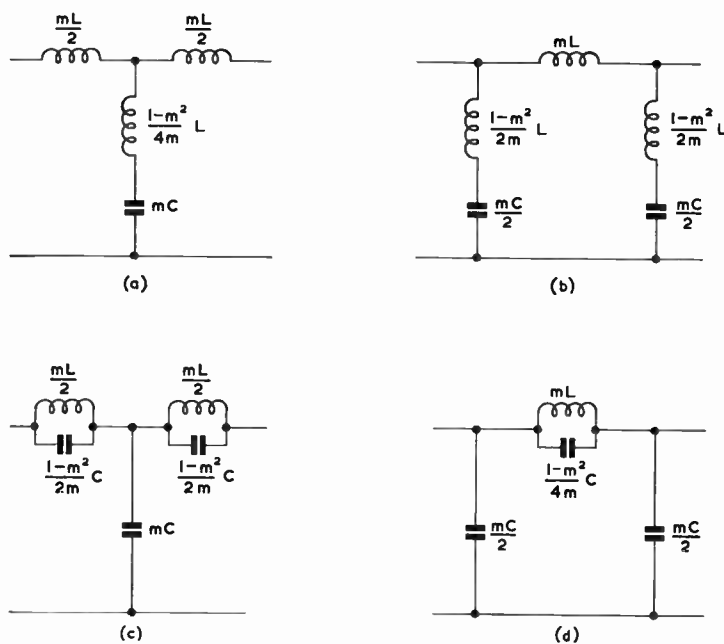

Fig. 84—Four basic types of m -derived section

of more complex sections the useful response can be extended by nearly one octave almost up to the cut-off frequency. Thus to obtain a given frequency response a network of complex sections requires a cut-off frequency only half that of a network of simple sections. The larger values of L and C needed to give the lower cut-off frequency also give the complex network a greater delay per section. Thus the number of complex sections required to give a required value of delay is less than the number of simple sections. One form of complex section which improves the delay characteristic in this manner is the m -derived section.

7.4.2 M -derived Sections

There are two methods of obtaining an m -derived from a simple section, (a) by including additional elements in the shunt arms and (b) by including additional elements in the series arms; both types are illustrated in Fig. 83. Part of a recurrent network with series inductors of value L and shunt capacitors of value C , is shown in Fig. 83 (a). One type of equivalent m -derived network is illustrated in Fig. 83 (b). The complex section may be regarded as derived from the prototype by using series inductors of mL (compared with L), shunt capacitors of mC (compared with C) and by using an additional component, namely an inductor of value $(1 - m^2) L/4m$ in series with each shunt arm. A second type of m -derived equivalent network is shown in Fig. 83 (c); this is also derived from the prototype network by using series inductors of mL and shunt capacitors of mC but the additional element is a capacitor of $(1 - m^2) C/4m$ connected in parallel with the series inductors.

By dividing networks of the type shown in Figs. 83 (b) and 83 (c) by vertical lines through the series or shunt arms (as in Fig. 79) we obtain the four basic types of m -derived section shown in Fig. 84.

In sections (a) and (b) the *series* elements are m times those in the simple prototype sections: these are therefore termed *series-derived* networks. In sections (c) and (d) the *shunt* elements are m times those in the prototype sections: these are therefore termed *shunt-derived sections*. Section (a) is hence described in full as a series-derived low-pass T-section and (d) as a shunt-derived low-pass π -section.

The frequency response of a properly-terminated m -derived section is similar to that of a prototype section up to the cut-off frequency but the rate of attenuation above the cut-off frequency is greater and when m is less than unity the response has a minimum, theoretically of infinite attenuation, at a frequency above the cut-off value and given by $f = f_c/(1 - m^2)$. Often m -derived sections are

included in multi-stage filters to improve the attenuation immediately above the passband.

The iterative impedance of an m -derived section depends on its configuration. Sections such as (a) and (d) in Fig. 84 which present at their terminals simple series or shunt components have iterative impedances which are approximately equal to those of the prototype T- or π -sections and are therefore independent of m : this is brought about by the additional series or shunt elements in the m -derived section. Thus the iterative impedance of network (a) is equal to Z_{0T} (see expression 17) and of network (d) to $Z_{0\pi}$ (see expression 16). It is therefore possible to cascade a number of sections of this type with any desired values of m and with prototype sections if necessary without significant mismatching.

The iterative impedance of m -derived sections such as those illustrated at (b) and (c) in Fig. 84 depends both on frequency and on the value of m . This can be shown from the expression for the iterative impedance which can be evaluated by the method used in Appendix A. For the series-derived T-section (Fig. 84 (c)) the iterative impedance is given by

$$Z_{0Tm} = \frac{Z_{0T}}{1 - (1 - m^2)x^2}$$

where $x = f/f_c$. Substituting for Z_{0T} from expression (17)

$$Z_{0Tm} = \sqrt{\left(\frac{L}{C}\right)} \cdot \frac{\sqrt{(1 - x^2)}}{1 - (1 - m^2)x^2}$$

This expression is plotted in Fig. 85 for $m = 0.2, 0.6$ and 1 . The value $m = 0.6$ was chosen because it gives least variations in Z_{0Tm} over the passband. The deviations from $\sqrt{(L/C)}$ are, in fact, less than $\pm 5\%$ up to 0.9 of the cut-off frequency. The curve labelled $m = 1$ applies to a prototype T-section because the network of Fig. 84 (c) degenerates into this when m is put equal to unity.

For the shunt-derived π -section (Fig. 84 (b)) the iterative impedance is given by

$$Z_{0\pi m} = Z_{0\pi}[1 - (1 - m^2)x^2]$$

where $x = f/f_c$. Substituting for $Z_{0\pi}$ from expression (16)

$$Z_{0\pi m} = \sqrt{\left(\frac{L}{C}\right)} \cdot \frac{1 - (1 - m^2)x^2}{\sqrt{(1 - x^2)}}$$

from which it is clear that the ratio of $Z_{0\pi m}$ to $\sqrt{(L/C)}$ is the reciprocal of the ratio of Z_{0Tm} to $\sqrt{(L/C)}$. Thus the curves of Fig. 85 apply to the shunt-derived π -section provided the ordinates are taken as

DELAY LINES

the ratio of $\sqrt{L/C}$ to $Z_{0\pi m}$. The iterative impedance of the shunt-derived π -sections also shows least deviations from $\sqrt{L/C}$ when $m = 0.6$ but the impedance rises to infinity at the cut-off frequency.

Sections such as (b) and (c) can be terminated in a resistance of value $\sqrt{L/C}$ and matching is good over most of the passband. A single section of either type could be used between a generator and a load both having a resistance of $\sqrt{L/C}$ but it is not good practice to cascade sections of type (b) or (c) with sections of type (a) or (d) or with prototype sections because the iterative impedances,

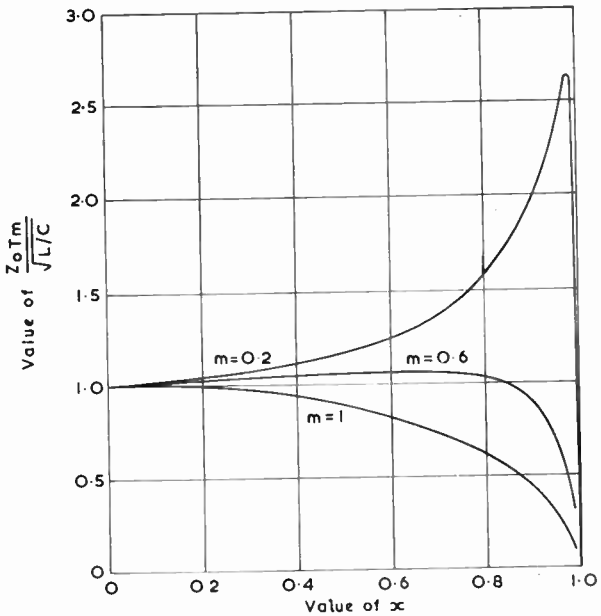

Fig. 85—Variation of iterative impedance of a series-derived T-section with frequency for $m = 0.2, 0.6$ and 1.0

though equal at low frequencies, differ over most of the passband. Mismatching means that the filter sections do not give the frequency response expected from them.

7.4.3 *M*-derived Half-sections

Sections such as (b) and (c) are thus of limited application but from them it is possible to derive networks which are very valuable. Suppose, for example, a section of type (b) is split by a vertical line passing through the series inductance. We then obtain a half-

section of the type shown in Fig. 86 (a). If this has $m = 0.6$ and is terminated at terminals a and b by a resistance of $\sqrt{L/C}$, the impedance presented at terminals c and d is approximately equal to that of a prototype T-section Z_{0T} over most of the passband, and these terminals can be connected to a T-section or to m -derived T-sections of type (a) without significant mismatch. Such half-sections are useful for terminating delay lines or filters composed of T-sections because they match the iterative impedance of such filters to a resistance of $\sqrt{L/C}$.

Similarly by splitting the m -derived section of Fig. 84 (c) through the shunt capacitance mC we obtain a half-section of the type shown in Fig. 86 (b). If this has $m = 0.6$ and is terminated at terminals a and b by a resistance of $\sqrt{L/C}$, the impedance presented at terminals c and d is approximately equal to that of a prototype π -

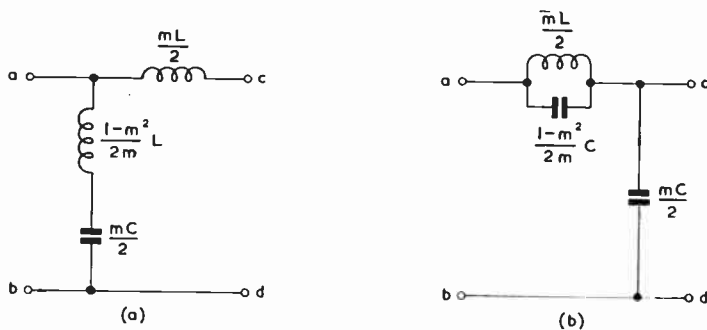

Fig. 86—Two basic forms of m -derived half-section

section $Z_{0\pi}$ over most of the passband and they can be connected to a π -section or to m -derived sections of type (d) without significant mismatch. Such half-sections are useful for terminating delay lines or filters composed of π -sections because they match the iterative impedance of such filters to a resistance of $\sqrt{L/C}$.

Thus where it is essential to terminate delay lines or filters accurately, either to avoid reflection or to obtain a precise frequency response, it is normal practice to have an m -derived half-section of the types shown in Fig. 86 (with $m = 0.6$) between the final section and the terminating resistance of $\sqrt{L/C}$. Two examples of the final stages of such delay lines are given in Fig. 87, (a) being composed of T-sections and (b) of π -sections.

7.4.4 Phase Response of Series-derived Low-pass Sections

In delay network considerations we are primarily concerned with the phase characteristics of networks and our chief interest in m -

DELAY LINES

derived sections is in the way the value of m affects the phase characteristics of the section.

The phase characteristic for a series-derived low-pass T-section (Fig. 84 (a)) is deduced in Appendix B where it is shown that maximal flatness of the group and delay-frequency characteristic is obtained when $m = 1.225$. However, by using a slightly larger value of m we can obtain a characteristic which deviates less from the ideal over a larger fraction of the passband and a value of 1.27 is commonly

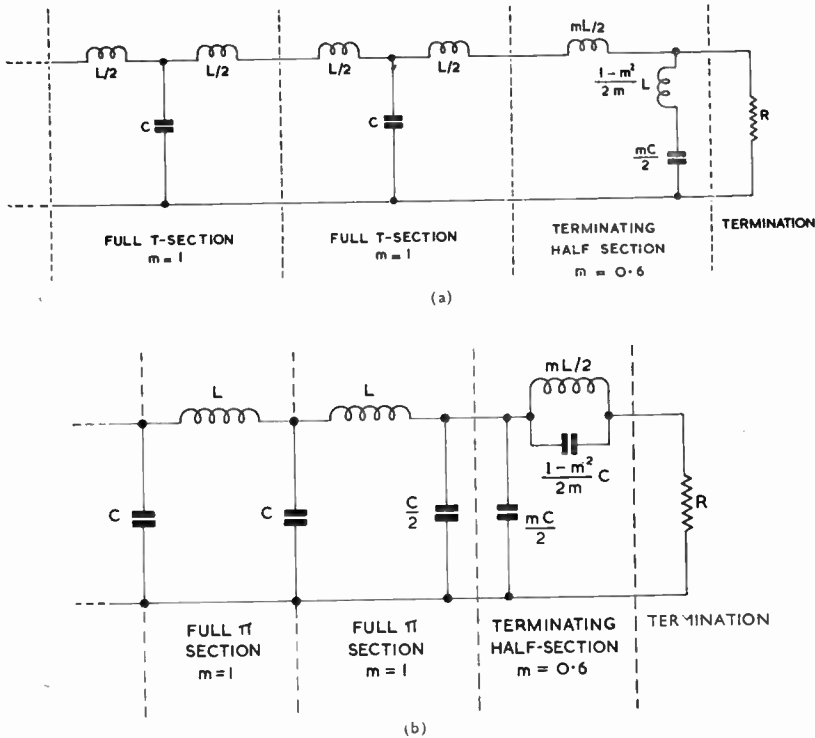

Fig. 87—Final sections of a delay line (a) of T-sections and (b) of π -sections

used. The group delay curve for this value of m is illustrated in Fig. 88: for comparison this also illustrates the curves for $m = 1$ (which applies to the prototype low-pass section) and $m = 2$.

7.4.5 Circuits for Series-derived Delay Networks

The shunt inductance (Fig. 84 (a)) is given by $(1 - m^2)L/4m$ and to obtain an m value of 1.27 the shunt inductance must be negative. Such an inductance is physically unrealisable but the same effect

can be obtained by coupling the series inductors mL as indicated in Fig. 89 (a) provided the sign of the mutual inductance is correct. The value of coupling coefficient k required between adjacent series inductors to give $m = 1.27$ can be calculated in the following way. In general the mutual inductance M between two inductances L_1 and L_2 is defined by

$$M = k\sqrt{(L_1L_2)}$$

and if $L_1 = L_2$ we have

$$M = kL$$

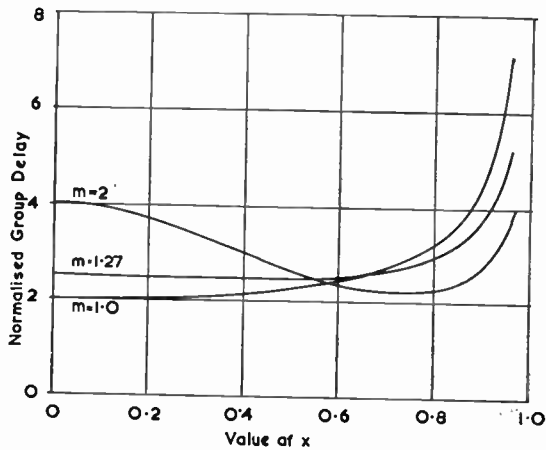

Fig. 88—Group delay curves for a series-derived, low-pass section for three values of m

Applying this to the m -derived low-pass section

$$\frac{1 - m^2}{4m} \cdot L = kmL$$

$$\therefore k = \frac{1 - m^2}{4m^2}$$

$$\text{If } m = 1.27$$

$$k = \frac{1 - 1.27^2}{4 \times 1.27^2}$$

$$= 0.1 \text{ approximately}$$

It is possible to obtain this value of k if all the series inductors are on a common former by choosing the coil spacing and dimensions appropriately but a better method is that illustrated in Fig. 89 (b). In this arrangement centre-tapped coils are wound on a common

DELAY LINES

former and the shunt capacitors are connected to the tapping points. Each inductance mL of the m -derived section is thus composed, as illustrated, of the two halves of adjacent coils. The advantage of this arrangement is that the mutual inductance linking adjacent sections is now between the two halves of a single coil and the required value of m can be obtained by choosing a suitable ratio of length to diameter and a suitable winding arrangement of this coil. A similar winding arrangement is commonly used in the anode and grid networks of distributed amplifiers.

7.5 TERMINATION OF DELAY NETWORKS

There are certain circuits in which a signal transmitted along a delay network is required to be reflected at the far end; one circuit

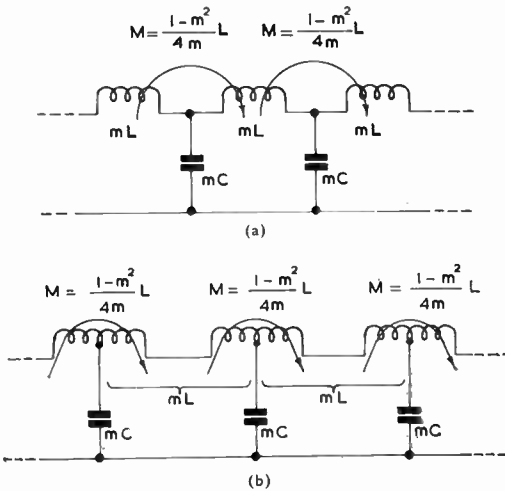

Fig. 89—The effect of a negative inductance in series with the shunt capacitance mC can be obtained by coupling the series inductors mL as shown at (a). A practical method of obtaining this coupling is shown at (b)

of this type is described near the end of this chapter. Such a reflection can be obtained by deliberately mismatching the network at its receiving end. One of the methods which can be employed to achieve this is to short-circuit the receiving end of the network or to leave it open-circuited.

In general no reflection is desirable and the matching must be good at the termination. The method of achieving this using m -derived half-sections has already been described. If these half-sections are omitted and the delay network is composed of prototype or shunt-

derived π -sections, terminated in a resistance of $\sqrt{L/C}$ matching is good at low frequencies but gets poorer as frequency rises. Absorption of power in the resistance is thus complete at low frequencies but becomes less complete as frequency approaches the cut-off value. As a result a backward-travelling wave is set up at the termination principally composed of the high-frequency components of the input signal.

The effect of such a reflection is illustrated in Fig. 90 which shows the voltage-time relationship at the *input* of a network. The step wave is the forward-travelling wave and the small-amplitude "blip" which occurs subsequently is due to the reflection of high-frequency components at the termination. The time interval between the forward-travelling wave and the "blip" is equal to twice the delay of the network. A "blip" observed at the *output* of a delay network indicates mismatching at *both ends* of the network. Partial reflection of the forward-travelling wave occurs at the *output* termination and the backward-travelling wave so generated is again reflected at the *input* termination to form a second forward-travelling wave, delayed with respect to the original forward-

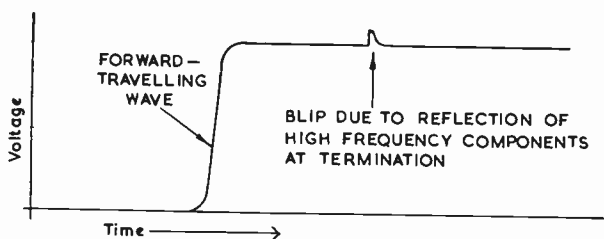

Fig. 90—Illustrating the spurious signal caused by reflection of high-frequency components at a resistive termination

travelling wave by an interval equal to twice the delay of the network. The amplitude of "blips" so generated can be reduced by improving the matching at the output or the input of the network by inclusion of m -derived half-sections having $m = 0.6$.

7.6 APPLICATIONS OF DELAY NETWORKS

7.6.1 Use of Delay Network to control Pulse Generators

The waveforms used in television are produced by combining the outputs of a number of generators and, to obtain the desired result, the generators must be triggered in the correct order and at correct intervals. The precision in timing is often achieved by use of a timing waveform, such as a steep-sided pulse, which is used to trigger

DELAY LINES

the generators but does not itself form part of the composite waveform ultimately produced. The timing waveform is applied to the input of a delay network and travels along it at a finite velocity. The generators are fed from tapping points along the network, the position of these points being so chosen that the generators are triggered in the right order and at the right instants.

An example of a delay network used in this way is illustrated in Fig. 91 which shows a network feeding a line-blanking generator, a line-sync generator and a clamping-pulse generator. The leading edge of the blanking pulses must precede those of the line-sync pulses in order to produce the front porch, and the duration of this porch must be accurately maintained. Thus the timing pulses must trigger the blanking-pulse generator before the sync-pulse generator. The tapping point A feeding the blanking-pulse generator thus

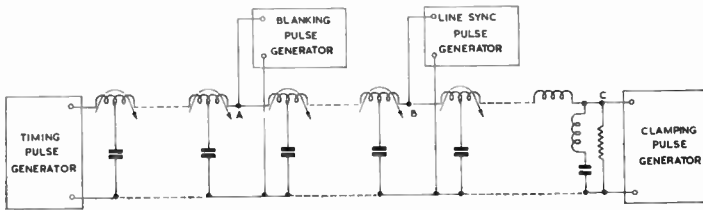

Fig. 91—Use of a delay network to time the operation of a number of generators

occurs before that (B) feeding the sync-pulse generator, the delay of the line section AB equalling the duration of the front porch.

The two generators are adjusted to deliver pulses of the required duration and the blanking pulses are longer than the sync pulses. The trailing edge of the sync pulse precedes that of the blanking pulse to give a period of blanking level after the sync pulse known as the back porch. We will assume that the clamping pulses are required to fall within the period of the back porch. Thus the clamping-pulse generator must be triggered at an instant several μsec later than the line-sync generator and it is therefore fed from a tapping point (C) later than that feeding the line-sync generator, the delay of the network section BC being equal to the interval between the leading edges of the respective line-sync and clamping pulses.

The timing pulses applied to the input of the network may be assumed to travel along it at a finite velocity. No reflection can be permitted at the end of the network because backward-travelling pulses would give unwanted triggering of the generators. The network is therefore accurately terminated at its end. No reflection is required at the tapping points A and B and the impedances placed

across the network at these points must be very high. The generators therefore require high input impedances and cathode followers are sometimes inserted between tapping points and the generators. Certain types of generator develop substantial output pulses at their input terminals and these must be prevented from entering the network; cathode followers between generators and tapping points serve this purpose also.

7.6.2 Use of a Delay Network to control Pulse Duration

In the application described above the delay network times the operation of pulse generators but does not control the duration of the pulses, this being determined by adjustment of the generators. Delay networks can, however, be used to control the duration of pulses and in circuits for this purpose the networks are deliberately mismatched by a short-circuit or an open-circuit at the receiving end to encourage reflection. In one circuit of this type the signal which initiates the leading edge of the output pulse is applied to the input of the delay network, is reflected at the receiving end and returns to the sending end where it times the trailing edge of the output pulse. The pulse so generated has a duration equal to the time taken by the timing signal in making the double journey and it thus equals twice the delay of the network. One advantage of a circuit of this type is that the pulse duration is dependent only on the physical properties of the delay network and is therefore likely to be more constant than in circuits where valve parameters have an effect on duration.

One circuit using a delay network in this manner is illustrated in Fig. 92; it is designed to produce the "broad" pulses required for the field-sync signal which have a duration of approximately 40 μsec with an interval between them of 10 μsec . The delay network is included in the anode circuit of a valve the input to which consists of a square wave of 50 μsec period as shown at *a, b, e, f, j, k* in Fig. 93. The network is terminated at the sending end in a resistor R_3 equal to the iterative impedance and is short-circuited at its receiving end. The output is taken from V1 anode and is applied to the grid of the limiting amplifier V2.

The network is designed to have a delay of 5 μsec and thus the square wave applied to the line takes 5 μsec to reach the receiving end and a further 5 μsec , making 10 μsec total, to travel back to the sending end after reflection at the short-circuit. During reflection there is a reversal of phase and thus an initial positive-going edge at the anode returns to the valve anode as a negative-going edge.

Consider now the waveform at V1 anode. In the absence of the network it would simply consist of a square wave of 50 μsec period.

DELAY LINES

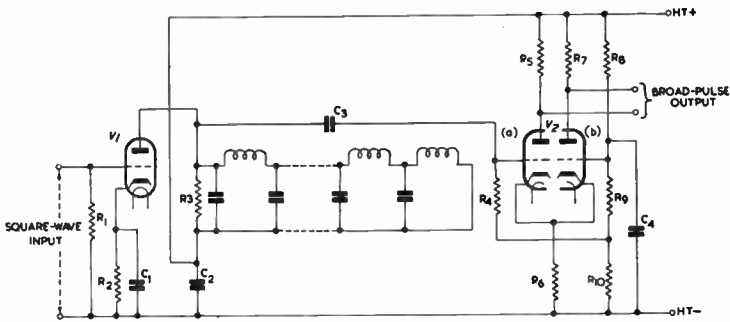

Fig. 92—A circuit in which a delay network is used to time the duration of a pulse

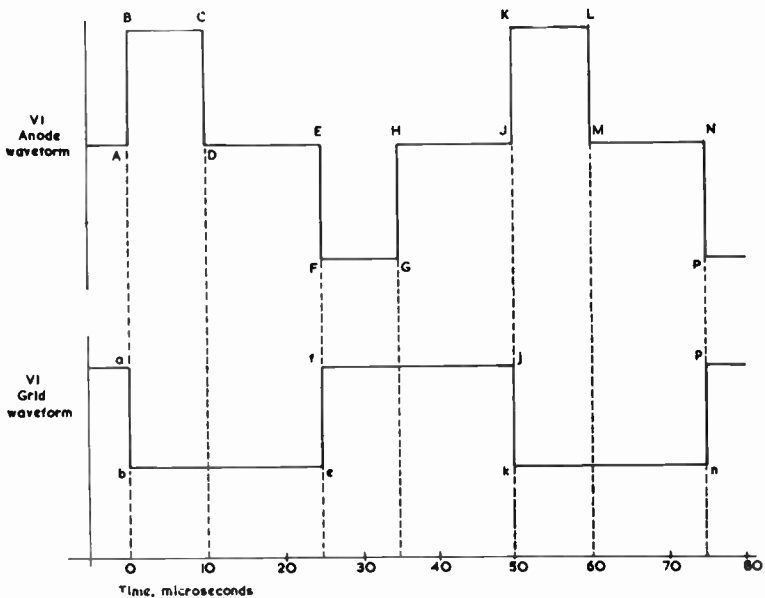

Fig. 93—Waveforms at the grid and anode of V1 in the above circuit

This is, however, modified by the network. The positive-going edge (AB) (Fig. 93) returns 10 μsec later as a negative-going edge (CD). The square-wave input to the valve causes a negative-going edge (EF) at the anode 25 μsec after (AB) and thus 15 μsec after (CD). Due to reflection at the short-circuit, this returns as a positive-going edge (GH) 10 μsec later. Thus the waveform at V1 anode consists of alternate positive (ABCD) and negative (EFGH) pulses of 10 μsec duration, the interval (DE) between successive pulses being 15 μsec . The interval (DJ) between successive positive pulses and also between successive negative (HN) is 40 μsec , the duration of the required output pulses. Moreover the interval (BC or FG) between these pulses is 10 μsec equal to that required

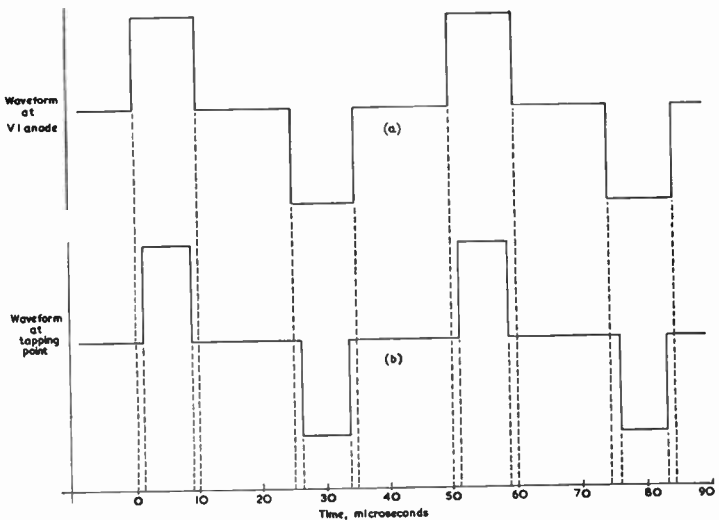

Fig. 94—The waveform generated at a tapping point on the delay network in Fig. 92 is shown at (b) and that generated at the anode at (a)

between the output pulses. Thus all that is necessary to obtain the desired output waveform is to eliminate either the positive-going or the negative-going pulses at V1 anode.

V2 is a cathode-coupled amplifier which has something in common with the double-triode limiting amplifier described in Volume 3. Both triodes are biased from the potential divider $R_8R_9R_{10}$ connected across the h.t. supply but valve (b) is given a more positive bias than valve (a) and, in the absence of a signal input, the anode current of valve (b), in flowing through the common cathode

DELAY LINES

resistor R_6 , makes the cathode potential sufficiently positive to cut off valve (a). Valve (a) is thus unresponsive to negative-going signals but takes current on positive-going signals provided these have an amplitude large enough to overcome the negative grid-cathode bias. On such signals V2 (a) takes current and raises the common cathode potential thus cutting off valve (b). Broad pulses corresponding to the positive-going output from V1 are obtained in push-pull from the two anodes of V2.

A useful feature of this circuit is that a tapping point on the delay network, gives short-duration pulses symmetrically placed in time with respect to the pulses generated at the anode of V1. For example suppose in the circuit of Fig. 92 the tapping point is so placed that the delay of the network between the anode and the tapping point is $1 \mu\text{sec}$. Then a positive-going edge generated at V1 anode by the input signal at its grid reaches the tapping point $1 \mu\text{sec}$ later and, after reflection at the short-circuited end, reaches the tapping point again, this time in reverse phase, after $9 \mu\text{sec}$, i.e. $8 \mu\text{sec}$ after the positive edge. Thus the waveform at the tapping point is as shown in Fig. 94 which is similar to that generated at the anode, shown for comparison at (a).

APPENDIX A

ITERATIVE IMPEDANCE OF PROTOTYPE LOW-PASS T- AND π -SECTIONS

Fig. A.1 gives the circuit of a prototype low-pass T-section and the purpose of this appendix is to deduce an expression for the iterative impedance of this section and the prototype π -section.

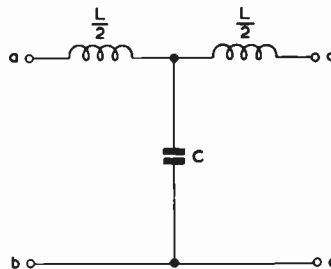

Fig. A.1—Prototype low-pass T-section

This can be deduced from the general relationship

$$\text{Iterative impedance} = \sqrt{(Z_{oc} Z_{sc})}$$

where Z_{oc} = impedance at terminals a and b when terminals c and d are open-circuited and Z_{sc} = impedance at terminals a and b when terminals c and d are short-circuited.

From Fig. A.1

$$\begin{aligned} Z_{oc} &= \frac{j\omega L}{2} + \frac{1}{j\omega C} \\ &= \frac{1 - \omega^2 LC/2}{j\omega C} \\ Z_{sc} &= \frac{j\omega L}{2} + \frac{j\omega L}{2} \cdot \frac{1}{j\omega C} \bigg/ \left(\frac{j\omega L}{2} + \frac{1}{j\omega C} \right) \\ &= \frac{j\omega L}{2} + \frac{j\omega L}{2} \bigg/ (1 - \omega^2 LC/2) \\ &= j\omega L \cdot \frac{1 - \omega^2 LC/4}{1 - \omega^2 LC/2} \\ Z_0 T^2 &= Z_{oc} Z_{sc} \\ &= \frac{1 - \omega^2 LC/2}{j\omega C} \cdot j\omega L \cdot \frac{1 - \omega^2 LC/4}{1 - \omega^2 LC/2} \\ &= \frac{L}{C} (1 - \omega^2 LC/4) \end{aligned}$$

But $\omega_c = 2/\sqrt{LC}$ where ω_c is the angular cut-off frequency

$$\begin{aligned} \therefore Z_0 T^2 &= \frac{L}{C} \cdot \left(1 - \frac{\omega^2}{\omega_c^2} \right) \\ \therefore Z_0 T &= \sqrt{\frac{L}{C}} \sqrt{(1 - x^2)} \end{aligned}$$

where $x = \omega/\omega_c = f/f_c$.

DELAY LINES

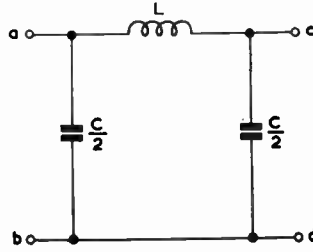

Fig. A.2—Prototype low-pass π -section

Fig. A.2 gives the circuit for a prototype π -section. From this

$$Z_{oc} = \frac{2}{j\omega C} \left(j\omega L + \frac{2}{j\omega C} \right) \bigg/ \left(\frac{2}{j\omega C} + j\omega L + \frac{2}{j\omega C} \right)$$

$$= \frac{2}{j\omega C} \left(j\omega L + \frac{2}{j\omega C} \right) \bigg/ \left(j\omega L + \frac{4}{j\omega C} \right)$$

$$Z_{sc} = \frac{2}{j\omega C} \cdot j\omega L \bigg/ \left(\frac{2}{j\omega C} + j\omega L \right)$$

$$Z_{0\pi}^2 = Z_{oc} Z_{sc}$$

$$= \frac{2}{j\omega C} \left(j\omega L + \frac{2}{j\omega C} \right) \cdot \frac{2}{j\omega C} \cdot j\omega L$$

$$= \frac{j\omega L + \frac{2}{j\omega C}}{j\omega L + \frac{2}{j\omega C}}$$

$$= \frac{2}{j\omega C} \cdot \frac{2}{j\omega C} \cdot j\omega L$$

$$= \frac{4}{j\omega L + \frac{2}{j\omega C}}$$

$$= \frac{L/C}{1 - \omega^2 LC/4}$$

But $\omega_c = 2/\sqrt{LC}$

$$\therefore Z_{0\pi} = \frac{\sqrt{L/C}}{\sqrt{1 - \omega^2/\omega_c^2}}$$

$$= \frac{\sqrt{L/C}}{\sqrt{1 - x^2}}$$

where $x = \omega/\omega_c = f/f_c$.

APPENDIX B

GROUP DELAY OF AN m -DERIVED SECTION

FIG. B.1 shows a single series-derived T-section terminated in an impedance Z_0 equal to the iterative impedance and fed from a source of voltage V_{in} . The purpose of this appendix is to derive an expression for the group delay of this section and hence to determine the value of m which gives maximal flatness of the group delay characteristic.

Z_0 and $mL/2$ can be regarded as forming a potential divider and thus

$$\frac{V_{out}}{V} = \frac{Z_0}{Z_0 + j\omega mL/2} \quad \dots \quad \dots \quad \dots \quad \dots \quad (1)$$

Moreover

$$V_{in} = i_1 j\omega mL/2 + V \quad \dots \quad \dots \quad \dots \quad \dots \quad (2)$$

Eliminating V between these equations

$$V_{out} = \frac{Z_0}{Z_0 + j\omega mL/2} \cdot (V_{in} - i_1 j\omega mL/2) \quad \dots \quad (3)$$

The input terminals of the network present an impedance Z_0 to V_{in} . Thus

$$i_1 = \frac{V_{in}}{Z_0}$$

Substituting for i_1 in (3)

$$\begin{aligned} V_{out} &= \frac{Z_0}{Z_0 + j\omega mL/2} \left(V_{in} - \frac{V_{in} j\omega mL/2}{Z_0} \right) \\ \therefore \frac{V_{out}}{V_{in}} &= \frac{Z_0 - j\omega mL/2}{Z_0 + j\omega mL/2} \quad \dots \quad \dots \quad \dots \quad \dots \quad (4) \end{aligned}$$

This expression is of the type $(R - jX)/(R + jX)$ for which the phase angle is given by

$$\tan \frac{\phi}{2} = -\frac{X}{R}$$

DELAY LINES

Thus

$$\tan \frac{\phi}{2} = -\frac{\omega m L}{2Z_0}$$

Now the iterative impedance Z_0 of a series-derived T-section is the same as that of a prototype T-section and, as shown in Appendix A, this is given by

$$Z_0 = \sqrt{L/C}\sqrt{1-x^2}$$

$$\begin{aligned} \therefore \tan \frac{\phi}{2} &= -\frac{\omega m L}{2\sqrt{L/C}\sqrt{1-x^2}} \\ &= -\frac{\omega m \sqrt{LC}}{2\sqrt{1-x^2}} \end{aligned}$$

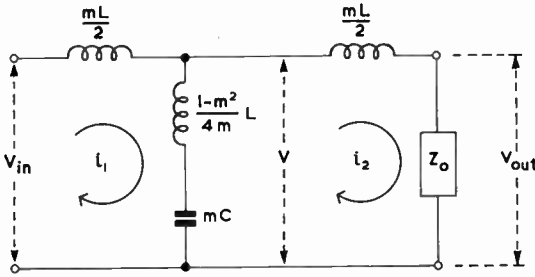

Fig. B.1—A series-derived T-section

Now $\omega_c = 2/\sqrt{LC}$

$$\begin{aligned} \therefore \tan \frac{\phi}{2} &= -\frac{m\omega/\omega_c}{\sqrt{1-x^2}} \\ &= -\frac{mx}{\sqrt{1-x^2}} \end{aligned}$$

Differentiating

$$\begin{aligned} \frac{1}{2} \sec^2 \frac{\phi}{2} \cdot \frac{d\phi}{2} \cdot \frac{d\phi}{dx} &= -\frac{m}{(1-x^2)^{3/2}} \\ \therefore \frac{1}{2} \left(1 + \tan^2 \frac{\phi}{2}\right) \frac{d\phi}{dx} &= -\frac{m}{(1-x^2)^{3/2}} \end{aligned}$$

But

$$\tan^2 \frac{\phi}{2} = \frac{m^2 x^2}{1 - x^2}$$

$$\therefore \frac{1}{2} \left(1 + \frac{m^2 x^2}{1 - x^2} \right) \cdot \frac{d\phi}{dx} = - \frac{m}{(1 - x^2)^{3/2}}$$

$$\begin{aligned} \therefore \frac{d\phi}{dx} &= \frac{-2m}{(1 - x^2)^{3/2} [1 + m^2 x^2 / (1 - x^2)]} \\ &= \frac{-2m(1 - x^2)^{-1/2}}{1 + (m^2 - 1)x^2} \end{aligned}$$

Expanding $(1 - x^2)^{-1/2}$ by the binomial theorem

$$\frac{d\phi}{dx} = \frac{-2m(1 + \frac{1}{2}x^2 + \dots)}{1 + (m^2 - 1)x^2}$$

The conditions for maximal flatness are given in detail in Volume 2: in this particular example they are that the ratio of the coefficient of x^0 in the numerator to that of x^0 in the denominator should equal the ratio of the coefficient of x^2 in the numerator to that of x^2 in the denominator, i.e.

$$\frac{-2m}{1} = \frac{-m}{m^2 - 1}$$

This gives

$$m^2 = 1.5$$

$$\therefore m = 1.225$$

CHAPTER 8

FIXED EQUALISERS

8.1 INTRODUCTION

WHEN video signals are sent to a distant point, they are often conveyed by a transmission line, usually an underground twin-wire or co-axial cable. A perfect transmission line is loss-free and has a level response extending to an infinite frequency. Theoretically, therefore, video signals should be received at the end of a circuit with no loss in amplitude and with no attenuation distortion. In practice there are losses, mainly due to the resistance of the line, and these cause attenuation of the signal. To make good these losses, amplifiers are required at regular intervals along a long cable; they are installed at repeater stations.

The losses of the line are greater at high than at low frequencies and thus the line has a falling frequency response although there is no sharp cut-off as in an artificial line or delay network composed of lumped components. To offset the attenuation distortion of the received signal, equalisers are included with the amplifiers at repeater stations. Long-distance cables include a number of repeater stations and further amplification and equalisation is carried out at the terminating point. A cable together with its equalisers and amplifiers is known as a circuit.

It was assumed in the previous paragraph that the video signals are applied directly to the line and thus occupy a frequency band in the cable extending from a very low frequency to say 3 Mc/s. Alternatively the video signals may be used to modulate a carrier wave which is then applied to the line: in such a carrier system using asymmetrical side-band transmission the frequency range of the signal in the cable might extend from 0.5 Mc/s to 4 Mc/s or 3.5 Mc/s to 7.0 Mc/s. In a carrier system the modulating and demodulating equipment is regarded as part of the cable circuit which effectively therefore has a frequency range from zero to 3 Mc/s, the frequency translation of the signals occurring in the cable itself being incidental.

Cable terminating equipment may include one fixed equaliser for each incoming circuit; this is practicable when the number of circuits is small but for a large number it is preferable to use a

relatively small number of standard types of variable equaliser which can be adjusted to compensate for any circuit. Variable equalisers can, in addition, be used to compensate for the small, though significant, changes in cable properties which occur due to temperature variations. To permit rapid adjustment of the equalisers they should have as few controls as possible; nevertheless the equalisation must be carried out with care and should cover the whole of the video spectrum. As an indication of the standard of equalisation required, a variation in amplitude-frequency response of as little as 1 dB between 50 kc/s and 200 kc/s can cause obvious streaks in reproduced pictures.

The equalisers employ networks of minimal phase-shift type, and when the amplitude-frequency characteristic has been levelled, the phase-frequency characteristic is in general also satisfactory. However, there may be residual distortion in the phase characteristic and to minimise this, line-terminating equipment usually includes a phase equaliser. This is sometimes termed an "all-pass" network because it is designed to have a level amplitude-frequency characteristic though the shape of the phase-frequency characteristic is controllable. Details of the lattice structures used for phase equalisation are given in Volume 2: the design of fixed equalisers for television cable circuits is described in this chapter and of variable equalisers in Chapter 9.

8.2 CONSTANT-RESISTANCE NETWORKS

8.2.1 *General*

The attenuation distortion due to a line only a fraction of a mile in length, such as a television camera cable, is confined to the upper end of the video spectrum and can often be corrected by an equaliser containing only one network section. The distortion due to a longer cable, say a few miles in length, is not confined to such a restricted frequency range and it is impossible to effect equalisation by so simple a means. A number of network sections are necessary, each designed to have maximum effect in different regions of the spectrum. For example one section might have maximum effect at 70 kc/s, a second at 270 kc/s, a third at 470 kc/s and the fourth and final at 3.5 Mc/s; these sections are commonly connected in cascade.

When a number of filter sections are connected in cascade, certain precautions must be observed to obtain the desired overall effect. The response curve for a particular section applies only when the filter is terminated in a certain impedance, usually a pure resistance. When this section is correctly terminated, it has

FIXED EQUALISERS

a particular value of input impedance and this constitutes, of course, the terminating impedance for the previous filter section. Usually the design is such that the input impedance is purely resistive and equal to the terminating resistance; this value of resistance is the "iterative impedance" of the section. Such sections are termed "constant-resistance" sections and it follows that if a number are connected in cascade, they are all correctly terminated when a resistance of the correct value is connected at the end of the chain. The overall response of the filter is then equal to the sum of the responses of the individual sections.

8.2.2 Constant-resistance Sections derived from a Bridge Circuit

The bridge circuit is a form of network which can give controllable frequency response over a certain band and at the same time can offer a constant-resistance input. It is therefore the basic form of a number of circuits commonly employed in equalisers and is shown in Fig. 95. This circuit contains two equal resistors of value R_0 and two impedances Z_1 and Z_2 , the nature of which need

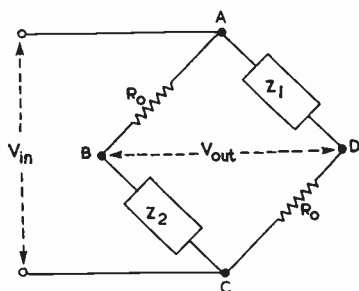

Fig. 95—Bridged circuit from which a number of constant-resistance networks can be derived

not yet be specified. If the values of R_0 , Z_1 and Z_2 are suitably chosen, a signal applied between terminals A and C, gives no output voltage between terminals B and D. The circuit is then said to be balanced. When the bridge circuit is balanced there is a certain relationship between Z_1 , Z_2 and R_0 which can be deduced in the following way.

The arms R_0 and Z_2 can be regarded as a potential divider connected across the signal source V_{in} and the voltage generated across BC is given by

$$\frac{Z_2}{R_0 + Z_2} \cdot V_{in} \quad \dots \quad \dots \quad \dots \quad (23)$$

Similarly R_0 and Z_1 also form a potential divider connected across V_{in} and the voltage generated across CD is given by

$$\frac{R_0}{R_0 + Z_1} \cdot V_{in} \quad \dots \quad \dots \quad \dots \quad (24)$$

At balance the voltages generated across BC and CD are equal. Equating expressions (23) and (24) we have

$$\begin{aligned} \frac{Z_2}{R_0 + Z_2} &= \frac{R_0}{R_0 + Z_1} \\ \therefore \frac{R_0 + Z_2}{Z_2} &= \frac{R_0 + Z_1}{R_0} \\ \therefore \frac{R_0}{Z_2} + 1 &= 1 + \frac{Z_1}{R_0} \\ \therefore \frac{R_0}{Z_2} &= \frac{Z_1}{R_0} \\ \therefore Z_1 Z_2 &= R_0^2 \quad \dots \quad \dots \quad \dots \quad (25) \end{aligned}$$

This is the condition for balance of the bridge circuit.

The input impedance of a balanced-bridge circuit is purely resistive and equal to R_0 . This can be proved in the following way.

In general the input impedance Z_{in} of the circuit, i.e. the impedance between terminals A and C, consists of $(R_0 + Z_1)$ in parallel with $(R_0 + Z_2)$ and is given by

$$\begin{aligned} Z_{in} &= \frac{(R_0 + Z_1)(R_0 + Z_2)}{(R_0 + Z_1) + (R_0 + Z_2)} \\ &= \frac{R_0^2 + R_0(Z_1 + Z_2) + Z_1 Z_2}{2R_0 + Z_1 + Z_2} \end{aligned}$$

If the bridge is balanced $Z_1 Z_2 = R_0^2$ and, substituting for $Z_1 Z_2$ in the numerator,

$$\begin{aligned} Z_{in} &= \frac{2R_0^2 + R_0(Z_1 + Z_2)}{2R_0 + Z_1 + Z_2} \\ &= R_0 \cdot \frac{2R_0 + Z_1 + Z_2}{2R_0 + Z_1 + Z_2} \\ &= R_0 \end{aligned}$$

FIXED EQUALISERS

showing the input impedance to be independent of the values of Z_1 and Z_2 and equal to R . Provided Z_1 and Z_2 satisfy the condition of equation (25) the bridge network offers a constant-resistance input impedance to the signal source V_{in} .

Having considered the constant-resistance properties of the network, we shall now show how it may be used as an equaliser section. When the bridge is balanced an input applied between terminals A and C yields zero output at B and D as we have already shown. If, however, with the input applied to terminals A and C, we take the output from C and D, as shown in Fig. 96, a finite output signal is obtained and by correct network design this output

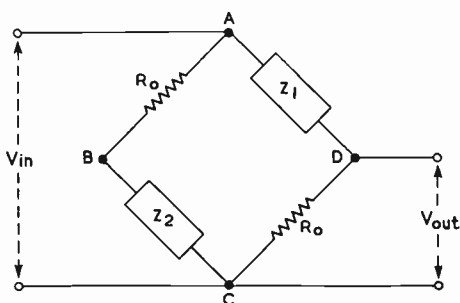

Fig. 96—Input and output connection used when the bridge circuit is employed as an equaliser

can be made to have the shape of frequency response required for equalising purposes. The equaliser section is regarded as composed of the three components Z_1 , Z_2 and the R_0 between A and B: the R_0 between C and D is not regarded as part of the equaliser but is an external terminating resistance and in practice is likely to be the input resistance of the equipment connected to the output of the equaliser which may be another equaliser section, an amplifier, a length of cable or even a pure resistance.

If Z_1 and Z_2 are pure resistances and are varied so that their product is at all times equal to R_0^2 (as in equation (25)), the level of the output signal will also vary. This is, in fact, the basic circuit of a constant-resistance attenuator.

If Z_1 and Z_2 are pure reactances, whose product is equal to R_0^2 , the circuit has an attenuation which varies with frequency, and the frequency characteristic can, by suitable design, be made suitable for equalising purposes; this is the basic circuit of a constant-resistance equaliser. The characteristic can be adjusted by varying Z_1 and Z_2 ; provided the product is kept equal to R_0^2 the input

resistance is equal to R_0 and thus independent of frequency. As shown later Z_1 and Z_2 must be reactances of opposite sign, i.e. one inductive and the other capacitive, if their product is to equal R_0^2 .

8.2.3 L-network

The bridge circuit of Fig. 96 is usually drawn in the form of the L-network shown in Fig. 97, in which the R_0 shown dotted is

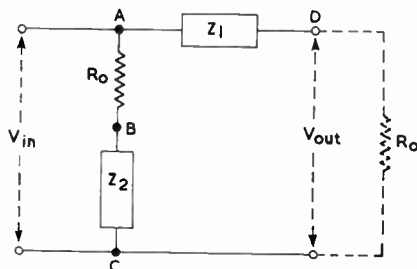

Fig. 97—The bridge circuit of Fig. 96 is usually drawn in this form

the external terminating resistance. When the bridge circuit of Fig. 96 is balanced there is no voltage between terminals B and D; these terminals can thus be short-circuited without effect on the circuit performance. By so doing we obtain the L-network shown

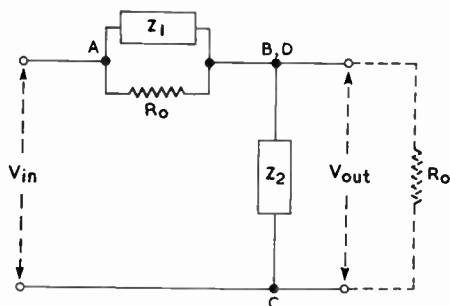

Fig. 98—Alternative form of constant-resistance L-network obtained from the bridge circuit of Fig. 96 by short-circuiting terminals B and D

in Fig. 98 which is an alternative basic form of network that can be used for a constant-resistance attenuator or equaliser.

8.2.4 Bridged-T Network

As a third possibility, terminals B and D in Fig. 96 can be bridged by a fixed resistor. These terminals are at equal potentials and

FIXED EQUALISERS

no current flows in this resistor irrespective of its value. If, however, the resistor is made equal to R_0 , as shown in Fig. 99, the circuit becomes symmetrical and the iterative impedance is equal to R_0 at both the input and the output terminals. Thus if the source or the load impedance is equal to R_0 , the required insertion loss of the equaliser is obtained at all frequencies. If, therefore, the source impedance from which the equaliser is fed is equal to R_0 , the desired insertion loss is obtained despite variations in terminating impedance. This property is of particular value at high frequencies because the terminating impedance is inevitably

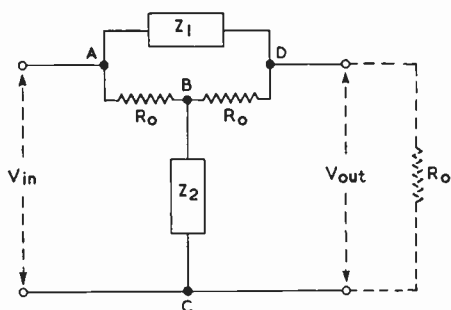

Fig. 99—Bridged-T network obtained by connecting a resistor R_0 between terminals B and D in Fig. 96

shunted by a small capacitance which causes the magnitude of the terminating impedance to fall as frequency rises.

8.2.5 Iterative Impedance of Constant-resistance Sections

All these forms of constant-resistance section illustrated in Figs. 97–99 have the property that their input resistance is equal to R_0 when the output terminals are connected to a resistance equal to R_0 . This value of resistance is therefore the *iterative impedance* Z_0 of the networks. It is significant that the networks contain fixed resistors equal to the iterative impedance.

8.3 PRACTICAL CONSTANT-RESISTANCE EQUALISER CIRCUITS

8.3.1 Introduction

The aim of equalisation is to offset the high-frequency loss of a cable. This is achieved by introducing further losses, which are greater at low frequencies than at high frequencies. Ideally the overall loss due to cable and equaliser should be constant and independent of frequency over the desired frequency range. The

overall loss must be made good by amplification and it is hence normal practice to follow equalisers by amplifiers in repeater stations and in line-terminating equipment. If the frequency response of the amplifiers is not level over the desired frequency range, the equalisers are designed to correct the combined frequency characteristic of line and amplifiers.

8.3.2 Simple Circuit

The simple circuit of Fig. 98 can be made to introduce more loss at low than at high frequencies by making Z_1 a capacitor and Z_2 an inductor as shown in Fig. 100. To obtain constant-resistance

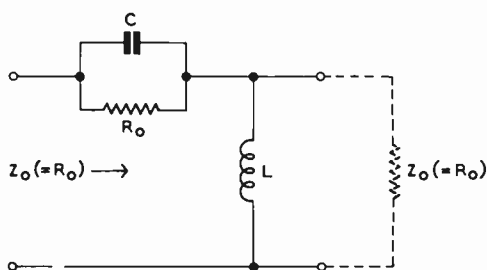

Fig. 100—Simple constant-resistance equaliser circuit

operation the two impedances Z_1 and Z_2 must satisfy equation (25); thus we have

$$R_0 = \sqrt{Z_1 Z_2}$$

in which $Z_2 = j\omega L$ and $Z_1 = 1/j\omega C$. Hence

$$\begin{aligned} R_0 &= \sqrt{\left(\frac{j\omega L}{j\omega C}\right)} \\ &= \sqrt{\left(\frac{L}{C}\right)} \quad \dots \quad \dots \quad \dots \quad (26) \end{aligned}$$

which has no term in j or ω and satisfies the condition that the input impedance is purely resistive and constant; this, of course, is true only for correct load termination. Expression (26) is more usually expressed

$$R_0^2 = \frac{L}{C} \quad \dots \quad \dots \quad \dots \quad (27)$$

Thus the values of L and C must be chosen to give the required frequency response and in addition the desired iterative impedance R_0 .

FIXED EQUALISERS

8.3.3 Frequency Response of Simple Circuit

As shown in Appendix C the frequency response of the network is given by

$$\text{response in dB} = 10 \log_{10} \frac{1 + x^2}{x^2}$$

where $x = f/f_0$ and $f_0 = 1/2\pi\sqrt{LC}$. The curve of this expression is plotted in Fig. 101 and shows that the loss is 3 dB when $f = f_0$ (i.e. at the resonance frequency of LC) and increases to a maximum rate of 6 dB per octave below this frequency.

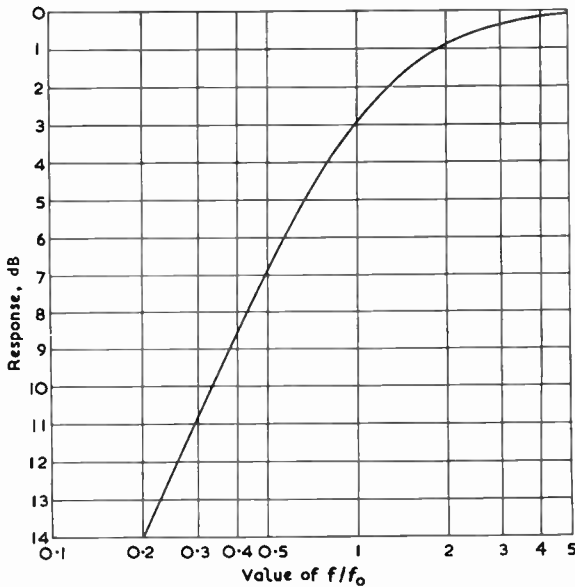

Fig. 101—Generalised frequency response for simple constant-resistance equaliser

In designing an equaliser of this type, the chosen value of iterative impedance fixes the quotient L/C as indicated in expression (26) or (27). Whilst maintaining this condition it is possible to vary the product LC and this is the only parameter available to match the frequency response curve of the equaliser with that of the circuit to be equalised. At least two or three independent parameters are desirable to give an equaliser adequate flexibility to be useful in practice and this particular circuit is useful only as an introductory step to more complex types.

The curve of Fig. 101 is familiar because it is also that of a simple circuit comprising series capacitance and shunt resistance or

series resistance and shunt inductance. It may therefore seem surprising that we have here used two reactances, a series capacitance and shunt inductance to achieve a response curve which can be obtained from a circuit containing only one reactance. The two reactances are, in fact, necessary to give the required constant-resistance input in addition to the necessary response curve. This is a feature which is common to all the equaliser circuits discussed subsequently: the required frequency response curve can be obtained from an equaliser which has frequency-discriminating elements in the series arm only or in the shunt arm only. Frequency-discriminating elements must be used in both arms, however, to give a constant-resistive input.

8.3.4 More Complex Circuit

Although the simple L-network introduces more loss at low frequencies than at high frequencies, the shape of the response curve is not suitable for equalising purposes primarily because of the great loss at low frequencies and, as just pointed out, no parameter is available in the simple circuit whereby the shape of the characteristic can be altered. This loss is due to the fall in impedance of the shunt arm of the network at low frequencies and can be reduced by including R_2 in series with L . The impedance Z_2 of the shunt arm now becomes

$$Z_2 = R_2 + j\omega L \quad \dots \quad (28)$$

To satisfy the constant-resistance condition of equation (25) $Z_1 Z_2$ must equal R_0^2 . Thus Z_1 is given by

$$\begin{aligned} Z_1 &= \frac{R_0^2}{Z_2} \\ &= \frac{R_0^2}{R_2 + j\omega L} \quad \dots \quad (29) \end{aligned}$$

This is of the general form $A/(B + j\omega D)$ where A , B and D are constants; an impedance of this type is obtained by making Z_1 of capacitance C and resistance R_1 in parallel as shown in Fig. 102. We have

$$\begin{aligned} Z_1 &= \frac{R_1/j\omega C}{R_1 + 1/j\omega C} \\ &= \frac{R_1}{1 + j\omega C R_1} \quad \dots \quad (30) \end{aligned}$$

FIXED EQUALISERS

Equating (29) and (30) we have

$$\frac{R_0^2}{R_2 + j\omega L} = 1 + j\omega CR_1$$

Cross multiplying,

$$R_1 R_2 + j\omega L R_1 = R_0^2 + j\omega C R_1 R_0^2 \quad \dots \quad (31)$$

This equality can be satisfied if the real part of the left-hand side is equal to the real part of the right-hand side and if the two imaginary parts are equal. Equating real parts we have

$$R_1 R_2 = R_0^2 \quad \dots \quad \dots \quad (32)$$

This relates the two resistors R_1 and R_2 with R_0 and hence with Z_0 . R_2 is the resistance in series with L ; R_1 is the additional

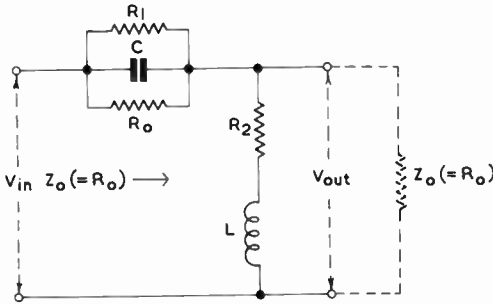

Fig. 102—Improved form of constant resistance L-section equaliser

resistance in parallel with C and R_0 . Equating imaginary terms in expression (31)

$$\begin{aligned} L &= C R_0^2 \\ L/C &= R_0^2 \quad \dots \quad \dots \quad (33) \end{aligned}$$

which confirms the condition of expression (25) for the parent circuit.

8.3.5 Zero-frequency Loss of More Complex Circuit

The shape of the frequency-response curve of this equaliser can be deduced in the following way. At high frequencies the reactance of C is small and effectively short-circuits R_0 and R_1 . The impedance of the shunt path $R_2 L$ is large and the equaliser introduces very little attenuation. At low frequencies the reactance of C is large and the series arm effectively consists of R_0 and R_1

in parallel. The reactance of L is small and the shunt arm is effectively R_2 and R_0 in parallel. There is thus a maximum loss which cannot be exceeded no matter how low the frequency of the applied signal. The response curve has the form of a step, the magnitude of which is equal to the loss at zero frequency. This loss can be calculated by considering the potential divider to which the network effectively reduces at low frequencies. The upper arm consists of R_0 and R_1 in parallel and the lower arm of R_0 and R_2 in parallel. Thus

loss at zero frequency in dB

$$= 20 \log_{10} \frac{R_0 R_2 / (R_0 + R_2) + R_0 R_1 / (R_0 + R_1)}{R_0 R_2 / (R_0 + R_2)}$$

The numerator of this expression is the input resistance of the network and is equal to Z_0 and thus to R_0 .

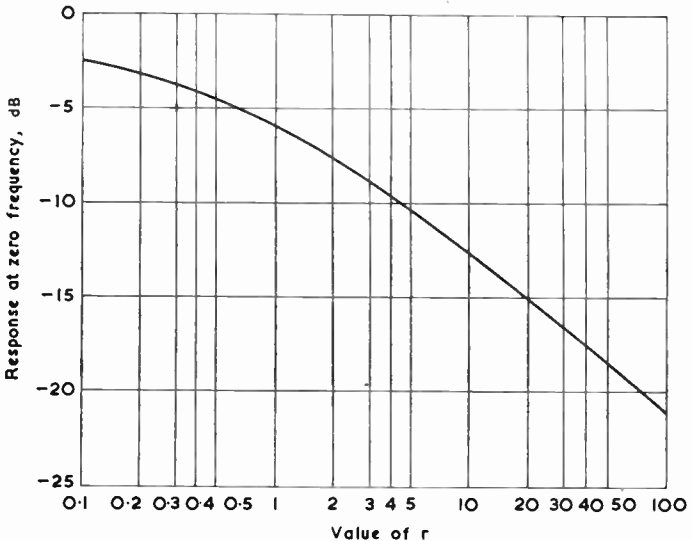

Fig. 103—Dependence of zero-frequency loss on R_1/R_2 for a more complex equaliser

$$\begin{aligned} \therefore \text{loss at zero frequency in dB} &= 20 \log_{10}(R_0 + R_2)/R_2 \\ &= 20 \log_{10}(1 + R_0/R_2) \quad \dots (34) \end{aligned}$$

Since $R_0 = \sqrt{(R_1 R_2)}$ this can alternatively be written

$$\text{loss at zero frequency in dB} = 20 \log_{10}(1 + \sqrt{R_1}/\sqrt{R_2}) \quad \dots (35)$$

$$\text{or loss at zero frequency in dB} = 20 \log_{10}(1 + R_1/R_0) \quad \dots (36)$$

FIXED EQUALISERS

Expression (35) is possibly more convenient in the form

$$\text{loss at zero frequency in dB} = 20 \log_{10}(1 + \sqrt{r}) \quad \dots \quad (37)$$

where $r = R_1/R_2$

In Fig. 103 the zero-frequency loss is plotted against r , the ratio of R_1 to R_2 . For large values of r , \sqrt{r} is great compared with unity and expression (33) reduces to

$$\begin{aligned} \text{loss at zero frequency in dB} &= 20 \log_{10}\sqrt{r} \\ &= 10 \log_{10}r \quad \dots \quad \dots \quad (38) \end{aligned}$$

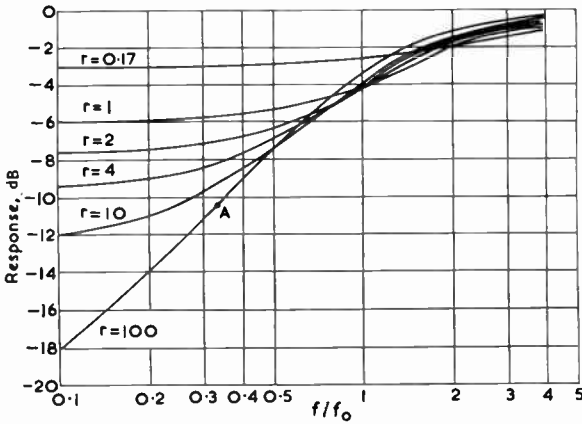

Fig. 104—Frequency response curve for more complex equaliser for various values of r

In practice the ratio of R_1 to R_2 is one of the factors which must be adjusted to control the frequency response of the equaliser.

8.3.6 Frequency Response of More Complex Equaliser

The response of a network of the type illustrated in Fig. 102 is given by

$$\begin{aligned} \text{response in dB} &= 20 \log_{10} \frac{V_{out}}{V_{in}} \\ &= -10 \log_{10} \frac{(1 + \sqrt{r})^2 + rx^2}{1 + rx^2} \end{aligned}$$

where $r = R_1/R_2$. This expression is deduced in Appendix D. The curves of this expression are plotted in Fig. 104 for a number of values of r .

These curves are all of the general shape shown in Fig. 105; such a shape is commonly referred to as a "step" response because it is asymptotic at each extreme to two horizontal straight lines, the vertical distance between these being the magnitude of the step. The loss of the equaliser at high frequencies tends towards zero; thus the magnitude of the step is equal to the loss at zero frequency and this can be made any desired value by appropriate choice of component values. An interesting feature of the step curve is that if plotted on a logarithmic frequency scale and with ordinates expressed in decibels, it is skew-symmetrical about the

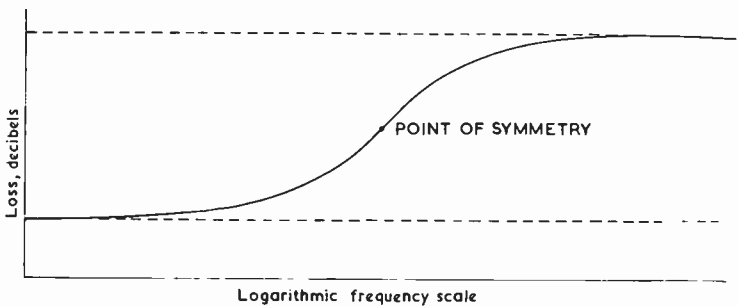

Fig. 105—General form of the curve for a "step" response

point corresponding to half the maximum loss; that is to say the curve, if rotated through 180° in the plane of the paper and about this point of symmetry coincides with its original position.

In Fig. 104 the point of symmetry for the curve labelled $r = 100$ is A corresponding to a loss of 10.4 dB, the overall loss being 20.8 dB. For the curve labelled $r = 1$, the point of symmetry corresponds to 3 dB loss, the overall loss being 6 dB. The frequency corresponding to the point of symmetry is known as the "half-loss" frequency and is an important parameter of the network, because it is the frequency at which the response curve has maximum slope.

The shape of these curves is better illustrated by redrawing them about a common point of symmetry. This has been done in Fig. 106 and this diagram shows how the slope of the characteristics increases with increase in r . In practice, of course, increase in r also lowers the half-loss frequency as shown in Fig. 104.

This form of equaliser (Fig. 102) is more flexible than the simple circuit (Fig. 100) because it has two independent parameters which can be adjusted to make the frequency response of the equaliser

FIXED EQUALISERS

agree with that of the cable to be equalised. These are the product LC (as for the simple equaliser) and the ratio of R_1 to R_2 ; to maintain the constant-resistance input the ratio L/C and the product R_1R_2 must be kept equal to R_0^2 , i.e. to Z_0^2 .

If the zero-frequency loss, half-loss frequency f_{hl} and iterative impedance are known, the component values of an equaliser can be calculated as shown below.

This is an analytic approach to the design which is usually carried out with the aid of a mask, carrying a nest of equaliser curves similar to those of Fig. 104, superimposed on the measured frequency response curve of the cable or circuit. The curve which effects best equalisation is noted and from the data on the mask alongside this curve the component values can be determined directly.

As the numerical example suppose an equaliser is required to correct a 3 dB variation in amplitude response, maximum rate of

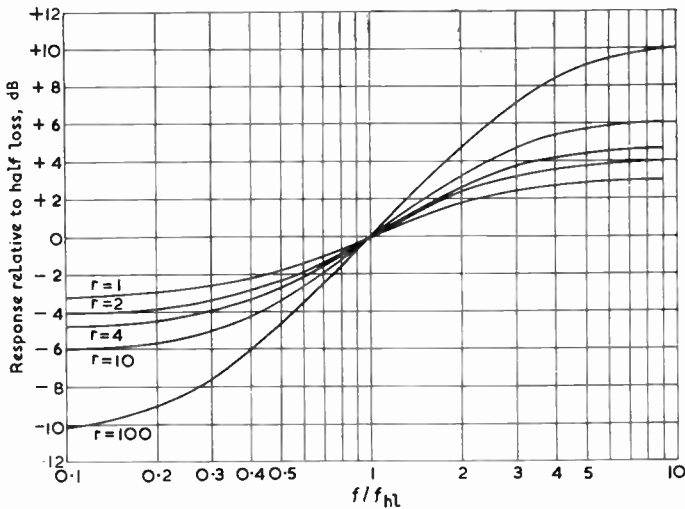

Fig. 106—The frequency response curves of the previous diagram redrawn about a common point of symmetry

change to be at 420 kc/s. The iterative impedance is to be 186 ohms. From Fig. 104 the curve labelled $r = 0.17$ gives the required 3 dB correction and the half-loss frequency is at $f/f_0 = 3$. f is 420 kc/s and hence f_0 is given by $420/3 = 140$ kc/s. This is the resonance frequency of L and C ; hence

$$\begin{aligned}
 2\pi\sqrt{LC} &= 140 \times 10^3 \\
 \therefore \sqrt{LC} &= \frac{1}{6.284} \times 140 \times 10^3 \\
 \therefore LC &= \frac{1}{(6.284 \times 140 \times 10^3)^2} \\
 &= 1.292 \times 10^{-12} \quad \dots \quad \dots \quad \dots \quad (39)
 \end{aligned}$$

From expression (27) we also have the relationship

$$\frac{L}{C} = R_0^2$$

But $R_0 = Z_0 = 186$

$$\begin{aligned}
 \therefore \frac{L}{C} &= 186^2 \\
 &= 3.46 \times 10^4 \quad \dots \quad \dots \quad \dots \quad (40)
 \end{aligned}$$

Multiplying expressions (39) and (40) we have

$$\begin{aligned}
 L^2 &= 1.292 \times 3.46 \times 10^{-8} \\
 \therefore L &= \sqrt{1.292 \times 3.46 \times 10^{-8}} \\
 &= 2.114 \times 10^{-4} \text{ H} \\
 &= 211.4 \mu\text{H}
 \end{aligned}$$

Dividing expression (39) by (40)

$$\begin{aligned}
 C^2 &= \frac{1.292 \times 10^{-12}}{3.46 \times 10^4} \\
 \therefore C &= \sqrt{\left(\frac{1.292 \times 10^{-12}}{3.46 \times 10^4} \right)} \\
 &= 6.11 \times 10^{-9} \text{ F} \\
 &= 0.00611 \mu\text{F}
 \end{aligned}$$

The calculation of the resistance values is carried out by a similar method. We know that

$$r = \frac{R_1}{R_2} = 0.17$$

To maintain a constant resistance input impedance we have, from expression (32)

$$R_1 R_2 = R_0^2$$

FIXED EQUALISERS

But $R_0 = Z_0 = 186$

$$\therefore R_1 R_2 = 186^2$$

Multiplying these two expressions

$$R_1^2 = 0.17 \times 186^2$$

$$\therefore R_1 = \sqrt{0.17} \times 186 \\ = 76.7 \text{ ohms}$$

Dividing the second expression by the first

$$R_2^2 = \frac{186^2}{0.17}$$

$$\therefore R_2 = \frac{186}{\sqrt{0.17}} \\ = 451 \text{ ohms}$$

The required network therefore has the form and component values shown in Fig. 107. The 186-ohm and 76.7-ohm resistors could,

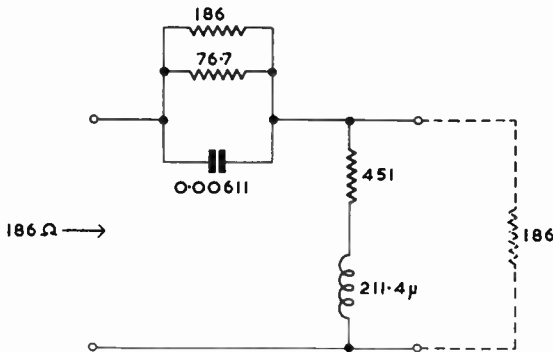

Fig. 107—Equaliser section giving 3-dB correction at a half-loss frequency of 420 kc/s, the iterative impedance being 186 ohms.

of course, be replaced by a single resistor of value $186 \times 76.7 / (186 + 76.7) = 54.3$ ohms.

8.4 RESONANT CONSTANT-RESISTANCE EQUALISER

8.4.1 Introduction

We have so far discussed constant-resistance equalisers of the type in which the frequency discriminating series and shunt impedances Z_1 and Z_2 each consist of a pure reactance and those in which the impedances each consist of a single reactance together

with a single resistance. For both types the maximum slope of attenuation-frequency curve obtainable is 6 dB per octave. Greater slopes than this are sometimes required, particularly near the upper end of the video spectrum where cable attenuation often increases rapidly. Increased slope of equaliser characteristic could, of course, be obtained by connecting two or more sections of the type shown in Fig. 102 in cascade, but an alternative method is to use a single section in which the reactance of the series and shunt arms changes more rapidly with frequency than for a single inductor or capacitor. This can be achieved by using a combination of inductance and capacitance in the series and the shunt arms.

Increase in frequency causes inductive reactance to increase and capacitive reactance to decrease; these reactances are of opposite sign and the net reactance of a series or parallel inductance-capacitance combination changes very rapidly with frequency as the resonance frequency of the combination is approached. To obtain the shape of response curve required for equalising high-

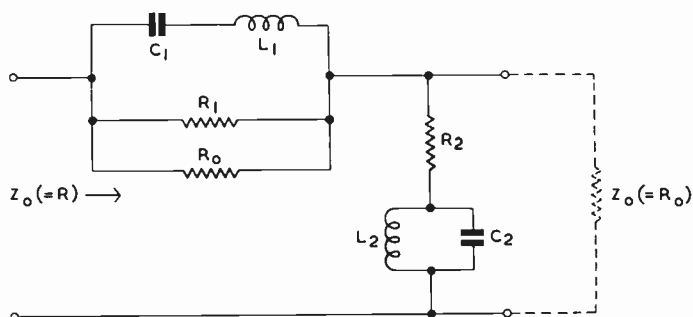

Fig. 108—Circuit of resonant constant-resistance equaliser

frequency losses a series LC combination is employed in the series arm and a parallel combination in the shunt arm, as shown in Fig. 108. As for the simpler equalisers just described it is still necessary for the series arm to be effectively capacitive and the shunt arm effectively inductive over the range of operating frequencies; this can be achieved by making the LC circuits resonant above the spectrum being equalised.

8.4.2 Conditions for Constant-resistance Operation

To obtain a constant-resistance input to the equaliser, the impedances must satisfy the relationship

FIXED EQUALISERS

$$Z_1 Z_2 = R_0^2$$

where $R_0 = Z_0$ the iterative impedance of the network.

As deduced in Appendix E this is only possible if

$$\frac{L_1}{C_2} = R_1 R_2 \quad \dots \quad \dots \quad \dots \quad (41)$$

and

$$\frac{L_2}{C_1} = R_1 R_2 \quad \dots \quad \dots \quad \dots \quad (42)$$

where $R_1 R_2 = R_0^2$. Division of (41) by (42) gives

$$L_1 C_1 = L_2 C_2 \quad \dots \quad \dots \quad \dots \quad (43)$$

showing that the series and parallel LC circuits must be resonant at the same frequency.

8.4.3 Frequency Response

The frequency response of a resonant equaliser is calculated in Appendix F; it is given by

$$\text{response in dB} = -10 \log_{10} \frac{(\sqrt{r} + 1)^2(1 - x^2)^2 + rpx^2}{(1 - x^2)^2 + rpx^2} \quad \dots \quad (44)$$

which shows that response is dependent on r , the ratio of R_1 to R_2 , and on p , the ratio of L_2 to L_1 . As for the equaliser circuits previously described, the value of r determines the zero-frequency loss. If $r = 1$, this loss is 6 dB. Some curves for this value of r are given in Fig. 109. They are plotted for three values of p to show how this parameter affects the shape of the response.

8.4.4 Design of Resonant Equaliser

In designing a resonant equaliser for a particular application there are three parameters which can be adjusted to make the equaliser curve fit that of the cable or circuit to be equalised. These are:

- (a) The value of r .
- (b) The value of p .
- (c) The value of the resonance frequency of $L_1 C_1$ and $L_2 C_2$.

By appropriate choice of these parameters equalisation can be made perfect at three frequencies. In a video system with an upper

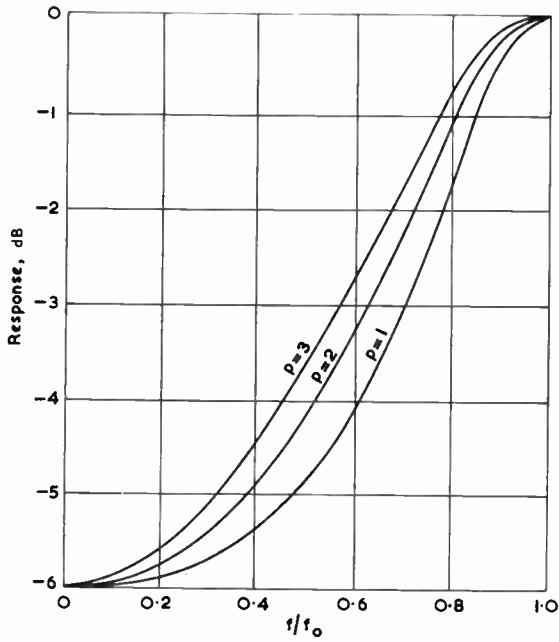

Fig. 109—Some frequency response curves for a resonant equaliser

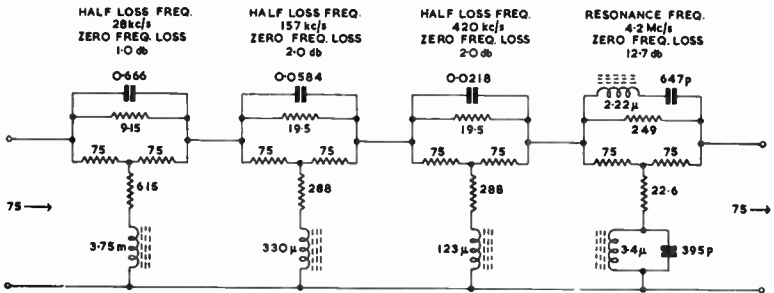

Fig. 110—Typical complete video constant-resistance equaliser

FIXED EQUALISERS

frequency limit of 3 Mc/s, circuits of this type are often employed to equalise the response between frequencies of say 1 Mc/s and 3 Mc/s and the design might be such as to give perfect equalisation at 1 Mc/s, 2 Mc/s and 3 Mc/s. Usually the resonance frequencies are well above 3 Mc/s, 4.2 Mc/s being a typical value. This would be expected from examination of Fig. 109. The response of a cable generally falls at an increasing rate as frequency approaches the upper limit of the passband. For perfect correction an equaliser must therefore have a response which rises at an increasing rate over this frequency range. The curves of Fig. 109 have a suitable shape up to 0.6 or 0.7 of the resonance frequency but above this the equaliser slope falls and would fail to compensate the steady increase in cable attenuation; hence the resonance frequency must be well above the passband.

8.4.5 Typical Complete Constant-resistance Equaliser

The frequency range over which a single equaliser section is effective is limited and to obtain compensation over the entire video range a number of sections are required. A circuit of a complete equaliser is given in Fig. 110; there are four sections in

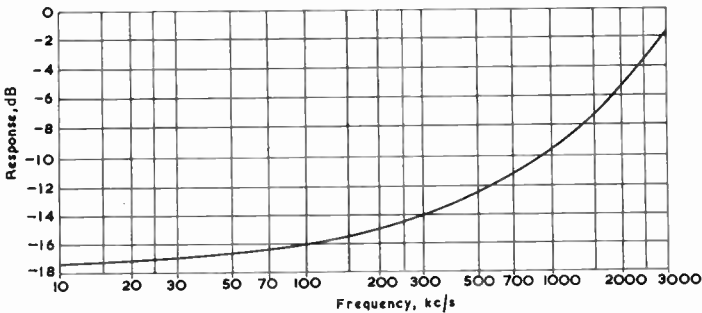

Fig. 111—Response curve for equaliser of previous diagram

cascade and each is identified by its zero frequency loss and its half-loss (or resonant) frequency. These values, together with the iterative impedance of the equaliser (75-ohms in this example) and the $L_1 : L_2$ or $L_1 : C_1$ ratio for a resonant equaliser are sufficient information to enable all component values to be calculated. The response curve for this particular circuit is given in Fig. 111, which shows that it has a loss of 1.6 dB at 3 Mc/s and of 17.3 dB at 10 kc/s. The equaliser therefore has an effective lift of 15.7 dB over the video spectrum.

APPENDIX C

FREQUENCY RESPONSE OF SIMPLE CONSTANT-RESISTANCE EQUALISER

The input resistance of a correctly-terminated constant-resistance equaliser is equal to the load resistance and therefore the insertion loss is given simply by $20 \log_{10} |V_{in}/V_{out}|$. For the simple network illustrated in the diagram V_{out}/V_{in} is given by

$$\frac{V_{out}}{V_{in}} = \frac{Z_b}{Z_a} \quad \dots \quad \dots \quad \dots \quad (1)$$

where Z_b is the impedance of L and R_0 in parallel, Z_a being the impedance of the entire network as measured at the input terminals. Z_a is, of course, equal to the iterative impedance Z_0 which is, in turn, equal to R_0 .

Z_b is given by

$$Z_b = \frac{j\omega L \cdot R_0}{R_0 + j\omega L}$$

Substituting for Z_a and Z_b in (1) we have

$$\begin{aligned} \therefore \frac{V_{out}}{V_{in}} &= \frac{j\omega L}{R_0 + j\omega L} \\ &= \frac{j\omega L/R_0}{1 + j\omega L/R_0} \end{aligned}$$

Now

$$\begin{aligned} \frac{L}{R_0} &= \frac{L}{\sqrt{L/C}} \\ &= \sqrt{LC} \\ &= \frac{1}{\omega_0} \end{aligned}$$

FIXED EQUALISERS

$$\begin{aligned} \therefore \frac{V_{out}}{V_{in}} &= \frac{j\omega/\omega_0}{1 + j\omega/\omega_0} \\ &= \frac{jx}{1 + jx} \\ \therefore \left| \frac{V_{out}}{V_{in}} \right| &= \frac{x}{\sqrt{1 + x^2}} \end{aligned}$$

where $x = \omega/\omega_0$ and is hence a variable expressing frequency in

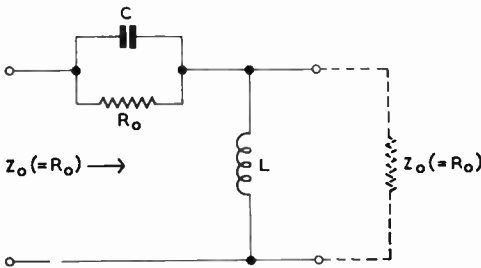

Fig. C.1—Simple constant-resistance equaliser

terms of the resonance frequency of L and C . The frequency response of the circuit is given by

$$\begin{aligned} \text{response, dB} &= 20 \log_{10} \left| \frac{V_{out}}{V_{in}} \right| \\ &= 20 \log_{10} \frac{x}{\sqrt{1 + x^2}} \\ &= -20 \log_{10} \frac{\sqrt{1 + x^2}}{x} \\ &= -10 \log_{10} \frac{1 + x^2}{x^2} \end{aligned}$$

which is the expression from which Fig. 101 was plotted.

APPENDIX D

FREQUENCY RESPONSE OF MORE COMPLEX CONSTANT-RESISTANCE EQUALISER

The input resistance of a correctly terminated constant-resistance equaliser is equal to its load resistance and the insertion loss is therefore given by $20 \log_{10} |V_{in}/V_{out}|$.

For a network of the type illustrated in the diagram we have

$$\frac{V_{out}}{V_{in}} = \frac{Z_b}{Z_a} \quad \dots \quad \dots \quad \dots \quad (1)$$

where Z_b is the impedance of R_2 , R_0 and L . Z_a is the impedance of the entire network as measured at the input terminals. Z_b is given by

$$Z_b = \frac{R_0(R_2 + j\omega L)}{R_0 + R_2 + j\omega L}$$

and Z_a is equal to the iterative impedance Z_0 which is in turn equal to R_0 . Substituting for Z_a and Z_b in (1) we have

$$\begin{aligned} \frac{V_{out}}{V_{in}} &= \frac{R_2 + j\omega L}{R_0 + R_2 + j\omega L} \\ &= \frac{R_2/R_0 + j\omega L/R_0}{1 + R_2/R_0 + j\omega L/R_0} \quad \dots \quad \dots \quad (2) \end{aligned}$$

But

$$\begin{aligned} \frac{R_2}{R_0} &= \frac{R_2}{\sqrt{R_1 R_2}} \\ &= \frac{\sqrt{R_2}}{\sqrt{R_1}} \\ &= \frac{1}{\sqrt{r}} \end{aligned}$$

where $r = R_1/R_2$

FIXED EQUALISERS

and

$$\begin{aligned} \frac{L}{R_0} &= \frac{L}{\sqrt{L/C}} \\ &= \sqrt{LC} \\ &= \frac{1}{\omega_0} \end{aligned}$$

Substituting for R_2/R_0 and L/R_0 in (2) we have

$$\begin{aligned} \frac{V_{out}}{V_{in}} &= \frac{1/\sqrt{r} + j\omega/\omega_0}{1 + 1/\sqrt{r} + j\omega/\omega_0} \\ &= \frac{1 + j\sqrt{r}\omega/\omega_0}{1 + \sqrt{r} + j\sqrt{r}\omega/\omega_0} \\ &= \frac{1 + j\sqrt{r}x}{1 + \sqrt{r} + j\sqrt{r}x} \quad \dots \quad (3) \end{aligned}$$

where $x = \omega/\omega_0$ and is a variable expressing frequency in terms of the resonance frequency of L and C . Expression (3) can be put

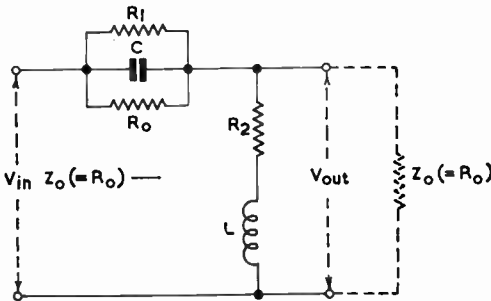

Fig. D.1—Constant-resistance equaliser

into a form suitable for calculation thus:

$$\left| \frac{V_{out}}{V_{in}} \right| = \frac{\sqrt{1 + rx^2}}{\sqrt{[(1 + \sqrt{r})^2 + rx^2]}}$$

The frequency response of the equaliser is given by

$$\begin{aligned}
 \text{response dB} &= 20 \log_{10} \left| \frac{V_{out}}{V_{in}} \right| \\
 &= 20 \log_{10} \frac{\sqrt{(1 + rx^2)}}{\sqrt{[(1 + \sqrt{r})^2 + rx^2]}} \\
 &= -20 \log_{10} \frac{\sqrt{[(1 + \sqrt{r})^2 + rx^2]}}{\sqrt{(1 + rx^2)}} \\
 &= -10 \log_{10} \frac{(1 + \sqrt{r})^2 + rx^2}{1 + rx^2}
 \end{aligned}$$

and this is the expression from which Fig. 104 was plotted.

APPENDIX E

CONDITIONS FOR RESONANT EQUALISER TO HAVE CONSTANT RESISTANCE

THE circuit of a resonant equaliser is given in the diagram. The condition which must be satisfied if this network is to present a constant input resistance of R_0 is that $Z_1 Z_2$ should equal R_0^2 where Z_1 is the impedance of the series arm (with R_0 removed) comprising $R_1 L_1 C_1$, Z_2 being the impedance of the shunt arm comprising $R_2 L_2 C_2$.

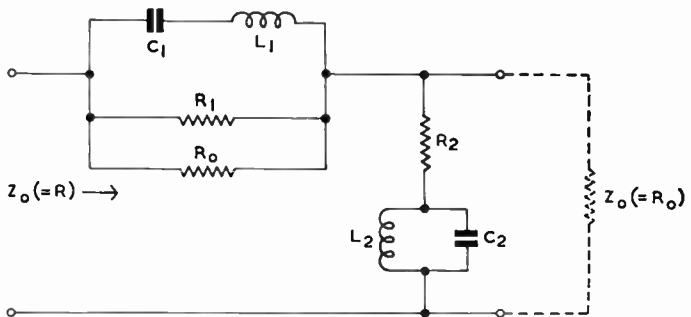

Fig. E.1—Resonant constant-resistance equaliser

Now

$$\begin{aligned} \frac{1}{Z_1} &= \frac{1}{R_1} + \frac{1}{j\omega L_1 + 1/j\omega C_1} \\ &= \frac{1}{R_1} + \frac{j\omega C_1}{1 - \omega^2 L_1 C_1} \\ &= \frac{1 - \omega^2 L_1 C_1 + j\omega C_1 R_1}{R_1(1 - \omega^2 L_1 C_1)} \end{aligned}$$

and

$$\begin{aligned} Z_2 &= R_2 + \frac{j\omega L_2/j\omega C_2}{j\omega L_2 + 1/j\omega C_2} \\ &= R_2 + \frac{j\omega L_2}{1 - \omega^2 L_2 C_2} \\ &= \frac{R_2(1 - \omega^2 L_2 C_2) + j\omega L_2}{1 - \omega^2 L_2 C_2} \\ &= R_2 \cdot \frac{1 - \omega^2 L_2 C_2 + j\omega L_2/R_2}{1 - \omega^2 L_2 C_2} \end{aligned}$$

$$\begin{aligned} \therefore Z_1 Z_2 &= R_1 R_2 \cdot \frac{1 - \omega^2 L_2 C_2 + j\omega L_2/R_2}{1 - \omega^2 L_2 C_2} \cdot \frac{1 - \omega^2 L_1 C_1}{1 - \omega^2 L_1 C_1 + j\omega C_1 R_1} \\ &= R_1 R_2 \cdot \frac{1 - \omega^2 L_1 C_1}{1 - \omega^2 L_2 C_2} \cdot \frac{1 - \omega^2 L_2 C_2 + j\omega L_2/R_2}{1 - \omega^2 L_1 C_1 + j\omega C_1 R_1} \end{aligned}$$

The network presents a constant input resistance if the numerator of each fraction equals its denominator. For the first fraction we have

$$1 - \omega^2 L_1 C_1 = 1 - \omega^2 L_2 C_2$$

giving $L_1 C_1 = L_2 C_2 \quad \dots \quad \dots \quad \dots \quad (1)$

For the second fraction we have

$$\frac{j\omega L_2}{R_2} = j\omega C_1 R_1$$

giving $\frac{L_2}{C_1} = R_1 R_2 \quad \dots \quad \dots \quad \dots \quad (2)$

Eliminating L_2 between (1) and (2) we have

$$\frac{L_1}{C_2} = R_1 R_2 \quad \dots \quad \dots \quad \dots \quad (3)$$

When these conditions are satisfied we have

$$Z_1 Z_2 = R_1 R_2$$

But

$$Z_1 Z_2 = R_0^2$$

$$\therefore R_1 R_2 = R_0^2 \quad \dots \quad \dots \quad \dots \quad (4)$$

Thus the conditions to be satisfied may be stated thus:

$$\frac{L_1}{C_2} = \frac{L_2}{C_1} = R_1 R_2 = R_0^2$$

APPENDIX F

FREQUENCY RESPONSE OF RESONANT CONSTANT-RESISTANCE EQUALISER

THE input resistance of a correctly terminated constant-resistance equaliser is equal to its load resistance and the insertion loss is therefore given by $20 \log_{10} V_{in}/V_{out}$. For a network of the type shown in the diagram we have

$$\frac{V_{out}}{V_{in}} = \frac{Z_b}{Z_a} \quad \dots \quad \dots \quad \dots \quad (1)$$

where Z_b is the impedance of R_2 , L_2 , C_2 and R_0 . Z_a is the impedance of the entire network as measured at the input terminals. This is, of course, equal to the iterative impedance Z_0 which in turn is equal to R_0 .

Z_b is given by

$$Z_b = \frac{R_0 \left(R_2 + \frac{j\omega L_2 / j\omega C_2}{j\omega L_2 + 1 / j\omega C_2} \right)}{R_0 + R_2 + \frac{j\omega L_2 / j\omega C_2}{j\omega L_2 + 1 / j\omega C_2}}$$

and $Z_a = Z_0$. Substituting for Z_a and Z_b in (1) we have

FIXED EQUALISERS

$$\begin{aligned} \frac{V_{out}}{V_{in}} &= \frac{R_2 + \frac{L_2/C_2}{j\omega L_2 + 1/j\omega C_2}}{R_0 + R_2 + \frac{L_2/C_2}{j\omega L_2 + 1/j\omega C_2}} \\ &= \frac{L_2/C_2 + R_2(j\omega L_2 + 1/j\omega C_2)}{L_2/C_2 + (R_0 + R_2)(j\omega L_2 + 1/j\omega C_2)} \end{aligned}$$

Multiplying numerator and denominator by $j\omega C_2/R_0$ we have

$$\frac{V_{out}}{V_{in}} = \frac{j\omega L_2/R_0 + R_2(1 - \omega^2 L_2 C_2)/R_0}{j\omega L_2/R_0 + (1 - \omega^2 L_2 C_2)(R_0 + R_2)/R_0} \quad (2)$$

Now

$$\begin{aligned} \frac{L_2}{R_0} &= L_2 \cdot \frac{\sqrt{C_2}}{\sqrt{L_1}} \\ &= \frac{\sqrt{L_2}}{\sqrt{L_1}} \cdot \sqrt{(L_2 C_2)} \\ &= \sqrt{p} \\ &= \omega_0 \end{aligned}$$

where $p = L_2/L_1$ and ω_0 is the angular resonance frequency of $L_2 C_2$ (and hence of $L_1 C_1$). Moreover

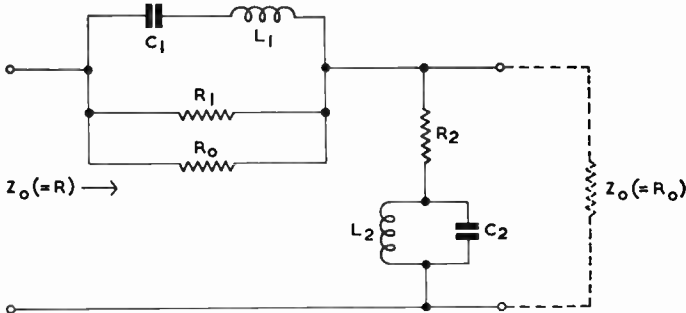

Fig. F.1—Resonant constant-resistance equaliser

$$\begin{aligned} \frac{R_2}{R_0} &= R_2 \cdot \frac{1}{\sqrt{(R_1 R_2)}} \\ &= \frac{\sqrt{R_2}}{\sqrt{R_1}} \\ &= \frac{1}{\sqrt{r}} \end{aligned}$$

where $r = R_1/R_2$.

Substituting for L_2/R_0 and R_2/R_0 in (2) we have

$$\begin{aligned} \frac{V_{out}}{V_{in}} &= \frac{j\omega\sqrt{p}/\omega_0 + (1 - \omega^2/\omega_0^2)/\sqrt{r}}{j\omega\sqrt{p}/\omega_0 + (1 - \omega^2/\omega_0^2)(1 + 1/\sqrt{r})} \\ &= \frac{j\omega\sqrt{(rp)}/\omega_0 + (1 - \omega^2/\omega_0^2)}{j\omega\sqrt{(rp)}/\omega_0 + (1 - \omega^2/\omega_0^2)(\sqrt{r} + 1)} \\ &= \frac{j\sqrt{(rp)}x + (1 - x^2)}{j\sqrt{(rp)}x + (1 - x^2)(\sqrt{r} + 1)} \end{aligned}$$

in which $x = \omega/\omega_0$ and is hence a variable expressing frequency in terms of the resonance frequency of L_1C_1 and L_2C_2 . For calculation, the modulus of V_{out}/V_{in} is given by

$$\left| \frac{V_{out}}{V_{in}} \right| = \frac{\sqrt{[(1 - x^2)^2 + rpx^2]}}{\sqrt{[(1 - x^2)^2(\sqrt{r} + 1)^2 + rpx^2]}}$$

The frequency response of the equaliser is given by

$$\begin{aligned} \text{response, dB} &= 20 \log_{10} \left| \frac{V_{out}}{V_{in}} \right| \\ &= 20 \log_{10} \frac{\sqrt{[(1 - x^2)^2 + rpx^2]}}{\sqrt{[(1 - x^2)^2(\sqrt{r} + 1)^2 + rpx^2]}} \\ &= 10 \log_{10} \frac{(1 - x^2)^2(\sqrt{r} + 1)^2 + rpx^2}{(1 - x^2)^2 + rpx^2} \end{aligned}$$

which is the expression from which Fig. 109 was plotted.

CHAPTER 9

VARIABLE (BODE-TYPE) EQUALISERS

9.1 INTRODUCTION

THE equalisers so far described are fixed types usually designed to correct a particular frequency characteristic such as that of a mile of cable. In practice such fixed equalisers are often augmented by further equalisers which are necessary to correct for shorter lengths of cable or to compensate for changes in cable characteristics caused by temperature variations. These additional equalisers are usually variable, i.e. their frequency response can be adjusted within limits.

The setting of such equalisers is simplified if they are designed with a single control for frequency response adjustment. Such an

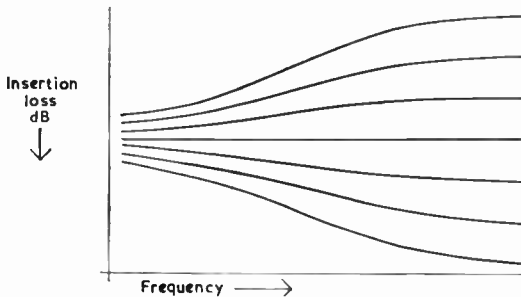

Fig. 112—Frequency responses obtainable from a variable equaliser

adjustment should ideally have the effect of varying the frequency characteristic as indicated in Fig. 112.

The design of variable equalisers giving a response curve of this type has been described by Bode* who demonstrated a general method which, in effect, compresses or expands the decibel insertion-loss scale for the network without significantly changing the shape of the response curve or its half-loss frequency.

* H. W. Bode, "Variable Equalisers." Bell System Technical Journal, April 1938.

9.2 BASIC CIRCUIT

One of the circuits described by Bode as being suitable for use in a variable equaliser can be deduced in the following way. In Fig. 113 R_{out} represents the output impedance of an item of equipment A which is supplying a signal to a second item of equipment B of which R_{in} is the input impedance. The problem is to insert a variable equaliser between A and B, the equaliser being such that its response curve can be made to take any of the forms illustrated in Fig. 112

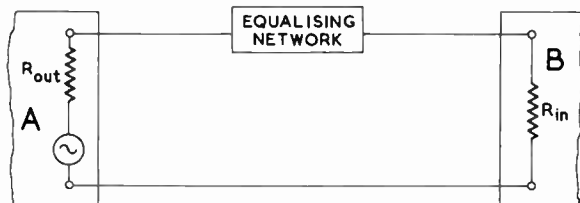

Fig. 113—First step in developing the circuit of a variable equaliser

by adjustment of a single element, preferably a resistance. In Fig. 113 the equaliser is represented as a single series-connected element.

If this element is resistive, as shown in Fig. 114 (b), it introduces the same loss at all frequencies and the frequency response is as shown by the middle curve in Fig. 112; a resistive series element thus behaves as an attenuator. If the series element is an inductor (Fig. 114 (a)), it introduces some frequency discrimination because the reactance is greater at high than at low frequencies; in fact such

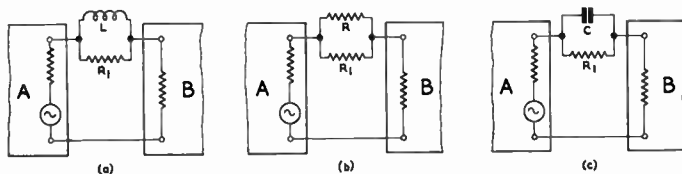

Fig. 114—In a variable equaliser the series element may be an inductor (a), a resistor (b) or a capacitor (c)

an element causes a relative loss of upper frequency response as indicated by the lower curves in Fig. 112. Conversely if the series element is made a capacitor, as shown at (c) in Fig. 114, there is a relative loss of low frequencies and the equaliser has a frequency response curve similar to the upper curves in Fig. 112. The fixed resistor R_1 is necessary in Fig. 114 (a) to prevent the insertion loss increasing indefinitely as frequency increases; at (c) it is necessary

VARIABLE (BODE-TYPE) EQUALISERS

to prevent the loss increasing indefinitely at low frequencies. In both instances it gives the frequency response curve the required step shape. For the sake of uniformity R_1 is also included in Fig. 114 (b).

To obtain a variable equaliser, therefore, what is wanted is a network to replace L , R or C in Fig. 114 which, by adjustment of a single resistor, can be made to have the impedance behaviour of an inductor, resistor or capacitor. Such a network is a bridged-T of the type shown in Fig. 99. If such a network is terminated in a resistance equal to its iterative impedance, its input impedance is purely resistive; if it is terminated in a resistance greater than the iterative impedance, the input impedance can be inductive; and finally if it is terminated in a resistance less than the iterative impedance, the input impedance can be capacitive. Thus by varying the terminating

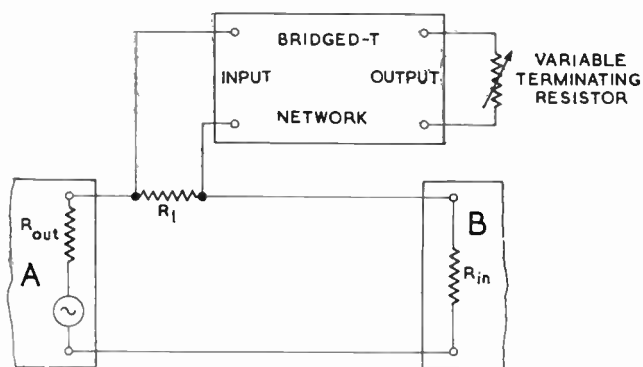

Fig. 115—A bridged-T network with variable terminating resistance can be used as the series element in a variable equaliser

resistance, the input impedance can be made inductive, resistive or capacitive at will. If L in Fig. 114 (a) is replaced by the input terminals of a bridged-T network as shown in Fig. 115, the insertion loss between items of equipment A and B can be made to vary with frequency by adjustment of the value of the terminating resistance of the bridged-T network.

9.3 BODE CONDITION

The simple circuit of Fig. 115 is not wholly satisfactory as a variable equaliser because the response curves do not follow sufficiently closely the shapes indicated in Fig. 112. To make the performance acceptable, Bode showed that it was necessary to

arrange that R_{in} and R_{out} are related to the iterative impedance Z_0' of the bridged-T network according to the equations

$$R_1 = aZ_0' \quad \dots \quad \dots \quad \dots \quad (45)$$

$$R_{in} = R_{out} = \frac{aZ_0'}{2(a^2 - 1)} \quad \dots \quad \dots \quad (46)$$

in which a is a numerical factor. When these relationships are satisfied, the impedance to which the input terminals of the bridged-T network are connected is equal to Z_0'/a : this is termed subsequently the Bode condition and it can easily be proved for the circuit in Fig. 115 as follows. The impedance to which the bridged-T network is connected is composed of R_1 in parallel with $(R_{in} + R_{out})$. Thus the impedance is given by

$$\frac{R_1(R_{in} + R_{out})}{R_1 + R_{in} + R_{out}}$$

Putting $R_1 = aZ_0'$, $R_{in} = R_{out} = aZ_0'/2(a^2 - 1)$ as stated in equations (45) and (46) we have

$$\frac{aZ_0' \cdot aZ_0'/(a^2 - 1)}{aZ_0' + aZ_0'/(a^2 - 1)}$$

Multiplying numerator and denominator by $(a^2 - 1)$ we have

$$\frac{a^2Z_0'^2}{aZ_0'(a^2 - 1) + aZ_0'}$$

If the numerator and denominator are divided by aZ_0' , this expression becomes

$$\frac{aZ_0'}{(a^2 - 1) + 1} = \frac{aZ_0'}{a^2} = \frac{Z_0'}{a}$$

which shows that the network of Fig. 115 satisfies the Bode condition provided equations (45) and (46) apply. To assist identification of components all those associated with the series bridged-T network are followed by a dash, thus R' , Z_0' , L' , etc.

9.4 FREQUENCY RESPONSE OF BODE EQUALISER

As we saw in the earlier section dealing with fixed equalisers, a bridged-T network has a frequency response in its own right. We are now employing such a network as a constituent part of a more elaborate equaliser; it follows that the frequency response of the variable equaliser must depend on that of the bridged-T network. It

VARIABLE (BODE-TYPE) EQUALISERS

also depends, of course, on the value of the terminating resistance R' as can be shown in the following way.

We must first determine the relationship between the input impedance of the bridged-T network and its terminating resistance. This is calculated in Appendix G and the relationship is

$$Z_{in}' = \frac{1 + (R' - Z_0')\beta^2 / (R' + Z_0')}{1 - (R' - Z_0')\beta^2 / (R' + Z_0')} Z_0' \quad \dots (47)$$

in which R' is the terminating resistance and Z_0' the iterative impedance as before and β is the frequency response of the bridged-T

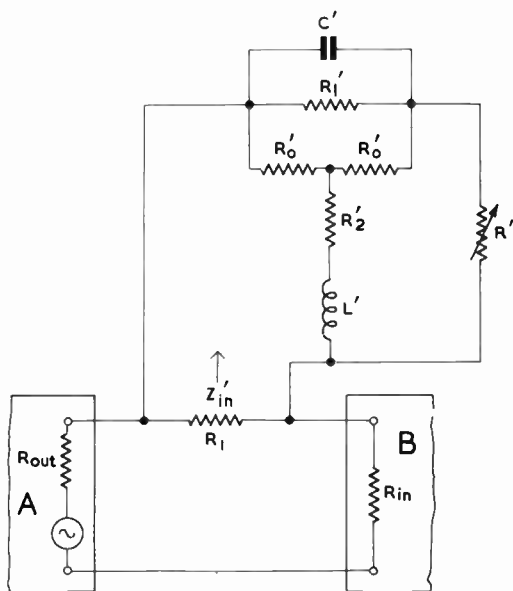

Fig. 116—Fundamental circuit of a Bode-type variable equaliser

network, being the value of V_{out}/V_{in} when the network is terminated in a resistance equal to the iterative impedance.

Bode shows that the insertion loss between equipment A and B can be expressed as an infinite series but a good approximation is given by the first two terms which, using the component nomenclature for Fig. 116, may be expressed

$$\text{loss in dB} = 20 \log a + 20 \frac{Z_{in}' - Z_0'}{Z_{in}' + Z_0'} \log a \quad \dots (48)$$

in which a is as defined by expression (45) and Z_{in}' by expression (47).

Substituting for Z_{in}' we have

$$\text{loss in dB} = 20 \log a + 20 \frac{R' - Z_0'}{R' + Z_0'} \beta^2 \log a \quad \dots \quad (49)$$

the derivation of which is given in Appendix G. This expression gives the frequency response of the variable equaliser in terms of a and of the terminating resistance, iterative impedance and frequency response of the bridged-T network.

When R' is equal to Z_0' , the bridged-T network is correctly terminated and expression (49) reduces to

$$\text{loss in dB} = 20 \log a \quad \dots \quad \dots \quad (50)$$

i.e. the variable equaliser gives a constant loss, independent of frequency; this corresponds with the centre curve in Fig. 112.

Now put R' equal to zero. The output of the bridged-T network is short-circuited and the equaliser response is given by

$$\text{loss in dB} = 20 \log a - 20\beta^2 \log a \quad \dots \quad \dots \quad (51)$$

Since the second term contains β this response now varies with frequency and may correspond with the upper curves in Fig. 112.

If R' is made infinite, the output of the bridged-T network is open-circuited and the equaliser response is given by

$$\text{loss in dB} = 20 \log a + 20\beta^2 \log a \quad \dots \quad \dots \quad (52)$$

Again the second term contains β , implying frequency dependence but its sign is opposite to that in expression (51) showing that the response curve corresponds now with the lower curves in Fig. 112.

Thus by varying R' between zero and infinity it is possible to obtain from the equaliser a family of response curves similar to those shown in Fig. 112.

9.5 CONSTANT-RESISTANCE BODE-TYPE VARIABLE EQUALISER

The network of Fig. 116 satisfies the Bode conditions (expressions (45) and (46)) and is effective as a variable equaliser but it is not a constant-resistance network. In other words the load connected across the output of equipment A is not constant: this load is composed of the parallel network $R_1 Z_{in}'$ in series with R_{in} . Z_{in}' varies both in nature and in magnitude when R' is adjusted and thus the load impedance for equipment A also varies. The network can, however, be modified to constant-resistance form in the following way.

VARIABLE (BODE-TYPE) EQUALISERS

Let R_{in} and R_{out} be doubled to $aZ_0'/(a^2 - 1)$ and, to maintain the Bode condition, add two further resistors R_b and R_c each of this same value in parallel with R_1 as shown in Fig. 117. This does not affect the Bode condition because the resistance connected across R_1 and Z_{in}' is still $aZ_0'/(a^2 - 1)$ and thus the resistance to which Z_{in}' is connected is still Z_0'/a . It is now possible to connect a further impedance of any value between points A and B without upsetting impedance relationships. This is possible because R_{in} , R_{out} , R_b and R_c constitute a balanced bridge circuit and signals applied to terminals C and D do not cause any potential difference between points A and B.

If the added impedance contains a series resistance R_2 the variable equaliser has the form shown in Fig. 118 in which the bridged-T network and its terminating resistance are shown as a single block labelled *series impedance* and the added shunt components

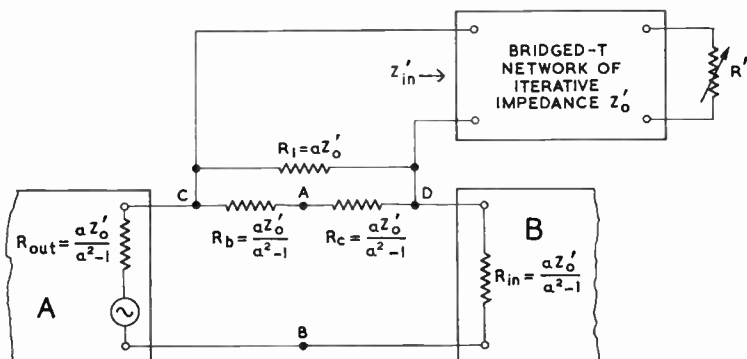

Fig. 117—First step in modifying the network of Fig. 116 to constant-resistance form

include a block labelled *shunt impedance*. If the series and shunt impedances include reactances of opposite sign, this network has the form of a bridged-T of the type illustrated in Fig. 99. Provided certain component relationships are satisfied this network can be made a constant-resistance type. Reference to the earlier section on fixed equalisers (p. 149) shows that these conditions are as follows:

1. That R_b and R_c should both be equal to the iterative impedance of the variable equaliser and hence to the terminating resistance R_{in} . Fig. 118 satisfies this condition and we thus know that the variable equaliser has an iterative impedance given by $aZ_0'/(a^2 - 1)$.

2. The product of R_1 and R_2 should equal the square of the iterative impedance of the variable equaliser; this is the condition of expression (32). This enables us to calculate the value of R_2 thus

$$R_1 R_2 = \frac{a^2 Z_0'^2}{(a^2 - 1)^2}$$

But $R_1 = aZ_0'$

$$\begin{aligned} \therefore R_2 &= \frac{a^2 Z_0'^2}{(a^2 - 1)^2} \cdot \frac{1}{aZ_0'} \\ &= \frac{aZ_0'}{(a^2 - 1)^2} \quad \dots \quad \dots \quad \dots \quad (53) \end{aligned}$$

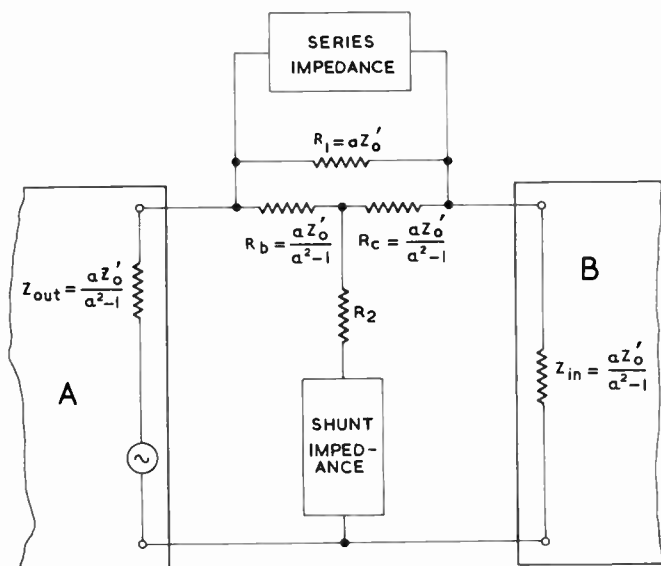

Fig. 118—Second step in modifying the network of Fig. 116 to constant-resistance form

3. The product of the series and shunt impedances should also equal the square of the iterative impedance of the variable equaliser. This is the condition of expression (25) and enables us to calculate the value of Z_{in}'' as follows. If the input impedance of the shunt element is represented by Z_{in}''

we have

$$Z_{in}' Z_{in}'' = \frac{a^2 Z_0'^2}{(a^2 - 1)^2}$$

giving

$$Z_{in}'' = \frac{a^2 Z_0'^2}{(a^2 - 1)^2} \cdot \frac{1}{Z_{in}'}$$

Substituting for Z_{in}' from (47) we have

$$Z_{in}'' = \frac{1 - (R' - Z_0')\beta^2 / (R' + Z_0')}{1 + (R' - Z_0')\beta^2 / (R' + Z_0')} \cdot \frac{a^2 Z_0'}{(a^2 - 1)^2} \quad \dots \quad (54)$$

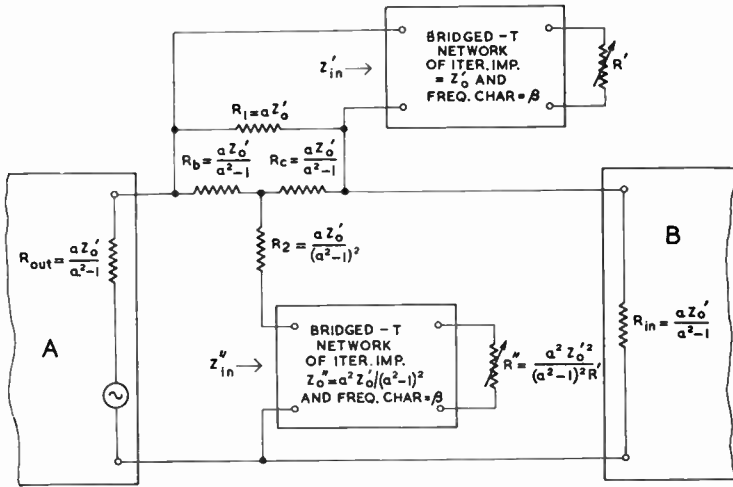

Fig. 119—Final form of constant-resistance Bode-type variable equaliser

As shown in Appendix H this is the expression for the input impedance Z_{in}'' of a bridged-T network with the same frequency response β as the series bridged-T network but having an iterative impedance Z_0'' and terminated in a resistance R'' where

$$Z_0'' = \frac{a^2 Z_0'^2}{(a^2 - 1)^2} \quad \dots \quad \dots \quad (55)$$

and

$$R'' = \frac{a^2 Z_0'^2}{(a^2 - 1)^2} R' \quad \dots \quad \dots \quad (56)$$

Thus the nature of the impedance to be added is a further bridged-T network and the constant-resistance Bode-type variable equaliser

includes two subsidiary bridged-T networks with the same frequency response; one a series network with an iterative impedance of Z_0' and a terminating resistance of R' the other a shunt network with an iterative impedance of $a^2 Z_0' / (a^2 - 1)^2$ and a terminating resistance of $a^2 Z_0'^2 / (a^2 - 1)^2 R'$. Both terminating resistances must be adjusted to alter the frequency characteristic of the equaliser, and the shunt-network terminating resistance is inversely proportional to the series-network terminating resistance. The final form of the variable equaliser is illustrated in Fig. 119 in which the bridged-T networks are shown as blocks. If the bridged-T networks are shown in full the circuit has the form shown in Fig. 120.

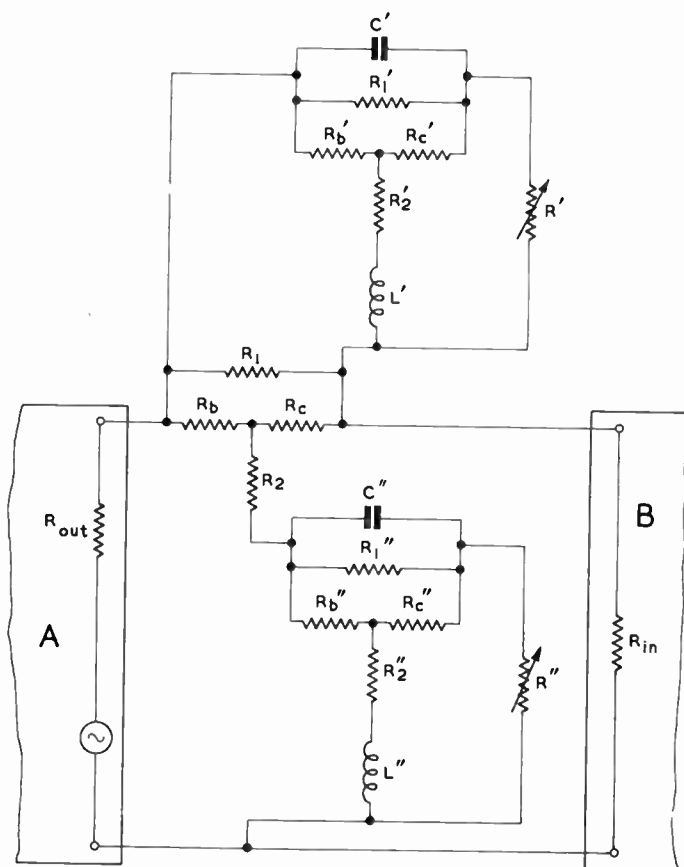

Fig. 120—Complete circuit of constant-resistance Bode-type variable equaliser
178

9.6 PRACTICAL CONSTANT-RESISTANCE BODE-TYPE EQUALISER

It was pointed out earlier that the frequency range over which a single equaliser section could be effective is, in general, only a fraction of the full video range. Thus a number of sections, commonly four, are necessary to effect equalisation over the entire video spectrum, each section operating in a particular part of the spectrum. As a numerical example we will calculate the component values required in one of the sections of such a multi-section equaliser. The chosen section operates at the high-frequency end of the video band, having a half-loss frequency of 1 Mc/s. It has to provide variable "top lift" up to a maximum of 2.5 dB at 3 Mc/s. The iterative impedance is to be 75 ohms.

A number of resistor values can be calculated immediately in the following manner. The iterative impedance of the equaliser is 75 ohms and, from Fig. 120 this is also the value of R_b and R_c .

Many of the resistor values in the equaliser depend on the parameter a and one of the first tasks is to decide on a suitable value for a . The value of a determines the flat loss of the equaliser according to expression (50)

$$\text{loss in dB} = 20 \log_{10} a$$

As shown in Fig. 112 the frequency response of a variable equaliser set to give maximum lift is asymptotic to the horizontal line representing zero loss and the horizontal line representing the flat loss. The curve therefore meets these horizontal lines at an infinitely high or at zero frequency. At the limits of the frequency range over which the equation is required to work the frequency response curve is unlikely to be nearer than 0.1 or 0.2 dB from these horizontal lines. Thus in a practical design the flat loss must be greater than the overall lift of the equaliser and in the design under consideration a suitable value for the flat loss is 3 dB, corresponding to a value of a of 1.414.

From condition 1 on p. 175 the iterative impedance of the equaliser is given by $aZ_0'/(a^2 - 1)$. Since this is 75 ohms and $a = 1.414$ we have

$$\begin{aligned} Z_0' &= \frac{75(1.414^2 - 1)}{1.414} \\ &= \frac{75}{1.414} \\ &= 52.8 \text{ ohms} \end{aligned}$$

This is then the iterative impedance of the series bridged-T network and also the value of the two resistors $R_{b'}$ and $R_{c'}$. R_1 is equal to aZ_0' , i.e. $1.414 \times 52.8 = 75$ ohms. R_2 is given by $aZ_0'/(a^2 - 1)^2$ which is also equal to 75 ohms. The iterative impedance of the shunt bridged-T network is given by

$$\begin{aligned} a^2 Z_0' &= \frac{2 \times 52.8}{(a^2 - 1)^2} \\ &= 105.6 \text{ ohms} \end{aligned}$$

and this will also be the values of resistors $R_{b''}$ and $R_{c''}$.

When the equaliser is adjusted to give zero top lift, each bridged-T network must be terminated in a resistance equal to its iterative impedance. Thus R' must be 52.8 ohms and R'' 105.6 ohms. As the control knob is advanced to give increasing top lift R' must become steadily smaller (to make Z_{in}' capacitive) reaching zero (a short circuit) in the position of maximum top lift. At the same time R'' must become steadily larger (to make Z_{in}'' inductive) reaching infinity (an open-circuit) in the position of maximum top lift. To maintain a constant input resistance for any position of the top-lift control, R'' must be related to R' according to expression (56) namely

$$R'' = \frac{a^2 Z_0'^2}{(a^2 - 1)^2 R'}$$

To obtain this law R' and R'' may be varied in steps by means of ganged switches which put a separate resistor into circuit in each position. If the maximum top lift is 2.5 dB and the control advances the lift in 0.25 dB steps, an eleven-position switch is required.

We have now to determine suitable values for R_1' , R_2' , L' and C' . These control the frequency response of the series bridged-T network and, as we have seen, this is not the same as that of the variable equaliser but is related to it and to the value of the terminating resistance according to equation (49). The components R_1'' , R_2'' , L'' and C'' similarly control the frequency response of the shunt bridged-T network and these must be chosen to give a response identical with that of the series bridged-T network.

Equation (49) gives

$$\text{loss of equaliser (dB)} = 20 \log_{10} a + 20 \cdot \frac{R' - Z_0'}{R' + Z_0'} \beta^2 \log_{10} a$$

For this circuit $a = 1.414$ and $20 \log_{10} a = 3$

VARIABLE (BODE-TYPE) EQUALISERS

$$\therefore \text{loss of equaliser (dB)} = 3 + 3 \cdot \frac{R' - Z_0'}{R' + Z_0'} \cdot \beta^2$$

When the equaliser control is set to give maximum lift, $R' = 0$

$$\begin{aligned} \therefore \text{loss of equaliser (dB)} &= 3 - 3\beta^2 \\ &= 3(1 - \beta^2) \quad \dots \quad \dots \quad \dots \quad (57) \end{aligned}$$

This may be written in the form

$$\beta = \sqrt{[1 - (\text{loss of equaliser in dB})/3]} \quad \dots \quad \dots \quad (58)$$

The equaliser is usually designed to minimise the loss at 3 Mc/s and we will assume that there is zero loss at this frequency. The total lift is 2.5 dB, making the loss 2.5 dB at low frequencies (say below 100 kc/s) and 1.25 dB at 1 Mc/s (the half-loss frequency). Substituting these values in equation (58) we obtain the following values for β .

Frequency	$\beta = \frac{V_{out}}{V_{in}}$	$20 \log_{10}\beta$
100 kc/s	0.41	-7.76 dB
1 Mc/s	0.764	-2.34 dB
3 Mc/s	1.00	0 dB

A practical bridged-T network to give such a response can be designed as described earlier. From Fig. 104 we can see that the curve labelled $r = 2$ has the required 7.5 dB step. The factor r relates the values of the two resistors R_1' and R_2' according to the relationship

$$r = \frac{R_1'}{R_2'} \quad \dots \quad \dots \quad \dots \quad (59)$$

We also know that the product of R_1' and R_2' must equal $Z_0'^2$

$$\therefore R_1'R_2' = 52.8^2 \quad \dots \quad \dots \quad \dots \quad (60)$$

Multiplying (59) and (60) and taking the square root

$$\begin{aligned} R_1' &= 52.8 \times 1.414 \text{ ohms} \\ &= 74 \text{ ohms} \end{aligned}$$

Dividing (60) by (59) and taking the square root

$$\begin{aligned} R_2' &= \frac{52.8}{1.414} \\ &= 37 \text{ ohms} \end{aligned}$$

The values of L' and C' can be calculated from Fig. 104. This shows that the curve $r = 2$ has the required 2.34 dB loss when f/f_0 is approximately 1.9. From the table above we know that this loss occurs at 1 Mc/s. Thus

$$\begin{aligned} f_0 &= f/1.9 \\ &= 1/1.9 \text{ Mc/s} \\ &= 526 \text{ kc/s} \end{aligned}$$

This is the resonance frequency of L' and C' and we have

$$\begin{aligned} \sqrt{L'C'} &= \frac{1}{2\pi f_0} \\ &= \frac{1}{6.284 \times 526 \times 10^3} \quad \dots \quad \dots \quad (61) \end{aligned}$$

The inductance and capacitance are also related to the iterative impedance thus

$$\begin{aligned} \frac{\sqrt{L'}}{\sqrt{C'}} &= Z_0' \\ &= 52.8 \text{ ohms} \dots \dots \dots (62) \end{aligned}$$

Multiplying (61) by (62)

$$\begin{aligned} L' &= \frac{52.8}{6.284 \times 526 \times 10^3} \text{ H} \\ &= 16 \mu\text{H} \end{aligned}$$

Dividing (62) by (61)

$$\begin{aligned} C' &= \frac{1}{6.284 \times 526 \times 10^3 \times 52.8} \text{ F} \\ &= 0.0057 \mu\text{F} \end{aligned}$$

This method of calculating the values of R_1' , R_2' , L' and C' can also be used to calculate R_1'' , R_2'' , L'' and C'' . All the component values are indicated in Fig. 121 which also gives the values of the resistors used for R' and R'' . This diagram also shows the three other sections of the complete equaliser.

If these also have 3-dB lift, the maximum lift of which the equaliser is capable over the whole video band, is 12 dB.

- POSN. 1 - 0 db LIFT
- 2 - 0.25 "
- 3 - 0.5 "
- 4 - 0.75 "
- 5 - 1.0 "
- 6 - 1.25 "
- 7 - 1.5 "
- 8 - 1.75 "
- 9 - 2.0 "
- 10 - 2.25 "
- 11 - 2.5 "

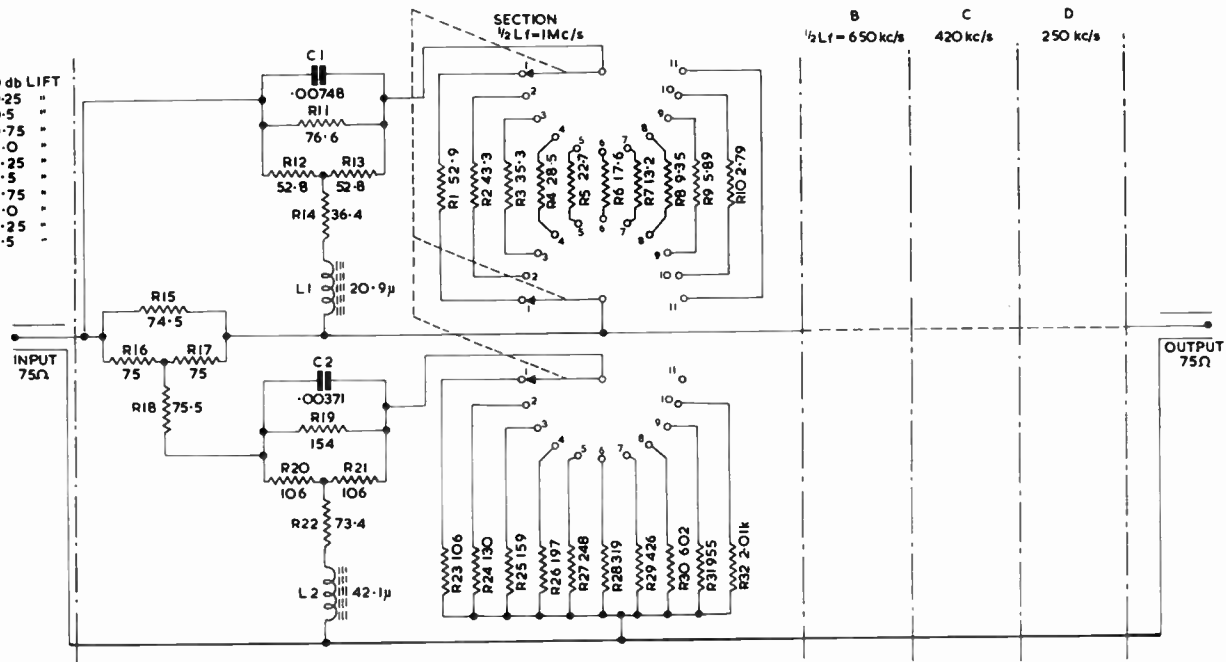

Fig. 121—Illustrating the component values in one section of a constant-resistance Bode-type variable equaliser

APPENDIX G

INPUT IMPEDANCE OF A FOUR-TERMINAL NETWORK

IN Bode-type equalisers the variable elements are four-terminal frequency-discriminating networks with a resistive termination which is varied to produce the desired overall characteristic. In calculating the performance of such an equaliser it is necessary to know how the input impedance of a four-terminal network varies when the terminating resistance is altered. There is a general expression for this which applies to networks and to sections of transmission line; it is given in textbooks on network theory (for example T. E. Shea, *Transmission Networks and Filters*, p. 113). For the particular type of network under discussion this expression is

$$Z_{in} = \frac{R + Z_0 \tan h\theta}{Z_0 + R \tan h\theta} \cdot Z_0 \dots \dots \dots (1)$$

where Z_{in} is the input impedance,

Z_0 is the iterative impedance,

R is the terminating resistance

and θ is the transfer constant; this is defined later.

Substituting for $\tan h\theta$ we have

$$\begin{aligned} Z_{in} &= \frac{R + Z_0(e^\theta - e^{-\theta})/(e^\theta + e^{-\theta})}{Z_0 + R(e^\theta - e^{-\theta})/(e^\theta + e^{-\theta})} \cdot Z_0 \\ &= \frac{(R + Z_0)e^\theta + (R - Z_0)e^{-\theta}}{(R + Z_0)e^\theta - (R - Z_0)e^{-\theta}} \cdot Z_0 \\ &= \frac{1 + (R - Z_0)e^{-2\theta}/(R + Z_0)}{1 - (R - Z_0)e^{-2\theta}/(R + Z_0)} \cdot Z_0 \dots \dots (2) \end{aligned}$$

The transfer constant θ is defined as half the natural logarithm of the volt-amps entering the network to the volt-amps leaving the network when it is correctly terminated. Thus

$$\theta = \frac{1}{2} \log_e \frac{V_{in} I_{in}}{V_{out} I_{out}}$$

VARIABLE (BODE-TYPE) EQUALISERS

Now the input impedance of a correctly terminated symmetrical constant resistance network is equal to its load. Thus $I_{in}/I_{out} = V_{in}/V_{out}$ and

$$\begin{aligned} \theta &= \frac{1}{2} \log_e \left(\frac{V_{in}}{V_{out}} \right)^2 \\ &= \log_e \frac{V_{in}}{V_{out}} \quad \dots \quad \dots \quad \dots \quad \dots \quad \dots \quad (3) \end{aligned}$$

$$\therefore e^\theta = \frac{V_{in}}{V_{out}}$$

$$\therefore e^{-\theta} = \frac{V_{out}}{V_{in}}$$

If we represent V_{out}/V_{in} , the frequency characteristic of the network, by β , we have

$$\beta = \frac{V_{out}}{V_{in}} = e^{-\theta}$$

Substituting in (2)

$$Z_{in} = \frac{1 + (R - Z_0)\beta^2/(R + Z_0)}{1 - (R - Z_0)\beta^2/(R + Z_0)} \cdot R_0 \quad \dots \quad \dots \quad (4)$$

which expresses the input impedance of a four-terminal network in terms of the frequency response β , the iterative impedance Z_0 and the terminating resistance R .

It is stated in the text (p. 173) that the loss of a Bode-type variable equaliser is given by

$$\text{loss in dB} = 20 \log a + 20 \frac{Z_{in}' - Z_0'}{Z_{in}' + Z_0'} \log a \quad \dots \quad \dots \quad (5)$$

where Z_{in}' is the input impedance of a four-terminal network of iterative impedance Z_0' and terminated in a resistance R' . From (4) the value of $(Z_{in}' - Z_0')$ is given by

$$\begin{aligned} Z_{in}' - Z_0' &= \frac{1 + (R' - Z_0')\beta^2/(R' + Z_0')}{1 - (R' - Z_0')\beta^2/(R' + Z_0')} \cdot Z_0' - Z_0' \\ &= \frac{R' + Z_0' + R'\beta^2 - Z_0'\beta^2}{R' + Z_0' - R'\beta^2 + Z_0'\beta^2} Z_0' - Z_0' \\ &= \frac{2(R' - Z_0')\beta^2}{R' + Z_0' - R'\beta^2 + Z_0'\beta^2} Z_0' \quad \dots \quad \dots \quad (6) \end{aligned}$$

Also from (4) the value of $(Z_{in}' + Z_0')$ is given by

$$\begin{aligned} Z_{in}' + Z_0' &= \frac{1 + (R' - Z_0')\beta^2/(R' + Z_0')}{1 - (R' - Z_0')\beta^2/(R' + Z_0')} Z_0' + Z_0' \\ &= \frac{R' + Z_0' + R'\beta^2 - Z_0'\beta^2}{R' + Z_0' - R'\beta^2 + Z_0'\beta^2} Z_0' + Z_0' \\ &= \frac{2(R' + Z_0')}{R' + Z_0' - R'\beta^2 + Z_0'\beta^2} Z_0' \quad \dots \quad \dots \quad (7) \end{aligned}$$

From (6) and (7)

$$\therefore \frac{Z_{in}' - Z_0'}{Z_{in}' + Z_0'} = \frac{R' - Z_0'}{R' + Z_0'} \beta^2$$

Substituting for $(Z_{in}' - Z_0')/(Z_{in}' + Z_0')$ in (5)

$$\text{loss in dB} = 20 \log a + 20 \frac{R' - Z_0'}{R' + Z_0'} \beta^2 \log a$$

which is expression (49) in the text

APPENDIX H

DERIVATION OF THE FORM OF THE SHUNT ARM IN A CONSTANT-RESISTANCE BODE-TYPE VARIABLE EQUALISER

It is shown in the text that a constant-resistance Bode-type variable equaliser requires a shunt impedance consisting of a resistance $aZ_0'/(a^2 - 1)^2$ in series with an impedance Z_{in}'' . The resistance depends only on a and Z_0' and is thus constant for a given equaliser. The impedance Z_{in}'' varies with frequency and with the terminating resistance R' of the series bridged-T networks, being given by

$$Z_{in}'' = \frac{1 + (Z_0' - R')\beta^2/(Z_0' + R')}{1 - (Z_0' - R')\beta^2/(Z_0' + R')} \cdot \frac{a^2 Z_0'}{(a^2 - 1)^2}$$

as deduced in the text. It is the purpose of this appendix to deduce the form and component values of a network having such a value of input impedance Z_{in}'' .

If we multiply all the Z_0 's and R 's in the first part of this expression by $a^2 Z_0' / (a^2 - 1)^2 R'$ we have

$$Z_{in}'' = \frac{1 + \left[\frac{a^2 Z_0'^2}{(a^2 - 1)^2 R'} - \frac{a^2 Z_0'}{(a^2 - 1)^2} \right] \beta^2 / \left[\frac{a^2 Z_0'^2}{(a^2 - 1)^2 R'} + \frac{a^2 Z_0'}{(a^2 - 1)^2} \right]}{1 - \left[\frac{a^2 Z_0'^2}{(a^2 - 1)^2 R'} - \frac{a^2 Z_0'}{(a^2 - 1)^2} \right] \beta^2 / \left[\frac{a^2 Z_0'^2}{(a^2 - 1)^2 R'} + \frac{a^2 Z_0'}{(a^2 - 1)^2} \right]} \cdot \frac{a^2 Z_0'}{(a^2 - 1)^2}$$

which can be simplified by writing Z_0'' for $a^2 Z_0' / (a^2 - 1)^2$ and R'' for $a^2 Z_0' / (a^2 - 1)^2 R'$. We then have

$$Z_{in}'' = \frac{1 + (R'' - Z_0'')\beta^2 / (R'' + Z_0'')}{1 - (R'' - Z_0'')\beta^2 / (R'' + Z_0'')} \cdot Z_0''$$

Comparing this with expression (4) of Appendix G we can see that this is the expression for the input impedance of a bridged-T network having an iterative impedance Z_0'' and terminated in a resistance R'' . Thus the network required in the shunt arm should be a bridged-T of iterative impedance Z_0'' given by

$$Z_0'' = \frac{a^2 Z_0'}{(a^2 - 1)^2}$$

and terminated in a resistance R'' given by

$$R'' = \frac{a^2 Z_0'^2}{(a^2 - 1)^2 R'}$$

CHAPTER 10

ELECTRICAL CHARACTERISTICS OF SCANNING COILS

10.1 INTRODUCTION

DEFLECTION of electron beams in camera and picture tubes is usually achieved by passing sawtooth currents through coils clamped to the exterior of the tubes, the current being supplied by an amplifier having a sawtooth input voltage. The output stage of this amplifier has to deliver a current of the desired waveform into the scanning coils which, in general, have an impedance with reactive and resistive components. The problem of supplying this current is by no means as straightforward as might be imagined and in practice is complicated by the addition of efficiency diodes and e.h.t. rectifiers to line-scanning output stages. This chapter describes the basic principles of line and field scanning output stages.

10.2 FUNDAMENTAL PRINCIPLES OF ELECTROMAGNETIC SCANNING

To give the required scanning pattern, tubes are fitted with two pairs of deflection coils, one pair being fed with current at line frequency to deflect the electron beam horizontally, the other pair being fed with current at field frequency to deflect the beam vertically. Each pair of coils operates by producing within the tube a magnetic field which reacts with the axial velocity of the electron beam to produce a deflecting force in the required direction.

If the electron beam in a tube is deflected through a small angle the displacement of the scanning spot is proportional to the magnetic field which is, in turn, proportional to the current in the scanning coils. For such small angular deflections a constant-velocity displacement of the spot requires a linear change of current in the coils. Accurate sawtooth currents at field frequency and line frequency are therefore required for scanning. This is true for angular beam deflections up to approximately ± 25 degrees and thus applies to camera tubes and to early types of picture tube. It does not, however, apply to more modern picture tubes which require a maximum angular beam displacement of ± 35 or ± 45 degrees.

ELECTRICAL CHARACTERISTICS OF SCANNING COILS

These tubes have flat screens and, if the beam is deflected at constant angular velocity (as by a true sawtooth current), the speed of movement of the spot varies across the screen, being a minimum at the centre of the screen (where the beam length is least) and a maximum near the edge (where the beam length is greatest). To obtain a linear movement of the spot, the waveform of the current fed to the scanning coils can be varied from the sawtooth form or the e.h.t. supply to the final anode of the tube can be modulated at field and line frequencies to vary the deflection sensitivity so as to produce linear horizontal and vertical scans.

Chapters 10 to 12 describe the basic principles of the circuits used in line-scanning and field-scanning output stages: it is assumed that the angular deflection is small and that scanning currents of sawtooth form are required to give a linear raster.

10.3 IMPEDANCE OF SCANNING COILS

The magnetic field required to deflect the beam of a cathode-ray tube through an angle depends on the electron-beam velocity and on the geometry of the tube. The field produced by a pair of scanning coils depends on the number of turns of wire, the current and on the properties and shape of any magnetic yoke used in the coils. It is possible to produce a given field by use of a small number of turns and a large current or, alternatively, by use of a large number of turns and a small current. Whether the number of turns is small or large, the scanning coils inevitably have inductance and their impedance therefore has an inductive reactive component in addition to the resistive component representing the ohmic losses in the windings.

Inductive reactance is, of course, directly proportional to frequency and at the low field frequency the reactance is in general small compared with the resistance. At the much higher line frequency, however, the inductive reactance is usually larger than the resistance. In confirmation of this, consider a pair of coils for which the inductance is 6 mH and the resistance 12 ohms; these are typical practical values. At a field frequency of 50 c/s the inductive reactance is given by

$$\begin{aligned}2\pi fL &= 2 \times 3.142 \times 50 \times 6 \times 10^{-3} \text{ ohms} \\ &= 2.04 \text{ ohms}\end{aligned}$$

only 1/6th of the resistance. The line frequency in the British system is approximately 200 times the field frequency and the reactance of this pair of coils at the line frequency is approximately

$2.04 \times 200 = 408$ ohms, 34 times the resistance. Thus the field coils may be regarded as being substantially resistive and the line coils as substantially inductive.

10.4 BASIC FEATURES OF SCANNING OUTPUT STAGES

The object in the design of a scanning output stage is to obtain a sawtooth current in the scanning coils. One way of achieving this is by use of a high-impedance source delivering current of the desired waveform directly into the scanning coils. Provided the source impedance is large compared with that of the coils the current in the coils approximates to the required sawtooth form in spite of any variation of scanning-coil impedance; in other

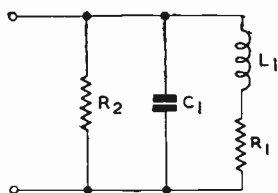

Fig. 122—Equivalent electrical circuit for a pair of scanning coils

words if the source impedance is sufficiently high it does not matter whether the scanning coils are resistive or reactive at the operating frequency.

If, however, the source has an impedance low compared with that of the scanning coils the current in the coils is affected by impedance variations and it is better to express the circuit behaviour in terms of the voltage generated across the coils. For a low-impedance source the voltage generated across the coils is substantially independent of variations in coil impedance. The low-impedance source should thus deliver an output voltage which gives a sawtooth current in the coils. If the scanning coils are resistive, the current in them is proportional to the output voltage of the source; this should therefore be of sawtooth waveform. If, however, the scanning coils are reactive, the output waveform must not be of sawtooth form and it is important to know the shape of the output waveform required to give the sawtooth current necessary for linear scanning. We will therefore determine the waveform of the voltage across a pair of scanning coils when the current in them is of sawtooth form.

10.5 EQUIVALENT CIRCUIT OF SCANNING COILS

In addition to the inductance and resistance the windings of scanning coils have self-capacitance (which usually lies between

50 pF and 200 pF) and if the coils contain a magnetic core, a parallel resistive component representing the hysteresis losses in the core. Thus the full equivalent circuit for a pair of scanning coils has the form shown in Fig. 122, in which R_1 , L_1 and C_1 represent the electrical properties of the coils and R_2 represents core losses. When a sawtooth current is passed through the coils, R_1 and L_1 primarily determine the voltage waveform during the change of current on forward strokes, whereas L_1 , R_2 and C_1 determine the waveform during the rapid change of current on flyback.

10.6 WAVEFORM OF VOLTAGE ACROSS FIELD-SCANNING COILS

We shall deal first with the field-scanning coils. The current waveform required for field scanning is shown in idealised form in Fig. 123 in which a double amplitude peak value of 0.4 A is assumed; this is a typical practical value for coils having an inductance of 6 mH and a resistance of 12 ohms. The voltage waveform generated across R_1 has the same waveform as that of the current and in fact is given by the product of resistance and current. If the resistance is 12 ohms the voltage across it varies between $-0.2 \times 12 = -2.4$ volts and $+0.2 \times 12 = +2.4$ volts as shown in Fig. 123. The voltage generated across L_1 depends on the rate of change of current, being given by $L \cdot di/dt$. On the forward stroke the current changes at the rate of 0.4 A in 18 msec and the voltage is thus given by

$$\begin{aligned} L \cdot \frac{di}{dt} &= \frac{6 \times 10^{-3} \times 0.4}{18 \times 10^{-3}} \\ &= 0.133 \text{ volts} \end{aligned}$$

in which the inductance is taken as 6 mH. During flyback the current changes at the rate of 0.4 A in 2 msec, 9 times as rapidly as on the forward stroke. The voltage across L_1 is thus $-0.133 \times 9 = -1.2$ volts, opposite in sense to that occurring across on the forward stroke because the current change is opposite in sign. The rate of change of current is constant throughout the forward scan and throughout the flyback period in these idealised waveforms; thus the voltage across L_1 is constant throughout both periods. The voltage across L_1 is small compared with that across R_1 on the forward stroke and equal to half of that across R_1 during flyback. The voltage across the scanning coil is the sum of those across L_1 and R_1 and is illustrated in Fig. 123 (d); it is very similar to the waveform across R_1 (given at (b)) thus confirming the point made above that the field-scanning coils behave as substantially resistive.

The magnetic field required for deflection of the electron beam in a cathode-ray tube depends on the angular deflection required, the final anode voltage of the tube and on the tube geometry. It has nothing to do with the line and field frequencies and the field required for horizontal deflection does not greatly differ from that required for vertical deflection. In fact, to a first degree of approximation, the ratio of horizontal to vertical deflecting field is 4 : 3, this being the aspect ratio of the picture. It follows that the current required in the line-scanning coils is 4/3 times that required in the field-scanning coils. In spite of this approximate equality of scanning currents the voltage generated across the line-scanning coils differs markedly from that generated across the field-scanning coils. This is because the rate of change of line-scanning current is much greater than that of field-scanning current. This is illustrated in the following calculations which determine the waveform of the voltage generated across line-scanning coils for a sawtooth current flowing in them.

10.7 WAVEFORM OF VOLTAGE ACROSS LINE-SCANNING COILS

Consider now the voltage generated across a pair of line-scanning coils. We shall assume that the current is of sawtooth form with a double amplitude peak value of 0.4 A as shown at (a) in Fig. 124; to facilitate comparison with the results for field-scanning coils this is the same amplitude as for the field-scanning coils. The forward stroke of the line-scanning current occupies approximately 90 μ sec and the flyback 10 μ sec. The scanning coils are taken to have a resistance of 12 ohms and an inductance of 6 mH (as for the field-scanning coils). The voltage generated by the line-scanning current in flowing through the resistance of the coils has the same waveform as the current and the double amplitude peak value is $12 \times 0.4 = 4.8$ volts as shown at (b) in Fig. 124. The voltage generated across the inductance is given by $L \cdot di/dt$. On the forward stroke the current changes at the rate of 0.4 A in 90 μ sec and the constant voltage across the inductance is therefore given by

$$\begin{aligned} L \cdot \frac{di}{dt} &= 6 \times 10^{-3} \times \frac{0.4}{90 \times 10^{-6}} \text{ volts} \\ &= 26.7 \text{ volts} \end{aligned}$$

On the flyback stroke the rate of change of current is nine times as great and the voltage generated across the inductance is therefore

ELECTRICAL CHARACTERISTICS OF SCANNING COILS

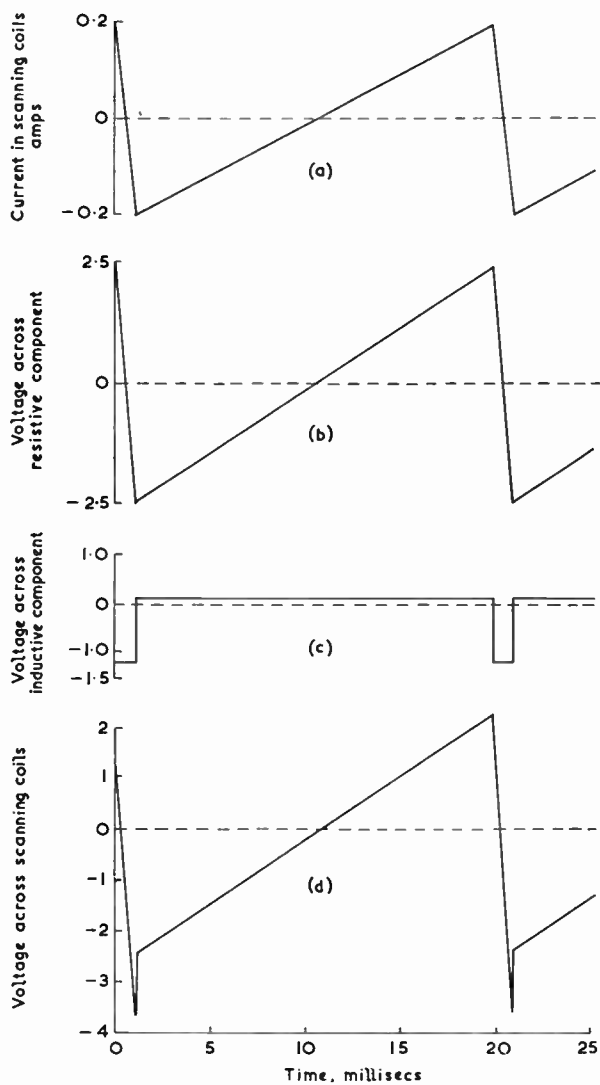

Fig. 123—Voltage waveforms in a pair of field-scanning coils fed with an ideal sawtooth current

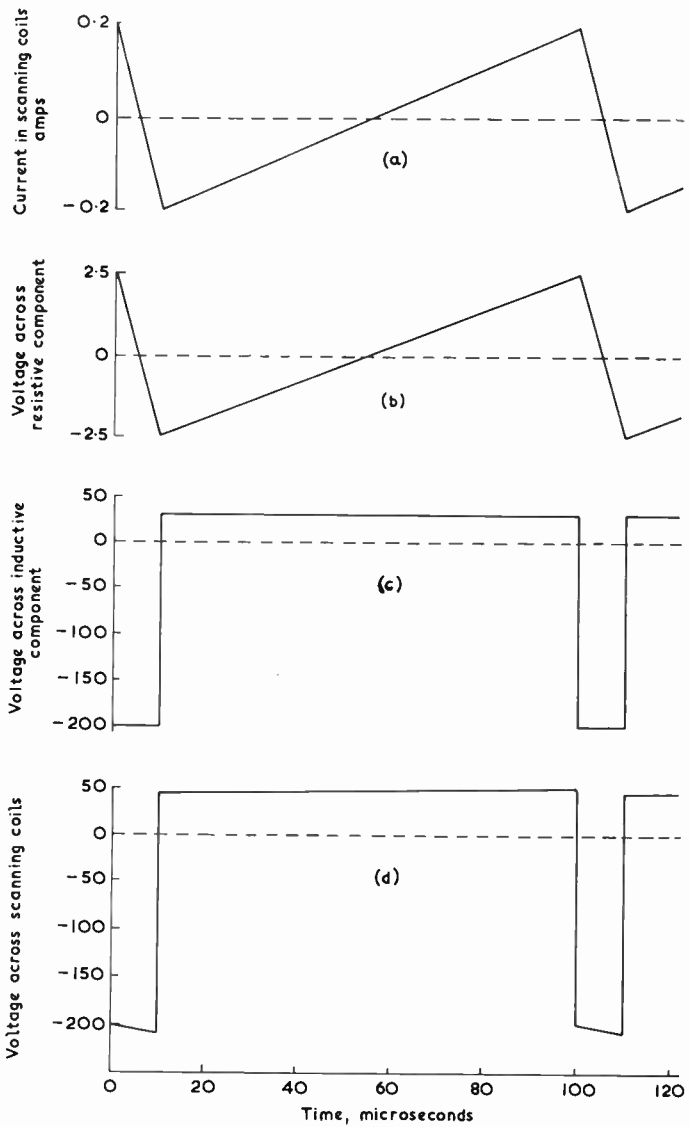

Fig. 124—Voltage waveforms in a pair of line-scanning coils fed with an ideal sawtooth current

$9 \times 26.7 = 240$ volts, the polarity being opposite to that generated during the forward stroke as shown in Fig. 124.

The voltage (d) across the line-scanning coils is the sum of (b) and (c); it is similar in waveform to (c), the waveform across the inductance, confirming a point made earlier, namely that the line-scanning coils behave as though they were predominantly inductive. The field-scanning coils were predominantly resistive in nature; this difference in behaviour of coils with the same resistance and inductance is due to the greater rate of change of the current at the line-scanning frequency.

In evaluating the waveform shown in the last two diagrams, it was assumed that flyback occupied 10 per cent of the period of the forward stroke. In practice the flyback time is often less than this and the voltage generated across the scanning coils is greater than that shown in the diagrams. For example the voltage across line-scanning coils during flyback may reach 600 volts. This is approximately three times that indicated in Fig. 124 and attention must be paid to the insulation of the coils to avoid breakdown or sparking. The voltage generated by the rapid collapse of line-scanning current is often used as the e.h.t. voltage for the final anode of picture tubes.

We have shown that line-scanning coils must be regarded as predominantly inductive and field-scanning coils as predominantly resistive. As a consequence the voltage which must be applied to line-scanning coils to give a sawtooth current has a different waveform from that which is needed across field-scanning coils. Thus the circuit of a line output stage differs from that of a field output stage and the two types of output will be considered separately. The field output stage is the simpler of the two and will be described first.

CHAPTER 11

FIELD OUTPUT STAGES

11.1 INTRODUCTION

THE prime mover in a scanning circuit is a sawtooth generator and most of these are designed to deliver a reasonably undistorted sawtooth output voltage. To obtain a sawtooth current, this voltage can be applied to the grid of a valve, the scanning coils being connected directly in the anode circuit of the valve as shown in Fig. 125. At the low field frequency, scanning coils are resistive and may be fed from a low- or a high-impedance source of sawtooth voltage; thus the valve may be a triode with low anode a.c. resistance or a pentode with a high anode a.c. resistance. In such a simple output circuit the scanning coils should be designed to give adequate scan for a peak current of less than say 40 mA, for this is the largest current which can be supplied without distortion by a small receiving-type valve; such coils would require an inductance larger than assumed earlier. Moreover the steady anode current of the valve gives a static magnetic field within the cathode-ray tube and the permanent beam deflection so produced must be offset.

11.2 TRANSFORMER-COUPLED CIRCUIT

For the reasons given above high-impedance scanning coils are not favoured and normal practice is to use low-impedance coils, with a resistance of say 12 ohms and an inductance of say 6 mH, connected to the output valve by a matching transformer as shown in Fig. 126. For simplicity the valve is shown as a triode but in practice a pentode is frequently used.

For adequate deflection the current in the scanning coils should be 0.2 A peak but if the transformer has a step-down ratio of $n : 1$, the current supplied by the valve to the primary winding is only $0.2/n$ A. The primary current may be made as small as desired by increasing n but a limit is set by the sawtooth voltage across the primary winding. For a given secondary current, this voltage is proportional to n and any attempt to make the primary voltage exceed a certain value will result in distortion of the output sawtooth. The problem is analogous to that of choosing the

FIELD OUTPUT STAGES

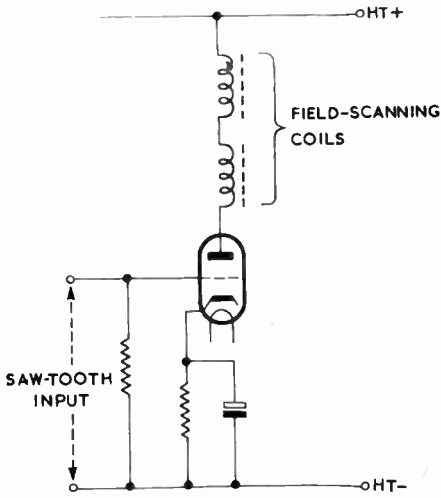

Fig. 125—Simple output stage with scanning coils connected directly in the anode circuit

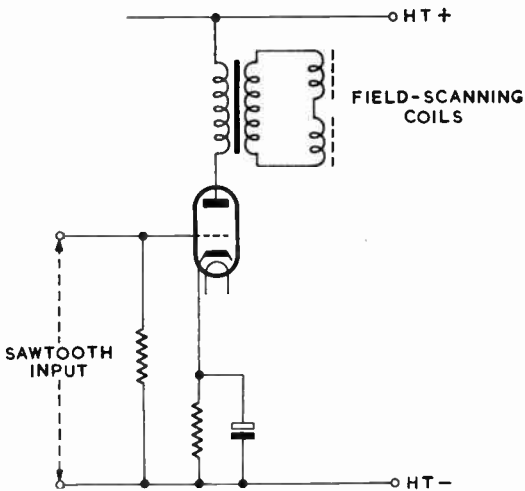

Fig. 126—Basic circuit for transformer-coupled field scanning output stage

ratio of a loudspeaker matching transformer except that in the deflection problem we started from a knowledge of the current required in the load, whereas, in the loudspeaker problem it is usual to begin from the loudspeaker impedance. In both examples the optimum value of n is given by

$$n = \sqrt{(\text{optimum load/load impedance})}$$

We have already shown that the field-scanning coils approximate to a resistive load and the load impedance is thus 12 ohms. The optimum load of the valve is that into which the valve can deliver maximum power; it is that value which gives maximum permissible anode voltage swing when the anode current swing is a maximum. If the valve is a triode the peak voltage swing is approximately one-half the h.t. voltage and the peak current swing is equal to the steady anode current. If the h.t. supply is 250 volts and the anode current 20 mA, the optimum load is given by

$$\frac{125}{20 \times 10^{-3}} = 6,250 \text{ ohms}$$

and the turns ratio of the transformer is

$$\begin{aligned} n &= \sqrt{(\text{optimum load/load impedance})} \\ &= \sqrt{(6,250/12)} \\ &= 23 : 1 \text{ approximately} \end{aligned}$$

For this value of n , the primary current has a peak value of $200/23$, i.e. 8.7 mA which is less than one-half the steady anode current. The peak primary voltage is given by

$$6,250 \times 8.7 \times 10^{-3} = 54.3 \text{ volts}$$

less than half the permissible undistorted anode voltage swing. Thus the valve is easily capable of supplying the voltage and current required by the field-scanning coils.

If the output valve is a pentode, the peak anode voltage swing permissible without distortion is nearly equal to the h.t. supply voltage; the optimum load is thus double that of a triode with the same anode current. If the h.t. voltage is 250 and the anode current 20 mA, the optimum load is $250/(20 \times 10^{-3}) = 12,500$ ohms and the matching transformer ratio $\sqrt{(12,500/12)} = 32 : 1$. The peak primary current is $200/32 = 6.25$ mA, approximately one-third the anode current. The peak anode voltage is $12,500 \times 6.25 = 78$ volts, one third of the h.t. voltage.

FIELD OUTPUT STAGES

Whether the output valve is a triode or a pentode, the anode current of 20 mA assumed above is more than adequate to provide the power output required by the field-scanning coils and, in fact, a pentode with only 10 mA of anode current could supply the required output.

11.3 EFFECT OF PRIMARY INDUCTANCE OF FIELD OUTPUT TRANSFORMER

The field coils approximate to a purely resistive load and the effective load impedance appearing at the primary winding of the output transformer is also purely resistive. For the pentode output stage the value of this resistance is 12,500 ohms, the optimum load. This is not, however, the only load in the anode circuit of the valve; in parallel with this resistance is the primary inductance

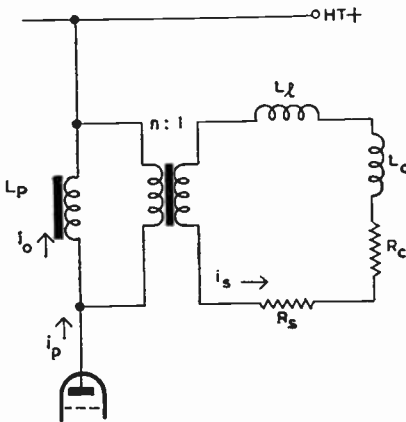

Fig. 127—Equivalent circuit of field output stage

of the output transformer and this can have a marked effect on the anode current waveform necessary to give a sawtooth current in the scanning coils. The precise effect of the inductance can be determined from an equivalent circuit such as that shown in Fig. 127. The transformer of $n:1$ turns ratio shown here is assumed to be a perfect component with infinite primary and secondary inductances. Such a transformer has the effect of transforming loads from secondary to primary circuits without impressing any of its own characteristics on the loads.

A real transformer cannot do this and in a field output stage the features of the transformer which fall short of perfection and must

be allowed for in a practical design are the primary inductance, leakage inductance and secondary resistance. These can be taken into account as shown in Fig. 127; the primary inductance L_p is connected in parallel with the primary winding of the perfect transformer and the leakage inductance together with the secondary resistance are included in series with the field coils in the secondary circuit. L_c and R_c are the field-coil inductance and resistance respectively. The current in the secondary circuit is i_s ; this is the current in the scanning coils which must be of sawtooth waveform to give linear scanning.

The circuit may be simplified as shown in Fig. 128 by omitting the perfect transformer, replacing i_s , L_l , L_c , R_c , R_s by their effective values at the primary of the transformer. In the primary circuit the transferred inductances and resistances have n^2 times their

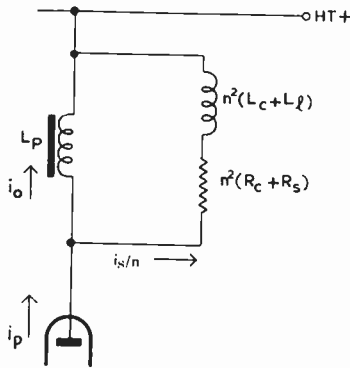

Fig. 128—Equivalent circuit of field output stage with all secondary loads referred to the primary side

values in the secondary circuit but the scanning current i_s has an effective value i_s/n in the primary circuit. The primary current i_p supplied by the valve has two components: one is i_s/n , the scanning current, and the other i_o , a current flowing in the shunt inductance of the output transformer. The first component i_s/n is, of course, useful but the second is an unwanted component which is present because the primary inductance of the transformer is not infinite. It is a distortion term, important because the valve must supply it in addition to the sawtooth component. Because of this distortion component the primary current i_p cannot be of the same waveform as i_s ; in other words i_p is not of sawtooth waveform.

FIELD OUTPUT STAGES

From the equivalent circuit of Fig. 128 it is possible to deduce the waveform of i_p which produces the required sawtooth waveform of i_s . To begin with consider Fig. 129 which shows the waveform of i_s in idealised form, having zero flyback period. The peak-to-peak amplitude of the sawtooth wave is I and the equation, referred to an origin coinciding with the mid-point of a flyback period, is

$$i_s = I \left(\frac{t}{T} - \frac{1}{2} \right) \quad \dots \quad \dots \quad \dots \quad (63)$$

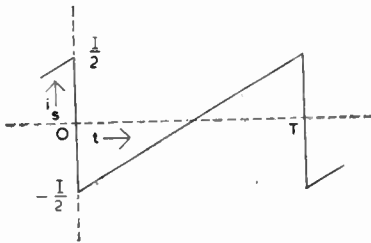

Fig. 129—Ideal sawtooth waveform required in scanning coils

The current i_s/n in the equivalent circuit (Fig. 128) flows through the resistance $n^2(R_c + R_s)$ and generates a voltage given by

$$\frac{i_s}{n} \cdot n^2(R_c + R_s) = ni_s(R_c + R_s) \quad \dots \quad \dots \quad (64)$$

which, like i_s , is of sawtooth waveform. The current i_s/n also flows in the inductance $n^2(L_c + L_l)$ and generates a voltage given by

$$\frac{1}{n} \cdot \frac{di_s}{dt} \cdot n^2(L_c + L_l) = n \cdot \frac{di_s}{dt} (L_c + L_l) \quad \dots \quad (65)$$

This voltage is proportional to the time differential of the sawtooth and hence has a rectangular waveform. The net voltage across the primary winding is given by the sum of the sawtooth and rectangular components thus

$$\text{voltage across } L_p = ni_s(R_c + R_s) + n \cdot \frac{di_s}{dt} (L_c + L_l) \quad \dots \quad (66)$$

From (63)

$$\frac{di_s}{dt} = \frac{I}{T} \quad \dots \quad \dots \quad \dots \quad (67)$$

Substituting for i_s from (63) and di_s/dt from (67) we have

$$\begin{aligned} \text{voltage across } L_p &= nI \left(\frac{t}{T} - \frac{1}{2} \right) (R_c + R_s) + \frac{nI}{T} (L_c + L_l) \\ &= nI \left[\left(\frac{t}{T} - \frac{1}{2} \right) (R_c + R_s) + \frac{1}{T} (L_c + L_l) \right] \end{aligned} \quad (68)$$

Now the voltage across L_p can also be expressed in terms of L_p and the current i_o in L_p thus

$$\text{voltage across } L_p = L_p \cdot \frac{di_o}{dt} \quad \dots \quad (69)$$

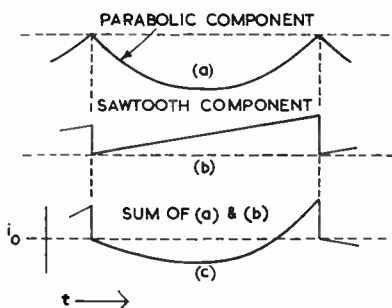

Fig. 130—The distortion current shown at (c) is composed of the parabolic wave (a) and the sawtooth wave (b)

Equating (68) and (69)

$$L_p \cdot \frac{di_o}{dt} = nI \left[\left(\frac{t}{T} - \frac{1}{2} \right) (R_c + R_s) + \frac{1}{T} (L_c + L_l) \right]$$

This can be integrated to obtain the form of the current i_o

$$\begin{aligned} i_o &= \frac{nI}{L_p} \int \left[\left(\frac{t}{T} - \frac{1}{2} \right) (R_c + R_s) + \frac{1}{T} (L_c + L_l) \right] dt \\ &= \frac{nI}{L_p} \left[\left(\frac{t^2}{2T} - \frac{t}{2} \right) (R_c + R_s) + \frac{t}{T} (L_c + L_l) \right] + a \text{ constant} \end{aligned} \quad (70)$$

This current i_o therefore contains a component which depends on t^2 and is therefore parabolic in form, another component which is proportional to t and is therefore of sawtooth form and a third component which is constant and independent of time. The wave-forms of the parabolic component is illustrated at (a) in Fig. 130, 202

FIELD OUTPUT STAGES

that of the sawtooth component at (b) and the sum which (if the steady component is neglected) is the waveform of i_o is shown at (c). The significant feature of the curve (c) is the negative slope for small values of t . Equation (70) shows that the value of this slope is inversely proportional to L_p ; that is to say small values of L_p give a large negative slope and large values of L_p small negative slope.

The primary current i_p is the sum of i_n/n and i_o as shown in Fig. 128 and is thus given by

$$i_p = i_s/n + i_o$$

Substituting for i_s from (63) and i_o from (70)

$$i_p = \frac{I}{n} \left(\frac{t}{T} - \frac{1}{2} \right) + \frac{nI}{L_p} \left[\left(\frac{t^2}{2T} - \frac{t}{2} \right) (R_c + R_s) + \frac{t}{T} (L_c + L_l) \right] + a \text{ constant} \dots (71)$$

Fig. 131 illustrates the waveforms of the two components i_o and i_s/n which make up the primary waveform. If the inductance L_p

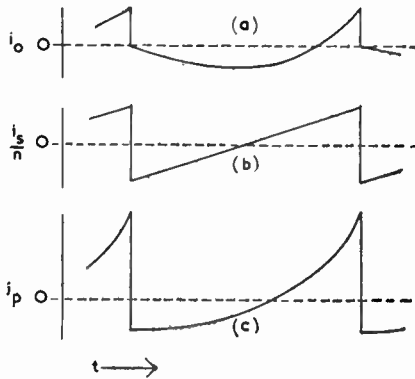

Fig. 131—The primary waveform (c) is made up of the distortion current (a) and the sawtooth current (b)

is large the initial negative slope of i_o is insufficient to offset the positive slope of i_s/n and the primary-current waveform has a positive slope which steadily increases throughout the working stroke. If the primary inductance is small the initial negative slope of i_p exceeds the positive slope of i_s/n and the slope of the primary current waveform changes from negative to positive during the working stroke as shown in Fig. 132. To give i_s the required

sawtooth shape. the current i_p delivered by the valve to the transformer primary winding must have a waveform of the type shown in Fig. 132. This implies that the valve input voltage should also have a shape similar to that of Fig. 132. If the scanning generator has a true sawtooth voltage output, then it will be necessary to include a shaping network between generator and output stage to give the required output current waveform.

It is possible to design, without great difficulty, a shaping network to produce a waveform such as that of Fig. 132 (a) in which there is no change in the sign of the slope during the working stroke. It is not at all easy, however, to obtain an output shaped as in

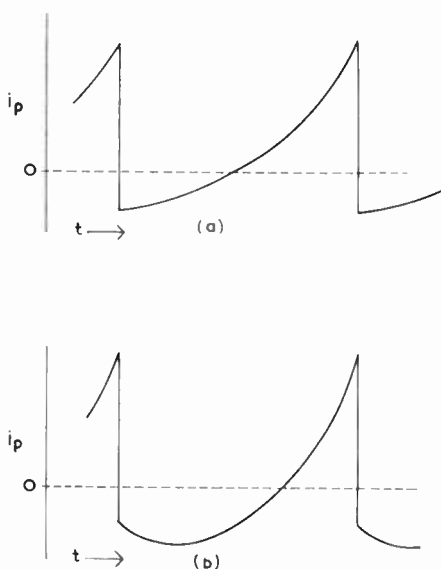

Fig. 132—Primary current waveforms needed to give a sawtooth secondary current for (a) a large primary inductance and (b) a small primary inductance

Fig. 132 (b) from a shaping network with a sawtooth input. To facilitate the design of shaping networks, therefore, the output stage should be such that the slope of the primary current waveform at the beginning of each working stroke does not fall below zero. This initial slope chiefly depends on the primary inductance of the output transformer, and this requirement sets a lower limit on the value of this inductance. The value of this lower limit can be calculated in the following way.

FIELD OUTPUT STAGES

The slope of the anode-current waveform can be obtained by differentiating expression (71). This gives

$$\frac{di_p}{dt} = \frac{I}{nT} + \frac{nI}{L_p} \left(\frac{t}{T} - \frac{1}{2} \right) (R_c + R_s) + \frac{nI}{L_p} \cdot \frac{L_c + L_l}{T} \quad \dots \quad (72)$$

At $t = 0$, the slope has a value given by

$$\frac{di_p}{dt} = \frac{I}{nT} - \frac{nI}{2L_p} (R_c + R_s) + \frac{nI}{L_p} \cdot \frac{L_c + L_l}{T}$$

Equating this to zero we have

$$0 = \frac{1}{nT} - \frac{n}{L_p} \left[\frac{R_c + R_s}{2} - \frac{L_c + L_l}{T} \right]$$

$$\therefore L_p = n^2 T \left(\frac{R_c + R_s}{2} - \frac{L_c + L_l}{T} \right) \dots \dots \dots (73)$$

To obtain an estimate of the value of this, the minimum value of primary inductance, let

$n^2 = 12,500/12$ as for the pentode field output stage mentioned above

$T = 20$ msec

$R_c = 12$ ohms

$R_s = 2$ ohms, a typical practical value

$L_c = 6$ mH

$L_l = 10$ mH, a typical practical value

Substituting in (73)

$$\begin{aligned} L_p &= \frac{12,500 \times 20 \times 10^{-3}}{12} \left(\frac{12 + 2}{2} - \frac{6 \times 10^{-3} + 10 \times 10^{-3}}{20 \times 10^{-3}} \right) \text{ H} \\ &= \frac{250}{12} (7 - 0.8) \text{ H} \\ &= 130 \text{ H approximately} \end{aligned}$$

In expression (73) for the minimum value of L_p the term $(L_c + L_l)/T$ is small compared with $(R_c + R_s)/2$. A simpler expression for L_p can thus be obtained by neglecting $(L_c + L_l)/T$. The value of L_p is thus given by

$$L_p \approx \frac{n^2 T (R_c + R_s)}{2}$$

A further simplification which can be made is to neglect R_s in comparison with R_c . Substituting R_{opt}/R_c for n^2 we have

$$L_p \approx \frac{R_{opt}T}{R_c} \cdot \frac{R_c}{2} \\ \approx \frac{R_{opt}T}{2} \quad \dots \quad \dots \quad \dots \quad \dots \quad (74)$$

As an indication of the error introduced by these simplifications, substitute the values of R_{opt} and T for the previous calculation. We have

$$L_p \approx \frac{12,500 \times 20 \times 10^{-3}}{2} \text{ H} \\ = 125 \text{ H}$$

Expression (74) shows that L_p depends primarily on the optimum load of the output valve and the period of the forward stroke. It is not greatly affected by the constants of the scanning coils or the leakage inductance of the transformer.

11.4 PRACTICAL FIELD-SCANNING CIRCUITS

In order to design a satisfactory field-output stage the non-linearity due to the finite primary inductance of the output transformer must be offset. There are a number of ways in which this can be achieved and the following paragraphs describe the chief methods employed.

11.4.1 *Circuit utilising the Curvature of a Valve I_a - V_g Characteristic*

The shape of anode current waveform required for linear scanning is shown in Fig. 132 (a). This is similar in form to the I_a - V_g characteristic of a valve and it is possible to obtain reasonable linearity of field scan by using a transformer with a primary inductance greater than the minimum value defined in equation (73) and by applying a sawtooth input to the grid of the output stage in such a manner that the whole length of the characteristic is used, from anode current cut-off to zero grid voltage. The valve is here used as a non-linear amplifier, i.e. as an active shaping network. This method is more satisfactory with triode than with pentode output stages because the dynamic I_a - V_g characteristic for a triode is a better approximation to the required shape. However, the performance of the circuit may vary when the triode

206

FIELD OUTPUT STAGES

ages or if the triode is exchanged for another with a different shape of characteristic. The chief merit of this method is its simplicity; the methods described below are better because their performance does not depend so critically on the shape of valve characteristics.

11.4.2 *Circuit utilising a Shaping Network*

The output valve may be operated on the linear portion of its I_a-V_g characteristic and the required parabolic anode-current waveform obtained by inserting a shaping network between the sawtooth voltage source and the valve grid. The effect of finite primary inductance is to cause a loss of low-frequency response and the shaping network must therefore provide an effective low-frequency boost. The RC network shown in Fig. 133 achieves this by attenuating high frequencies more than low. However, to obtain a true parabolic characteristic, as required for linear scanning

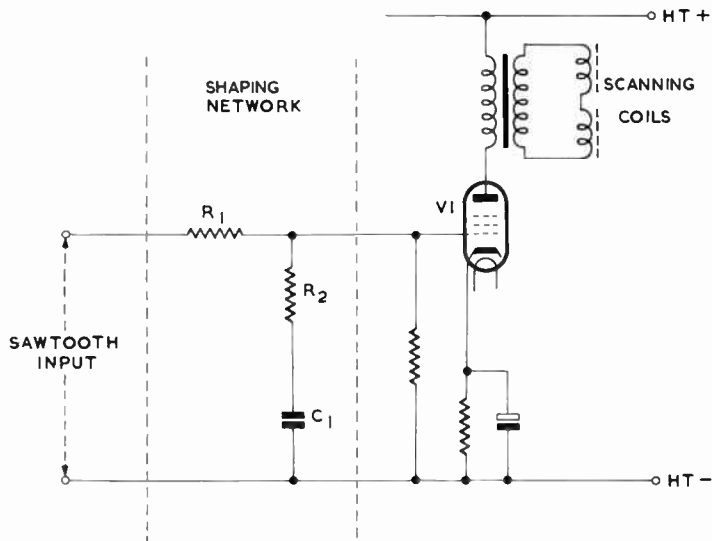

Fig. 133—Circuit in which linearity of field-scan is obtained by use of a shaping network at the input to the output valve

R_1 must be infinite. With such a value the network gives infinite attenuation and in practice R_1 is given the largest value which leaves V1 with adequate input signal. Provided the initial sawtooth input is of large amplitude this circuit can give satisfactory results. The values of R_2 and C_1 can be calculated as follows.

The current in the circuit is given by

$$i = \frac{V}{R_1 + R_2 + 1/j\omega C_1}$$

If R_1 is large compared with R_2 and $1/j\omega C_1$ we have

$$i \approx \frac{V}{R_1} \dots \dots \dots (75)$$

showing that the current is directly proportional to the applied voltage. If the voltage V is of sawtooth form, it may be written

$$V = V_o \left(\frac{t}{T} - \frac{1}{2} \right) \dots \dots \dots (76)$$

where V_o is the peak amplitude of the applied sawtooth voltage. Substituting for V in (75) we have

$$i \approx \frac{V_o}{R_1} \left(\frac{t}{T} - \frac{1}{2} \right) \dots \dots \dots (77)$$

The output voltage is generated across R_2 and C_1 by the current i and is given by

$$i \cdot R_2 + \frac{1}{C_1} \int idt$$

Substituting for i

$$\begin{aligned} \text{output voltage} &= \frac{V_o}{R_1} \left(\frac{t}{T} - \frac{1}{2} \right) R_2 + \frac{1}{C_1} \cdot \frac{V_o}{R_1} \left(\frac{t^2}{2T} - \frac{t}{2} \right) + \text{constant} \\ &= \frac{V_o}{2R_1 C_1 T} \cdot t^2 + \left(\frac{V_o R_2}{R_1 T} - \frac{V_o}{2R_1 C_1} \right) t - \frac{V_o R_2}{2R_1} + \text{constant} \\ &= \frac{V_o}{R_1} \left[\frac{t^2}{2C_1 T} + \left(\frac{R_2}{T} - \frac{1}{2C_1} \right) t - \frac{R_2}{2} + \text{constant} \right] \end{aligned} \quad (78)$$

If the coefficient of t is made zero, the resulting expression is parabolic in form and has an initial slope of zero; the shape is then in close agreement with that of the anode current when the primary inductance is reduced to the minimum permissible value defined by expression (73). This condition is obtained by making

$$\frac{R_2}{T} - \frac{1}{2C_1} = 0$$

$$\text{i.e.} \quad R_2 C_1 = \frac{T}{2} \quad \dots \quad \dots \quad \dots \quad (79)$$

The time constant $R_2 C_1$ should thus equal half the period of the forward stroke. If $T = 20$ msec we have

$$\begin{aligned} R_2 C_1 &= 10 \text{ msec} \\ &= 10^{-2} \text{ sec} \end{aligned}$$

Suitable values of R_2 and C_1 are $100 \text{ k}\Omega$ and $0.1 \text{ }\mu\text{F}$.

11.4.3 *Circuit utilising Negative Feedback*

The non-linearity due to finite primary inductance can be reduced by negative feedback. The application of feedback is, however, not as straightforward as might be supposed. The feedback voltage should, of course, be proportional to the current in the field coils and such a voltage can be obtained across a resistor connected in series with the field coils. The feedback resistor must be small compared with the field-coil resistance otherwise it absorbs appreciable power from the output stage. Moreover if the resistance is appreciable a still higher value of primary inductance is required to avoid initial negative slope of the anode-current waveform; this is shown in expression (73).

To be small enough to make these effects negligible, the resistance cannot exceed 1 or 2 ohms if the field coils are of 12 ohms resistance. The voltage generated across a 1-ohm resistor is only 0.2 volt peak value. This is too small to be used as a feedback voltage applied to the grid of the output stage, where the input signal may be, say, 10 volts peak. If the field amplifier has an earlier stage where the sawtooth signal is only a fraction of a volt in peak value, this small feedback voltage could be successfully injected here. An example of such a circuit is given in Fig. 134.

Alternatively a small feedback voltage could be amplified to an amplitude comparable with that at the grid of the output stage and applied to the grid or cathode of that stage. The feedback amplifier must be linear and its design is not easy.

A larger feedback voltage can be obtained from the secondary or better still the primary winding of the output transformer. However, the voltage at these points has not the same waveform as the current in the scanning coils (or the voltage across R_7) and should not be used directly for feedback. As pointed out earlier the difference is due to the presence in the primary and secondary windings of a voltage developed across the inductance (L_c and L_l)

through which the scanning-coil current flows. If the effect of this inductance could be eliminated, the primary or secondary voltage could be used for feedback. One way in which this can be achieved is indicated in Fig. 135 which shows a series circuit R_2C_2 effectively across the primary winding of the output transformer, the voltage generated across the capacitor being used for feedback.

The voltage generated across the anode circuit is given by

$$\begin{aligned} & \frac{i_s}{n} [n^2(R_c + R_s) + n^2j\omega(L_c + L_l)] \\ &= ni_s [(R_c + R_s) + j\omega(L_c + L_l)] \end{aligned}$$

in which the term in $(R_c + R_s)$ represents the amplitude of the sawtooth voltage and the term in ω measures the effect of leakage and scanning-coil inductance. R_2 and C_2 behave as a potential divider

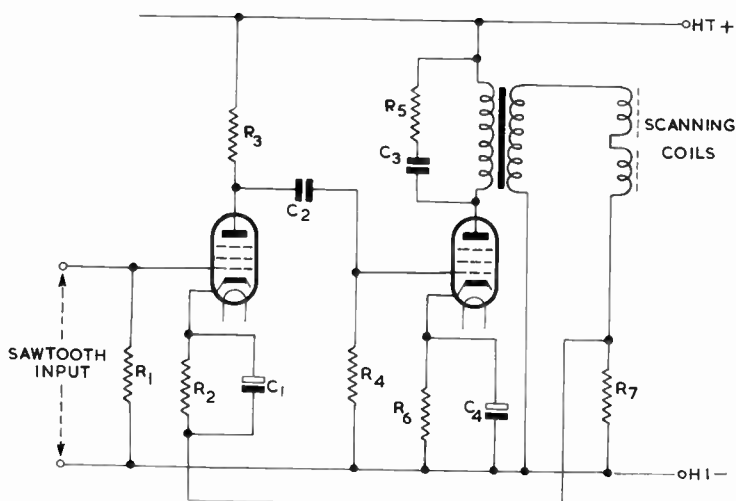

Fig. 134—A feedback circuit in which a small feedback voltage is returned to an early stage of the field amplifier

and the voltage across C_2 is given by

$$\begin{aligned} & ni_s [(R_c + R_s) + j\omega(L_c + L_l)] \times \frac{1/j\omega C_2}{R_2 + 1/j\omega C_2} \\ &= ni_s [(R_c + R_s) + j\omega(L_c + L_l)] \times \frac{1}{1 + j\omega C_2 R_2} \\ &= \frac{ni_s (R_c + R_s) [1 + j\omega(L_c + L_l)/(R_c + R_s)]}{1 + j\omega C_2 R_2} \end{aligned}$$

FIELD OUTPUT STAGES

This voltage will be a pure sawtooth if the terms in ω can be made to vanish. This is possible if

$$j\omega(L_c + L_l)/(R_c + R_s) = j\omega C_2 R_2$$

$$\text{i.e. if } C_2 R_2 = \frac{L_c + L_l}{R_c + R_s}$$

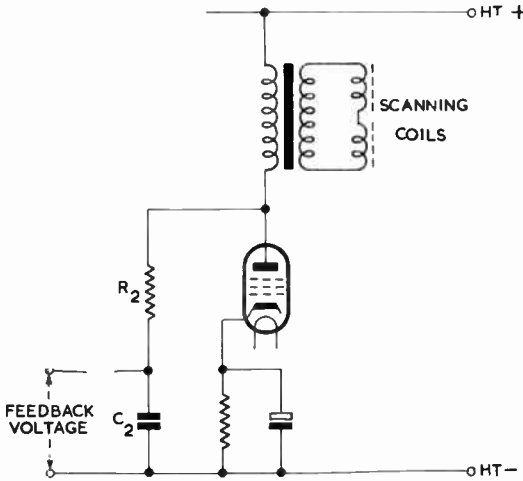

Fig. 135—Simple method of obtaining a feedback voltage from the primary winding of a scanning-coil output transformer

If this equation is satisfied the voltage across C_2 reduces to

$$n i_s (R_c + R_s)$$

which is independent of frequency, thus eliminating the effect of the inductance, leaving the voltage directly proportional to the coil current which is the required condition.

If $L_c = 10$ mH, $L_l = 6$ mH, $R_c = 12$ ohms and $R_s = 2$ ohms, all practical values, the time constant $C_2 R_2$ is given by

$$\begin{aligned} \frac{10 \times 10^{-3} + 6 \times 10^{-3}}{12 + 2} &= \frac{16 \times 10^{-3}}{14} \\ &= 1.14 \times 10^{-3} \text{ sec} \end{aligned}$$

Thus if R_2 is 1 megohm, C_2 must be $0.0014 \mu\text{F}$. Sometimes the resistor or the capacitor is made variable to give adjustment of the linearity. Such adjustment is desirable to enable the circuit to be

used for correction of non-linearity of the valve I_a-V_g characteristics in addition to the effects of leakage and scanning-coil inductance.

This circuit gives a feedback voltage which is directly proportional to the current in the scanning coils. If this voltage is introduced into an early stage of the field amplifier, such as the grid of the output valve, it has the effect of linearising the sawtooth current in the scanning coils. Better results can be obtained, however, if feedback is applied to a field amplifier which already contains a shaping network of the type illustrated in Fig. 133. Such a circuit is illustrated in Fig. 136 in which R_3C_2 are the feedback components and $R_1R_2C_1$ constitute the shaping network.

The performance of such a circuit is satisfactory and not significantly affected by changes in the parameters of the output valve. The effective values of R_2 and C_1 are modified by the use

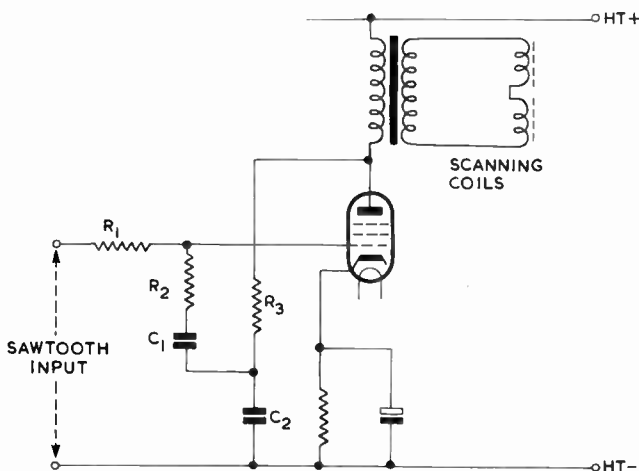

Fig. 136—Field output stage incorporating negative feedback and a shaping circuit

of feedback and allowance must be made for this in choosing their values. The effect of feedback of this type is to divide the impedance of the network R_2C_1 by $(A + 1)$ where A is the gain, from grid to anode, of the output stage. This can be shown by considering a signal of $+1$ volt peak value at the grid. This produces $-A$ volts peak at the anode and hence at the junction of C_1 and C_2 . The voltage across the network R_2C_1 is $(A + 1)$ and the current through R_2C_1 is $(A + 1)$ times greater than in the absence of feedback. The circuit R_2C_1 thus behaves as though the impedance were $1/(A + 1)$ of its physical value. The physical

FIELD OUTPUT STAGES

value of R_2 should thus be made $(A + 1)$ times the wanted effective value; that of C_1 should be $1/(A + 1)$ times the wanted effective value.

If the anode load of the output stage is 12,500 ohms (as assumed earlier) and if the mutual conductance of the output valve is 8 mA/V, the stage gain of the output stage is 100. To give effective values of R_2 and C_1 of 100 kilohms and $0.1 \mu\text{F}$, the physical values which must be used are 10 megohms and $0.001 \mu\text{F}$, i.e. 1,000 pF. In practice the capacitor may be made variable to permit adjustment of linearity; a suitable capacitance range is 500–1,500 pF.

11.4.4 *Blumlein Circuit*

In the feedback circuits so far discussed the feedback voltage has been directly proportional to the current in the scanning coils. The introduction of such a voltage into an early stage of a field amplifier brings about an improvement in the amplifier performance. The performance can however be further improved by including in the feedback loop a shaping network specifically designed to offset the distortion in the amplifier. For example the effect of finite primary inductance in the transformer of a field output stage is to cause a loss in low-frequency response, and this loss can be reduced by use of non-frequency-discriminating feedback. Results are better still, however, if a network is included in the feedback loop which attenuates the feedback voltage at low frequencies thus effectively boosting the bass response of the amplifier.

This technique is extensively employed in field output stages and one example is the Blumlein circuit illustrated in Fig. 137. This includes two RC networks in the feedback loop but only one is used for shaping. This is R_2C_4 which, as just suggested, introduces a bass loss in the feedback voltage to give a rising bass response in the amplifier which offsets the loss in the output transformer. The other network R_1C_2 is used in the same manner as R_3C_2 in the previous diagram: that is to say it is necessary to ensure that the feedback voltage (with R_2C_4 omitted) has the same waveform as the current in the scanning coils despite the fact that it is generated across the scanning coils and output transformer which contain appreciable inductance. C_1 and C_2 together constitute the capacitance of a discharger circuit; in other words a rectangular current waveform is applied to C_1 and C_2 and the sawtooth waveform developed across them is applied between grid and cathode of the output valve. The time constant R_5C_3 is made very large and the grid waveform is substantially that generated across C_1 and C_2 . Linearity is achieved by feedback from the anode to the grid via

the components $R_1C_2R_2C_4$. As shown in Appendix J the conditions which must be fulfilled for successful performance are

$$R_2C_4 = \frac{L_p}{R_p} \quad \dots \quad \dots \quad \dots \quad (80)$$

$$R_1C_2 = \frac{L_l + L_c}{R_s + R_c} \quad \dots \quad \dots \quad \dots \quad (81)$$

$$\frac{R_1}{R_2} = \frac{n^2(L_l + L_c)}{L_p} \quad \dots \quad \dots \quad \dots \quad (82)$$

As these expressions show, the time constant R_2C_4 is chosen to correct for the distortion due to the primary inductance of the output

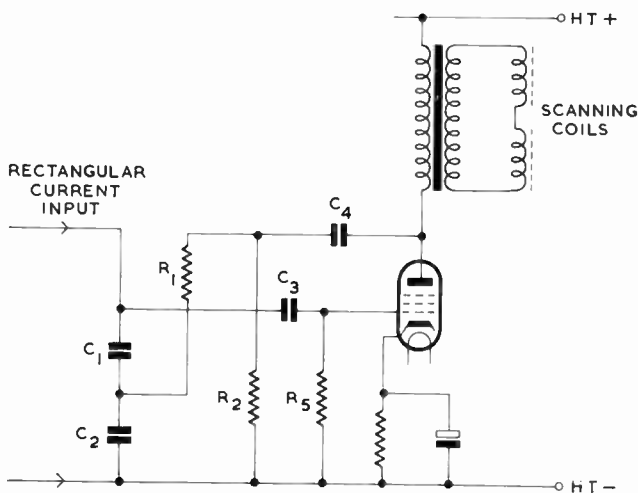

Fig. 137—Blumlein field output circuit

transformer and the time constant R_1C_2 is chosen to offset the effects of leakage and field-coil inductance.

Suppose:

- $L_p = 50 \text{ H}$
- $R_p = 500 \text{ ohms}$
- $L_l = 10 \text{ mH}$
- $L_c = 6 \text{ mH}$
- $R_s = 2 \text{ ohms}$
- $R_c = 12 \text{ ohms}$
- $n = 32 : 1$

FIELD OUTPUT STAGES

Substituting in the expressions above we have

$$\begin{aligned}
 R_2 C_4 &= \frac{50}{500} \text{ sec} \\
 &= 0.1 \text{ sec} \\
 R_1 C_2 &= \frac{16 \times 10^{-3}}{14} \text{ sec} \\
 &= 1.14 \times 10^{-3} \text{ sec} \\
 \frac{R_1}{R_2} &= \frac{1,040 \times 16 \times 10^{-3}}{50} \\
 &= 0.33
 \end{aligned}$$

These relationships determine the values of R_1 , C_2 , R_2 and C_4 once the value of one of these components has been decided. Suppose for example it is decided that R_2 shall be 200 k Ω , a value so large that there is no fear that it will appreciably shunt the primary circuit of the output valve. We then have

$$\begin{aligned}
 C_4 &= \frac{0.1}{R_2} \\
 &= \frac{0.1}{200 \times 10^3} \text{ F} \\
 &= 0.5 \mu\text{F} \\
 R_1 &= 0.33 R_2 \\
 &= 0.33 \times 200 \text{ k}\Omega \\
 &= 66 \text{ k}\Omega \\
 C_2 &= \frac{1.14 \times 10^{-3}}{R_1} \\
 &= \frac{1.14 \times 10^{-3}}{66 \times 10^3} \text{ F} \\
 &= 0.017 \mu\text{F}
 \end{aligned}$$

In practice these values do not give perfect linearity of scanning current primarily because of the non-linearity of the anode current-grid voltage characteristic of the output valve. The distortion due to this source can be minimised by adjustment of the value of R_1 and this is often made variable to permit this. In place of the 66 k Ω value calculated above, a 47 k Ω fixed resistor in series with a variable of 50 k Ω maximum resistance could be used.

APPENDIX J

DETERMINATION OF FEEDBACK COMPONENTS IN BLUMLEIN CIRCUIT

WHEN the field output transformer in a Blumlein circuit is replaced by an equivalent network, the circuit has the form shown in Fig. J.1. This can be simplified if L_l and L_c are combined to form an inductance L and the two resistances R_s and R_c are combined in one resistance R . The new circuit then appears as in Fig. J.2 and the relationship which the circuit must satisfy for good performance is that the feedback voltage V_{fb} should have the same waveform as the current in the coils, i.e. the voltage V_{fb} across C_2 should have the same form as the current i_s/n in L and R which is, in turn, of the same waveform as V_{out} across n^2R .

Provided R_1, R_2, C_2 and C_4 are correctly chosen the relationship between V_{out} and V_{fb} is independent of frequency and it is therefore

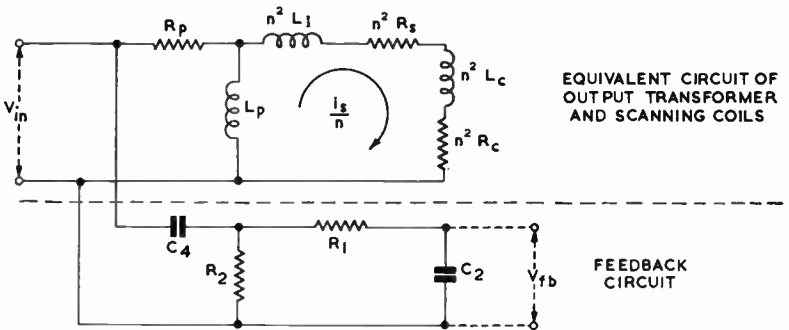

Fig. J.1—Blumlein circuit with output transformer replaced by equivalent network

permissible to set out the circuit equations in terms of ω . For the transformer equivalent circuit we have

$$V_{in} = i_o (R_p + j\omega L_p) - \frac{i_s}{n} \cdot j\omega L_p \quad \dots \quad (1)$$

$$0 = \frac{i_s}{n} (n^2 R + j\omega n^2 L + j\omega L_p) - i_o \cdot j\omega L_p \quad \dots \quad (2)$$

FIELD OUTPUT STAGES

Eliminating i_o between these equations we have

$$\frac{i_s}{n} = \frac{V_{in}}{(R_p + j\omega L_p) \frac{1}{j\omega L_p} (n^2 R + j\omega n^2 L + j\omega L_p) - j\omega L_p}$$

from which

$$\frac{V_{out}}{V_{in}} = \frac{i_s}{n} \cdot \frac{n^2 R}{V_{in}} = \frac{n^2 R / j\omega L_p}{\left(1 + \frac{R_p}{j\omega L_p}\right) \left(\frac{n^2 R}{j\omega L_p} + \frac{n^2 L}{L_p} + 1\right) - 1} \quad (3)$$

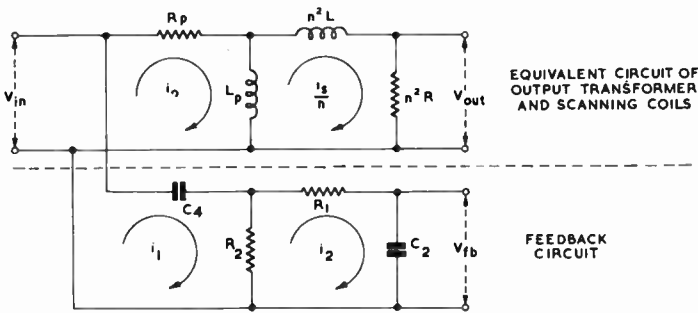

Fig. J.2—Simplified circuit equivalent to that of previous diagram

For the feedback circuit we have

$$V_{in} = i_1 \left(R_2 + \frac{1}{j\omega C_4} \right) - i_2 R_2 \quad \dots \quad (4)$$

$$0 = i_2 \left(R_1 + R_2 + \frac{1}{j\omega C_2} \right) - i_1 R_2 \quad \dots \quad (5)$$

Eliminating i_1 between (4) and (5) we have

$$i_2 = \frac{V_{in}}{\left(R_2 + \frac{1}{j\omega C_4} \right) \frac{1}{R_2} \left(R_1 + R_2 + \frac{1}{j\omega C_2} \right) - R_2}$$

from which

$$\frac{V_{fb}}{V_{in}} = \frac{i_2}{j\omega C_2} \cdot \frac{1}{V_{in}} = \frac{1/j\omega C_2 R_2}{\left(1 + \frac{1}{j\omega C_4 R_2}\right) \left(\frac{1}{j\omega C_2 R_2} + \frac{R_1}{R_2} + 1\right) - 1} \quad \dots \quad (6)$$

217

This is of the same form as expression (3). Comparing equations (3) and (6) we obtain three relationships namely:

$$(1) \quad \frac{1}{j\omega C_4 R_2} = \frac{R_p}{j\omega L_p}$$

giving $R_2 C_4 = \frac{L_p}{R_p} \quad \dots \quad \dots \quad \dots \quad (7)$

$$(2) \quad \frac{R_1}{R_2} = \frac{n^2 L}{L_p} \quad \dots \quad \dots \quad \dots \quad (8)$$

and (3) $C_2 R_2 = \frac{L_p}{n^2 R} \quad \dots \quad \dots \quad \dots \quad (9)$

which gives $C_2 = \frac{L_p}{n^2 R R_2} = \frac{L_p}{R_2} \cdot \frac{1}{n^2 R}$

But from (8)

$$\frac{L_p}{R_2} = \frac{n^2 L}{R_1}$$

$$\therefore C_2 = \frac{n^2 L}{R_1} \cdot \frac{1}{n^2 R}$$

$$\therefore R_1 C_2 = \frac{n^2 L}{n^2 R} = \frac{L}{R} \quad \dots \quad \dots \quad \dots \quad (10)$$

Expressions (7) and (10) express the two time constants $R_1 R_2$ and $R_2 C_4$ in the feedback circuit in terms of the constants of the output transformer and scanning coils; these results could have been obtained directly by inspection of the two circuits given in Fig. J.2. If L and R are written in full the time constants are given by

$$R_2 C_4 = \frac{L_p}{R_p}$$

$$R_1 C_2 = \frac{n^2(L_l + L_c)}{n^2(R_s + R_c)}$$

$$= \frac{L_l + L_c}{R_s + R_c}$$

CHAPTER 12

LINE OUTPUT STAGES

12.1 INTRODUCTION

WE shall now consider the fundamental principles of line output stages. Because of the greater rate of change of line-scanning signals these differ from those of field output stages in two respects:

- (a) line-scanning coils can be considered as approximating to pure inductances. Thus if the coils are fed from a low-impedance source this source should have a substantially rectangular voltage output to give linear scanning.
- (b) large voltages are generated across line-scanning coils, particularly during flyback, and precautions must be taken to provide adequate insulation of conductors and to prevent excessive power dissipation as a result of the existence of these voltages.

12.2 TRANSFORMER-COUPLED CIRCUIT

One possible basic circuit for a line output stage is shown in Fig. 138 and consists of a pentode connected to the scanning coils by a matching transformer. It is not usual to connect the coils

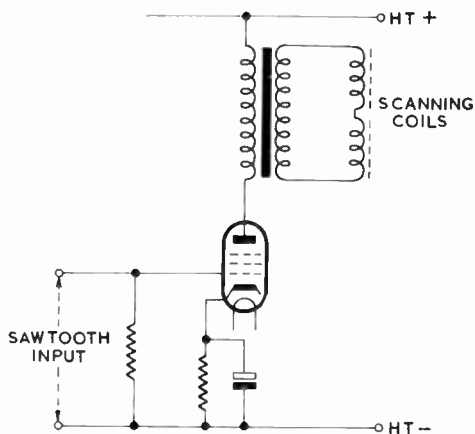

Fig. 138—Basic circuit for line output stage

directly in the anode circuit because they would need to be of high impedance and the voltage generated across them during flyback would be very high, causing insulation difficulties. Moreover the standing anode current would cause a static deflection of the beam. Thus it is normal to employ a matching transformer, and its ratio together with the impedance of the scanning coils should be chosen to give the pentode an anode load small compared with its anode a.c. resistance; the pentode thus behaves as a constant-current generator. The type of pentode employed in line output stages can deliver a current swing of say 33 mA peak value without difficulty and to give the 0.2 amp peak swing required by a pair of line-scanning coils, the matching transformer requires a turns ratio of 6:1.

As shown in Fig. 124 the voltage across the scanning coils approximates to a rectangular form, alternating between 27 volts on the forward stroke and 240 volts on flyback. The voltage at the pentode anode will be 6 times these values, i.e. 162 volts and 1,440 volts. A positive-going grid voltage causes the anode voltage to fall and thus the anode voltage is 162 volts below the h.t. value on forward strokes and 1,440 volts above the h.t. value on flyback. If the h.t. voltage is 250, the anode potential is steady at 88 volts during the forward stroke and at 1,690 volts during flyback. The waveforms for grid voltage, anode voltage, anode current and scanning-coil current for a basic circuit of this type are illustrated in Fig. 139. These, of course, represent the performance of an ideal line output stage in which the line-scanning coils and the matching transformer are free of resistance and capacitance.

12.3 EFFECT OF INHERENT RESISTANCE AND CAPACITANCE ON PERFORMANCE OF TRANSFORMER-COUPLED CIRCUIT

In practice scanning coils and matching transformer inevitably have resistance and capacitance and these both affect the voltage and current waveforms. The effect of resistance shows up chiefly during forward strokes, causing the anode voltage to have a positive slope during these periods (as shown in Fig. 140) compared with the zero slope of the ideal waveform of Fig. 139. This finite slope means that the valve has to supply a greater current swing than in the ideal circuit for a given current swing in the deflector coils. The effect of the capacitance is confined to the flyback period and the early part of the forward stroke. The capacitance and inductance together constitute a tuned anode circuit, which is forced into oscil-

LINE OUTPUT STAGES

lation by the rapid reversal in anode current at the end of each forward trace, a phenomenon often termed "ringing."

The oscillation amplitude decays exponentially due to dissipation of power in the resistance of the scanning coils and transformer but, unless additional resistance is introduced, the oscillations persist

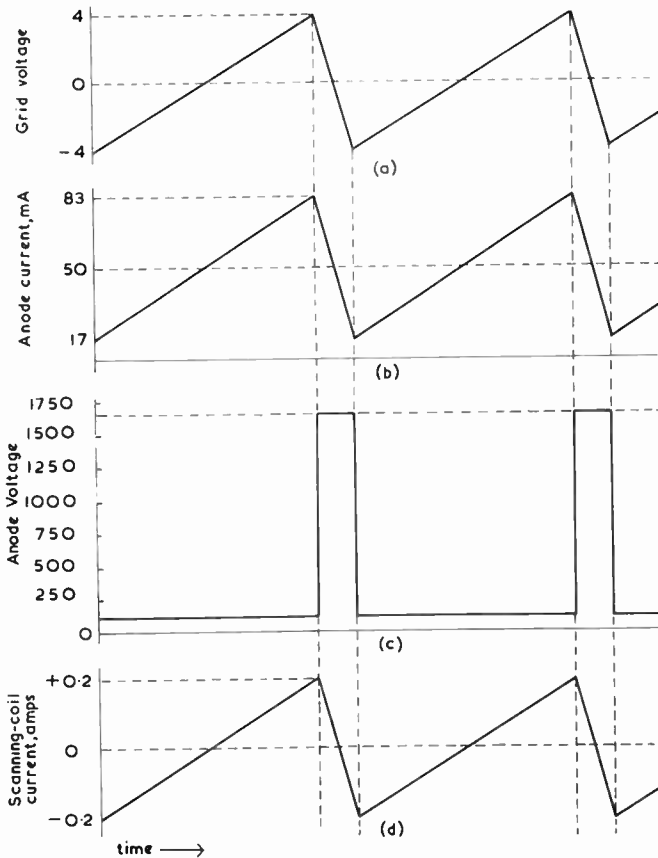

Fig. 139—Waveforms for ideal line output stage

well into the forward stroke and destroy linearity as shown in the waveforms of Fig. 140. The more efficient the matching transformer is, the less are its resistance losses and the more persistent is the ringing. The frequency of the oscillation depends on the

construction of the scanning coils and transformer and is commonly around 100 kc/s.

12.4 HEAVILY-DAMPED TRANSFORMER-COUPLED CIRCUIT

If ringing can be eliminated the basic circuit can give acceptable linearity of line scan. One method is to damp the circuit with resistance until it becomes almost non-oscillatory and to do this a resistor can be connected across the scanning coils as shown in

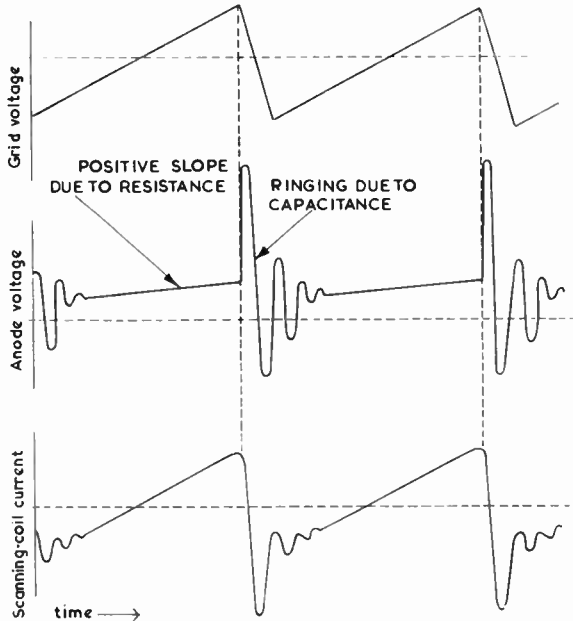

Fig. 140—Effect of resistance and capacitance on waveforms of basic line output stage

Fig. 141. If necessary capacitance is also added, as indicated in Fig. 141, to lower the resonance frequency of the circuit to around 75 kc/s. This increases the duration of the flyback period and reduces the voltage amplitude during this period. The resistor should have a value of the order of that required for critical damping. For a simple parallel LC circuit the value of parallel resistance which gives critical damping is $0.5\sqrt{L/C}$. Thus for scanning coils having $L = 6$ mH and $C = 200$ pF the resistance is given by

$$\frac{1}{2} \sqrt{\left(\frac{6 \times 10^{-3}}{200 \times 10^{-12}} \right)} = 2.7 \text{ kilohms}$$

LINE OUTPUT STAGES

Frequently the resistance is made variable to give adjustment of linearity. This damping resistor dissipates considerable power during the flyback period and reduces the voltage amplitude during these periods. The resistor also dissipates power on forward strokes and here the loss is undesirable because the output valve must supply the power in addition to supplying the scanning coils. The total dissipation in the damping resistor is surprisingly high—of the order of 12 W even for a 9-in. diameter cathode-ray tube. This is therefore a rather wasteful method of achieving linear line

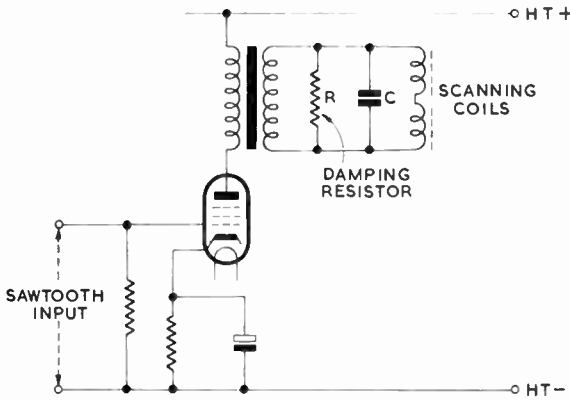

Fig. 141—Circuit of simple line output stage with a damping resistor

scanning but it was extensively used in television receivers before e.h.t. generation by line flyback became general.

The waveforms for a circuit with a damping resistor are given in Fig. 142. A perfect input sawtooth voltage is shown at (a), the amplitude of this and the grid bias being so chosen that the valve is cut off for a short period at the negative extremes of the waveform. The anode current waveform (b) shows brief intervals of cut-off followed by non-linear rises caused by the curvature of the I_a-V_g characteristics near cut-off. Due to the heavy damping, the anode voltage waveform (c) does not exhibit any oscillation but has a single pulse during flyback of smaller amplitude than in the less heavily damped circuits described earlier. If the effects of leakage inductance are neglected the capacitor can be connected across either winding of the transformer and for simplicity will be assumed to be across the primary winding. Thus the waveform (c) is also across the capacitor and the current in the capacitor has the form shown at (d): this being proportional to the slope of waveform (c). The

net current in the primary winding indicated at (e) is the sum of that due to the valve and that due to the capacitor.

As the negative capacitor current falls to zero at the beginning of each forward trace the anode current slowly rises from zero and one of the aims in the design of a circuit of this type is to ensure that these two currents combine to produce a linear change of current throughout the working stroke as illustrated in the final curve (f) showing the current in the scanning coils. To achieve this requires correct choice of R , C , output-valve bias and output-valve input signal. The input-signal amplitude cannot be varied without upsetting operation of the circuit and in this as in many other line-scanning circuits the input-signal amplitude must be constant. A small variation in output sawtooth current amplitude is possible by varying the inductance of a small coil connected in series with the scanning coils as shown in Fig. 146. In this way it is possible to achieve a variation in current amplitude up to say 20 per cent which is usually adequate for adjusting picture width in television receivers and monitors. This type of circuit is not suitable where a larger variation in output signal is required.

It is significant that the initial part of the working stroke is part of a damped oscillation which occurs whilst the output valve is cut off: this mode of operation occurs in a number of line-scanning circuits and in some of the more highly developed types the output valve is inoperative for nearly half the working stroke.

Some of the power wasted in the circuit of Fig. 141 could be avoided if it were possible to arrange for the damping resistor to be removed during the forward stroke but still effective during the flyback period. An approach to this ideal is possible if the damping resistor is connected in series with a capacitor as shown in Fig. 143.

To understand the improved performance of the series RC damping circuit suppose the voltage across the primary winding of the output transformer is constant throughout the forward trace. If a series RC circuit is connected across such a steady voltage a current flows in the combination, dissipating power in the resistance, for a period dependent on the time constant RC . To minimise this current and the consequent damping during the forward stroke the time constant should be small compared with the period of this stroke. In fact the voltage does change slowly during the forward trace and some current flows in the RC combination giving unwanted damping throughout the working stroke but the effect is small if the time constant is small.

To obtain the damping required during flyback a large current should flow in the RC circuit throughout the flyback period; this

LINE OUTPUT STAGES

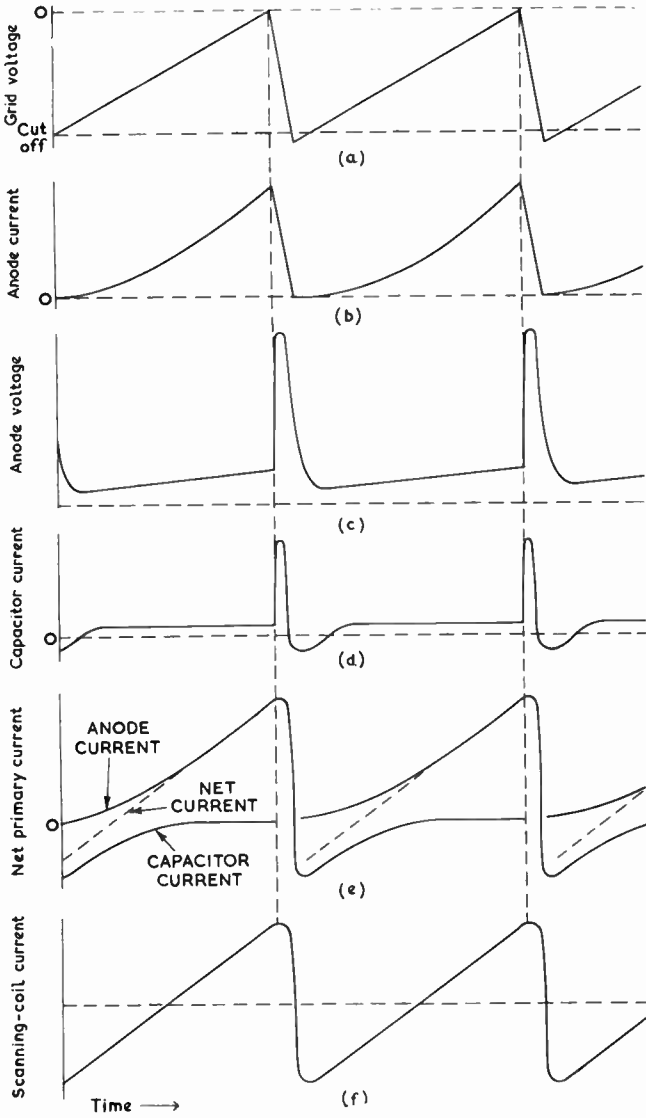

Fig. 142—Waveforms for the line output stage of the previous diagram

requires that the time constant should be long compared with the flyback period. The value of RC should hence be short compared with the forward trace (say $80 \mu\text{sec}$) but large compared with the flyback period (say $10 \mu\text{sec}$). A value of $30 \mu\text{sec}$ would appear to be a satisfactory compromise and if the damper circuit is connected across the scanning coils the resistance value required is 2,700 ohms as before, the capacitance being given by

$$\begin{aligned} C &= \frac{\text{time constant}}{R} \\ &= \frac{30 \times 10^{-6}}{2.7 \times 10^3} \text{ F} \\ &= 0.0111 \mu\text{F} \end{aligned}$$

Line-out stages with damping resistors can be made to operate satisfactorily with cathode-ray tubes in which a 7-kV beam is deflected through 50 degrees (as in early television receivers with

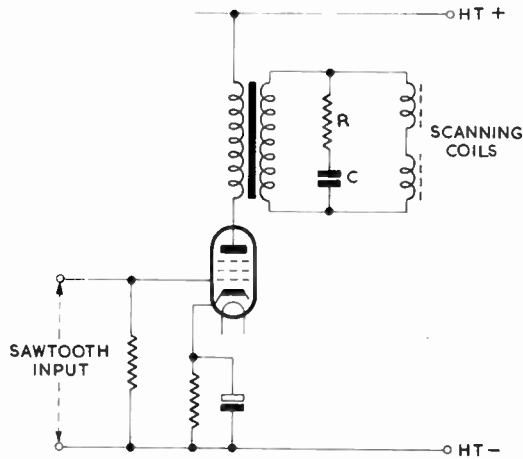

Fig. 143—Improved circuit of simple line output stage

9-in. diameter tubes) but they are inefficient, dissipating a total of approximately 50 W, one-third the total power requirement of an entire receiver. Some of this power is dissipated in the output valve, some in the output transformer and scanning coils but a large fraction (up to one-half) may be dissipated in the damping resistor, which must be capable of safely dissipating 25 W. If such a line
226

LINE OUTPUT STAGES

output stage were used to deflect a 14-kV beam through 70 or 90 degrees (as in modern receivers with 17-in. diagonal tubes) the power dissipation would be prohibitive.

12.5 CIRCUIT INCORPORATING EFFICIENCY DIODE

The use of a capacitor in series with the damping resistor increases the efficiency of a line output stage by effectively removing the damping resistor from circuit during part of the forward stroke. Still greater efficiency would be possible if the damping resistor could be removed from circuit for the whole of the working stroke and

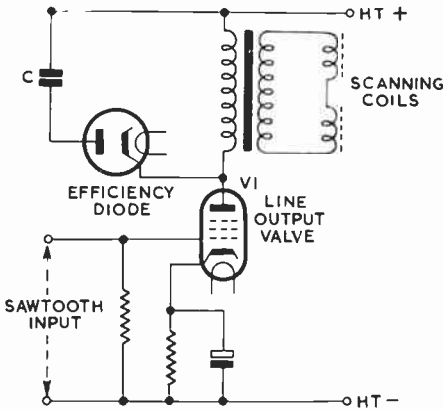

Fig. 144—Basic features of a line output stage incorporating an efficiency diode

restored to absorb energy from the scanning-coil circuit during flyback periods. Even so, the energy absorbed from the scanning-coil circuit during flyback is dissipated uselessly in the form of heat in the resistance. In an ideal scanning output stage the energy absorbed from the coils during flyback would be stored in a capacitance and released subsequently to perform useful work during the following working stroke. This occurred to a small extent in the heavily damped circuits described above, in which a capacitor effectively in parallel with the scanning coils is charged during flyback periods and discharges during the initial part of the following working stroke when the output valve is momentarily cut off. However, because of the heavy damping of the circuit, the improvement in efficiency due to the capacitance is small.

By removing the damping resistor, increasing the capacitance and by employing low-loss magnetic materials such as dust-iron or Ferrite in place of laminated cores in the transformer and yoke, it is

possible to store sufficient energy in the capacitor to perform up to 40 per cent of the following working stroke. This represents a marked improvement in efficiency and, in fact, enables a single output pentode (of the type used to scan 9-in. diameter tubes in highly damped circuits) to scan a 17-in. diagonal tube.

To ensure that the capacitor charges and discharges at the right moments the circuit employs a diode known as a "damper" or "efficiency" diode connected in series with the storage capacitor as shown in Fig. 144. The diode and capacitor are shown here connected across the transformer primary winding but they could be connected across the secondary (i.e. across the scanning coils themselves) or across a tertiary winding. The capacitance in this circuit is not required to time the duration of the flyback period and can be many times that used in a highly damped circuit (e.g. $1 \mu\text{F}$ in an efficiency diode circuit compared with $0.01 \mu\text{F}$ in a highly damped circuit).

12.6 OPERATION OF CIRCUIT INCORPORATING EFFICIENCY DIODE

12.6.1 *Towards the End of the Working Stroke*

We shall now describe the operation of this circuit beginning towards the end of the working stroke. As shown in Fig. 145 when $t = t_1$ the voltage on the output-valve grid is increasing positively causing the anode current to increase substantially linearly. In an ideal circuit with no resistance either in the scanning coils or transformer windings the anode voltage would be steady at a low voltage such as 100 volts during this period but because of inevitable resistance the voltage does have a small positive slope. The voltage across the capacitor C is nearly equal to that across the output-transformer primary winding (150 volts if the h.t. supply is 250 volts) and there is a small voltage drop across the diode, sufficient to give a small conduction current. The current in the scanning coils is increasing linearly as required.

12.6.2 *During Flyback Period*

The end of the working stroke occurs at $t = t_2$ when the grid input voltage abruptly reverses in direction. Anode current is compelled to fall suddenly and the anode voltage leaps to a high positive value of, say, 2 or 2.5 kV. The pentode anode is connected to the diode cathode which also takes up this high potential. The potential on the diode anode is maintained by the capacitor C at the value (100 volts) it had at the end of the working stroke and the diode is abruptly cut off by the jump in anode voltage. The circuit comprising output transformer and scanning coils now begins to

LINE OUTPUT STAGES

oscillate at its natural frequency and the upward leap in anode voltage can be regarded as the first quarter cycle of oscillation. The oscillation is at a higher frequency and is less damped than in the circuits described above. The second quarter-cycle of oscillation

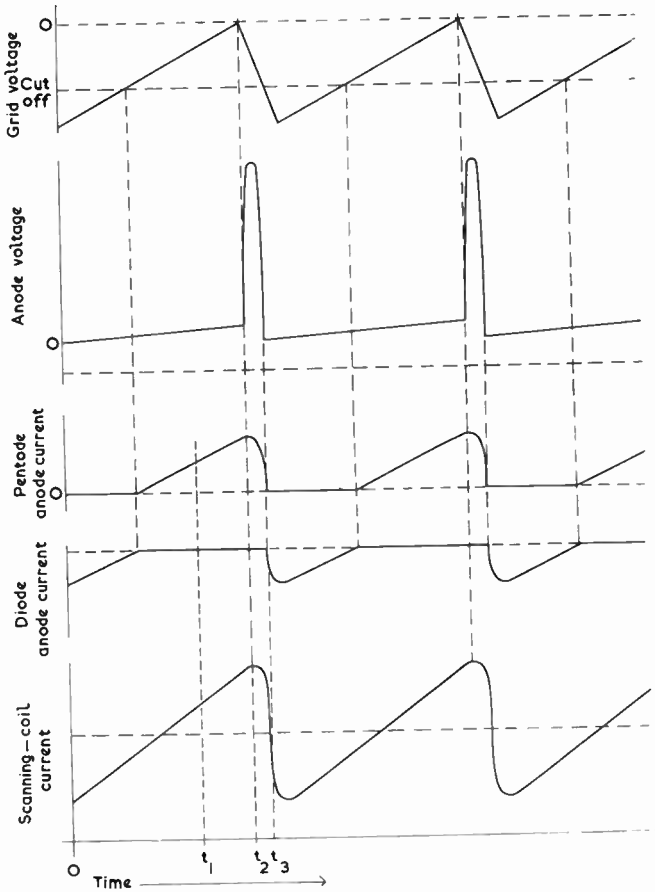

Fig. 145—Waveforms for the line output stage illustrated in the previous diagram

brings the anode voltage down to the value (100 volts) it had at the end of the forward stroke.

After the completion of the first half cycle of oscillation, the tendency is for the anode voltage to fall still lower (to negative values in fact) to perform the third quarter-cycle but the moment the

anode voltage falls below approximately 100 volts, i.e. at $t = t_3$, the diode begins to conduct. When it conducts, the anode-cathode resistance of the diode becomes very low and the effect of diode conduction is to connect the storage capacitor C across the primary winding of the output transformer, thereby greatly decreasing the resonance frequency of the oscillation. As a result the rate of change of anode voltage falls abruptly and after $t = t_3$ changes in anode potential are slight. We can in fact say that the effect of diode conduction is to stabilise the anode voltage at approximately 100 volts. This can be explained in another way: we can say that the capacitor C begins to charge when the diode conducts but because C is a large capacitor, considerable current is needed to change its voltage appreciably. The current available from the oscillatory circuit is not sufficient to alter the voltage across C appreciably.

12.6.3 *At the Beginning of the Next Forward Stroke*

The charging current which begins to flow into C at $t = t_3$ is also the diode current and its form is shown in Fig. 145: it rises rapidly to a maximum value and then falls slowly to zero. This current flows through C and the diode and then *upwards* through the primary winding (this is the direction of conventional current flow; electron flow is in the opposite direction). The anode current of the pentode, when this conducts, flows *downwards* through the primary winding. Thus a decreasing diode current and an increasing pentode current both give the same polarity of induced voltage in the secondary winding and the secondary voltage due to the diode current constitutes the beginning of the working stroke. If the bias and input-signal amplitude for the pentode are correctly chosen, the pentode remains cut off for the greater part of the period of diode conduction but begins to conduct just before the diode current ceases. There is a brief period during which both diode and pentode are conducting and one of the aims in design of circuits of this type is to ensure that the net effect of these currents is to produce a scanning-coil current of acceptable linearity.

Fig. 146 gives the complete circuit diagram of a line sawtooth generator and line output stage incorporating an efficiency diode. V_1 is a pentode operating as a combined blocking oscillator and discharger; this circuit and its method of operation are described in Volume 3. The control grid and screen grid are coupled to form the oscillator which is synchronised by negative-going edges injected into the screen circuit as shown. The natural frequency of the oscillator is controlled by R_1 which is adjusted until the oscillator frequency comes into step with that of the sync pulses. In a tele-

LINE OUTPUT STAGES

vision receiver R_1 is commonly labelled as a *line hold* control. The charger circuit consists of $R_3 C_1$, the values of which are chosen to give the required amplitude of sawtooth output across C_1 . This output, together with a feedback voltage obtained from the secondary winding of the output transformer is applied to the grid of the output stage.

As shown in Fig. 145 the voltage across the primary and hence across the secondary winding contains sharp spikes coinciding with the flyback periods and by returning a fraction of the secondary voltage to the output-valve grid as shown, provided the phase of the feedback voltage is correct, the cut off of V2 at the end of each forward stroke can be made very sharp. This is desirable when the anode current is used to generate the c.h.t. supply for the cathode-ray tube as in a television receiver.

In a circuit of this type the amplitude of the sawtooth input signal applied to the output valve is one of the parameters on which the linearity of the scanning-coil current depends and the amplitude

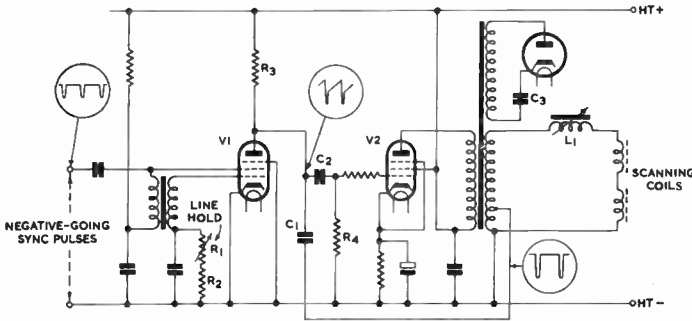

Fig. 146—Complete line oscillator and output stage incorporating an efficiency diode

of the input cannot be varied without impairing the output linearity. One problem which must be solved is therefore that of varying the amplitude of the current in the scanning coils without effecting the linearity: such variation is necessary, of course, to adjust the picture width. One method is indicated in Fig. 146: a variable inductor is connected in series with the scanning coils and its reactance is varied by movement of a dust-iron core within it.

12.7 CIRCUIT INCORPORATING A BOOSTER DIODE

A significant feature of the circuit of Fig. 146 is that the voltage generated across C_3 varies very little during the line period. More-

over in a practical circuit this voltage can easily be of the order of 150 volts. As both sides of C_3 are free, this voltage can be connected in series with the normal h.t. supply to provide a boosted h.t. supply of say 400 volts which can be used by the line output stage. This additional h.t. is useful because it enables a single output pentode to supply all the power required for line scanning in a 17-in. diameter picture tube. In an a.c.-d.c. television receiver it is difficult to obtain such a high value of h.t. by any other methods.

This circuit arrangement is successful only if the mean currents through the output valve and the economy diode are approximately

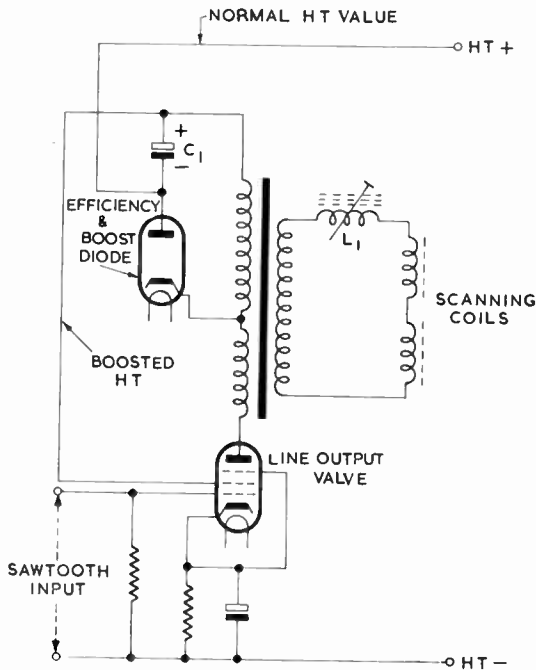

Fig. 147—A line output stage incorporating a booster diode

equal and the primary-to-diode winding turns ratio must be chosen to secure this. A diode used to provide additional h.t. is known as a booster diode and the circuit of a line output stage incorporating such a diode is given in Fig. 147. The diode is connected across part of the primary winding and the additional h.t. supply generated across C_1 is connected in series with the normal h.t. supply to give a boosted supply which is applied to the pentode screen. The

LINE OUTPUT STAGES

arrangement is such that the boosted supply is also applied to one end of the primary winding and is thus used by the pentode anode also.

12.8 GENERATION OF E.H.T. SUPPLY

At the end of each working stroke the anode current of a line output stage is suddenly cut off and, as we have seen, the anode voltage generates a spike of 2 or 3 kV amplitude. By increasing the number of turns on the primary winding to form an auto-transformer of say 1 : 5 turns ratio as shown in Fig. 148, pulses of 15 kV or more can be obtained. These can be rectified and smoothed to provide the e.h.t. supply for the final anode of the picture tube. The current

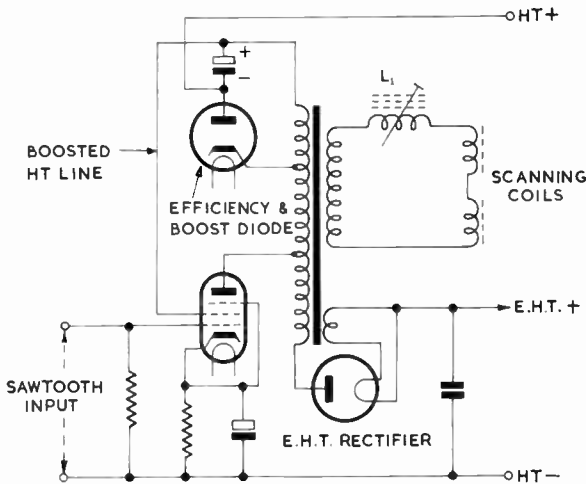

Fig. 148—A line output stage with provision for generating the e.h.t. supply

required is only a fraction of a milliamp and a small directly-heated rectifying valve can be used, the filament being supplied from a further winding on the line output transformer. This winding must be well insulated because the full e.h.t. voltage exists between it and the transformer core.

The rectifier output can be adequately smoothed by simple means because the frequency of the input pulses is very high (approximately 10 kc/s). A single capacitor of 0.001- μ F capacitance is frequently satisfactory and the capacitance between the final anode of the picture tube (i.e. the internal conductive coating) and the external earthed coating is often sufficient. The filament voltage of

the rectifier has the same peaky waveform as the anode voltage of the output valve and its r.m.s. value is difficult to measure.

The correct value is usually found empirically by adjusting the filament voltage (by a series resistor or by varying the screen voltage of the output valve) until the red glow of the filament is equal to that of a rectifier of the same type operating from a source of voltage known to be correct. Once this adjustment has been carried out, operating conditions in the output stage should not be changed and the amplitude of the current in the line-scanning coils is adjusted by varying the inductor L_1 . The regulation of an e.h.t. supply of this type is not good; in fact the circuit behaves as though the internal resistance were several megohms. Nevertheless it is customary to employ this type of circuit for economic reasons but the performance is not so good as that of a conventional e.h.t. supply obtained from a.c. mains by means of a step-up transformer and rectifier.

CHAPTER 13

SHUNT-REGULATED AMPLIFIERS

13.1 INTRODUCTION

VOLUME 2 described the design of video amplifiers to deliver small output signals, generally less than 100 volts in peak-to-peak value, such as those required to drive picture tubes. Such amplifiers require only small receiving-type valves with a cathode emission of 10 or at most 40 mA.

The design problems are more difficult in a video amplifier required to give a much larger output such as that required to modulate a high-power television transmitter. These problems can be illustrated by reference to the simplified circuit diagram of the

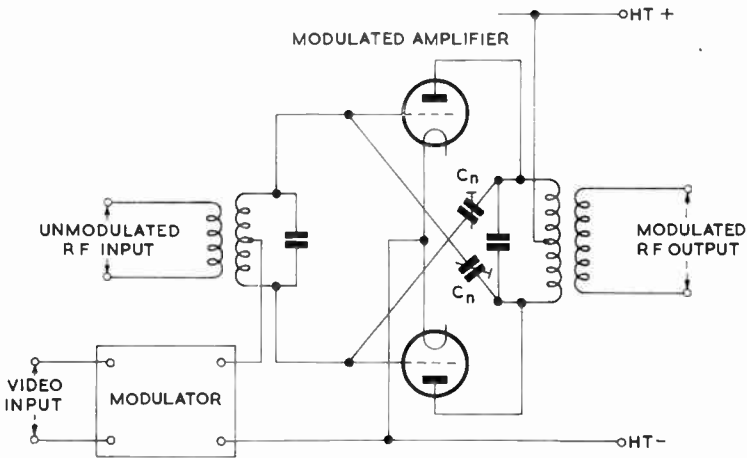

Fig. 149—Simplified circuit diagram of a class-C push-pull modulated amplifier

modulator and modulated-amplifier stages given in Fig. 149. This shows a pair of triodes connected in push-pull and neutralised by capacitors C_n connected from each anode to the grid of the other valve. The modulating signal is applied in series with the r.f. source and in effect varies the grid bias to vary the length of the characteristic used and produce an amplitude-modulated output.

The amplitude of the r.f. input and the value of the grid bias (the source of which is not indicated) are so chosen that the modulated amplifier operates in class B for 100 per cent modulation and in class C for smaller modulation depths. Operation of the circuit is illustrated in Fig. 150 which, for simplicity, illustrates the characteristic of only one of the modulated-amplifier valves.

For a transmitter of 50 kW output the modulator may be required to deliver a video signal of 1,100 volts peak-to-peak amplitude, without significant distortion, into the grid circuit of the modulated amplifier. The input impedance of the grid circuit has two components; one is the grid-filament resistance of the valves and this varies from a high value for small-amplitude video signals which

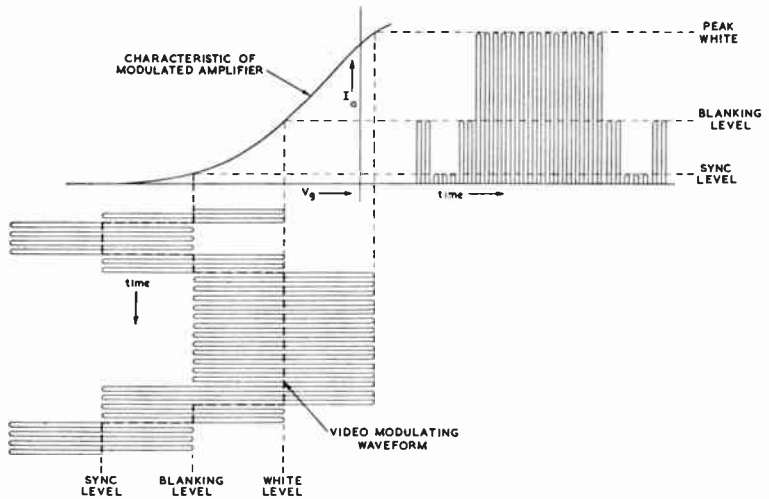

Fig. 150—Waveforms illustrating the mode of operation of the circuit in Fig. 149

cause little grid current to a value as low as 400 ohms for large-amplitude video signals which cause considerable grid current. The other component is capacitive contributed by the neutralising capacitors and the inter-electrode capacitances of the valves and may amount to 500 pF which is effectively in parallel with the resistive component. The reactance of this capacitance is, of course, inversely proportional to frequency and at 3 Mc/s, the upper extreme of the video band, is only 100 ohms.

Thus the input impedance of the modulated amplifier which constitutes the load for the modulator stage, is a very variable

quantity, having a resistive component which is independent of frequency and falls as signal amplitude increases to a minimum value of 400 ohms and having a capacitive component which is independent of amplitude and falls, as frequency increases, to a minimum value of 100 ohms. Of these two, the capacitive component is the more important because it is the smaller, and in much of the following text the resistive component is neglected. To achieve 100 per cent modulation at 3 Mc/s necessitates delivering a signal of 1,100 volts peak-to-peak to a load of 100 ohms. This requires a current swing of 11 A peak-to-peak, a swing which is necessary to reproduce even a single 3 Mc/s bar at maximum amplitude.

In a black-and-white television system the amplitude of high-frequency components in the picture signal is smaller than that of low-frequency ones and advantage is sometimes taken of this to achieve an economy in modulator operation. The modulator is designed to deliver the maximum undistorted current swing required for 100 per cent modulation at say 1.5 Mc/s. At higher frequencies the maximum undistorted depth of modulation which can be achieved falls in inverse proportion to the frequency, being 50 per cent at 3 Mc/s. This fall in high-frequency response is the price paid for the economy in modulator operation and, even when this economy is practised, the modulator must still supply an undistorted current swing of 5.5 A to generate the required 1,100-volt signal across the 500-pF capacitance, the reactance of which is 200 ohms at 1.5 Mc/s.

In a modulator for a colour television transmitter, the requirements may be more stringent. For example, in the N.T.S.C. colour system there is a colour sub-carrier near one extreme of the video band and with an amplitude of the same order as the main carrier. This sub-carrier is equivalent to 100 per cent modulation at a video frequency near 3 Mc/s and, as already pointed out, to supply a 1,100-volt peak-to-peak signal at this frequency into a 500-pF capacitive load, the modulator must be capable of delivering 11 A peak-to-peak current swing without significant distortion.

13.2 BASIC PRINCIPLES OF REGULATED AMPLIFIERS

The problem is to design a modulator stage which can deliver the required amplitude of output signal without significant distortion into a load whose resistive and reactive components can vary over a wide range.

There are two fundamental requirements to be met:

- (a) the frequency response of the modulator must be level over the video band.

(b) the modulator must be capable of supplying the required output current without distortion.

The modulator load is predominantly capacitive and the reactance falls as frequency increases. Ideally, to maintain a level frequency response over the video band, the output resistance of the modulator should be small compared with the lowest value of the load. The output resistance and the load form a potential divider and, if the output resistance is not low enough, this divider gives a loss which increases as frequency is raised. If, as suggested earlier, the minimum load impedance is 100 ohms, the internal resistance should preferably not exceed 20 ohms for which the loss at 3 Mc/s is 1 dB. This high-frequency loss occurs irrespective of the amplitude of the video signal.

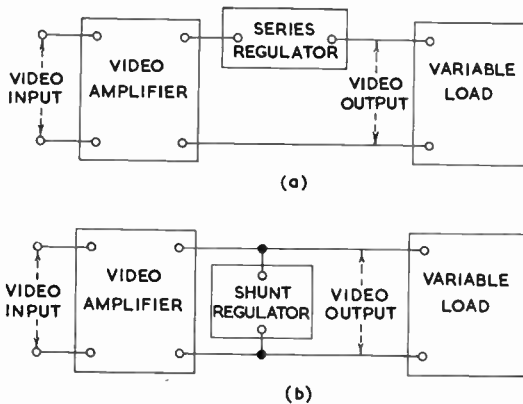

Fig. 151—Basic forms of (a) series-regulated and (b) shunt-regulated amplifiers

The provision of a low output resistance does not, however, completely solve the problem. A modulator with the necessary 20 ohms resistance may be incapable of supplying the 5.5 A or 11 A of current required on peak video signals. If the current output is inadequate, waveform distortion is inevitable on large-amplitude signals although signals of small amplitude are undistorted. Distortion due to inadequate output current can be particularly severe if the amplifier employs negative feedback: an example of this is described later in Chapter 14, which is concerned with the cathode follower.

The obvious solution to these difficulties is to design the modulator so that it is capable of supplying the largest current likely to be required. Such an amplifier, if it consisted of valves operating in

SHUNT-REGULATED AMPLIFIERS

class A as is usual in modulator stages, would be very inefficient because the anode dissipation would at all times be adequate for maximum output even when the output current required is very small. This difficulty is overcome, and more economic operation obtained, by using in addition to the modulator a further stage, known as a *regulator* stage, which supplies to the load signal-frequency power dependent on the load impedance.

When the load impedance is high and the modulator can supply the required current on its own, the regulator stage does little. As the load impedance falls (due to increased signal amplitude or increasing amplitude of high-frequency components) the regulator stage supplies more power. At minimum load values the regulator stage may deliver 2 or 3 times the power supplied by the modulator proper.

There are two basic forms of regulated amplifier and they are illustrated in Fig. 151. At (a) the regulator is shown connected *in series* with the load: such a regulator is designed to supply an output voltage dependent on the load value and is known as *series regulator*. At (b) the regulator is shown connected *in parallel* with the load: such a regulator is designed to supply an output current dependent on the load value and is known as *shunt regulator*. This is the form of circuit favoured in modulator design.

13.3 DEVELOPMENT OF BASIC CIRCUIT

The basic circuit of a shunt-regulated amplifier can be drawn as shown in Fig. 152. V1 is the amplifying stage, Z the varying load

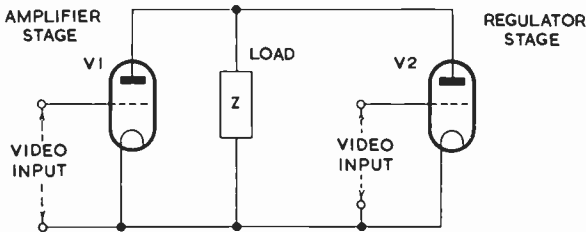

Fig. 152—Basic circuit of shunt-regulated amplifier

and V2 is the shunt regulator stage. For simplicity this diagram indicates signal-frequency circuits only and the h.t. supply is therefore omitted. V1 is of course supplied with the video signal required to be delivered to Z. V2 also must feed the same video signal to Z and therefore the grid of V2 must have a video input in phase with that supplied to V1. If the grid of V2 is connected to the same video

input as V_1 , the two valves simply operate in parallel. Although a larger current swing is obtainable in this way, this is not a shunt-regulated amplifier. To obtain the required performance the amplitude of video signal applied to V_2 must be dependent on the load value, increasing from a low value as the load impedance decreases.

One way of achieving this is illustrated in Fig. 153. A resistor R is connected in series with the load Z and the video signal generated across R by the anode current of V_1 is used to feed V_2 grid. R must clearly be small compared with Z otherwise useful power is wasted in it. The anode a.c. resistance of V_1 must be small compared with $(R + Z)$ to give a substantially constant video voltage across $(R + Z)$. When this constancy has been attained any decrease in the

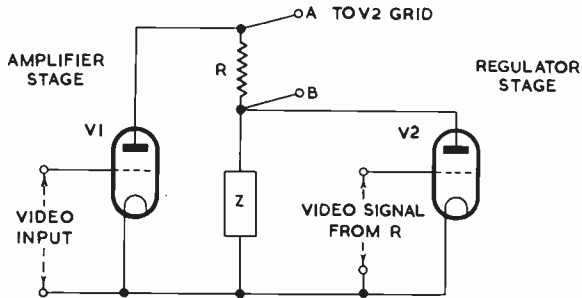

Fig. 153—Basic circuit of shunt-regulated amplifier illustrating one method of obtaining the input signal for the regulator stage

value of Z causes the video voltage across R to increase, thus increasing the amplitude of the video input to V_2 . The signal-frequency components of V_1 and V_2 anode currents in Z must, of course, be in phase and to achieve this, the grid of V_2 must be connected to A and the cathode to B. When these connections are made the circuit has the form shown in Fig. 154 which is the fundamental arrangement for one form of shunt-regulated amplifier.

This circuit resembles in some respects that of an amplifier stage V_1 feeding a cathode follower stage V_2 . There are, however, significant points of difference: for example the load of Z is common to both stages and at low frequencies V_1 may supply most of the power. Moreover R is much too low a resistance to be the grid resistor of a conventional follower and it so reduces the feedback inherent in the circuit of V_2 that the output resistance of V_2 considerably exceeds $1/g_m$ which applies to a cathode follower. If as is usual V_1 and V_2 are similar valves taking the same mean anode current they can be

SHUNT-REGULATED AMPLIFIERS

connected in series across the h.t. supply as shown in Fig. 155 from which, for the sake of simplicity, grid bias supplies are omitted.

The circuit of Fig. 155 is analysed in Appendix K in which it is shown that the ratio of the signal-frequency currents supplied by the two valves is given by

$$\begin{aligned} I_2 &= \mu_2 R - Z \\ I_1 &= r_{a2} + Z \end{aligned} \quad \dots \quad \dots \quad \dots \quad (83)$$

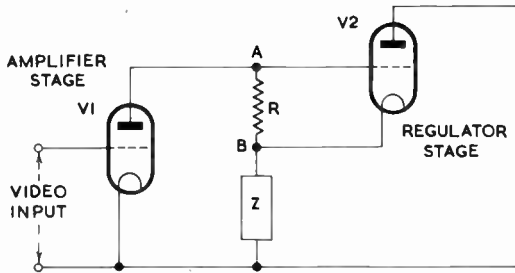

Fig. 154—Fundamental circuit of shunt-regulated amplifier with all d.c. feeds omitted

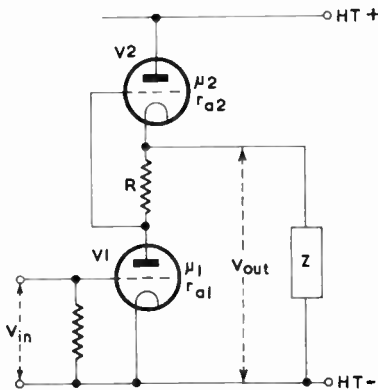

Fig. 155—Shunt-regulated amplifier with h.t. supply included

in which I_1 is the signal-frequency current contributed by the amplifier,

I_2 is the signal-frequency current contributed by the regulator stage,

μ_2 is the amplification factor of the regulator valve,

r_{a2} is the anode a.c. resistance of the amplifier valve,

R is the coupling resistor.

Normally $\mu_2 R$ exceeds Z and as Z becomes smaller, the numerator becomes larger and the denominator smaller, giving an increased ratio I_2/I_1 , confirming that the regulator stage supplies an increasing share of the combined output current. In a modulator stage of the type considered earlier the load impedance falls with increasing frequency causing the regulator stage to supply more current at high than at low frequencies. When Z becomes small compared with $\mu_2 R$, the division ratio tends to $\mu_2 R/r_{a2}$, i.e. $g_{m2} R$, the gain of the regulator valve with a load equal to R . In a practical modulator circuit g_{m2} may be 23 mA/V and R 100 ohms giving $g_{m2} R$ as 2.3; the regulator stage then contributes 2.3 times the current supplied by the amplifier.

If Z is made large compared with $\mu_2 R$ and r_{a2} we have, from equation (83)

$$I_2 = -I_1$$

This means that the amplifying stage is driving a current through the regulator stage and no current is flowing in the load.

13.4 OUTPUT RESISTANCE OF SHUNT-REGULATED AMPLIFIER

So far we have considered the performance of the shunt-regulated amplifier when supplied with a sinusoidal input and we have calculated the boosting effect of the regulator stage for input frequencies between zero and the limit of the video band. This does not, however, give a true estimate of the utility of the circuit in a television system because it does not indicate how the circuit reacts to steep-sided transients such as those contained in video signals. We will therefore now consider how the basic shunt-regulator amplifier of Fig. 155 behaves towards a step input and, for simplicity, we will assume the load impedance Z to be a simple capacitor C .

Ideally when the step input is applied it should appear magnified across the capacitor C . To change the voltage across a capacitor, however, it must be charged or discharged and this takes time, the precise time depending on the magnitude of the charging or discharging current. The greater this current, the more rapid is this voltage change and the more nearly does the amplifier approach the ideal. Alternatively we may say that the rapidity of change of voltage across the capacitor depends on the time constant $R_{out}C$, where R_{out} is the output resistance of the amplifier, and to obtain a rapid voltage change R_{out} must be small.

An expression for the output resistance of a shunt-regulated amplifier is derived in Appendix K; it is

$$\text{output resistance} = \frac{r_{a2}(r_{a1} + R)}{r_{a1} + r_{a2}(\mu_2 + 1)R}$$

SHUNT-REGULATED AMPLIFIERS

This output resistance is composed of $(r_{a1} + R)$ ohms due to V1, the amplifier stage, and $r_{a2}(r_{a1} + R)/[r_{a1} + (\mu_2 + 1)R]$ due to V2, the regulator stage. On receipt of a step input signal the two valves supply charging or discharging current to a capacitive load in the inverse ratio of these resistances.

To obtain an estimate of the current division ratio we will assume the two valves to be similar, having an anode a.c. resistance of 700 ohms and an amplification factor of 16. Thus $r_{a1} = r_{a2} = 700$ and $\mu_1 = \mu_2 = 16$. If R is 100 ohms, a typical value, we have

$$\begin{aligned} \text{output resistance of V1} &= r_{a1} + R \\ &= 700 + 100 \\ &= 800 \text{ ohms} \end{aligned}$$

$$\begin{aligned} \text{output resistance of V2} &= \frac{r_{a2}(r_{a1} + R)}{r_{a1} + (\mu_2 + 1)R} \\ &= \frac{700(700 + 100)}{700 + 17 \times 100} \\ &= \frac{700 \times 800}{2,400} \\ &= 233 \text{ ohms} \end{aligned}$$

These calculations show that the regulator stage contributes nearly four times as much current as the amplifier stage, a result which differs from that obtained by considering sinusoidal signals.

13.5 VOLTAGE GAIN OF SHUNT-REGULATED AMPLIFIER

Appendix K shows that the output current I from a shunt-regulated amplifier of the type illustrated in Fig. 155 is given by

$$I = \mu_1 V_{in} \frac{\mu_2 R + r_{a2}}{Z + \frac{r_{a1} + r_{a2} + (\mu_2 + 1)R}{r_{a2}(r_{a1} + R)}} \frac{r_{a1} + r_{a2} + (\mu_2 + 1)R}{r_{a1} + r_{a2} + (\mu_2 + 1)R}$$

This shows that the circuit behaves as a generator of voltage V given by

$$V = \frac{\mu_1 V_{in} (\mu_2 R + r_{a2})}{r_{a1} + r_{a2} + (\mu_2 + 1)R} \quad \dots \quad (84)$$

and of output resistance R_{out} given by

$$R_{out} = \frac{r_{a2}(r_{a1} + R)}{r_{a1} + r_{a2} + (\mu_2 + 1)R} \quad \dots \quad (85)$$

If the two valves are similar we may put $r_a = r_{a1} = r_{a2}$ and $\mu = \mu_1 = \mu_2$ and these expressions simplify to

$$V = \frac{\mu V_{in} (\mu R + r_a)}{2r_a + (\mu + 1)R} \quad \dots \quad \dots \quad \dots \quad (86)$$

and

$$R_{out} = \frac{r_a (r_a + R)}{2r_a + (\mu + 1)R} \quad \dots \quad \dots \quad \dots \quad (87)$$

If $r_a = 700$ ohms, $R = 100$ ohms and $\mu = 16$ as assumed above

$$\begin{aligned} R_{out} &= \frac{700 \times 800}{1,400 + 17 \times 100} \text{ ohms} \\ &= \frac{700 \times 800}{3,100} \text{ ohms} \\ &= 172.5 \text{ ohms} \end{aligned}$$

This, of course, is equal to the resistance of 233 ohms and 800 ohms in parallel, these being the individual output resistances of the two valves comprising the circuit.

If the load is large compared with the output resistance which is true at low frequencies the voltage gain is given by

$$A_{lf} = \frac{V_{out}}{V_{in}} = \frac{\mu (\mu R + r_a)}{2r_a + (\mu + 1)R} \quad \dots \quad \dots \quad \dots \quad (88)$$

Substituting $\mu = 16$, $r_a = 700$ ohms and $R = 100$ ohms

$$\begin{aligned} \frac{V_{out}}{V_{in}} &= \frac{16 (1,600 + 700)}{1,400 + 1,700} \\ &= \frac{16 \times 2,300}{3,100} \\ &= 11.86 \end{aligned}$$

13.6 COMPARISON WITH CONVENTIONAL AMPLIFIER

It is interesting to compare the performance of a shunt-regulated amplifier with a single-stage conventional amplifier RC-coupled to the modulated amplifier. To obtain the desired performance the amplifier must consist of two triodes in parallel, each having a μ of 16 and r_a of 700 ohms, with a common anode load resistor of 825 ohms. Such a modulator is illustrated in simplified form in Fig. 156: although it contains two valves of the same type as used in the shunt-regulated amplifier, there are marked differences in the

SHUNT-REGULATED AMPLIFIERS

efficiency of the two types of amplifier as illustrated in the following comparison.

The effective anode a.c. resistance of the two valves in parallel is $r_a/2 = 700/2$, i.e. 350 ohms. The amplification factor is 16 and the low frequency gain is given by

$$\begin{aligned}
 A_{lf} &= \frac{\mu R_L}{r_a/2 + R_L} \\
 &= \frac{16 \times 825}{350 + 825} \\
 &= \frac{16 \times 825}{1,175} \\
 &= 11
 \end{aligned}$$

not very different from that of the shunt-regulated amplifier. The output resistance of the conventional amplifier is equal to the resistance of $r_a/2$ and R_L in parallel.

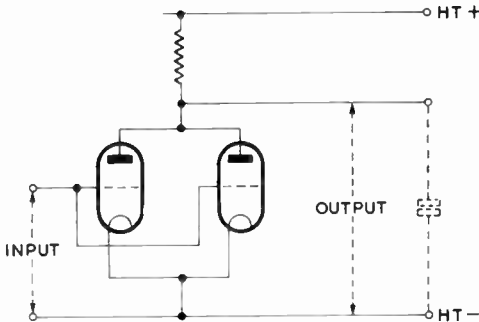

Fig. 156—Modulator consisting of two valves connected in parallel

Thus

$$\begin{aligned}
 \text{output impedance} &= \frac{R_L \cdot r_a/2}{r_a/2 + R_L} \\
 &= \frac{825 \times 350}{1,175} \\
 &= 240 \text{ ohms}
 \end{aligned}$$

again not very different from the value for the shunt-regulated amplifier and contributing almost the same loss at the upper extreme of the video band.

The shunt-regulated amplifier is, however, more economical; it requires a mean h.t. current of 0.8 A compared with 1.6 A for

the parallel-connected valves. At an h.t. voltage of 2,500 volts this is a saving of 2 kW. Moreover the power dissipated in the resistor R_L is 2.1 kW for the parallel-connected amplifier compared with 64 W dissipated in R in the shunt-regulated amplifier. The ability of the shunt-regulated amplifier to cope with variations in load resistance can be judged by measurements quoted by V. J. Cooper* who gives the distortion in reproducing a sawtooth wave-

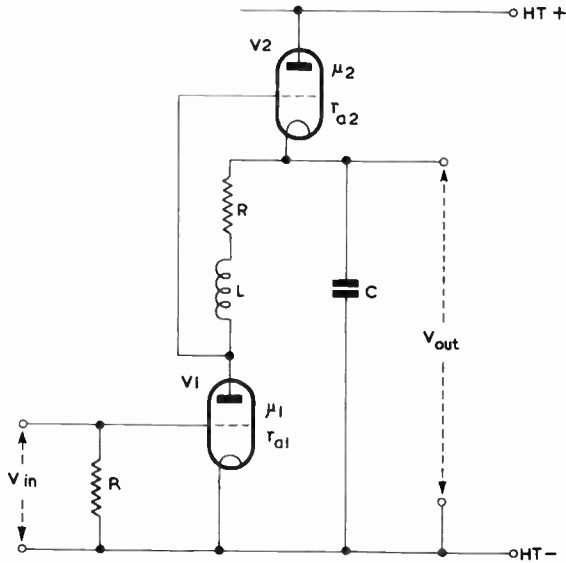

Fig. 157—An inductor L used to compensate a shunt-regulated amplifier

form as 1 per cent for the shunt-regulated amplifier compared with 6 per cent for a parallel-connected amplifier.

13.7 COMPENSATION FOR CAPACITIVE LOADS

The load into which a shunt-regulated amplifier works has a significant shunt capacitive component which tends to cause attenuation of the output voltage at high video frequencies. This fall in response can be reduced by the techniques used in video amplifiers and described in Volume 2. The first step usually applied to a simple RC-coupled video amplifier is to connect an inductor in series with the load resistor; this offsets the fall in impedance due to shunt

* Cooper, V. J., "Shunt-regulated Amplifiers." *Wireless Engineer*, May 1951, Vol. 28, No. 332, pp. 132-145.

SHUNT-REGULATED AMPLIFIERS

capacitance and the voltage supplied to the following valve can be made almost constant over the video band.

A similar principle can be applied to a shunt-regulated amplifier. In the simple amplifier (Fig. 155) the input voltage for the regulator stage is generated across a resistor R by the anode current of the amplifier stage. If an inductor is connected in series with this resistor as shown in Fig. 157, the input voltage of the regulator stage rises with increase in frequency. It thus supplies more signal-frequency current as frequency rises, eliminating the effects on the amplifier stage of a capacitive load. For a shunt-regulated amplifier

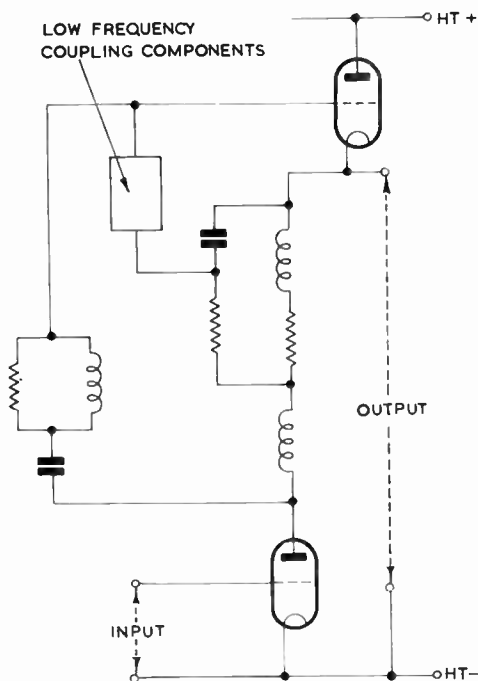

Fig. 158—A complex network used to compensate a shunt-regulated amplifier

with two similar valves, feeding a capacitor C , it is shown in Appendix L that if

$$L = \frac{r_a C (r_a + \mu R)}{\mu}$$

the effective load impedance for V2 becomes simply $(r_a + \mu R)$ in series with the coupling components R and L which is independent of frequency and of the capacitance C .

If $r_a = 700$ ohms, $\mu = 17$ and $C = 200$ pF the required value of L is given by

$$\begin{aligned} L &= \frac{700 \times 200 \times 10^{-12} (700 + 17 \times 100)}{17} \text{ H} \\ &= \frac{700 \times 200 \times 10^{-12} \times 2,400}{17} \text{ H} \\ &= 20 \mu\text{H approximately} \end{aligned}$$

The use of such an inductor can bring about an improvement of 3 or 4 dB at 5 Mc/s in a practical modulator.

Further improvements in high-frequency response are possible by the inclusion of additional components, the technique being similar to that employed in the 3-, 4- and 5-element circuits in video amplifiers described in Volume 2. An example of a complex network is given in Fig. 158 in which, for simplicity, the low-frequency coupling components are indicated as a single block. This circuit gives a 3 dB improvement at 5 Mc/s on that of Fig. 157.

APPENDIX K

DERIVATION OF EXPRESSIONS FOR THE OUTPUT RESISTANCE AND VOLTAGE GAIN OF A SHUNT-REGULATED AMPLIFIER

FIG. K.1 (a) gives a simplified circuit diagram of one type of shunt-regulated amplifier and Fig. K.1 (b) illustrates the same circuit with the two valves replaced by their equivalent generators. It is the purpose of this appendix to derive expressions for the output resistance and voltage gain of this type of shunt-regulated amplifier. Applying Kirchhoff's laws to Fig. K.1 (b) we have

$$\mu_1 V_{g1} = I_1 (r_{a1} + R + Z) + I_2 Z \quad \dots \quad (1)$$

$$\mu_2 V_{g2} = I_2 (r_{a2} + Z) + I_1 Z \quad \dots \quad (2)$$

But $V_{g2} = I_1 R$. Substituting for V_{g2} in (2)

$$\therefore \mu_2 I_1 R = I_2 (r_{a2} + Z) + I_1 Z$$

$$\therefore I_2 (r_{a2} + Z) = I_1 (\mu_2 R - Z) \quad \dots \quad (3)$$

SHUNT-REGULATED AMPLIFIERS

from which

$$\frac{I_2}{I_1} = \frac{\mu_2 R - Z}{r_{a2} + Z}$$

Eliminating I_2 between (1) and (3)

$$\mu_1 V_{g1} = I_1 (r_{a1} + R + Z) + I_1 Z (\mu_2 R - Z) / (r_{a2} + Z)$$

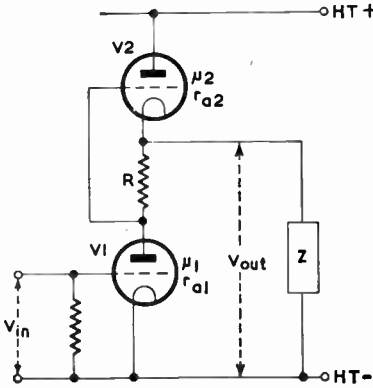

(a)

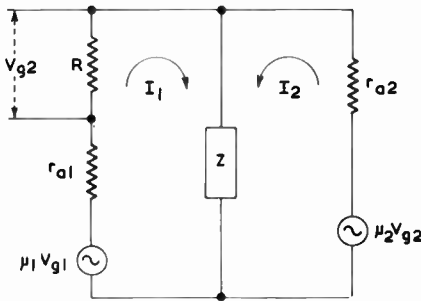

(b)

Fig. K.1—The simplified circuit diagram of one type of shunt-regulated amplifier is shown at (a) and its equivalent circuit at (b)

$$\begin{aligned} \therefore I_1 &= \frac{\mu_1 V_{g1}}{(r_{a1} + R + Z) + Z (\mu_2 R - Z) / (r_{a2} + Z)} \\ &= \frac{\mu_1 V_{g1} (r_{a2} + Z)}{r_{a1} r_{a2} + r_{a2} R + Z (r_{a1} + r_{a2}) + (\mu_2 + 1) R Z} \end{aligned} \quad (4)$$

Eliminating I_1 between (1) and (3)

$$\begin{aligned}\mu_1 V_{g1} &= I_2 (r_{a2} + Z) (r_{a1} + R + Z) / (\mu_2 R - Z) + I_2 Z \\ \therefore I_2 &= \frac{\mu_1 V_{g1}}{(r_{a1} + R + Z) (r_{a2} + Z) / (\mu_2 R - Z) + Z} \\ &= \frac{(\mu_2 R - Z) \mu_1 V_{g1}}{r_{a1} r_{a2} + r_{a2} R + Z(r_{a1} + r_{a2}) + (\mu_2 + 1) RZ} \quad (5)\end{aligned}$$

Now the current I in the load is the sum of I_1 and I_2 . From (4) and (5) therefore

$$\begin{aligned}I = I_1 + I_2 &= \mu_1 V_{g1} \frac{(r_{a2} + Z) + (\mu_2 R - Z)}{r_{a1} r_{a2} + r_{a2} R + Z(r_{a1} + r_{a2}) + (\mu_2 + 1) RZ} \\ &= \mu_1 V_{g1} \left[\frac{\mu_2 R + r_{a2}}{Z + \frac{r_{a1} + r_{a2} + (\mu_2 + 1) R}{r_{a1} r_{a2} + r_{a2} R}} \right] \quad \dots \quad (6)\end{aligned}$$

This expression is of the form

$$I = \frac{V}{Z + R_{out}}$$

and shows that the shunt-regulated circuit has an effective generator voltage given by

$$V = \frac{\mu_1 V_{g1} (\mu_2 R + r_{a2})}{r_{a1} + r_{a2} + (\mu_2 + 1) R} \quad \dots \quad (7)$$

and an effective output resistance given by

$$R_{out} = \frac{r_{a2} (r_{a1} + R)}{r_{a1} + r_{a2} + (\mu_2 + 1) R} \quad \dots \quad (8)$$

If the output resistance is small compared with the load impedance, the voltage generated across the load V_{out} is nearly equal to the generator voltage V . The voltage gain of the circuit V_{out}/V_{g1} is approximately given by V/V_{g1} which, from (7), gives

$$\frac{V_{out}}{V_{g1}} = \frac{\mu_1 (\mu_2 R + r_{a2})}{r_{a1} + r_{a2} + (\mu_2 + 1) R} \quad \dots \quad (9)$$

APPENDIX L

COMPENSATION OF SHUNT-REGULATED AMPLIFIER FOR CAPACITIVE LOAD

It is explained in the text that the first step in compensating a shunt-regulated amplifier for high-frequency attenuation caused by the shunt capacitive component of the load is to connect an inductor L in series with the resistor R as shown in Fig. L.1 (a). This alteration causes the input signal for V2 to become $I_1(R + j\omega L)$ as indicated in the equivalent diagram Fig. L.1 (b). Provided the correct value of L is used, the effective load impedance for V2 in this circuit, is $(r_a + \mu R)$ in series with R and L which is independent of the capacitive component of the load.

The circuit equations of Appendix K apply to the compensated circuit if we substitute $(R + j\omega L)$ for R . With this substitution, equation (4) of Appendix K becomes

$$I_1 = \frac{\mu_1 V_{g1}}{(r_{a1} + R + j\omega L + Z) + Z[\mu_2(R + j\omega L) - Z]/(r_{a2} + Z)}$$

As a simplification we will assume two valves to be similar. Thus we may put $r_{a1} = r_{a2} = r_a$ and $\mu_1 = \mu_2 = \mu$

$$\therefore I_1 = \frac{\mu V_{g1}}{(r_a + R + j\omega L + Z) + Z[\mu(R + j\omega L) - Z]/(r_a + Z)}$$

If the load is a capacitance $Z = 1/j\omega C$

$$\therefore I_1 = \frac{\mu V_{g1}}{r_a + R + j\omega L + \frac{1}{j\omega C} + \frac{1}{j\omega C} \cdot \frac{\mu(R + j\omega L) - 1/j\omega C}{r_a + 1/j\omega C}}$$

The denominator of this expression is the effective impedance through which I_1 , the signal-frequency component of the anode current of V1, flows. It includes r_a , R and $j\omega L$, as would be expected from examination of the equivalent circuit of Fig. L.1 and the additional terms represent the load impedance as modified by the shunt-regulator stage. The aim is to make this additional term independent of

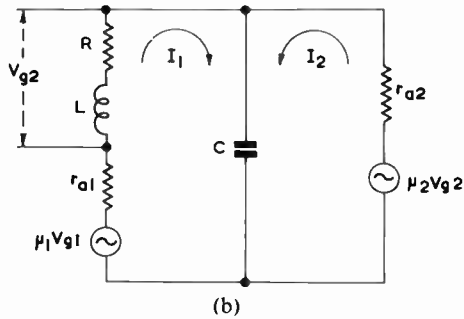
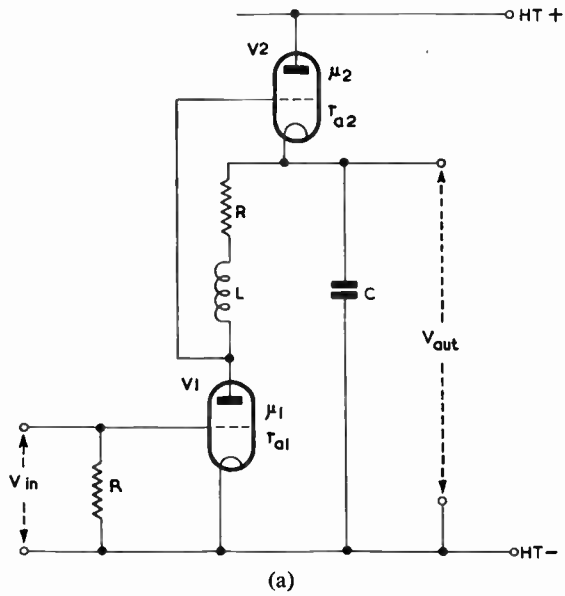

Fig. L.1—An inductance-compensated shunt-regulated amplifier is shown in simplified form at (a) and its equivalent circuit at (b)

frequency. It may be written in the form

$$\begin{aligned} & \frac{1}{j\omega C} \cdot \left[1 + \frac{\mu(R + j\omega L) - 1/j\omega C}{r_a + 1/j\omega C} \right] \\ &= \frac{1}{j\omega C} \cdot \left[\frac{r_a + \mu(R + j\omega L)}{r_a + 1/j\omega C} \right] \\ &= \frac{r_a + \mu R + \mu j\omega L}{1 + j\omega C r_a} \end{aligned}$$

The resistive term in the numerator of this expression is $(r_a + \mu R)$ times that in the denominator. If the reactive term $\mu j\omega L$ is also $(r_a + \mu R)$ times that in the denominator ($j\omega C r_a$), the required condition is obtained. Thus

$$\mu j\omega L = (r_a + \mu R) j\omega C r_a$$

$$\mu L = (r_a + \mu R) C r_a$$

$$\therefore L = \frac{(r_a + \mu R) C r_a}{\mu}$$

With this value of L the signal-frequency current of valve V1 is given by

$$I_1 = \frac{\mu V_{g2}}{r_a + R + j\omega L + (r_a + \mu R)}$$

showing the load as composed of R , L and $(r_a + \mu R)$ which is independent of the capacitance C .

CHAPTER 14

SHUNT-REGULATED CATHODE FOLLOWER

14.1 INTRODUCTION

A CATHODE-FOLLOWER stage is sometimes used to drive the modulated amplifier in a transmitter. Such a stage has, of course, less than unity gain but its output resistance is low, being given approximately by $1/g_m$. For the type of valve described earlier μ is 16 and r_a 700 ohms, giving g_m as 23 mA/V and $1/g_m$ as 43.5 ohms. This is lower than that of the shunt-regulated amplifiers described above but nevertheless the performance of a simple cathode follower as modulator is not fully satisfactory in a television transmitter where modulating signals may have short rise times. The chief disadvantage of the cathode follower occurs when the input signal has a rapid negative-going edge. The rate of fall of cathode voltage depends on the time constant RC where R is the effective resistance of the cathode circuit and is equal to the output resistance ($1/g_m$) of the cathode follower in parallel with the shunt resistance of the load.

If the input signal has a very short fall time or a large amplitude it is possible that the cathode voltage may not be able to change sufficiently rapidly to keep up with the input signal. The result is that the cathode follower is temporarily cut off. During the period of cut-off the valve is no longer able to supply current to the load; in fact, the load circuit is completely divorced from the source of input signal and the voltage across the load falls exponentially at a rate dependent on the time constant of the load resistance and load capacitance. This time constant is normally much longer than that which applies when the cathode follower is conducting. Thus the fall time of the output signal during the period of cut-off of the cathode follower is much longer than that of the input signal. This constitutes severe waveform distortion.

This form of distortion, though described for a cathode follower, can occur in any feedback amplifier and arises when the feedback voltage cannot change as rapidly as the input signal. It has the effect of causing overloading on signals with short rise times even when the amplitude is smaller than that which the amplifier can accept without distortion when the rise time is longer. Further details about this point are given in Volume 2.

SHUNT-REGULATED CATHODE FOLLOWER

The cause of the distortion is the inability of the feedback voltage to change sufficiently quickly, inability, that is, to change the voltage across a capacitance sufficiently quickly. It is therefore due to lack of sufficient charging or discharging current. This suggests that the addition of a regulator stage to a cathode follower, which will provide a substantial increase in charging or discharging current, should improve the performance. This is so, and shunt-regulated cathode followers are employed as modulators in some television transmitters. We shall now consider the basic principles of such circuits.

14.2 DEVELOPMENT OF BASIC CIRCUIT

The circuit of a shunt-regulated cathode follower can be developed in a manner similar to that employed for the shunt-regulated amplifier. Fig. 159 shows a cathode-follower stage V1 with the load Z connected in the cathode circuit. Across Z is also connected

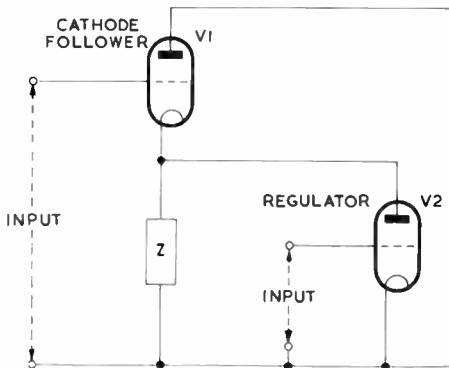

Fig. 159—Development of the circuit of a shunt-regulated cathode follower: stage 1

the regulator stage V2. The problem is to supply V2 with an input signal whose phase is such that the signal-frequency current outputs of V1 and V2 add in the load Z and whose magnitude increases as Z decreases in magnitude.

The input for the regulator stage can be obtained from a resistor R connected in series with the load Z as shown in Fig. 160. The output resistance of V1 is low and, for a constant-voltage variable-frequency input to V1, the voltage appearing across $(R + Z)$ is also substantially constant. Z normally has a shunt capacitive component and the magnitude of Z falls as frequency increases causing the signal-frequency voltage across R to rise as frequency increases, this being the required condition. In order that the

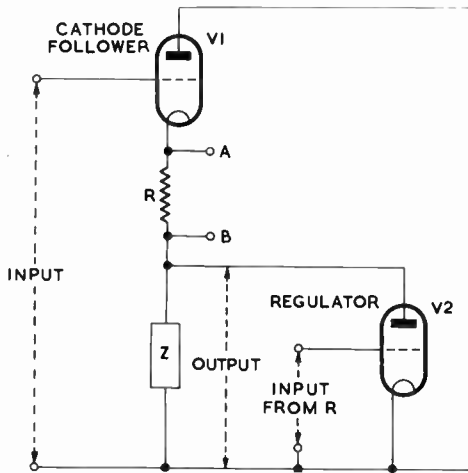

Fig. 160—Development of the circuit of a shunt-regulated cathode follower: stage 2

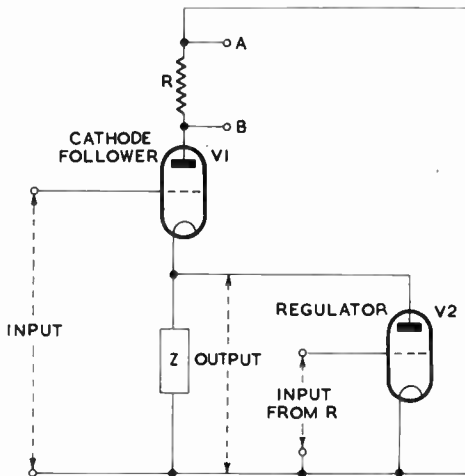

Fig. 161—Development of the circuit of a shunt-regulated cathode follower: stage 3

SHUNT-REGULATED CATHODE FOLLOWER

signal-frequency output of V2 shall be in phase with that of V1 the grid of V2 must be connected to terminal B and the filament to terminal A.

This, however, would cause a short circuit between anode and grid of the regulator stage, a difficulty which can be avoided by transferring the resistor R to the anode circuit of V1 as shown in Fig. 161: this change does not, of course, affect the operation of the circuit. To give the required performance the grid must be connected to the anode of V1 as shown in Fig. 162 which is the final basic circuit of the shunt-regulated cathode follower. As in the shunt-regulated amplifier circuit, the two valves if similar, can be connected in series across the h.t. supply as shown here. In a

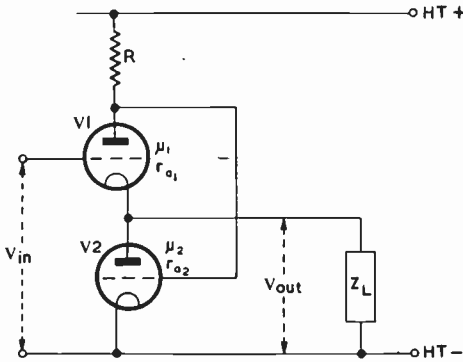

Fig. 162—Development of the circuit of a shunt-regulated cathode follower: final stage

practical circuit, a d.c. potentiometer incorporating a capacitor across the upper arm is likely to be employed between the anode of V1 and the grid of V2, and both valves would require grid bias supplies.

14.3 OUTPUT RESISTANCE OF SHUNT-REGULATED CATHODE FOLLOWER

In spite of the interchange of positions of the two valves the basic circuit of the shunt-regulated cathode follower (Fig. 162) is similar to that of the shunt-regulated amplifier (Fig. 155). This is best seen by redrawing the two circuits with the valves replaced by equivalent generators; the two diagrams are given in Appendices K and M. The difference in performance of the cathode-follower circuit compared with that of the amplifier circuit is due to the use of different input terminals. In the amplifier circuit the input is applied between the grid and filament of V1; in the cathode-follower circuit

it is applied across the series-connected grid-filament path of V1 and the output load. We may thus write

$$V_{in} = V_{gk} + V_{out} \quad \dots \quad (89)$$

where V_{in} is the cathode-follower input signal, V_{gk} is the grid-filament signal of V1 and V_{out} is the output voltage. This expression gives the relationship between the cathode-follower and amplifier performance and is used in Appendix M in which the output resistance and voltage gain of the cathode-follower circuit are deduced.

For a sinusoidal input the ratio of the output current supplied by the regulator to that supplied by the cathode follower proper depends on Z as for the shunt-regulated amplifier circuit and is defined by expression (83). For a step input the ratio of the current outputs is determined by the output resistance of the regulator stage and cathode-follower stage. From Appendix M the output resistance of the two valves acting together is given by

$$\text{output resistance} = \frac{r_{a2}(r_{a1} + R)}{(\mu_1 + 1)r_{a2} + r_{a1} + [(\mu_1 + 1)\mu_2 + 1]R} \quad (90)$$

Output resistance is composed of $(r_{a1} + R)/(\mu_1 + 1)$ due to the cathode follower in parallel with $r_{a2}(r_{a1} + R)/\{r_{a1} + [(\mu_1 + 1)\mu_2 + 1]R\}$ due to the regulator stage, and for a step input the two valves contribute current to the load according to the inverse ratio of these resistances.

If, as is often true, V1 and V2 are valves of the same type, then $\mu = \mu_1 = \mu_2$ and $r_a = r_{a1} = r_{a2}$. The output resistance becomes

$$\text{output resistance} = \frac{r_a(r_a + R)}{(\mu + 2)r_a + [(\mu + 1)\mu + 1]R} \quad \dots \quad (91)$$

and the two components of output resistance are $(r_a + R)/(\mu + 1)$ due to the cathode follower and $r_a(r_a + R)/\{r_a + [(\mu + 1)\mu + 1]R\}$ due to the regulator stage. To obtain an estimate of the individual output resistances let $\mu = 16$, $r_a = 700$ ohms and $R = 100$ ohms. The output resistance of the regulator stage is given by

$$\begin{aligned} \frac{r_a(r_a + R)}{r_a + [(\mu + 1)\mu + 1]R} &= \frac{700(700 + 100)}{700 + (17 \cdot 16 + 1)100} \\ &= \frac{560,000}{700 + 27,300} \\ &= \frac{560,000}{28,000} \\ &= 20 \text{ ohms} \end{aligned}$$

SHUNT-REGULATED CATHODE FOLLOWER

The output resistance of the cathode follower is given by

$$\begin{aligned} \frac{r_a + R}{\mu + 1} &= \frac{700 + 100}{17} \\ &= \frac{800}{17} \\ &= 47 \text{ ohms} \end{aligned}$$

These calculations show that the current contributed to the load by the regulator stage is nearly $2\frac{1}{2}$ times that contributed by the cathode follower. The net output resistance is equal to 20 ohms and 47 ohms in parallel, i.e.

$$\begin{aligned} \frac{20 \times 47}{20 + 47} &= \frac{940}{67} \\ &= 14 \text{ ohms} \end{aligned}$$

a result which can be confirmed by direct substitution in expression (91). This is a small output resistance compared with the value of 172.5 ohms for the shunt-regulated amplifier and satisfies the requirement of the ideal shunt-regulated stage namely that it is small compared with likely values of load. However, the gain of the cathode follower is less than unity and a modulator incorporating a cathode follower will require an additional stage of amplification before the follower, to supply the signal required by the modulated amplifier. The input impedance of the cathode follower is, however, much higher than that of the modulated amplifier and the additional gain stage does not require a valve as large as that needed to drive the modulated amplifier directly.

14.4 VOLTAGE GAIN OF SHUNT-REGULATED CATHODE FOLLOWER

Appendix M gives the following expression for the voltage gain of the shunt-regulated cathode follower

$$\frac{V_{out}}{V_{in}} = \frac{\mu_1 (\mu_2 R + r_{a2})}{(\mu_1 + 1)r_{a2} + r_{a1} + [(\mu_1 + 1)\mu_2 + 1]R} \quad \dots \quad (92)$$

If the two valves are similar, this reduces to

$$\frac{V_{out}}{V_{in}} = \frac{\mu(\mu R + r_a)}{(\mu + 2)r_a + [(\mu + 1)\mu + 1]R} \quad \dots \quad (93)$$

To obtain a numerical estimate of the gain, substitute $\mu = 16$, $r_a = 700$ and $R = 100$

$$\begin{aligned}
 \frac{V_{out}}{V_{in}} &= \frac{\mu(\mu R + r_a)}{(\mu + 2)r_a + [(\mu + 1)\mu + 1]R} \quad \dots \quad (94) \\
 &= \frac{16(16 \times 100 + 700)}{18 \cdot 700 + [17 \cdot 16 + 1]100} \\
 &= \frac{16 \times 2,300}{12,600 + 27,300} \\
 &= \frac{368}{399} \\
 &= 0.92
 \end{aligned}$$

14.5 COMPARISON WITH CONVENTIONAL CATHODE FOLLOWER

These values of output resistance and voltage gain may be compared with those for a cathode follower consisting of two valves in parallel (Fig. 163) each valve having $\mu = 16$ and $r_a = 700$ ohms as assumed for the two valves in the shunt-regulated cathode

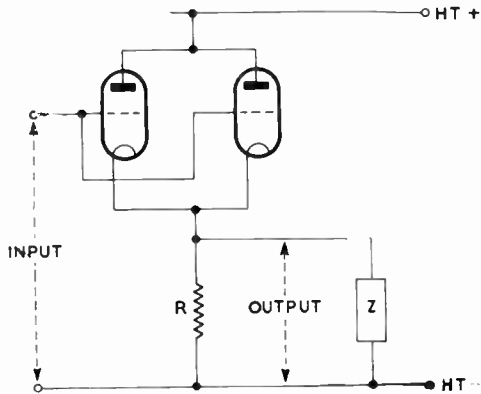

Fig. 163—Cathode follower circuit using two valves connected in parallel

follower. For the two valves in parallel the output resistance is given by $1/2g_m$, i.e. $r_a/2\mu$. This gives

$$\begin{aligned}
 \text{output resistance} &= \frac{700}{32} \\
 &= 22 \text{ ohms approximately}
 \end{aligned}$$

This is 1.5 times the output resistance of the shunt-regulated circuit. The voltage gain of the parallel-connected circuit is $\mu/(\mu + 1)$, 260

SHUNT-REGULATED CATHODE FOLLOWER

that is 16/17, approximately 0.94, not significantly different from the value for the shunt-regulated circuit.

The increased efficiency of the shunt-regulated circuit can be demonstrated by comparing the dissipations of the two circuits. The mean current required by the parallel-connected circuit may be 2.4 A at an h.t. supply of 3.5 kV giving a total power consumption of 8.4 kW. 5 kW of this is dissipated in the resistor, a typical value for which is 875 ohms. The shunt-regulated circuit requires a mean current of 1.2 A at an h.t. supply of 3 kV, a dissipation of 3.6 kW, less than half that required by the parallel-connected amplifier. The resistor value is 100 ohms and the dissipation in it is 140 W. Thus the shunt-regulated amplifier gives a better performance than the conventional cathode follower and needs less than half the input power. These figures are taken from a paper by V. J. Cooper.*

APPENDIX M

DERIVATIONS OF EXPRESSIONS FOR THE OUTPUT RESISTANCE AND VOLTAGE GAIN OF A SHUNT-REGULATED CATHODE FOLLOWER

FIG. M.1 (a) gives the basic circuit of a shunt-regulated cathode follower and it is the purpose of this appendix to derive expressions for its voltage gain and output resistance. The circuit is reproduced at (b) with the two valves replaced by equivalent generators: this circuit is similar to that of Fig. K.1 (b) for the shunt-regulated amplifier but the input signal V_{in} is applied across the grid-cathode input of the valve V1 and the output load. For this circuit, therefore, we have

$$V_{in} = V_{g1} + V_{out} \quad \dots \quad (1)$$

From expression (6) of Appendix K the current I in the output load of the amplifier is given by

$$I = V_{g1} \cdot \frac{\mu_1 (\mu_2 R + r_{a2})}{Z + \frac{r_{a1} + r_{a2} + (\mu_2 + 1) R}{r_{a2} (r_{a1} + R)}} \quad \dots \quad (2)$$

* Cooper, V. J., "New Amplifier Techniques." *Journal Brit. I.R.E.*, July 1952, Vol. 12, No. 7.

The two equivalent circuits are similar and this expression applies equally to the shunt-regulated cathode follower. To simplify the expression let

$$A = \frac{\mu_1 (\mu_2 R + r_{a2})}{r_{a1} + r_{a2} + (\mu_2 + 1) R} \quad \dots \quad (3)$$

This is the expression for the voltage gain of the shunt-regulated amplifier.

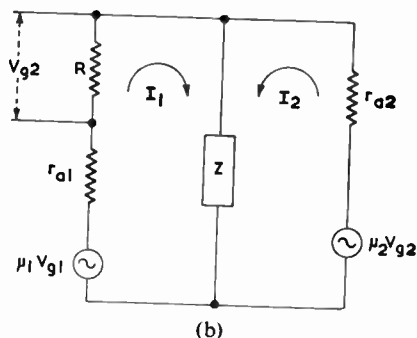
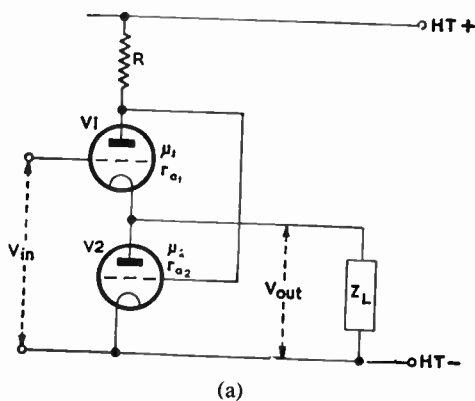

Fig. M.1—The basic circuit for a shunt-regulated cathode follower is shown at (a) and an equivalent circuit at (b)

Moreover we can put

$$R_{out} = \frac{r_{a2} (r_{a1} + R)}{r_{a1} + r_{a2} + (\mu_2 + 1) R} \quad \dots \quad (4)$$

This is the expression for the output resistance of the shunt-regulated amplifier. Expressing (2) in terms of A and R_{out} we have

SHUNT-REGULATED CATHODE FOLLOWER

$$I = V_{g1} \cdot \frac{A}{Z + R_{out}} \quad \dots \quad (5)$$

The output voltage V_{out} is given by IZ

$$\begin{aligned} \therefore V_{out} &= V_{g1} \frac{AZ}{Z + R_{out}} \\ \therefore \frac{V_{out}}{V_{g1}} &= \frac{AZ}{Z + R_{out}} \\ \therefore \frac{V_{g1}}{V_{out}} &= \frac{Z + R_{out}}{AZ} \\ \therefore \frac{V_{g1}}{V_{out}} + 1 &= \frac{Z + R_{out}}{AZ} + 1 \\ \therefore \frac{V_{g1} + V_{out}}{V_{out}} &= \frac{(A + 1)Z + R_{out}}{AZ} \end{aligned}$$

But $V_{g1} + V_{out} = V_{in}$, the input signal when the circuit is used as a cathode follower.

$$\begin{aligned} \therefore \frac{V_{in}}{V_{out}} &= \frac{(A + 1)Z + R_{out}}{AZ} \\ \therefore \frac{V_{out}}{V_{in}} &= \frac{AZ}{(A + 1)Z + R_{out}} \end{aligned}$$

This may be written in the form of expression (5) by putting IZ for V_{out} and rearranging. We then have

$$\begin{aligned} I &= V_{in} \frac{A}{(A + 1)Z + R_{out}} \\ &= V_{in} \cdot \frac{A}{Z + \frac{R_{out}}{A + 1}} \end{aligned}$$

which shows that the shunt-regulated cathode follower has a generator voltage of $AV_{in}/(A + 1)$ and an output resistance of $R_{out}/(A + 1)$. Substituting for A from (3) and rearranging, we have the following expression for the generator voltage

$$V_{in} \cdot \frac{\mu_1(\mu_2 R + r_{a2})}{(\mu_1 + 1)r_{a2} + r_{a1} + [\mu_2(\mu_1 + 1) + 1]R}$$

The output resistance is normally small compared with load impedances and the generator voltage is equal to the output voltage, giving the voltage gain as

$$\frac{V_{out}}{V_{in}} = \frac{\mu_1 (\mu_2 R + r_{a2})}{(\mu_1 + 1) r_{a2} + r_{a1} + [\mu_2 (\mu_1 + 1) + 1] R}$$

Substituting for A from (3) and for R_{out} from (4) in the expression $R_{out}/(A + 1)$ for the output resistance gives

$$\text{output resistance} = \frac{r_{a2} (r_{a1} + R)}{r_{a1} + r_{a2} + (\mu_2 + 1) R} \frac{\mu_1 (\mu_2 R + r_{a2})}{r_{a1} + r_{a2} + (\mu_2 + 1) R} + 1$$

Simplifying

$$\text{output resistance} = \frac{r_{a2} (r_{a1} + R)}{(\mu_1 + 1) r_{a2} + r_{a1} + [\mu_2 (\mu_1 + 1) + 1] R}$$

BIBLIOGRAPHY

- Maurice, R. D. A., Gilbert, M., Newell, G. F., and Spencer, J. G. "The Visibility of Noise in Television," *B.B.C. Engineering Monograph* No. 3. October 1955.
- Bode, H. W. "Variable Equalisers," *Bell-System Technical Journal*. April 1938. Vol. 17, No. 4.
- Shea, T. E. "Transmission Networks and Filters" (textbook). D. Van Nostrand Co., Inc., p. 113.
- Covill, D. H. "Frame-scanning output circuits for Wide-angle Cathode-ray Tubes," *Proc. I.E.E., Part IIIA Convention on British Contribution to Television*. April-May 1952. Vol. 99, No. 19.
- Cooper, V. J. "Shunt-regulated Amplifiers," *Wireless Engineer*. May 1951. Vol. 28, No. 332.
- Cooper, V. J. "New Amplifier Techniques," *Journal Brit. I.R.E.* July 1952. Vol. 12, No. 7.

INDEX

- ACTIVE DELAY NETWORK, 106
All-pass Network, 140
- BACK PORCH, 129
Black Level, 59, 63, 64, 99, 105
Black Stretching, 89, 96
Blanking Level, 59, 60–63
Blocking Oscillator, 23, 41, 48,
54–56, 230
Blumlein Circuit, 213–218
Bridged-T Network, 144, 145, 171–
181
- CATHODE FOLLOWER, 130, 240,
254–264
Characteristic Impedance, 109–115
Clamping Pulses, 63, 75, 76
Count Ratio, 17–19
C.P.S. Emitron, 81, 86, 87, 91
Critical Damping, 222
Cut-off Frequency, 106, 113–122
- DAMPING RESISTOR, 222–227
Decade Counter, 40
Delay, 35, 36, 106, 107, 109, 111,
116, 118, 119, 128
- FEEDBACK, 30, 31, 35, 37, 39, 40, 47,
57, 72, 98, 209–213, 238, 254
Field Frequency, 188, 189, 192, 196
Field Sync Signal, 71
Front Porch, 129
- HALF-LOSS FREQUENCY, 152, 159,
181
- ICONOSCOPE, 81, 86
Image Iconoscope, 81, 86
Image Orthicon, 81, 86
Infinite White, 102, 103, 105
Insertion Loss, 115
Iterative Impedance, 113, 115, 118,
119, 122–124, 130, 133, 134,
137, 141, 145, 146, 160, 162,
166, 172–180, 182, 184, 185,
187
- KEYING PULSES, 63
- LIMITING AMPLIFIER, 20, 23, 26
Line Frequency, 15, 20, 21, 47, 58,
62, 68, 69, 188, 189
Line Hold, 231
L-network, 144, 146, 148, 149
- MILLER INTEGRATOR, 46
Modulated Amplifier, 235–237, 259
Modulator, 235–238, 242, 244, 245,
259
Multivibrator, 20, 29, 33, 35, 38, 39,
41–44, 48–50, 55, 106
- N.T.S.C. SYSTEM, 237
- OBJECTIVE BRIGHTNESS, 90
- PHANTASTRON, 41, 45, 48, 106
- RELAXATION OSCILLATOR, 15
Ringing, 221

INDEX

- Rise Time, 19, 25, 26, 35, 69, 71, 118, 254
- SERIES-DERIVED SECTIONS, 121, 124, 125, 137
- Shaping Network, 204, 207, 212
- Shunt-derived Sections, 121, 125
- Speed-up Capacitor, 28, 31
- Staircase Generator, 17
- Step Response, 152
- Subjective Brightness, 90
- Sync Level, 59–63, 71, 72, 73, 77
- Sync Pulses, 67, 69, 72, 77
- TIME CONSTANT, 23–26, 32, 56, 65–69, 75–79, 97, 213, 214, 218, 224, 226, 242, 254
- Timing Circuit, 16, 41
- Transfer Constant, 184
- VIDEO SIGNAL, 58, 65, 73, 106, 109
- WEBER-FECHNER LAW, 90
- White Crushing, 90

