

ELECTRONICS WORLD

Denmark DKr. 70.00
Germany DM 15.00
Greece Dra.760
Holland Dfl. 14
Italy L. 7300
IR £3.30
Spain Pts. 780
Singapore S\$ 12.60
USA \$6.70

+ WIRELESS WORLD

JULY 1994

£1.95

A REED BUSINESS PUBLICATION

FREE with this issue
Hall effect device pack*

*First 500 replies, UK & Eire only

AUDIO

New look to
amplifier design?

COMPUTING

Sorting signals
from noise

APPLICATIONS

Using Hall to
good effect

DESIGN

Oscillators in
perspective

RF ENGINEERING

Millimetre wave
devices

PRECISION OP-AMPS:
First ever mass review

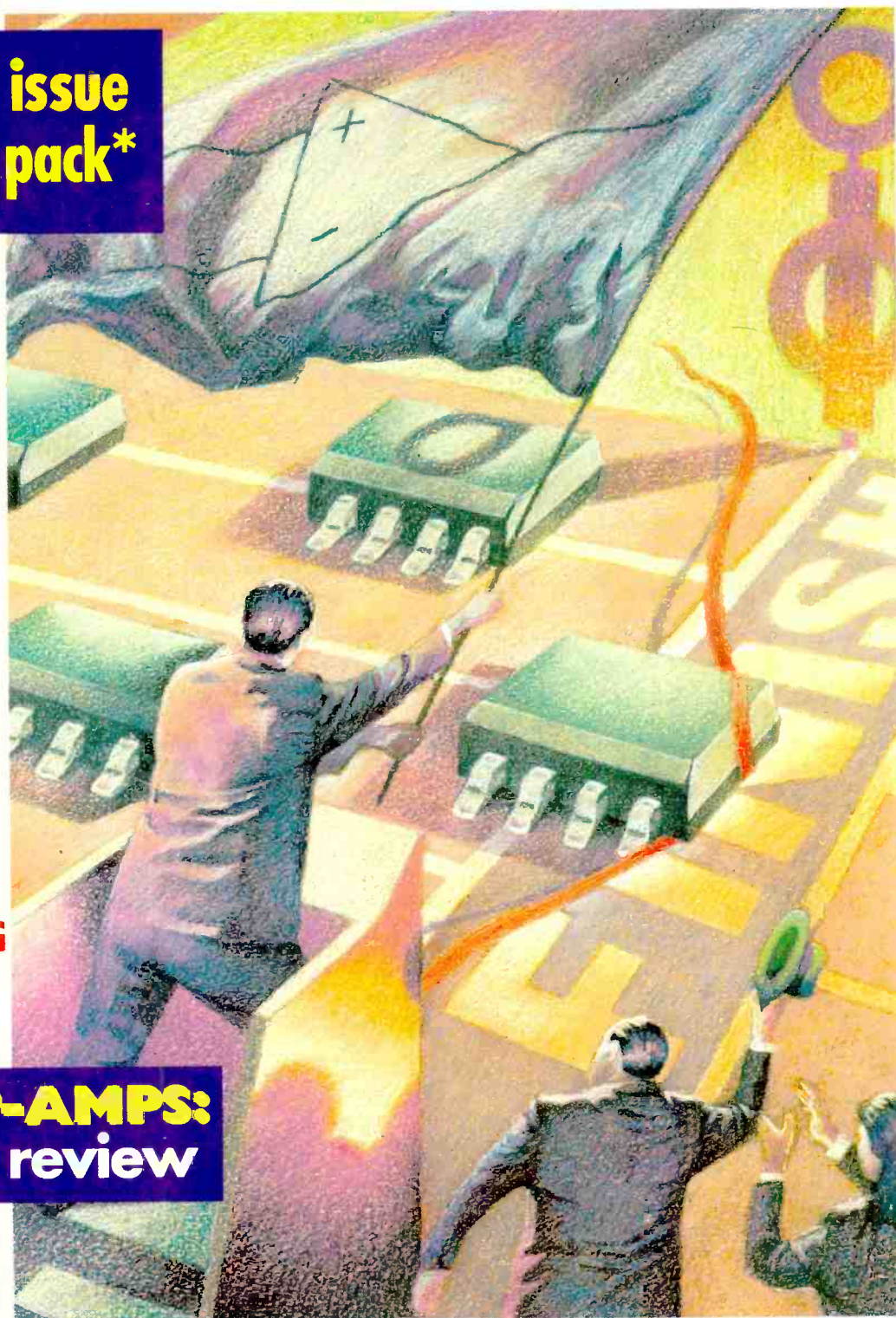



THE WORLDS No.1 BEST SELLING UNIVERSAL PROGRAMMING AND TESTING SYSTEM.

The PC82 Universal Programmer and Tester is a PC-based development tool designed to program and test more than 1500 ICs. The latest version of the PC82 is based on the experience gained after a 7 year production run of over 100,000 units.

The PC82 is the US version of the Sunshine Expro 60, and therefore can be offered at a very competitive price for a product of such high quality. The PC82 has undergone extensive testing and inspection by various major IC manufacturers and has won their professional approval and support. Many do in fact use the PC82 for their own use!

The PC82 can program E/EPROM, Serial PROM, BPROM, MPU, DSP, PLD, EPLD, PEEL, GAL, FPL, MACH, MAX, and many more. It comes with a 40 pin DIP socket capable of programming devices with 8 to 40 pins. Adding special adaptors, the PC82 can program devices up to 84 pins in DIP, PLCC, LCC, QFP, SOP and PGA packages.

The unit can also test digital ICs such as the TTL 74/54 series, CMOS 40/45 series, DRAM (even SIMM/SIP modules) and SRAM. The PC82 can even check and identify unmarked devices.

Customers can write their own test vectors to program non standard devices. Furthermore it can perform functional vector testing of PLDs using the JEDEC standard test vectors created by PLD compilers such as PALASM, OPALjr, ABLE, CUPL etc. or by the user.

The PC82's hardware circuits are composed of 40 set pin-driver circuits each with TTL I/O control, D/A voltage output control, ground control, noise filter circuit control, and OSC crystal frequency control. The PC82 shares all the PC's resources such as CPU, memory, I/O hard disk, keyboard, display and power supply.

A dedicated plug in card with rugged connecting cable ensures fast transfer of data to the programmer without tying up a standard parallel or serial port. Will work in all PC compatibles from PC XT to 486.

The pull-down menus of the software makes the PC82 one of the easiest and most user-friendly programmers available. A full library of file conversion utilities is supplied as standard.

The frequent software updates provided by Sunshine enables the customer to immediately program newly released ICs. It even supports EPROMs to 16Mbit.

Over 20 engineers are employed by Sunshine to develop new software and hardware for the PC82. Not many competitors can boast of similar support!

Citadel, a 32 year old company are the UK agents and service centre for the Sunshine range of programmers, testers and in circuit emulators and have a team of engineers trained to give local support in Europe.

- * More sold worldwide than any other of its type.
- * UK users include BT, IBM, MOD, THORN EMI, MOTOROLA, SANYO, RACAL
- * High quality Textool or Yamaichi zero insertion force sockets.
- * Rugged screened cabling.
- * High speed PC interface card designed for use with all PC models from XT to 486.
- * Over 1500 different devices (including more than 100 MPU's) supported.
- * Tests and or identifies a wide range of logic devices.
- * Software supplied to write own test vectors for custom ICs and ASICs etc.
- * Protection circuitry to protect against wrong insertion of devices.
- * Ground control circuitry using relay switching.
- * One model covers the widest range of devices, at the lowest cost.
- * No need to tie up a slow parallel port.
- * Two year free software update.
- * Speed optimised range of programming algorithms.



NOW SUPPLIED WITH SPECIAL VALUE ADDED SOFTWARE (worth over £300 if bought seperately):

- * MICROTEC disassemblers for Z8, 8085, 8048, 8051, 6809 & 68HC11.

- * NATIONAL SEMICONDUCTOR OPALjr PAL/PLD development software.
- * BATCH SOFTWARE for production programming.

Our stocked range of own manufactured and imported Sunshine products include:

- * Super fast EPROM Erasers.
- * 1, 4 & 8 gang EPROM 8Mbit production programmers.
- * Battery operated portable EPROM programmers.
- * "In circuit" Emulators.
- * Handy pocket IC testers.



ORDERING INFORMATION

PC82 complete with interface card, cable, software and manual only **£395**

Please add £7 carriage (by overnight courier) for UK orders, £20 for export orders, and VAT where applicable.

ACCESS, MASTERCARD, VISA or CWO. Official orders are welcome from Government bodies & local authorities.

Free demo disk with device list available.



CITADEL PRODUCTS LTD
DEPT. WW, 50 HIGH ST.,
EDGWARE, MIDDX. HA8 7EP.

Phone now on: 081 951 1848/9



CONTENTS

FEATURES

Cover: Hashim Akib



CMR UNDER TEST.....540

Designers often need to measure small signals superimposed on large voltages but information on common-mode rejection from IC manufacturer data is rarely more than superficial. In a world-exclusive review, consultant Ben Duncan compares this vital parameter in eleven of the top instrumentation amplifiers.

COMMON-EMITTER POWER AMPLIFIERS548

Taken by the idea of linearisation using square law fet's, Doug Self investigates the driving of power amplifier loads via collectors rather than emitters. Findings suggest that designers are looking from the wrong perspective.

ACQUIRING DATA FROM NOISE.....554

In travelling to its destination, a signal from a sensor can easily become corrupted by EMI, losses and noise sources. Dave Robinson looks various ways of removing the impurities.

GRAPH PLOTTING IN WINDOWS.....559

Reviewer Allen Brown enthuses about a new software package designed specifically for plotting complex engineering data under Windows - MicroCal's *Origin*.

COHERER-BASED RADIO563

A century ago, radio-signal detectors comprising metal particles in a glass tube were at the forefront of wireless technology. George Pickworth has been reproducing early equipment based on the 'coherer' and shares the results of his test transmissions.

NEW WAVE MICROWAVES.....570

Mike Hosking looks at the variety of active millimetre-wave devices now available for specific communications applications including receiving, generating and mixing.

APPLYING HALL TO GOOD EFFECT576

Integrated Hall-effect switches and linear-output devices have hundreds of uses, ranging from motor speed control to current monitoring. Martin Eccles looks at a handful of them.

FREE: Hall-effect sensors see page 578

USING RF TRANSISTORS.....606

Design criteria for transformers used in rf systems are very different from those of their lf counterparts. In an extract from their book *RF Transistors: principles and practical applications*, Norm Dye and Helge Granberg discuss the differences and provide an insight into the novel transformer solutions available to the rf designer.

REGULARS

COMMENT.....531

European R&D or Euro-waste?

NEWS.....532

Video games set to become the driving force behind microprocessor design; 200MHz serial speed-up for VME; Intel to drop X86 architecture rumour.

RESEARCH NOTES.....536

Gunn diode breaks frequency and power boundaries. The wobble that gave birth to a planet. Laser that could reshape conventional technology. Physicists find their missing link. Solar power reaps energy benefits.

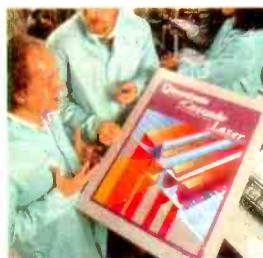

APPLICATIONS.....583

Battery-powered micro-ohm meter, power-fail and reset for PCs, Easy to use programmable oscillator.

DESIGN BRIEF.....586

Exploring the LC oscillator in detail reveals that it is rather more sophisticated than it first appears. Ian Hickman explains.

NEW PRODUCTS.....591

Scores of the industry's new products presented in a format designed to save you time.

LETTERS.....596

More distortion... clearly the best, Ears and knows, Military option, Charge build up, Mixing it, Science friction, Vision thing, Virtual intercourse, Theoretical limits.

CIRCUIT IDEAS.....600

Digital sinewave generator, Spare inverter converts 5V to $\pm 15V$, Square waves from a 555, Inrush current limiter, High-torque position servo, Monitor shows three-phase sequence, Electronic fuse, Two-wire switch status detection, Isolated I²C bus interface.

In next month's issue: Build a teletext card using Laurence Cook's proven design presented complete with PCB.

THE AUGUST ISSUE IS ON SALE FROM JUNE 30

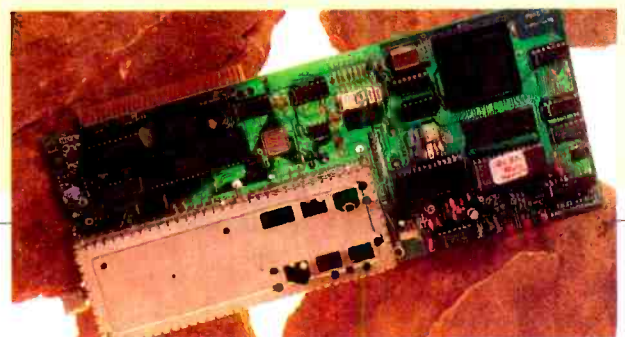

NEW LOW PRICE - NEW COLOUR HP141T SPECTRUM ANALYSERS TESTED

- HP141T + 8552A or B IF - 8553B RF - 1kHz - 110Mc/s - A IF £600 or B IF - £700.**
HP141T + 8552A or B IF - 8554B RF - 100kHz - 1250Mc/s - A IF £800 or B IF - £900.
HP141T + 8552A or B IF - 8555A RF - 10Mc/s - 18GHz - A IF £1400 or B IF - £1600. The mixer in this unit costs £1000, we test every one for correct gain before despatch.
HP141T + 8552A or B IF - 8556A RF - 20Hz - 300kHz - A IF £600 or B IF - £700.

HP ANZ UNITS AVAILABLE SEPARATELY NEW COLOUR - TESTED

- HP141T Mainframe - £350 - 8552A IF - £200 - 8552B IF - £300 - 8553B RF - 1kHz - 110Mc/s - £200 - 8554B RF - 100kHz - 1250Mc/s - £400. 8555A RF - 10Mc/s - 18GHz - £1000. 8556A RF - 20Hz - 300KHZ - £250.**
HP8443A Tracking Generator Counter - 100kHz - 110Mc/s - £300 - £400.
HP8445B Tracking Pre-selector DC - 18GHz - £400-£600 or HP8445A - £250.
HP8444A Tracking Generator - £750 - 1300Mc/s.
HP8444A Opt 059 Tracking Generator - £1000 - 1500Mc/s.

SPECIAL OFFER - 14 ONLY HP140T (NON-STORAGE)

- Mainframe Plus 8552A IF Plug-In Plus 8556A RF Plug-In 20Hz - 300kHz Plus 8553B RF Plug-In 1kHz - 110Mc/s. Tested with instructions - £700.**

Marconi TF2008 - AM-FM signal generator - also sweeper - 10Kc/s - 510Mc/s - from £250 - tested to £400 as new with manual - probe kit in wooden carrying box.
HP Frequency comb generator type 8406 - £400.
HP Vector Voltmeter type 8405A - £400 to £600 - old or new colour.
HP Sweep Oscillators type 8690 A & B - plug-ins from 10Mc/s to 18GHz also 18-40GHz. P.O.R..
HP Network Analyzer type 8407A - 8412A + 8501A - 100Kc/s - 110Mc/s - £500 - £1000.
HP Amplifier type 8447A - 1-400Mc/s £200 - HP8447F. 1-1300Mc/s £400.
HP Frequency Counter type 5340A - 18GHz £1000 - rear output £800.
HP 8410 - A - B - C Network Analyzer 110Mc/s to 12GHz or 18GHz - plus most other units and displays used in this set-up - 8411a - 8412 - 8413 - 8414 - 8418 - 8740 - 8741 - 8742 - 8743 - 8746 - 8650. From £1000.
Racal/Dana 9301A - 9302 RF Millivoltmeter - 1.5-2GHz - £250-£400.
Racal/Dana Counters 9915M - 9916 - 9917 - 9921 - £150 to £450. Fitted FX standards.
Racal/Dana Modulation Meter type 9009 - 8Mc/s - 1.5GHz - £250.
Marconi RCL Bridge type TF2700 - £150.
Marconi/Saunders Signal Sources type - 6058B - 6070A - 6055A - 6059A - 6057A - 6056 - £250-£350. 400Mc/s to 18GHz.
Marconi TF1245 Circuit Magnification meter + 1246 & 1247 Oscillators - £100-£300.
Marconi microwave 6600A sweep osc., mainframe with 6650 PI - 18-26.5GHz or 6651 PI - 26.5-40GHz - £1000 or PI only £600. MF only £250.
Marconi distortion meter type TF2331 - £150. TF2331A - 200.
Tektronix Plug-Ins 7A13 - 7A14 - 7A18 - 7A24 - 7A26 - 7A11 - 7M11 - 7S11 - 7D10 - 7S12 - S1 - S2 - S6 - S52 - PG506 - SC504 - SG502 - SG503 - SG504 - DC503 - DC508 - DD501 - WR501 - DM501A - FG501A - TG501 - PG502 - DC505A - FG504 - 7B80 + 85-7B92A
Gould J3B test oscillator + manual - £200.
Tektronix Mainframes - 7603 - 7623A - 7613 - 7704A - 7844 - 7904 - TM501 - TM503 - TM506 - 7904 - 7834 - 7104 - 7623 - 7633.
Alitech 757 Spectrum Analyser - 001 22GHz - Digital storage + readout - £2000.
Marconi 6155A Signal Source - 1 to 2GHz - LED readout - £400.
Barr & Stroud Variable filter EF3 0.1Hz - 100Kc/s + high pass + low pass - £150.
Marconi TF2163S attenuator - 1GHz. £200.
Farnell power unit H60/50 - £400 tested. H60/25 - £250.
Racal/Dana 9300 RMS voltmeter - £250.
HP 8750A storage normalizer - £400 with lead + S.A or N.A Interface.
Marconi TF2330 - or TF2330A wave analysers - £100-£150.
Racal/Dana signal generator 9082 - 1.5-520Mc/s - £500.
Racal/Dana signal generator 9082H - 1.5-520Mc/s - £600.
Tektronix - 7S14 - 7T11 - 7S11 - 7S12 - S1 - S2 - S39 - S47 - S51 - S52 - S53 - 7M11.
Marconi mod meters type TF2304 - £250.
HP 5065A rubidium vapour FX standard - £2.5k.
Systron Donner counter type 6054B - 20Mc/s - 24GHz - LED readout - £1k.
Racal/Dana 9083 signal source - two tone - £250.
Systron Donner - signal generator 1702 - synthesized to 1GHz - AM/FM - £600.
Tektronix TM515 mainframe + TM5006 mainframe - £450 - £850.
Rhodes & Schwartz power signal generator SLRD-280 - 2750Mc/s - £250-£600.
Ball Efratom rubidium standard PT256B-FRKL - £1000.
Farnell electronic load type RB1030-35 - £350.
Racal/Dana counters - 9904 - 9905 - 9906 - 9915 - 9916 - 9917 - 9921 - 50Mc/s - 3GHz - £100-£450 - all fitted with FX standards.
HP4815A RF vector impedance meter c/w probe - £500-£600.
Marconi TF2092 noise receiver. A, B or C plus filters - £100-£350.

Marconi TF2091 noise generator. A, B or C plus filters - £100-£350.
HP180TR, HP182T mainframes £300-£500.
Fluke 8506A thermal RMS digital multimeter. £400.
Philips panoramic receiver type PM7900 - 1 to 20GHz - £400.
Marconi 6700A sweep oscillator + 6730A - 1 to 2GHz - £500.
HP8505A network ANZ + 8503A S parameter test set + 8501A normalizer - £4k.
Racal/Dana VLF frequency standard equipment. Tracer receiver type 900A + difference meter type 527E + rubidium standard type 9475 - £2750.
HP signal generators type 626 - 628 - frequency 10GHz - 21GHz.
HP 432A - 435A or B - 436A - power meters + powerheads - Mc/s - 40GHz - £200-£1000.
Bradley oscilloscope calibrator type 192 - £600.
Barr & Stroud variable filter EF3 0.1Hz - 100Kc/s + high pass + low pass - £150.
Marconi TF2370 spectrum ANZ - 110Mc/s - £900.
Marconi TF2370 spectrum ANZ + TK2375 FX extender 1250Mc/s + 1st gen - £1.5k.
HP8614A signal generator 800Mc/s - 2.4GHz, new colour £400.
HP8616A signal gen 1.8GHz - 4.5GHz, new colour £400.
HP 3325A syn function gen 20Mc/s - £1500.
HP 3336A or B syn level generator - £500-£600.
HP 3586B or C selective level meter - £750-£1000.
HP 3575A gain phase meter 1Hz - 13Mc/s - £400.
HP 8671A syn microwave 2 - 6.2GHz - £2k.
HP 8668D S/G microwave 2.3 - 13GHz - opt 001 - 003 - £4.5k.
HP 8660 A-B-C syn S/G. AM + FM + 10Kc/s to 110Mc/s PI - 1Mc/s to 1300Mc/s - 1Mc/s to 2500Mc/s - £750-£2800.
HP 8640B S/G AM-FM 512Mc/s or 1024Mc/s. Opt 001 or 002 or 003 - £800-£1250.
HP 8656A S/G AM-FM 0.1 - 990Mc/s - £1500.
HP 8622B Sweep PI - 01 - 2.4GHz + ATT - £1750.
HP 8629A Sweep PI - 2 - 18GHz - £1000.
HP 86290B Sweep PI - 2 - 18GHz - £1250.
HP 86 Series PI's in stock - splitband from 10Mc/s - 18.6GHz - £250-£1k.
HP 8620C Mainframe - £250. IEEE - £500.
HP 8615A Programmable signal source - 1MHz - 50Mc/s - opt 002 - £1k.
HP 8601A Sweep generator. 1 - 110Mc/s - £300.
HP 4261A LCR meter + 16038A test leads - £400.
HP 4271B LCR meter 1MHz digital meter + 16063A test adaptor - £850.
HP 4342A Q meter 22kHz - 70Mc/s 16462A + qty of 10 inductors - £850.
HP 3488A HP - IB switch control unit - £500 + control modules various - £175 each.
HP 3561A Dynamic signal ANZ - £3k.
HP 8160A 50Mc/s programmable pulse generator - £1400.
HP 853A MF ANZ + 8558B - 0.1 - 1500Mc/s - £2500.
HP 8349A Microwave Amp 2 - 20GHz Solid state - £1500
HP 3585A Analyser 20Hz - 40Mc/s - £4k.
HP 8569B Analyser. 01 - 22GHz - £5k.
HP 3580A Analyser 5Hz - 50kHz - £1k.
HP 1980B Oscilloscope measurement system - £600.
HP 3455A Digital voltmeter - £500.
HP 3437A System voltmeter - £300.
HP 3581C Selective voltmeter - £500.
HP 5370A Universal time interval counter - £450.
HP 5335A Universal counter - 200Mc/s - £500.
HP 5328A Universal counter - 500Mc/s - £250.
HP 6034A System power supply - 0 - 60V - 0 - 10 amps - £500.
HP 3960A 3964A Instrumentation tape recorders - £300-£500.
HP 5150A Thermal printer - £250.
HP 1645A Data error analyser - £150.
HP 4437A Attenuator - £150.
HP 3717A 70Mc/s modulator - £400.
HP 3710A - 3715A - 3716A - 3702B - 3703B - 3705A - 3711A - 3791B - 3712A - 3793B microwave link analyser - P.O.R.
HP 3730A + B RF down converter - P.O.R.
HP 3552A Transmission test set - £400.
HP 3763A Error detector - £500.
HP 3764A Digital transmission analyser - £600.
HP 3770A Amp delay distortion analyser - £400.
HP 3780A Pattern generator detector - £400.
HP 3781A Pattern generator - £400.
HP 3781B Pattern generator (bell) - £300.
HP 3782A Error detector - £400.
HP 3782B Error detector (bell) - £300.
HP 3785A Jitter generator + receiver - £750-£1k.
HP 8006A Word generator - £100-£150.
HP 8016A Word generator - £250.
HP 8170A Logic pattern generator - £500.
HP 59401A Bus system analyser - £350.
HP 59500A Multiprogrammer HP - IB - £300.
Philips PM5390 RF syn - 0.1 - 1GHz - AM + FM - £1250.
Philips PM5519 Colour T.V. pattern generator - £250.
S.A. Spectral Dynamics SD345 spectroscope 11 - LF ANZ - £2500.
Tektronix R7912 Transient waveform digitizer - programmable - £400.
Tektronix 496 Analyzer 1kHz - 1.8GHz - £3.5k.
Tektronix TR503 + TM503 tracking generator 0.1 - 1.8GHz - £1k - or TR502.
Tektronix 576 Curve tracer + adaptors - £900.
Tektronix 577 Curve tracer + adaptors - £900.
Tektronix 1502/1503 TDR cable test set - £1000.
Tektronix 7L5 LF analyser - 0 - 5Mc/s - £800. OPT 25 - £1000.
Tektronix AM503 Current probe + TM501 m/frame - £1000.
Tektronix SC501 - SC502 - SC503 - SC504 oscilloscopes - £75-£350.
Tektronix 465 - 465B - 475 - 2213A - 2215 - 2225 - 2235 - 2245 - 2246 - £250-£1000.
Kikusui 100Mc/s Oscilloscope COS6100M - £350.
Farnell PSG520 Signal generator - £400.
Nicolet 3091 LF oscilloscope - £1000.
Racal 1991 - 1992 - 1988 - 1300Mc/s counters - £500-£900.
Tek 2445 150Mc/s oscilloscope - £1400.
Fluke 80K-40 High voltage probe in case - BN - £100.
Racal Recorders - Store 4 - 4D - 7 - 14 channels in stock - £250 - £500.
Racal Store Horse Recorder & control - £400-£750 Tested.
EIP 545 microwave 18GHz counter - £1200.
Fluke 510A AC ref standard - 400Hz - £200.
Fluke 355A DC voltage standard - £300.
Schlumberger 5229 Oscilloscope - 500Mc/s - £500.
Solartron 1170 FX response ANZ - LED display - £280.
Wiltron 610D Sweep Generator + 6124C PI - 4 - 8GHz - £400.
Wiltron 610D Sweep Generator + 61084D PI - 1Mc/s - 1500Mc/s - £500.
Time Electronics 9814 Voltage calibrator - £750.
Time Electronics 9811 Programmable resistance - £600.
Time Electronics 2004 D.C. voltage standard - £1000.
HP 8699B Sweep PI YIG oscillator .01 - 4GHz - £300. 8690B MF - £250. Both £500.
Schlumberger 1250 Frequency response ANZ - £2500.
Dummy Loads & power att up to 2.5 kilowatts FX up to 18GHz - microwave parts new and ex equip - relays - attenuators - switches - waveguides - Yigs - SMA - APC7 plugs - adaptors, etc.
B&K items in stock - ask for list.
W&G items in stock - ask for list.
Power Supplies Heavy duty + bench in stock - Farnell - HP - Weir - Thurby - Racal etc. Ask for list.

ITEMS BOUGHT FROM HM GOVERNMENT BEING SURPLUS. PRICE IS EX WORKS. SAE FOR ENQUIRIES. PHONE FOR APPOINTMENT OR FOR DEMONSTRATION OF ANY ITEMS, AVAILABILITY OR PRICE CHANGE. VAT AND CARRIAGE EXTRA
 ITEMS MARKED TESTED HAVE 30 DAY WARRANTY. WANTED: TEST EQUIPMENT-VALVES-PLUGS AND SOCKETS-SYNCHROS-TRANSMITTING AND RECEIVING EQUIPMENT ETC.

Johns Radio, Whitehall Works, 84 Whitehall Road East, Birkenshaw, Bradford BD11 2ER. Tel. No: (0274) 684007. Fax: 651160



CIRCLE NO. 102 ON REPLY CARD

EDITOR

Frank Ogden
081-652 3128

DEPUTY EDITOR

Martin Eccles
081-652 8638

CONSULTANT

Derek Rowe

DESIGN & PRODUCTION

Alan Kerr

EDITORIAL ADMINISTRATION

Lorraine Spindler
081-652 3614

ADVERTISEMENT MANAGER

Richard Napier
081-652 3620

DISPLAY SALES EXECUTIVE

Malcolm Wells
081-652 3620

ADVERTISING PRODUCTION

Paul Burgess
081-652 8355

PUBLISHER

Susan Downey

EDITORIAL FAX

081-652 8956

CLASSIFIED FAX

081-652 8956

SUBSCRIPTION HOTLINE

0622 721666
Quote ref INJ

SUBSCRIPTION QUERIES

0444 445566

NEWSTRADE DISTRIBUTION

Martin Parr
081 652 8171

BACK ISSUES

Available at £2.50
081 652 3614

ISSN 0959-8332



European R&D or Euro-waste?

It looks as if the Clinton administration is prepared to go further than ever before in directly intervening to encourage manufacturing activity.

The EU, which has always been prepared to subsidise research, but has been reluctant to finance manufacturing directly, must now start to take notice: in certain critical markets, it looks as if the EU could fall hopelessly behind the rest of the world.

One of these is flat-panel displays for which the US Government has just announced a \$1bn support programme aimed directly at manufacturers.

Japan has a 95 per cent share of the world flat panel market – now approaching \$5bn and set to grow to \$20bn within the decade. Just as with semiconductors in the 80s, such an imbalance threatens trade wars, shortages and over-pricing in the 90s as Japan, quite naturally, exploits its monopoly.

Europe, for many years, backed R&D into flat panel technology. Although this resulted in a successful series of programmes, no European company except Philips, is going to mass manufacture the panels.

Without mass manufacture, Europe will glean little benefit from the money spent on R&D. European electronics equipment manufacturers will have to pay high Japan-dictated prices.

President Clinton has been smarter than the EU. He has insisted, as a precondition of getting Federal R&D funds,

that the recipients put up a similar amount to build factories.

That is reminiscent of the famous chip R&D programmes which the Japanese Ministry of International Trade and Industry initiated in the 70s and 80s to give Japan a world-class semiconductor industry – manufacturing was a precondition for the R&D money.

The lesson for Europe is clear: giving money to scientific programmes is all very well but that doesn't produce future revenues from which profits can be taken to fund the next generation of R&D.

Yet though everyone in Europe is keen to spend government money on R&D, there is practically no one ready to take the commercial risk of putting high-tech components into volume manufacturing.

It is absolutely clear to everyone, except Europe's leaders, that the people who can afford to take the risk – the big companies – won't take it but those who are prepared to take the risk – small entrepreneurs – can't afford it.

The EU must therefore seek to create an environment for the entrepreneur to undertake high-tech manufacturing – fiscally, technically and socially.

For if manufacturing does not happen as the result of R&D then R&D is essentially no more than intellectual onanism – failing to produce the seed for next-generation products.

David Manners – Electronics Weekly

Electronics World + Wireless World is published monthly. By post, current issue £2.25, back issues (if available) £2.50. Orders, payments and general correspondence to L333, *Electronics World + Wireless World, Quadrant House, The Quadrant, Sutton, Surrey SM2 5AS*. Tlx:892984 REED BP G. Cheques should be made payable to Reed Business Publishing Group.

Newstrade: IPC Marketforce, 071 261-5108.

Subscriptions: Quadrant Subscription Services, Oakfield House, Perrymount Road, Haywards Heath, Sussex RH16 3DH. Telephone 0444 445566. Please notify change of address. Subscription rates 1 year (normal rate) £30 UK and £43 outside UK.

USA: \$52.00 airmail. Reed Business Publishing (USA), Subscriptions office, 205 E. 42nd Street, NY 10117.

Overseas advertising agents: France and Belgium: Pierre Mussard, 18-20 Place de la Madeleine, Paris 75008. United States of America: Ray Barnes, Reed Business Publishing Ltd, 205 E. 42nd Street, NY 10117. Telephone (212) 867-2080. Tlx 23827.

USA mailing agents: Mercury Airfreight International Ltd Inc, 10(b) Englehard Ave, Avenel NJ 07001. 2nd class postage paid at Rahway NJ Postmaster. Send address changes to above.

Printed by BPCC Magazines (Carlisle) Ltd, Newtown Trading Estate, Carlisle, Cumbria, CA2 7NR. Typeset by Marlin Graphics 2-4 Powerscroft Road, Sidcup, Kent DA 4 5DT

©Reed Business Publishing Ltd 1992 ISSN 0959 8332

Microprocessor game is the real business

Microprocessor evolution will in future be driven by the demands of games, not PCs, says Len Perham, president and chief executive officer of Integrated Device Technology.

"The games people are looking for tremendously high performance processors – one of the top five has asked me for a 64-bit processor with a 800Mbit data rate,"

Perham added: "We're developing it, and we can see it costing only \$20." IDT is a licensee of the Mips micro architecture.

Perham also sees the manufacturers of games machines moving inexorably into the computer market. "By the year 2000, Nintendo will be a computer company," he predicted.

The advantage which the games machine makers have over the computer companies is that they have to manufacture to very low costs. "Nintendo and Sega say you can't sell in volume for more than £250," said Perham.

NEC, Toshiba and Sony hold rights to the Mips processor.

It will not only be dedicated games machines that will require this power. The set-top controller driving remote terminals, the home entertainment system and home security will demand 64-bit performance because the graphics take so much processing power.

High flyers: the performance demands of video games coupled with enormous potential sales volumes are now more important to microprocessor development than business applications.

James Thomas, Director of Risc micro development at IBM, concurs: "Set-tops and PDAs are going to be the explosive areas of the second half of the 90s," he told Dataquest's recent European semiconductor Industry Conference in London. "Kids," concludes IDT's Perham, "can absorb as much computer power as you can give them."

Ordinary PCs can operate as effective video game players by placing video game machines onto PC cards. This approach is being taken by game player designer 3DO which is working on custom chips that will allow it to sell its system as a PC plug-in board. Atari, with its 64-bit *Jaguar* game system recently signed a deal with Sigma Designs to produce a board combining *Jaguar* with Sigma's full motion video technology.

The US based Software Publisher's Association (SPA) estimates that about 27 percent of US households own a personal computer. About a third of those PCs were purchased within the last year. As prices continue to fall for PC hardware and software, the SPA predicts that demand for powerful home based PCs will continue to grow. *David Manners, Electronics Weekly.*



Faster technology for speeding motorists

The automatic intelligent recognition system, named Talon, designed to recognise the most obscured, tilted or damaged vehicle number plates is latest piece of technology to persecute motorists.

The system uses neural networks for number plate pattern recognition. In its simplest form it consists of a camera, illuminator and a plate recognition unit (PRU) which contains the programmable DSP hardware. The PRU consists of an image grabber board, a general purpose PC

board and a DSP board on which the neural network is implemented.

The system triggers automatically when encountering the right colour (yellow or grey) or image of a number plate.

The plate is then segmented into individual characters before being fed into the recognition process that uses proprietary neural network techniques implemented on five Texas Instruments *TM320C50 DSP* chips.

All imperfections associated with number

plates are included in the training data which makes the recognition process resilient to noise such as dirt, poorly defined or distorted characters. In this way the network is also trained to de-skew and de-rotate in order to recognise the plate.

Talon recognises number plates in approximately 0.25s. The success rate is higher than 90 per cent.

Talon works in many weather conditions and for night vision any off-the-shelf infrared camera and illuminator can be used. Plate shadowing can be eliminated with infrared filters on the camera.

The system was originally developed by

Camcorder controlled by the eye

Canon of Japan claims to have developed the first camcorder which is controlled by eye movements. To focus, the camcorder uses infrared light to determine where the user's eye is looking in the field of view. It then focuses on this point automatically. Other camera functions are operated by the user looking at icons displayed alongside the image in the viewfinder.





**8 CAVANS WAY,
BINLEY INDUSTRIAL ESTATE,
COVENTRY CV3 2SF**
Tel: 0203 650702
Fax: 0203 650773
Mobile: 0860 400683

(Premises situated close to Eastern-by-pass In Coventry with easy access to M1, M6, M40, M42, M45 and M69)

OSCILLOSCOPES

Gould 400 - 20MHz D.S.O. 100 Ms/s	£1000
Gould 1602 - 2 channel D.S.O. 20MHz	£1300
Gould 1604 - 4 channel D.S.O. 20MHz	£1750
Gould 1421 - 2 channel D.S.O. 20MHz	£375
Gould OS4000, OS4200, OS4020, OS245	from £125
Hewlett Packard 1707A, 1707B - 75MHz dual ch.	from £275
Hewlett Packard 1740A, 1741A, 1744A, 100MHz dual ch.	from £350
Hewlett Packard 182C - 100MHz 4 ch	£350
Hitachi V-422 - 40MHz dual ch	£300
Nicolet 3091 - Low freq D.S.O.	£1100
Philips 3055 - 60MHz dual ch	£550
Tektronix 2201 - 20MHz D.S.O. dual ch	£675
Tektronix 2213 - 60MHz dual ch	£425
Tektronix 2215 - 60MHz dual ch	£450
Tektronix 2235 - 100MHz dual ch (portable)	£800
Tektronix 2246 - 100MHz 4 channel (as new)	£995
Tektronix 2235 - 100MHz dual ch (portable)	£750
Tektronix 465/465B - 100MHz dual ch	from £350
Tektronix 475 - 200MHz dual ch	£450
Tektronix 468 - 100MHz D.S.O. dual ch	£850
Tektronix 7313, 7603, 7613, 7623, 7633, 100MHz 4 ch	from £300
Tektronix 7704 - 250MHz 4 ch	from £850
Tektronix 7834/7844 - 400MHz 4 ch	from £750
Tektronix 7904 - 500MHz	from £850
Philips 3070 - 100MHz 2 + 1 channel + cursors, as new	£900
Philips 3206, 3211, 3212, 3217, 3226, 3240, 3243, 3244, 3261, 3262 (2ch + 4 ch)	from £125 to £350
Solartron Schlumberger CD1740 - 20MHz 4 ch	£250
Other scopes available too	

SPECTRUM ANALYSERS

Alltech 727 - 20GHz	£2200
Advantest TR4131 - 10KHz - 3.5GHz	£4500
Hewlett Packard 3580A - 5Hz - 50KHz	£1250
Hewlett Packard 8590A - 10MHz - 1.5GHz (as new)	£4500
Hewlett Packard 1827 with 8559A (10MHz - 21GHz)	£3750
£4500	
Hewlett Packard 4953 Protocol analyser	£2500
Marconi 2370 - 110MHz	£1250
Tektronix 7L18 with 7603 mainframe (1.5-18GHz)	£3500
Tektronix 492 - 21GHz	£6000
Texscan AL51A - 1GHz	£1300

MISCELLANEOUS

Anritsu ML93B/ML92B Optical power meter with sensor	£2000
Anritsu ME538C Microwave system analyser (Rx + Tx)	£3500
B&K 2511 - 1621 Vibration test set	£2000
B&K 2511 Vibration meter	£1500
B&K 2515 Vibration analyser	£4500
Daymarc 1735 Transistor tester/sorter (with all jigs)	£5000
Dragnetz 305 Phase meter	£250
Dymar 1585 AF Power meter	£175

Dymar 2085 AF Power meter	£200
Farnell RB 1030-35 Electronic load 1Kw	£450
Farnell ANM/B Automatic modulation meter	£150
Farnell 2081 R/F Power meter	POA
Feedback TWG300 Test waveform generator	£200
Fischer Betascope 2040/2060 Coating thickness computer & non destructive coating measurement instrument & many jigs and extras	all for £2000
Fluke 8840A Multimeter (IEEE)	£3000
Fluke 515A Portable calibrator	£300
Fluke 5200A Programmable AC calibrator	POA
Fluke 8010A Digital multimeter	£125
Fluke 8922A True RMS voltmeter	POA
Fluke 95020 Current shunt	POA
Gay Milano FTMIC/FTM3C - FTM - Fast transient monitor	£250
General Rad 1658 LCR Digibridge	£250
General Rad 1621 Precision capacitance measurement system	POA
Hewlett Packard * 80TR Display unit with 8755B swept amp an	£350
Hewlett Packard 3200B VHF oscillator 10-500MHz	£175
Hewlett Packard 3400A RMS voltmeter	£150
Hewlett Packard 3406A Broadband sampling voltmeter	£175
Hewlett Packard 3437A System voltmeter	£350
Hewlett Packard 3476A Digital multimeter	£100
Hewlett Packard 3478A Digital voltmeter, 4 wire system, 1EEE	£650
Hewlett Packard 349C Digital multimeter	POA
Hewlett Packard 3702B/3705A/3710A/3716A Microwave link analyser	£1500
Hewlett Packard 3730A Down converter (with 3738A or 3737A)	£200
Hewlett Packard 3760/3761 Data gen + error detector	each £300
Hewlett Packard 3762/3763 Data gen - error detector	each £350
Hewlett Packard 3777A Channel selector	£250
Hewlett Packard 3779A Primary multiplex analyser	£800
Hewlett Packard 400E/F AC voltmeter	£150
Hewlett Packard 4193A Vector impedance meter	£3500
Hewlett Packard 4204A Oscillator 10Hz - 1MHz	£250
Hewlett Packard 435A Power meter (less sensor)	£350
Hewlett Packard 456A AC current probe	POA
Hewlett Packard 415E SWR meter	£275
Hewlett Packard 5335A Universal counter with 1EEE	£1800
Hewlett Packard 5342A Microwave freq count 18GHz	£1400
Hewlett Packard 7402 Recorder with 17401A x 2 plug-ins	£300
Hewlett Packard 8005B Pulse generator	£250
Hewlett Packard 8011A Pulse gen. 0.1Hz - 20MHz	£500
Hewlett Packard 8012B Pulse generator	£750
Hewlett Packard 8013B Pulse gen. 1Hz - 50MHz	£500
Hewlett Packard 8406A Frequency comb generator	£500
Hewlett Packard 8443A Tracking gen/counter with 1EEE	£450
Hewlett Packard 8445B Automatic presetter	£700
Hewlett Packard 8601A 110MHz Gen/sweeper 110MHz	£350
Hewlett Packard 8920C Sweep oscillator mainframe	£500
Hewlett Packard 8750A Storage normaliser	£400
Hewlett Packard 938A Freq. doubler	£250
Hewlett Packard 8640B with opt 001	£825
Kelthley 197 20MHz with 1EEE	£400
Lyons PG73N/PG75/PG26B/PG Pulse generator	from £225
Marconi 2019A 80KHz - 1040MHz sig gen	£1800
Marconi 2306 Programmable interface	£500
Marconi 2337 Automatic dist meter	POA
Marconi 2356 20MHz level oscillator	£300
Marconi 2432A 500MHz digital freq meter	£200
Marconi 2610 True RMS voltmeter	£900
Marconi 2830 Multiplex tester	£1250
Marconi 2831 Channel access switch	£500
Marconi 5390 1GHz signal gen	£1250
Marconi 6920 Power sensor	£400

Marconi 2022E (10KHz-1.01GHz) sig gen	£1850
Marconi 2015A (10KHz-1.04GHz) sig gen	£1850
Phillips PM 2525 Multimeter WF 1EEE	£850
Phillips PM 5167 10MHz function gen	£400
Phillips PM 5190 LF synthesizer with GPIB	£800
Phillips PM 5119 Colour TV pattern gen	£400
Phillips PM 5716 Pulse generator high freq, mos	£600
Phillips PM 5770 Pulse gen - 1MHz - 100MHz	£150
Phillips PM 6672 1GHz timer/counter WF 1EEE	£650
Phillips PM 8772 XYT chart recorder	£500
Photodyne 800 Fibre optic attenuator	£350
Projectina CM9345 Microscope	£800
Racal Dana 202 Logic analyser + 68000 disassembler	£250
Racal Dana 3100 40-130MHz synthesiser	£750
Racal Dana 5002 Wideband level meter	£650
Racal Dana 5003 Digital m/meter	£150
Racal Dana 5000 Microprocessing timer/count 52MHz	£250
Racal Dan 9009 Modulation meter	£225
Racal Dana 9081 Synth sig gen 520MHz	£550
Racal Dana 9084 Synth sig gen 104MHz	£450
Racal Dana 9242D Programmable PSU 25V-2A	£300
Racal Dana 9246S Programmable PSU 25V-10A	£400
Racal Dana 9303 True RMS/R/L level meter	£650
Racal Dana 9341 LCR databrige	£250
Racal Dana 9500 Universal timer/counter 100MHz	£200
Racal Dana 9917 UHF frequency meter 560MHz	£175
Racal Dana 9919 UHF frequency meter 1GHz	£275
Rchde & Schwarz BN36711 Digital Q meter	£400
Solartron Schlumb 1170 Freq. response analyser	£500
Tektronix TM503, SG503, PG506, TG501 Scope calibrator	£2200
Tektronix 834 Data comms analyser	£250
W&G SPM12 Level meter 200Hz-6MHz	£500
W&G PS12 Level generator 200Hz-6MHz	£500
W&G SPM60 Level meter 6KHz-18.6MHz	£500
W&G PS60 Level generator 6KHz-18.6MHz	£500
W&G PS6 Level generator 6KHz-18.6MHz	£250
W&G SPM6 Level meter 6KHz-18.6MHz	£250
Watanabe WTR211 3 pen plotter	£250
Wavetek 157 Programmable waveform synthesiser	£300
Wayne Kerr B424N LCR Component meter set	£200
Wayne Kerr 4250 LCR meter (as new)	£1000
Wayne Kerr t42 Autobaiance universal bridge	£200
Weller D800/D801 Desoldering station	£175
Weller D900 Desoldering station	£150
Witron 352 Low freq. differential input phase meter	£350

SPECIAL OFFERS - Phoenix 5500A Telecomms analyser, ex demo as new with 12 months calibration + 12 months guarantee fitted with V24 interface. A variety of interface options available - FingFax for details. Navtel 9440 Protocol analyser, ex demo as new £8000 new - cost now £3500. Navtel 9410 PCB based protocol analyser ex demo as new £3000 new - cost now £1500.

MANY MORE ITEMS AVAILABLE - SEND LARGE S.A.E. FOR LIST OF EQUIPMENT ALL EQUIPMENT IS USED - WITH 30 DAYS GUARANTEE. PLEASE CHECK FOR AVAILABILITY BEFORE ORDERING - CARRIAGE & VAT TO BE ADDED TO ALL GOODS

CIRCLE NO. 103 ON REPLY CARD

SEETRAX CAE - RANGER - PCB DESIGN

Ranger1 £100

- * Schematic capture linked to PCB
- * Parts and wiring list entry
- * Outline (footprint) library editor
- * Manual board layout
- * Full design rule checker
- * Back annotation (linked to schematic)
- * Power, memory and signal autorouter - £50

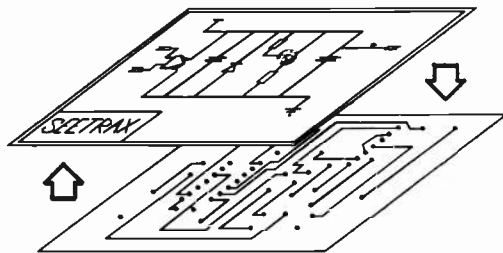

All systems upward compatible. Trade-in deals available.

Call **Seetrax CAE** for further information/demo packs.
Tel 0705 591037 Fax 0705 599036

Seetrax CAE, Hinton Daubnay House, Broadway Lane, Lovedean, Hampshire, PO8 0SG

All trademarks acknowledged.

Ranger2 £599

- All the features of Ranger1 plus**
- * Gate & pin swapping (linked to schematic)
 - * Track highlighting
 - * Auto track necking
 - * Copper flood fill
 - * Power planes (heat-relief & anti-pads)
 - * Rip-up & retry autorouter

Ranger3 £3500

- All the features of Ranger2 plus**
- * UNIX or DOS versions
 - * 1 Micron resolution and angles to 1/10th degree
 - * Hierarchical or flat schematic
 - * Unlimited design size
 - * Any-shaped pad
 - * Split power planes
 - * Optional on-line DRC
 - * 100% rip-up & retry, push & shove autorouter

Outputs to:

- * 8/9 and 24 pin dot-matrix printers
- * HP Desk/Laser Jet, Canon BJet, Postscript (R3 only)
- * HP-GL, Houston Instruments plotters
- * Gerber photoplotters
- * NC Drill Excellon, Sieb & Meyer
- * AutoCAD DXF

CIRCLE NO. 104 ON REPLY CARD

Big speed-up for VME

July will see the first production shipments of a *Spanceiver* chip for high speed serial data transfers across the VMEbus.

Called *Autobahn*, and developed jointly by Motorola and German real-time board maker PEP Modular Computers, the technique essentially provides a serial bypass, with transfer rates of between 200 and 400Mbyte/sec, to the 32-bit or 64-bit parallel bus transfers occurring on a standard VMEbus backplane.

Balloting to accept *Autobahn* as an ANSI standard should be completed by the end of the year, according to PEP president Josef Kreidl.

Autobahn was developed because the traditional way of boosting data throughput is to increase the word width or increase the clock frequency or both. But this cannot go on indefinitely because of the respective trade-offs of more board space and greater power dissipation.

Using a high speed serial link to transmit large amounts of data avoids many of these problems. The crucial device needed to convert the 32-bit parallel data into a

200Mbyte/s serial stream is Motorola's *Spanceiver*.

Kraus points out that the high speed of ECL can be achieved without a corresponding rise in power dissipation. The net result is that the power overhead associated with using the *Autobahn Spanceiver* chips is about 100Mbyte/s/W when performing transfers of 200Mbyte/s. This compares with figures of 8Mbyte/s/W for a typical VMEbus system transferring 32bit parallel data at a rate of only 40Mbyte/s.

The *Spanceiver* is also designed to minimise the protocol overhead, the time taken to set up transmissions. The chip contains a novel phase locked loop (PLL) design combined with a start stop oscillator that allows data to be transmitted in bursts without preamble bits. This means that when transmission starts, the PLL locks on the first sync bit so that the normal settling period required for clock recovery is eliminated. The data transfer is nearly overhead free with only one sync bit needed for every byte transmitted. The bit error rate will also be reduced. **David Darcy**.

New conversion leads the field

US firm Comlinear believes it has developed an analogue-to-digital converter (ADC) architecture capable of providing 12-bit performance at conversion rates as high as 50MHz.

The subranging architecture uses novel techniques in the second stage to minimise the comparator count, avoiding the associated power dissipation penalty while boosting conversion speed.

The firm has designed a 12-bit 25MHz ADC called the CLC950, which it claims has a better performance than any other monolithic converter of its class on the market. It is to be followed early next year by the CLC951 device with a 12-bit, 30MHz performance and a third chip with a target conversion rate of 50MHz.

In a classic subranging ADC architecture the comparator ladder is split into several smaller blocks or ranges. This scheme reduces power consumption and saves silicon area. Conversion errors caused by an input being close to a sub-range boundary

are usually detected by having a small number of extra comparators either side of the boundary. The errors are then corrected digitally.

The subranging technique is closely related to the two stage residue architecture. Both techniques need an overlap between the first and second stages, typically of two bits to correct for overall system errors. (six bits plus eight bits would be needed for a 12-bit converter).

The Comlinear architecture converts five bits in the first stage using a classic flash comparator ladder. However, according to engineer Kurt Rentel, the innovative second stage needs no overlap nor does it employ signal averaging techniques.

The CLC950 has a signal-to-noise ratio (SNR) of 65dB for a full-scale analogue input at 12.49MHz. However, the spurious free dynamic range (SFDR) is 70dB rising to 74dB for a 9.96MHz analogue input. The SNR is then 66dB.

Simon Parry, *Electronics Weekly*.

Fine vision of the future

Nikon, the world's top maker of stepper machines for lithography on chips, has started the R&D programme for the 16Gbit dram under the auspices of the Japanese government backed research organisation Sortec.

Nikon says it has already developed lithographic techniques for feature sizes down to 0.05µm using an X-ray with a 13nm wide beam, and a feature size of 0.015-micron using a 4.5nm X-ray beam.

Nikon's schedule for the stepper is to have it available for chip companies by 1999 when it is expected that the first prototypes of 16Gbit DRAMs will be made.

The current leading technology dram in mass production is the 16Mbit made on 0.5µm processes. It is expected to be succeeded by: 64Mbit on a 0.35µm process; 256Mbit on 0.25µm; 1Gbit on 0.15µm; 4Gbit on 0.065µm, and 16Gbit on 0.035µm.

Intel to kill off ageing family?

Solid rumours out of Intel claim that the US microprocessor company's next-but-one device will break with the existing x86 architecture, relying on x86 emulation to maintain compatibility with older systems. Sources say that the P7, that will appear close to the end of this decade, will be a pure risc design unlike the current Pentium and its successor, the P6, which mix risc and cisc designs.

Asked if it were true that the P7 would have to emulate some x86 instructions an Intel spokesman said: "We're really not talking about the P7 yet publicly. It's so early in the development of that product that I doubt there is much locked in concrete yet."

The company would hope that a risc design for the P7 will allow it to keep up with microprocessor rivals such as the PowerPC. The P7 will be able to separately process cisc and risc instructions with the cisc instructions being processed in a hardware emulation of an x86 microprocessor.

Intel plans to introduce its successor to the *Pentium*, code-named P6 by the end of 1995. This device is expected to be sold as a two-chip module featuring the CPU with 256kbytes of high speed cache memory.

Devereux dies

Frederick Leslie Devereux, who retired in 1965 as Editor of *Wireless World*, has died.

Born in Birmingham on May 5, 1900, "Dev" developed an interest in "wireless" very early, while at school. In 1917, he went to the Admiralty Board of Invention and Research at Harwich as a lab. mechanic working on asdic and in 1918 joined the anti-submarine division of the Royal Navy as a midshipman. Later, he joined his father's manufacturing jewellery business, but decided instead to take a degree in physics from Birmingham. Armed with that, he went into sound broadcasting, worked on receiver development, wrote on the subject for the *Birmingham Post* and naturally gravitated to WW, eventually becoming Assistant Editor under H F Smith' and Editor in 1957.

His knowledge of the industry was prodigious, particularly of the audio side. He appeared to know everyone, sometimes using this knowledge to bully nervous potential authors into writing for the journal, even though he knew the result might be in pidgin English.

His sense of humour was usually well to the fore and frequently in use to cut cocky journalists down to size.

My own experience of this was when I had written a piece about the 1963 deliberations on the choice of colour television system in and proudly submitted it for his comments. "You know, they have to chop trees down to print this stuff; it's a pity to waste them, don't you think?", he said. "Go away and rewrite it, preferably in English".

It was Dev who accepted Arthur C Clarke's 1945 piece on the possibility of communications satellites against the advice of his colleagues who thought it was nonsense. He took it home with him, did the sums and, realising it was feasible, went ahead, thereby presenting the journal with a cachet that has lasted fifty years.

Philip Darrington

Tektronix Das 9100 Logic analysers. Complete – £700.
Nicolet 800A Logic Analysers – 48 Ch–16 Bit – £450.
HP7580B–7585B Drafting Plotter – £1,000.
Bradley 127 DC Voltage Calibrator – £250.
Bradley 125B AC Calibrator + Ration Transformer 1255 + PI 1254B 50 C/s
 60–400–1KC/s – £250.
Marconi 6460/1 Power Meters + Heads RF various – £250 ea.
Marconi 6460 Power Meters + Heads RF various – £150 ea.
Marconi CT499 MkII RF Watt Meter Absorption 1–3–10–30–100W – 50ohm + 70ohm
 Converter Adaptor – £350. Includes RF Adaptors Low Loss.
HP59500A Multiprogrammer Interface
HP6940B Multiprogrammer or HP6941B – £100–£200.
Datalab DL1200 Waveform Recorder – £300.
Solatron 1170 FX Response ANZ–Led – £300.
HP59401A Bus System ANZ.
STC Optical Fibre Reflectometer OFR6 – £300.
HP3497A Data Acquisition Control Unit – £300.
Redifon Synthesized Receiver R1001–CW–AM–USB–LSB–PIC–STORE–Led
 Readout – 15KC/s–30MC/s – £600.
Racal LA1117 Piccolo Modem – £150.
Redifon RFS11 Pre-Selector – Post Selector –
 1MC/s–32MC/s – £200.
Sayrosa 3–39MC/s Programmable Freq Syn–Type
 607 + 607B – £200–£300.
Racal TA1816 1Kw Solid State Transmitter – MA1034 + 3 Pare Amps – £1,000.
H.C.D. Research Ltd Precision Oscillator 1519 5000/1000KHz – £250.
Nimbus 400Hz Converter Mains – 240AC–50OC/s Input–Output 115V–400Hz –
 500V/A Programmable 0–125V. G500 FPL – £300. G200R as above –
 200V/A – £200.
Hednair + Montford Environmental Ovens etc. Big + Small – £200–£1,000.
ICL Clean Linez Unit – £300.
HP6943A Multiprogrammer extenders – £300.
HP6525A DC P.U.O. – 4000V–50M/A – £350.
Polaroid + CR-9 Cameras for Oscilloscopes – £100.
HP3710A IF–BB Transmitter, HP3702B IF/BB Receiver +
 3705A Phase Detector – £250.
Moor + Reed Frequency Converter 400C/s 3 Phase Type SFC 6K/3AXR – Solid
 State – 20Amps/Mains 240V AC–50C/s Input – £600.
HP7586B Plotter Large Quantity Accessories Pens etc – HP–IB–RS2320 – £1,000.
Benson 16 BZ80 Asychrome Interface + Accessories & Pens etc – £600.
Intec 6000 Microfilm Reader & Printer, A4–A2 sizes –
 Plain Paper – Various Lenses – £750.
Fluke Y5020 Current Shunt – £150.
B&K 2107 FX Analyser – £250.
B&K BFO 1022 – £200.
Tektronix Spectrum ANZ–1L5–50HZ – 1MC/s – £150 –
1L20–10MC/s–4200MC/s – £250.
FARNELL P. U. AP60–50–60V–50Amps – £1,000.
Tracor 527E Frequency Difference Meter – £350.
HP8900B Peak Power Calibrator – £250.
B&K 2425 Electronic Voltmeter – £200.
HP4437A 600 ohms Attenuator – £150.
HP6177C DC Current Source – £250.
B&K Two Channel Level Recorder – £400.
Tektronix 2213 60MC/s Oscilloscope – £300 – 2213A – £350.
Tektronix 2215 60MC/s Oscilloscope – £350.
Tektronix 2445 150MC/s Oscilloscope – £1,200.
Tektronix 2246 100MC/s Oscilloscope – £1,000.
Tektronix 2225 150MC/s Oscilloscope – £800.
Tektronix 2245 100MC/s Oscilloscope – £700.
Tektronix 491 Spectrum ANZ 10ML/s–40GHC – £1,000.
Farnell P. U. H30/100 – £500.
Schlumberger S1 4922 Radio Code ANZ – £400.
Aerial Array on metal plate 9"x9" containing 4 aeriels plus Narda detector. 100–
 11GHz using N type and SMA Plugs + Sockets – ex equip – £100.
Marconi TF2175 Power Amplifier – 1.5MC/s–520MC/s + Book – £100.
Schlumberger 2741 Programmable Microwave Counter – 10HZ–7.1GHZ – £750.
Schlumberger 2720 Programmable Universal Counter – 0–1250MC/s – £600.
Tektronix 576 Calibration Fixture – 067–0597–99 – £250.
Texscan Rotary Attenuators BNC/sMA – 0–10–60–100DBS – £50–£150.
HP809C Slotted Line Carriage – Various Frequencies to 18GHZ – £100–£300.
HP532–536–537 Frequency Meters Various Frequencies – £150–£250.
S.E. Lab SM215 MkII Transfer Standard Voltmeter – 1000 Volts.
Ailtech Stoddart P7 Programmer – £200.
HP6181 DC current source – £150.
HP59501A HP–IB Isolated D/A Power supply programmer.
HP3438A Digital Multimeter – £150.
HP6177c DC Current Source – £150.
HP6207B DC Power Supply – £100.
HP741B AC/DC differential voltmeter standard (old colour) – £100.
HP6209B DC Power Unit – £100.
Fluke 431C High voltage DC supply.
Tektronix M2 Gated Delay Calibration fixture – 067–0712–00.
Tektronix Precision DC Divider Calibration fixture – 067–0503–00.
Tektronix Overdrive Recovery Calibration fixture – 067–0608–00.
HP5011T Logoc Trouble Shooting Kit – £150.
PPM 8000 Programmable Scanner.
Fluke 730A DC Transfer Standard.
B&K 4815 Calibrator Head – £150.
B&K 4812 Calibrator Head – £150.
HP FX Doubler 938A or 940A – £300.
HP461A Amplifier 1KC–150MC/s – Old Colour – £100.
Ailtech Precision Automatic noise figure indicator type 75 – £250.
Adret FX Synthesizer 2230A – 1MC/s – £250.
Marconi TF2512 RF Power Meter – 10 or 30 Watts – 50 ohms – £80.
Marconi 2830 Multiplex Tester.
Marconi 2828A Digital Simulator.
Marconi 2831 Channel Access Switch.
Marconi TF2337A Automatic Distortion Meter – £150.
HP489A Micro-Wave Amp–1–2GHZ – £500.
Fluke 893A Differential Meters – £100 ea.
EG&G Parc Model 4001 Indicator 4203 Signal Averager PI.

Tektronix Plug-In AM503–PG501–PG508–PS503A–PG502.
Cole Power Line Monitor T1085 – £250.
Claude Lyons LCM1P Line Condition Monitor – £250.
Bell + Howell TMA3000 Tape Motion Analyser – £250.
HP5345A Automatic Frequency Converter – 0.15–4GHZ – £350.
HP3200B VHF Oscillator – 10–500MC/s – £200.
Sencore SC61 Waveform ANZ–Microprocessor 60–100MC/s – £350.
Schlumberger 3531D Date Acquisition System – £300.
Marconi 6700A Sweep Oscillator with 1–2GHZ PI 6730A – £400.
B&K 2218 Sound Level Meter – £600.
EIP 331 18GHZ Counter–Microwave – Led – £700.
EIP 351D 18GHZ Counter–Microwave – Led – £800.
EIP 451 18GHZ Counter–Microwave – Led – £900.
EIP 545 18GHZ Counter–Microwave – Led – £1,200.
Systron Donner 6054D 18GHZ Counter – Led – £800.
Systron Donner 6057 18GHZ Counter – Microwave – Nixey – £600.
HP5340A 18GHZ Counter Microwave – Led – £1,200.
HP5340A 18GHZ Counter Microwave – Nixey – £800.
Systron Donner 6061 18GHZ Counter Microwave – Nixey – £500.
Austron 6014 FX Multiplier – £250.
Austron 2004 Receiver Loran – £250.
Austron 1201A Linear Phase Recorder – £250.
Austron 2010A Disciplined FX Standard – £250.
Microtel MSR-903 Microwave Receiver – 0.3–18GHZ – AM–FM – £2,000.
Microtel MSR-903 Microwave Receiver – 1–18GHZ – AM–FM – £2,000.
Microtel MSR-903A 18GHZ FX Counter for Above – £1,000.
Ailtech NM17/27 EMI/Field Intensity Meter – 0.1–32MC/s – £1,000.
Ailtech NM37/57 EMI/Field Intensity Meter – 30–1000MC/s – £1,000.
Ailtech NM65T EMI/Field Intensity Meter – 1–10GHZ – £1,000.
Fluke 5205A Power Amp – £1,200.
B&K 1623 Tracking Filter.
B&K 2607 Measuring Amp.
B&K 2134 Sound Intensity Analyser
B&K 280 Microphone Power Supply.
B&K 4408 Two Channel Microphone Selector.
B&K 4910 Stroboscope.
B&K 1606 Pre-Amp Vibration.
B&K 4420 Distribution Analyser.
B&K 1014 B. F. O. Oscillator.
B&K J2707 Power Amplifier.
B&K 2305 Level Recorders.
B&K 2307 Level Recorders.
B&K 7003 Tape Recorders.
B&K 2615 Charge Amplifier.
Fluke 9010A Micro-systems trouble shooter & many Pods – £350 + Pods or Probe.
Racal/Dana 5002 Wide Band Level Meter.
Racal/Dana 5006 Digital Multimeter.
Racal/Dana 5005–S–4622 Digital Multimeter.
AVO RM215 – L/2 AC/DC Breakdown Leakage & Ionisation Tester – £400–£450.
Fluke 80K – 40 High Voltage Probes – New in Case – £100.
Watkins Johnson 340A–4 RX LF–1–800KC/s AM–FM–CW – Led Readout – £750.
Watkins Johnson DMS – 105A Demodulator–AM–FM–SSB – Led Readout – £600.
Watkins Johnson RS–111–1B–40 V–HF Receiver – 30MC/s–1000MC/s – AM–FM–
 CW – Pan Display – £700.
Watkins Johnson 373A–2 HF Receiver – 0.5–30MC/s –
 AM–FM–CW – £400–£500.
Watkins Johnson Receivers from 1KC/s to 10,000MC/s also Tuning Heads –
 Amps–Counter Readouts – Signal Dislays – Distribution Amps – HF Multicouplers –
 IF Demodulators – Signal Monitors etc.
Racal MA1720 TX Drive Units 1–30MC/s – £500–£750.
Racal MA1723 TX Drive Units 1–30MC/s – £1,000–£1,500.
Racal MA1724 TX Drive Units 1.6–25MC/s – £500.
Racal RA1792 HF RX–100KC/s–30MC/s – £1,000 Back Lighting.
Racal RA1772 HF RX–15KC/s–30MC/s – £600.
Racal RA171L HF RX 5MC/s–30MC/s – £100–£250.
Plessey PR2250G & H–HF RX LF to 3C MC/s–Memory–Led Readout – £650–£1,000.
B&K 2609 Measuring Amp – £250.
B&K 1613 Filter – £100.
B&K 4215 Artificial Mouth – £250.
B&K 4219 Artificial Voice – £250.
B&K 4220 Piston Phone – £120.
Dynamic Sciences R-1250 Tempet Receiver –
 100HZ–1000MC/s – AM–FM – £2,000.
HP3406A Sampling Voltmeter (Broadband) – New Colour – £200.
HP7404A Oscillograph Recorder – 4 Track – £350.
HP9872B Plotter – 4 pen – £300.
HP11710B 0.1–11MC/s – Down Converter for 8640B – £350.
HP11720A Pulse Modulator – 2–18GHZ – £1,000.
HP8403A Modulator – 0.4–12.4GHZ (8731–8735B) Modulators – £100–£250.
HP Pin Modulators for above – Various Frequencies – 0.4–12.4GHZ – £150.
HP8699B Sweep Plug-in – 0.1–4GHZ – Using Yigs – Solid State – £300.
HP8690B Mainframe – £250. All PI available – 1–40GHZ Sweep.
Racal–SG Brown Comprehensive Headset Tester
 (with artificial head) Z1A200/1 – £350.
Marconi 893B AF Power Meter – £200.
Microwave Systems MOS/3600 Microwave Frequency Stabilizer –
 1GHZ–40GHZ – £1,000.
ACL SR-209–6 Field Intensity Meter Receiver – PI's – 5MC/s–4GHZ – P.O.R.
Ailtech 136 Precision Test RX + 13505 Head – 2–4GHZ – £350.
SE Lab Eight Four FM 4 Channel Recorder – £200.
Datron 1065 Auto Cal Digital Multimeter & Instruction Manual – £400.
Datron 1061 Auto Cal Digital Multimeter & Instruction Manual – £400.
Racal MA259 FX Standard – Output 100 KC/s – 1–5MC/s
 Internal Nicad Battery – £150.
Edwards E2M8 Rotary Vacuum Pumps – Brand New & Boxed – £500 ea
Fluke 9100A Troubleshooter & Pods – New Boxed – £750–£1,000
HP1140 & 1743 Oscilloscopes 100MC/s – £300–£450.
Tektronix PI 7A19–7A29–3A–4–6–7m11–
Tektronix 7000 Series Oscilloscopes We can supply all variations of Main Frames
 and Plug-ins for this range from stock up to 1GHZ – £300–£3,000.

All items in this advert are in stock at time of printing, most items are held in quantity at both our warehouses which is probably the largest stock of electronic surplus in the UK.
 Bulk and trade buyers from UK and abroad are welcome by appointment to bring own transport for quick purchasing and loading of listed and non-listed items.

Johns Radio, Whitehall Works, 84 Whitehall Road East, Birkenshaw, Bradford BD11 2ER. Tel. No. (0274) 684007. Fax (0274) 651160.

CIRCLE NO. 105 ON REPLY CARD

RESEARCH NOTES

Gunn diode blasts through output and frequency limits

Researchers at Litton Solid State in Santa Clara, California, and the US Army Research Laboratory in New Jersey and Maryland have taken Gunn diode technology to new limits of frequency and efficiency. JD Crowley and colleagues have developed a well-behaved indium-phosphide device

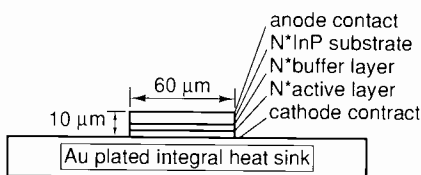

Exceeding the performance of any Gunn diode available to date, this indium-phosphide device achieves 65mW at 138GHz with 2.6% conversion efficiency.

capable of generating 65mW of cw power at 138GHz with an efficiency of 2.6% (*Electronics Letters*, Vol 30, No 6).

For reasons of its higher efficiency, indium phosphide is generally preferred to gallium arsenide for frequencies above 35GHz.

Up until now, though, very little work has been done with Gunn diodes above 100GHz. Yet, because of their reliability, low cost and ease of use, these devices have enormous potential for use in radio astronomy receivers, short range radio links and high-resolution atmospheric radars.

By normal standards the new device is exceptionally thin, though the authors say this style of construction is necessary to reduce the positive parasitic series resistance of the InP substrate and also to reduce skin effect losses.

The method of fabrication involves vapour

phase epitaxial deposition, after which the back side of the wafer is polished chemomechanically using a bromine-methanol solution. Metallisation and the fitting of an integral heatsink are then followed by the etching of individual mesas.

When packaged and fitted in a WR-6 waveguide oscillator circuit, each diode was found to perform with adequate stability over a 0-50°C range.

Frequency variation with temperature was -5MHz/°C, while output power was maintained within a few milliwatts over the entire temperature range.

Based on these experimental findings, the researchers confidently claim that low-cost, simple solid-state sources can now be constructed in the 140GHz range for use as local oscillators, drivers for multipliers, or as low power transmitters.

The wobble that gives birth to a planet

Stories of astronomers claiming to have discovered planets beyond our own Solar System are familiar in scientific circles. Now, after much scepticism, it appears that the astronomical world is taking such claims seriously following interpretation of 'wobbles' found in a pulsar.

Pulsars are rapidly rotating condensed stars that take their name from the powerful radio pulses they beam into space every few milliseconds. Three years ago British radio astronomer Andrew Lyne thought he had found minor perturbations in the otherwise highly regular radio emissions from a pulsar. He conjectured that minor irregularities in one pulsar's beat could only be due to the gravitational tug of objects in the vicinity - in other words, planets.

Lyne's calculations were subsequently proved wrong. But they inspired Alexander Wolszczan of the Pennsylvania State University and Dale Frail of the National Radio Astronomy Observatory to undertake observations of another pulsar, code-named PSR 1257+12. A year later, using new techniques to analyse signals from the 305m Arecibo radio telescope in Puerto Rico, they found perturbations in the pulsar's rhythm that could not be explained by any error in experimental procedures. The evidence this time was very much stronger. But the astronomical community was still in no rush to conclude that planets were responsible.

Now Wolszczan's latest calculations,

based on a further two years' statistical analysis (*Science*, Vol 264, p.538), have convinced, it seems, even the most sceptical.

In the same issue of *Science* Fred Rasio of the Institute for Advanced Study at Princeton says: "It would be difficult to imagine any other way the data could be fooling us".

So small is the perturbation in the pulsar's tick that Wolszczan had initially expected to take five years to come up with a definitive result. He describes the perturbation as being so slight that detecting it is like transporting a snail a distance of 1500 light years, making it crawl at its usual pace, attaching a transmitter to it and then measuring its movement to within a few millimetres a second.

Two years' of data from the pulsar (located in the constellation of Virgo) reveal the existence of two orbiting bodies each with about three times the mass of the Earth. Fortuitously they have closely related orbital periods of 66.6 and 98.2 days and, at that approximately 2:3 ratio, pass each other frequently and have a short overall orbital pattern. The result has been that Wolszczan and his team have been able to dig meaningful signals out of the noise in three years, rather than the expected five.

What has finally convinced Wolszczan's colleagues is the predictive aspect of his analysis. Back in 1992, soon after he discovered the first convincing pulsar 'wobbles', he used his data to predict

precisely, months in advance, the subsequent pulse patterns. The fact that later recordings have been exactly on target eliminate most possibilities of flaws in the data analysis - and also effects of the Earth's movements, which were not fully accounted for in Andrew Lyne's study.

The story is not yet complete by any means. Wolszczan says that the timing-data point to the existence of a third moon-sized object that orbits the pulsar every 25 days. There are also hints of a fourth body in a much larger orbit. All these planets are, of course, much too far away to detect in either the visible or the infra-red parts of the spectrum. So it is extremely unlikely that they'll ever be 'seen' in the conventional sense. Though Nasa is soon to inaugurate Aseps (astronomical studies of extra-solar planetary systems) using ground-based telescopes to search for large planets around a hundred much-nearer stars.

As ever, the \$64,000 question is: do these latest planetary discoveries increase the odds of ever finding life elsewhere in the Universe?

In the statistical sense the answer must be yes, though it is unlikely that such life would exist on planets circling a pulsar.

Wolszczan comments: "If you envisage someone with lead armour to protect them against the high energy radiation from the pulsar, maybe there are such creatures. But the sort of life we're accustomed to cannot possibly exist on a planet like that".

Laser that could reshape conventional technology

A semiconductor laser designed on a fundamentally new principle may open up a whole range of applications: from novel ways to detect air pollution, to collision avoidance radars for cars. Developed by Federico Capasso and his colleagues at AT&T Bell Laboratories in Murray Hill, New Jersey, the new quantum cascade laser produces infra red radiation in parts of the spectrum that other lasers cannot easily reach.

What makes the device special is that the wavelength is determined, not by the chemistry of the semiconductor material, but by its physical structure.

Unlike an ordinary semiconductor laser, whose emission occurs when excited electrons cross the intrinsic band-gap of the material, the AT&T laser generates its radiation when electrons spill down an 'energy staircase' of sandwich-like quantum wells. These steps can be made in different sizes, so the laser can cover a wide range of the infra-red spectrum.

The only semiconductor lasers capable of operating in the far infra-red have been based on



Until now, the only lasers capable of producing far-infra-red have been mercury-cadmium-telluride types, which are difficult to fabricate. This new device uses aluminium indium arsenide and indium gallium arsenide

mercury cadmium telluride – a difficult material to fabricate.

The idea of using quantum wells to make a laser goes back to the early 1970s when an IBM team led by Leo Esaki suggested using such wells to constrain electrons to specific energies or wavelengths. The team predicted that when electrons tunneled from well to well they would emit radiation of a wavelength determined by the geometry of the structure. Through the 80s, experiments at MIT and AT&T showed that it was indeed possible to create such quantum wells by delicate molecular beam epitaxy. The techniques were extremely complex however and, although sequential electron tunnelling was achieved, no radiation was emitted.

The latest results, achieved in a device with 25 active regions

is the end product of hundreds of attempts using nanometre-scale sandwiches of aluminium indium arsenide and indium gallium arsenide. Main snag, at the time of writing, is that the whole assembly needs to be cooled to 90K and can only be operated in pulsed mode. But this shouldn't be a serious limitation; it is only because the device is so inefficient. Without such operating constraints the necessarily large forward current would otherwise cause it to overheat.

On the credit side, the new 'staircase' laser has a much narrower spectrum than normal band-gap devices – a direct product of its operating principle. Electron energies are defined by the structure of the device so they can be specified extremely closely.

As yet the laser is still at the experimental stage and cannot be considered a practical device. But for a technology that is less than six months old, progress has been dramatic. And once the efficiency problems have been overcome commercial applications are expected to follow very quickly.

Conventional laser

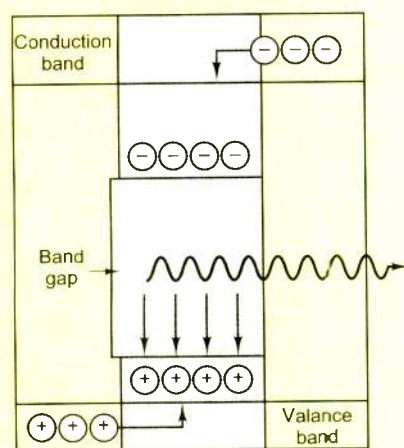

Quantum cascade laser

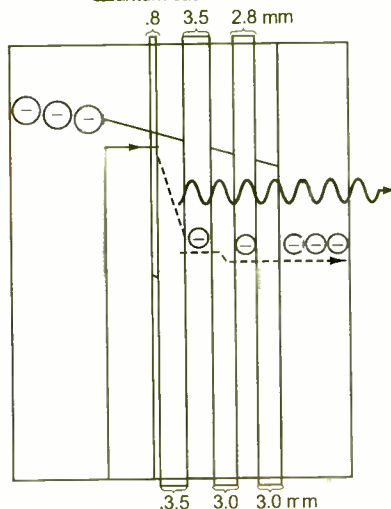

Semiconductor quantum-cascade laser operates on an entirely new principle. When current flows, electrons pass down the structure. Each time the an electron hits an energy-level step, a photon is emitted which in turn stimulates other photons by bouncing between mirrored surfaces.

Physicists find their missing link

Physicists at the Fermi National Accelerator Laboratory near Chicago have discovered what they believe is the last fundamental building block of matter. The top quark has come to light after decades of high energy experiments in which protons and anti-protons have been smashed into each other at speeds approaching that of light. From more than a million million such collisions, the team have isolated about a dozen events providing strong circumstantial evidence for the top quark.

Over 20 years ago Murray Gell-Mann, a Caltech physicist developed what is now known as the "standard model" of everything. His model postulates that all matter consists of various combinations of six quarks and a

matching set of six lighter particles, collectively called leptons (see table).

Its undoubted neatness and symmetry appeal immensely to physicists.

Up to now, most of the quarks – the name itself comes from James Joyce's 'Finnigan's Wake' – have obligingly turned up in the results from big atom-smashing experiments: except that is for the top quark.

The 'strange' quark was discovered in the early 1950s, while 'charm' and 'bottom' showed up two decades later. But without 'top', the standard model could hardly be regarded as complete.

In the continuing search, the main problem facing quark hunters is that such particles, because of the tightness with which they bind

together, cannot be observed directly. Free quarks do not exist in nature, and in the case of the top quark, they rarely exist in any form. To create them requires smashing protons and anti-protons together with enormous energies, the particles annihilating themselves in a blaze of energy, comparable on a small scale with that of the Big Bang that initiated the Universe.

It is from this blaze of pure energy that quarks sometimes condense.

Even then, quarks can remain irritatingly elusive. On a BBC World Service programme, Dr Bill Carrithers, one of the Fermilab team described it like this: "The top quark decays instantaneously after being produced. So what we look for are signatures of its daughters or even grand-daughters as the particles decay down to the ones we see in the detector. We then work backwards to reconstruct what the top quark must have looked like".

What is particularly fascinating about the top quark is its mass. Latest estimates suggest that is about as heavy as an atom of gold – by far the most massive of all the sub-atomic particles.

Next step for particle physicists, after finding events to strengthen the evidence for the top quark, will be to track down another entity called the Higgs boson. This particle, also predicted by the standard model, may explain the mystery of why some quarks are more massive than others.

It could even explain why they have mass at all.

Scientists believe that the 'top' quark is the last fundamental building block of matter. These are the four families of three generations of elementary particle constituents.

Generation Family	1	2	3	Electric charge
neutrinos	neutrinos ν_e ν_μ ν_τ			0
charged leptons	electron e^-	muon μ^-	taunon τ^-	-1
quarks	up	charm	top	$+\frac{2}{3}$
quarks	down	strange	beauty	$-\frac{1}{3}$

Periodic table of elementary particle constituents

Solar power reaps efficiency benefits

Environment-conscious engineers have long dreamed of being able to generate electricity – efficiently – from sunlight. Solar cells have no moving parts and little to wear out; create no pollution, consume no scarce fossil fuels and last for 20 years or more. In many senses they would be the perfect source of power. But they have four main drawbacks: they only work during the day, they are expensive, they are inefficient and they produce unpredictable amounts of dc.

Yet as environmental considerations become more important and as prices fall, solar cells are being taken increasingly seriously, especially in situations where an intermittent supply of low-voltage electricity is acceptable.

The main factor behind the recent surge of interest in solar cells is their rapidly improving efficiency. One example of progress is a low-cost cell made in the USA by a research group called United Solar Systems. This joint venture of Canon and Energy Conversion Devices has developed a cell based on a thin film of amorphous silicon that will capture sunlight with an efficiency of 10.2%. Two years ago, the best figure for this type of low-cost cell was about 6%.

The new cell is a triple sandwich of silicon with silicon/germanium alloys deposited on a panel of stainless steel. The construction not only helps a wider spectrum of light energy to be absorbed, but can also be physically bent.

Previously, most solar cells capable of efficiencies greater than 10% were made from single crystals of silicon or polycrystalline silicon. Such cells (and those made from III-V compounds) are necessarily much more expensive than their amorphous silicon counterparts.

Even so, they too have been getting progressively better. A recent report (*Physics World*, April 94) describes a record-breaking solar cell from the Japanese company Mitsubishi. They claim to have achieved an efficiency of 14.2% in what they believe is a commercially viable cell made of polycrystalline silicon. The previous record for this type of cell was 10.9%.

These efficiency figures may seem very low compared with, say, a steam generator. But once a solar cell is installed, the running costs are virtually nil. And even if the cell is only 10% efficient, a 1m square of it will

still generate 100W of electricity in full sunlight.

What these recent advances are now demonstrating is the closing gap between solar-generated power and that generated by the burning of fossil fuels.

According to some industry figures, the cost of solar power will not need to fall by much more than a factor of two before it becomes cost-effective for supplementing the ac grid. A coalition of US companies is already pledged to install 50MW of solar power over the next six years.

Here in the UK the climate may (literally) be less favourable: less sunlight and variable weather, especially in winter when electricity demand is high. Expensive land is also frequently cited as a major obstacle.

The way forward, according to many experts would be to fit solar panels to the walls and roofs of buildings and use the resulting power for supplementary purposes, using efficient dc-to-ac converters when necessary. ■

Research Notes is written by John Wilson of the BBC World Service.

THE BEST LOW COST PROGRAMMERS DESIGNED & MANUFACTURED IN THE UK

SPEEDMASTER 1000 SPEEDMASTER 1000E

UNIVERSAL PROGRAMMER

- Superfast PC based programmer
- Programmes; EPROMS UP TO 8M BIT, FLASH EPROMS, EEPROMS, BEPROMS, NVRAMs, MICROs (8748/51), PALs, GALs, EPLDs, PEELS, MACHS, MAPLs, MAX
- Plugs directly into parallel port
- 1000E Version has ROM/RAM emulator built in: 128k (1 Mbit) standard, optional 512K (4Mbit)

only
£445

only
£525

MICROMASTER 1000 MICROMASTER 1000E

UNIVERSAL PROGRAMMER

- Programmes: EPROMS UP TO 8M BIT. FLASH EPROMS, EEPROMS, BEPROMS, NVRAMs, PALs, GALs, EPLDs, PEELS, MACHs, MAPLs, MAX etc.
- PLUS over 80 different Micros including 8748/51, 68HC705, 68HC711, PICs, Z86, TMS320, TMS370 etc DIPs WITHOUT ADAPTORS OR PERSONALITY MODULES!
- Package adaptors available.
- 1000E Version has ROM/RAM emulator built in: 128K (1Mbit) standard, optional 512K (4 Mbit)

only
£575

only
£645

SPEEDMASTER 8000 GANG/SET PROGRAMMER

- 8 way, Pc or stand alone
- Super-fast programming times, manufacturer recommended algorithms
- 32 pin devices as standard
- Support for 8748,51, TMS370, PIC Micros and 40 pins.

only
£645

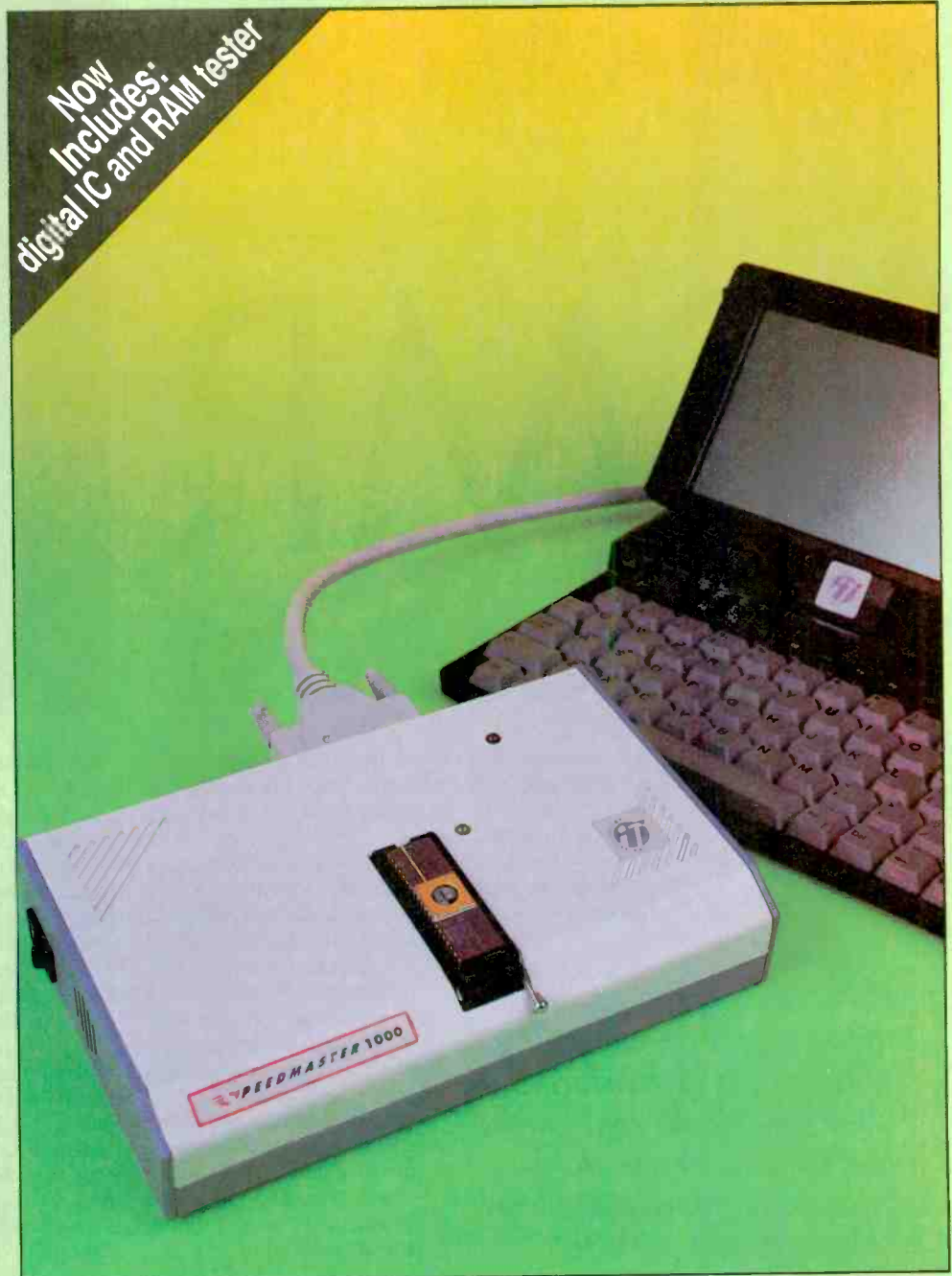

WHY BUY AN INFERIOR IMPORTED PROGRAMMER WHEN YOU CAN HAVE A MANUFACTURER APPROVED UNIVERSAL PROGRAMMER/EMULATOR DIRECT FROM ICE TECHNOLOGY!

- We offer the best range of low-cost programmers available, now including our unique **UNIVERSAL PROGRAMMERS WITH BUILT IN EMULATORS**
- Unrivalled device support, for example the Micromaster 1000 programmes PICS, Z86, 87C705, 68HC705, TMS370, 77C82 ETC WITHOUT ADAPTORS, as well as the full range of Eproms, PLDs etc supported by all our universal programmers.
- Approved by National Semiconductor** for their full range of PALs, GALs, and MAPLs - other programmers claiming approval are often only approved for EPROMS - a much less exacting specification!
- All our programmers and programme/emulators work off the standard parallel port with any IBM compatible PC, even laptops
- Unbeaten programming times: Programme a 27256 in just 5 SECONDS including download and verify.
- Easy upgrade path between Models.

**FOR MORE DETAILS, DEVICE LIST AND DEMO DISK CALL NOW ON
TEL +44 (0)226 767404 FAX +44 (0)226 370434**

ICE TECHNOLOGY LTD, UNIT 4, PENISTONE COURT, STATION BUILDINGS, PENISTONE, S. YORKS, S30 6HG, UK.

CIRCLE NO. 106 ON REPLY CARD

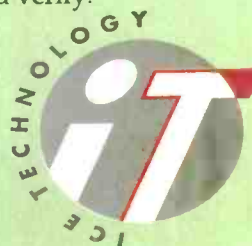

CMR

under test



Instrumentation amplifiers are front ends for signals arriving from hostile environments. They are available in many forms, but for the most part they have twin, differential or balanced inputs.

Unwanted common-mode signals – hum, noise, dc, etc – and dangerous voltages are generally attenuated or cancelled out. Gain is restricted to wanted, differential signals, which are often smaller than the unwanted interference.

Instrumentation amplifiers – or in-amps – can be built from discrete components, but most applications now use integrated circuits. Integrated-circuit data sheets contain a figure for common-mode rejection, cmr, usually at a spot frequency. Most also have a graph showing how cmr degrades with increasing frequency. But how far can this information be trusted when the test levels, topology and critical passive component values are rarely specified? And how much does cmr change when surrounding component tolerances are imperfect, or the circuit topology changes?

Although common-mode rejection is a key feature allowing signals to be distinguished from interference, many applications will also need instrumentation amplifiers with good performance in other dynamic areas such as noise, slew and bandwidth.

My reason for being interested in op-amp cm rejection is taken up in the panel.

The contenders

Table 1 lists devices considered. They are chosen for their combination of the following attributes.

High gain-bandwidth product. In order to provide a bandwidth of 1MHz at +40dB or more gain, minimum gain-bandwidth product was limited to 100MHz. Current feedback helps immensely here but is not a prerequisite. Many good in-amps and op-amps from manufacturers such as AD, Burr-Brown and LTC are ineligible since they have bandwidths below 500kHz at +40dB. The *LT1028* is marginal but included for illustration.

When selecting examples of current-feedback op-amps, I noticed that Analog Devices' current feedback op-amp data hampers the designer by omitting gain/bandwidth plots. These are needed all the more because with current feedback ordinary loop-gain-proportional bandwidth relationships do not arise.

Low noise. To avoid adding significantly to inevitable noise from the input attenuator-network, in most cases only devices with a noise figure of less than $5\text{nV}/\sqrt{\text{Hz}}$ were chosen, with noise from a typical input attenuator contributing about $5\text{nV}/\sqrt{\text{Hz}}$.

The rather noisier *AMP05*, and only slightly over-noisy *HA2548*, have been accepted because of their wider bandwidth and much higher slew limit. With current feedback op-amps in this class of circuitry, current noise dominates. This is because certain resistor values in practical circuitry capable of withstanding high cm voltage need to be higher than the ideal for current feedback.

Slew rate. As a minimum limit for slew rate I chose $10\text{V}/\mu\text{s}$. For switch-mode power supplies, the *AMP05* is marginal, while *HA2548*, *AD829*, and the *AD811* and *818* respectively meet and exceed the maximum requirement.

Offsets. DC gain may be over 100 so offsets need to be low. Offsets that do not displace the smallest wanted signals by more than 10% are not too problematical. Servo control of dc might be attractive, but the ideal differential summation almost doubles the parts count.

Common-mode voltage. Common-mode voltage capability, or cmv, is greater than $\pm 10\text{V}$ for the devices chosen.

many modern, very high speed op-amps, with ± 5 to $\pm 7V$ maximum supplies.

Common-mode rejection. Last but not least, the highest cmr is sought up to at least 100kHz or below. Makers' specifications are quite variable here.

High cmv topologies compared

Common-mode rejection performance will

depend on the topology used. **Figure 1** shows the simplest scheme for handling high cmv. I arranged it to allow either IC op-amps or in-amps to be plugged into the front end network. Instrumentation amplifiers were connected via a short, tightly twisted pair.

Compared to a previously published version² of Fig. 1, resistor values are lower. Also, recovery gain for the op-amp version, R_6/R_1 , is set for +18dB.

Fig. 1. First of three common-mode rejection test circuits. Mode switch setting and C_1 depend on the device under test. PR_1 and R_3 enable the cmr to be finely trimmed. Likewise C_1 and TC_1 allow the input capacitances to be finely balanced for maximum hf cmr. Potentiometer PR_1 is unaffected by most op-amp types, but required adjustment with the different in-amp types.

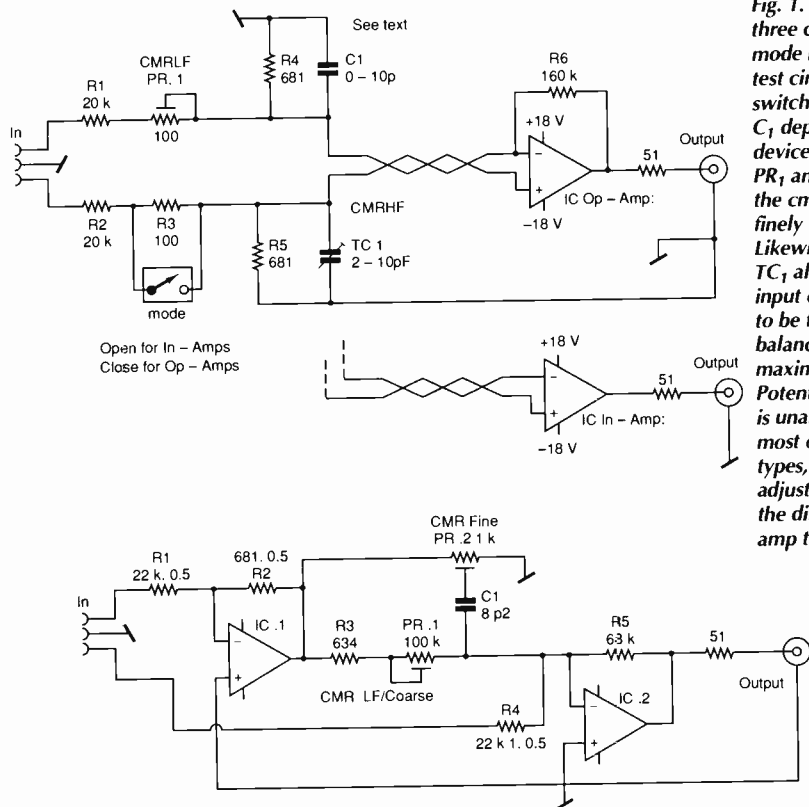

Fig. 2. Two op-amps use shunt feedback and common-mode voltage is actively subtracted. With this circuit, imperfect cancellation prevented deep nulls. For cmr better than -80dB above 100kHz, layout is critical.

Table 1. Dynamic specifications of shortlisted IC operational and instrumentation amplifiers, based on manufacturers' data.

Part	Maker	Noise @1kHz nV/√Hz	BW @40dB MHz	CMR @100kHz -dB	Slew limit V/μs	+Vs max volts	CMV @±15v volts
Instrumentation amplifiers:							
AMP05 CFB	AD	16	3	57	5-7.5	18	11.5
INA103	BB	1	0.7	85	15	25	11-12
SSM2016 CFB	AD	0.8	1	na	10	36	8.3
SSM2017 CFB	AD	0.95	1	97	10-17	22	8
Op-amps:							
AD797	AD	0.9	0.8/4.5*	56	12.5-20	18	12
AD811 CFB §	AD	1.9	50†	70	2500	18	13.5-14.5
AD818	AD	10	2.6†	65	400-500	18	12-14.3
AD829	AD	2	0.66/7.5†	83	230	18	13.5-14.5
HA5137	Harris	3.4	1	60	35	17.5	12
HA2548	Harris	8.3	1.5	62-74	120	20	7-10
LT1028	Lin Tech	1.1	0.5	80	11-15	22	11-12

Notes: All figures typical.
 * Higher with decomp C.
 † Estimated from ancillary data.
 § Noise current 20pA/√Hz.

CFB = current feedback. SSM2016, 2017 & AMP05 employ some cfb.

Even if there is enough gain-bandwidth product to support higher gain, this is about the maximum without adding complexity³. As shown, R_1 's value is as low as reasonably possible. With R_6 at 160kΩ, parasitic capacitance starts to affect bandwidth just above 1MHz.

Figure 2 shows another scheme described by Jung^{4,5}, using two op-amps. Monolithic in-amps are not applicable here. Shunt feedback means that neither op-amp front-end sees appreciable cmv, provided the feedback is operative.

Output of IC_1 is adjusted via PR_1 to precisely cancel IC_2 output originating from the lower input. Any cmv is manifest at the output of IC_1 . For a given recovery gain, noise gain in IC_2 is intrinsically 10dB higher compared to Fig. 1: at 50dB, it comprises 10dB from the direct input, and 40dB to make up IC_1 output. Recovery gain is kept to just +10dB accordingly. Potentiometer PR_2 provides phase trim, forming a T-network in conjunction with C_1 , for best cancellation at hf.

Figure 3 also uses two op-amps⁶. At $R_{6,7}$ junction, the differential-mode signal sums to zero, leaving the full cmv. A cancellation signal is fed forward across the differential inputs by IC_1 , actively suppressing the cmv it reads at the junction. Unlike the previous circuit, IC in-amps are applicable for IC_2 , and preferable, as the active impedances to ground are then in principle symmetrical.

Depth of hf cmr trim with the trimmer capacitors depends on IC_1 . A high slew rate and generous bandwidth is important for IC_1 if cmvs above 10kHz are expected. Otherwise progressively disorganising cancellation at vhf shows up as a spiky, un-nullable residue.

Test environment

All the test circuits had local wideband decoupling typically comprising 100nF+10μF. In addition they were powered by a low impedance, low noise Thurlby ±16V lab supply. Trimmer potentiometers were Bourns cermet types and trimmer capacitors were miniature low-k ceramics.

All tests were performed with Holsworthy 0.5%, 50ppm/°C metal film resistors in all the critical gain/cmr determining positions - including the attenuator front end. Each test circuit was driven from the Audio Precision generator with the hot and cold inputs joined, i.e. in common-mode test or 'cmtst' mode.

In all graphs, cmr+n is plotted in dB below a hypothetical output of +34dBV, i.e. 49V rms, to emphasise cm residue at the expense of noise. The noise floor will be much nearer with small differential-mode signals.

For **Figs 4-21**, the Audio Precision test set plots

cmr+n versus frequency in two bandwidths. Upper plots are from 10Hz up to 200kHz with a bandwidth from less than 10Hz to more than 500kHz. The lower plot is a narrower sweep with a -1dB bandwidth from 400Hz to 22kHz. Difference between the two can help indicate how much cmr in the upper plot is receiver noise (+n).

Despite the high reference level and 1/3rd octave sweep, often only noise is extant in the narrow band plots; literal cmr can only be estimated. In most cases diminishing cmr above 100kHz has been kept at bay by deft trimming.

Although the test set stops short of 1MHz, any rise can only go so far in the invisible top half decade from 200kHz-1MHz. In many cases, a little cmr decay above 200kHz is of little significance. When double checked, the cmr curves' repeatability was about ±3dB at 200kHz, ±2dB at 20kHz and ±1dB at 100Hz for wideband readings. Narrow-band plots were about 0.5dB closer.

Results Figs 4-14 show typical cmr+n versus frequency plots for the first eleven devices in Table 1 using test circuit Fig.1. All the devices achieve at least -90dB across the 500kHz measurement bandwidth. This is referred to a hypothetical 49V/+34dBV level however. Referred to 1V/0dBV, cmrr is a more prosaic -56dB.

In some cases, Fig. 6 for example, the 'real' cmr curve behind the noise appears to be the -6dB/octave slope that can be drawn down from 200kHz on the upper plot to intercept the narrow-band plot at about 20kHz⁷

On this basis, you can estimate that if cmr is more than -130dB, or better than -96dBV.

With careful trimming, even the narrow-band residue up to 5kHz in the lower plots is predominantly noise. The ranking has much in

common with the noise densities shown in Table 1, but with some surprises. This is in part because uniform extrapolation from 1kHz noise density out to 200kHz may be presumptuous. As you might expect, by having 20pA/√Hz noise in conjunction with resistor values as high as 160kΩ, the AD811 current-feedback op-amp appears to have the poorest cm rejection, Fig. 13. Effective total-noise density, V_n+I_n , is above 10nV/√Hz, emphasising the '+n' part.

Figures 15-17 show typical cmr+n versus frequency with test circuit Fig. 2. High-frequency kinks in Fig. 15 show that cmr involves non-linear phenomena. The residues looked like distortion harmonics and the nulling was only bluntly effectual. Common-mode voltage cancellation is critical. Minute changes in lead dress and component positioning had a large bearing on performance. Figure 16, with an un-compensated AD829 shows how PR_{1,2} can interact, depending on trim sequence. Such interaction can possibly be overcome, and better cmr attained by using the AD829's diverse compensation facility, with the compensation on IC₁ set at 68pF. Compensation on IC₂ requires tuning below 60pF for best results. With extra attention to detail, cmr+n may go lower, but the best result attained in these tests was -88dB or -54dBV, as shown in Fig. 15.

Figures 18-20 illustrate performance of test circuit Fig. 3. The 2017 was chosen for IC₂, to keep the circuitry simple with little trade-off. Other in-amps and IC op-amps were tested in IC₂ position. Differences broadly corresponded with Figs. 4-14, where stable. But some had vhf oscillations, or cmr+n versus frequency anomalies. These were helped no doubt by the abnormal source impedances presented to IC₂'s inverting input in the midst of

IC₁'s feedback loop.

Below 10kHz, cmr+n performance with an AD829 or HA5137 for IC₁ is clearly a little better than the results from the other test circuits. These devices were chosen for their good performance in test circuit Fig. 1. Inevitably, the trade-off with active cancellation is poorer high frequency performance compared with the passive method of Fig. 1.

Finally in this section, Fig. 21 shows how some of the circuits outperform the Audio Precision test equipment. Fortunately, cm rejection is not superimpositive.

The measurements appear to demonstrate that the 100kHz cmr of the op-amps and in-amps is both over- and under-stated by their makers., However cmrr depends on references and conditions, which are not so clearly defined.

What is clear is that surprisingly similar and repeatably high cmrs can be attained by all the modern IC op-amps and in-amps tested. These high cmrrs can be maintained up to surprisingly high frequencies, given informed layout and careful trimming - particularly with the test circuit of Fig.1.

Simulating cm rejection with Spice

Few of the op-amps tested here were available as Spice models but I evaluated those that were and others with MicroCAP-IV.

Harris's models do not presently cover cmr. Models for AD797 and 829 do, but since the devices have more than the basic five pins - i.e. inputs, output and power - they need 'hard pinning' for MicroCAP to run. This means that a six-pin op-amp shape has to be created or called up. Even if you do not need the compensation pin, MicroCAP will not accept it simply being disposed of by connecting it to ground via a resistor - a common trick with some other Spice simulators.

Other models had peculiarities, requiring tweaking to make them run. The AD845 model has a hyphen which causes difficulty because MicroCAP version 4 is written in C+.

Of ten Spice models tested, only five ran first time and plotted cmr. These were Analog Devices' AD811, 818, Burr-Brown's OPA27 and 604; and Linear Technology's LT1028. Burr-Brown had the best documentation - a booklet - while Analog Devices had the most models with cmr included.

Detailed examination of the different makers' models revealed behaviour that could trick the unwary. First, cmr can be 'tuned' way beyond its specifications by use of RC bridge values minutely offset from perfect matching. Second, tuning in this way reveals different ultimate depths and hf decay slopes. Few match the classical model⁷ of cmr decay with frequency - any more than the Audio Precision plots of Figs 4-20 do.

Thanks to Joe Buxton and other staff at Analogue Devices in the USA for guidance on Spice and cmr.

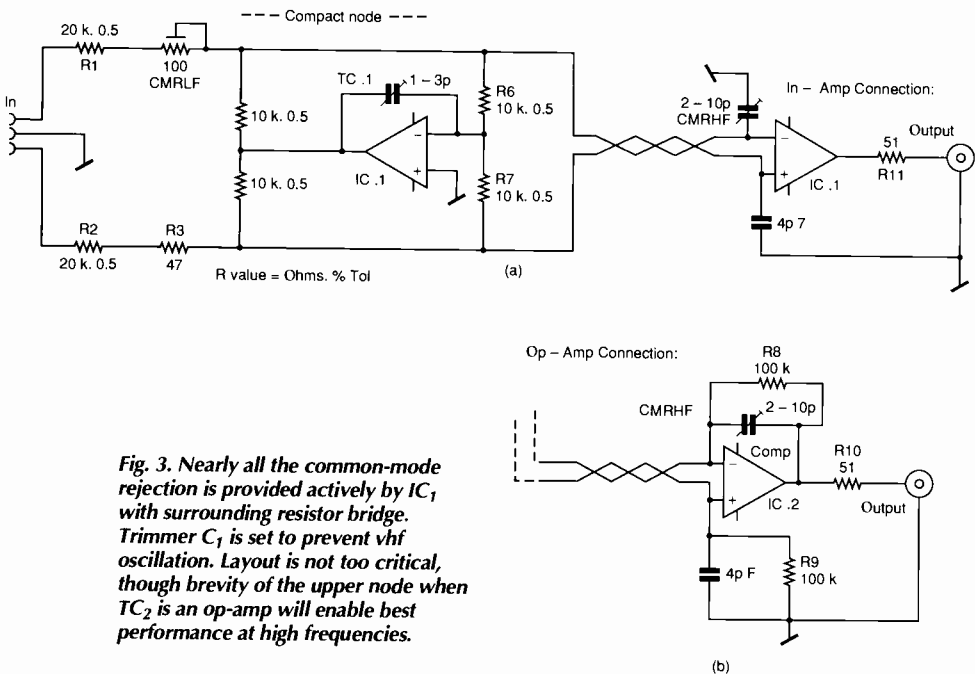

Fig. 3. Nearly all the common-mode rejection is provided actively by IC₁ with surrounding resistor bridge. Trimmer C₁ is set to prevent vhf oscillation. Layout is not too critical, though brevity of the upper node when TC₂ is an op-amp will enable best performance at high frequencies.

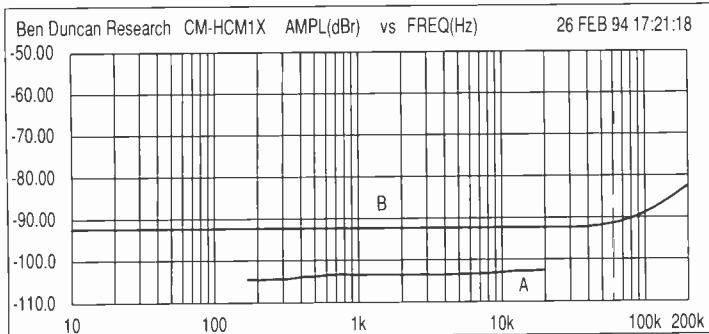

Fig. 4. Common-mode rejection for AD797 degrades above 500kHz, but the narrow-band plot does not show a corner.

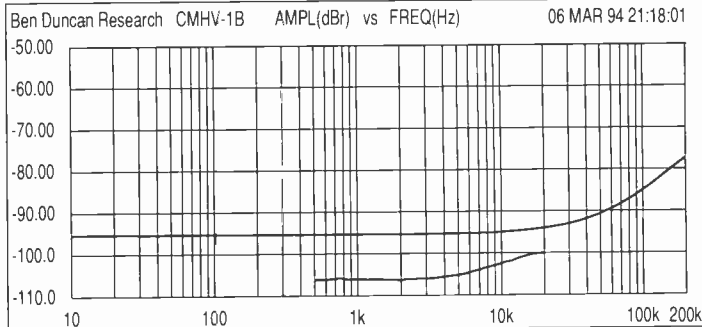

Fig. 5. For the LT1028, cmr degrades quite rapidly above 20kHz, while the narrow-band plot echoes this three octaves lower.

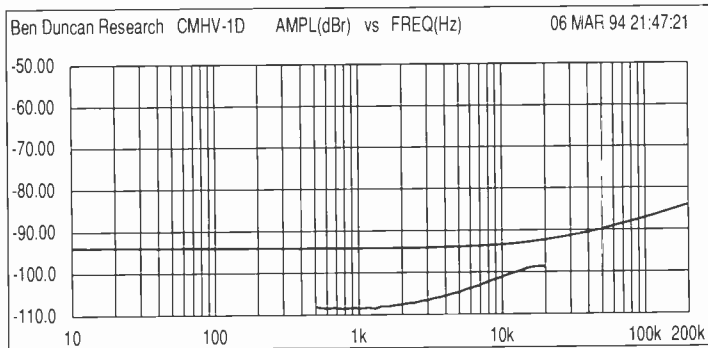

Fig. 6. Common-mode rejection of the SSM2016 audio in-amp degrades gracefully above 20kHz and is only 10dB worse at 200kHz. Its narrow-band cmr+n is one of the best but begins rising above 1kHz. Remember this device employs some current feedback.

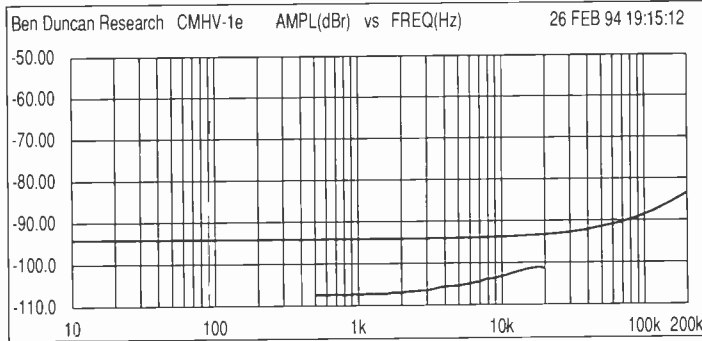

Fig. 7. Burr-Brown's INA03 in-amp combines aspects of the ICs in Figs 4 and 6.

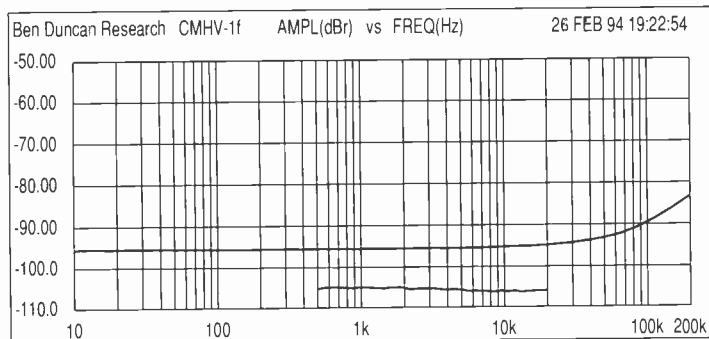

Fig. 8. Some current feedback is used in the SSM2017 audio IC. It performs similarly to the AD797 of Fig. 4 but with slightly more rapid cmr decay by 200kHz.

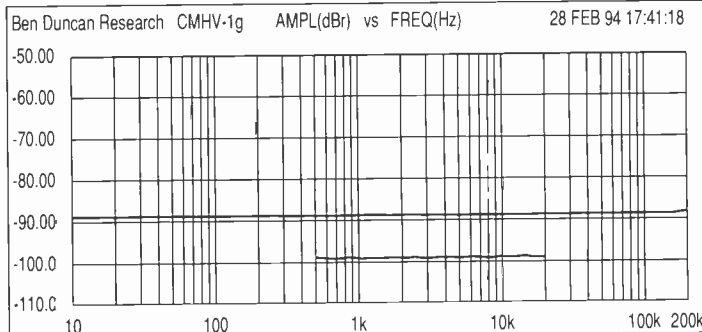

Fig. 9. The AMP05 in-amp has current feedback, and along with Fig. 10 displays joint widest cmr bandwidth before decay.

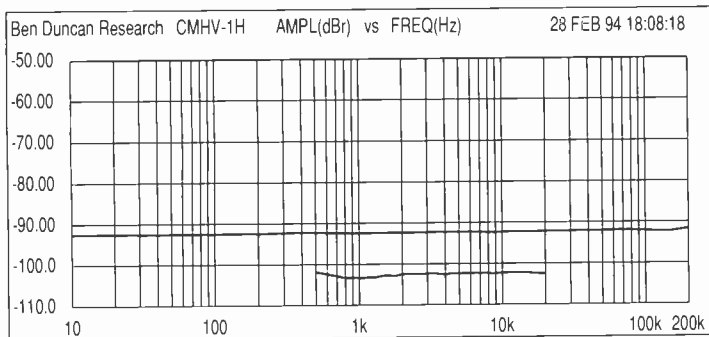

Fig. 10. Harris' HA5548 provides joint widest cmr bandwidth before decay. Compared to AMP05 in Fig. 9, its cmr+n is about 3dB better.

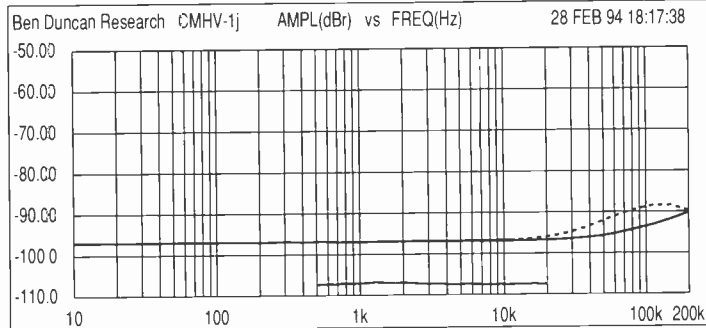

Fig. 11. One of the best combinations of low cmr+n and wide cm rejection bandwidth is provided by Harris's HA5137. The pair of hf variations show the typical effect (upper) of imperfect trimmer capacitor setting.

All upper graph curves relate to wideband cm rejection (10Hz to 200kHz).
 All lower graph curves relate to narrowband cm rejection: (400Hz to 22kHz). } Figs 4-14

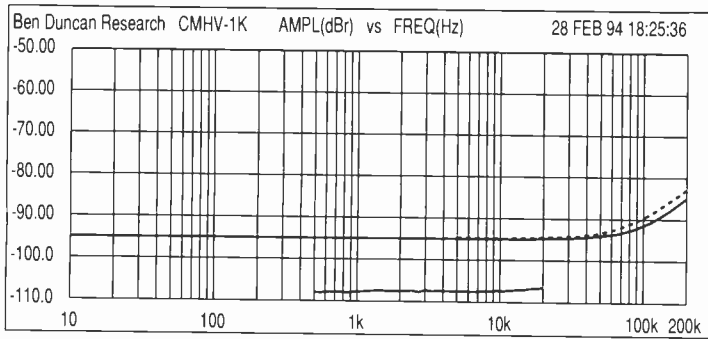

Fig. 12. The AD829 is similar to the AD797 but its cmr+n is a few decibels better.

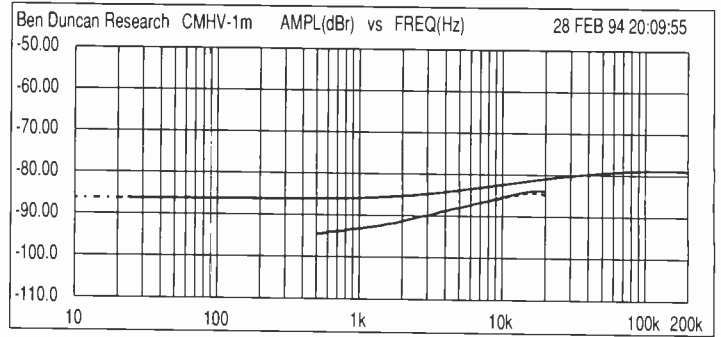

Fig. 13. The sole current feedback op-amp, the AD811 has a small but unusual cmr decay step at about 8kHz in the wideband plot. The poor cmr+n is degraded by noise as described in the text.

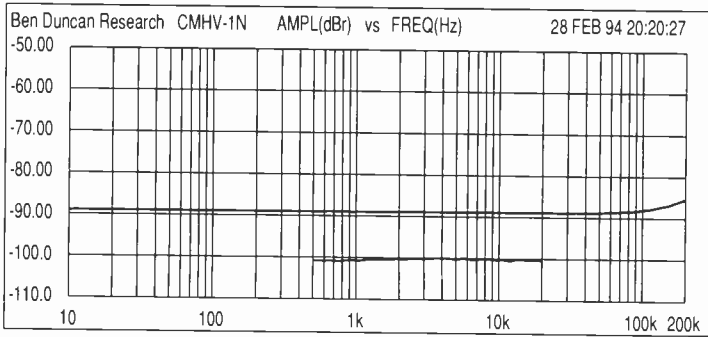

Fig. 14. In terms of cmr bandwidth before decay, the AD818 is second only to the HA2548 and AMP05. Its cmr+n on the other hand is intermediate.

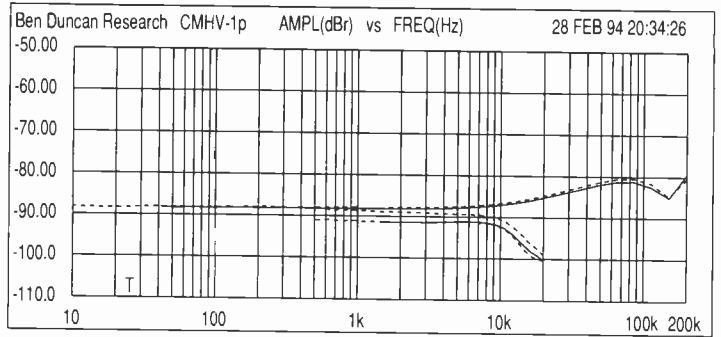

Fig. 15. Using AD797s in Fig. 2 test circuit, both narrow and wideband plots have similar cmr+n characteristics. At if they are about 3dB worse than the single AD797 in Fig. 4. Multiple plots with slightly varying trims of preset PR1, are shown. The hf inflexion can vary widely with PR2 setting.

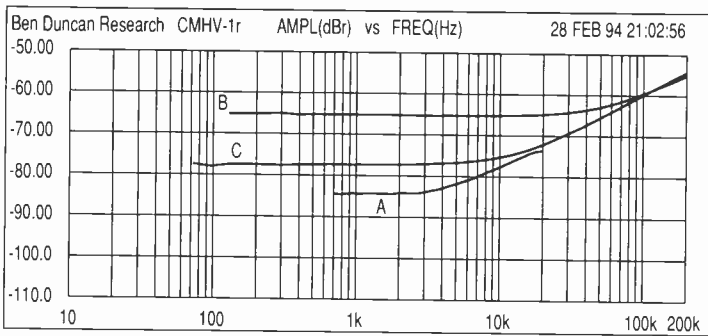

Fig. 16. Test circuit Fig. 2 with AD829s for three settings of PR2, (a-c). Op-amp compensation is not used. Cancellation is oddly poor at both lf and hf.

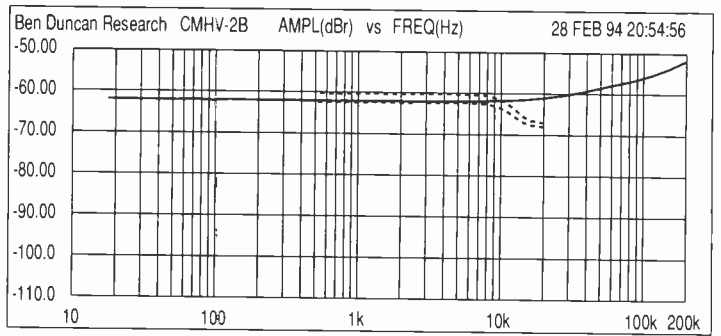

Fig. 17. Using HA2548s in Fig. 2 test circuit yields a poor cmr+n of only -60dBr (-26dBV). Two plots were made of the narrow-band response, which is no better than the wideband, signifying high cm and low 'n'.

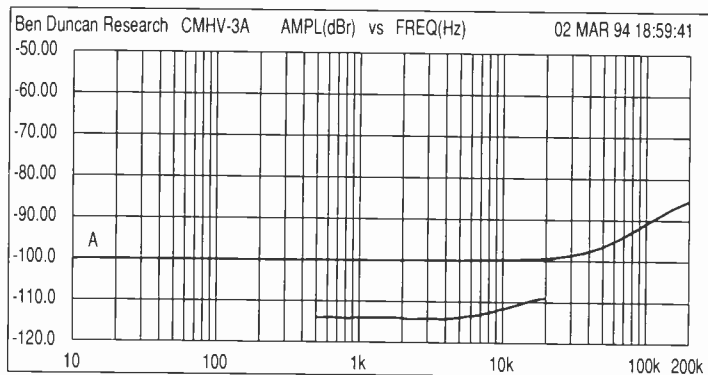

Fig. 18. Results from a Harris HA5137 with an SSM2017 in Fig. 3 test circuit. Compared to Fig. 11, noise is about 3dB lower, but cmr decays earlier, as you would expect.

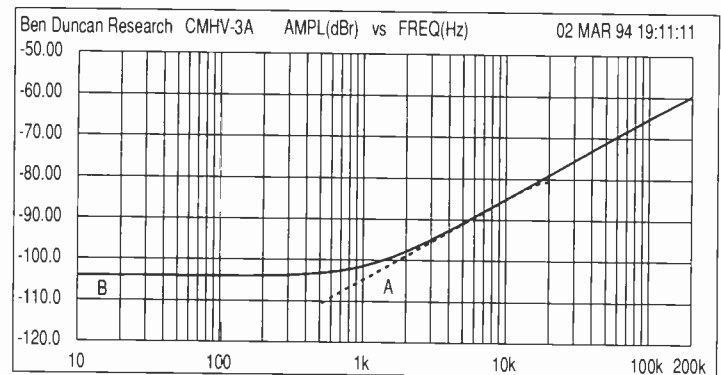

Fig. 19. With an AD797 and SSM2017 in Fig. 3, the null became very shallow. Narrow-band plot (A) is tangential to (B), the wideband. Note rapid cmr decay above 500Hz. In fact, cmr nulling was 'dulled' with the AD797, probably because of input parasitics. It remained so despite retrials.

Surplus always wanted for cash!

THE ORIGINAL SURPLUS WONDERLAND!

THIS MONTH'S SELECTION FROM OUR VAST EVER CHANGING STOCKS

Surplus always wanted for cash!

LOW COST PC's - ALL EXPANDABLE - ALL PC COMPATIBLE

THE OFFER OF 1994!

SPECIAL BUY

AT 286

40Mb HD + 3Mb Ram

PC SCOOP

COMPLETE

COLOUR SYSTEM

ONLY £99.00

A massive bulk purchase enables us to bring you a COMPLETE ready to run colour PC system at an unheard of price! The Display Electronics PC99 system comprises of fully compatible and expandable XT PC with 256k of RAM, 5 1/4" 360k floppy disk drive, 12" CGA colour monitor, standard 84 key keyboard, MS DOS and all connecting cables - just plug in and go!! Ideal students, schools or anybody wishing to learn the world of PC's on an ultra low budget. Don't miss this opportunity. Fully guaranteed for 90 Days.

Order as PC99COL £99.00 (E)

Optional Fitted extras: 640k RAM £29.00
2nd floppy drive, specify 5 1/4" 360k or 3 1/2" 720k £29.95
Above prices for PC99 offer ONLY.

VIDEO MONITOR SPECIALS

Superb quality 14" FOREFRONT MTS-9600 SVGA Multisync - Multimode monitor 0.28" dot pitch with resolution of 1024 x 768. The multi mode input allows direct connection to a host of computers including IBM PC's in CGA, EGA, VGA & SVGA modes, BBC, COM-MODORE (including Amiga 1200), ARCHIMEDES etc. The H version will also function with the ATARI in all modes inc HI RES monochrome. Complete with 'text' switching for WP use. Syncs down to 15 kHz

Supplied in EXCELLENT little used condition with full 90 day guarantee.
Order as MTS-9600/H for ATARI! £159.00 (E)
All modes as above Order as MTS-9600/S £139.00 (E)

ELECTROHOME ECM-1211SBU 12" VGA multisync monitor with resolution 640 x 480. Multi input selection; 9pin CGA/EGA; 15 pin VGA or 5 BNC connectors. 0.31 pitch. Compatible with PCs, Amiga, Atari and others. In good used condition (possible minor screen burns). 90 day guarantee. £99.00 (E)

KME 10" high definition colour monitors. Nice tight 0.28" dot pitch for superb clarity and modern styling. Operates from any 15.625 khz sync RGB video source, with RGB analog and composite sync such as Atari, Commodore Amiga, Acom, Archimedes & BBC. Measures only 13.5" x 12" x 11". Only £125 (E)

Good used cond tone. 90 day guarantee.
KME 10" as above for PC EGA standard £145.00 (E)
NEC CGA 12" colour IBM-PC compatible. High quality ex-equipment fully tested with a 90 day guarantee. In an attractive two tone ribbed grey plastic case measuring 15" x 13" x 12". The front cosmetic bezel has been removed for contractual reasons.
Only £49.00 (E)

20" 22" and 26" AV SPECIALS

Superbly made UK manufacture. PIL all solid state colour monitors, complete with composite video & sound inputs. Attractive teak style case. Perfect for Schools, Shops, Discos, Clubs, Point of Sale etc. In EXCELLENT little used condition with full 90 day guarantee.

20"....£135 22"....£155 26"....£185 (F)
9" Mono cased, Black & White for CCTV Used / Tested £49.00 (C)

DC POWER SUPPLIES

10,000 Power Supplies Ex Stock
Call for info / list

Power One SPL200-5200P 200 watt (250 w p.e.c.) Semi open frame giving +5v 35a, -5v 15a, +12v 4a (8a peak), -12v 1.5a, +24v 4a (6a peak). All outputs fully regulated with over voltage protection on the +5v output. AC input selectable for 110/240 vac. Dims 13" x 5" x 2.5". Fully guaranteed RFE. £85.00 (B)

Power One SPL130. 130 watts. Selectable for 12v (4A) or 24v (2A). 5v @ 20A, & 12v @ 1.5A. Switch mode. New. £59.95 (B)

Astec AC-8151 40 watts. Switch mode. +5v @ 2.5a, +12v @ 2a. -12v @ 0.1a, 6-1/4" x 4" x 1-3/4" RFE tested. £22.95 (B)

Lambda LVS-PV-12 200 watt switch mode +2V DC @ 29a semi enclosed. 10" x 5" x 5". RFE and fully tested. £59.95 (C)

Conver AC130. 130 watt hi-grade VDE spec. Switch mode. +5v @ 15a, -5v @ 1a, +12v @ 6a, 27 x 12.5 x 6.5cms. N.w. £49.95 (C)

Boshart 13090. Switch mode. Ideal for drives & system. +5v @ 6a, +12v @ 2.5a, -12v @ 0.5a, -5v @ 0.5a. £29.95 (B)

Farnell G6/40A. Switch mode. 5v @ 40a. Encased. £95.00 (C)

SPECIAL INTEREST

Zeta 3220-05 A0 4 pen HPGL RS232 fast drum plotter £210
Avitel VDA-3100 Video Distribution Amps. 1 in 92 out £575
Trio 0-18 vdc bench PSU. 30 amps. New £470
Fujitsu M3041 600 LPM band printer £2950
DEC LSV1102 CPU board £95
RED TOP IR Heat seeking missile (not armed!!) POA
Rhode & Schwarz SBUF TV test transmitter 25-1000mhz. £5995
complete with SBTFT Modulator £450
Caicom 1036 large drum 3 pen plotter £375
Thurby Lay LA 160B logic analyser £450
GEC 1.5kw 115v 60hz power source £550
Brush 2Kw 400 Hz 3 phase frequency converter £250
Anton Pillar 75 kW 400 Hz 3 phase frequency converter POA
Newton Derby 70 KW 400 Hz 3 phase frequency converter POA
Nikon PL-2 Projection lens meter/scope £750
Sekonic SD 150H 18 channel digital Hybrid chart recorder £1595
HP 7580A A1 8 pen HPGL high speed drum plotter £1850
Kenwood DA-3501 CD tester, laser pickup srm ulator £350
Computer MCA1613APC 16mm auto iris lenses 'C' mount £25
Seaward PAT 2000 dual voltage computerised PAT tester £585

LIMITED QUANTITY only of these 12Mhz HI GRADE 286 systems Made in the USA to an industrial specification, the system was designed for reliability. The compact case houses the motherboard, PSU and EGA video card with single 5 1/4" 1.2 Mb floppy disk drive & integral 40Mb hard disk drive to the front. Real time clock with battery backup is provided as standard. Supplied in good used condition complete with enhanced keyboard, 640k + 2Mb RAM, DOS 5.0 and 90 DAY Full Guarantee. Ready to Run!
Order as HIGRADE 286

ONLY £169.00 (E)

Optional Fitted extras: VGA graphics card £29.00
1.4Mb 3 1/2" floppy disk drive (instead of 1.2 Mb) £32.95
NE2000 Ethernet (thick, thin or twisted) network card £49.00

FLOPPY DISK DRIVES 3.5"- 8"

5.25" from £22.95 - 3.5" from £24.95

Massive purchases of standard 5.25" and 3.5" drives enables us to present prime product at industry beating low prices! All units (unless stated) are BRAND NEW or removed from often brand new equipment and are fully tested, aligned and shipped to you with a 90 day guarantee and operate from standard voltages and are of standard size. All are IBM-PC compatible (if 3.5" supported on your PC).

3.5" Panasonic JU363/4 720K or equivalent £24.95 (B)
3.5" Mitsubishi MF355C-L. 1.4 Meg. Laptops only * £36.95 (B)
3.5" Mitsubishi MF355C-D. 1.4 Meg. Non laptop £29.95 (B)
5.25" Teac FD-55GFR 1.2 Meg £29.95 (B)
5.25" BRAND NEW Mitsubishi MF501B 360K £22.95 (B)
* Data cable included in price.

Shugart 800/801 8" SS refurbished & tested £195.00 (E)
Shugart 851 8" double sided refurbished & tested £250.00 (E)
Mitsubishi M2894-63 8" sided switchable NEW £250.00 (E)
Mitsubishi M2896-63-020 8" DS slimline NEW £285.00 (E)

Dual 8" drives with 2 mbyte capacity housed in a smart case with built in power supply. Ideal as exterior drives! £499.00 (F)

HARD DISK DRIVES

End of line purchase scoop! Brand new NEC D2246 8" 85 Mbyte of hard disk storage! Full industry standard SMD interface. Ultra hi speed data transfer and access time, replaces Fujitsu equivalent model. Complete with manual. Only £299.00 (E)

3.5" FUJII FK-309-26 20mb MFM I/F RFE £59.95 (C)
3.5" CONNER CP3024 20 mb IDE I/F (or equiv.) RFE £69.95 (C)
3.5" CONNER CP3044 40mb IDE I/F (or equiv.) RFE £99.00 (C)
3.5" RODIME R03085S 70mb SCSI I/F (Mac & Acom) £129.00 (C)
5.25" MINISCRIBE 3425 20mb MFM I/F (or equiv.) RFE £49.95 (C)
5.25" SEAGATE ST-238R 30 mb RLL I/F Refurb £69.95 (C)
5.25" CDC 94205-51 40mb HH MFM I/F RFE tested £89.95 (C)
8" FUJITSU M2322K 160Mb SMD I/F RFE tested £195.00 (E)
Hard disc controllers for MFM, IDE, SCSI, RLL etc. from £16.95

THE AMAZING TELEBOX

Converts your colour monitor into a QUALITY COLOUR TV!!

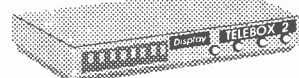

TV SOUND & VIDEO TUNER!

The TELEBOX consists of an attractive fully cased mains powered unit, containing all electronics ready to plug into a host of video monitors made by manufacturers such as MICROVITEC, ATARI, SANYO, SONY, COMMODORE, PHILIPS, TATUNG, AMSTRAD and many more. The composite video output will also plug directly into most video recorders, allowing reception of TV channels normally receivable on most television receivers (TELEBOX MB). Push button controls on the front panel allow reception of 8 fully tuneable 'off air' UHF colour television channels. TELEBOX MB covers virtually all television frequencies VHF and UHF including the HYPERBAND as used by most cable TV operators. A composite video output is located on the rear panel for direct connection to most makes of monitor. For complete compatibility - even for monitors without sound - an integral 4 watt audio amplifier and low level Hi Fi audio output are provided as standard.

TELEBOX ST for composite video input type monitors £32.95
TELEBOX STL as ST but with integral speaker £36.50
TELEBOX MB Multiband VHF-UHF-Cable-Hyperband tuner £69.95
For overseas PAL versions state 5.5 or 6mhz sound specification.
*For cable / hyperband reception Telebox MB should be connected to cable type socket. Shipping code on all Teleboxes is (B)

FANS & BLOWERS

MITSUBUSHI MMF-D6D12DL 60 x 25 mm 12v DC £4.95 10 / £42
MITSUBUSHI MMF-09B12DH 92 x 25 mm 12v DC £5.95 10 / £53
PANCAKE 12-3.5 92 x 18 mm 12v DC £7.95 10 / £69
EX-EQUIP 120 x 38mm AC fans - tested specify 110 or 240 v £6.95
EX-EQUIP 80 x 38mm AC fans - tested specify 110 or 240 v £5.95
VERO rack mount 1U x 19" fan tray specify 110 or 240V £45.95
IMHOF B26 1900 rack mnt 3U x 19" Blower 110/240v NEW £79.95
Shipping on all fans (A). Blowers (B). 50,000 Fans Ex Stock CALL

IC's TRANSISTORS DIODES

OBSOLETE - SHORT SUPPLY - BULK

5,000,000 items EX STOCK

For MAJOR SAVINGS - SAE or CALL FOR LATEST LIST

Issue 12 of Display News now available - send large SAE - PACKED with bargains!



LONDON SHOP
Open Mon-Sat 9:00-5:30
215 Whitehorse Lane
South Norwood
LONDON SE25

DISTEL © The Original
FREE On line Database
Info on 1000's of items
V21, V22, V22 BIS
081 679 1888

ALL MAIL & OFFICES
Open Mon-Fri 9:00-5:30
Dept WW. 32 Biggin Way
Upper Norwood
LONDON SE19 3XF

ALL ENQUIRIES
081 679 4414
FAX 081 679 1927



All prices for UK Mainland. UK customers add 17.5% VAT to TOTAL order amount. Minimum order £10. Bona Fide account orders accepted from Government, Schools, Universities and Local Authorities - minimum account order £50. Carriage charges (A)=£3, (AT)=£4.00, (B)=£5.50, (C)=£8.50, (D)=£12.00, (E)=£15.00, (F)=£18.00, (G)=CALL. Allow approx 6 days for shipping - faster CALL. Scotland surcharge CALL. All goods supplied to our Standard Conditions of Sale and unless stated guaranteed for 90 days. All guarantees on a return to base basis. All rights reserved on change prices / specifications without prior notice. Orders subject to stock. Discounts for volume. Top CASH prices paid for surplus goods. All trademarks etc acknowledged. © Display Electronics 1994. E & O E.

CIRCLE NO. 107 ON REPLY CARD

Common-emitter power amplifiers: a different perception?

Low voltage audio power amplifiers invariably deliver the output signal from a collector rather than emitter circuit to allow a larger output swing from a reduced supply voltage. Does this radical change in circuit topology affect the crossover characteristics... Indeed, does this represent a topology change at all?

Douglas Self examines the design issues.

When I read Michael William's intriguing article *Making a Linear Difference to Square-Law fets*¹, I was attracted by the prospect of applying it to an audio power output stage. I found the phrase "curvilinear class A" particularly appealing.

The basic concept of the difference-of-squares is not new, as several correspondents to *EW+WW* have pointed out.^{2,3} Another early reference (1949) to the quarter-squares principle can be found in the monumental MIT Radiation Lab series on radar techniques.

Mr William's basic circuit is shown in Fig. 1, and the first problem to overcome in applying it for audio power is that the wanted output is the difference of two currents whereas hard-bitten amplifier designers are more used to a low impedance voltage output. Note that with the usual enhancement-mode power fets, if V_1, V_2 are ac sources only, and carry no dc bias, then V_b will have to establish point M some volts below ground. No doubt something could be done with industrial-sized current-mirrors, but it struck me that the circuit

could be rearranged as Fig. 2, by making use of complementary devices. We now need two bias voltages V_{b1}, V_{b2} , and the positioning of the two signal sources V_1, V_2 on opposite rails looks a little awkward, but at least the current-difference will be mathematically perfect, if Kirchhoff has anything to say on the matter.

So far so good. We now have a single current output i_{out} . But is this any use for driving loudspeakers? I am assuming that current-drive of speakers is not the final goal; I appreciate that this can be made to work, and promises some tempting advantages in terms of reducing bass-unit distortion⁴. My immediate reaction to Fig. 2 was no, it can't work, because with a high impedance output, the output stage gain will vary wildly with load impedance making the amount of NFB applied a highly variable quantity. It would also appear that any capacitive loading of this high-impedance node would generate an immediate output pole that would make stable compensation a waking nightmare.

However... just as I was discarding the notion, it occurred to me that the structure in Fig. 2 looks very much like the bipolar common emitter (CE) stage in Fig. 3. This is widely used in low voltage op amps because the low saturation voltage allows a close approach to the rails⁵. The more usual emitter follower type of op amp output is usually called a CC or common-collector stage. It is highly probable that the widest application of these voltage-efficient CE configurations is in the headphone amplifiers of personal stereos.

At about the same time I encountered a paper by Cherry⁶ which pointed out that, so long as NFB is applied, the output impedance of such a stage can be as low as for the usual voltage follower type output. Cherry's paper is dauntingly mathematical, so I will summarise it thus. The vital point about using NFB to reduce the output impedance of an amplifier is

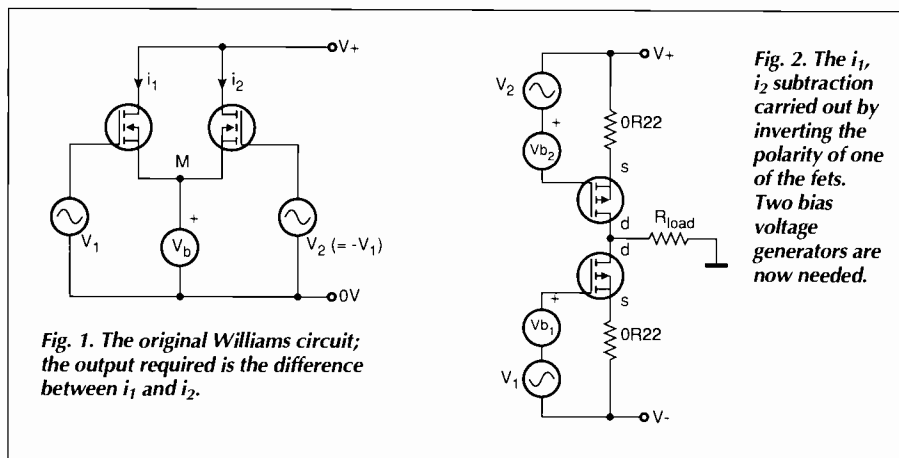

that the amount of NFB applied must be calculated assuming that the open-loop case is unloaded. This condition looks unfamiliar, because the average amplifier usually has a fairly low output resistance even when open-loop, due to its output follower configuration, and so the loaded/unloaded distinction makes only a negligible difference when calculating the reduction of output resistance by NFB.

Using this condition, Cherry shows that output impedance of a CE stage should be exactly equivalent to the usual CC stage, when the global NFB is applied. I appreciate that this result is counter-intuitive; it looks as though the current output version must have a higher output impedance, even with NFB, but it appears not to be so. Doubters who are unafraid of matrix algebra should consult Cherry's paper.

Topology to the test

Nonetheless, before reaching for the power fets, I felt the need for further reassurance that a CE output stage was workable. There are several low voltage op amps that use the CE output topology, so it seemed instructive to provoke one of these with some output capacitance and see what happens. A suitable candidate is the Analog Devices AD820, which has a BJT output stage looking like Fig. 3 and provides all you need for CE experimentation in one 8-pin package⁷.

My practical findings were that the op amp works well, and while THD may not be up to the very best standards, it was happy with varying load resistances, proved stable with capacitors hung directly on the output, and was relaxed about rail decoupling. Once again, so far, so good.

By this stage, the quarter-squares principle was slipping somewhat into the background. My attention was focusing on the possibilities of a BJT power output stage something like

Fig. 4, which shows the addition of drivers and emitter resistors to make the circuit more practical. A good output swing is facilitated by the inward-facing driver arrangement. In a conventional emitter follower output the need to leave the drivers room to work in further reduces output swing.

Fig. 4 could be configured into something like a normal Class-B amp, except that the novel use of a CE output stage would allow greater efficiency than usual because there would be the low $V_{ce(sat)}$ drops mentioned above. Also the crossover behaviour would presumably be different from a normal CC output, and quite possibly better, or at least more easily manipulated.

In a previous article⁸ I tried to demonstrate that for an amplifier in which all the easily manipulated distortion mechanisms had been suitably dealt with, the low frequency THD was below the noise when driving an 8Ω load... this without large global feedback factors: 30dB at 20kHz is quite adequate.

At high frequencies (say above 2kHz) the distortion is easily measurable, and almost all of it results from crossover effects in the output stage. Since NFB typically falls with frequency, these high-order harmonics receive much less linearisation. This is why any technique that promises a reduction in basic crossover nonlinearity is of immediate interest to those concerned with power amplifier design.

I began to think that Mr Williams had opened up a whole new field of audio amplification; each conventional CC output stage would have its dual in CE topology, perhaps with new and exciting characteristics.

The next stage of the investigation was more sobering. There was a familiarity about CE output stages. Readers old enough to recall paying 30 shillings for their first OC72 will recognise Fig. 5 as the configuration used

almost universally for low power audio output for many years when there was no such thing as a complementary device. Transformers provide one way to make a push-pull output. At first sight bias voltage V_b looks as if it will be far too low but bear in mind these are germanium transistors. Note the upside-down format of the circuit which is typical of the period. The circuit values are appropriate for an output of about 500mW.

While it is perhaps not obvious, this is the equivalent of Fig. 3. The need for an npn is

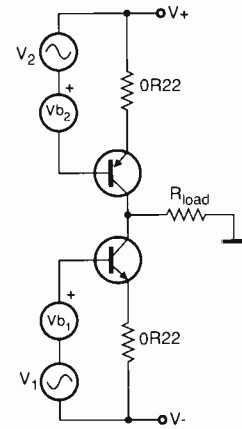

Fig. 3. The bipolar version of Fig. 2, as used in many low-voltage op amps and Walkman output amplifiers.

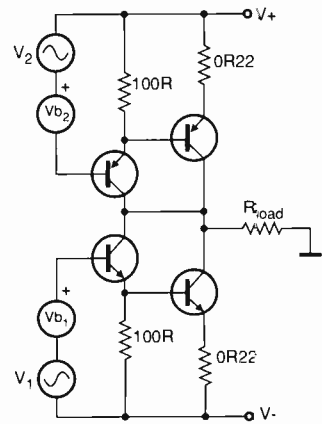

Fig. 4. A practical circuit based on Fig. 3. Drivers and emitter-resistors have been added.

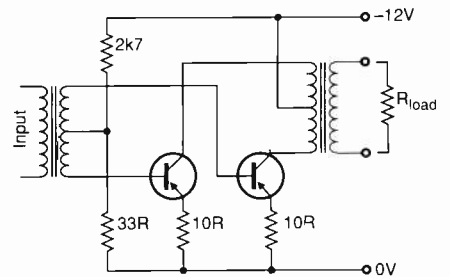
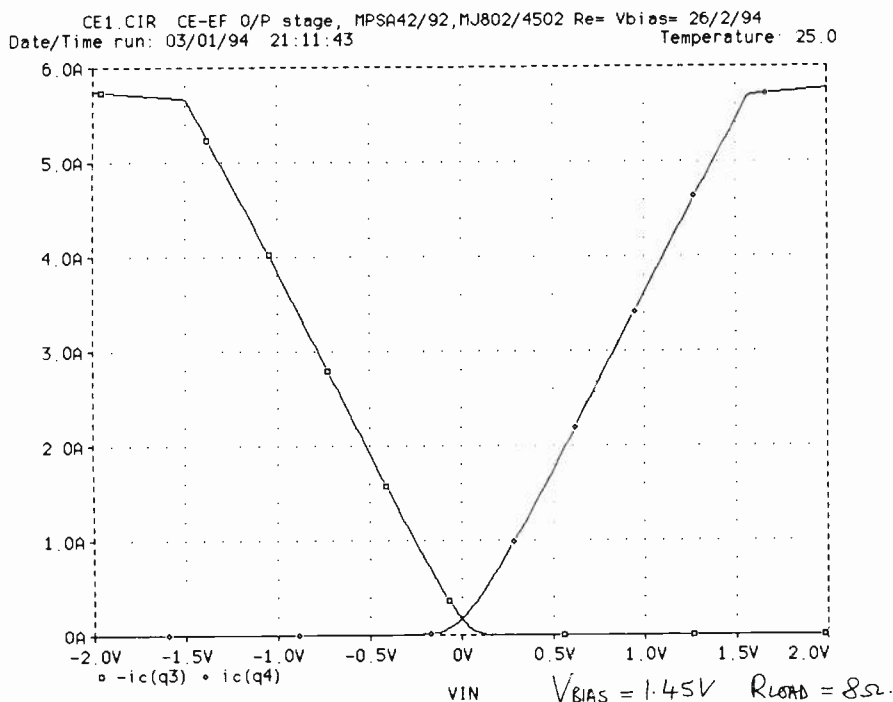

Fig. 5. A rather old-fashioned CE amplifier: the transformers are expensive but avoid the need for complementary devices.

Fig. 6. BJT Collector currents in Fig. 4 driving an 8Ω load.



avoided by using phase inversions in the transformers. So clearly CE output stages were not as rare and specialised as I thought; however they might still have handy distortion properties that were not obvious in the long-gone days of transformer coupling.

Adding Spice to the investigation

The next step was Spice simulation of the practical BJT output circuit in Fig. 4: Fig. 6 shows how the device currents vary in a relationship that looks ominously like classic Class-B... Somehow I was expecting more

overlap of conduction. The linearity results are presented in Fig. 7 as a plot of incremental gain versus output voltage for varying loads, as in the *Distortion In Power Amplifiers* series⁸.

The first obvious difference is that stage gain, instead of staying close to unity, varies hugely with load impedance – pretty much what we expect from a CE stage operating open-loop. Note that the X-axis is V_1 ($V_2 = -V_1$ to induce push-pull operation) and so represents the input voltage only rather than both input and output as before. Multiplying this input voltage by the gain taken from the Y-axis gives the peak output voltage swing. The vertical gain drop-offs that indicate clipping move inwards with higher load impedances because of the greater output gain rather than through any hidden limitation on output swing.

Fig. 8 shows the effect of varying the bias, and hence quiescent current, for an 8-Ohm load.

This circuit certainly works, but somehow the linearity results seem depressingly familiar. There is the same gain-wobble at crossover we have seen *ad nauseam* with CC output stages, and once again there is no bias setting that removes or significantly smooths it out. As before, the usual falling-with-frequency NFB will not deal with this sort of high-order distortion very effectively, leading to a rise in THD above the noise in the upper audio band.

In fact, the characteristics look so suspiciously similar to the standard emitter-follower CC stage, that it began to belatedly dawn on me they might actually be the same thing...

Fig. 9 shows the final stages of this conceptual hejira. 9a shows the simplified circuit of Fig. 3 with the power supplies V_+ , V_- included; they no doubt come from a mains transformer so we can float them at will, and it seems quite in order to pluck them from their present position and put them in the collectors of the output devices instead. All the other supplies shown are equally without ties forming an independent unit with the associated transistor and emitter resistor R_e . Thus they cannot effect device currents. Since there is only one ground reference in the circuit, it is also a legitimate gambit to put it wherever we like, which in this case is now the opposite end of the load R_L . (See reference 9 for another example of this manoeuvre). This gives us the unlikely looking but functionally equivalent circuit in Fig. 9b.

A purely cosmetic rearrangement of 9b produces 9c, which is topologically identical, and reveals that the new output stage is... a CC stage after all. Fig. 9d shows the standard output.

The only true difference between the “CE” stage and the traditional CC stage is the arrangement of the two bias voltages V_{b1} , V_{b2} . In a conventional CC stage, the output bases or gates are held apart by a single fixed volt-

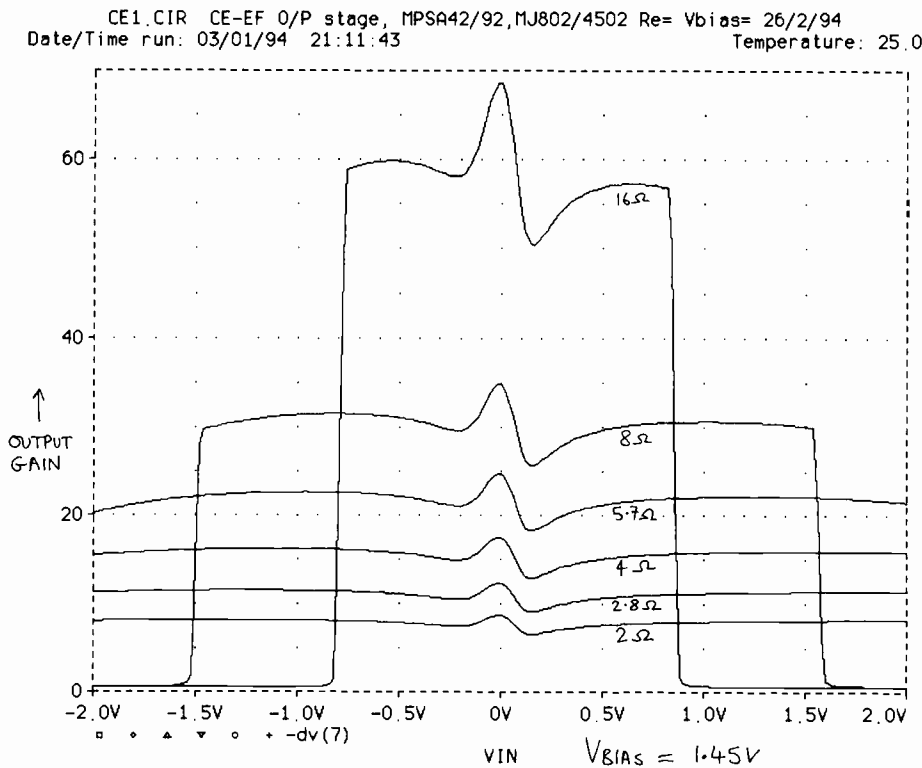

Fig. 7. Gain linearity of Fig. 4, various load resistances. (BJT)

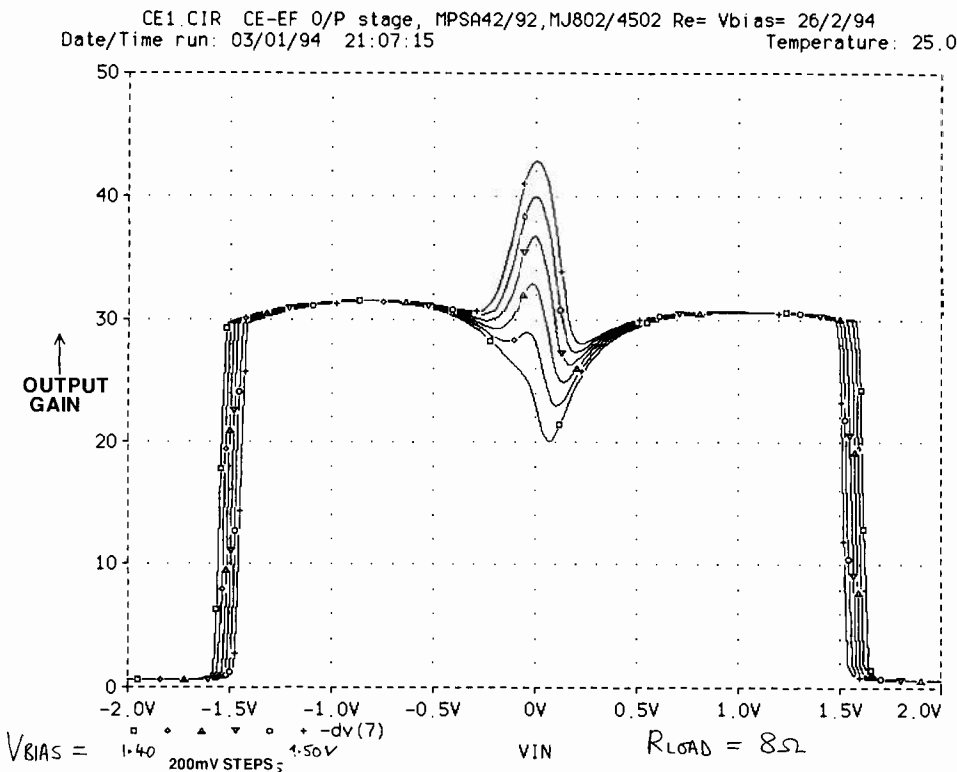

Fig. 8. Gain linearity of Fig. 4 for various bias voltages, load is 8Ω. (BJT)

Continued over page...

M & B RADIO (LEEDS)

THE NORTH'S LEADING USED TEST/EQUIPMENT DEALER

SIGNAL GENERATORS

MARCONI 2018 DKHZ TO 520MHZ SYNTHESIZED.....	£750
MARCONI 2008 DKHZ TO 520MHZ INC RF PROBE KIT.....	£300
MARCONI 2015/171 SYNCHRONIZER 10MHZ TO 520MHZ.....	£225
MARCONI 2016 DKHZ TO 120MHZ AM/FM.....	£200
MARCONI 2015 10MHZ TO 520MHZ AM/FM.....	£195
HP8683D 2.3GHZ TO 1.3GHZ OPT001/003 SOLID STATE GENERATOR.....	£4750
HP3336A SYNTHESIZER/LEVEL GENERATOR.....	£650
HP8640A 500KHZ TO 5.1MHZ OPT001.....	£550
HP8620C SWEEPER MAINFRAME (AS NEW).....	£300
HP8620C/86220A RF PLUG-IN 10MHZ TO 1300MHZ.....	£1200
HP8620C/86290B RF PLUG-IN 2GHZ TO 18.6GHZ.....	£2750
HP4204A 10KHZ TO 11MHZ OSCILLATOR.....	£250
FARNELL SSG52J 10MHZ TO 520KHZ SYNTHESIZED.....	£400
POLRAD 1106ET 1.8GHZ TO 4.6GHZ WITH MODULATOR.....	£400
GIGA GR101A 1.1GHZ TO 18GHZ PULSE GENERATOR (AS NEW).....	£750
SAYROSA MA30FREQUENCY OSCILLATOR 10HZ TO 0KHZ.....	£200
RHODE & SCHWARZ SMC1 4.8GHZ TO 12.6GHZ.....	£450
ADRET 20230A 1.1HZ SYNTHESIZED SOURCE.....	£195
HP8672A SYNTHESIZED SIGNAL GENERATOR 2GHZ TO 18GHZ.....	£6200
HP3586A SELECTIVE LEVEL METER 50HZ TO 32.5MHZ.....	£1850

SPECTRUM ANALYSERS

HP8903A 20HZ TO 100KHZ AUDIO ANALYSER.....	£3000
HP8565A 10MHZ TO 22GHZ SPECTRUM ANALYSER.....	£4250
B&K 2033 1HZ TO 20KHZ AUDIO ANALYSER.....	£2750
HP3581A WAVE ANALYSER 15HZ TO 50KHZ (AS NEW).....	£850
HP3582A 0.02HZ TO 25.5KHZ DUAL CHANNEL AUDIO ANALYSER.....	£3000
HP8588B 10MHZ TO 1500MHZ WITH 1821 MAINFRAME.....	£2000
HP141T 8552B/853B 10MHZ WITH 8443A TRACKING GENERATOR.....	£2000
HP141T 8552A/854B 100KHZ TO 1350MHZ (AS NEW).....	£1250
HP141T 8555A/852B 10MHZ TO 18GHZ SPECTRUM ANALYSER SUPPLIED WITH ADDITIONAL HP8553B 1KHZ TO 110MHZ RF PLUG-IN.....	£2000
HP8444A TRACKING GENERATOR OPT058.....	£1500
HP8553B 1HZ TO 110MHZ LATE MODEL ANALYSER PLUG-INS.....	£200
WAYNE KERR RM200 FREQUENCY RESPONSE ANALYSER.....	£400
HP3580A 5KHZ TO 50KHZ AUDIO ANALYSER.....	£1500
HP3581C SELECTIVE VOLT METER 15HZ TO 50KHZ.....	£750
TEXSCAN AL51 4MHZ TO 1000MHZ ANALYSER.....	£750
EATON 2075B NOISE GAIN ANALYSER 10MHZ TO 2GHZ.....	£2000

OSCILLOSCOPES

TEKTRONIX 24-5A 150MHZ 4 CHANNEL.....	£1550
TEKTRONIX 24-5 150MHZ 4 CHANNEL.....	£1300
TEKTRONIX 22 360MHZ 2 CHANNEL.....	£325
TEKTRONIX 22 560MHZ 2 CHANNEL.....	£400
PHILIPS 3305 35-MHZ DIGITAL STORAGE.....	£550
GOULD 5110 106MHZ INTELLIGENT OSCILLOSCOPE.....	£750
GOULD OS300 20MHZ 2 CHANNEL.....	£175
LEADER LB0524L 40MHZ DELAYED SWEEP.....	£325
TEKTRONIX SC41TMS01/DMS01 PORTABLE 80MHZ SCOPE/DVM.....	£600
TEKTRONIX 471 200MHZ DUAL TRACE.....	£400
TEKTRONIX 464 100MHZ DUAL TRACE.....	£345
TEKTRONIX 464-B 100MHZ OSCILLOSCOPE.....	£400
TEKTRONIX 464 100MHZ STORAGE.....	£395
HP1722B 275MHZ MICROPROCESSOR CAL MEASUREMENTS (AS NEW).....	£700

TEKTRONIX 7633 7A/7A1/3/7B53 200MHZ 4 CHANNEL STORAGE

TEKTRONIX 7603 7A/7A7A/7B53A 1GHZ OSCILLOSCOPE.....	£600
PHILIPS PM3217 5 IMP-Z 2 CHANNEL DELAYED TIMEBASE.....	£375
IWATSUI 55612 800-HZ 4 CHANNEL CURSOR READOUT.....	£900
KIKUSUI C04100 120MHZ 5 CHANNEL.....	£500
NICOLET 4094A DIGITAL OSCILLOSCOPE (TO CLEAR).....	£250
GOULD OS400 10MHZ DIGITAL STORAGE.....	£195
GOULD OS250B 15MHZ 2 CHANNEL.....	£95
TEKTRONIX 7104 7A1/3/7A2/7B1/53A 1 CHANNEL.....	£500
TEKTRONIX 5103-NS/5101NS/5A20NS/5A20NS OSCILLOSCOPE.....	£250

TEST EQUIPMENT

TEKTRONIX 521F PAL VECTOR SCOPE.....	£750
TEKTRONIX 1411 PAL GENERATOR SPG11/TSG11.....	£1750
SYSTEMS VIDEO 2344 COMPONENT VIDEO GENERATOR.....	£1500
PHILIPS PM5567 PAL VECTOR SCOPE.....	£750
HP5005A SIGNAL RESOLUTION METER.....	£495
BRUEL & KJAER 2-111 VIBRATION METER.....	£750
BRUEL & KJAER 2-103 98-DIGIT SINUSOID LEVEL METER/80812.....	£450
FILTER.....	£450
BRUEL & KJAER 1-922 3-BEAT FREQUENCY OSCILLATOR.....	£400
BRUEL & KJAER 4-199 FREQUENCY RESPONSE ANALYSER.....	£250
BRUEL & KJAER 2-105 LEVEL RECORDER.....	£225
EFRATRON FRT ATOMIC FREQUENCY STANDARD.....	£2500
HP3779A PRIMARY MULTIFLEX ANALYSER.....	£600
HP3780A PATTERN GENERATOR/ERROR DETECTOR.....	£350
HP3762A DATA GENERATOR.....	£350
HP3468D DIGITAL MULTIMETER LCD.....	£400
HP3463C DIGITAL MULTIMETER LCD.....	£150
HP8750A STORAGE NORMAUSER.....	£395
HP8405A VECTOR VOLT METER & ACCESSORIES 1000MHZ.....	£650
SIEMENS 2323 PSOPHOMETER (NEW).....	£500
SIEMENS 23108 LEVEL METER 200HZ TO 30MHZ.....	£400
SIEMENS 27108 LEVEL OSCILLATOR 30MHZ.....	£650
WANDEL & GOLTJERMAN SP19 LEVEL METER 10HZ TO 25MHZ.....	£650
WANDEL & GOLTJERMAN P5519 LEVEL GENERATOR 25MHZ.....	£650
SAYROSA AMH AUTOMATIC MODULATION METER 2GHZ.....	£200
BRUEL & KJAER 2425 ELECTRONIC VOLT METER 0.5HZ TO 500KHZ.....	£195
DRANETZ 526A MAINS DISTURBANCE ANALYZER FITTED WITH 6036 INTERFACE/6002A dc monitor/6001 line analyzer/6006 ac monitor/6020 broadband rf monitor.....	£1250
SCHLUMBERGER 7702 DIGITAL TRANSMISSION ANALYSER.....	£1250
MARCONI 6950/6910 POWER METER 10MHZ TO 28-GHZ.....	£850
MARCONI 4593A VSWR INDICATOR.....	£495
HP432A/479A RF POWER METER 10MHZ TO 10GHZ.....	£400
HP435A/8427B RF POWER METER TO KHZ TO 4.2GHZ.....	£650
HP435B/8427A RF POWER METER 100KHZ TO 4.2GHZ.....	£850
HP435B/841A RF POWER METER 10MHZ TO 18GHZ.....	£1000
HP436A DIGITAL POWER METER.....	£650
HP8447D AMPLIFIER 0.1MHZ TO 1300MHZ.....	£500
HP432A CRYSTAL DETECTOR.....	£150
SCD RF AMPLIFIER 10MHZ TO 1000MHZ 10 WATT 46dB.....	£1000
BIRD COAXIAL ATTENUATOR 500W 30dB.....	£200

BALLANTINE 6125C PROG TIME/AMPLITUDE TESTSET.....

HALCYON 500B/521A UNIVERSAL TEST SYSTEM.....	£500
AVO 810V1/2 AC/DC BREAKDOWN/POSITION TESTER.....	£300
MILTECH 5-33X-11 CALIBRATOR 1 HP355C/HP355D ATTENUATORS.....	£400
BIRD TENLINE 9343 100W 6DB ATTENUATORS (NEW).....	£100
BIRD TERMLINE 81B 80W COAXIAL RESISTOR.....	£85
NARDA 76W4 150W 6DB ATTENUATORS.....	£65
NARDA 30C1-30 DIRECTIONAL COUPLER 460MHZ TO 950MHZ.....	£100
NARDA 30C2 BI-DIRECTIONAL COUPLER 1GHZ TO 4GHZ.....	£150
MEMODPI 2-Phase Meter 1HZ TO 100KHZ (NEW).....	£150
IWATSUI 527104 10HZ TO 1000MHZ FREQUENCY COUNTER.....	£325
RACAL 900P MODULATION METER 30MHZ TO 1500PHZ.....	£275
RACAL 990M 50MHZ TIMER COUNTER.....	£95
RACAL 990M 50MHZ TIMER COUNTER.....	£145
RACAL 9911 10HZ TO 520MHZ FREQUENCY COUNTER.....	£150
RACAL 9911 10HZ TO 100MHZ FREQUENCY COUNTER.....	£300
RACAL DANA 1998 10HZ TO 1300MHZ FREQ/TIMER COUNTER.....	£500
RACAL DANA 9000 520MHZ MICROPROCESSING TIMER COUNTER.....	£250
RACAL DANA 6000 MICROPROCESSING DVM.....	£300
RACAL DANA 9303 TRUE RMS RF LEVEL METER.....	£700
RACAL DANA 488 IEEE STD BUS ANALYSER.....	£200
RACAL DANA 9102 RF MILLIVOLTMETER 10KHZ TO 500PHZ.....	£400
RACAL DANA 1002 THERMAL PRINTER.....	£150
RACAL 9088 TWO TONE GENERATOR SYNTHESIZED.....	£250
PHILIPS PM8252A DUAL PEN RECORDER.....	£295
DYMAR 20-5 AF POWER METER.....	£200
TEKTRONIX 328A VIDEO WAVEFORM MONITOR.....	£300
TEKTRONIX 338 LOGIC ANALYSER 32 CHANNEL 20MHZ.....	£400
TEKTRONIX 318 LOGIC ANALYSER 16 CHANNEL 30MHZ.....	£450
SIEMENS 2223 PSOPHOMETER (NEW).....	£500
SIEMENS 23108 LEVEL METER 200HZ TO 30MHZ.....	£400
SIEMENS 27108 LEVEL OSCILLATOR 30MHZ.....	£650
WANDEL & GOLTJERMAN SP19 LEVEL METER 10HZ TO 25MHZ.....	£650
WANDEL & GOLTJERMAN P5519 LEVEL GENERATOR 25MHZ.....	£650
SAYROSA AMH AUTOMATIC MODULATION METER 2GHZ.....	£200
BRUEL & KJAER 2425 ELECTRONIC VOLT METER 0.5HZ TO 500KHZ.....	£195
DRANETZ 526A MAINS DISTURBANCE ANALYZER FITTED WITH 6036 INTERFACE/6002A dc monitor/6001 line analyzer/6006 ac monitor/6020 broadband rf monitor.....	£1250
SCHLUMBERGER 7702 DIGITAL TRANSMISSION ANALYSER.....	£1250
MARCONI 6950/6910 POWER METER 10MHZ TO 28-GHZ.....	£850
MARCONI 4593A VSWR INDICATOR.....	£495
HP432A/479A RF POWER METER 10MHZ TO 10GHZ.....	£400
HP435A/8427B RF POWER METER TO KHZ TO 4.2GHZ.....	£650
HP435B/8427A RF POWER METER 100KHZ TO 4.2GHZ.....	£850
HP435B/841A RF POWER METER 10MHZ TO 18GHZ.....	£1000
HP436A DIGITAL POWER METER.....	£650
HP8447D AMPLIFIER 0.1MHZ TO 1300MHZ.....	£500
HP432A CRYSTAL DETECTOR.....	£150
SCD RF AMPLIFIER 10MHZ TO 1000MHZ 10 WATT 46dB.....	£1000
BIRD COAXIAL ATTENUATOR 500W 30dB.....	£200

BULK PURCHASE SPECIALS

BECKMAN DM110 DIGITAL MULTIMETERS WITH CASE/PROBES.....	£60
SOLARTRON 7045 HIGH SPECIFICATION BENCH DVM.....	£60
AVO 810V1 MULTIMETERS.....	£750
BIRD 43 THRU LINE WATT METERS.....	£75
SIEMENS PDRM82 PORTABLE LCD RADIATION METER (NEW).....	£45
EX GERMAN ARMY PORTABLE RADIATION METERS.....	£35

ALL PRICES PLUS VAT AND CARRIAGE · ALL EQUIPMENT SUPPLIED WITH 30 DAYS WARRANTY

86 Bishopgate Street, Leeds LS1 4BB
Tel: (0532) 435649 Fax: (0532) 426881

HEWLETT PACKARD Spectrum Analysers



HP 141T / 8555A 10 MHz to 18 GHz System
 Complete with 8552B IF Section
 High Sensitivity to - 125 dBm
 Resolve to 100 Hz
 Scan up to 8 GHz full screen
£1700.00

HP 141T / 8554B 100 KHz to 1250 MHz System
 Complete with 8552B IF Section
 High Sensitivity to - 122 dBm
 Resolve to 100 Hz
£1000.00

With the purchase of any of the above systems we will supply FREE of charge one HP 8553B 1 kHz to 110 MHz RF section. Normal retail price of £350.00.

All systems covered by 30 day warranty
 All prices plus Vat and carriage



M & B RADIO (LEEDS)

86 Bishopgate Street, Leeds LS1 4BB
Tel: (0532) 435649 Fax: (0532) 426881

CIRCLE NO. 108 ON REPLY CARD

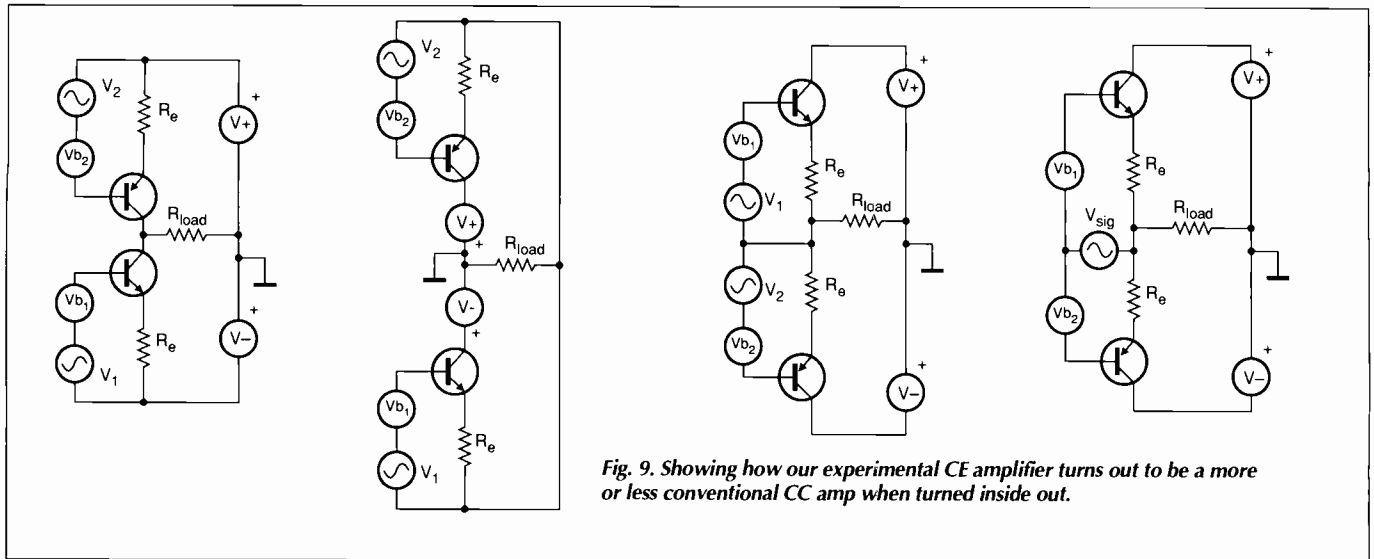

Fig. 9. Showing how our experimental CE amplifier turns out to be a more or less conventional CC amp when turned inside out.

age, shown here as V_{b1} and V_{b2} connected together. This rigid "unit" can be regarded as driven with respect to the output rail by the signal source V_{sig} , representing the difference between input and output of the stage. Normally, of course, it is more useful to regard the earlier circuitry as generating a signal voltage with respect to ground.

In contrast to Fig. 9d, Fig. 9c has two bias voltage generators, and the consequence of this is that voltage drops in the emitter resistors R_e are not coupled across to the opposite device by the bias voltage. This does not seem to offer immediately any magical stratagems for reducing the gain deviation around crossover, and creates the need for two drive voltages referenced about the output rail. This should be fairly easy to contrive, but is bound to be more complex than the traditional method.

Squaring the circle

Having gone through these manipulations, it is time to reconsider fets and the quarter-squares approach, knowing now that we are dealing with something very close to a standard power-amp configuration. To underline the point, Fig. 10 shows the gain characteristics for the circuit of Fig. 2, using 2SK135/2SJ50 power fets. Note the very close resemblance to a conventional source follower⁸.

As Mr Williams points out, the V_{gs}/I_d characteristic curve for power fets may follow a square law at low currents, but it is more or less linear at high ones, and this appears to rule out any simple approach to "curvilinear class A". For the fets I used, the "square law-ish" region is actually tiny, being roughly between 0 to 80mA which is of limited use for a power stage. In so far as second-harmonic cancellation occurs at all, it is in the crossover region where, without this effect, the central gain deviations would probably be greater than they are.

As I can see, the quarter-squares concept is already in use in most fet power amplifiers in heavy disguise but only operational in the crossover region. If this idea is to be pursued

CEFET.CIR CE O/P stage with power-FETs, 2SK135/2SJ50. Re=0R22 Vbias= 1/3/94
Date/Time run: 03/01/94 20:00:26 Temperature: 25.0

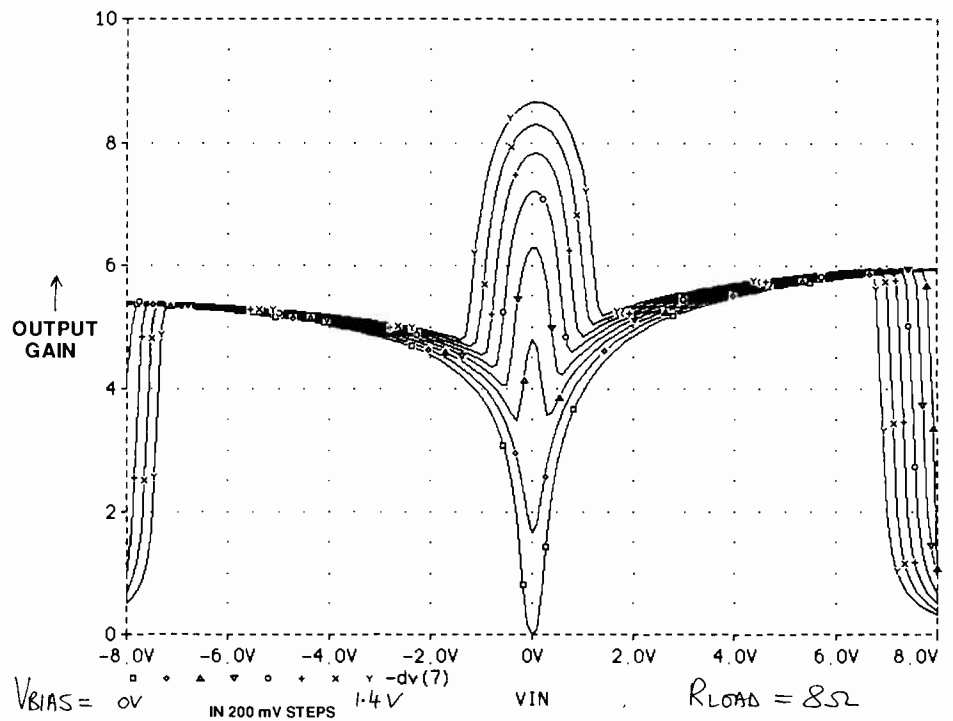

Fig. 10. The gain linearity of the fet circuit in Fig. 2 for various bias voltages. This looks very similar to a conventional source-follower output stage.

further, we need a true square-law output device. Since there is no such thing, it would need to be realised by some kind of law-synthesis circuitry. If amplifier distortion needs reducing below the tiny levels possible with relatively conventional techniques, there are probably better avenues to explore.

References

1. Williams, M, *Making a linear difference to square-law fets* EW+WW, Jan 94, p82.
2. Brown, S F, *Letters*, EW+WW, March 94, p247.
3. Owen, D, As 2.
4. Mills & Hawksford, *Transconductance*

5. Fonderie & Huijsing, *Design of Low-Voltage Bipolar Operational Amplifiers* Kluwer Academic Publishers 1993 Chapter 3.
6. Cherry & Cambrell, *Output Resistance & Intermodulation Distortion of Feedback Amplifiers* JAES Vol 30 #4, April 82
7. Jung & Wong, *High-Performance ICs in Single-Supply Analog Circuits*. Analog Dialogue #27-2 (1993) p16.
8. Self, D *Distortion in Power Amplifiers: Part 4* EW+WW, Nov 93, p932.
9. Baxandall, P *Symmetry in Class B* Letter, Wireless World Sept 1969, p416.

"... there is no doubt that running under *Windows* puts it ahead of the field and makes it a visually attractive package." **Electronics World + Wireless World July 1993**

High Quality PCB and Schematic Design for Windows 3/3.1 and DOS

- Supports over 150 printers/plotters including 9 or 24 pin dot-matrix, DeskJet, LaserJet, Postscript, and HPGL. Professional Edition imports GERBER files, and exports GERBER and NC-DRILL files.
- Up to 200,000 pads/track nodes depending on memory. Simple auto-router and schematic capture tools with SPICE compatible net-list output.
- Low cost DOS version (reduced features) also available. Ring for full details!

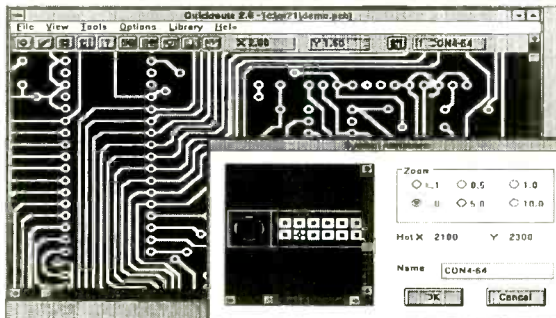

"Quickroute provides a comprehensive and effective introduction to PCB design which is a pleasure to use" **Radio Communication May 1993.**

Quickroute



POWERware, Dept EW, 14 Ley Lane, Marple Bridge, Stockport, SK6 5DD, UK.
Ring us on 061 449 7101 or write, for a full information pack.

Quickroute is available for Windows 3/3.1 in Professional (£99.00) and Standard (£59.00) editions, and for DOS with reduced features (£49.00). All prices inclusive. Add £5 P+P outside UK.

from
£49

CIRCLE NO. 109 ON REPLY CARD

**Z8 Z80 Super8
6502 65816
68HC11
68000...
8051...
and many more**

from only **£69**

COMPILERS
CROSS-
ASSEMBLERS
SIMULATORS

Call for data sheets

Tel: 081-441 3890
Fax: 081-441 1843



CIRCLE NO. 110 ON REPLY CARD

SYSTEM 200 DEVICE PROGRAMMER



SYSTEM: Programs 24,28,32 pin EPROMS, EEPROMS, FLASH and Emulators as standard, quickly, reliably and at low cost.

Expandable to cover virtually any programmable part including serial EEPROMs, PALs, GALs, EPLDs and microcontrollers, in many different packages.

DESIGN: Not a plug in card but connecting to the PC serial or parallel port; it comes complete with powerful yet easy to control software, cable and manual.

SUPPORT: UK design, manufacture and support. Same day dispatch, 12 month warranty. 10 day money back guarantee.



MQP ELECTRONICS Ltd.
Park Road Centre
Malmesbury, Wiltshire. SN16 0BX. UK
TEL. 0666 825146 FAX. 0666 825141

ASK FOR FREE INFORMATION PACK

IRELAND 1-2800395
GERMANY 089/4602071
NORWAY 0702-17890
ITALY 02 92 10 35 54
FRANCE 1 69 30 13 79
SWEDEN 08 590 32185
Also from ELECTROSPEED UK

CIRCLE NO. 111 ON REPLY CARD

ACQUIRING data from noise

Computerised data acquisition has never been simpler, with all manner of plug-in data acquisition boards available for the PC. Now, thanks to software packages designed to make these cards easy to use, a new term has entered the vocabulary – namely virtual instrumentation. Separate digital voltmeters and oscilloscopes are no longer needed. Sensors connect directly to the data acquisition card and facsimiles of hardware instruments present the measurement results on the vdu.

Virtual instruments are especially useful in laboratory type environments, where sensors are positioned within a few metres of the data acquisition card in a relatively benign electrical environment. However they are less useful in electrically noisy environments, such as a factory floor, where the sensor may be tens if not hundreds of metres from the computer. Used correctly, screened cables help, but they are by no means a complete solution.

The major problem in getting data from a remote sensor to your data logging station or computer is noise. From a practical point of view, noise can be divided into three rather loosely defined categories. These categories are, pickup, impulse noise and random noise.

Pickup is usually a narrow band interference mechanism. It is invariably due to ac power line inductive coupling. Impulse noise consists of very short duration, often very high amplitude spikes. These sometimes occur in bursts. Often these impulses are only microseconds in duration, but of sufficient amplitude to play

By the time it reaches a data-acquisition system, the signal from a remote sensor can be almost indistinguishable from the noise it picked up en route – particularly in an industrial environment. Dave Robinson looks at how such signals can be recovered.

havoc with any naively designed digital equipment. Random noise is just that, an amorphous mush that can completely swamp the signal that you are trying to observe.

Invariably all three types of noise are present to some degree. Basically, there are two ways of dealing with noise – one is to remove it, the other to avoid it. The first option includes algorithms designed to recover your signal once it has been contaminated with noise. This is obviously a not an ideal solution. However there are times when control of the noise is not in your hands.

Noise removal

All noise removal techniques are a compromise. They rely on redundant data which is used to estimate the wanted signal. These estimates are then used to reduce the noise.

With Shannon rate sampling, where data is sampled at the maximum theoretical rate, every sample represents new information. This makes noise removal techniques inappropriate and noise avoidance techniques are used instead.

It is however possible to obtain redundant information by over sampling the noisy signal. The more the signal looks like a slowly drifting dc level to your data acquisition system, the better chance you have of recovering useful information.

Basic statistics tell us that the signal-to-noise ratio can only be improved slowly. It goes up as the square root of the number of samples taken. Thus four independent samples of the same signal effectively halves the noise contamination, but 10,000 samples only reduces it by 100. From this basic rule of thumb you can roughly calculate the sample rate you will need to produce the quality of signal given a fixed degree of noise contamination.

Assume that you know that the maximum rate of signal you are looking for changes by an amount equivalent to the least-significant bit of your a-to-d converter in say T seconds. If your sample period is $N \times T$, the maximum theoretical improvement you can expect from any algorithm is \sqrt{N} . From this approximate analysis, and knowing the dynamic range required by your control process, you can identify the type of a-to-d converter your system requires, as described in the panel.

For demonstration purposes, the following algorithms are applied to the curve produced by a theoretical process **Fig. 1**. Before the algorithms are applied, this ideal curve is buried in noise, as in **Fig. 2**. Time would probably – but not compulsorily – be on the X axis. The Y axis could represent virtually any

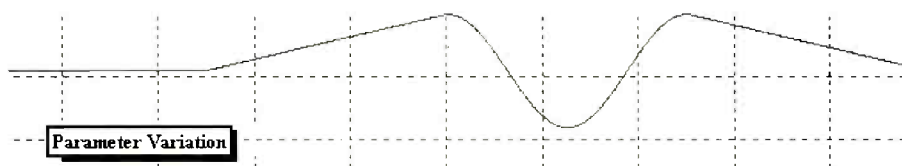

Fig. 1. Reference waveform – before noise is added – used to illustrate the various techniques of signal recovery.

parameter, for example voltage, temperature or even sugar concentration.

Waveform averaging

The simplest, and perhaps the most intuitive method of signal recovery is to find the average of a number of samples and use that as the estimate of the signal. Waveforms Fig. 3 shows this process in action. Each sample in these waveforms is simply the average of a block of fixed number of preceding samples.

It is clear that as the block length increases, so the noise level decreases. At the longest block length the data is almost as clean as the original. Be cautious however. Compare the pure original signal with the cleaned up version, Fig. 4. Note how it has been distorted. Although the problem looks simply like delay and attenuation, it is mathematically more complicated than this. The distortion is mathematically definable. It could be reversed, at least in theory, but such techniques are beyond the scope of this article.

Depending on the application, the distortion may be tolerable. But be careful if you are using the process within a feedback loop. Its apparent delay, or lag, could result in the control loop becoming unstable. This will result in the complete system oscillating, and in some circumstances lead to expensive damage to production machinery.

Although block averaging is fairly simple in concept, building a real-time implementation of the algorithm might not be so straightforward. Do you redo the complete average process for each new input sample? Or do you try to subtract the oldest value from the sum and add in the newest value? In either case a record has to be kept of the original block data samples. This is not so easy if you are using a small microcontroller with no external ram, particularly if you are trying to get a 100:1 improvement in signal to noise ratio.

As an alternative to block averaging, a running average can be used. Running averages are easier to compute. Exponential smoothing is perhaps the most common running average algorithm. It is an iterative algorithm which computes the following:

$$Y_{n+1} = Y_n - K(Y_n - \text{input})$$

Here Y_{n+1} is the estimate for the latest value. Y_n is the last sample estimate, variable *input* is the current input sample and K is some constant which is less than 1. Why it is called exponential smoothing when there is no exponential function in the equation can be explained by simply considering its response to be a step function. Assume that the original input has been zero, as is Y_n , and the input instantaneously steps up to one and stays there. Output from the algorithm for various values of K is shown in Fig. 5.

The curves are true exponentials whose time constant is controlled directly from the K value. Reducing the K value increases the time constant. The procedure is analogous to connecting a simple RC filter to a noisy electronic node in order to remove the noise. This

algorithm is the simplest form of recursive digital filter. Figure 6 shows results obtained from applying simple exponential smoothing to Fig. 2.

Predictors

Averaging can be considered as a limiting case of an algorithm known as a predictor. These use a block of data in order to predict what the next value will be. The averager models the data within its block as a simple dc level. As a result, the next value will be the average of the previous data points.

Predictors are classified in terms of orders. They attempt to model the data block in terms of a polynomial, and use a statistical mechanism such as least squares to find the best fit. The order of a predictor is simply the highest power of polynomial being used to model the data. Thus a linear fit $y=mx+c$ is a first order predictor. An averager $y=c$ is simply a zero order predictor.

Predictors do have problems. They have to be tailored for a particular task. As the predictor's order increases, so its ability to remove noise diminishes. This is illustrated by

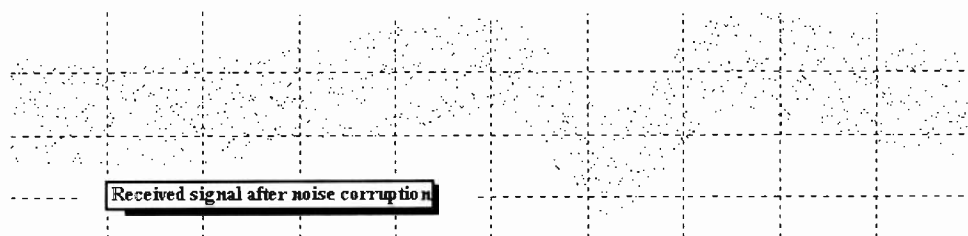

Fig. 2. In passing from a remote sensor to a data acquisition board, the reference signal of Fig. 1 would pick up noise. Before the signal can be analysed on computer, it needs to be recovered from the noise.

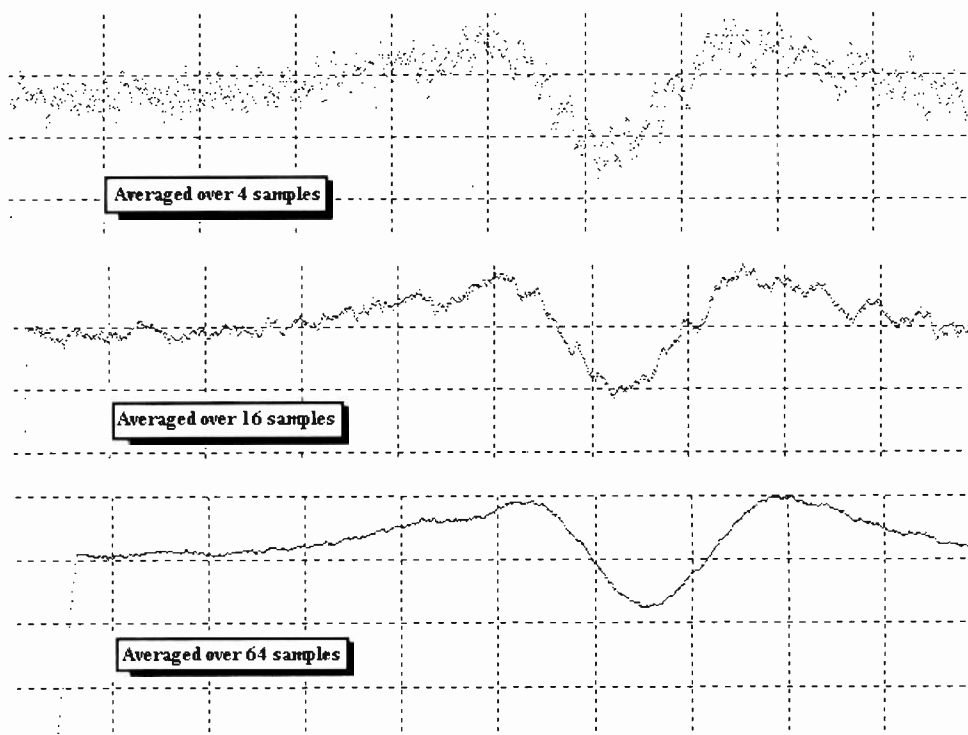

Fig. 3. Using averaging to recover a signal from noise, apparent quality of the recovered signal improves as the number of samples increases. But the results can be misleading.

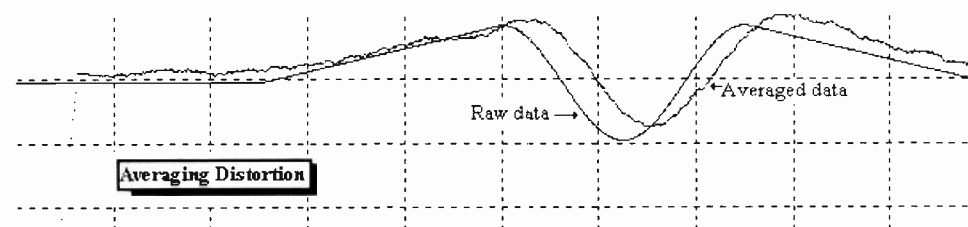

Fig. 4. Although the signal recovered using averaging and a high sample rate looks clean, it suffers from distortions that can cause problems, for example, if the measurements are used to determine feedback in a control loop.

considering, say, a 16th order predictor running with a block of 16 previous data values. An exact polynomial fit can be made to the data, noise and all – which is useless.

The higher the predictor's order, the more independent parameters the predictor is trying to estimate from the same data. An averager is only producing one value – the average – whereas a first order predictor needs to determine the offset and slope from the same data. The result must be inherently more noisy.

Predictors offer an advantage in that the data being extracted from the noise is probably going to be moving. This means that a polynomial model is likely to be a closer fit than a model that suggests that the data is a simple dc level. Consequently the apparent phase shift shown by an averager is a good deal less noticeable using a higher order predictor, and it is less susceptible to closed control loop oscillation.

More powerful statistics can be used to enhance the signal-to-noise ratio. For example the value of slope and offset computed at each new data sample can be averaged. Predictors can be made to react almost instantaneously to drastic changes in input signal. This is accomplished using statistical decision theory.

If you have calculated the optimum parameters for your model using data within the buffer, you can also calculate how far each data point is adrift from that model. In other words you have a measure of the local signal-to-noise ratio. By comparing the current predicted value with the latest sample, a decision can be made as to whether the current data point belongs to the rest of the distribution within the buffer. If it is, the prediction is output, maintaining the smoothed data output. If not, the actual value is output, and the contents of the predictor buffer can be deleted since the

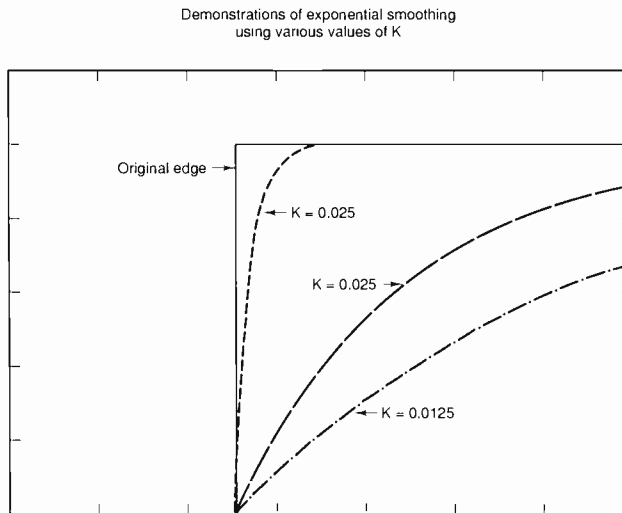

Fig. 5. In an averaging signal recovery filter with exponential smoothing, quantity K control the time constant directly.

previous value is no longer valid, and a discontinuity has occurred. The signal-to-noise ratio will return to its raw state until the predictor has gained sufficient data to be able to start making sensible estimates once more.

Figure 7 shows results from a simple first order predictor, using a 64 sample buffer and both slope and offset smoothing, applied to the sample noisy waveform. Note that the resulting waveform is not as smooth as the straight forward averager of similar buffer length. However the fit to the raw data is far better.

A priori knowledge

Methods described so far are recommended if and when you have no information regarding the distribution of the incoming data stream. If certain aspects of the data's distribution are known, they can be used to produce remarkable signal recoveries. What form this knowledge is in, or how it is best used, depends on the situation.

For example, suppose that the waveform being recovered is repetitive. Ideally its repetition frequency is known. It is not necessary to know the actual phase information. If you take a sample at a given time after the encoder synchronisation pulse, then you can expect to get the same value at the same point after the next pulse. Any discrepancy is due to the noise corruption on the signal.

Imagine setting up a number of averagers, or exponential smoothers evenly distributed throughout the repeat cycle. These would simply average out the noise and find the true value of the signal at that phase position. By sequentially interrogating these averagers, you can build up a very good picture of the underlying waveform.

Figure 8 shows how effective techniques like this can be. The signal is as used previously, but this time replicated to form the repeating waveform. It is buried in far more noise than was used in the previous examples, so much so that the underlying waveform is undistinguishable.

Each cycle is split into 256 points, and each point is equipped with its own exponential smoother with weight $K=1/64$. After running the system for a short time its output settles down to an equilibrium position as shown. The original waveform is almost completely recovered.

In this particular example we have two pieces of information, namely that the waveform is repetitive and its repetition frequency. Even if the repetition frequency is not known, all is not lost. There are signal processing techniques, such as auto-correlation, which allow you to determine repetition frequency, enabling the previous technique to be used.

A word of warning

Invariably, corruption of data by noise is mod-

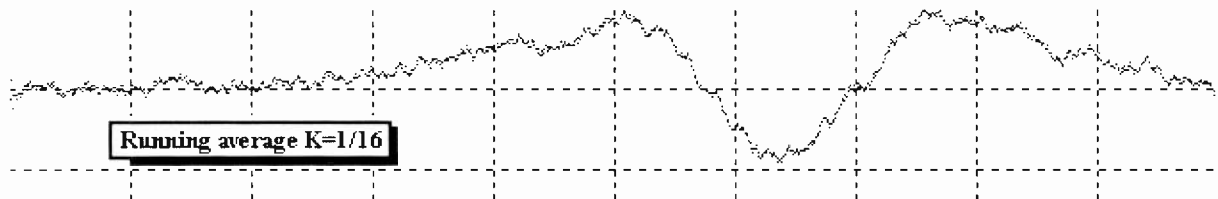

Fig. 6. Exponential smoothing is the most common running average algorithm used to recover a signal from noise. The procedure is analogous to adding an RC filter to remove the noise.

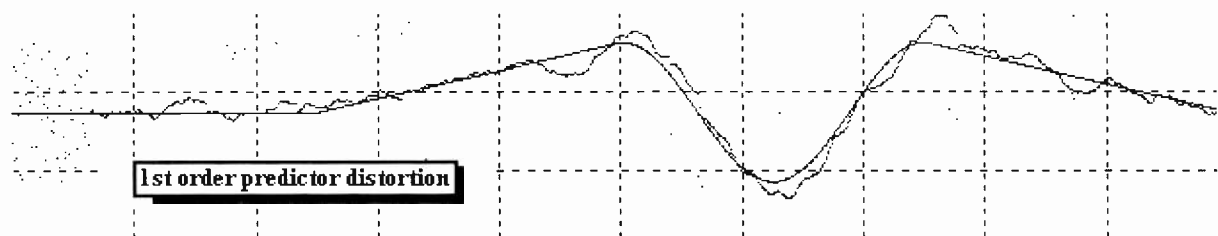

Fig. 7. Compared with an equivalent averaging filter, the simple first-order predictor produces a less smooth output but the overall fit with the original signal is much better.

elled as a linear process. The noise and the signal are viewed as two separate entities and are combined by arithmetical addition. Under these circumstances the processes described above work well.

However beware of multiplicative noise corruption. This is where noise and the signal are multiplied together. Under these circumstances the techniques mentioned no longer work. Multiplicative noise corruption can occur in many places. In data-acquisition systems, the most common sources are noisy illumination systems in optical sensors. Here, output from the sensor is the product of the reflectance of the object multiplied by the illumination. Similarly noisy excitation of resistive sensors can be a problem.

Output voltage from such sensors is the product of device resistance and excitation current. Removing the effect of such corruption is not easy, so make sure that these nodes are given the respect they deserve. ■

Next month, David discusses the alternative to noise removal techniques, namely noise avoidance.

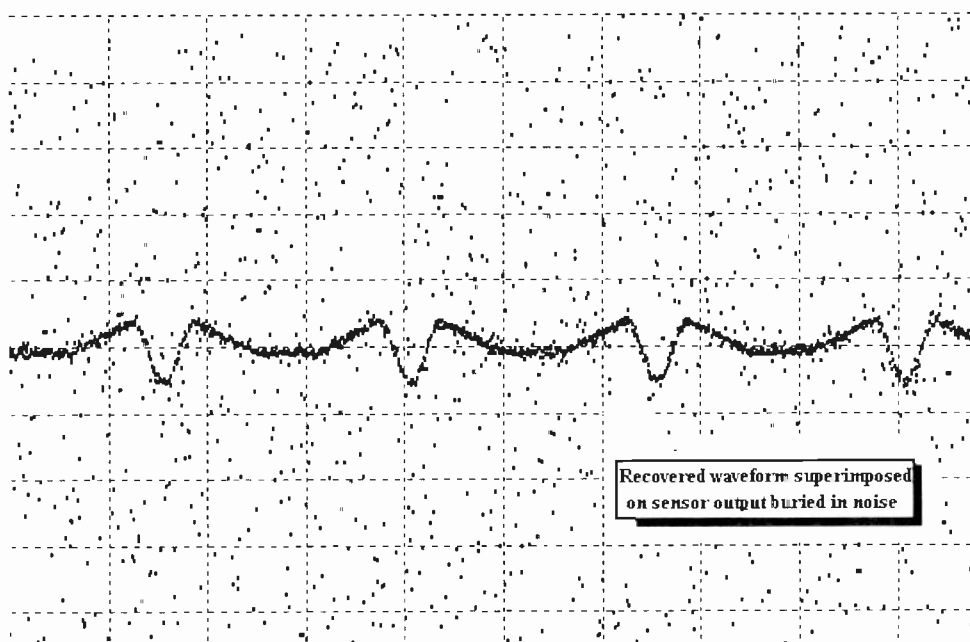

Fig. 8. If something is known about the original waveform, your chances of recovering it are much improved. This diagram shows a recovered signal superimposed on the noise that it was recovered from.

Analogue-to-digital conversion

Transducers monitoring real world parameters, for example temperature or strain, invariably produce an analogue output. In order to process such a signal digitally, it needs to be converted into a form that can be handled by a computer by an analogue to digital converter.

An analogue to digital converter, or ADC, is designed to produce a digital number approximating to the analogue input. Imagine taking a reading from a temperature sensor covering the 0 to 100°C. In theory, this thermometer could monitor any temperature within its range.

However the ADC splits the range into a finite number of steps. Combined, the thermometer and ADC are only capable of measuring discrete quantities, or quantization levels. It is the designer's task to ensure that the number of quantization levels provides adequate dynamic range for whatever their required task demands.

As is usual, trade offs have to be made. When designing analogue-to-digital converters, desirable parameters are high resolution, i.e. lots of quantization levels, high sampling rate and low cost.

There are several types of ADC. These include flash, half flash, successive approximation and charge integration types. The chart below shows how the important parameters are balanced for these four converter technologies.

Note how the number of quantization levels, or more conventionally the number of bits, is inversely related to digitisation rate. Commercially, ultra fast converters are normally only available with limited dynamic range. Similarly very accurate converters are only available with limited conversion speeds.

The question of conversion rate bears heavily on how the converter is connected to the input signal. Very fast converters only need a fast high quality amplifier. The speed of conversion is such that the input signal will have barely

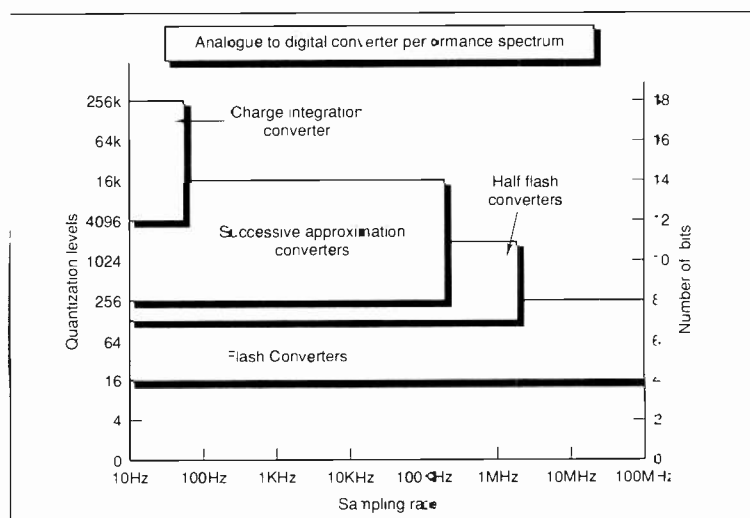

Fig. 9. Analogue-to-digital converters used for data acquisition are a compromise between resolution, cost and sampling rate capability.

moved during conversion.

For slower converters, this is no longer true. Input voltage needs to be frozen during the conversion period, otherwise the input signal may change appreciably during the conversion process. This wastes any advantage gained in the increased dynamic range of the slower converter.

A solution to this problem is to use a sample and hold circuit. The simplest form of sample and hold configuration comprises an RC circuit connected to the input signal via some form of switch. When the switch is closed, the capacitor rapidly charges up to the voltage at the input. When the switch is open, the voltage on the capacitor remains fixed while the conversion is completed, even though the input signal may change significantly.

POWERFUL SCHEMATIC CAPTURE, PCB DESIGN AND AUTOROUTING ALL FOR JUST £395...

PROPAK AR for DOS provides all the features you need to create complex PCB designs quickly and easily. Draw the circuit diagram using the powerful facilities of ISIS DESIGNER+ and then netlist into ARES AUTOROUTE for placement, autorouting and tidy up. Advanced real time design rule checks guarantee that the final PCB will correspond exactly with the schematic thus saving you from costly layout errors and time consuming debugging.

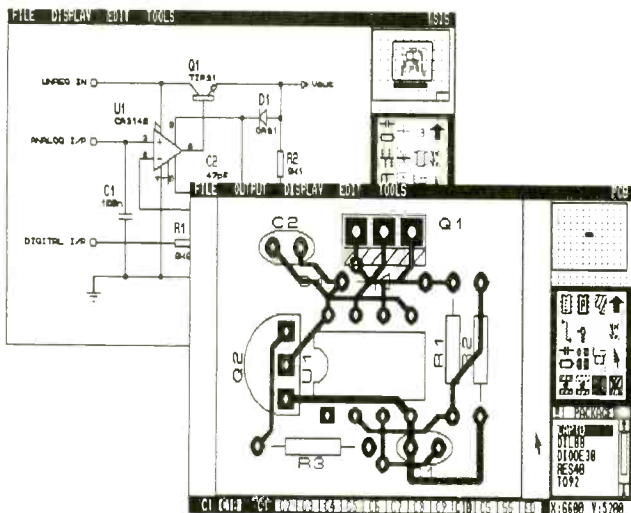

- Attractive, easy to use graphical interface.
- Object oriented schematic editor with automatic wire routing, dot placement and mouse driven place/edit/move/delete.
- Netlist generation for most popular CAD software.
- Bill of Materials and Electrical Rules Check reports.
- Two schemes for hierarchical design.
- Automatic component annotation and packaging.
- Comprehensive device libraries and package libraries including both through hole and SMT parts.
- User definable snap grids (imperial and metric) and Real Time Snap to deal with tricky SMT spacings.
- Manual route editing features include Auto Track Necking, Topological editing and Curved tracks.
- Autorouting for single, double and multi-layer boards.
- Non autorouting PROPAK is available for just £250 if you do not need or want the router.
- Full connectivity and design rule checking.
- Power plane generator with thermal relief necking.
- Graphics support to 800x600 Super VGA.
- Output to dot matrix and laser printers, HP and Houston plotters, Postscript devices, Gerber and Excellon NC machines plus DXF and other DTP file formats.

CADPAK

Two Programs for the Price of One

ISIS SUPERSKETCH

A superb schematic drawing program for DOS offering Wire Autorouting, Auto Dot Placement, full component libraries, export to DTP and much more.

**Only
£79**

Exceptionally easy and quick to use. For example, you can place a wire with just two mouse clicks - the wire autorouter does the rest.

PCB II

High performance yet easy to use manual PCB layout package. Many advanced features including curved tracks, auto track necking, DXF export, Gerber and NC file generation, Gerber viewing and more.

Alan Chadwick writing in ETI (January 94) concluded...
"At £79 I thought this was an excellent buy."

ISIS ILLUSTRATOR

Schematic Drawing for Windows

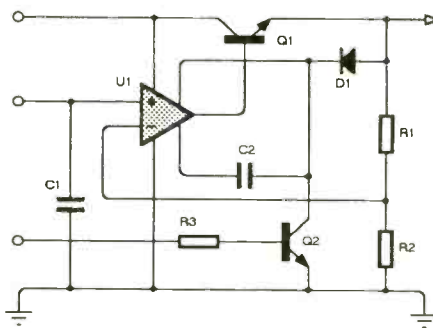

**From
£99**

Running under Windows 3.1, ISIS ILLUSTRATOR lets you create presentation quality schematic drawings like you see in the magazines. Furthermore, when the drawing is done, transferring it to another document is just a matter of pasting it through the Clipboard.

Now used by a number of prominent technical authors to illustrate their latest books and magazine articles.

Labcenter
Electronics



Call us today on 0756 753440 or fax 0756 752857 for a demo pack - state DOS or Windows. Multi-copy and educational discounts available.

WE HAVE MOVED - NOTE NEW ADDRESS

Prices exclude p&p (£5 for U.K.) and VAT. All manufacturers' trademarks acknowledged.

53-55 Main St, Grassington, North Yorks. BD23 5AA.

CIRCLE NO. 112 ON REPLY CARD

Graph plotting in Windows

Graphs are essential tools for conveying engineering and scientific information but producing them is tedious and time consuming. Not so, says Allen Brown, with this new plotting package.

Plotting data has never been easier than with PCs running under Windows. It is now common in engineering environments to see PCs with high resolution colour monitors, linked to laser printers. These standard tools, together with suitable software, make plotting an almost pleasant task.

The attractive features of Windows are its universal acceptance and dynamic linking facilities. In addition, its common user interface makes all Windows software look the same.

Most engineers now use word processors from time to time. Although many word processors include graph-plotting facilities, they tend to be rather limited in scope. This can result in the user wasting valuable time trying to fashion the supplied standard graphs into an acceptable format.

The alternative is to use a specialised graph plotting package that allows graphs to be imported into your favourite word processor.

A new graph plotting software package for Windows has recently been released by MicroCal Software of Massachusetts. Entitled *Origin*, it is a fully comprehensive graph plotting utility capable of producing both two and three-dimensional plots.

A remarkable feature of *Origin* is its high degree of control over the many display formats granted to the user. Also, the ease with which control can be exercised over the plotting formats is appealing.

User input is carried out via dialogue boxes that provide considerable choice of positioning, fonts, colour, scaling

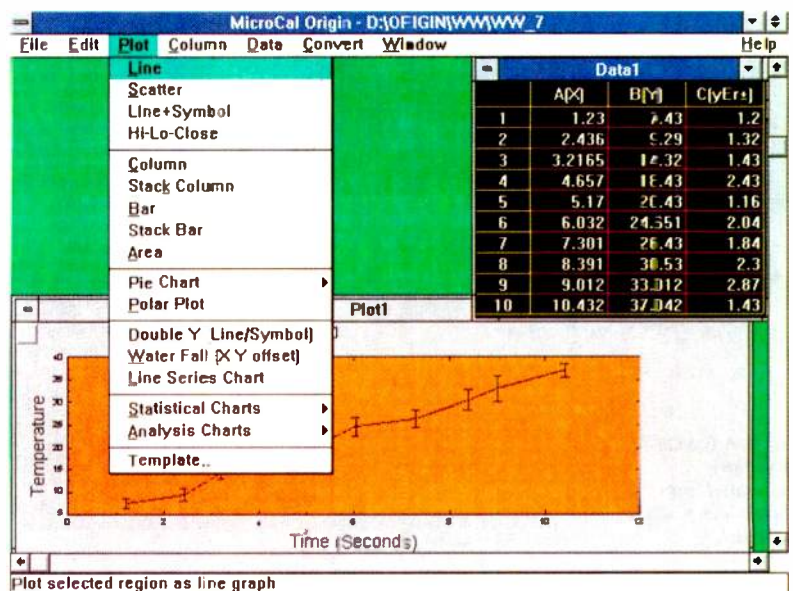

and plotting styles. Whatever feature is selected on a plot, a click with the mouse's right-hand button evokes the dialogue box associated with that feature. Each dialogue box contains numerous options for adjustment and display.

Part of the *Origin* package is a tutorial that will particularly benefit the new user in that it provides a good understanding of the mechanics of the software. Once *Origin* has been installed – a very easy task – the new user will find the *Getting started* section in the tutorial very useful. The tutorial exercises are well thought out, taking the new user through the majority of the features which the package has to offer.

One immediate feature which is very useful is the ease with which ascii data files can be imported. Even with files only having y axis data, the user is offered the choice of defining the x axis data and prompted for both starting point and increment. This is especially useful if the raw data has been obtained from an expansion card that only provides y data streams or batches.

Fig. 1. Error bars are a feature that graph-plotting programs usually find difficult. Not so Origin.

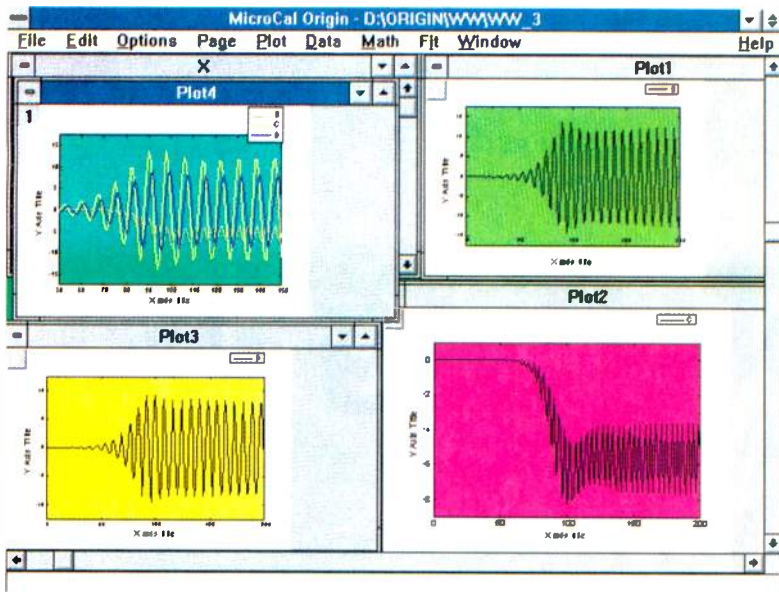
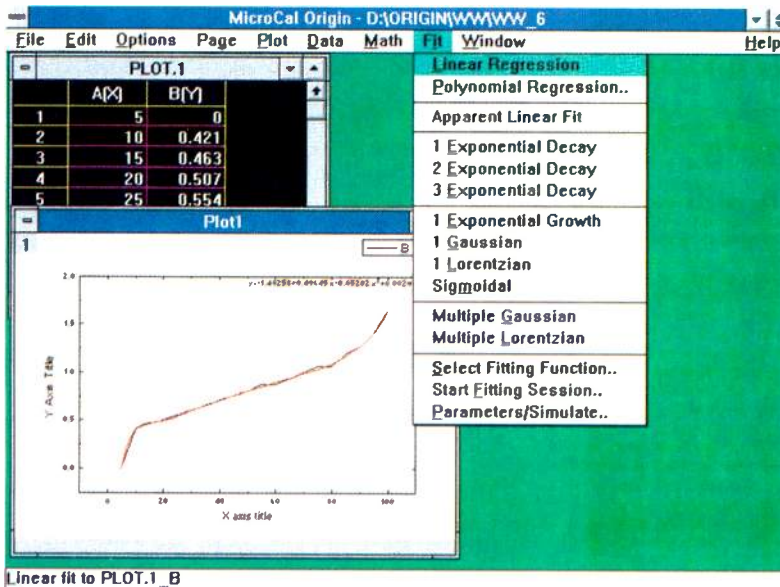

Fig. 2. From each worksheet, graphs can be created individually or displayed on the same graph.

Fig. 3. Origin offers a wide choice of curve fittings options. Most use the least-squares method

Fig. 4. A typical 3D trajectory generated from Origin – not overly impressive.



Dynamic linking

Data can be brought into the *Origin* window via the Windows dynamic linking facility from other concurrent software packages such as the spreadsheet *Excel*. This offers some exciting possibilities when using other data acquisition software.

An interesting feature of *Origin* is its error-bar capability. Scientists use error bars on their graphs but engineers rarely do. Including error bars has always been a problem for software displaying data graphically. With *Origin* however, error bars are very easily added to graphs. This is thanks to *Origin's* worksheet format.

Worksheets

When *Origin* starts up, a default worksheet is generated. It looks like a spreadsheet design with an array of cells. As data is imported into *Origin* it fills up the columns in the worksheet.

Graphs can be generated directly from the worksheet data. When error bars are needed, an extra column is produced – via a drop-down menu option. This column is dedicated to error bar, which are plotted at the same time as the worksheet data, Fig. 1. This display also shows the plotting options offered in the PLOT drop-down menu.

Imported data can be loaded directly into a worksheet or into a graph. From each worksheet, individual graphs can be created or alternatively the data can be displayed on the same graph as illustrated in Fig. 2.

By accessing the DATA option from the drop-down menu it is possible to generate a column of linearly increasing values. If need be these can be used to form the x axis. You can place, with ease, as many data columns in the same worksheet and they can be plotted as required.

Even if data is not available from an outside source it can be generated within *Origin* from the function-plot option. This can be displayed in either Cartesian or polar formats. Some elementary statistical processing can also be applied to each column or row.

This can provide information such as mean deviation, standard deviation and the result of t-testing. A further interesting feature of *Origin* is its ability to put several data plots in layers on top of each other and display them altogether. In addition, different axis limits can be attached to the top and right hand side of the graphs to show alternative scaling.

Several worksheets can be open at any one time. By using the Windows clipboard, data can be exchange between worksheets very easily. The worksheet also allows editing of the data values in each column – so

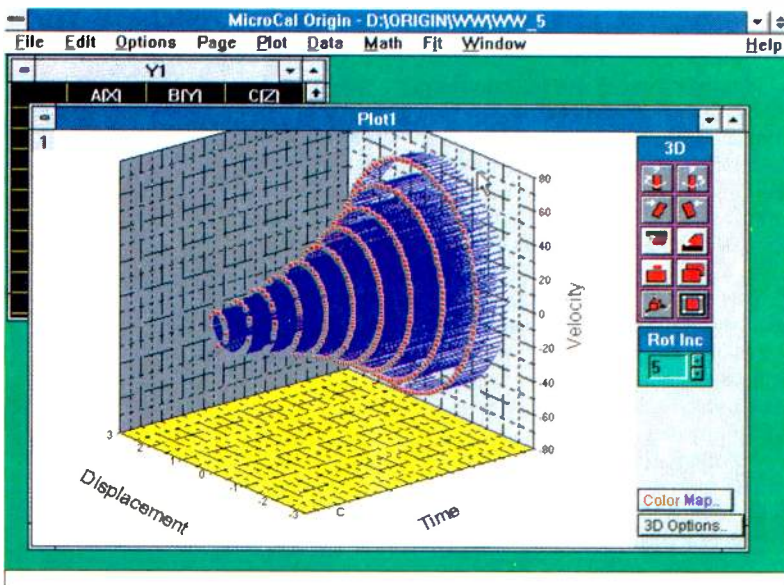

called data massaging. This feature should instantly endear *Origin* to statisticians working in the Treasury or Employment Department.

Templates

Many engineering and scientific tasks that need large amounts of data logging and plotting tend to be repetitive. With this in mind, *Origin* allows users to construct graphical templates.

Major features of templates – for example axis limits, scaling and labelling – remain fixed. Only the data plotting and possibly the legend will change from graph to graph.

This design feature would be very useful for proprietary graphs showing for example calibration and system performance for quality checking. A system performance graph can incorporate a tolerance envelope as part of the template. The actual performance curve, i.e. the data, is then inserted into the template graph. By looking at the resulting plot, an inspector can immediately determine whether the system under test conforms to expectation by staying within the tolerance envelope.

Curve fitting

Having imported a batch of data into *Origin*, you can exercise a variety of curve fitting options on the resulting curve. Some of the options are shown in Fig. 3 in the drop-down menu. Also shown in this shot is an example for fitting an eighth-order polynomial to a data batch. As the curve fit is in progress another window is opened to show the results of the calculations and to display the coefficients and the correlation values. This provides a measure of how well the polynomial fits the data.

Most curve fitting techniques use the least-squares method. When this is applied to an eighth-order polynomial, an 8-by-8 matrix is generated that has to be inverted. This requires a reasonable amount of computation.

Speed of the maths calculations in *Origin* while performing curve fits is remarkably quick.

3D and contour plotting

Three-dimensional plotting is the second part of *Origin*. It appears to be an addition to the *Origin* package proper. Contour plotting is quite impressive, particularly the automatic labelling.

I don't have the same enthusiasm for the 3D plotting however. Although it is easier to use than many other graphics packages, its range of options is small and it doesn't behave as you would expect.

For example, consider an unstable oscillator where time is along the z axis and velocity and displacement along the y and x axes respectively. You would expect to see an expanding helix along the z axis. Figure 4 shows what you actually get even when you specify a trajectory plot – not very impressive.

However the surface plots are acceptable, as you can see from Fig. 5, and colour grading is easy. Surface plots are produced by importing matrices into *Origin*, which is now

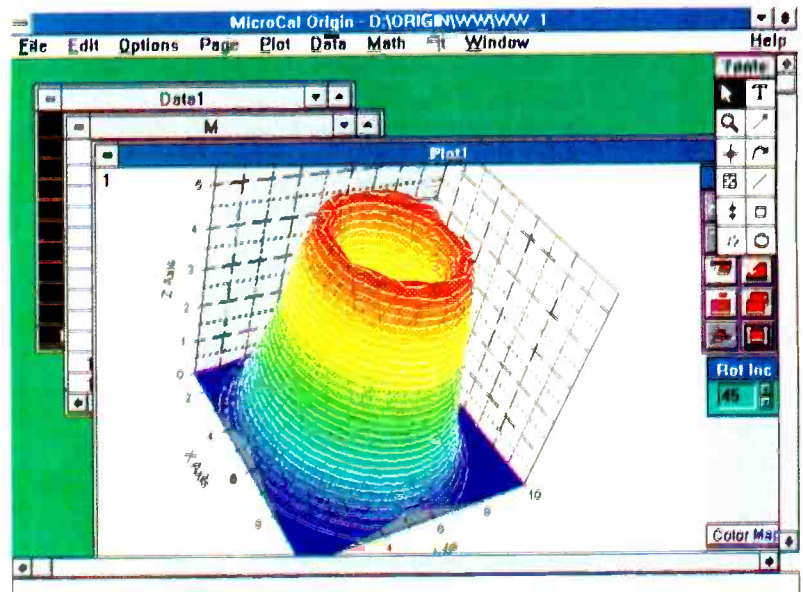

Fig. 5. Everyone likes looking at surface plots but are they really useful?

a common practice for plotting surfaces.

There is however a long wait for the redraw of the surfaces each time a slight change is made. This can be quite irritating after a while. Although the value of surface plots is sometimes questionable, they are quite useful when illustrating the significance of poles and zeros in the S-domain.

LabTalk

For really enthusiastic users who want to design custom graph formats, *Origin* comes with its own command language. This language, *LabTalk*, can also be used to determine how data is read into its associated worksheet.

LabTalk is a programming language providing access to the majority of *Origin* functions. These include the user-designed dynamic data links . or DLLs, for Microsoft Windows linking.

Syntax of *LabTalk* is not unlike that of dos batch commands, with operators, control flow and the customary structuring options. *LabTalk* is actually an interpreter that processes its native script or source code language.

The fact that *LabTalk* is an interpreter is useful if you

Fig. 6. With a little imagination and lot of time some interesting displays can be designed using LabTalk.

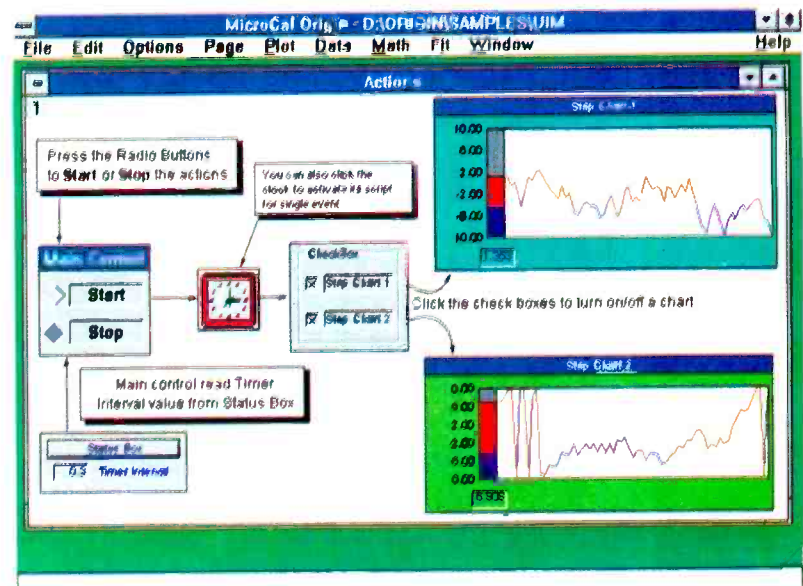

need to design a custom product with plotting features. However it is not the sort of feature that the casual user of *Origin* would use. An example of what can be achieved is shown in Fig. 6.

Reference manual

There are in four manuals with *Origin* – a tutorial guide, a reference manual, *LabTalk*'s user manual and a 3D/Contour supplement.

The tutorial guide is well written and is aimed at the general user. It provides a number of good examples illustrating *Origin*'s salient features. In addition it has many screen dumps and all the examples work according to the guide – a pleasant surprise.

As expected the reference manual contains all the functions of *Origin* and complements the screen help facilities provided in the software.

Round up

Origin is a package that I like very much. It is easy to use and its operation is logical. The range of 2D plotting options is most impressive. Above all, the flexibility afforded to the user makes it very attractive.

The learning curve needed is gradual. In no time, I was able to exercise a lot of control over plotting formats without having to cover all the features offered by the product. This is the sort of package that you can use a part of, quite competently, without having to worry about the rest of it.

On the down side there is only one problem – the 3D

SYSTEM REQUIREMENTS

- PC compatible with 386 or better
- Windows 3.1
- Mouse
- Good quality printer

SUPPLIER DETAILS

Origin plus *Contour* 3D modeller: £500 excluding £25 p&p and VAT. Quantity discounts are £1600 for 5 users to £5200 for 20 users.

Available from Rapid Data Ltd, Crescent House, Crescent Road, Worthing, West Sussex BN11 5RW. Tel. 0903 202819, fax 0903 820762.

plotting. You would not be able to plot a Lorentz Attractor and make any sense of it. However if you need no 3D plotting, then you should find *Origin* a treat to use. ■

Modelmaker a synthesis toolkit for

SpiceAge for Windows makes models accessible to all.

This new model maker includes tools for creating OpAmps, Transformers, Attenuators and Bipolar transistors. Straight from a catalogue...

The models are an accessible alternative to SPICE models which may also be used with SpiceAge. But because the information needed can be obtained straight out of a catalogue, you need never be kept waiting for a model again.

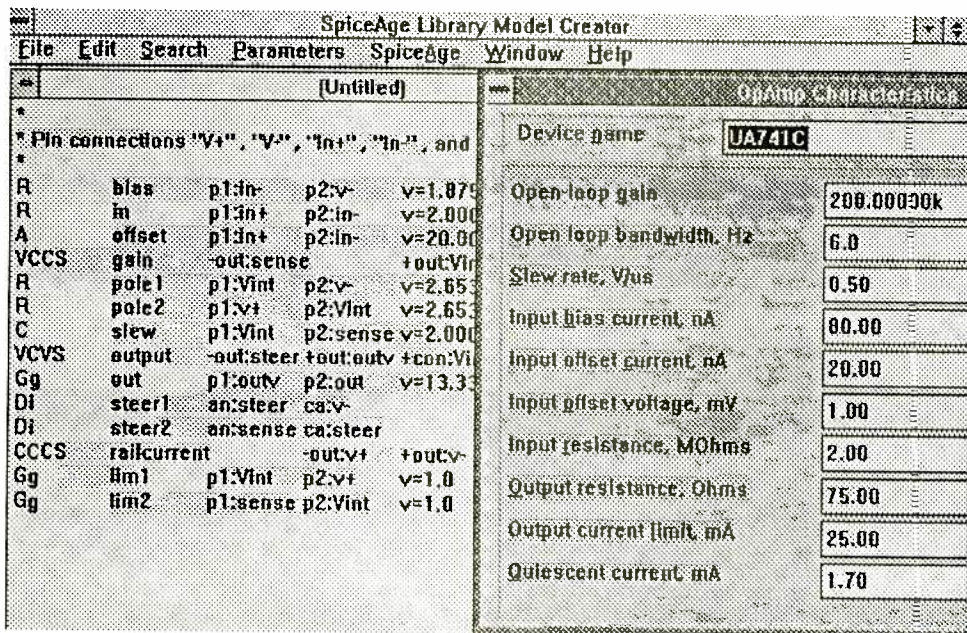

Unnecessary complexity removed...

The models synthesized are smaller than SPICE models yet they are adequate for most applications and calculate many times faster. This is partly achieved by exploiting special polynomial pragmas (not available to SPICE) that define the limits of validity of non-linear functions. The OpAmp models, for example, break new ground in simulation technology by representing many SPICE details yet calculating up to five times faster.

MODELMAKER is available in modules starting from £15 + VAT to £135 + VAT and links with version 3 (and later) and level 3 (and higher) of SpiceAge

for Windows through the DDE. Those Engineers operate a helpful policy of maintenance and upgrading to all their software. For further details, contact Those Engineers Ltd, 31 Birkbeck Road, LONDON NW7 4BP. Tel 081-906 0155, FAX 081-906 0969. CIRCLE NO. 113 ON REPLY CARD

Coherer-based radio

Following its introduction a century ago, the coherer electromagnetic wave detector helped radio evolve from being a curiosity to a practical communication tool. George Pickworth has been studying early designs and has even experimented with working transmitter/receivers capable of communicating at up to 1km.

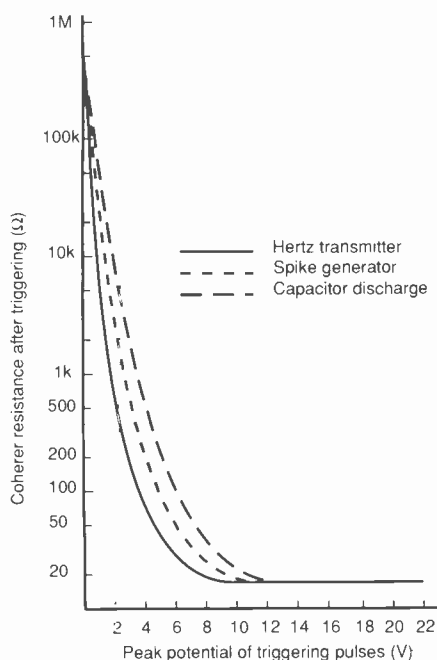

Fig. 1. Sensitivity of the coherer. Although sensitivity is important, it makes the coherer prone to false triggering due to natural discharges if too high.

The coherer can be seen as a very fast, self-latching relay. When triggered by a pulse induced in the receiver antenna, a local dc source of typically 1.5V operates a paper-tape Morse register, via an auxiliary relay. This provides a permanent record of the received signal.

The coherer was the first practical Hertzian wave detector. During its life, from about 1895 to 1905, it turned radio from a possibility into a practicality. History of the device was comprehensively covered by Leonid Kryhanovsky in his article (*The coherer*, *EW+WW* March 1992), but as he said, its physical mechanism was not fully understood.

As a technical historian, I am particularly interested in the sensitivity of the coherer, but as no meaningful information could be found in the literature, I decided to make a replica of a circa 1900 coherer and conduct my own research.

Pulses

My research showed that the coherer is actually a voltage-pulse triggered device. The pulse causes the coherer's resistance to drop to a level determined by the peak potential of the pulse. In a practical radio system, the pulse must be large enough to lower resistance to a certain threshold. If not, there will be insufficient current flow from the dc energiser circuit to operate the auxiliary relays and Morse register. **Fig. 1.**

The coherer can be triggered by a single unidirectional pulse, as may occur with natural discharges, or by the first negative or positive-going half cycle of current induced in the antenna by a train of exponentially declining Hertzian waves. However, multiple triggering can occur with pear-shaped wave trains during the incremental increase in the amplitude of successive half cycles.

You can see from Fig. 1 that a pulse with a peak potential in the order of volts is needed to cause the coherer's resistance to drop to a few hundred ohms. Polarity of the pulses relative to the 1.5V dc energising source was immaterial above the 3V threshold.

Working point

The threshold at which the system began operating would have depended upon the sensitiv-

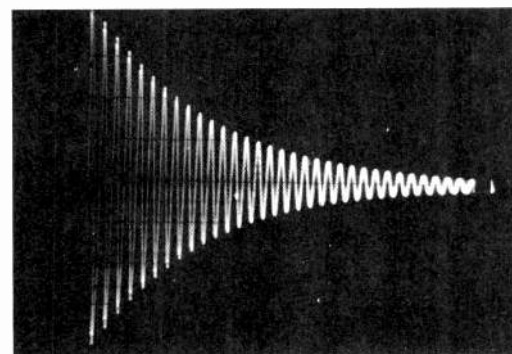

Fig. 2. Current induced in an antenna by an exponentially declining wave train. Triggering of the coherer occurs on the first half cycle pulse: remaining pulses are redundant.

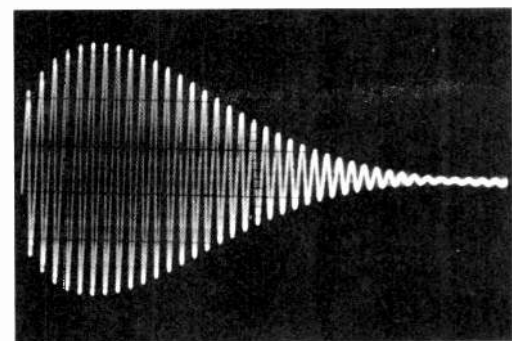

Fig. 3. Current induced in the antenna by a pear-shaped wave train. Successive pulses lead up to the final pulse at the peak. As with Fig. 2, subsequent pulses serve no purpose.

ity of the auxiliary relays. Reliable operation seems to start at the knee of the curve, and is best above the saturation level of 9V. While my research shows sensitivity of the replica coherer, overall receiver sensitivity would be influenced by sensitivity of the relays and this requires further research.

It appears that pulses with a peak potential in the order of volts would be needed for reliable working. At first sight, an induced pulse presenting a potential of this order seemed inconceivable. However I then realized that early spark transmitters packed an enormous amount of energy in the first wave of an expo-

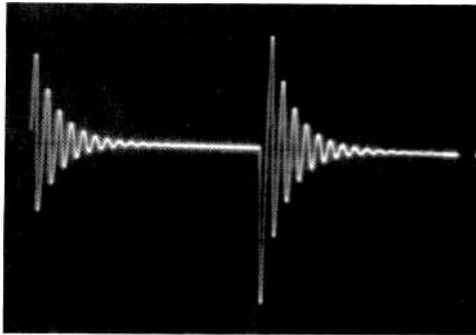

Fig. 4. Current induced in antenna by repetitive wave trains. Coherer triggering occurs on the first half cycle of each train. The period between triggering is long enough for operation of Morse register and restorer – typically 50 to 200ms.

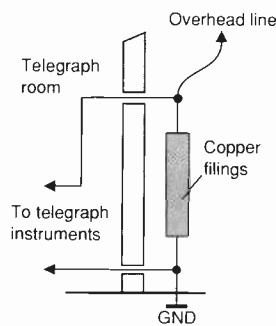

Fig. 5. Varley's lightning protector comprised a glass tube loosely filled with copper filings. Provided the lightning wasn't a direct hit, the protector could be restored by gentle vibration.

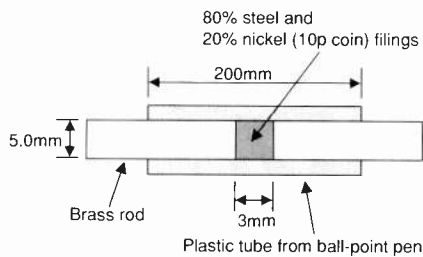

Fig. 6. My prototype experimental coherer had a plastic tube and could easily be triggered by esd. Replacing the tube with a glass alternative reduced this effect.

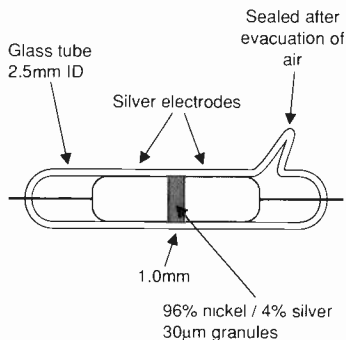

Fig. 7. In the Slaby Arco coherer, performance consistency was improved by having uniform granules.

nentially declining train. Much of this energy was present in the first half wave.

Moreover, the coherer presents a high resistance, typically 500kΩ. I saw no reason why the first wave should not induce a potential in the order of volts across the coherer at normal working range. Unfortunately, early spark transmitters cannot be replicated. As a result, direct measurements of currents induced in an antenna by waves propagating through space cannot be made.

However, thanks to co-operation of the DTI, experiments with a replica of Marconi's early vhf transmitter were made underground in a disused railway tunnel and substantiated measurements made on the bench and outdoors, as discussed later.

My experiments showed that once the coherer is triggered by a pulse of given amplitude, successive pulses of lesser amplitude have no further effect on resistance; this applies to exponentially declining trains, Fig. 2.

I found that if the magnitude of the pulses increases incrementally, as would occur with pear-shaped wave trains, the coherer is successively triggered as the wave train builds up to maximum amplitude; this of course assumes that lowering resistance of the coherer does not unduly load the pulse source. Thereafter resistance remains steady, Fig. 3.

Static

I demonstrated the fact that the coherer is pulse activated by rubbing a screwdriver against my pullover and touching its tip on a coherer terminal. It triggered instantly. Resistance drop was roughly proportional to charge on the screwdriver, so the coherer may well be adapted as an electrometer

This triggering mode was substantiated by experiments with a pulse/spike generator. Surprisingly, I found no reference in the literature to the coherer being triggered by a static charge, and concluded that it was caused by using plastic tube for my replica instead of the glass alternative used by the pioneers. Changing the tube material to glass dramatically reduced so the effect may not have been observed by the pioneers.

It has long been known that the coherer was susceptible to triggering by natural discharges. Both Popoff and Tesla used the coherer to study atmospheric electricity before it was applied as a detector of Hertzian waves.

For maximum range with a coherer receiver, energy should ideally be radiated as electromagnetic (em) pulses. True pulses however are untunable so syntony (oscillations progressively built up in a receiver by virtue of resonance) would be out of the question. Early spark transmitters radiated energy in trains containing very few waves, not unlike a lightning discharge. While well suited to the coherer, they precluded syntony, Fig. 4.

The coherer/Morse register was slow. In the quest for syntony and a higher signalling speed, the coherer was superseded by detectors better suited to the longer wave trains that were vital for syntony. These later detectors –

which include Marconi's magnetic detector, Fessenden's electrolytic detector and DeForest's audio – produced an audible sound in a telephone earpiece that corresponded to Morse code characters.

Evolution

The coherer had its roots in Varley's telegraph 'lightning protector'. This consisted of a glass tube loosely filled with copper filings, connected between an earth plate and the overhead line where it entered the building. In their loose state, the filings presented a high resistance and therefore did not significantly interfere with signalling, Fig. 5.

A pulse induced in the line by a lightning discharge caused the filings to cohere with a dramatic drop in resistance; this was so rapid that the pulse was shunted to earth before it could damage equipment. Moreover, unless the strike was very close, in which case the filings fused together, the protector could be restored to its original high resistance state by gentle vibration.

Branley seems to have been first to apply Varley's device to detecting Hertzian waves and it is named after him. But like many radio innovations, the coherer evolved through empirical experiments by a number of pioneers. It was applied to receiving Hertzian waves by Marconi and Popoff at around 1895. The name 'coherer' was invented by Lodge and aptly describes the device.

Throughout its life, the coherer gradually improved in sensitivity and operating consistency, culminating with the Slaby-Arco coherer in 1903. However, sensitivity was not the primary concern. If too sensitive, the coherer was susceptible to triggering by natural discharges. Consistency of operation was perhaps more important factor.

Construction

My experimenter's coherer consisted of a glass tube about 30mm long and 5mm inside diameter with a brass plug inserted in each end. The plugs served as electrodes and were separated by a 3mm gap at the centre of the tube, this gap was loosely filled with metal filings, typically steel with a small proportion of nickel.

I made four versions of coherer, each having different proportions of iron and nickel filings. In all cases the filings were sifted to remove fine particles. As explained in the main article, I used the plastic case of an old ball point pen instead of a glass tube, Fig. 6. All were physically the same size so that they clipped into a modified fuse holder.

I found 80% steel and 20% nickel (10p coin), as recommended by some early writers, gave best results. This article is based on data obtained with this version. All coherers are unique, but I believe the characteristics of my replica are similar to those used by early experimenters.

Setting up and preliminary adjustment involved gently forcing the electrodes into the tube until resistance fell to about 10Ω. The electrodes were then eased apart, while gently tapping the tube, until resistance increased to

about 500kΩ. To ensure maximum sensitivity, final adjustment was made with the aid of a buzzer type signal generator as described in early literature.

The Slaby-Arco coherer and other high quality coherers had silver electrodes and carefully graded metal granules. These were typically 5% silver and 95% nickel of the order 50µm in diameter. Air was removed and the electrodes sealed in the glass tube, Fig. 5.

Size of the granules determined sensitivity: the smaller the granules, the greater the sensitivity. Consistency of operation depended primarily on the uniformity of the granules. Fig. 7.

Regarding sensitivity, I doubt that early experimenters' coherers were inferior to the Slaby-Arco coherer. Experimenters could increase sensitivity by reducing the size of the filings. But with all coherers there is a limit to how far this can be taken and experimenters devices most probably approached this limit. However, the Slaby-Arco coherer would undoubtedly have operated more consistently.

Coherers have only two terminals so choking coils were necessary to isolate trigger pulses from the dc energising circuit. In some designs the relays served as choking coils. Fig. 8a. The antenna circuit must not present a dc path across the terminals.

Restoring

Once triggered, the coherer would remain in its low-resistance state indefinitely. In a practical signalling system, it had to be restored to its high resistance state in readiness for the next wave train. This was achieved by gently tapping the coherer with a device similar to the hammer of an electric bell; this operation was synchronized with the Morse register, Fig. 7a, but some systems had only one relay.

For my experiments it was more convenient to restore the coherer by gently tapping it with a pencil. Only the slightest vibration was required and some early experimenters suggested that it could be used as a seismometer.

Signalling was by transmitting short or long groups of wave trains representing a 'dot' or 'dash' of Morse code. Each train caused the Morse register to make a discrete mark on the paper tape. Successive wave trains caused the marks to merge, thus forming a continuous line. Length of the line corresponded to the duration of the group of wave trains.

Very fast

Varley's lightning protector had shown that coherence was very fast. I found that with pulses having a rise of 1ms, coherence occurred before the pulse reached maximum potential. There was no further drop in resistance as potential increased. Moreover, once triggered, the protector's resistance falls, loading on the source increases and this may inhibit a further rise in the pulse's potential.

Furthermore, pulse rise time must be so short that the choke coils are able isolate the pulse from the dc energising circuit. So, for greatest resistance drop, the pulse must approach maximum potential faster than

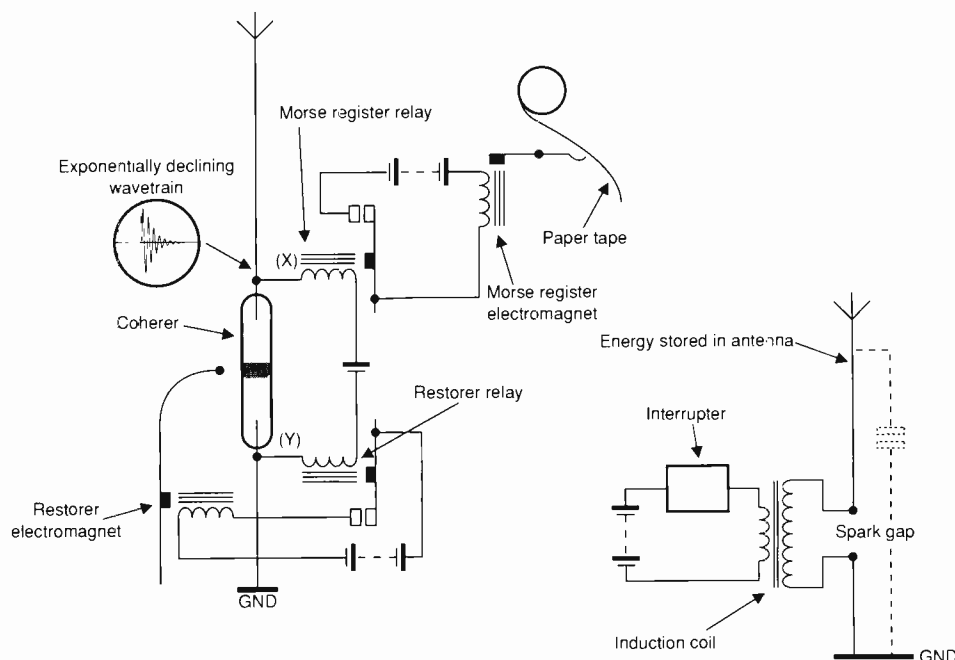

Fig. 8. In the 'untuned' coherer receiver, a hammer similar to the one on an electric bell provided the vibration needed to restore the coherer each time a pulse was received via the antenna. In the so-called untuned transmitter, b), length, capacity and resistance of the antenna actually set the operating wavelength.

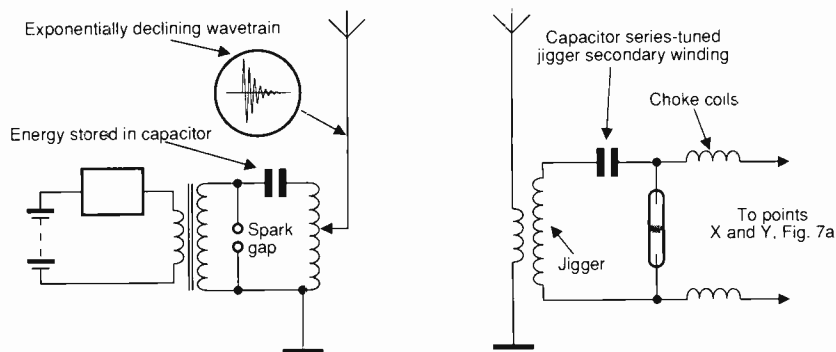

Fig. 9. Early tuned transmitter, a) and Marconi experimental jigger with dc blocking capacitor b).

coherence. For this reason, the coherer was well adapted to Marconi's early vhf system.

Coherence is generally accepted as being a physical effect. As a result, less energy would be required to overcome the inertia of small filings/granules. The effect is therefore faster than with larger filings/granules.

Untuned systems

With early vhf systems, it was logical to insert the coherer at the centre of a dipole antenna where it avoided shorting the coherer. This was adopted by Marconi. With later long-wave systems, employing Marconi type antennas, the coherer was inserted between the earth plate and the base of the antenna, Fig. 8a.

Similarly, the transmitter had its spark gap between earth and the antenna base; this became known as an untuned system, Fig. 8b. The term 'untuned' was in fact a misnomer. The length, capacity and resistance of the

transmitter antenna set the operating wavelength. Because the antenna was a very efficient radiator, the amplitude of the waves in each train declined steeply.

With large spark coils, ship-to-ship and ship-to-shore signalling over of 50km or more was achieved. Experimenters' manuals from around 1895 suggest that a transmitter using an induction coil comparable with a modern automotive spark coil and a 10m elevated antenna should have a range of about 1km.

Tuned transmitters

Second generation transmitters had inductors and capacitors and became known as tuned transmitters. Energy was still radiated as wave trains but each contained a greater number of significant waves than with the 'untuned' system.

Generally, transmitters employing one tuned stage, Fig. 9a, radiated exponentially declining wave trains while those having an inductively-

Fig. 10. Transmitter in a) had two tuned stages, and the complementary jigger in b) had two secondary windings.

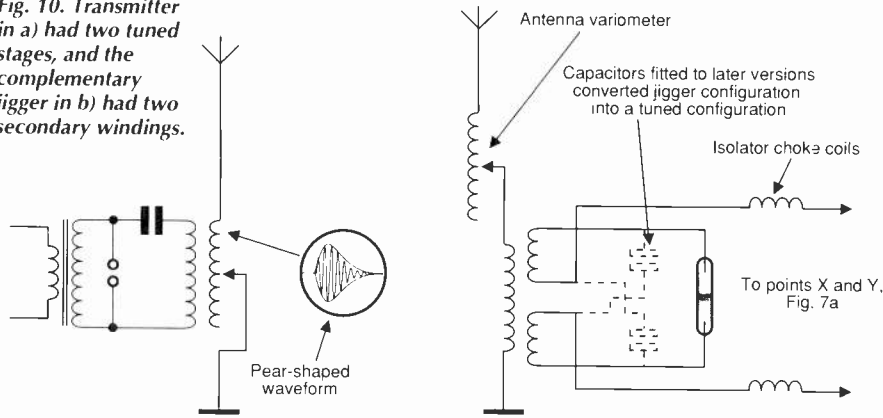

coupled, tuned-antenna system, Fig. 10a, radiated pear-shaped wave trains.

Inductance/capacity tuners were not well suited to exponentially declining waves. The pulse induced by the first half-wave simply shocked the tuner into generating a train of oscillations with a magnitude much less than the original pulse. So, it was logical to con-

tinue to connect the coherer directly to the antenna in the 'untuned' mode.

On the other hand, the gradual increase in amplitude of pear-shaped wave trains reduced the incidence of shocking the tuner into oscillation. But there were still too few trains, containing too few waves for a significant build up of voltage in an LC tuner by virtue of res-

onance. Syntony was minimal, but some voltage gain seems to have been achieved through standing waves.

Standing waves

Notwithstanding syntony, trains radiated by even the earliest 'untuned' transmitters contained more than one significant wave. Theoretically, a transient standing wave could develop in an antenna cut to an appropriate length.

There is of course, some voltage gain at a voltage antinode, but this was likely to have been insignificant with early Marconi untuned systems. What is more, diagrams from the time show the coherer inserted at a point where a voltage node could be expected to occur.

During experiments with my replica of Marconi's vhf system, which radiated very short trains, it made very little difference where the coherer was inserted. More remarkably, the actual length of the antenna made little difference either.

Standing waves were apparently very sig-

Coherer experiments

My first attempts to measure pulse potential against drop in resistance were carried out by incrementally charging a low-inductance capacitor of 1nF. It was then discharged it through the coherer via a high speed electronic switch.

For the experiments, the relays were substituted by an analogue ohmmeter. In all experiments, restoring was carried out by gently tapping the coherer with a pencil.

For the next measurement, a square wave generator was connected via a capacitor in parallel with a 500kΩ resistor. This component substituted for the coherer in its high resistance state, producing spikes.

Peak potential of the spikes was measured via an oscilloscope with the signal generator calibrated to produce spikes with increments of 1V. Next, the resistor was replaced by the coherer. Finally, resistance was plotted against the peak potential of the spikes.

In the tunnel. Experiments with the replica of Marconi's vhf transmitter were made without the reflectors. The antenna received only a few mJ, so energy in each wave train was minimal.

The experiment began with the transmitter operated manually so as to radiate single wave trains. Resistance was measured and plotted against distance as the receiver was moved away from the transmitter in 1m steps.

The coherer was then substituted by a resistor and the above exercise repeated with the transmitter set to automatically radiate wave trains with a repetition rate of 1kHz. Peak voltage across the resistor was measured by my 'magic eye' voltmeter. This related to resistance drop at a given distance from the transmitter

Open country. Following the experiments conducted in the tunnel, I conducted open-country trials with the Hertz type transmitter radiating

individual wave trains, Fig. 11. Pressing and quickly releasing the key generally caused a single discharge and a single wave train. Although a crude arrangement, it proved to be adequate for experimentation. I estimate that energy stored in the antenna was only in the order of a few mJ.

The receiver is shown in Fig. 12. You can see that instead of connecting the coherer to the centre of the dipole, it was offset to where a voltage antinode should theoretically exist. In practice it made little difference where the coherer was inserted. As with the tunnel experiments, the resistor was used in conjunction with my 'magic eye' voltmeter. Range for the above transmitter/receiver is shown in Fig. 13.

Having conducted the above experiments, the DTI kindly allowed me to radiate a few more wave trains to replicate Marconi's 'untuned' system and to compare the sensitivity of my

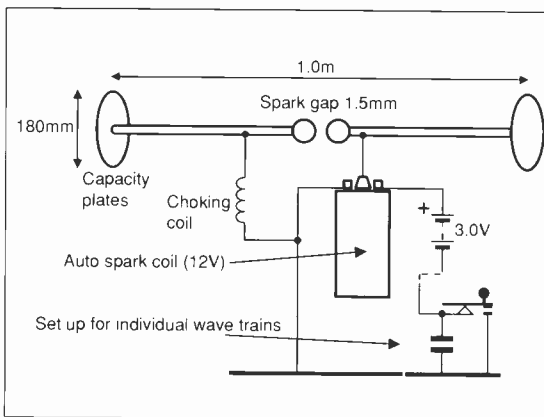

Fig. 12. Representation of a very low-power replica of a Hertz-type transmitter.

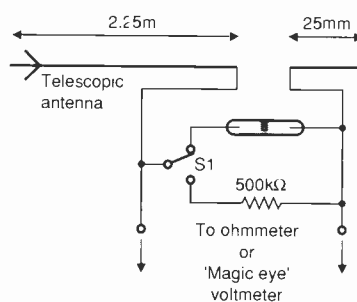

Fig. 13. Coherer receiver used in conjunction with the low-power Hertz transmitter, Fig. 12.

nificant with later transmitters radiating pear-shaped wave trains. A voltage antinode was the logical place to insert the coherer. With Marconi type antennas however, the voltage antinode was at the top of the antenna where it was impractical to insert the coherer. The Slaby-Arco system overcame this problem by using a quarter-wave matching section raised 3m above the ground. **Fig. 11.**

Marconi developed transformers to step up the voltage, which he called 'jiggers'. These were inserted at a voltage node occurring at the base of a Marconi type antenna. Coupling the jigger to the coherer however presented a problem. Direct-current resistance of its secondary winding was far less than that of the coherer.

If the jigger was connected directly across the coherer terminals it would simply have shunted both the coherer and the dc energising circuit. So a dc blocking capacitor was inserted between the secondary winding and the coherer. But as the coherer had a high impedance, this proved unsatisfactory because it series-tuned the secondary winding. **Fig. 9b.**

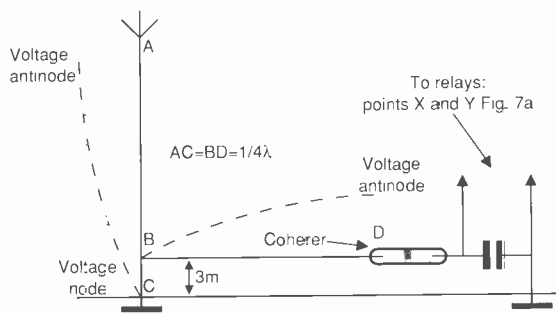

Fig. 11. In Marconi designs, the best place to insert the coherer was also the most impractical – i.e. in the voltage antinode at the top. Slaby-Arco antennas overcame this problem.

Marconi later developed a jigger with a pair of isolated secondary windings, which apparently was successful.

Ultimately, each secondary winding was parallel tuned by a fixed capacitor which converted it into a pre-set tuned transformer. **Fig. 10b.** This arrangement seems to have been successful, probably because of the successive triggering. Furthermore, it partially reconciled the conflicting requirements of synergy and the coherer. It was used by Marconi until

1906, when the coherer was ultimately superseded.

In conclusion, my research has shown the coherer to be something of an enigma and much remains to be learnt. Nevertheless, I hope that this discussion has filled a few gaps in our knowledge of the device.

I owe thanks to the DTI, Northamptonshire County Council, and to farm owner Mr Thomas for their co-operation in my experiments

coherer with data from the archives.

Transmitter details are shown in **Fig. 14.** The hand cranked magneto charged the capacitor to 100V, which was then

was discharged through the primary winding of the induction coil via a thyristor. The sloping antenna was attached to the apex of a farm building.

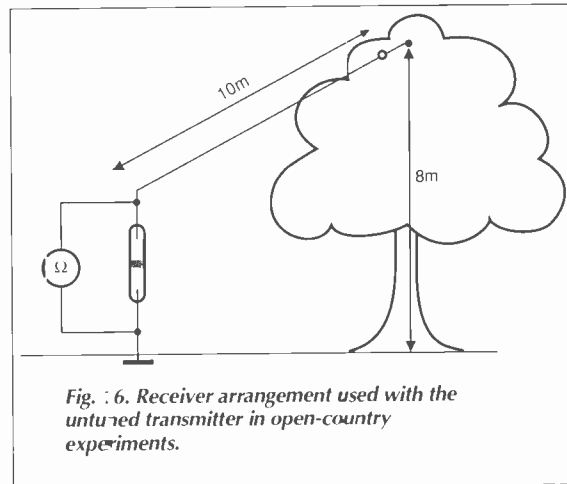
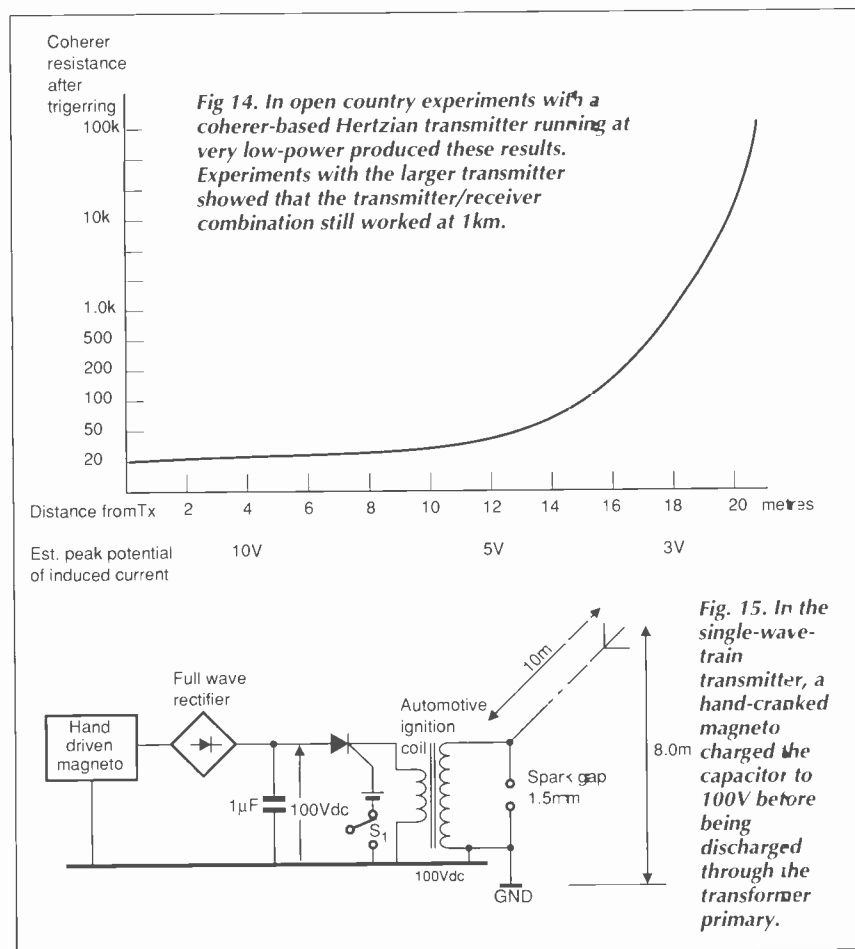

The receiver arrangement as shown in **Fig. 15**, but in this case the antenna was attached to a convenient tree.

Trials were made at distances of approx 500m and 1km. At 500m the coherer's resistance dropped to 50Ω and to about 500Ω at 1km. The curve obtained with the Hertz type transmitter indicates 1km approaches the maximum working range for equipment of this power. This agrees with data from experimenters working around the turn of the century.

Range would undoubtedly have been increased by experimenting with different spark gaps and using a longer more efficient antenna system, i.e. one with greater capacity to earth. Remarkably, the coherer receiver seemed immune to triggering by powerful radi-

SEALED LEAD ACID Battery, 6V 80/100 AH made for BT, ex equipment but ok £45 each ref APR47. Ideal electric vehicle etc.
ASTEC SWITCHED MODE PSU Gives +5 @ 3.75A, +12 @ 1.5A, -12 @ 4A, 230/110, cased, BM41012 £9.99 ref APR10P3.
TORRIDIAL TX 30-0-30 480VA, Perfect for Mosfet amplifiers etc. 120mm dia 55mm thick. £18.99 ref APR19

MOD WIRE Perfect for repairing PCB's, wire wrap etc. Thin insulated wire on 500m reels. Our price just £9.99 ref APR10P8.
12v MOVING LIGHT Controller. Made by Hella, 6 channels rated at 90watts each. Speed control, cased. £34.99 ref APR35.

ELECTRON FLASH TUBE As used in police car flashing lights etc, full spec supplied, 60-100 flashes a min. £9.99 ref APR10P5.
24v 96WATT Cased power supply. New. £13.99 ref APR14.

STETHOSCOPE Fully functioning stethoscope, ideal for listening to hearts, pipes, motors etc. £6 ref MAR6P6.

OUTDOOR SOLAR PATH LIGHT Captures sunlight during the day and automatically switches on a built in lamp at dusk. Complete with sealed lead acid battery etc. £19.99 ref MAR20P1.

ALARM VERSION Of above unit comes with built in alarm and pir to deter intruders. £24.99 ref MAR25P4.

CLOCKMAKER KIT Hours of fun making your own clock, complete instructions and everything you need. £7.99 ref MAR8P2.

CARETAKER VOLUMETRIC Alarm, will cover the whole of the ground floor against forced entry. Includes mains power supply and integral battery backup. Powerful internal sounder, will take external bell if req'd. Retail £150+, ours? £49.99 ref MAR50P1.

TELEPHONE CABLE White 6 core 100m reel complete with a pack of 100 clips. Ideal 'phone extns etc. £7.99 ref MAR8P3.

VIEWDATA RETURNS £6 made by Tandata, includes 1200.75 modem, k/bd, RGB and comp o/p, printer po. No PSU. £6 MAG6P7.

IBM PC CASE AND PSU Ideal base for building your own PC. Ex equipment but OK. £14.00 each REF: MAG14P2

SOLAR POWER LAB SPECIAL You get TWO 6"x6" 6v 130mA solar cells, 4 LED's, wire, buzzer, switch plus 1 relay or motor Superb value kit just £5.99 REF: MAG6P8

SOLID STATE RELAYS Will switch 25A mains. Input 3.5-26V DC 57x43x21mm with terminal screws £3.99 REF: MAG4P10

300DPI A4 DTP MONITOR Brand new, TTL/ECL inputs, 15" landscape, 1200x1664 pixel complete with circuit diag to help you interface with your projects. JUST £24.99. REF: MAG25P1

ULTRAMINI BUG MIC 6mmx3.5mm made by AKG, 5-12v regt condenser. Cost £12 ea. Our? four for £9.99 REF: MAG10P2
RGB/CGA/EGA/TTL COLOUR MONITORS 12" in good condition. Back anodised metal case. £99 each REF: MAG9P1

GX4000 GAMES MACHINES returns so ok for spares or repair £9 each (no games) REF: MAG9P1

C64 COMPUTERS Returns, so ok for spares etc. £9 ref MAG9P2

FUSELAGE LIGHTS 3 foot by 4" panel 1/8" thick with 3 panels that glow green when a voltage is applied. Good for nightlights, front panels, signs, disco etc. 50-100v per strip. £25 ref MAG25P2

ANSWER PHONES Returns with 2 faults, we give you the bits for 1 fault, you have to find the other yourself. BT Response 200's £18 ea REF: MAG18P1. PSU £5 ref MAG6P12.

SWITCHED MODE PSU ex equip, 60w +5v @5A, -5v @5A, +12v @2A, 12v @5A 120/220v cased 245x88x55mm IEC input socket. £6.99 REF: MAG7P1

PLUG IN PSU 9V 200mA DC £2.99 each REF: MAG3P9

PLUG IN ACORN PSU 19v AC 14w. £2.99 REF: MAG3P10

POWER SUPPLY fully cased with mains and o/p leads 17v DC 900mA output. Bargain price £5.99 ref: MAG6P9

ACORN ARCHIMEDES PSU +5v @ 4.4A, on/off sw uncased, selectable mains input, 145x100x45mm £7 REF: MAG7P2

GEIGER COUNTER KIT Low cost professional twin tube, complete with PCB and components. £29 REF: MAG29P1

SINCLAIR C6 13" wheels complete with tube, tyre and cycle style bearing £6 ea REF: MAG6P10

AA NICAD PACK encapsulated pack of 8 AA nicad battens (tagged) ex equip, 55x32x32mm £3 a pack. REF: MAG3P11

13.8V 1.9A psu cased with leads. Just £9.99 REF: MAG10P3

360K 6.25 brand new half height floppy drives IBM compatible industry standard. Just £6.99 REF: MAG7P3

PPCMODEM CARDS These are high spec plug in cards made for the Amstrad laptop computers. 2400 baud dial up unit complete with leads. Clearance price is £5 REF: MAG5P1

INFRA RED REMOTE CONTROLLERS Originally made for hi spec satellite equipment but perfect for all sorts of remote control projects. Our clearance price is just £2 REF: MAG2

TOWERS INTERNATIONAL TRANSISTOR GUIDE. A very useful book for finding equivalent transistors, leadouts, specs etc. £20 REF: MAG20P1

SINCLAIR C6 MOTORS We have a few left without gearboxes. These are 12v DC 3,300 rpm 6"x4", 14" OP shaft. £25 REF: MAG25

UNIVERSAL SPEED CONTROLLER KIT Designed by us for the above motor but ok for any 12v motor up to 30A. Complete with PCB etc. A heat sink may be required. £17.00 REF: MAG17

VIDEO SENDER UNIT. Transmits both audio and video signals from either a video camera, video recorder, TV or Computer etc to any standard TV set in a 100' range (tune TV to a spare channel) 12v DC op. Price is £15 REF: MAG15 12v psu is £5 extra REF: MAG5P2

***FM CORDLESS MICROPHONE** Small hand held unit with a 500' range! 2 transmit power levels. Reqs PP3 9v battery. Tuneable to any FM receiver. Price is £15 REF: MAG15P1

LOW COST WALKIE TALKIES Pair of battery operated units with a range of about 200'. Ideal for garden use or as an educational toy. Price is £8 a pair. REF: MAG8P1 2 x PP3 req'd.

***MINIATURE RADIO TRANSCENERS** A pair of walkie talkies with a range of up to 2 kilometres in open country. Units measure 22x52x155mm. Complete with cases and earpieces. 2xPP3 req'd. £30.00 pair. REF: MAG30.

COMPOSITE VIDEO KIT. Converts composite video into separate Hsync, Vsync, and video. 12v DC. £8.00 REF: MAG8P2.

LQ3600 PRINTER ASSEMBLIES Made by Amstrad they are entire mechanical printer assemblies including printhead, stepper motors etc etc in fact everything bar the case and electronics, a good snapper! £5 REF: MAG5P3 or 2 for £8. REF: MAG8P3

NEW BULL ELECTRICAL STORE WOLVERHAMPTON BRANCH

NOW OPEN AT 55A WORCESTER
ST TEL 0902 22039

100MHZ OSCILLOSCOPES now in stock, 12x10cm screen, delayed sweep, 1Mohm/25pf inputs, modes-ch1, ch2, add, chop, alt, dual. 460 x 305 x 200mm, 17kgs, £267+Vat includes insurance and carriage.

INFRARED LASER NIGHT SCOPES Second generation image intensifier complete with hand grip attachment with built in laser lamp for zero light conditions. Supplied with Pentax 42mm camera mount, 1.6kg, uses 1xPP3, 3xAA's (all supplied) £245+Vat

NEW HIGH POWER LASERS 15mW, Helium neon, 3 switchable wave lengths .63um, 1.15um, 3.39um (2 of them are infrared) 500:1 polarizer built in so good for holography. Supplied complete with mains power supply. 790x65mm. Use with EXTREME CAUTION AND UNDER QUALIFIED GUIDANCE. £349+Vat.

'PC PAL' VGA TO TV CONVERTER Just plug in and it converts your colour television into a basic VGA screen, perfect for laptops, saves lugging monitors about or just as a cheap upgrade. Intro price £49.99 +Vat.

AMSTRAD 1512DD

1512 BASE UNIT AND KEYBOARD AND TWO 5.25" 360K DRIVES. ALL YOU NEED IS A MONITOR AND POWER SUPPLY. WAS \$59.00

NOW ONLY \$39.00
REF: MAG39

3FT X 1FT 10WATT SOLAR PANELS
14.5v/700mA
NOW AVAILABLE BY MAIL ORDER
£33.95

(PLUS \$2.00 SPECIAL PACKAGING CHARGE)

TOP QUALITY AMORPHOUS SILICON CELLS HAVE ALMOST A TIMELESS LIFESPAN WITH AN INFINITE NUMBER OF POSSIBLE APPLICATIONS, SOME OF WHICH MAY BE CAR BATTERY CHARGING, FOR USE ON BOATS OR CARAVANS, OR ANYWHERE A PORTABLE 12V SUPPLY IS REQUIRED. REF: MAG34

*****WE BUY SURPLUS STOCK*****

TURN YOUR SURPLUS STOCK INTO CASH
IMMEDIATE SETTLEMENT. WE WILL ALSO QUOTE FOR
COMPLETE FACTORY CLEARANCE

1994 CATALOGUE

PLEASE SEND 45P, A4 SIZED SAE FOR YOUR FREE COPY.
MINIMUM GOODS ORDER £5.00. TRADE ORDERS FROM GOVERNMENT, SCHOOLS, UNIVERSITIES, & LOCAL AUTHORITIES WELCOME. ALL GOODS SUPPLIED SUBJECT TO OUR CONDITIONS OF SALE AND UNLESS OTHERWISE STATED GUARANTEED FOR 30 DAYS. RIGHTS RESERVED TO CHANGE PRICES & SPECIFICATIONS WITHOUT PRIOR NOTICE. ORDERS SUBJECT TO STOCK. QUOTATIONS WILLINGLY GIVEN FOR QUANTITIES HIGHER THAN THOSE STATED.

*SOME OF OUR PRODUCTS MAY BE UNLICENSEABLE IN THE UK

BULL ELECTRICAL

250 PORTLAND ROAD HOVE SUSSEX
BN3 5QT

MAIL ORDER TERMS: CASH PO OR CHEQUE
WITH ORDER PLUS £3.00 POST PLUS VAT.

PLEASE ALLOW 7 - 10 DAYS FOR DELIVERY

TELEPHONE ORDERS WELCOME

TEL: 0273 203500

FAX: 0273 323077



SPEAKER WIRE Brown 2 core 100foot hank E2 REF: MAG5P4

LED PACK of 100 standard red 5m leds £5 REF: MAG5P4

UNIVERSAL PC POWER SUPPLY complete with flylead switch, fan etc. Two types available 150w at £15 REF: MAG15P

(23x23x23mm) and 200w at £20 REF: MAG20P3 (23x23x23mm)

***FM TRANSMITTER** housed in a standard working 13A adapter! the bug runs directly off the mains so lasts forever! why pay £700?

or price is £26 REF: MAG26 Transmits to any FM radio.

***FM BUG KIT** New design with PCB embedded coil for extra stability. Works to any FM radio. 9v battery req'd. £5 REF: MAG5P5

***FM BUG BUILT AND TESTED** superior design to kit. Supplied to detective agencies. 9v battery req'd. £14 REF: MAG14

TALKING COINBOX STRIPPER originally made to retail at £79 each, these units are designed to convert an ordinary phone into a payphone. The units have the locks missing and sometimes broken hinges. However they can be adapted for their original use or used for something else?? Price is just £3 REF: MAG3P1

100 WATT MOSFET PAIR Same spec as 2SK343 and 2SJ413 (8A, 140v, 100w) 1N channel, 1P channel, £3 a pair REF: MAG3P2

TOP QUALITY SPEAKERS Made for Hi Fi televisions these are 10 watt 4R Jap made 4" round with large shielded magnets. Good quality. £2 each REF: MAG2P4 or 4 for £6 REF: MAG6P2

TWEETERS 2" diameter good quality tweeter 140R (ok with the above speaker) 2 for £2 REF: MAG2P5 or 4 for £3 REF: MAG3P4

AT KEYBOARDS Made by Apicot these quality keyboards need just a small mod to run on any AT, they work perfectly but you will have to put up with 1 or 2 foreign keycaps! Price £6 REF: MAG6P3

PC CASES Again mixed types so you take a chance next one off the pile £12 REF: MAG12 or two the same for £20 REF: MAG20P4

COMMODORE MICRODRIVE SYSTEM mini storage device for C64's 4 times faster than disc drives, 10 times faster than tapes. Complete unit just £12 REF: MAG12P1

SCHOOL STRIPPERS We have quite a few of the above units which are 'returns' as they are quite comprehensive units they could be used for other projects etc. Let us know how many you need at just 50p a unit (minimum 10).

HEADPHONES Ex Virgin Atlantic. 8 pairs for £2 REF: MAG2P8

PROXIMITY SENSORS These are small PCB's with what look like a source and sensor LED on one end and lots of components on the rest of the PCB. Complete with flyleads. Pack of 5 £3 REF: MAG: 3P5 or 20 for £8. REF: MAG8P4

SNOOPERS EAR? Original made to dip over the earpiece of telephone to amplify the sound-it also works quite well on the cable running along the wall! Price is £5 REF: MAG5P7

DOS PACKS Microsoft version 3.3 or higher complete with all manuals or price just £5 REF: MAG5P8 Worth it just for the very comprehensive manual! 5.25" only.

DOS PACK Microsoft version 5.0 original software but no manuals hence only £3 REF: MAG3P8 5.25" only.

CTM644 COLOUR MONITOR. Made to work with the CPC464 home computer. Standard RGB input so will work with other machines. Refurbished £59.00 REF: MAG59

PIR DETECTOR Made by famous UK alarm manufacturer these are hi spec, long range internal units. 12v operation. Slight marks on case and unboxed (although brand new) £8 REF: MAG8P5

WINDUP SOLAR POWERED RADIO AM/FM radio complete with hand charger and solar panel! £14 REF: MAG14P1

COMMODORE 64 TAPE DRIVES Customer returns at £4 REF: MAG4P9 Fully tested units are £12 REF: MAG12P5

MAINS CABLES These are 2 core standard black 2metre mains cables fitted with a 13A plug on one end, cable the other. Ideal for projects, low cost manufacturing etc. Pack of 10 for £3 REF: MAG3P8

PACK OF 100 £20 REF: MAG20P5

MICROWAVE TIMER Electronic timer with relay output suitable to make enlarger timer etc £4 REF: MAG4P4

MOBILE CAR PHONE £5.99 Well almost! complete in car phone excluding the box of electronics normally hidden under seat. Can be made to illuminate with 12v also has built in light sensor so display only illuminates when dark. Totally winning! REF: MAG6P6

ALARM BEACONS Zenon strobe made to mount on an external bell box but could be used for caravans etc. 12v operation. Just connect up and it flashes regularly! £5 REF: MAG5P11

FIRE ALARM CONTROL PANEL High quality metal cased alarm panel 350x165x80mm With key. Comes with electronics but no information sale price 7.99 REF: MAG8P6

REMOTE CONTROL PCB These are receiver boards for garage door opening systems. Another use? £4 ea REF: MAG4P5

6"X12" AMORPHOUS SOLAR PANEL 12v 155x310mm 130mA Bargain price just £5.99 ea REF: MAG6P12

FIBRE OPTIC CABLE BUMPER PACK 10 metres for £4.99 ref MAG5P13 ideal for experimenters! 30m for £12.99 ref MAG13P1

LOPTX line output transformers believed to be for hi res colour monitors but useful for getting high voltages from low ones! £2 each REF: MAG2P12 bumper pack of 10 for £12 REF: MAG12P3

BOTH SHOPS OPEN 9-5.30

SIX DAYS A WEEK

PORTABLE RADIATION DETECTOR

£49.99

A Hand held personal Gamma and X Ray detector. This unit contains two Geiger Tubes, has a 4 digit LCD display with a Piezo speaker, giving an audio visual indication. The unit detects high energy electromagnetic quanta with an energy from 30K eV to over 1.2M eV and a measuring range of 5-9999 UR/h or 10-99990 Nr/h. Supplied complete with handbook.

REF: MAG50



INTERFACING WITH C

by

HOWARD HUTCHINGS

Interfacing with C can be obtained from Lorraine Spindler, Room L333, Quadrant House, The Quadrant, Sutton, Surrey SM5 2AS.

Please make cheques for £14.95 (which includes postage and packing) payable to Reed Business Publishing Group.

Alternatively, you can telephone your order, quoting a credit card number. Telephone 081-652 3614.

A disk containing all the example listings used in this book is available at £29.96. Please specify size required.

C HERE!

If you have followed our series on the use of the C programming language, then you will recognise its value to the practising engineer.

But, rather than turning up old issues of the journal to check your design for a digital filter, why not have all the articles collected together in one book, *Interfacing with C*?

The book is a storehouse of information that will be of lasting value to anyone involved in the design of filters, A-to-D conversion, convolution, Fourier and many other applications, with not a soldering iron in sight.

To complement the published series, Howard Hutchings has written additional chapters on D-to-A and A-to-D conversion, waveform synthesis and audio special effects, including echo and reverberation. An appendix provides a "getting started" introduction to the running of the many programs scattered throughout the book.

This is a practical guide to real-time programming, the programs provided having been tested and proved. It is a distillation of the teaching of computer-assisted engineering at Humberside Polytechnic, at which Dr Hutchings is a senior lecturer.

Source code listings for the programs described in the book are available on disk.

Active devices fall into three groups: signal generation such as oscillators and amplifiers; signal reception using diode detection and mixing; signal control for attenuating, phase shifting, switching, modulating, limiting.

The silicon bipolar junction transistor (BJT) works well at the lower end of the microwave bands and is the preferred device for mobile phone transmitters, for reasons of its high output power and efficiency. Power levels of 100W or more are available from a single transistor operating around 1GHz and efficiencies in excess of 35% can be obtained. It also exhibits very low phase noise.

However, the BJT is a transit time device, in that its frequency of operation is ultimately limited by the time taken for electrons to travel from the base-emitter junction to the collector. In practice, this means that the BJT is restricted (with a few exceptions) to frequencies below about 4GHz. Above this frequency and through into the millimetre wave bands above 30GHz, the majority of amplifier and certain oscillator applications have become dominated by the n-type GaAs mesfet.

The metal-semiconductor junction is preferred for this and, as we shall see later, for other devices because of the virtual elimination of minority carrier

charge storage effects. N-type material is used because of the higher mobility of the electron as a majority carrier. A derivative of the mesfet, the high electron-mobility transistor (hemt), has revolutionised low-noise receiver design in the last few years and can give noise figures previously only attainable by cryogenic receivers. For example, noise figures of less than 0.4dB at 10GHz and 2.5dB at 60GHz are available at room temperature from hemt chips. Further improvements in noise figure and operating frequency are available in the pseudomorphic hemt (PHEMT).

However, as often happens, a dominating progress in one technology stimulates older processes and this has been the case with the bipolar transistor. Fet technology is a surface-orientated process, with performance limitations being set by pattern definition capability – 0.1µm lithography is now called for in millimetric devices which affects suitability for power generation. The response has been the GaAs heterojunction bipolar transistor (HBT). This device is likely to replace the fet in power applications, initially up to about 10GHz, and possibly up to millimetric frequencies. Advantages include non-critical lithography due to the 'vertical' bipolar process, leading to medium levels of output power (≈1W) and power-added efficiency of 50% or more.

New wave MICROWAVES

4: active devices for millimetre waves

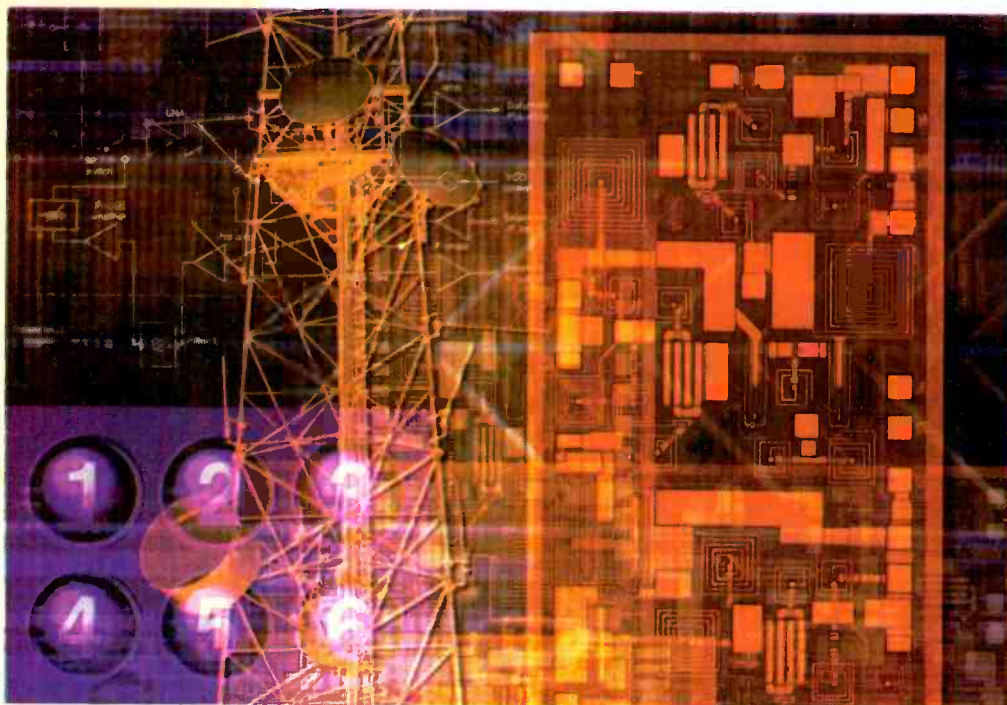

Most millimetre wave active devices are either unique to, or specially adapted for, this region of the spectrum.

Mike Hosking describes the specialities and their applications.

**Mike Hosking is a lecturer in telecommunications and microwaves at the University of Portsmouth.*

In addition, the circuit designer can easily implement class B or C operation, together with common base or cascode configurations. In effect, the GaAs HBT possesses the power, efficiency and spectral noise advantages of the lower frequency Si BJT, but translated to the higher frequency bands.

Substantial development work is also taking place in using indium phosphide as a replacement for GaAs in certain areas to improve power and frequency performance. However the final outcome is unclear and investment costs are high.

Two terminal semiconductors

There are classes of device not applicable to lower frequencies. Gunn-effect (or transferred electron) device and the Impatt (impact avalanche and transit time) diode have been the mainstay of solid state microwave power generation and, although becoming superseded by the transistor below about 30GHz, have wide application through the millimetre wave bands. Both are used as fundamental oscillators, as their inherent principles of operation give them a negative resistance characteristic, but they can also be designed into reflection amplifier circuits.

The Gunn device has traditionally been used in low-cost, high volume applications such as speed or intruder motion detectors and as the local oscillator in radar receivers. CW output powers of 0.5W or more are possible and operating frequencies up to about 140GHz; pulsed devices can deliver 40W or more of peak power.

Impatt diodes are the highest power solid state devices at millimetre wavelengths; output power is measured in 100's of mW, with several watts being possible at 10GHz. Operating frequency can be throughout the millimetre bands (to 300GHz). New applications are opening up for these devices in the 38 and 50GHz PCS bands, as well as the 60 and 77GHz bands for vehicle communication applications.

There are, of course, other solid state means of generating microwave signals, i.e. up-conversion, frequency multiplication, harmonic generation, and there are specialised, but little-used derivatives of some of the above devices. All systems raise questions about maintenance of frequency stability and tuning. These are best answered by examining practical circuits.

Gunn-effect device

Named after its inventor, J B Gunn of IBM, this represents a class of semiconductors known as transferred electron devices (TED). They are transit time devices, in that their frequency of operation is dependent upon the time taken for charge carriers to traverse the active region. The Gunn effect relies for its operation on a particular energy band structure found in certain III-V compounds: especially GaAs and InP, with GaAs being by far the most common material; Si and Ge cannot be used.

Basically, the device consists of an n-type active region sandwiched between two epi-

Fig. 1. Doping profile of a low power GaAs Gunn device (not to scale) showing a typical variation of carrier density. The product $n.L$ is used characterise modes of operation.

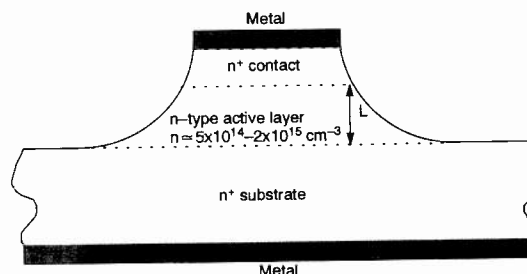

Fig. 2. Detail of the energy band structure of GaAs. Electrons transfer from the valence band to the high mobility lower band and thence to the higher energy, but lower mobility upper band.

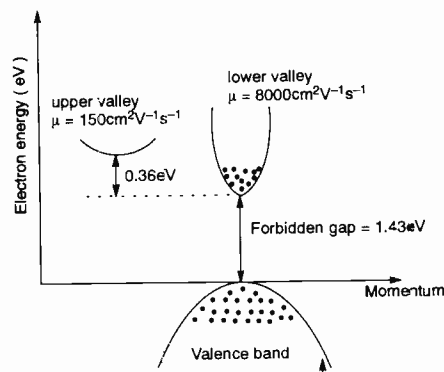
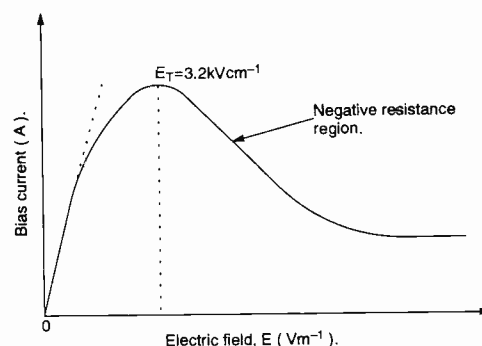

Fig. 3. DC bias curve for GaAs showing the gradual departure from the Ohm's law straight line and the Gunn effect negative resistance after the threshold field has been exceeded.



taxially grown n+ ohmic contacts, as shown in Fig. 1.

Important parameters are the doping density (charge carriers per cm^3), the active layer length, L , and the cross-sectional area. Figure 2 shows schematically a detail of the GaAs energy band structure as a function of the electron momentum as it drifts through the semiconductor.

The main features of this structure are the two regions of the conduction band close in energy to the valence band and separated from each other by an energy gap of 0.36eV. (An electron at room temperature has a thermal energy of about 0.026eV). In each of these bands, the electrons have an effective mass m_e and a mobility μ (same symbol as, but not to be confused with, permeability). Mobility has the units of $\text{m}^2\text{v}^{-1}\text{s}^{-1}$ (colloquially $\text{cm}^2\text{v}^{-1}\text{s}^{-1}$) and is a measure of electron speed in an applied electric field, i.e. $\mu = \text{velocity}/E\text{-field}$. The unusual situation in GaAs is that electrons in the lower energy band have a low mass and high mobility ($8000\text{cm}^2\text{v}^{-1}\text{s}^{-1}$), whereas those in the higher energy band have a high mass but a low mobility ($150\text{cm}^2\text{v}^{-1}\text{s}^{-1}$). Thus, higher energy electrons actually travel more slowly in the material.

If a small voltage is now applied across the

Gunn device and steadily increased, the resultant electric field and the electron velocity (i.e. current) will also increase: linearly at first, in accordance with Ohm's law. However, as shown in Fig. 3, as the voltage (E-field) increases, there is a departure from linearity, corresponding to electron transfer to the upper band.

Eventually, a threshold value, E_T , of about 3.2kVcm^{-1} is reached, at which point the great majority of electrons transfer to the upper band. However, in this band, the physical laws must be obeyed: the mobility is low and thus electrons slow down, even though they have more energy. The result is an electron 'traffic jam' at the cathode ohmic contact, a rapid build-up of charge called a domain. Thus, as the applied voltage is increasing, the electron current (proportional to velocity) is actually decreasing, giving rise to a region of negative resistance.

The domain continues to grow rapidly, creating its own E-field at the expense of the field across the rest of the device. The applied voltage, though, is still present and causes the domain to drift across the active region at a constant velocity (called the saturation velocity). On arrival at the anode contact, the domain will disappear as a current pulse, the

E-field will rise again and the whole process will repeat itself.

The frequency of these current pulses depends upon the transit time of the domain across the active region which, for a constant velocity, depends upon the length L only and can be made to occur at microwave frequencies. Bias requirements for the Gunn device are simple and require a constant voltage source supplying, for example, typically 4.5V at 1.5 A for a 200mW output at 60GHz. A low power motion sensing device giving 10mW at 10.7GHz would require about 7V at 100 mA. It can be seen that the dc to rf conversion efficiency is low, typically 1.5% to 4.5% for standard commercially available devices, although values up to 12% are possible.

As described so far, the Gunn device has been treated as an unpackaged chip and can be simply represented by a series combination of negative resistance $-R_D$ and a capacitance C_D . These parameters are functions of operating frequency, power output and temperature and are more complicated to determine than normal static values, as they are formed by the dynamic situation of growing and collapsing domains. However, a typical range of values is -4Ω to -15Ω for R_D and 0.5pF to 2pF for C_D . For this and other microwave power devices, it is usual to encapsulate the chip on an integral heat sink and there are a wide variety of package styles available for 2-terminal devices. Fig. 4a shows two such packages, the smaller being used more at millimetre wavelengths and Fig. 4b indicates an approximate equivalent circuit of the package alone, with typical element values.

The disadvantage is that the package intro-

duces small parasitic inductance and capacitance, the reactances of which are extremely significant at microwave frequencies and must be accounted for. Finally, in order to efficiently extract microwave power and to obtain a single frequency spectral output, the Gunn device must be embedded into a suitable resonant circuit.

At microwave frequencies, a resonant circuit may be simply produced from a length of transmission line, which appears as a distributed RLC circuit. For example, a length of transmission line, short-circuited at both ends, becomes resonant and can be represented by a parallel RLC network when its length in the direction of propagation is $1/2$ wavelength.

For 2-terminal Gunn and Impatt devices, the most popular resonant structure is a length of rectangular waveguide, short-circuited at one

end and with the active device mounted across the guide on a metallic post. Waveguide is preferred to coaxial line and to planar circuits of microstrip or coplanar waveguide due to its higher Q-factor, leading to a better frequency stability and lower fm noise. Heat sinking and dc bias connections are also readily implemented. Furthermore, as one enters the millimetre wave region, the physical size and weight of such resonators is not great. Ka-band waveguide, for example, which supports the frequency range 26.5-40GHz has internal dimensions of only 7.1x 3.6mm. A $1/2\lambda$ in the guide at 30GHz is 7mm.

There must, of course, also be a means of coupling the microwave signal out of the resonator and three different techniques are shown in Fig. 5.

In version (a), the resonator is formed

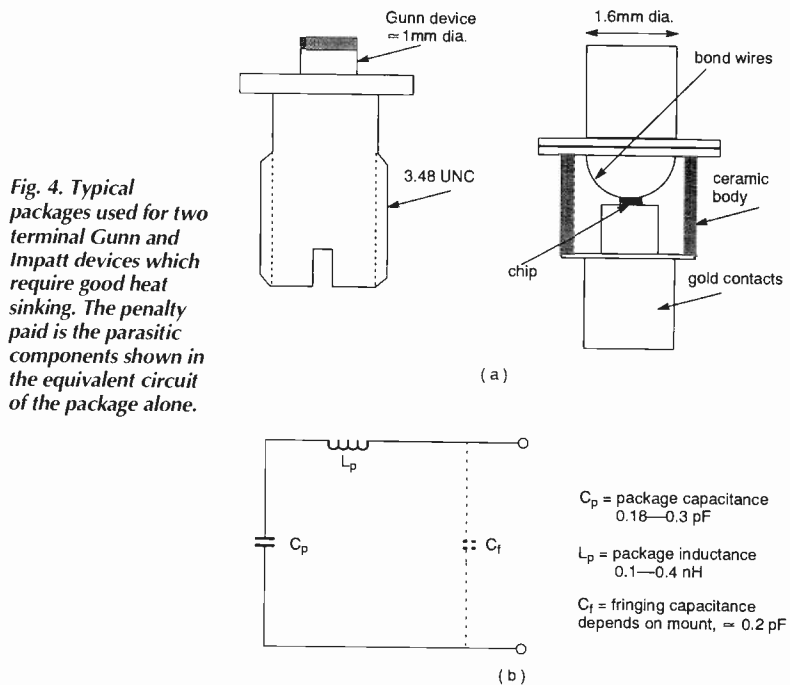

Fixed transit time but variable frequency?

If Gunn frequency is determined by the fixed width of the active region, then how may this frequency be changed?

The answer is that the external resonant circuit into which the Gunn device is mounted has its own loaded Q-factor and its own resonant frequency (which may be different from the transit frequency) and can be tuned independently.

When the Q-factor is sufficiently high, then the rf voltage swing across the Gunn device can affect the time at which the domain forms and may even suppress its formation for a time. This leads to modes of operation called the *delayed mode* and *quenched mode*, the frequencies of which are dictated by the external circuit and thus may be varied.

Within each of these three modes, a relatively small frequency control is possible by varying the bias voltage (called frequency pushing) as the electron transit time is a function of electric field. However, output power and mode stability are also affected and the technique is not often used.

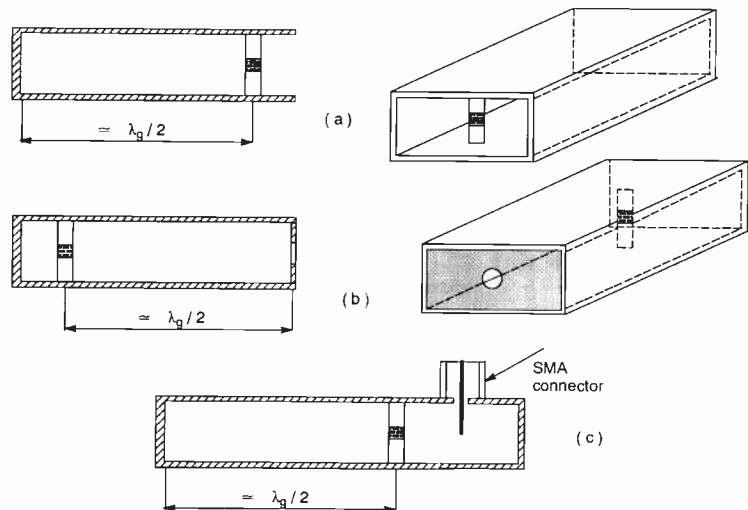

Fig. 5. Various forms of waveguide mounting for Gunn oscillators. a. Resonator formed by a short-circuited length of guide; b. Resonator formed by post and iris; c. Coaxial probe coupling to the guide.

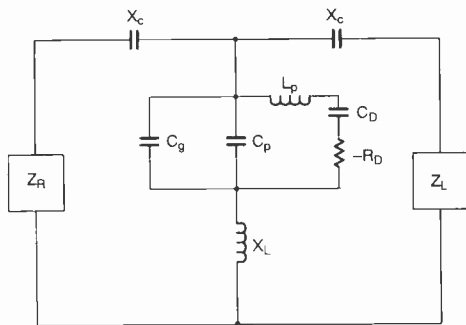

Fig. 6. Overall equivalent circuit of a waveguide mounted oscillator including the post, active device, packaging, resonator and load impedances.

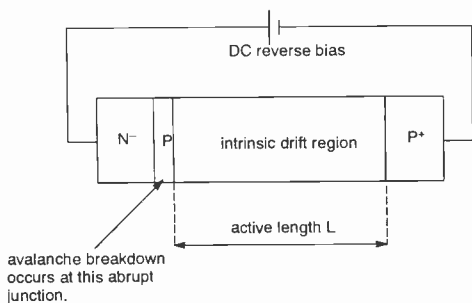

Fig. 7. Classical doping profile for the Si impatt diode. In practice, a double drift region is used in which domains of both electron and holes contribute to the output current.

between the short circuit and the device-post combination, with the output load impedance being that of the waveguide itself. In version (b), a thin metal diaphragm with a small coupling hole or slot cut in it (called an iris) forms the output. The short length of line between the post and short circuit forms part of the impedance tuning. Version (c) uses the same principle as (a), but with a coaxial output. The E-field in the waveguide is parallel to the probe formed by the centre conductor of the

coaxial line and will, therefore, couple to it. The adjacent short circuit position adds a length of line for impedance matching.

Figure 6 gives an overall equivalent circuit of this type of oscillator where the active device elements, $-R_D$ and C_D are modified by the package parasitics L_p and C_p . The post itself appears largely inductive to the field in the waveguide and is represented by the reactance X_L . Additional capacitive reactances X_C account for the finite diameter of the post. Capacitance C_g accounts for the gap in the post and fringing fields. The impedance Z_R is that of the short circuited length, ℓ , of waveguide of characteristic impedance Z_0 which, as we saw in Part 2 is given by $Z_1 = jZ_0 \tan \beta \ell$; $\beta = 2\pi/\lambda_g$. Impedance Z_L is the output transmission line impedance as transformed to or seen at the device terminals by the output coupling structure. Z_L itself may thus be quite complicated and the total oscillator design serves to illustrate the varied electrical effects which changes in physical structure cause at these frequencies.

Impatt diode

This specialised microwave device also behaves as a negative resistance and, like the Gunn device, can be used as a directly oscillating source without the need for feedback circuits. The mechanism for generating the negative resistance is completely different, although the Impatt is still a transit time device. Choice of semiconductor is not restricted to the III-V compounds although, in practice, only Si and GaAs are used, with developmental devices available in InP.

Impatt operation is based on a controlled avalanche breakdown process in a reverse biased semiconductor and depends upon the doping profile.

Figure 7 shows the simplified structure in which an intrinsic region is sandwiched between heavily doped n^+ and p^+ regions with

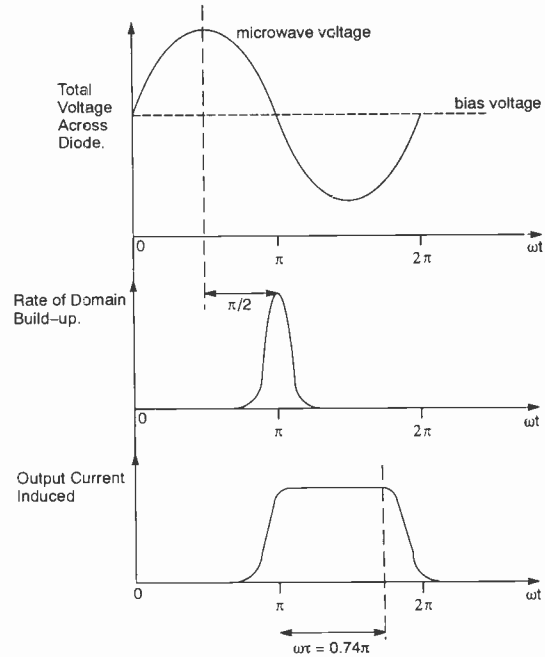

Fig. 8. The voltage and current relationships as the avalanche domain forms and then drifts across the active region of the impatt diode, creating an effective negative resistance.

the key profile being the abrupt n^+p interface and the narrow p-region.

As the reverse bias voltage is increased, the resulting electric field is sufficient to sweep the region between n^+ and p^+ clear of carriers to form a depletion layer. Thus at the abrupt n^+p interface a high electric field is formed. When this field reaches about 350 kV/cm^{-1} , avalanche breakdown occurs and electron-hole pairs are generated; once above this field value, the rate of charge build-up becomes exponential.

The electrons enter the n^+ region in this particular structure and can be neglected, while the charge of holes enters the depletion region. Electric field in this layer is very much less than the avalanche field: several thousand volts per cm and the charge carrier saturation velocity, due to scattering effects, occurring at about 5 kV/cm^{-1} in silicon, is about 10^7 cm/s^{-1} . This means that the time taken for the charge carriers to cross the depletion region can be made independent of bias voltage and depends only upon the length of this region.

To explain the Impatt mechanism, assume that the bias voltage is increased until the electric field intensity is just below that required for avalanche breakdown. At this point there will be sufficient energy in one of the ever-present, random noise carriers to trigger off the avalanche process. For clarity, Fig. 8 assumes the steady-state condition where oscillations have already built up.

During the first half of the ac cycle, the field is increased, avalanche multiplication commences and charge carriers build up at an exponential rate. When the alternating voltage falls below zero, the total field is less than the avalanche value and the process decays exponentially.

Gunn characteristics

In a semiconductor, the average electron drift velocity in the direction of an applied field does not continue to increase with increasing field strength, as in a conductor. Instead, even though the electrons become more energetic, they are scattered by the semiconductor lattice and gradually approach a limiting average velocity in the direction of the external field. In GaAs at normal Gunn operating voltages, this saturation velocity, v_s , is approximately 10^5 ms^{-1} . If we take the type of Gunn device used in intruder detectors, radar speed indicators and automatic door openers, then an operating frequency in the region of 10GHz is required. Thus, the active length, L , in Fig. 1 would be given by $L = 10^5 \times 10^{-10}\text{ m}$ or $10\mu\text{m}$ for a transit mode cycle time at 10GHz. The 10^{-10} quantity represents the period in seconds of one

signal cycle at the operating frequency.

The threshold field in GaAs is 3 kV/cm^{-1} and so, for a $10\mu\text{m}$ device, the threshold voltage would be 3.2V.

Typically, the bias voltage would be about 7V for a 20mW device at a supply current of 125mA, giving a dc to rf efficiency of 2.3%.

The current density, J , in the device can be estimated from the relationship $J = nev_s$, where n is the carrier density and e is the electron charge. In our example, $n = 1.2 \times 10^{15}\text{ cm}^{-3}$, $e = 1.6 \times 10^{-19}\text{ C}$ and $v_s = 10^7\text{ cm s}^{-1}$. Hence, $J = 2000\text{ A/cm}^2$.

With the actual size of the GaAs chip typically being less than $100\mu\text{m}$ square and, at 2.3% efficient, with nearly 1W being dissipated, heat sinking is vital, especially as devices delivering more than ten times this power are readily available.

Gunning for intruders

As an application example of the Gunn device, the Philips CL8960 series doppler radar module, Fig. 9, has been around for many years for motion sensing equipment such as intruder alarms and automatic door openers. This component works as a homodyne radar transceiver and antenna module along the lines shown in Fig. 9b.

A microwave CW signal is transmitted and the reflected signal is detected by a single diode mixer which uses a sample of the transmit power as the local oscillator. Just as with the acoustic doppler effect caused by a moving sound source, the microwave signal reflected from a moving object will be shifted in frequency. This 'doppler shift' f_D depends upon the relative velocity between moving object and detector and is given by:

$$f_D = 2 \left(\frac{\text{relative velocity}}{\text{wavelength}} \right)$$

With low-pass filtering at the mixer output, just the intermediate frequency is selected; which will be zero for stationary object. With movement present, the IF will be:

$$(\text{transmit frequency} \pm f_D) - \text{LO frequency}$$

which, as transmit and LO frequencies are the same, results in a mixer IF of f_D . In the alarm applications, it is not necessary to measure f_D ; the very existence of a non-zero IF implies movement.

The actual module shown in the picture uses a 10mW Gunn device, post-mounted across the left-hand section of rectangular waveguide, short-circuited at approximately a

half wavelength from the post.

Operating frequency, for an indoor application, is 10.687GHz \pm 12MHz, hence the advantage of the higher-Q waveguide form of resonator. The mixer is a single diode in a relatively large package that fits conveniently across the right hand guide and is impedance matched by positioning about a quarter wavelength away from another terminating short circuit. Both transmitter and detector couple to free space via the small tapered section of guide, which behaves as an antenna having approximately 5dBi of gain. There is, however, a deliberate slight mis-match associated with this coupling which causes spill over of the transmit signal into the mixer, thereby providing the LO input. A dielectric cover over the end (i.e. the wall of a plastic box) can be used to adjust this spill-over as well. Power supply requirements are 7V at about 140mA.

With these parameters, the doppler frequency generated is about 71.2Hz per ms^{-1} or 32Hz per miles per hour.

A variation on this type of radar is used in temporary traffic light systems where it is necessary to sense the actual direction of motion. This can be done by adding a second detector diode, suitably positioned and comparing the phase of the two outputs. Finally, of course, we must not forget the police radar speed indicator application!

Although mainly used as oscillators, both devices may also be designed as reflection amplifiers. With a load resistance greater than the negative resistance, the device will not oscillate and a low power incident signal can be reflected back out, but with amplification.

The result is shown in Fig. 8 where the charge density is seen to be a sharply defined spike and, in particular, *the peak charge now lags the peak alternating voltage by 90°*. Under the influence of the dc bias, this bunch of charge now drifts across the depletion region at constant velocity and therefore induces a constant current in the external circuit. If the diode depletion length is such that the carrier transit time corresponds to one half-cycle of the alternating voltage, then *the induced current will be 180° out of phase with the voltage*. Hence, negative resistance is produced and the diode will generate microwave power when incorporated into a resonant circuit with output coupling.

In fact, the maximum value of negative resistance occurs when the transit time of the domain τ is such that $\omega\tau=0.74\pi$ (called the transit angle) where ω is the angular frequency of operation.

Thus, the frequency of oscillation is approximately $v_s/2L$, where v_s is the saturated carrier velocity of about 10^5ms^{-1} and L is the depletion length. For a frequency of 10GHz,

Dimension $L=5 \times 10^{-3}\text{cm}$, i.e. half that of the Gunn effect device. Also, at this frequency, the junction area is about $5 \times 10^{-4}\text{cm}^2$ giving rise to bias current densities of about $10,000\text{A/cm}^2$. Thus, as with the Gunn device, good heat sinking is also essential and diamond heat sinks, within the package, are commonly used for millimetric operation. The overall equivalent circuit is the same as that of the Gunn device, but with R_D typically -0.9Ω and C_D 0.25pF for a millimetric power device.

The simple doping profile of Fig. 7 was the original structure proposed by W.T. Read of Bell Systems but, in practice, has been largely superseded by a double-drift profile. The principle of operation remains the same, but both hole and electron domains form and add to the output current. Efficiency is increased: values greater than 20% are possible, together with an increase in output power.

For example, 10W to 20W of peak power at around 10GHz and 1W at 100GHz would be typical, with slightly lower CW power available. One particular application has been in portable, outside broadcast communication links: much effort has been put into combining the outputs of many diodes to produce output wattage in the hundreds.

The Impatt requires a higher bias voltage than the Gunn device, but a proportionally lower current, from a current-stabilised source. For example, a 3W pulsed device at around 30GHz would require peak supply values of some 35V at 0.5A. ■

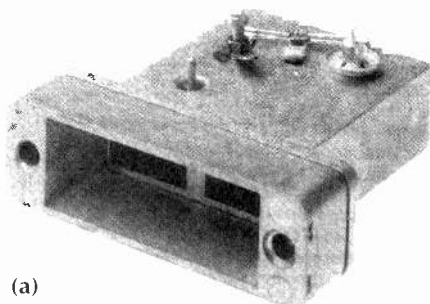
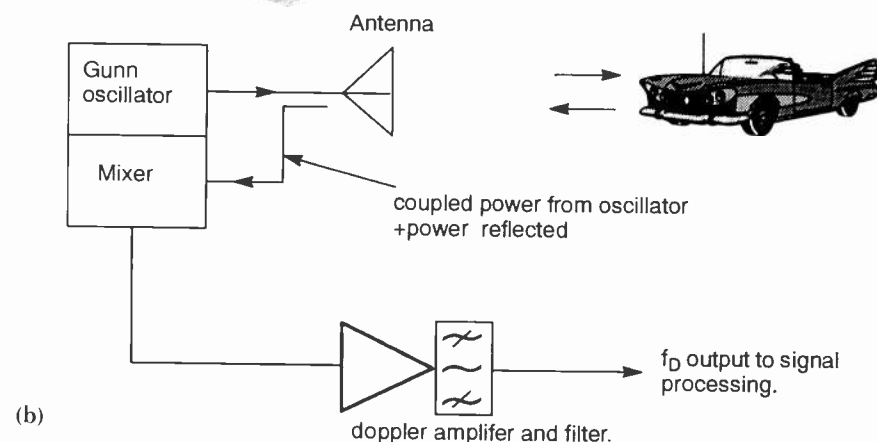

Fig. 9. A microwave signal reflected from a moving object will undergo a doppler shift in frequency and a simple motion sensing radar (a) comprising a transmitter/detector/antenna can be made using the Gunn device. Signal path processing is shown below.



Next month: devices such as the hemt, HBT and step-recovery diode, together with methods of oscillator tuning such as YIG and varactor and stabilising using the dielectric resonator.

KENWOOD

TEST & MEASURING INSTRUMENTS
A SUPERB RANGE OF OVER 100
QUALITY INSTRUMENTS.

Available from
B.K. ELECTRONICS



- FM-AM Signal Generators ★ Colour Pattern Generators ★ Video Signal Analyser ★ Video Timing Analyser ★ Video Noise Meter ★ Distortion Meter ★ Waveform Monitors
- ★ Vectorscopes ★ Audio Generators ★ Wow and Flutter Meters ★ Electronic Voltmeters
- ★ Digital Multimeters ★ Function Generators ★ Frequency Counters ★ Bus Analyser
- ★ Resistance Attenuator ★ Oscilloscopes ★ Fully Programmable Digital Storage Oscilloscopes
- ★ Regulated D.C. Power Supplies

A free, 50 page colour brochure, including price list, is available on request. Please make your request on company headed notepaper, by post or by fax, to:

B.K. ELECTRONICS
Unit 1 Comet Way,
SOUTHEND-ON-SEA,
Essex, SS2 6TR.
Tel.: 0702-527572
Fax: 0702-420243



CIRCLE NO. 115 ON REPLY CARD

UNIVERSAL PROGRAMMER

NEW



only **£595**

- ✓ Supports over 2000 ICs:-
EPROMs, E²PROMs, Bipolars, Flash, Serial PROMs
over 150 microcontrollers - including PIC17C42
PLDs, EPLDs, PEELs, PALs, GALs, FPGAs
including MACH, MAX and MAPL parts
- ✓ Very few adapters
Universal Adapter PACs for:
40 pin DIL and 44,68,84 PLCC parts
Also 4 and 8 gang PACs
- ✓ 256 pin drive capability for future expansion
- ✓ Uses standard pc printer port
- ✓ Powerful full colour menu driven software
- ✓ Regular updates

Contact SMART Communications for our full range of Programmers
Emulators, Cross-Assemblers, Compilers and Simulators

Tel: 081-441 3890
Fax: 081-441 1843

SMART
COMMUNICATIONS

CIRCLE NO. 116 ON REPLY CARD

Finally an upgradeable PCB CAD
system to suit any budget ...

Board Capture

BoardCapture - Schematic Capture

- Direct netlist link to BoardMaker2
- Forward annotation with part values
- Full undo/redo facility (50 operations)
- Single-sheet, multi-paged and hierarchical designs
- Smooth scrolling
- Intelligent wires (automatic junctions)
- Dynamic connectivity information
- Automatic on-line annotation
- Integrated on-the-fly library editor
- Context sensitive editing
- Extensive component-based power control
- Back annotation from BoardMaker2

£395

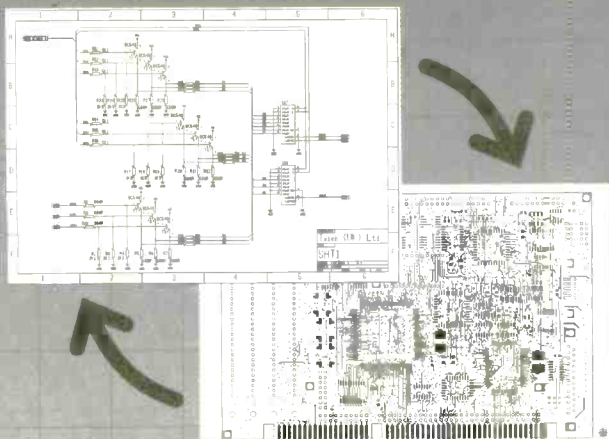

Board Maker

BoardMaker1 - Entry level

- PCB and schematic drafting
- Easy and intuitive to use
- Surface mount support
- 90, 45 and curved track corners
- Ground plane fill
- Copper highlight and clearance checking

£95

BoardMaker2 - Advanced level

- All the features of BoardMaker1 plus
- Full netlist support - OrCad, Schema, Tango, CadStar
- Full Design Rule Checking - mechanical & electrical
- Top down modification from the schematic
- Component renumber with back annotation
- Report generator - Database ASCII, BOM
- Thermal power plane support with full DRC

£295

NEW

Board Router

BoardRouter - Gridless autorouter

- Simultaneous multi-layer routing
- SMD and analogue support
- Full interrupt, resume, pan and zoom while routing

£200

Output drivers - Included as standard

- Printers - 9 & 24 pin dot matrix, HPLaserjet and PostScript
- Penplotters - HP, Graphtec, Roland & Houston
- Photoplotters - All Gerber 3X00 and 4X00
- Excellon NC Drill / Annotated drill drawings (BM2)

Call for info or full
evaluation kit
Tsien (UK) Limited
Tel (0354) 695959
Fax (0354) 695957



tsien

Tsien (UK) Ltd, Aylaby House, Wenny Road, Chatterton, Cambridge PE16 6UT

All trademarks acknowledged

CIRCLE NO. 117 ON REPLY CARD

Applying Hall to good effect

Integrated Hall-effect sensors have a vast range of uses, from limit switches to current monitors. Martin Eccles looks at some of the applications for both digital and analogue-output devices.

Free Hall-effect samples

A device pack comprising a choice of either a 3503 ratiometric linear sensor or a 3121 Hall-effect switch and data pack will be sent free of charge to the first 500 readers returning the special reply card located between pages 584 and 585 of this issue. Please note that this offer only applies to readers in the UK and Eire and that all enquiries relating to the offer should be directed to Ambar Cascom, whose details appear at the end of this article.

A Hall element is simply a small sheet of semiconductor material. A constant bias current flows through it and the output – a voltage measured across the width of the sheet – reads near zero provided that there is no magnetic field present. If the biased Hall sensor is placed in a magnetic field at right angles to the Hall current, the voltage output is directly proportional to the strength of the magnetic field. This is the Hall effect, discovered by E. H. Hall in 1879.

Integrated devices incorporating the Hall element together with amplifiers, regulators, drivers and schmitt comparators are now used widely: ignition distributors, motor speed controls, security systems, alignment mechanisms, micrometers, mechanical limit switches, computer peripherals, machine tools, key-switches and push buttons.

Linear sensor applications

Rotation detection. Normally, a linear Hall sensor's output is capacitively coupled to an amplifier that boosts the output above the millivolt level, as in Fig 1.

In two applications shown in Fig 2, a permanent bias magnet is attached with epoxy glue to the back of the epoxy package.

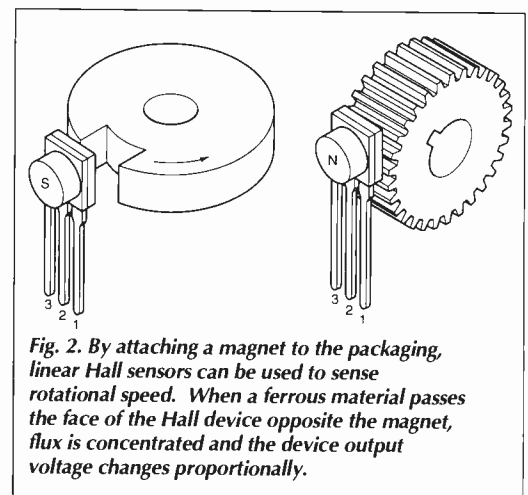

Fig. 2. By attaching a magnet to the packaging, linear Hall sensors can be used to sense rotational speed. When a ferrous material passes the face of the Hall device opposite the magnet, flux is concentrated and the device output voltage changes proportionally.

Presence of ferrous material at the face of the package acts as a flux concentrator.

The south pole of a magnet is attached to the back of the package if the Hall effect IC is to sense the presence of ferrous material. If the device is to sense the absence of ferrous material the north pole of a magnet is attached to the back surface.

Calibrated linear Hall devices – useful for

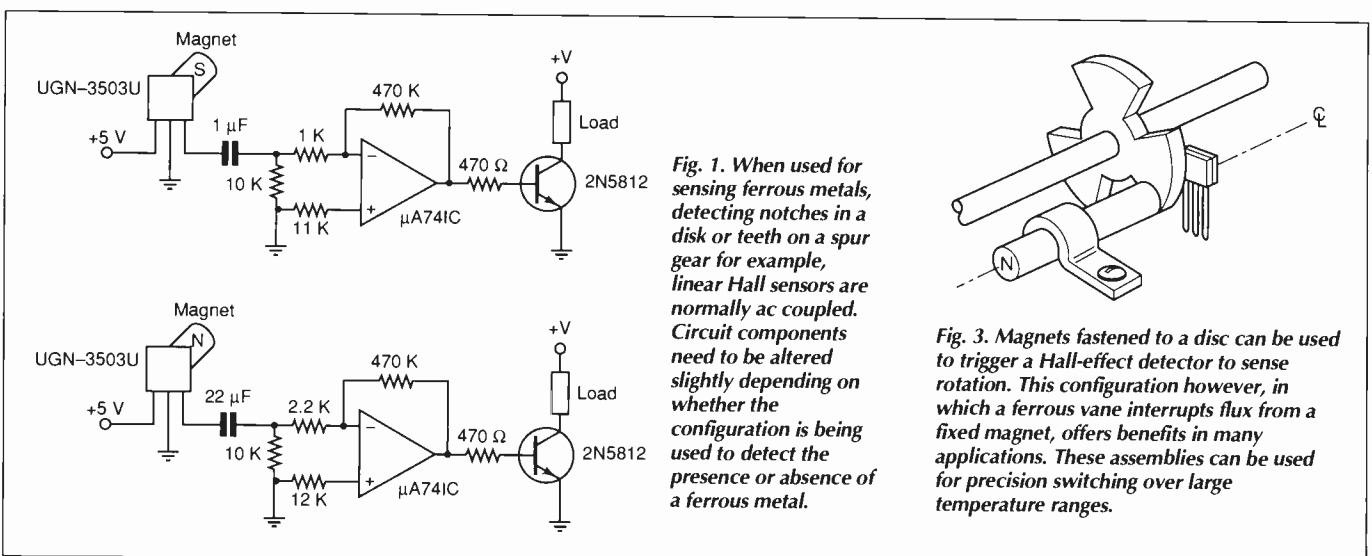

Fig. 1. When used for sensing ferrous metals, detecting notches in a disk or teeth on a spur gear for example, linear Hall sensors are normally ac coupled. Circuit components need to be altered slightly depending on whether the configuration is being used to detect the presence or absence of a ferrous metal.

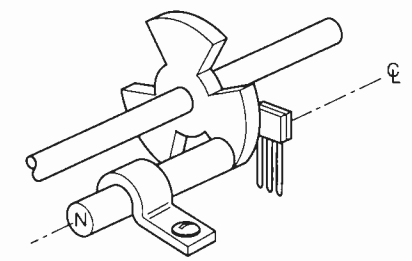

Fig. 3. Magnets fastened to a disc can be used to trigger a Hall-effect detector to sense rotation. This configuration however, in which a ferrous vane interrupts flux from a fixed magnet, offers benefits in many applications. These assemblies can be used for precision switching over large temperature ranges.

measuring heads and determining flux densities during the design stage – are available.

Since a Hall-effect sensor is triggered by magnetism, the obvious way to sense rotation is to fix magnets to the rotor. In many applications however, there are significant benefits to from having a fixed magnet and fixed sensor, as shown in Fig. 3.

With this arrangement, the magnet needs to be powerful enough to turn the sensor opposite on while unobstructed. When a blade of the ferromagnetic vane passes between the

magnet and sensor, flux is shunted and the sensor turns off.

Movable vanes are a practical way to switch Hall devices. The sensor and magnet can be moulded together to eliminate alignment problems and produce a rugged switching assembly. The ferrous vane or vanes that interrupt the flux can move linearly, or rotate as in an automotive distributor. Ferrous vane assemblies, due to the steep flux density/distance curves that can be achieved, are often used where precision switching over a large

temperature range is required.

Linear motion. Most magnet/sensor combinations produce a non-linear flux-distance relationship. The push-push configuration in Fig. 4 however produces an almost linear curve, as Fig. 5 illustrates.

Suitable for use with either linear or switching sensors, this arrangement produces a bipolar field with a fairly steep slope. While the sensor is in the centre of the space between the two magnets, flux is cancelled. With a ratio-

Switching Hall sensors

Integrated Hall-effect switches are easy to use, bounce-free, economical and reliable since they have no moving parts. Unaffected by dirt and light, they can also be used in harsh environments and they are fast – capable of cycling at up to 100kHz.

A Hall sensor is activated by a magnetic field created by either electro or permanent magnets. Magnetic fields have two important characteristics: magnitude and orientation. In the absence of any magnetic field, most common Hall-effect digital switches are designed to be off, i.e. open circuit at their output. They will turn on only if subjected to a magnetic field that is strong enough and of the correct polarity.

If an approaching magnetic south pole causes switching action of a digital sensor, the approach of the north pole should have no effect. In practice, a close approach by the south pole of a magnet will cause the output transistor to turn on.

The plot below shows transfer characteristics of input versus output. Hall effect switches have hysteresis, typically 20G. This hysteresis ensures that even if mechanical vibration or electrical noise is present, the switch output is fast, clean, and occurs only once per threshold crossing.

Detecting a threshold

Output from a Hall-effect element is linear. But in many applications a switching output representing whether magnetic field strength is above or below a given threshold is more appropriate. Examples of these applications are angular velocity detectors and end-of-travel indicators on slides.

Due to the Hall element's inherently small output, the best place for the comparator circuitry needed to turn the linear output into a reliable on-off signal is as close as possible to the sensor and its linear amplifier. Integrating a comparator into the Hall sensor also reduces interfacing costs.

Integrated Hall-effect switches like the 31xx series from Allegro are temperature

stable and stress-resistant. Three new parts with enhanced temperature stability have recently been added to the range, namely the 3121, 3122 and 3123. These have typical switch-on points of 350, 340 and 345G respectively but are otherwise identical.

In addition to a Hall element, linear amplifier and schmitt trigger, the devices include open-collector output buffering with 25mA capability. There is also built-in temperature compensation and a regulator capable of operating from any supply between 4.5 and 24V.

Standard parts are capable of operating in temperatures between -40 and 85°C but there are also L-suffix parts capable of operating at up to 150°C. Since the devices have unipolar switching characteristics they can be used with simple bar or rod magnets. The devices are best used in applications that provide steep magnetic slopes and low residual levels of magnetic flux density.

Output of the devices switches low when magnetic field at the Hall sensor exceeds the operate point threshold. At this point, the output voltage is the saturation voltage of the output transistor, which is typically 140mV.

When the magnetic field is reduced to below the release point threshold, the device output goes high. The difference in the magnetic operate and release points is hysteresis, of typically 105G. This built-in hysteresis allows clean switching of the output even in the presence of external mechanical vibration and electrical noise.

Features

- Good temperature stability
- 4.5 V to 24 V unregulated supply
- Open-collector 25 mA output, compatible with digital logic
- Reverse Battery Protection
- Activate with small, commercially available permanent magnets
- No moving parts
- Small size
- Resistant to physical stress

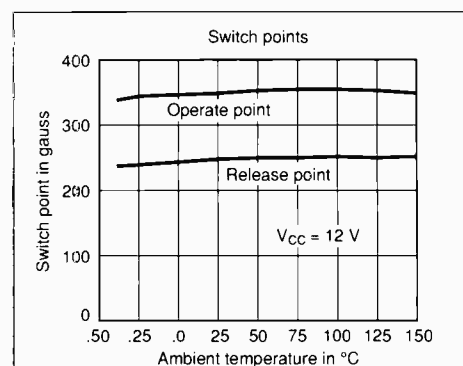

Operate and release points of 3120-series integrated Hall-effect switches remain constant over a wide temperature range.

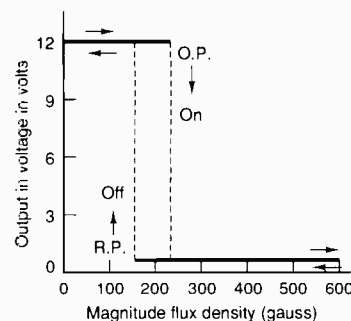

Transfer characteristic of a typical Hall-effect switch. Hysteresis is built into the device – in this case about 90G. This ensures clean switching even in the presence of mechanical vibration or electrical noise.

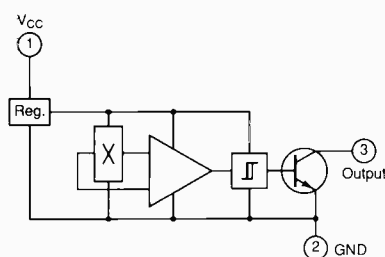

Within an integrated Hall-effect switch such as the 3121 are a Hall voltage generator, temperature compensation, a small-signal amplifier and schmitt trigger. In addition, an emitter follower provides 25mA output capability while a regulator extends supply-voltage capability to a range 4.5 to 24V.

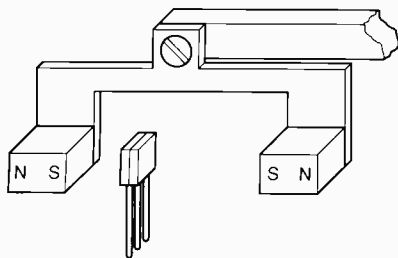

Fig. 4. Linear Hall-effect devices can be used to detect small displacements with high resolution using dual magnets in a push-push configuration.

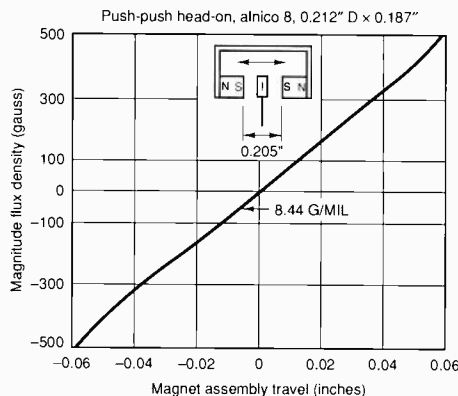

Fig. 5. In a push-push configuration, flux seen by the sensor is linearly proportional with displacement. In the middle of the travel, flux is zero since fields from the two magnets cancel each other.

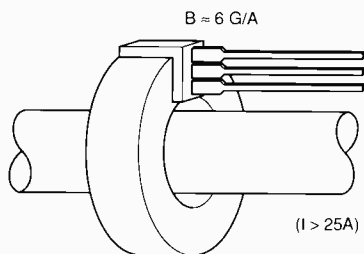

Fig. 6. When 25A or more is involved, a linear Hall-effect sensor in the gap of a toroidal ferrite can be used to measure current in a conductor simply passed through the toroid.

metric sensor such as the 3503, moving the sensor towards one magnet reduces output voltage while moving it towards the other increases output. Polarity depends on which way the sensor is facing.

Current monitoring. Hall effect devices

make excellent current limiting or measuring sensors. Their response bandwidth ranges from dc to kilohertz. For very high-current applications, detection can simply be a matter of placing the sensor in the gap of a slotted toroidal ferrite material wrapped around the conductor, as illustrated in Fig. 6.

Linear output Hall device

Linear Hall-effect linear sensors are used primarily to sense relatively small changes in magnetic fields – changes too small to operate a Hall-effect digital switch. They can detect the motion, position, or change in field strength of an electromagnet, a permanent magnet, or a ferromagnetic material with an applied magnetic bias.

Hall effect sensors like Allegro's UGN3503 not only cheaper but also more efficient and effective than inductive or optoelectronic sensors in many applications. Their power consumption is low and their output is temperature stable.

Linear sensors are useful as front-ends in flux measuring equipment and for detection motion. In addition, they can be used to measure current with negligible system loading while providing isolation from contaminated and electrical-noisy environments.

Between 0 and 900G, the 3503's sensitivity is typically 1.3mV/G. Linear Hall effect integrated circuits include a Hall sensing element, linear amplifier, and emitter-follower output stages. Problems

associated with handling very low level analogue signals are minimised by having the Hall cell and amplifier on the same chip.

Rated for operation over the range of -20 to +85°C, the 3503U is a ratiometric detector, i.e. output voltage depends not only on field strength detected but also by power supply fluctuations. For applications where ratiometric output is not appropriate, there is also a linear sensor with full internal supply regulation – 3501.

Response of the 3503 is flat to 23kHz, making it useful for ac as well as dc measurement. When no magnetic field is sensed, output null voltage is nominally one-half the supply voltage. A south magnetic pole at the part-marked face of the sensor drives the output higher than the null voltage level. A north magnetic pole will drive the output below the null.

Greatest sensitivity is obtained with a supply voltage of 6V, but at the cost of increased supply current and a slight loss of output symmetry. Minimum supply voltage is 4.5V.

In finding the flux reaching the sensor, radius r in inches from the centre of the conductor to the centre of the sensor is important. With r at 0.5in, a current of 1000A produces 159G at the Hall device in the toroid's gap. This is because B in gauss is approximately equal to current in amps divided by $4\pi r$, where r is in inches. Minimising the air gap between the ferrite and sensor generally improves performance.

Current sensing capability is increased by wrapping the conductor around the toroidal ferrite, as shown in Fig. 7. Each additional turn multiplies the gauss-per-ampere intensity seen at the sensor, i.e. ten turns increase the intensity tenfold. Main concerns are that the core retains minimal field when the current is reduced to zero and that the flux density in the air gap is a linear function of current. Consideration also needs to be given to the fact that the air gap changes with temperature.

Designing with Hall switches

Electrical interfacing. Hall-effect switches like those in the 312x series have an open-collector output transistor that can drive up to 25mA. As a result, many loads such as small lamps and relays can be driven without any additional components.

Since the output driver transistor has a saturation rating of typically 140mV – combined with nanovolt-level leakage – interfacing to nearly all common logic technologies rarely requires more than a pull-up resistor.

Driving low-voltage, high-current DC loads via a Hall effect switch requires few additional components. In many applications, an emitter follower will provide the necessary boost with

Features

- High sensitivity
- Flat response to 23kHz
- Low output noise
- 4.5 to 6V supply

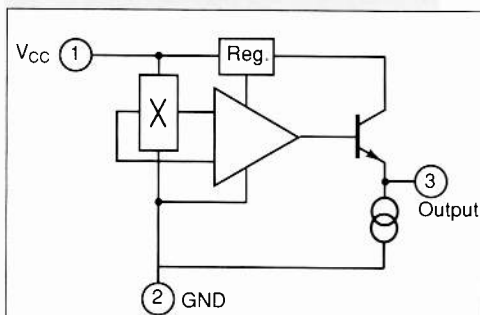

Integrated linear Hall-effect devices like the 3503 from Allegro incorporate a Hall cell, linear amplifier and emitter follower. Supply to the dc amplifier is regulated but the hall feed is not. As a result, this ratiometric device tracks supply voltage.

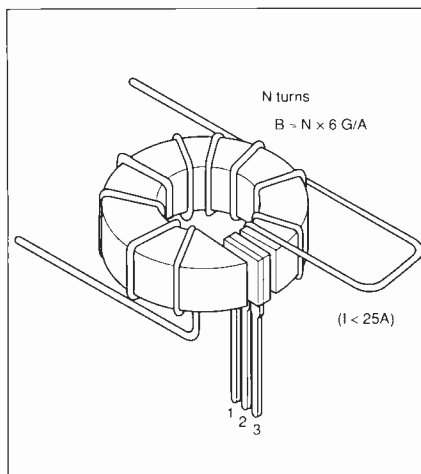

Fig. 7. Combined with slotted toroidal ferrites, Hall-effect devices make ideal non-contact current detectors. Winding the conductor around a slotted toroidal ferrite allows lower currents to be measured.

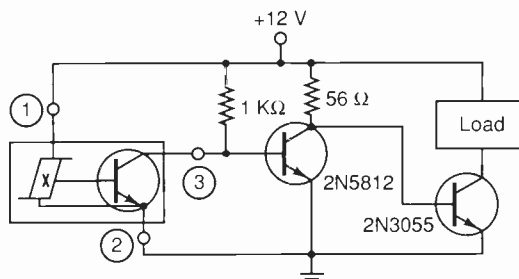

Fig. 8. For loads over 20mA, 3120 Hall-effect switches need buffering. With this configuration, loads of up to 4A can be switched. The first transistor is necessary not only for amplification but also for inversion to ensure that the load switch turns on rather than off when magnetic flux rises above the Hall-device threshold.

a slight loss in efficiency. As **Fig. 8** shows, switching efficiency can be increased by using an inverter amplifier – the 2N5812 – together with a low-cost 2N3055 driver.

Using the 2N5812 intermediate stage provides inversion as well as amplification. It ensures that the load is switched on when the sensor sees magnetic field and off when the field is removed.

Figure 9 demonstrates how easy it is to

adapt the digital Hall-effect device to mains switching applications. The triac needs 80mA of drive but the Hall IC provides up to 25mA. Adding the n-p-n emitter follower solves the problem.

Limit detection. Even with a simple bar or rod magnet, there are several possible paths for motion detection. The magnetic pole can move perpendicularly straight at the active

face of the Hall device. Known as head-on mode, this method is simple, works well, and is relatively insensitive to lateral motion. A drawback is that if the slide carrying the magnet travels too far, the sensor could be damaged.

Flux density plots for a typical head-on systems show that the magnetic slope is quite shallow for low values of flux density – a disadvantage that generally requires extreme

Magnetic materials

Materials most commonly used to provide flux in Hall-effect systems are various Alnicos, Ceramic 1 and barium ferrite in a rubber or plastic matrix materials. Manufacturers often have stock sizes, including cylindrical types with various numbers of pole pairs.

Alnico is the name given to number of aluminum nickel-cobalt alloys that have a fairly wide range of magnetic properties. In general, Alnico ring magnets have the highest flux densities, the smallest changes in field strength with changes in temperature, and the highest cost.

They are generally too hard to shape except by grinding and are fairly brittle which complicates the mounting of bearings or arbor. Ceramic 1 ring magnets, with trade names like Indox, Lodex, have somewhat lower flux densities (field strength) than Alnicos, and their field strength changes more with temperature. They are however considerably cheaper and are highly resistant to demagnetisation by external magnetic fields.

Ceramic materials are resistant to most chemicals and have high electrical resistivity. Like Alnico, they can withstand temperatures well above that of Hall switches and other semiconductors and must be ground if reshaping or trimming is needed.

Rubber and plastic barium ferrite ring magnets are roughly comparable to Ceramic 1 in cost, flux density, and

Material	Maximum energy product (gauss-oersted)	Residual induction (gauss)	Coercive force (oersteds)	Temperature coefficient	Cost	Comments
RE Cobalt	16×10^6	8.1×10^3	7.9×10^3	$-0.05\%/^{\circ}\text{C}$	Highest	Strongest, smallest, resists demagnetizing best
Alnico 1, 2, 3, 4	$1.3 - 1.7 \times 10^6$	$5.5 - 7.5 \times 10^3$	$0.42 - 0.72 \times 10^3$	$-0.02\%/^{\circ}\text{C}$ to $-0.03\%/^{\circ}\text{C}$	Medium	Non-oriented
Alnico 5, 6, 7, 8	$4.0 - 7.5 \times 10^6$	$10.5 - 15 \times 10^3$	$0.64 - 0.76 \times 10^3$	$-0.02\%/^{\circ}\text{C}$ to $-0.03\%/^{\circ}\text{C}$	Medium-high	Oriented
Alnico 8	$5.0 - 6.0 \times 10^6$	$7 - 9.2 \times 10^3$	$1.5 - 1.9 \times 10^3$	$-0.01\%/^{\circ}\text{C}$ to $-0.01\%/^{\circ}\text{C}$	Medium-high	Oriented, high coercive force, best temperature coefficient
Alnico 9	10×10^6	10.5×10^3	1.6×10^3	$-0.02\%/^{\circ}\text{C}$	High	Oriented, highest energy product
Ceramic 1	1.0×10^6	2.2×10^3	1.8×10^3	$-0.2\%/^{\circ}\text{C}$	Low	Non-oriented, high coercive force, hard, brittle, non-conductor
Ceramic 2, 3, 4, 6	$1.8 - 2.6 \times 10^6$	$2.9 - 3.3 \times 10^3$	$2.3 - 2.8 \times 10^3$	$-0.2\%/^{\circ}\text{C}$	Low-medium	Partially oriented, very high coercive force, hard, brittle, non-conductor
Ceramic 5, 7, 8	$2.8 - 3.5 \times 10^6$	$3.5 - 3.8 \times 10^3$	$2.5 - 3.3 \times 10^3$	$-0.2\%/^{\circ}\text{C}$	Medium	Fully oriented, very high coercive force, hard, brittle, non-conductor
Cunife	1.4×10^6	5.5×10^3	0.53×10^3	–	Medium	Ductile, can cold form and machine
Fe-Cr	5.25×10^6	13.5×10^3	0.60×10^3	–	Medium-high	Can machine prior to final aging treatment
Plastic	$0.2 - 1.2 \times 10^6$	$1.4 - 3 \times 10^3$	$0.45 - 1.4 \times 10^3$	$-0.2\%/^{\circ}\text{C}$	Lowest	Can be molded, stamped, machined
Rubber	$0.35 - 1.11 \times 10^6$	$1.3 - 2 \times 10^3$	$1 - 1.8 \times 10^3$	$-0.2\%/^{\circ}\text{C}$	Lowest	Flexible
Neodymium	$7 - 15 \times 10^6$	$6.4 - 11.75 \times 10^3$	$5.3 - 6.5 \times 10^3$	$-15.7\%/^{\circ}\text{C}$ to $-19.2\%/^{\circ}\text{C}$	Medium-high	Non-oriented

There is a wide variety of magnetic materials to choose from when applying Hall-effect devices, ranging from hard, brittle ceramics to rubber.

temperature coefficient. Unlike ceramics however, they are soft enough to shape using conventional methods. It is also possible to mould or press them onto a shaft for some applications. Rubber and plastic magnets do have temperature limitations ranging from 70°C to 150°C depending on the particular material, and their field strength changes more with temperature than Alnico or Ceramic 1.

Regardless of material, ring magnets

have limitations on the accuracy of pole placement and uniformity of pole strength. In turn, this limits the precision of the output waveform. Evaluations have shown that pole placement in rubber, plastic and ceramic magnets usually falls within 2 or 3° of target, but 5° errors have been measured. Variations in flux density from pole to pole will commonly be $\pm 5\%$ although variations of up to $\pm 30\%$ can occur.

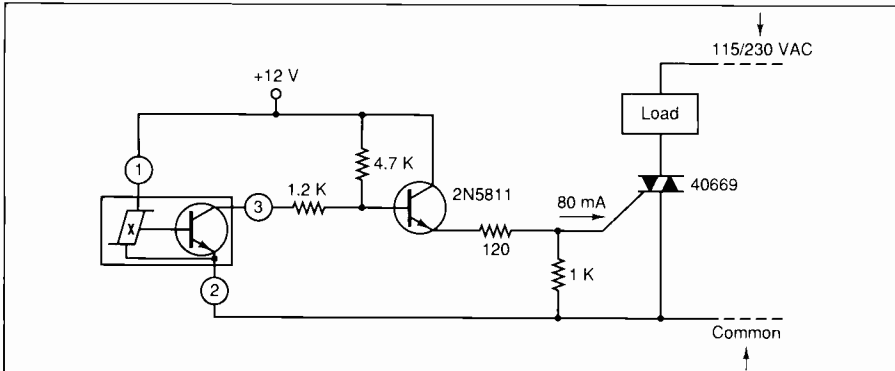

Fig. 9. Since Hall-effect switches in the 3120 range have a 25mA output capability, very few components are needed to control heavy loads. In this circuit, an intermediate n-p-n transistor boosts current to the 80mA or so needed to switch mains loads via a triac.

mechanism travel and extreme sensitivity to flux changes in operate and release points of the Hall switch. This problem can be overcome by selecting Hall switches with higher operate and release properties.

A safer option is to move the magnet in from the side of the Hall device, past its face – slide-by mode. Strong magnets and/or ferrous flux concentrators in well-designed slide-by magnetic circuits allow better sensing preci-

sion with smaller magnet travel than for head-on mode. This method is, however, very sensitive to lateral play, as the flux density varies dramatically with changes in the air gap.

Because the active area of a Hall switch is close to the branded face of the package, it is usually operated by approaching this face with magnetic south pole. It is also possible to operate a Hall switch by applying a magnetic

north pole to the back side of the package. While a north pole alone is seldom used, the push-pull configuration – simultaneous application of a south pole to the branded side and a north pole to the back side – can give much greater field strengths than are possible with any single magnet. Perhaps more important, push-pull arrangements are relatively insensitive to lateral motion and are worth considering if a loosely fitting mechanism is involved.

Another possibility is the push-push arrangement described earlier, Fig. 4. A natural extension of this is to use two oppositely polarised magnets in slide-by mode, moving across the face of a sensor

Hall sensor source

Integrated Hall sensors mentioned in this article – plus others – are available in the UK via Ambar Cascom Ltd, Rabans Close, Aylesbury, Buckinghamshire HP19 3RS. Tel. 0296 434141, fax 0296 29670. Applications literature, upon which this article was based, is also available.

FREE TO SUBSCRIBERS

Electronics World offers you the chance to advertise ABSOLUTELY FREE OF CHARGE!

Simply write your ad in the form below, using one word per box, up to a maximum of twenty words (remember to include your telephone number as one word). You must include your latest mailing label with your form, as this **free** offer applies to private subscribers only. Your ad will be placed in the first available issue.

This offer applies to private sales of electrical and electronic equipment only.

Trade advertisers should call **Pat Bunce on 081-652 8339**

All adverts will be placed as soon as possible. However, we are unable to guarantee insertion dates. We regret that we are unable to enter into correspondence with readers using this service, we also reserve the right to reject adverts which do not fulfil the terms of this offer.

Please send your completed forms to:
 Free Classified Offer: Electronics World, L333, Quadrant House, The Quadrant, Sutton, Surrey SM2 5AS

COMPUTER ICs

8742 1 SHOT	£8	8742 WIPED	£5 **NEW
TMS3201	£5	TMS3201 SHOT	£3 **NEW
AM27C020-125L1 SURFACE MOUNT EPROM	£3		
WIPED		£1.50 **NEW	
MM16450 UART CHIP		£5 ea **NEW	
MM16550 UART CHIP few only		£12 ea **NEW	
P8271 BBC DISC CONTROLLER CHIP EX EQPT		£20	
SAAS050 TELETEXT CHIP EX EQPT		£5	
2817A-20 (2K x 8) EEPROM ex eqpt		£2	
4D1256C-15 256Kx1 PULLS		9 FOR £5	
80C31 MICRO		£2	
P8749H MICRO		£5	
D8751-B NEW		£10	
MK48Z02-20 ZERO POWER RAM EQUIV 6116LP		£4	
NEW 4164-15		£1	
USED 41256-15		£1	
USED 4164-15		60p	
BBC VIDEO ULA		£10	
8051 MICRO		£1.25	
K582C55-250 SAMSUNG 89/90 1100 AVAILABLE		£3	
9 x 41256-15 SIMM		£10	
8 x 4164 SIP MODULE NEW		£8	
FLOPPY DISC CONTROLLER CHIPS 1771		£16	
FLOPPY DISC CONTROLLER CHIPS 1772		£17.50	
68000-8 PROCESSOR NEW		£6	
H06384-8		£5	
ALL USED EPROMS ERASED AND BLANK CHECKED			
2716-45 USED		£2 100/£1	
2732-45 USED		£2 100/£1	
2764-30 USED		£2 100/£1.60	
27C256-30 USED		£2	
27C512 USED		£3.50	
1702 EPROM EX EQPT		£5	
2114 EX EQPT 50p 4116 EX EQPT		70p	
6264-15 8k STATIC RAM		£2	
GR281 NON VOLATILE RAM EQUIV 6116		£5	
Z80A SIO-C		£1.25	
80387-16 CO PROCESSOR (OK WITH 25MHz 386)		£35	
7126 3 1/2 DIGIT LCD DRIVER CHIP		£2 ea	
2816A-30 HOUSE MARKED		£2	
IBM PART NO. 68X6271 PANASONIC PART NO			
MN4840512585 512K X 40			
TMS9000NL PROCESSOR		£20	
TMS9901NL		£10	
TMS9902/3NL TMS9904NL		£5 ea	
HM6167L-P-8		65p	
M27C4001-15		£8	
68000-10 PROCESSOR		£9	

REGULATORS

LM338K	£6
LM323K 5V 3A PLASTIC	£2
LM323K 5VA METAL	£3
SANKEN STR451 USED IN AMSTRAD MONITORS	£5
78H12ASC 12V 5A	£5
78M05 5V 0.5A	7/£1
LM317H T05 CAN	£1
LM317T PLASTIC T0220 variable	£1
LM317 METAL	£2.20
7812 METAL 12V 1A	£1
7805/12/15/24	25p
7905/12/15/24	25p
CA3085 T039 variable reg	2/£1

CRYSTAL OSCILLATORS

2M4576 3M6864 5M0 5M76 6M144 7M000 7M3728 8M000	
12M000 14M3181 17M6256 16M257 18M000 20M000 23M587	
24M000 25M175 27M0 27M036 28M322 32M000 35M4816	
40M000 44M4444 44M900 48M000 64M000 1M000 1M8432	
4M000 10M000 16M000 18M432000 19M0500 20M0500	
38M10000 56M6092 76M1 84M0	£1.50 each

CRYSTALS

4M0256 10M368 17M6256 18M432 25M000 28M4694 31M4696	
48M000 55M500 11M80 12M80 14M318 14M80 1M0	
1M8432 2M000 2M4576 2M77 3M000 3M2768 3M579545	
3M8564 3M93216 4M000 4M19304 4M43319 4M608 4M9152	
5M000 5M0688 6M000 6M400 8M000 8M488 9M8304 10M240	
10M245 10M7000 11M000 12M000 13M000 13M270 14M000	
14M31818 15M000 16M000 16M5888 17M000 20M000	
21M300 21M855 22M1184 24M000 34M368 36M75625	
36M76875 36M78125 36M79375 36M80625 36M81875	
36M83125 36M84375 38M900 49M504 54M19166 54M7416	
57M75833 60M000 69M545 69M550 BN 26M995 RD27M045	
OR27M095 YW27M145 GN27M195 BL27M245	£1 each

TRANSISTORS

MPSA92	10/£1
2N2907A	10/£1
BC477 BC488	10/£1
BC107 BCY70 PREFORMED LEADS	
full spec	£1 £4/100 £30/1000
BC557, BC238C, BC308B	£1/30 £3.50/100
2N3819 FETS short leads	4/£1

POWER TRANSISTORS

OC29	£1.35 ea
P POWER FET IRF9531 8A 60V	3/£1
N POWER FET IRF531 8A 60V	2/£1
2SC1520 sim BF259	3/£1 100/£22
TIP 141/2 £1 ea TIP 112/42B	2/£1
SE9301 100V TDA DARL SIM TIP121	2/£1
PLASTIC 3055 OR 2955 equiv 50p	100/£35
BUZ31 POWER FET TO-220 20V 12.5A	2/£1

TEXT TOOL ZIF SOCKETS

28 PIN USED	£3	40 PIN NEW	£10
SINGLE IN LINE 32 WAY CAN BE GANGED FOR USE WITH ANY DUAL IN LINE DEVICES . . . COUPLING SUPPLIED . . .	2/		
£1.50			

QUARTZ HALOGEN LAMPS

12V 50watt LAMP TYPE M312	£1 ea	HOLDERS 60p ea
24V 150 WATTS LAMP TYPE A1/215		£2.50 each

MISCELLANEOUS

MINIATURE FERRITE MAGNETS 4x4x3mm	10/£1
-----------------------------------	-------

ALPS MOTORIZED DUAL 47K LOG pots with spindle, works on 6v-12v	£1.50 ea
TL071 LO NOISE OP AMP	5 for £1 **NEW
47000u 25v SPRAGUE 36D	£3.50 (£2) **NEW
12 way dil sw	£3 for £1 **NEW
100nF 63V X7R PHILIPS SURFACE MOUNT 30K available	£42/4000 box
10NF 63V X7R PHILIPS SURFACE MOUNT 160K available	£30/4000 box
SWITCHED MODE PSU 40 WATT UNCASED QTY AVAILABLE + 5v 5A, + 12V 2A, 12V 500mA FLOATING	£9.95 (£2) £20/100
330nF 10% 250V X2 AC RATED PHILIPS	£20/100
220R 2.5W WIREWOUND RESISTOR 60K AVAILABLE	£50/1000
CMOS 555 TIMERS	2/£1
2/3 AA LITHIUM cells as used in compact camcass	2/£1.50
ICM7126CPL CMOS 3 1/2 DIGIT LCD DRIVER CHIP	£2 ea
36 CORE 7/0.2mm OVERALL SCREENED	£50/100m
LITHIUM CELL 1/2 AA SIZE	2 FOR £1
PASSIVE INFRA RED SENSOR CHIP + MIRROR + CIRCUIT	£2 each
EUROCARD 21-SLOT BACK PLANE 96/96-WAY "PROTONIC 24 VARIBUS" 16.7" x 5" FIBREGLASS MULTILAYER PRH PCB	£25 ea
EUROCARD 96-WAY EXTENDER BOARD 290 x 100mm	£10 ea

"PROTONIC 24" c/w 2 SUPPORT ARMS/EJECTORS	£1.30
DIN 41612 96-WAY A/B/C SOCKET PCB RIGHT ANGLE	£1.30
DIN 41612 96-WAY A/B/C SOCKET WIRE WRAP PINS	£1.30
DIN 41612 64-WAY A/C SOCKET WIRE WRAP PINS	£1
DIN 41612 64-WAY A/C PLUG PCB RIGHT ANGLE	£1
DIN 41612 64-WAY A/B SOCKET WIRE WRAP (2-ROW BODY)	£1
BT PLUG + LEAD	3/£1
13A MOULDED PLUG + 2m lead	£1
MIN TOGGLE SWITCH 1 POLE c/o PCB type	5/£1
LCD MODULE sim. LM018 but needs 150 to 250V AC for display	£10
40 x 2 characters 182 x 35 x 13mm	2/£1
TL431 2.5 to 36V TO92 ADJ. SHUNT REG	£1/100
6-32 UNC 5/16 POZI PAN SCREWS	£1.25/100
NUTS	2/£1
PUSH SWITCH CHANGEOVER	£1.30
RS232 SERIAL CABLE 25 WAY MALE CONNECTORS	£5.90 ea (£1.30)
25 FEET LONG, 15 PINS WIRED BRAID + FCOIL SCREENS	INMAG LIST PRICE £30
LCD DISPLAY sim Hitachi LM016L	£6.50
AMERICAN 2/3 PIN CHASSIS SOCKET	2/£1
WIRE ENDED FUSES 0.25A	30/£1
NEW ULTRASONIC TRANSDUCERS 32kHz	£2/pr
Also available 28 slot vari-bus backplane same size + Price	NEW
POWERFUL SMALL CYLINDRICAL MAGNE'S	3/£1
BNC 50OHM SCREENED CHASSIS SOCKET	2/£1
SMALL MICROWAVE DIODES AET OC1026a	2/£1
D.I.L. LIGHTCHES 10-WAY £1 8-WAY 80p 4/5 6-WAY	80p
180VOLT 1/2 WATT ZENERS also 12V & 75V	20/£1
MIN GLASS NEONERS	10/£1
RELAY 5V 2-pole changeover looks like RS 35-741 marked	£1 ea
STC 47WB3st	2/£1
MINIATURE CO-AX FREE PLUG RS 456-071	2/£1
MINIATURE CO-AX PCB SKT RS 456-093	2/£1
PCB WITH 2N2646 UNIUNION WITH 12V 4-POLE RELAY	£1
400 MEGAOHM THICK FILM RESISTORS	4/£1
STRAIN GAUGES 40 ohm Foil type polyester backed balco grid alloy	£1.50 ea 10+ £1
ELECTRET MICROPHONE INSERT	£0.90
Linear Hall effect IC Micro Switch no 613 SS4 sim RS 304-267	£2.50 100+ £1.50
HALL EFFECTIC UGS3040 + magnet	£1
OSCILSCOPE PROBE SWITCHED x1 x0	£12
1 pole 12-way rotary switch	4/£1
AUDIO ICS LM380 LM385 TDA 2003	£1 ea
555 TIMERS £1 741 OP AMP	6/£1
ZN414 AM RADIO CHIP	80p
COAX PLUGS nice ones	4/£1
COAX BACK TO BACK JOINERS	3/£1
4 x 4 MEMBRANE KEYBOARD	£1.50
INDUCTOR 20uH 1.5A	5/£1
1.25" PANEL FUSEHOLDERS	3/£1
CHROMED STEEL HINGES 14.5 x 1" OPEN	£1 each
12V 1.2W small watt lamps fit most modern cars	10/£1
STEREO CASSETTE HEAD	£2
MONO CASSETTE HEAD £1 ERASE HEAD	50p
THERMAL CUT OUTS 50 77 85 120°C	£1 ea
THERMAL FUSES 220°C/121°C 240V 15A	5/£1
TRANSIS'OR MOUNTING PADS TO-5/TO- 8	£3/1000
TO-3 TRANSISTOR COVERS	10/£1
PCB PINS FIT 0.1" VERO	200/£1
TO-220 micas + bushes	10/50p 100/£2
TO-3 micas + bushes	15/£1
Large heat shrink sleeving pack	£2
IEC chassis plug filter 10A	£3
POTS SHORT SPINDLES 2K5 10K 25K 1M 3M5	4/£1
40K U/S TRANSDUCERS EX-EQPT NO DA "A"	£1/pr
LM3352 10Mv/degree C	£1
LM2342 CONST. CURRENT I.C.	£1
BNC TO 4MM BINDING POST SIM RS 455-961	£1
MIN PCB POWER RELAYS 10.5v COIL 6A CONTACTS 1 pole c/o	£1
AVEL-LINDBERG MOULDED TRANSFORMER TYPE OB10 15 + 15V 10VA QTY. AVAILABLE	£2 ea
IN4148	100/£1.50
IN4004 SD4 1A 300V	100/£3

1N5401 3A 100V	10/£1
BA158 1A 400V fast recovery	100/£3
BY127 1200V 1.2A	10/£1
BY254 800V 3A	8/£1
BY255 1300V 3A	6/£1
6A 100V SIMILAR MR751	4/£1
1A 600V BRIDGE RECTIFIER	4/£1
4A 100V BRIDGE	3/£1
6A 100V BRIDGE	2/£1
10A 200V BRIDGE	£1.50
25A 200 V BRIDGE £2	10/£18
25A 400V BRIDGE £2.50	10/£22
2KBPO2 IN LINE 2A 200V BRIDGE REC	8/£1

SCRS

PULSE TRANSFORMERS 1:1 + 1	£1.25
2P4M EQUIV C106D	3/£1
TICV106D 800mA 400C SCR 3/£1	100/£15
MEU21 PROG. UNIUNION	3/£1

TRIACS

NEC TRAC ACO8F 8A 600V TO220	5/£2 100/£30
TXAL225 8A 500V 5mA GATE	2/£1 100/£35
BT4 08-400 ISO TAB 400V 5mA GATE	90p
TRAL22300 30A 400V ISOLATED STUD	£5 ea
TRIAIC 1A 800V TLC381T 16k AVAILABLE	5 FOR £1 £15/100

DIACS 4/£1

CONNECTORS

D25 IDC PLUG OR SOCKET	£1
34-way card edge IDCONNECTOR (disk drive type)	£1.25
CENTRONICS 36 WAY IDC PLUG	£2.50
CENTRONICS 36 WAY IDC SKT	£4.00
BBC TO CENTRONICS PRINTER LEAD 1.5M	£3
CENTRONICS 36 WAY PLUG SOLDER TYPE	£4
USED CENTRONICS 36V PLUG + SKT	£3
14 WAY IDC BLOCK HEADER SKT.	5/£1

PHOTO DEVICES

HI BRICHTNESS LEDS CQX24 RED	5/£1
SLOTT 3D OPTO-SWITCH OPCOA OPB815	£1.30
2N5777	50p
TIL81 F-OTO TRANSISTOR	£1
TIL38 INFRA RED LED	5/£1
4N25, CP12252 OPTO ISOLATOR	50p
PHOT. DIODE 50P	6/£2
ME112 PHOTODARLINGTON ON BASE n/c	50p
LED's RED 3 or 5mm 12/£1	100/£6
LED's GREEN OR YELLOW 10/£1	100/£6
FLASH SIGN RED OR GREEN LED 5mm 50p	100/£40
HIGH SPEED MEDIUM AREA PHOTODIODE RS651-995	£10 ea

STC NTC BEAD THERMISTORS

G22 222R, G13 1K, G23 2K, G24 20K, G54 50K, G25 200K, RES 2°C DIRECTLY HEATED TYPE	£1 ea
FS22B 1" NTC BEAD INSIDE END OF 1" GLASS PROBE RES	£1 ea
A13 D1 RECTIFY HEATED BEAD THERMISTOR 1k res. ideal for audio Wien Bridge Oscillator	£2 ea

CERMET MULTI TURN PRESETS 3/4"

10R 20R 100R 200R 500R 20K 2K 2K 5K 10K 47K 50K	
100K 200K 500K 2M	50p ea

IC SOCKETS

14/16/8/20/24/28/40-WAY DIL SKTS	£1 per TUBE
8-WAY DIL SKITS	£2 per TUBE
32-WAY TURNED PIN SKTS, 7k available	3 for £1
SIMM SOCKET FOR 2x 30-way SIMMS	£1

POLYESTER/POLYCARB CAPS

330nF 10% 250V AC X2 RATED PHILIPS TYPE 330	£20/100
100n, 20n 63V 5mm	20/£1 100/£3
1n/3n/5n/6n/8n/20n/10n 1% 63V 10mm	100/£5
10n/15n/22n/33n/47n/66n 10mm rad	100/£3.50
100n 250V radial 10mm	100/£3
100n 250V Sprague axial 10/£1	100/£6 (£1)
2u2 100V rad 22mm, 2u2 100V rad 15mm	100/£10
10n/33n/47n 250V AC rated 15mm	100/£1
1u 60CV MIXED DIELECTRIC	50p ea
1u0 100V rad 15mm, 1u0 22mm rad	100/£6

RF BITS

SAW FILTERS SW662/SW661 PLESSEY SIGNAL	£1.50 ea **NEW
TECHNOLOGY 379.5 MHz	£1.50 ea **NEW
FX3266 FERRITE RING (ON CX25) ID 5mm OD 10mm	10 for £1 **NEW
ASTE 7UM1233 UHF VIDEO MODULATORS (NO SOUND)	£1.50 **NEW
1250 2T OCK	£1.50 **NEW
MARCONI MICROWAVE DIODES TYPES DC2929, DC2962	£1 ea</

KESTREL ELECTRONIC COMPONENTS LTD

- ☆ All items guaranteed to manufacturers' spec.
- ☆ Many other items available.

'Exclusive of V.A.T. and post and package'

	1+	100+		1+	100+
EPROMS			STATIC RAMS		
2764A	2.50	2.20	62256ALP-10	3.00	2.30
27C64-150	2.30	1.90	6264ALP-10	1.85	1.40
27128A-250	2.40	2.10	6116ALP-10	1.10	0.70
27256-250	2.40	1.90	6522P	2.40	1.80
27C256-150	2.90	2.30	65C02P2	2.90	2.50
27C512-150	3.30	2.50	65C21P2	2.90	2.50
27C010-150	5.80	4.00	65C22P2	2.80	2.40
MAX232	1.35	0.95	146818AP	2.20	1.65
D8748H	4.20	3.20	75176BP	1.60	0.80
D8749H	4.40	3.40	Z80A CPU	1.33	0.99
80C31-12	2.60	2.10	Z80A CTC	1.20	0.75
80C39P	2.80	2.20	Z80A DAR7	2.10	1.40
82C55-2	1.95	1.58	ULN2803A	0.70	0.46

74LS, 74HC, 74HCT Series available

Phone for full price list

All memory prices are fluctuating daily, please phone to confirm prices

**178 Brighton Road,
Purley, Surrey CR8 4HA**

Tel: 081-668 7522. Fax: 081-668 4190.

CIRCLE NO. 119 ON REPLY CARD

CVC

Chelmer Valve Company

**Worldwide supplier
with 30 year's experience**

- **Electron tubes: Transmitting, Industrial, Microwave, Audio, Receiving, Display, etc, etc.**
- **For Maintenance, Spares or Production.**
- **Semiconductors: Transistors, Thyristors, Diodes, RF, Power I/C's, etc.**
- **We have one of the largest stocks in the U.K.**

★ TRY US! ★

FAX, PHONE, POST OR TELEX YOUR REQUIREMENTS
**130 NEW LONDON ROAD, CHELMSFORD,
ESSEX CM2 0RG, ENGLAND**

Telephone: (0245) 355196/265865
Telex: 995398 SEEVEE G Fax: (0245) 490064

CIRCLE NO. 121 ON REPLY CARD

JPG Electronics

Inverter toroidal transformers 225VA 10.5-0-10.5 primary 0.280-286 secondary..... £29.95
LEDs 3mm or 5mm, red or green..... 6p each
Yellow..... 11p each
High intensity red, green or yellow 5mm..... 30p each
Cable ties, 1p each, £5.95 per 1000, £49.50 per 10,000
High quality photo resist copper clad epoxy glass boards
Dimensions single sided double sided
3x4 inches £1.09 £1.23
4x8 inches £2.75 £2.99
6x12 inches £6.20
12x12 inches £12.25
Rechargeable batteries
A A (HP 7) AA 500mAH with solder tags..... £1.55
AA 700mAH..... £1.75 C/HP1 1.8AH..... £2.20
C 2AH with solder tags..... £2.60 D/HP2 1.2 AH..... £2.60
P P 3 8 1 V
D 4AH with solder tags..... £1.95 110mAH..... £1.95
Suh. C. with solder tags..... £1.95 1/3 AA with tags (Philips CTV)..... £1.95
180mAH..... £1.75
Standard charger charges 4 AA cells in 5 hours or 4Cs or Ds in 12-14 hours + 1xPP3 (1, 2, 3 or 4 cells may be charged at a time)..... £5.95
High power charger as above but charges the Cs and Ds in 5 hours. AAs, Cs and Ds must be charged in 2s or 4s..... £10.95
Nickel Metal Hydride AA cells high capacity with no memory. 1000mAH £3.85 1200mAH £4.40
Special offers, please check for availability.
Stick of 1 171mmx16mm dia with red & black leads 4s..... £1.45
42 x 16mm dia 1.2v..... £1.45
42 x 171mmx16mm dia with red & black leads 4s..... £1.45
Computer grade capacitors with screw terminals
3800uf 20v..... £2.50
87 0 0 u f 1 0 v..... £1.95 6 8 0 0 u f 1 5 v..... £2.95 10600uf 16v..... £1.50 5000uf 60v..... £1.95
7 segment common anode led display 12mm..... £0.45
LM2931A T5.0 low drop out 5v regulator T0220 package..... £0.85
7812 and 7912 12s 1A regulators..... £26.00 per 100
LM337K 103 case variable regulator..... £1.95 (£1.44 100+)
GaAs FET low leakage current SR873..... £12.95 each (£9.95 10+, £7.95 100+)
BS250 P channel mosfet..... £0.45 BC559 transistor..... £3.95 per 100
74LS05 hex inverter £10.00 per 100 Used 8748 Microcontroller..... £3.50
SL952 UHF Limiting amplifier I.C. 16 surface mounting package with data sheet..... £1.95
A M 2 7 S 0 2..... £1.25 each 9 0 p 1 0 0 + CD4007UB..... 10p 100+ (6p, 1000+)

Sinclair light gun terminated with a jack plug and PPS clip gives a signal when pointed at 50Hz Flickering light with output wave form chart..... £3.95
DC-DC converter Reliability model V12P5 12v in 5v 200ma out 300v input to output isolation with data..... £1.95 each or pack of 10..... £39.50
Hour counter used 7 digit 240v ac 50 Hz..... £1.45
QWERTY keyboard 58 key good quality switches new..... £5.00
Airpax A82903-C large stepping motor 14s 7.5 step 270hm 68mm dia body 6 3mm shaft..... £8.95 or £200.00 for a box of 30
Polyester capacitors 6v type 22.5mm lead push 0.9uf 250Vdc 18p each 14p, 100+ 9p 1000+ 1uf 250Vdc..... 20p each 15p, 100+ 10p, 1000+ 2.2uf 250Vdc (27.5mm pitch)..... 30p each 20p 100+ 15p, 1000+
3.3uf 10Vdc..... 30p each 20p, 100+ 15p, 1000+ 1uf 50v bipolar electrolytic axial leads..... 15p each 7.5p, 1000+
0.22uf 250v polyester axial leads..... 15p each, 7.5p 100+
Polypropylene 1uf 100Vdc (Wima MKP10) 27.5mm pitch 32x29x17mm case 75p each 60p, 100+
Philips 125 series solid aluminium axial leads - 33uf 10v & 2.2uf 40v..... 40p each 25p 100+
Philips 108 series 22uf 63v axial..... 30p each 15p, 1000+
Multiterm A series ceramic capacitors all 5mm pitch 100k, 100pf, 150pf, 220pf, 10,000pf (10m)..... 10p each 5p, 100+ 3.5p, 1000+
500pf compression trimmer..... 60p 10 of 370vdc motor start capacitor (dielectric type containing no PCBs)..... £5.95 or £49.50 for 10
Welwyn W239W 120ohm..... 35p each 20p 100+ 680 ohm 2W metal film resistor 4p 100+ 2p, 1000+
Solid carbon resistors very low inductance ideal for RF circuits - 270hm 2W, 680hm 2W..... 25p each 15p each 100+
We have a range of 0.25w 0.5w 1w and 2w solid carbon resistors, please send SAE for list.
P.C. 400W PSU (Intel part 201035-901) with standard motherboard and 5 disk drive connectors, fans and mains inlet/outlet connectors on back and switch on the side (top for tower case) dims 212x149x149mm excluding switch, £26.00 each £138.00 for 6
MX180 Digital multimeter 17 ranges 1000vdc 750vac 200mA transistor 110e 9v and 1.5v battery test..... £12.95
AMD 27256-3 E-proms..... £2.00 each £1.25 100+ D1P switch 3P/CD 12 pin (FRG SDC-3-023)..... 60p each 40p, 100+
Disk drive boxes for 3.25 disk drive with room for a power supply, light grey plastic, 65x208x247mm..... £7.95 £49.50 for 10
Hand held ultrasonic remote control..... £3.95
CV2486 gas relay, 30x10mm dia with 3 wire terminals, will also work as a neon light..... 20p each £7.50 per 100
A23 12v battery for car alarms or lighters..... 75p each £50.00 per 100

All products advertised are new and unused unless otherwise stated.
Wide range of CMOS TTL 74HC 74F Linear Transistors kits. Rechargeable batteries, capacitors, tools etc always in stock. Please add £1.95 towards p&ep. VAT included in all prices.

JPG Electronics, 276-278 Chatsworth Road, Chesterfield S40 2BH
Access/Visa **(0246) 211202** Callers welcome

CIRCLE NO. 120 ON REPLY CARD

MEGAPROM device programmer. EPROMS, E2PROMS, and FLASH memories from 2k (2716) to 8 Meg (27C080). Runs on IBM PC via the centronics port using standard printer cable. Works on all PC compatibles, laptops, and notebooks. No special port requirements.
Uses approved programming algorithms. Very fast program and verify 27C512 (64K Bytes) in 45 seconds.
Full screen editor software supports Bin, Intel Hex, Motorola S and Asc formats. **Only £99.95**
Top quality components used throughout including production ZIF socket.
Requires external power supply 18-25v AC or DC @ 250ma. (optional extra £6.50)
PICPROG Programs Pic16C54-55-56-57-71-84. Centronics port interface same as Megaprom. Powerful editing software to Read, write & copy Pic devices including data memory in Pic16C84. Unit supplied with IBM software & 12 months parts & labour guarantee. **Only £69.95**
Requires external power 15-20v AC or DC @ 250ma. (optional extra £6.50).
EPROM EMULATOR Works on ANY computer with centronics printer port. Data sent to the printer appears in the target board E-prom socket. Emulates from 1k to 32k Byte (27C256) roms, board switchable. Power supplied from target Rom socket (less than 10ma). Very fast download. Software supplied for IBM PC to convert and send Intel Hex, Motorola S, ASC and Bin files. **Only £49.95**
Board supplied with software and 12 months parts and labour guarantee.
PC SCOPE Convert your IBM PC into a Storage Oscilloscope with our A/D converter. Simply plug into the printer port (no power required). Sample rate 10k to 30k per second. Software supplied for Scope and Voltmeter. A/D source to write your own programs. **Only £29.95**
DEVELOPMENT SOFTWARE
Develop software on your IBM PC for other Microprocessors, Controllers, Pic's etc. Software has fully integrated Text Editor, Assembler, Disassembler and Simulator.
The Simulator displays all registers along with disassembled code program counter, Condition code register. The user can single-step, go with breakpoints, watch memory etc. change any/all registers/memory locations at any time (on the fly).
Code can be Saved to disk and/or downloaded directly to our EPROM Emulator. All software supplied with sample ASM files and user documentation.
Very powerful software as supplied to universities, colleges ITECS and Industry.
Available for the following:-
MCS8051/52/552 series Software £19.95 MCS8048/49 series Software £19.95
PIC16C54/5/6/7 Software £29.95 PIC16C71/84 Software £29.95
HD63689 Software £49.95

LOW COST PIC ICE (In-Circuit Emulator)
Plus into the printer port and runs in conjunction with the PIC development simulator software. Appears to the target system as a normal Pic device including OSC2 and RTCC in/out. Runs in real time from the IBM PC changes made to File registers reflected on target. Supplied with Software of your choice Pic54-57 or Pic 71/84 **Only £89.95**

All hardware carries a 12 months parts and labour Guarantee. No VAT payable.
Please add £1.50 for Carriage. SAE or TEL for further details.

JOHN MORRISON DEPT WW
4 Rein Gardens, Tingley
West Yorkshire
Tel (or Fax): 0532 537507



CIRCLE NO. 122 ON REPLY CARD

Please mention *Electronics World + Wireless World* when seeking further information.

Battery-powered circuit measures down to $\mu\Omega$

This simple battery-powered adapter converts an ordinary digital voltmeter into a four-wire milliohm meter. It is said to accurately measure the resistance of wiring, motor coils, solenoids, high-current inductors and meter shunts. It can also be used for locating short circuits in a power supply or a printed circuit board.

With components shown, the circuit shown is about $\pm 2\%$ accurate. For higher accuracy, you can make component adjustments described later.

The circuit applies 1A, 100mA, or 10mA to the unknown resistance via two test leads, depending on the range-switch setting. Next, the DVM is set to its 2V range and connected via two more test leads. This forms a four-wire connection to the resistance being measured.

Indications on the DVM are presented directly in ohms on pressing the momentary-on power switch. A 1.000 Ω resistance, for example, reads 1.000V on the circuit's 1A range, so one millivolt corresponds to one milliohm. Four and five-digit DVMs frequently have 1mV sensitivity, providing resolutions of 1m Ω .

Because the output is a current source, the unknown resistance of the connections and test leads does not cause measurement errors. Accuracy depends on the DVM, the op amp's input-offset voltage – which is $\pm 70\text{mV}$ maximum for the device shown – and the tolerance of resistors R_{1-6} .

To set up the circuit, first trim the 1A range by selecting R_4 or by adding a trimming potentiometer between R_1 and R_2 . Next, trim the 100mA range and then the 10mA range by adjusting the highest-valued resistors in the R_5 and R_6 networks.

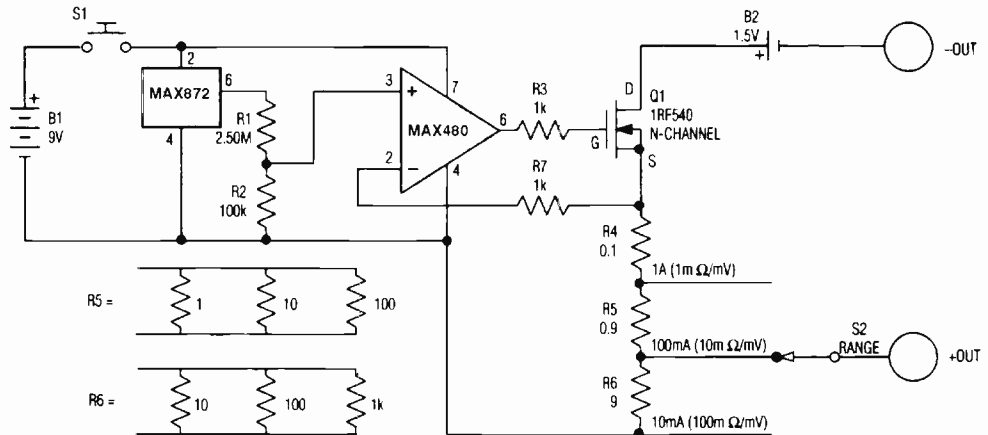

Added on to a digital multimeter, this circuit accurately measures resistances down to micro-ohms and can be used to detect shorts on PCBs.

Pressing the push-button turns on the micropower reference, which produces 2.500V. Resistors R_1 and R_2 divide that output to 0.1V, and the op-amp forces 0.1V at the source of the mosfet. This action creates a current source that develops 0.1V across R_4 , R_5 , and R_6 .

The range switch selects a current of 1A, 100mA, or 10mA in the loop formed by the resistors, the unknown resistance, the 1.5V battery, and the mosfet.

Note that releasing S_1 , or disconnecting the adapter, eliminates all current drain from the 1.5V battery. As a result, an alkaline 'D' cell can produce thousands of measurements – even on the 1A range, if the push button is used sparingly. The 9V battery can last for years because its load is less than 30 μA .

To search for a shorted component or a

short between tracks on a pcb, first connect the two adapter leads, one to each of the tracks in question. Connect a DVM lead to the same point as one adaptor lead, and use the other DVM lead to probe along the tracks.

Location of the short is revealed by the highest reading on one track and the lowest reading on the other. Constant readings indicate no adapter current flowing in that section of the track, so that section can be eliminated from the search.

The design is taken from Maxim's *Engineering Journal* number 14.

Maxim Integrated Products,
21C Horseshoe Park, Pangbourne,
Reading RG8 7JW. Tel. 0734 845 255,
fax 843863.

Power-fail and reset for PCs

A number of power management functions have been integrated into one chip by Dallas Semiconductor. This chip – the *DS1632* – produces the real-time clock reference, a controlled reset signal, power-source switching and power-fail indication.

Many PC chip sets already provide a real-time clock. For those that do not, or for applications where the existing RTC is not accurate enough, the *DS1632* provides a stable 32.763kHz reference. Tuning is provided on chip so no additional oscillator components are needed. Using a 6pF-load crystal such as the Daiwa *DT26S* or Seiko *DS-VT-200*, timing

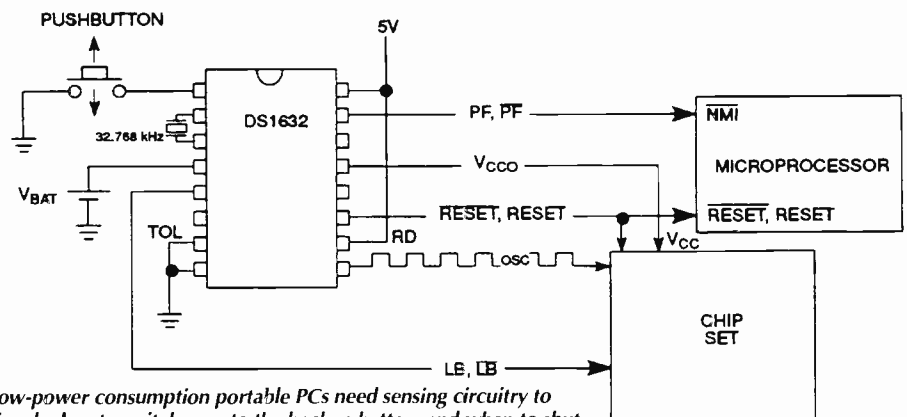

Low-power consumption portable PCs need sensing circuitry to signal when to switch over to the backup battery and when to shut down altogether if the battery fails. This IC provides those features together with properly timed resets and a stable 32.768kHz crystal oscillator for a real-time clock.

APPLICATIONS

accuracy is two minutes per month.

A reset signal for a microprocessor must be triggerable from a number of sources. Most important of these sources are power fail, power-up, and user demanded system resets. To provide these in discrete logic needs a fair number of chips, as shown. This logic however is built into the DS1632.

In addition to power-fail outputs signalling an out-of-tolerance supply voltage, the device can be used to switch between a main power source and a backup. Uninterrupted operation is ensured by window comparator circuitry. It switches the power fail line without causing reset when supply voltage falls enough to warn of impending failure but not enough to cause incorrect operation of the circuits fed by the power supply.

Further circuitry provides a signal giving warning when battery voltage becomes low so that the system can be shut down in an orderly fashion.

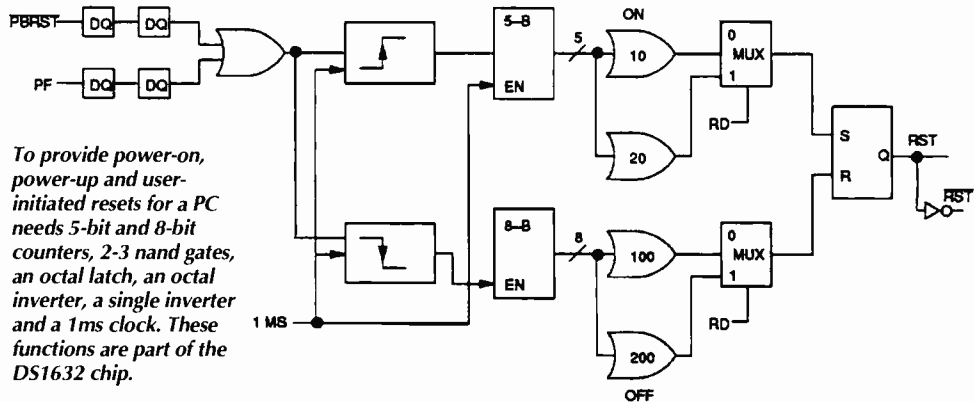

To provide power-on, power-up and user-initiated resets for a PC needs 5-bit and 8-bit counters, 2-3 nand gates, an octal latch, an octal inverter, a single inverter and a 1ms clock. These functions are part of the DS1632 chip.

According to Dallas Application Note 64 which includes further details on the circuitry described here, the DS1632 one-chip solution costs \$2.45 as opposed to \$5.75 for an equivalent discrete solution. There is also specific information on

interfacing the device to Intel's 386SL and the Chips Technologies/Siemens 82C206.

Dallas Semiconductor, Unit 26, Freeport, Birmingham B26 3QD. Tel. 021 782 2959, fax 021 782 2156.

Programmable oscillator is easy to use

Normally, oscillator ICs designed to work with crystals need additional passive components selected for the specific crystal frequency. The HA7210 from Harris can be externally programmed for any crystal between 10kHz and 10MHz by simply connecting two programming pins to logic one or zero. Apart from the crystal, it needs no additional components.

Operating from a single supply rail

between 2 and 7V, the 7210 is a low power device needing 130µA at 1MHz and only 5µA at 32kHz. As the device data sheet describes, it will drive two CMOS loads.

Applications of the oscillator include battery powered circuits, remote metering systems and palm-top notebook PCs. The 7210 also has a disable mode that switches the output to a high impedance state. This feature is useful for minimising power

dissipation during standby and when multiple oscillator circuits are used. The high impedance output provides a high resistance path to ground to avoid floating CMOS inputs.

Harris Semiconductor, Riverside Way, Camberley, Surrey GU15 3YQ. Tel. 0276 686886, fax 0276 682 323.

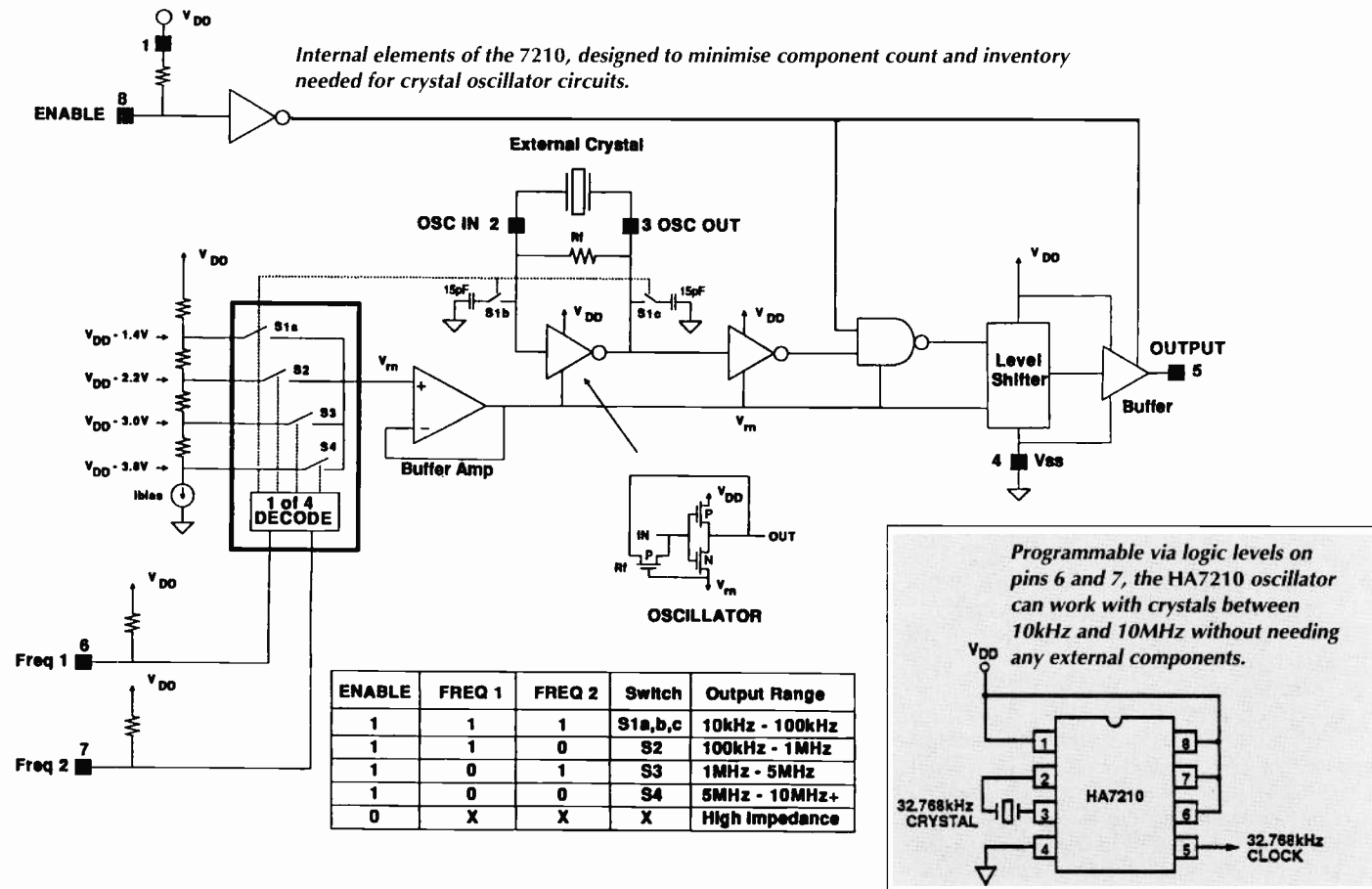

THE INTERNATIONAL GROUP FOR APT, HRPT, ETC.
INNOVATIONS, CONSTRUCTION, HARDWARE, SOFTWARE.

RIG

Remote Imaging Group
JOURNAL

For all
**WEATHER
SATELLITE**
Enthusiasts

Membership: £10.00 UK, £12.00 Europe
£14.00 All Others

All Enquiries to:

Membership Secretary, Ray Godden
RIG-SUB, P.O. Box 142, RICKMANSWORTH,
HERTS, WD3 4RQ. ENGLAND

CIRCLE NO. 123 ON REPLY CARD

R.S.T.

LANGREX SUPPLIES LTD

R.S.T.

One of the largest stockists and
distributors of electronic valves, tubes
and semiconductors in this country

Over 5 million items in stock covering more than
6,000 different types, including CRT's camera
tubes, diodes, ignitrons, image intensifiers, IC's,
klystrons, magnetrons, microwave devices, opto
electronics, photomultipliers, receiving tubes,
rectifiers, tetrodes, thyratons, transistors,
transmitting tubes, triodes, vidicons.

All from major UK & USA manufacturers.

Where still available.

Obsolete items a speciality. Quotations by return.
Telephone/telex or fax despatch within 24 hours
on stock items. Accounts to approved customers.
Mail order service available.

LANGREX SUPPLIES LTD
1 Mayo Road, Croydon, Surrey CR0 2QP
Tel: 081-684 1166
Telex: 946708
Fax: 081-684 3056

CIRCLE NO. 124 ON REPLY CARD

WE HAVE THE WIDEST CHOICE OF USED OSCILLOSCOPES IN THE COUNTRY

**TEXTRONIX 7000 SERIES OSCILLOSCOPES
AVAILABLE FROM £200. PLUG-INS SOLD
SEPARATELY**

TEXTRONIX 2235 Dual Trace 100MHz Delay Sweep	£800
PHILLIPS 3065 2+1 Channels 100MHz Dual TB Delay Sweep	£700
TEXTRONIX 475 Dual Trace 200 MHz Delay Sweep	£550
TEXTRONIX 465 Dual Trace 200 MHz Delay Sweep	£450
H.P. 1715A Dual Trace 200MHz Delay Sweep	£500
HAMEG 605 Dual Trace 60MHz Delay	£400
PHILLIPS PM3217 Dual Trace 50MHz Delay Sweep	£400
TEXTRONIX SC504 Dual Trace 80MHz in TM503	£500
TEXTRONIX 2215 Dual Trace 60MHz Delay Sweep	£450
TEXTRONIX 455 Dual Trace 50MHz Delay Sweep	£400
WITACM V905F Dual Trace 60MHz Delay Sweep	£400
TRIO CS1830 Dual Trace 30MHz Delay Sweep	£160
GOLDL OS1100 Dual Trace 30MHz	£225
IWATSU SS5702 Dual Trace 20MHz	£200
GOLDL OS3000 Dual Trace 20MHz	£175
GOLDL OS2508 Dual Trace 15MHz	£125
TEXTRONIX 2430 Dual Trace 150MHz Digital Storage	EP D.A.
TEXTRONIX 466 Dual Trace 100MHz Delay Sweep Analogue Storage	£450
H.P. 1741A Dual Trace 100MHz Delay Sweep Analogue Storage	£450

THIS IS JUST A SAMPLE. MANY OTHERS AVAILABLE

PHILLIPS PM5193 Programmable synthesizer/function Generator
0.1MHz-50MHz REEL-488 As new £1500

MARCONI 2018 Synthesized AM/FM Sig Gen 80kHz-520MHz	£900
RACAL 9081 Synthesized AM/FM Sig Gen 1.5-520MHz	£300
EIP/DANA 351D Microwave Frequency Counter 20Hz-18GHz	£950
RACAL 9521 Frequency Counter 30Hz	£300
RACAL/DANA 1891 Nanosecond Universal Counter	£800
RACAL 9302 Millivoltmeter True RMS 10kHz-1.5GHz	£450
RACAL 9301A RF Millivoltmeter True RMS 10kHz-1.5GHz	£300
RACAL 9009 Automatic Mod. Meter 10MHz-1.5GHz Wide Deviation	£250
LYONS PG73N Pulse Gen. PRF 1Hz-20MHz	£150
FARNELL PG5220H Synthesised Sig Gen AM FM 100kHz-520MHz	£800
PHILLIPS PM6399 Distortion Meter 0.01%	£300

BRUEL & KJØER Vibration Exciter System Consisting of exciter control
1047 Power Amp 2708 & Excite Body 4802 (up to 1780N - 400lbf)

OTHER B&K EQUIPMENT AVAILABLE

SPECTRUM ANALYSERS

HP 141T with 8555A & IF Plug-in 10MHz-18GHz	£2000
HP 141T with 8554B & 8552B 500kHz-1250MHz	£1300
HP 140T with 8554L & 8552A 500kHz-1250MHz	£1000
HP 141T with 8556A & 8552B 20Hz-300kHz	£1000
HP 140T with 8553L & 8552A 1kHz-110MHz	£800
MARCONI TF2370 30Hz-110MHz	£1500
HP 182C with 8558B 100kHz-1500MHz	£1500
HP 3182A 0.02Hz-25.5kHz	£2000

Used Equipment - GUARANTEED. Manuals supplied if possible.

This is a VERY SMALL SAMPLE OF STOCK. SAE or Telephone for lists. Please check availability before ordering.
CARRIAGE all units £16. VAT to be added to Total of Goods and Carriage

STEWART of READING

110 WYKEHAM ROAD, READING, BERKS RG6 1PL
Telephone: (0734) 268041. Fax: (0734) 351696
Callers Welcome 9am-5.30pm Monday to Friday (until 8pm Thursday)



CIRCLE NO. 125 ON REPLY CARD

H.P. 8640B Sig Gen 20Hz - 1024MHz	£1500
H.P. 8620C Sweep Osc with 86245A 5.9-12.4GHz	£750
MARCONI 2435 Digital Freq Meter 20Hz	£900
BRADLEY S2 Oscilloscope Calibrator	£600
WILTRON 560 Scaler Network Analyser with Detectors	£1000
FERRUGRAPH RT52 Audio Test Set with ATU	£550
LINDOS LA1 MA2B Audio Analyser	£500
DATRON 1061A - 6 1/2 digit True RMS AC/Current	£1250
DATRON 1055 Multimeter 5 1/2 digit AC/DC/Ohms IEEE	£800
HEWLETT PACKARD 3450A Bench Multimeter 5 1/2 digit AC/DC/Ohms	£200
PHILLIPS PM2534 Multifunction DMM 6 1/2 digit. GPB IEEE	£450
MARCONI Digital Frequency Meter 2430A 10Hz-80MHz	£125
MARCONI Digital Frequency Meter 2431A 10Hz-200MHz	£150
MARCONI Universal Counter Timer 2437DC 100MHz	£175
MARCONI Universal Counter Timer 2438DC-520MHz	£225
FEEDBACK FG600 Sine-Sp/Tr 0.01Hz-100MHz	£60
MULTIMETERS Hand Held M2355-32 ranges AC DC 10 Amps Diode/ Transistor Tester Freq counter	£32.50

SOLARTRON SCHLUMBERGER 1250 Frequency Response Analyser £3500

HP 8590 Sweep Osc with 86974 Plug-in 26.5-40GHz	£300
RACAL/DANA RF Power Meter 9104	£400
WAYNE KERR 8905 Automatic Precision Bridge 0.05%	£900
WAYNE KERR 8605 Automatic Component Bridge 0.1%	£350
FARNELL PSU 71570MHz 70W 5A 30V/10A	£300
FARNELL PSU H50725 0-65V 0-25amps Metered	£400
FARNELL B3070 0-30V 20Amps	£250
FARNELL B3010 0-30V 10Amps	£200
H.P. 6209B 0-320V 0.01Amps Metered	£125
BRANDENBERG 472R PSU +/-2kV	£200
MARCONI TF2700 Universal LCR Bridge Battery from	£150
AVO Valve Tester CT150	£75
FARNELL LAS20 RF Power Amp 1.5-520MHz 300mW	£175
RACAL 9100 Absorption Wattmeter 1MHz-10GHz 3W	£100

FARNELL Isolating Transformers

GU500, 240v 500VA, unused £50

NEW EQUIPMENT

HAMEG OSCILLOSCOPE HM1005 Triple Trace 100MHz Delay Timebase..	£847
HAMEG OSCILLOSCOPE HM604 Dual Trace 60MHz Delay Sweep	£553
HAMEG OSCILLOSCOPE HM203 7 Dual Trace 20MHz Component Tester	£382
HAMEG OSCILLOSCOPE HM205 3 Dual Trace 20MHz Dc.ital Storage	£653
All other models available - all oscilloscopes supplied with 2 probes	
BLACK STAR EQUIPMENT (P&P all in-its-ES)	
APOLLO 10-100MHz Counter Timer Ratio/Period/Time interval etc	£222
APOLLO 100-100MHz (As above with more functions)	£325
METEOR 100 FREQUENCY COUNTER 100MHz	£118
METEOR 600 FREQUENCY COUNTER 600MHz	£145
METEOR 1000 FREQUENCY COUNTER 1000Hz	£189
JUPITOR 500 FUNCTION GEN 0.1Hz-500kHz Sine/Sqr Tr.	£118
ORION COLOUR BAR GENERATOR Pal/TV Video	£229
All other Black Star Equipment available	
OSCILLOSCOPE PROBES Switchable x1 x10 (P&P £3)	£12

TWIN TWIN PPM

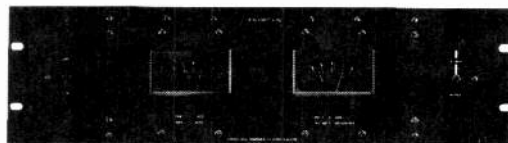

Comprising two PPM9 boards, featuring inherent stability with
law under micro-processor control, the unit gives simultaneous
monitoring of A/B on red/green and M/S on white/yellow
pointers. Together these provide complete information about
stereo signals. Manufactured under licence from the BBC.

PPM10 In Vision PPM and Chart Recorder generates a high
quality colour video display emulating the well known coaxial
twin movements, long regarded as a most satisfactory way of
monitoring stereo audio levels and mono compatibility. The
eye can judge the level displayed, at a glance, from the angle
of pointers, without needing to refer to scale markings. Also as
expansion board for Acorn computers.



Advanced Active Aerial 4kHz-30MHz Stabilizers and Fixed
Shift Circuit Boards for howl reduction *10 Outlet Distribution
Amplifier 4 *Stereo Variable Emphasis Limiter 3 *Stereo Disc
Amplifier *Peak Deviation Meter *PPM5 hybrid and PPM8 IEC/
DIN -50/+6dB drives and movements *Broadcast Stereo
Coders. *Broadcast Monitor Receiver 150kHz-30MHz

SURREY ELECTRONICS LTD
The Forge, Lucks Green, Cranleigh,
Surrey GU6 7BG.
Telephone: 0483 275997. Fax: 276477.

The ins and outs of oscillator action

Certain electronic circuits are taken for granted. Ian Hickman has explored the detailed functioning of the LC oscillator to reveal unsuspected sophistication to its operation.

I often wondered why it was that, in many respects, valve oscillators were so much better than the transistorised versions that replaced them. Clearly it had to do with the differences between a valve and a transistor. Comparing the grounded emitter circuit with the grounded cathode, the latter has a very high input impedance when, as is usual, the grid is negative with respect to the cathode, while the base input impedance of a transistor is by comparison, distinctly middling.

Comparing the collector and anode circuits, at dc and low frequencies the transistor presents a high output slope resistance rather like a pentode, although considering internal feedback via inter-electrode capacitances, the transistor is more like a triode.

And there is one other major difference between collector and anode circuits. When the voltage at the anode of a valve swings below the cathode voltage, the anode simply ceases to draw current. By contrast, when the voltage at the collector of an npn transistor swings below that of the base, the collector/base junction becomes forward biased and when it swings below even the emitter voltage, the transistor works in the inverted mode where the collector acts as an emitter and vice versa.

At one time, symmetrical transistors were manufactured, for use as crosspoint switches. Having identical emitter and collector structures, these devices worked equally well in either direction, although perhaps "equally badly" would have been a better description. But modern transistors have very asymmetric emitter and collector structures and, being optimised for operation in the normal mode, they

perform very badly in the inverted mode. In that mode, they present an impedance which might perhaps be described as a soggy mess, inflicting (in an oscillator) heavy resultant damping on the collector tuned circuit. There is no reason why a diode in series with the collector could not be fabricated on the die. But it never is, at least not in small signal or rf transistors.

The basic circuit

Now a typical transistor oscillator circuit, such as the Hartley oscillator of Fig. 1a, is designed with a small-signal loop-gain well in excess of unity, Fig. 1b. This guarantees that, when switched on, it will start to oscillate: nothing is more infuriating – and less useful – than an RF oscillator which works very well when running, but sometimes fails to get started at switch-on. But the excess loop gain at start-up has to be reduced somehow to a loop gain of just unity when running. In this type of single transistor circuit (as distinct from some other types of rf oscillator, Ref. 1), this is usually brought about by the collector voltage falling below that of the base. As a result, the collector/base junction thus becomes a forward biased diode connected directly across the tuned circuit, imposing heavy damping upon it and reducing the loop gain by lowering the tuned circuit's effective dynamic resistance R_d . At the same time, the transistor, operating in the inverted mode, clamps the collector to ground, adding to the harmonic distortion in the output.

By contrast, a valve oscillator limits its amplitude in an entirely different way. Fig. 2a shows a valve Hartley oscillator and the anode voltage and cathode current waveforms, Fig. 2b, from so lightly coupled that the circuit barely oscillates, to heavily coupled with lots of excess loop gain. The valve works in class C and generates its own negative grid bias. As the loop gain is increased, the peak cathode current increases and the peak to peak anode voltage swing rises until the valve bottoms on negative-going peaks. At this point, the cathode current cannot rise any

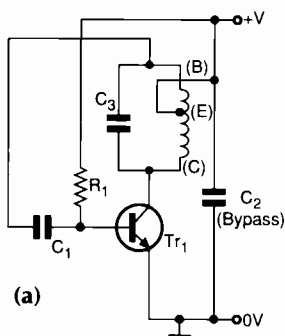
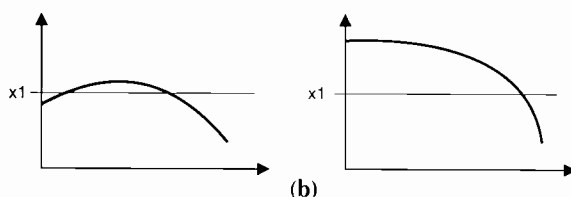

Fig. 1a. Basic bipolar transistor Hartley oscillator circuit.

b) Loop gain (Y axis) versus amplitude (X axis) of an oscillator which may fail to start i), and of a reliable rf oscillator circuit ii).



DESIGN BRIEF

Fig. 5a, left. Tank circuit waveform with tuning capacitor set to max, 2.5MHz (upper trace, 5V/div) and emitter current waveform (lower trace, 50mV/div). Ground level 2 divisions below centreline, 100ns/div horizontal.
b) As a) but tuning capacitor set for 5MHz output.

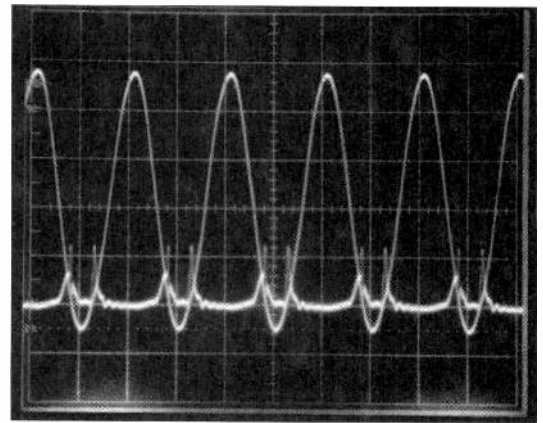
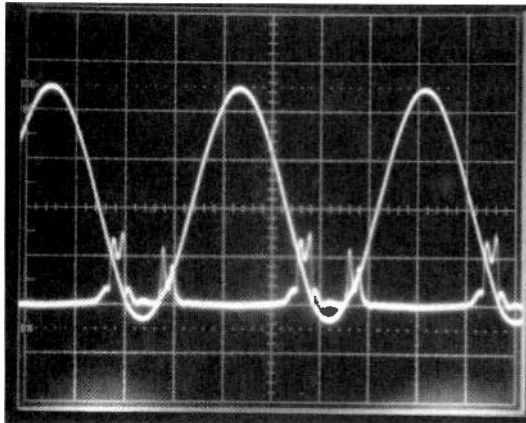
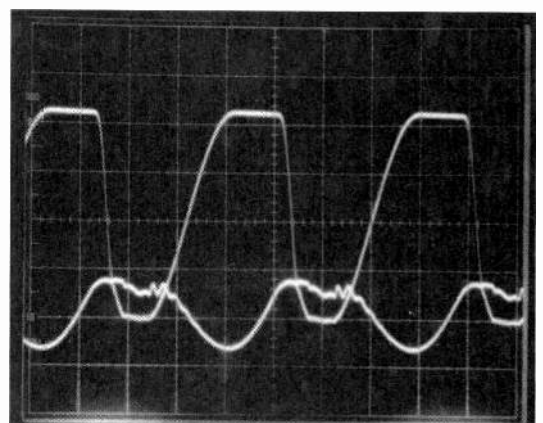
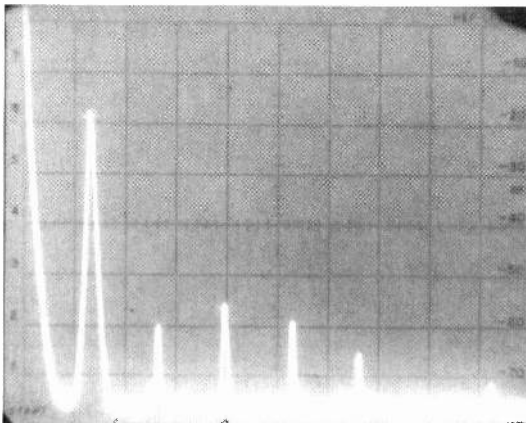

Fig. 6a. Spectrum of the output of the circuit of Fig. 4 at 2.5MHz. Vertical 10dB/div, ref. level -10dBm, span 0-20MHz, IF bandwidth 100kHz, video filter switched on.
b) Waveform at the collector (cathode of the diode) at 2.5MHz (upper rh trace, 5V/div) and the base (lower trace, 1V/div), 0V level two divisions below centreline, 100ns/div.



range 50-500 MHz, as well as performing (at first sight) as expected over a 2.5-5MHz tuning range. Parasitic stoppers only proved a partial answer.

A bipolar device was pressed into service. This was the BC182, with a minimum f_T of 150MHz, the particular sample used having an h_{FE} of 240. As with the J310, the circuit was constructed over a ground plane consisting of a sheet of copper-clad laminate, to which the frame of the tuning capacitor was firmly fixed. To permit grounding of the frame of the tuning capacitor, the Hartley circuit was modified to a tuned collector circuit with base feedback winding. A 4.7 Ω resistor was placed in series with the transistor's emitter, to permit current monitoring.

Initially, the inductor was grounded and the 4.7 Ω emitter resistor was connected to a locally decoupled negative rail. However, it proved impossible to measure the small drop across this resistor due to imperfect negative rail decoupling and other causes, so the circuit was modified to use a positive supply as in Fig. 4. From this it will be seen that in view of the higher operating frequency, the series resistor in the base circuit has been omitted as it would not well simulate the higher impedance of a valve grid circuit.

Fig. 5a with its 100ns/div timebase shows the voltage at the anode of the diode at maximum tuning capacitance, a shade over 2.5MHz. With the 10V collector supply voltage, the 25V peak-to-peak voltage across the tank circuit results in the anode of the diode swinging well below the base voltage and indeed well below ground - 0V ground is two divisions below the centreline, the upper trace at 5V/division. Both traces are dc coupled.

The other trace, at 50mV/div, is the voltage across the 4.7 Ω emitter current sensing resistor, and it proved quite difficult to measure. The magnetic field

from the coil coupled into the probe's ground lead, wherever it was placed. In the end, the probe ground lead was removed entirely and the probe's tip and earth ring strapped across the resistor body as indicated in Fig. 4.

As in a valve oscillator, the collector current has split, in this case due to the presence of the diode, into two separate pulses, each flowing only while the base is forward biased and collector voltage above the transistor's bottoming voltage. The ringing on these two pulses is possibly due to the inductance of the 4R7 resistor, and doubtless other circuit parasitics also suggesting the wisdom of not attempting the experiment at too high a frequency.

A case of conduction angle

Figure 5b shows the same picture, but with the circuit tuned to oscillate at 5MHz. Bearing in mind that the reactance of the inductor at 5MHz will have doubled relative to 2.5MHz and constant Q unchanged (only approximately true), the tank circuit's dynamic resistance would have doubled. Yet the amplitude of oscillation has increased by only a few percent. The reason is that the collector current pulses are now very much narrower, not only in absolute terms but as a fraction of a cycle. Thus the total conduction angle is reduced, and with it both the mean collector current and the component at the 5MHz fundamental. While the peak amplitude of the pulses is little changed, they are now only a few nanoseconds wide. With the 15 μ A base current supplied and the device's h_{FE} of 240, the collector current drawn when the base feedback was removed, stopping the oscillation, was 3.6mA. At 2.5MHz it fell to 1.6mA reducing to 1.3mA at 5MHz. The mean base current was of course unchanged, the excess being spilled through the base circuit during

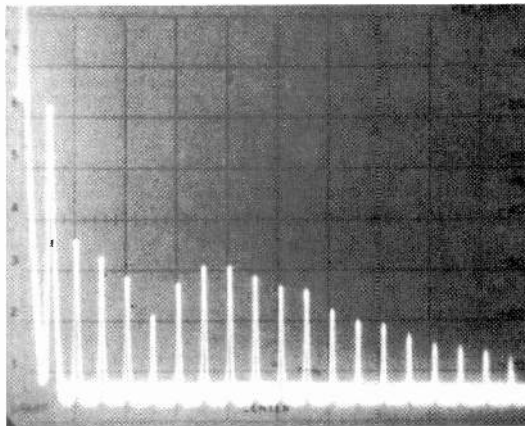
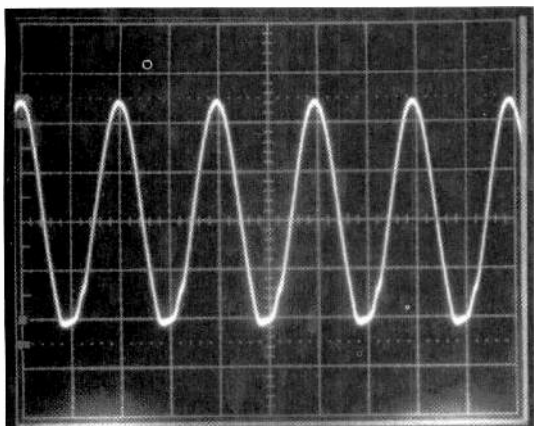

Fig. 7a, left. Waveform at the collector (tank circuit) with the diode short circuited, at 2.5MHz (10V/div), 0V level two divisions below centreline, 100ns/div, left-hand photo. Tank circuit voltage cannot swing below ground. b) Spectrum of a). Vertical 10dB/div, ref. level -10dBm, span 0-100MHz, IF bandwidth 1MHz, video filter on.

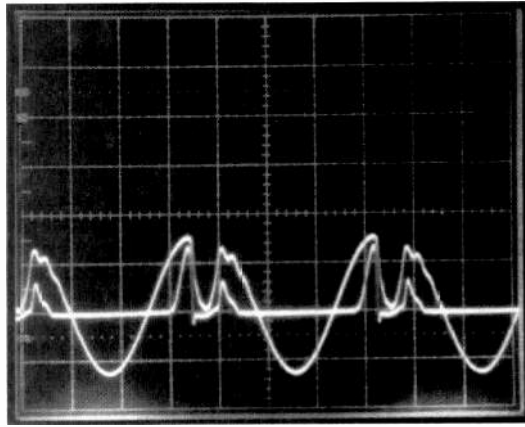
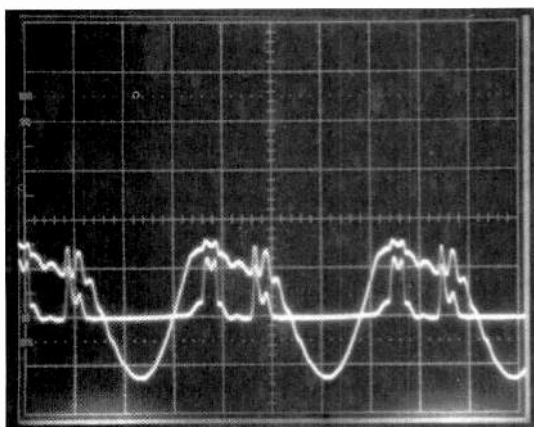

Fig. 8a. Pseudo valve circuit. Base circuit waveform with tuning capacitor set to max, 2.5MHz (larger trace, 0.5V/div) and emitter current waveform (smaller trace, 50mV/div). Ground level 2 divisions below centreline, 100ns/div horizontal. b) Conventional circuit. 2.5MHz. Traces and scope settings as a).

the period when the collector current was zero due to the diode being reverse biased.

Figure 6a shows the output spectrum at 2.5MHz (span 0-20MHz), that at 5MHz being the same, except that the second harmonic rose to -32dBc. Harmonics higher than the fifth were negligible in both cases. The spectrum analyser's reference level (top of screen) is -10dBm, but due to the 1000:1 attenuation introduced by the 47k Ω resistor, it corresponds to +50dBm - at least in terms of volts, though not in terms of power of course, as the tank circuit impedance is much higher than 50 Ω .

Figure 6b shows the base voltage waveform at 2.5MHz. (lower trace, 1V/div) and a waveform (upper trace, 5V/div) which could not be seen in the corresponding valve oscillator. This is the waveform at the cathode of the diode. The collector can be seen to be firmly clamped to ground at the negative peak (when the diode is reverse biased), subsequently rising to the positive peak of the tank circuit voltage. It remains there until the transistor turns on again, at the first of the two current pulses surrounding the following negative peak.

Figure 7a shows the tank circuit/collector voltage when the diode is short circuited, to give conventional transistor LC oscillator operation. Here, the negative peak is brutally clamped to ground: compare this with Fig. 5b, where the tank circuit voltage is free to swing 5V below ground. The extra damping has reduced the swing from 28V to 25Vp-p. The neat snipping off of the negative tip of the waveform does not affect the low order distortion greatly, but as Fig. 7b (span 0-100MHz) shows, the significant harmonics now extend to a much higher order. Incidentally, the emitter current also breaks up into two pulses in this circuit, but for an entirely different reason from the

case where the diode is present.

Nothing shows the difference between a conventional transistor LC oscillator and the 'pseudo valve' circuit better than Fig. 8. The base voltage waveform of the pseudo valve circuit at 2.5MHz (at 0.5V/div) and the emitter current pulses monitored across the 4.7 Ω resistor (at 50mV/div). Note that the base voltage stays positive during the period between current pulses, when the tank circuit voltage is negative. This is in complete contrast to the conventional circuit without the diode. (Fig. 8b). Here, when the collector tries to swing below ground, the base-collector diode turns on, dragging the base voltage down with it. This reverse biases the base-emitter junction, interrupting the emitter current and splitting it into two separate pulses. In this circuit, the excess base bias current is shunted into the collector circuit while the emitter current is off. In the pseudo valve circuit, it goes into the emitter circuit, while the collector current is cut off.

The differences between a conventional transistor LC oscillator and the 'pseudo valve' circuit shown here, can be expected to apply to the two circuits when operating at much higher frequencies. Some of the effects, such as the ringing on the emitter current pulses would not be present in a practical application. Given its advantages, the 'pseudo valve' oscillator could be seriously considered for applications at substantially higher frequencies. ■

References

1 Design Brief, *Oscillator tails off lamely?* Ian Hickman EW+WW Feb 1992.

£1 BARGAIN PACKS

In fact...cheaper than £1 because if you buy 10 you can choose one other and receive it free!

- 1 x 12v Stepper Motor. 7.5 degree. Order Ref: 910.
- 1 x 10 pack Screwdrivers. Order Ref: 909.
- 2 x 5 amp Pull Cord Ceiling Switches. Brown. Order Ref: 921.
- 5 x reels Insulation Tape. Order Ref: 911.
- 4 x 14mm Ball-races. Order Ref: 912.
- 2 x Cord Grip Switch lamp Holders. Order Ref: 913.
- 1 x DC Voltage Reducer. 12v-6v. Order Ref: 916.
- 1 x 10 amp 40v Bridge Rectifier. Order Ref: 889.
- Lightweight Stereo Headphones. Moving coil so superior sound. Order Ref: 896.
- 2 x 25W Crossovers. For 4ohm loudspeakers. Order Ref: 22.
- 2 x Nicad Constant Current Chargers. Easily adaptable to charge almost any nicad battery. Order Ref: 30.
- 18v-0-18v 10va Mains Transformer. Order Ref: 813.
- 2 x White Plastic Boxes. With lids, approx. 3" cube. Lid has square hole through the centre so these are ideal for light operated switch. Order Ref: 132.
- 2 x Reed Relay Kits. You get 8 reed switches and 2 coil sets. Order Ref: 148.
- 12v-0-12v 6va Mains Transformer. PCB mounting. Order Ref: 938.
- 1 x Blg Pull Solenoid. Mains operated. Has 1/2" pull. Order Ref: 871.
- 1 x Big Push Solenoid. Mains operated. Has 1/2" push. Order Ref: 872.
- 1 x Mini Mono Amp. 3W into 4 ohm speaker or 1W into 8 ohm. Order Ref: 495.
- 1 x Mini Stereo 1W Amp. Order Ref: 870.
- 15v DC 150ma PSU. Nicely cased. Order Ref: 942.
- 1 x In-Flight Stereo Unit is a stereo amp. Has two most useful mini moving coil speakers. Made for BOAC passengers. Order Ref: 29.
- 1 x 0-1mA Panel Meter. Full vision fact 70mm square. Scaled 0-100. Order Ref: 756.
- 2 x Lithium Batteries. 2.5V penlight size. Order Ref: 874.
- 2 x 3m Telephone Leads. With BT flat plug. Ideal for phone extensions, fax, etc. Order Ref: 552.
- 1 x 12V Solenoid. Has good 1/2" pull or could push if modified. Order Ref: 232.
- 4 x In-Flex Switches. With neon on/off lights, saves leaving things switched on. Order Ref: 7.
- 2 x 6V 1A Mains Transformers. Upright mounting with fixing clamps. Order Ref: 9.
- 2 x Humidity Switches. As the air becomes damper, the membrane stretches and operates a micro switch. Order Ref: 32.
- 5 x 13A Rocker Switch. Three tags so on/off, or changeover with centre off. Order Ref: 42.
- Mini Cassette Motor. 9v. Order Ref: 944.
- 1 x Suck or Blow-Operated Pressure Switch. Or it can be operated by any low pressure variation such as water level in tanks. Order Ref: 67.
- 1 x 6V 750mA Power Supply. Nicely cased with mains input and 6V output lead. Order Ref: 103A.
- 2 x Stripper Boards. Each contains a 400V 2A bridge rectifier and 14 other diodes and rectifiers as well as dozens of condensers, etc. Order Ref: 120.
- 12 Very Fine Drills. For PCB boards etc. Normal cost about 80p each. Order Ref: 128.
- 5 x Motors for Model Aeroplanes. Spin to start so needs no switch. Order Ref: 134.
- 6 x Microphone Inserts. Magnetic 400 ohm, also act as speakers. Order Ref: 139.
- 6 x Neon Indicators. In panel mounting holders with lens. Order Ref: 180.
- 1 x In-Flex Sinterstat. Keeps your soldering iron etc always at the ready. Order Ref: 196.
- 1 x Mains Solenoid. Very powerful as 1/2" pull, or could push if modified. Order Ref: 199.
- 1 x Electric Clock. Mains operated. Put this in a box and you need never be late. Order Ref: 211.
- 4 x 12V Alarms. Makes a noise about as loud as a car horn. All brand new. Order Ref: 221.
- 2 x (6"x4") Speakers. 16 ohm 5 watts, so can be joined in parallel to make a high wattage column. Order Ref: 243.
- 1 x Panostat. Controls output of boiling ring from simmer up to boil. Order Ref: 252.
- 2 x Oblong Push Switches. For bell or chimes, these can switch mains up to 5A so could be foot switch if fitted in patress. Order Ref: 263.
- 50 x Mixed Silicon Diodes. Order Ref: 293.
- 1 x 6 Digit Mains Operated Counter. Standard size but counts in even numbers. Order Ref: 28.
- 2 x 6V Operated Reed Relays. One normally on, other normally closed. Order Ref: 48.
- 1 x Cabinet Lock. With two keys. Order Ref: 55.
- 6 1/2" 8 ohm 5 watt Speaker. Order Ref: 824.
- 1 x Shaded Pole Mains Motor. 3/4" stack, so quite powerful. Order Ref: 85.
- 2 x 5 Aluminium Fan Blades. Could be fitted to the above motor. Order Ref: 86.
- 1 x Case. 3 1/2x2 1/4x1 3/4 with 13A socket pins. Order Ref: 845.
- 2 x Cases. 2 1/2x2 1/4x1 3/4 with 13A pins. Order Ref: 565.
- 4 x Luminous Rocker Switches. 10A mains. Order Ref: 793.
- 4 x Different Standard V3 Micro Switches. Order Ref: 340.
- 4 x Different Sub Min Micro Switches. Order Ref: 313.

BARGAINS GALORE

Speed Controller for 12v DC Motors. Suitable for motors with horse powers up to one third and drawing currents up to 30A. Gives very good control and speed. Uses mosfets and is based on a well tried circuit which appeared in the *Model Engineer* some time ago. The complete kit with case and on/off switch is available, price £18. Order Ref: 1EP8.

Ex-British Telecom Insulation Tester Offer. We have a quantity of these that are slightly faulty. There has been no attempt at repairing them. They are not missing any parts so should be repairable. The moving coil movement is in perfect working order so even if you cannot repair the instrument to perform all its original functions, you would be able to use it for another instrument that you need. We supply a circuit diagram of the instrument and chances are that you will find the fault and be able to repair it. Price of the instrument with circuit diagram is £3. Order Ref: 3P176.

Fig 8 Flex. Fig. 8 flat white pvc, flexible with .4 sq. mm cores. Ideal for speaker extensions and bell circuits. Also adequately insulated for mains lighting. 50m coil £2. Order Ref: 2P345. 12m coil £1. Order Ref: 1014.

Friedland Underdome Bell. Their ref: 792. A loud ringer but very neat. 3" diameter, complete with wall fixing screws. £4. Order Ref: 4P75.

12v 10amp Switch Mode Power Supply. For only £9.50 and a little bit of work because you have to convert our 135W PSU. Modifications are relatively simple - we supply instructions. Simply order PSU Ref: 9.5P2 and request modification details. Price still £9.50.

Are you making Mini Bugs? We can offer the ideal box. White plastic without any decoration or printing. This has an on/off switch in the top left-hand corner and a hole just above to take a telescopic or wire aerial. The case is large enough to take a PP3 battery and a PCB and when finished it will have a really professional look. Box with switch £1. Order Ref: 1006. Size approximately 4"x3"x1 1/2" thick and its cover is held by four screws.

Siren/Horn/Hooter/Klaxon. It isn't any of these - it does the same job but is quite nice to look at and could even be described as ornamental. It is Swiss made and in a grey plastic case, could be free standing or screwed down indoors or out. It is mains driven and when switched on it makes a shocking noise (its loudness is adjustable). You could switch it on to scare an intruder or arrange for your burglar alarm to do the same. Price £5. Order Ref: 5P226.

Magnetic Cupboard Alarm. Or it could be used to warn when any cupboard door is opened. The light shining on the unit makes the bell ring. Completely built and neatly cased, requires only a battery. £3. Order Ref: 3P155.

Don't Let It Overflow! Be it bath, sink, cellar, sump or any other thing that could flood. This device will tell you when the water has risen to the pre-set level. Adjustable over quite a useful range. Neatly cased for wall mounting, ready to work when battery fitted. £3. Order Ref: 3P156.

Very Powerful Mains Motor. With extra long (2 1/2") shafts extending out each side. Makes it ideal for a reversing arrangement for, as you know, shaded pole motors are not reversible. £3. Order Ref: 3P157.

Solar Panel Bargain. Gives 3v at 200mA. Order Ref: 2P324.

£1 Super Bargain

12V axial fan for only £1, ideal for equipment cooling, brand new, made by West German company. Brushless so virtually everlasting. Needs simple transistor drive circuit, we include diagram. Only £1. Order Ref: 919. When we supply this we will include a list of approximately 800 of our other £1 bargains.

40W-250W Light Dimmers. On standard plate to put directly in place of flush switch. Available in colours, green, red, blue and yellow. £2.50. Order Ref: 2.5P9. Or on standard 3x3 cream metal switch plate. £3. Order Ref: 3P174.

45A Double Pole Mains Switch. Mounted on a 6x3 1/2 aluminium plate, beautifully finished in gold, with pilot light. Top quality, made with MEM. £2. Order Ref: 2P316.

Amstrad 3" Disk Drive. Brand new and standard replacement for many Amstrad and other machines. £20. Order Ref: 20P28.

Touch Dimmers 40W-250W, no knob to turn, just finger on front plate, will give more, or less light, or off. Silver plate on white background, right size to replace normal switch £5. Order Ref: 5P230.

Motorise that Trolley!

You could with Sinclair C5 1/2rd hp
12v battery motor
Still available, price £18. Order Ref: 18P7

12/24 DC Solenoid. The construction of this is such that it will push or pull. With 24V this is terrifically powerful but is still quite good at 12V. £1. Order Ref: 877.

Don't Stand Out In The Cold Our 12m telephone extension lead has a flat BT socket one end and flat BT plug other end. £2. Order Ref: 2P338.

20W 5" 4 Ohm Speaker mounted on baffle with front grille. £3. Order Ref: 3P145. Matching 4 ohm 20W tweeter on separate baffle, £1.50. Order Ref: 1.5P9.

LCD 3 1/2 Digit Panel Meter

This is a multi range voltmeter/ammeter using the A-D converter chip 7106 to provide 5 ranges each of volts and amps. Supplied with full data sheet. Special snip price of £12. Order Ref: 12P19.

Telephone Extension Wire 4 core correctly colour coded, intended for permanent extensions. 25m coil. £2. Order Ref: 2P339.

High Power Switch Mode PSU. Normal mains input, 3 outputs: +12V at 4A, +5V at 16A and -12V at 1/2A. Completely enclosed in plated steel case. Brand new. Our special offer price of £9.50. Order Ref: 9.5P1.

Philips 9" High Resolution Monitor. Black and white in metal frame for easy mounting. Brand new, still in maker's packing, offered at less than price of tube alone, only £15. Order Ref: 15P1.

High Current AC Mains Relay This has a 230v coil and changeover switch rated at 15A with PCB mounting with clear plastic cover. £1. Order Ref: 965.

BARGAINS GALORE

Ultra Thin Drills, actually 0.3mm. To buy these regular costs a fortune. However, these are packed in half dozens and the price to you is £1 per pack. Order Ref: 797B.

You Can Stand On It! Made to house GPO telephone equipment, this box is extremely tough and would be ideal for keeping your small tools in, internal size approx. 10 1/2"x4 1/2"x6" high. Complete with carrying strap, price £2. Order Ref: 2P283B.

Ultra Sonic Transducers. Two metal cased units, one transmits, one receives. Built to operate around 40kHz. Price £1.50 the pair. Order Ref: 1.5P/4.

Power Supply with Extras. Mains input is fused and filtered and the 12V DC output is voltage regulated. Intended for high class equipment, this is mounted on a PCB and also mounted on the board but easily removed, are two 12V relays and Piezo sounder. £3. Order Ref: 3P80B.

Insulation Tester with Multimeter. Internally generates voltages which enable you to read insulation directly in megohms. The multimeter has four ranges, AC/DC volts, 3 ranges DC milliamps, 3 ranges resistance and 5 amp range. These instruments are ex-British Telecom but in very good condition, tested and guaranteed OK, probably cost at least £50, yours for only £7.50 with leads, carrying case £2 extra. Order Ref: 7.5P/4.

Mains Isolation Transformer. Stops you getting "to earth" shocks. 230V in and 230V out. 150 watt. £7.50. Order Ref: 7.5P/5 and a 250V version is £10. Order Ref: 10P97.

Mains 230V Fan. Best make "PAPST", 4 1/2" square, metal blades. £8. Order Ref: 8P8.

2MW Laser. Helium neon by Philips, full spec. £30. Order Ref: 30P1. Power supply for this in kit form with case is £15. Order Ref: 15P16, or in larger case to house tube as well £18. Order Ref: 18P2. The larger unit, made up, tested and ready to use, complete with laser tube £69. Order Ref: 69P1.

12v 8ohm speaker, only £1.50 and waterproof.

Solar Charger. Holds 4AA nicads and recharges these in 8 hours, in very neat plastic case £6. Order Ref: 6P3.

Ferrite Aerial Rod. 8" long x 3/8" diameter, made by Mullard. Complete with two coils, 2 for £1. Order Ref: 832P.

Air Spaced Trimmer Caps. 2-20pf, ideal for precision tuning UHF circuits, 4 for £1. Order Ref: 818B.

Modem Amstrad FM240 As new condition but customer return, so you may need to fault find, £6. Order Ref: 6P34.

Amstrad Power Unit. 13.5V at 1.9A or 12V at 2A encased and with leads and output plug, normal mains input £6. Order Ref: 6P23.

80W Mains Transformer. Two available, good quality, both with normal primaries and upright mounting, one is 20V 4A, Order Ref: 3P106, the other 40V 2A, Order Ref: 3P107, only £3 each.

Project Box. Size approx. 8"x4"x4 1/2" metal, sprayed grey, louvred ends for ventilation otherwise undrilled. Made for GPO so best quality, only £3 each. Order Ref: 3P74.

Sentinel Component Board Amongst hundred of other parts, this has 15 ICs, all plug in so do not need soldering. Cost well over £100, yours for £4. Order Ref: 4P67.

Sinclair 9V 2.1A Power Supply Made to operate the 138K Spectrum Plus 2, cased with input and output leads. Originally listed at around £15, are brand new, our price is only £3. Order Ref: 3P151.

Experimenting with Valves. Don't spend a fortune on a mains transformer, we can supply one with standard mains input and secs. of 250-0-250V at 75mA and 6.3V at 3A, £5. Order Ref: 5P167.

15W 8 Ohm 8" Speaker & 3" Tweeter. Made for a discontinued high quality music centre, gives real hi-fi and only £4 per pair. Order Ref: 4P57.

Water Pump. Very powerful, mains operated, £10. Order Ref: 10P74.

0-1mA Full Vision Panel Meter. 2 3/4" square, scaled 0-100 but scale easily removed for re-writing, £1 each. Order Ref: 756.

VU Meter. Illuminate this from behind becomes on/off indicator as well, 1 1/2" square, 75 each. Order Ref: 366.

Amstrad Keyboard Model KB5 This is a most comprehensive keyboard, having over 100 keys including, of course, full numerical and qwerty. Brand new, still in maker's packing, £5. Order Ref: 5P202.

1 RPM Motor. This is only 2W so will not cost much to run. Speed is ideal for revolving mirrors or lights. £2. Order Ref: 2P328.

Unusual Solenoid. Solenoids normally have to be energised to pull in and hold the core, this is a disadvantage where the appliance is left on for most of the time. We now have magnetic solenoids which hold the core until a voltage is applied to release it. £2. Order Ref: 2P327.

Mains Filter. Resin impregnated, nicely cased, pcb mounting. £2. Order Ref: 2P315.

200VA Mains Transformer. Secondary voltages 8v-0-8v. So you could have 16v at 12A or 8v at 25A. Could be ideal for car starter charger, soil heating, spot welding, carbon rod welding or driving high powered amplifiers etc. £15. Order Ref: 15P51.

Prices include VAT. Send cheque/postal order or ring and quote credit card number. Add £3 post and packing. Orders over £25 post free.

M&B ELECTRICAL SUPPLIES LTD

Pilgrim Works (Dept. WW),
Stairbridge Lane, Bolney,
Sussex RH17 5PA

Telephone (0444) 881965 -
phone for Fax
Callers to 12 Boundary Road,
Hove, Sussex

NEW PRODUCTS CLASSIFIED

ACTIVE

Asics

143MHz PLD. The Cypress *CY7C371* is a complex programmable logic device with a 143MHz performance and better than 8.5ns propagation delay, the device offering both electrical erasure and reprogramming. It has a programmable interconnect matrix and product term matrix, which allows product terms to be routed to macrocells individually without 'stranding' adjacent macrocells or introducing extra delay. Pin assignments are selectable so that logic changes do not affect the pinout. Ambar Components Ltd. Tel., 0844 261144; fax, 0844 261789.

10,000-gate FPGA. Already available from Actel are the 1500-gate *A1415A* and the 4000-gate *A1440A* field-programmable gate arrays; the 10,000-gate *A14100A* to be released in June. These devices extend the ACT 3 range which includes 2500-gate and 6000-gate types. New features are 167MHz counters and data paths and 7.5ns clock-to-out delays. Actel Europe Ltd. Tel., 0256 29209; fax, 0256 55420.

A-to-D and D-to-A converters

Lowest-power A-to-D. Harris's *HI5813* is a 3-6V single-supply, 12-bit converter that uses only 9mW maximum at full speed over the industrial temperature range. It includes an on-chip track-and-hold amplifier and the input bandwidth is 1MHz; conversion time is 25µs, giving 40ksamples/s. Total error, due to non-linearity, offsets and full-scale error before calibration, is 9LSB. Harris Semiconductor UK. Tel., 0276 686886; fax, 0276 682323.

Discrete active devices

9GHz transistor. With a typical f_T of 9GHz at 25mA, Zetex's *ZGF300F* is intended for use in cellular telephones, CATV and radio networking at frequencies over 2.5GHz. Noise figure at 10mA and 1GHz is 1.9dB and gain at 2GHz is 7dB and 12dB at 1GHz; unilateral power gain at 1GHz is 13dB. Collector/base capacitance is less than 0.5pF. Zetex plc. Tel., 061-627 5105; fax, 061-627 5467.

Low-noise hemt. Low-noise InGaAs high electron-mobility transistors from Mitsubishi, the *MGF4710A* are meant for C-band first and second stage

LNB use in the 3.7-4.2GHz band and in K band amplifiers. They are intended for microstrip circuitry, providing a 1dB noise figure and 9dB gain at 12GHz. Gate/drain and gate/source voltage is -4V with a drain current of 60mA. Mitsubishi Electric UK Ltd. Tel., 0707 276100; fax, 0707 278692.

Schottky barrier diode. The *BAS85* silicon Schottky barrier diode by ITT has a reverse breakdown voltage of 30V and forward voltages of 0.24V at 0.1mA to 0.8V at 100mA. Leakage is 2µA at 25V reverse voltage and reverse recovery time is 5ns. Power dissipation at 65°C is 250mW. ITT Semiconductors. Tel., 0932 336116; fax, 0932 33148.

High-voltage mosfet. Zetex's *ZVN4424* is a 240V, medium-power mosfet with a typical on resistance of 4Ω and a threshold voltage of 1.8V maximum, so that it interfaces directly with low-power logic. The device switches up to 260mA continuous or 1A in pulses, rise and fall times being 5ns and 16ns at 250mA drain current. Input capacitance is around 110pF. Zetex plc. Tel., 061-627 5105; fax, 061-627 5467.

Bipolar switches. Temic Telefunken has a new series of high blocking-capability bipolar switching transistors, *BUD 87/620* and *TD 13003/13005*, in Dpaks. Typical application is in the contactless switching of electronic fluorescent lamp ballasts. All types switch 30W loads and block up to 1kV at 4A collector currents. Operating

Stereo/dual sound processors. Philips is offering three new sound processors for television receivers and video recorders which have on-chip digital PLLs, synchronous detectors and digital integrators to give reliable identification of the stereo/dual sound pilot modulation. *TDA9840* provides level adjustment, stereo balance control and signal-source switching for I²C-bus-controlled TVs and VCRs, *TDA9845* gives simple logic control of signal switching in low-cost VCRs and *TDA3847* complex main/auxiliary input switching for equipment with Scart connectors. Philips Semiconductors (Eindhoven). Tel., 01031 40 722091; fax, 01031 40 724825.

frequency is up to 100kHz. *TD13005* is also made with a free-wheeling diode. Tem c Telefunken GmbH. Tel., 01049 7131 672747; fax, 01049 7131 993342.

Linear integrated circuits

Multiplexed-i/p video amplifiers. Two or four input multiplexed video amplifiers in the *EL4400* series by Elantec provide 8ns switching and 70dB channel isolation. Bandwidth at gains of 1 or 2 is 80MHz with gain error of 0.2% even with low-impedance loads. Two of the devices are two-input types with common inverting inputs, two have four inputs with all four taken to a common feedback line and a further two are four-input versions with positive and negative inputs separate. Microelectronics Technology Ltd. Tel., 9844 278781; fax, 0844 278746.

Precision dual op-amp. Micro Call has a dual op-amp which draws a maximum supply current of 20µA per amplifier at 5V. Features include an input offset voltage of 180µV maximum with 0.6µV/°C drift and input offset current 350pA maximum. Peak-to-peak current noise is 1.5pA and voltage noise 0.9µVpk-pk from 0.1Hz to 10Hz. Input range goes 300mV below ground and the npn output swings to within a few mV of ground, sinking current without pull-down resistors. Micro Call Ltd. Tel., 0844 261939; fax, 0844 261678.

500MHz mixer. AD comes to the RF area with a mixer giving low distortion (third-order intercept +23dBm) and only -10dBm local oscillator power over the 500MHz bandwidth. Local-oscillator driver and low-noise output amplifier are integrated with the mixer core in one 20-pin PLCC. RF, IF and LO ports can all be dc-coupled when the voltage rail is ±5V or ac-coupled when 9V is used. IF output is either single-ended or differential and can come directly from the mixer. Analog Devices Ltd. Tel, 0932 253320; fax, 0932 247401.

Low-voltage mosfets. Siliconix announces three more *Little Foot* surface-mounted mosfets: *Si9925DY*, *Si9434DY* and *Si9928DY* with on resistances of 40-80mΩ and 12V breakdown, being designed for 3.3V or 5V logic. The 9925 is for use in lithium-ion battery psus, in which the 2.5V end-of-charge voltage is matched with the mosfet's 80mΩ resistance at 2.5V gate voltage. Complementary 9928s in the output stage of a voltage converter provide

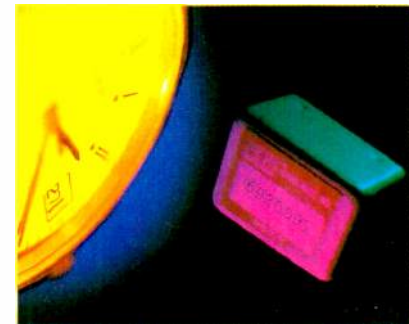

Crystal oscillator. Using an SC-cut crystal with a heater directly deposited on the crystal, the Sematron *DXCO* provides the performance of an oven oscillator with small size, low weight less than 1W of power. Frequency coverage is 7-20MHz at a frequency stability of 2×10^{-7} over -20°C to 70°C. Ageing is 1×10^{-7} per year. The direct heating gives rapid warm-up, low phase noise and relative invulnerability to vibration compared with some oven oscillators that are larger in size. Sematron UK Ltd. Tel., 0734 819970; fax, 0734 819786.

60mΩ and 130mΩ (p-channel); and for load switching, the *9434* gives 40mΩ on resistance at 4.5V and 1µA drain/source leakage. Siliconix/Temic Marketing. Tel., 0344 485757; fax, 0344 427371.

Analogue switches. Maxim's *MAX391/2/3* are quad single-throw, single-pole analogue switches, those in the 391 being normally closed, in the 393 normally open and in the 393 two of each. All are for 5V or ±5V working and offer 25Ω on resistance, <2Ω matching between channels and within 3Ω flatness over the signal range. Since the switches are of the break-before-make characteristic, they are suitable for multiplexers and multiple outputs can be connected with no risk of interchannel shorting. Maxim Integrated Products UK Ltd. Tel., 0734 845255; fax, 0734 845240.

GaAs fet bias generator. *MAX850/1/2/3* from Maxim supply a fixed -4.1V or variable output at 5mA and under 2mVpk-pk ripple to bias GaAs fet RF power amplifiers in cellular telephones and other communications equipment. They take up less than 0.1in² of board space and need only three 1µF

NEW PRODUCTS CLASSIFIED

Please quote "Electronics World + Wireless World" when seeking further information

capacitors and one 10 μ F one. Supply range is 4.5-10V at 3mA or 1 μ A quiescent. *MAX852* takes an oscillator signal to allow synchronisation in noise-sensitive systems. Maxim Integrated Products UK Ltd. Tel., 0734 845255; fax, 0734 845240.

RF video drivers. Motorola's *CR2428* and *CR3428* are hybrid RF amplifiers for use in high and very high resolution CRT monitors. Bandwidth of the *2428/3428* is 130/115MHz and rise and fall times 2.5/2.7ns. Motorola Inc. Tel., 0908 614614; fax, 0908 618650.

Voltage regulators. As a second source to Linear Technology, Semtech offers a series of low dropout regulators with output currents of 1.5A (*L1086*), 3A (*L1085*), 5A (*L1084*) and 7.5A (*L1083*) at fixed voltages of 3.3V, 5V and 12V, one version having adjustable output down to 1.2V. Regulation and stabilisation are 0.01% and 0.015%. Current limiting and thermal shutdown are provided. Semtech Ltd. Tel., 0592 773520; fax, 0592 774781.

Logic building blocks

24-bit video mixer. Raytheon's *TMC22080* video mixer is designed to mix graphics and live video, for lapping between two video sources and for fading and wiping. It mixes at speeds of up to 26 million pixels/second and is controlled by a 9-bit alpha-channel input. The device supports 24-bit RGB, YCbCr444, 16-bit YCbCr422 component video sources and the A channel also accepts 8-bit colour-indexed pixel data which addresses the three bypassable 256 by 8-bit colour look-up tables with a 15-colour overlay palette. Interpolation filters and the colour space conversion matrices are used when different pixel formats are in use. *TMC22080* is microprocessor-

controlled. Microelectronics Technology Ltd. Tel., 9844 278781; fax, 0844 278746.

3.3V programmable logic. AMD has its first 3.3V PLD family. *PALLV16V8-10* is a low-voltage cmos device that interfaces with 3.3V and 5V logic, having a maximum 10ns delay and taking an 83MHz clock. *PALLV22V10Z-25* takes 15 μ A standby current and has 10 macrocells programmable as registered or combinatorial and active high or low. *MACHLV210-15/20* is the first 3.3V *MACH* device, with 1800 gates and 64 macrocells, and handles a 50MHz clock. All are supported by the Palasm design software. Advanced Micro Devices (UK) Ltd. Tel., 0483 740440; fax, 0483 756196.

Active SCSI terminator. Claimed to be the industry's lowest-capacitance, 9-line SCSI active terminator, Unitrode's *UC5613* has only 3pF channel capacitance, provides improved impedance matching and eliminates transmission problems found in some other passive and active terminators. A special feature disconnects all lines and disables the 400mA sink/source regulator, the device drawing less than 10nA in this sleep mode and all channels being in a high-impedance state. Unitrode (UK) Ltd. Tel., 081 318 1431; fax, 081 318 2549.

Microprocessors and controllers

Bigger-rom micros. Hitachi's *H8/3837* and *H⁺3836* 8-bit microcontrollers are 2.7V devices taking 0.5mA in an intermediate speed mode and having 40Kbyte (3837) or 48Kbyte of program rom. Both have an lcd controller/driver for 160 segments and other on-chip features include 2Kbyte of ram, five timers, a 12-channel 8-bit a-to-d converter and three serial interface

channels. Minimum instruction time is 4 μ s. Hitachi Europe Ltd. Tel., 0628 585000; fax, 0628 585200.

133MHz Orion 64-bit R4600. The 133MHz version of IDT's *Orion R4600* risc processor is claimed to be the first offering the required performance, dynamic power management and low price for Windows *NT* and high-end embedded applications. IDT says it performs better than the *Pentium* at *486DX* prices. It is a full 64-bit implementation of the MIPS III instruction set architecture in the earlier *R4000PC* and *R4400PC* devices but with a five-stage pipeline to reduce stalls and therefore improve performance. There is also the cache: 1616Kbyte for instructions and 1616Kbyte for data. Integrated Device Technology. Tel., 0372 363734; fax, 0372 378851.

Comms processor. *Ruby* is an advanced communications processor chip from VLSI, which uses an *ARM* 32-bit risc processor core with a comprehensive set of comms peripherals, power management and 2.7V-5.5V operation. It contains a PCMCIA/ISA interface supporting direct memory, attribute space and comms port modes, a uart, serial comms controller, PIO and a serial port controller. The *ASRM FSB* core gives up to 20Mips. Sleep and stopped modes are provided, in which power dissipation is 3mW and 200 μ W. VLSI Technology Ltd. Tel., 0908 667595; fax, 0908 670027.

Mixed-signal ICs

Lan chipset. *Regatta 100* local area network chipset by AT&T allows the addition of multimedia services such as video and sound to Ethernet or Token-Ring wiring at 100Mb/s. The set conforms to IEEE 802.12 100VG-AnyLAN, the first silicon implementation to do so. Its high bandwidth is achieved by means of a new quartet signalling scheme using four pairs of UTP wiring. AT&T Microelectronics. Tel., 0732 742999; fax, 0732 741221.

RDS frequency synthesiser. Philips' *TSA6060* low-power PLL frequency synthesiser IC for AM and fm is intended for use in rds car radios, providing on-chip loop amplifiers and 2ms frequency locking, although the plls can be switched between high gain for fast lock and lower gain for frequency stability. The only externals needed are two passive feedback networks for the loop time constant. Philips Semiconductors (Eindhoven). Tel., 01031 40 722091; fax, 01031 40 724825.

Optical devices

Single-chip camera. A cmos single-chip camera by VVL, the *1070*, is claimed to be the first commercially available image sensor with a built-in a-to-d converter. It integrates a 160 by 120 pixel array with all the electronics needed for an auto-exposure camera in a windowed 44-

pin PQFP. Current consumption is 30mA and there is to be a range of lenses with differing fields of view. VLSI Vision Ltd. Tel., 031-539 7111; fax, 031-539 7140.

Photo-IC coupler. Toshiba's *TLP251* photocoupler drives low-power IGBTs directly, maintaining gate isolation. A GaAlAs led is the light source, a p-n photodiode, a high-speed, high-gain amplifier and output circuitry, comprising the photo-IC which is used as the detector. Operating voltage is 35V and an 8mA input produces a peak output of 100mA with a 1 μ s propagation delay. Toshiba Electronics (UK) Ltd. Tel., 0276 694600; fax, 0276 691583.

Oscillators

LF crystal oscillators. Crystal oscillators from GPS work at frequencies down to 1.5kHz. The *QC6109* oscillator will drive loads of up to 50pF (HCMOS) and the *QC6110* up to 10 TTL gates, both having rise and fall times of 10ns for 6-30MHz versions or 15ns for the lf types. Start-up time is 4ms. Two temperature ranges are available: -40°C to 85°C with a frequency tolerance of \pm 50ppm; and -55°C to 125°C with a tolerance of \pm 100ppm. GEC Plessey Semiconductors Ltd. Tel., 0793 518510; fax, 0793 518582.

Power semiconductors

Horizontal crt deflection. Power dissipation in horizontal deflection circuitry is reduced by short switching times and low power loss of Philips *BU2522AF* and *BU2527AF* n-p-n power transistors. These are intended for 14-17in high-resolution monitors scanning at up to 64kHz. Both are 1500V devices operating at 5-7A (DC peak ratings 10A and 25A for the *2522* and 12A/30 for the *2527*). When switching 6A in a 64kHz circuit, maximum charge storage time is 2 μ s, collector turn-off times being 0.25 μ s and 0.2 μ s. Philips Semiconductors (Eindhoven). Tel., 01031 40 722091; fax, 01031 40 724825.

PASSIVE

Passive components

Feed-through capacitors. Re-engineering of Cambion's *560-3265* series of feed-through capacitors has trebled the range of values to 220pF-1500pF in \pm 20% tolerance. They are screw-mounted and plated in 0.55 μ m gold, although other styles and platings can be made. Insulation resistance is over 10⁵M Ω and dissipation factor less than 2% at 1kHz. Interconnection Products Ltd. Tel., 0433 621555; fax, 0433 621290.

Wirewound resistors. Neohm *CWP*, *CWU* and *CWL* ranges of high-power wirewounds, in moulded chip packaging, use temperature sensing to achieve standard temperature coefficients down to 1-3ppm/°C. Type *CWP* are down to 2.4 by 3.2mm in

600V mosfet driver. IR's *IR2155* 600V chip has everything needed to control and drive power mosfets in electronic lighting ballast, with a clean waveform that virtually eliminates mosfet losses. Parts count is reduced by virtue of the high-side driver dispensing with transformer gate drives; by the on-chip oscillator; and by generating the IC supply voltage internally. Internal 1.2 μ s dead time is compatible with dv/dt snubbed circuits to 100kHz. Polar Electronics. Tel., 0525 377093; fax, 0525 378367.

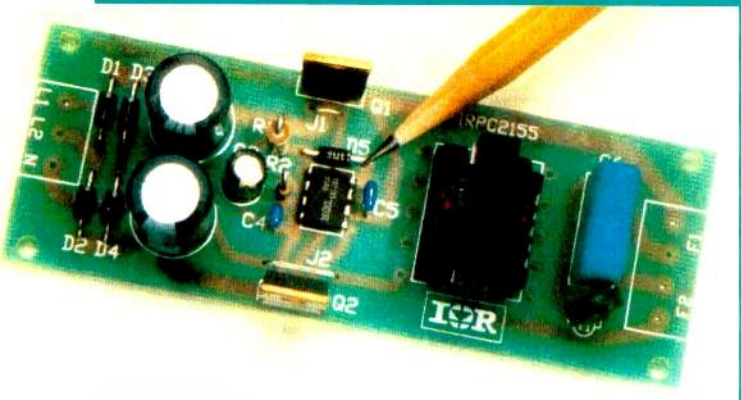

size and offer resistance ranges of 0.1 Ω -1.4k Ω , 0.1 Ω -5k Ω , 0.1 Ω -18k Ω and 0.1 Ω -45k Ω in tolerances of \pm 0.1% to \pm 5% and 0.75W to 4.5W power ratings. CWU resistors have standard tolerance down to 0.005% at 0.5W, while CWLs offer low values of 0.005 Ω -0.5 Ω at less than 7nH inductance. Surtech Interconnection Ltd. Tel., 0256 51221; fax, 0256 471180.

Transient suppressor. Giving board-level ESD protection in a 1.3mm² package, the AVX *Transguard 0603* version transient voltage suppressor clamps at 10V, 15.5V, 30V or 40V. Energy rating is 0.1J and peak currents up to 30A in eight 20 μ s pulses can be accepted, response time meeting the European EMC Directive. AVX Ltd. Tel., 0252 336868; fax, 0252 346643.

Transformers. ElectroSpeed has added new isolating transformers by Roxburgh and pulse types from Newport to its catalogue. Roxburgh's *TT81* range are of split-bobbin construction with a metal-shrouded coil in ratings of 25-1000VA with inputs from 0 to 415V. Newport's 766 series are ferrite-cored and meant for digital and data processing use, while the 1600 series are data isolators with 5 μ s pulse width capability at high rep. rates. ElectroSpeed. Tel., 0703 644555; fax, 0703 610282.

Ceramic resonators. Fuji's new ceramic resonators now operate up to 12MHz, with an initial tolerance of \pm 0.3% or \pm 0.5%, depending on frequency, anti-resonant resistance being over 50k Ω . Stability is \pm 0.3% from -20 $^{\circ}$ C to 80 $^{\circ}$ C and the resonators age at \pm 0.5% over 10 years. They come in plastic cases or epoxy-encapsulated versions from 190kHz to 830kHz, while higher-frequency types are in an epoxy dipped finish. Advanced Crystal Technology. Tel., 0635 528520; fax, 0635 528443.

Chip inductors. Three chip inductors by Murata are meant for EMI filtering in surface-mounted power supplies and DC converters at currents up to 6A. At 100MHz, the 1A *BLM41P01* has a typical impedance of 80 Ω , the 3A *BLM41P02* 70 Ω and the 6A *BLM41P03* 60 Ω . At 1GHz, all three retain an impedance above 70 Ω . Murata Electronics (UK) Ltd. Tel., 0252 811666; fax, 0252 811777.

Sealed rotary switch. Wasp's new *DR* 12-position rotary switches are sealed at both ends and can be flow-soldered. The 12.5mm switches have standard contact arrangements of 1, 2, 3 and 4-pole bcd and bcd complement, gold-flashed silver contacts being rated at 5V dc and 10V ac and 2A. The spindle is sealed to a maximum leakage of 1ml/h. Wessex Advanced Switching Products Ltd. Tel., 0705 453711; fax, 0705 473918.

Dielectric filter. AVX announces the *PDFC* series of dielectric filters meant for use in telecomms, particularly in

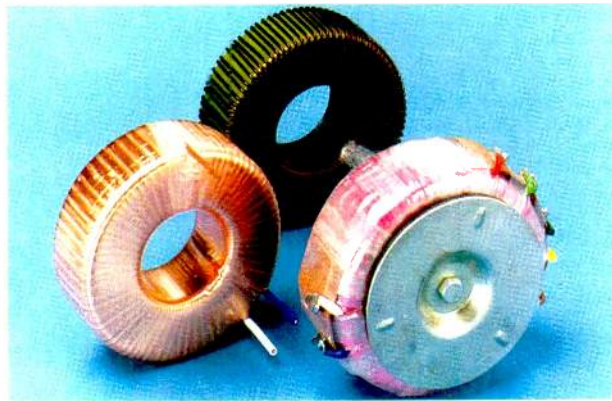

Toroidal transformers. A new series of toroidal mains transformers now being made by Willasden covers the 30VA-2000VA power range. Primaries are 1 ϕ /120V in parallel or 220/240V in series, secondaries being connected in series or parallel to obtain the required voltage. Flexible leads or tags are provided and insulation is Class B; finish is Melinex. Willasden Transformer Co. Ltd. Tel., 0920 821385; fax, 0920 822795.

the DECT sector. Frequency range is 1.8-2GHz, insertion loss 3dB and, for compatibility with the newest equipment, size is 6.5 by 5.5 by 3mm. Filters to provide lower insertion loss and improved stop-band attenuation are available to order. AVX Ltd. Tel., 0252 336868; fax, 0252 346643.

Displays

Multicolour leds. Dialight 552-3511 is a three-leaded led circuit-board indicator, offering true multicolour operation with less drive circuitry than is needed for the two-lead type. It uses two GaP led chips in a 5mm package, producing red, green, amber and a range of colours in between red and green. The red led provides 5mcd at 10mA at 2.1V and the green one 8mcd at 10mA and 2.3V, the drive coming from standard ICs with current-limiting resistors. Dialight. Tel., 0638 665161; fax, 0638 660718.

Filters

Switched-capacitor filter. Linear Technology's *LTC1066* 14-b.1 dc accurate, clock-tunable low-pass filter is meant particularly for data acquisition at up to 14-bit accuracy and rates up to 200kHz. To form an 8th-order elliptic or linear low-pass filter, an external RC circuit is needed for dc accurate working, but no active components. Input/output impedance is 500M Ω /0.1 Ω and the output handles 40mA. For frequencies up to 0.7 f_{co} , pass-band ripple is \pm 0.15dB, gain at f_{co} is -1dB and stop-band attenuation is 80dB at 2.3 f_{co} . Micro Call Ltd. Tel., 0844 261939; fax, 0844 261678.

Instrumentation

Programmable functions. TTI's *TG1304* programmable function generator is digitally controlled, generating complex waveshapes at frequencies up to 13MHz and using

digital measure-and-correct techniques to achieve frequency stability to within 0.01%. The instrument produces, as well as the usual sine, square and triangular shapes, unipolar pulses and dc levels; variable-symmetry start/stop phase allows more exotic shapes. fm and sweep control come from an auxiliary 5mHz-50kHz generator, as do AM, linear vca and log VCA. Thurlby Thandar Instruments Ltd. Tel., 0480 412451; fax, 0480 450409.

Level measurement. *LM311*, which is a level measuring test set from Seaward for voice band telecomms, is available in an improved version. There is now a multi-frequency, precise-output oscillator with variable frequency and level and a level meter measuring frequency and level in dBm. *LM311* also measures resistance and voltage and has an audio output and smoothing filter. Seaward Electronic Ltd. Tel., 091 586 3511; fax, 091 586 0227.

Literature

Amplicon. Amplicon Liveline's 1994 catalogue is now available. Additions to the range of products include automatic data switches, optical-fibre links/repeaters, optical RS232 modems, Combios for Windows, \pm 3.3V dc-to-dc converters, more DAP data acquisition boards and multifunction dpm's. There is a glossary of technical terms. Amplicon Liveline Ltd. Tel., 0800 525 335 (free); fax, 0273 570215.

Data access arrangements. AT&T Microelectronics has a free 12-page booklet showing a variety of data access arrangements. These are used to connect voice or data signalling circuits to the telephone line in modems, answering machines, etc. It is illustrated with circuit and block diagrams, with information on using solid-state relays to implement on/off hook control, ring detection and loop-

current sensing. AT&T Microelectronics. Tel., 0732 742999; fax, 0732 741221.

Power supplies. Astec Standard Power's short catalogue describes a range of products from 4.5W dc-to-dc converters to switching supplies up to the kW range. It also details a further-information service, by means of which engineers receive data sheets on their fax, anywhere in the world, simply by dialling a number and product code. Astec Standard Power Europe. Tel., 0384 440044; fax, 0384 440777.

Ceramic EMI filters. Miniature ceramic filters in the form of C, LL, LC, pi and T circuits are described by MPE in a new brochure. The publication contains application information and there is an EMC Helpline on 051 548 6525. MPE Ltd. Tel., 098 122481; fax, 098 122223.

RF semiconductors. Toshiba's new range of semiconductors for rf work is described in a new catalogue and comprises single and dual gate mosfets, jfets, bipolar transistors, pin diodes, Schottky diodes and tuning Varicaps. Other devices integrate hf devices and passive components on a single chip. Toshiba Electronics (UK) Ltd. Tel., 0276 694600; fax, 0276 691583.

Lithium batteries. A brochure from Battery Engineering Inc. describes high-energy lithium/thionyl chloride batteries; electrochemical systems, cell construction and characteristics. Battery Engineering Inc. (USA) 0101 617 361-7555; fax, 0101 617 361-1835.

SMD selection guide. A complete range of surface-mounted devices for power control is described in the International Rectifier short guide, including Hexfets, diodes, igbts and mos-gate driver ICs. International Rectifier. Tel., 0883 713215; fax, 0883 714234.

Digital radio testing. 2050 series signal generators by Marconi Instruments test many of the world's emerging digital radio systems with complex modulation. Digital and vector modulation allows receiver testing on systems including the new systems from North America and the Far East, as well as the Terrestrial Flight Telephone System (TFTS). This requires the generation of quaternary amplitude modulation, phase-shift keying, broadband AM and spread-spectrum signals; with extra equipment, the instrument can also generate Personal Handiphone (Japanese) and DECT signals. Marconi Instruments Ltd. Tel., 0727 859292; fax, 0727 857481.

NEW PRODUCTS CLASSIFIED

Please quote "Electronics World + Wireless World" when seeking further information

Power supplies

20W dc-to-dc converter. Semtech *MP9600* series 20W voltage converters produce pwm-regulated single or dual outputs of 5, 12, 15, 24, ± 5 , ± 12 , ± 15 and $\pm 24V$ to within $\pm 5\%$ and at a typical efficiency of 70%. The modules measure 0.83in high for board mounting. Inputs of 12, 15, 24 and 48V dc can be accepted and output currents of 800mA to 4A are available. Regulation and stabilisation are $\pm 5\%$ and ripple 200mVpk-pk. Semtech Ltd. Tel., 0592 773520; fax, 0592 774781.

200W dc-to-dc converters. Veropower 200 series voltage converters by BICC-Vero are 200W types with input ranges of 40-60V, 36-75V and 200-400V DC, giving at the outputs 3.3V, 5V, 12V, 15V, 24V and 48V, depending on the version. The 200-400V type is powered by rectified and filtered mains and can be configured to accommodate complex supply needs. A 700kHz switching frequency gives conversion efficiencies of over 80% and regulation and stabilisation of better than 0.1%. BICC-Vero Electronics Ltd. Tel., 0489 780078; fax, 0703 264159.

Wide-range dc-to-dc converter. Operating from a variety of input voltages, the *Calex LV* dc-to-dc converters provide a 6W output at fixed voltages of 5V, 12V and 15V from 4.8-12V input. Ground loops are eliminated by 700V dc isolation and noise levels are less than 50mVpk-pk over 20MHz – less with a specified external circuit. Regulation and stabilisation are both 0.1%. Calex Electronics Ltd. Tel., 0525 373178; fax, 0525 851319.

3.3V dc-to-dc converters. To cater for the increasing numbers of low-voltage ICs, Amplicon has introduced a series of dc-to-dc converters, the Z

series, providing a regulated 3.3V output from 9-18V, 18-36V or 36-72V inputs at 16W. Features include 500V DC input/output isolation, 78% efficiency, continuous short-circuit protection and 1%pk-pk ripple and noise. All the devices have remote on/off and an input pi filter. Amplicon Liveline Ltd. Tel., 0800 525 335 (free); fax, 0273 570215.

Radio communications products

Miniature mixer. ZP-11A is a mixer by Mini-Circuits Europe, accepting 1400-1900MHz rf and local oscillator input and producing a 40-500MHz IF. Conversion loss of 4.5dB is flat to within 0.6dB and compression 1dB, 1dBm typical. Mini-Circuits Europe. Tel., 0252 835094; fax, 0252 837010.

Power splitter. Mini-Circuits Europe offers the *SCP-4-4* surface-mounted, four-way power splitter for telecomms, radio and remote-control application. Bandwidth is 800-1000MHz and features include 24dB isolation, 0.9dB insertion loss, input VSWR 1.3:1 and 1.15:1 at the output. Power ratings are 0.5W input and 0.125W internal dissipation. Mini-Circuits Europe. Tel., 0252 835094; fax, 0252 837010.

Microwave resonator materials. New electroceramic materials by Morgan Matroc are intended to replace metals used in the manufacture of cavity resonators. Dielectric constants from 19 to 90 allow selection of the ideal size of resonator to balance ease of construction against miniaturisation. Barium-zinc-tantalate has a Q of 11000 and is meant for puck resonators from 5GHz to 26GHz. A 10GHz puck using material with a dielectric constant of 29.5, for example, measures 6mm in diameter and 3mm thick. Barium-neodymium has a constant of 87 for pucks in the 400MHz-8GHz range and



Bespoke power supplies. Gresham *XG* and *XF* series power supplies have one 5V output at 60A or 70A and up to three other regulated, adjustable and isolated outputs as additional modules, in any combination. These provide 2-6V at 15A, 5-15V at 12A or 15-36V at 7A. Stabilisation is $\pm 0.2\%$ over the input range and regulation 0.2%, zero to full load. Outputs are filtered to VDE and FCC Class A and optionally to Class B. Remote inhibit and sense are provided and the units are fully thermally, voltage and current protected. Gresham Power Electronics Ltd. Tel., 0722 413060; fax, 0722 413034.

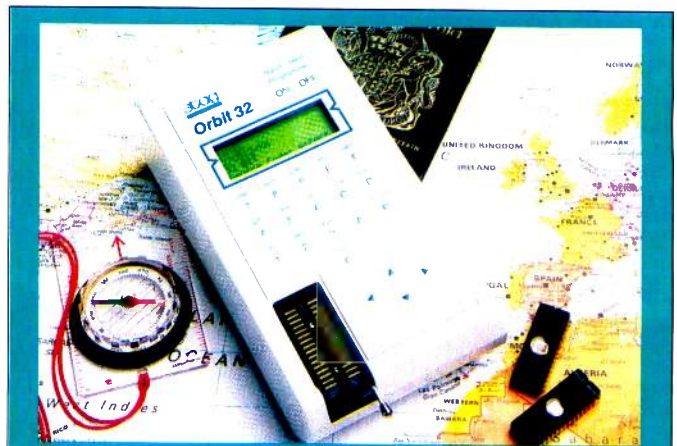

Programmer/emulator. Stag announces its new *Orbit 32* battery-powered, hand-held programmer, which it claims is the smallest stand-alone portable programmer available. It will program eeproms to 8Mbit, eeproms and flash devices. Some cmos proms and serial eeproms in 0.3in and 0.6in dips also fit the 32-pin wide-blade zif socket. *Orbit 32* has a high-speed emulator to allow connection to the target, so that there is no need to program devices until code is optimised. All device libraries are resident in non-volatile memory. Stag Programmers Ltd. Tel., 0707 332148; fax, 0707 371503.

magnesium-calcium-titanate at 19.5 is for coaxial resonators from 2GHz to 5GHz. Morgan Matroc Ltd. Tel., 0978 810456; fax, 0978 824303.

Transducers and sensors

Inductive sensors. Colvern's *Type 94* range of non-contact sensors are inductive types intended for rotation

speed measurement and position sensing for engine management, automatic braking, motor speed and ignition timing. In 13 standard and several specially designed forms, the devices consist of a magnet and toothed wheel varying the path reluctance and therefore producing a signal in the coil. Zero-crossing detection is incorporated. Colvern Ltd. Tel., 0708 762222; fax, 0708 762981.

COMPUTER

Computer board-level products

PC-based waveforms generator. *AWG7223PC* is a 50MHz arbitrary waveform generator by TTI that plugs into most ISA and EISA extension bus slots. Two output channels generate separate waveforms of up to 32K length, but the memory can be arranged to produce waveforms up to 100 gigapoints in length. Resolution of the nine different standard waveforms (sine, triangle, sawtooth, square, pulse, sine x/x , Gaussian pulse, exponential rise/decay pulse, pseudo-random noise and DC) is 12 bits from 100mV to 12Vpk-pk into 50 Ω , each channel having five filters cutting off at frequencies between 50Hz and 10MHz. Software includes a dos driver and Borland C++ library and optional WaveCAD. Thurlby Thandar Instruments Ltd. Tel., 0480 412451; fax, 0480 450409.

EISA 488.2 controller. An IEEE 488.2 interface board by National for EISA computers, the *EISA-GPIB* uses the *TNT4882C* controller chip and HS488 protocol for transfer rates up to 8Mbyte/s for both read and write. It includes *NI-488.2* dos and Windows software that is compatible with

LanView, *LabWindows* and *LabWindows/CVI*. Hardware base address, interrupt and dma settings are all software-configured; no jumpers or switches are needed. National Instruments UK. Tel., 0635 523545; fax, 0635 523154.

50MHz C40 products. LSI is the first supplier to use the Texas Instruments 50MHz *C40* digital signal processor in production equipment. Modules using the *C40* include memory, processor and i/o units, with sram and dram-equipped modules and application-specific *TIM-40s*. As an example, LSI's *MDC40T* is the first to use two *C40s* and allows PC or VME boards offering eight processors giving 400Mflops and 2.2Gflops; this is claimed to be the fastest DSP board in the world. Loughborough Sound Images Ltd. Tel., 0509 231843; fax, 0509 262433.

Computer systems

intelDX4 motherboard. The *SV2/GX4* PC motherboard from SPD uses the new 100MHz *IntelDX4* processor and power-management features. On the Norton SI V6 index, the *IntelDX4* shows a 50% gain in performance over its 66MHz

NEW PRODUCTS CLASSIFIED

predecessor, the 486DX2. There are seven VL and ISA bus slots on the board, which has 256Kbyte of cache as standard, expandable to 1Mbyte, eight 72-pin simm slots allowing 1Mbyte to 64Mbyte main system memory expansion. As well as the DX4, the zif processor socket accepts 486DX2, DX and SX devices and 487SX, Intel 486 and Pentium Overdrive chips. Special Products Distribution Ltd. Tel., 0420 563588; fax, 0420 562206.

Blue Lightning motherboards. Blue Micro has available PC motherboards based on Blue Lightning processors. First to appear are Cobalt Baby AT boards, which use the 75MHz clock-tripled version, 100MHz types soon being available. There is a 16K cpu cache and up to 512K external write-back cache can be fitted, four 72-pin simms allowing the installation of up to 64Mb of dram. The board has a maths co-processor and a local-bus IDE driver handles two hard disks; i/o includes two serial ports, a bi-directional parallel port and support for two floppy drives. Blue Micro Electronics. Tel., 0604 603310; fax, 0604 603320.

Tough PC. For the type of workplace where even a rack-mounted pc is not well enough protected and in which emc/rfi needs to be avoided, the Blue Chip ICON PC range meets EN55022 for interference radiation and mains terminal voltage, and IEC 801-3 for immunity to EM interference. The lockable PC is made from nickel-plated steel and is thereby protected against liquids, dust and, the company says, collisions. A 14-slot PC AT backplane is used that leaves at least 13 slots free, and processors up to P24 Pentium overdrive with local bus video and VESA expansion are available. Four drive bays are included. Blue Chip Technology. Tel., 0244 520222; fax, 0244 531043.

Data communications

Modem kit. A modem designers' kit, the MDK from RCS, assists engineers to develop new modems and applications quickly and easily. It enables a single board layout to become the foundation for a family of modems, from 2400-baud data-only types to a 28-Kbaud V.Fast Class modem with data, fax and voice. MDK is a serially configured modem complete with power supply, UK BAPT-certified line interface, external microphone and speaker, demo software, firmware and documentation. RCS Microsystems Ltd. Tel., 081 979 2204; fax, 081 979 6910.

Development and evaluation

Background debugger. Flash Designs' Universal MDS for developers of embedded programs has what the company claim is the world's smallest background debugger at 100-150byte, which allows on-the-fly viewing and editing of all microprocessor registers, stack, memory and i/o ports. It is non-intrusive and lets the code run in real time. Debuggers are available for

8031/51, 68HC11, H8, Z-80 and other 4/8-bit devices. Flash Designs Ltd. Tel. and fax, 0293 551229.

Computer peripherals

PCMCIA hard drive. Seagate's ST7050P is a 42.7Mb hard drive on a PCMCIA card for use in notebooks and desktops, as well as data collection and instrumentation systems. The drive incorporates the most popular operating systems, including dos and Windows and is compatible with all systems complying with PCMCIA release 2.1 or higher. A software driver on disk is provided to ensure drive/PCMCIA compatibility, but if the drive is integrated under the 68-pin ATA standard, the drive uses standard AT Bios support without the software driver support. There is a kit to ease the development of new equipment: using the drive. Ambar Components Ltd. Tel., 0844 261144; fax, 0844 261789.

Software

Transient data capture. Adept Scientific announces the Flash/SP, which combines the Strawberry Tree Flash-12 Model 1 data-acquisition board with Dadisp, the data-analysis software package. A software driver developed by Adept allows collected data to be taken directly to a Dadisp worksheet for reduction and analysis at sampling rates up to 1Msamples. The Flash/SP hardware driver module allows the Flash-12 board to be controlled from Dadisp, the system accepting inputs between $\pm 50mV$ and $\pm 10V$ and storing up to 64K data points (1 million points with an optional daughter board). Adept Scientific Micro Systems Ltd. Tel., 0462 480055; fax, 0462 480213.

Windows psu characterisation. Powerstar Characterisation Module is now part of the Interpro (Schaffner) Windows-based system for the repetitive test of power supplies in characterisation - a process normally necessitating thousands of measurements in a variety of conditions and needing a number of test instruments. The system's library contains over 100 standard tests and the characterisation procedure is able to measure many more test points than in the manual case. Results can be saved to disk and analysed by the Powerstar data analysis package. Schaffner EMC Ltd. Tel., 0734 770070; fax, 0734 792969.

Windows pcb design. Pentica's TangoPRO Schematic Lite and PCB Lite form an entry-level version of its Tango circuit design and board layout software, giving an upgrade path from its already workstation-class EDA software to the highest specification version. These tools run under Windows and offer features suitable for most modern pcb designs. Schematic Lite has powerful placement and editing tools, keyboard shortcuts and instantaneous netlist generation, with over 2000 library components. There intelligent wires and buses and automatic junction and bus entry placing. PCB Lite includes Cut/Copy/Paste and design error indication. Pentica Systems Ltd. Tel., 0734 792101; fax, 0734 774081.

Field Electric Ltd.

Tel: 0438-353781 Fax: 0438 359397

Mobile: 0836-640328/0860-213370

Unit 2, Marymead Workshops,

Willows Link, Stevenage, Herts, SG2 8AB.

JJ Inst XY Chart Recorder PL4	£75
Apple II GS and Apple colour monitor etc	£200 C/P £24
1.44Mb Laptop floppy disk drives new	£16 C/P £3
72 pin Simms for PS2 Compaq Dell etc	
Parallel & Serial data switches up to 8 ways - Ring for details	
Compaq enhanced alt keyboards (no cable)	£11 C/P £5
PC power supplies up to 600w, in stock - Prices start from	£19 C/P £6
IBM 3363 optical disk drive	£100 C/P £20
102 key AT enhanced keyboard with PS2 type plug	£13.95 PS2 to 5 pin Dm
adpt-plug	£3.25 C/P £3.50
Toshiba external 5.25" F. D. drive PA7225E new and boxed	£45 C/P £7.50
TEAC 5.25" BBC compatible F.D. drives 350K/720K refurbis	£8.95 C/P £3.75
16 bit hard disk/F. disk controller card	£12.00 C/P £3
SCSI hard disk drive's new CDC 344Mb	£250.00 C/P £10.00
New and boxed 286/116 Motherboards, on board, hard and floppy cont. serial/para ports on board VGA etc	
takes Simms	
Yusa maintenance-free rechargeable battery NP7-12 12v 7.0Ah 15x6.4x9.2	£21.00 C/P £4.00
Rose die-cast box 17 5x5.6x7.8 new	£4.25 C/P £1.80
Sony 7" colour monitor KTX-9000UB 240wAC input with manual. inbuilt modem, needs to be converted to RGB etc	£85 C/P £16.00
386 5x16 CPU (Intel) motherboard with Phnix Bios 6x16 slots, 2x8 bit slot. Takes dram or Simm memory	£25 inc C/P
310mmx215mm	£14 inc C/P
386 5x16 CPU (Intel) motherboard without Bios etc	

TEST AND MEASUREMENT EQUIPMENT

HP portable plus computer wch LCD screen, 1mb		HML 411 high voltage 0-20KV cap charger new	£200
MEM drawer software drawer etc	£75	AVO RM 215F3 AC Breakdown Tester	£95
Tektronix standard amplitude calibrator 047-	£100.00	Schlumberger 4000 Precision Sig. Gen	£150
502	£105	Schlumberger 4900 RF-AF Measuring Unit	£195
Fluke 8010A digital multimeter	£195	Wyse 60A Terminals new & boxed with keyboards	£350
EH microwave swept oscillator model 574-1.7-	£450		£150
12.4 GHz	£95	Fluke 335A DC voltage standard differential	£350
Syston donner pulse gen, 100c	£100	voltmeter null detector	£250
Complot series 7000 digitizer tablet with Complot	£800	Farnell B3020 0-30VDC @ 20A	£150
series 7000 digitizer	£800	AEI Gauss meter FB22 form with probe	£150
Hydrostatic stability indicator HSM-400 P1	£12.50	HP 331A distortion analyzer	£150
Astec SA 301306, new and boxed PSU 240V ac	£150	FM1 Rotary attenuator 27/11	£150
input, -5V at 2A + 15V at 1.8A - 15V at 0.3A	£150	HP Frequency meter X532B	£325
HP 7221A plotter	£300	HP 1740A 100MHz oscilloscope. Dual CHN with	£325
HP 1332 X-Y display with options 215/300 315/570/	£75	3rd CHN, trigger view etc	£325
631	£125	AS Elite switch mode variable PSU 250VAC input	£325
Hughes model 639 scan conversion memory	£200	0-50VDC 25A max metered 17x12.5x5" with	£325
JJ Inst PL4 recorder	£125	manual	£95
Sorenson SRL 40-12, 0-40 VDC 0-12A metered	£125	Inmac 300VA Batt. Back up & line conditioner	£95
115 VAC input	£200	model HQ 300VA	£95
KSM SCT-200 15W power supply 0-200V 0-15A	£200	HP 9872c plotter	£175

All above equipment + 17.5% VAT - Please ring for c/p prices



We would like the opportunity to tender for surplus equipment
Official orders, credit card telephone orders accepted with
Access, Amex, Diners, Visa cards. Overseas enquiries welcome
c/p rates UK mainland only. Please ring for c/p rates not shown
All prices inc VAT unless stated. Stock list available

CIRCLE NO. 127 ON REPLY CARD

THE DEFINITIVE 'OFF-AIR' FREQUENCY STANDARD

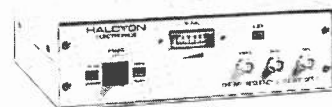

Still Only
£195 + VAT
carriage extra

- * Provides 10MHz, 5MHz & 1MHz
 - * Use fit for calibrating equipment that relies on quartz crystals, TCXOs, VXCOs, oven crystals
 - * Phase locks to DROITWICH (rubidium controlled and traceable to NPL)
 - * For ADDED VALUE also phase locks to ALLOUIS (cesium controlled and traceable to OP - French eq to NPL)
 - * British designed and British manufactured
 - * Options available include enhanced receiver, sine wave outputs and 13MHz output for GSM. Prices on application.
- Output frequencies —
10MHz, 5MHz, 1MHz
Short term stability — better than 1×10^{-8} (1 sec)
Typical — 4×10^{-9} (1 sec)
Long term — tends to 2×10^{-12} (1000 sec)

IDEAL BEGINNERS SCOPE, SCOPEX 466 AQUILASCOPE 6MHz SINGLE TRACE, INT/EXT TRIG, TRACE LOCATE, BRIGHT LINE AUTO, 10mV SENSITIVITY, 1µs-100ms/cm, etc. £95	
MURHEAD K231A TEMP CONT PRECISION STD CELL	£195
MARCONI TF2212 X-Y DISPLAY	£59
LEVEILL TM12 TRANSISTOR CHARACTERISTIC METER	£89
B&K 4420 STATISTICAL DIST ANALYSER	£39
BACHARACH MV2 MERCURY SNIFFERS	£39
DAWE M405(DR S) SOUND LEVEL METER	£95
QUAD 303 STEREO POWER AMPS	£95
DRAKE MN2700 MATCHING N/WORK & PS: PSU	£750
PHILIPS PM3065 10MHz DUAL TRACE & T B	£95
PLESSE Y TCT10 SIG GEN/ANAL 50-300 BDS	£195
LEADER LBO-9C ALIGNMENT SCOPE	FROM £99
TELEQUIPMENT D61A 10MHz DUAL TRACE	£135
IWATSU SS5116 DUAL TRACE 10MHz	£175
TELEQUIPMENT D1011 10MHz DUAL TRACE	£175
IWATSU SS-5802 DIGITAL STORAGE	£295
TEKTRONIX 2215 60MHz DUAL TRACE DEL T/B	£450
TEKTRONIX 453A 50MHz DUAL TRACE DEL T/B	£395
H.P. 8445A VECTOR V-METER 1GHz	£395
TELEQUIPMENT D67A 25MHz 2T DEL T/B	£215
HITACHI VC 6015 10MHz DIGITAL STORAGE	£295
HP134GA X-Y DISPLAYS	£149
OERTLING V20 SINGLE PAN BAL 0.1mg/20g	£69
ANAL YTICAL BALANCES WITH WEIGHTS .50g	£69
MARCONI TF2300 WAVE ANALYSER 20Hz-50KHz	£149
LEVEILL TM68 MICRO V-METER 450MHz	£95
LEVEILL TM38 MICRO V-METER 3MHz	£85
MARCONI TP2212 X-Y DISPLAY	£59
LEVEILL TM12 TRANSISTOR CHARACTERISTIC METER	£89
B&K 4420 STATISTICAL DIST ANALYSER	£39
BACHARACH MV2 MERCURY SNIFFERS	£39
DAWE M405(DR S) SOUND LEVEL METER	£95
QUAD 303 STEREO POWER AMPS	£95
DRAKE MN2700 MATCHING N/WORK & PS: PSU	£750
PHILIPS PM3065 10MHz DUAL TRACE & T B	£95
PLESSE Y TCT10 SIG GEN/ANAL 50-300 BDS	£195
LEADER LBO-9C ALIGNMENT SCOPE	FROM £99
TELEQUIPMENT D61A 10MHz DUAL TRACE	£135
IWATSU SS5116 DUAL TRACE 10MHz	£175
TELEQUIPMENT D1011 10MHz DUAL TRACE	£175
IWATSU SS-5802 DIGITAL STORAGE	£295
TEKTRONIX 2215 60MHz DUAL TRACE DEL T/B	£450
TEKTRONIX 453A 50MHz DUAL TRACE DEL T/B	£395
H.P. 8445A VECTOR V-METER 1GHz	£395
TELEQUIPMENT D67A 25MHz 2T DEL T/B	£215
HITACHI VC 6015 10MHz DIGITAL STORAGE	£295
HP134GA X-Y DISPLAYS	£149
OERTLING V20 SINGLE PAN BAL 0.1mg/20g	£69
ANAL YTICAL BALANCES WITH WEIGHTS .50g	£69
MARCONI TF2300 WAVE ANALYSER 20Hz-50KHz	£149
LEVEILL TM68 MICRO V-METER 450MHz	£95
LEVEILL TM38 MICRO V-METER 3MHz	£85
MARCONI TP2212 X-Y DISPLAY	£59
LEVEILL TM12 TRANSISTOR CHARACTERISTIC METER	£89
B&K 4420 STATISTICAL DIST ANALYSER	£39
BACHARACH MV2 MERCURY SNIFFERS	£39
DAWE M405(DR S) SOUND LEVEL METER	£95
QUAD 303 STEREO POWER AMPS	£95
DRAKE MN2700 MATCHING N/WORK & PS: PSU	£750
PHILIPS PM3065 10MHz DUAL TRACE & T B	£95
PLESSE Y TCT10 SIG GEN/ANAL 50-300 BDS	£195
LEADER LBO-9C ALIGNMENT SCOPE	FROM £99
TELEQUIPMENT D61A 10MHz DUAL TRACE	£135
IWATSU SS5116 DUAL TRACE 10MHz	£175
TELEQUIPMENT D1011 10MHz DUAL TRACE	£175
IWATSU SS-5802 DIGITAL STORAGE	£295
TEKTRONIX 2215 60MHz DUAL TRACE DEL T/B	£450
TEKTRONIX 453A 50MHz DUAL TRACE DEL T/B	£395
H.P. 8445A VECTOR V-METER 1GHz	£395
TELEQUIPMENT D67A 25MHz 2T DEL T/B	£215
HITACHI VC 6015 10MHz DIGITAL STORAGE	£295
HP134GA X-Y DISPLAYS	£149
OERTLING V20 SINGLE PAN BAL 0.1mg/20g	£69
ANAL YTICAL BALANCES WITH WEIGHTS .50g	£69
MARCONI TF2300 WAVE ANALYSER 20Hz-50KHz	£149
LEVEILL TM68 MICRO V-METER 450MHz	£95

LIST AVAILABLE BUT 1000'S OF UNLISTED BARGAINS FOR CALLERS. ALL PRICES EXC. OF P&P AND VAT
QUALITY ELECTRONIC EQUIPMENT ALWAYS WANTED

HALCYON ELECTRONICS
423, KINGSTON ROAD, WIMBLEDON CHASE, LONDON SW20 8JR
SHDP HOURS 9-5.30 MON-SAT. TEL 081-542 6383. FAX 081-542 0340

CIRCLE NO. 128 ON REPLY CARD

LETTERS

More distortion...

I would like to thank *EW+WW* and Douglas Self for an educational and interesting series on distortion in power amplifiers, articles which I thoroughly enjoyed. I do not wish to detract from the series but would like to propose an extra distortion mechanism to add to Mr Self's list: output (voltage) clipping through insufficient output current capability when driving loudspeakers instead of resistors.

I know of only one set of published measurements of loudspeaker current, cited by Ben Duncan in an *EW+WW* article some time ago, and peaks of sixty amps were recorded, using real loudspeakers and a music signal.

This may be an extreme case, but it makes the point. Five minutes with a calculator is enough to conclude that the load impedance (as opposed to resistance) must have been far from 8Ω and highly reactive. The output current capability of Mr Self's designs, class A and B, indicates that he (in common with many other esteemed designers) may not have addressed this problem.

All of his published data on output stage performance used a resistive load – normally 8Ω , sometimes 4Ω – unless I am mistaken.

Resistive-load measurements and simulations may be useful during development, but I suggest that they are all but irrelevant to the final product, expected to drive

loudspeakers with a music signal.

Many highly regarded amplifiers can deliver more output current than might be expected if a resistive load is assumed. I'm not just referring to American monster amps here – the *NAD3020* is a perfect example. Many thousands of consumers were sufficiently impressed to vote with their wallets.

Of course, I cannot prove that its high output current was responsible for its sound quality, but it's a thought...

Finally, the gibes against the subjective community which appear here and there do not sit well with an otherwise professional presentation. They are unworthy of Mr Self, and highly subjective in nature – and I would hate to have to describe Mr Self as a subjectivist.

There is high-end equipment that does not measure well (ref. part 1). But if – and only if – it reproduces music better than competing equipment, then this is sufficient. The only purpose for audio power amplifiers is reproduction of music. Thus music reproduction must be the primary criterion for judging the success of a design. Measurements are, at best, an indirect estimate of musical performance.

There are those who advise caution when applying techniques to reduce distortion, lest the cure be worse than the disease. Mr Self pointed out several examples of this, helping designers to avoid problems. To interpret such warnings to mean that low distortion is immoral (part 8) is a cheap debating trick, presumably intended to discredit those who do not share Mr Self's views.

Stephen J Merrick
Cheshire

...clearly the best

The difference of opinion between Douglas Self and Ben Duncan (*Letters*, May) would have more significance for practical audio fans if we had an amplifier construction project of Ben's that we could compare with Douglas' amplifier (*Distortion in power amplifiers*: pt 7, February, 1994, pp.137-142).

All electronics ends up at the end of a soldering iron and in audio what counts is the sound from the speakers – regardless of the semantics involved.

Offer of an excellent pcb for the class B amp is greatly appreciated as is the down-to-earth concepts using standard components from established UK sources. This contrasts with many offerings during the past decade from other UK and

foreign journals specifying parts that can only be obtained from foreign suppliers.

Ben will be well aware that existing UK construction kits have degenerated, in some instances, into value-added enterprises with component applications that are now stratospheric in price.

Douglas has brought us back to earth (sic). And about time too.

Hugh Haines
Sunderland

Ears and knows

Little did I think that my simple description of my use of listening in the development of audio-related products (*Letters*, *EW+WW*, November 1993) would embroil me in "subjectivist wars" with Douglas Self and elicit accusations of voodoo practices from Alan Dyke (both *Letters*, June 1994).

The fact is that audio electronics circuits are built and sold to be listened to. This basic and intractable truth should be justification enough for designers to use their own ears somewhere along the way. Yet it is one that I have yet to see Douglas Self address or even acknowledge.

The research I cited in my last letter – which shows that customers in the professional audio industry listen to competing products before making purchasing decisions – is my own. It is culled from a career spanning 25 years of talking and listening to customers in the broadcasting, sound recording, live sound and music markets around the world. They are all professional listeners in the sense that they make their living from the creative use of audio electronics.

Experienced sales and marketing people from any other audio equipment manufacturer or distributor would tell Douglas Self the same thing and indeed, in the case of the company for which he works, probably already have.

Whether or not he wishes to hear it, believe it or act upon it, the data exists.

Alan Dyke doubts that I would take part in the sort of independent listening tests suggested by Alan Thomas. Why should he doubt it? I will quite happily accept that challenge – as might a number of my colleagues – if in doing so we could help to move the study of the correlation of hearing and measurement beyond the limitation and self-defeatism of entrenched prejudice and selective study.

As to technique, and assuming that

Military option

The UK once had a strong electronics industry. It became involved in arms equipment manufacture and is now virtually dead. How strange then that you should conclude: "It is... certain that we would not have an indigenous electronics industry if it were not for military spending" (*Comment*, April).

I believe such involvement has been a bad thing, and would go so far as to say it is the single most significant factor contributing to the demise of the industry.

In the early 60s, when I started in electronics, the industry was strong, innovative and fiercely competitive. Domestic consumer choice was vast, and dozens of manufacturers produced radios, tape recorders, tvs and audio. The industry was not without its faults but it was certainly well placed to take on any foreign competition. Ferranti, GEC, Marconi, Ultra, Decca, Pye, Cossor, Bush Murphy, Ekco, and many more I could mention were all supplied by an equally vigorous and diverse component supply industry: names such as Mullard, Mazda, Ferranti, Brimar being active in the new and rapidly changing semiconductor field.

It is popular to blame the Japanese for the decline. But the early Japanese imports were plain rubbish (I well remember fixing batches of Sony radios and tape recorders before they could be offered for sale, a good 50% being u/s some beyond economic repair).

No don't blame the Japanese, they just moved in on a market that was being vacated by its home industry, and vacated with unseemly haste at times.

The reason for the decline was the MoD with its highly irresponsible cost-plus contracting. A seemingly inexhaustible supply of taxpayers' money could be used to divert the industry into military equipment supply.

Now the industry is being ditched with the same cynicism with which it was acquired. Unfortunately the companies that remain are no longer capable of operating in the domestic market. The management structures encouraged by the military market actively works against the efficient re-organisation such a move would require.

Was it not General Eisenhower who warned "...beware the military-industrial complex"? That a once proud UK electronics company should now be reduced to using timed-out government ministers to set up sordid little deals with dubious foreign governments is wholly consistent with such an alliance. That the once proud *Wireless World* should endorse those activities is just sad. Very very sad.

RM Burfoot
Avon

I agree totally that military contracts have been disastrous for the competitiveness and diversity of the UK electronics industry. However they now represent our only legacy – diminished and sad though they may be. Rebuild from them by all means. But don't ignore them.

Frank Ogden



**ANCHOR SURPLUS LTD
THE CATTLE MARKET
NOTTINGHAM
NG2 3GY**

**TEL: (0602) 864902 & 864041
FAX: (0602) 864667**



OSCILLOSCOPE SPECIAL

**50MHz
TWIN TRACE
TWIN TIMEBASE**



**Philips PM3217 oscilloscope Special Offer
for 1 month only tested + Cal verified **£295.00****

Hewlett Packard 8554B RF Plug in's for HP141 Series
Spectrum Analysers, 1250 Mhz
Special offer price: £395.00

Hewlett Packard 8660C RF Signal Generators
1Mhz-1300Mhz, AM, FM, CW, Synthesised
Special offer price: £1,200.00

Marconi TF2018 Synthesised Signal Generators
80Khz-520Mhz, AM, FM, CW, 3xLCD Displays
Special offer price: £650.00

NOW OPEN SEVEN DAYS A WEEK

**Monday to Friday: 9.00 am to 6.00 pm Saturday: 8.00 am to 4.00 pm
SUNDAY: 10.00 am to 4.00 pm**

All prices excluding VAT & carriage.



I would be required to hear differences between two unseen power amplifiers I would want to nominate the other components in the listening chain and choose my own source material and listening levels. I would then want to spend as long as I felt necessary listening to each amplifier. Once I was happy and relaxed (on the assumption that Self would not count these requirements as "fatal flaws" in my methodology), the two amplifiers could then be A/B'd until the cows came home and I would hear the difference *every single time*.

Jerry Mead
Herts

Charge build up

Having worked for the past 30 years as a capacitor engineer, both in design and applications, I eagerly read the article by Tony Wong on Choosing Capacitors (*EW+WW*, April, pp.327-329).

Unfortunately the article has a number of typographical errors which could confuse a user, and also makes fundamental mistakes – especially concerning electrolytic capacitors.

The most serious – "... If connected incorrectly [reversed], the insulating oxide film is not formed and there is no capacitance" – is incorrect.

Manufacture of non-solid aluminium electrolytic capacitors starts with rolls of pure aluminium foil etched to increase surface area. They are then electrolytically formed to produce the dielectric oxide by applying a positive voltage, typically 20% greater than rated voltage, in a bath of weak acid.

After slitting to width and winding into a capacitor, the cut edges are reformed by applying voltage at elevated temperature and using oxygen available from the capacitor electrolyte. This, oxide film, used with chemically suitable electrolytes, is inert. Indeed were this not so, the capacitor would fail in storage.

Consequently, every aluminium electrolytic capacitor contains this dielectric oxide film from day one.

Application of reverse voltage does not, in the short term, remove this oxide and the capacitance value is essentially unchanged. Indeed CECC-30-300 clause 4.15 requires change of capacitance to be less than 10% of initial value when subjected to 1V reverse, then rated voltage, each for 125h at upper category temperature.

A capacitor requires two foils each covered with dielectric oxide formed to the same (non-polarised) or different (polarised) voltages.

Given a polarised construction, the second foil (cathode) will have atmospheric oxide equivalent to 2-3V electrical. Both foils' capacitances are dependent on

formation voltage and surface area.

Assuming the cathode foil is 2000 μ F and the anode foil is 615 μ F and has been formed to 8V, the resulting 470 μ F capacitor could be modelled as two capacitors of the above values in series, each having a parallel zener diode of 2-3V and 8V respectively.

C Bateman
Norfolk

Mixing it

Many readers may have seen a television programme in the series 'From A to B' (BBC2) which explored the obsessive relationship between travelling sales reps and their motor cars. What was most worrying was that the obsession seemed to have spread from the reps to their customers. It appears that when you take delivery of your pretty new mixing desk, the slider pots are unlikely to have been selected on a careful calculation of price versus performance and reliability – they were very probably bought from the supplier whose sales reps arrived in the car with the fanciest logo on its rear end.

Is it any wonder that British manufacturing industry is vanishing before our eyes?

MT Hawkins
Hants

Science friction

All strength to *EW+WW* for allowing open debate in its letters column on many 'heretical' subjects, something which few other technical journals have the courage to do.

There exists an academic and media mafiosi which attempt to discourage individuals who even start to show an interest in 'heterodox ideas'.

Michael Williams' attack on me (*Letters*, May, 1994) employed name calling, ridicule and humour – just a few of the 28 deceptive stratagems used by those who have a weak scientific case: (see appendix 4 of *Science versus Evolution*, Malcolm Bowden, 1991).

Organised pressure groups, chicanery, sharp practice, and zealous histrionics abound in the scientific establishment, all geared to prevent and discredit any research and experimentation that threatens the establishment status quo or is against 'informed opinion'. This is especially so in the areas of today's three sacred cows of evolution, relativity and heliocentricity. See

Researchers like Immanuel Velikovsky (catastrophist), Halton Arp (anti-Big Bang), Stefan Marinov (anti-relativist), Pons and Fleischmann (cold fusion), Robert Gentry (pleochroic halos), Richard Milton (anti-evolution), Barry Setterfield (decrease in speed of light), Walter van der Ramp

(geocentrist).

They have all been shown to have strong cases, or even to be substantially correct. Yet they were all initially greeted as stupid or even harmless fruitcake. Conspiratorial attempts could then be made to silence them at the highest levels, in blatant disrespect of the pursuit of novel human knowledge.

Amnon Goldberg
London

Vision thing

The trouble with John de Rivas' virtual travel idea (*Letters*, May) is that, unlike VisionRing, it cannot easily be adapted as a mass broadcast medium.

VisionRing allows unlimited numbers of viewers to jump between one or more fixed VR pods, each supplying up to 360° of independent horizontal picture control with stereo vision.

Every VisionRing pod is essentially a weatherproof cylindrical caddy with a magazine of (typically nine or ten) cheap replaceable semi-pro video cameras at one end, trained on an outward-pointing ring of wide-angle lenses at the other via mirrors.

The multi-core feed from the pod is patched straight into the cable network (via a switcher box for commercial breaks) using one channel per camera. The home viewer uses head position to select which pair of consecutive channels is to be fed into the VR headset from a two-channel decoder.

A normal tv set could be fed by the decoder at the same time. For an outlay of a few thousand pounds per pod, a cable tv company can add a low-maintenance VR supplement to its live broadcasts, with no extra camera crew or production personnel: if a particular view becomes boring, the viewer can simply 'look away', jump to another pod's channels (if available), or switch back to the standard (monovisual) broadcast.

Viewers without special equipment can still 'channel hop' between individual views, and hotels or pubs could run multiple channels on separate tv sets to produce an impressive multi-view backdrop during sporting events.

Between major sporting features and the like, a VR pod could be left on-line for all live studio output, and when suitable programming is not available, the network could patch in live VR 'test cards' from permanently installed pods at, say, the Grand Canyon, a nice stretch of beach, or the top of the Empire State Building (live panoramic 3D sunsets over New York from any angle, anyone?).

The final commercial attraction of VisionRing is a little more painful.

While you can watch the Superbowl or the World Cup live in VR, you won't be able to videotape the experience on a domestic machine. So you will not be able to avoid the VR Coca Cola adverts. Sorry, everyone.

Eric Baird
Middlesex

Virtual intercourse

I was interested to read John de Rivas' letter (*Letters*, May) concerning virtual travel and the paying of virtual visits.

The system he envisages would certainly be possible, although I doubt if the data streams could ever be compressed enough to be sent down an ordinary twisted pair. I think the scheme would have to wait until we all have optical fibre laid to our houses.

Also, until the technology exists to sequence DNA in real time and to re-synthesise it at the other end of the link there will remain some interactions that cannot take place in virtual reality.

JS Linford
Oxford

Theoretical limits

I agree with Mr Goldberg's view (*Letters*, April 1994) that the foundations of theoretical physics are in just as poor shape as ever. I am quite familiar with the argument that physicists' perception of the speed of light is monotonically decreasing since first measured by Galileo (who found it to be ∞). When I was studying engineering physics fifteen years ago, my teachers told me that the effect was due to technological advancement and the fact that early measurement depended on astronomical constants – such as the length of the solar year – which are now recognised to indeed vary.

Mr Goldberg points out that the fundamental constants are inter-related so that a new electron mass gives a different Planck's constant and so forth. But it is ludicrous to say that: "the change is not due to limitations of equipment".

Dane Ole Romer, a contemporary of Hamlet, deduced from watching the stars that it takes a certain time before the light reaches Earth and to say that his vintage calculations are on an equal footing with those newfangled atomic clocks is too damned conservative. Extrapolations of laboratory reality such as determination of the age of the Universe are entirely the scraping of horns of the big rams concerning correct application of observed laws and need not be taken seriously.

Michael Williams
Beth Shemesh

INTRODUCING THE "WHAT THE HECK IS GOING ON?" METER

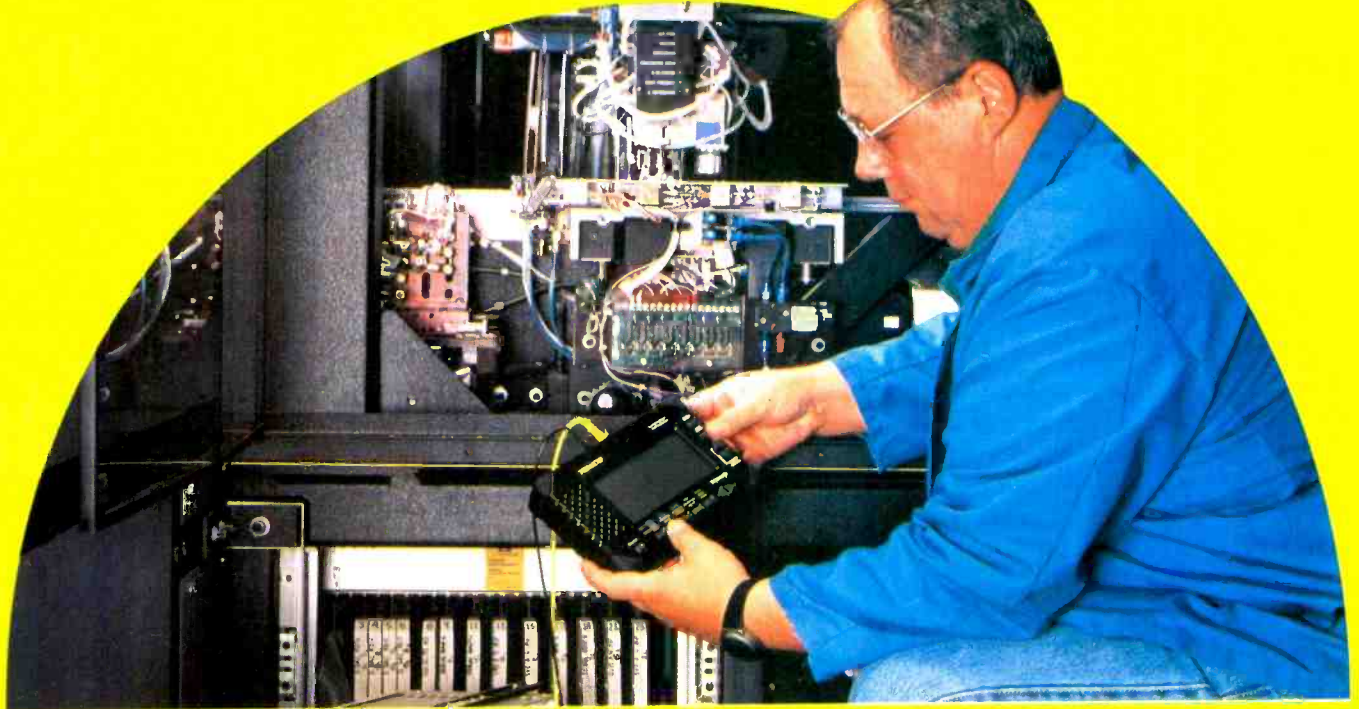

TEKMETER™

For Installation and Maintenance of:

- POWER DISTRIBUTION SYSTEMS
- VARIABLE SPEED MOTOR CONTROLLERS
- PROCESS CONTROL EQUIPMENT
- SECURITY & OTHER VIDEO SYSTEMS
- COMMUNICATION EQUIPMENT

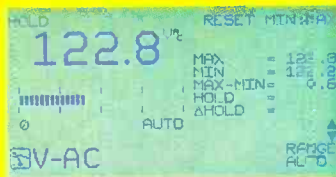

Large LCD Display gives clear indication including Max, Min and Max-Min values.



Dual channel operation allows relative timing of signals to be observed.

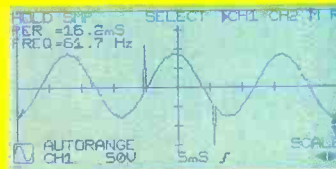

Display of signal shape lets you find faults that DMM can not show.

Today the Digital MultiMeter (DMM) is not always enough! Modern electronics permeates our lives and the installation/maintenance professional is faced with problems where voltage and current measurements are just not enough. The shape and timing of signals is an important factor in many applications.

The New TekMeter is a rugged, fully-featured, autoranging DMM and a rugged, fully featured autoranging oscilloscope all in one battery-powered 1kg package. TekMeter is so simple to use you don't need a training course – even to look at signal shapes!

Choose between 3 new models – the THM550 single-channel version at £649.00, the THM560 dual-channel version at £775.00 and the THM565 dual-channel version, with backlight at £995.00. Whichever one you choose, it will help you to find out what's going on and solve the problem!

TekTools™ - Smart Tools Work Better
Tel: 0800 412200

Tektronix

TekDIRECT, FREEPOST, Fourth Avenue, Globe Park, Marlow, Bucks, SL7 1YZ. Fax: 0628 474799

CIRCLE NO. 129 ON REPLY CARD

CIRCUIT IDEAS

SEND YOUR CIRCUIT IDEAS TO THE EDITOR, ELECTRONICS WORLD, QUADRANT HOUSE, THE QUADRANT, SUTTON, SURREY SM2 5AS

Do you have an original circuit idea for publication? We are giving **£100** cash for the month's top design. Other authors will receive **£25** cash for each circuit idea published. We are looking for ingenuity in the use of modern components.

Digital sinewave generator

£100 WINNER

As an alternative to using a look-up table, an analogue-to-digital converter and a fixed filter, this circuit possesses the advantage that the frequency of the programmable output filter varies automatically.

The clock input drives the MAX29x filter and, via a divide-by-10 counter, a second divide by 10 counter that develops a voltage across R proportional to the count. Output frequency is $f_{in}/100$.

Lee Szymanski
Stamford
Lincolnshire

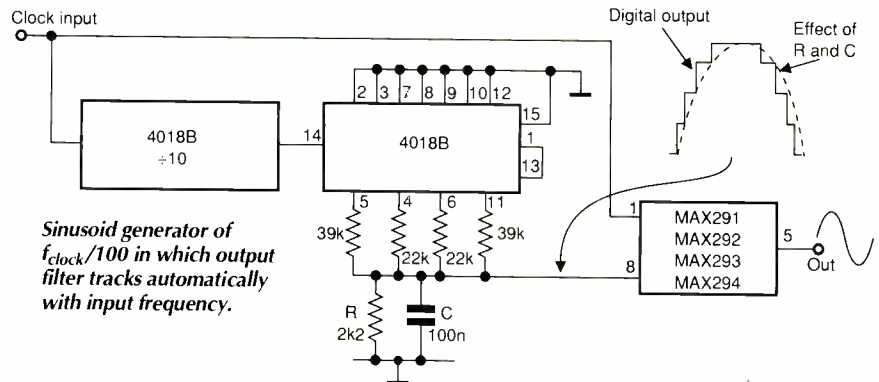

Spare inverter converts 5V to $\pm 15V$

If you have only a 5V rail and need a dual 15V supply, use this circuit to generate it cheaply.

A spare Schmitt inverter from, say, a 7414 operates as a free-running multivibrator at a frequency of about 100kHz using a resistor and capacitor with the values shown. As the transistor is driven on and off by the square wave from the oscillator, spikes of about four times the supply voltage develop across the 1mH primary of the 1:1 pulse transformer. Diode D_2 rectifies the spikes, which are filtered and regulated to give +15V, the current supplied being determined by the capabilities of the 5V supply and the wire gauge of the transformer. Diode D_1 rectifies the transformer output to form a -15V rail.

V Lakhshminarayanan
Centre for Development of Telematics
Bangalore India

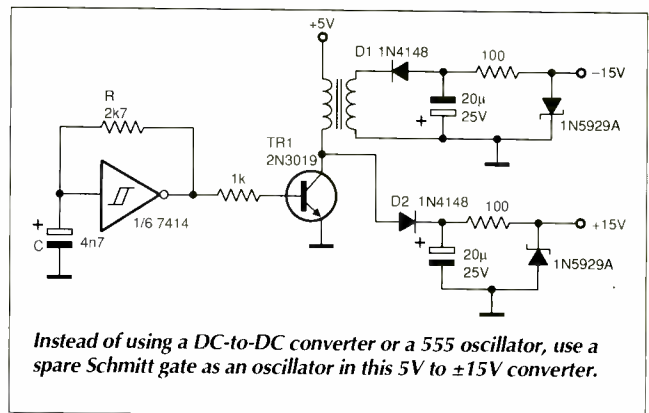

YOU COULD BE USING A 1GHz SPECTRUM ANALYSER ADAPTOR!

Got a good idea? Then this Thurlby-Thandar Instruments TSA1000 spectrum analyser adaptor could be yours.

Covering the frequency range 400kHz to over 1GHz with a logarithmic display range of 70dB ± 1.5 dB, it turns a basic oscilloscope into a precision spectrum analyser with digital readout calibration.

Recognising the importance of good design, TTI will be giving away one of these excellent instruments every six months to the best circuit idea published in the preceding period until further notice. This incentive will be in addition to our £100 monthly star author's fee together with £25 for all other ideas published.

Our judging criteria are ingenuity and originality in the use of modern components with simplicity particularly valued.

Square waves from a 555

In the usual 555 astable oscillator, the timing capacitor charges through two resistors and discharges through one of them, the two time constants therefore being unequal. In this circuit the charge/discharge paths are similar, giving a 50:50 mark:space ratio.

The capacitor C_1 charges and discharges via VR_1 and R_2 and it is necessary to ensure that D_1 and Tr_1 base/emitter diodes are similar to avoid timing errors. Charging takes place when pin 7 is high, turning Tr_1 on; when it is low, the capacitor discharges through the diode. To obtain accurate square waves, the 5-turn potentiometer VR_2 varies the comparator control voltage. Either mos or bipolar 555s work in the circuit shown, but the bipolar version gives a lower maximum frequency: the 555CN works up to 2MHz.

To set the waveshape at very low frequencies, temporarily replace a large C_1 with a small one, set VR_2 to obtain unity M/S ratio and replace the larger C_1 .

I C Rohsler

Harborne
Birmingham

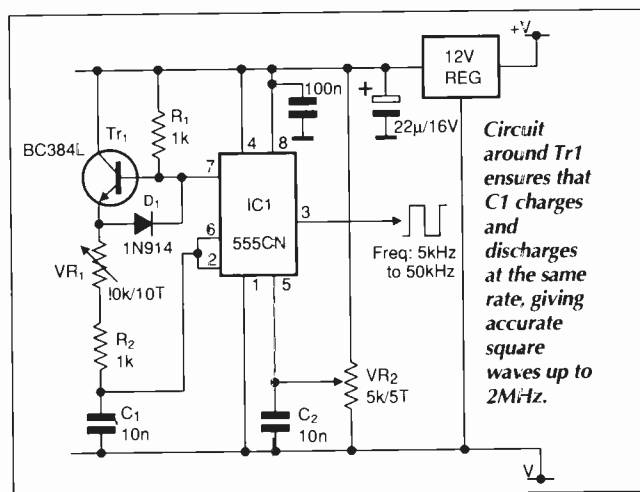

Inrush current limiter

Most of the methods of dealing with the inrush current into large smoothing capacitors have their disadvantages, whether they are to do with inconvenience, performance, reliability, size or cost. This circuit uses the high-impedance control and large switching safe-operating area of mosfets to do the job, with none of the above drawbacks.

It does not suffer from dv/dt limitations and works from zero current up to designed limits, it needs a small hold current and is proof against shorts if R_{12} is a positive temperature-coefficient type or has one in series. Under test without a PTC resistor, Tr_4 survived a short but R_{12} blew.

Resistor R_{12} determines the inrush current and R_{10} sets the maximum peak current allowed in steady-state conditions — about 4.5A with these values. A smaller maximum current would allow the use of a smaller mosfet, but would call for a higher-value resistor and more heat, so a small R_{10} is preferable.

In a switching supply, the four RGP30M diodes could be part of the diode bridge, the whole circuit preceding the smoothing capacitors.

Kristen Ellegård

Oslo
Norway

Inrush current limiter has none of the drawbacks of conventional solutions, such as relays, thermistors or thyristors, and can be made part of the diode bridge in a switching supply.

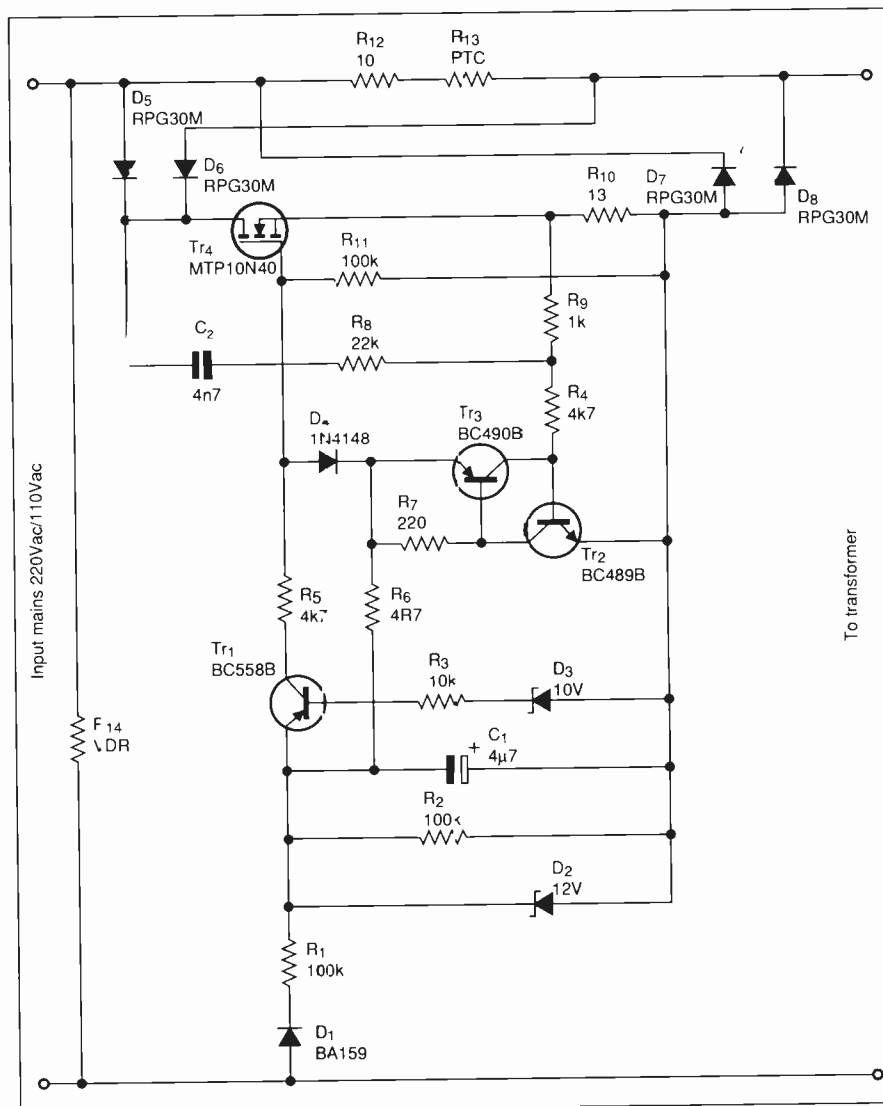

High-torque position servo

Parallel-connected power mosfets in an H bridge, driven by an SG3731N pulse-width modulator, form a simple, high-torque servo driver for a 12V, 380W DC motor.

Pairs of BUZ11A and RFP30P05 complementary mosfets are common drain connected to simplify gate driving and in parallel to obtain the necessary current. All the circuitry is supplied by two 6V, 100Ah lead-acid batteries.

As the motor turns, it drives the 5kΩ servo potentiometer, from which a voltage is taken to one input of the PWM, where it is compared with the reference input. For clockwise rotation, the SG3731N maintains mosfets 3 in conduction, while switching mosfets 1 and 2 on and off. For the other direction, mosfets 2 are on and mosfets 3 and 4 go on and off. The gain of the PWM's difference amplifier can be altered by

selecting new values for $R_{1,2}$ to suit different geared motors.

Capacitors $C_{2,3}$ reduce the effects of lead inductances and should be kept close to the mosfets, as should the back-to-back zeners across the motor, which absorb high-voltage spikes.

M T Iqbal
Rutherford Appleton Laboratories
Didcot

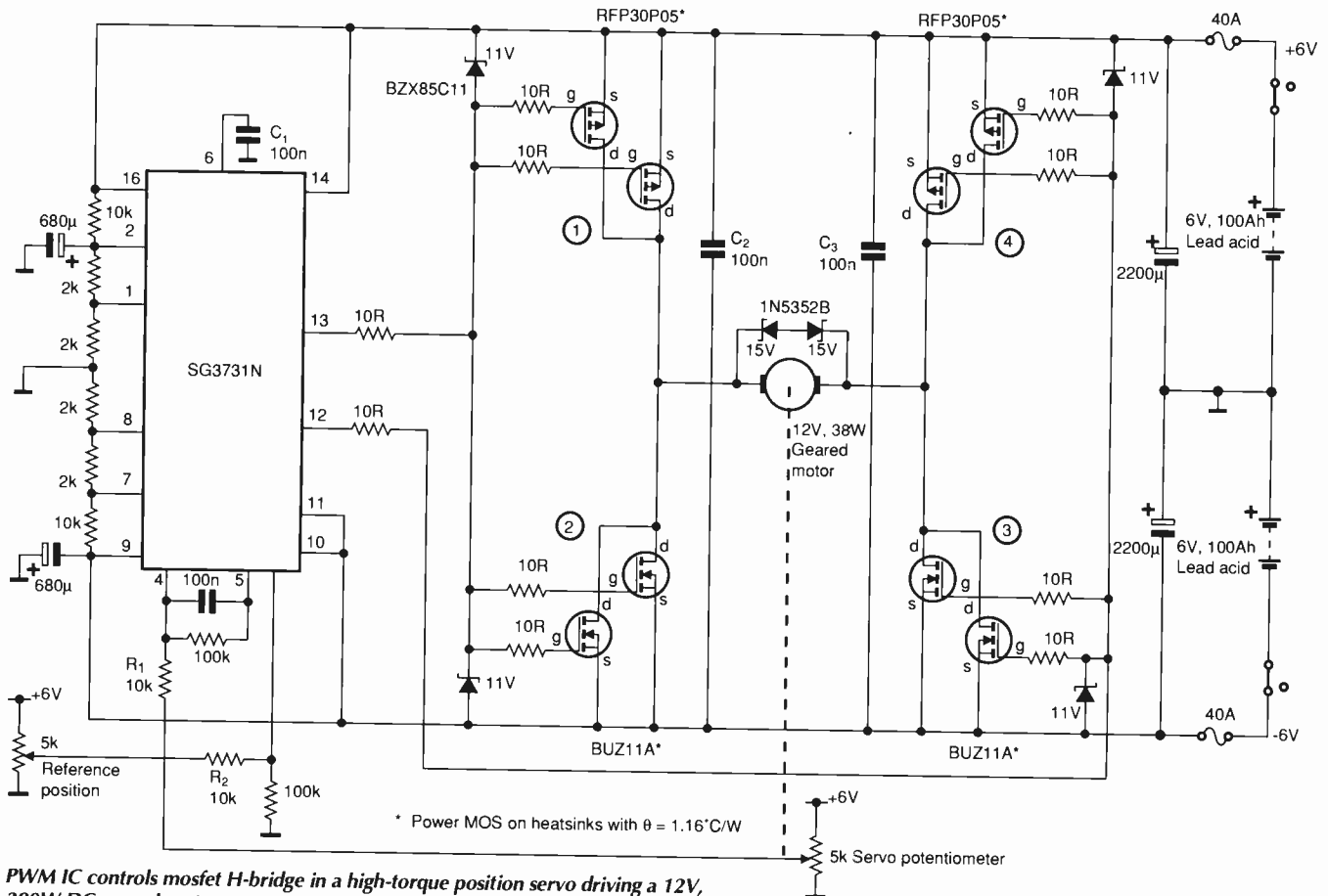

PWM IC controls mosfet H-bridge in a high-torque position servo driving a 12V, 380W DC geared motor.

Monitor shows three-phase sequence

Two of the phases in a three-phase supply have a 60° phase difference with respect to the third, but in an unknown order. The monitor shown indicates this phase sequence, needing no neutral point and few components.

If V_1 goes high, V_2 being low, Tr_1 remains cut off and Tr_2 draws base current through R_4 . After 60°, phase 3 goes high and Tr_2 , already conducting, holds Tr_1 off and led 2 lights during the 120° overlap to show the L1-L2-L3 sequence. In the reverse condition, V_2 goes high while V_1 is low and led 1 lights to show L1-L3-L2.

Cyril W W Paliawadana
Sana`a
Republic of Yemen

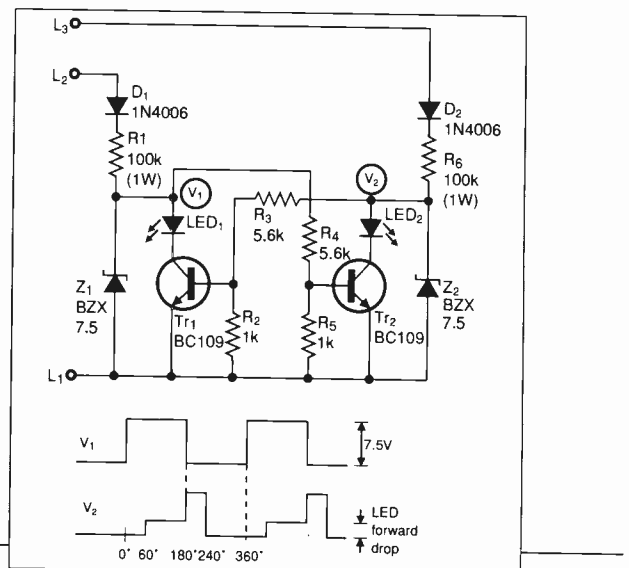

Electronic fuse

Having a voltage range of 10-36V and handling currents up to 1A, this circuit disconnects a load in a time variable up to 100ms by changing a capacitor. Much greater currents and voltages can be handled by the same design with changed component values. It simply goes in series with load.

Most of the voltage drop across the circuit, V_{AB} , which is proportional to the DC load current and less than 2V, is across $R_{11,12}$. At switch on, all the supply voltage is across the fuse and Tr_3 conducts, its base current being supplied by R_4 and its collector current set by D_3 and R_8 according to $I_{c3} = (V_{D3} - V_{be3})/R_8$. Base current of Tr_4 is therefore stabilised, Tr_4 conducting and turning on Tr_5 . Delay determined by C_1 prevents premature interruption of Tr_3 base current.

If load current increases excessively, the voltage dropped across R_{12} begins to turn Tr_2 on, reducing the collector current of $Tr_{3,4,5}$ and increasing the terminal voltage to more than 2V. When it exceeds 4.5V, D_1 avalanches, Tr_1 conducts and the cut-off of the three output transistors is cumulative, current through the fuse now being a few milliamps. Capacitor C_1 determines the time delay to cope with motor inrush currents or filament lamps and C_2 handles voltage

spikes. Diode D_2 prevents C_1 discharging through the load when V_{AB} is almost zero.

With component changes, the circuit should be able to operate with currents from 10mA to 40A and on voltages from 6V to 500V. It can also be used as an AC fuse, as seen in Fig. 2.

To re-establish the circuit after an interruption, switch off for a short time.

N I Lavrentiev
Kaliningrad
Moscow Region
Russia

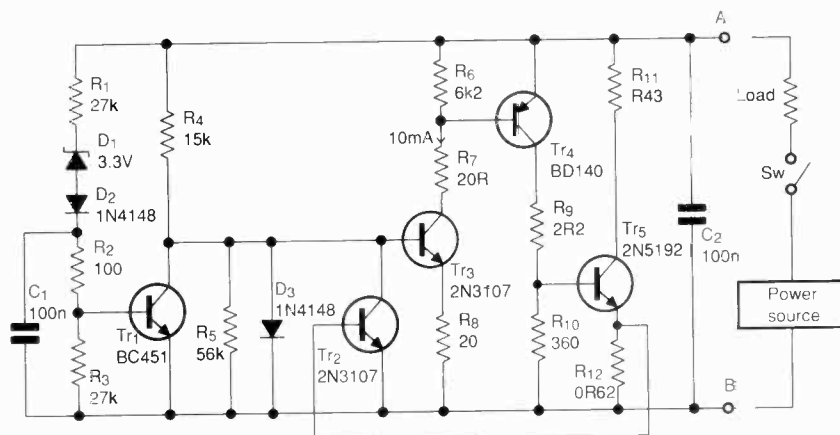
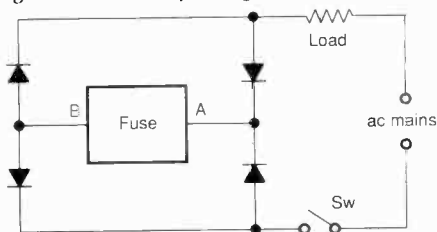

Fig. 1. Circuit acting as a fuse for voltages from 10V to 36V and currents up to 1A, with values shown.

Fig. 2. Same circuit operating in AC circuit.



PCBs for Douglas Self's power amplifier series

Circuit boards for Douglas Self's high-performance power amplifier are now available via EW+WW.

Detailed on page 139 of the February issue, Douglas Self's state-of-the-art power amplifier is the culmination of ideas from one of the most detailed studies of power amplifier design ever published in a monthly magazine. Capable of delivering up to 100W into 8Ω, the amplifier features a distortion figure of 0.0015% at 50W and is designed around a new approach to feedback.

Designed by Douglas himself, the fibreglass boards have silk-screened component IDs and solder masking to minimise the possibility of shorts. Sold in pairs, the boards are supplied with additional detailed constructional notes.

Each board pair costs £45, which includes VAT and postage, UK and overseas. Credit card orders can be placed 24 hours on 081-652 8956. Alternatively, send a postal order or cheque made payable to Reed Business Publishing to EW+WW, The Quadrant, Sutton, Surrey SM2 5AS.

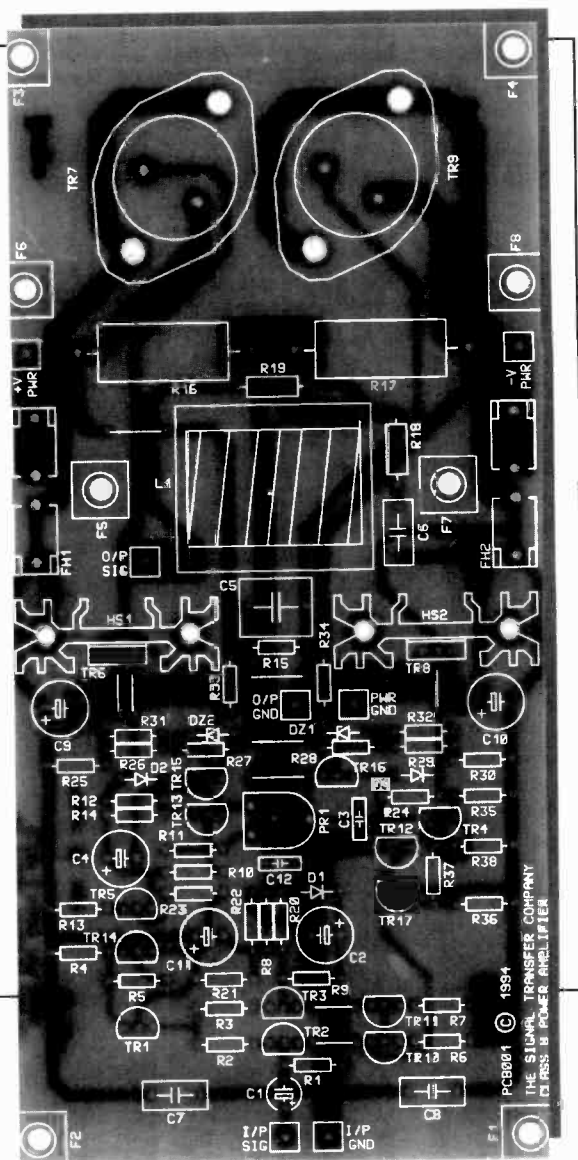

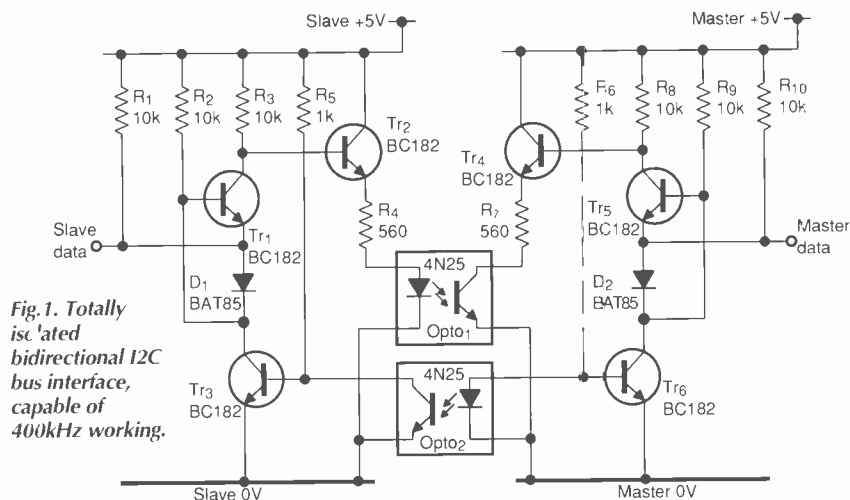

Fig. 1. Totally isolated bidirectional I2C bus interface, capable of 400kHz working.

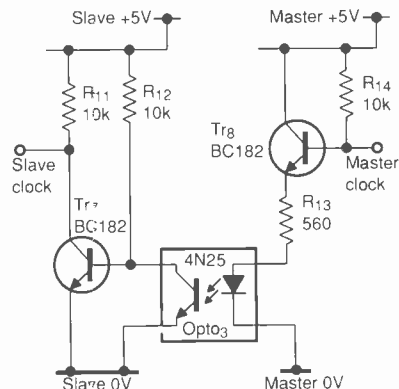

Fig. 2. Simpler circuit for unidirectional clock signal transmission.

Isolated I2C bus interface

While the I²C bus, which consists of a bidirectional data bus and a unidirectional clock, has many attractions, it is not easy to use it across an isolation barrier. This circuit performs that function at 400kHz.

In Fig. 1, the data transmission circuit is seen to be symmetrical to allow true bidirectional working. When data from the master is high, cutting Tr_5 off, Tr_3 's base draws current through R_8 . Opto 2 conducts,

Tr_3 cuts off and the slave data bus is pulled high by R_1 . A low from the master causes the opposite state. D_1 conducts and the slave data bus is low.

Since Tr_1 base is reverse biased, Tr_2 conducts. Opto 1 conducts and Tr_6 is off, so that it does not affect operation; $Tr_{1,5}$ are needed to prevent the circuit locking up when the master data line goes low, pulling the slave low, which would keep the master data line low and stop anything more

happening. When the slave transmits, the opposite to all the above takes place.

Since clock transmission is unidirectional, the simpler circuit of Fig. 2 is sufficient.

As the couplers are in base circuits of buffer transistors, the coupler transistors see constant-current loads and, since the base signal is only 0.6V, even slow 4N25 couplers work well.

C M Clarkson
Brownhills, West Midlands

Electronic Designs Right First Time?

Schematic Design and Capture

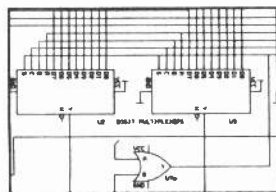

Create your schematics quickly and efficiently using EASY-PC Professional. Areas of the circuit can be highlighted on screen and simulated automatically using PULSAR, ANALYSER III and Z-MATCH our simulation and design programs.

Digital and Analogue Simulation

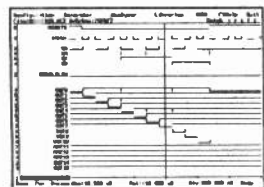

Modify the configuration and change component values until the required performance is achieved.

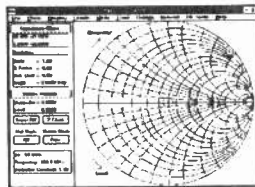

PCB Design

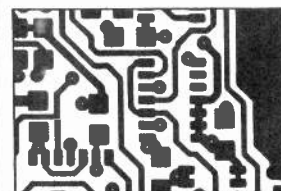

The design, complete with connectivity, can then be translated into the PCB. The connectivity and design rules can be checked automatically to ensure that the PCB matches the schematic.

Visa, MasterCard, Amex welcome

Affordable Electronics CAD

EASY-PC: Entry level PCB and Schematic CAD	£98.00
EASY-PC Professional: Schematic Capture and PCB CAD. Links to ANALYSER III and PULSAR.	£195.00
PULSAR: Entry level Digital Circuit Simulator ~ 1500 gate capacity.	£98.00
PULSAR Professional: Digital Circuit Simulator ~ 50,000 gate capacity.	£195.00
ANALYSER III: Entry level Linear Analogue Circuit Simulator ~ 130 nodes	£98.00
ANALYSER III Professional: Linear Analogue Circuit Simulator ~ 750 nodes	£195.00
Z-MATCH for Windows: Smith Chart based problem solving program for R.F. Engineers	£245.00
FILTECH: Active and Passive Filter design program	£145.00

No penalty upgrade policy. Prices exclude P&P and VAT.

Number One Systems Ltd.

Ref WW, Harding Way, St. Ives, Huntingdon, Cambs. PE17 4WR, UK.

For Full Information Please Write, Phone or Fax.

Tel: 0480 461778
Fax: 0480 494042

CIRCLE NO. 130 ON REPLY CARD

USING RF TRANSISTORS

Transforming wideband circuits

Multi-octave impedance matching is almost exclusively carried out using transformers. Norm Dye and Helge Granberg explain how different transformers work and indicate how to choose the most appropriate type.

From the book RF Transistors: principles and practical applications.

Norm Dye is Motorola's product planning manager in the Semiconductor Products Sector, and Helge Granberg is Member of Technical Staff, Radio Frequency Power Group (Semiconductor Products) at Motorola. Their *rf transistors* book includes practical examples from the frequency spectrum from 2MHz to microwaves, with special emphasis on the uhf frequencies.

RF Transistors: Principles and practical applications is available by postal application to room L333 EW+WW, Quadrant House, The Quadrant, Sutton, Surrey, SM2 5AS.

Cheques made payable to Reed Books Services. Credit card orders accepted by phone (081 652 3614).

288pp **HARDBACK 07506 9059 3 Cost £19.95 + Postage £2.50**

The dependence of device impedances on frequency means that any type of wideband impedance matching naturally compromises amplifier performance. Also, low impedance rf transformer-impedance ratios can only be realised with integers such as 1:1, 1:4, 1:9 etc. Other ratios are possible, but the structures usually become complex and bandwidth is lost through the increased leakage inductance coming from the numerous interconnections.

The effect of compromises in the input is to reduce power gain and increase return-loss and vswr. In the output the results are reduced efficiency, lowered stability against load mismatches and poorer linearity.

But *RLC* networks inserted between the device input and the matching transformer can compensate for the impedance versus frequency slope, as well as for the gain vs frequency slope. Corrective networks, with negative feedback and associated additional networks, can allow amplifiers to be designed that cover up to five or six octaves, from low band to vhf – or even uhf.

In the output, very little can be done to compensate for the output impedance/frequency slope, due to excessive power loss.

Fortunately, output-impedance variation with frequency, using both mosfets and bjts, is usually much smaller than that of the input. Sometimes a low value inductance or a microstrip between the device output and matching transformer considerably improves efficiency at the high end of the frequency range, by providing compensation for the device's output capacitance. Normally only 'over-compensation' of the output transformer will do an adequate job, calling for added capacitance across the transformer primary and in some cases also across the secondary.

Wideband operation

A wideband rf transformer performs one or a

combination of the following functions:

- impedance transformation;
- balanced-to-unbalanced transformation
- phase inversion.

Rather than using their primary-to-secondary turns ratios, transformers are most often referred to by their impedance ratios (turns-ratio, squared). In these applications, we are mostly interested in manipulating impedance rather than voltage or current.

RF transformers can, in basic terms, be compared to low frequency transformers – except that with increasing frequency a parameter called leakage inductance becomes an important factor.

To extend coverage to the low end of the frequency band, some type of magnetic core is required. Either powdered iron or ferrite cores are acceptable depending on the frequency range, with ferrites being the most common.

A general formula for calculating the maximum flux density of a ferrite core is:

$$B_{\max} = [V_{\max} / (2\pi f A n)] 10^2$$

where B_{\max} is the maximum flux density (gauss), V_{\max} is peak voltage across the winding, f is frequency in MHz, A is core cross-sectional area in cm^2 and n is number of turns.

Either the primary or secondary can be used for the B_{\max} calculations, although the 50Ω side – if applicable – is commonly used for convenience and standardisation. Then $V_{\max} = \sqrt{2PR}$ where P is rf power level and R is resistance (50Ω).

For example, if:

$$V_{\max} = 50V, f = 2.0\text{MHz}, A = 1.0\text{cm}^2 \text{ and } n = 4,$$

then

$$B_{\max} (50/50.2)(10^2) = 99.6\text{gauss.}$$

In certain types of transmission line transformers the rf voltage (V_{max}) used in the B_{max} calculations is lower than the value obtained from the V_{max} formula given above. This is because the maximum voltage across the winding(s) must be divided by the number of line segments connected in series in the transformer configuration in question.

The same result can also be reached using the formula if the full voltage across the 50Ω terminals is used for V_{max} as the numerator, and n is multiplied by the number of line segments in series.

Since high permeability ferrites tend to saturate sooner than low permeability ones, good practice is to limit their maximum flux densities as follows:

B_{max} of 40-60 gauss/cm² of cross-sectional area for ferrites with μ at 40000.

B_{max} of 60-90 gauss/cm² of cross-sectional area for ferrites with μ at 100-400.

B_{max} of 90-120 gauss/cm² of cross-sectional area for ferrites with μ at < 100.

In the B_{max} versus μ figures, the magnetic path is assumed to be solid: eg without air gaps such as in toroids and balun cores.

Importance of leakage inductance

At low frequencies, leakage inductance is virtually unknown and most designers are unaware of such a term. But in rf transformers it is the parameter that limits high frequency response.

Performance becomes more critical at low impedance levels, where tight coupling between the windings is of utmost importance. Leakage inductance is a product of the coupling between the primary and secondary and any exposed area in either winding. It is also affected by interconnection lead lengths and mutual coupling.

Leakage inductance (or reactance) is difficult to calculate. But it can be measured for each individual case with a vector impedance meter, vector voltmeter, or network analyser. Ideally, when one winding is shorted with a low inductance path, measurement in the other winding should show essentially zero R and phase angle. In practice this is never the case.

Deviation from zero in the value of the resistive component and phase angle can be used to calculate the leakage inductance (or rather the high frequency performance of the transformer).

Relating leakage inductance directly to rf performance of a transformer is difficult because it is impedance-level dependent.

At vlf (50-500kHz), where high μ cores are required, a problem may appear which looks inexplicable. It is called magnetostriction, and is a magnetic resonance of the ferrite core which can cause chattering, leading to disintegration of the core.

There are many resonant modes such as longitudinal and torsional, etc and the only cure is to select a physical core size and shape which

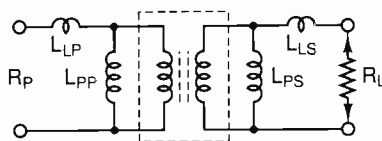

Fig. 1. Equivalent circuit for a conventional discrete-winding rf transformer. L_{LP} is leakage L primary, L_{PP} is parallel L primary, L_{LS} is leakage L secondary and L_{PS} is parallel L secondary.

has resonances outside the critical frequency spectrum.

Conventional transformers

The simplest design of rf transformer is a conventional type – spanning several different kinds – some of which are more suitable for certain applications than others.

But in all, the basic principle is roughly the same (Fig. 1): that low frequency coupling between the primary and the secondary is provided through the flux of magnetic media (core): as in audio transformers.

At high frequencies tight capacitive coupling between the windings is essential and the magnetic core has little effect except in the form of dielectric losses. So the quality of magnetic media employed is a very important factor in design. There is also the question of whether to use higher permeability core material and suffer high frequency losses; or design around the losses from the increased stray capacitances caused by additional turns in the windings required when using low permeability cores. A few tenths of a dB of unnecessary power loss in an output transformer can mean a significant increase in power consumption and device dissipation.

Conventional transformers are inferior in performance to transmission line transformers, with the differences mainly in power handling capability, loss factor and bandwidth. But conventional rf transformers can be constructed for a wider range of impedance ratios than transmission line types. Some ratios will have wider bandwidths than others due to the number of turns required to achieve the desired turns ratio. There are no fractional turns – as in all transformers – and if the wire passes through the core, one full turn is completed.

In Fig. 1, stray capacitances have been omitted since a relatively low impedance case is assumed and the capacitive reactance arising from applicable construction techniques rarely becomes appreciable in comparison to the low values of resistances involved.

Figure 2 shows a conventional rf trans-

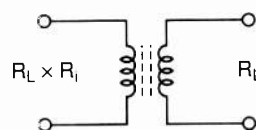

Fig. 2. Simplest form of conventional transformer. The windings are usually randomly wound one on top of the other. It finds use at high impedance levels, 200Ω and up, which dictates the frequency response of the unit.

former that finds wide usage at high impedance levels (200Ω and higher) in low power designs. One winding is simply wound on top of the other, usually providing good enough coupling at these impedance levels up to uhf. The most convenient core shape is a two-hole balun, although toroids can be seen in some designs if a sufficient number of turns is provided on the periphery for the coupling required.

As in all rf transformers, wire size also has an effect on the coupling between the primary and secondary. The heavier the wire size, the tighter the coupling will be. This increases the mutual winding capacitance, again resulting in compromise.

The capacitance can be lowered by using a high μ magnetic core, but core losses would be higher. Since the mutual winding capacitance has a larger effect at higher impedance levels, designers must determine which approach is most beneficial for a specific application.

One-turn advantages

The most popular conventional type of rf transformer is probably that (Fig. 3) with the one turn winding consisting of metal tubes going through sleeves or stacks of toroids of suitable magnetic material. The tubes are electrically connected together at one end of the structure and separated at the opposite end, where connections to the one turn winding are made.

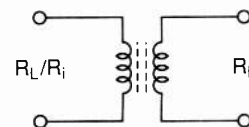

Fig. 3. The most common conventional type of rf transformer. One winding consists of metal tubes shorted at one end, thus forming only one turn. This limits the impedance ratios to integers 1:1, 4:1 9:1 etc. It is fairly efficient at impedance levels down to 2-3Ω if properly constructed and may have a bandwidth up to 50MHz.

In practice, connections are usually made with pieces of single-sided metal-clad laminate with proper patterns etched in the metal.

The construction also produces a physically-sturdy structure with all its components intact. To make up a transformer, the required number of turns of wire is threaded through the two tubes to form a continuous multi-turn winding. The resulting tight coupling between the two windings has relatively low mutual winding capacitance, and so permits use at very low impedance levels.

The wire ends of the multi-turn winding can be taken out from either end of the transformer, whichever is physically most convenient. The usual arrangement is to have the primary and secondary terminals at opposite ends (Fig. 3).

The disadvantage of this type is that its one-turn winding allows only integer-squared impedance ratios such as 4:1, 9:1, 16:1, etc...

Fractional integers look to be possible by

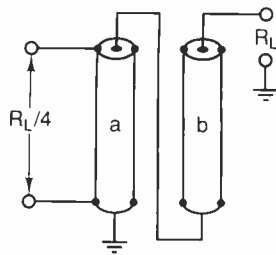

Fig. 4. Another form of conventional type transformer. a and b are segments of coaxial cable which, in practice, are bent to get the terminals of the low impedance winding close together (see Fig. 5).

threading the winding wire through one tube one more time than the other. But this offsets the balance and the transformer will not function properly. Bandwidth is actually determined by the impedance ratio, and a 9:1 impedance ratio transformer will be usable up to 50-60MHz. But higher impedance ratios reduce the bandwidth rapidly, because of the increasing leakage inductance. A 25:1 transformer will perform poorly at 30MHz, and a 36:1 unit is usable only to 15-20MHz.

The form factor – the length-to-width ratio – is important. If the transformer structure is short, the coupling between the windings is lowered and the leakage inductance is increased. At the other extreme, if the unit is long, the mutual winding capacitance is increased and the physical length of the multi-turn winding may produce resonances within the desired spectrum.

Another disadvantage with these transformers is that when used in an amplifier output, the one-turn winding makes the magnetic core saturate at a low flux density. But despite all these drawbacks, one-turn transformers are widely used in both input and output matching in the 2-30MHz frequency range and at power levels up to 100-150W, and as input matching transformers up to even higher frequencies.

A clear advantage is the transformer's sim-

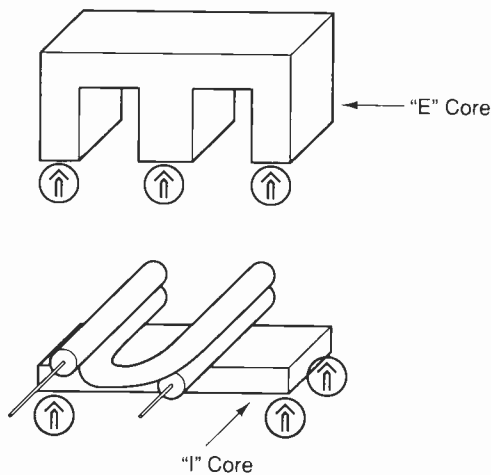

Fig. 6. Transformer shown in Figs. 4 and 5 provided with a magnetic core (E and I) to broaden its low frequency response. The arrows indicated points where epoxy can be applied to make the unit a solid structure.

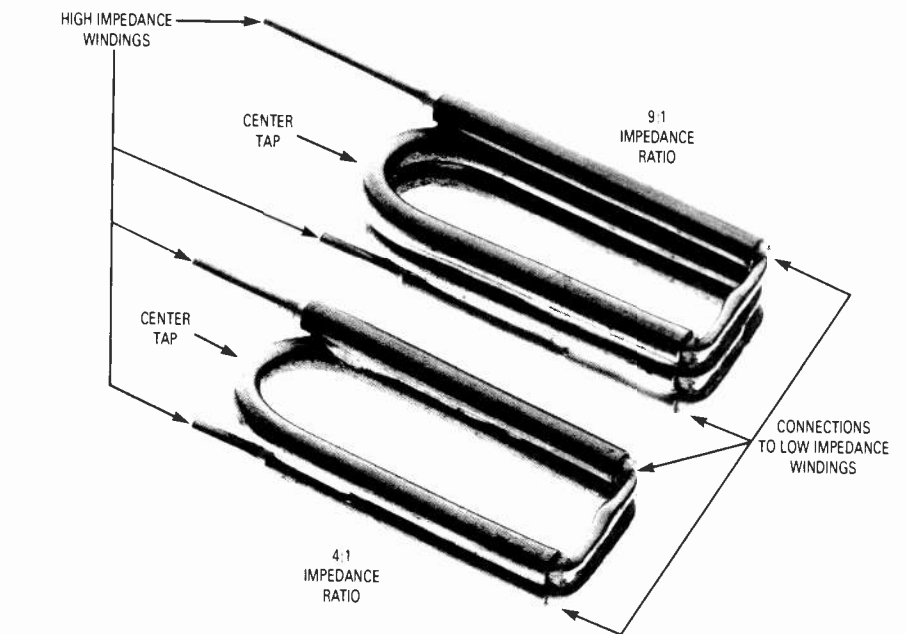

Fig. 5. One possible physical realisation of the transformer described. Note the height of the segment stacks with increasing impedance ratios. This produces a delay from the connection points of the low impedance winding to the uppermost segment.

ple construction, making it inexpensive and easily mass-producible.

Parallel winding connections

In other variations of the conventional transformer (Figs. 4-6), impedance transformation is obtained by connecting in parallel a number of windings on one side, and in series on the other.

For the most common type (Fig. 3), one turn in the low impedance winding, limits possible impedance ratios to full integers. Windings are made of segments of coaxial cable and the structure is formed into a shape of a 'U' or a circle (Figs. 5 and 6). Leakage inductance is lower than with most other conventional transformers making it usable up to 200-300MHz.

The high frequency end is limited by physical size of the structure because, to avoid major resonances, the length of the high-impedance winding should usually be kept below 1/8 wave-length at the highest frequency of operation.

So physical length of a U-shaped 4:1 unit is limited to about 3.5cm and a 9:1 unit to 2.5cm for operation up to 200MHz.

The characteristic impedance of the coaxial cable determines the coupling coefficient between the windings, and the optimum closely follows the line impedances calculated for transmission line transformers. If cable impedance is too high, bandwidth is reduced: if too low, the maximum bandwidth can be realised, but at a cost of capacitive reactance and reduced efficiency of output matching.

Transformer segments can be made from semi-rigid coaxial cable with all outer conductors tied together to form the low impedance side. The inner conductor will automatically make up the high impedance winding (Fig. 5).

With a U-shaped design, the bending radius

should be as small as possible, though limited by the recommended minimum for the specific cable used.

Spot welding would be the best way to connect the inner conductor segments together, but soldering (preferably with high temperature solder) is adequate. Some commercially available units use tiny pc boards at the front end of the cores to make the connections.

A typical 3cm-long coaxial cable transformer has a low frequency response of around 100MHz without a magnetic core.

With an E and I core of material (Fig. 6) having μ equal to 125, for example, the response will be lowered to 3-10MHz depending on impedance ratio.

Only a physical constraint limits the highest practical impedance ratio. If too many line segments are stacked, the structure becomes high and it is difficult to make the electrical connections to all segments without introducing excessive phase delay to the uppermost ones. The effect depends on the cable diameter, but for a power level of 200-300W a cable diameter of 2.3mm (standard with most manufacturers) can be considered a minimum and the highest practical impedance ratio would be 9:1. If 16:1 or higher is needed, a smaller diameter cable must be used, and the power handling capability lowered.

Twisted wire transformers

A unique and versatile rf transformer can be realised with twisted wires. Enamelled magnet wire is commonly used since it has a thin, but good, temperature-resistant insulation. It is also available with Teflon insulation for very high temperature applications.

Characteristic impedance of a twisted wire transmission line is determined by wire size, dielectric constant of the insulation and the number of twists per unit length. Twists/length

has the least effect on the line impedance (assuming the wires do not separate from each other in the winding process). A simple method of approximating line impedance is by measuring its capacitance per unit length and comparing it against a line of known impedance.

The most common twisted-wire transmission line is a single pair of wires. For a wire size of #28 AWG, the characteristic impedance will be approximately 50Ω . Lower line impedances are possible by using heavier gauge wire or by replacing each single wire with a multiple of smaller gauge wires.

In those cases where multiple numbers of smaller gauge wires are used to form a twisted-wire transmission line, location of the wires with respect to each other should maintain a symmetry (Figs. 11a and 11b discussed later).

Versatile solutions

The twisted wire transformers discussed here do not have a defined line impedance – except for Fig. 7d. They are versatile (Figs. 7a and 7b) and many more odd impedance ratios are possible.

Figure 7a is a normal 1:1 balun with a magnetising winding added (centre). If the balun's load is balanced – feeding fet gates in a push-pull amplifier for example – the magnetisation current flows through only one winding and only one half of the load. The effect causes undesirable phase and amplitude unbalance in the balun, restricting bandwidth. But balance can be restored with a third or tertiary winding to shunt the magnetisation current around the load.

Figure 7d is a standard 4:1 transmission line transformer where the required line impedance is $R_L \times 2$ or 25Ω for $R_L = 12.5\Omega$. Two twisted pairs of #28 AWG magnet wire are the best way to achieve the result, with each pair connected in parallel by shorting at both ends. Both pairs are twisted together to form the low impedance transmission line. (It is customary to locate the pairs with respect to each other as shown in Fig. 11).

In the twisted wire transformers we are considering (Figs. 7a, 7c and 8a-d) as stated earlier, there are no defined line impedances. Without data, a designer should experiment and make measurements with various interconnection combinations of the twisted wires. Although not shown in the figure, all terminals are referenced to ground.

Another example of the versatility of twisted wire transformers is that they can also be connected in balanced-to-balanced, and even in isolated primary and secondary configurations, providing several impedance ratios (Figs. 8a-c). Many other fractional integer impedance ratios are also possible with more wires.

The units make compact interstage matching elements in push-pull circuits and are especially suitable when dc isolation between the stages is required.

Figure 8c can be considered to represent a transmission line transformer if the line impedance is correct (25Ω in this case), which

Fig. 7. Conventional rf transformers using multiple twisted wires. A wide variety of impedance ratios are possible depending on the number of wires used and connection configurations. Although not shown, terminals are referenced to ground.

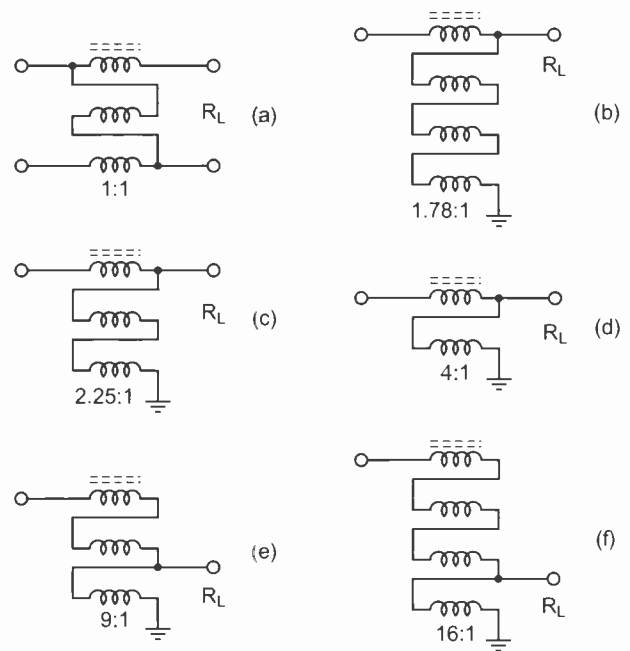

is also the case with the ones shown in Figs 7a and 7d.

Twisted wire transformers have bandwidths higher than most other conventional transformers, and up to seven octaves have been measured at 50Ω and lower impedance levels; and at least one octave higher when the impedance levels are higher and the transform ratios low.

Advantages of these transformers are their versatility for odd impedance ratios.

Disadvantages are their limited power-handling capability and, in some cases, difficulty of construction due to all the multiple interconnections.

Although the single wire transformer (Fig. 8d) is obviously not a twisted wire type, its description fits better here than with other conventional transformers since it uses capacitive coupling to a larger degree than magnetic coupling. The design represents a unique concept, where several 2-3 turn low impedance wind-

The attraction of ferrites

Ferrites are the most common magnetic materials used for rf transformers.

The two basic types are nickel-manganese with high permeabilities (μ_r =relative permeability) used in low frequency applications; and nickel-zinc ferrites. These have lower high-frequency losses, but with Curie points as low as 130° , they only can be manufactured with μ_s of less than approximately 1000. (Curie point is the temperature where magnetic material loses its magnetic properties.)

Low μ_r ferrites usually have higher volume resistivity than high μ_r ones, meaning lower eddy current losses. Detailed information on the behaviour of ferrites at rf is rarely available from ferrite manufacturers.

Core eddy current losses and winding dielectric losses heat up the core and its temperature must be held well below the Curie point or the magnetic properties of the material will be permanently altered.

To avoid saturating the core, operational flux densities must be kept

well within the linear portion of the material's $B-H$ curve. Saturation mainly occurs at low frequencies, where most of the coupling is through the core, producing non-linear operation, heat and harmonics. The area inside the $B-H$ curve normally represents the relative loss and so narrow curves are preferred for low loss designs. But the situation is confused since the curves are usually created under dc conditions and they do not really give the data needed for an rf designer.

High μ ferrites, though having higher saturation flux densities than low ones, saturate easier under rf conditions. One reason is that high μ cores require a smaller number of turns to satisfy the minimum magnetising inductance requirement. So use a ferrite core with relatively low μ and added turns in the windings – at least to the extent that the added inter-winding capacitance can be tolerated at higher frequencies.

As a rule, the winding reactance should be at least twice the impedance across it.

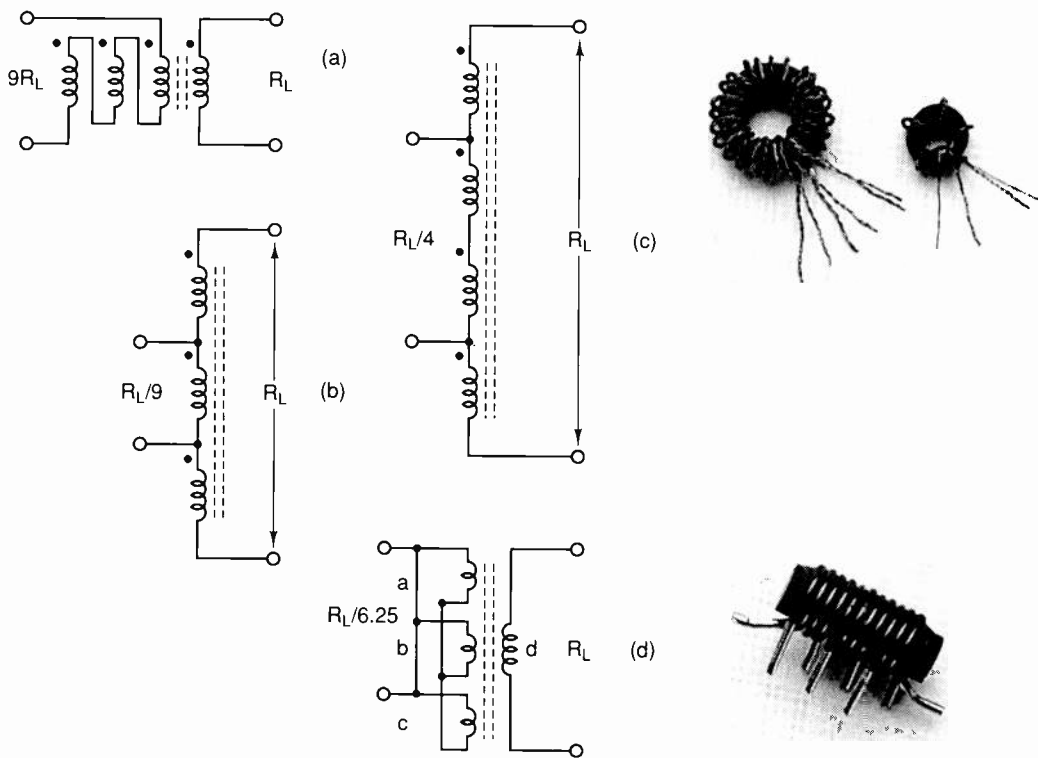

Fig. 8. Conventional transformers, providing balanced-to-balanced function and isolated primaries and secondaries. a) to c) are twisted wire types, while d is a unique single wire transformer with its parallel low impedance windings interlaced between the turns of the high impedance winding. Number of turns in winding d of the single wire transformer should equal $a+b+c-1$ not to have extra uncoupled turns to windings a, b and c. The schematic for the 2.25:1 balanced transformer as left in the photo c) is not shown.

ings are connected in parallel and interlaced between the turns of the high impedance winding. Heavy gauge enamelled wire (#18-16 AWG) increases the capacitive coupling between the windings and makes the unit a self supporting structure.

The windings are wound on a cylindrical core such as a length of ferrite rod (Fig 7d, photo) and all the winding connections are made when the transformer is mounted to a PC board.

Multiple impedance ratios are possible depending on the number of turns in the low-impedance windings.

These transformers have been in commercial use in equipment operating up to 175MHz and at power levels of 100-120W. Variations such as flat ribbon wound units have been experimented with, but their fabrication is more difficult and no significant improvement in performance has been found. Obvious advantages of the single wire transformer are its extremely compact size versus power handling capability and the dc isolation between the primary and secondary.

Transmission line transformers

Transmission line transformers are quite different from conventional ones in many ways:

- to take advantage of optimum performance, line impedance must be correct for the type of transformer in question;
- at high frequencies, the series reactance combines with the inter-winding capacitance and the circuit behaves as a transmission line, greatly extending the high frequency response;

- power transferred from input to output is not coupled through the magnetic core, except at very low frequencies, but through the dielectric medium separating the line conductors. This is an important point regarding the transmission line transformer principle;

- from the above point it follows that a relatively small cross-sectional magnetic core can operate unsaturated at very high power levels.

In practice, transmission line transformers can be realised with twisted enamelled wires, coaxial cables, paralleled flat ribbons (separated by a dielectric medium), or a microstrip on a two-sided substrate. Practicality and convenience in each case depends on the exact application and frequency spectrum.

The simplest transmission line transformer is a quarter wavelength line whose characteristic impedance (Z_0) is chosen to give the correct impedance transformation. It is a relatively narrow-band device and valid only at frequencies for which the line is an odd multiple of a quarter wavelength.

In a 1:1 balun (Fig. 9a), with line impedance (Z_0)= R_L , low frequency performance is limited by the amount of impedance offered to common mode currents. It should be at least twice the load impedance and can be increased with a core of suitable magnetic material.

Inductance of a conductor is in direct proportion to its relative permeability. As line length limits the high frequency response, these two factors seem to be in direct conflict – we should remember the $1/8$ wavelength rule discussed earlier.

The most commonly used material for transmission lines in these transformers is coaxial cable with Teflon dielectric. Cable can be either semi-rigid or flexible, of which both have equal velocity propagations, at least in theory.

For calculating the maximum line length allowable, the velocity factor must be known. Multiplier for the velocity factor is obtained as: $v_f=1/\sqrt{\epsilon_p}$ where ϵ_p is the relative dielectric constant of the insulating medium. For Teflon cable, with its $\epsilon_p=2.5$, the velocity factor multiplier is 0.633.

Unlike a microstrip line, where two dielectric materials (air and the main substrate) form the medium and the width-height ratio is a variable, coaxial cable has a constant velocity factor as a function of characteristic impedance.

Connecting points a and b in the 1:1 balun (Fig. 9a) as in Fig. 9b, produces an unbalanced 4:1 design. For minimal leakage inductance, connection must be kept short by bending the line to get the connection points close together. In this case the line Z_0 should be the geometric mean of the input and output impedances or $\sqrt{(50 \times 12.5)}$ or 25Ω .

The same is true of other impedance ratio transformers. Derivations are shown in Figs. 9c and 9e, of a balanced-to-balanced configuration, using two or four lines. A common magnetic core can be used for both if the coupling between the two can be kept minimal. But separate cores are usually recommended. Since this transformer has a 4:1 impedance ratio, the optimum line impedance is again 25Ω . If the 'centre tap' is left floating, dc can be fed through it – eg not by-passed to ground – and a balun normally seen to provide a bal-

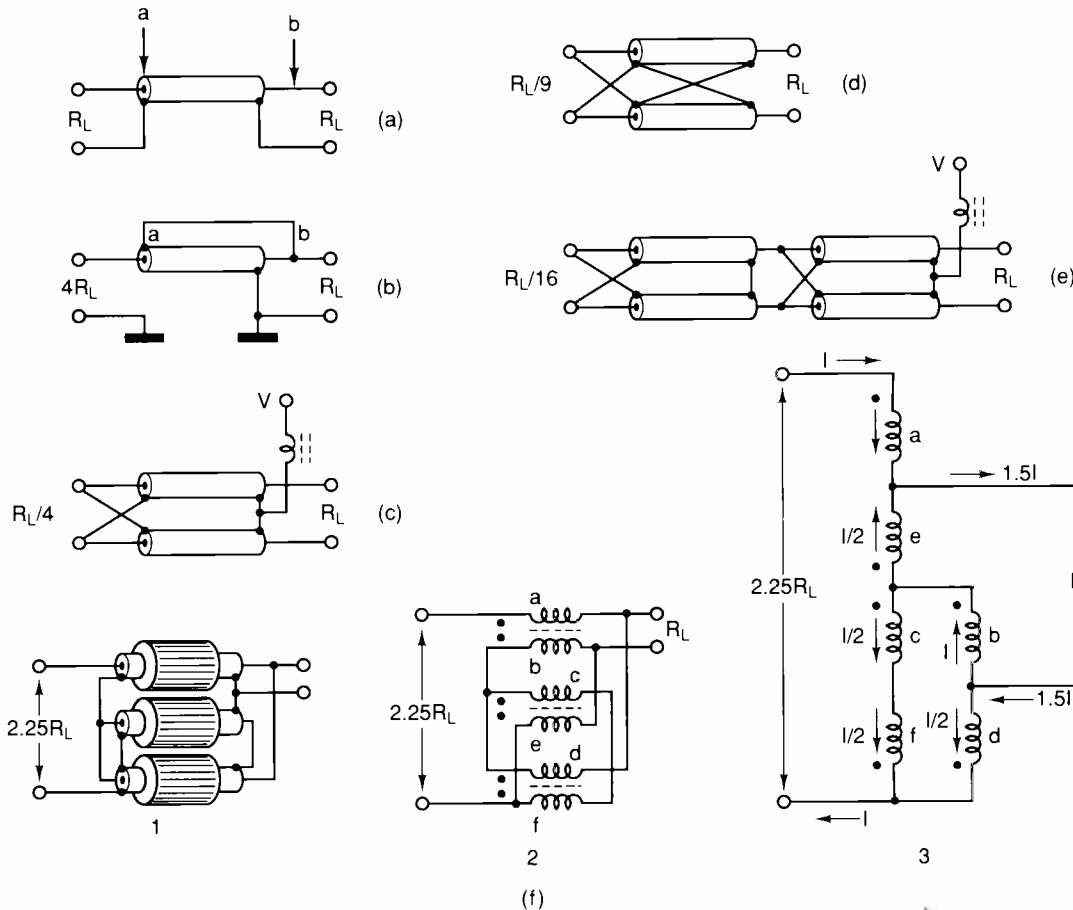
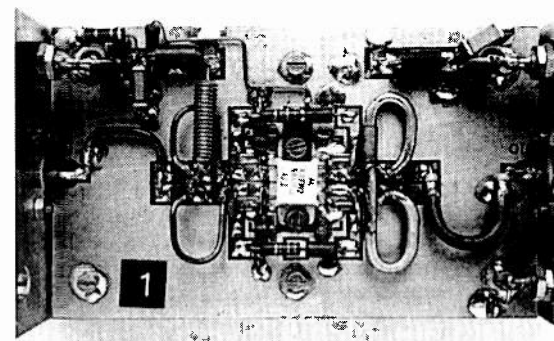

Fig. 9. Some examples of transmission line transformers. For simplicity, most are shown without magnetic cores and can be used as such in many vhf and uhf applications. All the lines must be formed into a physical shape which minimises the lengths of the interconnection for reduced leakage inductance. The photo at g) shows a uhf push-pull amplifier using transmission line transformers in its input and output matching. The input at the left uses a 4:1 as shown in c) and the output at the right uses a 1:9 transformer as shown as d).



and length as the main line, the phase difference between the input and output would be eliminated. The transformer topology would remain the same, except that the a-b connection would have the same phase delay as the main transformer line.

Such a transformer can be viewed as two coaxial lines with their input terminals in series and output terminals connected in parallel. Where one line is always used only to provide a delay of a controlled amount, it is also the case with equal delay transformers of any other impedance ratio.

For this reason, the sub-class is called equal delay transmission line transformers, serving applications from 1MHz to at least 500MHz depending on the impedance levels involved.

Transformer input and output connections can be physically separated – an advantage in many cases.

Figure 10b is a pictorial and schematic representation of a 4:1 equal delay transformer. If a third line is added to the 4:1 design (Fig.

anced-to-unbalanced function can be omitted. Otherwise, another dc feed method must be chosen.

This also applies to the 16:1 ratio transformer (Fig. 9e), which employs two 4:1 transformers in series, where the same rules are in effect.

Line impedance of the high-impedance 4:1 segment is 25Ω , which was previously determined to be the required value. The line impedance of the second section would be $\sqrt{(25 \times 3.12)} = 6.25\Omega$, making its design somewhat impracticable as line impedances of such a low value are difficult to achieve. But it would be possible to parallel two 12.5Ω coaxial cables, for example, which is standard practice.

Coaxial cables with impedances of 12.5, 16.7, and 25Ω are becoming standard items for cable manufacturers today. For many applications however, the line impedance is not critical provided that some bandwidth degradation is acceptable.

Figure 9d shows a 9:1 balanced-to-balanced transformer. Performance can be good if the interconnections can be kept short – but this is more difficult than with the 4:1 transformer since there are more interconnections and the impedance levels are lower. Here the optimum line impedance is $\sqrt{(50 \times 5.55)}$ or 16.6Ω . Unlike the 4:1 unit, the balanced 9:1 transformer always requires a balun in the end that is to be terminated with an unbalanced source or load. It also does not have a balanced point to allow dc feeding through the lines.

Overcoming limitations

As mentioned earlier, a limitation of squared integer transformation ratios is the biggest disadvantage of the transmission line transformer. There are ways to get around this, but the designs are complex and bulky, and call for additional lines and connections between them, greatly reducing bandwidths in some cases.

One such design for three different configurations is shown in Fig. 9f (in simplified form in Fig. 9f3 to make analysing its operation easier than using configuration Fig. 9f2 for example). An analysis of the current distribution between each winding reveals a ratio of 1.5:1 between the primary and the secondary, equalling the turns ratio and resulting in an impedance ratio of 1.5^2 or 2.25:1.

Assuming $R_L = 50\Omega$ (in which case the source would be 112.5Ω), optimum line impedance is $50/1.5$ or 33Ω . This transformer has a balanced-to-balanced circuit configuration, requiring a balun if interfaced with an unbalanced source or load in either a step-up or step-down mode.

Equal delay transmission line transformers

In normal 4:1 transmission line transformers, the high frequency response is limited by phase errors introduced between the interconnection points (such as a-b in Figs. 9, 10a and 10b

If the connection from a to b were made with a transmission line of equal impedance

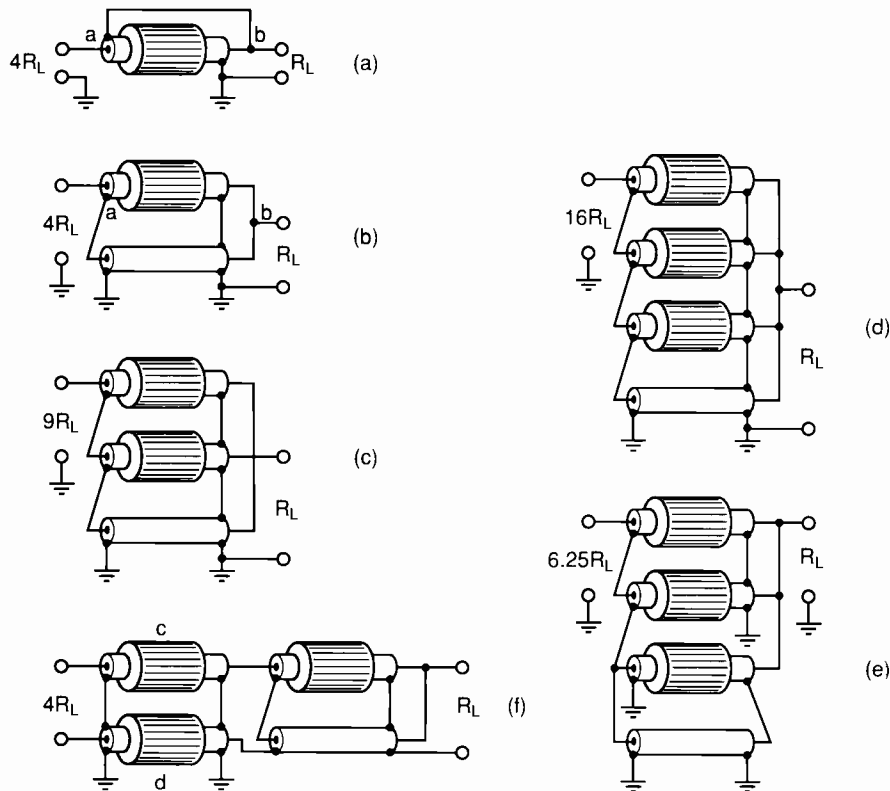

10c), a 9:1 impedance transformer results. Similarly, four lines will produce a 16:1 transformer (Fig. 10d) and so on.

Wideband requirements

Wideband operation demands that most of the transmission lines must be surrounded by magnetic material, generally in the form of toroids or sleeves. The amount of magnetic material required in each line depends on the level of the impedance transformation. The line impedances are equal, but the highest impedance transform line requires one unit of magnetic material, the next one two, the following one three and so on. By unit we mean a measure of cross-sectional area of similar magnetic material.

All these designs are unbalanced-to-unbalanced transformers – though baluns (Figs. 10f2 and 10f3) can be added to obtain a balanced interface.

Suppose we add a magnetic core to the bottom line of a 4:1 transformer. Now we can disconnect the grounds of the parallel connected lines (still keeping the shields connected) and add a balanced, floating load between the centre conductors and the shields to form a 4:1 balun.

Stray capacitances to ground can be balanced by connecting the centre conductor of one coax to the shield of the other and a transformer as in Fig. 9c) would be formed. In equal delay transformers of any impedance ratio, the last line only provides delay and has no external fields. It requires no magnetic core, but the presence of magnetic material will not affect its performance. The line characteristic impedance (Z_0) requirements are the

same as for standard transmission line transformers – eg Z_0 equals the ratio of voltage to current along the line. Or simply: Z_{IN}/N , where $N = \sqrt{Z_{IN}/Z_{OUT}}$.

Equal delay transformers have the full integer limitations of the standard transmission line networks. But their physical configurations make it easier to create fractional integer impedance ratios with equal delay transformers by using subgroups of additional lines (Fig. 10e).

If we describe group A (Fig. 10a) as the main transformer, providing the full integers of impedance transformation, adding group B (Fig. 10b) lines with their low impedance sides connected to the high impedance side of group A results in fractional impedance transform ratios. The resulting impedance ratios can be calculated as $N = (n_A + 1/n_B)$, where n_A is the impedance ratio of group A, i.e. the main transformer, and n_B is the impedance ratio of group B.

For example, if group A has one line and group B has two, the transform ratio is 2.25:1. Further, if $A=2, B=4, N=5.0625:1$; and $A=2, B=2, N=6.25:1$.

Line impedances are dictated by the transform ratio and the impedances required for the main transformer (group A).

How much improvement in bandwidth the equal delay transformer gives compared with the standard transmission line transformer depends largely on mechanical factors. Also even if both are correctly compensated, the insertion loss of the equal delay transformer can be at least 0.1dB less than the standard transmission line transformer in the frequency region up to 500MHz. ■

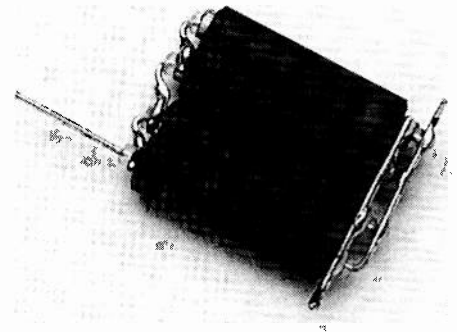

Fig. 10. Equal delay transformers. a) is a basic standard transmission line type shown as a comparison against b). b), c) and d) are basic configurations, whereas e) uses a sub-group of lines to provide a fractional integer impedance ratio. f) is a 4:1 unit with baluns (c and d) added for balanced interface.

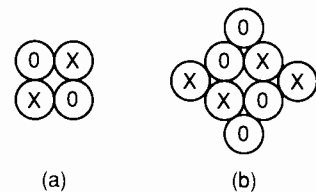

Fig. 11. Cross section of a correctly arranged twisted wire with two pairs of wires a) and four pairs of wires b). O represents one conductor of the line and X the other.

CLASSIFIED

TEL 081 652 3620

FAX 081 652 8931

ARTICLES WANTED

WE WANT TO BUY !!

IN VIEW OF THE EXREMELY RAPID CHANGE TAKING PLACE IN THE ELECTRONICS INDUSTRY, LARGE QUANTITIES OF COMPONENTS BECOME REDUNDANT. WE ARE CASH PURCHASERS OF SUCH MATERIALS AND WOULD APPRECIATE A TELEPHONE CALL OR A LIST IF AVAILABLE. WE PAY TOP PRICES AND COLLECT.

**R.HENSON LTD.
21 Lodge Lane, N.Finchley,
London N12 8JG.
5 Mins, from Tally Ho Corner.
TELEPHONE
081-445-2713/0749
FAX 081-445-5702.**

ARTICLES FOR SALE



Cooke International SUPPLIER OF QUALITY USED TEST INSTRUMENTS

ANALYSERS, BRIDGES, CALIBRATORS, VOLTMETERS, GENERATORS, OSCILLOSCOPES, POWER METERS, ETC. **ALWAYS AVAILABLE**

ORIGINAL SERVICE MANUALS FOR SALE
COPIES ALSO AVAILABLE

EXPORT, TRADE AND U.K. ENQUIRIES WELCOME, SEND LARGE "A3" S.A.E. + 50P POSTAGE FOR LISTS OF EQUIPMENT AND MANUALS.

ALL PRICES EXCLUDE VAT AND CARRIAGE
DISCOUNT FOR BULK ORDERS SHIPPING ARRANGED

OPEN MONDAY-FRIDAY 9AM-5PM

Cooke International

ELECTRONIC TEST & MEASURING INSTRUMENTS
Unit Four, Fordingbridge Site, Main Road, Barnham,
Bognor Regis, West Sussex, PO22 0EB

Tel: (+44) 0243 545111/2

Fax: (+44) 0243 542457

HIGH END TEST & COMMUNICATIONS
EQUIPMENT PURCHASED

CIRCLE NO. 133 ON REPLY CARD

ARTICLES FOR SALE

VALVES AND CRTs

ONE MILLION ITEMS IN STOCK INCLUDING MAGNETRONS, KYLSTRONS, VALVE SOCKETS FOR AUDIO RECEIVING TRANSMITTING, OBSOLETE BRANDS SUCH AS MULLARD, GEC A SPECIALITY. ALSO HUGE STOCKS OF RUSSIAN AND SOVTEK ITEMS. ASK FOR OUR 40-PAGE VALVE CATALOGUE OR CRT CATALOGUE.

VALVES WANTED FOR CASH

ESPECIALLY KT66, KT77, KT88, PX4, PX25, VALVE HI-FIs e.g. QUAD, LEAK, GARRARD 301. IF POSSIBLE SEND WRITTEN LIST.

BILLINGTON EXPORT LTD

1E GILLMANS IND EST, BILLINGSHURST, SUSSEX RH14 9EZ
CALLERS STRICTLY BY APPOINTMENT ONLY
TEL: 0403 784961 FAX: 0403 783519
MINIMUM ORDER £50.00 PLUS VAT

TURN YOUR SURPLUS TRANSISTORS, ICS ETC, INTO CASH
Immediate settlement.
We also welcome the opportunity to quote for complete factory clearance.
Contact:
COLES-HARDING & CO. 103 South Brink
Wisbech, Cambs PE14 0RJ.
ESTABLISHED OVER 15 YEARS
Buyers of Surplus Inventory
Tel: 0945 584188 Fax: 0945 475216

TOP PRICES PAID

For all your valves, tubes, semi conductors and IC's.

Langrex Supplies Ltd,
1, Mayo Road, Croydon,
Surrey, CRO 2QP
TEL: 081 684 1166
FAX 081 684 3056

ARTICLES WANTED

STEWART OF READING

110 WYKEHAM ROAD,
READING, RG5 1PL.
TEL: 0734 268041
FAX: 0734 351696

TOP PRICES PAID FOR ALL TYPES OF SURPLUS TEST EQUIPMENT, COMPUTER EQUIPMENT, COMPONENTS, etc. ANY QUANTITY

103

WANTED

Test equipment, receivers, valves, transmitters, components, cable and electronic scrap and quantity. Prompt service and cash

M & B RADIO
86 Bishopgate Street,
Leeds LS1 4BB
Tel: 0532 435649
Fax: 0532 426881

9956

WANTED

High-end Test Equipment, only brand names as Hewlett-Packard, Tektronix, Rhode & Schwarz, Marconi etc. Top prices paid.

Please send or fax your offer to:

HTB ELEKTRONIK
Alter Apeler Weg 5, 2858 Schiffdorf,
West Germany
TEL: 01049 4706 7044
FAX: 01049 4706 7049

WANTED

Receivers, Transmitters, Test Equipment, Components, Cable and Electronic, Scrap, Boxes, PCB's, Plugs and Sockets, Computers, Edge Connectors.

TOP PRICES PAID FOR ALL TYPES OF ELECTRONICS EQUIPMENT

A.R. Sinclair, Electronics, Stockholders,
2 Normans Lane, Rabley Heath, Welwyn,
Herts AL6 9TQ. Telephone: 0438 812 193.
Mobile: 0860 214302. Fax: 0438 812 387
Telephone: 0763 246939

780

**TO ADVERTISE HERE
TEL 081 352 3620**

ELECTRONIC UPDATE

Contact Pat Bunce on
081-652 8339

A regular advertising feature enabling
readers to obtain more information
on companies' products or services.

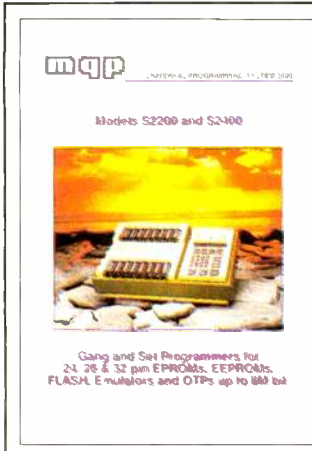

mqp MODELS S2200 and S2400

Gang and Set Programmers for 24, 26 & 32 pin EPROMs, EEPROMs, FLASH, Emulators and OTPs up to 8Mbit

The system 2000 is an ideal programmer for the production environment. Fast programming results in high throughput and rigorous verification leads to improved quality control. Single key functions and checks against misoperation facilitates its use by unskilled staff.

MQP ELECTRONICS LTD.
Tel: 0666 825146
Fax: 0666 825141
CIRCLE NO. 142 ON REPLY CARD

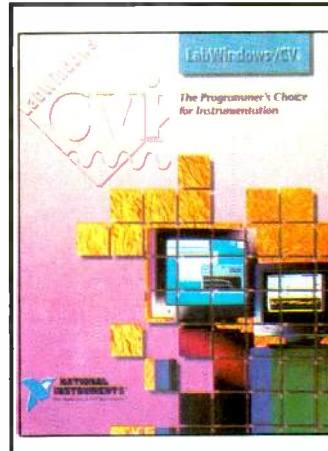

LabWindows/CVI
The Programmer's Choice for Instrumentation

LabWindows/CVI Brochure

The LabWindows/CVI Brochure, from National Instruments, explains how users can build instrumentation applications on Windows PCs and Sun SPARCstations using the ANSI C programming language and LabWindows/CVI data acquisition, analysis, and presentation libraries.

NATIONAL INSTRUMENTS
For further information
FREEPHONE 0800 289877
CIRCLE NO. 146 ON REPLY CARD



OLSON FUSED SUPER SLIM MAINS DISTRIBUTION PANELS WITH DOUBLE POLE SWITCHED SOCKETS

OLSON ELECTRONICS LIMITED is a leading manufacturer in the field of mains distribution panels of every shape and size to suit a variety of needs. For use in Broadcasting, Computing, Data Communications, Defence, Education, Finance, Health etc. All panels are manufactured to BS5733. BRITISH AMERICAN, FRENCH, GERMAN CEE22/IEC and many other sockets. Most countries catered for.

All panels are available ex-stock and can be bought direct from OLSON.

Olson Electronics Limited
Tel: 081 885 2884
Fax: 081 885 2496
CIRCLE NO. 143 ON REPLY CARD

SPICE A/D Simulation

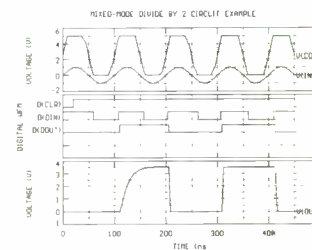

- Mixed Analogue and Digital
- All SPICE 2G6 analyses
- Behavioural Modelling
- Graphical post-processor
- FREE 10 transistor version
- 640K version £395
- 32 bit extd. mem. ver. £695
- Schematic front-end £149

To receive your FREE working evaluation version just send a 1.44MB HD 3.5in disk to: EW+WW Offer, CRaG Systems, 8 Shakespeare Rd, Thatcham, Newbury, Berks RG13 4DG, Tel (0635) 873670

CIRCLE NO. 147 ON REPLY CARD



ENGINEERING & SCIENTIFIC PC

Total Solution for PC-based Industrial and Lab Automation

ENGINEERING & SCIENTIFIC PC

The new 230 page 1994 PC-LAB catalogue covers an extensive range of PC-based data acquisition, measurement, control, and interface plug-in cards plus supporting software packages for engineering & scientific applications. Also includes 19" rack mounting industrial PCs, custom OEM PC chassis and associated sub-systems.

Please contact integrated measurement systems for a free catalogue copy.

Tel: (0703) 771143
Fax: (0703) 704301

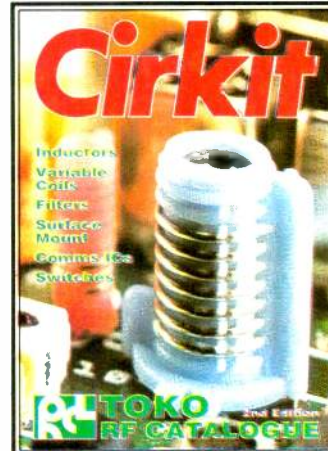

Cirkit

Inductors, Variable Coils, Filters, Surface Mount, Comm. ICs, Switches

TOKO RF CATALOGUE

2nd EDITION TOKO RF CATALOGUE

Cirkit have just published the 2nd Edition of the Toko RF Catalogue, featuring details of Tokos' extensive range of RF coils, inductors, filters and comms ICs.

The 128 page catalogue includes many new products such as; Surface mount high current inductors, surface mount multilayer inductors, helical filters at 2.5GHz and a new section of push button and tact switches.

Cirkit Distribution Ltd, Park Lane, Broxbourne, Herts, EN10 7NQ
Tel: (0992) 441306
Fax: (0992) 441306
CIRCLE NO. 148 ON REPLY CARD



PCbus Catalogue

Arcom

INDUSTRIAL PCs

Arcom's PCbus range is expressly developed for embedded control and data acquisition, providing high integrity industrial solutions with:

- * full range of CPU and I/O functions
- * industrial EMC enclosures
- * mezzanine bus expansion
- * industry standard signal conditioning
- * Windows I/O drivers with predictable performance.

Arcom Control Systems makes plug-together PC solutions for industry a reality!

Please forward all enquiries to Alan Timmins at: Arcom Control Systems Ltd, Units 8-10 Clifton Road, Cambridge CB1 4WH, UK. Tel: + 44 (0)233 411200 Fax: 410457



£295.00 + vat

High Speed EPROM & FLASH Programming from your PC

- Programs EPROMs to 4 Mbits/32-pins
- Superfast 8, 16 & 32-bit programming
- Approved algorithms
- Menu driven software included
- Sophisticated editor functions
- Easy file management
- FREE demo disk available

Stag Programmers Limited
Martinfild Welwyn Garden City, Hertfordshire, AL7 1JT UK
Tel: (0707) 332148
Fax: (0707) 371503

CIRCLE NO. 149 ON REPLY CARD

SPECTRUM ANALYSERS



- IFRA7550 1GHz portable analyser w tracking gen op £4500
- IFRA8000 2.46Hz version of above £5250
- HP3580A 5Hz-50kHz audio spectrum analyser £1500
- HP3582A dual-channel 25kHz analyser £3500
- HP3585A 20Hz-40MHz GPIB analyser £4500
- MARCONI TF2370 110MHz £1250
- ADVANTEST TR4133A 199kHz-200GHz Hi-spec spectrum analyser £8500

MARCONI INSTRUMENTS

- 2019 AM/FM synthesized signal generator 80kHz-1GHz £1750
- 2019A as above, improved spec £1950

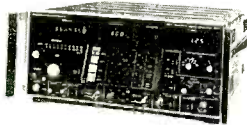

- 2828A/2829 digital simulator/analyser £1000
- 2830 multiplex tester £1500
- 6059A signal source 12-18GHz £750
- 6460/6420 power meter 10MHz-12.4GHz 0.3uW-10mW
- 6460/6423 power meter 10MHz-12.4GHz 0.3mW-3W
- 6700B sweep oscillator 8-12.4GHz & 12.4-18GHz
- 6912 power sensor 30kHz-4.2GHz for above series
- 893B audio power meter
- OA2805A PCM regenerator test set £750
- TF2910/4 non-linear distortion (video) analyser £1000
- TF2914A TV insertion signal analyser £1250
- TF2910 TV interval timer £500

RALFE ELECTRONICS

36 EASTCOTE LANE, S. HARROW, MIDDLESEX HA2 8DB
TEL: 081-422 3593, FAX: 081-423 4009

**NOW
IN
40th
YEAR**



DISTRIBUZIONE E ASSISTENZA, ITALY: TLC RADIO, ROMA, 061871 90254

TEST EQUIPMENT

- ANRITSU ME518A PCM portable error rate test set £2500
- BRUEL & KJAER 2511 vibration meter set/1621 filter £2250
- BRUEL & KJAER 2307 level recorder £1000
- BRUEL & KJAER 2317 portable level recorder £1850
- BRUEL & KJAER 1618 band pass filter £750
- BRUEL & KJAER 3513 portable vibration analyser £3500
- BRUEL & KJAER 2515 vibration analyser £5000
- AVORM215L-2 insulation & breakdown tester £650
- DATRON 1065 digital multimeter £750
- DRANETZ 626 mains disturbance analyser/2 x PA-6001 £750
- DRANETZ 606-3 line disturbance analyser £275
- KEITHLEY 192 programmable dmm £400
- MAURY MICROWAVE 8650E TNC-calibration kit £1500
- NAGRA IV-SJ tape recorder £2300

TEKTRONIX CSA803A COMMUNICATIONS SIGNAL ANALYSER

- As new, supplied with IXSD22 head £22000 each
- TEKTRONIX 1503C/3/4/5/6 tdr cable tester £3,250

MUCH MORE, FULLY RE-FURBISHED, FULLY GUARANTEED TEST EQUIPMENT AVAILABLE FROM STOCK. PLEASE REQUEST OUR CURRENT LISTINGS. WE CAN FAX LISTS & SHIP GOODS WORLD-WIDE. HIGH-END EQUIPMENT ALWAYS WANTED FOR STOCK.

■ CALL US NOW ■

- £350 RACAL 9008 automatic modulation meter £325, 9009 £300
- £400 RACAL 9082 synthesized AM/FM sig' gen' 5-520MHz £500
- £1000 RACAL 9300 RMS voltmeter -80dB to +50db £325
- £150 RACAL 9341 LCR databridge component tester £350
- £350 RACAL-DANA 9302 RF milli-voltmeter 1.5GHz £450
- £350 RACAL-DANA 9303 level meter, digital £1000
- £750 ROBERTS & ARMSTRONG f/o-cable end-cut measure unit £500
- £1000 TEKTRONIX A16 digital photometer £250
- £1000 TEKTRONIX 1503C/03/04/05/06 TDR cable tester £3250
- £1250 WAVETEX 20000-1400MHz sweep generator £750
- £500 WAYNE KERR B905 automatic precision bridge £950

HEWLETT PACKARD



- 331A distortion meter £200
- 339A distortion meter £1500
- 3457A digital multimeter £1250
- 3335A synthesizer/level generator with option 01 £2500

- 3336A level generator £2000
- 3552A transmission test set £1250
- 3586A selective level meter £2500
- 415E swr meter £350
- 4274A multi-frequency (100Hz-100kHz) LCR component meter £4000
- 4275A multi-frequency LCR component meter £5000
- 432A/478A microwave power meter 10MHz-10GHz £400
- 432A/R486A uwave power meter 26.5-40GHz (waveguide) £600
- 5005B signature multi-meter, programmable £500
- 54501A digitising oscilloscope 100MHz 10MS/s £1500
- 6253A dual power supply 0-20V 0-3A twice £225
- 6825A bipolar power supply/lamp -20 to +20vdc 0-1A £350
- 70300A tracking generator plug-in unit £2000
- 70907A external mixer for 70000-ser spectrum analyser £1750
- 7035B X-Y single pen analogue chart recorder £350
- 8011A pulse generator 0.1Hz-20MHz £500
- 816A slotted line 1.8-18GHz with carriage 809C & 447B £500
- 8350B sweep generator main-frame £2250
- 8405A vector voltmeter, voltage & phase to 1000MHz £950
- 8620C sweep generator, many plug-in units available £call
- 8671A synthesized signal generator 2-6.2GHz £2500

8753C with 85046A NETWORK ANALYSERS
with S-PARAMETER TEST SET as new, calibrated, £22500

PLEASE NOTE: ALL OUR EQUIPMENT IS NOW OPERATION-VERIFICATION TESTED BEFORE DESPATCH BY INDEPENDENT LABORATORY

We would be pleased to handle all grades of calibration or NAMAS certification by same laboratory at cost price. All items covered by our 90-day parts and labour guarantee and 7-day Right to Refuse (money back) warranty.

ALL PRICES SUBJECT TO ADDITIONAL VAT AND CARRIAGE

CIRCLE NO. 131 ON REPLY CARD

INDEX TO ADVERTISERS

	PAGE		PAGE
Anchor Surplus Ltd	599	Langrex	585
BK Electronics	575	M & B Electrical	590
Bull Electrical	568	M B Radio (Leeds)	551
Chelmar Valve	582	MQP Electronics	553
Citadel Products Ltd	IFC	Number One Systems	605
Dataman Designs	OBC	Powerware	553
Display Electronics Ltd	547	Ralfe Electronics	616
Field Electric Ltd	595	Remote Imaging Group	585
Halcyon Electronics Ltd	595	Seetrex Ltd	533
Ice Technology Ltd	539	Smart Communications	553
John Morrison	582	Smart Communications	575
John's Radio	530	Stewart of Reading	585
John's Radio	535	Surrey Electronics	585
JPG Electronics	582	Tektronix	597
Kestral Electronics	582	Telnet	533
Keytronics	581	Those Engineers Ltd	562
Lab Center	558	Tsien Ltd	575
		Ultimate Technology	IBC

FROM CONCEPT TO ARTWORK IN 1 DAY

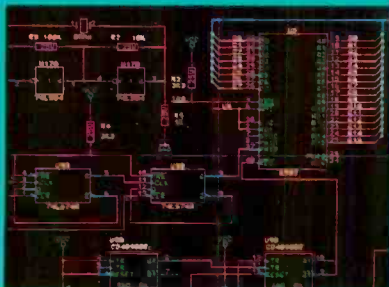

Your design ideas are quickly captured using the ULTIcap schematic design Tool. ULTIcap uses REAL-TIME checks to prevent logic errors. Schematic editing is painless; simply click your start and end points and ULTIcap automatically wires them for you. ULTIcap's auto snap to pin and auto junction features ensure your netlist is complete, thereby relieving you of tedious netlist checking.



ULTIshell, the integrated user interface, makes sure all your design information is transferred correctly from ULTIcap to ULTIboard. Good manual placement tools are vital to the progress of your design, therefore ULTIboard gives you a powerful suite of REAL-TIME functions such as, FORCE VECTORS, RATS NEST RECONNECT and DENSITY HISTOGRAMS. Pin and gate swapping allows you to further optimise your layout.

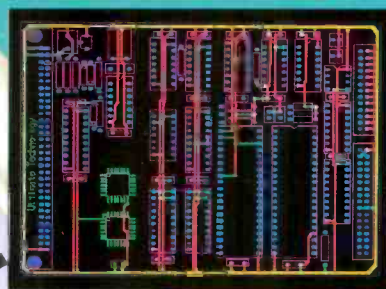

Now you can quickly route your critical tracks. ULTIboard's REAL-TIME DESIGN RULE CHECK will not allow you to make illegal connections or violate your design rules. ULTIboard's powerful TRACE SHOVE, and REROUTE-WHILE-MOVE algorithms guarantee that any manual track editing is flawless. Blind and buried vias and surface mount designs are fully supported.

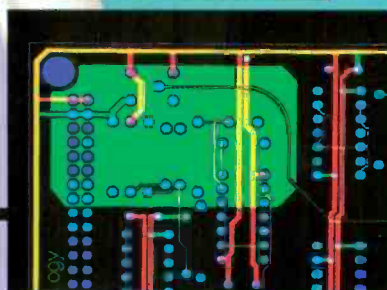

If you need partial ground planes, then with the Dos extended board systems you can automatically create copper polygons simply by drawing the outline. The polygon is then filled with copper of the desired net, all correct pins are connected to the polygon with thermal relief connections and user defined gaps are respected around all other pads and tracks.

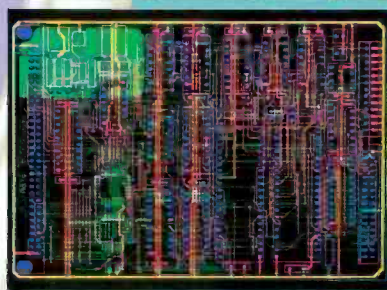

ULTIboard's autorouter allows you to control which parts of your board are autorouted, either selected nets, or a component, or a window of the board, or the whole board. ULTIboard's intelligent router uses copper sharing techniques to minimise route lengths. Automatic via minimisation reduces the number of vias to decrease production costs. The autorouter will handle up to 32 layers, as well as single sided routing.

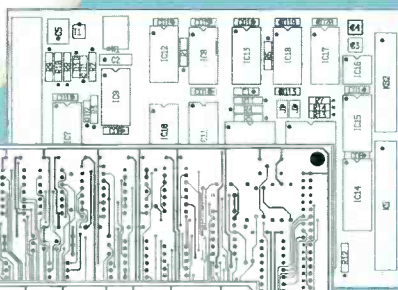

ULTIboard's backannotation automatically updates your ULTIcap schematic with any pin and gate swaps or component renumbering. Finally, your design is post processed to generate pen / photo plots, dot matrix/laser or postscript prints and custom drill files.

CIRCLE NO. 100 ON REPLY CARD

NEW

ULTIboard/ULTIcap evaluation system:

- all features of the bigger versions
- full set of manuals
- design capacity 350 pins

Price incl. S & H, excl. VAT:

£ 75

Purchase price is 100% credited when upgrading to a bigger version. • Also suitable for study & hobby

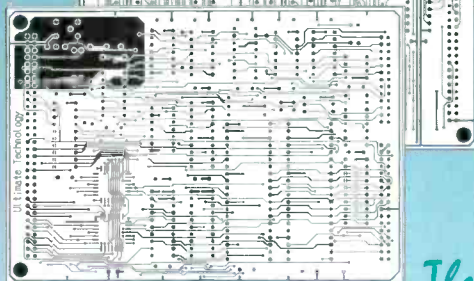

ULTIboard PCB Design/ULTIcap Schematic Design Systems are available in low-cost DOS versions, fully compatible with and upgradable to the 16 and 32 bit DOS-extended and UNIX versions, featuring unlimited design capacity.

The European quality alternative

ULTICAP + ULTIBOARD = MAXIMUM PRODUCTIVITY

I want it. What does it do?

- 8-BIT EPROM**
- 16-BIT EPROM***
- EEPROM**
- SERIAL EEPROM***
- FLASH**
- PIC***
- 8751***
- EMULATION**
- FREE UPGRADES**
- TOTALLY HANDHELD**
- 3 YEAR GUARANTEE**
- AVAILABLE TODAY!**

**Requires optional modules.*

A 32 pin ZIF socket programs a huge library of EPROMs, EEPROMs and FLASH devices up to 8Mbit. And our unique user loadable Library means that new parts can be added quickly, and at no cost. All software upgrades are free and available for 24hr download from our high speed bulletin boards.

Emulation

See your code running before committing yourself to an EPROM. With S4's powerful and easy-to-use internal emulation system, download your code to S4, press 'EMULATE', and your target system runs in real time as if an EPROM was plugged in to the socket. Use S4's 'EDIT' command to make minor alterations to your code and see the changes happen *immediately* - just one reason why S4 is used by the world's car manufacturers to develop advanced engine management systems in real time! With S4 emulation there's no need for trailing cables or external power sources; earth loop problems are a thing of the past. S4 even emulates RAM.

Remote Control

As well as being totally stand alone and self contained, S4 can be operated remotely via it's serial port at speeds up to 115,200 Baud. We supply you with a FREE disk containing custom terminal software and a pop-up TSR communications utility.

The Company

Dataman has been designing and selling innovative programmers world-wide for over 15

years. As well as having sales and support offices in both the UK and the USA, we supply the world demand for our products via a network of approved dealers stretching from Norway to Australia.

The Package

S4 comes complete with mains charger, emulation leads, comprehensive manual, PC software and a spare library ROM; there are no hidden extras to buy. Upgrading S4's device library is free, does not involve costly internal ROM upgrades and technical support is free for life. Only S4 comes with a three year guarantee.

Availability

S4 is always in stock and we ship worldwide on a daily basis. Call now for delivery TOMORROW. Bona-fide UK customers can try S4 for thirty days without risk. 16,000 users can't be wrong!



Size:
186 x 111 x 46mm
Weight: 515g

DATAMAN
Dataman Programmers Ltd

Credit card hotline:
0300 320719
for same-day dispatch

