

**Better filters using negative resistance**

# ELECTRONICS WORLD

Austria Sch. 66.00  
Denmark DKr. 67.00  
Germany DM 15.00  
Greece Dra. 1000.00  
Holland Dfl. 11.75  
Italy L. 8800.00  
Malta Lm. 1.55  
IR £3.30  
Singapore S\$12.60  
Spain Pts. 850  
USA \$5.75

A REED BUSINESS PUBLICATION  
SOR DISTRIBUTION

**INCORPORATING WIRELESS WORLD**

March 1997 £2.35

## CHARGE ALKALINE CELLS

**Wideband  
antennas**

**FPGA primer**

**Microwave  
power source**

**Light meter  
feeds RS232**

**Measure  
capacitor esr**

**Video switch**

**Scrambler  
for data**



**Last chance – DPMs for less than £9**



# Small PROBLEMS? BIG Awkward No Time SOLUTION!

PIC based TOOLS to help you realise your project:  
from single applications to full scale production

## BASIC STAMPS<sup>®</sup>

PIC based BASIC Stamps are perfect for one-off and low volume applications. Their easy to learn but powerful BASIC syntax (with familiar instructions such as GOTO, FOR ... NEXT, and IF ... THEN as well as instructions for serial I/O, pulse measurement, button debounce, DTMF, X-10 etc) will get your application up and running in hours. Once programmed, the Stamp runs independently of your PC and programs are stored in non-volatile EEPROM so they can be changed at will. Detailed manuals cover many commonly needed routines and the Stamp is well supported by a growing list of custom application kits to cut development time even further. Available in two formats:

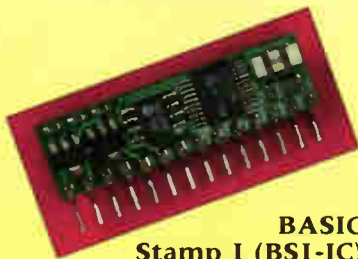

**BASIC Stamp I (BS1-IC)**  
8 I/O Lines  
up to 80 program lines  
Comms to 2400 baud  
35x10mm size  
£29 single price

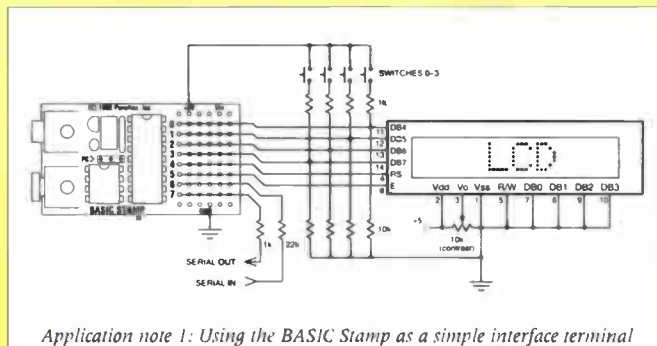

Application note 1: Using the BASIC Stamp as a simple interface terminal  
Typical Application

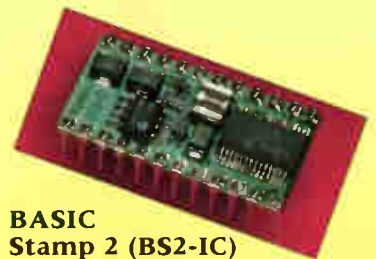

**BASIC Stamp 2 (BS2-IC)**  
16 I/O Lines  
up to 500 program lines  
Comms to 50 kbaud  
24pin DIP package  
£49 single price

BASIC Stamp Development Kits including PC software, manuals, 24+ application notes, downloader cables, Stamp (BS1-IC or BS2-IC) and corresponding Project Board - £99 / £119

## PIC16Cxx DEVELOPMENT TOOLS

For medium to large volumes and high speed requirements, the popular range of PICs is hard to beat. We offer an extensive range of programmers, emulators and associated hardware to support the following PICs: 52 54 55 56 57 58 620 621 622 61 62 63 64 65 71 72 73 74 84

### PIC16Cxx Programmer



Also stocked  
\* ZIF sockets  
\* SOIC/SSOP/PLCC adapters  
\* Prototyping boards  
\* Compilers/Simulator

OVER  
5000  
SOLD

### In Circuit Emulators

- \* True hardware emulation of program memory, registers and I/O
- \* Unlimited breakpoints.
- \* Single stepping
- \* Software-programmable oscillator
- \* Windows Environment
- \* Runs from 32Khz to 10Mhz ('xx) and 20Mhz ('5x)
- \* Source level debugging for PASM(X), MPASM and MPC
- \* Optional trace facility

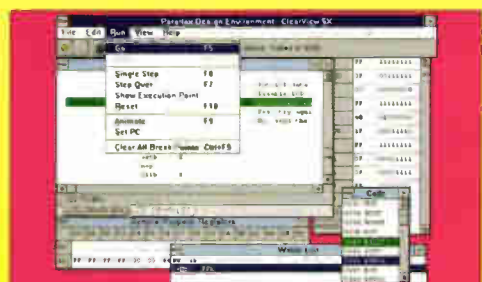

**Milford Instruments**  
Milford House, 120 High Street,  
SOUTH MILFORD LS25 5AQ  
01977 683665 Fax 01977 681465

Please call or fax to receive  
our catalogue and price list.  
All prices exclude VAT  
and £3 shipping.

BASIC Stamp and the Parallax logo are  
registered trademarks of Parallax, Inc

**PARALLAX**

3805 Atherton Road, #102  
Rocklin, CA 95765 USA  
916-624-8333, Fax 916-624-8303  
<http://www.parallaxinc.com>



# Contents



Cover - Hashim Akib

**190 CHARGE ALKALINE CELLS**  
Using a tapered and precisely administered charge/discharge cycle, alkaline cells can be charged safely, as **Rod Cooper** explains.

**197 TRUE ORIENTATION**  
Sensors schemes for orientation suffer offset and drift. **David Risk** and **Richard Noble** have developed a new algorithm that compensates for sensor inadequacies.

**202 WIDEBAND ANTENNAS**  
**Richard Formato** shows how to design efficient impedance-loaded antennas with high bandwidth.

**206 2.5GHZ POWER SOURCE**  
Microwave power sources for research and development are expensive, so **John Share** and **John Hakes** made their own.

**209 VIDEO CHANNEL SELECTOR**  
**Clem Tabor's** one-of-eight video channel selector is greatly simplified by a microcontroller programmed in Basic via a pc.

**211 LIGHT READING ON COM1**  
**Ed Buckley's** simple light meter feeds readings direct to a pc via its COM port.

**215 SOLUTION FOR STICKY PROBLEMS**  
New packaging takes the mess out of mixing and applying two-component adhesives.

**217 FILTERS USING NEGATIVE RESISTANCE**  
**Ian Hickman** explains the benefits of filters based on frequency-dependent negative resistors.

**224 HANDS-ON INTERNET**  
**Cyril Bateman** focusses on inductor design.

**227 SCRAMBLER FOR DATA**  
A relatively simple enhancement to an existing technique offers improved data security with low error rates, as **Wasim Ahmad** and **Mohiuddin Bhat** explain.

**239 PROGRAMMABLE-LOGIC PRIMER**  
**Geoff Bostock** looks at how logic elements are formed in various types of programmable logic.

**252 MEASURING LOW RESISTANCE**  
Applying ac to measure low resistance removes the dc drift problem. **Frantisek Michele** presents two measuring circuits, one for resistors and one for capacitor esr.

## Regulars

**179 COMMENT**  
Electronics and social change

**180 NEWS**  
CD quality question, Pentium successors, Free patent searches, GSM navigation without GPS, 0.8V supply op-amp, tv over the internet, Fractal antennas.

**186 RESEARCH NOTES**  
Spherical vision, **Neural silicon**, Lightning faster than light, **Air bag solution**.

**230 APPLICATIONS SUMMARY**  
Colour video on twisted pairs, **VC filter**, Carbon-monoxide sensing

**234 CIRCUIT IDEAS**  
**Programmable band-pass filter**, Two-rail switch, **Audio clipper**, Clean reset.

**247 NEW PRODUCTS**  
Pick of the month - classified for convenience.

**259 LETTERS**  
LV Directive, **Power factor correction**, Phase splitter, **Cable twists**.

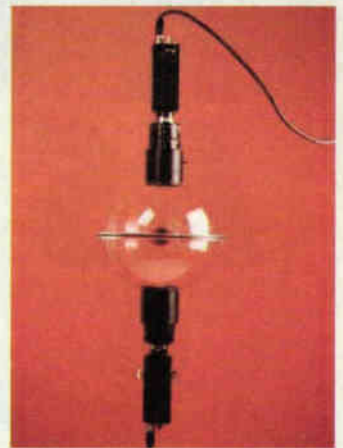

Using a spherical mirror, this camera can see in all directions at once - see page 186.



New packaging technique means that two-component epoxies can be prepared and applied without mess and mixing proportion errors - see page 215.

## Special offers



Panel meters for less than £9 - final offer - page 233.

**APRIL ISSUE**  
**ON SALE 6 MARCH**

# AT LAST A CATALOGUE AS ADVANCED AS YOUR THINKING

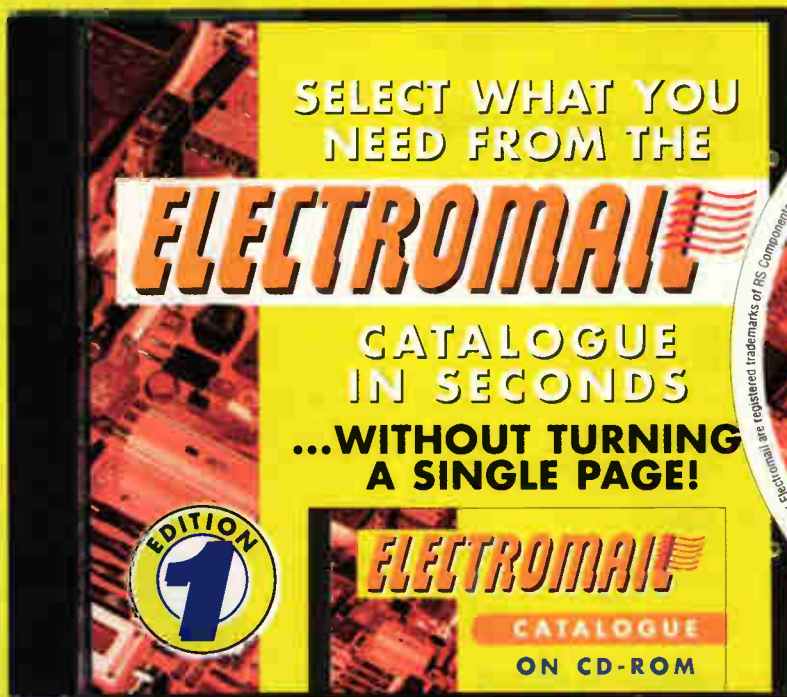

The most powerful source of reference for technical products and you can get it for **£5.00**

Electromail has always provided an outstanding range backed by the highest levels of service. Over 70,000 products from electronic components, electrical equipment to mechanical parts and tools, each one quality selected and available over the phone for next working day delivery.

You could say that's a service hard to beat, but that's just what we've done.

The new Electromail CD-ROM catalogue makes a technological breakthrough by providing full information about our complete range, with colour photographs and technical illustrations. There are powerful search functions by product type and word number - it's the fastest and easiest way ever to select and order the product you need. There's a special new products review section to keep you informed of new range additions and it contains the full RS library of Data Sheets as an added bonus.

But the best news is you can get all that for just £5 - send for your copy, and get in the fast lane to finding the components you need.

**ELECTROMAIL**

**ELECTROMAIL, P.O. Box 33, Corby, Northants, NN17 9EL.**  
Tel: 01536 204555 Fax: 01536 405555

Please send me  copies of the **ELECTROMAIL** CD-ROM catalogue at £5.00 each inc.

V.A.T. and P & P. Total value of order £



Name:

Address:

Postcode:

Tel:

Customer Ref. No.:

Please debit my Visa/Mastercard/American Express (please delete)

Card No:

Signed:

Expiry Date:

**CREDIT CARD ORDER HOTLINE : 01536 204555**

I enclose a cheque for £ to cover all items ordered.

**Ref: 234-4829**

EW

**CIRCLE NO. 106 ON REPLY CARD**



# Electronics and social change

**A**t one time the UK electronics industry used to perk up with special interest when a new government was expected. Governments went in for intervention: awarding contracts, supporting ailing firms, running national R&D organisations, the Inmos and IT initiatives, the electronics Neddy of the NEDC, and so on. Most of this has been thrown out during the past 18 years, and any Labour government would be unlikely to restore it. But, regardless of the shrinkage of the UK's industry, every new Parliament still has to work within an environment in which worldwide electronics technology brings about changes in the lives and minds of its citizens.

If a Labour government came in, you might expect an administration with a leaning towards socialism to start off by declaring its desired social values – since socialism is based on a moral principle – and then set about finding the practical means for their realisation. This is unlikely to happen. Given the economic constraints, Labour would simply continue to manage the prevailing system of welfare capitalism. But in fact public opinion, in reaction to events, is demonstrating again and again that fundamental human values are the main driving force behind our feelings of how the country should be governed.

There is disgust, for example, at the widening inequality that results from the internal dynamic of market capitalism. From being the original drive behind the labour movement in the 19th century, it is now recognised as a contributor to wider social ills. But growing numbers of people – especially the young – feel excluded from the Westminster political system, which they see as irrelevant to their main concerns. Thus we have the green movement and the women's movement – both outside the traditional arena of Left-Right confrontation – followed by a whole host of causes like human rights, abortion, *in-vitro* fertilisation, animal protection and penal reform. All these are pursued on ethical or philosophical grounds but start from gut feelings.

The intrinsic human values – truth, beauty, virtue, justice, charity, liberty etc. – have little to do with technology. But some of the instrumental values – those that work as means to an end – certainly do play a part. This is because technology is not an autonomous, one-way process, but develops through interaction with human beings. We modify the technology through what we choose to accept or reject, by our responses to whatever products or systems are on offer.

In electronic communications, for example, systems like mobile phones, the Internet and personal entertainment equipment tend to reinforce the instrumental values of flexibility and mobility, above the traditional ones of security and stability. This interaction is broadening what the motor car and the telephone started.

The physical distance between communicating individuals brings with it a behavioural and mental distancing. Automation and computing have a similar psychological effect on commercial and manufacturing workers. The work itself tends to become more abstract and intellectualised. It is done largely through the medium of symbols on vdu screens and computer print-outs. Direct sensory experience through physical contact with objects is being lost. Traditional, authoritarian manager-worker relationships are changing. Such automated work



**In electronic communications, systems like mobile phones, the Internet and personal entertainment equipment tend to reinforce the instrumental values of flexibility and mobility...**

strengthens our respect, already disciplined by the clock, for the values of order, uniformity, precision, calculability, efficiency.

Modern medical technology extends our control over life. Here electronics has become increasingly powerful through diagnostic and research techniques such as computerised tomography, magnetic resonance imaging, positron emission tomography, magnetoencephalography and DNA sequence analysis – in addition to the established radiological, electrophysiological and electro-acoustic methods. Patients routinely talk about having 'scans'. As a result of these and other advances, we are beginning to look at suffering and misfortune almost as technical problems which, *ergo*, can be fixed. Such perceptions tend to wear away our sense of the uniqueness of human life – perhaps justifiably.

Some of these instrumental values could become very strong in our society through the positive feedback of cultural reinforcement. The spread of personal computers and portable phones, for example, is much more the result of imitation and fashion than of sheer practical need. Values influence public opinion, and in a democracy this should theoretically proceed in an orderly, linear fashion into political decision making and legislation. In practice the technology-accelerated values may well sweep past the Westminster lawmaking machine, which will then have to take hasty, ill-considered measures in order to catch up with the resulting human behaviour. ■

Tom Ivaldi

*Electronics World* is published monthly. By post, current issue £2.35, back issues (if available) £2.50. Orders, payments and general correspondence to **L333, Electronics World, Quadrant House, The Quadrant, Sutton, Surrey SM2 5AS**. Tlx: 892984 REED BP G. Cheques should be made payable to Reed Business Information Ltd. **Newstrade:** Distributed by Marketforce (UK) Ltd, 247 Tottenham Court Road London W1P 0AU 0171 261-5108.

**Subscriptions:** Quadrant Subscription Services, Oakfield House Perrymount Road, Haywards Heath, Sussex RH16 3DH. Telephone 01444 445566. Please notify change of address. Subscription rates 1 year £32 UK 2 years £43.00 3 years £75.00. Surface mail 1 year £37.00 2 years £60.00 3 years £86.00 Air mail Europe/Eu 1 year £46.00 2 years £73.00 ROW 1 year £56.00 2 years £89.00

**Overseas advertising agents:** France and Belgium: Pierre Mussard, 18-20 Place de la Madeleine, Paris 75008. United States of America: Ray Barnes, Reed Business Publishing Ltd, 475 Park Avenue South, 2nd Fl New York, NY 10016 Tel: [212] 679 8888 Fax: [212] 679 9455

**USA mailing agents:** Mercury Airfreight International Ltd Inc, 10(b) Englehard Ave, Avenel NJ 07001. 2nd class postage paid at Rahway NJ Postmaster. Send address changes to above.

**Printed by** BPCC Magazines (Carlisle) Ltd, Newtown Trading Estate Carlisle, Cumbria, CA2 7NR

**Typeset by** Marlin Imaging 2-4 Powerscott Road, Sidcup, Kent DA1 4 SDT

© Reed Business Information Ltd 1997 ISSN 0959 8332

## EDITOR

Martin Eccles  
0181 652 3128

## CONSULTANTS

Jonathan Campbell  
Philip Darrington  
Frank Ogden

## DESIGN

Alan Kerr

## EDITORIAL

### ADMINISTRATION

Jackie Lowe  
0181-652 3614

### E-MAIL ORDERS

jackie.lowe@rbp.co.uk

### ADVERTISEMENT MANAGER

Richard Napier  
0181-652 3620

### DISPLAY SALES EXECUTIVE

Malcolm Wells  
0181-652 3620

### ADVERTISING

### PRODUCTION

0181-652 3620

### PUBLISHER

Mick Elliott

### EDITORIAL FAX

0181-652 8956

### CLASSIFIED FAX

0181-652 8956

### SUBSCRIPTION HOTLINE

01622 778000

### SUBSCRIPTION QUERIES

01444 445566  
FAX 01444 445447

### ISSN 0959-8332

### NEWSTRADE ENQUIRIES

0171 261 7704



## Doubts on digital recording quality

Digitally mastered recording leads to perfect replication of sound. This accepted premise is being questioned by a Cambridge-based specialist recording company which is investigating detected differences in cd sound quality.

Prism Sound is conducting a comprehensive research project into the audio differences between different cd pressings which are made from the same material and have identical data, but which are manufactured using a variety of methods.

Ian Dennis, Prism's technical

director, said that when he first heard of the problem he was, "very sceptical about the whole thing". But Prism, along with several compact discs pressing plants, produced 14 test cds, including tracks from Pink Floyd and Mariah Carey, all manufactured differently in order to validate the phenomenon.

Preliminary results of listening tests, using sound recording engineers, confirmed that there is indeed a problem. "It's something that offends the ears of people in the industry rather than Joe

Public," said Dennis, who wants to extend the tests to include lay people.

Dennis continued: "It seems that certain cd players are affected by the mechanical properties of the disc."

The differences in audio quality could be due to geometric variations between discs affecting a cd player's servo mechanism which, in turn, affects currents used in the mechanism's motors to cause crosstalk, and hence audible products, or cause jitter in the digital audio output.

## Intel releases details of Pentium successors

Intel revealed further details of its x86 roadmap during the launch of its latest MMX Pentium processor, the P55C.

The Klamath, the Pentium Pro (P6)-based device, is to be unveiled in the second quarter of the year. Klamath is aimed at high-end desktop and low-end server systems. The Pentium Pro itself, with

faster caches, will continue to be used in high-end servers.

Chris Hogg, market development manager for Northern Europe, said that Klamath will first be released at 233MHz, "and other speeds". He would not confirm whether 266MHz devices would be available, preferring to leave some mystery for the launch.

Competitors to Klamath are AMD's K6 and Cyrix's M2. Both devices have multimedia instruction sets (MMX) so as to compete with Klamath. However, both use a Pentium-style bus interface, unlike the Klamath, which has a P6 interface.

To pressure the cloners, Intel plans to exploit its leading process technology. "We're bringing up 0.25µm so we have the capability to go faster," said Hogg. This will allow for the Deschutes chip, a 300MHz Klamath, and also a faster Pentium Pro.

However, Linley Gwennap, editor of *Microprocessor Report*, said: "I'm not sure Intel will increase the speed of Pentium Pro, relying instead on Klamath."

Gwennap believes that, on the desktop, Klamath and Deschutes will hold off AMD and Cyrix.

The move to 0.25µm will also bring faster Pentiums. "Faster P55C parts will probably be only for notebooks," said Gwennap.

A future processor, dubbed Katmai, could enhance the MMX instruction set extensions. MMX2, believes Gwennap, "adds paired floating-point operations, motion estimation, and maybe fixes some of the silly restrictions of MMX1."

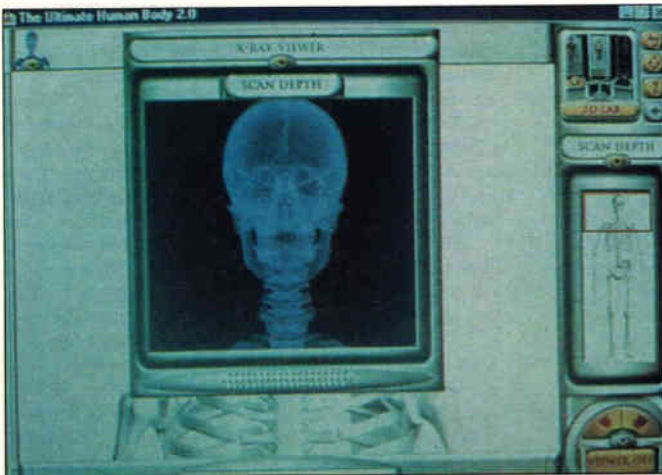

## Free patent searches on IBM Website

Want to find out if that hot idea of yours is original? IBM is now offering a Web-based patent searching service on its IBM Patent Server site with details of more than 2 million US patents issued over the past 26 years.

Users can search by title,

inventor, assignee, abstract, claims, attorney/agent and patent references. In addition, there are a million full images of US patents issued since 1987, with additional images added on a continual basis going back to 1974.

IBM says that the service is part

of a capability it developed for its own uses to search US patents and decided it would make a valuable public resource.

The good news is that the service is free to anyone with Internet access. The site is at:

<http://www.ibm.com/patents>



# ANCHOR SUPPLIES Ltd

The Cattle Market Depot  
Nottingham NG2 3GY. UK

Telephone: +44 (0115) 986 4902/  
+44 (0115) 986 4041 24hr answerphone  
Fax: +44 (0115) 986 4667



## Micro Video Cameras

Following our recent Readers Offer for the 721-S Micro Camera many readers have contacted us asking about other items in our range of Micro Cameras and Security Surveillance equipment.



We are **SOLE AUTHORISED IMPORTERS** of the entire range of Cameras and Video Surveillance equipment produced by the world's leading manufacturer. ALL items in the range carry a full 12 Months Guarantee. If you would like to receive our comprehensive catalogue of Cameras and associated equipment please send a large SAE with 48p postage, marked "Camera Catalogue"

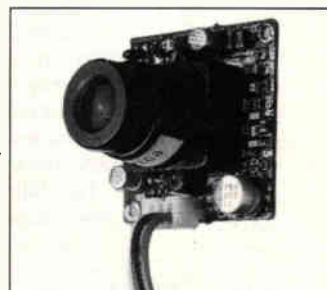

*Here is a sample of the available stock.*

- A-721-S Micro Camera 32mm x 32mm ... £85
- A-721-P Micro PIN-HOLE Camera ... 32mm x 32mm ... £85
- A-921-S Camera with AUDIO ... 30mm x 30mm ... £95
- A-1211 C/CS Mount Camera ... 110mm x 60mm x 60mm ... £110
- A-521 Micro Cased Camera 43mm x 48mm x 58mm ... metal cased ... £120
- 6001-A High Resolution COLOUR Cameras (420 lines) ... 0.45 lux ... £210
- Outdoor Camera Housings ... Aluminium ... £45
- Camera Mounting Brackets ... Universal Mounting ... £5.95
- Camera Switchers ... for up to 8 Cameras ... £85
- Auto Record Controllers ... Allow NORMAL VHS Videos to operate like professional Time Lapse or Security Recorders ... £75
- QUAD-1 Multi Vision Processors ... Digital Freeze ... Quad Pictures etc £275
- QUAD-2 Full COLOUR QUAD version of QUAD-1 ... £695
- SCI ... SCANNER ... 350° PAN ... Automatic / Manual ... £105
- IRA ... Infra Red Illuminator for "Total Darkness Surveillance" ... 20m range ... £125
- VMS-1 .. Video Motion Sensor ... replaced alarm sensors with totally electronic video monitoring system that detects changes in the video signal .. £175
- C/CS Format lenses ... Premium 3.6mm = £22.50 Superior 8mm = £27.50

PLEASE NOTE:

AS A CONTINUED SPECIAL OFFER ALL THE ABOVE CAMERA AND ACCESSORY PRICES INCLUDE VAT AND CARRIAGE TO UK ADDRESSES

### SPECIAL OFFER

New and Boxed 14" COLOUR MONITORS..Models 1412 24V DC operation @ 2.2A..Twin Composite Video Inputs (75ohm BNC) Black steel case...Supplied with a pair of trailing leads for DC connections. Very easy to convert to 240V operation by adding a 240V / 24V supply either internally or externally. 30 Day Warranty.  
NEW CONDITION

Circuit Diagram available..request at time of ordering  
**ONLY £125.00 INCL VAT**  
Courier delivery to UK addresses = £12.25)

VHS Video Players...Front Loading VHS Decks..12V operation. Rear Panel 2.6mm DC socket for power. Play..FF..RW..Stop Controls with the addition of REPEAT facility which allows the tape to be rewound and replayed time and time again.  
Video / Audio Outputs via Phono Sockets

AS-NEW Condition..  
**ONLY £75 INCL VAT**  
(Courier delivery to UK addresses = £8.75)

**OPEN 6 DAYS A WEEK**

**Mon-Fri 9am-6pm Sat 8am-4pm**

**NO APPOINTMENTS NEEDED. CALLERS ALWAYS WELCOME**

**All Prices are Ex VAT & Carriage**

**All items are Fully Tested with Verified Calibration  
and carry our Unique 30 Day Un-Conditional Warranty**



# GSM navigation without GPS

A Cambridge University researcher has designed a system which allows a GSM handset's position to be calculated without requiring the use of the Global Positioning System (GPS).

Dr Peter Duffett-Smith, inspired by his work in radio-astronomy, has designed a base station which calculates the handset's position within an accuracy of 50m. The technology is based on interferometry, with the positioning of an object determined through multiple readings taken from various points.

The ability to locate handsets will enable numerous additional GSM services to be added. For example, it would enable emergency services to locate broken-down cars or accident

sites, allow personal navigation, and even pinpoint a stolen phone or car.

Duffett-Smith believes the technology, dubbed Cursor, could be adopted as early as this year, and he is currently in discussion with major handset and base station manufacturers.

"There is a need for a system like that [location/navigation], and there is definitely a market for it," said one Ericsson spokesman.

The main approach to combining location/navigation technology with GSM is GPS. "GPS is the Rolls-Royce of technology," said Richard Fry from the Technology Partnership. "The GPS infrastructure is already there. The problem with Cursor is that people need to put the infrastructure in

and it has to be low cost."

But GPS has four disadvantages when compared with Cursor: it is expensive to fit into handsets, with a current accuracy of 100m it is not accurate enough for urban environments, it is power-hungry, and it takes a while to position itself as it consults geostationary satellites.

With Cursor, the only modification needed in the handset is applied to the software.

Cambridge Positioning Systems, with Duffett-Smith as its technical director, has been set up to exploit the technology's commercial potential. In addition to Cursor, several other similar technologies are currently under development.

Svetlana Josifovska

## Employers must say YES to skills training

British engineering employers must continue to invest in skills among the engineering workforce, according to Dr Mary Harris, director general of the Year of Engineering Success (YES).

"It's very important to realise that there is a shortage of engineers now, and that industry has to train skills and continually refresh and update these skills," said Harris.

She made it clear that the main objective of YES, which launched on 22 January, will be to get across to industry, government and opinion formers just how important

engineers are to the future economy of the country.

"Engineering supplies about 30% of our GDP, with inward investment supplying about 18%. Companies like Motorola, Fujitsu and Sony come to this country primarily because of our engineering expertise," she said.

Harris pointed out that "we need about 35,000 new engineers every year just to replace those that are leaving, and this year we're only getting about half that number. It's a real problem."

She revealed that a number of YES events that will be taking place in the coming year to "demystify the role of the engineer" to the general public.

These will include the BBC's *Tomorrow's World Live* exhibition at the NEC (19-23 March), organised in collaboration with YES, and a national tv and radio campaign.

"We need about 35,000 new engineers each year... and we are only getting about half that number," said Dr Mary Harris, Director General of YES.



## TI gambles on changed dsp focus

Texas Instruments is to end design and development of its TMS320C80 and C82 digital signal processors (dsps), used extensively in videoconferencing and compression.

A spokesperson for the company said: "TI believes it needs to have a more long-term look at visual communication. It is refocussing on ISDN, XDSL and cable modems."

The C80 and C82 will be succeeded, the spokesperson

said, by faster, more broadly focused products. Manufacture of the dsps will continue.

The lack of future development is likely to upset the many companies which have designed products based on the devices.

Unless TI brings out a new dsp architecture for video compression quickly, such firms could switch to other vendors' dsps which will have future enhancements, such as Analog Devices' *Sharc* processor.

## US non-profit bodies to get free radio allocations

The US Federal Communications Commission (FCC) has approved the allocation of part of the radio spectrum to enable schools, hospitals and other organisations to use fast, wireless communications technologies without being compelled to paying high prices for radio spectrum use.

The spectrum allocation falls into the 5.150 to 5.350GHz and 5.725 to 5.825GHz ranges, and will allow non-profit and commercial organisations to exploit wireless communications and thereby avoid the potentially high cost of wire installation in buildings.

The wireless devices will have a range as wide as three miles but supporters of the plan, which included Apple Computer, Lucent Technologies, Motorola and Northern Telecom, were disappointed that the FCC did not approve wider wireless links capable of extending as far as 13 miles.

The wider range would have enabled entire communities to share high-speed wireless data links.

The FCC faced opposition to the plan from companies that had paid billions of dollars for radio spectrum licences for Personal Communications Services.

The FCC says that the new wireless technologies will be best suited for rural areas or campus-type environments rather than in built-up areas. This is because the radio channels are adversely affected by buildings at such frequencies.



# Transform your PC

into a digital oscilloscope, spectrum analyser, frequency meter, voltmeter, data logger .. for as little as £49.00

Pico Technology specialises only in the development of PC based data acquisition instrumentation. **Call for your guide on 'Virtual Instrumentation'.**

The ADC-10 supplied with PicoScope gives your computer a single channel of analog input.

ADC-10 £49 with PicoLog £59



releasing PC potential

PICO Technology Limited

## Virtual Instrumentation

Pico's PC based oscilloscopes simply plug into the parallel port turning your PC into a fully featured oscilloscope, spectrum analyser and meter. Windows and DOS software supplied.

### ADC-100 Dual Channel 12 bit resolution

The ADC-100 offers both a high sampling rate 100kHz and a high resolution. Flexible input ranges ( $\pm 50\text{mV}$  to  $\pm 20\text{V}$ ) make the unit ideal for audio, automotive and education use.

ADC-100 £199 ADC-100 with PicoLog £219

### ADC-200 Digital Storage Oscilloscope

- 50 MSPS Dual Channel Digital Storage Scope
- 25 MHz Spectrum Analyser
- Windows or DOS environment
- $\pm 50\text{mV}$  to  $\pm 20\text{V}$
- Multimeter
- 20 MSPS also available

ADC 200-20 £359.00

ADC 200-50 £499.00

Both units are supplied with cables, power supply & manuals.



NEW ADC-200

## Data Logging

Pico's range of PC based data logging products enable you to easily measure, display and record temperature, pressure and voltage signals.

### TC-08 Thermocouple to PC Converter

- Supplied with PicoLog software for advanced temperature processing, min/max detection and alarm.
- 8 Thermocouple inputs
- No power supply required.

TC-08 £199

TC-08 £224 with cal. Cert.

complete with serial cable & adaptor. Thermocouple probes available.



Call for free demo disk and product range catalogue

Post & Packing UK £3.50, Export customers add £9 for carriage & insurance.

Pico Technology Ltd. Broadway House, 149-151 St Neots Rd, Hardwick, Cambridge. CB3 7QJ UK

Tel: + 44 (0)1954 211716 Fax: + 44 (0)1954 211880 E-mail: post@picotech.co.uk Web: http://www.picotech.co.uk/

Phone or FAX for sales, ordering information, data sheets, technical support. All prices exclusive of VAT

CIRCLE NO. 107 ON REPLY CARD

OSCILLOSCOPE LIVE CHOP Page -0.25

MEASURE MODE  
CH 1  
CH 2  
CHOP  
ADD  
COMPARE  
X-Y PLOT

1.06  
0.40  
-0.26  
-0.93  
-1.60  
-2.26  
-2.93  
-3.60  
-4.26

0.30(sec) 0.30 0.30

FREEZ ONE SHOT MODE CH1 SET CH2 SET ZOOM  
TIME DIV TIME MAG TIME OUT HYSTERESIS SLOPE + TRIG SOURCE  
PRINT COMMENT SETTINGS

FREE

INPUT 20 volt max.  
100 kHz sampling  
µScope  
to PC printerport

You get a free µScope when you buy a TP508 or a HS508 until september 1st 1996

resolution 8 bits  
sampling speed 100 kSamples/sec  
input range 2.5V, 5V, 10V and 20V  
connects to PC parallel printer port

SPECTRUM ANALYZER CH 1 5.967 U

WINDOW  
RECTANGLE  
HANNING  
HANNING  
BLACKMAN  
BARTLETT

3.70  
3.20  
2.70  
2.20  
1.70  
1.20  
0.70  
0.20  
-0.30

0(Hz) 2441406 2441406

MEASURE HOLD-OFF MODE  
FREQUENCY FREQ-MAG  
PRINT COMMENT

Software for the PC-based instruments

**TiePieSCOPE HS508**

- ▶ interface PC parallel printer port
- ▶ sampling speed 50 Msamples/sec
- ▶ resolution 8 bits
- ▶ input range 50 mV/div - 20V/div
- ▶ record length 32KByte/channel
- ▶ price £597.00, incl. software, user manual and 2 probes (1:1/1:10 switchable)

contains an Oscilloscope, a Spectrum analyzer, a Voltmeter, and a Transient recorder. All instruments are controlled in the same intuitive way and provide for saving and recalling waveforms and settings, cursor measurements, hardcopy on matrix/laser printer and online help. Minimum requirements: a 80286-based PC with 2MByte and running MS-DOS 3.3 or higher.

Fax for a free demo disk and catalog of all our products

Easy installation: just plug in and measure

**TP508**

- ▶ interface PC-XT/AT ISA slot
- ▶ sampling speed 50 Msamples/sec
- ▶ resolution 8 bits
- ▶ input range 5 mV/div - 20 V/div
- ▶ record length 32 KByte/channel
- ▶ price £ 630.00 incl. software, user manual and 2 probes (1:1/1:10 switchable)

Prices are excluding V.A.T.

TiePie engineering (NL)  
P.O. Box 290 Koperslagerstraat 37  
8600 AG Sneek 8601 WL Sneek  
The Netherlands The Netherlands  
Tel: +31 515 415 416 Fax: +31 515 418 819



TiePie engineering (UK)  
28, Stephenson Road, Industrial Estate,  
St. Ives, Cambs, PE17 4WJ,  
United Kingdom  
Tel: +44 1480 460028 Fax: +44 1480 460340

CIRCLE NO. 108 ON REPLY CARD

## Fractal antennas "in use within a year"

A US company is predicting that fractal antennas will be used in a commercial product this year.

Nathan Cohen, technical adviser to Fractal Antenna Systems, the company concerned, said: "You will see fractal antennas in transceivers in less than a year." While reluctant to discuss what kind of transceiver, he said it would be "a cell phone or a cordless phone".

A fractal antenna is effectively a track pattern on a pcb which is used as an antenna. The form of the pattern is determined using fractal maths.

Fractal Antenna Systems makes some significant claims for its designs. Its Fractal Micropatch is said to "incorporate the benefits of conventional patch antennas, but at a fraction of the size".

So what is magic about fractal antennae compared with deterministic designs? Cohen says: "There is no magic, we select the fractal equation genetically." He added: "I have yet to see a non-fractal shape that does what our antennas do."

Cohen cited a research project into genetically, non-fractally generated antennae that produced a fractal result. "After all," he said, "fractal patterns are a significant set of all possible patterns."

● A Spanish team has been researching a flat, fractal-tree-like monopole fractal antenna. The work, reported in *Electronics Letters*, describes a broad- or multi-band characteristic, with the distribution of frequencies relating to the distribution of segment lengths over the antenna.

## Samsung joins FRAM fray

Samsung is the fifth major semiconductor manufacturer to take a licence for ferroelectric ram (fram) technology from Ramtron of Colorado. The other four are Hitachi, Toshiba, Rohm, and Fujitsu.

Frams are just appearing on the commercial market. Rohm of Japan started making 1000 6in fram wafers a month in September. The company makes 4kbit, 16kbit and 64kbit density devices.

Hitachi has started sampling 256kbit frams.

Toshiba, Fujitsu and NEC are expected to have 1Mbit frams on the market later this year. Both NEC and Hitachi showed 1Mbit frams at the 1996 International Solid State Circuits Conference.

According to Hitachi Semiconductor's executive managing director, Dr Tsugio Makimoto, it will be five years before frams are cost-competitive with drams.

Before then, they will be widely used in portable equipment where their non-volatility and low power makes them ideal memory storage devices.

One key benefit of fram is its endurance. Ramtron spinoff Symetrix has demonstrated frams with 10 trillion read/write cycles. According to Hitachi's Makimoto, that will also be the endurance of Hitachi's commercial frams.

Ferroelectric technology has been pursued for many years without achieving commercial viability. The problem was the quality of the ferroelectric material available. With the development of a new material, layered perovskites, commercial production has become possible.

After wireless IC cards, the next big application for frams, says Makimoto, is in pocket organisers.

## Italians triumph with 0.8V bipolar op-amp

Engineers in Italy have developed a rail-to-rail output, precision input, bipolar op-amp operating with a supply of only 0.8V.

Designing the circuit with bipolar transistors brings with it the problem that the  $V_{BE}$  of a bipolar transistor is around 0.7V. This leaves only 100mV for other circuit elements to operate within.

Final measured characteristics, in a sample fabricated by SGS-Thomson Microelectronics, show an input offset of 0.4mV, current consumption of 0.75mA and an output swing of 90% of  $V_{CC}$ . The input common mode range, governed by the p-n-p input transistors, is -0.3V to  $V_{CC}-0.7V$ .

Output stage employs a complementary common emitter pair, rather than the usual emitter follower design. This type of output is difficult to drive effectively and doing so requires a lot of transistors. The design uses at least double the usual number.

Giuseppe Ferri, one of the co-designers, is no stranger to low-voltage design. He presented a paper at the 1996 ISSCC describing a 1.3V op-amp in conventional c-mos with rail-to-rail operation at both input and output.

## Breakthrough in tv-quality video over the Internet

WebTV Networks, the Silicon Valley-based company, says it has achieved a breakthrough in transmitting full-screen, television-quality video over the Internet using standard modems. Called *VideoFlash*, the technology will be incorporated into the company's set-top tv boxes which add Internet browsing features to regular televisions.

The company is unwilling to discuss details of its technology because of its patent applications, but said that it offers a data compression ratio ten times higher

than the industry standard MPEG-1.

VideoFlash was demonstrated at the Consumer Electronics Show in Las Vegas recently and is based on a software algorithm rather than dedicated hardware.

"In 1996, WebTV brought Internet capability to the television," said Steve Perlman, co-founder, and CEO of WebTV. "In 1997, with *VideoFlash* technology, WebTV will bring television capability to the Internet." The WebTV boxes are being manufactured and sold in the US by Sony and Philips.

While pre-Christmas sales were low, the company says that sales have been in line with expectations and will grow in 1997. Customers have to purchase a subscription to WebTV's Internet service. All will receive *VideoFlash* automatically downloaded as regular software.

The developers of *VideoFlash* include Bruce Leak, COO of WebTV, who helped develop Apple *QuickTime* video technology, and WebTV research fellow Peter Barrett, who invented the widely used *CinePack* video standard. ■





# When you need an answer for those challenging PCB layouts...

Now with EMC Adviser and Route Editor 2000 Elite

You've got the toughest designs on the shortest deadlines. You've got to save time and money. Sounds like you need CADSTAR. The UK's hottest PCB layout tool on Windows® 95 or NT.

CADSTAR brings you the tools to match the demands of PCB design in the late 90s - advanced schematic capture and PCB layout plus:

**Route Editor 2000** - the world famous, award winning routing tool for fast, time saving completion of complex layouts. New! Route Editor 2000 Elite brings you



MICROSOFT  
WINDOWS  
COMPATIBLE  
32-Bit Application

crosstalk and signal delay analysis on those high clock rate, ultra high speed designs.

**New! EMC Adviser.** CADSTAR now offers a new, easy to use and understand PC solution to analyse your layouts and help design PCBs with reduced EMC emissions. Save money with fewer board reworks for fast EMC compliance.

Discover more about what CADSTAR can do for you and your company. Call now for an information pack on (01684) 294161.

## CADSTAR

FOR WINDOWS

CADSTAR from Zuken-Redac, the world leader in PCB/MCM design and manufacture. (Dataquest 1996).



## ZUKEN-REDAC

World no.1 in PCB/MCM design

Green Lane, Tewkesbury, Gloucestershire, GL20 8HE England. Telephone: 01684 294161 Fax: 01684 299754 Internet: <http://www.redac.co.uk>  
Microsoft, Windows, Windows NT and the Windows logo are registered trademarks of Microsoft Corporation. CADSTAR is a trademark of Zuken-Redac.

CIRCLE NO. 109 ON REPLY CARD

# RESEARCH NOTES

Jonathan Campbell

## All-round – and up and down – vision

A Columbia University computer scientist has developed a video camera that can see in all directions at once. The Omnicam and special viewing software, developed by Shree Nayar, professor of computer science at Columbia's School of Engineering and Applied Science, and colleagues, gives complete spherical coverage without moving parts.

At the heart of the Omnicam is a video camera that uses a small parabolic mirror to obtain hemispheric views. A miniature off-the-shelf video camera, mounted in a frame, is aimed directly at the apex of the parabolic mirror – a small inverted cup of polished metal enclosed within a transparent hemisphere. So two Omnicams mounted back-to-back can be used to produce views of 360° in a

complete sphere.

Special software has also had to be developed to enable multiple images to be displayed on a computer screen in linear perspective at any magnification.

The parabolic optics ensure that the unit has a single effective centre of projection – a single point through which all rays from a scene must pass on their way to the camera's lens. Such a design mimics a camera that takes in only linear perspective, and allows the Omnicam's computer software to generate linear perspective images that are free of distortion.

Vision researchers have previously tried to create omnidirectional vision systems, using fish eye lenses or planar, spherical, conical or pyramidal mirrors. But most of these do not yield the single viewpoint necessary to construct linear perspective images, or, if they do, use moving parts and other complex elements to produce them, says Nayar.

So far, several prototypes of the sensor have been developed, geared towards a variety of applications, including, video surveillance, autonomous navigation, and teleconferencing.

Each prototype is a true video rate (30Hz) omnidirectional sensor that lets a remote user to interact with a dynamic scene. Software allows the user to visually navigate through scene as it changes as well as generate multiple video-rate views of

the scene.

For example, in teleconferences, an Omnicam can show every participant seated around a table, simultaneously, in either hemispheric or linear perspective.

It could also be used to allow a mobile robot to determine its location and direction of travel from local features. Or, placed over a concert stage or at midfield of a sports event, the camera could provide a 360° view to television viewers who could use a set-top box and joystick to bring any frame of that view to their screens. An online demonstration of Omnicam can be seen at the laboratory's web site at <http://www.cs.columbia.edu/CAVE>

*Left: The Omnicam is designed to provide distortion free images. Two units placed back to back can give complete spherical vision.*

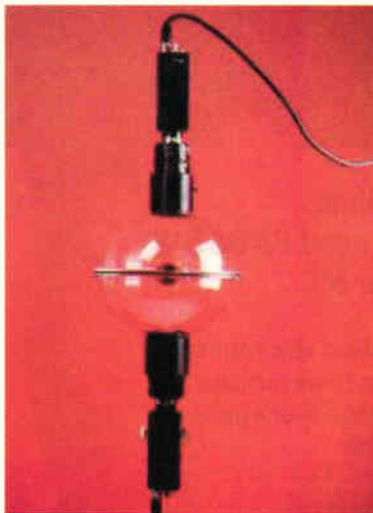

*Right: Prototypes have also been developed for specific applications such as navigation.*

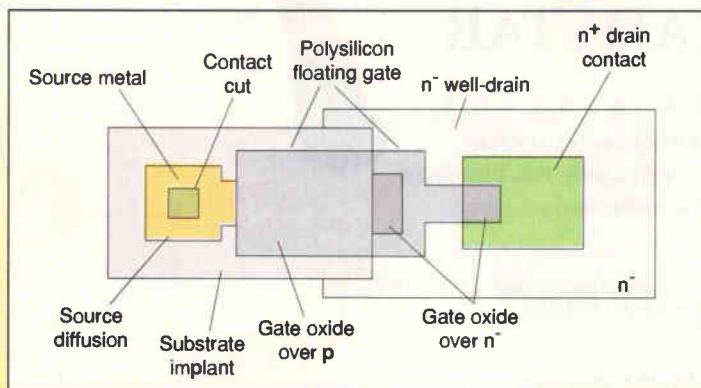
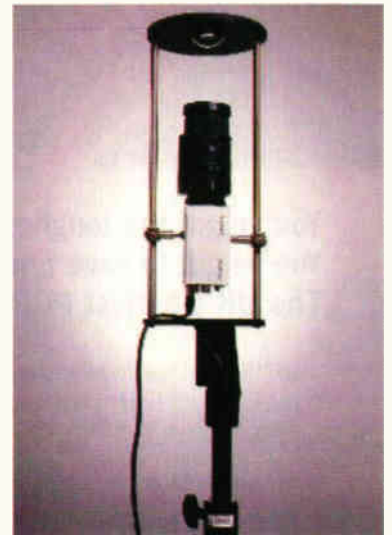

*Learning behaviour of brain synapses are now being simulated in silicon by a team at the California Institute of Technology.*

## Silicon device learns how we think

Scientists at the Physics of Computation Laboratory, California Institute of Technology, have fabricated a single transistor device that simulates the learning process in the brain. The device decides the result of a stored analogue value and an input in a process analogous to the operation of a brain synapse. By combining devices in an array, the researchers could be on the threshold of development of dense, low power silicon learning systems.

Behaviour of a neural synapse is complex, and the researchers admit that their single transistor can not model its behaviour



# Elves that travel faster than light

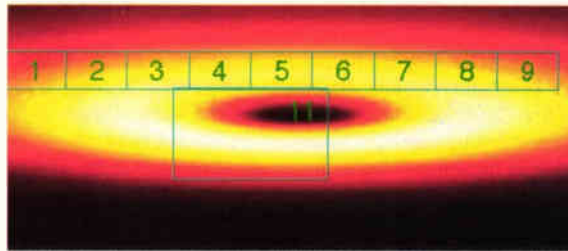
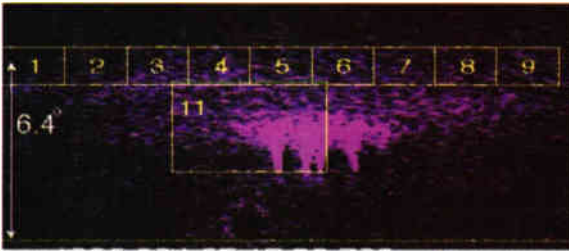

*Integrated model prediction compared with Fly's Eye video image shows the ring-like structure of individual elves. The brief flash begins at the centre and expands outwards. Numbered boxes show the specific areas where light intensity was measured by the Fly's eye.*

Researchers at Stanford's Very Low Frequency Research Group have, for the first time, measured the horizontal structure and dynamics of the new kind of stratospheric lightning that scientists have named 'elves.' The elves are actually high-altitude halos of flickering red light that sometime accompany thunderstorms, and the new measurements, obtained with a specially constructed device called the Fly's Eye, confirm that these flashes take the highly unusual form of luminous rings that spread across the sky at speeds 'faster than light'.

Umran Inan, professor of electrical engineering at Stanford explains that scientists have known for a long time that certain events in the upper reaches of the atmosphere, like solar storms, can affect the lower atmosphere resulting in significant consequences such as power blackouts.

Pilots have reported strange flashes of light above thunderstorms for some time but it wasn't until the late 1980s that scientists these reports were taken seriously.

The pulses of electromagnetic energy generated by the lightning are not anywhere near as strong as those generated by nuclear explosions which can destroy unshielded electrical equipment. But they should carry enough energy to create optical effects.

Researchers proposed that the pulses travel radially outward and upward from the lightning stroke and generate light when they intersect the bottom of the ionosphere – the region above the stratosphere that contains electrically charged atoms.

The pulse travels at the speed of light, with the first part of the wave front hitting the ionosphere as a small ring above the lightning stroke. This expands outward as portions of the pulse that travel longer and longer distances strike the ionosphere.

"The ring expands faster than the speed of light for the same reason that waves, when striking the beach at an angle, travel along the shore at a faster speed than the waves move through the water," says Inan.

fully. But it does demonstrate a local learning function (Chris Diorio *et al.*, "A single-transistor silicon synapse," *IEEE Transactions on Electron Devices*, Vol 43, No 11, pp. 1972-1980).

The silicon synapse is an n-type mosfet with a poly 1 floating gate, a poly 2 control gate, a moderately doped channel and a lightly doped drain. It uses channel hot-electron injection to add electrons to its floating gate and tunnelling to remove them.

Operation differs from conventional eeprom transistors in that not only does the silicon synapse provide non-volatile analogue memory storage, while computing locally the product of its stored memory value and the applied input, but it also provides simultaneous memory reading and writing, and can even compute locally its own memory updates.

The California team anticipates building synapse-based

Because of the ring's superluminal expansion rate, light from its newer parts actually reaches the instrument before the light from the older parts, and this had to be taken into account when interpreting the data.

To gather data on the shape and dynamics of the elves Inan and his colleagues built a special device, christened the Fly's Eye. The instrument has a dozen 45mm barrels, with each barrel pointing to a different part of the sky, and connected to electronics that amplify the incoming light to detectable levels. Because the Fly's Eye has a time resolution of 30µm, it can measure the way elves change over their brief lifetimes.

So far, the Stanford team has been able to record the flickering life cycle of ten elves. All started in a small region centred above the position of a lightning stroke and rapidly expanded outward until reaching sizes as large as 320km across.

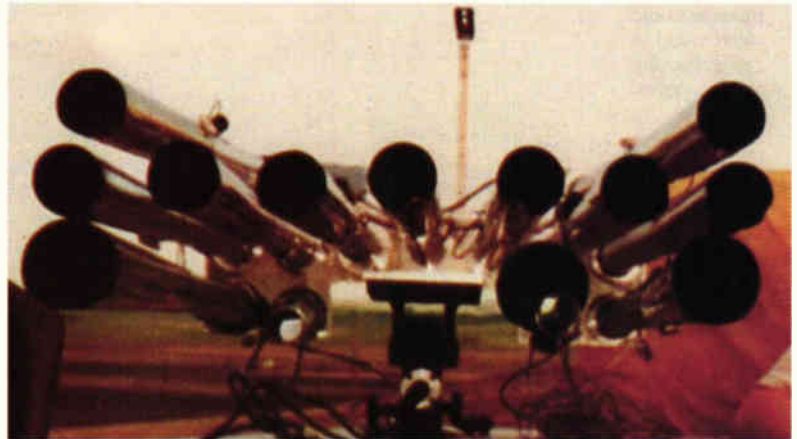

*Stanford's Fly's Eye is an array of photomultiplier tubes designed to time-resolve the horizontal development of intense sub-millisecond ionospheric flashes that have come to be known as 'elves'.*

learning systems in which both the system outputs and the memory updates are computed both locally and in parallel. By contrast, because conventional eeprom transistors are optimised for digital programming and binary-valued data storage, they typically possess few if any of these features, and so have seen only limited use in silicon learning systems.

So far a 2-by-2 synaptic array with a synapse transistor at each node has been tested and is reported to be performing well. The researchers have also developed a synapse learning rule which they believe will enable them to build an autonomous learning system that could form the basis for dense low power systems of the future.

*For more information contact Chris Diorio, Physics of Computation Laboratory, California Institute of Technology, Pasadena, CA 91125, USA.*



## Pixels systems know a thing or two about imaging

Many technologies still need to be perfected before video mail and computer-based teleconferencing become a reality. But Researchers in the School of Electrical and Computer Engineering, Packaging Research Center, at Georgia Institute of Technology look to be well on the road to a breakthrough in at least one key area: development of cheap and powerful smart pixel camera systems.

According to D Scott Wills and colleagues of Georgia Tech ("Processing architectures for smart pixel systems," *IEEE Journal of Selected Topics in Quantum Electronics*, Vol 2, No 1, pp. 24-34), the ideal system, combining high processing performance that scales with vlsi technology advances while achieving high chip efficiency, has not yet been found.

"But a successful solution can have an impact comparable to the introduction of the personal computer, video or fax machine," says the Wills team.

One of the most promising technologies currently being tested in the Georgia Tech labs is the integration of optoelectronics and the pixel system in an architecture given the name Simpil. This incorporates a specialised simd (single instruction stream, multiple data stream) parallel

processing architecture with an integrated array of optoelectronic devices.

A 1300nm optoelectronic link allows through-silicon wafer input of digital image data from a detector plane stacked above the processing plane. By reducing the image transfer bottlenecks found in decoupled detector-processor systems, high frame rates are possible without constraining processing power.

Each Simpil node includes a register, an arithmetic logic unit and local memory, and, using the instruction set architecture (isa) to enables addition, subtraction multiplication and multiply accumulation. The node is specifically designed to speed up image processing applications and also includes a-to-d circuitry to convert light intensities to digitally equivalent values.

Every node is then interfaced to an array of detectors bonded on top of silicon.

In operation, the parallel processing architecture allows the entire image to be sampled by the system synchronously.

In the Georgia Tech prototype, 64 pixels are connected to each node and the system has so far demonstrated edge detection, convolution and vector-quantisation image compression.

Vector quantisation is a significant application for image processing, and the researchers point out that is clearly demonstrates that high throughput computation can be supported with low memory.

The Georgia Tech chips link processing nodes with subarrays of optoelectronic devices and to neighbouring nodes.

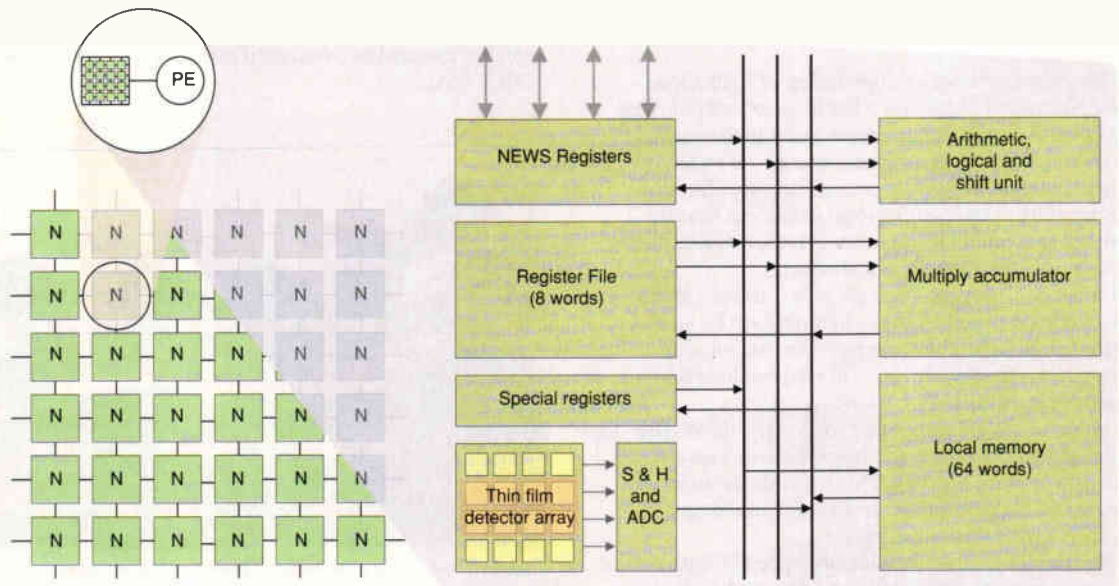

## Sensor protects babies from air bag injury

Field sensing technology developed at MIT has been integrated into a smart seating system that can detect the presence of a baby and which way it is sitting. Researchers hope that the system could stop the air-bag being triggered when a baby has been put into the front seat in a rear-facing child seat. So far, in the US, six babies have been killed by the force of a deploying air bag, propelling their seats backwards into the car with explosive force.

Development work on the field sensing technology, which has been taken up by NEC Automotive Electronics, has been carried out at MIT Media Lab's Physics and Media Group may soon prevent these fatalities. Electrodes embedded in a car's seat can distinguish between a rear- or forward-facing baby, and signal the air bag when not to deploy.

Electric field sensing is related to capacitive sensors, such as those

found in lift buttons. Though the MIT technology measures the physical quantity of capacitance, it is somewhat different to normal capacitive sensing too.

In capacitive sensing, the amount of current dumped out of a single electrode is measured. For example, as a hand approaches the electrode, the electrode becomes coupled more strongly to ground (through the person).

But in the shunt mode version of the MIT technique, there are distinct transmit and receive electrodes. As a hand approaches, the signal decreases. But since each measurement depends on two electrodes,  $n(n-1)/2$  distinct measurements can be made, rather than just  $n$  that can be made using conventional capacitive sensing.

While the first application is for baby-seat sensing, the same technology has broader capabilities, and could be used to read any occupant's size and position to determine the most effective air bag action.

Earlier applications of the wide-ranging sensor research have already included collaboration with musicians, creating furniture that can 'see,' and sending data through the human body. ■



# If a 12 stone engineer is asked by 3 project leaders to model the same problem with 50 different parameters in 1 day using a scientific calculator, find the time required for the calculator to hit the ground once it's been thrown out the window.

Most technical professionals face the same problem every day: the need to do (and re-do) complex calculations. Quickly. Armed with limiting graphing calculators and typical, hard-to-learn maths software, what's a (normally) mild-mannered engineer to do?

The answer is Mathcad PLUS 6. The only calculation software that does maths the same way you do. In your language (maths). At your speed (light). Mathcad turns your computer screen into a live worksheet. Allowing you to perform numeric and symbolic calculations, add graphics and annotate text wherever you want – just like with a pencil and notepad. (Only 1.7 zillion times faster!) And if you change a variable, Mathcad recalculates the results instantly.

*Mathcad 6 solves the most complex problems, from start to finish, with an intuitive, highly usable interface.*

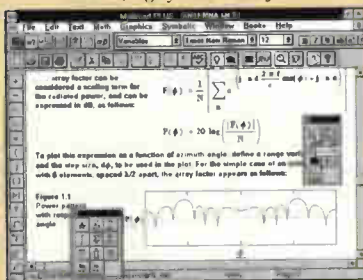

This free-form, interactive environment makes Mathcad perfect for formulating models, setting up problems, and evolving solutions. With hundreds of operators and built-in functions, you can solve linear and non-linear equations, and perform derivatives and integrals, advanced vector and matrix operations, statistical analysis – all the calculations you do many times a week.

Want to see more? Mathcad offers 2-D and 3-D graphing, multivariate curve fitting, data smoothing and locking, and animation capabilities. You can also build your own functional programs using procedural operators, and create function libraries

for analysis you perform frequently. And since technical people are human too, Mathcad has a Desktop Reference and Sampler filled with standard formulas and physical constants – lest you forget one. And QuickSheets – with example worksheets you can drag and copy onto your own worksheet. As if all this didn't promote enough office harmony,

Mathcad lets you share and discuss data and results through professional-looking documents, e-mail, and the World Wide Web.

Mathcad can solve your toughest technical problems. And maybe even a few personal ones.

**for information e-mail:**  
**mathcad@adeptsience.co.uk**

## MATHCAD PLUS 6 FEATURES

### Numeric Calculation

- Derivatives, integrals, summations and products
- Wavelet & Fast Fourier Transforms
- Automatic engineering unit assignment
- Root of Polynomial finder
- Differential Equation solvers
- Simultaneous equation solving

### Advanced Matrix Functions

- Matrix decomposition & multidimensional matrices
- Linear system solvers

### Symbolic Calculations

- Symbolic integration and differentiation
- Symbolic algebra and calculus

### Visualisation

- Polar, contour and parametric plots
- Animation

### Statistics and Data Analysis

- Includes: Gaussian, Binomial, Weibull, Poisson, Chi-square
- Linear and non-linear regression

### Programming

- Operators include branches, loops, recursion

### Usability and Interoperability

- Drag between documents

### Document Preparation

- WYSIWYG presentation-

- quality output
- Technical spell-checker

### Collaboration

- World Wide Web link built in

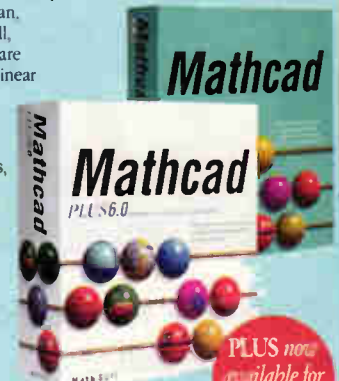

Adept Scientific plc, 6 Business Centre West, Avenue One,  
Letchworth, Hertfordshire, SG6 2HB Tel: (01462) 480055 Fax: (01462) 480213  
Email: mathcad@adeptsience.co.uk WWW: http://www.adeptsience.co.uk/  
New Mathcad SE and PLUS 6 are available for Windows NT, 3.1 and 95. Mathcad PLUS 6 now available for Macintosh.

Please send me:

- Mathcad catalogue: Mathematical Solutions
- Mathcad demo disk
- Adept Scientific Magazine: Technical Computing

Name \_\_\_\_\_

Telephone No. \_\_\_\_\_

Position \_\_\_\_\_

Organisation \_\_\_\_\_

Department \_\_\_\_\_

Address \_\_\_\_\_

Town \_\_\_\_\_

County \_\_\_\_\_

Postcode \_\_\_\_\_

**CIRCLE NO. 110 ON REPLY CARD**

# CHARGE

## alkaline cells



**If you try to charge an alkaline cell using any of the traditional methods – it will explode, causing a potentially serious health hazard. But, as Rod Cooper shows here, there is a recipe to recharge them safely – resulting in substantial cost savings if you rely heavily on alkaline cells.**

It has been known for a long time that the manganese dioxide/zinc couple is rechargeable. Even before World War II zinc-carbon cells were being given recharging treatment by some of the larger commercial users like cinemas but the techniques used were crude.

In 1953, R W Hallows wrote an article for *Wireless World* with an analysis of these simple methods. He followed this up in 1955 with a review of a device from Holland called the Electrophoor which recharged zinc-carbon cells using a principle called periodic current reversal.

Briefly, this system entailed the use of a continuous train of pulses to charge the cell – a method which had been tried before without much success. But in this case each large forward pulse of current which charged the cell was followed by a smaller pulse discharging it.

The combined result was to charge the cell in a series of steps, two steps forward, one step back. It may seem strange to apply what is in effect an ac charge to a decidedly dc device like a cell, but it works.

Periodic current reversal, or pcr, was already in use by the electroplating industry to prevent the formation of metal dendrites and to give smooth, hard, compact metal deposits. When used to recharge zinc-carbon cells, it had a similar effect on zinc. The main difference between plating and charging was that cell chargers tended to use the mains frequency for pulsing. Hallows pointed out that dendrite formation was one of the main reasons for failure in recharging the zinc-carbon cells. When using dc, pulsed or not, zinc dendrites would quickly form across the separator and short-

circuit the cell internally. Periodic current reversal prevented that to a large extent.

Following the Electrophoor, which was a very simple device and easily copied, several other chargers appeared on the market, and to counter their popularity the battery manufacturers started a campaign to convince the public that recharging zinc-carbon cells was unsafe. This was demonstrably untrue. In the mid-seventies there was a well-publicised success by the pro-charging lobby in the Japanese courts to stop this propaganda. This success was not repeated in the United Kingdom or the rest of Europe.

However, these chargers were soon overtaken by events as the popularity of the zinc-carbon cell was already falling – even though a design with an improved format – the zinc chloride type, had appeared. The alkaline-manganese cell, as typified by Duracell, was taking over and these simple chargers could not recharge the new cell. If it was attempted, the cell split and spewed caustic electrolyte everywhere – sometimes explosively.

In the brief period 1981 to 1985, the share of the market taken by alkaline cells increased from 24.5% to 42.6% a process that has continued – though perhaps less dramatically – to this day. The size of the market for alkaline-manganese cell just in the UK was then £230million – so what must the world-wide figures be now?

Rechargeable cells using NiCd have appeared since then but their progress has been dogged by technical shortcomings (see *Wireless World* Jun-Sep '85 'Failure modes in NiCd cells) and they have taken a compara-

### Warning

**You must not attempt to replicate Rod's charger design unless you understand the concepts discussed in this article in their minutest details – i.e. you are an experienced electronics design engineer with a good knowledge of cell and battery structures. Any attempt to modify any of the components and/or conditions prescribed for the charger circuit could well result in a health hazard due to explosion or burning.**



tively small part of the total market compared to the alkaline-manganese primary cell.

**Why bother to recharge primary cells?**

The amount spent on alkaline cells represents an enormous quantity of raw materials and engineering energy, and normally all of it goes away after just a brief period of use. This situation has always been seen as a good example of the profligacy of technological business by the environmental lobby – with justification.

The economical and ecological implications of this waste are all too clear. At present there is no recycling to speak of – as there is with glass, paper and aluminium – despite specific political directives to encourage recovery of the raw materials. Also, these cells are relatively expensive to buy.

In this context, even if a recharging device recycled each cell just once, the saving in raw materials and engineering effort would be enormous. In fact, the P24 design can recharge alkaline cells not just once but several times. The best way to recycle an alkaline cell is obviously not to re-cycle the raw materials but to recharge it.

Because of the continuing claims by battery manufacturers that any sort of recharging of alkaline cells is unsafe, this charger has been given two end-of-charge mechanisms and more than usual effort has been put into testing the safety aspect of the design.

The design below was commissioned for commercial use in 1988 before recharging alkaline manganese cells became generally accepted, so before being submitted commercially it was tested with many hundreds of recharge cycles using cells from many different sources. It has proved itself completely safe but only when used correctly.

**Recharging alkaline-manganese cells**

The 'rules' which shaped this design are listed as follows.

- To be effective, alkaline batteries should be recharged as a single cell, each cell being given its own separate charge regime. Packaged batteries like PP3, PP9 etc. are excluded. Charging these batteries always results in uneven distribution of charge, and leads to reverse charging when discharge takes place. The situation is acute when one cell fails, because this can lead to severe over-charging of the remaining cells in the battery during recharging – which is not safe with alkaline cells – and can result in malfunction of a badly-designed charger. The P24 design charges two cells at a time in

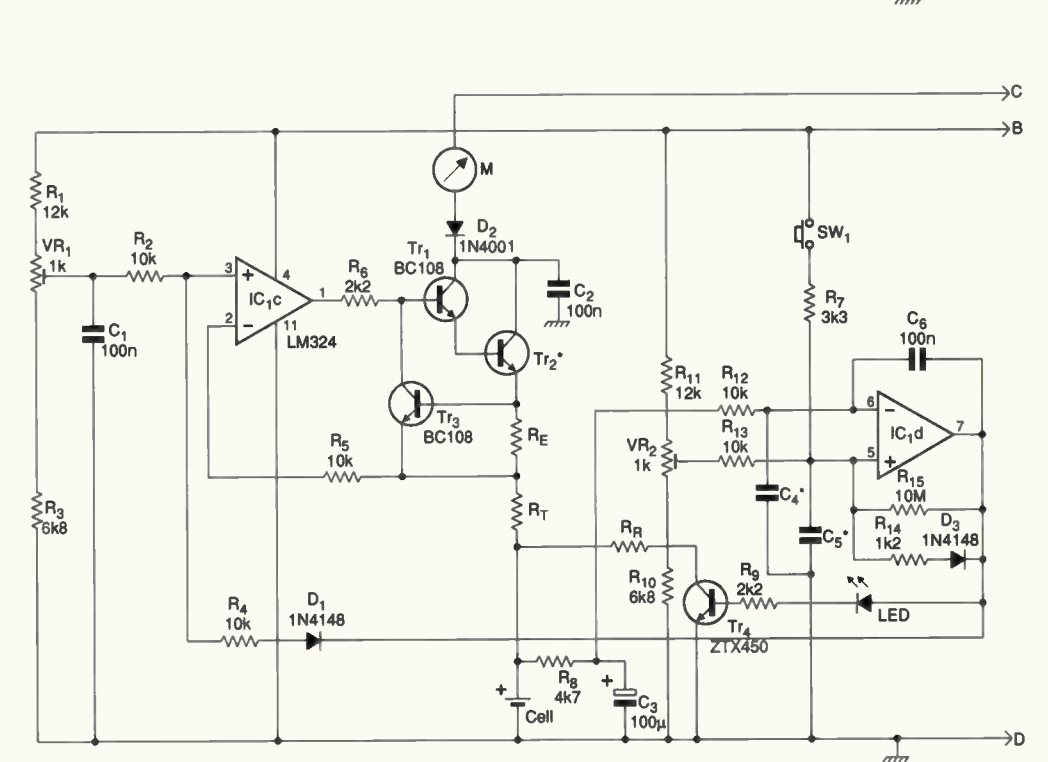
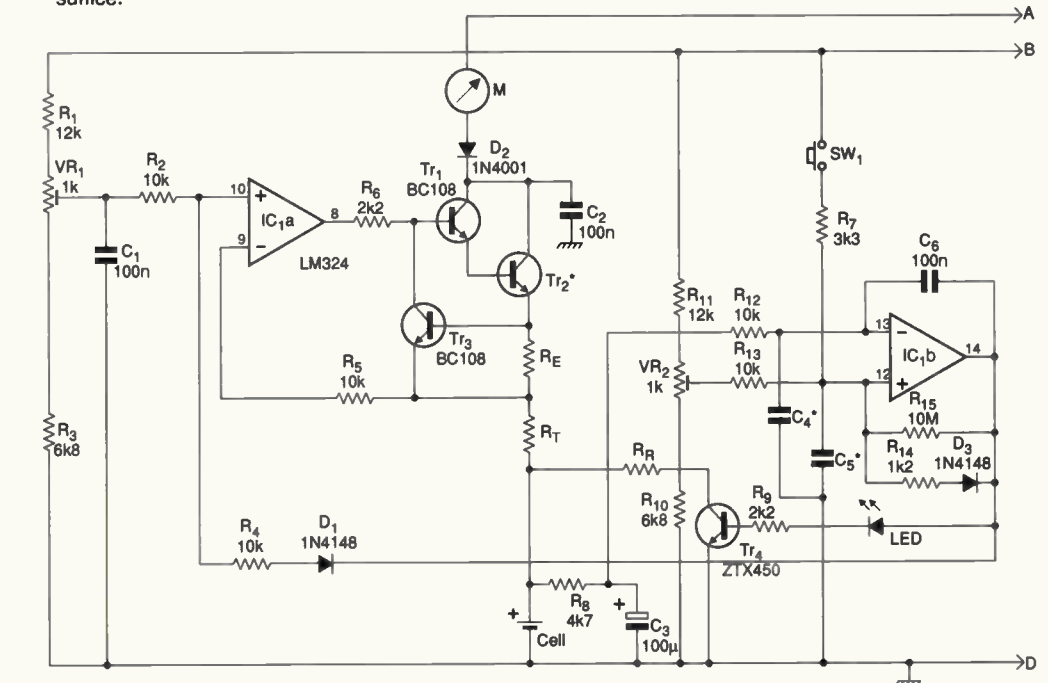
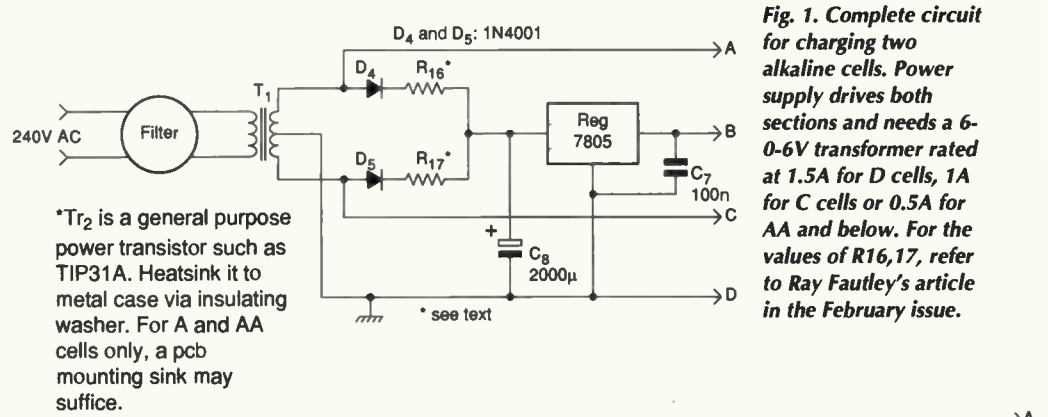

## COMPONENTS

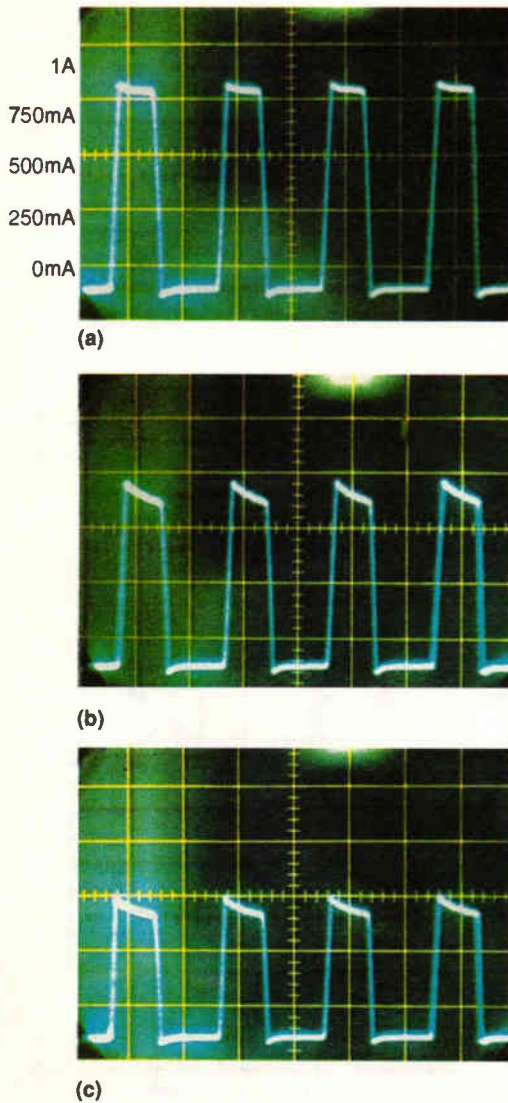

Fig. 2. Oscilloscope views of forward and reverse current in a D cell, a) at start of charge, b) after 1h, c) after 2h, d) after 4h and e) at end of charge, i.e. balance point.

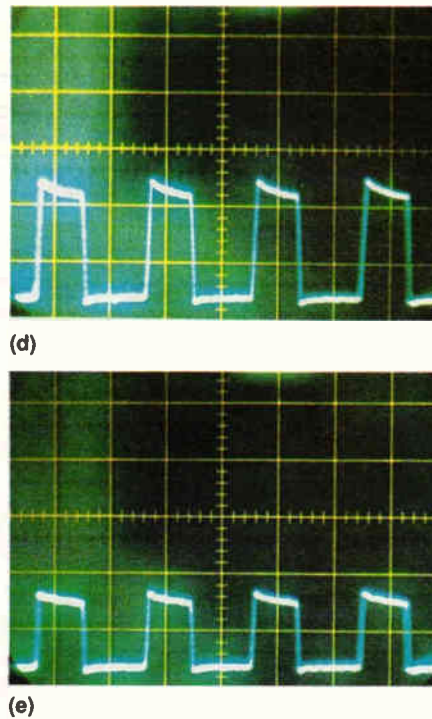

Table 1. Values needed to accommodate the various cell sizes.

	Ah	Rr	Re	Rt
D	15	9.25	0.7	0.3
C	7	20	1.5	0.66
AA	2.25	71	4.9	2.1
AAA	0.8	175	13.5	5.8

separate holders, and treats each cell individually.

● The charging current must be limited to match the charge-acceptance of the cell. One factor affecting the charge-acceptance is the state of charge of the cell. A partly-discharged cell will have a much higher charge-acceptance than a cell approaching the fully charged state – all other things being equal. At full

charge the charge-acceptance of an alkaline cell reduces to nothing, for practical purposes. Because of this characteristic, any charging circuit must adapt to give a charge current appropriate to the state-of-charge. A method called taper charging is commonly used with many batteries, which as the name implies, starts at a controlled large current and dwindles as full charge approaches. This technique is used in modified form in the charger.

Fig. 3. Mkl fixture used for monitoring pressure in the cell during charge incorporated a sensitive electronic pressure transducer. Although more sensitive than the mechanical pressure gauge, this version still showed no significant rise in pressure – as chart Fig. 4 illustrates.

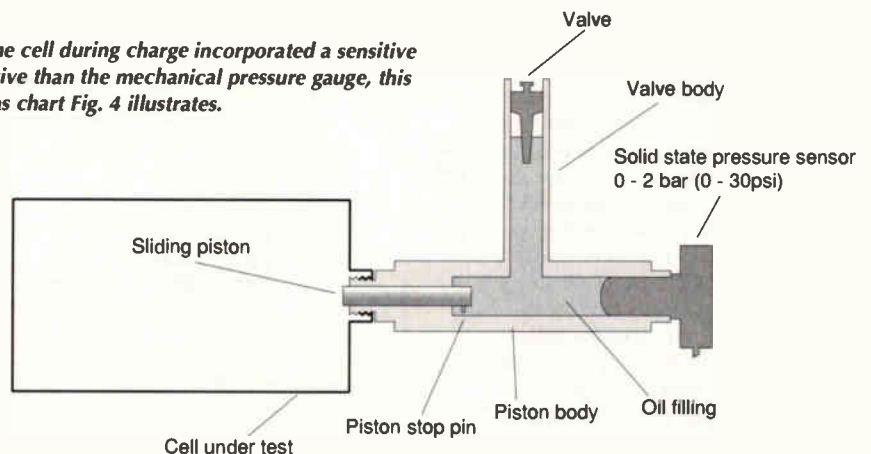

● This design is for use at room temperature. The properties of the alkaline cell vary significantly with temperature. In particular, charge acceptance decreases with falling temperature. Although the commercial version of this design had temperature control, there is no compensation in this version, so a 20°C environment is assumed.

● Current applied to the cell must not exceed a certain maximum charge-acceptance value. For alkaline-manganese cells, this rate is around C/35 to C/40 amps, where C is the capacity of the cell in ampere-hours. There is some variance depending on the origin of the cell. In addition, the charger must be short-circuit proof for safe household use. To deal with both issues, the P24 is made short-circuit proof at the maximum charge acceptance figure. For a D-size cell, the short-circuit current is below 0.5A – safe by any standard.

● Unlike NiCd cells, where overcharge is part of normal operation and is to some extent desirable, no overcharging is permissible with alkaline cells. In the NiCd cell there is a mechanism for recombining the gases produced inside the cell during overcharge, the net result being that the cell merely becomes warm. For the NiCd cell this provides a very convenient overcharge-limiting system. Although a similar mechanism exists for the alkaline-manganese cell, it is not encouraged by the internal structure of the cell, so it cannot be relied on for limiting overcharge. An alkaline-manganese cell could probably be designed with this characteristic but it is unlikely to be produced for obvious reasons. To prevent overcharge, two techniques are used in the P24 charger. First, the charger's taper is made to reduce to nothing well before overcharging can take place. Secondly, a simple voltage cut-out operates at a preset voltage slightly below that produced by the taper. One technique complements the other so that if one method fails the other will back it up. This makes the P24 very safe. In many hundreds of cycles, over eight years, it has never burst a cell.

● The charge method must be the periodic-current-reversal type as discussed above to prevent dendrite formation. In this design, pcr



is used at mains frequency for the sake of simplicity, but in a modified form as explained later.

● Lastly – but most importantly – for this charging method to be effective, the alkaline-manganese cell must not be discharged below a certain level. Below this level, irreversible chemical changes take place which render the cell progressively less rechargeable. The actual level is a subject of debate, but in the regime I use, I stop discharge after the top 30% of the total cell capacity has been used. For a typical D size cell of 15Ah total capacity, this gives a usable 5Ah to play with. This is about the same as a D-size NiCd cell provides, but without the snags of the NiCd.

### Terminating the recharge cycle

The potential at which gases are evolved from the alkaline-manganese cell is 1.7V at room temperature. Since a voltage slightly less than 1.7V still produces a fully-charged cell, the P24 charger is designed to taper the current to

zero at about 1.68V. The cut out operates at 1.62V.

I should mention here in case anyone is tempted to experiment, that this design was not arrived at in a single step. Many circuits were tried in order to provide the 1.68V ceiling – including constant-voltage transformers, electronically stabilised ac supplies, feedback-controlled switch-mode psu and many others. Eventually the circuit of Fig. 1 was arrived at.

### Pulse-balancing

In this technique, instead of charging the cell with a constant ratio of forward to reverse currents, the large forward pulse of the pcr charge is varied and the small reverse charge is kept constant. This gives the taper charge and can be arranged to give a natural balance at the end-of-charge point.

When the cell is in a partly discharged state, i.e. high charge-acceptance, the forward pulse is large but kept within limits by the current limiting circuit. The limit was set at about C/35 amps, but any setting from C/30 to C/40 provides good recharging.

Various criteria were used to fix the maximum limit; the length of charging had to be practical for everyday use; the cell had to show no signs of internal distortion after charging; and the charging components had to be low cost and therefore low power devices.

The maximum ratio of forward charge to reverse charge was set to 4:1 – but in fact any ratio around this figure will work. As charging continues, the size of the forward pulse is gradually lowered to keep within the cell's charge-acceptance limits as explained above, and the ratio of forward charge to reverse charge reduces, until at 1.68V it is 1:1. That is, the energy contained in each forward pulse equals the energy contained in the reverse pulse at this cell voltage. The oscilloscope screens of Fig. 2 show what happens. Note the period of this quasi-square wave is not quite even.

If left to itself, the cell/circuit combination would settle at a 1:1 pcr ratio at 1.68V and stay there indefinitely. The circuit so far could be regarded as a complete charging circuit, requiring no more components. However, leaving the cell in such a state for any length of time is not desirable because each forward and reverse pulse represents a charge/discharge cycle and there is a limit to the number of these the cell can take.

Also, failure of just one component of the circuit might result in overcharging, so for safety's sake and to preserve the life span of the cell, a further circuit has been added to stop charging. This consists of a simple comparator which effectively stops both forward and reverse pulses just before 1.68V. The voltage chosen is 1.62. This an arbitrary voltage which I found gave a good charge to the cell. Other voltages could be chosen, but voltage lower than this tended to give shorter charging times and not such a good charge. Voltages too close to 1.68V gave erratic turn-off – the reasons for which are mentioned later.

### Circuit details

Op-amp  $IC_{1a}$ ,  $Tr_1$  and  $Tr_2$  provide the 1.68V ceiling voltage for the forward charge pulse. The voltage reference is derived from the 5V power line provided by the 7805 regulator by means of resistor chain  $R_1$ ,  $R_3$  and  $VR_1$ .

Exactly how the ceiling voltage is set is described later, but adjustment is carried out with preset pot  $VR_1$ . The forward charging current is provided at mains frequency every half-cycle to this circuit by rectifier diode  $D_2$  from the 6V ac transformer line. On its own, this circuit would generate hf oscillations every half cycle, so this tendency is suppressed by  $C_1$ .

Since each of two cells takes a forward pulse every half-cycle, to balance the transformer these two circuits are used back-to-back with centre-tapped transformer.

To limit the maximum current that the above circuit can supply to around C/35,  $Tr_3$  and  $R_e$  are added. Transistor  $Tr_3$  simply clamps the base of  $Tr_2$  at a pre-set current level determined by  $R_e$ . However, the circuit would try to supply this current at all voltages up to the 1.68V limit, so  $R_1$  added to introduce a gradual tapering-off of current as the cell voltage rises. The internal resistance of the cell cannot be relied on for this.

The reverse-charge part of the pcr cycle is

### Deciding when to recharge

In practice, imposing a 30% limit does not reduce the usefulness of the method as much as you might think. For example, a typical portable radio running on alkaline manganese C cells can run for 24 hours before needing a recharge, and a flash-lamp with two D cells for about 5 hours.

Moreover, in real life, it seems no more trouble to recharge alkaline-manganese cells than it does when using NiCd. Of course, in contrast to NiCd cells, you can use up the whole of the remaining reserve capacity of an alkaline cell at any time if you wish. This is a big advantage.

A problem arises in deciding when the 30% limit has been reached.

With a NiCd cell, it is clear enough when the cell needs a recharge, but the 30% limit is more obscure with alkaline cells. Misunderstanding of the 30% limitation and lack of a method of determining the recharge point has resulted in assessments of this method of recharging, such as the *Which?* magazine survey, giving a negative verdict.

For good results, the current taken by the appliance must be known. Once you know this, you can either judge roughly when the cell needs a recharge from knowing the original Ah capacity, in which case you must put up with the effects of any misjudgement, or you can attach simple integrating timer. This could flash a light-emitting diode or operate a cut-out after C/3 Ah has been reached. A low-current timer design will be shown in a subsequent article.

### Safety issues

Safety has to be seen in context. For example, we use that most flammable of fuels, petrol, to power our most popular method transport, but few refuse to travel by car just because of the fire risk. The car makers do not put a warning about fire-risk on cars.

We use a lethal voltage instead of a safe one around the home to power various devices – and we actually hold some of these devices in our hands to operate them!

The risk in both cases is universally accepted despite the fact that people do occasionally come to grief, because the usefulness is great and the risk small when devices are used correctly.

Compared to the two examples above, any risks posed by the techniques put forward must be regarded as miniscule, when approached properly. From the tests conducted, and the continuous use this charger has had over many years, the risks appeared to be acceptable. Any risk would seem to come from random component failure and misuse.

In a well-ordered technology-based society, the warning on the side of alkaline cells should be amended to, "Do not recharge in an unsuitable charger" It would then be technically correct, which it is not at present.



provided by  $Tr_4$  and  $R_r$ . While the cell is being charged  $Tr_4$  is turned constantly hard on via the led and  $R_g$ . During the forward pcr pulse, the small reverse-charge current is swamped or cancelled out by the much larger forward current. This is a simpler and cheaper concept than one which uses a second pulsing circuit for the reverse pulse and is easy to turn off at the end of charging.

While charging is in progress, the led is on, and can be used to show when the cell is under charge, but there are better methods as discussed later. Different values of  $R_e$ ,  $R_r$  and  $R_f$  are used for cell sizes D, C, and AA. Table 1 shows values for these sizes.

Op-amp  $IC_{1b}$  and its associated components form a conventional comparator to detect the end of charging. It can be pre-set by  $VR_2$  to trip at around 1.62V. Voltage on the cell cannot be monitored directly by the comparator because of the small ripple voltage across the cell when being pulsed. The cell voltage is therefore filtered by  $R_8$  and  $C_3$  before being applied to  $IC_{1b}$ .

The comparator is biased towards the 'off' position, i.e. output low, so that once turned off by a voltage over the limit, it cannot be turned back on again except by manually-operated switch. This arrangement is needed because once a fully charged cell has tripped the comparator, the cell voltage soon drops and could turn the comparator back on to give more, unnecessary charging.

Once the comparator is tripped,  $Tr_4$  is turned off via  $R_9$  and the reference voltage presented to  $IC_{1a}$  is lowered via  $R_4$  and  $D_1$ . This effectively stops charging. In this state only small semiconductor leakage currents around the cell charging circuit are present, which can be

disregarded for practical purposes. However it would not be advisable to leave the cell in the charger for long periods, several weeks for example, because of these leakage currents.

The charge sequence can be started again by pressing momentary push-switch  $S_1$  which simply overcomes the bias of the comparator.

The IC chosen for this circuit is the LM324 quad op-amp – a cheap temperature compensated device which can do both functions of reference and comparator reasonably well. It makes a two-cell charger very economical.

**Setting up the circuit**

First, comparator  $IC_{1b}$  is disabled by being turned on, i.e. output high, by  $VR_2$ . A high-value low-leakage electrolytic capacitor is then substituted for the cell. I used 50,000µF computer-grade type which seemed to work very well.

At power on, preset pot  $VR_1$  is now adjusted to give 1.68V on  $C_2$  using a high-impedance dvm. The capacitor acts in approximately the same way as a cell, that is, as a store of electrical energy, so you can say that at 1.68V the energy in from the forward pulse equals energy out from the reverse pulse.

This method ignores the small amount of ripple on the large capacitor about 10mV peak. After this preliminary setting it is best to check the balance point with a real cell to ensure the voltage never rises above 1.68V, before you set the comparator. You could do the setting-up with a cell, but it would then take a much longer time, perhaps several hours, to reach the balance point, whereas you can get to it very quickly using a capacitor.

Having done this, the comparator can be set to trip at around 1.62V by observing the out-

put led while adjusting the voltage on the large capacitor to this value with a variable resistor, While you have the dvm at hand, the comparator voltage swing should be checked to ensure correct operation. This comparator will trip within 10mV of the set voltage.

The charger is then ready to use.

**Charge indication methods**

Although the led in series with  $R_8$  can show when charging is in progress, it cannot show what point has been reached. Small inexpensive moving-iron meters are on the market which could be used at point M in the circuit.

A meter is the best indicator with small cells. Alternatively, for D and C cells, a filament lamp-bulb can be successfully used. This is set for full brightness with a discharged cell – i.e. at the short-circuit current – and just glowing at the balance point. A parallel resistor may be needed with some bulbs. For this purpose, I have used a T1 1.5V 200mA, which is difficult to obtain, and a MES lens-end 1.2V type which is more readily available at 200mA and 300mA. Performance can be improved with an ntc thermistor in parallel instead of a resistor.

**Using the charger**

The charger has been proved from 15°C to 25°C so use outside this range is not recommended. As stated, there is no temperature compensation.

Also, the construction has to be such that the cells and circuit are kept within temperature limits by free ventilation. This means an open construction with plenty of slots for air circulation.

The comparator circuit is prone to trigger prematurely when approaching full charge if current spikes are allowed in from the mains, so a mains filter is essential. For the same reason, the whole circuit should be in a metal box to reduce incoming emi, although the absolute need for free ventilation will nullify most of this benefit. The metal box can be a safety feature if there is any remaining doubt about bursting cells. Also, any thermal effects from  $Tr_2$  can be reduced by using the metal box as the heat-sink.

A spike from a comparator rapidly turning off can trigger a neighbouring comparator to turn off before its time, if that was also in the sensitive region near the end of charging. To prevent an abrupt turn-off, capacitor  $C_6$  has been added.

If you live in an area of high interference, it may be necessary to current-slug the comparator with capacitors  $C_4$  and  $C_5$ , and the reference with  $C_1$ . The value chosen depends on how severe the interference is. Start with 1µF for  $C_4$  and  $C_5$  if you experience premature turn-off. These capacitors *must* have negligible leakage current.

Drift with age may be a problem if not detected. As a result, it would be reasonable to check the two important voltages with a meter now and then. I suggest a check after the first couple of cycles and then every six or twelve months.

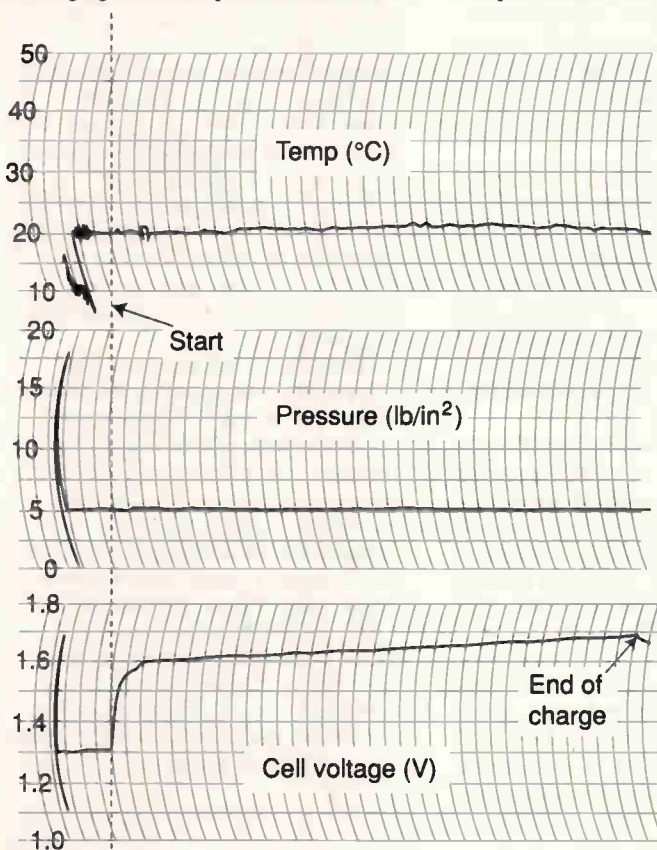

Fig. 4. Traced chart recordings of characteristics of an alkaline cell under charge using the circuit of Fig. 1. These show that temperature and pressure rise are negligible.



### Safety

Because of the likelihood of counter-claims about safety from battery manufacturers trying to protect their market, more than usual effort was put into checking the safety of this design.

There are two main areas that could pose a risk. Firstly, there is the possibility of internal pressure arising from an accumulation of gases caused by electrolysis. This is the most likely cause of leakage if recharging continues when the cell is fully charged. But it could occur at any point on the recharge cycle if the cell was given a current larger than the cell's charge-acceptance. This could be caused for example by using the charger at low temperatures.

Secondly, a risk could be posed if the temperature during recharge rose to excessive levels. Leakage could come from the expansion of any gases already inside the cell – from reverse-charging for example – or from steam being formed if the cell got hot enough for this. These two potential risks are examined in turn.

Regarding the first point, internal pressure, three methods were used to check internal cell pressure during recharging. I noticed that whenever a cell leaked due to internal pressure from deliberate abuse, it bulged slightly at the ends, and it was possible to measure this small

expansion with vernier callipers. In fact, a bulge could be easily detected before any leakage occurred. Both bulge and leak conditions could be readily achieved by deliberately trickle-charging the cell.

This formed the basis for the first method. I measured cells with callipers – with insulated jaws of course – before, during and shortly after being recharged in the P24 but there was never any size increase over many cycles. It was clear that there was no detectable pressure developed by normal recharging.

The second method I used to check pressure was to attach a bourdon type pressure gauge to the cell with an adapter. I did this to be able measure directly the pressure, if any, that was being developed inside the cell. The cell was firstly pressurised via a schraeder valve and left for a few hours to confirm the cell was gas-tight and then given several discharge/recharge cycles.

The gauge never showed any significant pressure increase or decrease. As the volume of the released gases is small, I tried to make this rather clumsy technique more effective by filling the 'dead space' in the gauge with silicon oil, plugged with light silicon grease to stop it escaping and contaminating the cell. But it still never showed any pressure increase.

The gauge was refined in a third, more sensitive test by attaching an electronic pressure sensor to a chart recorder so that the whole cycle could be recorded. The arrangement is shown in Fig. 3. This third method again showed no detectable pressure increase.

Regarding temperature rise, it was noted by Hallows that temperature rise with per is very small, in contrast to other methods of recharging. My tests confirmed this. A temperature sensor was attached to the metal jacket of the cell during cycling and connected to a chart recorder. As Fig. 4 shows there was no significant rise in temperature.

The overall conclusion from these tests was that the P24 simply does not create internal pressure in cells. Cells in many conditions from brand-new to totally dead were used in the tests to cover the range of possibilities in real life.

A post-mortem was conducted on cells that had been cycled to exhaustion to check if there had been any physical changes inside the cell. The cells were sliced up on a miniature milling machine with a 0.5mm slitting saw, which did not disturb the contents too much. In no case was there any tell-tale sign of electrolyte leakage.

No distortion attributable to internal pressure was observed. ■

# SEETRAX CAE RANGER PCB DESIGN

## WITH COOPER & CHYAN AUTOROUTER

RANGER3 - DOS	£2500
- Windows\NT	£2900

RANGER2	£150
---------	------

Hierarchical or flat schematic linked to artwork.

Unlimited design size, 1 micron resolution

Any shaped pad, definable outline library

Pin, gate & outline swapping - auto back annotation

Split power planes, switchable on - line DRC

**COOPER & CHYAN SPECCTRA**

autorouter (SP2)

Inputs: OrCAD, Cadstar,

PCAD, AutoCAD DXF

Outputs: Postscript, Windows bit map

R2 & R3 Outputs: 8/9 & 24 pin printers, HP

Desk & Laser Jet, Cannon Bubble Jet,

HP-GL, Gerber,

NC Drill, AutoCAD DXF

Upto 8 pages of schematic linked to artwork  
Gate & pin swapping - automatic back annotation  
Copper flood fill, Power planes, Track necking,  
Curved tracks, Clearance checking,  
Simultaneous multi-layer auto-router

RANGER2 UTILITIES	£250
-------------------	------

**COOPER & CHYAN SPECCTRA** auto-router (SPI)  
Gerber-in viewer, AutoCAD DXF in & out

UPGRADE YOUR PCB PACKAGE TO RANGER2	£60
--	-----

### TRADE IN YOUR EXISTING PACKAGE TODAY

Seetrax CAE, Hinton Daubnay House, Broadway Lane, Lovedean, Hants, PO8 OSG

Call 01705 591037 or Fax 01705 599036 + VAT & P.P

All Trademarks Acknowledged

CIRCLE NO. 111 ON REPLY CARD



# Luxuriant editing! SpiceAge interfaces smoothly to almost any PCB design suite.

Although we would like you to use our own excellent Geswin schematic capture program which is purpose built for SpiceAge, if you already have a schematic program, there is a good chance that SpiceAge will work with it better than any other circuit simulator.

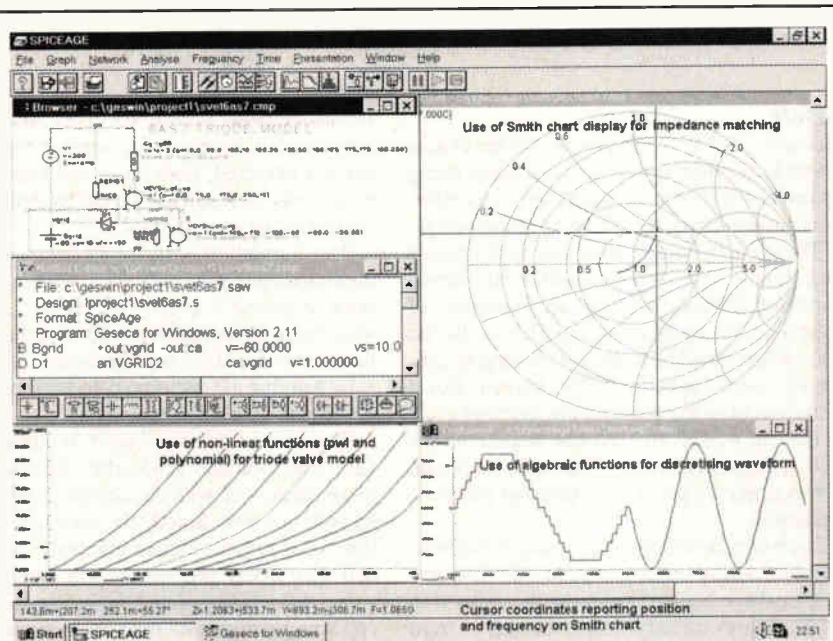

When you iterate between a schematic and a SPICE-like simulation environment while refining your circuits, the simulation settings and precious details such as polynomial functions on components can be lost. So without Geswin, it was sometimes easier to write the simulation netlist directly. However, SpiceAge's **circuit update** button only affects changes in the circuit built by the schematic and, because it retains all the previous information, you can spontaneously iterate between schematic and circuit.

To hear more about this and other nice touches in SpiceAge, please contact:  
Those Engineers Ltd, 31 Birkbeck Road, LONDON NW7 4BP.  
Tel 0181 906 0155 FAX 0181 906 0969 Email 100550.2455@compuserve.com

CIRCLE NO. 112 ON REPLY CARD

**8 CAVANS WAY,  
BINLAV INDUSTRIAL ESTATE,  
COVENTRY CV3 2SF**  
Tel: 01203 650705  
Fax: 01203 650773  
Mobile: 0860 400683

(Premises situated close to Eastern-by-pass in Coventry with easy access to M1, M6, M40, M45 and M69)

### MISCELLANEOUS

Adret 740A - 100KHz-1120MHz Synth. signal generator	£2000
Anritsu ME462B - DS-3 transmission analyser	£3000
Anritsu MG642A - Pulse pattern generator	£1500
Barr & Stroud - EFS variable filter (0.1Hz-100KHz)	£150
Dynaport TP20 - Intalliance tape peel tester, immac. cond.	£1750
E.I.P.331 - 18GHz frequency counter	£350
Fluke 5100A - Calibrator	£3500
Fluke 5100B - Calibrator	£4500
Fluke 5101B - Calibrator	£5000
Fluke 5205A - Precision power amplifier	EP, D.A.
Fluke 7105A - Calibration system (As new)	EP, D.A.
Guillidine 9152 - T12 Battery standard cell	£50
Helden 1107 - 30v-10A Programmable power supply (IEEE)	£850
Hewlett Packard 331A - Distortion analyser	£300
Hewlett Packard 339A - distortion measuring set	£1500
Hewlett Packard 432A - Power Meter (with 475A Sensor)	£275
Hewlett Packard 435A or B - Power Meter (with 8481A/8484A)	from £750
Hewlett Packard 16300 - Logic Analyser (43 channels)	£850
Hewlett Packard 16500A - Fitted with 16510A/16515A/16530A/16531A Logic analyser	£4000
Hewlett Packard 3325A - 21MHz synthesiser/function gen.	£1500
Hewlett Packard 3338A - Synthesised signal generator (10Hz-21MHz)	£1000
Hewlett Packard 3437A - System voltmeter	£200
Hewlett Packard 3438A - Digital multimeter	£250
Hewlett Packard 3455A - 6 1/2 digit multimeter (autozero)	£750
Hewlett Packard 3456A - Digital voltmeter	£750
Hewlett Packard 3478A - Multimeter (5 1/2 digit) HPB	£550
Hewlett Packard 3480A - HP-IB switch/control unit (various plug-ins available)	£850
Hewlett Packard 3711A/3712A/3791B/3793B - Microwave link analyser Sensor £2405	
Hewlett Packard 3776A - PCM Terminal test set	£2000
Hewlett Packard 3779 A/C - Primary mux analyser	£900/£500
Hewlett Packard 4271A - LCR meter (digital)	£300
Hewlett Packard 4275A - Multi-frequency LCR meter	£3850
Hewlett Packard 4279A - 1MHz, C-V meter	£800
Hewlett Packard 4338A - Milliohmmeter (as new)	£2000
Hewlett Packard 4342A - Q meter	£300
Hewlett Packard 4948A - transmission impairment measuring set	£2000
Hewlett Packard 4953A - Protocol analyser	£1800
Hewlett Packard 4954A - Protocol analyser	£2250
Hewlett Packard 4972A - Lan protocol analyser	£2000
Hewlett Packard 5314A - (new) 100MHz universal counter	£2250
Hewlett Packard 5328A - 100MHz universal frequency counter	£250
Hewlett Packard 5342A - Microwave frequency counter (19GHz)	£1600
Hewlett Packard 5385A - Frequency counter 1GHz (HPIB) with Opts 001/003/004/005	£300
Hewlett Packard 6034A - System P.S.U. 0-80v/10a	£1500
Hewlett Packard 6181C - D.C. current source	£150

Hewlett Packard 6281B - Power supply 20V-50A DISCOUNT FOR QUANTITIES £450

Hewlett Packard 8011A - Pulse gen. 0.1Hz-20MHz	£500
Hewlett Packard 8152A - Optical average power meter	£1250
Hewlett Packard 8158B - Optical attenuator with opt's 002 + 001	£1100
Hewlett Packard 8185A - 50MHz programmable signal source	£1000

## TELNET

Hewlett Packard 8349B - Microwave broadband Amp (as new) 2-20MHz	£2250
Hewlett Packard 8350B - Sweep oscillator mainframe (plug-in avail)	£2500
Hewlett Packard 8403A - modulator	£500
Hewlett Packard 8405A - Vector voltmeter	£500
Hewlett Packard 8620C - Sweep oscillator mainframe	£400
Hewlett Packard 8683A - Microwave signal gen. (2.3-6.5GHz)	£2500
Hewlett Packard 8684A - 5.4GHz to 12.5GHz Sig Gen	£2500
Hewlett Packard 8750A - Storage normaliser	£375
Hewlett Packard 8901A - Modulation Analyser	£2500
Hewlett Packard 8903A - Audio analyser (20Hz-100KHz)	£1800
Hewlett Packard 8950A - Cellular radio interface	£3500
Hewlett Packard 11729B - Carrier noise test set	£2000
Marconi 893B - A/F power meter	£250
Marconi 2618 - 80KHz-520MHz synth signal generator	£1500
Marconi 2619 - 80KHz-1040MHz synth signal generator	£1750
Marconi 2619A - 80KHz-1040MHz synthesised sig. gen	£1950
Marconi 2622A - 10KHz-1GHz - AM/FM signal generator	£2000
Marconi 2610 - True RMS voltmeter	£300
Marconi 2850BS - Digital Transmission analyser (as new)	£2250
Marconi 2871 - data communications analyser	£250
Marconi 2855 + 2855 - Radio Comms test set + tace adaptor	£3500
Marconi 8500 - automatic amplitude analyser	£1500
Philips PM 5187 - 10MHz function gen	£400
Philips PM 5190 - LF synthesiser with GPIB	£300
Philips PM 5193 - 50MHz synthesised function generator	£1500
Philips PM 6673 - 120MHz high resolution universal counter	£350
Philips PM 6670 - 120MHz high resolution timer/counter	£350
Philips PM 6652 - 1.5 GHz programmable high resolution timer/counter	£300
Racal Dana 1982 - 1300MHz frequency counter opt 48-55	£800
Racal Dana 3100 40 - 130MHz synthesiser	£750
Racal Dana 9084 - Synth. sig. gen. 104MHz	£450
Racal Dana 9301A - True RMS RF millivoltmeter	£300
Racal Dana 9303 - True RMS RF level meter	£350
Racal Dana 9321 - 3GHz frequency counter	£450
Schaffner NSG 203A - Line voltage variation simulator	£395
Schaffner NSG 222A - Interference simulator	£395
Schaffner NSG 223 - Interference generator	£750
Schlumberger 2720 - 1250MHz Freq. Counter	£300
7777 & Schwarz 4918 - 1GHz radio comms test set	£2000
Schlumberger 4031 - 1GHz radio comms test set	£2550
Schlumberger 4031 - Radio Comms Test Set	£8000
Schlumberger 4623 - Radio Code Test Set	£300
Syston Donner 1900B - Microwave Sweeper (12-18GHz)	£2500
7777 & Schwarz 596PZ - 1GHz radio comms test set + options	£2500
7777 & Schwarz LRS - RMS Voltmeter DC 10Hz to 25MHz	£500
Tektronix 577 - Curve Tracer	£1150
Tektronix Plug-ins - Many available such as PG508, FG504, SC504, SW503, SG502 etc	
Tektronix TM5003 - AFG6101 - Arbitrary Function Gen.	£1750
Tektronix 1240 - Logic Analyser	£750
Tektronix AM500 + TM501 + PG502 - current probe amplifier	£900
Tektronix AA5001 - TM5008 - Mainframe programmable distortion analyser	£1800
Tektronix PG508 + TG501 + SG503 TM503 - Oscilloscope calibrator	£1800
Time 9814 - Voltage calibrator	£750
Wavetek 1728 - Programmable sig. source (0.0001Hz-13MHz)	£450
Wayne Kerr 8850 - Precision LCR meter	£350
Wayne Kerr 3246 - Precision inductance analyser	£2250
Wayne Kerr 8425 - Precision component analyser	£2750
Wayne Kerr 4216 - LCR meter	£300
Wiltron 8820S - Programmable sweep gen. (3.6-6.5GHz)	£350

### OSCILLOSCOPES

Cosor 3102 - 60MHz dual channel	£250
Gould OS265 - 15MHz dual channel	£150
Gould OS3000 - 40MHz dual channel	£250
Gould OS3351 - 40MHz dual channel	£225

Gould 084000 - 10MHz Digital storage	£200
Gould 5110 - 100MHz intelligent oscilloscope	£750
Hewlett Packard 180D - 100MHz 4 channel	£300
Hewlett Packard 182C - 100MHz 4 channel	£350
Hewlett Packard 1746A, 1741A, 1744, - 100MHz dual ch	from £250
Hewlett Packard 54100D - 1GHz digitizing	£2995
Hewlett Packard 54200A - 50MHz 2 channel digitizing	£1000
Hewlett Packard 54201A - 300MHz digitizing	£1750
Hewlett Packard 54501A - 100MHz digitizing 4 channel	£1950
Hitachi V212 - 20MHz dual channel	£180
Hitachi V222 - 20MHz dual channel	£200
Hitachi V850F - 60MHz dual channel	£250
Hitachi V8205 - 100MHz digital storage (as new)	£2000
Intron 2620 - 120MHz digital storage (as new)	£750
Meguro M50 1270A - 120MHz digital storage (as new)	£750
Nicolet COS 6100 - 100MHz 5 channel 12 trace	£475
Nicolet 3091 - Low freq D.S.O.	£1100
Philips 3217 - 50MHz dual channel	from £250
Philips 3219 - 50MHz with analogue storage, Dual CH	£400
Philips 3293 - 100MHz dual channel with microprocessor cont. timing	£400
Philips 3295 - 350MHz dual ch	£1500
Philips PWS3295A - 400MHz dual channel	£1750
Tektronix 2445 - 150MHz - 4 channel	£1250
Tektronix 2445A - 150MHz - 4 channel	£1600
Tektronix 465 - 50MHz dual channel	£350
Tektronix 2221 - 60MHz digital storage	£1500
Tektronix 7854 - 400MHz Waveform processing oscilloscope	£1500
Tektronix 464/465 - 100MHz storage	from £350
Tektronix 465/465B - 100MHz dual ch	from £350
Tektronix 468 - 100MHz D.S.O.	£475
Tektronix 475/475A - 200/250 MHz dual channel	from £750
Tektronix 434 - 25MHz 2 channel + analogue storage	£250
Tektronix 2211 - 60MHz digital storage	£450
Tektronix 2213 - 60MHz dual ch	£425
Tektronix 2215 - 60MHz dual ch	£450
Tektronix 2225 - 50MHz dual trace	£450
Tektronix 2235 - 100MHz Dual channel	£300
Tektronix 2238 - 100MHz Dual Trace with Counter/Timer/Dmm	£395
Tektronix 2235 - 510MHz dual ch. (portable)	£750
Tektronix 7313, 7603, 7813, 7823, 7833, - 100MHz 4 ch.	from £300
Tektronix 7704 - 250MHz 4 ch	from £650
Tektronix 7904 - 500MHz	from £850
Tektronix 7934 - 500MHz with storage	from £1000
Teledquipment D83 - 50MHz dual channel	£200
Teledquipment DM63 - 20MHz 4 channel	£150

Other scopes available too

### SPECTRUM ANALYSERS

Alltech 757 - 10KHz-22GHz	£2750
Hewlett Packard 1411 + 8562B + 8565A - (10MHz-18GHz)	£1800
Hewlett Packard 182T with 8568B - (10MHz-21GHz)	£2750
Hewlett Packard 853A with 8568B - (0.01-21GHz)	£2550
Hewlett Packard 3562A - dynamic signal analyser, dual channel	£7500
Hewlett Packard 3562A - 5Hz-50KHz	£985
Hewlett Packard 3562A - 25KHz analyser, dual channel	£2500
Hewlett Packard 3799B - Constellation Analyser with 15709A High Impedance Interface (as new)	£9750
Hewlett Packard 8565A - Network analyser (500KHz-1.9GHz)	£4000
Hewlett Packard 8591E - 1.5GHz spec analyser	£8500
Marconi 2370 - 110MHz spec analyser	£750

MANY MORE ITEMS AVAILABLE - SEND LARGE S.A.E. FOR LIST OF EQUIPMENT ALL EQUIPMENT IS USED - WITH 30 DAYS GUARANTEE. PLEASE CHECK FOR AVAILABILITY BEFORE ORDERING - CARRIAGE & VAT TO BE ADDED TO ALL GOODS

CIRCLE NO. 113 ON REPLY CARD



# TRUE orientation

**In vector-based orientation schemes, compensating for sensor offset and drift is a major problem. Digital processing not only simplifies compensation, but also allows new techniques such as continuous error removal. David Risk and Richard Noble explain.**

**A**lthough developed specifically for use with magnetic field sensors, this algorithm is of more general application to any system in which fixed magnitude vector quantities are measured by less-than-perfect sensors. It applies equally well, for example, to the accelerations involved in measuring the gravity vector.

Both types of measurement are of interest in such areas as magnetic compasses, virtual reality devices, sea-bed wreck-finding systems and geophysical surveying.

The algorithm assumes that the sensors used for measurement are substantially linear but may have large, variable and differing zero-offsets coupled with significantly differing and variable sensitivities. This accords reasonably well with reality in that sensor manufacturers usually achieve reasonable linearity, or at least consistent, simply correctable non-linearity, but often suffer from a spread of large zero-offsets which may vary quite alarmingly with temperature, coupled with a spread of sensitivities equally affected by temperature or power supply changes.

In the past, analogue solutions to this type of problem have frequently resulted in a proliferation of trimpots and temperature compensation schemes of varying success.

The currently popular approach of digital processing throughout presents the opportunity to not just simulate these analogue palliatives, but to adopt new, more successful techniques permitting continuous error removal, even if the source of error is not clearly understood.

The approach described here applies specifically to fixed or slowly varying vector measurements, in two or three dimensions, in particular only to vectors which do change their orientation.

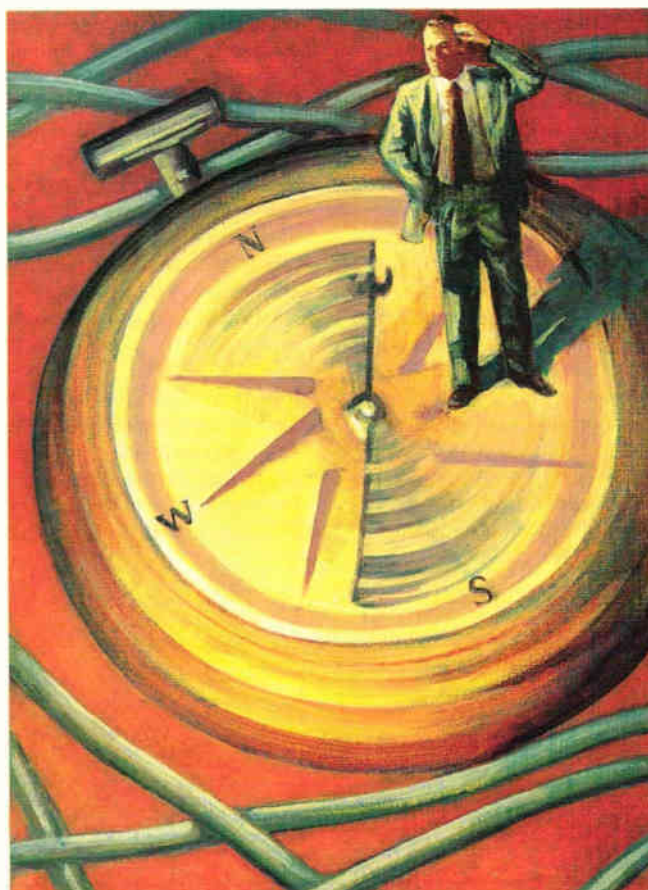

## The sum of the squares...

The underlying principle used here exploits the fact that the components of a vector, as projected on to the x, y and z axes of an orthogonal coordinate system, are related to that vector by Pythagoras' equation. The square of the total vector magnitude is equal to the sum of the squares of the component values.

Where the vector is of nominally fixed magnitude, the Pythagoras relationship permits the derivation of a unique solution to the sensor imperfections.

Any difference between the sensitivities of the sensors measuring the vector will distort the circle or sphere into an

ellipse or ellipsoid, still centred about the origin. The existence of zero-offsets will displace the centre of the ellipse or ellipsoid away from the origin.

Four known points on an ellipse will uniquely define it. Six known points will do the same for an ellipsoid in three dimensions. Hence a succession of real readings from imperfect sensors should permit the calculation of the unknown sensitivities and zero-offsets of each of those sensors.

Details of the algorithm are, for the sake of interest, described in terms of a practical application in which the orientation of the Earth's field is determined using magnetic sensors. The sensor referred here to is the *FGM-3* magnetic sensor developed by Speake & Co, but the principle applies equally well to other types of flux-gate device and to Hall effect or magneto-resistive devices, with appropriate modifications.

The *FGM*-type sensor's output is a large rectangular pulse whose period is proportional to the external magnetic field along its principal axis, within its linear range of operation. Unfortunately, since the output cannot have a negative period, this cannot be a direct proportionality. There has to be a zero field period in the form of a zero-offset large enough to accommodate negative values of magnetic field.

There are then two unknown parameters associated with each sensor, the first being the slope of the relationship between period and magnetic field, and the second, the zero-offset or period which corresponds to zero magnetic field. Both these parameters must be taken into account, when using sensor combinations to determine orientation information using the Earth's field.

Though an attempt is made to reduce the variation in these parameters, no two sensors are alike and some calibration is called for.

For small quantities, this calibration is fairly easy to carry out, but in the large scale production of application devices it would be much more desirable to remove the calibration requirement.

**Continuous autocalibration**

There are some circumstances in which continuous autocalibration is possible. One is the two-dimensional bolt-down type compass magnetometer, in which the sensors are constrained to rotate in a horizontal plane or at least in a fixed plane, which need not necessarily be horizontal. The other is the full three-dimensional sensor combination, used to determine the alignment of the Earth's field with respect to an orthogonal set of sensor axes.

The only other requirement for this type of autocalibration is that the sensor combination should be in continuous or intermittent motion of some sort. If this is the case, it is normally possible to continuously determine and update the values of the two (or three) sensitivities and the two (or three) zero-offsets, using only the readings taken in the normal operation of the orientation-determining device.

The fundamental principles behind the method is the fact that the earth's field can be regarded as substantially fixed in both magnitude and orientation and that the sum of the squares of the orthogonal field components will remain constant regardless of the orientation of the reference axes. In the three dimensional case, for example, if the field components are  $h_x$ ,  $h_y$  and  $h_z$  then:

$$h_x^2 + h_y^2 + h_z^2 = |h|^2$$

If there are any zero-offsets or unmatched sensitivity variations between sensors then this relationship will not hold true and can be made to indicate the required corrections.

For simplicity, a two-dimensional algorithm will be developed first from which the expansion

to three dimensions is obvious.

**Two dimensional autocalibration**

For an Earth field vector,  $h$ , having orthogonal components  $h_x$  and  $h_y$ , in the plane of the sensor axes, assume the sensors give output periods of  $t_x$  and  $t_y$ .

If the sensors have differing sensitivities (slopes of period against field)  $s_x$  and  $s_y$  and differing zero-offset periods  $t_{x0}$  and  $t_{y0}$ , then:

$$t_x = s_x h_x / h + t_{x0} \tag{1}$$

$$t_y = s_y h_y / h + t_{y0} \tag{2}$$

where the  $x$  and  $y$  components of the field are assumed to be divided through by  $h$ , the modulus of the field. This effectively converts the field components into their direction cosines, which are independent of the field magnitude.

Applying the condition that  $h_x^2 + h_y^2 = h^2$ , or more appropriately,

$$(h_x/h)^2 + (h_y/h)^2 = 1$$

gives,

$$(t_x - t_{x0})^2 / s_x^2 + (t_y - t_{y0})^2 / s_y^2 = 1 \tag{3}$$

This is the equation, in  $t_x$  and  $t_y$ , of an ellipse with its centre located at  $(t_{x0}, t_{y0})$  and having principal axes  $s_x$  and  $s_y$ , Fig. 1.

All measured pairs of sensor readings,  $t_x$  and  $t_y$ , must lie on this ellipse, and hence any four different points are sufficient to define the ellipse completely.

It must therefore be possible to deduce the centre,  $(t_{x0}, t_{y0})$  and the principal axes,  $s_x$  and  $s_y$  from any four different pairs of sensor readings. Although in theory any four points will do, the precision of calculation with measurements of finite accuracy will be adversely affected if the points are very close together. This should not be a problem with orientation systems which are in constant motion, and the algorithm should be designed to wait until it has collected sufficiently different inputs before proceeding to calculate.

If the four points are denoted by  $(t_{xi}, t_{yi})$ ,  $i=1, 2, 3, 4$  then four equations of type (3) above are available, having the typical form,

$$(t_{xi} - t_{x0})^2 / s_x^2 + (t_{yi} - t_{y0})^2 / s_y^2 = 1$$

Subtracting these from one another successively will yield three equations of the typical form,

$$((t_{xi}^2 - t_{xi+1}^2) - 2t_{x0}(t_{xi} - t_{xi+1})) / s_x^2 + ((t_{yi}^2 - t_{yi+1}^2) - 2t_{y0}(t_{yi} - t_{yi+1})) / s_y^2 = 0$$

Multiplying each through by  $s_x^2$  and setting  $k = s_x^2 / s_y^2$  will yield three equations of the form,

$$a_i t_{x0} + b_i (k t_{y0}) + c_i k = d_i$$

$$i = 1, 2, 3$$

where  $a_i$  is  $2(t_{xi} - t_{xi+1})$ ,  $b_i$  is  $2(t_{yi} - t_{yi+1})$ ,  $c_i$  is  $-(t_{yi}^2 - t_{yi+1}^2)$  and  $d_i$  is  $(t_{xi}^2 - t_{xi+1}^2)$

These three equations are linear in  $t_{x0}$ ,  $(k t_{y0})$  and  $k$  and are therefore soluble for these values, using the determinant method or the Gaussian elimination method of solving linear simultaneous equations.

This will immediately provide the values of  $t_{x0}$  and  $t_{y0}$ .

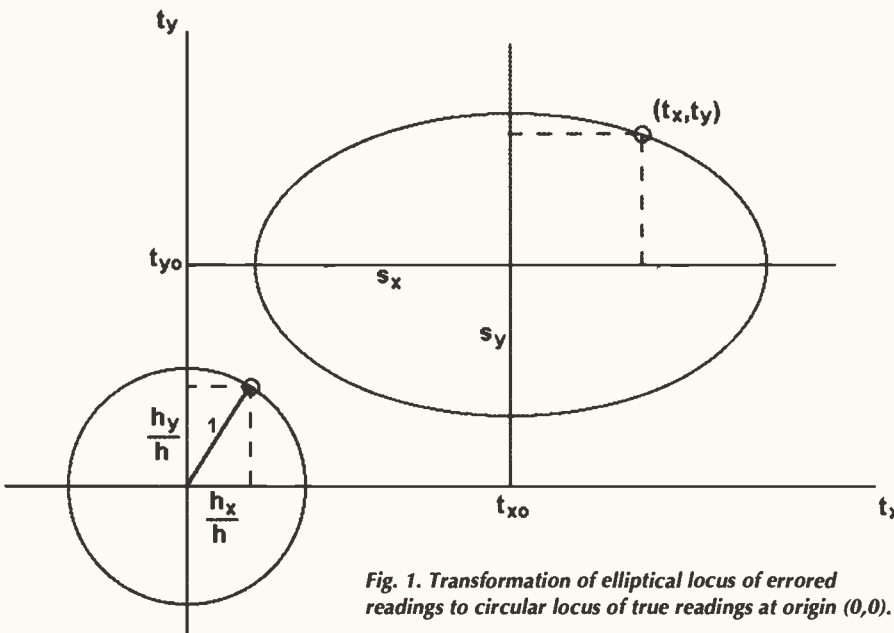

Fig. 1. Transformation of elliptical locus of errored readings to circular locus of true readings at origin (0,0).



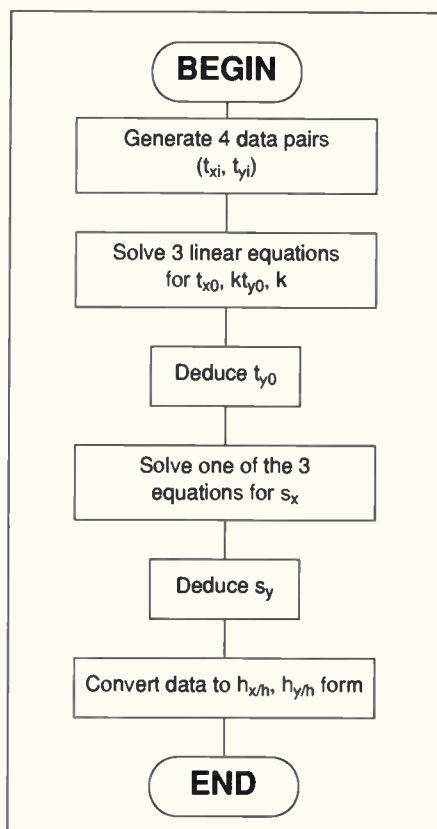

Fig. 2. Sequence of operations in the two-dimensional algorithm

Finally, the last of the type (3) equations, viz,

$$(t_{x4}-t_{x0})^2/s_x^2+(t_{y4}-t_{y0})^2/s_y^2=1$$

can be solved for  $s_x$  and hence for  $s_y$  by setting  $s_x^2=ks_y^2$  and inserting the other known values.

This gives the required sensitivities and zero offsets of the individual sensors. They can now be used to correct the incoming readings to give valid direction cosines for the orientation calculations, as follows.

For any pair of readings,  $(t_x, t_y)$ ,

$$h_x/h=(t_x-t_{x0})/s_x$$

$$h_y/h=(t_y-t_{y0})/s_y$$

giving the desired corrected values in terms of known constants and measured values.

Then measuring the orientation angle,  $\theta$ , of the vector  $h$  in the clockwise direction from the  $y$  axis, for example, gives,

$$\theta = \tan^{-1}(h_x/h_y)$$

Calibration can be carried out at whatever intervals are considered appropriate to maintain a suitable compromise of stability and speed of data acquisition.

The FGM sensors are generally stable enough for orientation purposes without continuous recalibration, if supplied from a stable voltage source, and may only need the initial start-up calibration. The technique can be used, however, to overcome the effects of drift from any potential source.

### Moving to three dimensions

The expansion to three dimensions follows the

same pattern and ends up defining a three-dimensional ellipsoid using six pairs of differing measurements, yielding five simultaneous equations to solve and giving, finally, three sensitivities and three zero-offsets as corrections.

With this many equations, the determinant method of solution is not very efficient and Gaussian elimination is probably the preferred approach. An excellent description of Gaussian elimination was given by John Hopkins in his article 'DIY Circuit Analysis' in the January 1996 issue of *Electronics World*, p. 31.

Figure 2 is a flow diagram of the sequence of steps required by the algorithm for use in two dimensions.

### Practical demonstration

A simple practical demonstration of the mechanics of the algorithm is sometimes useful. This can be carried out by means of a hypothetical experiment. Values for the sensitivities and zero-offsets are assumed and the readings from the sensors are back calculated. The algorithm is then run on the hypothetical readings to show that it can make reasonable estimates of the required corrections.

In practice, the techniques for obtaining readings will vary with individual designers, but a typical method might be to count how many internal processor clock pulses occur during, say, 128 or 256 incoming sensor pulse periods, using either internal hardware count registers or some software equivalent. This generates an arbitrary number which is proportional to the sensor period and therefore to the external field strength. The designer will usually arrange that this number ranges over sizes that stay within some register's capacity for convenience, but which is still large enough to provide the desired precision.

For orientation determinations, the field strength itself does not have to be known, so these arbitrary numbers can go directly into the algorithm as they stand.

Using again the two-dimensional example, suppose that the sensors have different zero-offsets of  $t_{x0}=2000$  and  $t_{y0}=1850$ . These are the arbitrary counts obtained at zero field respectively for the two sensors.

Suppose also that the sensitivities differ and can be simulated by slope factors of  $s_x=880$  and  $s_y=740$ . Then you can calculate the expected counts for any angle to, say, the  $y$ -axis from,

$$t_x=880h_x/h+2000$$

$$t_y=740h_y/h+1850,$$

the values of  $h_x/h$  and  $h_y/h$  being simply the sine and cosine of the chosen angle. These counts now contain the errors caused by the sensitivity and zero-offset factors chosen.

Using four arbitrarily selected angles, we can make up a table of the field's direction cosines,

$\theta$	0°	30°	60°	90°
$h_x/h$	0	0.5	0.86603	1
$h_y/h$	1	0.86603	0.5	0

From this we can calculate a table of errored readings,

$t_x$	2000	2440	2762	2880
$t_y$	2590	2491	2220	1850

Using these readings, coefficients of the three simultaneous equations can be calculated,

i	$a_i$	$b_i$	$c_i$	$d_i$
1	-880	198	-503019	-1953600
2	-644	542	-1276681	-1675044
3	-236	740	-1505900	-665756

In matrix form then the equations are:

$$\begin{bmatrix} -880 & 198 & -503019 \\ -644 & 542 & -1276681 \\ -236 & 740 & -1505900 \end{bmatrix} \begin{bmatrix} t_{x0} \\ kt_{y0} \\ k \end{bmatrix} = \begin{bmatrix} -1953600 \\ -1675044 \\ -665756 \end{bmatrix}$$

Solving by the determinant method gives,

$$t_{x0}=2000.9 \quad (0.05\% \text{ error})$$

$$kt_{y0}=2604.9$$

$$k=1.4086$$

giving  $t_{y0}=1849.3$  with 0.04% error. From the fourth Pythagoras-type equation using the last set of readings,

$$s_y^2=548642 \text{ and } s_y=740.7 \quad (0.1\% \text{ error})$$

from which, using  $s_x^2=ks_y^2$ :

$$s_x^2=772817 \text{ and } s_x=879.1 \quad (0.1\% \text{ error})$$

The four supposedly unknown parameters have been recovered with a reasonably good accuracy. It may be verified that the errors noted are almost entirely due to using five figure precision for  $\sin 60^\circ$  and  $\cos 30^\circ$  in the direction cosine table. If exact arithmetic is used, as for example in the computer algebra software Derive, then  $s_x$ ,  $s_y$ ,  $t_{x0}$  and  $t_{y0}$  may be recovered with zero error.

Using the corrections above to recalculate the original hypothetical angles from  $\theta=\tan^{-1}h_x/h_y$  gives:

$h_x/h$	-0.001	0.4995	0.8658	1.000
$h_y/h$	1.000	0.8663	0.5005	0.0009
$\theta$	0.06°	29.97°	59.97°	89.95°
Error	0.06°	0.03°	0.03°	0.05°

In any practical situation, the errors arising from other causes are likely to be much larger than this, but the demonstration does indicate the efficiency of the technique if other errors are small.

This type of hypothetical experiment can be set up as a computer program and usefully exploited to determine the effects of limited digital measurement precision, non-linearity and non-orthogonality on the success of the algorithms when working in less than perfect conditions.

### Compass gimbals

An interesting extension of the basic ideas used above applies to certain types of compass, particularly hand-held types, which often require some kind of calibration on a level surface after being switched on. It could also apply to other types of installed compass, used within a limited geographical area in which the earth's field is assumed to vary

very little.

For such systems, it should only be necessary to try to ensure a level attitude in one axis, rather than the two normally assumed necessary, since a simple Pythagoras calculation will immediately indicate whether the crossed sensor assembly is level or not, by comparison with the known horizontal component magnitude.

Furthermore, if one axis is known to be level, either by spirit level or gimbaling, it is relatively easy to calculate the correct level magnitude of the tilted sensor and even the extent of the tilt. The first case is found by ignoring the output of the tilted sensor and just calculating what it should be by Pythagoras. The second case is found by now using the erroneous tilted output value in conjunction with the calculated true value, in the appropriate trigonometric equation to find the angle between them.

For these restricted cases, then, one gimbal can apparently be discarded, making construction simpler.

**Vanishing vehicles?**

An even more interesting property of the algorithms, which was neither sought after nor even appreciated originally, is their ability to make surrounding magnetised or magnetisable material virtually disappear from the view of the orientation-determining device.

For a compass, this means that the ship or vehicle in which it is installed vanishes, as far as causing deviations is concerned. While this is not totally true, as will be seen later, it appears to be correct for any reasonably careful installation down to third-order effects. Even for a bad installation it should effect a major improvement.

We are indebted to W. Denne (Extra Master, F. Inst. Nav., Assoc. R.I.N.A.) for the background information and theory on which this analysis of effects is based. For the purpose of the analysis, two types of interfering material are considered.

The first is magnetised material, by which is meant anything which has acquired a degree of remanent magnetisation. This is magnetically 'hard' material with a reasonably high

coercivity which has become magnetised by some event in its history and retains this magnetisation, much like a deliberately fabricated permanent magnet. This type of magnetisation can occur during such processes as arc welding or construction and generally does not change much subsequently.

The second type is magnetisable material, by which is meant anything which can acquire a temporary magnetisation as a result of being in a magnetic field. This is magnetically 'soft' material with a low coercivity but reasonably high permeability, allowing it to magnify any local fields which surround it to much higher values. Such material will produce temporary magnets as a result of the Earth's field, for example.

These two types, either singly or in various combinations, account for all the interfering fields experienced by a compass installation and are described by Denne using the following notation.

X, Y and Z represent the true components of the earth's field, X being in the forward direction of the vehicle, Y being in the transverse direction to the right (or starboard) and Z being vertical.

X', Y' and Z' are the disturbed components as seen by the compass, using the same directional significance.

The disturbed values can be expressed in terms of the true values by the following,

$$\begin{aligned} X' &= X+aX+bY+cZ+P \\ Y' &= Y+dX+eY+fZ+Q \\ Z' &= Z+gX+hY+kZ+R \end{aligned}$$

where the coefficients a to k are attributable to errors arising from the 'soft' material being magnetised by the Earth's field, and P, Q and R are deviations caused by the permanent 'hard' material.

Rearranging the terms gives,

$$\begin{aligned} X' &= X(1+a) + P + bY + cZ \\ Y' &= Y(1+e) + Q + dX + fZ \\ Z' &= Z(1+k) + R + gX + hY \end{aligned}$$

The first term in each of these equations represents a variation in the amplitude of the field component or, in other words, a sensitivity variation in the measurement.

The second term in each equation is an added offset to the field value, exactly that which we have described as a zero offset previously. If the remaining two terms in each equation were zero, negligible or could be removed algorithmically like the others, then the effect of the disturbing material would be eliminated completely.

It has not proved simple to remove these remaining terms algorithmically, so it is of interest to examine them by a physical interpretation. In any magnetisable body, the direction of magnetisation arising from an external field would generally be expected to have the same direction as the field causing it. For example, in a spherical, totally isotropic piece of soft iron, the direction of magnetisation caused by Earth's field would align itself precisely with the earth's field. In this case, the cross-axis effects would not exist and coefficients such as b, c, d, f, g and h would be zero.

For shapes which are increasingly less symmetrical, then shape-dependent demagnetisation would give rise to some tendency to depart from true alignment of field and induced magnetisation, leading to finite values for the cross-axis coefficients. Nevertheless, for all but peculiarly shaped objects, such as long thin bodies, we would argue that the departure from alignment would represent an order lower effect than the main axis effects.

Magnetic anisotropy could also give rise to similar alignment errors but again, for all but highly anisotropic materials, should give rise to an order lower errors. Provided the initial installation is carried out with some consideration of such errors, it would seem that the cross-axis effects could be of a lower order than the main deviations.

In any case, a considerable improvement in performance might be anticipated from use of the automatic calibration algorithms in most cases.

**References**

1. Hopkins, J., DIY Circuit Analysis, *Electronics World*, January 1996, pp31-33
2. Denne, W., Magnetic Compass Deviation and Correction, Brown, Son & Ferguson, Ltd, Glasgow G41 2SG (ISBN 0 85174 332 3)

**Microcontroller implementation**

The algorithms described here are no longer purely academic. Since submitting this article, one of the authors, Richard Noble has successfully implemented a two dimensional version in a microcontroller type chip intended for use as a compass in conjunction with an FGM-2 two-axis magnetic sensor.

To obtain a reasonable precision, the internal computations are carried out in floating point using a 16-bit mantissa and 8-bit exponent and for economic memory usage the equation solution makes use of Gaussian elimination techniques. Although the FGM-2 in this type of configuration has zero offsets an order of magnitude larger than the expected signal variations, the immediate result was an orientation precision of one degree and accuracy of two degrees in the final output round the full 360° circle.

The autocalibration is carried out every time the system has

collected four sets of input readings which differ from one another by at least three percent.

The 'vanishing vehicles' theory was also put to a rather crude test by attaching a lightly magnetised steel bolt to the sensor. This produced an immediate deviation of about 11°, but after further rotation which triggered a calibration run, the original precision was promptly restored around the full circle.

The work described above was carried out as a FUSE project under the EC IT programme ESPRIT, under the guidance of Bournemouth University as Technology Transfer Node and Staffordshire University as First User Consultants, whose assistance along with that of the EU initiative is gratefully acknowledged.

A production version of the chip will shortly become available from Speake & Co Limited, Elvicta Estate, Crickhowell, Powys NP81DF, Tel: 01873 811281, fax 01873 810958.



**TEACHERS - STUDENTS -  
HOME USERS, ETC.**

*attention*

**Your opportunity to save £££££'s**

With this non commercial version of our software produced for single users, this is your dream come true!

Software as you are probably aware has no real material value, but is priced to recover the enormous costs of development. The software house tries to evaluate how many units will sell at a specific price to generate the amount needed and produce a healthy profit.

As the electronics marketplace shrinks, due to expanding competition, it means that, in reality, powerful user friendly software, such as EDWin, must be very highly priced and therefore remains inaccessible to the individual and small businesses.

Until today .... Norlinvest, one of the biggest software houses in the electronics sector, has decided to put onto the market a "Non Commercial" version of their EDWin software, which is known worldwide.

This is the first truly seamlessly integrated suite of software running in all Windows formats .... simulation, schematics and PCB design. At last allowing amateurs, teachers, students, .... in a word any "individual" to take advantage of *current technology, without any restriction.*

To avoid misunderstanding – there is no difference between the industrial software at £3,515.25 VAT inc. and the "NC Deluxe 3" at £114.00 VAT inc. – the difference rests solely in the licence. In other words, industry is subsidising the development costs and the individual can now take full advantage of this.

**Computer Compatibility**

To run the program you will need:

- Windows 3.x, Win95 or Win NT,
- a min. 386 processor
- 8mb of RAM • CD-ROM Drive



**All Major Credit  
Cards Accepted**

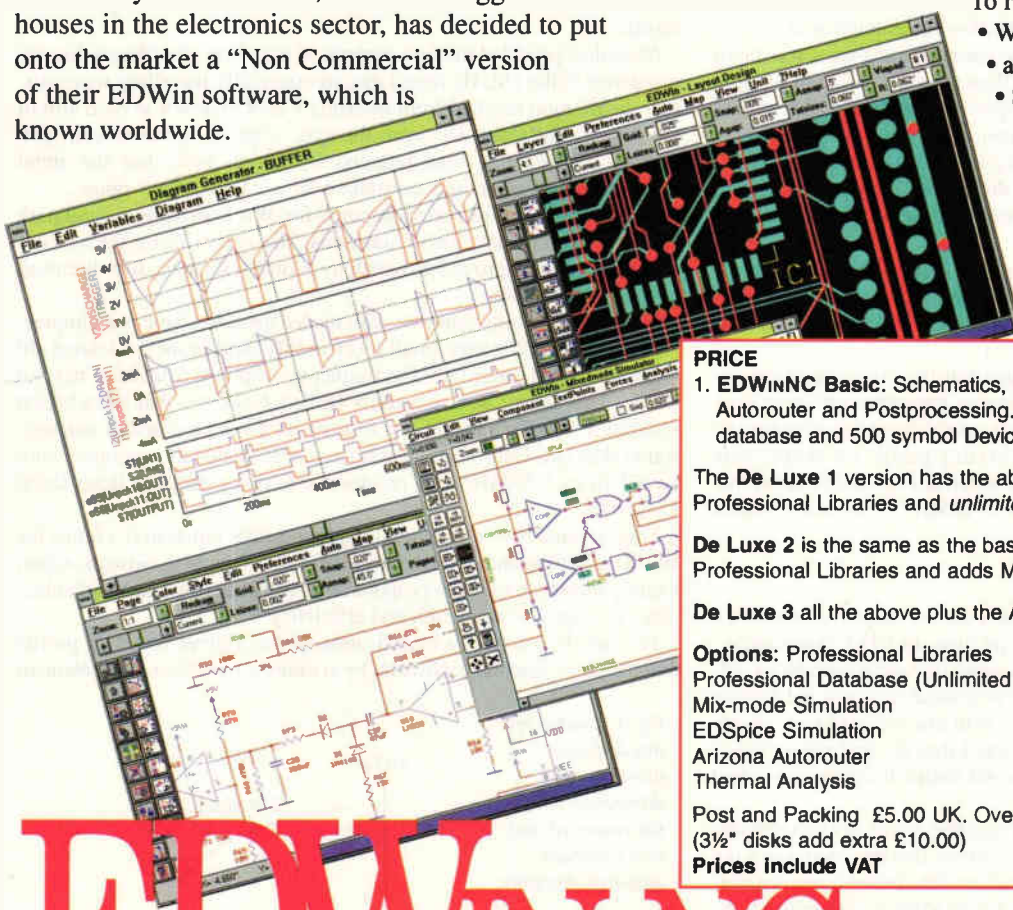

**PRICE**

- |   |          |
|---|----------|
| 1. EDWinNC Basic: Schematics, PCB Layout with Basic Autorouter and Postprocessing. Max. 100 component database and 500 symbol Device Library. | £49.00.  |
| The De Luxe 1 version has the above, but also includes Professional Libraries and <i>unlimited</i> database components.                       | £79.00.  |
| De Luxe 2 is the same as the basic version, but with Professional Libraries and adds Mix-mode Simulation.                                     | £79.00.  |
| De Luxe 3 all the above plus the Arizona Autorouter.  | £114.00. |
| Options: Professional Libraries   | £24.00.  |
| Professional Database (Unlimited components)  | £24.00.  |
| Mix-mode Simulation   | £24.00.  |
| EDSpice Simulation  | £49.00.  |
| Arizona Autorouter  | £24.00.  |
| Thermal Analysis  | £19.00.  |
| Post and Packing £5.00 UK. Overseas £10.00 for CD-ROM version (3½" disks add extra £10.00)  |          |
| <b>Prices include VAT</b>   |          |

*This offer also applies to all  
academic institutions –  
minimum order two systems.*

**EDWIN NC**

**ELECTRONIC DESIGN FOR WINDOWS NON COMMERCIAL**

Swift Designs Ltd., Business & Technology Centre, Bessemer Drive, Stevenage, Herts. SG1 2DX.

To order or for more information telephone: 01438 310133 fax: 01438 722751 or Email: designs@swiftdesigns.co.uk

**Building on Wu and King's landmark paper on continuously loaded antennas, Richard Formato's design procedure for impedance-loaded wideband antennas maximises bandwidth while improving radiation efficiency.**

# WIDEBAND ANTENNAS

**A**ntennas and resistors are usually like oil and water – they don't mix, at least most of the time. The classic example of an absolutely terrible 'antenna' with an excellent standing-wave ratio is a dummy load. A good dummy load's response is nearly flat well into the uhf range. But because essentially all input power is dissipated as heat from  $i^2R$  (Joule heating) losses, for practical purposes its radiation efficiency is zero.

Adding resistance to an antenna invariably reduces efficiency and, as a general rule, adding more resistance makes the antenna worse.

But resistance isn't always bad. As the dummy load shows, resistance can broaden an antenna's response by flattening the variation of input impedance with frequency. Certain types of communication system benefit substantially from wideband antennas, typical examples being spread spectrum, frequency-agile, and ALE, or automatic-link-establishment, systems. In each case, it is desirable to maximise antenna bandwidth while maintaining acceptable power gain and radiation pattern.

One way to accomplish this objective is to add resistance. The question is: how much resistance should be added to strike a reasonable balance between wider frequency response and reduced radiation efficiency?

Adding the correct amount of resistance at the proper location can significantly extend an antenna's frequency range while still providing quite acceptable efficiency and gain. This article describes an improved technique for computing the required loading profile for simple wire antenna elements. A typical monopole antenna is then discussed that provides continuous coverage from about 12MHz to beyond 150MHz with no tuner or matching network.

## This is not the first time

The idea of adding resistors to an antenna to improve frequency response has been around for quite some time. In 1953, Willoughby<sup>1</sup> discussed resistively loaded wires in a variety of configurations, including Vees and Rhombics, that provided wideband transmit and receive antennas. The wires were loaded either with discrete resistors or with a gradually tapered resistance profile such that the end nearer the rf source had the lowest resistivity and the end farther from the source had the highest.

Resistance can transform a resonant, standing-wave antenna element into a non-resonant, travelling-wave element, thereby increasing the loaded antenna's bandwidth. The distinction between resonant (standing wave) and non-resonant (travelling wave) antenna elements can be illustrated by considering the centre-fed dipole, or cfd, antenna in Fig. 1. In the unloaded antenna, resonance results from the superposition of outward-travelling waves produced by the rf source and reflected waves generated at the impedance discontinuity at the cfd's free ends.

These two oppositely propagating waves combine to produce a standing wave which determines the cfd's resonant frequency. If, however,

the outward-travelling wave were not reflected, then no standing wave would exist, and the cfd would not exhibit resonance.

One way to minimise reflections is to add resistance near the ends of the element. The resistors absorb incident energy that has not been radiated away from the antenna, thereby reducing the reflected wave amplitude. This general principle underlies all resistive loading schemes. Of course, there are many ways in which resistance can be added to an antenna, and different approaches can produce dramatically different results.

Altshuler<sup>2</sup> provided the first analysis of the effect of adding a discrete resistance to the cfd. He found that an essentially travelling wave current distribution resulted from inserting a  $240\Omega$  resistor in each arm of the dipole a distance  $\lambda/4$  from the end, where  $\lambda$  is the wavelength. Radiation efficiency was reduced by about 50%, but the input impedance was essentially constant over a 2:1 frequency range.

Altshuler's work provided impetus for Wu and King's<sup>3</sup> landmark paper on continuously loaded antennas. Their work forms the basis of recent efforts to improve bandwidth by adding resistance. It is discussed in more detail below.

Some of the results achieved with loaded antennas have been impressive. Kanda<sup>4</sup> built a very small receive-only field probe – a loaded cfd – that exhibited essentially flat frequency response from hf to beyond 1GHz. This sensor was so heavily loaded, however, that its radiation efficiency was far too low for it to be useful as a transmit antenna. Rama Rao and Debroux<sup>5,6</sup> described a 35ft loaded hf monopole with  $\text{swr} \leq 2$  from 5-30MHz and radiation efficiency ranging from about 15%-36%.

This antenna used a fractional loading profile equal to 0.3 times the Wu-King profile and a fixed, lumped-element matching network. Other loading profiles have been proposed that combine resistance and inductance to improve bandwidth and efficiency<sup>7</sup>.

This article describes a modification of the original Wu-King profile that increases antenna bandwidth by creating a travelling-wave element

**Fig. 1. Centre-fed dipole helps illustrate the difference between the resonant and non-resonant antenna elements.**

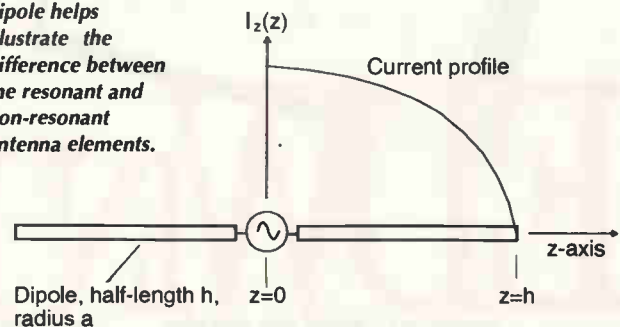



while at the same time improving radiation efficiency by increasing the antenna's average current. Because the radiated fields are proportional to the antenna's  $I dl$  product, a higher average current increases the radiated fields, which in turn improves efficiency. The motivation for this new profile is the realisation that the Wu-King current profile is a special case of a more general travelling-wave current distribution with higher average antenna current.

**Wu-King explained**

Figure 1 shows a centre-fed dipole antenna consisting of two elements of length  $h$  and radius  $a$ . Amplitude of the current profile is plotted schematically along one element's length. Maximum current occurs at the rfsource at the feed point, and the magnitude decreases along each arm until it reaches zero at the end. In the Wu-King model, the centre-fed dipole is assumed to have an internal impedance profile along the wire element given by  $Z^i(z)=R^i(z)+jX^i(z)$ , where  $Z^i$  is the (complex) internal impedance per unit length ( $\Omega/m$ ), consisting of lineal resistance  $R^i$  and reactance  $X^i$ , and where  $j=\sqrt{-1}$ .

Wu and King develop the differential equation satisfied by the current  $I_z(z)$ , and then determines by inspection that a travelling-wave current mode exists for one particular impedance profile,  $Z^i$ . The Wu-King current distribution is,

$$I_z(z) \approx \left(1 - \frac{|z|}{h}\right) \exp(-jk_0|z|) \tag{1}$$

linear amplitude decay      travelling wave factor

which consists of the product of a linearly decreasing ('straight line') amplitude and a travelling wave propagation factor in the complex exponential term. The wave number is  $k_0=2\pi/\lambda$ . The propagation factor represents a current wave progressing outward along each dipole arm. There is no reflected wave propagating toward the source to form a standing wave pattern, and consequently no resonance effect.

This current distribution exists *only* when the cfd element has a specific '1/z' internal impedance profile. The required profile is given by:

$$Z^i(z) = \frac{60(\psi/h)}{1 - |z|/h} \tag{2}$$

where  $\psi=\psi_R+j\psi_I$  is the complex expansion parameter discussed in Altshuler<sup>2</sup>, with real and imaginary parts subscripted  $R$  and  $I$ , respectively. The ratio of the antenna element's vector potential to current is  $\psi$ , and is approximately constant along its length. Because  $\psi$  varies with frequency, it is usually evaluated at the fundamental cfd resonance, that is, when  $h=\lambda/4$  (see ref. 3). The 1/z profile in equation (2) is the basis for the resistive loading used in refs. 4, 5 and 6.

**Improved loading profile**

An improved loading profile – that is, one that provides better radiation efficiency than the 1/z profile – can be obtained by generalising the Wu-King results. The first step is to assume a power law travelling-wave current distribution, of which the Wu-King current distribution is a special case.

The next step is to substitute the assumed current distribution into the current equation developed by Wu and King, which then yields the condition that must be satisfied by the element's internal impedance in order to generate travelling-wave only modes.

This approach is fundamentally different from the one in Wu-King because the loading profile for a particular travelling-wave current mode is now an unknown which is determined by solving the appropriate equations.

The generalised cfd current distribution is assumed to be of the form:

$$I_z(z) = C(h - |z|)^\nu \exp(-jk_0|z|) \tag{3}$$

power law amplitude decay      travelling wave factor

where  $C$  is a complex constant determined by the current at the feed point. Note that the amplitude decay is a power law variation with exponent  $\nu$ . The Wu and King case is recovered when  $\nu=1$ , but when  $\nu \neq 1$  the more general case is obtained.

The internal impedance profile that produces travelling-wave only

currents of the form in equation (3) is determined as follows. The derivatives  $dI_z/dz$  and  $d^2I_z/dz^2$  are computed and substituted into the equation satisfied by  $I_z(z)$  (Wu and King's equation<sup>11</sup>). This generates the equation that must be satisfied by the auxiliary function  $f(z)$  introduced in Wu-King equation (9). Its solution is,

$$f(z) = 2\nu(h - |z|)^{\nu-2} \left\{ 1 - j \frac{\nu-1}{2k_0(h - |z|)} \right\} \tag{4}$$

$f(z)$  determines the impedance profile. Equation (4) generalises Wu and King's equation (12), and recovers their results exactly when  $\nu=1$ .

Figure 2 shows several current amplitude distributions parametric in the power law exponent  $\nu$ . It is apparent that values of  $\nu$  less than 1 can lead to significantly higher average antenna currents. Radiating elements with these current distributions are more efficient than those using the 1/z loading profile which results by setting  $\nu=1$ .

The loading profile resistance and reactance per unit length are computed from  $f(z)$  and are given by:

$$R^i(z) = 60\nu(h - |z|)^{\nu-2} \left\{ \psi_R - \frac{(1-\nu)\psi_I}{2k_0(h - |z|)} \right\} \tag{5a}$$

$$X^i(z) = 60\nu(h - |z|)^{\nu-2} \left\{ \psi_I + \frac{(1-\nu)\psi_R}{2k_0(h - |z|)} \right\} \tag{5b}$$

The corresponding lineal inductance (henry/metre) or capacitance (farad/metre) is given by  $L^i=X^i/\omega$  and  $C^i=(\omega X^i)^{-1}$ , respectively, for  $X^i>0$  and  $X^i<0$ . The circular frequency is  $\omega=2\pi f$  where  $f$  is the frequency (Hz) at which  $\psi$  is computed.

It is apparent from equation (5) that the improved loading profile in

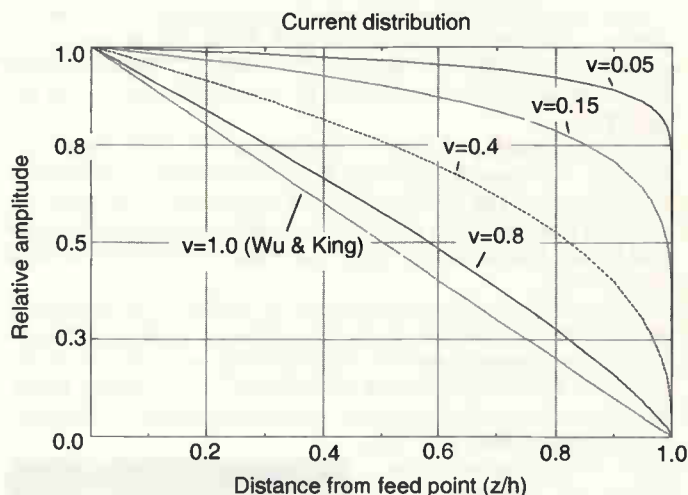

Fig. 2. Values of  $\nu$  less than 1 can lead to significantly higher average antenna currents.

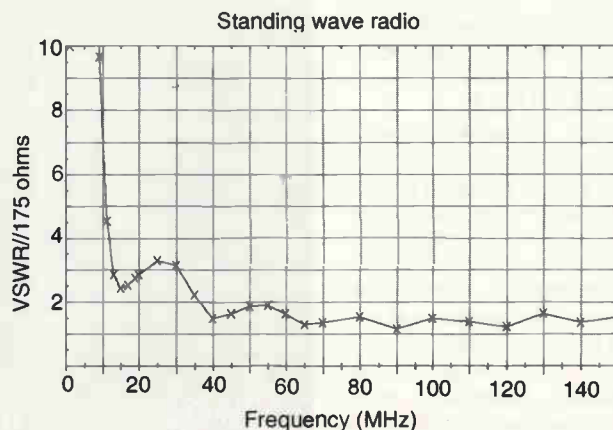

Fig. 3. Compound input swr for a 174Ω feed system, with calculated values marked at points x.

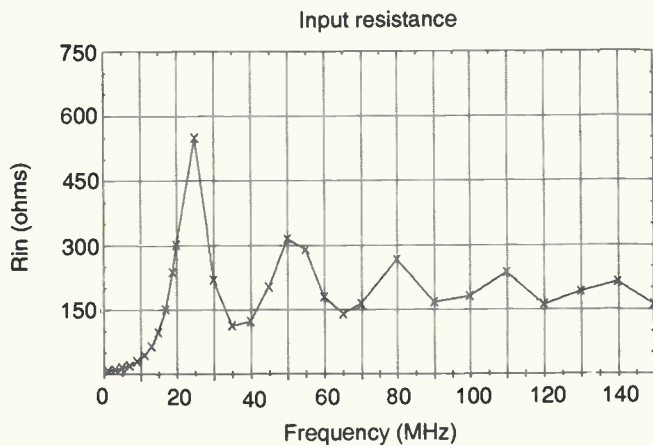

Fig. 4. Monopole feed-point resistance plot.

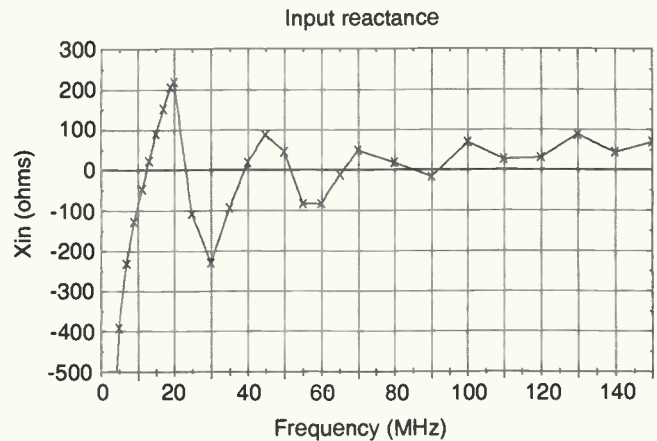

Fig. 5. Reactance plot for the monopole feed-point.

general contains both resistance and reactance. But adding reactance to the antenna, especially capacitive reactance, can complicate construction. As a consequence, many practical designs employ only resistive loading (see refs. 5 and 6, for example), because excellent results are often achieved even without the loading profile's reactive component.

**Loaded hf-uhf monopole**

To illustrate the degree of broadbanding achievable, a loading profile was computed for a monopole element fed at its base against an infinite, perfectly conducting ground plane. The radiating element height is 5.83m, and its radius 2.54cm. The design frequency for evaluating  $\psi$  is 12.86MHz, and the power law exponent  $\nu$  is 0.05.  $\psi$  is  $8.961-j2.431$ .

Using equation (5a), a resistance profile was computed for 14 discrete loading points along the antenna, Table 1. The profile increases very gradually from the 0.419 $\Omega$  near the base of the monopole to approximately 787 $\Omega$  near the top. Reactive loading (in this case, inductive) was not included.

The monopole's performance was computer-modelled from 1 to 150MHz. The computed input SWR for a feed system impedance of 175 $\Omega$  appears in Fig. 3; calculated points are marked x. Because swr was computed for a 175 $\Omega$  characteristic impedance, matching the usual 50 $\Omega$  coaxial feed requires a 3.5:1 Unun or another suitable broadband transformer.

The monopole antenna's performance is excellent at all frequencies above 36MHz. The swr is below 2 from there to 150MHz (the upper limit for the computer model), and somewhat worse from approximately 12 to 36MHz, reaching a maximum 3.3 at 25MHz. Below 11MHz, swr increases rapidly due to increasing capacitive reactance and decreasing radiation resistance. This behaviour is characteristic of electrically short antennas, and is evident in the monopole's feed point resistance and reactance plots in Figs 4 and 5, respectively. The data in these curves were used to compute the swr plot in Fig. 3.

The monopole antenna's impedance bandwidth is remarkably good – especially considering that there is no matching network and only discrete resistive loading is employed. In addition, no attempt was made to further improve the loading profile by, for example, modifying computed resistance values or adding reactance. Adjustments such as these can frequently yield even better performance, but they are not considered further.

Table 1. Resistance profile for 14 discrete loading points along the antenna.	
Height (m)	Resistance ( $\Omega$ )
0.208	0.419
0.625	0.489
1.041	0.581
1.458	0.699
1.874	0.859
2.290	1.080
2.707	1.401
3.123	1.889
3.539	2.689
3.956	4.129
4.373	7.131
4.789	15.102
5.205	49.473
5.622	786.910

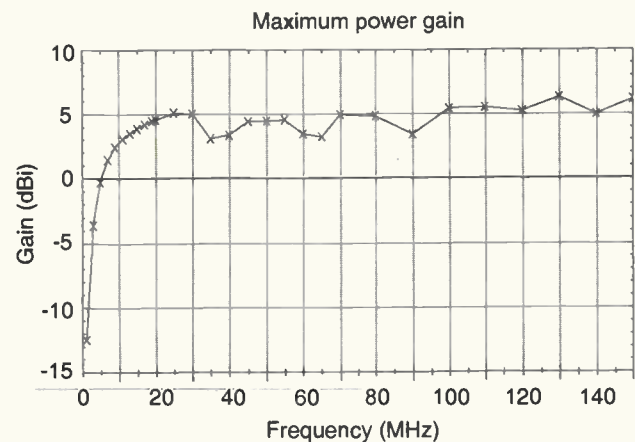

Fig. 6. Maximum gain of the wide-band monopole antenna.

The following observation illustrates how dramatic the effect of loading an antenna can be. For an *unloaded* monopole, the bandwidth for  $swr \leq 2.5$  (50 $\Omega$  feed) is typically 15-25% of its  $\lambda/4$  frequency, depending on the length-to-diameter ratio. A monopole  $\lambda/4$  high at 12.86MHz, such as the one considered here, would show a bandwidth of less than 3.2MHz. Increasing the bandwidth to greater than 115MHz, as the improved loading profile does, is indeed a very substantial improvement.

Of course, as the dummy load example teaches, impedance bandwidth alone does not a good antenna make. Two other key measures of the loaded monopole's performance appear in Figs 6 and 7, maximum gain and radiation efficiency, respectively.

Power gain, computed as the product of directive gain and efficiency, is plotted in dBi (decibels relative to an isotropic radiator). For comparison, the maximum power gain of a half-wave cfd in free space is 2.15dBi. The loaded monopole's gain at 10MHz is nearly 3dBi, and from 10 to 150MHz it is mostly in the 4-6dBi range. The monopole with the improved resistance profile thus exhibits power gain figures that are typical of similar antennas with no loading at all.

The point was made at the start of this article that the fundamental issue in choosing a loading profile is the trade-off between bandwidth and radiation efficiency. The merit of a particular profile is determined primarily by these performance measures. An examination of Fig. 3 showed that the monopole's swr curve is more or less flat from 36 to 150MHz, with somewhat higher but still acceptable swr from 12 to 36MHz.

The second measure of merit, radiation efficiency, is plotted in Fig. 7. The efficiency is generally above 60% over the entire range of 10 to 150MHz, with only minor dips below 60%, and some regions where it is near or above 70%. Even the minimum efficiency value of 45% or so near 35MHz is quite acceptable.

The improved resistive loading profile has produced an antenna with





# 2.5GHz

## power source

The fruits of research into applying microwaves to geological samples, this pulsed 2.5GHz power source is very inexpensive relative to laboratory sources since it uses mass-produced parts, as John Share and John Hakes demonstrate.

Dr John A. Share and Mr. John Hakes are with the Department of Earth Science at University of Liverpool

Generating significant power at microwave frequencies is inherently expensive. Producing 500W at 2.5GHz was, for us, prohibitively costly. Fortunately, mass production of a domestic appliance has resulted in 600W, 2.5GHz generators with integral power supplies being available for very little financial outlay. Second-hand units are readily available at even lower cost.

At first glance, a domestic microwave oven may not seem a likely candidate for conversion. One manufacturer suggested that the demise of the magnetron would be the inevitable result.

Essentially, the design of a domestic microwave oven consists of a magnetron, a cavity assembly, for the anode tuned circuit, an eht power supply interlocked with a heater supply and a blower. It also includes various control and timer circuits.

Operating frequency is governed by three factors – dimensions of the cavity, the magnetic field applied to the magnetron, and the actual value of the eht. Varying any one of these causes the frequency to alter. Significant changes will result in the magnetron ceasing to function.

Starting at component level without considerable expertise would be foolhardy. However, the conversion of a domestic microwave oven into a microwave power source is relatively straightforward.

Mechanical modification requires extracting the entire magnetron/cavity assembly from its domestic usage enclosure. This reveals that the oven space and the anode cavity are two separate items, and that there is an aperture between the two to allow coupling.

The first stage is to remove the oven with a hacksaw and fit a plate over the aperture. A sheet of thin metal and numerous self-tapping

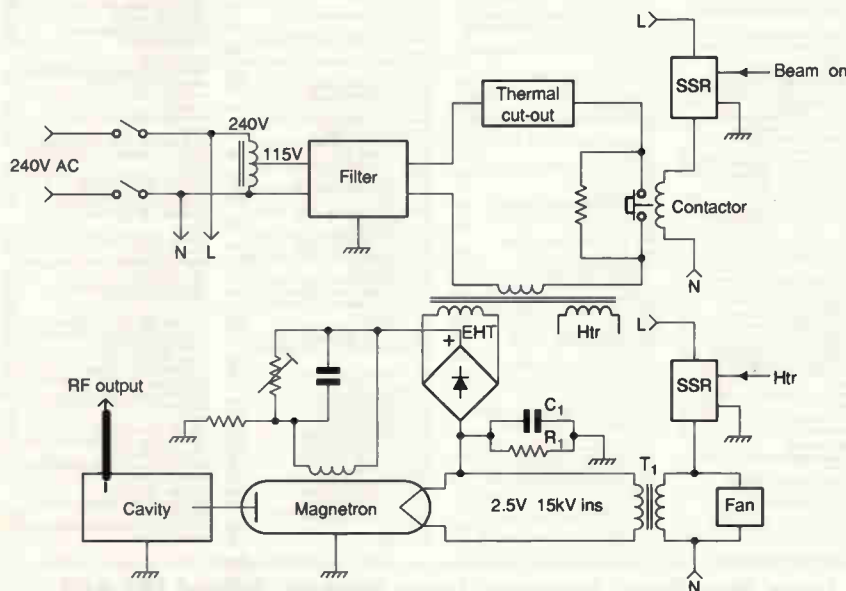

This 2.5GHz power source is based on a reconfigured microwave oven. Components  $T_1$ ,  $C_1$ ,  $R_1$  and the solid-state relays are part of the reconfiguration.

### Warning

Very serious hazards exist both within this apparatus, due to the presence of lethal power supplies, and from biological damage caused by the microwave energy generated. Duplication of this research work must not be undertaken by anyone who does not fully understand the dangers of microwaves and very high voltages. Extreme caution must be exercised during development and operation. Access to a certified microwave radiation detector is absolutely essential.



screws – no more than 2cm apart – will ensure a tight rf seal. The signal is extracted into RG8U by a quarter-wave E-probe, installed precisely on the centre line of the cavity at a distance of a quarter wavelength, i.e. 3.33cm, from the end wall.

Initial trials using N connectors and a probe, soft-soldered to the socket, resulted in numerous flashovers and carbon tracking. By drilling out the socket and arranging the plug so that the centre insulator and conductor of the RG8U coax passed directly into the cavity, far greater reliability was achieved. Trimming the projection to obtain maximum power output was then a very simple cut-and-try procedure.

A variable vane within the cavity was obviously intended by the manufacturer to compensate for manufacturing tolerances. This was reused to compensate for the presence of the new coupling.

In its original form, the heater winding was included on the eht transformer assembly and inevitably there was an indeterminate delay between operating the unit and the appearance of rf output. Our specific requirement was that the unit would produce bursts of rf under com-

puter control for programmable periods of one to ten seconds duration.

An additional heater transformer, T<sub>1</sub>, was required so that the rf output could be controlled by application of the eht. As with many high-frequency devices, the anode is external and is usually connected to the metalwork to assist cooling. This requires elevating the cathode by several kilovolts, and the heater supply must of necessity also be at several kilovolts, relative to ground. Suitable transformers are available as surplus; however, custom-built transformers are not out of the question.

Interlocked with a blower and thermal trip circuitry from the original unit, the heater supply remains active continuously while the eht can be controlled by solid-state switching of the transformer primary.

Interfacing to a pc-compatible used a commercial parallel i/o card and some custom-designed logic using 74-series devices. This operated the solid-state relays and provided interlocks and safety cutout features to provide automated software control.

Spectral purity of the output is not as horrendous as we first feared; in fact, it is sur-

prisingly clean, but frequency modulation due to eht ripple was very evident. Adding smoothing, namely C<sub>1</sub> and R<sub>1</sub> resulted in a significant improvement – an 8µF paper capacitor and 1MΩ glass-encased high-tension resistor were available, but these values do not seem to be critical.

The purpose of this system was to excite spin waves in rock samples. For this, it is necessary to achieve maximum current coupling into the rock sample. A coaxial cavity was used to achieve this. Such passive devices offer exceptional selectivity – even when crudely made to modest workshop machining tolerances.

The system was operated without failure for more than two years, and has only been made redundant by advances in experimental techniques and knowledge of the magnetic structures of the rock samples themselves, necessitating higher frequencies of excitation. ■

Initial funding for this project was provided by the University of Liverpool RDF Fund, British Petroleum and the Natural Environmental Science Research Council.

# M&B RADIO (LEEDS)

## THE NORTH'S LEADING USED TEST EQUIPMENT DEALER

### OSCILLOSCOPES

HP 54111D 500 MHz digitizing scope (colour display)	£3000
HP 54112D 100 MHz 4 channel digitizing scope (colour display)	£2250
HP 54201D 300 MHz 2 channel digitizing (27 channels logic state triggering)	£1900
TEKTRONIX 2465ADM 350 MHz 4 channel (digital multimeter, GP-BiScope 09)	£2500
TEKTRONIX 2465A 350 MHz 4 channel	£2800
TEKTRONIX 2220 60 MHz 2 channel digital storage	£1500
TEKTRONIX 2445 150 MHz 4 channel GP-IB	£1400
TEKTRONIX 2245 150 MHz 4 channel auto cal	£1400
TEKTRONIX 7844/7A2/7A19/7892B/7880 (600 MHz/2x 400 MHz)	£1200
TEKTRONIX 485 350 MHz 2 channel scope	£600
TEKTRONIX 475A 250 MHz 2 channel	£650
TEKTRONIX 475 200 MHz 2 channel	£600
TEKTRONIX 466 100 MHz 2 channel	£400
TEKTRONIX 465B 100 MHz 2 channel	£475
TEKTRONIX 465 100 MHz 2 channel	£400
TEKTRONIX SC504/TP503/DM501 80 MHz + DVM	£450
TEKTRONIX 434 25 MHz channel storage	£300
TEKTRONIX 214 10 MHz 2 channel storage	£400
TEKTRONIX 2225 50 MHz 2 channel	£450
TEKTRONIX 2234 100 MHz 2 channel timer/counter	£750
TEKTRONIX 1113 storage mainframe (new)	£275
TEKTRONIX 212 500 KHz 2 channel handheld battery portable	£195
PHILIPS PM 3375 100 MHz 250MHz GP-IB	£1650
PHILIPS PM 3855 50 MHz 2 channel	£425
PHILIPS PM 3857 50 MHz 2 channel	£475
PHILIPS PM 3217 50 MHz 2 channel	£400
LEWISU 55 8122 100 Hz 4 channel with cursors	£300
FWATSI 55 3710 60 MHz 4 channel	£400
WEADER LBS241 40 MHz 2 channel	£300
HITACHI V1100 100 Hz 4 channel with cursors	£750
GOULD 028 100 MHz OSC 2 channel 4 colour hardcopy	£1400
GOULD OS390 20 MHz 2 channel	£200
GOULD OS2508 15 MHz 2 channel	£145
UNAOHM 0598 0Y 20 MHz 2 channel (compact)	£140
BALLANTINE 1022B 25 MHz 2 channel portable	£225
<b>SPECTRUM ANALYSERS</b>	
TEKTRONIX 492 50 KHz-21 GHz OPT 001/002	£5500
TEKTRONIX 494P 10 KHz-21 GHz	£1900
TEKTRONIX 2710 10 KHz-1.9 GHz	£4000
TEKTRONIX 7L12 10 KHz-1.8 GHz + mainframe	£1000
TEKTRONIX 7L5 1.2 GHz OPT 25 tracking gen. + mainframe	£2000
HP 8714A 4 MHz-1300 MHz network analyser	£800
HP 84100/811A network analyser	£1000
HP 85588 100 KHz-1500 MHz + mainframe	£1750
HP 85590 10 MHz-22 GHz OPT 003/000/4/3	£4950
HP 3582A 0.02 Hz-25 KHz dual channel signal analyser	£1800
HP 3562A 64 uHz-100 KHz dynamic signal analyser + 1 year HP Cal	£6000
HP 1407/8552B/8553B 1 KHz-110 MHz	£450
HP 1417/8552B/8554B 100 KHz-1250 MHz	£1000
HP 1417/8552B/8555A 10 MHz-10GHz	£1500
MARCONI TF2370 30 Hz-110 MHz digital storage	£850
BRUEL & KJAER 2033 20 Hz-20 KHz audio	£1000
<b>SIGNAL GENERATORS</b>	
HP 8642A 100 KHz-1050 MHz signal generator	£19000
HP 8904A DC-600 KHz multimultifunction synthesizer	£2500
HP 8637A 100 KHz-1040 MHz signal generator	£3000
HP 3314A 0.001 Hz-19.99 MHz function/waveform monitor	£2750
HP 3586C 50 KHz-32.5 MHz selective level meter	£1750
HP 86430 2.3 GHz-13 GHz OPT 001/003 solid state generator (as new)	£2950
HP 8620C/86230B 1.8 GHz-4.2 GHz sweeper	£1000
HP 8620C sweeper mainframes (as new)	£250
HP 86140 10 Hz-520 MHz generator	£400
HP 3200B 10 MHz-500 MHz oscillator	£200
HP 3336B 10 Hz-21 MHz synthesizer/level meter	£600
HP 3320A frequency synthesizer 0.1 Hz-13 MHz	£450

HP 3312A 0.1 Hz-13 MHz function generator	£400
HP 3310B 0.0005 Hz-5 MHz function generator	£200
HP 8068B 0.3 Hz-20 MHz pulse generator	£375
TEKTRONIX 2901 200 MHz marker generator	£2000
MARCONI TF2019A 80 KHz-1040 MHz synthesizer	£2000
MARCONI TF2019/2171 10 MHz-520 MHz with synchronizer	£495
MARCONI TF2006 10 KHz-510 MHz RF generator	£350
MARCONI TF2018 10 KHz-120 MHz (E250) TF2016A	£300
PTS Inc. PFS 160 100 KHz-160 MHz frequency source	£200
FLUKE 6011A 10 Hz-11 MHz synthesized signal generator	£1000
ROHDE & SCHWARTZ APN663 0.1 Hz-260 KHz LF gen. (new)	£2000
WILTRON 6100D501 1 MHz-1500 MHz sweeper + log meter	£750
GIGA GR110A 12 GHz-18 GHz pulse generator	£600
PHILIPS PM5326 100 KHz-125 MHz RF generator	£400
ADMET 2238A 200 Hz-1 MHz synthesized source	£195
WAVETEK 193 20 MHz sweep modulation generator	£400
WAVETEK 171 2 MHz synthesized function generator	£225
WAVETEK 181 0.002 Hz-2 MHz function generator	£175
THANDAR TG503 0.005 Hz-5 MHz pulse/function generator	£225
SAYROSA NA 30 10 Hz-100 KHz	£175
<b>TEST EQUIPMENT</b>	
ELECTRO-METRICS EMC-25 MKII interference analyser 10 KHz-1 GHz	£995
BALL EPRATRON PRT-H rubidium frequency standard	£4000
TRACOTE 5175 frequency difference meter	£1000
WAVETEK 1018A log lin RF peak power meter DC-26 GHz	£1200
ANRITSU MS65A 2 GHz error detector	£1250
TEKTRONIX 1141/PG11/TS611 pal video generator	£1500
TEKTRONIX 145 pal gen. lock test signal generator	£1500
TEKTRONIX 521A vector scopes	£350
TEKTRONIX AA02A isolator	£450
DRANET 454 disturbance analyser	£1000
PHILIPS PM825A dual port recorder	£225
SCHLUMBERGER 7702 digital transmission analyser (new)	£600
SCHLUMBERGER 4900 AF/RF measuring unit	£400
SCHLUMBERGER AF-403 3 tone generator/modulator	£150
FERRUGINEI 100 Hz-20 MHz test set	£195
AMBER 4000A audio test set	£400
WANDEL & GOLTJERMAN PPS19 level generator	£500
MARCONI TF2385 mod meter 50 KHz-2.3 GHz	£2000
MARCONI TF1610 true RMS power meter	£850
MARCONI 6950/6910 10 MHz-20 GHz RF power meter	£2850
MARCONI 4591A VSWR meter	£495
MARCONI 6440/421 10 MHz-12.4 GHz RF power meter	£250
MARCONI TF2306 programmable interface unit	£400
MARCONI TF432A 10 Hz-560 MHz frequency counter	£1225
BIP 535 10 Hz-10 GHz microwave frequency meter 12 digit	£850
HP 4954A portocal analyser + HP 18135A pod	£2350
HP 70901A mainframe + 2x 70205A graphic displays	£6000
HP 5343A 500 MHz-18 GHz microwave frequency meter	£900
HP 5334A universal systems counter	£750
HP 5335A universal systems counter	£1200
HP 5345A 1.5 MHz-26.5 GHz counter/5355A/5356A+B sensors	£2000
HP 5328A universal frequency counter + div	£350
HP 4358/4481A/4844A/1708A 10 MHz-18 GHz (new/HP case/mainstb)	£1100
HP 4358/4481A RF power meter	£900
HP 435A/4482A/100 KHz-4.2 GHz RF power meter	£550
HP 432A/478A 10 MHz-10 GHz RF power meter	£275
HP 436A RF power meters	£250
HP 8477A RF power meter calibrator	£225
HP 5087A distribution amplifier (new)	£750
HP 3488A switch controller	£550
HP 3511C 15 Hz-50 KHz selective voltmeters as new	£400
HP 3779A primary multiplex analyser	£250
HP 333A distortion analyser	£295
HP 1110A down converter	£250
HP 3730B/3734M down converter/oscillator	£495
HP 4006 10 Hz-21 MHz AC voltmeter	£125
HP 3403C true RMS voltmeter (digital)	£195

HP 3406A 10 KHz-1200 MHz RF sampling voltmeter with probes	£200
HP 3465A 4.5 digit multimeter	£125
HP 3466A 4.5 digit autoranging multimeter	£200
HP 3467A 3.5 digit high speed signal voltmeter	£200
HP 3455A 6.5 digit bench multimeter	£695
HP 3468A 5.5 digit multimeter/scale cal (LCD)	£400
HP 5004A signature analyser	£150
HP 5005A signature multimeter	£200
HP 4448A DC power supply 0-400V/0-1.5 amp	£750
HP 6255A dual DC power supply 2x 0-400V/0-1.5 amp	£185
HP 6253A dual DC power supply 2x 0-200V/0.3 amp	£200
HP 6825A power supply/amplifier -20V to +20V/0.2 amp	£250
HP 6268B DC power supply 0-40V/0-30 amp OPT 003/01/0/0/4	£350
HP 355C RF sweep attenuators 0-12 dB DC-1 GHz (NEW)	£185
HP 255D RF sweep attenuators 0-120 dB DC-1 GHz (NEW)	£195
BIRD 43 RF wattmeters	£95
BIRD 322 30 db coaxial attenuator 100V	£300
BALLANTINE 6125C prog time/amplitude test set	£300
HALCYON 500B/521A universal test system	£150
BRADLEY 192 oscilloscope calibrator	£600
KEITHLEY DP1 1 Hz-100 KHz phase meter (new)	£150
WAYNE KERR CT-496 LCR meter battery portable	£575
AVO 215-1/2 AC/DC breakdown ionisation tester	£400
FARNELL RB103R/5 electronic load	£495
FARNELL T948 10 KHz-1000 MHz true RMS sampling voltmeter	£350
FARNELL PDD3502 dual power supply 0-35V 2 amp	£950
FARNELL TSV70 power supply 0-70V 0-10 amp	£100
SIEMENS U233 photometer (new)	£100
SIEMENS D2108 200 KHz-30 MHz level meter	£330
SIEMENS W2108 200 KHz-30 MHz level oscillator	£350
NARDA 3001 450 MHz-950 MHz directional coupler 20db	£1700
NARDA 3041-20 500 MHz 1000 MHz directional coupler 20db	£125
NARDA 3044B-20 3.7 GHz-8.3 GHz 20db directional coupler	£150
NARDA 3004-10 4 GHz-10 GHz 10db directional coupler	£100
NARDA 40132 solid state amplifier 8 GHz-12 GHz	£100
SAYROSA AMPI 1.5 MHz-2 GHz automatic modulation meters	£175
ROHDE & SCHWARTZ NRK RF power meter	£600
WATKINS-JOHNSON receivers various types in stock phone for details	£450
REDIFON RA500 100 Hz-30 MHz receivers	£695
RACAL RA17 30 MHz valve receiver	£200
RACAL RA128 30 MHz receiver	£350
RACAL RA1772 30 MHz receiver	£650
RACAL 2309/229/2295/2296 20 MHz-1000 MHz receivers	£1000
RACAL RA 6793A 30 MHz receiver (as new)	£1250
RACAL RA1779A 1107 30 MHz receiver	£1500
RACAL 9063 two tone oscillator	£200
RACAL 9008 1.5 MHz-2000 MHz automatic modulation meter	£300
RACAL DANA 9004/9 50 MHz universal counter timer	£95
RACAL DANA 9914 10 Hz-200 MHz frequency counter	£100
RACAL DANA 9915 10 Hz-520 MHz frequency counter	£100
RACAL DANA 9916 10 Hz-520 MHz frequency counter	£150
RACAL DANA 9919 10 Hz-1100 MHz frequency counter	£295
RACAL DANA 9908 10 Hz-1100 MHz universal counter timer	£400
RACAL DANA 9921 10 Hz-3000 MHz frequency counter	£400
RACAL DANA 1991 10 Hz-160 MHz universal counter timer 9 digit	£295
RACAL DANA 1992 10 Hz-1300 MHz nanosecond counter	£600
RACAL DANA 9300 RMS voltmeter	£350
RACAL DANA 9301A true RMS RF millivoltmeter	£400
RACAL DANA 6000 microprocessing digital voltmeter	£250
BRUEL & KJAER 2971 phase meter	£600
DATRON 1071 autocall digital multimeters	£600
FLUKE 8505A digital multimeter	£750
FLUKE 8506A thermal RMS multimeter	£1000
FLUKE 103A frequency comparator	£250
FLUKE 3308B prog constant current/voltage calibrator	£450
FLUKE 5100B calibrator	£2950
FLUKE 5200A programmable AC calibrator + 5205A precision power amp	£4950
FLUKE 5400B direct voltmeter	£4950
RF MICROSYSTEMS INC. ANUTRC-176 VHF/UHF KAL filters	£400

ALL PRICES PLUS VAT AND CARRIAGE • ALL EQUIPMENT SUPPLIED WITH 30 DAYS WARRANTY

86 Bishopgate Street, Leeds LS1 4BB  
Tel: (0113) 2435649 Fax: (0113) 2426881

CIRCLE NO. 116 ON REPLY CARD



# PROTEUS

For DOS and Windows 3.1, 95 & NT

The Complete Electronics Design System - Now With RIP-UP & RETRY!

NEW LOW PRICE OPTIONS AVAILABLE  
Level 1 (500 pins) from £250  
Level 2 (1000 pins) from £495  
Level 3 (unlimited) from £995

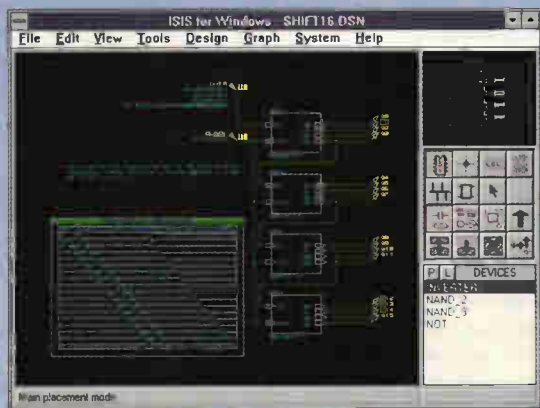

## Schematic Capture

- Easy to Use Graphical Interface under both DOS and Windows.
- Netlist, Parts List & ERC reports.
- Hierarchical Design.
- Extensive component/model libraries.
- Advanced Property Management.
- Seamless integration with simulation and



## Simulation

- Non-Linear & Linear Analogue Simulation.
- Event driven Digital Simulation with modelling language.
- Partitioned simulation of large designs with multiple analogue & digital sections.
- Graphs displayed directly on the schematic.

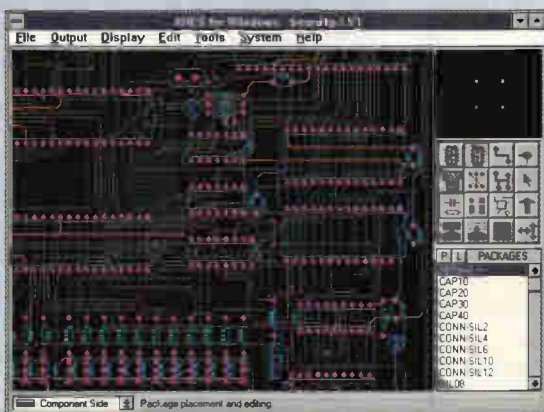

## PCB Design

- 32 bit high resolution database.
- Multi-Layer and SMT support.
- Full DRC and Connectivity Checking.
- RIP-UP & RETRY Autorouter.
- Shape based gridless power planes.
- Output to printers, plotters, Postscript, Gerber, DXF and clipboard.
- Gerber and DXF Import capability.

labcenter  
Electronics

Call now for your free demo disk  
or ask about the full evaluation kit.  
Tel: 01756 753440. Fax: 01756 752857.  
53-55 Main St, Grassington. BD23 5AA.

Fully interactive demo versions available for download from our WWW site.  
Call for educational, multi-user and dealer pricing - new dealers always wanted.  
Prices exclude VAT and delivery. All manufacturer's trademarks acknowledged.

EMAIL: [info@labcenter.co.uk](mailto:info@labcenter.co.uk)  
WWW: <http://www.labcenter.co.uk>



# VIDEO channel selector

Clem Tabor's one-of-eight video channel selector is greatly simplified by a small microcontroller that can be programmed in Basic.

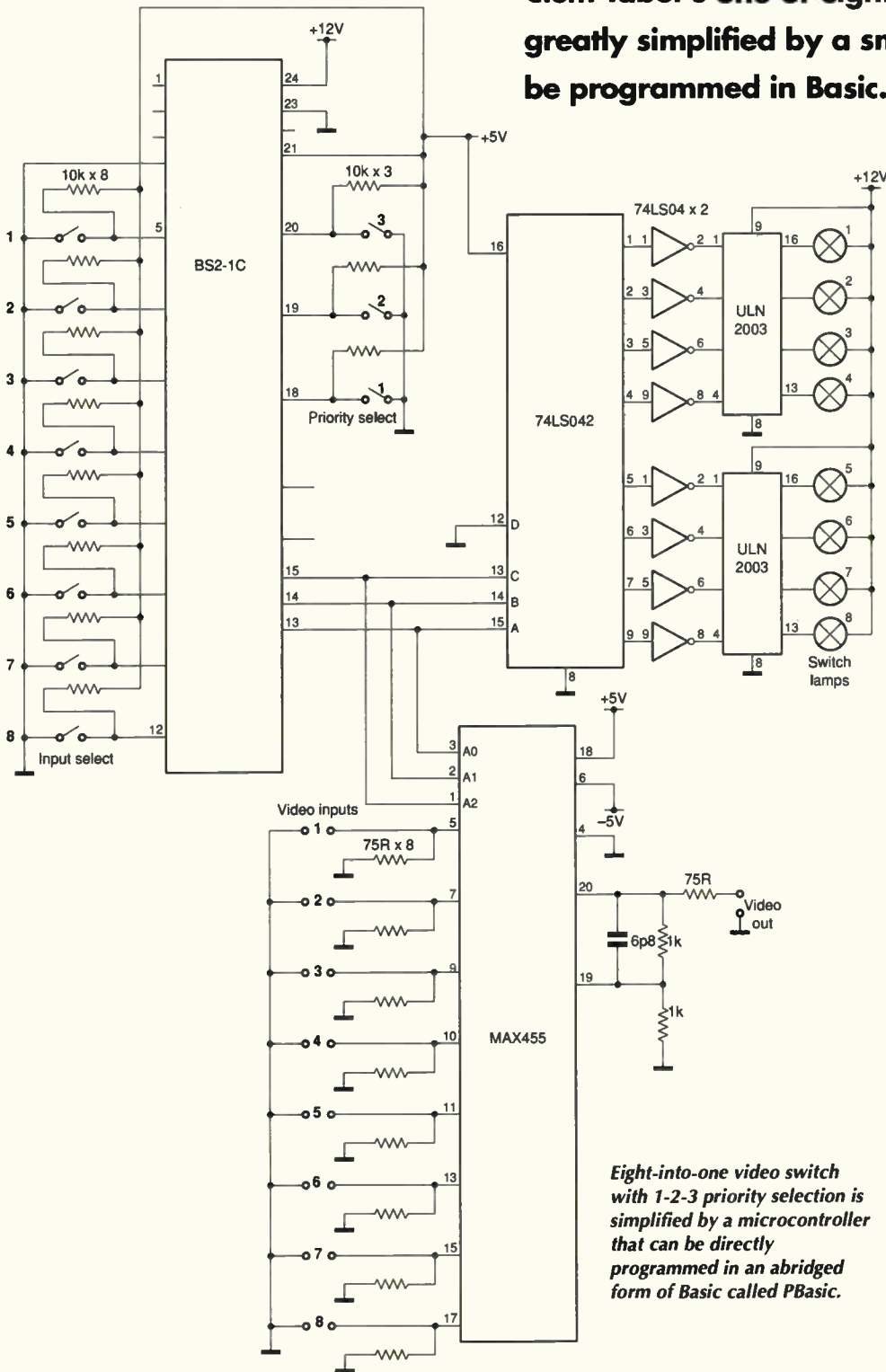

*Eight-into-one video switch with 1-2-3 priority selection is simplified by a microcontroller that can be directly programmed in an abridged form of Basic called PBasic.*

Recently, I was asked to produce an eight-into-one video switcher with the added complication of three priority switches for inputs 1, 2 and 3. These select the associated input for as long as the switch is depressed. On release the output reverts to the previously selected input.

To construct such a system using hard-wired logic was daunting, so I decided to use a Basic Stamp BS2-1C microcontroller module to provide some intelligence.

The circuit diagram shows eleven of the Stamp's sixteen i/o lines used as inputs, taken low by the momentary contact input select and priority select switches. The three lines configured as outputs control the MAX455 video switch and the ics driving the input selection indicator lamps. The video switch circuit was taken from a Maxim applications manual and the lamp driver components were used because they were to hand.

The Pbasic program is shown below. The program is split into several sub-routines. 'Loop' scans all the switches until one is closed. Then a jump is made to the routine shown at the end of the corresponding 'button' instruction. If switch 5 is pressed, the program jumps to 'SIX'. Binary 5 is placed on the three-bit output port and the number 6 is stored in memory location 0. A jump is then made back to 'loop', to wait for another switch closure.

If one of the switches 13, 14, or 15 is closed, the program jumps to the related 'PRIO' routine. In the case of switch 13 (priority 1), the jump is to 'PRIO 1'. Binary 0 is placed on the output port and the program returns to the start of 'PRIO 1' until the the switch is opened. At this point the number previously stored in memory location 0 is placed in variable 'last'. The 'if Last' lines ensure that the next jump is back to the routine which switched the last input selected before the priority switch was operated.

Readers familiar with Pbasic, will probably see ways of improving this program, but I think it illustrates that a 'jobbing' technician like me, with modest programming experience, can quickly produce quite complicated systems using a Basic Stamp.

**Basic listing reads the eight push switches and selects the appropriate video channel, subject to the information on the priority-select switches.**

'8 way switch driver. Binary outputs with three priority switches.  
'Clem Tabor. 12-12-95.

```

last var nib 'declare variable "last"

goto ONE 'select output 1 on power up

loop:
button 0,0,200,100,b0,1,ONE 'detect button 0 & go to next stage
button 1,0,200,100,b1,1,TWO 'detect button 1 & go to next stage
button 2,0,200,100,b2,1,THREE 'detect button 2 & go to next stage
button 3,0,200,100,b3,1,FOUR 'detect button 3 & go to next stage
button 4,0,200,100,b4,1,FIVE 'detect button 4 & go to next stage
button 5,0,200,100,b5,1,SIX 'detect button 5 & go to next stage
button 6,0,200,100,b6,1,SEVEN 'detect button 6 & go to next stage
button 7,0,200,100,b7,1,EIGHT 'detect button 7 & go to next stage
button 13,0,200,100,b13,1,PRIO1 'detect priority button 0 etc
button 14,0,200,100,b14,1,PRIO2 'detect priority button 1 etc
button 15,0,200,100,b15,1,PRIO3 'detect priority button 2 etc

goto loop 'back to start if no button change

ONE:
low 8 '0 out, output 1
low 9
low 10
write 0,1 'store latest button press
goto loop 'back to start

TWO:
high 8 '1 out, output 2
low 9
low 10
write 0,2
GOTO loop

THREE:
low 8 '2 out
high 9
low 10
write 0,3
goto loop

FOUR:
high 8 '3 out
high 9
low 10
write 0,4
goto loop

FIVE:
low 8 '4 out
low 9
high 10
write 0,5
goto loop

SIX:
high 8 '5 out
low 9
high 10
write 0,6
goto loop

SEVEN:
low 8 '6 out
high 9
high 10

write 0,7
goto loop

EIGHT:
high 8 '7 out
high 9
high 10
write 0,8
goto loop

PRIO1:
low 8
low 9
low 10
button 13,0,200,100,b13,1,PRIO1 'detect priority
'button 0 state & stay
'there until it is released
'read last button press
'if butt. 0 last,
'the back to ONE

if b13>0 then PRIO1
read 0,last
if last=1 then ONE

if last=2 then TWO
if last=3 then THREE
if last=4 then FOUR
if last=5 then FIVE
if last=6 then SIX
if last=7 then SEVEN
if last=8 then EIGHT
goto loop

PRIO2:
high 8
low 9
low 10
button 14,0,200,100,b14,1,PRIO2 'detect priority
'button 2 state & stay
'there until it is released
'read last button press

if b14>0 then PRIO2
read 0,last
if last=1 then ONE
if last=2 then TWO

'if button 1 last,
'then back to TWO

if last=3 then THREE
if last=4 then FOUR
if last=5 then FIVE
if last=6 then SIX
if last=7 then SEVEN
if last=8 then EIGHT
goto loop

PRIO3:
low 8
high 9
low 10
button 15,0,200,100,b15,1,PRIO3 'detect priority
'button 3 state & stay
'there until it is released
'read last button press

if b15>0 then PRIO3
read 0,last
if last=1 then ONE
if last=2 then TWO
if last=3 then THREE

'if button 2 last,
'then back to Three

if last=4 then FOUR
if last=5 then FIVE
if last=6 then SIX
if last=7 then SEVEN
if last=8 then EIGHT
goto loop

```



# Light reading for

# COM 1

**Edward Buckley Stamp-based subsystem for PCs reads the value on a dedicated light-to-frequency converter and transmits it to the pc via an RS232 link.**

In the January 1996 edition of *Electronics World* an article by Claus Kuhnel showed how easy it is to use the *TSL230* with the *Basic Stamp 1* microcontroller. The *Stamp* measured the width of one output pulse and converted this into a power flux measurement.

In application notes, Texas Instruments discusses two main measurement systems when using the *TSL230*. One is fast light measurement, the other longer term measurements offering a higher resolution. Slower measurements methods also incorporate the ability to reject spurious effects such as tube flicker.

Claus's article, based on the *Stamp 1*, used the fast method – measuring the width of the IC's output pulse. The newly introduced *Stamp 2* microcontroller has the benefit of several commands additional to those available on *Stamp 1*.

One of the new commands is COUNT. *Stamp 2* 'counts' the pulses coming from the

## Programming the Stamp

Basic Stamps comprise a PIC microcontroller, eeprom, oscillator and regulator. The PIC incorporates a Basic interpreter. Programs similar to the ones shown in these articles are stored in eeprom, making them non-volatile and allowing them to be changed within seconds as often as required.

Programs are constructed on a pc using special low-cost text editor software. Once completed, they are downloaded into the Stamp via a COM port in the case of Basic Stamp 2, or an LPT port for the Basic Stamp 1.

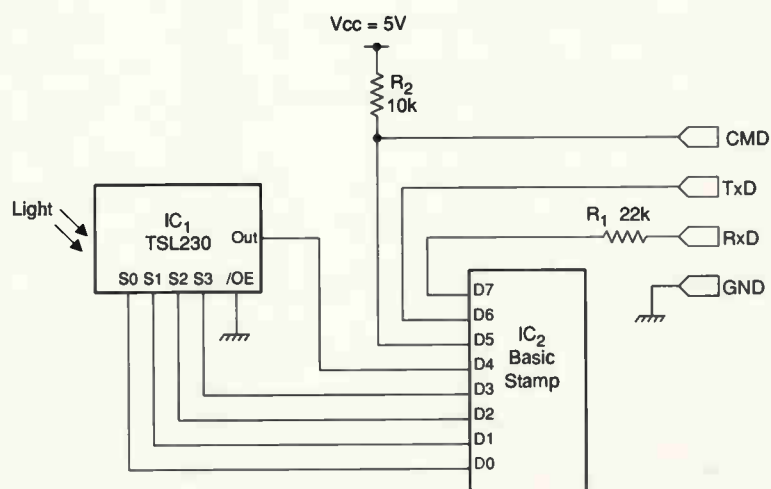

Interfacing to the pc via a COM port this circuit, together with the software shown, forms a subsystem for sensitive light measurement.

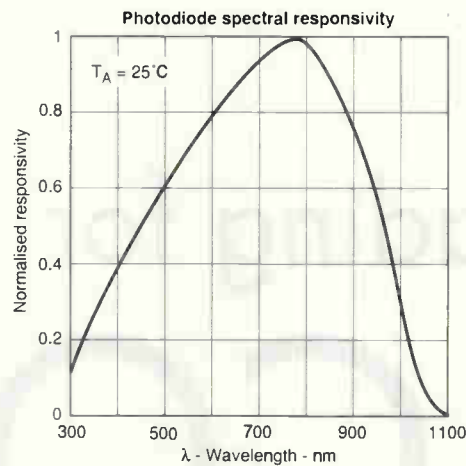
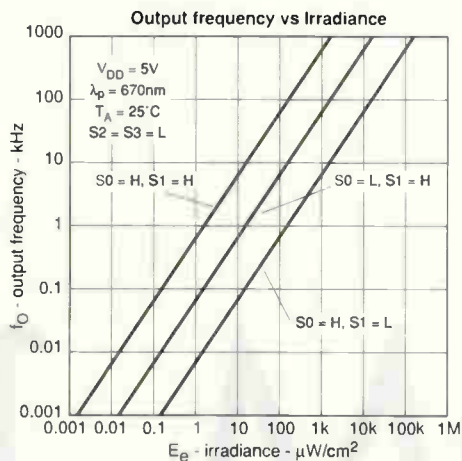
**Technical support**

Basic Stamp is distributed by Milford Instruments at Milford House, 120 High Street, South Milford, Leeds LS25 5AQ, tel. 01977 683665, fax 01977 681465.

**Stamp2 program for reading the TSL230 light-to-frequency chip.**

'Stamp2 first determines sensitivity range using Pulsin command  
 'Then switches to COUNT command for high- resolution measurement.  
 'The Stamp automatically switches sensitivity and frequency to give  
 'a power flux measurement range from 10nW to 100mW/cm<sup>2</sup>.

**'Variables**

sensitivity var byte 'TSL230 sensitivity range  
 freq\_range var byte 'Frequency scaling ratio  
 flux var word 'Light power flux result, 16 bits  
 puls\_in var word 'result from Pulsin command, 16 bits  
 cou\_nt var word 'result from Count command, 16 bits

**'Constants**

so con 0 'so connected to pin 0  
 s1 con 1 's1 connected to pin 1  
 s2 con 2 's2 connected to pin 2  
 s3 con 3 's3 connected to pin 3  
 CE con 4 'Chip-enable pin (active when low)  
 data\_in con 5 'data input line to pin5

**'Initialisation of pins**

'Pins read right to left

dir1=%00011111 '5 outputs and 3 inputs

'First section determines the sensitivity  
 'and frequency range for optimum operation.

**Start:**

'Start at x1 sensitivity  
 out1=%00001001 'F/10 and x1 sensitivity, chip enabled  
 sensitivity =1  
 puls\_in data\_in,1,puls\_in 'wait for high pulse-2µs increments  
 if puls\_in<300 AND puls\_in<>0 then measure 'if true goto measure

**'Increase sensitivity to x10**

sensitivity =10  
 out1=%00001010

puls\_in data\_in,1,puls\_in 'wait for high pulse again if  
 puls\_in<3000 AND puls\_in<>0 then measure 'if true measure

**'Increase sensitivity to x100**

sensitivity =100  
 out1=%00001011  
 puls\_in data\_in,1,puls\_in 'wait for high pulse again

if puls\_in<>0 then measure 'if true, measure

'Increase output frequency to F/2

freq\_range=5  
 out1=%00000111

'Now go to the COUNT command.

'Count gives a higher resolution than the puls\_in command and rejects  
 'flicker effects but takes longer.

'500ms count period taken to avoid overflow in count variable

**Measure:**

count data\_in,500,cou\_nt 'Measure number of pulses in 500ms

'Now sort out the units before writing to the screen!

'Due to the high dynamic range of the TSL230 need to re-arrange the  
 'power flux calculation depending on the sensitivity/freq\_range used  
 'otherwise may result in overflow in "flux" variable

if sensitivity>1 then skip1  
 flux=cou\_nt/10\*2/10\*13/100 'convert count to flux  
 'note maths sequence to prevent overflow to variable  
 debug "Power Level=",dec flux,"milliwatts/cm2" 'Display answer  
 goto start

skip1: if sensitivity>10 then skip2  
 flux=cou\_nt\*13/10\*2/10  
 debug "Power Level=",dec flux,"microwatts/cm2"  
 goto start

skip2: flux=cou\_nt\*2\*13/freq\_range  
 debug "Power Level=",dec flux,"nanowatts/cm2"  
 goto start



## DIGITAL DESIGN

*TSL230* over a period of time and uses this number to calculate the power flux. Being based on a large number of pulses, the result is now smoothed of spurious signals.

Both COUNT and PULSIN are used in this Stamp 2 version of Claus's article. The command PULSIN helps quickly find the best sensitivity and output frequency range, thereafter COUNT returns a smoothed result.

Variables and constants are defined in the usual way and the output pins set to produce the default sensitivity, namely  $\times 1$ , and a frequency division of  $f/10$ .

The Stamp 2 takes the first measurement, at Pulsin in the program, following which it decides whether to increase the sensitivity or to progress on to take a full measurement. Conditional statement `puls_in < 300` checks whether a better result could be obtained by increasing the sensitivity and the `puls_in > 0` checks for no result at all. If there is no input, a very low light level indeed is being measured. No input only occurs when the Stamp 2 has timed out at 131ms without any reading, resulting in the writing of 0 to the variable.

The above is repeated to check whether a jump to  $\times 100$  sensitivity would be beneficial. If very low light levels are being experienced, a further attempt to optimise the measurement

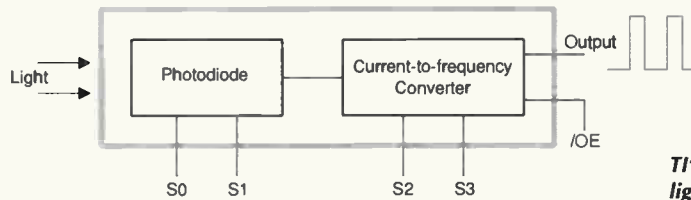

S1	S0	Sensitivity
L	L	Power down
L	H	1x
H	L	10x
H	H	100x

S1	S0	FO scaling (divide-by)
L	L	1
L	H	2
H	L	10
H	H	100

*TI's TSL230 is a light-to-frequency converter with programmable sensitivity and output frequency range.*

conditions is considered by the Stamp by increasing the *TSL230*'s output frequency from  $f/10$  to  $f/2$ . This 'hunting' for a suitable operating point is indicated on the accompanying frequency/flux diagram for the *TSL230*.

Once 'optimum' conditions are in place, the Stamp proceeds to take the actual power flux measurement using the Count command. It measures the number of cycles from the *TSL230* in a 500ms period.

The Stamp 2 can measure up to a maximum of 65 536 cycles at a maximum frequency of 125kHz. The start-up conditions/hunting pro-

cedure and count period should ensure the count is readable by Stamp 2.

Finally the actual power flux is calculated and written to the computer screen using the Debug command. A Stamp standard chunk of code may also be introduced here to send the result to either an liquid-crystal display, remote computer or store the result in electrically erasable prom.

The high dynamic range of the *TSL230* and the 16-bit integer maths capability of the Stamp mean that some care has to be taken with the arithmetic to avoid either overflows or loss of accuracy due to rounding errors. ■

## 'OFF-AIR' FREQUENCY STANDARD

CIRCLE NO. 116



- \* Provides 10MHz, 5MHz & 1MHz
- \* Use it for calibrating equipment that relies on quartz crystals, TCXOs, VCXOs, oven crystals
- \* Phase locks to DROITWICH (rubidium controlled and traceable to NPL)
- \* For ADDED VALUE also phase locks to ALLOUIS (cesium controlled and traceable to OP - French eq to NPL)
- \* British designed and British manufactured
- \* Options available include enhanced receiver, sine wave outputs and 13MHz output for GSM. Prices on application.

Output frequencies - 10MHz, 5MHz, 1MHz  
Short term stability - better than  $1 \times 10^{-9}$  (1 sec)  
Typical -  $4 \times 10^{-9}$  (1 sec)  
Long term - tends to  $2 \times 10^{-12}$  (1000 sec)  
Call for 'Off-Air' Standard list

## TEST EQUIPMENT

CIRCLE NO. 117

We are well known for our quality, new and used Test Equipment. Our list is extensive, ranging through most disciplines. Call for details and a complete list

Marconi Spectrum Analyser TF2370 .....	£895	Marconi LCR Bridge TF2700.....	£149
Bradley Oscilloscope Calibrator 156 .....	£395	Marconi LCR Bridge TF1313A .....	£125
Bird Termaline, 2.5kW 50Ω .....	£295	Mahogany Cased 5kV Megger (Collectors) .....	£POA
Philips Function Generator PM5134.....	£995	Taylor Valve Tester 474 .....	£59
Hitachi Oscilloscope V222, 20MHz .....	£249	Philips RF Generator PM5326 .....	£395
Rapid Oscilloscope 7020, 20MHz .....	£249	HP Frequency Counter HP5340 .....	£595
Philips Pulse Generator PM5716.....	£495	Taylor AM/FM Generator 62A .....	£69
Amprobe AC Recorder LAV3X.....	£75	Marconi Attenuator TF2163 .....	£195
Amprobe Temperature Recorder LT8100.....	£75	RE Mega-Ohmmeter/pica-Ammeter IM6.....	£295
Emerson UPS 1.5kW .....	£599	Ferrogaph Recorder test Set RTS2.....	£95
		HP Vector Voltmeter HP8405A.....	£249

**HALCYON ELECTRONICS**  
423, KINGSTON ROAD, WIMBLEDON CHASE, LONDON SW20 8JR  
SHOP HOURS 9-5.30 MON-SAT. TEL 0181-542 6383. FAX 0181-542 0340

CIRCLE NO. 118 ON REPLY CARD



## Field Electric Ltd.

Tel: 01438-353781 Fax: 01438 359397



Mobile: 0836-640328

Unit 12b, Parsons Green Ind. Est.  
Stevenage, Herts SG1

12" Colour VGA-SVGA 800x600 Monitors	£52.50
14" Colour VGA Monitors various 1st brand makes	£60.00
17" Colour VGA-SVGA Monitors 1st brand makes	£285.00
Sony 9" RGB Colour Monitors (Trinitron)	£39.00
Compaq Docking Stations for laptop & notebooks	£24.95
Tseng Dual Port VGA-SVGA ISA 16 Bit Card 1mb to run 2 monitors from 1 pc	£29.95
Hauppauge Win/TV Card 16 bit ISA card	£40.00
Roland DXY 1300 8 Pen Plotter	£135.00
Roland DXY 1100 8 Pen Plotter	£120.00
Hewlett Packard 7470A Plotter RS232 8 Pen	£75.00
Hewlett Packard Colour Pro Plotter RS232 8 Pen	£75.00
Hewlett Packard 7475A Plotter RS232 6 Pen	£70.00
Hewlett Packard 7550A Plotter HPIB RS232 etc	£200.00
Hewlett Packard Laserjet 11D Printer	£180.00
Hewlett Packard Scanjet	£95.00
Sony Lasermax Videodisk Player LDP 1500P	£165.00
Racal Inst. 9915 UHF Freq. Meter 500 MHz	£90.00
Racal Inst. 9916 UHF Freq. Counter 500 MHz	£130.00
Leader LMV 181A AC Millivoltmeter	£130.00
Blackstar Multimeter 3225	£50.00
Siemens Data Line Analyser K1190 with manual	£280.00
Farnell PSU 0-70VDC 0-5A/0-30 VDC 0-10A	£225.00
Marconi Inst. Data Comms Tester 2870	£295.00
Marconit Inst. Digital Line Monitor 2833	£270.00
Marconi Inst. Digital Analyser 2829	£270.00
Philips PM3233 10 MHz D/trace Scope	£50.00
Tektronix DAS9100 Digital Analysis System	£145.00
Iswatsu SS5702 20 MHz D/trace Scope	£140.00
Hewlett Packard 415E SWR Meter	£75.00
Hewlett Packard 3551A Transmission Test Set	£180.00
Hewlett Packard 5004A Signature Analyzer	£75.00
Philips PM 6611 Universal Counter 80 MHz	£90.00

**PLOTTERS • COMPUTERS • COMMUNICATIONS • PSU • VDU's • VIDEO  
• FANS • TEST • CABLE • NETWORK • PRINTERS •  
DISK DRIVES ALWAYS IN STOCK. OVERSEAS ENQ. WELCOME  
TELEPHONE ORDERS ACCEPTED  
C/P DETAILS PLEASE RING. ALL PRICES PLUS 17.5% VAT**

CIRCLE NO. 119 ON REPLY CARD



# The MICRO MODULE A NEW LOW COST controller that gives you customisation for as little as **£95** one off - VAT

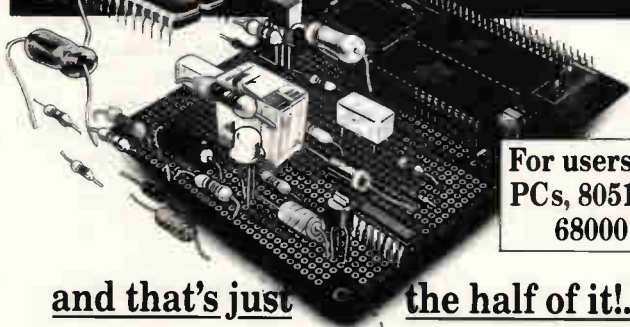

**For users of  
PCs, 8051 &  
68000**

**and that's just the half of it!!**

### FEATURES

- 16/32 bit 68307 CPU for fast operation
- Up to 1 Mbyte of EPROM space onboard
- Up to 512Kbyte SRAM space onboard
- 32 Kbyte SRAM fitted as standard
- RS232 serial with RS485 option
- MODBUS & other protocols supported
- Up to 22 digital I/O channels
- 2 timer/counter/match registers
- I<sup>2</sup>C port or Mbus & Watch dog facilities
- Large Proto-typing area for user circuits
- Up to 5 chip selects available
- Program in C, C++, Modula-2 & Assembler
- Real Time multitasking Operating System
- OS9 or MINOS with free run time license option
- Manufacturing available even in low volumes
- A full range of other Controllers available

### P.C. 'C' STARTER PACK AT ONLY £295 + VAT

The Micro Module will reduce development time for quick turnaround products/projects and with the P.C. 'C' Starter pack allow you to start coding your application immediately, all drivers and libraries are supplied as standard along with MINOS the real time operating system all ready to run from power on.

The 'C' Starter pack includes: A Micro Module with 128 Kbyte SRAM, PSU, Cables, Manuals, C compiler, Debug monitor ROM, Terminal program, Downloader, a single copy of MINOS. Extensive example software, and free unlimited technical support all for £295 + VAT.



**Cambridge Microprocessor  
Systems Limited**

Unit 17-18, Zone 'D', Chelmsford Road Ind. Est.,  
Great Dunmow, Essex, U.K. CM6 1XG  
Phone 01371 875644 Fax 01371 876077

**CIRCLE NO. 120 ON REPLY CARD**

# STABILIZER 5



In any public address system where microphones and loudspeakers are in the same vicinity, acoustic feedback (howlround) occurs if the amplification exceeds a critical value. By shifting the audio spectrum fed to the speakers by a few Hertz, the tendency to howl at room resonance frequencies is destroyed and increased gain is available before the onset of feedback:



★ Broadcast Monitor Receiver 150kHz-30MHz ★ Advanced Active Aerial 4kHz-30MHz ★ Stereo Variable Emphasis Limiter 3 ★ 10-Outlet Audio Distribution Amplifier 4 ★ PPM10 In-vision PPM and chart recorder ★ Twin Twin PPM Rack and Box Units ★ PPM5 hybrid, PPM9 microprocessor and PPM8 IEC/DIN -50/+6dB drives and movements ★

### SURREY ELECTRONICS LTD

**The Forge, Lucks Green, Cranleigh GU6 7BG  
Telephone: 01483 275997 Fax: 276477**

## The OneStop solution to process signal line protection

Din rail mounting radio frequency interference filter and transient voltage suppressor for voltage and current loop process signals

For all two wire twisted pair applications

Upgrading from light to full industrial EMC requirements

Provides protection against the following:

- \*Directly coupled RFI from such sources as inverter switching, electric motors, radio paging and signalling systems, broadcast transmitters, and locally high levels of radio frequency energy radiating from near by equipment (e.g. medical)
- \*Electrostatic discharge
- \*Mains switching transients
- \*Fast transient/burst requirements



Also professional units operating from battery/external DC:

- The Balance Box** - Precision mic/line amplifier
- Phantom Power Box** - 48 Volt mic powering
- Headphone Amplifier Box** - Mic/line to headphone driver

**Conford Electronics Conford Liphook Hants U30 7QW**

Information line 01428 751469 Fax 751223

E-mail contact@confordelec.co.uk

Web <http://www.confordelec.co.uk/catalogue/>

**CIRCLE NO. 121 ON REPLY CARD**

## New Special Offers

New mini waterproof TV camera 10x10x15mm requires 10 to 20 volts at 120mA with composite video output (to feed into a video or a TV with a SCART plug) it has a high resolution of 450 TV lines Vertical and 580 TV lines horizontal, electronic auto iris for near dark (1 LENS) to bright sunlight operation and a pinhole lens with a 92 degree field of view, it focuses down to a few CM. It is fitted with a 3 wire lead (12v in gnd and video out).....	£109.95 or 10+ £89.92 + VAT = £104.95
High quality stepping motor kits (all including stepping motors) Comstep independent control of 2 stepping motors by PC (via the parallel port) with 2 motors and software.....	Kit £67.00 Ready built £98.00
Software support and 4 digital inputs kit.....	£27.00
Power interface 4A kit.....	£36.00
Power interface 8A kit.....	£46.00
Stepper kit (manual control) includes 200 step stepping motor and control circuit.....	£23.00
Hand held transistor analyser it tells you which lead is the base, the collector and emitter and if it is NPN or PNP or faulty.....	£33.45
spare 6v battery.....	£1.20
LEDs 3mm or 5mm red or green.....	7p each yellow 11p
each cable ties 1p each £5.95 per 1000, £49.50 per 10,000	
Rechargeable Batteries	
AA (HP7) 500mAh.....	£0.99
AA 700mAh.....	£1.75
C2AH with solder.....	£3.60
D 4AH with solder.....	£4.95
1/2AA with solder.....	£1.55
AAA (HP16) 180mAh.....	£1.75
Standard charger charges 4 AA cells in 5 hours or 4 Cs or Ds in 12-14 hours + 1xPP3 (1, 2, 3 or 4 cells may be charged at a time).....	£5.95
High power charger as above but charges the Cs and Ds in 5 hours. AA, Cs and Ds must be charged in 2s or 4s.....	£10.95
Nickel Metal Hydride AA cells high capacity with no memory. If charged at 100ma and discharged at 250ma or less 1100mAh capacity (lower capacity for high discharge rates).....	£3.75
Special offers, please check for availability.	
Stick of 4 42x16mm Nicad batteries 17x16mm dia with red & black leads 4.8v.....	£5.95
5 button cell 6V 280mAh battery with wires (Varta 5x250DK).....	£2.45
Shaded pole motor 240Vac 5mm x 20mm shaft.....	£4.95 each
80x60x55mm excluding the shaft.....	£4.95 each
115v AC 80v DC motor 4x22mm shaft 50mm dia x 60 long body (excluding the shaft) it has a replaceable thermal fuse and brushes.....	£4.95 each (£3.95 100+)
7 segment common anode led display 12mm.....	£0.45
LM337k TO9 case variable regulator.....	£1.95
GsAs FET low leakage current S8873.....	£1.44 100+ £1.95 each
BS250 P channel mosfet.....	£0.45
BC559 transistor.....	£3.95 per 100
BC547A transistor.....	20 for £1.00
74LS05 hex inverter.....	£10.00 per 100
Used 8718 Microcontroller.....	£3.50
SI 932 L11F Limiting amplifier LC 16 surface mounting package with data sheet.....	£1.95
DC-DC converter Reliability model V12P5 12v in 5v 300ma out 300v input to output Isolation with data.....	£4.95 each or pack of 10 £39.50
Hour counter used 7 digit 240v AC 30Hz.....	£1.15
QWER IV keyboard 38 key good quality switches new.....	£6.00
Airfax A82903-C large stepping motor 14x 7.5".....	£6.00
27ohm 68mm dia body 5.3mm shaft.....	£8.95 or £200.00 for a box of 30
Polyester capacitors box type 22.5mm lead pitch	
0.9uf 250vdc.....	18p each
14p.....100+ 9p.....1000+.....	20p each
15p.....100+ 10p.....1000+.....	15p each
1uf 80v bipolar electrolytic axial leads.....	7.5p 1000+ 15p each
0.22uf 250v polyester axial leads.....	7.5p 100+ 15p each
Polypropylene 1uf 400vdc (Wima MKP10) 27.5mm pitch 32x29x17mm case.....	75p each 60p 100+ 40p each
Philips 123 series solid aluminium axial leads - 35uf 10v & 4uf.....	25p 100+ 30p each
Philips 108 series long lead 22uf 63v axial.....	15p 1000+ 25p 100+
Multivier AVX ceramic capacitors all 5mm pitch (0.0v 100pf, 150pf, 220pf, 10,000pf (10n).....	10p each 5p.....100+ 3.5p.....1000+
500pf compression trimmer.....	60p
40uf 370vdc motor start capacitor (dielectric type containing no pcb).....	£5.95 or £49.50 for 10
Solid carbon resistors very low inductance ideal for RF circuits - 27ohm 2W, 68ohm 2W.....	25p each 15p each 100+
We have a range of 0.25w, 0.5w, 1w and 2w solid carbon resistors, please send SAE for list.	
P.C. 400W PSU (Intel part 201035-001) with standard motherboard and 3 disk drive connectors, fan and mains inlet/outlet connectors on back and switch on the side (top for tower case) dims 212x149x149mm.....	£26.00 each excluding switch..... £138.00 for 6
MX180 Digital multimeter 17 ranges 1000vdc 750vac 2Mohm 200mA transistor Hfe 9v and 1.5v battery test.....	£9.95
AMD 27256-5 Eproms.....	£2.00 each £1.25 100+ DIP switch 3PCU 12 pin (ERG SDC-3-023).....
60p each	
Disk drive boxes for 5.25 disk drive with room for a power supply, light grey plastic, 67x268x217mm.....	40p 100+ £7.95 or £49.50 for 10
Hand held ultrasonic remote control.....	£3.95
CV2486 gas relay, 30x10mm dia with 5 wire terminals, will also work as a neon light.....	£26.00 each excluding switch..... £7.50 per 100
Verbatim R300N1 Streamer tape commonly used on machines and printing presses etc. it looks like a normal cassette with a slot cut out of the top.....	£4.95 ea. £3.75 100+
Heat sink compound tube.....	£3.95
1V5-2.05E5-5-240-50mA regulator ic 18-26vac input 8 pin DIL package.....	£3.49 each (100+ £2.25)
LM 555 timer ic 16p.....	8 pin DIL socket 6p

All products advertised are new and unused unless otherwise stated. Wide range of CMOS TTL 74HC 74F Linear Transistors kits, Rechargeable batteries, capacitors, tools etc always in stock. Please add £1.95 towards p&p. VAT included in all prices.

**JPG Electronics, 276-278 Chatsworth Road, Chesterfield S40 2BH**  
Access/Visa Orders (01246) 211202 Fax: 550959  
callers welcome 9.30am to 5.30pm Monday to Saturday

**CIRCLE NO. 122 ON REPLY CARD**





With this novel packaging, the components of any dual-component adhesive can be mixed and dispensed with ease and safety.

Anyone who has mixed high-performance epoxies will know that any glue finding its way on to a surface where it is not wanted can be a real nuisance to remove. With this new concept, the epoxy is mixed in a sealed bag and applied from the same bag via a snip on the corner. The result is thorough, precise mixing with much less mess.

# SOLUTION FOR STICKY PROBLEMS

It is a fact of life that some of the best adhesives are the trickiest to handle. They often have two components which must be mixed thoroughly in the correct proportions for optimum performance – not too easy with viscous liquids. Then there is the problem of delivery. The correct amount of adhesive must reach the repair surface without picking up contamination or sticking to everything else on the way – including your fingers.

These difficulties are overcome by a new approach where choice of adhesive is linked with a custom packaging and delivery system, designed and developed by Resintech.

A typical *TwinPack* sachet is shown in the photograph, top left. It contains 5ml of an epoxy resin adhesive. Contents of the sachet could also be polyurethane or silicones, with applications from adhesives to sealants, potting compounds and encapsulants. Pack sizes can vary from 1 to 1000ml with resin to hardener ratios easily varied.

Components are accurately preweighed and kept free from moisture or other contamination right up to the time of use. This leads to quicker, easier, cleaner safer installations compared with conventional packaging methods. A more reliable bond is generated time after time.

### High-strength adhesive

This epoxy sample is a high strength adhesive with a work life of 8-10 minutes. It is suitable for most substrates including metal, wood, china, ceramics, glass and hard plastics. Make sure surfaces to be bonded are clean, dry and free from grease, dust or dirt.

Remove the red clip and bar, which until now have acted as a barrier to separate the resin and hardener. Now, the innovative part of the packing is revealed as the sachet becomes one pouch, allowing the two components to be freely mixed. Contents still remain sealed during this process against moisture, air or particle contamination.

To help mix, use the red bar to push components together. Knead the pouch with your fingers until a uniform mix is obtained. This takes about a minute.

The plastic pouch is made from a strong, tough laminate which will withstand vigorous handling. To apply the adhesive, simply cut off a corner and squeeze out the contents. The

corner cut can be varied to provide the ideal bead size for the repair area. Allow adhesive to set before handling which can be 20 minutes to 2 hours depending on the application.

Any unused residue still in the pack will cure to a solid and in this form does not constitute a waste hazard.

In engineering, prototyping, maintenance and servicing, the convenience of small quantities, ease of handling and storage are most important. The *TwinPack* can be carried around in your pocket, bag or toolkit, at home or at work, without fear of leakage.

No associated equipment is needed. *TwinPack* is self-contained and ready for use.

### And other adhesives?

Given the correct choice of adhesive, then the packaging and delivery system have a major impact on factors such as convenience or installed cost. The mess and hassle associated with mixing from separate tubes or tubs can be reduced to a minimum by using a clip separated sachet – *TwinPack*, or a double barrelled cartridge called *DuoSyringe*. These two systems are largely interchangeable with the *DuoSyringe* preferred for non-sag sealants and *TwinPack* for easy spread adhesives.

For industrial applications benefits come through productivity gains, cost saving, improved quality and safety. These arise because quantities of adhesive and mix ratios are precisely controlled. Waste is minimised, and anyone handling the adhesive is protected from exposure to hazardous material.

*TwinPack* can be produced in almost any size and quantity to match production requirements. There is a choice of materials for most adhesive, potting encapsulation or sealant applications.

### Alternative delivery

As an alternative to the *TwinPack*, Resintech also offers the *DuoSyringe*. Here, the resin and hardener are contained in a side-by-side syringe. The material is discharged through a mixing nozzle directly on to the substrate, using a dual action dispenser gun.

*DuoSyringe* has specific application in handling adhesive sealants, where high degree of thixotropy is designed in to the system to enable a non-slumping bead to be formed. A typical *DuoSyringe* volume is 50ml. Resin to

\*Due to varying regulations in different countries regarding gifts with magazines, this offer is limited to UK readers only. However, Resintech has generously offered to supply a free sample to any overseas reader, on receipt of a written request, while stocks last.

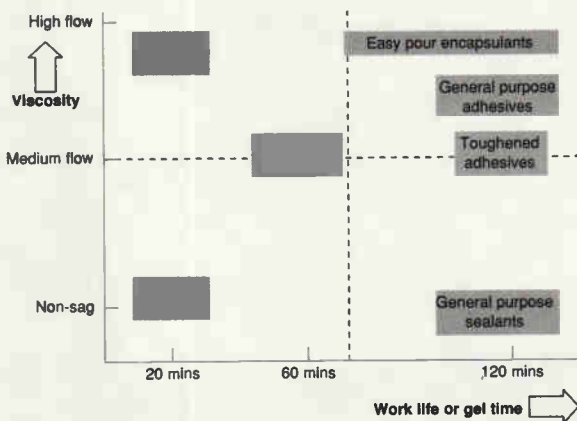

Fig. 1. Relative flow performance of available epoxy resin formulations.

hardener ratios can be varied up to 10:1 using different barrel diameters.

**Selecting the right adhesive**

Determining the right adhesive for the job is very much depends on the substrates to be handled and performance specification. More often than not the choice is subject to some trial and error before the right balance between bond strength, production requirements and cost can be established.

Some guidelines are offered here to help narrow the choice and these are backed up by a materials design and sample service from Resintech for those all important preliminary tests and trials.

**Process variables**

Figure 1 shows relative flow performance of available resin formulations at the incipient point of mixing. Once reaction starts, at a rate which can be varied according to desired work life, viscosity increases in all systems until first a gel and then a solid state is reached.

A vertical bond would need a low flow adhesive, a product in the lower half of the chart. A potting compound for intricate components may need a high flow material from the upper half of the chart. Printed-circuit board mounting, or other sequential tasks,

would need a fast cure product from the left hand side of the table.

Work life is defined as the approximate length of time a 25g standard mass of adhesive requires to begin to harden – known as the gel-point – at room temperature. The rate of reaction is very dependent on temperature. Oven cure is widely practised. As a rule of thumb for each 10°C rise in temperature work life or cure time will halve.

As a note of caution, an accelerated reaction may influence final properties.

**Performance matrix**

It is common to measure the mechanical performance of a bond in terms of shear strength and peel strength. Requirements will vary according to application. The higher up the chart, Fig. 2, the greater the shear strength, and the stronger the bond. The further to the right indicates more flexibility. Toughened systems have a good balance of both properties.

Environmental factors such as fluids, heat and sunlight may dictate that a different chemical system be chosen.

Resintech can offer custom formulation to achieve the desired balance of properties from any system. In addition to the options mentioned previously these might include high clarity for optical systems, colour matching,

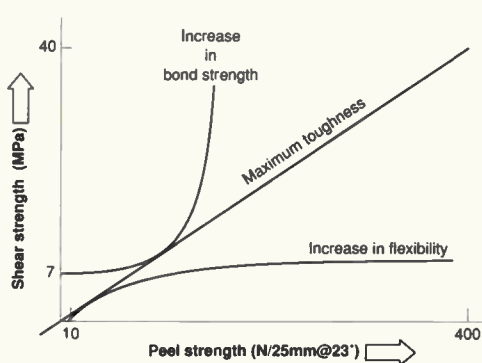

Fig. 2. Performance balance between various epoxies highlights the importance of choosing the right product for the job.

flame retardancy, zero halogen components, high purity electrical grades and more.

When combined with specific packaging and delivery systems such as the *TwinPack* or *DuoSyringe* a high performance adhesive can be used with minimum mess and hassle. ■

Resintech, manufacturers of a wide range of adhesives, is at Horcott, Fairford, Glos GL7 4BX, on 01285 712755 fax 713036.

**mqp** 10th Year of Quality Programmer Manufacture

# Pin-Master 48

EPROMs - EEPROMs - FLASH - Micros - PLDs - 3V Parts

State-of-the-Art Universal Programmer

Designed and Supported in England

Worldwide distribution

Phone Gina for free data pack

**MQP Electronics, Park Road Centre, Malmesbury, Wilts SN16 0BX, England**  
**Phone 01666 825 666 Fax 01666 825 141 email mqp@compuserve.com http://www.mqp.com.**



**Filters based on frequency-dependent negative resistors offer the performance of LC filters but without the bulk and expense. And component intolerance is lower than for other If filters types. Ian Hickman explains.**

# FILTERS using negative resistance

**W**hen it comes to filters, it's definitely a case of horses for courses. At rf the choices are limited; for tunable filters covering a substantial percentage bandwidth, it has to be an LC filter. If the tunable elements are inductors, you have a permeability tuner; alternatively, tuning may use variable capacitance, or varactors. Fixed frequency filters may use LCs, quartz crystals, ceramic resonators or surface-acoustic-wave (SAW) devices, while at microwaves, the 'plumbers' have all sorts of ingenious arrangements.

At audio frequencies, LC filters are a possibility. However, the large values of inductance necessary are an embarrassment, having a poor Q and temperature coefficient, apart from their bulk and expense.

One approach is to use 'LC' circuits where the inductors are active circuits simulating inductance. There is a number of these, and Fig. 1 is an example. For high-pass filters, synthetic inductors with one end grounded, Fig. 1a), suffice, but for low-pass applications, rather more complicated circuits simulating

**Fig. 1. Synthetic inductors.**

a) A 1H 'inductor' with one end grounded. Q is 10 at 0.00159Hz, and proportional to frequency above this. Below, it tends to a 0.001Ω resistor, just like the corresponding real inductor.

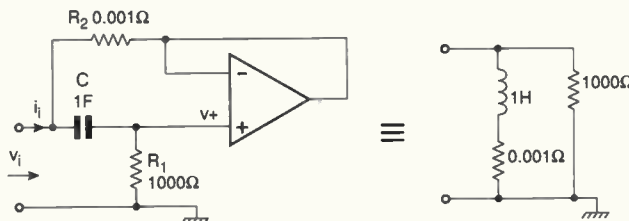

b) Floating synthetic 1H inductor. The high-value resistors shown dotted are necessary to define the op-amp dc conditions if there is no dc path to ground via input and output.

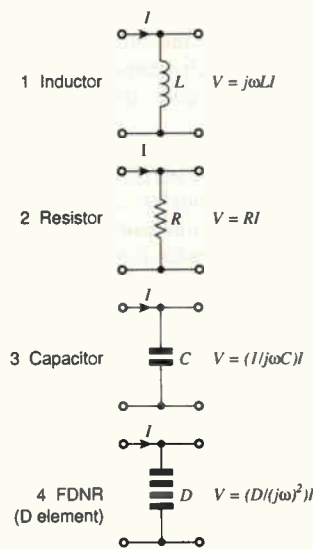
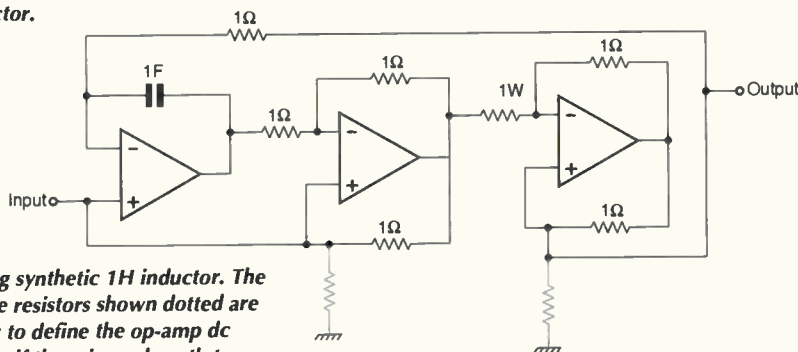

**Fig. 2. Resistance (reactance?) of an fdnr – also known as a supercapacitor or D element – varies with frequency.**

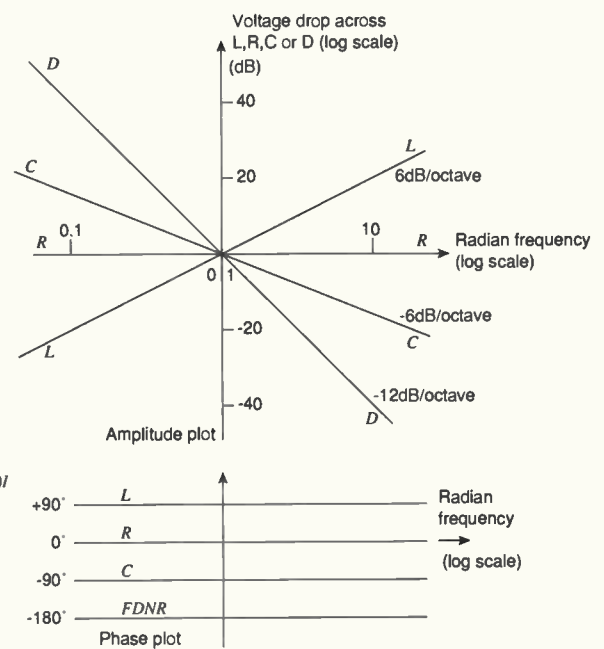

floating inductors are required, Fig. 1b).

More recently, switched-capacitor filters have become available, offering a variety of filter types, such as Butterworth, Bessel and Elliptic. These vary in complexity up to eight or more poles.

For narrow band-pass applications, a strong contender must be the N-path filter. This scheme uses switched capacitors but is not to be confused with switched capacitor filters; it works in an entirely different way. However, both switched capacitor and N-path filters are time-discrete circuits, with their cut-off frequency determined by a clock frequency. Hence both types need to be preceded by an anti-alias filter – and usually followed by a low-pass filter to suppress clock frequency hash. That is the downside: the upside is that tuning is easy – simply change the clock frequency.

The cut-off or centre frequency of a switched capacitor filter scales with clock fre-

quency, but the bandwidth of an  $N$ -path filter does not.

Where a time-continuous filter is mandatory, various topologies are available, including Salen and Key and Rausch. An interesting and useful alternative to these and to  $LC$  filters, with either real or simulated inductors, is the fdnr filter, which makes use of frequency-dependent negative resistances.

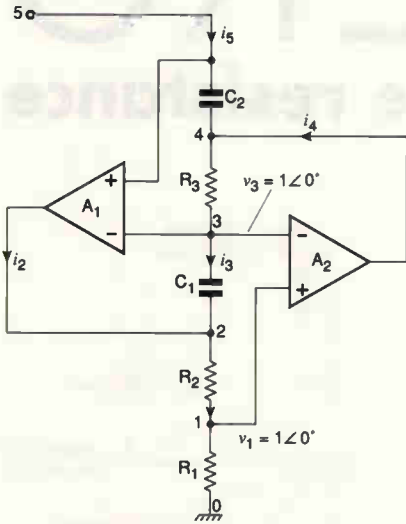

Fig. 3a). Circuit diagram of an fdnr. If  $V_1$  is the voltage at node 1, etc., then  $V_1=V_3=V_5$ . Also,  $i_1=i_2+i_3$  and  $i_3=i_4+i_5$ .

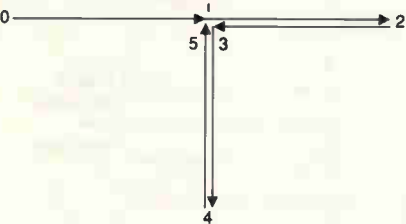

Fig. 3b). Voltage vector diagram for (a) when  $R_1=R_2=R_3=R$ ,  $C_1=C_2=C$  and  $f=1/2\pi CR$ .

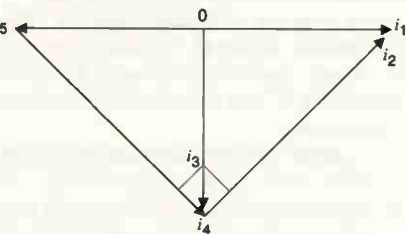

Fig. 3c). Current vector diagram for (a), for the same conditions as (b).

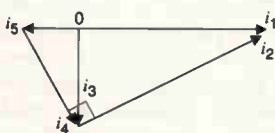

Fig. 3d). As (c) but for  $f=1/\pi CR$ . Note that  $i_2$  and  $i_4$  are always in quadrature.

**What is an fdnr?**

A negative resistance is one where, when you take one terminal positive to the other, instead of sinking current, it sources it – pushes current back out at you.

As the current flows in the opposite direction to usual, Ohm's law is satisfied if you write  $I=E/-R$ , indicating a negative current in response to a positive potential difference, or pd. This would describe a fixed, or frequency independent, negative resistance. But fdnrs have a further peculiarity – their resistance, reactance or impedance, call it what you will, varies with frequency. Just how is illustrated in Fig. 2.

With inductors, the voltage leads the current by  $90^\circ$ ; with capacitors, it lags by  $90^\circ$ . Combining these with resistive terminations, where the voltage leads/lags the current by  $0^\circ$ , you can make filters. Such filters may be high-pass, band-pass, low-pass, or whatever you want.

It was pointed out in a famous paper<sup>1</sup> that, by substituting for  $L$ ,  $R$  (termination) and  $C$  in a filter, components with  $90^\circ$  more phase shift and 6dB/octave faster roll than the  $L$ ,  $R$  and  $C$ , exactly the same transfer function could be achieved.

Referring to Fig. 2,  $L$ ,  $R$  and  $C$  are replaced on a one-for-one basis by  $R$ ,  $C$  and fdnr respectively. An fdnr can be realised with resistors, capacitors and op-amps, Fig. 3.

**So how does an fdnr work?**

Analysing Fig. 3 provides the answer. Looking in at node 5, you see a negative resistance; but what is its value?

First of all, note that the circuit is dc stable. At 0Hz, where you can forget the capacitors,  $A_2$  has 100% negative feedback via  $R_3$ , and its non-inverting input is referenced to ground.

Likewise,  $A_1$  has its non-inverting input referenced to ground, assuming there is a ground return path via node 5. It also has 100% negative feedback;  $A_2$  is included within this loop.

The clearest and easiest way to work out the ac conditions is with a vector diagram; just assume a voltage at node 1 and work back to the beginning. Thus in Fig. 3, assume that  $V_{1,0}$ , i.e. the voltage at node 1 with respect to node 0 or ground, is 1V ac, at a frequency of 1 radian per second ( $1/(2\pi)$  or 0.159Hz), and that  $R_1=R_2=R_3=1\Omega$ ,  $C_1=C_2=1F$ . Thus the voltage at node 1 is represented in Fig. 3b) by the line from 0 to 1, of unit length, the corresponding current of 1A being shown as  $i_1$  in Fig. 3c).

Straight away, you can mark in, in b), the voltage  $V_{2,1}$ , because  $R_1=R_2$ , and node 1 is connected only to an (ideal) op-amp which draws no input current. So  $V_{2,1}$  equals  $V_{1,0}$  as shown.

But assuming  $A_2$  is not saturated, with its output voltage stuck hard at one or other supply rail, its two input terminals must be at virtually the same voltage. So now  $V_{3,2}$  can be

marked in, taking one back to the same point as node 1. Given  $V_{3,2}$ , the voltage across  $C_1$ , whose reactance at 0.159Hz is  $1\Omega$ , the current through it can be marked in as  $i_3$  in Fig. 3c).

Of course, the current through a capacitor leads the voltage across it, and  $i_3$  is accordingly shown leading the voltage  $V_{3,2}$  by  $90^\circ$ . Since  $i_1=i_2+i_3$ ,  $i_2$  can now be marked in as shown.

As  $i_3$  flows through  $R_3$ ,  $V_{4,3}$  can now be marked in, and as the voltages at nodes 5 and 3 must be equal,  $V_{5,4}$  can also be marked in. The current  $i_5$  through  $C_2$  (reactance of  $1\Omega$ ) will be 1A, leading  $V_{5,4}$  as shown. Finally, as  $i_3=i_4+i_5$ ,  $i_4$  can be marked in, and the voltage and current vector diagrams (for a frequency of  $1/2\pi CR$ ) are complete.

The diagrams show that  $V_{5,0}$  is 1V, the same as  $V_{1,0}$ , but  $i_5$  flows in the opposite direction to  $i_1$  – the wrong way for a positive resistance. Fig. 3d) shows what happens at  $f=1/4\pi CR$ , half the previous frequency. Because the reactance of  $C_1$  is now  $2\Omega$ ,  $i_3$  is only 0.5A, and therefore  $V_{4,3}$  is only 0.5V. Now, there is only  $1/2V$  ( $V_{5,4}$ ) across  $C_2$ , but its reactance has also doubled. Therefore  $i_5$  is now only 0.25A; not only

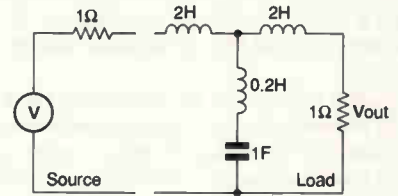

Figs. 4a), above, and b), below. A low component count elliptic low-pass filter with a minimum attenuation of 36dB from twice the cut-off frequency upward, the price being as much as 1dB pass-band ripple. The minimum capacitor design of 4a) is more convenient than 4b) for conversion to an fdnr filter.

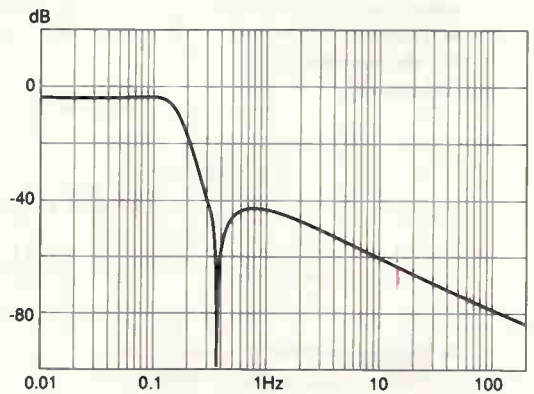
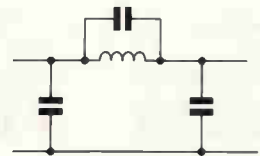

Fig. 4c). The frequency response of the filter.



is the current negative (a 180° phase shift), it is inversely proportional to the square of the frequency, as shown for the fdnr in Fig. 2.

**Pinning down the numbers**

Looking in at node 5, then, appears like a -1Ω resistor at 0.159Hz, but you need to know how this ties up with the component values. The values of the vectors can be marked in, on Figs. 3b) and 3c), starting with V<sub>1,0</sub>=1V. Then V<sub>2,1</sub>=R<sub>2</sub>/R<sub>1</sub>, and V<sub>3,2</sub>=-R<sub>2</sub>/R<sub>1</sub>. It follows that i<sub>3</sub>=(-R<sub>2</sub>/R<sub>1</sub>)/(1/jωC<sub>1</sub>)=-jωC<sub>1</sub>.R<sub>2</sub>/R<sub>1</sub>. Voltage V<sub>4,3</sub>=R<sub>3</sub>i<sub>3</sub>=-jωC<sub>1</sub>.R<sub>2</sub>.R<sub>3</sub>/R<sub>1</sub>, and V<sub>5,4</sub>=-V<sub>4,3</sub>.

So i<sub>5</sub>=-V<sub>4,3</sub>/(1/jωC<sub>2</sub>)=jωC<sub>1</sub>jωC<sub>2</sub>.R<sub>2</sub>.R<sub>3</sub>/R<sub>1</sub>. Looking in at node 5 the resistance is V<sub>5,0</sub>/i<sub>5</sub>=V<sub>1,0</sub>/i<sub>5</sub>, where V<sub>1,0</sub>=1V. So finally the fdnr input looks like,

$$\begin{aligned} \text{fdnr} &= R_1 / (j\omega C_1 j\omega C_2 \cdot R_2 \cdot R_3) \\ &= -R_1 / (\omega^2 \cdot C_1 \cdot C_2 \cdot R_2 \cdot R_3) \end{aligned} \quad (1)$$

With 1Ω resistors and 1F capacitors, this comes to just -1Ω at ω=1rad/s, or 0.159Hz. To get a different value of negative resistance at that frequency, clearly any of the R<sub>s</sub> or C<sub>s</sub> could be changed to do the job, but it is best to keep all the R<sub>s</sub> equal - at least roughly - and the same goes for the C<sub>s</sub>.

As a cross check on equation (1), note that it is dimensionally correct. The units of a time-constant CR are seconds, while the units of frequency are 1/seconds, be it cycles or radians per second. Thus the units in the denominator cancel out and, with a dimensionless denominator, the expression has the units of the numerator R<sub>1</sub>, which is ohms.

**A practical example**

Designing an fdnr filter starts with choosing an LC prototype. Consider a simple example - a low-pass filter with the minimum number of components, which must reach an attenuation of 36dB at little more than twice the cut-off frequency. This is a fairly tall order, but a three-pole elliptic filter will do the job, if you allow as much as 1dB pass-band ripple.

A little experimentation with a CAD program came up with the design in Fig. 4a). This has nice, round component values, although the cut-off frequency is just a fraction below the design aim of 1 radian per second, but never mind, it will do for starters.

If you were designing an LC filter as such, you would certainly choose the π section of Fig. 4b), rather than the tee section, as the π

section is the minimum inductor version. But for an fdnr filter, the minimum capacitor version is preferable, as the C<sub>s</sub> become fdnrs (fairly complicated), whereas the L<sub>s</sub> become R<sub>s</sub> and are therefore cheap and easy.

But before passing on to consider the fdnr, note that the computed frequency response of the normalised 1Ω impedance LC filter is as shown in Fig. 4c).

The low frequency attenuation shows as 6dB rather than 0dB. This is because the 1Ω impedance of the matched source (a 2V emf ideal generator behind 1Ω) is considered here as part of the filter - not as part of the source. To the 2V generator emf, which is what the CAD program models as the input, the source and load impedance appear as a 6dB potential divider.

The fdnr version of the filter is shown in Fig. 5. Not only do the L<sub>s</sub> become R<sub>s</sub> and the C<sub>s</sub> fdnrs, but the source and terminating resistors become capacitors. In an LC filter, the source and terminating resistors would usually be actually part of the source and load respectively. But an fdnr filter at audio frequencies will be driven from the 'zero' output impedance of an op-amp and feed into the nearly infinite impedance of another. As a result, you must provide the terminations separately if you want the response to be the same as the prototype LC filter.

In Fig. 5, the inductors have been replaced with resistors on an ohm-per-henry basis, and the R<sub>s</sub> and C<sub>s</sub> converted to C<sub>s</sub> and fdnrs similarly. As it happens, the required fdnr value is -1Ω, so values of 1Ω and 1F in the circuit of Fig. 3 will do the job.

If one had used the tabulated values for a 1dB ripple, 35dB A<sub>s</sub> three-pole filter, e.g. from Ref. 2, Fig. 6, the required value of C<sub>2</sub> in the tee-section version, would have been 0.865F.

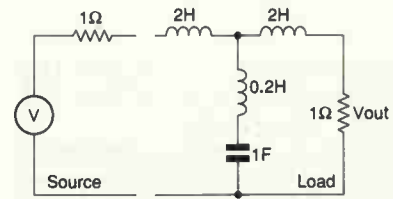
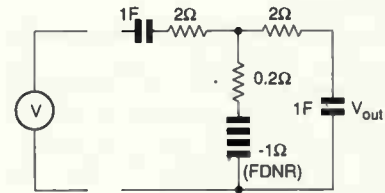

Fig. 5. An fdnr version of the low-pass filter.



Accordingly, from equation (1), R<sub>1</sub> in Fig. 3 would become 0.865Ω, or you could change R<sub>2</sub> and/or R<sub>3</sub> to achieve the same effect. Alternatively, you could scale C<sub>1</sub> and/or C<sub>2</sub>, but it is best to leave them at 1F - the reason for this will become clear later.

Having arrived at a 'normalised' fdnr filter design, i.e. one with a 0.159Hz cut-off frequency, the next step is to denormalise it to the desired cut-off frequency - let's say 10kHz in this case.

There is no need to change the R<sub>s</sub> at this stage, but to make the fdnr look like -1Ω, or -0.865, or whatever, at 10kHz, the capacitor values must be divided by 2π times 10,000. And since the termination capacitors must also look like 1Ω at this frequency, they must be scaled by the same ratio.

You now have a filter with the desired response and cut-off frequency, but the com-

Fig. 6. Tabulated, normalised component values for three-pole 1dB pass-band ripple elliptic filters with various values of A<sub>s</sub> at Ω<sub>s</sub>. Ω here means the same as ω elsewhere in the article.

Ω <sub>s</sub>	A <sub>s</sub> (dB)	C <sub>1</sub>	C <sub>2</sub>	L <sub>2</sub>	Ω <sub>2</sub>	C <sub>3</sub>
1.295	20	1.570	0.805	0.613	1.424	1.570
1.484	25	1.688	0.497	0.729	1.660	1.688
1.732	30	1.783	0.322	0.812	1.954	1.783
2.048	35	1.852	0.214	0.865	2.324	1.852
2.418	40	1.910	0.145	0.905	2.762	1.910
2.856	45	1.965	0.101	0.929	3.279	1.965

Ω <sub>s</sub>	A <sub>s</sub> (dB)	L <sub>1</sub>	L <sub>2</sub>	C <sub>2</sub>	Ω <sub>2</sub>	L <sub>3</sub>
1.295	20	1.570	0.805	0.613	1.424	1.570
1.484	25	1.688	0.497	0.729	1.660	1.688
1.732	30	1.783	0.322	0.812	1.954	1.783
2.048	35	1.852	0.214	0.865	2.324	1.852
2.418	40	1.910	0.145	0.905	2.762	1.910
2.856	45	1.965	0.101	0.929	3.279	1.965

© 1958 IRE (now IEEE)

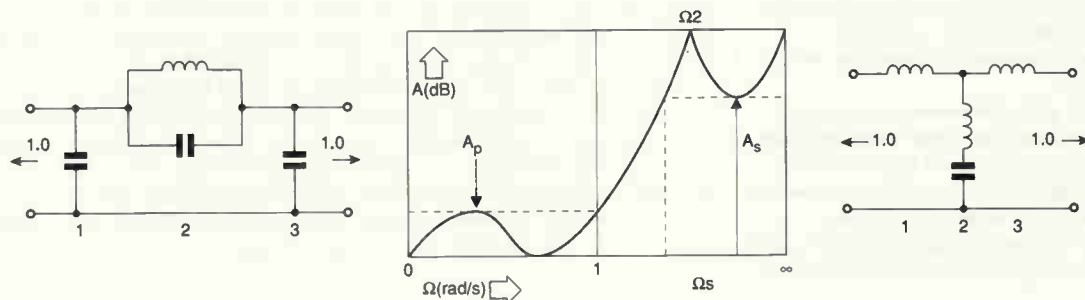

ponent values shown in round brackets in Fig. 7, are a little impractical. This is easily fixed, by a further stage of scaling.

Since resistors are more easily obtainable in E96 values and 1% selection tolerance, it pays to scale the 15.9µF capacitors to a round value, such as 10nF. So all impedances must be increased by this same ratio:  $N=1590$  – the resistors multiplied by  $N$  and the capacitors divided by  $N$ .

Conveniently, the  $C_s$  in the fdnr are the same value as the terminating capacitors, if, as recommended, any change in the required normalised fdnr negative resistance was effected by changing the  $R$  values only. The resultant practical component values are shown in square brackets in Fig. 7.

One peculiarity of an fdnr filter is due to its use of capacitive terminations. The impedance of these varies with frequency and, notably, becomes infinite at dc (0Hz). Thus any practical fdnr filter would have infinite insertion loss at this frequency.

This is remedied by connecting resistors in parallel with the terminating capacitors, to determine the 0Hz response. They are shown in Fig. 7a) and have been chosen, taking into account the two 3,180Ω resistors, to provide 6dB attenuation at 0Hz. This is done to match the filter's pass-band 6dB loss. With the addition of these, Fig. 7a) is now a practical, fully working low-pass filter, the computed frequency response of which is shown in Fig. 7b).

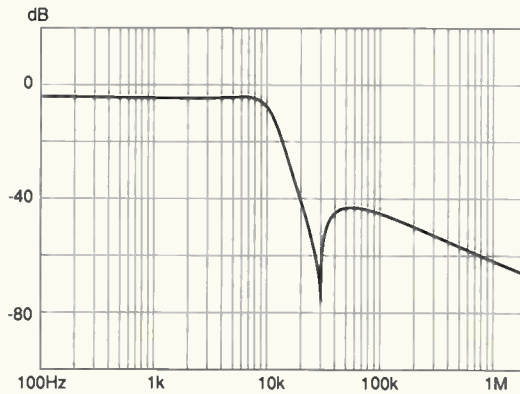
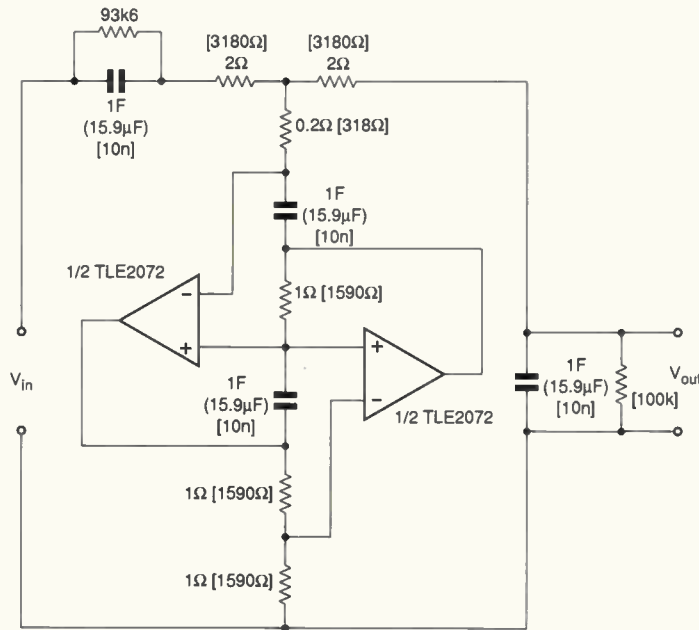

**Fig. 7a).** Complete fdnr filter with 10kHz cut-off frequency. The values in round brackets are a little impractical, but are easily scaled to more sensible values in square brackets. **Fig. 7b).** Computed frequency response of the above filter. The cut-off frequency (at -1dB) is a shade below the intended value, as was that in Fig. 4c).

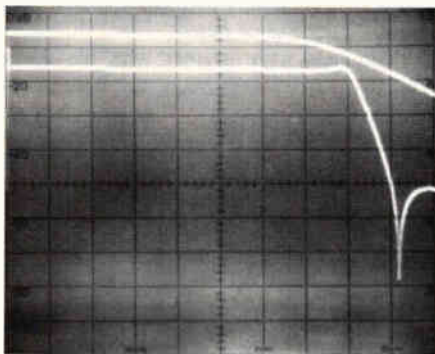

**Fig. 8.** Actual frequency response of the circuit of Fig. 7. The horizontal scale is logarithmic frequency, the left-hand vertical being 20Hz, the third, sixth and ninth vertical graticule lines representing 200Hz, 2kHz and 20kHz respectively. Horizontal graticule lines are at 10dB intervals. Upper trace, generator reference level top of screen, representing the source emf. This trace was recorded with the shunt leg of the filter open circuited with the 318Ω resistor removed. Lower trace, response of complete filter with the 318Ω resistor replaced. Reference level has been moved down one graticule division for clarity.

### Log sweeps and IF bandwidths

The response shown in Fig. 8 was taken using the log frequency base mode of the HP3580A 0-50kHz spectrum analyser. In this mode, the spot writes the trace across the screen at a steady rate, taking about 6 seconds to sweep from 20Hz to 44.3kHz. Thus the sweep rate in hertz per second increases greatly as the spot progresses across the screen.

This means that if a resolution bandwidth narrow enough to resolve frequency components encountered near the start of the sweep (e.g. 1Hz or 3Hz bandwidth) is used, then near the end of the sweep the analyser will be passing through any signals far too fast to record their levels even approximately.

On the other hand, if a bandwidth such as 300Hz – wide enough to accurately record signal amplitudes in the 20kHz region – is used, the zero frequency carrier breakthrough, response will extend half way across the screen. So, when using log sweep mode to record the amplitudes of stationary signals, compromises must be made.

But this is not the case in Fig. 8, for here the only signal of interest is the output of the tracking generator, to which the analyser is, by definition, always tuned. So the analyser is at no time sweeping through a signal and in principle it might seem that the 1Hz bandwidth could be used. There is a restraint on the bandwidth, however, set by the rate at which the signal amplitude changes. This can get quite fast in the vicinity of a notch, and accordingly the trace in Fig. 8 was recorded with a 30Hz resolution bandwidth. At 10Hz bandwidth, the notch appeared shunted slightly to the right and its full depth was not recorded.

On the other hand, at a 100Hz bandwidth, the notch response was identical to that shown, but the left hand end of the trace, representing 20Hz, was elevated slightly, due to the zero frequency carrier breakthrough response. If, due to a fortuitous conjunction of component tolerances, the actual notch depth had been much deeper than it actually was, the 100Hz bandwidth would have been necessary to capture it. In that case, it would be better to switch back to linear frequency base mode, and make the notch measurement at a span of 100Hz, or even 10Hz, per horizontal division.



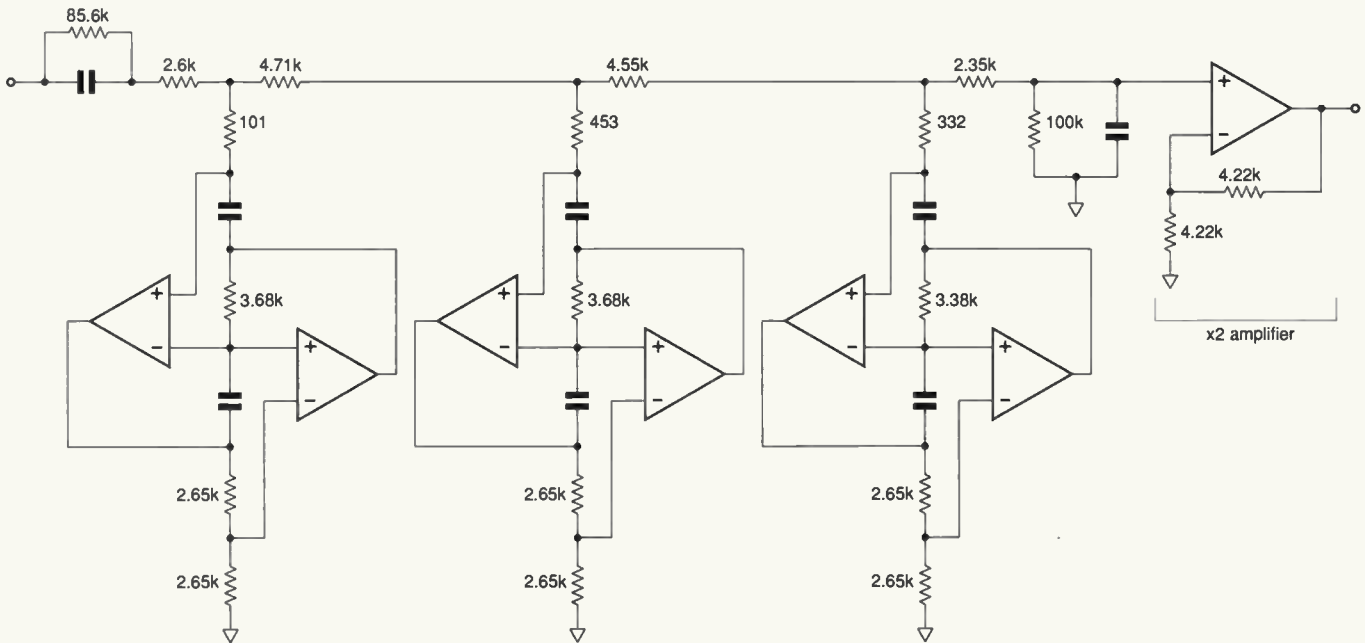

This is all fine in theory, but does it work in practice?

**Proof of the pudding**

Ever of a pragmatic – not to say sceptical – turn of mind, I determined to try it out for real. So I made the circuit of Fig. 7a) up almost exactly as shown, and tested it using an HP3580A audio frequency spectrum analyser.

The circuit was driven from the 3580's internal tracking generator. There were minor differences. Whereas the plot of Fig. 7b) was modelled with LM318 op-amps, these were not to hand, so a TLE2072CP low-noise, high-speed j-fet input dual op-amp device was used. This is a handy Texas Instruments device with a 35V/μsec slew rate and accepting supplies in the range ±2.25V to ±19V.

The required resistor values were made up using combinations of preferred values, e.g. 82kΩ+12kΩ for 93.6kΩ, 270Ω+47Ω for 318Ω, etc, all nominal values thus obtained being within better than 1% of the exact values. 100kΩ+12kΩ was used for the terminating resistor, to allow for the 1MΩ input resistance of the spectrum analyser in parallel with it. The resistors were a mixture of 1% and 2% metal film types, except the 47Ω, which was 5%. The four 10nF capacitors were all 2.5% tolerance polystyrene types.

Although the circuit worked, its response was not exactly as hoped, due to being driven from the 3580A's 600Ω source impedance. So a TLE2027 single op-amp – not to be confused with the TLE2072 dual device used for the main circuit – was used as a unity gain buffer to drive the filter from a near-zero source impedance. Its output level was set at

the top of the screen, Fig. 8.

First, the filter action was disabled by removing the 318Ω resistor, leaving a straight-through signal path. The upper trace shows the 6dB loss due to the terminations mentioned earlier. It also shows a first-order roll-off due to the effect of the terminating capacitor at the load end, with the two 3180Ω resistors.

Response of the complete filter, with the 318Ω resistor replaced, is shown in the lower trace. The reference level has been moved down one graticule division for clarity. The -1dB point is at two divisions in from the left, which, given the horizontal scaling of three divisions per decade, corresponds to 9.3kHz – pretty close agreement with the predicted performance of Fig. 7b).

In logarithmic frequency mode, the analyser's bandwidth extends only up to 44.3kHz. But this is far enough to see that the notch frequency and the level of the return above it, 36dB below the l.f. response, also agree with the computed results.

**Others like it, too**

Various applications have been found for fdnr filters, especially in measuring instruments. The advantage here is that the response is predictable and close to the theoretical.

Some other active filter sections, when combined to synthesise filters of a higher order, show a higher sensitivity to component tolerances. This is a disadvantage where the filters are used in the two input channels of an instrument, which requires close matching of the channel phase and amplitude responses. For this reason, fdnr filters were used in the input sections of the HP5420A, Fig. 9.<sup>3</sup>

Fig. 9a). Normalised seven-pole elliptic LC prototype filter, and b), below, derived fdnr input antialiasing filters used in the HP5420A.

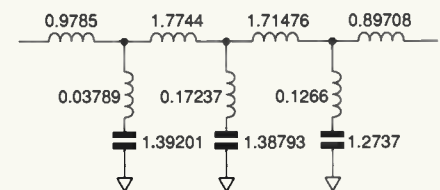

**References**

1. Bruton, L. T., 'Network Transfer Functions Using the Concept of Frequency Dependent Negative Resistance', *IEEE Transactions on Circuit Theory* Vol. CT-16, pp405-408, August 1969.
2. Hickman, I., 'Newnes Practical RF Handbook', 1993, ISBN 0 7506 0871 4, p245.
3. 'Front-end Design for Digital Signal Analysis. Patkay', Chu and Wiggers, *Hewlett Packard Journal*, Vol. 29, No. 22, October 1977, p9.







# Hands-on Internet

Focusing on inductor design this month, **Cyril Bateman's** has found that his searches are faster thanks to the new European version of **Yahoo**.

Since its inception, the Internet has seen a doubling in its usage each year, but in 1996 this growth tripled. This increased growth was in part due to the growth of access in Europe. Modem speeds also doubled during the year, but because of the growth in usage, real download speeds at the end of the year for the UK were little faster than those found a year ago when modems were generally slower.

Since the Internet is of US origin and US based, many accesses from Europe to European sites still require to be routed to North America and back across the Atlantic, which inevitably causes cable bottlenecks. Changes to routings to permit direct European access to European sites are planned for this year. This should remove the bottleneck, resulting in improved download speeds for *all* users.

The extremely popular original *Yahoo* search engine can become overloaded, making it slow to respond. A new subsidiary, optimised for the needs of UK and Ireland, is [www.yahoo.co.uk](http://www.yahoo.co.uk).<sup>1</sup> At the moment, it is much less used, and responds rapidly. Should your search request find no matches within *Yahoo*, then the search engine transparently defaults to search within the *AltaVista* site for you – which is very comprehensive – Fig. 1.

Fig. 1. This popular US search engine has been reworked for local European needs.

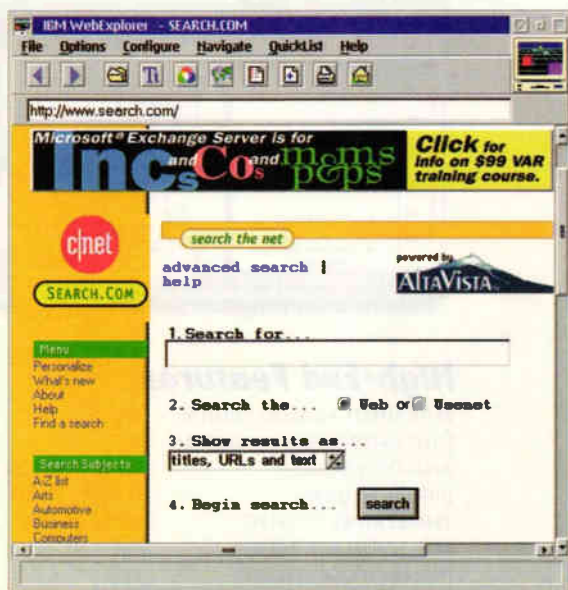
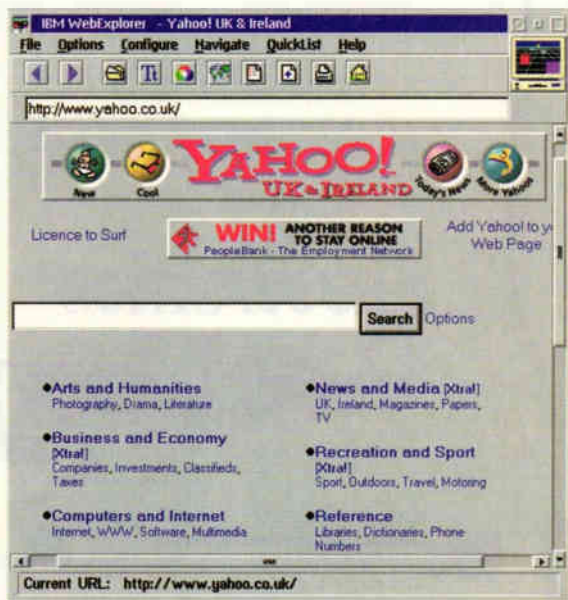

Fig. 2. Search.com part of the c|net organisation. Old favourite shareware source with a new role.



Fig. 3. Time-saving parallel search system at Cyber411.



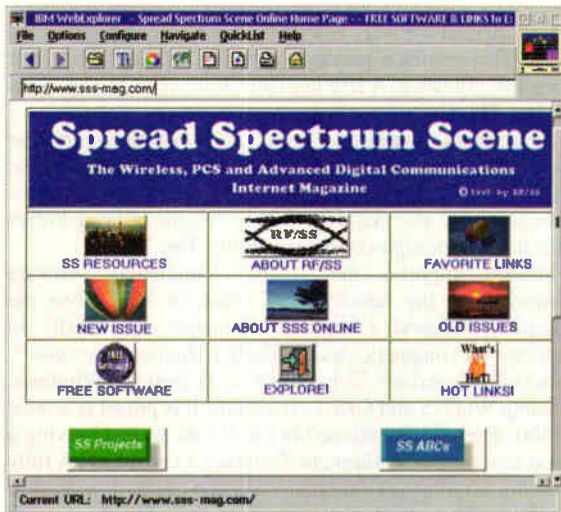

Fig. 4. On-line magazine and forum for designers. Good source of free rf and design software.



Fig. 6. The dTb home page is a useful source of slightly different design software.



Fig. 5. The FCIM site data bank of MIL standards and part numbers – caters for all electronic parts – not just inductors.

### A new search tool

Long established as a shareware source, Cnet.com, is a new dedicated Internet search engine. Its subsidiary, Search.com<sup>2</sup>, is powered by the AltaVista search engine, but it has custom refinements. Two forms of search are possible. The top level search, Fig. 2, is based on the AltaVista system. Further down the page is a second search enquiry box which allows preselection of your choice from the eleven most popular search engines.

Typical of the latest style search engines is CYBER 411<sup>3</sup>. It performs your search request by searching fifteen different search engines simultaneously. The default search option collates all results and removes duplicated items, before displaying its findings to you. If you prefer to maximise search speed and accept duplicate finds, then select the 'hyper' search mode, Fig. 3.

### Simulation software

Having followed the various articles for amplifier design and loudspeaker systems over the past year in *Electronics World*, you may be interested in further exploring measurement or design of a loudspeaker. A lengthy twenty-page FAQ, Software for Speaker Design, lists shareware, commercial

software packages and hardware. It can be downloaded from <http://harmony-central.com/Other/speakerfaq>.

Spread Spectrum Scene<sup>4</sup> – also known as RF/Spread Spectrum – is an on-line Internet magazine providing a meeting place for designers to exchange ideas and problems. Its consultants' corner holds reviews of simulation software packages and industry news.

Featured this month is a freeware program from Hewlett Packard called *AppCAD*. In addition to rf design and analysis routines, this package also includes an excellent tutorial on thermal analysis of semiconductor packages. I regularly use and recommend this package<sup>5</sup>. It can be downloaded using FTPSearch Norway.

Spread Spectrum Scene has a carefully selected library of free software. Some, such as the rf and Smith chart packages, are usually very difficult to find, but all are easily downloaded from this page. Especially interesting is Mathsoft's *Mathbrowser* which allows use of *Mathcad*'s live worksheets, in a browser, over Internet, Fig. 4.

### Models for passives

Simulation models for most semiconductors and integrated circuits are readily available, but simulation models for capacitors and inductors are much less common. In previous articles I have detailed sources of capacitor modelling data but not those covering inductors.

Both in practice and in modelling, inductors and magnetic devices are generally less well understood than capacitors. Realistic generic spice models for inductors seem not to exist anywhere on the Internet.

### Alternative source for inductor information

While it is not usually practicable to make your own capacitors, inductor cores are readily available, as is wire. But people wanting to fabricate their own inductors or transformers can find data sheets on magnetic materials difficult to interpret.

If you have to design inductors regularly and have standardised on a small selection of core materials, it is relatively easy to write a dedicated calculation software routine. It can incorporate the magnetic design data parameters to automate the design process. It can even be made to calculate effective inductance with dc load current.

Much of the basic design information on inductors is old. Many of the books on the subject are no longer in print. Many years ago I found in a second-hand store a 1946 copy of *Radio Designer's Handbook*, once distributed by *Wireless World*, which I treasure because it includes many useful inductor design tables.



Fig. 7. Miniature inductors and transformers. Speciality surface mount devices for all needs.



Fig. 8. Design of magnetic circuits, inductors and transformers made easy. The demonstration package is free.



Chip Bead Design Carries Five Times Amperage

Recent searches on inductors and magnetics have identified a few sources of helpful information. One which is easy to use and understand is part of the US military stores catalogue. It is the Army FCIM Electronics Module<sup>6</sup>. This lists a large number of US military-specification approved inductors. More usefully, it also includes design tables, which can be downloaded for local use. You will need to register yourself before you can access this site though, Fig. 5.

Commercial software is also available. A company called dTb Software<sup>7</sup> offers packages covering inductor design and wire size guidance. A free demonstration suite can be downloaded, Fig. 6.

Associated Components Technology<sup>8</sup> – a large volume Far Eastern inductor maker – provides detailed descriptions of the construction of potted air-cored surface-mount chip inductors. This company also claims to supply designs offering higher than normal through-current capability, Fig. 7.

Intusoft supplies the ICAP/4 simulation software mentioned in the January 1997 issue. In May 1996, the company released a package dedicated specifically to inductor and magnetic design. Called *Magnetic Designer*<sup>9</sup>, this tool is a serious 32-bit software system for Windows, needing Win32S and OLE2 extensions. It is priced at around \$1300. The page mentioned in ref. 9 lists an FAQ giving a good description of *Magnetic Designer's* capability. A fully working 4.5 Mbyte demonstration version can be downloaded, or obtained by postal service, on four discs, Fig. 8. ■

References

1. Yahoo! UK & Ireland, <http://www.yahoo.co.uk>
2. SEARCH.COM, <http://www.search.com>
3. CYBER411, <http://www.cyber411.com>
4. Spread Spectrum Scene, <http://www.sss-mag.com>
5. Bateman, C, 'Understanding emc filters', *Electronics World* May 1996
6. Army FCIM Electronics Module, <http://fcim.cscd.com>
7. dTb Software, <http://www.dtbware.com>
8. Associated Components Technology, <http://www.act1.com>
9. Intusoft, <http://www.intusoft.com/Magdemo.htm>

# Eight year EW index Hard copy or disk

Includes over 600 circuit idea references

Whether as a PC data base or as hard copy, SoftCopy can supply a complete index of *Electronics World* articles going back over the past eight years.

The computerised index of *Electronics World* magazine covers the eight years from 1987 to 1995 – volumes 94 to 101 inclusive – and is available now. It contains almost 2000 references to articles, circuit ideas and applications – including a synopsis for each.

The *EW* index data base is easy to use and very fast. It runs on any IBM or compatible PC with 512k ram and a hard disk.

Even though the disk-based index has been expanded significantly from five years to eight, its price is still only £20 inclusive. Please specify whether you need 5 1/4in, 3.5in DD or 3.5in HD format. Existing users can obtain an upgrade for £15 by quoting their serial number with their order.

Hard copy *Electronics World* index

Indexes on paper for volumes 100 and 101 are available at £2 each, excluding postage.

Circuit Ideas

Remote motor control Resistance multiplier SCR Inverter Sample-and-infinite hold Schmitt trigger, prog. thresholds Self-ID for plugs and sensors Sensor, Linear Current Servo, High-torque position Servo, Simple ▶ Single pot Polarity & Gain adjust Soft-start filament driver Speech compressor Square wave generator, 1:1 Status detection over two Stepper Motor Controller Stepper Motor Controller Stepper Motor Driver Stereo expander Switch, Low voltage	SIMULATOR, INSERTION & RETURN LOSS C J Hall May 1992, p422 "Simultaneous insertion and return loss plots" Modelling a return-loss bridge at the relevant port allow plot of insertion loss, and, without further computation, return loss plot simultaneously.
--	--

Design: RF

Directional couplers, hybrid Gigahertz Systems on a Chip HF receiver performance HF receiving loop, improved Hepa for RF power amplifier design High quality punch for radioconns Hybrids in RF combiners Impedance transformation Measuring Detectors Measuring with TDR Microwaves, New wave /2 Noise source, self-calibrating Polyphase SSB RF Design Revolution RF Power Measurements in milliwatts RF Transistors, Using /1 RF Transistors, Using /2 RF Transistors, Using /3 ▶ RF filter for electro-explosives	MICROWAVES, NEW WAVE Mike Hosking #1 Concepts, circuits & dev April 1994, p276 #2 The Laws of Microstrip May 1994, p418 #3 Lumped components & waves June 1994, p472 #4 Active devices for milli waves. July 1994, p571 #5 Oscillator and amplifier August 1994, p666
---	---

F1-Help F2-Search F3-Memo F4-Edit F5-Other F10-Exit T01

## Ordering details

The *EW* index data base price of £20 includes UK postage and VAT. Add an extra £1 for overseas EC orders or £5 for non-EC overseas orders.

Postal charges on hard copy indexes and on photocopies are 50p UK, £1 for the rest of the EC or £2 worldwide.

For enquiries about photocopies, etc,

please send an sae to SoftCopy Ltd at the address below.

Send your order to SoftCopy Ltd., 1 Vineries Close, Cheltenham GL53 0NU, tel 01242 241455, or e-mail at 100556.112@compuserv.com. Please make cheques payable to SoftCopy Ltd – not *EW* or Reed Business Publishing. Please allow up to 28 days for delivery.



# Scrambler for data

**Based on a pseudo-noise sequence generator, this scrambler scheme for digital bit streams combines good data security with low error rates. Designed by Wasim Ahmad and Mohiuddin Bhat**

**S**cramblers are a simple and effective means of making digital data communications secure. A simplified, generalised diagram of a scrambler and the corresponding descrambler are shown in Fig. 1.

For scrambling, an  $n$ -stage serial-input-parallel-output shift register, or sipo, is used. Its output taps  $a_1, a_2 \dots a_n$ , are added to give  $m_k''$ . The resulting bit sequence is added to the message bit sequence  $m_k$  to give the bit sequence  $m_k'$ , ready for transmission.

Output taps from the shift register are gated by a 0 or 1. Any tap gated with a 1 results in a connection being made to the corresponding shift register stage. When the gating is zero, no connection is taken from that stage.

The receiver has to know the pattern required for unscrambling the transmitted bits. Unscrambling becomes difficult if the number of shift register stages,  $n$ , is large. One problem associated with this technique – especially, for large values of  $n$  – is that of multiple errors may result in the unscrambled output. A single erroneous bit in the received message  $m_k'$  can cause a sequence of  $n$  erroneous bits in the unscrambled message. This problem of error propagation becomes even more serious if the transmission channel is noisy.

Various techniques have been reported for reliable and secure data transmission<sup>1-3</sup>. Usually, the scrambled bit stream is transmitted using some form of channel coding, but this naturally complicates the system.

Our method for scrambling the data is novel. It need not use large numbers of shift-register stages, yet it makes unscrambling very difficult for hackers.

## A new scrambling scheme

Figure 2 shows the proposed scheme. It is similar to that shown in Fig. 1, but the tap gating values are continuously

changed with the help of a pseudo noise sequence. Inputs  $Q_A, Q_B$ , etc, to the and gates are the outputs of the pseudo noise sequence generator<sup>3</sup> shown in Fig. 3.

In order to unscramble the received message, the receiver has to know the number of shift register stages and the pseudo noise sequence. It also has to know the starting pattern of  $Q$  outputs from generator used in the scrambler. This makes unscrambling very difficult for unauthorised receivers while minimising the problem of error propagation by allowing a smaller value for  $n$ .

We have tested the scheme with  $n=4$  and a pseudo noise sequence of 15 bits long. Performance was good. The system works equally well when the and gates of Fig. 2 are replaced by nand gates.

For a practical implementation, all the bistable devices of the pseudo noise sequence generator are initially cleared. This must be done at both the transmitting and receiving ends.

First, a synchronising word is passed. Since the  $Q$  outputs of Fig. 2 are zero,  $m_k''$  will be zero and the synchronising word will pass directly. At the end of synchronising word, the bistable devices of each pseudo-noise generator are loaded with the starting values of the pseudo-noise sequence. This generates the data sequence, with clock pulses, and the process goes on.

At the transmitting end, if the whole pseudo-noise sequence is registered – say a 31-bit sequence handled by a 31-bit circulating shift register – many binary signals could be scrambled separately using different groups of  $Q$  outputs. These signals could then be transmitted using time division multiplexing. Each receiver will obtain its corresponding  $Q$  codes from pseudo-noise sequence generator. In this way, only the proper receiver will receive its corresponding message.

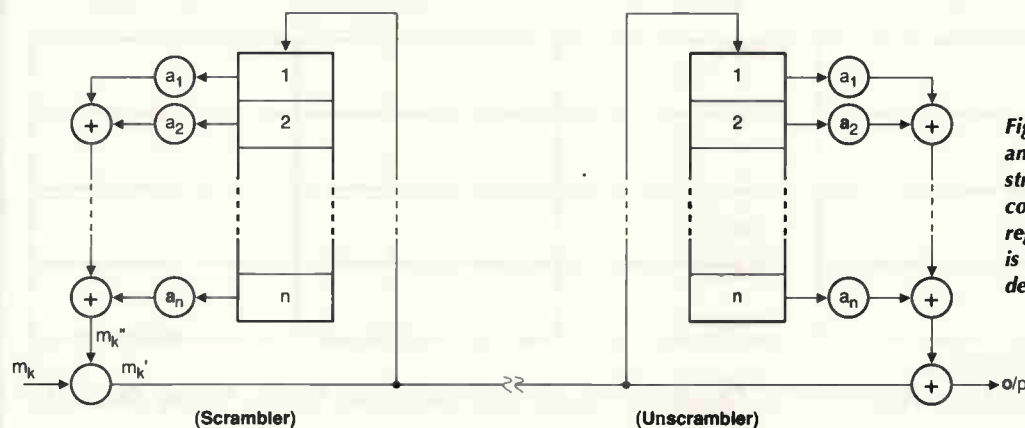

**Fig. 1. In the conventional scrambler and descrambler scheme, the data stream to be transmitted is added to a coding string produced by a shift register. The same register arrangement is used to remove the coding at the descrambler end.**

Fig. 2. Enhanced scrambler and descrambler. Data is made more secure without increasing the shift register length since the code fed to the And gate Q inputs is derived from a pseudo noise generator.

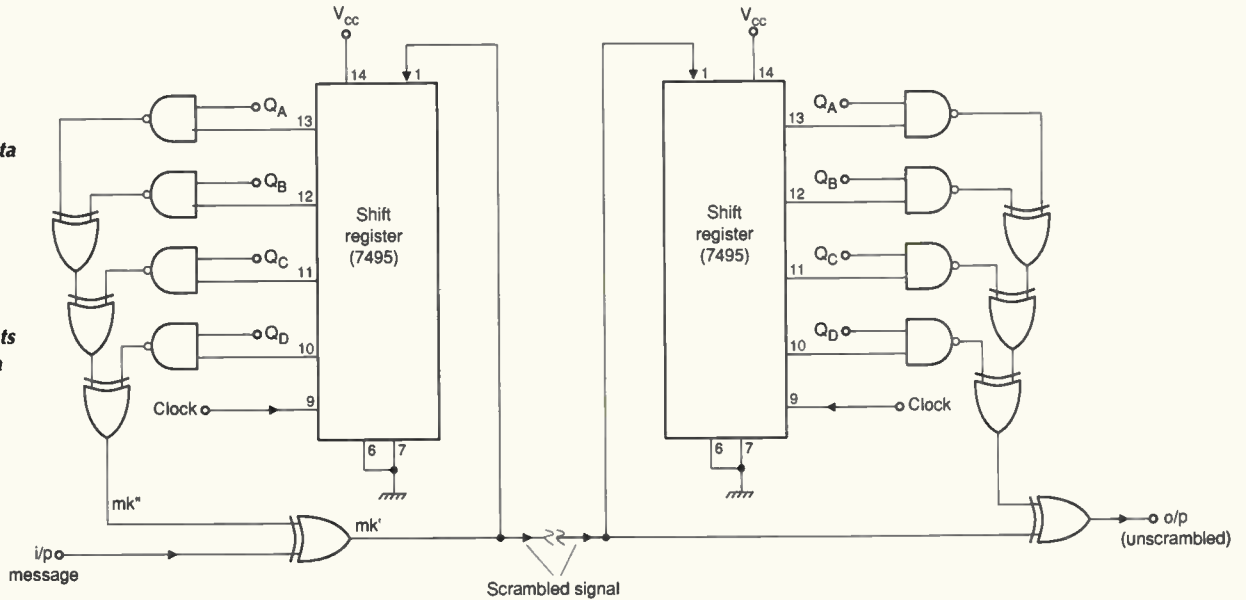
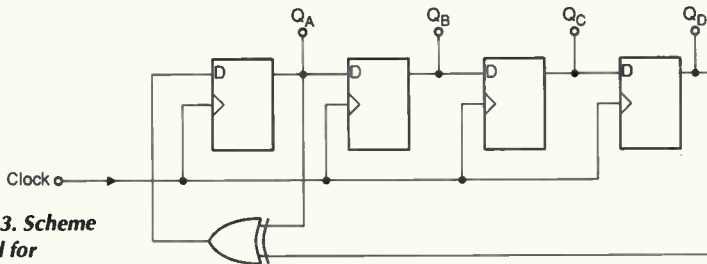

Fig. 3. Scheme used for producing the pseudo random sequence feeding the and gates of Fig. 2.



**In summary**

We have found this to be a reliable and secure method of data transmission. Scrambling is efficient and the scheme reduces the problem of bit-error propagation relative to the traditional method described earlier.

The concept has been tested with one 15-bit pseudo-noise sequence used for the message and another one for

scrambling/unscrambling at the transmitting and receiving ends. The scrambled message was passed through a cable producing negligible inter-symbol interference and noise. Unscrambling was found reliable.

In a proper implementation of the scheme, a synchronising word should precede the message. It is important to d

Detecting the ending point of the synchronising word is important. Therefore, a clock recovery circuit is needed at the receiving end if the channel can suffer from inter-signal interference or zero-crossing jitter. ■

**References**

1. Rao, TRN, 'Cryptosystems using Algebraic Codes', IEEE International Symp. Inform. Theory, Brighton, England, pp.146, June 1985.
2. Hwang T, & Rao, TRN, 'Secret Error-correcting Codes', *Journal of IETE*, Vol. 36, Nos 5&6, pp. 362-367, Sep-Dec 1990.
3. Haykins, S, 'Digital Communications', pub. John Wiley & Sons, Singapore, 1988.

# ADVERTISE FREE OF CHARGE

**Subscribers\* to *Electronics World* can advertise their electronics and electrical equipment completely free of charge**

Simply write your ad in the form below, using one word per box, up to a maximum of twenty words. Remember to include your telephone number as one word. You must include your latest mailing label with your form.

\* This free offer applies to private subscribers only. Your ad will be placed in the first available issue.

This offer applies to private sales of electrical and electronic equipment only.

**Trade advertisers - call Malcolm Wells on 0181-652 3620**

All adverts will be placed as soon as possible. However, we are unable to guarantee insertion dates. We regret that we are unable to enter into correspondence with readers using this service, we also reserve the right to reject adverts which do not fulfil the terms of this offer.

Please send your completed forms to:

Free Classified Offer: Electronics World, L333, Quadrant House, The Quadrant, Sutton, Surrey SM2 5AS



# HART

The Home of *Hi-Finesse*. Its not what you do,  
its HOW you do it that counts!.

## VISATON® SPEAKER KITS & DRIVE UNITS

New to the UK, VISATON offer a range of speaker kits and drive units that give the home builder access to units and designs that are unrivalled for quality, performance and value. Their designs are very well known in Germany, where they are based, and over 25 years they have built up an enviable reputation for high quality sound. All their designs come from a solid background of the best in design and research and their factory contains one of the largest anechoic chambers in the World, backed up by the very latest in computerised test equipment. This quality of research facility, added to design collaboration with major universities and high end magazines, produces products of impeccable performance and value that are the best available to the home speaker builder. Their range of products covers the whole spectrum of sound reproduction and includes speaker kits for home cinema, hi-fi and car use. There is also a vast range of drive units from 15" woofers to ribbon tweeters. Speaker design software and database are available for the home user who wants to try his hand, or for commercial manufacture. A small selection follows, our lists will give you more!

Hart Audio Kits and factory assembled units use the unique combination of circuit designs by the renowned John Linsley Hood, the very best audiophile components, and our own engineering expertise, to give you unbeatable performance and unbelievable value for money. We have always led the field for easy home construction to professional standards, even in the sixties we were using easily assembled printed circuits when Heathkit in America were still using tagboards! Many years of experience and innovation, going back to the early Dinsdale and Balley classics gives us incomparable design background in the needs of the home constructor. This simply means that building a Hart kit is a real pleasure, resulting in a piece of equipment that not only saves you money but you will be proud to own. Why not buy the reprints and construction manual for the kit you are interested in to see how easy it is to build your own equipment the HART way. The FULL cost can be credited against your subsequent kit purchase.

### 'AUDIO DESIGN' 80 WATT POWER AMPLIFIER.



This fantastic John Linsley Hood designed amplifier is the flagship of our range, and the ideal powerhouse for your ultimate hi fi system. This kit is your way to get EK performance at bargain basement prices. Unique design features such as fully FET stabilised power supplies give this amplifier World Class performance with startling clarity and transparency of sound, allied to the famous HART quality components and ease of construction. Standard model comes with a versatile passive front-end giving switched inputs, with ALPS precision "Blue Velvet" low-noise volume and balance controls, no need for an external preamp. Construction is very simple and enjoyable with all the difficult work done for you, even the wiring is pre-terminated, ready for instant use! All versions are available with Standard components or specially selected Super Audiophile components and Gold Plated speaker terminals and all are also available factory assembled.

K1100 Complete STANDARD Stereo Amplifier Kit, . . . . .	£415.21
K1100S Complete SLAVE Amplifier Kit, . . . . .	£353.62
K1100M Complete MONOBLOC Amplifier Kit, . . . . .	£271.20
RLH11 Reprints of latest Amplifier articles, . . . . .	£1.80
K1100CM Construction Manual with full parts lists . . . . .	£5.50

### ALPS "Blue Velvet" PRECISION AUDIO CONTROLS.

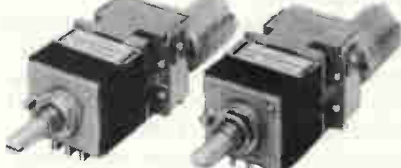

Now you can throw out those noisy ill-matched carbon pots and replace with the famous Hart exclusive ALPS "Blue Velvet" range components only used selectively in the very top flight of World class amplifiers. The improvement in track accuracy and matching really is incredible giving better tonal balance between channels and rock solid image stability. Motorised versions have 5v DC motor.

#### MANUAL POTENTIOMETERS

2-Gang 100K Lin. . . . .	£15.67
2-Gang 10K, 50K or 100K Log. . . . .	£16.40
2-Gang 10K Special Balance, zero crosstalk & centre loss. . . . .	£17.48

#### MOTORISED POTENTIOMETERS

2-Gang 20K Log Volume Control . . . . .	£26.20
2-Gang 10K RD Special Balance, zero crosstalk and less than 10% loss in centre position. . . . .	£26.98

#### 32W VALVE AMP TRANSFORMERS

Special set of toroidal transformers, 2 output & 1 mains for the "Hot Audio Power" valve amplifier design described in the Oct. 1995 issue of "Wireless World". Total Wt 4.8kg. Special price for the set, £99, Post £8. Photocopies of Article by Jeff Macaulay. £2.00

#### JOHN LINSLEY HOOD SINGLE ENDED CLASS 'A' POWER AMPLIFIER

A new concept in amplifier design to meet the needs of modern users who want the warmth and purity of sound given by valve amplifiers from the vintage years, without the problems of cost, deterioration and danger associated with trying to use valves today. It employs the newly re-discovered single-ended circuit configuration to give total freedom from crossover artifacts and to give a sound that is indistinguishable from the famous "Williamson" design, the undisputed leader of the field, with its triode connected KT66s and all-triode drivers. Described in the September 1996 issue of EWW the new version retains the basic simplicity and purity of the original but with modern components and an increased power rating of 15W RMS per channel.

Full Kit in 3u high Rackmount Case. . . . .	£388.25
Set of 3 PCBs only. . . . .	£60.50

### ASM100 ACTIVE SUBWOOFER MODULE



This attractive module consists of a low pass filter and power amplifier ready for you to mount in a suitable sub-woofer cabinet. The combined unit can then be combined with any new or existing hi fi or home cinema speaker system to add in the real bass punch missing from most setups.

The ASM 100 module comes as a ready-to-mount unit on a solid diecast aluminium frame/heatsink. Input signal can be at line or speaker level for easy system integration. There are three separate stereo inputs at line level and the unit will use any signal presented or mix all inputs to add bass to any signal. The speaker level inputs are used by simply wiring the unit in parallel with the existing speakers to provide them with strong bass support. Crossover frequency can be selected to 50, 100 or 200Hz and the bass level can be adjusted by a front panel control. The "Green" power supply switches the unit to standby if no signal is present. Drawings are included free for the compact 418 x 380 x 303mm cabinet.

With its powerful 125 watt output and versatile filtering the ASM 100 is the ideal universal active driver module for all subwoofer requirements.

ASM 100 Module, complete with IEC mains lead, instructions and ASM - W20 cabinet drawings. Pt. No. V7000. . . . .	£185.29
W 200 S 20cm Long Throw Drive unit for use in ASM - W20 cabinet. . . . .	£36.68

### FIESTA 30 LOUDSPEAKER KIT

An Ultra High Efficiency speaker, specially suitable for Valve Amplifiers.

Specially selected as the ideal partner for the new John Linsley Hood 15W Valve Sound Amplifier, or indeed any actual valve amplifier, the FIESTA 30 features the astonishing efficiency and sensitivity needed to achieve a satisfying sound level from amplifiers of limited power output.

To complement the sound purity of such amplifiers a full three speaker system is used with a 300mm (12") woofer, 200mm (8") mid-range and high quality horn tweeter in a vented bass reflex enclosure.

All these drive units have been carefully selected for their individual virtues, and collective excellence, the tweeter for instance being a high end unit with exceptional pulse response as a result of its combination of Kapton former, aluminium diaphragm and aluminium voice coil.

Nominal Power Rating is 150W, Max. Music Power 250W, Impedance 8 ohm, Mean Sound Pressure 91dB. Speaker kit comes with all parts to make a pair of speakers, but not the cabinet parts. Crossover units are factory assembled, ready to fit.

Kit No. LK5963 Per Pair. . . . .	£424.93
----------------------------------	---------

### HOME CINEMA SPEAKERS.

The VISATON range of speaker kits includes all you will ever need for your surround sound home cinema setup. The Hi-Tower Kit is ideal as a super luxury pair of stereo main speakers. The "Centre 80" uses special magnetically screened drivers to avoid picture disturbance and a pair of "Effect 80's" are used as rear speakers. Any of a range of sub-woofers then adds weight to the sound of the robot feet. Centre 80 Kits include drive units, crossover, terminals and grille. (You make the box) Price each. . . . . £64.08  
Effect 80, Rear Speaker Kits, per pair. . . . . £39.00

### DRIVE UNITS.



BG30NG 30cm. (12") Woofer. High efficiency, (95db) for sealed or vented cabinets. Peak power handling 250watts. 8 ohm. £69.61

W200S 20cm. (8") Woofer. Long throw unit with rubber surround and extended rear pole to give no less than 20mm cone displacement. Ideal for compact sub-woofers such as ASM-W20. 8ohm. £36.68  
NG8 Protective Metal Grille. £5.66



W100S 10cm (4") Low/Midrange. Coated paper cone, rubber surround, high temperature voice coil. Suitable as woofer in mini enclosures or midrange in 3-way systems. 4ohm. £18.06  
NG4 Protective Metal Grille. £3.20

FRS8 8cm. (3.3") Fullrange driver. Linear frequency response between 200 and 20KHz. Large Magnet, 20mm voice coil and rubber surround. 8ohm. £8.36



DT2.5 10mm Polycarbonate Tweeter. High efficiency ferrofluid tweeter for use over 4,500Hz. Very good price/performance ratio. 8ohm. £8.77

SC5 10mm. Magnetically shielded Tweeter for use in surround sound centre speakers. 8ohm. £9.24

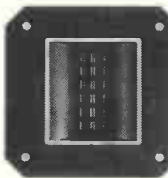

RHT12S High End Ribbon Tweeter. Superior double magnet construction gives an exceptionally low distortion and linear response from 4,000 to 30,000Hz. Cabinet cutout diameter 95mm. 8ohm. £87.77

DHT9AW-NG Hi-Tach, Hi-Fi, horn type tweeter. Frequency response from 3,500 to 38,000Hz and very good pulse response due to aluminium cone, Kapton voice coil and aluminium wire. Peak power handling 150W. 8ohm. £31.99

ASM100 and our 80 watt power amplifier are on demonstration at Wilmslow Audio's new premises at Broughton Astley near Leicester. Tel 01455 286603.

POSTAGE on UK orders is £2 up to £20,

£4.50 over £20.

Overseas please enquire.

Our LISTS are FREE on request.

Send for Your FREE copy of our LISTS

24 Hr. ORDERLINE 01691 652894  
Fax. 01691 662864

All Prices include UK/EC VAT.

**HART**  
HART ELECTRONIC KITS LTD.  
1 Penylan Mill, OSWESTRY,  
Shrops. SY10 9AF.  
UK



# APPLICATIONS SUMMARY

## Voltage-controlled low-pass high-pass and all-pass filter

An integrator within the feedback loop of an LT1252 current feedback amplifier creates a filter with three output functions – low-pass, high-pass and all-pass.

By using a variable time constant integrator as the feedback element, the cut-off frequencies of the low-pass and high-pass outputs are adjustable, set by control voltage ( $V_C$ ) on pin 3 of the LT1256. On the all-pass filter output, adjusting the control voltage alters the phase of the output. Resistors  $R_{5,6}$  set output impedance of the all-pass filter.

For the LT1252  $R_2$  should satisfy the cf amplifier's minimum resistance ( $750\Omega$ ) and all four resistors must satisfy  $R_2/R_1=R_3/R_4$ . Pass-band gain for all three outputs is  $-R_2/R_1$ .  
**Linear Technology, The Coliseum,**  
 Riverside Way, Camberley, Surrey GU15 3YL, tel. 01276 677676, fax 01276 64851.

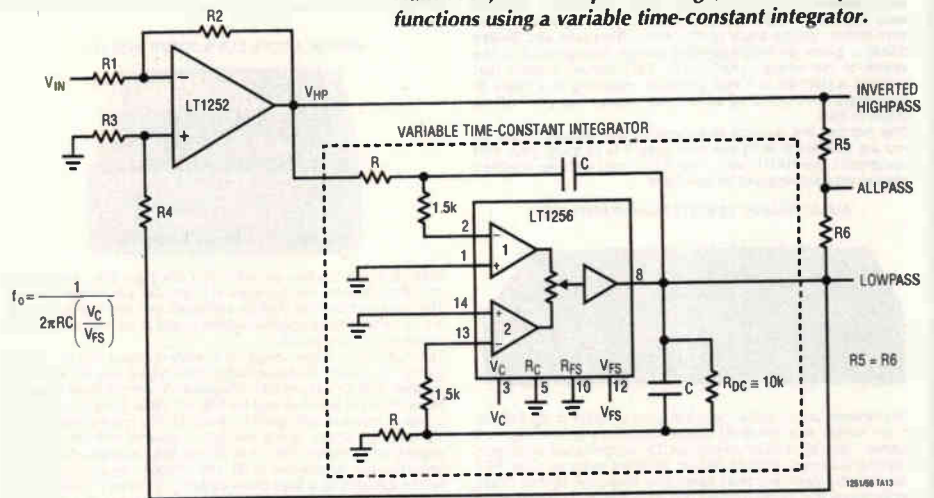

Taken from Linear's High-Speed Amplifier Solutions Handbook, this filter provides high, low and all-pass functions using a variable time-constant integrator.

## Send colour 1000 feet over low cost twisted pair

Composite video signals can be sent appreciable distances on low-cost twisted pair – in two directions. The cost advantage of this technique is significant. Standard 75Ω RG-9/U coaxial cable costs between 25¢ and 50¢ per foot, but PVC twisted pair is only pennies per foot. This means hundreds of dollars are saved in installations as short as 1000 feet, easily paying for additional electronics. The system also provides for 'drops' or receiver taps along the pair.

This bidirectional 'video bus' consists of the LT1190 op-amp and the LT1193 video

difference amplifier shown in Fig. 1. The two top-left LT1190s generate differential signals to drive the line, which is back-terminated in its characteristic impedance. The twisted pair receiver is an LT1193 video difference amplifier, bottom right, and it converts signals from differential to single-ended.

Because of the LT1193's unique topology, it is possible to provide cable compensation at the amplifier's feedback node as shown. In this case, 1000 feet of twisted pair is compensated with 1000pF and 50Ω to boost the -3dB bandwidth of the system from

750kHz to 4MHz. Attenuation in the cable can be compensated by lowering the gain-setting resistor  $R_G$ . At top right, another pair of LT1190s provides cable termination via low output impedance and generates differential signals.

A good indication of the system's ability to pass colour video is Fig. 2. This multiburst pattern was passed through 1000 feet of low-cost PVC twisted pair; it contains a 3.58MHz chroma subcarrier and a 4.5MHz sound subcarrier. Although the photo shows these frequencies attenuated about 3dB, a clean picture is present at the end of the twisted pair.

This and the above circuit are taken from Linear Technology's High-Speed Amplifier Solutions Handbook.

**Linear Technology, The Coliseum,**  
 Riverside Way, Camberley, Surrey GU15 3YL, tel. 01276 677676, fax 01276 64851.

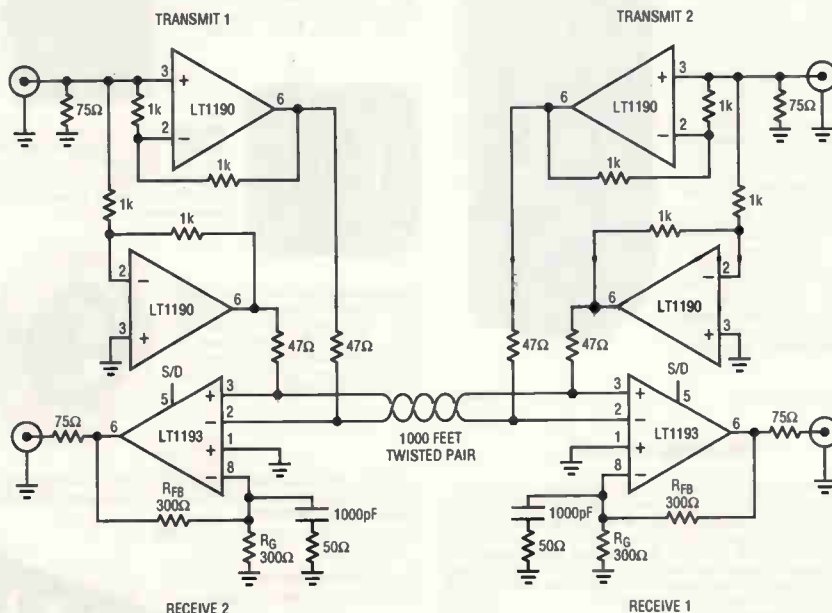

Fig. 1. Video transceiver uses low-cost PVC twisted pair.

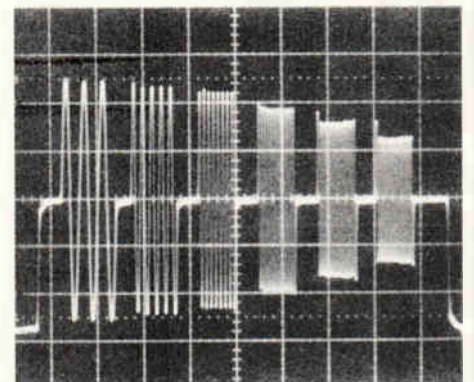

Fig. 2. Multi-burst pattern passed through 1000ft of twisted pair. Although -3dB at around 4MHz is indicated, colour video pictures are clear.



## Sensitive carbon-monoxide sensor

A new CO gas detector, namely the Motorola MGS 1100, is soon to become available. Tentatively priced at \$10 in small quantities, the detector will eventually be supported by application-specific hardware. But the published preliminary data, summarised below, should be enough to construct a complete CO detector.

Incorporated into the device is a 5V heater taking a maximum of 50mA. It

requires a 48 hours pre-conditioning period. This is intended to be a mains operated device. The associated circuitry needs to supply 5V at 50 mA, which is easily done. The recommended mode of operation is to switch the heater from 5V for 5 seconds to 1V for 10 seconds.

In still air the device has a nominal resistance of 10k $\Omega$ , which reduces by a factor of 1.8 at a CO concentration of 100ppm. The measurements should be

taken at consistent points in the on/off cycle, e.g after 4.5 seconds high and 9.5 seconds low. Two sample-and-hold circuits need to be gated at the appropriate times and compared.

Although unlikely to prove fatal unless exposure is prolonged, 100ppm is a toxic level.

Motorola, tel 01354 688040, fax 01354 688248 (please note that this number is not for general enquiries).

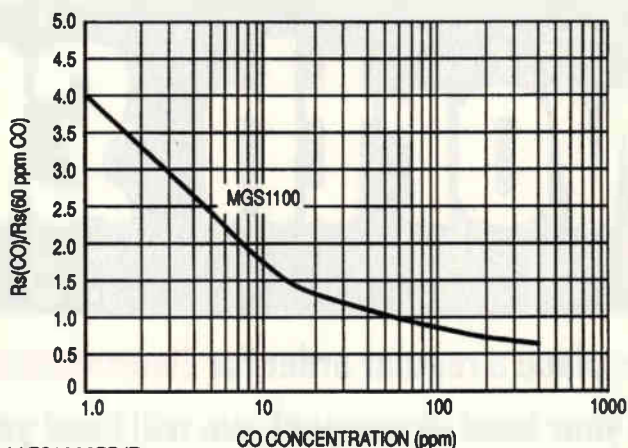
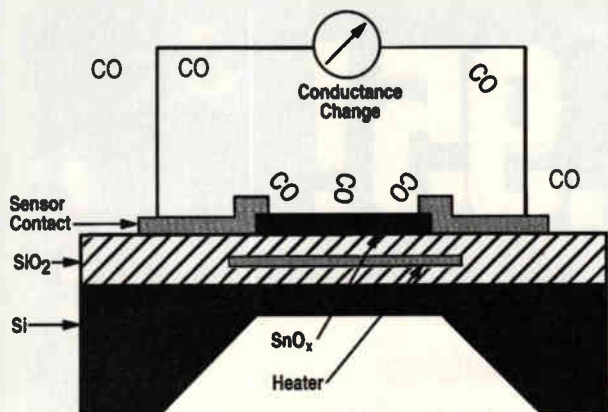

Sensitive at low gas concentrations, the MGS1100 is described in document MGS1000PB/D.

## RADIO DATA MODULES MODEM TRANSCEIVERS

UK, E.E.C, Scandinavia, Eastern Europe, North & South America, Middle East, South Africa, New Zealand, Far East or Australia. Wherever you are, we have a module on the right frequency for you!

### UHF Transceiver for the World!

- 400 to 500MHz Versions \*
- Range up to 5Km \*
- Compact Size Ideal for Hand Helds \*
- UK, North American, Australian \*
- MPT, I-ETS & FCC Approval \*
- Up to 64 selectable channels \*
- Starter Kit only £299.95 \*

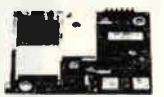

Only 55 x 73 x 15mm

### Low Cost High Speed Data Transmitters: UK, EEC and Beyond!

- Available UK Approved MPT1340 418MHz \*
- Export I-ETS-300-220, 433.92MHz \*
- Reduce Component Count, Cost, Size & Power Drain \*
- Operate to 20,000 bps \*
- Transceiver also available with up to 40K data rate \*



TXM-418-F Transmitter

### Licence Exempt Spread Spectrum on 2.45GHz

With up to 1Mbit data rate, RS485 interface and 100mW of output power these units are ideal for many high speed industrial or office data transfer applications. Even compressed colour video may be transferred. Price £480.00 each or starter kit for only £799.95.



### VHF Modules for UK, Australia and Beyond!

- UK, 173MHz to MPT1344 & MPT1328 Licence Exempt \*
- Miniature Low Cost or canned 1 & 10mW Transmitters \*
- 173.500MHz Transmitters & Transceivers for Australia & RSA \*
- PCB mount or canned, Superhet Receivers \*
- Low Cost Meter Reading Transceivers on 183.8875MHz \*
- Prices from £19.00 to £200.00 per unit \*



Radio - Tech Limited, Overbridge House, Weald Hall Lane  
Thornwood Common, Epping, Essex CM16 6NB.  
Sales +44 (0) 1992 57 6107 Fax +44 (0) 1992 56 1994  
Technical Support +44 (0) 1992 57 6114  
Internet: <http://www.radio-tech.co.uk>

CIRCLE NO. 130 ON REPLY CARD

## ANTRIM TRANSFORMERS LTD TOROIDAL TRANSFORMERS



Large standard range from 15VA to 1kVA approved to EN60742 & AS3108



Custom designs to most international standards from 10VA to 3kVA



Rapid quotation, design and prototype service  
Any size production run catered for



All transformers manufactured at UK factory allowing fast lead times at no extra cost



70V / 100V Line, valve output & low noise audio designs available



Medical designs to IEC601/BS5724 & UL544

### AGENTS / DISTRIBUTORS REQUIRED WORLDWIDE

Technical Sales Department, 30 Bramley Avenue

Canterbury, Kent, CT1 3XW, England

Tel: +44 (0)1227 450810

Fax: +44 (0)1227 764609

## BRITISH MADE & BUILT TO LAST

CIRCLE NO. 131 ON REPLY CARD

# Free test screwdriver worth £6.95!



If you place a regular order for **Electronics World** or **Television** with your local newsagent, we will send you a **FREE** multi-function indicator screwdriver worth £6.95!

Simply fill in the forms below. One is to give your newsagent, the other is to have signed by your newsagent and sent to the address on the form.

This offer is subject to availability.

Please ask your newsagent to sign this form, then send it to:

Pat Lloyd, Simmonds, 82-84 Peckham Rye, London SE15 4HB.

Your Name .....

Your Job Title .....

Your Address .....

.....

.....

Your Telephone Number .....

Please tick this box if you do not wish to receive direct marketing promotions from other companies.

Your Signature .....

Newsagent's Name .....

Newsagent's Address .....

.....

Newsagent's Telephone Number .....

Newsagent's Signature .....

Wholesaler Box No. ....

Please give this form to your newsagent

Please save me a copy of Electronics World/Television every month.

Name .....

Address .....

.....

Postcode .....

Tel .....



For more information about any of the products or services in this issue of **ELECTRONICS WORLD**, simply ring the relevant enquiry number.

Enquiry numbers may be found at the bottom of each individual advertisement.

- 101 102 103 104 105 106 107 108 109
- 110 111 112 113 114 115 116 117 118
- 119 120 121 122 123 124 125 126 127
- 128 129 130 131 132 133 134 135 136
- 137 138 139 140 141 142 143 144 145
- 146 147 148 149 150 151 152 153 154
- 155 156 157 158 159 160 161 162 163
- 164 165 166 167 168 169 170 171 172
- 173 174 175 176 177 178 179 180 181

Name _____
Job title _____
Company Address _____ _____ _____
Telephone _____ <b>MAR.</b>
Only tick here if you do not wish to receive direct marketing promotions from other companies. <input type="checkbox"/>

## Newsagent order form

Pass this order form to your newsagent to ensure you don't miss the next issue of *EW*.

To .....  
(name of Newsagent)

**Please reserve me the April issue of *Electronics World* - on sale 6th March - and continue to order every month's issue until further notice**

Name.....

Address.....  
.....  
.....  
.....

Thank you

# Subscribe today!

Guarantee your own personal copy each month

## Save on a 2 year subscription

# Subscribe today!

Guarantee your own personal copy each month

## Save on a 2 year subscription





# Exclusive to EW readers

## Digital panel meter for just £8.95

The PM-128 is a 3.5-digit lcd panel meter with a full-scale reading of 199.9mV dc and is configurable for 20V, 200V or 500V full-scale reading by adding two resistors. Jumpers then set the decimal point position. Supplied complete with mounting bezel, this low-power meter is available exclusively to Electronics World readers at the special price of £8.95 – fully inclusive of postage, packing and VAT – or even less in quantities above four off. The normal selling price is £12.95 – excluding VAT and postage.

Please use the coupon to order your panel meters, and address all correspondence relating to this order to Vann Draper Electronics at Unit 5, Premier Works, Canal Street, South Wigston, Leicester LE18 2PL, fax 0116 2773945 or tel. 0116 2771400.



*Incorporating the ICL7106 a-to-d converter, this digital panel meter has a full-scale input sensitivity of 200mV and a high input impedance of >100MΩ.*

### PM-128 digital panel meter

#### Features

- Single 9V dc supply
- Low 1mA consumption
- Very high input impedance
- Overrange indication
- Dual-slope integration a-to-d conversion
- Decimal point selectable
- Auto polarity indication
- Guaranteed zero reading for zero input

#### Specifications

- Maximum input 199.9mV
- 100MΩ input impedance
- Liquid crystal display
- 13.5mm high characters
- Maximum display 1999 counts, auto polarity
- Reading speed 2-3 times a second
- Accuracy  $\pm 0.5\%$  at  $23^{\circ}\text{C} \pm 5^{\circ}$  &  $< 80\% \text{ RH}$
- Power requirements, 9-12V dc at 1mA
- Size 68mm by 44mm

### Use this coupon to order your PM128

Please send me

..... PM-128 digital panel meter(s)

at the fully inclusive special offer price of  
£8.95 each for quantities up to 4 off  
£8.65 each for quantities of 5 or more or  
£8.35 each for 10 or more quantities

for which I enclose a total of £.....

Name

Company (if any)

Address

Phone number/fax

Make cheques payable to Vann Draper Electronics Ltd  
Or, please debit my Master, Visa or Access card.

Card type (Access/Visa)

Card No

Expiry date

Please mail this coupon to Vann Draper Electronics, together with payment. Alternatively fax credit card details with order on 0116 2773945 or telephone on 0116 2771400. Address orders and all correspondence relating to this order to Vann Draper Electronics at Unit 5, Premier Works, Canal Street, South Wigston, Leicester LE18 2PL.

\*Overseas readers can also obtain this discount but details vary according to country. Please ring, write or fax to Vann Draper Electronics.

# CIRCUIT IDEAS

Do you have an original circuit idea for publication? We are giving **£100** cash for the month's top design. Additional authors will receive **£35** cash for each circuit idea published. We are looking for ingenuity in the use of modern components.

## WIN A TTI PROGRAMMABLE BENCH MULTIMETER

*"High accuracy, resolution and bandwidth - performance beyond the capability of hand-helds"*



This high-performance bench multimeter could be yours in exchange for a good idea. Featuring a dual display, the 4.5-digit 1705 multimeter resolves down to 10µV, 10mΩ and 0.1µA and has a basic dc accuracy of 0.04%. Frequency measured is 10Hz to 120kHz with an accuracy of 0.01% and resolution to 0.01Hz. Capacitor and true rms measurements are also featured.

Recognising the importance of a good idea, Thurlby Thandar Instruments will be giving away one of these excellent instruments once every six months. This incentive is in addition to our monthly £100 'best circuit idea' award and £35 awards for each circuit published.

## £100 WINNER

### Frequency-programmable analogue band-pass filter

Centre frequency of this filter is linearly proportional to the digital inputs of an a-to-d  $R-2R$  ladder converter. Two main elements comprise the circuit: a gyrator and a band-pass filter. Figure 1 shows the gyrator, the input

impedance of which is given by,

$$z_{in}(s) = sR_1R_2$$

which appears as an equivalent inductor with a value of  $L_{eq} = LR_1R_2$ .

Figure 2 is a basic band-pass filter, whose transfer function is,

$$H(s) = s / CR'(s^2 + s/CR' + 1/LC)$$

compared with that of a second-order band-pass, which is,

$$H(s) = \omega_0 A_0 s / Q(s^2 + s\omega_0/Q + \omega_0^2)$$

Pass-band gain is 1 and centre frequency

$$f_0 = 1/(2\pi LC) = \omega_0 / 2\pi.$$

Bandwidth is  $f_0/Q = 1/(2\omega CR)$ .

An analogue-to-digital converter is represented in Fig. 3, in which  $b_{n-1}, b_{n-2}, \dots, b_0$  are the digital inputs to an  $n$ -bit  $R-2R$

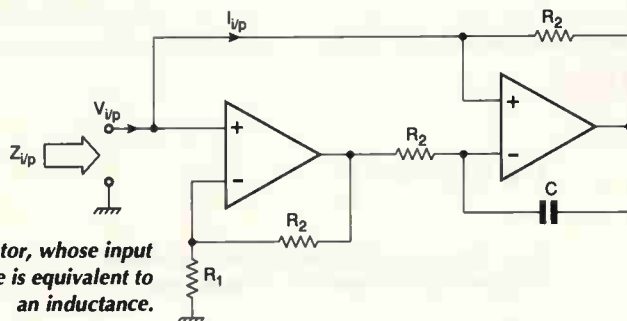

Fig. 1. A gyrator, whose input impedance is equivalent to an inductance.

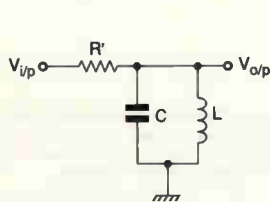

Fig. 2. Band-pass filter.

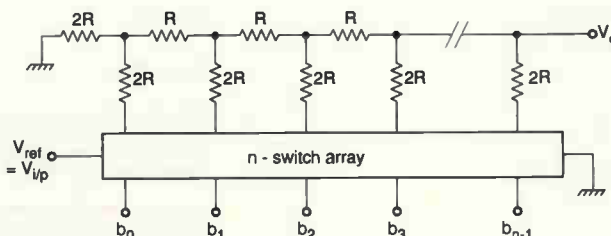

Fig. 3.  $N$ -bit ladder network used in an analogue-to-digital converter, the input voltage being represented by the resistor switches.



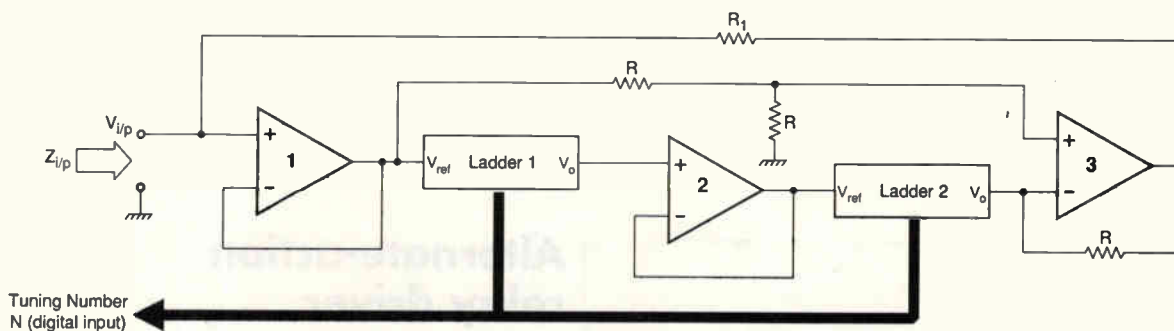

Fig.4. Input impedance of this arrangement is resistive and varying inversely with  $N^2$ .

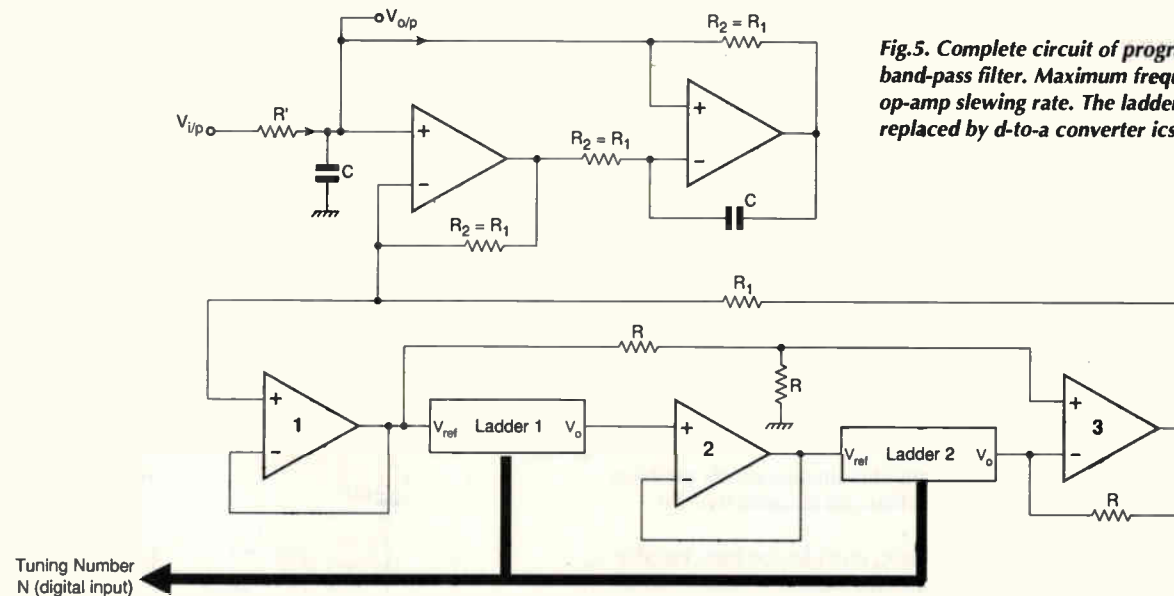

Fig.5. Complete circuit of programmable band-pass filter. Maximum frequency is set by op-amp slewing rate. The ladders may be replaced by d-to-a converter ics,

ladder network, whose output is  $v_o = N/2^n v_{in}$ . Output impedance is  $R$ .

Figure 4 is a development of this, in which the op-amps are simply buffers and both ladders have the same digital input. Output voltage of ladder 1 is  $(N/2^n)v_{in}$ , which is also the input to ladder 2, whose output is therefore  $(N/2^n)2v_{in}$ . The output impedance of the ladders being  $R$ , op-amp 3 output voltage is  $Av_{in}$ .

Now connecting  $R_1$  from input to output produces an input impedance,

$$z_{in} = R_1(1 - A) = R_1 / (1 - (N/2^n)^2) = R_1(2^n / N)^2$$

which is a resistance varying inversely as the square of  $N$ .

If now the resistor  $R_1$  in the gyrator circuit of Fig.1 is replaced with the circuit of Fig.3 and this new gyrator is used as the inductor in the circuit of Fig.2, the whole being shown in Fig.4, the centre frequency becomes,

$$f_0 = 1 / (2\pi(R_2 R_1 (2^n / N)^2 - C)^{1/2})$$

If  $R_2 = R_1$ ,

$$f_0 = N / (2\pi R_1 C * 2^n)$$

the centre frequency being proportional to the tuning number  $N$ , independently of bandwidth.

S. Santhosh Kumar  
Kerala  
India

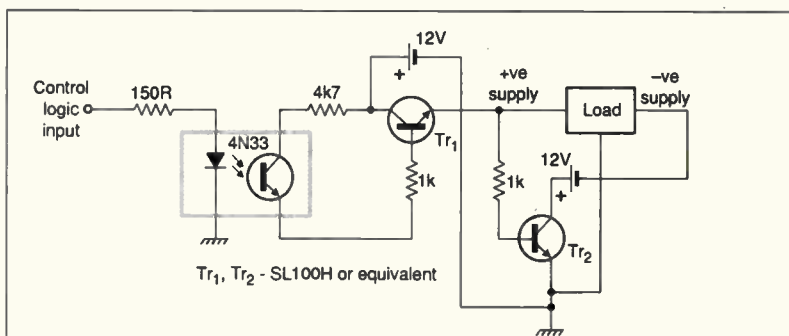

Both rails of a dual power supply are switched by logic input.

## Switch two supply rails at once, digitally

Logic-level signals control the on/off switching of dual power supplies.

Input switching logic signals go to an opto-isolator which, when conducting, supplies base current to  $Tr_1$  and completes the path from the +12V supply through the load to ground. At the same time,  $Tr_2$  receives base current via  $Tr_1$  and provides the path for the negative 12V supply. In the absence of drive to the opto-isolator, both transistors are off and neither power supply is connected.

V Lakshminarayanan  
Centre for Development of Telematics  
Bangalore, India

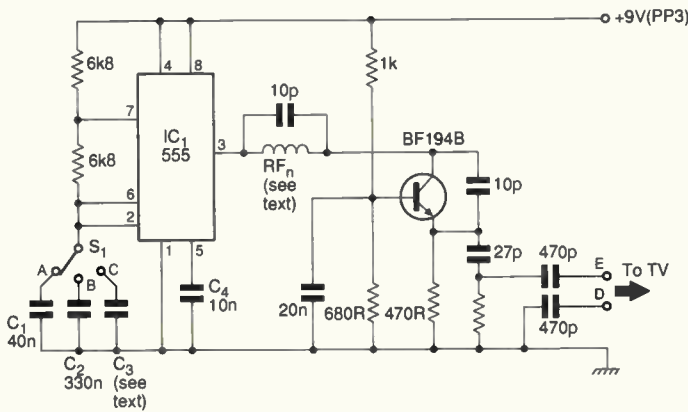

TV bar generator. Assemble it on strip board with the coil about 10mm above the board. Use a PP3 battery rather than a battery eliminator to avoid ripple.

## One-chip television bar generator

An uncomplicated circuit, this simultaneously produces a pattern of horizontal bars and an audio tone for servicing purposes.

A 555, used as an oscillator, provides the bars, variable in number by the switched capacitors  $C_{1-2}$  from 15 to 4;  $C_3$  is about 10pF, but will need to be selected to produce vertical bars.

Output from the BF194B rf oscillator, whose coil is not cored, falls in the vhf range. Its coil is eight turns of 24g enamelled copper wound on a small former, which is removed later.

Connect points E and D to the television aerial socket. Switch  $C_1$  or  $C_2$  into circuit and set the tv to channel 4, adjusting the coil spacing to obtain a clear pattern and audio. You might need to tune the tv to get a good pattern.

Raj K Gorkhali  
Kathmandu  
Nepal

Obviously not for UK use, Ed.

## Alternate-action relay driver

A relay was required to change state when a positive voltage of variable duration, and possibly noisy, was received.

Connecting a push-button switch in the position of the transistor in the circuit shown achieves the effect needed, since it is able to conduct in both directions, and the 40170 will drive the relay directly.

If a transistor is only required to switch, it can often be used with emitter and collector reversed. Here, an n-p-n type, a BC183, acts alternately in the conventional direction and in reverse, depending on the state of the circuit, and responds to a positive input to the base in both conditions.

L S Whitlock  
Taunton  
Somerset

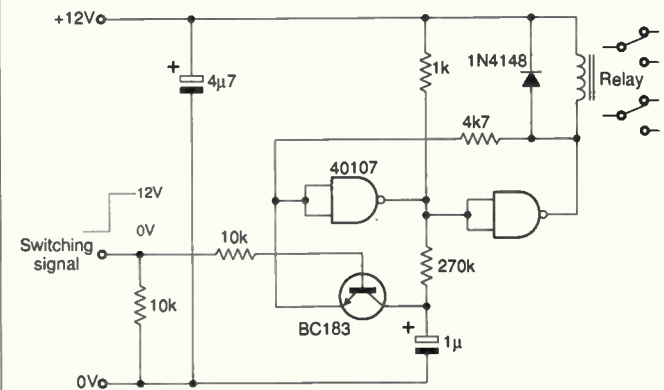

Transistor is used to replace a push-button switch to produce relay action on receipt of a positive voltage input to the circuit.

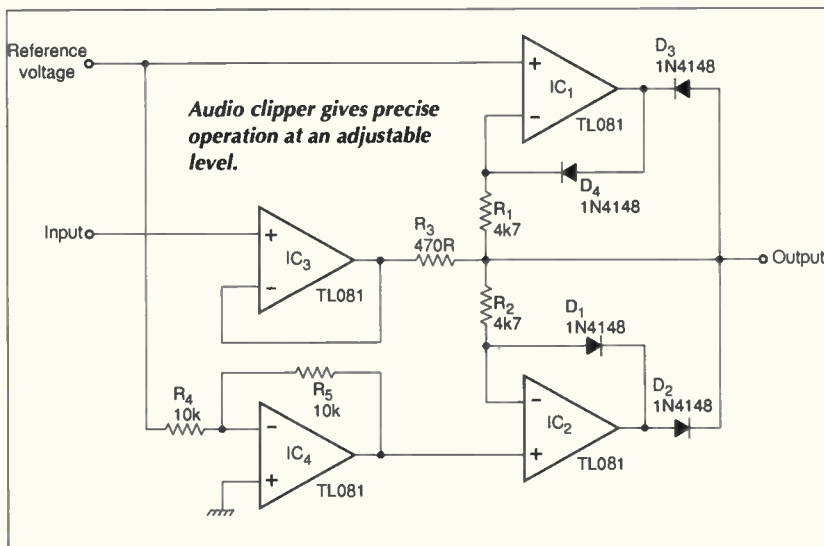

Audio clipper gives precise operation at an adjustable level.

## Symmetrical audio clipper

Virtually self-explanatory, the diagram shows an audio clipper which operates symmetrically at a level set by the reference input. Since the op-amps are never in saturation, the circuit operation is fast.

The only other point to make is that, when not clipping, the circuit attenuates by a factor  $R_3/R_1 R_2$ .

J A Burnill  
Camberley  
Surrey



## Clean power-on reset

These two inverters give a clean power-on reset, the reset time being determined by  $R_3C_1$  and the amount of hysteresis by  $R_{1,2}$ . Capacitor  $C_2$  is simply a speed-up component.

**J A Burnill**  
Camberley, Surrey

*Simple circuit to provide power-on reset with hysteresis.*

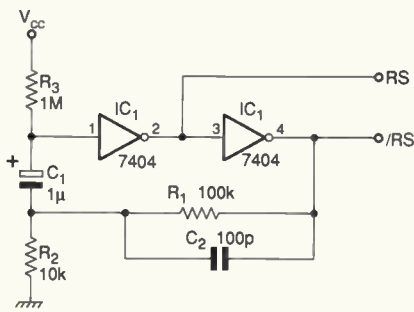

## RS 232-to-parallel conversion

Under control of a pc by way of Com1 or Com2 ports, the circuit takes in RS 232 serial data and converts it to parallel form.

Data comes in to a 74LS164 serial-to-parallel shift register, together with a pulse to set the latch. Data rate  $B$  in baud is around  $11.5/C_1\text{kHz}$ , where  $C_1$  is in nanofarads. Divisor value for the pc is  $(1.8432 \times 10^6)/16B$ , the pc being programmed for that rate by using this value in 16-bit form by means of Turbo C statements for Com 1:

```
output(0x2FB,131); /* 2FB for baud setting */
output(0x2F8,0xX); /* 1sb byte of divisor */
output(0x2F9,0xXX); /* msb byte of divisor */
output(0x2FB,3); /* 2FB for transmission */
```

Data in eight-bit form may be sent to pin 3 of the 9-pin D connector by the statement:

```
output(0x2FB,word);
```

For Com 2, use 3F8, 3F9 and 3FB.

**S Vijayan Pillai**  
Kochi  
Kerala State  
India

*RS 232 serial to parallel data converter for pc-based control.*

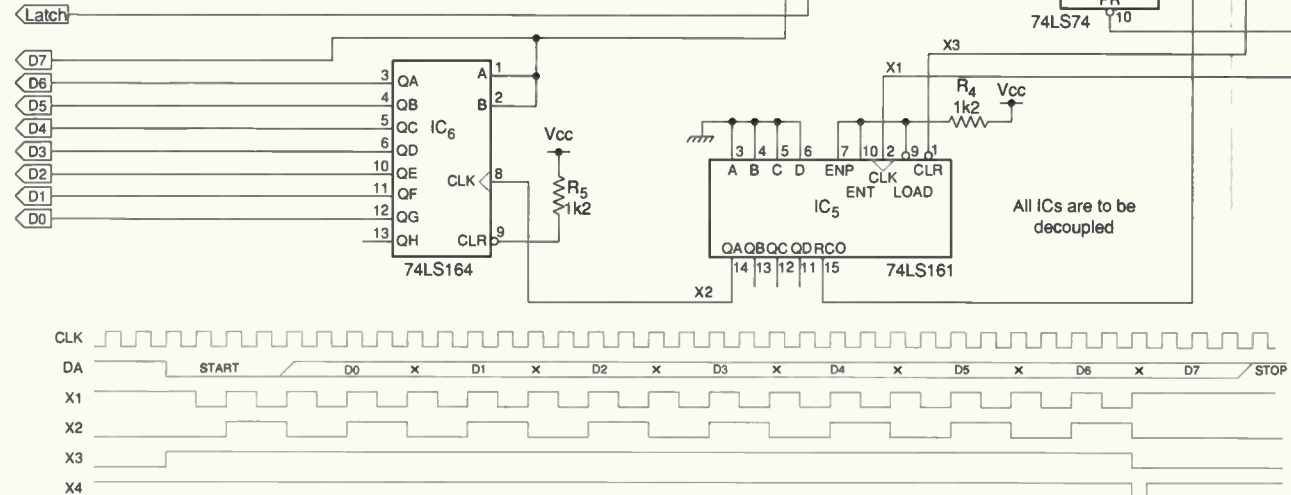
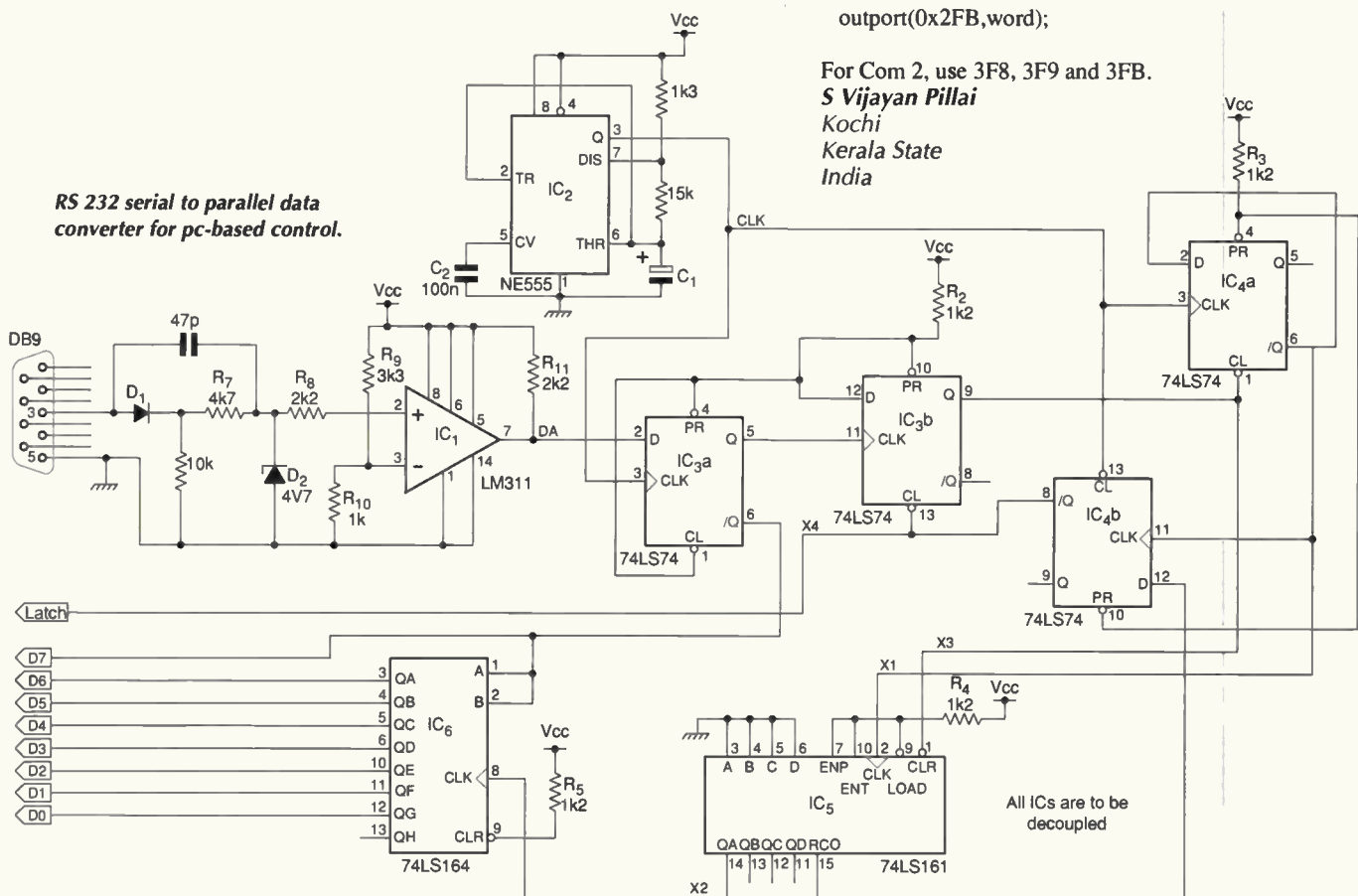

All ICs are to be decoupled

**SMALL SELECTION ONLY LISTED - EXPORT TRADE AND QUANTITY DISCOUNTS - RING US FOR YOUR REQUIREMENTS WHICH MAY BE IN STOCK**

**HP New Colour Spectrum Analysers**  
 HP141T+8552B IF + 8553B RF - 1KHz-110Mc/s - £700.  
 HP141T+8552B IF + 8554B RF - 100KHz-1250Mc/s - £900.  
 HP141T+8552B IF + 8556A RF - 20Hz-300KHz - £700.  
**Special Offer just in from MOD Qty 40 HP8555A RF Units 10Mc/s - 18GHz.**  
 HP141T+8552B IF + 8555A 10Mc/s-18GHz - £1200.  
**HP ANZ Units Available separately - New Colours - Tested**  
 HP 141T Mainframe - £350.  
 HP8552B IF - £300.  
 HP8553B RF 1KHz to 110Mc/s - £200.  
 HP8554B RF 100KHz to 1250Mc/s - £500.  
 HP8555A RF 10Mc/s to 18GHz - £800.  
 HP8556A RF 20Hz to 300KHz - £250.  
 HP8443A Tracking Generator Counter 100KHz-110Mc/s - £300.  
 HP8445B Tracking Preselector DC to 18GHz - £350.  
 HP3580A 5Hz - 50KHz ANZ - £750 - £1000.  
 HP3582A .02Hz to 25.6KHz - £2k.  
 HP8568A 100Hz-1500Mc/s ANZ - £6k.  
 HP8569B 10Mc/s-22GHz ANZ - £6k.  
**HP Mixers are available for the above ANZ's to 40GHz**  
 TEK 492 - 50KHz - 18GHz Opt 1+2 - £4k-£4.2k.  
 TEK 492 - 50KHz - 18GHz Opt 1+2+3 - £4.5k.  
 TEK 492P - 50KHz - 21 GHz Opt 1+2+3 - £5k.  
 TEK 494AP 1Kc/s - 21 GHz - £7k.  
 TEK 496P 1KHz-1.8GHz - £4k.  
 TEK 5L4N 0-100KHz - £400.  
 TEK 7L5 + L1 - 20Hz-5Mc/s - £700.  
 TEK 7L5 + L3 - Opt 25 Tracking Gen - £900.  
 TEK 7L12 - 100KHz-1800Mc/s - £1000.  
 TEK 7L18 - 1.5-60GHz - £1500.  
 TEK 491 10Mc/s-12.4GHz-40GHz - £750. 12.4GHz-40GHz with Mixers.  
**Tektronix Mixers are available for above ANZ to 60GHz**  
 Systron Donner 763 Spectrum ANZ + 4745B Preselector .01-18GHz + Two Mixers 18-40GHz in Transit Case - £3k.  
 HP8673D Signal Generator .05-26.5GHz - £20k.  
 Systron Donner 1618B Microwave AM FM Synthesizer 50Mc/s 2-18GHz  
 R&S SWP Sweep Generator Synthesizer AM FM 4-2500Mc/s - £3.5k.  
 ADRET 3310A FX Synthesizer 300Hz-60Mc/s - £600.  
 HP8640A Signal Generators - 1024Mc/s - AM FM - £800.  
 HP3717A 70Mc/s Modulator - Demodulator - £500.  
 HP8651A RF Oscillator 22Kc/s - 22Mc/s.  
 HP5316B Universal Counter A+B.  
 HP6002A Power Unit 0-5V 0-10A 200W.  
 HP6825A Bipolar Power Supply Amplifier.  
 HP461A-465A-467A Amplifiers.  
 HP81519A Optical Receiver DC-400Mc/s.  
**HP Plotters 7470A-7475A.**  
 HP3770A Amplitude Delay Distortion ANZ.  
 HP3770B Telephone Line Analyser.  
 HP8182A Data Analyser.  
 HP59401A Bus System Analyser.  
 HP6260B Power Unit 0-10V 0-100 Amps.  
 HP3782A Error Detector.  
 HP3781A Pattern Generator.  
 HP3730A+3737A Down Converter Oscillator 3.5-6.5GHz.  
 HP Microwave Amps 491-492-493-494-495-1GHz-12.4GHz - £250.  
 HP105B Quartz Oscillator - £400.  
 HP5087A Distribution Amplifier.  
 HP6034A System Power Supply 0-60V 0-10A-200W - £500.  
 HP6131C Digital Voltage Source + 100V 1/2 Amp.  
 HP4275A Multi Frequency L.C.R. Meter.  
 HP3779A Primary Multiplex Analyser.  
 HP3779C Primary Multiplex Analyser.  
 HP8150A Optical Signal Source.  
 HP1630G Logic Analyser.  
 HP5316A Universal Counter A+B.  
 HP5335A Universal Counter A+B+C.  
 HP59501B Isolated Power Supply Programmer.  
 HP8901A Modulation Meter AM - FM - also 8901B.  
 HP5370A Universal Time Interval Counter.  
**Marconi TF2370 - 30Hz-110Mc/s 750HM Output (2 BNC Sockets+Resistor for 500HM MOD with Marconi MOD Sheet supplied - £650.**  
 Marconi TF2370 30Hz-110Mc/s 50 ohm Output - £750.  
 Marconi TF2370 as above but late type - £850.  
 Marconi TF2370 as above but late type Brown Case - £1000.  
 Marconi TF2374 Zero Loss Probe - £200.  
 Marconi TF2440 Microwave Counter - 20GHz - £1500.  
 Marconi TF2442 Microwave Counter - 26.5GHz - £2k.  
 Marconi TF2305 Modulation Meter - £2.3k.  
**Racal/Dana 2101 Microwave Counter - 10Hz-20GHz - £2k.**  
**Racal/Dana 1250-1261 Universal Switch Controller + 200Mc/s PI Cards.**  
**Racal/Dana 9303 True RMS Levelmeter + Head - £450. IFFE - £500.**  
 TEKA6902A also A6902B Isolator - £300-£400.  
 TEK 1240 Logic Analyser - £400.  
 TEK FG5010 Programmable Function Generator 20Mc/s - £600.  
 TEK2465A 350Mc/s Oscilloscope - £2.5k + probes - £150 each.  
 TEK CT-5 High Current Transformer Probe - £250.  
 TEK J16 Digital Photometer + J6523-2 Luminance Probe - £300.  
 TEK J16 Digital Photometer + J6503 Luminance Probe - £250.  
 ROTEK 320 Calibrator + 350 High Current Adaptor AC-DC - £500.  
 FLUKE 5102B AC-DC Calibrator - £4k.  
 FLUKE 1120A IEEE - 488 Translator - £250.  
 Tinsley Standard Cell Battery 5644B - £500.  
 Tinsley Transportable Voltage Reference - £500.  
 FLUKE Y5020 Current Shunt - £150.  
 HP745A+746A AC Calibrator - £600.  
 HP8080A MF + 8091A 1GHz Rate Generator + 8092A Delay Generator + Two 8093A 1GHz Amps + 15400A - £800.  
 HP54200A Digitizing Oscilloscope.  
 HP1729B Carrier Noise Test Set .01-18GHz - LEF - £2000.  
 HP3311A Function Generator - £300.  
**Marconi TF2008 - AM-FM signal generator - also sweeper - 10Kc/s - 510Mc/s - from £250 - tested to £400 as new with manual - probe kit in wooden carrying box.**  
 HP Frequency comb generator type 8406 - £400.  
 HP Vector Voltmeter type 8405A - £400 new colour.  
 HP Sweep Oscillators type 8690 A & B + plug-ins from 10Mc/s to 18GHz also 18-40GHz. P.O.R.  
 HP Network Analyzer type 8407A + 8412A + 8501A - 100Kc/s - 110Mc/s - £1000.  
 HP Amplifier type 8447A - 1-4000Mc/s £200 - HP8447A Dual - £300.  
 HP Frequency Counter type 5340A - 18GHz £1000 - rear output £800.  
 HP 8410 - A - B - C Network Analyzer 110Mc/s to 12GHz or 18GHz - plus most other units and displays used in this set-up - 8411a - 8412 - 8413 - 8414 - 8418 - 8419 - 8420 - 8421 - 8422 - 8423 - 8424 - 8425 - 8426 - 8427 - 8428 - 8429 - 8430 - 8431 - 8432 - 8433 - 8434 - 8435 - 8436 - 8437 - 8438 - 8439 - 8440 - 8441 - 8442 - 8443 - 8444 - 8445 - 8446 - 8447 - 8448 - 8449 - 8450 - 8451 - 8452 - 8453 - 8454 - 8455 - 8456 - 8457 - 8458 - 8459 - 8460 - 8461 - 8462 - 8463 - 8464 - 8465 - 8466 - 8467 - 8468 - 8469 - 8470 - 8471 - 8472 - 8473 - 8474 - 8475 - 8476 - 8477 - 8478 - 8479 - 8480 - 8481 - 8482 - 8483 - 8484 - 8485 - 8486 - 8487 - 8488 - 8489 - 8490 - 8491 - 8492 - 8493 - 8494 - 8495 - 8496 - 8497 - 8498 - 8499 - 8500 - 8501 - 8502 - 8503 - 8504 - 8505 - 8506 - 8507 - 8508 - 8509 - 8510 - 8511 - 8512 - 8513 - 8514 - 8515 - 8516 - 8517 - 8518 - 8519 - 8520 - 8521 - 8522 - 8523 - 8524 - 8525 - 8526 - 8527 - 8528 - 8529 - 8530 - 8531 - 8532 - 8533 - 8534 - 8535 - 8536 - 8537 - 8538 - 8539 - 8540 - 8541 - 8542 - 8543 - 8544 - 8545 - 8546 - 8547 - 8548 - 8549 - 8550 - 8551 - 8552 - 8553 - 8554 - 8555 - 8556 - 8557 - 8558 - 8559 - 8560 - 8561 - 8562 - 8563 - 8564 - 8565 - 8566 - 8567 - 8568 - 8569 - 8570 - 8571 - 8572 - 8573 - 8574 - 8575 - 8576 - 8577 - 8578 - 8579 - 8580 - 8581 - 8582 - 8583 - 8584 - 8585 - 8586 - 8587 - 8588 - 8589 - 8590 - 8591 - 8592 - 8593 - 8594 - 8595 - 8596 - 8597 - 8598 - 8599 - 8600 - 8601 - 8602 - 8603 - 8604 - 8605 - 8606 - 8607 - 8608 - 8609 - 8610 - 8611 - 8612 - 8613 - 8614 - 8615 - 8616 - 8617 - 8618 - 8619 - 8620 - 8621 - 8622 - 8623 - 8624 - 8625 - 8626 - 8627 - 8628 - 8629 - 8630 - 8631 - 8632 - 8633 - 8634 - 8635 - 8636 - 8637 - 8638 - 8639 - 8640 - 8641 - 8642 - 8643 - 8644 - 8645 - 8646 - 8647 - 8648 - 8649 - 8650 - 8651 - 8652 - 8653 - 8654 - 8655 - 8656 - 8657 - 8658 - 8659 - 8660 - 8661 - 8662 - 8663 - 8664 - 8665 - 8666 - 8667 - 8668 - 8669 - 8670 - 8671 - 8672 - 8673 - 8674 - 8675 - 8676 - 8677 - 8678 - 8679 - 8680 - 8681 - 8682 - 8683 - 8684 - 8685 - 8686 - 8687 - 8688 - 8689 - 8690 - 8691 - 8692 - 8693 - 8694 - 8695 - 8696 - 8697 - 8698 - 8699 - 8700 - 8701 - 8702 - 8703 - 8704 - 8705 - 8706 - 8707 - 8708 - 8709 - 8710 - 8711 - 8712 - 8713 - 8714 - 8715 - 8716 - 8717 - 8718 - 8719 - 8720 - 8721 - 8722 - 8723 - 8724 - 8725 - 8726 - 8727 - 8728 - 8729 - 8730 - 8731 - 8732 - 8733 - 8734 - 8735 - 8736 - 8737 - 8738 - 8739 - 8740 - 8741 - 8742 - 8743 - 8744 - 8745 - 8746 - 8747 - 8748 - 8749 - 8750 - 8751 - 8752 - 8753 - 8754 - 8755 - 8756 - 8757 - 8758 - 8759 - 8760 - 8761 - 8762 - 8763 - 8764 - 8765 - 8766 - 8767 - 8768 - 8769 - 8770 - 8771 - 8772 - 8773 - 8774 - 8775 - 8776 - 8777 - 8778 - 8779 - 8780 - 8781 - 8782 - 8783 - 8784 - 8785 - 8786 - 8787 - 8788 - 8789 - 8790 - 8791 - 8792 - 8793 - 8794 - 8795 - 8796 - 8797 - 8798 - 8799 - 8800 - 8801 - 8802 - 8803 - 8804 - 8805 - 8806 - 8807 - 8808 - 8809 - 8810 - 8811 - 8812 - 8813 - 8814 - 8815 - 8816 - 8817 - 8818 - 8819 - 8820 - 8821 - 8822 - 8823 - 8824 - 8825 - 8826 - 8827 - 8828 - 8829 - 8830 - 8831 - 8832 - 8833 - 8834 - 8835 - 8836 - 8837 - 8838 - 8839 - 8840 - 8841 - 8842 - 8843 - 8844 - 8845 - 8846 - 8847 - 8848 - 8849 - 8850 - 8851 - 8852 - 8853 - 8854 - 8855 - 8856 - 8857 - 8858 - 8859 - 8860 - 8861 - 8862 - 8863 - 8864 - 8865 - 8866 - 8867 - 8868 - 8869 - 8870 - 8871 - 8872 - 8873 - 8874 - 8875 - 8876 - 8877 - 8878 - 8879 - 8880 - 8881 - 8882 - 8883 - 8884 - 8885 - 8886 - 8887 - 8888 - 8889 - 8890 - 8891 - 8892 - 8893 - 8894 - 8895 - 8896 - 8897 - 8898 - 8899 - 8900 - 8901 - 8902 - 8903 - 8904 - 8905 - 8906 - 8907 - 8908 - 8909 - 8910 - 8911 - 8912 - 8913 - 8914 - 8915 - 8916 - 8917 - 8918 - 8919 - 8920 - 8921 - 8922 - 8923 - 8924 - 8925 - 8926 - 8927 - 8928 - 8929 - 8930 - 8931 - 8932 - 8933 - 8934 - 8935 - 8936 - 8937 - 8938 - 8939 - 8940 - 8941 - 8942 - 8943 - 8944 - 8945 - 8946 - 8947 - 8948 - 8949 - 8950 - 8951 - 8952 - 8953 - 8954 - 8955 - 8956 - 8957 - 8958 - 8959 - 8960 - 8961 - 8962 - 8963 - 8964 - 8965 - 8966 - 8967 - 8968 - 8969 - 8970 - 8971 - 8972 - 8973 - 8974 - 8975 - 8976 - 8977 - 8978 - 8979 - 8980 - 8981 - 8982 - 8983 - 8984 - 8985 - 8986 - 8987 - 8988 - 8989 - 8990 - 8991 - 8992 - 8993 - 8994 - 8995 - 8996 - 8997 - 8998 - 8999 - 9000 - 9001 - 9002 - 9003 - 9004 - 9005 - 9006 - 9007 - 9008 - 9009 - 9010 - 9011 - 9012 - 9013 - 9014 - 9015 - 9016 - 9017 - 9018 - 9019 - 9020 - 9021 - 9022 - 9023 - 9024 - 9025 - 9026 - 9027 - 9028 - 9029 - 9030 - 9031 - 9032 - 9033 - 9034 - 9035 - 9036 - 9037 - 9038 - 9039 - 9040 - 9041 - 9042 - 9043 - 9044 - 9045 - 9046 - 9047 - 9048 - 9049 - 9050 - 9051 - 9052 - 9053 - 9054 - 9055 - 9056 - 9057 - 9058 - 9059 - 9060 - 9061 - 9062 - 9063 - 9064 - 9065 - 9066 - 9067 - 9068 - 9069 - 9070 - 9071 - 9072 - 9073 - 9074 - 9075 - 9076 - 9077 - 9078 - 9079 - 9080 - 9081 - 9082 - 9083 - 9084 - 9085 - 9086 - 9087 - 9088 - 9089 - 9090 - 9091 - 9092 - 9093 - 9094 - 9095 - 9096 - 9097 - 9098 - 9099 - 9100 - 9101 - 9102 - 9103 - 9104 - 9105 - 9106 - 9107 - 9108 - 9109 - 9110 - 9111 - 9112 - 9113 - 9114 - 9115 - 9116 - 9117 - 9118 - 9119 - 9120 - 9121 - 9122 - 9123 - 9124 - 9125 - 9126 - 9127 - 9128 - 9129 - 9130 - 9131 - 9132 - 9133 - 9134 - 9135 - 9136 - 9137 - 9138 - 9139 - 9140 - 9141 - 9142 - 9143 - 9144 - 9145 - 9146 - 9147 - 9148 - 9149 - 9150 - 9151 - 9152 - 9153 - 9154 - 9155 - 9156 - 9157 - 9158 - 9159 - 9160 - 9161 - 9162 - 9163 - 9164 - 9165 - 9166 - 9167 - 9168 - 9169 - 9170 - 9171 - 9172 - 9173 - 9174 - 9175 - 9176 - 9177 - 9178 - 9179 - 9180 - 9181 - 9182 - 9183 - 9184 - 9185 - 9186 - 9187 - 9188 - 9189 - 9190 - 9191 - 9192 - 9193 - 9194 - 9195 - 9196 - 9197 - 9198 - 9199 - 9200 - 9201 - 9202 - 9203 - 9204 - 9205 - 9206 - 9207 - 9208 - 9209 - 9210 - 9211 - 9212 - 9213 - 9214 - 9215 - 9216 - 9217 - 9218 - 9219 - 9220 - 9221 - 9222 - 9223 - 9224 - 9225 - 9226 - 9227 - 9228 - 9229 - 9230 - 9231 - 9232 - 9233 - 9234 - 9235 - 9236 - 9237 - 9238 - 9239 - 9240 - 9241 - 9242 - 9243 - 9244 - 9245 - 9246 - 9247 - 9248 - 9249 - 9250 - 9251 - 9252 - 9253 - 9254 - 9255 - 9256 - 9257 - 9258 - 9259 - 9260 - 9261 - 9262 - 9263 - 9264 - 9265 - 9266 - 9267 - 9268 - 9269 - 9270 - 9271 - 9272 - 9273 - 9274 - 9275 - 9276 - 9277 - 9278 - 9279 - 9280 - 9281 - 9282 - 9283 - 9284 - 9285 - 9286 - 9287 - 9288 - 9289 - 9290 - 9291 - 9292 - 9293 - 9294 - 9295 - 9296 - 9297 - 9298 - 9299 - 9300 - 9301 - 9302 - 9303 - 9304 - 9305 - 9306 - 9307 - 9308 - 9309 - 9310 - 9311 - 9312 - 9313 - 9314 - 9315 - 9316 - 9317 - 9318 - 9319 - 9320 - 9321 - 9322 - 9323 - 9324 - 9325 - 9326 - 9327 - 9328 - 9329 - 9330 - 9331 - 9332 - 9333 - 9334 - 9335 - 9336 - 9337 - 9338 - 9339 - 9340 - 9341 - 9342 - 9343 - 9344 - 9345 - 9346 - 9347 - 9348 - 9349 - 9350 - 9351 - 9352 - 9353 - 9354 - 9355 - 9356 - 9357 - 9358 - 9359 - 9360 - 9361 - 9362 - 9363 - 9364 - 9365 - 9366 - 9367 - 9368 - 9369 - 9370 - 9371 - 9372 - 9373 - 9374 - 9375 - 9376 - 9377 - 9378 - 9379 - 9380 - 9381 - 9382 - 9383 - 9384 - 9385 - 9386 - 9387 - 9388 - 9389 - 9390 - 9391 - 9392 - 9393 - 9394 - 9395 - 9396 - 9397 - 9398 - 9399 - 9400 - 9401 - 9402 - 9403 - 9404 - 9405 - 9406 - 9407 - 9408 - 9409 - 9410 - 9411 - 9412 - 9413 - 9414 - 9415 - 9416 - 9417 - 9418 - 9419 - 9420 - 9421 - 9422 - 9423 - 9424 - 9425 - 9426 - 9427 - 9428 - 9429 - 9430 - 9431 - 9432 - 9433 - 9434 - 9435 - 9436 - 9437 - 9438 - 9439 - 9440 - 9441 - 9442 - 9443 - 9444 - 9445 - 9446 - 9447 - 9448 - 9449 - 9450 - 9451 - 9452 - 9453 - 9454 - 9455 - 9456 - 9457 - 9458 - 9459 - 9460 - 9461 - 9462 - 9463 - 9464 - 9465 - 9466 - 9467 - 9468 - 9469 - 9470 - 9471 - 9472 - 9473 - 9474 - 9475 - 9476 - 9477 - 9478 - 9479 - 9480 - 9481 - 9482 - 9483 - 9484 - 9485 - 9486 - 9487 - 9488 - 9489 - 9490 - 9491 - 9492 - 9493 - 9494 - 9495 - 9496 - 9497 - 9498 - 9499 - 9500 - 9501 - 9502 - 9503 - 9504 - 9505 - 9506 - 9507 - 9508 - 9509 - 9510 - 9511 - 9512 - 9513 - 9514 - 9515 - 9516 - 9517 - 9518 - 9519 - 9520 - 9521 - 9522 - 9523 - 9524 - 9525 - 9526 - 9527 - 9528 - 9529 - 9530 - 9531 - 9532 - 9533 - 9534 - 9535 - 9536 - 9537 - 9538 - 9539 - 9540 - 9541 - 9542 - 9543 - 9544 - 9545 - 9546 - 9547 - 9548 - 9549 - 9550 - 9551 - 9552 - 9553 - 9554 - 9555 - 9556 - 9557 - 9558 - 9559 - 9560 - 9561 - 9562 - 9563 - 9564 - 9565 - 9566 - 9567 - 9568 - 9569 - 9570 - 9571 - 9572 - 9573 - 9574 - 9575 - 9576 - 9577 - 9578 - 9579 - 9580 - 9581 - 9582 - 9583 - 9584 - 9585 - 9586 - 9587 - 9588 - 9589 - 9590 - 9591 - 9592 - 9593 - 9594 - 9595 - 9596 - 9597 - 9598 - 9599 - 9600 - 9601 - 9602 - 9603 - 9604 - 9605 - 9606 - 9607 - 9608 - 9609 - 9610 - 9611 - 9612 - 9613 - 9614 - 9615 - 9616 - 9617 - 9618 - 9619 - 9620 - 9621 - 9622 - 9623 - 9624 - 9625 - 9626 - 9627 - 9628 - 9629 - 9630 - 9631 - 9632 - 9633 - 9634 - 9635 - 9636 - 9637 - 9638 - 9639 - 9640 - 9641 - 9642 - 9643 - 9644 - 9645 - 9646 - 9647 - 9648 - 9649 - 9650 - 9651 - 9652 - 9653 - 9654 - 9655 - 9656 - 9657 - 9658 - 9659 - 9660 - 9661 - 9662 - 9663 - 9664 - 9665 - 9666 - 9667 - 9668 - 9669 - 9670 - 9671 - 9672 - 9673 - 9674 - 9675 - 9676 - 9677 - 9678 - 9679 - 9680 - 9681 - 9682 - 9683 - 9684 - 9685 - 9686 - 9687 - 9688 - 9689 - 9690 - 9691 - 9692 - 9693 - 9694 - 9695 - 9696 - 9697 - 9698 - 9699 - 9700 - 9701 - 9702 - 9703 - 9704 - 9705 - 9706 - 9707 - 9708 - 9709 - 9710 - 9711 - 9712 - 9713 - 9714 - 9715 - 9716 - 9717 - 9718 - 9719 - 9720 - 9721 - 9722 - 9723 - 9724 - 9725 - 9726 - 9727 - 9728 - 9729 - 9730 - 9731 - 9732 - 9733 - 9734 - 9735 - 9736 - 9737 - 9738 - 9739 - 9740 - 9741 - 9742 - 9743 - 9744 - 9745 - 9746 - 9747 - 9748 - 9749 - 9750 - 9751 - 9752 - 9753 - 9754 - 9755 - 9756 - 9757 - 9758 - 9759 - 9760 - 9761 - 9762 - 9763 - 9764 - 9765 - 9766 - 9767 - 9768 - 9769 - 9770 - 9771 - 9772 - 9773 - 9774 - 9775 - 9776 - 9777 - 9778 - 9779 - 9780 - 9781 - 9782 - 9783 - 9784 - 9785 - 9786 - 9787 - 9788 - 9789 - 9790 - 9791 - 9792 - 9793 - 9794 - 9795 - 9796 - 9797 - 9798 - 9799 - 9800 - 9801 - 9802 - 9803 - 9804 - 9805 - 9806 - 9807 - 9808 - 9809 - 9810 - 9811 - 9812 - 9813 - 9814 - 9815 - 9816 - 9817 - 9818 - 9819 - 9820 - 9821 - 9822 - 9823 - 9824 - 9825 - 9826 - 9827 - 9828 - 9829 - 9830 - 9831 - 9832 - 9833 - 9834 - 9835 - 9836 - 9837 - 9838 - 9839 - 9840 - 9841 - 9842 - 9843 - 9844 - 9845 - 9846 - 9847 - 9848 - 9849 - 9850 - 9851 - 9852 - 9853 - 9854 - 9855 - 9856 - 9857 - 9858 - 9859 - 9860 - 9861 - 9862 - 9863 - 9864 - 9865 - 9866 - 9867 - 9868 - 9869 - 9870 - 9871 - 9872 - 9873 - 9874 - 9875 - 9876 - 9877 - 9878 - 9879 - 9880 - 9881 - 9882 - 9883 - 9884 - 9885 - 9886 - 9887 - 9888 - 9889 - 9890 - 9891 - 9892 - 9893 - 9894 - 9895 - 9896 - 9897 - 9898 - 9899 - 9900 - 9901 - 9902 - 9903 - 9904 - 9905 - 9906 - 9907 - 9908 - 9909 - 9910 - 9911 - 9912 - 9913 - 9914 - 9915 - 9916 - 9917 - 9918 - 9919 - 9920 - 9921 - 9922 - 9923 - 9924 - 9925 - 9926 - 9927 - 9928 - 9929 - 9930 - 9931 - 9932 - 9933 - 9934 - 9935 - 9936 - 9937 - 9938 - 9939 - 9940 - 9941 - 9942 - 9943 - 9944 - 9945 - 9946 - 9947 - 9948 - 9949 - 9950 - 9951 - 9952 - 9953 - 9954 - 9955 - 9956 - 9957 - 9958 - 9959 - 9960 - 9961 - 9962 - 9963 - 9964 - 9965 - 9966 - 9967 - 9968 - 9969 - 9970 - 9971 - 9972 - 9973 - 9974 - 9975 - 9976 - 9977 - 9978 - 9979 -



# Programmable logic primer

**Geoff Bostock explains how logic elements are formed in various types of programmable logic chips, in this second extract from his book 'FPGAs and Programmable Logic'.**

The two main technologies used for standard logic are bipolar, for the transistor-transistor logic, or ttl, families, and complementary metal-oxide semiconductor, or c-mos, for the 4000 and HC families. Examination of the basic circuit diagrams of a standard gate built in the two technologies, Fig. 1 for ttl and Fig. 2 for c-mos, illustrates the main differences in performance and application.

Invariably, ttl has a direct current path from  $V_{cc}$  to 0V; when any input is low, current will flow through  $R_1$  and via the output transistors of the driving stages. If all the inputs are high,  $T_2$  is switched on with a standing current determined by the values of  $R_2$  and  $R_3$ . Also, during switching, both output transistors conduct momentarily, causing a substantial current spike to be drawn from the power supply.

On the other hand, c-mos always has either the lower n-channel ladder turned off when any input is low, or all the upper p-channel transistors off when all the inputs are high. The only current which flows is a charging/discharging current when any of the nodes changes level; this is due to the capacitance associated with any node.

In terms of power consumption, then, there is a substantial

This article is derived from Geoff Bostock's new book 'FPGAs and programmable LSI – a designer's handbook'. The work covers designing FPGAs, large PAL structures, RAM and antifuse-based FPGAs and FPGA selection. Comprising 215 pages, this book is available by sending a postal order or cheque with a request for the book to Electronics World, Quadrant House, The Quadrant, Sutton, Surrey SM2 5AS. The fully-inclusive price is £27.50 UK, £30 Europe or £33 rest of world. Alternatively, fax your full credit card details and address on 0181 652 8956 or e-mail jackie.lowe@rbi.co.uk.

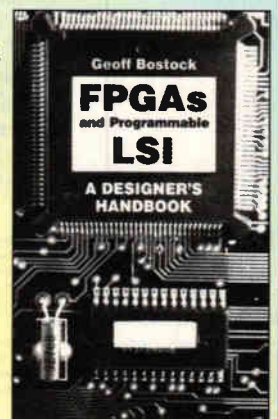

difference between the two approaches to standard logic. Consuming anything from less than 1mA to more than 6mA, ttl is a relatively power-hungry technology. Consumption depends on the resistor values, which are chosen according to

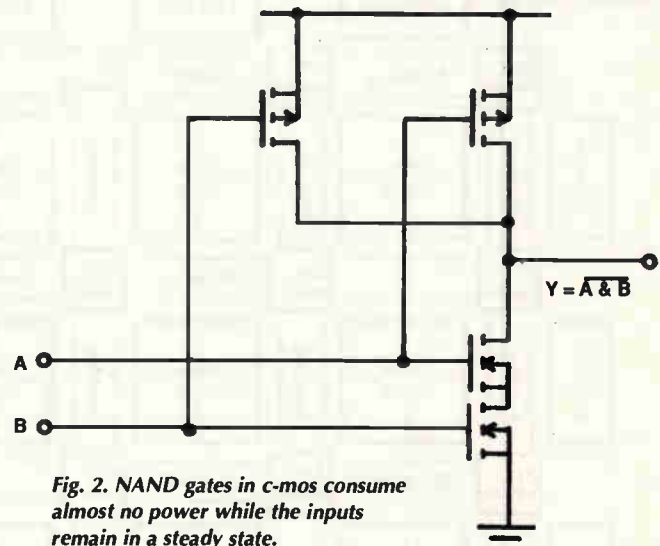
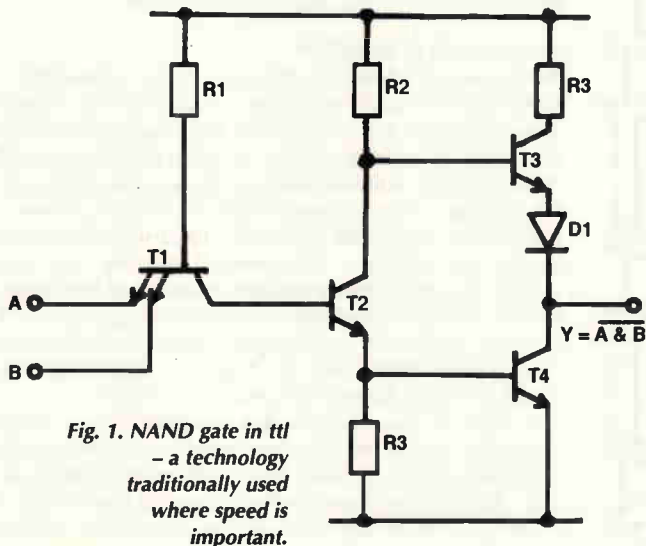
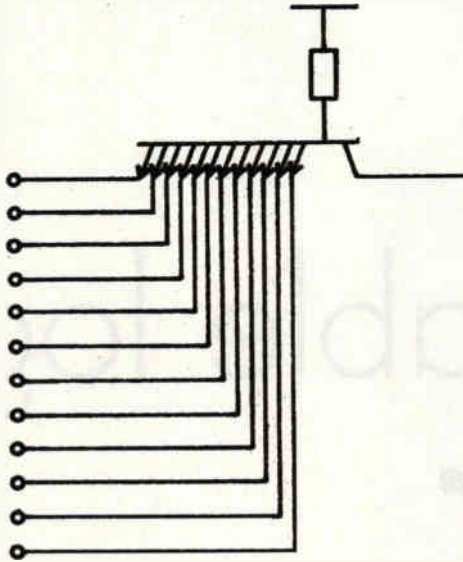

Fig. 3. With ttl, there is almost no limit to the number of inputs that can be attached to a single gate.



the speed of operation required for the particular ttl family. Current consumption also increases with operating frequency because of the current spike at each switching of the outputs.

In a cmos gate, when no inputs are being switched, the only current flowing will be leakage current through the mos transistors, which are in their off state. As a result, c-mos, consumes virtually zero power at zero frequency. As with ttl, the supply current increases with operating frequency as both internal and external capacitances are charged and discharged more often.

**Importance of operating speed**

The other major parameter which is usually important to circuit designers is operating speed. A crude measure of this is the propagation delay between the inputs and outputs of a

logic gate. The most important part of this delay is the time taken to charge and discharge the node capacitances inside and outside the circuit. Another component is the time needed to remove stored charge from transistors in the circuit.

The time for a change in voltage is  $(C \times V) / I$  where  $C$  is the node capacitance,  $V$  is the voltage change and  $I$  is the charge/discharge current. A low delay time is thus achieved by having a low capacitance and voltage change, but a high current.

Internal capacitance depends largely on feature size, which is likely to be a common factor between ttl and cmos. External capacitance depends only on the packaging of the integrated circuit and the pcb layout into which it is inserted. Both of these should be independent of the technology. The voltage change for ttl is 2.0V to 0.8V, allowing for noise margins for most families. At 5V, cmos noise margins dictate a voltage change of 3.5V to 1.5V. This is slightly more than for ttl, but the actual voltages at which switching occurs are not defined exactly. As a result, there will probably be little significant difference between the two technologies.

Current proves to be the real point of divergence. The ttl families are driven by transistors which are saturated, or held on the verge of saturation by Schottky diodes, while cmos current sources are more nearly resistive. For a given scale of technology, then, ttl families are traditionally the faster. Differences in the geometry of bipolar and cmos transistors have made c-mos transistors easier to scale down in size, so the current situation is that cmos devices can be as fast as ttl.

Another aspect of device speed is the output slew rate. If the rise or fall time of an output is comparable with the physical delay along the pcb tracks, reflections can become a problem and outputs may need to be terminated. The faster ttl families could fall into this category in some circumstances, while this was not usually a problem with the older c-mos devices. Now, however, with smaller geometries and faster edges, c-mos can need the same remedial treatment in some circumstances.

One other important difference between the two technologies lies in the input structures. A ttl input is a compact diode structure and there is virtually no limit to the number of inputs which can be attached to a single gate, as can be seen in Fig. 3.

In a c-mos gate, transistors must be stacked up, one transistor for each input. If there are too many transistors in the stack, the voltage drop across individual transistors becomes too small for correct operation and the gate fails to work. The consequence of this is that, for example, the 12-input gate in Fig. 4 must be made by using two stages of gating, where one stage is possible in ttl form.

Fig. 4. A twelve-input CMOS gate structure needs two stages whereas the same gate in ttl needs only one.

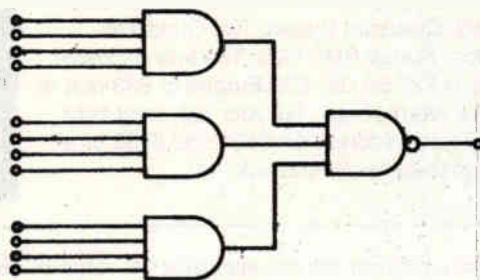
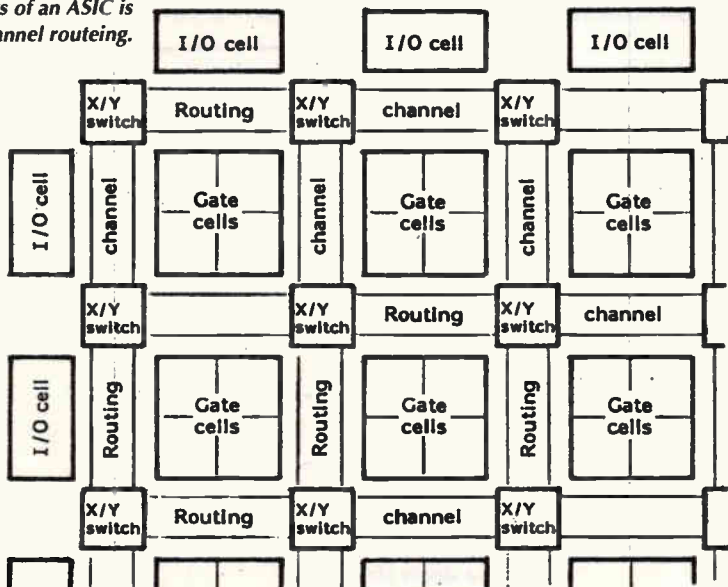

Fig. 5. One way of interconnecting components of an ASIC is channel routing.



**Large-scale integration**

As processes improved to the point where a thousand or more transistors could be laid on a single chip, lsi, or large-scale integration, became feasible. The situation is different from medium-scale integration, in which functions can still be looked on as building blocks with universal application. For example, a four-bit counter might be used in a computer, a cd player or a digital multimeter. large-scale integration circuits are usually a self-contained function, the most prolific example being the microprocessor, apart from which most lsi functions are specific to a particular application. For example, a universal asynchronous receiver/transmitter, or uart, will normally only be found in communications equipment and a frequency synthesiser in tuners.

At first it was thought that microprocessors would drastically reduce the volume of small and medium-scale integration chips being used, but two effects made the reverse true. Although microprocessors operate at frequencies in excess of 100MHz, a simple logic function, such as ANDING



two bytes, may need several operations to acquire the data, perform the function and then provide an output. The total cycle may occupy more than 100ns, compared with less than 10ns in readily available logic chips. The processor is also prevented from performing other tasks during this period, so it makes sense to continue with hard-wired logic or small-scale integration for simple logic functions.

The other effect is the need to interface the microprocessor to the outside world. Nearly every application, for example, needs an address decoder so that data and process instructions can be routed to and from the processor. This, and the need to customise many of the general-purpose peripheral circuits, adds to the number of discrete logic circuits surrounding the microprocessor.

In principle, these added chips can be combined into a single chip. Economies of scale dictate that this is not a practical approach unless the circuit is going to be used in upwards of a hundred thousand. These custom circuits are used in some applications where the quantities allow the cost of designing the chips, making masks, designing test sequences, and so on, to be amortised over a sufficiently large number.

Most applications are not large enough to benefit from this approach, but we can examine other ways in which the circuit designer can condense his hard logic into a small number of LSI chips.

**Application-specific integrated circuits**

The standard process for manufacturing integrated circuits involves growing a layer of silicon dioxide on a silicon wafer, etching windows in the surface layer and then introducing a controlled amount of impurity into the windows by vapour or electron-beam deposition. Successive layers of different impurities laid down through differently sized and shaped windows build up the active components in the surface layer of silicon.

Connections between the components are made by evaporating a conductor, usually aluminium or polycrystalline silicon, over the silicon dioxide. Previously etched windows allow contact to be made to the desired components. The conductor is then etched into tracks to define the circuit connections. Two or more conductor layers can be used by sputtering layers of silicon dioxide between the conductor layers.

In a standard or custom lsi circuit the layout is made by placing components on a 'floor plan' according to the schematic circuit diagram which defines the function of the chip. It will be laid out to minimise the area of the finished circuit, bearing in mind the design rules for the process. Usually, it is desirable to make the chip with a particular aspect ratio, often square, in order to aid assembly. Also, components which are close on the schematic will need to be close on the chip to make the conductor tracks as short as possible.

Clearly the arrangement of components is suitable for only the particular circuit under consideration; if any changes need to be made, or a new circuit laid out, the component positions will need to be changed as well. However, in a gate array – the simplest type of masked application-specific integrated circuit – the components are laid out in a predetermined pattern and the conducting layers tailored to the circuit schematic diagram.

Usually, the circuit components are set on a rectangular grid. Connections between components may be along muting channels in the gaps between components or, if no gaps are left, by routing across unused components. Figs 5 and 6 show the channel routing and 'sea-of-gates' approaches, respectively.

The other choice to be made in a gate array is what the basic component should be. The simplest component is a

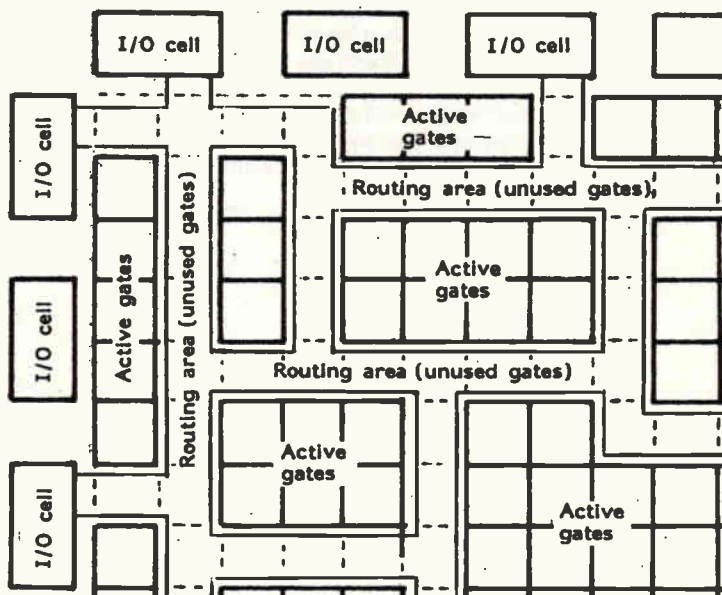

Fig. 6. In the 'sea-of-gates' ASIC, interconnections are made across unused components.

two-input NAND or NOR gate. In principle, any logic circuit can be built from basic gates; you have already seen, in Figs 3 and 5 of last month's article, how an exclusive-OR gate and a D-type bistable device may be constructed. On the other hand, using two-input gates to build a 16-input composite gate, which may be needed to decode a microprocessor address, would take five levels of logic plus at least 15 gates. This would result in a long propagation delay and use a significant proportion of the gate array resources.

An alternative approach is to use a more complex cell. One example is a cell containing four p-channel and four n-channel transistors. The cell can be configured in several different ways – a four-input gate, a three-input gate plus inverter and two two-input gates are examples. The transistors can also be made into transmission gates which form the basis of bistable ICs.

Gate arrays exist with a variety of cell designs and interconnection methods, but the ways in which designs are entered are, on the whole, quite similar.

**Designing an ASIC**

Designing a logic circuit is virtually independent of the physical form in which the circuit will be implemented. There are differences in the way in which tri-states and state machines, for example, are designed in different end products, but multiplexers, counters and other standard logic functions may be used to build up any logic system.

In effect, the designer is presented with a library of building blocks which are connected together to produce the desired result. If ttl or cmos standard logic is being used, the library will be listed in a data book which presents the relevant features of each device. These include the pin-out showing which functions appear on which pin, dc parameters showing how each device interfaces with any other, and ac parameters indicating how fast signals will pass through the system. The ac performance will be modified by

Fig. 7. ASIC design procedure.

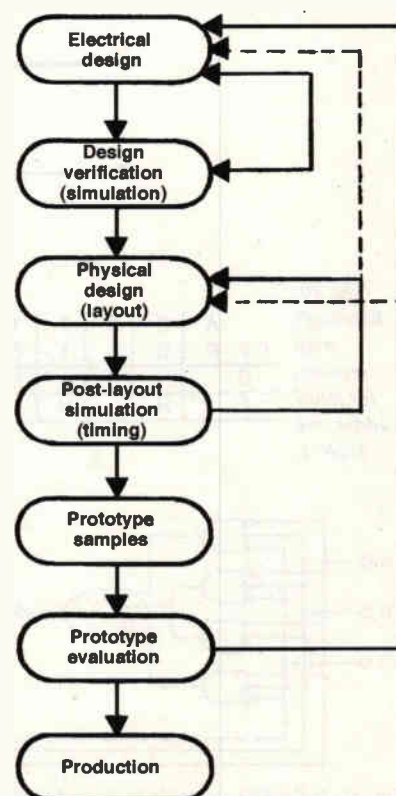

the way the devices are physically connected; the lengths of pcb tracks and the number of inputs driven by each output affect the load capacitance and, hence, the delay through each chip.

An asic designer will also work from a library. In this case the library may also take the form of a data book but the information will be presented in a different way. For a start,

Fig. 8. Diode array is the simplest form of AND gate.

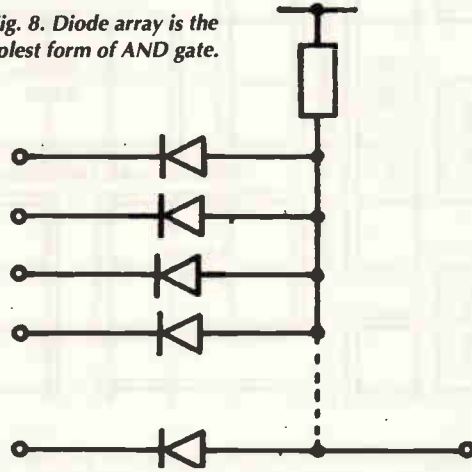
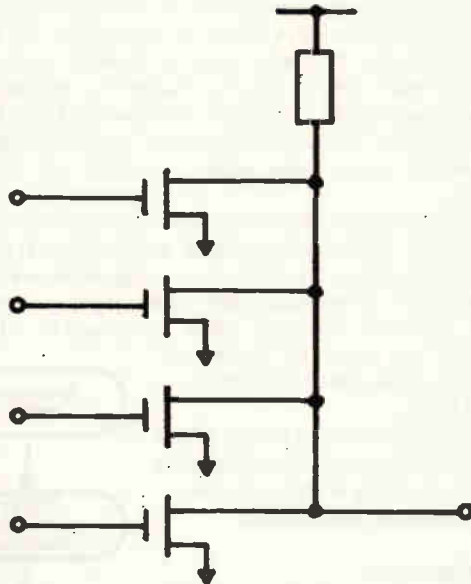

Fig. 9. MOS transistor alternative to the AND gate of Fig. 8 consumes far less power.



there is no need for pin-out information. The circuit is most probably being drawn on a computer-aided design system. Standard symbols for gates, bistable devices and more complex structures will be used.

The asic equivalent of a standard logic function is a macro. This is one or more cells with the wiring to produce the required function. When a signal path joins two cells in a macro, the physical location of the electrical nodes is built into the macro description so the designer does not need to know where the connections have to be made on the chip.

Parameters for dc and ac are quite significant in asic design. Standard logic functions have built-in buffers. These ensure that all devices in a given family will drive each other with compatible voltage levels and current drains. They also guarantee a maximum propagation delay when driving a specified load. In asics there are no internal buffers, so fan-out becomes an important factor when making a design.

Simulation is an important part of the asic design process. This is not only to ensure that the logic function of the finished device meets the original goal, but to check that the design rules have not been violated. Part of the skill lies in ensuring that all parts of the design are testable, that every part of the circuit can be exercised by applying signals to the various inputs, and that the results can be seen by changes at the outputs. Bed-of-nails testing is not feasible for an asic and simulation will show any deficiencies in device testability.

Macros for ASICs are usually more 'fine grained' than standard logic circuits. To use an inverter in ttl or c-mos means either specifying a chip with six inverters or wiring a NAND or a NOR gate as an inverter, if one is conveniently spare. This may mean wasting five inverters or, if they can be used elsewhere in the circuit, running long tracks to and from another part of the pcb. Similarly, bistable devices usually come in pairs, counters in four-stage blocks, and so on.

These restrictions do not apply to asics; an inverter will, at worst, take a single cell, and the inverter may be able to be included in a cell which includes another function. Likewise, a counter with five, six or seven stages can be included without wasting any cells; moreover, features such as fast lookahead carry can be designed in to give a better performance than might be possible with discrete logic chips.

The downside is apparent when the whole design is considered. Gate arrays are made with a fixed number of cells so a design will have to be built in the device with the next higher cell count than the actual number needed. If the smallest array has 1000 cells and the next highest 1500 cells, and a certain design needs 1010 cells, then more than 30% of the chip will be wasted.

Having selected a suitable array, the next stage is to map the logic diagram onto the physical cells. This is now normally automated, the process being referred to as place-and-route. The place function involves assigning cells to each of the macros in the design, routing being the connection of the cells according to the connections between the macros already specified.

With a channel architecture, it is usually possible to use 95% or more of the cells, depending on the number of connections allowed in each routing channel. The sea-of-gates type of array is often limited to about 60% utilisation as connections have to be made over unused cells. These usually give shorter track lengths, on the whole, as the connections can be made by more direct paths.

The final stage in the design process is post-layout simulation. The first simulation gives an idea of the delays and timing performance of the circuit, by including fan-out and a nominal delay for connections. Until the routing has been completed, though, an accurate measure of the delays cannot be obtained. The post-layout simulation includes an estimate of the extra delays due to the actual track lengths and should give an accurate picture of the performance of the

Fig. 10. Karnaugh map sections for a full adder, see Table 1.

	A	0	0	1	1
CI	B	0	1	1	0
0			H	H	H
1		H		H	

S

	A	0	0	1	1
CI	B	0	1	1	0
0				H	H
1			H	H	H

CO

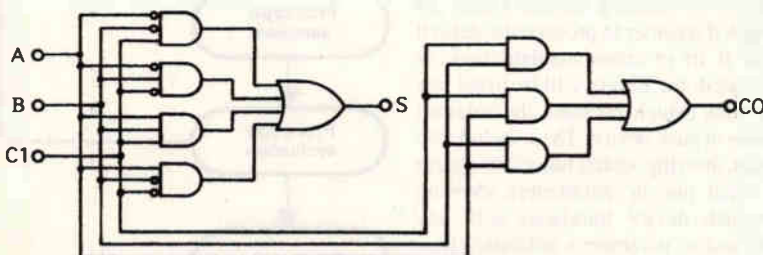

Fig. 11. Full adder example in discrete logic.



final device. If the performance does not measure up to the requirements, there is usually an opportunity to make manual changes to the layout to reduce the delay in critical paths.

A typical design flow is shown in Fig. 7.

**Applying asics**

Once a design is finalised, it will have to go to the manufacturing stage. The asic is a semi-customised integrated circuit; it starts out being processed as a standard component, because all the diffused components are independent of the final design. The final stages are, however, customised – each different design is application-specific and requires its own pattern to be imposed on the upper levels of the chip. A stock of partly finished wafers can be held in readiness for customisation.

Customisation is achieved by making masks to create the connections already specified by the place-and-route step in the design process. Four or more masks may be required – two to define the interconnection tracks to be etched into the two-track metallisation layers, and two to allow contact holes to the silicon and between the two metal layers to be made.

Mask-making and processing are both time-consuming and costly. Frequently, these activities take place in a different country from that in which the design is created, and the finished chip may be packaged in a third country. All is well if the final device performs as expected but, whether due to a design mistake or an imperfect specification, if changes have to be made, much delay and expense can result.

The non-recurring engineering, or nre, costs involved in masked asics make them more suitable for projects with expectation of long, stable, high-volume runs. As with all aspects of design and engineering, it is sometimes expedient to make trade-offs. Savings in packaging plus the need for high performance in a confined space might make it economic to use a gate array for an expected run of only a few hundred. But it is more usual to be looking at a volume in excess of 10 000 for gate array designs.

It seems from the analysis so far that circuit designers are stuck with only two choices for building logic circuits, standard families and masked asics. Fortunately, technology has evolved a third option – the programmable switch.

**Programmable logic devices**

There are four types of programmable switch which have been used in any volume on programmable logic devices.

The simplest form of AND gate is a diode array, Fig. 8. If all the inputs are near V+ then none of the diodes conduct and the output will also be pulled up to near V+. Any input taken to 0V will pull the output to a diode drop above 0V.

In a standard logic circuit, all the inputs are available at device pins, but in a programmable logic device, or pld, a programmable switch is placed in series with the input. This allows the user to select which signals will affect the gate.

A metal fuse was the first type of switch and is traditionally associated with bipolar plds. An alloy, such as nichrome or tungsten-titanium, is evaporated onto the surface of the chip and etched into small strips about 5µm wide and 20µm long. A current pulse of about 50mA is sufficient to vapourise the metal, which fuses into the overlying silicon dioxide, leaving an open circuit at the fuse site.

An alternative fuse in bipolar technology is the AIM, or avalanche-induced migration, device. This is a small transistor with a floating base, so that the emitter-collector path is normally high impedance. If the emitter-base junction is deliberately overstressed, the aluminium from the emitter contact migrates into the junction, causing a short circuit. The emitter-collector path is now a diode and can be used in its own right as a gating element; in this case, then, the fusing process is used to establish the required inputs to the gate.

In mos technology the transistors are, themselves, very

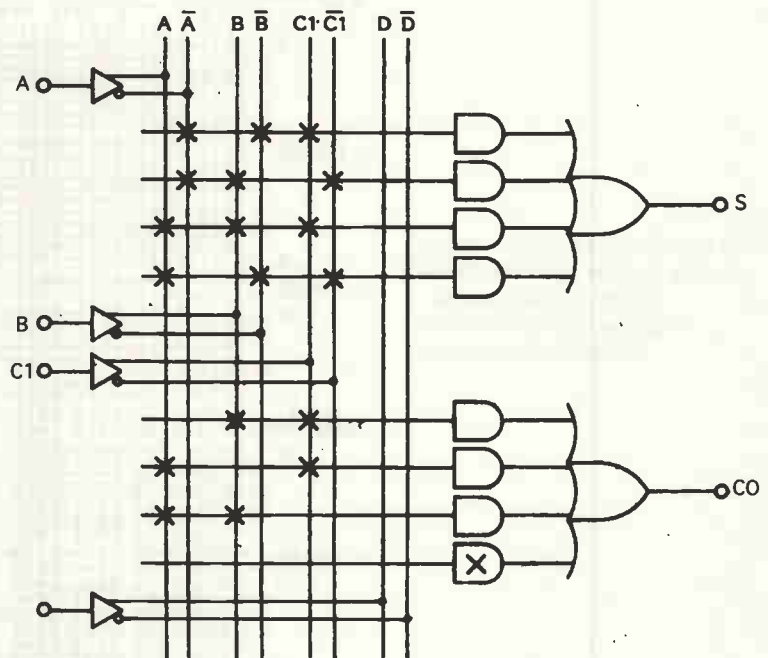

Fig. 12. Full adder of Fig. 11 implemented in a PAL4H2.

efficient switches which can be turned on and off by applying high or low signals to their gates. By adding a second gate, floating between the control gate and the conducting channel, the transistor threshold can be varied by charging or discharging the second gate. In the low-threshold condition, the transistor acts normally, but in the high-threshold state the channel is held off permanently.

The floating gate can be charged electrically but needs ultra-violet light to discharge it. By adding silicon nitride to the sandwich, the surface states can be defined for positive and negative charges and the floating gate can be predictably discharged electrically. The transistors themselves are used for logical gating, as in Fig. 9.

A later development is the antifuse. This is simply a thin layer of silicon oxide/nitride sandwiched between two conducting layers, which may be either silicon or metal. A short voltage pulse of 15-20V ruptures the insulating layer and the heat alloys the two layers together. A resistor of less than 1kΩ results, sufficiently low to appear as an on switch to signals in a cmos environment.

**Programmable array logic**

The most commonly used plds are programmable array logic, or pals. Although not the first plds, they are the easiest to use and took the largest share of the programmable logic market.

They are based on the idea that any combinational logic function can be represented by a 'sum-of-products' equation. Sometimes, AND functions are referred to as product terms, by analogy between logic equations and arithmetic equations, and OR functions as sum terms; sum of products means just the OR combination of a number of AND terms. The justification for this concept is the Karnaugh map.

A Karnaugh map, or K-map, is constructed by taking all the inputs to a given function and drawing a grid containing all the possible combinations of high and low for those inputs. Conventionally, each axis of the grid is numbered with Gray code, with half the inputs expanded along the x-axis and the other half in the y-direction. This can be illustrated by examining the truth table and K-map for an adder; the truth table is shown in Table 1.

The K-maps for S and CO are shown in Fig. 10; each needs four AND terms on first inspection, but consider the two cells circled together in the CO

Table 2 Truth table for PAL adder

A	B	C1	S	CO
L	L	L	0	0
L	L	H	1	0
L	H	L	1	0
L	H	H	0	1
H	L	L	1	0
H	L	H	0	1
H	H	L	0	1
H	H	H	1	1

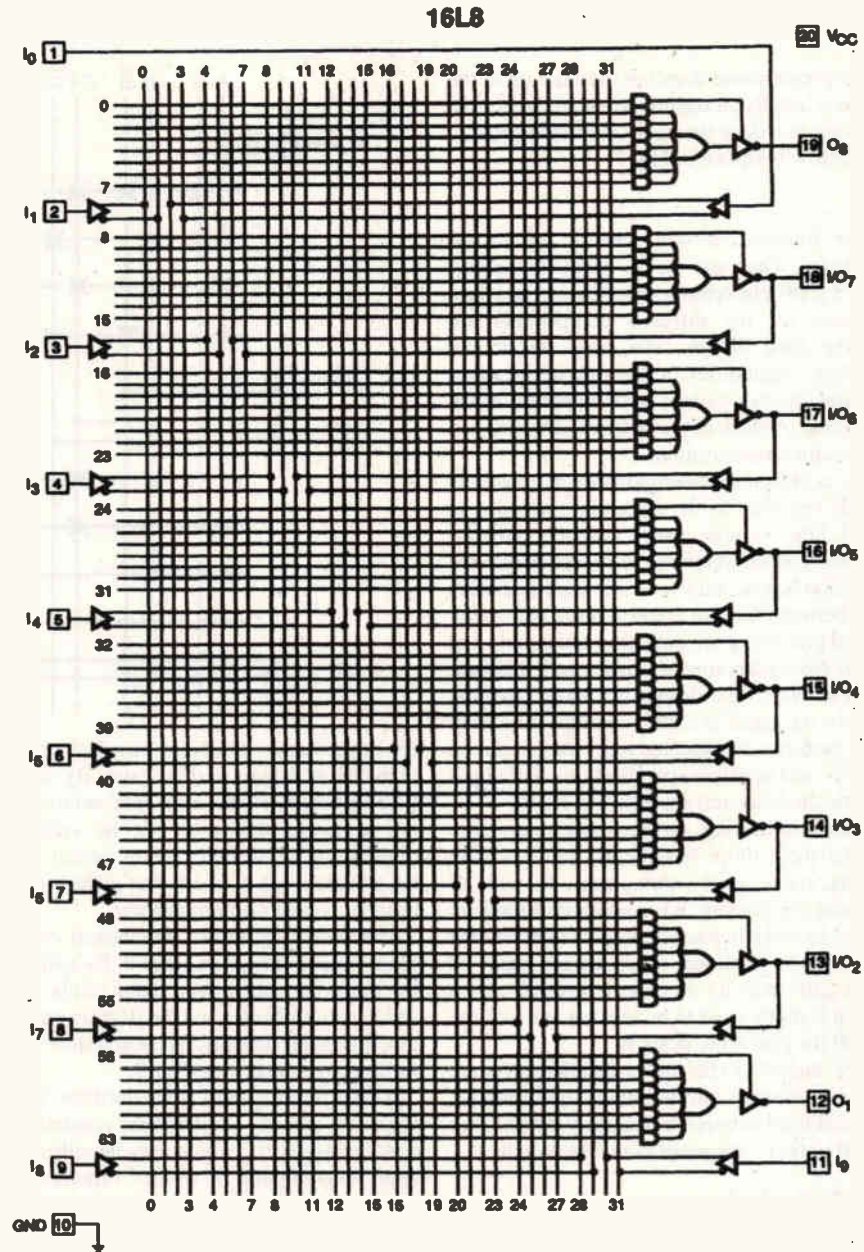

Fig. 13. PAL16L8 equivalent circuit – the simplest combinational pal currently in manufacture – reproduced by permission of Advanced Micro Devices.

map. These represent the AND terms:

$$\begin{aligned} & !A \& B \& C I \\ & A \& B \& C I. \end{aligned}$$

This simplifies to just  $B \& C I$ , because input A can take either sense. It can therefore, be eliminated from the equation. In terms of logic analysis, this is because  $!A \# A = 1$ .

The full equations for the adder are, therefore:

$$\begin{aligned} S &= !A \& !B \& C I \# A \& B \& !C I \# A \& B \& C I \# A \& !B \& !C I \\ C O &= B \& C I \# A \& C I \# A \& B \end{aligned}$$

In discrete logic these functions can be built as in Fig. 11.

The structure of a simple combinational pal is very similar to this circuit. Figure 12 shows how this same function could be incorporated into an imaginary PAL4H2. Numbering of the pal is quite logical; in this example, the '4' refers to the number of inputs to the AND array, Letter 'H' means that the outputs are high when one of the AND terms is true (active-high) and '2' is the number of outputs from the PAL.

The eight vertical lines in the figure carry the buffered/inverted signals from the four inputs – that is, A, !A, B, !B, C I, !C I, D, !D, although D and !D are not used in this example. Each crossing point between a vertical signal line and the input line – which is really an eight-bit bus in this

case – into each AND gate has a programmable switch which determines whether or not the signal is connected to the AND gate. The diagonal crosses indicate those fuses which are left intact for this application.

The simplest combinational pal currently in production is the PAL16L8, Fig. 13. As with the first example, the numbering means that this pal has 16 array inputs although, as six of these are fed back from outputs, the device has just ten dedicated inputs; in addition, there are eight active-low outputs.

Because of the feedback, any configuration from ten inputs/eight outputs to 16 inputs/two outputs can fit in to this pal. Alternatively, some of the feedback pins can be used to make functions such as latches, or to augment the seven product terms per output for more complex function.

By adding bistable devices to the outputs, it is possible to make pals capable of containing sequential functions. The PAL16R8 has all eight outputs registered and fed back to the AND-array, hence there are just eight direct inputs plus a common clock for the bistables and a tri-state enable to allow the outputs to be connected to a bus.

The range of registered pals also includes one with four flip-flops and four combinational outputs, the PAL16R4, and a device with six bistable devices and two direct outputs PAL16R6. ■



**MOONSHINE BIBLE** 270 page book covering the production of alcohol from potatoes, rice, grains etc Drawings of simple home made stills right through to commercial systems. £12 ref MS3

**NEW HIGH POWER MINI BUG** With a range of 800 metres or more and up to 100 hours use from a PP3 this will be popular! Bug measures less than 1" square! £28 Ref LOT102.

**SINCLAIR C6 MOTORS** We have a new ones available without gearboxes at £50 ref LOT25

**BUILD YOUR OWN WINDFARM FROM SCRAP** New publication gives step by step guide to building wind generators. Armed with this publication and a good local scrap yard could make you self sufficient in electricity! £12 ref LOT81

**PC KEYBOARDS** PS2 connector, top quality suitable for all 286/386/486 etc £10 ref PCKB. 10 for £65.

**TRACKING TRANSMITTER** range 1.5-5 miles, 5,000 hours on AA batteries, also transmits info on car direction and motion! Works with any FM radio. 1.5" square. £65 ref LOT101

**ELECTRIC DOOR LOCKS** Complete lock with both Yale lock and 12v operated deadlock (keys included) £10 ref LOT99

**GALLIUM ARSENIDE FSHEYE PHOTO DIODES** Complete with suggested circuits for long range communications/switching £12 complete.

**SURVEILLANCE TELESCOPE** Superb Russian zoom telescope adjustable from 15x to 60x! complete with metal tripod (impossible to use without this on the higher settings) 66mm lens, leather carrying case £149 ref BAR69

**WIRELESS VIDEO BUG KIT** Transmits video and audio signals from a miniature CCTV camera (included) to any standard television! All the components including a PP3 battery will fit into a cigarette packet with the lens requiring a hole about 3mm diameter. Supplied with telescopic aerial but a piece of wire about 4" long will still give a range of up to 100 metres. A single PP3 will probably give less than 1 hours use. £89 REF EP79. (probably not licensable)

**CCTV CAMERA MODULES** 46X70X29mm, 30 grams, 12v 100mA, auto electronic shutter, 3.6mm F2 lens, CCIR, 512x492 pixels, video output is 1v p-p (75 ohm). Works directly into a scart or video input on a tv or video. IR sensitive. £79.95 ref EF137.

**IR LAMP KIT** Suitable for the above camera, enables the camera to be used in total darkness! £5.99 ref EF138

**INFRA RED POWERBEAM** Handheld battery powered lamp, 4 inch reflector, krypton bulb, gives out powerful infrared light! 4 D cells required. £39 ref PB1.

**MONO VGA MONITORS**, Perfect condition, Compaq, 14", 3 months warranty £29 ref MVGA

**SOLAR COOKER GUIDE** Comprehensive plans

**9 WATT CHEFTAN TANK LASERS**

Double beam units designed to fit in the gun barrel of a tank, each unit has two semi conductor lasers and motor drive units for alignment. 7 mile range, full circuit diagrams, new price £50,000? us? £349. Each unit has two gallium Arsenide injection lasers. 1 x 9 watt, 1 x 3 watt, 900nm wavelength, 28vdc, 600hz pulse frequency. The units also contain an electronic receiver to detect reflected signals from targets. five or more units £299 ea. £349 for one. Ref LOT4.

**TWO WAY MIRROR KIT** Includes special adhesive film to make two way mirror(s) up to 60"x20". (glass not included) includes full instructions. £12 ref TW1.

**NEW LOW PRICED COMPUTER/WORKSHOP/HI-FI/RCB UNITS** Complete protection from faulty equipment for everybody! Inline units fits in standard IEC lead (extends it by 750mm), fitted in less than 10 seconds, reset/test button, 10A rating. £6.99 each ref LOT5. Or a pack of 10 at £49.90 ref LOT6. If you want a box of 100 you can have one for £250!

**RADIO CONTROLLED CARS FROM £6 EACH!!!** All returns from famous manufacturer, 3 types available, single channel (left, right, forwards, backwards) £6 ref LOT1. Two channel with more features £12 ref LOT2.

**THOUSANDS AVAILABLE RING/FAX FOR DETAILS!**

**MAGNETIC CARD READERS** (Swipes) £9.95 Cased with flyleads, designed to read standard credit cards! they have 3 wires coming out of the head so they may write as well? complete with control electronics PCB, just £9.95 ref BAR31

**WANT TO MAKE SOME MONEY? STUCK FOR AN IDEA?** We have collated 140 business manuals that give you information on setting up different businesses, you peruse these at your leisure using the text editor on your PC. Also included is the certificate enabling you to reproduce (and sell) the manuals as much as you like! £14 ref EP74

**PANORAMIC CAMERA OFFER** Takes double width photographs using standard 35mm film. Use in horizontal or vertical mode. Complete with strap £7.99 ref BAR1

**COIN OPERATED TIMER KIT** Complete with coin slot mechanism, adjustable time delay, relay output, put a coin slot on anything you like! TV's, videos, fridges, drinks cupboards, HI-FI, takes 50p's and £1 coins. DC operated, price just £7.99 ref BAR27.

**ZENITH 900 X MAGNIFICATION MICROSCOPE** Zoom, metal construction, built in light, shrimp farm, group viewing screen, lots of accessories. £29 ref ANAYLT.

**AA NICAD PACK** Pack of 4 tagged AA nicads £2.99 ref BAR34

**PLASMA SCREENS** 22x310mm, no data hence £4.99 ref BAR87

**NIGHTSIGHTS** Model TZS4 with Infra red illuminator, views up to 75 metres in full darkness in infrared mode, 150m range, 45mm lens, 13 deg angle of view, focussing range 1.5m to infinity, 2 AA batteries required. 950g weight. £199 ref BAR61. 1 years warranty

**LIQUID CRYSTAL DISPLAYS** Bargain prices, 16 character 2 line, 99x24mm £2.99 ref SM1623A  
20 character 2 line, 83x19mm £3.99 ref SM2020A  
16 character 4 line, 62x25mm £5.99 ref SMC1640A

**TAL-1 110MM NEWTONIAN REFLECTOR TELESCOPE** Russian. Superb astronomical scope, everything you need for some serious star gazing! up to 169x magnification. Send or fax for further information ref TAL-1. £249

**SOLAR ENERGY GENERATOR PLANS** For your home, loads of info on designing systems etc £7 ref PV1

**SOLAR COOKERS** Comprehensive guide to building solar powered cookers, includes plans, recipes, cooking times etc £7 ref SBC1

## WOLVERHAMPTON BRANCH NOW OPEN AT WORCESTER ST W'HAMPTON TEL 01902 22039

**CENTRAL POINT PC TOOLS** Award winning software, 1,300 virus checker, memory optimiser, disc optimiser, file compression, low level formatting, backup scheduler, disk defragmenter, undelete, 4 calculators, Dbase, disc editor, over 40 viewers, remote computing, password protection, encryption, comprehensive manual supplied etc £8 ref lot 97 3.5" disks.

**GOT AN EXPENSIVE BIKE?** You need one of our bottle alarms, they look like a standard water bottle, but open the top, insert a key to activate a motion sensor alarm built inside. Fits all standard bottle carriers, supplied with two keys. SALE PRICE £7.99 REF SA32.

# COLOUR CCTV VIDEO CAMERAS, BRAND NEW, CASED, £119.

PERFECT FOR  
SURVEILLANCE  
INTERNET  
VIDEO CONFERENCING  
SECURITY  
DOMESTIC VIDEO

Works with most modern video's, TV's,  
Composite monitors, video grabber cards etc  
Pal, 1v P-P, composite, 75ohm, 1/3" CCD, 4mm F2.8,  
600x682, 12vdc, mounting bracket, auto shutter,  
100x60x180mm, 3 months warranty, 10 or more £99 ea.



Check out our  
WEB SITE

<http://www.pavillon.co.uk/bull-electrical>

**GOT AN EXPENSIVE ANYTHING?** You need one of our cased vibration alarms, keyswitch operated, fully cased just fit it to anything from videos to caravans, provides a years protection from 1 PP3 battery, UK made. SALE PRICE £4.99 REF SA33.

**DAMAGED ANSWER PHONES** These are probably beyond repair so just £4.99 each. BT response 200 machines. REF SA30.

**IBM PS2 MODEL 160Z CASE AND POWER SUPPLY** Complete with fan etc and 200 watt power supply. £8.95 ref EP67

**DELL PC POWER SUPPLIES** 145 watt, +5,-5,+12,-12, 150x150x85mm complete with switch, flyleads and IEC socket. SALE PRICE £8.99 ref EP55

**1.44 DISC DRIVES** Standard PC 3.5" drives but returns so they will need attention SALE PRICE £4.99 ref EP68

**1.2 DISC DRIVES** Standard 5.25" drives but returns so they will need attention SALE PRICE NOW ONLY £3.50 ref EP69

**PP3 NICADS** Unused but some storage marks. £4.99 ref EP52

**DELL PC POWER SUPPLIES** (Customer returns) Standard PC psu's complete with fly leads, case and fan. +12v,-12v,+5v,-5v SALE PRICE £1.99 each worth if for the bits alone! ref DL1. TRADE PACK OF 20 £29.95 REF DL2.

**GAS HOBS AND OVENS** Brand new gas appliances, perfect for small flats etc. Basic 3 burner hob SALE PRICE £24.99 ref EP72. Basic small built in oven SALE PRICE £79 ref EP73

**ENERGY BANK KIT** 100 6"x6" 6v 100mA panels, 100 diodes, connection details etc. £69.95 ref EF112.

**PASTEL ACCOUNTS SOFTWARE**, does everything for all sizes of businesses. Includes word processor, report writing, windowing, networkable up to 10 stations, multiple cash books etc. 200 page comprehensive manual. 90 days free technical support (01342-

\*SOME OF OUR PRODUCTS MAY BE UNLICENSABLE IN THE UK

## BULL ELECTRICAL

250 PORTLAND ROAD, HOVE, SUSSEX.  
BN3 5QT. (ESTABLISHED 50 YEARS).

MAIL ORDER TERMS: CASH, PO OR CHEQUE  
WITH ORDER PLUS £1 P&P PLUS VAT.  
PLEASE ALLOW 7-10 DAYS FOR DELIVERY PHONE ORDERS  
WELCOME (ACCESS VISA, SWITCH, AMERICAN EXPRESS)

TEL: 01273 203500  
FAX 01273 323077  
E-mail [bull@pavillon.co.uk](mailto:bull@pavillon.co.uk)

326009 try before you buy! Current retail price is £120, SALE PRICE £9.95 ref SA12. SAVE £120!!!

**RACAL MODEM BONANZA!** 1 Racal MPS1223 1200/75 modem, telephone lead, mains lead, manual and comms software, the cheapest way onto the net all this for just £13 ref DEC13.

**BULL TENS UNIT** Fully built and tested TENS (Transcutaneous Electrical Nerve Stimulation) unit, complete with electrodes and full instructions. TENS is used for the relief of pain etc in up to 70% of sufferers. Drug free pain relief, safe and easy to use, can be used in conjunction with analgesics etc. £49 Ref TEN1

**PC PAL VGA TO TV CONVERTER** Converts a colour TV into a basic VGA screen. Complete with built in psu, lead and s/ware... Ideal for laptops or a cheap upgrade. Supplied in kit form for home assembly. SALE PRICE £25 REF SA34

**EMERGENCY LIGHTING UNIT** Complete unit with 2 double bulb floodlights, built in charger and auto switch. Fully cased, 6v BAH lead acid req'd. (secondhand) £4 ref MAG4P11.

**YUASHA SEALED LEAD ACID BATTERIES** Two sizes currently available this month. 12v 15AH at £18 ref LOT8 and 6v 10AH (suitable for emergency lights above) at just £6 ref LOT7.

**ELECTRIC CAR WINDOW DE-ICERS** Complete with cable, plug etc SALE PRICE JUST £4.99 REF SA28

**AUTO SUNCHARGER** 155x300mm solar panel with diode and 3 metre lead fitted with a cigar plug. 12v 2watt. £8.99 REF SA25.

**MICRODRIVE STRIPPERS** Small cased tape drives ideal for stripping, lots of useful goodies including a smart case, and lots of components. SALE PRICE JUST £4.99 FOR FIVE REF SA26

**SOLAR POWER LAB SPECIAL** You get TWO 6"x6" 6v 130mA solar cells, 4 LED's, wire, buzzer, switch plus 1 relay or motor. Superb value kit SALE PRICE JUST £4.99 REF SA27

**RGB/CGA/EGA/VGA/TTL COLOUR MONITORS** 12" in good condition. Back anodised metal case. SALE PRICE £49 REF SA16B

**PLUG IN ACORN PSU** 19v AC 14w. £2.99 REF MAG3P10

**13.8V 1.9A PSU** cased with leads. Just £9.99 REF MAG10P3

**UNIVERSAL SPEED CONTROLLER KIT** Designed by us for the C5 motor but ok for any 12v motor up to 30A. Complete with PCB etc. A heat sink may be required. £17.00 REF: MAG17

**PHONE CABLE AND COMPUTER COMMUNICATIONS PACK** Kit contains 100m of 6 core cable, 100 cable clips, 2 line drivers with RS232 interfaces and all connectors etc. Ideal low cost method of communicating between PCs over a long distance utilizing the serial ports. Complete kit £8.99. Ref comp 1.

**VIEWDATA SYSTEMS** made by Phillips, complete with Internal 1200/75 modem, keyboard, psu etc RGB and composite outputs, menu driven, autodialler etc. SALE PRICE £12.99 REF SA18

**AIR RIFLES .22As** used by the Chinese army for training purposes, so there is a lot about! £39.95 Ref EF78. 500 pellets £4.50 ref EF80.

**VIDEO SENDER UNIT.** Transmits both audio and video signals from either a video camera, video recorder, TV or Computer etc to any standard TV set in a 100' range! (tune TV to a spare channel) 12v DC op. Price is £25 REF: MAG15 12v psu is £5 extra REF: MAG5P2

**\*MINIATURE RADIO TRANSCENVERS** A pair of walkie talkies with a range up to 2kmin open country. Units measure 22x52x155mm. Including cases and earpieces. 2xPP3 req'd. £30.00 pr REF: MAG30

**\*FM TRANSMITTER KIT** housed in a standard working 13A adapter! the bug runs directly off the mains so lasts forever why pay £700? or price is £15 REF: EF62 (kit) Transmits to any FM radio.

**\*FM BUG BUILT AND TESTED** superior design to kit. Supplied to detective agencies. 9v battery req'd. £14 REF: MAG14

**GAT AIR PISTOL PAK** Complete with pistol, darts and pellets £12.95 Ref EF82B extra pellets (500) £4.50 ref EF80.

**6"x12" AMORPHOUS SOLAR PANEL** 12v 155x310mm 130mA. SALE PRICE £4.99 REF SA24.

**FIBRE OPTIC CABLE BUMPER PACK** 10 metres for £4.99 ref MAG5P13 ideal for experimenters! 30 m for £12.99 ref MAG13P1

MIXED GOODIES BOX OF  
MIXED COMPONENTS WEIGHING 2 KILOS  
YOURS FOR JUST £6.99

**4X28 TELESCOPIC SIGHTS** Suitable for all air rifles, ground lenses, good light gathering properties. £19.95 ref R77.

**GYROSCOPES** Remember these? well we have found a company that still manufactures these popular scientific toys, perfect gift or for educational use etc £6 ref EP70

**HYPOTHERMIA SPACE BLANKET** 215x150cm aluminised foil blanket, reflects more than 90% of body heat. Also suitable for the construction of two way mirrors! £3.99 each ref O/L041.

**LENSTATIC RANGER COMPASS** Oil filled capsule, strong metal case, large luminous points. Sight line with magnifying viewer. 50mm dia, 86gm. £10.99 ref O/K604.

**RECHARGE ORDINARY BATTERIES UP TO 10 TIMES!** With the Battery Wizard! Uses the latest pulse wave charge system to charge all popular brands of ordinary batteries AAA, AA, C, D, four at a time! Led system shows when batteries are charged, automatically rejects unsuitable cells, complete with mains adaptor. BS approved. Price is £21.95 ref EP31.

**TALKING WATCH** Yes, it actually tells you the time at the press of a button. Also features a voice alarm that wakes you up and tells you what the time is! Lithium cell included. £7.99 ref EP26.

**PHOTOGRAPHIC RADAR TRAPS CAN COST YOU YOUR LICENCE!** The new multiband 2000 radar detector can prevent even the most responsible of drivers from losing their licence! Adjustable audible alarm with 8 flashing leds gives instant warning of radar zones. Detects X, K, and Ka bands, 3 mile range, 'over the hill' 'around bends' and 'rear trap' facilities. micro size just 4.25"x2.5"x.75". Can pay for itself in just one day! £79.95 ref EP3.

**3" DISCS** As used on older Amstrad machines. Spectrum plus3's etc £3 each ref BAR400.

**STEREO MICROSCOPES BACK IN STOCK** Russian, 200x complete with lenses, lights, filters etc very comprehensive microscope that would normally be around the £700 mark, our price is just £299 (full money back guarantee) full details in catalogue..

## WE BUY SURPLUS STOCK FOR CASH

BUYERS DIRECT LINE 0802 660377



## DC TO DC CONVERTERS

DRM58 input 10-40vdc output 5v 8A £15  
DRM128 input 17-40vdc output 12v 8A £50  
DRM158 input 20-40vdc output 15v 8A £50  
DRM248 input 29-40vdc output 24v 8A £40  
DRS123 input 17-40vdc output 12v 3A £20  
DRS153 input 20-40vdc output 15v 3A £20  
DRS243 input 29-40vdc output 24v 3A £15

## SOLID STATE RELAYS

CMP-DC-200P 3-32vdc operation, 0-200vdc 1A £2.50  
SMT20000/3 3-24vdc operation, 28-280vac 3A £4.50  
SMT20000/4 3-24vdc operation, 28-280vac 4A £5.00  
ZRA6025F 28-280vdc operation, 28-280vac 25A £7.00

**200 WATT INVERTERS** Nicely cased units 12v input 240v output 150watt continuous, 200 max. £49 ref LOT62.

**6.0MW HELIUM NEON LASERS** New units, £65 ref LOT33  
**COINSLD TO TOKENS** You may have a use for these? mixed bag of 100 tokens £10 ref LOT20.

**PORTABLE X RAY MACHINE PLANS** Easy to construct plans on a simple and cheap way to build a home X-ray machine! Effective device, X-ray sealed assemblies, can be used for experimental purposes. Not a toy or for minors! £65/set. Ref F/XP1.

**TELEKINETIC ENHANCER PLANS** Mystify and amaze your friends by creating motion with no known apparent means or cause. Uses no electrical or mechanical connections, no special gimmicks yet produces positive motion and effect. Excellent for science projects, magic shows, party demonstrations or serious research & development of this strange and amazing psychic phenomenon. £45/set Ref F/TK1.

**ELECTRONIC HYPNOSIS PLANS & DATA** This data shows several ways to put subjects under your control. Included is a full volume reference text and several construction plans that when assembled can produce highly effective stimuli. This material must be used cautiously. It is for use as entertainment at parties etc only, by those experienced in its use. £15/set. Ref F/EH2.

**GRAVITY GENERATOR PLANS** This unique plan demonstrates a simple electrical phenomena that produces an anti-gravity effect. You can actually build a small mock spaceship out of simple materials and without any visible means - cause it to levitate. £10/set Ref F/GRA1.

**WORLDS SMALLEST TESLA COIL/LIGHTNING DISPLAY GLOBE PLANS** Produces up to 750,000 volts of discharge, experiment with extraordinary HV effects, 'Plasma in a jar', St Elmo's fire, Corona, excellent science project or conversation piece. £55/set Ref F/BTCLAGS.

**COPPER VAPOUR LASER PLANS** Produces 100mw of visible green light. High coherency and spectral quality similar to Argon laser but easier and less costly to build yet far more efficient. This particular design was developed at the Atomic Energy Commission of NEGEV in Israel. £10/set Ref F/CV1.

**VOICE SCRAMBLER PLANS** Miniature solid state system turns speech sound into indecipherable noise that cannot be understood without a second matching unit. Use on telephone to prevent third party listening and bugging. £65/set Ref F/VSS.

**PULSED TV JOKER PLANS** Little hand held device utilises pulse techniques that will completely disrupt TV picture and sound works on FM too! DISCRETION ADVISED. £85/set Ref F/TJ5.

**BODYHEAT TELESCOPE PLANS** Highly directional long range device uses recent technology to detect the presence of living bodies, warm and hot spots, heat leaks etc. Intended for security, law enforcement, research and development, etc. Excellent security device or very interesting science project. £85/set Ref F/BHT1.

**BURNING, CUTTING CO2 LASER PLANS** Projects an invisible beam of heat capable of burning and melting materials over a considerable distance. This laser is one of the most efficient, converting 10% input power into useful output. Not only is this device a workhorse in welding, cutting and heat processing materials but it is also a likely candidate as an effective directed energy beam weapon against missiles, aircraft, ground-to-ground, etc. Particle beams may very well utilize a laser of this type to blast a channel in the atmosphere for a high energy stream of neutrons or other particles. The device is easily applicable to burning and etching wood, cutting, plastics, textiles etc. £125/set Ref F/LC7.

**MYSTERY ANTI GRAVITY DEVICE PLANS** Uses simple concept. Objects float in air and move to the touch. Defies gravity, amazing gift, conversation piece, magic trick or science project. £65/set Ref F/ANTIK.

**ULTRASONIC BLASTER PLANS** Laboratory source of sonic shock waves. Blow holes in metal, produce 'cold' steam, atomize liquids. Many cleaning uses for PC boards, jewellery, coins, small parts etc. £65/set Ref F/ULB1.

**ULTRA HIGH GAIN AMP/STETHOSCOPIC MIKE/SOUND AND VIBRATION DETECTOR PLANS** Ultrasensitive device enables one to hear a whole new world of sounds. Listen through walls, windows, floors etc. Many applications shown, from law enforcement, nature listening, medical heartbeat, to mechanical devices. £65/set Ref F/HGA7.

**ANTI DOG FORCE FIELD PLANS** Highly effective circuit produces time variable pulses of acoustical energy that dogs cannot tolerate. £65/set Ref F/DOG2.

**LASER BOUNCE LISTENER SYSTEM PLANS** Allows you to hear sounds from a premises without gaining access. £125/set Ref F/LI1.

**LASER LIGHT SHOW PLANS** Do it yourself plans show three methods. £6 Ref F/LLS1.

**PHASOR BLAST WAVE PISTOL SERIES PLANS** Handheld, has large transducer and battery capacity with external controls. £65/set Ref F/PSP4.

**INFINITY TRANSMITTER PLANS** Telephone line grabber/room monitor. The ultimate in home/office security and safety! simple to use! Call your home or office phone, push a secret tone on your telephone to access either: A) On premises sound and voices or B) Existing conversation with break-in capability for emergency messages. £7 Ref F/TELEGRAB.

**BUG DETECTOR PLANS** Is that someone getting the goods on you? Easy to construct device locates any hidden source of radio energy! Sniffs out and finds bugs and other sources of bothersome

## WOLVERHAMPTON BRANCH NOW OPEN AT WORCESTER ST W'HAMPTON TEL 01902 22039

Interference. Detects low, high and UHF frequencies. £5/set Ref F/BD1.

**ELECTROMAGNETIC GUN PLANS** Projects a metal object a considerable distance - requires adult supervision £5 ref F/EM2.  
**ELECTRIC MAN PLANS, SHOCK PEOPLE WITH THE TOUCH OF YOUR HAND!** £5/set Ref F/EMA1.

**PARABOLIC DISH MICROPHONE PLANS** Listen to distant sounds and voices, open windows, sound sources in 'hard to get' or hostile premises. Uses satellite technology to gather distant sounds and focus them to our ultra sensitive electronics. Plans also show an optional wireless link system. £85/set Ref F/PM5.

**2 FOR 1 MULTIFUNCTIONAL HIGH FREQUENCY AND HIGH DC VOLTAGE, SOLID STATE TESLA COIL AND VARIABLE 100,000VDC OUTPUT GENERATOR PLANS** Operates on 9-12vdc, many possible experiments. £10 Ref F/HVM7/TCLA.

**INFINITY TRANSMITTERS** The ultimate 'bug' fits to any phone or line, undetectable, listen to the conversations in the room from anywhere in the world! 24 hours a day 7 days a week! just call the number and press a button on the mini controller (supplied) and you can hear everything! Monitor conversations for as long as you choose £249 each, complete with leads and mini controller Ref LOT9. Undetectable with normal RF detectors, fitted in seconds, no batteries required, lasts forever!

**SWITCHED MODE PSU'S** 244 watt +5 32A, +12.6A, -5 0.2A, -12 0.2A. There is also an optional 3.3v 25A rail available. 120/240v V P. Cased, 175x90x145mm. IEC inlet Suitable for PC use (6 d/drive connectors 1 mboard). £10 ref PSU1.

**VIDEO PROCESSOR UNITS?/6V 10AH BATT/12V 8A TX** Not too sure what the function of these units is but they certainly make good strippers! Measures 390X320X120mm, on the front are controls for scan speed, scan delay, scan mode, loads of connections on the rear. Inside 2 x 6V 10AH sealed lead acid batts, pcb's and a 8A? 12v toroidal transformer (mains in). Condition not known, may have one or two broken knobs due to poor storage. £17.50 ref VP2.

**RETRO NIGHT SIGHT** Recognition of a standing man at 300m in 14 moonlight, hermetically sealed, runs on 2 AA batteries, 80mm F1.5 lens, 20mw infrared laser included. £325 ref RETRON.

**MINI FM TRANSMITTER KIT** Very high gain preamp, supplied complete with FET electret microphone. Designed to cover 88-108 Mhz but easily changed to cover 63-130 Mhz. Works with a common 9v (PP3) battery. 0.2W RF. £7 Ref 1001.

**3-30V POWER SUPPLY KIT** Variable, stabilized power supply for lab use. Short circuit protected, suitable for professional or amateur use 24v 3A transformer is needed to complete the kit. £14 Ref 1007.

**1 WATT FM TRANSMITTER KIT** Supplied with piezo electric mic. 8-30vdc. At 25-30v you will get nearly 2 watts! £12 ref 1009.

**FM/AM SCANNER KIT** Well not quite, you have to turn the knob yourself but you will hear things on this radio that you would not hear on an ordinary radio (even TV). Covers 50-160mhz on both AM and FM. Built in 5 watt amplifier, Inc speaker. £15 ref 1013.

**3 CHANNEL SOUND TO LIGHT KIT** Wireless system, mains operated, separate sensitivity adjustment for each channel, 1.200 w power handling, microphone included. £14 Ref 1014.

**4 WATT FM TRANSMITTER KIT** Small but powerful FM transmitter, 3 RF stages, microphone and audio preamp included. £20 Ref 1028.

**STROBE LIGHT KIT** Adjustable from 1-60 hz (a lot faster than conventional strobes). Mains operated. £16 Ref 1037.

**COMBINATION LOCK KIT** 9key, programmable, complete with keypad, will switch 2A mains, 9v dc operation. £10 ref 1114.

**PHONE BUG DETECTOR KIT** This device will warn you if somebody is eavesdropping on your line. £6 ref 1130.

**ROBOT VOICE KIT** Interesting circuit that distorts your voice! adjustable, answer the phone with a different voice! 12vdc £9 ref 1131

**TELEPHONE BUG KIT** Small bug powered by the phone line, starts transmitting as soon as the phone is picked up! £8 Ref 1135.

**3 CHANNEL LIGHT CHASER KIT** 800 watts per channel, speed and direction control supplied with 12 LEDs (you can fit tracs instead to make kit mains, not supplied). 9-12vdc £17 ref 1026.

**12V FLOURESCENT LAMP DRIVER KIT** Light up 4 foottubes from your car battery! 9v 2a transformer also required. £8 ref 1069.

**VOXSWITCH KIT** Sound activated switch ideal for making bugging tape recorders etc, adjustable sensitivity. £8 ref 1073.



Check out our  
**WEB SITE**

<http://www.pavillon.co.uk/bull-electrical>

**PREAMP MIXER KIT** 3 input mono mixer, sep bass and treble controls plus individual level controls. 18vdc, input sens 100mA. £15 ref 1052.

\*SOME OF OUR PRODUCTS MAY BE UNLICENSABLE IN THE UK

**BULL ELECTRICAL**  
250 PORTLAND ROAD, HOVE, SUSSEX.  
BN3 5QT. (ESTABLISHED 30 YEARS)

MAIL ORDER TERMS: CASH, PO OR CHEQUE  
WITH ORDER PLUS £3 P&P PLUS VAT.

PLEASE ALLOW 7-10 DAYS FOR DELIVERY PHONE ORDERS  
WELCOME (ACCESS, VISA, SWITCH, AMERICAN EXPRESS)

TEL: 01273 203500

FAX 01273 323077

E-mail [bull@pavillon.co.uk](mailto:bull@pavillon.co.uk)

**SOUND EFFECTS GENERATOR KIT** Produces sounds ranging from bird chips to sirens. Complete with speaker, add sound effects to your projects for just £9 ref 1045.

**16 WATT FM TRANSMITTER (BUILT)** 4 stage high power, preamp required 12-18vdc, can use ground plane, yagi or open dipole. £69 ref 1021.

**HUMIDITY METER KIT** Builds into a precision LCD humidity meter, 9ic design, pcb, lcd display and all components included. £29  
**PC TIMER KIT** Four channel output controlled by your PC, will switch high current mains with relays (supplied). Software supplied so you can program the channels to do what you want whenever you want. Minimum system configuration is 286, VGA, 4.1.640k, serial port, hard drive with min 100k free. £24.99

**FM CORDLESS MICROPHONE** This unit is an FM broadcasting station in miniature, 3 transistor transmitter with electret condenser mic + fet amp design result in maximum sensitivity and broad frequency response. 90-105mhz, 50-1500hz, 500 foot range in open country! PP3 battery required. £15.00 ref 15P42A

**MAGNETIC MARBLES** They have been around for a number of years but still give rise to curiosity and amazement. A pack of 12 is just £3.99 ref GI/R20

**NICKEL PLATING KIT** Professional electroplating kit that will transform rusting parts into showpieces in 3 hours! Will plate onto steel, iron, bronze, gunmetal, copper, welded, silver soldered or brazed joints. Kit includes enough to plate 1,000 sq inches. You will also need a 12v supply, a container and 2 12v light bulbs. £39.99 ref NIK39.

**Miniature adjustable timers, 4 pole o/o output 3A 240v, HY1230S, 12VDC adjustable from 0-30 secs. £4.99  
HY1260M, 12VDC adjustable from 0-60 mins. £4.99  
HY2405S, 240v adjustable from 0-5 secs. £4.99  
HY24060m, 240v adjustable from 0-60 mins. £6.99**

**BUGGING TAPE RECORDER** Small voice activated recorder, uses micro cassette complete with headphones. £28.99 ref MAR29P1.

**POWER SUPPLY** fully cased with mains and op leads 17v DC 900mA output. Bargain price £5.99 ref MAG6P9  
**9v DC POWER SUPPLY** Standard plug in type 150ma 9v DC with lead and DC power plug. price for two is £2.99 ref AUG3P4.

**COMPOSITE VIDEO KIT.** Converts composite video into separate H sync, V sync, and video. 12v DC. £8.00 REF: MAG8P2.

**FUTURE PC POWER SUPPLIES** These are 295x135x60mm, 4 drive connectors 1 mother board connector. 150watt, 12v fan, iec inlet and on/off switch. £12 Ref EF6.

**VENUS FLYTRAP KIT** Grow your own carnivorous plant with this simple kit £3 ref EF34.

**6"X12" AMORPHOUS SOLAR PANEL** 12v 155x310mm 130mA. Bargain price just £5.99 ea REF MAG6P12.

**FIBRE OPTIC CABLE BUMPER PACK** 10 metres for £4.99 ref MAG5P13 ideal for experimenters! 30 m for £12.99 ref MAG13P1

**ROCK LIGHTS** Unusual things these, two pieces of rock that glow when rubbed together believed to cause rain! £3 a pair Ref EF29.

**3' by 1' AMORPHOUS SOLAR PANELS** 14.5v, 700mA 10 watts, aluminium frame, screw terminals. £44.95 ref MAG45.

**ELECTRONIC ACCUMULATOR KIT** Builds into an electronic version instead of needles! good to experiment with. £7 ref 7P30

**SHOCKING COIL KIT** Build this little battery operated device into all sorts of things, also gets worms out of the ground! £7 ref 7P36.

**FLYING PARROTS** Easily assembled kit that builds a parrot that actually flaps its wings and flies! 50 m range £6 ref EF2.

**HIGH POWER CATAPULTS** Hinged arm brace for stability, tempered steel yoke, super strength latex power bands. Departure speed of ammunition is in excess of 200 miles per hour! Range of over 200 metres! £7.99 ref R/9.

**BALLON MANUFACTURING KIT** British made, small blob blows into a large, longlasting balloon, hours of fun! £3.99 ref GI/E99R

**9-0-9V 4A TRANSFORMERS**, chassis mount. £7 ref LOT19A.

**2.6 KILOWATT INVERTERS, Packed with batteries etc but as they weigh about 100kg CALLERS ONLY! £120.**

**MEGA LED DISPLAYS** Build your self a clock or something with these mega 7 seg displays 55mm high, 38mm wide. 5 on a pcb for just £4.99 ref LOT16 or a bumper pack of 50 displays for just £29 ref LOT17.

**CLEARANCE SECTION, MINIMUM ORDER £15, NO TECHNICAL DETAILS AVAILABLE, NO RETURNS, TRADE WELCOME.**

2000 RESISTORS ON A REEL (SAME VALUE) 99P REF BAR340

AT LEAST 200 CAPACITORS (SAME VALUE) 99P REF BAR342

INFRA RED REMOTE CONTROLS JUST 99P REF BAR333

CIRCUIT BREAKERS, OUR CHOICE TO CLEAR 99P REF BAR335

MICROWAVE CONTROL PANELS TO CLEAR £2 REF BAR 328

2 TUBES OF CHIPS (2 TYPES OUR CHOICE) 90P REF BAR305

LOTTERY PREDICTOR MACHINE!! JUST £1.50 REF BAR313

HELLA L/ROVER ELECTRIC H/LAMP LEVELLER £2 REF BAR311

SINCLAIR CS 18" TYRES TO CLEAR AT JUST 75P REF BAR318

LARGE MAINS MOTORS (NEW) TO CLEAR AT 75P REF BAR310

MODEMS ETC FOR STRIPPING £2.50 EACH REF BAR324

110V LARGE MOTORS (NEW) TO CLEAR AT 50P REF BAR332

MODULATOR UNITS UNKNOWN SPEC JUST 50P REF BAR323

GX4000 GAMES COINLES JUST £4 REF BAR320

SMART CASED MEMORY STORAGE DEVICE, LOADS OF BITS INSIDE, PCB, MOTOR, CASE ETC. BUMPER PACK OF 5 COMPLETE UNITS TO CLEAR AT £2.50 (FOR 5) REF BAR 330.

2 CORE MAINS CABLE 2M LENGTHS PACK OF 4 £1 REF BAR337

PC USER/BASIC MANUALS, LOADS OF INFO. £1 REF BAR304

PCB STRIPPERS TO CLEAR AT 2 FOR 99P REF BAR341

3 M 3CORE MAINS CABLE AND 13A PLUG. 60P REF BAR325

**WE BUY SURPLUS STOCK**

**FOR CASH**  
**BUYERS DIRECT LINE 0802 660377**

**FREE CATALOGUE**

**100 PAGE CATALOGUE NOW AVAILABLE, 45P STAMPS.**



# NEW PRODUCTS CLASSIFIED

Please quote "Electronics World" when seeking further information

## ACTIVE

### A-to-D and D-to-A converters

**Low-power 8-bit a-to-ds.** A range of analogue-to-digital converters with serial i/o interfaces – the *WM0831/2* – are available with differential, dual, four or eight inputs, use little power and run from a single 3V or 5V supply. The *0831* has differential input, which can be single-ended, and its conversion result emerges under the control of clock and chip-select inputs. It uses a three-wire interface and a separate voltage reference input. The *0832* is arranged by the data-in input as two single-ended inputs or a differential input; voltage reference is ratiometric and is connected internally to the supply pin. Pronto Electronic Systems Ltd. Tel., 0181 554 5700; fax, 0181 554 6222.

### Linear integrated circuits

**1200V ic.** International Rectifier claims a world's first for the *IR2233*, a 1200V, three-phase gate driver for inverters operating from 460V ac, its main advantages over earlier circuitry being that no opto-couplers or other peripheral circuits are needed; the design confers high immunity from  $dv/dt$  noise from the igbt switching transients; matched delays and timing control of the three channels; and integrated protection circuitry; and a driver stage designed for igbts. The chip contains three each independent high-side and low-side gate drives; current sense amplifier; timing and logic circuitry and interfacing for analogue and digital inputs. Gate drive output is up to 500mA. International Rectifier. Tel., 01883 732020; fax, 01883 733410.

**Dtmf transceiver with micro interface.** Mitel's *MT88L89/85* are 3V integrated dtmf transceivers having an adaptive microcontroller interface, the *85* also having a full-chip, power-down pin. The receiver section is based on the *MT8870* dtmf receiver, the transmitter using a switched-capacitor d-to-a converter for low distortion and accurate switching. The use of internal counters makes for precisely timed tone bursts and a call-progress tone detector, which is sensitive to -30dB, allows a microprocessor to analyse the tones and have adjustable guard time. Mitel Semiconductor. Tel., 01291 430000; fax, 01291 436389.

**Cellphone amplifier.** *RF2131* by RF Micro-Devices is designed mainly for use in cellular telephone handsets. It is a gallium arsenide heterojunction bipolar device 1.3W output device (on 6dBm input), working in the 800-950MHz band on a single supply of between 4V and 6V, from which it draws 400mA at 1.2W output or 10 $\mu$ A in standby. Power control from minimum to maximum is a 0.2-4V voltage, the process taking 100ns. The device has been tested with both capacitive and inductive duplex filters for compatibility; it is protected against overvoltage and has temperature compensation. Anglia Microwaves Ltd. Tel., 01277 630000; fax, 01277 631111.

### Microprocessors and controllers

**Controllers with analogue features.** Microchip has new 8-bit, one-time programmable controller families that possess analogue circuitry for car electronics and appliance application. *PIC16C642/662* are the first in the 64 and 66 families and contain a 4V brown-out protection, two voltage comparators and a voltage reference module. There is 4K of on-chip program eeprom and 176byte of ram. Full development support is provided by Microchip's development tools. Arizona Microchip Technology Ltd. Tel., 01628 851077; fax, 01628 850259

### Mixed-signal ICs

**Single-chip baseband converter.** Harris has introduced the first single-chip if/quadrature modem integrating the functions of up and down conversion and quadrature modulation/demodulation. The *HFA3724* converts in both directions between baseband and .if. over a 10-400MHz frequency range and is intended for wireless lans and PCMCIA wireless network cards, time-division duplex binary and quad-modulated comms systems, tdm multiple-access packet protocol radio, etc. Power consumption is 390mW at 5.5V and 4.4mW in standby. Harris Semiconductor UK. Tel., 01276 686886; fax, 01276 682323.

**20-bit audio codec.** *AK4520* from AKM is a 20-bit stereo delta-sigma codec with data converters on-chip. The a-to-d converter has 64 times oversampling and a dynamic range of 96dB at 5V and 92dB at 3V operation, while the d-to-a converter uses 128 times oversampling. Component count is reduced by the inclusion of the second-order switched-capacitor filter and continuous time filters on the



**Miniature drill.** A small, 12V, 100W drill for modelling or repair work, the *MB1012* from Minicraft is available in a drill kit, which contains the *MB730* transformer with speed control and 40 accessories for cutting, grinding, routing, polishing and drilling, all in a storage case. The drill chuck takes bits from 0.3-6mm and the drill can be held by its pistol grip, as a pen or in the palm. Minicraft. Tel., 01388 420535; fax, 01388 817182.

chip, which also increases tolerance to clock jitter. Single-ended input and output also help to reduce the number of components and sampling rate can be from 30kHz to 50kHz, with master clock frequency at 256 or 384 times the clock. Power supply needed is 2.7/3.6V or 4.5/5.5V and power dissipation at 3V is 100mW. DIP International Ltd. Tel., 01223 462244; fax, 01223 467316.

### Power semiconductors

**High-current half bridges.** *Super Magn-a-pak* modules by IR contain a pair of semiconductors to make a half-bridge rectifier consisting of two thyristors, a thyristor/diode combination, two diodes or two fast-recovery diodes, the modules being rated at 400-600A and meant for large motor drives and similar applications. These modules use proven IR semiconductors, formerly in B-puks. International Rectifier. Tel., 01883 732020; fax, 01883 733410.

## PASSIVE

### Passive components

**Power chip resistors.** Philips' *PRC201* 1W power chip resistors are now available in a 1% tolerance and in values down to 0.02 $\Omega$  for current measurement uses. Values in the 0.02 $\Omega$ -1M $\Omega$  range are made. Philips Components. Tel., 00 31 40 2722790; fax, 00 31 40 2724547.

**450V electrolytics.** Nichicon *PJ* series electrolytics afford high reliability and high ripple current handling. Values offered cover the 0.47 $\mu$ F-15000 $\mu$ F range in the E12 progression to within  $\pm$ 20% at 120Hz and 20°C. Impedance of, for example, a 1000 $\mu$ F 16V capacitor is 0.072 $\Omega$  at 100kHz and its tolerance to ripple current 1.4A rms between 10kHz and 200kHz. The 450V versions at, say, 4.7 $\mu$ F handle a 55mA ripple at 120Hz. Case sizes are 10-16mm diameter and 16-31.5mm in length. Easby Electronics Ltd. Tel., 01748 850555; fax, 01748 850556.

### Connectors and cabling

**Mains connectors.** Rendar has a new series of rewirable connectors, the *478* model, which use pillar terminations, floating, captive contacts, reversible and captive clamp and three-point cover fixing. They are easy to wire and conform to the relevant safety standards. Rating



Please quote "Electronics World" when seeking further information

is 10A or 15A in the USA and the connectors take three-core cable up to 14awg. Models for hot or cold conditions to Class I or II, in straight or right-angled forms and in black or white finish are available. Rendar Ltd. Tel., 01243 866741; fax, 01243 841486.

**S-m connectors.** PAK-50, P50L surface-mounted, low-profile connectors have a mated height of 7-8mm and are designed for smt board stacking application, being available in vertical, horizontal and parallel board stacking forms. Insertion and withdrawal forces are low, due to the tapered contacts, being 3.36oz per pin and 0.49oz per pin respectively, and the contact design makes for low wear. Contact resistance is 40mΩ and isolation

resistance 1GΩ. Robinson Nugent (Europe) Ltd. Tel., 01256 842626; fax, 01256 842673.

**Waterproof connectors.** Should your interests necessitate the immersion of connectors under six feet of water, you could do no better than to consider the *Conxall Mini-Mizer* range of control and sensor connectors. They meet the requirements of UL, CSA, NEMA, ANSI and NFPA and use epoxy-sealed, all-moulded construction, with anodised, machined aluminium coupling ring and receptacle shell, which shrugs off most solvents, oils and other industrial hazards. The connectors come in two-pole to six-pole types, all having a lengthened earth pin for first-make, last-break connection. They handle 16g or 18g cable in lengths from 2m to 5m or to order. Astralux Dynamics Ltd. Tel., 01403 240055; fax, 01403 25565

### Displays

**Colour lcd for vehicles.** Philips Flat Panel Display Co. has introduced an lcd monitor for use in vehicles as navigation displays and fleet management systems, which need not be mounted on the dashboard and incur expense for dashboard redesign. The display is based on the 5.1in LDE052T active-matrix colour lcd module, designed for use in tough conditions and with a backlight giving a brightness of 300cd/m<sup>2</sup>. Monitors may have an RGB, NTSC or PAL interface or a 320 by 240 interface for digital indications. In addition, it can be supplied with a speaker, audio

amplification, infrared remote-control receiver and backlight control. It comes in a plastic case with a rounded shape and can be mounted almost anywhere, since it has a very wide viewing angle. Philips Components. Tel., 00 31 40 2722790; fax, 00 31 40 2724547.

### Filters

**Inlet filter.** FN9310 inlet filter modules can be fitted in a few seconds and take up only 24.05mm behind the front panel, using a 'lock and shield' fixture, whereby the inlet automatically locks in place when it is pushed through the mounting hole, no screws being needed. Metal fingers make contact between the panel and filter earth. If attack by the muscle-bound is envisaged, an extra locking nut can be used to give more security. The inlets come in current ratings of 1-15A and, as an example, a 3A version gives a minimum of 40dB differential and common-mode interference attenuation in the 3-30MHz band. Schaffner EMC Ltd. Tel., 0118 9770070; fax, 0118 9792969.

**Elliptic low-pass.** Linear has introduced its second eighth-order, elliptic low-pass filter in an SO-8 pack, the LTC1069-6, which draws 1mA at 3V and gives 72-80dB dynamic range. It needs no other components, apart from bypasses. To allow frequency variation, the clock is external, the cut-off being 1/50 the clock frequency. Pass-band ripple is ±0.1dB, stop-band attenuation 42dB at 1.3f<sub>cut-off</sub>, 66dB at twice that frequency and 72dB at 2.1 times the cut-off frequency, which can be up to 14kHz at 3V or 20kHz at 5V. Linear Technology (UK) Ltd. Tel., 01276 677676; fax, 01276 64851.

### Hardware

**Emc-proof cabinets.** Vero's VERAK EMC range of 27-42U cabinets provide over 80dB of attenuation at 100MHz. Available in plan sizes from 600/600mm to 800/800mm, the Verak EMC is rated at 750kg static load, being built in 2mm steel framework. Knife edges that meet the panel-mounted gasket to give the seal are part of the verticals, being self-located in slots in the end frames to give accuracy and repeatability, earth continuity being maintained throughout the cabinet. Doors can be hung either way. Steel or glass doors are available, both being emc protected and a new type of mechanism maintaining the seals. Vero Electronics Ltd. Tel., 01489 780078; fax, 01489 780978.

**VXibus chassis.** Ractal's 1269 VME/VXibus chassis allows the use of both C-size VXibus and B-size VXI/VME boards in one unit. It complies with both VXibus and

VXI *plug&play* specifications, having six VXI C slots and three VME B slots, no adaptors being needed. The slot 0 interface allows the use of VXI or VME controllers simply by changing the orientation of a small card. Power available is 720W, with cooling, and an option is a systems monitoring facility with a front indicator. Ractal Instruments Ltd. Tel., 01628 604455; fax, 01628 662017.

### Test and measurement

**Mobile 'phone tester.** CTS 55 from Rohde & Schwarz is a modular test set for the quality assurance and servicing of GSM and DCS1800/1900 mobiles. Main operations are call setup and clear-down for incoming and outgoing calls, free selection of channels, power and channel change, echo test, power measurement, Rx sensitivity using bit error rate measurement, phase/frequency error and power ramp v. time; none of all this needs any specialised GSM knowledge. Indications, selected from a menu, are on a tft colour display, results being presented graphically. Rohde & Schwarz UK Ltd. Tel., 01252 811377; fax, 01252 811447.

**Counter.** Thurlby Thandar's SR620 is a universal timer counter to measure all the usual parameters and also pulse width, phase and rise and fall times. In addition, it is capable of statistical work, including mean, maximum, minimum standard deviation and Allan variance, all being shown on a 16-digit display. Standard timebase is 10MHz ageing at 3x10<sup>-9</sup>/year, an optional oven-controlled oscillator providing 5x10<sup>-10</sup>/day. Time interval is measured to 25ps resolution, intervals up to ±1000s to within 50ps relative accuracy. There is start/stop hold-off, both of these inputs functioning as start or stop. Frequency range is 1.3GHz with gates from 1µs to 500s. The instrument can send histograms and strip charts to an oscilloscope with an X input and to HP-GL plotters and printers. GPIB and RS-232 interfaces allow remote control. Thurlby Thandar Instruments Ltd. Tel., 01480 412451; fax, 01480 450409.

**Multimeters.** Clarke Power Products has a new range of eleven multimeters, covering between them the requirements of kitchen-table amateurs to professionals, at prices from £6.95 to £64.95. Clarke Power Products. Tel., 0181 986 8231; fax, 0181 986 6512.

**Cable tester.** Microscanner by Microtest Inc. is the first in a family of cable test instruments, this one designed to verify and fault-find in twisted-pair cabling. By combining wiremap with length measurement, it

**Hand-held dvms.** Tektronix announces the DMM910 Series, an extension of the company's range of hand-held, true rms digital multimeters. The three instruments in the range are DMM912, 914, 916, the last two allowing the reading of two measurements at once and measuring temperature in both fahrenheit and celsius. In addition, the 916 has a 1ms peak hold function to capture fast transients. Of the other instruments, DMM912 is the most basic and the 914 a mid-range type. Tektronix UK Ltd. Tel., 01628 403300; fax, 01628 403301.





Please quote "Electronics World" when seeking further information

confirms continuity, wiring connections, indicates fault location and identifies wires. This is a hand-held unit, which will measure the length of a cable using tdr, identifying shorts, open circuits and connections to hubs, as well as tracing hidden cables in walls and floors. Microtest Europe. Tel., 01293 894000; fax, 01293 894008.

**Transient capture analyser.** Endevo offers the *Model 28989* transient analyser, which has four channels and works to a host pc. Its four voltage inputs store up to 50,000 samples/channel, each having a 12-bit analogue-to-digital converter for simultaneous, selectable sampling rates to 20kHz with one trigger channel active. Triggering is internal, external or via Windows software, repeated runs being performed by a mouse-controlled setup button. Both mains and dc-powered versions are available. Endevo UK Ltd. Tel., 01763 261311; fax, 01763 261120.

**Microwave counters.** *Escort 3000* counters is a range of four instruments covering in total 0.001Hz-3GHz on an eight-digit display. The four models are EFC-3305 giving 0.001Hz-100MHz and 80MHz-3GHz; the EFC-3303 reading 0.001Hz-100MHz and 50MHz-1.3GHz; 5Hz-100MHz and 50MHz-2.4GHz on the EFC-3203A; and 5Hz-175MHz with the EUC-3200. Various functions are available on some of the models, such as autoranging, ac/dc coupling, pulse-width average and rev/min measurement. Feedback Test and Measurement. Tel., 01892 653322; fax, 01892 663719.

## Interfaces

**Combiscope adaptor cable.** Fluke offers the *PAC33* print adaptor cable, which enables any Fluke instrument, such as the *PM 3394B* *Combiscope*s, with a standard RS-232 interface to be connected to any printer having a Centronics interface. It uses standard RS-232 and parallel connectors, a 9V battery and will take hard use. Fluke UK Ltd. Tel., 01923 240511; fax, 01923 225067.

## Literature

**Emc testing.** Seaward Electronic can provide a free booklet on the subject of emc testing in-house. It contains a guide to the EMC Directive, standards and methods of ensuring compliance; there are lists of basic, generic and product standards and descriptions of the Declaration and Technical Construction File. Technical descriptions are provided of rf, harmonic and flicker emission tests, esd, eft voltage dips and surge immunity tests. Seaward Electronic Ltd. Tel., 0191 586 3511; fax, 0191 586 0227.

## Materials

**Emc gasket.** Holland Shielding Systems BV can provide gaskets that give good shielding, extremely low closing force, 80% compression and negligible compression set. Dimensions range from 2 by 2mm to 40 by 60mm, all being available on a 200m roll. The gaskets can be supplied with an environmental seal and/or a self-adhesive layer, and there are flame-retardant versions. Holland Shielding Systems bv. Tel., 0031 78 613 13 66; fax, 0031 78 614 95 85.

## Printers and controllers

**Thermal printer.** Seiko's *LTP4242* lightweight thermal printer measures only 86.6 by 52 by 22mm, has a 75mm/s printing speed and is meant for journal and receipt printing. It is designed for ease of use, having simple paper insertion, rapid head cleaning and replacement and a new static electricity protection method by grounding the frame, all metallic components being in ground contact, so preventing damage. Resolution is 432 dots per line, printing width 54mm on paper 58mm wide and the supply needed is 5V and 24V. Craft Data Ltd. Tel., 01494 778235; fax, 01494 773645.

**Double-Y pen recorder.** Kipp and Zonen of Delft produces what it says is the only such instrument available with CE approval. *BD90/91* flat-bed recorders both have single and dual-pen *XY-t* facility and are for general-purpose use. They have modules for voltage, timebase sweep and can be remotely controlled. Kipp & Zonen. Tel., 01727 843939; fax, 01727 842185.

## Production equipment

**Ovens.** A range of electric ovens by Hednair is batch-produced, in contrast to the common arrangement in which companies build them to order; in this way, cost is minimised. The range contains ovens operating at up to 200°C, 300°C and 425°C, all of these being available in sizes up to 915mm cube internally. There is sufficient power to give a rapid heat-up time, air recirculation providing even heating, and a good exhaust rate means that solvent-based coatings on components can be tolerated. For these, a separate 50m<sup>3</sup>/h exhaust fan can be used, with an optional switch to turn off the heating if the air flow stops. Hednair Ltd. Tel., 0181 590 2090; fax, 0181 590 0262.

## Power supplies

**80A dc-to-dc converter.** Vicor has a dc-to-dc converter that accepts an input of 250-425V and produces an

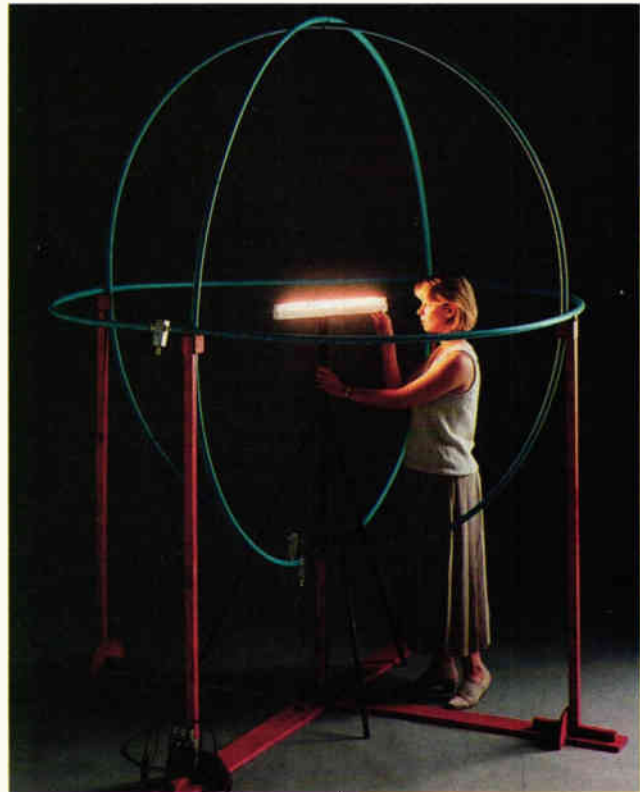

output programmable from 1V to 5.5V at 80A and 84% efficiency. Power density is 80W/in<sup>3</sup>, so that the converter helps to reduce power-supply size and zero-current switching has reduced input conducted noise and output ripple. Dimensions are 4.6 by 2.2 by 0.5in and the shape of the converter allows it to be recessed in the board to give a height of 0.43in. Vicor UK. Tel., 01276 678222; fax, 01276 681269.

**600W switcher.** From Coutant Lambda, the *Alpha 600* switched-mode power supply, the latest member of the range, which provides between one and seven outputs to customer configuration and meets all relevant standards. Input voltage is universal at 47-63Hz and start-up time is under 0.5s. Thermal, overcurrent and overvoltage protection are standard, as is power-factor correction. Output is adjustable; load regulation for a 100% change in load is <0.5% with remote sensing and <2% without. Options include curve B emc filtering, remote sensing, power good, ac failure parallelling and power supply inhibit. Coutant Lambda Ltd. Tel., 01271 865656; fax, 01271 864894.

**Open-frame, 55W.** Computer Products offers the *NAN55* open-frame, 55W (with a fan) power supply in the same size (5 by 3in) as many 40W units on the market. Input is universal and there are single, dual and two triple output models providing 5V, 5.2/12.1V, and 5.2/12.1/-12V. The 5V or 5.2V output of each is regulated to  $\pm 2\%$  and is protected. All the relevant standards, directives, laws, regulations and edicts have been respected. Computer Products, Power Conversion Ltd. Tel., 00353 24 93130; fax, 00353 24 03257.

**Emc-testing antenna.** Luminaires have their own European standard, EN55015, which requires that a large loop antenna be used for emc measurement. Laplace has a 2m diameter loop for this purpose covering 9kHz-30MHz, which is supplied with antenna factor data to enable its use with any emc receiver or spectrum analyser capable of factor compensation. Mounted on a collapsible wooden frame, it is a three-axis antenna with a switch to select each loop and screened housings for the current transducers. Software supplied with the kit automatically compensates for antenna characteristics, displaying EN55015 limits corrected for the 2m loops. Laplace Instruments Ltd. Tel., 01692 500777; fax, 01692 406177.

## Protection devices

**Resettable fuses.** Raychem has additions to its range of polymeric resettable fuses, the *miniSMD C110/075/050/020* which extend the range of protection from 200mA to 1.1A, while enabling visual inspection of solder joints on a board. The low-resistance 110 has a 1.1A hold current and is rated at 6V, the new package helping with joint inspection. The *075* and *050* have the same performance as *miniSMD 075/050* with hold currents of 0.75A and 0.5A, trip times being under 0.5s. The *020* holds at 200mA and trips 30% faster than the earlier SMD type. Raychem Ltd. Tel., 01793 572692; fax, 01793 572209.



Please quote "Electronics World" when seeking further information

### Switches and relays

**Reed switches.** Gentech Series GR10 miniature Form A pressurised reed switches have a maximum switching voltage of 500Vdc, maximum current 1A, dc contact rating of 15W and initial contact resistance of 0.1Ω, contacts being of ruthenium. Diameter of the switches is 2.54mm and they are 20mm long, with an uncut length of 53mm and minimum length of 25mm cut. They can be supplied potted for pcb mounting and sensing use. Gentech International Ltd. Tel., 01465 713581; fax, 01465 714974.

### Transducers and sensors

**Optical encoder.** Intended for use in applications needing what is effectively a highly accurate potentiometer, Control Transducers' optical encoder meets the requirement. The Model DP100BT Digital Potentiometer can be mounted on a board or a panel and produces 100 ttl two-phase square waves per revolution, which corresponds to 400 2-bit codes/rev., other arrangements being available. The device is rated for over five million revolutions. A free designers' guide is on offer. Control Transducers. Tel., 01234 217704; fax, 01234 217083.

**'Smallest' 50W open-frame.** Vero's BVS45 BVM45 open-frame, switched-mode power supplies measure 108 by 64 by 29mm and come in single, dual or triple output versions. Inputs are universal 47-440Hz ac and outputs various combinations of 5V, 12V and 15V. Overcurrent, overvoltage and short-circuit protection is provided and the units meet the relevant standards requirements for radiated and conducted noise. Hold-up time is over 70ms at 230V ac. Vero Electronics Ltd. Tel., 01489 780078; fax, 01489 780978.

**3000A current sensor.** Davtrend has a ±3000A current sensor for the measurement and control of static or dynamic ac or dc in plant and machinery control systems. It operates from dc to 25kHz to an accuracy of ±0.25% of range, with a gain drift of ±0.01% and zero offset drift of ±0.01% of range per degree. Response time is 10µs, coping with di/dt of 300A/µs and output is 0 to ±10V for 0 to ±3000A at 100Ω; these characteristics can be varied by the company to suit other uses. The sensor accommodates a 50mm busbar. Davtrend Ltd. Tel., 01705 372004; fax, 01705 326307.

**Position sensors/systems.** MTN/1E position sensors and electronics by Monitran are made in stainless steel and sealed against attack by all manner of dirt and fluids, connectors being of the heavy duty type, sealed and, as an option, armoured. Various fittings such as spring-loaded ends, rod end bearings and threaded extensions are available. Ranges cover ±0.5mm to ±550mm, outputs being ac, dc or 4-20mA. Instrumentation can be supplied for most engineering parameters. Monitran Ltd. Tel., 01494 816569; fax, 01494 812256.

**Coded car keys.** Philips' newly announced car immobiliser keys are designed to foil those lurking in car parks and trying to intercept the radiated codes as people unlock their cars. Both key and car process a random number generated by the car; both have to match before the car lets you in and, since the code is not transmitted, it cannot be intercepted, the transmission consisting only of random numbers. Keys cannot be copied. You can educate the car to recognise several keys so that it will go through its performance of adjusting mirrors and seats to suit whoever has come in. If you address it rudely, it will probably explode. Philips Semiconductors (Eindhoven). Tel., 00 31 40 2722091; fax, 00 31 40 2724825.

## COMPUTER

### Computer-aided design

**Image acquisition.** National Instruments introduces the IMAQ PCI-1408 image acquisition board for Windows 95/NT, which is accompanied by IMAQ Vision acquisition, process and analysis software and the NI-IMAQ driver software. The board works with several video standards and the software with National's virtual instrumentation packages. Used together, the package assists in on-line inspection, gauging, process



control, component sorting and handling and bar code reading. National Instruments UK. Tel., 01635 523545; fax, 01635 523154.

### Computer board-level products

**Backplane.** Vero has a new range of 10-layer, 3U backplanes for industrial use. CompactPCI is electrically compatible with the pc desktop specification, so that existing applications can be run in a rack-mounted computer. A Hard Metric 2mm connector gives 235 pins per slot, 25 being user-defined. The backplane supports 32 and 64bit PCI transfers at up to 132Mbyte/s and provides independent power rails for 5V and 3.3V, with decouplers. Throughout the connector, 28 pins are ground and defined early power pins enable hot swapping. Vero Electronics Ltd. Tel., 01489 780078; fax, 01489 780978.

**Single-board VME.** The 3.3V B10 single-Eurocard cpu from Men GmbH of Nuremberg offers scalable performance up to 100Mips by the use of a 68040 or 68060 with a 68360 risc processor in companion mode to handle Ethernet and all other serial input/output; the Ethernet interface supports AUI, Cheapernet and twisted pair. The four serial ports can be RS232, 422 or 485 and, as an option, optically isolated. Memory takes the form of 32Mbyte of dram, 8Mbyte of flash, 2Mbyte of sram and a 1Mbyte eeprom, the dram being in a PS-2 simm and therefore proof against shock and vibration. External mass memory devices use a SCSI-II controller supporting direct memory access and data transfer to 10Mbyte/s. Tellima Technology Ltd. Tel., 01484 866806; fax, 01484 866816.

**Dsp starter kit.** NEC has a starter kit, the EB-77016STARTER, for the company's µPD7701X family of dsp processors. The kit has the µPD77016 ram dsp processor, workbench and debugger software running under Windows. It is connected to the pc's printer port, program development proceeding by way of the JTAG debug interface of

OS-9-to-dos/Windows. Version 3.2 of BVM's PCLink, the networking package for OS-9 to dos/Windows 3.x, supports dynamic data exchange to allow real-time updating from an OS-9 machine to a standard Windows application running on a pc, so that packages such as Scada on a pc can be used to store and display system parameters with no complicated programming being needed. The OS-9 machine can access all pc peripherals and the pc has similar access, supporting most OS-9 calls and remote OS-9 commands, including remote login. PCLink allows networking of the two types of system over a number of media, and coexists with Microware's ISP and other Ethernet protocols. It can also be used on RS-232 or RS-485 ports at up to 2Mb/s. BVM Ltd. Tel., 01489 783589; fax, 01489 780144.

the processors. Programs are then down-loaded into the built-in flash memory and booted into the µPD77016 to allow operation independently of the host pc. Also in the kit is a stereo a-to-d-to-a converter, power supply, cables and documents, with some programming examples. NEC Electronics (UK) Ltd. Tel., 01908 691133; fax, 01908 670290.

### Data acquisition

**1MHz acquisition boards.** Win-30 data acquisition boards by United Electronic Industries Inc. are multi-function analogue and digital i/o boards supporting Windows 3.1, 95 and NT software. Throughput on all boards is 1MHz using data packing and bursting dma or 32-bit rep string operations, sampling up to 16 channels at 62.5kHz or 1 channel at 1MHz. Software controls input ranges, dma and interrupt levels. Other boards in the series have a variety of facilities, including various input types, input amplification, buffering and programmed gain. Amplicon Liveline Ltd. Tel., 0800 525 335 (free); fax, 01273 570215.

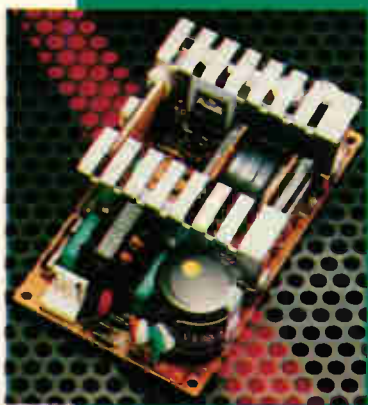



## COMPUTER ICs

TMS 9800NL-40 PULLS	£20 ea
S9800 NEW AMD EQUIVALENT	£30 ea
MC6802 PROCESSOR	£2 ea
AM27C020-125L1 SURFACE MOUNT EPROM USED/WIPED	£1.50
P8271 BBC DISC CONTROLLER CHIP EX EQPT	£25
28174-20 (2K x 8) EPROM ex eqpt	£2
D41258C-15 256K x 1 PULLS	9 FOR £25
P8748H MICROC	£5
6D751-8 NEW	£10
MK48202-20 ZERO POWER RAM EQUIV 6118LP	£4
USED 4164-15	£0p
BBC VIDEO ULA	£10
8061 MICROC	£1.25
FLOPPY DISC CONTROLLER CHIPS 1771	£15
FLOPPY DISC CONTROLLER CHIPS 1772	£17.50
68000-8 PROCESSOR NEW	£5
HD6384-8	£5
27C4001 USED EPROMS	£4
27C2001 USED EPROMS	£2.50
1702 EPROM NEW	£5
2114 EX EQPT	50p
4418 EX EQPT	70p
6284-15 8k STATIC RAM	£1.50
Z80A SIO-O	£1.25
7128 3 1/2 DQIG LCD DRIVER CHIP	£2 ea
2816A-30 HOUSE MARKED	£2
USED TMS2532JL	£2.50
2708 USED	£2
HM61871P-8	65p
68000-10 PROCESSOR	£5
8255-5	£1.40
2114 CMOS (RCA 5114)	£1.80
WD16C550-PC UART	£5
ZN427E-8	£4
27C258-26 USED	£1.50
PAL2016L-25 9000 ex stock	
M28F010-150K1 FLASH EPROM PLCC 500 ex stock	
LM091LN LCD DISPLAY	£15

## REGULATORS

LM338K	£5
LM323K 5V 3A PLASTIC	£3
LM350K (VARIABLE 3A)	£3
78H125C 12V 5A	£5
LM317T TO5 CAN	£1
LM317T PLASTIC TO220 variable	£1
LM317 METAL	£2.20
7812 METAL 12V 1A	£1
7805/12/15/24	30p
7905/12/15/24	30p
79HGASC + 79HGASC REGULATORS	£30 ea
LM1125 ST95 5V 3A TO3 REGS	£3 ea
UC3254AN SWITCHING REGULATOR IC	80p
78L12 SHORT LEADS	10¢/1
LM2850ACZ5.0	80p

## CRYSTAL OSCILLATORS

307.2KHZ 1M000000 1M8432 2M457800 3M8864 4M000000	
5M000000 5M06800 5M780000 6M000000 6M1440 7M000000	
3M372800 7M5 8M000000 9M21610M000 10M0 12M000000	
14M316 14M3816 16M40 17M825600 18M000000 18M432 19M050	
19M2 19M440 20M000 20M0150 21M0676 22M1184 23M587	
24M0000 25M1748 25M175 25M1889 27M + 36M 27M00000	
28M322 32M00000 32M0000 "S/MOUNT 33M3330 35M4816	
38M100 40M000 41M539 42M00000 44M444 44M900 44M0	
48M00000 50M00 55M000 56M0020 64M000000 68M4667 78M1	
80M0 84M0	£1.50 ea

## CRYSTALS

32K788 1MHz 1M8432 2M000 2M1432 2M304 2M44576 3M000	
3M2788 3M400 3M579545 3M58564 3M600 3M6884 3M93216	
4M000 4M190 4M194304 4M2056 4M33614 4M608 4M6152 5M000	
5M0888 6M000 6M041952 6M200 6M400 7M37280 8M000 8M06400	
8M448 8M863256 8M8670 9M3750 9M8304 10M240 10M245	
10M368 10M70000 11M000 11M052 11M98135 12M000 12M5	
13M000 13M270 13M87500 14M000 14M316 14M7450 14M7458	
15M0000 16M000 17M8250 18M432 20M000 21M300	
21M400M15A 24M000 25M000 26M965 27M045 RD 27M085 OR	
27M145 BL 27M145 YW 27M195 GN 28M4696 30M4696 31M4696	
31M4696 34M368 36M75625 36M76875 36M78125 36M79375	
36M80825 36M81675 36M83125 36M84375 36M900 48M000	
51M05833 54M1916 55M500 57M7416 57M7583 66M545 69M550	
96M000 111M800 114M8	£1 ea

## TRANSISTORS

MPSA42	10¢/1
MPSA92	10¢/1
2N2907A	10¢/1
BC487, BC488	10¢/1
BC107 BCY70 PREFORMED LEADS	
full spec	£1 £4/100 £30/1000
BC557, BC238C, BC908B	£1.30 £3.50/100
2N2907 PLASTIC CROPPED	£1/16 £4/100
BC548B SHORT LEADS	£3/100 £20/1000

## POWER TRANSISTORS

OC29	£2 ea
2SC1520 sim BF259	3/£1 100/£22
TIP 141/2 £1 ea TIP 112/42B	2/£1
IRF620 TO-220 6A 200v	2/£1
SE9301 100V 1DA DARL SIM TIP121	2/£1
BD980	4/£1
PLASTIC 3055 OR 2955 equiv 50p	100/£35

## TEXTOL ZIF SOCKETS

28 PIN USED	£3
ZIF 84 WAY SHRINK DIP SKT TEXTOL 284-1300-00 1.78mm	
SPACING ON PCB WITH 4MHz RESONATOR	£10
SINGLE IN LINE 32 WAY CAN BE GANGED FOR USE WITH ANY DUAL IN LINE DEVICES... COUPLING SUPPLIED	2/£1.50

# KEYTRONICS

TEL. 01279-505543

FAX. 01279-75765

E-MAIL. keytronics@btinternet.com

PO BOX 634

BISHOPS STORTFORD

HERTFORDSHIRE CM23 2RX

http://www.btinternet.com/~keytronics

## MISCELLANEOUS

AAA NICAIDS HI CAPACITY 360mHr 3 CELL PACK	£3
25A SOLID STATE RELAY 240V AC ZERO VOLTS SWITCHING	£10
XENON STROBE TUBE	£1.80
Narrow angle infra red emitter LED55C	2/£1
UM61 118M-2L surface mount 1000 available	£1
CNY65 OPTO ISOL 3000 available	50p
OPTO ICs also available TLP550 TLP686GF	
88 way PLCC SKT 100 available	£1 each
100 way PLCC SKT 100 available	£1.50 each
1250pF POSTAGE STAMP COMPRESSION TRIMMER	£1
LM324 (Quad 741)	4/£1
MINIATURE FERRITE MAGNETS 4x4x3mm	10/£1
TL071 LO NOISE OP AMP	5 for £1
TL081 OP AMP	4 for £1
47000u 25v SPRAGUE 36D	£3.50 (£2)
12 way dll sw	£3 for £1
10NF 63V X7R PHILIPS SURFACE MOUNT 100K available	£30/4000
SWITCHED MODE PSU 40 WATT UNCASED QTY. AVAILABLE +5v 5A, +12V 2A, 12V 500mA FLOATING	£9.95 (£2)

220R 2.5W WIREWOUND RESISTOR 60K AVAILABLE

CMOS 555 TIMERS

2/3 AAA LITHIUM cells as used in compact cameras

PASSIVE INFRA RED SENSOR CHIP + MIRROR + CIRCUIT

EUROCARD 98-WAY EXTENDER BOARD

290 x 100mm

DIN 41812 98-WAY A/B/C SOCKET PCB RIGHT ANGLE

DIN 41812 64-WAY A/B/C SOCKET WIRE WRAP PINS

DIN 41812 64-WAY A/C SOCKET WIRE WRAP PINS

DIN 41812 64-WAY AC PLUG PCB RIGHT ANGLE

DIN 41812 64-WAY AB SOCKET WIRE WRAP (2-ROW BODY)

BT PLUG + LEAD

MIN. TOGGLE SWITCH 1 POLE c/o PCB type

LCD MODULE sim. LM018 but needs 150 to 250V AC for display

40 x 2 characters 182 x 35 x 13mm

6-32 UNC 5/16 POZI PAN SCREWS

NUTS

PUSH SWITCH CHANGEOVER

RS232 SERIAL CABLE D25 WAY MALE CONNECTORS

25 FEET LONG, 15 PINS WIRED BRAID + FOIL SCREENS

AMERICAN 2/3 PIN CHASSIS SOCKET

WIRE ENDED FUSES 0.25A

NEW ULTRASONIC TRANSDUCERS 32kHz

POWER SMALL CYLINDRICAL MAGNETS

9NC 50OHM SCREENED CHASSIS SOCKET

SMALL MICROWAVE DIODES AE1 OC1028A

D.I.L. SWITCHES 10-WAY £1 8-WAY 80p 4/5/8-WAY

180VOLT 1 WATT ZENERS also 12V & 75V

MIN GLASS NEONS

RELAY 5V 2-pole changeover looks like RS 355-741 marked STC

47WBoat

MINIATURE CO-AX FREE PUG RS 458-071

MINIATURE CO-AX PCB SKT RS 458-083

PCB WITH 2N2846 UNIJUNCTION WITH 12V 4-POLE RELAY

400 MEGOHM THICK FILM RESISTORS

STRAIN GAUGES 40 ohm Foil type polyester backed

belco grid alloy

ELECTRET MICROPHONE INSERT

Unear Hall effect IC Micro Switch no 613 SS4 sim RS 304-267

1 pole 12-way rotary switch

AUDIO ICS LM380 LM388

555 TIMERS £1 741 OP AMP

2N414 AM RADIO CHIP

COAX PLUGS nice ones

COAX BACK TO BACK JOINERS

INDUCTOR 20uH 1.5A

1.25 inch PANEL FUSEHOLDERS

STEREO CASSETTE HEAD

MONO CASS. HEAD £1 ERASE HEAD

THERMAL CUT OUTS 50 77 85 120°C

THERMAL FUSES 220°C/121°C 240V 15A

TRANSISTOR MOUNTING PADS TO-5/TO-18

TO-3 TRANSISTOR COVERS

PCB PINS FIT 0.1 inch VERO

TO-220 mica + bushes

TO-3 mica + bushes

IEC chassis plug filter 10A

POTS SHORT SPINDLES 2K5 10K 25K 1M 2M5

40k U/S TRANSDUCERS EX-EQPT NO DATA

LM234Z CONST. CURRENT I.C.

BNC TO 4MM BINDING POST SIM RS 455-981

MIN PCB POWER RELAYS 10.5v COIL 6A CONTACTS 1 pole c/o

BANDOLIERS COMPONENTS ASSORTED Rs, Ca, ZENERS

LCD MODULE 16 CHAR. X 1 LINE (SIMILAR TO HITACHI LM10)

OP1284A 10KV OPTO ISOLATOR

'LOVE STORY' CLOCKWORK MUSICAL BOX MECHANISM

MADE BY SANKYO

Telephone cable clips with hardened pins

10,000/F 16V PCB TYPE 30mm DIA x 31mm

10µF 10 BEAD TANTALUM

EC CHASSIS FUSED PLUG B-LEE L2728

2A CERAMIC FUSE 1.25 inch QB

48 WAY IDC RIBBON CABLE 100 FOOT REEL

20mm PCB FUSEHOLDER

IEC CHASSIS FUSED PLUG B-LEE L2728

ASTEC MODULATOR VIDEO + SOUND UM1287

BARGRAPH DISPLAY 8 RED LEADS

NE567 PHASE LOCKED LOOP

NE564

TL084

IR2432 SHARP 12 LED VU BAR GRAPH DRIVER

10A CORCOM MAINS RFI FILTER EX. EQPT

8 OHM MYLAR CONE LOUDSPEAKER 55mm DIA x 10mm

DEEP

AD592AN Temperature sensor TO-92 package with 1.5m lead

## DIODES AND RECTIFIERS

A115M 3A 800V FAST RECOVERY DIODE	4/£1
1N5407 3A 1000V	8/£1
1N4148	100/£1.50
1N4004 SD4 1A 300V	100/£3
1N5401 3A 100V	10/£1
1N5819RL 20K Ex stock	1000 + 10p
BA158 1A 400V fast recovery	100/£3
BY254 800V 3A	8/£1
BY255 1300V 3A	6/£1
6A 100V SIMILAR MR751	4/£1
1A 800V BRIDGE RECTIFIER	4/£1
4A 100V BRIDGE	3/£1
8A 100V BRIDGE	2/£1
10A 200V BRIDGE	£1.50
25A 200V BRIDGE £2	10/£18
25A 400V BRIDGE £2.50	10/£22
BY287	10/£1
KBPC304 BRIDGE REC 3A 400V	4/£1

## SCRs

PULSE TRANSFORMERS 1.1 + 1

MEU21 PROG UNIJUNCTION

DIACS 4/£1

NEC TRIAC AC06F 8A 800V TO220

TXAL225 8A 500V 5mA GATE

ETA 08-40 ISO TAB 400V 5mA GATE

TRAL22300 30A 400V ISOLATED STUD

TRIAc 1A 800V Tlc381T 1k AVAILABLE

PHOTO DEVICES

HI BRIGHTNESS LEDS COX24 RED

SLOTTED OPTO-SWITCH OPCOA OPB815

2N5777

TL181 PHOTO TRANSISTOR

TL138 INFRA RED LED

4N25, OP12252 OPTO ISOLATOR

PHOTO DIODE 50P

MEL12 (PHOTO DARLINGTON BASE n/c)

LEDs RED 3 or 5mm 12/£1

LEDs GREEN OR YELLOW 10/£1

FLASHING RED LED 5mm 50p

HIGH SPEED MEDIUM AREA PHOTODIODE R8651-995

OPTEK OPB745 REFLECTIVE OPTO SENSOR

RED LED - CHROME BEZEL

OPI1108 HI VOLTAGE OPTO ISOLATOR

MOc 3020 OPTO COUPLED TRIAC

## STC NTC BEAD THERMISTORS

G22 220R, G13 1K, G23 2K, G24 20K, G54 50K, G25 200K, RES 20°C

DIRECTLY HEATED TYPE

FS225W NTC BEAD INSIDE END OF 1 inch GLASS PROBE RES

20°C 200R

A13 DIRECTLY HEATED BEAD THERMISTOR 1k res. ideal for audio Wien Bridge Oscillator

CERMET MULTI TURN PRESETS 1/4 inch

10R 20R 100R 200R 250R 500R 2K 2K2 2K5 5K 10K 47K 50K 100K

200K 500K 2M

## IC SOCKETS

14/16/18/20/24/28/40-WAY DIL SKTS

8-WAY DIL SKTS

32-WAY TURNED PIN SKTS

SIMM SOCKET FOR 2

# MEASURING low resistance

**Simple low-resistance measurement usually relies on high direct current to produce a voltage drop, stressing the component under test. Reducing the current and amplifying the voltage drop can result in offset problems. Frantisek Michele explains the advantages of using ac to produce the drop.**

**M**easuring resistors with low values can be tricky. The obvious method is to measure the voltage drop across the unknown resistor using a known current and then calculate its value.

Because the drop depends on the current through the resistor, the current needs to be large enough to produce a measurable voltage. For example, the voltage drop is only 10mV if the measured resistor is 0.1Ω and current through the resistor is 100mA.

Large currents supply large voltage drops. However, in many cases, the measured components will not tolerate such large currents. Also, the heat generated by within the component due to the large current can cause measurement errors.

This problem can be solved by amplifying the voltage drop so that less current is needed. If the amplifier has a 60dB gain, the output will be 0.1V if the current is 1mA and the resistor is still 0.1Ω.

### The ac alternative

Operational amplifiers however have a dc input offset voltage. This offset causes an error when the input level is very low. An ac amplifier technique circumvents this problem.

Referring to Fig. 1, IC<sub>A</sub>, C<sub>1</sub>, and R<sub>1-4</sub> form a square waveform generator operating at around 300Hz. Diode D<sub>1</sub> limits the square wave to 6V peak-peak. Because the values of the measured resistor R<sub>X</sub> and additional resistor R<sub>A</sub> are much less than R<sub>6</sub>, current through R<sub>X</sub> will be,

$$I_X = 6/R_6 = 2 \text{ mA}$$

Then, IC<sub>B</sub>'s input is,

$$V_{IN} = I_X \times (R_X + R_A) = 0.002 \times (R_X + R_A)$$

Amplifier IC<sub>B</sub> supplies the ac gain R<sub>8</sub>/R<sub>7</sub>=10. Diode D<sub>2</sub> with IC<sub>C</sub> converts the ac signal to dc with gain of 1+R<sub>11</sub>/R<sub>10</sub>=10. DC amplifier

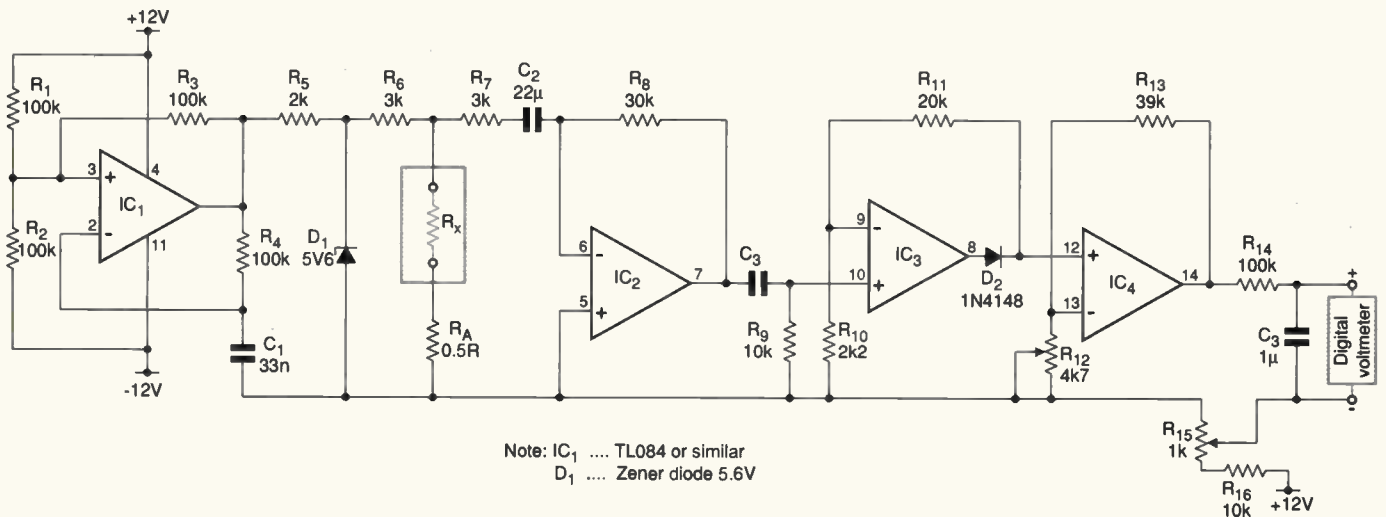

Fig. 1. Oscillator IC<sub>A</sub> produces an ac voltage over the unknown resistor, which is then amplified, rectified and displayed. Since the stimulus is ac, high current and drift associated with dc schemes for measuring low resistance are removed.



$IC_D$  has a gain of  $1+R_{13}/R_{12}$ . As a result, the output is,

$$V_O = 0.5 \times V_{IN} \times 10 \times 10 \times (1 + R_{13}/R_{12}) = 0.1 \times (R_X + R_A) \times (1 + R_{13}/R_{12})$$

where 0.5 is the conversion efficiency for a 50% duty-cycle waveform. After the dc output is smoothed by  $R_{14}$  and  $C_4$ , a digital voltmeter can measure  $R_X$ .

Resistor  $R_A$  supplies a base signal for the amplifiers. When  $R_X=0$ ,  $R_A$  sends a 1mV peak-peak signal to  $IC_B$ . If  $R_A=0$  and  $R_X$  is very small,  $IC_B$ 's noise may swamp the weak input. To compensate for the output offset due to  $R_A$ ,  $R_{15}$  calibrates the digital voltmeter to zero when  $R_X=0$ . Adjusting  $R_{12}$  makes the scale  $1\Omega/V$ . Thus, a 2V digital voltmeter can measure resistances from 0.001 to 1.999 $\Omega$ .

**Measure resistance of a capacitor**

The equivalent series resistance, or esr, of a capacitor can be measured using Fig. 2.

Oscillator  $IC_1$  forms a 50kHz square-wave generator. It drives a current waveform of about  $\pm 180mA$  into the capacitor under test through  $R_1$  and  $R_2$ .

When  $R_3$  is adjusted to the proper value, the voltage drop across the equivalent series resis-

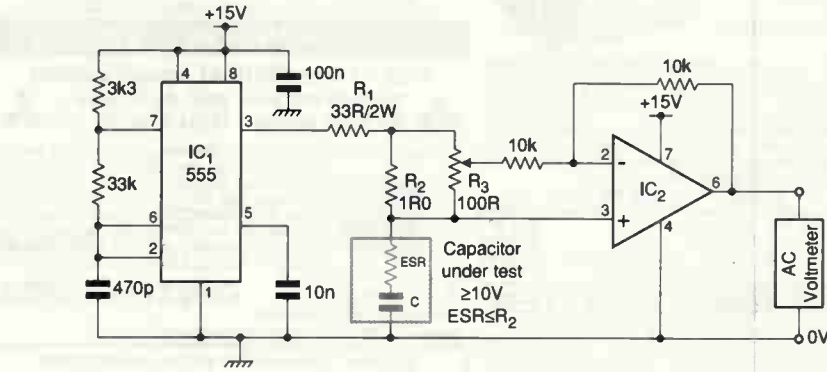

Fig. 2. Equivalent series resistance in a capacitor is particularly important in circuits such as switch-mode power supplies. Operating at 50kHz, this circuit drives about  $\pm 180mA$  into the capacitor and looks at the resulting ac voltage over the 1 $\Omega$  resistor via an op-amp.

tor is precisely nulled by the inverting amplifier  $IC_2$ . Thus,  $V_O$  is the pure capacitor voltage which is the minimum voltage that can be produced at  $V_O$ .

To make an ac voltage measurement, adjust  $R_3$  until  $V_O$  is minimised. Then note the position of the potentiometer and multiply it by the value of  $R_2$ . That product equals the capacitor's esr.

The capacitor is biased about to 7.5V.

Lower-voltage capacitors cannot be measured with this circuit. Changing the value of  $R_2$  allows other ranges of esr to be measured. However, for small  $R_2$  values, the current level should be increased to keep a reasonable voltage across  $R_2$ . This will require some sort of buffer.

The circuit is intended for capacitors greater than 100 $\mu F$ . Ripple voltage becomes large for smaller values and accuracy decreases. ■

**NEW & HARDLY USED TEST EQUIPMENT**



**DUAL TRACE 20MHZ OSCILLOSCOPE MODEL HC3502**  
5MV - 20V/DIV; 0.2 $\mu$  Secs to 0.5Sec/Div;  
X - Y; X5 Magnifier; TV Sync etc  
Used  $\pounds 180$  Un-used  $\pounds 220$

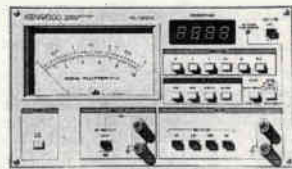

**KENWOOD FL100A W/W/FLUTITER METER**  
0.003% - 10%; Frequency 3KHZ/3.15KHZ;  
RMS/AVERAGE/PEAK; Weighted Filters; Digital Display  
of rpm; 4 digit Frequency Counter (0.01KHZ-9.999KHZ-  
55KHZ)  
Used  $\pounds 400$  Un-used  $\pounds 500$



**PANASONIC VP8177A FM/AM SIGNAL GENERATOR**  
100KHZ-110MHZ; Output -19dB to 99dB;  
FM 0-100KHZ; AM 0-60%; 32 PreSet Memory; Digital  
Display Frequency & Output  
Used  $\pounds 450$  Un-used  $\pounds 750$

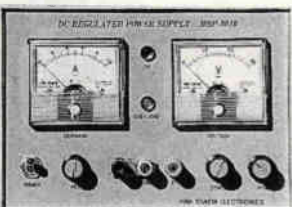

**POWER SUPPLY MODEL HSP3010**  
0-30 Volts; 0-10Amps; Current Limiting; 2 metres  
Used  $\pounds 235$  Un-used  $\pounds 275$



**PANASONIC VP7637A STEREO SIGNAL GENERATOR**  
Generates Broadcast FM - RDS/ARI PreSet Memory; GPIB  
Used  $\pounds 400$  Un-used  $\pounds 700$



**ANALOGUE MULTIMETER Model HC260TR**  
AC/DC Volts; DC Current  
10 Amps; 17 Ranges  
Continuity Buzzer;  
Transistor Tester  
Un-used  $\pounds 15$



**GODWILL GVT 427 DUAL CHANNEL AC MILLIVOLTMETER**  
10 $\mu$ V - 300V in 12  
ranges; Frequency 10HZ-  
1MHZ.  
Used  $\pounds 100$  Un-used  $\pounds 125$



**GODWILL GAG 8066 AUDIO GENERATOR**  
Sine/Square 10HZ-1MHZ  
in 5 ranges; 0.1% Low  
Distortion; 5 steps Output  
Attenuator.  
Used  $\pounds 60$  Un-used  $\pounds 80$



**GODWILL GFC 80106 FREQUENCY COUNTER**  
Range 1HZ-120MHZ; B  
Digit Display;  
15mVrms Sensitivity  
Un-used  $\pounds 95$

WE HAVE THE WIDEST CHOICE OF USED OSCILLOSCOPES IN THE COUNTRY

TEXTORNE 1A5465 Dual Trace 100MHz Delay/Current	$\pounds 1100$
TEXTORNE 2445 4Ch. 100MHz Delay/Current	$\pounds 1900$
TEXTORNE PHE2222 Dual Trace 350MHz Delay/Current	$\pounds 1900$
I.P. 5420NA Displaying Oscilloscope 50MHz	$\pounds 1100$
TEXTORNE 485 Dual Trace 350MHz Delay Sweep	$\pounds 700$
TEXTORNE 475 Dual Trace 200MHz Delay Sweep	$\pounds 600$
TEXTORNE 465 Dual Trace 100MHz Delay Sweep	$\pounds 500$
TEXTORNE 2215 Dual Trace 60MHz Delay Sweep	$\pounds 400$
PHILIPS 3055 2-1 Channel 50MHz Dual Trace/Delay	$\pounds 300$
PHILIPS PHE217 Dual Trace 50MHz Delay Sweep	$\pounds 400$
SONIX 6511808 Dual Trace 50MHz Delay Sweep	$\pounds 300$
SONIX 65381 Dual Trace 20MHz Delay Sweep	$\pounds 110$
ROBIN 2099 Dual Trace 20MHz Mono/Battery	$\pounds 400$
TEXTORNE 460 Dual Trace 100MHz Delay Sweep Dig Storage	$\pounds 700$
TECHNIP VC664 Dual Trace 100MHz Delay Sweep	$\pounds 1000$
TECHNIP VC661 Dual Trace 60MHz Dig Storage	$\pounds 600$
ROBINSON 3382 Dual Trace 200MHz Dig Storage Plotter Output	$\pounds 400$
I.P. 1741A Dual Trace 100MHz Analogue Storage	$\pounds 400$
TEXTORNE 460 Dual Trace 100MHz Delay Sweep Analogue Storage	$\pounds 400$
TEXTORNE 434 Dual Trace 25MHz Analogue Storage	$\pounds 200$
LEADER LCD100 DMM/Scope 200MHz Dig Storage LCD Display	$\pounds 300$

THIS IS JUST A SAMPLE. MANY OTHERS AVAILABLE

I.P. 8020C Sweep Osc with 80270B 2-1K.60MHz	$\pounds 2000$
I.P. 8020C Sweep Osc with 80270B 0.81-2.4kHz	$\pounds 2000$
I.P. 8054A Sig Gen 0.1-1000Hz	$\pounds 1700$
MARCONI 2019 Synthesised AM/FM Sig Gen 800Hz-1000MHz	$\pounds 1700$
MARCONI 2022 AM/FM Sig Gen 100Hz-10Hz	$\pounds 1000$
MARCONI 2018A Synthesised AM/FM Sig Gen 800Hz-520MHz	$\pounds 1600$
I.P. 8048A AM/FM Sig Gen 500Hz-100KHz	$\pounds 700$
I.P. 8020C Sweep Fac/Meter Main Frame only	$\pounds 200$
FMBHEL 330520 Synthesised AM/FM Sig Gen 10-520MHz	$\pounds 400$
MARCONI 175250 Transmitter Test Set 10-100Hz	$\pounds 400$
VAUTECH 3000 AM/FM Sig Gen 1-30MHz Synthesised	$\pounds 300$
MARCONI 172015 AM/FM Sig Gen 10-320MHz	$\pounds 110$
I.P. 8016A UHF Signal Generator 1.8-4.5GHz	$\pounds 200$
I.P. 80140 UHF Signal Generator 100Hz-3GHz	$\pounds 200$
MARCONI 17231A Distortion Factor Meter 20Hz-200Hz 0.05% Un-used	$\pounds 200$
MARCONI 17830B Audio Power Meter Stand	$\pounds 200$
B&S Video Meter UPF22 with UPF22 40Hz-1000MHz	$\pounds 1000$
VAUTECH 6010A Programmable Sweep Gen 1-20Hz	$\pounds 1000$
I.P. 3330B Synthesised Lev at Gen (10Hz-21MHz)	$\pounds 600$
I.P. 8100A Programmable Pre Pulse Gen 50MHz	$\pounds 1200$
MARCONI 2305 Modulation Meter	$\pounds 2200$
PHILIPS PMS134 Sweep Fun Gen 0.001Hz-200MHz Sin/Sq/Tri etc	$\pounds 200$
I.P. 5066 Signature Analyser	$\pounds 110$
I.P. 5084A Signature Analyser	$\pounds 110$
I.P. 8495B Attenuator DC-180Hz 0.70dB in 10dB steps	$\pounds 300$
I.P. 3531A Wave Analyser 150Hz-500Hz LED Readout	$\pounds 300$
I.P. 3495A Vector Voltmeter 1-1000MHz from	$\pounds 300$
I.P. 8112A Programmable 500MHz Pulse Generator	$\pounds -$
PHILIPS PM 5134 Sweep Func. Gen. 0.001Hz-200MHz Sin/Sq/Tri/Pulse	$\pounds 300$
I.P. 3312A Func. Gen 0.1Hz-100MHz Sin/Sq/Tri/Pulse etc	$\pounds 300$
I.P. 8494H with 8495B Attenuators Opt 0011 and 0P11713A	$\pounds 1700$
Attenuator/Switch Drive	$\pounds -$
TEXTORNE 780 Stereo Audio Monitor	$\pounds 2700$
QUINTZ OV Air Standard type 24-41	$\pounds 3000$
QUINTZ Series 800 Electric Power/Demand Analyser	$\pounds -$
ORNETZ Universal Disturbance Analyser Series 620A	$\pounds -$
JOP Universal AC/DC and Transient Tester RM215L/2	$\pounds 600$
PHILIPS PMS119 Colour Pattern Generator	$\pounds 400$
PHILIPS PM 5680 Colour Pattern Generator	$\pounds 200$
I.P. 5432A Counter 240Hz FFB	$\pounds 1700$
I.P. 5340A Counters 10Hz-10Hz	$\pounds 700$

MARCONI 2435 Prog Meter 10Hz-20Hz	$\pounds 200$
MARCONI 1998 Prog Counter 1.3GHz 50MHz/High Stab	$\pounds 600$
MARCONI 1991 Universal Counter/Timer 1600Hz 8 digit	$\pounds 600$
MARCONI 2437 Universal Counter/Timer DC - 1000Hz 8 digit	$\pounds 170$
MARCONI 2430A Frequency Counter 10Hz-200MHz 8 digit	$\pounds 120$
MARCONI 9116 Frequency Counter 10Hz-200MHz	$\pounds 170$
I.P. 3435 3 1/2 digit Multimeter AC/DC/Ohm/Current, LED	$\pounds 100$
MARCONI 2610 True RMS Voltmeter with GPIE	$\pounds 800$
MARCONI 5900A Universal Counter Timer 10Hz-200MHz	$\pounds 200$
ORNETZ 7150 8 1/2-3 1/2 digit DMM with EZE	$\pounds 400$
YOUNGSON 1583 4 1/2 digit Multimeter with Adapter	$\pounds 170$
FLUKE 8000A Digital Multimeter 5 1/2 digit	$\pounds 800$
FLUKE 8050A Bench/Portable DMM 4 1/2 digit True RMS	$\pounds 225$
FLUKE 8016A Bench/Portable DMM 3 1/2 digit True RMS	$\pounds 100$
VAUTECH 1024A Func Gen 0.004Hz-40Hz Sin/Sq/Tri/Pulse etc	$\pounds 225$
SONIX 230 Sim/Square Oscillator 10Hz-1000Hz	$\pounds 100$
MARCONI 7050A Sweep Func Gen 0.0005Hz-50Hz Sin/Sq/Tri etc	$\pounds 270$
FAMBELL LPT1 Stereo Oscillator 10Hz-1MHz	$\pounds 500$
MARCONI 5006 Automatic Mod Meter 1.5MHz-20Hz	$\pounds 300$
VAUTECH 252 Automatic Mod Meter 1.5MHz-1.2GHz	$\pounds 100$
MARCONI 5302 True RMS Millivoltmeter 100Hz-10Hz	$\pounds 200$
I.P. 4384 Power Meter with 8411A	$\pounds 1100$
I.L. SINTH AFFENNA TEST SET type 12-602-4	$\pounds 2000$
ORNETZ EP501 Audio Analyser	$\pounds 300$
FERRIMAGNET RT52 Receiver Test Set	$\pounds 200$
ROBIN Dual Variable Filter VDF5 0.1Hz-10Hz	$\pounds 400$
LEADER LSC216 Signal Generator	$\pounds 400$
TEXTORNE 1421 Vectorscope with 520A Waveform Monitor	$\pounds 1800$
PHILIPS 5667 Vectorscope with 5565 Waveform Monitor	$\pounds 1000$
ORNETZ 152 Scope Calibrator from	$\pounds 200$
MARCONI 9104 R.F. Power Meter 10Hz-10Hz 140MHz-300V	$\pounds 235$
MARCONI 172700 Universal Bridge/Battery Operated	from $\pounds 150$
VAUTECH 8424 Digital Component Meter LCR	$\pounds 200$
FAMBELL AP100/0 0-100V, 0-50A; Adversing	$\pounds 1000$
FAMBELL 100/100 0-30V, 0-100A	$\pounds 500$
SORREGER DCR600-4 50-0-500 Volts 0-4.5 Amps	$\pounds 700$
I.P. 6260 0-40 Volts 0-30 Amps	$\pounds 500$
FAMBELL 100/50 0-40 Volts, 0-50 Amps	$\pounds 500$
FAMBELL 100/25 0-40 Volts, 0-25 Amps	$\pounds 400$
FAMBELL 100/10 0-30 Volts, 10 Amps, Variable	$\pounds 100$
FAMBELL L30-5 0-30 Volts, 0-5 Amps, 2 Meters	$\pounds 100$
FAMBELL L30E 0-30 Volts, 0-5 Amps, Metrolux	$\pounds 100$
FAMBELL L30-2 0-30 Volts, 0-2 Amps, Metrolux	$\pounds 100$
FAMBELL L730-1 0-30 Volts, 0-1 Amp, Torco	$\pounds 100$
FAMBELL L30-1 0-30 Volts, 0-1 Amp, Metrolux	$\pounds 80$
TOWLETT-FRANBAU TSP2222 Programmable 32x 2 Amp Torco GPIB	$\pounds 200$
TOWLETT PL2000HD 0-30V, 0-2A Torco Digital	$\pounds 225$
Interchangeable Model 4728 -4V-20V Metrolux	$\pounds 200$

**BRIEL & KJÖER EQUIPMENT AVAILABLE PLEASE ENQUIRE**

**SPECTRUM ANALYSERS**

I.P. 8565A 0.01-250Hz	$\pounds 2000$
ALTECH 727 0.001-200Hz	$\pounds 2000$
I.P. 853A with 8530B 1000Hz-1500MHz	$\pounds 2700$
I.P. 182 with 8550B 1000Hz-1500MHz	from $\pounds 1000$
MARCONI 172370 30Hz-110MHz	$\pounds 700$
MARCONI 2370 with TR2373 30MHz-1.25GHz	$\pounds 1700$
MARCONI 2382 100Hz-400MHz	$\pounds 6000$
I.P. 3582A Dual Channel 250Hz	from $\pounds 2000$

Some I.P. 1417 Systems Available - Please enquire

**Used Equipment - GUARANTEED. Manuals supplied if possible.**  
This is a VERY SMALL SAMPLE OF STOCK. SAE or Telephone for lists. Please check availability before ordering.  
CARRIAGE all units  $\pounds 16$ . VAT to be added to Total of Goods and Carriage.

**STEWART of READING**  
110 WYKHAM ROAD, READING, BERKS. RG6 1PL  
Telephone: (0118) 9268041. Fax: (0118) 9351696  
Callers Welcome 9am-5.30pm Monday to Friday (other times by arrangement)



Surplus always wanted for cash!

# THE ORIGINAL SURPLUS WONDERLAND!

THIS MONTH'S SELECTION FROM OUR VAST EVER CHANGING STOCKS

Surplus always wanted for cash!

## LOW COST PC's -

### SPECIAL BUY 'AT 286'

40Mb HD + 3Mb Ram



LIMITED QUANTITY only of these 12MHz HI GRADE 286 systems Made in the USA to an industrial specification, the system was designed for total reliability. The compact case houses the motherboard, PSU and EGA video card with single 5 1/4" 1.2 Mb floppy disk drive & integral 40Mb hard disk drive to the front. Real time clock with battery backup is provided as standard. Supplied in good used condition complete with enhanced keyboard, 640k + 2Mb RAM, DOS 4.01 and 90 DAY Full Guarantee. Ready to Run!

Order as HIGRADE 286 **ONLY £129.00 (E)**

Optional Fitted extras: VGA graphics card £29.00  
1.4Mb 3 1/2" floppy disk drive (instead of 1.2 Mb) £19.95  
Wordperfect 6.0 for Dos - when 3 1/2" FDD option ordered £22.50  
NE2000 Ethernet (thick, thin or twisted) network card £29.00

## LOW COST 486DX-33 SYSTEM

Limited quantity of this 2nd year, superb small size desktop unit. Fully featured with standard simm connectors 30 & 72 pin. Supplied with keyboard, 4 Mb of RAM, SVGA monitor output, 256k cache and integral 120 Mb IDE drive with single 1.44 Mb 3.5" floppy disk drive. Fully tested and guaranteed. Fully expandable.

Only **£399.00 (E)**

Many other options available - call for details.

## FLOPPY DISK DRIVES 3 1/2" - 8"

5 1/4" or 3 1/2" from only £18.95!

Massive purchases of standard 5 1/4" and 3 1/2" drives enables us to present prime product at industry beating low prices! All units (unless stated) are BRAND NEW or removed from often brand new equipment and are fully tested, aligned and shipped to you with a 90 day guarantee and operate from standard voltages and are of standard size. All are IBM-PC compatible (if 3 1/2" supported on your PC).

3 1/2" Panasonic JU363/4 720K or equivalent RFE	£24.95(B)
3 1/2" Mitsubishi MF355C-L 1.4 Meg. Laptops only	£25.95(B)
3 1/2" Teac FD-55GFR 1.2 Meg. (for IBM pcs) RFE	£18.95(B)
5 1/4" Teac FD-55F-03-U 720K 40/80 (for BBC's etc) RFE	£22.95(B)
5 1/4" BRAND NEW Mitsubishi MF501B 360K	£29.95(B)
Table top case with integral PSU for HI 5 1/4" Flopp or HD	£29.95(B)
8" Shugart 800/801 8" SS refurbished & tested	£195.00(E)
8" Shugart 810 8" SS HH Brand New	£195.00(E)
8" Shugart 851 8" double sided refurbished & tested	£250.00(E)
Mitsubishi M2894-63 8" double sided NEW	£275.00(E)
Mitsubishi M2896-63-02U 8" DS slimline NEW	£285.00(E)
Dual 8" cased drives with integral power supply 2 Mb	£499.00(E)

## HARD DISK DRIVES

End of line purchase scoop! Brand new NEC D2248 8" 85 Mbyte drive with industry standard SMD interface, replaces Fujitsu equivalent model. Full manual. Only £299.00 or 2 for £525.00 (E)

3 1/2" FUJII FK-309-26 20mb MFM I/F RFE	£59.95(C)
3 1/2" CONNER CP3024 20 mb IDE I/F (or equiv) RFE	£59.95(C)
3 1/2" CONNER CP3044 40mb IDE I/F (or equiv) RFE	£69.00(C)
3 1/2" RODIME R03057S 45mb SCSI I/F (Mac & Acorn)	£69.00(C)
3 1/2" WESTERN DIGITAL 850mb IDE I/F Brand New	£185.00(C)
5 1/4" MINISCRIBE 3425 20mb MFM I/F (or equiv) RFE	£49.95(C)
5 1/4" SEAGATE ST-238R 30 mb RLL I/F Refurb	£69.95(C)
5 1/4" CDC 94205-51 40mb HH MFM I/F RFE tested	£69.95(C)
5 1/4" HP 9754B 85 Mb SCSI RFE tested	£89.00(C)
5 1/4" HP C3010 2 Gbyte SCSI differential RFE tested	£195.00(C)
8" FUJITSU M2322 160Mb SMD I/F RFE tested	£195.00(E)

Hard disc controllers for MFM, IDE, SCSI, RLL etc. from £18.95

## THE AMAZING TELEBOX

Converts your colour monitor into a QUALITY COLOUR TV!!



TV SOUND & VIDEO TUNER  
CABLE COMPATIBLE

The TELEBOX is an attractive fully cased mains powered unit, containing all electronics ready to plug into a host of video monitors made by makers such as MICROVITEC, ATARI, SANYO, SONY, COMMODORE, PHILIPS, TATUNG, AMSTRAD etc. The composite video output will also plug directly into most video recorders, allowing reception of TV channels not normally receivable on most television receivers\* (TELEBOX MB). Push button controls on the front panel allow reception of 8 fully tuneable 'off air' UHF colour television channels. TELEBOX MB covers virtually all television frequencies VHF and UHF including the HYPERBAND as used by most cable TV operators. A composite video output is located on the rear panel for direct connection to most makes of monitor or desktop computer video systems. For complete compatibility - even for monitors without sound - an integral 4 watt audio amplifier and low level Hi Fi audio output are provided as standard.

TELEBOX ST for composite video input type monitors	£36.95
TELEBOX STL as ST but fitted with integral speaker	£39.50
TELEBOX MB Multiband VHF/UHF/Cable/Hyperband tuner	£69.95

For overseas PAL versions state 5.5 or 6 MHz sound specification. \*For cable / hyperband reception Telebox MB should be connected to a cable type service. Shipping code on all Teleboxes is (B)

## DC POWER SUPPLIES

Virtually every type of power supply you can imagine. Over 10,000 Power Supplies Ex Stock. Call for info / list.

## Issue 13 of Display News now available - send large SAE - PACKED with bargains!

DISPLAY

-ELECTRONICS-

ALL MAIL & OFFICES  
Open Mon-Fri 9.00-5.30  
Dept Ww. 32 Biggin Way  
Upper Norwood  
LONDON SE19 3XF

LONDON SHOP  
Open Mon - Sat 9.00 - 5.30  
215 Whitehorse Lane  
South Norwood  
On 68A Bus Route  
N. Thornton Hall &  
Selhurst Park SR Rail Stations

NEW DISTEL ©  
The Original  
FREE On line Database  
Info on 20,000+ stock items!  
RETURNING SOON!

ALL ENQUIRIES  
0181 679 4414  
FAX 0181 679 1927



All prices for UK Mainland. UK customers add 17.5% VAT to TOTAL order amount. Minimum order £10. Bona Fide account orders accepted from Government, Schools, Universities and Local Authorities - minimum account order £50. Cheques over £100 are subject to 10 working days clearance. Cash on delivery (A)=£3.00, (B)=£4.00, (C)=£5.50, (D)=£12.00, (E)=£15.00, (F)=£18.00, (G)=CALL. Allow approx 6 days for shipping - faster CALL. Scotland surcharge CALL. All goods supplied to our Standard Conditions of Sale and unless stated guaranteed for 90 days. All guarantees on a return to base basis. All rights reserved to change prices / specifications without prior notice. Orders subject to stock. Discounts for volume. Top CASH prices paid for surplus goods. All trademarks etc acknowledged. © Display Electronics 1996. E & O E 066

## IC's - TRANSISTORS - DIODES

OBSOLETE - SHORT SUPPLY - BULK

6,000,000 items EX STOCK

For MAJOR SAVINGS - CALL FOR SEMICONDUCTOR HOTLIST

## VIDEO MONITOR SPECIALS

One of the highest specification monitors you will ever see -  
At this price - Don't miss it!!

Mitsubishi FA3415ETKL 14" SVGA Multisync colour monitor with fine 620 dot pitch tube and resolution of 1024 x 768. A variety of inputs allows connection to a host of computers including IBM PC's in CGA, EGA, VGA & SVGA modes, BBC, COMMODORE (including Amiga 1200), ARCHIMEDES and APPLE. Many features: Etched faceplate, text switching and LOW RADIATION MPR specification. Fully guaranteed, supplied in EXCEL-

LENT little used condition. TR & Swivel Base £4.75  
VGA cable for IBM PC included.  
External cables for other types of computers CALL.

Only £119 (E) Order as MITS-SVGA

As New - Used on film set for 1 week only!!  
15" 0.28 SVGA 1024 x 768 res. colour monitors.  
Swivel & tilt etc. Full 90 day guarantee. £145.00 (E)

Just in - Microvitec 20" VGA (800 x 600 res.) colour monitors.  
Good SH condition - from £299 - CALL for Info

PHILIPS HCS35 (same style as CM8833) attractively styled 14" colour monitor with both RGB and standard composite 15.625 KHz video inputs via SCART socket and separate phono jacks. Integral audio power amp and speaker for all audio visual uses. Will connect direct to Amiga and Atari BBC computers. Ideal for all video monitoring / security applications with direct connection to most colour cameras. High quality with many features such as front concealed flap controls, VCR correction button etc. Good used condition - fully tested - guaranteed

Dimensions: W14" x H12 1/4" x 15 1/2" D.

Only £95 (E)

PHILIPS HCS31 Ultra compact 9" colour video monitor with standard composite 15.625 KHz video input via SCART socket. Ideal for all monitoring / security applications. High quality, ex-equipment fully tested & guaranteed (possible minor screen bums). In attractive square black plastic case measuring W10" x H10" x 13 1/2" D. 240 V AC mains powered.

Only £79.00 (D)

KME 10" 15M10009 high definition colour monitors with 0.28" dot pitch. Superb clarity and modern styling. Operates from any 15.625 khz sync RGB video input source, with RGB analog and composite sync such as Atari, Commodore Amiga, Acorn Archimedes & BBC. Measures only 13 1/2" x 12" x 11". Good used condition.

Only £125 (E)

## 20" 22" and 26" AV SPECIALS

Superbly made UK manufacture. PIL all solid state colour monitors, complete with composite video & optional sound input. Attractive teak style case. Perfect for Schools, Shops, Disco, Clubs, etc. In EXCELLENT little used condition with full 90 day guarantee.

20"....£135 22"....£155 26"....£185 (F)

## SPECIAL INTEREST ITEMS

MITS. A. FA3455ETKL 14" Industrial spec SVGA monitors 2x40 to 400 kW - 400 Hz 3 phase power sources - ex stock	£245
IBM 8230 Type 1, Token ring base unit driver	£950
IBM 53F5501 Token Ring ICS 20 port lobe modules	£750
IBM MAU Token ring distribution panel 3228-23-5050N	£95
AIM 501 Low distortion Oscillator 9Hz to 320KHz, IEEE	£550
Trend DSA 274 Data Analyser with G703(2M) 64 V	£6500
Marconi 6310 Programmable 2 to 22 GHz sweep generator	£3750
HP1650B Logic Analyser	£3750
HP3781A Pattern generator & HP3782A Error Detector	£1800
HP APOLLO RX700 system units	£950
HP6621A Dual Programmable GPIB PSU 0-7 V 160 watts	£175
HP3081A Instrultra workstation clw Barcode swipe reader	£675
HP6264 Rack mount variable 0-20V @ 20A metered PSU	£1850
HP54121A DC to 22 GHz chann channel test set	£850
HP7580A A1 8 pen HPGL high speed drum plotter	£650
EG-G Brookdale 9503SC Precision lock in amp	£1425
View Eng. Mod 1200 computerised inspection system	£3750
Ling Dynamics 2kW programmable vibration test system	£1425
Computer controlled 1056 x 560 mm X Y table & controller	£3750
Kethley 590 CV capacitor / voltage analyser	£1450
Rascal ICR40 dual 40 channel video recorder system	£9500
Fiskers 45KVA 3 ph On Line UPS - New batts Dec.1995	£2200
ICI R5030UV34 Cleanline ultrasonic cleaning system	£1200
Mann Tally MT645 High speed line printer	£1150
Intel SBC 486/133SE Multibus 486 system. 8Mb Ram	£1450
Sata 3220-05 A0 4 pen HPGL fast drum plotters	£1450
Nikon HFX-11 (Ephiphot) exposure control unit	£550
Motorola VME Bus Boards & Components List. SAE / CALL	£1850
Trlo 0-18 vdc linear, metered 30 amp bench PSU. New	£1250
Fujitsu M3041R 600 LPM band printer	£2200
Fujitsu M3041D 600 LPM printer with network interface	£3750
Perkin Elmer 2998 Infrared spectrophotometer	£950
VG Electronics 1035 TELETEXT Decoding Margin Meter	£1995
Andrews LARGE 3.1 m Satellite Dish + mount (For Voyager)	£750
Sekonic SD 150H 18 channel digital Hybrid chart recorder	£485
TAYLOR HOBSON Tallysurf amplifier / recorder	£300
System Video 1152 PAL waveform monitor	£850
Test Lab - 2 mtr square quietised acoustic test cabinets	
Kenwood 9601 PAL Vectorscope - NEW	

Please call for further details on the above items

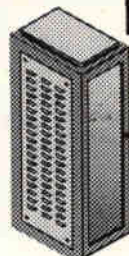

## 19" RACK CABINETS

Superb quality 6 foot 40U  
Virtually New, Ultra Smart  
Less than Half Price!

Top quality 19" rack cabinets made in UK by Optima Enclosures Ltd. Units feature designer, smoked acrylic lockable front door, full height lockable half louvered back door and louvered removable side panels. Fully adjustable internal fixing struts, ready punched for any configuration of equipment mounting plus ready mounted integral 12 way 13 amp socket switched mains distribution strip make these racks some of the most versatile we have ever sold. Racks may be stacked side by side and therefore require only two side panels to stand singly or in multiple bays. Overall dimensions are: 77 1/2" H x 32 1/2" D x 22" W. Order as:

OPT Rack 1 Complete with removable side panels. £335.00 (G)  
OPT Rack 2 Rack, Less side panels £225.00 (G)

## 32U - High Quality - All steel RakCab

Made by Eurocraft Enclosures Ltd to the highest possible spec, rack features all steel construction with removable side, front and back doors. Front and back doors are hinged for easy access and all are lockable with five secure 5 lever barrel locks. The front door is constructed of double walled steel with a 'designer style' smoked acrylic front panel to enable status indicators to be seen through the panel, yet remain unobtrusive. Internally the rack features fully slotted reinforced vertical fixing members to take the heaviest of 19" rack equipment. The two movable vertical fixing struts (extras available) are pre punched for standard 'cage nuts'. A mains distribution panel internally mounted to the bottom rear, provides 8 x IEC 3 pin Euro sockets and 1 x 13 amp 3 pin switched utility socket. Overall ventilation is provided by fully louvered back door and double skinned top section with top and side louvers. The top panel may be removed for fitting of integral fans to the sub plate etc. Other features include: fitted castors and floor levers, prepunched utility panel at lower rear for cable / connector access etc. Supplied in excellent, slightly used condition with keys. Colour Royal blue. External dimensions mm-1625H x 635D x 603 W. (64" H x 25" D x 23 1/2" W)

Sold at LESS than a third of makers price!!

A superb buy at only £195.00 (G)

Over 1000 racks - 19" 22" & 24" wide  
3 to 44 U high. Available from stock!!  
Call with your requirements.

## TOUCH SCREEN SYSTEM

The ultimate in 'Touch Screen Technology' made by the experts - MicroTouch - but sold at a price below cost!! System consists of a flat translucent glass laminated panel measuring 29.5 x 23.5 cm connected to an electronic controller PCB. The controller produces a standard serial RS232 or TTL output which continuously gives simple serial data containing positional X & Y co-ordinates as to where a finger is touching the panel - as the finger moves, the data instantly changes. The X & Y information is given at an incredible matrix resolution of 1024 x 1024 positions over the entire screen size!! A host of available translation software enables direct connection to a PC for a myriad of applications including: control panels, pointing devices, POS systems, controllers for the disabled or computer un-trained etc. Imagine using your finger with 'Windows', instead of a mouse!! (A driver is indeed available!) The applications for this amazing product are only limited by your imagination!! Complete system including Controller, Power Supply and Data supplied at an incredible price of only: £145.00 (E)

Full MICROTUCH software support pack and manuals for IBM compatible PC's. £29.95 RFE - Tested

## LOW COST RAM & CPU'S

INTEL 'ABOVE' Memory Expansion Board. Full length PC-XT and PC-AT compatible card with 2 Mbytes of memory on board. Card is fully selectable for Expanded or Extended (286 processor and above) memory. Full data and driver disks supplied. RFE. Fully tested and guaranteed. Windows compatible. £59.95(A1)

Half length 8 bit memory upgrade cards for PC AT XT expands memory either 256k or 512k in 64k steps. May also be used to fill in RAM above 640k DOS limit. Complete with data. Order as: XT RAM UG. 256K. £34.95 or 512K £39.95 (A1)

1 MB x 9 SIMM 9 chip 120ns	Only £16.50 (A1)
1 MB x 9 SIMM 3 chip 80 ns	£19.50 or 70ns £22.95 (A1)
1 MB x 9 SIMM 9 chip 80 ns	£21.50 or 70ns £23.75 (A1)
4 MB 70 ns 72 pin SIMM - with parity	Only £95.00 (A1)
INTEL 486-DX33 CPU £55.00 INTEL 486-DX66 CPU £69.00 (A1)	

FULL RANGE OF CO-PROCESSOR'S EX STOCK - CALL FOR LIST

## FANS & BLOWERS

EPSON D0412 40x40x20 mm 12v DC	£7.95 10 / £85
PAPST TYPE 612 60x60x25 mm 12v DC	£8.95 10 / £75
MITSUBISHI MMF-06D12DL 60x60x25 mm 12v DC	£4.95 10 / £42
MITSUBISHI MMF-08C12DM 80x60x25 mm 12v DC	£5.25 10 / £49
MITSUBISHI MMF-09B12DH 92x92x25 mm 12v DC	£5.95 10 / £53
PANCAEC 12-3.5 92x92x18 mm 12v DC	£7.95 10 / £69
EX-EQUIP AC fans. ALL TESTED 120 x 120 x 38 mm specify 110 or 240 V £6.95. 80 x 80 x 38 mm - specify 110 or 240 V £5.95	
IMHOF B28 1900 rack mount 3U x 19" Blower 110/240V New	£79.95

Shipping on all fans (A). Blowers (B). 50,000 Fans Ex Stock CALL



# NOW THE BATTLE IS REALLY OVER



After 10 years and with more than 20.000 users, ULTimate Technology now introduces the ULTiboard Wizard. This system is highly praised for its very powerful placement and routing algorithms by both the less experienced users and by the experts. The technology applied in the ULTiboard Wizard used to be available only as options on the more powerful and expensive Work stations. The PCB design depicted below illustrates the capability of the Wizard, its 4-layer version was employed in the ULTiboard Professional Design Contest at the Electronics'95 Exhibition. The same design was now executed in a 2-layer version with the ULTiboard Wizard in less than 2 hours.

## ULTIBOARD WIZARD



The schematic is ready, the board outline established and all components are imported. The components with a fixed location are placed interactively. (10 min.)



Autoface rapidly and conveniently places the remaining components with algorithms that approach the interactive method of expert designers. On line changes are possible. (5 min.)



Power and Ground are routed semi automatically (under the management of the designer). The (EMC) critical connections are also layed interactively. (15 min.)

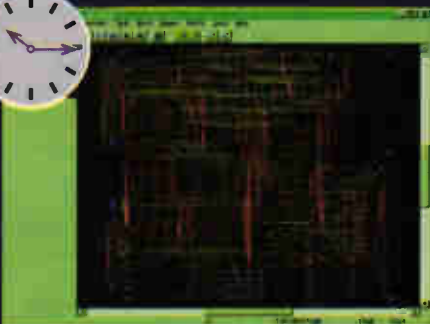

Now the SPECCTRA Autorouter is employed to finish the routing of the design at high speed and with high grade quality. All design rules

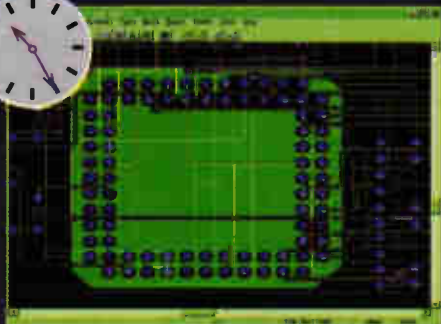

All adjustments are done quickly and efficiently with the interactive autorouter. All the corners of the traces are chamfered and polygons are placed. (10 min.)

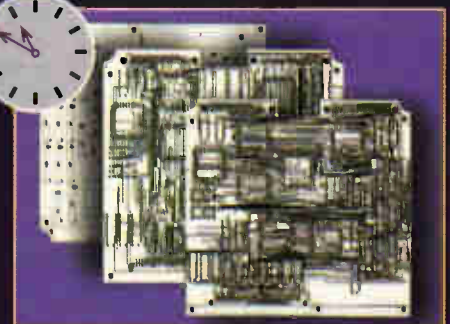

Following the connectivity and design rule checks, the output on matrix or laser printers, pen or photo plotters can be run. Back Annotation automatically updates the schematic. (25 min.)

ULTimate Technology now makes the best PCB Design tools available at very competitive prices from UK £ 2.675,- (Excl. VAT, 1400 pins version with 4 signal layers). We imagine you will want to see for yourself whether you too can achieve such fantastic results with the ULTiboard Wizard. Please come to our stand J135 at ICAT 97 at NEC (Birmingham) and convince yourself. A demo-CD is available.

CIRCLE NO. 138 ON REPLY CARD

**ULTIMATE**  
TECHNOLOGY

E-mail: sales@ultiboard.com  
Internet: http://www.ultiboard.com

UK/Ireland Sales Office:  
1 Viney Woodside • Lydney  
Gloucestershire • GL15 4LU • U.K.  
tel. : (+44) 1594 - 516647  
fax : (+44) 1594 - 516659

Corporate Headquarters:  
Energistraat 36 • 1411 AT Naarden  
The Netherlands  
tel. : (+31) 35 - 6944444  
fax : (+31) 35 - 6943345



4-6 MARCH 1997  
NEC BIRMINGHAM  
STANDNR. J135



## Dictionary of Communications Technology

*Terms, definitions and abbreviations*

Gilbert Held, 4-Degree Consulting, Macon, Georgia, USA  
In response to the changing face of the telecommunications industry and the rapid expansion in the use of microprocessors, fibre optics and satellites, Gil Held has updated his earlier telecommunications dictionary to bring readers in line with the very latest developments and terms in communications technology.

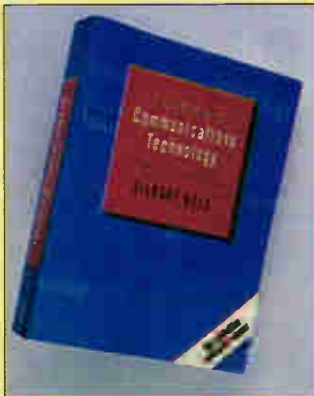

### Features Include:

- Over 9000 references and 250+ illustrations
- Comprehensive coverage of data and computer communications
- New entries on PC LANs, the Internet, client/server operations and communications testing
- Trade name information

### First Edition Review:

"For a consultant or telecommunications operative, this book is a must. It is comprehensive and timely ... an excellent reference for the IS professional."

### Data Processing Digest

ISBN 0471 95542 6, 512pp, hardback, UK £68.50, Europe £73, ROW £85

ISBN 0471 95126 9, 512pp, paperback, UK £38.50, Europe £43, ROW £55

## Testing, Troubleshooting and Tuning Local Area Networks

*Techniques and tools to isolate problems and boost performance*

Gilbert Held, 4-Degree Consulting, Macon, Georgia, USA.  
Recognising the problems

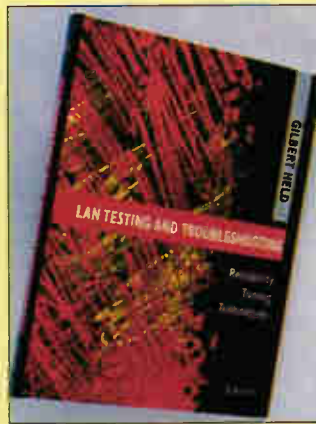

encountered by network users and administrators on a daily basis, this book is designed to assist readers by focusing on testing, troubleshooting and tuning of Ethernet and Token-Ring networks. It is devoted exclusively to: how things go wrong how to recognise, monitor and test for problems; network analysis and network management products that assist users in examining the flow of data in a complex network.

ISBN 0471 95880 8, 275pp, hardback, UK £37.50, Europe £40, ROW £50

## Wireless Information Networks

Kaveh Pahlavan, Worcester Polytechnic Institute and Allen H Levesque, GTE Government Systems Corporation.

*Wireless Information Networks* organises all major elements of wireless technology – cordless and cellular telephony, Personal Communications Systems (PCS), mobile data networks and Wireless Local Area Networks (WLANs), presenting them from a logical, systems engineering perspective. Technical material is thoroughly integrated with special applications and focuses on four main areas: Wireless

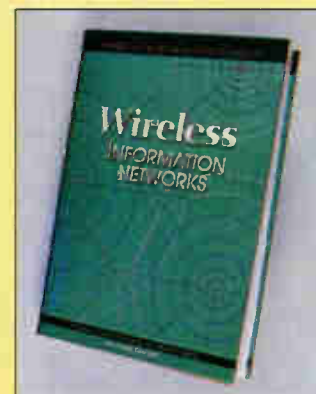

standards and descriptions of systems and products; Measurement and modelling of radio and optical wave propagations; Wireless transmission techniques and Wireless multiple access techniques.

**Contents:** Overview of Wireless Networks. Frequency Administration and Standards Activities. Characterisation of Radio Propagation. Channel Measurement and Modelling for Narrow-band Signaling. Measurement of Wide-band Channel Characteristics. Computer Simulation of the Radio Channel. Modem Technology. Signal Processing for Wireless Applications. Spread Spectrum for WIN Systems. Wireless Optical Networks. Networks and Access Methods. Standards and Products.

ISBN 0471 10607 0, 304pp, hardback, UK £63.50, Europe £68, ROW £81

## Applied Cryptography

*2nd Edition  
Protocols, Algorithms and Source Code in C*  
Bruce Schneier, Security Consultant and President of Counterpane Systems, USA  
This revision of the programmer's and system designer's guide to the practical applications of modern cryptography

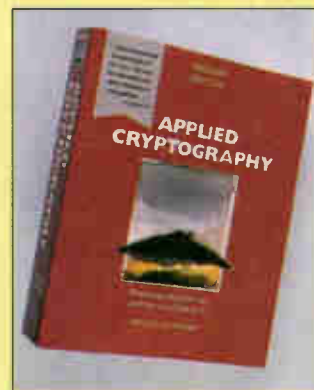

provides the most comprehensive, up-to-date survey of modern cryptographic techniques, along with practical advice on how to implement them.

### New to this edition:

- Detailed treatment of the US government's Clipper Chip encryption program
- New encryption algorithms (eg. 'GOST') recently obtained from the former Soviet Union
- More detailed information on incorporating algorithms and programming fragments

into working software

- The latest developments in the fields of message authentication ('digital signatures') and digital cash.

ISBN 0471 12845 7, 816pp, hard back, UK £59, Europe £64, ROW £78  
ISBN 0471 11709 9, 816pp, paperback, UK £44, Europe £49, ROW £63

## Data and Image Compression

*4th edition  
tools and techniques*

Gilbert Held, 4-Degree Consulting, Macon, Georgia, USA  
Data and image compression are key issues in computer communications with the increasing demand for data transmission capacity.

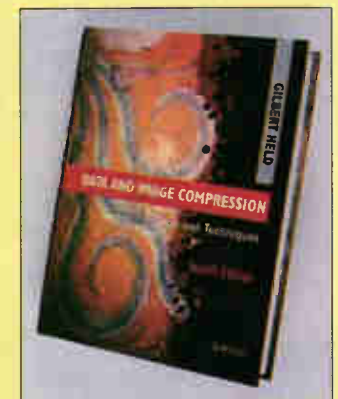

Guiding the reader through the main techniques, this book explains how practical data and image compression techniques are now vital for efficient, low-cost transmission and data storage requirements. Building on the success of the previous editions of *Data Compression*, the scope of the fourth edition has been considerably expanded. Now covering image and fax compression, the text has been restructured to take account of the many new advances in this important field. It is also accompanied by an updated disk containing compression routines.

ISBN 0471 95247 8, 450pp+disk, hardback, UK £58.50, Europe £63, ROW £75

## Handbook for Digital Signal Processing

S.K. Mitra, University of California and J.F. Kaiser, Bell Communications Research, New Jersey, USA  
This is the definitive source of detailed information on all important topics in modern



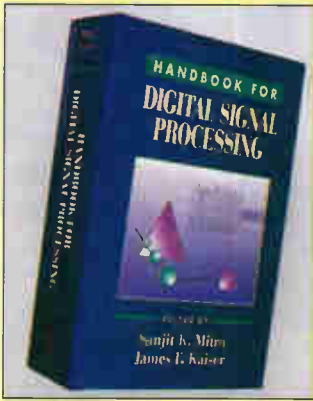

digital signal processing. The only current handbook of its kind, it meets the needs of practising engineers and designers of hardware, systems and software. Written by world authorities, the *Handbook for Digital Signal Processing* is supplemented with hundreds of informative tables and illustrations. For professional engineers, designers and researchers in electronics and telecommunications, this work will be an indispensable reference – now and for years to come.

**Contents:** Introduction; Mathematical Foundations of Signal Processing; Linear Time-Invariant Discrete-Time Systems, Finite-impulse Response Filter Design; Digital Filter Implementation Considerations; Robust Digital Filter Structures; Fast DFT and Convolution Algorithms; finite Arithmetic Concepts; Signal Conditioning and Interface Circuits; Hardware and Architecture; Software Considerations; Special Filter Designs; Multirate Signal Processing; Adaptive filtering Spectral Analysis; Index.

ISBN 0471 61995 7, 1302pp, hardback, UK £110.50, Europe £118, ROW £138

### Solving Interference Problems In Electronics

R. Morrison, Eureka California, USA Interference in electronic equipment is a constant source of difficulty for the design and systems engineer. Until now, there has not been a coherent theory that engineers can refer to in their design work and the solution of interference problems has therefore often considered to be an 'art'. Written by an acknowledged expert in the field, this new title provides methods and techniques for testing and evaluating

designs, and covers interference questions in computer manufacturing and systems design.

ISBN 0471 12796 5, 206pp, hardback, UK £47.50, Europe £48.50, ROW £54



### Diode Lasers and Photonic Integrated Circuits

L. A. Coldren and S. W. Corzine, both of the University of California, Santa Barbara, USA. Diode lasers are found in numerous applications in the optoelectronics industry,

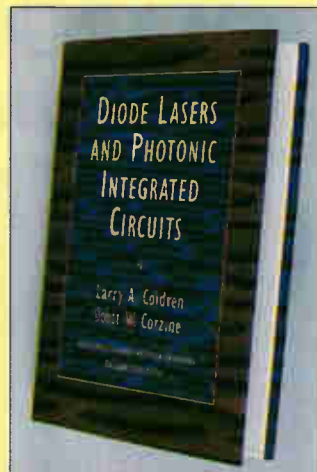

telecommunications and data communications, ranging from readout sources in compact disc players to transmitters for optical fibre communications systems. This new title provides a comprehensive treatment of diode laser technology, its principles and theory, treating students as well as experienced engineers to an in-depth exploration of this fast growing field.

ISBN 0471 11875 3, 620pp, hardback, UK £63.50, Europe £67, ROW £78

## All prices are fully inclusive of packing and delivery

Return to Jackie Lowe, Room L333, Quadrant House, The Quadrant, Sutton, Surrey, SM2 5AS

Please supply the following titles:

Qty	Title or ISBN	Price

\*\* All prices on these pages include delivery and package \*\*

Total \_\_\_\_\_

Name \_\_\_\_\_

Address \_\_\_\_\_

Postcode \_\_\_\_\_ Telephone \_\_\_\_\_

Method of payment (please circle)

Access/Mastercard/Visa/Cheque/PO

**Cheques should be made payable to Reed Business Publishing**

Credit card no \_\_\_\_\_

Card expiry date \_\_\_\_\_

Signed \_\_\_\_\_

**Please allow up to 28 days for delivery**

**YOUR  
Ideal Partner  
in UHF and VHF  
COMMUNICATION**



**One stop solutions  
for all your radio  
telemetry module needs.**

When the success of your products depends on radio telemetry modules, you need a business partner you can trust. A skilled and experienced manufacturer that can offer modules of the highest quality, operating over a wide range of frequencies.

In other words, a partner like Wood & Douglas. Founded on technical excellence, Wood & Douglas is a British company that specialises in the design, development and production of radio-based products. With over 30 staff dedicated to meeting your requirements, the company is able to provide true one-stop purchasing - whatever your RTM needs.

All radio modules are highly functional, capable of meeting a wide range of requirements. Designed to offer efficient, easy-to-use radio telemetry components for system designers, they can open up a whole new world of product possibilities.



From portable bar-code readers to earthquake monitors, Wood & Douglas can help you make the most of the opportunities in radio telemetry.

To find out more about the possibilities, contact...



**WOOD & DOUGLAS**

Lattice House, Baughurst, Tadley, Hampshire RG26 5LP, England  
Telephone: 0118 981 1444 Fax: 0118 981 1567  
email: info@woodanddouglas.co.uk  
web site: http://www.woodanddouglas.co.uk

**CIRCLE NO. 139 ON REPLY CARD**

**Radio Data  
Modems**



Range 2-3km  
Free Communications  
User-friendly pc interface  
Selectable channels  
Flexible Hand-shaking  
Unit Addressing

Faster operation:  
up to 9600 baud  
New synthesised radio  
5 Diagnostics LEDs  
Licence exempt to  
MPT 1329

**Have you considered it?**

Until seeing our advertisements many systems builders had not considered using radio data modems as a means of communicating between their devices to a base station. Could this be you? If you would like to know more about our Radio modems or perhaps you would like to try one we would like to hear from you.

**Typical applications are as follows:**

Weather Stations. Warehouse systems. GPS. Data loggers. Text to display systems. Sensors. Lighthouse equipment. Oil exploration. Intelligent buildings. Weighing equipment. Alarm systems. Camel racing. Roulette wheels. Cosmic ray measurements.

**Come on, Surprise us!**

**XL Systems Ltd**

Sole UK Distributor: XL Systems Ltd  
High Warren House, Tandridge Road,  
Warlingham, Surrey CR6 9LS  
Tel: 01883 622778, Fax: 01883 626991

**CIRCLE NO. 140 ON REPLY CARD**

**MARCONI 2370  
Spectrum analyser**

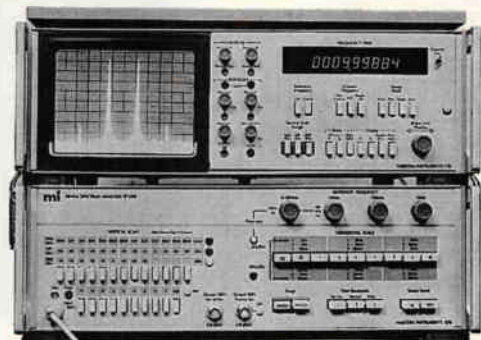

**30Hz - 110MHz Frequency range  
1Hz Resolution/phase lock tuning  
Digital storage with dual display  
Built-in tracking generator  
9 digit frequency counter**

**£850** + carriage/vat

**Includes 30 day unconditional warranty**

**M&B Radio, 86 Bishopgate Street, Leeds LS1 4BB**

**Tel: (+44) 0113 2435649**

**Fax: (+44) 0113 2426881**

**CIRCLE NO. 141 ON REPLY CARD**



# LETTERS

Letters to "Electronics World"  
 Quadrant House, The Quadrant,  
 Sutton, Surrey, SM2 5AS

## Splitting phase

I have been following with interest the recent correspondence regarding the concertina phase-splitter circuit. Like Mr McFadden, I too was a designer of valve audio amplifiers in the 1950s.

In the July/August 1996 issue of *Electronics World*, Morgan Jones attempted, unsuccessfully, to derive the Langford Smith formula for the voltage gain. In fact, the derivation is quite straightforward.

The diagram shows the usual linear equivalent circuit for a triode amplifier.

From this circuit:

$$V_{gk} = V_i - V_k \quad (1)$$

$$i(R_a + r_a + R_k) = \mu V_{gk} = \mu(V_i - V_k) \quad (2)$$

Also:

$$i = V_k/R_k \text{ and } i = -V_a/R_a \quad (3)$$

Substituting separately for these values of  $i$  gives, respectively, the gain to the cathode,  $G_k$ , and the gain to the anode,  $G_a$ .

$$G_k = V_k/V_i = \mu R_k / [R_a + r_a + R_k(1 + \mu)] \quad (4)$$

$$G_a = V_a/V_i = -\mu R_a / [R_a + r_a + R_k(1 + \mu)] \quad (5)$$

From these two equations, you can see that the respective output impedances are,

$$R_o(\text{cathode}) = (R_a + r_a) / (1 + \mu) \quad (4a)$$

$$R_o(\text{anode}) = r_a + R_k(1 + \mu) \quad (5a)$$

For the concertina phase-splitter, the anode and cathode loads are identical,  $R_k = R_a = R_L$ .

Substituting for  $R_L$  in equations (4) and (5) gives the Langford Smith gain equation,

$$\text{Gain, } G = \mu R_L / [r_a + R_L(2 + \mu)]$$

Clearly, it matters not whether the load  $R_L$  is a pure resistance or a complex impedance: the gain from both the anode and cathode will be identical. Further, providing the two loads are identical, gain is always

less than unity, and typically 0.9.

Consider what happens, however, if the anode and cathode loads are not identical. This situation could easily arise if a Class AB<sub>1</sub> push-pull amplifier is overdriven so that grid current flows during part of the positive half-cycle. I have taken an example of an ECC82 triode operating with anode and cathode loads of 50kΩ and a mean anode current of 2.5mA. Under these conditions  $\mu$  is 20 and  $r_a$  about 17kΩ. It is assumed that, for part of the positive output swing, when grid current flows in the power valves, the load resistors are shunted on alternate half-cycles by an additional 50kΩ. The changes of gain at the anode and cathode are shown in the table below.

You can see that variations in the anode and cathode load resistance have very little effect on the gain to

	$G_a$	$G_k$
No shunt load	-0.895	0.895
50Ω shunt, anode	-0.458	0.916
50Ω shunt, cathode	-1.689	0.845

the cathode but a significant effect on the gain to the anode.

Furthermore, when the shunt load is across the cathode during its positive half-cycle, enhanced gain at the anode can saturate the valve.

These problems can be minimised by operating the valve with lower values of load resistance, eg 10kΩ, and with a proportionately higher anode current. A better solution, however, is to use a different phase-splitter, such as a long-tailed pair.

**Keith Thrower**  
 Reading,  
 Berkshire

## Improving power factor

I read with considerable interest Irving Gottlieb's article 'Improving Power Factor' in *EW* July/August 1996. It reminded me of my first job 30 years ago, designing tv deflection and high tension circuits.

Deflection current is roughly sawtooth-shaped, and resetting the current after each line period causes a large di/dt. The resulting induced voltage pulse in a secondary

winding on the deflection transformer was rectified to generate the 25kV required for those days' colour tvs. Since the voltage pulse was narrow (I think some 10μs) with a prf of 15,625Hz, the high-voltage had a rather high source resistance, causing it to drop with increasing picture brightness, which of course 'blew-up' the picture.

We decreased source impedance by tuning the transformer to the 3rd harmonic of the tv line frequency of 15,625Hz. For even better performance we timed to the 5th harmonic, making the pulse shape even more rectangular. (See Gottlieb's Fig. 3).

Interestingly, the inductance part of the resonant tank was formed by the coupling induction between the primary and the secondary. Only a capacitor was then necessary to complete the circuit.

This method may not be practical for mains frequencies. However, tuning to higher harmonics might improve the power factor and also allow use of (physically and electrically) smaller tank parts. I

## Was LVD message from outer space?

Regarding John Woodgate's letter, I don't think many readers of *Electronics World* who are on the receiving end of the new EEC directives will be impressed by his pedantic distinction between the 'old' LVD of 1976 with which they will be familiar and the 'new' LVD of this year, which presents an entirely new dimension. The 'new' LVD uses the CE Mark as a type of public announcement of a legal commitment and woe betide anyone who falls foul of it. One wonders what the motive was in trying to make such a distinction.

I find his bland assertion that, "The chance of any large company trying to use a Directive against a very small competitor is minimal," quite astonishing. Is Mr Woodgate living on the same planet? One only has to pick up a newspaper to read every day of some new incident involving sleaze, criminal dishonesty and malpractice in business at all levels. The new LVD presents such a tempting opportunity for amoral big business to defeat competitors that it will be irresistible. Unfortunately, with this country's obsession with secrecy no-one will ever know how much of this connivance will be taking place, because you can be sure a clock of confidentiality will be drawn over it.

Thirdly, Mr Woodgate states that it is, "important for UK companies not to shut down for fear of the directives." By using the word fear he shows an almost total lack of understanding of an important part of this sorry business. If he had read the letter from Greece (Ann Baker, Letters in *EW* Jan '97) he would have realised that it is not some irrational dread of the directives themselves, nor even of the draconian punishments threatened, although they are bad

enough, but genuine anger and disgust at the way the directives have been implemented.

This is what all the fuss is about. The disproportionate cost to small companies of implementing the directives is of most concern. These two directives make life particularly difficult for small firms but hardly affect large companies, and I speak from my own experiences. This extra overhead will put up the cost of all electrical products made in the EEC by small firms, and will deter all grass-roots innovators. As the letter from Greece points out, this will backfire on the EEC as the bureaucratic and financial burden becomes too much to make new projects worthwhile for small companies. No doubt a few will persevere, but this is not good enough. As for third world and Far East exporters to the EEC, they will have a field day - and if any unworldly reader really wants to know how this will be done I can enlighten them.

I am sure small firms and designers on the brink of introducing new projects that need to pass the two hurdles will be asking the same question that I have been asking myself; is it any longer worth the trouble?

I can confidently repeat my assertion that the outlook for these firms in Europe is bleak, and has been made deliberately so by the EEC.

If Mr Woodgate spoke on behalf of a small manufacturing firm, his words would be more believable. Instead, his letter could have come straight from an EEC Ministry of Propaganda.

**Rod Cooper**  
 Sutton Coldfield  
 West Midlands

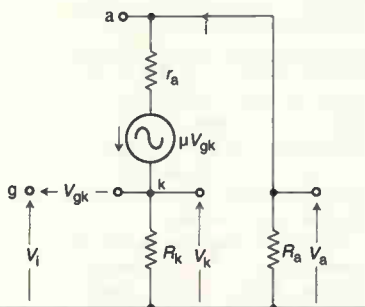

Linear equivalent circuit for a triode amplifier

wonder if Mr Gottlieb would care to comment on this.

**Jan Didden**  
Heerlen  
The Netherlands

**Twisted cables?**

With reference to Cyril Bateman's article in the February issue, as far as I can understand it, he claims to have proved that three hitherto unknown factors dominate loudspeaker cable performance:

- Addition of approximately 50kHz ringing to a special test signal when a load resembling no known loudspeaker is used.
- Generation of harmonic distortion by copper cables. This would be revolutionary if true, but it isn't.
- Generation and/or pickup of inharmonic distortion by copper cables. This would be amazing if true; it isn't.

While the first of these 'discoveries' appears to be merely irrelevant to audio, the second two seem to be important enough that some details should be given. However, Mr Bateman uses a high-distortion oscillator, which is cleaned up by an unspecified amount by an unspecified filter. He gives no details of the harmonics generated, or the nature of the thd residual. Nor, as far as I can tell, does the test set-up used correspond to any of the circuit diagrams given, which hardly aids those who might be concerned to replicate his experiments. The Blameless amplifier design he uses is certainly stable with any normal source

impedance and should give less than 0.001% thd at 1 kHz, if properly constructed.

I can see no reason why anyone should feel obliged to repeat Mr Bateman's experiments before commenting on them. As an attempt to stifle debate, it is unsubtle. And it is hardly reasonable to insist on replication if insufficient details are given to make this possible. Nonetheless, I have found time for a few minutes of my own experiments, and as a result I think I can help Mr Bateman with "the resolution of the matter" of these mysterious distortions.

Figure 1 shows a standard method for measuring a speaker impedance curve. The speaker is driven by an Audio Precision low-distortion test-set through a high resistance compared with its impedance, so the voltage measured across it - with a suitably chosen drive voltage of 6V rms - can be read off directly in ohms-magnitude. The unit I tested was a conventional two-unit reflex design of bookshelf size, Fig. 2. Bass resonance is double-humped due to the tuned port; the peak around 2kHz is more likely to be due to the crossover rather than tweeter resonance.

If a loudspeaker is so driven, non-linear distortion can indeed be detected at the loudspeaker end of the 600Ω driving impedance. With the values shown thd is about 0.3% around 500Hz to 1kHz, falling off as frequency increases above 1kHz. Clearly, the only possible source of non-linearity is the loudspeaker. Prime suspects are the BiL non-

linearity, and cone suspension force/displacement non-linearity of the bass unit; which is more important is not clear at this point.

In real speaker use, the driving impedance will be at least two orders of magnitude lower and the thd measured correspondingly less; in any case it is not exactly obvious whether this distortion would improve or impair the linearity of the overall voltage-in/sound-pressure-out relationship of a loudspeaker.

As for 'inharmonic distortions', my experiments suggest that their origin is the loudspeaker acting as a microphone and adding a room-noise signal to the harmonic distortion described above. A computer in the same room generates enough noise to swamp thd readings at low frequencies; traffic rumble is also a problem.

I believe that this resolves the matter of the mysterious distortions.

Having produced some numerical rankings - which I decline to accept - Mr Bateman then seems to leap to the conclusion that the vital parameters for speaker cable are minimal resistance, inductance, and characteristic impedance. Since the latter is meaningless for less than one-sixth of a wavelength - ie about 2 miles at 20 kHz - it can be ignored. Minimal resistance and inductance remain as criteria, and these are perfectly reasonable, and wholly conventional requirements, which appear to have been reached by a very convoluted route.

What is painfully absent is any estimate of just how low these parameters should be before they cease to cause any audible modification. His preference for coaxial cable appears to be solely based on its lower inductance, and there seems to be no evidence that the substantial extra expense over lawn-mower cable is justified.

My conclusion must be that I cannot discern any new discoveries at all in Mr Bateman's complicated investigations."

**Doug Self**  
London

**Cyril replies...**

The three conclusions Douglas has drawn bear no similarity with any conclusion I hold as a result of what eventually became several hundred hours experimentation and reporting. Douglas has closed his mind to this work, preferring to act as self appointed judge, jury and executioner on this topic.

I will try to deal with each of his points in turn.

As to my simulations using a capacitive load 'resembling no known loudspeaker', I can only commend that he measures both impedance and phase of speakers, by whatever method he prefers: and calculate the equivalent reactive

loading, since ignorance of this can result in much confusion. Figure 4 in the February issue clearly shows my test speaker equating to 9µF in parallel with 10.97Ω at 3kHz, while Fig. 5 clearly shows an inductive reactance at 1kHz of 3.3Ω or 5.3mH for the same speaker.

As to my distortion measurements, I clearly identified the distortion level of my 'cleaned up' generator and test amplifier when loaded with 8.2Ω in the text, as 0.045%. I also made it clear that comparative, conventional thd was measured, page 122 column 1 para 2, 3.

Furthermore on the two distortion results, Figs 6, 7, I deliberately included measurements at both amplifier output and speaker terminals on the plots in order to make absolutely clear any changes in my test source behaviour.

The reason I suggested readers should repeat these experiments was to encourage informed debate - certainly not to 'stifle debate'. For this reason, each test's conditions was carefully detailed, including PSpice netlists, components and circuits used if other than completely conventional and obvious to all. I seem to have failed in both where Douglas is concerned.

Since phase measurements were crucial to the investigation: Douglas's simple text book impedance test was obviously quite unsuitable, although I did describe it in a few words on page 121.

As to his distortion measurements I note he carefully avoided measurement of his speaker around 3kHz, when he might well have observed rather more interesting results. Also, he carefully avoids stating whether or not a speaker cable was used; if one was, perhaps he will enlighten us further.

As to his final nonsense regarding traffic rumble or the emanations from a computer in the same room, I have the fortune to live in a village in the Norfolk Broads which is bypassed to through traffic and has low density housing. My home is 35m from the nearest, and now quiet, road. My house is double glazed with low 'E' glass and well soundproofed, since before the bypass was built: traffic noise used to intrude.

My computers are located distant from my test workshop and neither were powered. Nor were any fluorescent lights, vacuum cleaners, washing machines, microwave or central heating systems, while measuring distortion. I tried deliberately to replicate normal household listening conditions, while completing a measurement of all cables in one session.

As to other computers locally, the nearest known to be in use was at the local Dentist's surgery some 300m distant. The loudest extraneous noise for these distortion

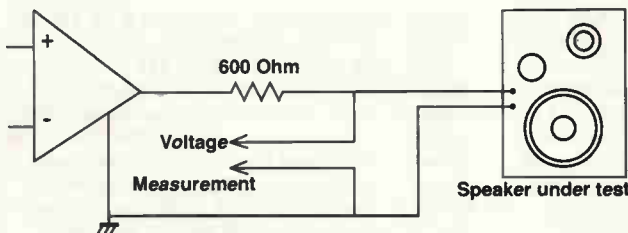

Fig. 1. Standard method for measuring a speaker impedance curve.

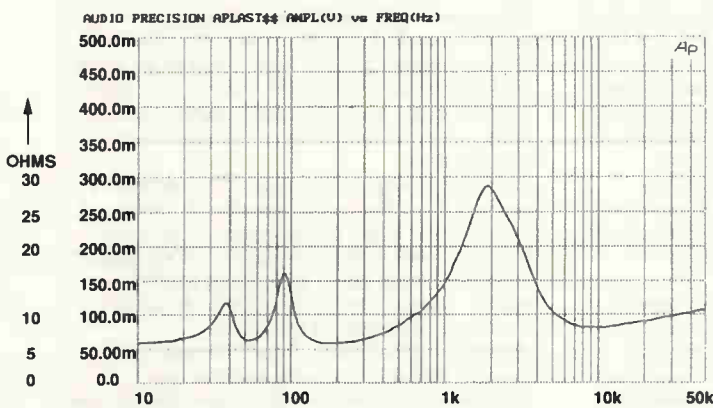

Fig. 2. Impedance curve of conventional two-unit reflex design of bookshelf size. Bass resonance is double-humped due to the tuned port; the peak around 2kHz is more likely to be due to the crossover rather than a tweeter resonance.



tests were birds also a squirrel eating hazelnuts in a nearby tree.

As an emc filter engineer of many years, I asked for a loudspeaker model, not help with the non-harmonically related noise. The most obvious source was wideband radiation from the domestic mains. This was picked up by the 0.54mH solenoid inductor in the crossover, which acted as an aerial, and by the speaker cables used – even though care was taken to avoid proximity to the ring mains layout.

As to Douglas' re-iterations of his disbelief in impedance having any bearing, he accepts cable resistance and inductance are important and while he doesn't mention capacitance as such, fails to realise that with low resistance, low inductance and some line to line capacitance, this exactly describes a low impedance cable. I, for one, find it much simpler to use one number – impedance – which is all embracing, rather than grapple with three or four interdependent parameters.

Having rejected impedance, Douglas offers no alternative explanation for the behaviour from 1kHz to 10kHz of the lower impedance cables in both Figs 1 and 2 of the January article, page 55. Certainly inductance and resistance alone cannot explain these curves and 1, 2, 3, 10 and 20kHz were among the actual spot measurement

frequencies for all tests.

As to his belief impedance or cable lengths less than 1/6 wavelength is meaningless, I could suggest some good text books for his education. For my part, I use the Reference Data for Radio Engineers (pub Sams) – commonly called the ITT (STC) Handbook, both being the same. STC for whom I once worked at a senior level, was a totally owned UK subsidiary or ITT. In this handbook the transmission line education I used for articles 1 and 2 is defined as a 'fundamental equation'.

His final critique – the excessive cost of co-axial cable – is equally false. Maplin sells RG58 at 35p/m, CT/FT100 at 57p, URM67 at £1.35, and 79 strand at 54p. The nearest lawnmower cable with low resistance 2.5mm<sup>2</sup> section, costs 52p/m in 100m reels from Farnell. Jenving's cable is £3.78/m.

As to the test amplifier, I built two samples using boards purchased from EW, with components exactly according to the parts list. All solder joints used Multicore low-melting-point silver alloy 62.36.2 solder. This is a true eutectic with coincident liquidus and solidus temperatures of 179°C. Solder joints were made using an Antex TCS 50W temperature controlled iron set to 290°C, fitted with a 3mm tip. To suggest the amplifier was built other

than correctly is at best insulting.

When first built, each sample was tested powered from my Advance 30-0 30V current-limited bench supply with each rail decoupled using 10,000µF 63V capacitors adjacent to the pcb. With bias set, the amp was left to stabilise, driven by the 60mV, 1kHz square wave from my oscilloscope, supplied via 0.5m of RG58 cable. Almost immediately, the bench supply shut down. I replaced the fuses with 1A F types and repowered but with no input drive. Following some evaluation using a 10kΩ preset, inserted between RG58 inner and amp input, while observing the output on my oscilloscope, I determined that the first sample oscillated at rf, blowing the 1A rail fuses with less than 2.1kΩ. Sample 2 did the same with less than 2.4kΩ, hence my use of a series 4.7kΩ.

Since I anticipated Douglas may well react to this, at the completion of all cable tests I carefully repeated the above, using both bipolar (Panasonic) and various makes of polarised 10µF electrolytic capacitors for C<sub>1</sub>. All combinations gave the same results.

I did not elaborate on this earlier since it was irrelevant to my results. However, I find it hard to believe that no one else found this problem. If Douglas wishes, I will gladly ship an amplifier for

clarification to an independent judge. Perhaps Ben Duncan would like to volunteer for this?

### Invention - or implementation?

With reference to the article, "Stepping Out" in your October edition, about a decade ago, much like Ian Hegglin, I followed the same steps of reasoning and arrived at the full-wave multiplier. It is not 'improved' over a conventional series multiplier because it requires double the terminal voltage from the transformer over its single-ended counterpart. It also necessitates the use of diodes of double the voltage rating (and half the current).

That said, it does lend itself to higher power systems. I have used it since 1989 at powers up to 35kW and voltages of 225kV for ion-beam generation, electron-beam welding, capacitor charging and x-ray systems.

As a plea to engineers in general; do not confuse implementation with invention or worse still, assume that because you may not have seen your idea before that it is a novel one. In the same way that Ian Hickman's parallel multiplier is 'old hat', so is this latest offering. ■

**Richard Aston**  
General High-Voltage Industries  
Brierley Hill  
West Midlands

## PCB Designer

For Windows 3.1, '95 or NT



Amex/Access/Delta/Visa

Looking for the price?  
It's just **£49.00** all inclusive!  
...no VAT...no postage...  
...no additional charges for  
overseas orders.

Dealers and distributors wanted.  
Phone (01432) 355 414 to order

### Internet

See our Web site at [www.niche.co.uk](http://www.niche.co.uk) for  
information and a working demo. e-mail  
[pcb@niche.demon.co.uk](mailto:pcb@niche.demon.co.uk).

- ✓ Produce Single or Double sided PCBs.
- ✓ Print out to any Windows supported printer.
- ✓ Toolbar for rapid access to commonly used components.
- ✓ Helpful prompts on screen as you work.
- ✓ Pad, track & IC sizes fully customisable.
- ✓ No charges for technical support.
- ✓ Snap-to grid sizes 0.1", 0.05" 0.025" and unrestricted.
- ✓ SMT pads and other pad shapes.

Also available from,

**South Africa:** JANCA Enterprises, PO Box 32131, 9317 Fichardtspark at R299.00. Phone/FAX: (051) 223744

**France:** Telindel, Quartier Les Pradets, Chemin des Veys, 83390 Cuers. Phone: 94 28 66 67

CIRCLE NO. 142 ON REPLY CARD

## ADVERTISERS PLEASE NOTE

For all your  
future enquiries  
on advertising  
rates

Please contact  
**Malcolm Wells** on

**Tel: 0181-652 3620**  
**Fax: 0181-652 8956**

# CLASSIFIED

TEL 0181 652 3620

FAX 0181 652 8956

## ARTICLES FOR SALE







**SUPPLIER OF QUALITY USED TEST INSTRUMENTS**



**CONTACT**

**Cooke International**  
ELECTRONIC TEST & MEASURING INSTRUMENTS  
Unit Four, Fordingbridge Site, Main Road, Barnham,  
Bognor Regis, West Sussex, PO22 0HD, U.K.  
Tel: (+44)01243 545111/2 Fax: (+44)01243 542457

CIRCLE NO. 137 ON REPLY CARD

**OPERATING & SERVICE MANUALS**

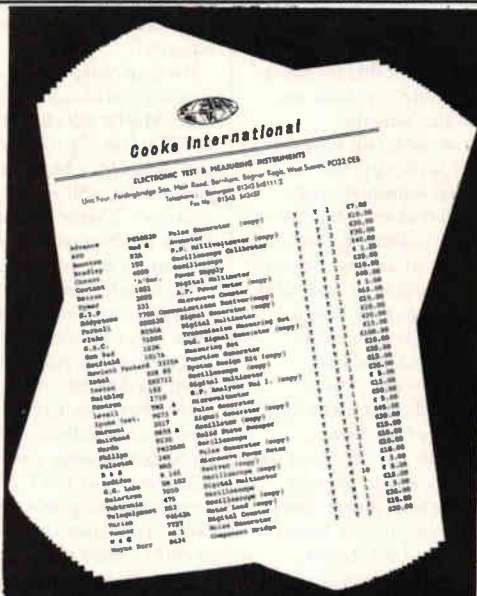

**CONTACT**

**Cooke International**  
ELECTRONIC TEST & MEASURING INSTRUMENTS  
Unit Four, Fordingbridge Site, Main Road, Barnham,  
Bognor Regis, West Sussex, PO22 0HD, U.K.  
Tel: (+44)01243 545111/2 Fax: (+44)01243 542457

CIRCLE NO. 138 ON REPLY CARD

## ADVERTISERS' INDEX

Adept Scientific .....	189	Niche Software .....	261
Anchor Supplies .....	181	Olson .....	OBC
Antrim Transformers .....	231	Pico Technology .....	183
Bull Electrical .....	245 & 246	Quickroute Systems .....	222
Chelmer Valve .....	222	Radio-Tech .....	231
CMS .....	214	Ralfe Electronics .....	264
Conford Electronics .....	214	Robinson Marshall .....	223
Display Electronics .....	254	Seetrax .....	195
Electromail .....	178	Stewart of Reading .....	253
Equinox Technologies .....	IBC	Surrey Electronics .....	214
Field Electric .....	213	Swift Designs .....	201
Halcyon Electronics .....	213	Telford .....	205
Hart .....	229	Telnet .....	196
Johns Radio .....	238	Those Engineers .....	196
JPG Electronics .....	214	Tie Pie .....	183
Keytronics .....	251	Ultimate Technology .....	255
Langrex Supplies .....	222	Warwick Industrial .....	222
M & B Radio .....	207 & 258	Wood & Douglas .....	258
Milford Instruments .....	IFC	XL Systems .....	258
MQP Electronics .....	216	Zuken Redac .....	185



## ARTICLES WANTED

### WE WANT TO BUY!!

**IN VIEW OF THE EXTREMELY  
RAPID CHANGE TAKING PLACE  
IN THE ELECTRONICS  
INDUSTRY, LARGE QUANTITIES  
OF COMPONENTS BECOME  
REDUNDANT. WE ARE CASH  
PURCHASERS OF SUCH  
MATERIALS AND WOULD  
APPRECIATE A TELEPHONE  
CALL OR A LIST IF AVAILABLE.  
WE PAY TOP PRICES AND  
COLLECT.**

**R. HENSON LTD.**

**21 Lodge Lane, N.Finchley,  
London N12 8JG.**

**5 Mins, from Tally Ho Corner.**

**TELEPHONE**

**0181-445-2713/0749**

**FAX 0181-445-5702**

### Consider . . . . .

Your costs to continue to stock  
UNWANTED SURPLUS . . . EXCESS . . . OBSOLETE  
STOCKS OF:-  
ELECTRONIC-ELECTRICAL COMPONENTS &  
ACCESSORIES

**RELEASE**  
for  
**PAYMENT IN ADVANCE**  
**OF COLLECTION**  
contact

**K.B. Components,**

**21 Playle Chase, Gt. Totham, Maldon, Essex, CM9 8UT**

**Tel:- 01621 893204 Fax:- 01621 893180 Mobile:- 0802 392745**

**REGISTER TO RECEIVE MONTHLY PUBLISHED STOCK LISTS AT NO CHARGE OF  
ALL EXISTING NEW, UNUSED, STOCKS OF ALL COMPONENTS AND ACCESSORIES.**

### TOP PRICES PAID

For all your valves, tubes, semi  
conductors and IC's.

**Langrex Supplies Limited**  
1 Mayo Road, Croydon  
Surrey CR0 2QP

**TEL: 0181-684 1166  
FAX: 0181-684 3056**

### ★★WANTED★★

Test equipment, Electronic Scrap,  
Valves, Transmitters/Receivers,  
Factory & Warehouse Clearance.  
Confidentiality Assured.

**TELFORD ELECTRONICS**

**Phone: 01952 605451  
Fax: 01952 677978**

### WANTED

#### TOP PRICES PAID

For all your Test Equipment,  
Receivers, Transmitters etc.  
Factory Clearance, Prompt  
Service and Payment.

#### HTB ELEKTRONIK

Alter Apeler Weg 5  
27619 Schiffdorf, Germany  
**Tel: 0049 4706 7044  
Fax: 0049 4706 7049**

40 YEARS WIRELESS WORLD '52-'75  
bound, '76-'92 unbound. Offers Telephone  
01276 65529.

WANTED. TEK 576 (577) Curve Tracers.  
Phone 01460 73557.

### HEWLETT PACKARD

#### TEKTRONIX MARCONI

#### TEST EQUIPMENT

#### WANTED!

#### M&B RADIO

86 Bishopgate Street, Leeds LS1 4BB

**Tel: (+44) 0113 2435649  
Fax: (+44) 0113 2426881**

SMALL SELECTION of Aircraft Starter  
motors, DC generators and rotary converters.  
Possibly suit electric vehicles etc. £10 to £50  
depending on condition and type. Tel: Bristol  
01179 793883.

MICROCHIP 'MICROMASTER' develop-  
ment system £1,150. Multicore 'Vaporette' sol-  
derring machine £500. Both unused. Icelab  
8051/2 Emulator £400. Tel: 01295 810859.

## RECRUITMENT

### Instrumentation Scientist/Technician

The British Antarctic Survey, a Government-funded body, organises and carries out a balanced and optimal programme of research in Antarctica of global significance in the Earth, Atmospheric and Life Sciences. As well as its headquarters building on the outskirts of Cambridge, three permanently manned stations and one summer only station are maintained in the Antarctic.

We are looking to recruit an Instrumentation Scientist/Technician to work with the atmospheric boundary layer group. Duties will include calibration and maintenance of micrometeorological equipment for eventual deployment in Antarctica. Responsible for the upkeep of hardware documentation, other duties will also include the repair and possible modification of returning field instruments and some upgrading of 'realtime' logger software.

As you will spend up to six months in the Antarctic each austral summer and assist in the deployment of new equipment, you must be physically fit.

The post is for three years.

You will have a degree in Electronic Engineering, Physics or equivalent. Post-graduate experience in instrumentation would be highly desirable. However, no experience of low temperature or extreme environment equipment design is expected and training in these areas will be provided at the BAS Headquarters in Cambridge.

Starting salary will be from £13,698 per annum depending on qualifications and experience.

For further details and an application form please contact the Personnel Section, British Antarctic Survey, High Cross, Madingley Road, Cambridge CB3 0ET. Tel: 01223 251508/507. Please quote ref: BAS 55/96. The closing date for completed application forms is 23 January 1997.



**British  
Antarctic  
Survey**



**Natural  
Environment  
Research  
Council**

## ARTICLES FOR SALE



**Protect Your Microchips  
from STATIC DISCHARGE!**

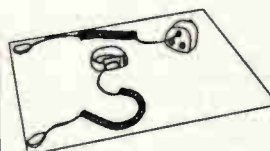

**Use an SSE grounding kit.**

Kit includes:

- static dissipative solder resistant rubber mat.
- wrist strap
- ground lead
- earth plug

**Mat size 70 x 30 cm - offer price £16.55 per kit + VAT - Ref: AGK1  
Mat size 25 x 20 cm - offer price £12.55 per kit + VAT - Ref: AGK2**

**STATIC SAFE ENVIRONMENTS**  
127 Hagley Road, Birmingham B16 8XU  
Tel: 0121 454 8238 Fax: 0121 625 2275

Payment by **CHEQUE / ACCESS  
VISA / MASTERCARD**  
Catalogue available

**SPECTRUM ANALYSERS**



ANRITSU MS420J 10Hz-30MHz network/spectrum analyser £5000  
AVCOM - portable, battery operated, to 1000MHz £2000

TEKTRONIX 492 21GHz portable spectrum analyser, with options 1, 2 and 3 £6500 or £7500 with multiplexor and mixers to 40GHz  
HP8711A 300kHz-1.3GHz network analyser £4000  
HP8753A vector network analyser, 3GHz £7500  
HP8702B lightwave component analyser (options 006/011) 6GHz £10000  
HP8559A/182T 21GHz £4500  
HP8557A/182T 350MHz £1500  
HP8590A 1.8GHz portable, RS232 option £4250

**MARCONI INSTRUMENTS**



2018 synthesized AM/FM signal generator 80kHz-520MHz £1250  
2019 synthesized AM/FM signal gen 80kHz-1040MHz £2000  
2305 modulation meter £2500  
2828A/2829 digital simulator/analyser £500  
2955 radio communications test set £3250  
6460/6421 power meter & sensor 10MHz-12.4GHz £350  
65xx waveguide detector for use with 6501/2-scalar analysers £350  
TF2910 TV interval timer £250

**ralfe electronics** exclusively professional T&M ©

• 36 Eastcote Lane • South Harrow • Middx HA2 8DB • England •  
TEL (+44) 0181-422 3593 • FAX (+44) 0181-423 4009

EST  
41  
YRS



DISTRIBUZIONE E ASSISTENZA, ITALY: TLC RADIO, ROMA (06) 871 90254

**TEST EQUIPMENT**

ADRET 740A synthesized signal generator 0.1-1120MHz £2500  
ANRITSU MS420J network/spectrum analyser 10Hz-30MHz £500  
BRUEL & KJAER 2307 level recorder £1000  
BRUEL & KJAER 2308 analogue X-Y pen recorder £750  
CHASE LFR1000 interference measuring receiver 9kHz-150kHz £1000  
DATRON 1061 & 1061A - various, digital multimeter & 1065 - call from £500  
DATRON 1065 digital multimeter all ranges plus IEEE £500  
FARNELL SSG2000 synthesized signal generator 10Hz-2000MHz £2500



**ISO9002 ACCREDITED STOCKIST MEASUREMENT & TEST EQUIPMENT**

PHILIPS PM5167 1mHz-10MHz function generator £275  
RACAL-DANA 9300 milli-voltmeter £400  
RACAL-DANA 9301A true RMS RF milli-voltmeter £350  
SCHLUMBERGER 7081 precision voltmeter 8.5 digits £2750  
TEKTRONIX P6201 FET PROBE £350  
WANDEL & GOLTERMANN WM30 level tracer £500  
WANDEL & GOLTERMANN PJM-4S jitter meter for SONET & SDH £5500  
WAVETEK 23 synthesized function generator 0.01Hz-12MHz £1250  
WAVETEK 1067 opt 522 1-500MHz sweep generator £500  
WAYNE KERR 3220 20A bias unit (for 3245 inductance analyser) £1250  
TEKTRONIX AM503/P6303 current probe £1500

**HEWLETT PACKARD**

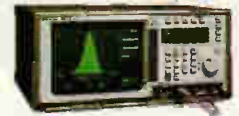

1640B serial data generator £500  
3764A digital transmission analyser £1500  
3335A synthesizer/level generator £2000  
3235A switch/test unit £1000  
3324A synthesized function generator £2000  
33320G/33322G programmable attenuators 4GHz, with driver 11713A £1000  
As above but 18GHz set £1500  
3581C selective voltmeter £1250  
3779D primary vector analyser £5000  
37900D signalling test set with 2 x 37915A interface cards £5500  
4140B pA/meter, DC voltage source £4000  
4272A multi-frequency lcr meter £3500  
435B microwave power meter, analogue £400  
5386A 3GHz frequency counter £1500  
54100A 1GHz digitizing oscilloscope, now inc 2 x 1GHz active probes £2000  
54502A digital oscilloscope 400MHz 400MSa/s £2500  
8007B pulse generator 100MHz £950  
8018A serial data generator £1000  
8082A pulse generator 250MHz £2000  
8111A pulse generator 20MHz £1250  
8146A optical tdr, with options 2/3/plug-in 81465SH (single-mode) £8500  
816A slotted line 1.8-18GHz with 809C & 447B probe £500  
8444A tracking generator with option 059 £1000  
8622A/8620C 10MHz-2.4GHz sweep generator £2000  
87510A gain-phase analyser 100kHz-300MHz £6500  
8753A 3GHz vector network analyser £7500  
J2215A FDDI portable multimode test set £1500  
J2219A 486-based, colour option main-frame £1000  
J2219A/J2171A 486-based colour screen option network advisor £3000

**SEND FOR LATEST STOCK LIST. WE FAX LISTS AND SHIP WORLDWIDE. ALL FULLY LAB-TESTED AND NO-QUIBBLE GUARANTEED**

CIRCLE NO. 143 ON REPLY CARD

**ELECTRONIC UPDATE**

Contact Malcolm Wells on  
0181-652 3620

A regular advertising feature enabling  
readers to obtain more information  
on companies' products or services.

A world of colour LCD



**Comprehensive new LCD brochure**

The widest range of colour LCDs, LCD monitors and plug and play kits available in the UK, all in one easy to use brochure, is now available FREE!

It includes products ranging from 2.9" monitors to 16.1" colour LCD screens, mono/colour STN TFTs and touch screen technology from the worlds leading manufacturers.

Phone Trident today for your free copy.

Tel.: 01737 765900  
Fax: 01737 771908

CIRCLE NO. 149 ON REPLY CARD



**1997 Full Catalogue Data File Words.**

The National Instruments 1997 catalogue features our new BridgeVIEW and Lookout software packages for industrial automation. Other software products include LabVIEW, LabWindows/CVI, and HiQ. In addition, our new line of IMAQ products provides a complete imaging solution. Hardware products include GPIB, DAQ, VXI and new serial interfaces for industrial communications applications.

**NATIONAL INSTRUMENTS, Tel: 01635 523545**

CIRCLE NO. 150 ON REPLY CARD



**NEW Feedback T&M Catalogue**

The latest edition of the Feedback Test & Measurement catalogue is now available. Over 60 pages packed with more than 800 products divided into over 20 sections. The catalogue is indexed for both product and manufacturer and is fully illustrated. Whether you are looking for an individual product, a complete workstation, or a solution to a particular Test & Measurement need the NEW Feedback catalogue will solve your problems, send for a copy NOW!

CIRCLE NO. 151 ON REPLY CARD

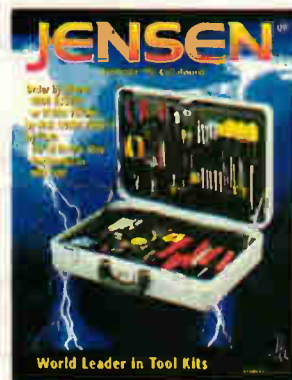

**NEW JENSEN TOOLS CATALOGUE**

Colourful new Catalogue, hot off the press from Jensen Tools, presents unique new tool kits for service/support of communications equipment. Also latest test equipment from many major manufacturers. Includes hard-to-find tools, PC/LAN diagnostics, bench accessories, static control, technical manuals and more.

Ring 0800 833246 or Fax 01604 785573 for a free copy.

Jensen Tools, 10-12 Ravens Way, Northampton NN3 9UD

CIRCLE NO. 152 ON REPLY CARD



# 8051 MICROCONTROLLERS + FLASH

## MICRO-PRO 51

State-of-the-art programmer for the 8051 family

- Programming support for the entire Atmel 89C and 89S microcontroller families
- Also supports many Philips, Intel, Dallas & Siemens 8051 derivatives
- Field programmable hardware ensures future device support

Order code: MP51-SYS £125.00

Products are now available from Farnell Components

## Microcontroller in-circuit re-programming adaptor

Now you can re-program the entire Atmel microcontroller family in-circuit!

No more re-moving chips - ideal for 8051 single-chip project development.

Supplied with AT89C2051 and AT89C52 + 11.0592 MHz Crystal.

(Requires Micro-Pro 51 programmer to operate - see above)

Order code: AD-MICRO-ICR £125.00

## Package Adaptors

### PLCC 44-pin adaptor

Suitable for most 8051 derivatives

Order code: AD-PLCC44-A £65.00



### SOIC 20-pin adaptor

Suitable for Atmel AT89C1051 & AT89C2051

Order code: AD-SOIC20-A £75.00

Please enquire for our full range of adaptors

## The **Atmel** 8051 FLASH microcontroller family

Atmel Part Code	89C51	89LV51	89C52	89LV52	89C55	89S8252	89C2051	89C1051
Flash Code ROM (bytes)	4K	4K	8K	8K	20K	8K	2K	1K
EEPROM	-	-	-	-	-	2K	-	-
I/O Pins	32	32	32	32	32	32	15	15
Watchdog timer	-	-	-	-	-	YES	-	-
Serial UART (full duplex)	YES	YES	YES	YES	YES	YES	YES	-
Analogue comparator	-	-	-	-	-	-	YES	YES
Package Pins (DIL)	40	40	40	40	40	40	20	20

- Atmel microcontrollers feature on-chip re-programmable FLASH code memory
- FLASH is electrically erasable in under 15ms (no need for UV eraser)
- 89C51/89C52 are drop-in FLASH replacements for the generic 87C51/87C52 devices
- 89C2051 is a single-chip 8051 in a 20 pin package...even retaining the serial port

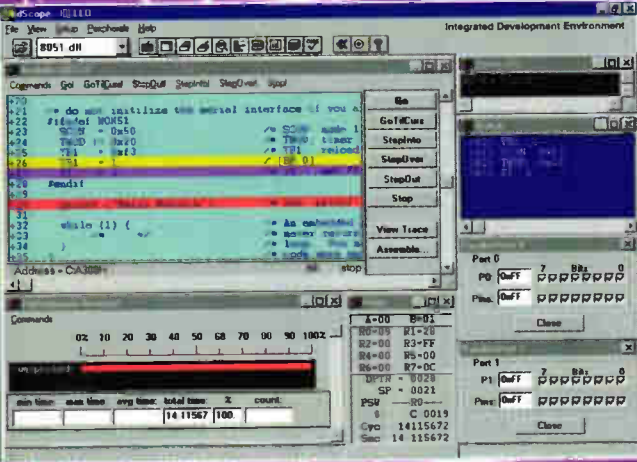

## 8051 STARTER SYSTEM

- ✓ Optimising C Compiler
- ✓ Macro Assembler
- ✓ Software Simulator
- ✓ Device Programmer
- ✓ Sample Devices
- ✓ Hardware/Software Documentation

Only £199.00

### Plus FREE Atmel CD ROM data book

- \* System supplied with 1 x Atmel AT89C1051 and 1 x AT89C2051 Microcontrollers
- \* C-compiler + Assembler output restricted to 2k total program code.

Order code: AT-89C051-ST

UPGRADE TO 8K VERSION NOW AVAILABLE

## 89C-1051/2051 Microcontroller Demo Module

A feature-packed evaluation module for the Atmel 20 pin derivatives. LED/switch array, RS-232, A/D, Watchdog, Piezo sounder

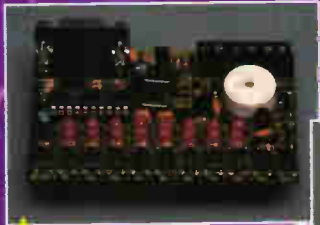

Order code: AT-89CX051-DEM0 £58.00



## 89C-1051/2051 Microcontroller OEM Module

An ideal OEM module which can be used for evaluation or can be designed into custom products. RS-232/485, \*EEPROM, A/D, I/O Header

Order code: AT-89CX051-OEM £29.00



The Embedded Solutions Company

Visit our web page at: [www.equinox-tech.com](http://www.equinox-tech.com)

Email: [sales@equinox-tech.com](mailto:sales@equinox-tech.com)

229 Greenmount Lane, Bolton BL1 5JB UK



SALES: 01204 492010 TECHNICAL: 01204 491110 FAX: 01204 494883 (INTERNATIONAL DIALLING CODE +44 1204)

Equinox reserves the right to change prices & specifications of any of the above products without prior notice. E20E. All prices are exclusive of VAT and carriage



