

ELECTRONICS & WIRELESS WORLD

JULY 1988

£1.95

**High-
definition
television**

**Joules Watt on
wave motion**

**Two
approaches to
risc processor
design**

**Sequency-
division
multiplexing**

**Pseudo-
science in
sound**

**Pioneers –
Strowger**



The first name to call for mobile radio test

Who else could offer you a comprehensive range of innovative instruments offering more features and simpler operation, for less money?

To test the performance of these dedicated radio systems plus our outstanding range including Spectrum Analyzers, Frequency Counters and Datacomms Analyzers call us first on 0727 59292.

Marconi Instruments Limited, Longacres, St. Albans, Herts. AL4 0JN, England.

2955 The multi-function civil and military mobile radio test set that is easy to use and makes others seem slow and overpriced.



2957 The first choice for AMPS cellular testing, now with EAMPS software.

2956 Now with 900MHz and worldwide NMT variants capability.

2958 TACS automated cellular radio testing in 45 seconds.



2306 MISATT Programmable semi automated radio test system with fast 2019A Signal Generator and accurate 2305 Modulation Meter now with comprehensive IBM PC test software.
ENTER 1 ON REPLY CARD

Marconi
Instruments



CONTENTS

JULY 1988 VOLUME 94 NUMBER 1629

FEATURES

COVER

High-definition television is in the news and is destined to be even more so in the coming months.

TWO APPROACHES TO RISC:

Two of the most recent reduced-instruction-set computers described
MC88100 RISC
637

A 17 Mips microprocessor made with existing technology
David Jones

SECOND-GENERATION RISC PROCESSOR
689

A new design from AMD overcomes some of the throughput limitations of earlier risc devices
M. A. Lehrer

H.F. DEVELOPMENTS

644

Notes from the 4th IEE International Conference on H.F. Radio and Techniques.
George Short

FILTER DESIGN USING A MICROCOMPUTER

652

Using a microcomputer to design active and passive Butterworth and Chebyshev filters.
S. Niewiadomski

SEQUENCY DIVISION

659

Walsh functions offer a number of advantages over traditional methods of time and frequency multiplexing.
Charles Langton

UPGRADING FROM 68000 TO 68020/68881

665

A Kaycomp-compatible platform board, holding a 68020 processor and a 68881 maths co-processor to plug into any single-master 68000 system which can keep up with the shorter bus cycle of the 68020.
Bob Coates



The shape of high-definition television. This picture from Philips signals the section on h.d.tv starting on p.708

PIONEERS – ALMON BROWN STROWGER, 1839 TO 1902

677

The inventor of the automatic telephone.
W. A. Atherton

THERMO-ELECTRIC TEMPERATURE CONTROLLER

687

Using a Peltier-effect device to control the temperature of components or laboratory specimens.
Peter Turner

SCIENCE AND SUBJECTIVISM IN AUDIO ENGINEERING

692

In spite of the mythology of audio, there is no magic involved in the high-quality reproduction of sound, claims Douglas Self.
Douglas Self

MAKING WAVES

699

The subject of wave propagation is J.W.'s topic this month. It is, he says, no trivial matter.
Joules Watt

MULTIPROCESSOR SYSTEMS

703

This second article describes how processors communicate and shows the techniques that can be used to link several 68000s together to form a multiprocessor.
Alan Clements

HIGH-DEFINITION TELEVISION

708

Two articles on a subject which is of increasing importance. *Peter Wilson* of Sony Broadcast presents his company's case for a Standard format, and *Wolfram Klemmer* of Broadcast Television Systems describes the design of a new camera which is flexible enough to accommodate the various standards that are being spoken of.

AMPLITUDE RESPONSE FROM PHASE RESPONSE

721

This article describes the reverse procedure to that used in last month's piece. Amplitude response of a network can be calculated if the phase response is known.
D. V. Mercy

REGULARS

COMMENT 635

CIRCUIT IDEAS 647

APPLICATIONS NOTES 663

TELECOMM TOPICS 673

FEEDBACK 681

SATELLITE SYSTEMS 697

NEW PRODUCTS 713,716,719

TELEVISION BROADCAST 724

RADIO COMMUNICATIONS 726

RADIO BROADCAST 728

RESEARCH NOTES 729

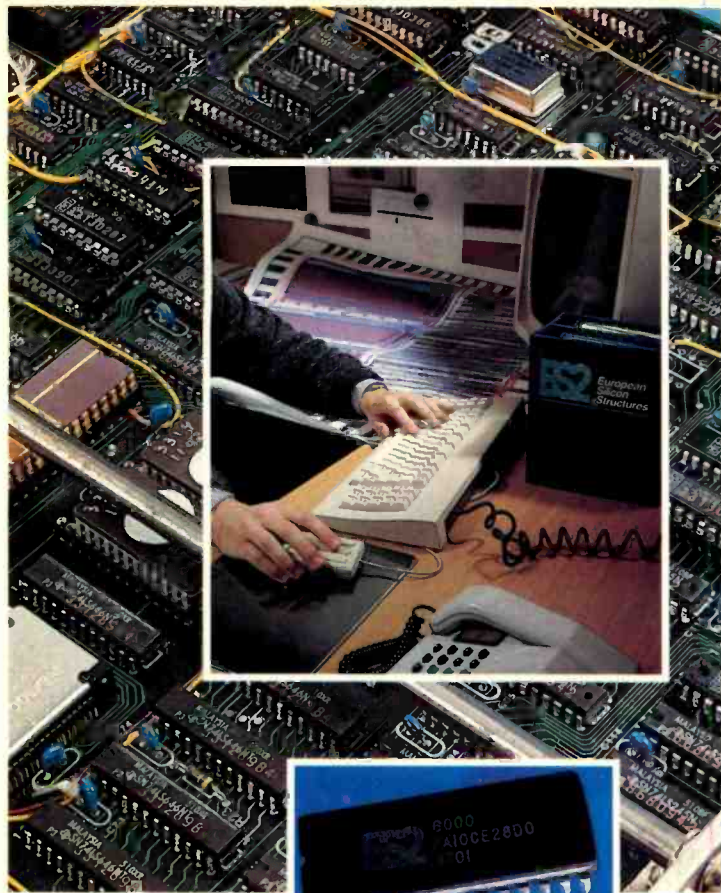

FREEDOM TO DESIGN...

ES2 The complete approach to custom silicon...

NO VOLUME COMMITMENT NEEDED, BUT SAFE VOLUME SUPPLY AVAILABLE LATER WHEN REQUIRED

European Silicon Structures' (ES2) complete approach to custom silicon means we specialise in providing everything your company needs to benefit from the revolution in Custom Silicon, from training on the basic technology and our SOLO family of design tools, to supplying software and workstations on a purchase or rental basis, right through to producing your prototype and production silicon chips in Europe.

Many companies have benefitted from designing with the ES2 approach, and have achieved more innovative, effective products through the use of custom silicon. They have found talking to our friendly staff straightforward and helpful.

To find out more about the ES2 approach, contact:

ES2 European Silicon Structures
Mount Lane, Bracknell, Berkshire RG12 3DY
Telephone: (0344) 525252

What some of our customers say about us:

"We've successfully completed 36 designs in 1987 and 31 in the first half of 1988 with ES2 and are very happy to have found a smooth route to low-cost full-custom silicon for educational users" -

Sandy Davidson, VLSI London University Consortium

"With no more than the usual development risk and with prudent scrutiny, the ASIC is a major weapon for providing the customer with a better product at a more competitive price. We have been very happy with the first design we did with ES2 and are now starting on a second" -

Dr Gordon Rankine, Managing Director of Raannd Systems

ENTER 49 ON REPLY CARD



New World Electronics (UK) Ltd

151A Milton Road, Gravesend, Kent DA12 2RC
Telephone: 0474 327854. Fax: 0474 327960
Telex: 94016512 (NWWO G)

A REFRESHINGLY NEW APPROACH TO ELECTRONIC COMPONENT DISTRIBUTION

Not your *SUPERMARKET* more your *CORNER SHOP*

Offering:

- ★ Personal Service
- ★ Fast Response
- ★ Worldwide procurement of active, passive and electromech. products
- ★ Proven track record
- ★ Experienced staff
- ★ Accurate and genuine delivery promises
- ★ Competitive pricing
- ★ Full traceability

If you are not getting this service from your current supplier then contact our sales office direct on 0474 327863 we may surprise you.

ENTER 43 ON REPLY CARD

AC POWER FROM DC SOURCE

DC-AC INVERTERS



SINE/SQUARE WAVE INVERTERS
30 to 2000 VA, 50 (or 60) Hz, 115/230V, single phase AC. From 12, 24, 50, 110 or 220 Volts DC.

Valradio Transvertors are being used all over the world to provide alternative AC Power for Standby purpose, Vital Services, Mobile, field, Marine, Laboratory, Computer, Alarm, Communications, Medical, Control and Industrial applications including Video, TV, Camera, Hi-Fi etc.

OTHER PRODUCT RANGE

- | | |
|---|--|
| <input type="checkbox"/> DC-DC Converters | <input type="checkbox"/> Battery Chargers |
| <input type="checkbox"/> AC-DC Power Supplies | <input type="checkbox"/> Standby/UPS Systems |
| <input type="checkbox"/> AC-AC Frequency Changers | <input type="checkbox"/> Line Conditioners |

THE POWER FOR YOUR BUSINESS

Valradio

OVER 50 YEARS OF EXPERIENCE
IN POWER CONVERSION

VALRADIO POWER LIMITED
LAWRENCE ESTATE,
GREEN LANE, HOUNSLOW,
MIDDX TW4 6DU, UK
Tel: 01-570 5622
Fax: 01-577 3703

ENTER 42 ON REPLY CARD

A broader view

EDITOR

Philip Darrington

EDITOR – INDUSTRY INSIGHT

Geoffrey Shorter, B.Sc.

01-661 8639

DEPUTY EDITOR

Martin Eccles

01-661 8638

COMMUNICATIONS EDITOR

Richard Lambley

01-661 3039

NEWS EDITOR

David Scobie

01-661 8632

ILLUSTRATION

Roger Goodman

01-661 8690

DESIGN & PRODUCTION

Alan Kerr

01-661 8676

ADVERTISEMENT MANAGER

Martin Perry

01-661 3130

ADVERTISEMENT EXECUTIVE

James Sherrington

01-661 8640

CLASSIFIED SALES EXECUTIVE

Peter Hamilton

01-661 3033

ADVERTISING PRODUCTION

Brian Bannister

01-661 8648

Clare Hampton

01-661 8649

MARKETING EXECUTIVE

Rob Ferguson

01-661 8679

PUBLISHER

Shobhan Gajjar

01-661 8452



**REED
BUSINESS
PUBLISHING**

In a report published by the Engineering Council, "A comparison of the statistics of engineering education: Japan and the United Kingdom", some remarkable figures are presented to account for the success of the Japanese in the years since the war.

For example, 150 000 Japanese students are studying technology until they are eighteen and over, while only around 35 000 do so in the UK, including those who leave school at 16+ to take National Certificates. Ninety per cent of the Japanese population take mathematics to 18+, compared with 18% here. In fairness, it must be pointed out that the report was commissioned to challenge earlier Government figures published in the December *Employment Gazette*.

While all the statistics are indeed thought-provoking – and a little depressing – it is the very last sentence in the whole report that seems to carry at least as much significance as any of them. "...their system ensures that... the important decisions on both technical and managerial matters at all levels up to President of the major industrial undertakings are generally made by engineers".

There is a clear difference here between the common practice in the UK, where engineers advise managers who then make the decisions, and the state of affairs in Japan, where the decisions are evidently made directly by engineers.

The report also makes mention of the kind of education provided in university engineering schools, which "includes languages and humanities/social sciences, mathematics, physics and chemistry as well as engineering".

In an editorial on this topic in the May issue, the phrase "mid-career diversion to financial and business affairs" was used. It is quite clear from this EC report that the Japanese view the education of engineers in a much more liberal light, so that the managers in an engineering company do not need to change direction: they have been educated in the relevant disciplines from the start, while still having their engineering background and therefore being able to draw from a more complete knowledge base when making the decisions. It means, too, that engineers lower down the scale should possess a more enlightened, broader view of their own efforts and the consequences thereof.

British industrial history over the last forty years at least is littered with abandoned projects, loss-making developments and a failure to capitalize on ideas. Not all of these disasters can be laid at the door of "captains of industry", but one is left with the feeling that, if their decisions on whether to go ahead with certain developments had been informed by a better education in all the subjects which possess relevance to an engineering question, we might not be looking to the Far East for inspiration on how to compete in an increasingly technological world.

Electronics & Wireless World is published monthly USPS687540. By post, current issue £2.25, back issues (if available) £2.50. Order and payments to: 301 *Electronics and Wireless World*, Quadrant House, The Quadrant, Sutton, Surrey SM2 5AS. Cheques should be payable to Reed Business Publishing Ltd. Editorial & Advertising offices: EWW Quadrant House, The Quadrant, Sutton, Surrey SM2 5AS. Telephones: Editorial 01-661 3614. Advertising 01-661 3130. 01-661 8469. Telex: 892084 REED BP G (EEP). Facsimile: 01-661 3948 (Groups I & II). Beeline: 01-661 8978 or 01-661 8986. 300 baud, 7 data bits, even parity, one stop bit. Send ctrl-Q, then EWW to start: NNNN to sign off. Newstrade – Quadrant Publishing Services No. 01-661 3240. Subscription rates: 1 year (normal rate) £23.40 UK and £28.50 outside UK. Subscriptions: Quad-

rant Subscription Services, Oakfield House, Perrymount Road, Haywards Heath, Sussex RH16 3DH. Telephone 0444 441212. Please notify a change of address. USA: \$116.00 airmail. Reed Business Publishing (USA), Subscriptions Office, 205 E. 42nd Street, NY 10117. Overseas advertising agents: France and Belgium: Pierre Mussard, 18-20 Place de la Madeleine, Paris 75008. United States of America: Jay Feinman, Reed Business Publishing Ltd, 205 East 42nd Street, New York, NY 10017. Telephone (212) 867-2080 Telex 23827. USA mailing agents: Mercury Airfreight International Ltd, Inc., 10(b) Englehard Ave, Avenel N.J. 07001. 2nd class postage paid at Rahway N.J. Postmaster – send address to the above.

©Reed Business Publishing Ltd 1988. ISSN 0266-3244

“It’s a pretty small battery-powered PROM programmer – so what?”

Tools which are convenient get used a lot – that justifies their existence. There is no way we could explain all the usefulness of S3 here. Instead, if you’re interested we’re going to let you see it, use it and evaluate it in your own workshop. We went to a lot of trouble to design S3 just the way it is – no other PROMMER is all CMOS and all SMT. So we must be convinced that S3 would be a formidable addition to your armoury. Now all we have to do is to convince you.

“Such a little thing can’t be powerful, like a big bench-programmer – er – can it?”

Yes, it can. It is more powerful. S3 leaves other prommers streets behind. S3 has continuous memory, which means that you can pick it up and carry-on where you left off last week. S3 has a huge library EPROMS and EEPROMS. S3 can blow a hundred or more PROMS without recharging. S3 also works remotely, via RS232. There’s a DB25 socket on the back. All commands are available from your computer (through a modem, even). Also S3 helps you develop and debug microsystems by memory-emulation.

“What’s this memory-emulation, then?”

It’s a technique for Microprocessor Prototype Development, more powerful than ROM emulation, especially useful for single-chip “piggy back” micros. You plug the lead with the 24/28 pin header in place of the ROM/RAM. You clip the Flying-Write-Lead to the microprocessor and you’re in business. The code is entered using either the keyboard or the serial interface. Computer-assembled files are downloaded in standard format – ASCII, BINARY, INTELHEX, MOTOROLA, TEKHEX.

Your microprocessor can WRITE to S3 as well as READ. You can edit your variables and stack as well as your program, if you keep them all in S3.

S3 can look like any PROM up to 64K bytes, 25 or 27 series. Access is 100ns – that’s really fast. Memory-emulation is cheap, it’s universal and the prototype works “like the real thing”.

S3 loads its working programs out of a PROM in its socket, like a computer loads from disk. Software expansion is unlimited. Upgrades will come in a PROM. Programs can be exchanged between users. How’s that for upgradability?

“Can I change the way it works?”

You surely can. We keep no secrets. System Variables can be “fiddled.” New programming algorithms can be written from the keyboard. Voltages are set in software by DACs. If you want to get in deeper, a Developers’ Manual is in preparation which will give source-code, BIOS calls, circuit-diagrams, etc. We expect a lively trade in third-party software e.g. disassemblers, break-point-setters and single-steppers for various micros. We will support a User Group.

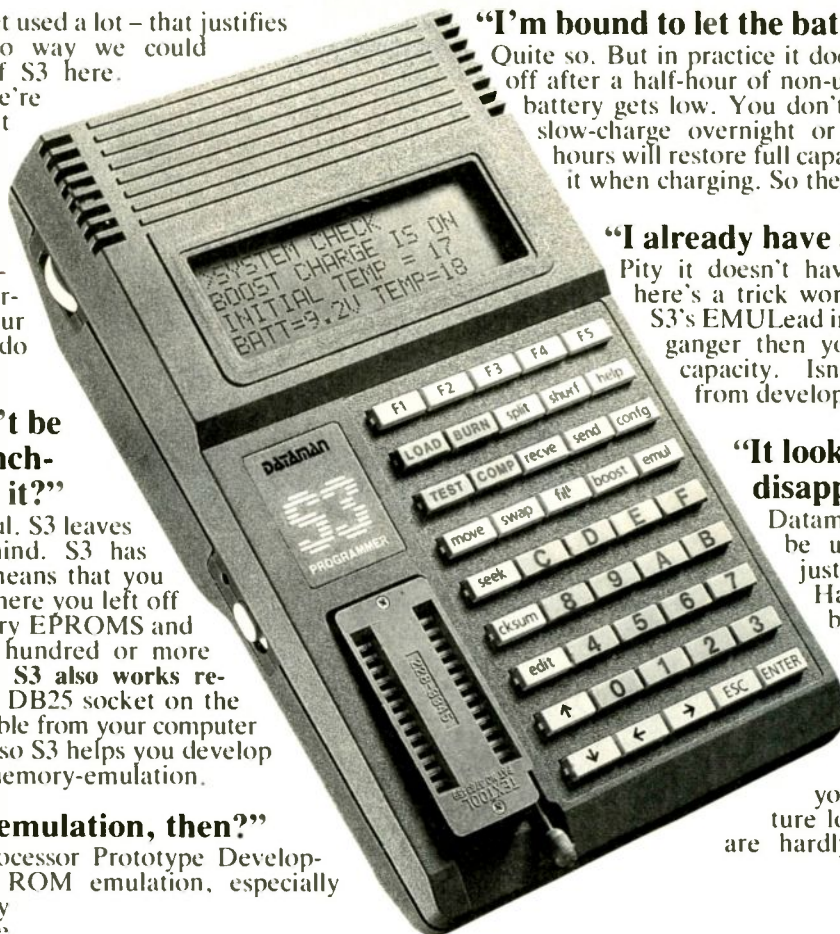

“I’m bound to let the battery go flat.”

Quite so. But in practice it doesn’t matter. S3 switches off after a half-hour of non-use anyway, or when the battery gets low. You don’t lose your data. Then a slow-charge overnight or boost-charge for three hours will restore full capacity. You can keep using it when charging. So there really is no problem.

“I already have a programmer.”

Pity it doesn’t have S3 features, eh? But here’s a trick worth knowing. If you plug S3’s EMULeAD into the master socket of a ganger then you get an S3 with gang capacity. Isn’t production separate from development anyway?

“It looks nice. Will I be disappointed?”

Dataman tools are designed to be used by Engineers. Not just sold to Management. Have you ever been misled by some mouthwatering ad for a new product? Great artwork and exciting promises which feed your fancy? On impulse you buy and when the thing arrives you feel let down. The picture looked better. The claims are hardly justified; not exactly misrepresentation, just poor implementation. But you’ve bought it. And you’re stuck with it. It stays in the cupboard, most of the time. So how about this: buy S3 and use it for up to a month. If you’re not still thrilled then you can have your money back.

Softy3 is here!

“Refund in the first month! How can you offer that?”

We trust S3 to fire your enthusiasm. We trust you not to use us as a free hire-service. We bet you won’t send it back. How would you manage without it?

“These things cost a fortune and take months to arrive.”

We wouldn’t get you all excited and then let you down. It Costs £495 plus VAT. That includes P & P, Charger, EMULeAD, Write Lead and a HELP program in ROM. S3 is in stock. Buy it today. Use it tomorrow. (That’s a fair promise. But please reserve product by phone or telex to make it come true).

DATAMAN



Lombard House,
Cornwall Rd.
DORCHESTER
Dorset DT1 1RX.
Phone 0305 68066 Telex 418442

If you purchase while this ad is current, you have 28 days to examine the goods and return them for refund. Carriage will be charged at cost. The right to charge the cost of refurbishment of damaged goods is reserved.



ENTER 48 ON REPLY CARD

MC88100 risc

Design goals for the 88100 were simple – a microprocessor capable of 17Mips that could be manufactured within the limits of existing design and wafer-fabrication technology.

DAVID JONES

TWO approaches to risc

Two of the most recent reduced-instruction-set computers are described in this article and the one on page 689 – the MC88100 from Motorola and the MA29000 from AMD. Both can run at 17Mips.

Over the past three years, Motorola has been researching advanced micro-processor architectures, in particular those used for reduced-instruction-set computers. The first product resulting from that research, the MC88100, was announced on April 18. It has a fully 32bit internal architecture, a 17Mips execution speed and 51 instructions, a group of which covers IEEE specified floating-point operations.

Although the 88100 is dubbed a reduced-instruction-set computer, it contains many architectural extensions for, say, multiprocessor, fault-tolerant and graphics applications. Perhaps the most important extension is the use of multiple execution units, each with its own pipeline.

The idea and use of pipelining is not new; microprocessors with between three and

eight levels of pipelining are already available. Unlike the 88100 though, existing processors generally have only one pipeline

One set of buses for code and one for data allows very fast simultaneous accesses of instructions and data, below left.

for instruction-address calculation, fetching and decoding. The penalties for change of flow instruction are obvious. Some form of invalidation or clearing of the pipeline needs to be performed, causing a processor delay. Rather than having just one pipeline, the 88100 has four, which eases the problem of change of flow instructions and increases overall parallelism.

Having the functions of the processor split between a number of execution units allows a high degree of parallelism. The 88100 is capable of executing up to five floating-point instructions and six floating-point or integer-multiply instructions at the same time as up to three data memory accesses and three instruction fetches.

Pipeline problems are reduced by allowing the processor to perform delayed branching

RISC OUTLINE

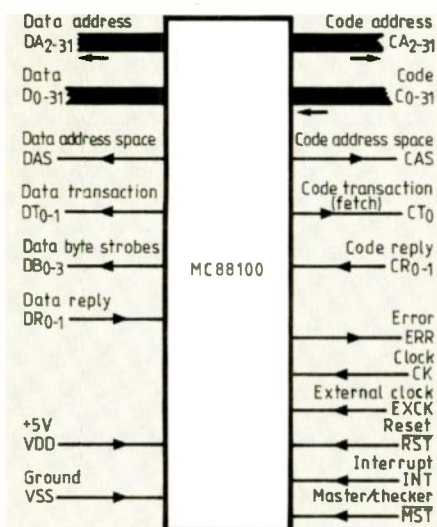

To fully explain the philosophy behind the term reduced-instruction-set computer would take at least a long article. This section simply outlines risc philosophy, and how it is implemented in the 88100.

Rather than having instructions with complex addressing modes designed into on-chip microcode, a simpler approach is adopted. This involves defining a small number of optimum instructions and designing them directly into the logic on the chip. When complex instructions and addressing modes are needed, they are simply built up from the simpler instructions.

Instructions of a risc processor, besides executing faster than those of a complex-instruction-set computer because of the removal of the delay through several layers of microcode decoding logic, take just one clock cycle to execute.

Perhaps the third most important aspect of the risc philosophy is that the processor's architecture should be designed for high-level languages. In other words, a large number of general-purpose registers should be available to aid compiler design and optimization.

If the 88100 is to execute code in only one clock cycle then considerable attention needs to be given to the process of fetching data and instructions. In fact this consideration gave rise to the first architecture extension implemented during the 88100's design.

Bus and control signals of the 88100 are shown in the diagram. You can see that the Harvard-style architecture which started to appear internally in 32-bit processors like the 68030 and NS32532 now extends outside the chip. Instructions and data can be fetched simultaneously in one clock cycle, and instructions can be fetched while data is being written.

Adopting Harvard-style rather than Von Neumann architecture increases throughput on the external buses, but it creates a problem for the system designer. Accessing data and instructions in only one clock cycle is fine, but it makes external decoding logic and memory difficult to design and expensive. For a processor running at 20MHz, only 50ns is available for decoding and accessing memory. In the future, the 88100's clock frequency will increase, leaving even less time. To make sure that memory technology does not impede the processor's progress, a cache memory-management unit has been designed.

so that the instruction fetched after the branch instruction can be executed before the branch is taken. In this manner the instruction fetched after the branch instruction is executed while the branch target instruction is fetched from memory by another section of the pipeline. This eliminates a "bubble", or delay in the pipeline.

Separate execution units permit concurrency; in other words each of the execution units can operate independently allowing instruction decoding and source-operand fetching to be performed at the same time by the same execution unit, and branch-instruction decoding or branch-target address calculations to be performed in parallel with sequential address generation.

Obviously with such extensive internal bus traffic some form of internal routing is required. The processor contains three internal 32-bit buses, allowing the 88100 to perform *simultaneous* rather than sequential op-code fetching.

For multiprocessor applications a memory exchange instruction, XMEM, has been added. When the instruction is executed the contents of two memory locations are exchanged in a locked bus cycle so that semaphore register bits can be updated without the risk of interruption from another processor.

Bit-field instructions are included in the instruction set for applications requiring manipulation of data that does not correspond to a particular standard format like, for example, frame buffers in graphic applications.

The method used by the 88100 in fault-tolerant systems, for example, p.a.b.x. military and medical applications, is shown in Fig. 1. Two 88000 processing nodes are wire-Ored together. By programming the processor, one node is assigned to be a master while the other acts as a checker. The checker floats all its outputs except for the error pin, ERR. Its outputs are then monitored as inputs. The checking processor executes the same instructions as the master, comparing its internally generated output signals with information on the floated pins (outputs actually produced by the master). If at any time there is a mismatch then the checker asserts the ERR pin to signal to the external logic a fault on the node.

In addition the master checks that the internal value of the signals which it is driving are the same as those on the output of the device. In other words the inputs and outputs of the processor's drive buffers are compared. If an error occurs it is likely that some form of external short circuit has occurred. Again the ERR pin is asserted, this time by the master. The external controller can then act on the output of the error signal to report or replace the faulted processing node.

INTERNAL ARCHITECTURE

A block diagram of the internal architecture of the 88100 is shown in Fig. 2. Comparing this to a typical complex-instruction-set computer highlights how clean the architecture of a reduced-instruction-set computer is. Rather than having complex areas of control logic, a number of separate

execution units are implemented, each containing their own complex but *independent* logic.

A simple load-and-store architecture is supported, allowing most of the instructions to be executed within the program registers. Triadic addressing, where two source registers are acted upon to yield a result for a separate destination register, is used extensively. This form of architecture supports non-destructive data manipulation of the source registers. Accessing three registers simultaneously in only one clock cycle is achieved via three parallel buses, two for the sources and one for the destination.

The three buses are responsible for routing data to the execution units and the registers, all of which are 32 bits wide and completely general purpose. Bus activity is monitored and controlled by the sequencer unit.

Dedicated instruction-execution units have been implemented, namely the integer unit and the floating-point unit. Pipelining these units provides simultaneous instruction execution with data and instruction fetching. For speed, integer arithmetic is performed on both the integer unit and the floating-point unit, whose instructions conform to the IEEE P754 specification.

Independent execution units control the operations on the code and data buses of the 88100. Data is fetched to or from memory or the c.m.m.u. immediately into a pipeline in the data unit. This allows prefetching of data into the device so that it is fetched on the external bus before the processor requires it. Effectively, this hides the time required to fetch or write data outside the processor. The instruction unit has a similar pipeline for instruction fetching; in this case some predecoding can be done on the instruction before it is required by the processor.

The remaining portion of the architecture is assigned to future execution units or special-function units. When a new family of microprocessors is developed it is very difficult to foresee the requirements that will be placed upon it in the future. Therefore it is common to include in the original design some elements which can be designated as "for future expansion".

This approach has been adopted for the 88100, which has "room" for expansion in

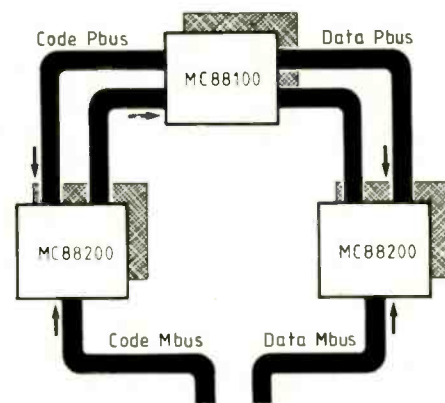

Fig. 1. In fault-detection mode, one 88000 node is a master and the other a checker. The checker monitors the activities of the master and asserts the ERR pin should a fault be detected.

the form of special-function units. The architecture allows up to eight special-function units to be designed into the processor; at present only one is used, namely the floating-point unit. Accesses to a new special-function unit will be the same as an access to the floating-point unit, the only difference being the bit-pattern change in the upper 32 bits of the opcode word that addresses a different unit.

Floating-point unit. As its name implies, the floating-point unit is responsible for all internal floating-point operations within the microprocessor. Indeed, this unit not only performs all the floating-point arithmetic instructions, but also integer/floating-point conversions and integer multiply and divide instructions.

When an integer unit exists within the 88100, why does the floating-point unit need to perform integer multiplication and division? The reason is that it allows the integer unit to perform many instructions in only one clock cycle, leaving the multiple-cycle instructions to execute in the more complex a.l.u.

Obviously, the inclusion of floating-point instruction-execution on chip implies that there are a number of instructions that the 88100 can execute which do not complete in only one clock cycle. Single-precision add, subtract and convert instructions require five cycles while the multiply requires six. Divide instructions execute by looping through one stage of the pipeline for each bit of required accuracy. To compensate for these delays the floating-point unit contains two pipelines, one of five stages and the other of six.

By proper scheduling of floating-point and integer add and divide instructions, the processor can be made to execute a number of floating-point instructions on each consecutive clock cycle.

Integer unit. Remaining integer arithmetic, bit field, logical instructions, etc, execute under control of the integer unit, which is also responsible for all the operations required for memory addressing calculations and program sequencing. During exception processing sections of the integer-unit control registers are used for storage of program status information.

The integer unit actually contains three separate functional units to increase throughput. All bit-field instructions are executed in a bit-field unit, alleviating the main a.l.u. from this task. Integer arithmetic instructions execute in a 32-bit a.l.u. and allow a wide range of logical and arithmetic operations. A separate branch unit is used to calculate the branch offset, permitting the implementation of delayed branching for all branch instructions.

This method of separating tasks in the integer unit allows a considerable amount of parallelism to be achieved in that three of the above types of operations can be executing simultaneously in different registers. A compiler designed to monitor register usage very carefully can take considerable advantage of this type of architecture.

Register file. The programmer's access to all the internal execution units is via programs

CACHE MEMORY MANAGEMENT REDUCES THE PROBLEM OF MEMORY SPEED

When 88100s are produced that run faster than 20MHz, it will be difficult for memory technology to keep pace. For this reason, a cache memory-management unit has been designed for use with the processor. It contains two sections: a four-way set-associative cache of 16Kbyte operating without waiting states, and a full demand-page virtual memory-management unit.

The c.m.m.u. is designed to operate on both code and data sides of the 88100 buses; indeed a typical 88000 node would consist of a minimum of one c.m.m.u. on each of the 88100 buses. A maximum of four c.m.m.us can be configured on either the code or data buses, allowing the sizes of the caches to be increased and the memory-management unit's address range to be increased.

Simulation results for the c.m.m.u. are showing greater than 95% hit rates in the caches when running typical Unix type code. With hit rates of this order, there is little need for two external buses linking to external memory so the memory ports on the c.m.m.us are multiplexed together to simplify external memory design.

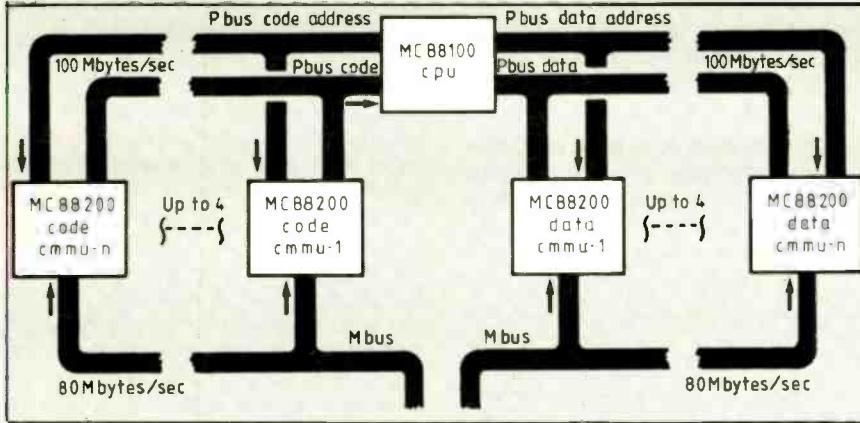

For zero wait-state access to memory, the 88100 interfaces to up to four cache memory-management units on each bus. These contain a 16Kbyte four-way set-associative cache and a demand-page virtual m.m.u.

executing in the register file containing 32 general-purpose user registers, r_0 .. r_{31} . The only restriction to the use of these registers is in the use of r_0 and r_1 . Register r_0 always returns zero when read. This allows very quick clearing of register contents for initialization code since r_0 can be moved to any of the other registers in the register file. The return address of a branch to a subroutine is held in r_1 by the processor.

To allow simultaneous access to the register file by the three internal buses they have three ports; two take input from the two source buses and one outputs to the destina-

tion bus. For multiple register usage a method of feeding forward information has been implemented for the internal buses. This places the destination result from the current operation required for execution by the next instruction on one of the source buses to ensure that the unit waiting for data receives it at the earliest possible time. The same applies if both source registers are in use: both source operands are obtained by

Fig.2. Internal architecture of the 88100 consists of a number of execution units that operate concurrently.

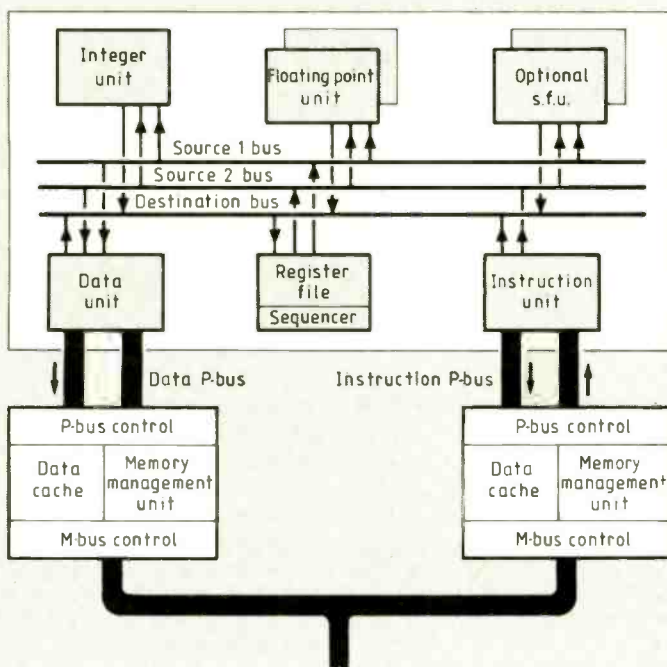

forward feeding from the destination bus.

A method of internal arbitration is performed by the register file for controlling internal control and storage register write protocols. The scheme is implemented to prioritize register writes from the execution units, the highest priority being the integer unit followed by the floating-point then the data unit.

Sequencer. Rather than a section of micro-code to control all the function of the 88100 a hardware sequencer is used. It controls register access, arbitration of the internal buses, exception processing and the generation of control signals for the integer and special-function units.

The main problem the sequencer has is knowing what register is actually being used at any one time. Due to the nature of this parallel concurrent processor several execution units have independent access to the register file. For this reason each of the general-purpose registers in the register file has an associated scoreboard bit to indicate usage. When a particular register is being used by one of the execution units a bit corresponding to that register is set in the scoreboard register. This ensures that parallel instruction execution does not use any source operand registers that have not yet been computed from a previous instruction. In other words the processor is not restricted to executing each individual instruction to completion before starting a new one.

To understand the role that the sequencer plays in handling exceptions the exact definition of an exception on the 88100 is required. There are two types of exceptions, precise and imprecise. A precise exception is one in which the exact processor context and exact causes are known. These include interrupts and bus errors. These types of exception contain all the information required by the processor for a complete recovery. Imprecise exceptions are those caused spuriously when executing instructions, for example, when the floating-point unit overflows. In this case the whole context is not required for recovery if the operation in progress was known.

The sequencer's responsibility for handling exceptions can affect performance: to minimize the effects, the sequencer has the ability to act on all pending precise exceptions before handling imprecise exceptions. Imprecise exceptions require investigation work by the exception handler.

Instruction unit. Operations required of the instruction unit are to fetch instructions from the instruction data bus and to perform the first stages of the instruction decoding before sending them to the integer unit. This operation is performed in only one clock cycle where possible.

The instruction unit has an integrated three-stage pipeline containing the value of three instruction pointers, the first of which is the execution instruction pointer (x.i.p). This pointer is the address of the instruction currently being executed in the instruction or floating-point unit. The second stage contains the next-instruction pointer (nip) which points to the instruction currently being received from memory or the

Fig.3. The programming model consists of 32 general-purpose 32bit registers and 128 control registers, also 32bit wide, in the integer and floating-point units. Note that there are unused control registers for future expansion.

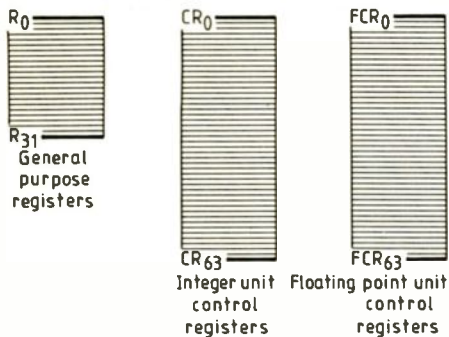

c.m.m.u. Due to the external bus operation, data is received on the clock after the address, therefore during this phase the fetch-instruction pointer (fip) contains the memory address location of the next instruction to be accessed. The three-stage pipeline caters for the prefetching of instructions before the processor is ready to use them and for recovery from an erroneous bus access.

Data unit. Within this execution unit, for controlling aligned 32bit data accesses, is a 30bit arithmetic unit for address calculations. A three-stage pipeline improves data fetching operations.

In the first stage of the pipeline the required fetching address is calculated, or for a store operation, data is fetched from the internal register file. During stage two the external address bus is driven to fetch the data; in the store operation the data bus is also driven. In the final stage of the pipeline the response of the external memory is monitored. For a store operation the data bus is read and for a write operation a register in the register file is loaded.

PROGRAMMING MODEL

Figure 3 shows the program and control register of the 88100. After the reset sequence the processor operates in supervisor mode. In this mode all the registers are available for programming and the hardware of the processor can be configured for the particular application area. In user mode, control registers are protected from being accessed to prevent system corruption, and the general purpose registers are used to program the processor.

Supervisor mode is normally restricted to kernel type software so only a small amount of very fast exception handling code, etc.

Fig.4. Rather than use a condition-code register, conditions, or predicates, are evaluated in a general-purpose register. All the predicates are shown here.

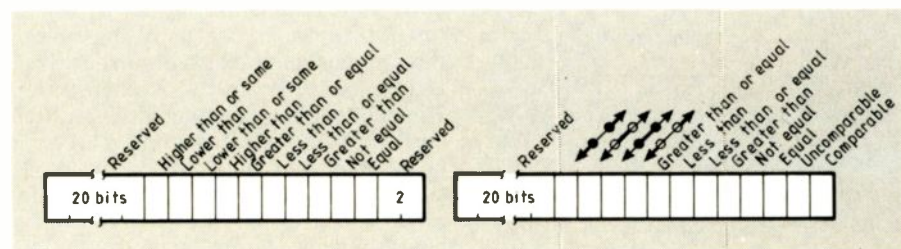

resides in this mode. While in supervisor mode the 88100 can be programmed to perform a number of functions. For fault-tolerant applications the processor can be programmed to be a master or a checker. Big Endian or little Endian* modes can be enabled to fetch data, which is useful for interfacing the 88100 to a number of different vendors' bus systems.

Serialized mode can be enabled for debugging code. In this mode no instruction can start execution until all the bits of the scoreboard register have been cleared. This ensures no overlap with the pipelines for concurrent instruction execution. To facilitate arithmetic operations the carry flag can

Fig.5. While the clock is high, the processor drives the addresses and the bus type indicating a read or write operation. Data is read on the next rising edge and the response is read on the next falling edge.

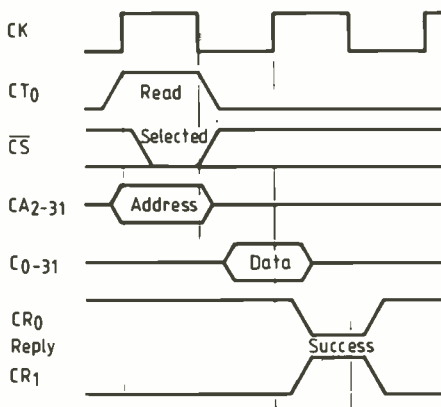
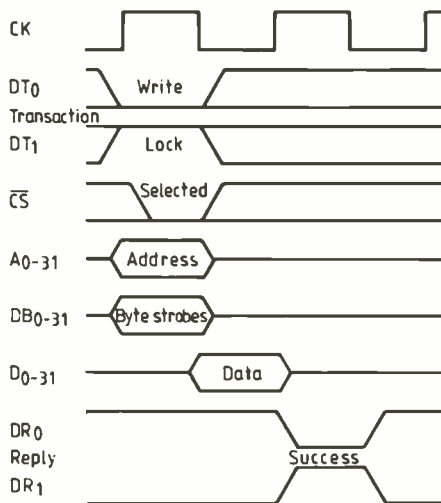

Fig.6. Write cycles are similar to read cycles, but byte strobes are asserted at the same time as the addresses and the data is driven immediately after the address.



be enabled or disabled for add and subtract instructions, and the floating-point unit can be enabled or disabled. The processor can be configured to generate an exception on a misaligned data access. Interrupts can be enabled or disabled as can the shadow registers.

The user has access to all the general purpose registers although r_0 and r_1 have special functions as explained earlier. Access to the floating-point unit by the user program is through the floating-point control and status registers. These are the only control registers accessible to the user.

No restriction is placed on the remaining general-purpose registers. The registers are not allocated special tasks, unlike for example, the 68000 family's data and address registers. There is no stack pointer or indeed condition-code register. If there is no stack in either the supervisor or user modes then obviously there must be some other method for handling interrupts etc. With no condition code register there must also be another method of handling branches and compares.

During the evaluation of this project these items were looked at with respect to performance. In many ways it was the old style architectures which contained both stacks and condition-code registers that hindered the performance of these processors.

The 88100 solves the problem of having to spend processor time staking registers during an exception in the following manner. Integrated into the interger unit are a number of "shadow" and "exception time" registers. The idea behind shadowing is to record the contents of the internal pipeline registers during instruction execution. In other words a copy of these registers is taken on each clock cycle. Information held in these registers is the three instruction pointers and the scoreboard register.

At the time of an exception the contents of the shadow registers are frozen, thus leaving a copy of instructions that the processor was about to act upon at the time of the exception. The exception-time registers are used to save other internal information at the time of the exception. With the contents of the shadow and exception-time registers the complete internal context of the processor is known at the time the exception was taken.

In addition, the user can create a stack for other register information and enable nested exceptions if required, utilizing the general-purpose registers or external memory. This method of exception handling in hardware reduces the interrupt latency time considerably compared to that of stack-oriented processors.

When the features of parallel architecture in a microprocessor are analysed the inclusion of a fixed condition-code register is detrimental to the processor's performance. If the condition-code register were fixed, evaluation of, for example, the result of a compare instruction would imply that one instruction takes priority over another for access to the results of the condition-code bits. If this were the case then the second instruction would be required to halt execution until the first had operated on the bits in the condition-code register.

* Most-significant data first or last.

In the 88100 this type of operation is impractical as it would have serious consequences on the performance of the entire machine. So rather than a fixed condition-code register the 88100 uses a string of predicates which can be evaluated in any of the general-purpose registers. As long as the destination register that the predicates are being evaluated in is not used by the instructions that follow then a string of compared or branch-like instructions can execute without delay. The full range of predicate values are shown in Fig.4.

It is not uncommon to see more than 128 general-purpose registers in a risc processor architecture, as opposed to just 32 as with the 88100. The number of registers used within the microprocessor will obviously effect the performance of the final device. During the design phase of this project, multiple register usage was simulated. It was found that 32 registers proved to be an optimum number for high-performance applications.

There were a number of findings that helped Motorola arrive at this conclusion, one of them being an analysis of high-level language programs running on register-based microprocessors. It was found that an overflow situation occurred which affected the performance of the compilers when controlling data allocation on such a large number of registers. It was physically impossible to keep track of such a large number of registers – with above about 25, compiler performance actually starts to decrease as the number of registers increases.

Physical limitations of the device also come into play; drive capability, or fan out of the decoder is affected by capacitive loading as the number of registers increases. This restricts register access times and hence slows down the processor clock frequency.

Another consideration is that the number of bits in the opcode word required to decode the register becomes greater, hence placing a restriction on the size of immediate data values.

INSTRUCTION SET AND ADDRESSING MODES

Bit field instructions allow the 88100 to operate on individual bits of information such as individual pels in a frame buffer of information. This is just one data size that the processor can work on. Single and double precision floating-point numbers conforming to the IEEE specification are operated on by the floating-point unit. The operating size of a word for the processor is 32 bits, but it can also act directly on 16bit quantities, known as half words, double words of 64 bits, and bytes of information.

Although not as complex as those of a complex instruction-set computer a number of addressing modes are present in the 88000 architecture for accessing instructions, data and the internal registers.

Instructions are fetched using three types of addressing mode. The first of these is called 'register with a 9bit vector table index'. It is used to place a value in the fetch-instruction pointer corresponding to the exception-vector address during exception processing. The addressing mode con-

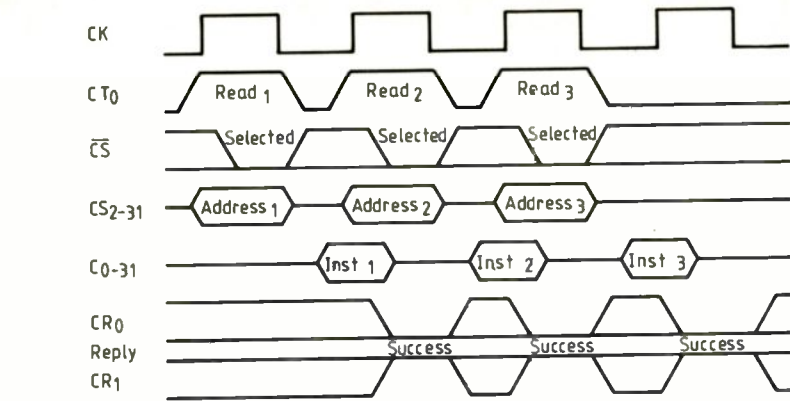

Fig.7. In pipeline mode, the 88100 can read and write data on consecutive clock cycles.

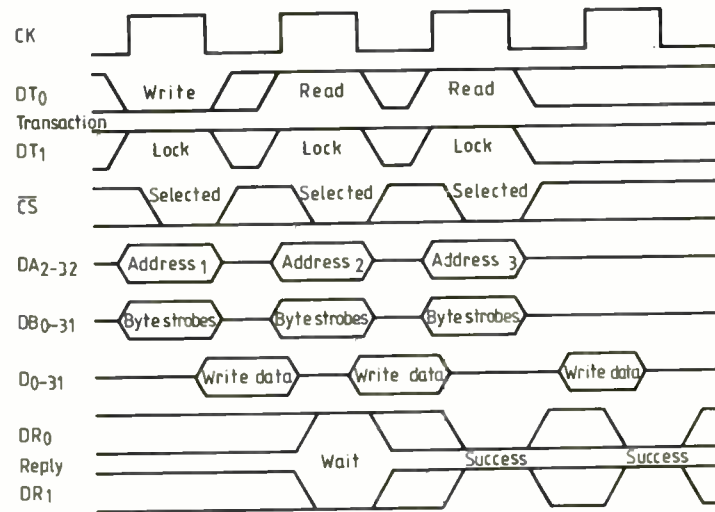

Fig.8. When a fault or wait-reply condition is read by the processor, the bus cycle is either repeated or ignored. When the reply is read, the second bus cycle has already started so the processor does not wait for slow responses from memory.

catenates the 9bit vector offset for the exception with the vector base registers to produce the final fetch-instruction pointer. At reset, the vector base register is programmed to an address corresponding to where the exception vectors are placed in memory. For a trap-on-condition exception, five bits in the opcode word are tested and only if they are true is a new value loaded into the fetch-instruction pointer.

The second instruction-addressing mode is 'register with 16bit field'. This mode is used by branch and trap instructions for target-address and test-condition generation. In this mode source register S_1 is tested. If the branch or trap condition is true then the 16bit offset is added to the execution instruction pointer and placed in the fetch-instruction pointer.

Branch instructions use the third instruction-addressing mode, '26bit branch offset', to specify the branch target address. The 26bit offset in the opcode word is added to the execution-instruction pointer to produce the fetch-instruction pointer.

Of the data-memory addressing modes register-direct with unsigned offset is the first. In this data fetching mode, content of source register S_1 is added to a 16bit literal field in the opcode word to produce an external memory address for data access.

The second data-addressing mode, called 'register direct with index' is similar to the first. In this case a second source register

replaces the literal value to index the first to produce the memory address where data is to be fetched or written to.

In the third data-addressing mode, 'register indirect with scaled index', contents of the second source are scaled by a factor of zero, one, two or three. Note that in this case, 'one' is the same as the second data-addressing mode.

Of the internal register-addressing modes, the first is triadic register. In this mode source registers S_1 and S_2 are acted upon by the integer or floating-point units to produce a result for a separate destination register. Note that no register contents are destroyed.

For bit-field instructions, the second internal register-addressing mode, 'register with 10bit field', is used. The ten-bit literal field in the bottom bits of the opcode word to be acted upon in source register S_1 .

In the final addressing mode, 'register with 16bit field', source register S_1 contents are added to a 16bit literal value of the opcode word to produce the destination result. This form of addressing is used by arithmetic and logical instructions requiring an immediate value.

THE P-BUS

Access to both code the data memory is via two processor buses called p-buses. These

are very fast synchronous buses operating in one processor clock cycle. Signals controlling access over these buses are shown in the first panel. The top of this diagram shows signals associated with the data and code p-buses.

Data accesses are made via a 30bit data-address bus, DA_{2:31}, and 32bit data bus, D_{0:31}. However since the 88100 only accesses data as aligned words this corresponds to an addressing range of 4Gbyte.

Controlling accesses to data memory are the following control signals; DAS, DT_{0,1}, DB_{0,3} and DR_{0,1}. Signal DAS is used to separate user from supervisor accesses to data memory. This signal could be used in the external control logic to double the size of directly accessible memory, that is to allocate 4Gbyte for user data and 4Gbyte for supervisor data. In addition supervisor data can be protected from corruption by user programs. When this pin is low, user data space is selected.

Signals DT_{0,1} indicate the type of data access being performed. Signal DT₀ is equivalent to the read/write pin on other processors, except that it is asserted at the same time as the address bus is driven. Signal DT₁ is asserted during a locked bus cycle. The XMEM instruction causes DT₁ to be asserted for the duration of the memory-exchange operation.

Response to a data access is reported by signals DR_{0,1}. Depending on the decoding of these signals they will indicate either a successful memory transfer, a memory fault, or a memory wait cycle. Signals DB₀₋₃ select individual byte locations within the fetched word of data.

Code accesses on the code p-bus are similar to those on the data bus. The differences are: there are no byte strobes since all opcodes are 32 bits wide and no extension words are supported; the code data bus, C₀₋₃₁, is unidirectional; the CT₀ is used to indicate that an instruction fetch is in progress.

To support accesses in one clock cycle the buses used for both code and data need to operate in only one clock, therefore a new type of fast bus was designed. Most microprocessors operate by first driving the address bus, qualifying the addresses with a strobe signal, reading from or writing to memory and then finally waiting for an acknowledgement from the memory device before terminating the cycle. Obviously with this type of bus operation the processor needs to wait for a period greater than one clock cycle between accesses.

The p-bus can assert addresses on each clock and drive or read the data bus on each clock. Latching of the acknowledgement occurs after the cycle so that the processor is not slowed down. Only when a fault exists does a delay occur. All p-bus activity is synchronized to the 88100 processor clock, therefore the requirement to supply strobing qualifying signals is eliminated, simplifying the external control logic.

Figure 5 shows how the p-bus performs a read cycle over the code bus. At the same time as the address bus is driven, just before the rising edge of the clock, CT₀ is asserted to indicate an instruction fetch. Next, the address is decoded by the external memory/

```

FFT(xr, xi, n, m, wr, wi)
single xr[ ], xi[ ], wr[ ], wi[ ],
unsigned n, m;
{
    unsigned n1, n2, ia, ie, i, j, k, l;
    single c, s, xrt, xit;

    n2 = n;
    ie = 1;
    for (k = 0; k < m; k++)
    {
        n1 = n2;
        n2 = n2 >> 1;
        ia = 0;
        for (j = 0; j < n2; j++)
        {
            c = wr[ia];
            s = wi[ia];
            ia = ia + ie;
            for (i = 0; i < n1; i += n1)
            {
                l = i + n2;
                xrt = xr[i] - xr[l];
                xrl[] = xr[i] + xr[l];
                xit = xi[i] - xi[l];
                xil[] = xi[i] + xi[l];
                xrl[] = c*xrt - s*xit;
                xil[] = c*xit + s*xrt;
            }
            ie = ie << 1;
        }
    }
}

```

List 1. Fast Fourier transform in C.

```

L3:
add     r16,r15,r8      * l = i + n2
ld      r19,r1,r15     * xr[i]
ld      r20,r1,r16     * xr[l]
fsub.sss r17,r19,r20   * xr[i] - xr[l]
fadd.sss r19,r19,r20   * xr[i] = xr[i] + xr[l]
st      r19,r1,r15     * xr[l] = xr[l] + xr[i]
ld      r21,r2,r15     * xi[i]
ld      r22,r2,r16     * xi[l]
fsub.sss r18,r21,r22   * xil = xi[i] - xi[l]
fadd.sss r21,r21,r22   * xi[l] = xi[l] + xi[i]
st      r21,r2,r15     * c*xrt
fmul.sss r23,r11,r17   * s*xit
fmul.sss r26,r12,r17   * s*xrt
fsub.sss r20,r23,r24   * c*xrt - s*xit
st      r20,r21,r16     * xr[l] = c*xrt - s*xit
fmul.sss r24,r12,r18   * s*xit
fmul.sss r25,r11,r18   * c*xit
fadd.sss r22,r25,r26   * s*xit + c*xrt
st      r22,r2,r16     * xil[] = s*xit + c*xrt
cmp     r15,r15,r7     * l = i + n1
cbp    r27,r15,r3     * l < n
bb1    lr,r27,L3

```

List 2. Assembler output of the inner loop of the FFT from a C compiler with no optimization.

```

add     r16,r15,r8      * l = i + n2
ld      r19,r1,r15     * xr[i]
ld      r20,r1,r16     * xr[l]
ld      r21,r2,r15     * xi[i]
ld      r22,r2,r16     * xi[l]
fsub.sss r17,r19,r20   * xr[i] - xr[l]
fadd.sss r19,r19,r20   * xr[i] = xr[i] + xr[l]
fsub.sss r18,r21,r22   * xit = xi[i] - xi[l]
fadd.sss r21,r21,r22   * xi[l] = xi[l] + xi[i]
fmul.sss r23,r11,r17   * c*xrt
fmul.sss r24,r12,r18   * s*xit
fmul.sss r25,r11,r18   * c*xit
fsub.sss r20,r23,r24   * c*xrt - s*xit
fadd.sss r22,r25,r26   * s*xit + c*xrt
add     r15,r15,r7     * l = i + n1
cmp     r27,r15,r3     * l < n
st      r19,r1,r15     * xr[l] = xr[i] + xr[l]
st      r21,r2,r15     * xi[l] = xi[i] + xi[l]
st      r20,r21,r16     * xr[l] = c*xrt - s*xit
bb1.n  lr,r27,L3
st      r22,r2,r16     * xil[] = s*xit + c*xrt

```

List 3. If the load-and-store instructions are grouped together at the start and end of the program and all floating-point operations are also grouped, a better result emerges. The code produces the same result, but it is arranged to take advantage of the processor architecture.

cache/c.m.m.u. and if accessed places the opcode word on C_{0:31} before the next rising edge of the clock. Response to the processor is read on the falling edge of the clock. For correct bus operation the only requirement is that the signals meet the set-up and hold times with respect to the processor's clock. The only difference between this cycle and a data-read cycle is that the byte strobes are also driven at the same time as the addresses.

During a write operation the 88100 places data on the data bus just before the falling edge of the first clock in the cycle. Timing of a data write operation is shown in Fig.6. Instructions are read-only so there is no instruction write cycle.

Pipelining the accesses increases the throughput of the 88100, making one-cycle instruction execution possible. The pipelined bus protocol for an instruction fetch is shown in timing diagram Fig.7. This method allows two instruction reads to be outstanding on the bus at any one time. Therefore the processor can initiate each transfer before the preceding transaction has completed. In effect this allows the processor to fetch instructions and/or data on every rising edge of the clock. Pipelining is also supported for data-bus writes.

In many cases it may not be possible to access code or data in only one clock cycle. In this case the external devices on the p-bus must send back a wait signal on reply pins, DR_{0,1}, as shown in Fig.8. When the processor reads this response it repeats the second address on the next rising edge of the clock. The first address that caused the fault should be latched externally. If a wait signal is encountered, then this latched address can be used to access the external devices. The p-bus operation allows enough time to latch the first address externally.

On an erroneous bus cycle the processor ignores the second bus cycle and continues execution on the third cycle. Enough time is given to buffer the erroneous access. This allows a memory-management unit to load a page containing the faulted address and begin execution by retrying the buffered address. Virtual memory systems, can thus be designed on both code and data buses.

CONCLUSION

Hardware and software features of the 88100 have been described in this article and indications of how high performance can be achieved from the architecture have been given. The reduced and simple instruction set makes designing code at assembly level very difficult, as with most risc microprocessors. For speed of software development there will therefore be a shift toward high-level languages.

The architecture of the 88100 is designed for very high throughput of code and data. Therefore the overhead of writing code in C for example is minimal. However the design of highly optimized compilers for the processor is important if all the advantages of the architecture are to be used.

To demonstrate how compilers can be used to develop highly optimized code an example is shown in List 1. This is a C source

Continued on page 691

CONQUERING NEW HEIGHTS

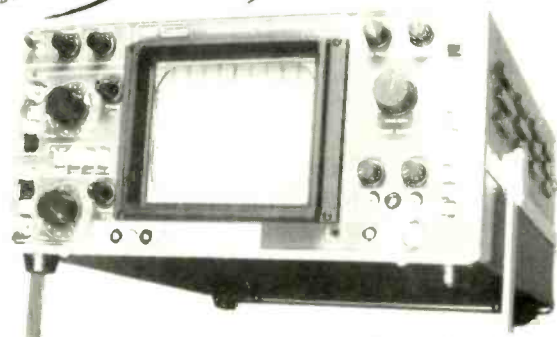
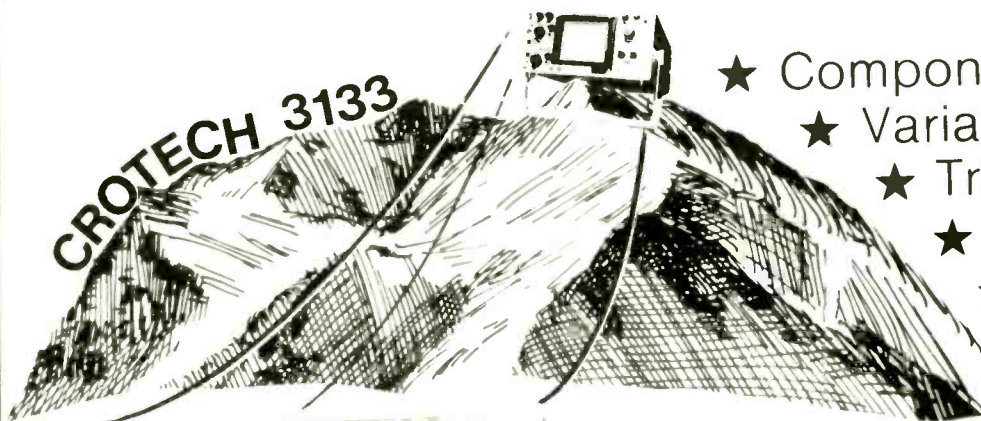

Yes its 25MHz for £319

- ★ Component Comparator
- ★ Variable Hold Off
- ★ Triple DC Source
- ★ DC – 25 MHz
- ★ 40ns/div
- ★ 2mV/div
- ★ Low Cost

£319*

To scale the heights, just call us for your FREE copy of our catalogue

*(Ex VAT & Delivery)

Crotech Instruments Limited

2 Stephenson Road, St. Ives, Huntingdon, Cambs. PE17 4WJ
Telephone: (0480) 301818

ENTER 34 ON REPLY CARD

Sowter Transformers

With 45 years' experience in the design and manufacture of several hundred thousand transformers we can supply

**AUDIO FREQUENCY TRANSFORMERS OF EVERY TYPE
YOU NAME IT! WE MAKE IT!**

OUR RANGE INCLUDES:

Microphone transformers (all types), Microphone Splitter/Combiner transformers, Input and Output transformers, Direct Injection transformers for Guitars, Multi-Secondary output transformers, Bridging transformers, Line transformers, Line transformers to B.T. Isolating Test Specification, Tapped impedance matching transformers, Gramophone Pickup transformers, Audio Mixing Desk transformers (all types), Miniature transformers, Microminiature transformers for PCB mounting, Experimental transformers, Ultra low frequency transformers, Ultra linear and other transformers for Transistor and Valve Amplifiers up to 500 watts, Inductive Loop transformers, Smoothing Chokes, Filter, Inductors, Amplifiers to 100 volt line transformers (from a few watts up to 1,000 watts), 100 volt line transformers to speakers, Speaker matching transformers (all powers), Column Loud-speakers transformers up to 300 watts or more.

We can design for RECORDING QUALITY, STUDIO QUALITY, HI-FI QUALITY OR P.A. QUALITY. OUR PRICES ARE HIGHLY COMPETITIVE AND WE SUPPLY LARGE OR SMALL QUANTITIES AND EVEN SINGLE TRANSFORMERS.

Many standard types are in stock and normal despatch times are short and sensible.

OUR CLIENTS COVER A LARGE NUMBER OF BROADCASTING AUTHORITIES, MIXING DESK MANUFACTURERS, RECORDING STUDIOS, HI-FI ENTHUSIASTS, BAND GROUPS AND PUBLIC ADDRESS FIRMS. Export is a speciality and we have overseas clients in the COMMONWEALTH, EEC, USA, MIDDLE EAST, etc. Send for our questionnaire which, when completed, enables us to post quotations by return.

E. A. Sowter Ltd

Manufacturers and Designers

E. A. SOWTER LTD. (Established 1941) Reg. No. England 303990
The Boat Yard, Cullingham Road, Ipswich IP1 2EG, Suffolk. PO Box 36,
Ipswich IP1 2EL, England.

Phone: 0473 52794 & 0473 219390 – Telex: 987703G SOWTER

ENTER 21 ON REPLY CARD

H.f. developments

Notes from the Fourth International Conference on H.f. Radio and Techniques, held at the IEE in April.

GEORGE SHORT

In these days of overcrowding and deliberate jamming in the short-wave broadcast bands, the domestic listener needs a little help from the engineer. The directional null property of a loop aerial is attractive as a potential weapon against co-channel interference. To be of use to the non-technical listener with minimal constructional skills any design must be simple to make and use and should preferably be small for use indoors.

Two ingenious new designs which both meet these requirements and break new ground were described. One of them is a notable advance in that it works against interference by sky-waves, where the nulling power of a traditional loop is seriously impaired by multi-path propagation. The other, which is effective against ground-wave interference from local transmitters, is particularly easy to make and use. Both derive from the ideas of Professor O.G. Villard of SRI International, California.

HORIZONTAL LOOP ANTENNA (HLA)

The HLA¹, developed by G. Hagn and C.A. Hagn (Fig.1), is a gapped rectangle of metal

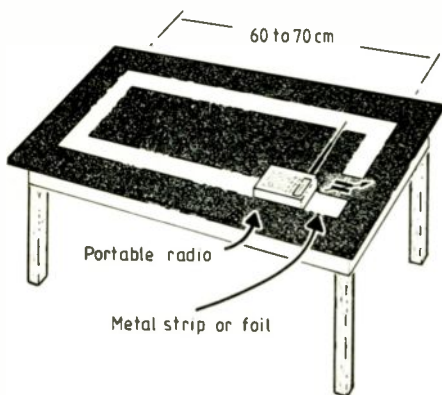

Fig.1 Horizontal Loop Antenna. This responds to the vertical magnetic field of a horizontally polarized wave. The loop is blind to vertically polarized groundwave interference because this has no vertical magnetic field. The loop inductance is low ($1\mu\text{H}$) and the resulting low impedance eliminates hand effects. Ways of improvising the tuning capacitance from domestic materials are described in the IEE paper.

plates or foil, laid on a table top or any similar rigid nonconducting horizontal plane. A variable capacitor (medium-wave type) in the gap tunes to the wanted signal.

Being horizontal, the HLA has minimal response to vertically polarized signals, which makes it blind to any vertically polarized local transmitter, irrespective of its direction. Sky waves from distant transmitters can be received, because even if the original transmission is vertically polarized, horizontal components are generated in the ionosphere. The HLA therefore discriminates against local jamming and interference while accepting distant transmissions. It is virtually omnidirectional and works well with signal-arrival angles 3-60 degrees above horizontal. Attenuation of unwanted ground waves is about 30dB.

A portable receiver with a non-conducting cabinet can be capacitively coupled to the HLA simply by laying it on one side of the gap and extending its built-in whip aerial to the opposite side. Actual electrical contact is not necessary.

A tuning capacitor can be improvised by overlapping the plates and inserting a sheet of dielectric between them; waxed paper and plastic film are suitable. A compression tuning effect is obtainable by slightly bowing the upper plate and moving a heavy object (book, etc.) along the plate over the dielectric. This suggests the possibility of hiding the HLA beneath a tablecloth and tuning by positioning a tray, teapot, samovar, etc. In areas of very strong groundwave field this may be impracticable, because for optimum rejection the table must be tilted to compensate for the tilting of the groundwave front by the earth. In such cases the HLA is best mounted on a separate, tiltable support plane.

Signals may also be extracted from the loop by a one-turn coupling loop of coaxial cable. They can then be taken to a fixed receiver. The Hagns report that, even when there is no interference, the HLA still often gives better reception than the receiver's pull-out whip. This is partly attributable to the Q of the loop (typically 30-40) which locally magnifies the signal field and also gives a useful amount of preselection. Loops like this, made from wide metal strip, have low inductance ($1\mu\text{H}$) and low impedance, making them free from hand effects.

COPLANAR TWIN LOOP (CTL)

To those familiar with the figure-of-eight bidirectional response of a simple loop aerial it comes as something of a shock to learn that loops can be arranged to give a unidirectional cardioid response pattern with a single broad acceptance lobe at the front and a sharp null at the back. This feat of technical legerdemain is performed by Professor Villard's Coplanar Twin Loop (CTL)².

The CTL exploits a little-known property of high-impedance loops (Fig.2), where L is

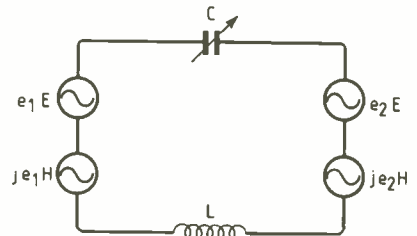

Fig.2 High-impedance loop. A one-turn wire loop is inductance-loaded (L) so that the required tuning capacitance C is small (10pF). Significant amounts of signal voltage are then produced by the electric (E) component of an incident wave as well as by the magnetic (H) component. Left-to-right waves produce different voltages from right-to-left waves. This directional effect is exploited in Villard's Coplanar Twin Loop to give a unidirectional response.

large and C small (10pF). Such a loop shows a significant amount of response to the electric (E) field as well as to the magnetic (H) field.

Assuming vertical polarization and a wave travelling left to right in the plane of the loop, e.m.f.s as shown are induced in the vertical sides. Since, in this orientation, the 'electric' e.m.f.s (e_1E , e_2E) are unequal, a net e.m.f. is available to drive current round the loop. The same goes for the quadrature 'magnetic' e.m.f.s (je_1H , je_2H). If the direction of the wave is now reversed, the instantaneous sign of the electric e.m.f.s is unchanged, but that of the magnetic e.m.f.s is reversed. Hence the loop's net response is changed when the wave direction is changed.

This effect is not noticeable in a low-impedance loop made from a broad band of metal and tuned with a relatively large capacitance (e.g. by using a medium-wave tuning capacitor). In this case the loop impedance is so low that the electric e.m.f.s are virtually shorted and only the magnetic response remains.

In the CTL, (Fig.3) a small, low-impedance magnetic loop is positioned inside a larger high-impedance loop. The two are kept in the same place by attachment to a rigid support such as a sheet of plywood. E.m.f.s are induced in the inner loop in two ways: directly by the incident wave and indirectly by the magnetic field set up by the current circulating in the outer loop. As we have seen, part of this current is due to the electric field of the wave. The resulting e.m.f.s in the inner loop oppose one another. If the coupling between the loops is adjusted

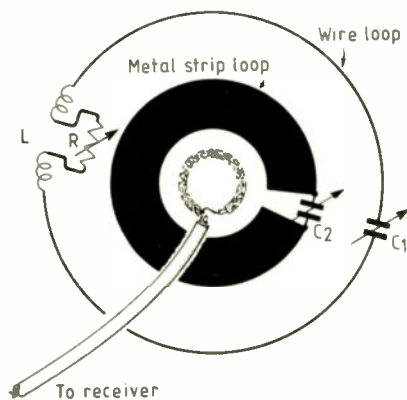

Fig.3 Coplanar Twin Loop aerial. A low-impedance metal strip loop is positioned inside a high-impedance loop. Both are tuned to the same signal. When coupling is adjusted by the damping resistance R a unidirectional null is obtained.

a setting can be found where they cancel.

However, this nulling effect holds good only for one loop orientation. If the coupling is set to produce a deep null for a wave approaching from the left then there is no null for one coming from the right. It turns out that when the loop is oriented to null a signal from the left then the response to signals from the right is maximum.

SKY WAVE NULLING

Since the two loops are close together, changes in the wave field caused by ionospheric variations affect both equally and the null holds good. This is just what is needed for combatting skywave interference. Provided there is enough angular separation between a wanted and an unwanted signal, the unwanted one can be nulled out, or at any rate reduced by more than 20dB. The sort of directional patterns seen in field tests of a CTL are indicated in Fig.4, with the response of a simple loop superimposed for comparison. The degradation of the nulls of the simple loop by multipath effects is typical and shows why such a loop is useless for nulling skywave interference.

The CTL is not too difficult to set up. The inner loop is tuned to mid-band then left alone. Next, the outer loop is tuned. It needs

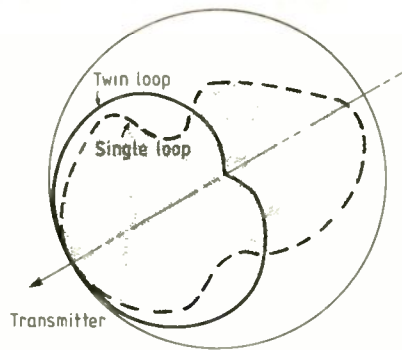

Fig.4 Directional response. The cardioid response of a CTL shows a broad acceptance lobe one way and a 20dB null the other way, when receiving even multi-hop skywave signals. The poor skywave performance of a single loop is shown for comparison.

readjustment if the frequency is changed by more than a few kilohertz. Coupling is adjusted by means of a damping resistance in the outer loop; one coupling adjustment per band is usually enough.

Diversity reception. The CTL lends itself to a form of diversity reception. Under normal multipath conditions it is possible to null out the direct paths to one receiver while a second receiver still responds to them. Thus the receivers respond to two directions of signal. Differences in the path lengths can be large enough to create a pseudo-stereo effect.

Clearly, the CTL can also be set to null groundwave interference, but its main attraction is for skywaves, where its relative insensitivity to arrival angle can be very useful.

H.F. RADAR

Historically, h.f. radar is quite venerable. The earliest practical system of 'radiolocation' (the CH system) used transmissions at 20-30MHz. In those days, however, it was logical to use horizontal polarization, to maximize reflections from aircraft wings. Today, one important type of h.f. radar, ground wave (surface wave) radar (Fig.5) invariably uses vertical polarization. This enables transmitters on the sea coast to take advantage of the refraction produced when vertically-polarized waves are launched over sea water. Such waves propagate far beyond the microwave horizon and can therefore extend the useful range of ground-based radars.

Suitable transmitter sites may be hard to find. A paper by Marconi researchers¹ spells out the requirements. The aerial must be at or very close to sea level, which rules out cliff-top sites. It must be on level ground soaked with salt water; fresh water has insufficient conductivity to refract decametric waves adequately. Since returning echoes are weak the receiver should be remote from man-made noise.

The logical answer is to site the system on a lonely salt marsh — a bleak prospect which might be slightly mitigated by engineering the ground¹. The required vertical mono-

poles can be erected over a wire ground screen. Research at Birmingham University has demonstrated that in one special case a further technique can be used. If the transmitter site consists of a stratum of dielectric material over an underlying high-conductivity layer (e.g., dry sand over brine-soaked sand) the dielectric layer can with advantage be inductively loaded by driving into it vertical metal rods. The researchers used over 600 aluminium rods each two metres long and obtained an improvement in field strength at ground level of around 3dB.

The fixed transmitting aerial of an h.f. radar is used to illuminate a wide sector (e.g. 90°) of ocean. The main directivity of the radar is obtained from the receiving antenna and its associated electronics. Since physical aerial movement is impracticable for large arrays at decametric wavelengths, this

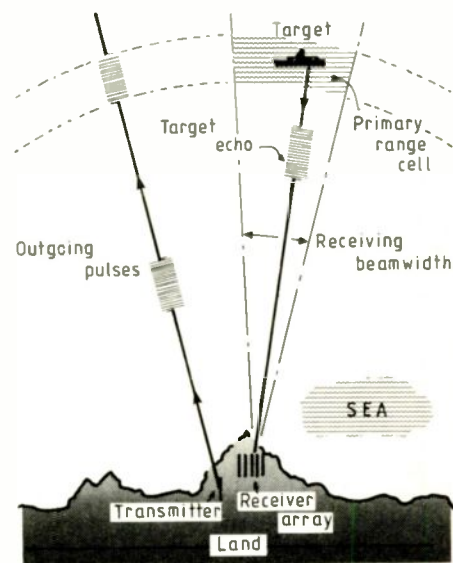

Fig.5 Essentials of a groundwave h.f. radar. The radar site is on the sea coast, so that decametric waves are refracted over the surface. Directivity is provided by a phased array capable of synthesising many narrow beams. Angular resolution can be improved by overlapping beamwidths by 50%. Adapted from ref. 4. Not to scale.

means using a phased array with many elements. Processing gives this the response equivalent to a number of beams each a few degrees wide. The receiving array is separate from the transmitting array (over 200dB of isolation between the two is needed¹), but both may be on the same site.

What can this heroic engineering achieve? The attraction of ground-wave radar to the military mind lies in its promise of detecting ships and low-flying aircraft at ranges which are not usually indicated by researchers but which must, to be useful, run at least to hundreds of kilometres. Civil applications include remote sensing of rough sea conditions, long-distance monitoring of ship and aircraft traffic and perhaps the early detection of tidal waves.

The problem of detecting small targets such as aircraft and ships amounts to picking out special target-echo features from an intense background of sea clutter and noise.

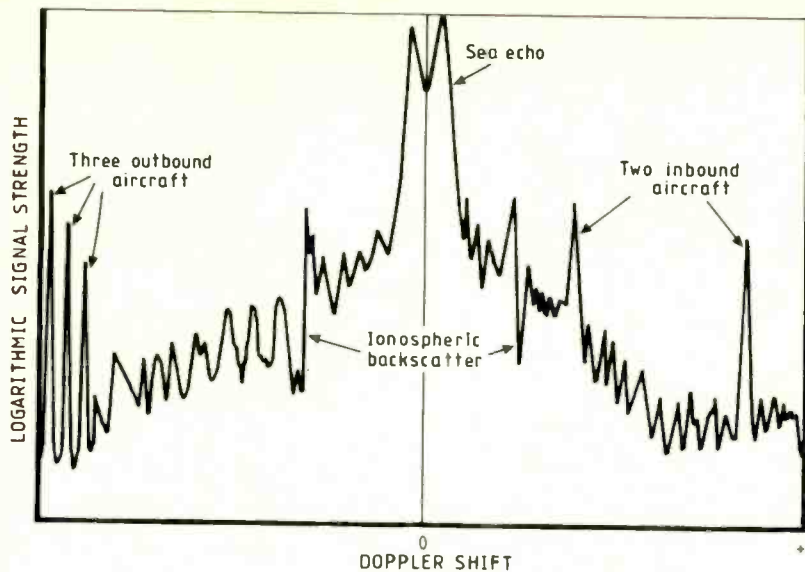

Fig.6 Doppler spectrum of signal returns from groundwave radar. The main sea response is central. Aircraft echoes show large Doppler shifts whose sense indicates the motion of the target towards or away from the radar. Adapted from ref.3.

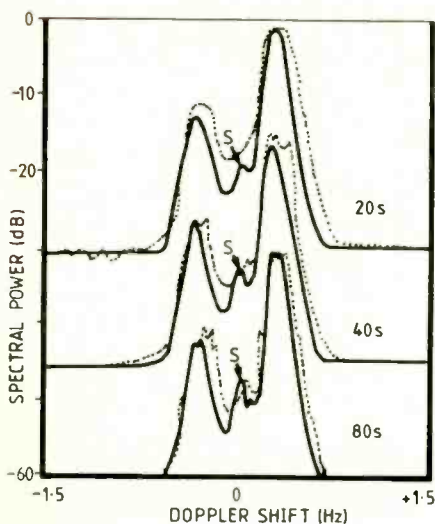

Fig.7 Skywave radar Doppler spectra. Improved target detection after allowing for frequency modulation by changes in the F2 layer. Solid lines, corrected signals; dotted, uncorrected, for three integration times. The two large peaks at about ± 0.5 Hz are the Bragg lines. The small peak (S) is the return from a ship. Adapted from ref.3.

Reflections from ocean waves have been much investigated. They show a small but characteristic Doppler shift, which takes the form of two unequally sized 'Bragg lines' surrounded by a continuum of lower-level Doppler noise. The Bragg lines may be less than 1Hz apart. Returns from aircraft show much greater Doppler shifts (Fig.6) but ships may produce very small shifts which lie between the Bragg lines in the thick of the noise.

In a pulse Doppler system, the need to limit the effective bandwidth (e.g. to 20kHz) calls for longish pulses (50 μ sec) and lowish repetition rates (a few kHz). To average out noise, integration times from a few seconds for aircraft up to a few hundred for ships are needed. Resolution is relatively poor; the pulse length limits the range resolution and the beamwidth the angular resolution. Clever processing may reduce the size of the primary range cell fixed by these quantities, but with aerials of moderate size it is good going to fix a target within a 10km square.

SKYWAVE RADAR

If no convenient ocean is available, or target areas are too distant, h.f. radar must rely for its range on reflections by the ionosphere. In

practice, this may mean using one hop via the F2 layer. A paper from the Chinese People's Republic gives details of a practical system⁶ capable of detecting aircraft at 700-1600km.

The transmitted pulses are frequency-modulated (linear sweep up to 30kHz), up to 3.5ms wide and with a repetition frequency down to 60Hz. Pulse compression based on Fast Fourier transforms is used at the receiver along with much other signal processing.

These measures ensure the *detection* of targets. But the great problem with skywave radar is to say just where your targets are. The ionosphere is notoriously variable. Under civil conditions fixed radar landmarks or transponders may be available to calibrate range but this may not be so in the military arena.

The Chinese system attempts to allow for the state of the ionosphere. A swept-frequency backscatter sounder (using the radar transmitting array on a time-shared basis) generates ionograms from which corrected range figures are calculated. Test runs illustrated in the paper show range errors of less than 4% (target located within about 30km). Old ionosphere hands are likely to have their doubts about calculated

corrections, but the paper shows that the system can work, at any rate on a good day in China.

A paper from France⁷ shows how both ionospheric and sea-surface-induced errors can be allowed for. The basic idea is that variations in the go and return paths produce a frequency modulation of the carrier. This appears as f.m. noise on the Doppler signal. By estimating the amount of f.m. and applying a correction, improved target detectability can be achieved. Target-induced shifts of a small fraction of 1Hz are detectable at long range (Fig.7).

References

- (Page numbers refer to IEE Conference Publication No 284: Fourth International Conference on HF Radio Systems and Techniques.)
1. G.A. Hagn: The Wide-Strip Horizontal Loop Antenna: an Effective Solution for Ground-Wave Interference to Shortwave Reception. (p. 145)
 2. Villard, O.G., Jr: Portable Unidirectional HF Receiving Aerial for Reducing Co-Channel Multi-hop Sky-Wave Interference. (p. 141)
 3. J. Bodonyi and T.W. Pegram: HF Groundwave Radar Theory and Practice. (p. 241)
 4. R.G.L. Evans, D.J. Bagwell and T.S. Maclean: Launching of HF Surface Waves. (p.250)
 5. A.M. Ponsford and D.J. Bagwell: Receiver Design for HF Groundwave Radar. (p.254)
 6. Jiao Peinan and Du Junhu: The Localization Technique for the Experimental HF Skywave Radar. (p.259)
 7. J. Parent and A. Bourdillon: Enhancement of Remote Sensing Capability of HF Skywave Radar by Correcting the Signal for Frequency Modulation. (p.268)

Summer school in broadcasting

If you move fast, you might still be in time to take advantage of a week's crash course in new broadcasting technologies, organized by the IEE. Listed in the provisional programme are sessions on high-definition television, component coding, digital audio and video, MAC, v.t.r. standards, satellite and terrestrial broadcasting, RDS (Radio Data System), measurement techniques, the EBU/SMPTE control system, and stereo sound for tv. Among the speakers are well-known names from manufacturing industry and from the broadcasters' engineering departments.

The vacation school, to be held at the University of Southampton, runs from mid-day on 18 July to 2 p.m. on 22 July. Residential accommodation is available at the University. Cost is £355, including meals, accommodation, an evening social function and v.a.t; non-residential participants pay £250 (£50 less for IEE and IERE members in each case). Two bursaries are offered to IEE members who work for small companies or in the academic field and cannot obtain alternative finance.

Further details and a booking form are available from Lorna Richardson at the IEE, Savoy Place, London WC2R 0BL (tel. 01-240 1871 ext. 330).

CIRCUIT IDEAS

Precision digital ramp generator using switches

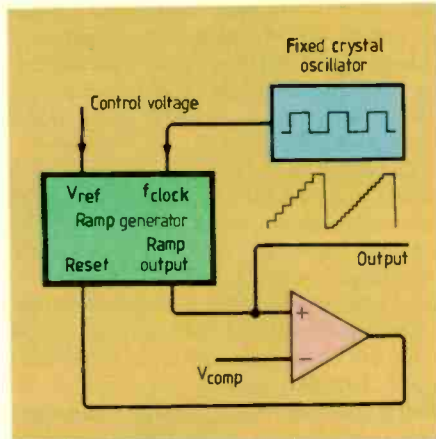

Unlike ramp generators made from digital-to-analogue converters, this circuit allows accuracy of the ramp to be varied. With a small reference voltage and high clock frequency, a staircase with very small steps results. Increasing reference voltage and decreasing clock frequency cause the steps to become larger. Digital-to-analogue converters, connected as shown right of the graphs, produce a fixed number of steps.

On each clock pulse, output increases by V_{REF} so voltage at time t is thus $V_{REF} \times t \times f_{CK}$. Op-amp IC_{1a} forms an adder and IC_{1b,c} form two sample-and-hold circuits. Output of IC_{1b} is the running total and thus final output.

Originally, the circuit was used as a sweep oscillator running under microcomputer control. Providing a crystal-based clock oscillator makes the circuit suitable for the basis of a high-stability v.c.o. in which a comparator would provide a reset pulse when the ramp reaches a specific level. Output frequency is,

$$\frac{V_{REF} \times f_{CK}}{V_{COMP}}$$

Peregrine Andrews
University of York

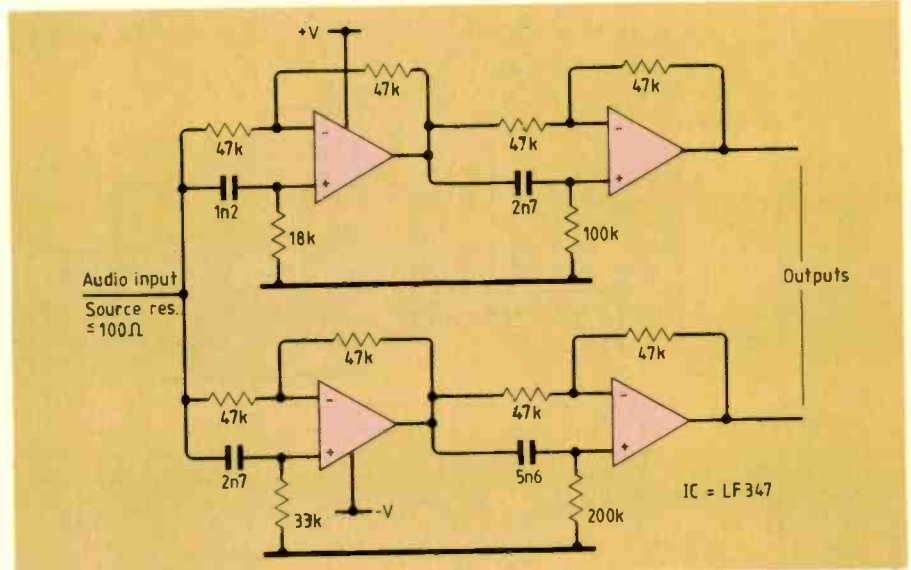

Phase shifter for single sideband

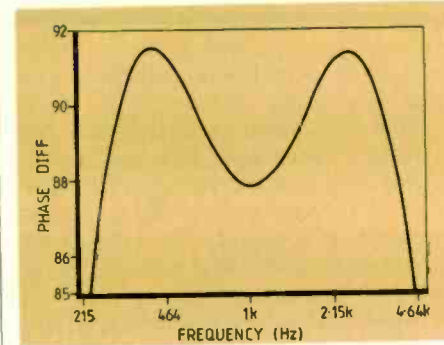

Using the second, or 'out-phasing', method of s.s.b generation eliminates the need for steep filters for reducing the unwanted sideband but requires an audio signal with a constant phase shift of 90° across the band. The two outputs of this circuit are in quadrature within 3° between 270Hz and 4kHz, which could theoretically produce up to 25dB rejection of the unwanted sideband.

Capacitor values are critical and I recommend Mullard 1% polystyrene 425 types; these should not be subjected to defluxing agents. The resistor values should also be within 1%.

J.R. Charlesworth
Kirkbymoorside
North Yorkshire

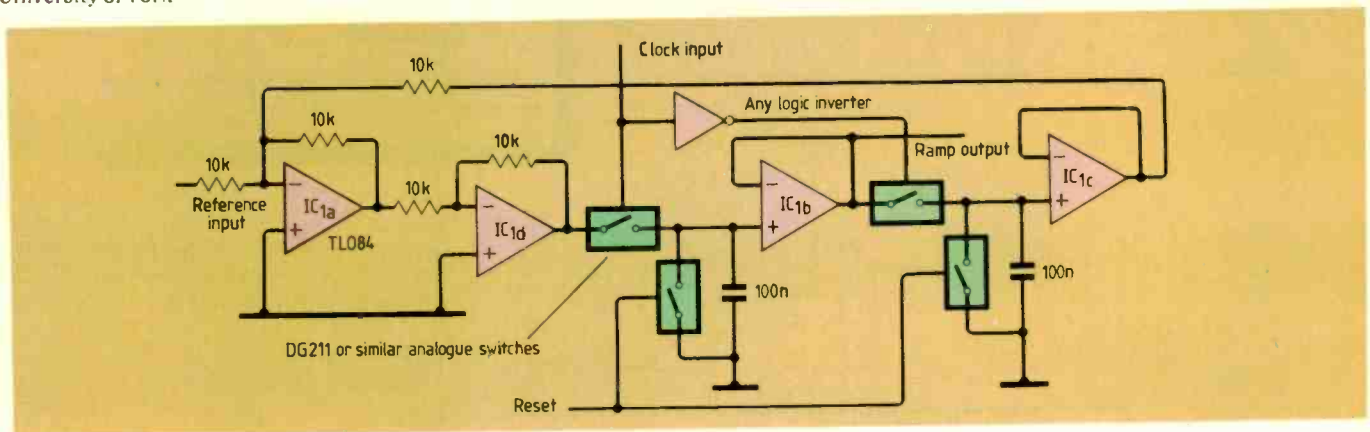
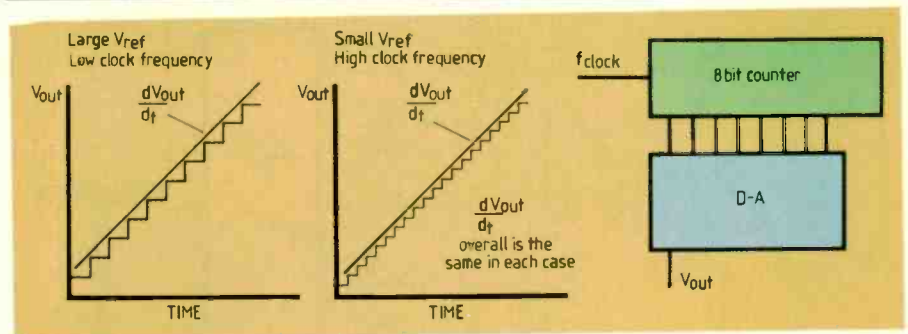

CIRCUIT IDEAS

Digital tendency indicator

Three leds and three c-mos i.c.s connected to the output of an analogue-to-digital converter provide an indication of the direction of change in an electrical signal representing, say, temperature. Eight-bit binary data from the converter is also available for decoding and display driving.

Converter output bits D_0-3 feed one set of inputs to a four-bit comparator. The other four comparator inputs are fed with the previous converter reading held in a latch. Comparator outputs $A=B$, $A>B$ and $A<B$ drive leds to indicate the direction of change.

Display updating occurs once a second since the converter is driven from a 256Hz clock. Oscillator-divider IC₁ provides the 256Hz converter clock, the start-conversion signal and the latch pulse, which can be set to latch data for 4, 16, 32 or 64 seconds. Clock output and the latch pulse can be altered to suit the application.

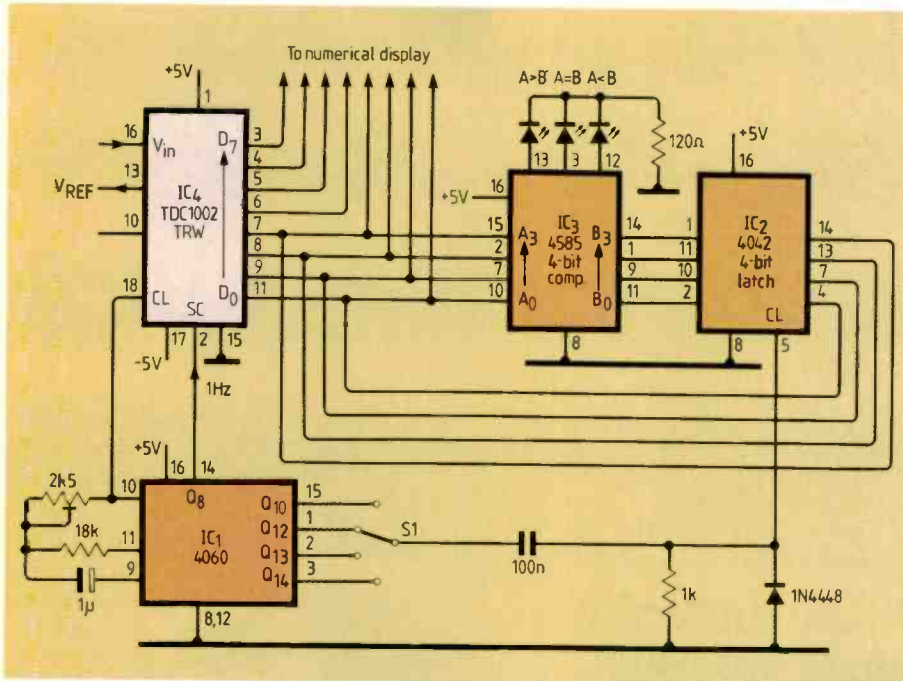

Analogue delay using a 12bit a-to-d converter

Delay lines in which an analogue signal is digitized and stored for later retrieval and conversion back to analogue form are widely used. Most published circuits though are

either slow or use low-resolution a-to-d and d-to-a converters.

With a $5\mu\text{s}$ conversion time and 12bit resolution, the AD7572 analogue-to-digital converter is both fast and accurate. Shown here is a circuit that can delay analogue signals from 20ms to 40.96s in binary steps at bandwidths of 10kHz and 5Hz respectively.

Input is taken through an op-amp to the

a-to-d converter's analogue input. A crystal oscillator provides the 2.4576MHz required to clock the converter and, after division through counters, the memory address lines. Monostable i.c.s, synchronized by pulses from the oscillator circuit, produce chip-select, read and output-enable signals for the a-to-d/d-to-a converters and ram.

The rams are accessed sequentially. At each address, the contents are read and the

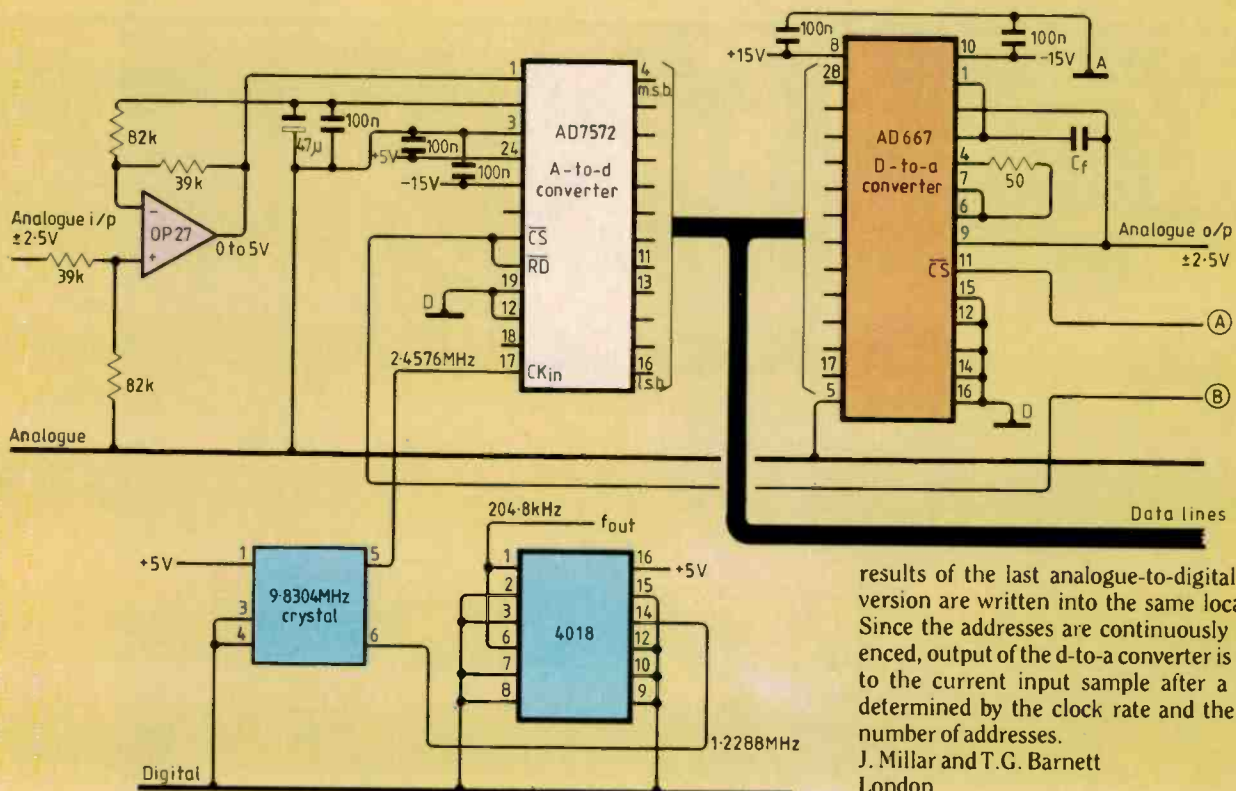

results of the last analogue-to-digital conversion are written into the same location. Since the addresses are continuously sequenced, output of the d-to-a converter is equal to the current input sample after a delay determined by the clock rate and the total number of addresses.

J. Millar and T.G. Barnett
London

CIRCUIT IDEAS

To prevent undesirable effects from noise and small voltage fluctuations, the comparator inputs are simply moved up one or two bits, i.e. connected to D_{1-4} or D_{2-5} . Replacing the comparator with an a.l.u. for subtraction, and connecting its output to an appropriate numerical driver will give a temperature gradient reading.
 Petrovic Tomislav
 Nis, Yugoslavia

Simple remote-controlled amplifier

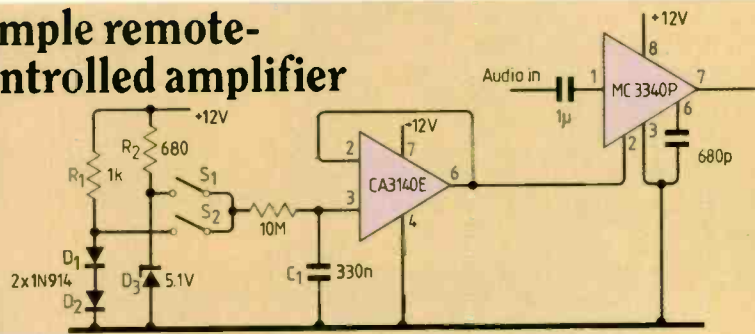

This is a cheap alternative to the usual digital circuitry required for remote control. It relies on the voltage across capacitor C_1 to control the gain of an MC3340 electronic attenuator. The capacitor, a low leakage type, must be buffered by a mosfet-input op-amp such as the CA3140 to ensure a very long discharge time.

Closing S_1 causes C_1 to charge, resulting in a decrease in volume, while closing S_2 increases volume. Both switches should

preferably be miniature relays since semiconductor switches like the 4016 allow small currents to flow in the off state, thereby altering the capacitor voltage.

Diodes D_{1-3} with $R_{1,2}$ set upper and lower limits of the capacitor voltage range for a 12V supply. With metallized polyester-film capacitors we observed a 90mV fall over a 13 hour period; over an hour, less than 2mV.
 C. Anyanwu and J. Agada
 University of Nigeria

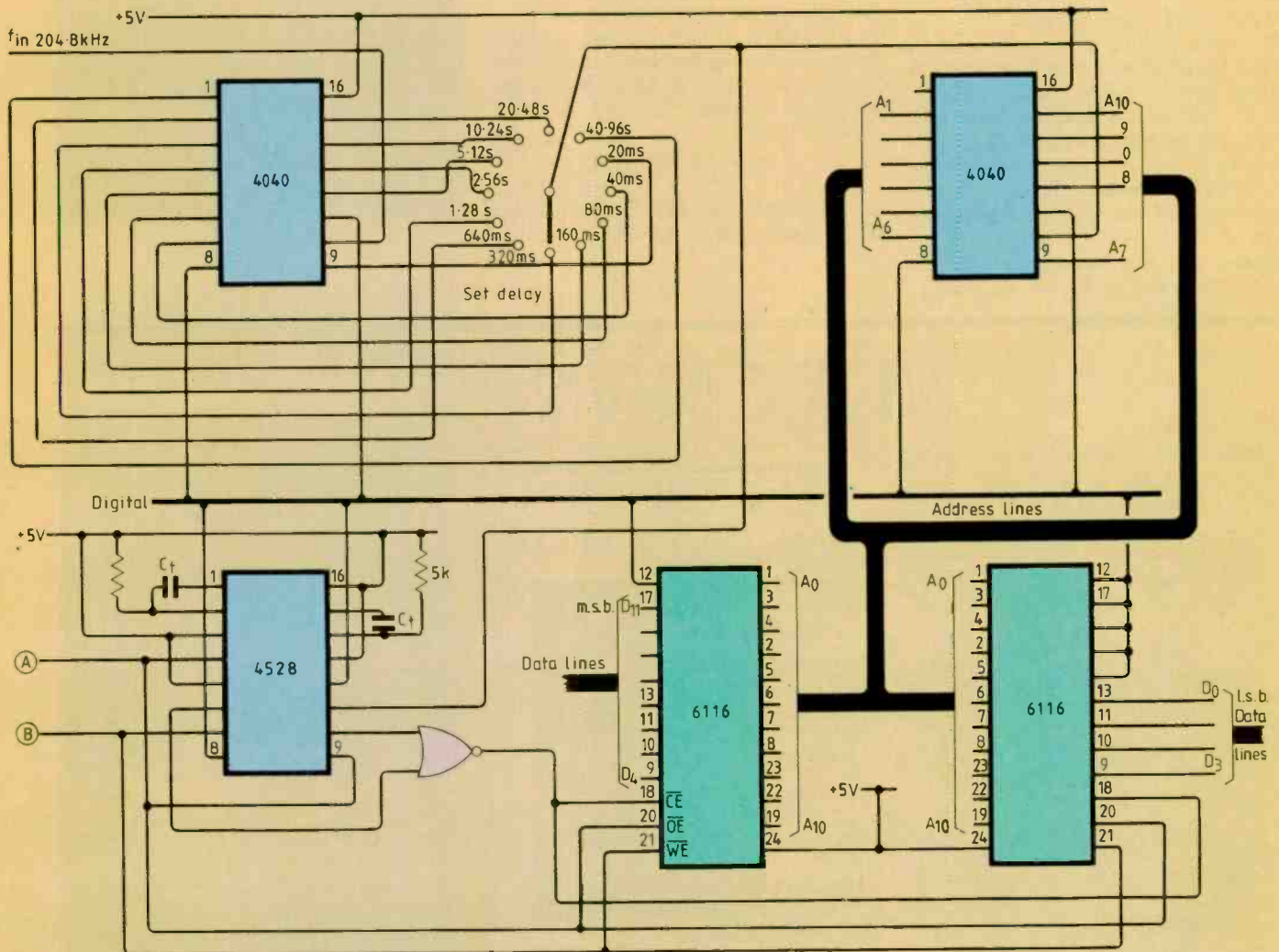
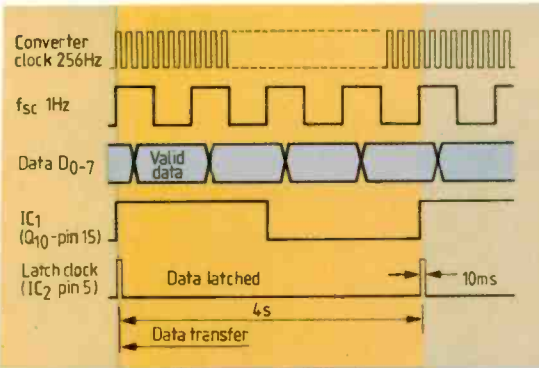

CIRCUIT IDEAS

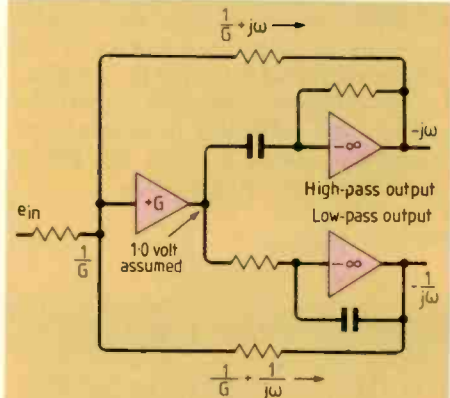
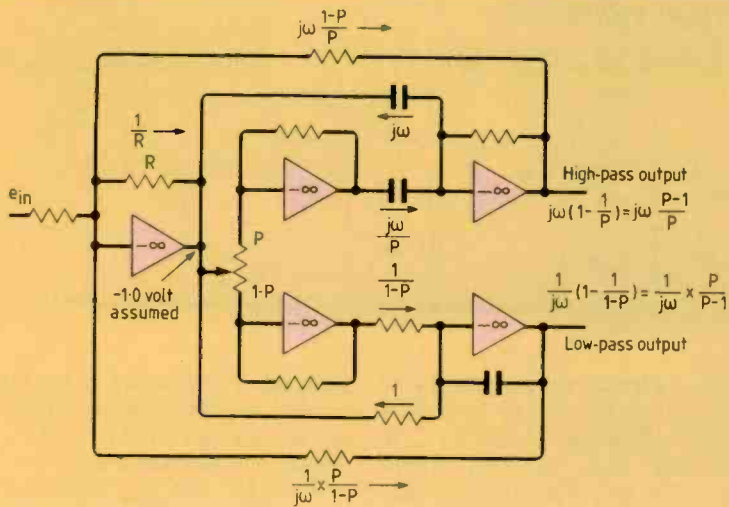

Crossover filter

These two circuits are combined high and low-pass filters useful as low-level crossover networks. In the first circuit, right, all values except gain G are normalized to unity. Output voltage of this amplifier is taken to be 1V and transmissions T_{LP} T_{HP} are the ratios of output to input.

As shown, with the proper choice of G , T_{LP} and T_{HP} are Butterworth functions with common cut-off frequency $\omega=1.0$. This is the usual choice for crossover networks. Crossover frequency can be scaled by simultaneously varying either both capacitors or both of their associated resistors so the network can be tuned with a dual potentiometer.

Tuning can also be accomplished by changing the gains in the two channels in

such a way that their product is a constant of, say 1.0. How a single potentiometer can be connected so that the resistance from wiper to one end controls one gain and resistance from wiper to the other end the other gain is shown in the second diagram. Overall resistance of this potentiometer is 1.0, with P being the setting and resistor R playing much the same role as gain G .

As is evident, $(P-1)/1$ is simply a multiplier on ω showing that the potentiometer controls the crossover frequency in the proper way. Contant,

$$e_{in} = \frac{1}{R} + j \left(\omega - \frac{1}{\omega} \right)$$

so following the analysis in the first diagram, outputs are maximally flat when,

$$R = \sqrt{2}$$

NEXT MONTH

Digital signal processing. Alan Swards raises and answers some of the questions that commonly occur to engineers facing d.s.p. for the first time. The aspect covered in this case is the sampling of an analogue signal, converting it by a-to-d and performing a fast Fourier transform.

Smith's chart. Philip Smith wrote of his Transmission-line Calculator in *Electronics* in 1939. It rapidly became known as simply the Smith Chart and has been in widespread use by r.f. engineers ever since. Joules Watt describes the background and application.

MosMarx. P.E.K. Donaldson, of the Medical Research Council, describes an alternative to the Cockroft-Walton voltage multiplier - the Marx generator. This modern variant incorporates mosfets and Schottky diodes in place of



spark gaps and resistors and is able to provide a d.c.-to-d.c. conversion efficiency of nearly 90%. As an illustration, a voltage quintupler to give 45V at 250mA is shown.

Measuring by ultrasound. It isn't very often that worthwhile development comes about as a result of a "blinding flash", it is more often the outcome of a long process of development work. R.J. Redding describes the development of a technique for ultrasonic flow measurement.

Pioneers - Faraday. Michael Faraday, a formidable and totally practical investigator, has been called the "plain man's scientist". Tony Atherton continues his series on the pioneers of communications with a look at one of the men who started it all.

Total confidence



is what you'll derive from Schlumberger's new 7150plus 6½-digit DMM ... because its components are specially chosen for performance and reliability and it is tested to military standards ... because you'll readily master its comprehensive range of facilities ... because it will meet all your measurement needs with outstanding accuracy and sensitivity ... and because, to underline our own total confidence, it comes with a two-year warranty.

Schlumberger Technologies
Instruments

Schlumberger-Solartron
Victoria Road, Farnborough, Hampshire GU14 7PW, England.
Telephone: Farnborough (0252) 544433
Fax: Farnborough (0252) 543854. Telex: 858245 Solfar G
Cables: Solartron Farnborough Hants

ENTER 20 ON REPLY CARD

KESTREL ELECTRONIC COMPONENTS LTD.

★ All items guaranteed to manufacturers spec.
★ Many other items available.
'Exclusive of V.A.T. and post and package'

	1+	50+		1+	50+
7406	0.28	0.20	8 Meg	0.45	0.35
74LS244	0.30	0.21	16 Meg	0.45	0.35
74LS245	0.30	0.21	ILQ-74	1.50	1.35
74LS373	0.30	0.21	1488	0.25	0.16
6809	2.50	2.20	1489	0.25	0.16
6821	1.25	0.95	LM2901	0.80	0.60
6845	2.50	2.20	LM2917-8	1.50	0.75
6850	1.60	1.40	2764-25	2.50	2.30
6502	2.80	2.40	2764A-25	2.20	2.00
6522P	2.80	1.85	27C64-20	3.00	2.60
8031	2.80	1.70	27128-25	3.70	3.40
8085	1.60	0.95	27C128A-25	3.40	3.10
8253-5	1.90	1.30	27C128-25	2.98	2.72
LM319N	0.50	0.46	27256-25	3.30	3.12
32.768Khz Crystal	0.25	0.16	27C256-25	3.50	3.22
1.8432 MHz	0.95	0.70	43256C12L	10.00	9.00
2.4576 MHz	0.75	0.65	ICL8211CPA	0.80	0.60
3.5795 MHz	0.50	0.35	TL084CN	0.50	0.45
4 Meg	0.45	0.35	8251A	1.25	1.00
4.194304	0.45	0.35	Z80ACTC	1.00	0.80
6 Meg	0.45	0.35	Z80AP10	1.00	0.80

All memory prices are fluctuating daily, please phone to confirm prices.

178 Brighton Road,
Purley, Surrey CR2 4HA
Tel: 01-668 7522. Fax: 01-668 4190

ENTER 40 ON REPLY CARD

STEREO AND AMBISONICS CODER: MPX4



MPX4 is a high performance stereo coder incorporating a 32nd order Walsh generator producing an inherently clean output spectrum with high and stable channel separation. In addition the unit will code 38kHz quadrature (Ambisonics T, front/back) and 76kHz double sideband (Q, height).

Other unique features are pilot fade up/down for clickless mono-stereo switching, a 31.185kHz oscillator which allows precision Bessel null adjustment or transmitter deviation to 75kHz and an illuminated peak deviation meter. All audio inputs have group delay compensated 15kHz filters and exceptional in band ripple of ±0.15dB giving unusually good preservation of waveshape.

SURREY ELECTRONICS LTD
The Forge, Lucks Green, Cranleigh,
Surrey GU6 7BG.
Tel: 0483 275997

Filter design using a microcomputer

Steps required in the design of active and passive Butterworth and Chebyshev filters

S. NIEWIADOMSKI

The modern approach to filter design, developed in the 1950s, greatly simplified the process of producing practical filters, making it possible for non-experts to design complex filter circuits. Briefly, the process depends on the use of pre-calculated catalogues of normalized component values for low-pass filters, which are then scaled to the desired frequency and impedance level. Filter responses other than low-pass can be implemented by applying a transformation to the low-pass prototype and then performing the scaling process. Over the years many books (see the bibliography) and articles have been published on this approach to filter design, and the method has been very successful. There are, however, three drawbacks to the catalogue method, namely:

- catalogues can only document a finite number of combinations of filter parameters, such as order and passband ripple, and so inevitably some compromise is required to match the filter specification with the designs available in the catalogue;
- catalogues tend to be published in expensive books which are not easily accessible;
- manual searching through catalogues for a suitable design, the extraction of data and scaling to the final frequency and impedance level are not entirely satisfactory processes today.

The underlying design equations which enabled the catalogues to be produced required formidable computing power thirty years ago, but can easily be tackled by even the cheapest personal computer today. It seems logical then, that these equations are now made available to enable programming into personal computers, liberating us from the restrictions of the catalogue method.

This article describes the steps required to design passive and active Butterworth and Chebyshev filters and also gives listings of programs which perform the necessary calculations. It would be possible to write a single program to handle the whole of Butterworth and Chebyshev filter design: the program could be menu-driven, taking the user through all the choices available at each step, and turning a specification into a final practical filter design. The drawback with this approach is that not all users will want such a comprehensive program and may require only a small part. The onus is therefore put on those who want a comprehensive package to merge together the individual programs presented here.

The programs are written in Basic for the Sinclair Spectrum computer, although the author recognises that many other types are in use. To aid the conversion of programs to other computers or languages, statements are avoided which might cause problems. Similarly, the graphical display of results, which again can make conversion difficult, is avoided. Details of the specific dialect of Basic implemented on a particular machine will be found in the language manual accompanying it. Some guidance on converting Basic programs to run on different machines can be found in Reference 1.

FILTER ORDER ESTIMATION

The first step when designing a filter to meet a given specification, whether a passive or active implementation is to be used, is to determine the order of filter required. Traditionally, nomographs (Reference 2) have been used which effectively transform the algebraic process of solving an equation into the geometric process of drawing lines on a graph. Clearly, the algebraic process is the more suitable for implementation on a computer. The nomograph method can also be inaccurate and in some instances results in the use of a more complex filter than strictly necessary.

With a Butterworth filter, only the stopband filtering requirement needs to be specified to enable the order to be calculated, as all Butterworth filters have an identical passband specification. Equation 1 calculates this order.

$$n = \frac{\log_{10} \sqrt{10^{A_p/10} - 1}}{2 \log_{10} \left(\frac{\omega}{\omega_c} \right)} \quad (1)$$

where n is the order of the Butterworth filter.

A is the stopband attenuation in dB,
 ω_c is the cut-off frequency,
 ω is the frequency at which the attenuation is specified.

Estimating the order of a Chebyshev filter is slightly more complex because a new variable, the passband ripple, has been introduced. Equation (2) shows how the order can be calculated from the passband ripple and the stopband performance.

$$n = \frac{\cosh^{-1} \sqrt{\frac{10^{A_p/10} - 1}{\epsilon^2}}}{\cosh^{-1} \left(\frac{\omega}{\omega_c} \right)} \quad (2)$$

where n is the order of the Chebyshev filter,
 A is the stopband attenuation in dB,
 ω_c is the cut-off frequency,
 ω is the frequency at which the attenuation is specified,
 ϵ is the ripple factor.

Since inverse hyperbolic functions (such as $\cosh^{-1} x$) are not usually available on home computers, a useful relationship is:

$$\cosh^{-1} x = 1n(x + \sqrt{x^2 - 1}) \quad (3)$$

In equation (2), the passband ripple is expressed in terms of the ripple factor, whereas a more common format is in terms of the maximum value of the ripple in dB. Equation (4) shows how the ripple factor can be calculated from the ripple in dB for use in Equation 2.

$$\epsilon = \sqrt{10^{A_p/10} - 1} \quad (4)$$

where A_p is the passband ripple in dB.

Program 1 (ORDER) implements these equations. If the answer "b" is given after the

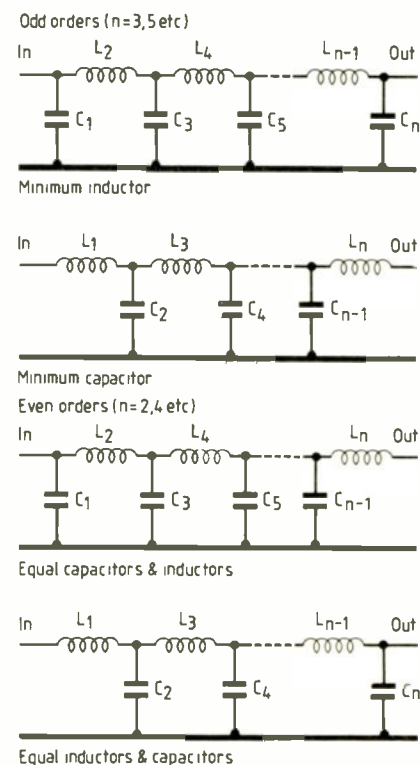

Fig.1. Passive Butterworth low-pass filter implementations

prompt for the filter type, the program works out the order of a Butterworth filter after further prompting for the appropriate values. The cut-off frequency and the frequency at which the stop-band attenuation is specified can be in rad/s or Hz, as long as they are both in the same units. The Butterworth section of the program takes advantage of the fact that the value of ratio of the logarithms of two numbers is independent of the base of the logarithms. Therefore, although the logarithms are taken to base 10 in equation (1), the Spectrum program uses logarithms to base e, which are all that are available in Spectrum Basic.

If the answer "c" is given after the prompt for the filter type, the program works out the order of a Chebyshev filter from equation (2). One additional value for the filter specification, the passband ripple, is required in the Chebyshev case. As for the Butterworth filter, the cut-off frequency and the frequency at which the stopband attenuation is specified can be in rad/s or Hz.

As well as printing the exact value of filter order needed to satisfy a specification, the program also rounds the order upwards and outputs this value. The orders estimated are equally valid for passive and active implementations of the filters.

PASSIVE LOW-PASS BUTTERWORTH FILTER DESIGN

Figure 1 shows the possible configurations for passive Butterworth low-pass filters. For odd orders, there is a minimum-inductor and a minimum-capacitor implementation which are duals of each other: that is, the responses of the duals are identical in all respects. When a low-pass filter is required, the minimum-inductor version is usually chosen, but if the low-pass filter is merely a prototype for transformation to a filter with a different response, the minimum-capacitor version can lead to a better transformed filter. Even-order filters have an equal number of capacitors and inductors, and therefore there is often little to choose between the duals.

Calculation of component values for passive Butterworth filters with equal source and termination impedances is fairly simple and equation (5) is presented here to enable this to be performed if required (reference 3).

$$COMP_k = 2 \sin \frac{(2k-1)\pi}{2n} \text{ for } k=1, 2, \dots, n \quad (5)$$

where $COMP_k$ is the k th component value, being either a shunt capacitor (in Farads) or a series inductor (in Henries) of the circuits shown in Fig. 1, and n is the order of the filter.

If filters with unequal source and termination impedances are required, the calculations are not so simple: this section describes the design of such filters and gives a program to perform the calculations. In fact, equation (5) can be ignored as the more general method can be used with equally terminated filters by entering 1 ohm as the terminating impedance.

Figure 2 shows two implementations of passive Butterworth low-pass filters: note

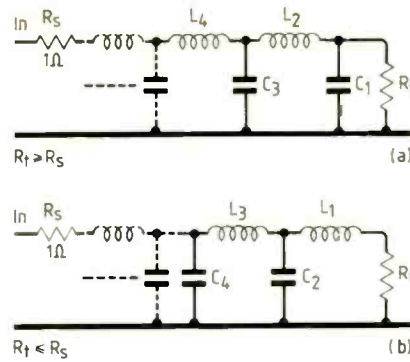

Fig.2 Passive low-pass Butterworth filter implementations showing the component designations produced by the general design method.

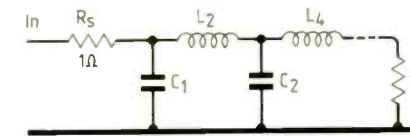

Fig.3 Passive low-pass Chebyshev filter circuit diagram showing component designations produced by the design method.

that in these circuits the filter components are not numbered in the conventional way, that is starting at the input and working towards the output. This is a peculiarity of the method of design described in this section. Circuit (a) has a shunt capacitor, C_1 , closest to the output, whereas circuit (b) has a series inductor, L_1 , closest to the output. Both circuits have source impedances of 1 ohm. With filters having equal source and termination impedances, the circuits are duals of each other and either implementation can be used. When a filter with unequal source and termination impedances is required, only one implementation is suitable: circuit (a) can be used where the termination impedance is greater than or equal to the source impedance, and circuit (b) can be used where the termination impedance is less than or equal to the source impedance.

The first step in the calculation of the component values (reference 4) is to determine λ

$$\lambda = \left(\frac{R_t - 1}{R_t + 1} \right)^{1/n} \text{ for } R_t \geq R_s \quad (6)$$

or

$$\lambda = \left(\frac{1 - R_t}{1 + R_t} \right)^{1/n} \text{ for } R_t \leq R_s \quad (7)$$

where R_t is the termination impedance, R_s is the source impedance (1 ohm), and n is the order of the filter.

The value of the first component can now be calculated from the expressions

$$C_1 = \frac{\alpha_i}{R_t(1-\lambda)} \text{ for } R_t \geq R_s \quad (8)$$

$$L_1 = \frac{\alpha_i R_t}{(1-\lambda)} \text{ for } R_t \leq R_s \quad (9)$$

where α_i is obtained by substituting $i=1$ into the expression:

$$\alpha_i = 2 \sin \frac{\pi i}{2n} \quad (10)$$

The remaining component values are now calculated by stepping m from 1 to $(n-1)/2$ when n is odd, or to $n/2$ when n is even, in the following equations.

$$C_{2m-1} L_{2m} = \frac{\alpha_{4m-3} \alpha_{4m-1}}{1 - \lambda \beta_{4m-2} + \lambda^2} \quad (11)$$

and

$$C_{2m+1} L_{2m} = \frac{\alpha_{4m-1} \alpha_{4m+1}}{1 - \lambda \beta_{4m} + \lambda^2} \quad (12)$$

for $R_t \geq R_s$, or

$$L_{2m-1} C_{2m} = \frac{\alpha_{4m-3} \alpha_{4m-1}}{1 - \lambda \beta_{4m-2} + \lambda^2} \quad (13)$$

and

$$L_{2m+1} C_{2m} = \frac{\alpha_{4m-1} \alpha_{4m+1}}{1 - \lambda \beta_{4m} + \lambda^2} \quad (14)$$

for $R_t \leq R_s$, where α_i is given by equation (10) and β_i is given by

$$\beta_i = 2 \cos \frac{\pi i}{2n} \quad (15)$$

Program 2 (BUTPASS) implements these equations. A major portion of the program is concerned with determining whether a particular component is a capacitor or an inductor and printing out the normalized component value preceded by a component designation. If the component designations are not required, the program can be simplified. The designations produced by BUTPASS correspond to Fig.2: that is, the value of the component closest to the output is generated first and is either shunt capacitor C_1 or series inductor L_1 . If an equal source and termination impedance filter is specified, the print out indicates that each component value refers to either a shunt capacitor or a series inductor.

PASSIVE LOW-PASS CHEBYSHEV FILTER DESIGN

The design of passive Chebyshev filters (reference 5) is similar to the Butterworth case, but is slightly more complex because of the incorporation of an extra variable, the passband ripple.

The first step is to calculate the quantity a , from the termination impedance and ripple factor, using the expression:

$$a = \frac{4R_t}{(R_t + 1)^2} \text{ when } n \text{ is odd} \quad (16)$$

or:

$$a = \frac{4R_t}{(R_t + 1)^2} [1 + \epsilon^2] \text{ when } n \text{ is even} \quad (17)$$

where R_t is the termination impedance, ϵ is the ripple factor, and n is the order of the filter.

In the case where the filter order is even, a test must be carried out on the value of a , and the specification can only be implemented by this method if a is less than or equal to 1.

The by letting

$$\alpha_i = 2 \sin \frac{\pi i}{2n} \quad (18)$$

$$\beta_i = 2 \cos \frac{\pi i}{2n} \quad (19)$$

$$\gamma = \left[1 + \sqrt{\frac{1}{\epsilon^2} + 1} \right]^{1/n} \quad (20)$$

$$\delta = \left[\sqrt{\frac{1-a}{\epsilon^2} + 1} + \sqrt{\frac{1-a}{\epsilon^2} + 1} \right]^{1/n} \quad (21)$$

$$x = \gamma - \frac{1}{\gamma} \quad (22)$$

and

$$y = \delta - \frac{1}{\delta} \quad (23)$$

The value of the first capacitor (the component closest to the input of the filter in this case) can be calculated from the expression:

$$C_1 = \frac{2\alpha_1}{x-y} \quad (24)$$

The remaining component values are now calculated by stepping m from 1 to $(n-1)/2$ for n odd, or to $n/2$ for n even, in the following equations. Figure 3 shows the component designations to which the results apply.

$$C_{2m-1} L_{2m} = \frac{4\alpha_{4m-3} \alpha_{4m-1}}{b_{2m}(x,y)} \quad (25)$$

and

$$C_{2m+1} L_{2m} = \frac{4\alpha_{4m-1} \alpha_{4m+1}}{b_{2m}(x,y)} \quad (26)$$

where the function $b_1(x,y)$ is defined by

$$b_1(x,y) = x^2 - \beta_{2i}xy + y^2 + \alpha_{2i}^2 \quad (27)$$

Program 3 (CHEBPASS) performs these calculations, after prompting for the appropriate values. The program gives component designations as in Fig. 3.

ACTIVE LOW-PASS FILTER DESIGN

Nowadays, active filters, using op-amps as the active elements, tend to be more popular than passive filters, especially for audio frequency applications. Whether a Butterworth or a Chebyshev (or Bessel, for that matter) response is required, a similar approach to the design of active filters can be adopted. The method relies on the fact that active sections with first and second responses can be cascaded to form filters of any complexity. Because of the inherent isolation of output from input of an op-amp, an active section retains its individual response even when cascaded with other sections. Figure 4 shows how active filters of orders from 1 to 4 can be built from first and second-order sections. Higher-order filters are implemented by simply adding further sections. The required overall response for the filter is obtained by selecting the correct design parameters for each of the sections.

The simplest implementation of a first-order section is an RC network. By adding an op-amp to the output of the network, a section which can be cascaded without load-

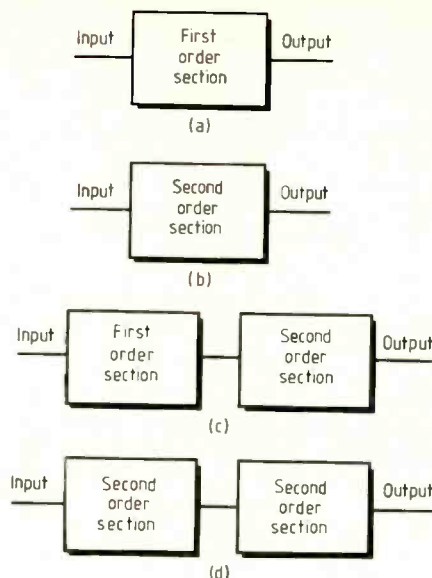

Fig.4 Active low-pass filters are built up by cascading first and second order sections. Adjustment of the parameters of the individual sections gives the desired overall response. At (a) is a first-order filter, (b) is a second-order filter and (d) is a fourth order filter

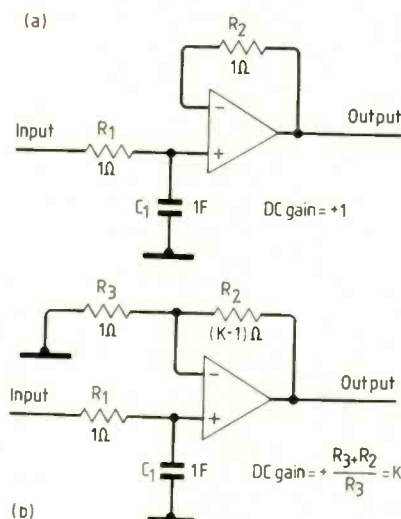

Fig.5 Simple normalized, first-order, low-pass active filter sections, where (a) has a d.c. gain value of 1, and (b) has a d.c. gain of

$$\frac{R_2 + R_3}{R_3}$$

ing effects is obtained. This type of first-order section is ideal for use in multi-section active filters. Figure 5 shows two possible implementations of first order active sections. Figure 5(a) is a unity gain (at d.c.) section whereas the circuit in Fig. 5(b) can have its d.c. gain set to any reasonable value by adjusting the ratio of R_2 to R_3 . The component values shown are for a cut-off frequency normalized to 1 rad/s. All that is required to change this cut-off frequency is to divide the capacitor value by a factor $\omega\phi$, so that for values of $\omega\phi$ greater than 1, the value of C_1 is decreased and so the cut-off frequency of the section is raised, and con-

versely when $\omega\phi$ is less than 1 the cut-off frequency is lowered.

Many different implementations for second-order sections have been developed over the years, each optimized for a particular aspect of performance. Typical parameters which can influence which type of section is used include the gain (if any) required from the section, the performance demanded for the op-amp for a given section specification, the ease of tuning the section to an exact cut-off frequency if required and the sensitivity of the section to small deviations of the component values which are inevitable when a section is built using real components. Figure 6(a) shows a normalized unity-gain Sallen and Key second-order section. The expressions for the values of C_1 and C_2 can be seen to contain the variable d , which is the reciprocal of the section Q . Figure 6(b) shows a Sallen and Key second-order section with equal capacitor values. With this circuit, the section gain cannot be set independently, but depends on the value of d chosen.

Figure 7 shows how the value of d affects the amplitude response close to cut-off of a unity gain section which has been scaled to 1 kHz. Lower values of d , and hence higher section Q , result in a greater peak before the response starts to tail off and tend towards infinite attenuation. With $d=1.414$, the attenuation at 1 kHz is 3.01dB, giving a Butterworth response: when $d=1.045$, 0.886 and 0.766, Chebyshev responses with peak gains of 1, 2 and 3dB respectively are obtained.

The amplitude response of a normalized second-order section can be moved up and down the frequency axis by dividing the capacitor values by the quantity $\omega\phi$, in the same way that the cut-off frequency of a first-order section can be varied. This allows the 3.01dB frequency (for Butterworth sections) or the peak gain frequency (for Chebyshev sections) to be set to suit the overall requirement of any filter into which they fit. To summarize, by choosing the appropriate values for d and $\omega\phi$, the cut-off frequency of a second-order section can be altered, and Butterworth or Chebyshev type responses can be obtained.

Figure 8 shows a different implementation of a second-order section. This circuit is a normalized, unity-gain, state-variable section (reference 6) which has some advantages over the rather simpler Sallen and Key circuits. One interesting feature is that it has high-pass and band-pass outputs as well as its low-pass output, which could be useful in some applications. Figure 9 shows a normalized state-variable section with gain. This circuit allows the section gain to be set independently of the value of d , which was not the case with the Sallen and Key circuits. These three and four op-amp sections do not necessarily have to cost a great deal more or occupy much more board area than the single op-amp circuits. Quad op-amp packages are cheaply available and allow easy implementation of these circuits.

Design of an active filter therefore consists of selecting a value for $\omega\phi$ for the first-order section (if the overall filter order is odd), and d and $\omega\phi$ for each of the second-order sections. Gain can be obtained

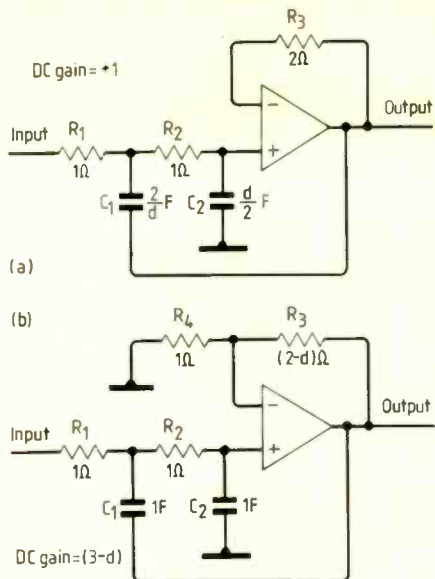

Fig.6 Second-order Sallen and Key filter sections. At (a) is a unity-gain section and at (b) an equal-component-value section.

if required by selecting the appropriate implementations of the sections. In the same way that catalogues of normalized component values for passive filters are available, there are also catalogues of d and $\omega\phi$ for active filters (reference 7). Some catalogues (reference 8) express this information in terms of the roots of the equations describing the responses in the complex plane, which can easily be converted into the $d, \omega\phi$ format. The methods of determining values of d and $\omega\phi$ for Butterworth and Chebyshev active filters will now be described.

ACTIVE LOW-PASS BUTTERWORTH FILTER DESIGN

The first step in obtaining the values of d and $\omega\phi$ for each of the sections in a Butterworth active filter is to determine the locations of the poles in the complex plane for the required response. Only the order of the filter needs to be specified to calculate these pole positions, using equations (27), (28) and (29) (reference 9).

$$\alpha_k = -\sin\theta_k \quad (28)$$

and

$$\beta_k = \cos\theta_k \quad (29)$$

where

$$\theta_k = \frac{(2k-1)\pi}{2n} \text{ for } k=1 \text{ to } (n+1)/2 \quad (30)$$

For even values of n , there will be $n/2$ pairs of poles which are complex conjugates of each other. For odd values of n , there will be one purely real pole (with $d=2$) and $(n-1)/2$ pairs of complex conjugates poles.

The complex pole format can now be converted into the $d, \omega\phi$ format by using equations (31) and (32).

$$\omega_0 = \sqrt{\alpha_k^2 + \beta_k^2} \quad (31)$$

$$d = \frac{-2\alpha_k}{\omega_0} \quad (32)$$

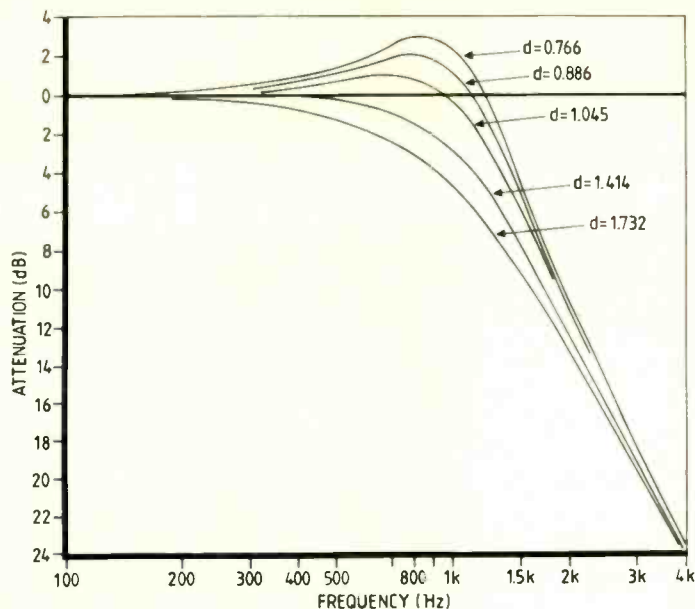

Fig.7 Amplitude response of a unity-gain, second-order, low-pass active section for various values of d . The response has been scaled to 1kHz.

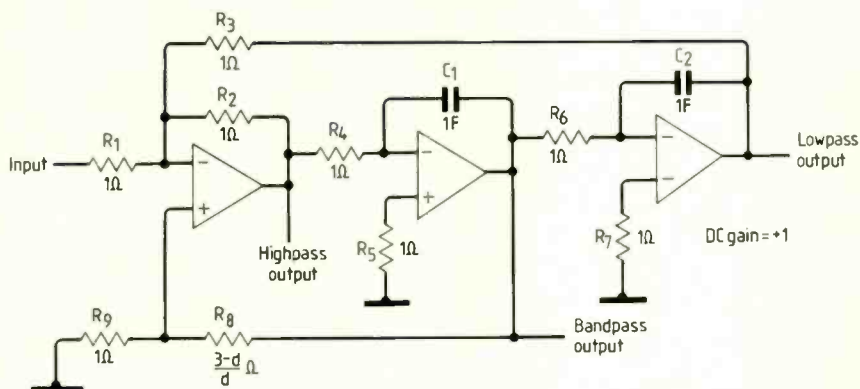

Fig.8 The normalized, unity-gain, second-order, state-variable active section. Note that this section has high-pass and band-pass outputs, as well as a low-pass output.

Program 4 (BUTACT) implements these equations, prompting for the filter order, and printing the values of d and $\omega\phi$ for each first and second-order section in the filter. In general, it is best to place the first-order section (if the filter order is odd) closest to the input and the second-order sections in order of descending d . This ensures that the greater peak gains obtained from higher-Q sections are less likely to result in overloading of subsequent sections.

ACTIVE LOW-PASS CHEBYSHEV FILTER DESIGN

The first stage in calculating d and $\omega\phi$ values for Chebyshev filters (reference 10) is to determine the quantity a using the formula:

$$a = \frac{1}{n} \sinh^{-1} \frac{1}{\epsilon} \quad (33)$$

where n is the filter order, and ϵ is the ripple factor.

A useful formula for determining the inverse hyperbolic sine function on a personal computer is:

$$\sinh^{-1} x = \ln(x + \sqrt{x^2 + 1}) \quad (34)$$

The locations of the poles in the complex plane for the response are given by

$$\alpha_k = -\sin\theta_k \sinh a \quad (35)$$

and

$$\beta_k = \cos\theta_k \cosh a \quad (36)$$

$$\text{where } \theta_k = \frac{(2k-1)\pi}{2n} \quad (37)$$

for $k=1$ to n

For even values of n , there will be $n/2$ pairs of poles which are complex conjugates of each other. For odd values of n , there will be one purely real pole (with $d=2$) and $(n-1)/2$ pairs of complex conjugates poles.

$\sinh a$ and $\cosh a$ are calculated from the relationship

$$\sinh a = \frac{e^a - e^{-a}}{2} \quad (38)$$

and

$$\cosh a = \frac{e^a + e^{-a}}{2} \quad (39)$$

The complex pole format can again be converted into the $d, \omega\phi$ format by using equations (31) and (32).

Program 5 (CHEBACT) implements these

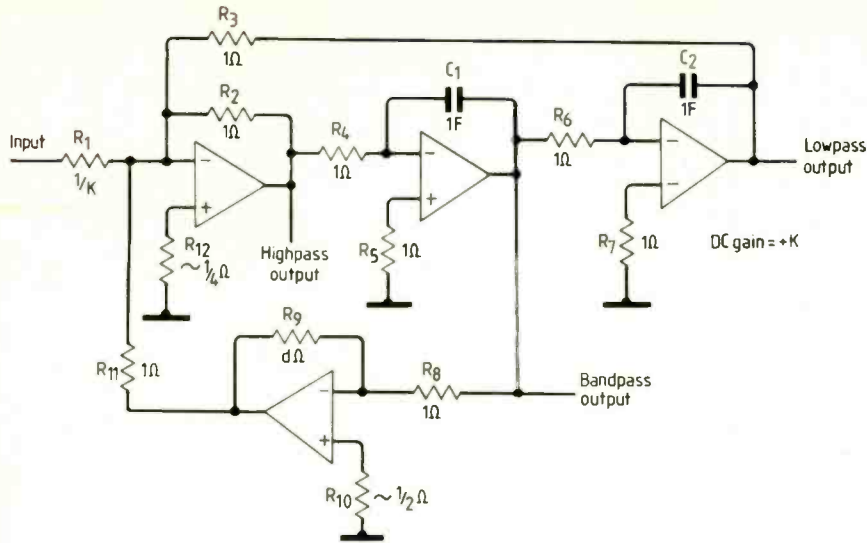

Fig. 9 The normalized, variable gain, second-order, state-variable active section.

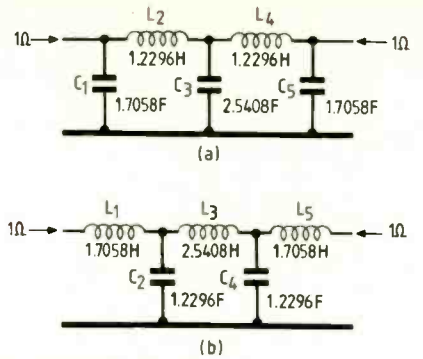

Fig. 10 Normalized component values produced by CHEBPASS for the design example.

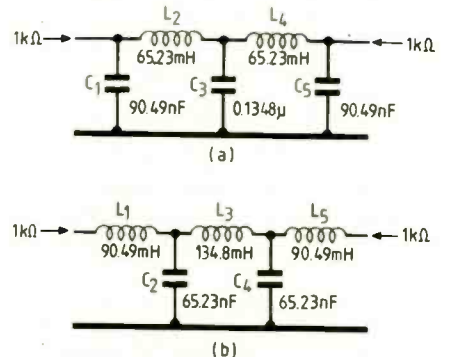

Fig. 11 Scaled (3kHz, 1KΩ) values produced by SCALE for the design example.

this scaling process. As well as scaling the components, the program adjusts the scaled value and prints it pF, nF or μF for capacitors, and μH, mH or H for inductors. Note that the parts of the program which adjust and print the values are constructed as subroutines, starting at line 1000 (for capacitors) and line 2000 (for inductors). The statements following the subroutine returns cause the prompt for another normalized component value to be printed. If the final frequency and impedance need to be modified each time the scaling process is carried out, lines 260 and 360 can be changed to GO TO 100.

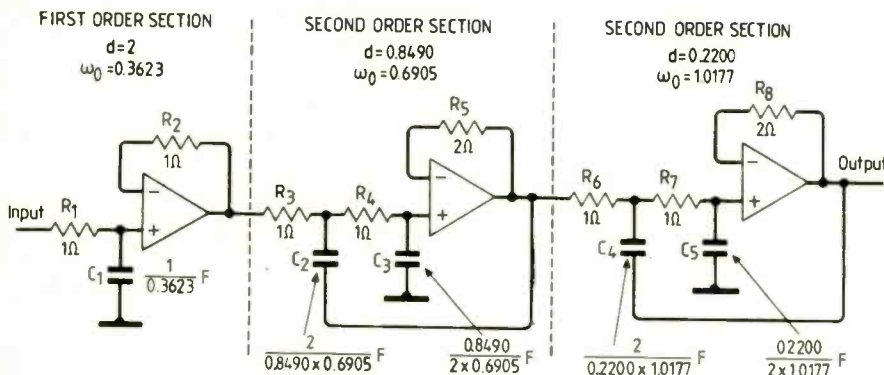

Fig. 12 The normalized Sallen and Key implementation of the active-filter design example.

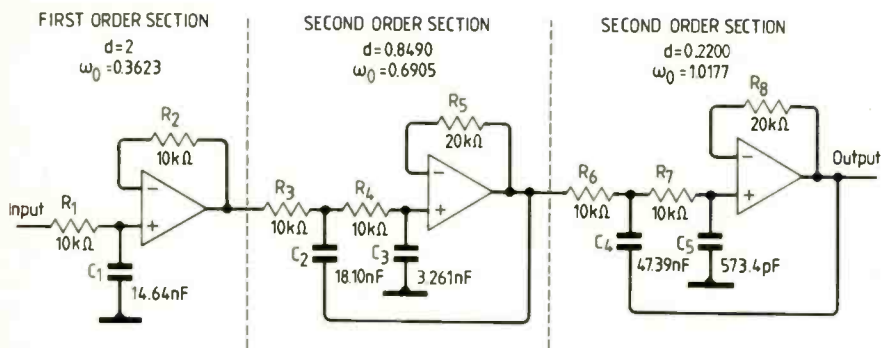

Fig. 13 The active-filter design example with component values scaled to 3kHz, 10kΩ.

equations, prompting for the passband ripple and the filter order, and outputting the values of d and $\omega\phi$ for each and second-order section in the filter.

COMPONENT SCALING

The scaling of filter components from their 1 rad/s, 1 ohm values to their final frequency and impedance is a vital part of the modern filter design process. Equations (40) and (41) show how capacitors and inductors are scaled.

$$C = C_n \frac{1}{2\pi f Z} \quad (40)$$

$$L = L_n \frac{Z}{2\pi f} \quad (41)$$

where C is the final capacitor value, L is the final inductor value, C_n is the 1 ohm, 1 rad/s capacitor value, L_n is the 1 ohm, 1 rad/s inductor value, Z is the final impedance, and f is the final frequency.

In active filters, resistors are scaled using the simple formula:

$$R = R_n \times Z \quad (42)$$

where R is the final resistor value, R_n is the 1 ohm, 1 rad/s resistor value, and Z is the final impedance.

Scaling capacitors and inductors can be a tedious process, especially if many components have to be scaled and several different final impedance and frequency combinations tried. SCALE (Program 6) performs

EXAMPLES

To illustrate the use of the techniques described in this article, two worked examples are now presented:

Obtain passive and active implementations of Chebyshev low-pass filters with the following specifications:

	Passive	Active
passband ripple	0.5dB	0.5dB
cut-off frequency	3kHz	3 kHz
stopband attenuation at a frequency of	40dB	40dB
system impedance	6 kHz	6 kHz
	1 kohm	10 kohm

Note that the filter specifications are identical except for the system impedances, and therefore the same order will be required for both filters. Running *FILTORD* in the "c" option gives exact and rounded orders of 4.82176 and 5 respectively.

Tackling the passive implementation first: the system impedance for the filter is specified as 1 kΩ, implying equal source and terminating impedances. When *CHEBPASS*

Program 1 (FILTORD)

```

5      REM This program is called FILTORD (Spectrum version)
100   INPUT "Butterworth or Chebyshev (b/c):";f$
110   IF f$ = "b" THEN GO TO 200
120   IF f$ = "c" THEN GO TO 300
130   REM invalid input
140   PRINT "invalid filter type, try again"
150   GO TO 100
200   REM Butterworth filter selected
210   INPUT "cut-off frequency:";fcut
220   INPUT "required attenuation (dB):";atten
230   INPUT "at a frequency of:";fatten
240   LET n = LN(10*(atten/10)-1)/(2*LN(fatten/fcut))
250   GO TO 1000
300   REM Chebyshev filter selected
310   INPUT "ripple cut-off frequency:";fcut
320   INPUT "required attenuation (dB):";atten
330   INPUT "at a frequency of:";fatten
340   INPUT "passband ripple (dB):";ripple
350   LET etasqu = 10*(ripple/10)-1
360   LET x = SQR((10*(atten/10)-1)/etasqu)
370   LET y = fatten/fcut
380   LET n = LN(x+SQR((x*x)-1))/LN(y-SQR((y*y)-1))
390   GO TO 1000
1000  REM order rounding and print routine
1010  LET nround = INT(n)-1
1020  PRINT "exact order = "
1030  PRINT "rounded order "
1040  STOP

```

Program 2 (BUTPASS)

```

5      REM This program is called BUTPASS (Spectrum version)
100   INPUT "filter order:";n
110   INPUT "termination impedance (ohm):";r1
200   IF r1>1 THEN LET lambda = ((r1-1)/(r1+1))^(1/n)
210   IF r1<1 THEN LET lambda = ((1-r1)/(r1+1))^(1/n)
220   IF r1=1 THEN LET lambda = 0
300   PRINT "Component designations are from output to input"
310   REM first component value
320   LET a = 2*SIN(PI/(2*n))
330   IF r1>1 THEN GO TO 400
340   GO TO 500
400   LET comp = a/(r1*(1-lambda))
410   PRINT "C1=";comp;" F"
420   GO TO 600
500   LET comp = (a*r1)/(1-lambda)
510   IF r1<1 THEN PRINT "L1=";comp;" H"
520   IF r1=1 THEN PRINT "C1/L1=";comp;" F/H"
600   REM calculating other components
610   FOR m=1 TO n/2
620   LET comp = (4*SIN((PI*(4*m-3))/(2*n))*SIN((PI*(4*m-1))/(2*n)))/
      ((1-lambda*2*COS(PI*(4*m-2)/(2*n))-lambda^2)*comp)
630   IF r1>1 THEN PRINT "L";2*m;"=";comp;" H"
640   IF r1=1 THEN PRINT "C";2*m;"="/C";2*m;"=";comp;" F/H"
650   IF r1<1 THEN PRINT "C";2*m;"=";comp;" F"
700   IF n<=2*m THEN STOP
710   LET comp = (4*SIN((PI*(4*m-1))/(2*n))*SIN((PI*(4*m-1))/(2*n)))/
      ((1-lambda*2*COS(PI*(4*m)/(2*n))-lambda^2)*comp)
720   IF r1>1 THEN PRINT "C";2*m-1;"=";comp;" F"
730   IF r1=1 THEN PRINT "C";2*m-1;"L";2*m-1;"=";comp;" F/H"
740   IF r1<1 THEN PRINT "L";2*m-1;"=";comp;" H"
800   NEXT m

```

Program 3 (CHEBPASS)

```

5      REM This program is called CHEBPASS (Spectrum version)
100   INPUT "filter order:";n
110   INPUT "passband ripple (dB):";ap
120   INPUT "termination impedance (ohm):";r1
200   LET refl = SQR(10*(ap/10)-1)
210   REM test for n odd
220   IF n = 2*(INT(n/2)+0.5) THEN GO TO 400
300   REM n must be even
310   LET o$ = "even"
320   LET a = (1-refl^2)*4*r1/((r1-1)^2)
330   IF a<=1 THEN GO TO 500
340   REM a > 1, therefore can't implement this specification
350   PRINT "Can't implement this specification"
360   STOP
400   REM n is odd
410   LET o$ = "odd"
420   LET a = 4*r1/((r1-1)^2)
500   LET x = (1/refl*SQR((1/refl^2)-1))^(1/n)
510   LET y = (SQR((1-a)/refl^2)+SQR(((1-a)/refl^2)+1))^(1/n)
520   LET x1 = x-1/x
530   LET y1 = y-1/y
540   LET num1 = PI/(2*n)
600   REM first component value
610   LET comp = (4*SIN(num1))/(x1-y1)
700   IF o$="odd" AND r1>1 THEN PRINT "L1 = ";comp;" H"
710   IF o$="odd" AND r1=1 THEN PRINT "C1/L1 = ";comp;" F/H"
720   IF o$="odd" AND r1<1 THEN PRINT "C1 = ";comp;" F"
730   IF o$="even" AND r1<1 THEN PRINT "C1 = ";comp;" F"
740   IF o$="even" AND r1>1 THEN PRINT "L1 = ";comp;" H"
800   FOR m=1 TO n/2
810   LET b = x1^2-2*x1*y1*COS((4*m-2)*num1)-y1^2-(2*SIN((4*m-2)*num1))^2
820   LET comp = (16*SIN((4*m-3)*num1)*SIN((4*m-1)*num1))/(b*comp)
830   IF o$="odd" AND r1>1 THEN PRINT "C";2*m;"=";comp;" F"
840   IF o$="odd" AND r1=1 THEN PRINT "L";2*m;"="/C";2*m;"=";comp;" H/F"
850   IF o$="odd" AND r1<1 THEN PRINT "L";2*m;"=";comp;" H"
860   IF o$="even" AND r1<1 THEN PRINT "L";2*m;"=";comp;" H"
870   IF o$="even" AND r1>1 THEN PRINT "C";2*m;"=";comp;" F"
900   IF n<=2*m THEN STOP

```

```

910   LET b = x1^2 - 2*x1*y1*COS((4*m*num1) + y1^2 + (2*SIN((4*m*num1))^2
920   LET comp = (16*SIN((4*m-1)*num1)*SIN((4*m+1)*num1))/(b*comp)
930   IF o$="odd" AND r1>1 THEN PRINT "L";2*m-1;"=";comp;" H"
940   IF o$="odd" AND r1=1 THEN PRINT "C";2*m-1;"="/L";2*m-1;"=";comp;" F/H"
950   IF o$="odd" AND r1<1 THEN PRINT "C";2*m-1;"=";comp;" F"
960   IF o$="even" AND r1<1 THEN PRINT "C";2*m-1;"=";comp;" F"
970   IF o$="even" AND r1>1 THEN PRINT "L";2*m-1;"=";comp;" H"
1000  NEXT m

```

Program 4 (BUTACT)

```

5      REM This program is called BUTACT (Spectrum version)
100   INPUT "required order:";order
200   PRINT "Values of d and v0 are:"
210   PRINT
300   FOR k = 1 TO (order-1)/2
310   LET thetak = ((2*k-1)*PI)/(2*order)
320   LET real = -SIN(thetak)
330   LET imag = COS(thetak)
340   LET v0 = SQR(real*real + imag*imag)
350   LET d = -(2*real)/v0
360   PRINT " d = ";d
370   PRINT " v0 = ";v0
380   PRINT
390   NEXT k
400   STOP

```

Program 5 (CHEBACT)

```

5      REM This program is called CHEBACT (Spectrum version)
100   INPUT "passband ripple (dB):";ap
110   INPUT "required order:";order
200   LET eta = SQR(10*(ap/10)-1)
210   LET inveta = 1/eta
220   LET a = (LN((inveta)-SQR((inveta^2)-1)))/order
230   LET sinha = (EXP(a)-EXP(-a))/2
240   LET cosha = (EXP(a)+EXP(-a))/2
300   FOR k=1 TO (order-1)/2
310   LET thetak = ((2*k-1)*PI)/(2*order)
320   LET real = -SIN(thetak)*sinha
330   LET imag = COS(thetak)*cosha
340   LET v0 = SQR(real*real+imag*imag)
350   LET d = -2*real/v0
400   PRINT " d = ";d
410   PRINT " v0 = ";v0
420   PRINT
430   NEXT k
440   STOP

```

Program 6 (SCALE)

```

5      REM This program is called SCALE (Spectrum version)
100   INPUT "final frequency (Hz)";freq
110   INPUT "final impedance (ohm)";impd
120   INPUT "capacitor or inductor (c/l)";c$
130   IF c$ = "c" THEN GO TO 200
140   IF c$ = "l" THEN GO TO 300
150   REM invalid component type
160   PRINT "invalid component, try again"
170   GO TO 120
200   REM capacitor scaling routine
210   INPUT "normalised capacitor value (F)";ncap
220   LET scap = ncap/(2*PI*freq*impd)
230   REM now get it printed
240   LET pcap = scap
250   GO SUB 1000
260   GO TO 120
300   REM inductor scaling routine
310   INPUT "normalised inductor value (H)";nind
320   LET sind = nind*impd/(2*PI*freq)
330   REM now get it printed
340   LET prind = sind
350   GO SUB 2000
360   GO TO 120
1000  REM capacitor adjusting and print subroutine
1010  IF pcap<=9 THEN GO TO 1100
1020  IF pcap<=7 THEN GO TO 1200
1030  GO TO 1300
1100  REM value will be printed in pF
1110  LET ppcap = pcap*1e12
1120  PRINT "scaled capacitor value = ";ppcap;"pF"
1130  RETURN
1200  REM value will be printed in nF
1210  LET ppcap = pcap*1e9
1220  PRINT "scaled capacitor value = ";ppcap;"nF"
1230  RETURN
1300  REM value will be printed in uF
1310  LET ppcap = pcap*1e6
1320  PRINT "scaled capacitor value = ";ppcap;"uF"
1330  RETURN
2000  REM inductor adjusting and print subroutine
2010  IF prind<=3 THEN GO TO 2100
2020  IF prind<1 THEN GO TO 2200
2030  GO TO 2300
2100  REM value will be printed in uH
2110  LET prind = prind*1e6
2120  PRINT "scaled inductor value = ";prind;"uH"
2130  RETURN
2200  REM value will be printed in mH
2210  LET prind = prind*1e3
2220  PRINT "scaled inductor value = ";prind;"mH"
2230  RETURN
2300  REM value will be printed in H
2310  PRINT "scaled inductor value = ";prind;"H"
2320  RETURN

```

prompts for the terminating impedance, 1 is therefore entered. CHEBPASS produces the following results:

$$C_1/L_1 = 1.70577 \text{ F/H}$$

$$L_2/C_2 = 1.22963 \text{ H/F}$$

$$C_3/L_3 = 2.54083 \text{ F/H}$$

$$L_4/C_4 = 1.22963 \text{ H/F}$$

$$C_5/L_5 = 1.70577 \text{ F/H}$$

These values correspond to the dual circuits shown in Fig. 10. SCALE can be run with a final frequency of 3000 Hz and a final impedance of 1000 ohm, giving the scaled values shown in Fig. 11.

The active implementation will now be designed. Running CHEBACT gives the following values (rounded to four decimal places here) for the three sections required (one first and two second order sections)

$$d = 0.2200$$

$$\omega\phi = 1.0177$$

$$d = 0.8490$$

$$\omega\phi = 0.6905$$

$$d = 2$$

$$\omega\phi = 0.3623$$

If unity-gain sections are used to build the filter, the circuit of Fig. 12 is the Sallen and Key implementation. Note that the capacitor values contain the d and $\omega\phi$ results, and the first-order section (with $d=2$) is placed nearest the input, then the $d = 0.8490$ and finally the $d = 0.2200$ section.

The circuit is scaled to 3kHz, 10k Ω by multiplying the resistors by 10000 and using SCALE on the capacitor values. Figure 13 shows the final component values.

Computer simulation of the circuits in Figs 5, 11 and 13 give identical results, as expected. The 0.5dB passband ripple and 3 kHz cut-off frequency specifications are met exactly, and the attenuation at 6 kHz is 42dB, better than specified because of the rounding upwards of the filter order.

Bibliography

- Analog and Digital Filters: Design and Realisation, H. Y-F. Lam, published by Prentice-Hall.
- Simplified Modern Filter Design, P R Geffe, published by John F Rider, 1963.
- Filter Design and Evaluation, G E Hansell, published by Van Nostrand Reinhold.

References

1. Amateur Radio Software, J. Morris, published by RSGB, 1985. Appendices: BASIC Program Adaptions, pages 319 to 324.
2. Handbook of Filter Synthesis, A.I. Zverev, published by Wiley, 1967. Pages 140, 141.
3. Analog and Digital Filters: Design and Realisation, H. Y-F. Lam, published by Prentice-Hall. Page 238..
4. As reference 3, pages 236 to 238.
5. As reference 3, pages 261 to 262.
6. Active Filter Cookbook, D. Lancaster, published by Sams, 1980. Page 156.
7. As reference 6, pages 73 to 76, 79.
8. Electronic Filter Design Handbook, A.B. Williams, published by McGraw-Hill, 1981. Pages 12-1, 12-19 to 12-23.
9. As reference 3, page 235.
10. Analog Filter Design, M.E. Van Valkenburg, published by Holt, Rinehart and Winston. Page 235.

Subscribe today...



...and receive 8 issues free!

A three year subscription to *Electronics & Wireless World* costs only £53, delivered free to the address of your choice; that's a massive saving of almost 25% – the equivalent of eight issues free!

SUBSCRIPTION ORDER FORM

Please send me *Electronics & Wireless World* for three years at the special price of £53.00*
*Includes postage and packing

I enclose a cheque/PO to the value of £ _____ made payable to Reed Business Publishing Limited.

Please debit my credit account:
 Access Barclaycard/Visa American Express Diners Club
 Expiry date _____

Name _____ Signed _____

Address _____

Please return to Electronics & Wireless World, Room L302, Quadrant House, The Quadrant, Sutton, Surrey SM2 5AS.

Subscribe today – you won't be disappointed.

Sequency-division multiplex

The use of Walsh functions offers a successful alternative to frequency-division multiplex or time-division multiplex.

CHARLES LANGTON

The problem is as old as the concept of electrical communication itself. How can several (perhaps many) stations at each end of a link communicate with each other when there is only one channel connecting them?

The solution, of course, is to multiplex, or interleave all the transmitting stations in some way, and send this composite signal down the line. At the receiving end the signals have to be disentangled or de-multiplexed, so that ultimately the separated signals are each presented to their appropriate reproducer. Figure 1 shows the general idea of multiplexing.

In a correctly adjusted system, each receiver will be able to listen to its appropriate transmitter and be oblivious to the fact that other messages are sharing the same link.

TRADITIONAL METHODS OF MULTIPLEXING

The two most well known methods of multiplexing are frequency-division multiplex (f.d.m.) and time-division multiplex (t.d.m.).

Frequency-division multiplex was certainly in force in the early days of wireless communication. It was necessary for each transmitter to impress its modulation upon a carrier frequency unique to that station. All such carriers were propagated through the same link (free space, alias aether). Upon reaching a receiving aerial, tuned circuits or filters selected the desired modulated carrier from the multitude of unwanted signals, thereby resulting in intelligible communication via one common medium.

This principle has been most elegantly refined to the extent that single-line links or radio beams are in normal use, each carrying very many channels of information simultaneously.

Time-division multiplex is an alternative system which allows many channels of information to be sent along one single link. The development of t.d.m. was accelerated by feasibility studies into pulse-code modulation (p.c.m.) by the international telecommunication authorities. P.c.m. was declared good but expensive, and could only be introduced if costs could be reduced by multiplexing many channels along each link. T.d.m., being a pulsed system, fitted in with p.c.m. ideally.

In practice, a t.d.m. system operates by

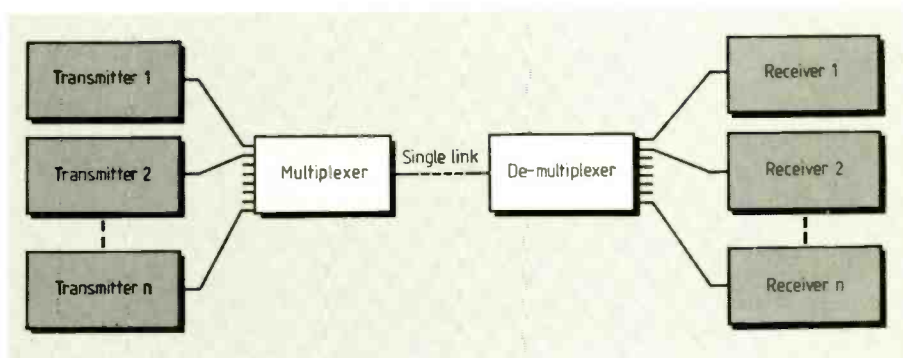

Fig. 1. General system of multiplexing.

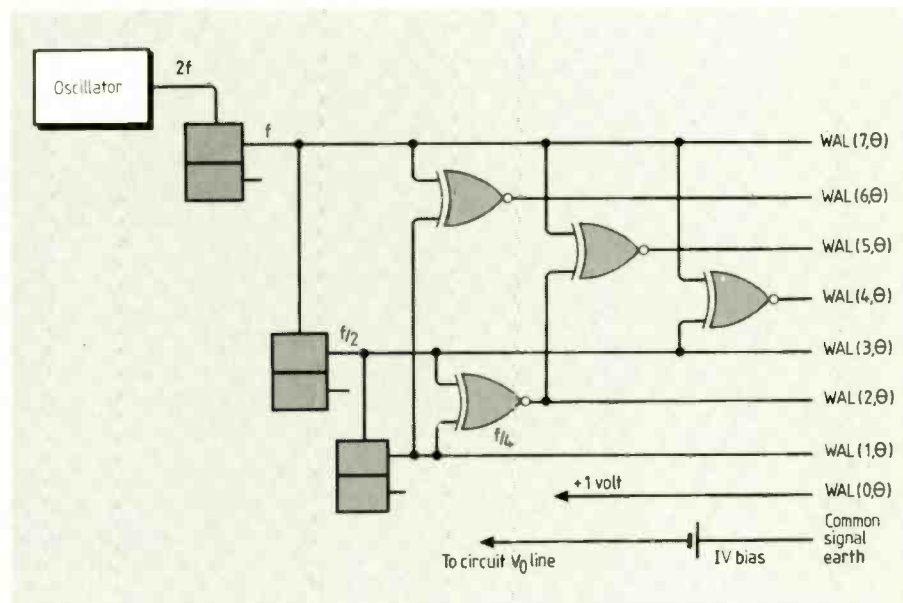

Fig. 2. Circuit to generate one set of eight Walsh functions

sampling the audio signal from each channel in turn at a rapid rate; the samples are sent down the link consecutively. This is done under clock control, so that the same clock may synchronize the re-assembly of the samples at a receiver. So long as the sampling rate is at least twice as great as the highest harmonic frequency to be transmitted, no information will be lost by this process.

SEQUENCY-DIVISION MULTIPLEX

A third method, sequency-division multiplex (s.d.m.), makes use of Walsh functions, and this is the subject of this article. In some

ways this system is similar to f.d.m., in that the audio (or data) signal modulates a carrier.

In other ways, as Walsh functions are pulses, the s.d.m. system resembles a t.d.m. system. The input signals may be analogue, such as audio waves, or they may first of all be sampled and the sampled pulses multiplexed. Alternatively the input may be data pulses in pure binary or other code.

Each signal modulates one particular Walsh function from the set of Walsh functions. The complete set of modulated Walsh functions is now added together, and the resultant composite waveform is transmit-

ted along a single link to the receiver. At the receiver, de-multiplexing is accomplished simply, because Walsh functions are orthogonal. This means that any desired signal may be recovered from the composite by multiplying this waveform by the Walsh function used as the carrier of the original signal. We will now look in a little more detail at the s.d.m. method.

Walsh functions. Walsh waves may be generated fairly simply in a suitable waveform generator. They must be generated in sets, each set containing N functions, N being a binary number. The order of functions in a set is designated by n, which may be any integer from n=0 to n=(N-1). The number of time-slots per function is also equal to N. Such time-slots are designated θ , which again may be any integer from $\theta=0$ to $\theta=(N-1)$. In general, the instantaneous value of any Walsh function n during any time-slot θ is

$$WAL(n,\theta)$$

This can only have a value of +1 or -1, as Walsh waves are rectangular waves having an amplitude of ± 1 . Figure 2 shows the circuit diagram of a Walsh function generator where N is equal to 8. There are thus eight output wires, the functions being

$$WAL(0,0), WAL(1,0), \dots, WAL(7,0)$$

If the t.t.l. is employed in the above circuit, the output pulses would normally have levels of about zero volts and two volts. The addition of a one-volt bias in series with the common lead results in output levels of +1 and -1 volts. Figure 3 shows the set of waveforms produced. $WAL(0,0)$ is a constant having a value of +1 volt.

MULTIPLEX TRANSMITTER

Each of the eight waves in the set has a different sequency, where sequency is defined as half the average number of zero crossings per second. As an example, if T seconds is the total time duration of 8 time-slots, we can see that the sequency of $WAL(5,0)$ is

$$0.5(6/T) = 3/T \text{ zero-crossings per second}$$

This is exactly analogous to the concept of frequency in more conventional waveforms, in which the period of the wave is constant cycle by cycle.

Walsh functions generated in this manner can now be used as carrier waves. However, to simplify our description, consider a system which uses only four Walsh carrier waveforms, namely $WAL(0,0)$, $WAL(1,0)$, $WAL(2,0)$, and $WAL(3,0)$. Each of these carriers may be modulated by one input signal. Hence the total of four input signals will be designated S_0 , S_1 , and S_2 . The basic schematic of this system is shown in Fig. 4 (transmitter) and Fig. 5 (receiver). The main transmitter waveforms are shown in Fig. 6.

Sequency-division multiplex transmitter. With reference to Fig. 6, the input signals S_0 - S_3 in this diagram are three-bit binary

numbers. In each case, the first (least significant) digit is transmitted during time period T_1 . The middle digit occurs during T_2 , and the most significant digit during T_3 . Note that, as we read these time intervals from left to right, the digit positions appear in the reverse order to that normally accustomed. For example, the numerical value of S_1 is 3, although at first glance at the diagram it looks like 6.

The signals from each channel pass into a modulator, and modulate a corresponding Walsh carrier. This modulator circuit is a multiplier, and therefore gives an output which is the product of the input signal S_n and the Walsh function $WAL(n,\theta)$

$$\text{Modulator output} = S_n \times WAL(n,\theta)$$

However, S_n is a binary digit having a value of 1 or 0, so the multiplication process is reduced to its simplest level.

During T_1 , then, there will be four activities in progress and the four modulated output carriers will be as shown under the T_1 column on the right hand side of Fig. 6. Furthermore, during each of the time-slots within T_1 the four modulated carriers are

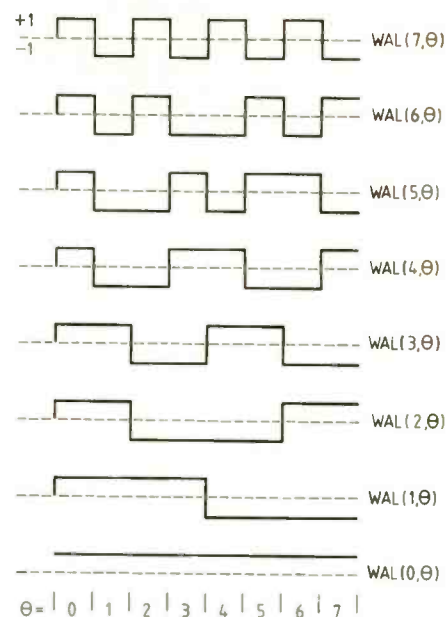

Fig. 3. Repetitive cycle of Walsh waveforms produced by the circuit shown in Fig. 2.

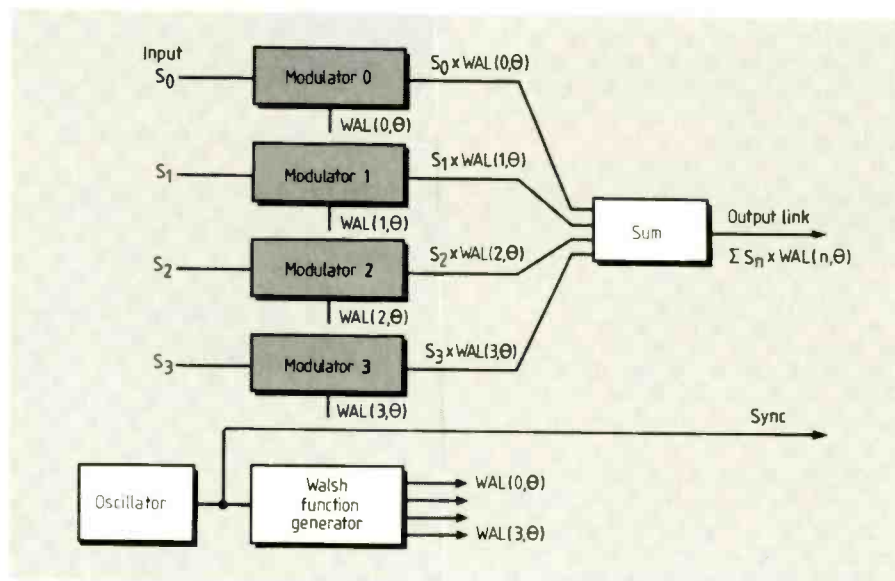

Fig. 4. Four-channel Walsh multiplexer.

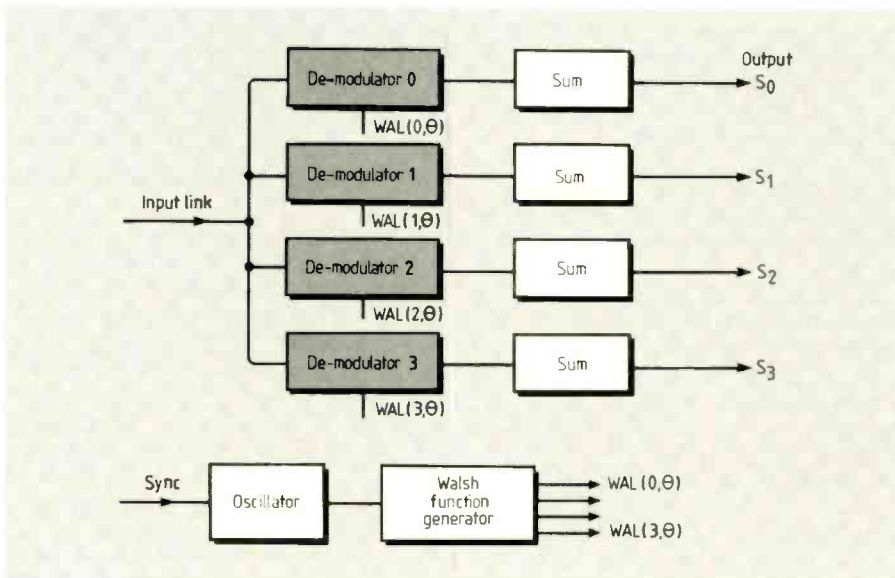

Fig. 5. De-multiplexer, or receiver, for four channels.

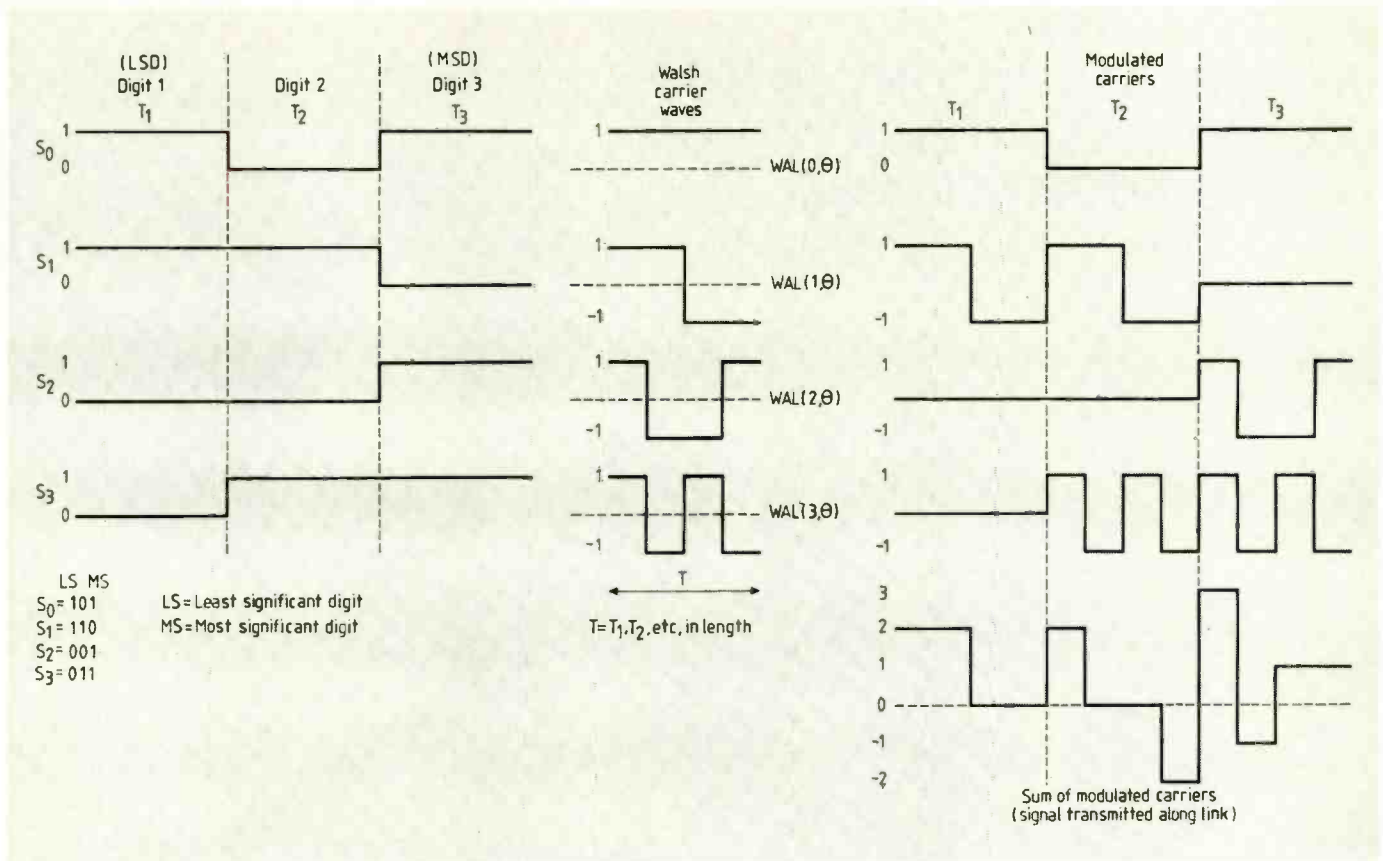

Fig. 6. Waveforms in the multiplexing process.

being instantaneously added, the resultant summed waveform being shown at the lower right of Fig. 6. This is the transmitted multiplexed signal produced during period T_1 .

The total action is repeated for each subsequent digit during periods T_2 and T_3 . By the end of T_3 , each of the four channels will have completed the transmission of one 3-bit word.

Synchronizing. In addition to transmitting the multiplexed signal, it is necessary to transmit a clock pulse to synchronize an identical Walsh function generator at the receiver. This is because at the receiver, identical Walsh functions are required to de-multiplex the signal.

RECEIVER

The incoming multiplexed wave is fed to input 1 of each of four demodulators, each of which is a multiplier. Input 2 of each is driven from the appropriate Walsh function, the Walsh function being generated at the receiver and synchronized by the incoming clock pulse.

Consider channel zero. During each digit period (T_1 , T_2 , and T_3) there are four time slots, $\theta=0, 1, 2$, and 3 . The amplitudes of pulses emerging from the demodulator are added together, giving a total value for each digit period. If this total value is finite, the value of the digit is 1. If zero, the digit is 0. In practice, the total value will be 4 or zero. Had we used eight channels (and eight Walsh functions) the total value would have been 8, and so on.

Similar remarks apply to channels 1, 2, and 3. Needless to say, if the system is

working correctly, the output digits per channel will be the same as those at the input.

The system described above accommodates only four channels and three-digit words. In practice, many channels of any reasonable word length can be multiplexed in this way, subject only to the usual factors which limit high-speed working such as bandwidth, device switching time, and signal to noise ratio. The number of channels must be matched by the number of Walsh functions in the set, and this must be a binary number.

All Walsh waves consist of rectangular pulses having values of +1 or -1, so that processing (such as multiplication) is reduced to very simple operations.

An important advantage of Walsh multiplexing compared with frequency-division multiplex is that modulating a Walsh carrier only produces a single-sequence sideband, whereas modulating a sinusoidal carrier produces two, the upper and the lower sidebands.

Furthermore, a Walsh system is less sensitive to noise than a time-division multiplex system. This is because any noise affecting the Walsh carrier is distributed evenly among all the multiplexed signals. The effective noise intensity per digit is therefore diminished.

Further reading

Gill, S.M., "The use of Walsh functions in data multiplexing", University of York, 1979.
Langton, C.H., "Orthogonality and Walsh functions", *Electronics & Wireless World*, March, 1987.

Leetronex '88

The North of England's electronics show moves to new premises this year: for the first time, it is to be staged in the newly-refurbished University of Leeds Exhibition Centre. All stands in the centre's two halls have been taken by exhibitors, and the show promises to be one of the best yet.

Leetronex, organized by the electrical and electronic engineering department of the University of Leeds, is now in its 25th year. Subject areas covered by the show include semiconductor products, hybrid circuits, instrumentation, data acquisition and control systems, signal conditioning, fibre optics, computer peripherals, p.c.b. artwork and manufacture, power supplies, technical training aids and recruitment. Many product launches have been promised.

To accompany the exhibition is a programme of seminars. This year's topics are

- Surface-mount technology, presented by Peter Grundy of Siemens Ltd, who will introduce some of the latest developments in circuit production.
- The Transputer and occam: Dr John Kerridge of the National Transputer Support Centre offers a practical guide to the Transputer and the Government's strategy for promoting its use.
- Mobile and cellular radio: Professor Peter Matthews of Leeds University examines the limitations on these systems imposed by Nature and considers the ways in which they affect system design and service to the user.

Dates for Leetronex are 5-7 July, 1988. Further information from the organizer's office on 0532-420339.

INTERNATIONAL
BROADCASTING CONVENTION
BRIGHTON • UNITED KINGDOM
23 – 27 SEPTEMBER 1988



INTERNATIONAL BROADCASTING CONVENTION

The 1988 IBC Technical programme will cover all aspects of broadcast engineering with particular emphasis on emerging technology including satellite and cable distribution, enhanced and high definition television systems, as well as multi-channel sound systems and associated information systems.

The IBC EXHIBITION complementing the technical sessions will have the latest professional broadcasting equipment on display and demonstration by leading world manufacturers.

The SOCIAL PROGRAMME during the Convention will include a Reception and a special Ladies Programme of talks and demonstrations and visits to places of interest.

FURTHER INFORMATION can be obtained by returning the reply coupon below.

The IBC Secretariat, The Institution of Electrical Engineers, Savoy Place, London, United Kingdom WC2R 0BL. Telex: 261176 Telephone: 01-240 1871

Please send further details of IBC 88 to:

Name & Position

Company/Organisation

Address

Post Code

APPLICATIONS SUMMARY

State machines explained

Mealy and Moore models are commonly used to simplify state-machine design. According to a note called 'State machines explained' from AMD, which of the two models is used depends to some extent on the designer's preference but there are also benefits of one method over the other that vary according to the application.

In a Mealy model, state-machine output is dependent on the inputs and the current state whereas in the Moore model, the outputs only depend on the current state. Being more general, the Mealy model tends to be more popular.

Although the seven-page note gives an example of each model, it leaves the reader to decide what the advantages and disadvantages of the two are. It briskly steps from simple state diagrams to Mealy and Moore models using the JK register as an example. Finally, it presents high-level language control software for a drinks machine using sequential synchronous logic.

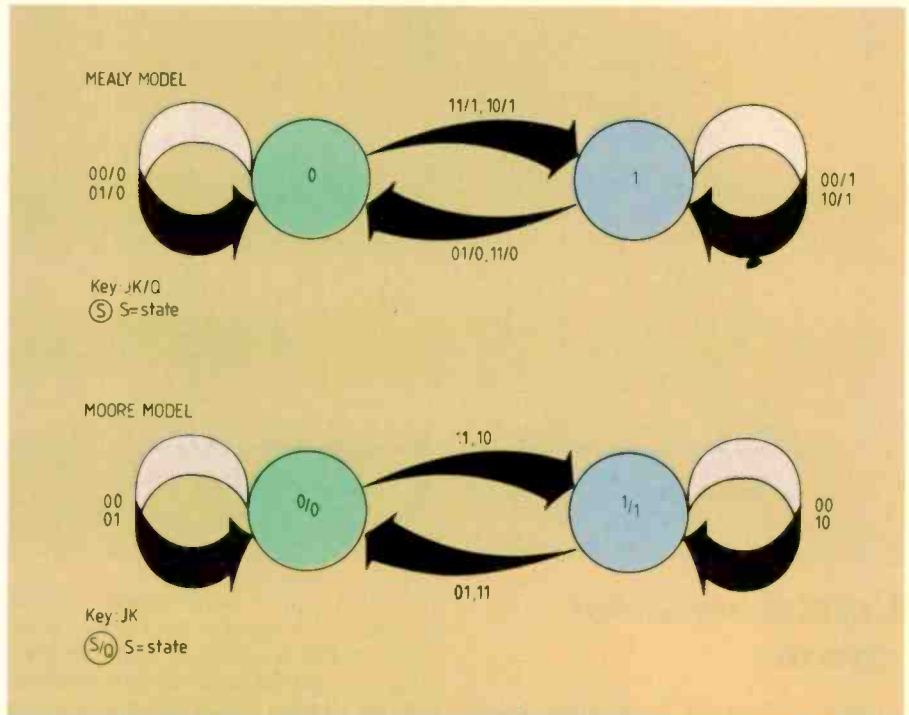

Telephone and terminal i.cs

Brief details of how to link together various integrated-services digital-network i.cs from Siemens are given in 'ICs for ISDN telephone sets and terminals'.

Divided into two sections, the note first outlines an ISDN 'feature telephone' and explains how this apparatus's X interface as specified by the Deutsche Bundespost* can be in two forms. Simple X interfaces allow only an auxiliary speaker on recording equipment to be connected to the port but

the more complex form can take various equipment such as automatic diallers, alarm systems and measurement/control units.

Voice and data terminals are covered in the note's second section. Such terminals, which include network terminators, repeaters, multiplexers and exchange systems, can incorporate many features including packet-switched data links and slower data links for Teleservices.

In order to fully understand the seven-page note, you will need a prior knowledge of ISDN abbreviations.

*There is no similar UK specification for the X interface.

ADDRESSES

AMD
 Applications Department
 AMD House
 Goldsworth Road
 Woking
 Surrey GU21 1JT
 04862 22121

Siemens
 Siemens House
 Windmill Road
 Sunbury-on-Thames
 Middlesex TW16 7HS
 0932 752626

IQD
 Hitek
 Ditton Walk
 Carbridge CB5 8QD
 0460 74433

Electrolube
 Blakes Road
 Wargrave
 Berkshire RG10 8AW
 073 522 4031

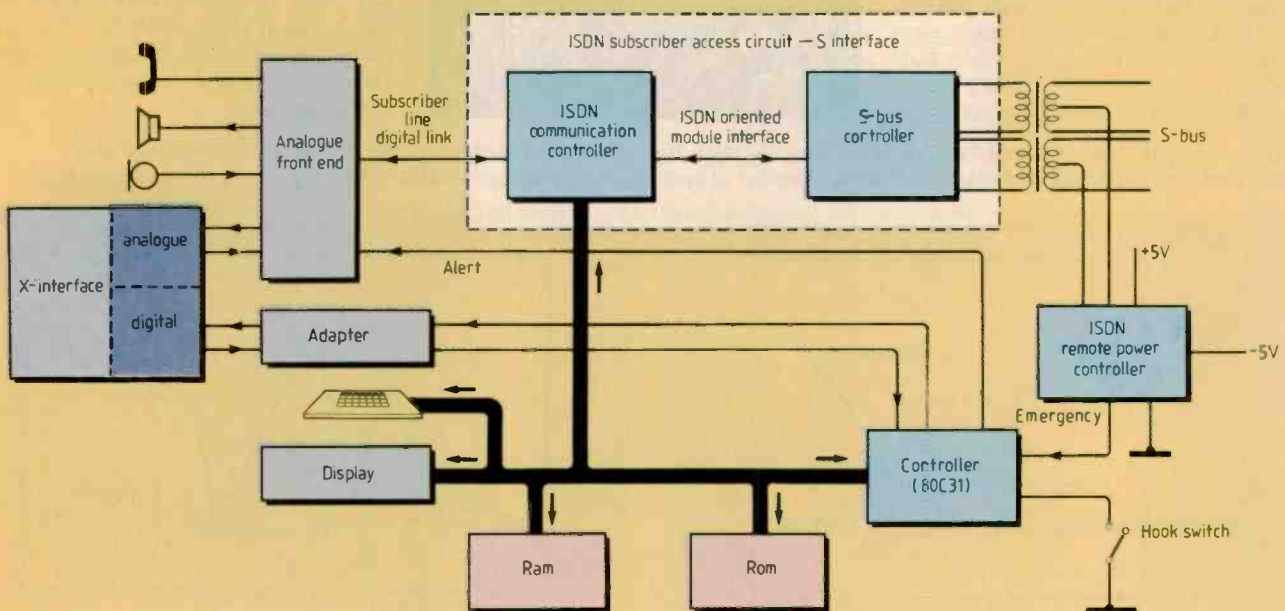

APPLICATIONS SUMMARY

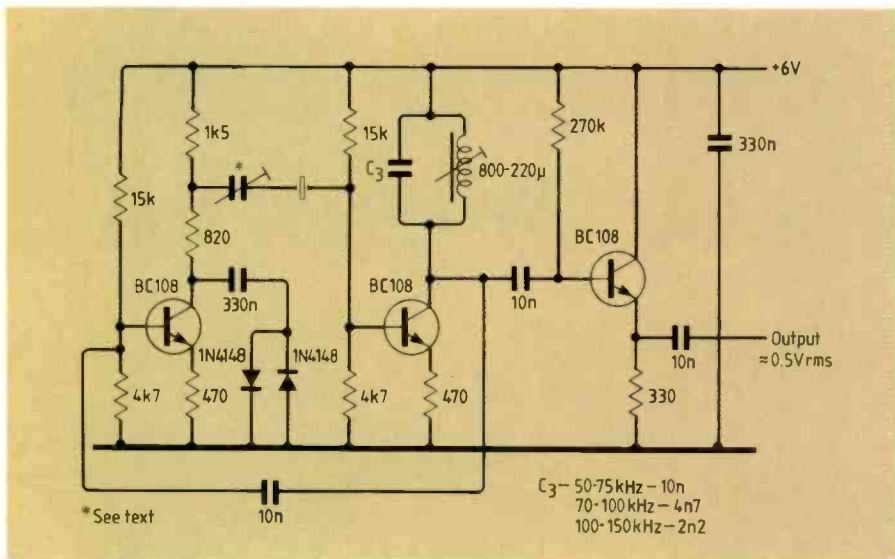

Crystal oscillator circuits

Quartz crystals for frequencies below 150kHz, having a relatively high equivalent series resistance, need a high-gain oscillator circuit. Cascading two common-emitter stages as shown in IQD's Crystal Catalogue provides sufficient gain for crystal frequencies down to 50kHz.

Diodes in the first transistor's collector

circuit limit the crystal drive level to avoid damage and the tuned circuit provides selectivity. Parallel resonance is set by the trimming capacitor; for series-resonance calibration, the trimmer should be replaced with a 1nF fixed capacitor and the inductor adjusted instead.

In the applications section of the catalogue is a number of other discrete and integrated-circuit oscillators, including a discrete-component circuit for up to 200MHz.

Contact lubrication

In a discussion of the merits of contact lubrication, Electrolube says that keeping contact surfaces clean and dry does not necessarily remove the problems of noise caused by high contact resistance.

Four main factors influence contact resistance — contact surface condition, contamination, fretting and contact bounce. Contact lubricant, says Electrolube, evens out the peaks and troughs of the contact surface, thus increasing the contact-surface area. This in turn reduces contact resist-



Peaks and troughs on a copper surface at x1000 magnification, top, gold-plated contacts under fretting conditions (left) with contact pressure of 50-60g, and resistance versus number of operations for sliding contacts of a wire-wound potentiometer (right).

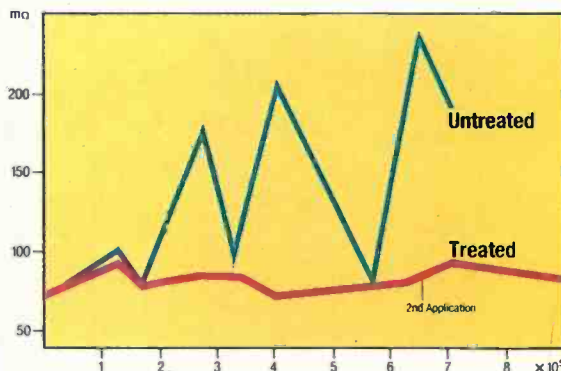
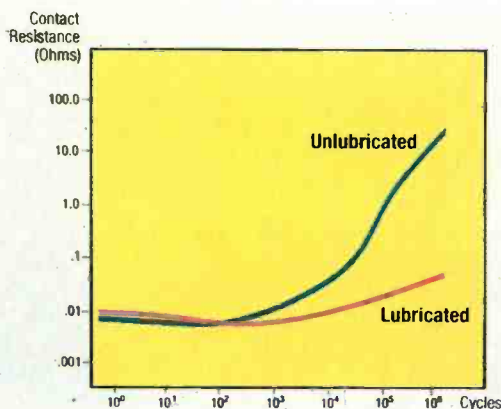

ance, minimizes the formation of hot spots and reduces surface deformation due to friction wear.

Arcing, occurring when the contact opens, causes airborne contaminants to react with the contact metal and form a surface film. It also causes electrochemical reactions in the air between the contacts which result in the formation of nitric acid, and it causes metal transfer between the contacts due to ionization, which is a particular problem when switching direct current (the pip-and-crater effect). Lubrication reduces the effects of arcing since the lubricant effectively forms a bridge between the partially-open contacts to prevent current concentration at the contact-surface peaks and reduce current flow more gradually.

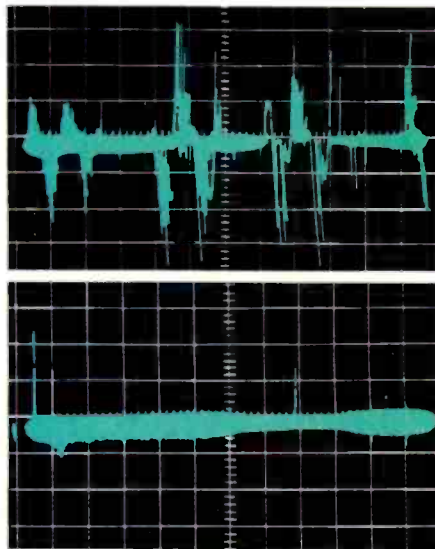

Noise on untreated (top) and treated contacts; Y is 0.15V/div., sweep is 20ms/div.

More precise information on how contact resistance is increased and prevented is included in the Contact lubricant brochure, and charts are used to illustrate the difference between the company's various lubricants. Two other new brochures cover conformal coatings and cleaning products in a similar way.

Upgrading from 68000 to 68020/68881

Bob Coates has designed a Kaycomp-compatible platform board holding a 68020 processor and 68881 maths co-processor; it should plug into any single-master 68000 system that can keep up with the 68020's shorter bus cycle.

BOB COATES

My design objectives were to produce a platform board for the 68020 microprocessor and 68881 maths co-processor, together with interface logic, which could plug into the 68000 processor socket on the Kaycomp board, Fig.1. Interface logic is necessary because of differences between the 68000 and 68020, like the number of data-bus bits and the control-bus signals.

The result is a six-layer board measuring 80 by 100mm holding the two processors, two 20-pin Pals and one t.t.l. device – ten components in all. It plugs directly into the Kaycomp but it should also be suitable for other 68000 systems provided that there is no bus master other than the main processor and that the memory and peripherals can cope with the 68020's shorter bus cycle.

In order to significantly reduce component count and hence board size, I have used programmable-array logic for the interfacing. A problem for small organizations wishing to use such devices can be the cost of specialized equipment required for development and programming. In this article, I will show that programmable logic devices can be designed without any capital outlay.

Both of the processors have 32bit data paths and communication between the two is over the full 32bit bus. Communications with the rest of the Kaycomp board is over a 16bit bus, making use of the 68020's ability to dynamically adjust its bus size. For readers with small pockets, I have made the 68881 maths co-processor optional. Later upgrading is possible by simply plugging in the i.c. and breaking a link.

Kaycomp's firmware has been extended to cope with the new processors. The monitor has been improved to accommodate some of the new facilities on the 68020 and also to display all the extra registers. I have removed the 40-column option since there are too many registers for a 40-column display.

Both the assembler and disassembler have been extended to cope with all the new addressing modes and instructions, including all the maths instructions for the 68881.

Installation of the upgrade consists merely of altering a link on the Kaycomp board to configure the system for 27256 eproms, swapping the eproms, removing the 68000 and plugging in the platform board. Having only ten components, the board is easily and

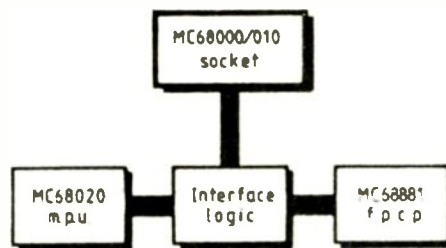

Fig.1. Platform board outline. Interface logic is needed because of differences between the 68000 and 68020.

quickly assembled. Details of how to obtain the board, etc., will be given later.

An application note published by Motorola describes a platform board that appears to the host board to be identical to a 68000 as far as functionality and bus timing is concerned, which guarantees that the platform board will work with any host board designed for the 68000. However, such a board would be excessive for a simple board such as the Kaycomp and there are certain features which can be simplified or left out providing that the design of the target board is known.

There are six basic areas that must be dealt with by the interface logic, these are:

- Dynamic bus-sizing considerations
- Bus-cycle timing modification
- M6800-family device communication
- Interrupt processing
- Bus arbitration
- Co-processor selection

Dynamic bus-sizing considerations. A new feature available on the 68020 is the ability to transfer byte, word and long word operands using its dynamic bus-sizing capabilities, allowing mixing of different-width memory and peripherals within one system. To allow this, the data-transfer acknowledge (DTACK) signal found in the 68000 is replaced by two data-transfer and size-acknowledge (DSACK_{0,1}) inputs. The two data strobe outputs (WDS, LWS) are replaced by a single data strobe (DS) and two size outputs (SZ_{0,1}) to indicate the type of transfer.

Since any 68000 host board always uses 16bit data transfers, the inputs are configured to always initiate 16bit transfers, except for accesses to the 68881 coprocessor when full 32bit transfers can be used.

Bus-cycle timing modification. There are some minor differences between the 68000 bus-cycle timing and that of the 68020. Assuming no wait states, a normal 68000 bus cycle takes four clock periods whereas a normal 68020 bus cycle takes three. To correctly emulate the timing of a 68000 would therefore require a modification to the bus timing. However, if it is known that the host board is able to cope with the shorter bus cycle then this removes the need for some of the interface logic, simplifying the design, and speeding up the system.

Kaycomp can cope with the shorter bus cycle provided that memories with an access time of 200ns or less (8MHz clock) are used, so I decided not to modify the 68020 bus cycle timing.

M6800 family device communication. On the 68000 the facility was available to interface to 6800-family peripheral devices, which require a synchronous bus transfer. This was initiated by the address decoding asserting the v_{PA} input when accessing a 6800 device area. On the Kaycomp this type of transfer is used for the G64 bus interface.

This synchronous bus interface is no longer available with the 68020 and so an equivalent function must be implemented in hard logic in order to allow the G64 bus interface to continue to be used. This function accounts for most of the interface logic on the platform board.

Interrupt processing. On the 68000 an interrupt-acknowledge cycle is indicated by the three function-code outputs, FC₀₋₂, being all logical one and this is used to produce the ack signal on the Kaycomp. With the 68020 however, all ones on the function-code lines indicates a c.p.u.-space cycle, which can indicate a breakpoint acknowledge, access-level control, co-processor communication or interrupt acknowledge cycles. Which it is is encoded in address lines A₁₆ to A₁₉ which have a different binary code allocated for each c.p.u.-space cycle type. The code for an interrupt-acknowledge cycle is all ones on the four address lines.

As the Kaycomp decodes only the function-code lines and not the address lines, FC₂ from the 68020 is gated with the four address lines before going to the Kaycomp and so this modified FC₂ signal will

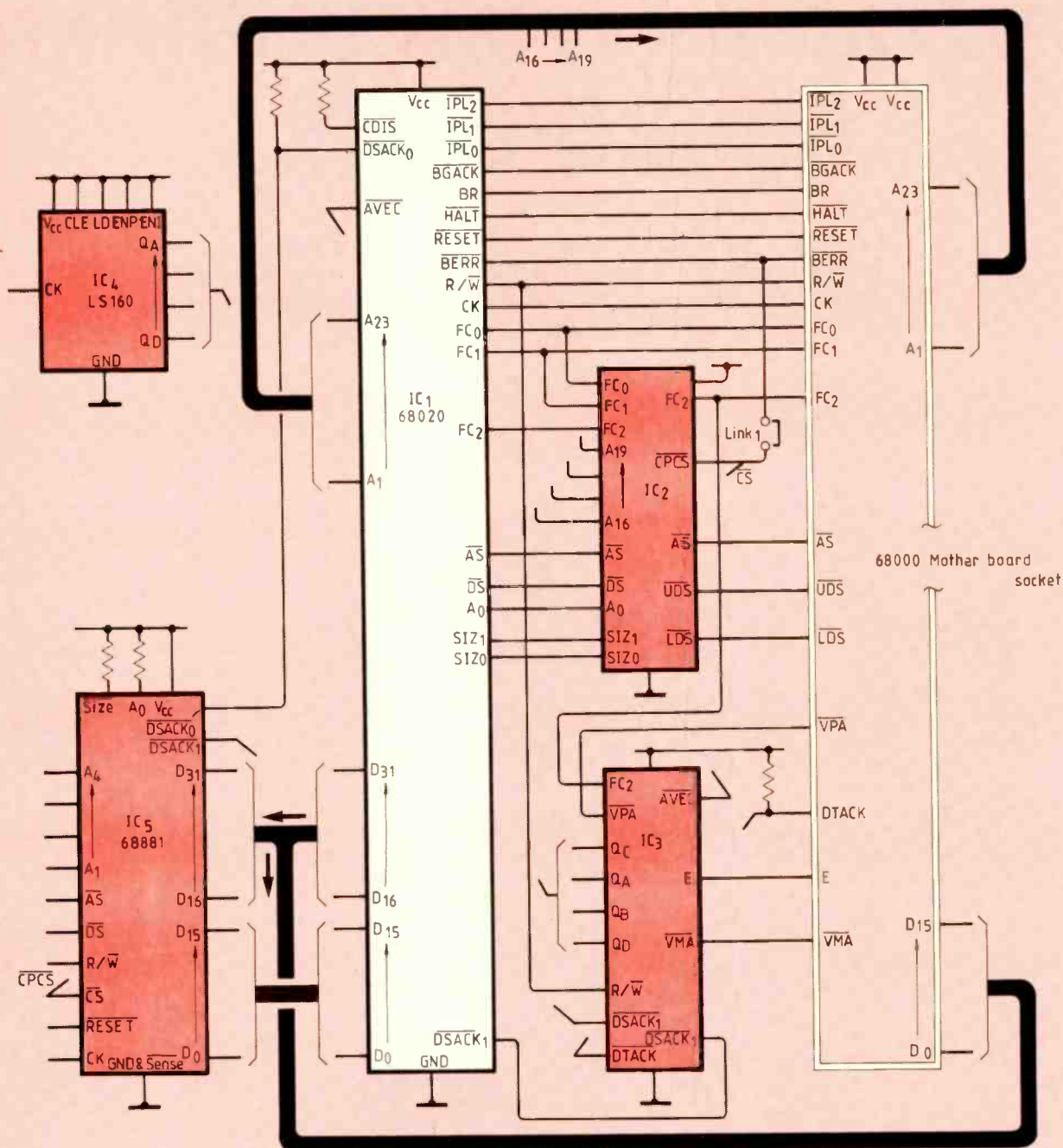

only go high if all of FC₂ and A₁₆₋₁₉ go high.

The only other c.p.u.-space cycle used in this design is the co-processor communication cycle.

On the 68000, the valid-peripheral address input, VPA, as well as being used for the M6800 communication mentioned previously is also used to indicate that an autovectored interrupt response is required. This pin is no longer used on the 68020 since synchronous transfers are not supported. It is replaced by AVEC which serves the same purpose as VPA for initiating autovectored interrupts.

Bus arbitration. On the Kaycomp board there is only one possible bus master, the 68000 processor itself. Consequently the platform board design was simplified by leaving out the interface-logic functions required to allow multiple bus masters. The only bus arbitration implemented is that

Figure 2. Two programmable logic i.cs greatly reduce the number of decoding components needed. Both the 68020 and 68881 are pin-grid arrays; their pin references have been omitted for clarity.

required to support co-processor communication. Address strobe signal AS must not be asserted on the host board while co-processor communication cycles are taking place, and so the AS output from the 68020 is gated with the co-processor chip-select signal CPCS produced by the interface logic before being sent to the host board.

Co-processor selection. A co-processor communication cycle is classed as a c.p.u.-space cycle and indicated by all ones on the three function-code lines, as mentioned previously. Whereas the code on address lines A₁₉₋₁₆ is all ones for an interrupt-acknowledge cycle it is '0010' for a co-

processor communication cycle. A co-processor chip-select signal (CPCS) is produced by the interface logic when the code appears.

In conclusion, although designed for the Kaycomp, this platform board should work with any 68000 board provided there can be no bus master on the host other than the processor and that the memory and peripherals can cope with the shorter bus cycle.

CIRCUIT DESCRIPTION

Figure 2 shows the full circuit diagram of the platform board. You can see that the complete circuit consists of the two processors IC₁ and IC₅, two programmable-array logic (Pal) devices IC₂ and IC₃, a t.t.l. decade counter IC₄, a few pull-up resistors, and the adaptor, SKT₁, which connects the board to the host's 64-pin dil processor socket.

The object of this board is that the interconnector, SKT₁, appears to the host board as if it were a 68000, even though a 68020 processor is actually connected. In the case of the majority of the processor pins this means simply connecting a pin on the 68020 to its equivalent pin number for the 68000 on SKT₁.

Address pins A₁₋₂₃ connect straight through, but note that A₀ cannot be routed through as this pin does not exist on a 68000. It is used though in generating the data strobe pulses. The upper address pins of the 68020, A₂₄₋₃₁, are ignored as these cannot be used in a 68000 system.

Sixteen of the thirty-two lines of the data bus are also connected straight through, but note that the most significant bit on the 68020, bit 31, should be connected to the most significant bit on the 68000, bit 15, to provide the simplest access mechanism.

Some of the control lines are also connected straight through, namely the interrupt lines, CLK, FC₀, FC₁, BGACK, BR, HALT, RESET, BERR and RW. An extra connection may also be made to BERR from the co-processor chip-select via a link. This link is inserted on the Kaycomp to allow the firmware to detect the presence or otherwise of the co-processor, which is optional. Remaining processor outputs, FC₂, AS, UDS, LDS, E and VMA are all produced by the interface logic as there is no direct equivalent available from the 68020, and likewise for the two inputs DTACK and VPA.

The interface logic consists of IC₂₋₄ and provides two basic functions, control-line modification and M6800 synchronous bus transfers.

Control line modification. A 16L8 PAL device, IC₂, handles the c.p.u.-space bus-cycle decoding. As discussed previously, on the 68000 when all function-code outputs (FC₀₋₂) are at logical one it indicates an interrupt-acknowledge cycle, but on the 68020 it can also indicate a co-processor communication cycle (and other conditions not used in this design). Kaycomp however assumes that if all three lines are one it is an interrupt acknowledge cycle and so it is presented with a modified FC₂ signal which only goes to one if the other conditions are correct for this particular cycle.

These other conditions are that A₁₉₋₁₆ should also be at logical one and so these address lines, along with the three function-code lines, are all Anded together so that the modified FC₂ signal at IC₂ pin 12 only goes to logical one if all these seven lines are one.

These same address and function-code lines are also used to indicate a co-processor communication cycle which requires the generation of a co-processor chip-select signal (CPCS) to enable the 68881 maths co-processor. Code on address line A₁₉₋₁₆ in this case though is '0010' and the logic generates a low at IC₂ pin 16 when this condition exists and the function code lines are logical one. Address lines A₁₅₋₁₃ also indicate which co-processor is being accessed, but as there is only one in this design these are ignored.

When the main 68020 processor is accessing the 68881 co-processor then valid addresses appear on the address bus and the AS line is asserted. It must be ensured though

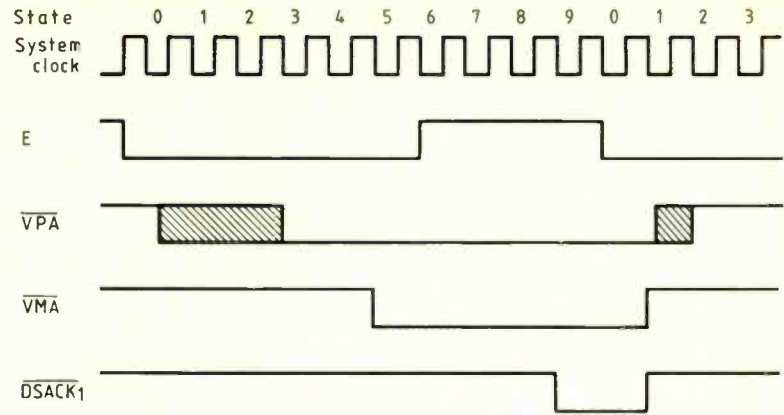

Fig.3. Timing for E-clock, valid memory address, valid peripheral address and data-transfer/size-acknowledge signals.

that the host board does not attempt to place data on the data bus at this time so the AS signal is gated with CPCS so that AS is not asserted if CPCS is.

The remainder of IC₂ is concerned with generating the two data-strobe signals, UDS and LDS, with the 68000 family, unlike some other 16bit processors, each address in the memory map signifies one 8bit byte and not a 16bit word. Consequently, as the 68000 can only access quantities of 16 bits, there is no need for an A₀ signal, the even address byte being considered to be the upper eight bits of the data bus and an odd address byte the lower eight bits. These quantities are strobed in and out of the processor by the upper and lower data-strobe lines (UDS, LDS) respectively.

However, the 68020, with its dynamic bus-sizing capabilities, can access bytes, words, three bytes, or 32bit long words at any base address, even or odd and so the A₀ signal is required and the actual framing of the external data bus connections indicated by the two size signals, SIZ₀ and SIZ₁, and finally strobed by a single data-strobe line DS.

This mechanism is fully explained in the 68020 User's Manual and so I shall just conclude that the equations for generating the UDS and LDS signals which are implemented in part of IC₂ are;

$$UDS = DS + A_0$$

$$LDS = \overline{DS} + A_0 \cdot SIZ_1 \cdot SIZ_0$$

Remaining modifications of control lines are carried out in IC₃, also a 16L8 Pal device. Production of the E and VMA signals for M6800 synchronous bus cycles will be considered later. Signal AVEC, which is an input to the 68020 indicating that an autovectored interrupt service is required, is taken from the VPA signal from the host board, to which it is equivalent, but also gated with the modified FC₂ signal. This ensures that AVEC is only asserted during an interrupt acknowledge cycle and not during a M6800 cycle which is also indicated by asserting VPA in a 68000 system, this pin serving a dual purpose.

The data-transfer acknowledge signal from the host board, DTACK indicates the termination of a normal bus transfer. There are two equivalent pins on the 68020, DSACK₀

and DSACK₁, the combinations of codes on the two pins indicating an 8, 16 or 32bit port size. All transfers to and from a 68000 board must be 16bit and this is indicated by DSACK₀=1 and DSACK₁=0. Consequently DSACK₀ is pulled high by a resistor and DSACK₁ is driven by DTACK, but Anded with the two other possible sources of DSACK₁, co-processor IC₅ and the MC6800 transfer-generation logic also in IC₃.

This leaves us with the production of E and VMA to implement M6800 synchronous bus transfers. Consider how this is done on the 68000. When this type of transfer is required, to access a synchronous peripheral device say, the address decoding asserts low the 68000 VPA input. After recognition of VPA, the 68000 assures that E, which is produced by dividing the system clock by ten with a 60:40 low-to-high ratio, is low by waiting if necessary and subsequently asserts VMA until after E has gone through the next high-to-low transition.

To emulate this, a system clock divide-by-ten circuit is required which is provided by IC₄, and other logic contained in IC₃. The state machine produces the two 68000 signals E and VMA and the DSACK₁ signal to the 68020 to terminate the transfer, according to the state table, Table 1. The E clock is produced quite simply from three of the divider outputs, Q_b, Q_c and Q_d.

Table 1. Decoding state table for E, VMA and DSACK₁.

Output (Q)					Action
d	c	b	a	E	
0	0	0	0	0	Negate VMA and DSACK ₁
0	0	0	1	0	
0	0	1	0	0	
0	0	1	1	0	
0	1	0	0	0	Assert VMA if VPA asserted
0	1	0	1	0	
0	1	1	0	1	
0	1	1	1	1	
1	0	0	0	1	Assert DSACK ₁ if VMA asserted
1	0	0	1	1	

Two RS type bistable devices are used to produce the two outputs, VMA which outputs on IC₃ pin 17, and DSACK₁ which is Anded with other sources of DSACK₁ before appearing as an output at pin 18. Both of these bistable devices are reset at the first state, that is when Q_a=0 and Q_c/Q_d=1, negating (logic 1) the two outputs. At the fifth state, if the VPA input is asserted (logic 0) then the VMA bistable device is toggled, asserting (logic 0) VMA. At the ninth state, if VMA is being asserted, then the DSACK₁ bistable device is also toggled, asserting DSACK₁. One clock cycle later, after the counter has reset to

state zero, both signals are once again reset. Resulting waveform timings are clarified in Fig.3.

CO-PROCESSOR INTERFACE

The 68881 is flexible in how it can be interfaced to the main processor, allowing 8, 16 or 32bit connections. Although an 8 or 16bit bus between the two would have reduced the number of tracks required, clearly maximum processing speed will result if all 32 data bits are used. Thus all 32 data-bus pins on the 68881 (IC₅) are connected to their equivalents on the 68020 (IC₁). The size and A₀ pins of IC₅ are tied to a logical one (V_{cc}) which configures the device in 32bit transfer mode.

Since the 68020 has a built in co-processor interface, other connections are relatively simple; just a few address lines to select the various registers, control lines and a chip-select signal (CPCS) – in fact very similar to interfacing a normal peripheral chip to a processor. Both DSACK pins on the 68020 are driven by the 68881, a low on both indicating to the 68020 a 32bit bus transfer.

The beauty of this system is that all this is totally transparent to the software designer. Attaching the maths co-processor means to the programmer that a new set of instructions and registers have been added to the 68020's. The fact that they are contained in a separate chip is not apparent to the programmer, who just uses the additional instructions as if they were all part of the main processor.

PAL IMPLEMENTATION

When the prototype for this design was first built, it was done using standard t.t.l. for the interface logic, using similar basic circuits to those shown in the blocks for the Pals, Fig.7. Unfortunately it took about 10 t.t.l. devices to implement the interface logic, which made the board rather large and complicated. Programmable-array logic (Pal) devices were therefore used for the final design which reduced the chip count to three and considerably reduced the complexity of the board.

The principle problem with using programmable logic devices can be the equipment required, which could perhaps be difficult to justify for the small development laboratory or educational establishment. I found that with a little time and effort and a Pal distributor who could program the devices from paper it was quite possible to produce the designs with no specialized equipment at all.

PAL CONCEPT

The Pals used on the 68020 upgrade board are one of the simpler types, the 16L8, whose designation indicates logic low or inverted outputs (L) and 16 inputs and 8 outputs. For a 20-pin device, this number of input and outputs means that some pins are dual purpose, programmable as inputs or outputs, as can be seen from the block diagram of the device, Fig.4.

A full explanation of the workings of Pals can be obtained from the various manufacturers' data, but I will briefly explain the

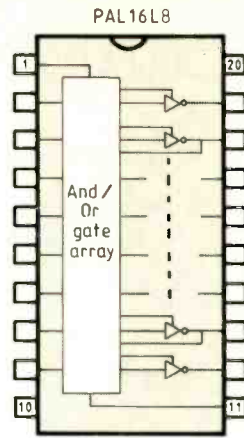

Fig.4. Up to 16 inputs and 8 outputs are available on the 16L8 programmable-array logic i.c.

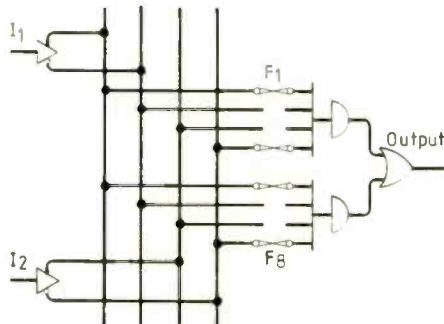
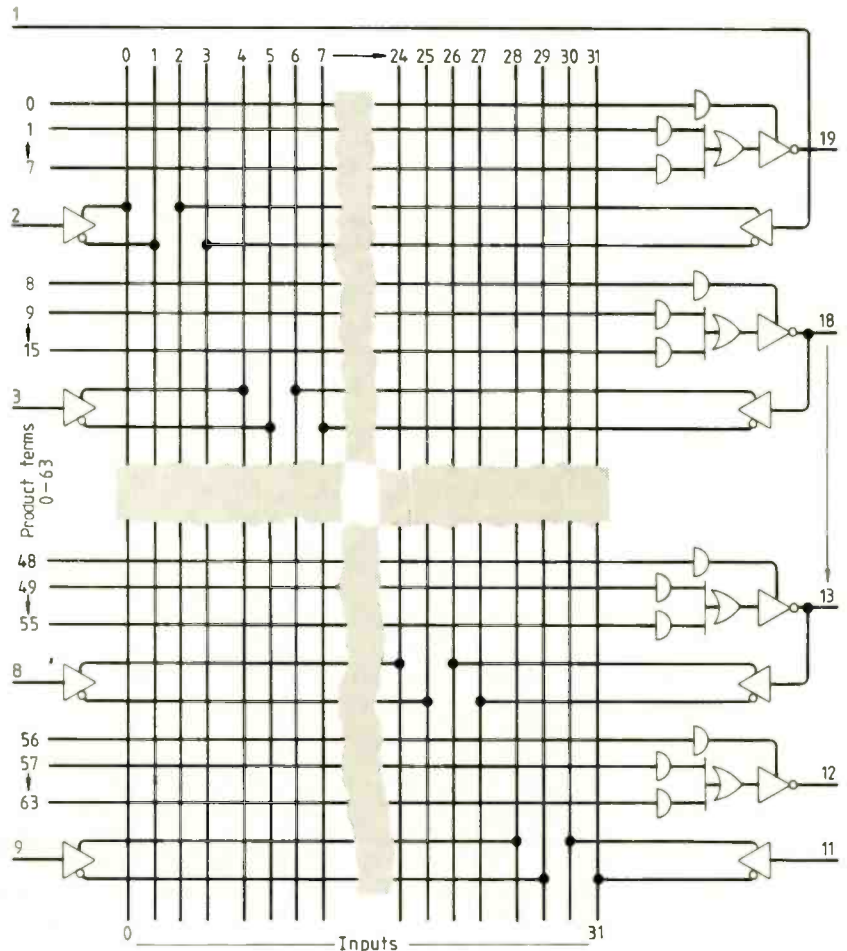

Fig.5. Basic Pal structure for a two-input, one output logic segment.

Fig.6. Logic diagram for the PAL16L8. Eight of the lines on the right can be programmed either as inputs or outputs.



basics. A Pal implements the familiar sum of products logic by using a programmable And array whose output terms feed a fixed Or array. Since the sum of products form can express any Boolean transfer function, the Pal's uses are only limited by the number of terms available in the And-Or arrays.

Basic structure of a cell within the array is shown in Fig.5. Working backwards, this shows the Or gate which drives the output, being driven by two And gates, each of which has four inputs connected through programmable fuses to the true and inverted states of two inputs. In an unprogrammed Pal these fuses are intact, but by programming may be selectively blown, opening the circuit to that particular And input, which then assumes a permanent one state.

In practice, the arrays are much larger than this. With the 16L8 device, each And gate has 32 inputs, the true and inverted version of each of the device input pins. Driving each of the eight Or gates there are seven individual And gates. An eighth And gate enables an output inverter-buffer which drives the output pin from the output of the Or gate. A quick calculation reveals a total of 2048 individual fuses. This would be difficult to show by way of a circuit diagram and so a diagrammatic representation is used as shown in Fig.6.

In this representation, at the point where the horizontal line to the And input (product term) crosses a vertical input line there is a fuse. We need to mark on this diagram crosses where a fuse is to be left intact and no mark where a fuse is to be blown. This 'fuse-plot' can then be handed to the supplier/programmer of the device to pro-

duce a Pal to your custom design. Clearly this will need to be entered into the device programmer manually, which takes time, and hence money. For each of the devices used for this project a charge of around £24 was made. This is a non-recurring cost though as when further devices are required, the first device can be used as a master, saving this charge.

DERIVING THE FUSE-PLOT

We now have a circuit diagram and this has to be translated to a fuse-plot. There are 'schematic capture systems' available to run on various computer systems which can take a circuit diagram and produce the necessary output to the device programmer from which the Pal can be programmed – clearly the best solution, but expensive. A simpler, more readily available software package is a Pal assembler (Palasm) which runs on IBM PC compatibles. This takes the Boolean expressions which define each output and produces the information for programming the device. Even these days though, not everyone has an IBM PC, let alone PALASM, so for this project a manual system had to be devised.

The first question to be answered is can the interface logic be contained in one Pal or if not how many? The main restriction will be the number of inputs and outputs required. I soon saw that more than one would be needed, and after some juggling around the logic was fitted into the 16L8 Pals and one t.t.l. decade counter. The decade counter too could have been implemented in Pal, using a registered output device, such as the

MONITOR ENHANCEMENTS

In order to accommodate the 68020's enhancements and the maths co-processor, the original 68000 monitor with line-by-line assembler has been supplemented with the following commands and modifications.

AS line-by-line assembler. Modifications – 'size' attribute for branch instructions is now 'B', 'W', 'L' for 8, 16 and 32bit offsets respectively, instead of 'S' and 'L'. Default start address is now 400600₁₆. All ram below this address is used by firmware.

CA examine/alter cache address register. Same as An command but for cache register address.

CC examine/alter cache control register. Same as An command but for cache control register. Note that only bits 0-3 are used.

DF examine/alter destination function-code register. Same as An but for destination f.c. register. Only bits 0-2 are used.

Fn examine/alter floating-point data register. Same as An command but for the eight f.p. data registers. Note that this is a 96bit value (24 hexadecimal characters).

FA examine/alter floating-point instruction address register. Same as An command but for the f.p. instruction-address register.

FC examine/alter floating-point control register. Same as An but for the f.p. control register. Only bits 0-15 are used.

FD disable floating-point register printing.

FE enable floating-point register printing.

FS examine/alter floating-point status register. Same as An command but for f.p. status register.

RD register display. Modifications – displays extra registers available on the 68020 and the 68881 registers provided that it is enabled by the FE command.

SC single-step on flow change. Similar to SS command but only stops and displays registers on a program flow change, i.e. when a jump or branch is executed.

SF examine/alter source function-code register. Same as An command but for source function-code register. Note that only bits 0-2 are used.

TC trace on flow change. Similar to TR but only displays registers on program flow change.

VB examine/alter vector base register. Same as An command but for the vector base register.

Fig.7. Gating within the programmable logic i.cs after programming.

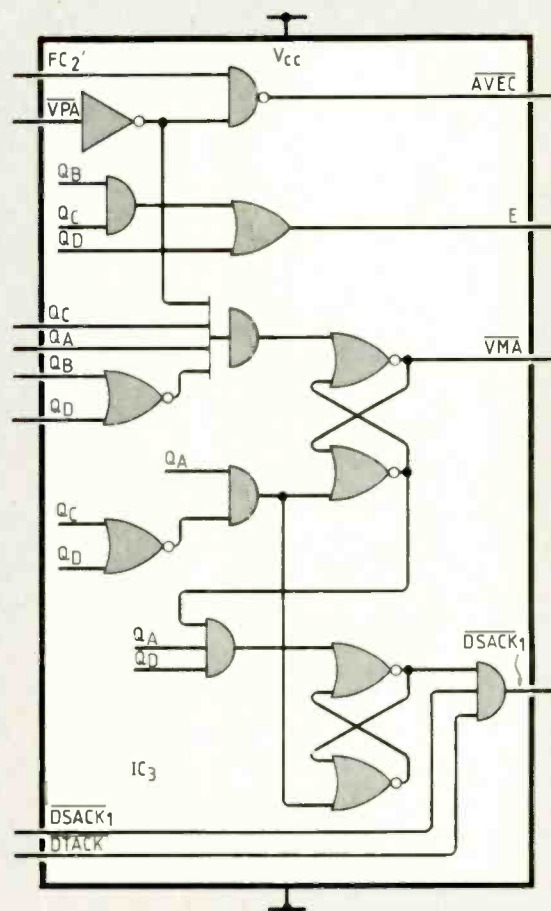
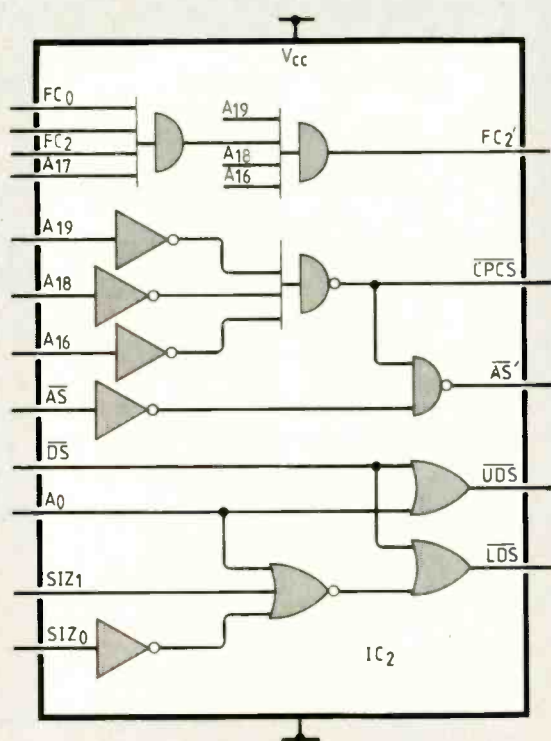

16R6, but the configuration used proved to be just as simple and more cost-effective in this instance.

The circuit required to produce one of these Pals, IC₂, is shown in Fig.7(a). You can see that 12 inputs and 5 outputs are needed, which is within the capabilities of the device. Next I had to decide which pins were to be allocated to each function. One of the great things about programmable logic is that you can assign the pins to suit your p.c.b. layout, making this easier and more flexible. The allocation chosen is shown in Table 2.

The circuit diagrams we have for each output of the device though is not in a form

Table 2. Allocation of pin functions for Pal IC₂.

I/O	Function	Pin	Pin	Function	I/O
I	FC ₀	1	20	V _{cc}	-
I	FC ₁	2	19	AS	0
I	FC ₂	3	18	UDS	0
I	A ₁₆	4	17	LDS	0
I	A ₁₇	5	16	CPCS	0
I	A ₁₈	6	15	LDS	I/O
I	A ₁₉	7	14	SIZ ₀	I
I	AS	8	13	SIZ ₁	I
I	DS	9	12	FC ₂	0
-	GND	10	11	A ₀	I

which reflects the internal structure of the Pal and so the next process is to translate the circuit diagram for each output of Fig.7(a).

Internally, this Pal has four gates in series, the appropriate inputs of each one of which must pass through to produce the output. These are, first either an inverting or non-inverting gate, an And gate, an Or gate, and finally an inverting buffer which may be tri-stated if desired. In this design all used outputs are permanently enabled.

Taking the simplest block first, the uds output, from Fig.7(a) you can see that this output must go low if both ds and A₀ are low, and high at all other times, i.e. an Or gate. How this is implemented in the Pal is shown in Fig.8. Two of the inputs to the And gate are used and driven from ds and A₀ after each is inverted. Unused And inputs must all be tied permanently high for the gate to function and this is done by blowing all the remaining fuses in that product term.

Thus the And output will be high only if both ds and A₀ are low. To get the required output from this merely requires inversion, the Or gate not being required. If the output from the And function is applied to one input of the Or gate and all the other inputs are low, then the Or gate will act as a non-inverting buffer and have no effect. The output inverter is permanently enabled, producing the required output.

With the circuit diagram in this form, we have the logic function defined in the same manner as the internal structure of the Pal and the fuse plot diagram can now be marked up. Figure 9 shows the section of the fuse plot for the uds output. The top And gate drives the output buffer which is to be permanently enabled. This is done by blowing all fuses on its input, denoted by no x's on that product term line.

For the next And gate shown, the one that is used, x's on inverted input lines from ds and A₀ indicate these fuses are intact, while all other fuses are blown. The remaining six And gates are not used and must output a logic low to the Or gate. If the fuses for both

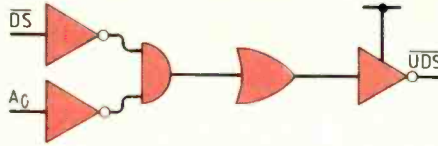

Fig.8. Pal equivalent circuit for the upper data-strobe.

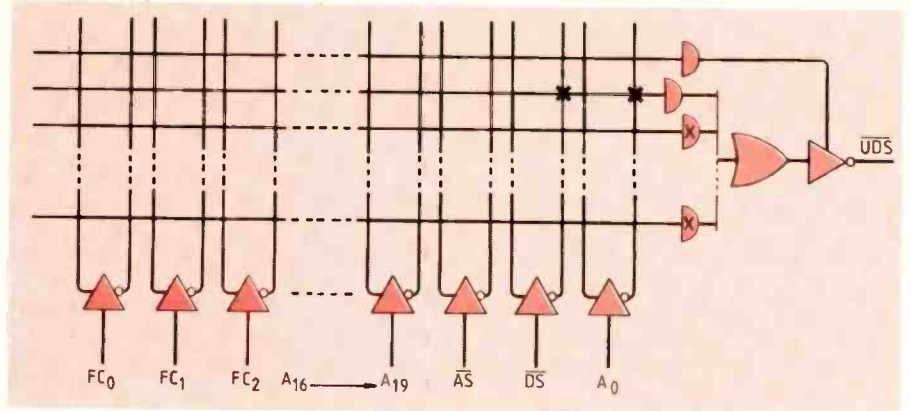

Fig.9. Fuse plot for upper data-strobe signal decoding.

the true and inverse of an input are left intact to an And gate then the output must always be false (low) whatever the state of the input. So all fuses to the unused And gates are left intact and this is indicated by placing an x inside the And-gate symbol.

This output was a fairly simple one, but the LDS output is a little more complicated, Fig.10. You can see that the first output gives the inverse of what is required and so this output, which is also an input, is fed back in and inverted to finally give the required function. The first output pin is left unconnected externally. Figure 11 shows the fuse-plot equivalent of this.

registers to be accessed individually by various extra commands and also displayed by the 'rb' command.

Since the 68881 maths co-processor is optional, the monitor also has to determine

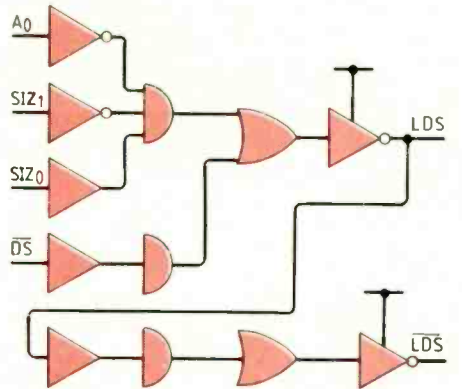
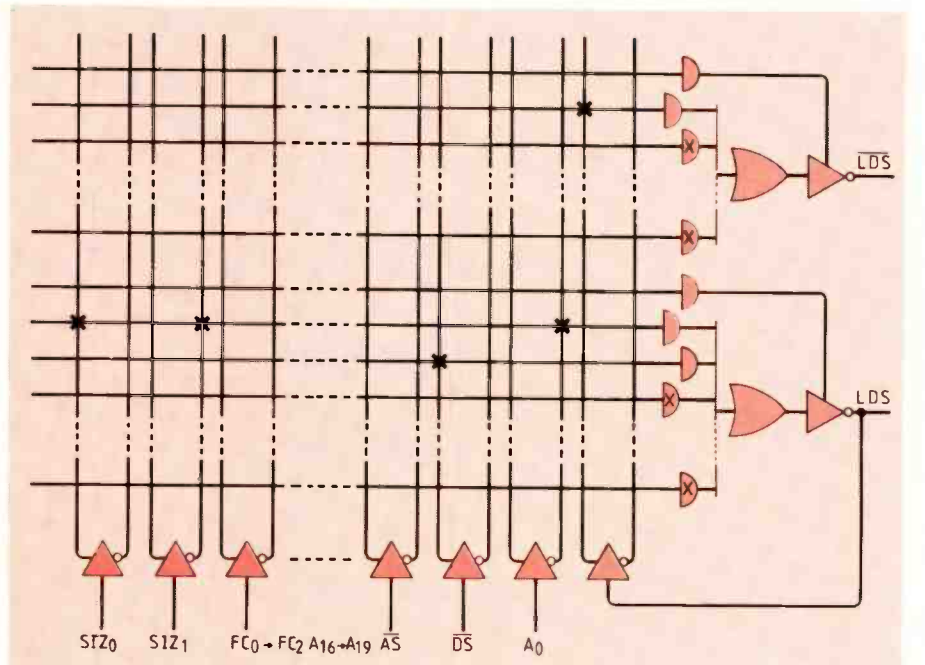

Fig.10. Pal equivalent circuit for the lower data-strobe.

FIRMWARE MODIFICATIONS

In order to accommodate the new processors that can now run on the Kaycomp board, the firmware has been extended to cover the extra features. The assembler and disassembler have obviously had to be extended to cover the extra instructions and addressing modes. And the monitor has had to be altered considerably to enable the extra

Fig.11. Lower data-strobe output fuse plot.



at reset whether or not it is fitted. If it is not fitted, a link from the co-processor chip-select line to the 68020 bus-error input, BERR, must be fitted (LK₁) which causes a bus error if a co-processor access is attempted. At reset this is intercepted and used to prevent further access by the monitor of the co-processor, instead of causing normal bus-error exception processing.

Otherwise the monitor has been kept the same wherever possible. One alteration is that the 40-column display mode has been removed, the reason being the extra number and size of the registers that have to be displayed make it really unworkable with anything less than an 80-column display. Also consider the maximum length of instruction that now has to be handled by the assembler and disassembler, for instance,

```
00400612 33D019370012345600056789213300ABCDEF00FEDCBA
MOVE (I$123456.A0),D1.L,$56789),(I$ABCDEF.A1,D2.W)$FEDCBA
```

which is difficult enough to make clear with an 80-column display!

All these extensions have virtually doubled the size of the Kaycomp firmware package which is now about 60Kbyte. Eproms therefore must be at least 32kbyte

each, so 27256 devices must be used.

ASSEMBLY AND INSTALLATION

Because of the use of Pals the board itself is quite simple and requires very little assembly. Parts for this design are available from Magenta Electronics Ltd whose address is given later. These include a high-quality six-layer plated-through-hole p.c.b. which makes the design very compact and reliable. There are only ten components in all to be mounted on the board and their positions are shown by a silk-screened legend. Remember though that the 64-pin board-to-board adapter is fitted on the underside of the board and soldered on the top (component) side. This adapter has pins which are a larger diameter at one end than the other. The larger diameter ends must be soldered

into the new board. Also, if the 68881 is not being fitted at this stage, wire together the two holes of LK₁.

To fit the kit, the new 27256 Eproms should be fitted first after altering the links on LK₁ on the Kaycomp to suit 27256

eproms (see November 1985 issue, page 53). Next remove the 68000 i.c. from the Kaycomp and in its place plug in the new board, ensuring it is the correct way round. The boards are now ready for powering up.

Getting the new upgraded Kaycomp working is probably the easiest part of upgrading. The harder part is upgrading the user to be able to program the two new processors, particularly the maths co-processor which requires new ways of working for the programmer but has great potential for real-time mathematical applications¹.

Two books therefore will be essential to the new user. These are the manufacturer's user manuals for the 68020² and the 68881³ processors.

Magenta Electronics is at 135 Hunter Street, Burton-on-Trent, Staffordshire DE15 0AB, tel: 0283 65435.

References

1. Using 68020 co-processors, Burns and Jones, *E&W* May 1987, pp.535-537.
2. Motorola MC68020 32-Bit microprocessor user's manual, part number MC68020UM/AD.
3. Motorola MC68881 floating-point coprocessor user's manual, part number MC68881UM/AD.

Bob is now Development Manager for computer systems and consultancy company, Barron McCann.

Numerical recipes in C: the art of scientific computing, by William H. Press, Brian P. Flannery, Saul A. Teukolsky and William T. Vetterling. Cambridge University Press, £27.50. Comprehensive handbook of scientific computing in the C language, the follow-up to an earlier work devoted to computing in Fortran and Pascal. Its 17 chapters and 200-odd program examples cover such areas as linear equations, differential equations, interpolation and extrapolation, random numbers, sorting, finding roots, eigensystems, FFTs, statistical methods and data modelling. Program examples are commented and fully explained in the accompanying text. In keeping with the informality of their title, the authors present their material in a sleeves-rolled-up, practical, and very readable style, and are not above tossing in the occasional touch of humour (illustrating one of their sections on C control structures is a program called 'badluk', which calculates occurrences of Friday the 13th when the Moon is full). Useful reading lists follow each section. C programmers will undoubtedly find this book invaluable; and in view of the sheer bulk of information it contains, they will probably think it very reasonably priced too. Hard covers, 755 pages. Recipes and examples are available from the publishers on disc (IBM PC format).

Electronics and computer acronyms (revised second edition) by Phil Brown. Butterworths, £24. Glossary of electronic technology from A for atto (10^{-18}) to Zr for zirconium: 2500 entries covering every branch of the art, including the commonplace, the esoteric and a few surprises. For example, none of us in the office knew until now that BNC (as in connector) stood for Bayonet Nut Coupling. This sent us scurrying to look up SMA – but alas, it wasn't

BOOKS

included. One error we spotted is that CTS, in serial communications links, stands for clear-to-send, not clear-to-stand. Useful, if expensive. Hard covers, 272 pages.

Computer Lib, revised edition, by Ted Nelson. Tempus (Microsoft Press, Penguin Books), £14.95. "This book is a multi-user, high-resolution, demand-paged, hardware-software, read-mostly memory, retrieval and display system with real-time interaction, tactile interface, audio and video feedback." Get the idea? Its cheerfully anarchic typography occupies territory somewhere between early *Private Eye* and *The Face*, and the scrapbook-style pages are a diverting mixture of computer facts, fantasy, ideas, opinion, jokes, cartoons, eccentricity, wisdom, whimsy and aphorisms (sample: "Wordstar is the second hardest video game yet made").

THE DECLINE OF MIND

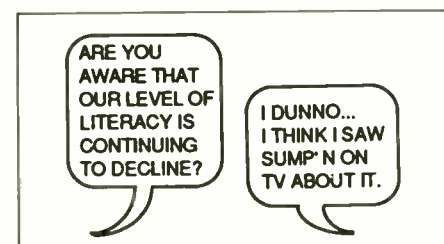

In fact, it's two scrapbooks – the second half, entitled "Dream Machines", is printed upside down, working from the back cover inwards, which means that two readers can enjoy the book at once (this must be the multi-user angle). Besides the humour,

there's plenty of serious analysis of the computer world: a favourite target is the industry's *eminence bleue*, IBM, which comes in for a good deal of criticism over its business policies. "A computer cult classic returns", says the blurb-writer, and who could dispute that? Enormous fun to dip in to. Large format paperback, 235×247mm, 305 pages.

• Following the appearance of our Research Notes item, "Building with atoms" (May 1988, page 452), a reader draws our attention to a book by an MIT visiting scholar, Eric K. Drexler, called "Engines of Creation".

This, he writes, discusses the full implications and implementation of this technology, in all fields, from mechanical engineering through computing and telecommunication to medicine.

Nanotechnology, the building of devices using individual atoms and molecules as working parts, is likely to make a major and profound change to humanity. Drexler discusses its use for good or ill. A real age of plenty could result. The medical implications are profound, leading to cures of cellular diseases such as cancer and ultimately to the immortality of the individual and possible revival to youthful good health of those being frozen upon death today.

"Engines of Creation" also discusses possible abuses of the technology, and the implications of its effects on present problems of society. The book is published by Doubleday at just under \$18. If any reader has difficulty in getting a copy through the usual channels, a limited number of copies are available at £11.20 each, post free, from John de Rivaz at West Towan House, Porthowan, Truro, Cornwall TR4 8AX. (Despatch by first class post within 28 hours; your money back if sold out.)

PROTEL

The Circuit Designer's Dream . . .

. . . becomes a reality!

The PROTEL family is the answer to all these dreams — at prices you can afford!

When you look at its price, specification and ease of use, it's not surprising that PROTEL is fast becoming a world standard for LOW COST PROFESSIONAL CIRCUIT DESIGN CAD on any IBM PC or compatible.

TRY FOR YOURSELF!

For £25 per program you can try our "full facilities" evaluation packs.

PROTEL *Route*



£499

I dreamt that the computer was laying the tracks automatically — right there on my IBM PC screen . . .

I dreamt that the computer was drawing perfect PCB artwork for me . . .

PROTEL *PCB*



£799

PROTEL *Schematic*



£499

I dreamt that the computer was drawing perfect schematic diagrams for me . . .

The dream becomes reality with Protel in action

Engineering Solutions Limited
King's House, 18 Kings Street,
Maidenhead, Berks. SL6 1EF
Tel: (0628)773444 Telex: 849462 Fax: (0628) 74928

ENGINEERING SOLUTIONS LIMITED

ENTER 30 ON REPLY CARD

NEW

FROM NUMBER ONE SYSTEMS

NEW

PCB CAD, FOR THE PC/XT/AT, THAT YOU CAN AFFORD

HAVE YOU BEEN PUTTING OFF BUYING PCB CAD SOFTWARE?
ARE YOU STILL USING TAPES AND A LIGHT BOX?
HAVE YOU ACCESS TO AN IBM PC/XT/AT OR CLONE?
WOULD YOU LIKE TO BE ABLE TO PRODUCE PCB LAYOUTS UP TO 17" SQUARE?
WITH UP TO 8 TRACK LAYERS AND 2 SILK SCREEN LAYERS?
PLUS DRILL TEMPLATE AND SOLDER RESIST?
WITH UP TO EIGHT DIFFERENT TRACK WIDTHS ANYWHERE IN THE RANGE .002 to .531" ?
WITH UP TO 16 DIFFERENT PAD SIZES FROM THE SAME RANGE?
WITH PAD SHAPES INCLUDING ROUND, OVAL, SQUARE, WITH OR WITHOUT HOLE, AND EDGE CONNECTOR FINGERS?
WITH UP TO 1500 IC's PER BOARD, FROM UP TO 100 DIFFERENT OUTLINES?
WITH AUTO REPEAT ON TRACKS OR OTHER FEATURES — IDEAL FOR MEMORY PLANES?
THAT CAN BE USED FOR SURFACE MOUNT COMPONENTS?
WITH THE ABILITY TO LOCATE COMPONENTS AND PADS ON GRID OR TO .002" RESOLUTION?
WITH AN OPTIONAL AUTO-VIA FACILITY FOR MULTILAYER BOARDS?
WITH THE ABILITY TO CREATE AND SAVE YOUR OWN SYMBOLS?
THAT IS AS GOOD AT CIRCUIT DIAGRAMS AS IT IS AT PCB's?
THAT CAN BE USED WITH EITHER CURSOR KEYS OR MOUSE?
WHICH, WITH "EASY-PLOT" CAN ALSO OUTPUT TO A PEN PLOTTER? (A PHOTO PLOT DRIVER WILL BE AVAILABLE SHORTLY)
WHERE YOU CAN LEARN HOW TO USE IT IN AROUND HALF AN HOUR?
THAT ONLY COSTS £275.00 + VAT
PLEASE CONTACT US FOR FURTHER INFORMATION.

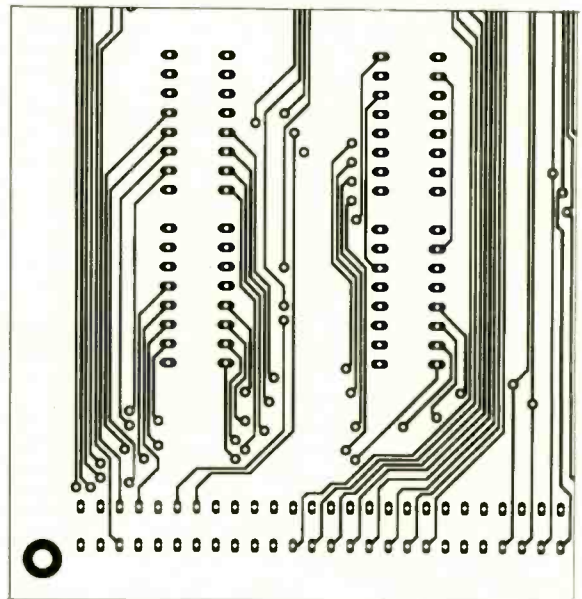

AFFORDABLE PCB CAD IS HERE!

NUMBER ONE SYSTEMS LIMITED
REF: WW, HARDING WAY, SOMERSHAM ROAD
ST IVES, HUNTINGDON, CAMBS PE17 4WR

Telephone: 0480 61778

ENTER 31 ON REPLY CARD

TELECOMMS TOPICS

Opto first from Ericsson

Ericsson's researchers in Stockholm have developed a new integrated optical switching device that can be interfaced directly to standard single-mode optical fibres. This polarization independence is claimed by Ericsson to be a world first and to represent a significant advance on earlier switching matrices.

A further interesting feature of the new switch is that it can be used as a non-blocking point-to-point switch; but the switch architecture means that it can also be used as a broadcast switch, with one input channel able to broadcast to all outputs.

The device, demonstrated as a laboratory version, is a 4x4 channel switch matrix, implemented in lithium niobate and operating at the telecom industry standard wavelength of 1300nm. Switching is executed entirely in the optical domain, under the control of electronic signals.

Ericsson's new device uses a completely different switching mechanism from the first 8x8 channel integrated optical switch matrix unveiled by the company two years ago, although that too was implemented in lithium niobate.

The new device uses an optical switch technique that can be electronically tuned so that high performance is achieved with

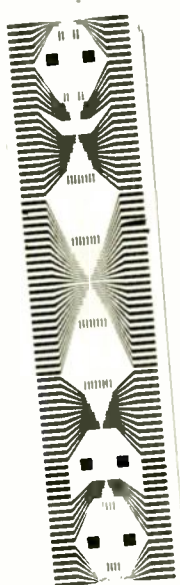

lower fabrication tolerances. This, coupled with an extremely low crosstalk between channels of less than -35dB (optical), augurs well for the development of more complex photonic switching networks.

At present the data stream on an optical fibre transmission route must first be converted to an electronic signal before it can be switched to another route. This imposes a severe restriction on the bandwidth and coding format of the information stream to be switched.

The attraction of development work into optical switching is the long-term promise of communication networks where transmission and switching takes place entirely in the optical domain. Optical space switching promises virtually unlimited bandwidth, and transparency to coding format. The ultimate aim is what are called "coherent optical networks".

System X enhancement

Under the System Enhancement Programme 2 (SEP2), the present installed base of System X telephone exchanges is being enhanced by the manufacturer GEC Plessey Telecommunications (GPT) to allow the new integrated services digital private branch exchanges to interoperate with the digitized public network, via a signalling system known as Digital Access Signalling System 2 (DASS 2). Other benefits of the upgrade include X.25 direct computer-to-computer interfacing links for more efficient network management and quicker reaction to operating statistics.

SEP2 is possibly one of the most complex improvement programmes undertaken in telecommunications. It is believed to be the world's largest progressive modification ever attempted to a real-time on-line computer-based telephone network.

Hull telephone department (now known as Kingston Communications p.l.c.) is the largest System X user outside British Telecom, and was in the forefront of this enhancement programme. It achieved a complete and smooth transition by the end of December 1987.

In total around 50 processor



One of the many private steam railway companies in the UK is on the Isle of Purbeck in Dorset, where the Swanage Railway Company is busy restoring the old line from Swanage to Corfe Castle and Wareham. One of its main areas of work lies in the establishment of modern signalling and communications systems, not only for normal operation of the trains, but to satisfy the Department of Transport's safety requirements. These include, for example, the installation of railway company telephones on both sides of every level crossing and farm crossing, as well as train-activated platform bells and all conventional signalling needs.

The system being installed along the trackside uses Duratube & Wire's Dropwire No.10 - a twin-pair telephone cable fitted with steel strength members for overhead distribution capability and sheathed with solid polyethylene to BS6234.

exchanges have been modified so far and this will rise to 230 by the end of 1988. SEP2 forms part of the progressive series of enhancements which are an inherent feature of System X's design evolution strategy known as 'future proofing'. This allows the incorporating of new facilities and function as they become technically achievable or are demanded by the customer.

Telecom Pocketbook

Philips Business Systems has published 'The Philips Pocketbook of Telecommunications'. It is intended to be a serious reference book covering virtually every aspect of the UK industry and technology, and is published at a time when many changes are happening in telecommunications.

Topics covered range from telephones and p.a.b.xs to signalling and i.s.d.n. Both cellular

and data communications are given prominence, while information on installation and maintenance will be of practical help to users. The various public networks and operators are described together with regulatory authorities and the regulations they supervise. Of particular significance and usefulness is the section on approvals.

Copies of the booklet are available free of charge from Philips Business Systems, Elektra House, Bergholt Road, Colchester, Essex, CO4 5BE; telephone 0206-575115.

Fibre link record

A record-breaking £6 million optical fibre cable between Britain and the Isle of Man has been inaugurated by a video call between London and Douglas. The cable spans the entire 90km (56 mile) route without intermediate boosting, making it the

TELECOMMS TOPICS

longest 140Mbit/s unregenerated system in Europe – and probably the world – in commercial service; though not for long (see “UK-Ireland opto link”, below).

The new cable, supplied by STC Submarine Systems, is the latest step in the programme to convert the Isle of Man network to digital operation by 1990. Manx Telecom Ltd, the British Telecom subsidiary responsible for running the Isle of Man's telecommunications services, has already installed 126km of optical fibre in links between its exchanges on the island.

Within the cable are six fibre pairs, five of which are being brought into immediate use at 140Mbit/s – equivalent to nearly 2000 simultaneous phone calls per pair. The cable augments analogue and digital links with the Isle of Man.

It is the first application by STC of 1535nm distributed feedback single-line lasers in submarine system terminals. These lasers have a very narrow spectral width, and may be used at this longer operating wavelength where the fibre attenuation is much less. As a result, systems well over 100km in length may be constructed without the need for submerged regenerators.

To minimize any risk of damage to the link by activities such as trawling, the cable was buried during laying by using British Telecom's special purpose seabed plough.

UK-Ireland opto link

A submarine fibre cable has been successfully laid by British Telecom between the UK and Ireland, at a cost of £7.2M.

When it comes into service this summer, it will become the longest optical unregenerated fibre cable in use. It runs 126km (80 miles) between Porth Dafarch, near Holyhead, Anglesey, and Portmarnock in the Irish Republic.

Jointly owned by British Telecom and Telecom Eireann, the cable has been supplied by French company Submarcom. It is being installed under modernization programmes which are bringing to customers the benefits of digital services and will carry speech, data, text,

graphics and facsimile.

The cable has 12 fibres of which six will be put into use immediately the cable comes into service. Each pair of fibres will support a system operating initially at 140Mbit/s. It will use the latest single-mode technology with high performance 1500nm lasers.

BT to improve packet service

British Telecom is to enhance its public packet data services, Packet SwitchStream (PSS), by introducing a range of new customer facilities during the year. Further benefits will come from improvements to be made to the International Packet Switching Service (IPSS).

Enhancements to PSS will follow BT's implementation of the 1984 recommendations for expanding the CCITT X.25 protocol. The principal enhancements initially include: increasing the permitted length of the facility field in call set-up and call clear packets for data terminating equipment (DTE) from 63 to 109 bytes, providing capacity for additional facilities; enhancement for fast select calls so that user data can be carried in the call request packet, even when the call has entered the data transfer phase; and notification of call redirection, by which a called DTE is informed that it is chosen as an alternative destination for a call.

Other enhancements include DTE-originated cause codes, expanded interrupt user data field, hunt group address replacement, called line address replacement.

Payphone monopoly abolished

OfTel has published its technical requirements for the approval of payphones. Up to now, payphones installed on private premises such as shops, restaurants, garages and public houses could only be obtained from BT. These new requirements effectively abolish BT's monopoly and will enable payphones to be evaluated for type-approval and – if approved – offered directly to users by suppliers other than BT.

Southwestern Bell Telecom UK, a subsidiary of the regional Bell operating company in the USA, is aiming to be the first company to take advantage of this change.

Its PP1000 desktop programmable payphone (pictured below) will, once it has been approved, be on sale in high street shops at £215+v.a.t. It does not require any special “payphone” tones from the exchange and so can be plugged into any BT telephone socket. It is supplied pre-programmed, but the user can readily alter the charges. For example, with a payphone installed by a company for staff to make private calls, or in a hospital for the convenience of patients, the charges would probably be set much lower than when the unit is sited in a pub or wine bar.

Currently some 300 000 private payphones are rented from BT, but according to SBT-UK's managing director, Stephen Carter, the total potential market could be as large as 800 000. This estimate is based on an analysis

of the total number of shops, garages etc. of a suitable size to employ such a device. However, he expects sales to reach about 50 000 units over the next year, with his company supplying over half.

V.42 protocol finalized

After more than three years of extensive development and negotiations between interested parties, CCITT V.42, error-correcting procedures for modems using asynchronous to synchronous conversion, has been finalized. It will go before the full CCITT for formal adoption next November in Australia, following agreements recently reached by the Plenary Modem Study Group XVII in Geneva.

Known as LAPM (link access procedure-modem), the primary protocol in the V.42 standard is based on the link access procedure-D channel (LAPD), used on the i.s.d.n. ‘D’ signalling channel) international standard. Both LAPB (used for error control in present Hayes V-series modems) and LAPD are based on the high-level data link control (HDLC) procedures.

Basing the primary protocol for modem error-control on the LAPD protocol adopted by ISO and the CCITT supports the position Hayes and many others favoured during the development of the V.42 standard. By developing LAPM, the CCITT has provided a firm foundation for continuing work on advanced modem features such as data compression, remote configuration and use of multiple virtual circuits. The new V.42 and the existing X.25 packet standard provide direction for the continuing evolution of dial-up data communications.

At the same time V.42 includes support for the well-established Microcom MNP protocol. This ensures that existing users of this *de facto* standard are not left out in the cold even though the progression is via the HDLC route.



Telecomms Topics is compiled by Adrian Morant.

...WE'VE SWITCHED THE LEEDS

LEETRONEX
25
YEARS

If you're involved in Electronics...as a buyer or as a seller...you really can't afford to miss LEETRONEX'88...not simply because it's the North's leading Electronics Exhibition but mainly because we've switched the venue to the new University of Leeds Exhibition Centre. For Exhibitors and Visitors alike it's going to be the best Leetronex Exhibition ever!

- Over 125 Leading Exhibitors ■ Superb Custom-built Exhibition Centre
- Free Parking for over 1,000 Vehicles
- City Centre Location ■ Cafeteria/Bars
- Seminar Programme Etc. Etc. ...

MAKE THE LEEDS CONNECTION IN '88!

NEW VENUE FOR '88

Now the North's longest established Electronics Exhibition is going to be bigger and better than ever before!!!

ORGANISED BY THE DEPARTMENT OF ELECTRICAL AND ELECTRONIC ENGINEERING

Leetronex88

TUESDAY 5th JULY 1988
WEDNESDAY 6th JULY 1988
THURSDAY 7th JULY 1988
AT THE
UNIVERSITY OF LEEDS
EXHIBITION CENTRE

For full information contact:-

Bill Black, Department of Electrical and Electronic Engineering, University of Leeds, LS2 9JT. Tel: 0532 420339

ENTER 5 ON REPLY CARD

Used equipment - with 30 days guarantee. Manuals supplied if possible. This is a very small sample of stock. SAE or telephone for LISTS. Please check availability before ordering. Carriage all units £16. VAT to be added to total on Goods and Carriage.

OSCILLOSCOPES

TEKTRONIX 577 Curve Tracer	£2,000
TEKTRONIX 576 Curve Tracer	£2,500
TEKTRONIX 475 Dual Trace 200MHz Delay Sweep	£1,400
TEKTRONIX 465B Dual Trace 100MHz Delay Sweep	£1,000
TEKTRONIX 2236 Dual Trace 100MHz Delay Sweep	£1,500
HITACHI V202F Dual Trace 100MHz Delay Sweep	£700
TEKTRONIX 2215 Dual Trace 60MHz Delay Sweep	£500
TEKTRONIX 455 Dual Trace 50MHz Delay Sweep	£500
H.P. 1707B Dual Trace 75MHz Delay Sweep	£450
H.P. 180A Dual Trace 50MHz Delay Sweep	£300
PHILIPS 3248 Four Trace 50MHz Delay Sweep	£900
PHILIPS 3240 Dual Trace 50MHz Delay Sweep	£400
TELEQUIPMENT D83 Dual Trace 50MHz Delay Sweep	£250
COSSOR OSCILLOSCOPE CD1150 Dual Trace 35MHz Delay Sweep	£250
Solid State Portable 8" x 10cm Display with manual	£180
Optional: Front Protection Cover Containing 2 Probes and Viewing Hood	£10
SOLARTRON OSCILLOSCOPE CD1400 Dual Beam 15MHz with manual	£85
TELEQUIPMENT D43 Dual Trace 15MHz	£100
TELEQUIPMENT 55A Single Trace 10MHz	£90
ADVANCE OS295 Dual Trace 15MHz	£225
ADVANCE OS207V Dual Trace 10MHz	£150
TEKTRONIX 466 STORAGE Dual Trace 100MHz	£2,000
PHILIPS PM3234 STORAGE Dual Beam 10MHz	£500
TELEQUIPMENT D43 STORAGE Dual Trace 15MHz	£300
TELEQUIPMENT DM64 STORAGE Dual Trace 10MHz	£225

7000 RANGE TEKTRONIX

Main Frames: 7028, Storage: 7704A, 7504 & 7603. Many Plug-in options available. **POA**

MARCONI MOBILE RADIO TEST SET TF2950 ONLY £800 each

GENERATORS

WAYNE KERR B905 Automatic Precision Bridge	£2,000
WAYNE KERR B603 Automatic Precision Bridge	£1,000
DATRON 1065 Automatic Digital Multimeter	£550
H.P. UHF Sig Gen - 8 & 194MHz	£900
MARCONI TF2006 FM 10-1000MHz	£600
MARCONI TF2006 FM 4-500MHz	£600
MARCONI TF2008 AM/FM 10MHz-510MHz	£1,200
MARCONI TF2015 AM/FM 10MHz-520MHz with TF2171 Synchronizer	£800
MARCONI TF2015 without Synchronizer	£600
MARCONI TF2016 AM/FM 10kHz-120MHz with TF2173 Synchronizer	£600
MARCONI TF2016 without Synchronizer	£400
MARCONI TF2002B with Synchronizer TF2170B 10Hz-88MHz AM/FM	£300
MARCONI MOD METERS FF2300A-2300B, 2304 from RACAL UNIVERSAL COUNTER 9900, 9903, 9904 from YECHEM (MARCONI TF2103) OSCILLATOR 10Hz-1MHz Sine Square	£60 (p&p £4)
FARNELL LF42 OSCILLATOR 1Hz-1MHz Sine Square	£80 (p&p £5)
DYMAR 1525 AM/FM 0.1-194MHz	£200
MARCONI ATTENUATOR TF2162 DC 1MHz-600 Ohm 0.111dB in 0.1dB Steps	£35 (p&p £7)
HATHFIELD ATTENUATOR DC-250MHz 50 Ohm 0.100dB	£60 (p&p £4)
MARCONI Automatic Distortion Meter TF2337A, 400Hz or 1kHz	£250
FERROGRAPH RTS2 Recorder-Test Set	£350
WOLKE Wow & Flutter Meter ME108	£125
LEADER LM186A 2 Channel Millivoltmeter, 100uV-300V, 5Hz-100MHz	£150

TRIO OSCILLOSCOPES

CS2150 4 Trace 150MHz Delay Sweep	£1,200
CS1100 Dual Trace 100MHz Delay Sweep	£800
CS1065 3 Trace 60MHz Delay Sweep	£600

H.P. SPECTRUM ANALYSER 182C with 8558B 0.1 1500MHz
H.P. VECTOR VOLTMETER £1,200
TEKTRONIX 520 PAL VECTOSCOPE £1,000

MULTIMETERS

AVO B Complete with batteries and leads from	£50
AVO 8 MV Complete with batteries, leads	£90
AVO TEST SET No. 1 (Military version of AVO B) Complete with batteries and leads	£65
TEST LEADS suitable for AVOMETERS Red & Black with 2 Croc Clips and 2 Prods	£5 (p&p £3)
AVO Model 72 Pocket Multimeter No. AC Range with batteries and leads	£10 (p&p £3)

DISK DRIVE PSU 240V in 5V 1.6A & 12V 1.5A Out Size W125mm, H75mm D180mm. Cased Un-used ONLY £10.00 each (p&p £3)
QUERY KEYBOARD (as in LYNX MICRO) Push to open ONLY £5 each (p&p £3)
Cancelled
SWITCHED MODE PSU - 12V 0.25A, 5V 40A, 1.2V 5A
OTHER SWITCHED MODE PSU AVAILABLE. Please enquire
DATRON 3000 PROM COPIES (Copies up to 10) £130 each (p&p £7)

BRUEL & KJØER EQUIPMENT AVAILABLE (Please enquire)

Audio frequency spectrometer type 211 (Un-used) £900

AVO VALVE TESTER CT160 Suitcase style 22 bars (p&p £25ea (p&p £7)
AVO TRANSISTOR ANALYSIS Mk2 CT446 suitcase style complete with batteries and operating instructions ONLY £35 (p&p £7)

MARCONI AF POWER METER FB933A 20Hz-35kHz, 20dB 10W with manual only £35 (p&p £7)
MARCONI HF POWER METER TF1152A/1 DC 500MHz, 0.5 to 25W 50 Ohm with manual only £45 (p&p £7)

NEW EQUIPMENT

HAMEG OSCILLOSCOPE 604 Dual Trace 60MHz Delay Sweep Component Tester - two probes	£575
HAMEG OSCILLOSCOPE 203.6 Dual Trace 20MHz Component Tester with two probes	£314
All other models available	
BLACK STAR COUNTER TIMERS (p&p £5)	
APOLLO 10-100MHz Ratio/Period/Time interval	£219
APOLLO 100-100MHz (As above with more functions)	£285
BLACK STAR FREQUENCY COUNTERS (p&p £4) Meter 100-100MHz	£99
Meter 500-600MHz	£126
Meter 1000-1GHz	£175
BLACK STAR JUPITER 500 FUNCTION GENERATOR Sine/Square/ Triangle 0.1Hz-500kHz (p&p £4)	£110
ORION COLOUR BAR GENERATOR Pal/T Video	£199
HUNG CHANG DMM 7030 3 1/2 digit Hand held 28 ranges including 10 Amp AC/DC 0.1%	£39.50
Complete with battery and leads (p&p £4)	£33.50
As above DMM 6010 0.25%	£30.00
Carrying cases for above	£3.00 ea
OSCILLOSCOPES PROBES Switched x1 x10 (p&p £3)	£11

STEWART OF READING Tel: 0734 68041 Fax: 0734 351696

110 WYKEHAM ROAD, READING, BERKS RG6 1PL

Callers welcome 9am to 5.30pm. MON-FRI. (UNTIL 8pm. THURS)

ENTER 32 ON REPLY CARD

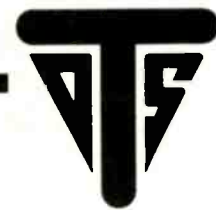

DATA LOGGER MODULE

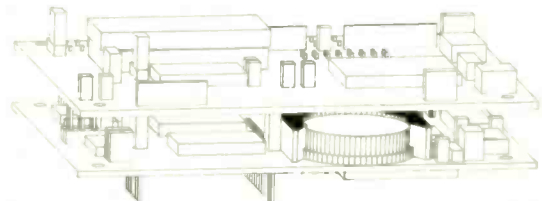

TDS9090-PIN Forth embedded computer (top) and TDS9095-PIN Multifunction card (bottom) together make an ideal module for data collection and analysis.

- 10 channel, 10 bit Analog to Digital.
- 128K bytes non-volatile RAM (Li battery).
- 6 channel Digital to Analog.
- Non-volatile clock with date and time.
- High level language on card.
- Assembler on card.
- LCD connection with software support.
- Matrix keyboard connection with support.
- Two serial ports at proper voltages.
- 35 parallel I/O lines.
- 25mA from 9V or 12V battery.
- Watchdog timer.

TDS9090 + TDS9095 under £290ea for 10 off.

Triangle Digital Services Ltd
100a Wood Street, London E17 3HX

Telephone 01-520-0442 Telex 262284 (quote M0775)

ENTER 8 ON REPLY CARD

SUPERKIT ELECTRONICS, INC.

BUY DIRECT FROM THE USA AT WHOLESALE PRICES AND TAKE
ADVANTAGE OF THE \$
... JUST A SAMPLING OF OUR PRICES!

I.C.'s									
TL081CP	TI	.13	SN74LS323AN	TI	.51	MK68000P6A	MOSTEK	2.70	
MC26S10L	MOT	.35	DN74LS366A	PAN	.08	S6802P	AMI	1.35	
LM319N	SIG	.12	DN74LS386	PAN	.08	HD6845P	HIT	.97	
LM320K5	NSC	.32	DN74LS90	PAN	.05	AD7503JN	AD	1.08	
MC34002P	MOT	.04	SN74S02J	TI	.04	D8048C	NEC	.46	
UA3406PC	FSC	.17	74S08PC	FSC	.08	M110B1	SGS	2.16	
MPQ3467	HIT	.26	SN74S195N	TI	.11	Z80HCPU	SGS	.97	
LS37	MOT	.03	74S32PC	FSC	.09	P8224	INT	.65	
LM392N	NSC	.13	SN74S51N	TI	.11	D8259AC	NEC	.54	
MN4035B	PAN	.04	ULN2032A	SPG	.21	P8287	AMD	.70	
MN4042B	PAN	.04	74S240N	SIG	.11	P8748H	INT	2.97	
HCF4052BEY	PAN	.03	SN74S241N	TI	.15	N8X305N	SIG	4.32	
MN4078B	PAN	.04	UA7812UC	FSC	.09				
MN4082B	PAN	.04	UA7912UC	FSC	.09				
MN4085B	PAN	.04	N8T245N	SIG	.11	TRANSISTORS & SCR's			
HCF4086BEY	SGS	.03	N8T26AF	SIG	.11	TIC206D	TI	.15	
MN4519B	PAN	.05	MC8T26AP	MOT	.11	TIC216D	TI	.15	
MN4539B	PAN	.06	N8T97N	NSC	.11	TIP2955	TI	.23	
MC14584BCP	MOT	.10	N9401N	SIG	.81	GI752	GI	.11	
MN4585	PAN	.08	96LS02DC	FSC	.30				
6331-1J	NMI	.46	MICROPROCESSORS			DIODES			
MPQ6700	MOT	.26	WD1015PL-00-02	WD	6.75	1N4001	ITT	.01	
SN74145N	TI	.15	FDC1797	SMC	1.62	1N4005	ITT	.01	
SN7433N	TI	.09	WD1943M00	WD	1.35	1N4006	ITT	.01	
SN7445N	TI	.15	D2147D2	NEC	.46	1N5225BRL	MOT	.05	
SN74ALS04AFN	TI	.03	COM2601	SMC	.54	1N5818	MOT	.06	
74H00N	SIG	.19	A12625-5	BURR BROWN	.38	1N6263	ITT	.04	
74H01N	NSC/SIG	.19	SCB2673BC5N40	SIG	.81	1N753A		.02	
74H108N	TI	.19	D2758	INT	.27	OPTOS			
74H10PC	FSC/MOT	.19	TMS2764-25JL	TV/SGS	1.54	H21A2	GE	.41	
74H20N	NSC	.19	TMS27C256-25JL	TI	2.16	OL500	LITRONIX	.16	
74H40N	SIG	.19	TMS2732A30JL	TI	1.72	HDSP5523	HP	.65	
74H51N	TI	.19	AM27S181DC	AMD	.65	HDSP5533	HP	.49	
74H55N	TI	.20	TBP28L22N	TI	.97	TPS603	TOSHIBA	.08	
74H74N	SIG/TI	.19	A14437	AMICON	1.62	COMPUTER			
74LS240N	FSC/PAN	.10	MM5290N4	NSC	.15	5 1/4" Floppy disk drive - Chlnon		.35	
74LS241PC	FSC	.10	SS1580CP	SSI	2.16	Keyboard 101 AT enhanced		.29	
74LS26	PAN	.04	R6500-IEAB3	ROCK	14.04				
SN74LS322AN	TI	.51	R6503AP	ROCK	1.30				

ALL PRICES IN £ STERLING

WE HAVE 10M US DOLLARS
IN STOCK! NEXT TIME,
TRY US.

SUPERKIT ELECTRONICS, INC.

7905 NW 60th Street, Miami, Florida, 33166 USA.

Tel: 305 477 4069 Telex: 153265 KIT UT Fax: 305477 4116

ENTER 53 ON REPLY CARD

New on the scene...

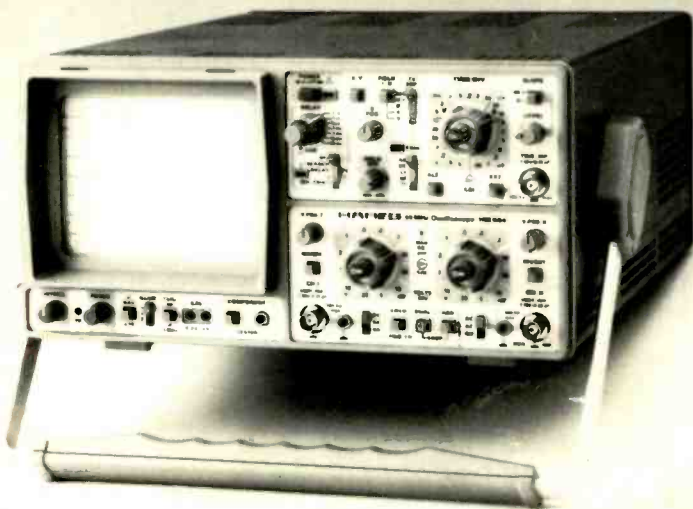

60 MHz Universal Oscilloscope

2 channels max. 1mV div. Delay Time - Component Tester.
Timebases 20ns-5µs Div. x 10. Sweep Delay.
Triggering DC to 80 MHz. Sync Separator. After-Delay Trigger.

The HM 604 is a new innovative general purpose oscilloscope satisfying a wide range of exacting requirements in laboratory, production, and service. The dual-channel measurement amplifier can be readily checked on the built-in fast-risetime 1MHz Calibrator from probe tip to CRT screen.

Another important feature is the internal delay line for observations of the leading edge of a signal. As in dual-time base oscilloscopes, the HM 604 features a calibrated sweep delay mode, allowing smallest waveform sections to be expanded up to 1000 times.

The HM 604's most outstanding feature is the automatic After-Delay Trigger mode to ensure extremely stable displays and jitter-free measurements of asynchronous signal sections and bursts or pulse trains, independent of amplitude fluctuations. An active TV-Sync-Separator further enhances trigger quality and in the alternate trigger mode, two signals of different frequencies can be compared.

At only £575 plus VAT the HM 604 from HAMEG again sets a new price/performance standard representing decades of successful design experience!

another winning scope from Hameg.

HAMEG

OSCILLOSCOPES

For those who compare

All Hameg Oscilloscopes are supplied with 2 probes mains lead and instruction manual
2 years warranty on instruments.

70-78 Collingdon Street, Luton, Bedfordshire LU1 1RX
Telephone (0582) 413174 Telex 825484 Fax (0582) 456416

ENTER 24 ON REPLY CARD

Pioneers

19. Almon Brown Strowger (1839-1902): inventor of the automatic telephone exchange.

W.A. ATHERTON

The "girl-less, cuss-less, out-of-order-less, wait-less telephone", was how Strowger's invention of the automatic telephone exchange was described. "I am often told that the telephone girls will be angry with me for robbing them of their occupation", Strowger said at a public demonstration of the first such exchange. "In reply I would say that all things will adjust themselves to the new order . . . The telephone replaced the messenger boy as this machine now displaces the telephone girl".

But not every telephone girl gave up without a fight, as one salesman discovered in North Carolina – where a town attorney feared for his girl-friend, the local telephone operator. Strowger's man lost the order because, the salesman was told, the automatic telephone "had no sex appeal".

The popular story behind the invention of the automatic telephone exchange has been told often. Strowger, at that time an undertaker in Kansas City, read in the local newspaper of the death of a friend and learned with surprise that the funeral arrangements were to be carried out by a rival. Always a man of quick temper he jumped to the conclusion that the lady telephone operator had connected the grieving relatives to his rival when they had really wanted to be connected to himself. This he judged to be either because his telephone was engaged at the time or for some more mischievous reason. His complaints brought denials and no satisfaction; and he turned to wondering how telephone callers might automatically connect themselves to their desired number without needing an unreliable operator.

Perhaps having seen a manual exchange, he soon conceived, in 1887, the basic idea of what he wanted and made a mock up by sticking pins into a circular cardboard collar box. (If you do not know what a collar box was, ask your grandfather!) Soon he had ten rows and ten columns of pins, representing contacts to 100 telephones. He envisaged a pawl and ratchet mechanism driven by pulsed electromagnets which would lift a wiper (which was connected to the caller's telephone) to the required row and then move it round to the required column. There the wiper would make contact with the distant telephone. A US patent for a 1000-line "automatic telephone exchange" was applied for on 12 March, 1889 and granted almost exactly two years later, number 447,918.

Strowger had little if any knowledge of electricity or mechanics and so his nephew, Walter, was given the task of making a working model. Even with the help of a

competent jeweller, a 1000-line switch proved beyond him. Instead, the first Strowger automatic switch consisted of just 100 contacts arranged in a single row inside a cylinder. It was exhibited at the Bell telephone exchange in Kansas City.

Fortune now smiled on Almon B. Strowger. Having failed to interest financial backers, Walter Strowger was approached by an enterprising salesman called Joseph Harris, on the look out for ideas which he could promote at the forthcoming World's Columbian Exposition. This was to be held in Chicago in 1892.

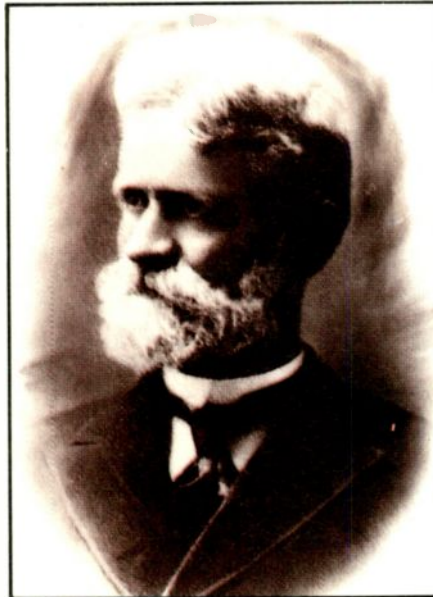

Almon B. Strowger (GTE Communications Systems).

Two years before the Exposition, Harris persuaded Strowger and his nephew to go to Chicago. There the Strowgers, Harris and a friend, M.A. Meyer, agreed to develop the system. Further financial backing was found, and on 30 October, 1891, the Strowger Automatic Telephone Exchange was incorporated in the state of Illinois. With a salary of \$100 a month, Strowger's days as an undertaker were over.

The automatic switch was exhibited at the Chicago offices of a railway company where Meyer worked. A firm of model makers was asked to make samples and work began on further development of the switch. Perhaps more importantly a telegram was sent to Baltimore to one Alexander Ellsworth Keith, electrician, asking him to come to Chicago at their expense. Keith came, saw, understood, and accepted an appointment as chief engineer. He proved to be a good choice.

NO NEED FOR GIRLS

The world's first automatic telephone service was opened in the autumn of 1892 at LaPorte in Indiana.

In 1890 the Bell Telephone Company had won a suit against the telephone system in LaPorte for infringement of the Bell patents. The judge ordered that all the telephones be burned! Presumably for the next two years LaPorte had no telephone service, enabling Strowger to obtain a franchise there in 1892.

For \$25 a month the Strowger Automatic Telephone Exchange rented premises above a shop, sub-letting spare space for \$15 a month. It was a reasonable start to business. By September wiring work had begun, and in mid-October the first telephones and automatic switches were installed. The service was up and running, serving a mere 52 subscribers.

On 3 November, 1892, was held a grand public demonstration. Formal invitations were sent out and a special train was laid on to bring guests from Chicago. About 50 or 60 were met by the mayor and the city band. At the telephone exchange they saw shelves carrying 80 of the new Strowger switches together with batteries. There were no "hello girls" (operators). The reporter from the *Chicago Daily Inter Ocean* could not get over the fact that the solitary employee present had "nothing, absolutely nothing, to do".

Even if he had nothing to do, the poor subscribers certainly had. From 12.30 to 4p.m. they were busy answering their telephones "very promptly" as the invited guests tried out the system. For Strowger and his companions the day was hugely successful and the Chicago newspapers duly reported the invention. "No need for girls" was a typical headline.

The dial telephone was an invention made by Strowger's engineers and it stood the test of time, until eased aside recently by push-button telephones. It is an historical curiosity that Strowger's original telephones also had push buttons. With less than a hundred subscribers the Strowger team simply provided two buttons. To call, say, number 37 the caller pressed the 'tens' button three times and then the 'units' button seven times. Although it worked well it was prone to errors as callers lost count!

Even as the LaPorte system was being publicly demonstrated, a second installation was under construction at Fort Sheridan in Illinois. By the end of 1896 Strowger exchanges had been installed in other towns in Indiana, and in Iowa, Minnesota, New Mexico, Colorado, New York State and Wisconsin.

In those early years almost every installation was a field trial, but by 1895 Strowger engineers (for Strowger himself played relatively little further part) had settled on the basic step-by-step 'up and round' motion. This came to characterize the Strowger switch which, of course, underwent many improvements. At LaPorte five wires were used: three for signalling, one for releasing and one for the conversation.

The dial was introduced in 1896 to reduce the number of mistakes made by callers, and the first dials used flanges instead of the later finger holes. Even dials gave problems. German settlers in Wisconsin pronounced '21' for example, as "one and twenty". So they dialled 1, then 2 and then possibly zero. An education programme on how to count in English solved the problem.

TRUNK DIALLING

In 1897 the concept of 'transfer trunking' was introduced whereby calls were directed through a series of switches. This meant that the size of the exchange was no longer limited to the size of the individual switch, which previously had provided contact to every telephone on the exchange.

Strowger's love affair with automatic telephony was short but very sweet. This major invention had been made by a man in his 48th year. (Who says you are past it at 40?) By the late 1890s his health was beginning to fail and he retired from the company which had been founded on his invention. The company, however, went from strength to strength and by the turn of the century it had opened operations abroad. In 1901, in effect, it became a new company: Automatic Electric. In 1955 Automatic Electric became part of General Telephones and Electronics and it is now part of GTE Communication Systems.

There was still life in Strowger himself however: for on his retirement he married his nurse, Susan Bellanger, and they moved to the healthier climate of St Petersburg in Florida. No-one now seems quite sure whether Susan was his fourth or fifth wife. It was in St Petersburg that he died on 26 May, 1902, aged 62. He was buried beneath a tombstone which read simply, "Lieut. A.B. Strowger, Co. A. 8 N.Y. Cav.". Forty-seven years later, 110 years after his birth, representatives of the telephone industry placed a bronze plaque on his grave commemorating his pioneering work on automatic telephony.

AN ARDENT BOOSTER

Life began for Almon Brown Strowger at Penfield in the state of New York on 19 October, 1839, one of a family of six boys and six girls. On his 22nd birthday, at the start of the American Civil War, he enlisted in the 8th New York Cavalry and served until the end of 1864. By this time he had been commissioned as second lieutenant. Shortly after, he married his first wife, who bore him two girls.

Strowger's career then moved from Civil War soldier to peace-time schoolteacher. He became principal of the school he had attended as a boy in Penfield. He taught in

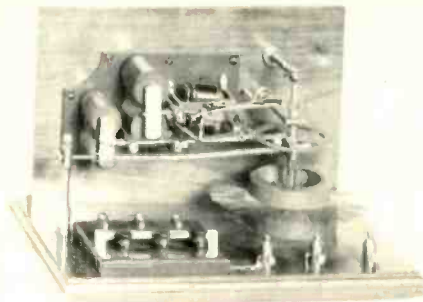

Original pre-patent Strowger switch, 1889 (GTE Communications Systems).



"No sex appeal": an early Strowger dial, 1898 (Museum of Independent Telephony).

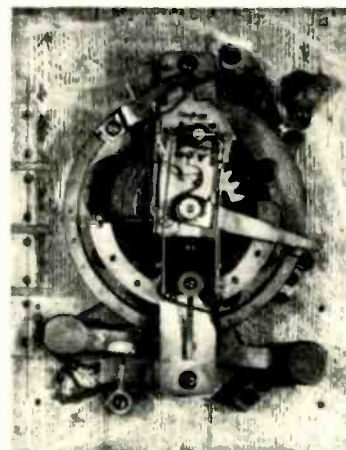

"All things will adjust themselves to the new order": the first Strowger switch installation at LaPorte, Indiana, 1892 (GTE Communications Systems).

other schools in Illinois, Michigan and Kansas before buying an undertaking business in North Topeka, some 60 miles west of Kansas City. There he lived at the shop with his second wife, his first wife having died.

What happened to this second wife is not certain. Whether widowed again or divorced, Strowger married again in 1886, this time to Alice Marie Hill who bore him his only son. They moved house and business to Kansas City where he continued his work as an undertaker. It was there, as we have seen, that he conceived the idea of an automatic telephone. He was not actually the first to have the idea, but he was the first to produce a working model which could be developed into a commercially successful product.

Strowger's retirement in St Petersburg, Florida, lasted four or five years to his death.

When his eyesight failed, a young man, R.H. Sumner, used to read to him. Sumner, who died in 1949, left this description of A.B. Strowger in his final years. "He was an ardent booster for the city and was very active in all political and civic affairs. He was not known locally as an inventor but rather as an investor. He gave generously of his time and money when the occasion demanded. Strowger became a familiar figure on the unpaved streets of St Petersburg as he drove a pure white horse and a shiny black buggy, and he was always on the move. He was a very outspoken, high tempered man and if he didn't like the way the city was

doing certain things he did not mind telling somebody how it should be done and oftentimes would take over and do it himself".

The author would like to thank GTE Communication Systems Corporation of Northlake, Illinois, and the Museum of Independent Telephony, Abilene, Kansas, USA, for their help in the research for this article.

Next in this series of pioneers of electrical communication will be Michael Faraday, the 'patron saint' of electrical engineers.

Further reading

1. J. Harwell Jones, *Telephony*, 15 October 1949, p11-13,34.
2. "Big day in '92" GTE Communications Systems Corporation, Northlake, Illinois.

HART – The Firm for QUALITY

LINSLEY-HOOD 300 SERIES AMPLIFIER KITS

Ultra high quality, Mosfet output. Fully integrated Hi-Fi amplifier kits by this famous designer. Two models, 35 and 45 watts per channel. Capable of superb sound quality with greater delicacy and transparency of tone than most commercial amplifiers. Building is very easy with our comprehensive building instructions as most components fit on the PCBs and setting-up only needs a multimeter.

K300-35 Total Parts Cost £138.28. Discount Price for Complete Kit £98.79. K300-45 Parts Cost £142.74. Kit Discount Price £102.36

RLH485, Reprints of Original Articles from 'Hi-Fi News' £1.05 (FREE with Kit)



LINSLEY-HOOD SUPER HIGH QUALITY AM/FM TUNER SYSTEM

A combination of his ultra high quality FM tuner and stereo decoder described in 'ETI' and the Synchronyne AM receiver described in 'WW'. Cased to match our 300 Series amplifiers this kit features a ready built pre-aligned FM front end, phase locked loop IF demodulator with a response down to DC and an advanced sample and hold stereo decoder. This tuner sounds better than the best of the high-priced exotica but, thanks to HART engineering, remains easy to build.

K400-FM, FM Only Kit Complete £134.61
K400AM-FM, Full AM/FM Kit £205.92

GREAT NEWS FOR KIT BUILDERS

As a result of popular demand we are now offering BLACK frontplates with matching collet knobs on our 300 Series amplifiers.

Price as option with kit £5.20

Price as upgrade for existing kits £15.90

Tuner versions will be ready soon.

SOLENOID CONTROLLED FRONT LOAD CASSETTE DECK

High quality (0.08%W&F) successor to our very popular SF925F. Offers all standard facilities plus cue and revue modes all under remote, logic of software control. Power requirements are simple with 12v solenoids and 12v motor with built in speed control. Logic and driver chips are available. Deck with stereo head, other heads to order £42.20
Full manufacturers data £2.90



HIGH QUALITY REPLACEMENT CASSETTE HEADS

Do your tapes lack treble? A worn head could be the problem. Tape heads are constantly improving and fitting one of our latest replacement heads could restore performance to better than new! Standard mountings fit most decks and our TC1 Test Cassette will make it easy to set the azimuth spot on. As we are the actual importers you get prime parts at lowest prices. All our heads are suitable for Dolby machines.



HX100 Standard Stereo Permalloy Head £2.49

HC20 High Quality Permalloy Stereo Head £7.66

HS16 Sendust Alloy Super Head. Quite simply the best. Longer life than permalloy, higher output than ferrite, fantastic frequency response, metal tape capability £14.86

HC551 4-Track head for auto-reverse or quadraphonic use. Full specification record and play head £14.60
Full data on these and other heads in our range are contained in our free list.

HART TRIPLE-PURPOSE TEST CASSETTE TC1

One inexpensive test cassette enables you to set up VU (Dolby) level, head azimuth and tape speed without test equipment. Vital when fitting new heads. Complete with instructions £4.66

Send for your FREE copy of our lists with full details of our complete range of Kits, Components, PCBs, Cassette Heads and Decks: - Overseas please send 5 IRCs for Airmail Post.



ELECTRONIC KITS LTD

1, Penylan Mill, Oswestry, Shropshire SY10 9AF
24 hr SALES LINE (0691) 652894 Please add VAT

COMMERCIAL QUALITY SCANNING RECEIVER



The IC-R7000, advanced technology, continuous coverage communications receiver has 99 programmable memories covering aircraft, marine, FM broadcast, Amateur radio, television and weather satellite bands. For simplified operation and quick tuning the IC-R7000 features direct keyboard entry. Precise frequencies can be selected by pushing the digit keys in sequence of the frequency or by turning the main tuning knob. FM wide/FM narrow/AM upper and lower SSB modes with 6 tuning speeds: 0.1, 1.0, 5, 10, 12.5 and 25kHz. A sophisticated scanning system provides instant access to the most used frequencies. By depressing the Auto-M switch the IC-R7000 automatically memorises frequencies that are in use whilst it is in the scan mode, this allows you to recall frequencies that were in use. Readout is clearly shown on a dual-colour fluorescent display. Options include the RC-12 infra-red remote controller, voice synthesizer and HP-1 headphones.



Icom (UK) Ltd. Tel: 0227 363859. Telex: 965179 ICOM G
N.B. Authorised Welsh distribution by:
MRS Communications Ltd. Cardiff. Tel: 0222 24167

Please send information on Icom products & my nearest Icom dealer.

Name/address/postcode:

.....

Status: Tel:

Post to: Icom (UK) Ltd. Dept. WW, FREEPOST, Herne Bay, Kent CT6 8BR

ENTER 10 ON REPLY CARD

ELECTRONICS CIRCUITS MANUALS

FROM HEINEMANN NEWNES

CMOS Circuits Manual

Describes the basic principles and characteristics of these most popular devices and includes circuits ranging from simple inverters, gates and logic networks to complex counters and decoders, with a large number of 'clock' and pulse generator designs.

0 434 91212 3/Paperback/192 pp/
268 illustrations/£9.95

NEW



Optoelectronics Circuits Manual

Covering one of the fastest-growing branches of modern electronics, the book includes basic principles, LED display circuits, LED graph circuits, seven segment displays, light-sensitive devices, optocoupler devices, brightness-control techniques, light-beam alarms, and remote control systems.

0 434 91211 5/Paperback/192 pp/
205 illustrations/£10.95

NEW

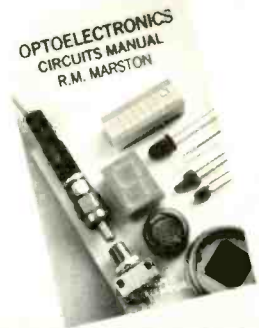

Electronic Alarm Circuits Manual

Useful alarm circuits designed to be activated by physical contact or by body proximity, or by variations in light or heat levels, or in voltage, current, resistance or some other electrical property. Covers both burglar and instrumentation alarms.

0 434 91214 X/Paperback/160 pp/
150 illustrations/£9.95

NEW

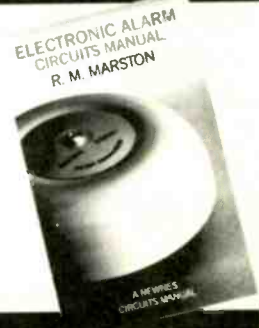

These three new books by R. M. Marston are the first volumes in a new series of practical circuits manuals from Heinemann Newnes. They deal with their subjects in an easy-to-read and non-mathematical manner, presenting the reader with many practical applications and circuits. They are specifically written for the practical design engineer, technician, and the experimenter, as well as the electronics student and amateur. Forthcoming manuals will describe Audio IC Circuits, Power Control Circuits, Op-Amp Circuits, Instrumentation and Test Gear Circuits, and IC Timer Circuits.

ORDER FORM

Marketing Dept, Heinemann Professional Publishing,
FREEPOST EM17 London WC1B 3BR.

Please send me:

___ copy/ies of CMOS Circuits Manual 0 434 91212 3 @ £9.95

___ copy/ies of Optoelectronics Circuits Manual 0 434 91211 5 @ £10.95

___ copy/ies of Electronic Alarm Circuits Manual 0 434 91214 X @ £9.95

Please add £2.00 for postage and packing. (Allow 28 days for delivery)

I enclose my cheque (made payable to Heinemann Professional Publishing Ltd) for Total _____

Please debit my credit card number _____

AMEX ACCESS VISA DINERS

NAME _____

*ADDRESS _____

POSTCODE _____

SIGNATURE _____ DATE _____

*Credit card customers should use address as shown on credit card statement

EW11

ENTER 6 ON REPLY CARD

A SMALL SELECTION FROM OUR STOCKS

THORN-EMI MODEL 6150/51 U.V. RECORDER

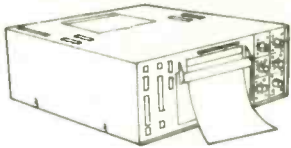

£1400 + v.a.t.

- 12 Channel Magnet Block
- 15cm Chart Width
- Trace Identification, Grid Lines & Event Marker
- Paper Speeds: — from 0.2mm/s to 1m/s
- 6 Channels Signal Conditioning Amplifier Built-In
- Record Duration, 1 or 2 Sec. Burst or Continuous with Timing Lines
- Galvanometers to Customer Choice (not included in the price)

WATANABE MODELS MC6601-6Z (& -4Z) 6 CHANNEL (& 4CH) FLAT-BED CHART RECORDERS

6 pen model 6601-6Z
£1600 + v.a.t.

4 pen model 6601-4Z
£1000 + v.a.t.

- Overlapping Fibre Tip Pens
- 280mm Wide Paper
- Paper Speeds: — 7.5-600mm/min & hour.
- Variable Gain Inputs from 1mV to 500V f.s.d

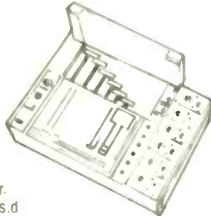

Is your Carston Stock Guide
Up-to-Date?

If not Phone 01-943 4477

CAN'T SEE THE ITEM YOU NEED? — THEN CALL US
— WE'LL TRY TO HELP YOU

HEWLETT-PACKARD MODEL 8565A SPECTRUM ANALYSER

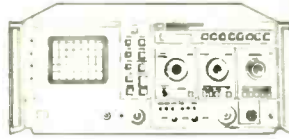

- Internal Pre-selection 1.7-22GHz
- Resolution Range 1kHz-3MHz
- Digital Readout of Control Settings
- Simple 3 Knob Operation
- Detailed Specification Available on Request

FREQUENCY 10MHz-22GHz
(40GHz EXT. MIXING)

A FIRST QUALITY 'SECOND-USER' DEAL £10,750 + v.a.t.

FIBRE OPTIC T.D.R. ANRITSU MODEL MW98A

inc. 1300nm monomode plug-in

- Range up to 72km
- Resolution down to 1m (at all distances)
- Loss measurement
- High-speed averaging
- Large crt display with "on-screen" alpha- numerics
- Fully programmable using HPIB interface

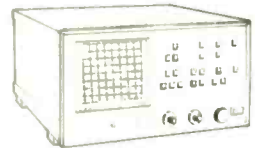

PRICE £6500 + v.a.t.

HEWLETT-PACKARD MODEL 8903A AUDIO ANALYSER



- Frequency range 20Hz-100kHz
- Measures: — • Distortion • SINAD
- Signal to noise • True RMS volts
- DC volts • Frequency
- Built-in low distortion oscillator
- Programmable via HPIB

PRICE £1950 + v.a.t.

Carston Electronics Limited

2-6 Queens Road, Teddington, Middlesex TW11 0LR
Tel: 01-943 4477 Telex: 938120 (CARLEC G)

ALSO IN FRANCE: Contact **OCCASELEC** Telephone Paris (1) 46 86 97 01

Carstonbuy Carstonell Carstonbuy Carstonell Carstonbuy Carstonell Carston

ALL ITEMS CARRY OUR COMPREHENSIVE PARTS & LABOUR GUARANTEE PRICES SHOWN. (SUBJECT TO AVAILABILITY), EXCLUDE DELIVERY AND V.A.T.
ENTER 14 ON REPLY CARD

Versatower:

A range of telescopic towers in static and mobile models from 7.5 to 36 metres with tilt-over facility enabling all maintenance to be at ground level.

Designed in accordance with CP3 Chapter V, part 2, 1972 for a minimum wind speed of 140 kph in conditions of maximum exposure and specified by professionals world-wide where hostile environments demand the ultimate in design, quality and reliability.

Suitable for mounting equipment in the fields of:
Communications
Security surveillance — CCTV
Meteorology
Environmental monitoring
Geographical survey
Defence range-finding
Marine and aero navigation
Floodlighting
Airport approach lighting
Further details available on request.



STRUMECH ENGINEERING LIMITED

Portland House, Coppice Side, Brownhills
Walsall, West Midlands WS8 7EX, England
Telephone: Brownhills (0543) 452321
Telex: 335243 SEL.G.
Fax: 0543 361050



ENTER 7 ON REPLY CARD

EPROM PROGRAMMER



AT LAST! Over 50 Generic Device Types. . . .

1-2508/10ms	15-2764	29-8749	43-8744
2-2508/50ms	16-2764A	30-8750	44-8051*
3-2516/10ms	17-27128	31-8748H	45-8052*
4-2516/50ms	18-27128A	32-8749H	46-8044*
5-2532/10ms	19-27256	33-8750H	47-87C51
6-2532/50ms	20-27256/21V	34-8741	48-63701V
7-2564/10ms	21-27512	35-8742	49-63701X
8-2564/50ms	22-27513	36-8041*	50-63705V
9-2758	23-87C64	37-8042*	51-63705Z
10-2716	24-87C256	38-8048*	
11-2732	25-8755	39-8049*	
12-2732A/10ms	26-8755A	40-8050*	
13-2732A/50ms	27-8355*	41-8751	
14-2764-50ms	28-8748	42-8752/21V	

*READ ONLY

. . . . at a price to suit any budget!

THE MQP ELECTRONICS MODEL 18 PROM PROGRAMMER

£189.95
+ VAT

- ★ Automatic Data Rate setting 300-19,200 Baud.
- ★ Two independent Communications Protocols built in.
- ★ Terminal Mode Protocol.
- Use any host computer with RS232 port and Terminal Emulator.
- ★ Host Computer Protocol.
- Use our PROMDRIVER Advanced Features User Interface Package available for all MS-DOS, PC-DOS and CP/M-80 computers.
- ★ No personality modules to install, no switches to set.
- ★ Fast interactive algorithms automatically selected as appropriate.
- ★ Upgradable for future types.
- ★ Designed, manufactured and supported in the UK. 'EX-STOCK!
- ★ Comprehensive 60 page User Manual.
- ★ n.b. Devices other than 24/28 pin require low cost socket adapter.

Write or telephone for further details:



ELECTRONICS, UNIT 2, PARK ROAD CENTRE, PARK ROAD,
MALMESBURY, WILTS SN16 91Y. Tel: 0666 825146

ENTER 45 ON REPLY CARD

FEEDBACK

Wagner, Debussy and electro-magnetism

As is well known, Richard Wagner conceived the notion that it would have a wonderful effect if, everytime a character in one of his operas appeared on stage, the orchestra played that character's signature tune. The resulting mélange led Claude Debussy to remark that Wagner's music reminded him of the inhabitant of a lunatic asylum who, every time he met you, presented you with his visiting card!

Much the same thing prevails in modern books on electro-magnetism, which start by pointing out that the magnitude, F , of the force between two charges separated by a distance, r , is given by

$$F = k_e \frac{q_1 q_2}{r^2} \quad (1)$$

where q_1 and q_2 are the moduli of the charges and k_e is a constant (which we may call the Coulomb constant). The practice in modern exposition is to remark, immediately after Coulomb's Law has been stated thus, that if another constant — the permittivity, ϵ_0 , of free space is defined by the equation

$$\begin{aligned} \epsilon_0 &= \frac{1}{4\pi k_e} \\ k_e &= \frac{1}{4\pi\epsilon_0} \\ F &= \frac{1}{4\pi\epsilon_0} \cdot \frac{q_1 q_2}{r^2} \quad (2) \end{aligned}$$

From then on all the analysis is done using $1/4\pi\epsilon_0$. Flick through most modern texts and you will see $1/4\pi\epsilon_0$ on practically every page — sometimes many times on a page. I have seen one page in which $1/4\pi\epsilon_0$ appears line by line thirteen times.

The situation immediately conjures up the vision of a madman wandering anachronistically through the Royal Society and

engaging everyone he meets with the remark "Ah! Good morning. You know, that fellow may be the brother of The Earl of Cork but I — I am the Coulomb Constant and I am related to The Permittivity of Free Space.

The reasons given for the above procedure are varied and some bizarre in the extreme. I was told when I was a student that it made the expression of all spherically symmetrical problems less complex — with (1) and (2) staring one in the face! A well-known and very popular book actually says

"...it (k_e) is usually written in a more complex way as $1/4\pi\epsilon_0$!". Often it is stated that ϵ_0 is "a more important" or "a more fundamental constant" than k_e — whatever these expressions mean. Even if they had a meaning and they were true that would hardly justify the procedure adopted!

Many authors state the value for ϵ_0 — viz.

$$\epsilon_0 = 8.854 \text{ p N}^{-1} \text{ m}^{-2} \text{ C}^2$$

and it is not clear to me whether some expect you painstakingly to go through the calculation $1 \div (4 \times \pi \times \epsilon_0)$ every time the Coulomb constant is required. But many people (not only students) actually do this! (I have seen a student's tutorial notebook on one page of which this calculation was carried out six different times in all its excruciating and agonizing detail, (who can blame her innocent little heart!). In recent years some authors have gone half-way by always using (2) but calculating $1 \div (4\pi\epsilon_0)$ once for all at the beginning. Thus

$$\frac{1}{4\pi\epsilon_0} = 8.988 \text{ G N m}^2 \text{ C}^{-2}.$$

In any calculation, this number is substituted immediately.

One would like to notice in passing that while (1) is superior to (2) for the mathematical reasons given above it has other glorious properties. Thus, putting numbers in (1)

$$F = \frac{q_1 q_2}{C^2} \left(\frac{r}{\text{m}} \right)^2 \quad (8.988 \text{ G N})$$

Again the equation for the

potential, V , at a point distant r from a charge, q , is given by

$$\begin{aligned} V &= k_e \frac{q}{r} \\ &= \frac{q/C}{r/\text{m}} \quad (8.988 \text{ G Nm}) \\ &= \frac{q/C}{r/\text{m}} \quad (8.988 \text{ G V}) \end{aligned}$$

i.e. V = pure number x unit of potential.

Thomas R. Boag
Department of Physics
University of Strathclyde
Glasgow

Atomic fission

I was surprised to find from H. Aspden's April letter that he doesn't know what the Mössbauer effect is. It refers to the phenomenon that in solids resonant absorption of nuclear gamma radiation can sometimes occur with *no recoil shift*. In Mössbauer measurements Doppler tuning is used to compensate, not for energy losses arising from nuclear recoil, but for minute changes in the energy of the absorbed or emitted radiation arising from the different environments of the emitting and absorbing atoms within different solids. For this purpose the velocities available from loudspeaker cones are adequate. Resonance measurements have been made on a few of the many nuclei which show no significant Mössbauer effect, but these measurements required the use of a something like a high speed rotor to compensate for the nuclear recoil. Unfortunately the Doppler techniques are effective only over very small solid angles.

He goes on to talk about '... two species of atom that are driven into instability...'. However, nuclei which are isotopes of the same element are just as varied in their binding energies and energy level structures as are nuclei containing the same number of neutrons, but different numbers of protons, and have as strong a bias in favour of having even numbers of protons and neutrons. Anyone familiar

with nuclear structure will be aware that the protons and neutrons in nuclei show independent shell closure phenomena analogous to those shown by atomic electrons. However the numbers associated with the closure of 'shells' of protons and of neutrons bear no simple relationship to those associated with the closure of the electron shells of atoms, and it is the latter numbers which determine the chemical classification of the elements embodied in Mendeléeff's Table. A particular nucleus is likely to be stable if it is more tightly bound than the nuclei which are related to it by exchanging one proton for a neutron, or the converse. Even if the ether oscillations Dr Aspden postulates were shown to exist, to affect proton binding, and not to affect neutron binding, I doubt whether they would produce more than a tiny fraction of the effects associated with the nuclear shell structure

C.F. Coleman
Grove
Oxfordshire.

Crossover

McKenny W. Egerton's three-way crossover network ("Circuit ideas" p.63 *EW* January 1988) is very pleasing in its symmetry and simplicity. I believe however that the design's starting point as stated by Mr Egerton is flawed by a misconception, and yet despite this the filter design may be adequate even if not quite as perfectly adequate as Mr Egerton appears to believe.

The misconception is clearly stated by Mr Egerton in his preamble: "...this means that ignoring phase angle, the total power delivered to the two channels is constant". The job of a loudspeaker crossover network is not to keep the total power constant*, but to keep the vector sum of the drive voltages constant. (Just imagine, if two speakers both produce the same power, but with opposite polarity drive signals, the result will be quite different from that obtained if the drive signals have the same polarity). Hence the

FEEDBACK

phase angle cannot be ignored. It is voltages that add, in effect, rather than power levels, since the conversion from drive voltage to sound pressure is essentially a linear process.

Now what does all this mean as regards Mr Egerton's design? He begins by showing, correctly, that the combined effect of maximally flat ($Q=1/\sqrt{2}$) two-pole, low-pass and high-pass filters with the same resonant frequencies is to keep the sum of the power levels in the two channels constant. Looking instead at the vector sum of the two channel voltages, the result is quite different, giving $1-\omega^2/(1-\omega^2+j\sqrt{2}\omega)$ (ω here is normalized radian frequency). Notice there is a complete loss of output, or notch, at $\omega=1$ (the crossover frequency). This can be rectified by reversing the polarity of one channel, to give a vector sum of $1+\omega^2/(1-\omega^2+j\sqrt{2}\omega)$. This response has a 3dB 'hump' at the cross-over frequency, and a rapid 180 degree phase shift around the crossover frequency. Between the Scylla and Charybdis of the notch, and the rapid phase shift-plus-hump, there is no respite, and both have been demonstrated to be audible.¹

From this unpromising beginning, Mr Egerton's three-way circuit actually leads to a considerable improvement. Taking first his wrong approach of summing the squares of the amplitudes (proportional to power) of each channel, the result from his circuit for $A=4$ is

$$\left[1 - \frac{\omega^2(1+\omega^4)}{2.5(1+16\omega^4+\omega^8)}\right]^{-1}$$

which is $+0.1 \pm 0.1$ dB for all frequencies.

Taking the correct vectorial addition of voltages gives

$$4 - \left(\omega^2 + \frac{1}{\omega^2}\right)$$

$$6.24 - \left(\omega^2 + \frac{1}{\omega^2}\right) - j3.52\left(\omega - \frac{1}{\omega}\right)$$

if the mid-range speakers connections are reversed with respect to the other two channels. This response shows a rise of 2.5dB at 0.1 and 10 times the centre frequency, reaching 3dB beyond that range.** For a cen-

tre frequency of 1kHz, for instance, this results in a relative boost of 2.9dB at 50Hz and 20kHz. This will be audible with comparative listening tests, though for at least some listeners, this may be felt to be an improvement rather than otherwise. The phase shift is quite modest (30 degrees maximum) and is unlikely to be audible.

In summary, an elegant circuit, though requiring further minor corrections for best results, and potentially causing a 50% drop in speaker efficiency (second footnote); a fair result considering the error on which the design appears to be based!

Brian J Pollard
Watford
Herts.

Reference

1. Ashley J.R. "On the transient response of ideal crossover networks" *J.A.E.S.* vol.10 No 3 July, 1962 pp.241-244.

* Constant power is usually a crossover and network design objective, but in this context it means making the power levels of each speaker the same at their crossover frequency.

** More accurately, this response results in partial cancellation at mid-band frequencies, causing a 3dB reduction in net output at mid-band. These effects will in practice be mitigated by any tendency of the low and high frequency speaker responses to naturally fall off at mid-band frequencies.

Poynting the way

Joules Watt's article "Poynting the way" in the February issue of *EWW* reminds me of an exercise given to us (students at the Technological University of Delft) in 1963 by Professor J.L. Borde-wijk. He told us that this exercise appeared in the technical litera-

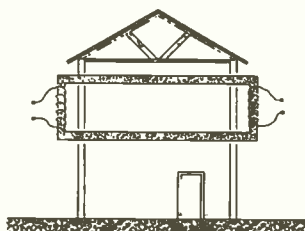

ture in his student days which must have been during or shortly after World War II.

Imagine a laboratory as shown in the diagram. By means of two iron bars, part of a huge transformer, energy is transported through the walls of this laboratory. The laboratory assistant is asked to find out whether the iron bars convey energy and if so in what direction. He has available all the equipment that can be found in a well-equipped physics laboratory.

This puzzle is easy to solve after reading Joules Watt's article.

Ir. P. van der Wurf
Geldorp
The Netherlands

Relativity

Thank you for the provocative article published in the February edition of your publication where the author expressed his rejection of Relativity. As students of physics we were smugly expecting a flood of angry reply letters but instead, March's contributions to 'Feedback' contained two replies: a letter assuring everyone that the formulae actually work, and a gentleman who constructed a new paradox in argument against Special Relativity.

First a response to February's article. We do not wish to involve ourselves with the so-called logical contradictions mentioned, as we believe it is subject to personal opinions and would distract from the main point we wish to make: this being that many physicists are confident that Relativity — especially Special Relativity — is a fact of life and, contrary to the concluding remark, is *not* a theory with no genuine experimental support. Some of the phenomena in support of Special Relativity which were not mentioned in the article include muon decay lifetimes, the concept of particles 'spin', mass-energy equivalence, Boucherer's 1909 experiment on the velocity dependency of an electron's mass³, and transverse Doppler broadening. More can be mentioned, but anybody can

find an undergraduate text on Special Relativity for more examples. Of the above list, stress must be placed on Dirac's work on the idea of 'spin' which came from a Special Relativistic treatment of Quantum mechanics, and is a central feature of Quantum theory. What all this means of course, is that any attempt to disprove Special Relativity will require an awful lot of work and thought in order to explain numerous experimental results. Compared to these, rewriting Quantum mechanics should be relatively straightforward.

We have deliberately separated Special Relativity from General Relativity because the latter requires a mathematical grasp beyond our present competence. However, evidence does exist in support of this theory apart from the famous Eddington experiment quoted. For example, a variation on the Eddington experiment has been done using radio waves from quasars to an accuracy sufficient to discount rival theories. Then there is the well known confirmation of Mercury's orbital precession (a procedure later repeated for Venus) which is considered a major triumph of General Relativity, yet to our surprise it is absent from Dr Essen's article.

As an aside we wish to comment on Dr Essen's interesting choice of Bertrand Russell to support his assertions, since he is acknowledged to have written an excellent introductory book on Special Relativity. Furthermore, it is puzzling what Dr Essen reads into the remark that Special Relativity is all contained in the Lorentz-Fitzgerald transformations. In reply, so what? One may equally say that Newtonian mechanics is all contained in $F=ma$, and yet this is hardly the height of contention.

In reply to Mr Hobden's paradox presented in March's Feedback, we shall use R.P. Feynman's definition of a paradox as a scenario where the physics has been misunderstood. If the inquisitor is sufficiently clever, then the misunderstanding may lie in the theory and awards and adulation will shortly follow. Unfortunately for Mr Hobden, the

FEEDBACK

misunderstanding lay elsewhere.

Before we substantiate that last statement, we wish to emphasise one of the two postulates of Special Relativity: physics is the same in all inertial frames and no one is preferred (the other being that the speed of light in vacuo is the same for all observers), where an inertial frame is a non-accelerating frame of reference — i.e. either stationary or moving at a constant velocity. The consequence of this is that the Galilean idea of an absolute reference frame simply does not exist.

With this in mind, one can see that the horologist "having read 'Relativity'", is entirely incorrect in thinking that as "the clock velocity increases, the mass increases". Relative to a stationary observer, the mass of the clock (and the entire vehicle) has increased; but in the inertial frame of the clock itself the mass of the clock is invariant. Hence the ingenious horologist's clock will have no increase in mass to compensate, for if there is a measurable increase then it would be possible to tell if one is stationary or merely moving at a constant velocity — i.e. the existence of an absolute reference frame and violating the above postulate. We are sorry to say this, but the physics in this compensating clock 'paradox' is badly flawed and appears to display a gross misunderstanding of reference frames — a construct that is prevalent in Special Relativity.

As for the accusation levelled against Einstein that he had little understanding of clocks (!), it ought to be realised that Special Relativity does not specify what the clocks are. They could be based on atomic transitions, spring-wound torsional oscillations, piezo-electric effect, or even massless photons. It does not matter! They are all physical systems and as such are covered by physical theories such as General and Special Relativity, Quantum mechanics, thermodynamics, and (sometimes) Newtonian mechanics. Compared to these deliberately general theories, worries about the non-linearities in the workings of clocks are extremely mis-

leading and irrelevant.

To conclude, it is conceivable that Dr Essen and Mr Hobden might have made errors in their understanding of Special Relativity, but Dr Essen's dogmatic statement of Relativity as a theory that "... lacks any genuine experimental support" is frankly incredible. Such a sweeping statement requires careful consideration and cannot be concluded after quoting three experiments and the cavalier dismissal of two of them. A man of Dr Essen's credentials will be aware of the everyday use of Special Relativity by a lot of physicists and yet he has neither quoted an experiment which blatantly violates Special Relativity, or given a reason why everybody else is wrong. Anybody can stand on a soapbox and declare the world is flat, but a scientist is expected to prove this, and show why all the prior data in fact supports one's claim in preference to the previous model. This is part of the scientific method, and is still the best objective way to describe the universe Mankind has discovered.

M.R. Taylor and H.W. Yau
Whalley Range
Manchester
Lancashire

References

1. P.A.M. Dirac, 'The Principles of Quantum Mechanics' Fourth edition, 1958. Oxford University Press.
2. D. Kleppner and P.J. Kolenkow, 'An Introduction to Mechanics' 1978. McGraw-Hill, inc.

L. Essen is quite mistaken when he writes that Bertrand Russell criticized the theory of relativity (*EWW* February 1988). Russell only pointed out the rather obvious fact that it was all contained in the Lorentz transformations to which I also draw attention following one of the articles of Essen on relativity (*WW* October 1978 and April 1979).

Russell wrote an excellent book on relativity (The ABC of relativity) which I can strongly recommend to anyone who wants to understand the theory.

Also it seems that Essen is oblivious to the decision in 1983,

of the General Committee on Weights and Measures, that the speed of light is now one of the basic constants to define the unit of length, the metre, and to blame Einstein for having "anticipated" this development (*Feedback* December 1986).

J.J. Bleeker
Geneva
Switzerland

Sinusoidal oscillators

Reading Damjanović's article (February 1988) describing a sinewave oscillator, reminds me of a plausible alternative if stability is the criterion at sub-audio frequencies: a time-sampled model of a dual integrator.

Visualize a 16 bit microchip driving a digital-to-analogue converter with the following program (rendered in generic Basic for simplicity):-

- ```
1: REM INITIAL CONDITIONS
2: ESIN = 0 : ECOS = 1 : AMP
 = 2 ↑ 15 - 1
3: DELTATIME = 0.001
4: REM SIN/COS INTEGRATOR LOOP
5: ESIN = ESIN + ECOS * DELTATIME
6: ECOS = ECOS - ESIN * DELTATIME
7: OUTPUT = INT (ESIN*AMP + 0.5)
8: GOTO 5
```

The loop consisting of statements 5 to 8 computes sin and cos to better than 1 part in a million, and estimates the value of pi through the following relation:-

Number of loop iterations per sinewave =  $2\pi/\text{DELTATIME}$ . The 'OUTPUT' value is scaled to a 16 bit integer whose most significant bit is the sign.

The output waveform error is  $\pm 1$  l.s.b. of the converter. Its stability is controlled by the crystal clock driving the micro.

Accuracy falls with increasing DELTATIME; at the limit of DELTATIME = 1, a cycle of 6 iterations produces a trapezoidal wave. For an execution speed of 1 Basic statement per millisecond, the upper frequency limit is then 167Hz.

Very low frequencies are produced, preferably, by inserting a delay loop within the main loop, rather than arbitrarily reducing the value of DELTATIME. (This would be defeated by the finite resolution of the arithmetic in lines 5 and 6) In a 'bare' micro using assembler, no sine table is needed, but double precision arithmetic is desirable.

Brian Whatcott  
Garland  
Texas  
USA

## Seven per cent

Ivor Catt, in his article on data compression (*EWW* April), is right; there is no need to use a 15 bit code for compressing English text. Neither is there any need to invent a new 7 bit code, since a 6 bit code with extensive text compression is already in wide use.

It is called Braille.

J.R. Heath  
Southampton  
Hampshire

A rule which leads to Ivor Catt's "7% Rule" (March) was put forward by Zipf in the late forties, and its application to information storage and retrieval was considered by Schuegraf and Heaps some fifteen years ago. The rule states that if the words in a particular text are arranged in order of decreasing frequency then the relative frequency of the Nth word is approximately  $Z/N$ , where Z is a constant near 0.07. For dictionaries of more than a couple of thousand words it would give a total relative word frequency of more than one, so that it must break down somewhere. Ten years ago I had occasion to determine the word frequencies in five legal texts, the largest of about half a million words, and found by plotting the Zipf 'constant' for the Nth word against  $\log N$  that in each case it began to decrease almost linearly with  $\log N$  when N exceeded about a thousand. As a result the Catt 7% rule fails when the fraction of all text words accounted for rises above 90%.

For the rule to be useful in

# FEEDBACK

data compression it must be shown that for different documents the same words tend to occur in about the same places in the frequency ordered lists. Analyses such as those applied to the documents contained in the Lob Corpus show that this is broadly true for the everyday words. However the frequency sequence Ivor Catt quotes (*the, of, and, to, a, in, that, is*) already departs from the corresponding sequence in the legal texts (*the, of, to, or, in, and, be, any*). The ratios of the maximum and minimum frequencies of the forty commonest everyday words over the five legal documents ranged from 1.1 for *not* to values near three for *any, such, made, so, and all*.

Certainly the frequencies of the nouns and other words which convey the particular meaning of a text vary wildly from one passage to another, and I have seen a specific word come as high as fourth in the frequency ordering. For one of the legal texts I estimated that there was better than a fifty percent chance that any passage of three hundred words would contain one word whose relative frequency taken over the whole document was less than one in ten thousand! Words which occurred once only accounted for between 20 and 30% of the dictionary entries for the legal documents (the Zipf rule gives 50%).

Ivor Catt's information on dictionary costs is already outdated. The word processing package PROTEXT marketed for the Amstrad PCW computers includes spell-checking facilities and a dictionary of 30,000 words and costs £60. The designers recognise that many users will want either to extend their dictionaries, or to generate supplementary dictionaries, and provide facilities for doing so.

1. G.K. Zipf, 'Human Behaviour and the Principle of Least Effort', Addison Wesley, Cambridge, Massachusetts (1949)
2. E.J. Schuegraf and H.S. Heaps, Information Storage and Retrieval 9(1973)697

C.F. Coleman  
Grove  
Oxfordshire

## "Lossy Ells for Pie Tea"

The loaded Q of a low-pass pi matching network is not given by  $R/X_A$  (Joules Watt, January 1988 issue), but by  $(R/X_A + R/X_C)$  (refs. 1 and 2). This may be derived easily using the equivalent shunt circuit shown in Fig.1.

The equations for  $X_A$  and  $X_C$  in Fig.1, are from Everitt (ref.3) and show that for the radical  $\sqrt{R_{in}R_L - X_B^2}$  to be real,  $X_B^2$  should not exceed the product  $R_{in}R_L$ . The maximum value of loaded Q (as in any tuned circuit) is limited in practice, by its effect on the efficiency of the network which is equal to  $P_o/P_{in} = (1 - (Q_{LOAD}E_{I})/Q_o)$  where  $Q_o$  is the unloaded Q of the network with  $R_L$  and  $R_g$  disconnected. The higher the loaded Q, the greater will be the power loss through the network.

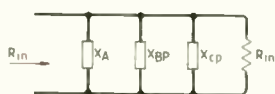

$$X_{BP} = \frac{R_{in}}{X_B} \left( \frac{X_C^2 R_L}{X_C^2 + R_L^2} \right)$$

$$X_{CP} = X_C \frac{R_{in}}{R_L}$$

$$R_{in} = \frac{X_B}{R_L} + R_L \left( \frac{X_B}{X_C} \right)^2$$

$$\frac{1}{X_A} + \frac{1}{X_{BP}} + \frac{1}{X_{CP}} = 0$$

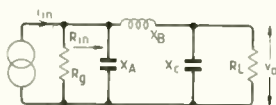

$$X_B = \frac{R_{in} + R_L + 2\sqrt{R_{in}R_L - (I_{in}^2/R_{in}R_L)}}{Q + 4/Q}$$

$$X_A = \frac{-R_{in}X_B}{R_{in} + \sqrt{R_{in}R_L - X_B^2}}$$

$$X_C = \frac{-R_L X_B}{R_L + \sqrt{R_{in}R_L - X_B^2}}$$

If the generator feeding the network has internal resistance  $R_g$  (which may or may not equal  $R_{in}$ ), then the presence of this resistance will reduce the loaded Q of the network.

The frequency response of the networks is a function of the ratios of  $R_{in}/R_L$ ,  $R_g/R_L$  and loaded Q; the variation of  $Z_{in}$  with frequency also is a function of the same parameters.

Finally, back to Joules Watt's

pi network: it works perfectly in transforming the load impedance to 75 ohms, but, and assuming that the generator resistance greatly exceeds 75 ohms, the loaded Q is 17.3 and not 15.

J.E. Diggins  
South Ascot  
Berkshire

### References

1. J.E. Diggins, "Tuned Radio Frequency Impedance Transformers", Racal Electronics Plc, International Paper, June 1982.
2. Elmer A. Wingfield, "New and Improved Formulas for the Design of Pi and Pi-L Networks", QST, August 1983 p23.
3. L. Everitt, "Communication Engineering", 2nd edition (McGraw-Hill Book Company Inc., 1937).

## Invention

Heinz Lipschutz (*EWV* March, 1988) raises a number of interesting questions in his discussions of inventors as an endangered species. He is correct in his belief that neither governments nor industry appreciates the need to succour inventive genius wherever it may be found. He does, however, confuse invention and development. He implies, for instance, that his 1939 system for inertial navigation was similar to that used today. The possibility of an i.n.s. was considered well before 1939 and for long-range use was critically dependent on the work of Schuler who, in 1923, described a gyroscopic method of establishing a true vertical. But to produce gyroscopes and computers with anything like the precision needed to navigate an aircraft to a town in Germany required the development of manufacturing and data handling techniques simply not available in the 1940s. Most engineers can look back over their careers and see a collection of inventions that might have been. For example, about 30 years ago I developed a very clever device that responded to the proximity of either ferrous or non-ferrous metals. It was cheap, reliable and required no adjustments. When it had served its purpose — in a

biomedical application — it was junked. I did not publish, protect or market it as I did not foresee a world where every traveller must be regarded as a possible terrorist.

In electronic and computer engineering the first need is for a rational patent system. At present the paper work is burdensome, much time is consumed and in the last analysis your patent grants you only the right to defend the invention in the courts. For a true invention (safety pins, zippers and 'cat's eyes' are examples from the recent past) the present tests of patentability are probably adequate but when vast numbers of concepts 'known to practitioners of the art' are combined (e.g. colour tv, digital recorders, inertial navigation systems) to make a 'new' product the process is one of development, not invention, to which patent law is scarcely relevant.

As a final thought, a visitor from outer space looking over the entire spectrum of human activities might well find "bashing a ball into a hole" one of mankind's least harmful competitive endeavours.

Harold W. Shipton  
St Louis  
Montana  
USA

## A question of waves

It is known that longitudinal waves all obey the same rules in an elastic medium. Might I ask the readers of *EWV* whether transverse waves in an elastic medium also all obey the same rules?

Alex Jones  
Swanage  
Dorset

### Ralfe moving

Ralfe Electronics, formerly of 10 Chapel Street, London NW1 have moved to new premises in 36 Eastcote Lane, Harrow, Middx. HA2 8DB. Telephone 01 422 3593.

# Teach IBM Microcomputer Troubleshooting and Repair the Hands-on Way DIGIAC 5501

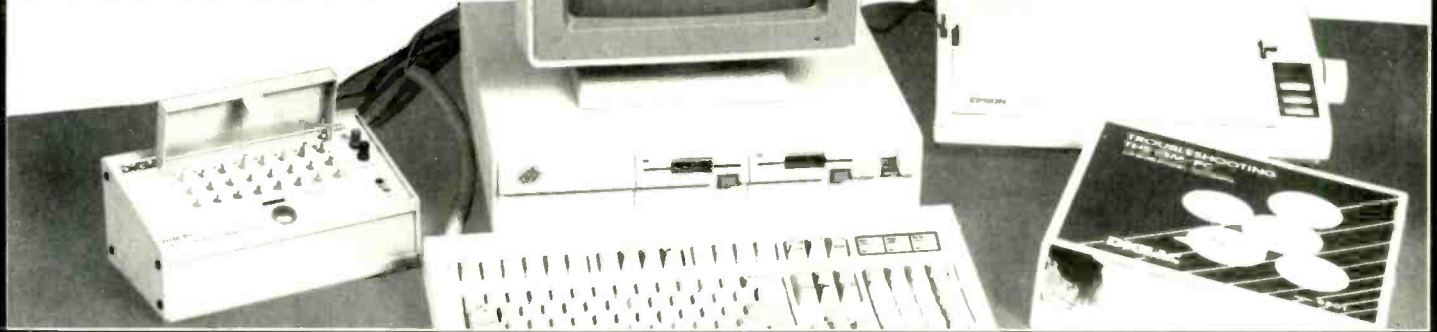

- Complete program for computer repair - Hardware and Courseware.
- Teach your students the specific skills necessary for computer troubleshooting and repair.
- System is based on modified IBM Hardware.
- Utilizes real hard-wired switched faults - enabling troubleshooting down to lowest replaceable modules.

- Comprehensive Teachware package based around IBM Diagnostic Software provides a complete self-teach course of study.
- Additional modules available for 'workshop' alignment and repair - including Monochrome Monitor, Floppy Disk Drive and Matrix Printer.

Send for full details today - Tel: (0603) 748001. Telex: 975504.

LJ Technical Systems Ltd., Francis Way, Bowthorpe Industrial Estate, Norwich, NR5 9JA.

ENTER 16 ON REPLY CARD

## HENRY'S

**ELECTRONICS FOR TRADE, INDUSTRY, EXPORT, EDUCATION AND RETAIL**

### \*INSTRUMENTS

- SCOPES ■ COUNTERS
- DMMS ■ PSU'S
- GENERATORS ETC.

### \*PUBLIC ADDRESS

- SPEAKERS ■ AMPLIFIERS
- MIXERS ■ MICS ETC.

### COMPONENTS

- HUGE STOCKS ALSO
- TOOLS ■ CABLES ETC.

### \*ACCESSORIES

- TV-VIDEO AMPLIFIERS
- AUDIO ■ TV/VIDEO
- SECURITY ■ CB RADIO ACCESSORIES

### COMMUNICATIONS

- INTERCOMS ■ CB RADIO

### \*SECURITY

- PANELS ■ PIRS ■ SIRENS
- DOORPHONES ■ STROBES

**FREE!**  
ILLUSTRATED  
CATALOGUES WITH  
RETAIL DISCOUNT  
VOUCHERS

- Instruments/Security Computer
- General Catalogue

Please state Trade/Education or Retail/mail order Send 9" x 4" SAE £1.00 each or £1.50 for both

## HENRY'S

404 Edgware Road, London W2 1ED  
Tel: 01-724 0323



\*ALSO AT Audio Electronics 301 Edgware Road W2 01-724 3564  
SALES OFFICE 01-258 1831 Telex 298102 Fax 01-724 0322

ENTER 13 ON REPLY CARD

## GPIB for IBM PC/XT/AT

IEEE 488 controller card  
With IEEE 488.2 language extensions

To fit your IBM PC or compatible  
Using your language  
At a price you wouldn't believe

**GPIB for AMSTRAD 1640 1512**

**Designed manufactured and supported in the UK**

For more information on this and all our other IEEE 488.2 products contact:

## M A INSTRUMENTS LIMITED

Axtown Lane, Yelverton, Devon PL20 6BU.

Tel: 0822 853585.

Telex: 45441 IMAGE (MAI).

Fax: 0822 854485

ENTER 29 ON REPLY CARD





# Thermo-electric temperature controller

Using a Peltier module to cool or heat components or laboratory specimens

PETER TURNER

The range of applications for this thermo-electric module controller is limited only by the imagination. Uses which I have come across are as diverse as cooling a charge-coupled device (c.c.d.) in vacuum to maintain constant operating conditions while the c.c.d. is under test to cooling a milk sample in a test laboratory while quality control tests are carried out. With the recent advances in superconductor technology bringing operating temperatures ever closer to ambient, researchers could soon be using thermo-electric modules to cool their samples rather than liquid helium or nitrogen.

## PELTIER EFFECT

The Peltier effect is the phenomenon discovered by Jean Peltier in 1834 whereby the passage of an electric current through two conductors of dissimilar material causes heat to flow from one side of the junction to

the other, depending on the direction of current flow. The rate of heat flow is proportional to the amount of current flowing. Of course the Peltier effect will also work in reverse, i.e. if a temperature difference is maintained across the junction a potential difference will be created proportional to the temperature difference (the thermocouple effect). The Peltier effect can be used to heat or cool an object depending on the direction of current flow.

## THERMO-ELECTRIC MODULES

Peltier heat pumps are made up of several p and n-type semiconductor couples connected in series electrically and in parallel thermally.

Three sizes of heat pump are obtainable from RS Components, having 4, 31 and 127 couples with a heat pumping capacity of 0.29W, 19W and 75W respectively. The controller was designed to operate with the

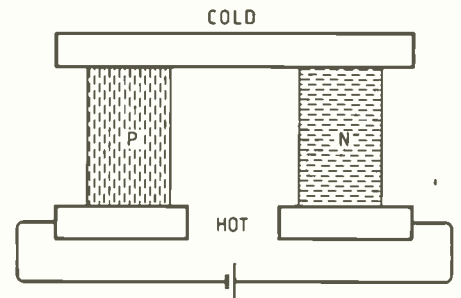
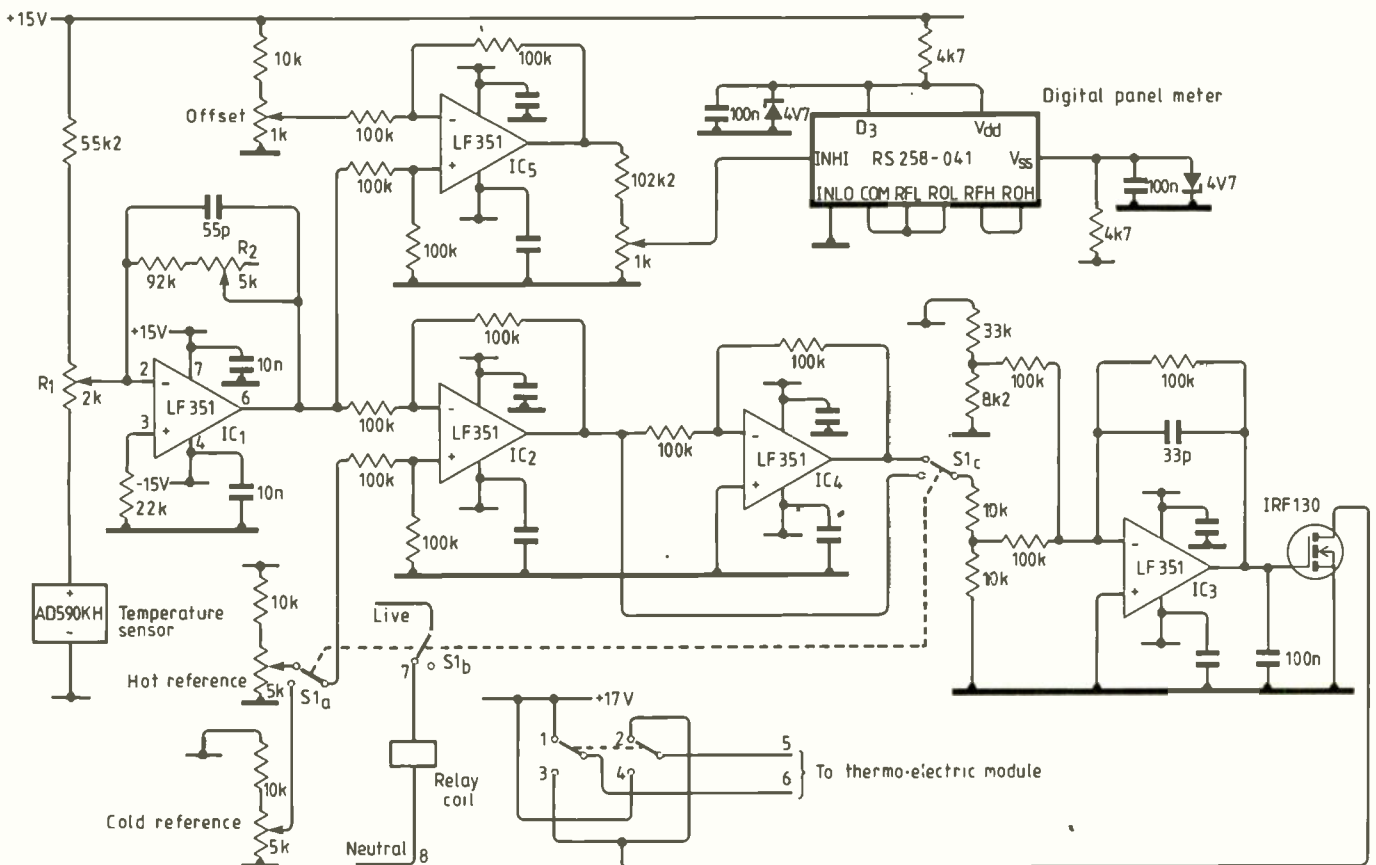

Fig.1. A single semiconductor couple connected as a heat pump.

Fig.2. Controller circuit diagram. The instrument was constructed on pin-board.



75W module although it could easily be modified for use with either of the other two.

### CONTROLLER

The controller provides a current proportional to the difference between the set point and the actual temperature of the item being cooled up to a maximum of 9A. The temperature of the item is sensed by an Analogue Devices AD590KH temperature-sensor i.c. and the current regulated by an IRF130 power mosfet. An l.c.d. panel meter module provides a temperature indication. The control circuitry is shown in Fig.2. The AD590KH temperature sensor, acts as a high-impedance current source passing 1 $\mu$ A per degree Kelvin. The op-amp IC<sub>1</sub> effectively converts this current into a voltage and provides a two-point temperature trim, R<sub>1</sub> setting the offset and R<sub>2</sub> the gain. Thus, at the output of IC<sub>1</sub> we have a voltage which varies with temperature at the rate of 100mV per °C. The capacitor between pins 2 and 6 on IC<sub>1</sub> prevent the circuit bursting into oscillation, as it was initially prone to do!

The op-amp IC<sub>2</sub> is configured as a differential amplifier and compares the reference voltage with the voltage from IC<sub>1</sub>, which is proportional to the actual temperature, and produces an error voltage. When cooling, this error voltage is taken directly to IC<sub>3</sub>, which is a summing amplifier. It adds an offset voltage to the error voltage and produces a voltage at the gate of the power mosfet somewhere in the conduction range of the transistor (see Fig.3).

As an example, consider when the actual temperature is 30°C and the cold set points is -40°C. There will be a voltage of +3V at the output of IC<sub>1</sub> and -4V at pin 3 of IC<sub>2</sub>, producing an error voltage of -7V at the output of IC<sub>2</sub>. One input to the summing amplifier is, therefore, 3.5V, the other being the output of another potential divider at a voltage of approximately -3V. The mosfet gate voltage is about 6.5V, giving a drain current of 9A. As the temperature falls the error voltage reduces and the voltage at the gate of the mosfet is +3V, which is the cut-off voltage of the device.

Again, the 33pF capacitor is to prevent oscillations, as is the 100nF capacitor to ground at the output of IC<sub>3</sub>, which is

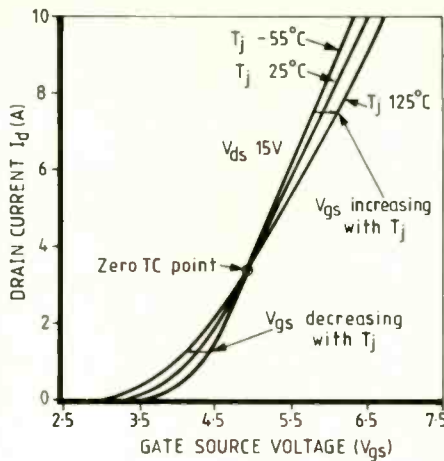

Fig.3. Gate voltage-drain current curves for the IFR130 power mosfet, showing cut-off at around 3V.

particularly necessary to prevent oscillation when switching from cool to heat.

To heat the sample, a 3-pole switch switches from cold reference to the hot reference; energizes a relay, which reverses the current flow through the thermo-electric module; and switches in a unity-gain inverting amplifier IC<sub>4</sub>, since the output from IC<sub>2</sub> is now in the reverse sense.

The remaining circuitry, IC<sub>5</sub> and the digital panel meter provide a constant read-out of the temperature of the sensor. IC<sub>5</sub> is arranged again as a differential amplifier to provide some offset adjustment.

The power mosfet was mounted on a 1.1°C/W heatsink along with the diode bridge for the high current supply.

To achieve temperatures mentioned in the text it would be necessary to enclose the module and item to be cooled in a vacuum. This cryostat enclosure could be maintained at, say, 0.5 of atmospheric pressure using a vacuum pump to prevent condensation of water vapour and heat gain by conduction and convection by air.

Of course, such an elaborate set up would not be necessary if using the mini-module to cool an i.c. or the larger ones for a lower temperature reduction.

Mr Turner is an electronics research technician at the University of York.

Fig.4. Simple suggested power supply for the controller.

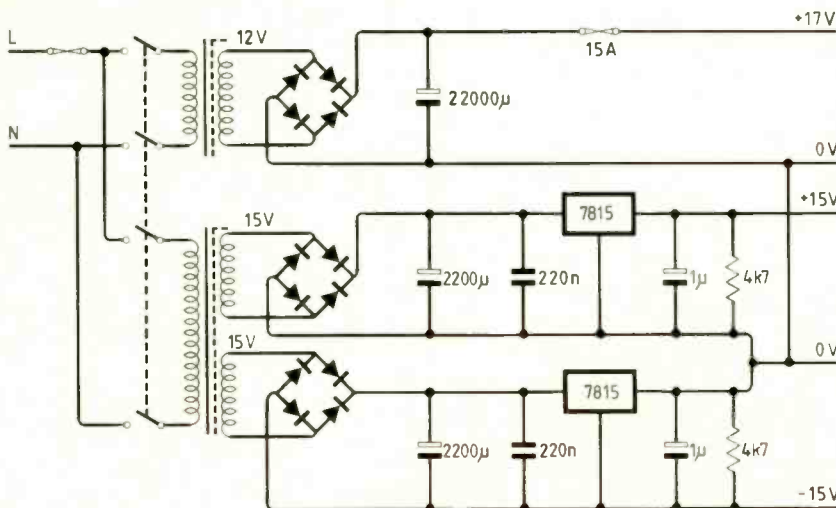

## Music database on CD-ROM

The world's first integrated audio database on CD-ROM, carrying both recorded music and computer data, has been launched by the British company Nimbus Records. CD-ROMs can store some 600M-byte of data, though in this case Nimbus has used only the first minute or two of the disc for data: the remainder consists of dozens of excerpts from the company's music recordings.

This electronic catalogue can be read on any personal computer with a CD-ROM drive plus the appropriate operating system extensions. With the help of its user-friendly retrieval software, record buyers can search the database for the music of their choice; and, having come across an interesting-looking item, they can listen to a sample of it in full CD quality. Besides listing the contents of each record, the database carries supplementary information, such as reviews by music critics, and a digitized image of the cover design.



Besides producing its own-label recordings, Nimbus manufactures discs in both large and small numbers for outside customers. The CD mastering equipment, designed by the company's own staff, last year won it a Queen's Award for Technological Achievement. Nimbus is now the UK's largest manufacturer of Compact Discs, with its factories at Wyastone Leys, Monmouth, and Cwmbran producing some 20 million discs per year. A further plant, at Charlottesville, Virginia, in the USA, was completed last September. A newly-established division now specializes in the exploitation of CD-ROM, from data compilation to the production of finished discs.

Further information from Nimbus Records on 0600-890682.

# Second-generation risc processor

A new design from AMD overcomes some of the throughput limitations of earlier risc devices.

M. A. LEHRER



With current semiconductor technology, it is possible to make chips which can process at incredible speeds. Unfortunately, much of this potential is never realised in a practical system because most of c.p.u.'s latent power is dissipated in decoding instructions, in communicating with the outside world via too few pins, or in housekeeping operations.

This article describes one approach to solving this problem. The Am29000 is the first microprocessor AMD has designed; and an overriding objective during the project was to ensure that as much as possible of the potential speed of the chip should be available to the system in which it is installed.

First of all, a decision was made to employ the reduced instruction set concept (risc) which enables instructions to be decoded and executed in the minimum possible time. By employing only the most commonly-used instructions, risc removes the need for the microcoded logic required for the large instruction sets of conventional microprocessors and allows most instructions to be executed in a single cycle.

The first generation of risc processors failed to exploit the technique fully because a high instruction-execution rate cannot be sustained without fast access to program data, and proper pipeline design. Lacking these, a processor can achieve only a fraction of its potential speed, because it has to wait for external data accesses or to refill the pipeline after a branch.

In addition, the external interface must be designed to achieve the shortest possible cycle time. To achieve high system through-

## TWO approaches to risc

put, the Am29000 has been designed for maximum performance by optimizing the product of instructions per task, cycles per instruction and time per cycle – not by minimizing one factor at the expense of others.

But a microprocessor cannot achieve this alone: compiler, operating system, application environment, arithmetic accelerator, system development and debug methodology all affect the speed of the device. Resources of the Am29000 include a 192-word register file to eliminate data access delays, on-chip branch target cache, 40ns cycle time, on-chip memory management unit and a high-performance channel interface.

Because efficient software is necessary if a system is to give its best, support is included

for procedural languages, real-time operating systems, optimizing compilers, multi-tasking operating systems and demand-paged virtual memory.

### MAXIMIZING THROUGHPUT

Within the microprocessor, which operates at 25MHz, is a four-stage pipeline which can execute an instruction on every 40ns cycle and can sustain a speed of 17Mips continuously. To realise this throughput, a new instruction must be delivered to the pipeline on each cycle.

When on-chip resources cannot cope with simultaneous instruction and data requests, the bus must have a 200Mbyte/s capacity. This is provided by the chip's external interface, which consists of three 32-bit buses and associated control signals: input-only instruction bus, bidirectional data bus and output-only address bus. This permits simultaneous instruction and data access even though the address bus is shared, because the address is pipelined. This arrangement offers the benefits of a full Harvard architecture (which is familiar to bit-slice designers), at a greatly reduced pin count and without the cost of four full 32-bit buses.

All 192 32-bit general purpose registers in the Am29000 are capable of storing variables, addresses and operating system values. In multi-tasking applications they can be used to hold processor status and variables for as many as eight different tasks. As a result, most instructions can be fetched without the delay of an external access. Compare this with microprocessors which

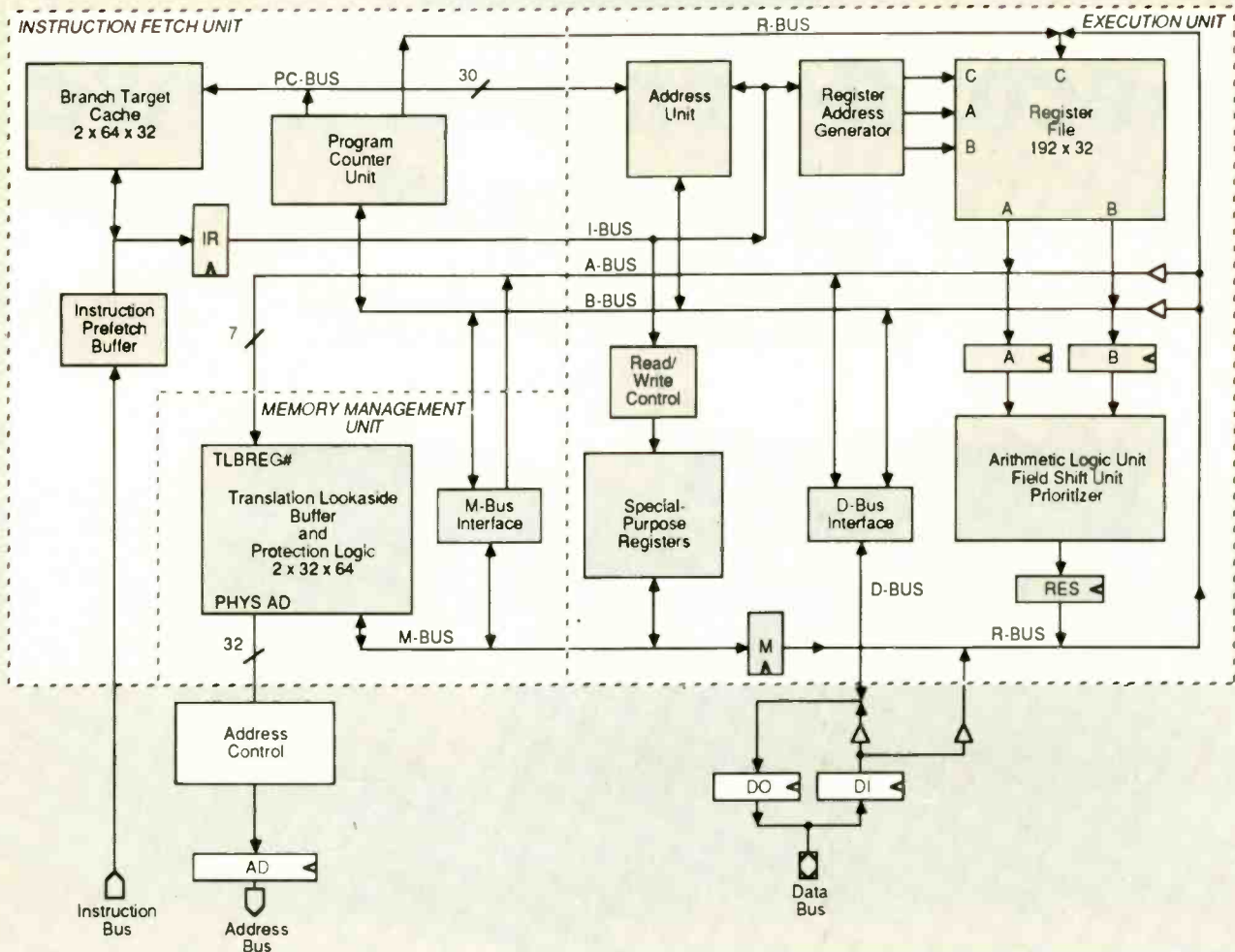

Data flow within the Am29000 risc microprocessor.

have only 16 general-purpose registers: these necessitate more frequent external memory accesses, making the instruction cycle time longer.

In multi-tasking applications when real-time response is most important, the register file can be banked into 12 blocks of 16 registers, each block dedicated to a separate process. A task switch can then occur in as few as 17 cycles, or 680ns.

Fastest transfer of instruction and data to sequential addresses is achieved through 'burst mode' accesses. Only the first address is sent: subsequent requests for information can occur at the rate of one access per cycle, without requiring additional address transfers. Using burst mode accesses, the Am29000 can load or store data at 100Mbyte/s, which is considerably faster than both FDDI and Ethernet. This ability makes it an ideal processor for high performance communications and local area networking.

Key features of the integral memory management unit (m.m.u.) include a 64-entry, two-way set associative translation lookaside buffer (t.l.b.) which performs the virtual-to-physical address translation. To make this more efficient, operation of the t.l.b. is pipelined to run parallel with other processor operations. Other features of the m.m.u. include 4Gbyte of virtual memory per process for up to 256 processes; pipelined address translation to reduce latency; software t.l.b. reload allowing user-defined

memory-management architecture for maximum flexibility; least-recently-used hardware to assist reload and memory protection. Software t.l.b. reload allows system designers to choose a memory management scheme best matched to the particular environment: for example, page selection of 1K, 2K, 4K or 8Kbytes. T.l.b. reload performance is enhanced by least-recently-used hardware as well as a low trap overhead.

A floating-point coprocessor, Am29027, interfaces directly to the microprocessor. It implements both single- and double-

precision floating point operations, offering also a complete range of integer and conversion operations. When one operand comes from the register file and the other from the input register, the Am29027 reduces operations by performing computations on one single-precision and one double-precision operand.

The accelerator can be used in pipelined or non-pipelined (flowthrough) mode, depending on system requirements. Pipelined mode maximizes the rate at which the accelerator produces new results; flowthrough mode minimizes the overall executive time for scalar operations.

Benchmarks can be run with various memory configurations using the Am29000 architectural simulator, to allow comparisons to be made with other processors. The diagram (left) shows that the Am29000 offers approximately 12 times the performance of the VAX11/780, and three to five times that of the 68020.

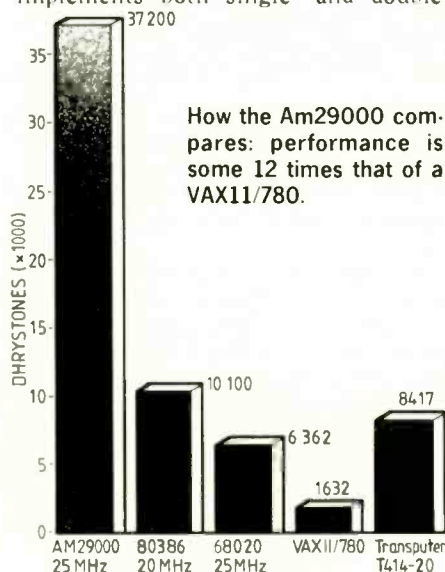

How the Am29000 compares: performance is some 12 times that of a VAX11/780.

#### APPLICATIONS

With its high performance, the Am29000 is suitable for many applications where real-time or super fast data processing is required - such as in embedded controllers, engineering and scientific workstations, desktop publishing, super minis, industrial robots, artificial intelligence and speech recognition. In ISDN networks, the Am29000 provides the high-speed switching control node.

Controllers based on this will give workstation networks access to large databases ten times faster than that of existing Ethernets. A multi-font laser printer built around an Am29000 is four times faster than printers based on a 68030.

Applications likely to benefit especially from the accelerator include graphics, robotics, simulation and array processing.

### UNIX MACHINES

The Am29000 addresses Unix by virtue of an architecture that supports the C programming language. This is done by using part of the register files to increase the speed of C function calls by five to ten times. Optimizing compilers are supported by a three-address load store architecture. Branch conditions are based on Boolean data stored in general-purpose registers instead of using condition codes. Within the C compiler are a number of optimization levels to suit the individual application. For example, when debugging software written in C, minimum optimization will be required because readability of the code will be of prime importance.

### DEVELOPMENT TOOLS

Included in the Am29000 development package are hardware design tools such as an interactive hardware simulator of Am29000-based systems. Software development tools currently include an optimizing compiler for C, high performance maths libraries and an assembler-linker. Fortran, Pascal, and Ada will be available later. Debugging tools include the XRAY29K, a source-level symbolic debugger for C; a target-resident moni-

tor; and ADAPT29K, the Advanced Development and Prototyping Tool.

To help the designer obtain the highest performance/cost ratio from his proposed 29000 system, an architectural simulator is provided. It gives the designer a detailed, clock-for-clock simulation of the behaviour of the entire system, exclusive of input/output. It allows the user to specify the size, speed and organisation of both cache and main memory. Results from the simulation will tell the designer what the program 'mix' is - for example, what the hit ratio of the translational look-aside buffer and the branch target caches are, and the overall system speed in Mips.

More advanced technology will allow even higher levels of integration and faster processing speeds. One option will be to integrate the arithmetic code-processor with the c.p.u. while maintaining software compatibility. In the next generation of products will be a 30MHz device, and development will eventually lead to a device capable of sustaining 37Mips.

Table 1. Typical simulation for a C program.

Time in cycles is 4246  
Simulation complete -- failure termination  
Statistics of "long" simulation:

User Mode: 8901 cycles (0.00035604 seconds)  
Supervisor Mode: 2797 cycles (0.0001188 seconds)  
Total: 11698 cycles (0.00046792 seconds)

Instructions executed: 8733

Simulation speed: 18.66Mips (1.34 cycles per instruction)

----- Configuration -----  
Inst memory decode time = 0  
Inst memory access time = 1  
Inst memory burst time = 1  
Inst memory pipelined = TRUE  
Inst memory burstable = TRUE

Data memory decode time = 0  
Data memory access time = 1  
Data memory burst time = 2  
Data memory pipelined = TRUE  
Data memory burstable = TRUE

Inst rom decode time = 0  
Inst rom access time = 2  
Inst rom burst time = 2  
Inst rom pipelined = FALSE  
Inst rom burstable = FALSE

----- Pipeline -----  
25.35% idle pipeline  
20.61% instruction fetch wait  
2.24% data transaction wait  
0.51% page boundary crossing fetch wait  
0.02% unfilled cache fetch wait  
0.23% load/store multiple executing  
1.07% load/load transaction wait  
0.67% pipeline latency

----- Branch target cache -----  
Branch cache access: 3750  
Branch cache hits: 2549  
Branch cache hit ratio: 67.97%

----- Translation look-aside buffer -----  
T.l.b. access: 0  
T.l.b. hits: 0  
T.l.b. hit ratio: 0.00%

----- Bus utilization -----  
Inst bus utilization: 67.38%  
7882 instruction fetches

Data bus utilization: 12.00%  
724 loads  
690 stores

----- Instruction mix -----  
1.66% Calls  
15.94% Jumps  
8.29% Loads  
7.79% Stores  
7.82% No-ops

----- Register file spilling/filling -----  
0 spills  
0 fills

## MC88100 risc

continued from page 642

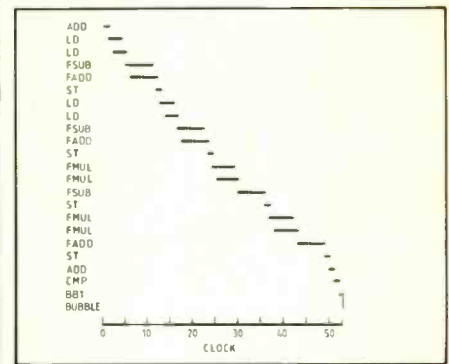

Fig.9. Cycle-by-cycle analysis of the unoptimized assembler-code sequence. Execution of 22 instructions takes 54 clock cycles. For a 20MHz processor, this corresponds to 3.7Mflops.

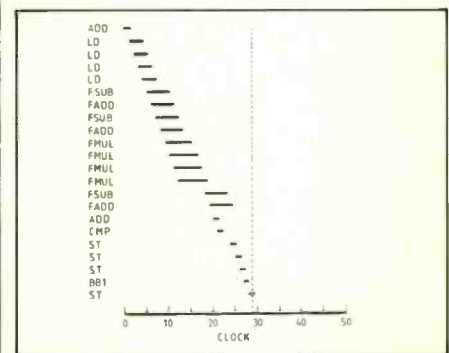

Fig.10. Optimized FFT code reveals better performance. There is more concurrent instruction execution. For the same 20MHz processor, the rate is now 6.9Mflops.

program for a fast Fourier transform. If this code is compiled using a simple C compiler containing no optimizing techniques, then straight-line code would result. List 2 shows a portion of this code for the inner loop of the program. A clock-by-clock analysis of this is shown in Fig.9, yielding a performance of 3.7 million floating point operations per second (Mflops) from a 20MHz clock.

While 3.7Mflops is a respectable performance from any microprocessor, if the timings are analysed carefully there are a number of areas in which improvements can be made. If the load and store instructions are grouped together then the use of the pipelines in the data and instruction units can hide the extra clock cycles required for data accesses. In addition, grouping the floating-point instructions together takes advantage of two pipelines, allowing a considerable amount of concurrency to take place.

Assembly code in List 3 demonstrates the output from a compiler that has an optimizer to produce carefully ordered code that takes advantage of the 88100 architecture. Executing this code on the processor reveals an almost doubling in performance as shown in Fig.10. Therefore highly optimized compilers can give performance figures that are very close to those of assembly language programs, yet enable software development to proceed much faster and easier.

David Jones is a microprocessor applications engineer at Motorola's East Kilbride plant.

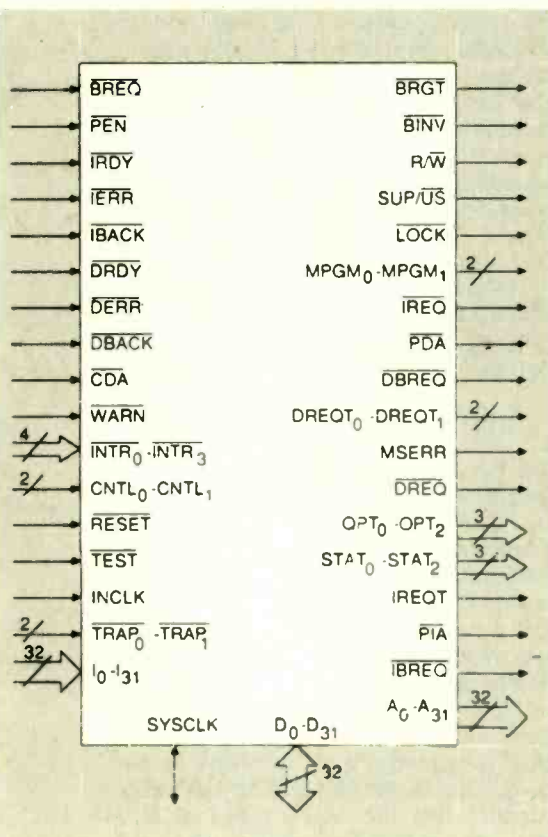

Above: control signals and buses of the Am29000 processor.

Mark Lehrer is a field applications engineer with Rapid Silicon.

# Science v. subjectivism in audio engineering

Douglas Self fights his way through the undergrowth of pseudoscience and magic that surrounds the subject of audio engineering.

D.R.G. SELF

**A**udio engineering is a subject in a singular position. It must be the only branch of engineering science today in which a significant minority of its practitioners, and a very vocal majority of those commenting on it, profess to have no idea how to set about it. Mercifully very few of my comments will apply to the professional audio field, where an intimate acquaintance with the original sound, and the need to earn a living with reliable and economical equipment, have provided an effective barrier against most of the irrational influences.

Most fields of technology have precise measures of excellence: car makers compete to improve miles per hour and miles per gallon; computer manufacturers quote millions of instructions per second and cost per kilobyte, and so on. Any improvement in these objective quantities is regarded as unequivocally a step forward. In the field of audio design, many people seem to have difficulty in deciding which direction forward is.

Working as a professional audio designer, I often encounter opinions, some rational, some not, which while they may be part of the mainstream of hi fi are treated with ridicule by practitioners of other branches of electrical engineering. In the course of publishing some preamplifier designs I have often triggered debates, usually concentrating on subjectivist claims, and sadly ignoring the technical merits or otherwise of each design.

I have often been told that audio is not far removed from witchcraft, that no-one truly knows what they are doing, that I am certainly no exception.

I have even been told at exhibitions that the operation of the human ear is so complex that its interaction with measurable parameters lies forever beyond human comprehension, though this is perhaps an extreme position.

This article deals mainly with the controversies surrounding amplifier design, as here the objective side of the argument is most closely defined; transducers such as cartridges and speakers are inherently subject to greater uncertainties due to the large number of variables involved in electro/mechanical/acoustical conversion.

Those pursuing the correspondence on 'capacitor sound' in the letters section of this

journal and others will know that, having studied the subject from the viewpoints of electronic design, psychoacoustics, and my own humble musical efforts, my own view is one of scepticism towards most of the subjectivist hypotheses. (Throughout this article I shall use the word 'hypothesis' in its proper sense as an idea or supposition which has no necessary connection with the truth; in contrast a 'theory' is a logical and self-consistent explanation of real experimental results.) Although often invited to jettison the knowledge gained from these fields, I am not likely to do so purely because some people passionately assert that logic-defying acoustic differences are real for them.

At this point I would like to make it quite clear that I have no doubt that most of the esoteric opinions are held in complete sincerity. Also, if hitherto unsuspected dimensions of audio quality are ever shown to exist, then I plan to be one of the first to make use of them.

It is not my purpose simply to propagate a currently unfashionable point of view; I am attempting a dispassionate analysis of a situation that is perhaps unique: an engineering discipline that seems to have wilfully lost itself in confusion.

## THE SUBJECTIVIST MANIFESTO

A concise definition of the subjectivist position on amplifier design might perhaps read as follows.

- Objective measurements of an amplifier's performance are unimportant compared with the subjective impression gained by listening tests. Where the two contradict the objective results may be dismissed.

- It therefore follows that degradation effects exist in amplifiers that are unknown to orthodox engineering science, and that are not revealed by the usual objective tests.

- Considerable latitude may therefore be employed in suggesting hypothetical mechanisms of audio impairment, such as mysterious capacitor shortcomings and subtle cable defects, without reference to the plausibility of the concept, or the gathering of objective evidence of any kind.

I hope that this is considered a reasonable statement of the situation; in passing one might mention that the great majority of the paying public go on buying 'midi' rack

systems, and ignore the whole esoteric high-end sector where the debate is fiercest.

In contemplating the state of hi-fi today, I looked for parallels in other fields. The destruction of the study of genetics under Lysenko in the USSR<sup>1</sup>, or perhaps the study of parapsychology seemed to be the only candidates. Lysenkoism is arguably irrelevant because external pressures (the need for the Soviet government to increase agricultural production as fast as possible) made it possible for Lysenko, a scientifically illiterate charlatan, to hi-jack the debate about his claims simply by accusing his opponents of obstruction. Opposition was not only futile but also dangerous; however I am assuming I will survive the publication of this article. Parapsychology as a quasi-serious subject is in deep trouble because after some 100 years of controlled investigation it has not uncovered the ghost (sorry) of a repeatable phenomenon<sup>2</sup>. This has a familiar feel to it. It could, however, be argued that parapsychology is also a poor analogy because most people would accept that there was nothing there to study in the first place, whereas nobody would assert that objective measurements and subjective sound quality have no correlation at all; one need only pick up the telephone to remind oneself what a 4kHz bandwidth and 10% or so t.h.d. sounds like. Parapsychology also labours under the crippling disability of being riddled with outright fraud.

## SHORT HISTORY OF SUBJECTIVISM

The early history of sound reproduction is interesting, if only for the number of times that observers report that a given acoustic gramophone gave results indistinguishable from reality. This would certainly not be the case today, but the mere existence of such statements throws an interesting light on how mind-set affects subjective impressions. As interest in sound reproduction intensified in the post-war period and technical standards such as DIN 45-500 were set, though they soon came to be criticized as too permissive. By the late 1960s it was widely accepted that the requirements for hi-fi would be satisfied by something along the lines of "t.h.d. less than 0.1%, with no crossover distortion worth mentioning, frequency response 20-20kHz, and as little

noise as possible, please". The early 1970s saw this expanded to include specification of slew-rates, properly behaved current-limiters and the like, but the approach was always scientific and it was quite usual to read amplifier reviews in which lab. test results were dissected but no mention at all made of listening tests.

Following the growth of subjectivism through the pages of one of the leading subjectivist magazines (*HiFi News*), the first intimation of what was to come was the commencement of Paul Messenger's column "Subjective Sounds" in September 1976, in which he said "The assessment will be (almost) purely subjective, which has both strengths and weaknesses, as the inclusion of laboratory data would involve too much time and space, and although the ear may be the most fallible, it is also the most sensitive evaluation instrument". Subjectivism as expedient rather than policy. Significantly, none of the early instalments contained references to amplifier sound. In March 1977, an article by Jean Hiraga was published vilifying high levels of negative feedback and praising the sound of an amplifier with 2% t.h.d. In the same issue, Paul Messenger stated that a Radford valve amplifier sounded better than a transistor one, and by the end of the year the amplifier-sound handwagon was rolling. Hiraga was back in August 1977 with a highly contentious set of claims about audible speaker cables, and after that no hypothesis was too unlikely to receive attention.

### THE LIMITS OF HEARING

Before evaluating the subjectivist position, it is relevant to consider the known abilities of the human ear. Contrary to the impression given by some commentators (who call for more psychoacoustical research at the drop of a tone-arm) a vast amount of hard scientific information already exists on this subject, and some of it may be briefly summarized as follows.

- The smallest step-change in amplitude that can be detected is about 0.3dB for a pure tone. In more realistic situations it is 0.5 to 1.0dB. This is about a 10% change.

- The smallest detectable change in frequency of a tone is about 0.2% in the band 500Hz-2kHz. In percentage terms, this is the parameter for which the ear is at its most sensitive.

- The least detectable amount of harmonic distortion is not an easy figure to set, as there is a multitude of variables involved, and in particular the continuously varying level of programme means that the level of t.h.d. introduced is also dynamically changing. However, a lot of careful work has been done on the subject and in normal circumstances (i.e., mostly low-order harmonics) the just-detectable amount is about 1%, though crossover effects can be picked up at 0.3%. There is certainly no evidence that an amplifier producing, say 0.001% sounds any cleaner than one producing .01%.

I would not dispute that t.h.d. measurements, done with the usual notch-type analyser, are of limited use in predicting the subjective impairment a given audio path will create. When music is in question,

intermodulation effects are demonstrably more important. However, t.h.d. tests have the unique advantage that visual inspection of the distortion residual can give an experienced observer a great deal of information about the cause of the non-linearity.

Other distortion tests exist which, while yielding less information to the designer, exercise the whole audio bandwidth at once and correlate well with properly-conducted tests for subjective impairment by distortion. The Belcher intermodulation test (the principle is shown in Fig.1) deserves more attention than it has received, and may become more popular now that digital signal-processing i.cs are readily available.

One of the objections often made to t.h.d. tests is that their resolution does not allow verification that no non-linearities exist at very low level — presumably a sort of micro-crossover distortion. Hawksford, for example, has stated "Low-level threshold phenomena . . . set bounds upon the ultimate transparency of an audio system" and Duncan has put on record his belief that some metallic contacts consist of a net of 'micro-diodes'.

In fact, this kind of hypothesis can be disposed of using t.h.d. techniques. Having evolved a method of measuring t.h.d. down to 0.01% at 200 microvolts r.m.s. I applied it to large electrolytics, connectors of varying provenance, and lengths of copper cable with and without allegedly magic properties. The method required the design of an ultra-low noise (EIN= -150 dBμ with a 1Ω source resistance — is this a record?) and very low t.h.d.'. The basic method is shown in Fig.2: using an attenuator with a very low value of resistance keeps the Johnson noise to a minimum. In no case was any distortion at all detected, and it would be nice to think that this red herring at least has been laid to rest.

- Interchannel crosstalk can obviously degrade stereo separation, but the effect is not detectable until it is worse than 20dB, which

would be a very bad amplifier indeed<sup>9</sup>.

- Phase and group delay have been an area of dispute for a long time, and it would take a big book to give all the contending arguments a fair crack of the woofer. As Stanley Lipshitz *et al*<sup>10</sup> have pointed out, these effects are obviously perceptible if they become gross enough; if an amplifier was so heroically misconceived as to produce the top half of the audio spectrum three hours after the bottom, there would be little room for argument. In more practical terms, and leaving aside specialized laboratory test-signals, concern about phase problems has centred on loudspeakers and their crossovers, as this would seem to be the only place where a phase-shift might exist without an accompanying frequency-response change to make it obvious.

Lipshitz<sup>10</sup> appears to have demonstrated that a second-order all-pass filter (one that gives phase-shift without frequency-response deviation) is audible, whereas BBC findings, as reported by Harwood<sup>11</sup> indicate the opposite, and the truth of the matter is still far from clear.

Fortunately, this controversy is of little importance to amplifier designers, as it would take spectacular incompetence to produce a circuit that included an unsuspected all-pass filter. Without such filters, the phase response of an amplifier is completely defined by its frequency response, and vice-versa; in control theory, this is called Bode's Second Law<sup>12</sup>, and it deserves to be much more widely known in the hi-fi world than it is. A properly designed amplifier has its response roll-off points not far outside the audio band, and these will have accompanying phase-shifts; there is however no evidence that these are in any way perceptible.

The picture of the ear that emerges is not that of a precision instrument. Its ultimate sensitivity, directional capabilities and dynamic range are far more impressive than its ability to measure level changes or detect

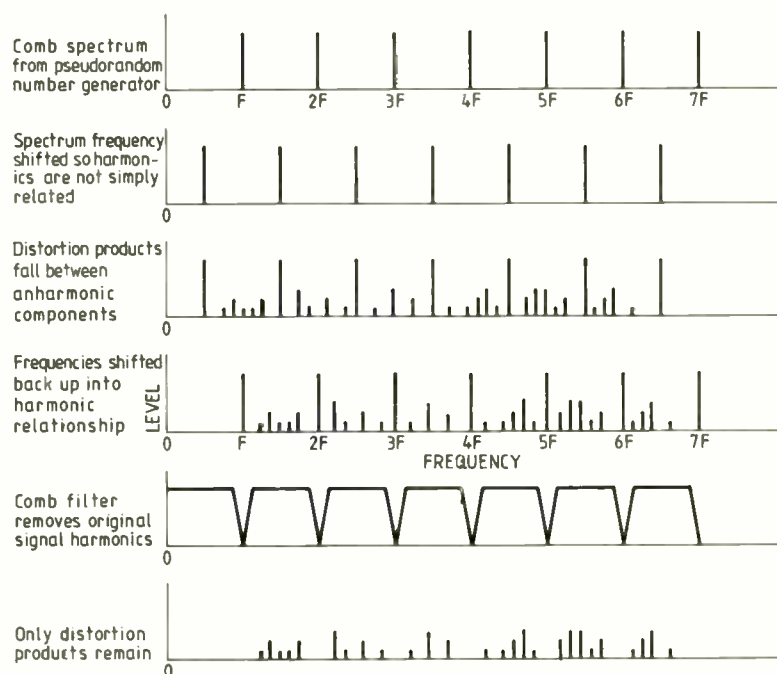

Fig.1. Basic principle of Belcher intermodulation test.

correlated low-level signals such as harmonic distortion products. This is unsurprising; from an evolutionary viewpoint the functions of the ear are to warn of approaching danger (sensitivity and direction being paramount) and for speech communication. For the latter, the perception of formants, the resonance-emphasized bands from the vocal-chord pulse excitation, and vowel/consonant discriminations, are far more important than the usual hi-fi parameters.

Presumably the whole existence of music as a source of pleasure is an accidental artefact of our remarkable powers of speech perception: why it should be able to act as a direct route to the emotions, however, remains profoundly mysterious.

All of the alleged effects listed below have received considerable affirmation in the audio press, to the point where some are treated as facts, though the reality is that none of them has in the last ten years proved susceptible to objective confirmation; a sad record that is perhaps equalled only by students of parapsychology. I hope that the brief statements below are considered fair by their proponents. If not I have no doubt I shall soon hear about it.

- Capacitors affect the signal passing through them in a way invisible to distortion measurements.

- Passing an audio signal through cables, p.c.b. tracks, or switch contacts causes a cumulative deterioration. Precious metal contact surfaces alleviate but do not eliminate the problem. This too is undetectable by tests for non-linearity.

- The sound of valves is inherently superior to that of any semiconductor, despite intractable problems of linearity, reliability and the need for intimidatingly expensive iron-cored transformers.

- Negative feedback is inherently a bad thing; the less it is used, the better the amplifier sounds, without qualification.

- Tone-controls cause an audible deterioration even when set to the flat position. This is usually blamed on "phase-shift".

- The design of the power supply has subtle effects on the sound, quite apart from ordinary dangers like ripple injection.

- Monobloc construction (i.e. two separate power amplifier boxes) is always audibly superior, due to the reduction in crosstalk.

There is not space to comment properly on all of these viewpoints in this article; each deserves an article to itself, and in any case the list is far from exhaustive. However I will just make a few points. Several people have praised the technique of subtracting pulse signals passed through two different sorts of capacitor, claiming that the non-zero residue proves that capacitors can introduce audible errors. My own view is that these tests expose only well-known capacitor shortcomings such as dielectric absorption and series resistance, plus perhaps the vulnerability of the dielectric film in electrolytics to reverse-biasing. No-one has yet shown how these relate to capacitor audibility in a properly designed amplifier.

A touching lack of faith in cables is widespread, but it can be said with confidence that there is as yet not a shred of

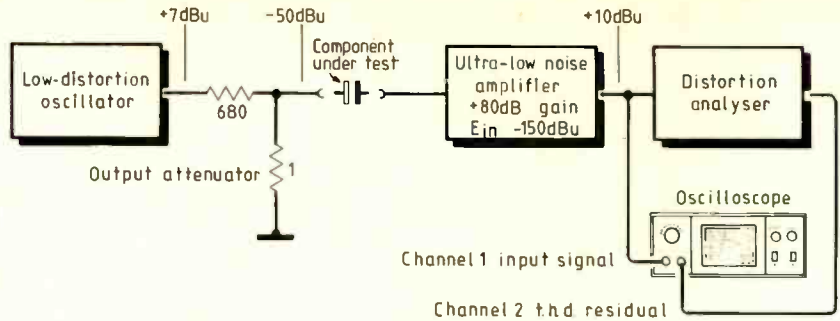

Fig.2. T.h.d. measurement at very low levels.

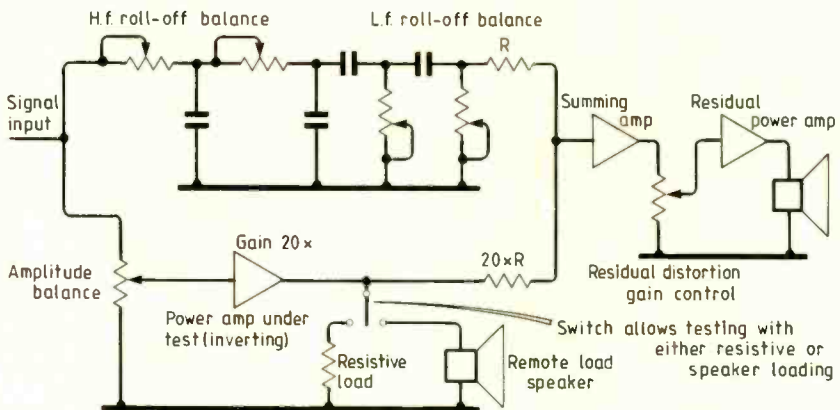

Fig.3. Baxandall cancellation technique.

evidence to support it. Any piece of wire passes a sine wave with unmeasurable distortion, and so simple notions of inter-crystal rectification can be discounted, quite apart from the fact that such behaviour is absolutely ruled out by materials science. No plausible means of detecting, let alone measuring, cable degradation has ever been proposed.

The valve sound is one phenomenon that seems to have a real existence; it has after all been known for a long time that listeners often prefer to have a small amount of second-harmonic distortion mixed in<sup>12</sup>, and all too many valve amplifiers do just that, due to grave difficulties in providing good linearity with modest amounts of feedback. While this may well sound nice, hi-fi is supposedly about accuracy, and if the sound is to be thus modified it should be controllable from the front panel by a 'niceness' knob.

Negative feedback is not inherently a bad thing; it is an absolutely indispensable principle of electronic design, and if used properly has the remarkable ability to make just about every parameter better. However, like all powerful techniques, it can be misused, and too high a feedback factor can require heavy dominant-pole compensation, restricting maximum slew rates. Normally this is not too hard to avoid. In fact slew rates do not need to be very high for disc and f.m. programme sources; Baxandall<sup>13</sup> argues convincingly that a clean full output at 2.2kHz is sufficient, though most people would prefer a good safety-margin over this. The arrival of digital audio has also rendered this figure rather dubious, and there seems no reason why all audio equipment should not be designed to reproduce an undistorted 20kHz sine wave at maximum amplitude.

At the time of writing, tone controls on a preamp badly damage its chances of street (or rather sitting-room) credibility, for no good reason. As pointed out above, well-designed tone-controls set to 'flat' cannot possibly contribute any extra phase-shift and must be inaudible. My own view is that they are indispensable for correcting room acoustics or tonal balance of the material, and that a lot of people are suffering for their devotion to fashion. It might be interesting to try and correlate minimalism in music with minimalism in the equipment designed to reproduce it.

All good amplifier stages ignore imperfections in their power supplies, op-amps in particular excelling at 'power-supply rejection-ratio'. More nonsense has been written on the subject of subtle p.s.u. failings than on most audio topics; recommendations of hard-wiring the mains or using gold-plated 13A plugs would seem to hold no shred of rationality, in view of the usual processes of rectification and regulation that the raw a.c. undergoes.

There is no need to go to the expense of monobloc power amplifiers in order to keep crosstalk under control, even when making it substantially better than the -20dB that is actually necessary. The techniques are conventional; the last preamplifier I designed managed an easy -90dB at 10kHz without anything other than the usual precautions. In this area dedicated followers of fashion pay dearly for the privilege, buying chassis, mains transformer, etc. twice over.

If the above hypotheses are taken as true, and yet their effects are not detectable by conventional measurement, then there are certain implications which need further exploration. Firstly, it can presumably be taken as axiomatic that for each hypothetical



defect some supposed change occurs in the pattern of pressure fluctuations applied to the ears, and that therefore a corresponding modification has occurred to the electrical signal passing through the amplifier. Any other starting point supposes we are dealing with magic or forces-as-yet-unknown-to-science, and mercifully no commentator has (so far) suggested this. Hence there must be defects in the signals, but these are not revealed by the usual tests.

There seem two possible explanations for this failure of detection: the standard measurements are relevant, but of insufficient resolution, although there is no evidence whatsoever that such micro-deviations are audible under any circumstances; or the standard measurements miss the point by, for example, failing in sinewave t.h.d. tests to excite subtle distortion mechanisms that react only to music. This assumes that the music-only distortions are also left undisturbed by multi-tone intermodulation tests, and even the complex pseudo-random signals used in the Belcher distortion test<sup>15</sup>. The Belcher method effectively tests the audio path at all frequencies at once, and it is hard to conceive of a real defect that could escape it. The general principle was shown in Fig 1.

Most damagingly, these alleged music-only mechanisms are not even revealed by music: the devastatingly simple technique of subtracting before-and-after amplifier signals and showing that nothing audibly detectable remains would, it might be thought, have finally shown as non-existent these elusive degradation mechanisms. The technique was proposed in a reasonably sophisticated form by Baxandall in 1977<sup>16</sup>. The principle is shown in Fig.3; note that careful adjustment of the rolloff-balance network prevents minor variations in bandwidth from swamping the true distortion residual. It is fair to say that the subjectivist camp made no effective reply.

A simplified version has been proposed recently by Hafler<sup>17</sup> which, while less sensitive, has the advantage that there is less electronics in the signal path to argue about. See Fig.4. A prominent subjectivist reviewer, on trying this test, was reduced to claiming that the passive switchbox used to implement the Hafler test was causing so much sonic degradation that all amplifier performance was swamped<sup>18</sup>. I do not feel that this is a tenable position. So far all experiments such as these have been brushed aside by the subjectivist camp; no attempt has been made to answer the extremely serious objections that this sort of demonstration raises. Similarly, in the ten years that have elapsed since the emergence of the Subjectivist Tendency, no hitherto unsuspected parameter of audio quality have emerged.

#### THE LENGTH OF THE CHAIN

One apparently insurmountable objection to obsessive concern with non-measurable amplifier quirks is that recorded sound of almost any pedigree has passed through a complex mixing console at least once; prominent parts like vocals or lead guitar will almost certainly have passed through at least

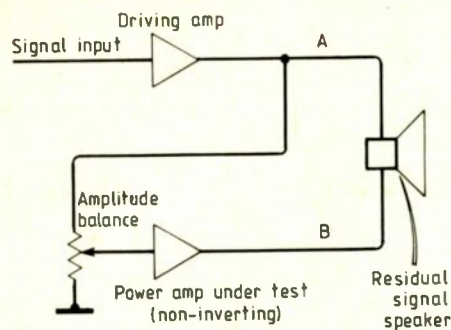

Fig.4. Hafler 'straight-wire' differential test.

twice, once for recording and once at mix-down. More significantly, it must have passed through the potential quality-bottleneck of an analogue tape machine or the ninth-order elliptical filters of digital storage. In its long path from here to ear the audio will have passed through at least a hundred op-amps, dozens of connectors and several hundred metres of ordinary screened cable. If mystical degradation can occur, it defies reason to insist that those introduced by the last 1% of the path are the critical ones.

#### THE IMPLICATIONS

The confused state of the art of amplifier design has many consequences, few of them good.

Firstly, if equipment is reviewed with results that appear arbitrary, and which are in particular incapable of replication or confirmation, this can be grossly unfair to manufacturers who lose out in the lottery. Since subjective assessments cannot be replicated, the commercial success of a given make can depend entirely on the vagaries of fashion. While this is fine in the realm of clothing or soft furnishings, the hi-fi business is still claiming accuracy of reproduction as its *raison d'être*, and therefore you would expect the technical element to be dominant. This unfair discrimination between manufacturers is complicated by a discernable xenophobia that seems to give British products an inside track.

It is reasonable to advocate the purchase of home products, if you make it clear that that is the reason why they get a better press. Most people active in the audio field remember vividly the Japanese destruction of the original British hi-fi industry, (I will not mention motorcycles) and it is perhaps not surprising that in times of recession there is a subconscious tendency to strike back. This may be more difficult if you make objective tests your criterion.

Another consequence of the dominance of subjectivity over measurements is that it places designers in a most unenviable position.

No degree of ingenuity or attention to technical details can ensure a good review, and the pressure to adopt fashionable and expensive expedients (such as linear-crystal internal wiring) is great, even if the designer is certain that they have no audible effect for good or evil. Most designers would seem to be faced with a choice between swallowing the subjectivist credo whole or keeping very quiet and leaving the talking to the marketing department.

While the double-think here seems trivial compared with, say, the activities of an uninhibited used-car salesman, it should be remembered that engineering aspires to be a profession, with the implication that certain moral as well as technical standards are observed. I for one would feel uncomfortable about foisting expensive and non-functional parts on an unsuspecting customer. It is hard to avoid the conclusion that the man who pays thousands of pounds for a preamp can only be described as a HiFi Victim.

Since objective measurements are given little weight, it would appear inevitable that therefore poor amplifiers will be produced, some so bad that their defects are certainly audible. Reading recent reviews<sup>19</sup>, it was easy to find a £795 preamplifier (Counterpoint SA7) that boasted a feeble 12dB disc overload margin, (another preamp costing £2040 struggled up to 15dB — Burmester 838/846) and another, costing £1550 that could only manage a 1kHz distortion performance of 1%; a lack of linearity that would have caused consternation ten years ago (Quick-silver). However, by paying £5700 one could get this down to 0.3% (Audio Research M100-2 monoblocs).

This does not of course mean that it is impossible to buy an 'audiophile' amplifier that does measure well — another example would be the preamplifier/power amplifier combination that provides a respectable disc overload margin of 31dB and 1kHz rated-power distortion below 0.003%; the total cost being £725 (Audiolab 8000C/8000P). I believe this to be a representative sample, and we appear to be in the paradoxical situation that the most expensive equipment provides the worst objective performance. Whatever the rights and wrongs of subjective assessment, I think that most people would agree that this is a strange state of affairs.

Finally, it is surely a morally ambiguous position to persuade non-technical people that to get a really decent sound they have to buy £2000 preamps and so on, when all technical orthodoxy indicates that this is quite unnecessary.

#### THE REASONS WHY

It is important to try to understand why hi fi has reached the pass that it has; some tentative conclusions are possible. I believe one basic reason is the difficulty of defining the quality of an audio experience; you can't draw a diagram to communicate what something sounded like. In the same way, acoustical memory is more evanescent than visual memory.

It is far easier to visualize what a London bus looks like than to recall the details of a musical performance. Similarly, it is difficult to 'look more closely' — turning up the volume is more like turning up the brightness of a tv picture; once an optimal level is reached, any further increase becomes annoying, then painful.

In the study of experimental psychology, particularly in experiments about perception, it has been universally recognised for many years that people tend to perceive what they want to perceive. This is often called the 'experimenter expectancy' effect; the history

of science is littered with the wrecked careers of those who failed to guard against it. It has most often occurred in fields such as biology, where although the raw data obtained may be uncompromisingly numerical, there is no mathematical theory to allow checking. Where the only 'results' are subjective impressions, the danger is clearly much greater, no matter how absolute the integrity of the experimenter. Thus great care is necessary in the use of impartial observers, double-blind techniques, and rigorous statistical tests for significance. The majority of subjectivist writings ignore these precautions, with predictable results. Only in relatively few cases have properly controlled tests been done, and at the time of writing those that have been resulted in different amplifiers appearing to be indistinguishable. I believe the conclusion is inescapable that experimenter expectancy has played a large part in the growth of subjectivism.

It is also interesting that in subjectivist audio the 'correct' answer is always the more expensive or inconvenient one. Electronics is rarely as simple as that.

A major improvement is more likely to be linked with a new circuit topology or new type of semiconductor, than with mindlessly specifying more expensive components of the same type; cars do not go faster with platinum pistons. It would be difficult to produce a rigorous statistical analysis, but it is my strong impression that the reported subjective quality of a piece of equipment correlates far more with the price than with anything else. There is perhaps here a resonance of the Protestant Work Ethic — you must suffer now to enjoy yourself later.

Another reason for the relatively effortless rise of subjectivism is the 'me-too' effect; many people are reluctant to admit that they cannot detect acoustic subtleties — nobody wants to be labelled as insensitive, outmoded, or just plain deaf. It is also virtually impossible absolutely to disprove any of the claims made, as the claimant can always retreat a fraction and say that there was something special about the combination of hardware in use during the disputed tests, or that the phenomena are too delicate for brutal logic to be used on them. In any case, most competent engineers with a taste for objectivity probably have better things to do than dispute every tendentious report. Under these conditions, vague claims tend, by a kind of intellectual inflation, to become regarded as facts. Manufacturers have some incentive to support the subjectivist camp as they can claim that only they understand a particular non-measurable effect; they may of course get their come-uppance if the dice fall badly in a subjective review.

## CONCLUSION

It seems unlikely that subjectivism will disappear for some time, given the momentum that it has gained, the entrenched positions that some people have taken up, and the sadly uncritical way in which people accept an unsupported assertion as the truth simply because it is asserted with frequency and conviction. In an ideal world every such statement would be greeted by loud de-

mands for evidence. However, the recent history of the real world, and of British politics in particular, sometimes leads one to suppose pessimistically that people will believe anything. By analogy, one might suppose that subjectivism would persist for the same reason that parapsychology has; there will always be people who will believe what they want to believe rather than what the hard facts indicate.

I hope that people will be moved to comment on the foregoing article. However, it is perhaps worth pointing out that anecdotes of the "I tied a knot in my speaker cables and it sounded much better" school do not constitute a refutation.

## References.

1. Martin Gardner. "Fads & Fallacies In The Name of Science" Ch.12, pp.140-151. Pub. Dover.
2. David F. Mark "Investigating The Paranormal". *Nature*. Vol. 320, 13 March 1986.
3. Harris J.D. "Loudness discrimination" *J. Speech Hear. Dis.* Monogr. Suppl. 11, p.1-63.
4. Moore, B.C.J. "Relation between the critical bandwidth & the frequency-difference limen." *J. Acoust. Soc. Am.* 55, p.359.
5. Moir, J. "Just Detectable Distortion Levels" *Wireless World*, February 1981, pp. 32-34.
6. Hawksford, M. "The Essex Echo" *Hifi News & RR*, May 1986, p.53.
7. Duncan, B. "With a Strange Device" *Hifi News & RR*, September 1986, p27.
8. Self, D. "Ultra-Low-Noise Amplifiers & Granularity Distortion" *JAES*, November 1987, pp907-915.
9. Harwood & Shorter "Stereophony — The effect of crosstalk between left and right channels" BBC Engineering Monograph No 52.
10. Lipshitz, Pocock & Vanderkooy "On the audibility of midrange phase distortion in audio systems" *JAES*, September 1982, pp.580-595.
11. Harwood, H. "Audibility of phase effects in loudspeakers" *Wireless World*, January 1976, pp.30-32.
12. Shinnars, S. "Modern control system theory and application" publ. Addison-Wesley, p310.
13. King, G. "Hi-fi reviewing" *HFN & RR*, May 1978, p.77.
14. Baxandall, P.J. "Audio power amplifier design" *Wireless World*, January 1978, p56.
15. Belcher, R.A. "A new distortion measurement" *Wireless World*, May 1978, pp.36-41.
16. Baxandall, P.J. "Audible amplifier distortion is not a mystery" *Wireless World*, November 1977, pp.63-66.
17. Hafler, D. "A Listening Test for Amplifier Distortion", *Hifi News & RR*, November 1986, pp.25-29.
18. Colloms, M. "Hafler XL-280 Test". *Hifi News & RR*, June 1987, pp.65-67.
19. "Hifi Choice — The Selection", publ. Sport-scene, 1986.

# Writing for EWW

## Notes for potential authors

**F**airly often, people write in or ring the editorial office to suggest a possible article. When we have discussed the project and made any suggestions that come to mind, the potential author asks whether there are any requirements about presentation he should bear in mind.

Well, there are a few, but they are not rigorous and articles are not rejected because the typing is not double-spaced or because it is on green paper.

First of all, the style. Different people write in different ways and there can be no changing that; varying styles have their attractions and there is no "correct" one. We prefer the simple kind, in the active voice; there is no need to use stilted company-report English and the kind of writing that is designed to exhibit your own knowledge rather than to explain the subject.

If you are not used to writing technical articles, there is still little need to worry, because the editorial staff is ever-present to knock things into shape, if required, although we do try to preserve the original as far as is possible. The essentials are that the piece should contain *all* the information, including illustrations and diagrams and, if the article refers to some obscure component, what it is and where it comes from.

Diagrams must be clear enough for our draughtsmen to interpret, but need not be masterpieces, since they will be re-drawn in our own style. It is helpful to have drawings and photographs kept separate from the rest of the article and to have captions on a separate sheet. Photographs can be negatives, glossy prints or transparencies. Typing should, ideally, be double-spaced with wide margins, so that we can scribble notes to the typesetters.

If you have relevant qualifications, please tell us what they are and also let us have a telephone number for daytime use — since we sometimes need to talk to authors in a hurry, particularly on press day!

# SATELLITE SYSTEMS

## Integrating space and ground nav aids

From the variety of radio navigational aids now in existence, we could well end up with a preferred system utilizing a partnership of Earth- and space-borne transmitters. A recent conference at the City University in London revealed that both of the world super-powers are considering the integration of satellite and terrestrial navigation systems. The idea is for each technique to back up and compensate for the limitations of the other, thus providing a combination that meets as many operational requirements as possible.

The great advantage of satnav systems, of course, is that they give global coverage, whereas terrestrial radio nav aids only serve particular areas. But the terrestrial systems provide better repeatability, and possible accuracy, for certain purposes (e.g. on fishing vessels). Furthermore the latest satnav schemes (GPS/Navstar and Glonass - see April 1987 issue, pp. 377-378) are still in a pre-operational phase and not yet complete anyway. Another possibility now being explored is the integration of satellite and inertial navigation systems.

At the Royal Institute of Navigation's 1988 international conference, W.L. Polhemus said that a plan for integrating the terrestrial hyperbolic system Loran-C and the satellite Global Positioning System (GPS) had been prepared for use throughout the USA. This plan was the work of members of Congress and specialists from the Department of Transportation. It would integrate the two systems in a "non-dependent but synergistic way" to ensure reliable, redundant signals for "virtually 100% of the year".

Although GPS is expected to have a signal availability of 99.8 to 99.9% when complete and similarly Loran-C provides 99.7 to 99.9%, these figures are several orders of magnitude removed from the desired level of availability. They represent a possible signal absence rate of as much as 1 500 minutes per year. For aeronautical use in the USA a radio nav aid must provide,



This small GPS satnav receiver, the MX4400 from Magnavox Systems Ltd, will determine position with two visible GPS satellites when the user's altitude is known and time is fed in from an external atomic frequency standard. It is a two-channel receiver (see main text) and works from the so-called L<sub>1</sub> signal transmitted from the satellites at 1575.42MHz. Data ports on the unit also allow Loran-C terrestrial and Transit satellite position data to be fed in. Position fixing accuracy is claimed to be better than 15m when the receiver is moving or 5.1m when it is stationary and half hour averaging is used. Land, sea and aircraft L-band antennas are available. Power consumption is 20W and weight is 7.2kg.

among other things, a continuous signal availability of 99.998% before it can be certified as a 'sole means' of position determination. According to Polhemus, a partnership of Loran-C and GPS would in fact increase their combined availability to this level.

In addition, he said, such an integrated system would provide a means for independent integrity checking and for redundant operation in the event of transmitter failures. It should also eliminate diurnal gaps in coverage and give protection against various forms of interference.

Loran-C, now installed in 11 countries, is the latest and most widely used version of the Loran

pulsed hyperbolic nav aid. The original system was developed in the USA, like Decca in the UK, for military purposes during the 1939-45 world war. Loran-A, a more advanced version, followed after the war, while a Loran-B was developed but never implemented.

Two speakers from maritime organizations in the Soviet Union, G.I. Moskvin and V. Sorochinsky, outlined a different terrestrial-celestial combination being tried in that part of the world, but first expressed doubts on the advisability of combining Loran-C with a satnav system. Their objection seemed to be one of operational incompatibility: "pulse-phase systems are known

to produce more accurate position data within their coverage areas" than that obtainable with satnav systems in those areas. But "other combinations may turn out to be more promising".

Moskvin and Sorochinsky said that the Soviet integrated system, called Biryuza, combined the use of the Russian Cicada and American Transit satellites (April 1987, p.377) with a v.l.f. terrestrial nav aid. Quasi-differential techniques were used to calculate corrections to navigational measurements produced by the v.l.f. system. The correction values were derived from a simple algorithm and then refined as soon as any of the Cicada or Transit satellites became available.

By comparison of the actual and measured values, a more accurate forecast of corrections was achieved in the intervals between successive usable satellite transits. This resulted in some improvement in position finding accuracy over that obtainable by other methods. But what they felt to be more important was that "a mutual check-out of position data" became possible because of the availability of two series of position fixes produced by data from two independent systems.

The Russian contributors added that equipment had been developed in the USSR to allow position fixing from just the two satnav systems, Cicada and Transit. An obvious advantage was some 1.8-fold reduction of the intervals between satellite observations. A four-channel shipborne receiver had been designed to operate with both systems - two channels for Cicada and two for Transit. It allowed selection of signals in both frequency and time, so that choices could be made of the most suitable satellites for obtaining position fixes if several were in view simultaneously.

Multiple channels in satnav receivers improve operational speed and flexibility. A single-channel receiver (e.g. as shown in the April 1987 issue, p. 378) will only work sequentially from satellite to satellite, whereas a multi-channel set will operate with a number of satellites simultaneously. The GPS receiver in the photograph above (on show at the conference) has two channels. One of these performs

Fig. 1. Comparison of satellite and terrestrial nav aids.

|                                | Terrestrial systems |                 |                 | Satellite systems |                        |             |
|--------------------------------|---------------------|-----------------|-----------------|-------------------|------------------------|-------------|
|                                | Decca               | Chaika          | Loran-C         | Cicada            | Transit                | Glonass GPS |
| Coverage (miles)               | 250-300             | 1000            | 1200            | global            | Up to latitude of ±88° | global      |
| Positioning accuracy (miles)   | 0.2-0.5             | 0.05-0.01       | 0.05-0.01       | 0.05-0.3          |                        | 0.05        |
| Availability of position fixes | continuous          | continuous      | continuous      | every 40          | -110 min               | continuous  |
| Duration of communications     | 3 fixes/min         | 10-20 fixes/min | 10-20 fixes/min | 6-16 min          | 8-18 min               | 1 s         |

Source: Moskvin and Sorochinsky, RIN 1988 International Conference, London.

# SATELLITE SYSTEMS

a general 'housekeeping' function, searching for whatever satellites are available, while the other channel handles the actual position finding process.

J.H. Beattie of Racal believed that there would be an increasing use of hybrid navaid receivers in the future. He mentioned, for example, the combinations GPS/Decca, GPS/Loran-C, GPS/Transit and GPS/Glonass. Regarding the last-mentioned, the two Russian speakers felt that serious consideration should be given to using both of these new satnav systems in conjunction. They said that there will be areas of oceans where the stated accuracy of GPS could not be maintained for some 40 minutes twice a day. Moreover, in the event of failure of one or more satellites, gaps could occur in providing positioning needs throughout overall areas.

A combined use of GPS and Glonass would have the advantage of preventing the appearance of areas of reduced position-finding accuracy. It would also allow a 1.4-times better accuracy of determination of position fixes and velocity vectors. There would be no need for either co-ordination of the two systems or unification of the transmitted signal parameters. It would be quite enough, they felt, to design a shipborne receiver capable of handling signals from both systems.

The accompanying table is the two Russians' comparative assessment of the basic characteristics and performance of current satellite and terrestrial nav aids. Note that Transit and Cicada, with their long intervals between position fixes and dependence of accuracy on user velocity, are due to be phased out in about 1996, leaving the field clear for GPS and Glonass. The Chaika (Seagull) system is a Russian terrestrial hyperbolic navaid similar to Loran-C.

- The Institute of Navigation in the USA is organizing a conference this year on "GPS around the world" at the Broadmoore and Antlers Hotels, Colorado Springs, Colorado, USA, September 19-23 1988. It will include a session on integration of GPS with other nav aids, as well as sessions on technical developments in equipment and applications.

## In brief

Following the failure of the German direction broadcasting satellite TV-Sat 1 last year, the French authorities have asked Arianespace to postpone the launch of their sister d.b. satellite TDF-1 (also built by Eurosatellite) from the originally booked date this summer until the autumn. Now, Ariane flight V24, planned for July 1988, will carry instead of TDF-1 the European ECS-5 comsat and the Indian multi-purpose Insat-1C (January 1988 issue, p. 57). The French d.b.s. craft is due to be launched now on flight V26 in October. Meanwhile a replacement German satellite, TV-Sat 2, is being built for delivery in the spring of 1989.

- First flight of the new, more powerful European rocket Ariane-4 is likely to be No. V22 this summer. Designed to carry heavier payloads, its first task will be to launch three satellites together - Meteosat P2, Pan American Satellite 1 and Amsat IHC. The Ariane-4 design encompasses six versions with various combinations of engines and boosters for different tasks. These allow payloads of 1900kg to 4200kg for putting satellites into geostationary transfer orbits and up to 7000kg for injection into low circular orbits.

- University of Surrey is building a third UoSAT-OSCAR spacecraft to carry engineering, science and communications experiments arranged collaboratively between professional engineering and amateur radio communities. Organizations likely to take part in this UoSAT-C mission include Amsat-UK, Amsat-NA (USA and Canada), Vita, Quadron, NASA, BNSC and ESA. The new spacecraft is expected to be launched in late 1988, by NASA using a Delta rocket, into a circular orbit of 500km altitude and 43° inclination.

- A career civil servant, Arthur Pryor, is the new director-general of the British National Space Centre. He succeeds Jack Leeming, who took over for a while from Roy Gibson and then retired in February. Mr Pryor joined the old Board of Trade in 1966 and held a variety of positions in the DTI. His last job was as regional director of the West Midlands DTI.

## Radio engineering terms in satellite links

### Carrier-to-noise ratio

An important performance figure in all communication channels is signal-to-noise ratio (s:n). But in many radiocommunication systems s:n depends on the characteristics of the signal itself, and engineers find it more appropriate, in working out the gain and loss performance of the r.f. parts of links, to use *carrier-to-noise ratio* (c:n). This is particularly relevant with the f.m. widely used in satellite links, as the carrier is transmitted at a constant amplitude which is not affected by the signal waveform. In the receiver's limiter the received carrier frequency is held at a constant amplitude and the noise power goes up and down according to how c:n is affected throughout the link. Of course, the s:n achieved overall by the link can be measured after f.m. demodulation in the receiver.

So the c:n at the receiving end of the complete satellite downlink consists basically of the equation for carrier r.f. power given earlier (May, page 489, under 'power budget') divided by the noise power as discussed. In the logarithmic form of dB, gains are added while loss and noise terms are subtracted to arrive at the carrier-to-noise ratio. To start with, we have the following relationship in decibels:

$$C/N_0 = \text{e.i.r.p.} - L - A + G - 10 \log_{10} kT \text{ dBHz}$$

Here,  $N_0$  is the *noise spectral density*. It is not noise power because the right hand side of the equation does not yet contain any term representing the noise bandwidth. Thus  $C/N_0$  means carrier over noise power per Hz, written dBHz. The term  $10 \log_{10} kT$  (where  $k$  is Boltzmann's constant, see below) represents the *noise power density* in the receiving system. The equation can be rearranged to give

$$C/N_0 = \text{e.i.r.p.} - L - A + G_R/T - 10 \log_{10} k$$

$G/T$  in general is a ratio of receiving antenna gain to total noise temperature from all sources, thermal and otherwise, collected by the receiver antenna system (e.g. from sky, earth, low-noise amplifier, antenna and waveguide structure). It is a *figure of merit* for the antenna performance, analogous to signal/noise ratio, and has become a standard performance figure for receiving stations in satcom engineering. Its value is expressed in dB/K (even though there is no natural relationship between a gain and a temperature). Thus, for a receiver antenna with a gain of 40dBi and a system noise temperature of 350K, the logarithmic form required for a value in dB is:

$$G_R/T = 10 \log_{10} (10^4/350) = 14.54 \text{ dB/K}$$

The symbol  $k$  on the right hand side of the  $C/N_0$  equation is *Boltzmann's constant* written in dB form. As a constant, its purpose is to convert the noise temperature  $T$  in the equation into noise power density. Being a very small number in the denominator of the carrier-power/noise-power-density expression, it therefore makes a very large contribution to the size of the overall c:n. In this  $C/N_0$  equation, the term  $10 \log_{10} k$  represents -228.6dB.

As an example, using values mentioned above, a downlink with an e.i.r.p. of 60dBW, a free space loss ( $L$ ) of 205.1dB, an atmospheric attenuation ( $A$ ) of 5dB, and a receiver antenna  $G/T$  of 14.5dB/K would have a carrier to noise ratio given by

$$C/N_0 = 60 - 205.1 - 5 + 14.5 - (-228.6) \text{ dBHz} \\ = 93.0 \text{ dBHz}$$

But, as mentioned above, this figure does not take account of the noise bandwidth, and a term representing this factor in dB must be subtracted. Thus, if the noise bandwidth is 27MHz, or 74.3dBHz, the carrier-power/noise-power ratio  $C/N$  is:  $93.0 \text{ dB} - 74.3 \text{ dB} = 18.7 \text{ dB}$ .

In practice,  $C/N$  ratios in a range of about 7 to 14dB are found to be adequate in downlinks, depending on the modulation method and the application.

I would like to thank IBA Engineering Information for very helpful discussions during the preparation of this material.

*Satellite Systems is compiled by Tom Ivall.*

# Making waves

JW propagates some views on wave motion and doesn't even try to avoid algebra.

JOULES WATT

After struggling for a number of weeks trying to get a group of people to see at least roughly how radio waves propagate, I gradually realised that the very idea of waves was so imperfectly understood that most of the young trainees in the group would never see how the ionosphere altered the velocity of propagation. At best this was unlikely without the elementary knowledge I was assuming.

"Aha", I thought, "more evidence of our neglect of basics in education, in favour perhaps of some fashionable 'black box' or another". As expected, my enquiries elicited that hardly anyone had studied waves, I mean *real* waves, although one young man said he had heard that everything was made of waves. He had been told that a chap called Schrodinger, or someone, had 'proved' it.

Once again an old radical like me found myself in a reactionary position claiming that you can't study radio, propagation, transmission lines — or understand reflection 'glitches' in computer interconnections for that matter — without a good grasp of classical wave theory. And when you consider that half of all physical science, with nearly all communications engineering theory turns out to be rooted firmly in wave motion, I thought my assertion hard to refute, in spite of being out of fashion.

## MATHEMATICS AGAIN

Judging by further comments, wave phenomena suffer from a reputation of being a 'mathematical' subject. Once again, in the increasingly innumerate climate as people continue to give up teaching maths to any depth in schools, such a reputation is a damning indictment. How often we see small books make a glowing claim that the author has taken a 'non-mathematical approach', or by some vast verbosity or another 'has reduced mathematics to a minimum'.

I would make two points here. The first is that studying waves is not necessarily 'more mathematical' than, say, mastering circuit design. The second point is that simple mathematical formulation is so economical in explanatory power and induces such precision of thought, that mastering it confers a considerable advantage. Besides, mathematical modelling that works well enables you to design systems and predict performance. Finally, whatever has happened to the fun and pleasure of learning and solving numerical problems. "Education" turns out a miserable lot these days.

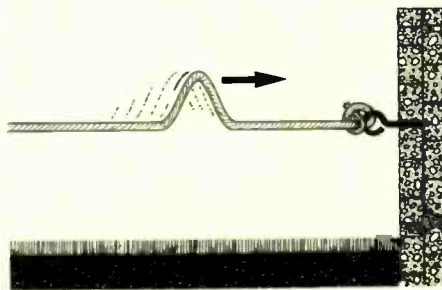

Fig.1. A pulse travelling along, say, a rope shows how little the rope moves, but how fast the energy travels by. A typical wave situation.

However, I would be the last to hint that maths is somehow mystical in its power, that it should be doled out in vast amounts or otherwise employed to give a false air of learnedness. Taking that line moves into the world of the "maths pushers", criticized by other authors. No, the maths should be an applicable tool for the engineer — clear, pragmatic and doing a job of work.

## FUNDAMENTALS

Further thought showed how far the basic fundamentals have become neglected. No one in my group had studied co-ordinate geometry, for example. This was confirmed later by a teacher who answered my question with, "That's correct, co-ordinate geometry has been reduced greatly. We cover Boolean algebra and set theory now. But there is considerable work on relations and the more restricted set of these — the functions".

I struggled for a long time to try to explain a little about waves with Boolean algebra, relations and functions but no, readers will have to put up with a quite ordinary approach, I'm afraid.

You should have noticed wave motion all around. The hoary old classic of water ripples which always used to turn up as an analogy when introducing radio transmission<sup>1</sup> is still studied by all the children I know (apparatus: stones and a pond). There are many other wave phenomena which do not go away. The universal international standards of length remain based upon the wave number of a certain Krypton line.

Many a discussion of waves starts by a consideration of 'vibrations'. The oscillator, and theory of simple harmonic motion (s.h.m.), receive a detailed development, which you should continue to find useful<sup>2</sup>.

Then waves are introduced via the idea that these vibrations might travel away (through some 'medium'). The oscillations propagate with a certain velocity — and so on. This is fine and anyone who has studied it all most probably would not be reading this.

Yet I have always wondered about such an approach, when many of the most interesting waves are not vibration at all, but are *pulses*, such as the kink travelling along a stretched rope in Fig.1 (again, children still regularly study this phenomenon), or perhaps as digital pulses going along a data bus.

One of the earliest mathematical difficulties many beginners seem to experience when they start to look at waves centres on the fact that the wave definitely *travels*, so that energy propagates from place to place, but the medium itself moves very little. Then later, to compound the problem, you may find that some waves 'stand' or remain stationary after all. The condition in which the wave moves means that the position of the wave's outline or *profile* varies as a function of time as well as being a function of distance.

Because of this, the wave function has two independent variables, a fact that immediately induces many people to assume a great increase in complexity. But, in my previous perambulations<sup>3</sup>, we often met functions of several variables. Agreed, any differentiation of functions of several variables means *partial* differentials, yet most people feeding back views concerning the earlier discussions said that these were 'pretty straightforward'. The thing to do every time, is to keep all the other variables constant while varying the one you are interested in. Then to get the total result, add all the partial bits thus obtained; at least, it is as simple as that in *linear* systems.

There are two ways of looking at a profile of a plotted function which varies in its position on the axes: either you have a moving function (going "along the axis"); or you move the position of the origin instead. No doubt it is best to imagine the wave as a moving function plot on fixed axes, whereas in co-ordinate geometry we often keep the function fixed and move the origin.

Now physically, all motion is relative, so in effect either of the above scenarios says the same thing: either you sit on the origin and see the wave go by, or you can sit on the wave and travel with it and watch the origin recede.

Take a look at Fig.2(a). This is just a quick revision of the coordinate origin shift (along

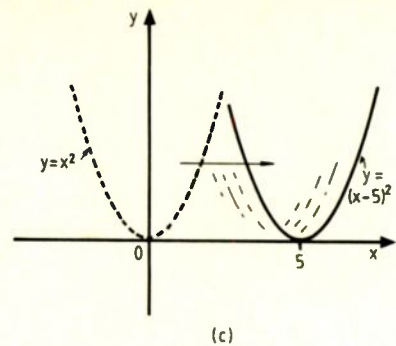
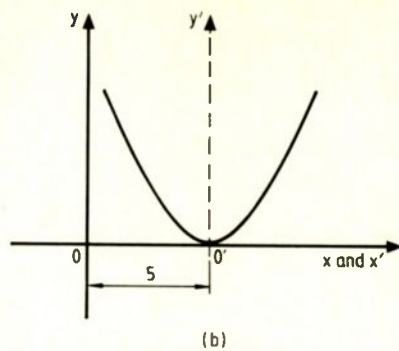
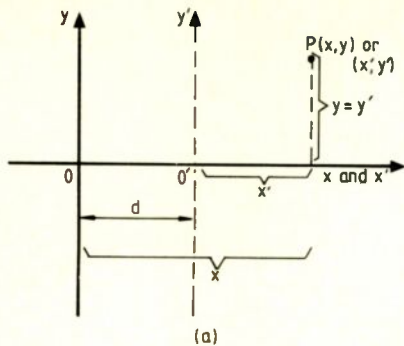

one axis for simplicity). If you place point P at  $(x, y)$  relative to origin 0 and therefore at  $(x', y')$  relative to origin  $0'$ , then with  $0'$  at distance  $d$  from 0, the coordinates relate according to  $x = x' + d$ . The  $y$  coordinate remains unchanged for this one-dimensional shift.

For example, if you plot the quadratic function  $y = x^2 - 10x + 25$  on the original axes and then shift the origin to  $0'$  where  $d = 5$ , then the new form this function takes relative to  $0'$  is,

$$y' = (x' + 5)^2 - 10(x' + 5) + 25$$

by putting in the  $x' + 5$  in place of  $x$ . Tidying up gives the new form in terms of  $x'$ , namely,  $y' = x'^2$ . You can see that  $0'$  sits right on the apex of the parabola, as Fig.2(b) shows.

The other way of looking at this problem means that you can consider that the apex of the parabola  $y = x^2$  has travelled away from 0, out to  $x = 5$  as in Fig.2(c). For  $y$  to equal 0 in this second position,  $x$  has to equal 5 and placing  $x = 5$  into  $y = (x - 5)^2$  duly makes it so. In a small book "Waves", C.A. Coulson gives alternative reasoning as follows.

"Imagine taking a snapshot of the wave profile at  $t = 0$ . You observe  $y = f(x)$ . Another snapshot taken  $t$  seconds later shows an identical picture, but with the profile moved  $ct$  metres to the right. If we took a new origin at the point  $ct$  and let distances measured from this be called  $X$ , then  $x = X + ct$ . Now  $y = f(X)$  and looks exactly the same (with this origin) as the first snapshot. But referred to the original fixed origin  $y = f(x - ct)$ ".

In general, subtracting the shifting quantity  $\tau$ , say, from the independent variable yields how far your function has moved to the right. In symbols this means  $f(x - \tau)$  is function  $x$  moved a distance  $\tau$  to the right.

Now consider any function. If we plot it we get a profile. From an engineering point of view, most functions of interest produce profiles which drop off towards zero in both directions — we do not have much to do with those that rise to infinity. This kind of shape that starts off small, rises up to a peak and then drops off again forms a typical pulse. If you imagine a function  $f(x)$  of this form and think of it moving towards the right with a velocity  $c$ , then after a time  $t$  it will be at a position  $ct$  along the axis, according to the above reasoning. In other words, the function will vary with  $x$  and  $t$  according to  $f(x - ct)$ . If the profile moves to the left, then the description becomes  $f(x + ct)$ , see Fig.3.

Now whatever the profile, and for our purposes they are reasonable ones like a Gaussian shape, or perhaps a rectangular

Fig.2. In (a) you see the standard way axes enables reference to a point from various origins and the relation between coordinates. In (b), the origin has been shifted to the point (5,0) relative to the original. The situation in (c) says the same thing, but now we consider the origin fixed and the plotted function moved by the same amount.

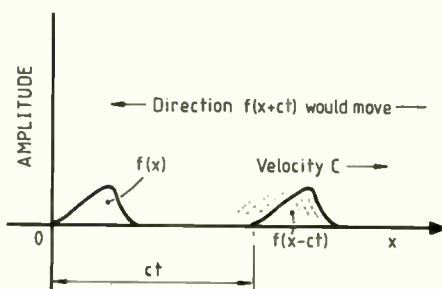

Fig.3. If the shifting term depends on a velocity, then as time ticks away the function travels off to the right at this velocity. If you change the sign of the shifting term, the function travels away in the opposite direction.

pulse, we often assume at this point in the discussion that the shape does not change as it travels along  $x$ . This rather dubious assumption (in general) means the form of  $f(x)$  stays the same. In addition we assume no dissipation or damping occurs. These simplifications yield functions we can differentiate both with respect to time and with respect to distance. Take  $y = f(x - ct)$ , and differentiate with respect to  $x$ ,

$$\frac{\partial f}{\partial x} = f'(x - ct) \text{ and again } \frac{\partial^2 f}{\partial x^2} = f''(x - ct)$$

(keeping  $t$  fixed of course).

Now keep  $x$  constant and differentiate with respect to  $t$ ,

$$\frac{\partial f}{\partial t} = \frac{df}{d(x-ct)} \cdot \frac{\partial(x-ct)}{\partial t} = -cf'(x-ct)$$

and again,

$$\frac{\partial^2 f}{\partial t^2} = c^2 f''(x-ct)$$

So whatever  $f$ , if it is behaving all right under differentiation, it fully satisfies the partial differential equation.

$$\frac{\partial^2 f}{\partial x^2} = \frac{1}{c^2} \frac{\partial^2 f}{\partial t^2}$$

as you can show by eliminating  $f''(x - ct)$ , putting the  $c^2$  on the "t" side and dividing through.

We have here the standard equation that

all non-dispersive wavemotion obeys, whatever is doing the waving and in whatever way it is doing it. We made no assumption about  $f$  except that it was well behaved from an engineering point of view and that it did not lose its shape, which is the meaning of non-dispersive. The wave velocity  $c$  is always obtained straight away, so that often you will not even need to solve the differential equation to get useful information from it.

### MAXWELL VINDICATED

In my discussion of James Clerk Maxwell's remarkable work<sup>3</sup>, his derivation of just such an equation, showing that  $\mathbf{E}$  and  $\mathbf{H}$  fields moved with a wave motion whose velocity  $c$  turned out to be the same as that for light, was the work that revolutionized electromagnetic theory. The equation,

$$\frac{\partial^2 \mathbf{E}}{\partial x^2} = \frac{1}{\mu_0 \epsilon_0} \frac{\partial^2 \mathbf{E}}{\partial t^2}$$

shows that electric waves travel in a vacuum at a velocity

$$c = \frac{1}{\sqrt{\mu_0 \epsilon_0}}$$

where  $\mu_0 = 4\pi \times 10^{-7}$  henries per metre is the permeability and  $\epsilon_0 = 10^{-9}/36\pi$  farads per metre is the permittivity

$\therefore c = 3 \times 10^8 \text{ ms}^{-1}$  nearly.

From the relations between  $\mathbf{E}$  and  $\mathbf{H}$ , an accompanying magnetic wave always appears, so that the wave always has an electromagnetic nature with the  $\mathbf{E}$  and  $\mathbf{H}$  vectors remaining at right angles with each other and with the direction of propagation. EM propagation forms a transverse wavemotion. In a similar way, while discussing transmission lines a wave equation arose there<sup>4</sup>. Again the wave velocity appeared naturally in the form of the wave equation.

### ANOTHER LOOK AT THE EQUATION

The wave propagation equation often receives the title of the mathematician who solved it in a particular way. This was d'Alembert. He obtained the two functions  $f(x - ct)$  and  $f(x + ct)$  from it, and therefore showed that waves travelling in both directions form solutions to it. I have already mentioned the interesting fact that vibration or periodicity has not necessarily appeared. Of course, periodic waves such as sinusoidal variations interest us greatly, but they are only special or simple cases of what is a very general result.

Yet harmonic waves, because of their

simplicity, turn out to be solutions to many more complicated wave type equations than d'Alembert's. If we stick to harmonic waves for a moment and write,

$$y = A \sin \beta(x - ct)$$

then the wave has a sine form (profile) travelling to the right without loss, as in Fig.4. Its peak value (crest) is  $A$  units above the mean level and its shape reproduces itself every  $2$  radians, thinking in terms of angle. Because of this periodicity, the phase, which is the angle  $(x - ct)$ , repeats every now and then if you look along  $x$  at a fixed time (i.e. take a snapshot of the wave) or it goes through repeated cycles at the same point (fixed  $x$ ) over a period of time as you watch. Thus you find periodic variations in space or wavelength associated with the motion, as well as repeatability in time — in other words frequency — as you watch.

### PERIODIC WAVES

In the case of  $y = A \sin \beta(x - ct)$ , you can find a number of parameters that describe the motion. They arise from the  $2\pi$  periodicity.

For example, at a certain instant, the wave profile repeats at a distance  $\lambda$  metres further on. This defines the *wavelength*. In other words,  $y = A \sin[\beta(x - ct) + 2\pi]$  assumes the same value as the original  $y$ .

$$\therefore y = A \sin \beta \left( x + \frac{2\pi}{\beta} - ct \right)$$

which shows that adding  $2\pi/\beta$  onto  $x$  reproduces the wave profile.

We put  $2\pi/\beta = \lambda$  so that  $\beta (= 2\pi/\lambda)$  is the number of waves in a distance of  $2\pi$  metres. Some people call  $\beta$  the *wave number*, others define wave numbers as  $k = 1/\lambda$ , i.e. the number of waves in a metre.

Electronic engineers usually call  $\beta$  radians  $m^{-1}$ , the *phase constant*, because it gives you the number of radians shift in travelling a distance  $d$  along the wave,

$$\beta = \frac{2\pi}{\lambda} d \text{ radians.}$$

Suppose now you observe over a period of time at a fixed point  $x$ , then,

$$y = A \sin \beta \left( x - c \left[ t - \frac{2\pi}{c\beta} \right] \right)$$

by inserting the  $2\pi$  into the time term and re-arranging in standard form. The wave therefore repeats after a time  $T = 2\pi/c\beta$ . We identify this time  $T$  as the *period*, so that you have immediately from its reciprocal the *frequency*  $f$  Hz of the oscillating wavemotion. This means,

$$f = \frac{c\beta}{2\pi} \text{ or } \frac{c}{\lambda}$$

By simple transposing, the other way of writing this turns out to be important in later work, namely,

$$c = \frac{\omega}{\beta},$$

where  $\omega$  is the familiar  $2\pi f$ . This shows if you find  $\beta$ , and know  $\omega$ , then dividing them gives the wave, or *phase velocity*,  $c$ .

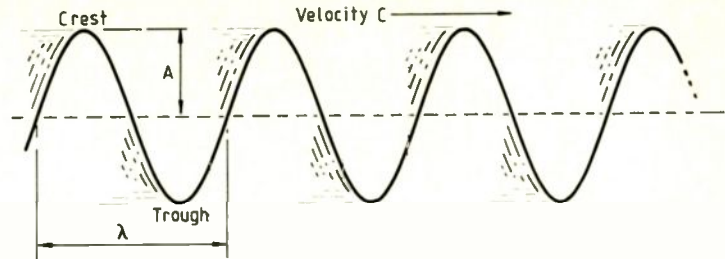

Fig.4. A periodic wave, in this example a harmonic function, shows other properties we associate with waves. The "crest" is obvious, the wavelength  $\lambda$  is well known and so is the meaning of the amplitude  $A$ .

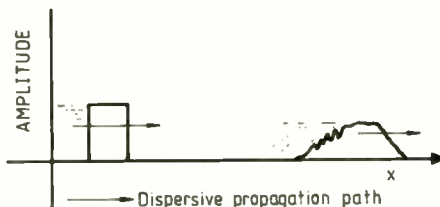

Fig.5. One of the obvious and troublesome effects of dispersion is that the harmonic components of a complex wave travel at different velocities and arrive at different times.

### EULER AGAIN

As soon as we deal with harmonic waves, Euler's identity soon comes into the picture again because of the ease with which complex quantities describe harmonic variations,

$$e^{i\theta} = \cos \theta + j \sin \theta$$

Therefore, wave equations have a complex exponential solution of the form,

$$y A e^{j(\beta x - \omega t)}$$

You could show that this certainly is a solution of d'Alembert's non-dispersive wave equation by differentiating it with respect to  $t$  and then with respect to  $x$  a couple of times and inserting into the differential equation. In general, what all this says is that such a solution exists for any single-frequency disturbance starting in a medium. Once started, a harmonic disturbance continues along as such, although it might fade away eventually, i.e. damping might be present.

It looks as though  $y$  is a solution of any equation where the differential operators  $\partial/\partial t$  and  $\partial/\partial x$  appear only as 'powers' in a polynomial function  $g$  operating to the right on  $y$ . In other words,

$$g \left( \frac{\partial}{\partial t}, \frac{\partial}{\partial x} \right) y = 0$$

forms a whole family of wave equations. For example, if

$$g = \left( \frac{\partial}{\partial x} \right)^2 - \frac{1}{c^2} \left( \frac{\partial}{\partial t} \right)^2, \text{ then } \frac{\partial^2 y}{\partial x^2} - \frac{1}{c^2} \frac{\partial^2 y}{\partial t^2} = 0$$

which is our familiar d'Alembert equation.

### DISPERSAL TIME

Now we can handle dispersion, which simply means that the velocity of the wave varies with its frequency (or alternatively you could say, with its phase constant). You would

quite rightly see this as a possibly awkward problem. As all communications signals cover a band of frequencies, those at the low end will turn up at a different time compared to those at the high end. For example, the low-frequency components of someone's telephone conversation might turn up at a different time compared to the high-frequency parts. Data pulses might start off erect and squared off but could arrive looking a very sorry state, having been smeared out by the dispersive effects, as in Fig.5.

Oliver Heaviside investigated dispersion on lossy telegraph cables and suggested ways of equalizing the delays of all frequency components, thus overcoming the distortion problem. As usual, no one took much notice of him at the time, but shortly afterwards he was vindicated by actual experiments that Professor Pupin carried out in the USA, showing that 'loading coils' would indeed reduce voice distortion on long telephone lines.

For example, if you had this rather fearful looking wave equation turning up in some work,

$$\frac{\partial^3 y}{\partial x^3} + 3 \frac{\partial^3 y}{\partial x^2 \partial t} = 2 \frac{\partial y}{\partial t}$$

then at least the harmonic solution would work. This is because of the particularly simple way exponentials differentiate,

$$y = A e^{j(\beta x - \omega t)}$$

$$\frac{\partial y}{\partial t} = -j\omega y, \frac{\partial^2 y}{\partial t^2} = \omega^2 y, \text{ etc. up to } \frac{\partial^n y}{\partial t^n} = (-j\omega)^n y$$

$$\text{and } \frac{\partial y}{\partial x} = j\beta y, \frac{\partial^2 y}{\partial x^2} = -\beta^2 y, \text{ etc. up to } \frac{\partial^n y}{\partial x^n} = (j\beta)^n y$$

This enables us to rewrite the above equation,

$$-j\beta^3 y + 3j\beta^2 \omega y = -2j\omega y$$

Cancelling through the  $y$  and the  $j$  results in,

$$\frac{\omega}{\beta} = \frac{\beta^2}{(2 + 3\beta^2)} = \text{the wave velocity } v.$$

This shows large dispersion, with the velocity being very small for small phase constants or what amounts to saying the same thing, for long wavelengths. The velocity becomes constant as  $\beta$  grows larger as Fig.6 shows.

### PHASE AND GROUP VELOCITY

The problem with dispersive media, in that the various components of a complex signal waveform turn up at different times, means that a point of constant phase in the wave moves faster than expected, while the energy flow becomes slower. The *phase velocity* agrees with what I have been calling the wave velocity, which we will now call  $v_p$ , and

the rate of energy flow gives rise to another velocity,  $v_g$ , called the *group velocity*.

You can see from  $y = A \sin(\beta x - \omega t)$  that  $\beta x - \omega t$  (the phase) must remain constant on a phase front. Differentiate this with respect to time,

$$\beta \frac{dx}{dt} - \omega = 0,$$

$$\text{phase velocity } v_\phi = \frac{\omega}{\beta} \text{ ms}^{-1}$$

as before. If  $v_g$  is a function of frequency, as it will be in a dispersive medium, then if you consider all the fairly close frequencies in a complex wave train, and further, that the wave group 'peaks' at the point where all the components come into phase, we have at this point  $(\beta x - \omega t) = \Phi$ .

The rate of change of  $\Phi$  with frequency (not time, as before) is zero — we are 'at the peak', then,

$$\frac{d\Phi}{d\omega} = t - x \frac{d\beta}{d\omega} = 0$$

Therefore the velocity of the peak of the group as it moves forward is,

$$v_g = \frac{x}{t} = \frac{d\omega}{d\beta} \text{ ms}^{-1}$$

You will find a good example exists in our subject illustrating these effects. Electromagnetic waves in a waveguide travel in a dispersive system. Well known results in waveguide theory show that various modes of propagation exist in both transverse electric (TE) and transverse magnetic (TM) wave types'. Each propagation mode 'cuts off' at certain critical frequencies,  $\omega_c$ , at the low end of the band and energy ceases to flow along the pipe. The phase velocity turns out to vary strongly with frequency according to,

$$v_\phi = \frac{c}{\sqrt{1 - \frac{\omega_c^2}{\omega^2}}}$$

for a particular mode in an unloaded (air filled) guide.

This shows, at first sight, the peculiar result that  $v_\phi$  appears to be much greater than the speed of light  $c$ , when  $\omega_c$  is near the cut off frequency  $\omega_c$ . Indeed the phase travels down the guide at a tremendous rate near cut off. The guide wavelength becomes correspondingly very long. Yet hardly any energy travels down the pipe. We see this by looking at the group velocity.

$$v_g = \frac{c}{\sqrt{1 - \frac{\omega_c^2}{\omega^2}}}$$

By squaring this and re-arranging, we get,

$$\beta^2 = \frac{\omega^2}{c^2} - \frac{\omega_c^2}{c^2}$$

which you can now differentiate with respect to  $\omega$ , thus obtaining,

$$\frac{d\beta}{d\omega} = \frac{1}{v_g} = \frac{v_\phi}{c^2}, \text{ or } v_g v_\phi = c^2$$

This shows that as  $v_g$  gets greater and greater as cut-off approaches,  $v_\phi$  becomes smaller and smaller, as shown in Fig.7. At cut-off, the propagation of energy (i.e. the signal) ceases because the wave just bounces up and

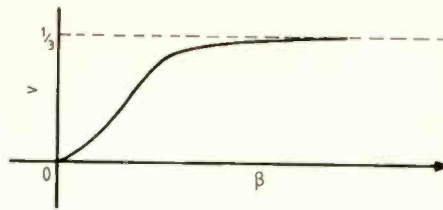

Fig.6. The example here shows a rapid change of velocity as a function of phase constant. Signals travelling in this medium would arrive very distorted.

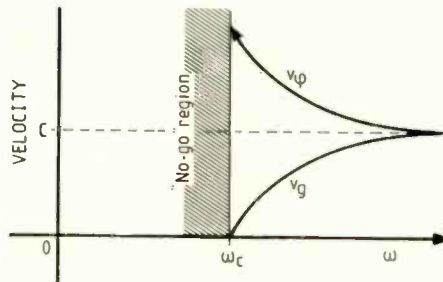

Fig.7. The rapid rise in the phase velocity of EM waves travelling in a waveguide as the frequency falls, is matched by a large decrease in the group velocity. Beyond cut-off no energy propagates at all.

down across the guide, with no propagation along it.

Of course, all the problems of signal dispersion turn up in optical-fibre design and equalizers need careful design to maintain the integrity of the data streams. In earlier line transmission systems, the parameters varied with the weather, and line dispersion changed all the time. Telecoms engineers had to expend much design ingenuity in developing *adaptive equalizers* to compensate this headache.

Thus, wavemotion turns out to be no trivial matter in understanding communications systems. Particular applications change all the time, but the basics hardly change at all — and these I have discussed here. Yet how interesting it all turns out to be again. There is no doubt about it, the fundamental natural phenomena behind the engineering become most worthwhile to study.

#### References.

1. Earlier introductory books on radio theory often used ripples on a pond as an illustration. Water waves still are used in a ripple tank. An hour or two experimenting with a tank often teaches more than a whole book on waves.
2. "Waves" J.P. Richards & R.P. Williams. Penguin Library of Physical Sciences, 1972.
3. Joules Watt. Parameters. *Electronics and Wireless World*, 93, Feb. 1987.
4. "Waves" C.A. Coulson. Ch.1 p.2. Oliver and Boyd.
5. Joules Watt, Maxwell's EM Theory Revisited. *Electronics & Wireless World*, 93, July 1987.
6. Joules Watt, Poynting the Way, *Electronics & Wireless World*, 94, Feb. 1988.
7. "Electromagnetic Waves and Radiating Systems" E.C. Jordan, Ch.8. Prentice Hall, 1968.

# Win our writing competition and spend a week in Japan

The final entry date for our writing competition is June 30. The competition, whose title is ASSERT (Assessments of the Social Significance of Engineering and Research for Tomorrow), was announced in the March 1988 issue.

It is being co-sponsored by NEC Electronics (UK) Limited, who have provided the first three prizes.

## FIRST PRIZE

An all-expenses-paid, week-long visit to Tokyo as guests of NEC, who will provide the winner with a tour of the NEC facility and Tokyo itself.

## SECOND PRIZE

One of NEC's newest PC-AT-compatible personal computers.

## THIRD PRIZE

A NEC digital video cassette recorder.

Plus additional prizes of books and subscriptions to this journal.

The subject of the competition is, as the title suggests, the role of engineering in the world of tomorrow. There is such a wide and depressing variety of unfulfilled need in the world that the continuing development of more and more consumer equipment might seem to be misplaced effort. Clearly, there is nothing wrong with improving the quality of life and electronics has been responsible for a great deal of that, but there might also be a part for our discipline — and not only ours, but engineering in general — to play in the alleviation of distress in so many areas of the world.

Let us have your thoughts on the subject in the form of an article of up to 4500

words, including any diagrams or photographs that you might feel desirable.

The first two or three articles will be published in *EW*.

**Electronics and Wireless World Writing Competition**  
**Quadrant House, The Quadrant, Sutton, Surrey SM2 5AS.**

Contributions to reach us before the end of June, if possible. There is no entry fee — simply post your entry to the above address.



# Multiprocessor systems

Multiple-instruction/multiple-data-stream architectures are discussed in this second article.

ALAN CLEMENTS

As discussed last month, multiple-instruction/multiple-data-stream architecture, m.i.m.d., is the most general purpose of the four main multiprocessor-system structures.

While the array or pipeline processor is likely to be constructed from very special units, the more general m.i.m.d. architecture is much more likely to be built from widely available devices like the 68000. Therefore, the major design consideration in the production of such a multiprocessor concerns the topology of the system, which is a measure of the way in which the communications paths between the individual processors are arranged.

Figures 3 to 7 depict the five classic m.i.m.d. topologies, which are (apart from the hypercube) incidentally, the same as those available to the designer of local area networks. Multiprocessor structures are described both by their topology and by their interconnection level. The level of interconnection is a measure of the number of switching units through which a message must pass when going from processor X to processor Y. The four basic topologies are the unconstrained topology, the bus, the ring, and the star, although, of course, there are many variants of each of these pure topologies. The principal features of each of these arrangements are defined as follows.

The unconstrained topology is so called because it is an ad-hoc arrangement in which a processor is linked directly to each other processor with which it wishes to communicate, Fig.3. It takes very little

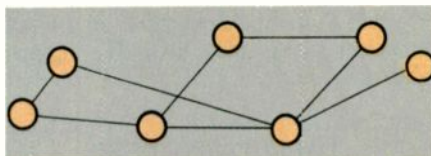

Fig.3. Unconstrained multiprocessor topology is not really practicable for any but the simplest of systems. Clearly, as the number of processors grows, the number of interconnections – buses – becomes prohibitive.

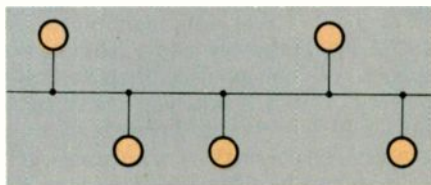

Fig.4. In the simplest of multiprocessor topologies, each processor is connected to a single common bus. Bus systems are simple in that they avoid the problem of how to route a message from processor X to processor Y.

thought to appreciate that the unconstrained topology is not really practicable for any but the simplest of systems. Clearly, as the number of processors grows, the number of interconnections, i.e. buses, becomes prohibitive. The advantage of such a system is the very high degree of coupling that can be achieved. As the buses are dedicated to communications between only two processors, there is no conflict between processor waiting to access the same bus.

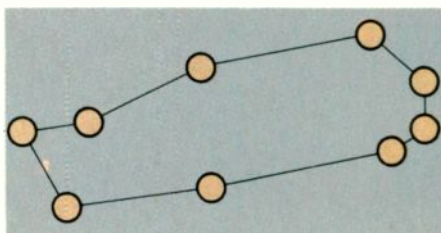
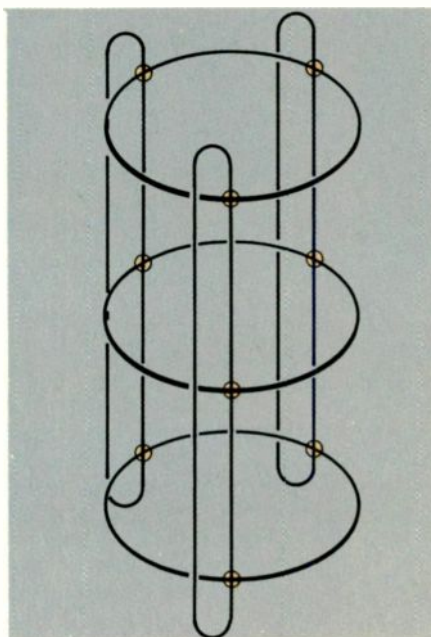

Fig.5. In ring topology, each processor is connected only to its two nearest neighbours. Information flows round the ring in one direction only, and a packet of information passes through each of the processors in the ring. Ring topology has advantages in some classes of loosely-coupled multiprocessor network and represents one of the most popular forms of local area network. Fig.5(b) shows a two-dimensional ring with nine processing elements and three horizontal plus three vertical rings.



## THE BUS

The bus is the simplest of topologies because each processor is connected to a single common bus, Fig.4. The bus is a simple topology not least because it avoids the problem of how to route a message from processor X to processor Y. In fact, the interprocessor bus is little more than an extension of the bus (back-plane) found in any conventional computer. Indeed, it is entirely possible to use the existing bus of many microcomputers to create a multiprocessor system. All that is required is a mechanism enabling control to be passed from one microprocessor to another.

The disadvantage of the bus as a method of implementing a multiprocessor system lies in the problem of controlling access to the bus. As only one processor at a time can use the bus, it is necessary to design an arbiter to determine which processor may access the bus at any time. Arbitration between two or more contending processors slows down the system and leads to bottlenecks. A bus offers a relatively high degree of coupling but is more suitable for schemes in which the quantity of data exchanged between processor is small. Because of the economic advantages of the bus, we concentrate on the MIMD bus architecture. In my final article I will consider the design of a suitable m.i.m.d. architecture for the 68000 microprocessor.

## THE RING

In a ring, each processor connects only to its two nearest neighbours, Fig.5. One neighbour is called the upstream neighbour and the other the downstream neighbour. A node receives information from its downstream neighbour and passes it on to its upstream neighbour. In this way, information flows round the ring in one direction only, and a packet of information passes through each of the processors in the ring. Information passed to a node contains a destination address. When a node receives a packet, it checks the address and, if the packet address corresponds to the node's own address, the node reads the packet. Similarly, a node is able to add packets of its own to the stream of information flowing round the ring.

Ring topology offers certain advantages for some classes of loosely-coupled multiprocessor network and represents one of the most popular forms of local area network. It is less widely used as a method of interconnecting processors in a tightly-coupled m.i.m.d. architecture. It is, in fact, possible

to construct two-dimensional ring networks. Figure 5(b) demonstrates a two-dimensional ring with nine processing elements and three horizontal plus three vertical rings. The two-dimensional ring offers multiple paths between nodes and is not catastrophically affected by the failure of a single node.

### STAR

Star topology, Fig. 6, employs a central processor as a switching network, rather like a telephone exchange, between the other processors which are arranged logically (if not physically) around the central node. The advantage of the star is that it reduces bus contention, as there are no shared communication paths, and it does not require the large number of buses needed by unconstrained topologies.

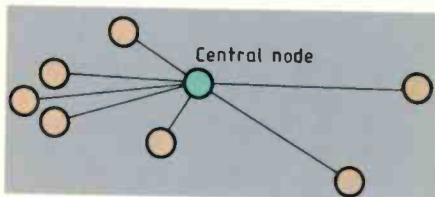

Fig. 6. Star multiprocessor topology reduces bus contention, eliminates shared communication paths and needs only a small number of buses – but it is only as good as its central node. Its central processor acts as a switching network, switching logically around the central node.

On the other hand, the star network is only as good as its central node. If this node fails, the entire system fails. Consequently, the star topology does not display any form of graceful degradation. Moreover, the central network must be faster than the nodes using its switching facilities, if the system is to be efficient. In many ways, the star topology is a configuration better suited to local area networks, where the individual signal paths are implemented by serial data channels, rather than by the parallel buses of the tightly-coupled multiprocessor.

### HYPERCUBE

An n-dimensional hypercube multiprocessor connects together  $N=2^n$  processors in the form of an n-dimensional binary cube. Each corner (vertex or node) of the hypercube consists of a suitable processing element and its associated memory. Because of the topology of a hypercube, each node is directly connected to exactly n other neighbours. Figure 7 illustrates the hypercube topology for  $n=1, 2, 3$  and 4.

Each processor in a hypercube has an n-bit address in the range  $0\dots00_2$  to  $1\dots11_2$  (i.e. 0 to  $2^n-1$ ) and each of the n nearest neighbours of a particular node has an address that differs from the node's address by only one bit. For example, if  $n=4$  and a node has binary address (0100), its four nearest neighbours have addresses (1100), (0000), (0110) and (0101).

A hypercube of dimension n is constructed recursively by taking a hypercube of dimension n-1 and prefixing all its node addresses by 0 and adding to this another

hypercube of dimension n-1 whose node addresses are all prefixed by 1. In other words, a hypercube of dimension n can be subdivided into two hypercubes of dimension n-1, and these two subcubes can, in turn, be divided into four subcubes of dimension n-2 and so on.

The hypercube is of interest because it has a topology that is particularly suited to certain groups of algorithm. In particular, it is well-suited to problems involving the evaluation of fast Fourier transforms. The first practical hypercube multiprocessor was built at Caltech in 1983. This was called the Cosmic Cube and was based on 64 8086 microprocessors plus 8087 floating-point coprocessors.

### HYBRID TOPOLOGIES

In addition to the above pure network topologies, there are very many hybrid topologies, some of which are described in Figs 8 to 11.

Figures 8(a,b) both illustrate the dual-bus multiprocessor, although this topology may be extended to include any number of buses. In Fig. 8(a) the processors are split into two groups, with one group connected to bus A and one to bus B. A switching unit connects bus A to bus B and therefore allows a processor on one bus to communicate with a processor on the other. The advantage of the dual-bus topology is that the probability of bus contention is reduced, because both buses can be operated in parallel (i.e. simultaneously). Only when a processor connected to one bus needs to transfer data to a processor on the other does the topology become equal to a single-bus topology.

The arrangement of Fig. 8(b) also employs two buses, but here each processor is connected directly to both buses via suitable

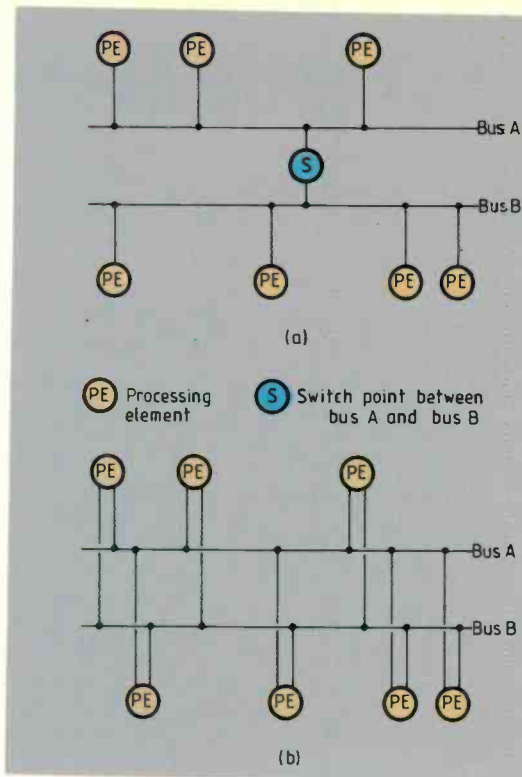

Fig. 8. These two examples of multi-bus multiprocessor structures have two buses, but the method can be extended to include any number of buses. Because both buses can be operated in parallel, the probability of bus contention is reduced. In (a) the processors are split into two groups. A switching unit connects bus A to bus B and therefore allows a processor on one bus to communicate with a processor on the other. In (b), each processor connects directly to both buses via suitable switches and two communication paths always exist between any pair of processors.

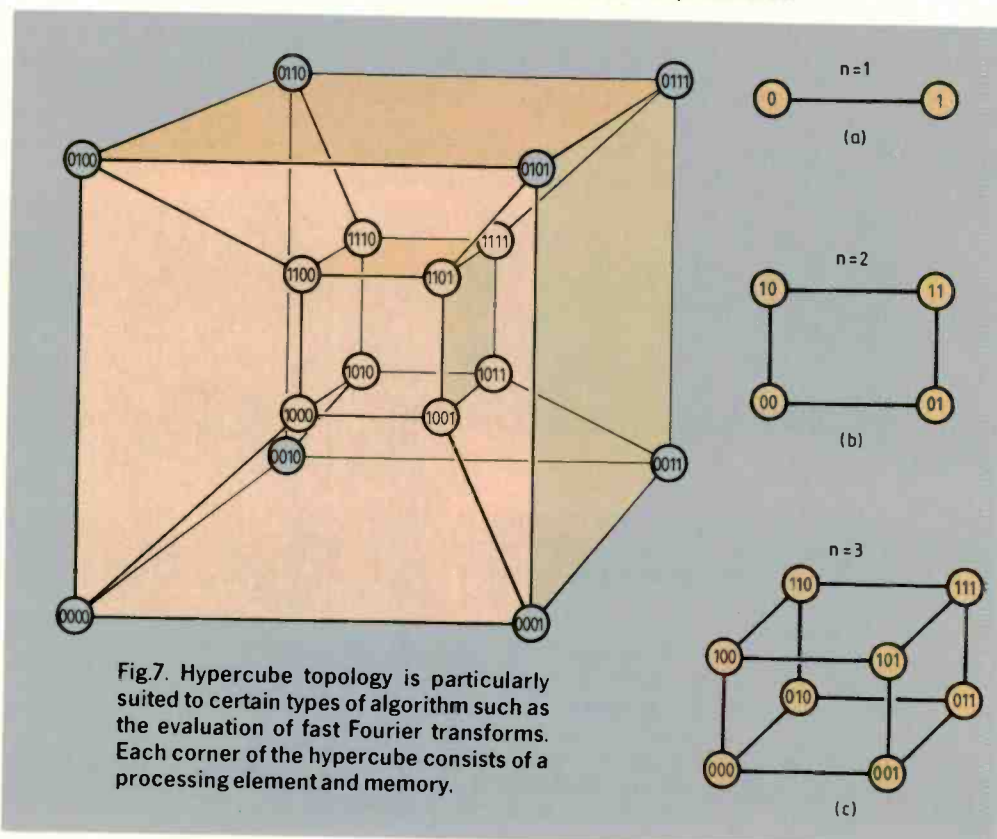

Fig. 7. Hypercube topology is particularly suited to certain types of algorithm such as the evaluation of fast Fourier transforms. Each corner of the hypercube consists of a processing element and memory.

switches. Two communication paths always exist between any pair of processors; one using Bus A and one using Bus B. Although the provision of two buses reduces the bottleneck associated with a single bus, it requires more connections between the processors and the two buses, and more complex hardware is needed to determine which bus a processor is to use at any time.

Another possible topology described in Fig.9 is the so-called crossbar switching architecture, which has its origin in the telephone exchange where it is employed to link subscribers to each other.

The processors are arranged as a single column (processors  $P_{c1}$  to  $P_{cm}$ ) and a single row (processors  $P_{r1}$  to  $P_{rn}$ ). That is, there are a total of  $m + n$  processors. Each processor in a column is connected to a horizontal bus and each processor in a row is connected to a vertical bus. A switching network,  $S_{r,c}$ , connects the processor on row  $r$  to the processor on column  $c$ . Note that there are  $m \times n$  switching networks for the  $m + n$  processors.

The advantage of the crossbar matrix is the speed at which the interconnection between two processors can be set up. Furthermore, it can be made highly reliable by providing alternative connections between nodes, should one of the switch points fail. Reliability is guaranteed only if the switches are fail safe and always fail in the off or no-connection position.

If the switches at the crosspoints are made multi-way (vertical-to-vertical, horizontal-to-horizontal or horizontal-to-vertical), you can construct a number of simultaneous pathways through the matrix. The provision of multiple pathways considerably increases the bandwidth of the system.

In practice, the crossbar matrix is not widely found in general-purpose systems, because of its high complexity. Another penalty associated with this arrangement is its limited expandability. If you wish to increase the power of the system by adding an extra processor, you must also add another bus, together with its associated switching units.

An interesting form of multiprocessor topology is illustrated in Fig.10. For obvious reasons this structure is called a binary tree.

Any two processors (nodes) in the tree communicate with each other by traversing the tree right-to-left until a processor common to both nodes is found, and then traversing the tree left-to-right. For example, Fig.10 shows how processor  $P_{0110}$  communicates with processor  $P_{0110}$ , by establishing backward links from  $P_{0110}$  to  $P_{01}$  and then forward links from  $P_{01}$  to  $P_{010}$  to  $P_{0100}$ .

The topology of the binary tree has the facility to set up multiple simultaneous links (depending on the nature of each of the links), as the whole tree is never needed to link any two points. In practice, a real system would implement additional pathways to relieve potential bottlenecks and to guard against the effects of failure at certain switching points. Note that the failure of a switch in a righthand column causes the loss of a single processor, while the failure of a link at the lefthand side immediately removes half the available processors from the system.

**Fig.9. Crossbar switching is a multi-bus multiprocessor architecture similar to the structure used in telephone exchanges. Processor interconnections can be set up very quickly and the structure can be very reliable but in practice expansion is difficult and the structure is complex.**

**Fig.10. In binary-tree structured multiprocessor system, any two processors communicate with each other by traversing the tree right-to-left until a processor common to both nodes is found, and then traversing the tree left to right. Potentially, multiple simultaneous links can be set up since the whole tree is never needed to link any two points. A disadvantage is that failure of a switch in a righthand column causes the loss of a single processor, while the failure of a link at the lefthand side immediately removes half the available processors from the system.**

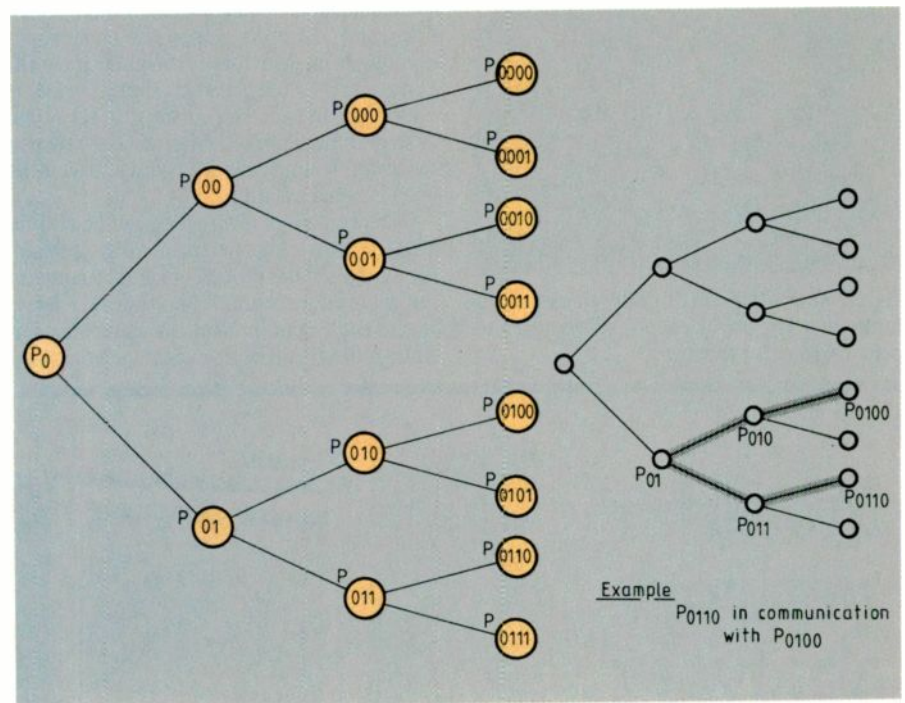
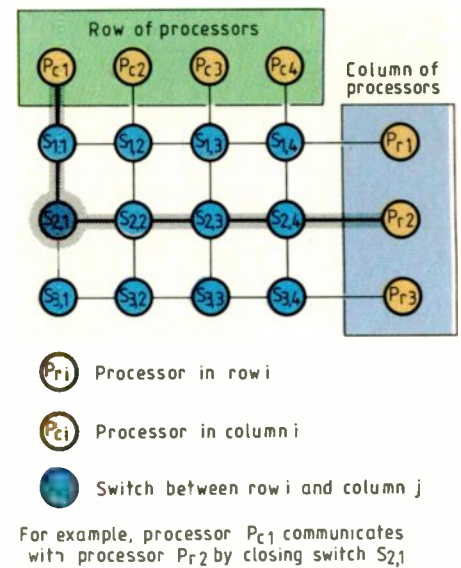

In some ways, the structure of Fig.10 can be found to exhibit interesting properties. However, due to its complexities, it is likely to remain an intriguing topology and almost never to raise its head above the pages of somebody's PhD thesis.

Finally, and more down-to-earth, Fig.11 illustrates the cluster topology which is a hybrid star-bus structure. The importance of this structure lies in its application in highly-reliable systems. Groups of processors and their local memory modules are arranged in the form of a cluster. Figure 11 shows three processors per cluster in an arrangement called triple modular redundancy. The output of each of the three processors is compared with the output of the other two processors in a voting network. The output of the voting circuit (or majority logic circuit) is taken as two-out-of-three of its inputs, on the basis that the failure of a single module is more likely than the simultaneous failure of two modules.

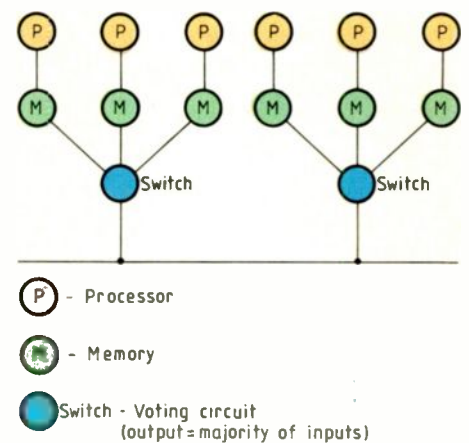

**Fig.11. Cluster topology is a hybrid star-bus structure for use in highly-reliable systems. In this three-processor example, each output is compared with the output of the other two processors in a voting network.**

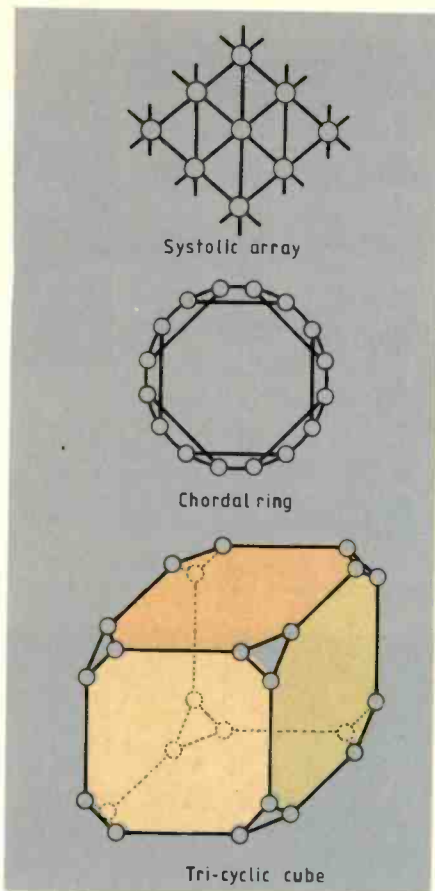

Fig.12. Topologies for multiprocessor systems are legion; these three topologies provide food for thought.

Although the clusters in Fig.11 communicate with each other via a bus, it is possible to use any other suitable mechanism to link them.

The design of a clustered triple modular redundancy system is not as easy as might be first thought. One of the major problems associated with modular redundancy arises from a phenomenon called divergence. Suppose that three identical processors have identical hardware and software and that they receive identical inputs and start with the same initial conditions at the same time. Therefore, unless one processor fails, their outputs are identical, as all elements of the system are identical.

In actual fact, the above statement is not true! In order to create truly redundant systems, each of the three processors in a cluster must have its own independent clock and i/o channels. Therefore, events taking place externally will not be 'seen' by each processor at exactly the same time. If these events lead to conditional branches, the operation of a processor in the cluster may diverge from that of its neighbours quite considerably after even a short period of operation. In such circumstances, it becomes very difficult to tell whether the processors are suffering from divergence or whether one of them has failed.

The problem of divergence can be eliminated by providing synchronizing mechanisms between the processors and by comparing their outputs only when they all wish to access the system bus for the same purpose. Once more it can be seen that, although the

principles behind the design of multiprocessor systems are relatively straightforward, their detailed practical design is very complex due to a considerable degree of interaction between hardware and software. As I have already pointed out, topologies for multiprocessor systems are legion. Figure 12 provides examples of three further topologies—just to provide food for thought.

My next article looks at how processors communicate with each other and describes some of the techniques that can be used to link together two or more 68000s to create a multiprocessor. In particular, I will look at the way in which 68000s are able to communicate with each other via shared memory. In the final article I introduce the VMEbus and discuss how it is used to implement practical 68000-based multiprocessor systems.

*Alan ...Clements, BSc., PhD., is... a reader in the School of Information Engineering at Teesside Polytechnic.*

## Modular network analyser

Tektronix has launched a modular PC-based telecommunications network analyser. Designated the TC-2000, its functions can include protocol analysis, PCM/BERT (pulse code modulation/bit error rate testing), 1an testing, trunk testing, remote communications, signalling and TIMS (transmission impairment measurement system) with voice band spectrum analysis. By using an 8088 for housekeeping and keyboard driving in conjunction with a series of individual tester modules using more powerful multiple processors, the unit is able to meet a wide range of requirements.

Its modularity allows a customer to purchase modules as and when needed and thus permits better control of costs and equipment usage. In addition, it

allows the same basic test equipment to be used all over the world, specific modules being available to meet the testing requirements of different markets.

For example, the technique for the measurement of the audio frequency response differs between the USA and Europe. In the USA, the Bell standard test requires the swept frequency test signal to be sent down the pair under test at the same time as being compared with a reference

signal being transmitted via another pair. On the other hand, a technique developed by Wandel & Goltermann has been adopted in Europe. Here, using just the one pair, the signal on the line is switched alternately between test and reference frequencies. This obviates the need to take a second pair out of service.

Options available include X.25, p.c.m. (both Bell and CEPT versions) and well as a number of local area network protocols including Ethernet 1.0 and 2.0 as well as IEEE803.2. The unit has seven slots; and since most analysers occupy only one slot, a single instrument can generally accommodate all analysers required.

A.J.M.



# NEW 8051 DEVELOPMENT CARD

The new Cavendish Automation development card carries a full symbolic Assembler and text editor as well as the MCS-BASIC 52 package. It will allow the user to write applications programmes in either BASIC or Assembler.

The text editor supports ORG, LOC, HIGH and LOW directives as well as the current location (\$) and the + and - operators. Full source text editing is included, and the source file as well as assembled code may be blown into PROM/E<sup>2</sup>PROM on-card. A powerful feature of the system is that a function library of over 60 routines within the interpreter may be accessed using assembly language CALL instructions, enabling simple negotiation of floating point, logical operations, relational testing and many other routines.

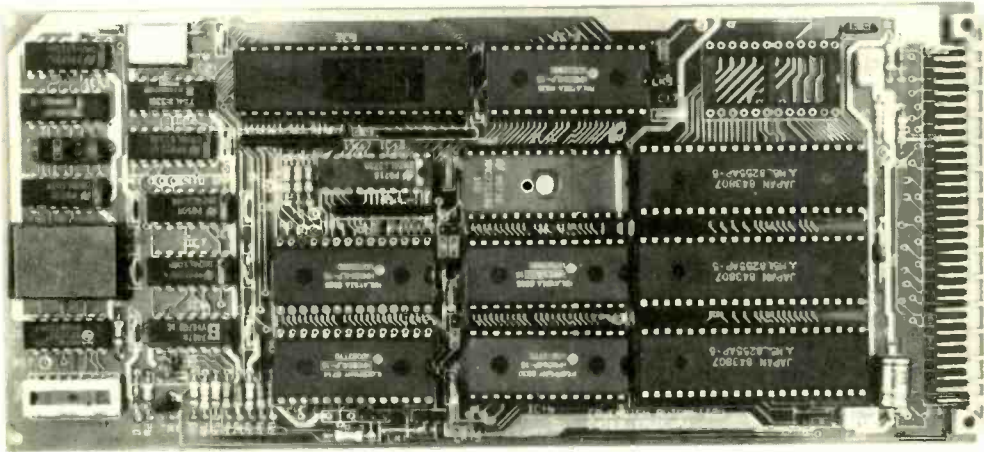

## FEATURES:

- Only requires +5V supply and dumb terminal
- Save assembled code or source text in PROM on-card
- Card I/O includes 9 x 8-bit ports and 2 serial lines.
- Very fast interpreter specifically written to access capabilities of '51 Family
- 32K user RAM, 16K user PROM (RAM jumped to access code or data space)
- Card supported by over 50 other types of CA I/O and CPU target cards

So, for professional implementations at super-low cost, call us on (0480) 219457.

Cavendish Automation, 45, High St., St. Neots, Huntingdon, Cambs PE19 1BN. Tel: 0480 219457. Telex: 32681 CAVCOM G.

ENTER 17 ON REPLY CARD

## QUALITY QUARTZ CRYSTALS QUICKLY

Our frequency ranges are:

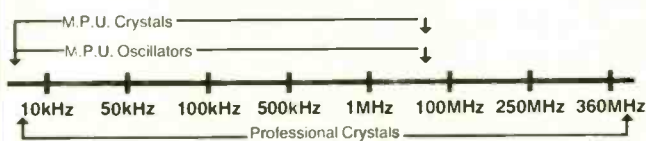

*We also supply quartz crystal filters, oscillators of all types and communication antennae.*

### Webster Electronics

ILMINSTER,  
SOMERSET TA19 9QA,  
ENGLAND  
TEL: (0460) 57166  
TELEX: 46571 FRQNCY G  
FAX: (0460) 57865



ENTER 39 ON REPLY CARD

## HIGH QUALITY - LOW PRICES

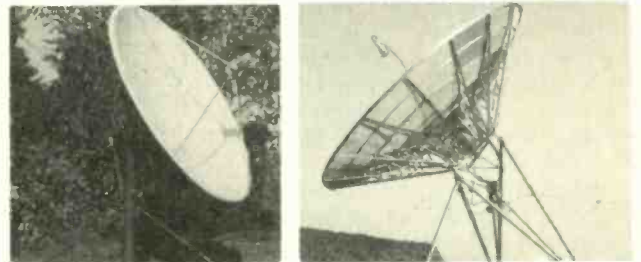

### 4 + 11GHz SATELLITE TV RECEIVING EQUIPMENT

RECEIVERS, LNB's, LNC's,  
FEED HORNS, ANTENNAS,  
ANTENNA POSITIONERS,  
POLAROTORS, LINE AMPLIFIERS, ETC.

For further details contact:

### HARRISON ELECTRONICS

Century Way, March,  
Cambs PE15 8QW  
Tel: (0354) 51289

# Multi-standard h.d.tv camera

This BTS design, suitable for studio or outside broadcasts, makes extensive use of automation.

WOLFRAM KLEMMER\*

In developing this camera, the aim was to secure the maximum image quality possible today. For this reason, the camera includes mixed-field high resolution camera tubes, a dynamic knee processor, and a digital two-dimensional aperture and contour correction unit. All critical analogue signal processors are stabilized by reference pulses. Registration and shading alignment is done fully automatically with the help of a test projector in the zoom lens, and lateral chromatic errors are compensated according to the lens setting.

Since the high-definition television production standard is still undefined, this development is based on a flexible concept allowing adaptation to various scanning formats. Some examples of possible scanning modes are 1050/59.94/2:1, 1125/60/2:1 and 1250/50/2:1.

The KCH 1000 is equipped with all the usual studio audio and intercom features. For its computer-aided operation it uses a serial data bus, which can be extended for the operation of several cameras from one master control panel.

## DESIGN BACKGROUND

Between 1982 and 1984, an experimental h.d.tv camera<sup>1</sup> was developed in the advanced development department of BTS (previously the Television Systems Division of Robert Bosch GmbH). Prototypes of this camera were supplied to various German institutes and used there as high-resolution picture sources.

With this earlier project too, there was no fixed scanning mode: the cameras were delivered with various line and field frequencies, and aspect ratios, or equipped with conversion sets to enable changing of the scanning format.

This first camera was developed for operation in a laboratory setting, and can thus be considered as a concept study. But the new BTS h.d.tv camera is intended for the future h.d.tv studio – which will nevertheless at first have an experimental character – and for h.d.tv o.b. vans. Important additions and even basic modifications were therefore needed to meet operational requirements.

At the same time, picture quality has been further improved by use of highest-quality camera tubes and digital signal processing.

The flexible scanning mode has been retained, since such a concept continues to be absolutely essential. Hence, the camera

\*BTS Broadcast Television Systems GmbH, Darmstadt, Federal Republic of Germany.

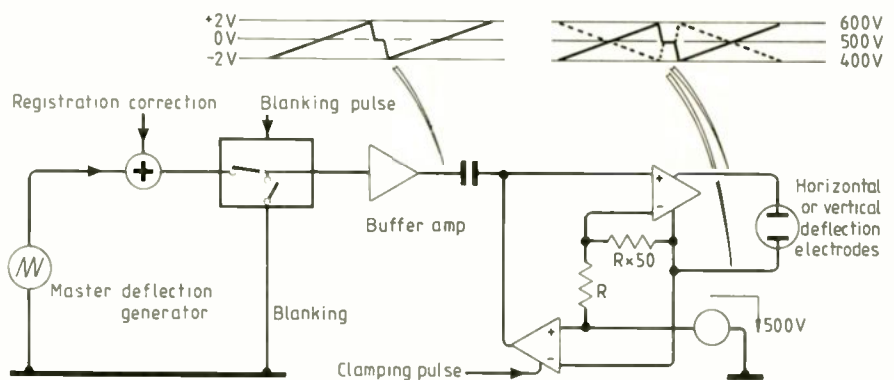

Fig. 1. Deflection circuit. To prevent random modulation of line spacing, a signal-to-noise ratio of 100dB must be achieved.

can be adapted to different scanning standards within the physical limits set by signal-to-noise ratio, flyback time, and the resolution of the camera tubes.

## CAMERA TUBES

The choice of camera tubes determines the picture quality of a television camera, especially a camera for h.d.tv use. In fact, all aspects of performance are limited by the quality of the pick-up sensor. Two-dimensional resolution, dynamic resolution and lag, signal-to-noise ratio, sensitivity, stability of registration and highlight characteristics are some of these parameters; moreover, they interact and thus cannot be considered separately.

Signal-to-noise ratio is particularly important in this regard, since it is directly dependent on the layer sensitivity at a given

lighting level, and is essentially determined by the target capacitance. But any attempt to compensate for insufficient static or dynamic resolution would worsen the signal-to-noise ratio.

Compensation of dynamic resolution, in particular for low-light lag effect through temporal high-pass filtering, is not practical because of its high technical complexity. The lag characteristics of tubes must therefore be given particular consideration, especially as the discrepancy between static and dynamic resolution in previous h.d.tv systems has been greater than in normal television.

BTS has been examining several tubes from European and Japanese manufacturers for possible use in the new h.d.tv camera. These tubes have various types of photoconductive layer (Saticon II, Saticon III, Plum-bicon) and different electron guns (triode system, diode-mode system), but all have

Fig. 2. Principle of coarse registration adjustment and serial distribution of correction data.

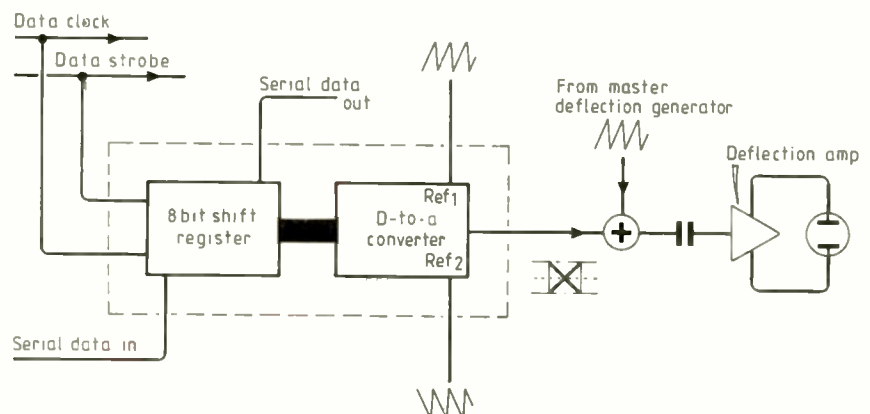

electrostatic deflection with magnetic focusing.

This type of beam deflection offers a number of advantages over the conventional method (magnetic/magnetic):

- uniform resolution
- low geometric distortion, and thereby
- low shading
- shorter flyback, since the stored field energy is lower than with magnetic deflection
- no eddy-current losses, which in case of magnetic deflection have a negative effect on flyback and line-start linearity
- high stability of registration, since there is no thermal drift of the deflection electrodes.

Generating the necessary deflection voltages (200—300Vpk-pk), however, is far from simple. The horizontal and vertical deflection amplifiers must likewise have a bandwidth of over 500kHz to be capable of transmitting the digitally-generated fine-correction signal.

At the same time – at the bandwidth specified – a signal-to-noise ratio of 100dB must be achieved in order to prevent random modulation of the line spacing. This applies in particular to the vertical amplifier.

Deflection voltages must continue to rise to the deflection bias voltage (grid 3) of about 400 — 600V. Naturally, it is necessary to superimpose fixed voltage components on this high voltage level for position shifting. In the BTS h.d.tv camera this problem is solved through capacitively coupling the high-voltage to the low-voltage level, with subsequent clamping in the high-voltage range. This requires a reference potential to be keyed into the deflection signal on the low-voltage level beforehand (Fig.1).

### AUTOMATION

Automatic functions in the new camera can be broken down into three groups: basic adjustment, pre-operating adjustment and continuously automated functions.

- Automatic basic adjustment:
  - geometry, fine
  - image registration, fine
  - white shading
  - black shading
- Pre-operating adjustment:
  - white balance
  - automatic filter-wheel selection
  - cable-length equalization
- Continuous automatic functions:
  - automatic iris
  - centring of red and blue channels
  - dynamic lens-error correction

With the exception of cable-length equalization, all automatic functions can be called up from the master control panel, either individually or in groups by menu control.

Automatic basic adjustment, i.e. geometry, registration, and shading adjustment, is done with the help of a special test slide which can be inserted into the optical path in the zoom lens. When the camera is first

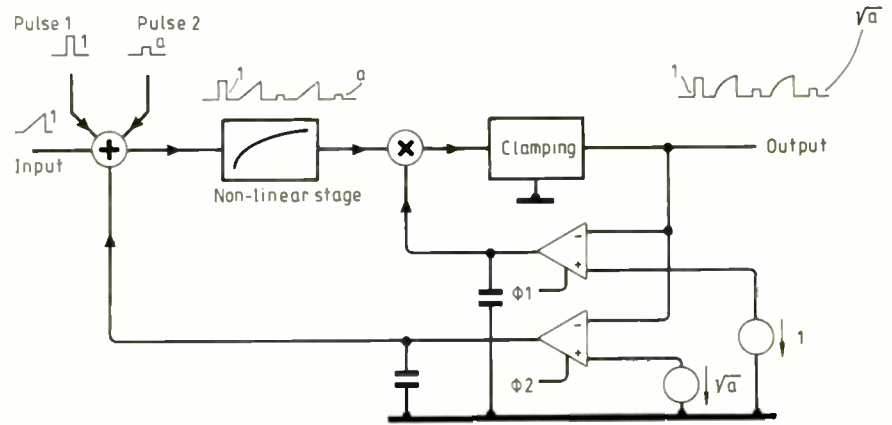

Fig.3. Video stages are stabilized and controlled throughout by the use of reference pulses.

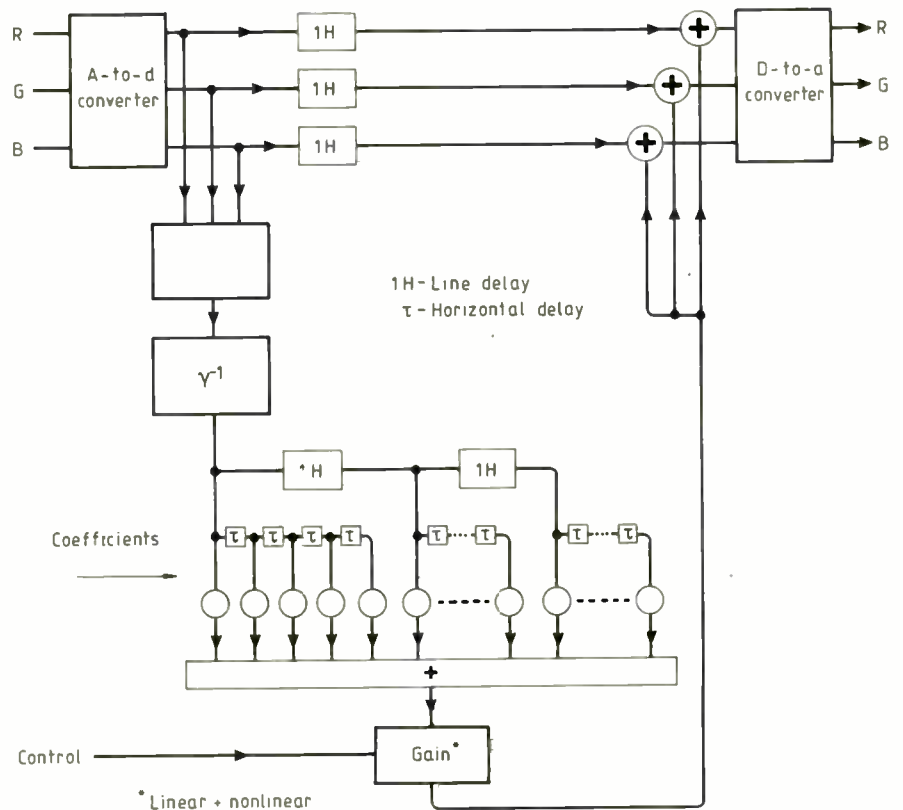

Fig.4. Block diagram of the two-dimensional processor for aperture and contour correction.

used, or after a tube change, this fine adjustment should be preceded by a coarse adjustment of registration. Coarse adjustment is manual, but menu-controlled from the master control panel with digital potentiometers. Here the highest stability is necessary, and so the signal is transmitted digitally to the analogue operating point.

This principle is illustrated in Fig.2, using manual adjustment of size for horizontal and vertical deflection as an example. The hybrid d-to-a converter is used here as a digitally-controlled potentiometer. At the same time, the example gives an idea of the general data transmission concept of the camera: data transmission through the camera cable as well as data distribution in the camera head and camera control unit (c.c.u.) take place serially in the vertical blanking interval.

The test pattern projector in the lens

simulates errors of the main lens for a fixed focal length and focusing distance.

The remaining chromatic errors and geometric errors of the lens are eliminated to a great extent by the dynamic lens error correction. Depending on the set values for focal length and distance, the following variables are affected:

- h, v position and size in red channel
- h, v position and size in blue channel
- pincushion correction for geometry

Correction data for different lens types can be stored.

Each time the camera is switched on the cable-length compensation system checks the cable length using a burst signal generated in the camera head. The resolution of measurement and compensation is 10m for

Continued on page 710.

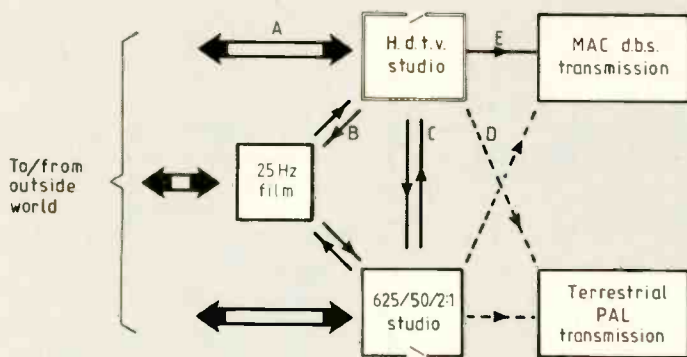

# The h.d.tv studio

M.D. WINDRAM  
and G.J. TONGE\*

In the context of UK broadcasting any high-definition studio or source must feed existing and new networks. A d.b.s. studio complex of the future may be configured as illustrated above in simple diagrammatic form. Five classes of interface with the h.d.tv studio standard are identified.

**A.** Interface with a (possibly different) h.d.tv standard used in other parts of the world.

**B.** Interface with motion picture film with a frame rate of 24Hz (or 25Hz as used in conjunction with current UK television). As a source, film is likely to form a significant proportion of h.d.tv broadcasts, especially in the early stages of an h.d.tv service. In addition electronic h.d.tv production is likely to be used increasingly in the making of feature films.

**C.** Interface with the 625/50/2:1 studio. As an input to the h.d.tv studio, archive material

\*Independent Broadcasting Authority

stored on the 625 line standard will be required from time to time to be included in h.d.tv productions. In the other direction, many h.d.tv productions will also be down-converted to a 625 line studio format, to be included in 625 line productions.

**D.** There may be a need (e.g. during prestige sporting events) to broadcast the same programme both in h.d.tv and over the terrestrial PAL network.

**E.** It is seen as essential that h.d.tv broadcasts are compatible with the 625/50/2:1 MAC transmission system (Eureka project EU95).

Some comments on the benefits and disadvantages connected with these interfaces are collected together in the Table (right). In considering these comments it soon becomes clear that there is only one interface (A) where the UK broadcaster may gain some advantage by adopting a 60Hz h.d.tv system, assuming that other parts of the world adopt 60Hz. For all the other interfaces a 50Hz h.d.tv studio standard provides both a more economic and a substantially higher-quality solution. In particular, a standard of 1250/50/1:1 (with initial equipment operating on 1250/50/2:1) is the ideal for studios related to UK broadcasting.

An obvious question arising from this argument is "What happens with the single worldwide h.d.tv studio standard?" There are two possible answers to this:

i) Adopt a 50Hz standard worldwide. This would create problems of conversion in the 60Hz countries.

ii) Adopt h.d.tv studio standards as higher members of the extensible family of digital standards of CCIR Recommendation 601 (i.e. 1250/50 and 1050/59.94).

If we assume that option (i) will not be followed, then the advantages offered by option (ii) are:

- Easier commonality of equipment between the two h.d.tv standards.
- Simpler compatible broadcasting options for USA and Japan etc.
- Further establishment of the already agreed Recommendation 601 standard.

Summary of benefits and deficits of 50 and 60Hz h.d.tv for the UK studio shown in the diagram.

|            | 50Hz h.d.tv                                                           | 60Hz h.d.tv studio                                                                                 |
|------------|-----------------------------------------------------------------------|----------------------------------------------------------------------------------------------------|
| <b>A</b>   | H.d.tv field-rate conversion may be necessary for exchanged material. | H.d.tv field-rate conversion may not be necessary for exchanged material.                          |
| <b>B</b>   | Simple, high-quality conversion to and from 25Hz film.                | More complex lower quality conversion to and from 24Hz film.                                       |
| <b>C,D</b> | Simple conversion with high quality.                                  | Complex conversion with motion artifacts.                                                          |
| <b>E</b>   | Compatible MAC transmission format possible.                          | H.d.tv field-rate conversion need for all programme material prior to compatible MAC transmission. |

## Further reading

1. Tonge G.J. and Windram M.D., D-MAC, a practical way forward for future TV services, ISBT '87, Beijing, China, 24-26 September, 1987.
2. Alard M., Distribution et Diffusion Terrestre en D2-MAC/paquets, Third International Conference on New Systems and Services in Telecoms, Liege, November 1986.
3. Lowry J.D., The evolution of B-MAC into a fully compatible EDTV system, Paper 3.8 in Second International Colloquium on New Television Systems: HDTV '85, Ottawa, Canada, 1985.
4. Collins R.I. and Wilson E.J., DBS sound and data multiplex new service possibilities, Proc. 10th IBC 1984, 296-302.

Continued from page 709.

a maximum length of 300m multi-core cable.

## VIDEO PROCESSING

Video signal processing was redesigned with the emphasis on extending signal dynamics. A module for automatic beam-current control for diode-gun beam generators is a prerequisite for this. The camera head furthermore incorporates a stage for selecting static gain and a dynamic knee processor.

This knee processor enables compression of signal levels up to 400% to the normal video level range of 100%, with the kneepoint (controlled by the picture content) lying between 80% and 100%. To ensure the transmission of fine image structures even in the compressed signal range (low differential slope), a special knee detail signal is mixed in.

Critical stages in the analogue video signal processing are stabilized with the help of controlled or fixed reference pulses in the

blanking intervals. This guarantees complete independence from all types of drift and from component tolerances. Furthermore, the characteristic parameters of these stages can be defined through external control voltages.

This concept is illustrated in Fig.3, using the gamma processor as an example. The use of both additive and multiplicative control ensures the equality of the reference pulse for grey and white with the set values, thus generating the desired characteristic curve.

A unit for two-dimensional aperture and contour correction is an important feature of the main camera amplifier. The unit forms an independent processor with RGB interface as well as synchronization and control interface. However, this processor is fully integrated into the system, so that the user is not aware of it except in terms of great improvement in picture quality.

Figure 4 shows the equivalent total structure of the internal fully-digital equipment. The central feature is a 5x3 coefficient matrix for the generation of the two-

dimensional detail signal. This matrix has proved extraordinarily flexible, and allows:

- smoothing (or, if desired, peaking) of the total frequency response
- suppression of diagonal frequency ranges for reasons of signal-to-noise ratio
- symmetrization of unequal diagonal resolution of h.d.tv camera tubes<sup>2,3,4</sup>.

## SYSTEM OUTLINE

The mechanics of the camera-head housing are broadly taken from the BTS studio camera KCM 125<sup>3</sup>. The interface for the zoom lens is absolutely identical, and the camera likewise includes a double filter wheel. Other components and assemblies taken from the KCM 125 are the power supply and the sound and intercom system.

Two high-quality microphone channels and three intercom communication paths are provided: producer intercom, engineering intercom, and programme sound. Headsets for the cameraman, reporter and dolly driver can be connected to the camera head.



A fault-diagnosis system allows remote monitoring of the video signals (test operation), the deflection sawtooth waveforms, the operating voltages and pulses, and the temperature in the prism mounting.

The control interface of the c.c.u. is designed so that multi-camera operation is possible. Data linkage between all participants is through a bidirectional bus with a transmission rate of 10Mbit/s. The main cable also includes the bus intercom and the power supply for the master control panel. Cross-connections provide intercom and power supply services to the remote control panels. Each system participant includes an 80186-based control computer with special data bus interface.

Correction data is stored in the camera

head, whereas operation-related data is stored in the control computer of the c.c.u. This means that the same picture is maintained even after the camera heads have been exchanged and the system turned back on. The master operating unit ensures access to all operating and adjustment functions of all cameras, with menu-controlled and software-protected adjustment.

Interfaces for the control oscilloscope and control monitor (monochrome) are likewise bus-capable. The output signals of all cameras can thus be monitored from the master operating unit.

#### References

1. W.H. Klemmer, Concept and realization of an HDTV studio camera. 14th International TV Sym-

posium. Montreux 1985. Symposium Record: Joint Sessions, 382-396.

2. A. Franken, Modulationsübertragungsfunktion einer Kameraröhre. *Fernseh u. Kino-Technik*, 1978 No4, 129-132.

3. M. Kurashige, Effect of self-sharpening in low-velocity electron beam landing. *IEEE Trans.*, Vol. ED 29 No10, October 1982. 1570-1579.

4. W.H. Klemmer, Betrachtungen zur zweidimensionalen Auflösung von Aufnahmeröhren in einem HDTV-Kamerasystem. *Rundfunktechnische Mitteilungen* 1986. No6. 275-280.

5. R. Kalhöfer and U.H. Reimers, Considerations on studio cameras for the component environment. 14th International TV Symposium. Montreux 1985. Symposium Record: Broadcast Sessions. 184-212.

## HIGH-DEFINITION TELEVISION

# Prospects and politics

Where is the search for a standard leading? Peter Wilson of Sony Broadcast, the 1125/60 system's leading proponent, presents his view.



Some time has now passed since the slogan "evolution or revolution" was bandied about. This has naturally died a death as technology seems to need a revolution to achieve evolution. The latest slogan in h.d.tv is "compatibility or convertibility".

Players in this game fall mainly in two camps: those who make a living from hardware, predominantly domestic (and are interested in compatibility); and those who make a living from software/programme production, and are concerned with convertibility – predominantly the broadcasters and production companies.

High-definition television is a system

Sony's second-generation h.d.tv camera, type HDC 300, seen in film-style mode.

which gives the viewers a much more powerful impression of being there. This is achieved by increasing the size of the picture and giving approximately five times the information seen on conventional tv.

Add to this a change in the aspect ratio from 4:3 to 16:9, an increased contrast ratio, more faithful colorimetry and an absence of coding artefacts, and the sum total results in simply amazing pictures.

Sony feels that this major advance in visual perception should not be subverted. Sensing that programme producers were

becoming worried about the future implications of h.d.tv on their business, the company has adopted a "seeing is believing" policy for programme production, especially over the very heated issue of 50Hz versus 60Hz.

The people we have been working with are European broadcasters. We have made productions, both long and short, with companies in many countries.

Of these broadcasters, Radiotelevisione Italiana is the most committed. It has made two test productions and one commercial production, *Julia and Julia* (Italian name, *Linea de Confine*). *Julia and Julia* featured the actors Kathleen Turner and Sting and

## EUROPEAN H.D.TV PRODUCTIONS MADE WITH SONY EQUIPMENT

|                       |                                                   |
|-----------------------|---------------------------------------------------|
| SFP, France           | Test production                                   |
| RAI, Italy            | Two test productions, one commercial feature film |
| Channel 5, Italy      | Test (musical)                                    |
| SRG, Switzerland      | Test (general)                                    |
| ORF, Austria          | Test (opera, <i>The Magic Flute</i> )             |
| ZDF/ARD, West Germany | Test ( <i>Wetten das</i> )                        |
| NDR, West Germany     | Test (documentary on Hamburg)                     |
| BR, West Germany      | Test (drama, <i>Rendezvous</i> )                  |
| BBC, UK               | Training production (wildlife); test production   |
| HTV, UK               | Technical test                                    |
| TVE, Spain            | Test (documentary on the architect Gaudi)         |

was technically acclaimed in its 35mm film version.

All these broadcast companies are enthused with h.d.tv and found the technical problems much slighter than they anticipated. An opinion appears to be forming that although broadcasters are apprehensive about down-conversion from 1125/60Hz h.d.tv to PAL for Europe, this is merely a technical problem to be solved with a black box. Far more frightening to them is the loss of revenue caused by a multiplicity of originating formats – that is, by the existence of more than one h.d.tv production standard. Broadcasters in the 1990s will only survive by programme exchange deals and co-productions.

### BUSINESS PROSPECTS

Sony has already sold 100 analogue high-definition video tape recorders. These are used in the main as studio mastering and post-production machines in the 1125/60 format. Sony has also sold around 40 high-definition cameras.

The European market area has two commercially operating high-definition studios, in Paris and in West Berlin. Today, 14 Sony recorders and five cameras are in operation in Europe. BTS Systems in Germany has several orders for its new multi-standard h.d.tv studio camera and is working on v.t.r. and telecine. Quantel in the UK has shipped around 30 high-definition Paintboxes to the graphics industry. These units output standard 1125/60 h.d.tv pictures or magnetic computer tape which is turned into printing plates, giving a very fast turn-around time for high resolution colour graphics. Rank Cintel is developing high-definition telecine machines and Avitel (UK) has delivered many distribution amplifiers.

### FUTURE TECHNOLOGY

Both Sony and BTS Systems exhibited at the NAB show in America real second-generation high-definition television cameras. The Sony camera is multi-role (film style or television studio) and the BTS camera is studio style. Sony demonstrated again its experimental digital high-definition v.t.r. with a video bit-rate recorded on tape of 1.188 gigabits per second and with eight digital audio channels. This machine uses metal tape in a reel-to-reel format.

Already in most European countries (certainly in the UK) there exists enough digital telephone network capacity to take wide-band high-definition signals for conferencing or closed circuit links. Both UK national

carriers are taking a very healthy interest in h.d.tv, as is the Bundespost in West Germany. The concept of seeing a prize-fight in the local cinema on a big screen is very attractive to many people. It could become a reality very soon.

Most Japanese manufacturers are now working on a half-inch wideband cassette v.t.r. for the industrial market. Sony has introduced a wideband video disc player for museums, exhibitions and general display purposes.

### THE POLITICS

Returning to my starting point, what about the question of compatibility or convertibility? There are now three players in the h.d.tv production standard stakes.

1. 1125/60: 1125 lines, 60 fields – known alternatively as Hi-Vision or HDVS (High Definition Video System, a Sony trade name).
2. 1250/50: 1250 lines, 50 fields – this is one form of the Eureka proposal.
3. 1050/59.94: this was recently suggested in USA by North American Philips (MAC 60) and the David Sarnoff Research Centre – AC TV (Advanced Compatible Television).

We can regard system 1 as convertible and systems 2 and 3 as compatible although not with each other. So let us examine these systems more closely.

### SYSTEM 1: 1125/60

Parameters of this system were laid down after exhaustive tests by NHK's laboratories in Japan, where it was found that 1125 lines were the best compromise between resolution and perception of resolution. The field rate of 60Hz was found very suitable for removing large-area flicker and the aspect ratio of 5:3 (modified to 16:9 by ATSC and SMPTE) gave a very high level of scene involvement at a viewing distance of 3 to 3.5 times the screen height. This standard is subject to a recommendation by SMPTE and ATSC in the USA.

**Advantages:** system was laid out after exhaustive evaluations, has shown spectacular performance and has proved itself capable of highest quality production, on a par with 35mm film. System is convertible to all current broadcast and film interchange formats.

**Disadvantage:** system is not PAL-compatible without complicated down-conversion (NTSC is easy).

### SYSTEM 2: 1250/50

This is the Eureka proposal. The system

currently under discussion is a revamp of the original HD-MAC proposals. The original aim was to upgrade studio systems gradually to an h.d.tv level. Upgrading was clearly unrealistic, and the plan has been replaced with an h.d.tv proposal down-convertible to PAL/SECAM or MAC-components. Several down-conversion phases are planned, starting with regular PAL and MAC and progressing to EMAC.

**Advantages:** system is easily down-converted to PAL or MAC, but not to NTSC or MAC 60.

**Disadvantages:** virtually impossible to convert to 1125/60 or 1050/59.94; suffers from large-area flicker. Broadcasters may dislike the spectre of conversion from 1125/60 to PAL/SECAM/625 MAC. But they will not accept a succession of interim conversions, from PAL to component origination to MAC to 1250/50 origination to EMAC. Nor will the consumer enjoy buying a new decoder box every three years and then a wide-screen display device.

### SYSTEM 3: 1050/60

The North American proposal. This system is designed to lessen the worries of the large American broadcasters.

**Advantage:** converts easily to NTSC.

**Disadvantage:** does not convert easily to 1125/60, 1250/50 or 625/50. Two primary players in 1050/59.94, NBC and CBS, have recently commissioned 1125/60 commercial productions with ZEBIG Productions and 1125 Productions, respectively, both of New York.

### THE FUTURE

High-definition television is accelerating at a frightening pace. It cannot be stopped now. The two evolving scenarios are:

1. A 1250/50 h.d.tv system where programme producers get left in the cold. This will mean increased production and transcoding costs, since 1125/60 already exists and will continue to do so. Beneficiaries will be European and foreign-owned tv set manufacturers based in Europe, and one or two local studio equipment manufacturers.
2. The 1125/60 system. Programme producers get what they always wanted, a universal tape interchange format. European industry has to sharpen up its act to compete in a new worldwide market.

**Footnote:** just as Europe imagines the Japanese threat from consumer manufacturers, so America worries about the European threat from within. So watch this space.

### Glossary

ATSC: Advanced Television Systems Committee (USA).

NAB: National Association of Broadcasters (USA).

SMPTE: Society of Motion Picture and Television Engineers (USA).

Eureka: European Technical Development Projects (Project no95).

# NEW PRODUCTS

## Frequency analysis workstation

Several instruments are combined to make an integrated analysis tool with uses in a variety of applications. The foundation of the Schlumberger 1220 is a two-channel f.f.t. analyser. Built-in software caters for four-channel sampling and the extra channels are added when the optional expansion card is plugged in. Any two of the four channels can be measured interactively through the 4 by 4 averaging matrix which, it is claimed, gives the equivalent of six two-channel analysers. The instrument operates over the frequency range 0 to 50kHz with up to 1000 lines frequency resolution and the ability to zoom in on any detail in 'real time'. The standard memory holds 256k samples. Optionally, this goes up to 1Msample. Other options include floppy-disc drive(s) and a built-in printer.

Incorporated within the 1220 are the facilities of a digital-storage oscilloscope, a transient recorder, a signal generator and synthesizer and several other functions. The instrument works from 0 to 50kHz and, because the signal generator is used to excite the system under test, can often be used by itself where formerly a cluster of instruments would be required.

Vibration analysis, acoustics and noise, loop response of control systems, speech and music analysis are among the areas of use for the instrument. With the 1Msample memory, it can record up to two

minutes of speech and offer several ways to analyse it, including a "waterfall" which offers time, frequency and spectrum plots combined into one display.

The green display (there is also an RGB output to a colour monitor) can be divided into two or four, or used to display a single channel. Channels may be superimposed. All measuring parameters are clearly labelled.

Similar care has been put into the design of the keyboard with all keys labelled with understandable words, so that the instrument is easy to use. Built-in amplifiers allow most transducers to be connected directly without further signal-conditioning equipment. Schlumberger Instruments, Victoria Road, Farnborough, Hants GU14 7PW. Tel: 0252 544433.



## Processor board tester

Simple debugging of complex boards can be carried out by the Polar B3T tester which is claimed to be easy to operate. No programming effort by the operator is required as the instrument runs pre-set test sequences. An interface pod plugs into the processor socket on the board and the test sequences are run through this.

Additional user ports enable the instrument to extend the test to include peripheral devices, edge connectors and external circuitry. Results are displayed on the instrument's l.c. display or output on its printer.

All buses and memory devices are exercised and tested. Rom contents can be disassembled using processor mnemonics. A logic/frequency probe is provided along with a power supply for the board under test. B3T can be controlled by an external computer through an RS232 port. Test sequences are stored internally on non-volatile memory or can be downloaded through a rom socket.

The instrument is said to be particularly useful in field service engineering, low-volume production testing, and prototype debugging. It can also be used to complement other test systems. Antron Electronics Ltd, Hamilton House, 38 Kings Road, Haslemere, Surrey GU27 2QA.

Tel: 0428 54541.

## Kit for prototyping surface mounts

'All that you could ever need' is the claim by Electrolube for its kit of chemicals and tools for working on surface-mounted components. Major components are solder paste, adhesive, syringes for applying both, multi-purpose cleaner, spray-on conformal coating, tweezers and even a little pot to store components. For reworking there is a spray flux, desolder braid and a cleaning brush.

The solder paste is a mixture of low-oxide solder powder in a flux binder. Small particle size permits use for screen printing and automatic dispensing. Heat cures the adhesive but it is sticky enough to hold the components before curing, and is flexible enough after curing not to stress the components. Conformal coating offers protection against moisture, solvents and lubricants. It can be soldered through for reworking. Before desoldering, a quick squirt of spray flux makes it easier and helps the replacement part to adhere. The solvent cleaner provided is non-

flammable and the aerosol spray is sufficiently powerful to penetrate under components and blow away any debris.

All parts can be re-ordered individually. Electrolube Ltd, Blakes Road, Wargrave, Berks RG10 8AW. Tel: 073 522 3104.



## Circuit breakers for p.c.b. protection

Ranges of circuit breakers have been developed which combine circuit protection with very small size. This makes them easy to design into complex p.c.b. layouts. Two types are available: the 808 series has 26 current ratings from 0.006A to 3.25A; and the 104 series with 24



ratings from 0.05A to 8A. The 108 Series is designed for vertical or horizontal mounting and can save as much as 70% board space compared with other breakers. ETA Circuit Breakers Ltd, Broadfields, Bicester Road, Aylesbury, Bucks. Tel: 0296 20336.

# NEW PRODUCTS

## Synthetic flux for wave soldering

Traditionally, p.c.b. manufacturers have maintained a loyalty to rosin-based fluxes, which although they produce little corrosion, are not self-cleaning. Many synthetic fluxes have given contamination problems.

Main features of a new synthetic flux from Fry's are its minimal residue and its ability to encapsulate fumes created during wave soldering and render them non-corrosive.

According to Fry's, these factors make this SM88/2X flux ideal for high-volume wave soldering, and especially for those who automatically test boards in their production process. Fry's Metals Ltd, Tandem Works, Christchurch Road, London W19 2PD. Tel: 01-468 7020.

## Microprocessor-board tester

By 1990, 80% of all digital p.c.bs will include a processor. So says Fluke, who have produced the Series 90 tester for use with such boards. This is fitted with a clip that plugs over the resident processor on the board under test. Switch-on initiates a number of tests including the system clock, the operation of memory access protocol, wait and reset states. Other tests, of memory and bus functions and of the input/output facilities are carried out from commands entered through the instrument's keyboard. Further tests use the tester's synchronized logic probe and a QuickTrace facility can identify and display the location of nodes to which the probe is connected.

Connectors are fitted for an external power supply (normally, the instrument is powered from the supply of the board under test), and for an RS232C interface. This adds further fault-finding power by allowing extra facilities, such as setting processor breakpoints, down and uploading the contents of memory. Even more tests can be automated through the RS232C link and a personal computer with a suite of software called QuickTools.

Each Series 90 tester is dedicated to a specific processor. Three versions are currently available for Z80, 6809 and 8085 processors. They cover a high proportion of all such processor cards especially as all the second-source and variations of the processors are included, so long as the pin-out remains the same.

An alliance between Fluke and Philips means that Philips are now the European agents for Fluke and details of all Fluke products can be obtained from Philips Test and Measurement, Colonial Way, Watford, Herts WD2 4TT. Tel: 0923 240511.



## Not just an i.c. tester

An addition to the ABI range of i.c. testers is the DIT-24XP which is used for in-circuit testing. It not only tests the functions of the chip under test but also identifies open circuit pins caused by broken tracks, poor soldering or plated-through holes that aren't. Short-circuits to the ground or supply pins and links between any pins are also detected. All faults are noted on the outline of the device displayed on the built-in c.r.t. — a feature which ABI claims unique.

Power to the circuit under test is provided by the instrument. The i.c. type number is entered on the keyboard and a test clip is hooked onto the device. If a device is unidentified the tester has a search routine to check its functions against its internal library and identify the

i.c. It makes no difference how the device is configured in a circuit: automatic compensation is included in the tester to cope and still requires a single test pattern for each device in the library. Loop testing modes are used to identify intermittent faults.

An additional facility is the ability to save the test results from a known 'good' board and then compare other boards. Differences lead to rapid diagnosis of any faults. Sockets on the front of the instrument check components before insertion.

Software supplied with the instrument for a variety of devices including t.t.l., c-mos, memory and interface chips. An update service adds new devices. ABI Electronics Ltd, Mason Way, Platts Common Industrial Park, Barnsley, South Yorks S74 9TG. Tel: 0226 350145.

## Optical communications light sources

Laser and led plug-in modules are accommodated in an Ando Electric 'mainframe' light source controller and modulator. AQ-4137 can house one laser source or two leds while the AQ-4141 accommodates up to three laser or six leds or a combination of these. Both models can attenuate the output by up to 6dB and they drive the sources in carrier-wave or chopped mode. Laser sources can be modulated by an external signal between 0.3kHz and 100kHz.

Wavelengths of the led modules are 660nm and 850nm unfiltered, or 1300nm and 1550nm with a choice of filtered output. One unit is switchable between 1300nm and 1550nm. The longer wavelengths are used for single or multi-mode operation.

Laser units have 850nm, 1300nm and 1550nm wavelengths and another can also switch between the two longer wavelengths.

All sources are temperature compensated to maintain stability. GPIB interface is provided on both models. Soon to be released is an additional range of high-output, high-stability led modules for use with the controllers. Available through Aspen Electronics Ltd, 1 Kildare Close, Eastcote, Ruislip, Middlesex HA4 9UR. Tel: 01-868 1311.

## Hybrid power circuits

Different circuit-building methods are combined by General Hybrid, who is able to partition a circuit and apply the specific method to a particular part of a circuit. This leads to improved thermal management and reduces the circuit size considerably. One design can combine direct heavy-wire bonding of chips onto a copper substrate, thick-film resistors, surface-mounted and conventional p.c.bs. Such circuits can carry up to 300A, and, depending on the provision of heatsinks, dissipate over 100W/in<sup>2</sup>. Similar circuits have been used for motor-drive controllers, robotics, d.c.-to-d.c. converters, uninterruptible power supplies, programmable voltage regulators, telecommunications systems and process control.

The same techniques are used to combine electronic control circuitry within power circuits to provide what Hybrid calls Smart Power. General Hybrid, Lawson Hunt Industrial Park, Broadbridge Heath, Horsham, West Sussex RH12 3JR. Tel: 0403 40400.



## New liquid crystal displays

Epson are confident that their new neutralized twisted nematic (NTN) liquid crystal displays will replace c.r.t.s for computers. Super-twisted nematics (STN) always had the disadvantage of being, usually, yellow and blue; of not having a good contrast and a relatively narrow viewing angle. NTN displays are black and white, offer twice the contrast of STNs and a wider viewing angle. Other advantages are a low power consumption, a compact (25mm thick) size and no flicker or electromagnetic radiation.

Electronics for driving the display are mounted on a flexible film p.c.b. leaving room behind the display to install a cold-cathode fluorescent backlight. Three displays are due for release in Autumn: 640 by 200 dots, 640 by 400 and 640 by 480. These correspond with the PC CGA, EGA and VGA display standards respectively. Prices have not been announced, but are expected to be less than one-and-a-half times those of STN equivalents. Epson UK Ltd, 388 High Road, Wembley, Middlesex HA9 6UH. Tel: 01-902 8892.

High power bench PSUs from

# KENWOOD



- Current to 30A, voltage to 110V
- Wide model range, 22 versions
- Analogue or digital meters, rack mount

**The TRIO connection.** Trio is a trade name of the giant Kenwood Corporation of Japan. The well known family of Trio test equipment now carries the Kenwood logo.

Let us send you data on the product featured above and update you on the extensive Kenwood instrument range.

**Thurlby** Thurlby Electronics Ltd., New Road  
St. Ives, Huntingdon. Cambs.  
PE17 4BG. Tel: (0480) 63570

ENTER 22  
ON REPLY CARD

Digital Storage from

# KENWOOD

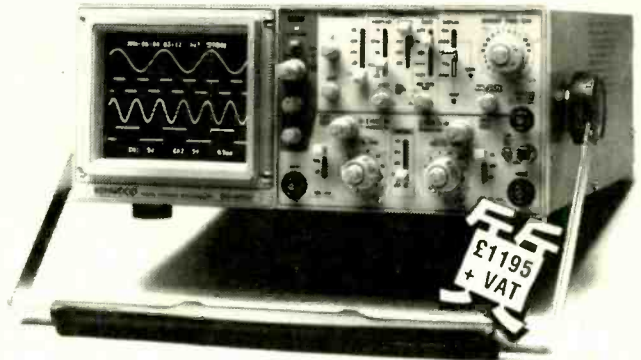

- 10 Mega Samples/sec on both channels
- Stored and real-time waveforms on-screen together
- Full cursor measurement facilities

**The TRIO connection.** Trio is a trade name of the giant Kenwood Corporation of Japan. The well known family of Trio test equipment now carries the Kenwood logo.

Let us send you data on the product featured above and update you on the extensive Kenwood instrument range.

**Thurlby** Thurlby Electronics Ltd., New Road  
St. Ives, Huntingdon. Cambs.  
PE17 4BG. Tel: (0480) 63570

ENTER 38  
ON REPLY CARD

## Real Time and Cross Support Software



MORE TIME IS SPENT DEBUGGING THAN CODING.

SAVE TIME AND DEBUG INTERACTIVELY WITH FORTH.

Course Forth

Modular Forth

GEM-Forth

STE ROM-Forth

Cross-compilers

Prom Programmers

Courses available

Catalogue available

### MICROPROCESSOR ENGINEERING LIMITED

133 Hill Lane, Southampton SO1 5AF.  
Telephone: 0703 631441

ENTER 33 ON REPLY CARD

## R.S.T. LANGREX R.S.T. SUPPLIES LTD

One of the largest stockists and distributors of electronic valves, tubes and semiconductors in this country.

Over 5 million items in stock covering more than 6,000 different types, including CRT's, camera tubes, diodes, ignitrons, image intensifiers, IC's, klystrons, magnetrons, microwave devices, opto electronics, photomultipliers, receiving tubes, rectifiers, tetrodes, thyratons, transistors, transmitting tubes, triodes, vidicons.

All from major UK & USA manufacturers.

Obsolete items a speciality. Quotations by return. Telephone/telex or fax despatch within 24 hours on stock items. Accounts to approved customers. Mail order service available.

### LANGREX SUPPLIES LTD

1 Mayo Road, Croydon, Surrey CR0 2QP.  
Tel: 01-684 1166  
Telex: 946708  
Fax: 01-684 3066

ENTER 23 ON REPLY CARD

# NEW PRODUCTS

## Microwave amplifier

Gallium arsenide transistors are used in the MMA 4500 series of linear amplifiers for use in the 14GHz band. Gain and output power are up to 65dB and 3W respectively. Modular microstrip circuitry conforms to the relevant British standard and incorporates isolators to ensure stability and v.s.w.r. under all operating conditions.

The modular construction also allows a high degree of flexibility in providing a number of options, which include: power monitoring, automatic level control, gain control, built-in test equipment, and higher output powers. Units can be built to meet the requirements of fixed or mobile ground-based transmitters for satellite communications. Densitron Microwave Ltd, 112 South Street, Braintree, Essex. Tel: 0376 551717.

## Take a look inside

It is very annoying to have to dismantle equipment to find a simple fault that is not visible otherwise. That problem can be solved by an endoscope and two are made by Scholly in Germany. These are designed for industrial use but the principle is the same as those used by surgeons to look inside people without taking them apart: light is conducted through optical fibres and an image is reflected through a bundle of thousands of fibres.

Miniflex uses rigid light guides and mirrors can be attached to the end to provide different viewing angles. The probes have diameters from 0.96mm, claimed to be the world's smallest, up to 2.7mm.

Fibrescope has a flexible light guide, interchangeable tips and mirrors are also available. Sizes start from 2.2mm up to 10.8mm.

Both instruments can be linked to a tv camera. Finlay Microvision Co. Ltd, Unit 6, Southfield Road, Kineton Road Industrial Estate, Southam, Warwicks CV33 0JH. Tel: 092 681 3043.

## Communications multiplexer

Synchronous multiplexing of four different data streams is possible with the Feshon Datamizer II. Each of the four may be half or full duplex at a different data rate and all are transmitted through a single high-speed data link.

Compression of data to a quarter of its normal length eliminates the need for additional leased lines and can reduce line charges by up to 75%. Feshon Systems Ltd, Resicon House, London Road, Sevenoaks, Kent TN13 2DN. tel: 0732 560088.

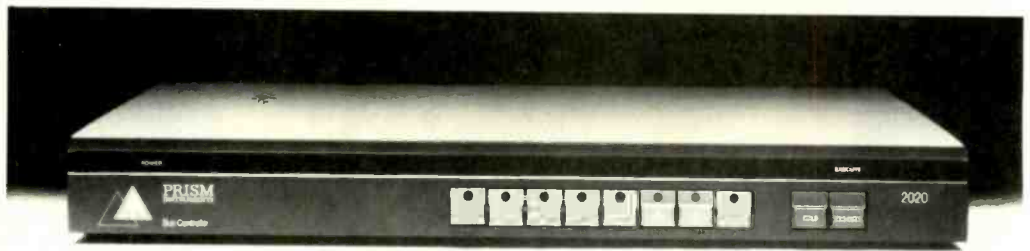

## Bus controller replaces computer

Dedicated control systems can take advantage of the facilities offered by the 2020 GPIB bus controller. This has the ability to store up to eight independent control programs. Each program is held in a 16Kbyte eprom or in 8Kbyte battery-backed ram. Two independent IEEE-488 buses may be controlled for up to 28 linked devices.

Simple command language instructions allow easy control of

devices on the bus including sending and receiving data, simple arithmetical operations and message handling, conditional testing and the logging of data to the RS232 output. Further commands adjust and read the internal facilities of the 2020, i.e. real-time clock, audible alarm, and status indicator lamps. Control programs can be prepared on a standard microcomputer and downloaded to the 2020 through the

RS232 interface. Initially they are held in ram but when fully operational and debugged, it is recommended that they be made more permanent in eprom.

At a price of £595, the 2020 can replace a more expensive computer normally used as an IEEE-488 bus controller. Prism Electronics Ltd, Burrell Road, Industrial Estate, St. Ives, Huntingdon, Cambs PE17 4NF. Tel: 0480 62225.

## Complex continuity testing by computer

Some cable harnesses can have many branches and be very difficult to test for continuity. Software has been developed for the IBM PC which can program a universal continuity tester and make the task much easier. The system can 'learn' a wire list which is created and edited on the computer. Test sequences run on the tester are controlled from the computer and offer an automatic documentation for quality-assurance testing. Short or open circuits, intermittent faults and incorrect wiring for up to 28,000 points can be detected at a rate of 1250 connections in a second. Expansion boards can be easily added to the UCT-1000 tester to enable the testing of even more points if needed. The software is called PC/UCT. Omnitest Ltd, Highcliffe House, 411 Lymington Road, Highcliffe, Christchurch, Dorset BH23 5EN. Tel: 04252 77731.

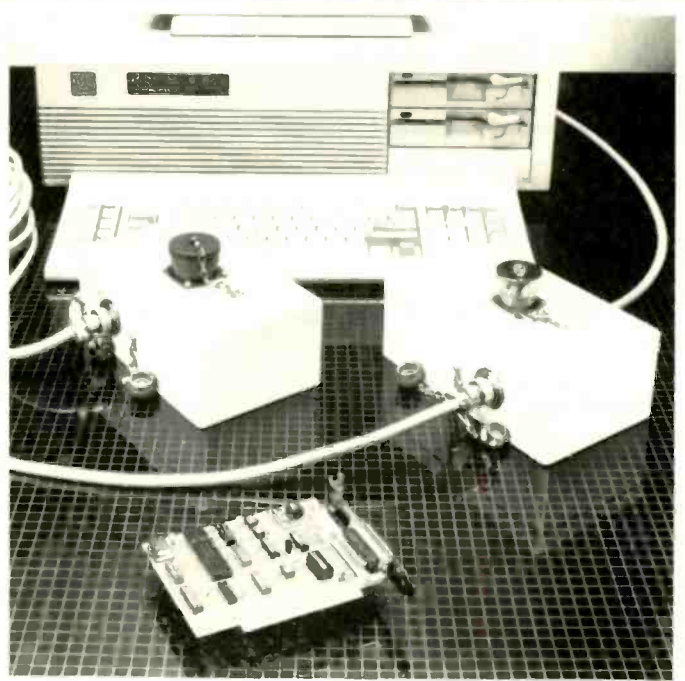

# TIME AND FREQUENCY

The Company is Registered to Def-Stan 05-21 (AQAP-1)



**RADIO CLOCKS**

- ★ Synchronisation of remote sites.
- ★ Time Stamping GMT/BST.

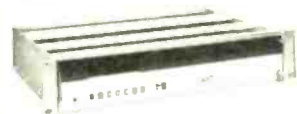

**CHRONOMETERS**

- ★ Quartz master/slave systems.



**STANDARD FREQUENCY RECEIVERS**

Accurate off-air standard (MSF Rugby).

- ★ Calibration and reference for timers, counters, frequency meters.



**TIME CODE INSTRUMENTATION**

Generators, Readers with high speed tape search and control. Timecodes IRIG A, B, vela, EBU, NASA, XR3.



**DISPLAYS**

Analogue, digital and self-setting analogue types (desk, wall or console mounting).

- ★ Public time displays for airports, bus, railway stations and factories.



**WATCHDOG**

A computer network monitoring and management system for synchronisation and fault reporting of up to 64 independent computers.



**CONSULTING AND MANUFACTURE**

- ★ Feasibility studies and consultancy.
- ★ Small quantity manufacturing and test services.
- ★ System design.

All the above can be supplied with a wide range of options and interfaces including Airborne, Military and Commercial versions. Customised systems available.



**European Electronic Systems Limited,  
Maldon, Essex CM9 6SW, UK.**

**Telephone: 024 541 5911 Telex: 995917 EULEC G Fax: 024 541 5785**

ENTER 18 ON REPLY CARD

## SMALL SELECTION ONLY LISTED

**RING US FOR YOUR REQUIREMENTS WHICH MAY BE IN STOCK**

**Latest bulk Government release – Cossor Oscilloscope CDU150(CT531/3)** £150 only. Solid state general purpose bandwidth DC to 35MHZ at 5MV/Cm – Dual Channel – High brightness display (8-10cm) full delayed time base with gated mode – risetime 10NS illuminated graticule – Beam finder – Calibrator 1KHZ squarewave power 100 – 120V 200V – 250 volts AC – size W 26CM – 14CM deep – WT 12.5 KG – carrying handle, colour blue, protection cover front containing polarized viewer and camera adaptor plate – probe (1) – mains lead. Tested in fair condition with operating instructions – £150.00.

**Racal RA17L Communications Receivers.** 500KC/S to 30MC/S in 30 bands 1MC/S wide from £175. All receivers are air tested and calibrated in our workshop supplied with dust cover operation instructions circuit in fair used condition – **Racal Ancillary Units** for all receivers mostly always in stock – **Don 10 Telephone Cable** ½ mile canvas containers or wooden drum new from £20 – **Army Whip Aerials** screw type F sections and bases large qty available now P.O.R. – **Test Equipment** we hold a large stock of modern and old equipment. **RF and AF Signal Generators** – **Spectrum Analysers** – **Counters** – **Power Supplies** – **Oscilloscopes** – **Chart Recorders** all speeds single to multipen – **XY Plotters A4 A3** – **Racal Modern Encryption Equipment** – **Racal Modern Morse Readers and Senders** – **Clark Air Operated Heavy Duty Masts** P.O.R. All items are bought direct from H M Government being surplus equipment price is ex-works. S.A.E. for enquiries. Phone for appointment for demonstration of any items, also availability or price change V.A.T. and carriage extra.

**EXPORT TRADE AND QUANTITY DISCOUNTS  
JOHNS RADIO, WHITEHALL WORKS,  
84 WHITEHALL ROAD EAST, BIRKENSHAW,  
BRADFORD, BD11 2ER TEL NO. (0274) 684007.**

**WANTED: REDUNDANT TEST EQUIPMENT – VALVES – PLUGS – SOCKETS,  
SYNCHRS ETC. RECEIVING AND TRANSMITTING EQUIPMENT**

ENTER 36 ON REPLY CARD

**IN VIEW OF THE EXTREMELY  
RAPID CHANGE TAKING PLACE  
IN THE ELECTRONICS  
INDUSTRY, LARGE QUANTITIES  
OF COMPONENTS BECOME  
REDUNDANT. WE ARE CASH  
PURCHASERS OF SUCH  
MATERIALS AND WOULD  
APPRECIATE A TELEPHONE  
CALL OR A LIST IF AVAILABLE.  
WE PAY TOP PRICES AND  
COLLECT.**

**R. Henson Ltd.**

**21 Lodge Lane, N. Finchley,  
London N12 8JG.**

**5 mins. from Tally Ho Corner**

**Telephone:  
01-445 2713/0749**

ENTER 35 ON REPLY CARD





# NEW PRODUCTS

## Three from HP

### Low-cost digitizing oscilloscope

Low-price, general-purpose, benchtop oscilloscopes account for about half of the total oscilloscope market, says Hewlett Packard, who has decided to provide an oscilloscope at £2499 for that half. Several integrated circuits have been developed specially for the HP 54501A four-channel, 100MHz digital oscilloscope, to produce all the controlling circuitry on one p.c.b. It offers a sampling rate of 10Msamples/s. Other key features are its ease of use, unattended measurement, its triggering facilities and the HP-IB link. An 'autoscale' button will automatically lock onto a signal and adjust parameters to give a clear trace on the screen. Specifications include 5mV sensitivity and 8-bit vertical resolution.

New features on the instrument include a measurement limit test which allows pass/fail testing between preset parameters; statistical analysis of measurements; and dual timebase windowing, which gives facilities similar to the delayed timebase on an analogue instrument for close up viewing of part of a trace.

The triggering facilities are particularly noteworthy. They include tv signal and inter-channel triggering. The ability to set a time window on a trigger means that the instrument can be set to trigger only on signals that are unexpected so that any glitches are automatically recorded.

The front panel has been designed to be easy to use with most parameters altered by a single keystroke or a knob.

Several accessories are offered as optional extras and include a tv/video sync. module with a clamped video output; and a number of probes, probe sockets, clips and adaptors.

### Signal analyser with built-in Basic

A fast Fourier transform (FFT)-based analyser is claimed to provide easier test solutions, faster, and at lower cost. HP 35660A two-channel dynamic signal analyser includes many test and automation features that traditionally have required the use of an external computer.

The HP 35660A provides spectrum analysis from 0 to 102.4kHz and network analysis from 0 to 51.2kHz. The FFT provides 400 lines of resolution in both one and two-channel modes. The analyser has two input channels with 70dB dynamic range and a signal source that provides signals for stimulus-response testing. It measures linear spectrum, power spectrum, frequency response, gain/phase, group delay, time history and power spectral density.

Test engineers can use the

analyser's new test-automation language, HP Instrument Basic. A built-in, 3.5-in disc drive stores traces, tables and Basic programs. Users can create algorithms and format results to provide answers not directly available from the standard analyser.

Tables of limits can be built into the memory for repetitive testing. Formerly measurements had to be transferred to a computer for comparison with specifications.

Using Instrument Basic, the HP 35660A can serve as a controller for HP-IB (IEEE-488) test systems. The systems might include peripherals such as hard discs, printers and plotters, and instruments such as switch matrices, voltmeters and signal generators. This makes it easy to automate smaller systems without the need for an external computer. Instrument Basic is a subset of HP Basic. It adds decision-making, branching and i/o facilities, including the control of other instruments. One very useful facility is keystroke recording. This automatically creates a Basic program as the user makes measurements from the front panel. A test sequence can be recorded and saved with no 'manual' programming required. Basic programs also can be developed on HP workstations and then transferred to the analyser on discs. This Basic is also useful for normal computer-aided tests with an external computer. Keystroke-recorded routines can be merged with the main program being written on the computer.

In addition to user-developed software there is also commercially available software. HP offers the 35681A analysis pack, which provides enhanced features for spectrum and network analysis in electronics. Third-party software suppliers also are providing application solutions: Entek Scientific has converted its Motor Monitor program to the instrument and SMS is writing several packages specifically for the HP analyser, the first of which is the ME Toolkit.

### Trigger to speed-up oscilloscopes

Many oscilloscopes offer the facility of external triggering where the internal trigger timebase might not be fast enough. HP has produced the 54118A trigger which runs from 500MHz to 18GHz. Moreover it actually runs at this speed and is based on a high-speed flip-flop linked to a tunnel diode without using count-down techniques. It can trigger on a leading or trailing edge. Its intended use is as an add-on for the HP 120 series of oscilloscopes in very high speed applications.

Details of all these HP products come from Hewlett-Packard Ltd, Winnersh Triangle, Wokingham, Berks RG11 5DZ. Tel: 0734 696622.

## Speedometer chip

The mechanical odometer or mileometer may soon become relegated to the motor museum if Siemens' non-volatile, non-resettable, counter that records 'mileage' is successful. Called the SLE4501, the eeprom can store more than four million events, the equivalent to some 250,000 miles (400,000km). Conventional eeproms are usually limited to much less but an additional chip, the SLE4502 c-mos pre-scaler, permits the electronic odometer to be adapted to any type of car.

The SLE4501 incorporates a shift register, a 22-bit binary counter, two non-volatile 22-bit registers, a programming power source, a sequence controller, and for the

command code, a two-bit shift register, and the 64byte eeprom, programmed by the car manufacturer according to wheel and tyre sizes and gearbox and differential gear ratios.

Counting is performed entirely on-chip and is immune to outside interference. The signals produced by the speedometer pulse generator are fed to the prescaler, the divider ratio of which is programmable from 1 to 65,000. The chip also contains a data protection facility that prevents tampering. What is more,

prospective buyers of a used car can be more certain that the mileage displayed is correct. Siemens Ltd, Windmill Road, Sunbury-on-Thames, Middlesex TW16 7HS. Tel: 0932 75 2323.

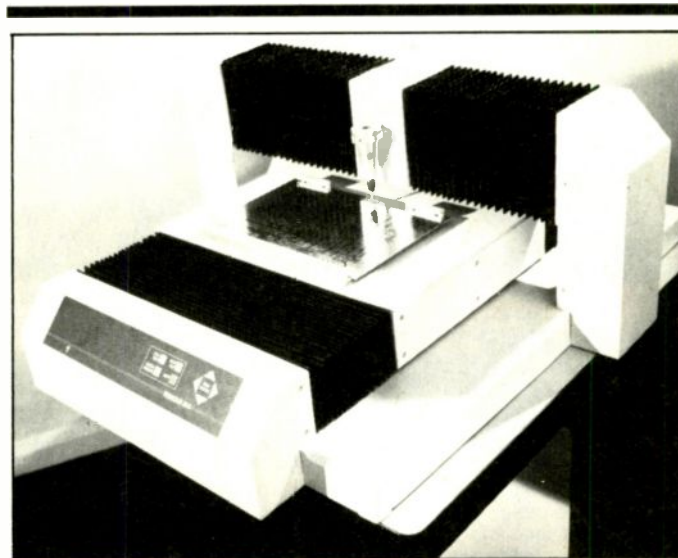

## Design computer for p.c.bs

By the time you read this, you should be able to get your hands on a Versatron 2000 p.c.b. development system that was on pre-launch demonstration at British Electronics Week. There are two main components; a computer dedicated to the task, and a plotter/drilling machine that produces prototype boards under the direct control of the computer. Combined, they are intended to ease the transition between hand drafting and cad by being easy to use and low in cost — 'about the price of a desk-top'.

Central to the system is the purpose-designed 16-bit, 10MHz computer with 1.2Mbyte of ram, colour monitor and a disc drive. Graphics have been developed to give smooth scrolling of images, and rapid zooming and panning. As a whole design is retained in memory these operations are very fast and do not suffer from the more usual redrawing delays experienced in such systems. Similarly, any erasures produce instant redrawing of the affected part of the design. The disc is

only used to store component libraries and completed layouts.

The software is specifically designed to be easy to use with pop-up menus and highlight selection of options, all driven by a mouse. Component pad patterns can be designed and added to the library provided. Once components have been positioned, a multi-pass autorouting program draws the tracks. In many cases it will complete the whole process with no supervision and is claimed to be very fast.

Making a board is carried out by the prototyping machine which plots the pattern directly onto the bare copper board in etch-resistant ink. It also drills the holes automatically. The board is then etched and optionally plated ready for component insertion.

Refinements to be added during this year are circuit design software and programs to produce net lists and check rules. Versatronics Ltd, Mardy Road, Cardiff CF3 8EQ. Tel: 0222 770488.

# What don't you get for £585?\*

- ① 20 megasamples/sec sampling rate?
- ② 4K words memory per channel?
- ③ 35 MHz repetitive bandwidth?
- ④ 16 non-volatile waveform memories?
- ⑤ On-screen text display and on-screen cursor measurement?
- ⑥ Digital sweep delay system?
- ⑦ Post storage processing including waveform multiplication?
- ⑧ Digital averaging for lower noise?
- ⑨ Digital interpolation using sine or pulse algorithms?
- ⑩ Fully programmable front panel with 50 setting memories?
- ⑪ RS-232C compatible interface plus optional IEEE-488 interface?
- ⑫ Full remote control and bi-directional waveform transfer?
- ⑬ Output to a dot-matrix printer digital or analogue plotter?
- ⑭ A free conventional oscilloscope to connect it to?

**Surprisingly it's only number 14 but you probably have that already!**

## Digital Storage

The Thurlby DSA524\* links to any standard oscilloscope (using only one cable) and converts it into a highly sophisticated digital storage 'scope with all the features listed above.

If you want to pay even less, the DSA511 has a few less features but costs only £395.



Thurlby Electronics Ltd., New Road/Burrell Road, St. Ives, Huntingdon Cambs PE17 4BG  
Telex: 32475 Fax: (0480) 64832 Tel: (0480) 63570

ENTER 22 ON REPLY CARD

**NOW AVAILABLE WITH 2MBYTE ON BOARD RAM**

## IMAGE-10

### HIGH PERFORMANCE SINGLE BOARD GRAPHICS COMPUTER

Image-10 is a high performance single board computer optimised for graphics intensive applications, and it's fast – very fast. Motorola's 68010 cpu and Intel's 82786 graphics co-processor work concurrently to produce displays of dazzling speed and quality. All graphic operations, including window manipulation, are generated by dedicated hardware which frees the cpu to concentrate on running your programs.

An impressive hardware specification is complemented by the availability of two professional disc operating systems.

**OS-9/68K** – A powerful UNIX like multi-tasking operating system supporting real-time applications. C, PASCAL, FORTRAN, BASIC, FORTH and PLuS languages available.

**TRIP0S-3** – A well established multi-tasking operating system with propriety window management scheme. Supplied with assembler, disassembler, debugger, screen editor, BCPL and C compilers.

#### Image-10 Specification:

Central Processor – MC68010 16/32 bit microprocessor.

Graphics co-processor – I82786 running with 16Mhz pixel clock.

Display resolution is 768 by 576 pixels (user definable). Actual resolution limited only by memory with instantaneous scroll and pan in any direction plus independent horizontal and vertical zoom from x1 to x64. Displayed colours may be 256, 16, 4 or 2 at all resolutions. Colour look-up table provides a palette of 262,144 colours.

Hardware managed windows.

Hardware generated lines, polylines, polygons, circles, arcs, fills, characters and bit block transfers at up to 20Mbit/sec.

Unlimited character fonts and character sizes supported.

Memory – 2.0M byte (Image-10.20) or 512K byte (Image-10.05) dynamic ram. 256K byte fast static ram. Shipped with 64K byte. 512K byte eeprom. Shipped with 128K byte system firmware. 32K byte high security battery-backed static ram plugs into RTC.

Floppy disc – WD1772 controller supports one or two 5.25/3.5 inch drives. Format may be single/double sided, single/double density. Step rates selectable from 2, 3, 6 or 12m secs.

Winchester disc – SCSI interface capable of supporting up to 7 drives. Serial I/O – MC68681 provides two independent RS232 input/output ports. Independently programmable baudrates 50-38.4K baud.

External clock permits transfers up to 1Mbit/sec. IMSC012 link adaptor provides 20Mbit/sec transfers to optional transputer co-processor.

Parallel I/O – Two MC68230 PIA's provide up to 48 lines of programmable input/output with multi-mode handshaking protocols. Disc operating systems use some of these lines for SCSI, parallel printer, mouse, digitizer etc.

Real-time clock – DS1216 maintains date and time to 1/100th of a second.

Sound generator – SAA1099 generates stereo sound output. Contains six frequency generators, two noise generators, six mixers and twelve amplitude controllers.

User expansion – A full 16 bit buffered bus is available via DiN connector.

Board format – Extended double eurocard. 218mm by 243mm.

Image-10 is available as a board level product or as a compact packaged system at prices starting at ..... **£1,295**

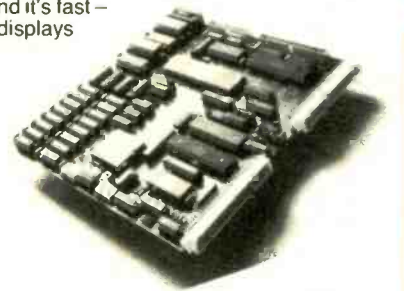

**Micro Concepts**

All prices shown exclusive of VAT and carriage

2 St. Stephens Road, Cheltenham, Gloucestershire GL51 5AA

Telephone (0242) 510525



ENTER 41 ON REPLY CARD

# Amplitude from phase

Calculation of a network's amplitude response when its phase response is known.

D.V. MERCY

In the last issue, I described a numerical method by which the phase response of a network can be calculated when the amplitude response is known. This article describes the reverse procedure, for obtaining the amplitude response. Some of the equations and figures referred to were shown in the first article.

## AMPLITUDE RESPONSE FROM PHASE RESPONSE

In this section the equations to be considered are eqns. (9) and (10). It can be seen that the answer is either referred to the amplitude value at zero frequency ( $A_0$ ), or at infinite frequency ( $A_\infty$ ). These formulas assume, therefore, that either  $\ln A_0$  or  $\ln A_\infty$  will be finite. This is not always true, but measures can be taken to deal with this problem when it arises and these are discussed later.

An additional point to consider when the insertion loss (transmission) characteristic of a network is being derived is that it is not possible uniquely to define the amplitude response from the phase data, since any number of amplitude characteristics, differing only by a fixed number of dB, have the identical phase response. This means that the value of  $A_0$ ,  $A_\infty$ , or the gain at another frequency can be chosen with complete freedom in this case.

It is helpful in the first instance to plot the phase data against frequency, with frequency on a log-scale. Enough data is needed so that the detailed behaviour of the characteristic can be seen as well as its asymptotic behaviour at low and high frequencies.

With a network defined by eqn.(1) and Fig.3, the general behaviour of the phase response follows a recognisable pattern. First of all, the phase of the function will be asymptotic to the value  $\{-(P-Z)\frac{\pi}{2}\}$  as  $\omega$  tends to infinity. Secondly, at very low frequencies, the phase will be asymptotic to the value  $L\pi/2$ . Thus, inspection of the phase curve will indicate the value of (P-Z), the excess of poles over zeros, and L, the number of zeros at the origin.

As in the previous section the integration is divided into three regions, with analytic expressions derived for the high and low-frequency regions and with numeric integration for the mid-frequency region.

**Amplitude response, Referred to zero frequency.** Equation (9) is applicable in this case. However, before proceeding with the evaluation of the integral, it is necessary to remove any zeros present at the origin. Of

course, this will not be necessary if the phase curve is that of a low-pass filter, but is certainly necessary if the network is a high-pass filter and probably necessary in the case of a band-pass filter. (Note that in the case of a high-pass filter, the use of equation (10) may be more appropriate and this is dealt with later).

To eliminate the zeros at the origin, the zero-frequency asymptote of the phase curve ( $=L\pi/2$ ) is first determined and then this value is subtracted from all the phase data that is to be used. As a result of this procedure, the high-frequency asymptote of the "new" phase curve will have the value  $\{-(P-M)\frac{\pi}{2}\}$ , where M is the number of zeros of the function not at the origin.

In other words, it is the function  $g(s)$ , whose phase is now to be considered, where

$$g(s) = K \frac{(s+a_1)(s+a_2)\dots\dots(s+a_m)}{(s+b_1)\dots\dots(s+b_p)} \quad (33)$$

Once the amplitude curve has been obtained by the procedure outlined below, the effect of the zeros at the origin, if any were present, can be reintroduced by adding an amplitude characteristic with a slope of 20.L dB per decade, or 6.L dB per octave, to the results.

**High-frequency contribution.** If a frequency  $\omega_h$  is selected in the high-frequency asymptotic region of the response, then the integral  $I_h$  can be expressed,

$$I_h = \frac{-2\omega_x^2}{\pi} \int_{\omega_h}^{\infty} \frac{\psi/\omega - \psi_x/\omega_x}{\omega^2 - \omega_x^2} \cdot d\omega \quad (34)$$

Now as  $\omega \rightarrow \infty$ , then  $\psi \rightarrow -(P-M)\pi/2$  and equation (34) becomes

$$I_h \approx \frac{-2\omega_x^2}{\pi} \int_{\omega_h}^{\infty} \frac{-(P-M)\pi/2\omega - \psi_x/\omega_x}{\omega^2} \cdot d\omega \quad (35)$$

$$I_h = (P-M) \cdot \omega_x^2 \int_{\omega_h}^{\infty} \frac{d\omega}{\omega^3} + \frac{2\omega_x \psi_x}{\pi} \int_{\omega_h}^{\infty} \frac{d\omega}{\omega^2} + \frac{9_x/\omega_x}{\omega^2 - \omega_x^2} \cdot d\omega$$

$$I_h = \frac{\omega_x^2}{\omega_h^2} \left\{ (P-M) + \frac{2\omega_h \psi_x}{\pi \omega_x} \right\} \quad (36)$$

To determine (P-M), estimate the value of the phase as  $\omega \rightarrow \infty$

$$(P-M) = -\psi_{hf} \cdot \frac{2}{\pi} \quad (37)$$

As (P-M) should be an integer value, it is permissible to round it up or down as necessary.

**Low-frequency contribution.** It is first

necessary to consider the behaviour of the phase curve at low frequencies. It is shown in the Appendix that, for functions of the type given by equations (1) or (33), the phase curve always has a constant slope at low frequencies, which is given by

$$\left. \frac{d\psi}{d\omega} \right|_{\omega \rightarrow 0} = k \quad (38)$$

The frequency range over which this condition holds true depends on the actual pole-zero pattern of the function. To determine the extent of the linear phase region the phase curve should be plotted, using a linear frequency scale this time, for low frequencies.

The integral for the low-frequency region is given by

$$I_l = \frac{-2\omega_x^2}{\pi} \int_0^{\omega_1} \frac{\psi/\omega - \psi_x/\omega_x}{\omega^2 - \omega_x^2} \cdot d\omega \quad (39)$$

$$I_l \approx \frac{-2\omega_x^2}{\pi} \int_0^{\omega_1} \frac{k - \psi_x/\omega_x}{-\omega_x^2} \cdot d\omega$$

The phase angle is zero at  $\omega=0$  and is linear for a range  $0 \leq \omega \leq \omega_1$  i.e.  $\psi = k \cdot \omega$  for small  $\omega$ .

Therefore,

maths

and finally

$$I_l = \frac{2 \cdot \omega_1}{\pi} \left\{ k - \frac{\psi_x}{\omega_x} \right\} \quad (40)$$

As discussed above, k is the slope of the phase curve near to  $\omega=0$ .

**Mid-frequency contribution.** The expression to be evaluated is

$$I_m = \frac{-2\omega_x^2}{\pi} \int_{\omega_1}^{\omega_h} \frac{\psi/\omega - \psi_x/\omega_x}{\omega^2 - \omega_x^2} \cdot d\omega \quad (41)$$

and, as before, it is necessary to use numeric integration to evaluate this expression.

Since only a limited number of values of phase are likely to be available to plot the phase curve, interpolation will be a necessary part of the procedure. However, a method similar to the one used earlier gives disappointing results, i.e. where points on a plot of phase against  $\log(\omega)$  are connected by a series of straight lines and where logarithmic interpolation is used to obtain phase values at intermediate frequencies.

A better procedure is to use a frequency scale normalized with respect to a "pivot"

frequency  $\omega_0$ , in the same way as was shown in Fig.1(b). This pivot or normalizing frequency is best chosen from inspection of the initial plot of phase against  $\log(\omega)$ . A good choice, for example, is a frequency about which the response is approximately skew symmetrical (if this is possible).

An incidental advantage of the new plot, because it has a linear frequency scale up to  $\omega_0$ , is that it can be used to determine the slope of the phase curve at low frequencies, as required in for the low-frequency contribution.

Interpolation between points is carried out in a linear manner on the new scale. Thus, if the initial frequency values are  $\omega_1$  to  $\omega_n$ , then the normalized frequency values  $u_1$  to  $u_n$  are given by

$$u_m = \omega_m / \omega_0 \text{ if } \omega_m \leq \omega_0 \quad (42)$$

$$\text{and } u_m = \omega_0 / \omega_m \text{ if } \omega_m > \omega_0 \quad (43)$$

so if two adjacent points on the phase curve have phase values  $\psi_a$  and  $\psi_b$  at frequencies  $\omega_a$  and  $\omega_b$  respectively, and the interval is subdivided into  $(n-1)$  equal intervals, then the intermediate values are given by

$$\psi_m = \psi_a + (\psi_b - \psi_a) \frac{m}{n} \quad (44)$$

for  $0 \leq m \leq n$

$$u_m = u_a + (u_b - u_a) \frac{m}{n} \quad (45)$$

for  $0 \leq m \leq n$

From (45), together with (42) and (43) the corresponding values of  $\omega$  can be found, as required.

If the amplitude value is currently being calculated at frequency  $\omega_x$  (or  $u_x$ ) and the phase value there is  $\psi_x$ , then the value of the integrand function is

$$BD_m = \frac{\psi_m / \omega_m - \psi_x / \omega_x}{\omega_m^2 - \omega_x^2} \quad (46)$$

The area of each sub-interval, obtained by the trapezium rule, is

$$\text{Area} \Big|_m^{m+1} = 1/2 \cdot (BD_{m+1} + BD_m) (\omega_{m+1} - \omega_m) \quad (47)$$

and the total area between these two adjacent nodes is the sum of the sub-areas as  $m$  is stepped from one to  $n$ . This process is repeated for all the segments in the mid-frequency range.

As before, however, there is a problem when  $\omega_m = \omega_x$ . Equation (47) cannot be used directly at this frequency, and it is necessary to find the limiting value of the expression as  $\omega \rightarrow \omega_x$

$$\text{i.e. } BD_x = \lim_{\omega \rightarrow \omega_x} \frac{\psi / \omega - \psi_x / \omega_x}{\omega^2 - \omega_x^2} \approx \frac{1}{2\omega_x} \frac{d(\psi)}{d\omega} \quad (48)$$

Two values of the limiting expression have to be found, one as  $\omega$  approaches  $\omega_x$  from the low-frequency side and one as  $\omega$  approaches  $\omega_x$  from the high-frequency side.

With these additional values, all the required values of  $BD$  can be calculated, so all areas for the mid-frequency region can be calculated. Then

$$I_m = -\frac{2 \cdot \omega_x^2}{\pi} \sum_{\omega_{11}}^{\omega_{12}} \text{areas}$$

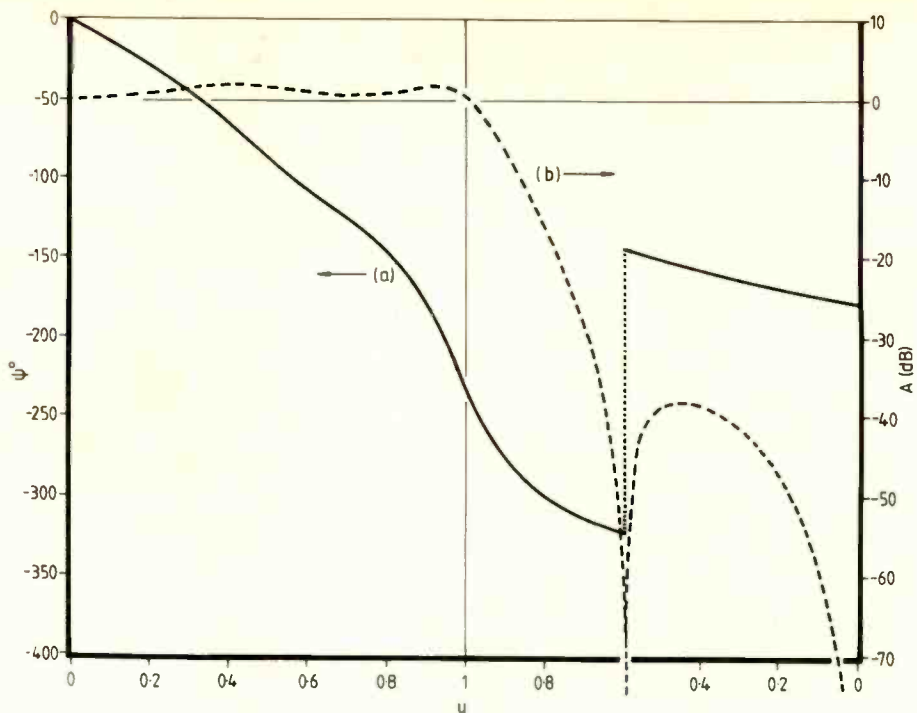

Fig.8. Amplitude (b) derived from phase (a).

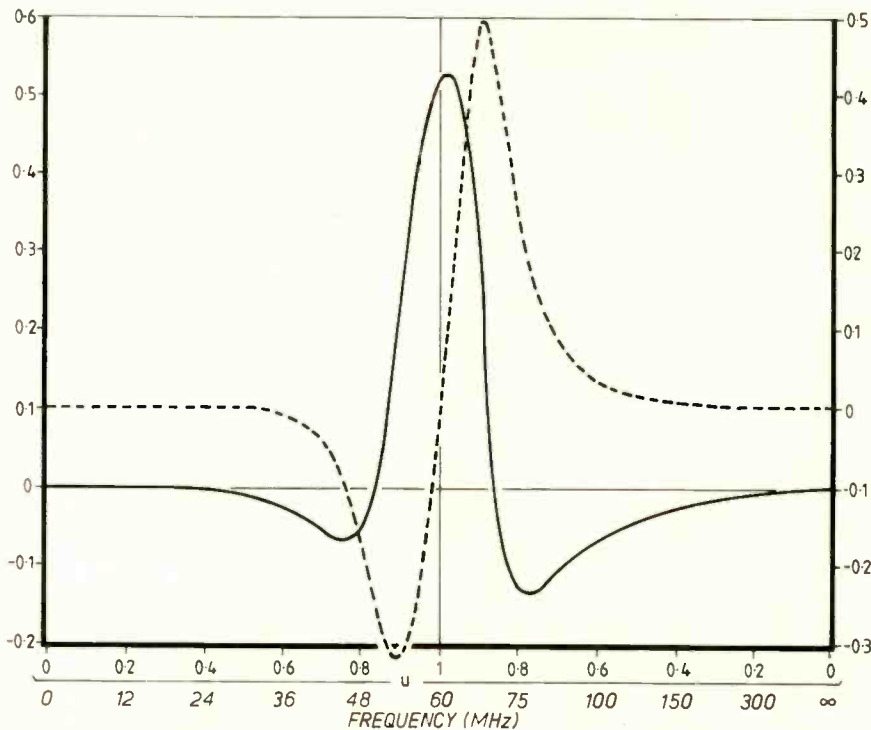

Fig.9. Real part (b) of transfer characteristic of band-pass filter, with its imaginary part at (a).

**Sum of all contributions.** At a given  $\omega_x$ , the sum of the three contributions gives the required answer, in nepers.

$$\text{i.e. } \ln A_x - \ln A_0 = I_1 + I_m + I_h \quad (49)$$

The results can be easily converted to dB, as mentioned earlier. Results at other values of  $\omega_x$  can be carried out as required.

**Examples.** Two examples are given in this section to demonstrate the procedure. As before the interval between adjacent nodes has been subdivided into 10 parts when carrying out the numerical integration.

**Example 4.** The phase plot for this example is given at (a) in Fig.8 and the analytic solution for the amplitude is the full line (b). The plots are those of a fourth-order, elliptic, low pass-filter with a pass-band ripple of 1.25dB and a stop-band attenuation of about 38dB.

Triangles on the first curve (phase) are the input data. Circles on the second curve (amplitude) show the initial output data, with additional interpolated results shown by squares.

**Example 5.** In this example the real part of a

Fig.10. Filter used in example of Fig.9.

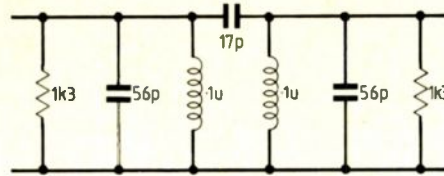
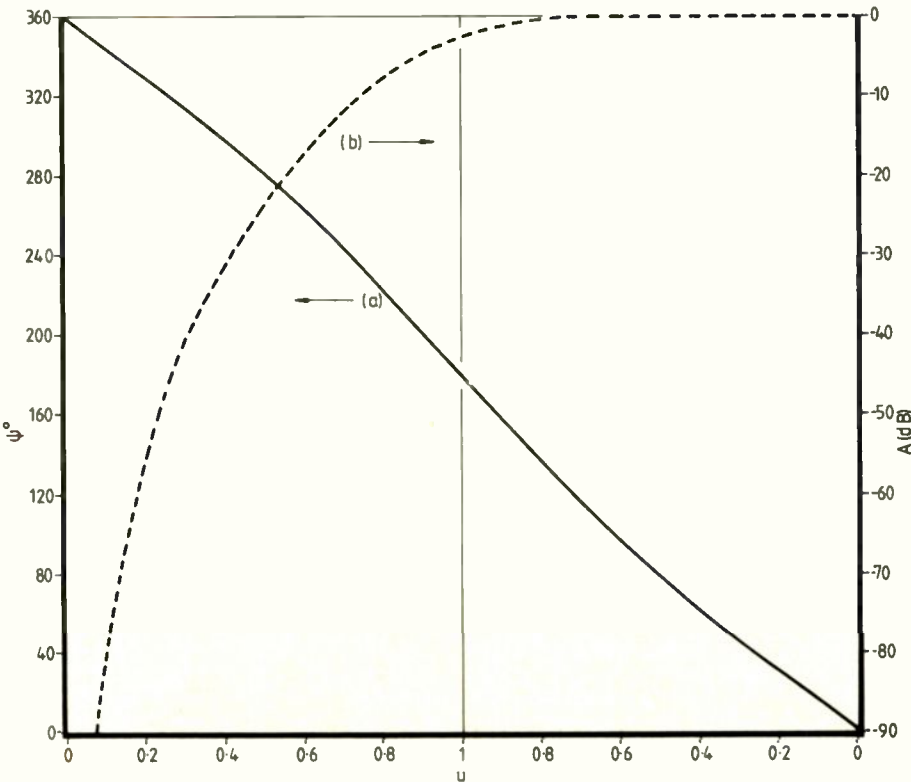

Fig.11. Phase response (a) of a 4th-order high-pass filter and its calculated amplitude response (b).



network function is derived from data on the imaginary part. Figure 9 gives the two analytically derived responses, which are the characteristics of the top-capacitively-coupled band-pass filter shown in Fig.10. The results are accurate to 0.02 worst case, with most of them well within this margin.

**Amplitude response, referenced to infinite frequency.** Equation (1) is the one to be considered. It should only be used in cases where the phase response is asymptotic to zero at high frequencies, which is the case, for example, when the network is a high-pass or band-stop filter. Although the procedure could perhaps be made more general, there is little point in doing so since all other situations can be dealt with by the methods described earlier.

As in the preceding sections, the integral is divided into three frequency bands. The procedures are very similar, so the results are given this time with little discussion.

At a given  $\omega_x$ , the amplitude  $A_x$  is given by

$$\ln A_x - \ln A_\infty = I_1 + I_m + I_h \quad (50)$$

where

$$I_h = \frac{2}{\pi \omega_h} \cdot \psi_x \cdot \omega_x \text{ provided that } \omega_h \gg \omega_x \quad (51)$$

$$I_1 = \frac{2\omega_1}{\pi \omega_x^2} \left( \frac{k \cdot \omega_1^3}{3} + \frac{\psi_0 \cdot \omega_1}{2} - \omega_x \psi_x \right) \quad (52)$$

$$\text{provided that } \omega_c \ll \omega_x \quad (53)$$

and where  $I_m$  is obtained by numerical integration methods.

In determining  $I_m$ , values of the integrand have the form

$$BD_m = \frac{\psi_m \cdot \omega_m - \psi_x \cdot \omega_x}{\omega_m^2 - \omega_x^2} \quad (53)$$

except where  $\omega_m = \omega_x$ , when

$$BD_x = \frac{1}{2\omega_x} \cdot \frac{d}{d\omega} (\psi \cdot \omega) \quad (54)$$

and where, as before, two values at each  $\omega_x$  are required. The summation of all the areas in the interval  $\omega_1$  to  $\omega_h$  calculated in a similar manner to those of the earlier sections, allows the value of  $I_m$  to be determined, since

$$I_m = -\frac{2}{\pi} \sum_{\omega_1}^{\omega_h} \text{areas} \quad (55)$$

**Example 6.** Figure 11 is the phase response (a) of a Butterworth fourth-order high-pass filter and the circles and squares on (b) show the calculated amplitude response points.

**Example 7.** The imaginary part of the network function shown in Fig.9 is asymptotic to zero at high as well as low frequencies, so it can be investigated by the methods of this section, using the same input data as was used in example 5 (i.e. the triangles in Fig.9).

## APPENDIX 1 Phase response of minimum phase shift networks at low frequencies.

The function being considered has L zeros at the origin, with M zeros and P poles in the left half plane. If the left-half plane zeros have positions given by

$$Z_i = \sigma_i + j\omega_i \text{ for } 1 \leq i \leq M$$

and the poles by

$$P_i = R_i + j\omega_i \text{ for } 1 \leq i \leq P$$

then the phase value at a given frequency is given by

$$\psi(\omega) = L \cdot \frac{\pi}{2} + \sum_{i=1}^M \tan^{-1} \frac{\omega + \omega_i}{\sigma_i} - \sum_{i=1}^P \tan^{-1} \frac{\omega + W_i}{R_i}$$

The slope of the phase curve is

$$\frac{d\psi}{d\omega} = \sum_{i=1}^M \frac{1}{1 + \left(\frac{\omega + \omega_i}{\sigma_i}\right)^2} - \sum_{i=1}^P \frac{1}{1 + \left(\frac{\omega + W_i}{R_i}\right)^2}$$

which at low frequencies approximates to

$$\frac{d\psi}{d\omega} \Big|_{\omega \rightarrow 0} = \sum_{i=1}^M \frac{\sigma_i}{\sigma_i^2 + \omega_i^2} - \sum_{i=1}^P \frac{R_i}{R_i^2 + W_i^2}$$

= a constant for a given pole-zero pattern  
= k

The frequency range over which the slope remains constant is determined by the location of the poles and zeros of the function. In some cases the linear region extends over a considerable portion of the passband.

Program listings for the procedure described in the two articles can be supplied from this office. Please write in and enclose an A4 stamped and addressed envelope. Mark your communication AMPHASE.

David Mercy is with Thorn EMI Electronics Ltd, Hayes, Middlesex.

## References

1. Bode, H.W.: Relations between Amplitude and Phase in Feedback Amplifier Design. *Bell Syst. Techn. J.*, vol.19, p.421, 1940.
2. Bode, H.W.: Network Analysis and Feedback Amplifier Design New York: Van Nostrand, 1945.
3. Goldman, S.: Laplace Transform Theory and Electrical Transients. New York: Dover 1965, p.233.
4. Murakami, T. and Corrington, M.S.: Relation between Amplitude and Phase in Electrical Networks *R.C.A. Review* p.602, vol.9, Dec. 1948.
5. Stewart J.L.: Fundamentals of Signal Theory New York: McGraw-hill, 1960, p.266.
6. Corrington, M.S.: Table of the Integral of

$$\frac{2}{\pi} \int_0^x \frac{\tanh^{-2} t}{t} dt$$

*R.C.A. Review*, p.432, Sept. 1946).

7. Thomas, D.E.: Tables of Phase Associated with a Semi-Infinite Unit Slope of Attenuation. *Bell Syst. Tech. J.*, vol.26, p.870, 1947.

8. Sekey, A.: Direct Computation of Delay from Attenuation. *Proc. IEE*, vol.112, June 1965, p.1103.

# TELEVISION BROADCAST

## Counting the costs

At a time when broadcasters everywhere are seeking to economize and are placing greater emphasis on the total costs of ownership of their engineering facilities, including staff costs, it may seem strange that there is so much talk of system changes. The days have gone when engineers alone largely determined, primarily on the grounds of technical quality, equipment procurement policies. The slimming-down of engineering costs and staff costs is now a priority objective of many companies.

The impact on the broadcast equipment industry is considerable. Major firms in Europe, North America and even Japan are finding the going tough, with the marked retreat from systems (turnkey) contracts. It is not surprising that engineers as well as accountants are increasingly concerned with the amount of money needed to continue the development of digital-component, h.d.tv and d.b.s. equipment which may, or may not, translate into major sales in this century. It is recognized that it is vitally important to invest in r&d but equally vital to pick potential winners.

Despite, or perhaps because of, such doubts, large industry exhibitions continue to expand and multiply. The Brighton IBC88 (September 23-27) will see more than 200 exhibitors filling a record amount of space – including a temporary marquee 'pavilion' near the West Pier. There will be a special Eureka (EU95) h.d.tv presentation, plus about 100 solidly engineering papers (of some 200 offered) stemming from ten countries.

But there has apparently been a retreat from the presentation of at least one keynote paper devoted to broadcast economics: one recalls Michael Checkland's prophetic "The economics of television production" in 1984; David Reay's similarly titled address in 1986; and R.V. Arnaldi's thought-provoking "Consumer electronics – the next five years" in 1982, in which he stressed that the improvements in systems must be clearly demonstrated in the High Street. All the

five keynote addresses this year appear, from the provisional programme, to concentrate on technology rather than economics. Perhaps few people are prepared to contemplate too realistically the short- and long-term commercial prospects for h.d.tv or d.b.s. Yet rather more than 30 of the papers bear upon the technology of h.d.tv and e.d.tv.

The IBA has recently demonstrated to the press a closed-circuit 625-line, wide-screen e.d.tv system using an eight-foot wide Sony projection display (priced at £50 000, not exactly geared to domestic use). For such demonstrations the IBA has made an attractive 20-minute video, "Images from Winchester" (director, Peter Sykes). This proved (at least to me) that 625/50 "component" video, when displayed as 100Hz progressive scan by means of frame-store memories, is capable of providing sufficient resolution, flicker reduction and absence of cross-colour effects for all presently-conceivable large domestic receiver displays likely to be available at consumer prices this century. It also showed that such material can be originated satisfactorily by modifying standard studio equipment, including cameras and v.t.r. machines.

There could, admittedly, be a role for 1125 or 1250-line systems for electronic cinematography, video-to-film transfers and for some master tapes where the picture quality does not have to be degraded by compression of the 50MHz or so baseband for transmission. Yet the degree to which r&d work is being concentrated on systems to provide improved pictures in the home is underlined in the February issue of the *IEEE Transactions on Consumer Electronics*. This 278-page issue is devoted entirely to "advanced television systems", including high definition (over 1000 lines) systems, "enhanced" (also called "extended quality") television and "improved composite television" (sometimes called "improved NTSC") together with questions relating to their digital transmission over the future broadband integrated services digital network (B-ISDN).

A recent listing of currently proposed advanced systems relating to 525-line, 60-field areas

shows that many of the proposals rely on the use of frame-store memories in the receivers. Among the proposals are: the NHK wide-screen studio system (1125/30/60); seven "single-channel" systems capable of being transmitted in the FCC 6MHz-wide broadcast channels: NBC/Sarnoff 5:3 "ACTV"; MIT 4:3 bandwidth-efficient system (1200/60/60); Fukinaki 4:3 system (1050/60/60); 5:3 HD-NTSC (Iredale); MIT's 16:9 receiver-compatible system; 4:3 Super-NTSC (Faroudja); and a 4:3 Yasumoto system. Additionally there are three proposals for compatible systems that would require two or one-and-a-half terrestrial channels: Bell Laboratories (Rzeszewski) 5:3, 6+6MHz, 1050/30/60 system; William Glenn's 16:9, 6+3MHz, 1125/30/60 system; and North American Philips 16:9, HD-NTSC, 1050/60/60. Three wideband (satellite channels) proposals are NHK's Hi-Vision with MUSE (10MHz baseband) 16:9, 1125/30/60; Scientific Atlanta's HDB-MAC (10.7MHz) 4:3, 1050/30/60; and HD-MAC-60 by North American Philips, 9.5MHz, 16:9, 1050/60 with a four-field sequence.

Although a majority of the 45 member-organisations forming the Advanced Television Systems Committee (USA) have voted for the adoption of the NHK 1125/60 system for the proposed h.d.tv production standard, both the influential National Association of Broadcasters (NAB) and the Association of Maximum Service Telecasters (MST) were among the 11 organizations opposed (26 voted for, eight abstained). NAB and MST believe the decision is too restricted and pressed for delaying a decision "in view of new information about serious technical issues that have not been evaluated to our satisfaction."

## O.b. vehicle trends

The first transportable production centres, mobile control rooms, scanners, call them what you will, for outside broadcasts ("remotes") date back to the 'thirties. Over the years there has been a wide variety of approaches, from the mammoth 'Type 5' BBC pantechicons to

battery-operated single-camera general-purpose units. The Royal Television Society's London Centre recently devoted a discussion meeting to attempting to estimate trends likely to affect the next generation of o.b. vehicles now being planned. Chaired by John Jarvie (BBC), panellists included Arthur Duff (Thames), Bob Warren (Thames) and Roger Jephcott (BBC) and an audience including many o.b. practitioners and representatives of specialist manufacturers including Ampex, Brabury and Sony.

The need to respond to programme requirements, involving more camera channels, more use of mobile recorders, character generators, digital video effects, stereo sound and longer programmes demands more and more on-board facilities. But sports o.b. programmes, for example, remain cost-effective, with an average cost (BBC) of about £24 000 per hour, less than half the average of all programmes. Bob Warren believes that fleets will evolve towards flexible super-large units with up to ten or a dozen camera channels, supported by more small units of one or two cameras, but with less use of "middle ground" units with three, four or five cameras.

A current problem is in deciding the extent to which o.b. operations will tend to component rather than composite video. Thames will soon have a small unit with a c.c.d. camera and M.II v.c.r. which will, in effect, be a component unit; but for large scanners an all-component approach would involve considerable extra cost, extra weight and extra equipment volume, and it seems unlikely that all-component working will come before h.d.tv is required.

There seems little prospect of large organizations buying off-the-shelf vehicles from a standard catalogue specification; most organizations cherish their own way of doing things and demand custom-built vehicles. Production staff as well as engineers have specific requirements and "in no way would use a standard vehicle".

*Television Broadcast is written by Pat Hawker.*

### MARCONI INSTRUMENTS



2019 signal generator 'as new' £2,250

|                                                 |       |
|-------------------------------------------------|-------|
| TF1202A RF power meter 0-100W 250MHz            | £75   |
| TF1152A/1 RF power meter 0-25W 250MHz           | £75   |
| TF1066B/6 AM/FM signal generator 10-470MHz      | £350  |
| TF1245/1246 Q-Meter and oscillator              | £500  |
| TF2002B AM/FM Signal Generator 10KHz-88MHz      | £400  |
| TF2011 FM signal generator 130-180MHz           | £325  |
| TF2012 FM signal generator 400-520MHz           | £325  |
| TF2016/2173 AM/FM signal gen' 10KHz-120MHz      | £600  |
| TF2092C noise receiver                          | £350  |
| TF2162 MF attenuator 0-111db in 0.1db steps     | £100  |
| TF2006 FM signal generator 10-1000MHz           | £750  |
| TF2001 AF signal source/monitored attenuator    | £200  |
| TF2300 modulation meter AM/FM to 1GHz           | £250  |
| TF2300A as above with deviation to 1.5KHz f/d   | £350  |
| TF2300B modulation meter as above               | £450  |
| TF2303 modulation meter AM/FM 2.5-520MHz        | £325  |
| TF2304 modulation meter automatic               | £425  |
| TF2700 Universal component bridge               | £250  |
| TF2356 level oscillator 20MHz                   | £650  |
| TF2430 frequency counter 80MHz 7 digits         | £75   |
| TF2501 power meter 0.3W f/d DC-1GHz             | £150  |
| TF2600 millivoltmeter AF 1mV-300V f/d           | £75   |
| TF2600B video voltmeter 1mV-300V f/d            | £175  |
| TF2604 electronic multi-meter                   | £150  |
| TF2807A PCM multiplex tester                    | £400  |
| 2019 AM/FM synthesized signal generator 1024MHz | £2250 |
| 2828A/2829 digital simulator/analyser           | £1500 |
| 2833 digital in-line monitor                    | £275  |
| TF2908 blanking & sync mixer                    | £250  |
| 6055B signal source 850-2150MHz                 | £500  |
| 6460 RF power meter                             | £350  |
| 6460/6420 power meter/microwave head            | £495  |
| TF893A audio power meter 1mW-10W f/d            | £75   |
| TF995A/5 AM/FM signal generator 1.5-220MHz      | £195  |
| TF995B/5 AM/FM signal generator 0.2-220MHz      | £250  |

### RALFE ELECTRONICS

Please note our new address:  
36 EASTCOTE LANE,  
HARROW, MIDDLESEX HA2 8BB  
TEL: 01-422-3593

EST.  
35  
YEARS

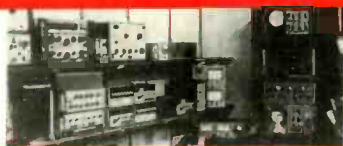

### TEST & MEASUREMENT EQUIPMENT

|                                                     |       |
|-----------------------------------------------------|-------|
| GREEN 2601 RF wattmeter 0.3-300W to 500MHz          | £200  |
| PHILIPS PM2554 audio milli-voltmeter                | £175  |
| PHILIPS PM6302 LCR component bridge                 | £250  |
| PHILIPS PM5590 TV IF Modulator                      | £2000 |
| PHILIPS PM5597 VHF TV Modulators                    | £295  |
| RACAL-DANA 9083 2-Tone signal source                | £350  |
| RACAL-DANA 9084/9934A sig gen/GPIB vface. 104MHz    | £2500 |
| RACAL-DANA 9303 digital RF mVmeter c/w 2 head       | £950  |
| TEKTRONIX 7S11 sampling plug-in unit                | £750  |
| TEKTRONIX S1 and S2 sampling heads £500             | £600  |
| RACAL 9918/04A 560MHz 9 digit counter               | £295  |
| WAYNE KERR B642 auto-balance bridge                 | £295  |
| WILTRON 350 phase meter 10Hz-2MHz                   | £295  |
| PM5565 Waveform monitor                             | £995  |
| DRANETZ series 305 Phase-meter 2Hz-700KHz           | £500  |
| WAVETEK 157 prog' wavelform synthesizer 100µHz-1MHz | £325  |
| WAVETEK Sweep gen 150G. 450-950MHz                  | £450  |
| TEKTRONIX 2213 60MHz oscilloscope                   | £495  |
| TEKTRONIX 191 constant amplitude signal gen.        | £150  |
| SYSTRON DONNER 410 Sweep function generator         | £395  |
| PHILIPS PM8251 single-pen recorder                  | £200  |
| PHILIPS PM8235 multipoint recorder                  | £295  |
| OSCILLOSCOPES - LARGE RANGE NOW IN STOCK            |       |
| FEEDBACK SFG606 sweep function generator            | £200  |

ALL OUR EQUIPMENT IS SOLD IN EXCELLENT, FULLY FUNCTIONAL CONDITION AND GUARANTEED FOR 90 DAYS. MAIL ORDERS AND EXPORT ENQUIRIES WELCOMED. PLEASE TELEPHONE FOR CARRIAGE QUOTE. ALL INSTRUMENTS ARE AVAILABLE EX-STOCK AS AT COPY DATE. GOOD QUALITY TEST EQUIPMENT ALWAYS WANTED FOR STOCK. PRICES QUOTED ARE SUBJECT TO ADDITIONAL VAT.

### HEWLETT PACKARD



3581A Wave analyser. 15Hz-50kHz. 30nV sensitivity. 80dB dynamic range. Price £1500

|                                                |        |
|------------------------------------------------|--------|
| 1122A power unit for fet probes                | £195   |
| 11602B transistor fixture                      | £395   |
| 355E & F attenuators, pair                     | £150   |
| 435A/8481A RF power meter/head                 | £750   |
| 608F AM signal generator UHF                   | £195   |
| 8007B pulse generator                          | £495   |
| 8407A/B412A network analyser/phase-mag display | £995   |
| 8733A pin modulator                            | £250   |
| 8600A & 86632A Sig gen/mod section             | £2500  |
| 400F milli-voltmeter                           | £250   |
| 180C 50MHz oscilloscope                        | £400   |
| 10529A Logic comparator                        | £275   |
| 10529A/10526T Logic troubleshooter             | £295   |
| 4342A Q-Meter                                  | £850   |
| 8405A Vector Voltmeter                         | £1,750 |
| 331A distortion meter                          | £750   |
| 334A distortion meter                          | £1,000 |
| 5300B/5305B 1300MHz 8 digit counter            | £295   |
| 2673A thermal printer                          | £250   |
| 3701A/2A/3A µ-wave link analyser               | £750   |

### ADDITIONAL EX-STOCK T & M KIT

|                                                                               |            |
|-------------------------------------------------------------------------------|------------|
| KEITHLEY 178 Dmm & 179 Dmm                                                    | £125, £145 |
| FLUKE 8050A DMM                                                               | £180       |
| TREND DATA Transmission test set 1-8                                          | £250       |
| RADICMETER FRA3 audio wave analyser                                           | £325       |
| WAYNE KERR B601 RF Bridge                                                     | £125       |
| RACAL 9911 120MHz counter                                                     | £120       |
| RACAL 9912 120MHz counter                                                     | £150       |
| RACAL 9024 600MHz counter                                                     | £225       |
| RACAL 9301 RF mV/meter                                                        | £325       |
| BIRD 4370 RF wattmeter                                                        | £325       |
| VALRADIO Inverters 24V DC-230V AC from SHIBASOKU envelope delay measuring set | £75        |
| TEKTRONIX 7603N11S Ruggedized scope system                                    | £395       |
|                                                                               | NEW £1,750 |

### TEXSCAN MODEL 9650 TRACKING SWEEP ANALYSER

400kHz-350MHz tracking sweep generator and spectrum analyser in one unit £1,750

ENTER 46 ON REPLY CARD

# Toroidal & E.I. Transformers

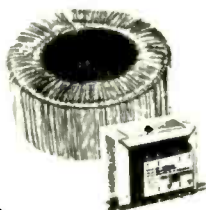

As manufacturers we are able to offer a range of quality toroidal and laminated transformers at highly competitive prices.

## Toroidal Mail Order Price List

prices inclusive of VAT & Postage

15va 9.12, 30va 9.48, 50va 10.16, 80va 11.02, 120va 12.23, 160va 14.44, 225va 16.37, 300va 18.05, 500va 26.46, 625va 30.66, 750va 34.14, 1000va 49.40.

Also available 1k2, 1k5, 2k, 2k5, 3k. Prices on request.

Available from stock in the following voltages: 6-0-6, 9-0-9, 12-0-12, 15-0-15, 18-0-18, 22-0-22, 25-0-25, 30-0-30, 35-0-35, 40-0-40, 45-0-45, 50-0-50, 110, 220, 240. Primary 240 volt.

Quantity prices and delivery on request



## Air Link Transformers

Unit 6, The Maltings, Station Road,  
Sawbridgeworth, Herts. Tel: 0279 724425

ENTER 25 ON REPLY CARD

# PCB MANUFACTURERS - WHICH TO CHOOSE?

With scores of PCB manufacturers falling over themselves to make your conventional boards, it can be very difficult to choose the right one.

You could however, choose a PCB manufacturer with more to offer. Such as assembly, panel printing, final build and design.

Slee Electro Products can provide you with these services and will still offer you competitive prices on your PCB's.

"We're hot on quality and delivery too. And being a member of the Printed Circuit Association, means we have to try harder."

## Slee Electro Products

Unit 4, Grange Lane Industrial Estate,  
Carrwood Road, Barnsley, South  
Yorkshire S71 5AS, England.

Tel: 0226 200717. Fax: 0226 731817

ENTER 27 ON REPLY CARD

# RADIO COMMUNICATIONS

## Role changes for h.f.

The selective nature of the resurgence of interest in the h.f. spectrum was evident at the IEE's well-attended (over 330 delegates from 25 countries) h.f. radio systems and techniques conference. A breakdown of the 161 UK delegates shows that 82 were from industry (almost all concerned with defence); 28 from universities and polytechnics; 22 from Government and Service research establishments; 11 from GCHQ, HMGCC and MoD; 9 from BBC External Services; 7 miscellaneous, including technical press; and just two from British Telecom International, with none from Cable & Wireless. My mind went back 25 years to the pre-satellite communications era to a March 1963 IEE "Convention on H.F. Communication" which enjoyed major participation by the Post Office and Cable & Wireless, with the industry still regarding civil communications as major markets.

One consequence of the change in role is that there is no longer the same drive towards universal standards and systems; instead organizations are much more interested in doing their own thing and keeping their traffic, modes and frequencies to themselves. It was perhaps unfortunate that a French slide unwittingly revealed that they operate their experimental Valensole skywave radar on 14.147MHz, right in the middle of one of the 'exclusive' amateur bands. Dr G.F. Earl assured the conference that the Australian 100kW Jindalee facility has a frequency management protocol that prohibits any incursion into exclusive amateur allocations.

The increasing use of h.f. skywave communications for medium distance (one hop) links has brought about more interest in antennas having a vertical radiation pattern which maximises near-vertical incidence. The need for frequency agility has directed attention towards horizontally-polarized transportable broadband antennas, rather than the customary vertical whip antennas, with their upward-pointing nulls. Dr B.A. Austin and André Fourie de-

scribed their resistive-loaded broadband wire antenna (see this column, September 1987). C&S Antennas Ltd has also developed "A wideband transportable antenna for n.v.i.s. links" based on a three-wire fan dipole with resistive loading near the ends of the dipole arms. The complete system, including a 12m, 8kg carbon-fibre telescopic mast, weighs only 16kg and has been erected single-handed in 15 minutes.

Efforts by a team at RAE to decide whether space diversity reception does or does not significantly improve the throughput of a meteor burst communications system had so far proved indecisive and "further study is necessary before a definitive statement can be made". Their basic "Blossom-A" system with 2400 baud bursts at 36MHz (other trial frequencies were 46, 70 and 71MHz) over the 813km North/South path from Wick in northern Scotland to the RAE's radio station at Corbett Hill, near Farnborough in Hampshire, has provided equivalent data rates of from about 5 to 45 baud averaged over ten-minute periods and from about 6 to 20 baud averaged over 60 minute periods. Maximum throughput is at about 10 hours GMT with an afternoon minimum at about 1700.

Featured on the first day were a number of ingenious adaptive and real-time channel evaluation systems, including the Plessey system developed to provide MoD with an "unattended" network of 100 terminals at up to 80 sites (see Radio Communications, October 1987). The prime objective of these systems is to reduce the need to train Morse and technical operators, though

one wonders whether keyboard systems will ever instill into users the same sense of personal involvement in getting messages though under adverse conditions. On the other hand there is no doubt that r.t.c.e. techniques involving constant sounding of several frequencies lead to more effective use of the h.f. spectrum, including the use of much higher frequencies for medium distance links during sporadic E propagation conditions. There appears to be a growing disillusion about the use of monthly average predictions made many months in advance, even when supported by d.i.y. computer systems such as Minimuf. The behaviour of the new sunspot cycle 22 has been virtually unpredictable in advance, moving the critical frequencies up and down erratically.

Keith Thrower (Racal-Chubb) in a keynote address pinpointed the current interest in adaptive systems and digital signal processing; the h.f. problems imposed by fading, multipath co-channel and the variable propagation conditions; the military desire to avoid detection and to defeat jamming; the constraints imposed on transportable systems in terms of power, antennas, size and weight; the desire of users to minimize data errors and improve voice quality. He noted that adaptive signal processing permits microprocessor control of the bandwidth of filters, type of demodulator, data rate and choice of frequency. He emphasized that adaptive and related techniques have become more viable with improved digital signal processing chips.

Keith Thrower noted the use of direct-conversion (zero i.f.)

receivers which at first sight appear very attractive for the implementation of d.s.p., but he felt that this does not negate the need for a superhet-type first mixer. The technique greatly reduces the problems of designing frequency synthesizers having to cover the five octaves from 1 to 30MHz with the high local oscillator output needed to increase dynamic range, but it also results in the leakage of the oscillator signal to the antenna. A super-d.c. 1-30MHz digital receiver could result in a synthesizer covering 42.4 to 71.4MHz (less than an octave) with only one high-quality mixer stage followed immediately by a-to-d conversion.

• See also the article 'H.f. developments', page 644.

## Mobiles win v.h.f. argument

The DTI has officially confirmed that the UK will continue with its policy of using v.h.f. Bands I and III for mobile radio communications rather than re-introduce v.h.f. television broadcasting. This would be possible under the international Radio Regulations although the DTI believes it could be "very difficult and costly to negotiate with neighbouring administrations who would regard a policy reversal by the UK as a serious disruption of the international understandings on which their domestic planning over the past few years has been based".

The DTI has also reported, following the initial meetings of the Council of Ministers' working group on the EMC Directive, that "progress is likely to be slow, in view of the detailed difficulties we and other Member States have raised, and there is now no prospect of Council final agreement by June 30". Initially the DTI found no support for the UK view that the Directive was unworkable where no national standards existed, but later the Italians expressed strong support. The Greeks have proposed that the Directive should not enter into force before the end of 1992, but this seems unlikely to achieve majority support.

Radio Communications is written by Pat Hawker.

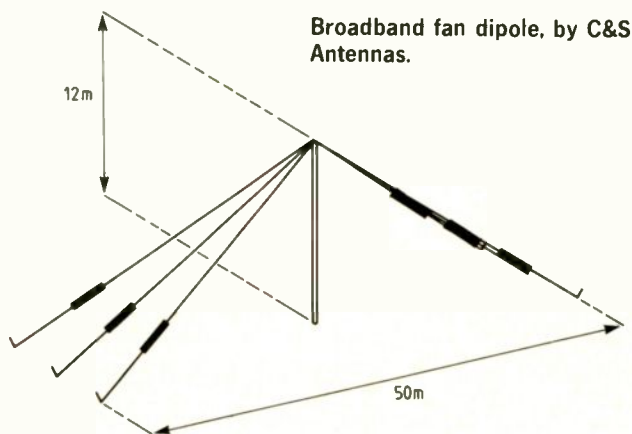



# SOAR ABOVE THE COMPETITION

## ▼ SOAR ME-1510 CABLE LENGTH CHECKER ▼

**FAULT LOCATION FOR COAXIAL, TWISTED PAIR, POWER AND FLAT CABLE.  
METER OR FEET DISPLAY. OPEN OR SHORT DISPLAY.**

- 4 digits display for the length of coaxial cable from 5m (15 feet) to 2000m (6000 feet) and indicate whether cable termination is "OPEN" or "SHORT"
- Convenient front panel switch allows selection of "Feet" or "Meter"
- Two digital switches allow easy setting of the cables "nominal velocity of propagation" (NVP) from 0.01 to 0.99
- Rechargeable Ni-Cad batteries, AC adaptor and car-battery cigarette lighter attachment permit long life, reliable, ready-where-you-are operation.
- Virtually any type of cable including coaxial cable, twisted pair power cable, cabletyre cable and multi-conductor shielded cable may be measured.
- Using a 5-10m (15-30 feet) sample cable, NVP value calibration is possible.
- The input is voltage protected to 50Vpp (150V surges) to enable measurement under even these conditions.
- Improved energy-efficient design requires only approx 300mA current

Soar's complete range of T & M equipment has an enviable reputation throughout the world for manufacturing high quality products at extremely competitive prices. Extensive product planning takes place throughout the year which leads to products with total uniformity of operation. The range of equipment available is extensive, from a basic pocket D.M.M. to the most sophisticated industrial energy monitor.

Full details from: Solex International,  
95 Main Street, Broughton Astley,  
Leicestershire LE9 6RE,  
Tel: (0455) 283486  
Telex. 342523. Fax: (0455) 283912

**SOLEX**  
INTERNATIONAL

The sole UK representative for the complete range of Soar T & M Equipment.



ENTER 52 ON REPLY CARD



CABLE LENGTH CHECKER ME-1510

## WE ARE A LEADER IN SPECIALISED ELECTRONIC MARKETING IN THE DOMINION OF CANADA

Our component division requires top quality electronic components to offer in this market (NATO approved or Milspec types if possible).

Our instrumentation division requires a line of digital storage oscilloscopes, *High Quality*, new (also used) *Electronic/Electrical Calibration Equipment* which, with recertification on traceable standards can be offered to industry, government, education and other fields.

Kindly send all info to:  
T E G Inc, 1179 Finch Avenue West,  
Unit #24, Downsview, Ontario,  
Canada M3J 2G1.  
Atten: MD

ENTER 44 ON REPLY CARD

THE JOURNAL FOR PROFESSIONAL ENGINEERS

## ELECTRONICS & WIRELESS WORLD

# INDUSTRY INSIGHT BUSES

The number of computer buses now proposed or actually in use, with no apparent attempt to any kind of standard, is reaching epidemic proportions. Industry Insight number 4 concentrates on computer buses and gathers together in one place with descriptions of them all, with their characteristics, advantages and disadvantages, chances of large-scale adoption from each camp.

TO ADVERTISE WITHIN INDUSTRY  
INSIGHT RING:

**JAMES SHERRINGTON ON  
01-661 8640 NOW**

# RADIO BROADCAST

## Beefing up h.f.

Under its External Services improved audibility project, the BBC is installing two more high-power transmitters at its Ascension Island relay base. Originally fed by an s.s.b. link, this relay has for several years had a high-quality satellite feed. It serves primarily West Africa and South America. These recent pictures by BBC engineer Gerry Mills show the receiving dish for programme feeds (note the almost vertical elevation, due to the site's equatorial latitude) and, below, the antenna feed lines leaving the switching matrix.

The BBC has now virtually completed the modernization of one of its main UK h.f. transmitter sites at Rampisham, Dorset. This site was originally opened in 1941 during the second world war with four 100kW Marconi SWB18 senders, each of which needed to be looked after by some eight technical operators per shift. Since 1981, about £30 million has been spent in installing eight fully-automatic 500kW transmitters and the complex computer-controlled multi-processor programme-unit, frequency and antenna changing system implemented last year at the two-transmitter site at Hong Kong (see Radio Broadcast, January 1988). With the Rampisham complex operating 24 hour schedules, the major running expense must now be electric power consumption. This costs an astonishing £6 per minute, or some £8500 per day.

## Satellite frequencies sought

The European Broadcasting Union has announced that it is still seeking, as a priority objective, the allocation of an exclusive frequency band, from 50 to 100MHz wide in the range from 500MHz to 2GHz, for satellite sound broadcasting. The Administrative Council has recommended that "EBU members should use every means at their disposal to convince their Administrations of the paramount importance of the allocation of sufficient suitable frequencies for satellite sound broadcasting



to ensure the unimpeded development of the sound broadcasting services of the national broadcasting organizations to meet developing and future consumer requirements".

An EBU planning exercise has suggested that a band between 50 and 100MHz wide is needed on a world-wide basis to provide with frequency modulation from five to ten programmes per country or, with an advanced digital system, up to 16 stereo programmes per country. The EBU does not consider that s.h.f. bands, such as 12GHz or higher, would be suitable for sound broadcasting reception on portable or car-radio (mobile) receivers but only where listeners used relatively expensive fixed installations. Services in the region of 1GHz could overcome such limitations.

Whether large numbers of listeners could be persuaded to use direct satellite radio is a moot point in view of the many years during which listeners have failed to respond to the "listen on f.m." exhortation. The problem facing the BBC in its

current campaign to persuade more f.m. listening, in advance of the proposed phasing out of simulcasting on both a.m. and f.m. on BBC network radio, is underlined by recent IBA audience research which shows that while f.m. reception is now available in some 86% of UK homes, about 50% of listeners claim always to use a.m., 25% f.m., 15% both, with more than 10% indicating that they had no idea which waveband they use.

## A.m. stereo in doldrums

Although some 550 American medium-wave stations now transmit a.m. stereo – about 450 using the Motorola C-QUAM system and about 100 using the Kahn-Hazeltine independent sideband system – most listeners remain virtually unaware of, or not interested in, the service. With more a.m. stations turning to talk and news rather than music formats, customer demand seems likely to remain

minimal although Motorola claims to have sold about 12 million C-QUAM-only decoder chips.

Leonard Kahn claims that Motorola has blocked the marketing of sets incorporating multi-standard stereo decoders by alleging infringement of a patent that he claims was "illegally obtained". Kahn's allegations are being investigated by the US Patent Office but future prospects for his system seem bleak. At present only Kenwood Electronics is marketing a "multi-standard" receiver range; other firms, including Sony, have now pulled out of the multi-standard market. One of the pioneer users of the Kahn-Hazeltine i.s.b. system, WTIC-AM, Hartford has, rather reluctantly, switched to C-QUAM although its director of engineering insists that the i.s.b. system performs much better under night-time sky-wave conditions than C-QUAM.

## In brief

A biography is soon to be published in the United States ("The Genius at Riverhead", by Alberta Wallen) of one of the surviving pioneers of long-distance radio communication: Harold H. Beverage, now 94 years old. He joined General Electric in 1915 on graduating from the University of Maine after deciding to take a \$560-per-year engineering job with GE rather than play trombone in a theatre orchestra at night to permit him to continue his post-graduate studies. He feared he would fall asleep during the daytime. With RCA, which split away from GE in 1922, Beverage pioneered the long, low directional wave antenna that still bears his name. In 1927, with Harold Peterson, he found that diversity reception, with spaced antennas, could greatly reduce the effects of fading. He came to London just before D-Day, 6 June, 1944 to direct air support communications and hurriedly persuaded the British that horizontal polarization would be more effective than vertical for communicating from the UK with aircraft over Normandy.

*Radio Broadcast is written by Pat Hawker.*

# RESEARCH NOTES

## Silent keys and cancer

Studies attempting to link human diseases with exposure to non-ionizing electromagnetic radiation have been as inconclusive as they have been numerous. For this reason safety limits are set rather arbitrarily in different countries. The problem is quite simply that of extrapolating from experimental results on the very edge of statistical significance. What does it prove for example if three cases of an extremely rare disease all occur in the same street?

To try and harden up the evidence for a possible link between exposure to radio energy and cancer, Samuel Milham Jr of the Washington State Department of Social and Health Services conducted a massive survey of nearly 68 000 US radio amateurs (*American Journal of Epidemiology* vol.127 no 1). The assumption was that such people probably suffer a much greater degree of exposure to high electromagnetic fields than the general public.

Milham investigated a computerized search of public records in the states of Washington and California to discover how many of these amateurs had died between 1971 and 1983 and what diseases they'd succumbed to. Given a reasonably large total number of deaths (2485), he then analysed the causes of death and compared the incidence of each disease with that for the general population in the same two states.

Interestingly enough, radio hams turned out to be a fairly healthy bunch. They had a lower than average incidence of respiratory infection – probably because they tend to smoke less. Cancer rates as a whole were surprisingly similar to those of the general population except in the case of relatively rare cancers of the blood and lymph systems. For leukaemia, for example, the actual number of deaths among the hams was 24 – almost twice the expected figure.

Obviously there's no cause for alarm; 12 extra cases among 68 000 people over a period of 12 years, even if electromagnetic radiation is to blame, doesn't

make amateur radio a risky hobby. You're much more likely to be killed by flying golf balls.

But even if the latest figures are more statistically significant than hitherto, they still don't necessarily implicate radiation. Radio hams are exposed to several other potentially carcinogenic agents such as soldering fumes, polychlorinated biphenyls etc. So, interesting though Milham's latest study is, there still remains a lot of investigative work to be done before amateur licences carry a government health warning.

## ... and more biological effects of radiation

Evidence such as the above comes rather late in the day if you're trying to discover what, if any, are the precise effects of non-ionizing radiation on biological cells. If such radiation does indeed cause cancer, there's still no clue as to what happens on the cellular level, maybe 20 years before the disease becomes apparent.

Surprisingly the same criticism applies in lesser degree to most of today's bench-top experiments on cell cultures. In nearly all the published investigations, biological samples are studied *after* exposure to the radiation. As a consequence such experiments are only able to detect permanent damage and not any transient, but possibly still significant changes.

A recent project (*Electronics Letters* vol.24 no 7) by Massa and Scaglione at the universities of Naples and Salerno respectively, set out to overcome this deficiency by studying the optical effects on enzyme systems contained entirely within a waveguide. The set-up consisted of a 8.2 – 12.4GHz signal generator, boosted by a t.w.t. and fed into a specially-made section of waveguide designed to hold a 4ml sample. The waveguide was then terminated with a reflectometer.

Two small holes were drilled into the waveguide to permit a beam of monochromatic light to pass through the sample and be

measured using a photo-diode. Other parameters such as temperature were also measured and controlled externally.

Initial results using power densities of around 50 – 200 mW/ml showed changes in optical density corresponding to a lower enzymatic activity, i.e. a lessening of biochemical activity. The results also prove the capability of this type of experimental set-up to distinguish temporary from permanent biological effects of radiation.

The enzymes used in this particular experiment were not intended to reveal any specific temporary effects; only to validate the methodology. Nevertheless it does seem that the Italians have developed a tool that could go a long way to answering many of the mysteries that still surround the biomedical effects of non-ionizing radiation.

## 113 GHz transistor

A transistor capable of more than  $10^{11}$  switching cycles per second, the fastest ever achieved, has been developed by a team of engineers from Cornell University and the Siemens Research and Technology Laboratories in Princeton, New Jersey.

The new transistor, described

in *Electronics Letters* (vol.24 no 6), is an improved modulation-doped field-effect transistor (modfet) which consists basically of a multiple-layer sandwich of silicon-doped gallium arsenide and aluminium gallium arsenide. Each layer is a few millionths of a centimetre thick, and the sandwich was created layer by layer using molecular beam epitaxy.

One key to this development is the control of the silicon doping in the layers to achieve the optimum electronic characteristics of the material. The ability to control the silicon doping means that critical regions of the transistor can be made with very few defects or scattering centres, which might otherwise reduce the speed of the electron flow.

Another aspect is the construction of an extremely small gate. This is fabricated using electron beam lithography and is  $10^{-7}$ m wide, about the width of 300 gold atoms.

The Cornell-Siemens transistor represents the first demonstration that a smaller gate size can mean an inherently faster device. Previously, the highest reported speed was 80GHz by engineers at Hewlett-Packard. Computer modelling of the new transistor indicates a potential unity gain cut-off frequency as high as 160GHz.

The next step for the Cornell-Siemens group will be to use

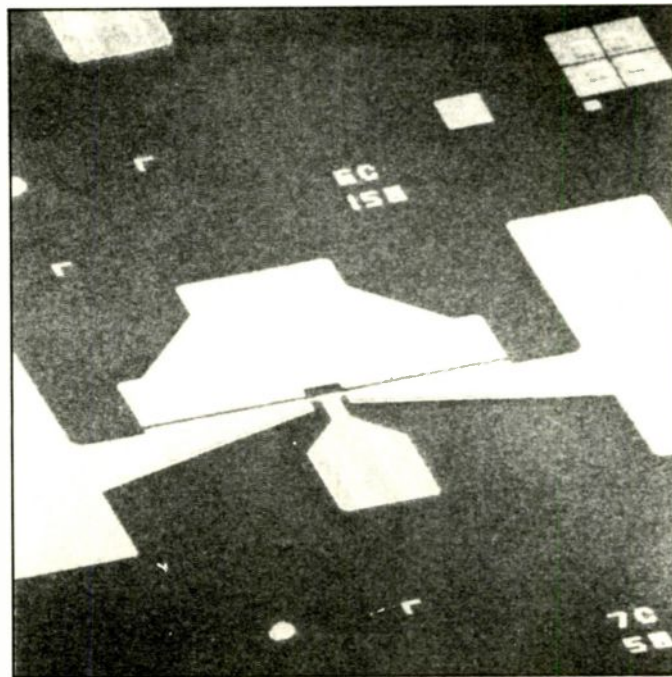

# RESEARCH NOTES

their improved processing to construct a modfet that will have the higher power-gain characteristics required of commercial operating devices. Such a further engineered device is likely to include layers of indium gallium arsenide in the sandwich.

## Methanol fuel cells

While many of us would dearly love something that would convert electricity into alcohol, industry is more interested in an efficient device for doing the reverse. Developments reported recently (*Platinum Metals Review* vol. 31 no.4) indicate that such a device may not be far away. The alcohol in this case is methyl alcohol (methanol) and the device a fuel cell.

Fuel cells convert chemical energy into electricity without any intermediate steps and have found many applications where a compact high energy power source is needed, for example on space vehicles. For such purposes the chemical energy is stored as oxygen and hydrogen and the waste product is water which can be used for drinking.

For more down-to-earth used compressed hydrogen is inconvenient, even if the oxygen can be obtained freely from the air. Fuels like methanol which are liquid at ordinary temperatures would be much more convenient if they could be used instead of hydrogen. Fuel cells based on methanol would have potential applications in portable high-current devices and for vehicle propulsion.

The main problem in the 25 years during which they have been researched is the catalyst that forms the anode and on which the methanol is oxidized. Several systems have been developed by organizations such as

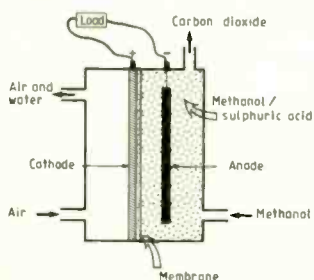

Shell, Esso, Hitachi and by the US Army and different catalysts have shown varying levels of efficiency. A platinum/ruthenium one has proved among the most active.

Devising suitable catalysts has proved something of a black art because it is by no means clear how they work. Several different theories now exist on the precise details of the electro-oxidation mechanism.

This and other difficulties such as the practical construction of the electrodes are now the subject of a collaborative research project involving organizations in France, Germany, Ireland and the UK. Initiated by the Commission of the European Communities, the programme is due for completion in late 1989.

## Measuring 100 million degrees

A system for computing real-time temperature profiles of the plasma within a nuclear fusion reactor has been developed by a group at ERA Technology Ltd in Leatherhead. It's intended for use at the JET (Joint European Torus) facility at Abingdon, where temperatures approaching 10<sup>8</sup> degrees Celsius are being created as part of the effort towards the long-term goal of generating energy by the fusion of hydrogen atoms.

In the JET experiments it is vital to have accurate information on the electron temperatures across the plasma in which the fusion reactions take place. This is important because plasma instabilities can occur on the scale of hundredths of a second and can, in certain situations, damage the plant. The object of the research at ERA has therefore been to compute complete temperature profiles in 10<sup>-8</sup>s. These can then be used either to generate shut-down signals or to produce graphic displays for later analysis.

Surprising as it may seem, the easiest bit of the whole operation is the sensing element. Temperature information is derived from millimetric electromagnetic emissions from the plasma. The algorithms required to transform this raw data into tempera-

ture profiles are, however, complex and demand considerable computation.

In order to make best use of the computing hardware, ERA has developed algorithms optimized for high-speed parallel operation, including a technique for calculating a 4096-point discrete Fourier transform in less than 3ms. Computer-based simulation has shown that the system operates effectively, particularly when presented with noisy or defective data.

ERA Technology Ltd believes that the benefits of high-speed real-time analysis are applicable not only to advanced projects like JET, but to a whole variety of scientific and industrial operations where complex changes take place rapidly.

## Meanwhile. . .

Casual readers of this column may have got the impression (*mea culpa*) that all research is a highly motivated and thoroughly down-to-earth search for exploitable knowledge. Indeed a quick scan of the national dailies may even dupe the unwary into believing that all worthwhile work is directed to solid commercial results at the earliest opportunity. At the risk of accelerating the brain drain, I've collected a few examples of research to show that adventurousness, original thinking and sheer uncommercial curiosity are still alive, albeit overseas.

First in this category, as an example of brilliant lateral thinking, is a scheme devised by the US military. They're going to build battle tanks out of uranium. . .

This clever idea (an improvement on shooting your own feet) is the result of years of behind-the-scenes research by the Pentagon into new materials that will survive the heat of the battle. True it is <sup>238</sup>U, it is the densest material available and it is pretty good at absorbing the odd stray neutron. But what I wonder would happen if a neutron bomb went off nearby? (Take another look at the theory of fission-fusion-fission weapons).

If that idea might just appeal to the British government's no-

tion of worthwhile pursuits, what about this next achievement from the Houston Area Research Centre in Woodlands, Texas? Walter N. Colquitt (*Science News* vol.133 no 6) has just discovered the third largest Mersenne Prime Number. This consolation prize-winning contribution to mankind's thirst for knowledge is the result of 11 minutes of number-crunching by a NEC SX-2 supercomputer.

Mersenne primes are expressed in the form 2<sup>p</sup>-1 where p is itself a prime number, though of course not all Mersenne numbers are prime. They do however offer something of a short cut in the search for truly huge primes. Up till now searches have covered exhaustively every potential Mersenne prime up to 2<sup>101 000</sup>-1 and have found 30 of them.

Colquitt and his colleagues wrote a Fortran programme in the hope of finding a record-breaking prime: bigger, that is, than 2<sup>216 091</sup>-1 (all 65 050 digits!). What they ended up doing was finding one that other workers had overlooked . . . its exponent a mere 110 503. But please don't ask me to print it — the Editor might conceivably have better use for three whole pages of the journal.

Finally some evidence that *perestroika* has done nothing to halt the progress of good fundamental research in the USSR. You only have to scan these columns to discover gems like electronic bird-scarers, the passionately serious search for extra-terrestrial intelligence or attempts to create element 111. But were I the Soviet equivalent of Senator William Proxmire, my 'Golden Fleece-ski' award would go without question to the recently-formed Yeti Research Group led by Dr Pavel Belenitsky. Sponsored by the Soviet Ministry of Culture and inspired by a recent sighting of the Abominable Snowman, the indomitable Dr Belenitsky is about to set off on an expedition to discover more about the creature's natural habits and psychology . . . Shy and retiring, at a guess.

*Research Notes is compiled by John Wilson of the BBC External Services science unit at Bush House, London.*



**COMMUNIQUE**

COMMUNIQUE UK LTD, COMMUNICATIONS HOUSE,  
FURLEY AVENUE, LONDON NW2 7SB.  
TEL: 01-450 9755 TELE: 293765

HX307 2 Channel  
HX307V 4 watt 160-174MHz  
HX307U 3 watt 450-470MHz

UKv62 1 Channel  
UKv62/2 25/40 watt 56-58MHz  
UKv62/4 25/40 watt 160-175MHz  
UKv62/9 25/35 watt 450-470MHz  
UKv62/4 Mini 10 watt 160-170MHz

HX407 25 Channel  
HX407V 5 watt 160-174MHz  
HX407U 5 watt 450-470MHz

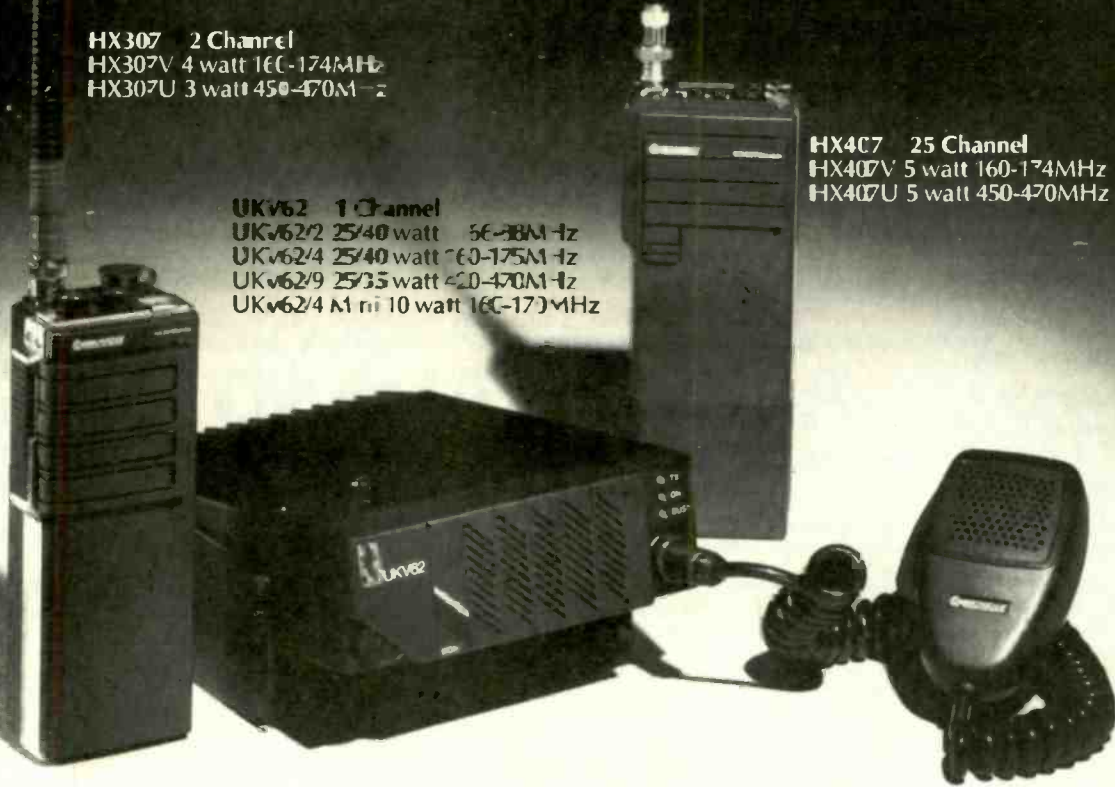

**COMMUNIQUE: MEET THE NEXT GENERATION. . . .**

ENTER 50 ON REPLY CARD

**L.J. Technical Systems**

# MODICOM - The Complete Digital Communications Training System



Now available from L.J. Technical Systems is a modular system that meets the needs of modern communications training.

The MODICOM series covers the spectrum of Digital Communications training from signal sampling and re-construction through to fibre optic technology.

For full details on the MODICOM System contact:-

L.J. Technical Systems, Francis Way, Bowdler Industrial Estate, Norwich, NR5 9JA, Tel (0603) 748001. Telex: 975504

ENTER 50 ON REPLY CARD

# APPOINTMENTS

Advertisements accepted up to 12 noon 1st July for August issue

DISPLAYED APPOINTMENTS VACANT: £25 per single col. centimetre (min. 3cm).  
 LINE advertisements (run on): £5.50 per line, minimum £44 (prepayable).  
 BOX NUMBERS: £12 extra. (Replies should be addressed to the Box Number in the advertisement, c/o Quadrant House, The Quadrant, Sutton, Surrey SM2 5AS).  
 PHONE: PETER HAMILTON, 01-661 3033 (DIRECT LINE)

Cheques and Postal Orders payable to REED BUSINESS PUBLISHING and crossed.



## ALWAYS AHEAD IN HARDWARE, SOFTWARE & SYSTEMS £10,000 - £30,000

FREE CASSETTE GUIDE!

- With the most successful companies and consultancies - both large and small - throughout the UK. Offering first class salary/benefit packages - several include company car - plus excellent career advancement opportunities.

BSc, MSc or PhD with interest and experience in any of these fields:

DIGITAL SIGNAL PROCESSING; ADVANCED PROCESSOR ARCHITECTURES; IMAGE ANALYSIS; GRAPHICS / SPEECH PROCESSING; LASER / FIBRE OPTICS; PARALLEL PROCESSORS; REAL-TIME CONTROL / C<sup>3</sup>I SYSTEMS; RADAR; SONAR; COMMUNICATIONS; OSI / X400 NETWORKS; AI & IKB SYSTEMS; ANALOGUE & DIGITAL VLSI / ASIC DESIGN; SIMULATION; MILLIMETRIC SYSTEMS; SOFTWARE - C, PASCAL, ADA, OCCAM, 68000 ASM, MODULA, UNIX / VMS; CAD TOOLS.

ECM offers confidential and professional guidance: we will listen to your requirements and identify opportunities to suit your plans.

Phone now for your FREE CASSETTE "Jobsearch Technology" and hear how ECM can help you to develop your career.

Call ECM on 0638 742244 - until 8.00 p.m. most evenings - or send your cv by FAX (0638 743066) or mail to:

**ELECTRONIC COMPUTER AND MANAGEMENT APPOINTMENTS LIMITED**  
 THE MALTINGS, BURWELL, CAMBRIDGE, CB5 0HB.

## TRAINEE RADIO OFFICERS

Are you looking for a secure shore-based job which offers a rewarding career in the forefront of modern Telecommunications technology... then consider joining GCHQ as a Trainee Radio Officer.

Training involves a 32 week residential course, (plus 6 weeks extra if you cannot touch type) after which you will be appointed RADIO OFFICER and undertake a variety of specialist duties covering the whole of the spectrum from DC to light.

**We offer you: Job Security · Good Career prospects · Opportunities for Overseas Service · Attractive Salaries · and much more.**

To be eligible you must hold or hope to obtain an MRGC or HNC in a Telecommunications subject with an ability to read Morse at 20 wpm. (City and Guilds 7777 at advanced

level incorporating morse transcription would be advantageous). Anyone with a PMG, MPT or 2 years relevant radio operating experience is also eligible.

The Civil Service is an equal opportunity employer.

**Salaries:** Starting pay for trainees is age pointed to 21 years. For those aged 21 or over entry will be at £7,162. After Training an RO will start at £10,684 rising by 5 annual increments to £15,753 inclusive of shift and weekend working allowance.

Write or telephone for an application form to:-



THE RECRUITMENT OFFICE, GCHQ, ROOM A/1108  
 PRIORS ROAD, CHELTENHAM, GLOS GL52 5AJ  
 OR TELEPHONE (0242) 232912/3

## Hardware/ Software/ Systems £9,000 - £25,000

As a leading recruitment consultancy we have a wide selection of opportunities for high calibre Design, Development, Systems and supporting staff throughout the U.K. If you have experience in any of the following then you should be talking to us for your next career move.

ARTIFICIAL INTELLIGENCE · IMAGE PROCESSING · ANALOGUE DESIGN  
 · MICRO HARDWARE & SOFTWARE · GUIDED WEAPONS · C · PASCAL · ADA · RF & MICROWAVE · ELECTRO-OPTICS · SIMULATION · C<sup>3</sup>I · REAL TIME PROGRAMMING · SYSTEMS ENGINEERING · ACOUSTICS · SONAR · RADAR · SATELLITES · AVIONICS · CONTROL · ANTENNA · VLSI DESIGN

Opportunities exist with National, International and consultancy companies offering excellent salaries and career advancement.

To be considered for these and other requirements contact John Spencer or Stephen Morley or forward a detailed CV in complete confidence quoting Ref. WW/101.



STS Recruitment, Telephone: (0962) 69478 (24hrs), 85 High Street, Winchester, Hampshire SO23 9AP.

## PAPUA NEW GUINEA UNIVERSITY OF TECHNOLOGY SENIOR/PRINCIPAL TECHNICAL OFFICER DEPARTMENT OF ELECTRICAL AND COMMUNICATION ENGINEERING

A Senior/Principal Technical Officer is required for the maintenance and repair of a wide range of electronic communication and computer equipment and the training of technical staff. Applicants should be well qualified and have substantial experience of electronic workshop and fault-finding techniques.

Salary: Principal Technical Officer K21,655 per annum; Senior Technical Officer K18,375-K20,430 per annum (K1 = £0.6089; level of appointment will depend upon qualifications and experience).

Initial contract period is for three years. Other benefits include a gratuity of 24% taxed at 2%, support for approved research, appointment and repatriation fares, leave fares for the staff member and family after 18 months of service, settling-in and settling-out allowances, six weeks paid leave per year, education fares and assistance towards school fees; free housing, salary protection plan and medical benefit schemes are available. Staff members are also permitted to earn from consultancy up to 50% of earnings annually.

Detailed applications (two copies) with curriculum vitae and the names and addresses of three referees (including telephone numbers) and indication of earliest availability to take up appointment should reach the Registrar, Papua New Guinea University of Technology, Private Mail Bag, Lae, Papua New Guinea by 30 June 1988. Applicants resident in the UK should also send one copy to the Association of Commonwealth Universities (Appts), 36 Gordon Square, London WC1H 0PF, from whom further information may be obtained.



### STATE OF THE ART BROADCAST TELEVISION EQUIPMENT

We are a flexible, growing company specialising in the research, development and manufacture of high performance analogue and digital microprocessor based video products for the Broadcast Television Industry.

Due to expansion, opportunities have arisen for:

# TEST ENGINEERS

Applicants, preferably with a broad test background ideally in broadcast television, must possess the ability to test and set up at least some of the following:

- Routing Switchers
- Vision Mixers
- Digital Processor Systems

Benefits will include competitive salary; flexible working hours; 5 weeks' holiday; contributory pension scheme.

Please send CV to:

**Susan White, Abekas Cox Electronics,  
Hanworth Trading Estate, Hampton Road West,  
Feltham, Middlesex TW13 6DH. Tel: 01-894 5622.**

## UNIVERSITY OF DURHAM LEVERHULME FELLOWSHIP IN MUSIC TECHNOLOGY and CASE STUDENTSHIP IN AUDIO ENGINEERING with SOLID STATE LOGIC LTD

Applications are invited for the above two posts based within an interdisciplinary environment between the School of Engineering and Applied Science and Department of Music.

Candidates for this 3 year FELLOWSHIP should hold either a Ph.D or a first degree and relevant experience in one or more of the following fields; Electroacoustic Music, Electronics, Parallel Computing, Transputer technology or Digital Signal Processing.

Initial salary £9,865 pa-£11,680 pa (Grade 1A) with superannuation.

The STUDENTSHIP is sponsored by SERC and Solid State Logic Ltd. It is intended that the successful applicant will register for a Ph.D and work on applications of massively parallel digital processing machines for audio engineering environments. The post carries studentship funding with an Industrial supplement.

Applications (3 copies) naming three referees and quoting reference (SEASM) should be sent by 30 June 1988 to the Registrar, Science Laboratories, South Road, Durham DH1 3LE, from whom further particulars may be obtained.

### HS CONSULTANTS LTD

Specialist Recruitment

URGENT CONTRACTS:

|                                  |       |
|----------------------------------|-------|
| ATE Prog Marconi Sys 80          | Herts |
| Inst Design 15th Ed Electr regs  | Beds  |
| Installation/Design/Cabling/MCPs | Beds  |
| Switch mode power supplies.      |       |

Please reply to:

**Jean Coulter, HS Consultants,  
Freepost 469, Harpenden,  
Herts AL5 2BR. Tel: 0582 460365**

### EXPERIENCED SERVICE ENGINEER

Experienced RF Service Engineer required for bench servicing of Marine/Land Mobile and Amateur radio equipment. Candidates must have at least 2 years experience with V.H.F. UHF communications equipment. Salary negotiable.  
Contact: C. Webster, 01 450 9755  
Communique UK Ltd.  
Communications House, Purley Avenue,  
London NW2 1SB.

## Professional Career Opportunities £8,000 - £22,000 p.a.

### The Effective Way to Find Your Next Job

We have many clients throughout the UK Seeking Engineers at all levels

- Systems Engineering ● Analogue Design
- Real-Time Software ● Project Management
- Digital Design ● Test Engineering

Simply return the coupon for one of our application forms or, alternatively, send us your C.V. today using our FREEPOST address.

Name \_\_\_\_\_

Address \_\_\_\_\_

Tel.no. \_\_\_\_\_

Bus.no. \_\_\_\_\_

**John Prodder  
Recruitment**

Freepost 499 St. Albans  
Herts AL3 5BR Tel: 0727 41101  
After hours and weekends  
0727 30602

## BROADCAST AND ELECTRONIC ENGINEERS

Ref: 40/88

Required for work in the Broadcast Engineering and Production Departments of the SSSVC, which provides Radio, Television and Training Services for the British Forces and their dependants in the UK and abroad.

Candidates (preferably aged 22-35) should be educated to HND standard in electronic and electrical engineering and have work experience in broadcast or related industries.

The work, often overseas, includes the operation, maintenance and installation of the full range of professional radio and television studio equipment and, in some areas, medium wave and VHF transmitters.

The salary offered is tax free when on overseas service, plus generous overseas allowance and other fringe benefits. There are promotion prospects to higher grades and opportunities for training and transfer to other departments of the SSSVC.

For further information and an application form please contact:

**Mrs A. R. Sive, Assistant Personnel Manager**

Tel: 02407 4461, ext 221



**The Services Sound and Vision Corporation**  
Chalfont Grove, Narcot Lane, Chalfont St Peter,  
Gerrards Cross, Bucks SL9 8TN

### SERVICES

## WOULD YOU SEND AN UNWRAPPED EGG BY POST?

Why entrust your valuable electronic equipment to a non-specialist carrier? We carry for many of Britain's leading users of sensitive electronic equipment on these guarantees:

- Each item insured up to £100,000
- Direct delivery
- No intermediate handling
- No need to pack
- Anywhere on UK mainland
- All one rate up to 50Kg
- Single items or full loads

**IF YOU PUT ALL YOUR EGGS IN ONE BASKET  
YOU SHOULD TRUST WHO'S CARRYING THEM**



0772 721666

## HAMAD MEDICAL CORPORATION

Doha, State of Qatar

### BIO MEDICAL ENGINEERS

... required to join a busy Hospital Bio Medical Engineering Department.

... qualifications should include B.Sc in Biomedical or Electronic Engineering or equivalent, and at least five years' experience in one of the following specialities.

1. Commissioning, and development and maintenance of general medical equipment.
2. Maintenance and modification of Pathology Laboratory Equipment.
3. Maintenance and modification of Medical Pneumatic Equipment.

... the terms of service are competitive and fringe benefits are excellent and tax free salaries.

... interested and qualified applicants should send a detailed copy of their resumé with references to:

**Head of Recruitment, Personnel Department,  
Hamed Medical Corporation, P.O. Box 3050, Doha,  
State of Qatar.**

560

## CLIVEDEN

Technical  
Recruitment

### FIELD SERVICE ENGINEER

To work in London area. Mini-computer experience essential.  
**up to £12,000 + car**

**REPAIR TECHNICIAN** London  
Service and maintenance of radio equipment. **up to £11,000**

**FIELD SERVICE ENGINEER** Berks  
Installation and maintenance of microcomputer based products.  
**up to £13,500**

**SERVICE ENGINEER** Berks  
Telemetry and telecomms equipment. **up to £14,000 + car**

**SERVICE TECHNICIAN** Surrey  
Service and repair of 2-way radios.  
**£12,000**

**SENIOR REPAIR ENGINEER** Berks  
Optical equipment repair, supervision of juniors. **£10,000 +**  
*Hundreds of other Electronic vacancies*

Roger Howard, C.Eng, M.I.E.E., M.I.E.R.E.  
CLIVEDEN TECHNICAL RECRUITMENT  
92 The Broadway, Bracknell, Berks RG12 1AR  
Tel: 0344 489489 (24 hour)

UNIVERSITY OF READING  
Computer Centre

### Technician (Grade 5)

required to work as part of a team maintaining a wide range of computer equipment. Equipment includes a large X25 network covering the attractive campus and a wide range of terminal equipment and microcomputers. Developments in the near future will include a high-speed network and an increase in distributed computing.

Candidates should have passed their BTEC and have 4 years' suitable experience. They will need to be able to work well on their own initiative and be able to relate to a wide variety of people. The range of equipment means that the work is complex and therefore we require a person who can work both intelligently and accurately.

Salary scale £7,696 to £9,086 pa (under review).

Application form available from the Personnel Officer, University of Reading, Whiteknights, PO Box 217, Reading, RG6 2AH, telephone: (0734) 875123 ext 220. Please quote Ref: T29A.

## CAPITAL

Sinclair House, 74 Willoughby Lane, London N17 0SP  
Telephone: 01-808 3050

### THE UK's No. 1 ELECTRONICS AGENCY

ELECTRONICS ENGINEERS if you are looking for a job in DESIGN, FIELD SERVICE, TECHNICAL SALES or SOFTWARE ENGINEERING.

Telephone NOW for one of our FREE Jobs lists or send a full cv to the address below.

Vacancies throughout the UK to £18,000 p.a.

Capital Appointments Ltd., FREEPOST London N17 0BR.

Please send me your list for \_\_\_\_\_ Engineers

Name \_\_\_\_\_ (WWW)

Address \_\_\_\_\_

Post Code \_\_\_\_\_

**01-808 3050 - 24 HOURS**

**For further details on  
Classified Advertising please  
contact: Peter Hamilton on  
661 3033**

## NEW RF SYSTEMS SOUTH EAST to £20K

Our company is designing a totally unique approach to communications. You will be involved in pushing this technology beyond current limits.

**RF Amplifier Design, Microprocessor and Digital Control, Systems Engineering, Reliability and Maintainability Engineer.**

You should have at least two years' experience of RF preferably in the High Frequency range or knowledge of mobile radio techniques.

Please telephone **GORDON SHORT** for a discussion on 0442 53300 (day or evenings) or send him your CV attached to this advert to:



Executive Recruitment Services

THE INTERNATIONAL SPECIALISTS IN RECRUITMENT  
FOR THE ELECTRONICS, COMPUTING AND DEFENCE INDUSTRIES

Maylands Avenue, Hemel Hempstead, Herts., HP2 4LT.

### ARTICLES FOR SALE

Radioactivity measurement, training, proximity to radioactive sources, radon in houses etc. three Epsylon portable Geiger counters, meter readout £89, meter plus light pulse indicator, meter, light and audio, protective carrying case with shoulder strap £7.50. Electrolytic capacitor bridge £39. 4-drawer cabinets mechanical components £12.50. Single and dual stabilised power supplies. Fractional h.p. motors. Oscilloscope probes, tektronix etc. £12.50. Sippicam micro spotwelding heads £59. 9.5mm projector/camera spares. Quantity of centrifuge accessories. Electrostatic voltmeters £7.50. Epsylon Crystal Millivoltmeter £35. Audio and RF generators. Weyhill Audio Generators, digital readout, £45. Oscilloscope dual beam electronic switch £35. Twin drive cassette tape mechanism, stereo head £12.50. 20,000 ohmv. Industrial grade BSS89 Super-50 Testmeter £45. Weld Tester £30. Farnell DC Voltage Standard £125. Wayne-Kerr Testmatic A.60 with manuals etc. £125. Mixed batch lenses, etc. £25. General radio 1607 P3 Variable Air Capacitor £35. Creed Teleprinter £29. 25-amp variac £59. Wayne-Kerr Wide Range LCR Bridge £89. Flat-field Illuminator (microscopes etc) £12.50. Laboratory Mhognlas hotplate panel 20" x 12" app. £20 etc. etc.

040-376236.

2016

### BUSINESS OPPORTUNITES

## Brazil

Company representing several British Manufacturers in the scientific electronics field for Sales and Service seeks further HI-TEC REPRESENTATIONS

Please contact:

Colin Southworth,

Inserpro Electronica Ltda,  
Av. Duquesa de Goias 852,  
Sao Paulo 05686, Brazil.

Telex: 11-54686.

Phone: 011-240 1988



**ARTICLES FOR SALE**

**TO MANUFACTURERS, WHOLESALERS  
BULK BUYERS. ETC.**

**LARGE QUANTITIES OF RADIO, TV AND  
ELECTRONIC COMPONENTS FOR DISPOSAL**

SEMICONDUCTORS, all types, INTEGRATED CIRCUITS, TRANSISTORS,  
DIODES, RECTIFIERS, THYRISTORS, etc. RESISTORS, C/F, M/F, W/W, etc.  
CAPACITORS, SILVER MICA, POLYSTYRENE, C280, C296, DISC  
CERAMICS, PLATE CERAMICS, etc.  
ELECTROLYTIC CONDENSERS, SPEAKERS, CONNECTING WIRE, CABLES,  
SCREENED WIRE, SCREWS, NUTS, CHOKES, TRANSFORMERS, etc.  
**ALL AT KNOCKOUT PRICES** — Come and pay us a visit ALADDIN'S CAVE

**TELEPHONE: 445 0749/445 2713**  
R. HENSON LTD.  
21 Lodge Lane, North Finchley, London, N.12  
(5 minutes from Tally Ho Corner) (1613)

**SPECTRUM  
ANALYSER PLUG-IN**

HP8555A, 18GHz RF plug-in, immaculate, recently calibrated.  
List £8,750 for sale at £3,450.  
Broadcast quality FM video transmitters/receivers 1.3GHz-3.5GHz.  
Call for information and price:  
**Cyberscan International,**  
3 Eastcote View, Pinner,  
Middlesex HA5 1AT.  
Tel: 01-866 3300  
Fax: 01-231 9323

**WANTED**

**PLATINUM, GOLD, SILVER SCRAP.** Melted assayed and paid for within 24 hours relay contacts, thermo couples, crucibles. Also printed circuit boards, plugs, connectors, palladium, rhodium, tantalum and ruthenium. We have the technology to do the difficult refining jobs that others can't handle. Totally free sampling service. Send samples or parcels (Regd post) or contact Eric Henderson, 0773 570141. Steinbeck Refineries (UK) Ltd, Peasehill Industrial Estate, Ripley, Derbyshire DE5 3JG. No quantity too large or small. 495

**WANTED**

**WANTED**

Test equipment, receivers, valves, transmitters, components, cable and electronic scrap and quantity. Prompt service and cash.

**M & B RADIO**  
86 Bishopsgate Street  
Leeds LS1 4BB  
0532 435649 4956

**G.W.M. RADIO LTD**  
40/42 Portland Road, Worthing, Sussex  
Tel: 0903 34897

Factory surplus, test equipment, radio telephones, miscellaneous lots, small or large wanted, immediate decision and settlement. 565

**SERVICES**

**RALFE ELECTRONICS IS MOVING**

Ralfe Electronics have moved to new premises. Please call in for all your professional Test & Measurement needs.  
Ralfe Electronics  
36 Eastcote Lane, Harrow,  
Middlesex HA2 8DB.  
Tel: 01-422 3593

**TEST EQUIPMENT**

**GOOD USED EQUIPMENT ALWAYS AVAILABLE & WANTED  
SIGNAL SOURCES/SCOPES/ANALYSERS/BROIGES/POWER SUPPLIES**

Here is but a small example of very considerable stocks available:  
Gould OS3500 portable 60MHz Dual Trace, rise time = <6ns £250.00  
Racal 9025 Frequency meter b/w 10Hz-1GHz 8 digit display £200.00  
Bird Thru-line wattmeters (various inserts available) from £65.00  
HP 614A UHF signal source 800MHz-2Ghz excellent order £450.00  
LOTS OF BARGAINS TO CALLERS \* BULK & TRADE TERMS AVAILABLE.  
Send for lists, updated monthly.  
Hours of business Monday-Friday, 9.30am-5.00pm. Saturdays by arrangement.  
BUYING OR DISPOSING you should contact:

**COOKE INTERNATIONAL**  
Unit 4, Fordingbridge Site, Main Road, Barnham, Bognor Regis,  
West Sussex PO22 0EB. Tel: 0243 68 5111/2 505

**MICROWAVE TEST EQUIPMENT FOR SALE.** HP5342A Frequency Counter £2,250. HP8970A Noise figure meter and 346B noise source £3,950. Wiltron Sweep Generator 6647A. Wilton Scatar network analyser 560A £12,250. HP8559A Spectrum analyser mainframe and storage normaliser £7,500. HP1740A oscilloscope £900. Saturn Satellite TV International Ltd., Cawsand Place, West Drive, Wentworth, Surrey. Tel: 09904 3399.

**GOLLEDGE  
ELECTRONICS**

**QUARTZ CRYSTALS OSCILLATORS AND FILTERS** of all types. Large stocks of standard items. Specials supplied to order. Personal and export orders welcomed - SAE for lists please. OEM support thru: design advice, prototype quantities, production schedules. Golledge Electronics, Merriott, Somerset YA16 5NS. Tel: 0460 73718. (2472)

**TRANSFORMERS EX-STOCK.** 3VA-10k VA. Continuously rated. All voltages full load. Autotransformers isolators low voltage ranges. Batch winding to spec. Plus CVTs, Inverters, UPS, Stand by Systems and Autochargers. Send stamp for lists. Barrie Electronics Ltd., 211 Stratford Workshops, Burford Road, London E15 2SP. Tel: 01-555 0228. 634

**VALVES TRANSISTORS I.Cs WANTED** also IC sockets, plugs, connectors, factory clearance etc. Valves types PX4 PX25 KT66 especially wanted. Billington Valves see below.

**FOR SALE AND WANTED TEST** and production equipment, computers and DOS software. Dedicated microprocessors Ltd, Unit B4 Acton Business Centre, School Road, London NW10 6TD. Tel: 01-965 2841 and 01-262 6902. 617

**TURN YOUR SURPLUS** i.e.s transistors etc. into cash, immediate settlement. We also welcome the opportunity to quote for complete factory clearance. Contact COLESHARDING & CO, 103 South Brink, Wisbech, Cambs. 0945 584188. (92)

**STEWART OF READING**  
110 WYKEHAM ROAD,  
READING RG6 1PL.  
TEL: 0734 68041

**TOP PRICES PAID FOR ALL TYPES OF SURPLUS TEST EQUIPMENT, COMPUTER EQUIPMENT, COMPONENTS etc. ANY QUANTITY**

**LOW COST CAD FOR PCB Design** and Development of YOUR IDEAS and Circuits with added In-House prompt Manufacture. Contact: Highland Itec. 13b, Harbour Road, Longmand Industrial Estate, Inverness IV1 1SY. Tel: (0463) 226505. Fax: 226506. Quote ref: EWW 7/88. 620

**VALVES - TRANSISTORS - ICs**

- \* USUALLY THE LOWEST PRICES ANYWHERE.
- \* RARITIES OUR SPECIALITY - HUGE STOCKS HELD.
- \* ALL VALVES GUARANTEED
- \* ALL VALVES NEW & GOOD QUALITY BRANDS.
- \* VALVE PRICES REDUCED DURING JUNE/JULY

|          |       |            |       |             |       |
|----------|-------|------------|-------|-------------|-------|
| 6L4GT    | 2.20  | EL84       | 95    | 00Y06-40A   | 24.00 |
| 6AR5     | 1.20  | GZ34       | 2.40  | UG442       | 2.00  |
| EB8CC    | 3.00  | GZ37 Mu    | 3.40  | UF41        | 1.10  |
| EB8CC Mu | 4.50  | KT66-75B1A |       | UL41        | 7.00  |
| EB10F    | 24.00 | RC4        | 9.00  | UY41        | 3.00  |
| ECC81    | 80    | RT88 USA   | 10.75 | 40K250B     |       |
| ECC82    | 80    | M8136 Mu   | 6.00  | Emac        | 58.00 |
| ECC83    | 93    | M8137 Mu   | 7.00  | 5B-254M     | 14.00 |
| ECC85 Mu | 1.00  | M8162 Mu   | 5.00  | 5B/259M     | 19.00 |
| EF86     | 2.10  | 0A2        | 1.40  | 50H6 Brenar | 6.90  |
| EF91     | 1.40  | 0B2        | 1.40  | 68A6        | 1.00  |
| EF92     | 1.85  | PCL82      | .80   | 6F33STC     | 9.00  |
| EF95     | .80   | PCL805     | .80   | 12E1        | 17.00 |
| EL34     | 2.80  | PL59-19    | 4.45  | 5763        | 5.75  |
| EL41     | 2.70  | Q0W03 20A  | 23.00 |             |       |

Please add 15% to all prices and £1.15 P&P per order.  
Rarities our speciality.  
Ask for price on any valve not listed.  
Overseas enquiries welcome.

**TRANSISTORS ICs & IC SOCKETS**

Please phone for up to date quotations.  
For quotations contact Martin Billington  
**BILLINGTON VALVES**  
39 Highlands Road, Horsham, W. Sussex RH13 5LS  
Tel: 0403 210729 Fax: 0403 210108 Telex: 87271

BY ORDER OF ERNST AND WHIPNEY  
**FOR SALE**

Thorn EM1 VX540 Prism Modem 2000 Anders SK6330  
Autorangeing Multimeter 2 Micro Control Systems  
M n buffer Box Kamoden HT100BA Multimeter,  
Microsystems ME10 Ultraviolet Tester Cival Automation  
Control Box Mitsubishi C50101 Color Line Printer  
Essex Chameleon SPI BBT computer IBM PC Ram Card  
Q BUS KT23 Memory Management Card 2 Unibus  
Cards PDF 11 23 CPD Q BUS Multi-func on Card Q Bus  
128K Ram Card Flopping Point Processor for PDF 11 23  
7 Graftek VP200 & Printer Sharer Devices

For further information contact:  
**Byron Henry Butcher, 23 Thistle Street,  
Edinburgh EH2 1DF. Tel: 031-225 4643**

**BRIDGES** waveform transistor analysers. Calibrators, Standards. Millivoltmeters. Dynamometers. KW meters. Oscilloscopes. Recorders. Signal generators - sweep, low distortion, true RMS, audio, RM, deviation. Tel: 040 376236. (2616)

**MARCONI TF2370 SPECTRUM ANALYSER** 110Mhz fully serviced £2,000 ono. Contact: AEL Crystals Ltd, Gatwick House, Horley RH6 9SU. Tel: 0293 785353. 621

**SERVICES**

**CIRCOLEC**  
**THE COMPLETE ELECTRONIC SERVICE**

Artwork, Circuit Design, PCB Assembly, Test & Repair Service, Q.A. Consultancy, Prototypes, Final Assembly. Full PCB Flow Soldering Service.  
Quality workmanship by professionals at economic prices.  
Please telephone 01-646 5686 for advice or further details.  
**TAMWORTH MANOR**  
302-310 COMMONSIDE EAST, MITCHAM (1391)

**When replying to classified advertisement readers are recommended to take steps to protect their interest before sending money.**

**MATMOS LTD**, 1 Church Street, Cuckfield, West Sussex RH17 5JZ.

Tel: (0444) 414484/454377.

**COMPUTER APPRECIATION**, 30/31 Northgate, Canterbury, Kent CT1 1BL

Tel: (0227) 470512.

**TRIUMPH ADLER/ROYAL OFFICE MASTER 2000 DAISY WHEEL PRINTERS.** 20 cps, FULL IBM AND DIABLO 630 COMPATIBILITY, CENTRONICS INTERFACE. Features include underscore, bold, subscripts, superscripts etc. Complete with typewheel and ribbon, manufactured to highest standards in West Germany by Europe's largest typewriter manufacturer and offered elsewhere at over £350.00 ..... £119.50 (carr. £6.50)

**VICTOR SPEEDPAK 286.** 80286 based speed up card for IBM PC and most compatibles. Features cache memory and runs 6 to 7 times faster ..... £99.50 each for quantities of 5+  
£139.00 (carr. £3.00)

**PANASONIC Model JU-363 3 1/2" floppy disc drives** Double Sided Double Density 80 track 1 megabyte capacity unformatted. Latest low component 1/2 height design. SHUGART compatible interface using 34 way IDC connector. Will interface to just about anything. BRAND NEW. (We can offer at least 20% discount for quantities of 10 plus) Current model. We can supply boxes of 10 discs for £15.95 plus £1.50 carriage ..... £59.50 (carr. £3.00)

**PLESSEY Model T24 V22/V22 bis 2400 Baud MODEM.** Including free software disc for IBM or MATMOS PC. Compact, automatic modem featuring the latest technology and the highest possible data rate over the ordinary phone system. Offers; both V22 and V22 bis compatibility, 1200/2400 Baud operation with auto bit rate recognition, operation on both ordinary phone (PSTN) and private circuit (PC), auto call and auto answer, duplex operation allowing simultaneous transmission and reception of data at 2400 Baud in both directions over a single phone line, compact size (9" x 9" x 2 1/2"), BT approved and suitable for new PRESTEL V22bis service. Software is included for IBM PC, MATMOS PC, and (including high speed Prestel) for BBC MICRO. BRAND NEW. NEW LOW PRICE ..... £169.00 (carr. £5.00)

**DUPLEX Model 100** green screen 12" high resolution monitor with composite video input. With tilt and swivel stand. BRAND NEW ..... £39.50 (carr. £5.00)

**ITT SCRIBE III WORKSTATION.** Monitor sized unit with high quality high resolution 12" green screen monitor (separated video and sync), 5V and 12V cased switchmode power supply, processor electronics incorporating TEXAS 9995 and Z80H processors with 128kbytes and associated support chips, all BRAND NEW but with only monitor and power supply guaranteed working. Original cost at least £2,500. .... £29.95 (carr. £5.00)

**ITT SCRIBE III KEYBOARD.** Low profile keyboard for above with numeric keyboard, serial interface. BRAND NEW but untested ..... £8.95 (carr. £5.00)

**MATMOS TERMINAL.** MATMOS PC with Ver.2 EPROM for terminal emulation. Probably the lowest cost terminal available anywhere. With set-up menu and with data rates up to 9600 Baud. Machine is easily modified for split Baud rate operation. 75/1200B, EPROM plugs into ROM socket accessible from exterior. Emulation is VT-52 compatible for cursor addressing; and for character attributes as far as the MATMOS PC allows. MICROSOFT BASIC is still available from the keyboard. (EPROM card on its own, £20.00; EPROM card with socket only for user's own EPROM, £8.00) BRAND NEW ..... £69.00 (carr. £5.00)

**TRANSDATA Model 307 ACOUSTIC MODEM.** Low cost self-contained modem unit allowing micro or terminal connection to BT lines via telephone handset. V24 interface. up to 300Baud, originate/answer modes, etc. BRAND NEW with manual ..... £14.95 (carr. £3.00)

**FUJITSU Model M2230AS 5 1/4" WINCHESTER disc drive.** 6.66mbyte capacity unformatted, 16/32 sectors, 320 cylinders. With ST506 interface. BRAND NEW ..... £47.50 (carr. £3.00)

**DRIVETEC Model 320 high capacity 5 1/4" disc drives.** 3.3mbyte capacity drive - same manufacturer and same series as KODAK 6.6mbyte drive. 160 track, downgradable to 48 tpi. No further info at present. BRAND NEW ..... £25.00 (carr. £3.00)

**ASTEC SWITCH MODE PSU.** 5V @ 8A; +12V @ 3A; -12V @ 0.3A - to a total 65W. Compact cased unit. Ex-equipment, tested ..... £14.50 (carr. £3.00)

**HEWLETT PACKARD Model 59307A dual VHF switch.** DC to 500MHz 50 Ohm switch for HP-IB ..... £185.00

**HEWLETT PACKARD Model 5045A digital IC tester with CONTREL Model H310 automatic handler.** With IEEE interface and print out of test results either pass/fail or full diagnostic including pin voltages at point of failure. With full complement of pin driver cards and complete with substantial library of magnetic card test programs for 74 series TTL and other ICs. CONTREL handler allows fully automatic testing of ICs which are sorted into 2 bins. Price includes a second HP5045A (believed fully operational) for maintenance back-up ..... £550.00

**HEWLETT PACKARD Model 28C pocket calculator with graphics.** ..... £100.00

**CASIO Model FX8000 calculator with graphics and interface.** ..... £50.00

**ICOM micro2E 2 metre transceiver with carrying case.** ..... £150.00

**TIME ELECTRONICS Model 9810 programmable power supply.** ..... £160.00

**HEWLETT PACKARD MODEL 5501A LASER TRANSDUCER.** With piezoelectric tuning for precise control of wavelength for measuring applications ..... £350.00

**VICKERS INSTRUMENTS MODEL M17 METALLURGICAL MICROSCOPE** with binocular/micrographic head and all eyepieces. With 4 'Microplan' objectives and Nomarski interference contrast ..... £1,250.00

**KRATOS MS30 DOUBLE BEAM MASS SPECTROMETER.** Approximately 8 years old with negative ion capability and fast atom bombardment (FAB). With gas and direct introduction sample probes and with gas chromatograph inlet system. Output spectra are available directly via a HEWLETT PACKARD storage display and a UV recorder. An on-line DATA GENERAL DS60 computer system, which includes a graphics printer and two TEKTRONIX 4014 terminals, analyses output ..... p.o.a.

**LUMONICS SYSTEM 2000 RUBY LASER** with Q-switch and frequency doubler. 0.3 Joule per pulse, 6 ppm ..... £3,500.00

Please note: \*VAT & carriage (also + VAT) must be added to all prices.

\* VISA and ACCESS orders accepted.

ENTER 11 ON REPLY CARD

## INDEX TO ADVERTISERS

Appointments Vacant Advertisements appear on pages 732-735

|                       | PAGE |                                     | PAGE |                             | PAGE    |                       | PAGE    |
|-----------------------|------|-------------------------------------|------|-----------------------------|---------|-----------------------|---------|
| Airlink Transformers  | 725  | European Electronic Systems         | 717  | Langrex                     | 715     | Ralfe Electronics     | 725     |
| Audio Electronics     | 685  | Field Electronics                   | 686  | Leetronex                   | 675     | R. Henson             | 717     |
| Carston Electronics   | 680  | Hameg                               | 676  | Livingston Hire             | OBC     | Slee Electro Products | 725     |
| Cavendish Automation  | 707  | Harrison Electronics                | 707  | L.J. Technical              | 685/731 | Solartron             | 651     |
| Communicue            | 731  | Hart Electrical Kits                | 679  | M.A. Instruments            | 685     | Solex                 | 727     |
| Computer Appreciation | 736  | Heinemann Professional Publications | 679  | Marconi                     | IFC     | Stewart of Reading    | 675     |
| Crotech               | 643  | Icom (UK) Ltd                       | 679  | M&B Instruments             | 685     | Strumech Engineering  | 680     |
| Dataman               | 636  | John's Radio                        | 717  | Micro Concepts              | 720     | Superkit Electronics  | 676     |
| Display Electronics   | 717  | Kestrel Electrical Company          | 651  | Micro Processor Engineering | 715     | Surrey Electronics    | 651     |
| E.A. Sowler           | 643  |                                     |      | MQP                         | 680     | Taylor Bros           | IBC     |
| Engineering Solutions | 672  |                                     |      | New World Electronics       | 634     | Thurlby Electronics   | 715 720 |
| ES2                   | 634  |                                     |      | Number One Systems          | 672     | Tradeport Electronics | 727     |
|                       |      |                                     |      | PMR                         | 686     | Triangle Digital      | 675     |
|                       |      |                                     |      |                             |         | Val Radio             | 634     |
|                       |      |                                     |      |                             |         | Websters Electronics  | 707     |

### OVERSEAS ADVERTISEMENT AGENTS

France and Belgium: Pierre Mussard, 18-20 Place de la Madeleine, Paris 75008.

United States of America: Jay Feinman, Reed Business Ltd., 205 East 42nd Street, New York, NY 10017 - Telephone (212) 867 2080 - Telex 23827.

Printed in Great Britain by E.T. Heron (Print) Ltd, Crittall House, Braintree Road, Witham, Essex CM8 3QO, and typeset by Graphac Typesetting, 181/191 Garth Road, Morden, Surrey SM4 4LL, for the proprietors, Reed Business Publishing Ltd, Quadrant House, The Quadrant, Sutton, Surrey SM2 5AS. © Reed Business Publishing Ltd 1988. *Electronics and Wireless World* can be obtained from the following: AUSTRALIA and NEW ZEALAND: Gordon & Gotch Ltd, INDIA: A. H. Wheeler & Co. CANADA: The Wm. Dawson Subscription Service Ltd., Gordon & Gotch Ltd. SOUTH AFRICA: Central News Agency Ltd; William Dawson & Sons (S.A.) Ltd. UNITED STATES: Worldwide Media Services Inc., 115 East 23rd Street, NEW YORK, N.Y. 10010. USA. *Electronic & Wireless World* \$5.95 (74513).

# TAYLOR

## R.F. EQUIPMENT MANUFACTURERS

### PERFORMANCE & QUALITY

#### 19" RACK MOUNT CRYSTAL CONTROLLED VESTIGIAL SIDEBAND TELEVISION MODULATOR

PRICES FROM £203.93 (excluding VAT & carriage)

Prices CCIR/3 £203.93  
CCIR/3-1 £260.64

#### 19" RACK MOUNT VHF/UHF TELEVISION DEMODULATOR

PRICE AT ONLY £189.00 (excluding VAT & carriage)



#### WALLMOUNT DOUBLE SIDEBAND TELEVISION MODULATOR

PRICES FROM ONLY £104.53 (excluding VAT & carriage)



| CCIR/3 SPECIFICATION           |                                                                                    |
|--------------------------------|------------------------------------------------------------------------------------|
| Power requirement              | - 240V 8 Watt (available other voltages)                                           |
| Video Input                    | - 1V Pk-Pk 75 Ohm                                                                  |
| Audio Input                    | - 8V 600 Ohm                                                                       |
| FM Sound Sub-Carrier           | - 6MHz (available 5.5MHz)                                                          |
| Modulation                     | - Negative                                                                         |
| IF Vision                      | - 38.9MHz                                                                          |
| IF Sound                       | - 32.9MHz (available 33.4MHz)                                                      |
| Sound Pre-Emphasis             | - 50us                                                                             |
| Ripple on IF Saw Filter        | - 6dB                                                                              |
| Output (any channel 47-860MHz) | - +6dBmV (2mV) 75 Ohm                                                              |
| Vision to Sound Power Ratio    | - 10 to 1                                                                          |
| Intermodulation                | - Equal or less than 60dB                                                          |
| Spurious Harmonic Output       | - -40dB (80dB if fitted with TCFL1 filter or combined via TCFL4 Combiner/Leveller) |

|          |                                                                              |
|----------|------------------------------------------------------------------------------|
| CCIR/3-1 | - Specification as above but output level 60dBmV 1000mV Intermodulation 54dB |
|----------|------------------------------------------------------------------------------|

|                         |                                              |
|-------------------------|----------------------------------------------|
| Other Options Available | - I.F. Loop/Stereo Sound/Higher Power Output |
|-------------------------|----------------------------------------------|

|                          |                                                                                                                                                   |
|--------------------------|---------------------------------------------------------------------------------------------------------------------------------------------------|
| Alternative Applications | - CCTV Surveillance up to 100 TV channels down one coax, telemetry camera control signals, transmitted in the same coax in the reverse direction. |
|--------------------------|---------------------------------------------------------------------------------------------------------------------------------------------------|

| 802 DEMODULATOR SPECIFICATION                               |                          |
|-------------------------------------------------------------|--------------------------|
| Frequency Range                                             | - 45-290MHz, 470-860MHz  |
| A.F.C. Control                                              | - +/- 1.8 MHz            |
| Video Output                                                | - 1V 75 Ohm              |
| Audio Output                                                | - 75V 600 Ohm unbalanced |
| Audio Monitor Output                                        | - 4 Ohms                 |
| Tunable by Internal preset Available for PAL System I or BG |                          |

|         |                                                                                   |
|---------|-----------------------------------------------------------------------------------|
| Options | - Channel selection via remote switching, Crystal Controlled Tuner, Stereo Sound. |
|---------|-----------------------------------------------------------------------------------|

| CCIR/5 MODULATOR SPECIFICATION                                                                |                                       |
|-----------------------------------------------------------------------------------------------|---------------------------------------|
| Power Requirement                                                                             | - 240V                                |
| Video Input                                                                                   | - 1V Pk-Pk 75 Ohms                    |
| Audio Input                                                                                   | - 1V rms 30K Ohms Adjustable 4 to 1.2 |
| Vision to Sound Power Ratio                                                                   | - 10 to 1                             |
| Output                                                                                        | - 6dBmV (2mV) 470-860MHz              |
| Modulation                                                                                    | - Negative                            |
| Audio Sub-Carrier                                                                             | - 6MHz or 5.5MHz                      |
| Frequency Stability                                                                           | - 25 Deg temperature change 150KHz    |
| Intermodulation                                                                               | - less than 60dB                      |
| Sound Pre-Emphasis                                                                            | - 50us                                |
| Double Sideband Modulator (unwanted sideband can be suppressed using TCFL4 Combiner/Leveller) |                                       |

| CHANNEL COMBINER/FILTER/LEVELLER to combine outputs of modulators |                                                          |
|-------------------------------------------------------------------|----------------------------------------------------------|
| TCFL2                                                             | 2 Channel Filter/Combiner/Leveller. Insertion loss 3.5dB |
| TCFL4                                                             | 4 Channel Filter/Combiner/Leveller. Insertion loss 3.5dB |
| TSKO                                                              | Enables up to 4x TCFL4 or TCFL2 to be combined.          |

| Prices   |              |         |
|----------|--------------|---------|
| CCIR/5-1 | 1 Modulator  | £104.53 |
| CCIR/5-2 | 2 Modulators | £159.99 |
| CCIR/5-3 | 3 Modulators | £226.28 |
| CCIR/5-4 | 4 Modulators | £292.56 |
| CCIR/5-5 | 5 Modulators | £358.85 |

ENTER 2 ON REPLY CARD

**TAYLOR BROS (OLDHAM) LTD.**  
BISLEY STREET WORKS, LEE STREET,  
OLDHAM, ENGLAND.

TEL: 061-652 3221 TELEX: 669911 FAX: 061-626 1736

# RENTAL

## THE SIMPLE SOLUTION FOR COMPLEX SIGNAL AND NETWORK ANALYSIS

**R**ental gives you the flexibility and power you need for the most advanced signal and network analysis solutions.

Livingston Hire's inventory is **expanding all the time**. So you can take advantage of the latest hardware design and test equipment, when you need it, without drawing on capital budgets.

Rental schemes range from **one week**, so you can meet peak demands and emergencies without affecting normal operations.

**Fast order turnaround and delivery** anywhere in the UK is backed by **full engineering support** including in-house maintenance and calibration.



### The Hewlett-Packard 8562A/B spectrum analysers

- Lightweight, portable and rugged
- Synthesised tuning
- Frequency counter
- Frequency range 1kHz to 22GHz, up to 325GHz with external mixers
- AM/FM demodulator/speaker
- HP-IB interface with direct plotter output
- Easy to use

### ▲ The Hewlett-Packard 8753A RF network analyser

- 300kHz to 3GHz
- Integrated 1Hz resolution synthesised source
- Direct save/recall to external disk drive
- Time domain analysis
- 100dB dynamic range
- Group delay and deviation from linear phase
- 0.001dB, 0.01°, 0.01ns marker resolution
- Built-in accuracy enhancement

ENTER 3 ON REPLY CARD



Livingston Hire  
01-977 8866

EUROPE'S No.1 IN ELECTRONIC EQUIPMENT RENTAL

Call your Livingston Helpline  
NOW for the rental solution:

**Tel: 01-977 8866. (South)**

**Tel: 061-998 7900 (North)**

**Tel: 0506-415757 (Scotland)**

