

PRE-AMPLIFIER FOR 20W DESIGN

Wireless World

ELECTRONICS • TELEVISION • RADIO • AUDIO

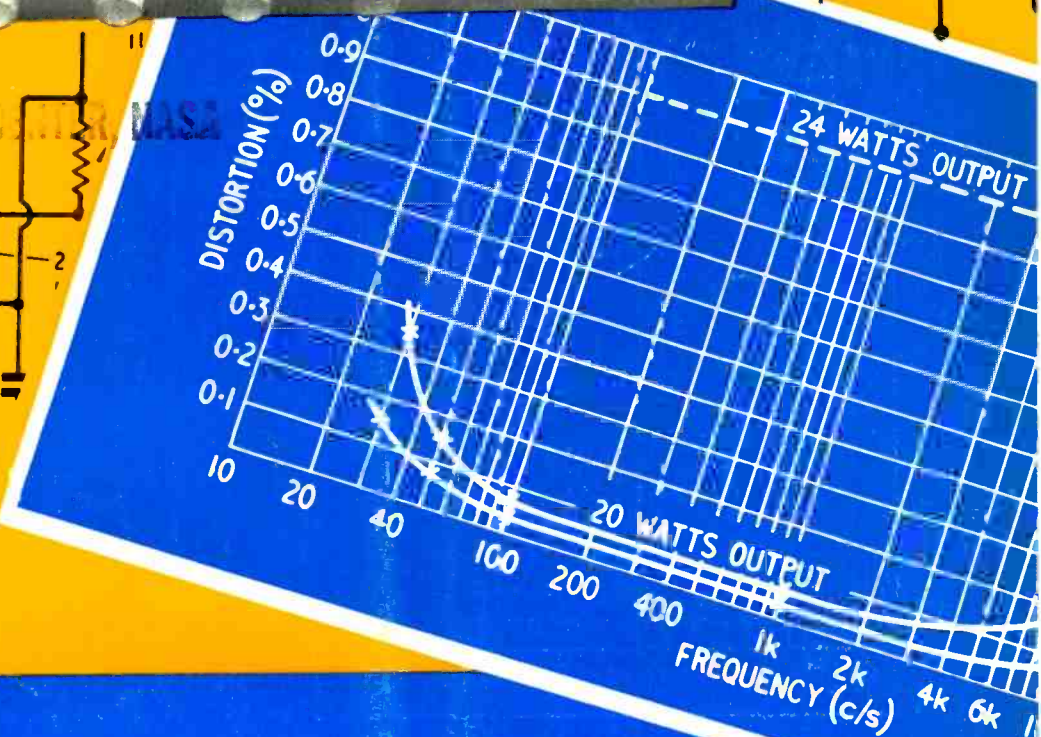
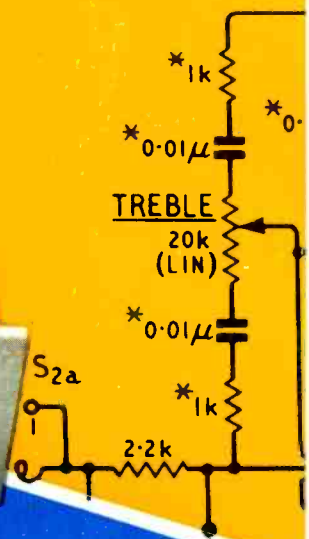
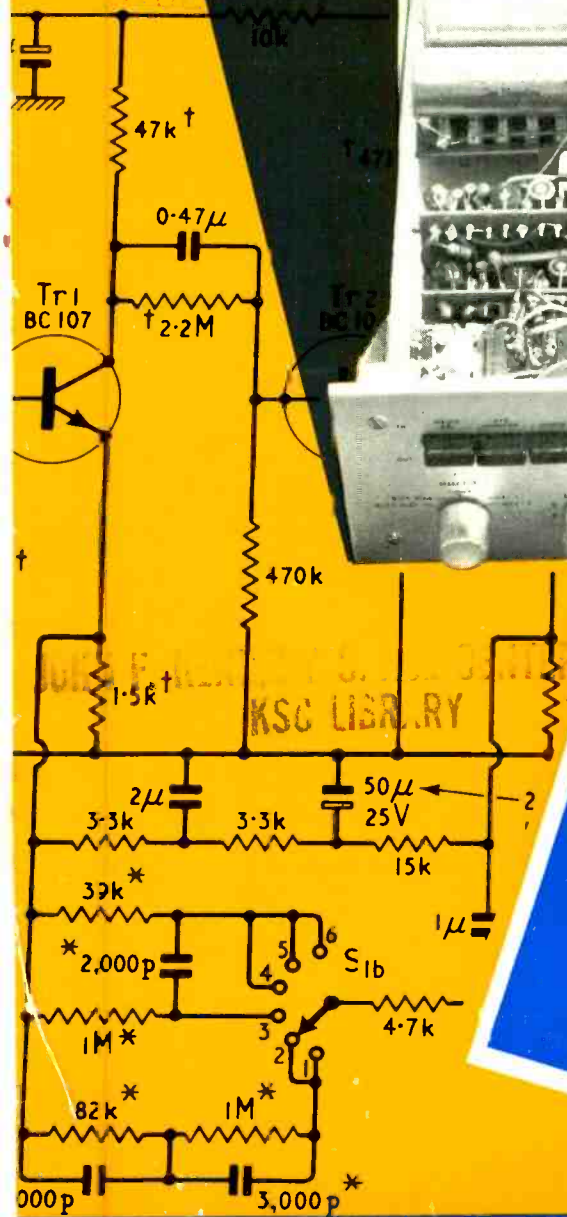
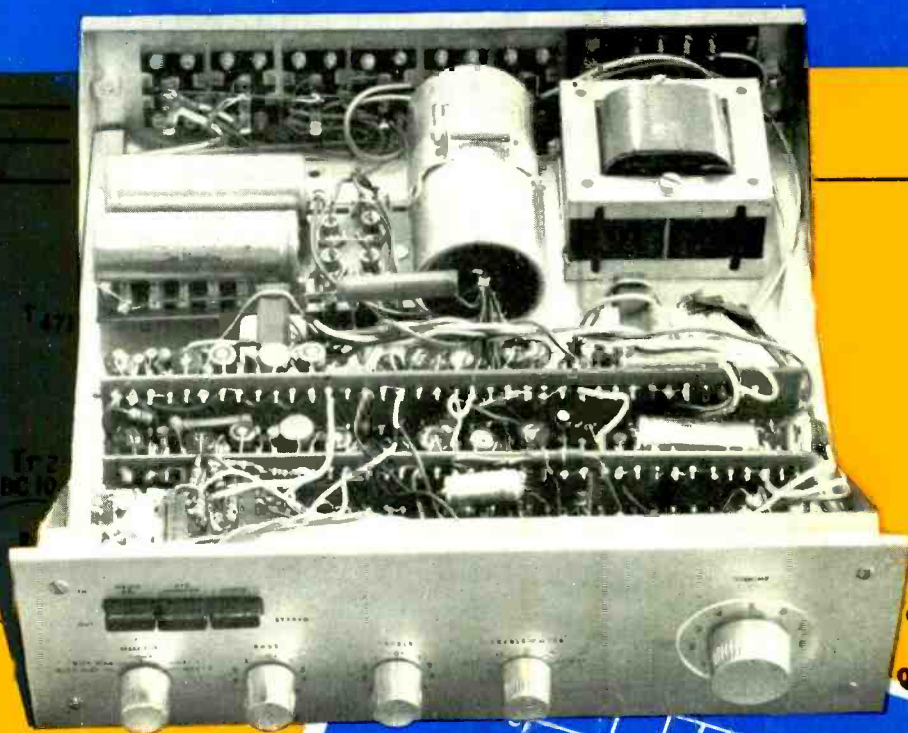

RELAYS

ex stock in 7 days

*C.S.A. APPROVED IN CANADA

***MK**

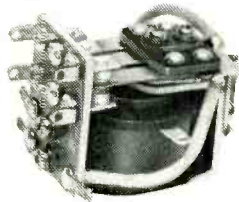

- ★ 3 pole 7.5 amp
- ★ 5 million ops. min.
- ★ **12/4** each per 1000
- Single pole **9/7** per 1000

- ★ 2 pole 5 amp
- ★ 5 million ops. min.
- ★ **14/8** each per 1000

MM Contactor



- ★ 2 pole 15 amps
- ★ 5 million operations minimum
- ★ **17/8** each per 1000

***MHP Plug-in relay**



- ★ 4 pole, 1 amp
- ★ 100 million operations
- ★ **13/-** each per 1000
- SOLDER TERMS
- 2 pole **8/-** per 1000

1051



- ★ Snap action microswitch relay
- ★ 7.5 amp, 1 million operations
- Also available in plug-in version
- ★ **7/5** each per 1000

***MKP Plug-in relay**



***MK103**

- ★ Single pole 3 amp
- ★ 1 million operations minimum
- ★ **5/11** each per 1000



MK403P NEW Plug-in relay



- ★ 4 pole 3 amp
- ★ 5 million operations minimum
- ★ **29/-** each per 1000
- SOLDER TERMS
- ★ **21/9** each per 1000

RELAYS

made to measure

APPROVALS: G.E.G.B. No. 131 & 92 · B.R. POST OFFICE KRL · U.K.A.E.A.

P.O. 3000 RELAY

- ★ Manufactured to full G.P.O. specification, also to Industrial Standards
- ★ Contacts up to 30 amp

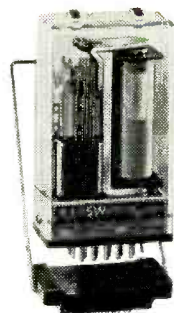
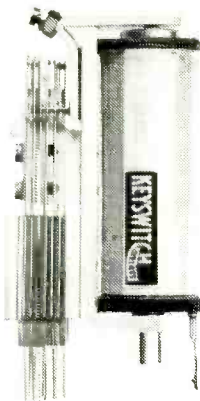

P33 PLUG-IN RELAY

- ★ Plug-in version to BPO 3000 relay, made to measure for Industrial Applications
- ★ Contact ratings up to 10A/750V
- ★ Positive-lock retaining clip
- ★ 30 million operations minimum

P.O. 600 RELAY

- ★ Compact version of BPO 3000 relay
- ★ Contacts up to 10A
- ★ Sensitivities down to 30mW
- ★ Up to 18 contact springs



COMPONENT BOARD P304



- ★ Plug-in component board unit for low cost, easy chassis fabrication
- ★ **15/-** each per 500
- FROM STOCK

CONTACTOR K700 RELAY

- ★ High-current/high-voltage 3000-type relay
- ★ Contact up to 30A240V a.c.
- ★ Sensitivities down to 45mW
- ★ PTFE armature bar/lifting rods

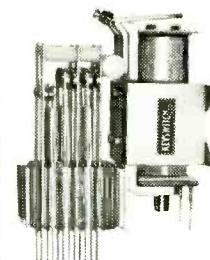

KEYSWITCH RELAYS

KEYSWITCH RELAYS LIMITED

120/132 Cricklewood Lane · London · NW2 · Tel: Gladstone 3344
Telex: 262754 STD 01-452-3344

WW—001 FOR FURTHER DETAILS.

"Wireless World"
Iliffe Electrical Publications Ltd.,
Dorset House, Stamford Street,
London, S.E.1

Managing Director:
W. E. MILLER, M.A., M.I.E.R.E.

Editor-in-chief:
W. T. COCKING, M.I.E.E.

Editor:
H. W. BARNARD

Technical Editor:
T. E. IVALL

Editorial:
F. MILLS
G. B. SHORTER, B.Sc.

Drawing Office:
H. J. COOKE

Production:
D. R. BRAY

Advertisements:
G. BENTON ROWELL
(Manager)
J. R. EYTON-JONES

© Iliffe Electrical Publications Ltd., 1966. Permission in writing from the Editor must first be obtained before letterpress or illustrations are reproduced from this journal. Brief extracts or comments are allowed provided acknowledgement to the journal is given.

VOLUME 72 No. 12
PRICE: 3s.

FIFTY-SIXTH YEAR
OF PUBLICATION

Wireless World

ELECTRONICS, TELEVISION, RADIO, AUDIO

DECEMBER 1966

- 589 An Opportunity for Re-thinking
590 Operational Weather Satellites *by C. E. Goodison*
595 R.S.G.B. Radio Communications Exhibition
598 High-performance Transistor Amplifier—2 *by A. R. Bailey*
603 Assessing 405- and 625-line Colour
615 Slow-Motion Video Tape Playback *by D. P. Robinson*
619 "Hanging on Cs" at High Frequency *by T. D. Towers*
625 Hybrid Computers—3 *by P. W. J. Van Eetvelt*

SHORT ITEMS

- 594 New Master Control for T.W.W. Studio
602 Leaffield Rebuilt
605 Son, Lumière et Fumée
606 Pulling Together—in the Same Direction
606 Equipment on Lunar Orbiter II

REGULAR FEATURES

- | | |
|---------------------------|-------------------------------|
| 589 Editorial Comment | 618 H.F. Predictions December |
| 606 World of Wireless | 623 Literature Received |
| 608 Personalities | 624 News from Industry |
| 609 Letters to the Editor | 630 New Products |
| 614 Books Received | 636 December Meetings |

PUBLISHED MONTHLY (3rd Monday of preceding month). Telephone: Waterloo 3333 (70 lines).
Telegrams/Telex: Wiworld Iliffepres 25137 London. Cables: "Ethaworld, London, S.E.1."
Annual Subscriptions: Home £2 6s Od. Overseas: £2 15s Od. Canada and U.S.A.: \$8.00. Second-class
mail privileges authorised at New York N.Y. BRANCH OFFICES: BIRMINGHAM: 401,
Lynton House, Walsall Road, 22b. Telephone: Birchfield 4838. BRISTOL: 11, Marsh Street, 1.
Telephone: Bristol 21491/2. COVENTRY: 8-10, Corporation Street, Telephone: Coventry
25210. GLASGOW: 123, Hope Street, C.2. Telephone: Central 1265-6. MANCHESTER:
260, Deansgate, 3. Telephone: Blackfriars 4412. NEW YORK OFFICE U.S.A.: 300
East 42nd Street, New York 10017. Telephone: 867-3900.

**IF YOUR
RENTAL
BUSINESS IS
SHOWING A
PROFIT,
KEEP ON
USING
Mullard
TUBES**

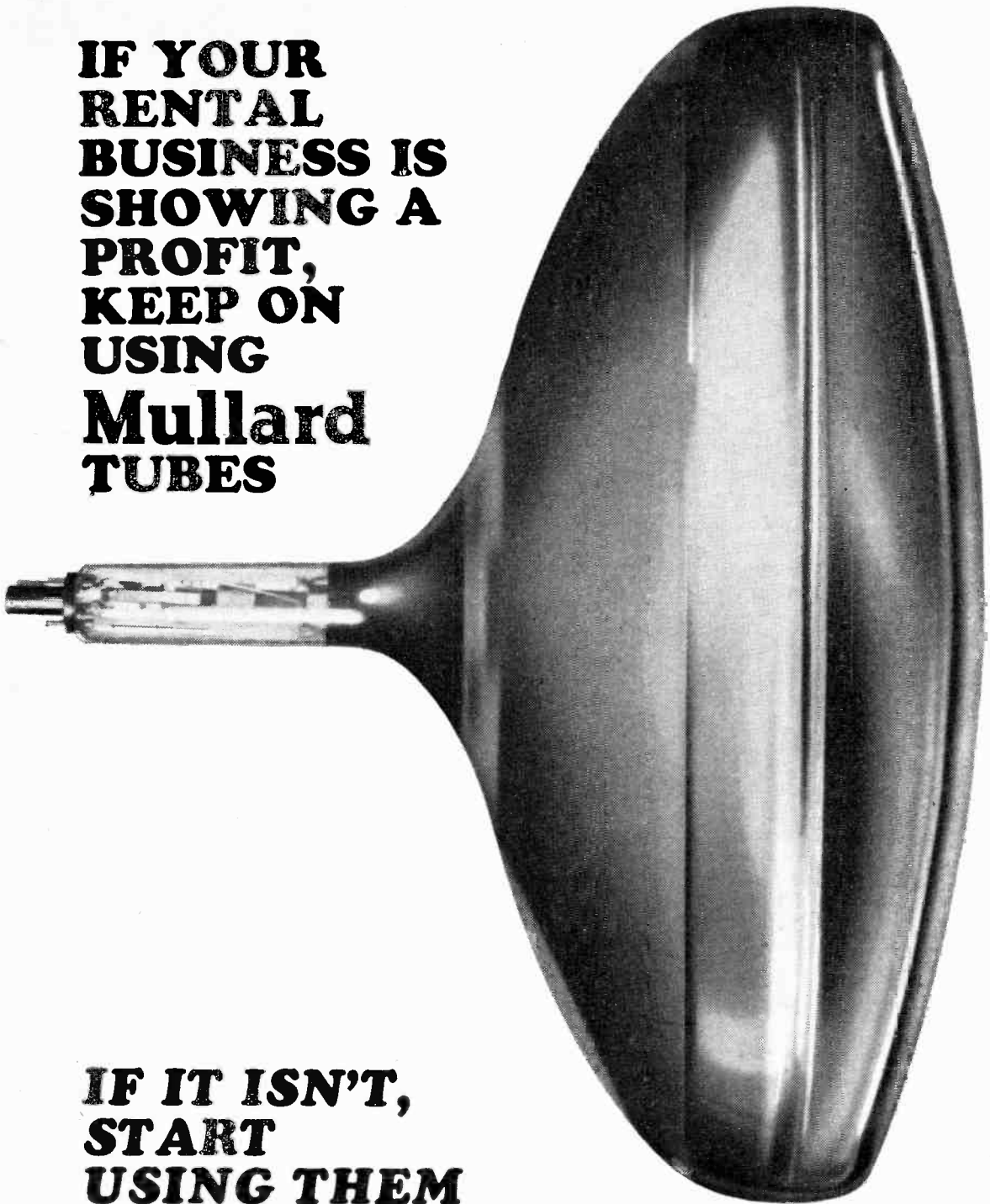

**IF IT ISN'T,
START
USING THEM**

Mullard

WW-123 FOR FURTHER DETAILS.

Wireless World

ELECTRONICS, TELEVISION, RADIO, AUDIO

An opportunity for re-thinking

SOME people in the domestic equipment industry see their current recession in the simple terms of a temporary, unpleasant episode which sooner or later will be followed by a return to normality. Meanwhile there are some obvious scapegoats on which to vent one's feelings, notably the Government, with its indecisive economic and broadcasting policies, and the importers of cheap transistor receivers. Other, perhaps more thoughtful, people see the recession as a phenomenon that calls for a re-appraisal of the whole structure and mode of operation of the receiver manufacturing business. One of the fundamental questions that might be asked is whether the set-making industry should necessarily continue to be—indeed whether it can *afford* to be—largely a mass-production industry dedicated to maximum-size markets and minimum-price products.

A revealing illustration has been the response of the industry to stereo records and broadcasting. The consumer magazine *Which?* in its November issue looked at stereo radiograms on the British market. The essence of its report (with which few of our readers will disagree) was that, while almost everybody considered the music reproduced on such stereograms to be more realistic and pleasant than with mono reproduction, the actual stereo effect achieved was poor, mainly because the loudspeakers were inadequate in quality, not properly matched and too close together. No doubt if one taxed the makers with these shortcomings they would reply: "Well, what do you expect for £70?" (One radiogram tested actually cost as little as £40.) And one tends to accept this view because the mass-production premise of "manufacturing down to a price" has become almost a law of nature. But one has only to look at the small, successful hi-fi equipment and quality receiver manufacturers to see that this is not the only way.

Again, when the B.B.C. substantially increased its stereo broadcasts in July, not one of the big set-making firms had any equipment on the market capable of receiving them. When we enquired the reason for this extraordinary lack of response we were told that stereo broadcasting was regarded as a minority interest, for the hi-fi enthusiasts only, and represented too small a market to be worth bothering about. (This reaction contrasts strangely with the big firms' enthusiasm for colour television, which might be equally a minority interest to begin with, considering the initial high price of sets and dearth of programmes.) Meanwhile the small manufacturers and the Continental competition marched on.

The industry which engendered this kind of outlook was, as "Vector" pointed out last month, built on two booms—the sound broadcasting boom of the 1920s and 30s and the television boom after World War II. Its markets did not have to be patiently built up like those of many other manufacturers of consumer goods: the demand was largely created by the broadcast programmes, initially paid for by public money. When, after a glorious all-time sales peak in 1959, the television market began to saturate, and competition from abroad began to bite, the industry rationalized itself and by various mergers coagulated its 25 companies into six major groups. The question now is whether the large mass-production units so formed are really the best means of coping with the market conditions to be expected in the U.K. Foreign competition, Government machinations and minority interests (e.g. people who want better sound from their television sets) will always be with us. Perhaps the time has come, not for further coagulation, but for some degree of fragmentation into smaller, more flexible set-making companies. The industry might then be better able to cope with the complex pattern of opportunities and obstacles presented by the market today.

VOL 72 NO 12
DECEMBER 1966

WIRELESS WORLD, DECEMBER 1966

589

Operational Weather Satellites

RECEIVING CLOUD COVER PICTURES

By C. E. GOODISON, A.M.I.E.R.E.

DURING the past year progress in satellite meteorology has made noteworthy strides. On February 28th ESSA 2, the first operational weather satellite equipped with two automatic picture transmission (A.P.T.) systems was launched from Cape Kennedy by N.A.S.A. in collaboration with the Environmental Science Services Administration (E.S.S.A.). On May 15th the second NIMBUS satellite, also equipped with A.P.T. and infra-red direct readout, was sent into orbit.

These two satellites are now broadcasting cloud cover pictures to many national weather services which have the simple ground equipment necessary to receive them.

ESSA 2 is the latest in a long series of weather satellites and is based on the design of early TIROS satellites. It is drum shaped, having a diameter of 42 in and a height of 22½ in. One side and its periphery are covered with 9,000 solar cells which, when illuminated by the sun, provide power to operate the satellite equipment and charge storage batteries. On the underside of ESSA 2 are mounted four transmitting whip aerials and on the other side is a command telemetry aerial. Projecting through the periphery at diametrically opposite apertures are the lenses of two independent A.P.T. camera systems. When the satellite is in orbit it rolls along like a wheel so that on each revolution there are two positions in which a camera points vertically to the earth's surface. Since the satellite is spin stabilized at 8-12 r.p.m., there are 16-24 suitable occasions per minute when photography is possible. The orientation of these cameras with respect to local vertical is sensed by horizon sensors mounted at right angles to the cameras. At the appropriate time the horizon sensor senses the dividing line between space and earth and the camera shutter is opened. Thus a picture is obtained while the camera lens is pointing directly towards the earth's surface.

ESSA 2 contains other telemetering equipment and carries the normal TIROS satellite fin stabilization system which includes spin-up rockets controlled from the ground and a cunning attitude controlling device. This magnetic attitude control consists of a few loops of wire circling the satellite. When an electric current flows

C. E. GOODISON has been on the staff of the Meteorological Office since 1948 and is an experimental officer in the Instrument Development Branch at Bracknell, Berks. He is mainly concerned with the design and development of electrical equipment. On leaving school in 1945 he served in the Royal Navy for three years as a petty officer radio mechanic

through the loop a magnetic field is produced which interacts with the earth's magnetic field to produce a torque on the satellite. The current flow is also controlled by telemetry from the ground and by adjusting it, the attitude of the space craft can be altered. It is by this means that the "rolling wheel" position of ESSA 2 is achieved and maintained.

The solar cells which form the primary power supply feed into a battery of nickel iron cells which supplies all the satellite electrical power.

NIMBUS 2 is a rather large 800 lb satellite which is the second in a series of research and development weather satellites developed by N.A.S.A. The first was launched in the autumn of 1964, but it had a complete power failure because of seizures of the solar paddles which could not then supply power to the storage batteries. Its configuration is completely different from ESSA 2 and is basically a two tier structure joined by a framework. The lower ring structure contains the radio transmitters, aerials, A.P.T. camera, infra-red radiometer, storage batteries and other instruments. The upper box-like structure contains a gas reservoir used to power stabilization jets, horizon sensors, and a control mechanism which keeps the solar cell paddles normal to the sun as the satellite progresses round the earth on its orbit. These paddles are covered on one side by solar cells which provide 450 watts when fully illuminated.

NIMBUS 2 is stabilized in an "upright" attitude, that is, the centre line of the two main structures always points to the centre of the earth. This attitude is maintained by the use of spinning fly-wheels mounted in the lower ring and gas jets projecting from the upper box. There are louvre-like flaps, black on one side and white on the other, mounted around the outside of the lower ring. The position of these flaps is governed by a control system which is sensitive to the internal temperature of the satellite. By this method of radiative cooling or heating, the temperature is controlled within the range 12-27 °C.

The most suitable orbit for a weather satellite may be generally described as one from which as much of the earth's cloud mantle may be observed as frequently as possible. These requirements may be met by a retrograde quasi-polar orbit, that is an orbit inclined at approximately 99° to the equator (in this context east is 0° and north 90°) and an orbital height of around 1,400 km. Such an orbit has certain very desirable characteristics

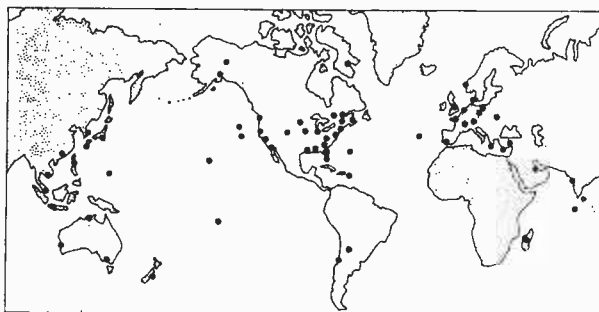

Distribution throughout the world of stations for the reception of the automatic picture transmissions from weather satellites.

for a weather observing satellite if launched during daylight hours. The orbital period of the satellite would be about 110 minutes and since the earth would rotate about 26° in longitude in that time then with the satellite at 1,400 km and an appropriate camera lens angle, picture swathes would entirely cover the earth's surface during one diurnal rotation of the earth. Also the retrograde angle of 99° and specified orbital height ensure that the orbital precession rate is 360° per year. One half of the orbit is always in daylight providing that the launch is carried out during the precise "launch window." This type of orbit is called sun synchronous and the satellite will be in sight of any particular place about the same sun time every day.

Since the drum shape of ESSA type satellites has one side which is covered with solar cells whilst the opposite

side has none, the satellite is injected into orbit either in the morning or afternoon so that the cells are fully illuminated. If it was launched at local noon then only the cells on its circumference would be illuminated.

Another advantage of a quasi-polar orbit is that reception of telemetry data and transmission of commands for such purposes as attitude control is also easily achieved by placing a Command and Data Acquisition station near the Pole. The American C.D.A. station at Greenbanks, Alaska, is well situated for such purposes.

A.P.T. camera system

The early weather satellites were equipped with television type vidicon cameras which, after taking a picture, were scanned and the line by line charge pattern read

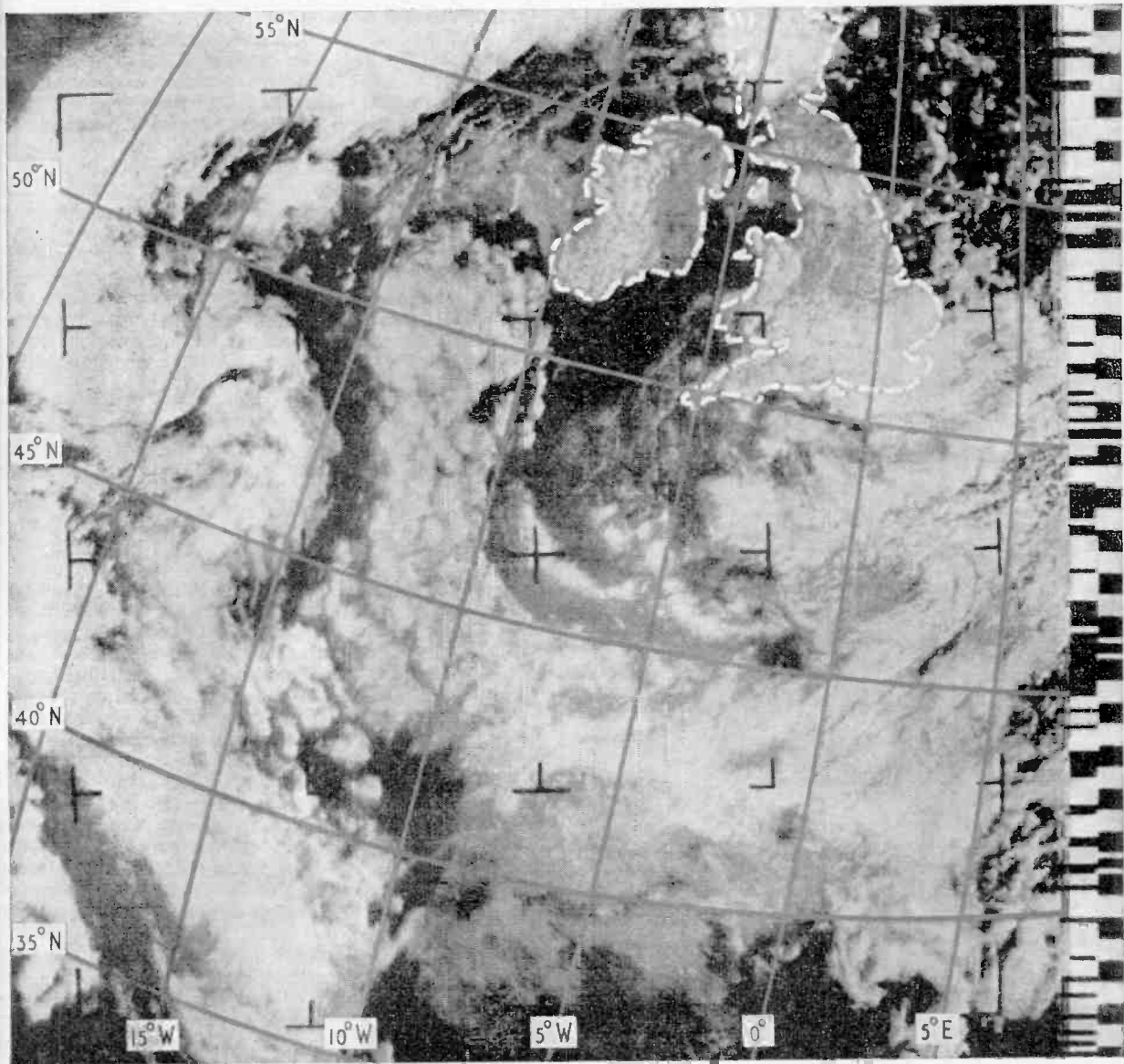

Cloud cover picture from NIMBUS received at Bracknell. The British Isles have been outlined and the lines of latitude and longitude added. The data coding on the right gives details of date and time of picture exposure plus information on future orbits.

into a tape recorder. This recorder was rapidly read out when the satellite was within range of an American C.D.A. station.

One of the disadvantages of this system was that the pictures were delivered to the C.D.A. station only and because of delays in transmission the picture of the area relevant to any one particular weather forecaster might reach him after a delay of up to 24 hours. This could invalidate its usefulness and usually did.

It was to overcome this problem, which is essentially a communications one, that the automatic picture transmission system, was used. This gives the space craft the dual role of observation and communication satellite.

After each cloud cover picture is taken it is broadcast by a narrow band v.h.f. facsimile radio transmitter and may be received by meteorological stations as far apart as Turkey in the East, Ocean Weather Ships in mid Atlantic in the West, Norway in the North and Morocco in the South.

On both satellites the A.P.T. camera is mounted so that as its shutter opens for 40 msec the lens is pointed vertically downwards. This exposure time does not cause visible deterioration of the picture since the satellite, which is moving at approximately 4.5 miles per second, will have covered 0.2 mile. With NIMBUS orbiting at 1,180 km the resulting picture is of 1,400 nautical miles square while ESSA 2 in a higher orbit of 1,410 km has a picture size of 1,700 nm square.

At the centre of the picture the definition extends down to objects 1.5 miles across and at the edge of the picture 4.5 miles. There is also a distortion at the edges and corners of the picture due to the earth's sphericity.

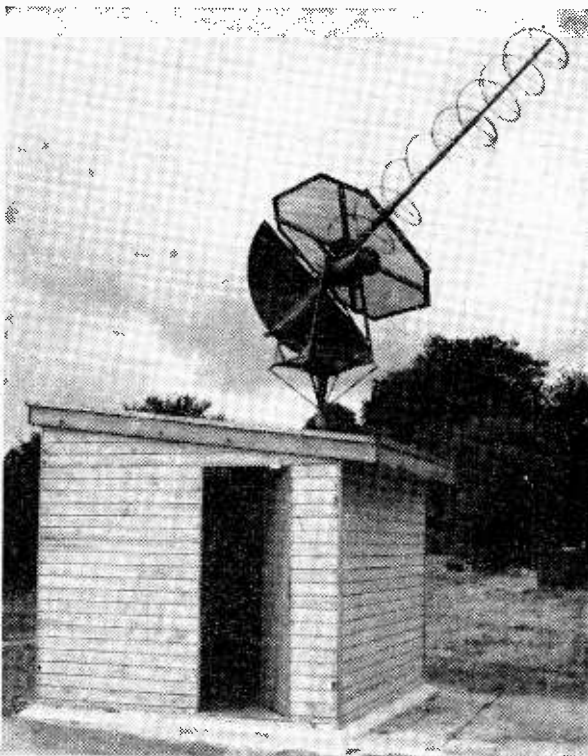

One of the helical aeriels made by Hawker Siddeley Dynamics for the ground receiving stations.

After the cloud cover image has been imprinted on the vidicon screen a charge transfer process is carried out in the camera and a polystyrene plate inside the camera holds the equivalent electrostatic charge image. This plate is then scanned at four lines per second for 200 seconds by an electron beam. As each element is discharged by the beam, the current flows in a common load resistor producing a voltage which amplitude modulates a 2,400 c/s sub carrier audio tone which in turn frequency modulates a 5-watt v.h.f. transmitter (NIMBUS 2 radiates on 137.5 Mc/s and ESSA 2 on 136.95 Mc/s).

There are various control and synchronizing waveforms also transmitted such as a 5 sec phasing signal and a 3 sec start tone which activates the ground receiving equipment.

During the picture transmission at the start of each line there is a 12.5 millisecond phasing pulse. The end of the 3 second start tone provides a time reference for the opening of the camera shutter which operates 2½ seconds later and thus provides a check of the satellite position. The cycle of operations of the A.P.T. system runs thus:—3 seconds start tone—5 second horizontal phasing pulses—200 seconds picture readout.

In NIMBUS which is in a lower orbit the pictures are taken in immediate succession, while with ESSA 2 there is a 120 second interval between pictures. The interval between pictures limits the overlap between adjacent pictures to approximately 30%.

For the reception of these cloud cover photographs all that is necessary is elementary receiving equipment. On consideration of the most distant transmission path when the satellite appears over the horizon it can be shown that the criteria for reception are an aerial system of 10 dB gain and a receiver noise factor of less than 4 dB.

By the use of an 8 turn helix aerial, a pre-amplifier with a noise factor of 3 dB (easily achievable with present-day transistors) and a simple receiver, signals are received which can drive a standard facsimile recorder.

A.P.T. ground station

The Meteorological Office has built two prototype sets of ground receiving equipment for assessment and operational use at Bracknell. The aeriels used are helices with dimensions suitable for a mid-frequency of 137.5 Mc/s, i.e., a diameter of 27.5 in and 21 in between turns. The ground plane is 5 ft in diameter and is made of expanded aluminium mesh. The helical aerial structure is fabricated from aluminium tubing and was initially supported at four points on each turn of the helix. It was found that in spite of Tufnol insulators on these supports the performance of the aerial was not to specification and it was only by removing every second support and using p.t.f.e. insulators on the others that the performance came up to standard. The aerial feed requirements were also found to be very critical and a type of stub matching improved the aerial gain considerably.

One of the aerial mounts is motor driven in elevation and azimuth and is remotely controlled, while the other is steered by hand at the aerial.

Different types of pre-amplifiers are used on each set. Both are mounted on the aeriels and are powered through the feeder cables linking them to their respective receivers. While both pre-amplifiers are two-stage low-noise transistor designs, one of them is a proprietary

model made in U.S.A. by Vitro Electronics and the other has been produced by Thorn Electronics Ltd. to a Meteorological Office specification.

Various types of communications receivers have been assessed as potentially useful for satellite signal reception. The one at present in use in the U.K. is a Pye air traffic communication set, type F.M.R.X. Its local oscillator is crystal controlled and is completely transistorized. The f.m. carrier from the satellite is detected and the amplitude modulated sub-carrier of 2,400 c/s is fed to a Muirhead D900S1 facsimile recorder.

This recorder uses electro sensitive paper which blackens when an electric current is passed through it. In the machine this paper passes between a stainless steel blade and a writing helix. Like a lawn mower's helix, as it turns the point of contact between plate and helix moves along the stationary blade. In this manner a line scanning action is produced.

The D900S1 recorder is based on commercial document machines and produces a $9\frac{1}{8} \times 9\frac{1}{8}$ in picture. The 300 c/s start tone from the satellite transmission starts the machine running. Then the 5 seconds transmission of 12.5 milliseconds phasing pulses which precede the actual cloud picture set the writing helix rotating. These pulses of 100% modulation of the sub-carrier produce a half-inch wide margin at the sides of the paper. If the machine were not phased properly the half-inch blank would appear down the centre of a split picture.

In order to be able to adjust the picture contrast range to compensate for deficiencies in the linearity of the transfer function of the paper, or contrast range of the satellite signal, a special circuit is interposed between the line amplifier and the writing amplifier.

A twin-track tape recorder working in parallel with the facsimile recorder obtains a magnetic tape record of each picture. The amplitude modulated 2,400 c/s sub-carrier from the radio receiver is recorded on one track and the 1,200 c/s reference tone is recorded on the second track. This tone is generated internally in the facsimile recorder. It is tuning fork controlled and is used to keep the speed of the writing helix accurately synchronized.

When playback from the magnetic tape is required the first track produces the picture information and the control of the facsimile machine helix is switched from the internal generator to the tone produced from the second track of the tape recorder. Since the picture signal and reference tone are correlated correctly on the magnetic tape then the correct relationship is maintained in the manner described. This method of playback prevents any picture slipping caused by unsynchronized mains frequency.

The waveform of the synchronizing 1,200 c/s tone has to be as near sinusoidal as possible since distortion of its shape produces harmonics which are detrimental to the operation of the helix drive circuits. The actual type of tape recorder used at Bracknell is a Vortexion CBL and the tape speed is $3\frac{1}{4}$ in/sec. Slower speeds have been used with success.

At present the accurate timing for satellite pictures (in one second the satellite covers approximately 4.5 miles) is derived from a crystal driven digital clock.

The description given above applies to two assessment prototype stations built by the Meteorological Office and installed at the Bracknell, Berks, headquarters.

A contract was placed with Hawker Siddeley Dynamics, of Coventry, some months ago for five self-contained ground stations for use at various overseas outstations of the British Meteorological Office. The

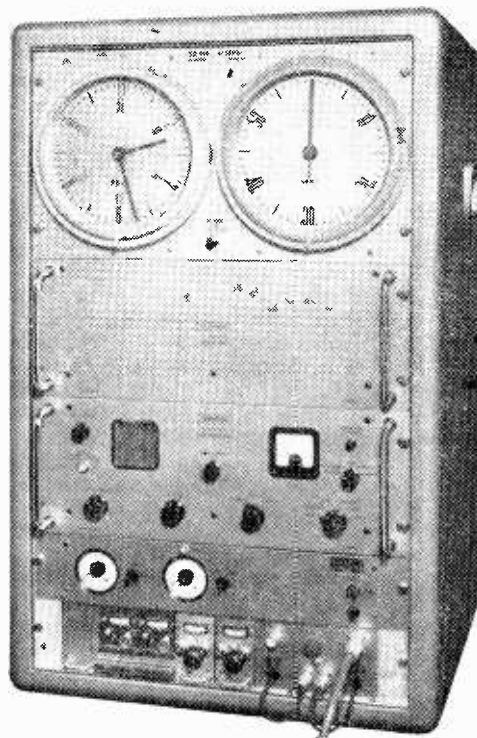

Rack-mounted receiving equipment produced by Hawker Siddeley. The bottom section includes duplicate pre-amplifiers and a.m./f.m. receivers made by Dynatel. The power supply unit and electronic control equipment for the Muirhead facsimile recorder are in the centre sections.

design of the stations follows that of the Meteorological Office prototypes but the aerial mount and drive system have been engineered for production. The radio receivers and pre-amplifiers are also new designs by Dynatel of Feltham

The first two stations will be installed at Singapore and at Gan in the Maldivé Islands.

A.P.T. operations

The cloud photographs received at Bracknell have been in use operationally as an aid to weather forecasting for some time now. The areas covered during any one day of operation usually extends from the Black Sea in the east to the Labrador Coast in the west and the North Pole to the 20th parallel of latitude.

The first pass of either satellite usually occurs at about 0600 local time and is an easterly transverse whilst afternoon passes are usually west of Greenland.

The two satellites are travelling in opposite directions in that NIMBUS is travelling from south to north whilst ESSA 2 is travelling from north to south during the daylight part of the orbits.

The orbits which are suitable for reception at Bracknell are detailed in regular messages from the U.S.A. These satellite prediction messages "A.P.T. predicts" give the sub-satellite points, i.e., the point on the earth's surface directly below the satellite in latitude and longitude every two minutes for daily reference orbits which are then used to deduce local orbital information.

By the use of special tracking diagrams a daily programme of operations is worked out and individual sheets of aerial steering data are prepared for each satellite pass. The satellite is not followed continuously but use is made of the 35° beamwidth of the receiving aerial and the elevation and azimuth angles of the aerial are changed at two minute steps to set values as indicated on the aerial steering programme of each particular pass.

Another aid to aerial steering is computed data provided by the Radio and Space Research Station at Slough. On each pass the number of complete pictures received varies according to how well favoured the orbit is in terms of maximum elevation angle from the receiving station. The overhead passes give the maximum number of pictures whilst those low on the horizon may give only partial pictures. An average of 20 pictures each day is received at Bracknell from the two satellites.

Identification of land masses when these are not cloud covered gives the quickest and most certain positional fix to the picture centre. (Fiducial marks are imprinted on each satellite picture, the centre of the picture being marked with a cross.) However, in mid-Atlantic and in totally cloud covered pictures the time of picture taking precisely fixes the picture centre. The "Predict" message is like a super timetable in this respect and, if the time is known and because of the absolutely constant orbital speed of the satellite, the position of the satellite can be very accurately known.

The cloud cover photographs produced by these satellites have now become a commonplace feature in the forecasting centre at Bracknell and are used to watch the movements of weather systems approaching U.K. The tropical storm "Dorothy" was identified on A.P.T. pictures received in U.K. before conventional methods spotted it.

When stations are set up in the Indian Ocean area at Gan and Singapore they will provide weather observations in these predominantly ocean areas where there is a natural paucity of weather information.

In the NIMBUS research and development satellite

two other interesting experiments are installed *viz* Datacode and D.R.I.R.

The Datacode experiment is an attempt to further supplement the role of NIMBUS as a communications satellite. Along one edge of the A.P.T. photograph a coded strip gives orbital details which enables A.P.T. stations to work out future aerial steering data, etc., without the necessity of receiving frequent "predict" messages. Also included in Datacode is the time of picture taking. This facility, if included in operational weather satellites, would allow A.P.T. ground stations to operate without the need for high accuracy clocks.

The other satellite borne instrument associated with A.P.T. is the Direct Readout Infra Red system. This uses the infra-red emission from clouds to photograph cloud formations at night.

The earliest of weather observation satellites used the progress of the satellite along its orbital path to provide one dimension of a scanning system for photographic purposes. The transverse scan was provided by a mechanical device in the satellite. In D.R.I.R. this type of scanning is once again employed for night-time photography of clouds and the resulting signal from the infra-red sensor modulates the A.P.T. transmitter. The mechanical scanning is considerably slower than that used on the daytime A.P.T. system and the circuits and helix speed of the facsimile recorder must be adjusted for these special purposes. To date at Bracknell reception on an experimental basis only has been obtained.

Automatic picture transmission is providing novel observations on a gigantic scale for meteorologists and will become increasingly an indispensable aid to weather forecasters who have to forecast the movement of large weather systems. The improvement in forecasting by the use of this new aid will, as always, be a very difficult factor to measure but already daily weather forecasts have been altered in the light of information received from these satellites.

The author thanks the Director-General of the Meteorological Office for permission to publish this article.

NEW MASTER CONTROL FOR T.W.W. STUDIO

IN its unique position of having to operate twin major studios (Bristol and Cardiff) and a bilingual service (Welsh and English), Independent Television for Wales and the West of England has special switching problems. It is the only regional programme company operating two separate, simultaneous transmissions—the T.W.W. general service ch. 10, and the Teledu Cymru network for Wales on ch. 7, 8, 10, and 11. A new master control for such switching problems has been built into the £0.25M extension at the Pontcanna studios in Cardiff. This switch complex designed by T.W.W. provides continuity and control for the two transmissions feeding five transmitters at St. Hilary (10 and 7), Presely (8), Arfon (10), and Moel-y-Parc (11). The special switching systems provide separate control of the two transmissions with a splitting arrangement on the Teledu Cymru transmission service. This is so that the ch. 7 transmitter at St. Hilary (Welsh) can be fed with the commercials that are transmitted on ch. 10 for the general service area. The switching system includes provision for 8-event pre-selection on both sound and vision for each of the two services. This

permits finger tip control of a total of 32 pre-selected events that can be held in memory stores. All T.W.W. transmissions can be controlled from either transmission desk, leaving the other suite free to provide more elaborate presentation sequences. In front of an engineer, operating from each suite is an electronic stop watch (giving a permanent digital display of "elapsed time") which starts a count from the moment of "fade up," ensuring correct programme timing. The system has provision for automatic control of the incoming network circuit, with automatic switching at Cardiff and Bristol Post Offices. The whole system has been planned for possible computer operation. Overlooking the presentation suites is an eight-channel telecine, and two-channel slide transmission control desk. Designed and built by T.W.W., it has standard control of all telecine channels. Above this desk is a 16-monitor bridge displaying the telecine and slide channel outputs, transmission and preview monitors, with provision for colour monitors. Adjoining the telecine area is the video tape department with three v.t.r. machines.

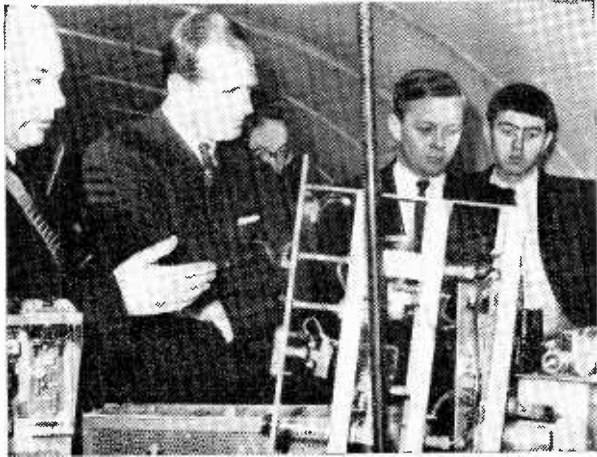

H.R.H. The Duke of Edinburgh, patron of the R.S.G.B. who opened the Exhibition, inspecting the display of home-constructed equipment.

R.S.G.B. Radio Communications Exhibition

THIS year's amateur radio exhibition sponsored by the Radio Society of Great Britain was a compact show of thirty-five exhibitors in the Seymour Hall, London W.1. The Armed Forces were represented by the Royal Naval Amateur Radio Society, and the Royal Signals, who were offering a crystal checking service.

On the same stand, the Royal Signals interference laboratory was demonstrating a technique for checking receiver response. It is perhaps significant that the Army is carrying out these tests on all receivers now being supplied to them. This feature introduced a typical front end of a Services' communication receiver which was being checked for spurious response. A sweep generator and display (Rohde and Schwarz Polyskop) was used. When a local crystal oscillator (in the receiver on test) was working on a relatively high harmonic, the response from 50-100 Mc/s was shown to be something resembling a comb filter response! It was also demonstrated that by operating the local crystal oscillator at its fundamental frequency, and not at a harmonic, the number of spurious responses was reduced to a few. The use of a higher i.f. (about 13 Mc/s instead of about 9 Mc/s) reduced the spurious responses to negligible proportions.

Interference was the main theme of the General Post Office stand, where a simulated interior of one of the new radio interference vehicles was displayed. One of these vans is to be supplied to each of the telephone areas to trace and deal with radio interference in the u.h.f. television Bands IV and V.

Manufacturer's award

The awards presented at the exhibition were the manufacturer's award, the Horace Freeman Trophy, the Thorogood Plaque, and a number of R.S.G.B. distinctions. The manufacturer's award went to Contactor Switchgear (Electronics) Ltd., a newcomer to the Society's exhibition. This company, who specialize in industrial static switching, entered the communications field earlier this year with a silicon transistor top-band transmitter intended for mobile use ("New Products," August and September issues). A companion receiver was announced prior to the exhibition and the award was presented for both items.

The receiver, covering about 1.8-2 Mc/s, is a single conversion superhet with an i.f. of about 511 kc/s. The circuit uses 14 silicon transistors and consumes between

120 and 280 mA, depending on output, from either a 12V car battery or a 12V HP1 (formerly TV1) dry battery. The circuit is fairly conventional up to the i.f. stages. Two tuned circuits and protection diodes precede the controlled r.f. amplifier (BSY95A). (A separate Colpitts v.f.o. feeds the mixer, both of which are BSY95As.) The first i.f. stage uses two ceramic resonators (Fig. 2) coupled by a series-tuned LC circuit, feeding a Darlington pair (BCY42-BSY95A). The second i.f. stage uses a similar arrangement, but the following circuit is split into two paths, one i.f. amplifier feeding the signal demodulator and another feeding the a.g.c. rectifier. This arrangement was chosen so that b.f.o. injection does not affect the a.g.c. circuit. The i.f. amplifier configuration gives the 3 dB bandwidth of 8 kc/s or 4 kc/s with a shape factor of 2.5:1 at 50 dB down, and is less costly than using a ceramic ladder filter. The bandwidth switch short-circuits the capacitor in one of the series LC circuits.

The b.f.o. consists of a Colpitts oscillator, tuned by a ceramic resonator, directly coupled to a BSY95A amplifier. This configuration gives a stability which enables s.s.b. signals to be received and the b.f.o. switch includes upper and lower sideband switch positions, shifting the

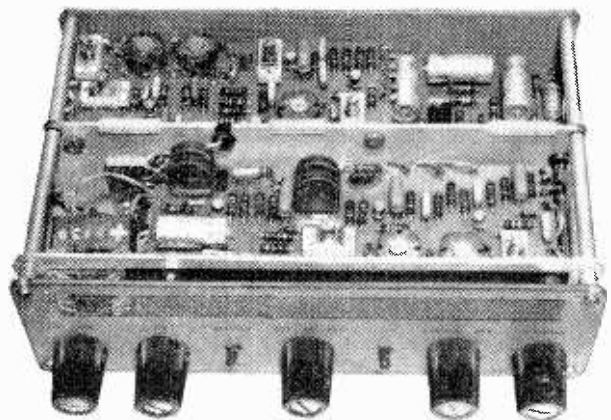

Fig. 1. View of top-band silicon transistor mobile receiver developed by Contactor Switchgear (Electronics) Ltd. The receiver and companion transmitter won the annual manufacturer's award.

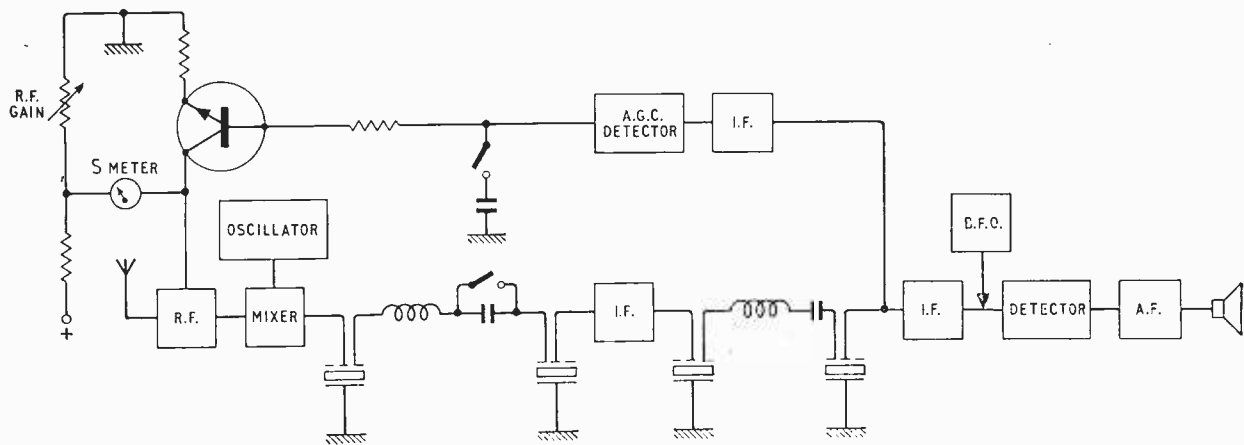

Fig. 2. Schematic of C.S.E. top-band receiver using ceramic resonators.

oscillator frequency by about ± 2 kc/s. The a.g.c. time constant (normally 100 ms attack time and 400 ms delay time) is switched to a delay of 1.5 s when the b.f.o. is switched in. The a.g.c. voltage is applied to a BSY95A transistor (Fig. 2), this controlling the supply voltage to the r.f. amplifier. An r.f. gain control also controls the r.f. supply voltage and an "S" meter records the amplifier a.g.c.—gain-control voltage differential. The four transistor audio stage is a 1.5 W class B transformerless circuit using a C426 and V410 complementary output stage. Receiver sensitivity is $1 \mu\text{V}$ for 10 dB s/n ratio.

Other awards

The Horace Freeman Trophy went to M. H. Emmerson (G3OQD) for a transistor receiver; the Thorogood Plaque to S. F. Weber (G8ACC) for a 7 W transistor transmitter for 70 cm; and the R.S.G.B. awards to D. R.

Bowman (G3LUB), M. J. Griffin (G3IIN), E. St. B. Sydenham (G3LOK), A. L. Mynett (G3HBW), H. C. Hopkins (G3NRI) and W. L. Kinchen (G2DZT).

The equipments designed by A. L. Mynett were converters using field-effect transistors, among them a 70 cm converter. The circuit of this is given in Fig. 3. Three silicon planar transistors (2N3826) are used in the local oscillator, the first as a crystal oscillator of 33 Mc/s, the second tripling to 99 Mc/s, and the third quadrupling to 396 Mc/s. This provides local oscillator injection to the common-source mixer which is a 2N3819 f.e.t. device, a Texas type costing about £1, which is preceded by another 2N3819 functioning as a common-gate r.f. stage. The mixer is followed by a 2N3826 common-emitter mixer, which converts the first i.f. of 36-38 Mc/s to second i.f. of 3 to 5 Mc/s, using the 33 Mc/s crystal oscillator. The converter noise figure is 5 dB and the strong signal performance is such that several 100 mV

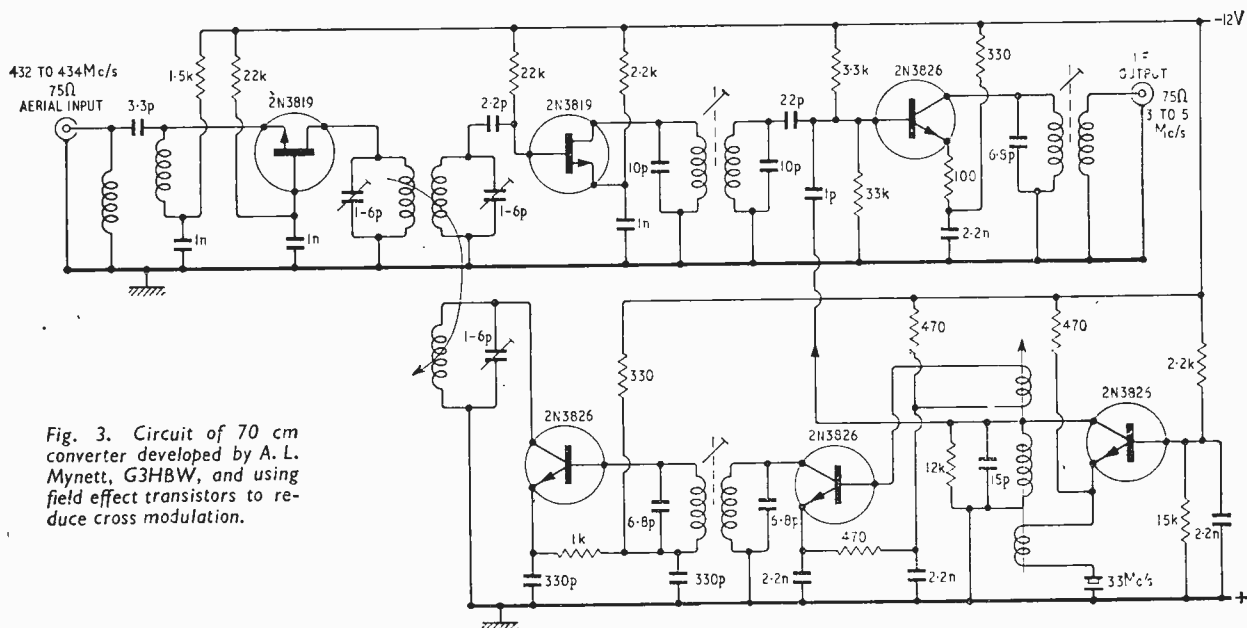

Fig. 3. Circuit of 70 cm converter developed by A. L. Mynett, G3HBW, and using field effect transistors to reduce cross modulation.

input signals simultaneously applied produce negligible cross modulation products.

Electroniques—S.T.C. link

Of great interest and significance to the home constructor, whether the hobby is radio communications or any other aspect of electronics, was the announcement by S.T.C., at the Show, that its recently acquired subsidiary, Electroniques (Felixstowe) Ltd., would provide a comprehensive electronic component and equipment supply service catering for the most sophisticated as well as the most simple needs of radio and electronics enthusiasts. Still using the name Electroniques, this service will operate from Edinburgh Way, Harlow, Essex, and will be part of the Electronic Services Division of S.T.C. at the same location.

Some items shown at the exhibition were aluminium die cast boxes with slots for component boards, complete sub-assemblies in the form of i.f. amplifiers and an aerial rotator referred to later. The professional grade i.f. amplifiers use silicon planar transistors and are available for 455 kc/s and 1.62 Mc/s. For 455 kc/s operation a version is available using ceramic resonators. Amplified a.g.c. and a stabilized b.f.o. or c.i.o. are included. Commercial grade i.f. amplifiers are also available using germanium transistors (AF117).

Other exhibits

An American company, Davco Electronics Inc., exhibited for the first time this year. The company showed a compact transistor communications receiver which has been available in the U.S.A. for 2-3 years (Fig. 4). About a year ago the front end was modified to incorporate two field-effect transistors. The set is a double conversion type with coverage from 3.5 to 54 Mc/s. Some of the features of this receiver are that toroidal inductors and ceramic resonators are used. A noise amplifier-limiter is included, the output from which is fed to a detector and used to mute the receiver. Noise limiter threshold is, of course, adjustable. Selectivity is switchable, diode switches being biased on or off and selecting either the relatively broad band i.f. stages alone, an additional 2.1 kc/s mechanical filter or a narrow band with a crystal and mechanical filter. The U.K. agents are expected to be announced shortly.

Some other items using field-effect transistors were shown by Green Electronic & Communication Equipment Ltd. These were 2- and 4-metre converters with noise factors of 2 and 1.5 dB respectively. Intermodulation and cross modulation distortion for these converters is claimed to be virtually non-existent. This firm also showed the new TMR-6 transistor communication receiver which uses an f.e.t. front end, again giving good cross modulation performance. Coverage is 80 m, 160 m and the m.w. band.

Daystrom have recently introduced two British Heathkit designs. One is a transistor car radio receiver (4 W) and the other is a stereo decoder (SD1) for f.m. broadcasts. (Fig. 5.) The circuit is similar to that used in the TFMT-1S tuner but using 2N3393 transistors instead of 2N2712s. In this design transistor switches are used in the subcarrier demodulator, a two transistor indicator circuit is included and a packaged RC filter used for removing unwanted signals in the output. Channel separation is given as 30 dB at 1 kc/s.

The "hula-hoop" circular aerial has been used by quite a number of amateurs in the past but does not seem to have found much favour elsewhere. J-Beam

Aerials, who produce a 2 m version, have now introduced a television Band 1 model (Fig. 6). This is for high signal-strength areas, where dipoles give no discrimination against multipath signals. The circular aerial has a directional characteristic similar to a figure of eight, and a gain 4 dB down on a dipole.

Another recent J-Beam aerial is the Parabeam, for u.h.f. use (70 cm and television bands). Using this type of aerial, which has a skeleton slot type of "driving" element and reflector but normal directors, a wide bandwidth can be obtained (e.g., 100 Mc/s) with a power gain of 2 dB over a Yagi array of similar length and using a folded dipole and multiple reflector.

Whilst on the subject of aerials mention might be made of another rotator that has become available. This is an American design made available through Electroniques. The aerial direction is "continuously" variable rather than the more common incremental type, and it is claimed that positioning to within 1° is possible.



Above: Fig. 4. Compact communications receiver by Davco (U.S.A.) using field-effect transistors in the front end.

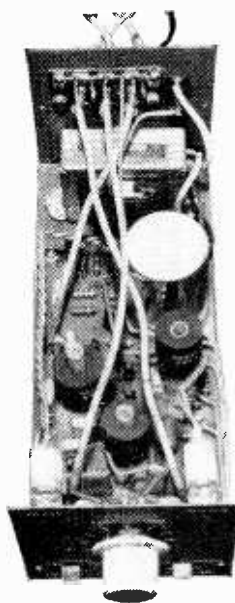

Left: Fig. 5. Heathkit silicon transistor stereo decoder.

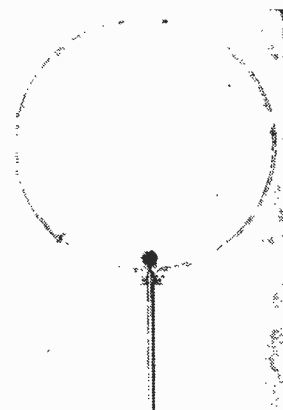

Right: Fig. 6. "Hula-hoop" Band 1 aerial for reducing multipath effects in high field strength areas.

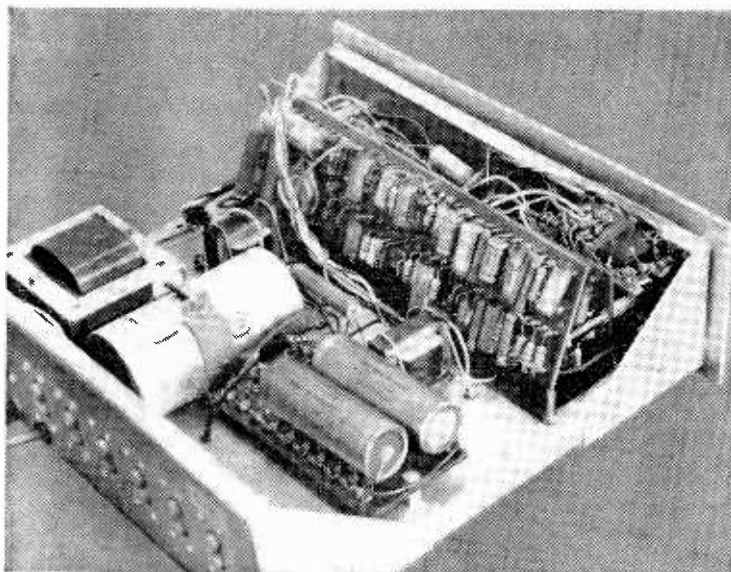

PART 2: FIVE STAGE SILICON TRANSISTOR PRE-AMPLIFIER DESIGN

HIGH-PERFORMANCE TRANSISTOR AMPLIFIER

By A. R. BAILEY,* Ph.D., M.Sc.(Eng.), A.M.I.E.E.

Last month the author described a design for a 20W power amplifier which has a number of interesting features. Two alternative output stages were given, one using germanium transistors for domestic use, and the other using silicon transistors for more exacting application. Positive and negative supply lines are used eliminating the loudspeaker coupling capacitor. The amplifier is stable with any load and may be used to drive electrostatic loudspeakers. Load short-circuit protection is built-in. The pre-amplifier, described below, uses five silicon transistors and apart from the usual facilities offers a high overload capacity—23 dB. Specifications of both the power amplifier and pre-amplifier are given on the next page.

THE input stage of the pre-amplifier provides recording correction (where necessary) by the use of over-all negative feedback. A feedback rumble filter is also included. The diagram of this first part of the circuit is shown in Fig. 9, where it is seen that a feedback triple circuit is used. This contrasts with the more usual feedback pair as shown in Fig. 10. There are two reasons for this modification. First, the gain of the circuit can be considerably increased by using a higher value for the collector load resistor of the second transistor. This gives sufficient reserve of gain to make overall feedback available below 50 c/s. This in turn gives a specified l.f. gain that is little affected by transistor variations.

The second effect is very important, and that is the

improvement in the overload capabilities of the circuit. The conventional feedback pair suffers badly at the extreme high-frequency end of the spectrum when recording correction is applied owing to the low impedance of the feedback network. (See Fig. 10.) This low impedance places a severe load on the second transistor collector and greatly reduces the output voltage available without severe distortion. This reduction can be as

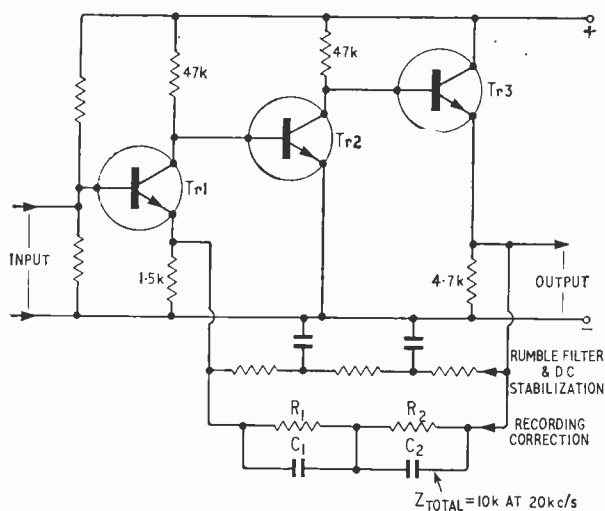

Fig. 9. Feedback-triple circuit for recording correction.

*University of Bradford

great as a factor of 10 times at 20 kc/s with consequent overloading. When it is remembered that the recording correction boosts these high frequencies, it will be appreciated that the high-frequency output from the pickup can be very far in excess of the rated pickup output. For this reason it is felt that the overload capability of a pre-amplifier should be over 20 dB over the whole of the audio-frequency range—particularly as most pickups exceed their rated output by a factor of several times when tracing a fully modulated record.

The circuit described gives an overload capability of about 23 dB over the whole of the audio-frequency range, the reduction in overload capacity being only about 2 dB at 20 kc/s compared with that at 1 kc/s. The difference is definitely audible with a fully modulated record when compared with the feedback pair and very noticeable when a 10 mV rated pickup is fed into a 3.5 mV rated input.

No provision has been made for crystal pickups as such except in that they normally perform better when driven direct into a 47 k Ω load and then subjected to normal recording correction. When using crystal pickups it is therefore only necessary to curb any high output models by a series capacitor or a resistor shunted across the amplifier input. In general such a mode of operation is preferable as it assists in damping resonances within the pickup.

High-pass filter

The use of planar epitaxial transistors gives a sufficient margin of gain so that some 14 dB of feedback can be applied below 50 c/s. This stable l.f. gain gives two advantages in that the l.f. recording characteristic can be met accurately and also the constant gain can be used for a negative-feedback rumble filter.

With feedback rumble filters the cut-off frequency is sensitive to the loop gain in the system, so it is imperative that the gain is not affected to any degree by transistor variations. This is provided by the circuit already evolved, so there is no difficulty in fitting a feedback rumble filter. The filter is of the two-section type having quite wide spacing between the time-constants of the sections. A close-tolerance electrolytic is preferable for the large capacitor, although the cut-off frequency only shifts by some 5 c/s for a capacitor having twice the recommended value. The smaller value capacitor can be of the polyester type and acts as a peaking capacitor to give maximal flatness to the characteristic. It is the effect of this capacitor that largely offsets the effect on cut-off frequency of the electrolytic capacitor. Purists can of course replace the electrolytic by a polyester type if they wish to pay the price of space and cost. The curve for the rumble filter alone is shown in Fig. 12.

Tone control

The gain control follows immediately after the recording correction amplifier so that overload difficulties are reduced to a minimum. This control feeds an emitter-follower Tr4 so as to obtain a low output impedance. This low impedance feed is necessary for the feedback tone control, or the characteristics of the tone control will be dependent on the setting of the gain control. The 2.2 k Ω resistor feeding the tone control is necessary to obtain balanced drive to the controls. With the controls set to their mid positions, the overall pass-band is quite flat, as can be seen from the square-wave

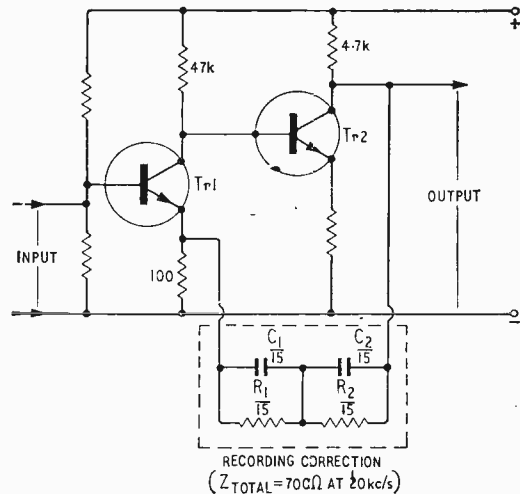

Fig. 10. Conventional feedback-pair circuit.

PRE-AMPLIFIER SPECIFICATION

Rated output:	500 mV r.m.s.
Harmonic distortion at rated output:	< 0.02 %
Noise:	- 60 dB all inputs - 80 dB for tuner and aux. inputs
Hum:	negligible with good layout.
Overload capacity:	23 dB over whole audio range (infinite for tuner and aux. inputs).
Sensitivity:	tuner—250 mV. aux.—250 mV. disc—3 and 12 mV. tape—4 mV. mic.—10 mV.
Input impedance:	47 k Ω for all inputs except tuner and aux., these varying between 60 and 100 k Ω depending on gain control setting.
Disc equalization:	R.I.A.A. characteristic to within ± 1 dB.
Tape equalization:	7 $\frac{1}{2}$ in/sec.*
Rumble filter:	see Fig. 12.
Low-pass filters:	see Fig. 15.
Tone controls:	see Fig. 14.

*Series resistor in feedback network (39 k Ω) should be halved for 15 in/sec and doubled for 3 $\frac{1}{2}$ in/sec.

POWER AMPLIFIER SPECIFICATION

Rated output:	20 W r.m.s. continuous into 16 Ω load.
Harmonic distortion:	< 0.1 % at 20 W and 1 kc/s rising to < 0.4 % at 20 kc/s.
Bandwidth:	6 c/s-100 kc/s (3 dB points).
Hum and noise:	- 80 dB.
Rise time:	< 4 μ s.
Rated input:	500 mV r.m.s.
Load stability:	unconditional
Short-circuit protection:	automatic current limiting at 130 % of rated peak output; over-dissipation prevented by quick-acting fuse.

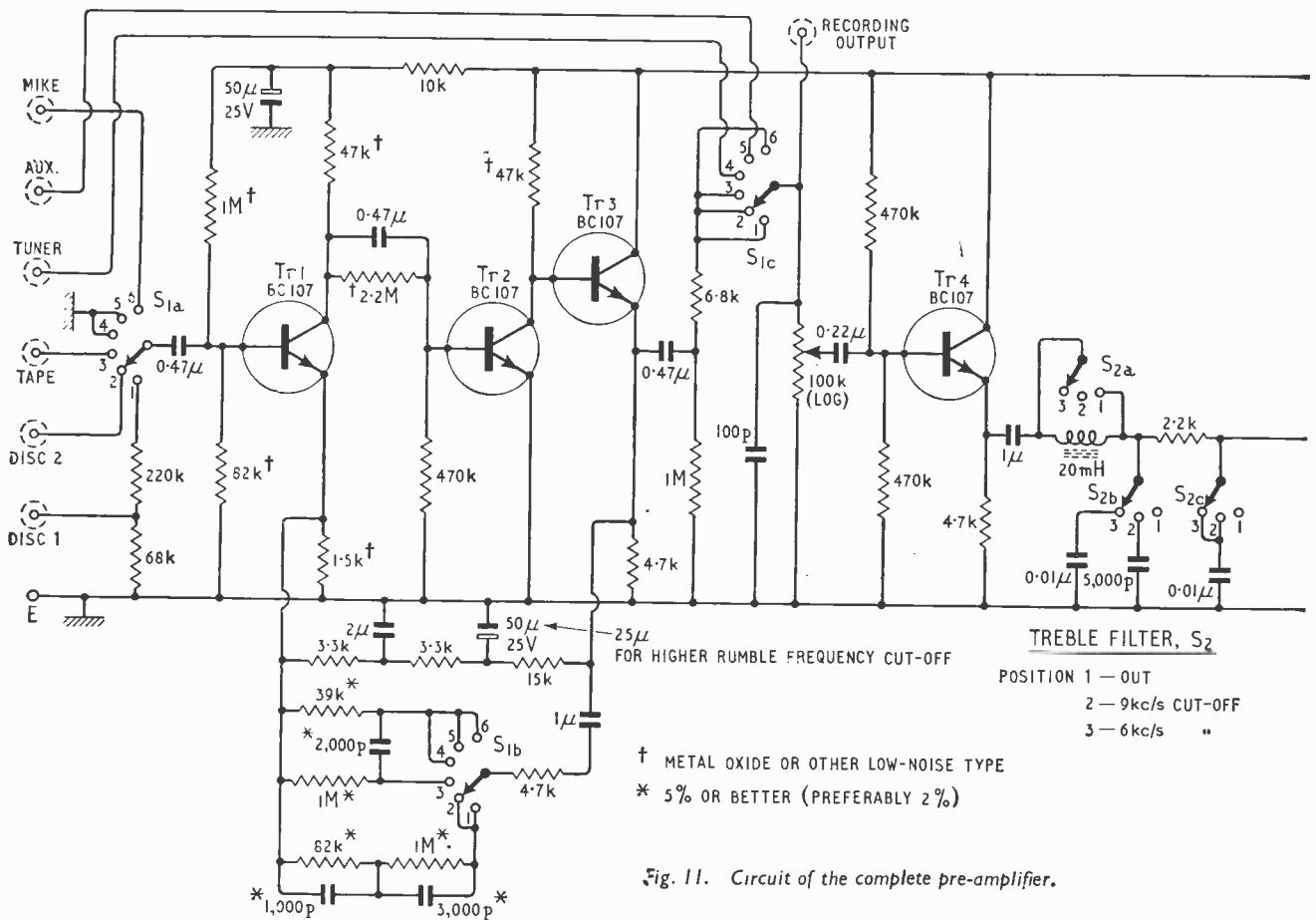

Fig. 11. Circuit of the complete pre-amplifier.

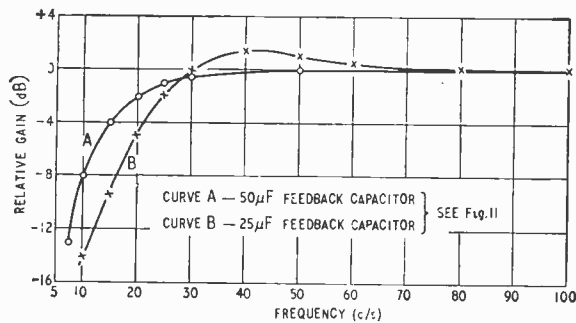

Fig. 12. Rumble-filter characteristics.

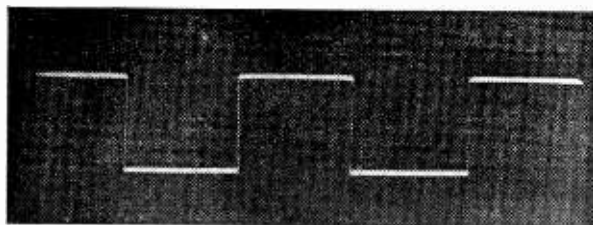

Fig. 13. Square-wave response at 1 kc/s of the tone control circuit set to "flat."

response shown in Fig. 13. The maximum lift and cut available is shown in Fig. 14, and this is considerably more than will be required for normal use. The load resistor of the tone-control collector is split so that the circuit gives an overall gain of just over two times. This was done so that the pre-amplifier can give an output of 500 mV with a rated input sensitivity of about 3 mV. This output is sufficient for many valve amplifiers, and as the tone control will deliver an undistorted output of over two volts, the pre-amplifier will in practice drive nearly all valve amplifiers quite satisfactorily. If an increased output is required, then it is merely necessary to tap off a smaller fraction of the collector load resistor voltage to the tone control.

Low-pass filter

The treble filter presented something of a problem. A feedback treble filter is possible over the tone control stage, but its performance is then dependent on the setting of the treble tone control. This was not felt to be satisfactory. Filters with very abrupt cut-off characteristics may not have a peaking response, but nevertheless they will ring very considerably at the cut-off frequency. The best compromise appears to be that of allowing a small amount of overshoot when square-wave tested.

The filter used in practice is an LC filter followed by an RC filter. This gives a fairly rapid ultimate rate of fall without appreciable transient ringing. The re-

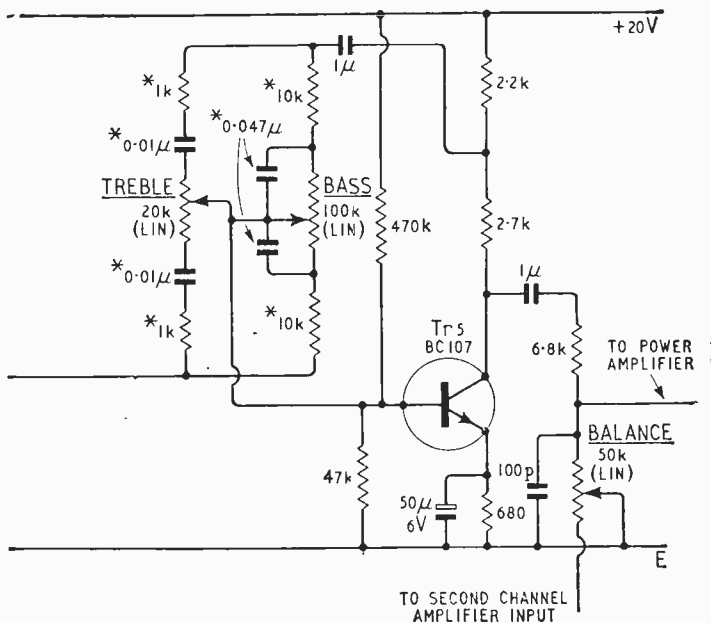

sponse of the filter is shown plotted in Fig. 15. A choice of two cut-off frequencies is provided, capacitor switching being used to change the cut-off frequency. The transient response to a square-wave is shown in Figs. 16 and 17, these clearly indicating the absence of serious ringing. The inductor is of the ferrite core type and should be sited away from strap magnetic hum fields.

The performance specification of the complete pre-amplifier is given in the panel on page 599.

Practical details

The sensitivity of the pre-amplifier can be changed most readily by changing the ratio of the two resistors in the collector of the tone-control transistor Tr.5. Providing that the total resistance of these is kept to about 4.7k Ω , then the rated output can be decreased to 250mV or increased to a volt or more. The nearer the tapping point is to the supply line, the greater will be the gain.

Although the pre-amplifier is for audio frequencies there is appreciable gain in the radio-frequency region so care must be taken to avoid spurious r.f. feedback paths. In particular all earth leads must be short; and any leads, such as the input connections, which are sensitive to capacitance pick-up, must be screened.

The "flat" position of the tone controls will be almost exactly at the electrical centre-point of the controls. This can be determined by a meter if in doubt, but the quickest check is to use a square-wave into the auxiliary input. Using a 500 c/s square-wave the correct settings are then immediately obvious.

The treble filter inductor is not critical, and any "Q" value over about 15 will be suitable. Very high-Q inductors do not give severe ringing as the circuit is arranged to provide the required damping. If ferrite pot-cored inductors are used, then the number of turns required is 4.5 times the number of turns specified for one millihenry. Enamel-coated wire is quite suitable and the gauge will be around the 34 s.w.g. mark. The wire size is unimportant for this application provided that sufficient turns can be accommodated on the bobbin.

The transistors specified have a high current gain and a high cut-off frequency as well as a low noise level. The first two stages are the most critical for noise and these are the most critical for gain as well. The other stages are more tolerant of poorer transistors but the author strongly recommends that silicon n-p-n planar epitaxial transistors are used throughout.

The author has had one of these pre-amplifiers and the associated power amplifier (described last month) running for over a year, and has not found any appreciable difference in performance compared with a good valve amplifier. There is a noticeable gain in extreme bass from the transistor amplifier, but this has been found to be due to the rumble filter frequency of cut-off in the valve amplifier (35 c/s as against 18 c/s in the transistor amplifier). Otherwise the pre-amplifier performance is indistinguishable.

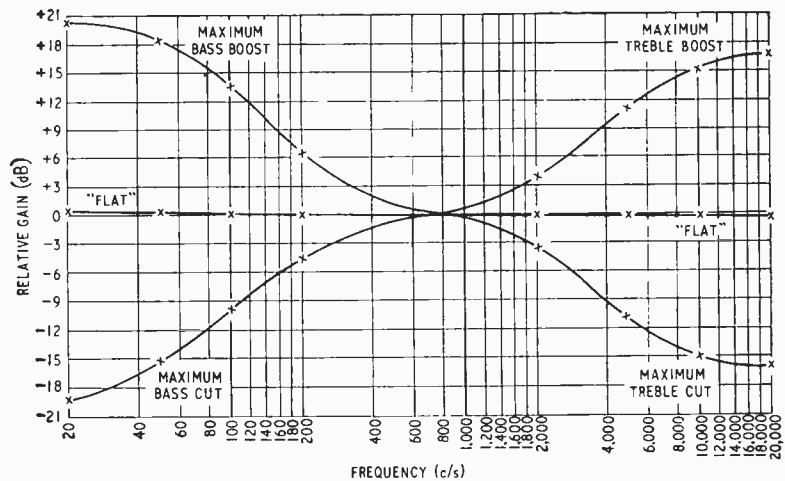

Above: Fig. 14. Tone control characteristics.

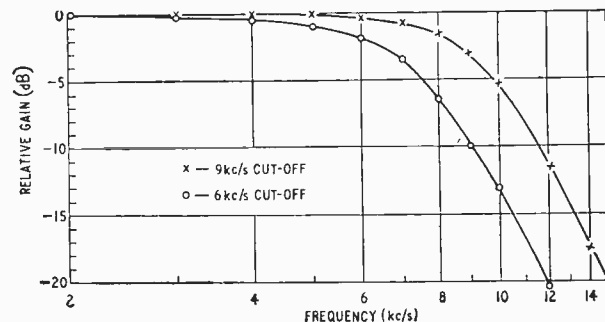

Right: Fig. 15. Treble filter characteristics.

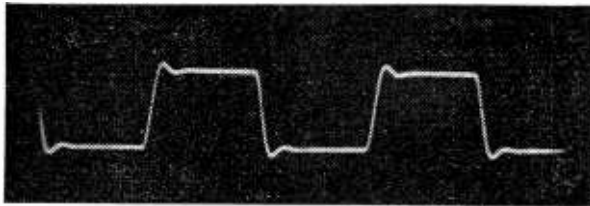

Fig. 16. Square-wave response of treble filter set to 9 kc/s cut-off. (1 kc/s square-wave.)

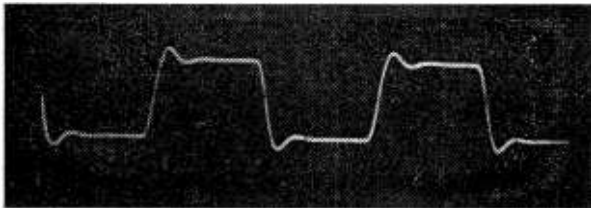

Fig. 17. As Fig. 8, but filter set to 6 kc/s cut-off.

This pre-amplifier is not the cheapest possible design (or germanium transistors would have been used), but was designed to give the best possible performance within the limits of reasonable cost. It is unlikely however that any audible improvement could be obtained even with considerably greater complexity and cost, as it would appear that all essential details in a pre-amplifier specification have been met.

Conclusion

The author would like to state that the designs presented are not intended to be the complete answer to transistor amplifiers, but merely one way of obtaining a high performance with economically available materials. Circuits change as available materials change, but it is felt that the circuits given have a performance that is considerably better than normal, and is unlikely to be radically bettered in the near future. Indeed it is getting to the point where increased performance on paper may give little, if any, subjective improvement in practice.

Acknowledgement

The author would like to thank all those friends and colleagues who have offered help and criticism, and would also like to acknowledge the facilities of the Bradford Institute of Technology where the testing was carried out.

Additional notes on the power amplifier

1. Where there is either inadequate heat sink area available or a risk of inadequate ventilation, the dissipation in the output transistors can be approximately halved under small signal conditions. The necessary reduction in quiescent current is obtained by reducing the $5\ \Omega$ base biasing resistors for the output transistors to $4\ \Omega$. This adversely affects distortion in the mid-band by about 0.03%, but it is unlikely to have an audible effect.
2. The low frequency stability can be improved by two series $22\ \text{k}\Omega$ resistors connected from the live side of the transformer primary to the base of the BC 107 transistor. The junction of these two resistors is taken to

Modification to power amplifier for use with badly regulated power supplies.

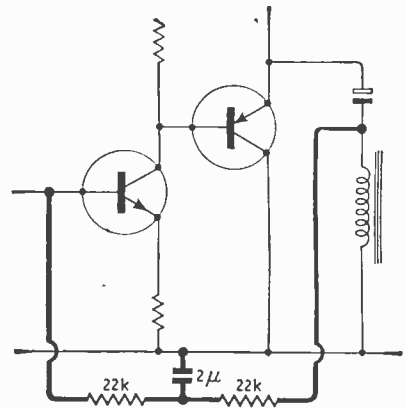

ground via a $2\ \mu\text{F}$ capacitor. It is most unlikely that this modification will be necessary unless the power supply has very bad regulation characteristics.

Leaffield Rebuilt

A NEW radio transmitting station has been built by the Post Office to replace the original built on the same site at Leaffield, Oxfordshire, in 1922. The station can be remotely controlled from London, but in fact, one man at a desk can start up and shut down services, select a free transmitter and synthesizer, select an aerial oriented in the desired direction and covering the right frequency, set the selected synthesizer to the correct frequency (then the transmitter self tunes, and adjusts to match the aerial impedance), set the level of the transmitted power, test the circuit and route the incoming traffic signal through the selected transmitter to the aerial.

Main equipment consists of twelve S.T.C. 30 kW transmitters for radio telegraph services to Aden, Athens, Beirut, Bombay, Dar-es-Salaam, Nairobi, Pretoria, and for combined telephone and telegraph services to Nicosia and Tehran. There are six 75 kW transmitters manufactured by S.T.C. for press services to East and West Africa, Middle East, India, and S.E. Asia. Here among the facilities and h.f. circuit techniques at the new station are self tuning, self-loading transmitters employing conventional tuned-amplifier stages with motorized drives of variable capacitors and inductors controlled by phase discriminators. As the tuning signals are applied to the transmitter, tuning and loading are completed automatically within 2 minutes using 5 motor drives. Solid state (silicon diodes) h.f. rectifiers in place of mercury vapour types improve reliability.

The aerial system has been designed to avoid congestion on the limited size site available (287 acres). For the fixed services, concentric tiered rhombics are used, and for the press and standby services a wideband log-periodic aerial is being employed for the first time at Leaffield. This log-periodic aerial horizontally polarized (6-25 Mc/s) has an array length of 382ft, while the height of the low frequency element is 164ft, and the high frequency element is 80ft.

All the radiated frequencies are derived from a stable 100 kc/s oscillator, accurate to 1 part of 10^7 . The whole crystal controlled unit including transistor oscillators is housed in a sealed container and placed in a tubular steel shaft 30ft below ground level.

Assessing 405- and 625-line Colour

RESULTS OF TESTS CONDUCTED BY THE B.B.C. AND I.T.A.

The latter half of 1966 has been enlivened by a public controversy on whether colour television broadcasting should be confined to the 625-line service (as laid down by the Government) or extended to the I.T.A. and B.B.C. 405-line services as well. The "625-line camp" is mainly identified with the B.B.C. and the "405-line camp" with the I.T.A. and commercial programme companies. Among the technical data being used by the two factions to support their points of view are subjective assessments of colour picture quality on 625 vs. 405 lines, and the following two articles, one from the B.B.C. and the other from the I.T.A., show the kind of results being obtained.—Ed.

B.B.C. COMPARATIVE 405/625-LINE TESTS

By G. O. ROE,* B.Sc.(Eng.), A.C.G.I. and F. G. PARKER,* B.Sc., A.M.I.E.E., A.M.I.E.R.E.

SUBJECTIVE colour viewing tests to compare the acceptability of the N.T.S.C. and PAL colour television systems on both the 405-line and 625-line scanning standards were conducted by the B.B.C. some months ago. The observers, drawn from the technical and non-technical staff of the B.B.C. Designs Department, were invited to assess the quality of pictures reproduced from colour slides displayed to them at random on the two systems and different line standards. The observers were not informed as to the system and line standard presented.

The quality was assessed on the E.B.U. six-point quality scale, defined later.

The colour pictures were produced from two flying-spot transparency scanners adjusted to have similar and substantially uniform responses within the frequency band appropriate to each scanning standard.

The amplitude/frequency response measured on a test card on the 625-line transparency scanner was uniform to 5.5 Mc/s in each channel, and on the 405-line transparency scanner to 3 Mc/s in each channel.

The signal/noise ratios (both standards, at transparency scanner output) were:—green channel 40 dB; red and blue channels 30 dB.

The bandwidths of the channels of the coders were:—Luminance 625-line 6 Mc/s; 405-line 3.6 Mc/s.

Chrominance

625-line N.T.S.C. $I=1.6$ Mc/s; $Q=800$ kc/s
 625-line PAL $B-Y=1.6$ Mc/s; $R-Y=1.6$ Mc/s
 405-line N.T.S.C. $I=1.0$ Mc/s; $Q=300$ kc/s
 405-line PAL $B-Y=1.0$ Mc/s; $R-Y=1.0$ Mc/s.

The bandwidths of the channels of the decoders were:—Luminance

625-line non-restricted except for the sub-carrier notch (3dB points) ± 500 kc/s
 405-line non-restricted except for the sub-carrier notch (3dB points) ± 350 kc/s

* B.B.C. Designs Department

Chrominance

625-line { N.T.S.C. $I=1.6$ Mc/s; $Q=800$ kc/s
 simple PAL $B-Y=1.6$ Mc/s; $R-Y=1.6$ Mc/s
 delay PAL $B-Y=850$ kc/s; $R-Y=850$ kc/s
 405-line { N.T.S.C. $I=1.0$ Mc/s; $Q=300$ kc/s
 simple PAL $B-Y=1.0$ Mc/s; $R-Y=1.0$ Mc/s
 delay PAL $B-Y=500$ kc/s; $R-Y=500$ kc/s

The display monitors were Bush type 681, fitted with sulphide phosphor display tubes, driven to a peak brightness of 15 foot lamberts.

Four slides were used for the tests, these being chosen to exploit the full gamut of the colour systems under test. The same slides were used in both transparency scanners to ensure that the colour reproduction on each standard should be the same.

Each slide was displayed for thirty seconds using one of the six possible colour systems listed above.

Both the selection of slide and system was in random order, the observers being uninformed about the system and standard in use during each test. Observers with a technical background, however, would have found no difficulty in identifying the 405-line pictures and so their results have been analysed separately.

A total of 48 observers took part in the tests, each test having a maximum of five observers sitting at distances of between 4 and 6 times picture height from the two colour displays. The sequence of slides and systems was changed from test to test in order that results should not be affected by the order of presentation.

Picture quality was assessed on the six-point quality scale devised by the European Broadcasting Union and defined as:—

Grade 1—Excellent	Grade 4—Rather Poor.
Grade 2—Good	Grade 5—Poor
Grade 3—Fairly Good	Grade 6—Very Poor

As some observers used in the tests had never seen colour television before, they were first shown a slide,

not from those to be used during the tests, reproduced from full bandwidth red, green and blue signals direct from the transparency scanner (i.e. not coded and decoded) on 625-lines.

The 48 observers, of whom 13 had some experience of colour television techniques, assessed the six systems as shown in this table:—

	Mean Grade	Standard Deviation	Standard Error
(a) 625-line N.T.S.C.	2.68	0.96	0.07
(b) 625-line simple PAL	2.38	1.03	0.07
(c) 625-line delay PAL	1.98	0.82	0.06
(d) 405-line N.T.S.C.	3.12	1.03	0.07
(e) 405-line simple PAL	3.13	1.03	0.07
(f) 405-line delay PAL	3.21	1.13	0.08

The percentage of observers awarding each grade to the six systems is shown tabulated below and in the histograms (a) to (f).

	Grade					
	1	2	3	4	5	6
(a) 625-line N.T.S.C.	17%	34%	35%	13%	1%	—
(b) 625-line simple PAL	18%	42%	30%	7%	3%	1%
(c) 625-line delay PAL	29%	50%	17%	3%	1%	—
(d) 405-line N.T.S.C.	4%	20%	43%	24%	6%	3%
(e) 405-line simple PAL	4%	24%	36%	26%	9%	1%
(f) 405-line delay PAL	6%	21%	32%	28%	11%	2%

The results from the 13 technical observers and the 35 non-technical observers were analysed as below.

	Grade	
	Technical	Non Technical
(a) 625-line N.T.S.C.	2.60	2.71
(b) 625-line simple PAL	2.41	2.37
(c) 625-line delay PAL	1.97	1.98
(d) 405-line N.T.S.C.	3.24	3.03
(e) 405-line simple PAL	3.07	3.07
(f) 405-line delay PAL	3.22	3.19

Both technical and non-technical observers were definite in their opinion that the 625-line PAL system with a delay line decoder provided the most acceptable pictures. This would indicate that the cross colour present in the simple PAL and N.T.S.C. systems was found disturbing by observers and the lower vertical

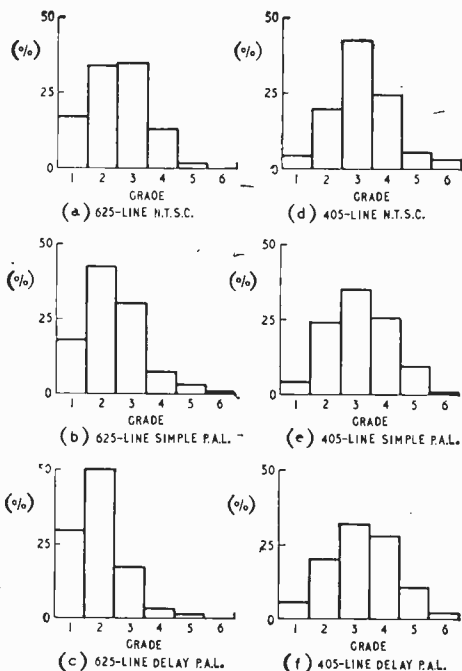

chrominance resolution and absence of cross colour provided a more pleasing result.

All 405-line colour systems were awarded a grade about one lower than the 625-line systems, it being difficult to differentiate between the systems because of the large values of standard error. This uncertainty was possibly due to the fact that some observers found the flicker effects on the 405-line monitor particularly disturbing whilst others were not greatly annoyed.

Results from the technical observers and those without any technical experience corresponded very closely. This indicated that, although the technical observers may have guessed at the line standard and even the system in use, it had not influenced their assessment of picture quality.

The authors thank the B.B.C. Director of Engineering for permission to publish these results.

I.T.A. 405-LINE TESTS USING PAL

By W. N. ANDERSON,* O.B.E., M.I.E.E.

DURING the past few months there has been some discussion on a proposal which would allow the I.T.A. and the B.B.C. to add colour to their 405-line services which are at present transmitted in the v.h.f. bands. Some recent B.B.C. tests, the details of which (see page 603) were disclosed at a recent Television Society meeting†, tended to suggest that the 405-line PAL system was incapable of giving good quality colour pictures and if used for public broadcasting could lead to fairly widespread dissatisfaction and to complaints from viewers. The I.T.A. and the programme com-

panies have been working in this field for some considerable time and have conducted many tests on the 405-line PAL system. In general it may be said that the results do not support the B.B.C. conclusions and that a very high standard of picture quality is obtainable on the 405-line standard. In what follows there is given a description of tests which were made on the 4th and 5th October, this year, with the help and co-operation of the members of the Press who acted as the observers.

Method of assessing pictures

The method of making subjective assessments of picture quality was the same as that adopted by the E.B.U. *ad*

* I.T.A. Telecommunications & Experimental Group.

† Television Society Meeting, 25th August, 1966, entitled, "Should Britain Have a Single or Dual-Standard Colour Television Service?"

hoc Group on Colour Television. This group has had the task of assessing various colour systems and has made recommendations on such matters as the viewing distance and grading scales to be used in the assessment of picture quality. The E.B.U. has also produced a special colour film covering a wide range of scenes and a number of 2×2 in slides suitable for use in the evaluation of colour systems.

Eleven of the fourteen items shown in this picture assessment test employed this recognized material; one was a special colour slide; the two remaining items were provided by a live studio camera.

For each of the pictures shown in the test the observers were asked to write down a quality grading in accordance with the E.B.U. six-point scale:—

- | | |
|---------------------|---------------------|
| Grade 1—Excellent | Grade 4—Rather Poor |
| Grade 2—Good | Grade 5—Poor |
| Grade 3—Fairly Good | Grade 6—Very Poor |

In each test the observers were free to use half picture grades if they so wished.

Two colour monitors were provided and the seating was arranged in two groups at a mean distance of six times the picture height from the screen. The highlight brightness on the screens was about 11.6 ft-lamberts. Some background lighting was provided behind the monitor screens and above the observers in order to allow them to complete the grading forms during the test.

The picture generating equipment was located at the Teddington studios of A.B.C. Television and the display equipment was at the I.T.A. premises in Knightsbridge. The overall bandwidth of the system was limited to a nominal 3.0 Mc/s by the use of an appropriate linear phase low-pass filter at the output of the picture source. A G.P.O. circuit using video transmission on coaxial cable was used to send the signal from Teddington to Knightsbridge.

With the exception of the studio camera, which was a Marconi Mk. 7 four-tube Plumbicon type of recent design, the remainder of the generating and display equipment had been in use for about three or four years. The film material was scanned on a Cintel polygonal prism teleciné machine modified for colour and the slides were displayed through a normal colour slide scanner also made by Cintel.

Results

A total of 27 observers took part in the two-day tests and the results are presented in the following histograms and tables:

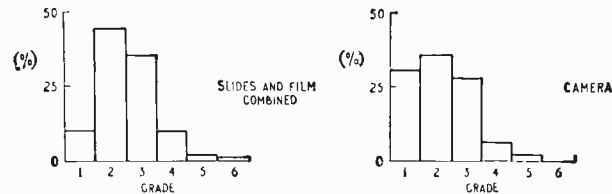

Material	Slides		Film		Camera		Overall		
	1st	2nd	1st	2nd	1st	2nd	1st	2nd	Both days
Mean grade ..	2.49	2.56	2.38	2.63	2.09	2.10	2.4	2.52	2.43
Standard deviation ..	0.92	0.79	0.89	0.80	0.85	1.0	0.9	0.84	0.88
90% confidence limit of mean	0.16	0.17	0.15	0.17	0.24	0.37	0.10	0.12	0.08

The distribution of the gradings can be seen from the following analysis where the figures indicate the percentage of the audience awarding each grade.

Grade	1	2	3	4	5	6
Slides	9	43	35	9	3	1
Film	12	43	34	10	1	1
Camera	30	35	28	6	2	0
Overall result ..	13	42	34	9	2	1

Conclusions

The results show that the mean quality grading for the 405-line (delay-line) PAL pictures used in this test was 2.43. That is to say, between "good" and "fairly good" on the six-point scale. The best quality pictures were obtained from the studio camera which gave a mean grading of about 2.1. The results on slides and film were slightly worse.

There was hardly any difference in the ratings given by technical and non-technical observers.

On the overall result 13% of the audience gave ratings which were in grades 4, 5 or 6. In the case of camera pictures only 8% of the results were worse than grade 3. From these results it may be inferred that the 405-line PAL system is capable of giving a very good standard of picture quality and that few complaints, which could be directly attributed to the inherent quality of the picture, would arise.

Finally, it would seem reasonable to suppose that the use of more modern equipment for slides and film would lead to slightly higher picture gradings than those obtained in the tests.

Thanks are due to the Chief Engineer of the I.T.A. for permission to publish this material. The author would also like to express his thanks to A.B.C. Television, who provided the equipment and gave their full support throughout the work.

Son, Lumière, et Fumée

ONLY a ride in H. G. Wells' time machine could surpass the experience at Madame Tussaud's Exhibition in London where the Battle of Trafalgar is vividly relived. This new £50,000 spectacle makes full use of light, sound, smoke and smell, electronically programmed and controlled to impart a high degree of realism to the recreated scenes from the lower gun and orlop decks of the *Victory*. The sound of a gun being run in and out and loaded, the commands, and drum and bugle signals were all recorded on the *Victory*, and the noise of one of her Trafalgar guns being specially fired was also recorded at Portsmouth. All these sound effects, with the noises of a real sailing vessel at sea, and the simulated noise of battle, combine to produce a five minute sound cycle. A series of command pulses on a separate track synchronize the lighting, sound, smoke and smell effects.

The complete programme is recorded on multitrack tape running at 3½ in/sec in endless loop cassettes. Four 50 W Electrosonic ES1138 amplifiers are used to drive five 15 in speakers. There are also six 10 W Electrosonic modular amplifiers ES1272 (based on the Dinsdale design). These are modular plug-in types with tape pre-amplifiers and provide continuous background noise through five 12 in units, four 8 in units, and a 3 ft line source unit. The pulse replay units are operated by the control tracks on the tape, and their output is fed to the programming and control equipment. The main control unit includes automatic dimmers for lighting control. The programming equipment permits the selection of any of 40 functions by 50 cues—thus a 2,000 hole pegboard arranged as a 40×50 matrix is provided.

WORLD OF WIRELESS

Pulling Together—In the Same Direction

PERTINENT questions concerning "a few of the many uncertainties" that are causing "grave disquiet" in the industry, were asked by the chairman of the Conference of the Electronics Industry (Mr. F. N. Sutherland) when speaking at its third annual dinner attended by many representatives of the Government on November 8th.

"We have a new sponsoring Ministry, the Ministry of Technology; but it is anything but clear to us what is to be the role of this new Ministry. Are the establishments of the Ministry of Aviation and Admiralty, with whom we have worked so closely and satisfactorily in the past, to pass over to the Ministry of Technology in part, or in total? Is the Ministry of Defence to be responsible for procurement and the placing of research and development contracts in the military field? If so, will a similar responsibility be placed on the Ministry of Technology on the civil side? Whatever is decided, our industry is wholeheartedly against any arrangement that will divorce the responsibility of procurement from research and development."

Referring to the close association of the electronics industry with the field of civil and military aircraft Mr. Sutherland, who is chairman of the Marconi Company, said the uncertainty in this sector of our industry is equally as great. "Is Plowden to be implemented wholly or in part; and what is the Government's policy for the British Aerospace Industry? Again, has the Government any plans to back our very young industry in the field of satellite communications?"

We live in a world of ever-increasing specialization and Mr. Sutherland voiced the opinion that our Ministers and their advisers have not the adequate knowledge in this specialized technological age to formulate policies without regular and formal consultation with industry. To keep pace with the rapidly changing environment it is essential, he

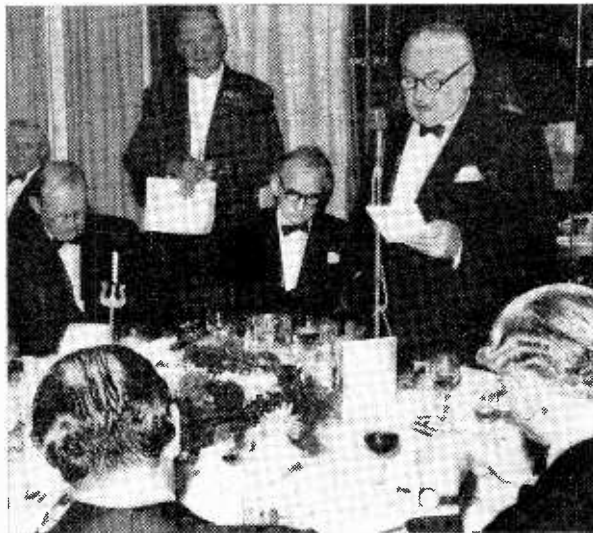

F. N. Sutherland speaking at the annual dinner of the Conference of the Electronics Industry attended by nearly 500. On his right is Mr. Douglas Jay, President of the Board of Trade.

said, "that Government and industry adjust themselves just as rapidly, and also ensure that we are both moving in the same direction."

Go-ahead for Relay Services

THE companies who distribute broadcast sound and television programmes by wire and cable can see their way ahead to a further period of development now that the Government is proposing to grant new relay operating licences that will remain in force until July 1976. Announcing this at the annual luncheon of the Relay Services Association of Great Britain, the P.M.G., Mr. Edward Short, said that July 1976 had been chosen as it was the date on which the charters of the broadcasting organizations fall due for renewal, and it would therefore enable the Government of the time to survey the whole field of broadcasting. The Association's chairman of council, Mr. F. E. Hall, said in reply that he was not sure that the proposed 8½ years was entirely satisfactory. This period of licensing did not give very much security. Now that saturation had been

nearly reached growth was much slower, and relay operators would have to consider carefully whether further investment would be sufficiently justified. Nevertheless he mentioned that growth was approximately 100,000 subscribers per year. The present totals are 979,000 combined television and sound installations plus 240,000 sound only.

It emerged from conversations with relay people at the luncheon that they are anxious about possible competition from the G.P.O., who are looking into the question of providing new types of services on the telephone network. Indeed the P.M.G. made specific reference to a future national integrated wire communications network which users of various kinds—schools, offices, factories, public utilities—could simply "plug into" to obtain different types of information or programme material.

Equipment on Lunar Orbiter II

THE second Lunar Orbiter spacecraft was launched on November 6th by N.A.S.A. from Cape Kennedy, Florida. This is the second in a series of five spacecraft which follow the Ranger and Surveyor programmes in exploring the moon's surface. (Lunar Orbiter I, launched August 10th, was caused to impact with the moon on October 29th so that it would not interfere with Lunar Orbiter II.) The aims are to photograph possible landing sites, define the moon's gravitational field more precisely and monitor radiation.

Photographs are taken in a special way because the spacecraft moves at 4,500 m.p.h. and exposure speed is slow. An electronic sensor scans the image formed and provides a

signal, dependent on the spacecraft velocity/height ratio, which controls the speed of the film during exposure. After exposure, the film is passed through a processor and a buffer or storage area and fed into a flying-spot film scanner. The scanning beam is obtained from a line scan tube in which an electron beam impinges on a drum coated with phosphorescent material. The drum is rotated to avoid burning at the electron beam energy used. The light generated is focused to a spot diameter of 5 µm, scanning about 2½ in-wide film with 17,000 lines per 1/16-in section. The light beam passes through the film and illuminates a photo-multiplier which provides a video signal for transmission. A complete

scan takes 20 s, and 40 min is required to read the $1\frac{1}{2}$ in of film which corresponds to a single exposure. Readout of one complete frame takes 43 min, and the total number of frames is 211.

A 10 W transmitter, feeding a 10° beam-width, 36-in parabolic aerial, is used for the picture transmissions. Telemetry and environmental data are transmitted on low power (0.5 W) using an almost omni-directional aerial. Transmissions take place in the S-band.

Her Majesty The Queen has granted the Television Society permission to use the title **Royal Television Society**. The Society, which now has a membership of over 1,600, was formed in Leeds in 1927. The 40th anniversary on September 7th next year falls on the last day of the annual meeting in Leeds of the British Association for the Advancement of Science when it is planned to have a commemorative function. The Society is also planning a symposium on the production of colour programmes in March.

"**Waves, Waveguides and Radar**" is the title of the I.E.E. Christmas holiday lecture for schoolchildren to be delivered this year by Dr. P. J. B. Clarricoats, Professor of Electronic Engineering, University of Leeds, assisted by Dr. J. R. Richardson. The lecture, which is intended for boys and girls of the fifth and sixth forms, will be given at the Institution on December 29th at 2.30 and will be repeated at the same time the following afternoon. Admission is free, and application for tickets, stating for which afternoon they are required, should be made to the Institution of Electrical Engineers, Savoy Place, London, W.C.2.

R.S.G.B. Show.—Attendance at this year's R.S.G.B. Show (see p. 595) which was opened by H.R.H. the Duke of Edinburgh, exceeded 10,250 an increase of over 1,500 on 1965. The demand for space at the Show has necessitated a move to a new venue. The 1967 exhibition will therefore be held (September 27th-30th) at the New Horticultural Hall, Westminster.

Although the number of entries for the **Radio Amateurs' Examination** held in May by the City & Guilds of London Institute was higher than the two preceding years the percentage of passes was lower (58.7%). The number of candidates was 1,519 of which 891 passed. The report on the exam states that "more candidates failed to attempt all eight questions than has been the case for many years and there were many cases where only five or six questions in all were attempted."

Ferroglyph Festivals of Sound are being held in various parts of the country during the winter. The next is on November 30th at Campkins Audio, Cambridge.

Support for British Integrated Circuits.—It seems clear that the Government, through the N.R.D.C., is determined to support the native British effort in i.c.s against American competition. N.R.D.C. say they are discussing proposals with a number of companies, and it has been reported (*Financial Times*, November 9th) that "The Ferranti company's already considerable activities in microcircuit work are likely to receive fresh impetus in the form of several million pounds" from N.R.D.C. Ferranti is, of course, the company responsible for the major output of "indigenous" i.c.s—those resulting from entirely British development and not relying on licences from U.S. firms. The company make no comment on the *F.T.* report but do not deny it. John Pickin, manager of Ferranti's Electronics Department, said earlier this year "the equipment design of the future will be done on a slice of silicon and if we do not have the ability to do this we will not have an electronic equipment industry in this country."

The first prize winner in the "best students of the year" awards of the Radar & Electronics Association was Sgt. Elizabeth Hollingsworth, W.R.A.C., a student at the R.E.M.E. School of Electronic Engineering, Arborfield, Berks. During 1965 she completed the Telecommunication Technician examination in which she was top of a class of 16, the remainder being male students. Her marks included maths 100%, electrotechnology 96%, electronics 90%. The second prizewinner was H. Shah who has completed an electronic engineering course at the Northern Polytechnic, London; third was F/O D. M. Allen, R.A.F. College, Cranwell; and fourth C. H. Makan, Northern Polytechnic.

An evening course of six lectures on **low-noise amplifiers** (including masers, parametric and tunnel diode amplifiers and varactor multipliers) is to be held on Tuesdays at 7.0 commencing January 10th at Norwood Technical College, Knight's Hill, London, S.E.27. (Fee 15s.)

Non-resonant Loudspeaker Enclosure.—A Yorkshire firm is prepared to supply long-fibre wool at 10s 6d per pound, including postage, for the loudspeaker enclosure described by Dr. A. R. Bailey in our October 1965 issue. Enquiries should be sent to John W. Pennington (Dowley Gap) Ltd., Midland Wool Warehouses, Briggate, Windhill, Shipley.

Three of the six **amateur tapes** entered through the Federation of British Tape Recording Clubs for the 15th international contest held in Amsterdam in October won prizes in different classes.

The **humidity classification** quoted in Dubilier's advertisement on p. 59 in the November issue should have read DEF 5132-H5.

MASTER CONTROL for two television services is provided by this composite installation at the Cardiff studios of the independent television programme company T.W.W. (Television for Wales and the West of England) described on page 594.



PERSONALITIES

Group Captain E. Fennessy, C.B.E., B.Sc., M.I.E.E., director of Plessey Electronics Group, has been appointed chairman of the board of World Satellite Terminals Ltd., the consortium recently formed by A.E.I., G.E.C., and Plessey to build complete ground terminals for satellite communications. Group Captain Fennessy, who is 54, joined the Decca Navigator Company after war service in No. 60 (Radar) Group of the R.A.F. and in 1950 became managing director of Decca Radar Ltd., the position he held when he left to join Plessey in March 1965. Also on the board of World Satellite Terminals is **E. Alexander, A.M.I.E.E.**, director and general manager of the Electronic Apparatus Division of A.E.I., and **J. Bell, B.Sc., F.Inst.P.**, who recently relinquished the managing directorship of the M-O Valve Company and is now managing director of the Aerospace and Defence Division of the G.E.C.

L. E. Thompson, managing director of Westinghouse Brake and Signal Company, has been appointed chairman of the new £2M company, Westinghouse Brake English Electric Semi-Conductors Ltd., set up jointly by Westinghouse and E. E. to design, develop and manufacture power semiconductors. **J. M. Ferguson**, a director of English Electric Automation and chief engineer of English Electric's Electrical Products Group, is deputy chairman.

A. D. Patterson, B.A. (Sc.), nominee for the 1967 presidency of the Radio Society of Great Britain, graduated at Trinity College, Dublin, in 1955 and then joined Short Bros. & Harland (Belfast) as an electronics engineer. Mr. Patterson, who is 34, obtained his first amateur transmitting licence while still a student and now operates under the call G13KYP. His particular field of activity is in the 70 Mc/s band.

A. G. Wray, M.A., M.I.E.R.E., has been appointed chief engineer of Marconi Instruments Ltd. A graduate of Emmanuel College, Cambridge, he joined Marconi Instruments in 1944 and has successively been company physicist (1952), deputy chief engineer (1960) and engineering manager (1963).

R. J. H. Branthwaite, B.A., M.I.E.E., has been appointed manager of the Radio Laboratory at the M.E.L. Equipment Company, Crawley, Sussex, where he will be responsible for the development of military and professional radio communication equipment. He was previously deputy manager and chief engineer of the Power Electronics Department at G.E.C. Computers and Automation Ltd.

S. R. Wilkins, managing director of Avo since 1960 has become deputy chairman of both Avo and Taylor Electrical Instruments and will also retain his technical directorship of both companies. Mr. Wilkins, who is 55, joined Avo as a development engineer in 1934. **R. Woolliscroft, M.A.**, who is 44, succeeds Mr. Wilkins as managing director and chief executive of the two companies. He joined the parent company, Metal Industries, in 1960.

G. W. A. Dummer, M.B.E., M.I.E.E., has left the Royal Radar Establishment, Malvern, where he has been for 27 years, and is taking up consultancy work and extending his literary work. While at R.R.E. he has been concerned especially with components and micro-electronics, on which he has lectured extensively and written many articles. In 1964 Mr. Dummer was awarded the Wakefield Gold Medal of the Royal Aeronautical Society for his work in micro-electronics. He will be operating from his home at 27 King Edwards Road, Malvern.

"For a life dedicated to development and progress of telecommunications and in particular for the invention of Pulse Code Modulation, an ingenious system which is being diffused all over the world and which makes it possible to extend telephonic transmission to the greatest possible distances, without loss of quality." Thus reads the citation of the award of the "City of Columbus" gold medal made to **A. H. Reeves**, of Standard Telecommunications Laboratories Ltd., Harlow, Essex. The medal was presented to him in Genoa, the birthplace of Columbus, at the opening of the 14th International Convention on Communications. Mr. Reeves, who is 64, joined the International Western Electric Company (the parent company of S.T.C.) in 1921 and worked on the transatlantic radiotelephone systems. He joined the associated laboratories in Paris at their inception in 1928, and while there he originated the method of p.c.m. From 1940 to 1945 he worked on radio-countermeasures and on guidance and accurate bombing systems. Since 1946 he has been at Standard Telecommunications Laboratories doing advanced circuit development.

M. D. A. B. Rackowe, M.A., A.M.I.E.E., who joined Coutant Electronics Ltd., of Reading, Berks., two years ago, has been appointed chief engineer of the Electrotech Instrument Division. He graduated in the mechanical sciences tripos at Pembroke College, Cambridge. After spending a year with English Electric Aviation working on guided weapon control circuitry, he joined Everett Edgcombe & Company. For 18 months prior to joining Coutant in June 1964 he was with A.M.F. International. In our issue of January 1965 Mr. Rackowe, who is 30, contributed an article describing a design for a monostable blocking oscillator, that will produce medium power, fast pulses.



A. D. Patterson



G. W. A. Dummer



S. R. Wilkins



M. D. A. B. Rackowe

LETTERS TO THE EDITOR

The Editor does not necessarily endorse the opinions expressed by his correspondents

Constant-Current Circuits

I HAVE been very fascinated by the constant-current circuits described by G. Watson in his article in the August issue, and by P. Williams in a letter published in the September issue.

The common feature of these circuits is that they are true two-terminal circuits, powered, so-to-speak, by their own constant current. They require no separate d.c. supply lines, and could, indeed, be made, using micro-miniature techniques, as very small sealed components with only two leads.

Whilst Mr. Watson's circuit looks novel and unfamiliar drawn his way, it is interesting to find that his Fig. 1 circuit can alternatively be drawn as in my Fig. A. This shows that the circuit is really a known form of stabilized power supply circuit^{(1) (2)} except for the rather trivial difference that Tr1 collector, in a power supply, would normally be taken to Tr3 collector. When the voltage between terminals 1 and 2 is varied, the stabilizer circuit holds the voltage across points 3 and 4 nearly constant, so that the current taken by R_1 , R_2 , and extra load R_6 if added, is also nearly constant, thus requiring an almost constant current to be supplied to terminal 1.

The resistor R in Mr. Watson's Fig. 2 applies positive feedback to the "error amplifier," which is a known means of improving the performance of a stabilized power supply circuit.

The Fig. 1 circuit in Mr. Williams's letter is most elegant—I feel this must be the simplest and most straightforward solution to the problem. It seems to me rather misleading, however, to regard it as an application of positive feedback; there would seem to be significant positive feedback only during the short time between switching on the supply and the Zener diodes catching. Once the Zener diodes are conducting, it seems to me that the circuit is best regarded simply as a combination of the simple constant-current circuit of Fig. B with a complementary version of the same circuit, the constant current of each circuit being used to energize the Zener diode of the other. The total constant current of the complete circuit is the sum of the constant currents of the individual circuits, which need not necessarily be equal.

Whilst the circuit of Fig. B is quite a good constant-current circuit, it is not perfect because of the effects of collector voltage variation on the ratio of division of emitter current between base and collector, and on the emitter-base voltage. Also, temperature variations affect the current because of their influence on current gain, emitter-base voltage and collector-base leakage current.

A circuit which is almost free from most of these defects is described in detail by E. W. Shallow and myself in a recent issue of the I.E.E. *Electronics Letters*⁽³⁾, and

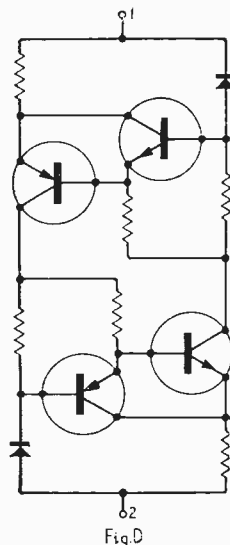
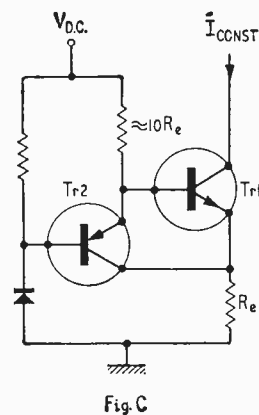
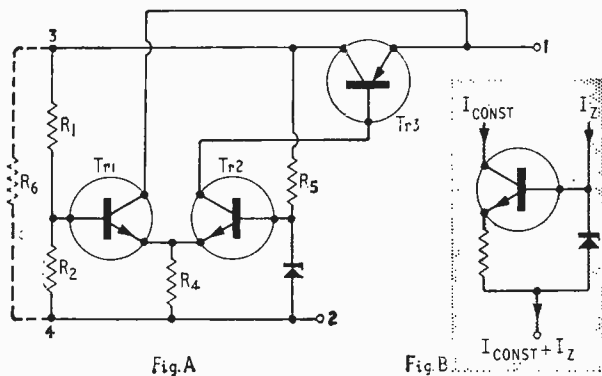

the essentials are shown here in Fig. C. A differential output resistance of about $50 M\Omega$ is typical when operating at 1 mA. The effect of collector-base capacitance in Tr1, which shunts the output in the Fig. B circuit, is degenerated in the Fig. C circuit, and output capacitance values of well under 1 pF are obtained.

Two circuits of the Fig. C type could be connected together as shown in Fig. D to produce a two-terminal constant-current circuit. Whilst this would give a higher degree of current constancy than Mr. Williams's attractively simple circuit, it has the shortcoming that it would not work with such a low voltage between terminals 1 and 2.

PETER J. BAXANDALL

Royal Radar Establishment,
Malvern, Worcs.

I WAS interested to read Mr. Watson's lucid account of a simple constant current circuit (August issue p. 403). It may be worth commenting on the versatility of the circuit described: with slightly different external connections, the same circuit is widely used as a voltage

(1) P. J. Baxandall, "Transistor Crystal Oscillators and the Design of a 1-Mc/s Oscillator Capable of Good Frequency Stability," *Radio and Electronic Engineer*, Vol. 29, No. 4, April 1965.

(2) F. J. U. Ritson and R. C. Foss, "Transistor Power Supplies with Limited Overload Current," *Electronic Engineering*, Vol. 34, No. 414, August 1962.

(3) P. J. Baxandall and E. W. Shallow, "Constant-Current Source with Unusually High Internal Resistance and Good Temperature Stability," *I.E.E. Electronics Letters*, Vol. 2, No. 9, p. 351, Sept. 1966.

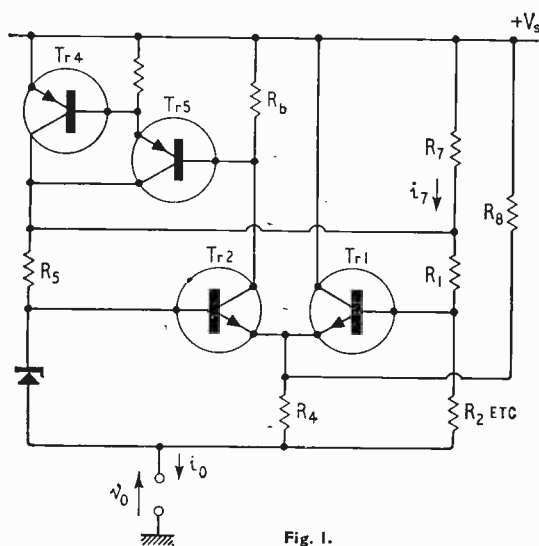

Fig. 1.

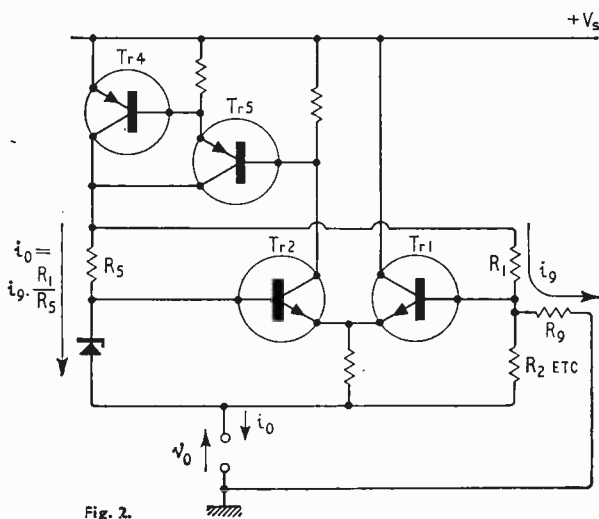

Fig. 2.

regulator, and its use as an impedance converter has also been described (e.g. *Electronics*, May 3rd, 1963; *Electronics Letters*, March, 1965).

I would like to comment briefly on some points of difference between Mr. Watson's circuit and a similar one which I developed some three years ago.

(1) No allowance is made in Mr. Watson's circuit for manufacturing tolerances in h_{FE} of transistor Tr3. Of course Tr3 operates at constant collector current, so that its base current (supplied by Tr2 collector) will vary, from circuit to circuit, over a range which could be 4:1 or more. This will result in considerable unbalance between the emitter currents of Tr1 and Tr2 (unless the value of R_4 is adjusted individually). It is preferable to replace Tr3 by a Darlington pair Tr4-5 (my Fig. 1), arranging that the base current of Tr5 is fairly small compared with the current in R_b . This gives better defined working points, plus some increase in loop gain.

(2) Omission of the base return resistor for Tr3 is undesirable, and the reason given for its omission is not valid. Satisfactory starting of the circuit may be obtained e.g. by using a resistor R_7 (see my Fig. 1). This resistor can also help to reduce the dissipation in

Tr3 (or Tr4) the current (i_7) through R_7 will increase as the supply voltage increases, but the output current is held virtually constant by the negative feedback loop, so that, as i_7 increases, Tr4 collector current falls. The small unbalance in Tr1-2 demanded by this can be minimized by the addition of R_8 , which takes current equally from Tr1 and Tr2 as the supply voltage increases.

(3) In my application, the circuit was required to operate as a negative impedance converter, as well as providing a constant bias current. This was achieved by the addition of one resistor (R_9 , my Fig. 2). The value of negative resistance appearing at the output terminals can be calculated very simply as follows. Application of a small increase of voltage v to the output terminal will raise the potential of Tr2 base, and thus Tr1 base also, by precisely v volts (assuming infinite loop gain). Therefore, a current $i_9 = v/R_9$ must flow through R_9 , and this current must be drawn entirely from R_1 (because the potential across R_2 etc. is fixed). The resulting change across R_1 appears across the whole bridge, and will result in an increase in output current of $i_0 = i_9 \times \frac{R_1}{R_5}$, so the effective output resistance $-R_n = \frac{v}{i_0} = -\frac{R_9 \cdot R_5}{R_1}$. Production versions of this circuit show very satisfactory stability of both i_0 and R_n .

Farnham, Surrey.

JOHN WILLIS

THE elegant complementary transistor current stabilizer which Mr. P. Williams describes in his letter in the September *Wireless World*, p. 456, has an impedance of $Z = r_{c1} || r_{c2} || R_{bb}$, where R_{bb} is the value of the starting resistor between the bases of the two transistors which he states may not normally be needed.

May I offer as an improvement the introduction of a resistance R_{ee} as shown here.

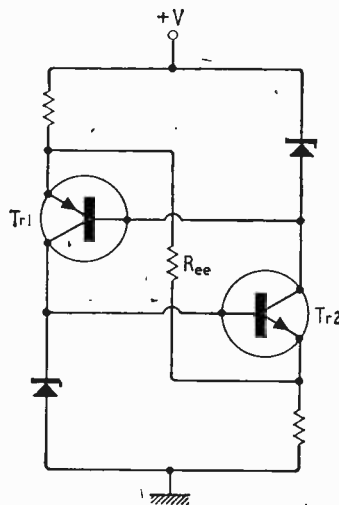

A change of voltage $+\Delta V$ will cause a current change of $+\Delta V/R_{ee}$ to flow through this resistor, but each transistor will then pass this amount less current.

The net effect is that the original voltage change causes a current change of $+\Delta V/R_{ee} - 2\Delta V/R_{ee}$ through the circuit.

The value of R_{ee} can thus be chosen to cancel the effects of R_{bb} and the two r_c terms, or to exceed them and so give a two-terminal negative resistance device.

E.M.I. Ltd.,
Hayes, Middx.

JOHN C. RUDGE
(Continued on page 611)

LETTERS TO THE EDITOR (Continued)

Receiving Stereo Broadcasts

THE article "Receiving Stereo Broadcasts" in the September issue reflects a philosophy of extreme caution if not gloom towards the pilot-tone Zenith-G.E. system.

It is noteworthy that a rather similar attitude of near despondency heralded the start of the v.h.f.-f.m. service, when much was written about the "severe" problems of oscillator drift, reliability of v.h.f. receivers, problems of discriminators and so forth. Of course the magic term "phase linearity" cropped up, being guaranteed to invoke an awesome silence in any argument, since many people don't quite understand what it means.

An academic analysis of the effects of poor a.m. suppression, multipath propagation, and all forms of non-linearity known to man can quickly convince one that the pilot-tone stereo system is quite unworkable. Such an analysis is valuable in promoting a fuller understanding of the system, but can become a liability if it leads to the design of unduly complex decoders designed to accommodate deficiencies in a tuner, which may well not exist in practice.

If a tuner is found to cause signal distortion surely it is more appropriate to correct its design than to employ elaborate circuitry in the decoder.

The waveforms of Fig. 2, which show the pilot carrier at a level of 50% rather than the actual figure of 9%, in context with statements like "the necessity of filtering the 38 kc/s subcarrier by twin-T filters," tend to imply that the simple switching decoders described by G. D. Browne in *Wireless World* are unworkable. Such a conclusion would be totally unjust.

In my own experience, using a tuner some 13 years old, and a loft-mounted dipole aerial, a very simple decoder (See Fig. 3 "Transistor Decoder from FM Stereo Broadcasting" G. D. Browne, *Mullard Technical Communications* Vol. 7, No. 67, December 1963) gives quite adequate results. The cross-talk figure is better than 20 dB, and no background noise is apparent. How about keeping our feet on the ground?

Oxted, Surrey.

D. R. BIRT

[Mr. Birt would perhaps have preferred reference to constant time delay to avoid what he considers to be "magic."

We agree with the writer's fourth paragraph.

In connection with his comments on Fig. 2, we would point out that it was stressed in the caption that the vertical axes were not to scale. We should, admittedly, have said "... any necessity. . . ."

It might be emphasized that it does not follow from his last paragraph that all or the majority of tuners will be suitable. Hence the peroration in our reply to Mr. Browne's letter last month.—Ed.]

"High-Performance Transistor Amplifier"

JUDGING from its published performance the amplifier described by Dr. A. R. Bailey in the November issue is quite outstanding and it is of special interest that it should incorporate an interstage transformer, the use of which is rigorously eschewed these days by so many designers.

Dr. Bailey's article, however, does less than justice to many earlier writers who have covered much of the same ground and reached some of the same conclusions. There are no references to such work in the text and

one is left to speculate whether he has been influenced by it or not. In an attempt to set the record straight and give credit where it is due, this letter makes brief reference to earlier original work, from which the impartial reader may well conclude that Dr. Bailey's circuit is only one of many which are capable of reaching the desired standard of performance. At the same time I shall comment on a number of design features and principles which may stimulate further discussion.

One of the first people to describe a really high-grade transistor amplifier was A. B. Bereskin¹, using a circuit basically similar to Dr. Bailey's. If built with the transistors available today, the performance might well be indistinguishable.

More recently, R. C. Bowes² and P. J. Baxandall³ have evolved designs which in my view have not been surpassed in excellence and which incorporate features of great technical interest. Though of lower output power than Bailey's design these amplifiers could readily be scaled up to give any desired output.

In 1961 I described a 50-W amplifier⁴ which was virtually a doubled-up version of Bailey's model, with four transistors (Texas 2N458) in the output stage and with four secondary windings on the driver transformer. Although the measured distortion figure at full output was 1.3%, the use of high-frequency power transistors would divide this figure by 10.

Soon after publication of this article I received a private communication from C. F. Wheatley and H. M. Kleinman of R.C.A., describing their version of a high-power high-quality amplifier, and a paper on this has since been published.⁵

Coming now to some specific design features of Bailey's amplifier, I am by no means convinced that constant-voltage drive to the output transistors is the best idea. Some work⁶ carried out at the General Radio Company, U.S.A., made out a compelling case for constant-current drive. Crossover distortion virtually disappears, zero-bias working is feasible, dangerous over-driving is less likely and so is thermal runaway. One amplifier gave 16 W output with 0.03% distortion.

In the circuit described by R. C. Bowes, there was a transition at one particular frequency from constant-current to constant-voltage drive, this being the best compromise between conflicting requirements. A true constant-voltage drive is not in fact achieved in Bailey's design because of the 5-ohm output-stage base bias resistor, despite the presence of low resistances in the emitter leads. He would find a pronounced rise in distortion if he reduced the value of the 5-ohm resistors (while of course altering the 500-ohm resistors to give the same quiescent current). He uses no means of temperature compensation in the output stage and relies on an unusually large value of emitter resistance to check the high-temperature rise of standing collector current, whereas most other writers make use of diodes in the interests of gain and efficiency.

The diode strings across the driver transformer primary certainly give some protection against overloads

1. A. B. Bereskin, "A High-Power High Quality Transistor Audio Power Amplifier," 1957 I.R.E. National Convention Record, Part 7, Audio Broadcast Transmission Systems.

2. R. C. Bowes, "Transistor Audio Amplifier," *Wireless World*, July 1961, p. 342.

3. P. J. Baxandall (Circuit disclosed and amplifier exhibited at Physical Society Exhibition).

4. F. Butler, "Transistor 50-W Audio Amplifier," *Electronic Engineering*, December 1961, p. 792.

5. C. F. Wheatley and H. M. Kleinman, "An Ultra-Low Distortion Transistorized Power Amplifier," *I.R.E. Transactions on Broadcast and Television Receivers*, June 1961.

6. J. J. Farn and R. G. Fulks, "High Impedance Drive for the Elimination of Crossover Distortion," *Solid State Journal*, August 1961, p. 36.

but not as much as might be expected because of the low output impedance of the driver transistor. A current-source here would have given better protection at the cost of severe inter-modulation distortion. His use of a single fuse seems an obvious and elementary precaution. Here again a better idea would be to use a fuse in each emitter circuit where it could also serve as a resistor.

Neither Bailey's circuit (nor any of the others so far quoted), gives protection against a particularly vicious overload condition, very familiar to users of operational amplifiers. The condition is known as "latch-up." Briefly, in a circuit with strong negative feedback applied from the output to some earlier stage, overload results in a loss of the phase-inverting property of the early amplifiers. The original negative feedback thus becomes positive, with potentially disastrous consequences. A diode, or pair of diodes, across one of the feedback resistors will give complete protection at the price of an appreciable increase of distortion.

Next, I suspect that the core size of the driver transformer is inadequate. His curves show a rapid rise of distortion and drop in gain below 10 c/s. Inspection of the supply decoupling to the first two stages shows a 100-ohm resistor followed by a 500 μ F capacitor. This should give *increasing* gain at the lower frequencies, so that the transformer loss is worse than it appears on paper. I would recommend a core with four times the cross-sectional area which he specifies.

As regards operation into reactive loads, there is a substantial literature on this topic, principally concerning safe operating areas (SOAR) on the V_{ce} - I_c transistor characteristic curves. A particularly useful treatment has been given by P. P. Balthasar.⁷

It is difficult to see how the small inductance of coil-wound emitter resistors could possibly account for a rise in distortion at 20 kc/s, though ringing might be noticeable on a square wave. In any event the effect can be compensated by the use of shunt capacitance $C=L/R^2$ (about 2 μ F across a resistance of 0.75 Ω), inductance 1 μ H).

My final technical point concerns the design of the power transformer. With the particular arrangement chosen it would have been better to use bifilar winding of the halves of the low-voltage secondary.

Dr. Bailey has developed a simple, high-grade and reproducible amplifier of straightforward design and excellent performance, the last due principally to the ready availability of high-frequency power transistors which did not exist when the earlier work was done. Its other design features are not unique. All of them, and more, are to be seen in the circuit due to R. C. Bowes and most of them are incorporated in one or other of the arrangements which I have quoted.

Cheltenham, Glos.

F. BUTLER

7. P. P. Balthasar, "Avoid Power Transistor Failure," *Electronic Design*, 2nd August, 1966, p. 52.

The author replies:—

I WAS very interested to read Mr. Butler's letter; the difficulty is in replying to it without taking up too much space. However I will try to deal with his points in order, and be as brief as possible.

First the problem of giving references to work previously done—this was very difficult in view of the large number of articles that have been published on the subject in the past few years. The whole amplifier was in fact developed from "scratch" by working back from the power transistors and looking at each design para-

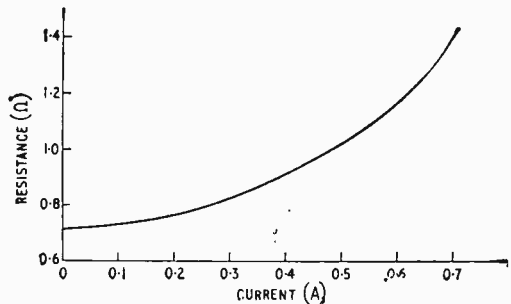

Fig. 1. Resistance characteristic of 500 mA fuse.

meter in turn. There was no intentional copying from any circuit, although it is impossible to design anything without making use of the work of many other people—whether in circuit design or transistor amplifier design. There was certainly no intention whatsoever to detract from previously published work, but on the other hand the circuit was not based on modifications to any particular circuit. If one bases design on a particular circuit, then unless one is extremely careful it is very easy to copy undesirable characteristics as well as the good ones. However I am sure that interested readers will find the list of references given by Mr. Butler a very interesting background to the problem of amplifier design.

I am rather perturbed by the statement that the amplifier in reference 4 would have its distortion reduced by a factor of no less than ten times by the mere replacement of its output transistors by more modern h.f. power types. This has not been my experience, and normally a complete redesign is necessary in order to obtain the necessary gain-phase-bandwidth characteristics.

Regarding the drive impedance to the output transistors, this was intentionally made relatively low. As I said previously, the amplifier was designed by, what I hoped, was a logical process. The reason for the use of this low drive impedance (about 40 Ω mid-band) was for the following benefits.

1. Reduction of distortion at low frequencies owing to the greatly reduced effect of transformer magnetizing current non-linearities.
2. Effective negative feedback from the emitter resistors of the output stage. This considerably helps h.f. stability and would be lost with constant current drive to the output stage.
3. The emitter follower being direct coupled gives performance down to d.c. and removes the extra d.c. coupling that is otherwise difficult to remove with common emitter circuits.
4. The circuit is cheaper to produce.

Incidentally even with the standing current reduced to 50 mA, crossover distortion is not a problem. The drive impedance is about 40 Ω and not 5 Ω as mentioned by Mr. Butler due to the finite output impedance of the emitter follower driver. The effect of varying the potential divider resistors in the same ratio over quite a wide range has therefore no appreciable effect.

In spite of his previous references Mr. Butler then states that I am being unconventional in my temperature compensation (or lack of it) and the size of my emitter resistors. Again this was done intentionally. The emitter resistors do cause a small loss of output power (about 1 W at full power output) but this will be just about inaudible. The thermal stability however is greatly improved by the use of these high resistor values, and this is the reason

for omitting temperature compensation in the form of diodes. It was felt better to make the circuit fairly insensitive to temperature changes rather than try to compensate for them. In any case the diode voltage spread in practice would make the design of circuit rather difficult, as well as increasing the cost. Also the diode non-linearity will tend to increase distortion by feedback from the potential divider chain unless it is decoupled with a very large capacitor.

Regarding the diode protection, here there will be little or no difference between voltage or current drive from a class A driver, as the act of limiting removes the negative feedback from the main loop. This gives full drive to the driver stage, so the current in the diodes is settled by the peak current available from the driver rather than whether the output is taken from its collector or its emitter.

Protection by including fuses in the emitters of the output transistors appears very attractive at first sight. Unfortunately there is a very serious drawback due to the temperature coefficient of resistance of the fuses. Fig. 1 shows the d.c. characteristic of a standard long-break 500 mA fuse. From this curve it can be seen that the current-resistance characteristic is very non-linear due to the heating of the wire. Using 500 mA fuses in the emitters would give about the same cold resistance as the resistors that I use, but under full

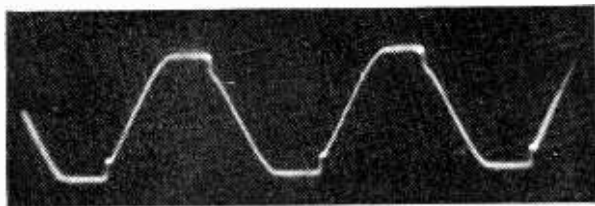

Fig. 2. Output voltage under overdrive conditions. (17Ω resistive load, 5 kc/s drive).

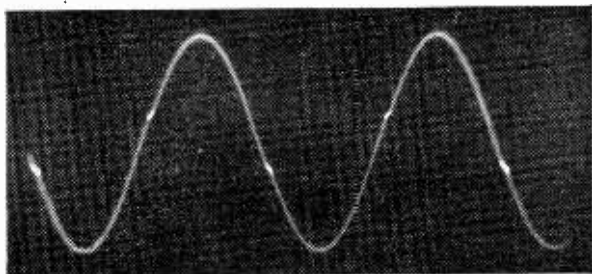

Fig. 3. 20 kc/s output waveform at full power output using coil wound resistors. (Note "nicks" in waveform)

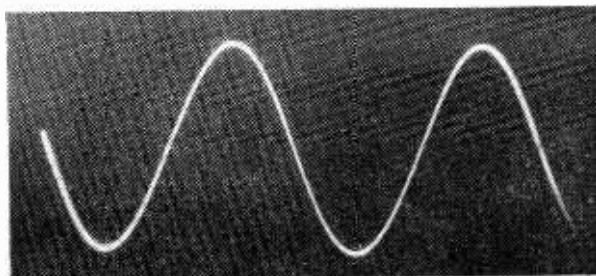

Fig. 4. As Fig. 3. but output emitter resistors wound in non-inductive manner.

sine-wave drive conditions their value would be over one and one half times that of the zero drive condition. For the transistors in use this would cause the manufacturers rated reverse emitter-base voltage to be exceeded with the corresponding risk of catastrophic failure of the output transistors. In addition, the output power would be reduced by a further 1 W. Even if this extra emitter resistance could be withstood by the circuit, it would be preferable to use increased value emitter resistors of the type specified as increased thermal stability would be obtained.

I am rather puzzled by the reference to "latch-up" as it is not present to any degree in the circuit. The first transistor is driven in common base so far as feedback is concerned, and the second transistor is common collector connected. In neither case is there any phase-inversion that could be reversed by overload. The output stages are the only ones that would appear to possess any possibility of phase-reversal on overload. If the amplifier is overdriven so that it squares off, then the only effect appears to be at the extreme end of the treble range where the collectors "stick" for a few microseconds before resuming their correct waveform. The resulting nick in the output waveform is very small (Fig. 2) and only occurs when limiting takes place. There is no tendency whatever to latch-up as in d.c. amplifiers and therefore no protection has been provided for it.

Regarding the size of the driver transformer core, this was optimized to give the best performance over the audible spectrum. For the purposes for which the amplifier was designed a rapidly rising distortion below 20 c/s was felt to be of no consequence. I agree that the l.f. performance can be extended below 10 c/s by a larger core, but the increase in transformer winding capacitance will impair the performance at 20 kc/s. In any case how many valve amplifiers will give full power output below 20 c/s?

The emitter resistors were made non-inductive for the simple reason that coil-wound types were found to be the cause of unexpected "nicks" in the 20 kc/s waveform. Figs. 3 and 4 show, respectively, the 20 kc/s waveform with and without coil-type winding. The reason is due to the switching mode inherent in class B, so the individual class B output stages must have a clean performance to well above the maximum frequency to be reproduced. Even one microsecond of error in changeover is very noticeable on the output waveform.

I would like to thank Mr. Butler for the point about a bifilar secondary on the mains transformer. This has obvious advantages in leakage inductance and would be preferable. I suspect that the effect in practice, however, may be negligible.

Regarding the last statement in Mr. Butler's letter, I would merely point out that it is very difficult to be original in basic circuit design. Engineering, however, involves optimization as well, and this is where much of the difficulty lies. One has only to look at the complete specification of current transistor power amplifiers (filling in omitted information where necessary) to realize that the design of high-performance circuits is not particularly easy. Circuit originality (such as the Sharma amplifier referred to by Mr. Butler) often causes extreme complexity and the economics become very difficult to justify. The Sharma protection circuit for "lo-zee" has to be seen to be believed—eight transistors and at least an equal number of diodes for the stereo amplifier.

Very complex amplifiers have appeared—and rapidly

disappeared, as complexity in general gives too many phase-shifts for feedback amplifiers.

In conclusion, I would like to state that the amplifier described was not intended to give the ultimate performance regardless of cost—the performance can be considerably improved if much more expensive transistors are utilized in the design of transistor amplifiers. The circuit given is a carefully optimized design and gives a performance that is comparable with the best valve amplifiers while remaining low in cost. That is all that I would wish to claim.

ARTHUR R. BAILEY

Light Modulated Pickup

ALTHOUGH the "Miniconic" pickup is not a current subject of discussion in *Wireless World*,[†] a recent experience with a baffling "fault" unique to a semiconductor pickup would, I am certain, be of interest to many of your readers.

A friend recently installed such a pickup which performed with the expected excellence except for a noticeable 50 c/s hum. It was easily determined that this emanated from the pickup head, in view of the fact that a magnetic head in the identical position was entirely hum-free the mind boggled at thoughts of induced hum in semiconductors.

However, hum can be induced in this type of element by means of photo-conductivity and therein lay the answer. A 15W pilot bulb installed to assist record changing gave sufficient light to modulate *one channel only* of the transducer. (Presumably the other element was shielded from illumination by the shadow of the first one).

I may add the answer did not come to us by Sherlock Holmes type deduction but by half an hour's process of elimination in complete bafflement.

Durham.

D. V. ELLIS

† But see "Audio 1966," *Wireless World*, June 1966, p. 269.—Ed.

BOOKS RECEIVED

Phasor Diagrams, by M. G. Scroggie, B.Sc., M.I.E.E. The author introduces what is believed to be the first integrated system for dealing with a.c. circuits, valid in all branches of electrical engineering. The book commences by criticizing the current methods of presenting the basic theory of electrical engineering, pointing out that there is no common language between different branches. Mr. Scroggie then presents the arguments for, and introduces his system. It is the aim of the book to provide a clear and concise method of dealing with a.c. circuits compatible with such concepts as Kirchhoff's laws duality and Maxwell's cyclic currents. The method is applied to a wide range of a.c. technologies including valve, transistor and electrical engineering. Present methods are discussed and compared with the new method. Appendices discuss the difference between p.d. and e.m.f. and summarize the recommended conventions. Pp. 181. Price 42s (limp cover 27s 6d). Iliffe Books Ltd., Dorset House, Stamford Street, London, S.E.1.

Measuring Methods and Devices in Electronics, by A. C. J. Beerens. This book from the Philips Technical Library translated from Dutch by E. Grubba deals with general as opposed to specialist measuring techniques. Divided into three parts, this work is suitable for advanced amateurs, students of electronics as well as practising technicians. Part 1 describes a variety of the more common type of measuring instruments, including digital voltmeters, under the following headings: Principle, Operation, Properties and Application. Part 2 covers the measurement of components and networks concluding with a chapter devoted to practical hints. Part 3 covers the simple theory of errors in measuring techniques. Pp. 182. Price 35s. Macmillan & Co. Ltd., Little Essex Street, London, W.C.2.

Principles and Applications of Boolean Algebra for Electronic Engineers, by Salvatore A. Adelfio and Christine E. Nolan. Suitable for those who wish for a comprehensive grounding in the subject, this book starts by discussing basic number systems and finishes by applying Boolean principles to electronic circuitry. Early chapters describe the various binary number systems and arithmetical operations with them. Venn and Veitch diagrams are used as a visual aid to assist in the understanding and proving of Boolean concepts and identities. A complete chapter is devoted to solving illustrative Boolean problems. D.C. principles, network theorems, semiconductor physics together with other electronic funda-

mentals, diode logic circuits, transistor logic circuits and electronic counters form the remainder of the subject matter of this book. Each chapter is concluded with a number of problems to enable the student to assess his progress. Pp. 319. Price 45s. Associated Iliffe Press Ltd., Dorset House, Stamford Street, London, S.E.1.

Television Receiver Theory, Part 1, by G. H. Hutson. Aimed at those engaged on television servicing or those preparing for the intermediate or final examination for the City and Guilds Television Servicing Certificate, this book describes the composite television signal, vision detectors, video amplifiers, sync separators, differentiators and integrators, interlacing and field pulse processing circuitry. As well as describing the British 405- and 625-line standards, the French and Belgian 819-line and American 525-line systems are also discussed. A large number of diagrams together with associated waveforms are included. Pp. 238. Price 35s. Edward Arnold (Publishers) Ltd., 41, Maddox Street, London, W.1.

Radio Valve Data. This completely revised 8th edition is produced by Iliffe Books Ltd., and not, as in the past, by the staff of this journal. The title is perhaps something of a misnomer since the section dealing with semiconductor devices has been greatly expanded and now occupies nearly one half of the issue. Separate sections deal with germanium p-n-p and n-p-n transistors, silicon p-n-p and n-p-n transistors, small signal diodes, power rectifiers (up to 10 A), thyristors (s.c.r.s. only, up to 16 A), rectifier stacks and voltage references diodes. A number of devices are not included, e.g. tunnel diodes, field-effect transistors, and voltage-variable capacitors; but a few four-layer diodes are included in the signal diodes section. Almost all of the semiconductor devices listed are current types; some obsolescent or replacement types have not been listed—for instance most of the OC series of transistors including such well-known types as OC35, OC71, and OC170 are missing. Another set of absences is the OA series of diodes.

The thermionic device section follows the format set in the past, but with the exception that American types have been omitted. Television cathode-ray tubes are included but not instrument c.r.t.s. Valve and transistor connections are included and valve, but not transistor, equivalents are listed. Pp. 230. Price 9s 6d. Iliffe Books Ltd., Dorset House, Stamford Street, London, S.E.1.

Slow-motion Video Tape Playback

B.B.C. EQUIPMENT USES INTERMITTENT TAPE MOTION AND MAGNETIC-DISC FIELD STORAGE

By D. P. ROBINSON, M.A., Grad. I.E.E.

UNTIL recently television pictures in slow motion have been possible only by the use of conventional film techniques—that is, with film exposed in a fast-running camera and later run through a telecine machine at normal speed. This has many disadvantages, not the least of which is the time delay involved in the processing of the film. It is true that there have been experiments using a standard tape machine running at half speed, followed by standards restoration, but these methods suffer from poor definition and, further, the reduction in speed is only two to one. Such systems have been abandoned as technically unsatisfactory. In 1963 a Japanese video tape machine was built incorporating a slow-motion facility for use at the Tokyo Olympic Games (see *Wireless World*, October, 1965). This machine is not suitable for use on the U.K. 50 field standard as it was built specifically for the 525-line system, and modification to European standards would have involved costly and difficult work—quite apart from the problem of keeping spares for one machine a long way from the country of origin.

The latest British slow-motion apparatus is one designed by the B.B.C., using a standard VTR equipment and operating on 625-line signals. Constructed initially for the World Cup football series, it is based on three programme requirements. First, the machine should be capable of replaying any standard video tape in slow motion. Secondly, it should be able to “freeze” and hold any picture at any time. Thirdly, it should be able to record and playback in normal motion. These functions should be as separate as possible—for example, the “freeze” mode should work from the tape replay in either slow or normal motion, or from the incoming signal if the machine is recording or not in operation at all.

Television slow-motion differs fundamentally from film slow-motion in that the incoming pictures occur at a fixed rate (50 fields per second) and this cannot be altered; to achieve slow motion, each of these fields is

D. P. Robinson, who a few months ago joined Dolby Laboratories, London, was in the B.B.C. Designs Department from 1962 until August this year working on the design and development of telecine equipment, colour video-tape recorders and latterly the slow-motion v.t.r. described in this article. Educated at Christ's Hospital, Horsham, he spent a year with Marconi's before going to Pembroke College, Cambridge. In his present position he is working on projects to improve the signal/noise ratio in audio and video equipment.

taken and played back a number of times to give the required slowing-down effect. Early experiments suggested that ratios of 3, 4 or 5 to 1 would be suitable—less than this gives insufficient slowing down while more produces a very jerky picture, since the eye is very conscious of the sudden picture change. It was decided to build the machine for a ratio of 4 to 1. Once this is decided, it had to be accepted that the mechanical construction would not allow the ratio to be changed at will, and in fact the machine will only play at this 4:1 speed reduction.

If the machine is to play any other broadcast video tape, it follows that the slow-motion system must use 2 in tape and rotating heads with transverse scanning. On such a tape the recorded information occurs in a regular manner, succeeding television fields being laid down at similar positions along the tape. The principle used to obtain slow motion is to scan one such field on the tape and store it in a memory, effectively stop the playback and read the field from the store four times, then re-start the playback and deal with the next field on the tape in a similar manner. The problem is to provide this intermittent motion in the playback machine without damaging the tape in any way.

The basis of the playback machine was an older type

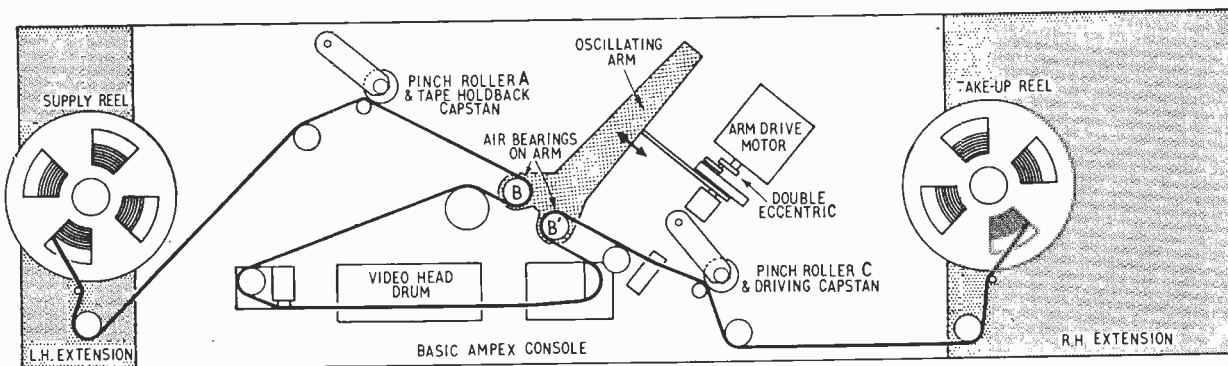

Fig. 1. Tape path in slow-motion playback machine, a modified Ampex VTR equipment.

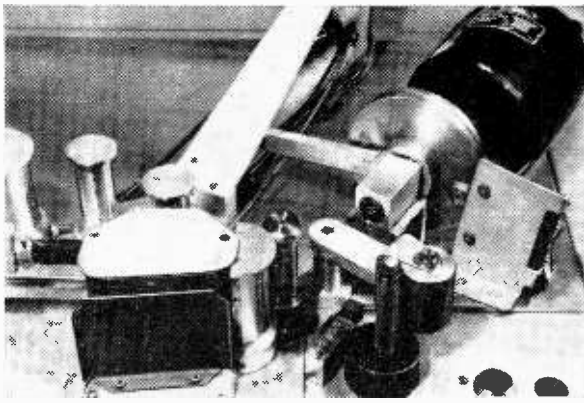

Fig. 2. Detail of the playback machine, showing oscillating arm (with guides B and B' in Fig. 1) and its drive motor.

of Ampex quadrature recorder, similar to the model VR1000C, which was extensively modified. The tape path is shown diagrammatically in Fig. 1. The tape leaves the supply reel (left), passes the first pinch roller A then roller B and goes on to the video head. Threaded round roller B' it passes the driving capstan and second pinch roller, C, and so on to the take-up reel. Apart from this unusual lacing, the normal record-replay functions are left unaltered.

In slow-motion playback, the capstan motor is de-energized and power is transferred to a similar motor which drives the original, now acting as a flywheel, through a 4 to 1 pulley system using a flexible toothed belt so that the tape travels at a quarter of its normal linear speed—that is, at about $3\frac{1}{2}$ in/second. The two guides, B and B', are joined together and mounted on an arm which oscillates at $12\frac{1}{2}$ c/s, thereby adding an oscillating velocity component to the normally constant tape velocity (quarter speed) in the loop between the guides. The amplitude of this oscillation is such that the tape moves in reverse at the video head for part of the cycle, and it is to prevent tape spilling off the guides during this time that the extra pinch roller A is added. During the forward stroke of the arm, the tape is accelerated to the normal relay speed, about 15 in/second, and this lasts for just over one field on the tape, so that for this time the replay head "sees" a standard tape in all respects. One field is thus replayed, with an overlap at each side acting as protection. For the following period of time, corresponding to three fields, the arm slows down and moves in the opposite direction, revers-

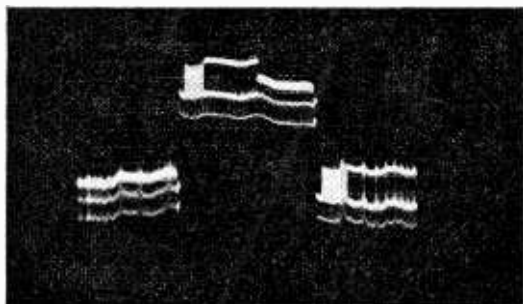

Fig. 3. Oscillogram of video output from playback head with added square pulse.

ing the tape travel at the head, and finally moves forward again. Since there is also a constant quarter-speed component of velocity provided by the capstan, the second field on the tape is now replayed. The final output from the video tape recorder is thus one field followed by spurious signals for three field periods, then the next tape field, and so on.

The success of this operation depends on the inertia at all points inside the moving loop being extremely low. If conventional roller guides were used their inertia would be such that it would be impossible to reverse the tape with the rapidity necessary. All the guides within and including the guides B, B' are air bearings, in which the tape is isolated from the metal surface of the guide by a thin film of air, which also provides a very low frictional drag. The air pressure needed is in the region of 5 p.s.i., and this is derived from a small oil-free pump and piped around to the five guides inside the oscillating tape path. Some of these pipes can be seen in Fig. 2.

The motor shaft also incorporates a mechanism for producing a pulse once every revolution, at a point in time just following the linear portion of the arm movement, that is, at the time when the information must be read from the tape. The pulse lasts for one television field, and is used to synchronize all the switching functions in the whole machine. An interesting waveform can be made by addition of this pulse to the video output from the rotating head, and this is shown in Fig. 3. It can be seen that the video information is continuous throughout the wanted field, but breaks up outside this time when the arm is slowing, retracing its path, and finally accelerating again. This is most clearly seen by examining the sync waveform in the photograph. The waveform is in fact used for test purposes and is of low quality since it is also processed to give greater visibility to the breakup regions.

Initially a simple eccentric was used to provide the oscillation of the two guides B, B', but in practice this did not give satisfactory performance as the straight portion of the resulting sinewave motion of the guides was not long enough to track the whole of one field, and picture break-up resulted. A simple double eccentric was then devised which successfully extended the linear portion of the oscillation to slightly over one field, allowing satisfactory tracking with a little margin for servo errors. The eccentric is driven by a motor locked to station field trigger pulses. This assembly can be seen in Fig. 2.

The single field played back by the VTR is taken and recorded in the field store, and is then replayed four times from this to form the output signal, thus filling in the gap until the next field from the tape is available. All four fields of the output signal are taken from the store (as opposed to one from the VTR and three from the store) to minimize any flicker effects which might be caused by slightly differing frequency responses or similar faults. The store used is manufactured by Siemens & Halske, of Karlsruhe, West Germany. It was originally intended for recording single frames, so that it required extensive modification to record and replay in the cyclic manner needed for slow motion. The recording medium is a flat thin disc of Melinex coated with magnetic oxide (in a similar manner to the more usual 2 in video or $\frac{1}{4}$ in audio tape), and this rotates at 3,000 r.p.m., that is, once every field. The disc floats about 1 micron above the recording heads, and this distance is maintained by a flow of air dragged by centrifugal action from a series of small holes at the centre of the disc motor shaft. In this way wear is virtually

TABLE SHOWING FIELD-STORE OPERATING CYCLE

Original recording	Field 1 (even)	Field 2 (odd)	Field 3 (even)	Field 4 (odd)	etc.								
VTR slow-motion replay	Field 1 (even)			Field 2 (odd)				Field 3 (even)				Field 4 (odd)	
Store head 1	Record (even)		Play (even)	Play (even)	Play (even)	Erase	Erase	Record (even)		Play (even)	Play (even)	Play (even)	Play (even)
Store head 2				Record (odd)		Play (odd)	Play (odd)	Play (odd)	Play (odd)	Erase	Erase	Record (odd)	
Combined store output			Play (even)	Play (even)	Play (even)	Play (even)	Play (odd)	Play (odd)	Play (odd)	Play (odd)	Play (even)	Play (even)	Play (even)
1/2 line delay			out	in	out	in	in	out	in	out	out	in	out
Final output			even	odd	even	odd	even	odd	even	odd	even	odd	even

eliminated. The life of the disc is about 100 hours and that of the heads over 500 hours.

The two heads on the store each combine the erase, record and replay functions, and they follow an eight field cycle arranged so that the final output is continuous. The table above shows this cycle, and also the method of achieving interlaced pictures. Since the recording is initially made on the tape in a normal manner, the replayed fields follow in the sequence of even, odd, even, etc. (lace, interlace, lace), but on replay from the store the same field (say even) is played four times. To make an even field appear to be odd, a half-line delay must first be added to the video path. The technique of adding a delay ensures that the line sync information is correct but the field sync is still wrong, since on even fields it is coincident with line sync while on odd it is not coincident but half a line late. Thus even after the half-line delay is added, the field sync must be extracted and modified in a similar manner. The waveforms for this switching, and those needed to switch the record and playback signals and their amplifiers, are generated in a small rack added into the store electronics. If the generation of these waveforms is stopped immediately after one of the heads has switched to playback, the picture which has just been recorded on the disc will be played back continuously—this is the "freeze" facility.

The signal recorded in the store is taken directly from the VTR using that machine's modulating system to produce the r.f. signal necessary. The frequencies involved are a carrier of 5.5 Mc/s, moving to 5.0 Mc/s at sync tip and 6.8 Mc/s at peak white. This corresponds to the E.B.U. low-band recording standard for quadrature recorders, and was used since video tapes for the World Cup were on this

standard. In principle, however, there is no reason why any of the recording standards should not be used. The only additional circuitry added between the VTR and the store is a simple limiter to keep the f.m. signal entering the store at a constant level. This is necessary since the recording current through the store heads must be well defined; errors lead to signal distortion on demodulation. As in normal VTRs, the signal from the rotating heads varies in amplitude as the servo errors cause the heads to move off the track, and this is normally eliminated in the limiter in the demodulator. Since this is not in circuit at this point in slow-motion, the extra limiter is necessary.

The quality of the slow-motion picture is very acceptable, but any defects in the incoming picture are more noticeable in slow motion as there is four times as long to inspect each picture. As with a photographic camera, a television camera recording fast action will produce blurred images, particularly when the subject and background are moving at different speeds; in normal speed such shots are deliberately kept short and so are not

Fig. 4. Complete equipment for slow-motion playback.

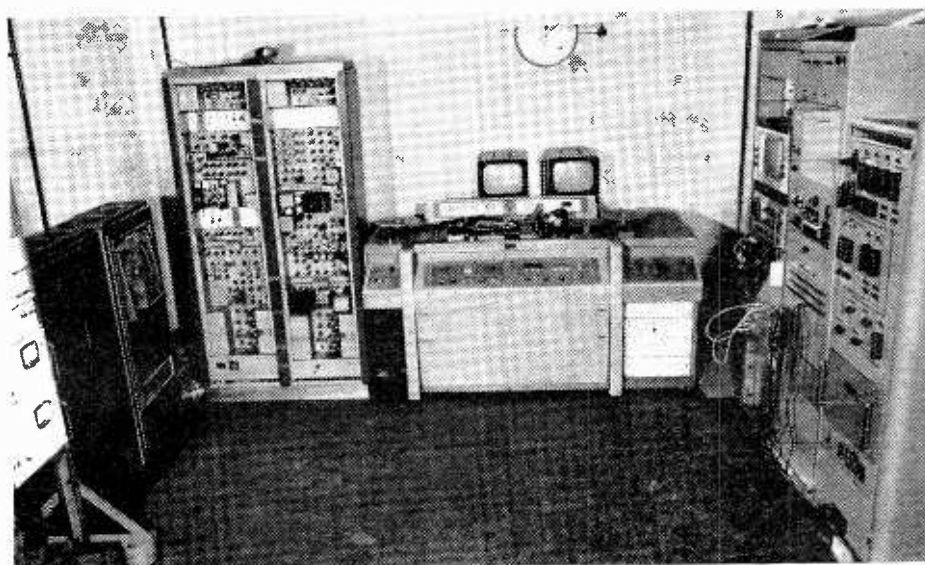

noticed to the extent that they are in slow motion. Fortunately with the "freeze" facility, the same shots at normal speed can be held and of course these are blurred also. In the same manner, the random noise on the input signal is recorded in the disc store, and then replayed as frozen noise for four fields, and this too is rendered much more visible. With these two problems outside control, there remain those that can be remedied. The disc store is driven from station field trigger pulses, and does not have any further servo system. It was hoped that the stability of the device, with its large inertia, would be sufficient that the errors accumulated in four fields would be small (at which time new correct information is recorded). Unfortunately, a jitter of about 3 μ sec can be observed per revolution, producing a sync mistiming of this amount. While hard-lock receivers would ignore this error, certain flywheel sync receivers, with long time constants, would produce a pronounced hook at the top of the picture. In order to provide a satisfactory signal at all times to all receivers, the signal is passed through a standards converter, which, while producing a picture at any required line standard, does, of course, lower the picture quality. It is hoped that it will be possible to modify the system shortly to remove the converter.

Referring back to the table, it can be seen that when head 1 on the store is recording, head 2 is playing back. The signal level during recording is over 100 V, and the replay signal is of the order of 3 mV, so that there is also a problem of crosstalk between the two channels. Early magnetic discs had a rather low output which aggravated this problem, and thanks are due to E.M.I. Tape Ltd.,

who at very short notice manufactured a set of discs with an increased stable output making the crosstalk problem negligible. It is, however, still important to clean the heads every hour or so to remove the thin film of oxide dust which would otherwise reduce the output and so increase the crosstalk.

Fig. 4 shows the general arrangement of the equipment. On the extreme left is a bay containing the drive equipment for the store, followed by two dark-painted bays which form the store itself. The disc is at the top of the second of these bays, behind a Perspex cover. The two tall racks are those normally associated with this type of VTR machine, containing the bulk of its electronics, but with additions (the white painted units) for the added functions required in slow motion, such as the line delays. In the centre is the transport mechanism, with two added extensions designed to match the original machine. Under the right hand extension are the amplifiers associated with the servo system and the oscillating arm motor drive. The equipment on the far right is the standard line terminating equipment and communication amplifiers used with normal VTR installations.

In conclusion it should be mentioned that the machine was developed from the original idea of P. Rainger, of the B.B.C. Designs Department, where the machine was designed and produced. I would also like to thank my colleague P. White for his invaluable work on the project, which was completed in the very short time of some nine months and finished in time for the World Cup 1966 broadcasts. Finally, I would like to thank the Director of Engineering of the B.B.C. for permission to publish this article.

H. F. PREDICTIONS — DECEMBER

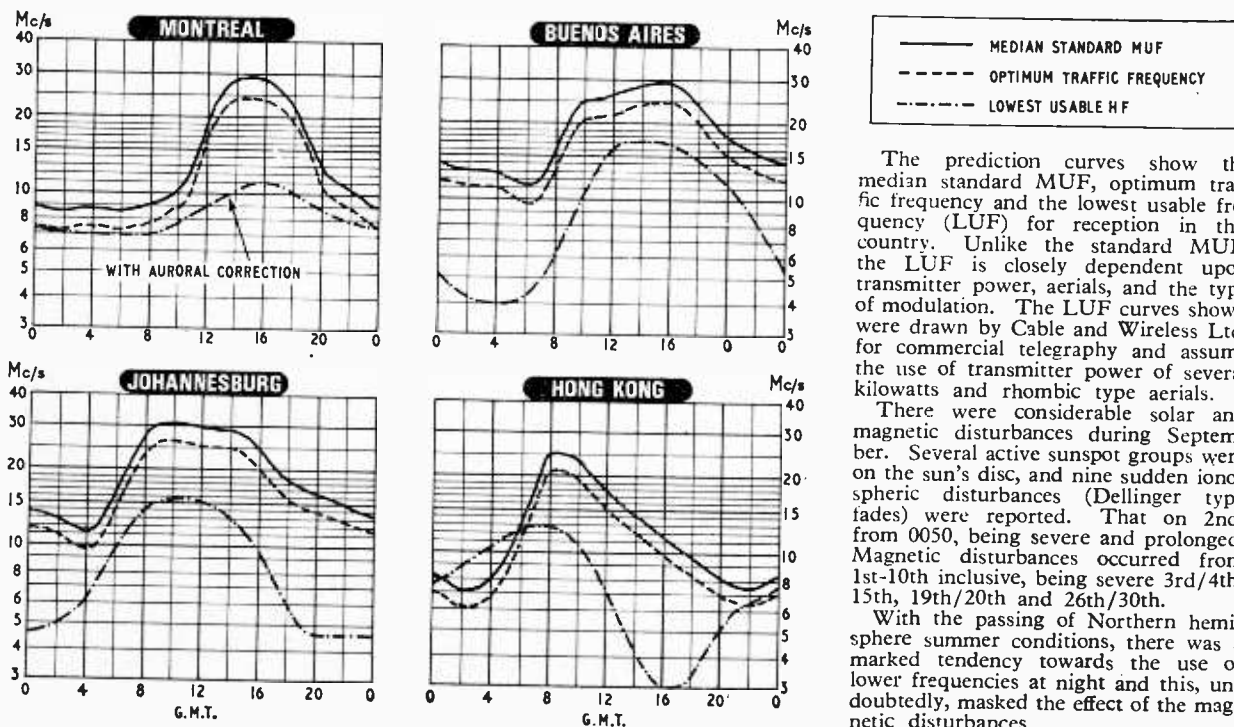

The prediction curves show the median standard MUF, optimum traffic frequency and the lowest usable frequency (LUF) for reception in this country. Unlike the standard MUF, the LUF is closely dependent upon transmitter power, aeriels, and the type of modulation. The LUF curves shown were drawn by Cable and Wireless Ltd. for commercial telegraphy and assume the use of transmitter power of several kilowatts and rhombic type aeriels.

There were considerable solar and magnetic disturbances during September. Several active sunspot groups were on the sun's disc, and nine sudden ionospheric disturbances (Dellinger type fades) were reported. That on 2nd, from 0050, being severe and prolonged. Magnetic disturbances occurred from 1st-10th inclusive, being severe 3rd/4th, 15th, 19th/20th and 26th/30th.

With the passing of Northern hemisphere summer conditions, there was a marked tendency towards the use of lower frequencies at night and this, undoubtedly, masked the effect of the magnetic disturbances.

"Hanging on Cs" at High Frequencies

By T. D. TOWERS*, M.B.E.

Reflections on the art of decoupling with capacitors when you have to leave the safety of a few Mc/s and venture up among the tens and hundreds of Mc/s where pitfalls lie in wait, unsuspected even by the wary.

WHEN you get instabilities in a circuit you are designing, one of the first things you suspect is inadequate decoupling. If you are a practical engineer, you then—to use the vernacular of the fraternity—proceed to “hang on Cs.” This means you fit additional decoupling capacitors at various circuit points until the instability disappears. At low frequencies, this usually works. At high frequencies, it very often does not. This is because a capacitor has self-inductance in its leads and body, which can make its characteristics depart far from the ideal capacitor.

Decoupling characteristics of ideal capacitors

Fig. 1(a) illustrates the basic problem involved in decoupling. Here, an a.c. residual voltage, v_1 , arises at the

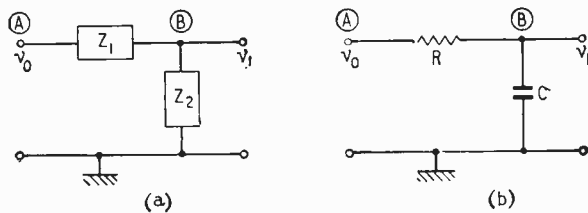
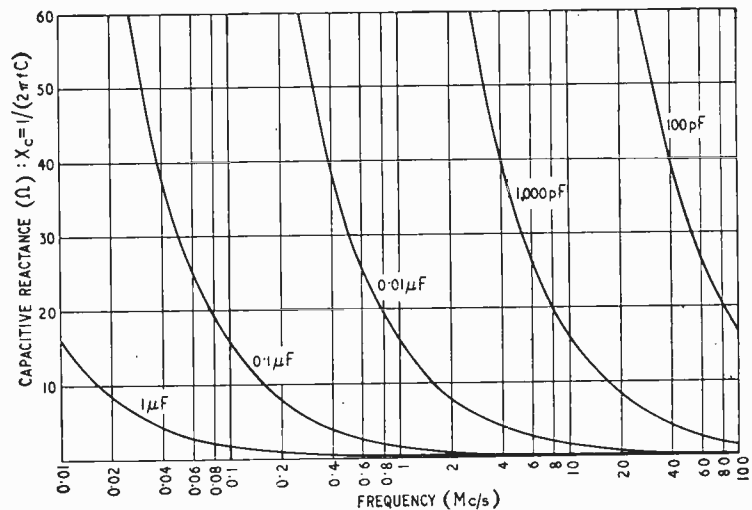

Fig. 1. Fundamental problem of decoupling. (a) General representation where impedance Z_1 should be small compared with Z_2 at frequencies of interest so that output voltage at B is small compared with input voltage at A, i.e. is heavily attenuated. (b) Common RC decoupling arrangement, a special case of (a).

Fig. 2. How the reactance of a perfect capacitor would fall ideally as frequency increases (illustrated for values of capacitance commonly used for high-frequency decoupling up to 100 Mc/s).



point B from an input voltage, v_0 , at point A. The decoupling impedances, Z_1 and Z_2 , are designed to reduce the a.c. signal at B below a specified level, while preserving any d.c. bias voltage at that point.

Fig. 1(b) illustrates the commonest case—RC decoupling—where a series resistance R is combined with a shunt capacitance C to earth. In this case, the attenuation at B for a sinewave a.c. signal is given by $v_1/v_0 = 1/(4\pi^2 f^2 C^2 R^2 + 1)^{1/2}$ where C = capacitance in farads and R = resistance in ohms.

At low frequencies, a rule of thumb that designers often use (sometimes intuitively) in choosing a starting value for a decoupling capacitor such as this is to make C at least 10 times $1/2\pi fR$. A little elementary mathematics will show that this gives a decoupling signal attenuation of not less than ten times, i.e. more than 20 dB.

The attenuation formula given two paragraphs above also explains why the policy of “hanging on Cs” can theoretically be expected to give good results. The higher the capacitance, the greater the attenuation of the unwanted signal.

Fig. 2 has been devised to show the approximate impedance values of pure capacitances commonly used for decoupling. It shows how the reactances or impedances of ideal 1 μF, 0.1 μF, 0.01 μF, 1,000 pF, and 100 pF capacitances vary with frequency from 10 kc/s to 100 Mc/s. In the figure the horizontal frequency scale has been chosen logarithmic to make it possible to display a wide frequency range. The vertical scale is linear to bring out clearly the rapid fall of impedance with frequency. You can use these curves easily for design purposes. Suppose you want a capacitance with an impedance of about 15 Ω at 10 Mc/s; you will find this

*Newmarket Transistors Ltd.

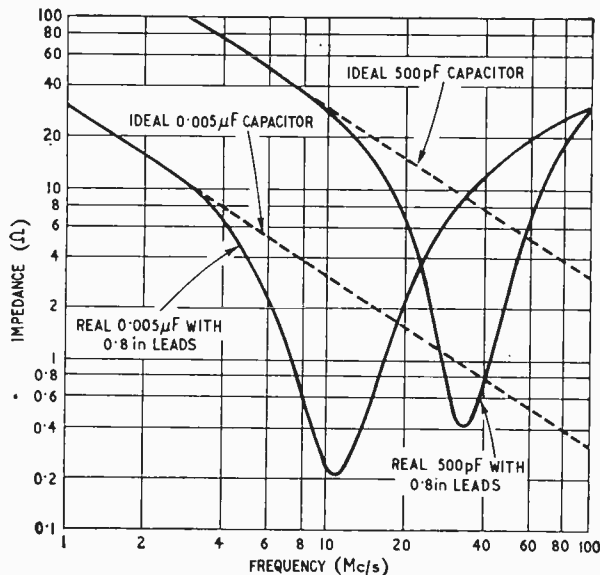

Fig. 3. How the impedance of real capacitor can depart from the ideal as frequency increases: illustrated for 0.005 μ F and 500 pF metallized paper capacitors.

impedance corresponds to an ideal capacitance of about 1,000 pF.

Decoupling characteristics of real capacitors

The curves of Fig. 2 are, of course, for ideal inductance-less, lead-less capacitors. You will find the characteristics of real capacitors quite a bit different owing to the influence of stray, "parasitic" inductances, mainly in the device leads. This is illustrated in Fig. 3 which shows how two typical paper-dielectric capacitors of 0.005 μ F and 500 pF depart from the ideal at high frequencies. The curves are for capacitors with two 0.8 in leads. Taking the 0.005 μ F capacitor, you will find that at 4 Mc/s its impedance has begun to fall below the ideal. At just above 10 Mc/s the capacitance resonates with the self-inductance of the leads and body, and the impedance falls to a small fraction of the ideal. Above resonance the impedance rises again. Around

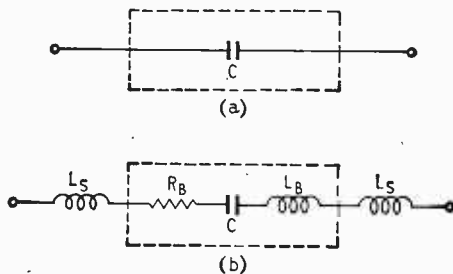

Fig. 4. Equivalent circuit of real capacitor (b) compared with ideal capacitor (a).

Fig. 5. Curves giving the inductance of an isolated straight length of non-magnetic (e.g. copper) wire of 16, 20, 24, or 28 s.w.g. at high frequency.

20 Mc/s it reaches approximately the ideal value. After that the impedance of the real capacitor rises rapidly above the ideal, and by 40 Mc/s it has a general impedance about ten times the ideal. You will see the same general pattern repeated at a higher frequency in the curve for the 500 pF capacitor.

In the curves of Fig. 3, you can also see the foundation of the circuit-design rule I was taught in my own early days: "Do not use a capacitor at a frequency above half its self-resonant frequency if its leads are more than 1 in or so long." If you follow this dictum, you can fairly safely assume that the real capacitor will behave effectively like an ideal lead-less, loss-less capacitor.

In resistance-capacitance decoupling circuits you are not so much interested in the absolute impedance value of the capacitor as in ensuring that the impedance is not greater than for an ideal component. You can therefore, carry on beyond the self-resonant frequency, f_R , up to about $1.5f_R$ before the impedance begins to rise above the ideal. Beyond that, however, the real capacitor impedance soon rises above the ideal and adequate decouplings become progressively more difficult.

Fig. 4 gives the clue to what to do at these higher frequencies. This shows the high-frequency equivalent circuit of a capacitor with leads. At Fig. 4(a) is the circuit symbol for a pure, loss-less, inductance-less capacitor of value C . At Fig. 4(b) is a series-equivalent circuit for a real capacitor which shows two equal-length external leads, each of self inductance L_S , and, internal to the device, a body resistance R_B and body inductance L_B accompanying the "pure" capacitance C . For most good capacitors at high frequencies, R_B is relatively small and can be neglected. The major parasitic elements at high frequency are the inductances of the two leads.

Inductance of straight lengths of lead wire

The first step towards estimating the parasitic inductance of the capacitor leads is to consider the inductance in isolation of a straight, round wire of non-magnetic material. This inductance depends on the wire length and diameter, and at high frequency may be approximated closely by Neumann's formula:—

$L(\text{in microhenries}) = 0.005S[2.3 \log(4S/d) - 1]$
 where S = length in inches, and d = diameter in inches. (Incidentally, the same formula can be used for arriving at the inductance of the capacitor body if it is tubular.)

If, like me, you are a bit weak on elementary mathe-

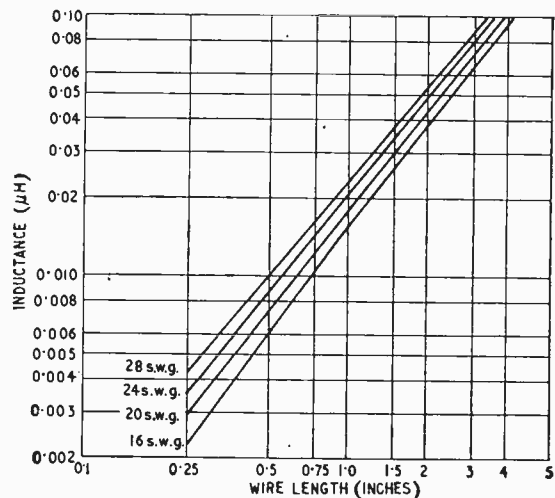

Fig. 6. Curves for approximate estimation of the frequency of self-resonance of a given capacitor C (in the range of 10 pF to 0.1 μ F) with different overall lengths (S) of two leads of 20 s.w.g. by noting frequency at which capacitive and inductive reactances are equal.

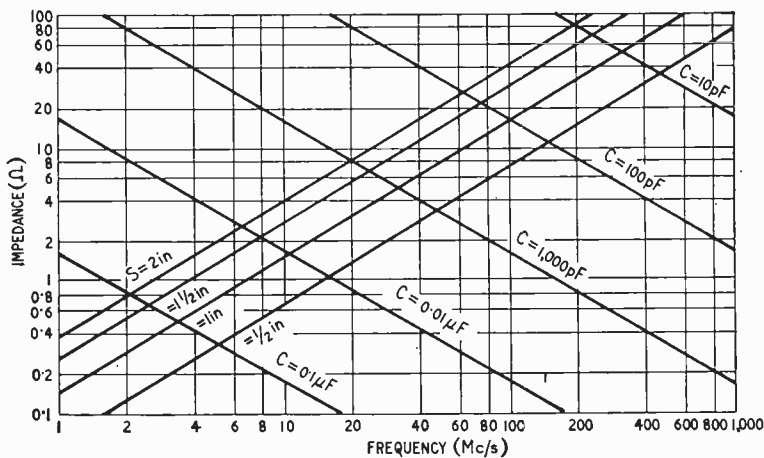
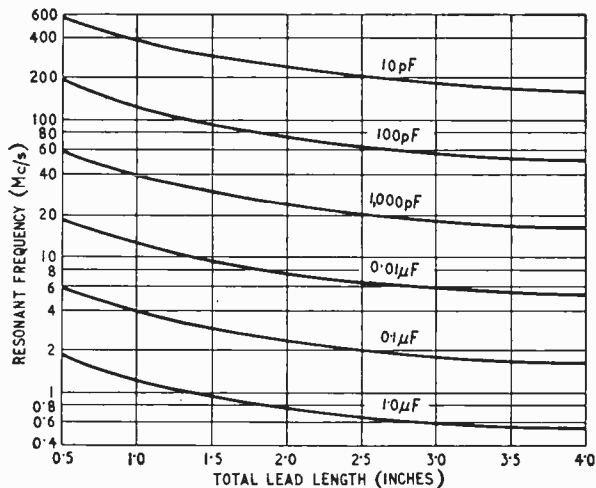

Fig. 7. Curves showing how the self-resonant frequencies of typical decoupling capacitors (with values in the range from 10 pF to 1.0 μ F) vary with total combined lead lengths (for 20 s.w.g. leads).



matics, and you are not over-fond of log tables, you can get from Fig. 5 some idea of the order of magnitude of inductances to be expected with gauges of wire normally used in electronic equipment. Here you will find set out in graphical form the inductances of isolated straight lengths of wire between a quarter of an inch and four inches long and of 16, 20, 24, and 28 s.w.g. From these curves you will see that 1in. of 24 s.w.g. wire has an inductance of approximately 0.02 μ H. If you are used only to working at lower frequencies, you may not think this appreciable. You may be surprised to note that at 100 Mc/s it represents a reactive impedance of about 15 Ω .

Inductance of capacitor leads

We noted earlier that every real capacitor has, besides its basic theoretical capacitance, a certain value of inherent self-inductance in its leads and body. We have been able above to compute the inductance of straight leads in isolation, but these theoretical inductance figures may not apply to real leads attached to the capacitor body. Actually, the inductance of leads in proximity to conducting surfaces usually falls below the ideal value obtained from Neumann's formula. If, however, we take into account the inductance of the capacitor body itself (which is usually somewhere between a third and a half of the inductance in free air of an equivalent length of

wire), it will be found in practice that for the normal, physically small, capacitors used for high-frequency decoupling, the inductance of the capacitor leads by themselves (computed according to Neumann's ideal formula) gives a fair approximation to the total overall parasitic inductance arising from the capacitor body and from the leads in proximity to the body and to other conducting surfaces as used in practice. On this basis, we shall in the rest of this article take the parasitic inductances to be those of the leads alone calculated as if straight and isolated.

In any capacitor, the parasitic inductance will form a self-resonant circuit with the "intrinsic" ideal capacitance at some specific self-resonant frequency f_R . You can get from Fig. 6 some idea of the values of f_R you might expect to meet in practice. This figure plots the inductive reactances of $\frac{1}{2}$ in, 1in, $1\frac{1}{2}$ in and 2in lengths of 20 s.w.g. wire as functions of frequency from 1 to 1,000 Mc/s. This corresponds to pairs of 20 s.w.g. capacitor leads from $\frac{1}{2}$ in to 1in long. At the same time the figure shows the capacitive reactances of ideal capacitors of 10 pF, 100 pF, 1,000 pF, 0.01 μ F and 0.1 μ F for the same range of frequencies. The frequency at which any ideal capacitance is in resonance with a specified total length of lead is indicated by the crossing of an inductive reactance line with a capacitive one. As an example, you will see that a 1,000 pF capacitor with $\frac{1}{2}$ in leads (i.e., total lead length of 1in) has a resonant frequency around 35 Mc/s.

The importance of the self-resonant frequency f_R was outlined earlier where it was indicated that if you used a capacitor at a frequency more than 50% above f_R with given lead lengths, the decoupling impedance it presented could be substantially higher than the theoretical impedance of an ideal lead-less, inductance-less capacitance of the same value. To give you an idea of f_R to be expected with capacitors normally used for decoupling at high frequencies, Fig. 7 sets out curves showing how the self-resonant frequencies of a selection of typical decoupling capacitors (with values from 10 pF to 1.0 μ F) vary with the total combined lead lengths of 20 s.w.g. wire. Taking 1in (i.e. two $\frac{1}{2}$ in) leads as typical for normal circuit layout you will see that it is unsafe to use a 0.01 μ F capacitor much above 20 Mc/s.

Now Fig. 7 is for 20 s.w.g. leads only, but if you look back to Neumann's formula given earlier, for the inductance of a straight wire, you will find that the inductance is a relatively-slowly-varying function of the wire diameter. This you can actually see from the narrow spread in inductance for any given length of wire, in

Fig. 5 where the wire diameter spreads widely from 16 to 28 s.w.g.

The most important point that emerges from an examination of Fig. 7 is that it is of little use considering a high-value capacitance for decoupling above a few tens of megacycles if any significant length of lead is used. Indeed, you will see that anything more than a 1,000 pF cannot really be considered at these higher frequencies.

High-frequency decoupling techniques

There are two basic approaches to the problem of effective decoupling with real capacitors at high frequencies. One is to try to reduce the parasitic inductances of the leads and body as far as possible. The other is to use the parasitic inductances to resonate with the intrinsic capacitance to give the overall low impedance of a series tuned circuit.

The simplest approach is, of course, to keep parasitic inductances low. In recent years this has led to the almost universal adoption of ceramic capacitors for high-frequency bypass decoupling. Typical of these is the disc ceramic shown in Fig. 8(a). This consists of a disc so small that it can be conveniently tucked away in the circuitry with very short leads, thus keeping the overall parasitic inductance low. Where even this low inductance is too high, it is possible to use leadless ceramics of the type illustrated in Fig. 8(b). In this style, leads are dispensed with and soldered connections are made direct to the silvered contacts on opposite sides of the disc. No protective encapsulation is used round the ceramic disc.

A further reduction of parasitic inductance can be effected by using the tubular feed-through type of capacitor such as that illustrated in Fig. 8(c). And nowadays, these are probably the type in most general use, except where cost considerations (e.g. in some television receiver circuits) argue the use of leadless disc types.

At frequencies in television Bands IV and V, even the small series inductance of the tubular feed-through capacitor imposes a significant limitation on decoupling efficiency. "Discoidal" feed-through capacitors, which typically take the form of Fig. 8(d), have been developed for even lower parasitic inductance. In these the r.f. current fans out into a 360° pattern from the centre terminal to provide the shortest possible electrical path from it to earth. This keeps the internal series inductance very small. Heavy short terminals also help in this respect.

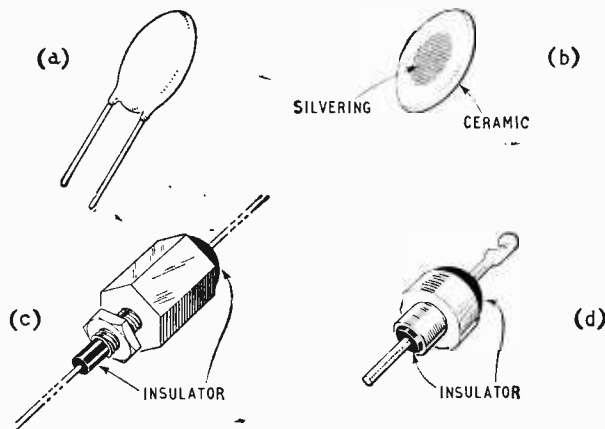

Fig. 8. Capacitor types commonly used for high-frequency decoupling (a) disc ceramic, (b) lead-less disc ceramic, (c) tubular feed-through and (d) discoidal feed-through.

For even more effective capacitor decoupling from 200 to 2,000 Mc/s, you can use ceramic-ferrite low-pass filters. In appearance these are very similar to discoidal feed-through capacitors.

Inductance-resonance techniques of capacitance decoupling

The resonant frequency, f_R , is an indicator of the upper limit of the usable frequency of a given capacitor for decoupling. It has been usual to try to keep well below f_R in operation. But the property of f_R can be used intentionally. At series resonance, the capacitor has extremely low effective impedance, but at frequencies at the lower end of the r.f. band the resonance curve is normally too narrow for practical use. In the higher frequency range, however, with much smaller values of capacitance and particularly with ceramic types, the losses at high frequencies are not negligible and the self-resonant dip in impedance around f_R is much lower and wider due to the lower Q for such capacitances. The impedance may then be substantially less than the theoretical over a band as wide as 20 Mc/s within the resonance dip. Over the resonance dip the capacitor will provide better decoupling than any large capacitance of similar size and equal lead length. We illustrated this earlier in Fig. 3. Very good use can be made of the series self-resonance properties of small capacitors within the 40-70 Mc/s television band where capacitors of the order of 500 pF using 1½ in or so of connecting lead can provide excellent by-passing over a large portion of the band.

By using such low-value capacitors at series self-resonance in conjunction with small inductors at parallel self-resonance (also with wide frequency band coverage), very effective filters can be made over the 40-70 Mc/s band. These filters are unique in that they provided greater attenuation at these frequencies than can be provided by any combination of higher value capacitances and inductances. The filters occupy little space, and have been successfully used for television interference suppression of electrical appliances.

The wide tolerance and extreme temperature-dependence of the capacitance of a disc ceramic make it difficult sometimes to achieve satisfactory resonant-mode wide-band decoupling in production runs of equipment. For "one-off" equipments, however, the decoupling capacitor can be individually selected to give optimum decoupling at a particular spot frequency. To do this you select a capacitor on the basis of calculations outlined earlier for the lead lengths your layout calls for, solder the two lead ends together and with a grid-dip meter check the resonant frequency of the complete loop. Now unsolder the ends of the leads and fit the capacitor into circuit. The series-resonant frequency of the unit will be the same as the parallel resonant frequency measured with the grid-dip meter.

Feed-through capacitors compared with disc ceramic

Earlier we indicated that the lowest practical parasitic inductances are obtained with feed-through capacitors. To give some idea of the impedance levels involved, Fig. 9 has been drawn to illustrate how the impedance types of capacitors commonly used for decoupling at very high frequencies compare with an ideal capacitor from 10 to 2,000 Mc/s. You will note that disc ceramic with any length of lead ceases to be much use for decoupling above 50 Mc/s. The tubular feed-through carries

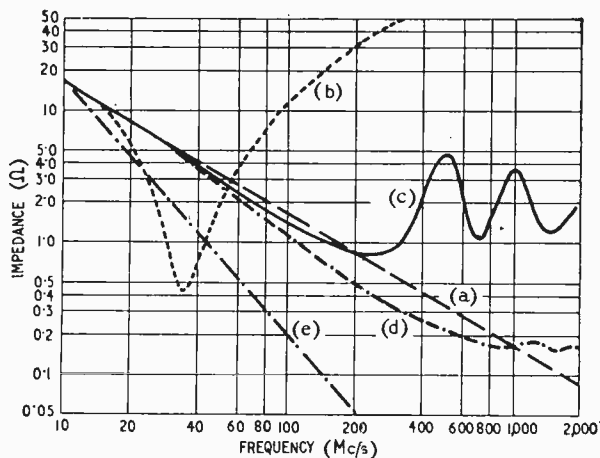

Fig. 9. Impedance-frequency characteristics of comparable types of capacitors used commonly for high-frequency decoupling, illustrated for (a) ideal, lead-less, inductance-less capacitor, (b) disc ceramic with two 2in leads, (c) tubular feed-through ceramic, (d) discoidal feed-through ceramic, and (e) ceramic-ferrite filter.

on to about 200 Mc/s before its impedance rises above the ideal. The discoidal feed-through does not become worse than the ideal until 1,000 Mc/s. Finally, the ceramic-ferrite filter has an impedance less than an ideal capacitor up to at least 2,000 Mc/s.

Capacitor decoupling for several frequencies at once

So far, we have tacitly been thinking of decoupling in terms of a single-signal-frequency sinewave. Difficulties may arise when the signal being decoupled contains a number of different, widely separated frequencies. When

you are studying a decoupling problem of this sort, you may find it necessary to parallel large value capacitances to deal with low frequencies, and some low-inductance arrangement of small capacitance to deal with the high. This is particularly important where 50 c/s mains hum or some audio frequencies exist which would not be adequately decoupled by a small capacitor designed to deal with the high frequencies.

Dos and don'ts of capacitor decoupling

Out of all the discussion above, certain common-sense rules emerge for satisfactory high-frequency decoupling with capacitors:

(a) Do look hard at every lead and *picture it as a coil of wire*.

(b) Do, if you must use leads on the capacitor, keep them as short and straight as humanly possible. (This also implies designing your equipment layout always with an eye to "topological compactness.")

(c) Do keep any leads you use as thick as possible.

(d) Do always estimate the departure of a capacitor configuration from its ideal impedance, and be particularly careful where you have to operate above its self-resonant frequency.

(e) Do, for really low impedance at very high frequencies, use a low-inductance feed-through type of capacitor or enlist the aid of a series-self-resonant arrangement of a disc capacitor.

(f) Do not, in the case of multiple-frequency signals, rely solely on resonance-mode capacitor decouplings to provide adequate decoupling at all frequencies.

(g) Do take into account capacitance tolerance spreads when using ceramic capacitors in resonance-mode.

(h) Do, if possible, make your chassis of brass or copper to which you can solder leadless capacitors directly without the need to introduce a possibly-inductive terminal lug as would be required with aluminium.

LITERATURE RECEIVED

"**Calibration Equipment.**"—This 12-page booklet gives detailed specifications of the G. & E. Bradley d.c. and a.c. calibrators, d.c. current calibrator, and a programmer for batch calibration of identical products, such as valve voltmeters, oscilloscopes, etc. This publication (No. 102) is available from G. & E. Bradley Ltd., Electral House, Neasden Lane, London, N.W.10.

WW 323 for further details

A specification for the characteristics and performance of **Radio Frequency Signal Generators** has been issued by the British Standards Institution, 2, Park Street, London, W.1. This standard (B.S. 4014: 1966) is based on an original British draft, and has been published in view of the increasing variety and complexity of design, uses and requirements of telecommunication equipment. Only the most commonly employed methods of modulation (a.m. and f.m.) are considered in detail. Price is 10s.

Publication number 4450-255 is an 8-page report on the reliability of A.E.I. semiconductors (**miniature Zener diodes**) that has been released, and it is intended to be read in conjunction with publication 4450-251. Available from Associated Electrical Industries Ltd., Semiconductors, Carholme Road, Lincoln.

WW 324 for further details

Digital frequency meters, counters, timers, ratio meters, tachometers, and a time and frequency calibrator are des-

cribed in a 7-page catalogue on Dawe 900 series digital modules and instruments. Issued by Dawe Instruments Ltd., Instrument & Digital Measurement Division, Western Ave., Acton, London, W.3.

WW 325 for further details

A 6-page technical bulletin "Product News" gives details of design procedure and test procedure for engineers wishing to employ Cambion **thermoelectric devices**. This publication 60401 is issued by Cambion Electronic Products Ltd., Cambion Works, Castleton, Nr. Sheffield.

WW 326 for further details

English Numbering Machines Ltd., Queensway, Enfield, Middlesex, have issued a 12-page booklet giving a fully detailed specification of the type 482 **double channel print-out counter**, recording quantity, time, and date.

WW 327 for further details

The 1966 **Sasco catalogue** of electronic components comprising 526 pages has been received from Stewart Aeronautical Supply Co. Ltd., P.O. Box 20, Gatwick Road, Crawley, Sussex.

WW 328 for further details

Leaflets on the Celestion studio series of 12in **co-axial high-fidelity loudspeakers**, and the Ditton full-range loudspeaker system have been received from Celestion Ltd., Ferry Works, Thames Ditton, Surrey.

WW 329 for further details

NEWS FROM INDUSTRY

BRITISH BATTERY FACTORY FOR BULGARIA

Technoport, the Bulgarian State agency responsible for importing plant and machinery, have accepted a tender from Vidor Ltd. to provide a complete factory for battery production. The building itself already exists at Nikopol on the bank of the Danube and Vidor will equip it with machinery now being built at South Shields, Co. Durham. Initially the five-year contract is worth £340,000, but it is stated that it could eventually be worth much more. This month Technoport will send ten technicians to Vidor for six months' training, and in mid-1967, a team from Vidor will go to Nikopol to supervise not only the installation of machinery and equipment, but also to ensure the smooth functioning of the factory. A weekly production of 100,000 batteries will include five types of domestic battery and four other kinds, all to be marketed under a Bulgarian brand name.

The diversity of microwave energy transfer applications, particularly in industrial techniques, such as heating, drying, sterilization and pasteurization, are well known. On the other hand advanced areas such as the generation of plasmas for electronics, manufacturing techniques, and medical uses are new developments. In order to disseminate all available technical information on such applications, a new international technical society was recently incorporated in Canada and is known as the **International Microwave Power Institute**. A group of Canadian and U.S. scientists have formulated the policies and functions of I.M.P.I., which include annual symposia on microwave power techniques, information exchange, and the publication and distribution of technical proceedings to members. The Institute also plans an information programme to broaden the awareness of microwave power applications among all process industries. Leading the technical group as chairman is Dr. W. A. Geoffrey Voss, professor of electrical engineering, University of Alberta. Membership information can be obtained from I.M.P.I., 1744 West Broadway, Vancouver, British Columbia, Canada.

An agreement has been made between Feedback Ltd., and Elliott Automation (Microelectronics Division) in which Feedback becomes responsible for the manufacture, further development, and marketing of the BT1 educational computer training equipment. This was originally developed at Battersea College of Advanced Technology in con-

Ferrograph tape recorders in the Control Room of Manchester City Fire Brigade, have been used continuously twenty four hours a day since 1953. Simultaneous recording of 999 calls and TIM signals are made on a dual channel machine. A recorder with an endless loop cassette provides instantaneous replay of messages. Normally quiescent, both recorders operate immediately the operator depresses the key to receive a 999 call.

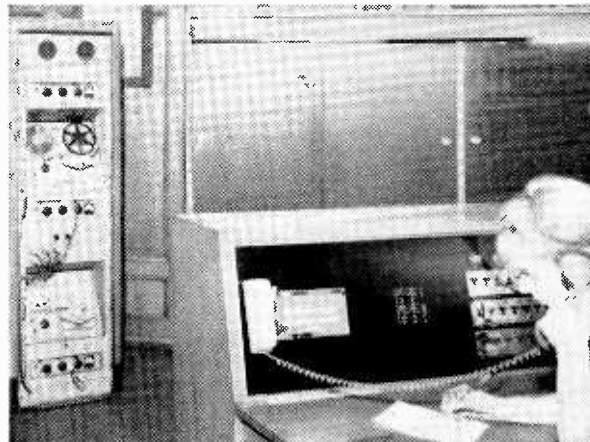

junction with Elliott Automation. With this equipment a complete range of logic, mathematics and computer techniques can be offered for teaching.

P.J.N. Collaro Electronics Ltd., of 1 Regent Street, London, S.W.1, have been appointed U.K. concessionaires for **KLH** sound reproducers. **KLH** Research and Development Corp., manufacturers of loudspeaker systems, have produced domestic music systems for 5 years in the U.S.A. The equipments are designed for those who do not want the inconvenience of many-component hi-fi apparatus or have the desire for large radiograms. The systems range in price from about £90 to £170, one includes two loudspeakers and a single unit comprising a Garrard turntable, amplifier and, in the more expensive category, an f.m. stereo tuner. The company has the unusual policy of not disclosing equipment performance figures, but amplifier distortion is low and output is thought to be about 12-18 W into loudspeakers of 2½% efficiency.

Special glass required by Mullard Ltd. in the production of colour television tubes is to be made by the company at a new plant to be installed at their Simonstone, Lancs. factory. This £1M plant, when in full production, will obviate the present need to import the glass; hence there should be a significant reduction in the total cost of a colour tube. It will also contribute to the total glass output that is exported (in terms of monochrome and colour tubes). Special equipment for precision grinding and polishing the finished glass will be part of the new installation, since the assembly of the screen and cone of a colour tube require techniques different from those used in monochrome tube production.

E.E. and Westinghouse Brake Link.—English Electric have acquired for £1M a 49% interest in the subsidiary company already established by Westinghouse Brake and Signal Company to undertake the research, development and manufacture of power semiconductor devices. The company, which will be known as **Westinghouse Brake English Electric Semi-conductors Ltd.**, will be concerned with power semiconductor devices with a capacity of over 10 amps.

Against a background of proposed legislation which will make the carrying of two-way radio in light aircraft compulsory in the U.K., G.E.C. Electronics' Communications Group at Spon Street, Coventry, will market the "Sky" range of air radio equipment, manufactured by Skycrafters Inc. of U.S.A. The first product to be available here will be the "Sky 505" a lightweight v.h.f. air/ground transceiver costing £295.

Avo's new 100,000 sq ft factory and office block at Dover overlooking the Channel was officially opened by Earl Mountbatten of Burma on October 24th. Built at a cost of £400,000, it has a clean air working zone of 18,000 sq ft. The company which is now a subsidiary of Metal Industries, was started in 1923 and will eventually be closing its old premises in Vauxhall Bridge Road, London, S.W.1.

Kelvin Electronics Co. of Kelvin House, Wembley Park Drive, Wembley, Middlesex, have been appointed exclusive U.K. and Eire, sales and service agents for Princeton Applied Research Corporation, N.J., U.S.A., whose products are precision instruments for research and development.

WHY THEY ARE NEEDED AND HOW THEY WORK

HYBRID COMPUTERS analogue + digital

3. PROGRAMMING HYBRID COMPUTERS

By P. W. J. VAN EETVELT, Dip.Tech.(Eng.), Grad.I.E.E.

THE programming of pure analogue computers is now a well established routine. Hybrid programming techniques are somewhat less simple, although a good deal of research work is being done at major computing centres to develop programming techniques to relieve the burden on the computer user. The two examples of programming which will be discussed in this article have been chosen carefully so as to point out some of the available parallel hybrid computing techniques which have distinct advantages over the pure analogue techniques previously used to solve the same type of problem.

First, however, it will be helpful to lodge in the back of the mind a general picture of a typical hybrid computer --that is, an assembly of individual computing elements

Peter W. J. Van Eetvelt graduated in Electrical Engineering at Brighton College of Technology in 1964. He then joined Electronic Associates Ltd. as a member of their United Kingdom Computation Centre, where he worked until February 1966. Since that date he has been senior applications engineer in charge of the company's Northern Area Computation Centre working mainly with hybrid computers.

of the kind described in Part 2 last month. For this purpose, two commercial hybrid computing systems will now be described.

A medium-sized transportable hybrid computation system is the "Hybrid 48" machine, designed and developed by Electronic Associates Ltd. and introduced in Part 1 in October (p. 509). The layout is explained in detail in Fig. 1. The computer is self-contained within a volume of 48 in \times 33 in \times 20 $\frac{1}{4}$ in and weighs 360 lb. Total power consumption is approximately 150 watts. These factors enable the machine to be operated in limited space rather than computer laboratories since no special installation, cooling or maintenance problems have to be overcome.

The computer is a 10-volt machine with a linear component accuracy of 0.01%. The central region of the equipment houses the modules for both analogue and digital operations. These modules are associated with a corresponding patch block on the pre-patch panels; both the module and patch block may be interchanged with alternate modules and patch blocks, allowing the equipment complement to be altered from problem to problem and thus diversification of the application. The d.c. operational amplifier complement may be expanded up to a maximum of 70, although the basic complement is 48 amplifiers and since several of the non-linear units provide built-in inverters the total amplifier complement may be of the order of 80.

The analogue patch panel enables up to 60 modules to be contained within the computer framework; 24 of these are committed to the amplifiers and 12 are normally associated with potentiometers and reference lines. A single module is used to provide output and trunk lines to peripheral equipment. The remaining 23 modules are completely flexible, with certain minimal restrictions, and are used for integrators or non-linear functions.

Units which may be plugged into the 23 remaining positions include: electronic mode controlled dual integrator networks; medium or high accuracy quarter-

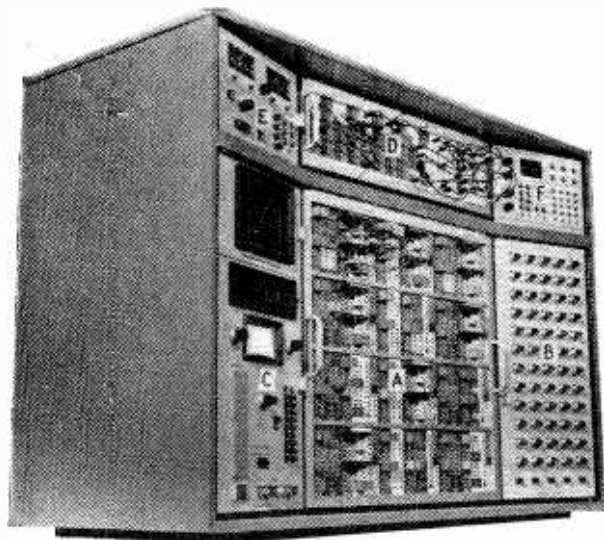

Fig. 1. "Hybrid 48" machine produced by Electronic Associates. (A) Analogue section provides continuous operations of summation, inversion, integration, multiplication, division, resolution and function generation. (B) 10-turn helical potentiometers for setting up problem parameters. (C) Analogue control, monitoring and check facilities, and oscilloscope display. (D) Discrete operations of timing, selection sequencing, comparison, switching, counting, and mode control. (E) Mode control panel provides push-buttons for selecting modes of hybrid operation, digital clock rates, mode timers and function switches. (F) Logic indicator panel provides push-buttons for pre-setting logic elements and neon indicator lights.

square multipliers; fixed or variable break-point manual diode function generators; fixed diode function generators (including x -squared, $\log x$ and sine-cosine functions); amplitude and dead-space limiters; electronic comparators; trunks; and function switches.

Directly above the analogue patch panel is a logic patch panel providing means for "electronic mode controlled" expansion. This gives: a flexible digitally controlled timing system; parallel high speed logic modules; buffered control lines for driving integrator mode relays (and track store units); high-speed integrator controls for solid-state mode switching and individually selecting time scales (replacing the relay mode control integrators as and where required); track/store units with control for solid state switches; solid-state d/a switches; and high-speed comparators (with optional relay).

A somewhat larger hybrid computer, also developed by Electronic Associates Ltd., is the EAI 680. This machine has been designed with the emphasis on ease of programme setting-up and convenience of operation. The layout has been arranged so that the average operator may reach all controls while seated at the console. Readout and display devices have been arranged for maximum visibility from the operating position. Only those controls used for setting-up and adjustment of the computer are located behind swing-out doors. This helps to avoid confusion and allows a new operator to become familiar with the machine in a reasonably short period of time. An optimum "mix" of equipment was established by a statistical evaluation of a large number of typical problems previously carried out by the maker's computation centres.

Programme patching on the EAI 680 is simplified through the use of a single patch panel for both analogue and logic patching. The patch panel may be broken up into five horizontal rows. The top row is used for logic signal patching, while the bottom four rows are used for analogue signal patching. The patch panel contains 4,080 holes, 840 of these being used for logic signals and 3,240 for analogue signals.

Since the termination of all computing component inputs and outputs at the patch bay makes the electrical design of the patching system critical to computer performance, special care has been taken to prevent cross-talk by means of a metal grid located on the front of each of the computing modules that plug in behind the patch panel. This grid forms individual shielding cells for the contacts, thereby minimizing noise and allowing maximum frequency of operation.

To realize the full potential of hybrid computation, the chopper-stabilized operational amplifiers have a 500 kc/s minimum bandwidth when connected as inverters. The velocity limit at this frequency for a 10-volt pk to pk swing is 20×10^6 volts per second.

A full EAI 680 system contains the following computing components:

Analogue equipment complement:—30 combination amplifiers; 24 summer amplifiers; 102 inverter/high-gain amplifiers; 18 variable diode function generators; 24 quarter-square multipliers; 120 servo-set potentiometers; 12 hand-set potentiometers; 12 sin/cos function generators; 6 log function generators; 12 feedback limiters; 12 hard zero limiters; and 36 diodes.

Logic and interface equipment:—24 electronic comparators; 24 d/a electronic switches; 24 d/a relays (d.p.d.t.);

12 track/store units; 6 four-bit general-purpose shift registers; 36 AND gates; 6 monostable multivibrators; 6 logic differentiators; and 3 b.c.d. counters (2-decade, bi-directional).

The two hybrid computers outlined above are both provided with adequate "software" developed at various computation centres. In order to familiarize the reader with some of these techniques two typical engineering applications will be described in the remainder of this article.

Programming a boundary value iteration problem.—The first type of programming problem to be considered is that of boundary value iteration. One of the simplest illustrations of this is the problem of aiming a missile to hit a target. Referring to Fig. 2, consider a missile having an initial velocity V_0 at an angle θ_0 to the horizontal plane. It is required to compute the initial velocity V_0/θ_0 for the missile to hit a target at a range R assuming square law velocity drag to act throughout this range.

The equation of motion for such a problem may be written as follows:—

$$\ddot{x} = \frac{-k \dot{x}}{\sqrt{\dot{x}^2 + \dot{y}^2}} \quad \dots \quad \dots \quad \dots \quad (1)$$

$$\ddot{y} = -g - \frac{k \dot{y}}{\sqrt{\dot{x}^2 + \dot{y}^2}} \quad \dots \quad \dots \quad \dots \quad (2)$$

where x is the horizontal displacement from the origin and y the vertical displacement from the horizontal plane through the origin, g being the acceleration due to gravity.

The initial conditions for this problem are specified thus.

$$x|_{t=0} = 0 \quad \dot{x}|_{t=0} = V_0 \cos \theta_0$$

$$y|_{t=0} = 0 \quad \dot{y}|_{t=0} = V_0 \sin \theta_0$$

Such a problem could be easily implemented directly on a pure analogue computer, the value of V_0 being altered manually until the missile hit the target i.e. when $x = R$ and $y = 0$ simultaneously. Although manual iteration is feasible in this case, it is inefficient and, furthermore, if several initial parameters have to be determined it becomes impossible to manually iterate towards the boundary conditions. Thus automatic boundary value iteration subroutines have become an established technique of hybrid computation.

Let $x_{0,n}$ and $y_{0,n}$ be the initial values of x_0 and y_0 computed after the n th iteration cycle. Then it will be realized that an iteration policy must be established so that the $(n+1)$ th iteration will produce a subsequent improvement. This policy may be expressed in the form

$$\dot{x}_{0,n+1} = \dot{x}_{0,n} + F(R_n - R) \quad \dots \quad \dots \quad (3)$$

$$\dot{y}_{0,n+1} = \dot{y}_{0,n} + G(R_n - R) \quad \dots \quad \dots \quad (4)$$

R_n is the missile range for the n th iteration cycle. Obviously for convergence

$$\begin{array}{l} \text{Lt} \\ n \rightarrow \infty \end{array} \dot{x}_{0,n+1} = \begin{array}{l} \text{Lt} \\ n \rightarrow \infty \end{array} \dot{x}_{0,n} = \dot{x}_0$$

$$\begin{array}{l} \text{Lt} \\ n \rightarrow \infty \end{array} \dot{y}_{0,n+1} = \begin{array}{l} \text{Lt} \\ n \rightarrow \infty \end{array} \dot{y}_{0,n} = \dot{y}_0$$

so that the iteration functions $F(R_n - R)$ and $G(R_n - R)$ must tend to zero ultimately. The form of the iteration formulae used is usually based on experience of the nature

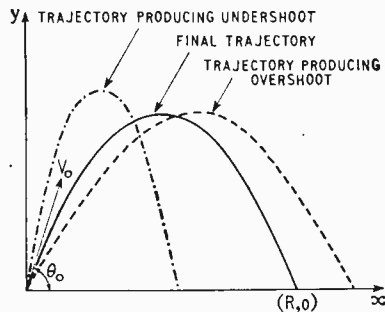

Fig 2. Trajectories of missiles aimed at a target at range R .

of the problem, since analytic techniques are generally not available for non-linear problems of this type.

Two-parameter boundary value iteration subroutine.—Let us consider the mode of operation of the parallel hybrid programme shown in Fig. 3.

The problem is driven from a timer generating a logic signal A and its complement \bar{A} . This timer is arranged to generate a rectangular pulse train with a low mark-space ratio. The output A is logic "0" for a period exceeding the estimated time of flight and logic "1" for say one-hundredth of this time. It is convenient to consider a point in time when an iteration cycle is being executed. The solutions \dot{x} , \dot{y} , x and y are generated at the outputs of integrators 1, 2, 3 and 4 respectively. As the missile approaches the ground plane, i.e. $y = 0$, the input to comparator C_1 is gradually decreasing until when y passes through zero and becomes negative the comparator logic output C changes state and becomes logic "0." \bar{C} becomes logic "1" and the flip-flop FF_1 is set high or logic "1," thus latching the comparator.

The T/S unit 1 now stores the final value of x reached at this point, which is the range R_n . This is compared with the required range R by amplifier 1 and the functions F and G computed from its output. The T/S units 3 and 5 are now storing the values of x_n and $y_{0,n}$ since C is logic "0." T/S units 2 and 4 are tracking these outputs and summing them with F and G respectively. Thus the outputs of 2 and 4 become $x_{0,n+1}$ and $y_{0,n+1}$. Since $A + \bar{C}$ must be high these initial conditions are accepted by integrators 1 and 2 respectively, the outputs of integrators 3 and 4 being restored to zero. When A goes high the flip-flop FF_1 is reset via differentiator DIF_1 and the output of the comparator C changes state and becomes logic "1" since the comparator is provided with a small positive bias internally, i.e. $C = "1"$ when $y \geq 0$; this means that T/S units 2 and 4 now store the values $x_{0,n+1}$ and $y_{0,n+1}$ and T/S units 3 and 5 track these values for the end of the next iteration cycle.

Note that since A is logic "1," $A + \bar{C}$ is still logic "1"; thus the initial conditions are still retained at the outputs of the integrators, 1, 2, 3 and 4 respectively. When A becomes logic "0" the $(n+1)$ th solutions of x , y , \dot{x} and \dot{y} are produced. When y passes through zero again the cycle is repeated until after a number of cycles the values of $\dot{x}_{0,n}$ and $\dot{y}_{0,n}$ remain constant from run to run, R_n having converged to R , the required target range. The ultimate values of \dot{x}_0 and \dot{y}_0 may now be read out and V_0 and θ_0 calculated simply from the formulae,

$$V_0 = \sqrt{\dot{x}_0^2 + \dot{y}_0^2} \quad \dots \quad (5)$$

$$\theta_0 = \tan^{-1} \left(\frac{\dot{y}_0}{\dot{x}_0} \right) \quad \dots \quad (6)$$

Suitable functions for F and G are

$$F(R_n - R) = K_1(R_n - R)$$

$$G(R_n - R) = K_2(R_n - R)$$

where K_1 and K_2 are constants determining the rate of iteration convergence.

Although this particular problem could be solved by a manual iteration scheme without much difficulty it will be appreciated that in problems where more parameters are required to meet boundary conditions, this is not the case. Multi-parameter boundary value iteration subroutines have been developed for problems where as many as 8 initial values are required to meet several

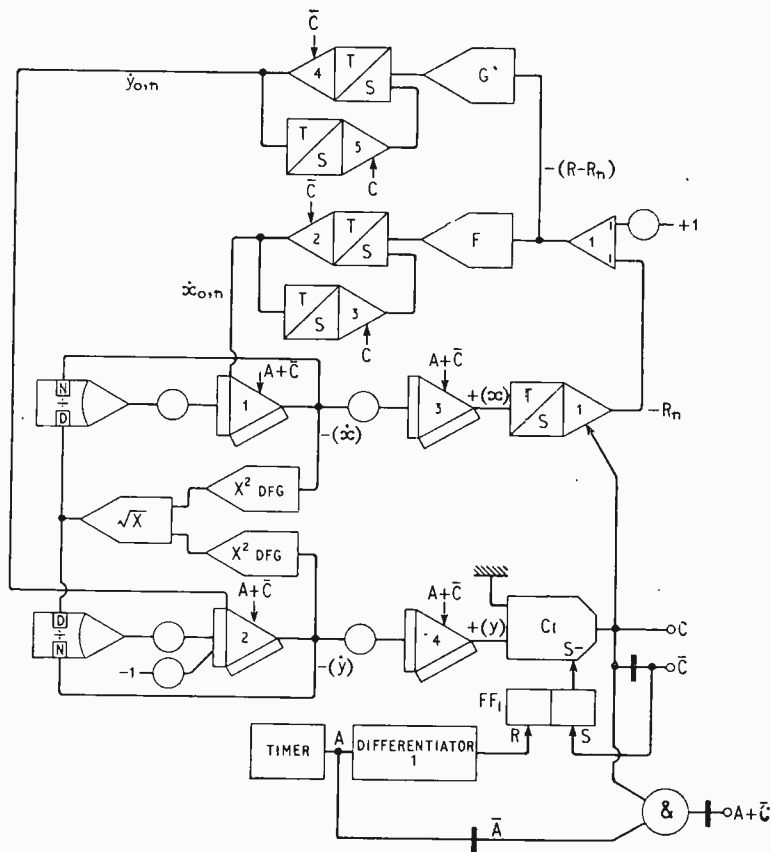

Fig. 3. Programming arrangement for the missile-aiming boundary value iteration problem.

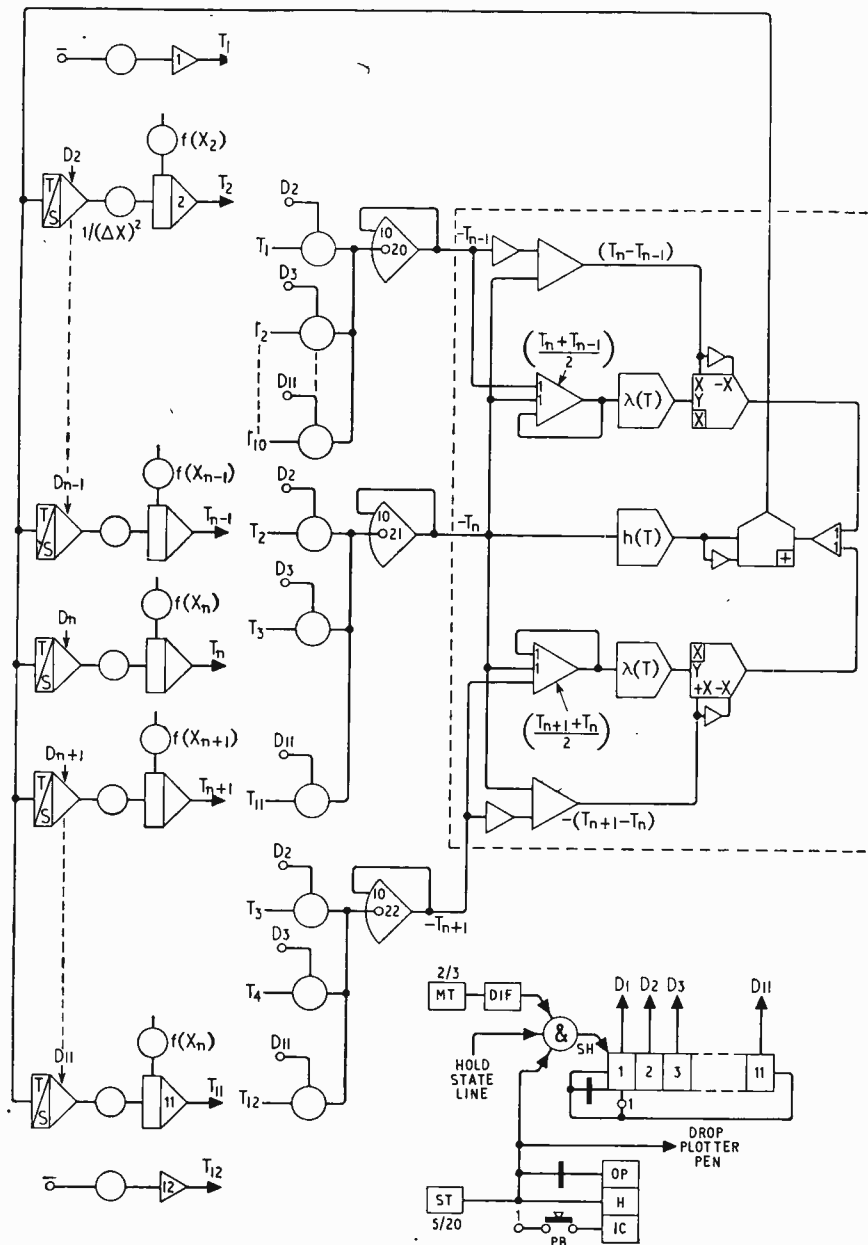

Fig. 4. Programming arrangement for solution of the thermal diffusion equation of heat transfer.

boundary conditions. The iteration formulae are sometimes difficult to find for boundary value problems involving several unknown initial conditions. In these cases part of the problem will be to establish such formulae on an empirical basis from results obtained by a coarse manual search routine. With the advent of the full hybrid system these search routines will probably become fully automated and software for problems of this type are being produced.

Thermal diffusion equation of heat transfer.—

Let us now consider a second type of problem which is more conveniently tackled on a hybrid computer than on

either analogue or digital computers. The mathematical formulation of any engineering problem leads almost invariably to a set of ordinary differential equations or partial differential equations, depending on the nature of the problem. Ordinary differential equations are easily solved on the analogue computer, since this is the main field of its application. Partial differential equations, which describe distributed parameter systems, however, are not easy to solve on either analogue or digital computers, although varying degrees of success have been obtained for specific types of problem. Since with partial differential equations more than one independent variable is involved in the solution, and the analogue computer is only available to handle a single independent variable, it follows that finite difference formulation of the equations must be accomplished before solutions may be obtained. Thus partial differential equations may be conveniently reduced to a set of ordinary differential equations dependent upon a single continuous variable. The dependence upon other variables is represented discretely by a number of cells or stations assumed in the finite difference formulation.

For simplicity we will use as an illustration the hybrid parallel solution of the thermal diffusion equation of heat transfer. Consider the uni-dimensional non-linear heat diffusion equation where both the specific heat (k) and the thermal conductivity (λ) are given non-linear functions of the temperature (T):—

$$k(T) \frac{\partial T}{\partial t} = \frac{\partial}{\partial x} \left[\lambda(T) \frac{\partial T}{\partial x} \right] \quad (1)$$

with simple boundary-conditions:

$$\begin{aligned} T(0, t) &= T_1 \text{ constant} \\ T(L, t) &= T_{12} \text{ constant} \\ T(x, 0) &= f(x) \text{ given.} \end{aligned}$$

This equation describes the temperature behaviour of a slab of material with an initial temperature distribution $f(x)$ established over its thickness L . The temperatures at both faces of the slab are held constant, at T_1 and T_{12} respectively.

In order to implement such a partial differential equation on a computer, it is necessary to subdivide the width L into a number of equal intervals or cells, $n = 1, 2, \dots, 12$, and replace the space derivative (x) by a

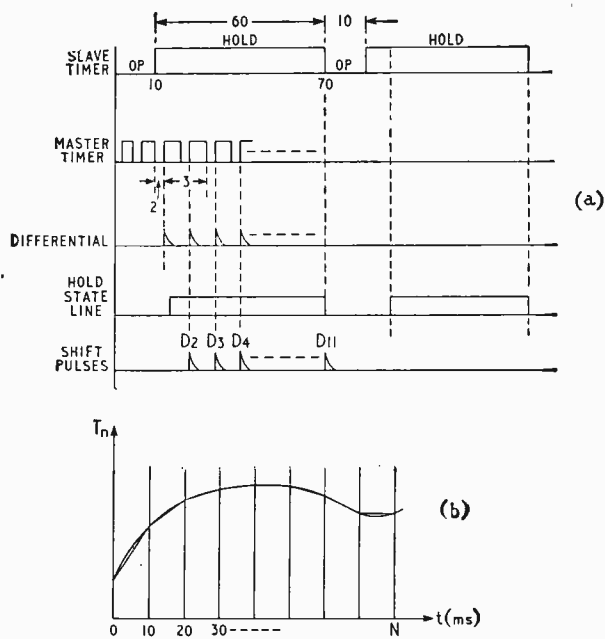

Fig. 5. Timing arrangements (a) and plotted result (b) for thermal diffusion equation.

finite-difference formula. Using central differences, Equation 1 then becomes:

$$\begin{aligned}
 \frac{dT_n}{dt} &= \frac{1}{k(T_n)} \cdot \frac{\partial}{\partial x} \left[\frac{\lambda(T_{n+\frac{1}{2}}) \cdot T_{n+\frac{1}{2}} - \lambda(T_{n-\frac{1}{2}}) \cdot T_{n-\frac{1}{2}}}{\Delta x} \right]_{x=n} \\
 &= \frac{1}{\Delta x k(T_n)} \left\{ \frac{\partial}{\partial x} \left[\lambda(T_{n+\frac{1}{2}}) \cdot T_{n+\frac{1}{2}} \right] - \frac{\partial}{\partial x} \left[\lambda(T_{n-\frac{1}{2}}) \cdot T_{n-\frac{1}{2}} \right] \right\} \\
 &= \frac{1}{(\Delta x)^2 k(T_n)} \left\{ \lambda \left(\frac{T_{n+1} + T_n}{2} \right) (T_{n+1} - T_n) - \lambda \left(\frac{T_n + T_{n-1}}{2} \right) (T_n - T_{n-1}) \right\} \dots \dots \dots (2)
 \end{aligned}$$

Thus the time-derivative of temperature at cell n is dependent upon T_n as well as the temperatures T_{n+1} and T_{n-1} of the adjacent cells.

The finite difference form of Equation 2 may be directly implemented on a pure analogue computer, this method being referred to as the "classical parallel method" of solution. To implement this by the classical method would require 3 function generators, 3 multipliers, 11 summers and 14 inverters for each cell. It is obvious that for a reasonable number of cells (say 12) the equipment requirements become prohibitive. This state of affairs led to the development of powerful hybrid computing techniques in order to eliminate the problem.

The method to be considered here is the "cell time sharing method." The idea behind this is that a single non-linear block may be time-shared using multiplexed inputs. The technique is best described by the diagrams in Figs. 4 and 5. In order to time-share the block of equipment we require a means for cyclically scanning three temperatures (T_{n-1} , T_n , T_{n+1}) at a time for successive values of n from 1 to 12. Referring to Fig. 4, the necessary high-speed rotary switches can be built-up from a number of digital analogue electronic switches which are cycled through by means of an 11-bit ring shift-register. At the end of each "operate" period lasting 10 msec (Fig. 5), the integrators are thrown into

the "hold" mode for a fixed length of time of 60 msec. The shift-register then begins to shift through its stages one at a time at the rate of 5 msec per stage. For example, at the n th stage only the d/a switches connected to T_{n-1} in amplifier 20, T_n in amplifier 21 and T_{n+1} in amplifier 22 are conducting, making these instantaneous voltages available at the output of the three amplifiers. These represent the inputs to the non-linear block (dotted enclosure) which computes the necessary derivative for station n . Note that one non-linear block is time-shared by all cells. The output of the non-linear block is applied to all the input track/stores. The states of these track/stores are also controlled by the shift-register stages so that only one track/store at a time is in the "track" mode while the other 9 are in the "store" mode.

Thus at the n th stage of the shift-register, the track/store for station n is tracking the presently computed derivative. At the end of the cycle the shift-register returns to stage 1, all the integrators have received their fresh derivative inputs, and the computer is thrown into another "operate" period of 10 msec. The sequence is then repeated over and over again until the complete transient has been obtained. An X-Y plotter can be arranged to make point plots of the temperatures at the end of each "operate" period. The necessary timing signals for the programme are derived from a master timer and a slave timer. Fig. 5 (b) shows the straight-line approximation to the transient that is typically obtained in this method. For a transient lasting N secs in real time, there will be $100N$ updating cycles.

It will be realized that the output profiles $T_1, T_2 \dots T_{12}$ are discontinuous in nature. However, if the time

intervals are made small so that, say, 10,000 or more of them occur in a single solution, then pseudo-continuous curves are produced which are almost identical to those which would be produced by the classical method of solution. The problems posed by this type of problem lie in the economic usage of available equipment, since although the non-linear equipment complement is considerably reduced, the number of track/store units and digital-analogue switches required for the parallel hybrid solution tends to limit the number of cells which may be used. Ultimately with the full-scale hybrid machine the use of digital memory and analogue/digital subroutines will overcome this limitation. Meanwhile much work is devoted to the development of alternative methods for reducing the equipment still further.

Summing up the series.—Hybrid computation has now developed to the state where it provides a practical and economic alternative to either analogue or digital computation. Eventually the full-scale hybrid computer will completely dominate the field of scientific computation, although at present the software is not readily available and is still in the process of being produced. Within the next decade this basic limitation will be largely eliminated as more and more major computation centres begin to use hybrid systems.

NEW PRODUCTS

equipment systems components

Radiometric Multi-receiver

DESIGNATED LR-102, the Teltronics Inc. r.f./i.f. multi-function receiver has specialized radiometric applications for the measurement of atmospheric, astronomical, and plasma phenomena. It will operate as an r.f. radiometer, super-heterodyne receiver, or as a 30 Mc/s i.f. radiometer. With a sensitivity of $0.1 \mu\text{V}$ which yields a better than 2:1 signal-to-noise ratio, this instrument will operate with any external lock-in amplifier to complement the system. By choosing the correct interconnections between the front panel and the user's instruments, the desired function can be obtained. The LR-102 is also intended for demonstration of laboratory techniques for the detection and measurement of ultra-low level signals and for

low level signal recovery by synchronous detection. The r.f. frequency ranges covered by the receiver with various plug-in converters are 50 to 1500 Mc/s; 1000 to 2000 Mc/s; 2000 to 4000 Mc/s; and 4000 to 8000 Mc/s. The i.f. is 30 Mc/s or as specified and the i.f. bandwidth is a nominal 10 Mc/s with the above i.f. or as specified. The i.f. attenuator has a range of 0 to 42 dB in 1 dB steps plus 1 dB vernier, and the i.f. gain is greater than 30 dB, with a stability of ± 0.5 dB. Rack mounted, the dimensions are $8\frac{3}{4}$ in high \times 19 in wide. The cabinet is $11\frac{1}{4}$ in high \times $21\frac{5}{8}$ in wide \times $14\frac{1}{2}$ in deep. The weight is 30 lb. Marketed by Roberts Electronics Ltd., 17 Hermitage Road, Hitchin, Herts.

WW 301 for further details

Twelve-channel Oscillograph

FOR instrumentation recording in research, industrial, medical, and educational establishments there is a portable 12-channel direct writing oscillograph, designed and manufactured by Consolidated Electrodynamics, of 14, Commercial Road, Woking, Surrey. The Type 5-127 produces a 7 in wide record, and it employs an ultra-violet print-out technique which requires no chemical processing. It has 12 switchable recording speeds from 0.08 to 64 in/sec, the speeds can be changed instantly without interrupting the recording process. Using Consolidated Electrodynamics 7-300 series galvanometers, static and dynamic data d.c. to 13 kc/s

can be recorded. Trace widths of 0.01 in yield good resolution. Optional facilities are flash timing, grid lines, trace interrupter, trace numbering, and two reference traces. Other features include individual galvanometer input and low-power consumption.

WW 302 for further details



630

Silicon Bilateral Switch

SILICON unilateral and bilateral switches have similar characteristics to the four layer or Shockley diode. These General Electric (U.S.A.) devices are intended for triggering thyristors or other power devices especially in low-voltage configurations. Switching from the high impedance state to the low state occurs between 6 and 10 volts, the maximum switching current being 500 μA .



The bilateral switch comprises two unilateral switches in inverse parallel, the equivalent circuit being four transistors, two Zener diodes and two resistors. Both devices employ planar integrated circuit techniques. The switching voltage varies less than 0.05% per deg C. Both devices are encapsulated in three lead T018 packages, the third lead (gate lead) can be used to trigger the device, suppress rate effect and act as a terminal for transient free waveforms. These two devices have many applications including ring counters (up to 50 kc/s), power logic, and frequency dividers. U.K. agents are Jermyn Industries, Vestry Estate, Sevenoaks, Kent.

WW 303 for further details

Zener Diode Kit

THE Zener "40 Plus" Semiconductor-kit has been specially prepared by International Rectifier to meet all the immediate requirements of those developing equipment incorporating Zener diodes. This kit contains 40 (lifetime guaranteed) glass-to-metal seal encapsulated diodes, comprising five 10 W type 10 Z, twenty 1 W type 1 Z, and fifteen 0.75 W type MZ. These cover the complete voltage range 3.9 to 27 volts in 10% steps. A Zener diode slide rule calculator and application handbook covering the theory and application of Zener diodes, reference elements and temperature stabilized units are also included. The complete semiconductor kit costs £10 10s and an E.I.D. released version

is available at £12. International Rectifier Company, Hurst Green, Oxted, Surrey.

WW 304 for further details

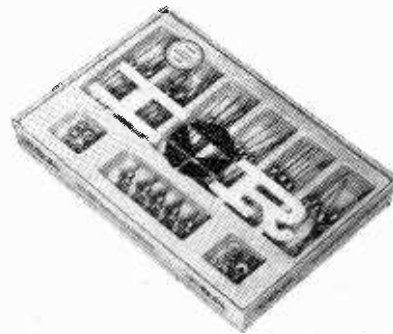

WIRELESS WORLD, DECEMBER 1966

TRANSISTOR TOOL KIT

THE transistor tool kit 1900 TR contains 18 tools held in cut-out plastic foam to eliminate retaining straps. The selection includes a 14 mm magnifying contact mirror, a 30 W soldering pencil iron, a flexible screwdriver, a screw-positioner, hook tweezers for removing excess solder and a special side cutting nipper. Among the more conventional tools are miniature screwdrivers in five sizes, two sizes of screwdriver for grub screws and one for Phillips' screws, a crown shear and two pairs of specially shaped electrician's pliers. The complete kit weighs just over 2lb and measures $10 \times 13 \times 1\frac{1}{2}$ in. The price is 10gns from Henri Picard and Frère Ltd., 34-35, Furnival Street, London, E.C.4.

WW 305 for further details

Medical Tape Recorder

EIGHT-channel operation is possible with the Pitman PI-6200 portable medical tape recorder. Other features include a closed-loop drive system with a crystal-controlled phase locked servo system. F.M. or direct recording is provided for each channel. Flutter is less than 1% peak to peak d.c. to 10 kc/s at 37.5 in/sec. The speed accuracy is $\pm 0.2\%$ long term. The three-speed operation of this recorder is based on a 100:10:1 ratio, the centre speed being 3.75 in/sec. From 1 to 8 data or audio modules can be added, by sliding in a drawer type module. The recording and reproduction heads each have 2 stacks with 4 tracks per stack, and the erase head covers the full track. The tape itself is $\frac{1}{4}$ in wide and 1.0 mil thick; length

is 1,800 feet. Track width is 0.020 in with 0.030 in spacing. The rewind and fast forward speed is 1,800 feet in less than 2 minutes. In the direct record/reproduce mode, input sensitivity is 0.050 to 10 V r.m.s., with a nominal input of 1 V r.m.s.; input impedance is 50 k Ω or greater. Frequency response at 0.375 in/sec is ± 3 dB from 50 c/s to 1 kc/s; at 3.75 in/sec it is ± 3 dB from 50 c/s to 10 kc/s; and at 37.5 in/sec it is ± 3 dB from 300 c/s to 100 kc/s. The s/n ratio ranges from 30dB at 0.375 in/sec to 35dB at 3.75 in/sec and 37.5 in/sec. In the f.m. record/reproduce mode the frequency response at a speed of 37.5 in/sec is ± 1 dB from d.c. to 10 kc/s with a s/n ratio of 42 dB. The centre frequency drift is $\pm 2\%$ or less of full scale over range of temperature 35 to 115°F. An eight-channel recorder weighs approximately 110 lb. D. A. Pitman Ltd., Mill Works, Jessamy Road, Weybridge, Surrey.

WW 306 for further details

Solid State Oscilloscope

CIRCUITRY of the Hewlett-Packard Model 180A oscilloscope is solid state, except of course for the cathode-ray tube. A 50 Mc/s plug-in instrument with an 8×10 cm screen, it is designed to operate normally from -28°C to $+65^\circ\text{C}$, and at altitudes up to 15,000-ft. There are two plug-in positions. One is for the vertical amplifier. The first of a series to become available is a two-channel unit which achieves a deflection factor (sensitivity) of 5 mV/cm at 50 Mc/s. The trace won't jump when the calibrated sensitivity control is switched. There is said to be virtually no trace drift when the instrument is turned on. The manufacturers state that these characteristics result from the use of new low-noise all solid-state circuitry, with matched pairs of f.e.t.s kept constantly in the same thermal environment, permitting all attenuation to precede the amplifiers. The new timebase plug-in units are offered for the 180A. The first of these, Model 1820A, achieves a sweep speed of 5 ns/cm, when its $\times 10$ magnifier is turned on at the fastest (0.05 $\mu\text{s}/\text{cm}$) calibrated setting. Reliable triggering to 90 Mc/s, gives high resolution in the observation of high-speed traces. Variable hold-off in Model 1820A permits the user to synchronize smoothly on asymmetrical pulse trains. Optional with the 180A is the 1821A timebase and delay generator plug-in. The delayed timebase begins to sweep after a time-delay from the main sweep, which is controllable. A bright dot on the screen identifies the point on the trace where the delayed sweep begins; this locates and identifies that part of any trace which the observer may wish to expand for detailed exami-

nation. The 180A oscilloscope consumes only 95W, thus, no fan is necessary, and the instrument operates silently. All active elements of the circuit, on etched circuit boards, are accessible for test, while operating. Accessories offered for this instrument include the 197A electronic-shutter camera that fits directly to the new scope, and adapters are offered for most other cameras. Flexible viewing hood, panel cover, carrying cover, and high-impedance divider probe are all designed to match. The price of Model 180A oscilloscope, without plug-in units, is £324 and model 180AR, the $\frac{5}{4}$ in high rack-mounting version, £354. The 1801A dual-channel amplifier costs £255, the 1820A timebase £187, and the 1821A timebase and delay generator £314. Hewlett-Packard Ltd., 224, Bath Road, Slough, Bucks.

WW 307 for further details

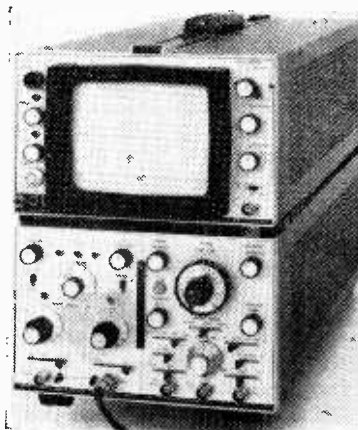

Audio Response Control Unit

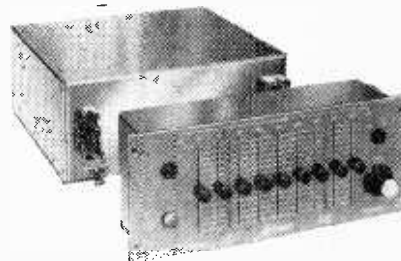

DESIGNED for the professional user this audio response control unit, Type A1671, is constructed in two sections so that the larger main amplifier section can be remotely operated from the smaller control unit, which can be built into a console. When all nine controls are in the zero position there is a "flat" response of ± 0.25 dB at 20 c/s to 20 kc/s. Each of the nine selector slide switches has fourteen steps of 2 dB, seven "lift," and seven "cut" positions. The nine selector frequencies are 50, 100, 160, 320, 640, 1,280, 2,560, 5,120 and 10,240 c/s. The total harmonic distortion including noise is 0.3% at 0 dBm. Input impedance and output impedance is 600 Ω . Price £145 from Audio Electronic Engineers Ltd., Dalston Gardens, Stanmore, Middlesex.

WW 308 for further details

Audio Noise Reduction System

A NEW audio noise reduction or *s/n* "stretcher" system has been developed by Dolby Laboratories of 590 Wandsworth Road, London, S.W.8. The company was set up in 1965 mainly to develop and produce equipment using this scheme. The system, type A301, has particular application in recording, where master tapes limit *s/n* ratio. Restricted *s/n* ratio may not be obvious on popular recordings, but it is obvious with material demanding a wide dynamic range, in particular with pianos and other stringed instruments.

Most noise reduction systems rely on compression, before recording on tape (or transmission over a line), and subsequent expansion, of signals having large amplitudes. In the Dolby system, however, compression and expansion are carried out at a low signal level. When signal levels are so high that this is not possible, reliance is placed on the masking effect. Since the masking effect is most effective when the wanted (signal) and unwanted (noise) frequencies are close, the audio spectrum is split into four parts, so that a high level signal in one band cannot prevent noise reduction in another band in which the signal level is low.

The system reduces high- and medium-frequency hiss, noises produced

by tape irregularities, hum and rumble, and tape print-through by 10 dB at 20 c/s, rising to 15 dB at 15 kc/s. Modulation noise and scrape flutter are also substantially reduced. The distortion introduced by the system is less than 0.2% and typically 0.05%. Overall noise level is better than 80 dB and typically 85 dB.

The equipment is simple to use, no adjustments being necessary after initial setting up. The cost is stated to be about £700.

We understand that the system is in use at the Decca recording studios, and l.p. disc material using the system—the first is Mahler's 2nd Symphony—is due to appear on the market.

WW 309 for further details

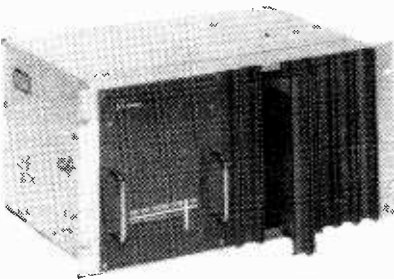

UNISELECTOR-COUNTER

MARKETED in the U.K. by Simmonds & Robinson the West German Emmerich Counting Selector ZW2 is a plug-in, ten position, two bank, reverse-driven uniselector with self-drive and normally-off auxiliary contacts, a drum dial engraved 0-9 in characters 4 mm high and a moulded cover with a window through which the displayed number can be seen clearly. They can be

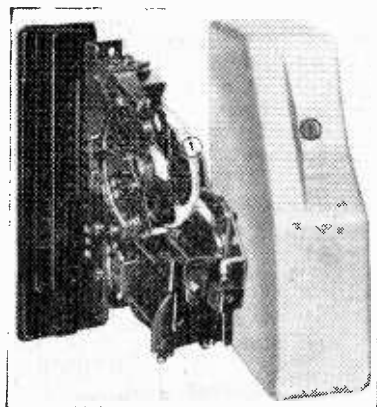

mounted in groups as they are flat and only 1½ in wide. A pulse to one terminal causes the wipers to step forward (at the end of the pulse), and a pulse to another terminal causes the wipers to reset forward to the zero position. This is done without tying up one of the banks as the armature operated "self-drive" contacts are connected in series with a normally-off auxiliary contact opened by a cam at zero. Methods are given in a leaflet for connecting these units in cascade for normal decade counting up to any number, and for batch counting—the required number being set up on ten-way manual switches. It also gives circuits for manual and auto-resetting from a single contact. The maximum counting or stepping rate is about 33 steps per second. They step on a pulse of 20 ms and only require an interval between pulses of 10 ms. Life expectation is claimed in excess of twenty million steps. Simmonds & Robinson Ltd., Victoria House, 44 Park Street, Camberley, Surrey.

WW 310 for further details

SOLDERING INSTRUMENT

DESIGNED to be used either as a gun or pencil, the Westinghouse Electric Corporation (U.S.A.) Positerm soldering instrument applies electrical energy to the piece to be soldered. Positerm soldering tips cause this electrical energy to be converted to heat right on the work-piece surface. The tips remain cool because they are good conductors electrically, but bad conductors thermally. The blade edges of the tips cut through oxides and films so that good electrical contact can be easily established. Six different heating rates are available from the power supply unit at the push of a button. It is available for operation from 115-120 V, 60 c/s, or 220 V, 50 or 60 c/s. Power delivered to work can range from 13 to 62 W, and the current during soldering can vary from 40 to 100 A. The duty cycle is 1 minute on, 4 minutes off when on high position. The gun spool will take 0.025 to 0.050 in solder. U.K. agents, Voice and Vision (International) Ltd., 26, Upper Brook Street, London, W.1.

WW 311 for further details

POWER TRIODE FOR R.F. HEATING

A LOW amplification factor of 11, making the tube less sensitive to changes in load impedance is a characteristic of the BR1169 triode for industrial r.f. applications such as welding, brazing, and heat treatment. This tube is an air-cooled version of the water-cooled BW1169J3. It has an anode dissipation of 10 kW. When operated at 6.5 kV in a class "C" industrial oscillator, an output of 18 kW can be obtained. The anode voltage is 7.5 kV max., and the maximum operating frequency for full ratings is 20 Mc/s. Filament voltage and current are 6.6 V and 103 A respectively. English Electric Valve Co., Ltd., Chelmsford, Essex.

WW 312 for further details



Coaxial Relays

COAXIAL relays in the Amp-phenol Dynaform 360 series can be assembled in hundreds of different combinations by the use of 23 standard modules. The technique is shown in the illustration, in the centre of which is the basic unit to which has already been attached two Type N sockets and one of a range of coil assemblies. If, for example, changeover operation is required with all sockets on the same side, and with earthing of the disconnected socket to prevent break-through, then component 3 is mounted over the centre hole and component 5 under it. The operating coil moves both the blades visible through the hole, and when one is in contact with the centre socket, the other is earthed by being in contact with component 5. If, however, it is preferred to have the centre socket on the other side of the relay, then components 3 and 5 are reversed. If it is desired to terminate the unused line in a resistive load, then component 5 is replaced by component 4. D.P.D.T. action is obtained by connecting two relay units by component 1. Transfer or crossover action is obtained by replacing component 4 or 5 by component 2. With the coil non-energized the right-hand socket will be connected to component 2 and the left-hand one to the other central socket. The sockets can either be of the BNC Type (as component 1), the N Type (component 2) or the TNC

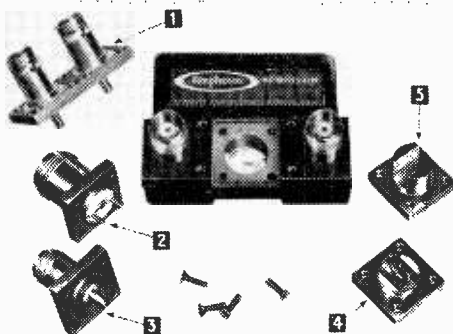

Type (component 3). All contacting surfaces are heavily gold plated. The performance exceeds the requirements of classes B2b and B3b of Specification MIL-S-3928B, and they extend the usable frequency range up to 6Gc/s and provide significantly lower s.w.r. The v.s.w.r. varies from 1.03 to 1.05 at 0.3 Gc/s and from 1.3 to 1.4 at 6 Gc/s, insertion loss varies from 0.6dB to 0.3 dB, and cross-talk varies between -18 and -72 dB. These relays will stand 1kV peak r.f. and at 6 Gc/s will handle 50W c.w. or 2kW peak. False operation is not produced by shock up to 10g with vibration between 10 and 55 c/s; temperature range is -55 to +100°C and they can be used up to an altitude of 70,000 feet. Distributed by Simmonds & Robinson Ltd., Victoria House, 44, Park Street, Camberley, Surrey.

WW 313 for further details

POLYCARBONATE CAPACITORS

A SERIES of resin-protected polycarbonate capacitors intended for applications where severe environmental conditions are not encountered has been introduced by Standard Telephones and Cables Ltd., Capacitor Division, Brixham Rd., Paignton, Devon. These are high reliability components wound from ultra-thin plastic-film of metallized polycarbonate. Their electrical and physical characteristics are stated to be superior to other plastic-film capacitors and remain stable over a wide temperature range. They are housed in robust rectangular-moulded cases of thermo-setting resin (providing environmental protection to H3 of DEF 5011). Terminal wires are radial and spaced to suit printed-circuit mounting. STC resin-protected polycarbonate capacitors are available in values from 0.01 to 4.7 μ F 100 V d.c. working, and are suitable for operation over the temperature range -40 to +85°C. Standard toler-

ance is $\pm 20\%$, with a $\pm 10\%$ tolerance available to special order. Surge voltage (at a max. of 1 min/hour) is 1.5 times the working voltage. The working voltage at 50 c/s and 85°C is 63 V. STC Capacitor Division, Brixham Road, Paignton, Devon.

WW 314 for further details

High Power A.C. Sources

A RANGE of precision a.c. sources with high-power outputs made by Optimization Inc. of North Hollywood, U.S.A., is now available in the U.K. from Livingston Laboratories. Model AC 104A, which has applications in calibration laboratories and vibration studies, covers the frequency range 10 c/s to 100 kc/s and is capable of providing an output of up to 200 VA with distortion as low as 0.05%, from 50 c/s to 10 kc/s at 1,000 V r.m.s. Frequency is indicated by a 4 digit plus

Another Ceramic C.R.T.

EARLIER this year a 1 in ceramic cathode-ray tube was announced.* This tube used magnetic deflection and focusing. Now Ferranti's have announced a ceramic c.r.t. using electrostatic focusing, this being claimed to give greater freedom from vibrational effects. In a ceramic tube, the components of the electron gun are formed either on metallized inner surfaces or as metal discs sealed to the tube walls. The gun thus becomes part of the tube, eliminating any relative displacement between gun and tube due to acceleration or vibration. Screen size is 0.5 in, and it is possible to obtain a resolution of better than 500 lines. With a first anode voltage of 450 V and a third anode



voltage of 7kV, line brightness is around 6,000 ft lamberts.

Normal deflection coils are not used, the deflection system consisting of printed-circuit coils mounted on a sleeve which fits over the front part of the tube. Ferranti, of Gem Mill, Oldham, Lancs, are investigating the use of electrostatic deflection, in which the deflector plates will be mechanically integrated with the tube envelope.

*p. 241, May issue.

WW 315 for further details

vernier in-line readout accurate to 1%, and output voltages from 10 μ V to 1,500 V r.m.s. can be selected by a 5 digit ratio transformer. Constant voltage/current permits calibration of precision voltmeters and ammeters while maximum current output is 20 A from 45 c/s to 10 kc/s. Livingston Laboratories Ltd., Livingston House, Greycaine Road, North Watford, Herts.

WW 316 for further details

TRANSISTORS WITH NICHROMED EMITTERS

HIGH-POWER silicon planar transistors BLY25 and BLY26 with nichromed emitters have been introduced by SGS-Fairchild for use in applications requiring reliable performance in extremely severe environmental conditions. They are stated to be the first solid-state power devices to make use of nichrome deposition to aid power dissipation. The nichromed emitter, in these new devices, consists of a micro-thin film resistor deposited on the surface of the emitter to distribute current flow evenly throughout the entire emitter region of the transistor. Current concentration, the major contributor to secondary breakdown, is thereby reduced by means of the negative feedback established by the emitter resistance. High current beta fall-off is also minimized. These advanced power transistors have a 30 W power dissipation at 40 V and 100°C. All terminals are electrically isolated from the case; the devices can therefore be strapped on to a chassis or similarly mounted without any isolation, enabling full power dissipation to be achieved. They are

encapsulated in compact stud packages with a thermal resistance of 2.7°C per W; both are shock and vibration resistant, and capable of withstanding accelerations of many thousands of g. The low output capacitance of 120 pF maximum and the high f_T of 70 Mc/s minimum ensure extremely good high-frequency performance. High V_{CEO} (80 V for the BLY25 and 60 V for the BLY26), a guaranteed minimum h_{FE} of 20 at 5 A collector current, with very low saturation voltages, make these devices suitable for a very wide variety of applications—linear amplifiers, power supply inverters, servo amplifiers and Class C amplifiers operating over ranges from d.c. to over 30 Mc/s. They are said to be particularly suitable for military and professional applications where high performance with complete dependability under rigorous conditions is essential, such as in high power static inverters subject to strenuous operating conditions and severe environmental changes. SGS-Fairchild Ltd., Planar House, Walton Street, Aylesbury, Bucks.

WW 317 for further details

D.C. VOLTAGE SUPPLY

STABILIZED d.c. voltage supply units in the 600 range by Electro Process of Sun Street, Hitchin, Herts., possess separate meters to monitor current and output voltages. These have an accuracy that is within 2% f.s.d. Overload trip takes place at 120% full load current. Current limiting is also provided, so that the supply will not be damaged should the trip circuit fail to operate. Input voltage required is single-phase 45-65 c/s, 230 V \pm 10%. The output voltage of Types 601, 602 and 603 is

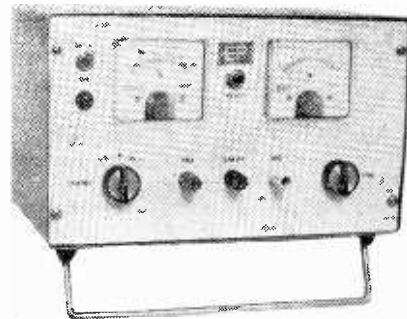

25 V with three switched ranges giving continuous fine adjustment from 0.8 V, 7-16 V, and 15-25 V. From the 604 the output is 75 V and the ranges are 0-25 V, 23-50 V, and 48-75 V. Output impedance is less than 0.4 Ω below 300 kc/s. The ripple and noise content is less than 1.5 mV peak-to-peak, and the stabilization ratio is 5,000:1. The prices of these units are: Type 601 £25 10s; 602 £29 10s; 603 £39 10s; and 604 £43 10s.

WW 319 for further details

Moulded Track Potentiometer

TYPE 80 miniature moulded track pre-set potentiometer by Davall Group Ltd. uses a one piece high grade mineral filled phenolic moulding which allows the insulating base, resistive track and terminals to be moulded into a single solid integrated unit. It is stated that this type of construction gives high stability under all conditions of humidity, temperature and vibration. Variation in performance is less than five per cent over the temperature range -40°C to $+70^\circ\text{C}$. Specification DEF 5214 has been used as a minimum standard in the development of this unit. The linear Type 80 potentiometer has a power rating of 0.25 W at 70°C and a maximum working voltage of 500 V d.c. The resistance range available is 20 Ω to 1 M Ω . Two versions are available, one with tags for direct soldering into printed circuits, the other for mounting on insulated boards using a 6 B.A. centre stud. The standard Type 80 is compact and can be contained in a cylinder 0.60 inch in diameter and 0.26 inch deep (excluding mount-

ing and tags). The Type 80 can be adjusted manually or by screwdriver. A variant, Type 80/1, is available with a larger knob for customer adjustment. Davall Electronics Ltd., Rothersthorpe Avenue, Northampton.

WW 318 for further details



634

Six Digit Silicon Clock

AN all-silicon digital electric clock, Type TSA 6686 by Venner Electronics Ltd. uses glass fibre printed circuit boards, and gives a display in hours, minutes and seconds derived from six gas-filled numerical indicator tubes. Two versions, 12 or 24-hour, are available. Electrical outputs are available for driving a printer or a punched tape unit. Start/stop facilities are provided either by negative-going pulses of 4 V amplitude or by the operation of push buttons mounted on the front panel. The display can be manually set for the independent

showing of hours, minutes and seconds, and it has a single reset to zero. Designed to operate over the ambient temperature range of -5 to $+60^\circ\text{C}$, the clock has an accuracy of two parts in 10^6 . It is for 19 in rack mounting. Venner Electronics Ltd., Kingston By-Pass, New Malden, Surrey.

WW 320 for further details

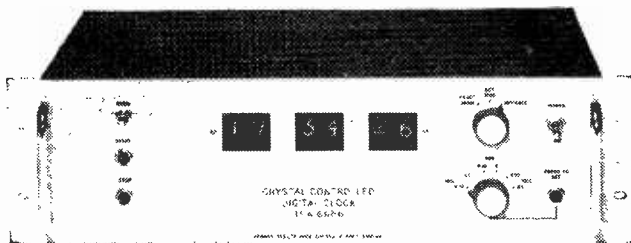

WIRELESS WORLD, DECEMBER 1966

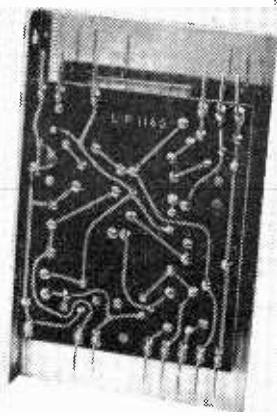

AUDIO AMPLIFIER MODULE

MULLARD transistor circuit modules now include an audio amplifier (LP1162) giving an output of 4W into 12Ω. Operating from a 24V supply, the circuit uses a complementary push-pull output pair (AC128/176) mounted on an integral heat sink to allow operation up to 50°C. A thermistor is employed to achieve bias stabilization, and the adoption of d.c. coupling between all stages ensures stability of the circuit against voltage and temperature variations. The module has a typical input sensitivity of 85mV and can therefore be fed from the majority of gramophone pickups. The frequency response (to -3dB points) is 60 c/s to 14 kc/s and the input impedance is 40kΩ. Provision has been made for the incorporation of top cut and bass boost control circuits. Mullard Ltd., Mullard House, Torrington Place, W.C.1.

WW 321 for further details

Low-frequency Thyristors

THE General Electric (U.S.A.) 2N681 to 2N692 series of thyristors are for use in power switching and control applications requiring blocking voltages of 800 volts or less, and average load currents (single phase 180° conduction angle) up to 22 amperes. The peak forward and reverse voltages for the 2N681 to 2N692 are 25 volts to 800 volts respectively. The peak one-cycle surge current is 150 amperes and the maximum junction temperature is 125°C. This JEDEC registered device, encapsulated in the TO-48 can, will operate at frequencies up to 400 c/s making the device suitable for low frequency inverters. The r.m.s. forward current is 35 amperes. From Jermy Industries, Vestry Road, Sevenoaks, Kent.

WW 322 for further details



THE HOUSE OF BULGIN AT YOUR SERVICE

VISUAL INDICATORS WHICH CAN NEVER BE CONFUSED

We were the pioneers of Message Indicators, producing our first model over 34 years ago in the early days of the Radio Industry. This was a mains fitting using S.E.S. capped neons which could be legended GRAM or RADIO.

Today we manufacture over 280 varieties, from 7/8" x 3/8" to 2 1/8" x 5" in panel area accepting a wide range of lamps from Lilliput Edison Screw to Small Bayonet Cap types. Legends can be supplied in a choice of five different colours, Red, Amber, Green, Blue or Water Clear, and are "always visible" or "secret-until-lit" with LEGEND engraved in ANY LANGUAGE according to customers requirements.



List No. D.901/M/SS.



List No. D.920/M/SS



List No. D.902/M/SS/2



List No. D.872/2S/4L



List No. D.830



List No. D.610



List No. D.720/M/SS

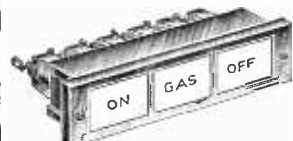

List No. D.870/3

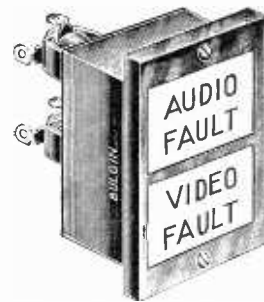

List No. D.871/2/VERT

SEND FOR LEAFLET 1512/C

A. F. BULGIN & CO. LTD.,
Bye Pass Rd., Barking, Essex.
Tel: R1Ppleway 5588 (12 lines)

MANUFACTURERS AND SUPPLIERS OF RADIO AND ELECTRONIC COMPONENTS TO
ADMRALTY
WAR OFFICE
AIR MINISTRY
HOME OFFICE
CROWN AGENTS
MINISTRY OF WORKS
MINISTRY OF AVIATION
MINISTRY OF SUPPLY
RESEARCH ESTABLISHMENTS
U.K.A.E.A.
B.B.C.
G.P.O.
I.T.A.
N.P.L.
D.S.I.R.

WW-134 FOR FURTHER DETAILS.

DECEMBER MEETINGS

Tickets are required for some meetings: readers are advised, therefore, to communicate with the society concerned

LONDON

1st. I.E.E. & I.Mech.E.—Discussion on "Numerically controlled machine tools" at 6.0 at 1 Birdcage Walk, S.W.1.

1st. I.E.E. Grads.—"Numerical control of machine tools" by B. J. Davies at 6.30 at Woolwich Polytechnic, Wellington St., S.E.18.

6th. I.E.R.E.—"An introduction to acoustic measurements" by F. H. Brittain at 6.0 at the London School of Hygiene and Tropical Medicine, Keppel Street, W.C.1.

7th. I.E.R.E.—"The design of radio navigation stations for unattended operation" by D. H. Boycott, D. L. Hillman and J. H. G. Huggins at 6.0 at 9 Bedford Sq., W.C.1.

7th. R.S.A.—"Holography: Photography without lenses in three dimensions" by Dr. D. Gabor at 6.0 at the Imperial College of Science and Technology, Kensington, S.W.7.

7th. S.E.R.T.—"Industrial electronics" by H. L. Gray at 7.0 at the London School of Hygiene and Tropical Medicine, Keppel Street, W.C.1.

8th. I.E.R.E. & I.E.E.—Colloquium on "Miniature computers" at 6.0 at London School of Hygiene and Tropical Medicine, Keppel St., W.C.1.

12th. I.E.E.T.E.—"Quality and reliability" by D. J. Hewitt at 6.0 at I.E.E., Savoy Pl., W.C.2.

13th. Radar & Electronics Assoc.—"How electronics can contribute to medical research" at 7.0 at B.I.C.C., 21 Bloomsbury St., W.C.1.

14th. I.E.E.—Discussion on "Light-emitting diodes" at 5.30 at Savoy Pl., W.C.2.

14th. B.K.S.T.S.—"Film and television in education" at 7.30 at C.O.I., Hercules Rd., S.E.1.

15th. I.E.E.—"Thermoelectric materials" by G. E. Hare and H. J. Goldsmid at 5.30 at Savoy Pl., W.C.2.

15th. I.E.R.E.—Presidential address of Professor Emrys Williams at 6.0 at 9 Bedford Sq., W.C.1.

BASINGSTOKE

1st. I.E.R.E.—"Television camera tubes and image intensifiers" by R. S. Filby at 7.30 at the Technical College.

BIRMINGHAM

8th. I.E.R.E.—"Fuel cells" by T. M. Fry at 7.15 at The University, Dept. of Electronic and Electrical Engineering.

BRISTOL

7th. I.E.E. & I.E.R.E.—"Mediator—a comprehensive air traffic control scheme for U.K." by D. R. Evans at 7.0 at the Queen's Building, The University.

12th. I.E.E.—"Lasers and their uses" by J. C. North at 6.0 at the Queen's Building, The University.

20th. S.E.R.T.—"Oscilloscopes and their practical applications" by R. A. Watson at 7.15 at the Royal Hotel.

CAMBRIDGE

8th. I.E.E. & I.E.R.E.—"Modern telephone developments" by L. R. F. Harris at 8.0 at No. 4 Lecture Theatre, University Engineering Dept., The University.

CARDIFF

2nd. Royal Television Soc.—"Acoustics in broadcasting studio design" by A. N. Burd at 7.30 at Llandaff Technical College, Western Avenue.

7th. I.E.E. & I.E.R.E.—"The nature of musical sounds and the significance of the transient" by Prof. C. A. Taylor at 6.30 at the Physics Dept., The University.

7th. I.E.E.T.E.—"The future of telecommunications" by D. A. Barron at 6.30 at the Assembly Room, City Hall.

COVENTRY

8th. I.E.E.—"Electromagnetic puzzles" by Prof. E. R. Laithwaite at 6.15 at the University of Warwick.

CREWE

1st. I.E.E.—"Modern applications of closed circuit television" by V. J. Cooper at 7.0 at the Crewe Arms Hotel.

EDINBURGH

7th. I.E.E. & I.E.R.E.—"Field effect transistors" by J. M. Morrison at 6.0 at the Carlton Hotel, North Bridge.

14th. I.E.E.—Discussion on "Transistor circuit design" at 7.0 at Heriot-Watt University.

EVESHAM

6th. I.E.R.E.—"Radiophonic workshop" by F. C. Brooker at 7.0 at B.B.C. Club, High Street.

FARNBOROUGH

6th. I.E.E.—"The history of computers" by Dr. D. J. Truslove at 6.30 at the Technical College, Boundary Road.

GLASGOW

7th. I.E.E.—"Radiophonic workshop" by C. Brooker at 6.0 at the Inst. of Engineers & Shipbuilders, 39 Elmbank Cresc., C.2.

8th. I.E.E. & I.E.R.E.—"Field effect transistors" by J. M. Morrison at 6.0 in Room 24, University of Strathclyde.

IPSWICH

6th. I.E.E.—"Transistors—the first encounter" by V. H. Attree at 6.30 at Electric House.

KIDSGROVE

19th. I.E.E.—"Pattern processing in the human visual system and some engineering applications" by Dr. C. R. Evans at 7.0 at English Electric Leo Marconi Computers Ltd.

LEEDS

6th. I.E.E.—"Static electronic protection" by J. B. Patrickson at 6.30 at The University, Elec. Eng. Lecture Theatre.

8th. I.E.R.E.—"High-quality sound reproduction" by A. W. Dakin at The University, Dept. of Electrical Engineering.

LEICESTER

2nd. Royal Television Soc.—"Colour television—a practical approach" by B. J. Rogers at 7.15 at Vaughan College, St. Nicholas St.

8th. I.E.R.E.—"Field effect transistors" by C. S. Den Brinker at 6.30 at The University.

LIVERPOOL

14th. I.E.R.E.—"Exploring the upper ionosphere with very high power radar" by Dr. C. D. Watkins at 7.0 at the College of Technology, Byrom St.

MANCHESTER

8th. I.E.R.E.—"Four-tube colour camera" by W. T. Underhill at 7.0 at Renold Building, the College of Science and Technology, Altrincham St.

NEWCASTLE-UPON-TYNE

14th. I.E.R.E.—"A.C. motor control" by K. H. Williamson at 6.0 at the Institute of Mining and Mechanical Engrs., Neville Hall, Westgate Rd.

NORWICH

13th. I.E.E.—"The choice between analogue and digital computing; techniques in electrical engineering analysis and design" by R. A. Laws at 7.30 at the Assembly House.

NOTTINGHAM

6th. I.E.E.—"The future of world communication" by Prof. C. Cherry at 6.30 at T.I. Building, The University.

PORTSMOUTH

6th. I.E.E. Grads.—"Outline of echo sounding" by M. I. Dodd at 6.30 at the College of Technology, Anglesea Rd.

READING

8th. I.E.R.E.—"Field effect transistors" by R. G. Bailey at 7.30 at J. J. Thomson Physical Lab., The University.

SHEFFIELD

14th. I.E.E.—"Some electrical transducers" by J. Dean at 6.30 at the Industries Exhibition Centre.

SOUTHAMPTON

13th. I.E.E. & Brit. Computer Soc.—"Character recognition" by Dr. H. A. Bell at 6.30 at the Lancheater Theatre, The University.

WEYMOUTH

2nd. I.E.E.—"Electro-luminescence" at 6.30 at South Dorset Technical College.

LATE-NOVEMBER MEETINGS

LONDON

30th. I.E.R.E. & R.T.S.—"Pay television" by Dr. G. H. Hamburger and K. A. Russell at 6.0 at the London School of Hygiene & Tropical Medicine, Keppel St., W.C.1.

30th. R.S.A.—"Science and the Post Office" by D. A. Barron at 6.0 at John Adam St., W.C.2.

CHELMSFORD

28th. I.E.R.E.—"The Watkins-Gunn effect: negative resistance in semiconductors" by B. K. Ridley at 7.0 at the Technical High School, Broomfield.

GLOUCESTER

29th. I.E.E.T.E.—"Micro-miniaturization techniques in electronics" by G. W. A. Dummer at 8.0 at the Technical College, Brunswick Rd.

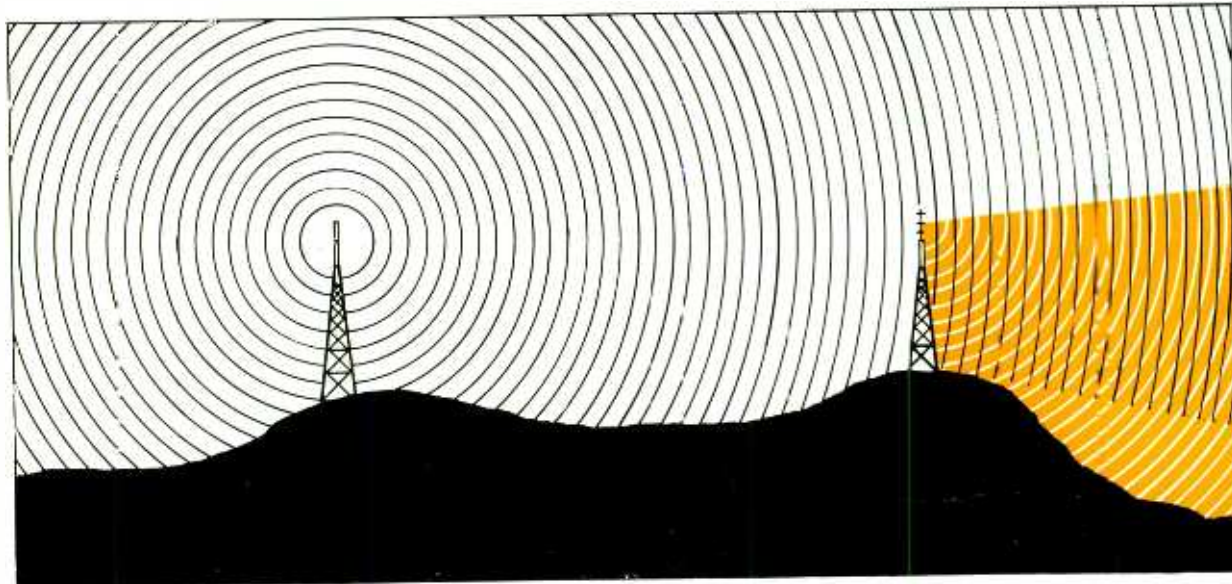

Filling in the shadows

To increase the coverage of UHF television stations and to fill in the 'shadows' in main station coverage caused by uneven features of the terrain, STC has produced the FT.1-A medium power television translator for combined vision and sound channels. STC has received orders from the British Broadcasting Corporation for bands IV and V translators and from the Independent Television Authority for band III equipments.

The use of solid state techniques virtually eliminates the risk of failure and consequent shut-down. The travelling wave tube power amplifier guarantees long service. Such is the reliability of the FT.1-A that the stations can run

entirely unattended for long periods. Standby equipment is generally unnecessary and the need for skilled maintenance reduced to a minimum.

- Suitable for European and American systems
- Suitable for monochrome and colour transmissions
- Designed for unattended operation
- Common circuits for sound and vision
- Extensive use of solid state techniques
- TWT Power amplifier
- Front access for ease of maintenance

Standard Telephones and Cables Limited, Radio Division, Oakleigh Road, New Southgate, London N.11. Telephone: ENTenterprise 1234. Telex: 261912.



STC

world-wide telecommunications and electronics



The world's finest cored solder



FOR THE FACTORY

- Contains 5 cores of non-corrosive high speed Ersin flux. Removes surface oxides and prevents their formation during soldering. Complies with B.S. 219, 441, DTD 599A, B.S.3252, U.S. Spec. QQ-S-571d.
- Savbit alloy contains a small percentage of copper and thus prolongs the life of copper soldering iron bits 10 times. Liquidus melting temperature is 215°C—419°F. Ministry approved under ref. DTD/900/4535
- Solder Tape, Rings, Preforms and Washers, Cored or Solid, are available in a wide range of specifications.
- Liquid fluxes and printed circuit soldering materials comply with Government specifications. Ask for special details.

STANDARD GAUGES IN WHICH MOST ALLOYS ARE MADE AND LENGTHS PER LB. IN FEET.

S.W.G.	INS.	M.M.	FT. PER LB.	
			60/40	SAVBIT
10	.128	3.251	25.6	24
12	.104	2.642	38.8	36
14	.080	2.032	65.7	60.8
16	.064	1.626	102	96.2
18	.048	1.219	182	170
19	.040	1.016	262	244
20	.036	.914	324	307
22	.028	.711	536	508
24	.022	.558	865	856
26	.018	.46	1292	1279
28	.014	.375	1911	1892
30	.012	.314	2730	2695
32	.010	.274	3585	3552
34	.009	.233	4950	4895

STANDARD ALLOYS INCLUDE LIQUIDUS

TIN/LEAD	B.S. GRADE	MELTING TEMP.	
		°C.	°F.
60/40	K	188	370
Savbit No 1	—	215	419
50/50	F	212	414
45/55	R	215	419
40/60	G	234	453
30/70	J	255	491
20/80	V	275	527

HIGH AND LOW MELTING POINT ALLOYS

ALLOY	DESCRIPTION	MELTING TEMP.	
		°C.	°F.
T.L.C.	Tin/Lead/Cadmium with very low melting point	145	293
L.M.P.	Contains 2% Silver for soldering silver coated surfaces	179	354
P.T.	Made from Pure Tin for use when a lead free solder is essential	232	450
H.M.P.	High melting point solder to B.S. Grade 5S	296-301	565-674

FOR THE MAINTENANCE ENGINEER AND ELECTRONICS ENTHUSIAST

SAVBIT ALLOY REDUCES WEAR OF SOLDERING IRON BITS.



Size 12 reel 15/- (subject)
Contains 102 ft. approx. 18 s.w.g. on a plastic reel.

Size 1 carton 5/- (subject)
C1SAV14 11ft. of 14 s.w.g.
C1SAV16 16ft. of 16 s.w.g.
C1SAV18 30ft. of 18 s.w.g.



Size 5 dispenser 2/6 (subject)
Contains 12 ft. of 18 s.w.g. in a handy dispenser.



60/40 HIGH TIN CONTENT



Size 1 carton 5/- (subject)
C16014 9 ft. approx. 14 s.w.g.
C16018 29 ft. approx. 18 s.w.g.



Size 4A Dispenser 2/6 (subject)
Contains 9 ft. of 18 s.w.g. 60/40 alloy in a handy dispenser.

PRINTED CIRCUIT AND TRANSISTOR SOLDER, FOR SOLDERING TEMPERATURE SENSITIVE COMPONENTS



Size 10 15/- (subject)
Contains 212 ft. of 22 s.w.g. 60/40 alloy on a plastic reel.



New! Size 15 Dispenser 3/- (subject)
21 ft. coil of 60/40 alloy, 22 s.w.g. Solder used direct from dispenser, cannot tangle or fall back inside.

BIB INSTRUMENT CLEANER



Anti-static cleaner for tape heads, dials, plastic, glass and chrome. **4/6** (subject)



MODEL 3 BIB WIRE STRIPPER AND CUTTER
Strips insulation, cuts wires and splits plastic twin flex. **4/-** (subject)

Write for full details to:

MULTICORE SOLDERS LTD., MAYLANDS AVENUE, HEMEL HEMPSTEAD, HERTS. HEMEL HEMPSTEAD 3636