

STABLE PHASE-SHIFT OSCILLATOR

NOVEMBER 1965

Three Shillings

Wireless World

ELECTRONICS • TELEVISION • RADIO • AUDIO

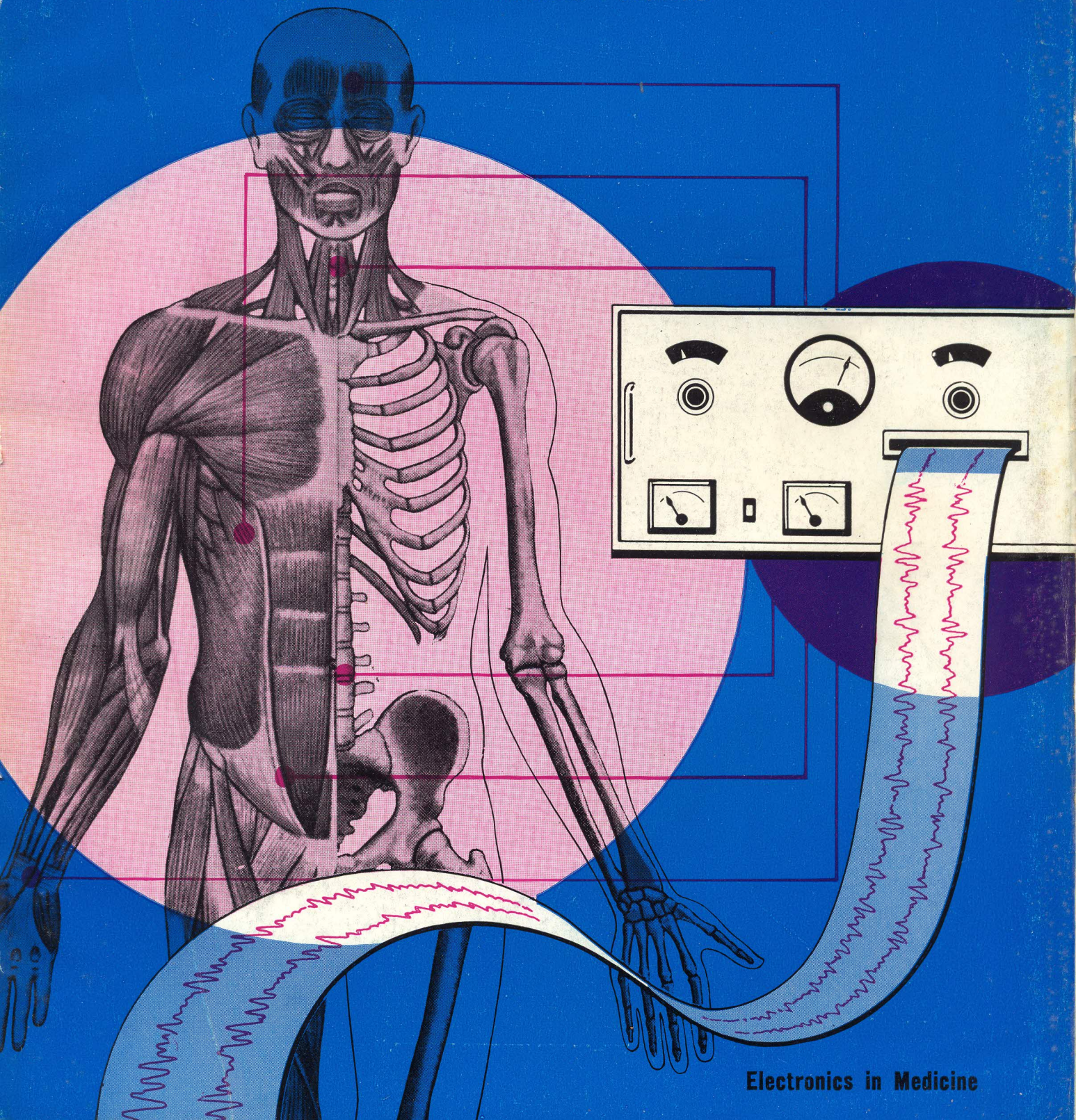

Electronics in Medicine

"Wireless World"
Iiffe Electrical Publications Ltd.,
Dorset House, Stamford Street,
London, S.E.1

Managing Director:

W. E. MILLER, M.A., M.I.E.R.E.

Editor-in-Chief:

W. T. COCKING, M.I.E.E.

Editor:

H. W. BARNARD

Technical Editor:

T. E. IVALL

Editorial:

D. C. ROLFE

B. L. SEXTON, Grad. I.E.R.E.

G. B. SHORTER, B.Sc.

Drawing Office:

H. J. COOKE

Production:

D. R. BRAY

Advertisements:

G. BENTON ROWELL

(Manager)

J. R. EYTON-JONES

© Iiffe Electrical Publications Ltd., 1965. Permission in writing from the Editor must first be obtained before letterpress or illustrations are reproduced from this journal. Brief extracts or comments are allowed provided acknowledgement to the journal is given.

VOLUME 71 No. 11

PRICE: 3s.

FIFTY-FIFTH YEAR
OF PUBLICATION

Wireless World

ELECTRONICS, TELEVISION, RADIO, AUDIO

NOVEMBER 1965

- 535 Editorial Comment
- 536 Amplitude Stabilized RC Oscillator By L. Nelson-Jones
- 539 Conferences and Exhibitions
- 540 Electronics in Medicine
- 543 Commercial Literature
- 544 Microelectronics
- 547 World of Wireless
- 549 Personalities
- 551 News from Industry
- 553 Letters to the Editor
- 556 Books Received
- 556 H.F. Predictions—November
- 557 Redundancy in Systems Design By D. W. Lewin
- 561 Fifth International Congress on Acoustics
- 566 Electronic Laboratory Instrument Practice—II By T. D. Towers
- 572 New Products
- 579 Wescon 1965
- 582 Amateur Convention at Knokke
- 584 November Meetings
-

PUBLISHED MONTHLY (4th Monday of preceding month). Telephone: Waterloo 3333 (70 lines). Telegrams/Telex: Wiworld Iiffepres 25137 London. Cables: "Ethaworld, London, S.E.1." Annual Subscriptions: Home £2 6s Od. Overseas: £2 15s Od. Canada and U.S.A. \$8.00. Second-class mail privileges authorised at New York N.Y. BRANCH OFFICES: BIRMINGHAM: 401, Lynton House, Walsall Road, 22b. Telephone: Birchfield 4838. BRISTOL: 11, Marsh Street, 1. Telephone: Bristol 21491/2. COVENTRY: 8-10, Corporation Street, Telephone: Coventry 25210. GLASGOW: 123, Hope Street, C.2. Telephone: Central 1265-6. MANCHESTER: 620, Deansgate, 3. Telephone: Blackfriars 4412. NEW YORK OFFICE U.S.A.: 111 Broadway, 6. Telephone: Digby 9-1197.

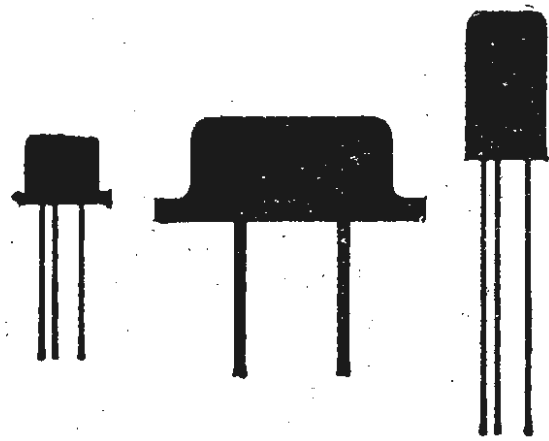
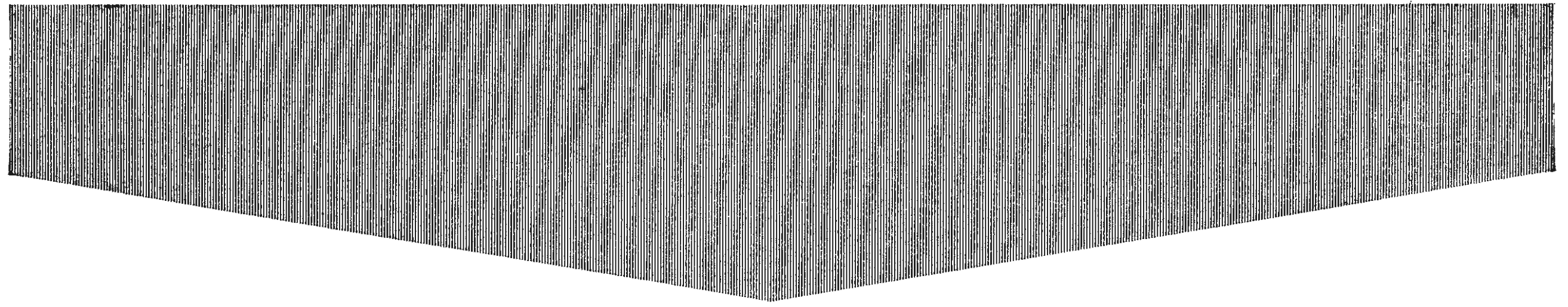

amplifier circuit

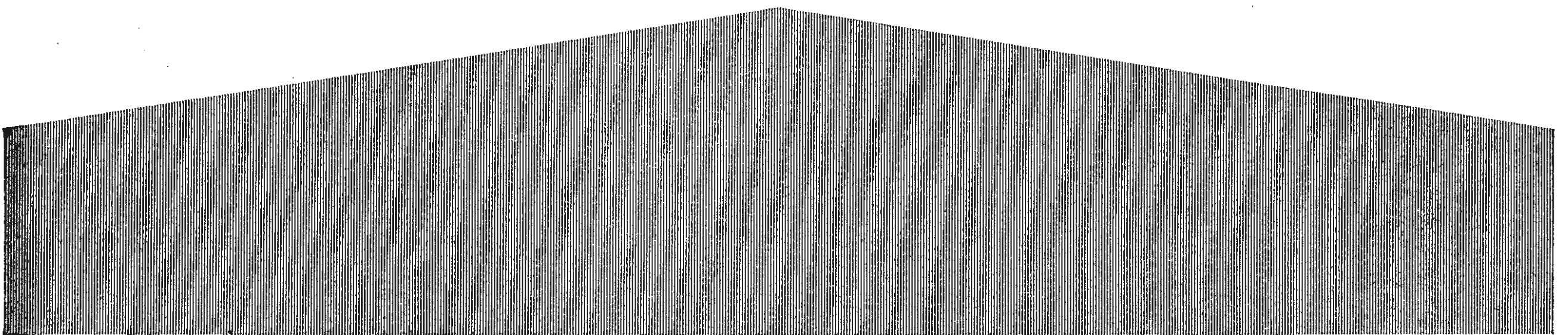
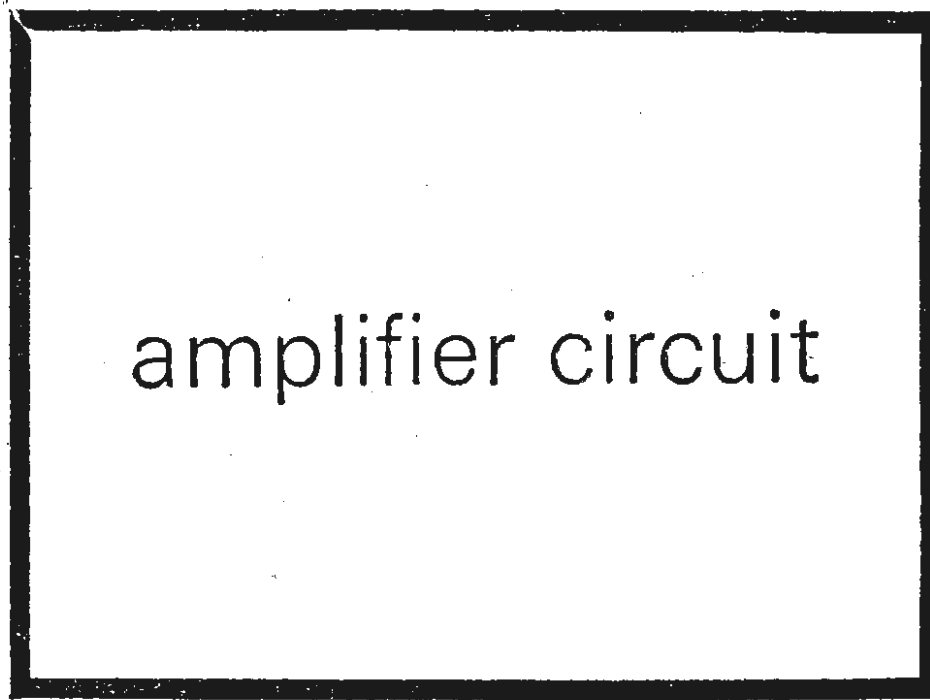

Just for fun,
slowly bring this page close
to your eyes and see the transistors
go into the circuit. It's only an optical
illusion but it will remind you that the
best transistorised amplifiers use
Mullard audio transistors.

Mullard

Wireless World

ELECTRONICS, TELEVISION, RADIO, AUDIO

Where the Disciplines Meet

TO what extent should the user of electronic equipment be expected to know something about electronics? Should the user's knowledge overlap that of the electronics engineer, and *vice-versa*, or should there simply be a meeting of minds at the interface—if the parties concerned can decide where that is? Now that electronic systems are being used in so many fields of science and industry this problem of communications is coming up time and time again. It occurs at the R & D level, at the equipment engineering level and at the sales level. There were heated arguments, for example, at the Brighton symposium on electronics in medicine (reported in this issue), on whether the medical man ought to have some training in electronics, or merely be asked to give specifications for black boxes and discouraged from messing about with what doesn't concern him. It seemed to be taken for granted, however, that the electronics man would learn all he could about the medical side.

These problems of demarcation often seem to arise when some new interdisciplinary activity is formalized by being given a name—medical electronics, industrial electronics, automation and so on. The workers on each side of the fence, as a result of their encounters with a sometimes quite alien discipline, suddenly become conscious of having special positions and responsibilities, and it is not unknown for the relationship to be bedevilled with intellectual and job snobbery. The attitude of electronics people in these circumstances is usually one of didactic zeal: the folk on the other side have a deplorable gap in their education if they know nothing about electronics.

While this is not a bad attitude in principle—for all of us benefit from a widening of our knowledge—in practice it must be handled with caution. Doctors, for example, are already overburdened with a vast and still multiplying load of medical information which they cannot hope to absorb in a lifetime, and in such circumstances they cannot be expected to do justice to a branch of applied science quite different from their own work. In any case, people do not take kindly to being told that it is good for them to learn this or that—they rightly suspect that it is not entirely their own interests which are being considered.

A more subtle danger of this enthusiasm for educating the other man is that it can lead to an over-selling of electronics, both in the technical and the commercial sense. This has happened in the past, and has not been a good thing either for the profession or for the industry. Frequently the user has a wide variety of engineering techniques available to him, electronics, important as it is, being only one of them. The term "medical electronics," for example, is a highly presumptuous one (invented by the electronics industry?) since what is called medical "electronics" apparatus usually includes other types of devices and instrumentation without which it could not possibly work. It would be unfortunate, and ultimately bad for the electronic engineering profession, if the user were pressed to adopt electronic solutions to problems or to purchase electronic equipment when mechanical or other methods might be more advantageous.

Of course, a great many applications use a combination of scientific or engineering techniques. At the Brighton symposium several physicists in the audience were at pains to point out that, in view of this, if doctors were to be given additional training in any of the sciences it should be in physics. As one speaker remarked, in medical electronics the interface between the instrumentation and the human subject is not at the terminals of the electronic unit but where the probe enters the vein or the transducer is attached to the patient. This principle is equally true in other fields of application. We in electronics must not, in our enthusiasm, forget the natural limits of our technology.

VOL 71 NO 11
NOVEMBER 1965

Amplitude-stabilized RC Oscillator

Modified phase-retard oscillator uses amplifier saturation to achieve amplitude stabilization, thereby giving both square-wave and sine-wave outputs. Direct coupling simplifies the design for v.l.f. operation and ensures good temperature stability

By L. NELSON-JONES,* A.M.I.E.R.E.

IN nearly all sine-wave RC oscillators, whether they be of the Wien bridge, bridged T, parallel T, or the normal phase-advance phase shift type (Fig. 1), require some form of amplitude control or a.g.c. in order to limit the oscillations to within the linear section of the dynamic range of the amplifier section of the oscillator. The usual method of achieving this control of level is to incorporate a thermistor in a negative feedback path. Such systems work extremely well for such applications as laboratory test oscillators which are not normally subject to large temperature excursions. However, since the thermistor relies on heating to achieve such control, it must necessarily cause the oscillator to have a considerable temperature coefficient of output level. In addition, unless one is prepared to expend considerable power in the oscillator circuit, it is necessary to use a thermistor requiring only milliwatts of power for its operation. Such thermistors have very short thermal time constants and it is therefore very difficult to design an oscillator for low distortion using such a thermistor if the frequency range is to extend below about 10 c/s.

The circuit to be described overcomes these difficulties by using a different method of level control and, while it is in general best adapted to fixed-frequency operation, it has considerable application in the l.f. and v.l.f. range as a source of a.c. waveforms in apparatus having only d.c. supplies. One particular attribute which is of special interest is that the circuit gives both sine and square waveforms, and these are in exact anti-phase (Fig. 4). This last-mentioned feature can be useful—for example with differential transformer transducers, where the sine wave can be amplified to provide drive for the transducer and the associated square wave used to switch the output demodulator of the associated amplifier.

The basic oscillator

The most common type of phase shift oscillator is that shown in Fig. 1, using a phase advance network together with an amplifier having a gain of more than -29 , this figure being the reciprocal of the loss of the network at the oscillation frequency of the circuit (when the input and output are in exact anti-phase).

The input impedance of the amplifier must be high in relation to the resistance value R and the output impedance low in comparison with R if the frequency as derived from the formula in Fig. 1 is to be closely attained. If this requirement is not adequately met the frequency of oscillation will be somewhat dependent on the variations of the parameters of the amplifier,

and a gain higher than 29 will be required for oscillation to commence.

The circuit of Fig. 2 gives the basic layout of a phase retard oscillator. It will be seen that although the gain required of the amplifier is the same as for the circuit of Fig. 1, the oscillation frequency is six times greater for the same CR values. The derivations of the formulae are given in the appendix, since, although the derivation of the Fig. 1 formulae is fairly well known, very little seems to have been written about the circuit of Fig. 2.

Normally the operation, and the requirements for operation, of the Fig. 2 circuit will be the same as for that of Fig. 1. However, one particular difference between them should be noted. The phase advance

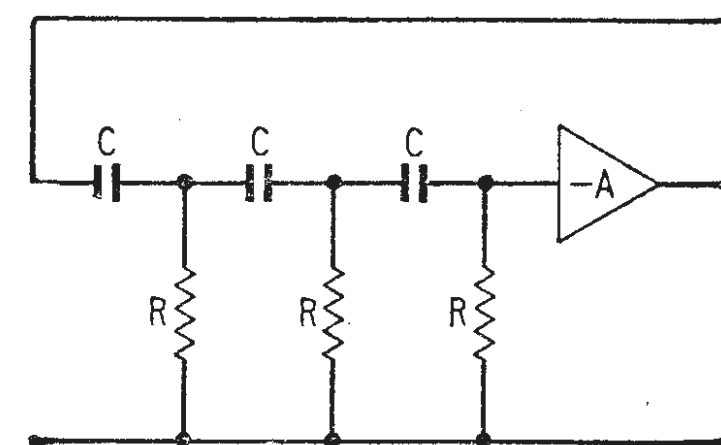

Fig. 1. Common type of phase-shift oscillator, using a phase-advance network.

network will tend to accentuate any harmonics, dependent on their relative phase shift, since the attenuation of the network is less for harmonics than for the fundamental. The phase retard network of Fig. 2, however, gives progressively higher attenuation of the harmonics. Calculated values of the attenuation constants for the fundamental, 2nd, 3rd, 4th and 5th harmonics are 29, 148, 144, 1003 and 1913 respectively, or, as ratios to the fundamental, 1, 5.1, 15.3, 34.6 and 65.9.

Let us now consider what the output of such a phase retard network would be if the input were to be a square wave of frequency as before $f = \sqrt{6}/(2\pi RC)$. A square wave, according to Fourier analysis, consists of a fundamental component of peak-to-peak amplitude equal to 1.274 times that of the square wave, together with odd harmonics only, having amplitudes equal to that of the fundamental times the reciprocal of their harmonic number (i.e. the amplitude of the 3rd harmonic is 1/3rd of that of the fundamental, the 5th is 1/5th, etc.). Thus, multiplying these various factors together, we get the harmonic content of the output of such a network with a square wave input as 2.18% 3rd harmonic, 0.304% 5th harmonic, plus negligible amounts of higher harmonics.

Looking again at the circuit of Fig. 2, we can now

* Formerly with Kelvin Hughes Division, S. Smith & Sons

Fig. 2. Basic arrangement for a phase-retard oscillator.

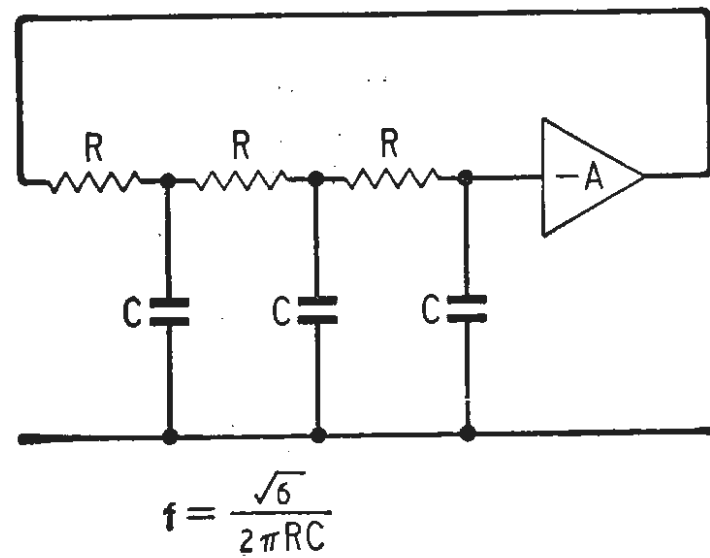

make the amplifier have a gain far higher than the minimum of 29 required to maintain oscillation and, in fact, we can allow the amplifier to saturate to the point where the output becomes a square wave. If care is taken with the design, the output of the oscillator at one end of the phase retard network will be a sine wave, and at the other end a square wave, the relative amplitudes being 23 : 1. The wave amplitudes will be dependent almost entirely on the value of the supply voltage.

We have thus eliminated the need to control the gain of the amplifier in order to maintain a constant level of oscillation, and consequently we have to a large extent eliminated the effect of such gain variations, provided that the gain is far greater than 29 times. A further point which can be an aid to stability of operation is that there is a d.c. path through the phase retard network, so that if the maintaining amplifier is also d.c.-coupled, full d.c. negative feedback can be applied to the amplifier *via* the phase retard network. Further, if d.c. coupling is used, the only lower limit to the oscillation frequency is the physical size of the phase shift capacitors.

A 1kc/s oscillator

Fig. 3 is the circuit of an oscillator designed on the lines indicated above. Transistors Tr1 and Tr2 form a two-stage emitter follower in order to present a high input impedance to the output of the phase retard network. The resistor R_4 is necessary to ensure sufficient current in Tr1 for satisfactory operation, but may be increased in value or omitted if the first transistor Tr1 is a very high beta type such as 2N929, 930, 2483 or 2484. The output of the dual emitter follower is coupled *via* the potentiometer R_5 , R_6 to the base of the amplifying transistor Tr3. Capacitor C_4 enables the full value of the a.c. voltage at the emitter of Tr2 to be applied to the base of Tr3. The potentiometer is necessary in order to obtain correct d.c. levels in the amplifier, and the values of R_5 and R_6 are chosen to obtain symmetrical limiting in the output

Fig. 3. Complete 1kc/s phase-retard oscillator incorporating the amplitude stabilization feature.

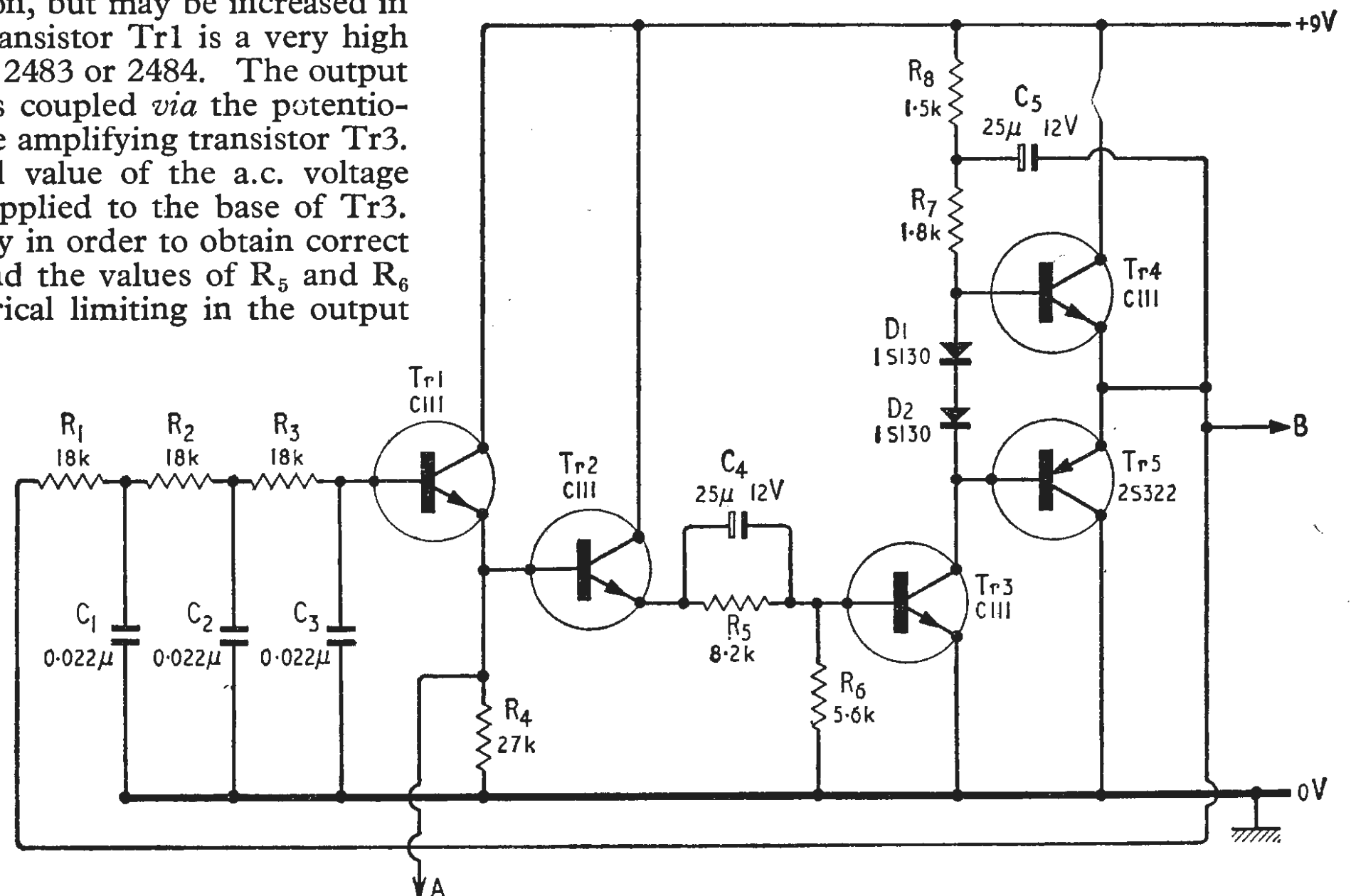

stage and hence a square wave of equal "on" and "off" times. In certain circumstances, especially with higher supply voltages than that shown, R_5 and C_4 can be replaced by a Zener diode.

A low-impedance output for both half cycle of the square wave is ensured by arranging that the anti-skying stage is followed by a complementary class B emitter follower stage (Tr4 and Tr5). Cross-over distortion is eliminated and correct biasing over a wide temperature range is ensured by the two forward biased diodes D_1 and D_2 . To increase further the gain of the amplifier and also to improve the risetime of the square-wave output, the collector load of Tr3 is "boot-strapped" to the output of the amplifier. The sine-wave output of the oscillator is approximately 350 mV p-p, 124 mV r.m.s., for a supply voltage of +9 V.

The best output point for the sine wave has been found to be point A of Fig. 3, but this point should not be too heavily loaded (in general the load impedance should not be lower than 10k Ω , depending on the transistor type used). The waveform at the emitter of Tr2 is rather poor because of the very non-linear input impedance of the overdriven amplifier stages.

The calculated frequency for $R = 18k\Omega$ ($\pm 0.25\%$) and $C = 0.022\mu F$ ($\pm 1\%$) is 984.3 c/s. and the actual oscillation frequency for the circuit of Fig. 3 is 1004 c/s. (2% high). Variations of the supply voltage of ± 0.5 V produced corresponding changes in the output levels, but the frequency changed by only ± 2 c/s. Owing to the very high loop gain, one case of "squegging" at a very much higher frequency has been experienced; a small capacitor (470 pF) across R_6 completely eliminated the effect.

Fig. 4 shows both the square- and sine-wave outputs of the oscillator, as seen on a twin-beam oscilloscope (chopped beam). The very exact anti-phase relationship of the waveforms is clearly shown. Figs. 5 and 6 show the rise and fall times of the square-wave output. The upper level of the square wave corresponds closely to the supply line voltage, while the lower level corresponds to approximately +0.8 V. It should be noted that the rise and fall times are a percentage of the period of the oscillation, and as the frequency is lowered the rise and fall times

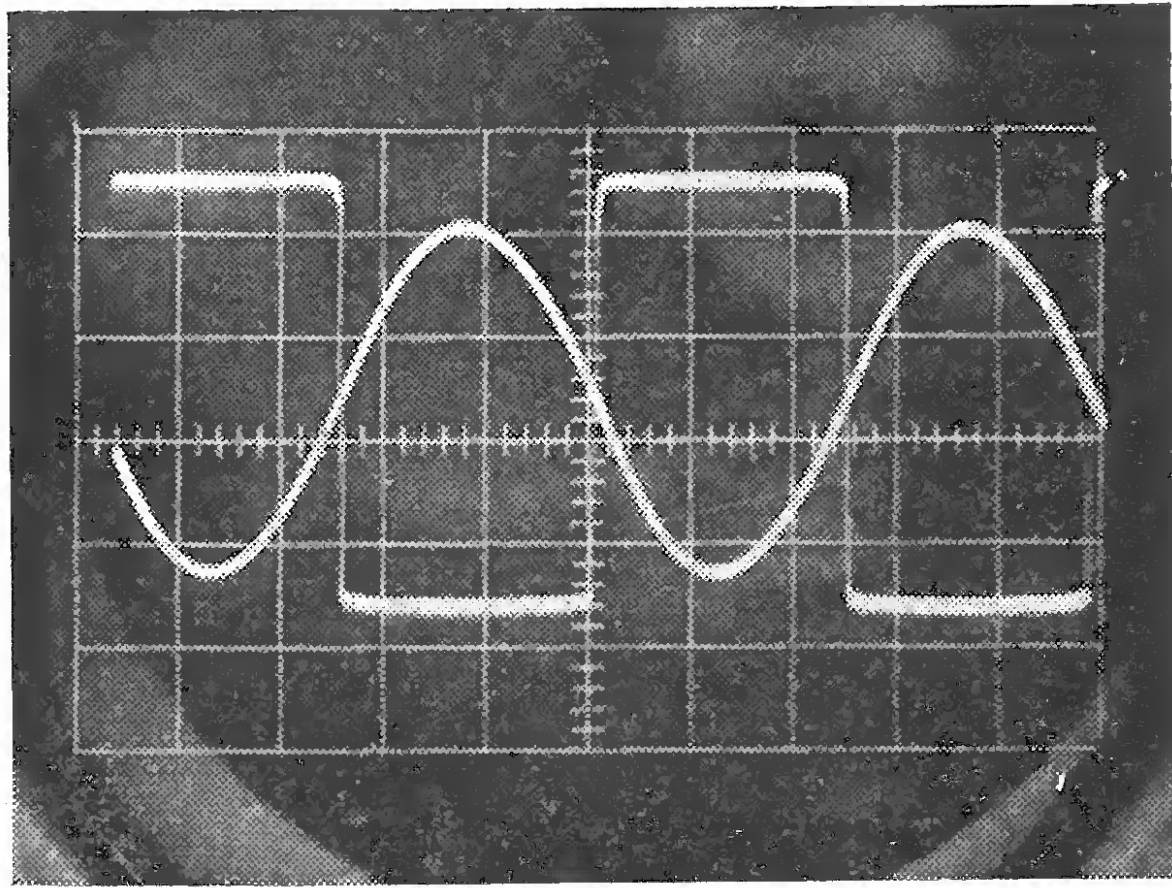

Fig. 4. Square-wave and sine-wave outputs of oscillator shown on a twin-beam c.r.o. ($x=200\mu\text{s}/\text{cm}$; for square-wave $y=2\text{V}/\text{cm}$; for sine wave $y=0.1\text{V}/\text{cm}$).

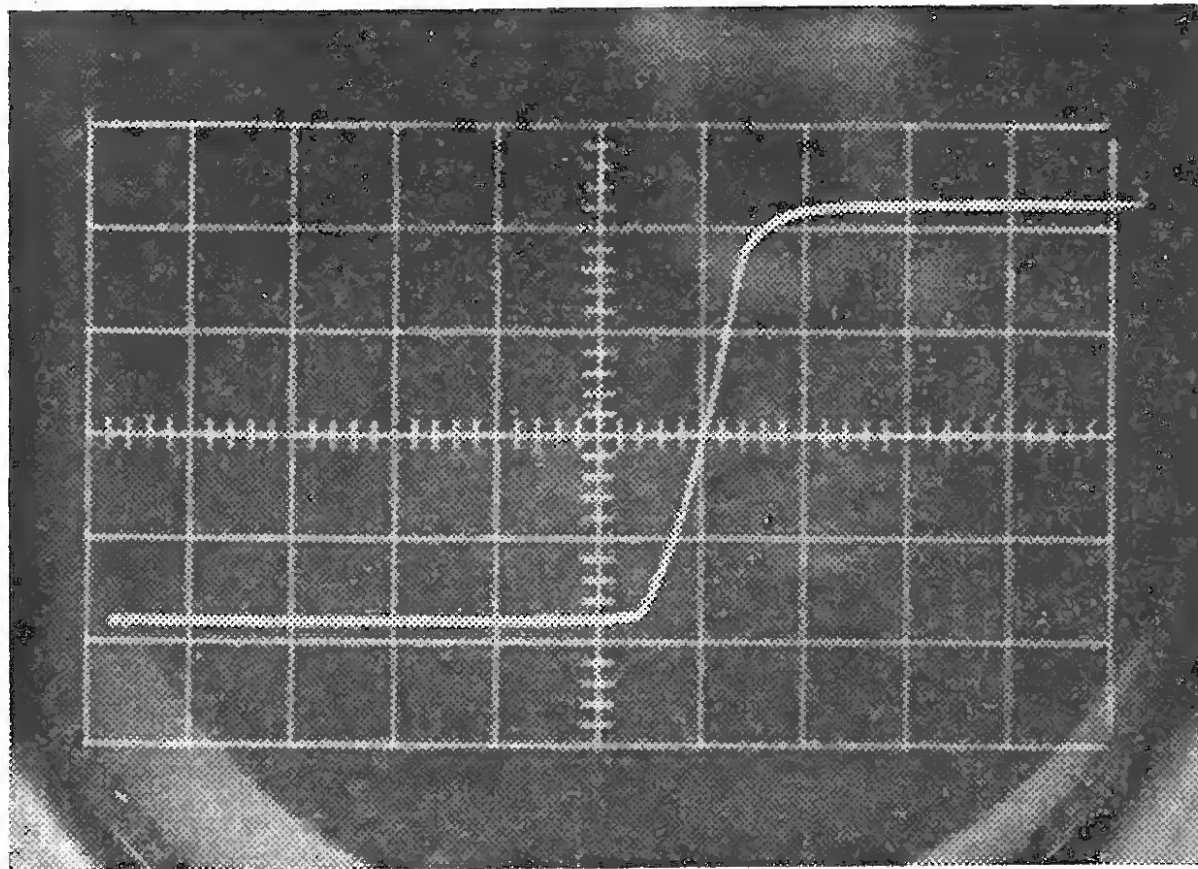

Fig. 5. Risetime of square-wave output ($x=10\mu\text{s}/\text{cm}$; $y=2\text{V}/\text{cm}$).

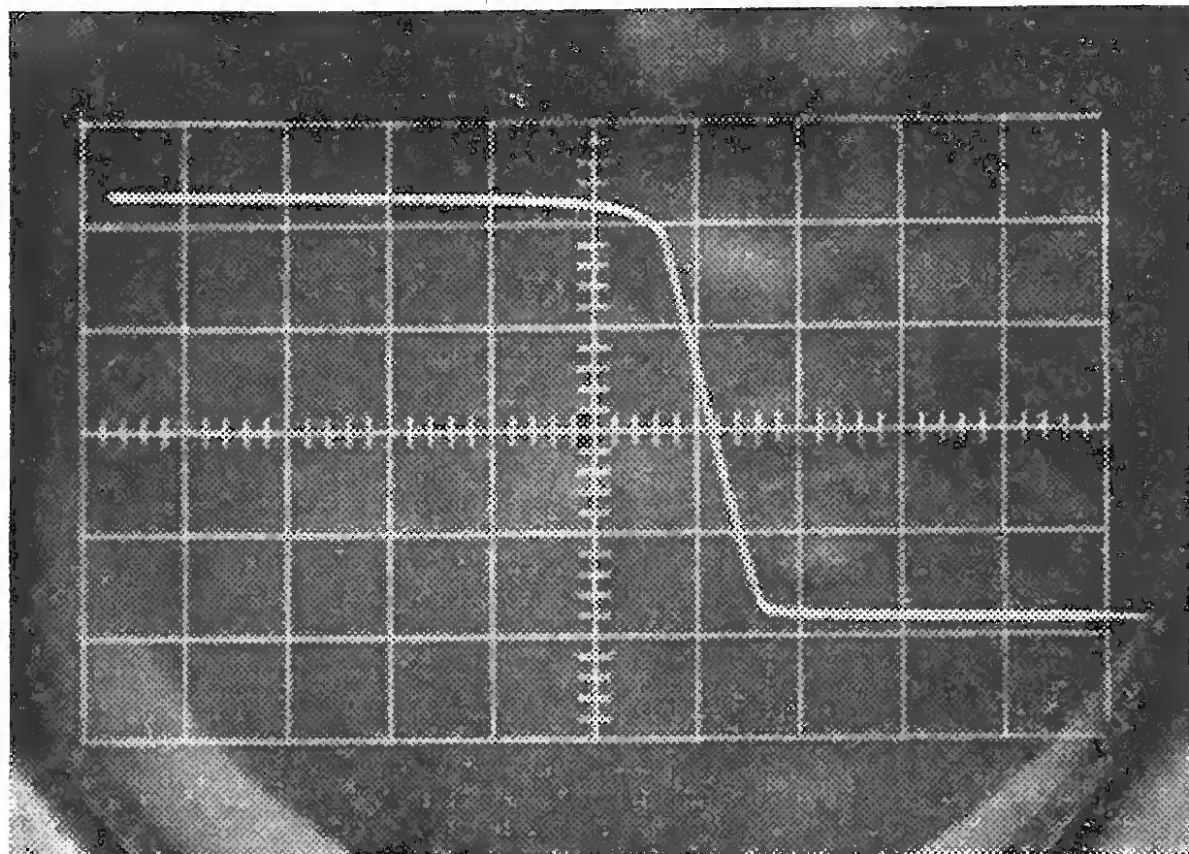

Fig. 6. Falltime of square-wave output ($x=10\mu\text{s}/\text{cm}$; $y=2\text{V}/\text{cm}$).

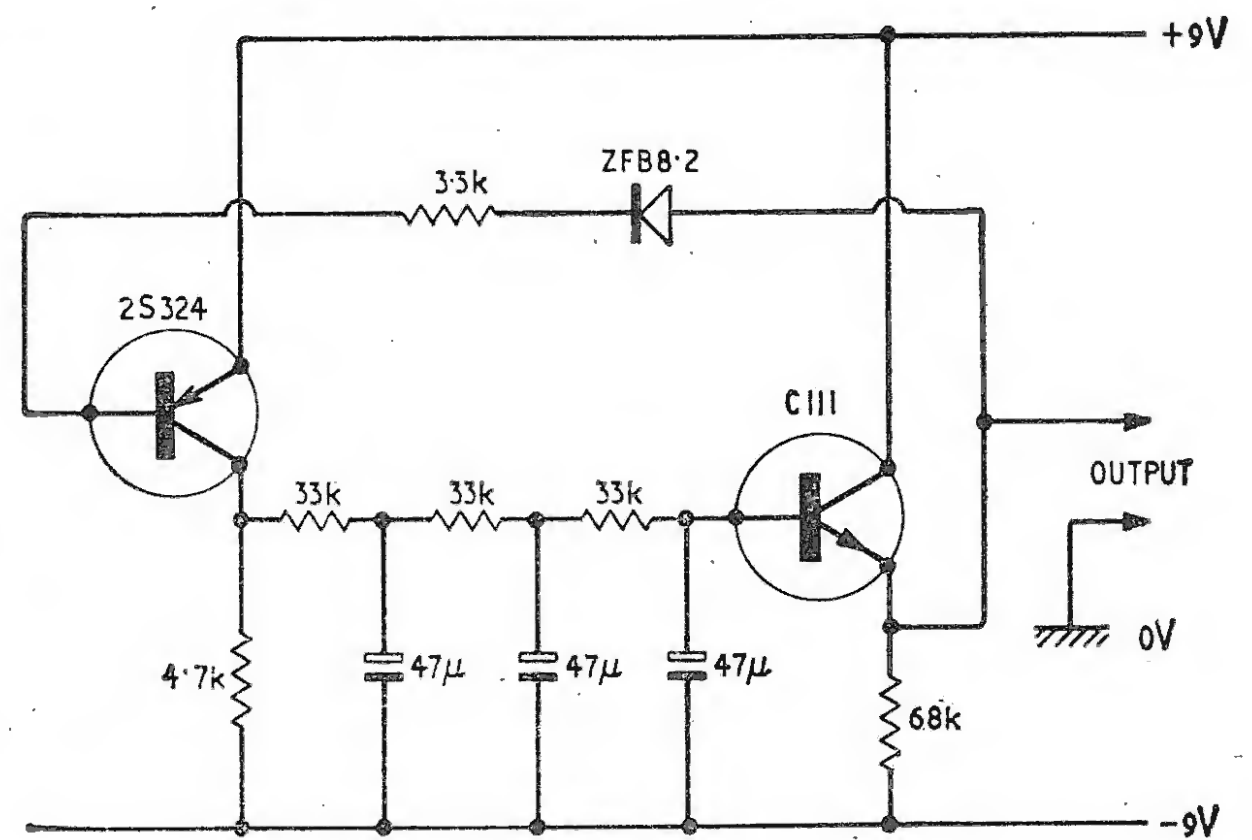

Fig. 7. Complete 0.25-c/s oscillator of simpler design, giving square wave with unequal on and off times.

will lengthen correspondingly. Fine adjustment of the oscillator's exact output frequency can be achieved by inserting a variable resistor in series with one of the phase shift resistors, so that the average value of this section of the phase shift network is approximately equal to the nominal value. For example, the circuit of Fig. 3 has the first phase shift resistor R_1 replaced by a $5\text{k}\Omega$ (variable) and a $16\text{k}\Omega$ (fixed) resistor.

An 0.25 c/s oscillator

The circuit of Fig. 7 is rather simpler than that of Fig. 3 and the waveforms produced are not so exact; in particular the square wave is of unequal "on" and "off" times. Nevertheless the performance of the circuit is excellent for the purpose for which it was designed—a source of calibration waveforms for a v.l.f. amplifier covering 0.01 to 10 c/s. The $47\mu\text{F}$ capacitors are of the "solid" tantalum type, and if required it would be quite possible to construct the whole oscillator within one cubic inch.

Possible improvements

The type of oscillator described has been found by the author to be of considerable practical use and has now been incorporated in a number of differing equipments, mainly on account of the very stable output level achieved—the only special requirement being that the parent equipment, from which the oscillator is powered, must have regulated supply lines.

With the greater availability of field-effect devices the requirements of the oscillator for a high input impedance amplifier will be more easily met. Such devices will enable much higher values of phase shift resistor to be used, thus easing the design of v.l.f. oscillators.

Where very good risetimes are needed, it should be a simple matter to incorporate a Schmitt trigger circuit between the amplifier and output stage. Amplification prior to the trigger circuit will be needed as the level at the output of the phase shift network is normally too low for reliable and stable triggering.

Acknowledgement.—The author wishes to thank Mr. G. Wikkenhauser, Director of S. Smith & Sons (England) Ltd., for permission to publish this article, which is based on work carried out by the author in the development department of the Kelvin Hughes Division of the company.

REFERENCES

1. Mullard Reference Manual of Transistor Circuits, First Edition 1960, pp. 235-242.
2. E. L. Ginzton and L. M. Hollingsworth. "Phase Shift Oscillators," *Proc. I.R.E.* February 1941, pp. 43-48. (It should be noted that in Fig. 3 of this article the frequency of the phase shift oscillator using three identical phase retard sections is given correctly, but the required gain is wrongly given as 5.)
3. J. A. B. Davidson. "Variable Frequency Resistance Capacity Oscillators." *Electronic Engineering*, January 1944, pp. 316-319, and February 1944, pp. 361-364.

APPENDIX

In the accompanying phase retard network:—

$$E = i_1 R + i_1 jX_c - i_2 jX_c \quad \dots \quad (1)$$

$$i_1 jX_c = i_2 R + 2i_2 jX_c - i_3 jX_c \quad \dots \quad (2)$$

$$i_2 jX_c = i_3 R + 2i_3 jX_c \quad \dots \quad (3)$$

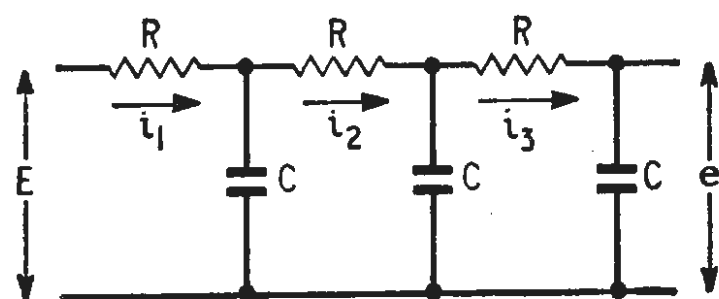

Now from (3) we get:—

$$i_2 = \frac{i_3(R + 2jX_c)}{jX_c} \quad \dots \quad (4)$$

Substituting (4) in (2) we get:—

$$i_1 = i_3 \left[-\left(\frac{R}{X_c}\right)^2 + 4\left(\frac{R}{jX_c}\right) + 3 \right] \quad \dots \quad (5)$$

Substituting (4) and (5) in (1) we get:—

$$E = i_3 \left[-\frac{R^3}{X_c^2} + \frac{5R^2}{jX_c} + 6R + jX_c \right]$$

But $e = i_3 jX_c$, thus the ratio of input to output voltages is:—

$$\frac{E}{e} = \left[j \left(\frac{R}{X_c}\right)^3 - 5 \left(\frac{R}{X_c}\right)^2 - 6j \left(\frac{R}{X_c}\right) + 1 \right] \quad \dots \quad (6)$$

Now at the oscillation frequency input and output are in anti-phase so that all imaginary terms must equate to zero, and thus:—

$$j \left(\frac{R}{X_c}\right)^3 - 6j \left(\frac{R}{X_c}\right) = 0$$

$$\text{or } \left(\frac{R}{X_c}\right) = \sqrt{6} \quad \dots \quad \text{but } X_c = \frac{1}{2\pi f C}$$

$$\text{hence } f = \frac{\sqrt{6}}{2\pi C R} \quad \dots \quad (7)$$

Now from (6) if the imaginary part is equal to zero:—

$$\frac{E}{e} = \left[-5 \left(\frac{R}{X_c}\right)^2 + 1 \right] = [-5(\sqrt{6})^2 + 1] = -29 \quad (8)$$

Equations (7) and (8) thus give the oscillation frequency and minimum gain necessary for oscillation.

The harmonic attenuation of the network may be calculated from (6); also when $f = \frac{\sqrt{6}}{2\pi RC}$ then $\frac{R}{X_c} = \sqrt{6}$ and hence at

a frequency of $2f$, $\frac{R}{X_c}$ will be $2\sqrt{6}$ since X_c will be halved. At

$$3f, \frac{R}{X_c} = 3\sqrt{6} \text{ at } 4f, \frac{R}{X_c} = 4\sqrt{6} \text{ etc.}$$

Thus, for example, at $3f$:—

$$\frac{E}{e} = [j(3\sqrt{6})^3 - 5(3\sqrt{6})^2 - 6j(3\sqrt{6}) + 1]$$

$$\frac{E}{e} = [144j\sqrt{6} - 269]$$

$$\left| \frac{E}{e} \right| = \sqrt{(144\sqrt{6})^2 + 269^2}$$

$$\left| \frac{E}{e} \right| = \sqrt{196,777}$$

$$\left| \frac{E}{e} \right| = 443.6$$

As a percentage of the fundamental frequency f , the third harmonic will be as below (where the input is a square wave):—

$$\frac{E_{3f}}{E_f} \cdot \frac{\left(\left|\frac{E}{e}\right|\right)_f}{\left(\left|\frac{E}{e}\right|\right)_{3f}} \cdot 100\% = \frac{29 \times 100}{443.6 \times 3} \% = 2.18\%$$

CONFERENCES AND EXHIBITIONS

LONDON

Nov. 15-20 Earls Court
Industrial Photographic & Television Exhibition and Industry '65 Exhibition
 (Industrial & Trade Fairs, 1-19 New Oxford St., W.C.1)

Nov. 18-19 Savoy Place
Computational Methods in Crystallography
 (Inst. Phys. & Phys. Soc., 47 Belgrave Sq., S.W.1)

Nov. 22-23 Savoy Place
U.H.F. Television Conference
 (Joint Conference Secretariat, I.E.R.E., 9 Bedford Sq., W.C.1)

EASTBOURNE

Nov. 7-10
Bristol Automation Conference
 (Instn. of Production Engineers, 10 Chesterfield St., London, W.1)

ABROAD

Oct. 30-Nov. 7 Genoa
Intercom-Communications Fair
 (Exhibitions & Trade Fairs, 10 Clifford St., London, W.1)

Oct. 31-Nov. 5 Montreal
Technical Conference
 (Soc. of Motion Picture & Television Engrs., 9 E. 41st St., New York, N.Y. 10017)

Nov. 2-4 Miami Beach
Space Electronics Symposium
 (A. J. Wood, Information Div., Patrick Air Force Base, Florida)

Nov. 16-19 San Francisco
Magnetism and Magnetic Materials
 (P. E. Wigen, Box 11432, Palo Alto, Cal.)

Nov. 22-26 Bombay
Nuclear Electronics
 (International Atomic Energy Agency, 11 Kaerntnerring, Vienna)

Electronics in Medicine

NEW BIO-ENGINEERING TECHNIQUES PRESENTED AT EUROPEAN SYMPOSIUM
AND EXHIBITION AT BRIGHTON

THE real interest in medical electronics lies not so much in the circuitry or other detailed design aspects of the "black boxes" but in the engineering techniques used to tackle difficult measurement and observation problems on biological structures. Already the term "bio-engineering" (not to be confused with what happens in *Genesis 1* or *Frankenstein*) has been invented to cover this important field. In particular, the "interface" between the electronics and the human or animal body calls for much ingenuity in the design of transducers or other linking devices. Then, once a signal has been obtained, the need to analyse the biological information raises problems in signal processing of a kind which are seldom met in industrial applications. A fair selection of these unusual techniques was presented at a European symposium and exhibition on medical electronics held in Brighton at the end of September. Organized by the journal *World Medical Electronics*, the event was intended to provide a European meeting place for those workers who were unable to attend the international conference on medical electronics held in Tokyo in August. It certainly did this very successfully, and some 370 delegates travelled from all parts of Europe (a few from the U.S.A. and Australasia) to take part in the symposium and visit the exhibition. The number of exhibitors, although not large (41), was evidence of the growing interest of manufacturers in this expanding field of technology.

Cardiological techniques

A large proportion of the papers and commercial exhibits dealt with observations on the heart and circulatory system. This is understandable, since cardiological techniques are perhaps the oldest branch of medical electronics and heart diseases are currently a matter of great concern in industrially developed countries. A paper exemplifying the two main centres of interest mentioned above and presented by D. Mendel, of St. Thomas' Hospital, London, described a technique for instantaneous measurement of the rate of change of ventricular blood pressure pulses. The way in which the ventricular pressure rises during the heart beat gives the clinician useful information about the condition of the ventricle. For example; the rate of change of pressure in a diseased ventricle has been found to be much slower than in a normal ventricle, and it is thought that a measurement of rate of change may indicate when one is about to fail. Thus it is necessary to be able to measure the blood pressure inside the heart and then devise the rate-of-change of the pressure signal.

In Mendel's equipment the intracardiac pressure is measured by a remarkably small manometer, made by the French company Telco, which is mounted on the end of a catheter and inserted into the heart through a vein. This transducer (see Fig. 1), which is 8 mm long and 2.6 mm in diameter, is an inductive device in which the pressure changes are applied to a membrane and so cause

movements of a Mumetal core within a coil. The resulting variations of inductance are measured by a frequency modulation technique. The device has a frequency response of 0 to 5000 c/s and a noise level of 0.7 mm Hg (the pressure working level being normally in the range 0 to 200 mm Hg). The electrical signal proportional to the measured pressure is then passed to an electronic unit which obtains the rate-of-change of pressure by a differentiating circuit and gives a continuous indication of this value in mm Hg/sec. Dr. Mendel mentioned that there was a correlation between the rate of change of pressure and the intensity of the heart sounds.

Since the Telco manometer is virtually a microphone it can also be used for investigating intracardiac sounds, and E. M. Allard of Telco described a new phonocardiograph which enables recordings of the waveforms of the internal sounds to be compared with those of the external heart sounds. The instrument provides four band-pass filters and a special filter which compensates for the attenuation/frequency characteristic of the thorax.

Another type of rate measurement device, outlined by J. M. Neilson of the Royal Infirmary, Edinburgh, was for continuously indicating the instantaneous rate of the heart beat (if, indeed, an instantaneous rate can be said to exist in the intervals between beats!). This particular measurement is useful in studying rapid heart-rate variations such as occur during exercise, or in investigating the reflex response of the heart to respiratory changes or other stimuli.

The system works on the principle of measuring the time interval between two successive pulses in the cardiac signal waveform. The input signal is first applied to a Schmitt trigger, which produces square pulses corresponding to the heart beats. The first of the two voltages initiates a linear ramp voltage which is continuously

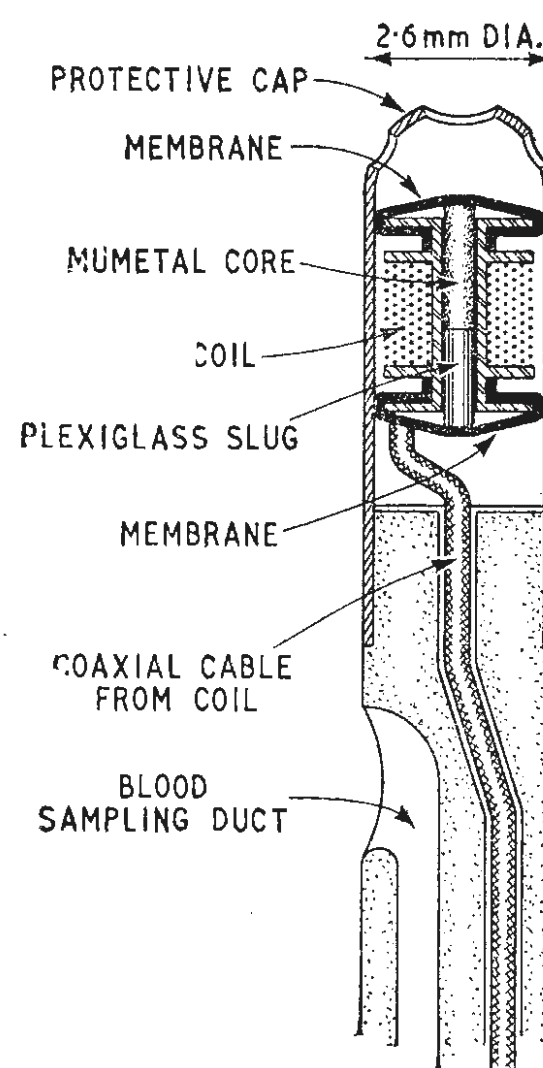

Fig. 1. Construction of the Telco manometer, used for intra-cardiac blood pressure measurements and also as a microphone for internal heart sounds. The transducer is 8 mm long.

proportional to the time elapsing after this pulse. When the second pulse arrives the ramp generator output is sampled, thereby obtaining a fixed voltage which is proportional to the time interval between the two pulses. This voltage is stored in a capacitor (until the next pulse arrives) and is passed through an inverting circuit to obtain a reciprocal value which is presented as an analogue voltage represents the instantaneous heart rate.

One application of this signal processing equipment is to obtain the heart rate when the cardiac signal is very noisy—the idea being to make the rate measurement in the lulls between noise bursts. Such is the situation when attempting to measure the pulse rate of an unborn baby, in particular when the mother is in labour, and J. B. Cornwall of the New Zealand D.S.I.R. described a foetal pulse-rate recorder similar in principle to Neilson's but incorporating an anti-noise protection facility.

The signals are obtained from a microphone attached to the mother's abdomen and their level is automatically controlled by a feedback circuit. Two stages of protection are used. In one, the intervals between successive pulses are compared so that pulses which are outside the maximum rate of change of foetal pulse rate can be disregarded. Then, after rejection on this basis, the instrument compares all subsequent pulse intervals with a reference interval corresponding to the last accepted rate reading, so that the genuine rate can be quickly identified.

Yet another heart-rate measuring device, described by V. Rohlicek of the Czechoslovak Academy of Sciences, is for monitoring the deviation of the heart rate from a median frequency, particularly during studies of conditional reflexes. Again the principle used is to measure every interval between pulses, by means of a ramp generator and storage of analogue voltages in a capacitor. The operating range of the instrument is 0.5 c/s to 6 c/s.

Restriction of blood circulation by thickening of the inner layers of the artery walls—atherosclerosis—is becoming an increasingly serious problem, but research has been hampered by the difficulty of studying the gradual formation of atheromatous matter in living subjects. The Karolinska Institute of Sweden has contributed to this field of research by devising an electro-optical technique for estimating the degree of atheromatosis in the aorta, and this was described by B. Jacobson. Reflection spectrometry is used to determine the difference between the reflection spectra of the atheromatous deposits and the normal internal wall of the aorta. For this purpose light is conveyed into the aorta and reflected light taken out by flexible fibre-optic light guides enclosed by a catheter. The intensity of the reflected light is determined by a two-channel spectro-photometer system comprising a light chopper, colour filters, an adjustable transmission wedge, two photocells and electronic circuits. Two light wavelengths are used, and the ratio of reflected light intensities is recorded independently of the absolute values, which, of course, vary with the degree of contact between the tip of the catheter and the aortic wall. The electronic system will also indicate when too thick a layer of blood is interposed between the catheter and the wall.

At a time when scientific advances depend so much on the availability of apparatus of great complexity, it is refreshing to see someone come up with an apparently simple and obvious idea which has never, in fact, been utilized before. An example of this was a new kind of cardiograph electrode invented by D. Lewes of Bedford General Hospital. Conventional electrodes normally have to be applied to the skin using a conductive saline jelly to reduce the contact impedance. This can be time consuming, particularly with cardiac emergencies,

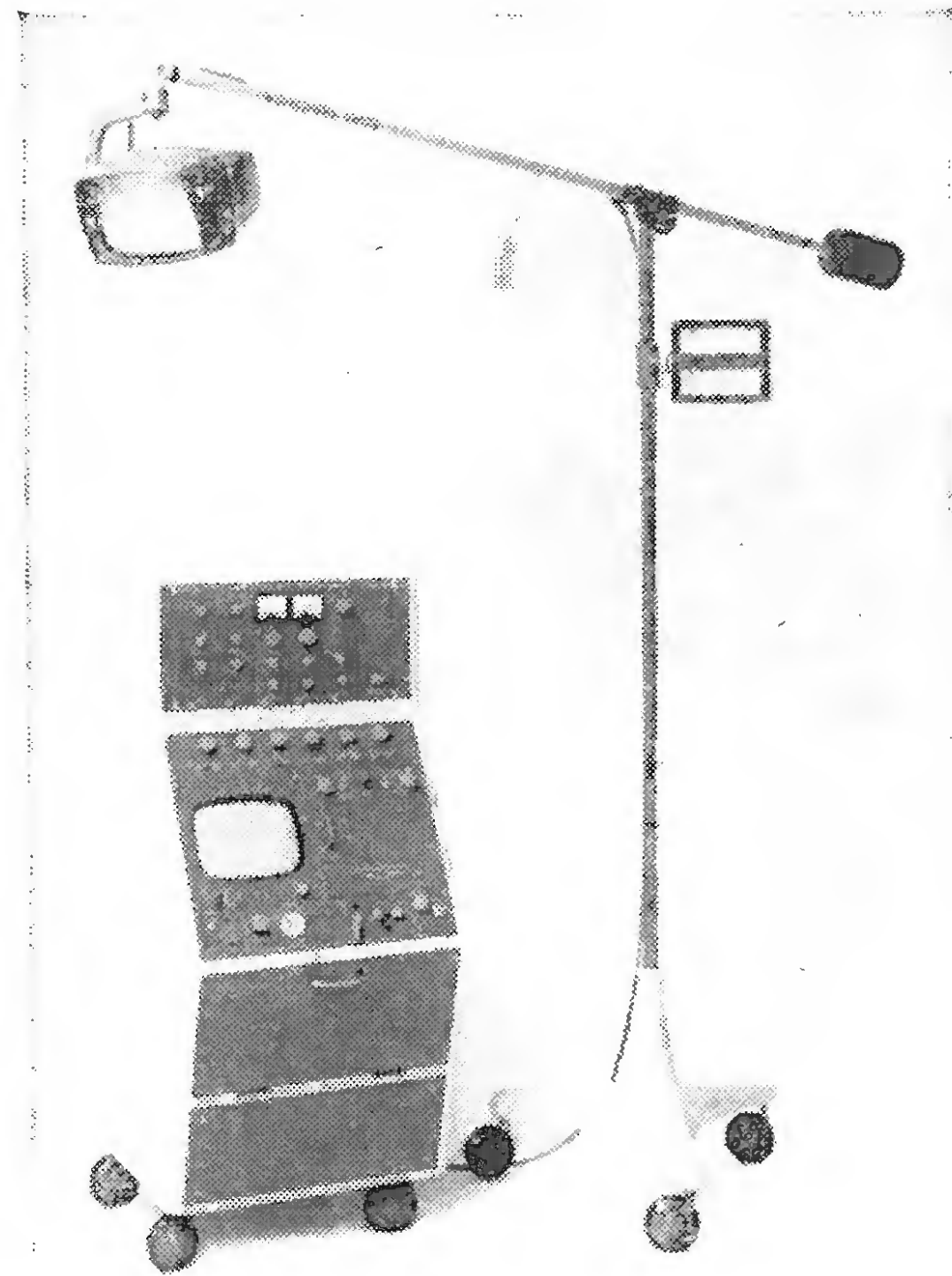

Fig. 2. Six-channel monitoring and recording equipment for routine cardiac examination (Cambridge Instruments). This, and other monitoring equipments on show, used a multiple-trace c.r.t. display with traces formed by dot brightening on an (invisible) television-type raster.

and also messy and expensive. Mr. Lewes' electrode requires no jelly but achieves a performance equivalent to that of conventional electrodes by presenting to the skin a multiplicity of projections—in fact, the prototype used a section cut out of an ordinary tin-plated nutmeg grater. This multi-point electrode, as it is called, is now being manufactured by Hewlett-Packard. (Any readers who may have been intrigued by seeing deliveries of nutmeg graters to H-P's factory will now know the reason why!)

The question of tissue resistance also came up when A. Vejarano-Laverde, of the Fundacion A. Shaio, Colombia, reported on some experiments in heart stimulation using pulses of r.f. energy at 420 Mc/s for energizing a heart pacemaker. R.f. energy had been tried and found successful in several cases where the patient's heart had developed a resistance to normal pacemaker pulses after prolonged courses of stimulation. The reason for the success of the r.f. stimulation was not known, but during the discussion one speaker suggested that it might be due to the well-known ability of a.c. to break down the polarization effects which occur when metal electrodes are applied to certain substances. The 420 Mc/s energization had been used merely because such an r.f. generator happened to have been available.

Electro-optical techniques

Stroboscopes are being used to examine the action of the larynx, both for diagnosing diseases and for physiological research on the human voice. The vocal chords, however, unlike moving parts in a machine, do not vibrate continuously, with constant frequency and phase, so that it is extremely difficult to obtain a stationary

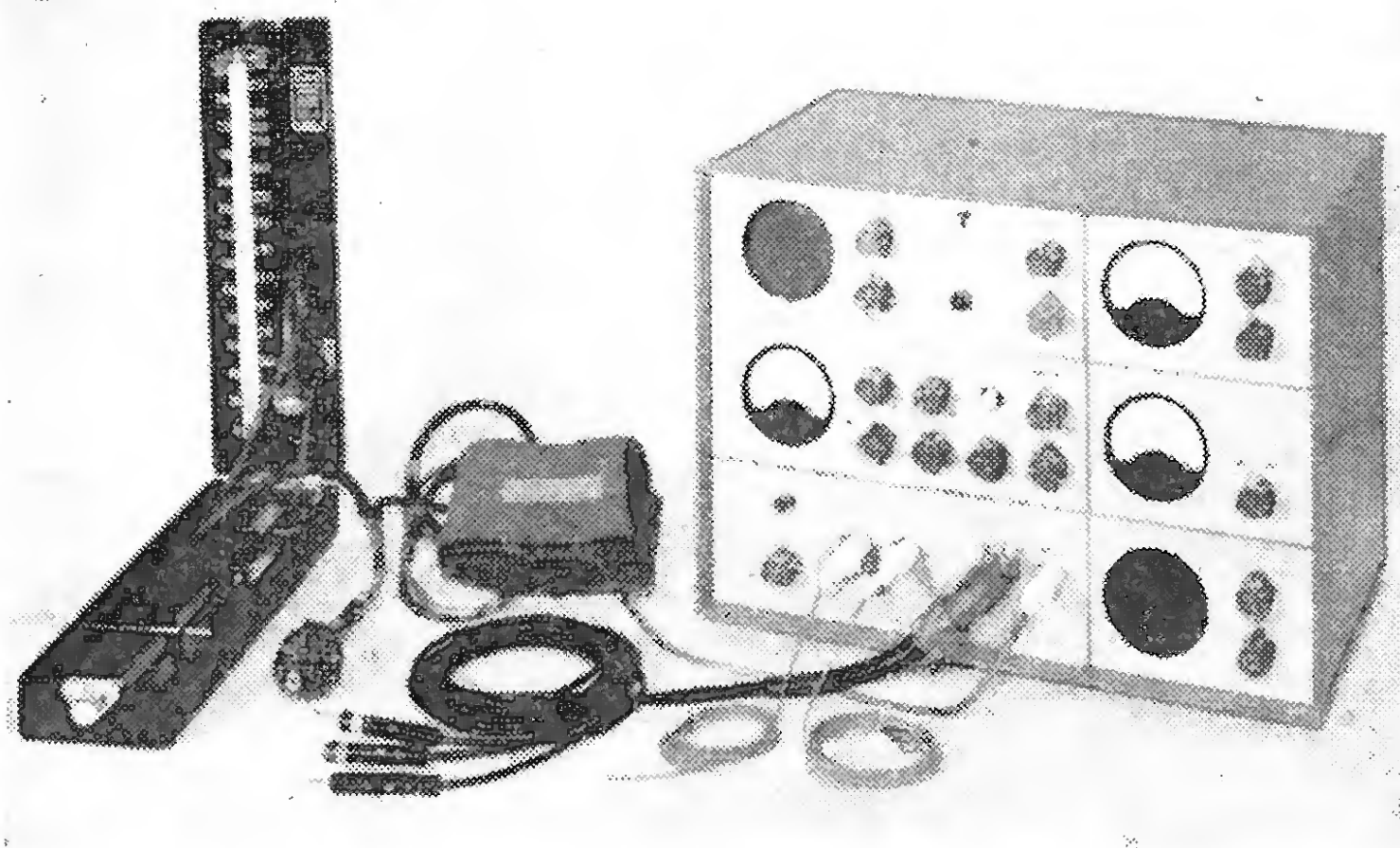

Fig. 3. Example of "medicine-automation" for hospitals. Philips low-priced intensive-care patient monitoring equipment (£200-£400) providing read-out of five physiological variables at the bedside (e.g., pulse rate, temperature, respiration rate and blood pressure). Audible out-of-limit alarms are given. A transducer is fitted to the blood-pressure sphygmomanometer and cuff seen on the left.

image. W. Steglich, from a medical electronics and radiological laboratory in Dresden, E. Germany, explained how this problem had been tackled by automatically controlling the flashes of the laryngostroboscope from voice signals picked up by a microphone. The basic frequency of the voice sounds is selected from the overtones by the use of filters, and a facility is included for continuous adjustment of the phase of the standing image (achieved by shifting in time the initiation of the flash). An East German commercial laryngostroboscope incorporating this automatic control feature was shown in the exhibition by T.E.M. Sales Ltd. The flash repetition rate (range: 30 to 500 c/s) is half that of the voice control frequency.

The value of video signal processing techniques in reducing the x-ray dose necessary for radiography examinations was brought out in two papers. D. J. Wilson Taylor, of the Sheffield Regional Hospital Board, in a survey of video tape recording, pointed out that a fluoroscopic image obtained by an image intensifier and scanned by a television camera could be recorded on a short loop of video tape which could be replayed continuously and as long as necessary to allow the clinician to see what he wanted. Similar results could be obtained by cine film recording, but the tape recording method was much cheaper (excluding the capital cost of equipment at present prices) and it eliminated the time delay necessary for film processing—an important factor during operations.

P. Osypka, of the Mayo Clinic, U.S.A., was concerned with video techniques applied to x-ray fluoroscopic images of parts of the circulatory system, obtained while subjects were experiencing acceleration in a centrifuge. In order to study bloodflow patterns under these stress conditions, substances giving a change of x-ray contrast were injected into the bloodstream. The fluoroscopic image given by an image intensifier was then scanned by an image orthicon camera and recorded on video tape—a process called videangiocardiology.

To determine the x-ray opacity of any particular area of the image recorded on the tape, a further technique called videodensitometry, was brought into play. This used an electronic switching circuit to sample the video signal during the time intervals corresponding to a selected area of the image (e.g. a small rectangle, a fraction of a scanning line wide and several lines deep) and an integrator to obtain the time integral of the video voltage over the selected area. The output of the densi-

tometer was recorded on magnetic tape, together with other cardiological variables, for subsequent analysis in a computer. It was possible to detect contrast changes as small as 2%.

Ultrasonic observation and treatment

Now that ultrasonic waves can be generated and detected at frequencies up to tens of megacycles, ultra-sound has proved to have a directivity and resolving power which can be of great value in medical work. An example is the ultrasound camera—an alternative to the potentially harmful x-ray machine. At the symposium two papers in this field were presented. P. N. T. Wells, of the Bristol Royal Hospital, outlined briefly an unusual technique in which 1.5 Mc/s ultrasonic waves are used for internally echo-scanning the liver and building up two-dimensional images on a c.r.t. A small ultrasonic transducer 0.3 cm in diameter is mounted on the end of a flexible stainless steel rod and inserted through a vein to a position suitable for scanning the liver. Scanning is performed by rotating the transducer, using an electric motor coupled to the external end of the rod, and the angular position of the rod is measured by a sine/cosine potentiometer which provides an electrical signal to synchronize the radial time base of the c.r.t. Echo signals from the transducer are applied to the c.r.t. as intensity modulation. Preliminary experiments have not been greatly successful, owing to the low sensitivity and wide beam divergence of the small transducer.

No such problems occur with the ultrasonic brain surgery method described by D. Gordon of the Willesden General Hospital and West End Hospital for Neurology and Neurosurgery, London. Here a large ceramic transducer similar to a concave focusing mirror is used for both the location of a particular group of cells in the brain or spinal cord (using low power) and then for its destruction (using high power). This technique, called ultrasonic stereotaxic surgery, is intended for selectively destroying deeply situated groups of cells which cause functional disorders such as Parkinson's disease, but without disturbing the intervening parts of the brain or nervous system (as is necessary with existing surgical methods). Because of the focusing principle employed, the ultrasonic energy is widely dispersed where it passes through the skull and outer parts of the brain and so causes no damage, but at the focus point the concentrated energy is sufficient to destroy the selected group of cells.

Such is the accuracy of the location procedure that the position of an object of only 1 mm in diameter can be determined with a precision of 0.1 mm.

Biological data processing

Many of the measurements and observations of living organisms made by instruments produce lengthy records of apparently random events which only have real significance when analysed statistically. Special-purpose computers are now being produced commercially to perform such analyses, and two examples seen at the exhibition were the Biomac 500, made by Data Laboratories, and the 7100 Data Retrieval Computer made by Nuclear Chicago. The Biomac 500 was also the subject of a paper presented by D. Aspinall, of Manchester University, who had been concerned with the original development of the instrument.

The main function of both of these computers is averaging of bio-electric signals immersed in noise, the principle being that the wanted periodic signals are enhanced by summing while the random noise signals are averaged towards zero. This process is performed by sampling the input signal at regular intervals, converting the values to binary number form by an analogue-to-digital converter and storing the binary numbers in separate storage locations. The Biomac 500, for example, has a 7-bit a/d converter and a ferrite core store with 500 addresses (locations) each of 16-bit capacity. A particular feature of the machine is its high speed of operation, which enables it to resolve 1-millisecond pulses if required.

In addition, both of the machines on show provided facilities for giving statistical distributions of the input data—an amplitude histogram (as in a pulse height analyser) and two types of time-interval histograms (using the time intervals between successive input pulses). Cross-correlation analysis could also be performed.

A somewhat simpler and cheaper device for averaging of noisy signals is a rotating wheel fitted with storage capacitors and a system of brushes for feeding samples of the signals into the capacitor stores. If the wheel is rotated at a speed related to the frequency of the wanted signal, the increments of charge on the capacitors resulting from the periodic signal augment each other while the increments resulting from the random noise tend to average out to zero. This device, invented by G. Dawson some years ago, has been used in a new application at the Royal Infirmary, Bristol, which was described by G. E. Hesse. The object is to study brain potentials evoked by painful sensory stimuli, but these potentials are so small that they are normally quite indistinguishable from the spontaneous electrical potentials recorded on the electroencephalogram. The Dawson machine is used to recover these evoked potentials from the e.e.g. "noise" by making them periodic, the painful stimuli being generated in periodic form by a set of contacts on the spindle of the rotating wheel.

Bio-electrical control of artificial limbs

As is well known, artificial limbs can be controlled by muscle action potentials picked up from any remaining parts of the limbs. Much has been heard about the Russian bio-electric hands now being supplied in this country under the National Health Service, as an indirect result of the Lady Hoare Thalidomide Appeal. There are, however, a number of centres in other countries working on these prostheses, as they are

called, for both hands and arms—notably Britain, U.S.A., Yugoslavia and Italy.

At the symposium the work of one British and one American centre was represented. D. C. Simpson, of the Royal Infirmary, Edinburgh, is concerned mainly with children born without arms who therefore have no muscle action potentials available. Here the problems are almost entirely mechanical—pneumatic control of the artificial arm mechanism by shoulder and neck movements—and are all the more formidable for that. The American work, by the Applied Bio-Cybernetic Laboratories of Philco, although perhaps more interesting to electronics engineers, is a more general research programme not concerned with the immediate problems of particular individuals. W. L. Wasserman explained, with the aid of a film, that one of the most important aspects of their work was the computer analysis of electromyograph signals from the arms of normal people to find correlations between patterns of electrical activity and particular movements of the arms.

At present the Philco experimental artificial arm was controlled from a relatively large number of pick-up electrodes attached to a human arm above the more easily identifiable centres of muscular electrical activity. Eventually, however, as a result of the pattern recognition work, it was hoped that the number of electrodes could be reduced to two, and placed in positions high up on the arm or shoulder, so that an artificial arm could be used, for example, by those with only a short stump left at the shoulder. A good signal/noise ratio in the e.m.g. signals is obtained by the use of tiny integrated-circuit head amplifiers (emitter-followers) actually built into the pick-up electrodes themselves. Integrated circuits are also used in the main control circuits, which contain logic and signal weighting circuits derived from the pattern recognition analysis.

Commercial Literature

"A.F. Book 1, Non-linearity in audio amplifiers" is the title of a 22-page publication produced by Marconi Instruments Ltd., of St. Albans, Herts. This booklet, which is available on request, is sub-divided into the following chapters: non-linear distortion, distortion factor measurements, harmonic analysis, intermodulation measurement (two-frequency methods), and comparing the results. An appendix explaining the expansion of transfer functions with one and with two signals, is also included.

WW 324 for further details

H.F., S.S.B. Transmitter/Receiver.—The Marconi Company, of Chelmsford, Essex, have available a leaflet (SP167) on their Type H4000 h.f., s.s.b. transmitter/receiver. This unit has a peak-envelope-power of 100 W and covers the frequency range 1.6 to 15 Mc/s.

WW 325 for further details

West Hyde Developments Ltd., of 30 High Street, Northwood, Middx., have reproduced a resistor nomograph on the back of one of their general leaflets giving details of the neon indicators and instrument cases they manufacture. A resistor tolerance table is also included on this leaflet which is available on request.

WW 326 for further details

"Getting acquainted with spectrum analysers" is the title of a booklet Tektronix have produced from a series of articles which have recently appeared in one of their internal publications. This will prove useful to readers wanting preparatory reading on the subject and is obtainable from Tektronix U.K. Ltd., Beaverton House, Station Approach, Harpenden, Herts.

WW 327 for further details

"Planar News".—The European silicon semiconductor manufacturing group of the SGS-Fairchild organization have started a bi-monthly publication (in four languages) containing company news, details of new products and reports from their research laboratories, etc.

WW 328 for further details

MICROELECTRONICS

SOME CURRENT CONCEPTS PRESENTED
AT THE SOUTHAMPTON SYMPOSIUM

THAT the golden age of the electronics industry is approaching was one of the impressions gained at the Microelectronics Symposium held at Southampton University from 21st-23rd September. When this age will finally dawn depends upon the resolution of the problems associated with cost and manufacturing techniques. The tantalizing carrot of low cost is still dangling in front of the industry but has yet to be enjoyed. One reason for this appears to be due to a contraposition of attitudes of the manufacturer and the user. Someone once said that caution is a brake on progress, and this is undeniably true at the present stage of integrated-electronics. The potential user, although recognizing the advantages of the new techniques, is reluctant to change his proven established methods of system fabrication until the promise of low cost materializes. The manufacturer, on the other hand, faced with the expense of nurturing this new technology finds it costly to produce small, "customer special" quantities and naturally hopes for more business to encourage his research and development activities. With quantity playing such an important role in pricing, the fact that many identical elements are normally required in digital equipment has led to the trend in which digital circuits have been given most attention. In addition, it is easier to manufacture a digital circuit than a linear circuit; as a result, for linear applications, the philosophy of circuit design has had to be modified to enable digital techniques to be applied as extensively as possible.

Examples of such circuit philosophy were discussed in papers by J. Tomlinson and H. Ras & J. Rongen. In "A digital i.f. system for use in a thin film radar receiver" by J. Tomlinson (of E.M.I. Electronics Ltd.) aspects of the operational requirements of the radar system indicated the use of a logarithmic i.f. amplifier in which, as the input increases, the stages limit successively and each stage of the amplifier can be considered as providing a digital output. Accordingly, the design was treated on the basis of an analogue-to-digital converter. Modifications of conventional circuit configurations enabled a circuit to be constructed in microelectronic form. The arrangement was shown simply as in Fig. 1. As can be seen, the output from each stage caused detectors to operate successively for every $1\frac{1}{2}$ dB increase in output. At each step an associated bistable circuit was triggered and the level of the pulse measured by the number of bistables which had been triggered. The bistables were reset to normal by a pulse from the radar transmitter. Thin film techniques were used for each stage. Conventional methods were used to deposit nichrome resistors, gold connectors and capacitors comprising aluminium plates and silicon monoxide dielectric. With thin film techniques, linking between stages would normally be by soldered or welded joints. However, by using mutually coupled circuits, the secondary winding of the input and the primary winding of the output were formed on the same substrate; substrates were then jig aligned and the primary winding of the output of one stage aligned coaxially with the secondary winding of the input of the next stage.

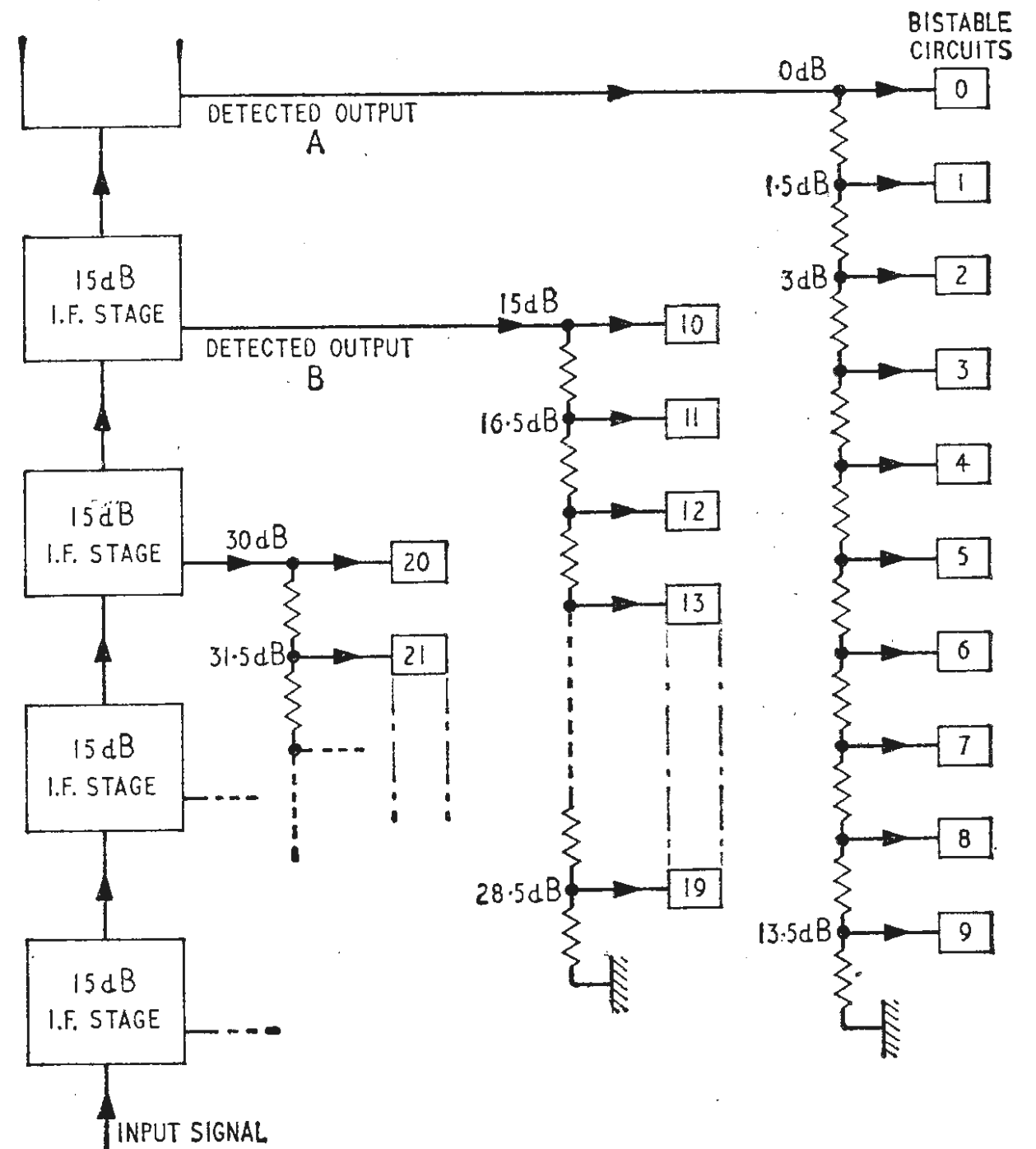

Fig. 1. Block diagram showing analogue to digital conversion of logarithmic i.f. amplifier.

In the paper, "The application of integrated circuits in radio receivers," by H. Ras and J. Rongen (of Philips Semiconductors Application Laboratory) an example was given showing the circuit configuration of part of a domestic radio receiver fabricated by using the silicon integrated technique. With this technique, inductances cannot be formed and i.f. stages were dispensed with by using a lumped selectivity, lumped gain approach. The block diagram of the superhet rearranged for the silicon integrated technique is shown in Fig. 2. Selectivity was achieved by using a ceramic filter, which followed a conventional mixer, and the gain obtained by using a wideband amplifier. The detector circuit was combined with the wideband amplifier.

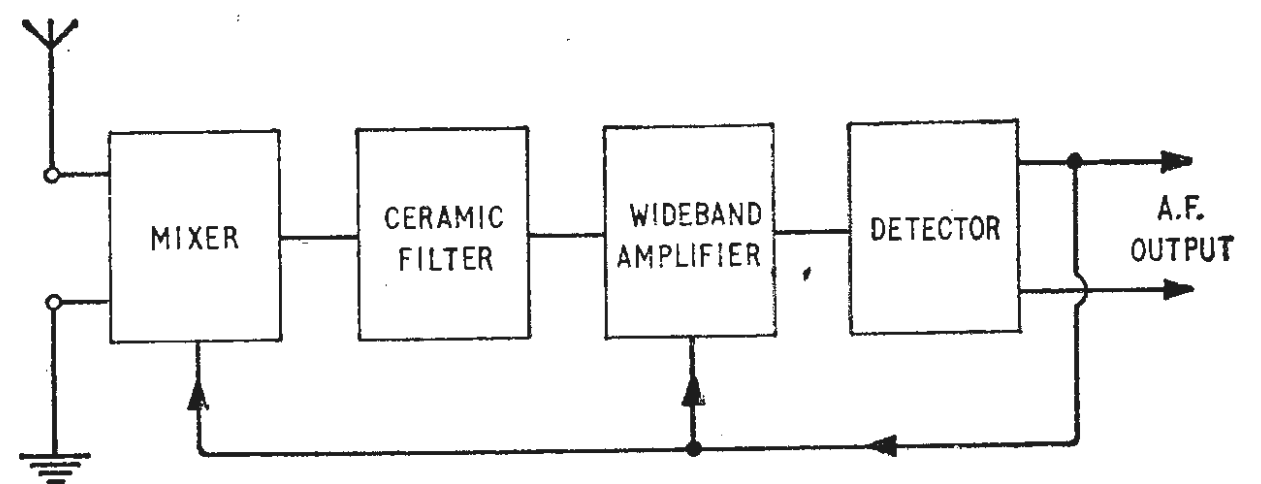

Fig. 2. Block diagram of superhet with "lumped selectivity and lumped gain".

In this paper the point was also made that a direct final cost comparison of a conventional design with an integrated-electronics design is not always fair. For instance, in the example quoted, because inductances cannot be made the basic design had to be changed. Other factors such as the inability to make large value capacitors, and the inherent parasitic elements can dictate a much more intricate design far removed from the original conventional circuit.

The current position of microelectronic manufacturing techniques was reviewed by A. T. Watts (of Mullard Ltd.) in his paper "Recent trends in applications of microelectronics." Advances had been so rapid that the user had experienced great difficulty in assessing the significance of recent developments. In turn, this has led to confusion and accounts for the general hesitation of the potential user. The original separated approaches of thin film and solid circuits appeared to be merging and in the future two closely related techniques, differing only in the use of passive or active substrates, would be used. Where the ratio of active to passive components is high, passive components would be formed by thin film evaporation on the oxide layer on an active silicon substrate. Where the ratio is low, active devices would be evaporated on a passive substrate.

Six techniques, currently in use, were reviewed and are listed in Table 1 together with the passive and active elements which can be manufactured by the different techniques. Except for monolithic silicon, circuit performance of devices manufactured by the techniques is the same as or better than the equivalent conventional component; for monolithic silicon the performance is the same or worse. General data given in the table must be treated as representative of typical results.

The construction of monolithic silicon integrated components were discussed in a paper, "Solid circuit design considerations" by P. Cooke, J. D. Evans, M. J. Gay and J. S. Brothers (of Plessey Company Ltd.). Components were produced by a process in which an epitaxial n layer with buried n+ regions was formed but did not include a gold doping step. The process is suitable for linear and slow or non-saturating logic circuits.

A plan view and a section of a U12 transistor were shown; these illustrations are reproduced together with

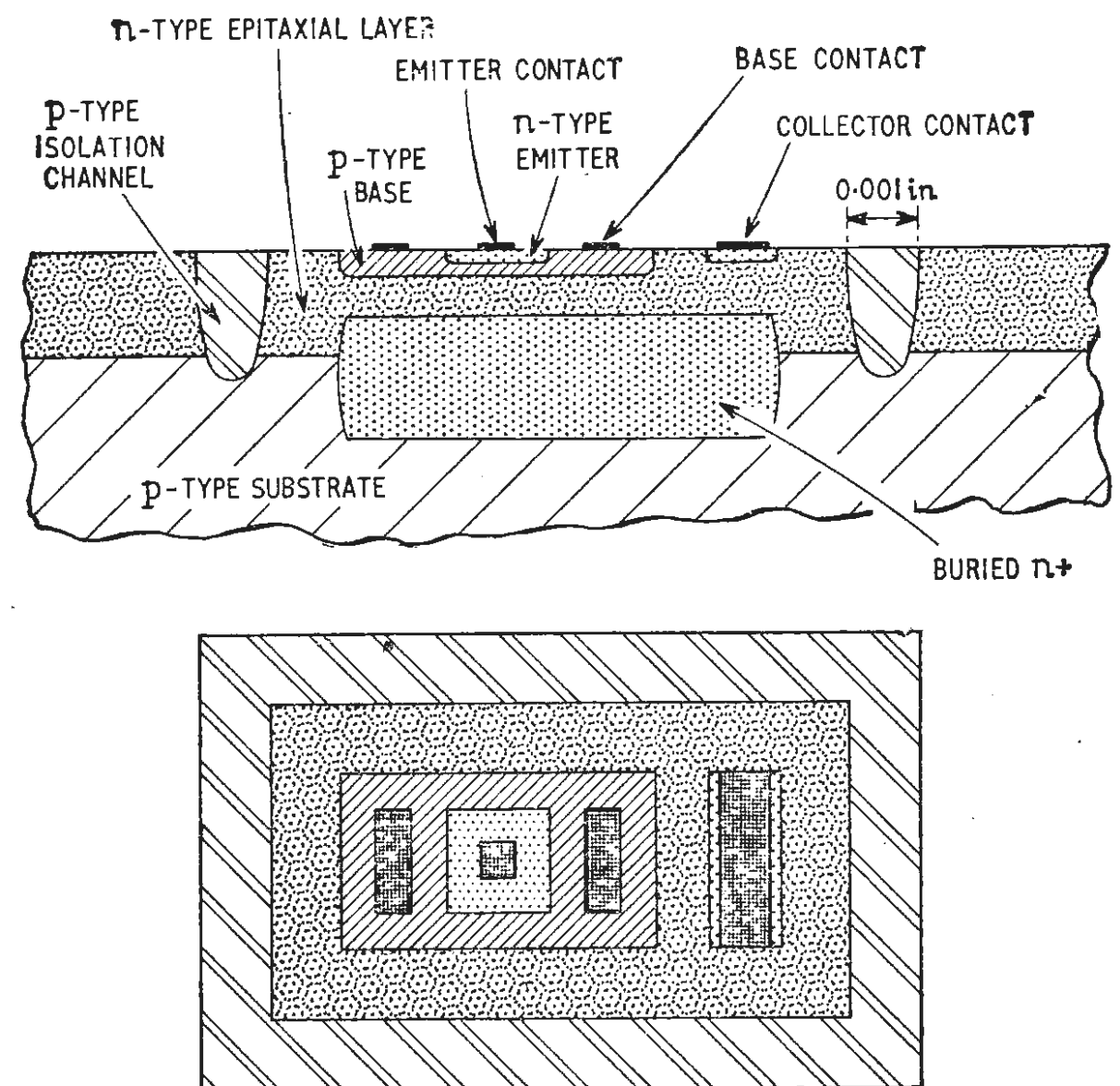

Fig. 3. Formation of monolithic silicon transistor.

other component diagrams. The transistor, Fig. 3, differed from a conventional planar transistor in two respects: the collector region of the solid-circuit transistor was isolated by a junction from the bulk of the silicon chip, whereas the whole chip of a conventional transistor is connected to its collector; the collector contact of the solid-circuit transistor must be on the top surface of the chip, whereas the contact to a conventional transistor is to the bottom of its chip via the base of the can. Because a solid-circuit transistor has its collector contact on the top surface the current must cross the high-resistivity epitaxial layer twice and this, for the transistor shown, led to collector resistance of 30Ω . Furthermore, since the collector resistance was mostly in high-resistivity material it had a high temperature coefficient; the resistance was about 35% higher at 120°C

Table 1	Component Properties													Types	Tooling cost
	Resistors				Capacitors				Inductors			Transistors and Diodes			
	Values (Ω)	% Tolerance	Temp. Coeff. (p.p.m./ $^\circ\text{C}$)	Max. Operating Frequency (Gc/s)	Values (pF)	% Tolerance	Temp. Coeff. (p.p.m./ $^\circ\text{C}$)	Polarized	Voltage Dependence	Values (μH)	% Tolerance	Q @ 50 Mc/s			
Thin Film on Passive Substrate ..	25 to 100k	± 5	± 100	2	20 to 2k	± 10	± 200	no	none	<2.5	± 5	60	none	low	
Thin Film Hybrid, with Attached Semiconductors	25 to 100k	± 5	± 100	2	20 to 2k	± 10	± 200	no	none	<2.5	± 5	60	any	low	
Monolithic Silicon ..	25 to 20k	± 20	± 1000	0.1	10 to 200	± 20	1000	yes	$C = KV^{-1/2}$	none	—	—	any silicon planar	high	
Monolithic Silicon with Dielectric Isolation	25 to 20k	± 20	± 1000	0.1	10 to 200	± 20	1000	yes	$C = KV^{-1/2}$	none	—	—	any silicon planar	high	
Monolithic Silicon with Thin Film Passive Components	25 to 100k*	± 10	± 100	1	20 to 2k*	± 10	± 200	no	none	<2.5*	± 5	60	any silicon planar	medium	
Multichip ..	25 to 100k	± 5	± 100	2	20 to 2k	± 10	± 200	no	none	<2.5	± 5	60	any silicon planar	medium	

* Upper value may be limited by available area.

than at 25°C. By adding a second collector contact at the other end, the resistance could be reduced to about 18Ω. Two solid-circuit transistors on the same chip had well-matched properties because they received almost identical processing.

Solid-circuit resistors were made at the same time as the bases of the transistors; p-type strips were diffused into the n-type epitaxial layer and aluminium contacts were made at the ends. The process described gave a sheet resistance of 100 ohms/square. (Note. Dimensions of the square do not affect the resistance. For example, measuring across the face of the square, the resistance will remain constant as the area of the square is changed.) The widths of resistors may be from 0.5 thou.-2 thou. (0.0005 in-0.002 in) for values down to 150 Ω. Resistors below 150 Ω were usually made 3 thou. long and wide enough to give the required resistance. Wide resistors had the disadvantage of larger area but were more accurate because the photoengraving errors are less important. Resistors cannot be shorter than 3 thou. and there was a minimum value of resistor that could be made in each width. Resistors on a chip were made at the same time and as a result of this their ratios were more accurate than their absolute values; wider resistors had more accurate ratios.

Diodes could be made from either transistor junction or from transistors connected in various ways. The choice in a particular circuit depended on the forward voltage, reverse breakdown, capacitance and storage time required. A particularly useful diode was the one made by shorting the collector and base of a transistor; it was practicable to use diodes like this because the cost of a transistor in a solid-circuit was hardly any higher than that of a diode. The forward voltage drop of this type of diode was the base-emitter voltage of the transistor and was low. The device also had a shorter re-

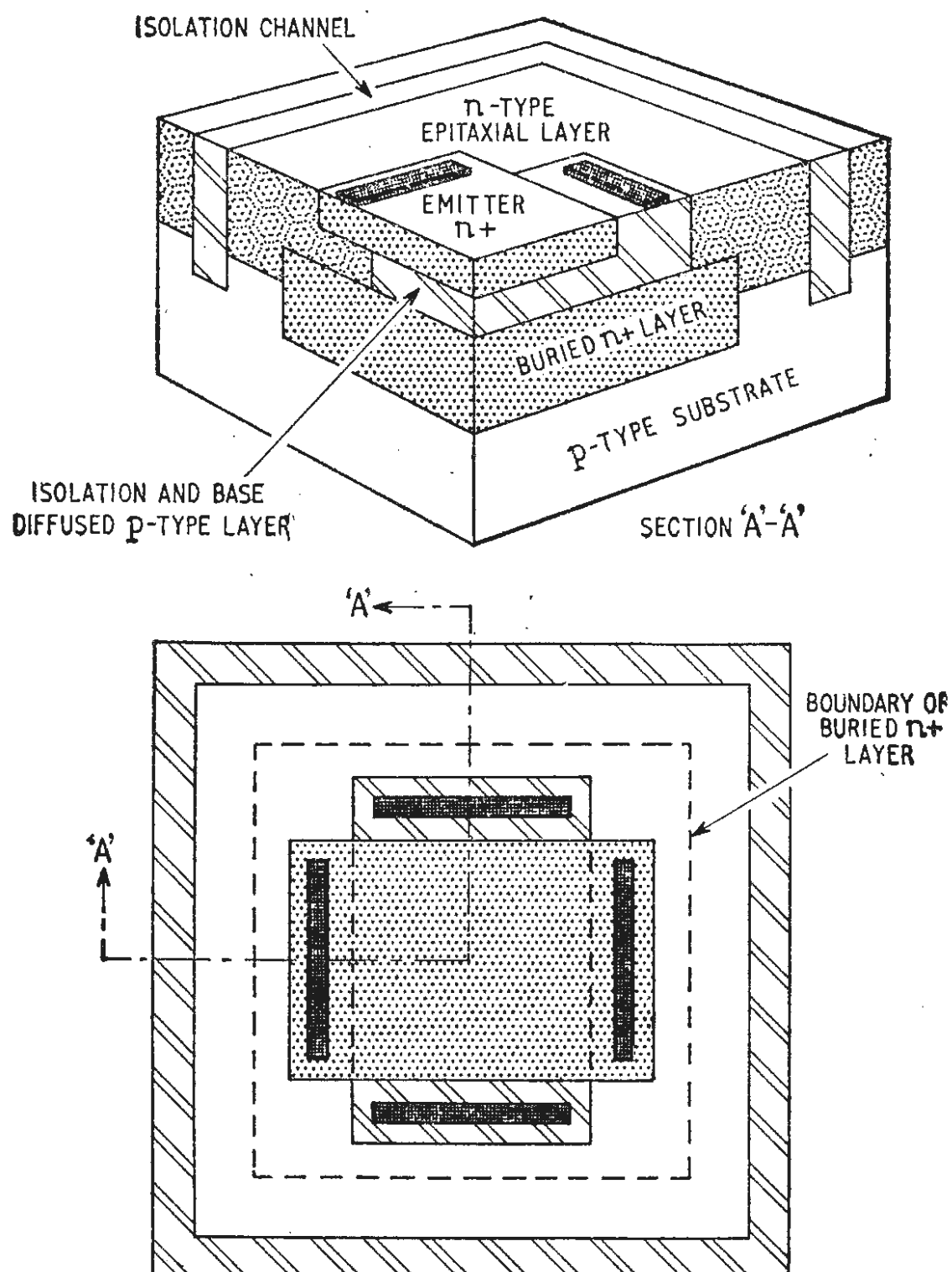

Fig. 4. Formation of monolithic silicon capacitor.

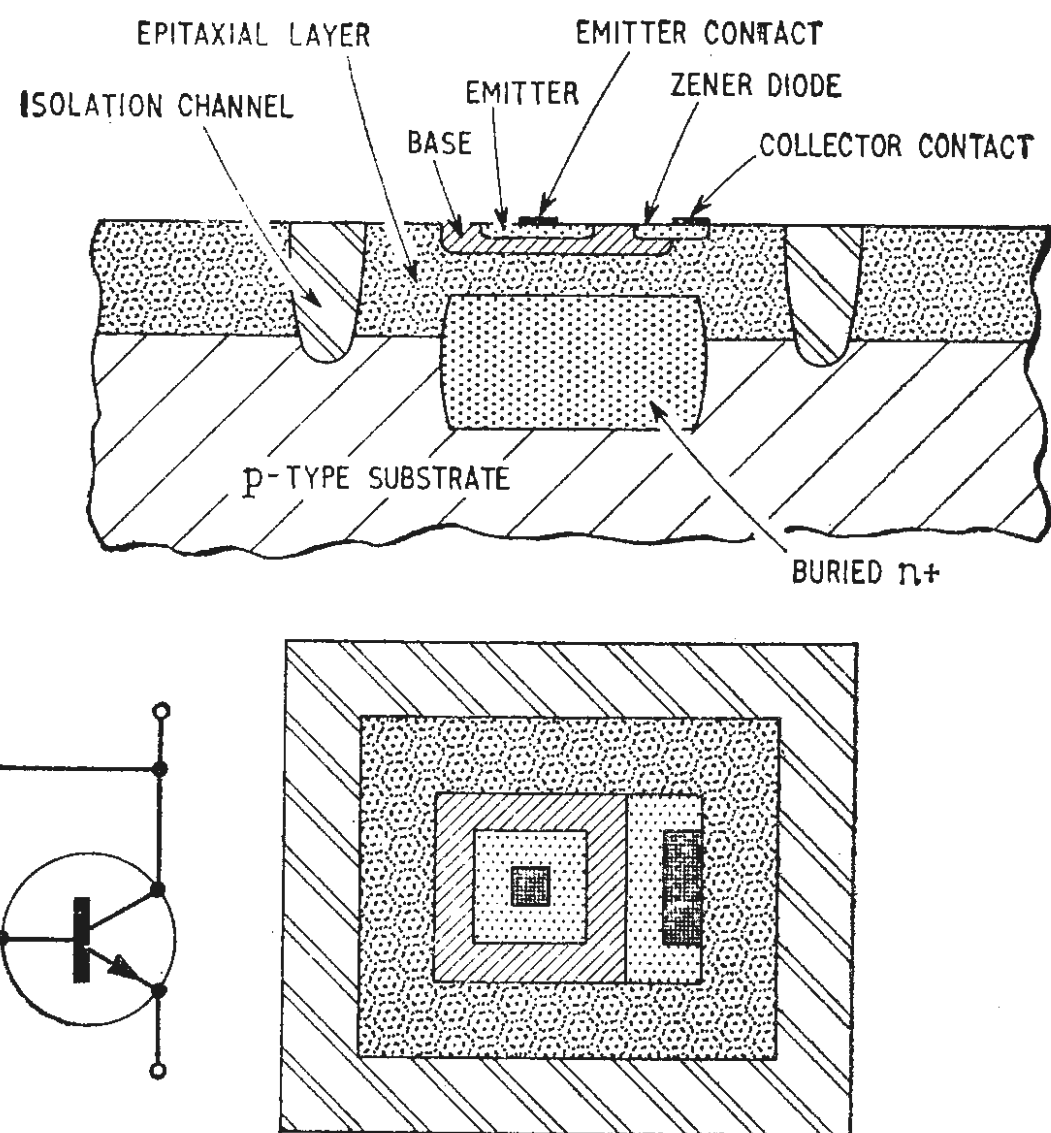

Fig. 5. Formation of monolithic silicon Zener diode.

covery time than a single-junction diode because the transistor was not saturated; a typical recovery time was 2 ns.

It was possible to construct special high-capacitance junctions for use as capacitors. One of these was formed by putting the isolation diffusion into a region that had buried n+ below it; the other was formed by putting base and isolation diffusions into the same region to give a high doped p-type layer and then putting the emitter diffusion on top of this. Moreover, it was possible to connect these two junctions in parallel in a structure like the one shown in Fig. 4. This capacitor had 2.4 pF per sq. thou. (pF/0.001²in) with no bias, an isolating capacitance of 0.09 pF per sq. thou. with no bias, and a breakdown voltage of 5V.

The breakdown of the emitter junction occurred at a reverse bias of about 5.4V and this was used as a Zener diode. The series resistance was fairly high; it was impracticable to reduce it below about 10 Ω because the device became large. A lower resistance diode was made in the way shown in Fig. 5. This device is a transistor with no base contact and with its collector partly overlapping its base, and it has an equivalent circuit as shown in the illustration. It therefore behaved like a Zener diode with a transistor as an emitter follower and broke down at 6.1V instead of 5.4V. A device as small as the one shown had a slope resistance of about 6 Ω at a current of 5 mA.

The last paper, "Education for the microelectronic age", was presented by Dr. B. H. Venning (Department of Electronics, University of Southampton) and included reference to a subject which must affect every designer of conventional circuits—the future pattern of employment. It would appear that only a small section of the industry will be concerned with research, development and manufacture of the microelectronic modules and workers in this section will need to be specialists such as production technologists, designers of active and passive devices and circuit-module designers. Few workers can afford to remain as pure physicists or pure circuit designers. In fact, the circuit designer becomes a solid state technologist familiar with chemical and metallurgical processes and photo-engraving methods.

Hirsch on Colour Systems

A LECTURE on the present status of colour television systems by C. J. Hirsch, of R.C.A., to the Television Society on October 1st seemed almost to be based on the assumption that the British authorities had already chosen the PAL system for the U.K. This approach was, as he jocularly admitted, to "damn the PAL system with faint praise." He sought to show that only marginal improvements in quality could be expected, mainly in the distribution and transmission system, and that these would not be justified by the probable extra cost of the receiver (estimated as 10%, or \$40, on an American receiver). However, several people in the audience said they would be quite prepared to pay such an "extra" cost for the better quality.

Revealing that the choice of the N.T.S.C. system in the U.S.A. was the indirect result of a wrong Government decision (the initial choice of the C.B.S. non-compatible frame-sequential system by the F.C.C.), Mr. Hirsch said he felt the Post Office and other authorities tended to choose systems which made things easier for themselves. He challenged the representatives present to stand up and justify their reasons for their (assumed) choice—but nobody accepted the challenge.

He refused to be drawn by the suggestion that the U.S.A. might have chosen PAL had suitable receiver delay lines been then available. Likewise, to the question "what improvements would you be in favour of adopting if you could start again in the States?" Mr. Hirsch compromised by mentioning better gamma correction to obtain correct constant luminance operation.

Secam Demonstrations in London

AS THE contestants for the "colour television stakes" enter what may be the final stage of the contest each is making an all-out effort to win. Mr. Hirsch, of R.C.A., has been going around the Continent extolling the virtues of N.T.S.C. (see note above on his visit to this country). Dr. Bruch is also coming to London to lecture on the PAL system.

The French contestant CFT went one better and staged a series of SECAM demonstrations in London in September. These were not on closed circuit but came from the Paris studios of O.R.T.F. via a microwave link to Bouvigny, near Lille, where they were broadcast on channel 27, picked up by the G.P.O. station at Tulsford Hill, near Folkestone, sent by the B.B.C. microwave link to the White City and thence by cable to the Hilton Hotel. To demonstrate the versatility of the system the transmission included live shots, film and tape, and a considerable stress was placed on the fact that the colour receivers do not need hue or saturation controls, there are but three—contrast, brightness and volume.

Trade Test Transmissions

RECENTLY the times of test transmissions (Monday to Saturday inclusive) were altered by the B.B.C. and I.T.A. Times are as tabulated; during the times shown the test card is transmitted continuously by both B.B.C. and I.T.A.

B.B.C.		I.T.A.	
Time (BBC-2)	Sound	Time	Sound
09.00—09.04	440 c/s tone	09.30—09.35	400 c/s tone
09.04—09.05	No sound	09.35—09.36	No sound
09.05—09.30	Recorded music	09.36—10.00	Recorded music
This half-hour sequence is then repeated until 13.00 and from 14.00 to 18.00		10.00—10.05	400 c/s tone
Time (BBC-1)	Sound	10.05—10.06	No sound
09.00—09.25	Recorded music	10.06—10.30	Recorded music
09.25—09.29	440 c/s tone	10.30—10.35	400 c/s tone
09.29—09.30	No sound	10.35—10.36	No sound
This half-hour sequence is then repeated until 13.00 and during any programme intervals between 14.00 and 17.00.		10.36—11.00	Recorded music
		The sequence of the last hour is then repeated until 15 minutes before commencement of programmes.	

Progress of the Electronics E.D.C.

THE Economic Development Committee for the electronics industry was set up by the Government in 1964. The two main aims of the E.D.C. are to help formulate the role of the electronics industry in the National Plan, follow its progress, and to help improve the competitive power and efficiency of the industry.

Products which this E.D.C. cover include radio, radar and electronic capital goods, domestic radio and television receiving equipment and gramophones, telegraph and telephone apparatus, valves, semiconductors and other radio and electronic components. The E.D.C. has prepared a progress report describing its activities which include the examination of imports and exports, work in conjunction with the National Plan, improvement of efficiency in the industry and study of statistics and manpower working groups. Copies of the report are being distributed through various channels in the industry.

BBC-2 Sutton Coldfield Station on Full Power.—On October 4th, the effective radiated power from Sutton Coldfield BBC-2 transmitter (channel 40, vision 623.25 Mc/s, sound 629.25 Mc/s) was increased from 50 kW to 1 mW. The height of the permanent aerial above ground level is 739 ft compared with the 144 ft temporary aerial. The service area has increased considerably and BBC-2 is now available to about 3¼ million people in the Midlands.

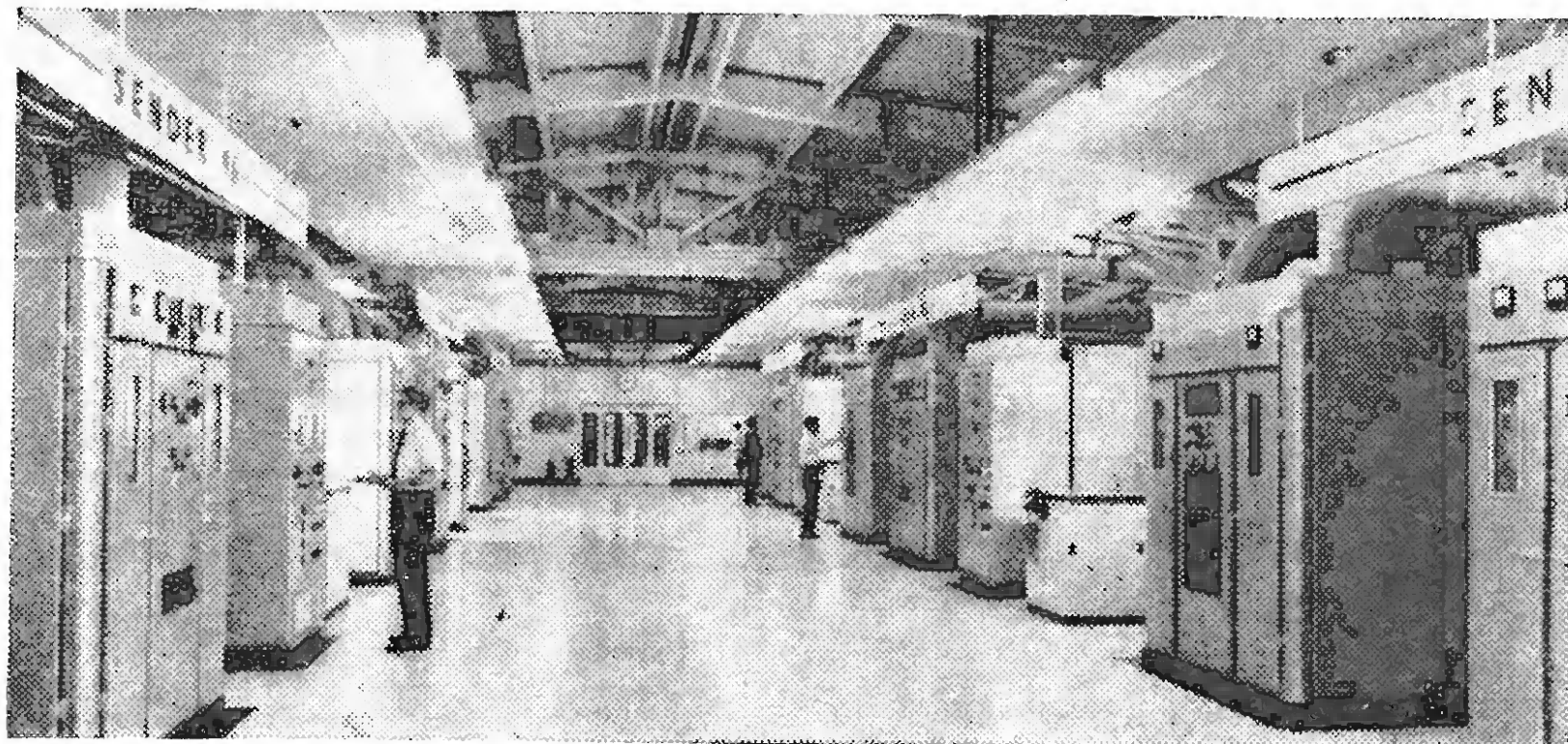

Transmitter power is effectively doubled by the technique of **trapezoidal modulation** used in the Marconi transmitters at the B.B.C. short-wave station, Woofferton. With this technique an audio signal of 9 dB above that required for 100% modulation is clipped and shaped in the audio input circuits to give 95% modulation. As a result, the output from the modulator is a trapezoidal waveform and consequently the modulated carrier envelope is no longer a sine wave. Under these conditions the intelligibility of the signal received at a given distance is increased at least 3.5 dB above that produced by sine wave operation at equivalent output power. The illustration shows six B612 transmitters each of which radiates 250 kW in the frequency range 5.95 to 26.1 Mc/s.

A unique course entitled the **Science and Technology of Navigation** has been arranged by the Sir John Cass College in consultation with the Institute of Navigation. The 30-week course started on September 15th at the College, 31 Jewry Street, London, E.C.3, and leads to the award of a diploma which will be regarded as a certificate of competence in both navigation and associated engineering principles. It is the only course of its kind in the U.K. and is designed for physicists, electronics engineers and others who are concerned with the definition and interpretation of operational requirements of navigation. The syllabus covers astronomical navigation and chart work, modern radio and radar aids, instruments and inertial systems and the use of computers. Lectures will be given on all aspects of navigation and collision avoidance of ships, aeroplanes and other craft. Meteorology and oceanography will be dealt with in so far as they effect navigation. The course includes a voyage in the College training vessel and visits to the Air Traffic Control centre at London Airport and the R.A.F. College of Warfare at Manby.

Weather Ship Activities.—During routine operations in 1964, the North Atlantic ocean station's network of the International Civil Aviation Organization made radio contact with 86,641 aircraft and 15,452 ships; it provided navigational assistance to aircraft flying over the Atlantic in the form of 66,138 radar fixes, 32,260 non-scheduled radio beacon transmissions and 4,651 direction-finding bearings. The network consists of nine stations manned by 21 ships supplied or paid for by 22 nations of the I.C.A.O. whose airlines cross the Atlantic Ocean. Each station is responsible for a ten-mile square patrolled by one ship which is on duty for a three-week period until relieved. Two or three ships are required for one station, depending how far the station is from their home bases.

A three-day course, **Power System Electronics**, outlining the applications of modern electronic and associated techniques to the design and operation of electric power supply systems will be held in Brunel College, Woodlands Avenue, Acton, London, W.3, on November 24th, 25th and 26th. The course, which costs 6gn, has previously been given at Heriot-Watt College, Edinburgh; Rutherford College of Technology, Newcastle-upon-Tyne; College of Technology, Liverpool and Derbyshire Technical College, Wrexham.

B.B.C. Alters Schedule of PAL transmissions.—The times of the B.B.C. experimental PAL colour television transmissions from Crystal Palace (channel 33, vision 567.25 Mc/s, sound 573.25 Mc/s) were recently changed. Afternoon transmissions (Monday to Friday inclusive) are made during two periods, 14.00-17.00 (15 minutes of test card in black and white, 10 minutes of colour bars and 35 minutes of colour slides and occasional films in each hour) and 18.30-19.00 (colour bars and colour slides). Evening transmissions of live studio scenes and colour films are on Mondays, Wednesdays and Fridays and take place for 20 to 45 minutes after the close-down of BBC-2.

Research Award.—Professor P. R. Wallace, professor of theoretical physics at McGill University, has been given an award under the Royal Society and Nuffield Foundation Commonwealth Bursaries Scheme to enable him to continue work at Oxford on collective motions of electrons in solids in the presence of a magnetic field (especially helicons) and on the annihilation of positrons in molecular solids, and to investigate collective excitations of atoms.

On October 4th, the number of **B.B.C. experimental pilot-tone stereophonic transmissions** on 91.3 Mc/s from Wrotham was increased from two to three each week and now takes place on Monday, 14.30 to 15.00, Thursday 11.00 to 11.30 and Friday 14.30 to 15.00. The transmissions are also re-radiated from the Swingate station (near Dover) on 92.4 Mc/s.

A short-wave **log-periodic aerial system** has the unusual distinction of forming the motif of a special Swedish stamp (60 and 140 öre) commemorating the centenary of the International Telecommunication Union. The aerial system, installed at Grimeton, 62 miles south of Göteborg, is 141 ft high, weighs 16 tons and was built by Rohde and Schwarz.

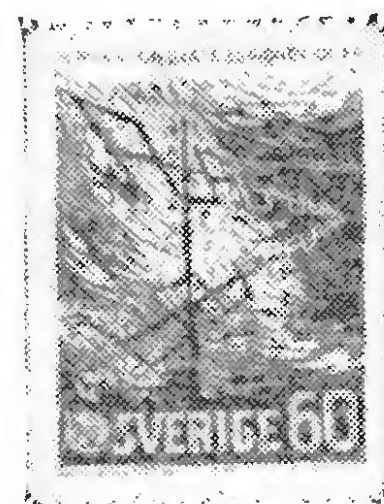

The B.B.C. has improved the **frequency stability of the 200kc/s transmission from Droitwich**. Stability is now ± 5 parts in 10^{10} and the excursion from nominal does not usually exceed 1 part in 10^{10} . Daily comparison of the frequency of the Droitwich transmission with the National Standard of Frequency is made at the National Physical Laboratory, Teddington, Middlesex. Results are available on application to the Director.

News from Poland.—Experimental ultrasonic apparatus which can measure both velocity and amplitude of ultrasonic waves penetrating through various strata of the earth's crust to a depth of 2,000 m has been built by the Institute of Basic Technical Problems at the Polish Academy of Science. The equipment is intended for oil prospecting and can be used to find joints in pipelines and to check whether the cemented pipes used during drilling are leak proof. In Warsaw, work on the radio and television centre is under way. Representing the largest capital construction ever undertaken in Poland, the centre will contain 15 studios, five of which will be for television; the largest studio will be suitable for mono and stereo broadcasting in addition to television. According to O.I.R.T. (the radio and television information organization of Eastern European countries) a special laboratory for the investigation of colour television for industrial and medical purposes has been established in a leading television factory in Warsaw.

International Interchange of Scientists.—Under an agreement recently concluded between the Royal Society and the Academy of the Socialist Republic of Rumania, an interchange of five scientists will take place annually. Three scientists will be interchanged for a period of 14 days for the purpose of lectures and visits to scientific institutions; two scientific research workers will be interchanged for a nine-month period to study problems of the physical and biological sciences. The agreement also calls for the exchange of publications associated with specialized branches of the physical and biological sciences.

New BBC-2 Stations.—Work on Black Hill, Lanarks. (channel 46, vision 671.25 Mc/s, sound 677.25 Mc/s) and Emley Moor, Yorks. (channel 51, vision 711.25 Mc/s, sound 717.25 Mc/s) has been delayed by adverse weather conditions. Black Hill should be in service by Spring 1966 and Emley Moor, together with Rowridge, Isle of Wight (channel 24, vision 495.25 Mc/s, sound 501.25 Mc/s), should be in service by the end of the year. Winter Hill, Lancs. (channel 62, vision 799.25 Mc/s, sound 805.25 Mc/s) is in service from October 31st. By Spring 1966, BBC-2 should be available to half the population of the U.K.

A Satellite Communications Course has been organized by the British Council in association with the Engineering Department of the G.P.O. Thirty senior engineers from 19 countries will attend the course which will be held from November 14th to December 9th at the British Council's Overseas Students Centre.

Grundig Great Britain have asked us to correct a misstatement in our last issue. The cabinets used for their television receivers are not imported (as stated on p. 479) but are made in this country.

PERSONALITIES

John A. Ratcliffe, C.B., C.B.E., F.R.S., since 1960 director of what is now the Radio and Space Research Station at Ditton Park, Slough, Bucks, is retiring at the end of next February and will be succeeded by **John A. Saxton, D.Sc., Ph.D., A.R.C.S. M.I.E.E.** Mr. Ratcliffe was born in 1902 and graduated at Sidney Sussex College, Cambridge. Apart from the war years, he remained at Cambridge as a reader in physics until his appointment to the Radio Research Station in 1960. His first work on the subject which was to become his main interest,



Dr. J. A. Saxton

radio wave propagation, was done while he was still an undergraduate, when as a research student under the late Sir Edward Appleton he helped in the experiments which led to the discovery of the Appleton layer in the ionosphere. Throughout the war Mr. Ratcliffe was closely concerned with the development of radar at the Telecommunications Research Establishment (now Royal Radar Establishment) at Malvern. Dr. Saxton, who is 51, is director of the U.K. Scientific Mission in Washington, D.C., and a scientific councillor at the British Embassy there. A graduate of Imperial College London, Dr. Saxton joined the staff of the college after graduation and carried out research on artificial radioactivity before joining the Radio Division of the N.P.L. in 1938. He is well known throughout the world for his work on the dielectric properties of the atmosphere and on the study of v.h.f. propagation.

Earl Mountbatten of Burma has accepted the invitation of the British Computer Society to be president during 1966-7. Earl Mountbatten is already associated with the Society through his chairmanship of the National Electronics Research Council which is working closely with the B.C.S. on the N.E.R.C. Selective Dissemination of Information project.

F. P. Campbell, B.Sc., A.M.I.E.E., has been appointed project manager for the UK3 space research satellite which is being designed and built at the Guided Weapons Division of the British Aircraft Corporation, Stevenage. Mr. Campbell, who is 41 and is a graduate of Queens University, Belfast, served in the Technical Branch (Signals) of the R.A.F. from 1944 to 1947. He joined the English Electric Company at Luton in 1954 where after working as a design engineer on the electronic pack for the Thunderbird 1 surface-to-air guided weapon he became section head in 1956. From 1959 to 1963 he was assistant project manager for Thunderbird 2 and until recently project manager on the Vigilant anti-tank missile.

N. Gibson, M.I.W.M., and M. G. Miller, B.Sc.(Eng.), A.M.I.Mech.E., A.M.I.E.E., have been appointed to the board of directors of Decca Radar Ltd. Mr. Gibson, who now becomes production director, joined the Decca group of companies in 1946, and worked first with the Decca Navigator Co. He later transferred to Decca Radar, where he was general works manager. During the war he served as an officer in the R.A.F. working on radar. Mr. Miller joined Decca Radar as head of the Service Division in 1963 and was formerly a project manager for the Guided Weapons Division of the British Aircraft Corporation, following service as a regular officer in R.E.M.E.

Colonel L. C. Libby, M.B.E., A.M.I.E.E., has relinquished command of the R.E.M.E. School of Electronic Engineering at Arborfield, Reading, and has been appointed head of the Organization and Policy Branch of the Director of Electrical and Mechanical Engineering in the Ministry of Defence. Col. Libby has been commandant of the School (see *W.W.*, October, p. 507) since March, 1963, prior to which he was chief instructor at the School of Electrical and



Colonel L. C. Libby



Colonel H. G. Frost

Mechanical Engineering at Bordon, Hants. The new commandant at Arborfield is **Colonel H. G. Frost, A.M.I.E.R.E.**, who recently returned from the Far East where he commanded R.E.M.E. Malaya.

James Watt, B.Sc., D.I.C., A.M.I.E.E., chief maritime engineer of the Marconi Company since 1954, has been appointed



J. Watt

manager of the newly formed Mercantile Marine Division of the Company. After obtaining his degree at Edinburgh University in 1934 he went to Imperial College, London, for two years and was awarded the college diploma. He then joined Marconi and after a period as a development engineer on broadcasting transmitters he became resident Marconi engineer at the B.B.C. Droitwich station. In 1941 he assumed responsibility in the Company's Echo Sounding Development Laboratories for the design and field trials of a number of underwater devices for the Royal Navy. Mr. Watts will now be responsible for handling all the Company's business with the Marconi Marine Company through which the sales of their radio navigation and communication equipment are conducted.

C. E. Tate, M.I.E.E., M.I.E.R.E., manager of the Electronics Research Laboratories of the Plessey Company at Roke Manor, Romsey, Hants, has been elected chairman of the I.E.E. Southern Centre for 1965-6. He joined Plessey as chief engineer of the Braxted Laboratories near Witham in 1956 and in 1959 he founded the Telecommunications Division Development Laboratories at West Leigh, near Havant. In March this year Mr. Tate, who is 45, joined the Electronics Research Laboratories at Roke Manor and has been manager since July. After studying at the Mid-Essex Technical College he was for ten



C. E. Tate

years with S.T.C. before taking charge of the Radio Development Group of Rediffusion Services Ltd. For seven years prior to joining Plessey he was with the Airborne Development Group of Marconi's at Chelmsford.

F. H. Brittain recently retired from G.E.C. after nearly 40 years' service and has joined the Decca organization where he is undertaking research in stereo reproduction. Mr. Brittain received his technical training at Faraday House, and joined the Research Laboratories of the G.E.C. at Wembley in 1926. He worked originally on photo-electric cells and

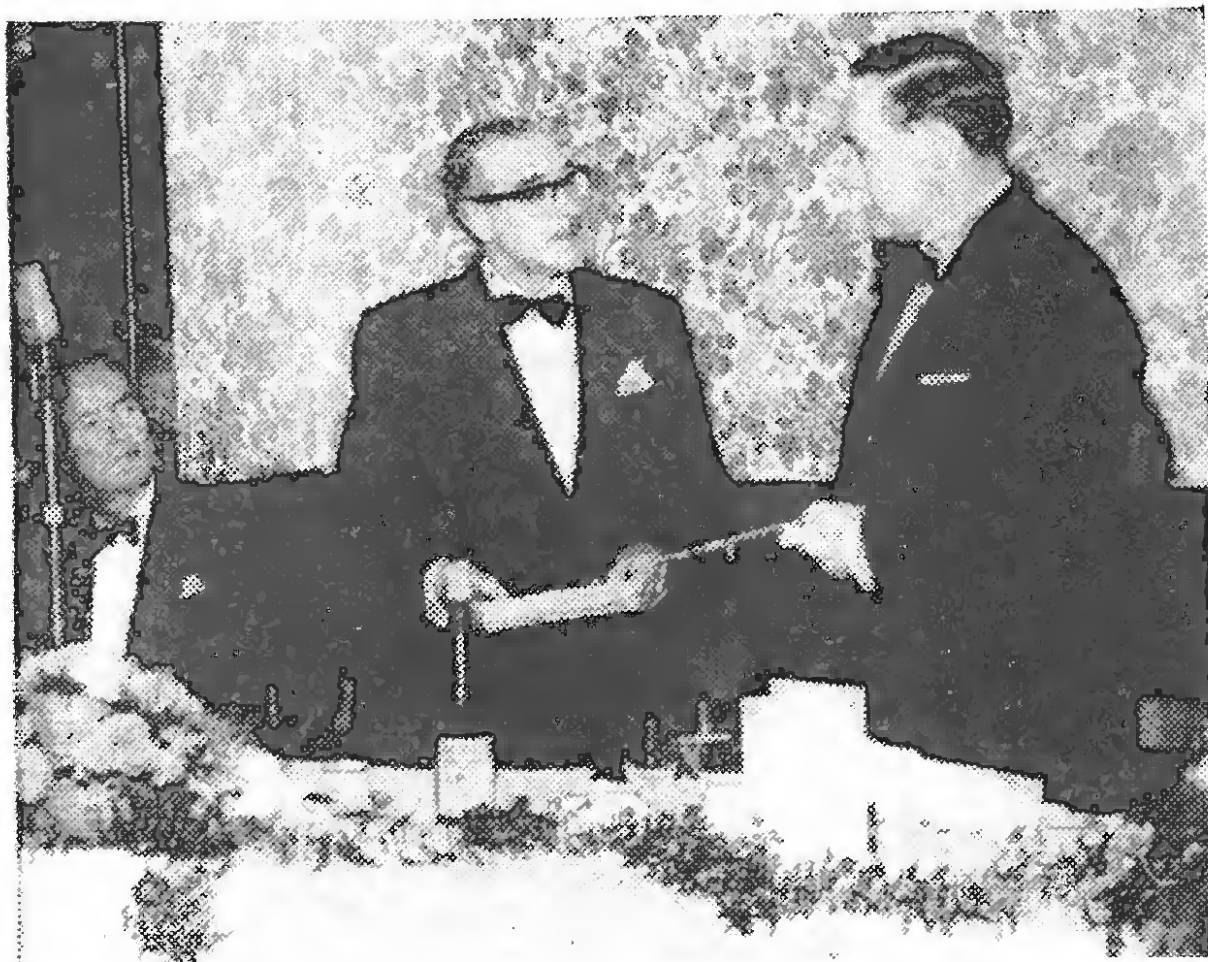

E. A. W. Spreadbury (centre), chairman of the Radio Trades Examination Board, presenting to **G. D. Clifford, C.M.G.**, a silver salver inscribed with the signatures of the members of the Board of which, until recently, he had been secretary since its formation. On the left is **Sir Ian Orr-Ewing, Bt., M.P.**, the guest of honour at the Board's 21st anniversary dinner.

talking films and in 1929 joined the newly formed acoustics section. It was during his ten years in this section that he introduced "white noise" as a reference sound and used an analysis of white noise for measuring loudspeaker performance in reverberant surroundings. From 1939 until 1947 (when he returned to the acoustics division) Mr. Brittain was concerned with the production of silicon for radar frequency changers.

J. D. Esler, A.M.I.E.E., A.M.I.E.R.E., has been appointed Engineering Recruitment Officer of the B.B.C. in succession to **W. K. Newson, M.B.E., M.I.E.R.E.**, who is retiring after more than 41 years' service. In 1948 Mr. Newson was appointed assistant-in-charge of the Recruitment Section of the Engineering Establishment Department. In 1963 this section became a separate department under Mr. Newson as Engineering Recruitment Officer. He is a member of the Education and Training Committee of the I.E.R.E. and has been active for many years in the Royal Naval Reserve of which he is Honorary Commander. Mr. Esler joined the B.B.C. in 1943 as a recording engineer. Since 1953 he has been in the Engineering Training Department.

H. R. Henly, A.M.I.E.R.E., was incorrectly given as an A.M.I.E.E. on his article "Economical Logic" in the October issue. Apologies to Mr. Henly and both institutions.

L. Nelson-Jones, A.M.I.E.R.E., who writes in this issue on the design of an amplitude stabilized RC oscillator, was until recently senior electronics engineer with the Radar Department of Kelvin Hughes Division of S. Smith & Sons. He has now joined the Land Line Systems Division of Standard Telephones & Cables at Basildon, Essex, as a senior engineer. Mr. Nelson-Jones, who is 36, studied at Enfield Technical College and Sir John Cass Technical

College, Aldgate, London, after serving a radio engineering apprenticeship with Ediswan Electric Co. at Brimsdown. He



L. Nelson-Jones

served in the R.A.F. for two years before joining Kelvin Hughes as a development engineer.

OBITUARY

Emrys Gwynne James, O.B.E., Ph.D., B.Sc., A.M.I.E.E., who headed a team of scientists at the laboratories of Associated Semiconductor Manufacturers Ltd., Hirst Research Centre, Wembley, died suddenly on October 5th while on business abroad. Dr. James, who was 58, and a graduate of the University College of Wales, Aberystwyth, joined the G.E.C. Research Laboratories in 1934. During the war he worked on microwave amplifier valves and crystal mixers and when the G.E.C. Laboratories started research on semiconductors he was put in charge of this work. When Mullard and G.E.C. combined their semiconductor activities in 1962 and formed Associated Semiconductor Manufacturers Ltd. to develop and manufacture Mullard semiconductors, Dr. James was transferred to the new company.

Kenneth S. Davies, B.Sc., A.M.I.E.E., who died on October 9th, aged 58, had been with Murphy Radio since 1933. After gaining an honours degree in engineering at Cardiff University he spent some time with Standard Telephones and Cables before going to Cambridge University for a post-graduate course in the science laboratories, which included work on the development of television tubes. He joined Murphy Radio to lead the company's research into television production. After work on radar and military electronics during the war, he was made general manager of Murphy's new electronics division and became a director of Murphy Radio in 1960. On the amalgamation of Murphy with Bush in 1962, he became a director of Rank Bush Murphy. He had resigned from the board a few weeks before his death, but remained with the company as technical consultant.

NEWS FROM INDUSTRY

Perdio Electronics Ltd. have made application to the courts for permission to go into voluntary liquidation. The directors of Perdio Electronics made a statement at the end of September to the effect that the company was insolvent and that they could see no alternative other than to liquidate. Dealings in Perdio shares have been suspended by the Stock Exchange. Perdio Ltd. was registered as a private company in 1956 and converted into a public company in 1962. In the same year, the company's name was changed to Perdio Electronics Ltd. Perdio own Kenure; Holt Electronics; and Electric Audio Reproducers Ltd. In February of this year negotiations were made with Brayhead Ltd. to purchase some of their subsidiaries. This, however, was not completed, but at the same time Brayhead agreed to purchase from Perdio's chairman and managing director, Viscount Suirdale, and from another director, Mr. D. R. Willmott, 850,000 Perdio ordinary shares. Viscount Suirdale and Mr. D. G. Gee (a Brayhead director), who both joined the other company's boards at the start of negotiations have since relinquished their positions. Perdio Electronics Ltd. were the first British manufacturers to produce domestic transistor radio and television receivers.

New Microphone Manufacturer.—A new company, called the London Microphone Co. Ltd. (incorporated with a private share capital of £5,000) has been formed to manufacture and market dynamic microphones. Business is to be conducted from its registered address at Eardley House, 182-184 Camden Hill Road, Kensington, London, W.8. (Tel.: PARk 0711, telex 23894.) Among the first directors are Mr. G. Eardley (managing) who is also managing director of Politechna (London), Ltd.—agents for A.K.G., the microphone manufacturers of Vienna—and Mr. E. G. Lennard, who until recently was the general manager and commercial director of Cosmocord Ltd. Two types of hand microphones, one with omnidirectional and one with cardioid characteristics, will initially be made at Eardley House, where there is also a fully equipped service department including an anechoic chamber.

Sonic Bangs Recorded.—The applied physics division of the Acoustic Section of the National Physical Laboratory have set-up four oscilloscope cameras in their mobile experimental vehicle to record the wave formations of sonic bangs produced by high-speed aircraft. Polaroid backs are fitted to these Avo-Beattie-Coleman cameras and allow prints to be produced in ten seconds.

Automatic Telegraph Switching by Computer.—Elliott-Automation Ltd. have received a contract from the Ministry of Aviation for a fully automatic computer controlled message switching system which is to be installed at the main U.K. station of the world-wide Aeronautical Fixed Telegraph Network at Croydon. Two NCR Elliott 4100 computers will be used to re-route and distribute messages at the rate of 67 words per minute over 127 channels or, alternatively at the rate of 100 words per minute over 95 channels. The Croydon centre at present has 65 channels, with connections to other international centres and to subsidiary switching centres, air traffic control centres and airports throughout the United Kingdom and Eire.

Czechoslovakian Computer Order Worth £1M.—KOVO, the Czechoslovakian import agency, has placed orders for three computer systems valued at more than £1M with the English Electric Group. Under the first contract, English Electric-Leo-Marconi Computers will supply a LEO 360 system which will be used by the State Railways. The second contract is for a LEO 360 and a KDF7 which will control the entire production of Czechoslovakia's largest steel works, the Nova Hut Klementa Gottwalda at Ostrava-Kuncice. All three computers will be made at the English Electric-Leo-Marconi's factory at Kidsgrove, Stoke-on-Trent. The design of the automation

system for the steel mills will be the responsibility of the Metal Industries Division of English Electric and this work will be done at Stafford and Kidsgrove. English Electric already has eight computers operating in steelworks in production control and process control applications.

Major Changes at Livingston's.—In the next few months all the companies in the Livingston Group—with two exceptions—are moving to new premises, now under construction, on the Greycaines Estate, North Watford, Herts. Parts of the production area are almost complete and the transfer of manufacturing operations from the two nearby factories of Livingston Control and Pitt & Underwood (Engineering) will start during November. Other companies within the group to be moved to the new premises will include Livingston Laboratories, Livingston Electronics, Livingston Burge Electronics (the electronic organ division), and Livingston Recordings. Livingston Studios at 32a East Barnet Road, New Barnet, will continue to provide its film and recording services from that address. Circetch Ltd., the most recent acquisition of the Livingston Group, will remain at Bognor Regis. This company has doubled its production area—to 10,000 sq ft—through the acquisition of adjoining premises and has recently had its name changed to Livingston Components Ltd. Also, in addition to

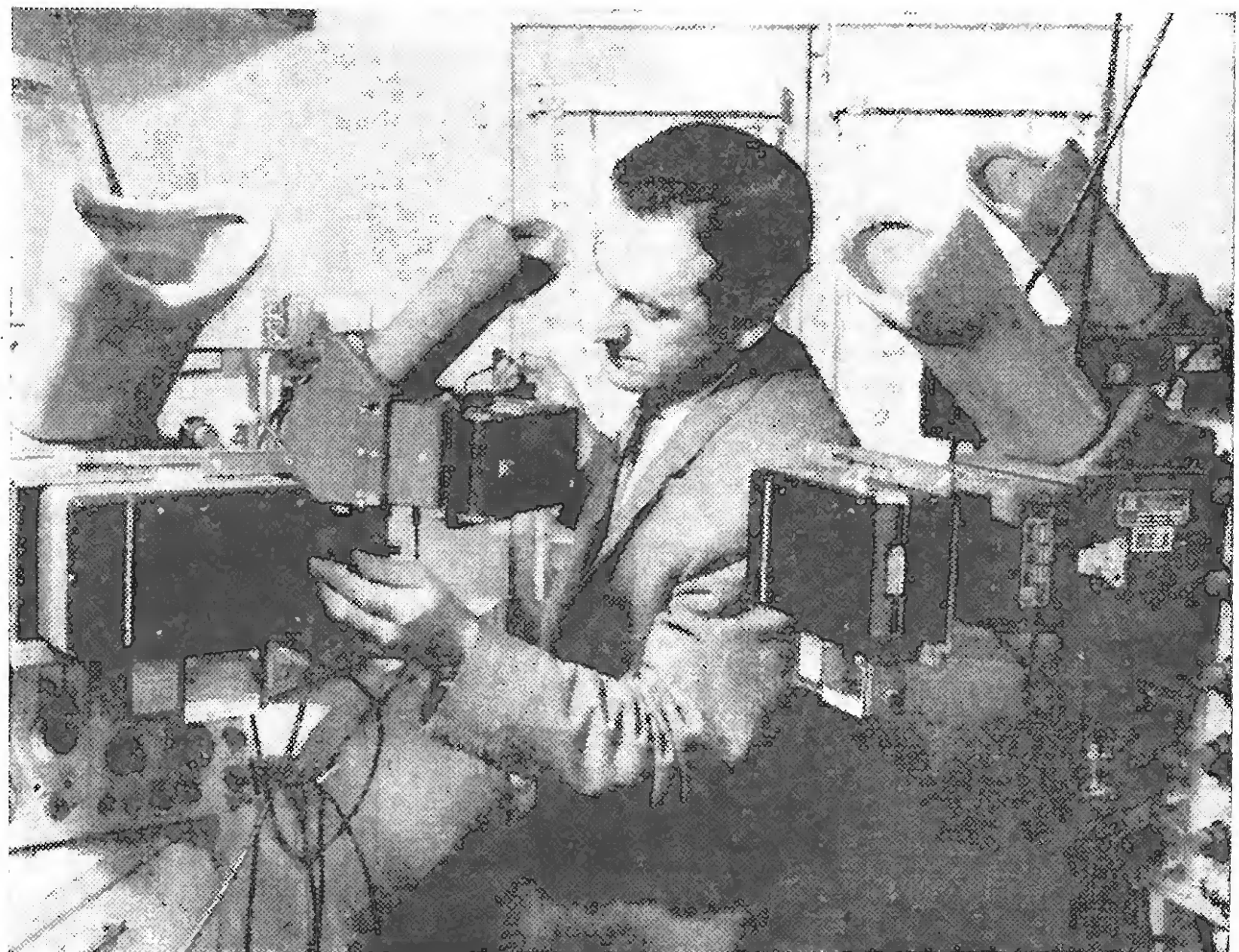

making and marketing printed circuit boards, it is now responsible for the marketing of a wide range of components previously handled by Livingston Control at Watford.

E.M.I. Electronics Ltd. and Belling & Lee Ltd. have been examining whether it would be advantageous to both companies to achieve a measure of financial co-operation. After full exploration they have come to the view that present conditions do not offer the opportunities of a successful conclusion and negotiations have been terminated.

S.T.C. Headquarters Move.—The head office of Standard Telephones and Cables Ltd. has moved from Connaught House, Aldwych, to S.T.C. House, 190 Strand, London, W.C.2 (Tel.: TEMple Bar 8055, Telex (unchanged) 22385/6). I.T.T. Industries Ltd., an associate of S.T.C., has also moved from Connaught House to the Strand.

Australians Order Marconi Doppler. An order for approximately £A500,000 worth of airborne doppler navigation equipment and associated computers has been received by the Marconi Company, of Chelmsford, from Qantas Airways. The equipment will be fitted to their fleet of Boeing 707 airliners.

Ultra Electronics Ltd. have received an order from the Home Office for 600 of their mobile v.h.f. transmitter/receivers. Once this order has been completed, Ultra's will have supplied more than 2,000 of these to the country's police and fire services.

The Micro Instrument Company, of California, who manufacture solid state instruments and accessories for test systems, have appointed Claude Lyons Ltd., of 76 Old Hall Street, Liverpool 3 (Southern offices, Hoddesdon, Herts.), exclusive United Kingdom representatives.

The Allied Control Company Inc., of New York, which manufacture relays for commercial and military applications, has appointed Lectropon Ltd., of Kinbex House, Wellington Street, Slough, Bucks., sole British concessionaires.

Research and Engineering Controls Ltd., of Durban Road, Bognor Regis, have changed their name to Rosemount Engineering Co. Ltd. The change was made to more closely identify the company with its American and Swiss associates and will not in any way affect the structure of the company or its policies.

Redifon - Astrodata Ltd.—Redifon Ltd., of London, and Astrodata Incorporated, of California, have formed a new company—to be known as Redifon-Astrodata—with the object of manufacturing specialized computing and other electronic devices. It operates from Gatwick Road, Crawley, Sussex.

Radar Simulator at Hurn Airport.—The digital systems department of Ferranti Ltd. has received a contract from the Ministry of Aviation which calls for a radar simulator system for use at the Air Traffic Control Evaluation Unit at Hurn Airport. The system to be supplied will include a Ferranti Hermes computer which, with its associated circuitry, will provide primary and secondary radar video outputs representing up to 40 aircraft as seen from four independent radar sites. The radar site positions are programme-controlled. Tracks of the simulated aircraft can be either pre-programmed or manually controlled by operators at six aircraft control positions, or by a mixture of both. Each control position has a Marconi tabular display for presentation of aircraft data and a Ferranti-developed special key-board for data entry.

Marconi Self-tuning Communications Equipment.—The Marconi Company have received contracts worth over £700,000, for their self-tuning communications equipment from the Ministry of Defence (Navy). These contracts, together with contracts received last year, bring the total value of this type of equipment being supplied to the Navy to over £1½M. In terms of equipment it includes fifty-three 30 kW transmitters, 47 dual drive units (incorporating frequency synthesizers and modulators) and a quantity of associated equipment.

£½M R.A.F. Order for Heightfinders. Plessey Radar Ltd. have received a contract from the Ministry of Aviation for £½M worth of Type HF200 Heightfinders. This equipment will be used in the United Kingdom's new radar scheme linking civil and military air traffic control.

Elizabethan Tape Recorders Ltd., of Crow Lane, Romford, Essex, have decided to change their name to Elizabethan Electronics Ltd. as it is their intention to enter other fields while retaining their interest in tape recorders.

Thermoelectric Power Generation.—At the Allen Clark Research Centre (one of Plessey's research organizations) an investigation is being conducted into the possibilities of using thermoelectric generators as a source of power for remote installations and also for installations in under-developed areas where electrical power is not readily available. The rig illustrated uses propane gas as the heat source and exploits the thermoelectric properties of sintered iron disilicide modules, forming a chain of electrically linked p- and n-type semiconductor layers separated by insulating ceramic. Life test data is being recorded, while the experimental unit is being used to drive a small fan.

Another TV Rental Company.—A new television rental company called Rental Services has been started within the Standard Telephones and Cables Group. Only one type of television receiver is being used (23-in K.B. dual-standard receiver made by the consumer division of S.T.C.) and is available through any of the 37 regional depots. Cost of rental is £9 deposit and a payment of 9s per week.

A.B. Metal Products Ltd., the component manufacturers, have entered into a manufacturing agreement with the American component manufacturers, the CTS Corporation of Indiana. The agreement with CTS covers the micro-electronic components and the fixed and variable resistors CTS manufacture. CTS have privately acquired a 35% share-holding in A.B. Metal Products and their president, B. S. Turner, is to join the board of the British company.

Arco Electronics Incorporated, component manufacturers, and the Alpha Wire Corporation (both of New York) have given sole United Kingdom distribution rights to Celdis Ltd., of 4 Trafford Road, Reading, Berks.

Ferranti Radio and Television Ltd. have moved their headquarters from Old Street, London, to Cambridge. Their new address is P.O. Box 31, Cambridge. (Tel.: Cambridge 63366.)

Cannon Electric (G.B.) Ltd. have moved their sales and service departments from London, N.19, to Basingstoke, Hants., where their factory is already well established. All Cannon's British interests are now centred at Lister Road, Winchester Road, Basingstoke, Hants. (Tel.: Basingstoke 3171, telex 85105.)

T. W. Welch & Partners Ltd., of 64 Ash Hill Road, Ash, Surrey, has recently been formed as a company to act as consultants in radar, radio-navigation and applied electronics.

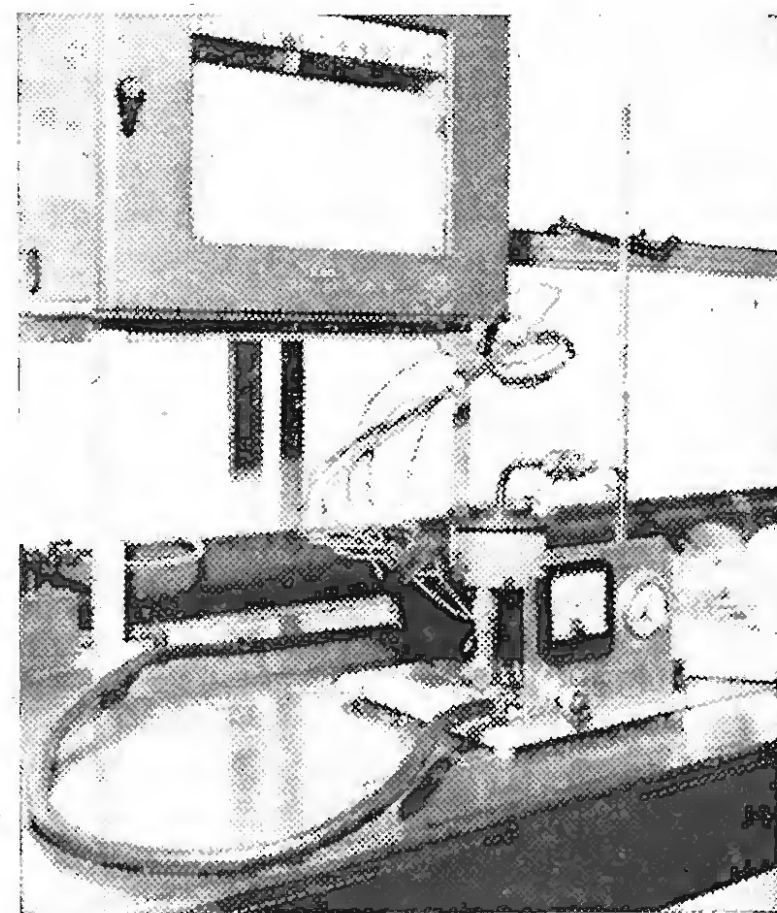

LETTERS TO THE EDITOR

The Editor does not necessarily endorse opinions expressed by his correspondents

Non-resonant Loudspeaker Enclosure

SINCE writing the article on the non-resonant loudspeaker, I have been examining further the performance of acoustic absorbents. Of those that are readily available, kapok is about the best but is not up to the performance of long wool. If the kapok is very well teased out then its properties are quite good. Unfortunately however it gradually compacts with use and the acoustic performance suffers accordingly. It may be possible to support it with wire netting, but this in turn can give resonance troubles.

Unfortunately wool in fibre form is only sold commercially in large quantities, all attempts at finding a small order supplier have failed. (My original samples came from the Institute's Textile Department.) To assist readers wishing to make up this type of speaker I have therefore made arrangements to buy wool in bulk and will be glad to supply readers at 10s 6d per pound weight, carriage paid, if they write c/o the Editor.

The short fibre wool mentioned originally is very un-critical and cotton wool, kapok, or any usual cushion stuffing material is quite suitable. The purpose is only that of mid-frequency absorption and this is easily done by most textile materials.

Bradford.

ARTHUR R. BAILEY

IT was particularly interesting to read Dr. A. R. Bailey's article describing a non-resonant loudspeaker enclosure, using a transmission line as a load. I would agree entirely with his contention that it is difficult to design a conventional reflex cabinet which is devoid of boom when reproducing the double bass or one which does not produce objectionable coloration of orchestral bass transients. However, I have established that it is possible to remove this defect from the conventional bass reflex cabinet by filling the interior of the cabinet with a fibrous material which provides a resistive load to the cone at low frequencies.

This system also becomes virtually non-resonant and was named a resistive reflex cabinet. The principle was used commercially early in 1962 and was the subject of a patent application on my behalf in May 1961. It is not unlikely that the subjective impression of music reproduced by means of a resistive reflex cabinet would compare favourably with Dr. Bailey's system, although their design concepts are clearly different.

Further research and development has established that reflex cabinets of only 1 ft³ can be made virtually non-resonant in the frequency range above 30 c/s. The bass quality is life-like and there is an absence of boom or chestiness in speech. As a result of further research I have established that the amplifier stability margin at the bass resonance frequency is more satisfactory with such a loudspeaker, and that the transient response of the amplifier and loudspeaker in tandem is well damped. Undoubtedly Dr. Bailey's system possesses the same virtue. It is perhaps strange that speech should sound coloured when the main system resonance is around 40 to 50 c/s. This phenomenon appears to be due to the

fact that the d.c. component of the distortion produced in the amplifier appears as a pulse when there is a rapid change of signal level unless the feedback loop is d.c. coupled throughout or has a very long time constant. This internally generated pulse excites the transient response of the amplifier speaker combination and gives rise not only to boomy speech and music, but to excitation of speaker cone resonances as well.

It would seem then that those people who maintain that no two amplifier-speaker combinations sound alike are probably right after all.

The transient testing procedures adopted by Dr. Bailey undoubtedly show up the spurious coloration of an enclosure very well.

Another alternative method which I have found useful is to apply a step function to the speech coil from a lead-acid battery by means of a mercury switch. The latter produces very fast rise times without contact effects. Any spurious coloration is revealed outdoors or in an anechoic chamber. It is by the same process possible to identify whether the loudspeaker or room acoustics are producing unsatisfactory bass response.

Sevenoaks, Kent.

J. R. OGILVIE

The author replies:—

I was very interested to read Mr. Ogilvie's comments with regard to loudspeaker systems. There are, however, one or two points that I would like to comment on.

Firstly, there is the perennial problem of obtaining the best possible performance from small loudspeaker enclosures. This has always been a difficult requirement due to diffraction and other effects. I would agree with Mr. Ogilvie that it is possible to make a small bass reflex cabinet virtually non-resonant, but I have always found that the small port size necessary for a low Helmholtz resonance gives very little benefit unless the cabinet is very resonant. If he has indeed solved the problem, then there will be many people grateful to him.

I would be interested to know the method of damping that Mr. Ogilvie uses, as all that I have tried in small systems either put up the effective stiffness of the enclosed air to an unacceptable value, or alternatively cause distortion due to the non-linear air friction effects. These same shortcomings exist in the damping materials used in the now popular closed-box systems. Too much stuffing in a bookshelf speaker can make it sound terrible.

Regarding the effect of resonant speaker systems on their driving amplifiers; I will agree that the speaker impedance can rise steeply at resonance peaks, but this should not upset any reasonable amplifier except perhaps under overload conditions. A good amplifier should give a satisfactory transient response at the bass end even with an open-circuit as a load. Overloads on output voltage levels should also not be capable of seriously upsetting the amplifier, irrespective of the output load conditions. Any high-fidelity amplifier worthy of that name should not be upset by load conditions to an audible degree, but then I would agree that there are some amplifiers that are not as good as their title suggests.

Regarding the coloration of speech by resonant speaker

systems. I feel that Mr. Ogilvie is being confused between the lowest continuous tone that can be sung and the complex components of speech. The explosive components of speech have constituents that extend below the audible spectrum, these being easily isolated by a third-octave band filter. It is these components that are subjected to the bass resonance frequency of cabinets and speakers and cause the resulting coloration.

I am rather puzzled by the reference to d.c. components of distortion producing coloration effects. This is contrary to my own experience, where tone-burst testing an amplifier with bandwidth-limited waves gave no measurable d.c. components whatever. With a low-distortion amplifier I would not expect that any distortion products could produce audible colouring from resonances, due to their extremely low level.

When deciding on how to impule-test loudspeaker enclosures, step waveforms were applied to loudspeakers and their acoustic outputs examined. Unfortunately no loudspeaker was found with a sufficiently good performance for the purpose. Even the best tested had far more coloration than that of the acoustic line cabinet to be tested. Certainly there is still useful work to be done before loudspeakers can be classed as giving true reproduction.

ARTHUR R. BAILEY

Television Picture Quality

WHILE I must agree with your strictures (Editorial, October issue) on the standard of present-day TV reception, I feel you have too readily exonerated the broadcasting authorities from blame in this respect. They may, as you say, go to great lengths to ensure a good-quality picture; unfortunately success does not always appear to attend their efforts.

I possess an eight-year-old set (bought secondhand for £10) which I believe would qualify as hi-fi television by today's standards. Unfortunately the effect of its true 4×3 picture with full black level (gated a.g.c.), near perfect linearity and focus, and 2.8 Mc/s bandwidth is to reveal clearly the deficiencies of the all-too-frequent poor transmission.

The B.B.C., at least in this area (East Anglia), is usually quite good. Its best efforts are reserved for highbrow programmes such as "Monitor" and prestigious outside broadcasts; its worst for American "singing star" recordings, in which truly bad definition and gamma are combined with a distortion of horizontal linearity noticeable even by non-technical viewers. One detects a policy of lowering standards for the "undiscriminating" audience, a policy which certainly appears to be in force in Independent Television, at least as viewed in this area.

Thus "quiz" shows, in particular, often appear to have been recorded on the video equivalent of a dictating machine, and "Westerns," especially those which have already gone the rounds in other parts of the country, are at times almost indiscernible. But it is the "old film" which provides a heaven-sent excuse for poor quality. The innocent viewer naturally expects a 20-year-old film to look a bit tatty, and arrangements are made to ensure that, in this respect at least, he will not be disappointed. I have just winced through one of these from Anglia Television. It had every fault in the book: flicker, halation (the most common and unpleasant fault), definition to about half a megacycle, and non-existent d.c. level. Not only were night scenes blown up to the usual fog, but even dark patches in otherwise normal scenes were shot through with a kind of fuzz,

while the whole picture was subject to a smear which made everything and everybody translucent. May I add, in case you suspect my aerial or ancient set, that all these faults disappeared like magic during the commercials.

Now there really is no excuse for this. Good telecine can provide one of the most sparkling and satisfying pictures. Like good camera channels and good video recording it may be expensive; but to transmit a picture, whether live, telecine or tape, which does less than justice to the not-very-stringent requirements of a 30-year-old television standard is equivalent to giving the customer short weight. No business, however strained its finances, is entitled to do that; and I think that the Government, or the I.T.A., or the Consumer Council, or the Inspectorate of Weights and Measures, or *Wireless World*, might profitably initiate a campaign for the tightening-up of television transmission standards. Then, perhaps, it might be worthwhile to exhort the manufacturers to make better sets.

Norwich.

J. G. WHITE

I READ the last part of your October editorial with great interest. There is no doubt that the greatest single improvement to a television set would be better sound reproduction.

Sometimes the difficulty can be circumvented, as, for instance, on the last night of the Proms., when the sound side can be received on an f.m. set with a good loudspeaker.

It seems that there are three possible ways of improving the sound reproduction, namely:—

- (1) The quality is usually quite good up to the diode detector (though looking at a typical circuit, the a.c./d.c. load ratio of the detector could be improved). Therefore, provide a suitable socket, so that an output can be fed into a separate amplifier and loudspeaker, if the user so wishes, and reduce the sound from the TV set to zero. As a long cable may have to be used, the output should be through a cathode follower or emitter-follower type of circuit to produce a low impedance output.
- (2) Incorporate in certain models of the TV receiver a good amplifier, with a better speaker and better acoustic loading for the speaker. Again, the user should have the option of being able to drive a good external loudspeaker from this improved amplifier.
- (3) Use, as suggested in your editorial, a tuner for Bands I and III to feed a good amplifier and speaker. But why not a tuner for Bands I, II and III? When a television programme is not wanted, the tuner can then be used to receive the f.m. programme. The difference in the modulation system is not an insuperable technical problem.

I think that if something of this sort were done, the user would have more choice and control over the sound reproduction from his television receiver.

Guildford, Surrey.

J. H. HASKELL

I THOROUGHLY agree that there is a strong potential market just waiting for a really high-quality television receiver with particular emphasis on the audio department. It was a joy recently to hear some of the French and Spanish television sound, which was nectar after our vinegar.

I would look forward very much to the publication of a no-compromise sound tuner circuit for Bands I and III, and how about an add-on BBC-2 converter, just to keep it up to date.

In fact, while you are on the job, why not publish a

high-fi vision circuit as well. The demand for this, I feel sure, would be enormous.

South Queensferry,
West Lothian.

I. G. JACK

Warning—Mains Substitutes

Mr. Levell's letter regarding the dangers from transistor battery "mains substitutes" should be taken very seriously indeed.

Some two years ago I was called by the Oxford Coroner to examine a similar device installed in a quite blameless receiver which had caused the death of a young German student. In this case the unit was made in Hamburg and the student had brought it over with him. A chain-store lampholder adaptor, the pull out v.h.f. rod aerial and a desire to hear music in the bath combined to end his life.

Oxford.

G. H. HORN

TECHNICIANS

THE important role of the technicians who "form the pyramid on which the boffin rests" was stressed by Sir Ian Orr-Ewing, O.B.E., M.P., president of the Society of Electronic and Radio Technicians when speaking at the 21st anniversary dinner of the Radio Trades Examination Board on October 12th. The R.T.E.B. is in fact 27 years old but it is 21 years since it was incorporated.

The first examinations in servicing were held in May 1944 and during the past 21 years over 25,000 candidates have submitted entries for the examinations. Of this total number of candidates over 9,000 have received the intermediate certificate and over 2,500 the final certificate in radio and/or television servicing. There are now over 140 technical colleges which run courses in preparation for the examinations conducted jointly by the R.T.E.B. and the City & Guilds of London Institute.

The Board has recently sponsored the formation of the Society of Electronic & Radio Technicians which now has a membership of some 900 certificated technicians.

Novel Electrostatic Loudspeaker

LOUDSPEAKERS which radiate through 360° have made appearances in the past, and these have generally used moving-coil loudspeakers as drive units. A loudspeaker system using an electrostatic high-frequency unit to radiate through 360° in the horizontal plane has been developed in the U.S.A. by Acoustic Associates Inc.* The interesting feature of this loudspeaker is the electrostatic unit, which is cylindrical and forms the shade of a table lamp (illustrated). An inverted 6 in bass unit is housed in the base of the lamp so that the lower frequencies also radiate through 360° by reflection from the surface on which the lamp stands. Also housed in the base is the bias supply, which is in continuous operation, and a crossover network.

The translucent shade comprises two concentric cylinders of insulated steel-wire mesh acting as fixed electrodes of the push-pull system, between which is sandwiched a light-weight conductive diaphragm (moving electrode). Between the fixed and moving electrodes are two further plastic films (Mylar) which are moved mechanically by the moving electrode and act as the sound source. The purpose of these is to maintain a controlled spacing between the diaphragm and fixed electrodes, which is a maximum of 0.03 in at the spacers, placed at 3 in intervals. Corona discharge is prevented by six layers of plastic insulation applied to the fixed electrodes. The inward radiation of sound toward the bulb is, apparently, of little consequence.

A method of measurement of the acoustic power radiated

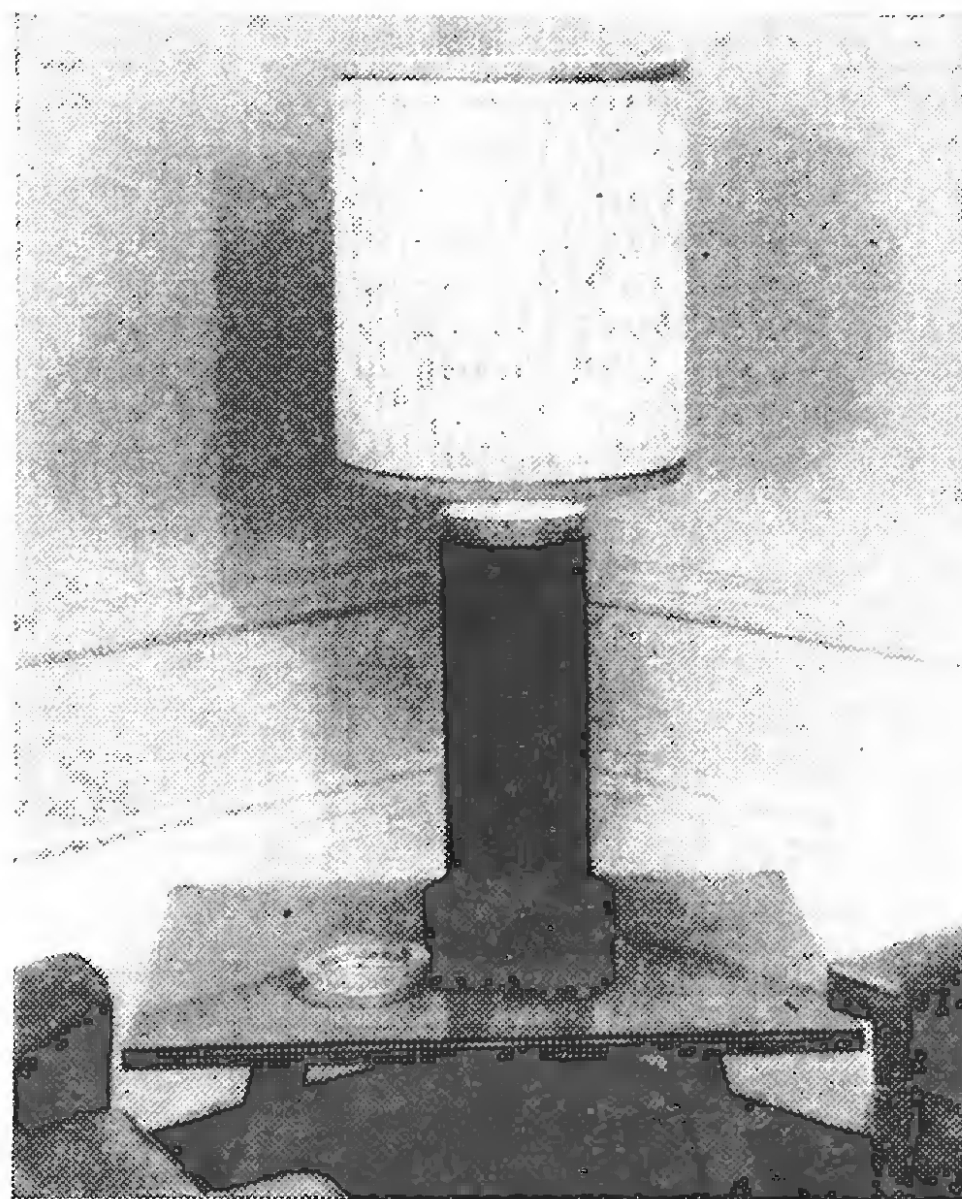
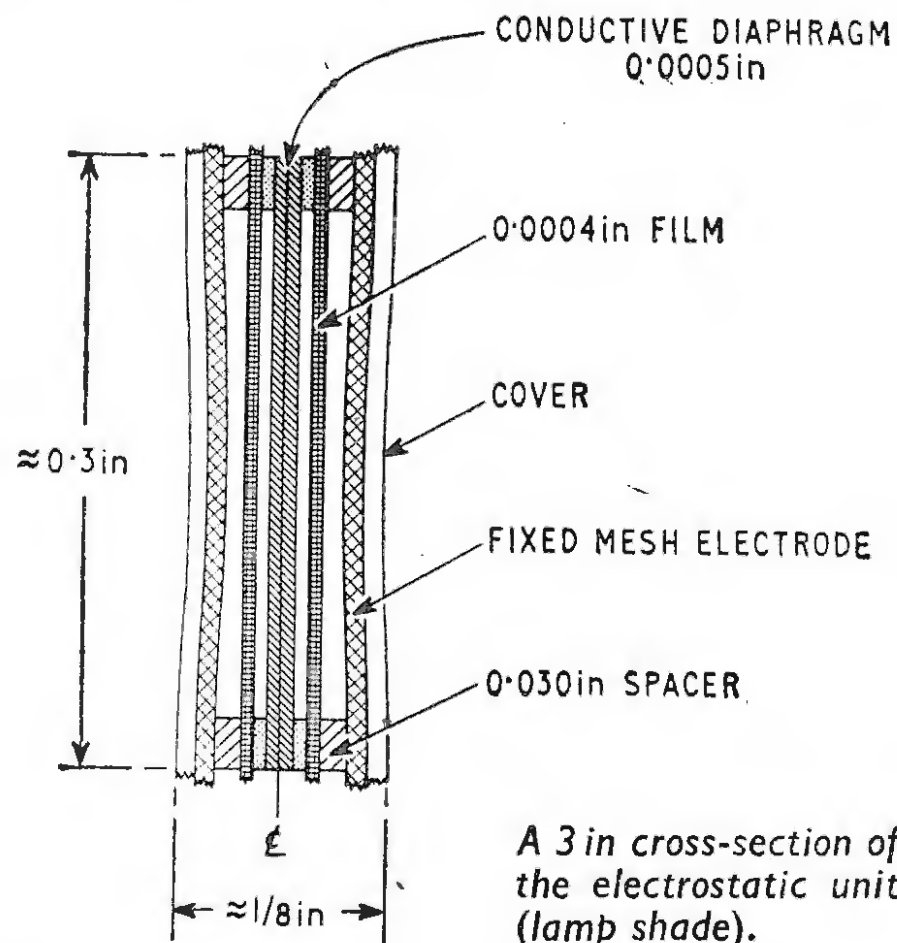

Loudspeaker giving 360° sound radiation. The lamp shade forms a high-frequency electrostatic unit, and a 6 in low-frequency unit is housed in the base of the stand.

by such a sound source in a reverberation chamber was described in a paper† presented at the recent Acoustics Congress at Liège. By statistical analysis of the sound pressure level maxima of the interference pattern due to the source, it was shown that the mean of the maxima are related to an "effective r.m.s." s.p.l., from which the radiated acoustic power can be calculated, knowing the volume and reverberation time of the chamber. Measurements have not yet been made on the loudspeaker, however.

Various models are available, all with a shade diameter of about 15 in and a height of about 19 in. Prices range from 92 gn to 130 gn.

* U.K. distributors: L.L. Electronics Ltd., 5 Shakespeare Road, London, N.3.

† Maling and Nordby, paper J65, 5th International Congress on Acoustics. A paper describing the loudspeaker was also presented by R. L. Rod, (J61).

BOOKS RECEIVED

Electronic Equipment in Industry, by W. D. Gilmour. Intended as a guide to the industrial application of electronics, the book outlines techniques and systems in current use. The contents are in two parts. In the first part, general details are given of measurements, communications and telemetry, servo control, computers, data logging and photo-techniques. The second part describes the preparation of a specification, design requirements, development stages, installation, commissioning and maintenance. Complete coverage of the wide range of subjects is not possible but extensive cross references to other literature are provided throughout the book. Pp. 265; Figs. 101. Price 50s. Iliffe Books Ltd., Dorset House, Stamford Street, London, S.E.1.

Design Theory and Data for Electrical Filters, by J. K. Skwirzynski. A comprehensive treatment of the design theory, together with tabulated design data, of filter networks having Chebyshev response in pass- and attenuation-bands. The text is in two parts. The first part deals with theory and includes a description of ladder networks, insertion loss, frequency transformations, types of filter, group delay and equalization. The second part has been arranged to be independent of the first and contains a summary of design parameters for low-pass, high-pass, band-pass and band-stop filters. Approximately 250 pages contain tables of computer prepared design data which enable a filter to be designed by making only a few slide-rule calculations. Use of the tables is illustrated by worked examples. Pp. 701; Figs. 185. Price £8 10s. D. Van Nostrand Company Ltd., 358 Kensington High Street, London, W.14.

Eurolec 1965 Pocket Guide to the Electronics and Instruments Industry in the U.K. Lists the products of, or services offered by about 1,000 companies together with the position, name and telephone number of the sales contact. Where applicable, branch offices and distributors are given. Pp. 153; Price 18s 6d, postage 1s 6d. David Rayner Associates, 18 Pentonville Road, London, N.1.

Ham Antenna Construction Projects, by J. A. Stanley. A practical guide to building and installing many types of aerials. Opening chapters on basic horizontal and vertical aerials cover directional characteristics, feed points, folded dipole, multi-band aerials and tuner details. Further chapters describe the use of aerial test equipment and construction of indoor transmitting aerials, v.h.f., u.h.f. and special purpose aerials. Pp. 160; nearly 170 Figs. Price 24s. W. Foulsham & Co. Ltd., Yeovil Road, Slough, Bucks.

"Wireless World" Diary

THE change of format—it now measures $4 \times 2\frac{1}{2}$ in—has given an opportunity for the complete revision of the data included in the 1966 Diary. The 80-page reference section is still a mine of information and the majority of the features which, over the years, have been found to be most useful are retained. Among the new features are abridged colour television standards for N.T.S.C., PAL and SECAM; logic symbols; and a list of transistor near equivalents. Among the circuits included are a frequency-modulated stereo decoder and several which have appeared in the journal, such as the *Wireless World* transistor f.m. tuner and the revised Tobey-Dinsdale pre-amplifier.

The Diary, now in its 48th year of publication, costs 7s 6d for leather and 5s 6d for rexine, including purchase tax. Overseas prices are 6s 6d (leather) 4s 9d (rexine), postage 4d. Inside the front cover is a colour map of the London Underground Railways. The diary gives a week-at-a-time opening and has perforated corners which, when torn off week by week, facilitate the finding of the current week.

H. F. PREDICTIONS — NOVEMBER

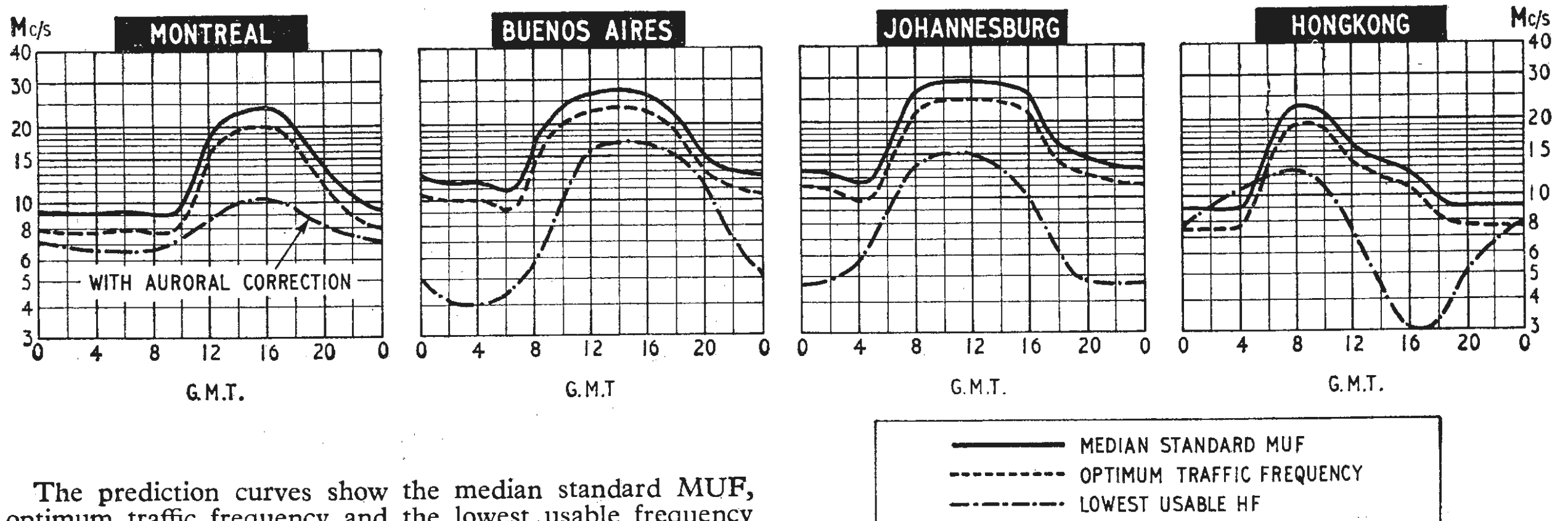

The prediction curves show the median standard MUF, optimum traffic frequency and the lowest usable frequency (LUF) for reception in this country. Unlike the standard MUF, the LUF is closely dependent upon such factors as transmitter power, aerials, and the type of modulation. The LUF curves shown are those drawn by Cable and Wireless Ltd. for commercial telegraphy and assume the use of transmitter power of several kilowatts and aerials of the rhombic type.

The higher daytime MUFs, characteristic of the winter

months, are now becoming apparent for circuits predominantly in the Northern hemisphere.

The Northern Auroral Zone passes roughly through Alaska, Hudson Bay, Iceland and Northern Norway. Radio paths passing through this zone are subject to additional absorption, and a correction is made for this in the calculation of the LUF.

Redundancy in Systems Design

By D. W. LEWIN,* A. Inst. P., A.M.I.E.R.E.

A MAJOR consideration in the design of large systems is that of reliability. This may be achieved in many ways, but this article is concerned with one aspect only, the concept of redundancy. This is the process of increasing the reliability by incorporating additional equipment and data paths into a system. For example, the English language is redundant in the sense that more words are used than are strictly required for comprehension; thus intelligibility can be maintained under difficult conditions. The use of standby equipment such

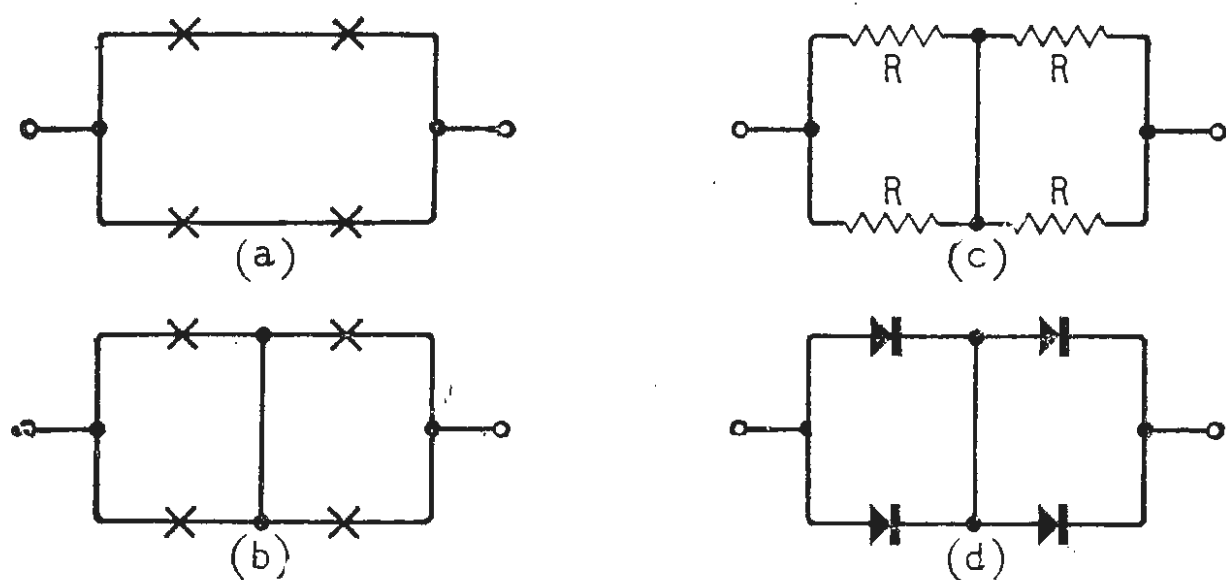

Fig. 1. Hammock networks providing component redundancy.

as generators, or the duplication of lorry tyres are examples of hardware redundancy. Note that in a non-redundant system every component must operate (similarly all data must be present) for the system to function correctly.

Redundancy, then, may be introduced into data-handling systems in several ways:—

- (1) **Coding of data.**—Additional information bits are included to allow error detection and/or correction.
- (2) **Replication of components and/or logic sub-systems.**—Extra hardware, either at component or sub-system level, provides alternative (parallel) paths, and ensures that if any failures occur the system continues to operate.
- (3) **Programme checks.**—In programmed systems, self-checking routines (redundant operations) can be used to detect errors, and in some cases correct them.

We shall now consider the first two methods in more detail, starting with hardware redundancy.

Component redundancy

Moore and Shannon¹ investigated the design of reliable relay circuits by replication, giving multiple signal paths, and this work can be directly applied to digital circuits. Each component in the circuit is replaced by a “hammock” network of the type shown in Fig. 1. Many different hammock circuits are possible;

they are identified by their width, number of parallel paths, length and number of components in the path. Fig. 1 shows what are categorized as 2×2 networks.

As relay contacts are either open or closed (infinite or zero impedance), this form of redundancy is ideal for diodes. Allowance must be made, however, for the finite impedance of other two-terminal components such as capacitors, and resistors. Special consideration must also be given to the use of three-terminal devices, notably valves and transistors.

In the case of resistors catastrophic failures are normally due to the component becoming an open-circuit; thus each resistor can be replaced by n equal resistors of value nR in parallel. However, n must be large (at least 4) to ensure correct operation for a single failure. An alternative circuit is shown in Fig. 1(c) which guards against both short-circuit and open-circuit failures. In this case for one s/c the value of the network becomes $0.5R$ and for one o/c, $1.5R$, giving a swing in resistance of 3:1. Similar problems exist if capacitors are used in hammock circuits, except that the capacitor appears to be a more reliable type of component. Hammock networks have also been applied to transistor circuits (Sorensen² used a 2×2 network); however, owing to the extra input power required as a result of replication, they have not been greatly successful.

One of the major difficulties of implementing redundancy, especially at the component level, is the problem of how to incorporate some form of automatic testing. This is essential, since if faulty components (or sub-systems) are not replaced the system will progressively deteriorate, leading to a sudden and dramatic failure! A further disadvantage of component redundancy lies in the constraints it places on the design of logic circuits. The increase in current and power together with some

*Brunel College, London, W.3.

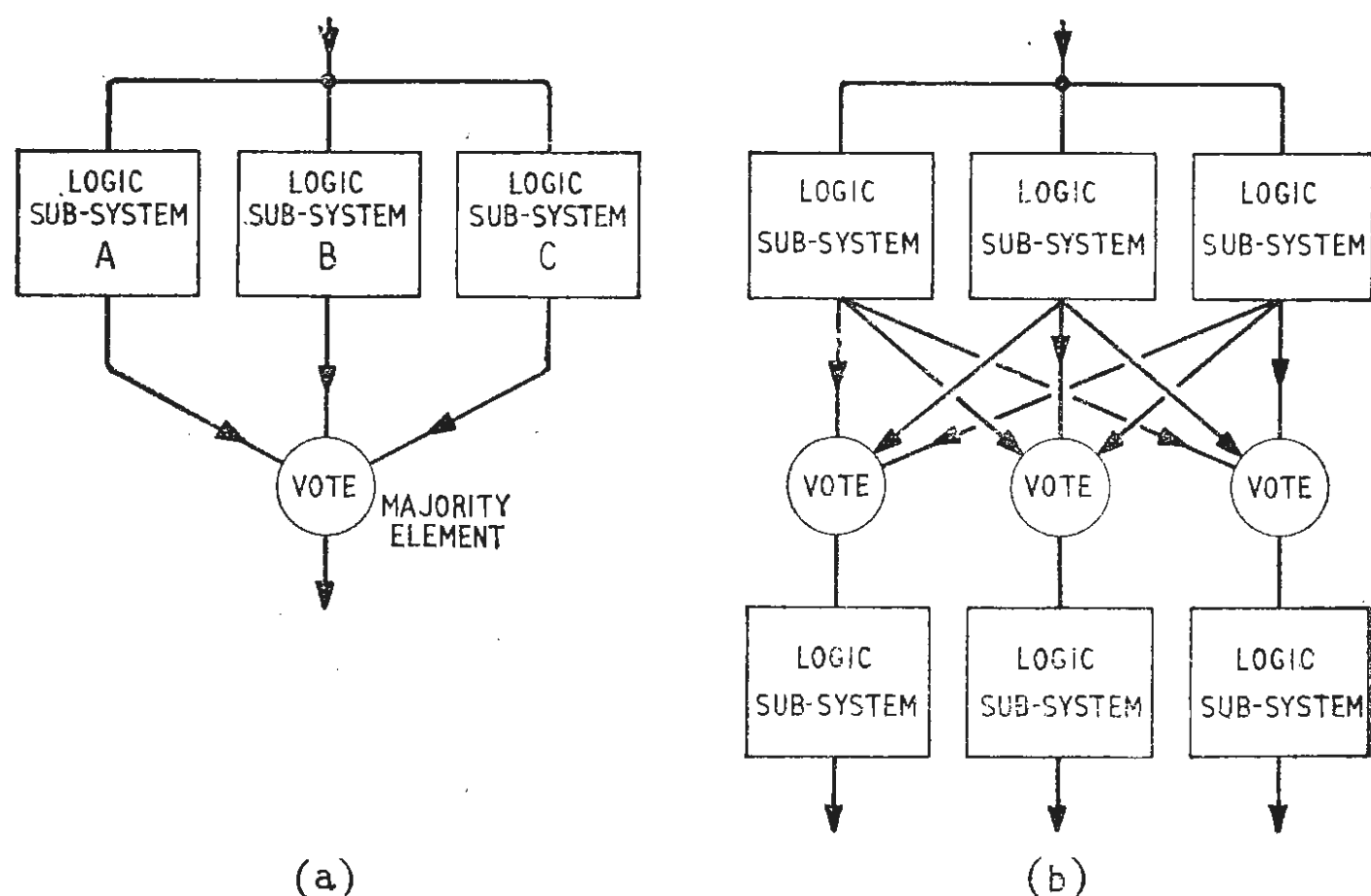

Fig. 2. Redundant logic system using the voting principle.

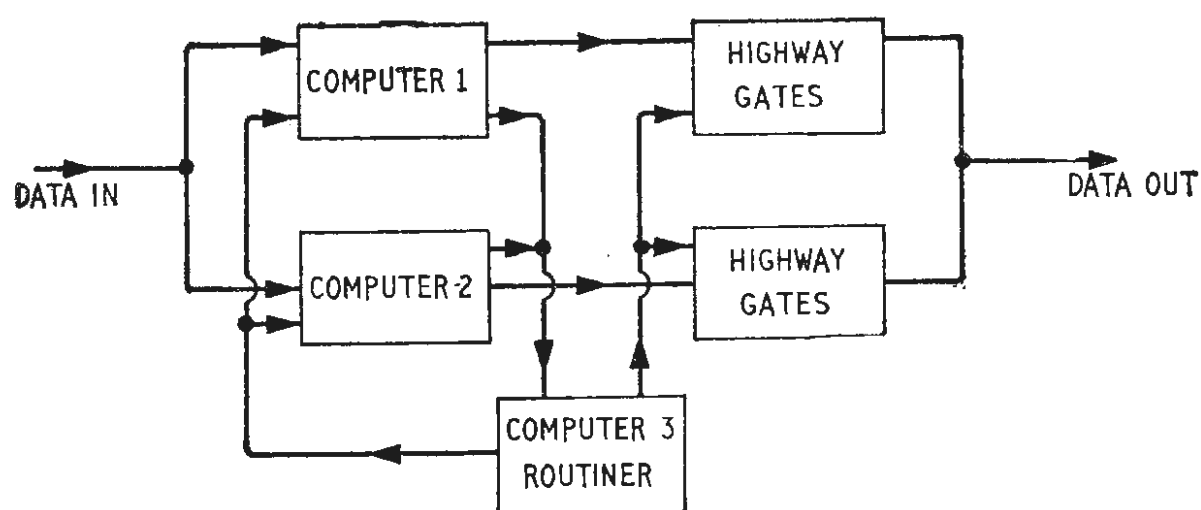

Fig. 3. Redundant logic system using the switched standby principle.

deterioration of performance, tend to diminish any advantages in reliability.

Logic sub-system redundancy

Except for some work done by Tryon³ on the quadruplication of basic logic circuits of the AND/OR type, redundancy has been applied mainly to large logic blocks or sub-systems. Two methods have been tried: (1) the voting or majority decision system, and (2) the switched duplicate system.

In the voting systems shown in Fig. 2, each sub-system has been triplicated and there are outputs taken to a majority decision (voting) element (a). The action of the voting element is to compare the outputs of all three sub-systems and accept the majority result, that is 2 (or 3) out of 3. Since the voting element, if used singly, is itself the weakest link, it must be triplicated also. The resulting triple, or first-order system (b), will continue to function correctly if any one sub-system goes faulty. The method can be extended to produce a second-order system using 5 sub-systems, with a majority vote of 3 or more. As with all forms of redundant circuitry it is essential to provide some means of checking and replacing faulty equipment. In a large system the logic equipment blocks could well be digital computers, providing self-checking facilities.

The second method, switched standby equipment, illustrated in Fig. 3, has the advantage that the extra equipment required is not necessarily much over 100%. Furthermore, if a comprehensive testing scheme can be employed, together with automatic electronic switching, a high degree of reliability can be obtained. For a large digital system such as an air-traffic control installation, which could require, say, ten general-purpose digital computers, the standby and checking function could be performed by one or two computers plus the necessary switching hardware to give automatic changeover. A computer used for systems checking is sometimes called a routiner. The checking programme would be included as an integral part of the systems operational software on a time-sharing basis. Should the routiner detect a fault in any of the operational computers it would immediately signal the error and initiate changeover procedures, which could be either manual or automatic. If general-purpose computers are used, normal methods of fault-finding using diagnostic programmes can be used to locate the computer fault off-line. Moreover, there is no reason why the standby computer itself should not be used as a routiner. This does mean, however, that there is no systems testing during the maintenance period.

It is in the sphere of systems software that a form of data redundancy can be employed. The actual programme, both operational and monitoring, can contain self-checking facilities such as tests on feasibility and order of magnitude, parallel calculations, and summing

checks on data-transfers. Sufficient error indication would be given to allow appropriate action to be taken.

Binary codes

Before a description of redundant codes is given the essentials of binary digital number systems will be reiterated. The binary system is a method of counting using a base, or radix, of two, rather than the more accepted decimal system with its radix of ten. There are several practical reasons for employing a number system based on this radix in digital machines; for example, many physical devices are by their very nature two-state systems—a switch or set of contacts may be open or closed or a transistor may be bottomed or cut-off.

Data coding is necessary in a digital system since logic circuits (as in digital computers) operate in pure binary. The human operator however finds it more convenient to communicate with the system in decimal notation. Thus it is necessary to use both binary and some form of binary-coded decimal (b.c.d.) to represent data; in both methods the only symbols used are 0 and 1. Table 1 shows various forms of binary codes.

In order to represent the decimal numbers 0 to 9 we need four bits, giving 2^4 or 16 possible combinations, of which only 10 are used. Each code, then, has four bits and these bits can in general be assigned values—weights—which when summed give the decimal number represented by the four-bit combination. Such codes are also called *arithmetic codes*. Many of these codes are possible, but the weights must be chosen in such a way that their sums are >15 or <9 ; moreover, one of the weights must be 1 and another either 1 or 2. Weights can also be either positive or negative; examples of combinations are:—3321, 5321, 4221 84-2-1, 432-1.

Some b.c.d. codes have useful properties; for example, the 7421 code has a minimum number of ones and if used in such a way that an electrical device must be on, or in a power consuming state, to represent a 1, it results in minimum power consumption. Arithmetic codes in which the sum of weights is exactly nine have the property that the nine's complement of the number can be obtained by inversion (a further requirement is that the code must be symmetrically organized about its centre—see the 5211 code in Table 1). Self-complementing codes such as these are very useful when performing decimal arithmetic⁵. A further example is the excess-three code also shown in Table 1, which has the additional property of no all-zero combination.

The reflected or Gray code (also called a cyclic progressive code) is used chiefly in analogue-to-digital conversion equipment and has the merit of incurring only 1 digit change when passing from any one combination to the next. A code is said to be reflecting when it is symmetrical, excluding the most significant digit, about

TABLE 1—BINARY CODES

Decimal No.	Pure Binary $2^3 2^2 2^1 2^0$	Binary-coded decimal		Reflected or Gray code $a_4 a_3 a_2 a_1$	Excess three code
		7 4 2 1	5 2 1 1		
0	0 0 0 0	0 0 0 0	0 0 0 0	0 0 0 0	0 0 1 1
1	0 0 0 1	0 0 0 1	0 0 0 1	0 0 0 1	0 1 0 0
2	0 0 1 0	0 0 1 0	0 1 0 0	0 0 1 1	0 1 0 1
3	0 0 1 1	0 0 1 1	0 1 1 0	0 0 1 0	0 1 1 0
4	0 1 0 0	0 1 0 0	0 1 1 1	0 1 1 0	0 1 1 1
5	0 1 0 1	0 1 0 1	1 0 0 0	0 1 1 1	1 0 0 0
6	0 1 1 0	0 1 1 0	1 0 0 1	0 1 0 1	1 0 0 1
7	0 1 1 1	1 0 0 0	1 0 1 1	0 1 0 0	1 0 1 0
8	1 0 0 0	1 0 0 1	1 1 1 0	1 1 0 0	1 0 1 1
9	1 0 0 1	1 0 1 0	1 1 1 1	1 1 0 1	1 1 0 0

the midpoint of a complete ascending tabulation of the code. For example, in the Gray code column of Table 1 the first eight combinations form a three-bit Gray code of length eight (ignoring digit a_4). That this reflects can be seen by noting that digits a_1, a_2 are symmetrical about the midpoint, with the most significant digit a_3 inverted. We can attach weights to the elements of the code according to the scheme:—

$$a_1=1, a_2=(1+2)=3, a_3=(1+2+4)=7, \\ a_4=(1+2+4+8)=15.$$

The weights are added or subtracted depending upon whether the digit is odd or even, counting from the least significant digit position.

Error-detecting and correcting codes

If codes are used which utilize all possible combinations, such as representing decimal numbers 0—15 by pure binary equivalents, any error which may occur will go undetected, since any incorrect combination will still be a valid number. To overcome this problem, redundancy must be introduced in the form of adding extra bits to the code. All the codes described above, if used to represent decimals 0-9, contain some redundancy in the sense that not all of the 2^4 possible code combinations are used. However, this is not enough, since there is still a chance of undetected errors occurring—for example, in the 5211 code the correct combination, 0100, can, by picking up a digit, become 0110.

The simplest method of adding redundancy is to insert an extra bit, called a *parity bit*, into each code combination. The value of this, 0 or 1, is such as to make the total number of ones in each and every combination either even or odd, according to the checking system adopted; see Table 2. Another approach is to arrange

TABLE 2—ERROR DETECTING CODES

Decimal No.	Odd parity check Pure binary				Even parity check				2 out of 5 code	Diamond code							
	P.B.	2^3	2^2	2^1	2^0	P.B.	7	4			2	1					
0	1	0	0	0	0	0	0	0	0	1	1	0	0	0	1	0	
1	0	0	0	0	1	1	0	0	0	1	1	0	0	0	1	0	1
2	0	0	0	1	0	1	0	0	1	0	0	0	1	0	0	1	0
3	1	0	0	1	1	0	0	0	1	1	0	0	0	1	1	0	1
4	0	0	1	0	0	1	0	1	0	0	1	0	1	0	0	1	1
5	1	0	1	0	1	0	0	1	0	1	0	0	1	0	1	0	1
6	1	0	1	1	0	0	0	1	1	0	0	1	1	0	1	0	0
7	0	0	1	1	1	1	1	0	0	0	1	1	0	0	0	1	1
8	0	1	0	0	0	0	1	0	0	1	0	1	0	0	1	1	0
9	1	1	0	0	1	0	1	0	1	0	0	1	0	1	0	1	1

that an error will give rise to a non-valid combination; an example is the 2 out of 5 code shown in Table 2. It is possible to devise many codes like this, for example, 2 out of 7, 3 out of 8, or in general p out of q (⁶). Since if an error occurs the number of ones will be wrong, both these methods will detect single errors. Double errors, however will go undetected, except if they are in the same direction (0→1 or 1→0) in the case of the 2 out of 5 code. Blocks of information can be checked by doing parity checks on all rows and columns and then including an additional test column and row in the data. This method will detect multiple errors and will correct single errors, becoming more efficient if different types of codes are used for rows and columns.

Hamming⁷, of Bell Telephone Laboratories, has invented a method of employing check digits, distributed throughout the message group, to correct single errors and detect multiple ones. These check digits provide even parity checks on particular message digit positions

in such a way that if the parity checks are made in order, successful checks being designated by a 0 and failures by a 1, the resulting binary number gives the position of the incorrect digit. For this to apply means that the first parity digit must check those digit positions (see Table 3) which contain a 1 in the 2^0 column (that is, 1, 3, 5, 7,

TABLE 3—HAMMING CODE

Digit Position	Binary 2^3 2^2 2^1 2^0	Digit function	Weight
1	0 0 1	Check	
2	0 1 0	Check	
3	0 1 1	Data	8
4	1 0 0	Check	
5	1 0 1	Data	4
6	1 1 0	Data	2
7	1 1 1	Data	1

9, 11, 13, 15, etc.), and similarly the second digit checks those positions which contain a 1 in the 2^1 column (2, 3, 6, 7, 10, 11, 14, 15, etc.), and the third digit checks the positions with a 1 in the 2^2 column (4, 5, 6, 7, 12, 13, 14, 15, etc.). This process can be continued indefinitely for message groups of any length. The amount of redundancy required becomes appreciably less as the message length is increased, for example, a 7-bit message group requires 3 check bits but only 5 check bits are required for a 30-bit group. As an example of its use, suppose the message group 1011 is to be transmitted. This would be encoded, including 3 check digits, 0110011. Should an error occur in the 4th position, giving 0111011, application of the checks would yield: 1st check 0, 2nd check 0, 3rd check 1; which, taking the 1st check digit to be the least significant, gives position 4 as incorrect.

Diamond⁸ has also devised a checking code for multiple errors which takes the form of all numbers which obey the formula $3n+2$. This b.c.d. code complements on nine, and the sum of two numbers can be obtained by normal binary addition and then subtracting 2. The checking process is to subtract 2 from the received number and reduce it to modulo 3 (the remainder after division by three). If the answer is zero it is a valid number (with a low probability of error). The code may be extended to 8-bit numbers by using the formula $27n+6$ in a similar manner.

A further class of redundant codes which are being increasingly exploited in digital systems are *chain or cyclic codes*^{9, 10}. These can be formed logically by using, for example, a four-stage shift register with feedback which generates the next input digit according to the relationship $x=ad+ad=a\oplus d$ (this is known as the exclusive OR function or addition modulo 2); see Fig. 4. Each time the register is shifted one place to the left, a new input digit is formed and inserted into the least significant position. Table 4 shows the complete chain code sequence obtained using this technique. Many such chain code sequences can be formed using shift

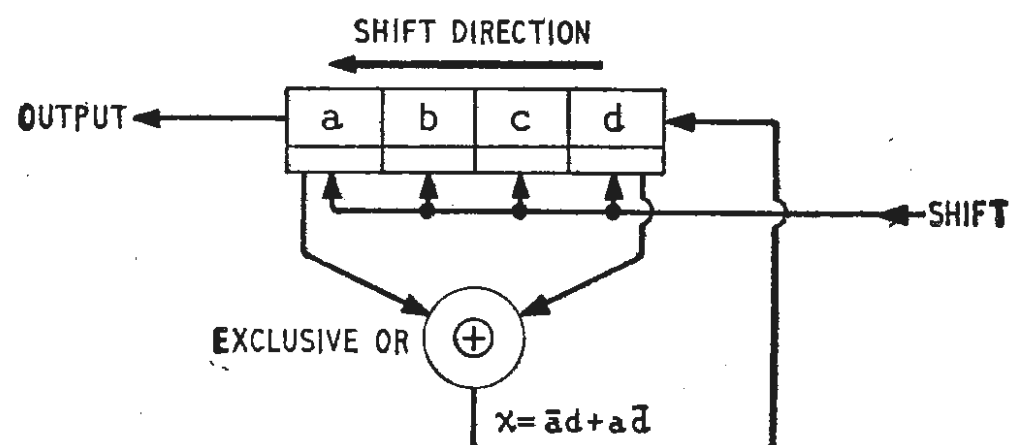

Fig. 4. Chain code generator.

TABLE 4—CHAIN CODES

Shift	Resulting pattern				Redundant version							
	a	b	c	d	a	b	c	d	e	f	g	h
0	1	1	1	1	1	1	1	1	0	1	0	1
1	1	1	1	0	1	1	1	0	0	1	0	1
2	1	1	0	0	1	1	0	0	0	1	0	0
3	1	0	0	0	1	0	0	0	1	1	0	0
4	0	0	0	1	0	0	0	1	1	0	0	1
5	1	0	1	1	1	0	1	0	0	0	1	0
6	0	1	1	0	0	1	0	0	0	1	0	0
7	1	0	0	0	1	0	0	1	1	0	0	0
8	1	0	0	1	1	0	0	1	0	0	0	1
9	0	0	1	0	0	0	0	0	0	0	1	1
10	0	0	0	0	1	0	0	0	1	1	1	1
11	1	0	0	0	1	0	0	0	1	1	1	1
12	0	0	0	1	0	0	0	1	1	1	0	1
13	0	0	1	1	0	0	1	1	1	0	0	1
14	0	1	1	1	0	1	1	1	0	1	0	0

TABLE 5—TRUTH TABLE FOR THREE BINARY VARIABLES

x	y	z	T
0	0	0	1
0	0	1	0
0	1	0	0
0	1	1	0
1	0	0	1
1	0	1	0
1	1	0	1
1	1	1	0

registers of various lengths together with appropriate feedback logic.

In order to use these codes for error-correction and detection, redundant information must be added, thereby lengthening the sequences. These are also shown in Table 4. The digits are generated for an 8-bit pattern, according to the logical relationships:—

$$a, b, c, d, e = a \oplus d, f = a \oplus b \oplus d, g = a \oplus b \oplus c \oplus d, h = a \oplus b \oplus c,$$

which enables both checking and correction (for single errors) of the transmitted message.

Though there is a great deal of published material on the theory of error-correcting codes¹¹, most of it is highly mathematical in nature with no apparent engineering interpretation. Consequently in this introduction we shall not attempt any theoretical explanation except for the important concept of *minimum-distance coding*. Error-detecting (and correcting) codes are so arranged that each code group differs by a certain minimum number of digits, for example, in the 2 out of 5 code each group differs by at least 2 digits. Codes (and hence group differences) can be represented geometrically, as logical functions can be, by a *n*-dimensional hypercube. Consider all possible combinations of 3 binary variables shown in Table 5 and represented geometrically by a three-dimensional cube in Fig. 5. The function *T* representing a code can be plotted on to this cube by marking these points corresponding to a truth values of 1. The spacing of these points on the cube is an indication of how useful the code will be for detecting and correcting errors. This distance apart is the number of cube edges which have to be traversed in going from one point to another. In this example the code groups are distance *d*=2 apart. Note that if *d*=1 single errors will go undetected, if *d*=2 an odd number of errors can be detected but not corrected. For *d*=3, if a single error occurs the received group will be distance 1 from one valid group and distance 2 from another; thus we can detect 1 or 2 errors, or correct single errors. In order to represent higher orders of distance we must consider *n*-dimensional geometry, which is essentially a problem in topology.

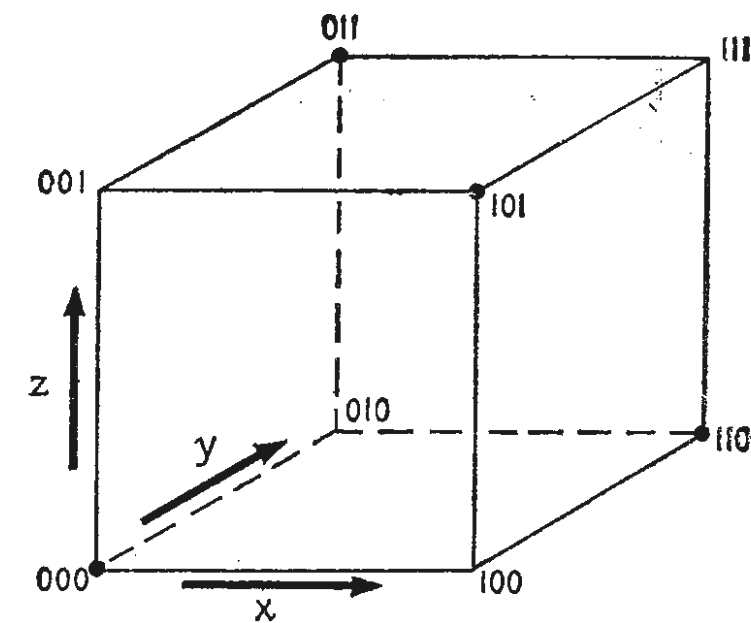

Fig. 5. Geometrical representation of binary codes.

To sum up, when redundancy is necessary in order to obtain a high degree of reliability (such as in real-time on-line systems) the most economical method is to use switched hardware redundancy at sub-system level, with automatic fault location (and switching) on a routine test basis. For maximum reliability, other forms of redundancy such as error-detecting and correcting codes and programme checks should also be included.

REFERENCES

1. E. F. Moore and C. E. Shannon. "Reliable Circuits using Less Reliable Relays," *J. Franklin Inst.*, p. 191, and 281, 262, 1956.
2. A. A. Sorensen. "Digital Circuit Reliability through Redundancy." *Electronic Reliab. and Micromin.*, p. 27, 1, 1962.
3. J. G. Tryon. "Quadded Logic: Redundancy Techniques for Computing Systems." Ed. by R. H. Wilcox and W. C. Mann. Spartan Books, 1962, 205.
4. J. C. Cluley. "Low-Level Redundancy as a Means of Improving Digital Computer Reliability," *Electronic Reliab. and Micromin.*, p. 203, 1, 1962.
5. R. K. Richards. "Arithmetic Operations in Digital Computers." Van Nostrand, 1955.
6. W. D. Gilmour, "P out of Q Codes," *Electronic Engineering*, p. 41, 35, 1963.
7. R. W. Hamming. "Error-Detecting and Error-Correcting Codes," *Bell. System Tech. Journal*, p. 147, 29, 1950.
8. J. M. Diamond. "Checking Codes for Digital Computers," *Proc. I.R.E.*, p. 487, 43, 1955.
9. F. G. Heath and M. W. Gribble. "Chain Codes and Their Electronic Applications," *Proc. I.E.E.*, Monograph No. 392M, p. 50, July 1960.
10. P. E. K. Chow and A. C. Davies. "The Synthesis of Cyclic Code Generators," *Electronic Engineering*, p. 253, 36, 1964.
11. W. W. Peterson, "Error Correcting Codes." Wiley (London 1961).

Educational Electronic Experiments

TWO new pamphlets—numbers 14 and 16—in the series Educational Electronic Experiments are now available from the Mullard Educational Service.

Number 14, four pages, describes two substitution boxes for resistance and capacitance. The circuit of the resistance box contains six potentiometers whose values range in decade steps from 10 Ω to 1 MΩ and provide a total resistance of 1,111,110 Ω. The circuit of the capacitance box contains nine capacitors which can be selected individually to give fixed capacitance values in decade steps from 100 pF to 10,000 μF.

Number 16, four pages, describes an electronic organ which uses two separate circuits for treble and bass with switched tremolo. Each circuit uses four transistors and comprises a tremolo oscillator, a key-controlled multivibrator note generator and a transformerless output stage. Power output is 50 mW.

FIFTH INTERNATIONAL CONGRESS ON ACOUSTICS

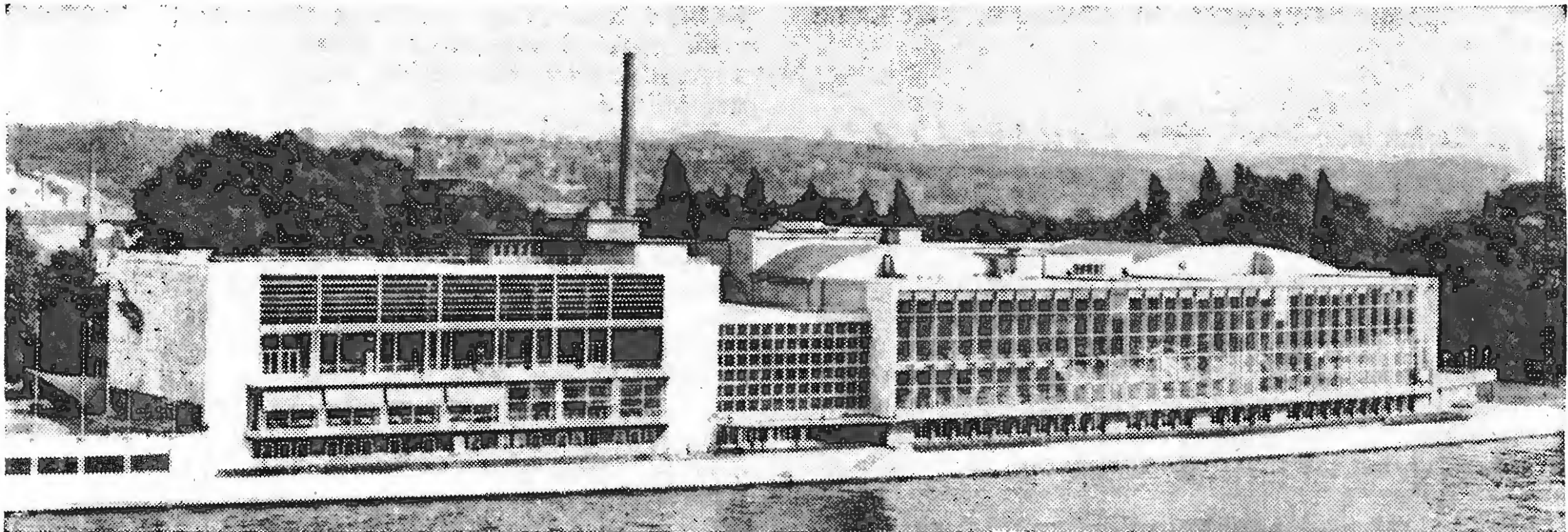

PALAIS DES CONGRES, LIÈGE, 7-14 SEPTEMBER

THE rapid increase in activity in the field of acoustics which has taken place in the post-war years is well reflected in the five international congresses which have been held so far. As Professor Powell pointed out in an invited paper at the latest Congress at Liège, the number of papers in the field of aeroacoustics alone has increased roughly by a factor of ten over the last 15 years, and the rate of increase is now greater than exponential!

The first congress at Delft in 1953 ran four concurrent sessions in which 90 papers were presented and was attended by about 300 delegates from 19 countries. At this year's congress nearly 450 papers were read in nine concurrent sessions, and nearly 1,500 delegates from 35 countries were present.

The proceedings were divided into two sections, one devoted to invited papers of general interest and with a broad coverage and the other to specialized papers covering 12 broad areas of activity in acoustics.

Speech analysis and synthesis

Information on the pitch of a voice may be extracted by a number of techniques, one of the simpler methods using a microphone attached to the throat, where a large amplitude of vibration exists. An equally simple method, but providing more information and using an accelerometer attached to the throat, was described by P. Pickels and V. Riso (I.M.B., France). One advantage of this is that a better s/n ratio is obtained since interference from the mouth and other noise sources is reduced. Also a flat response down to 10 c/s is obtained. Integrating the output twice, of course, provides a characteristic similar to that of a displacement microphone.

More direct methods for investigation of speech sounds were discussed in a number of papers. Bordone-Sacerdote, Sacerdote and Righini (Istituto Elettrotecnico Nazionale, Torino) described two simple methods for investigation of the glottis during speech, one using electrodes at either side of the throat to which an r.f. signal was applied (1 Mc/s), modulation of the signal being directly displayed on an oscilloscope. The other, similar, method used a 1 Mc/s ultrasonic wave, produced by an 8 mm dia. piezoelectric transducer (matched to the skin

with wet gauze) on one side of the throat and received by a similar transducer on the same or opposite side of the throat. The authors suggest that this technique may have value for medical diagnosis of some disorders of the vocal system.

Three papers described the use of cineradiographic technique for studying the vocal tract. The equipment used was described and comprised an X-ray tube and collimator on one side of a subject (housed with a microphone in soundproof enclosure) and on the other side an image converter-amplifier feeding a high-speed (120 ft. sec⁻¹) cine camera. Heinz and Stevens (M.I.T.) showed how frame-by-frame tracings were used with a suitable coordinate system to provide cross-sectional area functions of the vocal tract and reported on the use of a digital computer for such procedures.

Examples of the usefulness of on-line digital computing were described by Denes (Bell Telephone). In one instance it was required to examine sharp changes in the acoustics of the vocal tract and the process of inverse filtering (cancellation of the vocal tract transfer function in order to provide a signal resembling the original sound source) was computed in real-time and frequencies of two inverse formants were adjustable by the operator, who could view the waveform or spectrum of the filtered speech. Another experiment involved sentence synthesis in which a phoneme sequence was fed into a computer which calculated the formant tracks. These tracks controlled an analogue formant synthesiser, the operator controlling, for instance, syllable duration and fundamental frequency and noting directly the result. The advantage of such on-line processing, of course, is that the operator can see the result of varying parameters immediately, which is not possible with conventional computing.

A number of papers were devoted to speech intelligibility and one in particular dealt with intelligibility in school classrooms. Tolk & Peuty (Netherlands) investigated the relationship between speech intelligibility (measured by articulation loss or relative number of incorrectly perceived phonemes) and reverberation time. Rooms with volumes between 70 and 13,000 m³, and reverberation times from 0.5 to 4.5 s (these being roughly constant with frequency) were tested. It was found that

the decrease of intelligibility with increasing distance d , from the source (a non-directional loudspeaker) continued up to a critical distance d_c after which it remained constant and largely dependent on the reverberation time (τ). The approximate relations for consonants were found to be:—

for $d < d_c$

$$\% \text{ articulation loss:—} = \frac{200 d^2 \tau^2}{V} + a \text{ and for } d \geq d_c \\ = 9\tau + a$$

$$\text{from which } d_c = 0.2 \sqrt{\frac{V}{\tau}}$$

where V = room volume and a = a correction factor to take account of both good and bad listeners. (For vowels articulation losses were small and reliable figures were not obtained.) The authors also concluded that the effect of reverberation on intelligibility could not be accounted for by assuming that the effect was simply due to masking.

Physiological and psychological acoustics

The phenomenon of beating occurs most noticeably when the frequencies of two tones are nearly equal, but beats can also be produced when a consonant interval (e.g., 1:2, 2:3, etc.) is slightly mistuned. R. Plomp (Institute of Perception, Netherlands) supported the view that these beats were not caused by the non-linearity of the ear but by variations in waveform. The stimulation produced by the two tones is superimposed at the basilar membrane, thus causing periodic variations of the nerve impulses and giving rise to the beat sensation. In one experiment tones of 200 c/s and 301 c/s gave rise to two beats per sec. which, if non-linearity were responsible, would be produced by difference tones of 101 c/s and 99 c/s (200-101 c/s) or the harmonics 602 c/s and 600 c/s. However, when frequencies of <200 c/s and >301 c/s were masked by thermal noise, the beats were still heard. Further, the intervals 5:9 and 4:9, for example, when mistuned gave beats of approximately the same intensity as beats due to the interval 1:2 and if non-linearity was the cause one would expect the beats 5:9 and 4:9 to be less intense since these would be due to the 4th 5th and 9th harmonics. A "swept-tone" effect was also observed in which periodic shifts in pitch occurred for very slow beats and this phenomenon did not support the belief that the beats were due to non-linearity.

Hearing thresholds under various conditions were the subject of more than one paper. The effect of impulses from firearms was investigated by Kryter and Carinther (U.S.A.) who analysed the physical characteristics of rifle noise in relation to the degree of hearing loss. It was concluded that the ear appeared to be traumatically affected above a certain peak sound pressure level (s.p.l.) and the threshold shift was found to increase at a very high rate for each dB rise in s.p.l. The critical s.p.l. appeared to be about 168 dB for 25% of the ears, under the conditions of the tests. Rice and Coles (Institute of Sound and Vibration Research, Southampton University) also investigated impulsive noise characteristics from small-arms and suggested maximum peak pressure levels of 155 dB for occasional single impulses in the open, while adding that since duration is an important factor the time taken for the maximum s.p.l. to fall by, say, 20 dB should be quoted—in this case 20ms.

Guignard and Coles reported on the effects of **infra-sonic vibration** on the hearing threshold of subjects with a vibration of 15 c/s and an amplitude of 0.7 g and 0.036

in applied to the seat. The vibration appeared to have a protective effect against a noise-induced threshold shift in the region of 4 kc/s, which did not support the results of an earlier investigation by Morita. It was felt that perhaps facial resonances may stimulate the hearing in some way. A questioner pointed out that the effects of a possible vibration of the headphones had not been determined.

Tempest, Bryan and McRobert (Liverpool University) in a paper on the **estimation of relative loudness** discovered that estimates of observers were different for loudness increase and decrease and in neither case did the data for intensity intervals of >20 dB agree with the sone scale. The results suggested that observers' judgements were not based on a psycho-physical scale of loudness against intensity but rather on a scale of relative loudness against intensity difference.

In one of the papers dealing with **masking** by Flanagan, O'Leary and Ingels (Bell Telephone) the masking effect of a pair of tones by a third tone was considered. The results of one test showed that one masking tone contributed to the masking effect almost independently of the other and suggested a phenomenon similar to the f.m. capture effect.

The loudness of a complex sound of constant intensity increases with bandwidth beyond a critical bandwidth. Scharf, Holohan and Hillman (U.S.A.) found that in ears suffering from cochlear impairment this **loudness summation** effect was small or did not exist and proposed possible mechanisms. A new artificial ear was described by Delaney and Whittle (N.P.L.). Dr. Delaney pointed out that recent precise determination of the impedance of human ears had been used in the design.

Molecular acoustics

Some interesting effects with sound generation and transmission in a weakly ionised gas were presented by V. Ingard (M.I.T.). A gas-discharge tube containing neutral and ionized gas particles was subjected to an electric field to provide energy (by collision) for a discharge to take place. Sound can be generated by the neutral gas if the energy transfer from the electrons to the neutral gas, causing heating of the latter, is made to vary with time and the effect produced is similar to thunder. By this process **acoustic oscillations** have been observed in plasma and in some cases light emission from the plasma has been made to vary with the sound wave. Perhaps more interesting is the amplification of a sound wave when it is transmitted through the plasma, which arises from the fact that the heating of the gas by the electrons is greater at compressions than rarefactions. The presence of a sound wave in the plasma causes a variation in heating from one point to another and the sound takes energy from the electrons (as in the case of water waves taking energy from the wind). Amplification exists only if the energy transfer to the neutral gas is greater than the energy loss in the sound wave caused by viscosity and heat conduction. The author also presented an expression for an amplification criterion for the case of a plasma contained in a cylindrical tube.

Sonoluminescence† from various viscous-liquid/water mixtures while varying the viscous-liquid content from 0-100% was reported by F. R. Young (Imperial College). The four liquids, glycol, cyclohexanol, ethylene glycol and 3-chloropropane 1-2 diol, were subjected to an

† See *Ultrasonics* Vol. 1. April-June 1963

acoustic power of 10 W at 21.5 kc/s from a magnetostrictive transducer and titanium $\lambda/4$ transformer to produce cavitation. For the four liquids, luminescence increased as the water content decreased. There was no obvious connection between physical properties of the liquid-water mixture and sonoluminescence, but it is thought likely that viscosity is the determining factor.

Underwater sound

One of the few papers in this section, written by B. J. Urick (U.S. Navy) and read in his absence by a colleague, described an experiment in **long-range sound transmission** in which explosive charges were dropped into the sea within a 600-mile radius around Bermuda. The purpose of this was to investigate the similarity of signals received due to a number of charges at 100-mile intervals, and to determine if the similarity could be accounted for by using a single velocity profile. The results illustrated that there was indeed a repeated pattern in all the received signals, variability being evident in arrival time and amplitude only.

In **underwater transducers** which are small in comparison to a wavelength, efficiency is limited because of the low radiation resistance. A method of overcoming this by using a resonant gas-filled balloon between the transducer and the water to act as a transformer was outlined by C. C. Sims (U.S. Navy). Analysis of the equivalent circuit for the transducer showed that an increase in power output of 35dB could be obtained, this figure decreasing with depth. Maximum theoretical efficiency was 7%, and efficiencies of 3 to 5% were measured.

Ultrasonics

One of the most interesting developments announced at the 4th Congress, and elsewhere, was that of **acoustic amplification** in a semiconducting piezoelectric crystal (or ultrasonic travelling-wave amplification). The results obtained agreed only qualitatively with theory, the effect being observed only in certain samples of CdS and the gain being low. The deviations from the theory were attributed to inhomogeneous material or electron trapping or both. D. L. White and E. T. Handelman (Bell Telephone) described some recent results in this field which gave good quantitative agreement with a small-signal theory in which there was no electron trapping. Several samples of CdS gave consistently good results and agreement with theory had been obtained for resistivities between 10^6 ohm cm and less than 10^3 ohm cm at frequencies from 50 Mc/s to 1 Gc/s. The highly photoconductive CdS crystals were produced by sulphur doping at 100°C for either 24 or 40 hours at a critical S_2 pressure of about 0.17 atmosphere. Two opposite faces of the crystal were polished to give surfaces flat to 15 seconds of arc. Low-resistance ohmic contacts were made by diffusion of indium in a sealed tube at 500°C for 1 hour. The sample was then bonded to two $\frac{1}{2}$ in quartz bars with sodium silicate upon which two Foster-type evaporated CdS transducers were deposited. The desired resistivity was obtained by variation of light intensity. By using crystals prepared by this process, quite large net gains had been achieved in pulsed operation with about 200 V across the sample and at frequencies around 100-200 Mc/s.

The ultrasonic testing of structures and investigation of materials has found wide application, mainly for homogeneous media but with heterogeneous media

properties are investigated and deductions made generally on an empirical basis. Szilard and Bilhari (Hungary) discussed the possibility of obtaining information on the **structure of heterogeneous media** from the distribution of scattered energy and using the pulse-echo technique. For the purposes of their investigation the authors defined a medium as being heterogeneous when, at a particular wavelength and with either shear or pressure waves, the scattering ceased to be negligible. (Attention was drawn to the fact that two types of inhomogeneity may be distinguished, *viz*, discrete particles could exist when the medium parameters were discontinuous and also particles could exist with the medium parameters as continuous functions of space.)

An annoying factor in the use of industrial ultrasonic cleaning equipment is the often loud audible response at around 10 kc/s in equipment which is run at or around 20 kc/s (for maximum efficiency). It was suggested in a paper that, in order to avoid this, equipment should be run at a higher frequency and at higher acoustic power to offset the decreased efficiency. The authors, Neppiras and Parrot (Imperial College, discussed the various proposals for the existence of the **subharmonics** and also investigated the use of this as a measure of cavitation intensity and threshold. The white noise produced by the cavitating liquid was found to correlate linearly with the intensity cavitation, whereas the half-frequency response was found to be a more sensitive criterion of the onset of cavitation.

It has been known for some time that ionizing radiation can induce ultrasonic cavitation in suitable liquids. More recently, it has been proposed by Prof. D. Sette and F. Wanderlingh that a similar mechanism may be useful for high-energy **neutron detection**. The same authors described some preliminary research into this possibility by two approaches. In one of the methods water was passed from a reservoir through a helix in which it was irradiated by a Ra-Be neutron source, after which the delay in the onset of cavitation after the application of acoustic energy was determined, this being dependent on the neutron flux. The irradiated oxygen atoms in the water were found to be inadequate as nucleating centres (too low an energy) and carbon atoms were introduced in the form of ethanol. The results show that the arrangement presents a feasible and sensitive method for neutron flux measurement, with the advantage that actual measurements are made well away from the neutron source.

Noise control

In a paper entitled "My Neighbour's Radio" van den Eijk and van Ierland (Netherlands) investigated the amount of **sound insulation** required in addition to a 9in brick wall to reduce the majority of complaints in a block of flats. Roughly speaking, in order to satisfy 75% of the subjects, an extra 9dB of sound insulation was required to enable subjects to study, when the neighbour's radio was adjusted to a certain level above average. By another method it was established that an extra 16dB of insulation was required, but this difference in results of the two methods was not investigated. The experiments, however, were performed in the laboratory and correlation with actual living conditions had not yet been obtained.

A common type of **interior wall** used in the U.S.A. is constructed of wooden studs and gypsum wall board $\frac{1}{2}$ in thick, but this has been found inadequate for many uses. This type of wall can provide a sound transmission loss of 50dB at 2kc/s, 35dB at 500 c/s and 17dB

at 125 c/s. Details of a modified and improved wall were given by R. Lindall (U.S.A.) which consisted of $\frac{1}{2}$ in cellulose fibre insulation board between the studs and the gypsum facing. By using this insulation board and following a definite method of construction, an improvement of 6dB at 125 c/s, 14dB at 500 c/s and 5dB at 2 kc/s could be obtained. It was pointed out that a laminating compound was preferred to nailing since nails could "short circuit" the resilience of the construction with harmful effects. Further improvements were also described.

A. F. Nickson (C.S.I.R.O., Australia) discussed attempts to forecast community reactions to increased **traffic noise** under free flow conditions in Australia, where noise levels are slightly less than in Europe and the U.S.A. The I.S.O. suggestion that sporadic complaints may be experienced if the noise level is about 10dB above the background level was borne out. An interesting point emerged in connection with background noise levels. As distance away from the traffic increased the noise reduced by 3dB for a doubling of distance (and not 6dB as is the case for a point source) and the high frequency attenuation was somewhat greater than this figure. Consequently, the spectrum of traffic noise became similar to that of background noise and suggested that general background noise was largely produced by the traffic. Present evidence suggested that sporadic complaints may occur from noise due to n vehicles per hour (with a mean speed of 40 m.p.h. and containing 10 per cent lorries) at a distance d ft if the background noise level in the absence of traffic was $40 + 10 \log n/d$ (dB).

Milner and Dunsbee (Ferranti) drew attention to the fact that it was now possible to estimate the likely noise level at any point distant from a **transformer** before its installation. Further, the probability of complaints could be assessed by calculating thresholds for the harmonics (of 50 c/s) in the presence of background noise from masking data. One point of interest was that enclosure of a transformer did not result in a noise reduction/frequency relationship as predicted. There was an increase in noise level inside the enclosure ("build-up") which tended to offset the reduction provided by an enclosure. This could be due to reverberation or to an increase in sound pressure caused by the enclosure presenting an impedance higher than in free air, but still lower than the source.

A survey of noise produced by **radiator valves** in water heating systems was presented by Strumph and Ovesen (Denmark). Valves of nine different types of construction were tested and noise levels found for various rates of flow and pressure difference.

Architectural and room acoustics

Four papers were devoted to the acoustical design of large halls—the new **Rotterdam concert hall**, the National Gymnasium, Tokyo, the Grady Gammage Auditorium, Arizona State University, and the Palais des Congress, Liège. The Rotterdam hall, described by Prof. Kosten and de Lange, has an audience arrangement similar to that at the R.F.H., with a steeper floor slope in parts and an audience distribution well to the fore. An interesting approach was made to the calculation of volume. The reverberation time was to be about 2.1s, hence the total absorption was required. This was the sum of three absorption terms due to the audience and orchestra, the remaining area and the air. Normally the absorption coefficients for the audience and remaining area were assumed to be reasonably constant for most halls, but Prof. Kosten showed that the information available on

halls was insufficient to split the absorption into three terms. The problem was resolved by assuming an "equivalent" absorption coefficient, which was in fact the total absorption divided by the audience and orchestra area, and which was found to be sufficiently constant. This quantity was estimated over more than 40 concert halls and used to calculate the volume.

The recently opened **Palais des Congress** in Liège was in the unfortunate position of being near to a helicopter terminal and regrettably the funds did not run to double windows, which would reduce the mean sound transmission loss by about 10 db. A. C. Raes, the accoustical consultant, disclaimed responsibility for the rise of partitions in some of the committee rooms—there was noticeable interference between the divided regions.

D. Fitzroy (U.S.A.) referred briefly to a new trend in **school design** which prompted acoustical separation measurements between classrooms. The school design was in the form of an open space where most classes were separated by medium-height partitions and doors were eliminated. Recently carpeting had been used throughout these schools, and it was claimed that this was more economical than other absorptive coverings, apart from reducing the noise levels. The results of a survey gave the average noise reductions between centres of the open classrooms as 18 dB and, in the case of the closed classrooms studied, 28 dB. The surprising result was obtained that both types of classroom were rated roughly equal by teachers (on the basis of suitability of the environment for teaching) and that only 4% of those questioned found the open classroom not acceptable.

The need for different reverberation times for different styles of music has led to the experimental regenerative system for reverberation control now installed in the **Royal Festival Hall (assisted resonance)**. The system relies on a number of channels (for different frequencies) producing a regenerative reverberation time by altering the loop gain of the channels, after a suggestion by Parkin. Curtis (Q.M.C., London University) discussed the system in detail. Another system which achieves a modification of the reverberation time of a theatre (initially designed for speech) was outlined by Fowweather and Sharp (College of Science and Technology, Manchester University). The ambiophonic system increases the reverberation time from 0.8s for speech to 1.2s for music by use of a "reverberation machine"—a continuous-loop tape recorder with a tape speed of 30 in/sec and eight replay heads arranged to give four delay channels and one feedback channel to the recording head. The channels feed four 70W amplifiers operating 37 8 in loudspeakers, most of which are situated on a suspended ceiling (the architect objected to the loudspeaker cabinets in the side walls). Adjustment of the feedback channel provides the lengthening of the reverberation time. The system was adopted partly because it was less bulky and less expensive than the R.F.H. system.

An interim report on experimental research into **audience absorption** was presented by van Raalten (Netherlands), who considered churches, large lecture rooms and classrooms. The presence of children, desks, the covering of chairs and audience density were included in the preliminary work.

Electroacoustics

A disadvantage in the normal **inductive-loop communication** system for use in schools for the deaf is the cross-

(Continued on page 565)

talk between adjacent classrooms. A system employing multiple rectangular loops may be used to confine the induction field to the desired reception area and such a scheme was outlined by Bosman and de Boer (Netherlands). A disadvantage of the multiple-loop system is that at points above locations where the field is horizontally oriented a vertical pick-up coil experiences zeros in the field. This was avoided in the author's system by interleaving two loops and arranging that the a.f. signals differed in phase by 90° . A complex function was derived for the field, the zeros being arranged to fold back either at infinity or outside the reception area—the latter case being chosen. A conformal transformation was chosen which yielded the optimum distribution.

An electrostatic microphone using a foil electret was described by Sessler and West (Bell Telephone). The principle is that of the electrostatic headphone outlined at the 4th Congress. Polarized foil is prepared by heating to 150°C , in the case of a polyester (Mylar), or 230°C for a fluoro-carbon (Teflon), and then exposed to a potential of 4kV across a 2mm gap. Next the foil is allowed to cool in a d.c. field, after which the material exhibits polarization. The free-field amplitude response of an electret microphone is 50 c/s to 14 kc/s $\pm 1.5\text{dB}$ and with its capacitance of 500pF, a $6\text{M}\Omega$ load gives a lower cut-off frequency of 50c/s. The sensitivity is typically between -50 and -60dB with respect to $1\text{V}\mu\text{bar}^{-1}$. The sensitivity is constant to within $\pm 1\text{dB}$ over a period of 1.5 year and then decays with a time constant of 1.5 year.

The problems concerning the use of capacitor microphones are well known and, in particular, the low capacitance presented by the microphone has been an embarrassment. The technique of using an r.f. oscillator modulated by the capacitance variation presents a solution but introduces additional components, with their attendant problems. Another approach is used in a recently introduced S.T.C. microphone, and was described by M. L. Gayford. A field-effect transistor, with its high input impedance, is built into the microphone head and the associated circuitry consists of only three resistors. Mr. Gayford also referred to a further development in which a slice of semiconductor material forms the capacitor back-plate and the f.e.t. input stage and resistors may be formed on the same slice. Further, additional amplifier stages may be deposited or diffused on the same slice.

Measurements of loudspeaker intermodulation distortion were presented by Nakajima, Yamamoto and Nishimura (N.H.K., Japan) who pointed out that measured distortion gave greater values than could be accounted for by the usual explanation of suspension non-linearity, non-uniform air-gap flux and the Doppler effect. Intermodulation distortion measured against frequency for two non-axial and one axial positions showed that distortion increased with increasing off-axis angle. In the case of a dual loudspeaker, sound from the high-frequency cone was reflected by the diaphragm of the low-frequency cone, causing interference between the direct and reflected sound. In order to minimize this, the two cones had to be mounted in the same plane or two separated loudspeakers used.

Physical acoustics

An interesting paper in this section was read by R. K. Cook (National Bureau of Standards, U.S.A.) on sound radiation by earthquakes. Travelling surface waves originated by an earthquake gave rise to sound radiation by virtue of the vertical component of the earth's surface

motion. It was shown that sound waves were propagated upward at an angle almost perpendicular to the earth's surface. If the waves were sufficiently strong, they would reach the ionosphere and could cause appreciable Doppler shifts in frequencies of reflected radio waves. The infrasonic vibrations due to an earthquake in Alaska in 1964 produced recorded Doppler shifts of more than 3 c/s at a radio frequency of 4 Mc/s. Such shifts corresponded to a vertical motion of 200 m/s. The velocity of the sound waves was about 0.5 km/s.

A study of high-altitude noise background produced by atmospheric turbulence was made by Prof. Meecham and J. W. Wescott (University of Minnesota). The authors suggested that the infrasonic sound so produced may affect ground measurements and also that turbulence in the clear air, of interest to aircraft, may be detectable by the radiated sound. Power spectra and amplitude distributions were discussed and a theory presented of turbulent sound, incorporating shear effects.

Mechanical vibrations and aeroacoustics

An investigation into the effects of jet aircraft take-off procedures on noise control was reported by Gallo-way and Woodall (U.S.A.). The study was aimed at comparing the noise produced by various departure procedures including standard airline practice at Kennedy International Airport. The perceived noise levels associated with all current procedures used at the airport were found to be 5dB less than that produced by aircraft at full take-off power (over noise-sensitive areas). The greatest reduction of noise occurred for the F.A.A. "minimum noise" procedure which suggests a maximum power climb to the edge of the noise-sensitive area followed by a power cut-back to maintain a 500 ft/min climb rate at a fixed airspeed until an altitude of 3,000ft is reached.

The average reductions of perceived noise level were 7.5dB for turbo-prop and 8.8dB for turbo-jet aircraft compared with the "all procedures" case.

Musical acoustics

An unusual subject was contained in this section dealing with industrial music in Japan and given by T. Yoshida. It was expected that for certain types of factory work, music would have the effect of increasing production, but morale would not be affected. The results of various tests on 500 workers for over a year showed that the music had no effect on production but that morale could be controlled. Over the year morale and a positive attitude to work had developed to a large degree.

Dr. D. M. J. Manley discussed the subjective judgement of liveness and quality of recorded organ music. Subjects were required to estimate the relative quality and "liveness" (based on the amount of echo present) in recordings made from different positions in a cathedral. It was shown that a fair agreement existed between judgements of quality and liveness. Some of the tests resulted in a very even balance of judgement suggesting that only the most critical ears are capable of the refined judgements. The microphone position which gave the best quality and liveness was next to the choir—perhaps to be expected since the organist plays according to sound heard at this point. But it was expected from the liveness point of view that the nave would give more "live" results, owing to its length.

Electronic Laboratory Instrument Practice

11—TRANSISTOR TESTING

By T. D. TOWERS,* M.B.E., A.M.I.E.E., A.M.I.E.R.E.

VALVES have been around for over half a century and measuring instruments for them have become stereotyped. Transistors have been in common use only since the late 1950's, and new types still keep appearing, so that standard transistor test sets are yet some way off. This article examines the problems of testing transistors in the ordinary electronic laboratory, and gives some guidance on what commercial test sets are available.

Over the last decade national bodies have done much work on standardization of semiconductor measurements and have now reached some uniformity. In Britain, the work of the British Standards Institution is crystallized in its publication BS 3494 "Memorandum on Light-current Semiconductor Devices"—a mine of measurements information available from them at 2 Park Street, London, W.1.

In an ordinary laboratory, two types of transistor measurements arise: (1) "service" tests to ensure a device is not defective, and (2) "scientific" measurements to study exactly the characteristics of a device (usually for educational or circuit design purposes). Service tests are far the most common and can usually be carried out with relatively simple and inexpensive equipment. Many firms market suitable special testers for this, but engineers sometimes set up their own arrangement of standard laboratory instruments to do the job.

Commercial test sets for scientific measurements are not so readily available, and most investigators end up by building their own. For this work, no adequate text book yet exists, but BS 3494 is a useful guide both on what to measure and how to measure it.

Transistor measurements can be classified into four groups: (1) d.c., (2) low-frequency a.c., (3) high-frequency a.c. and (4) switching. As these call for different measurement techniques, we will deal with them separately below, although, in actual testing of a single transistor, you may have to use tests from more than one of the groups.

D.C. measurements

The d.c. (and a.c.) characteristics of transistors are much more affected by temperature than those of valves. Many transistor manufacturers specify their devices at a standard ambient temperature of 25°C. (a useful norm), but in Great Britain you will find, that, for much of the year, laboratory room temperature hovers around 18°C. Since semiconductor junction leakage currents can double when the temperature rises some 10°C., it is prudent to record ambient temperature, if you are looking for high accuracy. This will put you in a position to make compensating corrections if you want to.

The other peculiar feature of semiconductor devices that is sometimes overlooked is that measured character-

istics can be subject to "drift". A leakage current may fall quite considerably below its initial value after a short time. Some engineers always wait a fixed time after applying test bias voltages before taking a reading. (I myself count ten slowly, where drift is significant.)

And now, as to what d.c. tests tell you about a transistor, we might consider a common lab. problem—the "orphan" transistor. A good engineer picks up an unknown device and finds his mind working—p-n-p or n-p-n?—germanium or silicon?—high or low voltage?—high or low gain?—high or low frequency?

Multimeter D.C. Tests.—With nothing more exotic than the ohms range of your multimeter, you can discover a great deal about a transistor. The semiconductor diode shown in Fig. 78(a) shows a low resistance when a positive voltage is applied to the "anode", A, and a

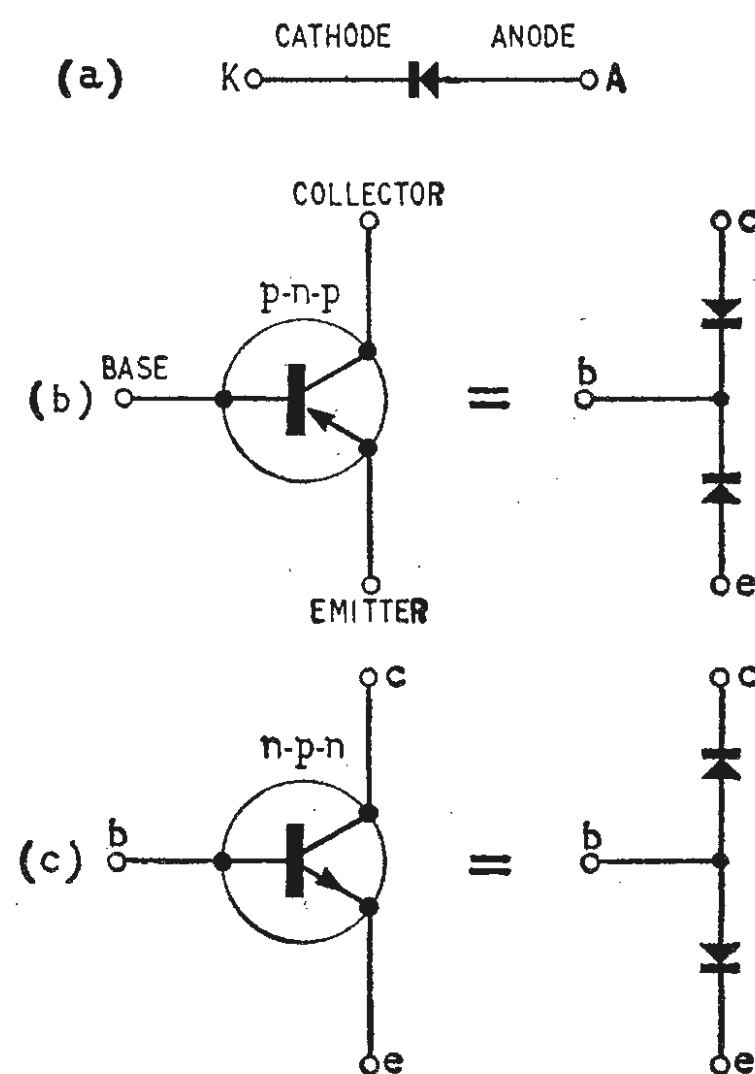

Fig. 78. Equivalent diode representation of transistor: (a) diode (low resistance when A positive, high resistance when A negative); (b) p-n-p transistor; (c) n-p-n transistor.

high resistance for a negative voltage. Now, for some purposes, you can treat a transistor as two diodes back-to-back as in Fig. 78(b) for p-n-p, and Fig. 78(c) for n-p-n; this enables you to use a multimeter for simple d.c. tests.

First of all you can identify the device leads, if not known. Measure the forward and reverse resistance between pairs of leads until you find two that measure high (over 10 kΩ or so) in both directions. In a good device, these must be the collector and emitter (which present the bidirectional high resistance of a pair of diodes back-to-back). In the normal three-lead device the remaining lead is the base.

Whether a device is p-n-p or n-p-n can also be worked out with the multimeter. (This depends on how the

* Newmarket Transistors Ltd.

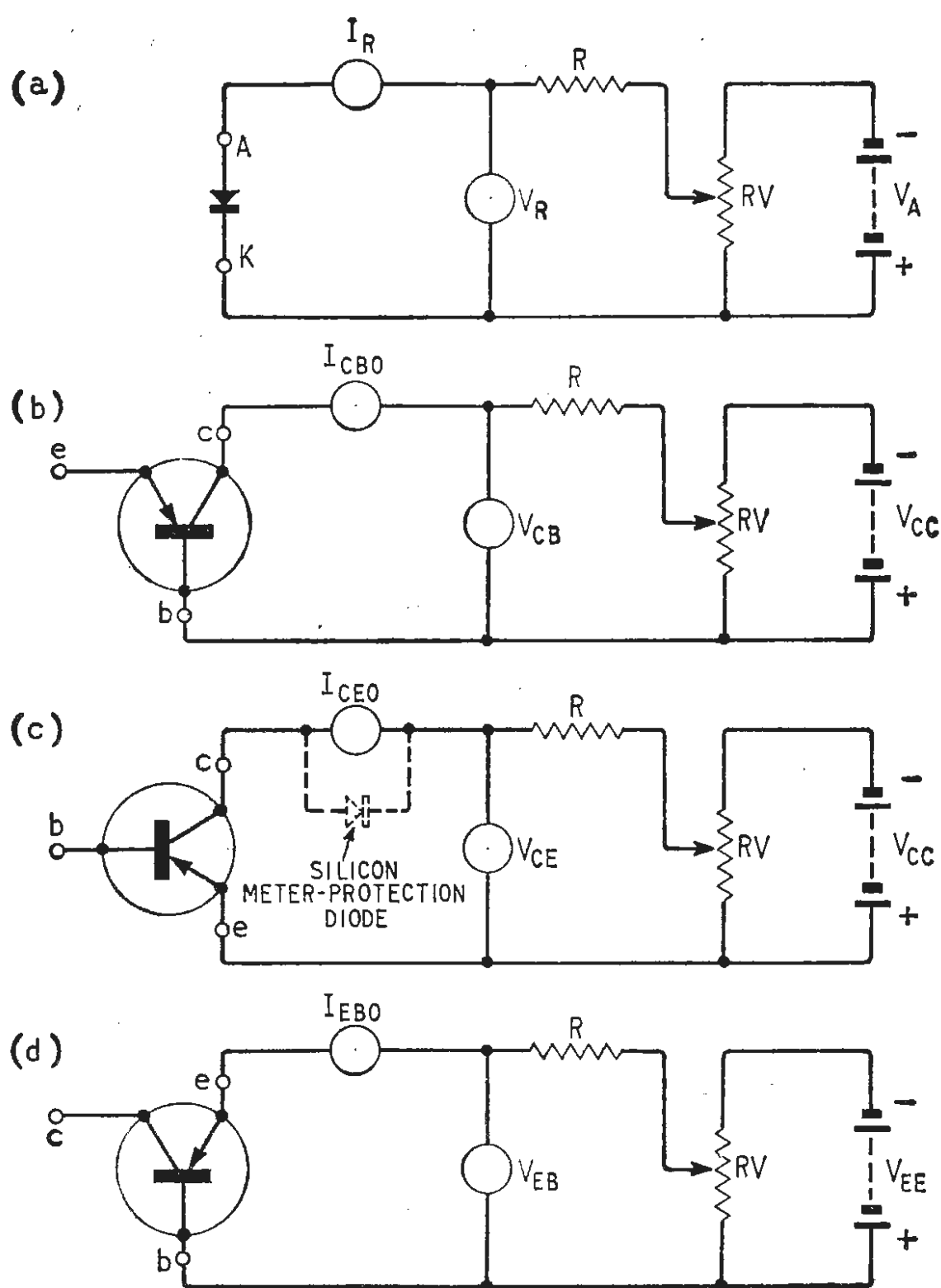

Fig. 79. D.C. tests of cut-off leakage currents: (a) reverse-biased diode (I_R); (b) collector-base junction (I_{CBO}); (c) collector-emitter junctions (I_{CEO}); (d) emitter-base junction (I_{EBO}).

internal battery of your multimeter is connected. In most instruments, in the resistance range, the battery provides at the meter terminals a voltage polarity opposite to the markings, e.g. at the positively marked—red—terminal there is a negative voltage.) If you measure the resistance from base to one of the other device leads, you should find it low (less than 5 k Ω) in one direction and high (greater than 10 k Ω) in the other. If the low resistance occurs when the positively-marked meter lead is connected to the transistor base, the transistor will be p-n-p-type, and the other way round, n-p-n.

The above check also tests that both emitter-base and collector-base junctions in the transistor are good. If either junction shows up high resistance in both directions, it is open circuit; and low resistance in both directions, it is "broken down."

With a multimeter, you can distinguish the collector of a transistor from its emitter, when you have identified these two leads as above. For a p-n-p. device, if you connect its base to the negative marked multimeter lead and measure collector-emitter resistance, you will find that in one direction the high collector-emitter resistance will have dropped more than the other. The device lead to which the multimeter positive-marked terminal is connected for greatest change of collector-emitter resistance is its collector. (For n-p-n. devices, interchange positive and negative in this procedure.)

Whether a transistor is silicon or germanium can also be decided with a multimeter. If the transistor base-collector junction measures more than 10 M Ω in the

high resistance direction, the device is silicon; if a few megohms or less, germanium.

The multimeter resistance measurements on transistors described above are essentially qualitative only. For more exact quantitative d.c. measurements, special test circuits must be set up as follows.

D.C. Current Leakage Tests.—The commonest current leakage tests carried out on transistors and diodes are the reverse-biased junction currents (illustrated below for p-n-p transistors):

- I_R = diode reverse current (Fig. 79 (a))
- I_{CBO} = transistor collector-base cut-off current with emitter open-circuit, sometimes known as I_{CO} (Fig. 79(b)).
- I_{CEO} = collector-emitter cut-off current with base open-circuit, sometimes known as I'_{CO} (Fig. 79(c)).
- I_{EBO} = emitter-base cut-off current with collector open circuit—sometimes known as I_{EO} (Fig. 79(d))

For I_{CBO} and similar tests, the bias voltage across the device is not usually set very high, because a lowish voltage test measures the highly-temperature-dependent part of the leakage current (which we are primarily interested in). Tests at high voltages, near to the device voltage rating, bring in other components of leakage current not much affected by temperature. Tests for temperature dependent leakage currents are, therefore, conventionally carried out at about 4.5–6 V for low power devices and 1.5–2 V for high power transistors.

In current leakage d.c. measurements accuracy better than about $\pm 20\%$ should not be looked for because of the effects of drift and the difficulties generally experienced in accurately measuring temperature and very small currents. Some indication can be given, however, of the order of magnitude of low-voltage leakage current to be expected at room temperature in different types of devices as follows:—

	Silicon		Germanium	
	Low power	Low power	Low power	High power
I_R, I_{CBO}, I_{EBO} (any single junction)	1-10nA	1-10 μ A	1-10 μ A	10-100 μ A
I_{CEO} (double junction)	10-200nA	10-200 μ A	10-200 μ A	1-10mA

There are several practical points connected with the leakage test circuits of Fig. 79. The one that sometimes strikes people most forcibly (in the form of a bent needle or other overload damage to a meter!) is that, if you do not limit the maximum permissible current by a series resistance R , a short-circuit junction can damage the current meter. Suggested starting design values for the circuit components are V_{CC} (V_{EE}) = 12 V, $R = V_C / (2 I_{max})$, where I_{max} is maximum current limit of the device in the table of the last preceding paragraph, and $RV = V_{CC} / (10 I_{max})$. As an alternative to an unprotected meter, you can use the current range of a multimeter with an overload protection relay.

Another meter protection arrangement becoming fairly common is a silicon planar diode connected in the forward-biased direction directly across the meter terminals (as dotted in Fig. 79(c)). Such diodes conduct only nanoamps until a voltage of some 500 mV is reached and then go rapidly into low resistance. As a moving-coil meter movement full-scale voltage drop is nowadays generally of the order of 100-200 mV, the silicon diode restricts overload to a safe value of not more than 500%. A good planar diode takes less than a nanoamp up to 200 mV forward current, and the shunt effect is negligible while the meter is on scale.

Direct-reading moving-coil meters with a better sensi-

tivity than $20\mu\text{A}$ full scale are unusual. Now silicon (and some low-power germanium) devices have leakages in the fraction-of-a-microamp region and for these a simple meter cannot be used for I in Fig. 79. This has meant that many of the general purpose testers now on the market are unsuitable for silicon measurements. A new generation of testers is appearing for this purpose, such as the Comark Type 180 capable of reading down to 100 nA f.s.d.

D.C. Breakdown Voltage Measurements.—Transistor manufacturers specify voltage ratings for their devices. These are *absolute* ratings which must not be exceeded, but users often want to know whether a transistor has been degraded in operation and what its "breakdown" voltage is. One way of doing this is to measure its leakage current as the test voltage is increased until the current begins to show a rapid rate of increase. The basic test circuit for this is the same as for the low voltage leakage tests in Fig. 79 except that V_{CC} (or V_{EE}) will now be high with R and RV values suitably selected. Rule-of-thumb leakage current limits sometimes used by engineers to estimate the breakdown voltage of a single junction of a device (I_R , I_{CBO} , I_{EBO}) are: silicon planar $5\mu\text{A}$, germanium low-power $50\mu\text{A}$, germanium power 5 mA . Typical breakdown voltages to be expected are: low-power devices $15\text{--}60\text{ V}$, high-power $30\text{--}100\text{ V}$. Typical circuit values for Fig. 79 when testing for breakdown voltages are $V_{CC}=200\text{ V}$, $RV=V_{CC}/(10 I_{max})$, $R=V_{CC}/(2 I_{max})$ where I_{max} is now one of the three limit values specified immediately above.

D.C. Current Gain Measurements.— After leakage current and breakdown voltage tests, the most important d.c. test is current gain. This is nowadays usually specified and measured as the current gain with input at the base and output at the collector (known usually as the "common emitter" configuration). The basic measurement circuit is shown in Fig. 80(a) for a p-n-p device. The characteristic, h_{FE} , being measured is formally known as the "static value of the short-circuit current transfer ratio" but in the engineer's jargon is usually called "d.c. beta" or "large signal beta" or "h-big-fe." The manufacturers usually specify h_{FE} for a stated collector current I_C and collector-emitter voltage V_{CE} . Under these conditions, a base current I_B is required to

Fig. 80. D.C. current gain (h_{FE} , "beta"); (a) basic measurement circuit; (b) convenient practical circuit for measuring h_{FE} ($V_{CB}=0$).

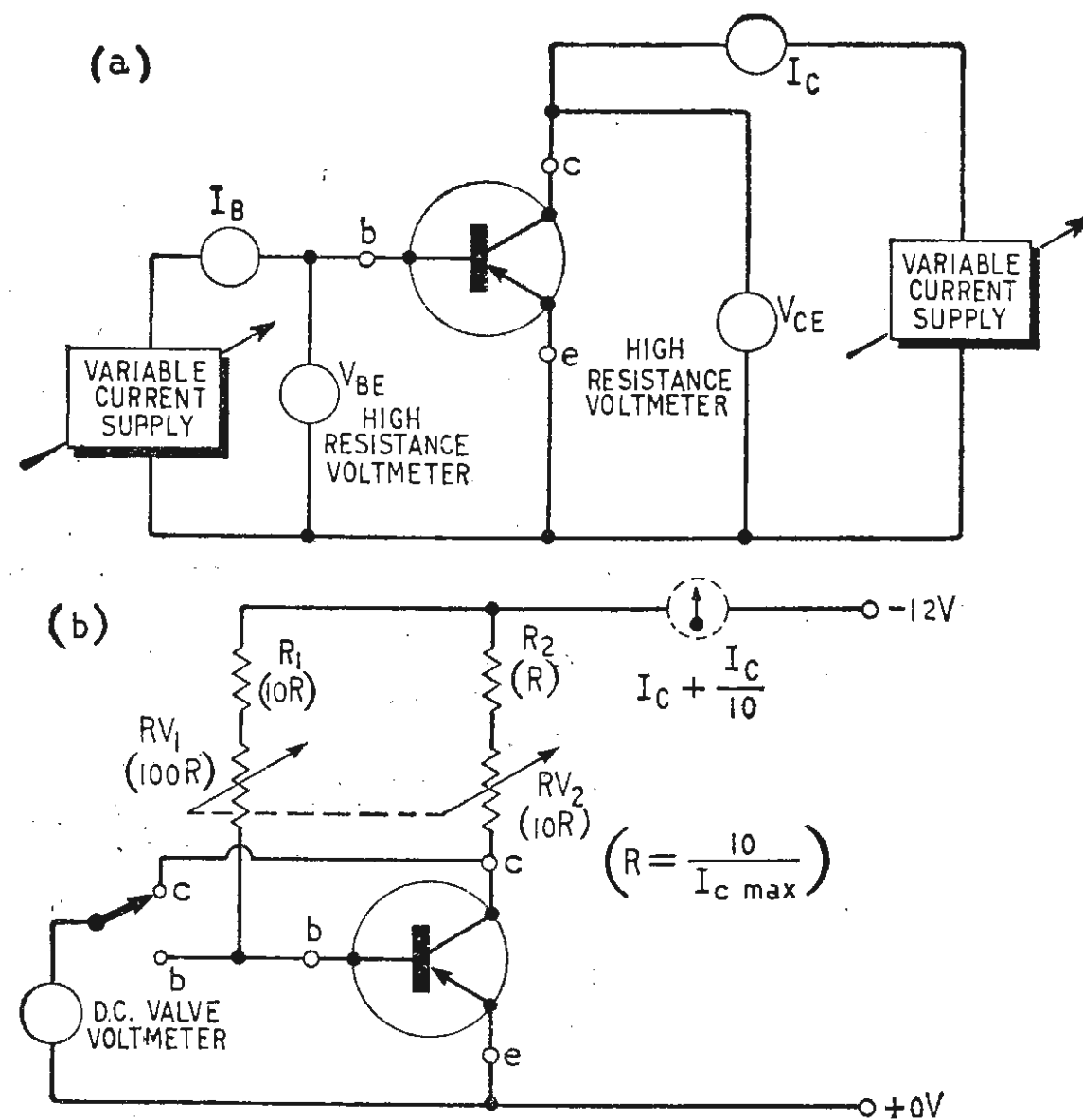
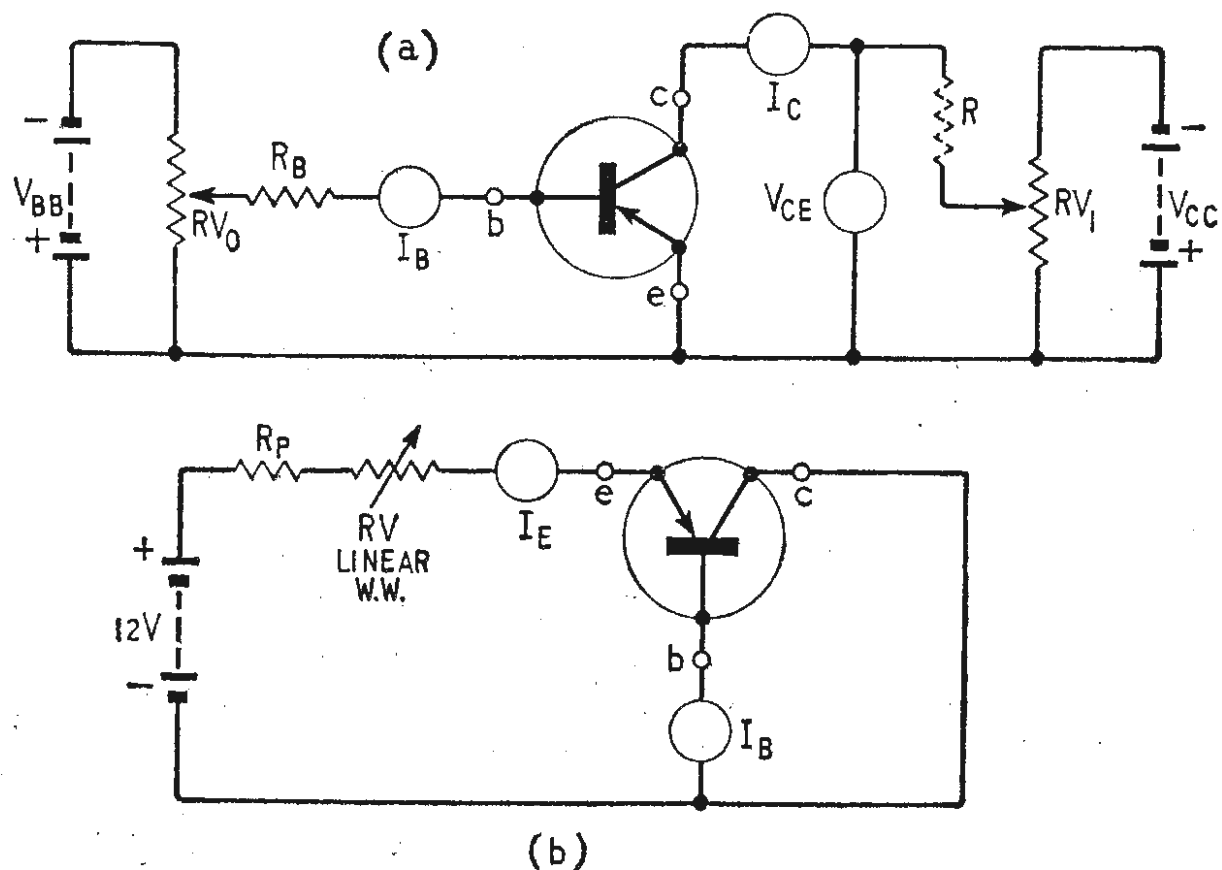

Fig. 81. Transistor d.c. saturation voltage measurements: (a) basic measurement circuit for $V_{CE\text{ sat}}$, $V_{BE\text{ sat}}$; (b) practical arrangement using d.c. valve voltmeter.

provide, by current amplification, the specified I_C . Then the d.c. current gain $h_{FE}=I_C/I_B$.

In practical test instruments there are many variants of the basic circuit used in an attempt to reduce the number of meters and to simplify measurement adjustments. The approximate collector current levels at which h_{FE} is measured varies from $0.1\text{--}10\text{ mA}$ for low-power silicon, through $0.5\text{--}50\text{ mA}$ for low-power germanium up to $50\text{ mA--}5\text{ A}$ for high-power devices. Collector voltages of some $6\text{--}10\text{ V}$ at the low-current end of the range and $1.5\text{--}2.0\text{ V}$ at the high-current end are common.

The d.c. beta of a transistor can vary considerably with collector current, but it does not change much with collector voltage above a certain minimum. This makes possible the simple practical d.c. beta test circuit of Fig. 80(b), which, with two multimeters, measures the current gain of the transistor with the collector and base virtually at the same voltage, i.e. $V_{CB}=0$. The approximate design value for the protective resistor R_P is $12/I_{Cmax}$ where I_{Cmax} is the maximum collector current at which h_{FE} is to be measured. The variable resistor RV can then be taken as approximately $9 \times R_P$ to permit measurement of h_{FE} with I_C from I_{Cmax} down to $I_{Cmax}/10$. A transistor is inserted and RV adjusted until the emitter meter reads the desired I_C (I_E can be taken as approximately equal to I_C). I_B is then read off and h_{FE} calculated from I_E/I_B . It will be found possible to calibrate RV approximately in terms of I_E , and do without the I_B meter, if many measurements are to be taken.

D.C. Saturation Voltage Measurements.—One other d.c. characteristic of a transistor that is of great interest, particularly in switching applications, is the collector-emitter saturation voltage, $V_{CE\text{ sat}}$. The basic circuit for measuring this (and the corresponding base drive voltage $V_{BE\text{ sat}}$) is given in Fig. 81(a). In operation, I_C is adjusted

(continued on page 569)

to the desired value, and I_B set at a value not less than I_C/h_{FE} . In recent years there has been a tendency to standardize on what is called a "forced beta" of 10, i.e., to set $I_B = I_C/10$ for saturation voltage measurements. The saturation voltage V_{CEsat} is then read on the collector voltmeter (V_{CE}), and the base drive voltage V_{BEsat} on the base voltmeter (V_{BE}). Both the voltmeters should be high resistance instruments taking a current of not more than 1/100th of the current in the circuit they are attached to. This is easy to arrange for the collector because the circuit current is high, but more difficult at the base where the circuit current is an order of magnitude less.

A practical circuit arrangement for rapid V_{CEsat} and V_{BEsat} tests is given in Fig. 81(b) using a sensitive d.c. valve voltmeter. By monitoring the total current ($= I_C + I_B = I_C + I_C/10$) with a multimeter (shown dotted in the figure) when a transistor is in the socket, it is possible to calibrate the ganged potentiometers RV_1, RV_2 in terms of I_C . The value of R is chosen equal to $12/I_{Cmax}$ for the transistor type to be tested. Then, with the values of other components shown, it is possible to preset I_C from I_{Cmax} down to $I_{Cmax}/11$, and measure both V_{CEsat} and V_{BEsat} by switching the d.c. valve voltmeter to collector and base.

A.C. measurements

Over half this article has been devoted to d.c. tests on transistors. The reason for this is not simply that they are easy to make. An engineer used to transistors soon learns that the d.c. characteristics are the ones that are most likely to change with time. Indeed it can be said that, except for current gain, the a.c. characteristics once built into a device by the manufacturer are virtually immutable.

The other important thing is that the a.c. gain correlates, very closely with the d.c. gain, so that if, for example, a device has a high d.c. beta it cannot have a low a.c. beta. This explains why knowledgeable engineers can repair transistor equipment with only a multimeter. If a suspected transistor passes the d.c. tests mentioned earlier, it is extremely unlikely that its a.c. characteristic will have changed substantially, so that there is usually no need to carry out a.c. tests on the device.

Low Frequency A.C. Measurements.—Much discussion will be found in standard transistor textbooks on equivalent circuit low-frequency small signal parameters. The more commonly used ones (for which commercial test sets are available) are the "tee" and "h" parameters. These are of considerable educational interest for theoretical circuit design. In practice, however, manufacturers do not set limits to them (even if they quote them in data sheets) so that they are little used for practical design work. Students interested should consult BS 3494 for details of a.c. low-frequency parameter measurements.

My own approach as a transistor engineer is perhaps a little unusual. When questions about small signal parameters at audio frequencies arise, I tend to reply that, with modern transistors, if a device is revealed to be good by appropriate d.c. tests, then I can assume that the collector output resistance will be so high and the collector-base feedback so low that they can be ignored. The a.c. beta can be taken for most purposes as equal to the measured d.c. resistance. For circuit design purposes, the only other characteristic of interest is the a.c. base input resistance. With audio transistors operated in the milliamp collector current region, the input resistance

can be taken to be $R_{IN} = 25h_{FE}/I_E$ ohms, if I_E is in mA. This and a knowledge that the base-emitter d.c. drive voltage will be of the order of 150 mV for germanium and 450 mV for silicon enables me to produce a circuit design to a practical degree of accuracy.

If you really must measure the low frequency a.c. beta of a transistor, then you may care to try the circuit given in Fig. 82 designed around instruments available in an ordinary laboratory. To calibrate, connect a $10\mu F$ capacitor from B to C and note valve millivoltmeter reading, V_o (corresponding to $h_{fe} = 1$). Remove shorting capacitor and note valve millivoltmeter reading

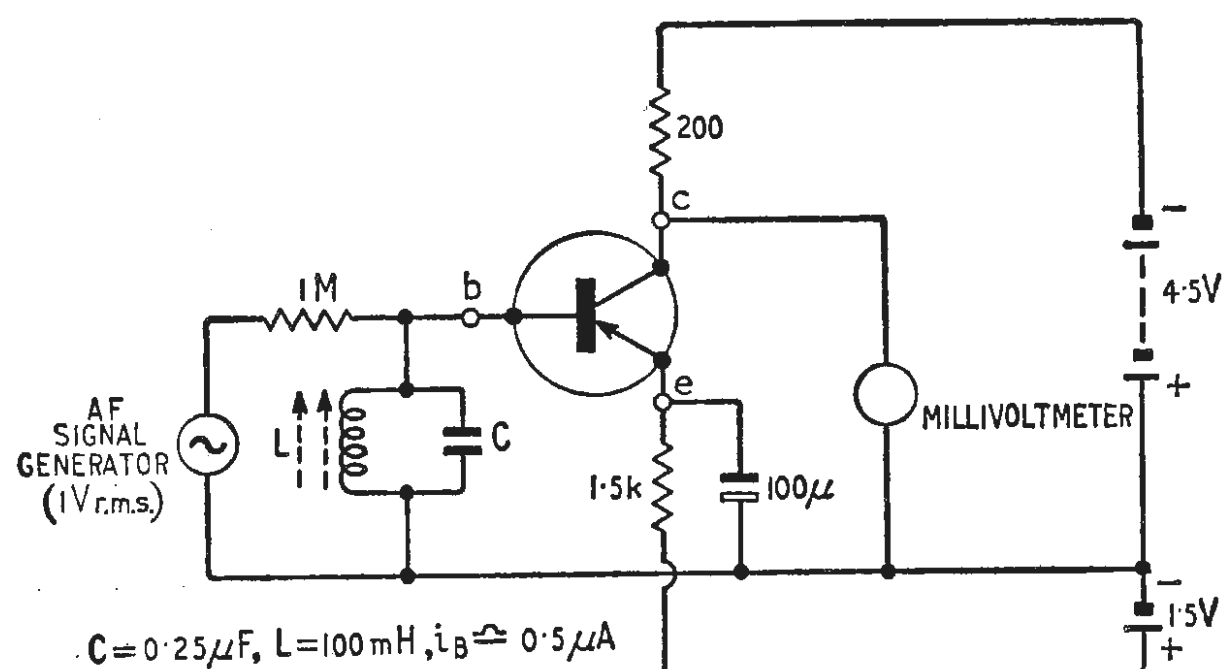

Fig. 82. Practical test set for low-frequency a.c. current gain— h_{fe} (1mA, 4.5V).

V_n (corresponding to transistor h_{fe}). Compute $h_{fe} = V_n/V_o$.

High Frequency A.C. Measurements.—The philosophy of substituting d.c. for a.c. tests applies also in r.f., v.h.f. and u.h.f. measurements. Accurate high-frequency measurements on transistors are much more difficult than audio frequency, and quite specialized. Because of the technical difficulties in making these measurements, you will find few commercial test sets which are direct meter reading. At the present stage of the art, there is a tendency to rely on bridge circuits. Well known in the transistor high-frequency bridge measurement field are the Boonton (Hewlett Packard) RX250A (250 Mc/s), the General Radio GR1607A (1500 Mc/s), the Hatfield Instruments LE300A (30 Mc/s), the Rohde and Schwarz ZDU/ZDD:Z-g Diagraph (3000 Mc/s), and the Wayne-Kerr B801B (100 Mc/s) and B901 (250 Mc/s).

The commonest problem connected with high-frequency transistors in the ordinary electronics lab. is to try to identify the frequency capability of an unknown device. In the absence of a good admittance bridge, there are two significant characteristics that you can measure with normal lab. equipment—not, it must be admitted, without a little difficulty. These tests are illustrated in Figs. 83 and 84.

As the frequency of operation of a transistor is gradually raised, the a.c. current gain h_{fe} (h.f.) begins to fall as illustrated in Fig. 83(a) eventually falling to unity at approximately f_T Mc/s. In the figure, a logarithmic scale is used on both axes. In the higher frequencies the curve tends to be linear, and it is found that h_{fe} halves for each doubling of frequency. This feature enables us to estimate the frequency at which h_{fe} falls to unity (and thus current gain ceases). At any frequency f on the linear fall-off part of the curve, $h_{fe} = f_T/f$. We can thus measure at a much

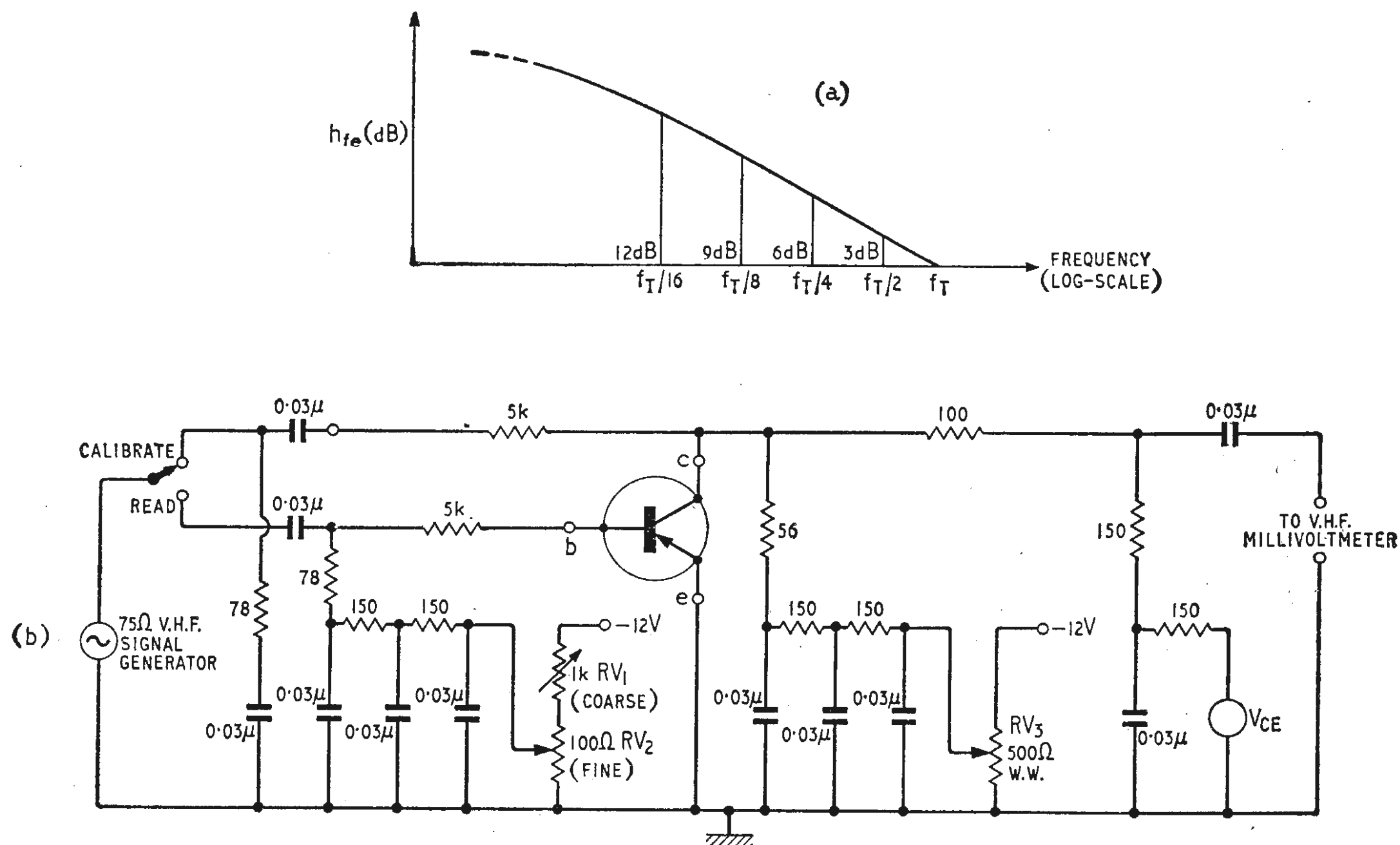

Fig. 83. Variation of transistor a.c. current gain with frequency: (a) fall-off of current gain with rising frequency; (b) circuit for measuring h_{fe} at frequency f well below f_T in order to calculate f_T ($f_{fe} \times h_{fe}$).

lower practicable test frequency and extrapolate to the high f_T frequency.

A suitable test circuit for measuring h_{fe} at a high frequency is given in Fig. 83(b). Calibration is done by switching the input through to the output in "calibrate" position (a) and noting the reading V_0 for $h_{fe} = 1$. Next change to "read" position (b) on the switch, and read output V_1 , corresponding to the actual h_{fe} of the transistor. Then f_T is computed from $f_T = f \times h_{fe} = fV_1/V_0$, where f is the measuring frequency.

The other significant high frequency parameter that can fairly easily be measured is T_{RC} , the "collector time constant" (which is the product of $r_{bb'}$, the extrinsic base resistance and C_c , the collector-base capacitance, of the transistor). Fig. 84 gives a suitable circuit for measuring T_{RC} .

To appreciate the significance of f_T and T_{RC} we should note that a good approximation to the maximum available

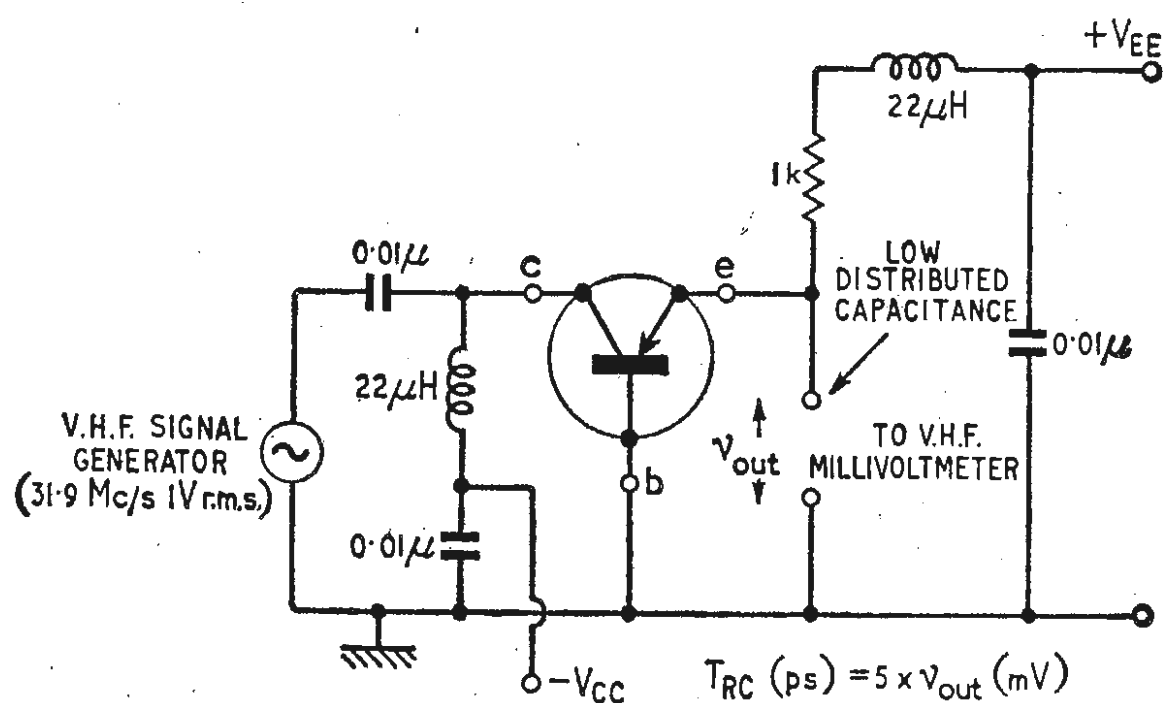

Fig. 84. Circuit for measuring "collector time constant" — $T_{RO} = r_{bb'} C_c$.

gain in a common-emitter tuned amplifier with matched source and load is

$$G_e = f_T / (8\pi f^2 T_{RC})$$

for a centre-frequency of $f > f_T / h_{fe0}$. Other things equal, therefore, a high f_T and a low T_{RC} are desirable.

Some idea can be given for values of f_T and T_{RC} to be expected. Germanium alloy r.f. transistors have an f_T (fairly accurately $= 0.8f_{co}$) of up to 20 Mc/s and a T_{RC} of the order of 500×10^{-12} seconds, i.e. 500 ps. Alloy diffused germanium transistors have f_T typically about 100 Mc/s and T_{RC} about 75 psec. Silicon n-p-n transistors are available with f_T from 50-1500 Mc/s and T_{RC} from 20-100psec. (For diffused transistors, incidentally, f_T is about half of f_{co} , in contrast to the figure of 0.8 quoted above for alloy devices).

Nowadays much transistor work at higher frequencies is being done by silicon planar devices, of which there are two main families—epitaxial and non-epitaxial. It is possible to distinguish them by their d.c. beta variation with current. In non-epitaxial devices, d.c. current gain falls off as the collector current is raised towards 10 mA; in epitaxial devices, current gain remains constant or even rises at the higher current.

Switching measurements

No explicit standard methods of measuring switching transistors have yet been devised. At one time it looked as if a special system of "charge parameters" might be universally adopted but this has not proved so. Most manufacturers tend to specify their transistors by switching response times in a functional test circuit. The switching time terminology (t_d , t_r , t_s , t_f) for a transistor is illustrated in Fig. 85(a). A typical manufacturers' data sheet functional switching time test circuit is given in Fig. 85(b) based on the Newmarket Transistors NKT120 series of germanium alloy r.f. switching transistors.

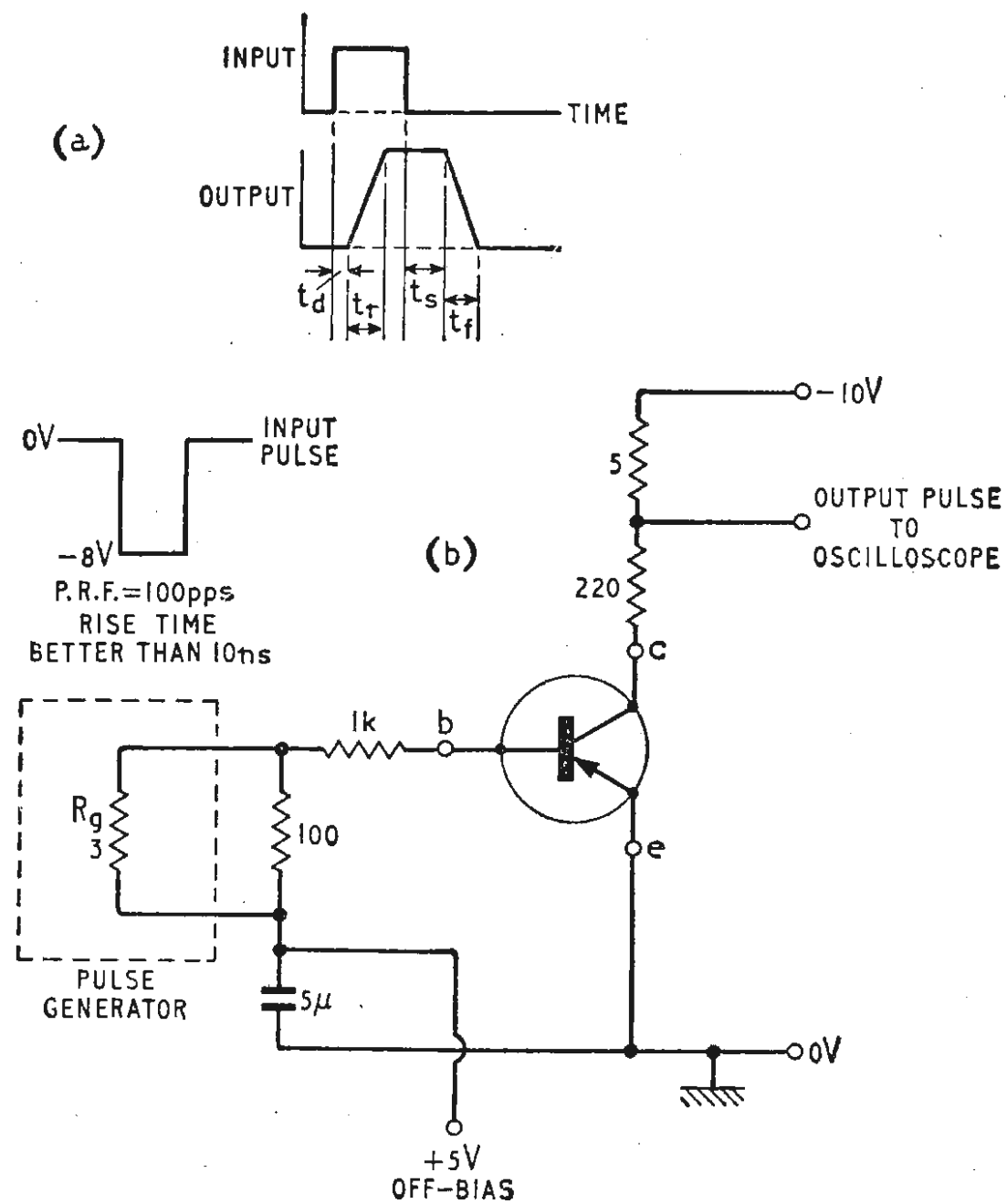

Fig. 85. Measuring switching characteristics of transistor: (a) transistor switching times (idealised) — t_d , t_r , t_s , t_f ; (b) typical measuring circuit for germanium alloy r.f. devices.

In practice it is difficult to carry out switching time measurements without special input pulse equipment. Several firms provide such equipment as indicated in the directory of manufacturers at the end of this article.

Curve tracers

The characteristics curve tracer is an oscilloscope fitted with special time-base facilities to enable the user to display the characteristics of a semiconductor device on the c.r.t. screen. There are many practical problems in building your own curve tracer and nowadays good commercial instruments are available from firms listed in the appendix.

The visual display of transistor characteristic curves has many advantages over a series of point-to-point measurements. Small irregularities are easily seen, two parameters may be observed together, short-sweep duty cycles enables inspection of characteristics in regions where spot tests would be thermally impracticable, dynamic performance can be inspected, and permanent photographic records are easy to make. The curve tracer is a most powerful tool for transistor investigation.

Practical aspects of transistor testing

The transistor tester field is changing so rapidly, that if you are contemplating investing in a tester you should consult the firms listed in the appendix.

If you are contemplating building one, get a copy of BS 3494 and work from there.

To save time in identifying transistor leads, you will find in Fig. 86 details of lead connections for a number of more common transistor encapsulations currently used.

When handling transistors remember that some have the casing electrically connected to one of the internal electrodes, so be careful not to short it accidentally to

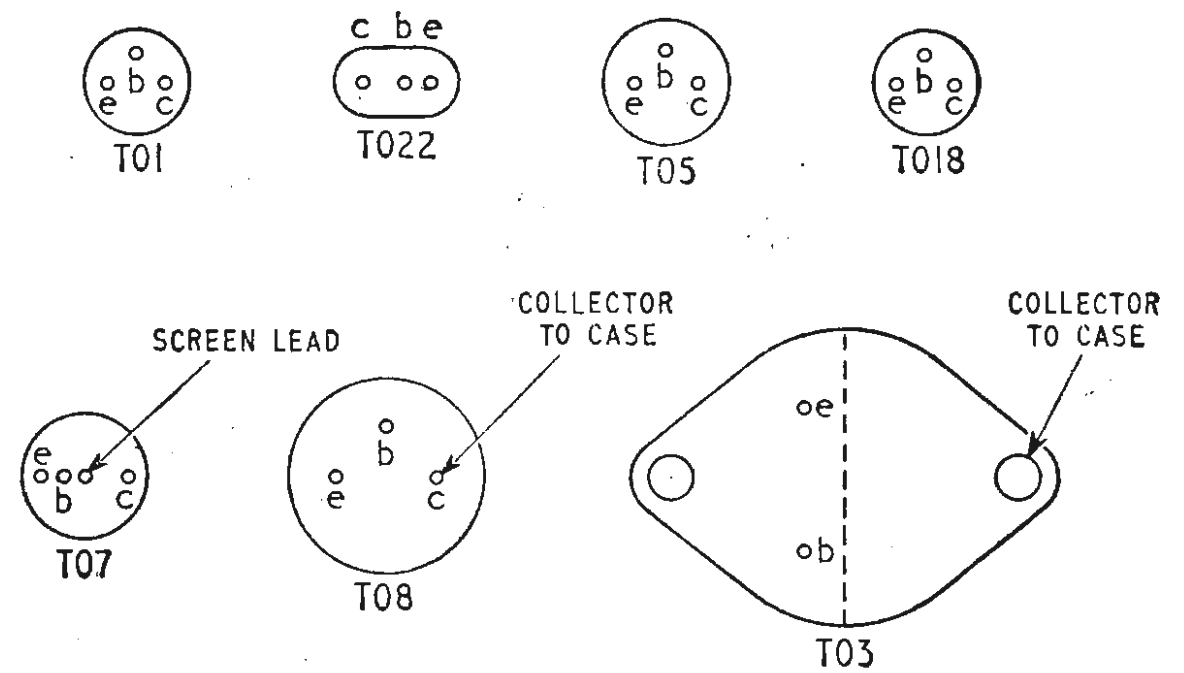

Fig. 86. Lead arrangements for more common transistor encapsulations.

other components in a circuit. Transistors do not stand overloads as happily as valves, and an accidental touch with a screwdriver on a transistor case can easily leave a "dead" device.

Finally if you are measuring leakage currents, remember how temperature-dependent they are, and hold the transistor by its leads rather than its case when setting up the test. You would be surprised how wildly leakage currents can vary with body heat applied *via* the casing.

MAKES OF TRANSISTOR TEST EQUIPMENT AVAILABLE IN THE U.K.

- Advance Electronics Ltd., Roebuck Road, Hainault, Essex (a)
 - A.E.I. Ltd., Telecommunications Transmission Dept., Woolwich, London, S.E.18 (a)
 - Avo Ltd., Avocet House, 93 Vauxhall Bridge Road, London, S.W.1 (a)
 - Baird-Atomic from H. Wood & Son Ltd., 23 Leman Street, London, E.1 (a), (e), (f)
 - Boonton from Hewlett-Packard Ltd., Dallas Road, Bedford (a), (b)
 - Comark Electronics Ltd., Gloucester Road, Littlehampton, Sussex (a), (e)
 - Cossor Instruments Ltd., The Pinnacles, Elizabeth Way, Harlow, Essex (a)
 - Elliott Brothers (London) Ltd., Wigton Gardens, Stanmore, Middlesex (c)
 - General Radio Company (U.K.) Ltd., Bourne End, Bucks (b)
 - Hatfield Instruments Ltd., Burrington Way, Plymouth, Devon (b)
 - Heathkit, Daystrom Ltd., Gloucester (a)
 - K. & N. Electronics Ltd., Cordwallis Street, Maidenhead, Berks. (a)
 - K.L.B. Electric Ltd., 335 Whitehorse Road, Croydon, London (a)
 - K.S.M. Electronics Ltd., 139 Fonthill Road, Finsbury Park, London, N.4 (a)
 - Labgear Ltd., Cromwell Road, Cambridge (a)
 - Metrix from S.T.C. Ltd., Testing Apparatus Div., Corporation Road, Newport, Mon. (a)
 - M.L. Aviation Co. Ltd., White Waltham, Maidenhead, Berks. (a)
 - Philips from M.E.L. Equipment Co. Ltd., 207 Kings Cross Road, London, W.C.1 (a)
 - Rohde & Schwarz from Avey Electric Ltd., South Ockenden, Essex (a), (b), (e), (f)
 - Taylor Electrical Instruments Ltd., Montrose Avenue, Slough, Bucks. (a)
 - Tektronix (U.K.) Ltd., Beaverton House, Station Approach, Harpenden, Herts. (c), (d)
 - Texas Instruments, Manton Lane, Bedford (d), (f)
 - Wayne Kerr Labs. Ltd., Sycamore Grove, New Malden, Surrey (b)
- Notes:—(a) direct reading test instruments; (b) bridge instruments; (c) curve tracers; (d) switching-time testers; (e) special device testers; and (f) production test sets.

NEW PRODUCTS

equipment systems components

U.H.F. "POCKET-TYPE" TRANSCEIVER

COMPRISING two units, a receiver and a transmitter, the new u.h.f. radio-telephone being made by Pye Telecommunications of Cambridge can easily be carried in the pocket and—through a base station—will provide good communication in densely populated areas with a range of 2 to 5 miles; the range being dependent upon the type of base station employed.

Operating in the band of frequencies 450 to 470 Mc/s, these "Pocketfones,"



as they are called, are substantially free from noise and interference and need only a very small aerial. On the transmitting unit the aerial can be pushed back into the case when not in use and

re-erected simply by operating a button (the press-to-talk switch) on the side of the case. An internal aerial is used in the receiver.

Frequency modulation is employed in a two-frequency simplex system with a peak deviation of 15 kc/s and channel spacing of 50 kc/s. The r.f. power output of the transmitter is 80 mW, and the a.f. output of the receiver is 60 mW.

Transistors are used throughout the receiver and the transmitter and each unit contains its own power supplies. These may take the form of either nickel cadmium, mercury or standard dry batteries; the first two types can be recharged without having to be removed.

A type of pulsing circuit is used in the power supply section of the receiver which, the makers claim improves the battery life by five times when compared with a more conventional circuit. No details are available on this circuit, other than that a patent has been applied for under No. 09850/65.

Dimensional details of the "Pocketfones" are as follows: the receiver is $6\frac{1}{2} \times 2\frac{1}{8} \times 1\frac{1}{16}$ in, and the transmitter is $6\frac{1}{16} \times 2\frac{1}{8} \times 1\frac{1}{16}$ in. Weights, when fitted with standard batteries are 9.7 and 9.4 oz respectively. The "Pocketfones" cost approximately £100 each and suitable base stations are about £300.

WW 301 for further details

Potted Bridge Rectifier Units

SINGLE PHASE, full-wave bridge rectifiers—in potted form and suitable for industrial and domestic applications—are being offered by the semiconductor department of the Electronic Apparatus Division of Associated Electrical Industries Ltd., Carholme Road, Lincoln. Six different types are available in the PJ series, with peak inverse voltage ratings of 100 to 1,000 V at temperatures of up to +150°C. Maxi-

mum mean forward current of 2 A is retained up to +55°C. It then falls linearly (according to the provisional derating curve) to zero at +150°C. Approximate d.c. output voltage is from 59 to 630 V according to type and price is from 20s 6d for the lowest p.i.v. unit (the PJ11B-A) to 45s 11d for the highest (PJ110B-A). Dimensions of the PJ units are $0.562 \times 1.38 \times 1.38$ in.

WW 302 for further details



ELECTRICALLY OPERATED TELESCOPIC MAST

A NEW series of telescopic masts, called Super E, with extended heights ranging from 16 to 40 ft are now available from A. N. Clark (Engineers) Ltd., of Binstead, Isle of Wight. These masts are suitable for mobile applications, such as in radio telephone installations, and can be extended in quite a short time; under 20 seconds for a 25ft mast. A similar time is taken for retraction.

Operating from a 12 volt supply, these masts may be driven from a vehicle's battery and are raised by means of compressed air. A dashboard-mounted switch is provided and can be connected (through the ignition system) to make the mast retract as soon as the ignition is switched on.

WW 303 for further details

Anti-static Cleaner

A GENERAL-PURPOSE cleaner that can be used on most surfaces to remove finger and grease marks, etc., is now being produced by Multicore Solders Ltd., of Multicore Works, Hemel Hempstead, Herts. It is non-toxic, non-flammable, and is available in 4 fl oz bottles, 1 and 5 gal drums. The retail price for the bottles is 4s 6d.

WW 304 for further details

MICRO-ELECTRONIC COMPUTERS for Scientific, Industrial and Commercial Applications

A NEW range of computers in which every central processor will use multi-chip integrated circuitry exclusively is announced by English Electric-Leo-Marconi Computers Ltd. This feature, the makers claim, has three main advantages—in cost, speed and reliability—over all previous computers and, of course, a substantial reduction in physical size. Another feature is compatibility with current machines. In fact, the Series 4, as it is known, will accept programmes now running—or scheduled to run—on many of the computers made by I.C.T., I.B.M., R.C.A. and General Electric Bull.

Although the Series 4 is a range of computers—containing four different central processors—it may be considered as one computer with a large range of capabilities, because each model is compatible with all larger models, and because each can be expanded (through modular construction) in computing power until the time comes to replace the main processor by a larger model.

The smallest central processor is the 4/10, which is no larger than an office desk. This is designed for small commercial applications—or for use as a satellite in larger installations—and has a core store of 4,096 bytes. Each byte is made up of eight bits (plus one for parity) and can represent either two decimal digits, one character or a binary number. The store capacity of the 4/10 can be increased up to a maximum of 16,384 bytes by plugging-in further or replacement units on site. Storage cycle time of 1.5 μ sec is quoted for one byte.

The next up in the range is the 4/30. This processor has core store of 16,384 bytes—which can be increased to 65,536 bytes—with a cycle time for two bytes of 1.5 μ secs.

The medium-sized processor in the range, the 4/50, has a cycle time of 1.4 μ sec for two bytes. Core storage is from 16,384 to 262,144 bytes.

The 4/70 is the largest in the range and has a very high store capacity—65,536 to 1,048,576 bytes. It has a cycle time for four bytes of 1 μ sec; interleaved to give an effective cycle time of 0.7 μ sec.

Initial programming languages chosen for commercial and scientific work on System 4 are Cleo, Cobol, Fortran and Algol. Other languages can, and will, be added as they gain international acceptance and as their efficiency is proved. All instructions in System 4 are

carried out by micro-programmes, which speed performance. In the 4/50 these micro-programmes can be supplemented by alternative sets to enable the computer to run programmes written for a wide variety of machines on the market (cutting down re-programming costs when changing from one machine to another). Internally the extended binary coded decimal interchange code is used.

For real time applications—such as in industrial process control applications, air traffic control, etc.—an interrupt facility is provided in System 4, and thus minimizes the time required to change from one programme to another by use of a system in which the contents of all registers do not have to be stored each time one programme interrupts another.

Multiprogramming (running simultaneously several programmes, which use different parts of the computer) is done on all of the machines in System 4, and on the two larger machines 15 programmes can be run at the same time. Only three programmes can be run at the same time on the 4/10 and 4/30 machines. Multiprogramming is controlled by an executive system which supervises programme priority and the general running of the machine.

In addition to standard peripheral apparatus, the System 4 range includes magnetic card files—with capacities of up to 500 million bytes—optical readers for characters and marks, and magnetic

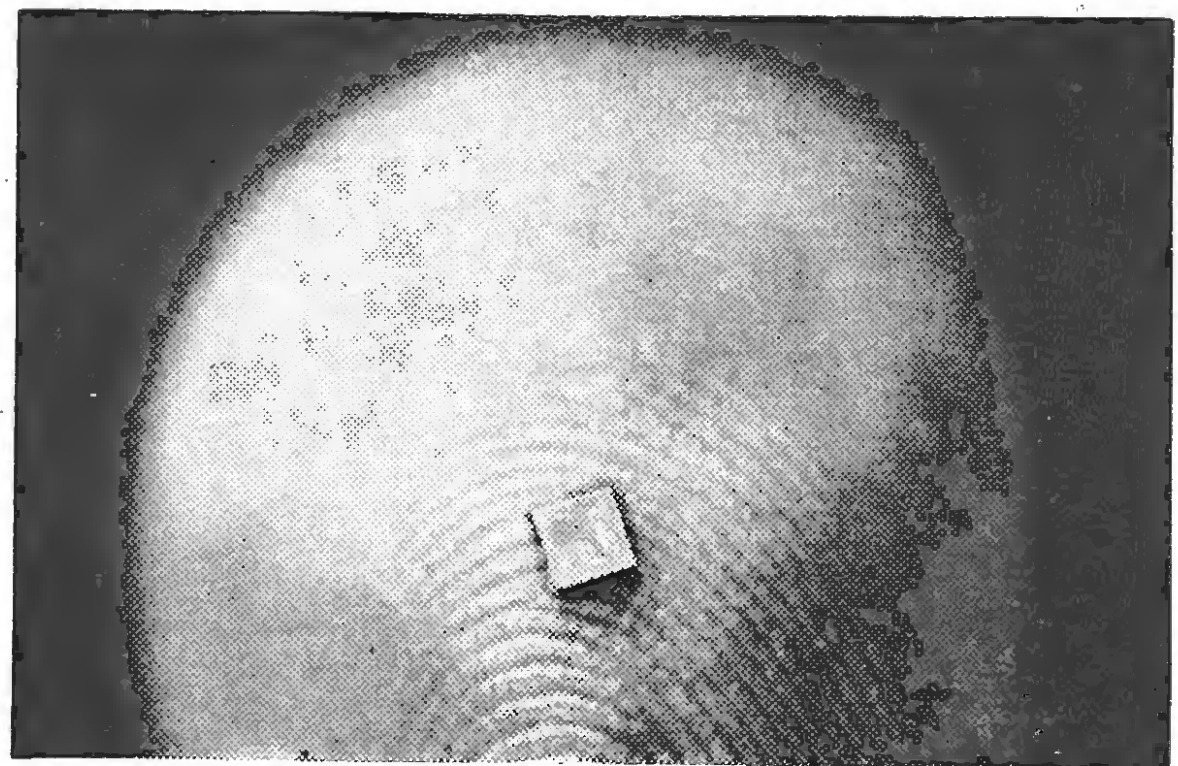

ink reading equipment. All the peripheral equipment, with the exception of very specialized and infrequently used equipment, will be made by E.E.L.M. In this way, the makers state, the American content of System 4 will be kept to a minimum.

Multi-chip integrated circuitry has been proved in the Marconi Myriad high-speed computer—the first production computer in the world to use this technique. This machine was developed for real-time radar data processing, but through its versatility is now being used as a high-speed, general-purpose computer for scientific applications. Three years' development work has gone into the System 4; at the company's research and development centres at London, Kidsgrove (Staffs.), and at the Marconi Company (Chelmsford, Essex). Production has begun at Kidsgrove and Chelmsford and the first System 4 computers are expected to be delivered during 1967.

The price of a small 4/10 installation is about £60,000 and the price of a large 4/70 installation is in the region of £1M.

WW 305 for further details

WIDE BAND ATTENUATOR

MAXIMUM error of 1.2 dB, including insertion loss, over the frequency range zero to 1 Gc/s is claimed for the Model 90-0 miniature attenuator announced by the Kay Electric Company, of Maple Avenue, Pine Brook, New Jersey. This unit has an input and output impedance



of 50 Ω and has a maximum power dissipation of 1 W. Maximum v.s.w.r. is quoted to be 1.2 up to 250 Mc/s and 1.5 from 250 Mc/s to 1 Gc/s.

One-per-cent tolerance carbon-film resistors are used in the attenuator pads which are switched into circuit by toggle switches with solid silver contacts. Nine pads are incorporated making it possible to select any attenuation level between 1 and 101 dB.

WW 306 for further details

LOW-COST COMPUTER

A FULL-SCALE computer has recently been introduced by International Computers and Tabulators for the smaller users, such as growing companies who cannot yet justify the cost of larger machines. The new I.C.T. 1901 central processor forms the basis of a new low-cost processing system, which is easy to install and to operate, and can cost as little as £20,000.

Although conventional paper- and magnetic-tape units can be used with this machine, a new type of magnetic-tape unit (illustrated) employing "push-in" cassette loading has been specially developed for use with the 1901 central processor. This unit does the same job as a conventional magnetic unit but is considerably cheaper. It uses 1-in magnetic tape (four cassettes), has eight recording tracks and operates at a nominal data transfer rate of 10,000 characters a second.

Magnetic-tape ancillary equipment is, of course, more expensive than paper-tape units, but the 1901 installation with the new cassette-loaded tapes is available for under £40,000.

A new commercial programming language has been developed for the 1901 called NICOL (Nineteen hundred Commercial Language). This simplifies transferring procedures from punched-card tabulator and calculator installations and enables users to transfer their work without a high level of programming skill. The manufacturers claim that personnel experienced in punched-card techniques can be trained to programme the 1901—using NICOL—in four days.

Several other programming languages are available for the 1901 and include:



Plan, an assembly system employing mnemonics specially prepared for the 1900 series; Cobal, an international programming language for general commercial applications; Rapidwrite, a simplified version of Cobal developed by I.C.T.; and Fortran, an international autocode for mathematical and scientific applications.

Core store capacities of 4,096, 8,192 and 16,384 are available for the 1901 central processor. Word length is 24 bits (plus parity) and store cycle time is 6 μ sec. Arithmetic is carried out in the binary mode, addition and subtraction each taking 34 μ sec.

WW 307 for further details

Moving-Magnetic Cartridge

FURTHER development on the STS 222 stereo cartridge by Elac has resulted in the announcement of a new cartridge, the STS 240. This retains the same basic design, but features a different stylus. Through the use of a light metal tube for the stylus holder, it has been found possible to further reduce the oscillating mass without any loss of strength. It has also resulted in better linearity of the response curve in the middle and upper frequency range. Frequency response is within ± 2 db from 20 c/s to 15 kc/s and less than 5 dB down at 20 kc/s.

The cartridge STS 240 is designed for

playing stereo and microgroove records and is fitted with a diamond stylus of 0.7 mil tip radius. A life span of approximately 1,000 hours is quoted for this stylus but, of course, this depends to a large extent upon the condition of the records played.

The stylus, which can easily be replaced, consists of a magnet, needle sleeve and tip forming one unit.

Electroacoustic, G.m.b.H., of West Germany, the manufacturers of these cartridges, are represented in the United Kingdom by Mitchell Enterprises Ltd., of 61 West Street, Dorking, Surrey.

WW 308 for further details

RESISTIVITY BRIDGE

RAPID measurement of the resistivity of semiconductor material in the range 0.01 to 1,000ohm cm is claimed with the semiconductor resistivity bridge being manufactured by the J. A. Radley Research Institute, of 220-222 Elgar Road, Reading, Berks. No preliminary calibration against standard samples of accurately known resistivity is necessary with this instrument which gives a direct reading—on a ten-turn dial—with an accuracy of $\pm 5\%$.

A simply-designed probe head using low-cost, replaceable needle probes with a spacing of 0.05 in is offered as standard. If one requires a higher degree of accuracy, the manufacturers recommend that probe heads and mountings produced by A. & M. Fell Ltd., of Lambeth High Street, London, S.E.1, be employed. The standard probe head uses a four-point, in-line assembly and has a maximum point pressure of approximately 250 gm.

An a.c. null-balance system is employed in this instrument. Low-frequency square-waves are applied to the outer probe contacts, with the measuring potentiometer (of the helical type with a scale length of 1,000 divisions) in series. A voltage is tapped off the potentiometer and applied to the primary of a transformer, the secondary of which is placed in series with the two inner probes and is 180° out of phase with the primary. The unbalance voltage is,

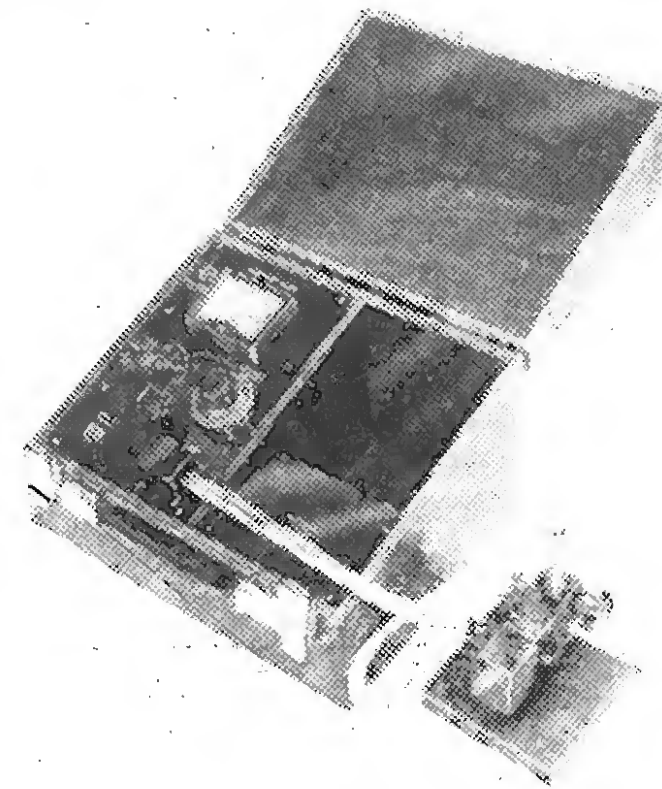

after amplification and rectification, applied to a microammeter which operates as a null indicator. To avoid conductivity modulation, series resistors are provided on each range to limit the current in the sample to 1 mA.

Dimensions of the instrument are 7 \times 11 \times 9 in; weight is approximately 10 $\frac{1}{4}$ lb. The price, including probe head and batteries, is £195. Less probe assembly it costs £165.

WW 309 for further details

LOW-COST SCOPE

THE OS15 general-purpose oscilloscope is the first to be produced by Advance Electronics Ltd., of Roebuck Road, Hainault, Ilford, Essex, although, of course, they have been marketing the Nagard range of oscilloscopes for some time. In the latter part of 1962 Advance acquired Nagard Ltd., but since the acquisition they have gradually run-down the production lines and have now closed Nagard's factory. (A number of Nagard engineers have been transferred to Hainault.)

Features of the new scope, which uses a 5-in helical PDA (Philips) tube giving a display area of 8×10 cm, include a calibration accuracy of 5% in both axes and ease of servicing—through the use of only one type of valve (ECF82) throughout the instrument and mounting most of the components on one board.

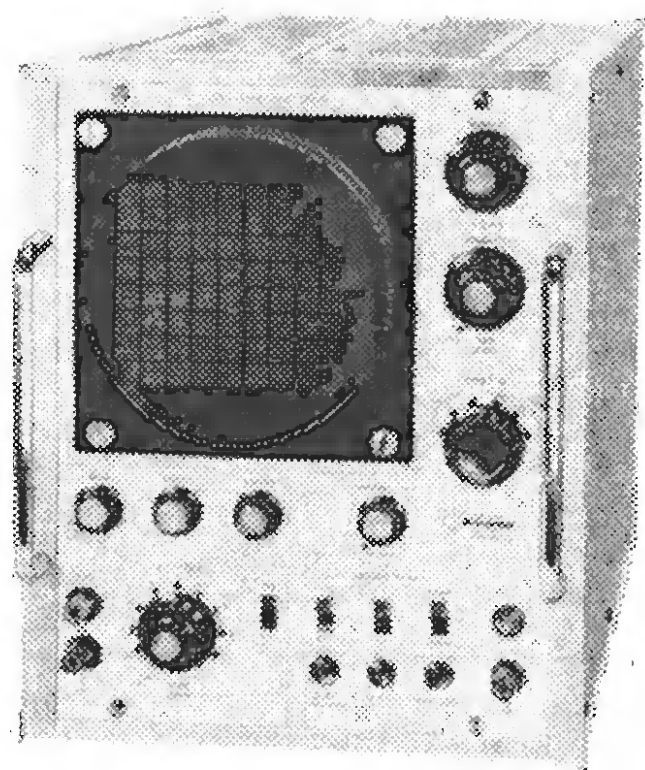

The total bandwidth of the vertical amplifier is from d.c. to 3 Mc/s with a sensitivity of 100 mV/cm. The timebase is adjustable (switched and continuous controls being provided) from 1 sec/cm to $0.5 \mu\text{sec/cm}$. Using the continuous control it is possible to expand the trace by up to two screen diameters along the X axis and any part of the expanded trace can be viewed at the centre of the screen.

Full internal triggering facilities are provided and external sources can be accommodated, including the triggering of the timebase from frame pulses of a composite television waveform.

The dimensions of the OS15 are $10\frac{7}{8} \times 8\frac{3}{4} \times 16\frac{1}{4}$ in and it weighs $18\frac{3}{4}$ lb. The price is £55 or £49 10s to educational establishments.

WW 310 for further details



Automatic Direction Finder

NO moving parts are used in either the tuning stages or in range selection in the new airborne a.d.f. equipment being produced by the Marconi Company, of Chelmsford, Essex. Designated AD370, it has crystal-controlled tuning, covers the frequency range 190 kc/s to 1.8 Mc/s and conforms to the latest airline specification ARINC 550.

Varactor diodes are employed for tuning in the r.f. stages—which are continuously variable, in 0.5 kc/s steps—and in the i.f. stages. Semiconductor diodes are used for range and crystal switching functions. Hence, moving parts have been eliminated from the receiver with the exceptions of a goniometer and servo meter—which replace the rotating loop aerial found in earlier direction finders. (The associated synchro transmitter has been retained to pass bearing information to the pilot's indicator.) Two relays used to switch the aerials out of circuit when the equipment is not being used are the only other moving parts in the receiver.

The tuning section contains three crystal-controlled oscillators to produce i.f.'s within 130.5 to 180 kc/s (accurately tuned by varactor diodes) with only 13 crystals instead of the usual complement of 36. Another feature of the receiver is that three separate detectors are employed—for servo amplifier, audio amplifier and for a.g.c. circuits. This permits a beat frequency oscillator to be used without affecting the direction finding accuracy, which is quoted as $\pm 2^\circ$, including Q.E. correction errors on all signals above $25 \mu\text{V/metre}$.

A decade type of frequency selector is employed which shows the selected frequency in $\frac{1}{4}$ -in high numerals. No fine tuning is necessary as the frequency controls select resistance networks that feed correct control voltages to varactor diodes in the r.f. and i.f. tuning stages.

At the moment, some 10,000 Marconi a.d.f. installations are in use in military and civil aircraft throughout the world.

WW 311 for further details

STYLUS TIMER

A SIMPLE manually operated stylus timer has been introduced by Lennard



Developments Ltd., of 7 Slades Hill, Enfield, Middx. Two versions are available, one for sapphire styli which indicates replacement after 70 to 75 hours' playing time, and another which indicates replacement after approximately 350 hours for diamond styli. The timer has to be operated once for 7-in records, twice for 10-in, and three times for 12-in records. Both versions are priced at 19s 6d and have adhesive backs.

WW 312 for further details

Portable Microwave Terminal

USING microelectronic techniques (thick-film circuits), the International Telephone and Telegraph Corporation have developed a portable microwave terminal that occupies only one cubic foot of space; including the weather-proof housing. Called the "Pico" terminal it is entirely self-contained (power supplies and an internal aerial being incorporated) and can be used for military and civil applications for carrying speech, radar or television signals.

Overall bandwidth is approximately 3 Mc/s (i.f. bandwidth is 35 Mc/s) and through associated equipment "Pico" can carry up to 96 telephone channels using pulse code modulation or up to 600 channels using frequency division multiplex. A linear modulation-demodulation system is employed to accommodate simultaneous multi-channel or broadband traffic.

"Pico" terminal equipment can be operated either in the frequency range 4.4 to 5 Gc/s or 7.125 to 8.5 Gc/s and has an output of 0.2 watts using varactor diodes. A 1 watt version is available, but is considerably heavier (27 lb as against 17 lb). Line-of-sight range is approximately five miles for the 0.2 watt version and about 10 to 15 miles for the high-power version. These figures can be increased by using external aerials, which are readily available.

Features of this terminal equipment include ease of setting-up and of operation. Another is that it may—with

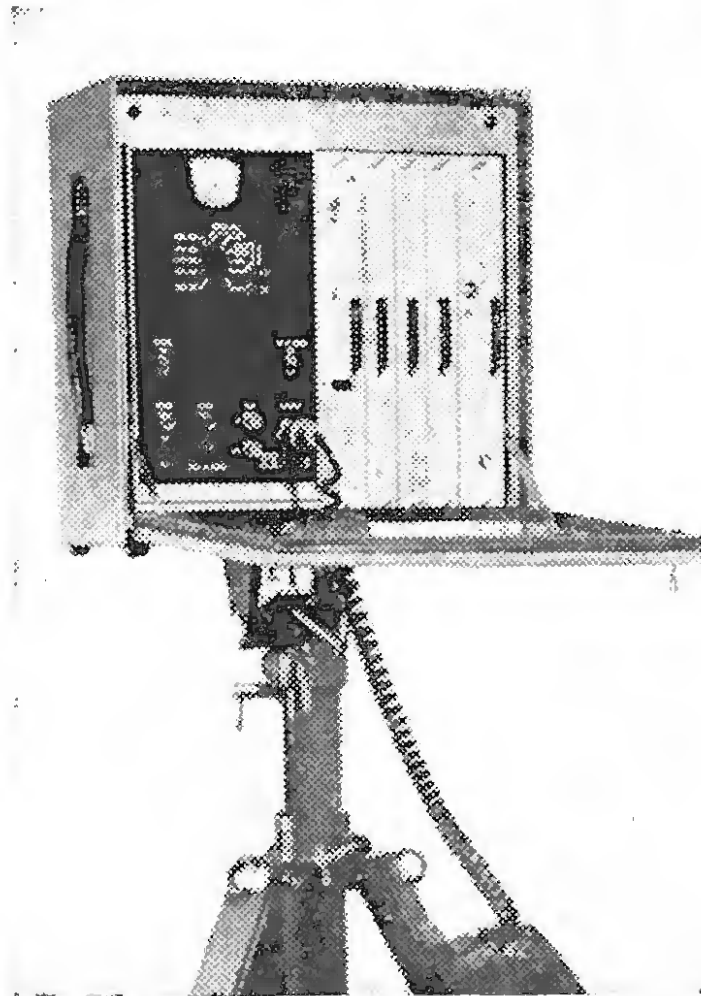

additional units—be used to provide tropospheric scatter transmission. Associated units for this application, including a 1 kW power amplifier, have been developed.

A Mk. II version with an improved internal aerial (illustrated) is to be made in the United Kingdom by Standard Telephones and Cables, an associate company of I.T.T. In addition, S.T.C. offer a wide range of equipment for use in conjunction with "Pico," including portable 4-channel frequency division multiplex, 24-channel p.c.m., telegraph, telemetering and data communication equipment.

WW 313 for further details

PHOTO-CHOPPERS

CONSISTING of a light source and a photocell, the photo-choppers being made by James Electronics Incorporated, of Chicago, operate as solid state switches and are designed to replace the mechanical choppers in d.c. operational amplifiers. They are also suitable for many other applications, for example in pH meters, electrometers, servo-control, speed sampling and similar systems where a low-noise switch is required.

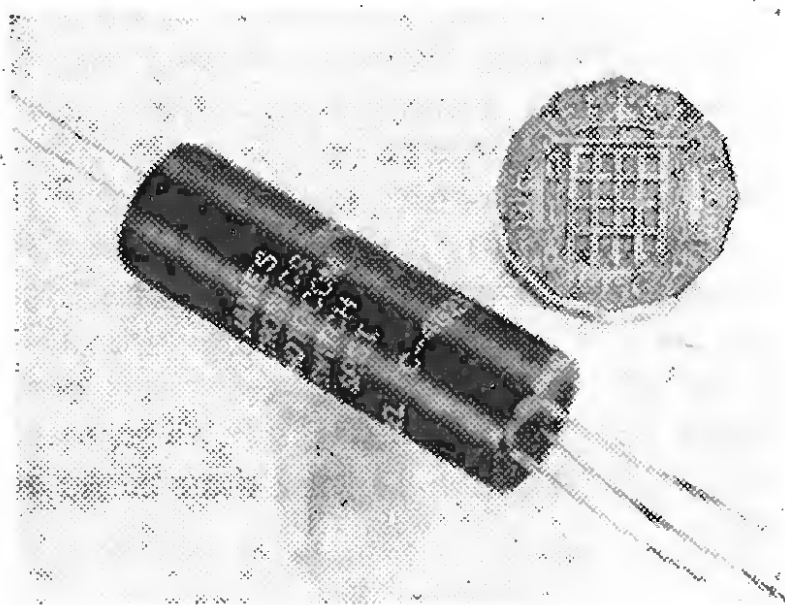

The standard unit, a single-pole, single-changeover device, can be supplied with either a low "on" resistance of 50 to 1,000 Ω (with an "off" resistance of 100 M Ω) or with an "on" resistance as high as 600 k Ω with an "off" resistance of 1,000 M Ω . Both low- and high-speed versions are available. When employed in chopper applications, the drive voltage quoted is 125 V d.c. with a maximum current of 50 mA; switched power maximum in all cases is 100 mW. Conversion efficiency is quoted as 90% at 25° C, 50 c/s with a 1 M Ω load and zero source impedance.

Each type of device is available with either axial connecting leads for printed circuit board mounting or with a shielded control lead. All types are encapsulated and internally shielded.

These photo-choppers are available in the United Kingdom through Kynmore Engineering Co. Ltd., 19 Buckingham Street, London, W.C.2.

WW 314 for further details

BRITISH MICROWAVE TUNNEL DIODE

RESULTING from work done at Associated Semiconductor Manufacturers Ltd., the manufacturing and development company for Mullard semiconductors, Mullard's have introduced a tunnel diode for microwave applications. Designed for use in low-noise amplifiers at frequencies up to S-band (2 to 4 Gc/s), the samples now available have minimum cut-off frequencies of 6, 8 and 10 Gc/s. These carry the Type Numbers AEY13 AEY15 and AEY16 respectively.

Characteristics of this diode include a typical negative resistance of 50 Ω , peak point current of 2 mA, peak point voltage of 50 mV and a series resistance of approximately 0.75 Ω . The valley voltage is 300 mV with a typical peak/valley ratio of 8.

An additional feature of this diode is its robustness, which has been achieved by using a tin/arsenic bead of only 15 microns in diameter. This small size reduces the amount of electrolytic etching necessary to produce the small junction capacitance essential in a device of this type.

The housing of the diode measures 1.5 mm diameter by 1.4 mm long. It has been designed to give a low inductance, by using a thin ceramic annulus of small diameter and by making short connections of rectangular cross-section to connect the p-n junction to the housing. The use of rectangular cross-section foil, instead of circular cross-section wire, also increases the mechanical strength of the device.

WW 315 for further details

Soldering Guns

HOT within three to four seconds after switch-on, is the tip of the soldering gun now available from the Weller Electric Corporation, of Blatchford Close, Horsham, Sussex. Two models are available, one with a 120-watt rating and another with a 275-watt rating. Both of these are suitable for operation from 240 volt, 50 c/s supplies (115 volt versions to order) and, in addition to warming up very quickly, they cool within eight seconds.

The smaller of the two guns is available as part of a kit containing two spare soldering bits, a supply of resin cored solder, brush, spanner and soldering aid. The price of this kit is £3 12s 6d. The small gun on its own (8100D) costs £2 17s 6d and the 275-watt gun (X8250 AD) costs £4 9s.

WW 316 for further details

NEW

PRODUCTS seen at the

Manchester Electronics Exhibition

EXPANSION was the key note to the Institution of Electronics' Northern Exhibition and Convention held this year, for the first time, at the Lancaster Hall, Belle Vue, Manchester. More than twice the size of previous exhibitions (held at the College), this year there were 71 stands, on which the products of nearly 200 companies were shown. These included components, instruments, industrial equipment and systems and attracted quite a lot of attention considering that a high proportion had been shown in London earlier this year. There were, however, a number of things on show for the first time and a few of these appear on this and the following page.

Several lectures and film shows were put on during the exhibition (Sept. 28 to Oct. 2) in the two theatres, also in the Lancaster Hall. These ranged from a lecture/demonstration for schools on the principles of colour television to a film on thin-film microcircuits.

Small Multipurpose Instrument

FORTY different measurement ranges covering a.c. and d.c. voltage and current, resistance and output, are provided on the small multipurpose instrument made in West Germany by Normafabrik Elektrik and marketed in the United Kingdom by Croydon Precision Instrument Co., of Hampton Road, Croydon, Surrey. In addition to these ranges the instrument, known as the Normatest Model 785, also contains a 12 mV d.c. range with a high sensitivity (40,000 ohm/volt) and a temperature scale in degrees Centigrade for connection to iron/constantan thermocouples.

The sensitivity on d.c. is 20,000 ohm/volt and on a.c. 4,000 ohm/volt. D.C. accuracy is $\pm 2.5\%$ and a.c. accuracy varies with frequency; maximum error being $\pm 3.5\%$ within 15 c/s to 500 c/s, $\pm 5\%$ to 5 kc/s and $\pm 7.5\%$ to 30 kc/s. The actual ranges are as follows: direct current 30 and 120 μ A, 0.6, 3, 12 and 60 mA, 0.3, 1.2 and 6 A; d.c. voltage 12, 60 and 300 mV, and 1.2, 6, 30, 60, 120 and 600 V; alternating current 150 and 600 μ A, 3, 15, 60 and 300 mA, and 1.5 and 6 A; a.c. voltage 1.5, 6, 30, 150,

300 and 600 V; resistance (with internal 1.5 V battery) 0 to 50 k Ω and 1 k Ω to 5 M Ω ; temperature $+20^\circ$ to $+240^\circ$ C; and level -20 to $+6$ dB at 1.5 V a.c.; with additional reading constants $+12$, $+26$, $+40$ and $+46$ dB at 30, 150 and 300 V a.c. The length of the scale is approximately 85 mm.

The dimensions of the instrument are 160 x 98 x 44 mm, and weight is approximately 0.35 kg. The price is £9 18s.

WW 317 for further details

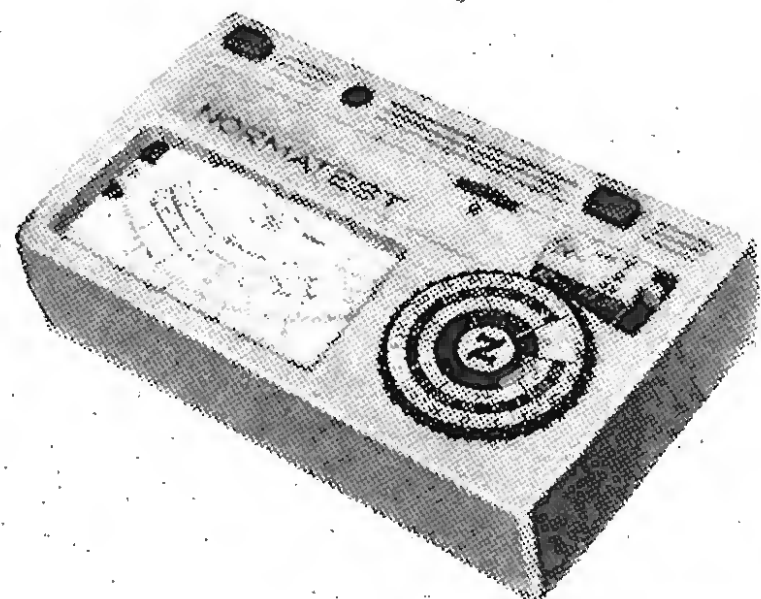

20c/s to 1Mc/s Signal Generator

THE sine and square wave outputs of the new Heathkit Model IG-82U signal generator may be used separately or simultaneously, without affecting either waveform. Through the use of separate output terminals and attenuator, the amplitude of either waveform can be varied without affecting the other.

Four switched ranges of attenuation, each with continuous variation, are provided for sine wave output from 0-0.01 V in decade steps to 0-10 V, and three for square wave—0-0.1 V in decade steps to 0-10 V pk-pk. Other specification details include a sine wave distortion figure of less than 0.5% and a square wave rise time of less than 0.15 μ sec.

In kit form, the Model IG-82U is available from Daystrom Ltd., Gloucester, price £24 10s. Assembled and tested, it costs £36 10s.

WW 318 for further details

COUNTER ACCESSORIES

TWO accessories have been introduced by Racal to improve the performance of their counters; a 15 Mc/s decade unit and an active probe unit.

Designed for direct use with the Racal Universal Counter/Timers Type SA 535A/B, the decade divider unit Type SA 548 (illustrated beneath a SA 535 counter) extends the frequency range of

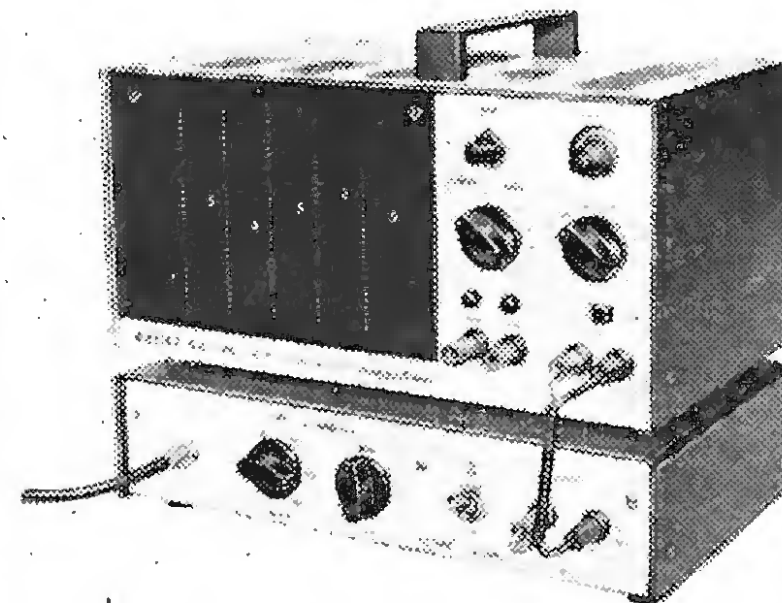

this series of instruments to at least 15 Mc/s. No degeneration is made to the basic counter accuracy, which in this case is ± 1 count ± 1 part in 10^6 . The divider will operate on signals as low as 100 mV and through attenuator pads (six ranges are provided) can cope with inputs up to ± 300 V. Output frequency is 1/10th of the input frequency and has an amplitude of 10 V pk-pk (8:2 mark-space ratio). The divider may also be used to extend the frequency range of the Racal counters Types SA 520A and SA 520B to at least 3 Mc/s.

The active probe unit, designated Type SA 544, contains a five-stage,

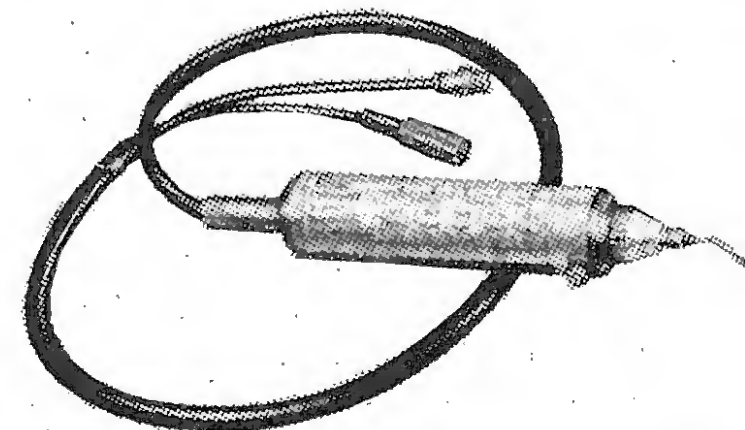

wideband transistor amplifier, frequency compensated to provide an overall gain of at least 40 dB at all frequencies between 10 kc/s and 100 Mc/s. A switched attenuator precedes the amplifier and allows selection of the desired sensitivity/impedance range. With this probe the sensitivity of the SA 540 and SA 550 counters, for which it was designed, is increased to 5 mV (from 10 kc/s to 10 Mc/s). For broadband coverage (0.1 to 100 Mc/s) the sensitivity figure quoted is 300 mV, with an input impedance of less than 5 pF.

The address of Racal Instruments Ltd. is Crowthorne, Berks.

WW 319 for further details

RANDOM SIGNAL GENERATOR

MANY applications are envisaged for the new random signal generator announced by the Solartron Electronic Group Ltd., of Victoria Road, Farnborough, Hants. Through the use of thyratrons working as noise generators, it is possible with this instrument to create a composite random signal with an adjustable crest factor (i.e., peak-to-r.m.s. ratio).

By means of push-buttons, cut-off frequencies from 0.032 and 0.1, by multiples of ten to 3.2 kc/s and 10 kc/s may be selected. An additional range with a cut-off frequency of 20 kc/s is also provided but requires external control.

The peak-to-r.m.s. ratio (crest factor) is adjustable in 12 steps from unity (random telegraph signal) to nearly ten

(for a near gaussian of 128 discrete levels). In general the absolute value and the crest factor of the output signal will be modified by the transfer function of any external filter, or by the system under test. However, provided these are linear, the change of crest factor with absolute value will not be affected.

Another feature of this instrument is that the bandwidth may be adjusted without affecting the total output power, which is adjustable up to 10 V pk (into 600 Ω with source impedance of 600 Ω). The peak level is independent of supply voltage, temperature variations, and the setting of any controls.

To obtain the random signal, the outputs of the thyatron noise generators are repetitively sampled and the polarity information of the samples is put into a counter. After n samplings, the output of the counter is "staticised" and provided in parallel binary code at the rear of the instrument and in analogue form at terminals on the front panel.

WW 321 for further details

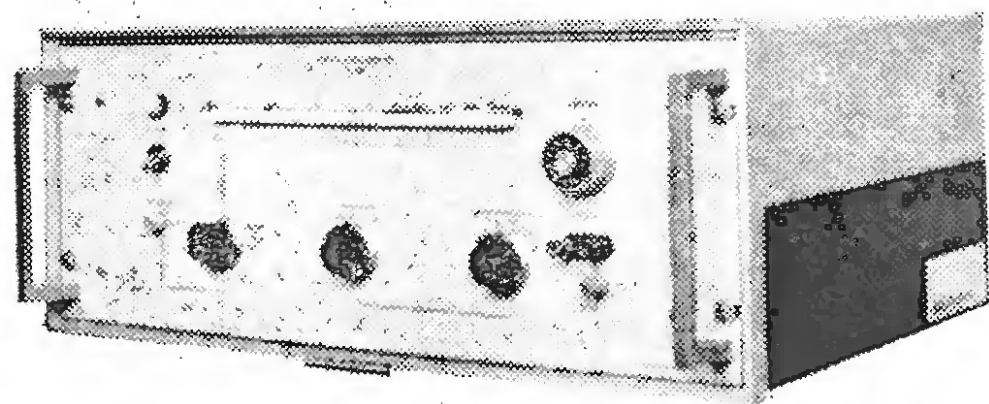

Push-button Bridge

A READOUT of up to five significant figures is possible with the Model B 641 Autobalance Universal Bridge being offered by the Wayne Kerr Laboratories Ltd. It is suitable for the measurement of capacitance, conductance, resistance and inductance, and has separate displays for resistive and conductive terms thus allowing the two components of impedance or admittance to be measured simultaneously. Overall coverage is from 1 pF to 10 μ F, 2 m Ω to 50,000 M Ω , 10 Ω to 100 M Ω and 1 mH to 10,000 H.

No rotary balance controls are fitted to this instrument as it incorporates two nulling circuits which automatically balance, giving continuous resistive and reactive terms of the measured component. Push-buttons are provided for range selection and for backing off (by decades). This results in a complete four-figure reading with continuous indication of any variations in either of the "unknown" terms. The meter sensitivity is automatically increased by a factor of ten when a digit is transferred. Both sets of push-buttons also include a zero to give increased meter resolution where backing off is not required, and a 10 to permit a measure of overlap without range changing.

The internal source and detector cir-

cuits operate a 1592 c/s ($\omega = 10^4$). Should other frequencies be required, it is possible to operate this instrument from external sources and detectors within the frequency range 50 c/s to 20 kc/s. Low impedance source and detector outputs are made available for feeding recorders, digital voltmeters and printers etc.

Although primarily designed for operation from 110 or 230 V a.c. supplies, the Model B641 can be driven from a 9 V d.c. supply. In this case, however, there is no illuminated display of the digital readout. The dimensions of the a.f. bridge are 10 $\frac{1}{2}$ \times 6 \times 19 in and the weight is 16 $\frac{1}{2}$ lb.

The address of the Wayne Kerr Laboratories is Sycamore Grove, New Malden, Surrey.

WW 320 for further details

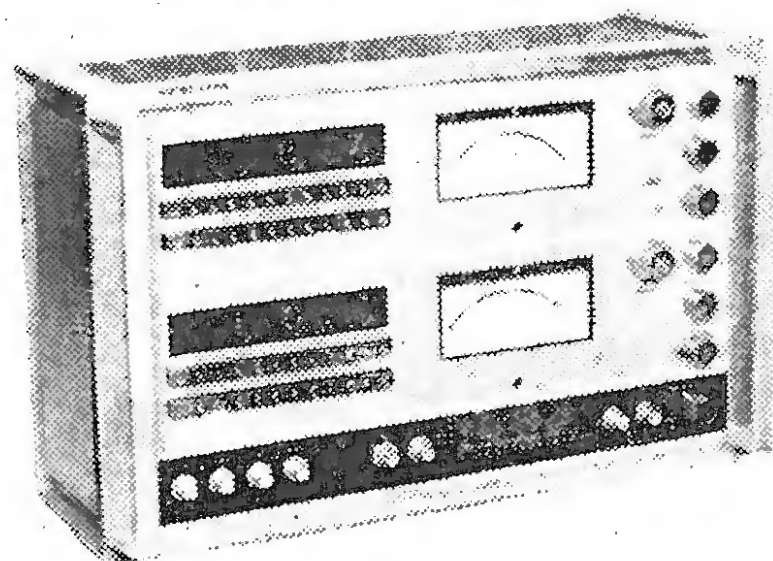

Power Supply Units

THE range of power supply units made by Trygon Electronics, of New York, which for some time have been marketed in the United Kingdom by Livingston Electronics Ltd., are now being manufactured in Britain. These units, which make use of silicon transistors, feature a regulation accuracy of 0.01 %, a recovery time of less than 25 μ sec and less than 0.5 mV ripple.

These units can be short-circuited without causing any damage and once the short-circuit is removed, the output voltage takes up its original setting. Other features include constant voltage operation with adjustable current limiting, and constant current operation with adjustable voltage limiting. An automatic cross-over network is also included that provides transition from constant voltage to constant current operation at any operating point. Remote voltage and current programming, and remote sensing facilities are also provided.

Measuring 5 \times 7 $\frac{3}{4}$ \times 7 in, these units may be rack mounted if required. Adaptors are available.

The address of Livingston Electronics is 31 Camden Road, London, N.W.1.

WW 322 for further details

Security Alarm Using Doppler Radar

THE French organization Société de Fabrication d'Instruments de Mesure (S.F.I.M.) have produced a security alarm using doppler techniques to detect movement. The equipment operates at 9 Gc/s and employs a transmitter giving a continuous output of 10 mW. This feeds a horn type of aerial (horizontally polarized) which has a beam width of 20 deg.

As a high frequency is used it is possible to detect quite slow moving objects and in this equipment any movement above 1.1 ft/sec operates the alarm circuit. As to range, the equipment will detect a man walking at a distance of over 50 yd.

The alarm may be operated from either the mains or from batteries and has a consumption of 25 W. If the mains from which it is driven are tampered with, the alarm circuit will automatically operate. The dimensions of the unit are 12 \times 12 \times 8 in and, inclusive of battery, it weighs 33 lb.

This equipment is available in the United Kingdom through their subsidiary S.F.I.M. (Great Britain) Ltd., at 218-221 Bedford Avenue, Slough, Bucks. The price is approximately £200.

WW 323 for further details

WESCON 1965

By AUBREY HARRIS, A.M.I.E.E., A.M.I.E.R.E.

HIGHLIGHTS FROM THE WESTERN ELECTRONIC SHOW AND CONVENTION IN SAN FRANCISCO

THE U.S. Western Electronic Show and Convention (WESCON) is held annually in California, and is the West Coast equivalent to the big I.E.E.E. show in New York every March. In alternate years WESCON comes to San Francisco which is the centre of a large complex of electronics companies and educational establishments with electronics interests. This year some 800 firms and other organizations were represented at the Show, which was held at the Cow Palace. The attendance during the four days of the event was over 38,000.

Two features not seen at similar European exhibitions were the Future Engineers' Show and the Industrial Design Exhibit and Awards. Participating in the former were 35 high school students, who were given the opportunity of exhibiting the results of their individual scientific investigations. The students' work covered widely diverse areas, as was indicated by the titles of their exhibits: "A controlled thermonuclear reaction," "Original design and construction of a tick tack toe (noughts and crosses) machine" and "Modulation of a laser beam." In the Industrial Design Exhibit were 17 designs selected by a jury from 150 entries. The purpose of the exhibit was to reflect the role of the designer in the electronics project team and to emphasize specific aspects of design—visual clarity and function, selection of materials for ease of production and maintenance, and human considerations.

At the accompanying convention, 132 papers were presented, divided into individual sessions on specific subjects. Of the 25 technical sessions scheduled, all but five featured project teams of engineers discussing a single project or programme. Five special sessions featured authors and panellists individually invited to participate. Twenty of the sessions were selected from proposals made by companies, universities, and military or private research centres. Each session was made up entirely of papers presented by engineers from the proposing organization or colleagues and consultants from other organizations contributing to the project. This method of presentation was a welcome change from the type of convention made up of many submitted papers from different sources grouped under loosely fitting session titles.

A session on a new series of computers—Spectra 70—was presented by RCA. Through the use of a standard interface new devices can be added without incurring major redesign costs. The series of computers is a "multi-lingual" system capable of accepting and processing a wide range of accepted codes and programmes. The common code structure is based on the Extended Binary Code Decimal Interchange Code (EBCDIC) of eight bits plus parity. The standard memory unit is called a byte. Memory access is as low as 0.84 microsecond and storage capacity is up to 524,288 eight-bit bytes.

One very important piece of peripheral equipment which must keep pace with computer development is the character reader. A. J. Torre described Videoscan, a high speed optical numeral scanner. A stylized font is used (designated RCA N-2) which can be read up to

a maximum rate of 1,500 characters per second. Initially a matrix of photo diodes was used to match the character to be read against a stored vocabulary. Increasing the resolution of the memory was costly and the system was intolerant of character distortion. Improvements in reliability and ability to operate at higher ambient light levels were obtained through the use of a vidicon tube as the optical transducer. Lag was kept to a minimum by increase target thickness and by the use of scan-to-scan cancellation. Character identification is performed by comparison of the video waveform against a 16-zone density reference.

Two papers were presented by Charles F. Spitzer and R. V. Markevitch (Ampex Corporation) on film scanning and recording by electron beam. Very little has been written on this subject since Dr. Glenn's report in 1959. In the system described by Dr. Spitzer an electron beam accelerated by a potential of the order of 15 kV is made to scan transversely a 3 mil thick 35-mm polyester film (Fig. 1). The film is coated with a silver halide emulsion which is only slightly sensitive to visible light (about ASA 0.003). However, the emulsion needs only a short exposure under direct electron beam bombardment as the energy in the beam is several times that of a light beam. Intensity modulation is normally employed. Only a small amount of y-deflection is needed as most of the longitudinal scan is effected by the movement of the film.

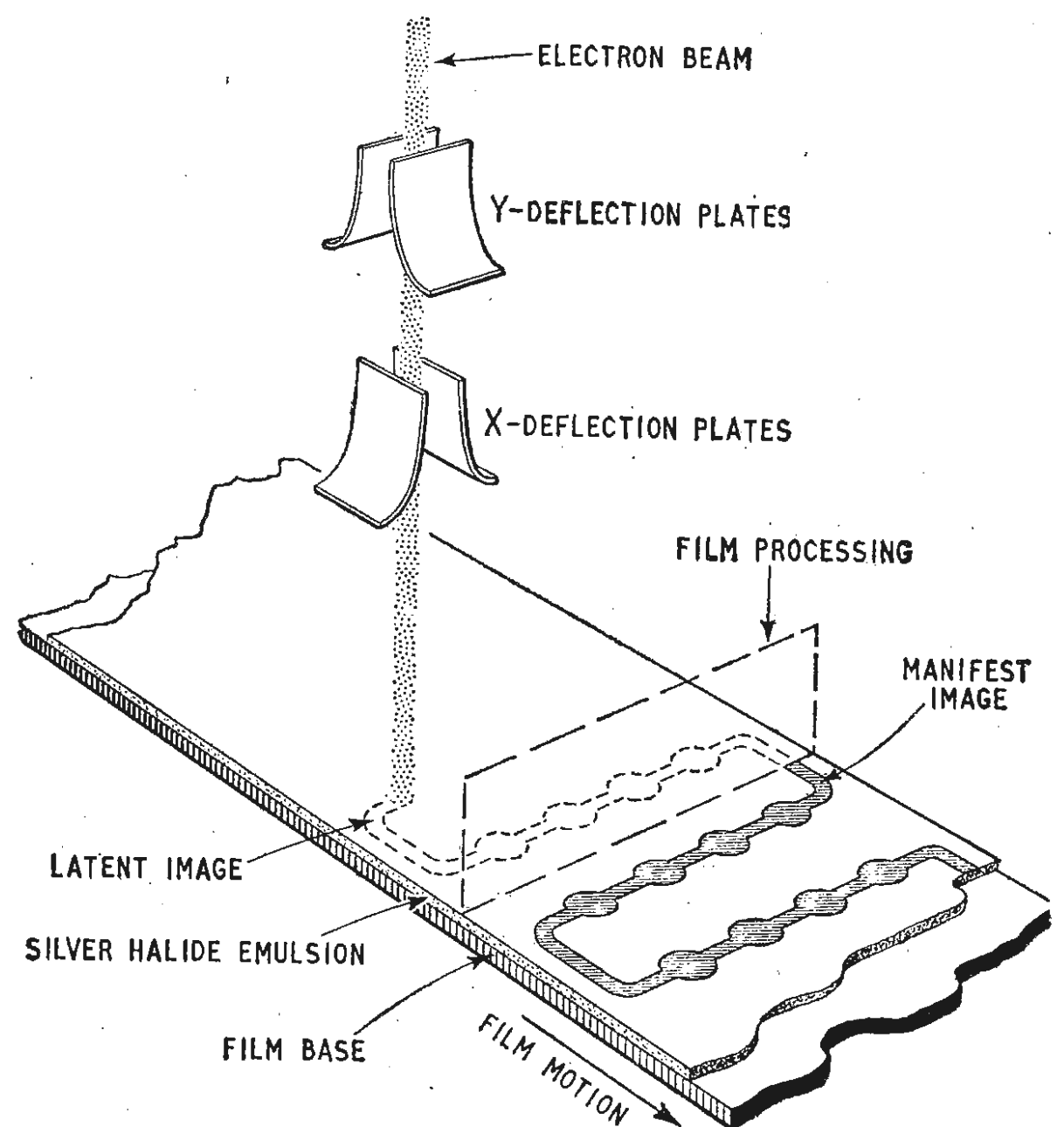

Fig. 1. Electron-beam recording. The beam is made to traverse a silver halide coated film as shown, and the image so produced is subsequently made visible by conventional photographic processing.

At the end of each scan in the x -direction, the y -plates move the beam just enough to avoid double exposure of the film as the x -scan is reversed.

The film is processed in a similar manner to regular photographic film and the result is a transparency with a high-resolution raster, the lines of which are some 0.0003 inch wide. During processing, the film is coated with a plastic scintillator.

Reproduction of the recorded image is performed by scanning again with an electron beam in a vacuum. The beam impinges upon the scintillator, which produces light in a grainless manner, and the light is then collected by photomultiplier tubes. Typical performance figures given were: bandwidth 65 Mc/s, signal-to-noise ratio 30 db, and line scanning velocity 8.2×10^4 in/sec.

"Miniaturized power conversion techniques" were discussed by D. E. Wuverlein (Gulton Industries). He described a typical design for an inverter power supply for a fighter aircraft, in which transistor storage time losses were compensated for automatically. It is storage time loss that in many cases limits the frequency at which the inverter in a power supply will operate. Higher frequency of operation allows reduction in the size of power transformers and filter components, and in the example quoted, the inverter operates at a frequency of 4 kc/s. Compared with the conventional aircraft supply, using a 400-c/s input with a transformer followed by rectifier, the efficiency has been increased from about 60% to 73%. The overall packaging density is approximately 50 watts per cubic inch and 800 watts per pound.

A solution to the problem of transmitting from airborne or orbiting bodies the great mass of data collected by them has long been sought by telemetry engineers. C. M. Kortman (Lockheed) in his paper "Data compression and adaptive telemetry" described some

methods now being tested which enable a reduction in bandwidth to be made, with a consequent lowering of transmitter power requirements. Basically, the equipment deliberately takes more samples of the data than strictly necessary but rejects all samples with values lying between certain predetermined limits or tolerances. One technique, known as the "zero-order predictor," assumes that if each new sample of data is the same as the last one transmitted, it is redundant and therefore can be rejected. However, as soon as the value of a sample falls outside the range of a predetermined reference, the value is transmitted and is also used as the new reference. This method is superior to a simple slow-rate sampler, which could easily fail to detect a brief but significant change in data level.

A further refinement is the "zero-order polynomial interpolator" which is similar to the predictor except in the method of selecting the redundant information. The interpolator averages the highest and lowest values within a set of data and uses the arithmetic mean as the reference for determining the out-of-tolerance value.

Some new monolithic integrated circuits for computer applications were described by J. W. Martin (Texas Instruments). A very common circuit using discrete components for NAND-NOR logic applications is shown in Fig. 2 (a). This arrangement is a very effective one, but the resistor values must be kept within a relatively close tolerance (10%), a negative supply is required and a low spread on the transistor beta must be maintained. The monolithic equivalent of this circuit, Fig. 2 (b), overcomes these disadvantages. This intermediate amplifier Tr1 provides sufficient drive to the output transistor, Tr2, to permit the use of a low value R_3 , thereby eliminating the negative supply requirement. Further, the tolerance on the values of the resistors may

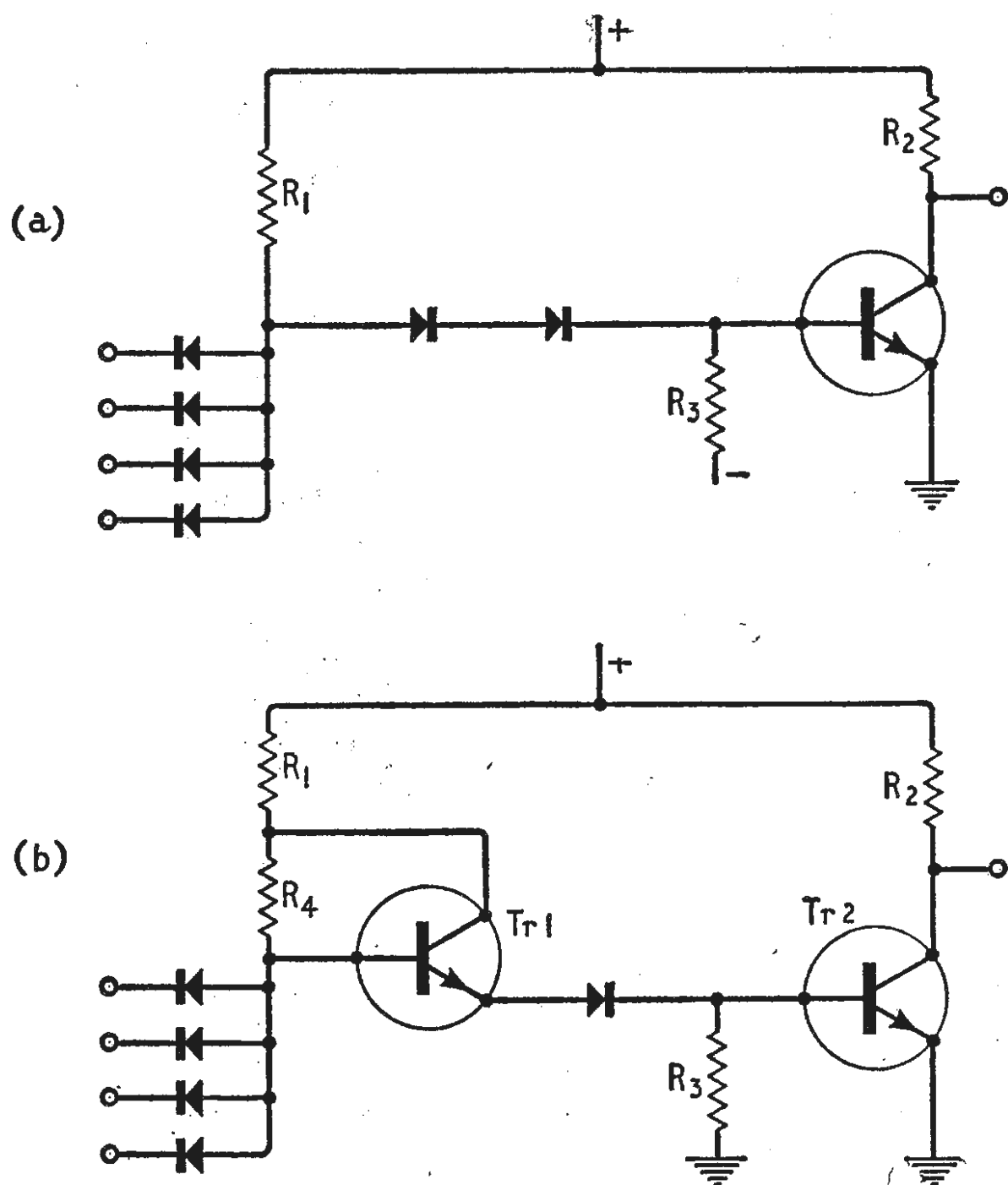

Fig. 2. (a) Conventional diode-transistor logic circuit for NAND-NOR functions; (b) monolithic integrated circuit with intermediate gain stage, Tr1, allowing, among other advantages, looser resistor tolerances.

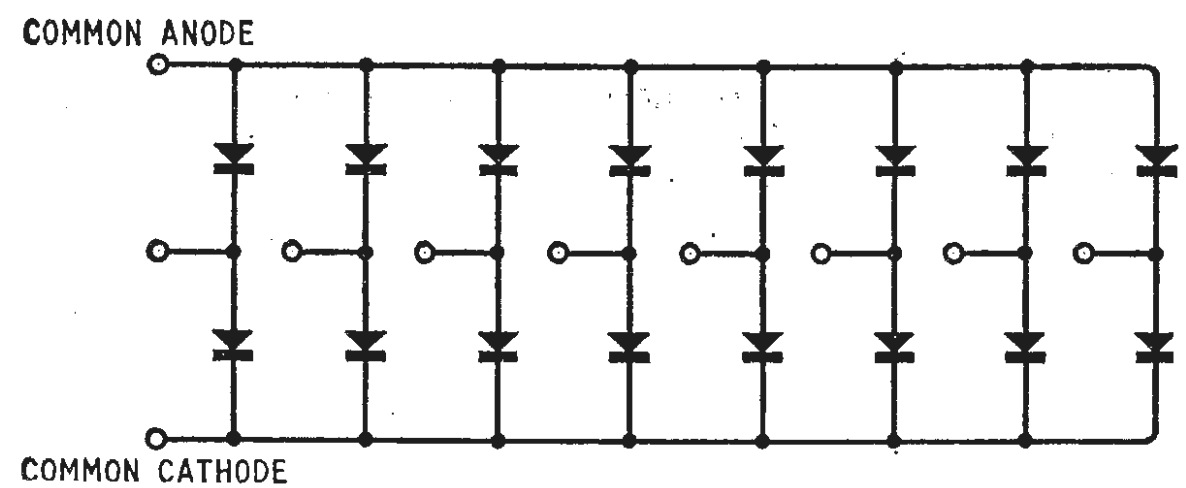

Fig. 3. This planar diode array is made from two silicon chips and is mounted in a 10-lead flat-pack moulding.

be extended to 25%. It is anticipated that this type of circuit will become standard in the industry because of its high yield reproducibility in monolithic form.

A "flat pack" (0.26 in \times 0.26 in) planar diode array has been produced which is designed to carry up to 0.7 amp with low forward voltage drop (Fig. 3). Two silicon chips are used, one with a common anode and the other with a common cathode.

Seen in the Show

Plastics encapsulation of semiconductor units was much in evidence, and examples were shown by Motorola, Texas Instruments and General Electric. Many of the devices are assembled in Japan or Hong Kong and for this reason their cost is very low compared with other types. Motorola have a line of plastics-encapsulated silicon transistors which sell in large quantities for between 3s 6d and 6s. They are designed primarily

Fig. 4. Plastics-encapsulated field-effect transistors. The cases are about 0.2in x 0.2in.

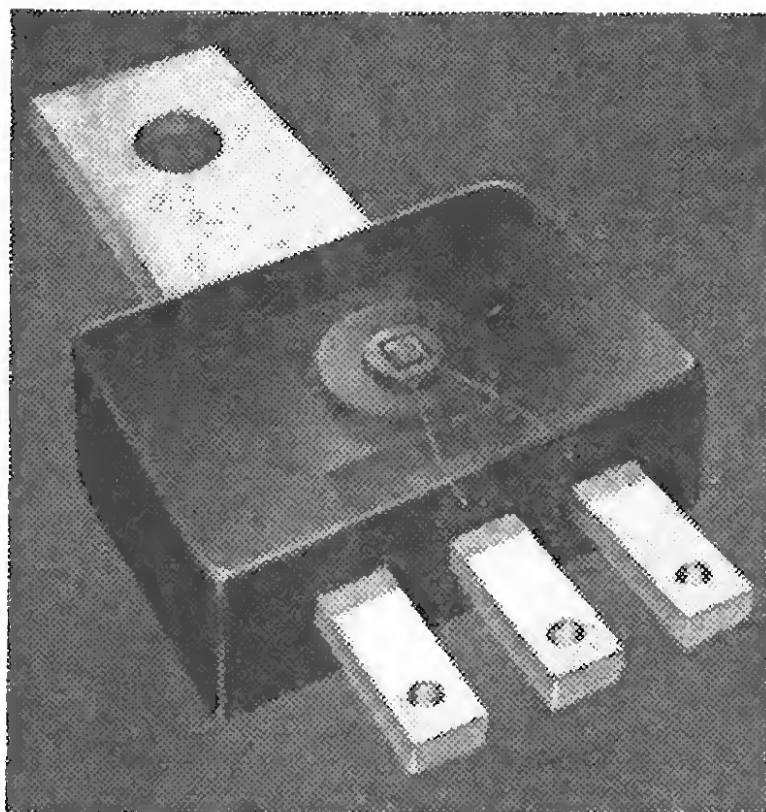
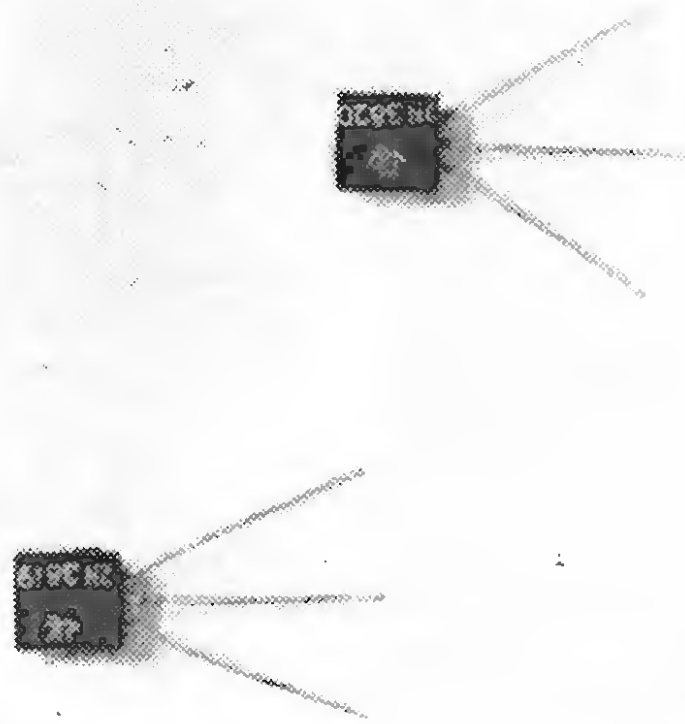

Fig. 5. Texas Tab-Pac plastic encapsulated transistor assembly. Connection to the collector is made either by the heat-sink tab or by the collector lug at the opposite end



for general switching applications and are made in both n-p-n and p-n-p types.

The first plastics-encapsulated field-effect transistors were announced by Texas Instruments. Both n-channel (2N3819) and p-channel (2N3820) were shown (Fig. 4). The 2N3819 is rated at 2000 micromhos minimum transconductance at 1 kc/s and 1,800 micromhos at 100 Mc/s. Capacitance is 4 pF maximum. It is expected that the low cost of these units (less than 7 shillings each in quantity) will double the use of f.e.t.s. during the next year in such applications as a.m./f.m. tuners, mixers, low-, medium-, and high-frequency amplifiers and in digital equipment.

Also introduced by Texas was a new plastics-packaged silicon n-p-n planar transistor, the TIP14. This is a low-cost device intended for economy applications in audio amplifiers and the like. Mounting is simplified by the provision of a hole in the collector tab (Fig. 5). A single sheet-metal screw is all that is necessary for fixing the device to a chassis which then also acts as a heat sink. The TIP14 is a 15-watt device with a 0-1V saturation voltage at $I_c=200$ mA. Beta is fairly linear over a wide range, 35 at 50 mA and 30 at 1 A.

In a similar type of package (Fig. 6) is a range of small thyristors suitable for industrial and domestic control applications. Designated C106, the devices are available in five versions for blocking voltages of between 30 and 200 V. R.m.s. forward current is 2 A with a typical gate requirement of 0.5 V at 25 μ A.

Tektronix showed a new addition to the family of high-performance plug-in units for their 560-Series oscilloscopes. The unit, the Type 3A5 y amplifier (Fig. 7), incorporates an "automatic-seeking" feature. By pressing the "seek" button located on the special probe or front panel, one can make the plug-in unit automatically select the appropriate volts/division setting for the amplitude of the displayed signal. This "seeking" feature is particularly useful for applications where the instrument is located out of the reach of the operator, or for production-line testing that would normally require continuous readjustment of the volts/division control. Upon receipt of the "seek" command, the vertical sensitivity is brought to maximum, and then decreases to the appropriate setting. A front-panel adjustment establishes the maximum display size. With the display size adjusted for 6 divisions, the signal always returns to within ± 3 divisions of the c.r.t. centre. A display of luminous

Below:—Fig. 7. Tektronix Type 3A5 oscilloscope pre-amplifier incorporating automatic seeking of volts/division and time/division scales. The illuminated panels indicate the range.

Above:—Fig. 6. General Electric low-cost thyristor of 2-amp capacity. The plastic case is 0.4in. x 0.3in. x 0.175in. The heat sink tab is connected to the anode.

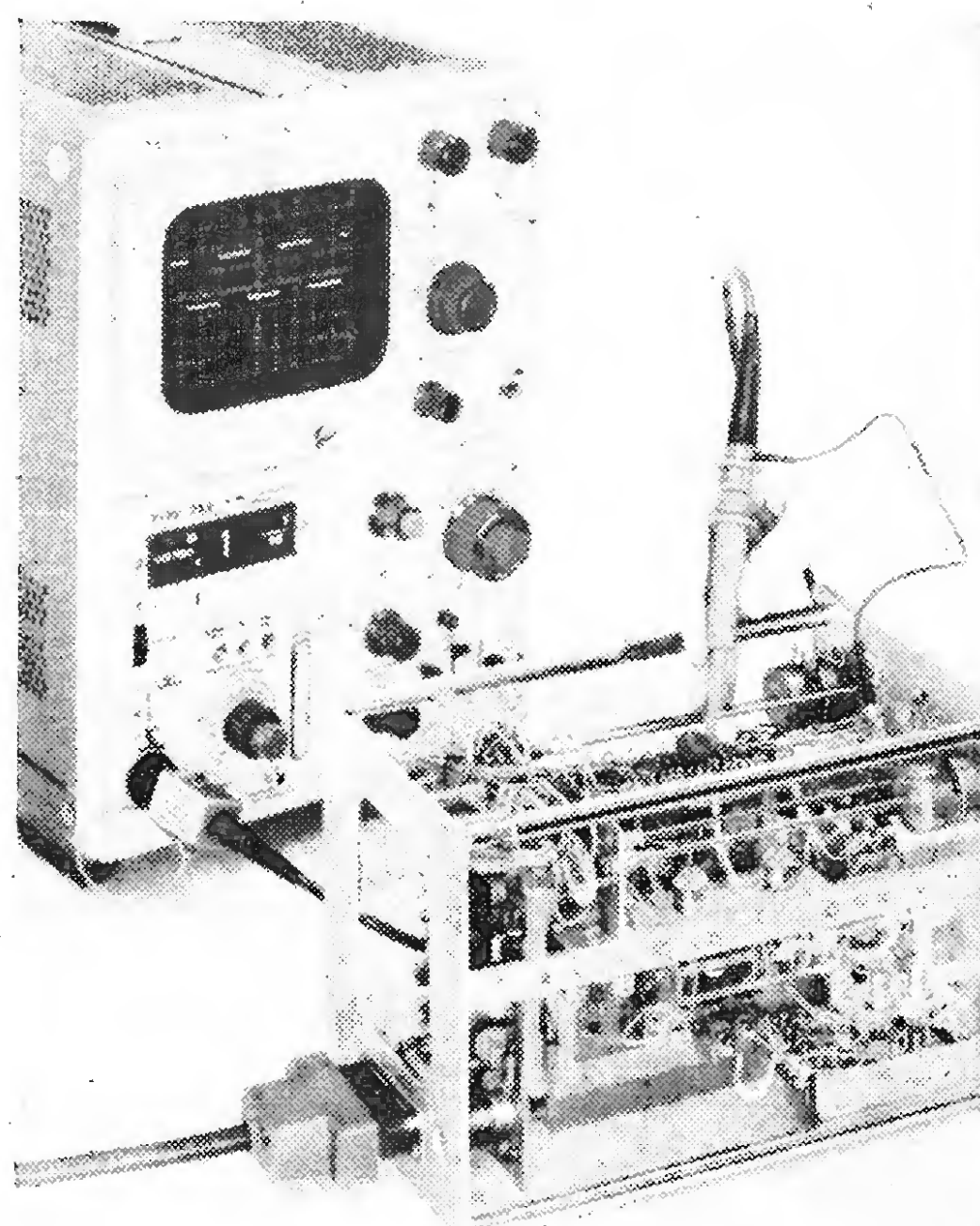

digits across the top of the panel provides readout data, including the V/div. setting, input coupling, and uncalibrated operation of the variable V/div. control. The readout facility also indicates an automatic V/div. correction when the instrument is used with a 10 times multiplier probe.

In addition to the "automatic-seeking" feature and manual control functions, the plug-in unit has a facility by which it can be programmed remotely, using a multi-pin connector located on the front panel.

AMATEUR CONVENTION

INTERNATIONAL "HAM" MEETING

AT KNOKKE

NORMALLY placid Belgians at the fashionable seaside resort of Knokke were startled last month when over 200 licensed amateurs from nearly a dozen different countries arrived in force for the first International Friendship Ham Convention. What startled the local population and holidaymakers was the mysterious passage of a radio-controlled "doll-driven" car and a driverless lawn mower, complete with a police escort, along the promenade, and the huge number of cars adorned with every conceivable type of aerial seen in practically every street. Also delegates were not labelled by name as in an ordinary convention but by indecipherable combinations of letters and numbers!

Although the convention was entirely unofficial and informal it was notable for the number of official representatives of amateur organizations present. Among the British contingent were Bert Allen (G2UJ) U.K. coordinator of the Project Oscar amateur satellite experiments; Len Newnham (G6NZ) past-president of the R.S.G.B.; Leslie Cooper (G5LC) another R.S.G.B. past-president who was recently licensed as ON8IZ under the

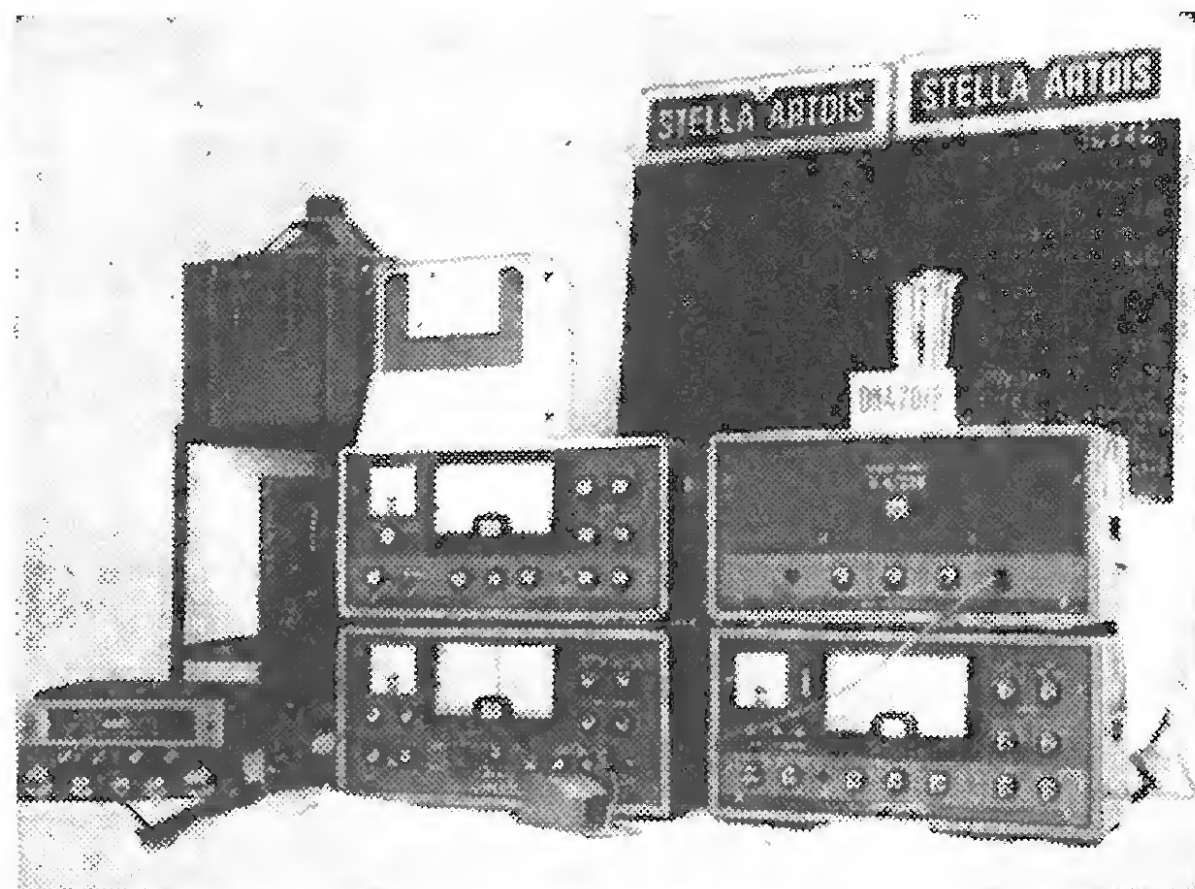

The main station, ON4UMF, installed at the Albert-Plage Hotel. British amateurs were among the operators.

new reciprocal licensing agreement; and J. C. Foster (G2JF) chairman of the v.h.f. committee of the R.S.G.B.

The business meetings were conveniently split into fields of interest such as Old Timers, U.H.F./V.H.F., S.S.B., R.T.T.Y., and Amateur Television.

The chairman of the Old Timers session was J. J. Mussche (ON4BK) a founder member of the Belgian society U.B.A. A sprightly 66, he started in radio in 1912 and as a 15-year-old boy was in charge of the batteries of an 800-metre, 400-W transmitter that put out a once-a-week music programme in 1914. When Belgium was invaded

the station was dismantled and the batteries thrown in the canal. But in 1919 the young ON4BK managed to salvage sufficient good units to provide 240 volts for his first (unlicensed!) station.

Commenting on Belgium's licensing policy, A. De Smet (ON4CC) stated that very good relations had resulted from an incident in the Second World War when the country was being overrun in May, 1940. Every Belgian broadcasting station had been closed and he, as a known amateur in the Belgian Army, was asked to establish an official broadcasting station in Bruges where King Leopold was sheltering. The station



Aerials over Knokke. Five and seven-element yagis for two metres and a bottom-loaded whip for h.f. at the Convention last month.

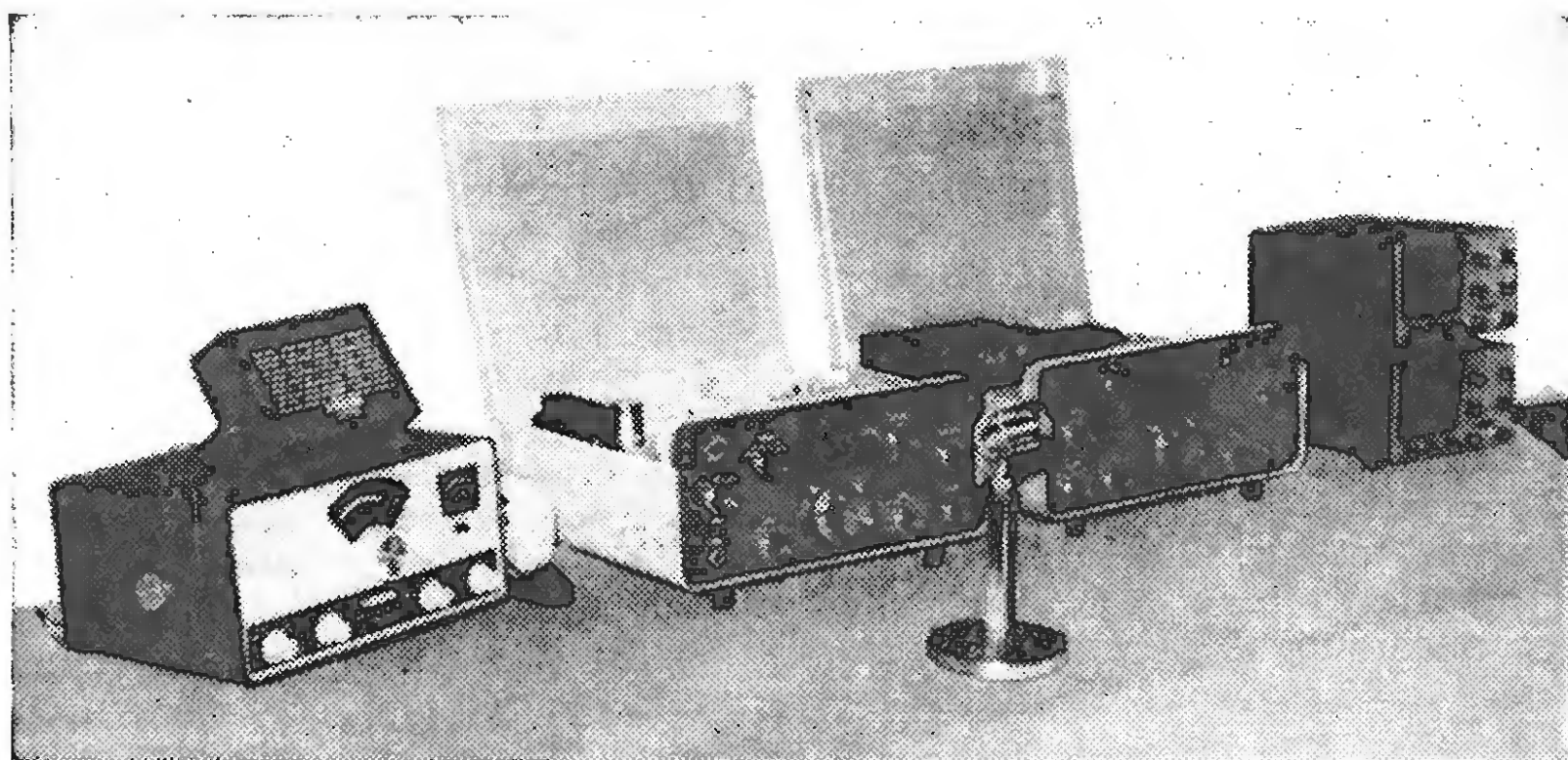

Heathkit s.s.b. equipment opened for inspection at the Hotel du Soleil.

was established using the transmitter of J. Mahieu (ON4AU) quickly modified to operate on 29.4 metres. The station was not able to operate for long but it was a unique occasion for an amateur station to be the only broadcasting facility for the Government.

A. Labout (PAODX) from Rotterdam recalled the excitement of 5-metre operation in the mid-thirties. He was the first to use crystal control on 5 metres, made the first Netherlands-Sweden contact on that band and was deeply involved in the Royal Netherlands Air Force experiments in using v.h.f. for air-to-ground communications—a revolutionary idea in 1936.

And so the meeting progressed, recalling memories of the R-valve, getting valves re-filamented, making valves out of carbon lamps, communications achieved by oscillating receivers and remarkable performances from imperfectly understood equipment.

At the other end of the scale were talks by M. Gewillig, chief engineer of the Belgian Television Service, on v.h.f./u.h.f. propagation, meteor scatter communications by G. Felix (ON4FG), and television demonstrations by both Belgian and British amateurs.

Gaby Felix in approximately half-an-hour took his audience through months of preparation, the study of meteor shower forecasts, synchronizing times of transmission, the 48-hour warm up for absolute frequency stability and the excitement—through actual recordings—of establishing an exchange of reports through meteor scatter. Nobody at the convention was better qualified to discuss this unusual amateur activity than ON4FG who has already worked 28 countries on v.h.f. by this mode of communication.

J. Tanner (G6NDT/T) gave the first Continental demonstration of slow-scan television. It took some little time to convince an audience reared on 625-line equipment to realise that slow-scan can be used on 28 Mc/s, can be recorded on an ordinary domestic tape recorder, needs only a 3 kc/s bandwidth and has been transmitted on a 20-W carrier across the Atlantic.

Some sessions of the convention and a number of interviews were filmed for Belgian television. The spread of trades and professions represented at the convention would have coped with any eventuality. By a coincidence, even the pilot of the plane that flew some of the British delegates to Ostend was a licensed amateur.



THE HOUSE OF BULGIN AT YOUR SERVICE

A SMALL SELECTION FROM OUR LARGE RANGE OF MICRO-SENSITIVE SWITCHES

The latest additions to the Bulgin range of Micro Switches are illustrated left. *Top left* of the group is the basic model List No. S.800 which can be fitted with a leaf operator (List No. S.800/L) or double ganged under a push button operator (S.801). All types are manufactured from top quality materials and have a long reliable life. Other models from our basic range are illustrated below.

S.500-502 S.735/MA S.2/735 S.530-532

S.506-508 S.530+S.L./R.B S.735-S.739 S.530 with clear cover

S.610-612 S.770 S.690-691 S.530+/L

S.715 S.710/R.B. S.530+/L/R-S.S.

ILLUSTRATIONS APPROX. 2/3 FULL SIZE
SEND FOR LEAFLET NO. 1501/C

A. F. BULGIN & CO. LTD.,
Bye Pass Rd., Barking, Essex.
Tel: RIPpleway 5588 (12 lines)

MANUFACTURERS AND SUPPLIERS OF RADIO AND ELECTRONIC COMPONENTS TO

ADMIRALTY	MINISTRY OF WORKS	B.B.C.
WAR OFFICE	MINISTRY OF AVIATION	G.P.O.
AIR MINISTRY	MINISTRY OF SUPPLY	I.T.A.
HOME OFFICE	RESEARCH ESTABLISHMENTS	N.P.L.
CROWN AGENTS	U.K.A.E.A.	D.S.I.R.

WW-132 FOR FURTHER DETAILS.

NOVEMBER MEETINGS

Tickets are required for some meetings: readers are advised, therefore, to communicate with the secretary of the society concerned

LONDON

- 1st. I.E.E.—“HS 303 (Early Bird) and the Post Office earth station at Goonhilly.” Colloquium at 9.30 a.m. at Savoy Pl., W.C.2.
- 3rd. I.E.E.—Two papers on “Atmospheric radio noise” at 5.30 at Savoy Pl., W.C.2.
- 3rd. I.E.R.E.—“High intensity acoustic noise sources” by Dr. B. L. Clarkson at 6.0 at 9 Bedford Sq., W.C.1.
- 4th. I.E.E. & I.E.R.E.—Discussion on “The selection of topics for research in electrical and electronic engineering” at 5.30 at Savoy Pl., W.C.2.
- 5th. I.E.E.—“Operational experience with tropospheric-scatter systems” by R. W. Cannon, G. C. Rider and D. Wilkinson at 5.30 at Savoy Pl., W.C.2.
- 8th. I.E.E. Grads.—“Some manufacturing and processing techniques in the electronics industry” by A. G. Page at 6.30 at Savoy Pl., W.C.2.
- 10th. I.E.R.E. & I.E.E.—Discussion on “Medical electronics round the world” at 6.0 at 9 Bedford Sq., W.C.1.
- 15th. I.E.E.—“Phase measurement throughout the spectrum.” Colloquium at 10.30 a.m. at Savoy Pl., W.C.2.
- 17th. I.E.E.—“Electroacoustics” by Prof. Erwin Mayer at 6.0 at Savoy Pl., W.C.2.
- 17th. I.E.R.E.—“The use of doppler radar in meteorological research” by Dr. P. G. F. Caton at 6.0 at 9 Bedford Sq., W.C.1.
- 17th. B.K.S.T.S.—“Audio signal control” symposium at 7.30 at Central Office of Information, Hercules Rd., S.E.1.
- 19th. Inst. Navigation.—“Multi-purpose airborne radar” by T. G. Thorne at 5.30 at the Royal Aeronautical Society, 4 Hamilton Pl., W.1.
- 24th.—I.E.R.E.—“Analogue circuit techniques using transistors” by G. J. Crask and S. F. Miles at 6.0 at 9 Bedford Sq., W.C.1.
- 24th. B.K.S.T.S.—“Colour film for colour television” by C. B. B. Wood and F. A. Griffiths at 7.30 at Central Office of Information, Hercules Rd., S.E.1.
- 26th. TV Soc.—“Television audience measurement” by D. J. Wheeler at 7.0 at I.T.A., 70 Brompton Rd., S.W.3.
- 29th. I.E.E. Grads.—“Control and its applications” symposium at 6.30 at Savoy Pl., W.C.2.

ABERDEEN

- 10th. I.E.E.—“Transistors—the first encounter” by V. H. Attree at 7.30 at Robert Gordon's Technical College.

BATH

- 28th. I.E.R.E. & I.E.E.—“Infra-red technology and applications” by V. Roberts at 7.0 at the Technical College.

BEDFORD

- 22nd. I.E.E. & R.Ae.S.—“Navigation on the flight deck” by E. R. Bonner at 7.30 at the Bridge Hotel.

BELFAST

- 9th. I.E.E.—“Computers in control of processes” by Dr. D. M. Truscott at 6.30 at Ashby Institute, Stranmillis Rd., 9.

BIRMINGHAM

- 17th. TV Soc.—“Colour—where do we go from here?” by T. C. Macnamara at 7.0 at Broadcasting House, Carpenter Rd., Edgbaston.
- 29th. I.E.E. & Inst. Marine E.—“Automation and electronics in ships” by D. S. Townsend at 7.0 at M.E.B., Summer Lane.

BOURNEMOUTH

- 10th. I.E.R.E.—“Ultrasound in medicine” by P. N. T. Wells at 7.0 at the Municipal College of Technology and Commerce.
- 24th. I.E.E.—“Closed-circuit colour television and applications” by V. J. Cooper at 6.30 at the Municipal College of Technology and Commerce, Lansdowne.

BRISTOL

- 1st. I.E.E. & I.E.R.E.—“Measurements at sub-audio frequencies” by H. Sutcliffe at 6.0 at the University.

CAMBRIDGE

- 10th. I.E.E.—“Television broadcast cameras” by D. Allanson at 6.30 at the College of Art & Technology.
- 11th. I.E.E.—“Feedback & transfer functions in man” by P. E. K. Donaldson at 8.0 at the Engineering Labs., Trumpington St.
- 25th. I.E.E. & I.E.R.E.—“Ionospheric propagation with special reference to the effect of the earth's magnetic field” by G. Millington at 8.0 at the Engineering Labs., Trumpington St.

CARDIFF

- 10th. I.E.R.E.—“Underwater acoustical engineering” by Prof. D. G. Tucker at 6.30 at the Welsh College of Advanced Technology.

CHELMSFORD

- 9th. I.E.R.E.—“The application of integrated circuits” by G. C. Padwick at 6.30 at the Technical High School.

CHESTER

- 22nd. I.E.E.—“Numerical control of machine tools” by D. F. Walker at 6.30 at the College of Further Education.

DUNDEE

- 10th. I.E.E.—“Telemetry—the present position and future trends” by R. E. Young at 7.0 at the Electrical Engineering Dept., Queen's College.
- 11th. I.E.E.—“Transistors—the first encounter” by V. H. Attree at 7.0 at the Electrical Engineering Dept., Queen's College.
- 24th. I.E.E.—“Organization of research” by Dr. D. H. Parkinson at 7.0 at the Electrical Eng'g Dept., Queen's College.

EDINBURGH

- 9th. I.E.E. & I.E.R.E.—“Telemetry—the present position and future trends” by R. E. Young at 6.0 at the Carlton Hotel, North Bridge.

GLASGOW

- 8th. I.E.E. & I.E.R.E.—“Telemetry—the present position and future trends” by R. E. Young at 6.0 at the University of Strathclyde.
- 23rd. I.E.E. & I.E.R.E.—“Use of analogue computers in medicine” by W. J. Perkins at 6.0 at the University of Strathclyde.

HATFIELD

- 8th. I.E.E.—“Is laboratory work really necessary?” Discussion opened by Dr. K. R. Sturley at 6.0 at Hatfield College of Technology, College Lane.

IPSWICH

- 23rd. I.E.E.—“Developments in industrial telemetry” by S. M. G. Geercke at 6.30 at Electric House.

LIVERPOOL

- 1st. I.E.E.—“Research and development in control engineering” by Dr. J. H. Westcott at 6.30 at the Royal Institution.
- 17th. I.E.R.E.—“Disc recording and production—some modern developments” by D. G. Jacquess at 6.30 at the Walker Art Gallery.

LOUGHBOROUGH

- 3rd. I.E.E.—“The recruitment of suitable students into engineering” by B. J. Holloway at 6.0 at the College of Technology.
- 16th. I.E.E. & I.E.R.E.—“B.B.C. radiophonic workshop” by F. C. Brooker at 7.0 at the College of Technology.

MANCHESTER

- 18th. I.E.R.E. & I.E.E.—“Low-noise solid-state amplifiers” by Dr. H. N. Daghish at 7.0 at the College of Science and Technology.

MIDDLESBROUGH

- 3rd. I.E.E. & Soc. Instrument Tech.—Discussion on “Systems engineering” at 6.30 at Cleveland Scientific Institution.

NOTTINGHAM

- 23rd. I.E.E.—“Principles covering the design of systems for continuous numerical control of machine tools” by D. V. Mynall at 6.30 at the University.

OXFORD

- 10th. I.E.E.—“Development in modern international communications” by L. Thomas at 7.0 at 37 George St.

PLYMOUTH

- 11th. I.E.E.—“Research and development in control engineering” by Dr. J. H. Westcott at 2.30 at the Royal Naval Engineering College, Manadon.
- 16th. I.E.R.E. & I.E.E.—“Television recording” by P. Leggatt at 7.0 at the College of Technology.

PORTSMOUTH

- 3rd. I.E.R.E.—“Satellite communications” by A. E. Bailey at 6.30 at the Highbury Technical College.
- 17th. I.E.E.—“The impact of liquid cooling upon the design of electronic equipment” by A. Bickers at 6.30 at the College of Technology, Anglesea Rd.

PORT TALBOT

- 18th. I.E.E.—“The ballistic missile early warning system” by B. S. Batt at 6.0 at the Steel Co. of Wales.

READING

- 2nd. I.E.E.—“Computer logic” by H. Goddard at 7.30 at the Great Western Hotel.
- 10th. I.E.R.E.—“Electronic design” by H. V. Beck at 7.15 at the Technical College.

RUGBY

- 10th. I.E.E.—“Sound reproduction” by J. Moir at 6.15 at the Rugby College of Engineering Technology.

SHEFFIELD

- 16th. I.E.E.—“Computers, control and automation” by F. D. Hall at 7.30 at the City Hall.

SOUTHAMPTON

- 9th. I.E.E.—“Phonon devices and active relay lines” by Dr. E. A. Ash at 6.30 at the University.
- 24th. I.E.E.—“The radiophonic workshop of the B.B.C.” by F. C. Brooker at 6.30 at the University.

WHITBY

- 9th. I.E.E.—“Tracking servo systems for large steerable aerials” by P. N. Prior at 7.0 at Bothams Cafe.