

PULSE WIDTH MODULATED AUDIO AMPLIFIER

APRIL 1965  
Three Shillings

# Wireless World

ELECTRONICS • TELEVISION • RADIO • AUDIO

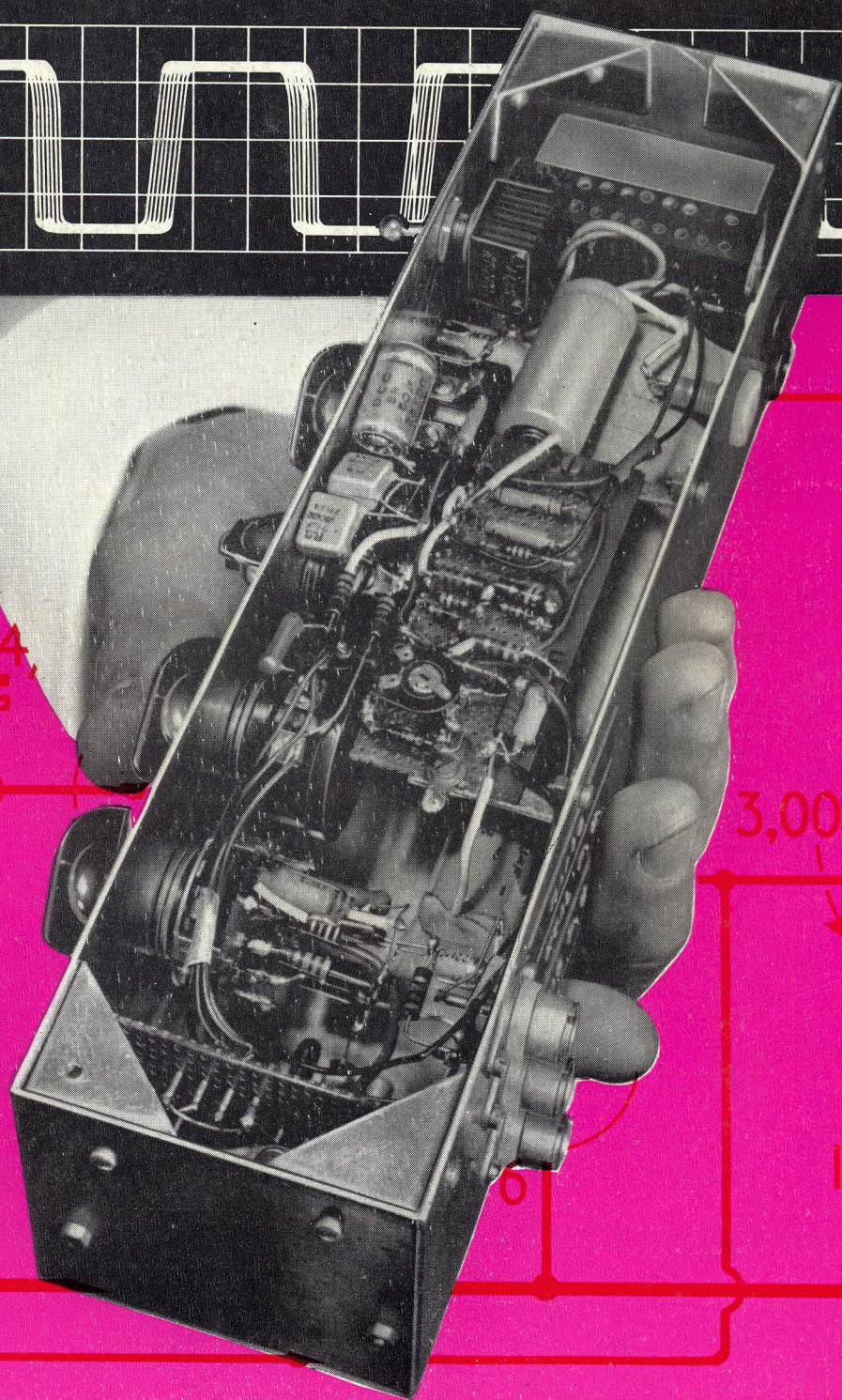
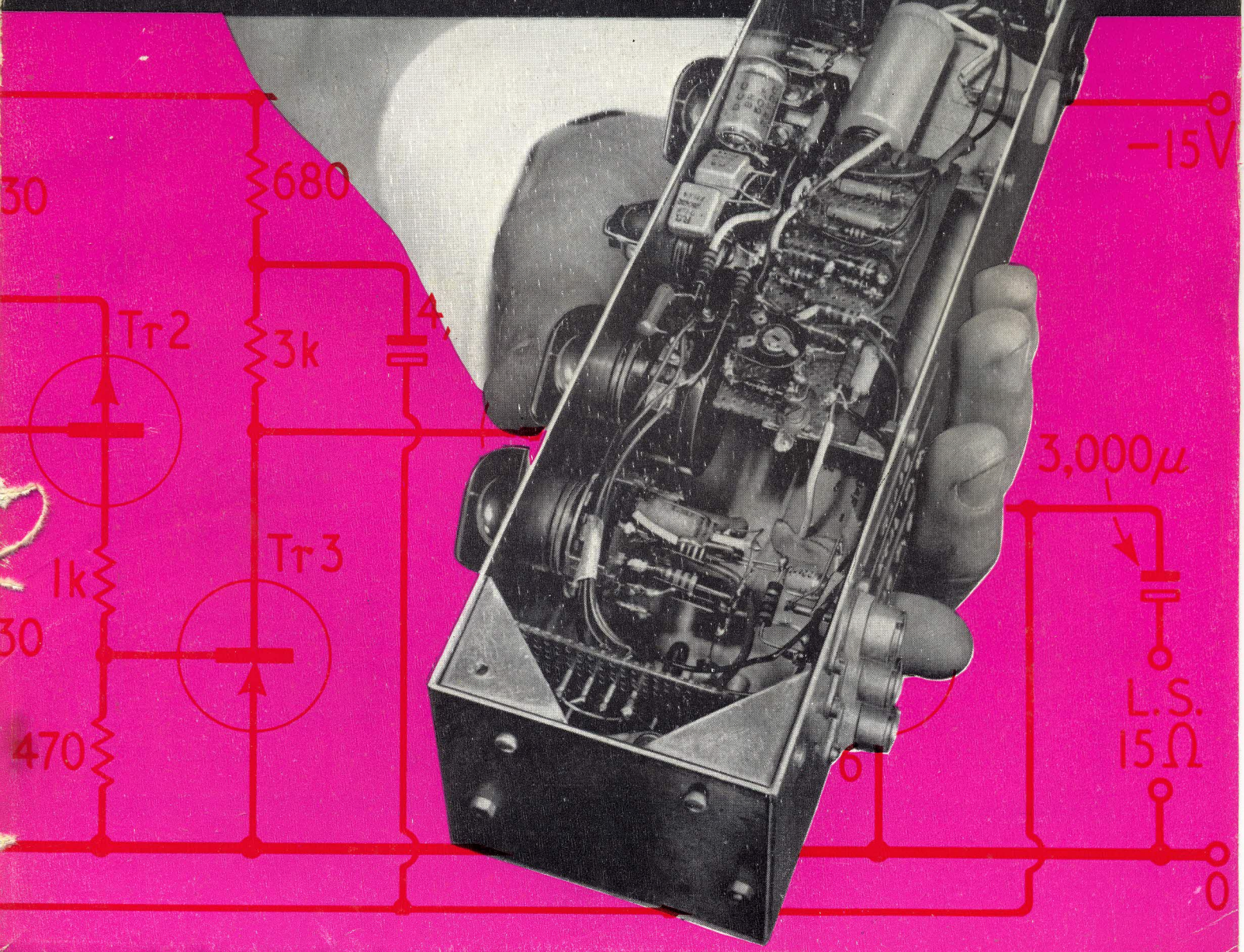
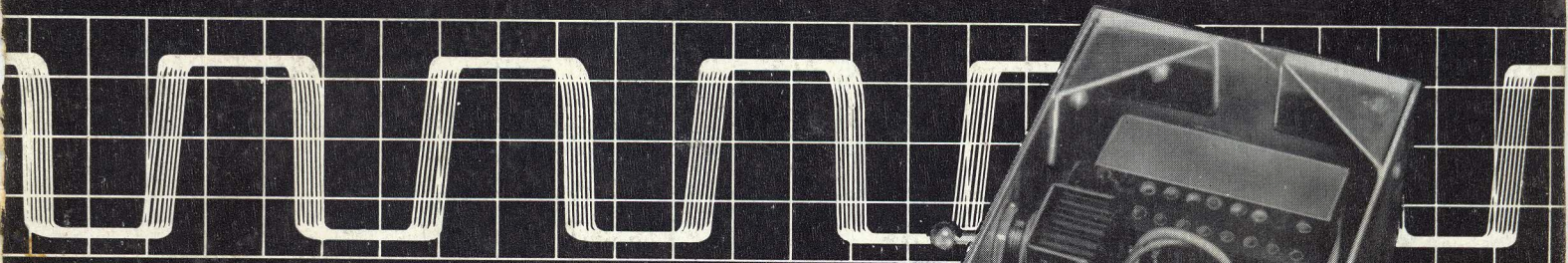



Iliffe Electrical Publications Ltd.,  
Dorset House, Stamford Street,  
London, S.E.1

*Managing Director:*

W. E. MILLER, M.A., M.I.E.R.E.

*Editor:*

F. L. DEVEREUX, B.Sc.

*Assistant Editors:*

H. W. BARNARD

T. E. IVALL

*Editorial:*

D. C. ROLFE

G. B. SHORTER, B.Sc.

*Drawing Office:*

H. J. COOKE

*Production:*

D. R. BRAY

*Advertisements:*

G. BENTON-ROWELL  
(Manager)

J. R. EYTON-JONES

Please Address to Editor, Advertisement  
Manager or Publisher as appropriate

© Iliffe Electrical Publications  
Ltd., 1965. Permission in writing  
from the Editor must first be  
obtained before letterpress or  
illustrations are reproduced from  
this journal. Brief extracts or  
comments are allowed provided  
acknowledgement to the journal  
is given.

VOLUME 71 No. 4

PRICE: 3s. 0d

FIFTY-FIFTH YEAR  
OF PUBLICATION

# Wireless World

ELECTRONICS, TELEVISION, RADIO, AUDIO

---

## APRIL 1965

- 159 Editorial Comment
- 160 A Feedback Pulse Width Modulated Audio Amplifier  
By G. F. Turnbull and J. M. Townsend
- 169 Matrix Algebra—2 By G. H. Olsen
- 172 This Month's Conferences and Exhibitions
- 173 Manufacturers' Products
- 179 World of Wireless
- 181 Personalities
- 183 News from Industry
- 185 Physical Society Exhibition—List of Exhibitors
- 185 H.F. Predictions—April
- 186 Audio Fair Preview
- 193 Letters to the Editor
- 198 Electronic Laboratory Instrument Practice—4 By T. D. Towers
- 203 Books Received
- 204 Audible Rate-of-Climb Indicator By J. M Firth
- 206 Real and Imaginary By "Vector"
- 207 Commercial Literature
- 208 April Meetings
- 

PUBLISHED MONTHLY (4th Monday of preceding month). Telephone: Waterloo 3333 (70 lines).  
Telegrams/Telex: Wiworld Iliffepres 25137 London. Cables: "Ethaworld, London, S.E.1."  
Annual Subscriptions: Home £2 6s 0d. Overseas: £2 15s 0d. Canada and U.S.A. \$8.00. Second-class  
mail privileges authorised at New York N.Y. BRANCH OFFICES: BIRMINGHAM: King  
Edward House, New Street, 2. Telephone: Midland 7191. BRISTOL: 11, Marsh Street, 1.  
Telephone: Bristol 21491/2. COVENTRY: 8-10, Corporation Street. Telephone: Coventry  
25210. GLASGOW: 123, Hope Street, C.2. Telephone: Central 1265-6. MANCHESTER:  
260, Deansgate, 3. Telephone: Blackfriars 4412. NEW YORK OFFICE U.S.A.: 111,  
Broadway, 6. Telephone: Digby 9-1197.

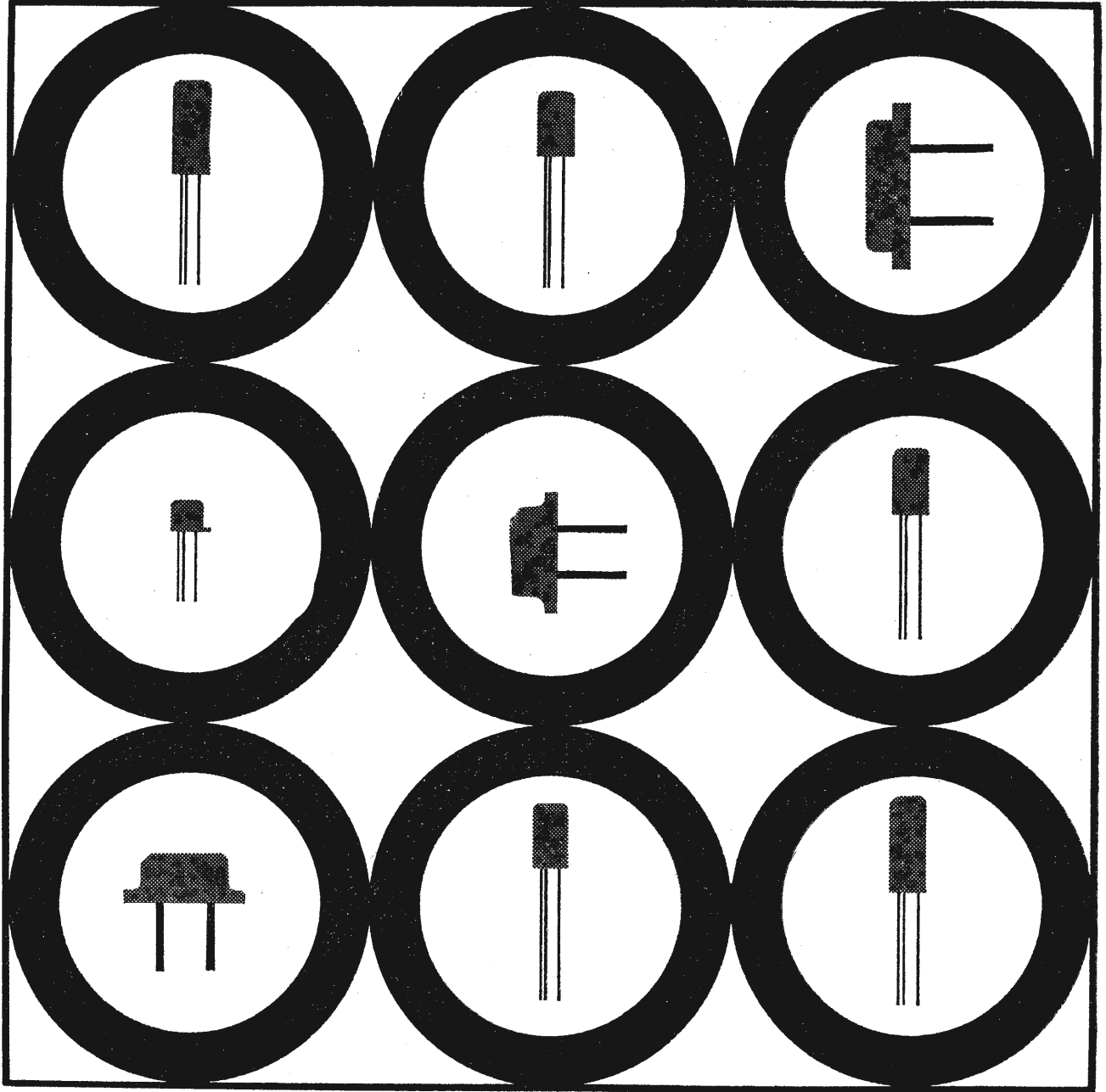

## These nine Mullard Audio Transistors cover every application from 40mW to 40W

More and more transistorised equipment is becoming available for domestic entertainment. Mullard is helping to speed the day with a harmonious range of transistors for all audio applications: Outputs from 40mW to 40W.

*Note for equipment makers who are planning new models:*  
Details of the range and the usual Mullard advisory services are ready for you.

# Mullard

Mullard House, Torrington Place, London, W.C.1. Telephone: Langham 6633 Telex: 22281

4WW-105 FOR FURTHER DETAILS.

CA 5824

# Wireless World

ELECTRONICS, TELEVISION, RADIO, AUDIO

## Audio Topics

WHAT will be the topics of conversation (occasionally of declamation) to be heard among the knots of enthusiasts as they move from floor to floor of the Audio Festival and Fair demonstrations at the Russell Hotel in London this month? Headphones *versus* loudspeakers, cross-field magnetic recording? Almost certainly transistor amplifiers of every class from A to D (pulse width modulated).

The choice of circuitry for transistor high-quality amplifiers is wider than ever and we foresee much argument between the devotees of what must now be regarded as the tried basic conventional designs of Toby and Dinsdale, Tharma and Osborne, and the modulated pulse amplifiers stimulated by D. R. Birt's article in this journal two years ago and represented in this issue by the design described by G. F. Turnbull and J. M. Townsend.

The advent of the transistor has reopened argument about the power ratings of amplifiers. This interests us not only because it is a frequent cause of wrangles between advertisers and customers (in spite of the fact that most of our readers are sufficiently well informed to apply the principle of *caveat emptor* effectively) but because it has shown how our attitudes and judgments in matters of this kind are conditioned by precedent.

Power in electrical engineering is the root-mean-square power of a sine wave. What more natural, then, than to rate an amplifier on the same basis, even though it is not normally used to boil an egg, make tea or even to reproduce sine waves?

No one is going to argue that an amplifier which will be called upon to reproduce music at a satisfying level in an average living room is any the worse for being able to sustain indefinitely an undistorted sine-wave power of, say, 10 watts r.m.s. which, incidentally, means that 20 watts peak power will be touched twice in every cycle. On music it will be called upon to touch peak power less than 1% of the time and the average power will be 20 dB below this, or 200 milliwatts if one is a purist and insists on preserving the dynamic range of the original sound. But the B.B.C. and the gramophone recording companies are not giving you the original peak powers anyway. If they did their service areas would shrink and the record groove walls would break down; both know to a nicety just how to fit good sound between the limits of background noise and over-modulation.

Thinking like electrical engineers in terms of sine-wave power has hitherto done no one any harm because valve amplifiers are robust pieces of equipment, at least in the sense that if you don't drop them you can abuse them in the matter of occasional overloading and mishaps with bias and in ninety-nine times out of a hundred get away with it with no more to show than a slight brightening of the glow of the anodes.

Habits of thought induced by long experience with valves are likely not only to be wrong but costly when applied to transistor amplifiers. Basically the difference is in the size and accessibility of the heat generating surfaces in valves and solid-state devices; the semiconductor solids are poor conductors, the junctions are buried and are also more vulnerable to heat. So the limiting factor is the junction temperature and the temperature gradients between it and the heat sinks. While the junction may be capable of handling the normal quota of peaks met with in music it may not survive sustained sine-wave power at the full output. Allowing generously for compression of dynamic range at the source, a ratio of 10dB between peak and average power could mean that a 10 watt (peak) amplifier might be required to run (and be tested) at the equivalent of a sustained sine-wave r.m.s. power of only 50 milliwatts. It all depends on the type of circuit and the rating of the transistors used.

Clearly there is a need for rethinking on the rating of transistor amplifiers and the old single figure accepted for valve amplifiers may no longer be sufficient. For class A and B transistor amplifiers we can still give one (possibly small) figure for sustained power performance at a specified distortion level, but the question of testing for distortion at peak powers is one which still needs to be settled.

**VOL 71 NO 4**  
**APRIL 1965**

# A Feedback Pulse Width Modulated

By G. F. TURNBULL,\* M.Sc., and J. M. TOWNSEND,\* M.Sc.

THE advantages of on-off control systems, that is systems in which the power is controlled by a two-state switch, have been recognized for a long time in industrial applications, but only recently has serious consideration been given to the possibility of audio power amplification using the technique, the main problem being the difficulty of obtaining a suitable switch capable of operation at a high enough frequency.

The biggest advantage possessed by systems of this type is that large powers can be controlled by switches which themselves dissipate only a small amount of power. The overall power efficiency of the amplifying system is thus increased compared with the conventional (i.e. continuous control) type of power amplifier. Other advantages of the on-off type of system, compactness for example, stem from this principal fact, which enables heat dissipating surfaces of large physical size to be dispensed with.

The switching frequency of such systems must be several times higher than the highest frequency to be amplified, which may be taken as 20kc/s for audio work. Mechanical switches are therefore completely impracticable.

It has recently become possible to use both transistors and valves as switches at these frequencies but with

valves the voltage and current values for a given power are not suitable to enable them to be coupled directly to a loudspeaker unless a special loudspeaker having a voice coil resistance of about  $1k\Omega$  is used and these are relatively expensive. Transistors, however, are basically high current, low voltage devices which makes them ideal for coupling directly to the low impedance of a loudspeaker.

This article describes the development of a transistor low power feedback audio amplifier which employs on-off control of the loudspeaker and has a simple circuit which is not particularly critical on component tolerances, and is quite simple to set up to the required operating conditions.

A simple form of on-off control of a loudspeaker is shown in Fig. 1(a), where the loudspeaker is connected by a switch to a voltage source. The voltage waveform appearing across the loudspeaker is shown in Fig. 1(b). The average value of the loudspeaker voltage is given by:—

$$V_L = \frac{VT_1}{T_1 + T_2}$$

where  $T_1$  and  $T_2$  are respectively the times for which the switch remains closed and for which it remains open. The mean level of the loudspeaker voltage can thus be varied by alteration of the ratio of the times  $T_1$  and  $T_2$ . In an audio amplifying system this variation will be produced by the audio signal. The general form of the amplifier will thus be that shown in Fig. 1(c), where the switch is operated by a signal derived by addition of the audio signal and the switching waveform which is a continuous oscillation. This is shown graphically in Fig. 1(d). The switch is shown as possessing a certain amount of hysteresis (i.e. the point at which it changes state is dependent upon the direction of the change). This is a necessary feature of a two-state switch in order to ensure positive changes of state at well defined points on the characteristic.

For a fixed switching waveform it is possible to draw a curve relating the mean level of the load voltage to the instantaneous value of the audio signal. This curve can then be considered as the input *versus* output curve for the non-linearity (in this case the switch) modified by the switching waveform.

The exact shape of the modified non-linearity will depend upon the particular switching waveform used and it is possible to calculate the curve for any waveform. The best switching waveform to use is that which gives a linear input *versus* output curve, since any curvature of the amplifier characteristic will cause harmonic distortion of the audio signal. It can be shown that a switching waveform which is a symmetrical triangle will give a modified non-linearity which is exactly linear between two limits which are set by the ratio of the hysteretic width of the switch ( $2\delta$ ) to the pk-pk height ( $\Delta$ ) of the triangular switching waveform (see Appendix 1). The modified non-linearity for a hysteretic switch for two

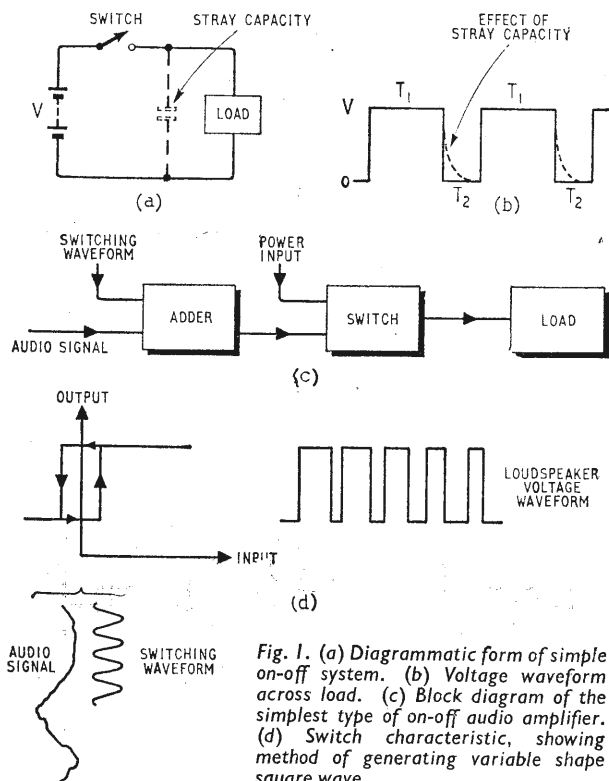

Fig. 1. (a) Diagrammatic form of simple on-off system. (b) Voltage waveform across load. (c) Block diagram of the simplest type of on-off audio amplifier. (d) Switch characteristic, showing method of generating variable shape square wave.

\*Electrical Engineering Laboratories, Manchester University.

# Audio Amplifier

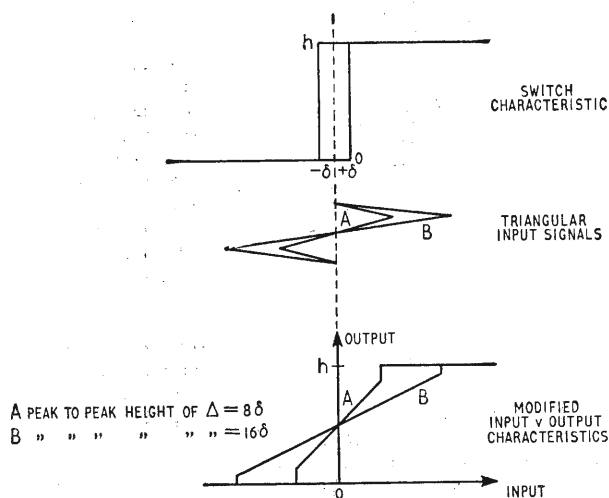

Fig. 2. Modified input versus output curves for a hysteretic switch operated by triangular waves of different sizes.

values of  $\Delta$  is shown in Fig. 2. As can be seen, for  $\Delta = 8\delta$  the effective gain through the modified non-linearity is greater than for  $\Delta = 16\delta$ , but the range of control is reduced because of the effect of the hysteresis of the switch. In order to obtain both high gain and full range of output level, the hysteresis width must be made very small. The most direct implementation of on-off control would thus use a switch with very low hysteresis, switched by a waveform generated by the addition of a very small triangle and the audio signal.

Before a system can be designed, however, it is necessary to decide upon the exact form to be taken by the switch. In general, the simple type of switch shown in Fig. 1(a) suffers from several disadvantages. The biggest of the disadvantages arises from the fact that when the system is operating at the centre of the linear region, as would be the case, for example, when no audio signal were present, there is a mean current  $V/2R$  flowing in the load, since  $T_1 = T_2$ . This results in the loudspeaker being displaced from its normal equilibrium position and may alter the loudspeaker characteristics and introduce distortion of the audio signals. A further disadvantage of the simple system is that stray capacity across the load will cause the square wave to be asymmetrical. This is shown dotted in Fig. 1(b). This asymmetry will cause curvature of the modified non-linear characteristic and, therefore, distortion to the audio signal which is again undesirable.

The disadvantages of the simple switch are largely overcome in the double switch system shown in Fig. 3(a). The practical implementation of this system can be achieved by following a simple switch (operated by the triangular waveform) by the arrangement shown in

Fig. 3(b). Since the load is driven in both directions from a low impedance source the effect of stray capacity is very much reduced, and is approximately the same on both edges. The square wave across the load, when  $T_1 = T_2$ , has a mean level of zero and since in audio applications the d.c. component of the audio signal is always zero, the loudspeaker load can in fact be driven via a capacitor. In this case the battery supply need not be centre tapped, the load being returned to either the positive or the negative end of the supply. As stated earlier, the frequency of operation of the switch must be greater than 20 kc/s in an audio system, and at these frequencies the effect of extra capacitance in all parts of the switch cannot be neglected. Due to imperfections in the driving waveform and stray capacity at the output the edges of the square wave will in fact occupy a finite time and although use of a double switch makes the edges more nearly symmetrical, the finite slopes of the edges will cause a certain amount of curvature of the modified non-linearity, mainly at the ends of the linear range, since it is there that the output wave will depart most from the ideal. The time occupied by the change over from one state to the other will have a further effect since during this time the product of voltage and current in the switching transistors is not zero. The power dissipated in the switching transistors will therefore increase as the proportion of the total time occupied by the edges of the square wave is increased. It is apparently most important therefore to ensure that the edges of the square wave occupy only a very small portion of the duration of the square wave, in order to keep both distortion and power dissipation to a low level. The actual power dissipated in each output transistor is calculated in Appendix 2.

## Amplifier Design

In order to ascertain the potentialities of the on-off type of audio system a small, low power system was constructed to the following specification:

- (1). Power output 2 watts r.m.s. into a 15 ohm loudspeaker.
- (2). Frequency response within  $\pm 3$ dB from 50 c/s to 20 kc/s.
- (3). Amplifier sensitivity such that 100mV r.m.s. input signal shall produce full output.
- (4). Input impedance approximately 10k $\Omega$ .

The specification was chosen so that the system would be comparable with low power amplifiers of more con-

Fig. 3. (a) Double switch on-off system. (b) Practical implementation of (a) using two transistors.

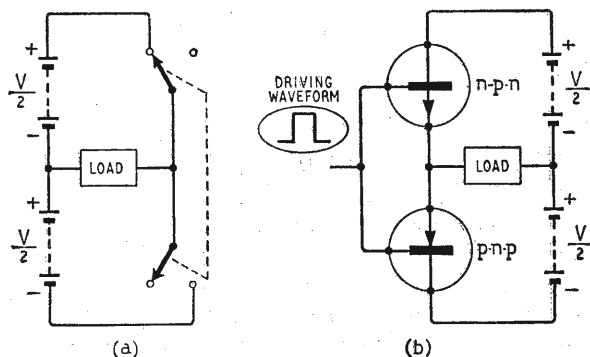

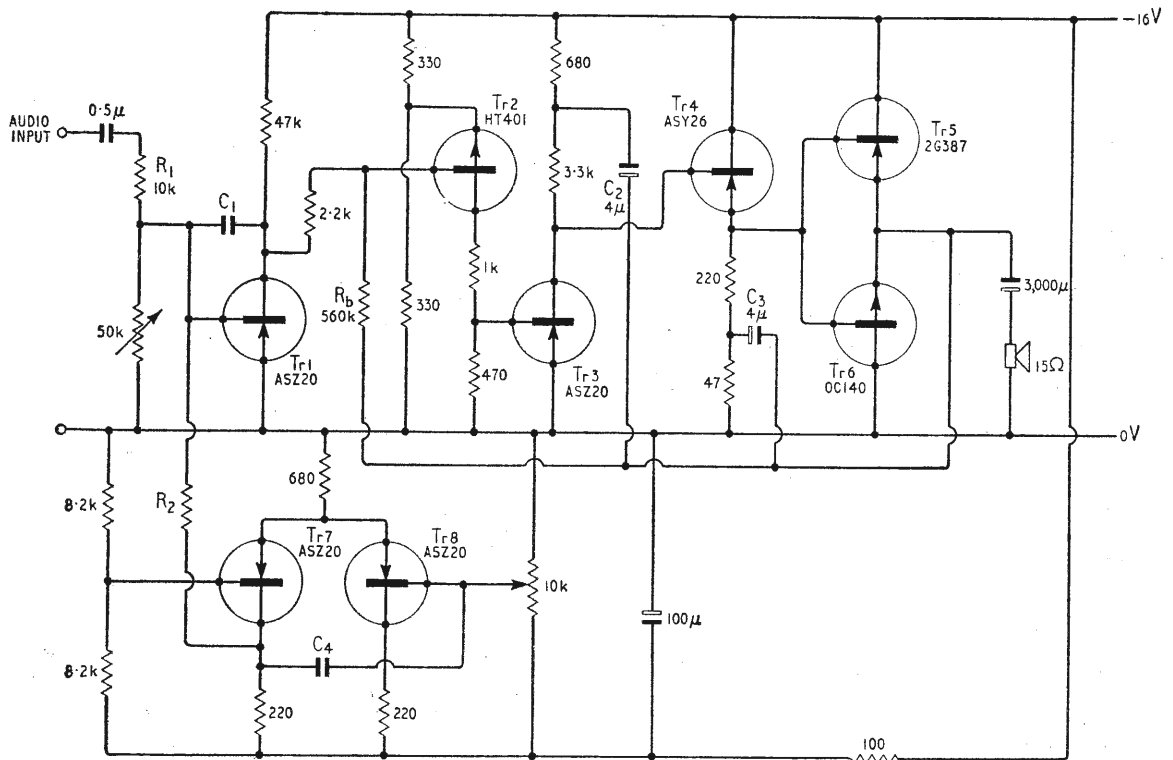

Fig. 4. Circuit diagram of the open-loop audio amplifier.

ventional design. Various aspects of the design procedure will now be considered.

### Design of the Switch

Neglecting the bottoming potentials the maximum power in the loudspeaker (see Fig. 3(b)) will be given by

$$(P_o)_{max} = \frac{V^2}{8R}$$

so that the output square wave should have a pk—pk height of about 16V. Thus the supply to the system is fixed at 16V. The peak load current will then be approximately 0.5A, so that the output switching transistors must be capable of handling this current. With the arrangement of Fig. 3(b) it is necessary to ensure that sufficient base current can be provided to hold the output transistors sufficiently well bottomed. The switch is shown in Fig. 4. In order that the triangle generator (Tr1) shall not be heavily loaded, the switch is made up of three current gain stages (Tr2, Tr4 and Tr5/Tr6) and one stage of voltage gain (Tr3). Positive feedback is provided of a magnitude just sufficient to ensure that the switch has only two states, thus keeping the hysteretic width of the switch characteristic to a minimum.

Tr5 and Tr6, the output switching transistors, are driven from the emitter follower transistor Tr4 which has one of its emitter resistors bootstrapped *via* C<sub>3</sub> to enable it to hold Tr6 fully bottomed during the positive half of the square wave. C<sub>3</sub> must be large enough to provide an almost constant potential during the period that Tr6 remains bottomed, and the emitter resistor is

chosen so that it can supply the necessary base current to hold Tr6 bottomed whilst the collector current of Tr6 is 500mA. Tr4 is driven from a positive gain amplifier Tr2/Tr3 which has a load resistor bootstrapped by C<sub>2</sub> to ensure that Tr4 and Tr5 are well bottomed during the negative half cycle of the square wave. The positive feedback is taken *via* the resistor R<sub>b</sub> to the base of Tr2 from the output. In the design R<sub>1</sub> is set to 560kΩ. Values larger than this give a region of continuous variation in output potential which during normal operation will only slow the edges of the output square wave and possibly the subsequent increase in power could be tolerated. Even so this is surely to be avoided if possible and furthermore, under freak conditions (e.g., removal of the triangle), the output could attain potentials between the two supply lines with probable excessive dissipation in the output stage.

### Switching Waveform Generator

The triangular switching waveform is obtained by integrating a square wave, which is obtained from a multivibrator circuit. The minimum permissible oscillation frequency of the switch is about 50 kc/s and the actual one used is 100 kc/s. An emitter-coupled multivibrator produces a good square wave at this frequency provided the transistors are not allowed to bottom. The multivibrator comprises transistors Tr7 and Tr8 (Fig. 4) and Tr1 is connected as a feedback summing integrator. The frequency of the square wave is set by varying C<sub>4</sub>, and the 10kΩ potentiometer on the base of Tr8 is used to adjust the shape of the square waves at the collectors to be symmetrical, that is to have a mark to space ratio of

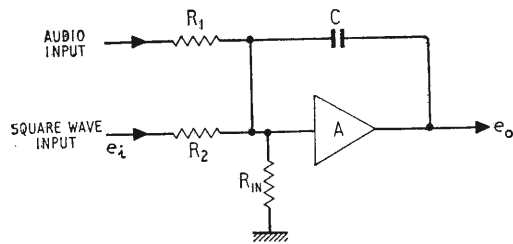

Fig. 5. Circuit of summing integrator with imperfect amplifier.

unity. Referring to Fig. 5, the transfer function of an amplifier of gain  $A$ , with input impedance  $R_{in}$ , connected as an integrator, is:-

$$\frac{e_o}{e_i} = \frac{R_c A}{R_2} \cdot \frac{1}{1 + pCR_c(1+A)}$$

where  $R_c$  is the parallel resistance of  $R_1$ ,  $R_{in}$  and  $R_2$ . To obtain this transfer function it is necessary to consider the audio input point to be earthed (since the audio signal is normally derived from a low impedance source).

This equation may now be used in the design of the integrator. Before this can be done, however, it is necessary to decide on the distribution of the gain between the integrator and the modified switch. The overall audio voltage gain required is about sixty times. If it is attempted to obtain all this gain from the modified switch, then even a very small hysteretic width can restrict the extent of the linear region quite appreciably, and in addition the effect of a small drift in the output stages of the switching circuit will cause the operating point of the modified non-linearity to move from the centre of the linear region by a large amount, this obviously being undesirable. If the gain of the modified non-linearity is set to be approximately 3 then with the value of hysteresis chosen the linear region extends over almost the whole range of possible mean levels of the output, and at the same time drift effects are reduced. Having decided upon the gain through the switch to the audio signal the pk-pk height of the triangle must be  $16/3 \approx 5$  V and the integrator must have an output swing capable of accommodating this size of triangle. The emitter of Tr2 is held at the mid-point of the supply by a low impedance resistance chain, and since the switch has only a very small hysteresis the mid-point of the triangle, and thus the mean level of the collector of Tr1 will be at this potential. Under conditions of peak drive, the triangle will not intersect with the switch operating point and thus the integrator must be capable of accommodating a swing of  $\pm 5$  V at the output.

As previously stated, the integrator transistor is used for the dual purpose of generating the triangular waveform, and adding the audio waveform to it. The input resistor ( $R_1$ ) for the audio signal is a  $10k\Omega$  resistor to obtain the required input impedance. If we make the collector current in Tr1 when the collector potential is at the centre of the supply, about  $200 \mu A$ , this will allow sufficient current to charge the feedback capacitor and operate the switch, and at the same time give an input impedance at the base of Tr1 of about  $10k\Omega$ . In the equation for the transfer function of the integrator to the audio signal (obtained by replacing  $R_2$  by  $R_1$  in the previous equation) we therefore have:-

$$R_c \approx 5k\Omega \text{ and } R_1 = 10k\Omega \text{ (assuming } R_2 \gg 5k\Omega)$$

The measured value of  $A$  was found to be approximately 40, so that the d.c. gain through the integrator will be about 20 to both the triangle and the audio signal.

The gain to the audio signal will remain within 3dB of the d.c. gain up to a frequency given by:-

$$f = \frac{1}{2\pi R_c C_1 (1+A)}$$

this frequency must be greater than at least 20kc/s. Substitution of the above values leads to a maximum value for  $C_1$  of approximately 25pF. With this value of feedback capacity and with  $R_2 = 27k\Omega$  the square wave required to produce a triangle of 5 V pk-pk is about 0.7 V pk-pk.  $R_2$  must not be made too large since this will reduce the gain of the integrator as far as the square wave is concerned. This will cause exponential curvature of the triangles and consequent distortion of the modified non-linear characteristic. With  $R_2$  set to  $27k\Omega$ , the square wave height is adjusted by variation of the collector resistors of Tr7 and Tr8 to obtain the 5 V pk-pk of the triangular waveform at the integrator output.

### Test of the System

The system constructed according to the above design procedure was tested for frequency response and distortion. The frequency response curve is shown in Fig. 6 and the distortion terms at certain points in the system are given in Table 1. Both frequency response and

TABLE 1  
Distortion in open-loop amplifier at 2V r.m.s. across loudspeaker

POINT IN SYSTEM	f (= 1kc/s.)	2f	3f	4f
Input	40mV (0dB)	-52dB	-54dB	> -60dB
Integrator Output	0.7V (0dB)	-34dB	-50dB	> -60dB
Loudspeaker	2V (0dB)	-31dB	-40dB	> -60dB
	f (= 10kc/s.)	2f	3f	4f
Input	60mV (0dB)	-52dB	-52dB	> -60dB
Integrator Output	0.7V (0dB)	-33dB	-50dB	> -60dB
Loudspeaker	2V (0dB)	-36dB	-50dB	> -60dB

distortion were measured at an output swing of 2 V r.m.s. across a simulated loudspeaker load of  $15\Omega$  and 5 mH in series. The low frequency fall-off in frequency response is due to the coupling capacitor on the input, and can be varied to suit particular requirements. The high frequency fall-off is wholly due to the integrator, since it was found that the integrator frequency response and the overall frequency response were identical in shape. The combined effect of the feedback capacitor, the miller capacitance of the transistor and stray capacitance, has apparently doubled the effective integrator time constant since the 3dB point is at 9kc/s rather than the 20kc/s designed for.

The distortion figures show that a large part of the

Fig. 6. Amplitude-frequency response of open-loop amplifier.

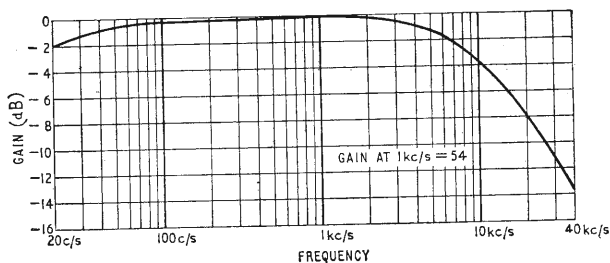



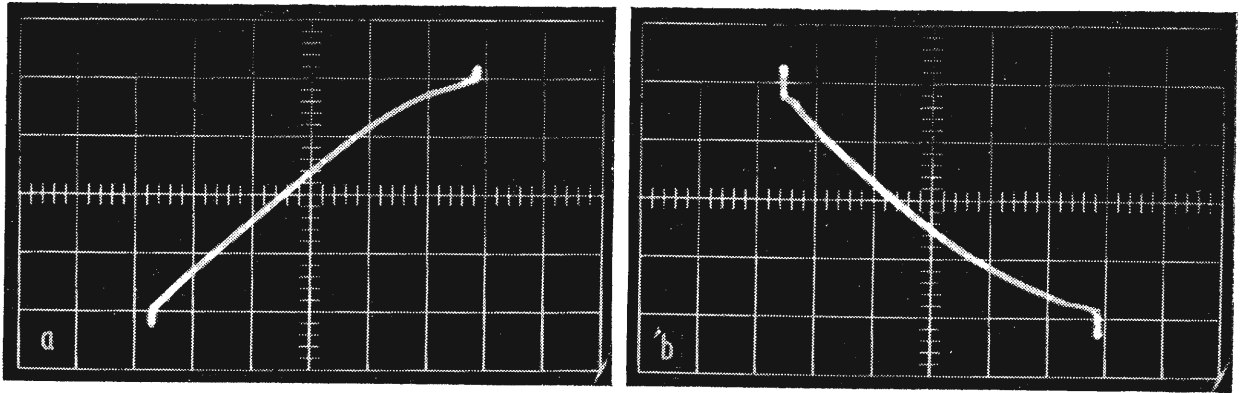

Fig. 7. Characteristics of open-loop amplifier. (a) Relay input v. relay output. (Input 1V/cm, output 2V/cm.) (b) Overall input v. output characteristic. (Input 50mV/cm, output 2V/cm.)

distortion of the amplifier occurs in the integrator stage. This must be due to the large swings which are required at the integrator output.

The input *versus* output characteristics of various parts of the system were displayed on an oscilloscope and photographed; these are shown in Fig. 7. The curvature of the input-output characteristic for the switch shows that there is significant distortion through this element as well as through the integrator.

Since the system functions as a modulator, sidebands will be produced. For large audio inputs at high frequencies these sidebands can be quite large and, more important, they can be frequencies which are in the audio spectrum and can thus be heard as unwanted high frequency outputs. In the system tested with large input signals at 10 kc/s these sidebands could both be heard and measured with a wave analyser and were found to be rather obtrusive.

The system so far described has a performance which is rather mediocre, particularly in respect of its distortion figures. It does, however, have the main advantages of on-off systems in general, notably low power dissipation. However, it is a relatively complex system since to produce the switching waveform a square wave generator must be built. This generator has no function as far as the audio signal is concerned. A further disadvantage found in practice during tests on the system was that the operating point tended to move by quite large amounts away from the centre of the linear region. This effect is caused by relative drift between the operating point of the switch and the mean level of the triangle. It produces undesirable asymmetrical limitation of the output swing and increased distortion.

Various means may be employed to improve the system performance. The distortion can be reduced by improving the integrator design. This will improve the shape of the triangular waveform and thus improve the linearity of the modified switch characteristic, whilst at the same time it will possibly reduce the distortion through the integrator to the audio signal. The improved integrator will almost certainly require extra transistors.

The audio signal could be applied direct to the switch, thus eliminating one source of distortion from the audio path. This would waste potential audio gain and further increase the complexity of the system since additional amplifying stages would then be required to obtain the desired audio gain.

Without increasing the complexity of the system, the

only alternative seems to be to attempt to reduce the triangle size, possibly even to the point where the audio signal can be applied directly to the switch. To maintain the same gain would require a triangle height of 260mV pk-pk. This would require that both the relative drift and the hysteric width be well below this figure. These extremely stringent conditions mean that the optimum design for the present configuration and the specification

Fig. 8. Characteristics of an oscillating loop. (a) Block diagram of the loop. (b) Oscillation frequency of the loop and the d.c. input to the switch as function of the mean level of the output. (c) Low frequency equivalent circuit of the loop.

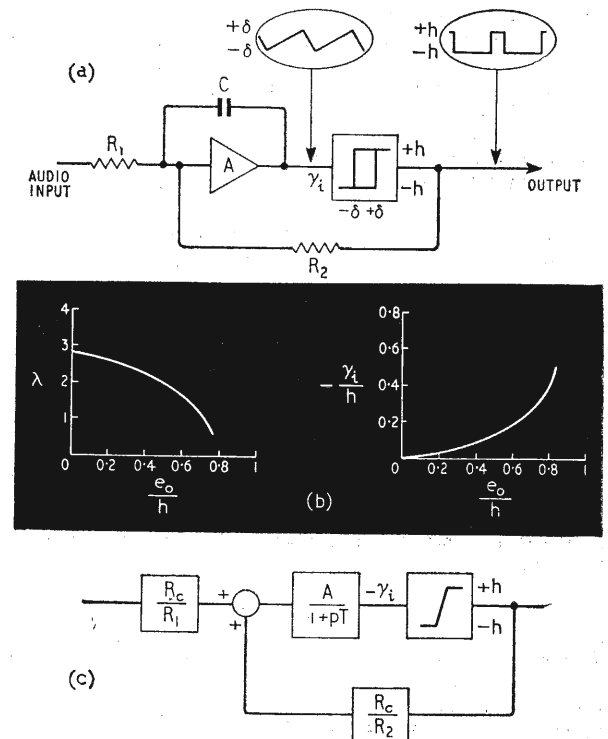

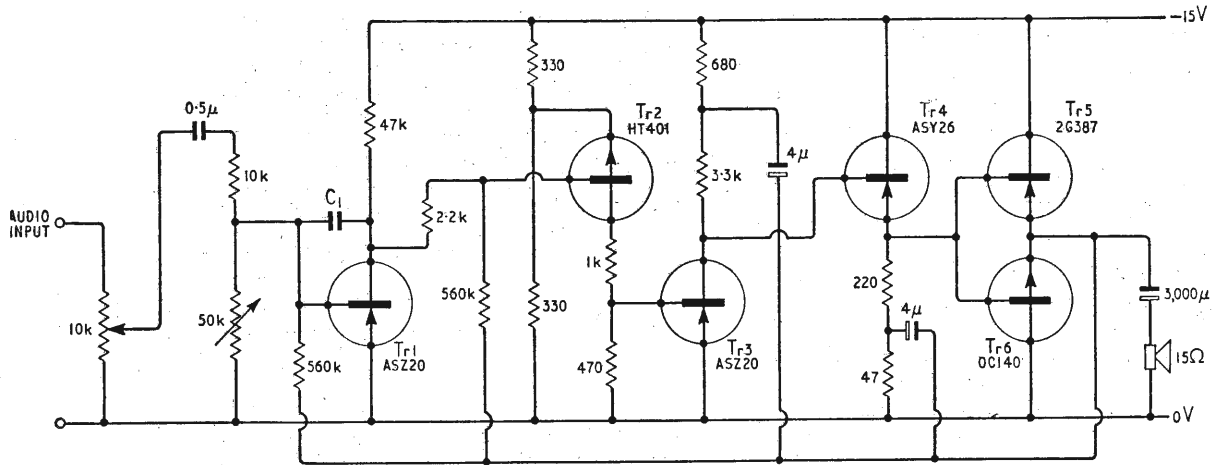

Fig. 9. Circuit diagram of the closed-loop on-off audio amplifier.

adopted is probably somewhere between this solution and the system described.

The square wave generator could be dispensed with altogether merely by connecting the loudspeaker driving point (i.e. the emitters of Tr5 and Tr6) to the integrator input base by a resistor. This causes a negative feedback oscillation to be set up due to the phase shift around the loop, resulting in a square wave oscillation across the loudspeaker, whose mean level is controlled by the audio input signal in such a way that the average input signal into the integrator base is approximately zero. It is important to note that in this oscillating system there is inherent negative feedback to the audio signal. This has certain advantages just as feedback has advantages in more conventional systems. It can reduce distortion due to the amplifier, and it can increase the system bandwidth. The overall gain of the system is better defined and the requirements for ripple in a mains derived power supply are reduced. It reduces the output impedance of the amplifier, thus driving the loudspeaker from a low impedance source which is necessary to damp out loudspeaker resonances at low frequencies.

### Theoretical Aspects of the Closed-loop System

As noted previously the closed loop system functions in a totally different way from the open loop system. The pk-pk height of the triangle is now constant at  $\delta$ , and different values of the mark-space ratio of the output square wave are obtained by varying the slope of the sides of the triangle (see Fig. 8(a)). The limitations of the integrator performance will cause the triangle sides to be part of exponential curves, and will thus modify the effective input *versus* output curves for the switch. It is possible to analyse the closed loop system which is shown in Fig. 8(a).<sup>\*</sup> The integrator here has the transfer function:—

$$\frac{e_o}{e_i} = \frac{K}{1+pT}$$

The hysteretic width of the switch is  $2\delta$  and its two output

levels are  $\pm h$ . For this system it is found that:—

$$\frac{2hK}{\delta} = \coth \frac{B}{\lambda} + \coth \frac{\pi - \beta}{\lambda}$$

$$\frac{\gamma_i \pi}{2hK} = \frac{\pi}{2} \left[ 1 - \frac{\sinh \frac{\pi - \beta}{\lambda}}{\sinh \frac{\pi}{\lambda}} \right]$$

where  $\lambda = 2\pi T \times f_{osc}$  ( $f_{osc}$  being the oscillation frequency of the loop),  $\gamma_i$  is the switch d.c. input, i.e. the

mean level of the switching waveform, and  $\frac{\beta}{\pi - \beta} = \frac{T_1}{T_2}$

(comparing Fig. 8(a) and Fig. 1(b)). From these results it is possible to draw curves relating oscillation frequency and d.c. input to the switch ( $\gamma_i$ ) with the mean level of the output. These are shown in Fig. 8(b) for the case when  $K = 1$  and  $\delta/h = \frac{1}{2}$ . Examination of the curve for  $\gamma_i$  shows that the switch behaves as a gain of about 5 over a large region of the characteristic which has considerable curvature over its full range. The oscillation frequency can be seen to vary considerably over the full range of output. Both oscillation frequency and gain are dependent on the ratio of  $\delta/h$  (being high when  $\delta/h$  is small) and also on the integrator d.c. gain  $K$ . The bigger the value of  $K$  the higher the gain through the switch to the d.c. signal. (For  $K = \infty$ ,  $\gamma_i$  is always zero.)

So far as the audio input and output are concerned, we may represent the system to that shown in Fig. 8(c) which is a feedback loop containing a saturating amplifier. The frequency response of a self-oscillating loop of this type can be calculated although the calculation is laborious. Theoretical results indicate that the frequency response is almost flat up to about one half of the oscillation frequency provided that the gain  $K$  is large.

### Design Details of the Closed-loop System

The main elements of the closed loop system, notably the switch and the integrator are common to both systems, and in order to allow a fair comparison to be made between the two systems, the same switch and the same integrator were used as for the open loop system, the only difference is that the square wave from the

<sup>\*</sup>"A Method for the Theoretical Analysis of Relay Amplifiers." G. F. Turnbull, D. P. Atherton and J. M. Townsend, to be published in *Proc. I.E.E.*

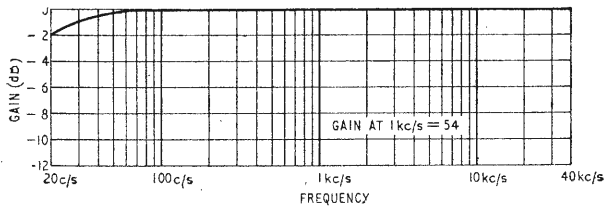

Fig. 10. Amplitude—frequency response of closed-loop amplifier.

output is taken to the integrator *via* a 560kΩ resistor. This defines the gain to the audio signal as 560/10 = 56. The feedback capacitor round the integrator was adjusted to make the oscillation frequency when  $T_1 = T_2$  about 100 kc/s. With zero input signal the square wave was initially set to be symmetrical by adjustment of a 50kΩ potentiometer between base and emitter of the integrator transistor. The practical circuit is shown in Fig. 9.

### Test of the Closed-Loop System

The closed loop system described was tested in the same way as the open-loop system described previously, and the results are shown in Fig. 10 and Table 2. One factor immediately apparent from Fig. 10 is that the

TABLE 2  
Distortion in closed-loop amplifier at 2V r.m.s. across loudspeaker

POINT IN SYSTEM	f (= 1kc/s.)	2f	3f	4f
Input	40mV (0dB)	-52dB	-54dB	> -60dB
Loudspeaker	2V (0dB)	-40dB	-52dB	-50dB
	f (= 10kc/s.)	2f	3f	4f
Input	40mV (0dB)	-52dB	-54dB	> -60dB
Loudspeaker	2V (0dB)	-40dB	-52dB	-50dB

frequency response of the closed-loop system is rather better than that of the open loop system, in spite of the fact that the integrator capacitor was about five times as large in the closed-loop system as it was in the open-loop system. Comparison between Table 1 and Table 2 also shows that the overall distortion is very much reduced in the closed-loop case. Photographs of the overall input *versus* output and switch input *versus* output characteristics of the amplifier were taken and are shown in Fig. 11. The effect of the feedback in improving the distortion in a non-linear system is clearly seen. Measurement of the signals at the input and output of the switch indicated that the gain through the switch to small signals was about 200, thus giving a low frequency open-loop gain of about 75 (the integrator d.c. gain (A) being about 40, as before). Fig. 12(a) shows the shape of the switching waveform and the output waveform from the switch in the closed-loop amplifier. Fig. 12(b) shows the same waveforms in the open-loop

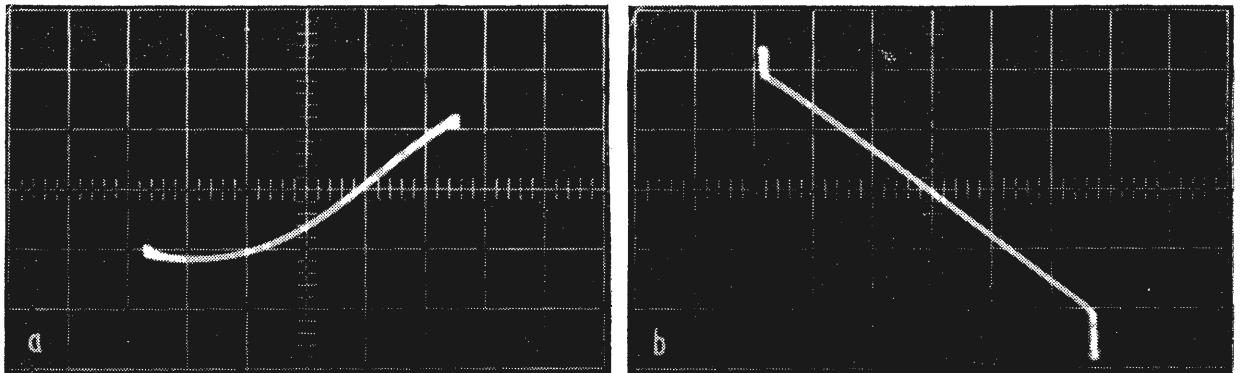

Fig. 11. Characteristics of the closed-loop amplifier. (a) Relay input v. relay output. (Input 50mV/cm, output 2V/cm.) (b) Overall input v. output. (Input 50mV/cm, output 2V/cm.)

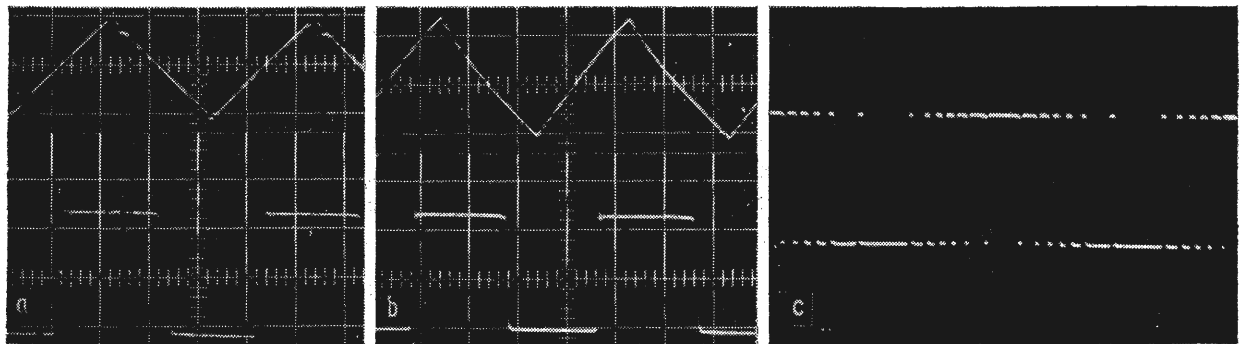

Fig. 12. (a) Switching and output waveforms in the closed-loop amplifier. (Top 100mV/cm, 2μsec/cm; bottom 5V/cm, 2μsec/cm.) (b) Switching and output waveforms in the open-loop amplifier. (Top 2V/cm, 5μsec/cm; bottom 5V/cm, 5μsec/cm.) (c) Loudspeaker driving waveform for closed-loop amplifier driven with 6 kc/s signal.



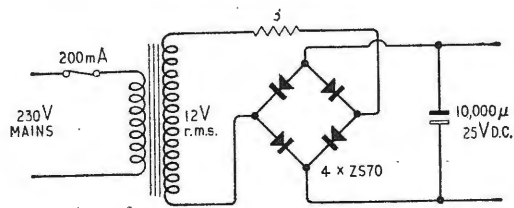

Fig. 13. Mains power supply.

amplifier, and Fig. 12(c) is included since it illustrates the principle of operation of the on-off type of system, being a photograph of the output waveform as a function of time when the system is modulated by a sinusoidal signal.

The sideband components at the output of the system mentioned earlier in the tests on the open-loop amplifier represent spurious signals. These should be reduced by the negative feedback over the audio region when the negative feedback is operative. It was found during tests that this was indeed the case; over the audio range there was almost complete suppression of these unwanted signals.

The frequency change measured in the amplifier as a function of mean output level was very close to that theoretically predicted for the case when  $K = \infty$  which is

$$\lambda = \lambda_0 \left[ 1 - \left( \frac{e_0}{h} \right)^2 \right]$$

where  $\lambda_0$  is the maximum oscillation frequency, so that the frequency change over the working range of the amplifier is not so great as is suggested by Fig. 8(b)."

## Conclusions

Two types of on-off audio amplifier have been described and the performance of the two systems using the same principal components has been compared in a way which was considered to be the most fair to both systems. Whilst it is obviously possible to construct an open-loop system to give an extremely good performance it would appear that a closed-loop system can be made to give the same performance with every much less complexity, and thus at a lower cost. In the systems described every attempt was made to use transistors of minimum cost throughout and no transistor used cost more than ten shillings.

The output power achieved in the circuits described may be considered rather low. The decision to keep to a low power circuit was taken because it was desired to achieve small size and low cost, and there appears to be a dearth of cheap transistors in small cans which will handle collector currents of greater than 500mA, particularly in the npn category. Higher output can, however, be obtained by uprating everything in the circuit, once suitable output transistors have been obtained. An alternative solution would be to use parallel operation of the output transistors. It would be advisable under these circumstances to include a small resistor in each emitter lead to ensure equal current sharing between the transistors. It is also possible to use four transistors in a bridge circuit for the output stage, with an increase of a factor of four in the power output for a given supply. This system has the disadvantage that the loudspeaker is "floating" relative to the supply so that it is extremely difficult to employ the circuit in a closed loop system. It also uses twice as many transistors in the output stage since the current rating of the transistors still needs to be

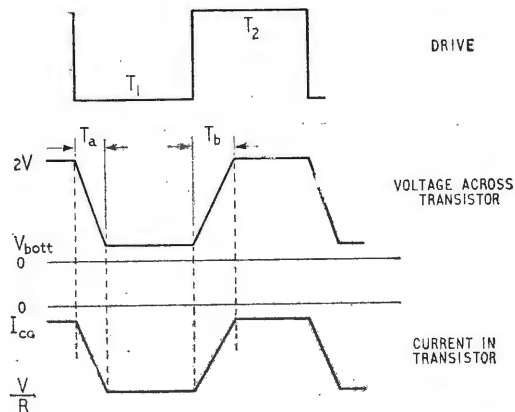
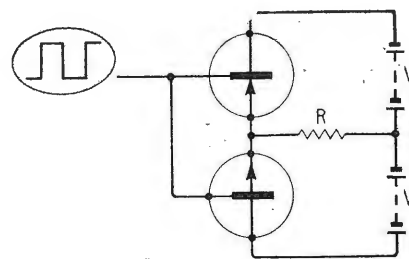

Fig. 14. Approximate conditions in the output stage during change of state.

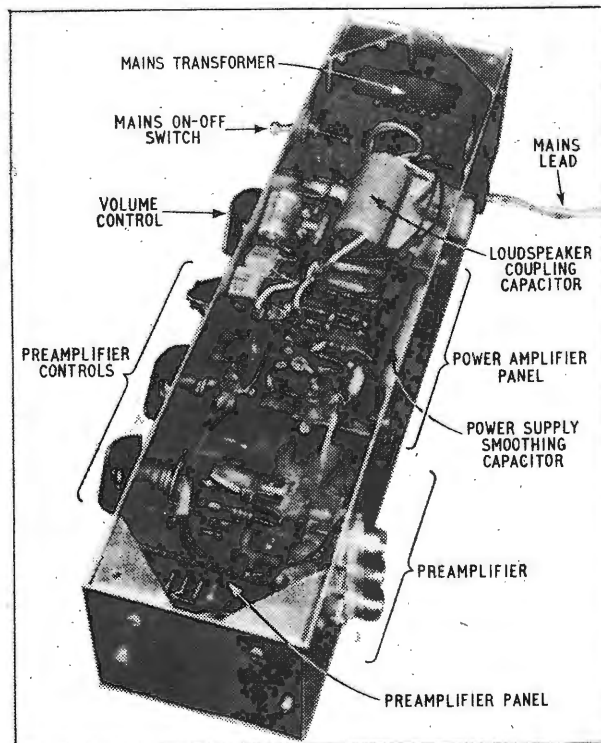

Fig. 15. Closed-loop amplifier with pre-amplifier and power supply.

the same as in the case when the supply voltage is doubled, to obtain the higher power output.

One disadvantage of on-off systems running at 100 kc/s which is brought out by practical tests is that of radiation. The circuit whether open or closed loop, is a prolific source of radiated harmonics and this is a serious disadvantage if it is to be driven from a medium wave tuner. Radiation can, however, be reduced very greatly by screening the amplifier. No interference has been caused to neighbouring equipment working in anything but the long and medium wave bands, and the field of radiation from an enclosed system does not appear to extend more than a few feet.

Comments on the actual power efficiency are contained in Appendix 2.

### Power Supply

The circuit of a mains power supply suitable for driving the amplifier is shown in Fig. 13. The value of the smoothing condenser is large enough to give a hum level at the output of the amplifier which is about -80dB relative to full output. There is insufficient smoothing to give a satisfactory hum level in the open-loop amplifier.

Fig. 15 shows a photograph of the prototype closed-loop audio system with an input pre-amplifier equalised for f.m. radio, l.p. and standard play recordings, etc. The system is sensitive enough to be driven from a magnetodynamic pick-up. The whole system including the mains power supply is contained in an aluminium box 11in. x 3in. x 2in., and the majority of the space in the box is taken up by the potentiometers and the 10,000µF smoothing condenser in the power supply.

### APPENDIX 1

#### Calculation of the Modified Switch Characteristic

Referring to Fig. 2, assume that the triangular switching waveform is displaced to the right by an amount  $\gamma_i$ . This corresponds to the situation which occurs in the open-loop system (Fig. 1 (c)) when the audio input signal has an instantaneous value  $+\gamma_i$ .

Denoting  $T_2$  in Fig. 1 (b) by  $T_2 = t_2 - t_1$ , where  $t_2$  and  $t_1$  are the times at which the switch operates measured from the zero on the triangle in Fig. 4:—

$$t_1 = \pi + \frac{\pi}{\Delta} (\gamma_i + \delta)$$

$$t_2 = 2\pi - \frac{\pi}{\Delta} (\gamma_i - \delta)$$

i.e.  $t_2 = \pi - \frac{2\pi}{\Delta} \gamma_i$

Thus the mean level of the output is given by:—

$$e_o = h\left(\frac{1}{2} + \gamma_i/\Delta\right)$$

The characteristic  $e_o$  versus  $\gamma_i$  does not extend over the whole range from 0 to  $h$ , since some value of  $e_o$  are physically unrealizable because the triangle does not intersect with the relay operating point. This occurs when

$$|\gamma_i + \delta| \geq \frac{\Delta}{2}$$

The limiting values on the characteristic are thus

$$e_o = h\left(1 - \frac{\delta}{\Delta}\right)$$

and  $e_o = h\left(\frac{\delta}{\Delta}\right)$

The fraction of the total characteristic actually covered by

the linear region is  $\left(1 - \frac{2\delta}{\Delta}\right)$ , and the gain in the linear region of the modified characteristic is  $h/\Delta$ .

With the values used in the open-loop system described (i.e.  $h = 16$  volts)  $\Delta = 5$  volts and  $\delta = 100$  mV) the percentage of the range covered is  $100 \left[1 - \frac{200}{5000}\right] = 96\%$  and the gain is  $16/5 = 3.4$ .

### APPENDIX 2

#### Calculation of the Power Dissipation in the Output Transistors

Referring to Fig. 14, the power (P) dissipated in each output transistor is obtained by considering each of the four regions in turn, each region being integrated separately.

$$P = \frac{1}{T} \int_0^T V.I dt$$

$$\therefore P = \frac{1}{T_1 + T_2} \left[ \int_0^{T_a} \left[ 2V - (2V - V_{bott}) \frac{t}{T_a} \right] \frac{V.t}{RT_a} dt \right.$$

$$+ \int_0^{T_1 - T_a} V_{bott} \cdot \frac{V}{R} dt$$

$$+ \int_0^{T_b} \left[ V_{bott} + (2V - V_{bott}) \frac{t}{T_b} \right] \left[ \frac{V}{R} - \frac{Vt}{RT_b} \right] dt$$

$$\left. + \int_0^{T_2 - T_b} 2V I_{co} dt \right]$$

Thus the total power in each transistor is

$$P = \frac{1}{T_1 + T_2} \left[ \frac{VV_{bott}(3T_1 - 2T_a + T_b)}{V^2(T_a + T_b)} + \frac{6RVI_{co}(T_2 - T_b)}{3R} \right]$$

In the design described,

$$T_1 + T_2 = 7.5 \mu\text{sec.}$$

$$T_a = 0.4 \mu\text{sec, } T_b = 0.5 \mu\text{sec.}$$

$$V_{bott} = 0.3V, I_{co} = 1\text{mA (maximum)}$$

$$V = 8V, R = 15 \text{ ohms}$$

giving P approximately 250 mW in each transistor.

This gives an efficiency of  $\frac{200}{2.5} = 80\%$ . If the oscillation frequency were reduced to 50 kc/s, making  $(T_1 + T_2) = 20 \mu\text{sec}$ , then this increases the efficiency to almost 90%. With this frequency of oscillation the frequency response of the closed loop system is still very good. The use of higher frequency transistors can, of course, increase the efficiency even more.

### "Signal Flow Diagrams"

In W. Grant's article in the February issue, the mathematical working in Theorem 2g.1 (page 96) should end as

$$C = \frac{ac + b}{1 - cd}$$

Also, the right-hand diagram in Example 3d.2 (page 97) is incorrectly annotated. It should be:

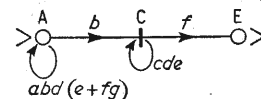

# MATRIX ALGEBRA

## 2. - ITS APPLICATION TO CIRCUIT ANALYSIS

By G. H. OLSEN,\* B.Sc. A.M.I.E.R.E.

READERS of last month's article on matrix algebra will recall that many arrangements of linear components may be regarded as four-terminal networks such networks being represented by a "black-box" as in Fig. 1.

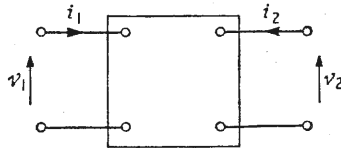

Fig. 1

With circuit arrangements that can be reduced to two-terminal networks we find it very convenient to describe such a network by the simple expression  $R + jX$ . Unfortunately such a simple expression is inadequate for four-terminal networks because of the increased number of variables involved. However, we saw that a two-by-two matrix is a sufficiently simple and adequate expression to describe four-terminal networks, the elements of such a matrix giving valuable information about the network's behaviour.

The four independent variables  $v_1, i_1, v_2, i_2$  may give rise to six different ways of describing the external behaviour of the network. For our purpose we need only consider four of these ways.

The first, discussed in detail in the previous article may be expressed by the two equations :-

$$v_1 = a_{11} v_2 - a_{12} i_2 \quad \dots \quad \dots \quad \dots \quad (1)$$

$$i_1 = a_{21} v_2 - a_{22} i_2 \quad \dots \quad \dots \quad \dots \quad (2)$$

which in matrix form reduces to :-

$$\begin{pmatrix} v_1 \\ i_1 \end{pmatrix} = [A] \begin{pmatrix} v_2 \\ -i_2 \end{pmatrix}$$

The elements of the A-matrix describe the particular network involved; and by applying certain rules we saw how combinations of networks in cascade could be described by a single matrix, the latter being obtained by multiplying together the individual matrices of the networks making up the combination (see Fig. 2).

The transfer function of the composite network was one of the most valuable items of information obtained from a consideration of the elements of [A].

Circuits are not always, however, made up of networks connected in cascade as above. We may have networks connected in parallel (e.g. the parallel-T filter) or in series at their inputs and outputs; or we may have the inputs in series and the outputs in parallel. In such cases

the A-matrix may not be the best description available. Other matrices are possible and, especially for certain transistor work, these alternatives have distinct advantages over the A-matrix. For those readers who are just starting on transistor work it is hoped that this article will show how some of the parameters associated with transistors arise; and perhaps they will then take some comfort in the fact that some order does indeed exist among the bewildering number of parameters that can be used.

The A-matrix and other matrices are all obtained by using one central idea or theme. From the quantities  $v_1, i_1, v_2, i_2$  in Fig. 1 we may regard any pair as known and the other pair as unknown. With  $v_2$  and  $i_2$  known,  $v_1$  and  $i_1$  can be expressed as in equations (1) and (2). From these equations the A-matrix is defined. Similarly the following matrices may be obtained:

$$i_1 = Y_{11} v_1 + Y_{12} v_2 \quad \dots \quad \dots \quad \dots \quad (3)$$

$$i_2 = Y_{21} v_1 + Y_{22} v_2 \quad \dots \quad \dots \quad \dots \quad (4)$$

which in matrix form is

$$\begin{pmatrix} i_1 \\ i_2 \end{pmatrix} = \begin{pmatrix} Y_{11} & Y_{12} \\ Y_{21} & Y_{22} \end{pmatrix} \begin{pmatrix} v_1 \\ v_2 \end{pmatrix} = [Y] \begin{pmatrix} v_1 \\ v_2 \end{pmatrix} \quad \dots \quad \dots \quad (5)$$

The elements of the y-matrix are known as the y-parameters since each has the dimensions of an admittance. The matrices are particularly useful when analysing circuits consisting of two networks in parallel at their input and output terminals (Fig. 3).

The overall matrix is given by  $[Y] = [Y_1] + [Y_2]$  i.e. the elements in corresponding positions in  $[Y_1]$  and  $[Y_2]$  are merely added. An example of an analysis using this technique is given later.

If we take as our starting point

$$v_1 = Z_{11} i_1 + Z_{12} i_2 \quad \dots \quad \dots \quad \dots \quad (6)$$

$$v_2 = Z_{21} i_1 + Z_{22} i_2 \quad \dots \quad \dots \quad \dots \quad (7)$$

which in matrix form is

$$\begin{pmatrix} v_1 \\ v_2 \end{pmatrix} = \begin{pmatrix} Z_{11} & Z_{12} \\ Z_{21} & Z_{22} \end{pmatrix} \begin{pmatrix} i_1 \\ i_2 \end{pmatrix} = [Z] \begin{pmatrix} i_1 \\ i_2 \end{pmatrix} \quad \dots \quad \dots$$

we obtain the z-matrix for the network. The z-matrices are most useful in the analysis of networks arranged in series as in Figure 4.

The overall matrix is given by  $[Z] = [Z_1] + [Z_2]$

The individual elements of a z-matrix all have the dimensions of an impedance.

The last matrix we need consider is the h-matrix. It is this matrix that is most useful when considering transistors. The individual elements of this matrix are the

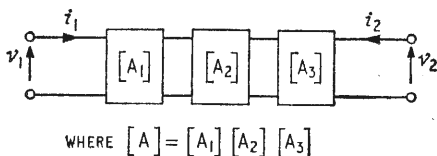

Fig. 2

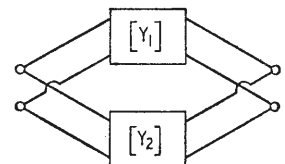
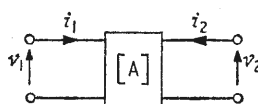

Fig. 3



hybrid or h-parameters often quoted by manufacturers of transistors. The matrix is defined from the following equations:—

$$v_1 = h_{11} i_1 + h_{12} v_2 \quad \dots \quad \dots \quad \dots \quad \dots \quad (8)$$

$$i_2 = h_{21} i_1 + h_{22} v_2 \quad \dots \quad \dots \quad \dots \quad \dots \quad (9)$$

which in matrix form is:—

$$\begin{pmatrix} v_1 \\ i_2 \end{pmatrix} = \begin{pmatrix} h_{11} & h_{12} \\ h_{21} & h_{22} \end{pmatrix} \begin{pmatrix} i_1 \\ v_2 \end{pmatrix} = [H] \begin{pmatrix} i_1 \\ v_2 \end{pmatrix}$$

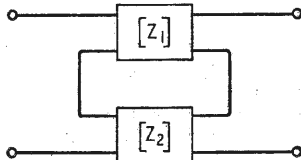

Fig. 4

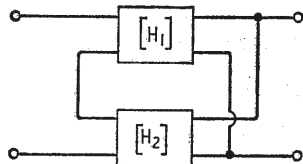

Fig. 5

In circuit analysis the h-matrices are most useful in the configuration of Fig. 5.

The overall h-matrix is given by  $[H] = [H_1] + [H_2]$ .

Consider now the transistor manufacturer's dilemma when wishing to publish design data on his products. The matrices described so far each have their advantages when applied to suitable circuit configurations; but from the manufacturer's point he wishes to describe his transistors with parameters that can easily be measured accurately and unfortunately the z- and y-parameters do not permit of easy determination because of the way in which they are defined. An examination of the h-parameters shows that they can all be determined easily

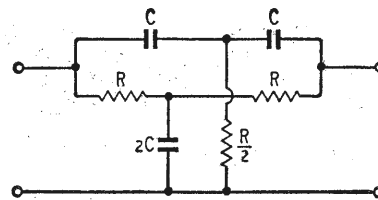

Fig. 6

and accurately. This is why the h-parameters are now widely used in manufacturers' data sheets, in textbooks and articles. D. N. Tilsley in the May 1964 issue of the *Wireless World* (p229) has described the parameters in detail and it is thus unnecessary to go over the same ground again. It is essential however to point out that it will be necessary to be able to convert the h-parameters into the corresponding z-, y- and A-parameters depending upon the particular circuit arrangement it is wished to examine. Since no one can rapidly convert one set into another from first principles every time a conversion is required it is usual to refer to a table. There is nothing complicated about the use of the tables. Like the log. tables with the trig. ratios etc., and the tables of Laplace transforms, the tables of matrix conversions should be readily available to all electronic engineers especially in examinations. Such a table is given in Table I. Only one symbol used has not been defined so far, and that is the one used for the determinant of a matrix. Taking the A-matrix as an example we have

$$[A] = \begin{pmatrix} a_{11} & a_{12} \\ a_{21} & a_{22} \end{pmatrix} \text{ and } \det. A \text{ (written } |A|) = a_{11}a_{22} - a_{12}a_{21}$$

### Applications

When using matrices in circuit analysis we must first determine the most useful matrix form to use. As an example let us take the case of the parallel twin-T network shown in Figure 6.

To obtain the overall matrix of this configuration we

TABLE I

CONVERSION FROM	To						
<b>A-Matrix parameters</b>	$z_{11} = \frac{a_{11}}{a_{21}}$	$z_{12} = \frac{ A }{a_{21}}$	$y_{11} = \frac{a_{22}}{a_{12}}$	$y_{12} = \frac{- A }{a_{12}}$	$h_{11} = \frac{a_{12}}{a_{22}}$	$h_{12} = \frac{ A }{a_{22}}$	$ A  = a_{11}a_{22} - a_{12}a_{21}$
	$z_{21} = \frac{1}{a_{21}}$	$z_{22} = \frac{a_{22}}{a_{21}}$	$y_{21} = \frac{-1}{a_{12}}$	$y_{22} = \frac{a_{11}}{a_{12}}$	$h_{21} = \frac{-1}{a_{22}}$	$h_{22} = \frac{a_{21}}{a_{22}}$	
<b>z-parameters</b>	$a_{11} = \frac{z_{11}}{z_{21}}$	$a_{12} = \frac{ z }{z_{21}}$	$y_{11} = \frac{z_{22}}{ z }$	$y_{12} = \frac{-z_{12}}{ z }$	$h_{11} = \frac{ z }{z_{22}}$	$h_{12} = \frac{z_{12}}{z_{22}}$	$ z  = z_{11}z_{22} - z_{12}z_{21}$
	$a_{21} = \frac{1}{z_{21}}$	$a_{22} = \frac{z_{22}}{z_{21}}$	$y_{21} = \frac{-z_{21}}{ z }$	$y_{22} = \frac{z_{11}}{ z }$	$h_{21} = \frac{-z_{21}}{z_{22}}$	$h_{22} = \frac{1}{z_{22}}$	
<b>y-parameters</b>	$z_{11} = \frac{y_{22}}{ y }$	$z_{12} = \frac{-y_{12}}{ y }$	$a_{11} = \frac{-y_{22}}{y_{21}}$	$a_{12} = \frac{-1}{y_{21}}$	$h_{11} = \frac{1}{y_{11}}$	$h_{12} = \frac{-y_{12}}{z_{11}}$	$ y  = y_{11}y_{22} - y_{12}y_{21}$
	$z_{12} = \frac{-y_{21}}{ y }$	$z_{22} = \frac{y_{11}}{ y }$	$a_{21} = \frac{- y }{y_{21}}$	$a_{22} = \frac{-y_{11}}{y_{21}}$	$h_{21} = \frac{y_{21}}{y_{11}}$	$h_{22} = \frac{ y }{y_{11}}$	
<b>h-parameters</b>	$z_{11} = \frac{ h }{h_{22}}$	$z_{12} = \frac{h_{12}}{h_{22}}$	$y_{11} = \frac{1}{h_{11}}$	$y_{12} = \frac{-h_{12}}{h_{11}}$	$a_{11} = \frac{- h }{h_{21}}$	$a_{12} = \frac{-h_{11}}{h_{21}}$	$ h  = h_{11}h_{22} - h_{12}h_{21}$
	$z_{21} = \frac{-h_{21}}{h_{22}}$	$z_{22} = \frac{1}{h_{22}}$	$y_{21} = \frac{h_{21}}{h_{11}}$	$y_{22} = \frac{ h }{h_{11}}$	$a_{21} = \frac{-h_{22}}{h_{21}}$	$a_{22} = \frac{-1}{h_{21}}$	

first note that two T-networks are connected in parallel at their input and output terminals. The y-parameters are therefore used since simple addition of the y-elements for each T-network gives us the overall y-matrix. If only the A-matrix parameters are known we would proceed as follows:—

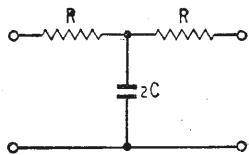

Fig. 7

The A-matrix of the T-network can be found from the individual matrices of the components as shown in the last article. The result (see Fig. 7) is given by

$$[A_1] = \begin{pmatrix} 1 + 2j\omega CR & 2R + 2j\omega CR^2 \\ 2j\omega C & 1 + 2j\omega CR \end{pmatrix} = \begin{pmatrix} \alpha & \beta \\ \gamma & \alpha' \end{pmatrix} \text{ say.}$$

(It should be noted in passing that  $|A| = 1$ , a property of the A-matrices of passive linear symmetrical networks). Using the conversion table

$$[Y_1] = \begin{pmatrix} \alpha & 1 \\ \beta & -\beta \end{pmatrix}$$

Similarly the A-matrix of the network of Fig. 8 is given by

$$A_2 = \begin{pmatrix} 1 + ZG & 2Z + Z^2G \\ G & 1 + ZG \end{pmatrix} \text{ where } Z = \frac{1}{j\omega C} \text{ and } G = 2/R$$

$$= \begin{pmatrix} \alpha' & \beta' \\ \gamma' & \alpha' \end{pmatrix}$$

Thus

$$[Y_2] = \begin{pmatrix} \alpha'/\beta' & -1/\beta' \\ -1/\beta' & \alpha'/\beta' \end{pmatrix}$$

The overall y-matrix for the parallel T-network is therefore

$$[Y_3] = \begin{pmatrix} \alpha + \alpha' & 1 \\ \beta + \beta' & -(\beta + \beta') \end{pmatrix}$$

From Eqn. (3) + (4) the transfer function is  $-y_{21}/y_{22}$  i.e.  $(\beta + \beta')/(\alpha\beta' + \alpha'\beta)$ . For infinite attenuation  $\beta + \beta' = 0$ .

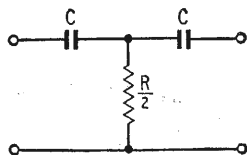

Fig. 8

This occurs when  $\omega = \omega_0$  say.

$$\therefore 2R + 2j\omega_0 C R^2 + \frac{2}{j\omega_0 C} - \frac{2}{\omega_0^2 C^2 R} = 0$$

$$\therefore \omega_0 = \frac{1}{CR}$$

Infinite attenuation therefore results at a frequency  $f_0 = 1/(2\pi CR)$ .

Before looking at the application of matrix algebra to transistor circuit analysis let us consider the symbol conventions used since we need to be quite clear about the interpretation of any symbol. As the h-parameters appear in the conversion table they apply to transistors used in the grounded-base mode of operation. When considering the grounded-emitter mode the same expressions are used except that all the h's are primed thus,  $h'_{11}$ ,  $h'_{12}$  etc. By considering the defining equations (8) and (9) we see that  $h_{21} = \alpha$  (when  $v_2 = 0$  i.e. the output is short circuited to a.c.);  $h_{21}$  is therefore the current gain in the grounded base mode of operation.  $h'_{21} = \alpha' = \beta$  i.e. the current gain of a grounded-emitter transistor. We also have the conventional symbols described by D. N. Tilsley where  $h'_{11} = h_{ie}$ ;  $h'_{12} = h_{re}$ ;  $h'_{21} = h_{fe}$  and  $h'_{22} = h_{oe}$ .

The matter of conventions is not yet settled and many writers still go by preference. This writer prefers the numeral subscripts since the position in the matrix requires no effort on the part of the memory; additionally, the letter subscripts refer to English words such as "forward" and "reverse" and these are not likely to be adopted by non-English-speaking countries.

With many important practical circuits we often need to know one or more of the following: input impedance, voltage gain, current gain, power gain and output impedance. All of this information is available in compact form when using matrices. Take as an easy example a straightforward transistor amplifier, Fig. 9(a) and its matrix equivalent, Fig. 9(b).

Regarding this as two four-terminal networks in cascade we find it convenient to use A-matrices. The overall A-matrix will give the information we need; but let us say that only the h-parameters are available from the manufacturer's data. We first convert the h-parameters to A-parameters, using the table; then multiply the matrix by that representing the load. The overall matrix [A] is given by

$$[A] = \begin{pmatrix} -|h'| & -h'_{11} \\ h'_{21} & h'_{21} \end{pmatrix} \begin{pmatrix} 1 & 0 \\ G_L & 1 \end{pmatrix} \text{ where } G_L = \frac{1}{R_L}$$

The required information can then be easily extracted.

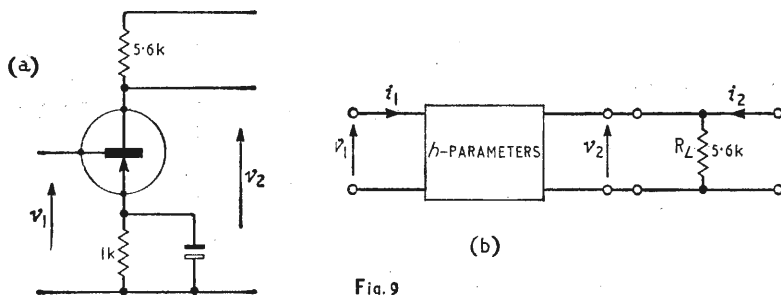

Fig. 9

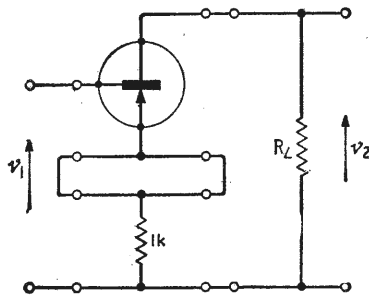

Fig. 10

For example the voltage gain will be given by the reciprocal of the  $a_{11}$  element of [A]

$$\text{i.e. } \frac{-h'_{21}}{|h'| + Gh'_{11}}$$

Suppose therefore that  $h'_{11} = 1k\Omega$ ,  $h'_{12} = 3 \times 10^{-4}$ ,  $h'_{21} = 50$  and  $h'_{22} = 50\mu\Omega$  then  $|h'| = 50 \times 10^{-3} - 150 \times 10^{-4} = 35 \times 10^{-3}$ . The voltage gain is therefore  $-50 / (35 \times 10^{-3} + G_L \times 10^3)$ . For a 5.6k load resistor the voltage gain is therefore 235. The input resistance is found from equations (1) and (2) to be  $a_{11}/a_{21}$  of [A] ( $i_2$  being zero for the cascaded pair). This turns out to be

$$R_{in} = \frac{h'_{11} + |h'| R_L}{1 + h'_{22} R_L} = 930 \text{ (approx.)}$$

If feedback is introduced by omitting the by-pass capacitor across the emitter resistor ( $= 1k\Omega$  say) we have Fig. 10 as a four-terminal equivalent.

The procedure here would be to notice that since the transistor and emitter resistor networks are in series at their inputs and outputs we require the z-parameters of each network. Addition gives the overall z-matrix which can then be converted to the A-matrix and multiplied by the A-matrix for the load resistor. It will be found that the intermediate working becomes rather cumbersome if symbols are retained so, if the configuration includes a transistor and emitter resistor with known parameters it is better to work out the numerical values of the matrix elements as one goes along. Once the overall A-matrix is obtained the voltage and current gains, and input and output impedances are readily determined. Provided the writer has done his homework satisfactorily readers should find that the gain is now  $\approx 5.5$  and the input resistance about 39k $\Omega$ .

Although matrix algebra is not the answer to every problem of circuit analysis, it is a powerful tool that ought to be more widely used. Criticism that precise formulations are a waste of time with transistor circuits (because of the wide spread of transistor parameters) is not likely to be permanently valid. As manufacturing techniques improve better control of parameters will be effected. In any case some attempt should be made at analysing the circuits we use; and it is hoped that these articles have gone some way in encouraging readers to adopt matrix methods where appropriate.

## THIS MONTH'S CONFERENCES & EXHIBITIONS

### LONDON

- Apr. 11-14 Chelsea Coll. of Science  
**Educational Requirements for the Professional Inspection & Quality Engineer**  
 (Instn. of Engineering Inspection, 616 Grand Buildings, Trafalgar Sq., W.C.2.)
- Apr. 21-30 Olympia & Earls Court  
**International Engineering Exhibition**  
 (F. W. Bridges & Sons, 1-19 New Oxford St., W.C.1.)
- Apr. 22-25 Hotel Russell  
**International Audio Festival & Fair**  
 (C. Rex-Hassan, 42 Manchester St., W.1.)
- Apr. 30 & May 1 Royal Albert Hall  
**Technical Publications & Aids to Technical Publications**  
 (Technical Publications Assoc., 17 Bluebridge Ave., Brookmans Park, Herts.)

### BIRMINGHAM

- Apr. 5-7 The University  
**Conference on Elementary Particles**  
 (Inst. Phys. & Phys. Soc., 47 Belgrave Sq., S.W.1)

### BRISTOL

- Apr. 7-9 The University  
**Stress Analysis Conference**  
 (Inst. Phys. & Phys. Soc., 47 Belgrave Sq., S.W.1)

### MANCHESTER

- Apr. 5-8 Col. of Science & Tech.  
**Physics Exhibition**  
 (Inst. Phys. & Phys. Soc., 47 Belgrave Sq., S.W.1)

### NOTTINGHAM

- Apr. 6-9 The University  
**Automatic Control Convention**  
 (Inst. Mechanical Engineers, 1 Birdcage Walk, S.W.1)

### OVERSEAS

- Apr. 5-10 Paris  
**Symposium on Memory Techniques**  
 (Société Française d'Électroniciens et des Radiotechniciens, 10 avenue Pierre-Larousse, Malakoff (Seine))

- Apr. 8-13 Paris  
**Electronic Components Exhibition**  
 (F.N.I.E., 16 rue de Presles, Paris 15e)
- Apr. 8-13 Paris  
**Audio Equipment Exhibition**  
 (F.N.I.E., 16 rue de Presles, Paris 15e)
- Apr. 12-17 Los Angeles  
**Technical Conference**  
 (S.M.P.T.E., 9 East 41st St., New York 17, N.Y.)
- Apr. 13-15 Houston  
**Telemetering Conference**  
 (R. W. Towle, Advanced Technology Labs., 369 Whisman Rd., Mountain View, Cal.)
- Apr. 14-15 Cincinnati  
**Electronics and Instrumentation Conference**  
 (J. R. Ebbeler, Avco Corp., 2630 Glendale-Milford Rd., Cincinnati)
- Apr. 20-22 New York  
**Symposium on System Theory**  
 (Polytechnic Institute of Brooklyn, 333 Jay St., Brooklyn 1, N.Y.)
- Apr. 20-22 Atlantic City  
**Frequency Control Symposium**  
 (M. F. Timm, U.S. Army Electronics Labs., Fort Monmouth)
- Apr. 21-23 Pittsburgh  
**Optimization Techniques**  
 (I.E.E.E., Box A, Lenox Hill Station, New York 21, N.Y.)
- Apr. 21-23 Washington  
**Nonlinear Magnetics**  
 (Dr. E. W. Pugh, IBM Building, 703-2, Poughkeepsie, N.Y.)
- Apr. 24-May 2 Hanover  
**Hanover Fair**  
 (Schenkers Ltd., 13 Finsbury Sq., London, E.C.2)

"Simple Transistor Power Supply":—In Fig. 4, page 139 of the March issue, the resistances assume a meter resistance of 1450 $\Omega$  (0.5 mA, f.s.d.). In the second paragraph, left-hand column, page 140 the reference is to Fig. (a) (not (b)) and in the performance table the ripple should be in millivolts.



# MANUFACTURERS' PRODUCTS

## NEW ELECTRONIC EQUIPMENT AND ACCESSORIES

### Plug-in Component Module

A NEW component board unit consisting of a twenty-two way plug-in base (identical to that used for the Key-switch P33 relay) and a circuit component board enclosed in a transparent dust-proof cover has been introduced by Keyswitch Relays Ltd., of 120-132 Cricklewood Lane, London, N.W.2. The component mounting area is 3.125 × 2.218 × 1.093 in and as a demonstration of what can be achieved, Keyswitch have successfully built into a standard unit a ring counter stage complete with power pack. This included 11 trigger tubes, 11 diodes, 65 resistors and 35 capacitors.

Longitudinal copper strips 0.0015 in thick and spaced at 0.2 in intervals are bonded to the board which is pierced with a regular matrix of holes. The maximum working voltage between adjacent copper strips is 500 volts d.c. The price of the Type 304 plug-in component board unit is 30s.

4WW 301 for further details

### Cold-cathode Indicator Diode

AMBIENT illumination does not interfere with the operation of the new ZA1004 cold-cathode indicator tube from Mullard Ltd. This tube is primarily intended as a display device for medium/low voltage transistor circuits and a prominent feature is that the control voltage is less than 10 volts and in certain circuits may be kept as low as 3.5 V. The tube has a breakdown voltage of 93.5 V maximum, an extinction voltage of 83.5 V minimum, and a preferred cathode current of 1 mA. Minimum illumination at a distance of 2 mm from the bulb surface is 45 lux. The makers claim a life expectancy of 2,500 hours when the tube is operated at a constant cathode current of 1 mA and a bulb temperature of 35° C.

4WW 302 for further details

### Temperature Gauge

A COMPACT portable temperature gauge suitable for measuring temperatures to an accuracy of 1% from -20°C to +120°C has been introduced by Startronic Ltd., of 117a-119a Malden

Road, New Malden, Surrey. The instrument has two scales covering -20 to +55 and +50 to +120°C and can be located some distance away from the probe without seriously affecting the accuracy. In fact, a lead resistance of 2Ω only introduces ¼°C error at 100°C.

A selection of matched thermistors are available for the measurement of surface temperatures and a selection of probes can be supplied for the measurement of gas or liquid temperatures. Other accessories include a ten-way selector box and a selection of leads. The instrument weighs 4 lb and measures (case size) 2¼ × 5¼ × 7⅜ in. The price is £31.

4WW 303 for further details

### Capacitance Bridge

A THREE-TERMINAL 100 kc/s capacitance bridge able to measure

0.0002 to 110,000 pF with a basic accuracy of 0.1% has been developed by the Boonton Electronics Corporation, of New Jersey. This instrument, known as the Model 74D, may also be used for the measurement of conductance, from 0.0001 to 1,000 micromhos, and shut resistance, from 1,000Ω to 1,000 MΩ.

Features of the Model 74D include a continuously variable test signal from 1 mV to 4 V, an internal bias adjustable from -7 V to +144 V, provision for external bias up to ±400 V, negligible warm-up drift, and less than 0.001 pF capacitance drift in 24 hours.

The Model 74D may also be used as a comparison bridge or for "go"- "no-go" testing, as a d.c. output proportional to the bridge unbalance is provided.

This instrument is obtainable in the United Kingdom through Livingston Laboratories Ltd., of 31 Camden Road,

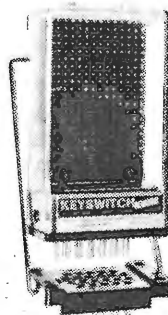

Plug-in component board unit from Keyswitch Relays Ltd.

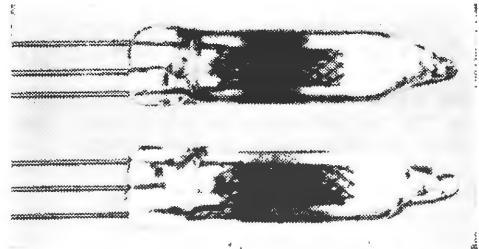

Two Type ZA1004 cold-cathode indicator diodes from Mullard.

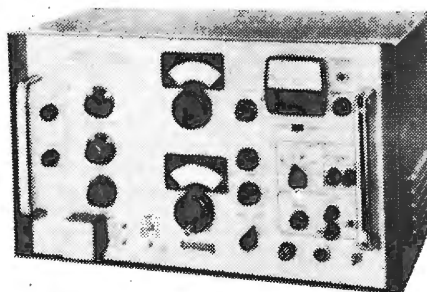

Wide-range three terminal capacitance bridge manufactured by the Boonton Electronics Corp.



Battery-operated Model 142 temperature gauge from Startronic Ltd. It covers the range -20° to +120°C.

London, N.W.1. The price, excluding duty, is £568.

4WW 304 for further details

### Professional Tape Recorder

A PORTABLE tape recorder that weighs less than 11 lb inclusive of batteries is announced by EMI Electronics Ltd., of Hayes, Middx. Features of the new machine include provision for a fourth magnetic head for film and television synchronization, two tape speeds— $3\frac{3}{4}$  and  $7\frac{1}{2}$  in/sec—with a run-up time of less than one second, a remote stop-start control which can be embodied in one of the microphones and microphone mixing facilities.

This machine, which should be of interest to those in the broadcast, audio and industrial fields, is designated Type L4. Two microphone amplifiers are incorporated, each with separate volume controls, and require less than 50 microvolts for peak recording level. An EMI motor is used in the machine and speed stability (measured on either speed at a constant 14 volts) is better than 0.2% of the mean speed from start to finish of a  $4\frac{1}{2}$  in spool (maximum size). Wow and flutter is quoted to be better than 0.2% at both speeds when played back on the same machine. At the higher speed the overall response is within 2 dB from 50 c/s to 12,000 c/s and at  $3\frac{3}{4}$  in/sec within 2 dB from 50 c/s to 5,000 c/s.

Separate record and replay amplifiers are housed within the main chassis with a monitor amplifier (provided with a 3 in speaker for checking the information on the tape on replay only) and oscillator unit which operates, with variable bias, at approximately 60 kc/s. The 14 volt battery for this machine is rechargeable.

4WW 305 for further details

### Wall Speaker Unit

AN inexpensive sound reinforcement loudspeaker unit, Type BG, that can be fitted into a wall is announced by

K.L.B. Electric Ltd., of 335 Whitehorse Road, Croydon, Surrey. A seven by four-inch speaker with a three-watt power-handling capacity is fitted as standard although speaker size can be varied to customer requirements.

The unit requires a wall area of  $9 \times 6$  in and can easily be accommodated after the removal of two bricks. Alternative fixings are provided for mounting in a standard builder's "knock-out box." The price of the unit complete with 100 volt line transformer is £2 17s 6d.

4WW 306 for further details

### Digital Circuit Modules

INTENDED for applications up to 10 kc/s are the new Series 10A (open) and 10B (potted) digital modules from the electronic services division of Standard Telephones and Cables Ltd. The Series so far includes two- to five-input gates; low-, medium- and high-power inverters; low-, medium- and high-power buffers; and several multi-stable and peripheral equipment circuits. Module design is characterized by very sharp pulse edges ensuring positive response and immunity from noise. These units are designed to have a life span of at least twenty years and will operate within the temperature range  $-10^\circ$  to  $+70^\circ$  C. The division's address is Edinburgh Way, Harlow, Essex.

4WW 307 for further details

### Nanovolt Source

PRIMARILY designed to function as a secondary standard for calibrating low-voltage ranges on instruments, the Model 260 nanovolt source manufactured by Keithley Instruments Inc., of Cleveland, Ohio, is simple to operate and may be set with a three-digit resolution for any value from one nanovolt to one volt. Separate take-off points are provided for nanovolts, microvolts and millivolts. A source resistance of  $1 \Omega$  is quoted for the two lower ranges and  $100 \Omega$  for millivolt outputs. Long-

term accuracy is specified to be within 0.25% to 0.75%, according to the range in use.

The Model 260, which can also be used to provide an accurate voltage source for zero suppression, potentiometric measurements and the like, is available in the United Kingdom through Livingston Laboratories Ltd., of 31 Camden Road, London, N.W.1.

4WW 308 for further details

### D.C. Multimeter

THIRTEEN voltage, thirteen current and sixteen resistance ranges are provided on the Millivac Type MV-77B d.c. multimeter. This instrument features a floating input, an output suitable for connection to a recorder, and a six-inch mirror-scale meter with taut-band suspension.

As a voltmeter it covers 1 mV to 1,000 V full scale in 13 ranges, each of which has individual calibration controls. The accuracy is quoted to be within 3% on the 1 mV range, 2% on the 2.5 mV to 10 mV ranges and within 1% on all ranges from 25 mV up to 1,000 V. Input impedance is  $10 M\Omega$  on the ranges up to 100 mV,  $25 M\Omega$  on the 250 mV range and  $100 M\Omega$  on all higher ranges.

The accuracy of the instrument in the current mode is within 2% on all ranges, except on the lowest, where it is 3%. Shunt resistances range from  $1 k\Omega$  on the lowest range to  $0.01 \Omega$  on the highest, thus keeping the voltage drop to below 10 mV full scale over the entire range from  $1 \mu A$  to 1 A.

The first 13 resistance ranges, from  $1 \Omega$  to  $1 M\Omega$  full scale, utilize the voltage scales which are linear and provide an accuracy of  $\pm 2\%$ . The terminal voltage on these ranges never exceeds 10 mV, thus making the instrument suitable for testing micro-miniature electronics, such as thin films. The three other resistance ranges, which have their own logarithmic scales, extend the measurement range up to  $100 M\Omega$  with a 5% accuracy and up to  $5,000 M\Omega$  at  $\pm 10\%$ .

Overall dimensions of the instrument are  $13 \times 8\frac{1}{2} \times 11$  in and it weighs 25 lb. A rack-mounted version, designated Type RM-77B, is also available in the United Kingdom through the instruments division of Claude Lyons Ltd., of 76 Old Hall Street, Liverpool, 3 (Southern offices Hoddesdon, Herts.). The price, excluding Government charges, is £148 2s 6d.

4WW 309 for further details

### Spark Eroder

BROKEN taps and drills of minute dimensions—down to 12 B.A.—can be

#### INFORMATION SERVICE FOR PROFESSIONAL READERS

To expedite requests for further information on products appearing in the editorial and advertisement pages of *Wireless World* each month, a sheet of reader service cards is included in this issue. The cards will be found between advertisement pages 48 and 51.

We invite readers to make use of these cards for all inquiries dealing with specific products. Many editorial items and all advertisements are coded with a number, prefixed by 4WW, and it is then necessary only to enter the number(s) on the card.

Readers will appreciate the advantage of being able to fold out the sheet of cards enabling them to make entries while studying the editorial and advertisement pages.

Postage is free in the U.K. but cards must be stamped if posted overseas. This service will enable professional readers to obtain the additional information they require quickly and easily.

removed with the "Arc-out" spark eroder developed by Watton Electronic Ltd., of Welwyn Garden City. The cores of taps and drills from any metal down to 12 B.A. size can be removed, claim the manufacturers, without damage to the thread or hole. The "Arc-out" can also be used for machining hardened metals, and any shape of hole is possible.

Apart from a normal a.c. mains supply (consumption 2 A to 240 V a.c.), it requires only a small flow of water. Two models of the "Arc-out" are available, the Model 1A which has a height clearance of 10 in and the 1B which has a 16 in clearance. Both models are supplied complete with electrode clamp nut, two electrode adaptors, a tubular electrode, five different sized insulated wire electrodes, and a water hose. The Model 1A is priced at £65 15s 0d and the 1B at £69 17s 6d.

These units are available through Roberts Electronics Ltd., of 17 Hermitage Road, Hitchin, Herts.

4WW 310 for further details

### Sub-miniature Electrolytics

SOLID electrolytic tantalum capacitors comparable in size to lighter flints—a typical example is 4 mm long by 1.8 mm diameter—are being produced by the dielectric and magnetic division of Plessey-UK Ltd., at Towcester, Northants. Designated Type M, the capacitance range of the new series is from 0.047  $\mu$ F to 10  $\mu$ F at d.c. working voltages from 1.5 to 50 V. Other characteristics include a temperature range of -55°C to +85°C, a power factor of 25% of maximum at 120 c/s, leakage current not greater than two microamps at 20°C and a surge voltage rating of 16% above the rated working voltage.

These polarized units are designed to operate with a d.c. bias and to avoid reverse polarity, the peak value of any a.c. component must not exceed the applied d.c. bias. Also, the sum of the d.c. bias voltage and the peak value of any a.c. component must not exceed the rated working voltage of the capacitor.

Tinned nickel contact leads of 0.010 in diameter are welded to the anode and soldered to the cathode. Each unit is metallic coated and encapsulated in epoxy resin.

4WW 311 for further details

### Logic Circuit Elements

THREE new series of logical switching elements presented in rectangular encapsulations are announced by Ferranti Ltd. The 400 Series, an alternative to the current 300 Series, employ sili-

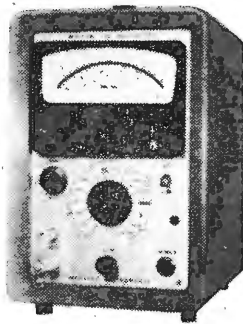

Millivac d.c. multimeter obtainable through Claude Lyons Ltd.

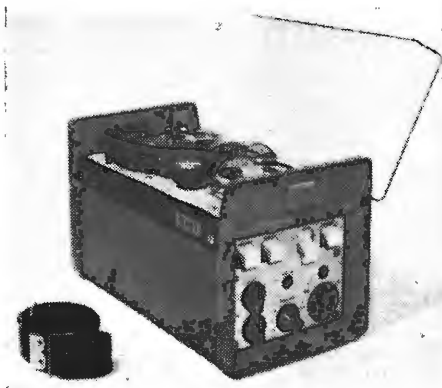

EMI Electronics Type L4 portable tape recorder. Full and half track versions are available.

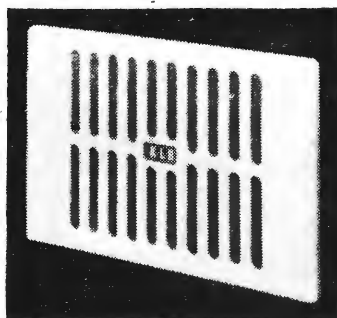

Wall loudspeaker unit from K.L.B. Electric Ltd. It can be fitted in place of two bricks.



Plessey Type M "Castanet" tantalum capacitor shown against a cigarette lighter.

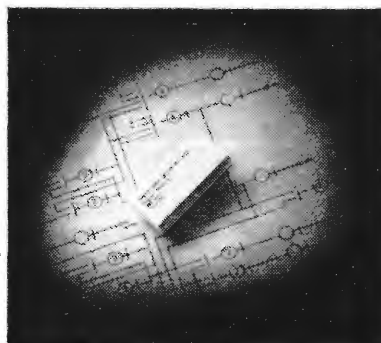

Type 10B potted circuit module for control and data systems from S.T.C. This unit measures  $2\frac{1}{2} \times 1 \times 1$  in, excluding connections.

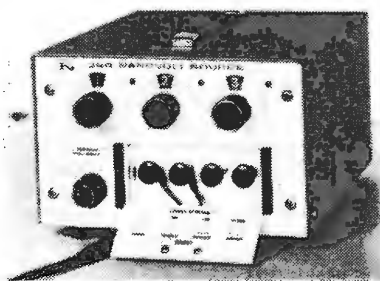

Model 260 nanovolt source made by Keithley Instruments Inc.

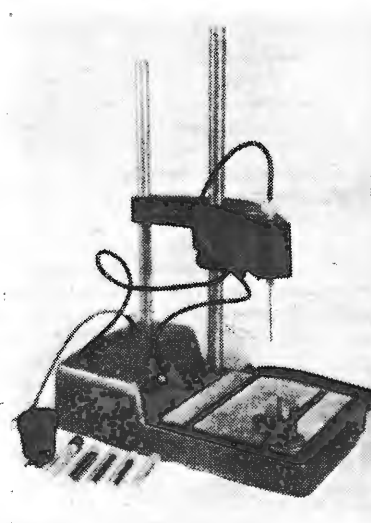

Watton "Arc-out" spark eroder for removing small broken taps and drills. It is suitable for use down to 12 B.A.



Ferranti 700 Series of logic circuit elements. They weigh less than 10 gm.

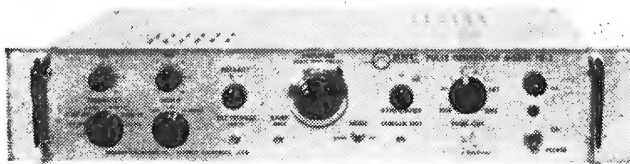

Sliding pulse generator from Berkeley Nucleonics.

con active elements and have switching speeds in excess of 3 Mc/s; temperature range is from  $-40^{\circ}$  to  $+100^{\circ}$ C. Switching speeds in excess of 5 Mc/s are quoted for the 500 Series, which contain silicon transistors and gold-bonded germanium diodes.

The other new modules, the 700 Series, have been developed primarily for industrial applications and have switching speeds in excess of 1 Mc/s. Operating temperature range for this series and the 500 Series is from  $-20^{\circ}$  to  $+90^{\circ}$ C.

All circuits operate on standard supply rails of +12 V and  $-6$  V, with a nominal tolerance on all rails of  $\pm 0.5$  V. Logic levels for the new modules are similar to those specified for the current Ferranti range, and all electrical outlets are in the form of flying leads; the maximum number is 14. These modules measure  $1.48 \times 0.45 \times 0.55$  in, and in many cases can be provided mounted on printed circuit boards to fulfil standard functions such as decade counters, shift registers, adders, decoders, etc.

4WW 312 for further details

### Sliding Pulse Generator

CAPABLE of producing a train of linearly increasing pulses suitable for testing differential linearity in amplifiers, pulse height analysers and

analogue-to-digital converters is the Model PB-2 generator from Berkeley Nucleonics Co., of California. Transistors are used throughout the PB-2 which can also be used as a conventional precision pulse generator.

Pulse height linearity and stability are stated to be better than 0.1%. Repetition rate is adjustable from 1 c/s to 1 Mc/s and the output amplitude is calibrated from 1 mV up to 10.1 V. Coarse adjustment is by a step attenuator and fine adjustment by a 10-turn potentiometer. The rise time is adjustable from 0.05 to 2  $\mu$ sec and pulse width from 0.3 to 100  $\mu$ sec.

The Model PB-2 is available in the United Kingdom through High Volt Linear Ltd., of 1 Cardiff Road, Luton, Beds.

4WW 313 for further details

### Microwave Marker Generator

DESIGNED to provide marker intervals on swept frequency displays is the Model TMS-1 microwave marker generator from Telonic Engineering Incorporated. This instrument will operate on any frequency within the range 5 Mc/s to 10 Gc/s and provide 5, 10, 50 or 100 Mc/s markers accurate to  $\pm 0.001\%$ . Other markers between 2 and 200 Mc/s may be generated by feeding the instrument with a signal of

the appropriate frequency. The TMS-1 is marketed in the United Kingdom by Livingston Laboratories Ltd., of 31 Camden Road, London, N.W.1. The price, excluding Government charges, is £646.

4WW 314 for further details

### Plug-in Scope Units

TWO new plug-in units for the Solartron Type CD1212 (CT484) and CD1220 oscilloscopes are announced. One of these, a high-gain differential amplifier designated CX1258 features a high d.c. sensitivity (100  $\mu$ V/cm), high in-phase rejection (80 dB) and very low drift. The maximum bandwidth of this amplifier is 200 kc/s making it suitable for a wide range of general purpose applications. The sensitivity of the amplifier is adjustable from 100  $\mu$ V/cm to 2 V/cm in 14 calibrated ranges and maximum sensitivity is quoted to be 100  $\mu$ V from d.c. to 50 kc/s, 200  $\mu$ V from d.c. to 100 kc/s and 500  $\mu$ V from d.c. to 200 kc/s. Maximum in-phase voltage is  $\pm 25$  V peak from 100  $\mu$ V/cm to 20 mV/cm and  $\pm 250$  V peak from 20 mV/cm to 2 V/cm. Calibration accuracy is 3%.

The other unit, the CX1259, is a wide-band amplifier and has a similar performance to the CX1256, but includes an additional  $\times 10$  d.c. coupled transistor amplifier providing a maximum sensi-

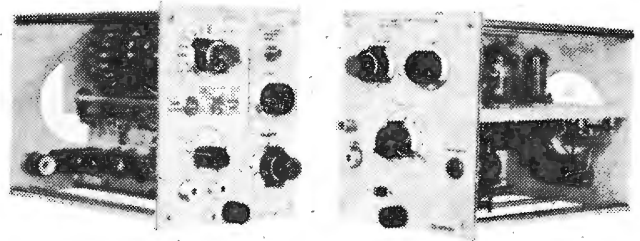

Two new plug-in units for Solartron oscilloscopes. A high-gain differential amplifier is shown on the left and a wide-band amplifier on the right

Telonic microwave marker generator. It features push-button controls.

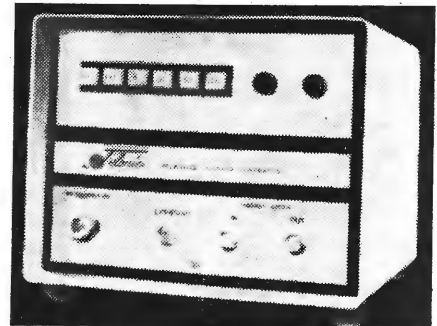

tivity of 5 mV/cm at a bandwidth of d.c. to 24 Mc/s. With the additional amplifier out of circuit, the sensitivity of the CX1259 is 50 mV/cm from d.c. to 40 Mc/s. Both of these units are available from the Solartron Electronic Group Ltd., whose address is Farnborough, Hampshire.

4WW 315 for further details

### Slip Clutches & Couplings

A RANGE of precision slip clutches and couplings for use in servomechanisms and small mechanical devices are now available from Bowmar Instrument Ltd., of Sutherland Road, London, E.17. Two sizes of slip clutches are being offered which can be pre-set to slip at torques between 2 oz/in and 20 oz/in. Various combinations of shaft sizes can be accommodated from 0.120 to 0.250 in and these are clamped by means of two set screws in the hub. These should be found particularly use-

ful for the protection of multi-turn precision potentiometers in servo systems.

The precision couplings are also in two sizes, one for transmitting up to 8 oz/in torque without backlash, the other for 16 oz/in. Shaft sizes are also from 0.120 to 0.250 in and are held in position by either a set screw in the hub or a split collet type of hub.

4WW 316 for further details

### Frequency Selective Amplifier

A PORTABLE frequency selective amplifier covering 10 c/s to 100 kc/s has recently been introduced by H. Tinsley & Co., of Werndee Hall, South Norwood, London, S.E.25. Four ranges are used to cover the spectrum, and frequency is selected by decade switches. A "Q" factor of better than 30 is quoted.

Three stages of amplification are incorporated in the Model 5710 providing voltage gains of the order of  $10^6$ . The

input impedance of the instrument, which can handle signals from  $1 \mu\text{V}$  to 10 V, varies according to the amount of internal attenuation. This may be adjusted from 10 to 120 dB and will cause the input impedance to vary from  $10 \text{ k}\Omega$  for a  $10 \mu\text{V}$  signal to  $1 \text{ M}\Omega$  for larger signals requiring more than 50 dB attenuation.

The dimensions of the Model 5710 are  $12 \times 4 \times 8\frac{1}{2}$  in and it weighs 5 lb. An alternative model, designated 5711, calibrated in angular frequency is also available. Both instruments use transistors throughout.

4WW 317 for further details

### Ultra-pure Hydrogen Machine

A SIMPLE-TO-OPERATE machine for producing ultra-pure hydrogen by the silver-palladium diffusion method is announced by Johnson, Matthey & Co. Ltd., of 73-83 Hatton Garden, London, E.C.1. This unit, known as the A.1 diffusion unit, should be of particular interest to those in research and development laboratories as it will give an ultra-pure output of up to 1.5 cu ft/hr. Connection to a hydrogen source is made by a steel coupling pipe and the output points are rust-protected to allow plastic tubing to be used.

The unit will operate from any 220-250 volt a.c. supply, via a power regulator—such as the Variac Duratrack—and requires only 600 watts when operating at the maximum temperature ( $400^\circ \text{C}$ ). The average working temperature of the instrument is  $350^\circ \text{C}$ , providing an output level of 1 cu ft/hr. This diffusion unit is housed in an aluminium case and is mounted on a laboratory retort stand.

4WW 318 for further details

### Transistor Analyser

THE latest transistor analyser from Philips, the Model PM6505A, which is an improved version of the PM6505, has a 10 nanoamps f.s.d. range for leakage currents.

A continuously adjustable collector voltage source, a base current supply, a tuned 1 kc/s oscillator for dynamic measurements, and an adjustable half-wave voltage source for the display of breakdown voltage characteristics are provided. All of these supply circuits are protected against accidental short-circuiting, and all with the exception of the half-wave source are fully stabilized. The measurements that may be made are: collector-emitter short-circuit test; collector-emitter, emitter-base and collector-base leakage currents; collector current as a function of base current and also as a function of base-emitter volt-

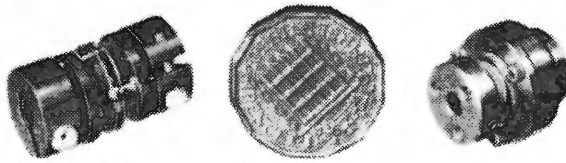

A precision coupling (shown on the left) and slip clutch from Bowmar Instrument Ltd.



Frequency selective amplifier covering 10 c/s to 100 kc/s made by H. Tinsley & Co.

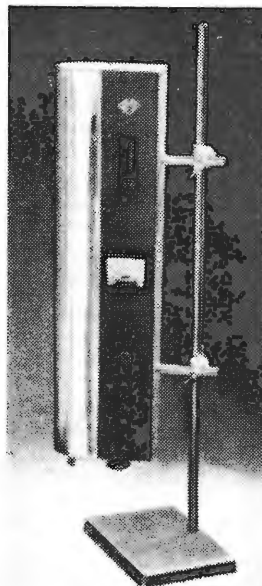

Machine for producing ultra-pure hydrogen (Johnson, Matthey & Co.) It weighs less than 15 lb.

Philips transistor analyser Model PM6505A. It can measure leakage currents down to 10 nA f.s.d.

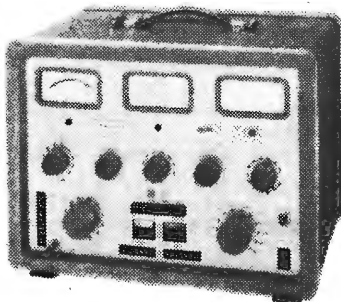



age; knee voltage; short-circuit impedance  $h_{ie}$ ; and short-circuit current gain  $h_{fe}$ . The collector voltage is adjustable from 0 to 60 volts with a maximum collector current of 3 amps. The  $h$  parameters are measured at 1 kc/s,  $h_{ie}$  covering the range 0 to 30 k $\Omega$  and  $h_{fe}$  0 to 1,000.

The analyser, which is a mains-operated unit and weighs 42 lb, can also be used for selecting and matching transistors. Its dimensions are 13 x 16 x 11½ in, and it is obtainable in the U.K. through the M.E.L. Equipment Company, 207 Kings Cross Road, London, W.C.1.

4WW 319 for further details

### Portable 2-12Mc/s Transceiver

A NEW "Manpack" transmitter-receiver that covers the frequency range 2-12 Mc/s in 1 kc/s steps is being manufactured by the communications division of Redifon Ltd., of Broomhill Road, London, S.W.18. Although this s.s.b. is being manufactured under licence from the Hughes Aircraft Company, of California, it has full a.m. capability—making it suitable for use with existing military and civil equipment—and better sensitivity figures than the original Hughes version.

A frequency synthesizer is used to obtain the 10,000 channels in the frequency range 2-12 Mc/s. This, of course, does away with the need for "netting" and enables the equipment to be operated by relatively unskilled personnel. A typical frequency tolerance for the equipment, designated GR 345, is quoted to be  $\pm 25$  c/s, and never greater than  $\pm 50$  c/s under any combination of extreme conditions.

The power output of the transmitter is 15 W p.e.p. on c.w. and s.s.b., and 3.75 W carrier (minimum) on a.m. with 100% modulation. Receiver sensitivity is quoted to be 1.4  $\mu$ V (3.0  $\mu$ V on a.m.) for a 10 dB signal plus noise to noise ratio. The basic transmitter-receiver including the power pack—which is one of the six modules—weighs 22 lb. Many accessories are available for the GR 345.

4WW 320 for further details

### Solid State Process Timers

A NEW range of solid state process timers for industrial applications is announced by Kent Precision Electronics Ltd., of Vale Road, Tonbridge, Kent. These instruments, which are suitable for timing over the range 10 msec to 15 sec with an overall accuracy of  $\pm 1\%$ , can also be supplied with pulsed outputs; to fire thyristor circuits for the control of power circuits. They are housed in panel-mounting instrument

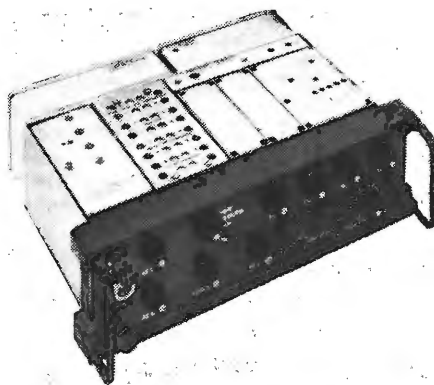

Redifon Type GR 345 10,000-channel 2-12 Mc/s portable transmitter-receiver.

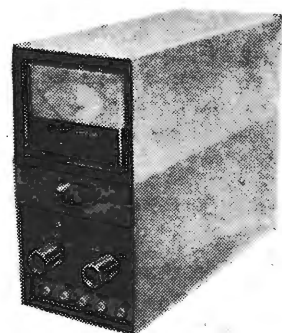

In-circuit transistor leakage tester made by Transition Inc.

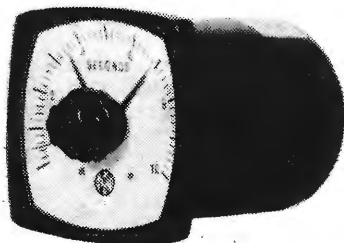

Industrial solid state process timer being made by Kent Precision Electronics Ltd. Range is from 10 msec to 15 sec.

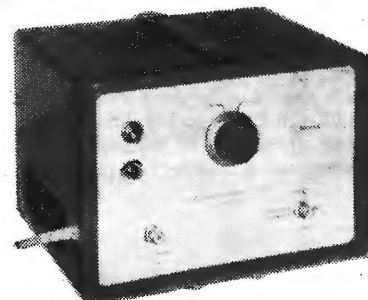

Add-on unit from Advance Electronics Ltd to extend the frequency range (to 100 Mc/s) of electronic counters.

cases and consist basically of a stable resistive-capacitive timing circuit and a transistor voltage threshold detector which fires the thyristor output circuit. For relay operation a low-power thyristor is used to operate an internal relay.

A feature of these instruments is that two units can be housed in the same case enabling the instruments to be interconnected. This allows one instrument to be initiated after the first has elapsed, etc. Alternatively, a dual instrument may be used as two separate timers with concentric controls.

4WW 321 for further details

### In-circuit Transistor Tester

AN instrument designed for in-circuit measurement of transistor leakage current, which was developed by the IIT Research Institute, of Chicago, is now being manufactured and marketed by Transition Incorporated, of 10 W 35th Street, Chicago, Illinois. Collector-to-base leakage currents from 1  $\mu$ A to 2.5 mA with a collector resistance down to 100  $\Omega$  can be measured with this instrument, which is claimed to be simple to operate and not to damage other circuit components.

The accuracy for transistor leakage between collector and base with emitter and collector junctions reverse biased is quoted to be within 1% for collec-

tor resistances greater than 500  $\Omega$  with full scale meter readings. For collector resistances between 100  $\Omega$  and 500  $\Omega$  accuracy is within 5%.

4WW 322 for further details

### Counter Add-on Unit

ABLE to extend the range of most electronic counters now commercially available to 100 Mc/s is the new add-on unit Advance Electronics Ltd. have introduced. Designated TCD100, the new instrument provides division factors of 100 or 20 and has an input sensitivity of 50 mV (into 50  $\Omega$ ). Both the input and output parameters are flexible to accommodate a wide range of input sources and the instrument will provide output pulses at 3 V peak-to-peak (50  $\Omega$ ) from 10 kc/s to 1 Mc/s on the divide by 100 setting and from 50 kc/s to 5 Mc/s on the  $\div 20$  setting. The manufacturers claim that the accuracy of the basic counter is not affected by the divider unit.

Transistors and tunnel diodes are used in the instrument which measures 6½ x 9½ x 8½ in and weighs 8½ lb. The price of the TCD100 is £195 and it is available from the company's headquarters in Roebuck Road, Hainault, Ilford, Essex.

4WW 323 for further details

# WORLD OF WIRELESS

## *The Computer Industry*

A FLOURISHING British computer industry and a rapid increase in the use of computers and computer techniques in industry and commerce are considered essential by the Government, and plans to serve these ends were announced by the Minister of Technology, Mr. Frank Cousins, on March 1st.

A Computer Advisory Unit within the Ministry of Technology to advise on computer requirements over the whole public sector is to be formed. All proposals for computers required by Government Departments for civil purpose and those to be purchased with public monies by universities, colleges and research councils will be referred to this unit for objective technical appraisal before purchases are authorized.

The Government has also initiated a full-scale review of the computer requirements of universities, colleges and research councils so that a new five-year programme of procurement can be planned. The Government proposes to start this five-year programme at a rate of £2M a year.

Further programmes of research into computer techniques and the development of new equipment within industry, the universities and in Government research establishments and in the Post Office will be initiated. In addition, the National Research Development Corporation will be greatly expanding its work in this field, and in this connection is to invest £5M in a series of joint projects with International Computers and Tabulators Ltd.

The Minister is also exploring with the industry and with users the possibilities of establishing a National Computer Programme Centre in which they would be partners with the Government.

## *Reciprocal Amateur Operation*

THE Postmaster-General announced on March 16th that in future he will, subject to certain conditions being met, grant licences to engage in amateur transmissions in Great Britain to nationals of countries which are prepared to grant similar facilities to United Kingdom licensed radio amateurs.

The U.S. Federal Communications Commission has, with effect from March 27th, also adopted rules to carry into effect the "reciprocal operating" provisions included in the U.S. Communications Act. A permit will be issued to those who hold a valid amateur transmitting licence in their own country, if there is a bilateral agreement between the U.S. and that government for reciprocal operation as now provided for in the U.K.

America is therefore the first country with which we have this reciprocal arrangement. It will be necessary to negotiate with other countries to make similar arrangements although, of course, not with countries within the Commonwealth.

## *Dutch Nationalized Relay System*

THE success of the Dutch P.T.T.'s experiments with a central aerial system to provide a four-programme piped-television service together with ten v.h.f. sound programmes to 2,200 homes in a district in the Hague has prompted the government to make plans to introduce the system on a national scale. The P.T.T. will be responsible and the investment cost is estimated at the equivalent of about £16M. The subscription is expected to be about 8s per month.

In the Hague experiment subscribers have had the choice of television programmes from Belgium, France and Germany as well as the Dutch service. Normal receivers can be linked to the system.

## *Subscription TV in the U.S.*

AFTER nearly three years' experimental operation of its "over-the-air" subscription television system in Hartford, Conn., the Zenith Radio Corporation has asked the Federal Communications Commission to authorize subscription TV on "an extended nation-wide basis." Analysis of the first two years' operation of the pilot scheme, using the Phonevision system and serving 4,775 homes, shows that a little over 5% of viewing time was devoted to subscription television. Charges for programmes ranged from 25 cents to \$3.

In the Phonevision system the vision signal is scrambled by inverting the picture polarity, shifting picture information relation to sync by some 3% of the width of the picture on alternate strips of seven lines and by varying the vertical position of these displaced strips in each field. Sound is also scrambled. Each programme is coded and in the subscriber's "box" is a punched tape with sets of holes for some 2,000 different programme numbers. When the appropriate number has been selected and the switch set to "buy" a programme the tape is marked for subsequent payment of the fee.

An international conference on u.h.f. television covering receiver and transmitter design, propagation, receiving and transmitting aerials, parametric amplifiers, and test equipment, is to be held in London on September 1st and 2nd—during the Radio Show. The sponsoring bodies are the I.E.E., I.E.E.E., I.E.R.E. and the Television Society. The venue is not yet decided. It is hoped that technical visits will take place on the day immediately after the conference. Details of these, and of the registration fee, will be available later from the Joint Conference Secretariat, 8-9, Bedford Square, London, W.C.1.

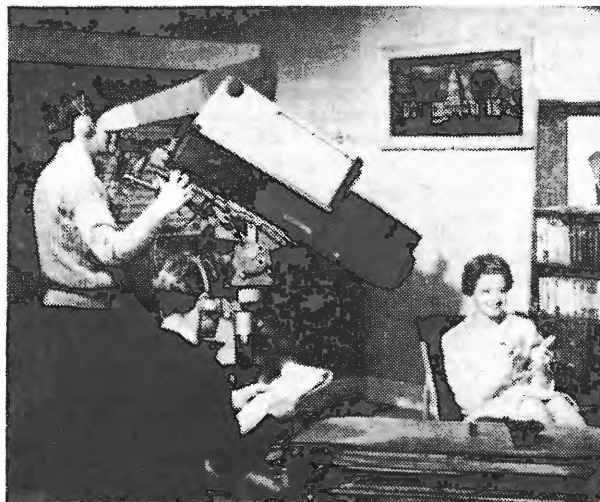

*Ease and flexibility of operation characterize Marconi's small and light transistorized 4½-inch image orthicon television camera, Mark V. A single zoom lens, with means for preselecting under servo control any of four fixed zoom positions, eliminates the restrictions imposed by a number of separate lenses of fixed focal length. Controls for the camera electronics have been transferred to the associated equipment racks, and a tilting viewfinder enables the operator to view comfortably at any camera angle.*

For the next two years the **Physics Exhibition** will be held in London but at a new venue—Alexandra Palace. The dates are March 28th-31st, 1966, and April 17th-20th, 1967. The organizers, the Institute of Physics & Physical Society, say that the following two exhibitions may be held in the Provinces.

**Three exhibitions** to be held simultaneously at Earls Court, London, from June 15th to 19th will all have items of interest to some readers of *Wireless World*. They are: the first Noise and Vibration Reduction Exhibition (NAVREX), the second Church and School Equipment Exhibition (CASEX) and the first Pumping Exhibition. The organizers are Iliffe Exhibitions Ltd., Dorset House, Stamford Street, London, S.E.1, from whom tickets are obtainable free for NAVREX and the pumping show. Admission to CASEX will cost 2s 6d.

Next year's conference on **solid state physics**, organized by the Institute of Physics & Physical Society, will be held in Manchester instead of Bristol as in the past. The date will be January 4th-7th and the place, the Renold Building, Manchester College of Science and Technology.

"**Microwave applications of semiconductors**" is the title of the joint I.E.R.E.-I.E.E. symposium being arranged for June 30th to July 2nd at University College, London. The six main sessions will cover microwave properties of semiconductor devices, generators, p-i-n diode circuits, tunnel diode circuits and mixers, low-noise devices and systems. Further information and registration forms are obtainable from the I.E.R.E., 8-9 Bedford Square, London, W.C.1.

**A British Joint Computer Conference** is to be held at the Congress Theatre, Eastbourne, Sussex, from May 3rd to 5th, 1966, under the aegis of the United Kingdom Automation Council. Participating organizations include the I.E.E., I.E.R.E. and the British Computer Society. Further details and registration forms will be available in due course from the conference secretariat, I.E.E., Savoy Place, London, W.C.2.

"The challenge of improving the exports of the electronics industry" is to be the theme of the second **Exports Day** to be held by the Radio & Electronic Component Manufacturers' Federation. The conference, which is to be on May 11th at the Federation's headquarters at 11 Hanover Street, London, W.1, will be attended by representatives from the 200 or more member firms of R.E.C.M.F.

**V.H.F./U.H.F. Convention.**—The eleventh international v.h.f./u.h.f. convention organized by the Radio Society of Great Britain, will be held at Kingsley Hotel, Bloomsbury Way, London, W.C.1, on April 10th. It opens at 11.0 with a trade exhibition and in the afternoon there will be a lecture programme. Tickets, costing 4s 6d (convention only) or 30s (convention and dinner), are obtainable from F. E. A. Green (G3GMV), 48 Borough Way, Potters Bar, Middx.

**Microelectronics.**—A symposium on the applications of microelectronics is to be held at Southampton University from September 21st to 23rd. It is under the joint sponsorship of the Southern Sections of the I.E.E. and I.E.R.E. in association with the Department of Electronics at the University, from which registration forms are obtainable.

The eighth **International Instrument Show** to be staged by B & K Laboratories will this year be held at Grosvenor House, Park Lane, London, W.1, from May 17th to 21st. The second Environmental Engineering Symposium will also be held during the same period. Tickets for both are obtainable by bona-fide engineers and designers from B & K Laboratories, 4 Tilney Street, London, W.1.

This year's **Fleming Memorial Lecture** of the Television Society is being given at the Royal Institution, Albemarle Street, London, W.1, at 7.0 on April 29th, by Dr. R. D. A. Maurice, assistant head of the B.B.C.'s Research Department. His subject is "The specification of an adequate television signal." Admission is by ticket obtainable from the Society at 166 Shaftesbury Avenue, London, W.C.2.

**E.E.A. Officers.**—At the annual general meeting of the Electronics Engineering Association on March 16th R. Telford, of the Marconi Company, was elected chairman in succession to W. D. H. Gregson (Ferranti) who held the office for two years. The new vice-chairman is R. J. Clayton (G.E.C. Electronics).

**B.B.C. in West Africa.**—In order to extend the coverage of the B.B.C.'s transmissions in West Africa arrangements have been made for a new medium-wave transmitter in Monrovia to relay programmes for 10 hours every day. The Liberian Broadcasting Corporation, for which Rediffusion provides commercial and technical management, will be responsible for the operation and maintenance of the transmitter and for the reception, recording and relaying of programmes. The agreement is the first of its kind that the B.B.C. has made in Africa involving a commercial organization.

**Baird Scholar.**—The Television Society invites applications for the third award of the John Logie Baird Travelling Scholarship. Valued up to £200 it is open to post-graduate students (in United Kingdom educational establishments) who are concerned with television engineering or an allied technology. The Scholarship is intended to assist the successful applicant in undertaking a period of investigation abroad of approximately 6-8 weeks. Application forms, which must be returned by April 17th, are obtainable from the Society at 166 Shaftesbury Avenue, London, W.C.2.

**Oscar III** the translator satellite for amateur use, was launched by the U.S. Army on March 9th at 18.30 G.M.T. into an orbit with a period of 103½ minutes. The orbit is circular, with a height of 502 miles and an inclination of 70°. The beacon and translator are reported to be functioning. Information regarding Oscar III may be obtained from W. H. Allen, 24 Arundel Road, Tunbridge Wells, Kent, who wrote on the project in our January issue.

A southern section of the **Society of Electronic and Radio Technicians** has been formed in the Portsmouth-Southampton area bringing the total to nine. The others are in Birmingham, Bristol, Glasgow, Leeds, London, Manchester, Newcastle upon Tyne and Nottingham. The Society's membership had grown to 366 in ten weeks.

**Radio and Television Servicing Film.**—A 16 mm colour film showing how a radio and television service engineer is trained and what his work involves was made for the British Radio Equipment Manufacturers' Association and shown for the first time at last year's National Radio and Television Show. The 14-minute sound film is now available on free loan from the Central Film Library, Central Office of Information, Hercules Road, London, S.E.1, and also from Sound Services Ltd., Wilton Crescent, Merton Park, S.W.19.

The twelfth **International Spectroscopy Colloquium** is to be held under the auspices of the British Spectroscopists Coordinating Committee and the Institute of Physics & Physical Society in the University of Exeter, from July 12th-17th. Information and registration forms may be obtained from Mrs. C. E. Arregger, 1 Lowther Gardens, London, S.W.7.

**R.E.C.M.F. Directory.**—A list of the member firms of the British Radio and Electronic Component Manufacturers' Federation, together with a list of trade names and buyer's guide, has been produced. It is available free from the R.E.C.M.F., 6 Hanover Street, London, W.1.

# PERSONALITIES

Admiral of the Fleet the **Earl Mountbatten of Burma**, K.G., P.C., has been elected to honorary membership of the Institution of Electrical Engineers "for his distinguished services to the United Kingdom and Commonwealth in war and peace, and for his contributions to the progress of electrical and electronic



Earl Mountbatten

science and engineering." Lord Mountbatten, who is Chief of the Defence Staff, joined the Royal Navy in 1913, and during his early naval career specialized in wireless and wrote two handbooks for the Navy on wireless telegraphy. He has retained his interest in radio and electronics and has been vice-patron of the Institution of Electronic & Radio Engineers (formerly Brit. I.R.E.) since 1948. He became chairman of the newly formed National Electronics Research Council last July.

**C. L. G. Fairfield**, M.A.(Cantab.), M.I.E.E., Barrister at Law, has been appointed assistant managing director of Submarine Cables Ltd. (owned jointly by A.E.I. and B.I.C.C.). He joined the board of the Company in 1958. Mr. Fairfield was with Mullard from 1948 to 1953 first as assistant to the directors on technical matters and later as manager of the valve division. He was also a director of Mullard Equipment Ltd. He joined the Telegraph Construction & Maintenance Co.—a subsidiary of B.I.C.C.—in 1953 and was appointed to the board in 1958.

**Graham Miller**, B.Sc., who joined Wayne Kerr in 1959 and for the past three years has been sales manager of the Company's American subsidiary in Philadelphia, has been appointed general sales manager of the parent company. Mr. Miller graduated in physics at Swansea University after studying electronics at the Manchester College of Technology and was for two years head of the Ferranti Standards Laboratory before joining Wayne Kerr.

The forty-third award of the Faraday Medal of the Institution of Electrical Engineers is to be made to **Dr. Vladimir K. Zworykin** "for his notable scientific and industrial achievements, including the invention of the iconoscope, and for his important role in medical electronics." Dr. Zworykin, who is honorary vice-president of the Radio Corporation of America, was born in Murom, Russia, in 1889, went to the United States in 1919, and was naturalized in 1924. He holds the degrees of Ph.D. (University of Pittsburgh) and D.Sc. (Polytechnic Institute of Brooklyn). After research work with Westinghouse Electrical and Manufacturing Company, Dr. Zworykin was, from 1929 to 1942, director of electronics research at the R.C.A. Manufacturing Company. Since 1942 he has devoted himself to the activities of R.C.A. Laboratories.

**Group Captain E. Fennessy**, C.B.E., B.Sc., M.I.E.E., has resigned as managing director of Decca Radar Ltd., and also his directorships of other companies in the Decca Group. He has joined the Plessey Group which, as reported elsewhere, has acquired the ground radar and data-handling divisions of Decca. Gp. Capt. Fennessy, who is a graduate of London University, was a member of the original radar research team under Sir Robert Watson Watt at Bawdsey and in 1940 was commissioned in the R.A.F.V.R. and worked on the planning, construction and operation of radar systems both in this country and abroad. After the war he joined the board of the Decca Navigator Company and became managing director of Decca Radar when the company was formed in 1950.

**Peter H. Parkin**, B.Sc., A.M.I.E.E., acoustics scientist at the D.S.I.R. Building Research Station, has received the 1964 Wolfe Award "for his work on acoustic design in buildings and his invention of 'assisted resonance' for modifying and improving hearing conditions in auditoria." The £500 award is made under the terms of the Wolfe bequest for research workers in D.S.I.R. who make an outstanding contribution to the Department's research during the previous year. Mr. Parkin was in the Admiralty during the war working on counter-measures to magnetic, acoustic and pressure mines. He has been at the Building Research Station, near Watford, since 1946 where he latterly devised the system of "assisted resonance," or electronic-controlled reverberation time, which has recently been introduced in the Royal Festival Hall. He was concerned with the original design of the Hall and he devised the speech reinforcement system installed in St. Paul's Cathedral in 1951.

**Sir Albert Mumford**, K.B.E., B.Sc., M.I.E.E., engineer-in-chief at the Post Office since 1960, retired on March 19th. Sir Albert, who is 62, entered the Post Office in 1924 after graduating at Queen Mary College (London University), of which he is a Fellow. He was for some time in the Radio Laboratories of the Dollis Hill Research Station before joining the Radio Branch staff at Headquarters, where in the early post-war years he led the U.K. delegations to a number of international radio conferences. Sir Albert was president of the Institution of Electrical Engineers last year. The new engineer-in-chief is **D. A. Barron**, C.B.E., M.Sc., M.I.E.E., who graduated at Bristol University and joined the Post Office in 1927 at the age of 20. He has been in the Telephone Branch of the Engineering Department since 1940 and played a major part in the introduction of the Subscriber Trunk Dialling system and in



D. A. Barron

the development of electronic telephone exchanges. He has been deputy engineer-in-chief since 1960 and is succeeded by **J. H. H. Merriman**, O.B.E., M.Sc., A.Inst.P., M.I.E.E., who became an assistant e.-in-c. in 1963. Mr. Merriman graduated at King's College, London, and did post-graduate work on non-linear oscillations to gain his M.Sc. He joined the Post Office in 1936, and worked at Dollis Hill Research Station on measurement of the arrival angles of short-wave pulses from the U.S.A. At the outbreak of war he set up and ran radio laboratories at Castleton, near Cardiff, working on v.h.f. for multi-channel telephony and television. In 1949 he returned to London to work on the planning and provision of radio links.

**Peter Lowry**, A.M.I.E.E., A.M.I.E.R.E., until recently assistant technical manager, television, with Rank Cintel, has joined Elliott Brothers as chief engineer of the airborne display division.



The Prince Philip Medal of the City & Guilds of London Institute for 1964 is being presented to **Derek A. Rush**, A.M.I.E.E., C.G.I.A., engineering manager at the Basingstoke Branch of the Aviation Division of S. Smith and Sons, by His Royal Highness on March 31st at Buckingham Palace. The medal, which is awarded annually in recognition of outstanding promise or achievement in the promotion, theory or practice of science and technology, is restricted to those who have "travelled the City and Guilds path." Mr. Rush, who is 41, began his career at the Post Office Research Station, Dollis Hill, and between the years 1941 and 1946 he gained nine C. & G. certificates in telecommunication subjects. He was



D. A. Rush

awarded the City and Guilds Insignia Award in Technology (C.G.I.A.) in the field of electronic equipment in 1959. He entered industry in 1946 and was for three years with Sperry Gyroscope before going to Sydney in 1951 to join Amalgamated Wireless Australasia. He later returned to Sperry where he was concerned with gunfire control systems. He joined Smith's in 1955 as project officer for guided weapons.

**W. A. Penkman**, who has been in charge of the Marconi International Marine Company's service organization since 1953, latterly as service and supplies manager, has been appointed to the new post of equipment controller. Mr. Penkman began his career with the company's shore staff in 1918. Two years later he joined the sea-going staff as a radio operator. He then joined the Radio Communication Company which in 1928 was amalgamated with Marconi Marine and he rejoined his original company. He became deputy manager of the service division in 1952. The new service and supplies manager is **J. S. E. Riddle** who has been with the company since 1940. He was a sea-going radio officer for six years. In 1956 he became an inspector and later was marine manager of the company's Norwegian associates, Norsk Marconikompani. He has been manager, service department, at Chelmsford since last August.

**Professor T. Kilburn**, D.Sc., Ph.D., M.A., M.I.E.E., who is the first incumbent of the chair of computer engineering established at Manchester University in 1960, has been appointed a Fellow of the Royal Society "for his contributions to the development, design and engineering of electronic digital computers and high speed computer components." Dr. Kilburn was at the Telecommunications Research Establishment (now R.R.E.), Malvern, from 1942 until 1946 when he joined the staff at the University as reader in electronics. In collaboration with Professor F. C. Williams, head of the Electrical Engineering Laboratories, he built the University's first computer.

**J. R. Tillman**, B.Sc., Ph.D., A.M.I.E.E., has been appointed deputy director of research at the Post Office Research Station, Dollis Hill. Dr. Tillman was a Beit Research Fellow, 1934-36, and with P. B. Moon discovered the thermal neutron and the selective absorption of slow neutrons. He joined the Post Office Research Station in 1936. Dr. Tillman has latterly concentrated on solid state research and on the reliability of transistors for submarine cable repeaters. He is joint author with F. F. Roberts of the book "Theory and practice of the transistor."

**Robert Telford**, B.A.(Cantab.), M.I.E.E., the new chairman of the Electronic Engineering Association, joined Marconi's in 1937 at the age of 22 as a management trainee and in 1940 became manager of the Hackbridge Works where he was responsible for the production of airborne and portable radio equipment. He was appointed managing director of Marconi Brasileria in 1946 and on his return to this country four years later became assistant to the general manager at Chelmsford. He was appointed general manager of the company in 1961 and has been a director since 1963.

**Charles A. R. Pearce**, M.Sc., M.I.E.E., has been appointed deputy managing director of Ericsson/Etelco a principal operating company of the Plessey Group. Mr. Pearce joined Ericsson/Etelco in 1958 as controller of engineering. His earlier experience included engineering development and research with D.S.I.R. and with the London Telecommunications Region of the G.P.O. He was chief factories engineer to the Post Office from 1948 to 1951. Mr. Pearce, who is 53, received his technical education at the City and Guilds Engineering College and London University.

**Richard C. Norwood**, who has been deputy to the managing director of A. C. Cossor since February last year, has been appointed a managing director. **Professor C. L. Calosi**, who has been a managing director since January, 1964, has relinquished his appointment, but will continue as a director of the company in addition to his vice-presidency of Raytheon Company.

**H. S. Payman**, B.Sc.Tech., B.Sc. (Eng.), M.I.E.E., A.Inst.P., managing director of B. & R. Relays, has been co-opted a director of the parent company, Gas Purification & Chemical Co. Ltd. Mr. Payman, who is a graduate

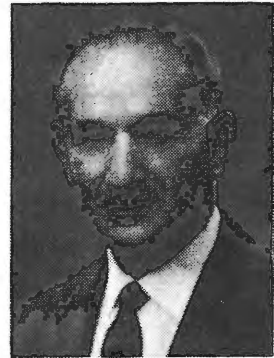

H. S. Payman

of both Manchester and London Universities, joined B. & R. Relays in 1958, having been general manager of Suflex for the previous three years. Earlier he was with A.B. Metal Products as deputy director of component production.

**R. H. W. Burkett**, B.Sc., M.I.E.E., has been appointed managing director of Welwyn Electric Ltd. Mr. Burkett, who has been 19 years with Welwyn, was appointed to the board as technical director in 1958 and has been general manager since December, 1963.

## OUR AUTHORS

**G. F. Turnbull**, M.Sc., and **J. M. Townsend**, M.Sc., who describe a pulse width modulated amplifier in this issue, are both on the staff of the electrical engineering laboratories of Manchester University. Mr. Turnbull graduated at the University in 1959 and did a year's post-graduate research obtaining his masterate in 1960. He was appointed assistant lecturer in electrical engineering in 1961 and was promoted to lecturer the following year. Mr. Townsend graduated at the University in 1961 and after a year's research was appointed assistant lecturer. He obtained his M.Sc. in 1963.

**J. M. Firth**, author of the article on an audio warning circuit in this issue, has recently gone to Canada to work with RCA Victor on the scientific satellite which is to succeed *Allouette*. After reading mechanical sciences at Cambridge from 1954-58 he spent three years with Smith's Aircraft Instruments, Cheltenham. From 1961 until last year he worked for the Radio Astronomy Group at the Cavendish Laboratory, Cambridge, on equipment for the scientific experiments included in the UK-2 satellite. This work took him to Washington for 15 months.



# NEWS

---

## FROM

---

## INDUSTRY

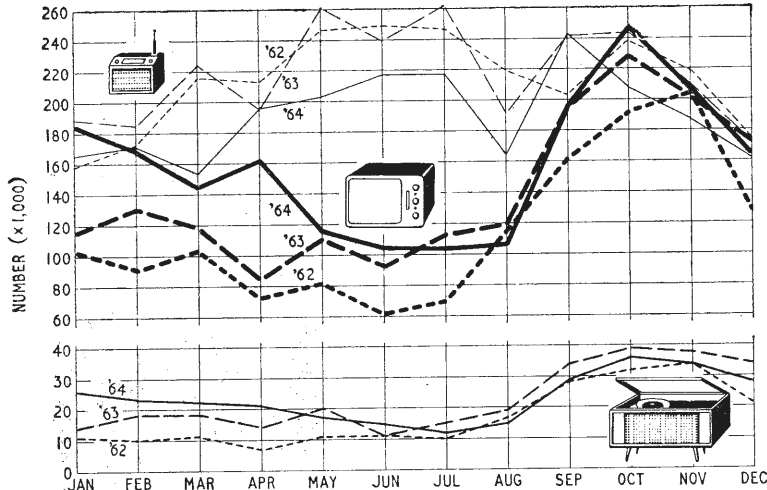

**Manufacturers' Despatches to the Home Market** for the past three years are shown above. This graph was compiled from monthly figures issued by the British Radio Equipment Manufacturers' Association. They are net figures of deliveries by manufacturers to the home market and include those despatched to the specialist rental and relay companies. Car radios are included in the sound receiver curves.

**Plessey Buy Part of Decca.**—Agreement has been reached whereby the ground radar and data handling divisions of Decca Radar Ltd. at the Isle of Wight and Tolworth are to be transferred to the Plessey Company at the end of March. This transfer, which is to cost Plessey approximately £4M—payable in cash—does not include any trade mark rights and there are no restraints on the future activities of either company.

**Audio Fidelity Ltd.**—Radio Supply Co. (Leeds) Ltd., which was incorporated as a private limited company in 1952 and has had several changes in name in recent years, is in future to be known as Audio Fidelity Ltd. It is also announced that the company has made application to the London Stock Exchange for permission to deal in, and for quotation of all their Ordinary Shares. Audio Fidelity Ltd. have a controlling interest (75%) in Fane Acoustics Ltd., the manufacturers of audio equipment.

The specialized components division of the Marconi Company, which was formed in July 1962, has moved from Writtle into new headquarters at Billericay, Essex. The address is Billericay Works, Radford Crescent, Billericay, Essex. (Tel.: Billericay 3431.)

**JFD Electronics Corporation**, of New York, have opened a European sales office in Paris. Correspondence should be addressed to JFD Electronics, Europe SA, 7 rue de Rocroy, Paris 10.

**Clarke & Smith.**—Electric & Musical Instruments Ltd. have relinquished their 49% interest in the Clarke & Smith Group.

**Two Million Transistor Order.**—International Computers and Tabulators Ltd. have placed an order for two million silicon planar epitaxial transistors with SGS-Fairchild Ltd. These semi-conductors are for use in the I.C.T. 1900 Series of computers, which were introduced last October.

**Digital Airborne Data Recorder.**—High accuracy recording equipment for use in the assessment trials of aircraft navigational systems has been installed in a Comet 4C belonging to the Experimental Navigation Division of the Ministry of Aviation, Aeroplane and Armament Experimental Establishment at Boscombe Down. The recorder is designed to record flight data on punched tape and will replace the photographic methods previously used by the Aeroplane and Armament Experimental Establishment.

**Weymouth Radio Manufacturing Co. Ltd.** is in future to be known as **Weyrad (Electronics) Ltd.** The address remains the same: Regent Factory, Weymouth, Dorset.

**No Patent Infringement.**—At the end of February, the Honourable Mr. Justice Lloyd-Jacobs dismissed two actions brought by AMP Incorporated, of Pennsylvania, who sought an injunction to restrain Hellermann Ltd. and Hellermann Terminals Ltd. from infringing their Letters Patent 661,192, which relates to a hand crimping tool.

**Webb's Radio**, of 14 Soho Street, Oxford Street, London, W.1, are discontinuing their business with effect from 31st March, 1965. They have, for many years, carried an extensive range of Eddystone receivers.

**English Electric 1964 Results.**—Turnover for the English Electric Group in 1964 amounted to £227M and represented an increase of £18M on the previous year's result. Group profit after tax charges of £4.8M as against £4.3M in 1963, depreciation of £4.8M (£4.4M) amounted to £6,743,000. This represents an increase of £2,948,000. The Marconi Company and its subsidiaries contributed £35.7M (£32.3M) to the Group's record turnover figure and £3M (£1.7M) to the Group's £19M pre-tax profit. More than 50% of the Company's output was exported in the year under review.

An associated company to the English Electric Group, the **Marconi International Marine Company**, reports a profit for 1964 of £734,401, which represents an increase of £65,544 over the previous year. Profit after taxation amounted to £416,145 (£315,625).

**Westinghouse.**—After deduction of the loss of £800,271 incurred by Gresham & Craven Ltd. (who are not in the electronics field) and general interest charges of £345,296, the group profit of the Westinghouse Brake and Signal Company for the year to 3rd October was £1,078,152. This shows a substantial improvement on the previous year when Westinghouse suffered a deficit of £863,559. Net taxation for the year under review was £220,915, leaving a profit after tax of £857,237.

**Advance Electronics Ltd.** group pre-tax profit for 1964 amounted to £236,347 and represents an increase of £49,128 over the 1963 result. After taxation, profits for the year totalled £121,347 as against £89,396 in 1963. This is the first financial year under the company's new name (formerly Advance Components Ltd.).

**Telegraph Condenser Co.**—Group trading profit of the Telegraph Condenser Company for 1964 amounted to £506,846 and shows an increase of £85,064 on the previous year's result. After deductions, including £156,335 (£156,991) for depreciation and £107,811 (£92,171) for taxation, the net profit rose from £114,323 in 1963 to £181,845.

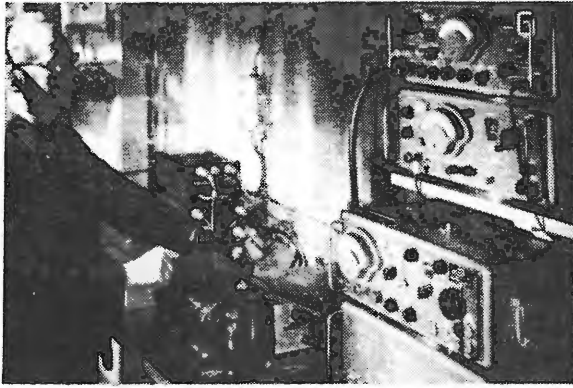

**Interference.**—New screened rooms, extra staff, new equipment and facilities for on-site testing have been added to the measurement and suppression of radio interference service offered by Standard Telephones and Cables to industry. This service covers aircraft, marine and industrial equipment and installations.

## From overseas

### Canada

A closed circuit television system that enables "downtown business houses" to monitor the quotation boards of the Vancouver stock exchange recently went into service. Eight cameras are used in the system, which was designed by the British Columbia Telephone Company and produced by Sylvania Electric Products Inc.; both subsidiaries of the General Telephone & Electronics Corporation.

### El Salvador

G.E.C. (Telecommunications) Ltd. have received a contract, valued at £350,000, for a microwave radio relay system for the Central American republic of El Salvador. The system will have a capacity of 300 telephone channels, operate in the 7 Gc/s band and will connect the towns of San Miguel, Santa Ana, Sonsonate and Usulután with the capital, San Salvador.

### Finland

The Finnish Department of Telegraphs and Posts have ordered a six-target surveillance and precision approach radar simulator, Type SY2027, from the Solartron Electronic Group. This simulator is to be installed at Jyväskylä airfield and will be used to train air traffic controllers.

### Hong Kong

Marconi Self-Tuning (MST) high-frequency radio communications equipment has been ordered by Cable and Wireless Ltd. for their Hong Kong transmitting station.

### Pakistan

Sui Northern Gas Pipelines Ltd., of Karachi, have awarded the Marconi Company a contract, worth over £500,000, for the supply and installa-

**Mobile u.h.f. radio relay equipment,** known as the Type C50, which has recently been undergoing field trials, has now been accepted for use by the British Army. The equipment, which was developed as a private venture by the Automatic Telephone & Electric Company, is frequency modulated and provides six spot frequencies in the 225-400 Mc/s band. Extra channels can easily be obtained by the inclusion of a Plessey frequency synthesizer. The power rating of the transmitter is 250 watts.

tion of instrumentation, telemetry and telecommunications equipment for the first phase of a new natural gas pipeline to be laid in the northern part of West Pakistan.

Marconi Sixty Series of airborne radio communications and navigation equipment has been ordered for three Hawker Siddeley Trident aircraft shortly to enter service with the Pakistan International Airlines Corporation.

### South America

The Bank of London & South America and English Electric-Leo-Marconi Computers Ltd. have formed a company to provide computer services in Latin America. The new company is named Intercontinental Data Services Ltd. and a KDF 8 computer will be installed in Buenos Aires at the end of this year.

### Spain

Ten 13,000 ton cargo vessels now under construction in Spanish shipyards are to be fitted with Marconi Marine navigation and communications equipment. This order, which was placed through Empresa Nacional Radio Marítima, is valued at over £110,000.

### U.S.A.

A "Certificate for Instrument Operations" approving the Decca Navigator system has been issued to New York Airways, who operate large passenger helicopters in and around the greater New York area. This certificate allows the Decca Navigator system to be used in all weather operations as a primary navigational aid. This is the first time that a passenger helicopter has received such a certificate for route as well as terminal area operations. The helicopter equipment consists of a dual Mark 8 installation with twin flight logs and will operate from the New York chain of Decca stations which has been in operation since January, 1958.

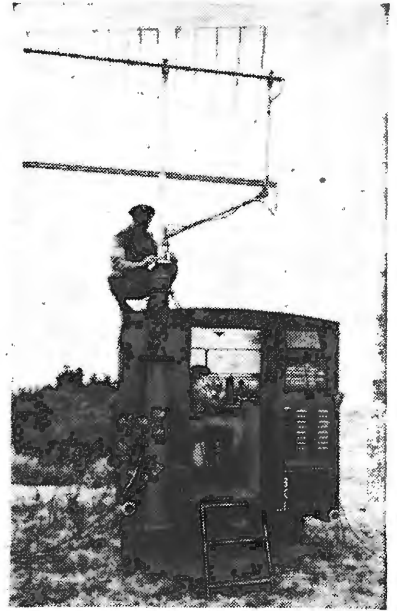

## Agencies and agreements

The M-O Valve Company has reached a licensing agreement with the Microwave Electronics Corporation, of California, under which they will manufacture and market in the United Kingdom M.E.C. low-noise metal/ceramic travelling-wave tubes.

Federal Electronics, of California, have appointed Forinco Ltd., of 52 Broad Street, Worcester (Tel.: Worcester 28171), as distributors of their valves and semiconductors.

The Telectric Corporation have appointed Britec Ltd., of 17 Charing Cross Road, London, W.C.2 (Tel.: WHItchhall 3070), to act as U.K. distributors for the aeronautical equipment they manufacture in Switzerland. It includes an automatic tester for aircraft marker beacon receivers.

High Volt Linear Ltd., of 1 Cardiff Road, Luton (Tel.: Luton 23816), now represent Oak Ridge Technical Enterprises Corporation, of Tennessee, who manufacture surface barrier semiconductor detectors and associated equipment for use in nuclear research.

The electronic tube division of Westinghouse, New York, have appointed Ad. Auriema Ltd., of 125 Gunnersbury Lane, London, W.3 (Tel.: ACOrn 8762), as U.K. distributors for their receiving valves and microwave tubes and devices.

Klein and Hummel, the West German manufacturers of audio amplifiers, tuners and studio loudspeakers, have appointed The High-Fidelity Centre, of 61 West Street, Dorking, Surrey (Tel.: Dorking 4229), to act as U.K. agents.

# Physics Exhibition

FOR the first time since the Physical Society started its series of exhibitions in 1905, this year's—the 49th—is to be held outside London. Another change is in its title which is simply "The Physics Exhibition." Now organized by the Institute of Physics and the Physical Society, which amalgamated under their joint names in 1960, this year's exhibition opens at the Manchester College of Science and Technology on April 5th for four days. Admission is by ticket obtainable free from the secretary at 47 Belgrave Square, London, S.W.1. Applicants are asked to send a stamped addressed envelope. The exhibition will be open from 10 a.m. to 8.30 p.m. (5.30 p.m. on the last day) but admission before 2 p.m. on the first day is restricted to members and invited guests.

We give below a list of the 125 exhibitors. In addition to universities, colleges, and research laboratories there are some 90 U.K. manufacturers who will be showing new instruments, apparatus and materials of special interest to physicists in their work in research, development or in teaching. We hope to give in our next issue a report of some of the more outstanding exhibits, the majority of which will be in the research or development stage.

A.W.R.E.  
 Admiralty  
 Airflow Developments  
 Associated Electrical Industries  
 Associated Engineering  
 Atomic Power Constructions  
 Automatic Telephone & Elec. Co.  
 Aviation, Ministry of  
 Baldwin Instrument Co.  
 Barr & Stroud  
 Beck, R. & J.  
 Bell & Howell  
 Birmingham University,  
 Electronic & Elect'l. Eng'g. Dept.  
 Physics Dept.  
 Boulton Paul Aircraft  
 Bradford Inst. of Technology  
 Bradley, G. & E.

Bristol Siddeley Engines  
 Bristol University  
 Brit. Nat. Com. for High Speed  
 Photography  
 British Oxygen Co.  
 British Railways  
 Brunel College  
 Bryans  
 Cambridge Instrument Co.  
 Cambridge University  
 Central Office of Information  
 College of Aeronautics  
 D.S.I.R.  
 Data Laboratories  
 Dawe Instruments  
 Deakin Phillips Electronics  
 Decca Radar  
 Defence, Ministry of

Devices  
 Digital Measurements  
 D-mac  
 E.M.I. Electronics  
 Edwards High Vacuum  
 Electronic Associates  
 Electronic Instruments  
 Elliott-Automation  
 Enfield College of Technology  
 Ether Langham Thompson  
 Evans Electro Selenium  
 Fairey Engineering  
 Ferranti  
 Frigistor Laboratories  
 General Electric Co.  
 Genevac  
 Goethean Science Foundation  
 Grubb, Parsons & Co.  
 Gulton Industries  
 Haigh & Hochland  
 Hilger & Watts  
 Imperial Chemical Industries  
 Agricultural Div.  
 Central Instrument Lab.  
 Fibres Div.  
 Mond Div.  
 Nobel Div. (Instrument & Elec-  
 tronics)  
 Plastics Div.  
 Imperial College  
 Industrial Instruments  
 Instron  
 International Research & Dev. Co.  
 Isotope Developments  
 Joyce, Loeb & Co.  
 King's College, London  
 Labgear  
 Lan-Electronics  
 London Hospital Medical College  
 Manchester College of Science &  
 Technology  
 Manchester University  
 Mechatronics (London)  
 Mercury Electronics (Scotland)  
 Metals Research  
 Microwave Instruments  
 Middlesex Hospital Medical School  
 Mullard

Nat. Inst. of Agricultural Eng'g.  
 Newcastle University  
 Newport Instruments  
 Nuclear Enterprises (G.B.)  
 Optec Reactors  
 Optical Works  
 Oxford Instrument Co.  
 Panax Equipment  
 Perkin-Elmer  
 Planer, G.V.  
 Plessey Co.  
 Post Office Research Station  
 Pye, W. G., & Co.  
 Rainbow Radio  
 Rank Nucleonics & Controls  
 Research Electronics  
 Research & Engineering Controls  
 Research & Industrial Instruments Co.  
 Research Instruments  
 Royal College of Advanced Tech-  
 nology, Salford  
 Dept. of Elect'l. Eng'g.  
 Dept. of Pure & Applied Physics  
 Royal Military College of Science  
 Safety in Mines Research Establ.  
 Sangamo Weston  
 Scientifica  
 S.E. Laboratories (Eng'g.)  
 Smith, S., & Sons  
 Solartron Electronic Group  
 Standard Telephones & Cables  
 Strathclyde University  
 Techne (Cambridge)  
 Technology, Ministry of  
 Telequipment  
 Telford Products  
 Telsec Instruments  
 Tinsley, H., & Co.  
 20th Century Electronics  
 U.K.A.E.A.  
 Unicam Instruments  
 United Power Co.  
 University College, London  
 Vacuum Generators  
 Verner Electronics  
 Wareham (Measuring Systems)  
 Wayne Kerr Laboratories  
 Wild Barfield

## H. F. PREDICTIONS — APRIL

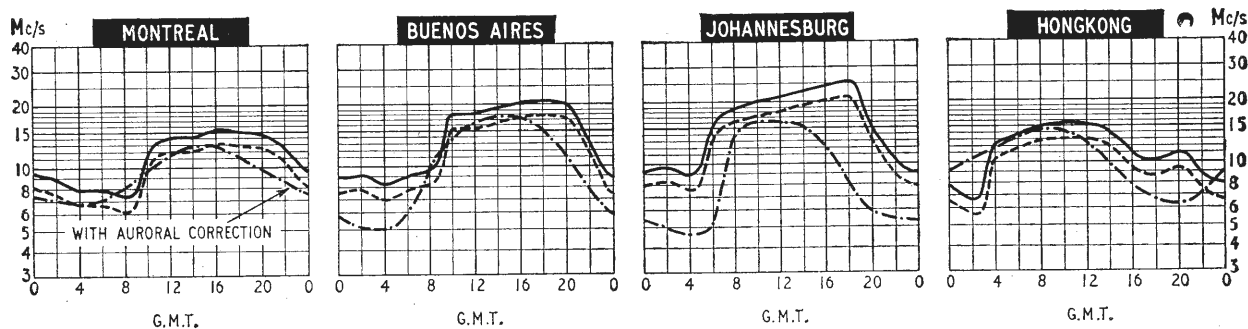

The predictions for this month are beginning to show the flatter shape, characteristic of the approach of summer. This should permit the use of higher frequencies for a longer period each day, though it is too early to expect the increased sunspot number to have any effect yet. Circuit working will still prove difficult, notably on the relatively short Montreal-London route, and little advantage can be expected due to Sporadic-E ionization. The reverse path London-Montreal might prove somewhat easier, due to lower LUF.

The curves show the median standard MUF, optimum traffic frequency and the lowest usable frequency (LUF) for

reception in this country. Unlike the standard MUF, the LUF is closely dependent upon such factors as transmitter power, aeriols, and the type of modulation. The LUF curves shown are those drawn by Cable & Wireless Ltd. for commercial telegraphy and assume the use of transmitters with a power of several kilowatts and rhombic type aeriols.

# AUDIO FAIR PREVIEW

## GUIDE TO NEW EQUIPMENT EXHIBITED

ON April 22nd the International Audio Festival & Fair opens at the Hotel Russell, London, W.C.1, for four consecutive days. This preview of the Fair is compiled from information supplied by exhibitors in response to our request. Some manufacturers, however, did not wish to release information on their latest products before the opening date of the show. We hope, none the less, that in the following few pages readers will find a useful guide to most of the new equipment to be seen at the Fair.

We plan to include in our June issue our usual review of some of the outstanding exhibits seen at the Fair.

The reports are arranged alphabetically under trade names or abbreviated company title. Where, however, the trade name bears no relation to the manufacturer's name it is given

in square brackets after the firm's name in the list of exhibitors below. At the end of reports on overseas companies' exhibits we give the name and address of the U.K. agents.

Plans are being made for the B.B.C. to provide demonstrations of pilot-tone stereo transmissions during the Fair. On the last day of the Fair and also on the Monday, record manufacturers are providing a series of demonstrations as well as displays of their discs at the nearby Royal Hotel.

The Fair will open each day at 11.0 but admission on the first day until 4.0 is restricted to invited guests. It will close at 9.0 (Sunday 8.0). Tickets (admitting two) are available from exhibitors, dealers or the editorial office of *Wireless World*. Please send a stamped addressed envelope.

### A.D.C.

The full range of cartridges made by the Audio Dynamics Corporation is to be shown. The Point-Four and Point-Four/E cartridges will be featured in A.D.C. Pritchard tone arms fitted to Thoren Type TD 124 turntables, and the ADC-770 cartridge in a Goldring Type GL70 transcription unit.

Agents: *K.E.F. Electronics Ltd., Tovil, Maidstone, Kent.*

### A.K.G.

In addition to their existing range of dynamic and condenser microphones a number of new types will be shown.

The DX11 reverberation microphone announced last year has now reached the production stage. The D19C range has been extended with the introduction of the D119CS which incorporates a bass-cut switch and windshield. A high-low impedance switch and an on-off switch are included in the new D14S. The D77 stereo microphone has been superseded by the D66. A smaller version of the C12 condenser microphone has been introduced (the C12A) using a Nuvistor amplifier, a directional pattern switch and stabilized power unit.

Agents: *Politechna (London) Ltd., Eardey House, 182 Campden Hill Road, London, W.8.*

### AGFA

The complete range of Agfa magnetic recording tapes is to be shown, including the Novodur library storage cassette, which is available with several different size reels as an alternative to the more usual swivel type cassettes.

Agents: *Agfa Ltd., 27 Regent Street, London, S.W.1.*

### AKAI

Pullin Photographic, now part of the Rank Audio Visual Aids Division, will be displaying four new Japanese Akai tape recorders. All models are suitable for stereo operation and incorporate some novel features. The M-8 and X-4 (illustrated) use a cross-field head which results in higher frequency response at low tape speeds. The M-8 also includes a vertically directed supplementary loudspeaker system. The ST-1, being shown for the first time in this country, is a two-speed portable model with a transistor pre-amplifier. Other exhibits include the 345 recorder and the SS-110 stereo loudspeaker system.

Agents: *Pullin Photographic, 11 Aintree Road, Perivale, Middlesex.*

### AMPEX

A new magnetic tape recording equipment on show will be the MR-70, for making master recordings. The main advances over previous designs are a 10dB improvement in signal/noise ratio, to take advantage of low-noise tapes now available, a better frequency response and improved control of tape motion. Domestic tape recorders to be seen will include the 2,000 Series which feature automatic threading, automatic reverse, automatic shut-off and ability to operate in horizontal or vertical positions.

Agents: *Ampex Great Britain Ltd., 72 Berkeley Avenue, Reading, Berkshire.*

## LIST OF EXHIBITORS

A.K.G.  
Acoustical Manufacturing Co.  
[see Quad]

Agfa  
Akai  
Amateur Tape Recording Magazine  
Ampex Great Britain  
Armstrong Audio  
Audio Dynamics Corp.

BASF Chemicals  
B.M.B. Sales  
Bang & Olufsen  
Beyer Elektrotechnische Fabrik  
Boosey and Hawkes [see Jordan-Watts]

Braun  
Brenell Engineering Co.  
Brown, S. G.  
Butoba

Celestion  
Clarke & Smith Mfg. Co.

Decca Record Co.  
Decca Radio & Television Co.  
Derritron Radio [see Chapman]  
Design Furniture  
Dual Electronics A/S

E.M.I. Tape  
Elcom (Northampton)

Fane Acoustics  
Ferrograph Co.

Field, N. & S. B. [see Record Housing]  
Fi-Cord International

G.K.D.  
Garrard Engineering  
Goldring Mfg. Co.  
Goodmans Industries  
Gramplan Reproducers  
Gramophone, The

Hammond, C. E., & Co.  
Ilford

K.E.F. Electronics  
Kelly Speakers  
Kodak

Leak, H. J., & Co.  
Link House Publications  
Long Playing Record Library  
Loewe-Opta AG  
Lowther Manufacturing Co.  
Lustraphone

Mallory Batteries  
Mastertape (formerly MSS)  
Minnesota Mining & Mfg. Co.  
Mullard

Ortofon A/S

Peto-Scott  
Philips Electrical  
Planet Projects  
Print & Press Services  
Pye

Radford Electronics  
Records and Recording  
Reslosound  
Rogers Developments  
Revox-Studer A/S

S.M.E.  
Saba Electronics  
Scandinavian Radio & TV Cie.  
[see S.R.T.]  
Scott, H. H. Inc.  
Shure Electronics  
Sonotone  
Sony Corp. of Japan  
Standard Telephones & Cables  
Sugden & Co. [see Connoisseur]  
Svenska Hogtalfabriken [see S.H.B.]

Tandbergs Radiofabrik A-S  
Tannoy Products  
Telefunken  
Thorens, S.A.  
Trio  
Truvox

Vortexion

Wharfedale Wireless Works  
Whiteley Electrical Radio Co.  
William, K. H., & Co.  
Wilmax  
Wilson Stereo Library  
Wireless World & Wireless Trader

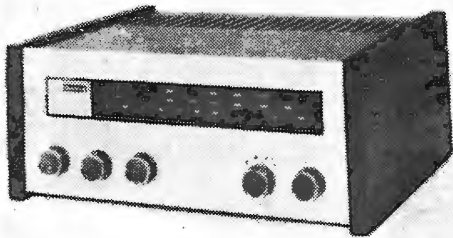

Armstrong 127M tuner-amplifier.

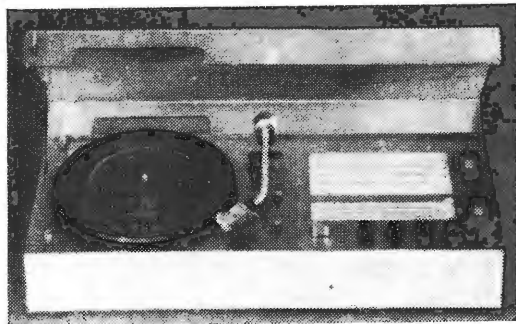

Braun Audio 2 Hi-Fi Stereo Combination.

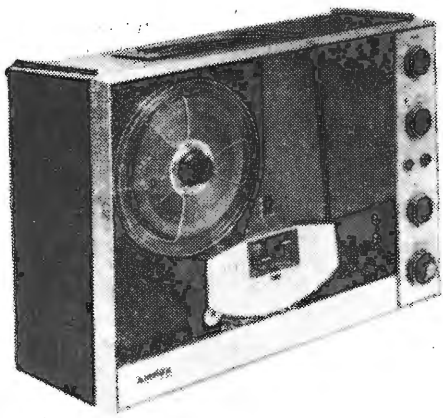

Ampex Model 2000 tape recorder.

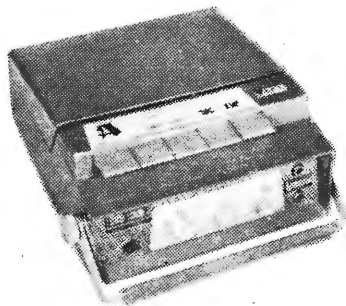

Akai X-4 battery/mains tape recorder with cross-field head.

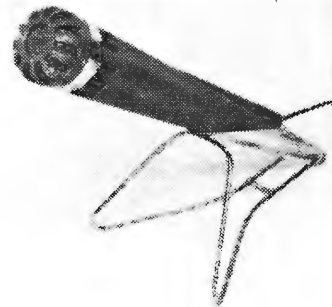

Dual function microphone by S. G. Brown.

#### ARMSTRONG

Designed for users requiring lower power outputs (5 watts) than those provided in the main Armstrong range are the 127 stereo tuner-amplifier and the 127M mono tuner-amplifier. Each unit will receive a.m. and f.m. broadcasts and can be used as an amplifier for tape recording or for reproducing records. The stereo model has provision for addition of a multiplex decoder for reception of f.m. stereo broadcasts.

Armstrong Audio Ltd., Warlters Road, London, N.7.

#### BASF

Visitors will be invited to listen to tape recorded talks on subjects of their own choice, and at the same time copy tapes will be made for them to take away free. Details of the range of BASF tapes, library boxes, spools and other accessories will be available. The company makes tapes with playing times up to 90 minutes at 7½ ins/sec (and correspondingly for lower speeds).

BASF Chemicals Ltd., 5a Gillespie Road, London, N.5.

#### B.M.B.

More than 70 types of sapphire and diamond styli will be exhibited for the first time by B.M.B. (Sales) Ltd. These are manufactured by the Stylus Division of British Manufactured Bearings Company.

B.M.B. (Sales) Ltd., Crawley, Sussex.

#### BANG & OLUFSEN

A wide range of B. & O. equipment is available in this country. It includes portable and table radios, stereograms, tape recorders, record players and accessories—from pickup cartridges to loud-speaker units.

Agents: Debenhams Electrical & Radio Distribution Company, Eastbrook Road, Eastern Avenue, Gloucester.

#### BEYER

A number of new microphones manufactured by Beyer Elektrotechnische Fabrik are to be shown. This includes the Beyer M 80 cardioid with a frequency response of 50 to 16,000 c/s and the Type M 110 dynamic directional microphone with a frequency response of 60 to 12,000 c/s.

Agents: Fi-Cord International Ltd., 40a Dover Street, London, W.1.

#### BRAUN

Reception of f.m. stereo broadcasts and medium-, long- and short-wave stations, as well as mono and stereo reproduction of disc and tape records, is provided for in the transistorized Audio 2 Hi-Fi Stereo Combination. Two other recent introductions will be the PS 400 stereo record player with counterbalanced tubular pickup arm and lowering system, and the CE 16 tuner covering f.m. stereo and m.w. broadcasts.

Agents: Argelane Ltd., 251 Brompton Road, London, S.W.3.

#### BRENELL

The well-known Mark 5 range of equipment is now into Series 3 and includes a tape deck, amplifier and tape recorder. These will be on show together with the Type M tape recorder, which has separate record and playback heads and amplifiers, and the Mark 510 recorder which will accommodate reels up to 10½ in dia. A stereo tape recorder (STB/5/2) will also be on view, with a monitor amplifier and loudspeakers as optional extras.

Brenell Engineering Co. Ltd., 231 Liverpool Road, London, N.1.

#### BROWN

Most audio products will be demonstrated, including the new dual function microphone (illustrated) which is transformed into a differential microphone by operation of a shutter. The Universal handset will be shown, with built-in pre-amplifier, as used for communication in aircraft. The recently announced miniature headset, developed for use in Mercury space craft, will also be on view.

S. G. Brown Ltd., King George's Avenue, Watford, Herts.

#### BUTOBA

The latest tape recorder to be introduced is the three-speed portable model MT22. It has remotely controlled rewind and pause, a digital tape counter, an automatic tape stop, a recording level meter,



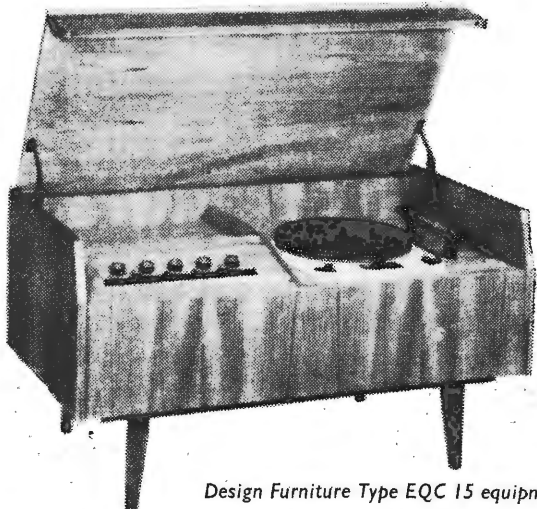

Design Furniture Type EQC 15 equipment cabinet.

a 7-inch circular loudspeaker and transistor electronic circuits. Also on show will be the MT5 recorder, notable for its robust construction.

Agents: *Denham & Morley*, 173/175 Cleveland Street, London, W.1.

#### CELESTION

The new Ditton 10 wide-range loudspeaker system with a power handling capacity of 10 watts r.m.s. will be featured together with existing models CX1512 and CX2012.

*Celestion Ltd.*, Ferry Works, Thames Ditton, Surrey.

#### CHAPMAN

The range of tuners to be shown includes an f.m. model; an a.m./f.m. type giving also long, medium and short wavebands; an a.m. bandspread receiver covering the 11, 13, 16, 19, 25 and 31 metre bands in bandspread ranges; and a similar bandspread receiver covering also f.m. at 87.5-108 Mc/s.

Amplifiers on view will include the 306 Stereo, an 8+8 watt integrated equipment with a frequency response claimed to be flat within 0.2dB from 30 c/s to 20 kc/s. Inputs are selected by push-button switches.

*Derritron Radio Ltd.*, 24 Upper Brook Street, London, W.1.

#### CLARKE & SMITH

Although no details of the exhibits to be shown by this firm were available at the time of going to press it is reasonable to assume that they will include high-quality amplifiers and sound reproducing equipment.

*Clarke & Smith Manufacturing Co. Ltd.*, Melbourne Road, Wallington, Surrey.

#### CONNOISSEUR

Two transcription turntables in the Connoisseur Craftsman series (one a two-speed and the other a variable three-speed unit) are to be shown by the manufacturers—Sugden. The units are very similar and have identical wow (0.15%) and flutter (0.1%) characteristics.

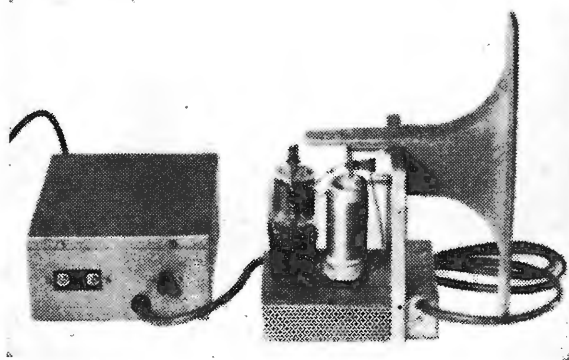

Fane Acoustics "Ionofane" loudspeaker.

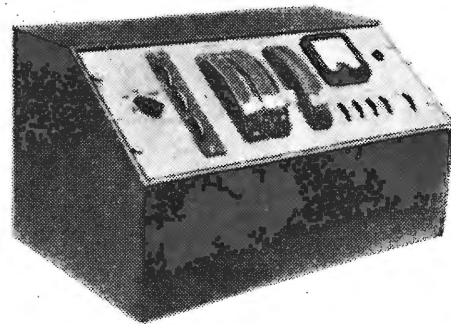

Elcom transistorized sound studio unit.

Hum level is less than 80 dB and rumble is 50dB down on both machines. The Craftsman series of loudspeaker enclosures, which are available with and without speakers, and a selection of pickup arms and cartridges are also to be shown.

*A. R. Sugden & Co. (Engineers) Ltd.*, Market Street, Brighouse, Yorkshire.

#### DECCA

The *ffss* Mark III pickup will be demonstrated with a new magnetic bias adjuster. This fits on to the pivot pillar of all Decca pickup arms and magnetically neutralizes the lateral bias force. A new *ffss* Deccadec includes a non-ferrous turntable and a pickup arm to take all *ffss* heads except those with elliptical stylus. The current TSA range of "budget stereo" equipment will also be demonstrated, including the TSA33 transistor stereo amplifier and the Deccadec with the Deram ceramic cartridge.

*Decca Radio & Television Ltd.*, Albert Embankment, London S.E.1.

#### DESIGN FURNITURE

Two new equipment cabinets with motor mounting boards that are adjustable in height are to be featured. The motor mounting board in the larger of the two cabinets, the EQC 14, can be stepped in height if required. A record storage cabinet and a loudspeaker enclosure, containing Celestion speakers, are also to be featured.

*Design Furniture Ltd.*, Calthorpe Manor, Banbury, Oxon.

#### DUAL

Of this range of German equipment, the 1009 turntable and pickup arm will be shown with the CV2 transistor integrated stereo amplifier and loudspeaker unit CL3. The 1009 turntable, which weighs 7½ pounds, has a fine speed control which uses a conical motor drive pulley. The tracking weight is adjustable and, incidentally, it is claimed that the pickup will track with a tilt of 45° and a tracking weight of 1 gram. The

unit provides for automation operation with a tracking weight of ½ gram.

Agents: *Celsa Electric Company Ltd.*, Kelway Place, London W.14.

#### EMI

In addition to showing current tape recorders, EMI Electronics will present their new L4 portable professional recorder. This two-speed model with remote control and mixing facility includes a fourth magnetic head for sound sync. EMI Tape Ltd. will also be showing their range of recording tapes, film and blank discs.

*EMI Electronics*, Hayes, Middlesex.

#### ELCOM

Transistorized sound equipment for recording and broadcasting studios will be displayed. The units are available in portable or console form and facilities include input switching, tone equalization, channel and group fading by quadrant faders, mid-lift units and pre-fade listen. Separate modules, available as plug-in units, will include line amplifiers, microphone amplifiers, compensating units, faders and peak programme meter units.

*Elcom (Northampton) Ltd.*, Weedon Road, Industrial Estate, Northampton.

#### FANE

The new Ionophone loudspeakers should create much interest since they have no mechanical moving parts and

(Continued on page 189)



Duette equipment cabinet from GKD which can be used as a room divider.

use ionized air to propagate sound. The Ionofane 601 frequency response extends from 3 kc/s-30 kc/s and is claimed to have a better transient response than conventional loudspeakers. The 602 model includes the 601 unit and a mid-range unit, and in the 603 model a 15in bass unit is added to the 602.

Fane Acoustics Ltd., Hick Lane, Batley, Yorkshire.

#### FERROGRAPH

An addition to the range of well-known equipment will be shown, but at the time of going to press details had not been released.

The Ferrograph Company Ltd., 84 Blackfriars Road, London S.E.1.

#### FI-CORD

A new tape recorder, the Fi-Cord 202A, is to be introduced at the Fair. This machine is to replace the 202, which was first seen three years ago. At the higher of the two speeds (7½ in/sec) the frequency response of this portable machine is quoted to be within 3 dB from 50 to 12,000 c/s. Other features include a re-designed control panel and a new Vu-meter. Fi-Cord will also be showing the first two microphones of their own make. Both are of studio quality and use the moving coil principle.

Fi-Cord International Ltd., 40a Dover Street, London, W.1.

#### GKD

The Huntingdon and Anglian series of cabinets have been completely redesigned and will now accommodate almost any manufacturer's equipment. A number of modifications have also been made to the remainder of the G K D range, but without change to styling.

G K D Ltd., 74 Langley Street, Luton, Beds.

#### GARRARD

In addition to the present range of products, the new Model SP25 single-disc player will be displayed. This unit has a calibrated stylus pressure adjustment, a bias compensator and a pickup arm lowering device. An unusual feature for a single player is the automatic arm return. The unit also has a balanced non-magnetic die-cast turntable with a dynamically balanced rotor.

Garrard Engineering Ltd., Swindon, Wilts.

#### GOLDRING

A four-speed turntable unit with a fine speed adjustment of ± 10% on each speed will be introduced. Designated G 66, the unit has a built-in lowering device coupled with the on/off switch, and the pickup arm is wired for stereo. The idler wheel is automatically disengaged as the unit is switched off. Also on show will be the Pickering V 15 cartridge and a range of three transcription units, GL58, GL70 and GL88.

Goldring Manufacturing Co. (Gt. Britain) Ltd., 486-488 High Road, Leytonstone, London, E.11.

#### GOODMANS

Loudspeakers from eight to eighteen-inches in diameter are to be shown. Included in the selection of high-fidelity speakers is to be the 12-in Axiom which incorporates several new design features, such as a new pressure die-cast chassis. The small Maxim reproducer (10½ × 5½ × 7¼ in), which was introduced at last year's festival is also to be shown.

Goodmans Industries Ltd., Axiom Works, Lancelot Road, Wembley, Middx.

#### GRAMPIAN

A selection of their range of microphones, amplifiers and loudspeakers will be shown, including three new amplifiers and a new 12in loudspeaker.

Grampian Reproducers Ltd., Hanworth Trading Estate, Feltham, Middlesex.

#### HAMMOND

A custom built sound system will be introduced, containing an a.m./f.m. tuner with stereo decoder, a stereo am-

plifier giving 12 watts per channel, a Garrard A70 transcription turntable with magnetic cartridge, and loudspeakers. A new condenser microphone, a redesign of the Microkit model, includes an encapsulated pre-amplifier, balanced low-impedance output and a regulated power supply. Also new are two loudspeaker units, the Europa with four drive units and the L.7 with a double-cone wide-range loudspeaker.

C. E. Hammond & Co. Ltd., 90 High Street, Windsor, Berks.

#### ILFORD

Zonatape magnetic recording tape, which is specially manufactured for amateur tape recording, is to be shown. It is available in several grades on spools up to 8¼ in diameter, which are colour-coded to indicate the grade of tape. Diacetate, p.v.c. and polyester based tapes are featured in the Zonatape range.

Ilford Ltd., Ilford, Essex.

#### JORDAN-WATTS

Five examples of the Jordan-Watts modular loudspeaker design will be demonstrated. The Mini 12, with a single module, has a power handling capacity of 12 watts and a frequency response claimed to be level down to 80 c/s. The A 12, also one module, has a response level down to 40 c/s. A more advanced domestic system is the A 25, in which the radiation pattern is tailored to reduce spurious effects of room acoustics. The B50 is similar in performance but has four modules in distributed line source array and handles 50 W. Radiation pattern control techniques used in the A 25 and B 50 are adapted in the DPS 100 to provide a more precise stereo image.

Boosey & Hawkes (Sales) Ltd., Sonorous Works, Deansbrook Road, Edgware, Middlesex.

#### KEF ELECTRONICS

The T.15 tweeter unit has been redesigned and is now claimed to provide an additional octave at the top end of its frequency response and a smoother response over its whole range. Floor-mounted and suspended versions of the B.B.C. monitoring loudspeakers will be

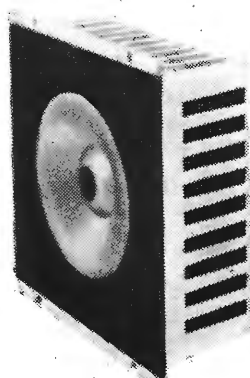

Jordan-Watts modular loudspeaker.

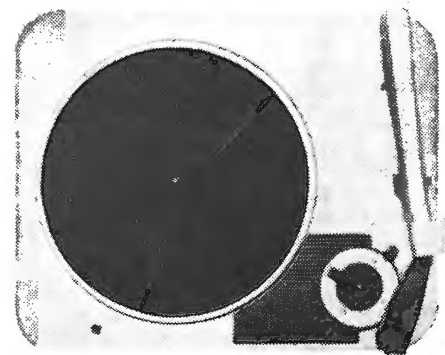

Goldring Model G66 turntable unit.

demonstrated. The company will also introduce a loudspeaker system in an 0.8 cu. ft cabinet which they say comes halfway between their existing Celeste and Duette models. This is their contribution to the Group 4 venture, which aims to offer genuine hi-fi equipment in attractive cabinets.

*KEF Electronics Ltd., Tovil, Maidstone, Kent.*

#### KELLY

Kelly loudspeakers (now marketed by Decca) will include an improved version of the well-known Mini and a larger enclosure operated with an "acoustic lens" high-frequency diffusion technique. The Mini loudspeaker will be demonstrated in conjunction with the latest turntable unit, the ffs Deccadec, which has a magnetic pickup, a pickup arm extension/adaptor with standard ffs head fitting and a non-ferrous turntable.

*Decca Record Co. Ltd., 9 Albert Embankment, London S.E.1.*

#### KODAK

A wide range of sound recording tapes are to be featured, including the Kodak P.400 quadruple-play tape which is claimed to be particularly good at slow speeds. This tape is now available on 3-, 3½- and 4-in spools.

*Kodak Ltd., Kodak House, Kingsway, London, W.C.2.*

#### L.P. RECORD LIBRARY

The Long Playing Record Library will be publishing volume 3(1) of its "Guide to the Bargain Classics" and also a new edition of its "Classical Catalogue & Handbook" specially for the Fair. Details will also be available of the Professional Stereo Record Library.

*The Long Playing Record Library Ltd., Squires Gate Station Approach, Blackpool, Lancs.*

#### LEAK

Demonstrations of the Stereo 30 two-channel transistor amplifier together with the Sandwich loudspeaker system will be given. In the amplifier, the power section following the tone control pre-amplifier in each channel is a directly coupled transformerless push-pull circuit with over 60 dB of negative feedback, giving an output of 10 watts into a 15-Ω load or 15 watts into a 4-Ω load. The Sandwich loudspeaker system comprises a treble unit and a bass unit, both with rigid, lightweight cones to give improved piston action and freedom from cone break-up. The cone is constructed as a "sandwich" of two skins of thin aluminium enclosing a ⅜-in thick core of light expanded plastics material.

*H. J. Leak & Co. Ltd., Brunel Road, Westway Factory Estate, London, W.3.*

#### LOEWE-OPTA

Receivers, radiograms and tape recorders will be exhibited, including the recently announced Optacord 408 tape recorder. The two-speed Optacord 416 will be on display for the first time in this country.

*Agents: Highgate Acoustics, 71 Great Portland Street, London, W.1.*

#### LOWTHER

This company is well known for its range of loudspeakers using a single high-flux twin-cone drive unit in a horn-loaded enclosure. These include the Acousta folded-horn enclosure (14in × 18in × 33in); corner reproducers; and a twin enclosure for stereo reproduction. A feature of the drive unit is a central stabilizer plug which spreads the high frequency radiation and provides horn loading of the inner cone, thereby smoothing the response. Also on view will be the company's range of power amplifiers, control units and f.m. tuners, and a battery-powered a.f. test oscillator for setting up sound reproducing equipment.

*The Lowther Manufacturing Company, Lowther House, St. Mark's Road, Bromley, Kent.*

#### LUSTRAPHONE

A wide range of microphones including dual-head stereo types, studio ribbon velocity microphones and moving-coil units, will be displayed together with floor and table stands, booms, flexible positioning tubes and other accessories. A folding mobile floor stand is a new addition to the range.

Also on show will be a microphone and radio transmitter combination, called the Radiomic System, which has received Post Office type and specification approval. Single- and multi-channel receivers are available for the system.

*Lustraphone Ltd., St. George's Works, Regent's Park Road, London, N.W.1.*

#### 3M

All "Scotch" magnetic tapes to be shown, excluding the acetate-based standard type, will have the recently introduced Superlife protective coating, claimed to increase tape life up to fifteen times. Also displayed will be a tape machine that records and plays tapes in cartridge form, both mono and stereo. Up to 20 tape cartridges may be stacked on the loading platform, giving up to 15 hours playing time. Recording, replaying and cartridge changing are all automatic. Accessories on show will include a self-threading reel.

*Minnesota Mining & Manufacturing Co. Ltd., 3M House, Wigmore Street, London, W.1.*

#### MALLORY

The full range of cells and batteries of particular value in audio equipment will be displayed. The 1.5V manganese-alkaline dry cells have been improved to give a lower internal impedance.

*Mallory Batteries Ltd., Crawley, Sussex.*

#### MASTERTAPE

Four grades of magnetic recording tape are featured. These are available on five reel sizes—from 3 to 7 in—and are to be shown with a new splicing kit and a wide range of accessories for the recordist. Other items to be featured in-

clude the "Min-voice letter" and the "Senda-message" ultra-lightweight postal pack on a miniature reel.

*Mastertape (Magnetic) Ltd. [formerly MSS Recording Co.], Poyle Trading Estate, Colnbrook, Slough, Bucks.*

#### MULLARD

Valves, capacitors, new transistor equipment circuits and the new range of transistors will be shown. The range of transistors comprises complementary output pairs: the AD128/AC176 for 3 watt class B stages and the AD161/AD162 for 6 watt stages. The AD149 can give 5 watts class A and is supplied in matched pairs for higher power stages. Also shown is a silicon planar epitaxial transistor, BC107, for high gain, low noise input stages and pre-amplifiers.

*Mullard Ltd., Torrington Place, London W.C.1.*

#### ORTOFON

A stereo moving-coil pickup cartridge with the high compliance of  $10 \times 10^{-6}$  cm/dyne and an equivalent mass at the stylus point of 1 mgm will be exhibited. Without a transformer (type SPU) it weighs 8gm, and has an impedance of 2Ω and an output of 0.05 mV/cm/sec. With a transformer (type SPU-T) it has an output impedance of 15kΩ and an output of 2 mV/cm/sec. The stylus is diamond and three versions are available—for stereo only, for stereo/mono, and elliptical-point for stereo/mono.

*Agents:—Metro-Sound (Sales) Ltd., Bridge Works, Wallace Road, Canonbury, London, N.1.*

#### PETO SCOTT

The range of Philips professional sound recording equipment is to be shown this year, along with a new video tape recorder, Type EL 3400.

*Peto Scott Electrical Instruments Ltd., Addlestone Road, Weybridge, Surrey.*

#### PHILIPS

A variety of tape recorders and accessories will be shown, including a four-speed stereo model (EL3534) and the cartridge loading model (EL 3300). Other models to be shown are EL 3548, EL 3549 and EL 3552.

*Philips Electrical Ltd., Century House, Shaftesbury Ave., London, W.C.*

#### PLANET PROJECTS

A continuously operating magnetic tape transport mechanism, type C.D.2, will be shown. Designed to provide continuous music, the mechanism automatically reverses when the end of either reel is reached and electrically selects the appropriate one of the two heads. Using standard ¼-inch tape, it operates at either 1⅞ in/sec or 3⅜ in/sec and is available for ½ or ¼ track mono replay or stereo replay only. The deck accepts 7-inch reels (or smaller if required) and the normal international recording direction is used.

*Planet Projects Ltd., Goodman Works, Belvue Road, Northolt, Middx.*

#### PYE

A transistorized version of the well known "Black Box" mono record reproducer is to be shown along with the "Achoic Box" stereo record reproducer which was first seen at last year's Radio Show. The current range of "Brahms" hi-fi equipment, which is available either as a complete unit or separate chassis, will also be shown.

*Pye Ltd., Radio Works, Cambridge.*

#### QUAD

A multiplex decoder for reception of stereophonic broadcasts on the pilot-tone system is now available, but for export only at present. Designed for use with the Quad f.m. tuner and Quad 22 control unit, the unit recovers the stereo information signal (difference between left- and right-hand channels) and combines it with the sum signal, so that the original two channels are obtained separately.

In addition, the well-known range of power amplifier, control unit, a.m. and f.m. tuners and electrostatic loudspeakers will be displayed.

*The Acoustical Manufacturing Co. Ltd., Huntingdon.*

#### RADFORD

Items on show this year include the Series 3 Super Bookshelf loudspeaker unit with a response of 80 c/s—14 kc/s  $\pm 3\frac{1}{2}$  dB and handling up to 25 watts r.m.s. A new transistor control unit will be on display—the SC22—and f.m. tuners will be introduced with facilities for interstation noise suppression and multiplex stereo output. If the B.B.C. multiplex stereo transmissions are suitably timed it is hoped to demonstrate the stereo f.m. tuner. Other established Radford items will also be shown.

*Radford Electronics Ltd., Ashton Vale Estate, Bristol 3.*

#### RECORD HOUSING

Most of the range of 20 cabinets will be on show, including the new Hi-Flex units which can be placed together, vertically or horizontally, to form a con-

tinuous cabinet. The system comprises an equipment unit, a record unit and a 12 in loudspeaker unit. The Nordyk range has been extended to include a Hi-Rak which is used for a shelf-mounting system. Changes in style have been made to the Lowflex and the Lowline-Two—both will be on show.

*N. & S. B. Field & Co., Brook Road, London, N.22.*

#### RESOSOUND

The complete range of Relso ribbon and dynamic microphones are to be shown with a comprehensive range of accessories, including floor-stands, table-stands, adaptors, etc.

*Resosound Ltd., 24 Upper Brook Street, London, W.1.*

#### REVOX

The model 736 stereo tape recorder, exhibited at last year's Audio Fair, will be on show. This two-speed model accepts up to 10 $\frac{1}{2}$ -in spools and incorporates equalization time-constants to the latest C.C.I.R. standard of 70  $\mu$ sec and 140  $\mu$ sec. An automatic transparency projector unit—the Slide-o-Matic—will be demonstrated working in conjunction with the Revox tape recorder.

*Agents: C. E. Hammond & Co. Ltd., 90 High Street, Windsor, Berks.*

#### ROGERS

The latest version of the "eighty-eight" stereo amplifier and an f.m. receiver are to be shown for the first time. The receiver covers the frequency range 88 to 108 Mc/s and has a sensitivity of 1.5  $\mu$ V. Other items to be shown include several amplifiers, f.m. tuners, speaker systems and equipment cabinets.

*Rogers Developments (Electronics) Ltd., 4-14 Barmeston Road, Catford, London, S.E.6.*

#### S.R.T.

Two transcription units and a record player made by the Scandinavian Radio & Television Company are to be shown. An eight-inch diameter speaker, driven by a 2.5-watt amplifier, is incorporated in the four-speed record player. Distortion

is claimed to be less than 1% at 2.5 watts. The transcription units also have four speeds and one is fitted with transistor pre-amplifiers.

*Agents: Denham & Morley Ltd., Denmore House, 173-175 Cleveland Street, London, W.1.*

#### S.H.B.

Loudspeaker units manufactured by Svenska Hogtalfabriken are to be shown. These units are quite small (i.e. a unit of 10 $\times$ 5 $\frac{1}{2}$  $\times$ 7 in has a power handling capacity of 8 watts undistorted) and are hermetically sealed.

*Agents: Metro-Sound (Sales) Ltd., Bridge Works, Wallace Road, Canonbury, London, N.1.*

#### S.M.E.

The Series II range of precision pickup arms and accessories will be on view, and a new addition this year will be a light-weight stainless steel lifting handle.

*S.M.E. Ltd., Steyning, Sussex.*

#### S.T.C.

Two new microphones are to be shown by Standard Telephones and Cables. A field effect transistor head amplifier is incorporated in the Type 4126 capacitor microphone. The price of this unit, which is also available with a cardioid insert, is around £120. The other new microphone, Type 4119, is a tubular unit with a ribbon insert that has narrow cardioid characteristics. It has a spherical woven-wire windshield and a tubular bass chamber. A novel collapsible microphone floor stand is to be shown.

*Standard Telephones and Cables Ltd., 29-30 Glasshouse Yard, Aldersgate Street, London E.C.1.*

#### SABA

Two tuner amplifiers will be shown for the first time, the Stereo Studio T II with 24 watts output and the Stereo Studio T III with bandspreading, automatic tuning and 70 watts output. Both are transistorized and cover long-, medium- and short-wave and v.h.f./f.m. bands. Also on show will be the TK 230s stereo tape recorder, incorporating two loudspeakers.

*Saba Electronics Ltd., Eden Grove, Holloway, London, N.7.*

#### SCOTT

The American company H. H. Scott will be exhibiting their 299 stereo valve amplifier, rated at 32 watts r.m.s. per channel at 0.8% harmonic distortion with a bandwidth of 20 c/s—20 kc/s  $\pm 1$  dB. This amplifier can also drive a third centre loudspeaker, the signal being derived from both left and right channels. Two new amplifiers will be on show this year for the first time, the model 200 rated at 12 watts r.m.s. per channel at 0.8% harmonic distortion (I.H.F.M. power band: 25 c/s—15 kc/s) with the derived centre channel and the model 260, a solid state design with silicon-output transistors and rated at 30 watts per channel.

*Agents: A. C. Farnell Ltd., Hereford House, North Court, Vicar Lane, Leeds.*

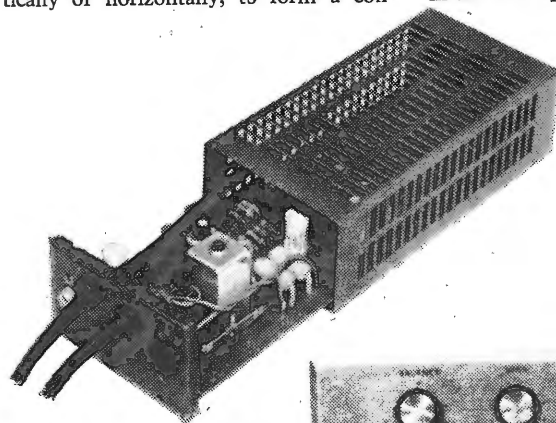

*Rogers Cadet III stereo amplifier and control unit.*

*Quad multiplex decoder for stereo reception.*

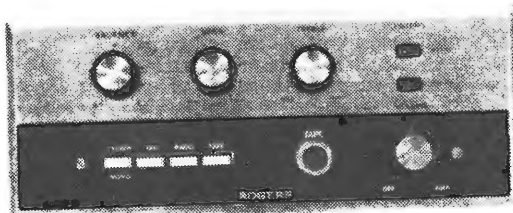



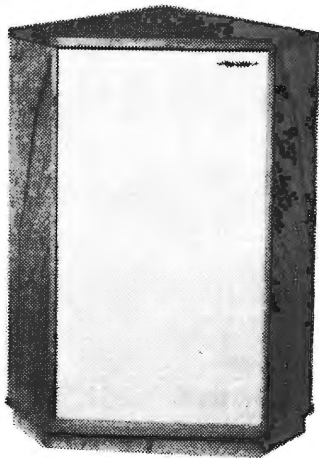

Tannoy "Lancaster" corner loudspeaker unit.

#### SHURE

An addition to the Dynetic range of stereo cartridges will be the M44-C, intended for use with record reproducers requiring a tracking pressure of 3-5gm, and the M55-E, with elliptical stylus for use with transcription unit arms tracking at  $\frac{3}{4}$ -1 $\frac{1}{2}$ gm. All types in the range are compatible, allowing stereo and mono records to be played through stereo or mono equipment. Microphones not previously shown include the 550S omnidirectional dynamic type.

Shure Electronics Ltd., 84 Blackfriars Road, London, S.E.1.

#### SONOTONE

Two stereo pickup cartridges are to be shown. The Type 9TA has a sensitivity of 80-120 mV/cm/sec at 1,000 c/s and a compliance of  $5.3 \times 10^{-6}$  cm/dyne. Tracking weight is 2-4 gm, and response is within 3 dB from 30 to 15,000 c/s. The other ceramic cartridge, the 9TAHC, has a similar specification and both have average channel isolation figures of better than 20 dB. An electrical load of 2 M $\Omega$  and 100 pF is quoted for both cartridges.

Agents: Metro-Sound Manufacturing Company, Bridge Works, Wallace Road, Canonbury, London N.1.

#### SONY

Four tape recorders along with a precision stereo tape transport and a complete stereo record pre-amplifier are to be shown. The tape recorders are multi-track machines suitable for mono and stereo applications, with the exception of the TC 777A, which is a professional twin-track recorder. The record pre-amplifier has been designed primarily to be used with the new tape transport.

Agents: Debenhams Electrical & Radio Distribution Company, Eastbrook Road, Eastern Avenue, Gloucester.

#### TANDBERG

Two cabinet loudspeakers will be shown for the first time, the Model 8 and the Model Hi-Fi. They have an impedance of 4 ohms and are suitable for use with the company's transistorized amplifiers,

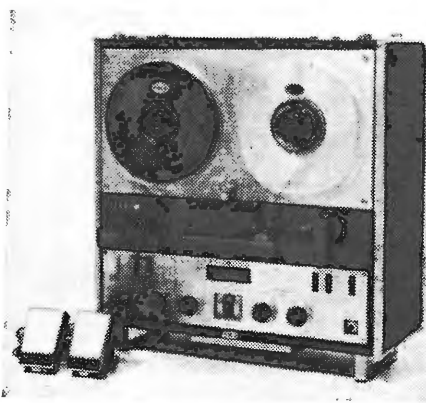

Sony TC 600 four-track tape recorder.

tape recorders and Huldra receivers. The Huldra receivers provide f.m. and a.m. reception and include stereo amplifiers and loudspeakers for record reproduction. Mono tape recorders Series 8 and Series 9 will be introduced, in two-track and four-track versions.

Agents: Elstone Electronics Ltd., Edward Street, Templar Street, Leeds.

#### TANNOY

The new range of Lancaster loudspeaker units will be shown in addition to the complete range of high-fidelity equipment. The corner Lancaster enclosure (illustrated) is available as a reflex unit with a 12 in loudspeaker and as an aperiodic unit with a 15 in loudspeaker.

Tannoy Products Ltd., Norwood Road, London S.E.27.

#### TELEFUNKEN

Two a.m./f.m. tuner-amplifiers are featured this year. Both of these cover four wavebands and are fitted with multiplex decoders. Other exhibits are to include two four-speed transcription units, a 30+30 watt amplifier and speaker units.

Agents: Welme Corporation Ltd., 27 Chancery Lane, London, W.C.

#### THORENS

A selection of transcription units, including one combined with an automatic record changer, are to be shown. This novel unit, designated TD 224, does not carry a stack of records on the central spindle of the turntable, but selects records (up to eight) from a separate stack at the side of the turntable. When the record on the turntable is finished, it is automatically returned to the bottom of the stack and another from the top is selected and placed on the turntable.

Agents: Metro-Sound (Sales) Ltd., Bridge Works, Wallace Road, Canonbury, London, N.1.

#### TRIO

F.M. tuners, stereo amplifiers and combined tuner-amplifiers with this Japanese trade name are to be shown. A stereo multiplex adaptor which is suitable for all Trio tuners and can be used on many other makes of tuner is also to be featured.

Agents: Winter Trading Ltd., 95-99 Ladbroke Grove, London, W.11.

#### TRUVOX

Amongst equipment that will be demonstrated is a new stereo system, the details of which had not been announced at the time of going to press.

Truvox Ltd., Neasden Lane, London, N.W.10.

#### VORTEXION

The C.B.L. professional tape recorder aims to provide a versatile twin-channel equipment for mono work as well as stereo recording and playback. Mixing is provided on both channels for microphone and gram/radio inputs. Cross-channel mixing allows special effects in monophonic work, such as a singer or musician accompanying himself. Echoes may be introduced and a monitoring facility allows comparison of the original and recorded sounds.

Vortexion Ltd., 257-263 The Broadway, Wimbledon, London, S.W.19.

#### WHARFEDALE

Two new products which will be on show are the Dalesman and Dovedale enclosures, both with 5in and 12in loudspeakers. The Dalesman can handle 10 watts r.m.s., has an impedance of 10-12 ohms and the 12in loudspeaker uses a ceramic magnet. The larger and wider range Dovedale enclosure houses a bass loudspeaker with an open-baffle resonance of 15-18 c/s, and a Neoprene suspension. The 5in high-frequency unit uses a ceramic magnet with cloth suspension. The impedance of the Dovedale is 12-15 ohms; it can handle 15 watts r.m.s. and incorporates a treble volume control.

Wharfedale Wireless Works Ltd., Idle, Bradford, Yorks.

#### WHITELEY

Loudspeakers, f.m. tuners, amplifiers and ready-to-assemble bass reflex cabinets are to be shown by the Whiteley Electrical Radio Company. The speakers vary in diameter from 1 $\frac{1}{4}$  in to 18 in and are available with several different cone constructions, speech coil impedances and magnetic flux densities.

Whiteley Electrical Radio Company, Radio Works, Mansfield, Notts.

#### WILLIMAN

Overseas visitors will have the opportunity of seeing a selection of British audio equipment available to them through K. H. Williman & Co. This includes products from Armstrong, Kelly, Planet and Rogers, for whom Willimans are exclusive exporters.

K. H. Williman & Company, Blackford House, Sutton, Surrey.

#### WILMEX

As an export house, Wilmex will be showing several makes of audio equipment, placing emphasis on Ferrograph.

Wilmex Ltd., 151 Clapham High Street, London S.W.4.

#### WILSON STEREO LIBRARY

The latest edition of the Stereo Index will be exhibited. The book includes reviews of classical and popular stereo records by well-known critics.

The Wilson Stereo Library Ltd., 463 Streatham High Road, London, S.W.16



# LETTERS TO THE EDITOR

The Editor does not necessarily endorse opinions expressed by his correspondent

## The Colour Situation

MAY I correct two wrong impressions which may be given by the article on pages 30, 31, of your March issue.

In the BREMA Home Viewing Trials no overall assessment was made of compatibility, but, as the heading to the overall histogram in our report shows, a question was asked on the "Impairment of the monochrome picture (on a colour receiver) due to a colour cast." The sole purpose of this was to assess the effect that any convergence or misregistration errors in the shadow-mask tubes would have on the quality of the colour picture, and no conclusions on dot patterns can be drawn from the results.

These trials were conducted solely to assess whether the average non-technical viewer was capable of adjusting N.T.S.C. receivers so as to obtain good quality pictures, and any other results were incidental. The fact that this was the only supporting evidence given with our statement in favour of the N.T.S.C. system does not mean that supporting evidence for the other claims is not available, but that this aspect was thought to be of such importance as to warrant a special investigation, with a summary of the results being included as an appendix to our statement.

London, W.C.1.

D. P. DOO,  
Technical Secretary,  
British Radio Equipment Manuf. Assoc.

## "Applications of Metal Oxide Silicon Transistors"

MR. F. Butler, in his article in the February issue has provided an introductory survey of possible uses of field effect transistors. I would like to point out what I regard as some significant omissions and to comment on one or two of his statements which seem to me to be misleading.

He writes, "In view of the very high input impedance, the amplifier noise figure is exceptionally low, . . .". In fact, the noise behaviour of the device is related only indirectly to the input impedance. A number of theories of the origin of noise prevail, including the effect of high electric fields in the pinch-off region, channel noise, leakage noise, etc. It is beyond the scope of this letter to discuss the pertinent device physics. I think that Mr. Butler means, "Even when coupled to sources having an internal impedance of several megohms, the noise figure is exceptionally low, . . .".

In my evaluation of some ten dozen f.e.t.s of United States manufacture while I was actively engaged at de Havilland Aircraft of Canada, I found that m.o.s. f.e.t.s exhibited noise performance in the audio range much inferior to p-channel planar diffused silicon junction f.e.t.s. However, at radio frequencies, the reverse is said to be true.

This leads to another point of contention. The m.o.s. f.e.t. really comes into its own in high-frequency (r.f.) applications. A good m.o.s.t. should have a noise figure under 3dB at 100 Mc/s and a neutralized power gain of, say, 10dB. The applications illustrated by Mr. Butler can be carried out by junction f.e.t.s and do not require a wait for the availability of m.o.s. devices. An excellent summary of the unique features of m.o.s. devices and their relation to junction f.e.t.s is contained in a recent feature series<sup>(1)</sup>.

Does Mr. Butler seriously advocate using bias resistors as high as 50 megohms. Leakage currents, sufficient to bias a device into cut-off (or hard on) can arise so unexpectedly, as when a "good" blocking capacitor at the input of an amplifier passes a few nanoamperes of current from, say, an infra-red detector biased at 100 volts when the entire assembly is subjected to a 125°C ambient environment. Further, to maintain good noise performance, carbon resistors cannot be

used (even though ideal performance should be achieved as the current to cause current-noise is infinitesimal); wirewound resistors are bulky, costly and pick up noise through their inductive properties; metal film resistors would have to be used in large quantity.

Mr. Butler advocates bootstrapping. Experience shows that the transconductance of f.e.t.s is not high enough for this method to provide much increase in the input impedance. At the moment, one of the facts of life is that the purchase price of these devices soars with the gain. Then, too, the valve boys will dig out their mildewed texts and show us that the drain resistive load (plate load) reduces the effective  $\mu$  available for bootstrapping.

The answer to the dilemma of attaining a high input impedance with components of a reasonable size and securing low noise performance is provided in exploiting positive and negative feedback together in just the manner that Mr. Butler described for bipolar transistors in *Wireless World*<sup>(2)</sup>, and others have described elsewhere. In a recent paper<sup>(3)</sup> I described the advantages of a hybrid design in which input impedance multiplication is achieved by greater-than-unity-gain drive for the bootstrap connection. The two-transistor amplifier there cited has an input impedance at the input end of a length of shielded cable of hundreds of megohms in parallel with 6pF of capacitance and an output impedance of less than three-hundred ohms at a stabilized voltage gain of ten. It maintains its performance over a wide temperature range and is independent of device differences.

London, S.W.7.

IAN H. ROWE,  
Imperial College of Science & Technology.

(1) *Electronics*, Vol. 37, No. 30, November 30th, 1964.

(2) F. Butler. "Analysis of the Bootstrap Follower," *Wireless World*, January, 1963.

(3) I. H. Rowe. "Design of Low Noise, High Impedance Amplifiers Using F.E.T.s," *Electronics and Communications (Canada)*, March, 1963.

### The author replies:—

Since I wrote this paper a number of articles on the basic physics of field effect transistors have appeared and there have also been one or two accounts of practical applications, including a bulletin by Mullard which contains useful information. One cannot track down and read everything and I fear that I missed seeing Mr. Rowe's own contribution. American literature deals mainly with junction-type f.e.t.s. as distinct from the insulated-gate type. Both devices are equally suitable for many applications and I chose to discuss the Mullard transistor because of its novelty and topical interest.

Many American papers deal with choppers, low-noise amplifiers and voltage-controlled resistances. Application notes of U.S. manufacturers (Crystalonics, Fairchild and Texas Instruments), tend to cover the same ground, whereas my chief concern was with a broader field of more general interest.

As regards noise figures, I accept Mr. Rowe's correction to my sentence beginning "In view of the very high input impedance, the amplifier noise figure is very low . . ." His version is more nearly what I meant to convey, as should be apparent from the context.

I should also like to comment on the spectral distribution of noise power in f.e.t.s. I said that the 1/f component seems to be absent or abnormally low but now doubt very much if this is true. Everybody seems to agree that the spectrum of f.e.t. noise is not the same as normal transistor noise but much more work is required by physicists and device manufacturers before the facts are fully known. I suspect that some of the noise is inherent in f.e.t.s and some

is capable of reduction by improved manufacturing techniques.

Mr. Rowe's remarks on f.e.t. noise figures at high frequencies are irrelevant to the subject of my paper. Since he has raised the point it should be said that a low noise figure is only one of many design requirements for a tuned r.f. amplifier. Others, perhaps of greater consequence, are linearity (absence of intermodulation), ease of applying a.g.c. and the possibility of wideband neutralization or unilaterization.

I am taken to task for suggesting the use of a 50 megohm bias resistor. Mr. Rowe will therefore be horrified to see the elegant and original electrometer circuit described by Mr. C. J. Mills in the letters on p. 141 of the March issue of *Wireless World*. In this a resistance of 100 kilomegohms is shown, though naturally one would not put a 100-volt d.c. supply in series with it through a blocking capacitor. For normal supply voltages, many modern plastic-foil capacitors have sufficiently good insulation for use in this type of circuit. There is another point. My circuits, and that of Mr. Mills, provide automatic source bias which will do something to offset the effects of capacitor leakage. Furthermore, there is a simple trick for eliminating or greatly reducing the effect. Connect two input capacitors in series and from the junction point connect another high resistance to ground. At d.c. the double CR network gives a potential-dividing effect, causing resistive attenuation of the leakage current.

Mr. Rowe has a point concerning the noise power in carbon resistors, or any other resistors for that matter but he cannot expect me to fight the laws of nature. The r.m.s. noise voltage across a 100 megohm resistor at 17°C in a bandwidth of 100 kc/s is around 400 microvolts. For a carbon resistor carrying d.c. the figure is much worse. The situation is inescapable and the f.e.t. is not to blame.

Because I gave the circuit diagram of a bootstrap amplifier it does not follow that I endorse or advocate the general use of this arrangement. In the past, Mr. G. W. Short and I have pointed out some of the disadvantages of this connection. Moreover I am well aware of the effect of the device transconductance on the performance. Almost the sole merit of the circuit is that its input impedance can exceed the physical resistances of the bias network.

The point about the use of combined positive and negative feedback to give a high input impedance has no relevance to the subject of my article, but while I am writing I would like to correct an error in Fig. 9 of my paper. The high tension line should be marked positive, not negative as shown. Next, I learn from Mullard Ltd. that the substrate lead, left floating in all my circuits, should preferably be connected to the source terminal. If desired, this lead may be used for a.g.c. purposes or for oscillator injection if the transistor is used as a mixer. Another point to note is that in later samples of the 95 BFY device, two electrode leads have been transposed. The base connections shown in my Fig. 1 apply only to early samples. There is also a mistake in Fig. 5. The middle resistance of the three at the bottom of the diagram should be 560 ohms, not 560 kΩ.

To conclude I would like to make a further comment on the electrometer amplifier described by Mr. Mills and on the interesting hybrid circuit noted by Mr. Short. One of the drawbacks of the f.e.t. is Miller feedback through the gate-to-drain capacitance. It is neatly avoided by using the source-follower connection. However, if the source load is capacitive there is some risk of instability as there can be with the ordinary cathode follower, though this cannot happen in the circuit described by Mr. Mills which, incidentally, has almost ten times the bandwidth of more conventional arrangements. The high input impedance makes possible a convincing demonstration of the piezoelectric effect in quartz merely by sandwiching a plate or bar between foil electrodes, adding two insulating outside sheets and compressing the assembly with a pair of pliers. Gentle pressure with a measuring micrometer is enough to show a perceptible reading on an output voltmeter. Screening is required to prevent hum pick-up.

Mr. Short's circuit\* is new to me though I believe a similar

[\* In G. W. Short's letter (March, p.141, the expression  $-\alpha/g_m$  should be  $-1/\alpha g_m$ —Ed.]

arrangement was described in the Hewlett Packard Journal for April, 1961. It seems ideally suited for use with f.e.t.s and could probably be used as a relaxation oscillator as well as the controlled negative resistance or sinusoidal oscillator which he suggests.

F. BUTLER

## Units

MR. D. F. Gibbs' letter (p. 85 February issue) illustrates, I believe, more a continuing defect in mathematical pedagogy than any crankiness in Mr. Gibbs. "Cathode Ray" is fully justified in his strictures on the matter of Mr. Gibbs' letter, yet the fault may properly lie with the latter's teachers. It is, and has been for many decades, fashionable (and ego-flattering) to claim that mathematics, which ought properly to be called arithmetic is *the* school subject that demands thought. That claim has no foundation.

Until computers became common no self-evident rebuttal of the claim was available. Computers do not think, they *do!* The fact that they do faster than man-moved pencils is irrelevant. The man behind the pencil need think no more than the computer, he need only remember and do.

"Thinking" leads to the class of error demonstrated by Mr. Gibbs, viz., the overlooking of the principle that each arithmetical discipline becomes meaningless when any "foreign" axiom is allowed to creep in. There is no single, complete and exclusive set of axioms to link the c.g.s. electrostatic and electromagnetic systems. The systems touch, but do not coincide. Each is true *within the boundaries set by its own axioms* and, in practice, a change of scale at the proper place permits transfer from one system to the other and from both to the m.k.s. systems.

"Cathode Ray" has explained at length in several of his articles that these scale changes are numerical and dimensional, and that the axioms of the m.k.s. systems are preferable to those of the c.g.s. system. It is an interesting (although potentially mischievous) thought that the preference might have been made explicit by calling the new systems c.g.s. (Giorgi).

To make explicit the implications of the above, may it be suggested that our educationists strive towards improving our memories without ruining our ability to think. Thought can be a time-wasting substitute for memory, and is wastefully productive without accurate memory of a fair "quantity" of information.

Glasgow.

W. GRANT

THE m.k.s.A system may well be the most suitable for present engineering purposes, and knowing how easily strong feelings are aroused, I was careful to make no direct criticism of it in my letter published in your February issue. "Cathode Ray," as I had feared, sees the matter as a battle between the reactionaries and the progressives. It was rather tempted on reading his reply to pick up the gauntlet and act out the villainous but not altogether unsympathetic part thrust upon me, no doubt disappearing down the trap in the final scene, to the accompaniment of red fire and hisses, my end delayed but not prevented. But I would prefer to stick to my original purpose, which was to emphasize the arbitrary nature of units and dimensions, and to refute suggestions that the c.g.s. systems are unsound.

There is little disagreement on the main observations in experiments in classical electricity and magnetism. Having discovered certain proportionalities, we refer some of the quantities measured to existing standards, such as the metre, and define certain new quantities, such as electric charge. When we have a system which we find consistent and convenient, we all too easily assume that all other systems must contain some essential flaw. We are liable to feel that there "must" be some "true" dimensions for every physical quantity. I believe on the contrary that our systems are largely man-made, like a monetary system, or about as arbitrary as our habit of doing arithmetic in the decimal system. It is, of course, possible to devise systems which are self-contradictory, but between the many which are not, we can hardly choose with any degree of objectivity. In classical mechanics, for example, the conventional choice of mass length and time

as "fundamental" dimensions is not a necessity, one may perfectly well regard force as fundamental and mass as derived.

Perhaps "Cathode Ray's" insistence that volume must be of dimension  $L^3$  demonstrates his own unwillingness to consider an unfamiliar system. I might measure volumes with reference to a standard pot, and decide that volume is an independent dimensional quantity, related to my standard of length by having dimensions  $kL^3$ , where  $k$  is a dimensional constant. The unit of volume in this system would resemble the ampere in the m.k.s.A system.

The misunderstanding about the dimensions of  $\epsilon$  and  $\mu$  is probably mainly verbal. In the context in which they were defined, I would indeed deny that " $\epsilon$  and  $\mu$  possess (separately) certain dimensions." By this denial I mean that they are (separately) dimensionally indeterminate, not that they are both pure numbers. The indeterminacy results from our introduction of two constants instead of one, and the further arbitrary assignment of a magnitude and dimension to one of them results in one of the many systems which seem to cause us so much worry.

The analogy between the mass and volume of a quantity of sugar and the electrostatic and electromagnetic measures of an electric charge still seems to me a fair one. We perform different operations in each case, and our resultant measures differ in magnitude and dimensions unless we insert dimensional constants in our definitions. I cannot see why it should be loose and unscientific to speak of a quantity of sugar if it is not equally so to speak of a quantity of electric charge. Why should electric charge be the same thing no matter how it is measured, while sugar is not? I would say they both remain the same no matter how measured, but methods of measurement may differ.

I cannot, alas, claim any originality in expressing electrical quantities in terms of mechanical ones, for that we must thank such giants as Gauss and Weber. I do not know why "Cathode Ray" says this is in contradiction to Maxwell. In his "Treatise on Electricity and Magnetism," Part IV, Chapter X, the first sentence is "Every electromagnetic quantity may be defined with reference to the fundamental units of Length, Mass and Time." Some users of m.k.s. systems say explicitly that they regard the introduction of a fourth dimensional quantity as a matter of convention and convenience, but some, like "Cathode Ray" and your correspondent Mr. Frank Smith, seem to think it a matter of necessity, often giving as their reasons the avoidance of fractional indices, and of the appearance of different dimensions for different measures which they feel should be the same. The different dimensions may be reconciled, if desired, by the use of dimensional constants in the definitions. I do not understand why fractional indices are considered objectionable. While the matter cannot be settled by appeal to authority, I would sincerely recommend anyone interested in the fundamentals of the subject to read "Dimensional Analysis" by P. W. Bridgman (Yale University Press).

Mr. W. M. Wrigley's letter illustrates the difficulties in discussing this subject. I have carefully searched Condon and Odishaw's "handbook" for the passage which he implies shows that zero dimensions cannot be ascribed to  $\epsilon_0$ , and I do not even get the impression that this is the author's belief! To be pedantic, I agree with Mr. Wrigley that one cannot ascribe zero dimensions to  $\epsilon_0$ , "any more than to the velocity of light for instance," but the latter is indeed possible, and is a fairly common practice among certain theoreticians. The resultant equations can be numerically and dimensionally correct. If it is objected that the units used are not practical, that may be true, but it depends on your practice, and in this age of radar and space travel it is not self-evident.

I had read Mr. Bigg's paper, having as a matter of fact been a subscriber to the journal mentioned since its inception, but I take leave to doubt his predictions. As for being "forward-looking"; when I hear that word I reach for my revolving chair. I like to look all round.

Bristol.

D. F. GIBBS

"CATHODE Ray" does well to advise us to use the SI system of units. There is little doubt as to the wisdom of his

advice, but I wonder if I may comment on the reasons he has given in his article and in the reply (Feb. issue) to Mr. Gibbs? For it is not immediately clear from the article that there are two related issues involved; the need in electricity for 1. an arbitrary unit of measurement, and 2. a fourth fundamental magnitude for dimensional analysis.

"Cathode Ray" does not define what he means by "dimensions" (an unusual omission), and perhaps as a result, is less than fair to the gravitational system of units. I take it that the dimensions of a physical quantity show how its numerical value will change when a change is made in the magnitude of the primary units. For the British gravitational system convenient primary magnitudes are those of length (ft), time (sec), and force (lbf). Retaining the pound, mass can be assigned the dimensions  $[F L^2 T^{-1}]$ . The dimensions of energy are  $[F L]$  and so are the dimensions of  $\frac{1}{2}m.g.v.^2$ . The point is that there need be nothing wrong dimensionally with the gravitational system, even in this curious form; though it is true that people are thoughtless in its use. The reasons against accepting the gravitational system for scientific work are experimental, not dimensional; the standard mass—as a lump of material—is more accurately reproducible than the standard force defined gravitationally. Surely it is for similar experimental reasons that the ampere is chosen as the arbitrary electrical unit.

If, for example, we take as the independent experimental equations the Coulomb laws and the expression for the force on a free pole due to a current element

$$F = \frac{1}{\epsilon_0} \cdot \frac{q_1 \cdot q_2}{r^2}$$

$$F = \frac{1}{\mu_0} \cdot \frac{m_1 \cdot m_2}{r^2}$$

$$F = \frac{1}{A} \cdot \frac{m \cdot I \cdot \delta s \cdot \sin \theta}{r^2}$$

and for good experimental reasons assume the identity  $I = \frac{dq}{dt}$

we have five quantities and three equations. It is not possible to proceed without some assumption. In the SI system,  $A$  is taken to be unity leaving  $\mu_0$  to be defined. By setting  $\mu_0 = 4\pi \times 10^{-7}$  (and thereby defining the magnitude of the force in the definition of the ampere) the SI system obtains as its "absolute" units those found to be of a convenient size for "practical" use. Is it not this simplification which is the great virtue of SI units in electricity?

In dimensional analysis, however, the choice of fundamental magnitudes is—in theory—arbitrary, ranging from one to the total number of quantities used. In any problem the number of fundamental magnitudes are chosen to extract the maximum information by dimensional means. Maxwell seems to have believed that all phenomena were ultimately reducible to mechanical terms and so derived dimensional equations for electrical units in terms of the fundamental magnitudes of mass, length, and time. This leads to inconsistency between the e.s. and e.m. system of units, but this reflects only the different way in which the quantities are defined. An alternative treatment to Maxwell's was given by Rucker in 1889 and from this basis generally used dimensional analyses in terms of mass (or energy), length, time, and electric charge, have developed. There are other alternatives for the fundamental magnitudes: mass, length, time, and resistance; length, time, current, and resistance; length, time, charge, and magnetic flux—all have been used for particular problems. The important thing is that these methods use a primary magnitude other than  $M$ ,  $L$ , and  $T$ . Dimensional analysis—in practice—has regard for the "physics of the situation". Perhaps in this light Mr. Gibbs is seen to be defending a theoretical position while "Cathode Ray" maintains an experimental one. Certainly even given the generally felt need for an independent electrical unit, we do not necessarily have to use the unit which is defined practically as the fourth fundamental magnitude for dimensional analysis.

All of this may be dismissed as academic nicety, but from the point of view of the teacher it represents a serious practical problem. Efforts to introduce m.k.s. units in schools are often associated with independent ideas for reform in the theoretical structure of electricity courses. It seems to me that this is a

tactical mistake. The SI system represents a convenient and internationally acceptable method of simplifying units in physics and engineering—for this reason alone, there is every advantage in adopting it. Whether or not we decide to retain magnetic poles in teaching is, by comparison, of minor importance. Unfortunately, theoretical problems similar to those above seem to have obscured what is fundamentally a simple issue.

“Cathode Ray” complains also of mental inertia in other fields. I sympathize. I listen hopefully to B.B.C. weather forecasts; someday they may change to degrees Celsius instead of degrees Centigrade. Of course it is early yet, the recommendation was only made in 1948.

Uppingham.

D. G. F. EASTWOOD

*The author replies:—*

If I believed that there could be only one right system of units I would not have said in my article that two possibilities exist for a coherent f.p.s. system and then gone on to point out that mass and force are alternative fundamental quantities—as Mr. Gibbs now also does. That is not in dispute. What Mr. Gibbs has to do, but so far has not even attempted, is to show why the c.g.s. systems should be retained, when:

(1) Abandoning them in favour of the m.k.s.A. system reduces the number of systems from three to one.

(2) C.g.s. electrical units differ from those in common use.

(3) Their magnitudes are in some cases quite unrelated to practical or even scientific purposes; e.g., the farad is admittedly rather too large, but the e.m.u. unit of capacitance is one-thousand-million times larger still.

(4) The c.g.s. systems conceal the fundamental difference between H and B, to the confusion of students and sometimes their elders.

(5) In dimensional formulæ they involve fractional indices, which are repugnant to common sense.

(6) The constant  $\pi$  occurs where it is inappropriate and is missing where it would be appropriate.

Since the m.k.s.A. system is free from all these disadvantages the term “reactionary” that Mr. Gibbs puts into my mouth for those who, like him, spring to the defence of the c.g.s. systems would seem to be not altogether undeserved.

And is their case really strengthened by the arguments used by Mr. Gibbs? I said that any method of measuring volume that gave it dimensions other than  $L^3$  would have to be looked at rather carefully. Does Mr. Gibbs deny that? If he chooses to introduce a dimensional constant  $k$  let him, but I think he would have some difficulty in justifying it, let alone persuading others to follow his example. There is no difficulty on either count as regards the ampere.

Then how does he define “quantity” of sugar? If he defines it so as to make it dimensionally the same as mass, then unit “quantity” would always comprise the same number of molecules. If he defined it in terms of volume, it would not. A “quantity” of electric charge always gives consistent results in terms of, say, electrons. If we found that equal surpluses of electrons appeared to provide unequal charges, some investigation would seem to be desirable. Certainly the mass-defined “quantity” of sugar could be measured by measuring the volume, but density has to be brought in, which converts the result to mass, so there is no dimensional difference between the two measures.

In Art 2, of Maxwell’s “Treatise” he says “The dimensions of each term of . . . an equation, with respect to each of the fundamental units, must be the same. If not, the equation is absurd, and contains some error.” And in Art. 623, after giving equations connecting the various electric and magnetic quantities, he says, “In order to deduce the dimensions of the twelve units involved, we require one additional equation. If, however, we take either  $e$  or  $m$  as an independent unit, we can deduce the dimensions of the rest in terms of either of these.” He, then, required an independent unit as well as length, mass and time.

I now gather that Mr. Gibbs protested against my saying “nobody knows what the dimensions of  $\epsilon$  and  $\mu$  are” instead of “nobody can know. . . .” But, of course, if “nobody can know” my statement must be true! If he can give

incontrovertible reasons why “nobody can know” and my substituting “can know” for “knows” makes him any happier I would willingly do so.

I do not know why Mr Eastwood thinks I was unfair to gravitational systems. I wrote not a word of criticism of them and acknowledged the foot-pound(force)-second as a coherent system. My criticism was directed at the British mixture of two systems, in which the same name is used for the unit of mass and the unit of force.

I am well aware of the fact that other independent units than the ampere could have been chosen as the fourth in SI; in fact, until the CGPM had made up its collective mind,  $\mu_0$  and Q were among those being considered.

I had rather Mr Smith (March issue) did not credit me with the sugar analogy; Mr Gibbs must bear that burden alone. And does he (Mr Smith) deny that electric charge is the same kind of thing no matter how it is measured? That was all I said about it in the letter he criticizes.

My surprise that physicists have, contrary to Mr Gibbs’ impression, so largely gone over to m.k.s.A. units was due to the general feeling when they were introduced that if we were lucky they might be adopted by all electrical engineers within about a generation, but pure scientists could hardly be expected to make the change. I am glad that this forecast has proved to be too pessimistic. The progressive reduction of the partition between pure and applied scientists may well have contributed to the result. I am obliged to Mr Wrigley (March) for substantiating my statement that the c.g.s. systems are rapidly moving into past history.

“CATHODE RAY”

### Darlington-Cascode Trio

I WAS very interested to read F. Butler’s article in the March issue on transistor cascade amplifiers and their various forms that “people keep re-inventing.”

I was rather surprised to find that one permutation that I have often used myself, and which I feel is a bit “obvious,” did not appear.

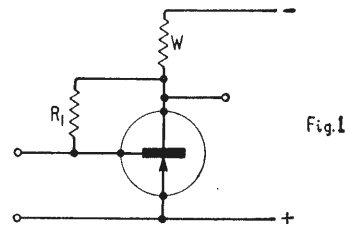

Fig. 1

It derives logically from the feedback stabilized transistor (Fig. 1) which is well known.

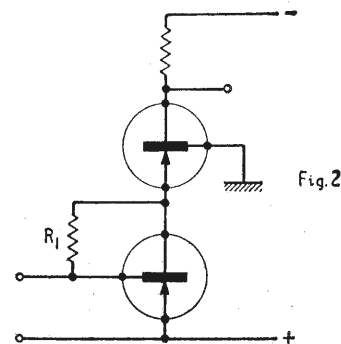

Fig. 2

Substitute a transistor for W and there appears the simple cascode, (Fig. 2) also stable.

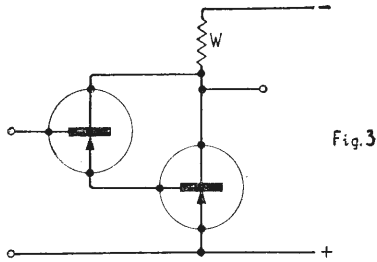

Fig. 3

Substitute a transistor for  $R_1$ , instead, and there appears the Darlington Pair in its stable form.

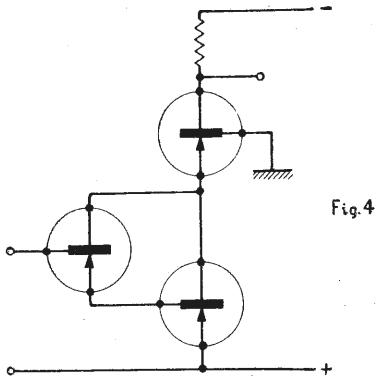

Fig. 4

Substitute *both* and there arrives that chamber-music ensemble, the "Darlington-Cascade Trio"!

Both have a high input impedance (especially 5(b)) and this is useful for r.f. purposes where the input may well be

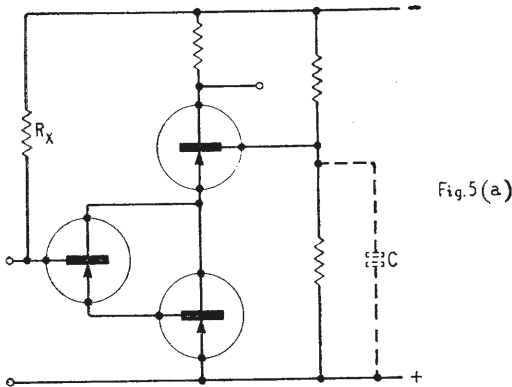

Fig. 5(a)

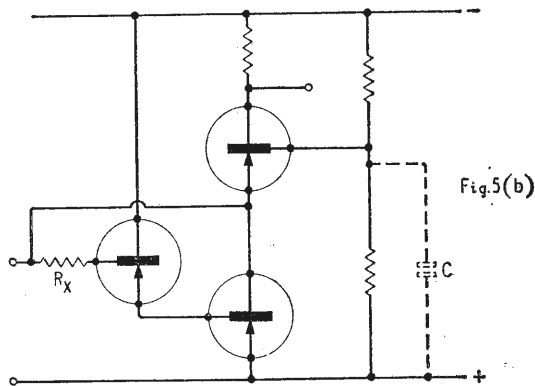

Fig. 5(b)

a tuned circuit that must not be damped too much. Gain is better than with a simple cascode (especially 5(b)) and although I have not had the opportunity of checking its band-width quantitatively, it gives, empirically good results and, minus  $C$ , might well give a fairly linear response.

Perhaps Mr. Butler will favour me with one of his scholarly analyses in a future issue of "W.W."

The value of  $R_x$ , by the way, needs a rather careful estimate, especially for the 5(b) configuration. In a practical circuit it is high, in the  $\frac{1}{2}M\Omega$  neighbourhood.

Nottingham.

D. B. PITT

## Transistor High-quality Audio Amplifier

THE surge of joy with which I read, in the article by Mr. Dinsdale (January issue), that the signal-to-noise ratio of a transistor amplifier could be improved by introducing a low resistance from the base of the first transistor to earth, was, I'm afraid, quickly damped. It is not true. It is true that the noise output from a transistor in common-emitter will usually decrease as the resistance from base to earth is decreased; but this resistance will inevitably attenuate the signal to at least the same extent. In the circuit of Mr. Dinsdale's Fig. 6(a), I estimate that the removal of the  $1k\Omega$  resistor (with appropriate adjustment of the frequency compensation) would improve the signal/noise ratio by about 10 dB.

This is not a serious criticism of the design, as the signal-to-noise ratio with the resistor included, assuming maximum output from the crystal pickup, should still be greater than 70 dB.

It is fairly safe to assume, in general, that for the highest signal-to-noise ratio (1) resistances in parallel with the signal path should be as large as possible. (2) resistances in series with the signal path should be as small as possible.

Such resistances would (a) attenuate the signal at least as much as they might reduce the noise output, and (b) introduce their own thermal noise.

Maxims (1), (a) are neatly illustrated by the examples in Mr. Johnson's letter in the same issue, in which the thermal noise of the resistances is evidently neglected. Maxims (1), (2), (b) are illustrated by the fact that with a low-noise valve such as the EF86 the thermal noise of resistors  $R_1$  and  $R_2$ , in Mr. Johnson's second example, would form the major part of the noise in the circuit, and the improvement due to changing  $R_2$  would be, not 17 dB, but about 10 dB.

The feedback, incidentally, has a negligible effect on the noise performance; the same figures would apply if the  $10M\Omega$  resistor were removed.

Accra.

F. HIBBERD

University of Ghana, Department of Physics.

## National Certificate Courses

IS it not time for the professional institutes and the Ministry of Education to take a more liberal attitude over the entry standards for the Higher National Certificate?

I speak for the thousands who drift into electronics with "A" level qualifications. Even with three "A" levels we still have to start at the beginning of the O.N.C. if we don't have the correct "O" levels.

In my case I have three "A" levels. I have been working in electronics for seven years and I earn £1,400 a year purely because of my knowledge of electronics. Yet I can't study for an H.N.C. I can get £16 per week grant if I study for an H.N.D., a Dip.Tech. or a degree, but it seems that an H.N.C. is in a more exclusive class.

The really annoying thing is that professional institutes accept the H.N.C. as an exemption for their intermediate examinations. This means technical colleges do not run courses for these intermediate examinations. Just to help things along, the professional institutes won't accept candidates who have not taken these non-existent courses. The last time I pointed this out I was informed that I could take an external degree to exempt me from part 1 of the Grad.Inst.P. examination.

London, N.W.5.

I. LESLIE



# ELECTRONIC LABORATORY INSTRUMENT

## 4.—MEASUREMENT OF ALTERNATING VOLTAGE AND CURRENT

IN any good electronics laboratory nowadays you will find a range of instruments for measuring alternating voltages and currents at frequencies from 10 c/s to 1,000 Mc/s. Such instruments, on whatever principle they work, pose two main problems for the user: how to check calibration easily, and how to avoid "waveform errors."

Calibration checking, as we saw in an earlier article, is not too difficult with d.c. measurements because d.c. standards of voltage and resistance (and hence current) are not too hard to come by. But no a.c. primary reference standards exist, and a.c. meters have to be calibrated from a d.c. standard by means of some "transfer instrument." Such an instrument responds equally to a.c. and d.c., so that readings for a.c. can be taken and compared with readings from a d.c. standard.

The other practical difficulty with a.c. measuring instruments is that readings can vary with the waveform of the applied signal. Depending on its principle of operation, an a.c. meter may have a response (i.e., give a reading) proportional to the average, the effective (i.e., r.m.s.) or the peak value of a signal. Most a.c. meters, however, are scaled to read the r.m.s. voltage of an assumed sinewave signal, irrespective of their real response law. "True r.m.s. reading" instruments (i.e., with an r.m.s. response law), should show a correct reading, whatever the waveshape. On the other hand, average-reading or peak-reading instruments, when scaled to read r.m.s., may display large errors if the waveform departs materially from a sinewave. In general, average-reading meters are likely to give more accurate "r.m.s." readings than peak-reading ones. It can be shown in theory that for average-reading meters the error may vary from -100% to +11%, and for peak-reading meters from -100% to +0%.

There you have, then, the two main practical difficulties that beset the measurement of alternating current or voltage—the difficulty of calibrating, and the difficulty of measuring non-sinusoidal waveforms. Keeping these in mind, you are now faced with the problem of "what to use to measure what?"

### A.C. Meter Types

Some a.c. meters primarily measure voltage, and others current. The distinction is not important, however, because you can always use a current meter to measure voltage by measuring the current through a series resistor, or a voltage meter to measure current by measuring the voltage drop across a shunt resistor.

Over the years, many different types of instruments have been used to make measurements of alternating voltage or current. Those which you may possibly come across in an electronics laboratory are:

(1) Dynamometer, (2) moving-iron meter, (3) rectifier meter, (4) thermocouple meter, (5) valve voltmeter, (6) digital voltmeter, (7) electrostatic meter, (8) oscilloscope, (9) a.c. potentiometer, and (10) heterodyne-mixer meter.

Of these ten types, you will find three used in almost

every laboratory: (3) rectifier meter, (5) valve voltmeter, and (8) oscilloscope. It is, however, useful to know something of the other types, particularly where the all-important problem of calibration arises. We will therefore take a look at all of them before we go on to the practical aspects of "ordinary" a.c. measurements.

### Dynamometers

The dynamometer (also known as the "electrodynamometer") is the basic instrument for a.c. measurements, just as the permanent-magnet moving-coil meter is the basic instrument for d.c. measurements. The dynamometer comprises a movable coil, with a pointer attached, suspended in the field of another fixed coil. The current to be measured passes through both coils in series and the deflection of the pointer indicates the value of current measured. The instrument responds to d.c. as well as a.c. and is therefore a basic transfer instrument for calibrating. It has an r.m.s. response, and the a.c. reading for any deflection can be checked by applying known d.c. to give the same deflection.

The main limitations of the dynamometer are:

(1) Not having a strong fixed permanent magnet, it is much less sensitive than the moving-coil meter, and its lower current limit tends to be in the mA rather than the  $\mu$ A region.

(2) While accuracies as high as 0.1% can be achieved with a precision dynamometer at frequencies up to a few hundred cycles per second, it is normally not of much use above 1,000 c/s since its accuracy falls off rapidly with rising frequency. (A special form of r.f. dynamometer has been developed for use into the r.f. range but



Fig. 21. Typical commercial example of a.c./d.c. dynamometer: Sangamo Weston S93 dynamometer-type ammeter.

# PRACTICE

By T. D. TOWERS,\* M.B.E., A.M.I.E.E., A.M.I.E.R.E.

it is not likely that you will come across this in the ordinary laboratory.)

Dynamometers you will meet are likely to come from one of the following firms: Cambridge Instruments, Elliott's, Pullin, Salford and Sangamo Weston. Fig. 21 shows a typical good example, the Sangamo Weston, S93 dynamometer type ammeter. With a guaranteed accuracy of 0.1 f.s.d. from 25 to 2,500 c/s and a maximum sensitivity of 1A f.s.d., this instrument has a 12-in scale, is magnetically shielded, has a self-contained thermometer, and is provided with a spirit-level and levelling feet.

## Moving-iron Meters

Another class of instrument widely used for a.c. measurements is the moving-iron meter (also called iron-vane meter). This comprises a single fixed coil and a soft-iron movable vane with a pointer attached to it. When current is passed through the coil, it deflects the iron vane and thus the pointer.

This meter responds to both d.c. and a.c. Its response to a.c. is r.m.s. Without a permanent magnet, sensitivity again tends to be low compared with a moving-coil meter—only about 10 mA at best.

As the moving system carries no current, the moving-iron meter can be used for measuring higher currents than the dynamometer. Also since the moving parts can be designed without considerations of current carrying, the meter can be more ruggedly constructed and is not so easily liable to damage by overload. Finally, because a wide range of instruments can be constructed with the same moving system merely by changing the coil, the moving-iron meter tends to be relatively inexpensive. In summary, moving-iron meters are cheaper, sturdier and less accurate than electrodynamic meters.

Eddy currents and coil inductances can cause frequency and waveform errors in moving-iron instruments. Ordinary voltmeters and ammeters of this type are calibrated at a single frequency, usually between 25 and 125 c/s. Compensated instruments are available also for use up to 2,500 c/s, but it is at mains frequency that the moving-iron meter is most commonly used.

The accuracy of a moving-iron instrument can vary from several per cent on robust portable units down to 0.5% on the best lab. standards.

Among the companies marketing moving-iron meters are Pullin, Salford, Sangamo Weston, Taylor, Turner and Weir. No illustration of a moving-iron meter is given, because they look externally very similar to the dynamometer types discussed immediately above.

## Rectifier Meters

Dynamometers and moving-iron a.c. meters generally are low in sensitivity, they load circuits unduly, and are limited in frequency response to a few hundred cycles

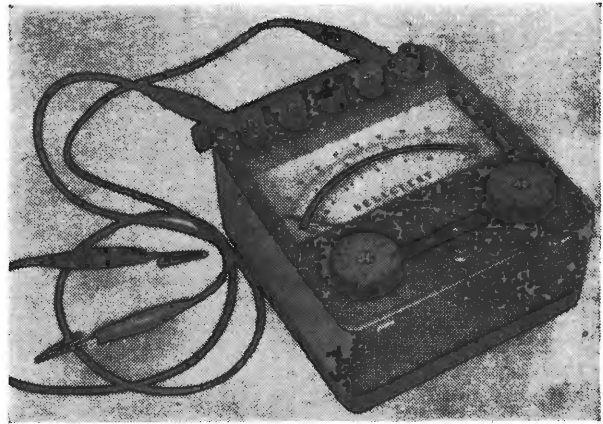

Fig. 22. Typical multimeter exemplifying use of rectifier meter arrangement in a.c. ranges: Salford Selectest 50.

per second. Improvement in these respects can be achieved by using the inherently more sensitive moving-coil d.c. meter in conjunction with an a.c. rectifier to produce the a.c. "rectifier moving-coil meter" or simply "rectifier meter."

The moving-coil meter indicates the average value of the rectified a.c. signal. Usually, however, the scale is calibrated in terms of r.m.s. for a sinewave. Measurement of non-sinusoidal waveshapes is accompanied by an error varying with the form factor (which was theoretically not present with the dynamometer and moving-iron meters).

Rectifier meters can be basically more sensitive than the others, and can be obtained with current sensitivities as high as  $100\mu\text{A}$  f.s.d. a.c. or with voltage sensitivities as high as 2.5V f.s.d. a.c.

The input impedance of the rectifier meter is about ten times higher than for dynamometers or moving-iron meters, typically 1,000 ohms per volt, compared with 100 ohms per volt.

The modern rectifier meter is reasonably accurate up to about 10,000 c/s as compared with a limit of 1,000 c/s for the other two types.

The B.S.I. Standard Specification No. 89/1954 for industrial grade portable moving-coil instruments specifies  $\pm 24\%$  f.s.d. on a.c. ranges. This is a little over twice as wide a tolerance as the d.c. specification for the same type of instrument. In practice, when an instrument has been in use for a little time, it is prudent not to expect much better than a 5% accuracy on an a.c. rectifier meter.

The main advantages of the rectifier meter are ruggedness, resistance to overloads, long life, small size and no requirement for external power supply. Its main disadvantages are that its accuracy is somewhat low except at normal room temperature and for low-frequency pure sinewaves. You should look on rectifier meters as excellent general-purpose instruments but not ideally suited to precision work.

The a.c. ranges of general-purpose multimeters use the rectifier meter basic arrangement. Rectifier meters are also available separately as single-purpose instruments. In a laboratory you may thus come across rectifier meters in instruments of such firms as Avo, Daystrom, Philips, Pullin, Salford, Sangamo Weston, Smith, Taylor and Turner. Fig. 22 illustrates one example in the well-

\* Newmarket Transistors, Ltd.



Fig. 23. Example of commercial a.c. thermocouple meter: Taylor "Clarity" Model 42.

known Salford Selectest Super 50 multimeter with an a.c. range of voltage down to 2.5 V f.s.d. and current down to 25 mA f.s.d.

### Thermocouple Meters

Another class of a.c. instrument which may be met with (although a little uncommon) is the thermocouple meter. In this, the current to be measured is passed through a thermocouple (or through a wire in close proximity to a thermocouple) and the resultant heat produces a thermal e.m.f. which is measured. Since it is the heating effect only which is significant, either a.c. or d.c. may be measured.

Such types of meters can cover from d.c. to 100 Mc/s, and find their principal use as transfer instruments from high frequency a.c. to d.c. The usual current ranges are from 3 mA to 300 A f.s.d. Accuracies are of the same order as other a.c. meters, i.e. about 2% for panel instruments, and up to 0.5% for the more expensive portable standard instruments when used in the lower frequency ranges.

A major disadvantage of the thermocouple meter is its susceptibility to overload damage. Permissible overloads range only from 50% to 200% at maximum.

Among the companies supplying thermocouple meters are Pullin, Sangamo Weston and Turner. Fig. 23 shows a typical example in the Taylor Clarity range with a f.s.d. of 100 mA capable of operation with  $\pm 2\%$  accuracy.

### Valve Voltmeters

Probably the commonest way nowadays to measure an alternating signal voltage or current in the laboratory is to use an a.c. valve voltmeter. Like the rectifier meter, this functions by rectifying the alternating signal and reading the result on a d.c. meter. The main difference is that the valve voltmeter uses amplification either by an a.c. amplifier before rectification or by a d.c. one after rectification.

Valve voltmeters can be used at low frequencies as an alternative to rectifier or other type meters, but they come into their own for higher frequency measurements. Instruments can be obtained to operate up to 1,000 Mc/s.

In the lower frequency ranges, the valve voltmeter has a very high input impedance, normally between 0.5 and 100 M $\Omega$ , typically 10-20 M $\Omega$ . Input capacitances as low as 1 pF are possible, but 20-30 pF is more usual. Generally the input impedance decreases considerably as the frequency rises.

Valve voltmeters are usually scaled in terms of r.m.s. Since the diode rectifier responds basically to peak voltage, errors can occur when non-sinusoidal waveforms are measured. The errors may be positive or negative and can vary in amount with the phase of the harmonic content of the measured waveshape. There is also a polarity effect in that the positive and negative peaks may not be equal. When very short pulses are measured, a very large error can occur. You should always look carefully at the reading of a valve voltmeter and consider whether the waveshape can have any significant effect on it.

Fig. 24 shows two good examples of commercial a.c. valve voltmeters in common laboratory use. (A) is the Marconi TF 2600 with 1 mV f.s.d. in its most sensitive range and a 5% accuracy bandwidth of 10 c/s - 5 Mc/s. (B) is the Advance VM78, which is transistorised. This, too, has a most sensitive range of 1 mV f.s.d. and a 3% accuracy range of 1 c/s-1Mc/s. Apart from Advance and Marconi, some other names in the a.c. valve volt-

(Continued on page 201)

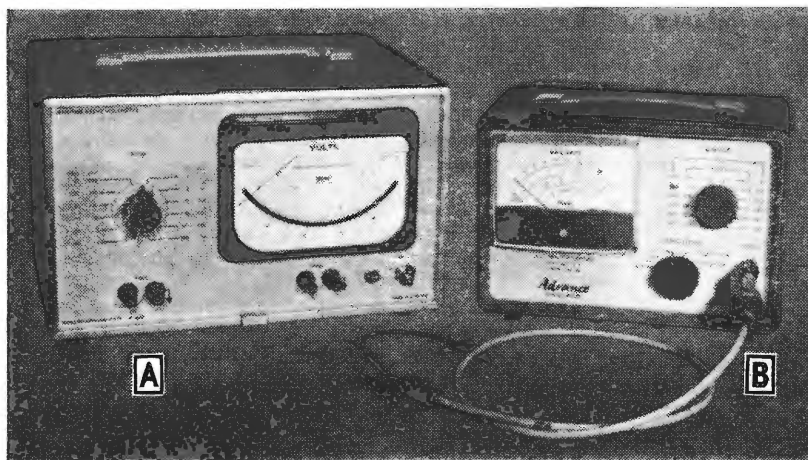

Fig. 24. A.C. valve-voltmeters: (A) Marconi TF2600; (B) Advance VM78 (transistorised).

meter field are Airmec, Avo, Dawe, Daystrom, Furzehill and KLB (Paco).

### A.C. Digital Voltmeters

The digital voltmeter (d.v.m.) is essentially a d.c. measuring instrument. However, by using an a.c.-to-d.c. converter, the d.c. d.v.m. can be turned into an a.c. one.

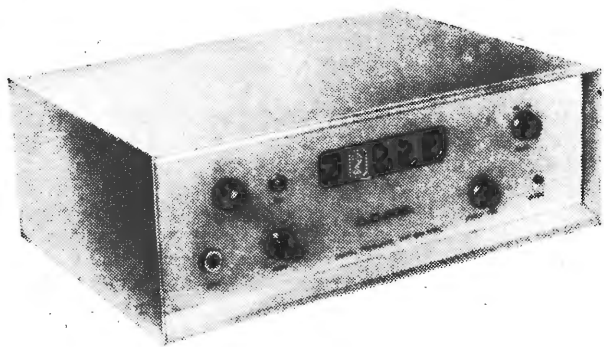

Fig. 25. A.C./D.C. digital valve voltmeter: Applied Developments 1055.

The converter can be a separate unit, or can be incorporated in the main d.v.m. to give the a.c./d.c. type of d.v.m. that is now becoming common. Fig. 25 illustrates a typical example, the Applied Developments Type 1055. Instruments of this type are capable of 0.3% accuracy on a.c., but for this order of accuracy are normally used only in the audio and supersonic frequency ranges. At reduced accuracy, or for accurate differential measurements, it can be used out to the megacycle range however. Other manufacturers supplying a.c. d.v.m.s are Digital Measurements, EAL, Gloster, Hewlett-Packard, Roband and Solartron.

### Electrostatic Voltmeters

Electrostatic attraction or repulsion forces are used in a type of instrument known as the electrostatic voltmeter. This is capable of measuring voltages, d.c. or a.c., up to megacycles, from millivolts to hundreds of kilovolts. As the d.c. and a.c. responses are alike when the meters are suitably constructed, they may be used as transfer instruments. With proper design they can also be used as primary standards in the measurement of high voltage.

Electrostatic voltmeters have high input resistances, often of the order of  $10^{15}$  ohms. On d.c. there is thus practically no current drawn. However, input capacitance causes a small current drain in a.c. instruments, and this is the limiting factor in the upper frequency range.

The full-scale deflection in commercial units can be as low as 120V or as high as 100kV. One practical point is that the input capacitance tends to increase with deflection and can range from a few picofarads up to several hundred.

A good commercial example of the electrostatic voltmeter, the W. G. Pye Type 11314, is illustrated in Fig. 26. This instrument gives direct readings of up to 40kV, d.c. or r.m.s. a.c., with an absolute accuracy of

$\pm 10\%$  full-scale deflection, regardless of waveform. When special mounting precautions are taken the accuracy of comparative readings can be of the order of 0.1% and the d.c./a.c. transfer characteristic even better. It finds particular application in measuring the high voltages encountered in work on cathode-ray tubes.

### Oscilloscopes

The oscilloscope can be used for measuring alternating voltage and current. It has the basic advantage that the waveform can be seen and consequently waveform errors estimated.

The usual method of measurement is to apply the voltage to be measured at the Y-amplifier input terminals. Where the oscilloscope has been calibrated at its main sensitivity control, the peak voltage can be read immediately. Oscilloscopes afford the most accurate method of making true pulse peak measurements.

Calibration can be by means of an a.c. signal source of known amplitude operating within the known bandwidth of the signal of the oscilloscope, or by a known d.c. voltage. The more common method is the d.c. approach, where you apply a known d.c. to the Y-amplifier (direct coupled) and note the vertical shift difference necessary to return the trace to its original position. You then apply the a.c. signal to be measured, and measure the peak-to-peak voltage by Y-shift on the calibrated shift control. Cathode-ray tubes can be used as precision transfer instruments.

Instead of calibrating by comparison, a slide-back technique may be applied with a d.c. 'scope. This uses a variable d.c. source in series with the unknown voltage to bring the peak deflection back to the zero point.

A.c. measurements on an oscilloscope can be accurate over the frequency range of the Y-amplifier. The oscilloscope can be used beyond these limits but separate calibrations will have to be made at the frequencies to be measured.

We have been discussing so far the measurement of alternating voltage signals on the oscilloscope, but clearly current may be measured by shunting the oscilloscope input with a known standard resistor.

In standard oscilloscopes, the input impedance is generally greater than  $1M\Omega$ , making it possible to measure alternating voltages in circuits of fairly high impedance. The input impedance of the oscilloscope

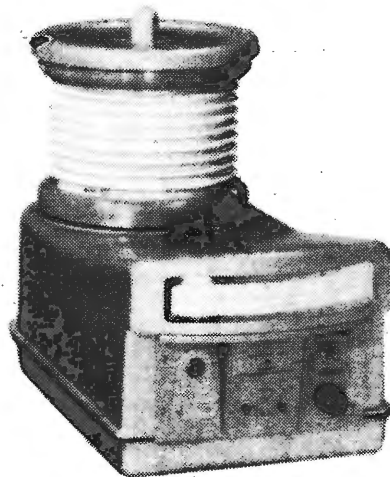

Fig. 26. Commercial electrostatic a.c./d.c. voltmeter: W. G. Pye 11314.

can be much greater if the signal is applied directly to the deflection plates rather than to the amplifier input.

### A.C. Potentiometers

In a.c. work the potentiometer is not as widely used as in d.c. work for the accurate comparative measurement of voltage. This is because in the a.c. case it is necessary to balance phase as well as magnitude, to take stray pick-up and coupling into account, and to consider the effect of harmonics on one or other of the voltages being compared. Also, for a.c. there is no standard voltage source for reference corresponding to the d.c. standard cell. Generally a transfer technique has to be applied to establish an a.c. reference voltage. Despite these difficulties, however, a.c. potentiometers are available commercially. A good example of this is the Cambridge Instruments A.C./D.C. Comparator illustrated in Fig. 27. This is designed to measure r.m.s. value of currents and voltages to an accuracy of  $\pm 0.05\%$  over a frequency range of 25c/s to 20kc/s. The instrument contains its

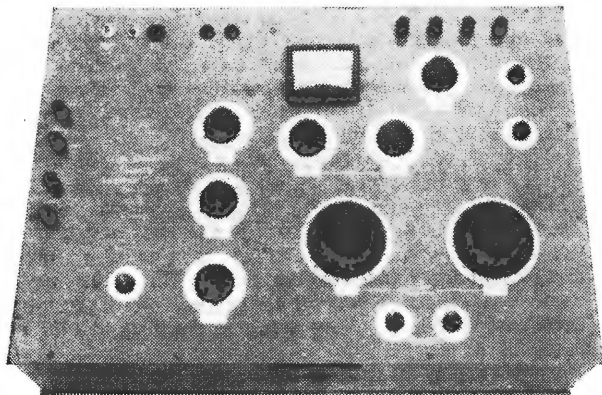

Fig. 27. AC/DC potentiometer: the Cambridge Instruments AC/DC Comparator.

own potentiometer circuit, and the only external units required are a standard cell and a suitable reflecting galvanometer. A meter is incorporated so that the approximate value of the unknown signal can be determined before the setting of the controls. This reduces the probability of overloading the vacuo-junction which is used as an internal a.c./d.c. transfer standard. The comparator has eight voltage and current ranges from 0.5V to 300V full scale and from 5mA to 300A respectively.

### Heterodyne-mixer Meter

A linear mixer can be employed to reduce measurements over a range of high frequency to measurements at a single low frequency. A known fraction of the unknown signal is applied to a mixer together with an auxiliary local-oscillator signal of a much greater magnitude. The resulting intermediate frequency passes through a standard attenuator to a meter. A single calibration point is established at each frequency by feeding a known signal into the input. Provided signal linearity is maintained by keeping the unknown signal sufficiently small,

the change in attenuation necessary to keep the meter at its reference level is an indication of the desired measurement value. The heterodyne-mixer type of a.c. meter is not commonly used in ordinary laboratories.

### Special Problems of V.H.F. and U.H.F. Measurements

In general the measuring instruments described so far have been primarily for frequencies below 150 Mc/s. Above 150 Mc/s difficulties creep in. In the v.h.f./u.h.f. range, voltages and currents often have to be measured in tuned circuits, and it becomes extremely difficult to make measurements without disturbing the circuit unduly. Apart from this, circuit elements can no longer be treated as lumped, so that it becomes difficult to locate two specific circuit points across which a voltage, for example, can be measured. Because of this, you very often find that at v.h.f. and higher frequencies you do not make a voltage or a current measurement so much as a power measurement. The power measurement is usually made by looking at the temperature rise in some indicator due to the dissipation of the r.f. power. This implies the use of some thermal meter such as a thermocouple unit.

The other major difficulty is that at v.h.f. and higher frequencies, the input impedance of the meter becomes complex and varies with frequency; this can lead to calibration difficulties.

Some specially developed versions of the basic instruments referred to earlier for lower frequencies have been developed to operate into the v.h.f. range. In general, however, in the normal laboratory, voltage (and derived current) a.c. measurements above 150 Mc/s or so are normally made with some form of valve voltmeter, at least up to 1,000 Mc/s. Above 1,000 Mc/s the field becomes very specialized and bolometer or other thermal-type meters are normally used.

### Practical Points on the Use of A.C. Meters

- (1) Always follow the "good-practice" precautions for instruments generally outlined in previous chapters. In a.c. measurements some of the precautions take on a special importance, however. For example, always look extra carefully to the earthing of the equipment under test and the measuring instrument. Earth loops can easily give rise to inaccurate readings, particularly at radio frequencies.
- (2) Watch out for mains hum or other spurious frequencies getting on to the signal you are testing. Mains hum is particularly difficult at very low level a.f. measurements, i.e. in the millivolt r.m.s. region.
- (3) Always adopt some standard procedure in recording measurements. Do not use r.m.s., average, peak, peak-to-peak interchangeably at random. Over the years I have built up a consistent habit of recording the signals for linear amplifiers in terms of r.m.s. (i.e. in effect assuming a sinusoidal waveshape), and for non-linear circuits (pulse, or large-signal sinewave with some clipping) in terms of peak (i.e. half peak-to-peak) because this can be read off so easily from an oscilloscope.
- (4) Always consider the frequency of the a.c. signal you are measuring, and check that it falls within the specified bandwidth capabilities of your measuring instrument. A common failing in this is to try to measure signals at say 10 Mc/s with a valve voltmeter not capable of accurate measurement over say 1 Mc/s. This may seem very elementary, but it is surprising how often you



find quite competent bench engineers doing this without thinking.

(5) At r.f. always look to see that the circuit disturbance introduced by your measuring instrument is fully taken into account.

(6) Where you are using an instrument, such as an Avo multimeter, with floating input, i.e. with no specified earth terminal, always as a precaution reverse the leads and take a second reading. If this does not agree with the first reading, something is wrong. This is a useful practical step which soon becomes a reflex action with a good engineer. It is just another illustration of always trying to cross-check everything you do.

(7) Where you are trying to measure the voltage or current of an unknown waveshape, try if possible to display it on an oscilloscope at the same time, so that you can interpret the meter reading properly.

(8) Don't rely on the mains voltage to help you with calibrating an a.c. instrument except as a rough check. Nowadays, a nominal mains voltage of 230 V a.c. can lie at any time anywhere between 200 and 250 V. It is not uncommon to find the mains even lower than 200 V on occasion.

(9) Don't forget that a multimeter in its a.c. range has a certain d.c. input resistance. It is not capacitor-isolated and so may affect the d.c. bias conditions of the circuit being tested. This is important in the new-generation direct-coupled audio power amplifiers. Always look to see if you should d.c.-isolate the meter in its a.c. ranges by means of a large coupling capacitor. In other terms, don't forget that if a multimeter in its a.c. range is connected into circuit with a standing d.c. voltage on it, the a.c. meter reading can be inaccurate because of the spurious d.c. imposed.

---

## BOOKS RECEIVED

**Transistor Ignition Systems Handbook**, by Brice Ward. A short, down-to-earth American text, including a good deal of material on commercial systems already in use in the U.S.A. but with a sufficiently general treatment to interest the British reader (who is warned of possible dangers in a British foreword). Pp. 128. W. Foulsham & Co. Ltd., Yeovil Road, Slough, Bucks. Price £1.

**Simplified Modern Filter Design**, by Philip R. Geffe. Nearly half of this 182-page book consists of tables and associated diagrams, compiled to enable the circuit engineer to design filters without the use of higher mathematics. In addition to the usual filter configurations, the book describes measurement techniques and the design of practical high-Q inductors. Published in Great Britain by Iliffe Books Ltd., Dorset House, Stamford Street, London, S.E.1. Price £2 10s.

**Wireless for Beginners**, 5th edition, is an old book (by C. L. Boltz and first published in 1933) completely revised by Thomas Roddam, who is well known to *Wireless World* readers. The original material on television has been expanded and includes colour television. Transistors, sound reproduction and frequency modulation are dealt with. Pp. 232. George G. Harrap & Co. Ltd., 182 High Holborn, London, W.C.1. Price 18s.

**Automatic Voltage Regulators and Stabilizers**, 2nd edition, by G. N. Patchett, Ph.D., B.Sc.(Hons. Lond.), M.I.E.E., M.I.R.E., M.Brit.I.R.E. New material on the Zener diode, transistor circuits, tap changers on large power transformers and alternator voltage regulators has been added to the original text, first published in 1954. There are now 80 pages of references, indexed! Pp. 468. Price £3 5s. Sir Isaac Pitman & Sons Ltd., Pitman House, Parker Street, Kingsway, London, W.C.2.

**Writing Technical Reports**, by Bruce M. Cooper. A Pelican paper-back, drawing on the author's experience of conducting report-writing classes for scientists and engineers. Numerous extracts from typical reports are provided and analysed, and there is a section on illustrating technical writing. Pp. 188. Penguin Books Ltd., Harmondsworth, Middx. Price 3s 6d.

**Elementary Particles**, by A. A. Sokolov. English translation of a short Russian guide to the more recently identified elementary particles, their prediction and discovery (the positron, nucleons and pions, the neutrino, muons, resonons, etc., together with the various anti-particles). Pp. 75. Pergamon Press Ltd., Headington Hill Hall, Oxford. Price 10s.

**Introduction to Semiconductor Devices**, by M. J. Morant, B.Sc.(Eng.), Ph.D. Intended to bridge the gap between applications books and books on pure semiconductor physics. This concise work (pp. 126) is about equally divided between the physics of the subject and semiconductor devices considered as active elements of electrical networks. Level: second year of a degree course in electrical engineering. George G. Harrap & Co. Ltd., 182 High Holborn, London, W.C.1. Price 18s.

**Gas-Discharge Tubes**, by H. L. van der Horst. A comprehensive review of the most important tubes in common use, intended to assist technicians in application problems. Some of the tubes described are now being superseded by semiconductor devices, but others, such as counter and indicator tubes and mercury vapour rectifiers, are still in wide use. Pp. 318. Philips Technical Library. Distributed in U.K. and Eire by Macmillan & Co. Ltd., 10-15 Martin's Street, London, W.C.2. Price £2 17s 6d.

**ABC's of Boolean Algebra**, by Allan Lytel, explains symbolic logic and how electronic circuits perform logical functions. The translation of algebraic expressions into practical switching circuits is dealt with, and numbering systems are discussed in order to explain how logic circuits can be combined to perform calculations. Pp. 112. W. Foulsham & Co. Ltd., Yeovil Road, Slough, Bucks. Price 16s.

**Design of Low-Noise Transistor Input Circuits**, by William A. Rheinfelder. The first half of the book discusses the general characteristics of noise, the noise factor concept and measurement of noise figure, while the second half deals with the design of particular classes of circuits: above 100 Mc/s; receiver front ends below 100 Mc/s; and audio circuits. Pp. 160. Published in Great Britain by Iliffe Books Ltd., Dorset House, Stamford Street, London, S.E.1. Price £1 10s.

**Elementary Electrical Network Theory**, by D. G. Tucker. Professor Tucker excuses himself for producing yet another book on network theory by pointing out that this is a small one (pp. 169) which aims to provide all the theory required by a student in the first two or three years of a university course or in a course for a professional qualification. An introduction to non-linear circuit theory is included. Price 17s 6d. **Linear Network Theory**, by K. F. Sander is rather more advanced, covering network analysis as taught in the last years of an honours degree course. Again small (pp. 164), it concentrates mainly on the algebra. Price £1 1s. Both from Pergamon Press Ltd., Headington Hill Hall, Oxford.

# Audible Rate-of-Climb Indicator

SIMPLE ELECTRONIC DEVICE FOR GLIDER PILOTS

By J. M. FIRTH

It has been recognized for some time that it is undesirable that a glider pilot should spend a great deal of his time concentrating on his instruments; he should be looking out for other aircraft. His most important instrument is a sensitive rate-of-climb meter, or variometer, usually electrical, working on a hot bead principle.\*

A typical circuit is shown here, Fig. 1. The thermistors Th 1 and Th 2 are heated by the current in them. Air flowing into or out of a Thermos bottle, due to the

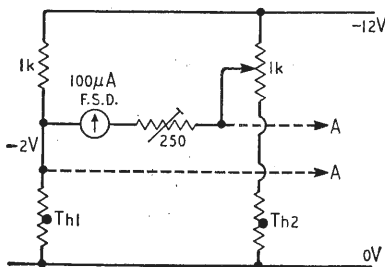

Fig. 1. Basic "variometer" or rate-of-climb meter circuit.

pressure change with rise or fall, is directed by small jets over one thermistor or the other, hence giving an up or down reading on the meter.

A recent improvement has been the addition of an audio circuit producing a varying tone with pitch proportional to the meter reading, above a certain threshold. The pilot can set the threshold to bring in the audio

\*See, for example, "The Electric Variometer," by P. G. Davey, Technical Papers of OSTIV (Organisation Scientifique Internationale du Vol à Voile), June 1961.

circuit at any desired rate of climb, thus relieving him of the need to glance at the meter frequently.

There must be many other fields in which this device might be of use, e.g., coupled to an electrical r.p.m. meter, and generally in any situation where an electric meter presents continuous information.

The circuit shown in Fig. 2, for a glider variometer, can be easily modified to accept different input levels. It can be constructed using cheap transistors and no special components.

The first stage is a long-tailed pair, with emitter resistors to raise the input impedance and stabilize the gain. It was designed to be driven fully by the voltage across the meter. Other input circuits are suggested later.

Tr3 and Tr4 are current sources driven by the first stage. They feed current to the bases of Tr5 and Tr6 which form an astable/bistable multivibrator. No output will be produced from this stage until the signal is large enough to turn on Tr3 and Tr4. Tr6 drives the output stage directly.

The threshold is set by RV<sub>1</sub>, and RV<sub>2</sub> is a simple volume control which, used in series in this way, gives a saving in current when the volume is turned down. An ordinary cheap headphone can be used as the loud-speaker. This makes quite enough noise in a glider cockpit on a 12 V supply.

In this circuit the oscillation starts at 300-400 c/s and continues up to 8-10 kc/s at the top of the useful range. Tr1, Tr3, Tr5, and Tr6 can all be low-frequency, small-signal germanium types, with the proviso that Tr5 and Tr6 must be able to support a reverse base bias equal to the supply. If Tr6 is chosen to have a higher  $\beta$  than Tr5, Tr6 will normally be bottomed in the quiescent

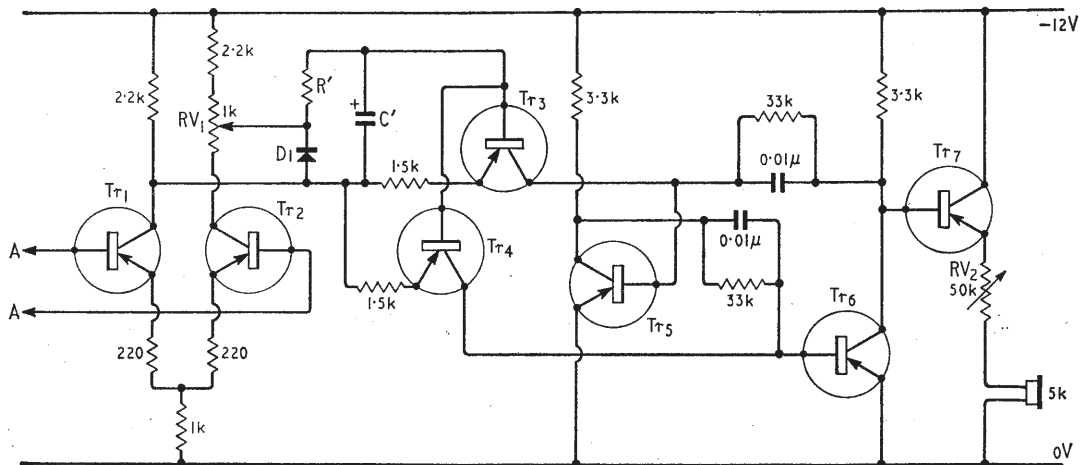

Fig. 2. Transistor tone generator circuit.

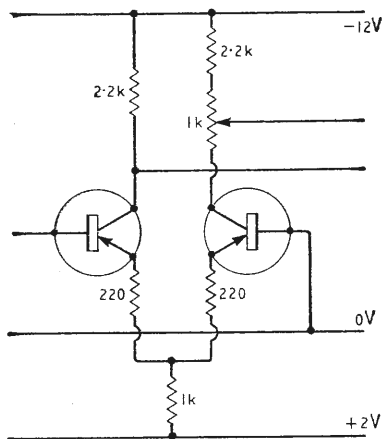

Fig. 3. Modified circuit for inputs varying about, or just above the 0V line.

state, and Tr7 will draw no current. Tr3 and Tr4 must be silicon n-p-n types, but can have quite low  $\beta$ 's. Tr7 does not dissipate much power, as it is switched hard on and off, but it must have an adequate current gain at full working current. Again, it can be a low-frequency germanium type.

More gain can be obtained from the first stage at the expense of lowering the input impedance, by decreasing the emitter resistors, but care must be taken to leave Tr1 and Tr2 with sufficient working collector voltage.

Fig. 3 shows how the input circuit can be modified to accept an input which varies about, or just above, the 0V rail. Fig. 4 indicates how one might eliminate the +2V rail, but can only be used where the source provides an

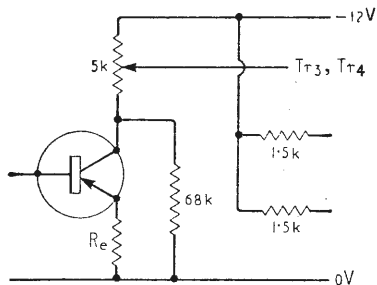

Fig. 4. Alternative circuit for inputs about 1V with respect to earth.

input of about one volt as the knee voltage of the transistor must first be overcome. The 68k $\Omega$  resistor provides a little forward bias for the second stage. With the above disadvantage goes those of poor initial linearity and large temperature drift. However, this circuit may be suitable for use with a car r.p.m. meter, where one side of the meter is probably grounded.

A word of caution here; many frequency indicating devices such as the r.p.m. meter, supply the meter with pulsed current, and the audio circuit may not cope with this, or may produce an objectionably modulated output. The addition of C' and R' shown in Fig. 2 will overcome this. With RC=0.1 sec, suggested values are R=10k $\Omega$  and C=10 $\mu$ F. D1 prevents the electrolytic capacitor from being reverse biased.

The circuit can be used with other supply voltages, but the 0.01 $\mu$ F capacitors may have to be changed to give acceptable audio frequencies.

I shall be interested to hear of other uses which *Wireless World* readers can find for this device.

## BRITISH BROADCASTING 1927-1939

**The History of Broadcasting in the United Kingdom: Vol. II.—The Golden Age of Wireless.** By Asa Briggs. Pp. 663+xvi; 54 illustrations. Oxford University Press, Amen House, Warwick Square, London, E.C.4. Price 75s.

This volume of Professor Briggs's monumental history covers the period from 1927, when the British Broadcasting Company became the present Corporation, to the outbreak of war in 1939. During that epoch receiving licences rose from some two million to nine million. The B.B.C. was in process of consolidating itself into a national institution.

Though there is some emphasis on internal organization and policies, everything is covered—programme analyses and listener surveys, overseas broadcasting, the beginnings of television and preparations for war, with just enough of the technical background to help the story along as each development arises. Everything is fully documented and the history derives unique authority from the fact that the author had access to Lord Reith's diaries and private papers. Now we need no longer guess as to what really happened: Reith was Director-General for practically the whole period and played a dominant part in every important event. Naturally and properly, he overshadows the book.

Almost as soon as the possibilities of shortwaves for world-wide broadcasting became evident in the 1920s, accusations were levelled against the B.B.C. of dragging its feet in failing to set up a service of what was then called Empire Broadcasting. Criticism would have been largely disarmed had all the obstacles been fully known at the time. Money was one of the major troubles; the Dominions and colonies were not enthusiastic about contributing to the cost while the home government did not take kindly to the idea of the

British taxpayer footing the bill. Reith objected in principle to the use of British listeners' money for the service. In 1930 he wrote in a private memorandum: "We are likely to be left with the baby to carry because everybody else is too selfish and we are too decent to let it drown." At that stage he was finding the Post Office unhelpful but later got its blessing and in 1932 a regular service was started from the multiple transmitter at Daventry. "The design of a broadcasting station to give effective world-wide coverage was a new concept."

The story of experimental 30-line television transmission (from 1929 to 1935) is largely one of protracted triangular negotiations between Baird interests, the B.B.C. and the Post Office, made still more involved by "the publicity seekers with whom Baird was to have so many complicated dealings" when television moved into the arena of high finance and speculation. When higher-definition television came on the scene the situation developed into a more straightforward contest between Baird's mechanical system and the "all-electronic" Marconi-E.M.I. Clearly, the B.B.C. and the Post Office as umpire were still making an effort to give Baird every chance. But the issue did not remain long in doubt; as Campbell-Swinton had forecast decades earlier, the "weightless cathode rays" were bound to win.

One could wish that someone with Briggs's powers of detachment, industry and ability to ferret out sources of information had arisen to write a history of the earliest days of radio communication in, say, the mid-1930s—when many of the pioneers were still alive, before records were destroyed and late enough to get the story in perspective.

H. F. S.

## The Case of the Micromin Ostrich

**O**NE of the precepts which I learned at my mother's knee—or perhaps it was some other low joint—runs as follows:—

"If you can keep your head when all around you are losing their's—perhaps it's because you just don't understand the situation?"

Now, be it far from me to suggest that this is the reason behind the British electronics industry's attitude towards microelectronics. Perhaps it's a superb example of stiff upperlip manship or—horrible thought—the hypnotized immobility of a rabbit when confronted by a weasel. Whatever the cause, it seems to be remaining incredibly calm about the economic implications behind the advent of the new technology.

These thoughts stem from a point I tried to make last month, namely that microelectronics is not just another step towards the ultimate in miniaturization, but a brand new process of manufacture which owes nothing to the conventional art of making and assembling components. Its adoption demands completely different plant, completely new categories of engineering and completely new thinking.

Our industry has evolved over the years on a sort of twin-tub basis comprising two complementary units, equipment manufacturers and component manufacturers. To change the simile abruptly, this *mariage de convenance* has been established for a very long time, and the partners, despite the inevitable domestic tiffs, have been tolerably happy, with never a thought of separation, much less divorce, entering their heads.

But recently the plot has thickened. Enter the villain, microelectronics, to make a triangle of the situation; a triangle with a difference, however, because the interloper is, so to speak, bi-sexual, and is dallying with both partners.

This character, microelectronics, is fast becoming irresistible. To descend to our own terminology he/she is offering a considerable increase in equipment reliability and the mass production of circuits (as distinct from discrete components) in a shorter space of time and from a smaller manufacturing area. And as a dowry, these circuits come in a very small size; a feature which the computer and avionics boys (among others) are prepared to give their right arms for. All this at a cost which promises to be highly competitive.

One of the potential crises in all this is that in the micromin world the manufacturer of discrete components vanishes in a puff of silicon dioxide as soon as integrated circuits are mentioned. Or, rather, he and the equipment designer suddenly fuse into one. The 64,000 dollar question here is, in which camp is this composite being to pitch his tent?

There is much to be said on either side; no doubt it will be said in due course and the sooner the better, for the ostrich attitude never got anybody anywhere.

In default of concerted action, three individual courses are possible. One is that the equipment manufacturers turn out their own microcircuits (this is in fact already being done on pilot scales). If this becomes general, then the components industry will lose a lot of business, thereby finding itself in the middle of a large creek with no paddle and a hole in the bottom of the canoe.

Secondly, the converse could materialize, with the components industry making microcircuits for offer to the equipment people (again, this is already being done). But any mass attack will surely be mounted over the dead bodies of the equipment circuit designers, who regard it as a Divine Right of Kings to exercise absolute control over each and every individual component which goes into their designs.

The third potential course (and alas! only too possible) is the good old British compromise in which everybody makes microcircuits, the components people have a stab at the

equipment market and the devil takes the hindmost. This would be an admirable way of squandering time, money and effort and of killing the entire industry stone dead in one fell swoop.

The advent of microelectronics is, in a sense, phase two of the transistor breakthrough, so might not its introduction be as orderly as that of the transistor? It might, but the two events are not wholly comparable. The invention of the transistor did not threaten the stability of the two-partner set-up; moreover, the higher price of transistorized equipment put an effective brake on the speed of changeover. Micromin could gather momentum much faster by being cheaper.

True, micromin techniques can't be used in all equipment, and so the equipment manufacturer who offers a diversity of products—and particularly large capital goods—it likely to experience a gradual transition over the years, with some departments in which micromin may never encroach. This in turn would ease the situation somewhat for the components people.

But the big boys are better able to look after themselves anyway. It is the little boys we have to worry about, and particularly those who market a small range of products which happens to make ideal micromin material. Even supposing that their pockets are deep enough to dig into for the very expensive new plant, they cannot reorganize overnight; neither can they immediately switch to the "new thinking" engineering which micromin demands. What will they do when such competitors as the U.S.A. and Japan launch into the field on a vast scale, as they are likely to do any moment? One thing is sure; if they do nothing they will cease to be competitors.

Has there been an all-out effort by the various electronics associations to resolve such problems? And if not, why not? This is not an idle question because upon the answer may depend the matter of whether you and I make a down payment for an electric lawnmower this spring or whether we have to hock the old one.

On the face of it, quite apart from the overall problems, the outlook for engineers seems mixed. The chap who will probably be best off in micromin is the newcomer from University with a mind relatively uncluttered by conventional techniques. The older engineer who has lived by conventional techniques for years may find the change more than a bit of a jolt, while those who firmly maintain that there's nothing to touch the thermionic valve will be well advised to rub their rabbit's foot and pray that micromin won't touch their sphere of activity until after their retirement.

For, no doubt about it, a micromin outlook has to be developed. The overall field of knowledge has to be very wide; in the U.S.A. there is a school of thought which says that the man who dreams up a project should design it and take it right through production, only stopping short of actually posting it to the customer.

With integrated circuits layout and breadboarding as discrete operations are certainly abolished. And design approach is different, too. You can't take a conventional circuit and micromin it, because present limitations make it necessary to "design out" as far as possible items that can't be coped with (line inductors and large capacitors). And it is not enough to design. It has to be done with a much more careful eye on the economics of the thing.

I could go on, but the Editor insists that I mustn't be exclusively depressive. So let's end on a bright note. It looks as if there will be a lot more girls around the industry when microelectronics really get going; which is another very good reason why the industry should get down to some solid co-operative planning without further delay.

## Commercial Literature

### Signal Generator Comparison Chart.

—A comparative list of signal generators operating below 100 Mc/s has been compiled by Marconi Instruments from the published literature of various manufacturers. Sixteen generators are included on this chart, which is available on request. Many technical details are given along with price guidance, dimensions and weight.

4WW 324 for further details

**Broadcast Equipment.**—Two items of transistor equipment that should interest broadcast engineers—an equalizer and a video amplifier—are described in new leaflets available from the broadcast and recording division of EMI Electronics Ltd., of Hayes, Middx. The equalizer (Type 920, leaflet No. B/920/2) is a twin-channel unit and the response at both ends of the frequency range can be lifted or lowered, and a peak can be introduced towards the centre of the range. The video amplifier (Type 254, leaflet No. B/254/2) contains two independent amplifiers, each of which provide two isolated 75-ohm outputs. Sync pulses can be added to one or both outputs of each amplifier.

4WW 325 for further details

Literature describing transistor heat sinks made by the D.T.V. Group, and others for which they are representatives, is now available from the Group's headquarters, 126 Hamilton Road, West Norwood, London, S.E.27.

4WW 326 for further details

**Resistor Measurement.**—Two new application bulletins, one covering the measurement of standard resistors with a differential voltmeter (AB-1) and the other covering the measurement of megohm resistances with a differential voltmeter (AB-2), have been published by the John Fluke Manufacturing Company Incorporated. Both of these are available in the U.K. from Livingston Laboratories Ltd., of 31 Camden Road, London, N.W.1.

4WW 327 for further details

Issue three of the precision resistor chart published by Alma Components Ltd., is now available from the company's headquarters in Park Road, Diss, Norfolk. Alma's "J" range of loose wound resistors and their metal film resistors are included in this edition.

4WW 328 for further details

**Counter Details.**—Circuit details of the Type TF2401 along with the facilities this electronic counter can offer are included in a publication Marconi Instruments have produced for this eight-digit, all transistor counter. The company's address is St. Albans, Herts.

4WW 329 for further details

**Scattering Calculations.**—A leaflet describing how electromagnetic scattering by bodies of any shape can be determined accurately by digital computer programmes developed by TRG Incorporated is now available from the instrument division of Claude Lyons Ltd., of 76 Old Hall Street, Liverpool 3.

4WW 330 for further details

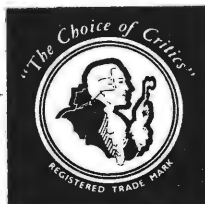

## THE HOUSE OF BULGIN AT YOUR SERVICE

### A SMALL SELECTION FROM OUR LARGE RANGE OF INSTRUMENT KNOBS

Made to the highest standards and finish in high gloss black and other coloured thermo-setting materials. Heavy, non-rotatable brass inserts with grub or Allen screws. Standardised by many leading instrument manufacturers.



List No. K.495



List No. K.432



List No. K.435



List No. K.430

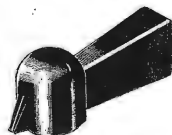

List No. K.390



List No. K.421

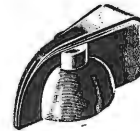

List No. K.107



List No. K.442



List No. K.424



List No. K.491



List No. K.503



List No. K.500



List No. K.464



List No. K.400/Skirt

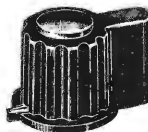

List No. K.462

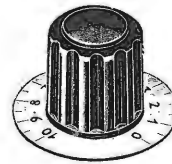

List No. K.463/Dial



List No. K.465



List No. K.463

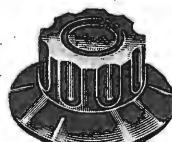

List No. K.438

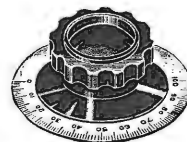

List No. K.402/S/D



List No. K.482



List No. K.370 + K.372 Dial



List No. K.436

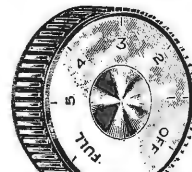

List No. K.473

Send for Brochure No. 1500/C

Illustrations approx. two-thirds full size.

**A. F. BULGIN & CO. LTD.,**  
Bye Pass Rd., Barking, Essex.  
Tel: R1Ppleway 5588 (12 lines)

MANUFACTURERS AND SUPPLIERS OF RADIO  
AND ELECTRONIC COMPONENTS TO

ADMIRALTY	MINISTRY OF WORKS	B.B.C.
WAR OFFICE	MINISTRY OF AVIATION	G.P.O.
AIR MINISTRY	MINISTRY OF SUPPLY	I.T.A.
HOME OFFICE	RESEARCH ESTABLISHMENTS	N.P.L.
CROWN AGENTS	U.K.A.E.A.	D.S.I.R.

4WW-114 FOR FURTHER DETAILS.



# APRIL MEETINGS

*Tickets are required for some meetings; readers are advised, therefore, to communicate with the secretary of the society concerned.*

## LONDON

1st. I.E.E.—“Ranger 8 spacecraft, with special reference to moon-shot camera systems” by B. P. Miller at 5.30 at Savoy Place, W.C.2.

5th. I.E.E. & I.E.R.E.—Colloquium on “The design of real time computer systems” at 2.30 at Savoy Place, W.C.2.

6th. I.E.E.—“The future impact of integrated circuitry on the work of professional engineers” by Dr. J. T. Kendall at 5.30 at Savoy Place, W.C.2.

7th. I.E.E.—“The mode of use and the assessment of precision coaxial connectors” by I. A. Harris at 5.30 at Savoy Place, W.C.2.

7th. I.E.R.E.—Papers on “Inertial navigational systems for airborne & shipborne uses” at 6.0 at 9 Bedford Square, W.C.1.

8th. Radar & Electronics Assoc.—“The big screen—film has a future in radar & electronics” by C. Barwell at 7.0 at the Mullard Theatre, Mullard House, Torrington Place, W.C.1.

8th. Television Soc.—“Advanced television technical problems in Japan” by Dr. K. Suzuki at 7.0 at the I.T.A. 70, Brompton Rd., S.W.3.

9th. I.E.E. & I.E.R.E.—Discussion on “Electromyography” at 2.30 at Savoy Place, W.C.2.

12th. I.E.E. & I.E.R.E.—“Solid circuits in computers” by N. Miller at 5.30 at Savoy Place, W.C.2.

13th. I.E.E.—Colloquium on “Problems and developments in electron linear accelerators and associated radio-frequency valves” at 2.30 at Savoy Place, W.C.2.

14th. I.E.E.—“Acoustics and telephone transmission—examples of the problems of human judgement” by H. S. Leman at 5.30 at Savoy Place, W.C.2.

14th. I.E.R.E.—“B.R.E.M.A. colour television home viewing tests” by R. N. Jackson, K. E. Johnson & B. J. Rogers at 6.0 at London School of Hygiene & Tropical Medicine, Keppel Street, W.C.1.

21st. I.E.R.E.—“Effect on the ionosphere of nuclear explosions” by F. L. Hill, at 6.0 at the London School of Hygiene and Tropical Medicine, Keppel Street, W.C.1.

26th. I.E.E.—“Standards and converters” by P. Rainger and E. Rout at 5.30 at Savoy Place, W.C.2.

28th. I.E.R.E.—“Synchronously tuned methods of harmonic and intermodulation distortion analysis” by D. E. O’N. Waddington at 6.0 at 9 Bedford Square, W.C.1.

29th. I.E.E.—Kelvin lecture: “The particles of modern physics” by Prof. R. O. Frisch at 5.30 at Savoy Place, W.C.2.

29th. S.E.R.T.—“Some problems of computer maintenance” by L. Baldwin at 7.15 at London School of Hygiene & Tropical Medicine, Keppel Street, W.C.1.

29th. Television Soc.—Fleming memorial lecture on “The specification of an adequate television signal” by Dr. R. D. A. Maurice at 7.0 at the Royal Institution, Albemarle Street, W.1.

30th. I.E.E.—“Equipment and the results of tests with the NIMBUS meteorological satellite” by Dr. N. E. Rider at 5.30 at Savoy Place, W.C.2.

## BEDFORD

26th. I.E.E.—“Frequency-modulated stereo broadcasting” by G. D. Browne at 7.0 at the Bridge Hotel.

## BIRMINGHAM

1st. S.E.R.T.—“Colour television” by B. J. Rogers at 7.30 at the College of Advanced Technology, Gosta Green.

6th. I.E.E. & I.E.R.E.—One-day symposium on “Electronics in industry—the next five years” at the University.

21st. Television Soc.—“Post office towers” by R. E. G. Back and P. J. Edwards at 7.0 at the College of Advanced Technology, Gosta Green.

26th. I.E.E.—“Birmingham Post Office radio relay tower” by S. G. Young at 6.0 at the James Watt Memorial Institute.

## BRISTOL

12th. I.E.E.—“An introduction to analogue and digital computers—their differences and their uses” by K. C. Parton at 6.0 at Electricity House.

13th. Television Soc.—“Lasers in applications allied to television” by M. Wall at 7.30 at the Royal Hotel, College Green.

24th. I.E.R.E. and Inst.P. & Phys. Soc.—“Microstructure and physical properties of thin film” by Dr. A. J. Forty at 7.0 at the University Engineering Laboratories.

26th. I.E.E.—“Static switching—principles of electronic logic” by F. S. Brown and S. L. Hurst at 6.0 at the College of Science and Technology, Ashley Down.

## CHELTENHAM

30th. I.E.R.E.—“Integrated circuits” by G. C. Padwick at 7.0 at North Gloucestershire Technical College.

## COVENTRY

13th. I.E.E. & I.E.R.E.—“Data transmission in industrial processes” by H. Cox and J. Adderley at 6.0 at the Lanchester College of Technology.

## EDINBURGH

1st. I.E.E.—Faraday Lecture on “Colour television” by F. C. McLean at 7.0 at the Usher Hall.

## GLASGOW

7th. I.E.E.—“Fuel cells” by Dr. I. Fells at 6.0 at the Institution of Engineers & Shipbuilders, 39 Elmbank Crescent.

12th. I.E.E.—“Speech compression” by Dr. J. Swaffield, at 6.0 at the University of Strathclyde.

## LEATHERHEAD

7th. I.E.E.—“The measurement of noise” by C. M. Brownsey, at 7.30 at the C.E.R.L.

## LEEDS

14th. I.E.R.E.—“405/625 line conversion systems” by C. R. Longman at 6.30 at the University.

## MALVERN

1st. I.E.R.E.—“Small high-fidelity loudspeaker systems” by K. F. Russell at 7.0 at Abbey Hotel, Abbey Road.

## LIVERPOOL

14th. I.E.R.E.—“Field effect transistors and their applications” by C. S. den Brinker at 7.30 at Walker Art Gallery.

## MIDDLESBROUGH

7th. I.E.E.—“Computers in control of processes” by Dr. D. N. Truscott at 6.30 at Cleveland Scientific Institution.

## NEWCASTLE-ON-TYNE

4th. I.E.R.E.—“Pulse modulation systems” by J. Balmer at 6.0 at the Institute of Mining & Mechanical Engineers, Westgate Road.

6th. I.E.E.—Faraday Lecture on “Colour television” by F. C. McLean at 2.30 and 7.15 at the City Hall.

8th. I.E.E.—“Loudspeakers” by K. F. Russell at 6.30 at Rutherford College of Technology.

## NOTTINGHAM

5th. S.E.R.T.—“The 625-line television system and its reception problems” at 7.15 at the East Midlands Gas Board, Lower Parliament Street.

7th. S.E.R.T.—“U.H.F. aerials” at 7.15 at the Midlands Design Centre, Mansfield Rd.

## ST. ANDREWS

9th. I.E.E.—Symposium on “Application of semiconductor devices to biological electronics” at 11.0 at the University of St. Andrews.

## STONE

26th. I.E.E. & I.P.O.E.E.—“Trunking and traffic principles of a P.C.M. telephone exchange” by E. Walker and W. T. Duerdoth at 7.0 at Duncan Hall.

## CLUB NEWS

**BEXLEYHEATH.**—At the April 8th meeting of the North Kent Radio Society, Ian Lever will speak on “Television servicing” at 8.0 at the Congregational Church Hall.

**HECKMONDWIKE.**—Members of the Spen Valley Amateur Radio Society will visit the Royal Naval Reserve Communications Centre in Leeds on April 1st. A fortnight later C. R. Green, of Green & Davis, will talk about “commercial equipment” and on the 29th M. A. Browne will deal with “manned spaceflights.” Meetings are held at 7.30 at the Grammar School, High Street.

**LEAMINGTON SPA.**—The fourth in a series of talks on radio theory will be given to members of the Mid-Warwickshire Amateur Radio Society on April 5th. It will cover valve performances. Fortnightly meetings are held at 7.45 at Harrington House, Newbold Terrace.

**NORTH MIDLANDS MOBILE RALLY.**—The University of Keele Radio Society will provide an “out-station” as part of the “talk-in” facilities for the Mobile Rally which will be held at Trent-ham Gardens on Sunday, April 11th. The Society’s transmitters will be on 1960 kc/s and 145.4 Mc/s; call signs G3COY and G3SMD.

**WELLINGBOROUGH.**—“Transistorized TV” is the title of the talk to be given by K. Knibs at the April 1st meeting of the Wellingborough Radio Club which meets every Thursday at 7.45 at the Silver Street Club Room.