

Wireless World

Show Guide

SEPTEMBER 1962 Price Two Shillings and Sixpence

ELECTRONICS
RADIO
TELEVISION

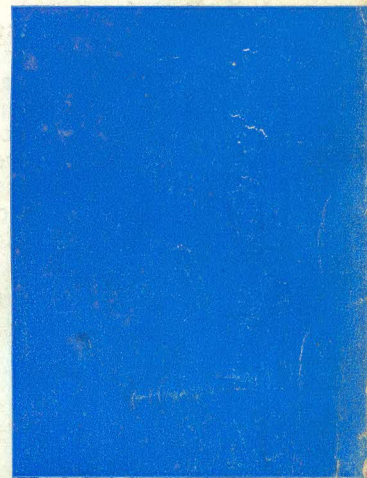
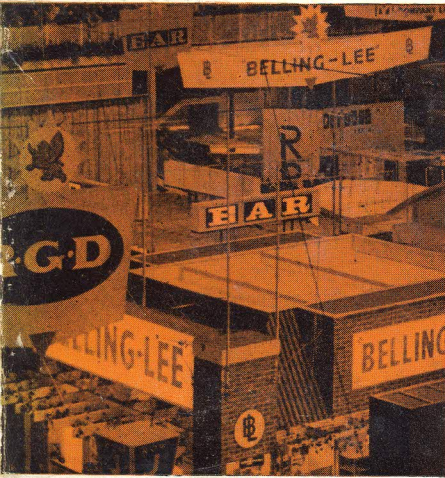

**NATIONAL
Radio
Show 1962**

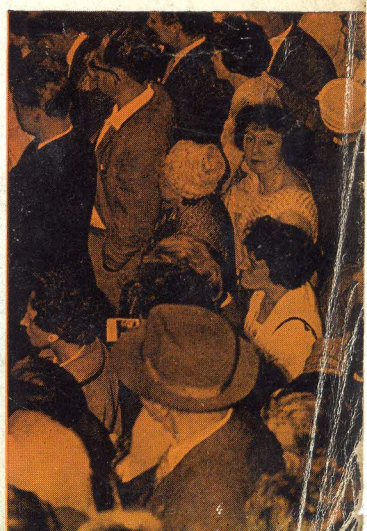
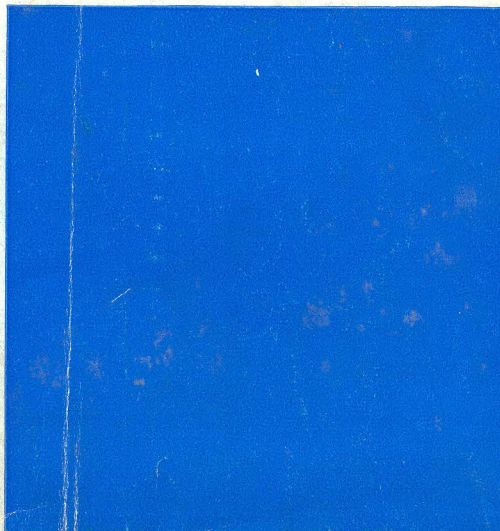
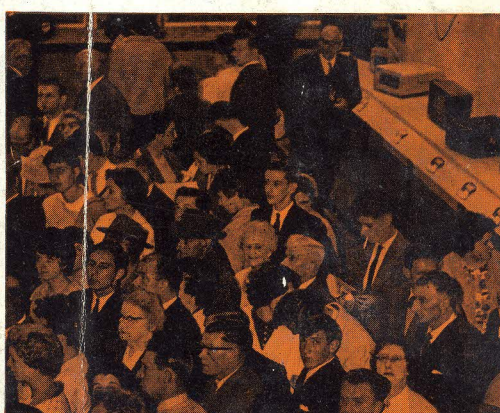

Wireless World

ELECTRONICS, RADIO, TELEVISION

SEPTEMBER 1962

Managing Editor:

HUGH S. POCOCK, M.I.E.E.

Editor:

F. L. DEVEREUX, B.Sc.

Assistant Editor:

H. W. BARNARD

Editorial:

P. R. DARRINGTON

M. G. LAZENBY, M.A.

W. J. A. WOODYER

Drawing Office:

H. J. COOKE

Production:

D. R. BRAY

Advertisement Manager:

G. BENTON ROWELL

- 403 Editorial Comment
- 404 Electronic Editing of Videotape *By N. F. Bounsall*
- 409 Ban the Reciprocity Theorem *By T. Roddam*
- 411 New Phase-Splitter *By A. R. Bailey*
- 414 World of Wireless
- 416 News from Industry
- 418 Personalities
- 419 Modulation Meter *By H. B. Dent*
- 421 Short-wave Conditions
- 422 National Radio Show Guide
- 432 Classification and Retrieval of Technical Information—2
By A. E. Cawkell
- 435 Turntable Rumble and Pickup Arm Design *By J. Walton*
- 437 S.B.A.C. Air Show—List of Exhibitors
- 438 Letters to the Editor
- 441 Combination Lock *By V. J. Phillips*
- 445 New Tunnel Diode Circuits *By M. Lorant*
- 447 Excitations and Responses—continued *By "Cathode Ray"*
- 451 Manufacturers' Products
- 453 Fundamentals of Feedback Design—9 *By G. Edwin*
- 456 Technical Notebook
- 458 Unbiased *By "Free Grid"*

VOLUME 68 No. 9.

PRICE: 2s. 6d.

FIFTY-SECOND YEAR
OF PUBLICATION

Chairman: H. S. Pocock, M.I.E.E.

Managing Director: W. E. Miller, M.A. M.Brit. I.R.E.

Iliffe Electrical Publications Ltd., Dorset House, Stamford Street, London, S.E.1

Please address to Editor, Advertisement Manager, or Publisher as appropriate

© Iliffe Electrical Publications Ltd. 1962. Permission in writing from the Editor must first be obtained before letterpress or illustrations are reproduced from this journal. Brief abstracts or comments are allowed provided acknowledgment to the journal is given.

PUBLISHED MONTHLY (4th Monday of preceding month). *Telephone:* Waterloo 3333 (65 lines). *Telegrams:* "Ethaworld, London, Telex." *Cables:* "Ethaworld, London, S.E.1." *Annual Subscriptions:* Home and Overseas, £2 0s. 0d. Canada and U.S.A. \$5.50. Second-class mail privileges authorized at New York, N.Y. *BRANCH OFFICES:* BIRMINGHAM: King Edward House, New Street, 2. *Telephone:* Midland 7191. COVENTRY: 8-10, Corporation Street. *Telephone:* Coventry 25210. GLASGOW: 62, Buchanan Street, C.1. *Telephone:* Central 1265-6. MANCHESTER: 260, Deansgate, 3. *Telephone:* Blackfriars 4412. NEW YORK OFFICE: U.S.A.: 111, Broadway, 6. *Telephone:* Digby 9-1197.

MULLARD MINIATURE ELECTROLYTICS

Mullard Frame-Grid Valves

FOR VISION AND SOUND I.F. STAGES

THE Mullard EF183 and EF184 are frame-grid pentodes used widely for vision and sound i.f. amplification in present-day television receivers. The EF183 is a variable-mu valve designed particularly to give improved gain in stages where automatic gain control is required and where there may be cross-modulation



or distortion problems. It is especially suitable for use in common sound and vision amplifiers. The EF184 is a straight pentode designed to give improved gain in i.f. stages where little or no control is required.

Because of the frame-grid construction, both valves have exceptionally high values of mutual conductance. It is 12.5mA/V for the EF183 and 15mA/V for the EF184, each of which is roughly twice as high as that of the types the new valves have superseded. These high values of mutual con-

for performance and reliability

MULLARD miniature electrolytic capacitors are being used increasingly in modern transistor radio receivers. They are made in five sizes of insulated can: the smallest is roughly 3.5mm in diameter and 10mm long; the largest is about 10mm in diameter and 30mm long.

Eight different combinations of capacitance and working voltage are available in each can size, the product of capacitance and voltage being roughly constant for each can. The voltage ratings available are 2.5, 4.0, 6.4, 10, 16, 25, 40 and 64V, and the capacitances range from 0.32 μ F in the smallest can size to 640 μ F in the largest. The tolerances on these capacitance values are generally much closer than those of other makes of comparable component.

WHAT'S NEW IN THE NEW SETS

These articles describe the latest Mullard developments for entertainment equipment

A low a.c. impedance is a desirable characteristic of a capacitor and indicates the quality of the component. Its value is related to the power factor of the capacitor, which for the Mullard electrolytics is extremely low.

The length of life and reliability of the Mullard components are exceptionally good, and comprehensive statistical tests indicate that a long and trouble-free service life can be expected. The exceptional properties of these

ductance are accompanied by low valve capacitances, so that full advantage can be taken of the high slopes. The gain of i.f. stages in receivers using the EF183 and EF184 is thus also about double that of stages in sets not using frame-grid valves. Present-day sets using these Mullard frame-grid valves are therefore characterised by high sensitivity and good signal-handling capacity.

components explain their ready adoption by service engineers for replacements in older equipment and for use by set manufacturers in up-to-date receivers.

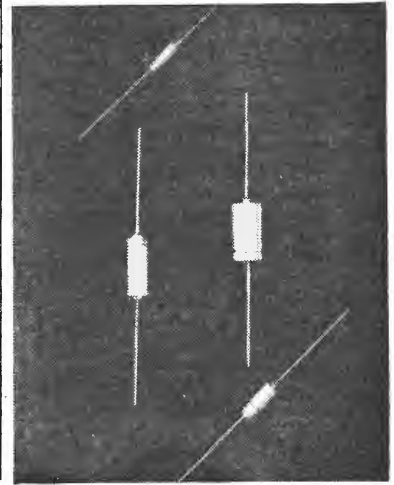

PL36 OUTPUT PENTODE FOR LINE TIMEBASES

The Mullard PL36 is designed specifically for use as a line output valve and is being employed in very large quantities in modern television receivers. The valve has higher peak anode current and dissipation ratings than valves previously recommended for this application. The peak anode voltage rating is also higher. These ratings enable the valve to be used in stabilised circuits under conditions in which the anode potential at the end of scan is above the knee of the anode characteristic. The high ratings of the PL36 facilitate use of the valve generally under conditions well removed from its limits, and this contributes considerably to the reliability of the timebase circuits and prolongs the useful service life of the valve.

MVE 1529

Buying the New Set

ONCE more the Radio Show is upon us, and once more, as we write these lines, the Jeremiahs and the Mark Tapleys are doing their best to depress and elate us at the prospect. On these occasions we are reminded of those films in which different facets of a single event are presented through the eyes of various participants and of the difficulty, indeed the futility, of attempting an objective assessment of what it is all in aid of. The accounts departments of exhibiting firms can no doubt produce exact figures to show the discrepancy between orders taken at the Show and the cost of participation, but they can only guess at what proportion of future business will be attributable to the stimulus of this public exhibition.

The National Radio and Television Exhibition at Earls Court is, this year, of special significance. It comes at the end of a period of uncertainty for manufacturers and of hesitancy on the part of potential customers for new receivers.

As a nation we have in the past shown a much higher addiction to the viewing of television than our Continental neighbours. Those of us who are ever likely to own a television set already have one. We begin to think seriously of buying a new receiver only if the one we possess looks old-fashioned, has too small a picture or is beginning to run up too large a monthly bill for repairs. No doubt many of us have been holding off for longer than we could have wished because the future technical position was not clear.

The section of the Pilkington Report dealing with such matters was unequivocal and the Postmaster General's ruling prompt; we are all set to expand our television services into Bands IV and V on a 625-line standard. So anyone buying a new television receiver would be wise to see that it is capable, either now or later by conversion, of reception on the new channels. The London buyer can decide whether to pay the extra now for a dual-standard 405/625, v.h.f./u.h.f. set capable of receiving, from the start, the test signals soon to be radiated on channels 34 and 44 from Crystal Palace, or to wait until the establishment of a regular service on u.h.f. A similar choice is open to provincial viewers, but they will have to wait longer before a u.h.f./625-line picture is available to them. Many will prefer to

buy a convertible 405 lines/v.h.f. receiver and add the auxiliary components to be supplied later by the manufacturer. No doubt the canny northerners will be content to watch the southerners having fun with u.h.f. and to benefit by their early experience.

As far as the sets themselves are concerned everything is already "shipshape and Bristol fashion." Anticipating the trend of events, the industry were exhibiting prototypes at last year's Show, and it is safe to assume that teething troubles, if any, have now disappeared. All this work has been done with signal generators on the bench. A more difficult task confronts the aerial manufacturers and installation technicians who must cope with the vagaries of u.h.f. propagation. They have not been idle, and visitors to the Show will have some opportunity of learning more of how they propose to deal with this problem. Incidentally, we hope that all dealers will find time to get down to serious business with the aerial manufacturers *before* they settle down in the armchairs of the set makers' demonstration rooms and offices.

Sound broadcasting is more than adequately catered for by the manufacturers who will be showing a wide range of types from pocket portables to high-quality radiogramophones and also export models of interest to overseas visitors. The exhibition organizers in addition to providing cable distribution of v.h.f. sound and 405, 625, v.h.f., u.h.f. and colour television programmes have established medium and long-wave a.m. fields inside the hall by inductive coupling to the closed loop aerials of transistor portables.

Although most of our readers' interests will be concerned with the technical aspects, with which we shall deal more fully next month, the Show would lose its character if the programme side were neglected. We do not begrudge the space allocated by the organizers for viewers who may wish to sit for half an hour to see their favourite programme, or for the teenagers who wish to see their idols in the flesh. At this turn of the tide in the affairs of the industry it is well to remember that the trickle can be turned into a flood only if the attention of the public can be arrested and held by a sustained choice of programmes of the highest quality, reflecting every interest and taste.

Electronic Editing of Videotape

"SPLICING" THE RECORDED INFORMATION BUT NOT THE TAPE

By NORMAN F. BOUNSALL *

THE many advantages of magnetic tape as a recording medium had been well established in the audio field when in 1956 the first demonstration of television pictures recorded on magnetic tape was given. The principal use of tape for video recording in the early days was for time delay purposes. That is, it provided a convenient means of recording a television programme for use later; and in this way the scheduling of artists and programme transmission times was greatly facilitated. The programmes themselves, however, were still produced as "live" shows, using multiple camera techniques and continuous action, and it was not until the medium had been in use for some time that producers attempted to edit the recorded tapes and thereby alter the normal time relationships existing between various scenes in the original recordings.

It was at this point that television tape appeared at a disadvantage compared with motion picture film. In the production of motion picture films the individual scenes are photographed with a single camera in any random time relationship and subsequently rearranged and assembled into a complete programme. The apparatus used for the editing operation had been developed by the motion picture industry to an advanced degree of sophistication and it appeared that the television industry would need to develop parallel equipment for tape editing. However, fundamental differences exist between images recorded photographically and magnetically, and these prevented the straightforward development of similar editing equipment. The images recorded on magnetic tape are not "pictures" in a conventional sense, but are a magnetic analogue

of the electrical waveforms present in a composite television signal. It became obvious that splicing would have to be accomplished with a high degree of precision in order to preserve all the elements of the composite signal in their correct time/space relationship on the tape. Another, and probably more dramatic, difference was the fact that when the recorded tape was stopped for cutting and splicing operations, the operator could no longer see a "picture" and, therefore, was faced with the problem of deciding exactly where to make the splice.

To answer the requirement for precision in splicing, units were developed that provided for accurate alignment of a section of tape under the cutting shear. Usually the splicer was fitted with a medium-power microscope in order to facilitate alignment, but at best the splicing operation was time consuming and required considerable skill on the part of the operator. The second problem of finding the correct editing point on the tape had, until recently, never been satisfactorily answered. Efforts toward a solution had, in the main, been directed towards methods of marking the tape while it was playing and then transferring single frame information into storage devices for study. In Germany rotating magnetic discs were tried as a means of storing single frames of a television picture, while in the United States cathode-ray tubes having long persistence phosphors were used. None of these devices proved to be very practical and they were never manufactured in any quantity. Thus, the question of editing magnetic television tapes remained a difficult and expensive one having little appeal to editors, producers or technical staff.

In 1961 the first demonstration was given of an

* Ampex Corporation, California.

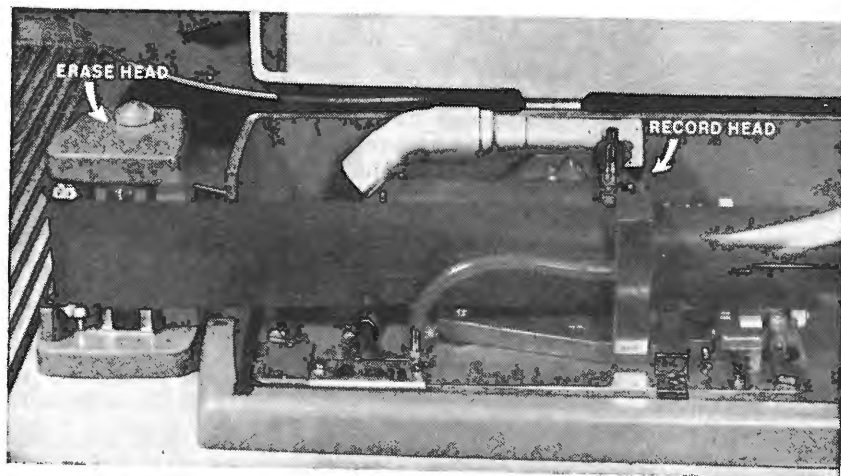

Fig. 1. Separation of video erasing and recording heads in the Ampex Electronic Editor.

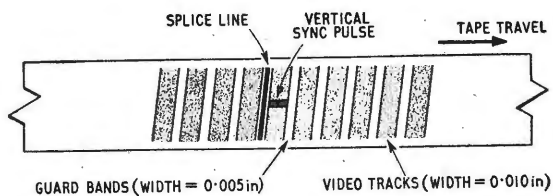

Fig. 2 Position of electronic splice in guard band.

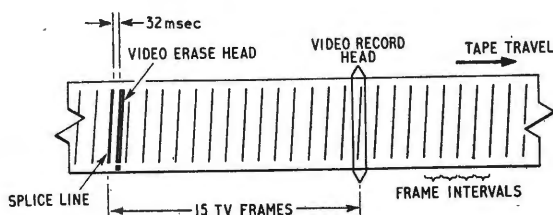

Fig. 3. Method of computing delays.

entirely new form of editing in which splices were made in television programmes by push-button methods. The new technique was called Electronic Editing and 1962 saw equipment of this type available in production form. Some of the 72 Ampex Videotape recorders in the United Kingdom are being modified to accommodate the new technique.

A completely new design philosophy has been adopted in the new system in which no attempt is made to stop the tape or store individual frames. Rather, splices are made while the tape is running at normal speed. These splices do not involve physically cutting and joining the tape, but are accomplished by activating recording circuits while the tape is running so as to record a new scene onto an existing scene or programme. Scenes in the original programme may be transferred to other tapes or erased. The splices thus made are splices in the recorded information, but not in the recording media.

The new electronic editing equipment is easily installed in any Videotape television recorder where it allows the recorder to be started and stopped between recordings, at will, without any loss of synchronism in the final tape. It becomes possible to assemble a first generation, completely edited master tape by using motion picture shooting techniques with only one camera and one recorder. Scenery changes, costume changes and other effects not feasible with the continuous action usually employed in television recording, become easily achievable on tape. The recorder may also be used to insert new scenes into the middle of an existing programme at some time after it was originally recorded. In this mode, commercials or announcements may be inserted into a programme, or a scene containing a production "fluff" may be replaced by a new scene.

In converting a standard Videotape recorder to operate under the new system, three basic areas are modified.

First, it is obviously important that, when an electronic splice is made, the pictures recorded on the tape are in correct time relationship, or phase, with the pictures that are to be spliced onto the

tape. In other words, the end of the last wanted frame on the tape must occur at exactly the same time as the beginning of the first frame of the pictures to be added to the tape. This video phasing is accomplished by equipping the recorder with an Intersync unit. This unit is a precision servo control mechanism that guarantees that synchronizing information recovered from tape is in very close time relationship with synchronizing information reaching the recorder from an external source. In this way, any possibility of splicing in, for example, an extraneous quarter of a frame, is avoided.

The second area of modification is concerned with transients in the drive capstan and head drum servo-mechanisms. In order to make an electronic splice it is necessary to play the last scene on the tape, and, at the end of it, operate the record control to start the new recording. When the machine changes its operating mode, from playback to record, the servo-mechanisms normally also change operating conditions. For example, during playback the capstan is driven by a Wein bridge oscillator, whereas during record the drive signal is derived from two binary counters which divide the 250-c/s signal from a photoelectric cell on the head drum assembly by four. Whilst both of these signals have a frequency of 62.5 c/s, they have no particular phase relation-

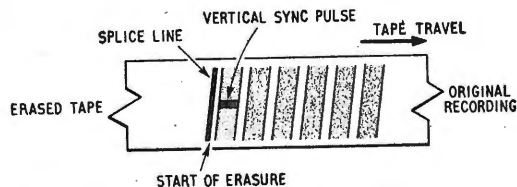
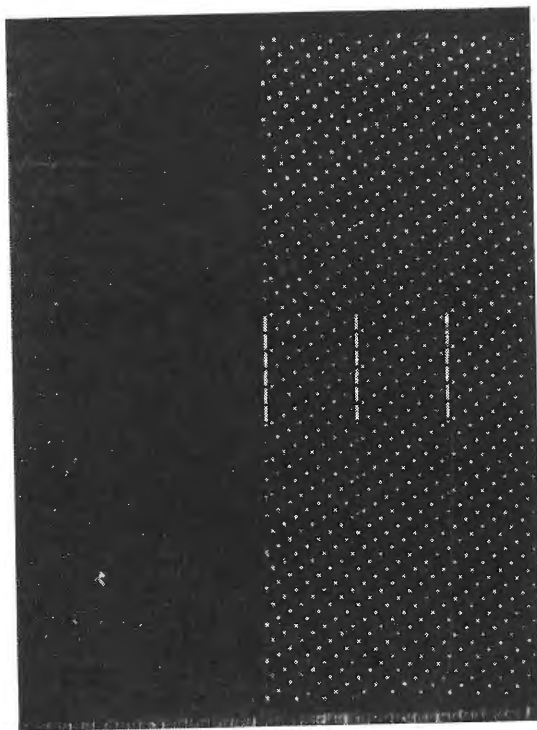

Fig. 4. Portion of video tape showing erasure of recording.

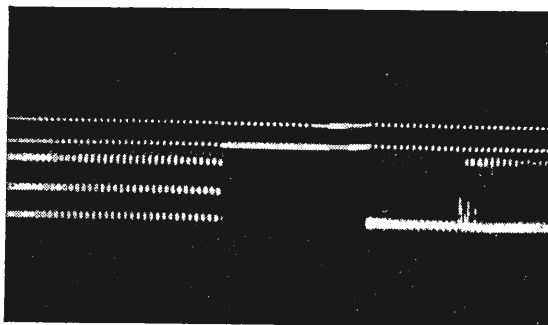
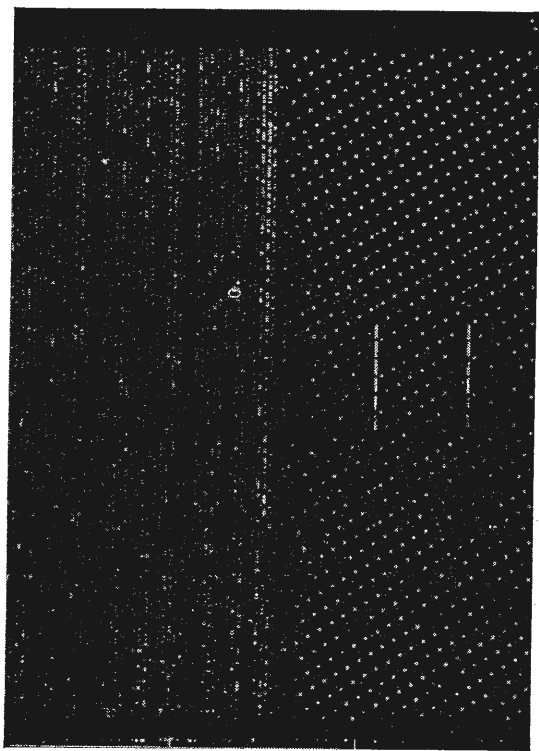

Fig. 6 Waveform of electronic splice.

absence of recording on the tape for the same distance. To circumvent this, the "Editor" controls the timing of the turn-on and turn-off of both signals so that they are effective at the same point on the tape. This timing is further controlled so that the point on the tape may be represented by a line drawn through the centre of the guard band following the transverse video track containing vertical synchronizing information. This line (Fig. 2) may be considered as marking the location of electronic splice. Electronically, therefore, the splice will occur during the vertical back porch. The "Editor" must therefore decide when the splice line passes the erase and record heads, and turn on the existing recording currents at these times. In order to compute the delay which occurs while the splice line moves up from the erase head to the record head, a method has been developed which is shown diagrammatically in Fig. 3. Timing is referenced to a vertical gating circuit which operates at the first frame interval following the operation of the record button. At this time a vertical interval will lie under the video record head and another vertical interval will precede the erase head by some small distance. These two vertical intervals are 15 frames apart.

The operation of the vertical gate triggers a mono-

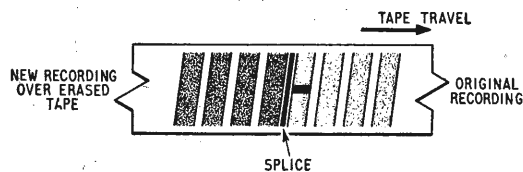

Fig. 5. Electronic "butt" splice of original and new video recording.

ship to each other. To switch from one to the other when entering the record mode would introduce transients into the capstan drive signal which would momentarily jerk the tape and cause mis-tracking at the splice. Similarly, phase transients may occur in the signal used to drive the recording head drum. Therefore, when the recorder is used for electronic editing, the servo-mechanisms are controlled so that the same sources of drive signals are used when entering the record mode as were used during playback. A 250-c/s oscillator is used to drive the head drum and this oscillator is frequency locked at all times to system vertical sync. The capstan is also driven by an oscillator which, during playback, is servo controlled and, during record, becomes free running. Due to its time constants, however, no short term phase shifts can occur.

The third area requiring change for editing purposes relates to the timing of the video erase and video record currents. The erasing and recording heads are separated by a distance of approximately 9in (Fig. 1). If the erasing and recording currents were turned on together and subsequently turned off together, a double recording would exist for some 9in of tape at the beginning of the new scene, and at the end of the scene there would be an

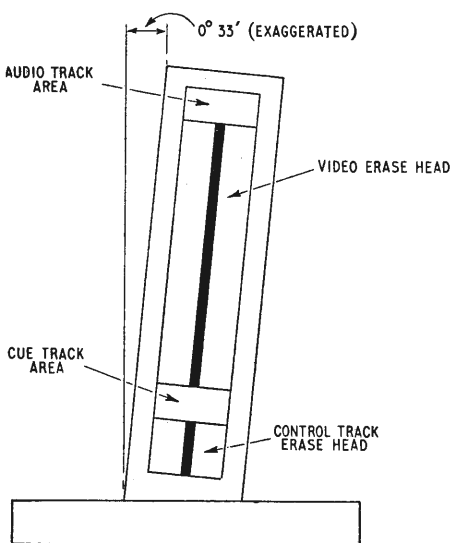

Fig. 7. Erase head for electronic editing.

stable multivibrator which provides a 32 msec delay at the end of which the erase current is turned on. The splice line will have travelled up to the erase head during the delay period and erasure will start in the centre of the desired guard band as shown in Fig. 4. Concurrently a binary counter system counts off 15 frames from the original vertical gating reference and then turns on the record current. During the delay provided by the counter, the splice line will have travelled along to the record heads and the recording of the new scene will start immediately following the guard band. The combination of the gated erase and record currents produces a perfect butt splice as shown in Fig. 5. The accuracy of the delay method is better than 0.05%, and the preservation of all video blanking and synchronizing information at a splice is shown in Fig. 6. This figure is an oscillogram of the recorder output waveform when a splice between two 625-line test signals passed the replay heads.

The "Editor" has two modes of operation referred to as "insert" and "assemble." In the latter mode the unit may be used to add further material to the end of an existing sequence and in this way assemble a complete programme from individual short scenes. The "insert" mode, on the other hand, is used to introduce new material into the middle of an existing tape.

In the "insert" mode, it is obviously necessary to make two splices per operation and still maintain synchronism. The operation of making the first (or in-going) splice was described above. The second (or out-going) splice is made in a similar manner except at the end of the measured time intervals, the erase and record currents are turned *off* instead of *on*. This is performed with the same precision as that of the first splice.

However, during the recording of the insert, the capstan oscillator frequency is not controlled and may drift slightly if the inserted material is of considerable length. This in turn may cause a variation in the wavelength of the recorded control track signal which would cause an abrupt shift in the phase of the reproduced control track signal at the out-going splice.

A possible solution to this problem would be to employ a phase correction system in the capstan oscillator output circuit in the record mode. This, however, would be extremely complex. The solution adopted utilizes the fact that, in the "insert"

mode, a control track signal already exists on the tape. This information would normally be erased by the full width video erase head when recording. However, a new head has been developed, shown in Fig. 7, which has a separate section for erasure of the control track. This section is disconnected when the "insert" mode is selected. This means that although the machine is switched to record, reproduction of the control track continues, thereby retaining normal servo control of the capstan oscillator, and avoiding any possibility of control track phase shift.

The video erase head is of entirely new design using only a half-turn in contact with the tape. It has been found that improved erase efficiency results. The gap is optically straight, has an electrical width of 0.005in, and is inclined to the perpendicular at an angle of 33 minutes of arc. This places the erasure pattern parallel with the video record pattern. The audio and cue tracks are not affected by the new head; and, as mentioned above, erasure of the control track is optional.

Fig. 8 shows a block diagram of the Electronic Editor from which it will be noted that the unit is composed chiefly of such logic modules as flip-flops, binary counters, AND gates and one-shot multivibrators. The functions may be traced from the figure as follows:

Following initiation of the record mode, a delay multi-vibrator provides 60 msec delay during which

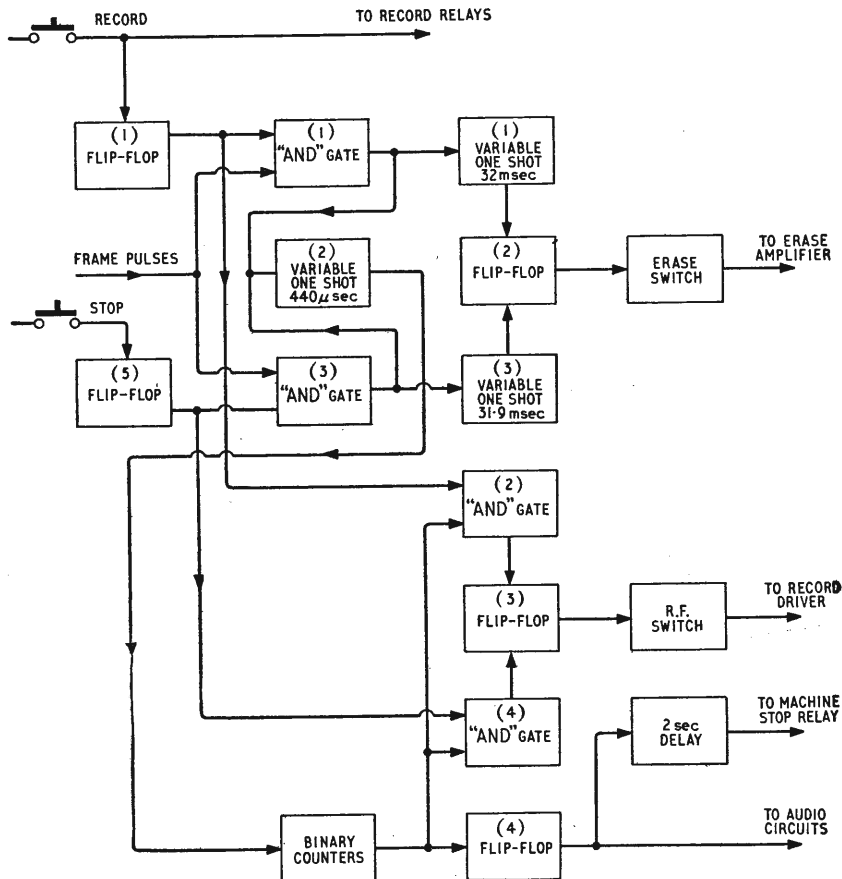

Fig. 8. Block schematic of the Electronic Editor.

all normal record relays have time to operate. Flip-flop 1 then operates, which places AND gates 1 and 2 in a "ready" state. Pulses, derived from the Intersync unit, that mark the vertical sync pulse in every frame interval, are reshaped in a pulse former and routed to AND gates 1 and 3. Gate 1, which is in a "ready" state, therefore, operates at the first frame pulse and triggers variable delay multivibrators 1 and 2. Multivibrator 1 serves to provide the necessary

32 msec of delay before the video erase current is turned on. Erasure turn-on is accomplished by flip-flop 2 and an electronic switch.

Because timing is referenced to the sync pulse in the vertical interval, at which time the rotating video head drum is positioned to place the active head tip at the centre of a video track, a 440 μ sec delay is provided by multivibrator 2. This allows the head to travel to the end of the track, at which time the succeeding head on the drum periphery is positioned at the beginning of the next track. From this timing reference, 15 television frames are counted off by the binary counter system and at the end of this period gate 2 operates. Video record current is then switched on by the action of flip-flop 3 and a second electronic switch.

Timing for the out-going splice is provided by the operation of gates 3 and 4, and variable delay multivibrator 3 which together with the re-use of the counter train resets flip-flops 3 and 4 and places the two electronic switches in the off condition.

The electronic switches are classic 6 diode transmission gates driven by the flip-flops in the

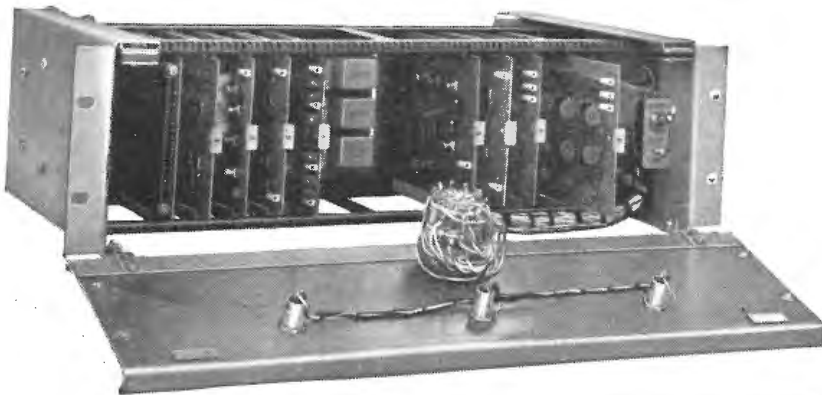

Fig. 9. Electronic Editor showing printed card construction.

"Editor." One switch is connected in the r.f. cable to the recording amplifier and the other switch is mounted in the erasing amplifier.

Flip-flop 4 is operated by the binary counters exactly 15 frames after the video record current is turned off. This permits the audio track to be cleared of all extraneous video signals by the action of the audio erase head. (New audio has, of course, accompanied the new video.) A time delay circuit allows all audio functions to revert to normal before stopping the machine. In this way any possibility of transients on the audio track is avoided.

The physical appearance of an Electronic Editor is shown in Fig. 9. Fig. 10 shows a unit installed in the monitor assembly of a Videotape recorder.

It is inevitable that comparisons will be drawn between conventional film editing techniques, as hitherto applied to television tape, and the new electronic method. Comparisons of this nature will, however, be somewhat misleading since the new technique will establish completely different standards of reference. It may be said, however, that considerable savings in production costs will result, since editing can now be accomplished by "push button" methods, in a fraction of the time formerly required. In addition, of course, the consumption of recording stock will be greatly reduced and "short ends" will become increasingly scarce.

The television tape recorder may now be used for any form of stop motion recording thereby allowing rearrangement of the original timing which is primarily the essential function of editing. Animation and time lapse work are now possible, and units now being developed will extend the flexibility of the new technique even further.

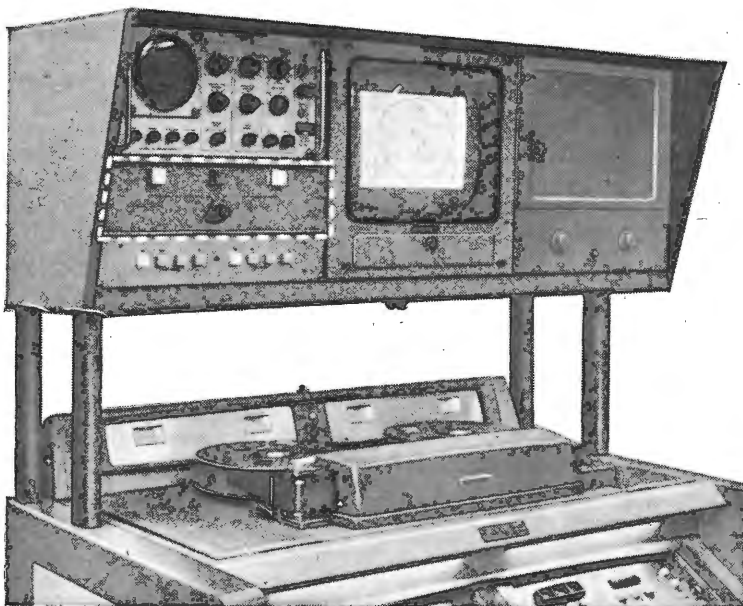

Fig. 10. "Editor" (outlined) installed in a Videotape recorder.

Ban the Reciprocity Theorem

THE SOURCE AND POINT OF OBSERVATION MAY
BE INTERCHANGED WITHOUT AFFECTING THE RESULT

By THOMAS RODDAM

THE subtitle, neatly packaged, is a formal statement of the Reciprocity Theorem and is taken from Volume 1 of *Communication Networks* by E. A. Guillemin (John Wiley). Here too may be found a proof which, in the author's words, "owes its elegance and simplicity entirely to the determinant method of solution, without which it would be exceedingly difficult." "By means of the determinant method it follows directly from the almost trivial fact that the common branch between meshes i and k is the same as that between k and i ."

The basic theorems of network analysis are the foundations of all our circuit work, even though we often leave them unformulated while we are using them. When, for example, did you last think consciously about the Superposition Theorem, yet how long could you get along without assuming it to be true? From time to time, therefore, it seems to be a good idea to take a careful look at these basic ideas, rather in the way that the owners of motor cars take their machines in to have the steering wheel covered in black grease and the wheel nuts loosened. It is, by the way, rather interesting for an electronics engineer to notice just how often the mechanical engineer expects maintenance. If you average 25 m.p.h. it only takes 200 hours to cover 5,000 miles, only 2,000 hours to cover 50,000 miles. Just try to sell a motor manufacturer a piece of electronic equipment which needs a major service every 200 hours and must be regarded as pretty well worn out after 2,000 hours, 50 weeks at 40 hours a week.

Network Analysis

I am aware that network analysis is a pretty dry sort of topic and that for those of you who have spent the day over a hot soldering iron the temptation to turn over to read that other chap may be enormous. The only point is that with a little thought you can save yourself the job of making and unmaking a good few joints. Better still you can usually do the thinking in a more comfortable seat. Even better, what I have to say will be news to some of you, even to at least one *Wireless World* author who I should not dare to identify even if the Editor agreed. (No, not him, he knows as much as Jowett.)

Network analysis deals with a delightful abstraction called a general linear passive network, which is made up of a number of meshes linked together. Each mesh may contain inductance, capacitance and resistance. Mutual inductance makes its appearance with positive or negative sign when we consider that meshes may be coupled together by any of our basic elements. We have a simple, logical, closed system and we are well on the way to the Reciprocity Theorem.

What we usually do at this stage is to label two

of the meshes. In practice they get their labels very early on, because the labels are simply "Input" and "Output", and the rest of the network is smartly bundled into a black box and the lid slammed down. A view of this box, which is never photographed, is shown in Fig. 1. The directions shown for the currents are not, to my mind, the most generally convenient, but they do happen to fit in rather well here. The transistor equivalent circuit papers must have made everyone aware that there is almost no limit to the ways in which we can inter-relate the V's and I's. For our purposes the most convenient form is the so-called impedance form:

$$\begin{aligned} V_1 &= Z_{11} I_1 + Z_{12} I_2 \\ V_2 &= Z_{21} I_1 + Z_{22} I_2 \end{aligned}$$

We can measure the values of the Z's very easily. Suppose that we force in a current I_1 and make I_2 zero by leaving the terminals open. Now we measure V_1 and V_2 and immediately we can calculate $Z_{11} = V_1/I_1$ and $Z_{21} = V_2/I_1$. Starting again with a fixed I_2 and $I_1 = 0$ we can find Z_{22} and Z_{12} .

Provided that the Reciprocity Theorem is true there must be another equation connecting the Z's. Consequently there are really only three independent terms and so we can assume the contents of the black box to be the three impedances arranged in T-form shown in Fig. 2. When we now perform the experiment of forcing in I_1 we find that $V_2 = Z_2 I_1$, so that $Z_2 = Z_{21}$, and that $V_1 = (Z_1 + Z_2) I_1$ so that $Z_{11} = (Z_1 + Z_2)$, or $Z_1 = (Z_{11} - Z_2)$. Forcing in I_2 gives us $Z_2 = Z_{12}$ and $Z_3 = (Z_{22} - Z_{12})$.

Thrown up by this operation is the result $Z_{12} = Z_{21}$, which is not too surprising when you look at Fig. 2. Remember, however, that we only drew Fig. 2 because we had assumed that there must be a connection between the Z's. If the Reciprocity Theorem is true, this equality is a statement of it.

Notice, by the way, that you may not be able to produce a real network in just this T form: the Z's may turn out to need negative inductances or

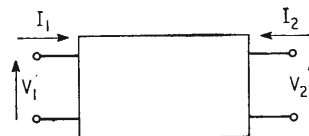

Fig. 1. A Black Box.

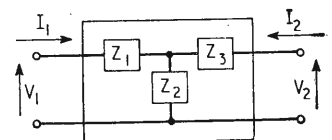

Fig. 2. The lid is lifted.

capacitances. This is a topic quite outside our present field of study.

Let us now ignore the Reciprocity Theorem and consider a black box which we know has no resistors in it. The test for this is to put a thermometer in the box and apply currents or voltages: our ideal box shows no temperature rise. We can immediately see that at any instant the total power supplied must be zero, since once power is supplied it turns into

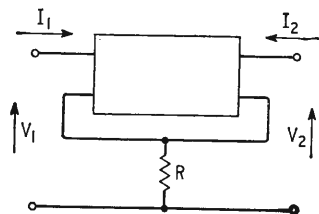

Fig. 3. An anti-reciprocal box in use.

heat and cannot be turned back again inside the box. If we call the instantaneous values of the voltages and currents by lower case letters we have

$$v_1 i_1 + v_2 i_2 = 0$$

For this to be true, we could have

$$i_1 = -ni_2$$

$$\text{and } v_1 = \frac{1}{n} v_2$$

These are the equations for an ideal transformer, which is a perfectly normal element of our system. As all its parameters are infinite it is a little untidy, but the infinities still give us $Z_{12} = Z_{21}$. Suppose we go back to the basic (though now instantaneous)

$$v_1 = Z_{11} i_1 + Z_{12} i_2$$

$$v_2 = Z_{21} i_1 + Z_{22} i_2$$

Now put $v_1 i_1 + v_2 i_2 = 0$ and we have

$$Z_{11} i_1^2 + (Z_{12} + Z_{21}) i_1 i_2 + Z_{22} i_2^2 = 0$$

This is to be true for any values of i_1 and i_2 , so we must have

$$Z_{11} = 0, Z_{22} = 0 \text{ and } Z_{12} + Z_{21} = 0$$

$$\text{or } Z_{12} = -Z_{21}$$

Put that in your T-network and smoke it. The basic equations reduce to the form

$$V_1 = Z_{12} I_2$$

$$V_2 = -Z_{12} I_1$$

One's first temptation is to say that there just ain't no such animal. Well, perhaps there ain't, but if that is so, it is necessary to invent it. This may seem rather odd to the practical man, which only goes to show that he is not really practical.

Anti-Reciprocal Box

Let us look back. We have said that our business was with linear passive constant networks and that most of our work is done with these and active elements like valves and transistors. In the course of exploring the rules of the network game we have found that one rule, the Reciprocity Theorem, does not have to be true. There could exist a network for which, in fact, one would find anti-reciprocity. We must consider whether this is of any value and whether it is practicable.

First of all we shall assess the value of the anti-reciprocal box and to do this I make use of the rather

simple circuit shown in Fig. 3. Let us write $Z_{12} = S$ for the box itself, so that for the complete network of box plus resistance we have

$$V_1 = RI_1 + (R + S) I_2$$

$$V_2 = (R - S) I_1 + RI_2$$

We can choose S to have any size we like at this stage since we have not yet decided that the black A-R box is anything more than a figment of our imagination. Choose, then, that

$$S = R$$

and we see that

$$V_1 = RI_1 + 2RI_2$$

$$V_2 = +RI_2$$

If we force in a current I_2 , we obtain a voltage of $2RI_2$ at the left-hand terminal pair: if we force in a current I_1 we get absolutely no voltage at the right-hand terminal pair. The system of Fig. 3 is thus a one-way network, passing signals from right to left but blocking them completely from left to right. Notice that these are *signals*, of quite a general form, so that it is not a question of putting in a rectifier; a rectifier is not a linear element anyway. Notice also that there is not any energy source inside the box, because the input and output energy are in instantaneous balance; the box does not contain any valves or transistors. We are, after all, dealing with linear passive networks.

Practical Gyrator

You will agree, I hope, that a device of this kind has many applications: all that remains to be seen is whether it is practicable. This article is about the Reciprocity Theorem and black boxes, not brass boxes, so I do not propose to describe the ways in which the gyrator, for that is what we have been discussing, can be realized. Let me just say that you can make a unit containing no active elements which apart from the losses associated with any practical circuit gives us the characteristic we want. I think, though no one has ever shown me a proof, that you must have a permanent magnet inside the box, but a permanent magnet is not an energy source.

The gyrator is not just another passive circuit element: it is *the* other passive circuit element. It has been shown theoretically that the set of five elements, capacitance, inductance, resistance, the ideal transformer, and the ideal gyrator will permit us to make any linear constant passive network. There are no loose ends lying about. Oddly enough this benefits the chap who does not go much on theory, because he is the one who ignores the loose ends until they trip him up, and then retires, not only hurt but confused.

The price we have paid for this clean-up is not really very high: we have demoted the Reciprocity Theorem from its position as a basic idea of network theory to a rule which only applies in the absence of one kind of element. We threw it away for transmission through the ionosphere a long time ago because the electrons moving in the earth's magnetic field gave us, though we did not say so, gyrator action. Now we can compress this action with a lump of a ferrite in a waveguide the gyrator is, in every sense, within our reach. Always remember, therefore, that if you can only achieve a result by relying on the Reciprocity Theorem you are only achieving a limited result.

New Phase-Splitter

IMPROVED HIGH-FREQUENCY RESPONSE

By A. R. BAILEY*, M.Sc.(Eng.), A.M.I.E.E.

IN the past many phase-splitters have been investigated and the reader would be quite justified in asking why a further circuit has been developed. The answer is quite simple in that the performance of high-fidelity amplifiers may be no longer limited by the output-transformer but by the response of the phase-inverter. With the best transformers available this is very true, and the improvement in amplifier performance that is obtained by using better circuits is quite startling.

In order that the reasons for discarding the present circuits may be seen, it is essential that all the requirements of the phase-inverter be first evaluated.

The first requirement of all phase-inverters is that they should deliver an output that is balanced to within a few per cent and does not alter as the valves age in use. Most of the phase-inverter circuits in use have this property, but the paraphase-inverter (Fig. 1) does not, as there is no negative feedback to stabilize the gain of the stage.

The second requirement is that the output-impedances from both halves of the phase-splitter should be approximately equal. The reason for this is nothing like so obvious at first sight. In fact there are two reasons for this requirement. The first is that severe grid-blocking can occur if the amplifier is accidentally over-driven (ref. 1). This can be overcome by using high-value grid stoppers but this gives an additional high-frequency time-constant due to the input capacitance of the following stage. As will be mentioned later, this gives a very undesirable tendency to h.f. oscillation when high values of negative-feedback are applied. The second disadvantage is that the drive to the two output valves may unbalance severely at high frequencies due to the different time-constants produced. This will have the effect of severely limiting the h.f. power available and will also increase the h.f. distortion. The two circuits that suffer from this drawback are the floating paraphase (Fig. 2) and the concertina (Fig. 3). In both circuits the valve loads that drive the output

stage are balanced, but unfortunately the output impedances are not balanced. This is due to the voltage negative-feedback inherent in the circuits. This negative-feedback overcomes the problem of valve ageing mentioned before, but brings the disadvantages that have been just mentioned. In addition, these circuits are not readily d.c. coupled to the previous stage. This is a severe disadvantage where large amounts of feedback are contemplated, as the additional low-frequency time-constant of a further coupling capacitor can easily cause instability at low frequencies.

Up to the present it seems to have been generally assumed that these were the only circuits to be avoided, if at all possible. Unfortunately this has proved not to be the case and the cause of the distressing tendency of high-feedback amplifiers to go unstable can often be laid at the door of the phase-splitter. The reason is quite simply one of poor h.f. response. A poor h.f. response in the phase-splitter will cause a falling loop gain, but what is more important it will also give a phase shift that tends towards 90 degrees retard. Now, if there is a total of 180 degrees retard at some high frequency, the

* Bradford Institute of Technology.

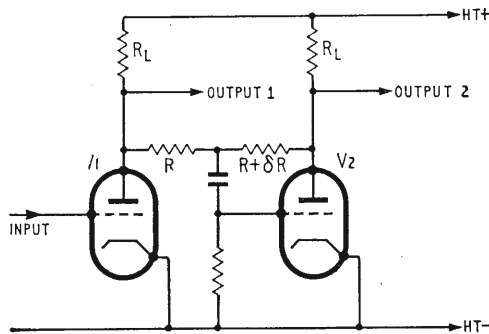

Fig. 2. Basic circuit of "floating" paraphase phase-splitter.

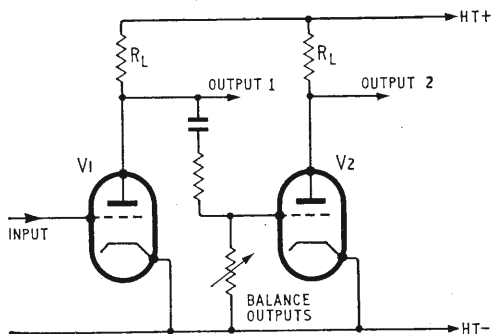

Fig. 1. Basic circuit of paraphase phase-splitter.

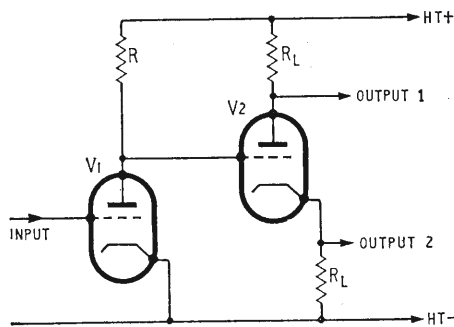

Fig. 3. Basic circuit of direct-coupled concertina phase-splitter.

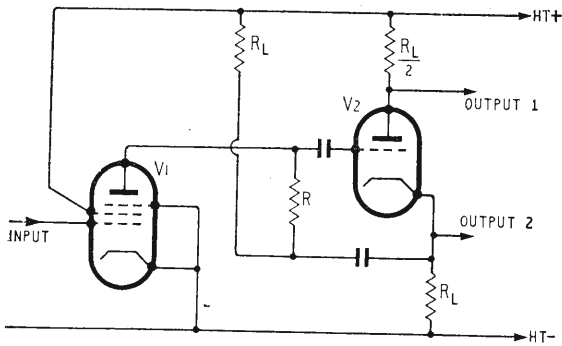

Fig. 4. Basic circuit of Jeffery's high-gain phase-splitter.

feedback will no longer be negative but positive. If the gain round the amplifier loop exceeds unity at this frequency then the amplifier will oscillate. Even if the loop gain is below unity then the amplifier may go unstable with even quite short leads to the loudspeaker due to the capacitive loading placed on the amplifier. Indeed it has been stated by Crowhurst (ref. 2) that the effect of near instability is quite audible and the amplifier gain margin should be at least eight times if this effect is to be inaudible.

For this reason it is essential that all phase shifts that can be removed should be removed: either completely, or at least as far out of the way as possible. Here it might be well noted that the use of grid stoppers in feedback amplifiers is to be deplored unless they are absolutely necessary. Many parasitics have been caused rather than stopped by them!

Two circuits that suffer from excessive h.f. phase shift are shown in Figs. 4 and 5. Fig. 4 shows the circuit due to Jeffery (ref. 3) and it is unnecessary to go into the details of the phase shift in this circuit again. The interested reader is referred to the correspondence following the publication of a subsequent article (ref. 4).

The circuit shown in Fig. 5 is well known and widely used but the fact remains that its h.f. response is relatively poor. This cannot be due to the second half of the valve as this section is effectively driven as a grounded-grid amplifier. The trouble is due to the first half of the valve and is due to that hardy perennial—Miller effect. The gain of this first valve is effectively halved due to the input impedance at the second valve cathode. Even so the Miller capacitance is quite large and certainly cannot be neglected. In order that some estimated value of frequency response can be obtained, some typical values will be taken. Using the ECC83 as a typical valve, the quoted anode-to-grid capacitance is 1.6 pF so the total value will be certainly as large as 2.0 pF when writing and base capacitances are taken into account. The gain of each half of the valve can be as much as 60 times, but this would be better reduced to a factor of 50 as there is a supply voltage loss in the common-cathode resistor. The overall gain will therefore be about 25 times when used in this phase-splitter. This will give a reflected Miller capacitance of approximately 50 pF, so the total capacitance loading on the previous stage will be about 60 pF if 10 pF is allowed for all other capacitances. With a 100 kΩ source impedance this will give a -3 dB point at about 25kc/s, and this is clearly not good enough when output transformers with primary resonances of

about 150 kc/s are considered. The phase shift of the amplifier circuits must be as small as possible where the output transformer reaches its first primary resonance; and therefore the bandwidth of this type of phase-splitter can easily degrade the total amplifier performance. The use of a step network across the anode load resistor of the driving valve can help in this matter, but only if the step starts well before the natural fall-off frequency of the circuit itself. In the case just considered this would mean starting the fall-off of amplifier gain by the step network at approximately 2.5 kc/s or lower. This would obviously give excessive reduction in loop gain at the high frequencies, with consequent increase in distortion.

The answer therefore lies in producing a fall-off at the h.f. end of the spectrum that starts at a much higher frequency. This could be attempted by reducing the value of the output impedance of the previous stage. This could be done by negative feedback with consequent gain loss; or alternatively by using a smaller value of anode load resistor. This latter also gives a severe loss in gain, quite apart from the increased noise that is produced by the increased valve current. The answer was therefore seen to lie in producing a phase-splitter that did not give the large input capacitance of the previous circuit.

Circuits are known (e.g. ref. 5) that do give good h.f. response in phase-splitter service, but they suffer from high cost due to the complexity of the circuitry involved. The circuit that was finally evolved (Fig. 6) has a cost that is only slightly more than that of

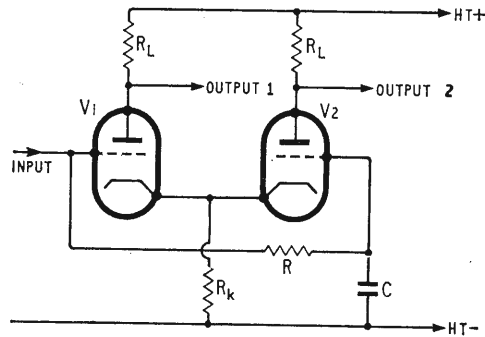

Fig. 5. Basic circuit of long-tailed-pair phase-splitter.

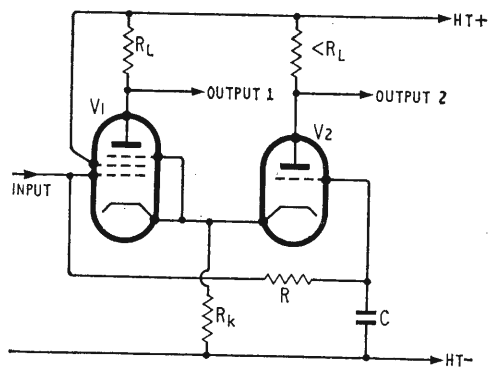

Fig. 6. Basic circuit of modified long-tailed-pair phase-splitter.

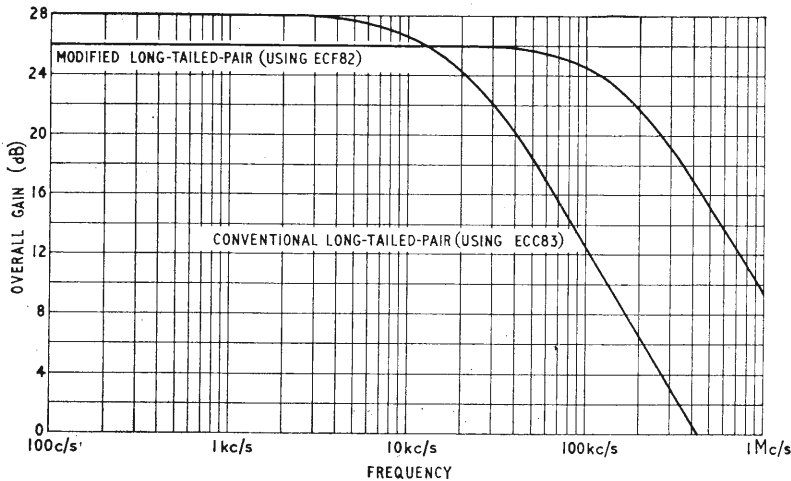

Fig. 7. Relative gain/frequency response curves of original and modified long-tailed-pair phase-splitters.

the conventional circuit, but has a greatly improved response at high frequencies.

The operation of the new circuit is just about identical with that of the conventional long-tailed pair except that the first valve is a pentode. This reduces the Miller effect to negligible proportions and increases the total bandwidth by a factor of just under ten times. Even allowing that the gain of the circuit is about 2 dB less than the conventional circuit, this still gives a gain/bandwidth improvement of about seven times. The comparative gain/frequency plots are shown in Fig. 7, where it is seen that the final rate of fall in both cases is identical at 20 dB per decade. This indicates an ultimate phase shift of 90 degrees which was borne out by measurement.

Owing to the partition of valve current in the pentode, the anode load resistor is made somewhat greater than that of the triode stage so that a balanced output is obtained. The circuit can be d.c. coupled to the previous stage as can the usual one, and a complete "front-end" for driving the output valves of an amplifier is shown in Fig. 8.

no difficulty in providing drive for the largest output valves.

A double-pentode having video amplifier characteristics and low input capacitance would enable greater overall gain to be obtained, but so far the author has not been able to find a valve with suitable characteristics. If such a valve were available, then the overall gain could be increased by a factor of about four times. Where sufficient spare stability margin was available this could lead to a further reduction in the distortion of the amplifier in use.

REFERENCES

1. High Fidelity Sound Engineering, by N. H. Crowhurst (Newnes), p. 130.
2. Why do Amplifiers Sound Different, by N. H. Crowhurst, *Radio and Television News*, March 1957.
3. Push-Pull Phase-Splitter, by E. Jeffrey, *Wireless World*, August 1947, p. 274.
4. Economical High-Gain A.F. Amplification, by Arthur R. Bailey, *Wireless World*, January 1960, p. 25, (*Letters*) March, p. 133, April, p. 181, May, p. 244.
5. The New "Isodyne" Phase-Splitter, by E. F. Worthen, *Audio*, August 1958, p. 26.

Fig. 8. Circuit of complete pentode amplifier and phase-splitter for use in a high-fidelity amplifier with a large amount of negative feedback.

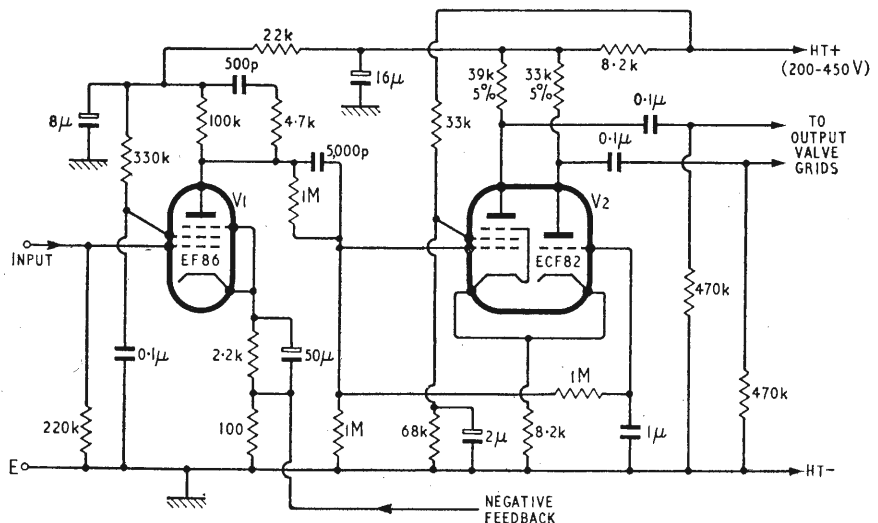

WORLD OF WIRELESS

How Many Councils?

THIS was the title of the editorial in our April 1960 issue, in which we commented on the announcement by the Electronic Engineering Association of the formation of the Electronic Industry Council. We concluded by saying "If B.R.E.M.A. and E.E.A. will stand together once again, and, with their many friends and relations, speak with one voice in all matters affecting the industry, the title of its council will be immaterial." We have heard little, if anything, about the E.I.C. since that date.

Now, each of the associations has announced the formation of a president's council or committee. E.E.A.'s 14-man council, headed by O. W. Humphreys, will confine itself to "major questions of industry policy." The five-man president's committee of B.R.E.M.A., headed by C. O. Stanley who is the only person appointed to both councils, "has been established to formulate policy on major matters concerning the industry." Perhaps our earlier title should now be amended to "How many more councils?"

The members of the E.E.A. president's council are:—

P. Adorian (Redifon)	S. Z. de Ferranti (Ferranti)
Sir Leon Bagrit (Elliott)	O. W. Humphreys (G.E.C.)
E. H. Ball (A.E.I.)	Sir Edward Lewis (Decca)
E. B. Banks (English Electric)	Sir Joseph Lockwood (E.M.I.)
M. W. Clark (Plessey)	C. O. Stanley (Pye)
J. Davis (Rank)	F. N. Sutherland (Marconi's W/T)
S. S. Eriks (Mullard)	F. C. Wright (S.T.C.)

The members of the B.R.E.M.A. president's committee are:—

C. O. Stanley (British Electronic Industries)	D. Saward (Rank)
A. Weinstock (G.E.C.)	J. Thorn (Thorn Electrical Industries)
J. P. Engels (Philips)	

The management of both the associations continues to be vested in their respective executive councils.

Broadcasting Problems

STEREO broadcasting, colour television and tropical broadcasting were among the subjects considered by some 150 delegates from 20 countries, including a 12-man delegation from the U.K., who met in Bad Kreuznach, West Germany, at the end of June. It was the first time the three study groups of the C.C.I.R. concerned with broadcasting (X), television (XI) and tropical broadcasting (XII) had held joint meetings. The draft recommendations from these meetings will be submitted for consideration by the C.C.I.R. plenary assembly in New Delhi next January.

The U.K. delegation, which included representatives from the G.P.O., B.B.C., I.T.A. and B.R.E.M.A., was led by J. H. H. Merriman of the G.P.O.

One of the problems before study group X concerned stereo broadcasting. A draft recommendation based on the Zenith-G.E. system adopted in the U.S.A. was drawn up although there was not unanimous agreement. It was felt by some delegations (the U.K. in particular) that further investigation, especially regarding reduced service area and protection ratio, should be undertaken. Four systems (American, Dutch, Czech and Russian) of compatible s.s.b. transmission for medium-wave broadcasting were considered. A draft report on the "state of the art" was prepared but a similar note of caution to that expressed over stereo was sounded.

The delegates considered the claims of both the N.T.S.C. and the S.E.C.A.M. colour television systems but there appeared to be no desire on their part to reach an early agreement on a European standard.

As a result of close collaboration between the radio industry and the G.P.O. the U.K. delegation was able to make a very worth-while contribution to the study on tropical broadcasting. A performance specification for a domestic low-cost broadcast receiver and for a community receiver for use in the tropics was prepared. There is growing concern at the overcrowding of the h.f. section of the spectrum and the specification therefore provides for the use of v.h.f. in tropical regions.

Receiver Manufacturers' Report

FROM the wealth of data on the production, home sales and export of domestic receivers given in the annual report of B.R.E.M.A., we have culled the following:—

The number of sound receivers incorporating f.m. has fallen from 378,000 in 1957, the peak production year, to 169,000 last year. These figures are 31% and 7% respectively of the years' total set production. The decrease is to some extent accounted for by the increased proportion of transistor sets (83% of last year's set production), which, in general, are for a.m. reception.

Whereas in 1960 85% of all television sets manufactured in this country incorporated tubes of 17in or smaller, and less than 1% had 19in tubes, the percentages in 1961 were 11 and 78 respectively.

Exports of domestic sound receivers declined from 237,300 in 1960 to 197,640 in 1961, but television receivers (including chassis) increased from 30,500 to 45,070. Audio equipment valued at £10,481,000 was exported last year—an increase of 15.2% on 1960.

Of the quarter of a million transistor receivers imported into the U.K. in 1961, 106,000 (37%) came from Hong Kong; 51,000 (20%) from Japan, and 18,000 (9%) from Germany. Imported transistor receivers increased from 72,000 in 1960 to 253,000 last year.

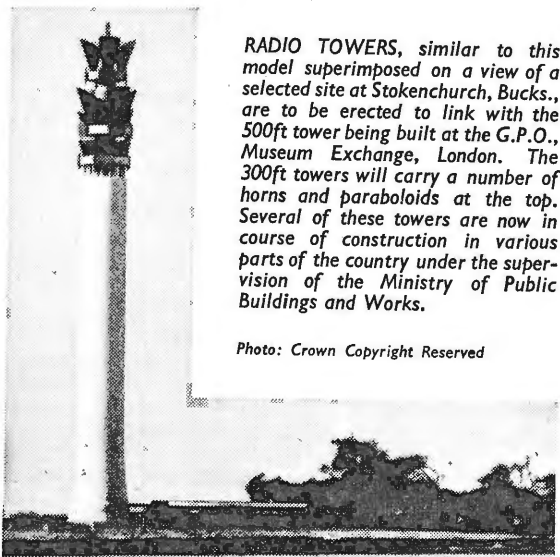

RADIO TOWERS, similar to this model superimposed on a view of a selected site at Stokenchurch, Bucks., are to be erected to link with the 500ft tower being built at the G.P.O., Museum Exchange, London. The 300ft towers will carry a number of horns and paraboloids at the top. Several of these towers are now in course of construction in various parts of the country under the supervision of the Ministry of Public Buildings and Works.

Photo: Crown Copyright Reserved

B.B.C. European Service

SINCE 1953 some of the programmes of the B.B.C.'s European Service have been broadcast by the West German 100-kW medium-wave transmitter at Osterloog, near Norden. In April this station closed down and its wavelength (1295 kc/s) is now being used by the B.B.C.'s 150-kW transmitter at Crowborough, Sussex, which previously radiated the European Service on 1340 kc/s. A new 5-kW transmitter at Brookmans Park, operating on 1340 kc/s, has also been brought into service by the B.B.C. for the European Service.

Two I.T.A. Stations Open This Month.—The Channel Islands and West Wales will have independent television programmes this month. Transmissions begin on Saturday, September 1st, from the Fremont Point, Jersey, station and programmes will be broadcast on Channel 3 (horizontal polarization) by the Authority's programme contractor, Channel Television Ltd. Two weeks later, on September 14th, programme transmissions will begin from Presely, Pembrokeshire. The latter station is the nineteenth to be completed by the I.T.A. in just over eight years. It will broadcast on Channel 8 and the signal will be horizontally polarized. Later this year it will be joined by the Llyn transmitter, in Caernarvonshire, and by the Moel-y-Parc station, near the borders of Flint and Denbigh. Programmes for these three Welsh transmitters will be provided by Wales (West and North) Television Ltd., Cardiff.

Purchase of telecommunications equipment by the G.P.O. under bulk supply agreements with the principal telecommunication manufacturers has recently been under review and the Postmaster-General (Mr. Reginald Bevins) has announced revised arrangements. The Post Office is to purchase all cable and loading coils as from April next by competitive tender. The P.M.G. is also proposing that, when the telephone apparatus agreement comes to be renewed next April, provision should be made to increase the proportion of orders that may be placed outside the agreement from 10% to 25%. Mr. Bevins stated that there is no monopoly position in the sphere of exchange equipment and the existing arrangements would continue.

Amateur TV Convention.—The sixth convention of the British Amateur Television Club will be held in the Conway Hall, Red Lion Square, London, W.C.1, on September 8th, from 10.0 to 7.0. Amateur-built television equipment will be on show and in the evening there will be a series of lectures including one on colour television by G. B. Townsend, the club's president. Admission costs 5s (2s 6d after 2 o'clock).

International Radio Communications Exhibition is the new title of the Radio Society of Great Britain's annual amateur radio exhibition, until now more familiarly known as the Radio Hobbies Show. As announced in the July issue the venue has been transferred to the Seymour Hall, Seymour Place, Marble Arch, London, W.1 (October 31st-November 3rd). Exhibition organizer is again P. A. Thorogood (G4KD), of 35 Gibbs' Green, Edgware, Middx., from whom further details may be obtained.

Noise and vibration measurement is the subject of a five-day course to be held by the Royal College of Advanced Technology, Salford, 5, Lancs., from September 10th-14th. Course fee is £5, and enrolment forms may be obtained from the College.

"The Darlington Connection."—It is regretted that a transposition of Figs. 2 and 3 occurred in this article in our August issue. The circuit having a direct connection between collectors is properly Fig. 2.

For A.I.E.E. and I.R.E. read I.E.E.E.—The American Institute of Electrical Engineers and the Institute of Radio Engineers are to merge their activities into a new Institute of Electrical and Electronic Engineers, which is to begin functioning on January 1st next. Both institutes held separate members' votes on the merger and each returned 7-1 majorities in favour. With 55,156 eligible to vote, A.I.E.E. said 29,464 favoured and 4,381 voted against merging. In the case of I.R.E. 67% of the 66,152 eligible members voted. In favour were 87% (36,221) and opposed were 13% (5,489).

British Aerial Standards Council.—Aerialite, Antiference, Belling & Lee, J-Beam, Telerection and Wolsey are the founder members of this new council. They have "mutually agreed to set and adhere to standards for technical performance and construction, for domestic radio and television aerials, including those for communal systems." B.A.S.C. is affiliated with the R.E.C.M.F. and has offices at 21 Tothill Street, London, S.W.1.

London Audio Festival 1963 is to be held from April 18th to 21st, inclusive, and the venue will again be the Russell Hotel, Russell Square, London. R. W. Merrick (Ferrograph) continues as chairman of the exhibitors' committee, which comprises representatives of Acoustical, Armstrong, E.M.I., Ferrograph, Goodmans, Leak, Lowther, Rogers and Tannoy.

A.P.A.E. Manchester Symposium.—The Association of Public Address Engineers has arranged for a p.a. symposium and supporting exhibition to be held on Sunday, September 16th next, from 2.15 p.m., at the Queen's Hotel, Piccadilly, Manchester. Further details from the Association's secretary, Alex J. Walker, at 394 Northolt Road, South Harrow, Middx.

National Exhibition Centre.—The Federation of British Industries has issued a report covering the proposed construction of an exhibition centre at Crystal Palace, London, at a cost of £12M. It provides for three exhibition halls (with an overall area of 900,000 sq ft) each with an associated conference hall, a large open air display area and parking for nearly 9,000 cars.

Southall Technical College offer for the 1962/63 session part-time day courses, at City & Guild's Certificate intermediate and final levels, in telecommunications, radio and television servicing, electronics servicing, and instrumentation. Classes commence on September 24th, and further details are available from the College at Beaconsfield Road, Southall, Middx.

Medway College of Technology, Chatham, Kent, have planned with the co-operation of S.T.C., four transistor courses for the coming session. Each course is of ten evenings' duration.

Comparative figures for U.K. imports and exports during the first six months of 1961 and 1962 which have been extracted from the Board of Trade Accounts (June).

BALANCE OF TRADE

	Imports (£M)		Exports (£M)	
	1961	1962	1961	1962
Valves and c.r. tubes	2.36	2.32	5.35	5.30
Transistors	0.53	0.85	—	—
Domestic and car radio	0.47	0.80	1.31	0.71
Television sets	—	—	0.66	1.75
Communication and Nav aids	2.78	3.50	10.85	11.55
Broadcasting transmitters	—	—	0.42	0.36
Sound reproducing equipment	—	—	0.56	0.63
Components	—	—	7.77	7.27
Other radio apparatus	2.80	2.58	1.16	1.99
Electro-medical equipment	0.85	0.94	0.21	0.25
Industrial electronics	0.65	1.07	1.15	1.16
Scientific instruments	1.40	2.10	3.88	4.47
	11.84	14.16	33.32	35.44

Amateur Exam Courses.—Details of courses to be held during the coming session in preparation for the Radio Amateurs' Examination have been received from the following:—Bradford Technical College, Bradford 5, Wednesdays at 7.0; Bristol Technical College, Ashley Down, Bristol 7, Mondays at 6.45 and Wednesdays at 7.0; Ilford Literary Institute, Cranbrook Road, Ilford, Essex, Wednesdays and Thursdays at 7.15 with Morse on Mondays at 7.30; and Northwood Evening Institute, Potter Street School, Northwood Hills, Middx., Mondays at 6.30.

Wandsworth Technical College, London, S.W.18, is holding a number of special one-year evening courses beginning in September. They include:—"Transistors" (Tuesdays and Wednesdays); "Inspection of Electronic and Light Electrical Equipment" (Thursdays) and "Electronic Measurements" (Fridays). The fee for each course is 50s.

Technical courses (full-time, part-time and evening) in various aspects of telecommunication engineering, radio operating, servicing and electronic instrumentation are listed in the 1962/63 prospectus received from the Norwood Technical College, London, S.E.27.

Correction to "**Bootstrap Follower Characteristics.**"—On page 323 of the July issue, an error appeared in the expression for peak gain, in which C_1 and C_2 were transposed.

News from Industry

Mazda and Brimar Service.—Thorn-AEI Radio Valves & Tubes Ltd. have merged the service organizations of their Brimar and Mazda Divisions. F. H. Cook has been appointed service manager for the new joint organization and is located at the Valve Sales Department at Brimsdown, Enfield, Middx. This department serves the entire U.K.

Dansette Products.—Group profits for the year ended March 31st last totalled £425,074 and compare with those of £316,497 for the previous year. After taxation the net balance is £181,917, against £138,715. Sales in the first quarter of the current year have been maintained, and the company's first tape recorder is announced.

Dubilier Condenser Co. (1925) Ltd.—Chairman, F. H. McCrea, reports that the net profit for the year to March 31st was £90,619 compared with £102,054 for the preceding year. Referring to the new plant for making new types of tubular paper capacitors, he says the initial results are "most encouraging" and that Dubilier are now ready for large-scale production. The company has issued a brochure celebrating 50 years of service to the electrical and electronics industry.

Telefunken G.m.b.H., Berlin, report that sales in 1961-62 increased by about 7% to DM 741M as against the previous year. Referred to domestic business alone, the quantity of sales rose by 13%, in respect of value however by 10% only to DM 576M. At approximately DM 165M exports amounted to 22% of total sales, a slight drop in comparison with last year.

Thorn Electrical Industries Ltd.—Group trading profits for the twelve months period to March 31st last amounted to £5,062,039 as compared with £4,113,907 for the previous year. After all charges, including taxation, the net profit is £2,154,737 (£1,548,769).

The Toroid Division of Avey Electric Ltd., South Ockendon, Essex, has been registered as a separate limited company and is now operating and trading at the above address under the name of Avel Products Ltd.

Three new filmstrips intended for training student electronic engineers and Services trainees have been released by the Mullard Educational Service. Their titles are: "Amplification and Amplifiers: Parts V and VI." (Further additions to the series covering all aspects of this subject), "Transmitters," and "Aerials." All three strips are available now from Unicorn Head Visual Aids Ltd., 42 Westminster Palace Gardens, London, S.W.1. Price 25s per strip, including comprehensive teaching notes.

SEPTEMBER MEETINGS

LONDON

21st. Television Society.—Discussion on the Pilkington Report at 7.0 at the Cinematograph Exhibitors' Association, 166, Shaftesbury Avenue, W.C.2.

26th. Brit.I.R.E.—Discussion on the Pilkington Committee Report at 6.0 at London School of Hygiene and Tropical Medicine, Keppel Street, W.C.1.

29th. Electronic Organ Constructors' Society.—Demonstration of organ built by P. Vickery at 3.0 at Northern Polytechnic, Holloway Road, N.7.

BRISTOL

11th. Television Society.—"Pilkington Report" by R. C. Harman at 7.30 at the Royal Hotel, College Green.

LEICESTER

17th. Television Society.—"Vision tape recording" at 7.30 at the Leicester Technical College.

Cossor Research Laboratories.—Typical of work being carried on at the new research and development laboratories of Cossor Radar & Electronics Ltd., officially opened at Harlow, Essex, on July 6th, is the development of a new secondary radar airborne transponder. When the first models become available in November their use will enable air traffic controllers on the ground to be automatically presented with important flight information not provided by conventional primary radars. Airborne transponders within range will be "interrogated" by a radar transmission from the ground, and will reply by transmitting any of up to 4096 information codes. Previously only 64 codes have been available. Cossor, pioneers of secondary radar, claim to be the only company outside the U.S.A. who can supply a complete secondary surveillance radar system.

KEF Electronics Ltd., the company formed by R. E. Cooke, has arranged London showroom facilities for its range of loudspeakers and the ADC pickup. This has been effected in conjunction with Expert Gramophones Ltd., at the latter's premises at 82 Kensington High Street, London, W.8. (Tel.: Western 0037.) Demonstrations can be arranged by appointment. KEF Electronics has head offices at Tovil, Maidstone, Kent (Tel.: Maidstone 55761).

Denham & Morley Ltd., importers and distributors of radio and electrical goods, of Denmore House, 173-175 Cleveland Street, London, W.1 (Tel.: Euston 3656), have added the French Sonolor range of transistor radio receivers to their list of agencies, which now includes the Japanese Standard and German Akkord ranges of transistor radio receivers in addition to Butoba tape recorders and accessories.

Aerials and associated electronic equipment for a new \$2M U.S. Naval Radio Station at Thurso, Caithness, is to be supplied by RCA Great Britain Ltd. The station is due to be operational by June, 1963.

CTH Electronics have moved from Cheshunt to premises at Burford Works, Burford Street, Hoddesdon, Herts (Tel.: Hoddesdon 4798).

OVERSEAS TRADE

Murphy To Close Factory.—Murphy Radio has announced that its factory at Hirwaun, the industrial estate at Aberdare, Glamorgan, where 600 are employed, will close at the end of the year. A statement said: "There are now more production facilities than can be used at the present time, and it is essential to achieve economies." The factory, which once employed 1,000, was set up 15 years ago.

I.C.T.-E.M.I. Computer Deal.—Electric & Musical Industries Ltd. and International Computers & Tabulators Ltd. announce that the data processing activities of E.M.I. Electronics Ltd. have been merged with the I.C.T. organization as from July 24th. These arrangements do not cover analogue computers or computers designed for process control purposes. E.M.I. is developing and will also sell a special range of basic components for computers.

S.T.C.'s Northern Ireland Plant.—The Prime Minister of Northern Ireland, Lord Brookeborough, welcomed "the beginnings of an important new industry" in Ulster when he officially opened the first factory of Standard Telephones & Cables (Northern Ireland) Ltd. at Monkstown, Newtownabbey, on July 25th. This "advance factory," employing over 300 people, was provided by the Northern Ireland Development Council to enable S.T.C. to train staff and to build up production facilities in readiness for its main 280,000 sq ft factory now under construction nearby. This is due to be completely occupied by the end of 1963, when some 2,000 people will be employed there.

The Dutch Philips concern now has a total of 215 factories in operation in 31 countries in all parts of the world, according to the latest annual report. Statistics indicate that television receiver business (18% of total) is the most important single field of operation for the Philips organization.

Elliott-Automation has formed a subsidiary company in Luxembourg in which it is proposed to concentrate and develop the group's main interest in the Common Market. The new company, Elliott-Automation Continental S.A., has a capital of 400M Luxembourg francs, and its chairman is Sir Leon Bagrit with Dr. Lawrence L. Ross as managing director.

Elac record players, record changers, and stereo ceramic and crystal pickup cartridges, manufactured by Electroacoustic G.m.b.H., of Keil, Germany, are now available from the High-Fidelity Centre (F. C. Mitchell), 61 West Street, Dorking, Surrey (Tel.: Dorking 4229), who are now the sole British agents.

Recordacall, manufacturers of a fully integrated telephone answering equipment of that name, have been taken over as a wholly owned subsidiary of the Radio Rentals group. Recordacall equipment will be installed on a rental basis and the rental will cover all installation, servicing and maintenance charges.

Largest television studio to be used by the British Broadcasting Corporation—Studio 1 at the White City Television Centre—is to be equipped by E.M.I. Electronics with eight 4½in image orthicon cameras and associated equipment. Special feature of the cameras is the provision for changing the line standard by remote control from 405 to 525 or 625 lines. Studio 1 is scheduled to be opened in the summer of 1963.

A low-noise receiver, forming part of equipment to be used in the tracking, telemetry reception and frequency measurement of transmissions from deep space probes, is being supplied by G. & E. Bradley Ltd. to the University of Manchester.

Davy-AEI Automation Ltd. has changed its name to Steelworks Automation Ltd., with effect from July 23rd. The company's address is Booth Hall, Knutsford, Cheshire.

Radiotelephone equipment has been supplied by Associated Electrical Industries Ltd. to the Indonesian Post, Telegraph and Telephone Department, to supplement facilities available to the press representatives attending the Asian Games which commenced in Djakarta on August 24th. Associated with A.E.I. in this project were Redifon Ltd. and the contract was valued at over £86,000.

Belgian Government ships on the Dover-Ostend car ferry service are now fitted with additional Decca radars of a special type to assist them in berthing in low visibility. The aerials of these radars are specially sited aft to give a clear view astern and the equipment will assist the ships in the difficult stern-to berthings they have to make at each end of their run. The radars are of the type originally developed for Rhine navigation.

V.H.F. communication equipment to the value of £250,000 is to be supplied to the Swedish Government by British Communications Corporation Ltd., a subsidiary company of Radio & Television Trust Ltd.

The two largest tankers afloat, the 88,500-ton dead weight *Naess Champion* and *Naess Sovereign*, built at Nagasaki by the Japanese Mitsubishi Shipbuilding Company for the Anglo-American Shipping Co. of Bermuda, have been fitted with main radar installation, direction finder and Escort radar equipment by Associated Electrical Industries Ltd.

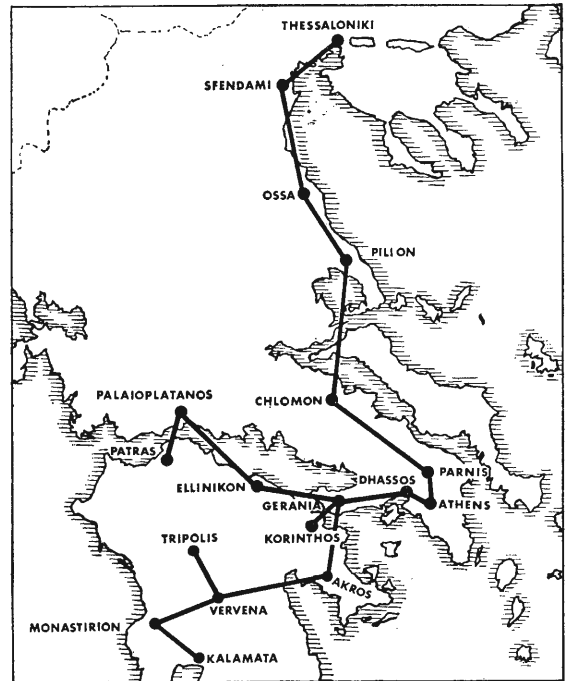

A Microwave Radio Network to provide long-distance multi-circuit telephone and television transmission links to cover most of Greece is to be supplied by Standard Telephones & Cables Ltd., London, to the Hellenic Telecommunications Organization (O.T.E.). The total route length is over 500 miles, in 17 radio "hops," 9 of which involve over-water paths requiring the use of the latest type of STC space diversity equipment. Future expansion of the network with a view to linking up with the Eurovision television system is catered for, and the equipment will provide initially two working broadband radio channels and one standby channel in the 4,000 Mc/s frequency band.

Personalities

Lord Nelson of Stafford, managing director of the English Electric Company since 1956, who succeeded to the barony on the death of his father (see obituary on this page), has been appointed chairman and chief executive of the company. Lord Nelson, who is 45, succeeded his father as chairman of Marconi's W/T Co. last year. **E. B. Banks**, deputy managing director of English Electric since April, and **G. A. Riddell**, comptroller since 1954, became joint managing directors of the company.

M. L. Jofeh, O.B.E., A.M.I.E.E., has been appointed deputy managing director of Sperry Gyroscope Co. Ltd. In addition to his new duties, Mr. Jofeh will continue as general manager—operations. He joined A. C. Cossor in 1936 as a television research engineer, becoming technical assistant to the director of research before leaving in 1947 to join Sperry to carry out research and development work on radar, fire control and missile systems. Mr. Jofeh was appointed an O.B.E. for his work on defence projects in 1956. He became chief engineer in 1957 and was appointed manager of Sperry's newly formed Industrial Division in 1959. He joined the board in 1960.

F. B. Turner has joined the staff of Channel Television as operations manager, and is based at St. Helier, Jersey. Mr. Turner joined the G.P.O. as a trainee in 1938 and served during the war years with the R.A.O.C. on radar installations, later transferring to the R.E.M.E. on its formation for duties in the technical branch as a lecturer and on research. On demobilization he rejoined the G.P.O. on transmission duties and subsequently on planning. In 1956, he joined A.B.C. Television and in 1959 was appointed senior planning engineer in charge of technical planning for the outside broadcasts division of that company.

Don Richards, A.M.Brit.I.R.E., who joined the Solartron organization as a junior engineer in 1952, has been appointed a director of Solartron Laboratory Instruments Ltd. His field of experience with Solartron has been as a project engineer in general instrument development, section leader in the development of oscilloscopes, and in charge of development of magnetic data tape recording, during which time he was on the Data Processing Equipment Committee (E.E.A.) representing Solartron.

H. ApSimon, D. Phil., has been appointed by I.B.M. United Kingdom Ltd. to the newly created post of manager, university programmes. A graduate of Oxford University, where he obtained his doctorate in 1951 for research in the theory of numbers, he joined I.B.M. in 1958 and became manager of the Applied Science Department in 1960. Dr. ApSimon's experience before joining I.B.M. included three years with Fairey Aviation and four years with Decca Radar Research Laboratories. He was at one time on the technical training committee of the Radio Industry Council.

The appointment of **E. E. Bivand**, M.I.E.E., as marketing manager (home), is announced by Standard Telephones & Cables. Mr. Bivand will be responsible for all of the company's marketing operations in the U.K. He succeeds **A. L. Sommerville**, a well-known figure in the telecommunication industry, who has retired after 38 years' service with S.T.C.

Sydney E. Storey has been appointed chief engineer of Wyndor Recording Co. Ltd. Previously Mr. Storey was for eight years with the Grundig organization, latterly as assistant production manager.

Sir Harold Wernher, Bt., G.C.V.O., T.D., has been appointed chairman of the Plessey Co. Ltd. following the death of Sir Allen Clark. It is also announced that the Plessey board has been partially reconstructed. **Field Marshal Lord Harding of Petherton** and the **Rt. Hon. Harold Watkinson, M.P.**, have joined the board, and **J. F. Mallabar**, **B. G. W. Attwood** and **A. F. Roger** have resigned.

OUR AUTHORS

Norman F. Bounsall, writes in this issue on the electronic editing of video tape on which he has been engaged since he joined the Ampex organization in America in 1959. Born in the U.K. in 1923 he was employed first as a sound recording engineer at the Denham studios of Ranks and later as a communication engineer with E.M.I. before going to Canada in 1953. For six years prior to joining Ampex he was chief transmission engineer with the National Film Board of Canada.

A. E. Cawkell, the concluding section of whose article on indexing technical information appears in this issue, is director and general manager of Cawkell Research and Electronics Ltd., which is now a member of the Simms Group. Educated at Stowe School Mr. Cawkell founded his company in 1948 after war service in the Communications Branch of the Royal Navy. He is interested in non-destructive testing, storage devices and precision measuring equipment. He has latterly been concerned with the problems of transmitting television pictures over telephone lines.



A. E. Cawkell.

Vivian J. Phillips, Ph.D., B.Sc.(Eng.), A.C.G.I., D.I.C., author of the article describing a combination lock, graduated with First Class Honours at Imperial College (City and Guilds) in 1955, and after a period of post-graduate research received the degree of Ph.D. in 1959. Dr. Phillips spent two years at the General Electric Company's Research Laboratories at Wembley, working on problems connected with pulse-communications, before taking up his present lecturing post at the University College, Swansea, in 1960.

OBITUARY

Lord Nelson of Stafford, chairman of English Electric Company, died on July 16th in his 75th year. Educated at the City & Guilds College, London, where he studied under Professor Sylvanus Thompson, George Horatio Nelson joined the Brush Crystal Engineering Company as a student. He then went to the Westinghouse Company (later Metropolitan Vickers) where he stayed until 1930 when he joined English Electric and within three years became chairman and managing director. He was also chairman of several subsidiary companies including Marconi's W/T, Marconi Instruments and Marconi Marine. He was knighted in 1943, received a baronetcy in 1955 and was raised to the peerage as the first Baron Nelson of Stafford in 1960.

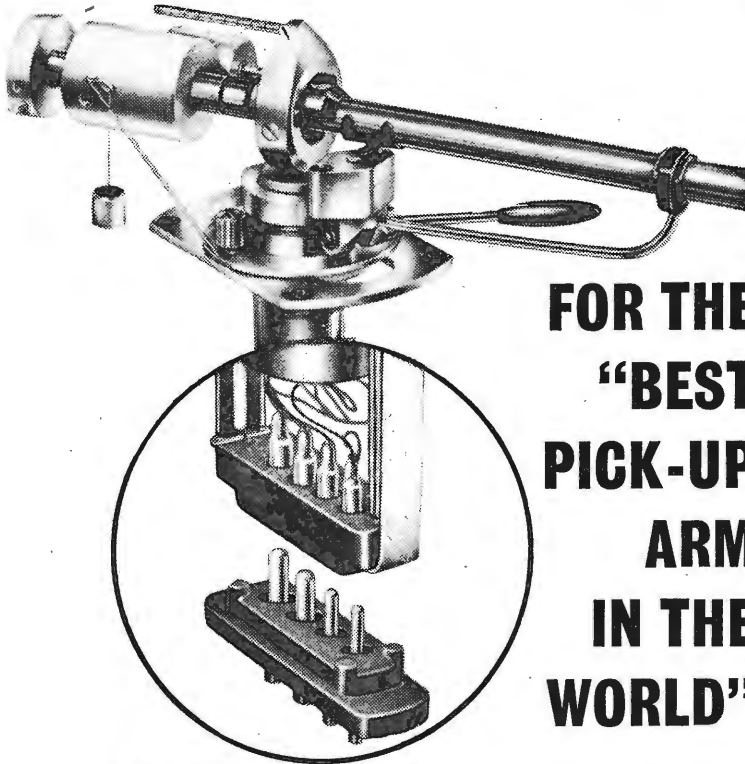

**FOR THE
"BEST
PICK-UP
ARM
IN THE
WORLD"**

**- ONLY
"Belling-Lee"
UNITORS
ARE GOOD ENOUGH**

The S.M.E. precision pick-up arm, which won the 1962 Design Centre Award, uses "Belling-Lee" Unitors.

This is just one example of the many applications for Unitors which were designed as reliable connectors for a wide variety of uses. Made to an exacting M.o.S. specification, they have been extensively used in NATO equipment all over the world, and are available in 4, 8, 12, 18 and 25-pole versions. There is a range of covers and retainers for cable-to-chassis use.

- Specification:**
D.E.F. 5321:1958
- Current rating:**
Small poles: 3A
Large poles: 10A
- Max. working volts:**
500V. peak
- Humidity:** Class H.5
- Temperature range:**
-40°C to +100°C
- Materials:**
Black nylon-filled phenolic resin moulding; silver-plated solid brass pins; beryllium-copper sockets. Tin-dipped solder spills.

Most "Belling-Lee" products are covered by patents or registered designs or applications

BELLING & LEE LTD
GREAT CAMBRIDGE ROAD, ENFIELD, MIDDXX., ENGLAND

Telephone: Enfield 5393 • Telegrams: Radiobel, Enfield

"BELLING-LEE" NOTES

No. 43 of a series

Why we are not at the Radio Show

The times are changed, and we with them. In the early days of wireless, Radiolympia was able to accommodate this magical new branch of electricity, for the vast electronics industry that we know today had not yet come into being.

"Belling-Lee" was born into this new industry in 1922, the same year as the British Broadcasting Company was founded. Almost from the start, we supplied components both to the B.B.C. and the radio setmakers, and we are proud to number them still among our customers. However, today we are more closely allied to the professional side of the industry, e.g. communications, transport, radar and navigational aids, electro-medical equipment, computers, satellites, nuclear electronics, etcetera. These are the fields in which we must concentrate if we are to meet the wages of our ever increasing pay-roll.

This is why we are now conserving our efforts for the R.E.C.M.F., I.E.A. and S.B.A.C. exhibitions. The way that "Belling-Lee" like to be represented at such important events calls for a tremendous amount of the time of all our Directors and senior executives, and there just is not enough to devote to three such exhibitions in a year.

Aerials for UHF

"Belling-Lee" participated in the original series of tests in 1955. Much research and development have taken place since then, and new arrays have been made, which meet the requirements of the B.B.C. and have been approved by them. These cover a band of 11 channels.

Mass production aerials will not be available for the new series of tests, and in any case, the transmission frequencies are different from those which will ultimately be used. However, "small batch" designs, engineered to Professional standards, have been offered to industry, and to the trade in London and the Home Counties, for channels 34 and 44. The price of a single array covering both channels is £7/10/- list.

If any reader would like an aerial for experimenting, they can be obtained in the normal way; but remember that another aerial will be required later, albeit the price will be much lower when quantity production begins. Literature and a coverage map are available on request.

There is an announcement of historical interest on page 42.

Advertisement of
BELLING & LEE LTD.
Great Cambridge Rd., Enfield, Middxx.

ACOS ADVANCE | styli *

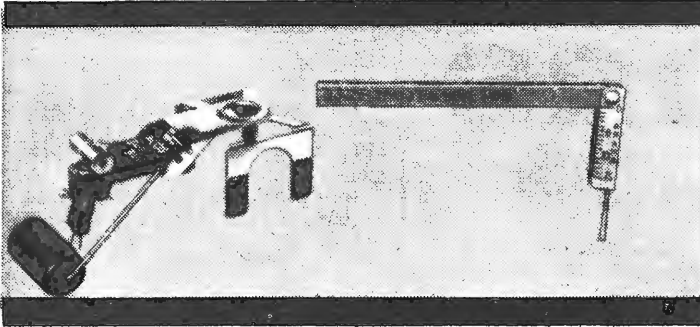
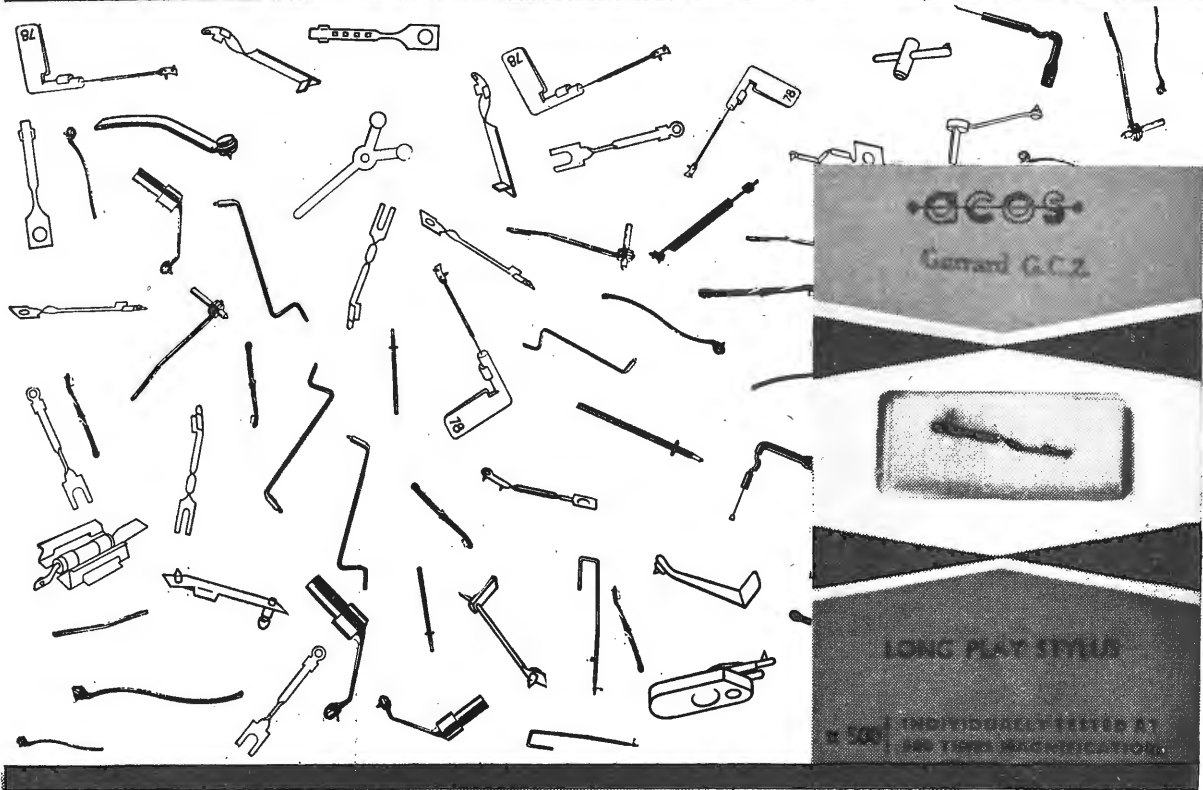

*
& changer dust bug
& stylus pressure
gauge

Acos continue to advance and be recognised. Recognised as the finest range of replacement styli now available. Diamond and sapphire, mono and stereo, there are now over 150 types of Acos x500 styli, to fit all makes of pick-ups and cartridges. There is one to fit *your* equipment. All Acos x500 styli are individually tested at 500-times magnification, yet they cost no more than other makes. Look for Acos styli in the characteristic pack. *Accessories after the fact:* Don't overlook the Acos Changer Dust Bug that sweeps all before it, and the Acos Stylus Pressure Gauge which stops pick-ups from throwing their weight about.

Other Acos products: mono and stereo pick-ups, cartridges, microphones.

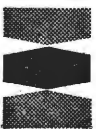

acos

ARE DOING THINGS IN STYLI

COSMOCORD LTD, WALTHAM CROSS, HERTS. TEL: WALTHAM CROSS 27331

MODULATION METER

By H. B. DENT*

SIMPLE TEST SET FOR MONITORING MOBILE A.M. TRANSMITTERS

ONE method of measuring the depth of modulation in an amplitude-modulated transmitter is by the use of an oscilloscope.† Either the modulated carrier can be examined using a suitable time-base frequency and a pick-up circuit, such as that shown in Fig. 1(a), or the combined arrangements of Figs. 1(a) and (b) can be employed without the oscilloscope time-base. The first-mentioned method provides an oscilloscope pattern of the modulated carrier which under ideal conditions takes the form of Fig. 2(a). The second arrangement gives the so-called "trapezoidal" pattern as in Fig. 2(b), where the

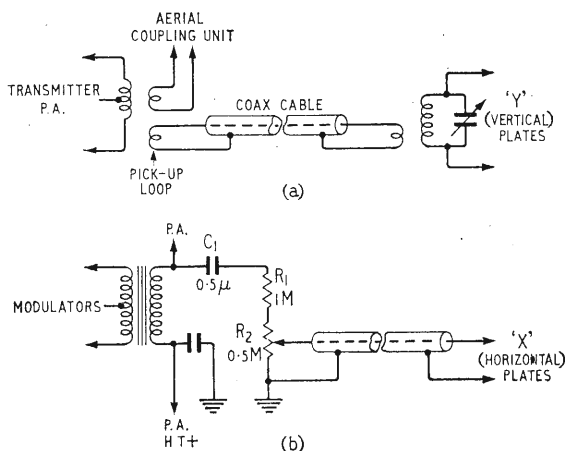

Fig. 1. Arrangement for checking modulation in an amplitude-modulated transmitter with an oscilloscope. With (a) an external sweep oscillator is required. Circuit (b) can be used in place of external sweep oscillator, but amplifiers should not be used in the oscilloscope. Values for R_1 , R_2 and C are suitable for low power transmitters of 500/600 volts working.

relative amplitudes $c d$ (unmodulated carrier) and $e f$ (modulated carrier) provide a measure of the depth of modulation.

With full, or 100%, modulation, using the circuits of Fig. 1(a) and (b) in combination, an oscilloscope pattern as illustrated in Fig. 2(b), but with the whole of this triangle illuminated and its apex resting on the x axis should result. Under these conditions the distance $e f$ should be twice $c d$. Less than 100% modulation gives a truncated triangle as shown shaded in Fig. 2(b): over-modulation is characterized by a pattern such as Fig. 2(c) with a bright-line extension of the apex of this triangle. Various other patterns may appear on the cathode-ray tube if distortion of one kind or another is present in this transmitted signal.

This cursory description of checking the modula-

tion of a transmitter by means of an oscilloscope serves two purposes. It shows that there is a fairly reliable means of checking and calibrating the performance of the compact modulation meter to be described and also exemplifies the type of equipment otherwise required in order to obtain comparable data on the modulating conditions obtaining in a transmitter. The numerous snags likely to be encountered when applying the oscilloscope method to v.h.f. transmitters have not been discussed, but they can be extremely troublesome and difficult to circumvent.

It was principally these difficulties that led to a search for a compact, portable and self-contained test set, which would be easy to handle and which could be conveniently used with mobile and portable transmitters. It was preferable to have no direct electrical connection to the transmitter and no reliance on either power supplies or batteries.

The writer remembered seeing the circuit of a modulation test set some years ago that appeared to fulfil all these requirements, but the details had been forgotten and could not be traced. As remembered, the basic principle of the meter is that the unmodulated carrier is first tuned in on a simple built-in receiver and the d.c. component arising from the rectification is indicated on a milliammeter. The carrier is then modulated from a tone source and the modulated signal, which now appears after the detector, is itself rectified and its d.c. component, independent of the r.f. carrier d.c. component, indicated on a second milliammeter. The ratio of these two independent d.c. components is a measure of the depth of modulation.

With these brief facts as a guide a meter was constructed which functioned in a most satisfactory way and with later improvements and additions is shown in Fig. 3. In this circuit one milliammeter serves for both r.f. and a.f. measurements, switch S_2 changing the meter over to the appropriate points in the circuit. One very important condition must be observed and this is that no alteration in the coupling between the test meter's pick-up aerial and the transmitter must occur between the r.f. and a.f. measurements. However, this is not difficult to observe.

Switch S_3 is included to enable either "upward" or "downward" modulation of the carrier to be checked, and jack J_1 is included so that aural monitoring of the transmitted signal can be effected merely

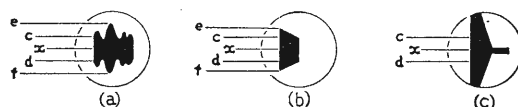

Fig. 2. Oscilloscope pattern (a) is produced using circuit arrangement of Fig. 1(a). Patterns (b) and (c) are obtained with combination of Fig. 1(a) and (b). In (a) the peak of modulation is 100%; in (b) about 50%, while (c) illustrates over-modulation.

* Amateur station G2MC.

† Detailed description can be found in R.S.G.B. *Amateur Radio Handbook*.

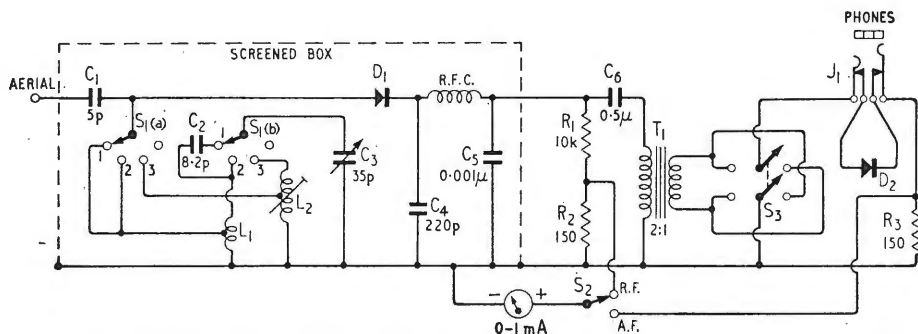

Fig. 3. Circuit diagram of the modulation meter and monitor described in the text.

by plugging in headphones. This jack automatically disconnects the audio rectifier D_2 (not to be confused with the r.f. detector D_1) which is a necessary requirement for listening to the actual audio signal.

Included in the modulation meter is r.f. circuit switching so that the set can be used on more than a single waveband, but only the v.h.f. and two of the short-wave amateur bands are covered by the meter in its present form. Any of the amateur wavebands can be covered by fitting an appropriate size of tuning capacitor and suitable coils, but the overall size of the test set will have to be increased.

R.f. switching is effected by $S_1(a)$ and $S_1(b)$, both switches being incorporated in a single two-pole, four way switch, so far only three positions being used.

In position 1 the coverage with the 35-pF variable capacitor C_3 is 135 Mc/s to 160 Mc/s; position 2 gives a coverage of 68 Mc/s to 150 Mc/s and position 3 covers 13 to 30 Mc/s. The original plan was for Range 1 to take in the 145-Mc/s band with non-critical tuning, hence the inclusion of C_2 which restricts the capacitance swing of C_3 . Range 2 was intended to cover the 70 Mc/s band using the same coil (L_1) as for Range 1, while Range 3 was intended to take in the 29 Mc/s, 21 Mc/s and 14 Mc/s bands. In this respect it falls a little short of requirements

and if the meter is required to cover the whole of Range 3 a larger capacitor will have to be substituted at C_3 . So far only the 2-metre band is required at the writer's station.

The 2 to 1 step down ratio for transformer T_1 was selected after several different ratios had been tried as it gave the best agreement with measurements made on an oscilloscope. Calculating the optimum ratio for this component could offer an interesting diversion for anyone so inclined.

One point of interest arose in the early stages of developing the meter and that was that after tuning in the carrier with switch S_2 in the r.f. position and switching to the a.f. position the milliammeter registered a current reading before modulation was applied to the signal. This was traced to a leakage of r.f. into the audio part of the instrument despite the r.f. filter C_4 , C_5 and r.f.c.: this r.f. was being rectified by D_2 . Enclosing the whole of the r.f. part of the circuit in a metal box, as shown within the broken lines of Fig. 3, remedied this defect. There should, of course, be no meter reading with S_2 in the a.f. position when the carrier is not modulated.

Operation.—The procedure for using the test meter is very simple and is as follows:—A short length of stiff wire is connected to the "aerial" terminal and with S_2 in the r.f. position (and S_1 on the appropriate studs), the "aerial" is brought sufficiently near to the p.a. circuit of the transmitter to produce a full-scale deflection on the 0-1mA meter when the unmodulated carrier is tuned in with C_3 . Without changing the coupling, S_2 is moved to the a.f. position, modulation applied to the transmitter and the milliammeter then indicates the approximate percentage depth of modulation. If, for example, a milliammeter scaled 0-1 mA reads, on "a.f." 0.8 mA when modulated, the modulation depth is approximately 80%. A 0.5 mA reading represented 50% modulation.

Point contact crystal diodes are used for D_1 and D_2 , while a matched pair was actually selected, the most important requirement is that D_1 be a v.h.f. type.

Construction.—Complete screening of the modulation meter has been found unnecessary; the screened r.f. section seems to provide adequate protection against r.f. leakage into the a.f. section. The model described here is assembled on an aluminium plate measuring $8 \times 4\frac{1}{2}$ in which forms the top of a wooden box 3 in deep.

Coil L_1 has five turns of 18 s.w.g. tinned copper wire, is self-supporting, has an inside diameter of 0.25 in and an overall length of 0.5 in. It is centred-tapped, one end of the coil being soldered direct by a short lead to No. 2 contact on S_1 (b), (Fig. 3), the

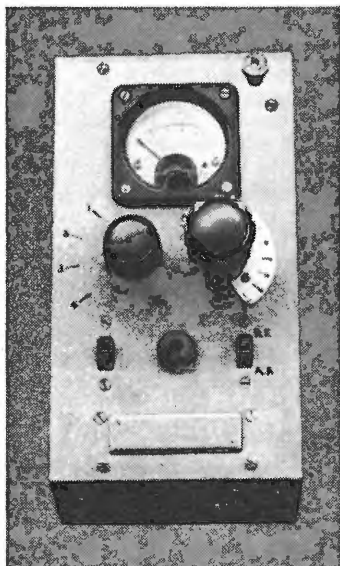

Front panel of the instrument. The aerial terminal is at top right, jack J_1 between the switches.

other end to an "earth" tag on the aluminium plate close to the appropriate side of the switch. Capacitor C_2 is soldered direct to contacts Nos. 1 and 2 of $S_1(b)$.

L_2 is close-wound with 24 turns of No. 24 s.w.g. enamelled copper wire on a moulded 0.3in diameter coil former with a dust-iron core. It is centre-tapped. The centre taps on the coils are switched by $S_1(a)$.

The tuning capacitor, C_3 , is a miniature type on a ceramic base $1\frac{1}{4}$ by 1in and has five fixed and four moving vanes with an air gap of (approx.) 0.02in. It is similar in construction to the Jackson Bros. Type C804. A 6 to 1 reduction epicyclic ball drive is fitted on the outside of the top panel, that is to say, the top surface of the panel. A short pointer of $\frac{1}{16}$ in steel rod, threaded 6BA one end, is used in place of one of the fixing grub screws. Although useful, the pointer is not essential.

The r.f. choke has 150 close-wound turns of No. 38 s.w.g. enamelled copper wire on a $\frac{3}{16}$ in diameter Paxolin rod, $1\frac{1}{4}$ in long, drilled axially at one end and tapped 6BA.

Switch S_1 , as already mentioned, is a single plate type and is $1\frac{1}{4}$ in in diameter. S_2 and S_3 are Arcoelectric slide-type switches $1\frac{1}{4}$ in long overall and $\frac{5}{8}$ in wide. The telephone jack is an all-insulated, 4-spring moulded type.

Transformer, T_1 , is home-made using "E" and "I" laminations (taken from a discarded loud-speaker transformer) measuring $2 \times 1\frac{1}{2}$ in, stacked to $\frac{5}{8}$ in. They are similar to the MEA† Type 74A. The primary is wound with 3,720 turns of No. 40 s.w.g. enamelled copper wire and the secondary has 1,860 turns of the same gauge wire. The core is not gapped. Its measured primary inductance is 25H. The milliammeter is a small 2in diameter (body) flush-fitting type.

The whole of the r.f. section within the screening box is assembled on an "L"-shaped sub-panel measuring $3 \times 2 \times 2$ in. When assembled a "V"-

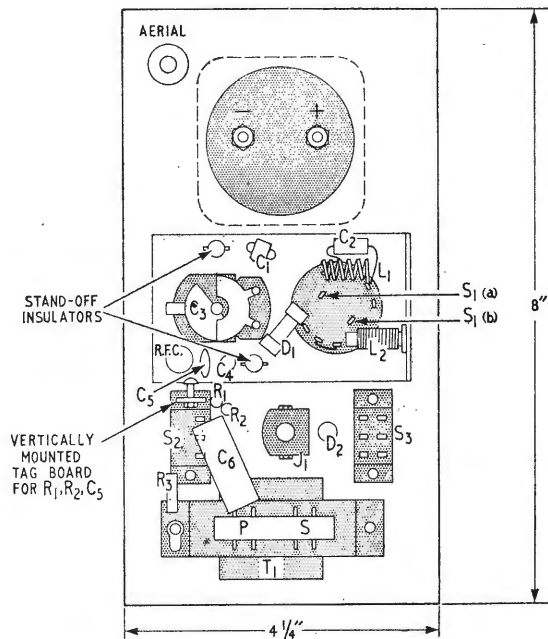
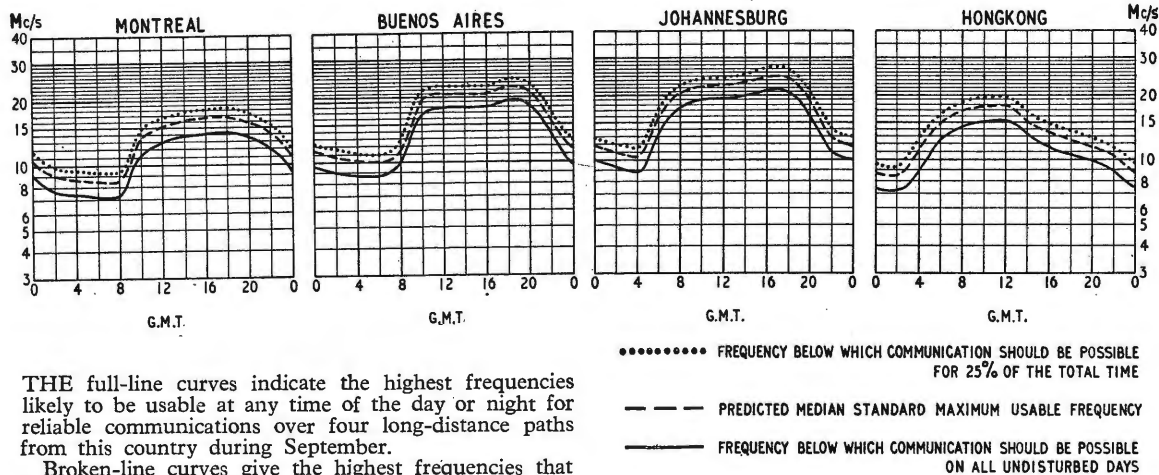

Fig. 4. Component layout used by the writer.

shaped piece is fitted with the bottom edges (those adjacent to the sub-panel) turned inwards and fixed by 6-BA screws and nuts. The sub-panel is spaced from the main panel by the large nuts holding the capacitor C_3 and switch C_1 in position. It is secured to the main panel by additional nuts on the fixing bushes of both these components, the bushes passing through clearance holes in the main panel. The side of the screening box remote from the main panel is left open in the writer's model, but if r.f. leakage is still troublesome it might have to be closed in. A sketch of the layout of the underside of the main panel is shown in Fig. 4 with the components annotated for identification in Fig. 3.

† Magnetic and Electrical Alloys, Ltd., Mercury House, Theobald's Road, London, W.C.1.

SHORT-WAVE CONDITIONS



THE full-line curves indicate the highest frequencies likely to be usable at any time of the day or night for reliable communications over four long-distance paths from this country during September.

Broken-line curves give the highest frequencies that will sustain a partial service throughout the same period.

National Radio Show Guide

WITH a preview for overseas visitors and specially invited guests on August 21st, the 29th National Radio and Television Show opens to the public at Earls Court, London, on the 22nd for ten days.

A stand-by-stand survey of the technical exhibits, prepared from information provided by the exhibitors, is given in the following pages. This, together with the list of exhibitors and plan opposite, should provide a useful guide for those attending the show. For those unable to visit the exhibition it is hoped that this will give a general picture of the show which will be supplemented by next month's review of the trends in sound and television receivers as exemplified at Earls Court.

It is essentially an exhibition of domestic sound radio and television and some 50% of the 84 exhibitors are manufacturers of domestic equipment. The remainder include the Services, G.P.O., B.B.C., I.T.A., publishers and those providing services for the industry.

A "Television Avenue," has been re-introduced this year. Here, on the first floor at the west end of the hall, five manufacturing groups are demonstrating 14 brands of colour receiver. They are Thorn (Ferguson, H.M.V. and Ultra); Pye Group (Dynatron, Ecko, Ferranti, Invicta, Pam and Pye); Rank (Bush and Murphy); Kolster Brandes (K.B.); and Philips (Philips and Cossor). The receivers are fed with a 625-line signal, with negative modulation and f.m. sound, transmitted by line from the B.B.C. studio at Lime Grove. The carrier frequencies are 48.25Mc/s vision and 54.25Mc/s sound (European channel 2). With the Government pronouncement of the adoption of the 625-

line system and the eventual use of the u.h.f. bands, manufacturers are featuring convertible and/or switchable 405/625 monochrome television receivers.

The technical services provided for the demonstration of receivers on the stands and in the demonstration rooms are even more elaborate than in the past. In addition to the 625-line colour signal mentioned, there is a 625-line v.h.f. and u.h.f. service providing both sound and vision. The channels being used are European and 11 and 25 (216-224 and 502-510 Mc/s). The signal levels are 1 mV on channel 11 and 5 mV on channel 25. The service providing the signal for the demonstration of 405-line receivers (U.K. channels 4 and 11) is also supplying sound signals for the three v.h.f. sound programmes of the B.B.C. There is also an a.m. service for medium- and long-wave receivers by inductive coupling.

Several composite features have been mounted by the organizers (Radio Industry Exhibitions Ltd.) including one comprising transistor receivers, another educational television and the third featuring export receivers. An innovation this year is the introduction of a small section on the first floor devoted to manufacturers of electronic organs. Nearby will also be found some of the piano manufacturers who have been participating in the radio show for the past few years.

Although physically it is a smaller exhibition than in the past, it would appear from information to hand—and there are bound to be last-minute disclosures—that the exhibition is none the less the focal point of the radio industry.

ALPHABETICAL LIST OF EXHIBITORS

Alba 46	G.P.O. 316	Peto Scott Electrical Insts. ... 22
Alberice Meter 34	Garrard Engineering 68	Philips Electrical 52, X10
Audix 81		Portogram Radio 77
	Hacker Radio 55	Pye 2, X11
B.B.C. 66		
B.R.C. 3, 12, X6	I.T.A. 303	R.A.F. 307
Barclays Bank 14	Invicta Radio 1	R.G.D. 56
Bird, Sydney S. 315		R.S.G.B. 318
Brasted Bros. 310	Keith Prowe 73	Radio & Television Services ... 25, X8
Burge Electronics 313	Kemble & Co. 308	Rediffusion Vision 41, 69
Bush Radio 17, X15	Kolster-Brandes 20, X2	Regentone Products 51
		Roberts' Radio 32
C.S.I. 76	Labgear 24, X7	Rola Celestion 21
Choiceview 38	Lee Products 65	Royal Navy 312
Co-operative Wholesale Soc. ... 10	Linguaphone 23	
Cossor Radio & Television ... 57, X13	Lloyds Bank 58	S.A.G.E.R. 314
	Lowther Manufacturing Co. ... 78	Slingsby 50
D.T.V. Group 60		Stella Radio & Television 47
Dansette Products 39	Markovits 62	
Daystrom 15	Martins Bank 9	T.C.C. 13
Domain Products 26	Mercantile Credit Co. 33	Tape Recorders (Electronics) ... 75
Dynatron 48, X14	Metropolitan Police 301	Teleng 44
	Midland Bank 37	Territorial Army 311
E.A.R. 79	Mullard 16, 59, X12	
E.M.I. 82	Multicore Solders 54, 67	Ultra Radio & Television ... 19
Econasign 27	Murphy Radio 11	
Ecko Radio & Television ... 40, X9		Vidor 53
Electronic Technology 28	National Provincial Bank ... 8	
Encyclopaedia Britannica ... 45	Newnes 4	Westminster Bank 7
Ever Ready 31, X16	Nicholas Luard Associates ... 70	Wireless & Electrical Trader ... 28
		Wireless for the Bedridden ... 74
Ferguson Radio Corp. ... 30, 304, X5	Odhams Press 72	Wireless World 28
Ferranti Radio & Television ... 18, X3		
Fidelity Radio 5	Pam Radio & Television ... 6, X4	Zender 309
Fountain Press 63	Perdio Electronics 29	Zonal Films 80
Fund for the Blind 317		

Guide to the Stands

ALBA (46)

Radios, television receivers and audio equipment are on show. A completely new range of record players includes the Model 216 high-fidelity portable instrument which provides an output of 5 watts from an 8 x 5-in elliptical "woofer" and a 2½-in "tweeter." The television receivers displayed are convertible to the new standard, and the "Concord" remote control is used on some models. Transistor radios are also shown, and several new stereo radiogramophones have been designed with an eye also to their function as pieces of furniture.

*Alba (Radio and Television) Ltd.,
Tabernacle Street, London, E.C.2.*

ALBERICE (34)

Slot meters for "pay-as-you-view" television, as used by rental organizations and retailers operating coin-in-the-slot television services, are featured on this stand. Fixed-tariff and variable-tariff meters are available. These are generally mounted on the TV receiver and are connected into the internal circuit, and controlled by the set on/off switch.

Alberice Meter Co., 87-89 Sterte Avenue, Poole, Dorset.

AUDIX (81)

The wide range of public address equipment on show includes a 60-watt combined amplifier and 4-channel mixer/pre-amplifier (the A60), two 15-watt 12-volt transistorized amplifiers combined with 3-channel mixer/pre-amplifiers (one of these can also be operated from a.c. mains), two combined a.m./f.m. receivers, pre-amplifiers and twelve-watt amplifiers and a six-channel pre-amplifier/mixer. Also shown are ranges of re-entrant horn, column and cabinet loudspeakers, as well as ribbon and moving-coil microphones and microphone stands. Speech trainer equipment for use by the partially deaf is also available.

*Audix B.B. Ltd., Bentfield End,
Stansted, Essex.*

B.B.C. (66)

The major part of the B.B.C. stand, which is on the ground floor this year, is given over to "programme material." In addition to the very valuable technical information service, which is always a feature of the

Corporation's stand, there is a demonstration simulating colour television. Visitors can try their "skill" at adjusting the colour content of a picture.

*British Broadcasting Corporation,
Broadcasting House, London, W.1.*

B.R.C. (3, 12, X6)

Highlights of the H.M.V., Marconiphone and Philco range of television sets, radio receivers, record reproducers, radiograms and tape recorders shown on these stands are the new 405/625 line sets which will be able to receive the new 625-line programmes with the addition of a continuously variable u.h.f. tuner. The Philco Selectafash torch-controllable TV set, the H.M.V. Model 1644 radiogram (incorporating variable artificial reverberation) and two miniature a.m. transistor receivers are also on show. Good sound quality is ensured in the H.M.V. Model 2104 a.m. transistor receiver by the one watt push-pull output stage, relatively large (8in by 5in) loudspeaker, and overload diode.

*British Radio Corporation Ltd., 21
Cavendish Place, London, S.E.1.*

BIRD (315)

Shown are a range of four electronic organs and the Golden Eagle series of amplifiers. These amplifiers feature the provision of two alternative degrees of reverberation (ob-

tained using the Bird spring delay unit), five alternative repetitive echo rates and a variable speed and depth tremolo control. One of the electronic organs—the Contemporary—is portable in three units. The others feature built-in reverberation and a true (frequency variation) vibrato. Mains variations are compensated for to avoid mistuning. Voicing is carried out by means of filters in two of the organs and tuned amplifiers in the other two.

Sidney S. Bird & Sons Ltd., Fleets Lane, Poole, Dorset.

BURGE (313)

Shown on this stand are a range of four electronic organs. One of these—the model 261—features two 61-note manuals and a 25-note pedal board. Both this and the model 244 have "sustain" and "pedal percussion" effects.

Burge Electronics Ltd., Greycains Ind. Estate, Bushey Mill Lane, Watford.

BUSH RADIO (17, X15)

Colour television, a stereo radiogramophone and new television receivers are shown on this stand. In the SRG.106 stereogram, 10-in speakers are used with concentric high-frequency pressure units. Sockets are provided for the making of stereo or mono tape records, and the tapes may be played back through the SRG.106. The 19-in and 23-in

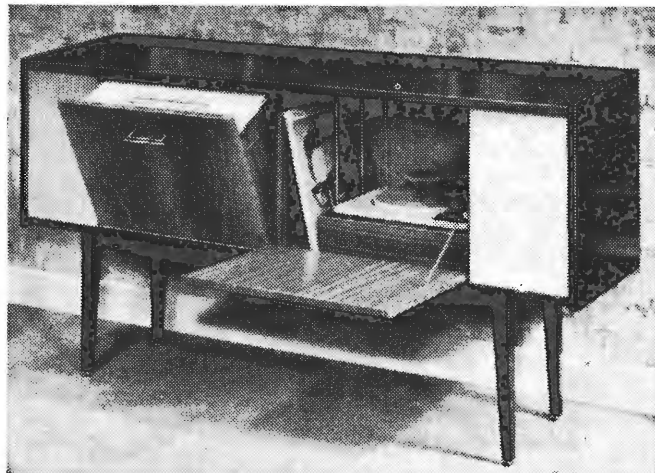

Alba 7903 stereophonic radiogram.

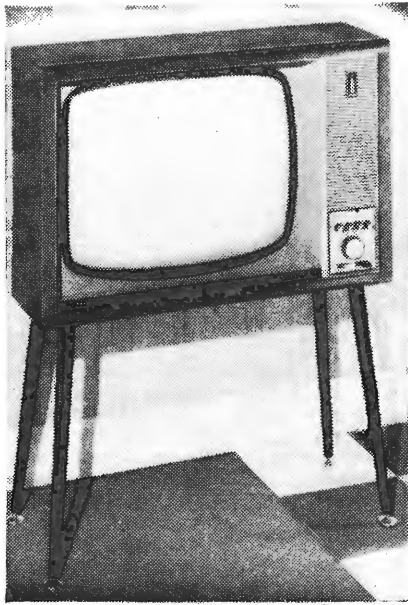

Bush TV115R fringe area model with flywheel sync.

television receivers are already fitted with time-bases which will operate on 405- and 625-line standards; the i.f. amplifier and tuner for u.h.f. reception can be added at a later stage.

Bush Radio Ltd., Power Road, Chiswick, London, W.4.

C.S.I. (76)

The two amplifiers in the new "His Master's Voice" range are among the first to have been checked for unconditional stability under the conditions recently laid down by the Audio Manufacturers Group. Also demonstrated is the current range, notable features of which are the provision (in the 555 and 556) of a 1-in c.r.t. for stereo balancing, loud-speaker phasing, output level monitoring and response checking, and the E.M.I. stereo pickup and arm. Also shown on this stand are Easco marine and office intercommunication systems. Home Maintenance will also be there to discuss the servicing of all types of domestic and commercial equipment.

Clarke and Smith Industries Ltd., Melbourne Works, Wallington, Surrey.

CHOICEVIEW (38)

Choiceview Ltd., a company formed in equal partnership by the Rank Organization and Rediffusion, shows on its stand how the Choiceview system of Pay-TV would operate and demonstrates reception with both wired distribution and independent-aerial receivers with either coin box or credit-meter. Four 19-in television receivers are used for this purpose, two of Bush manufacture and two

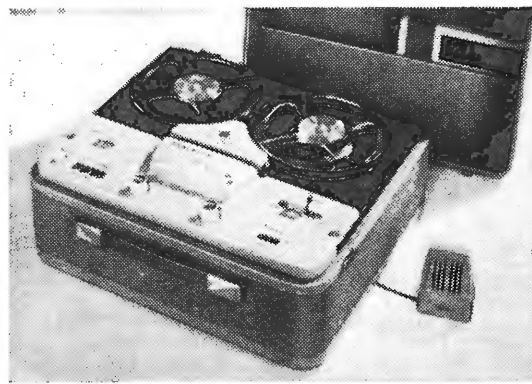

Dansette "Consort" single-speed two-track recorder—the first tape recorder made by this company.

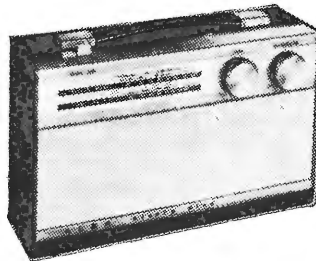

Alba "Swallow" portable radio.

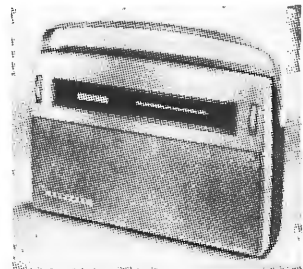

Defiant A57 transistor portable (C.W.S.).

by Rediffusion. Visitors to the stand will be able to see how to operate the Pay-TV units, also the Choiceview control room in operation.

Choiceview Ltd., Carlton House, Lower Regent Street, London, S.W.1.

CO-OPERATIVE WHOLESALE SOC. (10)

Among a range of Defiant radio and television receivers, a number of new transistor radios make their appearance, of both the "pocket-size" and "portable" classes. New television receivers employ 19-in tubes and have provision for conversion to the 625-line standard by either a plug-in adaptor or by switching. A separate on-off switch is used in the 9A41 model, with a view to prolonging the life of the control normally ganged with it. An advantage of this arrangement is that the brightness or volume control remains adjusted. Tape recorders are also on show.

Co-operative Wholesale Society, Ltd., Radio and Television Department, Alma Park, Worley Street, Upminster, Essex.

COSSOR RADIO AND TELEVISION (57, X13)

A very full range of easily-adaptable 19-in and 23-in television receivers includes several with many automatic facilities such as motor-driven tuners, contrast control and remote-control of channel selection, brightness and

volume. Cossor also have a colour receiver in Colour Television Avenue. Several sound radio receivers are displayed, both "pocket" type and "portable," and monaural and stereophonic radiograms and record-players are to be seen.

Cossor Radio and Television Ltd., 233 Tottenham Court Road, London, W.1.

D.T.V. GROUP (60)

One of the firms in this group, Beulah Electronics, is demonstrating a range of closed-circuit television equipment, including the new "Tele-Audio", by means of which sound as well as vision can be handled. A microscope coupling unit is shown. Direct TV Replacements are showing a selection of radio and television components and two test instruments—the D.900 transistor tester and the Skantest shorted turn detector.

Direct TV Replacements Ltd., 138 Lewisham Way, London, S.E.14.

DANSETTE (39)

This company are showing their first tape recorder—the Consort—an inexpensive single-speed two-track model. A socket for feeding a tape recorder is one of three provided in the Bermuda record player, the other two sockets being for an extension speaker and second-channel amplifier and speaker for stereo. Transistorized units include the Princess, which is

a push-button radiogram, and two miniature models—the Classic record player and RT66 receiver. The Classic record player is fitted with one of this company's inexpensive diamond styli: the RT66 receiver measures only 4¼-in × 3-in × 1½-in.

Dansette Products Ltd., Plus-a-Gram House, 112-116 Old Street, London, E.C.1.

DAYSTROM (15)

Audio equipment on show includes the S-99 stereo amplifier, which gives 9 watts output per channel at a maximum of 0.42% distortion (40 c/s). A printed-circuit transistor amplifier is offered as an output amplifier for a radio tuner, battery turntable, etc., and gives an output of 500 mW into 3 ohms. An a.m./f.m. tuner, the AFM-1, is provided with flywheel tuning and a tuning indicator, and a 2-position a.m. selectivity switch. The output is either high-impedance or 600 ohms from a cathode-follower. A Q-multiplier and telephone amplifier are also shown, and all items, though offered as kits, can be obtained already built.

Daystrom Ltd., Bristol Road, Gloucester.

DOMAIN (26)

frolley specialists, Domain have a wide selection suitable for housing service, intercommunication and sound reproducing equipment, including a special trolley for the Mullard valve tester. A range of display stands includes a new "LS" series which will display a variety of merchandise on pegboard. Plate glass tiered displays, browser boxes, and a lettering and pricing system for pegboard displays are also on view.

Domain Products Ltd., Domain Works, Barnby Street, London, N.W.1.

DYNATRON (48, X14)

Newly introduced are three television receivers which, with the addition of an inexpensive u.h.f. tuner, will be able to receive both 405- and 625-line transmissions. Among the three stereo a.m./f.m. radiograms which are also introduced is the Marlow, which has as many as three loudspeakers for each stereo channel. One of the two new transistor portables—the Nomad de-luxe—features a combined tuning and battery drain indicator and "peak performance" control for prolonging the battery life. Also shown is the TRP2 semi-professional tape recorder, an unusual feature of which is the provision of two microphone inputs.

Dynatron Radio Ltd., St. Peter's Road, Maidenhead, Berks.

E.A.R. (79)

An addition to the Packagram range of portable transistor radiograms and record reproducers is the four-speed



Ekco mains/battery transistor radio.

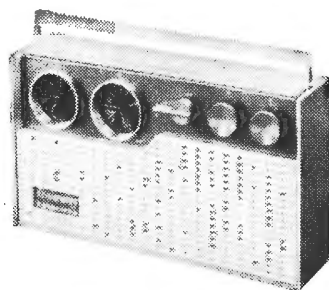

Ferguson "Freeway" transistor receiver.

Automatic Radio-packagram. Other models in the wide range of transistorized equipment available from this company are the Astor receiver and Auto-bat four-speed record reproducer. Other new (mains valve) models are the Music Maker Stereo and Bantam Super record reproducers; a feature of the latter is that it is fitted with a diamond stylus for l.p.s. Also shown are the well-known Triple-four (four loudspeakers, four speeds, four controls) mono and stereo record reproducers.

Electric Audio Reproducers Ltd., The Square, Isleworth, Middlesex.

E.M.I. (82)

Complete units on show include the ET40 two-speed four-track tape recorder (which can replay, but not record, stereo), a range of mono and stereo record reproducers, the Glyndebourne V. a.m./f.m. stereo radiogram, and a range of loudspeaker systems, one of which—the Minispeaker—has been specially developed as an extension speaker for portable receivers. Components on show include a range of ceramic-magnet loudspeakers, and the 985 mains or battery 4-speed record turntable. Also shown is the full range of professional and domestic Emi-tapes, the six new Emiguide instructional tapes for sound recordists and, also by John Borwick, a new book called the Emitape Guide to Better Recording.

E.M.I. Ltd., Blyth Road, Hayes, Middlesex.

ECONASIGN (27)

Showcard and price ticket writing are facilitated by Econasign transparent stencils available in a choice of type designs. Each lettering outfit is supplied complete with an alignment bar, paints (red, black, blue, green) brushes and all necessary accessories. The company also offer cardboard blanks including fluorescent card.

Econasign Co. Ltd., 19-21 Palace Street, Victoria, London, S.W.1.

EKCO RADIO & TELEVISION (40, X 9)

A full range of 19-in to 23-in dual standard television receivers can be seen, including several motor-tuned

types and those incorporating the "Magic Ray" channel selector which is operated by a torch beam. A transistor television camera is demonstrated operating on 625 lines in Band I (Ekcovision receivers operate on 625 lines in both Band I and Bands IV/V). A range of transistor radios is shown, including a mains/battery type, most of which employ a battery-saving circuit. Car radios, radiograms and record players are also on display.

Ekco Radio and Television Ltd., Southend-on-Sea, Essex.

EVER READY (31, X16)

The main emphasis is on the well-known Sky Leader and Car Portable Transistor receivers. The latter model is a dual purpose transistor portable and car radio receiver which, on insertion into its screening container in the car, is automatically connected via an ignition interference filter to the 12-V car battery (which increases the output power from 400 to 1000 mW) and to a larger loudspeaker (8-in by 5-in in place of 4-in diameter). Also shown are the full range of the well-known Power Pack batteries for transistor receivers.

Ever Ready Co. (Great Britain) Ltd., Hercules Place, Holloway, London, N.7.

FERGUSON (30, 304, X5)

Shown are four new television receivers which are adaptable for 625-line operation by the addition of a sub-chassis and u.h.f. tuner (fitted with a preset fine tuning control). An interesting feature of two new tape recorders using Ferguson's deck is that the deck and amplifier are constructed as one unit to facilitate servicing. Among new transistor receivers is the "Freeway" which has been styled like an instrument with independent "watch dial" tuning scales. Also shown are the "Tune-time" clock switched transistor radio and (high pitched continuous) alarm, and a new transportable a.m. radiogram.

Ferguson Radio Corporation Ltd., Thorn House, Upper St. Martin's Lane, London, W.C.2.

FERRANTI RADIO & TELEVISION
(18, X3)

The record-player and stereo radiogramophone introduced this year are both fitted with a tone-compensated volume control. The RP.1088 auto-changing record player has an output of 7 watts from an 8 x 5-in speaker, independent bass and treble controls being provided. Television receivers are dual-standard types, only the u.h.f. tuner being required for 625-line operation. The u.h.f. tuning scale is already fitted.

Ferranti Radio and Television Ltd., 41/47 Old Street, London, E.C.1.

FIDELITY (5)

An interesting new exhibit is the Duet Ampligram, which is a combined record reproducer and microphone amplifier (with independently adjustable level control). An input socket is also provided for an electric guitar. The record player is fitted with a mono/stereo pickup though an additional amplifier and speaker are needed for stereo. Also shown are two- and four-track versions of the inexpensive Argyll Minor tape recorders, the HF range of record players, two transistor receivers, and the RG-27 a.m./f.m. radiogram.

Fidelity Radio Ltd., 11-13 Blechynden Street, London, W.11.

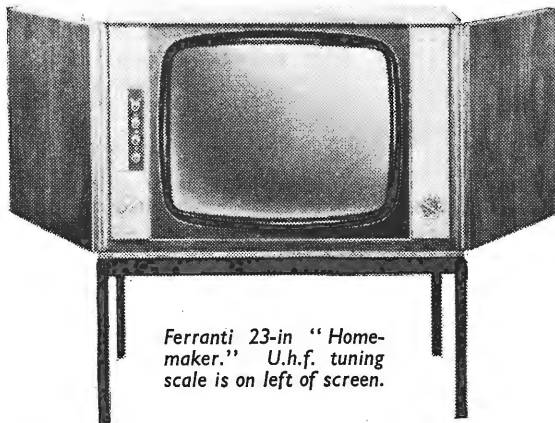

Ferranti 23-in "Home-maker." U.h.f. tuning scale is on left of screen.

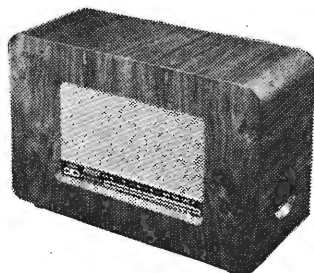

Hacker "Mayflower" f.m. only eight-valve receiver featuring three i.f. stages and push-pull output.

FUND FOR THE BLIND (317)

Information is available on the work of this Fund, which organizes collections and distributes money to 14 institutions for the civilian blind in Greater London. A blind telephonist is operating a modified switchboard which is serving the nearby stand of the G.P.O.

Greater London Fund for the Blind, 2 Wyndham Place, London, W.1.

G.P.O. (316)

Radio communication, from the early experiments of Hertz and Marconi (who was encouraged by the then chief engineer of the Post Office), to the latest means of telecommunications via earth satellites, is traced in a series of animated displays. Readers will be particularly interested in the section devoted to the work of the television switching centres through which the whole network of U.K. television stations and the sources from which programmes originate are linked.

General Post Office, St. Martin's-le-Grand, London, E.C.1.

GARRARD (68)

Record players shown by this company include the well-known 301 transcription turntable, the Laboratory Series Auto Turntable Type A with its unusual sandwich-constructed turntable, and the small-

depth Autoslim record changer. Also shown are a range of pickups, and a stylus pressure gauge. The magazine-loading tape deck now exists in several versions, and a two-speed battery tape deck is also shown. Other exhibits include a range of fractional horse-power motors and the TR series of heat-dissipating valve shields.

Garrard Engineering & Manufacturing Co. Ltd., Newcastle Street, Swindon, Wilts.

HACKER (55)

Models shown by this company include the Cavalier record reproducer with its associated GP15/ST speaker/amplifier unit for stereo, the Herald and Mini-Herald transistor portables, and the Mayflower valve f.m. receiver, features of which are its high sensitivity and good limiting (obtained by using three i.f. stages), seven-watts push-pull output and large (10-in by 6-in) loudspeaker. Features of the Herald are its acoustically loaded relatively large (8-in by 5-in) loudspeaker, one-watt push-pull output stage and (treble cut) tone control.

Hacker Radio Ltd., Norreys Drive, Cox Green, Maidenhead, Berks.

I.T.A. (303)

The growth and regional development of independent television is the

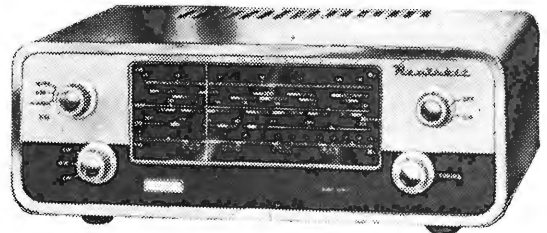

Heathkit a.m./f.m. tuner by Daystrom. V.h.f. circuitry is in sealed unit, remainder being on printed board.

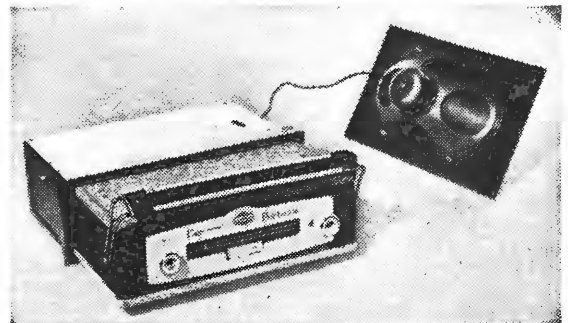

Ever Ready "Car Portable" combined transistor portable and car receiver in its car screening case with, on the right, car loudspeaker.

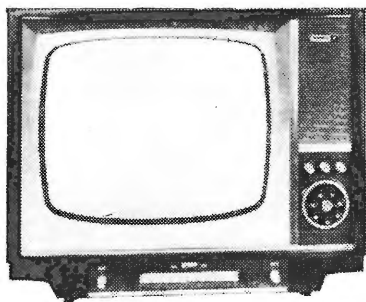

Murphy Astra Mark II television receiver fitted with u.h.f. converter.

theme of this display. The focal point is a circular cinema in which is shown a film describing the planning and construction of the Authority's newest station—at Preseli, Pembrokeshire. This station, which will radiate in channel 8, is planned to be brought into service in mid-September.

Independent Television Authority, 70 Brompton Road, London, S.W.3.

INVICTA RADIO (1)

A range of dual-standard (less tuner) television receivers with 17, 19 and 23-in tubes are displayed and, representing the alternative philosophy, two 405-line receivers, which may be converted to u.h.f. working when required. These latter feature motor-driven, push-button tuning and remote control. Among the collection of sound radio receivers is the Model 331, which is an a.m./f.m. transistor instrument. A portable stereo record-player, the Model 63, is demonstrated.

Invicta Radio Ltd., 100 Great Portland Street, London, W.1.

K.B. (20, X2)

Five new television receivers are shown, most being completely suitable for reception of the 625-line transmissions. For areas where these are not due to start for some time, receivers are available which are switchable, but which will need u.h.f. tuners later. All sets use bonded-face tubes and forward-facing speakers. A novel feature is the provision for connection of a baby alarm, and the latter feature is also available on the Cavalier transistor radio, one of a selection of new receivers. Radiograms and record players are also displayed.

Kolster-Brandes Ltd., Footscray, Sidcup, Kent.

LABGEAR (24, X7)

Of topical interest is the introduction of a series of u.h.f. aerials for the projected television service. Preliminary test transmissions will take place in channels 33 and 44, and will then give way, in the London area, to transmissions in channels 23 and 33. With an eye to the future, then,

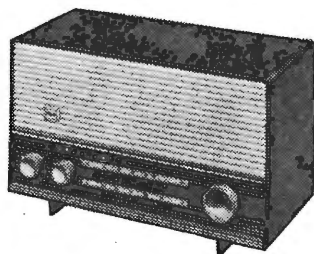

Pam transistor radio Model TB90.

Labgear have developed four new aerials, two of these covering each set of channels with either 8 or 14 elements. Average gain of the 14-element arrays is about 10.5 dB with a front-to-back ratio of 15:1. The aerials are designed to match a 75-ohm feeder. Intercommunication units for the home and works are also on show.

Labgear Ltd., Cromwell Road, Cambridge.

LEE PRODUCTS (65)

The wide range of products shown by this company include Dulci and other amplifiers, pre-amplifiers and tuners, record reproducers, the Dulci H5 a.m./f.m. radiogram chassis, a transistor receiver and record reproducer, two car radios, a wide range of car aerials, and three combined guitar amplifiers and loudspeakers. Two of these feature a variable speed and depth tremolo control and, in addition, the 30-watt Shaftesbury Double 20 has an overload indicator.

Lee Products (Great Britain) Ltd., 10/18 Clifton Street, London, E.C.2.

LINGUAPHONE (23)

Home study of foreign languages (37 in all) with the aid of recordings is being demonstrated. The courses are available on 45 r.p.m. or 78 r.p.m. "semiflex" records or on tape.

Linguaphone Institute Ltd., 207-209 Regent Street, London, W.1.

LOWTHER (78)

On show are a wide range of loud-speaker systems, driver units, audio amplifiers, pre-amplifiers, and f.m. tuners. The loudspeaker systems are horn-loaded and include the well-known TP1 and the Acousta Twin stereo unit with its interesting adjustable arrangements for reflecting and diffusing the sound. The loud-speaker drive units feature a very high flux density and internal fixed cone stabilizing bungs, and are suitable for horn loading. The amplifiers are unusual in providing feedback to the output valves at both their screen (ultra-linear) and suppressor grids.

Lowther Manufacturing Co., St. Mark's Road, Bromley, Kent.

MARKOVITS (62)

Filigree cut-out nameplates, finished in electro-plated gilt or chrome, are shown by Markovits, who now offer for the first time a three-dimensional metal and plastic cut-out nameplate. Advertising "give-away" novelties in a variety of forms are also exhibited.

Istvan Markovits Ltd., 34 Stronsa Road, London, W.12.

METROPOLITAN POLICE (301)

An operator's position, similar to those in the Information Room at New Scotland Yard, is a feature of the Metropolitan Police stand. It is linked to the Scotland Yard v.h.f. R/T system and communication is available to or from any of the several hundred mobile units (including river boats and aircraft) which may be in the area of some 700 square miles covered by the Metropolitan Police. The availability of the mobile units at any given time is shown by a Fleet Indicator System, which gives, on an illuminated display, combinations of up to 30 different suffixes to call signs within 23 Divisions, grouped in four Districts.

So far as police radio equipment is concerned the emphasis has shifted from the problems of adjacent channel selectivity to those of linearity and intermodulation products in the crowded spectrum.

Metropolitan Police, New Scotland Yard, London, S.W.1.

MULLARD (16, 59, X12)

The well-known range of circuit design booklets for home constructors will be on sale to the public. These cover mono and stereo amplifiers and pre-amplifiers, f.m. tuners and tape record and replay amplifiers. For manufacturers there is also a Set Maker Room where components for the industry are displayed.

Mullard Ltd., Torrington Place, London, W.C.1.

MULTICORE SOLDERS (54, 67)

A demonstration is mounted of the winding and packing of coils of Savbit solder. A new type of dispenser is introduced, which contains 16ft of 18 s.w.g. solder, and can be held in the hand while in use. Some of the output of the demonstration "factory" will be sold at the main stand.

Multicore Solders Ltd., Maylands Avenue, Hemel Hempstead, Herts.

MURPHY (11)

Highlights of the new Astra Mark 2 range of 405/625-line receivers are the possibility of receiving the future 625-line programmes with the simple addition of a u.h.f. tuner (fitted with both coarse and fine tuning controls) and provision for plugging in a vision limiter or flywheel sync. Also shown

(Continued on page 429)

**OUTSTANDING FEATURES
ASTOUNDING PRICE**

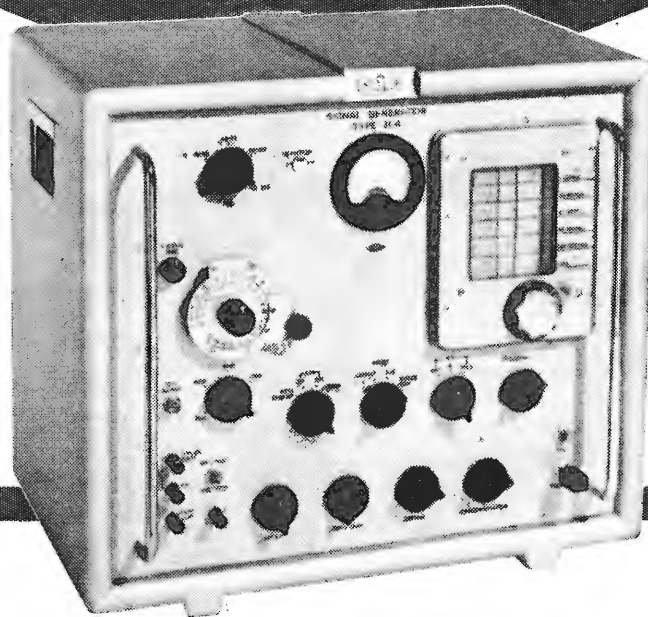

The **AIRMEC** V.H.F. Signal Generator
TYPE 204
for development and testing

The Signal Generator Type 204 is of advanced design, and provides, over the frequency range 1 Mc/s. to 320 Mc/s., a highly stable signal from a constant impedance. The facilities provided for modulation are comprehensive and the output may be either continuous wave, amplitude-modulated, pulse-modulated or combined amplitude and frequency-modulated

- ★ 1-320 Mc/s in 5 range
- ★ Scale length 48 inches
- ★ Crystal Calibration
- ★ A.M., F.M. and Pulse Modulation Facilities
- ★ Stabilised output 2 μ V to 200mV r.m.s.
- ★ Output Impedance 75 and 52 ohms.

IMMEDIATE DELIVERY

ALL THIS FOR ONLY £240

Airmec

V.H.F. Signal Generator

AIRMEC LTD., HIGH WYCOMBE, BUCKINGHAMSHIRE, ENGLAND. Tel.: High Wycombe 2501/7. Cables: Airmec, High Wycombe

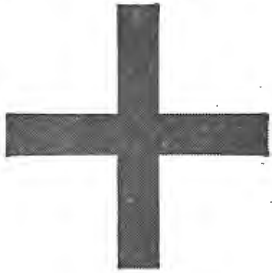

an extra
plus feature is the
Low Price
of the Solartron
Pulse Generator GO 1101

The GO 1101 is proving to be an essential tool for analysing fast switching circuits, computers, data handling systems, counters, amplifiers, modulators, filters, etc.

- * **SINGLE OR DOUBLE RECTANGULAR PULSES OR SQUARE WAVES**
fastest edge < 12 nanosec
- * **CONTINUOUSLY VARIABLE PARAMETERS INCLUDE:**
PERIOD: 2 μ sec—100 msec (5 ranges)
PULSE DURATION: 1 μ sec—100 msec (5 ranges)
PULSE AMPLITUDE: 0.5 V—100 V (4 ranges)
DELAY: 1 μ sec—10 msec (4 ranges)
- * **SQUARING FACILITY** produces 0.5—100 V square-waves from sine-wave or poor square-wave inputs between 25 c/s and 5 Mc/s.
- * **-10 V PREPULSE**
- * **EXTERNAL SYNCHRONISATION FACILITY**
—for frequency dividing or oscilloscope sweep delay
- * **WEIGHT** 15 lb (6.75 kg)
- * **DIMENSIONS** 11 $\frac{3}{8}$ in. \times 7 $\frac{7}{8}$ in. \times 15 in. (H \times W \times D) (28.7 \times 18.5 \times 38.1 cm)

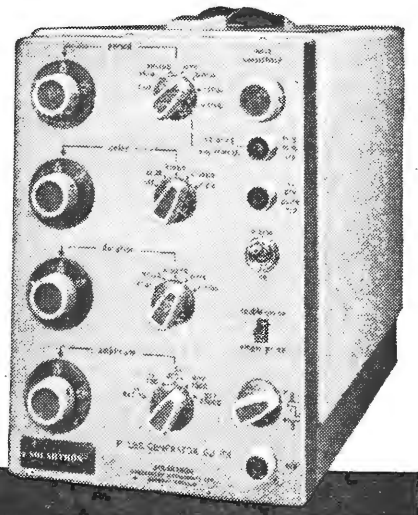
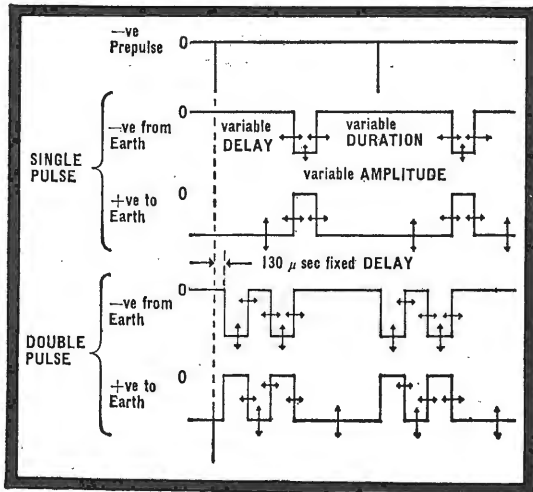

PRICE £150

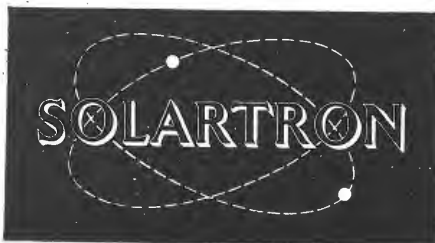

For full details write to:
SOLARTRON LABORATORY INSTRUMENTS LTD.,
Cox Lane, Chessington, Surrey.
Telephone: LOWER Hook 5252.
Telex: 23842 Solartron Chess. Cables: Solartron Chess.

M & P S 113

are two receivers in which the channel switch and volume can be remotely controlled by an ultrasonic (cordless) transmitter. One highlight of the range of receivers, radiograms and record reproducers is the B585 small a.m./f.m. transistor receiver. Also shown is the TR1 tape recorder.

Murphy Radio Ltd., Welwyn Garden City, Herts.

PAM RADIO & TELEVISION (6, X4)

A range of 19-in and 23-in television receivers are exhibited, capable of working on both 405- and 625-line standards. U.h.f. tuners can be fitted immediately or obtained when required. The emphasis this year is on radio receivers, ranging from large table models to pocket portable sets, all using a battery-saving circuit. One of them, the TB71, offers v.h.f. reception, slow-motion tuning and a negative-feedback a.f. amplifier. A tape recorder socket is provided. A portable stereo record player, the SP63, is shown.

Pam (Radio and Television) Ltd., 295 Regent Street, London, W.1.

PERDIO (29)

One model in the wide range of transistor receivers shown by this company, the Town and Country, features a one-watt output, large (8-in x 5-in) loudspeaker, and special switch for isolating the internal aerial to reduce ignition interference when the receiver is used in a car. Also shown is the 10-transistor Multi-Band 102, which offers continuous coverage from medium waves to the 11-metre band (as well as covering long waves). Other exhibits include standard and de luxe versions of the small-size (2½ in by 4½ in by 1½ in) Mini 66.

Perdio Electronics Ltd., Bonhill Street, London, E.C.2.

PETO SCOTT (22)

A range of 19-in and 23-in television receivers are on show, two of which are dual-standard, apart from a u.h.f. tuner, which will be available later.

Peto Scott Electrical Instruments Ltd., Addlestone Road, Weybridge, Surrey.

PHILIPS (52, X10)

The widest range of Philips equipment yet seen at a Radio Show is presented. Five new television receivers are offered, all with provision for reception of the 625-line transmissions, and all with power-tuning for remote control, and automatic brightness adjustment. The new radiograms incorporate the Philips AG1015 autochanger, which has adjustable playing weight and push-button controls. The drive-wheel is retractable to prevent the formation of flats. Colour television is demonstrated.

Philips Electrical Ltd., Century House, Shaftesbury Avenue, London, W.C.2.

PIANO MANUFACTURERS

Several manufacturers of pianos are again represented at the Radio Show, though not as numerically strong as at last year's exhibition. Brasted Brothers (Stand 310), Kemble (308), and Zender (309), offer a selection of upright, grand, baby-grand and miniature pianos.

Brasted Brothers Ltd., Hermitage Road, Harringay, London, N.4.

Kemble & Co., Ltd., 97 Carysfort Road, London, N.16.

Zender, Sydney, Ltd., Milborne Street, London, E.9.

PORTOGRAM (77)

An interesting product is a four-transistor one-watt amplifier intended for use as a baby alarm. Highlights of the wide range of record reproducers are the various versions of the Varsity, all of which incorporate push-pull amplifiers and one of which incorporates a variable speed (15-80 r.p.m.) transcription turntable. Also available are a battery record player and two and four-track tape recorders.

Portogram Radio Electrical Industries Ltd., Audio Works, Paxton Road, Tottenham, London, N.17.

PYE (2, X11)

The main feature of the stand is the display of dual-standard television receivers. The most elaborate instrument on show is the "Trio," a combination of radio, gramophone and television, whose volume and channel selection is performed by ultrasonic remote control. Several car radios are shown, one of them being a dual-purpose type. A small, pocket-size receiver, which is usable outside the car, plugs into a recess supplied with

power from the car battery and with signals from an external aerial. A transistorized television receiver, the TT1, uses a 14in tube and will work from mains or, for a short time, from internal batteries.

Pye Limited, Cambridge.

R.A.F. (307)

The U.K. Air Traffic Control System forms the central feature of the Air Ministry's stand where visitors can also see some of the equipment used for the instrumentation of guided weapons such as Firestreak and Bloodhound I. The radio control of Jindivik target aircraft and the operation of the search and rescue beacons (SARBE) are also being demonstrated. Particulars of the R.A.F. Amateur Radio Society, membership of which is open to past as well as present members of the Service, are available on the stand.

Air Ministry, Whitehall, London, S.W.1.

R.G.D. (56)

A quartet of radiogramophones is the attraction on this stand, two being stereo console models and one a portable transistor instrument. The Garrard "Autoslim" autochanger is used in the console models, with the Acos GP.67/1 cartridge in a monoaural version, while the portable radiogram is fitted with the B.S.R. T.U.7 turntable. The 207 Deluxe Stereo radiogram uses two 10x6in speakers, with a pair of 4-in diameter "tweeters." Convertible and switchable television receivers are also displayed.

Radio Gramophone Development Co., Ltd., Eastern Avenue West, Romford, Essex.

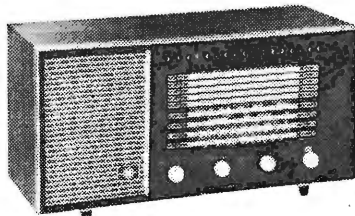

Pye Model 1101 mains radio with bandspread on one short-wave band.

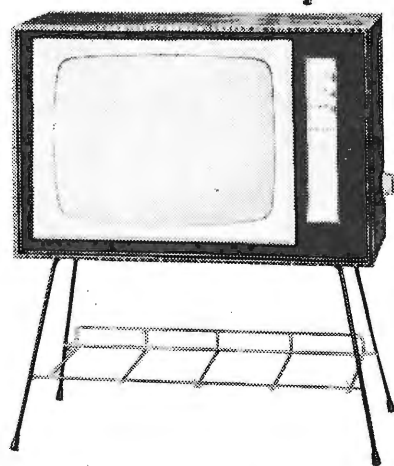
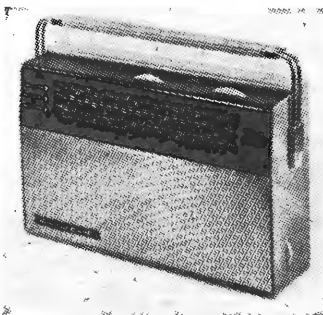

Peto-Scott Model 239 23-in television receiver.

Perdio "Town and Country" transistor receiver.

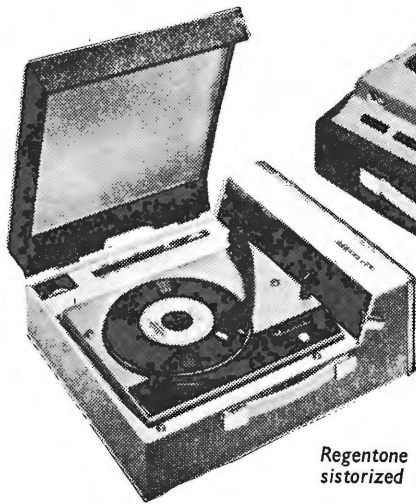

Regentone BRG 19 transistorized radiogram.

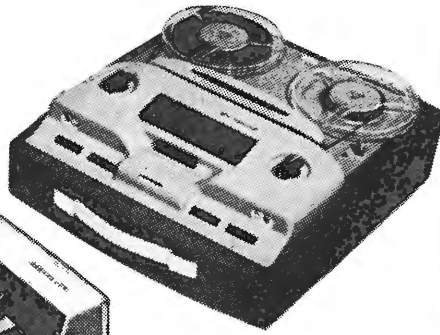

Sound "Slimline" tape recorder.

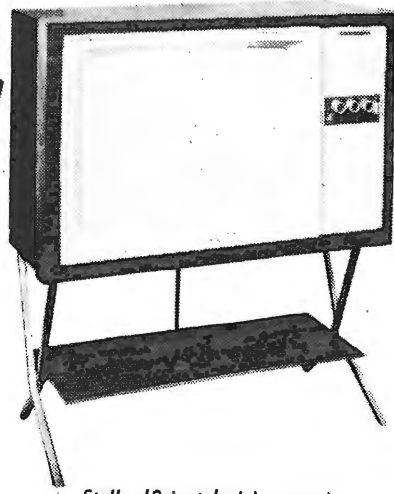

Stella 19-in television receiver.

R.S.G.B. (318)

Amateur transmitting and receiving equipment, both commercial and home-constructed, together with publications and information on the activities of the society, are to be found on this stand.

Radio Society of Great Britain, New Ruskin House, Little Russell Street, London, W.C.1.

REDIFFUSION VISION (41, 69)

On Stand 41, a demonstration is mounted of television and sound distribution by wire. A complete system is shown carrying one 625-line and two 405-line television programmes, and the B.B.C. Home, Light and Third sound programmes on a six-pair cable. Distribution at low frequencies considerably simplifies receiver design, especially as regards standards switching, and several receivers are shown which are capable of receiving the two television standards and sound broadcasts. Details of a maintenance service are shown on Stand 69.

Rediffusion Vision Ltd., Carlton House, Lower Regent Street, London, S.W.1.

REGENTONE (51)

19-in television receivers displayed are completely workable on 625-line operation, apart from the u.h.f. tuner. Alternatively, they are obtainable for 405-line working only, with provision for replacement of the relevant units. All types employ amplified, delayed automatic picture control, and both vertical and horizontal flyback suppression. Plug-in flywheel synchronizing units are available. In the audio field, a transistor portable radiogramophone is shown, which uses the BSR TU7 4-speed turntable. The power output is 750mW from a 6 x 4-in speaker.

Regentone Radio and Television, Ltd., Eastern Avenue West, Romford, Essex.

ROBERTS' (32)

Shown on this stand is the R200 medium and long-wave transistor receiver, an unusual feature of which is the use of an OC78 transistor to stabilize the bias to the push-pull output stage and thus reduce the distortion at the end of the battery's life. This receiver is fitted with a 5-in loudspeaker. Its directional aerial can be readily correctly positioned because the cabinet is mounted on a turntable.

Roberts' Radio Co., Ltd., Molesey Avenue, West Molesey, Surrey.

ROLA CELESTION (21)

Sound reproduction enthusiasts will be interested in the well-known Colaudio II loudspeaker system. Two unusual features of this are the bass loudspeaker—which has a "solid" cone made of expanded polystyrene for increased rigidity and to reduce "break up"—and the small cabinet volume (less than 2 cu ft). Also showing, for manufacturers, are a wide selection of loudspeakers with diameters ranging from 2½ to 15 inches, and, for public address purposes under arduous conditions, a number of re-entrant pressure-driven horns as well as column loudspeakers.

Rola Celestion, Ltd., Ferry Works, Thames Ditton, Surrey.

ROYAL NAVY (312)

Anti-submarine warfare is the main theme of this stand where some of the latest types of radar displays, plotting tables and part of the A/S detection set are to be seen. Shore terminal communications equipment on display includes s.s.b. transmitters and receivers. The Fleet Air Arm's contribution to anti-submarine warfare is illustrated by a sectioned helicopter fitted with the "Dipping Asdic" and the airborne lightweight u.h.f. communications set, radio alti-

meter and doppler navigator now being fitted to helicopters.

Admiralty, Whitehall, London, S.W.1.

S.A.G.E.R. (314)

Features of the Curtis Minor Classic electronic organ which is on show are a four-octave fully polyphonic keyboard (the total range is over six octaves), seventeen rocker-type tablet stops which may be mixed as desired, a variable speed and depth vibrato control, and a brilliance control for adjusting the organ to suit the room or hall acoustics. A solo tablet is available which reduces the sound level of the lower half of the keyboard to permit the upper section to be used as a solo manual.

S.A.G.E.R., Ltd., 106, Bellingdon Road, Chesham, Bucks.

SLINGSBY (50)

Trucks for handling television receivers and other bulky electronic equipment, etc., are displayed by Slingsby. A selection of aluminium ladders includes models having rubber padded pressure plates to reduce risk of damage to tiles and ridges and are especially designed for aerial erectors.

H. C. Slingsby, Ltd., 89, Kingsway, London, W.C.2.

STELLA (47)

The main emphasis is on television, with 12 receivers being demonstrated on both 405- and 625-line standards. Specifications range from simple 19-in sets to a de-luxe 23-in receiver—the ST1043. The latter incorporates automatic brightness control and remote control of "viewer variables". Several "steam" radios are shown, in all classes, and both stereophonic and monaural radiograms are offered.

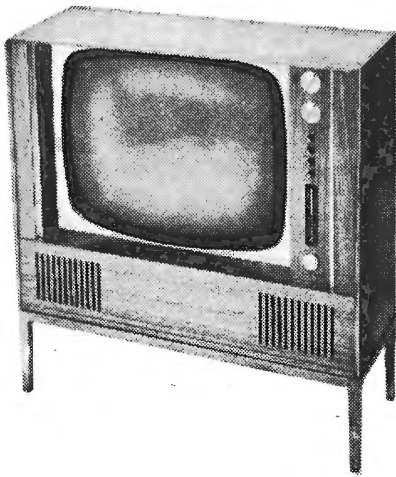

Ultra 23-in console television receiver, with visual u.h.f. tuning scale.

the new Philips autochanger being used.

Stella Radio and Television Company Ltd., Astra House, 121-3 Shaftesbury Avenue, London, W.C.2.

TAPE RECORDERS (75)

As many as eight new models are introduced by this company. These are in two ranges—the Slimline and Riviera, each range having both single and three-speed models in both two- and four-track versions. Features of the Slimline range are the provision of superimposition and two-channel mixing facilities, stereo playback on the four-track models, a record/replay frequency response at 7½-in/sec within ±3dB from 80c/s to 14kc/s, and a signal-to-noise ratio of at least 40dB.

Tape Recorders (Electronics), Ltd., 784-788, High Road, Tottenham, London, N.17.

T.C.C. (13)

Recently-developed exhibits are the "Supamold" and "Duomold" capacitors, which are paper and paper-and-polyester dielectric types with moulded cases. They are chiefly intended for high temperature working. Prominent in the range of printed-circuit products are plated-through circuits and flush-bonded types intended for use as commutators and switches. Applications shown include modules such as filters, amplifiers and television sub-assemblies. Products of the Ceramics Division are also on show.

Telegraph Condenser Co., Ltd., North Acton, London, W.3.

TELENG (44)

A wide range of equipment for communal-aerial television and broadcast reception is on view, with a new series of amplifiers and channel con-

verters in the "U" series. Wide-band amplifiers are available to cover Bands I, II and III at three different gains, and signals in Bands III, IV and V are more easily handled by conversion to a lower frequency in the U166 and U194 crystal-controlled converters. For a comprehensive system, amplifiers are available for the medium and long-wave bands.

Teleng, Ltd., Teleng Works, Church Road, Harold Wood, Romford, Essex.

TERRITORIAL ARMY (311)

A representative selection of receivers and ancillary communications equipment used by the Army is being demonstrated on this stand which is manned by men and women of the 65th Signal Regiment T.A. Information is available on the technical training given the various Signals "trades" in the regular Army, T.A. and Army Emergency Reserve.

65th Signal Regiment, Territorial Army, 79/85 Worship Street, London, E.C.2.

ULTRA (19)

Newly introduced are two dual-standard television receivers (with space for the addition of the continuously variable u.h.f. tuner). Also shown are three 19-in receivers, mono and stereo a.m./f.m. radiograms (the latter featuring an earphone socket for mono or stereo private listening) and an extra-slim portable record reproducer. The range of transistor receivers includes three a.m. and one a.m./f.m. model: this last—the TR81A—incorporates sockets for external aerials for a.m. or f.m. and for feeding a tape recorder.

Ultra Radio and Television Ltd., Television House, Eastcote, Ruislip, Middlesex.

VIDOR (53)

Among the wide range of batteries on show are a new range of metal clad transistor batteries, the Double Life V0042, the weather proof "Metal Clad" Fencer (L5074 and "Kalium" mercury miniature hearing aid batteries.

Vidor Ltd., West Street, Erith, Kent.

WIRELESS FOR THE BEDRIDDEN (74)

Over 9,000 sound receivers or relay installations have been supplied by this society, which was founded in 1939 to provide free radio to needy bedridden, housebound and aged invalids. The society, which also maintains the installations free of charge and provides the licence where necessary, is now extending its activities to supply television sets to Voluntary Old People's Homes, etc. The space for this stand is given by the exhibition organizers to the society which relies entirely on voluntary contributions for the support and continuance of its work.

"Wireless for the Bedridden" Society (Inc.), 20 Wimpole Street, London, W.1.

ZONAL (80)

The Zonatape range of standard and long-playing magnetic recording tapes is available in three types of base, di-acetate, standard and polyester extra play, with grade identification by coloured spools (diameters 3in to 10½in). A feature of these tapes is the incorporation of a coating lubricant for reducing tape lead wear. Tapes may be inspected and a selection of professional recordings heard in the Zonal demonstration room.

Zonal Film (Magnetic Coatings) Ltd., Zonal House, Westfields Road, Acton, W.3.

"WIRELESS WORLD" PUBLICATIONS

	Net Price	By Post
PRINCIPLES OF SEMICONDUCTORS M. G. Scroggie, B.Sc., M.I.E.E.	21/-	21/11
COLOUR TELEVISION: N.T.S.C. System, Principles and Practice. P. S. Carnt, B.Sc. (Eng.), A.C.G.I., A.M.I.E.E. and G. B. Townsend, B.Sc., F.Inst.P., M.I.E.E., A.K.C.	85/-	87/3
RADIO VALVE DATA Compiled by the staff of "Wireless World." 7th Edition	6/-	6/10
RADIO AND ELECTRONIC LABORATORY HANDBOOK M. G. Scroggie, B.Sc., M.I.E.E. 7th Edition	55/-	57/3
BASIC MATHEMATICS FOR RADIO AND ELECTRONICS F. M. Colebrook, B.Sc., D.I.C., A.G.G.I. Revised by J. W. Head, M.A. (Cantab.). 3rd Edition	17/6	18/6
PRINCIPLES OF TRANSISTOR CIRCUITS S. W. Amos, B.Sc. (Hons.), A.M.I.E.E. 2nd Edition	21/-	22/-
HIGH-QUALITY SOUND PRODUCTION AND REPRODUCTION. H. Burrell Hadden.	42/-	43/5
SOUND AND TELEVISION BROADCASTING. General Principles. K. R. Sturley, Ph.D., B.Sc., M.I.E.E.	45/-	46/4
GUIDE TO BROADCASTING STATIONS Compiled by "Wireless World." 13th Edition	3/6	4/-

A complete list of books is available on application.
Obtainable from all leading booksellers or from

ILIFFE BOOKS LTD., Dorset House, Stamford Street, London, S.E.1.

Classification and Retrieval of TECHNICAL INFORMATION

2.—THE NOTCHED CARD SYSTEM IN PRACTICE

By A. E. CAWKELL

(concluded from page 357 of the previous issue)

IN the author's organization a number of private systems existed together with a conventional catalogue index, available to all but understood completely by few.

The Index.—The first step was to list every subject known to be of interest in the various fields of activity in which the organization was engaged. A certain amount of anticipation was used at this stage to embrace subjects of possible future interest. From a study of the completed list it became evident that there were a large number of subjects of interest which belonged to no particular hierarchy such as "paint," "painting," "static electricity," "tuning forks," etc. There were also a number of subjects such as "acoustics" and "non-destructive testing" which it was desirable, if not essential, to sub-divide.

tive testing," etc.; each was then sub-divided alphabetically into "B" level subjects, which occasionally were sub-divided again into "C" level subjects, but it was never found necessary to extend to "D" level. There were about 14 such hierarchies so that a searcher will find comprehensive coverage should he desire to retrieve any information by selection from the whole subject.

There are likely to be occasions, however, say in the case of a new searcher, where the hierarchies will be unfamiliar and may be by-passed, and a "B" level subject would be looked for initially. Moreover, the logic of the searcher may differ from that of the classifier. For instance, should "fuel cells" be a sub-division of "power supplies" or listed alphabetically in the "F's"?; would "photography" be searched for under "optics"? "Vibration pick-ups" could be listed under the "V's," "P's," "acoustics" or "transducers."

All these possibilities were allowed for in the index by entering every subject in every place where it was considered likely that a searcher would look. Extensive use of the expression "see under —" was therefore avoided.

The result of this extensive multiple entry system, coupled also in some cases with "rotated entries," leads to an increase of bulk in the index. However, even if there are double the number of entries, there is a much greater probability of finding the subject, and finding it more quickly.

There is no problem from the abstractors' point of view when making out new cards. Assume that the punched card code number for "vibration pick-ups" is 04 10 16 29 this number will be found in the index against the subject wherever it appears. If the abstractor has made out a reference card in respect of an article dealing with "vibration pick-ups" in the "transducer" context, he looks under "transducers" and finds "vibration pick-ups 04 10 16 29"; this number is slotted on to the card, automatically making the retrieval connection between the card and all other positions of the group in the index. If the searcher looks for "vibration pick-ups" under "V," he finds the same code number and hence retrieves the desired card.

Retrieval based on a combination of subjects is often valuable and this is taken account of in the index. Consider, for instance, "non-destructive testing." Here there are a number of independent variables—the "material," the "testing principle," and the "property of interest." The main subject

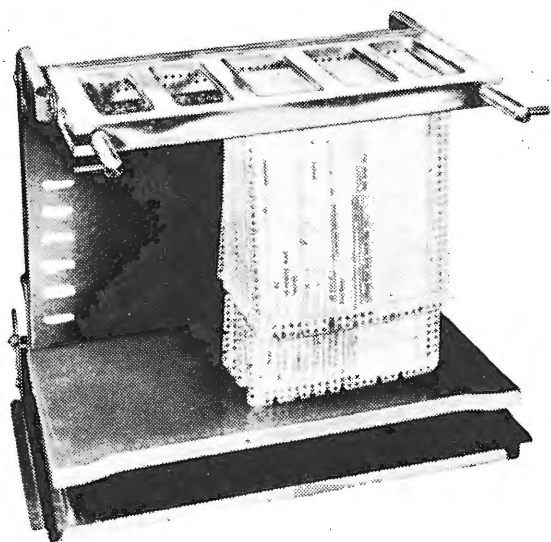

Fig. 3. Typical "key-sort selector" (Royal McBee, 36, Worship Street, London, E.C.2.)

The rough index was then broken-down and the subject matter classified alphabetically in a thumb indexed loose-leaf book as follows.

A number of hierarchies were established and placed in their correct alphabetic position—"acoustics," "amplifiers," "power supplies," "non-destructive

in this case is divided into three "B" level sections, with "C" level sub-divisions as follows:—

Materials	Testing Principles	Property
Bricks	Damping constant/Q.	Coating thickness
Coal	Eddycurrent	Corrosion
Concrete	Elasticity/electro-dynamic	Curing
Ceramics etc.	Gamma ray Magnetic etc.	Cracks Porosity Strength etc.

The appropriate combination is selected by the abstractor according to the contents of the abstract. For example, an article on "non-destructive testing of concrete by damping constant measurements in order to detect porosity," would be detected by using the three code groups found opposite each subject.

To cope with the varying logic of users of the system, all "C" level subjects were also listed alphabetically in the index as, for instance, "Bricks—non-destructive testing of," "Cracks—non-destructive detection of." The need for this becomes evident by posing a question such as "if porosity is of interest, will a searcher invariably look under non-destructive testing?" If the answer is no, then alphabetic classification is also necessary.

Mechanical Handling of Cards—Exclusive Sections.—The idea of sectionalizing the cards is attractive from several points of view, particularly if their number becomes large. For instance, if there are 10,000 cards (and this is the number that we consider may exist in the foreseeable future), it would be convenient to concoct 10 categories such that there were about 1,000 cards per category. When retrieving, the searcher's attention would be directed to a drawer holding one category of cards and the 1,000 cards would be sorted in two packs of about 500—this being a conveniently handled quantity. The operation is quite rapid particularly if a "key-sort selector" (Fig. 3) is used. Such a device is particularly useful if a number of needles are used when sorting.

Two ways of arranging the categories come to mind; first, by the classification of all materials under 10 broad subject headings; secondly, by sectionalizing according to abstract content. For the latter method only three categories can at present be conceived—"Electronic Circuitry," "Electronic Arts" (circuitry incidental), and "Allied Sciences."

If any kind of sectionalization is decided upon each category must be mutually exclusive, so that any card can be held in one section only, without ambiguity. If a particular article covers subjects which have been allocated different sections, then separate cards must be made out to be held in each section.

Once again we are confronted with the possibility of ambiguity due to human logic. This is not a "private" system; classifiers and searchers may come and go. It was therefore considered desirable, at least during the early stages of operation, not to sectionalize, but to bear in mind the possibility of it as the system grew. All cards in the system must therefore be sorted for every retrieval.

To this end (and for a very useful occasional review of effectiveness) it was decided to maintain a record of the "transactions" of the system during its early operation. A pattern of "mutual exclusive-

Bandpass Filters (Passive)	07 03 13 14
Bandreject Filters	04 18 21 09
Barretters	02 10 12 05
Batteries, Accumulators, Standard Cells	01 25 17 16
Bibliographies, Classification and Retrieval, Libraries	05 24 19 15
Blindness, Aids for	06 28 20 10
Blocking oscillators	
General	22 22 11 03
Nanosecond	12 08 29 23
Sawtooth waveform generators, as	09 27 01 04
Transformer design	07 17 28 09
Bolometers	14 06 24 19
Boolean Algebra	26 11 02 01
Bootstrap circuit (General, Specifically)	21 15 08 13
Bricks, Testing of	15 01 28 16
Bridges	
Bridged T	27 10 04 18
Campbell	05 22 16 29
Comparison	23 15 19 03
Detection/Balance Techniques	06 17 12 08
General	11 07 16 20
Hay	29 25 12 02
High Resistance Measurements for	26 27 14 03
Impedance, universal	19 28 08 17
Inductive Ratio Arm	25 24 18 20
Limit Resistance	10 06 13 11
Low Resistance measurements for	23 05 15 14
Owen	03 29 13 18
Schering	27 09 29 16
Twin T	02 16 22 20
Wagner Earths	06 17 12 08
Wheatstone	26 01 04 19
Wien	07 23 24 04

ness" may then emerge to form the basis of effective sectionalization.

A section of the index is shown above.

Coding Subjects.—Direct, sequence, selector, and random superimposed coding were considered. For subject coding the latter appears to be the most suitable, bearing in mind the size of the cards, the number of holes available, and the number of subjects, which was over 1,000 and might increase. It therefore became necessary to consider the implications of Table 1, given in the early part of this article.

An analysis of several hundred typical references showed that 55% contained one subject of interest, 28% two subjects, 14% three subjects, 3% four subjects with a negligible percentage above four.

For a pack of 10,000 cards made up of references having the above mentioned subject composition, the unwanted drops will be as in Table 2 below.

If sectionalization is to take place when the number of cards exceeds, say 3,000, then the above situation would be acceptable. If, however, it is assumed that sectionalization will never take place,

TABLE 2

No. of subjects in ref. of interest	Average no. of needles required to retrieve	No. of unwanted cards dropping				
		Four Sub.	Three Sub.	Two Sub.	One Sub.	Total
4	13	<1	<1	<1	<1	<1
3	10	<1	<1	<1	<1	<1
2	7	<1	<1	<1	<1	<1
1	4	7.8	10.78	3.64	<1	22 approx

Number of unwanted cards dropping out of a pack of 10,000 cards when composition of pack is 55% 1 subject cards, 28% 2 subject,—14% 3 subject, and 3% four subject.

S U B J E C T S																																							
AUTHOR(S) — <i>J. Miedginski & S. A. Patel</i>																																							
PUBLICATION — <i>E. R. A. publication ref. V/T 140</i>																																							
TITLE — <i>Versatile feedback amplifiers for computers, laboratories and industrial use.</i>																																							
LOCATION OF PUBLICATION — <i>C.R.E. file No. 58 paper No. 1738</i>																																							
ABSTRACT — <i>A mathematical analysis of the design and performance of the E.R.A. simple versatile feedback amplifier is given. Working circuits, tables, curves, and variations of circuits are included. The basic circuit is a ring of three, with high impedance input and cathode follower output. One version has a gain of 50, and a 2 Mc/s bandwidth with 60 db/s of feedback.</i>																																							
SUBJECTS CODED:														INITIALS OF ABTRACTOR																									
<table border="0"> <tr><td>16</td><td>08</td><td>15</td><td>22</td></tr> <tr><td>26</td><td>28</td><td>04</td><td>08</td></tr> <tr><td>12</td><td>03</td><td>17</td><td>18</td></tr> </table>														16	08	15	22	26	28	04	08	12	03	17	18														
16	08	15	22																																				
26	28	04	08																																				
12	03	17	18																																				
D E F I N I T I O N S																																							

Fig. 4. Example of a completed card.

and that perhaps one day the number of cards will exceed 10,000, then a drop out of 22 unwanted cards every time a one-subject search is conducted might be considered unacceptable. In this case the remedy is to limit the number of subjects per card to three, and make out two cards for abstracts embodying more than three subjects.

We decided to adopt random superimposed subject coding and, as soon as mutually exclusive sections become apparent, to confine certain categories of cards to labelled drawers so that there will never be an embarrassing number of drop outs.

It will be appreciated that the unwanted drop outs of Table 2 will only be correct for random distribution. If most of the abstracts deal with a relatively small number of subjects—and this tendency is likely to exist—then the number of unwanted cards may under certain conditions increase. This may well lend force to the need for sectionalization.

Coding Other Concepts

1. Author's name.

This is coded by the 7, 4, 2, 1 sequence code, in three separate fields, using one letter per field for the first three letters of the author's name, or the initial letter of the names of the first three authors in the event of multiple authorship. The code is A=1, B=2, etc., the alphabet being split into two halves. When "N-Z" is slotted N=1, O=2, etc.

Two fields of a selector code are used for the decade and the year.

3. Composition and common variables

Direct coding is used.

Example of a complete card.—A card is shown in

Fig. 4. The cards are supplied by the manufacturers with all holes punched and all information shown in the outside margins printed on every card. The abstractor writes or types in the abstract, marks the holes to be slotted, then sends the card to the system operator who slots the marked holes.

In the example shown three subjects have been coded. The groups are also written on the card by the abstractor; this is to facilitate the task of differentiating between wanted and unwanted cards when hand sorting.

Acknowledgments. The writer would like to thank members of the staff of Cawkell Research & Electronics Limited, in particular Mr. R. Reeves, and of the staff of Dawe Instruments Limited, for much valuable assistance in devising this system.

Correction.—Line 18, left-hand column of page 356 of the previous issue should start "slotting 20 into Fig. 1(b) . . ."

Receiver/Recorder Connections

RECOMMENDATIONS drawn up jointly by the British Radio Equipment Manufacturers' Association and the Audio Manufacturers' Group include circuit connection points in the receiver or radiogram, sockets and plugs, wiring, arrangements for paralleling the channels of a stereo radiogram for use with a mono recorder, additional resistors to avoid harmful interaction between the two units, and input and output sensitivity requirements for the tape recorder. Free copies of the recommendations ("Connections between Tape Recorders and Radio Receivers") may be obtained from the secretary of B.R.E.M.A., 49 Russell Square, London, W.C.1.

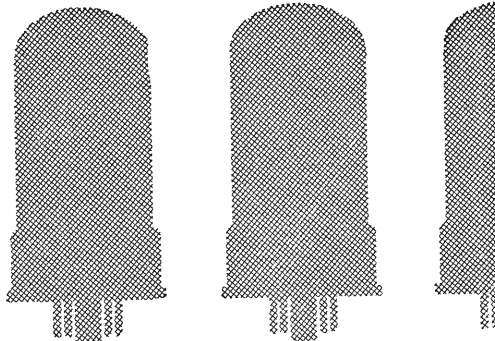
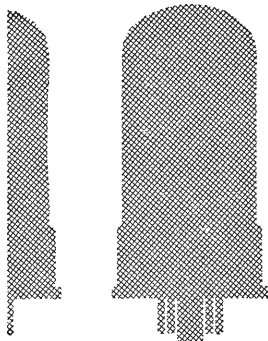

The newly-introduced 12E14 is pre-eminent among stabiliser valves—in performance, design and construction. It is based on the well-known and successful 12E1 and has the same unique electrical characteristics, but it has considerably improved mechanical features. In the 12E1 the anode electrode was connected to a top cap while the 12E14 is of single-ended construction with the anode connected to one pin of an International Octal base. The 12E14 is very much more compact, more convenient for paralleling, easier to install and more rugged. You can gauge its fine performance from the details in the table, together with those of other AEI stabiliser valves.

13E12—a low impedance version of the 13E1—gives 15% more current under stabiliser (triode connected) operating conditions. It is also suitable for servo amplifier applications.

11D12—a low mu power double triode with separate cathodes—is for use as a series regulator valve in d.c. power supplies, in servo applications or as a booster triode.

11E14—an output beam tetrode—is for use as a series regulator valve as well as a pulse modulator and radar and TV scanning valve.

			12E14	13E12	11D12	11E14
Heater voltage	volts	V_h	6.3	26.0 13.0	6.3	6.3
Heater current	amps	I_h	1.6	1.3 2.6	2.5	1.2
ABSOLUTE MAXIMUM RATINGS						
Anode voltage volts	V_a (max)	800	800	250	5kV
Screen voltage volts	V_{g2} (max)	300	300	—	500
Control grid voltage volts	V_{g1} (max)	-100	-100	—	-300
Anode dissipation watts	P_a (max)	35	90	13	10
Screen dissipation watts	P_{g2} (max)	5	10	per section	3
Anode plus screen dissipation watts	P_{a+g2} (max)	—	95	—	—
Cathode current mA	I_k (max)	300	800	125	4A
Resistance between grid & cathode... (cathode bias) $M\Omega$	R_{g1-k} (max)	—	—	1.0	—
Resistance between grid & cathode... (fixed bias) $k\Omega$	R_{g1-k} (max)	—	—	100	—
Heater to cathode voltage volts	V_{h-k} (max)	300 (k+ve)	300 (k+ve)	300	—
Peak inverse voltage (booster) kV	PIV (max)	—	—	3.0	—
CHARACTERISTICS						
Anode voltage volts	V_a	150 at $V_{g2}=150V$	150 at $V_{g2}=150V$	—	100 at $V_{g2}=100V$
Anode current mA	I_a	200	600 at $V_{g1}=23.5V$	125 per section	120
Mutual conductance mA/V	g_m	14	25	7.0	14.5
Amplification factor	μ	—	2.8	2.0	—
Inner amplification factor (g_1 to g_2)	μ_{g1-g2}	5.3	—	—	—
DIMENSIONS & BASING						
Overall length mm	—	106	140	103	110
Seated height mm	—	93	128	88.5	95
Diameter mm	—	44	65	43.5	32
Base	—	10	B7A	10	10

*Pulse modulation ratings. Pulse duration 1μs, duty factor 0.001



Associated Electrical Industries Ltd

Radio Components Department PD16

155 Charing Cross Road, London WC2

Telephone: GERrard 9797 Telegrams: Sieswan Westcent London

NEWS

for all who plan
Radio Communications
systems

REDIPLEX by REDIFON

the answer to medium distance
multi-channel communications
problems

REDIPLEX gives you 4 voice-frequency channels (speech, teleprinter, facsimile or tone) on one r.f. pilot carrier on a low or medium-power radio link at *a cost far below that of other ISB systems*. Multi-channel ISB communication becomes thoroughly economic *for the first time* on low-power radio links.

REDIPLEX is available as separate transmitting or receiving terminals or as an ISB drive system.

Find out more about REDIPLEX. Full technical particulars are available on request.

Redifon LIMITED

Communications Sales Division,

BROOMHILL ROAD, LONDON, S.W.18 • TEL: VANdyke 7281 A manufacturing company in the Rediffusion Group.

RED/RED 1

Turntable Rumble and Pickup Arm Design

By J. WALTON*

ADJUSTING THE MASS AND COMPLIANCE TO PROVIDE BUILT-IN FILTER ACTION

DURING the past two or three years one or two pickup arms have appeared on the market with various refinements and improved principles of construction, some of which principles were described in an article in *Wireless World*, June 1959 (p. 269).

In spite of the above, however, one important principle, that of relating the arm to the particular pickup head, has often gone unheeded or unnoticed. Articles have appeared describing methods of reducing turntable rumble, yet the fact that this can primarily be determined by co-ordination of arm and pickup design seems to warrant a further discourse on the subject.

Now the bass response range of a pickup is determined by the combined effective mass of the pickup arm and head, resonating with the compliance of the stylus movement, according to the relation $f_0 = 1/2\pi\sqrt{MC}$ where f_0 is the bass resonance below which the response of the pickup falls off rapidly, and M and C are respectively the combined effective mass of arm plus head and stylus compliance.

Bass Resonance Adjustment

If the resonance is arranged to be *just* at the lower limit of the recorded range (see Fig. 1) it will also usually be found to be *above* the range of the most troublesome rumble frequencies, and improvements of some 10 to 20dB can often be obtained in the signal-to-rumble ratio. Of course the resonance should be adequately damped, and some crystal pickups have sufficient mechanical resistance (not stiffness) in the stylus movement to achieve this without further trouble, whilst some magnetic pickups will require a fairly large amount of damping (resistance, not friction) to be incorporated in the pivot system of the arm.

It should be mentioned that whilst such damping to the pickup stylus movement may affect the ultimate tracking capability of the pickup in the mid-audio range, it need not impair its performance under the most stringent practical conditions required of the pickup (see Fig. 2). The inclusion of damping at the pickup arm pivots could, on the other hand, encourage the transmission of vibration from the turntable and deck to the pickup head. This can be understood if one considers turntable and deck to have vibratory motion in relation to one another as also described by other authors, the resistance at the pivots then providing transmission for vibration, according to its velocity, to the arm and head (in relation to the disc and stylus). On the other hand, damping in the head tends to negate this process.

*Decca Record Co.

Since the masses involved in this fundamental bass resonance are large compared to other functional masses in the pickup, surprisingly high "Q's" are approached and surprisingly sharp cut-off curves (about 24 dB/octave) are usually obtained, which could otherwise necessitate complex rumble filter arrangements. Apart from the "mechanical poetry" of integrally in-built mechanical rumble filters arrangements, another advantage of eliminating the effect of rumble at its source of excitation is to improve the tracking capability of the pickup and to reduce any tendency (sometimes experienced at very low tracking weights) of the rumble to "modulate" the required music signal. Rumble is seen by the pickup mainly as a vertical signal which from even a moderately good turntable may be as high as to be equivalent to 1 cm/sec at 1kc/s and, if the pickup is undamped and with its bass resonance at a rumble frequency point, this effect can be magnified several times.

Now following from the above it would be possible to achieve a better arrangement still if the inertia of the head and arm could be arranged to give a higher cut-off frequency in the vertical mode than the lateral. This is, in fact, permissible since not only does low-frequency vertical motion on a stereo pickup produce out-of-phase signals that should produce no net output under normal listening conditions (long wavelength in relation to room size or loud-

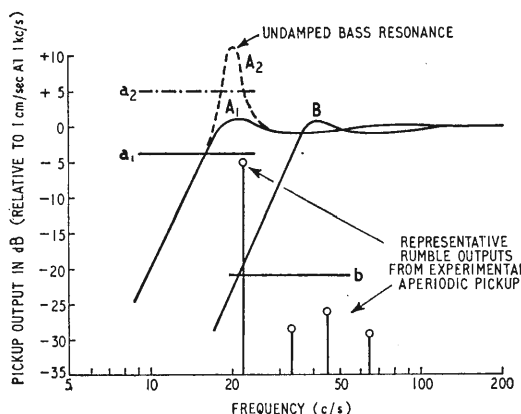

Fig. 1. Curve sketches show effect of position and damping of bass resonance in relation to reproduction of rumble in pickup output; i.e. with bass resonance at A_1 (20c/s) the rumble level a_1 may be only a few dB below a recorded level corresponding to 1 cm/sec at 1 kc/s or may be higher (a_2) if resonance is undamped at A_2 ; whilst with the bass resonance at a higher frequency B (40c/s) a reduction of over 15dB can be achieved in the reproduced rumble level (b).

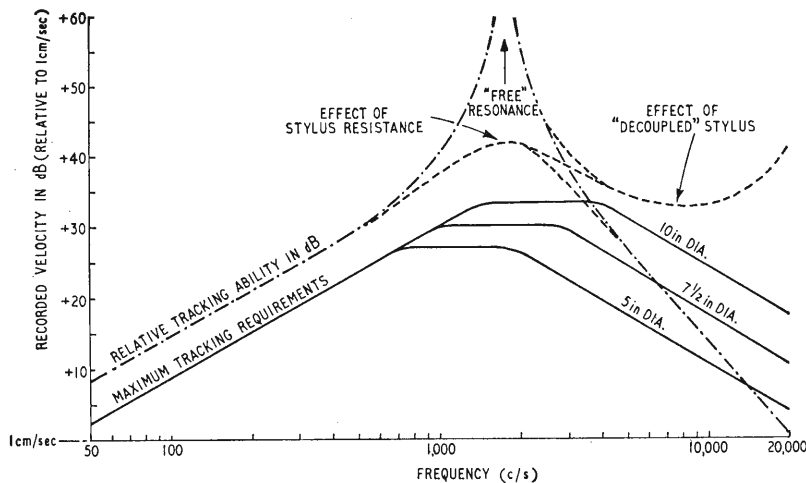

Fig. 2. The low-frequency tracking limitation is set by the maximum recording amplitude, the upper-frequency limitation by the modulation curvature, where this reduces to the stylus radius (0.0007in), and the middle-frequency limitation by the conception that the lateral recorded velocity should not exceed the linear groove velocity for normal stylus-groove relations to continue. The relative tracking ability is given as the reciprocal of the stylus impedance, compensated in the upper-frequency section for the increasing proportion of damage to the groove modulation in relation to the decreasing amplitude.

speaker spacing) but it must be remembered that two out-of-phase low-frequency pressure waves are in fact no pressure change at all, so that modulation from such cannot appear on a true stereo recording (long wavelength in relation to microphone spacing). Thus low-frequency vertical (out-of-phase) signals should ideally be non-existent, and partly out-of-phase low-frequency signals should produce only the required components of lateral modulation.

The above required difference between lateral and vertical low-frequency range of a pickup is often achieved to a worth-while extent because its vertical compliance is usually lower than its lateral compliance. The arm described in *Wireless World* for June 1959 (p. 269) achieves a further worth-while improvement by offering a lower inertia in its vertical than its lateral mode. This is accomplished through its freedom to rotate about the main longitudinal axis of the arm itself, thus providing a partial inertia "bye-pass" in the vertical direction, as described in that article in relation to the stability of the arm.

Compliance Rates Design

Apart from the above method of altering the vertical/lateral mass ratio of the arm, it is obvious that the ratio of the vertical to lateral low-frequency response ranges can be determined also by design of the ratio of stylus compliances in the vertical and lateral planes. It would thus appear that whilst high compliance even also in the vertical plane is extremely desirable (see *Wireless World*, July 1960, p. 342) the vertical compliance should, to ensure least rumble trouble, be related to the lateral compliance so as not to be greater than necessary (see Fig. 3). Experience of comparative recorded levels suggests that the ratio of vertical to lateral compliances can be up to 1 to 3 without loss of tracking capability, provided that care is taken to see that the mechanical impedance curves of the pickup still follow the inverse of the tracking requirements for optimum performance in the 45° mode (as well as in the vertical and lateral modes, see Fig. 2).

It should be mentioned in this connection, however, that the compliance of a pickup in the most important 45° mode is often not much more than 1 1/2

times the lesser compliance where the vertical and lateral compliances are widely different (see also Fig. 3).

Thus with higher compliance pickups now becoming more and more common, it is seen that lighter and lighter arms are also required if these pickups are not to be more troublesome than need be due to rumble. I contend that it is cheaper, easier, and also more advantageous to design the arm "correctly" in the first case rather than try to design a turntable and mounting giving less rumble. In support of this are here presented results of comparative measurements between two of the "better" pickup arms and heads now available (see Fig. 3).

I would also mention that whereas the new lightweight crystal and ceramic pickup heads start their development with their gross weights in the region of 3 to 4gm, magnetic pickup heads after many years of development still have weights in the region of 10 to 15 gm. Unless, therefore, some drastic change can be made in the construction of magnetic pickups, it would appear that the new crystal and ceramic pickups will be more suitable to the era of elastic-region tracking, provided that their cart-

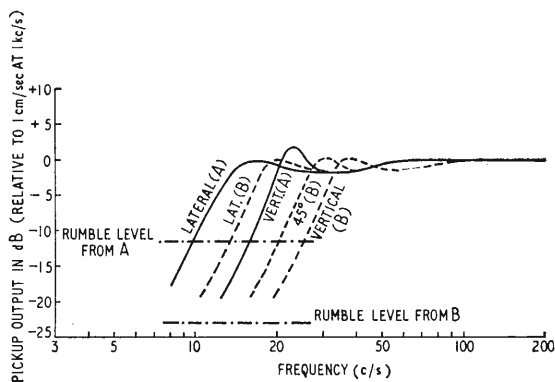

Fig. 3. Curves show both lateral and vertical bass responses of the same pickup in two esteemed pickup arms, and how the reduced inertia (particularly in the vertical mode in this case) of one of these arms (B) causes 11dB less reproduction of rumble, without prejudice to its ability to reproduce any "real" components of bass modulation from 28 c/s upwards.

ridges can be rid of a clutter of heavy mounting brackets, head shells, plugs, and other unnecessary "ironwork".

In conclusion, I would say that since pickups are now being produced with vertical compliances of 2×10^{-6} cm/dyne and over, it is desirable that the combined effective mass (at the stylus, and in

the vertical mode) of these heads plus the arms into which they are mounted should not exceed 8 gm, if the pickup is to avoid unnecessary excitation by rumble and other low-frequency vibrations. Higher compliance pickups need proportionately lower mass arms if this stability and rumble interference are to remain unimpaired.

S.B.A.C. SHOW

RADIO AND ELECTRONICS EXHIBITORS AT FARNBOROUGH

AN ever-growing proportion of manufacturers showing at the static exhibition, which is an established feature of the Farnborough Air Show, are in the electronics field. This year some 45% of the 275 or so exhibitors are showing items of interest to electronics and radio engineers. The show, organized by the Society of British Aircraft Constructors, will again be held at the Royal Aircraft Establishment, Farnborough, Hants., from September 3rd to 9th. In our next issue we hope to include a survey of developments in aeronautical radio and electronics as seen at the exhibition.

A.E.I.
A.K. Fans
Airmed
Amalgamated Wireless
Amphenol-Borg
Amplivox

B.I. Callender's Cables
Bakelite
Belling & Lee
Beme Telecommunications
British Aircraft Corp.
British Communications Corp.
British Mfd. Bearings Co.
Brown, S. G.
Bryans Aeroequipment
Burgess Products Co.
Burndept
Bush Radio.

Canadian Marconi Co.
Cannon Electric
Chelton (Electrostatics)
Chloride Batteries
Ciba (A.R.L.)
City & Guilds Institute
Cole, E. K.
Cossor, A. C.
Cossor Radar & Electronics

Davall, S., & Sons
Decca Navigator Co.
Decca Radar
Delaney Gallay
"Diamond H" Switches
Dowty Group
Dzus Fastener Europe

E.M.I. Electronics
Ekco Electronics
Elliott Brothers (London)
Engel & Gibbs
English Electric Aviation

Ferranti
Formica

G.E.C. (Electronics)
General Electric Co.
General Precision Systems
Girdlestone Electronics
Goodmans Industries
Graseby Instruments
Guest, Keen & Nettlefolds

Hairlok Co.
Hawker Siddeley Aviation
Hellermann
Hendrey Relays
Honeywell Controls

Imhof, Alfred
Imperial Chemical Indust.
Integral
International Nickel Co.

Kent, George
Ketay
Kidde, Walter, Co.

Lancefield Aircraft Comps.
Lep Transport
Lodge Plugs
Lucas, Joseph

M.L. Aviation Co.
Marconi Instruments
Marconi's W/T Co.
Micanite & Insulators Co.
Microcell
Ministry of Aviation
Morfax
Murphy Radio

Napier, D., & Son
Negretti & Zambra
Newmark, Louis
Newton Brothers (Derby)

Pinchin, Johnson & Assoc.
Plannair
Plessey Co.
Pritchett & Gold
Pullin, R. B., & Co.
Pye
Pye-Ling

Rank Cintel
Rank Taylor Hobson
Rawplug Co.
Redifon
Rotax
Royston Industries

S.T.C.
Salford Electrical Inst.
Sanders (Electronics)
Sangamo Weston
Short Brothers & Harland
Smart & Brown
Smith, Herman
Smiths Aviation Division
Solartron Electronic
Solus-Schall
Southern Instruments
Sperry Gyroscope Co.
Stone, J., & Co.

Tecalemit
Technograph
Teddington Aircraft Controls
Texas Instruments
Thermionic Products
Thorn Electrical Indust.
Tiltman Langley
Trist, Ronald, & Co.
Trix Electronics

Ultra Electronics
Unbrako Socket Screw Co.

Vactic Control Equipment
Venner
Venner Accumulators

W.S. Electronics
Wandleside Cable Works
Ward, Brooke & Co.
Western Manufacturing
Westinghouse
Westland Group
Whiteley Electrical Radio
Wiggin, Henry, & Co.
Wireless Telephone Co.



Display system developed by Ferranti-Packard Electric of Canada, used in this instance as a flight information board. Matrices of discs with black and white faces are mounted on threads and provided with permanent magnets. Electromagnets with switching coils are fixed behind them, the direction of magnetization of the cores determining the face of the disc that is visible. No information is lost by power failure, as the discs remain in position until the onset of a new switching pulse.

LETTERS TO THE EDITOR

The Editor does not necessarily endorse opinions expressed by his correspondents

The Boucherot Effect

MR. J. F. YOUNG (August issue) states that the fact that the Boucherot effect can occur in electronic circuits tends to be overlooked. I would suggest that in fact electronic engineers, like Chicago pork-butchers, use everything but the squeak. The circuit described and named after Boucherot is a special case of a much more general pattern, a pattern which is familiar and which gives us a good many applications.

Consider the circuit of Fig. 1. This is simply a length l of transmission line having a characteristic impedance Z_0 and propagation constant α . For this circuit we have

$$V_1 = V_2 \cosh \alpha l - I_2 Z_0 \sinh \alpha l$$

$$I_1 = -V_2 \frac{1}{Z_0} \sinh \alpha l + I_2 \cosh \alpha l$$

When we terminate the line with the impedance Z_T we have $V_2 = Z_T I_2$. I do not propose to go right through the analysis here but it is well known that for a quarter-wave line without dissipation we get the results

$V_2/V_1 = -jZ_T/Z_0$ and $I_2/I_1 = -j/Z_0$ from which we see that the input impedance must be Z_0^2/Z_T . The equation $I_2/V_1 = -j/Z_0$ is, of course, a statement that if V_1 is constant I_2 depends only on Z_0 and not at all on Z_T .

Let us not consider applications at this stage, but go on to one lumped equivalent. If we take the system of Fig. 2, we know that we have $Z_0^2 = L/C$ and $\alpha = (-\omega^2 LC)^{1/2}$. This result applies, of course, to a line without dissipation. When we consider the simplest lumped form working well below cut-off we can use either of the circuits shown in Fig. 3. For the quarter-wave line we must have $\alpha = j$, since α in the pass-band of the non-dissipative case is the phase constant, and for a

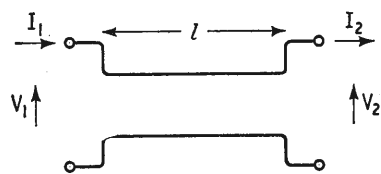

Fig. 1

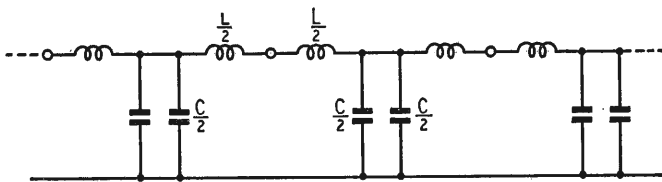

Fig. 2

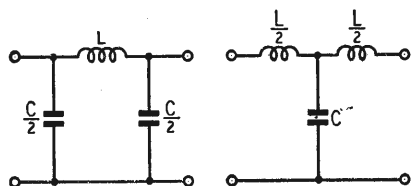

Fig. 3

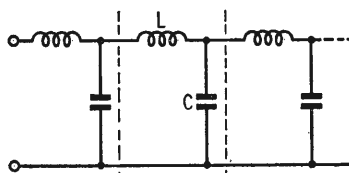

Fig. 4

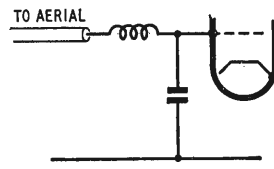

Fig. 5

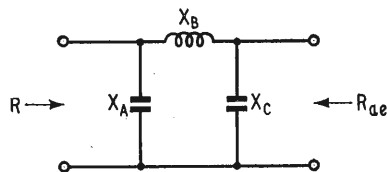

Fig. 6

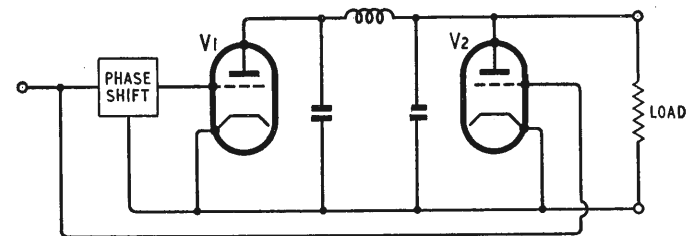

Fig. 7

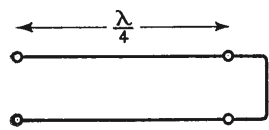
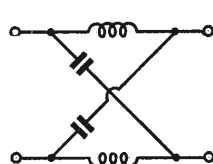
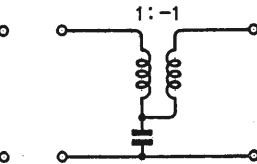

Fig. 8



(a)



(b)

Fig. 9

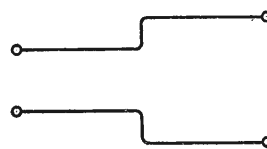

Fig. 10

quarter-wave line this is 90° . This gives us the condition $\omega_0^2 LC = 1$ and $Z_0 = \omega_0 L$, where ω_0 is the frequency at which the circuit is $\lambda/4$.

An alternative way of cutting up the circuit is shown in Fig. 4 and it is this form which is generally regarded as the Boucherot form. I cannot lay hands on an active circuit diagram at the moment, but a good many v.h.f. receivers use the arrangement shown in Fig. 5 at the input. This is the Boucherot network in action, trying to force constant current into an unresponsive grid and generating (in a loose sense) a lot of volts in the process. Fig 6 comes from a description of a 500-kc/s transmitter in the Mullard Transistor Manual (p.211) and is a π -network widely used for matching transmitters to aerials. Fig. 7 is a very elementary circuit diagram for the Doherty amplifier. When the valve V_2 is cut-off the Boucherot network transforms the local impedance before it is presented to the valve V_1 . Full descriptions are given in the textbooks.

Fig. 8 shows another familiar form. Since the voltage at the right-hand end is zero the current at the left must also be zero. The quarter-wave stub used as a feeder support is one of the long-established applications.

The ideal transmission line does nothing to a signal but delay it. The properties which we see in this application are the result of the delay between the signal transmitted and the signals reflected and re-reflected. An important approximation is therefore the all-pass delay network shown in Fig. 9(a), which can be drawn in an unbalanced form as Fig. 9(b). This is, of course, only one of the many available equivalents.

We do not always want to work with a single frequency and we can broaden the bandwidth of the Boucherot effect by the device indicated symbolically in Fig. 10, the stepped transmission line. It is tempting to suggest that the wide-band 90° networks used for Hartley modulation systems could be used, but the costs of that are too high to give results of any value, I suspect.

The Boucherot effect, like the Ferranti effect, appears to me to be simply a special solution of a special transmission line equivalent. The underlying principle is widely used. If we base our study of this type of network firmly on the concept of a 90° phase shift or of a quarter-wave line we can deal much more easily with the problems which arise when the voltage source has a finite impedance.

London, W.8. THOMAS RODDAM.

The author replies:

I would like to thank Mr. Roddam for confirming my suspicions of wastefulness in Chicago abattoirs and elsewhere.

J. F. YOUNG.

Television Line Standards

NO one has suggested that the definition of a 625-line picture is spectacularly better than that of a 405-line one, but neither does the improvement merit the term "marginal," as it has been described a number of times recently.

The improvement is fundamentally $\left(\frac{625}{405}\right)^2 \approx 2.4$, and no one can alter it.

If a direct comparison between the two systems shows only an apparently marginal improvement then it is certain that the 625-line picture is not being displayed to full advantage.

If a 405-line picture is viewed at a distance approaching the optimum viewing distance (i.e., the distance at which the eye can no longer appreciably resolve the false information inherent in the line-structure) an increase in the number of lines can hardly be expected to provide a very startling increase in definition. Any comparison of line standards on screens of equal size is bound to reduce the apparent advantage of the higher standard as the eye can less readily resolve the smaller detail provided. The fair method is to display the systems, on receivers of the correct relative size, when the liness at any particular

viewing distance will be seen to be the same. The increase in screen area then fairly represents the improvement of the higher standard. Thus a 405-line picture on a 14-in set would compare with a 625-line picture on a 21-in set. The difference can hardly be called "marginal."

Referring to the July editorial of *W.W.*, I wonder if the scanning spot size was altered to suit the various standards?

It was also suggested in the editorial that our 50 c/s frame frequency be increased to 60 c/s to reduce flicker. Flicker is only apparent in daylight viewing due to the high brightness required to provide a reasonable contrast ratio, but I hardly think it objectionable enough in any reasonably situated set to justify such a costly and inconvenient change. In any case it is to be hoped that the TV set of the future will have overcome the problem of room light reflecting from the screen, for surely there is nothing that generally spoils the picture more than the resulting poor contrast. Neither must we forget that the colour set will in addition suffer from colour de-saturation.

It has been recommended that we adopt the Continental 625-line system but with increased vision bandwidth. It is generally accepted that a Kell factor of 0.6 is adequate; indeed many think 0.5 to be optimum. Why then is it proposed to increase on the Continental standard of 0.7? This retrograde step will encourage viewing at closer than optimum viewing distance in order to see the excess horizontal information provided.

If we have this extra bandwidth "to play with," why not use it to provide a 625-line picture of increased aspect ratio? The result would be a picture with better definition and more natural proportions than the present 625-line system, but would still be fully compatible with it for programme interchange, simple line-by-line translation being used.

Assuming, for instance, an aspect ratio of 5:3, the increase in definition over 405 lines compares as follows:

405 lines :	1
625 lines :	2.38
625 lines :	3 (aspect ratio 5 to 3)
819 lines :	4.24.

The system compares reasonably well with the 819-line system having less definition but making more use of it, due to more natural proportions.

Have.

R. C. MARCH.

Magnetic Static Switching

IN his article "Nands and Nors and Sheffer Strokes" (July issue) Mr. J. F. Young implies that transistor static switching has virtually superseded magnetic static switching.

Whilst I agree that for computer and similar complex circuits this is true, I would respectfully remind him that magnetic static switching is very much alive and will continue to find a substantial market for the following reasons:—

(a) Only magnetic systems offer electrical isolation between input and output circuits, a considerable advantage when preparing input signals from available electrical parameters.

(b) Magnetic amplifier latching units will "remember" the signals over supply failure or switch-off periods, by virtue of magnetic-core storage.

(c) Whilst the high-speed operation of transistors is a great advantage in most control circuits, there are some cases where it can be a disadvantage, with spurious operations of latching circuits resulting from short pulses appearing at input connections, etc. Magnetic amplifier systems can be arranged to operate with time lags between a few milliseconds and one or two seconds simply by varying the resistance across a winding.

(d) The higher power level normally employed in

magnetic units allows for lamp indication of the state of each unit—this would involve additional units in transistor stages.

(e) In transistor logic, the "signal present" state varies between successive stages which complicates calculations and makes "fail-to-safe" design impracticable. The magnetic system works on the basis that if a positive voltage (to a common line) exceeding 1.5V is present, then the signal is present, which simplifies design work considerably.

(f) Whilst not belittling the advantages of limiting all functions to one type of unit, the W. H. Sanders' system produces seven entirely different units all using identical printed circuit boards and toroids. The only differences are in the linking, and diodes and resistors on the board.

These seven functions, i.e., Preamp-Inverter-OR-AND-AND/OR-AND/NOT and LATCH, enable the logic to be performed with fewer stages than a comparable transistor circuit, thus minimizing the difference in cost between the two systems. For instance, the transistor circuit using eight stages, described in the article (Fig. 2) can be performed with three magnetic stages, with the additional facilities of permanent memory, lamp indication, and up to 5 watts output. The cost of the three units would be approximately double that of the transistor units but the interconnections would be fewer and the power supplies to the three units would consist only of a single 12.5-0-12.5V 50c/s transformer.

To sum up, there are many systems where magnetic logic will prove simpler, more reliable, and will offer

additional advantages over transistor logic, and engineers would be well advised to consider both systems before committing themselves.

Stevenage.

P. DIXON.

W. H. Sanders (Electronics) Ltd.

Back to Jorrocks

ONE evening in spring, about the middle of the last century, two of the immortals were sitting by the light of a fire and drinking liberally of brandy-and-water.

These were Mr. John Jorrocks, M.F.H., and his Geordie huntsman, James Pigg. The latter was told: "Look out of the winder, James, and see wot'un a night it is," and, doing his best in the semi-darkness, was misled by a cupboard door painted like the window shutters. "Hellish dark, and smells (sic) of cheese," said he.

In misrepresenting this epic passage, Thomas Roddam (August issue, p.370), only makes the point that his notes might be mistaken for the real thing by a tipsy man in the dark. One looks forward to a formal ceremony of expiation, in which ritual brandy-and-water is drunk by all Geordies present?

Newcastle-upon-Tyne

P. SHORT,

Electrical Engineering Department,
Kings College, Univ. of Durham.

[We apologize to Mr. Roddam, Mr. Short and all other followers of the Master for having overlooked the degradation of the immortal prose which took place somewhere between Mr. Roddam's original (and correct) quotation and the printed page.—Ed.]

HIGH-ALTITUDE EXPLOSION : EFFECTS OBSERVED AT TATSFIELD

THE third, and successful, attempt at exploding a nuclear bomb at high altitude in the nuclear test series at Johnston Island was made on the morning of 9th July at about 0900 G.M.T. At this time a watch was being kept, at the B.B.C.'s station at Tatsfield, Surrey, on Shepparton, Australia (11,710 kc/s) as this was regarded as a key station on which observations should be made.

On 9th July Shepparton was first observed at 0700 G.M.T., signal strength 50 μ V/m. Other Australian transmissions on 9, 17 and 21Mc/s were all weaker signals. At 0854 G.M.T. the pen chart recording of the Shepparton 11,710-kc/s signal was started and at 0900.10 G.M.T. the recording showed a sudden decrease in signal strength of about 20 dB, which was accompanied by a roar of noise and rhythmic heavy rumbling at a frequency of about 130 c/s. At 0901.55 G.M.T. the signal disappeared entirely for 95 seconds, but it is believed that this was due to a transmitter fault. Afterwards it appeared with a slight increase in level to 30 μ V/m and remained until the scheduled close-down at 0915 G.M.T.

B.B.C. External Service transmissions on 25,840, 21,710, 21,550 and 21,470 kc/s all displayed fairly severe flutter and heavy rumbling and meteoric whistles were frequently heard. This effect was first noticed at 0915 G.M.T. (it was not present prior to 0900 G.M.T.) and continued with decreasing intensity until 0930 G.M.T. when it cleared leaving the signal strength weaker than before the effect started. The transmissions became normal at about 0940 G.M.T. The 17 and 15 Mc/s transmissions from the U.K. were unaffected. The transmissions from Tebrau were not audible at 0915 G.M.T. but 30 minutes later those on 17,755 and 15,310 kc/s were both stronger than is usual at this time.

At 0945 G.M.T. transmissions from South Africa (21,690 kc/s), Pakistan (21,590 kc/s), India (15,310 kc/s) and Far Eastern U.S.S.R. on 21, 17 and 15 Mc/s were all normal, but Tokyo on 15,235 kc/s, which is normally weakly audible, could not be detected. A fading recording of Washington N.S.S. on v.l.f. (17.8 kc/s) was not

unduly affected—perhaps some slight enhancement was apparent but the received signal is not particularly stable at any time.

The Tatsfield recording equipment normally operating on Paris 6,175 kc/s to give early warning of sudden ionospheric disturbances showed no significant change at the time of the explosion, but after 1215 G.M.T. the absorption increased until approximately 1405 G.M.T. when conditions became normal.

" Junction Transistor Circuit Analysis "

THIS new Iliffe book, written by S. S. Hakim, Ph.D., B.Sc., A.M.I.E.E., is intended for the advanced student of electronic engineering who may or may not have been previously introduced to transistors. For the man who has not, the first two chapters are concerned with the basic theory of semiconductor physics and with the derivation of several commonly-used types of equivalent circuit, all of which are used in the relevant discussions later in the book. The next seven chapters deal, theoretically, with a wide range of applications in which transistors are used in the linear mode. All three configurations are analysed, and a complete chapter is devoted to a discussion of the negative-impedance converter—a device which is assuming rapidly-increasing importance. In the last two chapters, an analysis is given of the large-signal (non-linear) operation of transistors, and transient response is dealt with from the point of view of charge control rather than the somewhat hard-to-pin-down small-signal parameters. Switching and pulse circuits such as counters, analogue/digital converters and logic circuitry are described in a practical way, and several appendices are concerned, among other things, with the evaluation of transient response using the Laplace transform, and a discussion of h -parameters.

The book is published by Iliffe Books Ltd., Dorset House, Stamford Street, London, S.E.1, and costs 105s.

NOW!
YOU can MASTER ELECTRONICS!

BRITAIN'S MOST COMPREHENSIVE PRACTICAL COURSE in RADIO · ELECTRONICS · TELEVISION!

THESE SPECIAL TRAINING KITS — YOURS TO KEEP

Multi-Range TEST METER

CATHODE RAY OSCILLOSCOPE

AM and VHF/FM LUXURY RECEIVER

SIGNAL GENERATOR

Complete set of Picture Way books and Experimental Manuals

LEARN BY BUILDING NOW for your CAREER · HOBBY · OWN BUSINESS

- YOU RECEIVE**
- Complete kits of equipment as illustrated.
 - Complete set of experimental manuals.
 - Complete set of 'picture way' theory books.
 - Modern test - yourself examination sheets.
 - Study programme.
 - Unlimited consultation with Tutors.

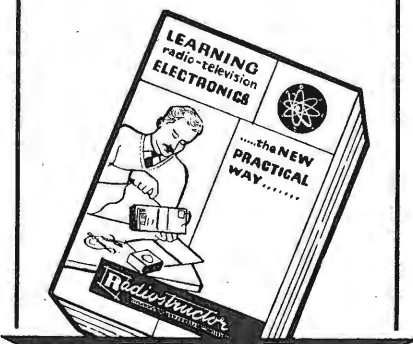

FREE POST BROCHURE NOW

RADIOSTRUCTOR

TO: RADIOSTRUCTOR (DEPT. M.66)
 READING, BERKS.

NAME

ADDRESS

.....

(BLOCK CAPITALS PLEASE)

(We do not employ Representatives)



3 Oct 61
 Dear Sir:
 I obtained one of your B.S.R. record
 players this summer from the hold of
 the freighter Fort Hearne. This vessel sank
 in the Arctic Ocean in July and the player
 was under water about three weeks. Although
 the case was ruined the player needed
 only a new cartridge and a volume control.
 Since there is no service shop here in the
 Arctic I installed these myself, and the
 changer has worked very well in daily use.

From Arctic Canada comes authentic
 and dramatic proof of BSR supreme
 reliability.

Monarch
UA 16

"Unsinkable" BSR

What other changer would work normally
 after 3 weeks in the Arctic Sea? What an
 example of built-in ruggedness, the BSR
 dependability that cuts out service
 costs and keeps profits high! Leading makers
 select BSR Monarch autochangers
 for reliability, perfect performance
 and fine styling.

The sheer new UA16 (styled by
 Raymond Loewy/William Snaith
 Inc.,) has dynamically balanced
 tone-arm for featherlight tracking,
 lowest wow, rumble and flutter
 figures and has test-run through
 1,000,000 trouble-free cycles.

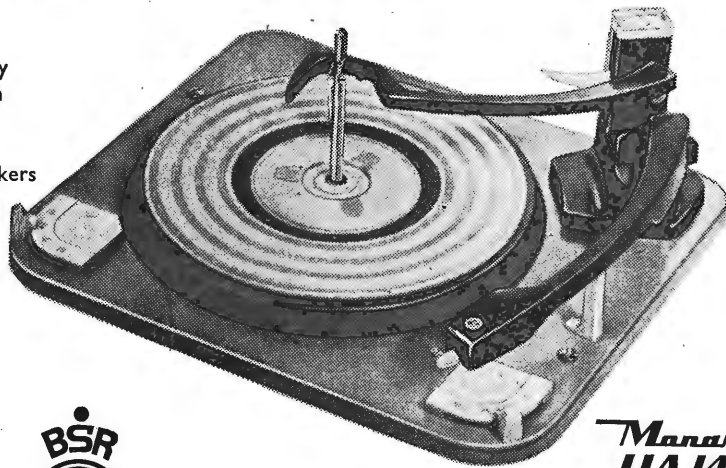

Monarch
UA 14



Stock players fitted with BSR Monarchs, the world's
 best-selling record changers!

BSR LIMITED, OLD HILL, STAFFS.

Combination Lock

AN EXERCISE IN RELAY SWITCHING

By V. J. PHILLIPS,* Ph.D., A.C.G.I., D.I.C.

THE device described in this article is a three-dial combination lock which combines the merit of simplicity with a high degree of protection against operation by unauthorized and felonious persons. The particular lock pictured in Fig. 1 was constructed on a small cupboard door, and was not intended to give protection against intruders armed with T.N.T. and other such heavy artillery. There is no reason, however, why the principle of operation of this lock should not be applied to much heavier installations, the chief modifications required being a door of greater thickness, and a securing bolt (or bolts) of greater size and strength.

Mounted on the outside of the door are three dials, each one being marked from 1 to 12 as shown in Fig. 1(a). In order to operate the lock, three separate operations are necessary. (For the purpose of explanation we shall be duodecimalists, and consider the numbers 10, 11, and 12 to be "digits" in their own right, although unlike the true duodecimalists we shall not refer to them as "dek, el and do"!) The dials are first set to one three-digit number; say for the sake of illustration 3.4.9. They are then set to another number; say 11.9.3, and finally to a third number; say 1.2.8, when the bolt is automatically withdrawn by means of a solenoid, allowing the cupboard door to be opened. In order to operate to the lock, it is essential that these three numbers are dialled in the correct sequence and, as will be shown later, dialling in the wrong order, or dialling numbers composed of the correct digit but in the wrong arrangement (say 3.4.3), will not cause the lock to open.

As will be seen from Fig. 1(b), the components required for the lock are very few in number, consisting of three 12-way, 1-pole rotary wafer switches, two Post Office-type relays, a solenoid to operate the bolt and one or two other small items. In fact, as far as the electrical components are concerned, the lock can be built for £3 or £4.

Principle of Operation.—The circuit diagram of the lock is shown in Fig. 2. When the dials are set to the first 3-digit number, which we will call *a.b.c.*, the 12-way 1-pole wafer switches mounted behind the dials allow current from the battery to pass to the coil of RL_A via the first pair of contacts of that relay which are normally closed (designated contacts A1 (N.C.)). This relay then operates, and its second pair of contacts A2 (N.O.), which are normally open, close and allow current from the battery to reach the coil of RL_B so that this relay is kept energized or "held-on." At the same time, contacts A1 (N.C.) open so that the original current path via *a.b.* and *c.* is broken. In addition, the

operation of RL_A causes contacts A3 (N.O.) and A4 (N.O.) to close. If the second 3-digit number *d.e.f.* is now dialled, current now passes to the coil of RL_B through contacts A3 (N.O.), B1 (N.C.) and A4 (N.O.) so that the RL_B is energized. Contacts B2 (N.O.) again act as "hold-on" contacts so that the second relay is kept energized. As well as causing operation of the "hold-on" circuit the energizing of RL_B also causes B2 (N.C.) to open, thereby breaking energizing path *d.e.f.*, and closes the contacts B3 (N.O.) and B4 (N.O.).

Finally, when the dials are set to the third number *g.h.i.*, current is permitted to flow through B3 (N.O.) and B4 (N.O.) to the solenoid which draws back the bolt and allows the door to be opened.

The whole lock is reset by depressing the push-button switch marked "RESET," which momentarily disconnects the battery, thereby releasing both relays and the solenoid.

Notice that it is necessary for the three numbers *a.b.c.*, *d.e.f.*, and *g.h.i.* to be set up in the correct

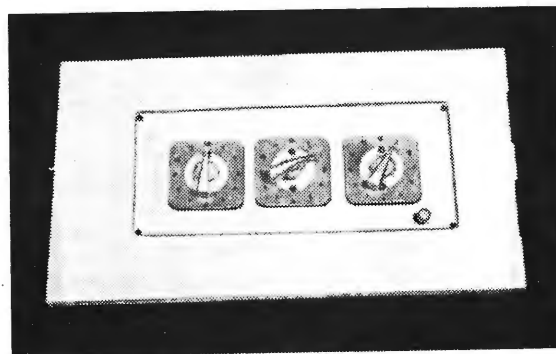

(a)

Fig. 1. Completed unit.

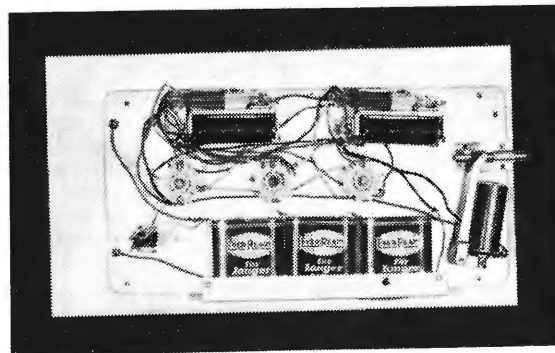

(b)

*Lecturer, University College of Swansea

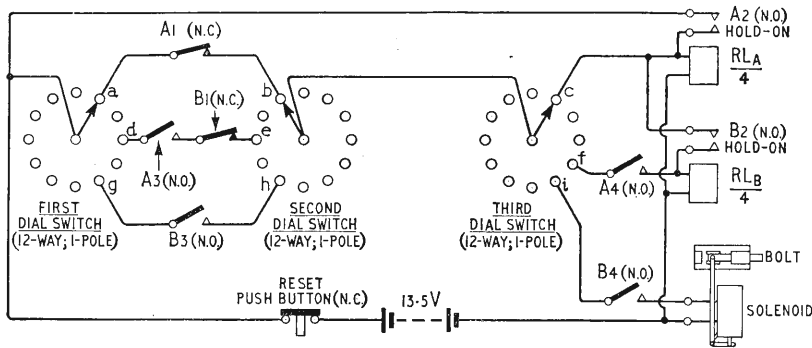

Fig. 2. Circuit diagram of the lock.

sequence so that the two relays are energized and held-on in the correct order. If the second number *d.e.f.* is dialled first, RL_B cannot operate since contacts A3 (N.O.) have not closed, and there is no complete current path to the coil of RL_B via *d.e.* and *f.* Similarly, if the third number *g.h.i.* is dialled first the solenoid cannot be energized because B3 (N.O.) have not closed.

The other possibility which arises is that of dialling the digits in mixed order. For example, if the digits *a.b.i.* were set up at the first attempt the solenoid would be energized were it not for the presence of contacts B4 (N.O.). These contacts ensure that the solenoid cannot operate until RL_B has been energized. Another set of digits which could cause false operation at the first attempt is *a.b.f.* This is avoided by the use of contacts A4 (N.O.) which only allow current to pass when RL_A has been energized.

Thus, as previously stated, it is necessary for the relays to be energized in the correct order, and this in turn means that the numbers must be dialled in the correct sequence.

Construction.—In the particular lock constructed it was found convenient to mount all the components on a single plate which could be screwed to the rear of the cupboard door. This is not the only possible arrangement, of course, and provided that the three wafer switches are mounted behind the dials the rest of the components may be mounted elsewhere (inside the cupboard door for preference!). Having all the components close together, however, naturally eases the wiring problem.

The wafer switches used are quite standard components which may be available on the surplus market, or otherwise can be obtained from Radiospares Ltd.† Since these are quite ordinary items, no more need be said about them.

It will be seen from the circuit of Fig. 2 that each of the relays has three normally-open contacts, and one normally-closed. Since the current which initially energizes the coil flows through the normally-closed contacts of that coil it is clear that these and the normally-open "hold on" pair should form a make-before-break combination if the relay is to hold satisfactorily. This is most easily arranged by using two sets of the more usual make-before-break changeover contacts as illus-

trated in Fig. 3. If these are properly adjusted (and this is easily done), the normally-open contacts of one set will close before the normally-closed contacts of the other set part. The other two sets of contacts on each relay are just the ordinary normally-open type.

The coil resistance of the relays must naturally be selected to suit the particular battery voltage used. It will be found that with a 13.5 V battery, which can be constructed from three 4.5 V flat torch batteries, a 500

ohm coil is suitable, and the relays will close firmly and easily.

As in the case of the wafer switches, it will probably be found that suitable relays can be found in the government surplus stores, but in case of difficulty various firms who advertise in this journal would probably make them to specification at a reasonable cost.

The provision for operating the bolt electrically can be a source of real ingenuity. Many mechanisms are possible, and perhaps the simplest and sturdiest is the simple solenoid and plunger type illustrated in Fig. 4(a). Another way of doing the job is to use one of the very neat solenoids which are available on the surplus market. (What would we do without the ex-W.D. shops?) This type of solenoid, which is illustrated in Fig. 4(b), has a coil resistance of approximately 35 ohms and also has a built-in lever system which magnifies the movement available to half an inch or so. In the lock illustrated in Fig. 1, a solenoid of this type was used to move an ordinary small door-bolt of the sort available at any ironmonger's shop. The handle was removed from the bolt, and a large hole was drilled in the movable part as shown in Fig. 4(b). A small 8 B.A. bolt was fixed on to the end of the solenoid lever, using a hole which already existed, and this was arranged to project into the hole drilled in the door-bolt. As the relay is energized, the lever withdraws the door-bolt. It should be noted at this point that many of the better quality door-bolts are provided with a ball-and-spring arrangement in the movable part, which bears on the slide portion, giving the whole a "silky" feel when being moved. This should be removed to lessen friction in the movement.

This type of bolt-withdrawing mechanism provided ample strength for the particular purpose for which the lock of Fig. 1 was required, but if it is felt that a stronger system is needed then there is

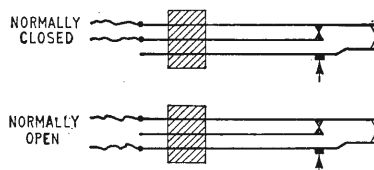

Fig. 3. Make-before-break changeover sets may be used instead of make and break type in RL_{A1} , RL_{A2} , RL_{B1} , and RL_{B2} positions.

plenty of room for experiment and improvement.

The "RESET" button can be any push-switch of the normally-closed variety; a Post Office-type switch was used in this case, and proved quite suitable.

Refinements.—It is possible to add many variations to the basic lock of Figs. 1 and 2, quite apart from any questions of mechanical strength. The first of these refinements should really be classed as a necessity. When the two relays and the solenoid are all energized, the battery must supply a total current of

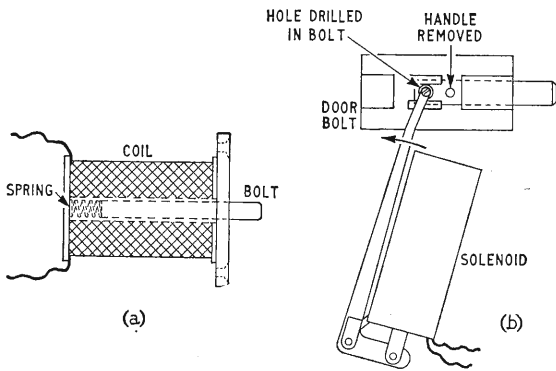

Fig. 4. Bolt mechanisms. Simple straight pull type (a) and ex-Government solenoid with lever (b).

approximately $\frac{1}{2}$ amp—a current well within the capabilities of the torch batteries used. From the point of view of battery life it is clearly an economy to operate the "RESET" button, releasing the relays and the solenoid, as soon as the door is opened, particularly if the door is to remain open for any length of time. When the door is eventually closed again, the combinations can be re-dialled to withdraw the bolt, or the lock catch-plate can be shaped so that the bolt closes of its own accord.

In spite of all these precautions it is inevitable that the time will come when the batteries will be "flat" in the electrical as well as the physical sense, and will no longer be able to operate the lock. If they are mounted inside the cupboard or on the back of the door, this could be a source of embarrassment. For this reason, it will be seen from the photograph of Fig. 1(a) that four small bolts are mounted on the outside of the door. Two of these are there purely for decoration, but the other two are connected to the terminals of the battery. In the event of battery failure, an external source of e.m.f. can be connected across them, and the lock can be operated in the normal way by dialling the combination, enabling the door to be opened without resort to crow-bar or jemmy.

Another refinement which is quite worth while is to replace the "RESET" button by a microswitch mounted on the inside of the door and bearing on a stop inside the cupboard. When the door is closed, the microswitch button is depressed and the battery is connected to the rest of the circuit so that the lock can be operated. As soon as the door is opened, the microswitch is released, the battery is disconnected from the circuit, and the lock is automatically reset.

This immediate reset is naturally an advantage from the point of view of battery economy as outlined above.

When a combination lock is installed for any purpose the main point of interest is the degree of protection afforded by the lock against unauthorized entry. The effectiveness of the lock will depend to a certain extent on the knowledge of the person attempting to operate it, and for the sake of illustration we shall be pessimistic and assume that the burglar is a person who knows roughly how the lock operates; knows that three numbers must be dialled; but does not know which three numbers they are.

If he is a methodical sort of chap, he will start by setting the dials to 1.1.1., and will run through all the combinations up to 12.12.12.—a total of $12^3=1728$ combinations. After doing this, he will know that the first relay will be bound to have been energized. However if he is able actually to hear the relay clicking over either with unaided hearing, or even with the aid of a stethoscope held against the door, then he will be able to stop setting up the numbers before he reaches the full 1728 combinations. It follows from this that an obvious precaution is to mount the relays on sponge-rubber cushions or in a special soundproof enclosure so that it is impossible to hear the relays clicking over when they are energized.

An alternative circuit arrangement which could be used to cause him some confusion is shown in Fig. 5. This circuit still makes it necessary to operate the dials in the given sequence, but now it will be observed that if the number *a.b.f.* is dialled at the first trial RL_B will operate. However, since contacts A_4 (N.O.) are not closed it will not hold on, and as soon as the digits *a.b.f.* are altered RL_B will release. This false operation is of no assistance whatever in opening the lock but it would serve to confuse the intruder

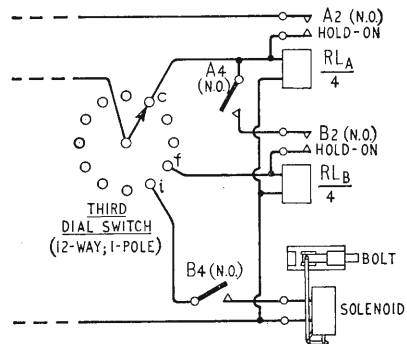

Fig. 5. Circuit modified to make RL_B click ineffectively.

listening for the relays. If digit *c.* is larger than digit *f.* the methodical burglar will reach number *a.b.f.* before number *a.b.c.* and will hear RL_B operating. He would then most likely remove his stethoscope to reset the dials 1.1.1. for the second operation and would assume that the first relay had energized and held on. The second session of methodical dialling would again cause false operation of RL_B and so he would get nowhere with his dialling procedure. He might spot the fact that the two relay clicks occurred on the same numbers, and might begin to suspect that all was not as it seemed, but even so, this false operation would cause him much confusion.

Notice that contacts A4 (N.O.) are necessary for the following reason: When RL_B is energized by the dialling of *a.b.f.* its hold-on contacts B2 (N.O.) close, and in the absence of A4 (N.O.) would supply current to the coil of RL_A . This would close and hold-on due to the action of its own contacts A2 (N.O.) and could now supply hold-on current via B2 (N.O.) to RL_B . Without contacts A4 (N.O.) this dialling of *a.b.f.* can result in the permanent closure of both RL_A and RL_B —a most undesirable occurrence!

If the intruder is unable to hear the relays closing, then he must dial all 1728 numbers before he is sure that the first relay has operated, 1728 for the second, and anything up to 1728 again before the bolt is withdrawn. This means that he has to dial something in the region of 4,000 numbers to be sure of opening the lock, which is quite a fair degree of protection. If he is not the intelligent fellow we have assumed him to be, and if he does not know anything about the construction of the lock then his chances of opening it by dialling numbers at random are slender in the extreme.

It may be, however, that the master of the household is wintering for three months in the South of France and has left his wife's minks and jewels in the care of the combination lock. In these circumstances it is clear that any burglar would have ample time to dial the required 4,000 numbers, and it may

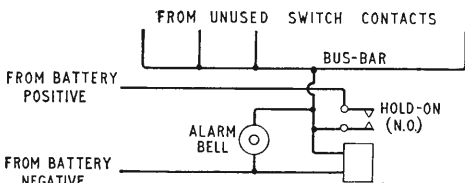

Fig. 6. Alarm bell rings when switches are set to spare contacts.

be thought that some further degree of protection is necessary. This is easily arranged by removing the solenoid and connecting a further set of three dials, identical with the first set, to the output of contacts B4 (N.O.). To open this lock, the first three dials must be set three times, and left on the third setting, and the dials of the second set must also be set three times before the solenoid, which is now on the output of the second set, withdraws the bolt. This obviously increases the degree of protection afforded by a considerable amount. To start with, the third number of Set 1 no longer causes any mechanical motion in the lock, but merely connects a source of voltage to Set 2. Thus, even with imperfectly mounted relays, a stethoscope is of no use in determining this third number of Set 1. To be certain of energizing the first relay of Set 2 any burglar must dial 1728 numbers even when the third number is correctly dialled on Set 1. To find the correct third number of Set 1 as well he must set up a total of 1728^2 numbers—a truly astronomical number which increases the odds against his opening the lock very considerably.

Just to make it even harder for him, the dials could be arranged in two rows of three, but in mixed

order so that he has no means of telling which belong to Set 1 and which to Set 2.

Another possibility whereby the degree of protection can be increased is to have no battery inside the lock, and to make it necessary to connect an external voltage source before the lock can be operated. For example, the outside of the door could be ornamented with a pattern of metal studs across just two of which the battery must be wired in order to make contact with the circuit of the lock. Any burglar thus has to find the two correct studs before he even starts to dial, and there is no means whereby he can know when he has found the right ones. He may not even realize that an external source of e.m.f. is needed.

Whilst on the question of burglars it is worth while considering the fitting of a burglar alarm system. Perhaps the simplest way of providing such an alarm is to connect the unused contacts of switches 1 and 3 to a common bus bar as shown in Fig. 6. We shall assume that a contact *x* on switch 1 and a contact *z* on switch 3 are left blank so that the dials can be "parked" without the alarm sounding continuously. Contacts *a* to *i* are needed for the lock, of course, as in Fig. 2. When a number beginning with any digit except *a, d, g* or *x* is dialled, the battery will be connected to the bus bar; the alarm relay will be energized, will hold-on, and will cause the bell to sound. In addition, the spare contacts of switch 3 are connected to the bus bar so that even if switches 1 and 2 could be set correctly to *a* and *b* without the alarm sounding, the turning of switch 3 is again likely to set off the alarm.

Another way of providing an alarm system which gives an even greater degree of protection is to add a further switch wafer behind each of the existing ones so that turning of the dial moves both wafers. The centre contacts of these three new wafers are connected to the battery, and all contacts except *a* to *i*, and three "parking" contacts *x, y,* and *z* are connected to the bus bar. As soon as any dial is turned to any other digit, the alarm device will be energized.

This means that the alarm sounds even when an authorized person wishes to open the door, but this is not a serious objection if complete security and protection are important. (Alarms on shop doors usually do this anyway.) It is possible, of course, to turn off the alarm circuit by means of a hidden switch if this is thought desirable.

A further desirable feature which could be incorporated is the connection of an alarm circuit across the solenoid. Even an intruder who knew the combination, and also the location of the main alarm-disabling switch would be unable to operate the lock without this second alarm sounding—surely the ultimate in security.

Clearly, then, there are all sorts of interesting possibilities for those who wish to protect their gems and bullion from marauders, or for those who, like the author, have no gems and bullion worth protecting, and who merely look upon this sort of thing as an exercise in ingenuity. For example, what about a plug-board system on each dial which enables the combination to be changed at will?

Have you for instance thought of installing such a lock on the garage door? Imagine the scene; a cold wet November evening, with the fog swirling around. You stand there dialling *a.b.c., d.e.f.* . . . well, perhaps not; it was just a thought.

NEW TUNNEL DIODE CIRCUITS

USE AS HIGH-SPEED COMPUTER ELEMENTS

By MICHAEL LORANT

RESearch engineers of the International Business Machines Corporation's Thomas J. Watson Research Centre in New York State have recently achieved successful operation of a new computer circuit, a full serial binary adder, at a speed of 125 megacycles. This very high rate is made possible by two new tunnel diode circuits developed at the Centre.

Several tunnel diode logic circuits have been reported in current technical literature, but these have certain limitations when used in high-speed computing systems. The new circuits overcome some of these limitations and make the practical realization of a tunnel diode computer more feasible.

The new circuits both use matched pairs of tunnel diodes connected in series, and both perform majority logic (produce an output whose polarity is determined by the polarity of the majority of the input signals). One circuit is unusual in its use of delay lines, which give a flat-topped output pulse and eliminate undesirable interaction between circuits. The other circuit generates output pulses of considerably greater current than is possible with other matched-pair circuits. Both circuits have relatively large tolerances for power supply variations. A 250-megacycle operating rate has been achieved with the individual circuits.

The two new tunnel diode circuits are called BLLE, for "Balanced Line Logical Element", and BILE, for "Balanced Inductor Logical Element". The BLLE circuit (Fig. 1.) is especially suited for performing logic, because it either eliminates or minimizes a number of the most serious tolerance

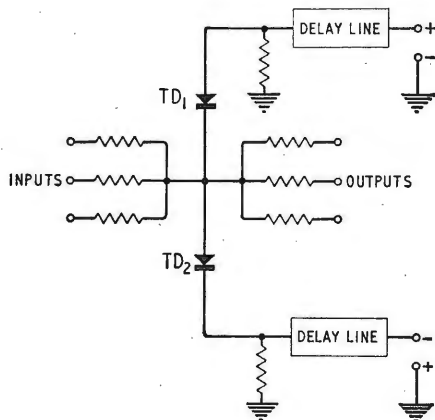
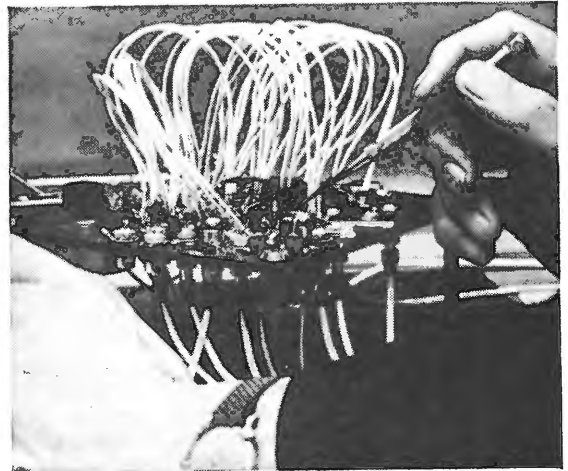

Fig. 1. Circuit diagram of the "Balanced Line Logical Element". The delay lines provide a relatively flat-topped output pulse and, in addition, decouple the circuit from its power supply, thus permitting many circuits to be connected to the same power supply.



This new experimental computer element, a full serial binary adder, has been operated at a 125-megacycle rate, one of the highest yet recorded. The adder is composed of fourteen matched-pair tunnel diode circuits. The wire loops above the circuit board are coaxial-cable delay lines, an important feature of a new tunnel diode computer circuit.

problems associated with very-high-speed logic circuits. The BILE circuit is well suited for driving other computer elements, such as memory devices, since it puts out a relatively large pulse.

The BLLE circuit is composed of a pair of matched tunnel diodes in series with two delay lines. The delay lines are $7\frac{1}{2}$ -in long coaxial cables, or strip transmission lines, which produce a delay of one nanosecond. A push-pull power supply composed of both d.c. and a.c. components is applied across the series combination, and input and output terminals are connected between the two diodes.

The d.c. component of the power supply is adjusted so that the d.c. load-line intersects the composite characteristic of the two diodes only in their negative-resistance region. The circuit is then unstable and oscillates. The a.c. component in the power supply synchronizes this oscillation with the machine clock. The polarity of the output pulse of the BLLE circuit is determined by that of the input pulse, which determines which of the two diodes switches between the low-voltage and negative-resistance regions. The output pulse of the BLLE is characterized by a relatively flat top (whose width is determined by the length of the delay lines) and very short rise and fall times.

The BLLE circuit minimizes some of the most serious timing and layout tolerance problems inherent in extremely fast logic circuits. Like other

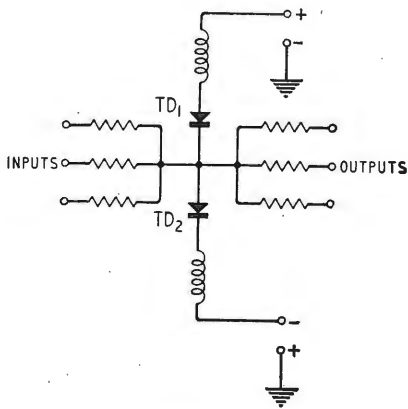

Fig. 2. Circuit diagram of "Balanced Inductor Logical Element". The use of inductors provides a relatively large output pulse, which is desirable for driving other computer circuits.

paired-diode circuits, it is sensitive to input signals for only a very short time interval before it switches. This is an advantage in majority logic since the circuit will not in general be switched incorrectly if one or more of the input pulses arrives slightly ahead of the others. Unlike other paired-diode circuits, the BLLE has the additional advantage that its output pulses have flat tops and short rise times, thus minimizing the synchronization problem for succeeding stages.

An important advantage is gained by the use of delay lines in the BLLE circuit. Ordinarily, one of the more serious problems that arises with tunnel diode logic circuits is the tendency of one circuit to influence the switching of other circuits connected to the same power supply. This is because the switching of one circuit produces a voltage drop across the power supply, which tends to switch the other circuits in the same direction. If all circuits switched at exactly the same instant the problem would not arise, but there is always some spread in switching times. This problem is eliminated by the delay lines, since the power supply does not "see" the switching of a BLLE until a nanosecond has elapsed. This is much longer than the possible difference in time between the switching of any two circuits on the same power supply terminals.

The second tunnel diode circuit developed, the "Balanced Inductor Logical Element" (BILE), consists of a pair of matched tunnel diodes in series with two inductors (Fig. 2.) The power supply is similar to that of BLLE, as is the arrangement of input lines. Two different modes of operation are possible. In the first mode, both diodes are biased in their low-voltage positive-resistance region by the d.c. voltage, and the a.c. component of the power supply carries one of the diodes into its negative-resistance region. The polarity of the input signal determines which diode goes into the negative-resistance region, and hence the polarity of the output pulse.

In the second operating mode of BILE, the d.c. voltage biases one diode in its negative-resistance region while the other is in its low-voltage positive-resistance region. Under these conditions, the circuit oscillates without need of the a.c. power supply. The a.c. voltage is then used simply as a synchroniz-

ing signal to hold the free-running frequency at the power-supply frequency. As in the first mode, the polarity of the output pulse is determined by the polarity of the input signal, which determines which diode goes into its negative-resistance region.

The use of inductors in the BILE circuit gives it two main advantages over previous paired-diode circuits. The first is its ability to deliver relatively high output currents: the output of other tunnel diode circuits is generally limited to the difference between the peak and valley currents of the diode. A second important advantage is its relatively large tolerance to variations in the amplitude of the a.c. component of the power supply. This arises because the a.c. component is used merely to shift a diode somewhere into its negative-resistance region in the first mode of operation, and to lock the circuit's oscillations to the power supply frequency in the second mode. The same considerations enable the BILE to operate with a power supply of considerably lower power than other matched-pair circuits.

Flight Simulation in Colour

EXTENDING the facilities provided by the well-known static system, a new simulator by Redifon gives a visual presentation, in colour, of the terrain in front of the "aircraft" so that, apart from a general impression of realism, coloured-light landing aids can be simulated.

An E.M.I. colour television camera is moved past a relief model of the ground at a speed and angle relative to the model which are governed by the pupil's controls. The picture is displayed on either an 8x6ft screen by means of a Rank-Cintel projector, or on a 21in monitor.

"Weather" conditions are variable, as is visibility and, together with flight sounds and accelerations already provided, the system appears to suffer only the lack of a stewardess bearing coffee.

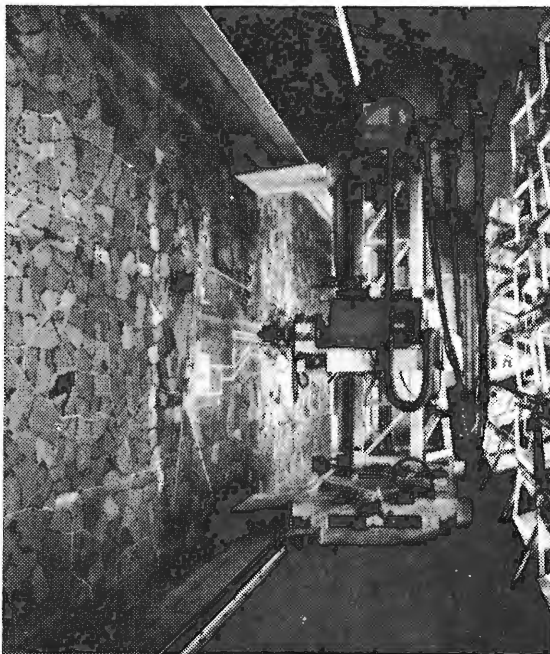

The Redifon visual flight simulator. The position of the camera on its dolly is controlled by the pupil pilot.



THE BRITISH BROADCASTING CORPORATION

Head Office: Broadcasting House, London, W.1

The White House, Motpur Park, New Malden, Surrey

TELEPHONE AND TELEGRAMS: MALDEN 0051/2/3

Reference: O2/OMT/JBW

Thorn-A.E.I. Radio Valves & Tubes Ltd.,
Rochester,
Kent.

Dear Sirs,

You may be interested to learn that we have received a report from our transmitting station at Lisnagarra, which states that they have just rejected a valve type AC/P, Serial No. 4418. The valve has been rejected for low emission and has had a life of 232,592 hours. This, as far as I am aware, is the highest life that we have so far recorded.

The valve was placed in circuit on the 22nd November 1935, which was about four months prior to the opening of the station.

Yours faithfully,

J. B. Webb
(J.B. Webb)
Head of Valve Section

MAZDA

MAZDA VALVE COMMERCIAL DIVISION

Thorn-AEI Radio Valves & Tubes Limited
155 Charing Cross Road, London, W.C.2
Telephone: GERRard 9797.



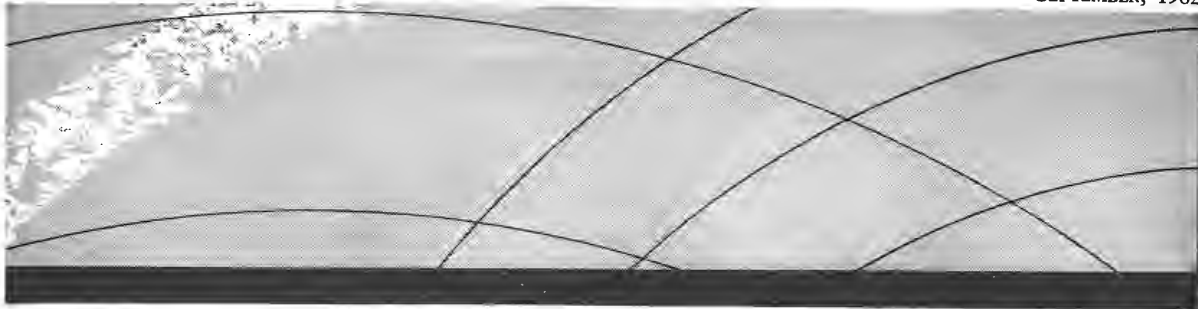

FERRANTI T.R. CELLS

are used in marine radar
throughout the world

A comprehensive range of T.R. Cells is available covering frequencies from 2,500 Mc/s. to 35,000 Mc/s. Write for further information.

FERRANTI LTD · KINGS CROSS ROAD · DUNDEE · Tel: DUNDEE 87141

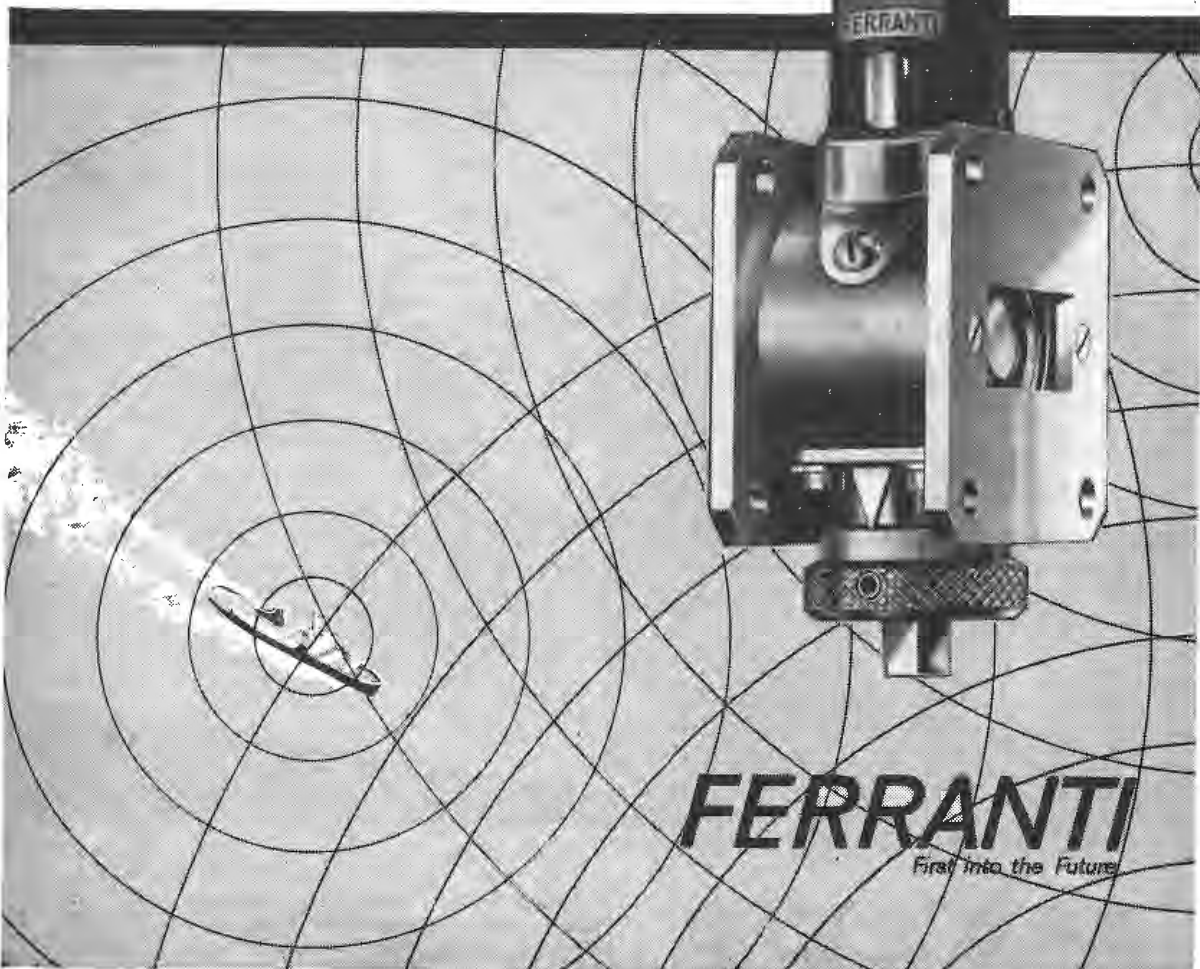

Excitations and Responses — continued

By "CATHODE RAY"

LAST month I rather unkindly deserted you just as we had come to an apparently absurd and impossible situation. Perhaps you have found your own way out of it. Most likely you have forgotten where we were. Anyway, the recapitulation is about to begin.

We had become acquainted with the idea of complex frequency. "Complex" is here in its mathematical sense, denoting any number made up of (in general) two parts, one "real" (an ordinary number) and the other "imaginary" (containing the factor j , which is $\sqrt{-1}$). If real numbers are represented on a piece of paper as horizontal distances (positive to the right and negative to the left), logical results are obtained if imaginary numbers are represented as vertical distances (positive upwards and negative downwards). Then, if the paper is marked with an origin and scales like a graph, any complex number can be plotted on it as a point. This idea, although it smacks of the occult, has been found so useful in studying a.c., impedances, etc. (as well as all subjects involving vector quantities) that it is now handed out at quite an early stage. So I have been assuming

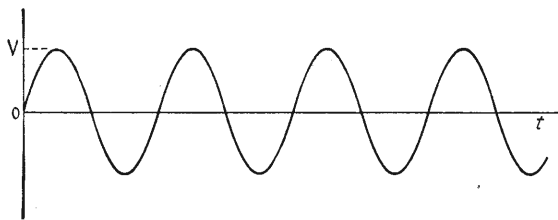

Fig. 1. Sinusoidal waveform, having the real radian frequency ω , which appears on a complex frequency plane as the imaginary $j\omega$.

from the start that all present know what is meant by the impedance Z being $R + jX$.

The idea of complex frequency is a little more recondite. It seems nonsensical to speak of imaginary frequency, even in a mathematical sense. It seems particularly silly to denote ordinary frequency by imaginary numbers, and then invent imaginary frequency, denoted by real numbers.

Yet this procedure is justified by a chain of curious but unshakeable logic, and still more by the fact that it helps one to solve circuit problems.

The only waveform that has only a single real frequency is the sinusoid, Fig. 1. It can be produced by a suitable generator or source. A well-known way of specifying, say, a voltage having this waveform, is as $V \sin \omega t$, or $V \cos \omega t$. But an alternative is $V e^{j\omega t}$, and in many cases there are good practical reasons for preferring this rather surprising form. The most surprising thing is the j , when there is no doubt about the frequency

itself (ω radians per sec, or $\omega/2\pi$ cycles per sec) being thoroughly real.

But the same waveform appears in the natural or free response of a circuit to an electrical disturbance of any form, if that circuit is made up wholly of reactances, which, as we have already recalled, are reckoned as imaginary quantities. That is significant.

With rare exceptions, however, all circuits have

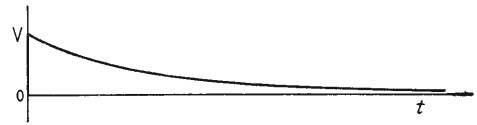

Fig. 2. Die-away form, having an imaginary frequency represented on a complex frequency as a negative quantity such as $-1/T$.

resistance as well as reactance. We considered at length a simple one having resistance and inductance in series. Its natural response to an electrical disturbance has the form shown in Fig. 2, for which the mathematical expression is $V e^{-t/T}$, T being the time constant of the circuit, L/R . By analogy with $V e^{j\omega t}$, in which the $j\omega$ indicates a real frequency (of a source or a circuit), $-1/T$ is an imaginary frequency, because it can be regarded as derived from a real frequency, represented by the imaginary number j/T , by multiplying it by j . Carrying the analogy a stage farther, we can say that a source that produced a voltage as in Fig. 2 would have the imaginary frequency $-1/T$, T being the time taken for the voltage to fall to V/e , as with the circuit response.

Circuits having all three elements, L , R and C in suitable proportions, are known to have natural responses such as Fig. 3, combining the features of Figs. 1 and 2. This form can be obtained graphically by multiplying the ordinates in these other two. Multiplication is represented by adding indices, and so the exponential form is typically $e^{(j\omega - a)t}$; here the coefficient of t , which we have found represents the frequency, is a complex number. So in

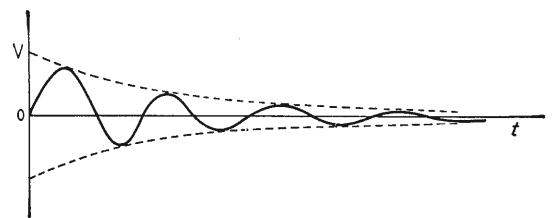

Fig. 3. Damped oscillatory waveform, combining the features of Figs. 1 and 2 and having a complex frequency, with both real and imaginary parts.

Fig. 4, which depicts a complex frequency plane, it would be represented by a point such as that marked with a cross, its distance from the origin being made up of real and imaginary parts.

We found the natural (imaginary) frequency of the simple RL circuit, represented by a point on the $-\omega$ axis, was $-1/T$. The natural frequency of the resistanceless LC circuit, represented by a point on the $j\omega$ axis, is $1/\sqrt{LC}$. This too can be expressed solely in time constants, as $1/\sqrt{T_1 T_2}$. In this case you may think there is a bit of a fiddle, because T_1 is CR and T_2 is L/R and we said our circuit had no resistance! If this worries you, try

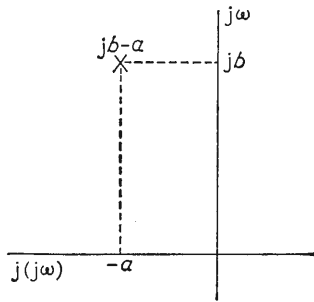

Fig. 4. Complex frequency plane, on which a general complex frequency is plotted as a \times . If this is the natural frequency of a circuit, its free response is of the Fig. 3 type.

studying the mathematical theory of limits. In the much more usual circuits that do have resistance, the natural frequency is still expressible in terms of these time constants:

$$-\frac{1}{2T_2} \pm j\sqrt{\frac{1}{T_1 T_2} - \frac{1}{4T_2^2}}$$

which has the general form $jb - a$ shown in Fig. 4.

So the concept of frequency, normally applied only to the Fig. 1 waveform, can be extended to any form that can be expressed as an exponential time function (e to the power of something times t). That something is the frequency as plotted on a graph like Fig. 4, in which real frequency is measured along the imaginary axis.

This extended notion of frequency holds for both sources and circuits. When a source is applied to a circuit there are two responses: the free or natural response, whose form is fixed entirely by the circuit, only its amplitude depending on the source; and the forced response, whose form (in linear circuits) is a copy of the source's, only amplitude and phase depending on the circuit. In linear circuits, the only possible free forms are expressible as exponential time functions, so all of them have natural frequencies, in the extended sense. Sources, on the contrary, can be made to give any variation of voltage or current with time. Fig. 1 shows much the commonest. Figs. 2 and 3 are not so widely favoured. But Fourier showed that any periodical form can be made up of a fundamental and harmonics, all of Fig. 1 form. And we mustn't overlook the one point common to both real and imaginary axes—the origin. It represents zero frequency, or d.c. It is an extreme case of any of the three forms shown, and in perfect analogy is denoted mathematically by Ve^{0t} , which is just V .

The two-fold response of a circuit to a source can be calculated by differential equations, in which the exponential form is the basis for the solution. But a graphical technique has been worked out, in which circuits and sources are represented by

points on the complex frequency plane, and the responses by lines drawn from one to t'other.

This is the method of poles and zeros, so called because all except the very simplest circuits have several natural frequencies, and the points to be marked are of two kinds: those where the frequency so represented would make the circuit function (impedance, admittance, or transfer function) zero or infinite. They are marked respectively by noughts and crosses.

For instance, the single cross in Fig. 5 is recognized by the experienced (us, now) as our simple RL circuit, the distance to the left of the origin being $1/T$. Its free response is revealed by the position of the pole. The forced response to a source of sinusoidal voltage (marked by the point on the $j\omega$ axis representing its frequency) is found according to rules, by measuring distance and angle between the two points.

This was all right in the early instalments, when the idea of a source of imaginary frequency was too ludicrous for us to think of actually putting our definition of a pole to the test by making source frequency coincide with pole. But when we gave a meaning to imaginary frequency, so that a real live source could have it, and found that it was the transient form in Fig. 2, the idea that applying this to an RL circuit having an identical natural frequency would make the impedance vanish (because there is no distance between two coincident points) looked ridiculous. Obviously such a transient voltage applied to a resistive circuit couldn't produce an infinite response. (And if anyone, more cautious in his use of the word "obvious", put it to experimental test, he would find that the response was indeed finite.) That is where we left off.

One fallacy is to assume that a voltage applied to zero impedance will give an infinitely large current. Even if we were to transfer our coincident points to the $j\omega$ axis so that the voltage was of the familiar waveform supplied (to a reasonably close approximation) by the Electricity Board, applied to a perfectly loss-free resonant circuit and therefore having zero impedance in the familiar sense, the current would not, even in theory, be infinitely large—at least, not in a finite time. It would grow at a steady rate, as shown in Fig. 6, like the swinging of a pendulum in response to an alternating pressure at its natural frequency. We shall see why later.

The free response would have the same frequency, but constant amplitude, depending on the amplitude of the source and the phase at which it was switched on. As we saw before, the free response is such, when added to the forced response, as to ensure that currents don't grow instantaneously in inductances or voltages change instantaneously across capacitances.

So even with real frequency it is a mistake to

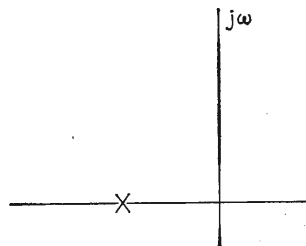

Fig. 5. Pole diagram for the simple series RL circuit.

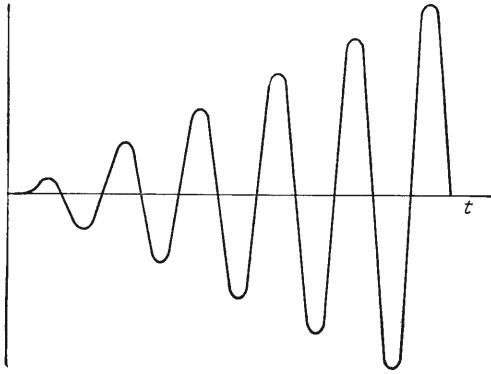

Fig. 6. Forced response of a resistanceless LC circuit to sinusoidal excitation.

suppose that a voltage applied to zero impedance would immediately cause infinite current. It would take an infinitely long time. So a transient voltage would hardly qualify.

But there is a subtler obstacle to our vision of infinite current. To understand it we'll have to go a little more closely into how to find the two-fold or total response.

One method is to write out the relevant differential equation or equations—by applying Kirchhoff's laws—and solving them in the approved textbook manner. Except perhaps for the approved manner, this is what we did two months ago, at least in outline. The emphasis was rather on avoiding differential equations, by noting that with exponential functions of time the process of differentiation boiled down to multiplying by the coefficient of t in the exponent—the thing we now know as frequency in the wider sense—and integration meant dividing by it. When the excitation is, as commonly, sinusoidal, the complex frequency is $j\omega$, and that is how we get the reactances $j\omega L$ and $1/j\omega C$.

Last month we learnt that the same principle was valid for any complex frequency, so we could apply it to sources having non-sinusoidal exponential forms, and we could apply it to the natural responses of all linear circuits, for all of them are exponential.

In the case of our old familiar series RL circuit with the sinusoidal source, the by-passing of differential equations leads to the familiar "Ohm's law for a.c." giving the forced response:

$$I = \frac{V}{R + j\omega L}$$

Those are peak values of current and voltage (they could also be r.m.s. values) but now that we are considering non-sinusoidal transients even when the source is sinusoidal we must work in instantaneous values:

$$i = Ie^{j\omega t} = \frac{Ve^{j\omega t}}{R + j\omega L} = \frac{Ve^{j\omega t}}{L(j\omega + \frac{1}{T})}$$

The usual symbol for complex frequency is s ; as both sources and circuits have them, let us distinguish them as s_s and s_c . In this case s_s is $j\omega$ and s_c is $-1/T$, so

$$i_s = \frac{Ve^{s_s t}}{L(s_s - s_c)} \quad \dots \quad (1)$$

When these complex frequencies are marked on the usual plane, they give us the pole-zero diagram, Fig. 7 (with no zero in this simple case). In our original rule for using such a diagram, the response was obtained by dividing the excitation by the length of the line joining the two points shown, taking into account also its angle to indicate the phase difference. This directed distance now appears in our equation as $s_s - s_c$. But whereas our s_s was originally limited to the sinusoidal $j\omega$, it is now free to roam anywhere on the plane, representing Fig. 2 or Fig. 3 sources, for instance.

For the same reason, it is possible to use the method for finding the free response. The natural frequency of this circuit is $s_c = -1/T$, so the response is

$$i_c = Ae^{s_c t} \quad \dots \quad (2)$$

where A is a constant whose value we find (as we did two months ago) from information about the phase at which v is switched on. (2) shows that the form of this free response is as in Fig. 2—as if we didn't know by now!

At the moment of switching on, the current is zero, and there is no scope for smart Alecks to confuse the issue by asking whether we mean just before or just after the contact is made, for we have already noted that in an inductive circuit the current grows at a finite rate, so it makes no difference which we mean. Therefore we can say that, at $t = 0$, $i = i_s + i_c = 0$. From (1) and (2),

$$i = \frac{Ve^{s_s t}}{L(s_s - s_c)} + Ae^{s_c t}$$

Putting $t = 0$ and equating i to 0 we get

$$0 = \frac{V}{L(s_s - s_c)} + A$$

$$\therefore A = -\frac{V}{L(s_s - s_c)}$$

$$\text{and } i = \frac{V(e^{s_s t} - e^{s_c t})}{L(s_s - s_c)} \quad \dots \quad (3)$$

for any value of t . We now have a beautifully

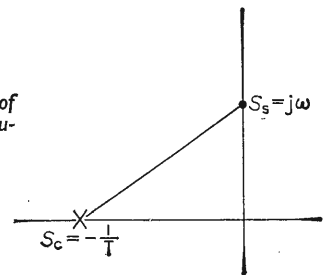

Fig. 7. Elaboration of Fig. 5 to show a sinusoidal source.

symmetrical expression for the total response, in terms of the source and circuit frequencies, s_s and s_c respectively. What is more, we have a graphical method of finding the total response—forced and free—of a circuit to an excitation, not limited to the sinusoidal form but valid for any that can be expressed as an exponential function. Briefly, this method is to regard the source frequency as just another pole on the diagram and to use the rules to find each component of the response in turn, by regarding each pole in turn as the source. In Fig. 7 there is only one circuit pole and one source pole, so only two components of response to be added

together to make the total response. Each term consists of an appropriate constant (in our example, V/L , where V is the peak value of the source voltage) multiplying e to the power of t times the complex frequency of whatever is for the moment being regarded as the source, divided by the complex distances from the pole of that source to all the other poles. (By complex distances I mean distances treated vectorially, with regard for angle.)

You will no doubt want to see how this works out for a less simple circuit, but it must be remembered that just now we are exploring what happens when the source frequency is the same as the circuit frequency, so that the two poles coincide. In particular, we were trying to imagine what would happen if the circuit pole was as in Fig. 7 and the source voltage as in Fig. 2, so that its pole was on the same axis and could be made to coincide by making its rate of die-away the same as that of the circuit transient.

As this condition is approached, the denominator $s_s - s_c$ becomes less and less, and when the poles coincide it is zero; that, in fact, was our definition of a pole. So, according to the laws of algebra, both forced and free responses become infinitely large. Physically, that is absurd—which was our dilemma last month. Or at least it would be if the forced and free responses could occur separately. As they cannot, we have the situation

$$\dots \dots i = \infty - \infty \dots \dots (4)$$

which is not very helpful.

The mathematicians rescue us from this impasse by rewriting equation (3) in a form where the difference between the two poles is shown as δ , a very small quantity. The term is then expanded by Maclaurin's theorem—we came across that in "e"—and δ allowed to dwindle to zero. In this subtle way, (4) is found to have quite a reasonable finite value:

$$\dots \dots i = \frac{V}{L} t e^{s_c t} \dots \dots (5)$$

The significant feature about this is the factor t that has joined the party. It ensures that the current starts from zero at $t = 0$, and it would grow indefinitely (providing some basis for the infinite current with zero impedance idea) if it were not more than counteracted by the index s_c which in this kind of circuit is negative. In a resistanceless LC circuit, s_c is $j\omega_0$, so the amplitude of i would grow steadily

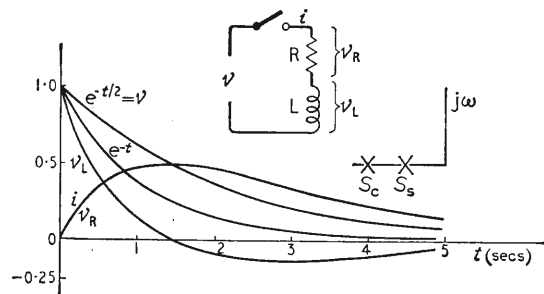

Fig. 8. Curves of excitation and response of a series RL circuit to a Fig. 2 source having half the "frequency."

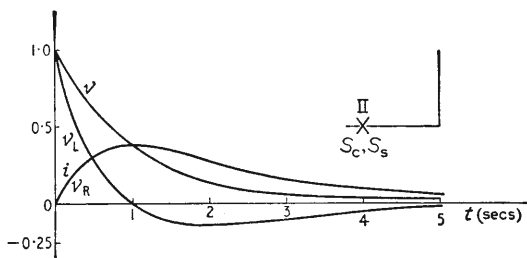

Fig. 9. Corresponding to Fig. 8 but with source and circuit frequencies equal, achieving perfect (but imaginary) resonance.

without limit (as in Fig. 6) if the frequency of the source were the same.

It is quite interesting to plot the responses (3) and (5). For simplicity let us choose $R = L = T = 1$, so $s_c = -1$. And for a source voltage of Fig. 2 form but different complex frequency let $s_s = -\frac{1}{2}$; this puts the source pole half-way between the origin and the circuit pole. In other words, the forced response takes twice as long to die away as the free response. In Fig. 8 this form, v , is shown, and also e^{-t} for comparison. The total response, i , is plotted from (3); it starts from zero because the free and forced responses exactly cancel out when $t = 0$. Since $R = 1$, the same curve does for v_R , the voltage across R . That is an example of economy of effort. Since v_L , the voltage across L , is what is left, it is plotted by subtracting v_R from v , with the result shown. Note that it becomes negative, owing to the inertia effect of L , so that after 1.4 seconds the voltage across R is actually greater than that provided by the source.

Doubling the rate of v die-away (i.e., doubling its complex frequency) so that it comes into exact resonance with the circuit, and using (5) to plot the results, we get Fig. 9, which is remarkably un sensational. So far from the response being infinitely large, it is actually less than before, owing to the shorter duration of the excitation. Otherwise, there is no significant difference, although now the rise from zero i is due to the factor t in (5), not present in (3).

Well, I have only just managed to deal with last month's dilemma and time is up. But I hope that in the process the pattern of the whole subject has become clearer.

We are no longer bound to sinusoidal excitation and forced response, but can find—either by calculation or graphically—the total response to any excitation that by hook or by crook can be manipulated into exponential form. The weak spot is that so far we have exercised these remarkable powers only on a laughably small target. Next month, without troubling to explain everything from the beginning, I propose to demonstrate on something a little less elementary.

I hope too much confusion was not caused last month by certain transcription errors that appeared in Fig. 5. $1/T_2$ therein ought to have been $1/2T_2$, and $1/4T_2$ ought to have been $1/4T_2^2$. Also in Fig. 2 for i_p please read i_t . My sincere apologies.

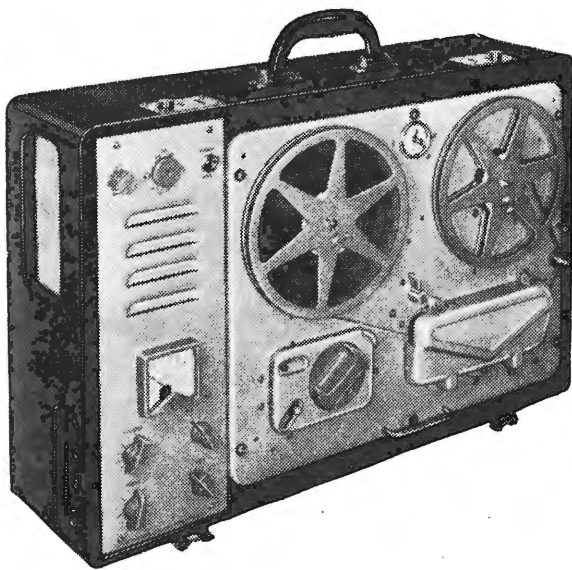

Vortexion quality equipment

The W.V.B. recorder has an additional amplifier and head with provision for "before" and "after" record monitoring while the recording is in progress, and this also has echo facilities.

The W.V.A. recorder has provision for a plug in stereo head and can be supplied with this and stereo playback pre-amplifiers with equalisation each having an output of 1 volt from a cathode follower. This is type W.V.A./S.

A heavy mumetal shielded microphone transformer is built in for 15-30 ohms balanced and screened line, and requires only 7 micro-volts approximately to fully load. This is equivalent to 20ft. from a ribbon microphone and the cable may be extended to 440 yds. without appreciable loss.

The 0.5 megohm input is fully loaded by 18 millivolts and is suitable for crystal P.U.'s, microphone or radio inputs.

The playback amplifier may be used as a micro-

phone or gramophone amplifier separately or whilst recording is being made.

The meter fitted for reading signal level will also read bias voltage to enable a level response to be obtained under all circumstances. A control is provided for bias adjustment to compensate low mains or ageing valves.

The power output is 4 watts heavily damped by negative feedback and an oval internal speaker is built in for monitoring purposes.

THE VORTEXION W.V.B. or W.V.A/S

are eminently suitable for making a high quality recording almost indistinguishable from the original since these models have facilities for monitoring the recording actually put on the tape with only a fraction of a second delay.

By this means, when for any reason the signal is distorted or not as required, the result of the recording on the tape can be heard almost instantly, and adjustments can be made until the results are as required.

Many types of music today have the treble boosted considerably, and may result in greater power being recorded at high frequencies than at

middle frequencies, an overload of the tape at high frequencies gives a mushy quality with lots of hiss and background noise.

Adjustment to the bias level while listening to the result is useful in this connection especially where the brand of tape and the bias setting for it are not exactly known.

Again if clean treble recordings at $3\frac{3}{4}$ in. are of prime importance it is now recognised that no other method is quite so effective in achieving this as reducing the bias slightly while listening to the results. The meter reading of the new bias setting for the particular tape used may be noted for future use.

VORTEXION LIMITED, 257-263 The Broadway, Wimbledon, London, S.W.19

Telephones: LI Berty 2814 and 6242-3.

Telegrams: "Vortexion, Wimbledon, Lon."

the truest sound

For sound reproduction as it should be—as close as possible to the original—make Shure microphones your unvarying choice. They are the finest for every purpose, years ahead of others in the technical excellence of their design and performance, the most comprehensive range obtainable anywhere.

Model 545 'Unidyne III' for public address, tape recording, communications and similar applications requiring compactness with maximum operating efficiency.

Model 420 'Commando' can be used indoors or outdoors, for all general-purpose applications. Quality performance at moderate cost.

Model 540S 'Sonodyne II' This versatile new microphone features *variable frequency response*, allowing the user to tailor the microphone to the application.

Model 55SW 'Unidyne' The most widely used microphone in the world, specified by leading sound engineers and requested by celebrities.

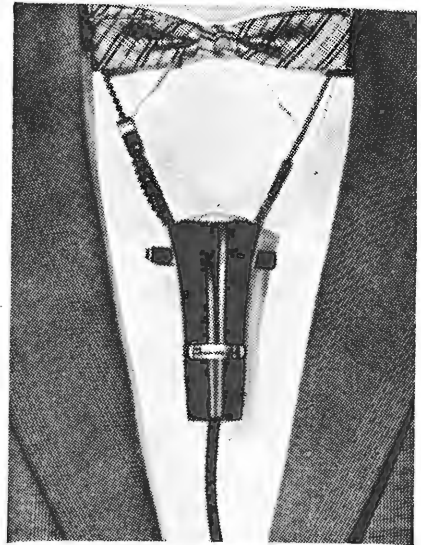

Model 420 'Commando'

The new Shure microphone catalogue is available on application to the address below

SHURE ELECTRONICS LIMITED

84 Blackfriars Road · London SE1

Telephone: WATERloo 6361

SHURE

Setting the world's standard in sound



Model 55SW
'Unidyne'

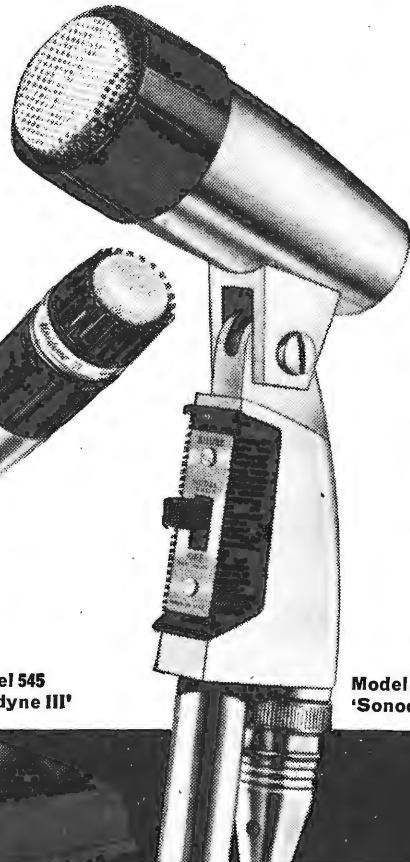

Model 545
'Unidyne III'

Model 540S
'Sonodyne II'

MANUFACTURERS' PRODUCTS

NEW ELECTRONIC EQUIPMENT AND ACCESSORIES

Portable V.H.F. R/T Set

THE type TRT/2 portable v.h.f. radio telephone made by R.E.E. Telecommunications uses transistors throughout, even for the transmitter power-output stage. Completely self-contained, the TRT/2 is powered by two 6-V mercury batteries giving a minimum of 40 hours' use on a 10/1 receive/transmit ratio. For reception a moving-coil loudspeaker is fitted, but headphones may be used if desired. The receiver is a double superhet with two r.f. stages and three i.f. (plus two mixers) am-



R.E.E. Telecommunications type TRT/2 portable transistor v.h.f. R/T.

plifiers working at 10.7 Mc/s and 460 kc/s. The transmitter is crystal-controlled and uses a Mullard AFY10 transistor in the output stage.

R.E.E. Telecommunications Ltd., Telecomm Works, Market Square, Crewkerne, Somerset.

A.C./D.C. Transfer Meter

THERMAL techniques are adopted in the John Fluke Model 540/A Transfer Standard, which is marketed by Livingston Laboratories Ltd., 31 Camden Road, London, N.W.1. The heating effect of an alternating voltage is

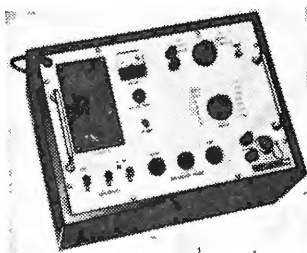

The John Fluke Transfer Standard. The meter is used when the relevant voltage range is to be determined. Thermocouple burn-out is thereby avoided.

compared with that of an easily-measurable direct-voltage by means of a null indicator. The r.m.s. value of the a.v. can be determined to within $\pm 0.02\%$ from 300mV to 1000V, and the calibration holds up to 50kc/s. Input impedance is $200\Omega/V$.

Pre-amplifier

FOR investigations involving measurements on low-frequency signals of fractions of a millivolt amplitude or

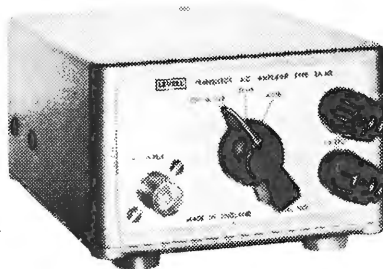

Levell transistor pre-amplifier. Input socket is B.N.C.

less, the Levell Transistor A.C. Amplifier TA40 increases the sensitivity of an oscilloscope or voltmeter by 20dB or 40dB to within 0.1dB. Gain at the two positions is adjusted by preset controls. The bandwidth of the amplifier is 4c/s—400kc/s (-3 dB) and the input impedance is about $3M\Omega$ and 10pF. Noise level is less than $75\mu V$ when the source of impedance is $100\Omega k$, distortion being less than 1% from 15c/s to 15kc/s. The instrument, which is powered by a PP9 battery, is made by Levell Electronics, Park Road, High Barnet, Herts.

Transistor Tester

STATIC characteristics of low-power transistors in either common base or common emitter connection may be plotted by the use of the M.L. tester. All hybrid parameters can be determined for both p-n-p and n-p-n types within $\pm 5\%$, and collector leakage current down to less than $15\mu A$ is indicated. A leaflet on the instrument is available from the M.L. Aviation Company

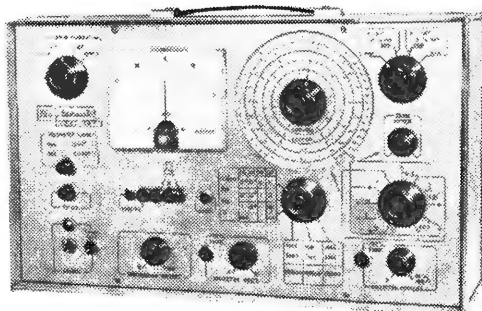

The M.L. Transistor analyzer and tester.

Limited, White Waltham Aerodrome, Maidenhead, Berkshire.

Sensitive Pen Recorder

ALTHOUGH possessing a sensitivity of $0.1\mu\text{A}$ or 0.05mV , the Kipp "Micrograph" pen recorder is linear to within 0.25%, and the deflection accuracy is better than 1% of full scale. Backlash is less than 0.25% of full scale. Chart speed is adjustable to five values in each of three models and the complete range of speeds is from 60-57,600 millimetres/

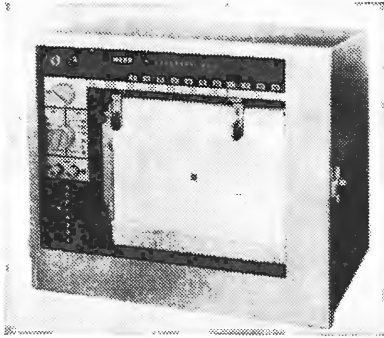

Kipp "Micrograph" recorder. Either rack—or wall-mounting versions are available.

hour. A channel selector is available to enable four signals to be multiplexed. The recorder is marketed by the Shandon Scientific Company Ltd., 6, Cromwell Place, London, S.W.7.

Indicator-Controller

BOTH of these functions are performed by the International Instruments Model 2547, which is marketed in the U.K. by Leland Leroux Ltd., 145 Grosvenor Road,



International Instruments indicator-controller. The limits are set by the two pointers over the scale.

Westminster, London, S.W.1. Contactless, variable limit trips are responsible for greatly improved operation, free from contact resistance and bounce. An extension of the pointer moves between oscillator and pickup coils, the output from the latter depending on the position of the pointer. If the reading is beyond pre-set limits, the signal is amplified by a built-in circuit, while the reading beyond limits is still available. When the parameter returns within limits, resetting is automatic. The meters are available in current or voltage measurement form, the ranges being $50\mu\text{A}$ -500mA, and 10mV-500V. Alternating voltage can be measured from 50V to 500V.

Protection of Silicon Rectifiers

ENGINEERS confronted for the first time by a silicon rectifier might be excused for suspecting that there was a snag in it somewhere. And, of course, they would be right, for even though the minute device will rectify enormous voltages and pass ridiculously high currents,

the price must be paid, and this takes the form of spike protection.

One is used to a certain amount of liberty-taking with the older selenium and valve rectifiers, but the immediate and noiseless result of this in the case of silicon is catastrophe. The usual cause of the trouble is voltage spikes on the rectifier supply line caused by switching, or mains-borne noise, and the latest form of protection is a device known as the "Klip-Sel," made by International Rectifier (Great Britain) Ltd., Hurst Green, Oxted, Surrey. These are selenium rectifiers which are specially made to exhibit a characteristic which is rather like that of a Zener diode, in that the voltage across it remains sensibly constant for a large variation of current. Additionally, the device possesses a large shunt capacitance, and the two effects, when the Klip-Sel is placed across the supply lines, tend to reduce in amplitude any transients that appear.

Klip-Sels are available in wire-ended cartridge or stack types and clamping voltage is from 63V to 890V at currents between 250mA and 15A.

Frequency Analogue Converter

THERE are many applications where a variable frequency signal is required to produce an output which is the voltage analogue of the frequency, for example shaft-speed control, conveyor belt control, or any application where phenomena occurring at a rate of 2c/s to 400c/s need to be measured or controlled. The Grunther Industrial Developments Lintegrater is an extremely linear and stable frequency discriminator working on the pulse integrator principle. A voltage is developed across a resistor in the output circuit which is fed back to correct for variations in the output due to load or supply fluctuations. No periodic setting-up is required, and linearity is 0.1%. The device will work with an input of greater than 200mV peak, input impedance being $1\text{M}\Omega$. A leaflet is obtainable from the makers at 14, Oriental Street, E.14

Clock-face Indicator

THE long search for the ideal device for number indication is taken a step forward by the Mullard Z550M cold-cathode tube. It takes the form of a central electrode with ten more disposed in a circle, in the manner of a counting tube, and surmounting the whole, a metal disc with punched-out numerals. When the potential applied to a given electrode is above that of the rest, a glow forms from this to the central electrode, and the associated 3 m.m. numeral is indicated. The tube is particularly suited to transistor circuits, as the trigger voltage needed is only 5V; power is 110V r.m.s. at about 3mA. The tube is 26.5 m.m. high when in the B13B base and 30 m.m. in diameter. A complete description can be obtained from Mullard House, Torrington Place, London, W.C.1.

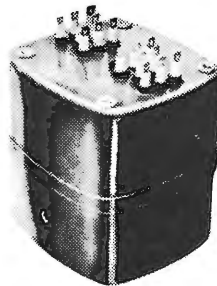

G.I.D. Lintegrater. Four models are available covering 20-400c/s. fullscale. Power required is about 12V at 15mA.

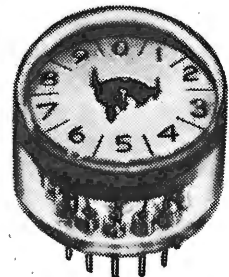

Mullard neon indicator tube for low signal-voltage applications, such as transistor counters.

FUNDAMENTALS OF FEEDBACK DESIGN

9.—AMPLIFIER TERMINAL IMPEDANCES

By G. EDWIN

THE use of negative feedback is often regarded as chiefly directed towards improving the frequency response and reducing the distortion of an amplifier. When we come to treat this second aspect we shall see that we must be careful in assessing the benefit of the apparent improvement in frequency response. Improvement in gain stability is, indeed, often the factor which determines the feedback to be used, for when reasonable limits are set on this the response and distortion will normally be more than adequate. Another condition which is often the chief parameter in deciding how much feedback must be used is one or other of the amplifier terminal impedances.

A simple example will show how this impedance specification may be made necessary. An amplifier is required to feed a number of lines, let us say up to 20, each of impedance $600\ \Omega$ and each long enough to require to be matched at both ends. At the sending end, therefore, we shall put a $600\text{-}\Omega$ resistor in series with each line. The load presented to the amplifier may be anything from $1200\ \Omega$ down to $60\ \Omega$. The practical application of this is in feeding a number of transmitters from a central programme source, so that the level is controlled at the input. For a number of reasons the amplifier impedance should be low. First of all, the level to transmitter A should not depend on whether any or all of the other lines are connected. An extension of this is that the level should not change if any or all are connected while a signal is being emitted. Secondly, if due to some fault there is noise on one of the lines it should not get back through the common impedance of the amplifier and thus react on the other lines. A specification for such an amplifier might call for a system to work into loads down to $60\ \Omega$ but to have a source impedance of only $2\ \Omega$. This would be determined mainly by the line-to-line protection required but in other cases the regulation is dominating and we must use Thévenin's Theorem. The author recently encountered a problem in which the amplifier output impedance was required to be only one hundredth of the load impedance.

The other side of the story comes with the input impedance. Here we may have a requirement for a very high input impedance and may have to deal with the grid-cathode capacitance of the input valve. The resistive term is usually, though not always, too high to be troublesome in valve circuits. When we are using transistors, however, the input resistance will normally be rather low and a good deal of ingenuity is needed to achieve the high impedances needed for some measuring amplifiers.

These are the two usual problems, but there are real practical demands for very high output impedances. One of these is to get a well defined source impedance by making the amplifier impedance extremely high and then regarding it as the current generator in the Norton form of Thévenin's Theorem. A resistor connected in parallel then defines the impedance. This leads to a relatively simple circuit

and is very convenient if a second output is to be taken off, without mutual interference: this output is, of course, in series with the first. Low input impedance is also needed for certain types of combining amplifier.

Effect of Feedback on Output Impedance

To determine the effect of feedback on an amplifier output impedance we shall first of all consider the arrangement shown in Fig. 51. Without feedback the output impedance of the amplifier is R_0 and the equivalent source is shown at the right of the black

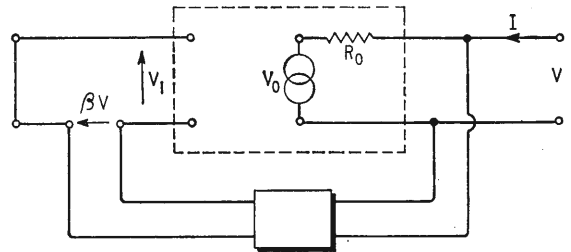

Fig. 51. Circuit for determining the effect of voltage feedback on the output impedance of an amplifier.

box. The impedance is determined by applying a signal V to the output and measuring the current I which flows. The input terminals are short-circuited so that there can be no input signal and if the feedback were not connected the generator voltage would be zero, so that we should just have $V/I = R_0$.

With the feedback connected, however, there is a signal of βV reaching the input. This signal, V_1 , is amplified, of course, and $V_0 = \mu_1 V_1$. It is very important to notice that μ_1 is the open-circuit amplification of the system which may be very much greater than the gain into the normal load. This is because R_0 may be very much more than the normal load resistance: in an output pentode the ratio may be ten times. We can write down the equation for the output mesh

$$\begin{aligned} I &= (V - V_0)/R_0 \\ &= (V - \mu_1 \beta V)/R_0 \end{aligned}$$

so that $V/I = R_0/(1 - \mu_1 \beta)$

This is the textbook form for the output impedance with voltage feedback. The factor $(1 - \mu_1 \beta)$ is similar to the one used in gain questions, except for this new meaning for μ_1 , and with negative feedback of normal form we can write

$$R_{eff} \approx R_0/|\mu_1 \beta|$$

It is more convenient to go a step further. When the normal load of the amplifier is R the terminal voltage will be $V_0 R/(R_0 + R)$, and when $R_0 \gg R$ this reduces to $V_0 R/R_0$. The gain we usually measure, with the amplifier loaded, is $\mu = \mu_1 R/R_0$. It is an easy substitution to derive $R_{eff} \approx R/|\mu \beta|$.

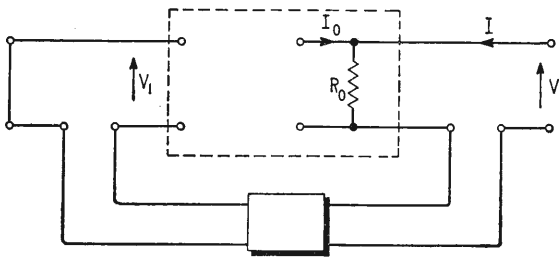

Fig. 52. Circuit for determining the effect of current feedback on the output impedance of an amplifier.

By expressing the impedance reduction in this form we have eliminated two factors which we usually do not know, μ_1 and R_0 , and obtained a form which is much more practical. We see at once that with 20dB of feedback the impedance is 0.1 of the load impedance so that the regulation of the system will be 10%. Our earlier discussions have provided a warning against being too precise in expressing results which depend on $\mu\beta$, because much of the justification for using negative feedback would disappear if μ were really a well-defined constant. If $|\mu\beta|$ is only defined as being between 10 and 20 it is the sheerest pedantry to worry because $(1 - \mu\beta)$ is 11, not 10.

When the feedback is taken in series with the output, so that it is proportional to the current, we have the form shown in Fig. 52. Here we shall write $I_0 = AV_1$ and $V_1 = BI$, so that A is a measure of the gain (which must be examined in more detail) while B is a measure of the feedback. We have very simply

$$V = (I + I_0) R_0 \\ = I(1 + AB) R_0$$

$$\text{so that } \frac{V}{I} = R_{eff} = (1 + AB) R_0$$

Now let us connect the system as an amplifier in the usual way. We apply a signal V_0 and in the absence of feedback we should get a current of I_0 into a short-circuit at the output or a voltage of $I_0 R_0 / (R + R_0)$ across a load R. Thus $A = I_0 / V_0$ and the usual gain with a load is $\mu = ARR_0 / (R + R_0)$. The current in the load is $\mu = I_0 R_0 / (R + R_0)$ and it is this current which must be multiplied by B to give V_1 . So

$$V_1 = BI_0 R_0 / (R_0 + R) = BV_{out} / R$$

Hence $\beta = B/R$. From this we rapidly derive

$$AB = \mu\beta(1 + R/R_0)$$

No account has been taken of signs in this derivation but quite obviously to maintain the convention we are using we must introduce a minus sign, and then we can write

$$R_{eff} = [1 - \mu\beta(1 + R/R_0)] R_0$$

which, if $|\mu\beta|$ is large, reduces to

$$R_{eff} \approx |\mu\beta| (R_0 + R)$$

Normally, with negative feedback, we can say that the use of voltage feedback will decrease the output impedance of an amplifier while the use of current feedback will increase it. Over the major part of the working range and with the amount of feedback commonly used the factor involved will be $|\mu\beta|$.

Near the edges of the frequency range, and possibly

well within them if full advantage is being taken of the flattening of the response, $|\mu\beta|$ starts to fall and we become closely concerned with the actual amount $(1 - \mu\beta)$. The impedance characteristic of an amplifier is likely to preserve its wanted behaviour only over the range in which the gain is high, and although, for example, the response may be flat up to 20kc/s, the impedance may start to depart from its carefully chosen very low or very high value at only 2kc/s.

Let us now turn to the consideration of the input impedance. In Figs. 51 and 52 we have applied the feedback voltage in series with the input voltage, but this is not the only way of connecting the feedback. We shall, however, treat this method first. The input circuit can be drawn in the form shown in Fig. 53. We have

$$V_1 = V_0 + \mu\beta V_1 \\ \text{so that } V_1(1 - \mu\beta) = V_0 \\ \text{and } I_0 = V_1/R_0 = V_0/(1 - \mu\beta)R_0$$

The input impedance is therefore $(1 - \mu\beta)R_0$ instead of simply R_0 , so that by this method of connection we can multiply the input impedance by about the usual factor $|\mu\beta|$.

The alternative arrangement is to introduce the feedback in series with R_0 in the way shown in Fig. 54. For this circuit we can again write down the equations, which are simply

$$V_0 = V_1 \\ I_0 = (V_0 - V_f)/R_0 \\ V_f = \mu\beta V_1 = \mu\beta V_0$$

$$\text{so that } \frac{V_0}{I_0} = R_0/(1 - \mu\beta) \approx R_0/|\mu\beta|$$

The input impedance is here reduced by the factor $|\mu\beta|$ in the region where this is high. This form of the circuit is more familiar when drawn in the style of Fig. 55 although it is quite easy to see by using Thévenin's Theorem and looking in at the point A that this is really just the same as Fig. 54.

We have seen that the effect of feedback is to multiply the input and output impedances or admittances by a factor $(1 - \mu\beta)$ and that the method of connection of the feedback path determines whether it will be the impedance which is multiplied, giving a higher impedance, or the admittance, giving a lower impedance. This presumes that $\mu\beta$ is in fact negative. There is no reason why we should not consider the possibility of $\mu\beta$ being in fact a positive

Fig. 53. Circuit for determining the effect of series applied voltage feedback on the input impedance of an amplifier.

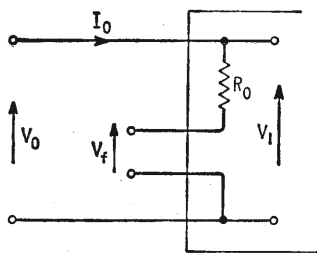
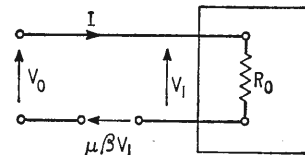

Fig. 54. Circuit for determining the effect of parallel applied voltage feedback on the input impedance of an amplifier.

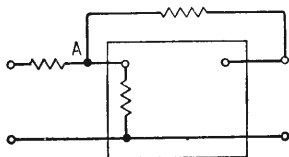

Fig. 55. Alternative and more familiar version of Fig. 54.

quantity having a value less than unity. We know, indeed, from our earlier studies, that at the extremes of the working range it is very common for the phase of the amplifier to have come round through 180° and that this point, where we measure the gain margin, corresponds to just such a condition. Let us take, for example, $\mu\beta = 0.9$, when we shall have $(1 - \mu\beta) = 0.1$, and in the circuit of Fig. 52, with current feedback, the output impedance will be reduced by a factor of 10. At the same time, of course, the overall gain with feedback connected will increase by the same factor.

A reduction of output impedance of this order is a matter of very considerable importance because it greatly eases the problem of obtaining amplifiers of very low output impedance without introducing large amounts of negative feedback. The system as a whole will always be provided with negative feedback to maintain its characteristics uniform but local positive feedback can be used at the output to produce this lowering of gain, with a further reduc-

tion produced by the negative feedback. A split of this kind is easily seen to be desirable. If we look at the form $(1 - \mu\beta)$ and note that $\mu\beta$ is to be in the region of 0.9 we see that μ must be well defined: obviously we must have as few valves in the loop as possible. The working point of these valves is then stabilized and the feedback adjusted to give the required performance. Circuits of this kind have proved very satisfactory in operation although we have no space here to consider the details.

The other application is the production of infinite input impedance. By using positive feedback of the type shown in Fig. 54 we can again get this multiplication by $1/(1 - \mu\beta)$ which with $\mu\beta = 0.9$ becomes a factor of 10. For experimental work using a system of this kind, the forward gain μ can be obtained from a high-gain amplifier with a lot of negative feedback, the type of amplifier used in analogue computers. This will give a small but very stable value of μ so that $\mu\beta$ can be trimmed to be reliably within, say, 1% of unity. Starting off with a high impedance the resulting impedance will be as high as the drift of the system will allow.

It will be noted that if we make $\mu\beta > 1$ in this sort of circuit, we shall have a negative value for the two impedances $R(1 - \mu\beta)$ and $R/(1 - \mu\beta)$. There are important applications for this effect and we shall discuss it.

BOOKS RECEIVED

Satellite Tracking, by Stanley Macko. The technology of satellite launching and tracking is still regarded as a "mystic art" by many non-technical people, and this book is intended to convey a little more enlightenment on the subject. Introductory chapters on the structure of planetary systems are followed by a discussion on the computation and evaluation from tracking data of orbital elements (parameters which define the satellite's track). The essentials of missile trajectories are explained, and brief descriptions are given of the instrumentation of the Atlantic missile range. Pp. 128. John F. Rider Publisher Inc., 116, West 14th Street, New York 11, N.Y. Price \$5.50.

The Wave-guide Mode Theory of Wave Propagation, by K. G. Budden. A study of the propagation of two types of wave which, though physically entirely different in form, possess certain similarities. Radio waves between the earth and ionosphere, and sound waves between the bed and surface of the sea can be treated mathematically in broadly similar ways, and this book, which is based on a series of lectures, deals in a general way with wave propagation in stratified systems. A knowledge of calculus and the theory of complex variables is assumed. Pp. 325. Academic Press Inc. (London), Ltd., Wing 1, 7th Floor, Berkeley Square House, Berkeley Square, London, W.1. Price 70s.

Handbook of Electronic Tables and Formulae, edited by D. Herrington & S. Meacham. A collection of useful formulae, constants, symbols, etc., in constant use. The book was originally published in the U.S.A. and the fact is reflected in some of the information given. Television, for instance, is assumed to be of the American standard, and valve equivalent tables are U.S.-to-European. Pp. 126. George Allen & Unwin Ltd., Rusklin House, 40, Museum Street, London, W.C.1. Price 15s.

British Standards Yearbook 1962. Contains information on the Institution and its services. In addition to a list of British Standards, publications of the international standards organizations are listed and briefly described. A list of British Standards Codes of Practice in building and engineering is given. Pp. 670. British Standards Institution, British Standards House, 2, Park Street, London, W.1. Price 15s.

Intelligent Machines, by D. A. Bell. An introductory text for the scientifically inclined layman on the subject of cybernetics. A broad background is given on information theory, communications and the elements of control systems, after which more specific information is presented on computers and "learning" machines. Biological cybernetics are discussed, and the philosophical aspects of "automation" dealt with in the epilogue. Pp. 98. Sir Isaac Pitman & Sons Ltd., Pitman House, Parker Street, Kingsway, London, W.C.2. Price 12s 6d.

The Broadcasting of Music in Television. In four parts, this B.B.C. Engineering Division Monograph is written by four members of the B.B.C. staff from the points of view programmes, engineering and operation. In the section on operational technique, subjects dealt with include artificial reverberation and problems associated with operatic productions. A complete section is devoted to studio acoustics. Pp. 24. B.B.C. Publications, 35, Marylebone High Street, London, W.1. Price 5s.

The Measurement of Frequency, by L. Essen, E. G. Hope and K. Morris. No. 28 of the N.P.L. *Notes on Applied Science*, this booklet gives an account of techniques and equipment used in frequency measurement to an accuracy of a few parts in 10^{10} . Both digital and resonance meters are described. Pp. 16. H.M.S.O., York House, Kingsway, London, W.C.2. Price 1s 9d.

TECHNICAL NOTEBOOK

Flutter measurement by pulse techniques enables measurements to be made on tape transport mechanisms instantaneously, and avoids the superimposition of playback flutter on that incurred during recording. In a method described by A. Schulbach in *Electronics* for May 11th, 1962, two playback heads are spaced apart by 0.1 in, and the time taken for a recorded pulse to travel from one head to the other is measured. As the pulse is detected by the first head, a monostable multivibrator is triggered, the trailing edge of whose pulse initiates the operation of a ramp generator immediately before the arrival of the pulse at the second head. The output of the second head is passed to a pulse shaper to provide a sampling pulse, which enables a capacitor to charge to the instantaneous value of the ramp waveform. If the time between pulses varies, the capacitor will charge to a different voltage at the onset of each sampling pulse and integration of the capacitor waveform yields the flutter "envelope." The highest flutter frequency discernible is governed by the speed of the tape and the separation of the heads.

"**Ultrasonic Corona Hunter**", as it is called, has been developed by three Westinghouse research engineers, W. E. Pakala, J. H. Thompson and R. A. Lester, for detecting leakage of high-voltage electricity from transmission lines. Such leakage wastes electrical power and produces interference. If there is enough of it, it shows up in the dark as a hazy bluish glow; usually, however, it is difficult to locate. The new detector locates leakage from a distance by tuning in

on 40kc/s ultrasonic sound waves which are generated by the corona. The detector resembles a gun, being built on the stock of an ordinary rifle and using a telescopic gunsight. Around this sight are mounted in a circle twenty small ultrasonic transducer detectors, the spacing and placing of these providing a reception beamwidth of less than two degrees. The trigger of the rifle acts as a switch for a transistorized circuit which makes the transducer outputs audible through a small loudspeaker built into the gun stock at ear level. Static-like noises from the loudspeaker indicate that the device has a corona source exactly in its sights. Laboratory tests show that this new corona detector is sensitive enough to locate the ultrasound of running water up to 20ft away. It can also distinguish sources only a few inches apart at a distance of 75ft.

Current stabilizer used in a surface ionization type of mass spectrometer is required to hold filament current constant to within 0.01%, the operation being complicated by the presence of 6kV on the filament supply. J. D. Milne *et al.* describe, in the *Journal of Scientific Instruments* for May, 1962, a method of obtaining the current stability while dissociating the stabilizer from the high voltage. Part of the a.c. filament current is passed through a torch bulb operated at less than rated voltage, so that the curve of light output against current is steep. The light from the bulb is incident on one of a pair of OC44's in a long-tailed pair amplifier, the relevant transistor being made light-dependent by the removal of its masking paint. The amplified signal is used to operate a series-transistor current regulator. Control of current is obtained by varying the standing current through the bulb, although the use of an optical wedge between the bulb and phototransistor is being considered.

Semiconductor microwave sources have been developed by G. and E. Bradley, Electrical House, Neasden Lane, London, N.W.10. The output of an oscillator working at 125 Mc/s, which may be crystal-controlled, is applied to a reverse-biased semiconductor diode, the non-linear capacitance/voltage characteristic of which enables the generation of harmonics. The efficiency, when used in a 100 Mc/s doubler circuit employing conventional components is about 75%, falling to 20% when used in a waveguide tripler from 3000 to 9000 Mc/s. If efficiency can be sacrificed,

the multipliers may be given a bandwidth of 30%, so allowing the l.f. oscillator to be varied. The ease with which lower-frequency oscillators may be controlled eliminates expensive microwave a.f.c. devices.

New switch has been developed by A.B. Metal Products to accommodate the high surge currents (up to 35 amps) associated with the use of silicon rectifiers in the mains circuits of television receivers. Such surges are caused by the combination of the low forward resistance of such rectifiers and the high value of reservoir capacitor usually employed. This new series SR double-pole, on-off mains switch is available with slide, rocker, rotary or push-button actions.

Pumping lasers by means of exploding wires is being investigated by Westinghouse Electric (see page 24 of the March 30 issue of *Electronics*). Because they produce a very high output in very short pulses, such wires should be very suitable as pulsed laser pump sources, although at present they have not given laser outputs as high as the few joules which can be obtained with normal gas discharge tube pumps. In the experiments capacitor banks storing about 30,000 joules of energy were discharged through the wire, and the line source output focused on to the laser ruby rod by a polished elliptical stainless steel mirror.

Three-dimensional display system to accommodate positional information in two planes was described by Coddington and Schipper at the I.R.E. International Convention. The display is formed by an electroluminescent x-y matrix, a bright point occurring at the intersection of energized co-ordinates. The electroluminescent panel is spun about its vertical axis at 20 r.p.s., and the signals to the matrix are modulated at this frequency, the phase of the signals being governed by the z information. The spot then appears to float in space, and interpretation of, say, range/bearing/height information is very much simplified.

Sputtering tantalum film resistors in a partial nitrogen atmosphere increases their stability against temperature and time according to a paper given before the Electron Components Conference in Washington by D. Gerstenberg and E. H. Mayer of the Bell Telephone Laboratories. Normally tantalum resistors are sputtered in an inert gas such as argon. However, this usually contains impurities such as oxygen and



water vapour which then appear in the tantalum films, producing resistors with a relatively wide range of resistivity and temperature coefficient. These ranges can be greatly reduced by adding small amounts (one to ten per cent by pressure) of nitrogen to the argon so as to override the other impurities. Resistors produced by this process are also more stable with time by a factor of ten.

Biological transmitter power may be obtainable from body movements according to a paper given by F. M. Long at the International Convention of the I.R.E. Normally internally implanted radio transmitters for providing physiological data are powered by batteries whose relatively short life limits the usefulness of the transmitter. However, Long proposes to use the relative motion between the diaphragm and rib cage to drive an ordinary gramophone pickup cartridge to produce a power of the order of a microwatt—such a power being sufficient to drive a tunnel diode oscillator transmitter.

Triple play tape introduced into this country by B.A.S.F. has a total thickness of 0.018mm—one-third that of standard play tape. A polyester base and normal magnetic coating are used. It is available on 3, 4 and 4½ inch spools holding 450, 900 and 1,200 feet of tape respectively.

Photomultiplier valve without an envelope has been developed by the International Telephone and Telegraph Corporation for use in outer space where, since there is no air, there is no need for an envelope (see page 100 of the April issue of *Telecommunication Journal*).

Frequency divider or non-displaying scaler is described in *Rectifier News* published by International Rectifier. The division is performed by the "cup-and-bucket" or diode pump staircase generator, a double-base diode being used to empty the "bucket." The staircase is exponential, but the temperature stability of the device is such that jitter-free operation is obtained, the ratio being determined solely by the capacitors according to the formula $f_{out} = C_1 f_{in} / C_1 + C_2$. The diode, known as the QT-1, is designed specifically for the triggering of silicon controlled rectifiers, and operates over the range -65°C to 140°C.

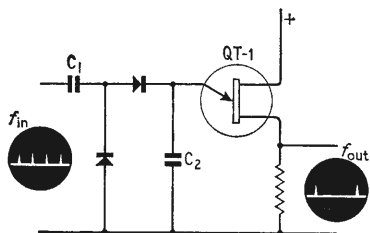

ORIGINAL PRODUCTS

SUB-MINIATURE MICRO-SWITCH

A fully enclosed, precision micro-switch, of extremely small size, only 25/32in. long x 5/8in. high x 1/4in. thick. Operated by a centrally positioned button, switching arrangement is either S.P.C.O. or alternative circuit. Connections are solder tags with contacts of Heavy "Fine Silver" for best possible electrical performance.



List No. S.800

THREE POSITION ROCKER-SWITCHES

A complete range of moulded switches, consisting of eight double-pole and eight single-pole models rated 6-10A. at 250 v. A.C. All are manufactured to the highest possible standards, and have smooth snap action, terminal connections and chrome plated dollies and fixing nuts are standard.

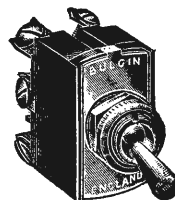

List No. S.780-787
List No. S.790-797

MINIATURE FUSE-HOLDERS

A new pair of panel-mounting Miniature Fuse-Holders, moulded in glossy black bakelite, with screw-in front knob, silver plated metal parts and shock proof construction. One model takes 3/16in. x 5/8in. fuse links and the other 5 mm. x 20 mm. fuse links.



List No. F. 296-297

SIGNAL LAMP WITH BUILT-IN RESISTOR

A simple and inexpensive, yet very efficient Neon Indicator. Having a polished chrome bezel and a choice of three lens colours, Red, Yellow or Water-Clear, it is supplied complete with wired-in resistor and twin leads ready for immediate use at 110 v. or 250 v. operation.

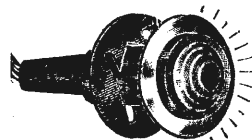

List No. D.841/Voltage

MAGNIFYING CURSOR INDICATOR

For easy reading and precise adjustment of dials that have fine legending etc., this accessory is gaining popularity. Cursor gives approximately 2 x magnification and two cursor-lines avoid parallax-error. Two models are available, non-illuminated or illuminated, the latter throwing a gentle, uncoloured glow on the dial edge and panel.

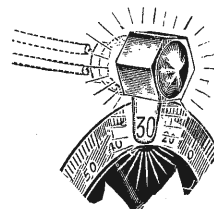

List No. D. 845-846

FURTHER DETAILS/DRAWINGS AVAILABLE ON REQUEST

A. F. BULGIN & CO. LTD.,

BYE-PASS ROAD, BARKING, ESSEX.
Telephone: RIPpleway 5588 (12 lines)

UNBIASED

By "FREE GRID"

M & B Tablets

THE title of this note is not intended to give a free advertisement to the well-known firm of manufacturing chemists one of whose products is popularly known by this name. It is intended to draw attention to the fact that, as far as I know, there is no tablet commemorating Baird's pioneering achievement of transatlantic television in 1928, while, of course, Marconi's parallel accomplishment of transatlantic telegraphy in 1901 is recorded on a very large tablet erected at Poldhu in Cornwall.

I think this is all the more deplorable because there can be no doubt at all about Baird's accomplishment, as I and many others who saw the pioneer picture can bear witness. But Marconi's reception of esses at Signal Hill, Newfoundland, was witnessed by, at the most, two people.

I raise this point now because amid the pæans of praise showered on the Telstar engineers for the success of their transatlantic TV transmissions, it was stated by many newspapers, which ought to have known better, that this was the first time that television had bridged the Atlantic. I am glad to say that one or two of the better-informed newspapers had the grace to admit that Baird was the first man to span the Atlantic by television 34 years ago, in February, 1928.

Of course, Baird, had no Telstar to aid him, nor did he need one, because his crude 30-line picture enabled him to use waves of sufficient

length to be bounced across the Atlantic by the ionospheric layers. Baird's transmissions were received with the same degree of success and with the same drawbacks of fading, distortion and atmospheric interference as were the transatlantic sound transmissions of those days. These drawbacks vetoed any possible chance of a regular 30-line transatlantic service. Nevertheless the first transatlantic TV transmission was undoubtedly made in 1928 and not in 1962.

The only thing new about the Telstar technique is the use of an artificial astral body as a relay station. I recall someone advocating the use of the principle during the war for getting British propaganda into German homes, this being very difficult by normal means as Hitler had cunningly popularized the insensitive and unselective Volksempfänger. The idea was to fly at ceiling height over Germany planes fitted with a s.w. receiver to pick up the B.B.C.'s transmissions and a transmitter to relay them to the German cities, ten miles or so below.

Somnidicta and Somnidocta

AN advertisement in the June issue of the American journal *Radio Electronics*, invited readers to apply to the Sleep-Learning Association for details of how to learn the subject of their choice while they slept. Apparently this is done by means of a series of recorded lessons played to them in their sleep.

This system of somnidicta is, of course, merely a reversal of the recorded somnidicta system which I described in *Wireless World* over eight years ago (July 1954) whereby psychiatrists record the vocal rambles of a sleepwalker, and use them to diagnose his trouble.

The whole idea behind these twin systems of somnidicta and somnidocta is, of course, developed from the fact that, in sleep, a person's normal inhibitions are lifted; in other words, his sub-conscious mind is stripped of the barrier formed by the conscious mind so that, among other things, the truth about himself can be extracted, and knowledge pumped in.

There is, however, nothing basically new in this process because over twenty years ago when wireless operators were so badly needed in the dark days of the war, details were given in this journal of a method whereby one could become an expert morse reader and sender almost

overnight. Using this method it was not even necessary to put the would-be morse learner to sleep; he merely had to take enough alcoholic drink to cause the inhibitions of his conscious mind to be lifted.

This way of learning morse became extremely popular, and it surprised me that the Editor of those days did not receive his due reward in the post-war honours list, for having the courage to publish what he did.

Data or Danda?

IT is with a considerable amount of diffidence that I take up my pen to criticize what the Editor had to say last month concerning 405- and 625-line TV.

His arguments were sound enough but almost at the beginning of them he gave us some very doubtful data. In fact it was not data at all, but danda, which, of course, means something which *ought* to be, rather than something which actually is. He said: "... the verdict of the viewing public ... has been that 12 million of them have seen fit to buy 405-line sets, and take out licences."

Undoubtedly the issue of 12 million licences is a piece of easily verifiable fact and is, therefore, entitled to be called data, but the Editor's assumption that the number of people who have bought sets is the same as the number who have bought licences is, I feel sure, all wrong. It is what ought to be, and not what is, and, therefore, danda is the correct word to use. Strictly speaking, the words here should be datum and dandum as there is only one of each, but we won't quibble about that.

The trouble is, I think, that the Editor has not the same knowledge of human nature as myself and the Post Office authorities, and so does not realize what a large number of unlicensed sets there are.

I.R.C. Exhibition

I AM glad to see that the organizers of what was known as the Radio Hobbies Exhibition have heeded the criticism I made in these columns last January about the name of the show. I said the name of the exhibition suggested something juvenile, frivolous or lacking in dignity, like the old name ping-pong for table tennis, and I asked if any of you could suggest a better one.

I don't know which of you stepped into the breach and suggested the excellent name of International Radio Communications Exhibition, but I should be very surprised indeed if the nomenclaturologist in question did not see what I wrote.

My congratulations to him, and to the organizers for the choice of venue, Seymour Hall, Marble Arch, London, W.1 (October 31st to November 3rd).

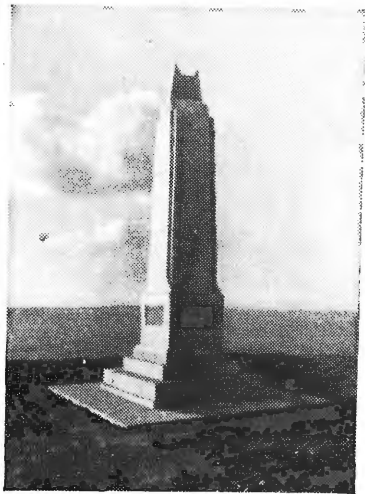

Marconi memorial at Poldhu, Cornwall