

Wireless World

ELECTRONICS, RADIO, TELEVISION

Managing Editor: HUGH S. POCOCK, M.I.E.E.
Editor: F. L. DEVEREUX, B.Sc.

NOVEMBER 1958

In This Issue

- VOLUME 64 No. 11
PRICE: TWO SHILLINGS
FORTY-EIGHTH YEAR
OF PUBLICATION
◆ ◆ ◆ ◆ ◆ ◆
- Offices: Dorset House,
Stamford Street, London,
S.E.1
- Please address to Editor,
Advertisement Manager or
Publisher, as appropriate.
- Telephone:
WATERloo 3333 (60 lines)
- Telegraphic Address:
"EThaworld, Sedist, London."
- 513 Editorial Comment
514 Instability in Radio Receivers *By D. R. Bowman*
520 Brussels P.A. System
522 What Goes Wrong? *By W. Oliver*
524 World of Wireless
526 Personalities
527 News from the Industry
529 Transistor Audio Amplifier *By F. Butler*
535 Tracking Errors in Record Reproduction *By F. J. Hennessy*
537 Stabilization by Zener Diodes *By J. Pereli*
539 Return Loss—3 *By Thomas Roddam*
540 Short-Wave Conditions
541 Car Radio Design *By F. Grimm*
544 The ARR3 Sonobuoy Receiver *By Capt. R. V. Taylor*
549 Letters to the Editor
551 Waves and Particles *By "Cathode Ray"*
555 Technical Notebook
557 Manufacturers' Products
558 November Meetings
560 Random Radiations *By "Diallist"*
562 Unbiased *By "Free Grid"*

PUBLISHED MONTHLY (4th Tuesday of preceding month) by ILIFFE & SONS LTD., Dorset House, Stamford Street, London, S.E.1.
Telephone: Waterloo 3333 (60 lines). Telegrams: "Iliffeprs, Sedist, London." Annual Subscriptions: Home and Overseas, £1 15s. 0d.
Canada and U.S.A., \$5.00. Second-class mail privileges authorised at New York, N.Y. BRANCH OFFICES: BIRMINGHAM: King
Edward House, New Street, 2. Telephone: Midland 7191. COVENTRY: 8-10, Corporation Street. Telephone: Coventry 25210. GLASGOW:
26B, Renfield Street, C.2. Telephone: Central 1265. MANCHESTER: 260, Deansgate, 3. Telephone: Blackfriars 4412. NEW YORK
OFFICE: U.S.A.: 111, Broadway, 6. Telephone: Digby 9-1197.

Transistor

15W Public Address Amplifier

The design is based on a supply voltage of 14V, which is the average voltage of a 12V battery under 'charge' conditions. It operates at ambient temperatures of up to 45°C, but occasional excursions up to 55°C are permissible. The output stage is preceded by an OC16 driver stage and amplifier stages using OC72 and OC71 transistors. The amplifier is sufficiently sensitive to be driven fully by a low impedance microphone.

Output Stage

This stage uses a matched pair of OC16 transistors in class B push-pull arrangement. Although in the circuit shown, the collectors are taken to the negative line, the transistors operate as common-emitter amplifiers. This enables the transistors to be mounted directly on a common heat sink connected to the negative line. The 0.5Ω emitter resistors are necessary for thermal stability at higher ambient temperatures. The secondary resistance of the driver transformer forms the lower part of a potential divider. Peak current on full drive is 3.0A and maximum transistor dissipation is 5W at 55°C ambient temperature. With transistors mounted on a heat sink to give a total thermal resistance from junction to mounting to ambient temperature of 6°C/W, the maximum junction temperature is 85°C.

Overall negative feedback is applied from the output to the base of the driver transistor. With a 14V supply the distortion is less than 4% up to about 15W output.

Driver Stage

This stage uses a single OC16 transistor in a conventional class A circuit. The collector current should be adjusted to

250mA. Total thermal resistance from junction to mounting base should be less than 9°C/W.

Amplifying Stages

The first uses an OC71 transistor amplifying the microphone input signal. It is followed by OC71 and OC72 current amplifying stages. The second OC71 is directly coupled to the OC72 and has overall a.c. and d.c. negative feedback. Cross-over distortion of the output stage increases at higher frequencies. It is therefore preferable to limit the upper cut-off frequency to 7kc/s. C6 is included in the feedback loop for this purpose. Reproduction of frequencies below 150c/s is not desirable in public address systems. A smaller value of C10 can be used to limit the low-frequency response.

Driver Transformer

Turns ratio	2:1+1 (secondary winding bifilar)
Primary inductance	> 150mH at 250mA d.c.
Primary d.c. resistance	< 2Ω
Secondary d.c. resistance	5Ω+5Ω

Each half of the secondary should be 5Ω±10%, resistances may be added to achieve this value.

Output Transformer

A centre tapped choke can be used.

Total d.c. resistance	< 0.2Ω
Total inductance	> 100mH

The sensitivity is 0.5μA (or 0.5mV) for full output. The frequency response is flat within 3dB from 150c/s to 7kc/s: Quiescent current is 450mA and with speech and music current consumption is about 1A.

200mW AMPLIFIER

The circuit shown in the August issue should be amended. R2 should be connected to the same side of the secondary winding of the input transformer T1 as R3, not, as shown, to the base of the transistor.

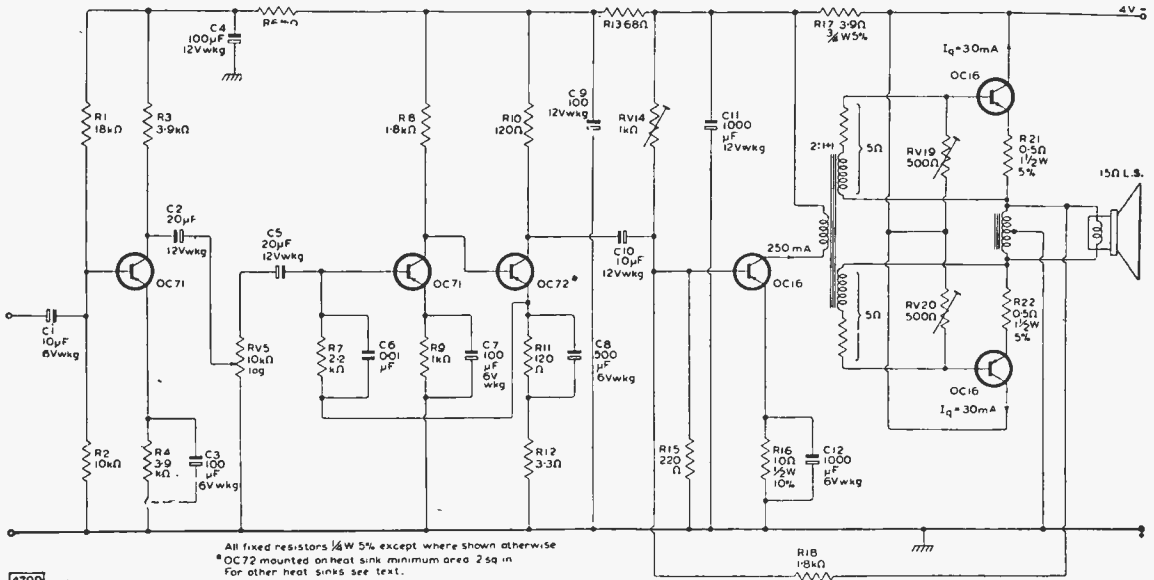

Radio as a Hobby

THIS month the second Radio Hobbies Exhibition is to be held at the Royal Horticultural Old Hall in London. As a journal we have often deplored the multiplicity of exhibitions, but this is one which we should not like to see absorbed or otherwise rationalized, for it is in many ways unique and serves as a focal point for the many enthusiasms and interests of the wireless amateur. Though the new name may lead some people to think that it is yet another new venture, it has in fact been running for 10 years or more as the annual exhibition of the Radio Society of Great Britain. Originally planned to attract those whose interest was mainly in amateur transmitting its scope has been widened to include "hi fi," test instruments and indeed any branch of the electronic arts.

The man whose interests lie in radio and its allied subjects is indeed fortunate in that he can pursue his hobby at first hand in the home, and at remarkably little expense. In this respect he has a marked advantage over those whose bent may be towards, say, civil engineering!

The raw materials of radio are generally cheap and abundant. When they are not we "roll our own." In the very early days before variable condensers were mass produced, amateurs cut their own vanes from plumber's zinc and laboriously planished, filed and assembled them on screwed rods. More recently when the first transistors were the closely guarded treasures of the big research departments, amateurs pursued a parallel course with improvised point-contact types, made from surplus germanium diodes. These they cheerfully burnt out and reformed (at no extra cost) until the "feel" of the new circuitry was acquired. They were thus able to buy and use the more efficient commercial products with complete confidence when eventually they became available.

In the past there have been occasions when a certain degree of disapproval, if not of antagonism, has been evident in the attitude of commercial interests towards the amateur constructor. There may have been some justification for this in the early days of broadcasting when better and cheaper receiving sets could be built by amateurs than were available from the mushroom growth of new firms who had hoped to cash-in on the rising tide of public interest. This phase passed when efficient firms produced reliable sets at prices lower than

the cost of the component parts on the retail market, and it is safe to say that radio amateurs no longer threaten the livelihood of the captains of the radio industry.

The radio amateur today is blood brother to the pre-broadcasting pioneers, who were driven by an insatiable curiosity to find out at first hand the how and why of the phenomenon of communication without wires. Then, as now, the borderline between professional and amateur is hard to draw. In *Wireless World's* 25th anniversary number (May 1st, 1936) we said: "The rapid development of the radio art is due in part to the fact that so many of the pioneers were fervent enthusiasts who lived for wireless, turning to it as a hobby with renewed interest after the working day was over. One of these enthusiasts was Admiral Sir Henry Jackson. . . ." Today there are many famous men who are as well known in the fields of amateur transmitting or sound recording and reproduction as they are among their professional peers in other branches of the art. As true amateurs they do it first because they like it, but no doubt they also find that to "gang their ain gait" on a project of their own choosing gives a wonderful sense of relief from the stresses of imposed tasks, and that this reorientation quite often points the way to the surmounting or circumvention of difficulties met with in their everyday work.

Many fine achievements stand to the credit of amateurs, notably the first bridging of the Atlantic by short waves in 1922 and in recent years the early pioneer work on tropospheric propagation. When observations on a world-wide basis are required, as during the International Geophysical Year, the collaboration of amateurs is sought and the material they provide is treated on an equal footing with the work of professional scientists.

The motive for home construction, as distinct from experimenting, is more often than not the satisfaction of creating something useful with one's own brain and hands, though sometimes it may be merely the saving of money. Either way it serves a useful function. It will gain useful recruits to the ranks of radio technologists; at the very least it will serve as an indication of the success or otherwise of industry in meeting consumer demands at a fair and economical price.

Instability in Radio Receivers

Locating and Remedying Self Oscillation in R.F. and I.F. Amplifiers

By D. R. BOWMAN, B.Sc.

EVERY experimenter has at some time or another been unlucky enough to experience instability in a radio-frequency amplifier. In fact one may regard an unstable amplifier as the normal thing; ironing out the tendency to oscillate is a routine which one usually has to take in one's stride.

The following discussion aims to explore the chief causes of instability, and is to be taken as referring to receiver-amplifiers operating at frequencies of more than about 100 kc/s. R.F. power amplifiers are not included here, as the problems involved, though similar in kind, are different in degree. Audio-frequency amplifiers also present a rather different state of affairs. Nevertheless, much of the following will have some relevance.

Radio-frequency amplifiers, whether tunable or operating at a fixed frequency, normally consist of one or more stages of amplification, are usually single-ended, and in general rely upon tuned circuits at or near resonance to establish the required degree of selectivity. The gain is usually required to be high; an overall amplification of 10,000 is quite normal in such amplifiers, and higher gain is often required.

Conditions for Instability.—Whenever a fraction of the amplified voltage is fed back to an earlier point of an amplifier, potential conditions exist for continuous oscillations to be set up. If the amplification is A , and $1/A$ of the amplified voltage is fed back in the right phase, oscillation will begin. If more than $1/A$ of the output is fed back oscillation will begin and will increase until grid current begins, or a bend in an anode-grid characteristic is encountered, or some other effect occurs which causes the overall gain to decrease. Where more than one stage of amplification are involved the phase in which the voltage is fed back does not matter greatly, since in circuits at or near resonance considerable phase changes take place with very little change in gain and there is thus always a frequency at which oscillations can be maintained. Over one amplifying stage the phase may be important in deciding whether the amplifier will self-oscillate, but if the instability

is caused over one stage it will nearly always be caused by incorrect or badly executed wiring, or some other mistake (including the use of defective components).

The problem of stabilizing an r.f. amplifier thus becomes that of finding out where unwanted coupling exists between two points, and removing that coupling. It is a tedious business to go about this in a haphazard manner. It is better to take stock of the size of the couplings required to cause instability, and then it becomes a simpler matter to recognize where these couplings may be found in an amplifier.

Couplings Causing Instability.—There is a wide variety of possible couplings, and by no means all are obvious. The majority of constructors will, for example, manage to keep the anode lead of a second stage amplifying valve from approaching too closely to a grid connection of a first stage; but many couplings are not as well known as this. The following are the more common ones:—

- (i) Capacitive coupling in the wiring.
- (ii) Capacitive coupling inside valves.
- (iii) Inductive coupling between coils.
- (iv) Inductive coupling between wiring.
- (v) Common impedance coupling.
- (vi) I.F. harmonics fed back to the signal-frequency stages (in superheterodyne receivers).

The above will be discussed in turn.

(i) **Capacitive Coupling in the Wiring.**—(a) *Over one stage of amplification.* The only really dangerous coupling is between anode and grid circuits. This effectively causes an increase in the anode-grid capacitance, and is conveniently dealt with in the next section. (b) *Over more than one stage of amplification.* As stated previously, the phase in which voltage is fed back is of minor importance over more than one stage; the determining factor is the actual value of capacitance in the feedback path. It is quite surprising what feedback can arise from very small capacitances, as the following example taken from the writer's recent experience will show.

A television receiver was, during development, found to be unstable. The frequency-changer valve came at a corner of the chassis; the sound receiver went straight on down one side (no instability); the vision section forked back into the centre of the chassis (Fig. 1) bringing the first vision i.f. stage next to the r.f. stage. The i.f. was about 34Mc/s., and at that frequency the r.f. grid circuit showed an appreciable response, though tuned to 43Mc/s, the London mid frequency approximately. Below the chassis, the grid leads to the r.f. and first vision i.f. stages each consisted of approximately 1in of No. 20 s.w.g. wire, 3in apart but parallel.

The capacitance between these two leads is about 0.05pF; and it can be shown that a gain of about 40 over the two stages will give rise to oscillations under these conditions. As a corollary to the above,

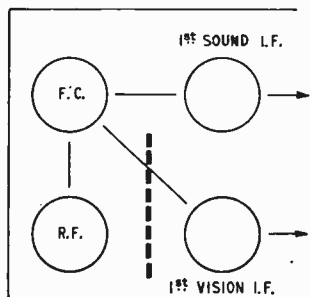

Fig. 1. Layout of one corner of a television receiver chassis.

on tuning the r.f. stage to the Sutton Coldfield frequency, the instability should disappear, since the response of the r.f. circuit at the i.f. should be negligible. This was found to be the case. The cure was a sub-chassis screen between the r.f. and i.f. stages as shown dotted in Fig. 1.

The example quoted refers to direct capacitance between two critical points. If each such critical point has capacitance to a common unearthed component—for example, switch contacts, heater leads, imperfectly earthed screens, etc.—coupling will still take place.

If two circuits in a receiver like the above have a tuning capacitance of 15pF (strays and valve capacitances), a Q of about 30, and the unearthed heater lead has an "earth" capacitance of 20pF, if the amplification is 900, the circuits are separated by two stages, and the capacitance between circuits and heater leads is 0.1pF, will the circuit oscillate? It can be shown that oscillations are easily maintained. The cure is either to screen the circuits more effectively so as to decrease their capacitance to the heater leads, or to increase the capacitance of the heater leads to earth. The latter is the better

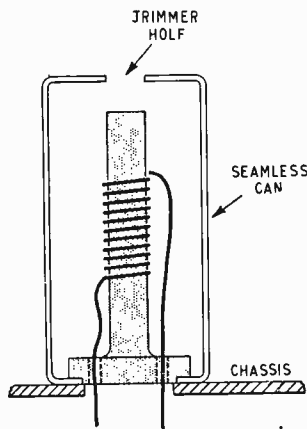

Fig. 2. Typical screened dust-cored coil.

method, since stray couplings, even inside a valve may easily amount to more than 0.1pF. At 34Mc/s (the i.f. used) a capacitor of 0.001 μ F at each valve-base between the "floating" heater lead and the common earth point sufficed to remove the instability in the i.f. amplifier. It should be noted that this method is not closely related to that of putting chokes in the heater leads; the chief purpose of chokes is to avoid inductance couplings. Enough will have been said about capacitance couplings in the wiring to indicate the need for care in layout and for anti-capacitance screening. The straight-line type of construction is much better than layouts where amplifiers turn round corners; partitions or complete boxing-in may be needed, and it is certainly necessary, as a rule, to decouple heater leads with suitable capacitors at the valve heater pins when amplifiers have to operate at frequencies greater than about 10Mc/s.

(ii) **Capacitive Coupling Inside Valves.**—The anode-grid capacitance is here the important cause of instability. When grid and anode circuits are tuned to the same frequency, oscillation, if it takes place, will occur at a lower frequency than the resonant

frequency, and it can be shown that oscillation will start when the following equation is satisfied:—

$$Z_e^2 g_m \pi f C_{ag} = 1$$

Z_e being the anode load impedance, g_m the mutual inductance of the valve, f the frequency and C_{ag} the anode-grid capacitance. This equation is useful because it indicates the maximum gain possible from a single stage, and an example illustrates how to use it.

Example (i): A 6AM6 is to be used in an i.f. amplifier at 38Mc/s. What gain can be expected from the stage?

$$(g_m = 7.5 \text{ mA/V}, C_{ag} = 0.007 \text{ pF}).$$

$$Z_e = \sqrt{\frac{1}{g_m \pi f C_{ag}}} \\ = 12,500 \text{ ohms}$$

$$\text{Gain} = g_m Z_e = 94$$

In practice at 38Mc/s the above Z_e could hardly be realized, and a figure of about 3,000 to 4,000 ohms, with a stage gain of about 20, would be normal. The stage described is therefore safe.

If, however, the capacitance between anode and grid should rise, because of stray circuit capacitance or because the screen-grid was not properly decoupled, it might easily become unstable.

Example (ii): An EF50 of g_m 6.5 mA/V is used with anode and grid circuits each of 3,000 ohms impedance at the oscillator frequency (if it oscillates); $f = 60$ Mc/s. What is the maximum permissible capacitance between anode and grid leads for stability?

$$Z_e^2 g_m \pi f C_{ag} = 1$$

$$C_{ag} = \frac{1}{Z_e^2 g_m \pi f} \\ = \frac{1}{11} \text{ pF approx.}$$

This capacitance corresponds to that existing between two pieces of No. 20 s.w.g. wire $\frac{1}{2}$ in long and 1 in apart. A sub-chassis screen across the valveholder, properly earthed, is a useful precaution here.

From the above it will be seen that half a 6J6 valve cannot be used in an ordinary triode amplifying circuit, having C_{ag} of 1.6pF. If the anode circuit were damped by a 1-k Ω resistor, and damping also applied to the grid circuit as necessary, a 6J6 might be just safe at the Band-I frequencies. With such heavy damping it would be unnecessary to tune the grid circuit and it might be usable as a first r.f. amplifier. The gain of the stage would be about 4; hardly worth while, unless the other half of the 6J6 were being used anyway as a local oscillator.

Pentodes, as generally used in r.f. amplifiers, seldom give much trouble in the above way, unless a mistake in the wiring has occurred, or a defective component has been used. The writer was once puzzled by serious instability over one stage, which was found to be due to decoupling the anode (pin 5) instead of the screen (pin 7) of a 6AM6. The valve thus acted as a plain triode, with a high C_{ag} . In another case a defective 0.01- μ F capacitor left the screen completely "in the air", with similar results. Using too small a capacitor here would have the same effect.

(iii) **Inductive Coupling Between Coils.**—It is easy to visualize the alternating flux which will link coils placed end to end and coils side by side are also inductively coupled. In a recently constructed

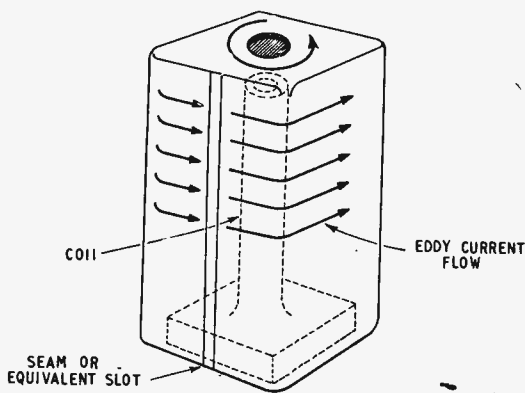

Fig. 3. A longitudinal seam in a coil screening can is equivalent to a slot so far as eddy currents are concerned.

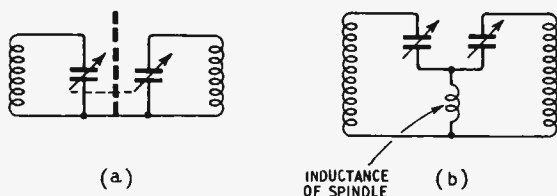

Fig. 4. Rotor spindle in a gang capacitor may act as a common-impedance coupling, as shown at (b).

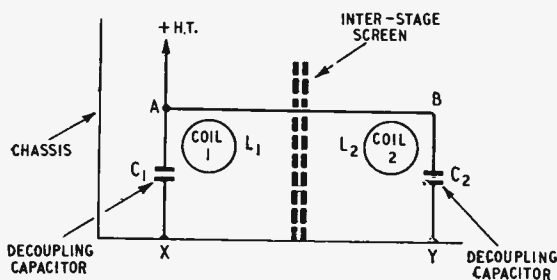

Fig. 5. Common coupling formed by h.t. lead, bypass capacitors and chassis.

receiver, using an i.f. of 10.7Mc/s, iron-cored coils of 0.3in dia. and a tuning capacitance of 100pF, critical coupling was obtained by placing the coils side by side and 0.8in between centres. This looks close, however, and would not be done accidentally or in real ignorance. Where several stages of amplification are used stray couplings between coils may not be so apparent and it is invariably the practice to use screening cans, and this normally overcomes any difficulty.

It is worth remembering that with some screening materials, more especially with tinned iron cans, the inductive field outside the can is not zero; with usual aluminium components it is reduced to about 30% of the field there would be without a can. With tightly packed (miniaturized) circuits it may occasionally be worth while using copper cans, silver plated inside for preference. With signal generators it is better to use two screens, one within the other. For high frequencies this is almost a necessity.

The effectiveness of a screening can depends upon the presence of eddy currents in the can material.

The alternating currents flowing in the coil induce currents (on the inner surface of the can, particularly at high frequencies) in the screening material which oppose the coil currents and reduce the field outside the can to nearly zero. It follows that high resistance in the can material impairs its usefulness as a screen. Thus, cans should not be made of relatively high resistance magnetic material (tinplate), nor should they have slots or other openings which impede the flow of eddy currents.

In Fig. 2 there is illustrated a typical screened coil of good design. The hole hardly affects the flow of eddy currents, neither does the opening at the bottom where the can is fixed to the chassis. If, however, the can had a seam down the side, a poor-contact region equivalent to a slot parallel with the coil axis might be set up. Fig. 3 shows how this could interfere seriously with the flow of eddy currents. Such a can might prove an effective capacitive screen, but would be of little use as an inductive screen. Deep-drawn cans, even of thin aluminium, are much to be preferred to bent-up copper boxes unless these are soldered well at the seams.

(iv) **Inductive Coupling Between Wiring.**—It must not be forgotten that it is usually impossible to screen the whole of the coil, because "hot" leads from tuning inductances are usually essential to connect them to switches, valves, capacitors and so on. Such leads may form a very large part of the total circuit inductance, especially at high frequencies; there then exists the possibility of coupling, perhaps over several stages of amplification, with the accompanying likelihood of instability. Unfortunately, switching is now an accepted hazard in television receiver construction, in addition to which variable tuning is often included for Band II. General rules are very difficult to formulate where switching is concerned, and perhaps the best advice to follow may be summarized as follows:

- (a) Never try to switch more than one circuit with one wafer.
- (b) Use high-quality switches, so that contact resistance is unlikely to cause common impedance coupling problems.
- (c) Keep all leads extremely short.
- (d) In arranging switching, try to visualize the "hidden" inductances, especially those which may couple with coils. Try also to visualize the invisible capacitances which may link critical points in the circuitry.
- (e) Avoid where possible metal spindles passing from one box to another, or passing through a metal partition screen. Such a spindle, earthed only at each end, may easily form a closed loop in which r.f. currents can be induced by proximity to coils; and thus couple two circuits very inconveniently. If this cannot be avoided, earth the spindle in several places, using leaf-springs (not coil springs as have sometimes been seen!) attached to the chassis.

Where variable tuning by ganged capacitors is needed, serious difficulties are likely to arise at high frequencies. Apart from the possibility of the spindle acting as an inductive loop coupling r.f. and f.c. circuits, there exists the possibility of the spindle acting as a common impedance coupling (Fig. 4). This will be discussed separately later under the appropriate heading.

One is tempted to advise the experimenter to avoid circuit switching at frequencies above 30Mc/s.

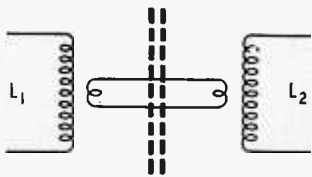

Fig. 6. The equivalent circuit of Fig. 5.

The writer not long ago spent twelve weeks, on and off, in "ironing out" the switching of a receiver front-end covering Bands I, II, and III; and is still not satisfied.

Other inductive loops which may couple tuned circuits are heater leads, badly fitting common lids to compartments, and, in the writer's own experience, h.t. supply leads. Fig. 5 shows an arrangement which gave rise to trouble.

The arrangement is in skeleton form in the diagram. The action was as follows. The r.f. currents flowing in coil L_2 induced an r.f. current in the complete circuit formed by the wire AB, C_1 , C_2 , and the chassis between X and Y. The presence of the inter-stage screen was of no avail in preventing the currents from flowing, and the current flowing in the loop induced a further current in L_1 —thus causing instability. Fig. 6 shows the equivalent circuit. The cure, paradoxically, was to remove C_2 altogether; this prevented a closed loop being formed in which r.f. current could flow. Other cures would have been to put the h.t. lead somewhere else, or to insert in it a choke. This last method is usually employed if the unearthed heater lead is likely to form such a coupling.

(v) **Common Impedance Coupling.**—An example of this has already been mentioned, but it is more usual to find that, due to thoughtlessness or lack of experience, wiring introduces the coupling and not a component directly. Fig. 4 shows the circuit which is usually arrived at by neglecting the invisible component, the inductance of leads. But, of course, common capacitance or resistance, or a mixture of these, will sometimes be found. In Fig. 7 one or two examples are shown, each with

its "equivalent circuit," ignoring non-essentials.

In Fig. 7(a) the nigger in the woodpile is stray capacitance between grid and filament, filament and chassis; but a similar effect can easily take place with indirectly-heated valves; although the cathode prevents much capacitive coupling inside a valve, the leads inside the valve, the holder and the external connections still provide enough stray coupling to cause trouble. Well-screened grid circuits afford the proper cure, with heater leads tucked well down on to the chassis, and screened if necessary. Heater decoupling capacitors are also effective, as has been mentioned earlier.

Another example of common-impedance coupling, which is sometimes met with, is that formed when a chassis earthing point is used for more than one stage. If the earth point is actually on the chassis little harm usually results, but more commonly there is a lead of an inch or so in length connecting it to, say, a decoupling capacitor. Here again, common inductance coupling can result.

The cathode-lead inductance can also prove a source of trouble; even over one stage (which is usual) it can cause serious instability at certain settings of grid and anode tuning controls. Fig. 8 shows the circuit concerned, and the equivalent circuit including the invisible components.

The cathode circuit inductance L_k includes not only the external connections to the bias capacitor (and sometimes the bias resistor), but also the internal connections inside the valve. The former may be kept as low as possible by careful wiring, but the latter is not under the control of the constructor. Valves for use at high frequencies are specially designed to minimize the effect, which can otherwise be considerable. An example will illustrate this point, using the SP61 operating at 45Mc/s. with the following circuit parameters:

- Anode-cathode capacitance, $C_{ak}=6\text{pF}$.
- Grid-cathode capacitance, $C_{gk}=11\text{pF}$.
- Cathode lead total inductance, $L_k=0.02\mu\text{H}$.
- Q of each tuned circuit=30.
- Mutual conductance, $g_m=8.5\text{mA/V}$.

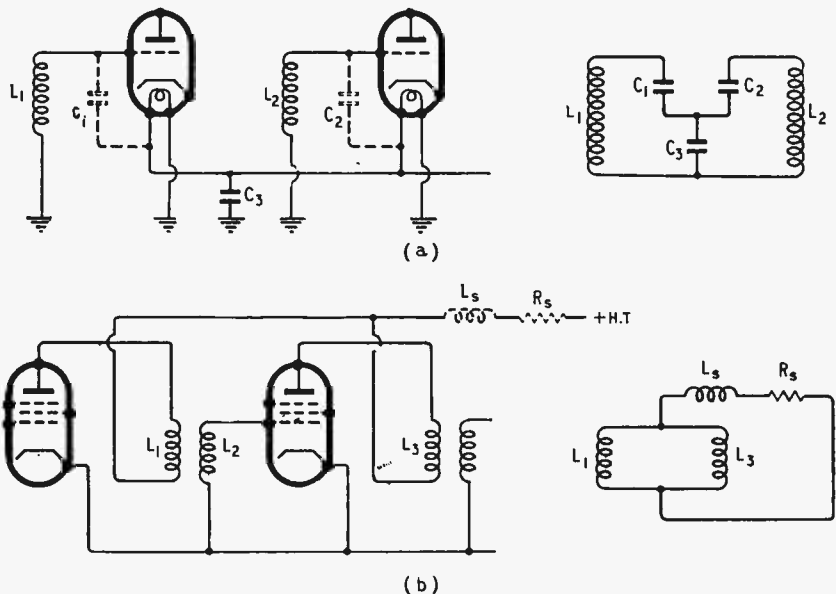

Fig. 7. Examples of common-impedance couplings likely to exist in a typical receiver: (a) due to capacitance between grid, filament and chassis as shown by C_3 , (b) due to inductance, and impedance, of un-bypassed h.t. leads. Equivalent circuits shown.

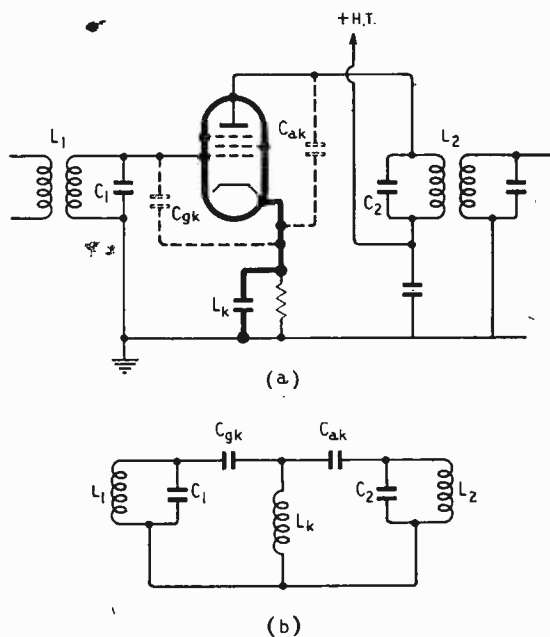

Fig. 8. Cathode-lead inductance and stray capacitance causing common-impedance coupling: (a) the physical circuit, (b) the equivalent circuit.

In this case a stage gain of about 20 will provide conditions in which oscillation may occur. The use of a 6AM6, or the equivalent, reduces the cathode-lead inductance to perhaps a quarter of the value quoted, and a stage gain of nearer 40 can then be obtained under suitable conditions. With some valves, such as the EF54, multiple cathode leads are provided (four for the EF54); one each should be used for grid circuit connection and anode-decoupling respectively, while the remaining two should be used for cathode decoupling. By this means impedance common to grid and anode circuits can be reduced to a very small amount. The worst effect of cathode inductance, however, is the reduction of input resistance of a valve, whereby the grid circuit is increasingly damped as the operating frequency rises. This does not contribute to instability, of course, but rather the converse. Moreover, it is always possible to avoid instability due to cathode inductance coupling by re-tuning anode or grid circuits, though this is rarely convenient. The obvious plan is to avoid the difficulties altogether.

Accordingly, cathode resistors should never on any account be wirewound or of the spiral-carbon element type. Bypass capacitors of the moulded-mica or ceramic type are quite good. Two things should, however, be remembered; the first is that each half-inch of lead is equivalent to about $0.01\mu\text{H}$, the second that a capacitor has both capacitance and inductance. At high frequencies this can sometimes be taken advantage of, in the following way.

Example: A capacitor of total length $\frac{1}{2}$ in, leads $1\frac{1}{2}$ in long (each) and capacitance 230pF is available. To what length should the leads be cut to give best decoupling at 50Mc/s?

The decoupling circuit can be represented by a 230-pF capacitor and an inductance in series (counting $\frac{1}{2}$ in of lead = $0.01\mu\text{H}$). The problem is to calculate what inductance gives series resonance with

230pF at 50Mc/s, and to cut the leads accordingly. Using the well-known equation:—

$$f = \frac{1}{2\pi\sqrt{LC}}$$

and inserting values, a simple calculation shows that the inductance required is about $0.04\mu\text{H}$. Each lead should be cut to $\frac{3}{4}$ in in length and this, together with the length of the capacitor, will give the required inductance.

This seems an elegant way of doing it, depending as it does on series resonance conditions giving a lower impedance path than either capacitance or stray inductance taken separately. However, the calculation can easily give misleading results unless the leads are quite straight. If they have to be bent round at all more inductance is introduced and then it is clearly best to use the shortest possible leads.

To improve matters, decoupling capacitors can be mounted in a little can let into the chassis, as shown in Fig. 9. The can must fit the capacitor closely, and should be soldered into the chassis, as near the common earth point for the stage as possible. This is not easy for amateurs, as a rule, and it must generally suffice to wire up carefully in the orthodox way.

The screen-grid of a tetrode can easily lose much of its effect in screening the anode from the grid if the inductance of the bypass capacitor and its leads becomes appreciable. With a pentode the problem is less acute because two grids separate anode and control grid. However, if the suppressor-grid earth lead has any appreciable inductance, or if it is connected to the cathode instead of to earth (chassis), the effect can readily arise. For this reason, in wiring up, one of the first tasks must be to connect all suppressor-grids to earth by the shortest possible route.

(vi) **I.F. Harmonic Feedback.**—In a superheterodyne receiver an additional source of instability, as compared with a straight receiver, exists in that at the detector stage severe distortion of the i.f. wave-

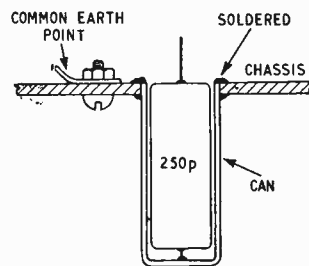

Fig. 9 Non-inductive method of assembling bypass and decoupling capacitors on chassis of v.h.f. equipment.

form has to be brought about in order to effect demodulation. Harmonics of the i.f. are produced at just the point where the i.f. amplitude is greatest; if the r.f. amplifier is tuned to a frequency near one of these harmonics the gain is particularly large and the merest trace of capacitance coupling is certain to give rise to instability.

On medium and long waves, using an i.f. of about 465kc/s, it is not difficult to avoid instability because the reactance of strays (say 0.0001pF) at 930kc/s or even 1,395kc/s is extremely large and there is little danger of instability; nevertheless, whistles are often heard when the receiver is tuned to these medium-wave frequencies.

In television receivers tunable to only one fre-

quency an i.f. can always be found whose harmonics are far from the sound or vision channel. If, however, multi-channel tuning is employed the only safe manageable i.fs. are the new standards (34.65Mc/s vision, 38.15Mc/s sound). Even here there exists the possibility that harmonics will cause trouble on the commercial frequencies; the fifth harmonic of 38.15Mc/s is 190.75Mc/s. Here the fifth harmonic only is involved, and because (mercifully) this is weak it will usually only cause patterning, the vision equivalent of a whistle. The choice of i.f. is nevertheless clearly of the greatest importance and it is essential that the experimenter should be fully aware of the snags he may meet.

Conclusion.—In this survey only the fringe of the matter has been touched upon, but it is hoped that enough has been given to indicate what circuits are likely to be involved and the most suitable remedies to apply. It is most infuriating and discouraging if, after a lot of thought and careful construction, a receiver is found to be quite unusable because a few fundamental facts were overlooked. The chief needs are practice and patience; after all, the development of a commercial television receiver may cost well over £100,000, and the curing of instability may often represent an appreciable fraction of that cost in time and skill.

Northern Audio Fair

FOUR Continental manufacturers are among the 48 exhibitors at the Northern Audio Fair which opens at the Grand Hotel, Harrogate, on October 24th for three consecutive days (11 a.m. to 9 p.m.). Admission is by ticket obtainable free from exhibitors and audio dealers or from this office by sending a stamped addressed envelope. Exhibitors, with their stand numbers and (in brackets) demonstration room numbers, are listed below.

A.K.G.	45(247)	Lockwood	24(306)
Acoustical	9(312)	Lustraphone	48(314)
Alto bass	4(212)	M.S.S.	13(246)
Astronic	15(346)	Mullard	10(353)
B.A.S.F.	21(355)	Multimusic	32(217)
Beam-Echo	25(233)	Pamphonic	26(333)
B.T.H.	42(209)	Philco	20(211)
Capital Radio	33(308)	Philips	37(248)
Chapman	44(301)	Pilot	1(202)
Decca	47(258)	Pye	31(231)
Dulci	28(206)	Pye Group Records	35(302)
Dynatron	23(304)	Rogers	30(255)
E.A.P.	27(331)	Rola Celestion	36(351)
E.M.I.	34(215)	S.T.D.	2(251)
Fane Acoustics	16(357)	Simon	3(201)
G.E.C.	38(253)	Sonomag	8(208)
Garrard	5(237)	Sugden	6(315)
Goldring	18(337)	Tannoy	41(347)
Goodmans	17(309)	Telefunken	29(235)
Grundig	22(214)	Trix	40(204)
Harting	19(311)	Vitavox	39(249)
"Hi-Fi News"	43	Wharfedale	7(257)
K.B.	14(358)	Whiteley	12(348)
Leak	46(349)	Wright & Weaire ..	11(335)

MULTI-PURPOSE STATION

• THE Swiss P.T.T. recently brought into service a multi-purpose transmitting station at Säntis in north-eastern Switzerland. The station, which is claimed to be the highest in Europe (2,504-metres above sea-level), provides a two-programme v.h.f. sound service, a Band III television service, a radio-telephone service for cars and acts as a relay station both for the national television network and Eurovision.

The Säntis station is the second in Switzerland introduced for the car radio-telephone service, the other being at Chasseral. The Swiss car radio-telephone network operates from a central exchange linked with the public telephone service. From this centre calls are sent by u.h.f. radio links to the two 1-kW transmitters which together cover practically the whole of Switzer-

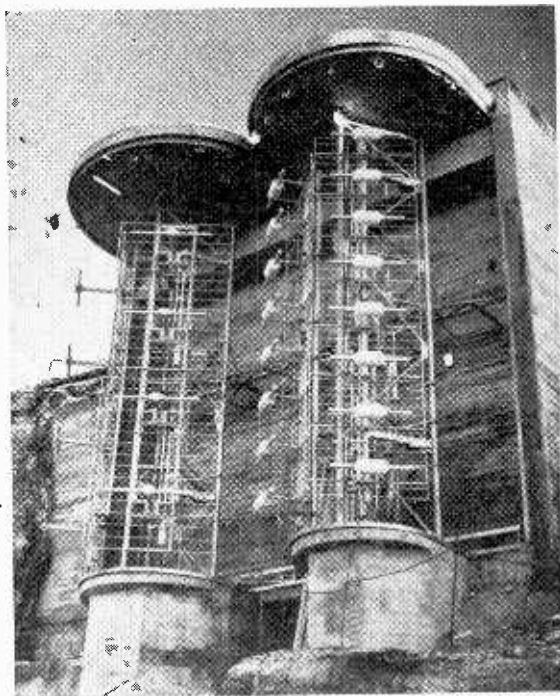

Aerials for the Säntis v.h.f. sound and television transmitter before the outer semi-circular plastic coverings had been fixed. Left, a general view of the station.

land north of the Alps. Each car equipped for receiving radio-telephone calls is allotted a six-figure telephone number which may be dialled by any telephone subscriber.

Brussels P.A. System

SOUND DISTRIBUTION BY V.H.F./F.M. AT
THE 1958 UNIVERSAL EXHIBITION

THE public address system used at the Brussels Universal Exhibition is of more than usual technical interest. It was developed on the bold and imaginative lines which characterized the whole exhibition and was a practical demonstration of Belgian skill in the electronic arts.

At an early stage it was decided that a low-level, multiple-source system would be necessary to cover the 500-acres of exhibition grounds so that everyone could hear announcements clearly and without conflicting echoes; and also to enable several types of background music appropriate to the environment to be diffused simultaneously in different sections of the exhibition grounds.

Flexibility

A second, and more interesting decision was to avoid the use of cables and to adopt a radiated v.h.f./f.m. distribution system. Although more expensive (each loudspeaker was provided with its own power amplifier and radio receiver) this system more than justified itself during the opening week when it was able to function without interruption in the midst of the usual exhibition last-minute rush to complete roads and buildings which would have played havoc with a complex and necessarily temporary cable system. Subsequently, minor adjustments of the positions of loudspeaker units could be made with ease, as mains supplies were available within a few feet of any point in the grounds.

Five separate radio transmitters were installed on the first floor above the main entrance hall of the exhibition, feeding simple dipoles on the roof just behind the façade. These operated on five channels, allocated by the Belgian Post Office, in the frequency range 76.6-78.35 Mc/s and were designed and built by the Société Belge Radioélectrique and employed the FMQ directly-modulated crystal system of frequency modulation. The output power was 500 watts so that an ample field strength was available not only in the exhibition grounds but throughout the greater Brussels area. Close attention was paid to linearity throughout the transmitter, not only in the interest of good quality but also to avoid spurious frequencies which might cause interference with adjacent police service channels.

Low Modulation Levels

The transmitter is linear for deviations of well over $\pm 100\text{kc/s}$, but the maximum is limited to the standard $\pm 75\text{kc/s}$. When *Wireless World* was privileged to visit the station it was noted that the deviation meters were rarely showing more than 15 or 20kc/s on peaks. These meters were not solely relied upon for monitoring and the master volume indi-

cator was a calibrated c.r. tube showing the instantaneous a.f. waveform. Most of the music and many of the routine announcements came from tape records and there was, of course, a studio microphone for special announcements. The transmitters were switched on in April and ran continuously until October when the exhibition closed. As some parts of the exhibition were open from 10 a.m. to 4 a.m. there was little point in going through the warming-up processes for the sake of less than six hours' saving of current.

The receiver-amplifiers (no fewer than 450 in all) also ran continuously throughout the exhibition period, partly to avoid the possibility of locking on to the wrong channel when warming-up but principally to keep the equipment dry (most of the units were exposed to the elements in flower beds and near fountains!). Two stages of r.f. amplification preceded the mixer as there were no external aerials, and there were three i.f. amplifying and limiting stages, with the limiting function distributed throughout this section of the receiver. A balanced ratio detector followed, from which an a.f.c. voltage was derived to control the local oscillator through a conventional reactance valve circuit. Two EL84s in push-pull in the output stage of the a.f. amplifier were rated to deliver 14 watts. No a.f. gain control was provided and the sound volume was determined solely by the modulation deviation of the transmitters in the control centre.

A wide variety of loudspeakers of different Continental and British makes were adopted for the many forms which the sound reproducing units took. It is gratifying to be able to record that British units (Goodmans) were chosen for units near the main entrance gates, for the music background to the Garden of the Four Seasons, where better than average quality was called for, and for monitoring purposes in the control rooms. The types chosen were "Axiom" 150 Mk. IIs in special enclosures with ARU acoustical resistance vents, supplemented in some cases by "Axiettes." In the Grand Auditorium of the Exhibition the monitoring loudspeakers were Axiom 80s.

Quality of Reproduction

We were particularly impressed with the sound quality in the Garden of the Four Seasons where the loudspeakers had been incorporated in the trellis work separating the sections of the garden. It was free from every kind of distortion including the stridency which might have been expected if there had been any striving after "hi fi".

Throughout the rest of the exhibition there was a complete absence of the multiple echoes which are so often associated with multiple-source p.a. systems. Even flutter echoes between parallel walls of pavilions, which we understand were experienced in the early stage of testing, were conspicuous by their absence when we visited the exhibition. These were eliminated either by arrangement of the loudspeaker groups or by reversing the phasing of the inputs to units within the group.

Correction.—It is regretted that in the article "Apparent Saturation in F. Layer" on page 472 of the October issue the blocks of Figs. 1 and 2 were inadvertently transposed.

Stereophonic Broadcasting

THE PERCIVAL SYSTEM: TWO CHANNELS FROM A SINGLE TRANSMITTER

FURTHER details of the E.M.I. Percival system have been made available since "Diallist" wrote his notes for this issue (p. 561). As in the Crosby system now being tried out in America (see our October issue p. 466) the second channel is transmitted on a side-band of the main frequency, above the audio band. These two systems are also similar in that the main carrier frequency is modulated by a combination of the left and right stereophonic channels. (This combination is simply the sum of the two channels in the Crosby system.) In both systems the main frequency thus carries a compatible signal for reception by an ordinary receiver, and the sub-carrier must carry all the directional information.

The division of the transmitter power between the main frequency and the sub-carrier and between the left and right channels involves a loss in the effective power. In the Crosby system the sub-carrier is modulated by the difference of the left and right signals. There is a considerable amount of information in this difference channel, so that the loss of effective transmitter power when carrying this additional information is of the order of 6dB or more. In the Percival system, the sub-carrier modulation has been compressed to a bandwidth of 100c/s, so that the loss of effective transmitter power need be only about 2dB. Moreover, the phase of the sub-carrier modulation need not be accurately adjusted.

In the new E.M.I. system the directional-information modulation of the sub-carrier is derived from the ratio of the envelopes of the left and right signals. It is found that satisfactory results are obtained when the bandwidth of this ratio signal is about 100c/s.

It might be thought that simultaneous directional information about a number of separate sources could not be obtained from a single envelope ratio. Nevertheless, results showed that successive sounds from different directions interleaved so as to give the impression of simultaneous separate sources.

The direction of some types of sound can be determined by ear more readily than the direction of other types; and moreover, some sounds can completely mask the direction of others. In the Percival system the directional information is weighted according to these differences in importance in hearing. This involves altering the frequency responses of the channels before taking the ratio of their envelopes, and also in non-linear processing of the ratio itself.

The directional-information signal finally obtained is used to modulate the sub-carrier, the modulated sub-carrier is added to the combined compatible signal, and the resultant used to modulate a standard transmitter. In some experiments frequency modulation in Band II was used with a transmitter power of about one watt giving a range of a quarter of a mile.

In the complementary stereophonic receiver the sub-carrier must be separated from the main frequency signal and then demodulated. The signal for one loudspeaker is obtained from the product of the two signals, and that for the other loudspeaker by subtracting this product from the combined compatible signal.

To prevent the directional information signal from appearing in the audio, the multiplication must be linear. Following a suggestion by E. W. Taylor the Hall effect in semiconductors has been used to ensure this linearity. The combined signal is used to produce a current through the semiconductor, and the directional-information signal to produce a magnetic field at right angles to the direction of the current. A voltage proportional to the product of these signals is then developed in a direction at right angles to the current and field.

Computer Exhibition and Symposia

OVER 40 manufacturers of electronic computers and ancillary equipment, plus a number of publishers of technical and business efficiency journals (listed below) are participating in the Electronic Computer Exhibition which opens at Olympia on November 28th. The exhibition has been organized by the Electronic Engineering Association and the Office Appliance and Business Equipment Trades Association at the instigation of the National Research Development Corporation. Admission costs 2s 6d.

Concurrently with the exhibition there will be a Business Computer Symposium. Twenty-three papers covering various business applications of computers will be delivered during the six sessions. The charge for each session is 2½ gns. Details are obtainable from Mrs. S. S. Elliott, 11/13, Dowgate Hill, London, E.C.4.

Immediately preceding the exhibition an associated scientific symposium, organized by the National Physical Laboratory, will be held at Teddington (November 24th to 27th). Admission to this conference, which will be attended by representatives from overseas, is strictly limited and is by invitation only.

Air Trainers Link	1a	Jenkins Fidgeon	32
Benson-Lehner (GB)	12	Lamson Paragon	31
Boyden & Smith	1	Leo Computers	27
British Computer Society	41	Logabax	46
British Tabulating Machine Co.	5 & 7	London Office Machines ..	44
British Thomson-Houston	8	Metropolitan-Vickers	22
Bulmer's (Calculators)	45	Morgan Bros.	21
Burroughs Adding Machine	28	Mullard Equipment	11
Business Publications	38	Mullard	2
Creed & Co.	30	National Cash Register 35 & 43	
Current Affairs	20	Neosid	37
Data Recording Instrument Co.	25	Pancellit	49
Egry	3	Plessey	6
Electronic & Radio Engineer	47	Powers-Samas	10 & 14
Elliott Brothers	35 & 43	Punched Card Accessories ..	29
E.M.I. Electronics	26	Rank Precision Industries ..	48
E.M.I. Sales & Service	33	Saunders-Roe	19
English Electric	36	Short Bros. & Harland ..	4
Fairey Aviation	43a	Siemens Edison Swan	16
Fanfold	17	Solartron	9 & 18
Ferranti	10 & 14	Southern Instruments	24
Heywood & Co.	40	Sperry	39
IBM United Kingdom	34	Standard Telephone & Cables	23
Ing. C. Olivetti & Co.	42	United Trade Press	11a
		Wireless World	47

What Goes Wrong?

By W. OLIVER

An Analysis of 600 Sound Receiver Repairs

ACAREFUL analysis of repairs carried out on 600 sound receivers has revealed some interesting and rather surprising facts and figures. The sets under review comprised a wide variety of models of 55 different well-known makes—British, American and Continental.

Possibly the most surprising thing about these findings is the small number of different faults encountered. Of the many things which can go wrong in theory, only a few seem to give trouble in actual practice; these comparatively few faults occur and recur over and over again.

This striking discrepancy between theory and practice probably explains why a practical service engineer with a long experience of repairing commercial receivers can often put his finger on a fault with almost magical speed, whereas another class of radio technician whose knowledge is mainly theoretical will be liable to muddle about for hours, testing this and that, before he is able finally to locate the fault.

A little learning may be a dangerous thing, but too much book-learning and too little practical experience is certainly a great handicap in quick fault-finding.

Of the 600 sets under review, nearly one-third (190 to be precise) needed one or more new valves to restore them to reasonably good working order. For optimum results, this number could easily have been doubled, but in most cases the customers would not have stood for the extra expense and therefore replacements had to be restricted to those that were really essential.

The number of valves that really *had* to be re-

placed totalled 228. Frequency-changers outnumbered any other single type, with 79 replacements. Next came output valves with 51, then rectifiers with 40, r.f. pentodes (chiefly in the i.f. stages) with 34, double-diode triodes with 17 and all other types with a total of seven.

This last figure is a bit misleading, because the majority of the 600 sets repaired were of pre-v.h.f./f.m. vintage. When these latest models become aged and need valve replacements in a big way, the proportion of double triodes and triple-diode triodes will undoubtedly be very much larger than in the present analysis.

Fixed Capacitors

The next biggest item on the replacement list is the fixed capacitor. In the 600 sets, 103 fixed capacitors simply *had* to be replaced. Here again, had expense been quite an immaterial consideration and efficiency the only criterion, one could easily have doubled this number. Electrolytics had to be replaced in 63 cases, and as a large proportion of these were multiple units (comprising, say, 8 plus 8 plus 32 μ F), the total number of individual capacitors involved would be perhaps double this figure. It therefore far outnumbers all other types put together, which total 40 all told.

Variable resistors come next on the list. Of 61 that were faulty, 57 were volume controls and only four were tone controls. Three out of the four last-mentioned were in sets which had the on-off switch ganged with the tone control. The conclusion which can be drawn from this is that the

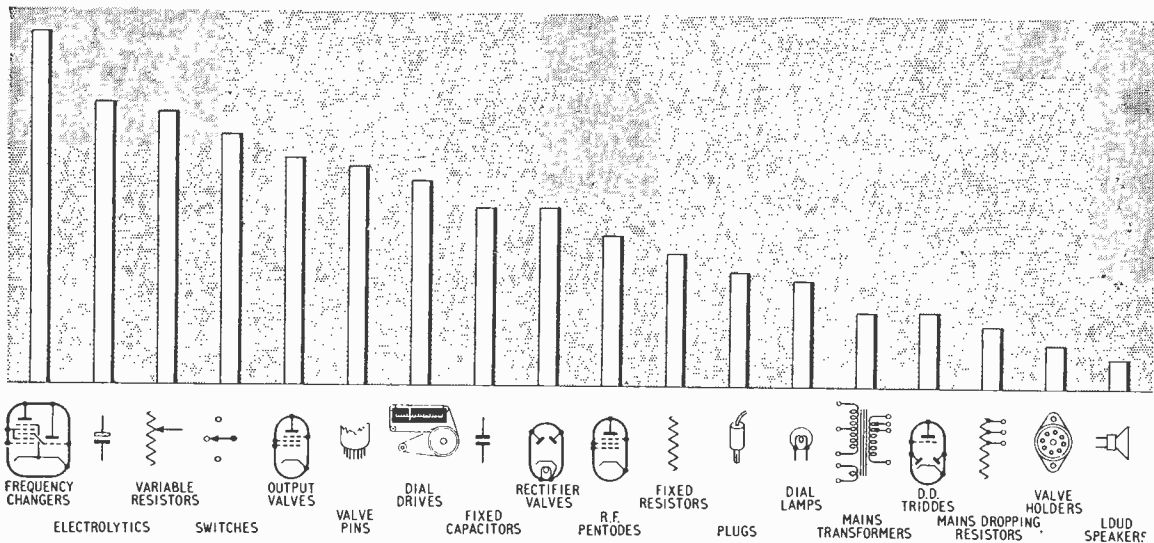

Faulty Components—In this diagram the heights of the columns are proportional to the number of breakdowns due to components listed by the author. It gives some guide to the relative probabilities with which the components can be expected to give trouble in sound broadcast receivers.

average listener readjusts the tone control very little, unless it is combined with the on-off switch and therefore *has* to be readjusted every time the set is switched on. Nearly all the volume controls replaced were of the switched type; where the on-off switch was separate from the volume control the last-mentioned seldom appeared in the replacement list.

Trouble with the on-off switch occurred in 26 sets; but, in addition, some of the cases listed under faulty volume control really came under the faulty switch category, as they comprised volume controls which were changed because the on-off switch attached to them was faulty as well.

Faulty Alignment

Realignment, sometimes of r.f. circuits only, sometimes i.f. only and often of both, was needed in 55 cases. A large proportion of the sets involved were small personal portables, and no doubt vibration in carrying the sets around was largely responsible. One very popular model was found to be especially prone to getting right out of alignment through the iron-dust cores of the i.f. transformers gradually screwing themselves downwards. Sealing the cores with wax effected a more or less permanent cure in every case.

Another older type of portable frequently showed serious misalignment of the compression-type trimmers in the r.f. circuits. Quite half the sets of this particular type which came in for checking were found to suffer from this defect. Here again proper sealing after readjustment effected a lasting remedy.

Valve pins were the next biggest headache. Octal valves very seldom gave any trouble in this respect, owing to the large surface-area of the pins contributing to good and lasting low-resistance contact. Unless the associated valve-holders were of poor design or bad quality, this type of valve usually maintained satisfactory contact almost indefinitely. But the modern miniatures, with their very slender pins, seem to be more susceptible to contact troubles. In fact, in 49 cases defective contact was found to be causing loud "scratching" noises or poor signal strength or even complete failure. Admittedly the fault was often partly due to the design of the valveholder; types with contacts which exerted a really firm grip on the valve-pins were generally found to be trouble-free.

Defective fixed resistors of various kinds accounted for 47 faults. Of these, 14 occurred in mains-dropping resistors, three in line cords, and 30 in other fixed resistors, mostly of the miniature type and usually through overheating due to excessive current passing through a broken-down bypass capacitor connected between the resistor and the chassis.

Next on the list, accounting for 46 jobs, were repairs to drive cords and dial-drive mechanisms of one kind or another. A good many of the drive-cord breakages were due to excessive pulling on the cord occasioned by neglect of lubrication on pulleys and other moving parts. In many cases the life of the drive cords would have been lengthened almost indefinitely by regular attention to lubrication of pulleys, etc.

Switch faults totalled 56; 30 of these were in wave-change switches and 26 (as already mentioned)

in on-off switches. In some sets wave-change and on-off were combined, so the figures are somewhat elastic in this case as the faults were difficult to classify.

Battery plugs, spade tags and mains plugs caused 26 faults, of which 20 occurred in battery-powered sets. Dial lamps failing caused a number of breakdowns in cases where they were in series with valve heaters. The total number of such cases amounted to 24 in all. Dry joints in the wiring caused 21 breakdowns. One particular make of set seemed particularly unlucky in this respect. Evidently some of the soldering in that factory was—in more than one sense—none too hot!

Mains transformers accounted for 17 failures. Some of these could have been prevented by more timely servicing of rectifier valves, smoothing capacitors and so on. Others would have caused less expensive damage if the manufacturers of the sets had incorporated one or two suitable fuses. Only in two or three instances were the failures due to actual internal breakdown in the transformers themselves.

Mains leads had to be replaced in 13 instances, and ten new valveholders had to be fitted (an average of only one in every 60 sets). Metal rectifiers had to be replaced in ten sets, but this figure is a little misleading as a good many had to be fitted in pairs. Eight frame aerial leads had to be renewed, in portable receivers which had the frame aerial windings in the hinged cabinet lid. Opening and closing of the lid caused the breakage of the flexible leads through continual bending.

Other components replaced or repaired included five loudspeakers, four trimmers, four i.f. transformers, two tuning capacitors and two loudspeaker field coils.



Economical Servicing of sound and television receivers is achieved in the Philips Service Department at Waddon by equipping each technician individually with a complete set of test gear. This has been found more satisfactory than maintaining a central pool of instruments as it avoids the waste of time resulting from more than one technician needing to use a particular instrument. The economy obtained in this way is said to more than offset the greater cost of the duplicated equipment.

WORLD OF WIRELESS

First Dip.Tech. Awards

ALTHOUGH the scheme for the conferment of the Diploma of Technology at the completion of a four-year course was introduced less than two years ago, the first awards have been announced by the National Council for Technological Awards. This is because a sandwich course in electrical engineering started in 1954 at the Birmingham College of Technology was recognized by the Council.

Thirty-four of the 40 entrants for the final examination passed—27 of them reaching honours level. The subjects were electrical engineering, mathematics, human relations and industrial relations, plus two of the following:—electrical measurements and measuring instruments, electric power, applied thermodynamics, theory of electrical machines, electronics or telecommunications.

The students received their industrial training with the General Electric Co. on whose initiative the course was started.

A census, taken last February, of students attending the 45 courses recognized by the Council as leading to the Dip.Tech. shows that over a third of the 1,394 were attending the nine courses in electrical engineering—which includes electronics and telecommunications.

B.B.C. Report

THE Annual Report and Accounts of the B.B.C.,* presented by the Board of Governors to the P.M.G., makes interesting reading and includes a

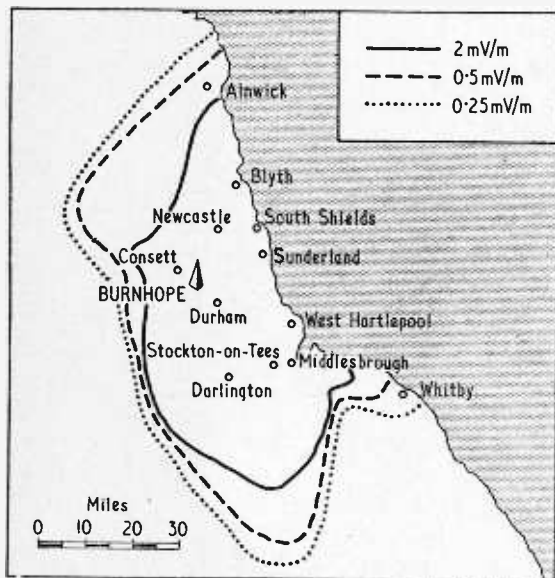

ESTIMATED COVERAGE of the I.T.A. North East England station being built at Burnhope, 6 miles N.W. of Durham. It is estimated that 95% of the 2.66M people living in the area will be within the 2mV/m contour. The transmitter will have an e.r.p. of 100kW when brought into service in Channel 8 on January 15th.

wealth of information on broadcasting in the U.K. Much of the report is concerned with programme matters but there is an interesting survey of engineering activities.

Among the facts and figures in the appendices which, incidentally, occupy nearly a third of the 154 pages, is a table showing the distribution of licences by counties. At the end of last March there were 91.08 licences (both sound and TV) per 100 families in the U.K. The distribution of television licences was then 50.31 per 100 families.

The accounts show that nearly 30% of the Corporation's expenditure of £23M for 1957/58 on the home sound and television services, was for engineering. Incidentally, the Corporation paid the Post Office over £1M for the rental of radio and cable links; £653,286 being for the television service.

* Cmnd. 533, H.M.S.O. 8s.

Radio Hobbies Exhibition

THE second Radio Hobbies Exhibition will be opened at the Royal Horticultural Old Hall, Vincent Square, London, S.W.1, by Air Marshal Sir Raymond Hart, controller of engineering equipment at the Air Ministry, on November 26th. The 29 exhibitors are listed below. Among the attractions provided are demonstrations of 405-line colour television (not closed circuit) with monochrome monitors for comparison. Admission to the exhibition, which will be open for four days from 11 a.m. to 9 p.m., costs 2s.

Army	33	Navy	25
British Amateur TV Club	34	Philpot's Metalworks	15
British National Radio		Premier Radio	16
School	5	R.A.F.	4
Clyne Radio	28	R.S.G.B.	1
Data Publications	29	Racal Engineering	24
Daystrom (Heathkit)	29	Relda Radio	9
Electronic & Radio Engineer	22	Richard Maurice Equip-	
Enthoven Solders	23	ment	32
Home Radio (Mitcham)	20	S.T.C.	17
Jason	8	Short Wave Magazine	14
K. W. Electronics	18	Taylor	6
London Electric Wire Co.	27	Teleton	31
London U.H.F. Group	3	Whiteley	19
Minimitter Co.	13	Wireless World	22
Mullard	26		

I.S.M. Interference.—The committee set up two years ago by the Postmaster General to advise him on the problems of interference caused by industrial, scientific and medical radio-frequency apparatus has made its report to him. Regulations are being drawn up by the Post Office in the light of the recommendations of the committee, of which O. W. Humphreys is chairman.

Data Processing.—The Solartron ERA (Electronic Reading Automaton, see April, 1957, issue, p. 173), to be used at the Nottingham office of Boots for reading till rolls from the firm's chemist shops, will operate directly into an Elliott numerical accumulator for analysing the figures. Boots have also ordered an E.M.I. Emidec digital computer for stock control and they are financing research on new types of input systems.

Hire Purchase.—Although the recent amendment to the Hire Purchase and Credit Sale Agreements (Control) Order (S.I.1958/1512) releases a wide range of goods from hire purchase control, domestic sound and television sets are still controlled. The minimum deposit is 33½ per cent.

Faraday Lecture.—This year's Faraday Lecture of the I.E.E. is concerned with automation and is being given by Dr. H. A. Thomas, who is manager of the instrumentation and control section of Unilever's engineering department. It is being delivered in various centres including Swansea (Brangwyn Hall, November 25th), Bristol (Colston Hall, November 27th), Birmingham (Town Hall, December 2nd), Leicester (De Montfort Hall, December 4th), and London (Royal Festival Hall, January 26th). Tickets must be obtained from the Institution for each of the lectures. These are free and applicants are asked to enclose a stamped addressed envelope.

Free Lectures.—Under a scheme for the interchange of British and Austrian lecturers, Dr. Heinz Zemanek, of the Technische Hochschule, Vienna, is delivering a lecture entitled "Some Automata of the Eighteenth Century," at the Royal College of Science, Imperial Institute Road, London, S.W.7, at 5.30 on October 28th. The University of London is also arranging a course of five lectures on information theory and its applications to fundamental problems in physics, which are being given by Professor Leon Brillouin (formerly professor of physics at Harvard University), at King's College, London, W.C.2, at 5.30 on October 21st, 23rd, 24th, 27th and 29th. Admission to these six lectures is free.

Basic Electronics.—Brunel College of Technology, Acton Hill, London, W.3, is arranging a course of evening lectures on basic electronics extending over about twenty weeks. The lectures will be given on Tuesday evenings at 6.30 beginning on November 25th (fee £3).

Transistors and their Applications.—A course of twelve weekly evening lectures covering transistors and their applications has been arranged by the Ewell (Surrey) County Technical College in collaboration with Mul-lard, who are providing the lecturers. The demand for admission to the course exceeded accommodation, as it did last year, and if there is sufficient demand it may be repeated in the spring or summer term.

Receiving Licences.—Combined television-sound licences in the U.K. at the end of August exceeded sound-only licences by just over two million. The month's increase in TV-sound licences of 49,740 brought the total to 8,344,649. Sound-only licences fell by 48,449 to 6,338,476 (including 354,460 for car radio) making an overall total of 14,683,125.

"Unconverted" Television Sets.—According to a survey by the Television Audience Measurement, Ltd., there are in the London and Midland television areas nearly 1M television sets that have not been adapted to receive the I.T.A. transmissions. At the time of the survey last March 371,000 (62%) of the 595,000 Channel I sets in the London area were unsuitable for modification. In the Midlands 114,000 (29% of the B.B.C.-only sets in the area) were also unsuitable for modification.

The United States, with some 530 television stations in operation (about 45% of the world total) has over 42M sets installed in 84% of its homes. According to the latest edition of "Television Factbook" more American homes have television sets than baths! The figures for sound broadcasting receivers are: 161M in homes, 40M in cars and 10M in public places.

Car radio-telephone service, linked to the public telephone system, is now provided on 85 channels by the New Zealand Post Office. Subscribers total 345 who operate nearly 3,000 vehicles equipped for receiving the service. In areas where the demand does not warrant the introduction of this service, individual organizations are licensed to operate their own mobile radio equipment as in this country.

"Radio Show Review" Correction.—In Fig. 2 of the "Television" section (October, p. 478) the resistor from h.t. + to the top of the 100kΩ limiter setting control should be 6.8MΩ and not 150kΩ as shown.

Medical Electronics.—The I.E.E. has instituted a Medical Electronics Discussion Group "to provide a forum in which electrical engineers specializing in electronics can meet members of the medical profession to discuss problems in which they have a common interest." The first meeting of the Group will be held on November 7th when there will be a discussion on "Problems in the Measurement of Blood Flow." Details of forthcoming meetings, which are open to non-members, are obtainable from the Institution, Savoy Place, London, W.C.2.

E.M.I. College of Electronics is being closed from next July when most of the current courses will have been completed. Arrangements have been made for the two unfinished courses to be completed at the Norwood Technical College. The present Director of Studies of the College, J. B. McMillan, M.A., B.Sc., is founding the Pembrige College of Electronics, 34a, Hereford Road, London, W.2, with some members of the present staff, and this will be opened in September next year. The home-study section (E.M.I. Institutes) of the original organization has already been taken over by Cleaver-Hume Press, Ltd., who also control the British Institute of Engineering Technology.

Scottish V.H.F. Sound Service.—The fifteenth permanent v.h.f. sound broadcasting station to be brought into service by the B.B.C., built on the same site as the television station at Rosemarkie, near Inverness, was opened on October 12th. It radiates a 3-programme service on 89.6, 91.8 and 94.0 Mc/s, each with an e.r.p. of 6kW. Transmissions are horizontally polarized.

WHAT THEY SAY

"The transformer, like other electro-magnetic devices, has resisted the powerful influences of change arising from the systematic exploitation of the fundamental physical discoveries of the past 100 years. There is no modification to the original make-up of iron core and copper coil, yet all things are permeable and gases conduct."—*From historical notes by Haynes Radio on the development of the iron-cored transformer.*

"Binary System, according to C. E. Shannon [the well-known American pioneer in the field of information theory], has its roots in the Bible. With somewhat of a tongue-in-the-cheek he quotes Matthew 5, 37: 'Let your communication be yea, yea, nay, nay, for whatsoever is more than these cometh of evil.'—*Electronic Industries.*

Scatter Interference—with Agriculture!—The Isle of Wight county branch of the National Union of Farmers is raising objections to the proposed erection of a forward scatter station at St. Lawrence, "on the grounds of interference with agricultural operations in the area."—*The Times.*

CLUB NEWS

Bradford.—Communications receiver design and construction will be discussed by H. Makin (G3FDC) at the November 18th meeting of the Bradford Amateur Radio Society. The club meets on alternate Tuesdays at 7.30 at Cambridge House, 66, Little Horton Lane, Bradford, 5.

Bury.—"Single Sideband" is the title of a lecture by R. Hammans (G2IG) to be given at the November 11th meeting of the Bury Radio Society. It will be held at 8.0 at the George Hotel, Kay Gardens, Bury.

Cleckheaton.—At the November 26th meeting of the Spen Valley Amateur Radio Society, G. N. Newman, of N.S.F., Ltd., will speak on crystal microphones. Meetings are held at 7.30 at the George Hotel, Cleckheaton.

Coventry.—The Coventry Amateur Radio Society meets each Monday at 7.30 at 9, Queens Road, Coventry, where morse classes are held each Tuesday. On November 10th V. A. Dalkin will give a lecture on radio theory.

Personalities

Sir Thomas Spencer, chairman of Standard Telephones and Cables, Limited, has had conferred upon him by the Pope the title of Knight Commander of the Order of St. Gregory the Great, for "distinguished services to the Holy See in the field of telecommunications."

Dr. R. L. Smith-Rose, C.B.E., Director of Radio Research in the Department of Scientific and Industrial Research, has accepted the invitation from the Radio Society of Great Britain to become its president for 1959. Dr. Smith-Rose has for many years been keenly interested in the activities of amateurs in this country, in fact, he was a member of the council of the Wireless Society of London (forerunner of the R.S.G.B.). He is well known internationally for his researches on radio-wave propagation, as a member of international bodies and as a writer. He is vice-president of the International Scientific Radio Union. Dr. Smith-Rose has been associated with the radio research side of the D.S.I.R.'s work since 1920 and was appointed to his present position in 1948, having previously been superintendent of the Radio Division of the National Physical Laboratory.



K. I. Jones, Associate I.E.E., Cossor's chief engineer since 1932, has been appointed to the board of Cossor Radio and Television Limited. He is a member of the International Radio Consultative Committee (C.C.I.R.) study group (XI) concerned with television and represents the Radio Industry Council on the technical sub-committee of the Government's Television Advisory Committee. He is a member of the P.M.G.'s Frequency Advisory Committee and of the B.R.E.M.A. Technical Committee, of which he was chairman from 1952 to 1954. The company also announces the resignations from the board of K. W. King (see below) and S. H. Lines.

K. W. King, A.M.Brit.I.R.E., has resigned from the Board of Cossor Radio and Television Limited to join the Decca Navigator Company. He will be concerned with the development of navigational systems, particularly overseas.

Grp. Capt. Anthony G. Powell, since 1955 chief of the electronics branch of the signals division of SHAPE, has been appointed senior air staff officer, No. 90 (Signals) Group, R.A.F. at Medmenham, Bucks., with the acting rank of Air Commodore. He passed out from the R.A.F. College, Cranwell, in 1932. His appointments have included those of deputy director of telecommunications; deputy director of signals in the R.A.F. delegation in the U.S.A.; deputy chief signals officer, M.E.A.F. headquarters; and deputy director of signals (plans).

F. S. Richmond has relinquished the positions of deputy managing director and sales director of A. H. Hunt (Capacitors), Ltd., but will remain on the board as an executive director.

Dr. J. S. McPetrie has been appointed Director-General of Electronics Research and Development in the Ministry of Supply in succession to **Dr. H. Black** who, as announced in our August issue, is now director of the Ministry's Armament Research and Development Establishment at Fort Halstead. Dr. McPetrie, who received his Ph.D. and D.Sc. degrees from Aberdeen University, was from 1925 to 1943 at the National Physical Laboratory. For six years from 1944 he was superintendent in charge of research at the Signals Research and Development Establishment of the M.o.S. at Christchurch. Since 1950 he has been head of the Radio Department of R.A.E., Farnborough. Dr. McPetrie was chairman of the Radio and Telecommunications Section of the I.E.E. for last session.

D. Hinchliffe, B.Sc., A.M.I.E.E., has been appointed engineer-in-charge of the B.B.C.'s Holme Moss television and v.h.f. sound transmitting station in succession to **C. Buckle**, who recently became engineer-in-charge of the Droitwich transmitter. Mr. Hinchliffe joined the Corporation as an assistant maintenance engineer in 1936, and he has been assistant engineer-in-charge at Holme Moss since 1952.

W. H. Thorneycroft, B.Sc., A.M.I.E.E., is the new engineer-in-charge of the B.B.C.'s Moorside Edge transmitting station, in succession to **C. H. J. Wheeler** who is retiring after 34 years' service, of which 23 have been as engineer-in-charge of the Yorkshire station. Mr. Thorneycroft joined the B.B.C. in 1936 as an assistant maintenance engineer. In 1952 he was appointed engineer-in-charge of the Washford transmitter and since 1955 has been assistant engineer-in-charge of the Sutton Coldfield television station.

Winston Electronics have appointed four new U.K. regional technical sales engineers. **K. P. Reynolds**, M.I.E.E., who is 29 and will operate from Manchester, spent two years apprenticeship with B.T.H., Rugby, and was a sales engineer in the electronics sales department before joining Winston. **P. Reeves**, B.Sc. (Eng.), Grad.I.E.E., aged 33, who will be in Birmingham, obtained his London degree at the Northampton Engineering College, London, and served a post-graduate apprenticeship with Metropolitan-Vickers at Trafford Park. He later became chief test engineer at Sunvic Controls Ltd., and was with the English Electric Co. at Whetstone, Leicester, immediately prior to his present appointment. **D. A. Jamison**, who with V. H. A. Diederichs, will cover the southern counties, served his apprenticeship with A. T. & E. before joining the Post Office engineering department at Glasgow as a technician. After war service in Royal Signals he went to Philips and since 1955 has been technical sales engineer to Murray, Swanson & Co. He is 35. **V. H. A. Diederichs**, A.M.Brit.I.R.E., who, in 1954, at the age of 36, retired as Lt. Col. from R.E.M.E., was general manager of the Minerva Detector Co. until joining Winston Electronics.

G. A. Dwyer, recently appointed assistant export sales manager of Marconi Marine, joined the company as a sea-going radio officer in 1929. In 1941 he was appointed to the shore technical staff at Glasgow, and subsequently served at various depots overseas, returning to the United Kingdom when the company's European staff were withdrawn from Egypt in 1956.

M. H. Tarbitt recently resigned his appointment as contracts manager of the Research and Engineering Division of E.M.I. Electronics, Ltd., which he joined in 1949, and is now with Andec, Limited, of Reading, as commercial manager.

Col. A. E. Tyler, O.B.E., appointed general manager of W. S. Electronics (Production), Ltd., last year, is now appointed a director of the company, which is a subsidiary of K. G. (Holdings), Ltd.

Professor E. E. Zepler, D.Phil., president-elect of the British Institution of Radio Engineers (he gives his presidential address on November 26th), came to this country from Germany at the age of 37 in 1935. After obtaining his doctorate at the University of Wurzburg he joined the staff of Telefunken in Berlin, later becoming head of the receiver development laboratories. On coming to this country he went to Marconi's where he remained until 1940. Then followed two years lecturing at University College, Southampton, and a further three years at the Cavendish Laboratory, Cambridge, after which he returned to Southampton as head of the department of electronics, telecommunications and radio engineering. When in 1949 a chair in electronics was created at the college, Dr. Zepler was appointed the first professor, which position he still holds.



Dr. E. Colin Cherry, who has been on the staff of Imperial College since 1947, has had conferred upon him the title of Henry Mark Pease (Standard) Professor of Telecommunications in the University of London in respect of the readership in telecommunications he has held at the College for the past 9 years. He is engaged in research in experimental psychology in communications and in our April, 1957, issue he discussed the importance of this subject in telecommunications engineering. Dr. Cherry, who graduated at the Northampton Polytechnic in 1936 whilst a research student with G.E.C., received his D.Sc. engineering degree from London University in 1952. During the war he was doing radar research at T.R.E.

Dr. D. B. Fry, who has been head of the Department of Phonetics at University College, London, since 1949, has been appointed Professor of Experimental Phonetics at the College. Dr. Fry is editor of the recently introduced quarterly journal *Speech and Language*.

OUR AUTHORS

Captain R. V. Taylor, Royal Signals, author of the article on the conversion of an ex-Government receiver for v.h.f. sound broadcasting, was commissioned from the Royal Military Academy, Sandhurst, in 1949 and is now engaged in training radio technicians at the Corps training establishment at Catterick, Yorkshire. After service in the 3rd G.H.Q. Signal Regiment in the Middle East, Captain Taylor was from 1953 to 1956 in wireless units on technical and administrative duties.

W. Oliver, writer of the article on radio repairs in this issue, served as a radio operator in the G.P.O. Engineering Department and in Royal Signals during the war. Of recent years he has worked on the staffs of some radio retail and servicing firms. He has held a transmitting licence (G3XT) since 1938.

J. Pereli, who writes on Zener diode voltage stabilizers in this issue, came to this country about 18 months ago and has since been employed as a development engineer in the transmission laboratory of the G.E.C. at their Coventry Telephone Works. Born in Budapest in 1925 he studied physics at that city's university and was employed for several years in a semiconductor laboratory in Hungary.

F. Butler, B.Sc., M.I.E.E., M.Brit.I.R.E., who discusses the design of a transistor audio amplifier in this issue, was trained as a teacher and in 1935 joined the R.A.F. Educational Service. He was commissioned in the Signals Branch at the outbreak of war, but in 1947 resigned his commission to join the Foreign Office Specialist Communications Headquarters. He subsequently transferred to the Royal Naval Scientific Service of which he is still a member.

News from the Industry

The Cossor Group's turnover for the year ended last March was £7.6M, which was £100,000 less than the previous year. The group trading profit fell from £444,116 to £294,106. In his annual report the chairman, the Marquess of Exeter, said "The post-war boom, particularly in television, induced an expansion of manufacturing capacity beyond the needs of the market, and intense competition between manufacturers resulted. At first, this competition was largely technical; . . . but more lately the general standard of performance has become so high that there is less to choose technically, between one make of set and another; price becomes the essential feature."

A television hire service has been introduced by Pye. It is being operated by its Television Transmission Services division, 11 Hinde Street, London, W.1 (Tel.: Welbeck 7961), and makes available cameras, monitors and microwave links.

E.M.I. Electronics are to supply the six f.m. transmitters for the v.h.f. sound broadcasting station being built by the B.B.C. at Llanddona, Anglesey, and a further six for the projected Orkney station. The transmitters are to be installed in duplicate for each of the three services, Home, Light and Third. They employ a new method of modulation providing an improved signal-to-noise ratio with reduced harmonic distortion. The system uses direct frequency modulation of an oscillator operating at half carrier frequency with a.f. feedback from a frequency demodulator fed from the oscillator.

Plessey's are to manufacture silicon rectifiers in this country under licence from the General Instruments Corporation, of New Jersey. The agreement signed between the two companies also provides for Plessey to receive technical information on manufacturing techniques and British and West European manufacturing and sales rights.

Hartley Baird.—In his review of the year ended last April, C. Collaro, chairman of the Hartley Baird group, reported a net profit before taxation of £42,619 compared with a loss of nearly £23,000 during the previous sixteen months. The group of nine companies, which is part of the larger Camp Bird group, includes Ambassador, Duratube & Wire, Hartley Electromotives and Telecast Rentals.

S.T.C. supplied the cable and the 10 repeaters for the new telephone link between the mainland and the Channel Islands. Carrier equipment for the terminal stations at Tuckton, Hants., and St. Helier, Jersey, was also supplied by S.T.C. The cable, providing 120 telephone circuits, is 132 nautical miles long.

British Communications Corporation have been awarded a contract by the U.S. Air Force for the installation and maintenance of equipment

for a series of mobile v.h.f. schemes covering U.S.A.F. bases in Eastern England. The equipment to be used is the B.C.C. 5-watt mobile transmitter/receiver (Type 69), and 15-watt fixed station equipment (Type 311/201).

Marconi closed-circuit television equipment, operating over Post Office telephone lines with equalizing amplifiers, was used to bring to visitors to the Fuel Efficiency Exhibition at Olympia, demonstrations conducted at the Shell Continuous Combustion Laboratory some three miles away. The televised pictures were projected on to an 8ft by 6ft screen.

Television Afloat.—Well over 500 vessels have now made use of the television service for shipping under which Marconi Marine provide and maintain receiving equipment either for short periods whilst in U.K. ports or as a permanent installation.

E.M.I. Electronics have supplied a television outside broadcast vehicle to Southern Television Ltd., the programme contractors, for the new I.T.A. station at Chillerton Down, Isle of Wight. The vehicle is equipped with three camera channels and carries microwave equipment for linking with the studio in Southampton.

Pilot Radio have arranged for Direct TV Replacements, of 138 Lewisham Way, London, S.E.14, to supply all time-base components for their non-current television receivers.

Amos of Exeter, Ltd. (Instrument Division), announce that Soundrite, Ltd., of 83 New Bond Street, London, W.1, are no longer their sales representatives in the United Kingdom.

Goodmans Industries have ceased production of the Midax 400 pressure driven horn unit because of the increasing popularity and demand for the Midax 650.

A. H. Hunt (Capacitors), Ltd., have been allotted a new telephone number—Vandyke 6454.

Keith, Prowse & Co. have acquired over 50 per cent of the issued share capital of John E. Dallas & Sons, Ltd., the well-known wholesalers. They have been established for over 80 years.

Belling-Lee television distribution system has been installed at the recently completed section of the Architects' Benevolent Society homes at Frenchlands Hatch, Surrey. The amplifier initially serves 8 outlets.

Esco Electrical (Holdings), Ltd., of Brixton, London, S.W.9, have installed a public address system for passenger announcements at Grimsby Town Station.

Aerialite.—Five members of the staff of Aerialite, Ltd., which was established 26 years ago, recently received gold watches on the completion of 25 years' service with the company.

EXPORTS

Communications Equipment.—Three orders for radio channelling equipment worth almost £250,000 have been received by Automatic Telephone & Electric Co. The Yugoslav authorities have ordered equipment for 24 terminals, which will operate on wideband radio links. Carrier channelling equipment providing 180 circuits for a microwave radio system to link St. John's, Newfoundland, with Sydney, Nova Scotia, has been ordered by Canadian National Telegraphs. Similar equipment is to be supplied for use on microwave links at R.A.F. installations overseas.

Broadcast Transmitters.—Jordan's new broadcasting station being built at Amman is to be equipped with two Marconi 100-kW transmitters—one medium-wave (already ordered) and one short-wave.

A quadrilingual catalogue has been produced by Marconi Instruments in which are given brief summaries in English, French, German and Spanish of some 100 pieces of test and measuring equipment.



RIGID INSPECTION and, where necessary, correction and adjustment is carried out on every imported Grundig tape recorder at the new Sydenham premises of Grundig (Gt. Britain) Ltd., to ensure that frequency response, etc., are up to the standards claimed. Each test booth in the background is provided with its own set of calibrated signal generators and measuring instruments.

Lisbon.—A comprehensive display by the British Radio Equipment Manufacturers' Association as well as space for individual manufacturers are included in the plans for the radio, television and electronics section of next year's British Trade Fair in Lisbon. It will be held from May 29th to June 14th.

Radar and associated control and data equipment for the Bristol/Ferranti Bloodhound guided weapons ordered by the Royal Swedish Air Board is being supplied by Decca.

Antiference aeriels are to be produced on the Continent by the recently formed company Antiference (Belgium) S.A., 99-105 Boulevard de la Ite Armée Britannique, Forest, Brussels.

Television Cameras.—A further order from the Canadian Broadcasting Corporation for six Marconi television camera channels brings the total number purchased by the C.B.C. to nearly seventy.

Radio communication and navigation equipment for the first three De Havilland Comet 4's ordered by the Argentinian airline Aerolineas Argentinas, is being supplied by Marconi's. The installation includes the selective calling system "Selcal."

Holland.—Among the eighty or so founder members of the Anglo-Dutch Trade Council recently set up in The Hague are a number of radio-electronics firms including Advance Components, B.T.H., G.E.C., Metrovick, Philips and Siemens Ediswan.

Kentucky Distributors.—The Hart Distributing Company, 413-415 West Main Street, Louisville, Kentucky, would like to get in touch with United Kingdom suppliers of transistor radio sets, tape recorders and record changers.

West-German Agents.—F. C. Ehlers, Gotenstrasse 10/16, Hamburg 1, wish to represent a United Kingdom manufacturer of domestic television receivers.

"**Qui Représente Qui?**" is the title of a publication listing the French representatives of foreign manufacturers. The publishers, Editions Sopal, 16 rue St. Marc, Paris 2e, will be glad to receive information from manufacturers for publication in the next issue, which will include three sections covering French representatives, foreign manufacturers, and commodities. A copy of the publication can be seen in Room 620 of the Board of Trade Export Services Branch, Lacon House, Theobalds Road, London, W.C.1. Manufacturers sending information to the publishers are asked to send a copy of their letter to the British Embassy, Commercial Department, 35 rue du Faubourg St. Honoré, Paris 8e, through whom the request for information was made.

Transistor Audio Amplifier

By F. BUTLER, B.Sc., M.I.E.E., M.Brit.I.R.E.

USE OF MULTIPLE PUSH-PULL
STAGES IN SERIES

USING transistors in a push-pull class-A connection it is not difficult to construct an audio output stage in which the total harmonic distortion is about the same as that of a conventional amplifier employing thermionic valves. The theoretical maximum efficiency of a class-A amplifier is only 50 per cent., and the quiescent energy dissipation must be at least twice as great as the desired maximum output power. These disadvantages are particularly objectionable in the case of battery operated equipment and also impose serious limitations on the available output power from a transistor amplifier in which the collector energy dissipation must be held down to a rather low level to avoid any risk of thermal runaway. The obvious alternative is to use a class-B output stage with a maximum efficiency of 78 per cent. and in which the quiescent energy dissipation is almost zero. Common-emitter class-B transistor amplifiers need careful design in order to reduce distortion to an acceptable figure. The four principal sources of distortion are (1) wide variations of input resistance under large signal operation, (2) reduction of current gain factor at high emitter currents, (3) differences between the characteristics of the two output transistors, and (4) ringing caused by resonances in the driver transformer. By using closely matched pairs of transistors and by careful circuit design, it is possible to keep the distortion down to a fairly low level. To correct this residual distortion it becomes necessary to use a large amount of negative feedback. In practice, the art of constructing a good amplifier becomes that of making one which will accept this feedback while maintaining an adequate margin of stability. In what follows an account is given of the design and construction of a 10-W amplifier suitable for operation from a 12-V battery. A low-noise pre-amplifier is also described, and some reference is made to the design of tone control stages to give any required overall frequency response.

A recently published book on transistor audio-frequency amplifiers¹ contains a great deal of valuable practical design information. Another on transistor circuit engineering² covers a much wider field but devotes a good deal of attention to audio amplifiers. Both these books have been used extensively in working out details of the amplifier and low-noise pre-amplifier to be described.

Output Stage Design.—The design of a transistor amplifier should start with a consideration of the output stage. Assuming that the supply voltage and amplifier load resistance are known, that the output transformer efficiency is either known or can be estimated, and that the amplifier is to have

some prescribed overload capacity (say 20 per cent.), the design proceeds along the following lines:—

(a) Take the required output power and increase it by the factors corresponding to the transformer efficiency and the desired overload capacity to give the maximum output required from the transistors.

(b) Maximum output from the transistors requires that their collector voltages should swing between the limits of zero and twice the supply voltage. In practice, the collector voltage cannot drop to zero but only to a lower limit of about half a volt. With a 12-V supply the collector potential can thus swing over the range 0.5 to 23.5 V, corresponding to a sine wave having a peak value of 11.5 V. The r.m.s. value is then 11.5×0.707 V.

(c) Knowing the r.m.s. collector voltage and the total output power, the transistor load resistance can be calculated by squaring the r.m.s. voltage and dividing by the output power in watts.

(d) The collector-to-collector load resistance for a class-B transformer-coupled stage is four times that computed for a single transistor.

(e) The output transformer turns ratio is then chosen to match the actual load resistance to the optimum collector-to-collector load resistance. The required ratio is the square root of the ratio of these two resistances.

Applying these principles to the present amplifier we have: desired output = 10 W, transformer efficiency (assumed) = 0.9, overload capacity of amplifier = 20 per cent, transistor output = $(10 \times 1.2) / 0.9 = 13.3$ W; supply voltage = 12 V, minimum collector voltage = 0.5 V, peak sine wave output = $12 - 0.5 = 11.5$ V, r.m.s. output voltage = $11.5 \times 0.707 = 8.13$ V, load resistance per transistor = $8.13^2 / 13.3 = 5\Omega$ (approximately), collector-to-collector load = $4 \times 5 = 20 \Omega$, assuming an actual load resistance of 5Ω , output transformer ratio (total primary to secondary) = $\sqrt{20/5}$ to 1 i.e., 2 to 1.

It is worth noting that if the actual load is a 16 Ω loudspeaker, the impedance of which might well rise to 20 Ω or more over a large part of the frequency range, a double-wound output transformer is unnecessary and an auto connection can be used. In fact, for small transformer ratios the auto-transformer is preferable on the grounds of higher efficiency, lower leakage reactance and greater power handling capacity for a given core size.

The point about low leakage reactance is specially important in class-B amplifiers as the abrupt current conduction transfer from one transistor to the other is liable to cause a particularly objectionable form of distortion. To avoid this effect it is necessary to ensure very tight coupling between the trans-

former windings by close interleaving or, alternatively, by using bifilar windings. Normally this latter construction results in very high inter-winding capacitance but, with transistors, so few turns are required that this capacitance is not large.

It is almost universal practice to connect the output stage of a transistor amplifier in the common-emitter mode since this gives the highest power gain even though it is much less linear than the common base or common collector alternatives.

Driver Stage Design.—The wide variations of input impedance and the reduction in current gain at high emitter current which are characteristics of the common-emitter connection make it difficult to design a satisfactory driver stage. Although a single-ended stage can be used, it was decided to employ a push-pull class-A driver in the present case. With a class-B output stage, large signal

transformer is commonly constructed by empirical methods. In order to reduce the risk of cross-over distortion it should have bifilar secondary windings of low resistance, and the primary should be split so as to enclose the secondary, thus giving close magnetic coupling between the two coils. It is worth while overdesigning this component by making it capable of supplying an output power between one-tenth and one-fifth of the final amplifier output.

The driver transistors can be of a lower rating than those in the output stage. However, in the interests of standardization it is convenient to use identical types but to run the drivers with about one-half the collector voltage applied to the output stage.

Output Transformer Design.—The iron losses of a transformer at a particular frequency depend essentially on the working flux density, while the full-load copper losses depend on the winding resistance. In the present case the output transformer has been designed for a flux density of 10,000 lines/sq cm at a frequency of 20 c/s. It is required to supply 13.3 W to a 20-Ω load so that the r.m.s. primary voltage is 16.26 V. The basic transformer equation is:

$$E = 4.44 BANf \times 10^{-8},$$

where E = primary voltage, B = flux density (in lines/sq cm), A = core area (in sq cm), N = number of turns, and f = frequency (in c/s).

Assuming that a winding of 120 turns is used, the fundamental equation gives:—

$$A = \frac{16.26 \times 10^8}{4.44 \times 10,000 \times 120 \times 20} = 15.3 \text{ sq cm} = 2.4 \text{ sq in (approximately).}$$

This design is unnecessarily conservative and expensive since it is unlikely that full output would ever be required at 20 c/s. A core area of 2 sq in is ample, and even this is much larger than is used in commercial practice.

Stalloy T and U laminations having outside dimensions of $3\frac{3}{8}$ in \times $2\frac{3}{4}$ in and with centre limb and leg widths of $\frac{1}{8}$ in and $\frac{1}{2}$ in respectively are interleaved to form a stack $3\frac{3}{8}$ in \times $3\frac{3}{8}$ in \times $2\frac{3}{8}$ in deep. The 120-turn coil is put on as 60 + 60 turns, bifilar wound, each 60-turn winding being centre-tapped and the taps brought out to terminals for feeding a 5-Ω load (Fig. 1). A 20-Ω load can be connected directly across the ends of the coil. All windings are connected series-aiding. The wire is 16 s.w.g. copper, enamelled and double-cotton covered. The total winding resistance is 0.25Ω. It is meaningless to quote the inductance of an iron-cored coil without specifying the excitation voltage and frequency, but tests show that the inductance of this coil is sufficient to preserve a good low-frequency response at least down to 20 c/s.

Driver Transformer Design.—This has a core assembled from the same size stampings as are used in the output transformer, but the stack depth is $1\frac{1}{4}$ in, giving a core area of 1.17 sq in. The windings are more complicated. Both primary and secondary are bifilar wound and the primary is split so that the secondary lies between the two half-primaries. The winding sequence, starting from the core, is:—

Primary	: 100 + 100 turns, bifilar wound.
Secondary	: 150 + 150 " " "
Primary	: 100 + 100 " " "

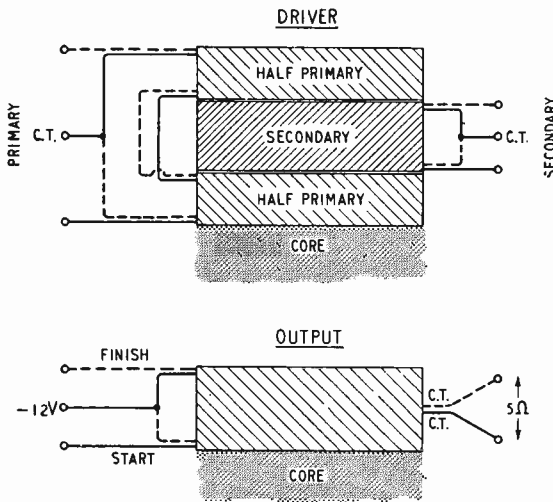

Fig. 1. Interconnections of the driver and output transformer windings.

currents flow in the power supply circuit so that if this has an appreciable internal impedance elaborate decoupling of earlier stages will be required to remove all risk of feedback instability or distortion. This effect is nullified if all the early stages are connected in class-A push-pull. In the amplifier under discussion, only the first stage is decoupled. This stage is a low-gain phase splitter and is inherently stable, but the decoupled collector voltage is also available to supply any earlier pre-amplifier stages which may be needed.

Ideally, a common-emitter amplifier should be driven from a source of low impedance. If the driver is another common emitter transistor it will have a relatively high output impedance and so must be connected to the output stage by a step-down impedance matching transformer. The input driving power is one or two orders of magnitude lower than the output power, but a variety of losses, in some cases unavoidable and in others deliberately introduced to reduce distortion, make it advisable to use a driver stage with an ample reserve of power.

The precise design of the driver transformer requires a great deal of information on the characteristics of the transistors which precede and follow it. This information is seldom available and the

The two half-secondaries are connected series-aiding, the two outers and the centre tap being brought to a terminal board (Fig. 1). The four primary sections are similarly connected series-aiding, but in such a way that each half of the finished winding includes one inner and one outer section. Again the two outers and the centre tap are brought out to the terminal panel (Fig. 1). The wire is 24 s.w.g. copper, enamelled and double cotton covered. The total primary winding resistance is 5.2Ω and that of the secondary 2.5Ω . The form of construction adopted ensures a very low leakage inductance at the expense of considerable inter-winding capacitance. It might be preferable to employ a symmetrical subdivision of the primary without bifilar winding, but such winding is essential in the case of the two half-secondaries.

Feedback in Transistor Amplifiers.—A large amount of degenerative feedback must be employed in transistor power amplifiers to reduce harmonic distortion to an acceptable level. Feedback applied locally to each individual stage is of some value, but to be fully effective it should be applied round two or more stages. Several difficulties are at once encountered. If feedback from the output stage is taken to an earlier stage, this earlier stage becomes more difficult to drive. Either its input impedance is reduced to such a low value that it is grossly mismatched to its driver stage or, alternatively, feedback which increases its input impedance calls for an increase in the amplitude of the driving voltage. In this latter case, the limitation of the collector voltage supply may make it impossible to use conventional interstage coupling techniques. For example, if so much feedback is used that the main amplifier requires a 20-V input signal (even at high impedance) it is impossible to get this from any form of resistance-coupled pre-amplifier operating from a 12-V collector supply. Transformers can be used, but high-grade types are expensive and not readily available.

When feedback is taken round three stages it is not difficult to supply the necessary drive voltage, even when 20 or 30 dB of feedback is employed. The problem is now to ensure a sufficient margin of stability, and this is not easy because of the unavoidable phase shifts in the transistors and various interstage coupling networks. The difficulty is eased if one stage can be direct-coupled to the next and, at least one high-grade amplifier has been built using this technique³. In this amplifier a simple and elegant use has been made of the comple-

Fig. 2 (a). Simple p-n-p transistor amplifier. (b) Direct coupling of n-p-n and p-n-p transistors.

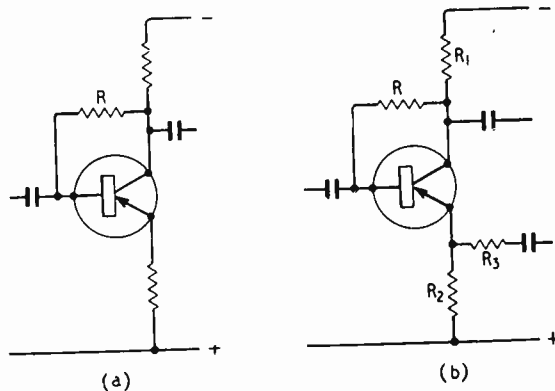
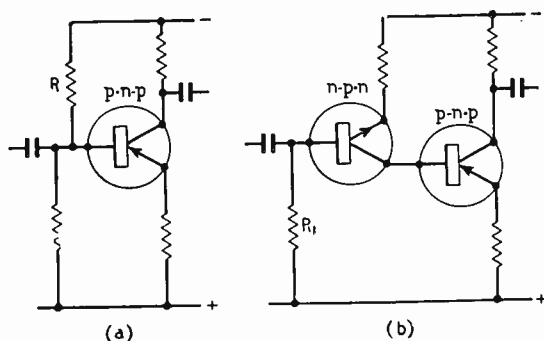

Fig. 3. Mixed feedback in resistance-coupled transistor amplifiers. A phase-splitter is shown at (b).

mentary properties of n-p-n and p-n-p transistors, the same principle being employed in the author's amplifier. The basic circuit is shown in Figs. 2 (a) and (b). In this diagram (a) shows a simple p-n-p transistor amplifier in which the desired operating conditions are established by correct choice of the base biasing resistance R . In (b), the resistance R is replaced by an n-p-n transistor, and the correct operating conditions for both transistors can be set simultaneously by proper choice of the single resistance R_1 . The collector load resistance of the n-p-n transistor is in effect the input resistance of the p-n-p transistor; and clearly the collector current of the n-p-n transistor is the same as the base current of the p-n-p transistor. The additional resistances shown enable the optimum coupling conditions to be satisfied, and also provide local feedback sufficient to reduce distortion and to modify suitably the input and output impedances of the amplifiers.

Referring again to Fig. 2 (a), it will be seen that there is no decoupling capacitance across the resistance in series with the emitter. The resulting current feedback reduces the stage gain and percentage harmonic distortion, while increasing the input and output impedances of the amplifier. When feedback is applied in series with the input signal, the effect is to increase the input impedance of the associated amplifier. Conversely, feedback applied in parallel with the input signal lowers the input impedance. Fig 3 (a) shows how mixed feedback can be applied to improve the linearity of the amplifier while preserving the original impedances or, if desired, changing them to some preferred value. It will be seen that the shunt feedback is obtained by connecting one end of the base biasing resistance R to the collector of the amplifier stage or, if less feedback is required, to a tapping on the collector load resistance. When setting the d.c. operating conditions of an amplifier stage of the type shown in Fig. 3 (a), it is usual to arrange that the voltage drop across the transistor is one half of the collector supply voltage. This condition, combined with a suitable choice of load resistance, ensures the maximum possible undistorted output voltage.

A low-distortion phase splitter circuit is shown in Fig. 3 (b). In this, which is the exact counterpart of a well-known circuit using thermionic valves, equal collector and emitter load resistances are used, ($R_1=R_2$). It follows then that equal open circuit

output voltages will be developed across these two resistances. An important point to note is that the output impedance at the collector terminal is much higher than that at the emitter terminal. This is because the transistor with the load resistance R_2 behaves as an emitter follower, modified in some respects by the presence of the collector load R_1 . To equalize the two impedances requires the addition of a resistance R_3 in the position shown. The precise value should be chosen experimentally so as to give equal output voltages from the push-pull amplifier which is driven by the phase splitter.

Main Amplifier Circuit.—With the foregoing principles in mind, little difficulty should be found in following the circuit diagram of the complete amplifier shown in Fig. 4. In the low-level stages T_1 to T_5 , various types of transistors have been used because they were already on hand. A preferred selection is given later. Transistors T_4 and T_5 are n-p-n units; all the rest are p-n-p types.

Starting at the input terminals, T_1 (Ediswan XA 102) forms a phase splitter with a very high input impedance and a collector current of 0.5 mA. It drives the low-level push-pull stage employing T_2 and T_3 (Newmarket—Pye V6/R4). This stage is entirely conventional and is capacity-coupled to the n-p-n transistors T_4 and T_5 (Texas Instruments 2S002). The collector currents of T_2 and T_3 are set at 1.7 mA. The base biasing resistances of T_4 and T_5 are so chosen that the collector currents of T_6 and T_7 (Newmarket—Pye V15/10P) are exactly equal and as near as possible to 100 mA each. It will be found that the collector currents of T_4 and T_5 are then between 2.5 and 3 mA. The 2- Ω resistances in the emitter circuits of T_6 and T_7 provide a small amount of feedback, while the 15- Ω resistance in the

collector supply circuit gives a potential drop of 3V and limits the collector dissipation to a safe maximum value.

The driver stage is transformer coupled to the final output stage consisting of T_8 and T_9 (Newmarket—Pye V30/10LP). Base bias for T_8 and T_9 is provided by 180- Ω resistances forming a potential divider across the collector voltage supply in conjunction with the transformer half-secondary winding resistance (1.25 Ω) and a fixed resistance of 1.5 Ω . The output stage is biased so that the quiescent collector currents of T_8 and T_9 are each 50 mA. This removes any possibility of cross-over distortion at low signal levels since under these conditions the output stage is operating in class A. In the amplifier T_8 and T_9 are a matched pair; the rest are random units. The performance would be considerably improved if all the push-pull pairs were accurately matched.

Feedback is applied from the output transformer to the emitter circuits of T_4 and T_5 through a parallel-connected 400- Ω resistor and 0.01 μ F capacitor. This feedback is operative down to zero frequency. The resistance controls the low-frequency feedback, while the capacitance is effective at high frequencies. In spite of the very large amount of feedback, the circuit has an ample margin of stability. A limit to the permissible amount of feedback is set in practice by the impossibility of supplying sufficient drive voltage to T_4 and T_5 without overloading the previous stage.

Before finally connecting up the feedback elements it is vital to ensure that the feedback is indeed negative. A limiting resistance should temporarily be connected in series with the battery supply and a light fuse should also be used. No damage can then

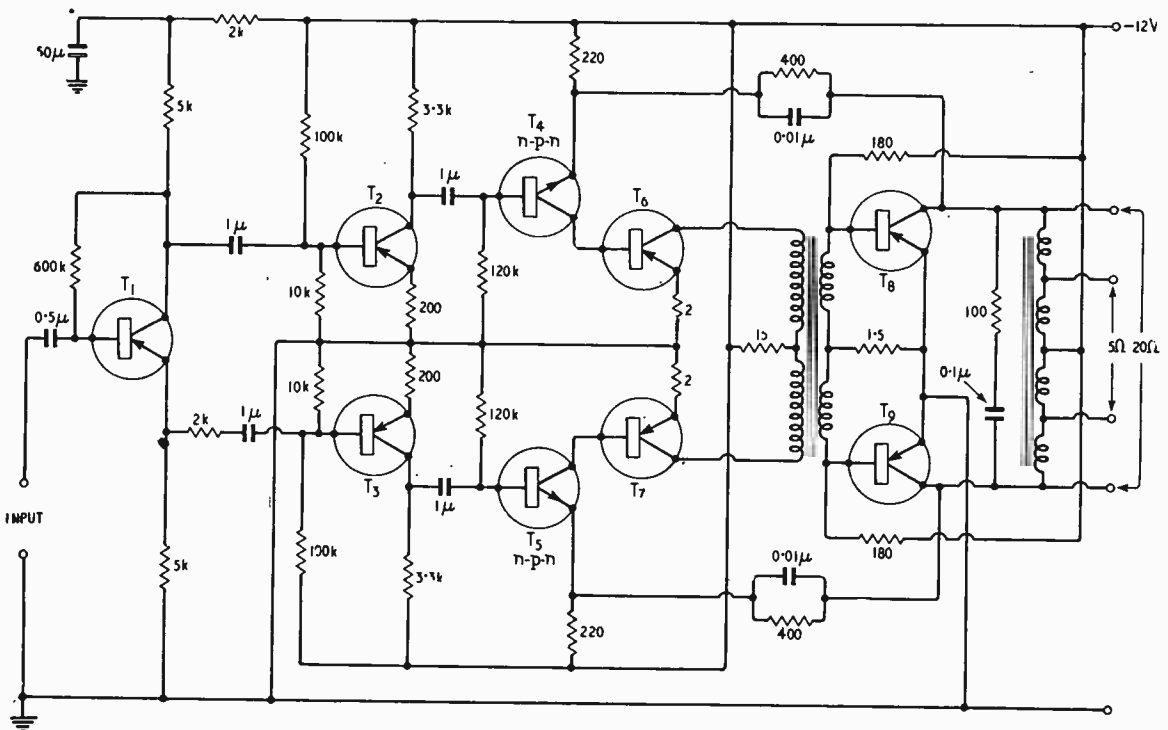

Fig. 4. Complete circuit diagram of 10-watt amplifier.

be caused by violent self-oscillation. A dummy load must always be used if for any reason the loudspeaker is disconnected.

As stated earlier, the transistors used in the amplifier were types conveniently on hand. A preferred selection would be:—

T_1 —G.E.C., low noise Type GET 6,
 T_2, T_3 —Ediswan, Type XB103 or Type XB102,
 T_4, T_5 —Texas Instruments, Silicon n-p-n Type 2S004,

T_6, T_7 } G.E.C., Type GET 108, (When available; these are not yet in production).
 T_8, T_9 }

With this transistor complement the amplifier should easily give 20 watts output into a 15- Ω load.

Construction and Wiring.—The finished experimental amplifier is shown in the accompanying photographs. There are only two heavy and bulky components. These are the driver and output transformers, which are bolted to the upper surface of an inverted metal tray, size 9 in \times 6 in \times 2 in. Most of the minor components are assembled on bakelite tag boards and mounted underneath the chassis. The driver stage transistors are mounted on 18 s.w.g. copper cooling plates 5½ in \times 2¾ in which are supported vertically by stiff paxolin strips to insulate them from the chassis. The output transistors are similarly mounted, but the cooling fins are larger (7 in \times 5 in).

The amplifier is designed to use a car battery as the collector power supply. Normally the positive pole is earthed and care must be taken if the amplifier is used under other conditions. On this account no direct connection has been made between the circuit wiring and the chassis, which is left floating. In some cases this might lead to instability, but no trouble of this kind has been experienced.

Wiring presents no difficulties. The only neces-

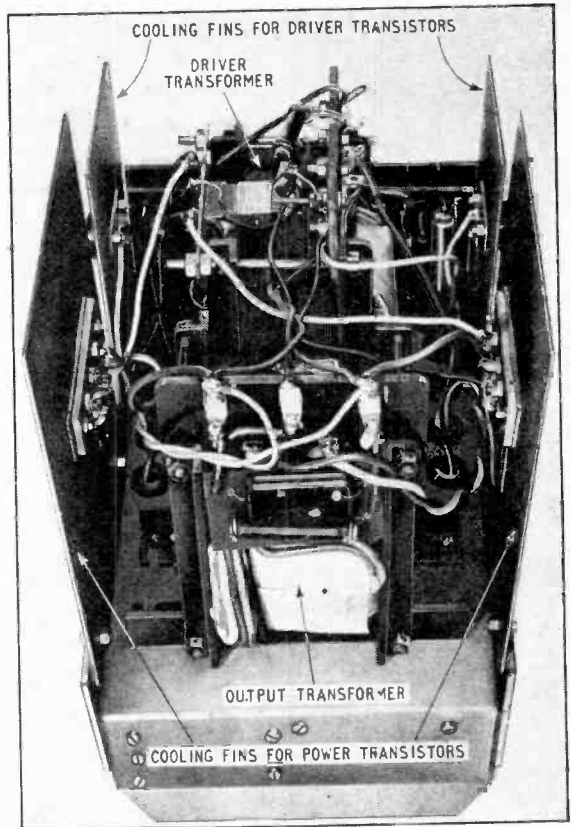

Amplifier chassis showing output and driver transformers, and associated transistor cooling plates.

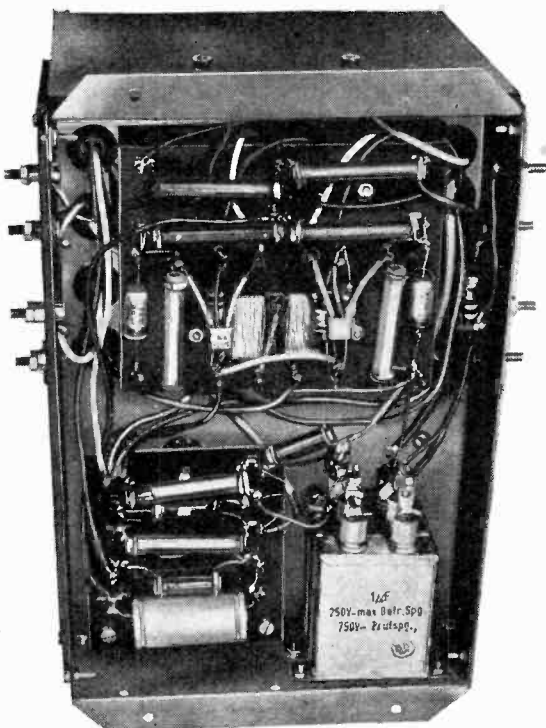

Amplifier chassis viewed from below.

sary precaution is to leave a reasonable spacing between the low-level input circuits and the output stage. No screening is required.

A simple drill must be followed in establishing the correct d.c. working conditions for all the transistors. All wiring should be completed with the exception of the base biasing resistors of all the transistors. The two main feedback loops should be made inoperative in the a.c. sense but left effectively in the emitter circuits of T_1 and T_5 so that the d.c. bias conditions are preserved unchanged. This can be done by connecting both output transformer ends of the feedback leads to the centre tap of this transformer. In the absence of all the base-biasing resistors, the transistors are virtually cut off and draw negligible collector currents. A start can then be made on the output stage and the transistor collector currents set to the selected value of 50 mA each. A minor difficulty arises because a portion (1.5%) of the bias potentiometer is common to both transistors so that the two bias adjustments are not independent. A few trials made with variable rheostats of about 250 Ω maximum resistance will soon lead to the correct setting. To measure the individual collector currents it is unnecessary to open the circuit to include a milliammeter. Instead, a millivoltmeter can be used to check the voltage drop across each half winding of the output transformer. In the present case the half winding resistance is 0.125 Ω , so that with a current of 50mA the voltage drop is 6.25mV. After the correct biasing resistances have been ascertained, the rheostats should be removed and replaced

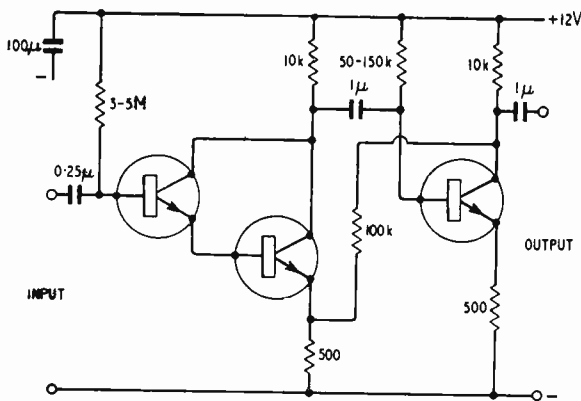

Fig. 5. Circuit diagram of low-noise pre-amplifier.

by fixed resistors of identical values. This may require the series or parallel connection of two resistors to achieve the desired close tolerance (preferably 1 per cent).

Attention can now be turned to the driver stage. Here the quiescent collector currents are each 100mA, and the half primary transformer resistance is 2.6Ω so that the working voltage drop across the half winding is 0.26V. Adjustment of the base-biasing resistances of the two silicon n-p-n transistors will enable these figures to be obtained. Resistances of the order of $0.1M\Omega$ will be required.

In a similar manner the collector currents of transistors T_2 and T_3 should be set to 1.7mA each, and that of T_1 to 0.5mA. Here a very high resistance voltmeter may be used to check the voltage drop across the collector or emitter load resistances if it is desired to avoid the trouble of opening circuits to include a milliammeter.

Characteristics and Performance—The salient characteristics of the amplifier are given below:—

Input impedance	160,000 Ω .
Input voltage to give 10W output	0.3V.
Power gain	$1.8 \times 10^7 = 72.5dB$.
Internal output impedance at 20 Ω load terminals	2.0 Ω .
Internal output impedance at 5 Ω load terminals	0.5 Ω .
Quiescent current consumption	500mA.
Full load current	1.3A.

Frequency response:—

Flat from 30c/s to 9kc/s., 1.6dB down at 10kc/s, 3.5dB down at 12kc/s, 6dB down at 14kc/s.

Harmonic Distortion at 1,000c/s with 5W output:—

Second Harmonic	1.4 per cent.
Third	3.8 " "
Fourth	0.14 " "
Fifth	0.66 " "
Total Distortion (r.m.s.)	4.1 " "

Low Noise Pre-amplifier—Fig. 5 shows the circuit diagram of a low-noise pre-amplifier designed to have a very high input impedance. It is particularly suitable for use after a diode demodulator. Texas Instruments n-p-n silicon transistors type 2S002 or 2S004 are used. Their base biasing resistances should be set so that the collector currents of the second and third transistors are each 0.5mA.

Some feedback is used to reduce distortion in the pre-amplifier to a negligible level. More gain is available if this is omitted, and the resulting distortion

is still very much lower than that due to the first push-pull stage of the main amplifier (T_2 , T_3) which in fact contributes most to the measured total distortion. It would be easy to avoid the trouble if this particular stage could be operated with higher load resistances from a collector supply of at least 24V.

Conclusion—Although the overall distortion figure seems rather high, listening tests with a good loud-speaker show that it is tolerable. There is a very great difference between the performance on good musical programmes broadcast "live", and the best of recorded music. Since there is so much of the latter, it really seems hardly worth while making an attempt to come closer to perfection. It is nevertheless almost certain that by changing the driver and output transistors for types having a higher current gain, the amplifier could be made to deliver 20 watts output with less than 2 per cent distortion. If this change is made, the performance can be further improved by applying local feedback to the output stage in order to decrease its input and output impedances. This can easily be done by disconnecting the h.t. negative end of the leads to the 180Ω bias resistances, and reconnecting them to the other ends of the output transformer windings, i.e. to the transistor collector terminals. If this degree of feedback proves extreme, a reduced amount can be provided by connecting the bias resistors to the low-impedance load terminals, taking care that the phase of the feedback is correct.

It is worth while drawing particular attention to a valuable property of push-pull transistor amplifiers, including low-level stages. This is that neutralization techniques are very easily employed, and simply require the cross-connection of passive R-C elements between the collector of one transistor of the push-pull pair and the base of the other. The technique is familiar in r.f. valve amplifiers, but with transistors the strong internal feedback makes it useful at audio frequencies. Partial neutralization can improve the high frequency response of an amplifier and make it easier to drive, even if it proves impossible to achieve exact neutralization over the whole frequency range.

Many users will wish to employ some form of equalization or tone correction ahead of the main amplifier. Suitable pre-amplifier designs are described in the book by Jones and Hilbourne already mentioned¹. A small amount of correction may be applied to the amplifier in Fig. 5 by inserting some convenient frequency sensitive network (e.g. a suitably damped series or parallel tuned circuit) in the feedback line. Care will be necessary to see that the d.c. conditions are not unduly disturbed. As regards volume control arrangements, the amplifier described has a very high input impedance so that normal radio or audio frequency practice may be employed.

In the near future it will be possible to build transistor amplifiers of extremely high fidelity, rivaling the best thermionic valve amplifiers. Users will then wish to operate them from a.c. mains in preference to batteries. It is not difficult to design a suitable power unit. The essential requirements are for extremely good voltage regulation and low output impedance. Some years ago the writer described a controlled rectifier developed for use with a high power class-B valve amplifier². This achieved good regulation by making use of the properties of saturable core reactors in conjunction with mercury

vapour rectifiers. For low voltage applications, germanium rectifiers can be used in a similar circuit. A power supply unit of this type was used in conjunction with the high power amplifier described by A. B. Bereskin³. It can easily be modified to meet any special requirements as regards input voltage or frequency, and can be made to give any desired output power.

REFERENCES

¹ "Transistor A.F. Amplifiers", D. D. Jones and R. A. Hilbourne, (Iliffe).

² "Transistor Circuit Engineering", edited by R. F. Shea, (Wiley).

³ "A High Power High Quality Transistor Audio Power Amplifier", A. B. Bereskin, 1957 *I.R.E. National Convention Record, Part 7, Audio Broadcast Transmission Systems*.

⁴ "The Use of Transistors in Physiological Amplifiers", E. F. MacNichol and T. Bickart, *I.R.E. Transactions on Medical Electronics*, March, 1958.

⁵ "Rectifier Voltage Control Using Saturable Core Reactors", F. Butler, *Wireless World*, June, 1949, p. 227.

⁶ "15-watt Public Address Amplifiers using OC16 Transistors", P. Tharma, *Mullard Technical Communications*, August, 1958, p. 30.

SIMPLE GEOMETRICAL ANALYSIS

By F. J. HENNESSY

Tracking Errors in Record Reproduction

WHEN a master disc record is made, the recording stylus cuts the grooves while travelling along a screwed rod radially towards the centre of the record. But when a record is replayed using an ordinary arm with a single pivot, the needle-tip or stylus describes an arc of a circle, so that it will be apparent that perfect tracking is not obtained at all points. In the following geometrical treatment it will be shown that if the vertical plane through the stylus and its cantilever mounting passes through the arm pivot point for horizontal movement, perfect tracking is obtainable only at one point; whereas when the vertical plane through the stylus and cantilever is angularly offset from this position, perfect tracking at two points may be obtained.

For convenience, it is best to consider a pickup which uses a stylus supported by a cantilever. In all cases, however, the needle or stylus has to be supported in such a way that it is free to vibrate horizontally. For perfect tracking, the vibratory path of the stylus must be at right angles to the grooves. In other words, the vertical projection of the line joining the stylus tip and the cantilever pivot point must be tangential to the grooves.

Consider first a straight arm in line with the stylus and cantilever—AN of Fig. 1. B is the centre of the record and a semi-circle is described on AB as diameter. This semi-circle would be the perfect track for the needle-tip (N) as at any point X on this semi-circle $\angle AXB$ is a right angle, that is, AX is always tangential to the grooves. However, to follow this semi-circular ideal track, we would need an arm of varying length. In practice, of course, the arm is of fixed length and the track of the needle tip is the arc of a circle of centre A and radius AN. This arc can be made to cut the ideal semi-circle at any one point, but only at one point, e.g. at X_1 in the diagram. At this position of the arm, therefore, perfect tracking is obtained, but at other positions errors exist.

Next, consider an arm with offset head—Fig. 2. AN is the arm but the stylus and cantilever are now in line with CN at an offset angle, α say, to the arm

AN. AC is made perpendicular to AB and a semi-circle is described on CB as diameter. As $\angle CNB$ is a right angle, CN (and therefore the stylus and cantilever) is tangential to the grooves at N. If the arm length could be varied so that the stylus moved along the semi-circle described on CB, then perfect tracking would be obtained. This is because for any point X on this semi-circle, CX gives the stylus

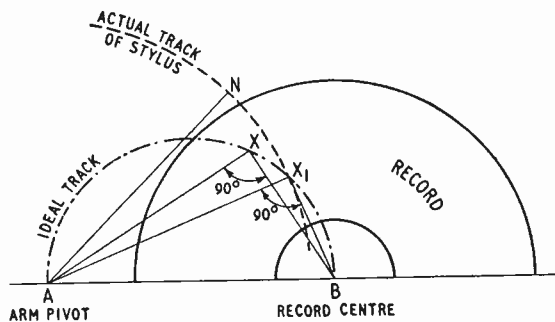

Fig. 1. Correct tracking point (X_1) with a straight arm and head.

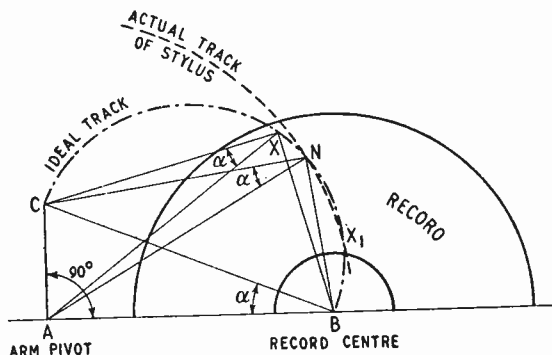

Fig. 2. Correct tracking points (X_1 and N) with an offset head.

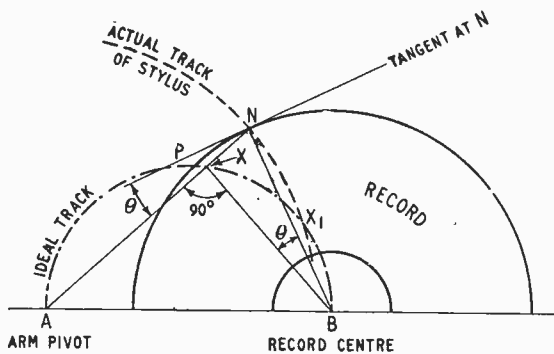

Fig. 3. Tracking errors with a straight arm and head.

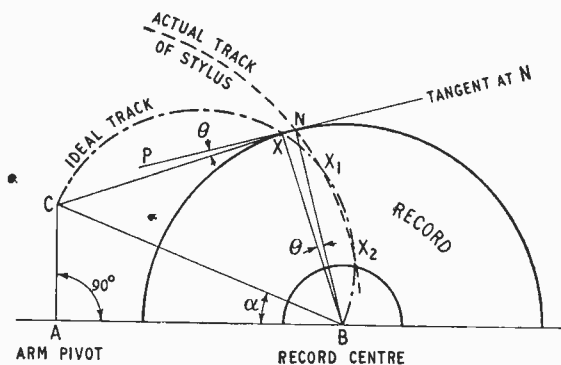

Fig. 4. Tracking errors with an offset head.

and cantilever direction as, from the equality of angles in the same segment, $\angle CXA = \angle CNA = \alpha$, and CX is always tangential to the grooves. In practice, an arc of a circle of centre A and radius equal to the fixed arm length AN, can be made to cut the ideal semi-circular track at two points, N and X_1 , say. Therefore, perfect tracking is obtained when the stylus is at these positions, while errors exist at other points.

So far, the magnitude of the error has been ignored. By pursuing this geometrical analysis, however, the angular tracking error at any point can readily be measured and its variations seen.

To investigate the magnitude of the angular tracking error, consider first a straight arm, AN, in line with the stylus and cantilever—see Fig. 3. Suppose perfect tracking is obtained at X_1 (where the actual stylus track cuts the ideal track) but that we wish to find the tracking error at N. If PN is the tangent to the grooves at N, the angular tracking error is obviously $\angle PNA = \theta$, say. In the right-angled triangle BXN, $\angle XNB + \angle XBN = 90^\circ$. Also $\angle XNB + \angle XNP = 90^\circ$. Hence, $\angle XBN = \angle XNP = \theta$ (the angular tracking error). Therefore, the angular tracking error is the angle subtended at the centre of the record by the line XN. It can be proved that this is also true when N is inside the ideal semi-circle instead of outside as shown.

Next consider a curved arm or a straight one with offset head—see Fig. 4. As far as tracking behaviour is concerned, these types of arm are obviously identical as the curved arm automatically produces an offset stylus. Again PN is tangential to the grooves at N and, taking complementary angles as before, $\angle XBN$ is again found to be the angular tracking error. It can be seen that this angle, never very large, becomes zero at X_1 and X_2 , and changes sign, so to speak, twice across the record.

To determine the tracking error for any position of the needle (N), the rule is therefore as follows:—Draw a straight line joining A and N in the case of non-offset heads, or joining C and N in the case of offset heads. If X is the point where this line cuts the ideal semi-circle, then the angle subtended at the centre of the record by the line XN is equal to the angular tracking error. The method of finding the position of C is obvious from an examination of Fig. 2, as $\angle ABC$ is the offset angle, and $\angle BAC$ is a right angle.

The foregoing analysis shows how the angular tracking error can be determined for any given set

of record and pickup arm dimensions, including the distance from record centre to arm pivot. It clearly shows the advantage of an offset stylus in reducing the magnitude of the tracking error. It does not show how the optimum offset angle for a given set of conditions can be arrived at, however, because for one thing it does not take into consideration the fact that the same angular tracking error will cause greater distortion as the radius of the groove decreases.

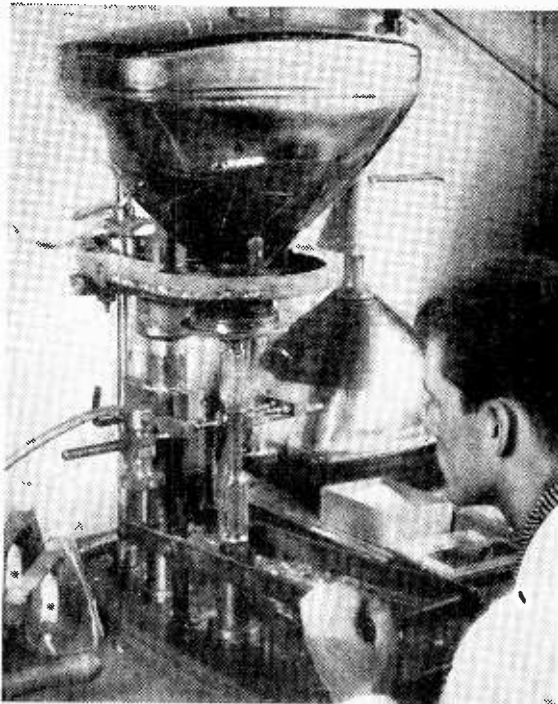

RECONDITIONING CATHODE-RAY TUBES.—This machine, at the factory of C.R.T., Ltd., Baldock, is used for sealing-in the reconditioned electron guns. The tube is rotated in a cradle while gas burners, under the control of the operator, melt the neck glass on to the glass of the gun support. The other reconditioning processes are similar to those described in the May, 1958, issue (p. 247).

Stabilization by Zener Diodes

By J. PERELI*

Elementary Principles of Design

THE Zener diode is now being used quite extensively in the control of supply voltage for transistorized equipments. The circuits in these equipments do not require a great quantity of power, so the stability of their supply can be controlled by a single diode. The reverse current characteristic is used to produce the stabilizing effect. Fig. 1 shows that at the breakdown voltage the reverse current curve becomes steep ($\Delta V/\Delta I$ is small and the dynamic resistance is also small), and as the breakdown voltage is comparatively high the diode is particularly suitable for regulation of supply voltages. A special diode has been designed for the purpose which has a specified breakdown voltage and adequate power handling capacity to protect it from the comparatively high inverse current.

The stabilizing circuit is shown in Fig. 2, where the input voltage is V_1 and the stabilized voltage is V_s .

To understand the circuit let us examine the characteristics of the diode and the resistance R_1 . As can be seen from Fig. 1, the R_1 characteristic (upper line) intersects the axis of voltage at V_1 and the axis of current at V_1/R_1 . The voltage V_s , where the two characteristics intersect, is that which can be measured across the output terminals of Fig. 2. If V_1 changes to V_2 the gradient of line R_1 remains unaltered (see lower line marked R_1), and because of the steep characteristic of the diode

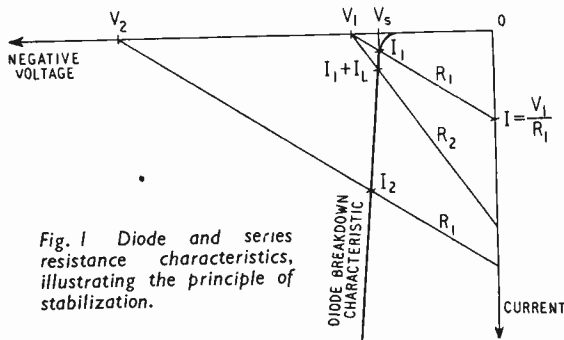

Fig. 1 Diode and series resistance characteristics, illustrating the principle of stabilization.

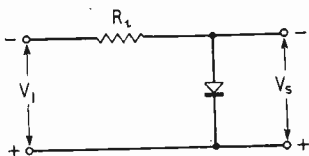

Fig. 2 The Zener diode stabilizing circuit.

Fig. 3 Circuit for measuring the characteristics of a Zener diode.

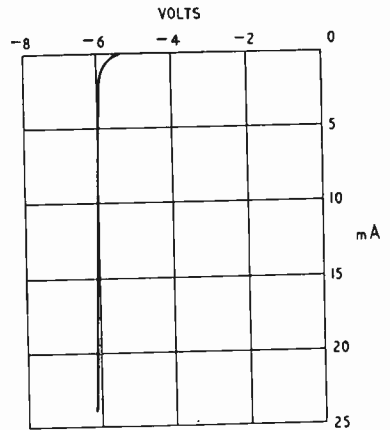
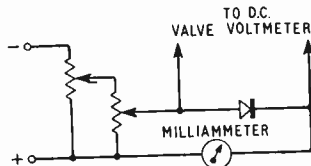

Fig. 4. Reverse-current characteristic of an EW77 (or SX 68) Zener diode.

the voltage V_s changes only slightly or hardly at all.

The stabilization of voltage lasts, of course, as long as the line R_1 cuts the characteristic of the diode on the steep portion.

The evaluation of the resistance R_1 will now be considered. After drawing the characteristic of the diode we indicate the minimum value of regulating current (beginning of the steep part, I_1). The lowest voltage that can be expected from the unstabilized voltage supply is also indicated (V_1). The line connecting these two points cuts the axis of current at a point (I) and V_1/I gives the value of the necessary resistance R_1 . The value of the highest possible voltage which can be used is to be found by drawing a line parallel to the resistance R_1 through the point of the maximum permitted current on the characteristic of the diode (I_2). This line cuts the voltage axis at a point showing the maximum supply voltage (V_2). The diode will stabilize variations in the supply voltage between values of V_1 and V_2 . Lines of resistance drawn from each of these points cut the characteristic of the diode at points approximating to an ordinate drawn from V_s .

The above calculation refers to an unloaded circuit. Where a load is connected to the stabilized supply we have to add the load current (I_L) to the value of current I_1 , and the line which intersects this value of current ($I_1 + I_L$) and the point V_1 indicates the value of resistance to be used, R_2 . On loading the circuit the range of stabilization is, of course, smaller, but is still sufficient for most applications.

Fig. 3 shows a method of measuring the characteristic of a diode. A double potentiometer is used because of the sensitive voltage adjustment which is necessary in the breakdown region. To obtain an exact measurement of the characteristic it is essential to read each 0.1 volt in the breakdown region.

Measurements carried out on a G.E.C. Zener

* General Electric Company.

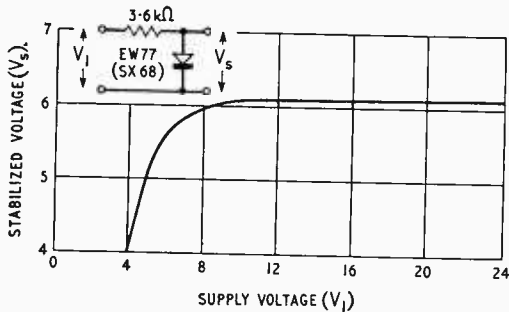

Fig. 5 Stabilization characteristic of an EW77 (or SX68) Zener diode with $3.6k\Omega$ series resistor.

diode type EW77 (or SX68) are shown in Figs. 4 and 5.

In conclusion, the formulæ will be given for calculating the range of stabilization and the resistance R .

- Let V_1 be the minimum supply voltage
 V_2 be the maximum supply voltage
 V_s be the stabilized voltage
 I_1 be the minimum of stabilizing current
 I_2 be the maximum of stabilizing current
 I_L be the load current
 W be the maximum power rating of the diode
 R_1 be the stabilizing resistance in unloaded cases
 R_2 be the stabilizing resistance when loaded with I_L .

Calculation of R_1 :

$$R_1 = \frac{V_1 - V_s}{I_1}$$

Calculation of R_2 :

$$R_2 = \frac{V_1 - V_s}{I_1 + I_L}$$

$$\text{So } \frac{1}{R_2} = \frac{I_1}{V_1 - V_s} + \frac{I_L}{V_1 - V_s} = \frac{1}{R_1} + \frac{I_L}{V_1 - V_s}$$

$$\text{and } R_2 = \frac{R_1 R_1}{R_1 + R_1}; \text{ where } R = \frac{V_1 - V_s}{I_L}$$

The maximum stabilizing current

$$I_2 = \frac{W}{V_s}$$

The maximum voltage which can be stabilized

$$V_2 = (I_1 + I_2)R_1 + V_s$$

Approximate stability of voltage (as shown on Fig. 1) is given by

$$\Delta V_s = \Delta I R_D = \frac{R_D}{R_i} \Delta V$$

where ΔV_s is the change of stabilized voltage, R_D is the dynamic resistance of the diode, and ΔV is the change of supply voltage. When R_i is replaced by R_1 or R_2 the approximate stability is obtained for the unloaded or loaded circuits respectively.

Commercial Literature

Amite, the well-known silicon-carbide compound whose resistance falls rapidly with increase of applied voltage, is described in great detail in a booklet from the Automatic Telephone and Electric Company, Strowger Works, Liverpool. Physical properties and typical applications are covered.

Transformers; an illustrated booklet describing the Gresham group of companies and their products and services, in English, French, German and Spanish. From Gresham Transformers, Ltd., Hanworth, Feltham, Middlesex.

Signal Lampholder requiring $\frac{3}{8}$ -in panel hole: one type for low-voltage bulbs, another for mains-voltage neons. Leaflet from Arcoelectric (Switches), Central Avenue, West Molesey, Surrey.

Australian Semiconductors; a catalogue of Radiotron diodes and transistors with American type numbers, including germanium point contact and junction diodes, silicon junction and coaxial diodes, and transistors classified into audio, power, r.f. and switching types. From Amalgamated Wire-less Valve Company, 47 York Street, Sydney, Australia.

Anodized Aluminium Wire, providing an integral film of aluminium oxide as insulation, allows operation of windings at higher temperatures (up to 550°C) and so permits weight reductions and consequent savings in wire costs. Properties and gauges available listed in a leaflet from the Aluminium Wire and Cable Company, 2 St. James's Square, London, S.W.1.

Transformers; an illustrated survey of many types used currently in electronic and electrical engineering, including chokes, coils and other windings. Includes interesting historical notes with diagrams on the development of the transformer from Faraday to the present day. From Haynes Radio, Queensway, Enfield, Middlesex.

Unit Aerial System for amateur v.h.f. and u.h.f. aerials. Basic arrays for 2m and 70cm made up from the system illustrated on a leaflet from J-Beam Aerials, Westonia, Weston Favell, Northampton.

Grease-Filled Sleeves of polythene for insulating individual conductor joints in plastic-insulated communication cables against ingress of moisture. A non-melting, non-solidifying silicone grease is used. Literature from British Insulated Callender's Cables, 21 Bloomsbury Street, London, W.C.1.

Oscilloscopes by Tektronix of America. Illustrated catalogue, including a section of new professional instruments, from Livingston Laboratories, Retcar Street, London, N.19.

Vacuum Furnaces, by Degussa Wolfgang of Germany, as used for production of tantalum capacitors, processing of silicon iron for transformers and other purposes. Leaflet from Leybold Vacuum Sales, Colquhoun House, 27-37 Broadwick Street, London, W.1.

Servo Components, a.c. and d.c., including motors, motor generators, synchros, resolvers, gear boxes, tachometer generators and magnetic and transistor amplifiers, are described briefly in a leaflet from R. B. Pullin & Company, Phoenix Works, Great West Road, Brentford, Middx.

Small Selenium Rectifiers by Siemens & Halske, including contact-cooled flat and block types, and miniature, midget and cartridge types. Illustrated catalogue, giving ratings and dimensions, from R. H. Cole (Overseas), 2 Caxton Street, London, S.W.1.

SARAH Civilian Beacon, a development of the well-known military Search And Rescue And Homing equipment, intended for use by fishermen, yachtsmen, mountaineers, etc. The speech facility has been omitted. Details of the small beacon transmitter and search receiver in a brochure from Ultra Electric, Western Avenue, Acton, London, W.3.

Carbon Film Resistors; technical data on the range of Electronic types (1Ω to $100,000M\Omega$, $1/20W$ to $6W$, tolerances from 0.1%) in a catalogue from Aveyley Electric, Ayrton Road, Aveyley Industrial Estate, South Ockendon, Essex.

Multi-Range Meters.—Two new types from Taylor: Model 100A with a sensitivity of $100,000\Omega/\text{volt}$ and resistance ranges up to $200M\Omega$; and Model 127A, a pocket-sized instrument with a sensitivity of $20,000\Omega/\text{volt}$ and resistance ranges up to $20M\Omega$. Leaflets from Taylor Electrical Instruments, Montrose Avenue, Slough, Bucks.

RETURN LOSS

By THOMAS RODDAM

3.—Application of a Transmission-line Concept to Multipath Problems

A YEAR or so ago I had occasion to think about return loss and, as always when I think about anything, I communicated my thoughts to *Wireless World* readers in the November and December (1957) issues. One of the axes I grind most frequently is that the engineer must remember that the differenter things are the more likely they are to be the same. (This statement is available in English and also, if you can remember where to put the accents, in French.) Hardened readers will not therefore be surprised if I reveal that I was reminded of these articles on return loss by a paper* on multipath propagation which I read recently. The authors are

on the staff of the Swiss P.T.T. and they are in the personally happy but professionally unhappy situation that their country is largely made up of mountains separated by lakes or plains. For the system planner, of course, a few good mountains on which aerial masts can be planted are ideal. The neighbouring peaks, which provide unpleasant diffraction effects, are a nuisance, but this can be dealt with by planting relay stations on as many peaks as the money will bear. The lakes are quite a different

* "The Influence of Multipath Propagation on the Spectrum of a Received Television Signal." *E.B.U. Rev. Part A*, No. 47, Jan. 1958, p. 12, by K. Bernath and H. Brand.

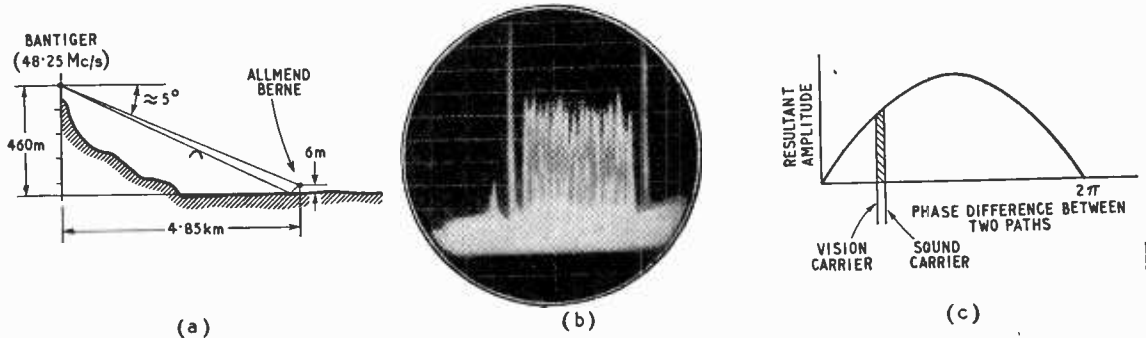

Above: Fig. 1. Reception of the Bantiger transmission near Berne. (a) Profile of propagation paths. (b) Observed response. (c) Calculated response.

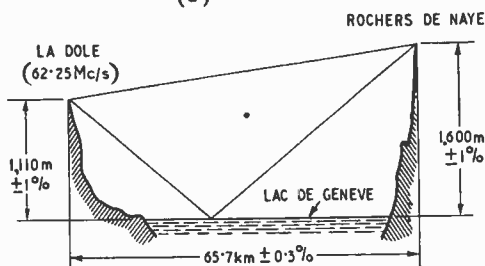

Left: Fig. 2. Reception of the La Dole transmission at the Rochers de Naye. (a) Profile of propagation paths. (b) Observed response. (c) Calculated response.

Below: Fig. 3. Reported tolerances on echo amplitude as a function of echo delay.

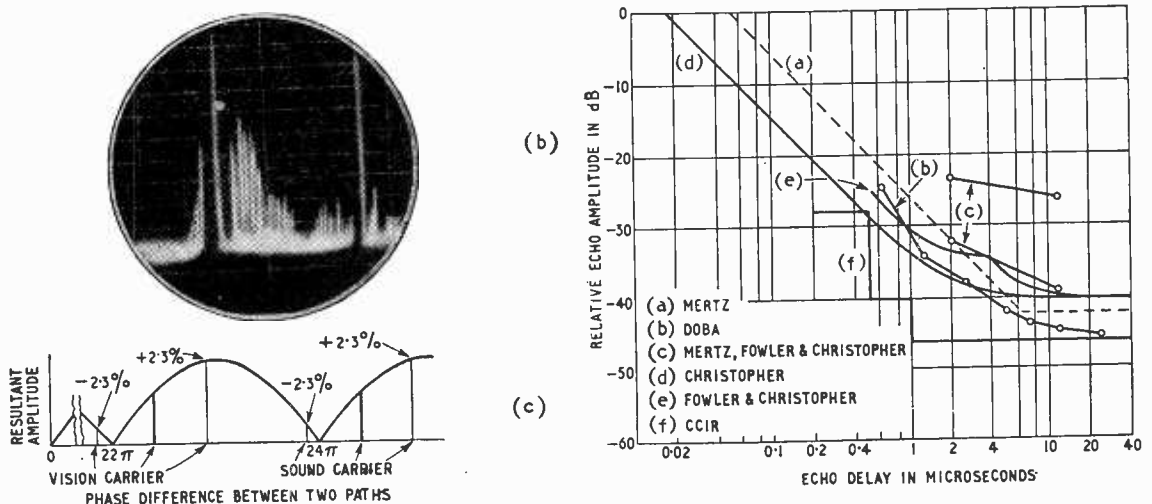

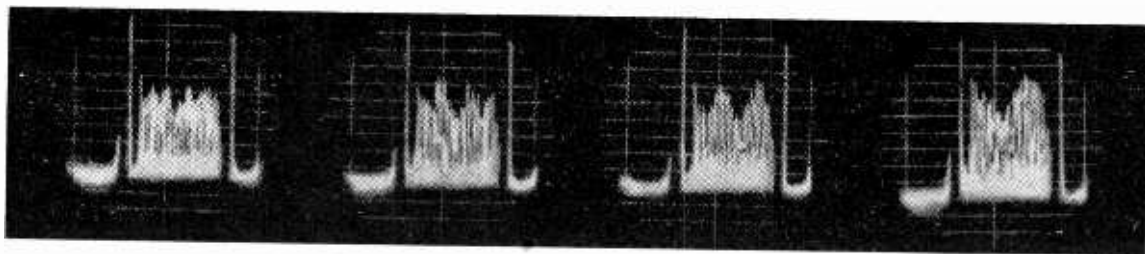

Fig. 4. Observed response from the Bantiger transmission with the receiving aerial at various distances from an isolated house in open country. The first oscillogram corresponds to a distance of about 200m between the aerial and the house, the last corresponds to 50m. The aerial was between the house and the transmitter.

kettle of fish: they form good reflecting surfaces to provide a second, rather longer, path from peak to peak. Now this business of a signal going both directly from A to B and also reaching B after reflection at C is just the sort of thing we were concerned with in our discussion of return loss. The Swiss study shows some very interesting frequency responses produced by modulating two transmitters, both in Band I, with a video signal swept from 0.5 to 5.5Mc/s. The paths and frequency responses are shown in Figs. 1 and 2 (Figs. 6 and 7 of the Swiss paper). The vision carrier is the large signal on the left, and the sound carrier is on the right. The smaller drawings show the authors' calculation of the path-difference spectrum distortion to be expected. This is especially interesting in Fig. 2, where the experimental errors in determining the path difference will produce quite different frequency responses. Now what does all this mean?

To find out, I turned to Fig. 3 of my own article in the December 1957 issue of *Wireless World* (which fortunately also comes out as Fig. 3 of this article). From this I read that for 0.18 μ sec echo delay the picture will be noticeably degraded if the amplitude of the second signal is 12dB (Mertz) to 20dB (Christopher) below the main signal. More important, I see that a change of $\pm 2.3\%$ in the time delay, a change which has a profound effect on the frequency response, has very little effect indeed on

the actual subjective picture distortion. It is of some value to know this, for a change of path length amounting to only a foot or so will produce a large effect on the frequency response under the conditions of Fig. 2.

Fig. 4 (Fig. 8 of the *E.B.U.* paper) shows the effect on the frequency response of the house next door, if the neighbours live out of earshot. Here again we might have worked out path length differences. By making use of the information in Fig. 3 we can say that in a given situation we need to have the echo at least x dB below the main signal. This is the key figure we need in designing or choosing the receiving aerial, for even a perfect reflector, such as we seem to have in Fig. 2, will be harmless if we provide sufficient directivity. In the third picture of Fig. 4 I estimate that the echo is about 12dB down. We should use the geography of the situation to calculate the delay, and then we could say that, perhaps, only 6dB of aerial protection would be needed.

The great interest of this particular problem to me is that although it is apparently one of some complexity, it can very easily be turned into an exercise in simple trigonometry followed by the use of material already published. There are quite a number of these situations where the problem itself is difficult but all the really hard bits have been done before. It is always worth while looking closely to see whether this is true.

SHORT-WAVE CONDITIONS

Prediction for November

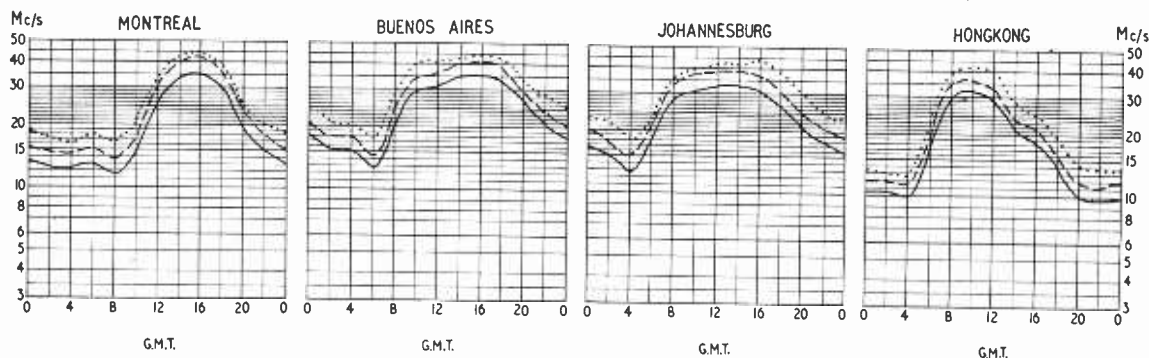

THE full curves given here indicate the highest frequencies likely to be usable at any time of the day or night for reliable communications over four long-distance paths from this country during November.

Broken-line curves give the highest frequencies that will sustain a partial service throughout the same period.

- FREQUENCY BELOW WHICH COMMUNICATION SHOULD BE POSSIBLE FOR 25% OF THE TOTAL TIME
- - - - PREDICTED AVERAGE MAXIMUM USABLE FREQUENCY
- FREQUENCY BELOW WHICH COMMUNICATION SHOULD BE POSSIBLE ON ALL UNDISTURBED DAYS

Car Radio Design

—OR RECEPTION UNDER DIFFICULTIES

By F. GRIMM,* A.M.Brit.I.R.E.

THERE is no doubt that car radio is gaining in popularity. At the same time the various new advances in electronics appear to have more direct influence on the car receiver than on other sound broadcast sets, and consequently the design of this type of equipment is undergoing a considerable change.

To understand better the various problems connected with the design, manufacture and operation of car radios, we have to survey the situation existing at the moment.

In Great Britain the car radio has always been considered by the automobile manufacturers as a non-essential accessory, and meagre provisions have been made in the car for installing the receiver, with its speaker and aerial. If the car radio has been catered for in the layout of the vehicle at all, it has been done somewhat grudgingly. This has resulted in the receiver having the curious dimensions of 2in×7in×7in. And this shape, which has been more or less forced on the car radio manufacturers, is far from ideal. The fact that the designers have managed to include a complete sound receiver into this shape is in itself a tribute to their ingenuity. Nevertheless, such a restriction makes for difficult engineering, which must be reflected in the eventual cost to the customer. The situation is particularly unfortunate with printed-circuit technique, where it is important that as much of the circuitry as possible should be assembled as one unit to obtain the maximum saving in assembly time and consequent cost.

The power supply unit, when separate from the receiver, is accommodated in the car wherever space can be found for it, and no great harm results. However, the speaker, the siting of which can completely spoil the sound reproduction of any set,

is fitted in cars in a variety of positions ranging from the parcel shelf (facing downwards) to the panels next to the passengers' feet. The acoustic performance of the speaker varies accordingly.

The next important consideration for car radios is the elimination of ignition interference. Only a certain degree of immunity from this can be built into the receiver itself; for the rest we must rely on the soundness of the electrical wiring and bonding in the car. If one realizes that in the confines of a small vehicle there is a built-in system for the generation of sparks of several thousands of volts and a radio receiver having a sensitivity of 1 microvolt, only then can one appreciate the magnitude of the problem. This situation is not helped by some cars having to rely on the earth return of the ignition system being through the car transmission and rear axle. It is interesting to observe that if the wiring of a car is rearranged to allow a car radio to operate satisfactorily, little trouble is experienced with the Post Office radiation test, which every type of car must pass. Usually it is a question of rearranging the run of wires in the car and ensuring sound earth returns both for the l.t. and h.t. circuits of the ignition system; no additional expense, but only practical experience, need necessarily be involved. If these precautions are neglected, additional expensive suppressor resistors may be required, if not for the receiver then to enable the car to pass the P.O. interference test.

To come to the car radio itself. A car radio is basically a broadcast receiver covering the usual bands. It does, however, differ from the ordinary indoor domestic sound receiver in several important respects.

A car radio relies for its signal collection on a small capacitive aerial with poor effective height. The signal is transmitted from the aerial to the set through a screened cable having a capacitance comparable in magnitude with the capacitance of the aerial itself. Both of these capacitances can vary with each individual installation.

These factors more or less dictate the form of the input circuit. The low level of signal picked up makes it desirable to use a tuned r.f. stage. The second reason for using such a stage, and it may be the more important one, is the need for an extremely good a.g.c. characteristic, which only an additional controlled valve will give. A permeability tuner will allow for a closer coupling of the aerial to the tuned circuit. Also it makes for a substantially flat aerial gain characteristic over the band covered. An aerial trimmer, which compensates for the previously mentioned variations in aerial and cable capacitance, is made part of the input circuit. This is in contrast to capacitance tuning, where a loss due to cable capacitance must be accepted and where the gain varies over the covered waveband. The gain variation is not necessarily as serious a

* Pye Telecommunications, Ltd.

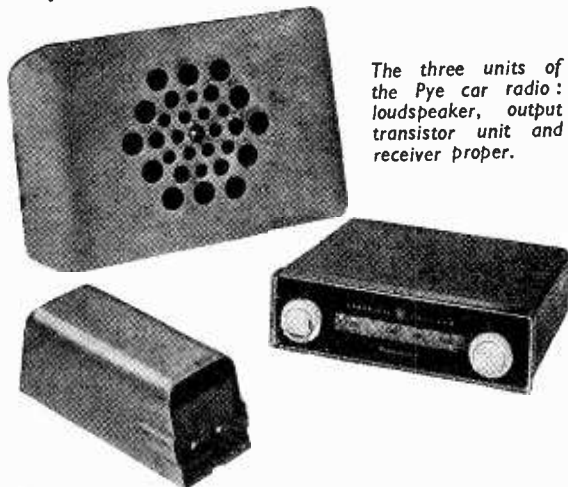

The three units of the Pye car radio: loudspeaker, output transistor unit and receiver proper.

handicap as it may seem, as the signal-to-noise ratio is kept almost constant over the band.

The a.g.c. system of a car radio must be very efficient, as already mentioned, and it is advisable to approximately halve the holding time constant, as compared with ordinary broadcast sets, as variations in signal level are not mainly due to the propagation characteristics of the signal but to the rapid movement of the car in heavily screened localities. It is not always possible to obtain a good a.g.c. characteristic in the signal and i.f. stages, particularly if no r.f. amplification is used. In this case a satisfactory performance can be achieved by applying part of the a.g.c. voltage to the audio amplifier valve. One thing which may be of benefit to listeners would be a certain degree of volume compression. Normally one is forced continually to readjust the volume control while driving, particularly when listening to variety programmes. If the volume control is adjusted for comfortable listening to speech, the following burst of music can at times be startling. After turning down the volume control, the speech is hardly intelligible over the engine noise.

The fact that a car radio operates from the car batteries leads to the next difference from an ordinary broadcast set. We must have a means of converting the l.t. to h.t. of required level for valve operation. This has been accomplished fairly successfully, though not very efficiently, by means of a vibrator. The problem of vibrator hash has also been solved; the mechanical noise accompanying the operation of the vibrator is to a great extent still with us.

Screening and Filtering

To eliminate ignition interference pick-up, the complete receiver must be fully screened and all leads entering or leaving the set must be suitably filtered and decoupled. The aerial lead has a "TT" or inverted "L" low-pass filter in front of the tuned circuit and possibly another one is placed between the tuned circuit and the signal grid of the first valve. Only a certain degree of filtering can be achieved. For the rest, careful siting of the aerial itself and the screening properties of the bonnet have to be relied upon. In this connection an interesting problem is created by cars having plastic bodies.

In the battery lead a low-pass filter must be incorporated. Here the comparatively heavy battery current is something of a problem. Much ingenuity has been shown in the design of filter coils to obtain high inductance, low capacitance and resistance in the smallest possible space and as cheaply as possible. Generally all rules of screening have to be scrupulously observed if the degree of filtering necessary is to be achieved economically. The trouble here is that some of the causes of coupling of interference into the signal circuits become obvious only when the solution is found experimentally.

The third means of interference entering the set is by direct induction from interference fields present inside the car. Good overall earthing of all covers is essential, and even then it may be advisable to double screen all the r.f. coils.

Strong magnetic fields present in some cars will induce circulating currents in the metal case of the receiver. Depending on the conductivity of the

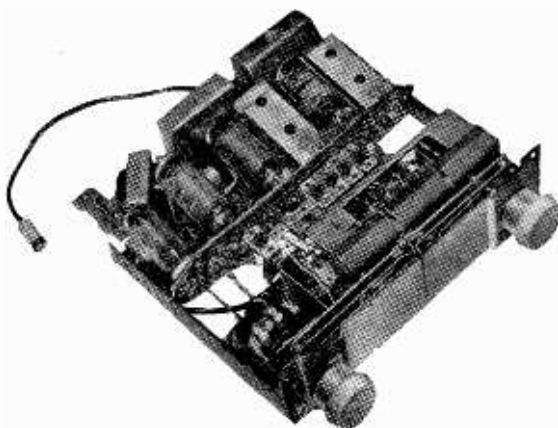

Main chassis of the Pye transistorized car radio.

screening material, these currents may induce interference into internal wiring loops or set up earth potentials between various earth points in the circuitry. If the set comprises several units, interference may be experienced as a result of earth current loops formed by the screen of the interconnecting cables. All these contingencies must be borne in mind during design.

The situation as described was prevailing up to about a year ago, when the advent of transistors made its impact on car radio design.

The car radio has been one of the first amongst the various types of sound receivers to benefit from transistorization, as the power supply has to be taken from the vehicle's low-voltage battery. The disappearance of the h.t. supply unit will partially compensate for the more costly transistors.

Although it is possible to build a fully transistorized car radio it has not yet proved to be either practical or advisable at a reasonable cost. One of the intermediate steps was to use one or more transistors to replace the vibrator. This, coupled with the use of a transistor output stage, proved to be quite an attractive expedient. A bulky power unit was replaced by a very compact one, as h.t. was required only to operate the r.f., i.f. and a.f. valve stages.

The current consumption of this set was about half that of a conventional receiver. The cost, however, was quite high.

Considerable quantities of sets embodying these features were made and marketed prior to the appearance of the more advanced design which eliminates the power unit altogether by making use of valves operating directly off 12V h.t. These valves—to some extent the valve manufacturers' answer to the transistor—give useful gains at the low-voltage h.t. supply.

The circuit of this later design (Pye Type TCR1000) has a fairly conventional appearance. An r.f. stage is followed by a frequency changer which, in turn, is followed by an i.f. amplifier stage. Detection and a.g.c. are accomplished by separate thermionic diodes. The a.f. voltage is first amplified by a triode and then passes to a tetrode power amplifier capable of driving the Class A output transistor stage.

Two points peculiar to the circuit are the grid-leak biasing of the frequency changer and i.f.

amplifier and the slight positive bias applied to r.f., frequency changer and i.f. stages.

The problem of positive or negative electrical earth systems of vehicles presented itself, and to cater for both it was found advisable to "float" the whole set and provide only one point for earthing which can be switched as required. The already serious ignition interference troubles were not helped by this feature and various stratagems had to be employed to overcome the problem. For instance, the input circuit is earthed to the chassis directly and both the negative and the positive "h.t." lines are carefully r.f. and a.f. decoupled to the chassis. All the filtering is placed in front of the supply voltage change-over point to ensure satisfactory filtering both on negative and positive earth systems.

There are several pitfalls which have to be avoided with this construction. For example, the power unit in a conventional receiver provides a considerable amount of filtering, both r.f. and a.f. This filtering has still to be built into a 12V "h.t." set to attain satisfactory working in all makes and types of car.

The inferior linearity of the valves used—a price to be paid for 12V working—makes a higher degree of interference suppression imperative. As a matter of fact, the interference level allowed to reach the signal grid of the first valve must be 40dB lower for the same degree of suppression as with a conventional set. This is because of the possibility of the cross-modulation of noise and signal which could occur. Cross-modulation itself may not be as objectionable as the generation of spurious responses in the presence of strong signals due to the same cause. Fortunately the cure for this trouble is quite simple—reduce the length of the aerial.

The output transistor must be stabilized against thermal run-away to a temperature of at least 120°F. The thermal stability is not only governed by heat generation at the collector junction, the rate of heat transfer from junction to surrounding space and the value of the circuit elements, but also by the collector leakage current and current amplification factor (α). These last two parameters vary widely and in any calculation the most unfavourable limits for both of them should be used in place of the mean design values. Also in any confirmatory experiments one should use transistors having these unfavourable combinations of parameters. The danger of overheating curiously does not arise primarily in hot climates, where presumably not many people will switch on a car radio in a car in which the air temperature has reached 120°F, but in winter when the heater is used. Even when the set is not in the direct hot air stream, pockets of hot air can form under the fascia panel where the car radio is usually accommodated.

To allow for good heat dissipation even in these extreme circumstances, an adequate heat sink must be used. In order to achieve this as well as to keep the transistor away from the hot valves, it has been found advisable to use a separate output unit housing the transistor and its associated components.

Another point with Class A amplifiers is to make sure that the transistor works into its proper load, as otherwise distortion will occur due to shift of working point. When connecting more than one loudspeaker, it is necessary to ensure that the load is always near the nominal value. This effect

is not so serious with valves because of their inferior efficiency.

Serious trouble can be caused by sets working into an open circuit. High back e.m.f. can develop which may damage the transistor. This is equivalent to "flash-over" occurring in an output valve under similar circumstances.

All these difficulties have been overcome and now it is possible to make any form of set, broadcast band receiver, combined a.m./f.m., and short-wave set, using this combination of transistor and 12V valves. Attempts have been made to operate on 6 volts as well, and although reasonable results have been obtained, it is felt that this is pushing the valves too hard. The solution to this problem lies possibly in an additional rechargeable battery or small rotary converter. Still, the field is open, and the designer of 6-volt sets has a wide range of possibilities in front of him.

The question may be asked whether these hybrid receivers are a passing phase between the valve set and the fully transistorized set, and, if they are a passing phase, how long will it last?

A fully transistorized set will have only a few additional advantages over the hybrid set. It may be more compact and its power consumption will be about one half of the hybrid set; also it may be more robust and have the inherent long life of transistors instead of the limited one of valves. How much these advantages are worth in a car radio is questionable.*

Space in a car is difficult, but not extremely so, and battery consumption is perhaps not as important with a portable set. The only advantage which may prove attractive is the possibility of using such a transistor set as a combination car radio and portable, as has been done in other countries.

Generally a valve set still gives a better performance than a transistor set using commercially available transistors; in particular the signal-to-noise ratio is considerably higher with valve r.f. amplifier and frequency-changer stages.

Production experience has now proved that the above described hybrid sets are a sound engineering and economic proposition. It has been possible with this construction to keep the price at least comparable with, or even better than, conventionally powered receivers. The absence of vibrator noise, low consumption, small size and greater inherent reliability are the advantages which this new development brings.

* We think they are worth quite a lot—Ed.

QUIZ

DO you know the relationship between m.k.s. and c.g.s. units?

The colour code for fuses?

What external resistance is needed in series with a 100-volt meter (1,000 ohms/V) to read voltages up to 500?

The length of the dipole for a Band II aerial?

The value of a resistor with a yellow body, a violet end and an orange spot? or

The base connections for a LZ329 valve?

If the answers to any of these questions evade you then you should get a copy of the 1959 *Wireless World* Diary. It includes, in addition to the usual week-at-an-opening diary pages, an 80-page reference section giving in tabloid form much of the technical and general information one so often requires but is seldom readily available. It costs 6s 3d (leather) or 4s 6d (Rexine), including purchase tax. Overseas prices are, respectively, 5s 3d and 3s 9d, plus 4d postage.

The ARR3 Sonobuoy Receiver

Conversion for V.H.F./F.M. Broadcast Reception

By CAPT. R. V. TAYLOR*

THE R2A/ARR3 is an American "Sonobuoy" receiver covering the band 60-72Mc/s. It is housed in a neat metal cabinet and is available on the surplus market at a most modest price for a 13-valve receiver. In its unmodified form it lacks a power supply but room can be found on the chassis for the necessary components to make it a complete, self-contained f.m. receiver. An older version, the R2/ARR3, is also available; it has no intercommunication facility but is otherwise an identical set.

The receiver uses 12SG7 r.f. pentodes for the two r.f. amplifiers, mixer, local oscillator and two i.f. amplifiers. The remaining stages also use valves with 12-volt heaters; the Foster-Seeley discriminator a 12H6; two a.f. stages, 12SQ7 and 12A6; two a.f.c. valves and limiter 12SH7s, and the tuning indicator a 1629. As can be seen from the circuit diagram (Fig. 1) the design contains little that is unusual. The grid circuit of V_1 is naturally broad band and is tuned only by a trimmer tapped down the coil. The input impedance of a 12SG7 is low at 90Mc/s and damps the tuned circuit heavily. The grid circuit of V_2 is tuned by a section of the

three-gang variable capacitor. This stage shares the anode decoupling capacitor of the local oscillator and is inductively coupled, with the oscillator output, to the grid of the mixer. The mixer and local oscillator are tuned by the two remaining sections of the three-gang capacitor. The local oscillator operates below the signal frequency. The i.f. is 5Mc/s.

The local oscillator circuit is quite conventional except for the two connections to the reactance modulator and the phase-shifting valve. An r.f. voltage is taken from the oscillator cathode by a 5-pF capacitor to the grid of the phase shifter (V_9). This valve derives its grid-control voltage from the discriminator via a low-pass filter. A voltage-dividing circuit, connected across the h.t. supply, maintains the cathode at a constant positive voltage. The anode load resistor (R_{132}) is very low compared with the anode impedance. The output of this valve is coupled by a 50-pF capacitor to the grid of the reactance valve (V_{10}). The r.f. voltage at the grid of the reactance valve will be approximately 180° out of phase with the phase-shifter grid voltage, the difference from 180° depending on the control-grid voltage of the phase-shifter (which is derived

* Royal Corps of Signals.

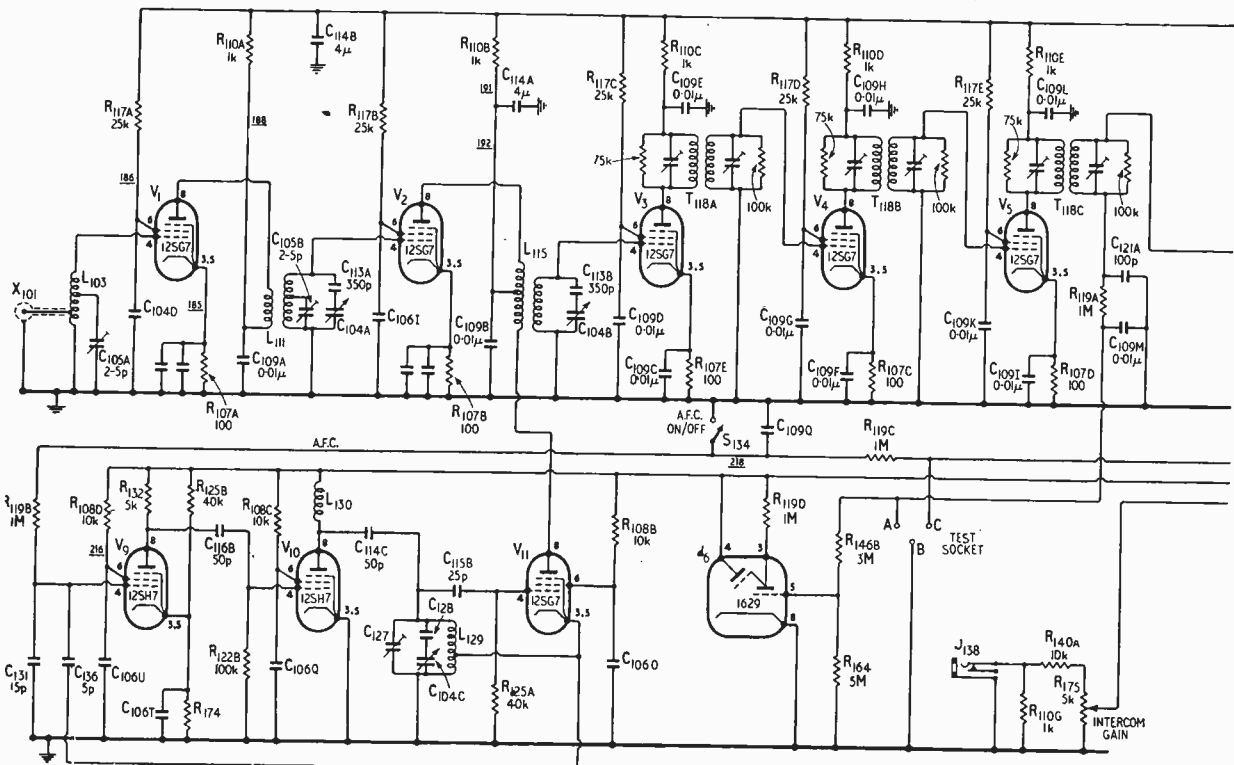

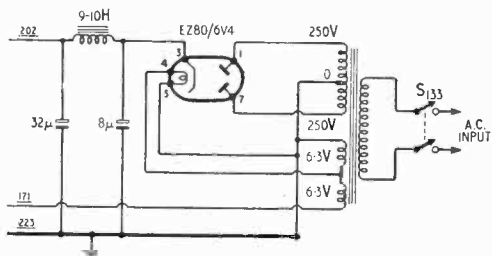
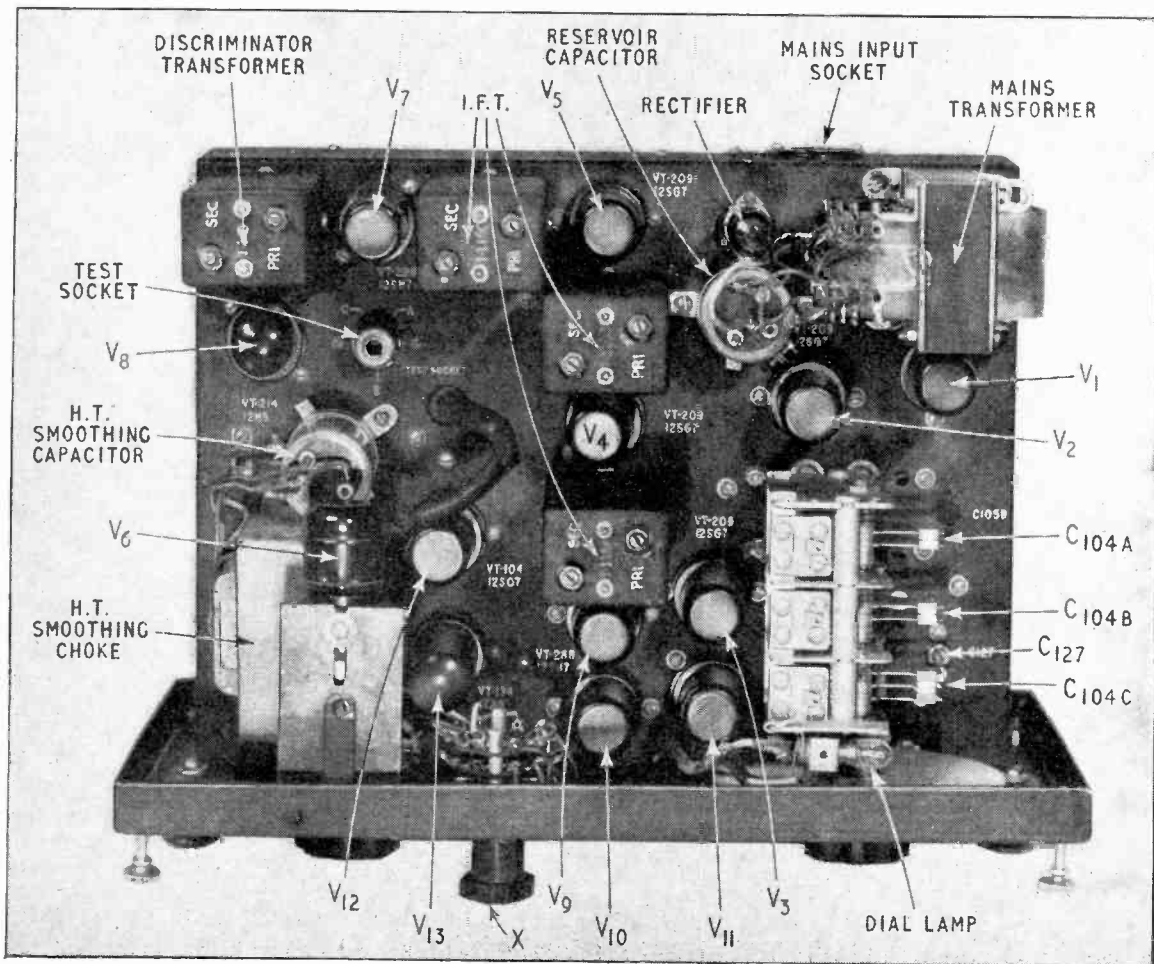

Fig. 2. Power supply circuit and connections to existing leads in the receiver.

A replacement type mains transformer with two 6.3-volt l.t. windings can be mounted on the right-hand rear corner of the chassis. The receiver l.t. consumption is about 2A and the rectifier requires 0.6A at 6.3V. A transformer rated at 6.3V, 2A and 6.3V, 2.5A is satisfactory. The two 6.3-volt windings must be connected in series in the correct sense to give the required 12.6 volts. The correct inter-connection is best found experimentally before the transformer is fitted. An h.t. supply of 250V, 80-90mA will be required. A B9A base for an

EZ80/6V4 rectifier is fitted next to the transformer, in the space left by the removal of C_{114A} . A 9- to 10-H, 100-mA choke is mounted above the chassis between the 12H6 and the space left by the old output transformer. A substitute output transformer is mounted below the chassis where the group board carrying the 10kΩ and 500Ω resistors was previously fixed. Two of the jacks previously removed are replaced, one in the lower original position and one where the intercommunication gain control was fitted. The new electrolytic capacitors can be mounted below the chassis near the mains transformer, or above the chassis in any convenient spaces. Between them they should provide 8μF for the reservoir and 32μF for the filter of the h.t. supply and 4μF to replace C_{114A} which was part of the filter in the h.t. supply to the local oscillator.

The newly fitted power supply components should now be wired up, following the circuit shown in Fig. 2. The power supply switch (S_{133}) is used to switch the mains lead to the power transformer. One side of the series-connected heater windings is earthed and the other is taken to lead 171. The leads from the electrolytic capacitors to the smoothing choke are laced to the mains lead to the switch to make a
(Continued on page 547)



Top view of the chassis after modification. Mains transformer, rectifier and reservoir capacitor are accommodated in the right-hand rear corner. N.B.: I.F.T.-primary trimmers are "live."

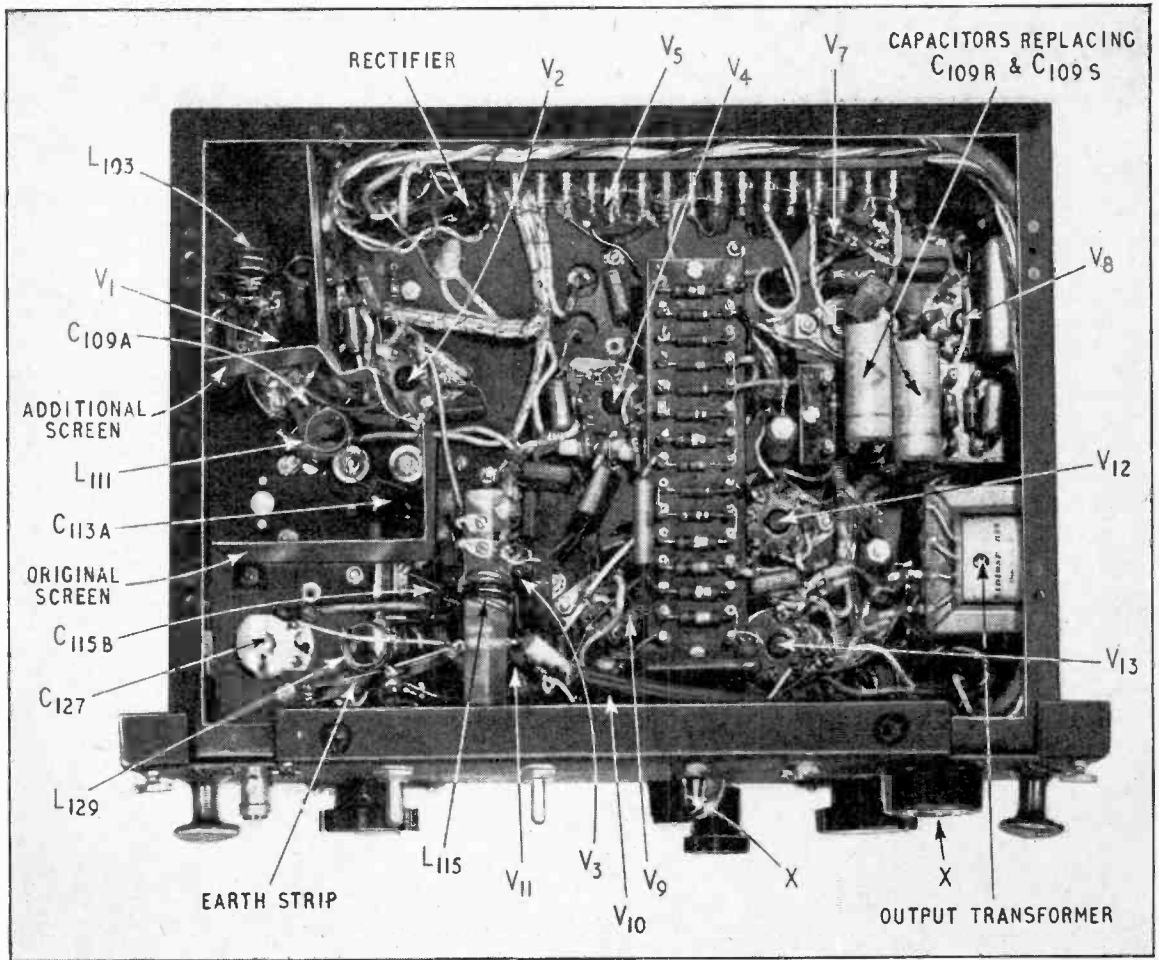

Under-chassis view after modification. Position of output transformer, extra r.f. screening and general lay-out are shown.

neat job. The other power supply leads can be tucked into the angle at the bottom of the edge of the chassis.

The output transformer primary is connected to the 12A6 anode and h.t. line, its secondary being taken to one of the jacks, for connection to an external loudspeaker. The 12A6 cathode-bias resistor is 600Ω which is a high value for the valve, but it keeps the h.t. current within reasonable bounds and it need not be changed. A screened lead is taken from the discriminator output (where lead 230 joins the group board) to the other jack.

The latter jack now allows the receiver to be used as a tuner together with an amplifier. C_{109R} and C_{109S} are removed and replaced by $0.1\mu F$ tubular paper components. These details are given in Fig. 3.

The 12SQ7 a.f. stage will operate satisfactorily without modification; but quality of reproduction might be improved by adding a cathode-bias resistor of $3.3k\Omega$ and a $25\mu F$ by-pass capacitor. If the R2A version is being modified the "earthy" end of R_{119K} (on group board between C_{109R} and C_{109S}) must be connected to chassis.

The receiver should now be checked, using a signal generator if possible, and any faults cleared before the r.f. end is modified. It will be realized that the valves used in the r.f. stages of this receiver

are not the best now available for frequencies up to $100Mc/s$, but with a little rearrangement to reduce stray capacitance and shorten leads, a useful gain can be achieved. A single EF91 could be used to replace the two r.f. amplifiers and another as the mixer, but this would entail a considerable amount of stripping and rebuilding. It is simpler to use the

Fig. 3. Modifications to the a.f. stages are shown here. Values of new components only are given.

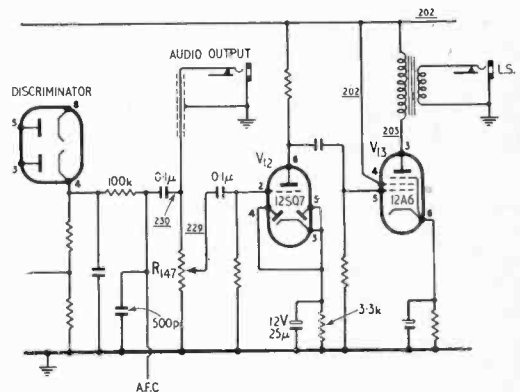

existing design as far as is possible.

Start by removing L_{103} and L_{111} , C_{105A} , C_{105B} , C_{113A} and its bracket. More screening will be required to prevent instability at the higher frequencies at which the set is now to be used. To effect this, a screen, the same depth as the existing one, is placed roughly parallel to the front panel passing over the valveholders of V_1 and V_2 , so as to isolate the anode of V_1 and the grid of V_2 from the remaining pins of the valveholders. This screen cannot be straight, a couple of slight bends over V_1 and a 45° bend over V_2 will allow the screen to be made in one piece. Thin copper is the best material as the screen can then be soldered to conveniently placed earth tags. A second screen is required between the two r.f. amplifiers. This runs parallel to the side of the chassis, midway between the two valveholders, and is soldered to the earth tag already in place and to the first screen where it meets it. The amount of work involved can be reduced by first making paper templates and then transferring these to the sheet metal. The locations of these screens can be seen in the photograph of the underside of the receiver.

The r.f. stages can now be rewired where necessary. Fig. 4 shows the new circuit but most of the changes are in layout, not in circuitry. Stray capacitance must be drastically reduced to the absolute minimum. L_{103} is replaced by a 4-turn coil of the same wire and diameter. This coil is damped and tuned by the input impedance of the first r.f. amplifier. The aerial is tapped one turn from the bottom. The coil is supported where it is connected to earth, aerial, and the grid of V_1 and a coil former is not required. It is placed so that the leads to it are as short as possible. All the 500-pF decoupling capacitors associated with V_1 are taken to the same earth tag on the valveholder.

L_{111} is next replaced by a similar coil of $2\frac{1}{2}$ turns; before this is fitted in place, the capacitor C_{109A} decoupling the anode of V_1 (a moulded $0.01\mu\text{F}$ type) and the lead to it (188) are re-sited so that the high-potential end of the capacitor is close to the anode pin of V_1 . The anode coupling coil of $1\frac{1}{2}$ turns (insulated in the original sleeving) is interwound at the earthy end of the $2\frac{1}{2}$ -turn coil. The two coils are soldered in place over the decoupling capacitor, about half an inch above it, with their common axis at right angles to the chassis. A thermal shunt should be used to prevent melting of the sleeving during this operation. The grid of the second r.f. amplifier can now be tapped into the coil about half a turn from the top. The top of the coil is connected to the 350-pF capacitor C_{113A} in series with the first section of the three-gang tuning capacitor. No trimmer is needed as the coil can be pulled out or compressed as required when aligning the r.f. stages. A 500-pF moulded capacitor is taken from the cathode of V_2 to the earthed end of the coil. A convenient point for the necessary earth tag is just at the end of C_{109A} , the $0.01\mu\text{F}$ anode decoupling capacitor.

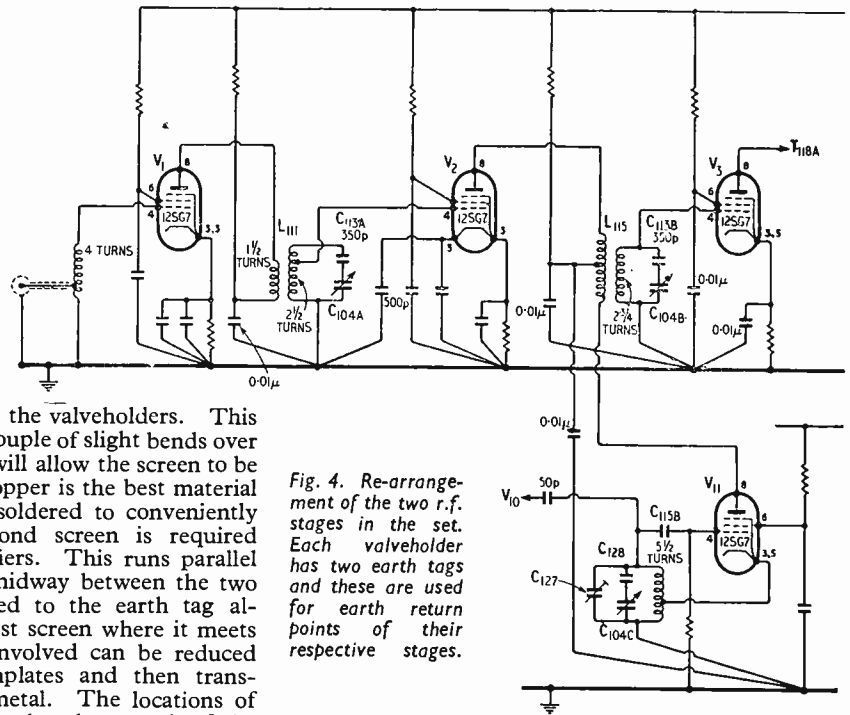

Fig. 4. Re-arrangement of the two r.f. stages in the set. Each valveholder has two earth tags and these are used for earth return points of their respective stages.

The mixer grid coil L_{115} is now re-wound to $2\frac{3}{4}$ turns; the tag fixed to the coil former at the grid end of the coil is removed and a wire taken straight from the end of the coil to the grid tag on the valveholder. The 350-pF capacitor C_{113B} is re-sited on the tag of the centre section of the tuning capacitor so that the shortest possible connection can be made direct to the grid of V_3 . The braid leads earthing the rotor of the centre section of the tuning condenser to the chassis are replaced by leads direct to the earth tag on the mixer valveholder.

The oscillator tuned circuit in its original form is earthed to the chassis at several points. This is no longer satisfactory at the new higher frequencies to be covered. To prevent instability a flat strip of copper about a quarter of an inch wide is taken from the earth tag on the oscillator valveholder (at the mixer side) to the rotor earth contacts on the end section of the tuning capacitor (C_{104C}). This strip is then bent and passed back through a hole in the chassis to earth the rotor of C_{127} . The earth tag on C_{127} must be moved through 120° to make this lead as short as possible. The strip should be insulated by sleeving where it passes through holes in the chassis.

Half a turn is then removed from the bottom of L_{129} and the new end of the coil soldered to the earth strip. To make these operations easier both L_{129} and C_{127} should be removed. At the same time the tags and screws retaining them at either end of the coil should be removed. One turn is taken off the top end of the coil, which is reconnected to C_{127} and the 500-pF capacitor C_{128} in series with the end section of the tuning condenser, C_{104C} . An extra $0.01\mu\text{F}$ mica decoupling capacitor should be connected from the h.t. positive end of the oscillator anode coil to the earth tag on the oscillator valveholder. C_{127} is replaced and set to about 5° in mesh. The r.f. stages are now ready for alignment.

With a signal generator tuned to the h.f. end of the band and connected to the anode coil of V_2 (remembering that this is at h.t. potential), adjust C_{127} until the signal is heard with the main tuning capacitor at nearly minimum capacity. Check that the oscillator is on the low-frequency side of the signal by increasing the capacity of C_{127} . Connect the signal generator to the aerial socket and adjust C_{105A} and the second r.f. amplifier grid coil for maximum deflection of the tuning indicator. It is assumed that the i.f. stages are not in need of re-alignment or were re-aligned when the receiver was checked before modification of the front end. The i.f. transformer-primary trimmers are "live" to h.t. positive—an insulated trimming tool is recommended!

Should it be found that all three B.B.C. programmes cannot be tuned in, C_{127} can be re-adjusted so that the Home Service is received with the tuning capacitor about 5° from the minimum capacity position. As in any one region the three programmes lie inside a band of less than 5Mc/s it should now be possible to receive all three.

The existing tuning scale can be moved round through 180° so that a blank black disc appears in

the tuning window. The paint can then be scratched away to make suitable calibration markings. Alternatively, the black paint can be removed with paint remover and Indian ink used for the scale calibration.

No mention of a de-emphasis circuit has so far been made. A time constant of $50\mu\text{sec}$ is required for this circuit and the receiver is modified as follows. Remove the 50-k Ω resistor R_{149} from pin 4 of the 12H6 to test point C and replace it by one of 100k Ω . Connect a 500-pF capacitor across the tags of test points B and C. This will have no effect upon the a.f.c. but will provide the required top cut.

The i.f. tuned circuits may be re-aligned, if desired, to give greater bandwidth, as long as the limiter grid and anode tuned circuits are kept at the centre frequency. No measurements have been carried out but the bandwidth appears to be more than adequate as originally aligned on the centre frequency of 5Mc/s.

The modified receiver compares most favourably with the average broadcast receiver, sensitivity is good and signal-to-noise ratio high. Drift is only slight while warming up and the a.f.c. is effective except on very weak signals.

LETTERS TO THE EDITOR

The Editor does not necessarily endorse the opinions expressed by his correspondents.

Stereo Under Fire

IT is about three years since you quoted me in your columns as having said that the success of the push-pull electrostatic speaker would depend, not on perfection, but on facility and cost of manufacture, and versatility and reliability in use. The moving coil still seems to reign supreme. I wonder if I may issue a similar warning about stereo?

The trouble with stereo is that it was launched on the public six months too soon; too many fantastic claims have been made about it; and beautiful, hand-made, precision instrument-type magnetic pickups have been demonstrated, and eulogised in the press, *before* production runs and life tests have been made, and before supplies are available to the public. The result is that dealers and would-be buyers are being driven round the bend with an uncertain and obscure vista before them when they reach the straight.

We noticed the red light at the Audio Fair in April 1958 when we found that, after carefully balancing our two channels before the show commenced, the output from each side varied by as much as 6dB when the room was full of people, and temperature and humidity went up. (Any talk about "matched" speakers under such conditions is absolute piffle.)

More red lights appeared in the Audio Hall during the recent Radio Show, when one firm informed me that six stereo pickups had packed up in their hot demonstration room during the first few days.

Then, only last week, a well-known maker of magnetic pickups informed me that his commercial stereo pickup will be a ceramic type. If this is not a red light I must be colour blind. After paying higher prices for superior performance from magnetic pickups during many years, are we to lower our standards for stereo; or pretend that the same standards do not apply; or just admit meekly that we were wrong?

We are told that stereo pickups can be used with

safety on ordinary discs, but the voltage output is much lower, and the quality of reproduction—type for type—on single channel is definitely inferior, with the magnetic and crystal types we have so far tested. The basic fact is that a wide-response stereo pickup is more delicate and complicated than a mono type, and its expectation of a trouble-free life is correspondingly lower.

As things are, it would be extremely foolish to discard our high-class single-channel pickups, amplifiers and loudspeakers in favour of a stereo system, and the high quality of thousands of existing records must still be recognized. Stereo should be accepted as a possible extra channel to give us greater realism when it comes off; so far it often misses the mark, and it is certainly much more difficult than single channel to get right and keep right. The change to stereo can then be a gradual process instead of a jump.

First-class single-channel results will always surpass second-rate stereo, and we don't want to hear any more trains.

As regards loudspeakers, one good one and one mediocre one sound better than two mediocre ones, whether on stereo or single-channel input. This is just a law of nature, which no fiddle-faddle with recording can alter.

G. A. BRIGGS,
Wharfedale Wireless Works, Ltd.

Idle, Bradford, Yorks.

I FEEL Free Grid's approach (October issue) to the problem of the comparison of stereophonic and single-channel reproduction does not go far enough. Most of us have a certain sum of money to spend so we should compare the results to be obtained by spending equal sums on either system. It therefore follows that no system of simple switching can result in a fair comparison, quite apart from a number of technical considerations.

(a) Present-day stereo records are on the average not of such good quality as single-channel ones.

(b) Neither channel will in itself be a properly balanced signal though the sum of the two might be.

(c) Stereo pickups with few exceptions are at present inferior from the fidelity viewpoint, both when used on stereo records, or if suitable, on single channel ones.

(d) It is to be expected (see James Moir's article in the June issue) that there will be an optimum position for two speakers used for stereo and a different one for a single speaker. It is by no means impossible that the stereo pair used as a pair on single-channel reproduction could sound better than one of them.

(e) With stereo there is less prospect of intermodulation distortion arising in amplifier or speaker. Since bass notes do not give rise to stereo effects it is possible deliberately to arrange the recording with the object of putting the low frequencies in the channel carrying at that instant the lesser high-frequency signal. Even where this is not done there must be some improvement because the bass is likely to divide equally.

The unsuspecting public is, however, having something even worse perpetrated upon it. One of the test records now in use contains a single channel repeat of some music previously (and subsequently) played stereophonically. This artifice suffers from every one of the objections previously mentioned to the greatest possible degree since it is a loud passage containing many low-frequency and extreme high-frequency notes (cymbal clashes). And there is another objection. With one channel in use there is a 6dB drop in volume. Immediately the reproduction seems poor and "thin"—but then, no doubt, without a compensated type of volume control, this effect would arise with any equipment.

If one must compare stereo and single channel on the same equipment then it might be a little less objectionable simply to destroy the stereo effect by placing the two loudspeakers side by side in the most suitable position.

I cannot, I regret to say, see any prospect of a true comparative demonstration being given. It would require:

(a) Two complete equipments of equal cost.

(b) Stereo and single-channel records of the programme material(s) the prospective customer is interested in, which is much more likely to be music than trains rushing around.

(c) The customer's own room or an identical one, since the listening position is important.

(d) Sufficient time for listener fatigue to set in, which of course will be several hours.

I have yet to hear a really impressive stereo demonstration—I have attended many but I remain unconvinced though I am at a loss to explain why since I enjoy attendance at the live performance in theatre or concert hall. It is not that I am unable to "place" sounds but I must say I never consciously try to place them in ordinary life though a stereo demonstration encourages one to do just that by using the train and the ping pong ball.

Parkstone, Dorset.

L. STREATFIELD.

Improving Interlace

I HAVE read, with interest, P. T. Weston's article (September) on "576 Lines" and the remarks made by your correspondents E. Mansfield and R. J. Newman in the October issue.

It would seem to me that one of the main reasons why we have so much difficulty in this country in obtaining a near perfect interlace is that we are hampered from the outset by the type of frame pulse waveform transmitted. It is acknowledged that in the British system odd and even frames present slightly different voltage conditions to the frame shaping circuits (whether they be simple integrator or a more complex circuit). Would not the answer be for the transmitting authorities to alter the type of frame pulses transmitted so as to incorporate a train of equalizing pulses before and after the frame train on the American pattern? These equalizing pulses

obviate the voltage differences mentioned above and should enable much more satisfactory interlacing to be obtained.

Their effect upon existing receivers would be to produce a few black lines at the bottom of the picture which could easily be removed by altering the preset controls. It would not even be essential for the B.B.C. to change all of their equipment at once, as use of the present equipment would simply produce slight vertical shift together with a return to present interlace standards.

For the future I should like to see a radical departure from our present standards and that when Band 5 opens we have at least 819 lines with sufficient bandwidth to give first-class definition together with space for a colour sub-carrier when required.

Newcastle upon Tyne.

D. W. ALDRIDGE.

Norwich Transmitter

I WAS glad to see on page 511 of the October issue that "Diallist" has noticed an "enormous improvement" in the reception of our television station at Norwich since it came on to full power last June. "Diallist" is, however, incorrect in saying that the power of the station had to be reduced shortly after it first came into service. This is not so. Norwich was first opened in February 1955 with a temporary installation of low power. On 1st December 1957 the e.r.p. was partially increased, by agreement with the Belgian Authorities, and on 9th June this year it was further increased to its present full power which varies from 1.3 to 15kW in different directions. The reason why the Belgians were then able to agree to the increased power was that the power of their station at Liège has also been increased.

E. L. E. PAWLEY

British Broadcasting Corporation.

London, W.1.

Shooting the Moon

YOUR contributor "Diallist," writing in the October issue, expressed himself puzzled by the problem of taking pictures of the "dark" side of the moon.

The problem does not exist because there is no dark side to the moon. When people use this misleading expression, they are either ignorant of the facts or intending the word "dark" as a synonym of "unknown" as in the phrase "in darkest Africa." Both Africa and the "dark" side of the moon have more than plenty sunshine.

Since the moon revolves around the earth, the *unknown* side of moon (always turned away from us) enjoys sunlight when it appears black to us (new moon) and is in darkness when it is sunlit to us (full moon). "Diallist's" problem is therefore solved by orbiting during the new-moon period.

As opposed to "Diallist's" imaginary problem, there is a very *real* problem connected with his television rocket. The apparatus, circling round the far side of our natural satellite, would have plenty of light entering its lens but would be in a position where its signal to the earth would be blocked by the moon itself. The carrier would bounce back and scatter into space. As the moon has *no* atmosphere, there would not even be a helpful bending of the carrier path round the surface a little by refraction.

To send a picture to the earth, the rocket would have to orbit a great distance out on the far side of the moon, and to transmit its message when at a slight angle to the earth-moon line.

This would necessitate a telescope on the rocket. The only feasible alternative would be to cram a miniature version of V.E.R.A. into the rocket to radio a *delayed* version of its view after it had emerged from "behind" the moon.

As video-frequency carriers obey roughly the laws of optics, this is, I think, not oversimplifying the problem.

Nottingham.

D. B. PITT.

Waves and Particles

The Paradox of Wave Mechanics

by "CATHODE RAY"

I DON'T know whether the Editor had readers demanding their money back for the March issue containing the article I entitled "Wave Mechanics" on the ground that it didn't really explain wave mechanics, or whether they merely cancelled their subscriptions. The reason I gave for not attempting more than the briefest and roughest outline—actually one paragraph—of wave mechanics itself was that it is so mathematical. Another reason, not given, was that any more about it would certainly have involved phase and group velocities, and for the uninitiated they are quite a tricky subject in themselves. But having, with the Editor's kind cooperation, devoted the last two instalments wholly to them I am full of hope that they may by now be understood. On that basis we ought to be able to go farther, though even now I am not proposing to venture on to the heavily mathematical ground.

But first a quick refresher on phase and group velocities.

Speeds through Space

If a waveform is confined strictly to one frequency, every cycle of it must be identical with every other cycle, so it inevitably extends to infinity in both past and future, and no cycle is distinguishable from any other. It cannot therefore be used to convey any intelligence. One can't even be sure that the observed speed of its phase pattern through space or along a line (i.e., its phase velocity, v_p) is the speed of any real thing such as energy. A signal waveform necessitates more than one frequency, and the sharper and clearer the signal the more frequencies. If whatever carries the waves from A to B—the medium—treats all frequencies alike, well and good. The signals arrive in the same condition as they were dispatched, and they travel at the same rate (v_p) as the sine waves of which they are composed. But if v_p varies with frequency, the rate at which the signal waveform or "envelope" travels (i.e., the group velocity, v_g) may be quite different from v_p . This doesn't much matter, so long as v_g is the same at all frequencies. It can be, even when v_p varies; but more often v_g varies with frequency, in which case the different parts of the signal travel at different speeds, and on a long run that may change its waveform so much that it is unrecognizable. In technical terms, it has been subject to dispersion. (What the recipient calls it is of course another matter!)

It is amazing until one examines it, as we did, that v_p can surpass the "speed of light" (c), right up to infinity if need be. Meanwhile v_g is much less and may even be negative. It is most important in what follows that we visualize this difference between phase and group velocities. I know it is difficult enough to visualize a stationary signal waveform such as a single pulse being made of continuous sine waves of different frequencies, even if the rules allow an infinite number of them; and it really is

quite hard to see them hurrying along at assorted high speeds and making their resultant signal waveform travel at some other speed and at the same time gradually disintegrate. The divergent speeds (but not the disintegration) can be studied with the help of two combs, if their tooth spacings are unequal, by sliding one past the other.

We pursued this phenomenon through waveguides and carcinotrons, along telephone cables, aloft in the ionosphere, alongside light through prisms and with supersonic sound through the air. If you were enthusiastic enough you may even have pursued it across the lake with ripples. I emphasize this ubiquity, so that you may not be overcome with astonishment at the idea of transferring this whole theory bodily to the realm of particle structure. Even so, it may seem quite an odd thing to do. But in fact it wasn't just a freak of fancy but a very bold and imaginative way of responding to the results of experiments which showed that very small particles—in particular, electrons—behave in some respects as if they weren't really particles at all, or at least not particles as we think they ought to be. The earlier classical experiments on electrons showed them to have a definite measurable mass and a definite measurable electric charge, both of which are given to several places of decimals in any book of physical tables. Although electrons are too small to be seen directly, their individual impacts on a suitable screen can be observed and counted. And although there was no way of discovering their shape, at least an approximate size was determined, their radius being estimated at about 10^{-13} cm. One tended, then, to visualize them as incredibly small spheres. This view was encouraged by the Bohr picture of the atom, in which the electrons moved in orbits around the nucleus like planets around the sun.

Electron Behaviour

It was evident even then, however, that this analogy was not perfect. For one thing, according to classical theory an electric charge revolving at high speed in this way would radiate energy continuously and (unless replenished equally continuously in some way unknown) would inevitably spiral down into the nucleus. So every atom in the universe would collapse in a small fraction of a second! By contrast, innumerable and most diverse experiments showed that each electron had only a limited number of fixed orbits in which it could move, which it did stably without energy change, unless a chunk of energy of the right size came along and lifted it suddenly into one of the larger orbits, from which it tended to descend again by re-radiating the same quantum of energy.

For years this strange but highly beneficial behaviour of electrons was a perplexing mystery that challenged investigation. But it was hardly enough to alter ordinary people's idea of them as something like revolving grains of dust only much smaller and

faster. What really did shake this view to the core (if a view has a core) was the discovery that in at least one respect a beam of electrons behaves exactly like a beam of X-rays, which were known to be electromagnetic waves of very high frequency. Of course, the fact that a man periodically eats, which is exactly what a monkey does, would not justify us in concluding that he was not a man but a monkey. It would be necessary for his behaviour to be monkey-like in some respect inconsistent with humanity before one could entertain serious doubts. Electrons behave in a way that not just superficially resemble waves but actually enables one to determine their wavelength!

The books* explain how the regularly spaced waves of light interact with obstructions having a regular spacing of the same order of magnitude, producing an interference pattern. We can see it in the colour pattern from light shining at a glancing angle on the grooves of a gramophone record. The same thing on a larger scale makes the radiation from an array of spaced dipoles go out in beams at certain angles with gaps between. If the wavelength is known, the angles of maximum and minimum radiation can easily be calculated. Conversely, if the angles are measured the wavelength can be calculated.

Electronic Wavelength

The wavelengths of X-rays are so much shorter than those of light that even the finest manufactured grating is too coarse, but it was found by Laue and his friends in 1912 that the regularly-spaced arrays of atoms themselves in crystalline substances give rise to interference patterns with X-rays. In 1927 G. P. Thomson demonstrated that exactly the same kind of pattern was produced by a stream of electrons, such as one has in a cathode-ray tube. Their wavelength, whatever that might mean, was therefore measurable. It turned out to be inversely proportional to the velocity (v) of the electrons, which is determined by the anode voltage of the c.r.t.† In 1924 de Broglie, the father of wave mechanics, showed that this electronic wavelength (λ) was related to Planck's constant (h) and the mass of an electron (m) thus:

$$\lambda = \frac{h}{mv} \quad \dots \quad (1)$$

This is the basic relationship of wave mechanics, because it connects λ , which is a wave property, with v and m , which are particle properties, by means of h , which you remember, is the small constant relating the frequency f of any e.m. radiation (such as X-rays) and its smallest possible unit or quantum of energy, E:

$$E = hf \quad \dots \quad (2)$$

Although this equation dates much earlier (1900) it too hints at a relationship between waves and particles through h , for f is a wave property but the "photon" of which E is the energy suggests a particle. That in both these curious cases of a wave-and-particle relationship the link is h is surely significant. But we mustn't be so carried away by it as to guess that electrons and photons are two different kinds of the same thing; photons only exist when they are travelling at "the speed of light," whereas

electrons can travel at any speed lower than that, right down to zero.

Very early in elementary radio one learns that the length and frequency of waves are related through their velocity. In elementary radio only one velocity for e.m. waves is known— c , which is constant at nearly 300,000,000 metres/sec. But we have been studying conditions in which the velocity varies with wavelength and frequency, in which case two velocities have to be recognised; phase (v_p) and group (v_g). The one connecting λ and f is v_p , so we write

$$\lambda = \frac{v_p}{f} \quad \dots \quad (3)$$

Now equation (1) gives a relationship between a wavelength and a velocity. Let us assume for the moment that it is a phase velocity; then we can substitute v/f for λ . This yields $v = \sqrt{hf/m}$, and since h and m are constants it means that v varies with f ; in other words, whatever these electron waves are travelling in is dispersive, and therefore there is a group velocity different from the phase velocity. But the group velocity is the speed at which energy travels, and this is presumably the same as v , the speed of the electron. Moreover being something that has position, an electron must be analogous to a wave group rather than to a continuous sine-wave train. So, as v can't be v_p , let us start again on the basis that $v = v_g$.

The fundamental formula for any v_g , as we saw two months ago, is

$$v_g = \frac{df}{d(1/\lambda)} \quad \dots \quad (4)$$

Identifying this v_g with v in (1), in which $1/\lambda$ is mv/h , we get

$$v = \frac{df}{d(1/\lambda)} = \frac{h}{m} \cdot \frac{df}{dv}$$

$$\text{So } \frac{df}{dv} = \frac{m}{h}v$$

$$f = \frac{m}{h} \int v dv$$

$$= \frac{m}{h} \cdot \frac{1}{2}v^2$$

$$= \frac{1}{2}mv^2/h \quad \dots \quad (5)$$

Now $\frac{1}{2}mv^2$ is the kinetic energy of any mass m travelling at velocity v , in this case an electron; and we have just proved that it is equal to hf , where f is the frequency of the waves whose length is λ in (1), assuming that their group velocity is the velocity of the electron. Though we may still be just as much in the dark as to how an electron can be waves, our acceptance of experimental evidence that this is so has led us to the conclusion that the kinetic energy of an electron is related to the frequency of these waves in precisely the same way (2) as the energy of a "particle" of radiation is related to its frequency, namely by the constant factor h . However fantastic the wave picture of an electron may seem, this is too significant a coincidence to ignore.

And of course they didn't ignore it. De Broglie and Schrödinger, I mean. The result was wave

*Such as "X-rays and Crystal Structure," by W. H. and W. L. Bragg (Bell, 1924).

†Up to about 10,000 volts, the velocity is $594\sqrt{V}$ km/sec, where V is the accelerating voltage.

mechanics. Its outstanding success, as I tried to bring out in March, was that the mathematical follow-up from this wave idea led to Schrödinger's famous equation which indicated certain fixed orbits for electrons in atoms, of just the magnitudes that had been found by experiment. Only the word "orbit" had to mean something much less easily visualized than the orbit of a satellite. I'm not going to go into all this atomic stuff again now, but will concentrate on the nature of the electron itself.

Before proceeding with that, however, I have to confess what mathematical readers will have already noticed if their wits were about them, that equation (5) doesn't tell the whole story and—not to put too fine a point on it—I was guilty (along with more distinguished authors) of pulling a fast one. In integrating I added no constant of integration. So we must admit the possibility that $\frac{1}{2}mv^2$ is not the only energy included in hf , and that f may be greater than (5) shows, and that it might not be safe to use it to calculate the phase velocity of an electron (whatever that may mean) in the usual way as $f\lambda$ from (1) and (5), which would make it $v_p/2$. Readers who remember Einstein's law ($E = c^2m$) will break in to exclaim, perhaps in excusably emphatic language, that my admission is a grossly excessive understatement, for $\frac{1}{2}mv^2$ is only the usually minute increase in the electron's total energy (c^2m) due to the relativistic increase in mass m with velocity. Their reminder gives us a clue to the constant of integration. If we make the reasonable assumption that hf in (5) refers only to the energy of movement and that it should be augmented by c^2m_0 (where m_0 is the mass of the electron at rest) then the constant of integration must be c^2m_0/h . The same assumption gives us $hf = c^2m$, and $f = c^2m/h$, and multiplying this by $\lambda = h/mv$ we get $v_p = \lambda f = c^2/v = c^2/v_p$. Here is yet another significant coincidence, for it is exactly the same relationship between v_p and v_g as we found in the remote subject of waveguides! So when an electron is at rest its v_p is infinite, and falls towards c as the electron's velocity rises towards c .

Band Widths

This last long paragraph may have been difficult or even unintelligible to readers who are new to all this; if so, they can skip it, for I only put it in to forestall awkward questions or murmurs of protest from the brighter boys. One thing I would like to carry forward from it, though, is the last sentence, about the very high phase velocity electrons must have. At the moment, no doubt, all three wave properties of electrons— λ , f and v_p —are equally unimaginable. We did get quite "warm" however when we assumed a parallel between the electrons and signals, both of which are more or less clearly located in space and time, in contrast to continuous waves of strictly one frequency which go on and on to infinity in both directions without any identifiable markings. By putting together waves of several different frequencies we can build up wave groups which can be used as signals. The sharper and clearer and briefer a signal pulse, the greater the number and diversity of frequencies needed (Fig. 1). Similarly, the smaller and more clearly defined a particle, the wider the band of waves needed to make it.

Waves of what? Ah, that is the question! Nobody knows. To avoid the embarrassment of having to say "waves of what nobody knows" every

time, it is usual to call them waves of ψ . But while that may increase convenience it doesn't increase knowledge. Just as waves of electric field strength E carry power proportional to E^2 , so that E^2 can be called the intensity of the waves, ψ^2 is the intensity of electron waves, interpreted as the probability of finding an electron there, or the number of electrons per unit volume.

Just as with a "dot" signal, then, we must try to picture an electron as the resultant of a large number of ψ waves streaming through space at incredibly high speeds. Everywhere outside an extremely small volume these waves cancel out, so we may regard the electron as occupying that volume.

We found that when a sharply-defined signal

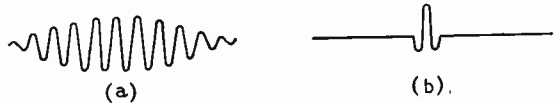

Fig. 1. (a) A signal made up of frequencies within a narrow band spreads over a considerable interval of time. (b) A sharply defined signal spreads over a wide band of frequencies, so its sharpness is lost if it travels through a dispersive medium.

is sent through a dispersive medium, it becomes less sharply defined because of the different speeds at which its components travel. The sharper it was at the start, the more it suffers, because of the diversity of frequencies composing it. If, to avoid this, we reduce its frequency band width, the signal cannot be clear and sharp even at the start. We have noted that whatever the medium for ψ waves it is dispersive, so the same sort of thing must be expected to happen to electrons. If the position of an electron is sharply defined, the ψ waves must occupy a wide frequency band, so their velocity is dispersed and indefinite. If on the other hand the velocity is definite there can be only a narrow band of frequencies, which means that the wave group is spread out and the position of the electron is indefinite. In brief, according to wave mechanics it is not possible for both the position and velocity of an electron to be clearly defined. The more precisely we know its position, the less precisely we know its velocity; and vice versa.

Like most things in modern atomic theory, this sounds silly at first. But it is in agreement with the conclusion we are driven to when we ask ourselves how we would measure the position or the velocity of an electron. Whatever method is proposed, the act of observation alters the very thing we are trying to observe—like trying to see how well a seedling is growing by pulling it up. This difficulty is not one due just to the imperfections of current laboratory technique; it is a matter of principle which no conceivable technique could overcome. I have touched on it occasionally in recent months, under the name Heisenberg Uncertainty Principle. Consideration of this experimental difficulty, and the theory of wave mechanics, both lead to the same conclusion, namely that the uncertainty in position multiplied by the uncertainty in momentum (which is velocity times mass) is of the order of magnitude h .

Because I have concentrated entirely on electrons

you may have got the impression that wave mechanics applies only to them. But actually it applies to everything. The more accurately the police measure the speed of your car, the less certain they can be about its position. But since the product of the two uncertainties, h , is only about 6.6×10^{-34} joule-secs (to get some impression of this number you have to write it out in full) it is not likely to impress the magistrates. It is only when things are of sub-atomic size that the uncertainty is something to be reckoned with. So all the things we can see with our eyes, even with the aid of the most powerful microscope, are virtually free from it, and that is why we have such difficulty in visualizing electrons, in which uncertainty is dominant. The clear sharp orbits of satellites dissolve into hazes of probability, which render meaningless the questions we ask such as "How does an electron get from one orbit to another, when all between is 'forbidden'?"

We have seen that wave mechanics resulted from applying to the experimentally observed wave properties of electrons the same theory of dispersion as crops up in so many connections, notably signals along cables and waveguides. When we came to the numerical expression of Heisenberg's principle (usually written as $\Delta x \Delta p \sim h$) you may have felt you had seen something like it before. If you have come across the Hartley Communication Law (about which I meandered in the July, 1947, issue), then you did. For that has been expressed by Gabor in similar form, namely $\Delta f \Delta t = \frac{1}{2}$, which means that the smallest element of signal (numerically equal to $\frac{1}{2}$) is the product of frequency and time. If you cut down on frequency band by using highly selective apparatus, you need a relatively long time to send a given amount of signal; on the other hand, if you want to signal rapidly you must use a relatively wide frequency band. The most obvious example of this is a gramophone record; playing it faster increases the frequency band required to handle its signals. The two extremes are a continuous sine wave, which has zero bandwidth so needs infinite time, and a pulse of zero duration which needs an infinite bandwidth. Correspondingly, if the velocity or momentum or energy of an electron is within very narrow limits its position may be anywhere within wide limits (Fig. 2). In practice it is mainly within the limits of space occupied by one atom, but compared with the size of an electron that is rather like St. Paul's Cathedral to house a grain of dust. That is why an electron is better likened to a faint fog in the cathedral than a clearly defined grain.

Constitution of a Particle

One's first reaction to wave mechanics is to ask how on earth an electron can be both a particle and waves at the same time. This difficulty arises because we have a preconceived idea, based on experience with visible objects, that a particle is something solid occupying a small but definite region of space. But in fact (so it appears) that definiteness and solidity of a thing we see is just a particular case of wave mechanics, the object being so large that the wavelikeness and uncertainty are negligible. In the same way it used to be argued that light consisted of particles, not waves, because waves would give rise to diffraction patterns, which are not observed when objects cast shadows. But in fact such patterns are

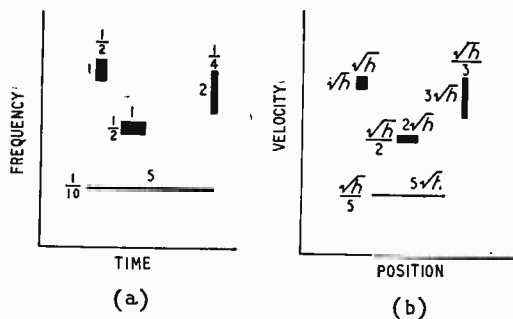

Fig. 2. The smallest possible signal is represented by an area of $\frac{1}{2}$ on a frequency/time graph. Here (a) are several examples, having different frequency bands and time durations but all the same size. Similarly (b) a particle cannot be pinpointed on a velocity/position graph: there is a minimum uncertainty, represented by the area h .

produced, and the reason one seldom notices them is merely a question of scale.

You may still feel very sceptical about these ψ waves, and I think you have every right to be, if what you are asked to believe is that all matter is made of waves of we know not what, travelling at anything up to infinite speed. Wave mechanics doesn't necessarily commit us to that, however. An alternative view is that the behaviour of pieces of matter (especially in the smallest sizes, where such things as uncertainty and standardized orbits come in) is calculable by the same mathematical equations as the behaviour of waves, but that this is no more than an interesting and useful coincidence. If we take this view we must be prepared to adopt it also for light and other so-called electromagnetic waves. We may be reluctant to do this, because we were brought up to accept them as waves. But there is equally a difficulty in explaining what they are waves of or in, for it has been demonstrated that no such thing as ether exists. And calling them waves of electric and magnetic field doesn't really answer the question. The real reason is not that the reality of electromagnetic waves is any more certain than that of ψ waves, but that we happen to be of such a size that properties of e.m. radiation most conveniently handled by wave mathematics come more within our everyday scale of values than do those of matter. Although there are plenty of experiments to show that the energy of radio and light distributes itself in a manner that can be calculated on a basis of hypothetical waves in space, that doesn't prove that waves of anything exist. It is possible to calculate the behaviour of a mechanical structure on the basis that it is an electrical circuit, but nobody argues that the fact that this procedure gives the right answers proves that the mechanical structure is an electrical circuit.

Having been brought up on Euclid, Newton and Clerk Maxwell, I have found it as difficult as anyone to accept Einstein, Planck, Schrödinger and Heisenberg; but if one gives their ideas a chance to sink in gradually it is remarkable how reasonable they become. "Common sense" is seen to have been just another name for prejudice. So if your first reaction to these modern ideas is either to ridicule them or be discouraged by your inability to follow them, my advice is to persevere!

Colour Brightness Standards for tri-colour television c.r. tubes have recently been created in America by the National Bureau of Standards in co-operation with the Joint Electron Tube Engineering Council of the Radio, Electronics and Television Manufacturers' Association. In physical form they consist of three filters—red, green and blue—and an electric lamp. Master standards are kept at the Bureau and corresponding sets of filters and lamps are sent out to the manufacturers, who use them to calibrate instruments for measuring the colour and brightness of the c.r.t. phosphors. In order to match the spectral energies of the phosphors as closely as possible (see graphs), a light blue-green glass and a dark blue glass are used as filters for the blue standard, a sextant-green glass for the green standard and a traffic-red glass combined with a blue-green glass for the red standard. Each of these filters or filter combinations is fitted with an opal glass that diffuses light from the calibrated 500-watt projection lamp provided in the set. The standards can

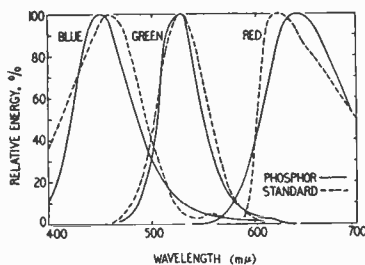

be used for calibrating either photoelectric or visual photometers. Instructions for doing this are provided with each set of standards, giving the distances required between the opal glass of the filters and the lamp, together with the lamp voltages necessary for the standards to have luminances of 50, 20 and 2 foot lamberts respectively. These particular values of luminance were chosen as the most useful for industrial purposes, but the conditions required to produce other values can be easily computed.

Electronic Yarn Filament Counter using a crystal transducer has been developed by the British Rayon Research Association. A link is attached to the crystal as in an ordinary gramophone record pickup, and a short length of the yarn is stretched out so as to press against this link. The filaments in this length of yarn are also spread out across a knife edge. A second knife blade then slowly cuts the yarn with a scissor-like action. As each filament is cut, the force on the link is suddenly altered and a train of damped oscillations is produced from the crystal. Each train is converted electronically to a single pulse,

Technical Notebook

and these pulses are counted by a two-decade deatron counter. The counter will give an accurate figure for the number of filaments, provided that the next filament is not cut before the recovery time of the pulse shaping and counting for the previous filament. To satisfy this proviso in the first place the yarn must not be cut too quickly; and secondly, the filaments must be spread out over the knife edge so that only one filament can be cut at a time. Only in yarns with about 50 or more filaments does the difficulty of satisfactorily spreading out the filaments over the knife edge result in a few per cent undercounting. This method replaces laboriously counting by eye under a microscope.

Stereo Record Changers.—Modifications to record changers which may be necessary to render them suitable for use with stereophonic pickups are discussed in an interesting leaflet available from Collaro. The automatic stop and pickup pivot bearings may have to be altered to allow a lower tracking pressure in order to keep record wear down to an acceptable amount. Better balancing of the motors may also be necessary to reduce rumble, since this tends to occur more in a vertical than a lateral direction, and vertical stylus motion produces an output in stereophonic reproduction

Unexpected Ferromagnetism at low temperatures has been discovered in an intermetallic compound which does not contain any of the commonly known ferromagnetic elements. This discovery, by B. T. Matthias of the Bell Telephone Laboratories in America, was made while studying the properties of a zirconium zinc compound (ZrZn.) at low temperatures. The behaviour of zirconium zinc indicates that ferromagnetic and perhaps antiferromagnetic compounds may be formed by the combination of many more metals than had been supposed until now. Hitherto, no ferromagnetic intermetallic compound was known that did not contain any ferromagnetic elements—iron, cobalt, nickel, chromium, manganese, or a few rare earth metals. This has led to the tacit assumption that no ferromagnetism could occur in an intermetallic compound unless it contained at least one strongly paramagnetic element.

Zirconium zinc becomes ferromagnetic below 35°K. Its ferromagnetic characteristics are similar to and of the same order of magnitude as those exhibited by conventional ferrites at room temperatures. The discovery of these properties provides an interesting new field of study in the fundamental characteristics of magnetism and magnetic materials.

DO/IT is not followed by “yourself,” but, on the contrary, eliminates what was originally a human task in the operation of at least one electronic analogue computer. It is, in fact, an abbreviation for the “digital output/input translator” system which is being used on a Beckman Instruments analogue machine to automatically set up and check problems by means of punched tape and electric typewriters. The computer can be set for initial conditions, computing or checking; coefficient potentiometers can be set or read and their values printed out; and various points in the computer circuit can be scanned and their voltages and signs be printed out. The punched tape can be used as a means of storing information on setting values, so that the computer can be cleared for other work and then the original information be reinserted later.

Electron-beam Parametric Amplifier shown in the illustration has been developed by the Zenith Radio Corporation of America. Amplification in this valve is by means of the so-called fast wave or electron charge density wave with a velocity greater than that of the electrons themselves (see

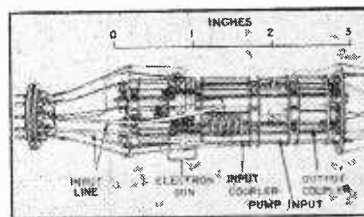

Wireless World, July 1958, p. 311). The noise component of the fast wave can be absorbed in the signal input coupler and a noise figure as low as about 1dB achieved. In this valve, the signal frequency does not affect the amplifying process so that, it is claimed, the bandwidth is limited only

by the input and output coupling characteristics. In many types of parametric amplifier, amplification is equally possible in both forward and reverse directions, so that any reflections at the output or input coupler lead to signal feedback and are likely to produce oscillations. However, in this valve up to 30dB gain can be achieved with, it is claimed, unconditional stability. A 200 gauss magnetic field directed along the valve from the signal input to the output couplings produces spiral motion of the electrons as they move from the input to the output under the action of an accelerating potential which is only 6V. The angular velocity of the spiral motion is fixed by the magnetic field strength, and the amplitude of this motion corresponds to the signal strength. The input centre frequency is 560Mc/s, and 10mW of pump power at 1,120Mc/s is fed in.

New Type of Grain Orientation in silicon-iron magnetic alloys is described on p. 363 of *J. App. Phys.* for March, 1958. In the usual grain-oriented sheet, the individual crystals of the material are aligned with one of their axes for easy magnetization and low loss parallel to the rolling direction along the length of the sheet. This direction is then taken advantage of in transformer construction. (This idea of grain orientation has been described in greater detail in an article by D. H. Martin in our March, 1958, issue, on p. 128). Unfortunately, in standard varieties of grain-orientated material, there is a less easy magnetization direction in the plane of the sheet at right angles to its length. This will tend to introduce losses where the flux must bend at right angles to the sheet length, such as at corners. This disadvantage is avoided by arranging that another direction of easy magnetization lies in the plane of the sheet at right angles to its length, in addition to the direction in the plane of the sheet along its length. This type of crystal arrangement (known as cube textured) has been produced in silicon-iron magnetic sheet by workers at the G.E. Co. of America's research laboratories. The losses in a transformer made of cube textured silicon-iron were compared with those in a dimensionally similar transformer made with standard grain-orientated material. At all inductions, the losses were found to be significantly lower using the cube textured silicon-iron transformer. For example, at 17,000 gauss the losses were 40% less and, moreover, only half as much current was required to produce this induction in the cube textured transformer.

Bright Silver Plating process introduced by the Baker Platinum Division of Engelhard Industries gives mirror-finish deposits which are hard and highly ductile and may therefore be suitable for electrical contacts. The plating liquid is a high cyanide

solution with special brighteners added, and is clear like water so that the plater can watch the work in process of deposition. Current densities ranging from 10 to 40 amperes per square foot can be used.

Pulse Generation by shock waves is described on p. 500 of *J. App. Phys.* for March, 1958. An explosion shock wave is used to demagnetize a ferromagnetic material, a voltage pulse being then induced in a coil wound on the magnet owing to the sudden change in magnetic field. The interest of this method is that relatively large peak powers of the order of 100 kW (pulse length $\approx 1 \mu\text{sec}$) can be obtained from structures only a few inches in size.

Secondary Emission Digitizer is an electronic analogue/digital converter based on secondary emission from the screen of a c.r. tube. Developed by J. Willis and M. G. Hartley, of Manchester University, it makes use of the fact that when potentials are applied to electrodes on the outside face of the tube there is an appreciable variation in the secondary emission from the screen as the electron beam sweeps across the area behind the electrodes. This method avoids the need for c.r. tubes with external

resistor develops a pulse of 1-Mc/s alternating voltage each time the c.r.t. beam passes an electrode, and this is amplified and demodulated to give the digit pulse output. The lower diagram shows that the input analogue voltage is used to deflect the beam vertically as it scans horizontally across the electrodes, the last-mentioned being arranged in a pattern to give a digital output (binary here) corresponding numerically to the vertical deflection voltage. More details are given in the June, 1958, issue of the *Journal of Scientific Instruments*.

"Hemisphère" Radar Aerial.—As higher performance is demanded of a radar, so (usually) the size of its aerial increases. This naturally leads to very difficult problems in rotating smoothly a conventional 50- or 70-ft long structure in high winds. An alternative scheme is to use a continuous "lens" or "mirror" encircling a small, central rotating feed. This is the method employed in the "Hemisphère" aerial, reported in the 1958 National Convention Record of the I.R.E. This aerial consists of a dielectric "goldfish-bowl" inverted over the radiating mechanism. The bowl is covered with narrow, parallel conducting "stripes," placed at an angle of 45° to the vertical meridians: these are "illuminated" from the internal feed with such a polarization that currents flow along the strips making them behave as a large illuminated reflector, so focusing energy out through the opposite side of the sphere. Because the conducting "stripes" are at 90° to the plane of polarization of the wave from the other side of the "bowl," they exert little effect on it. To produce a rotating beam it is necessary to rotate only the feed which is relatively small and is protected from outside weather conditions by the sphere (which could be an inflated balloon). Azimuthal "beam-wagging" can also be achieved by tilting the feed. A $5\frac{1}{2}$ -ft diameter (53 λ) model gave a beam-width varying between $1^\circ 20'$ and $3^\circ 50'$ —a similar, conventional paraboloidal reflector would have a beam-width of $1^\circ 32'$. The side-lobe pattern, too, seems quite favourable.

Diode Voltage References, as an alternative to standard cells, have been introduced in America by North Hills under the name "Solidcells." They utilize selected and aged Zener diodes connected in cascade and enclosed in ovens to render them insensitive to ambient temperature changes. Advantages claimed for the units over standard cells are that they can withstand short circuits, are readily transportable and are unaffected by mechanical shock, temperature variation and mounting position. One model provides three fixed reference levels. Another is used in conjunction with a 10-k Ω decade voltage divider to form a precision source of any desired voltage up to 10 volts.

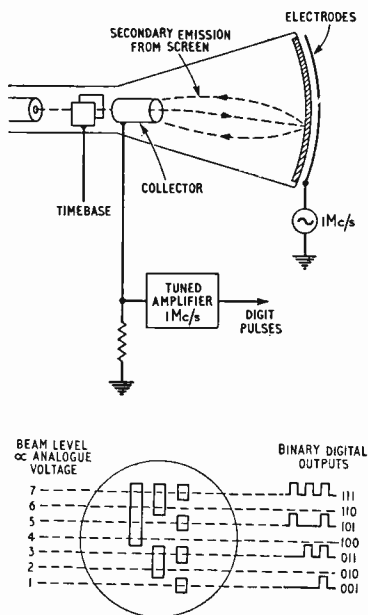

optical masks or special tubes with built-in masks, as are used for existing c.r.t. analogue/digital converters. An alternating potential of 1Mc/s is applied to the screen electrodes (upper diagram). This causes the screen material in the region of the spot to fluctuate about its mean potential. As a result there is a small alternating component superimposed on the steady secondary emission current, which is picked up by a cylindrical anode acting as a collector. Thus the

Manufacturers' Products

NEW ELECTRONIC EQUIPMENT AND ACCESSORIES

Column-shaped Loudspeaker System

NOT to be confused with columns of loudspeakers often used in sound reinforcement, the cabinet in the new Wharfedale "Column Eight" loudspeaker system has been made in the shape of a column to provide a relatively large cabinet volume in a small floor space. There is thus no great difficulty in finding the space for two such systems for stereophonic reproduction. The 8-in loudspeaker is mounted at the top of the column facing upwards on to a 4-in diameter inverted truncated-cone diffuser so that the frequencies above about 3000c/s are equally distributed horizontally, as is often advocated for stereophonic reproduction. Since the diffuser is somewhat smaller than the cone, frequencies below 3000c/s are not obstructed and a "boxed-in" sound is avoided. An acoustically resistive filter constriction consisting of a number of long, narrow slots cut in a wooden panel is placed one-third of the way up the cabinet. This constriction, together with two ports at the bottom, makes the enclosure perform as a reflex cabinet with a resonance at about 85c/s. The filter, it is claimed, also subdues air-column resonances (particularly the third harmonic), and being fixed to the column on all four sides helps to reduce panel resonances. The panel resonances are further reduced and their frequencies spread apart by making the cabinet with solid wooden corners and inserting a dowel between two opposite walls at a suitable point. The outside dimensions of the cabinet are 14in x 12in x 3ft 8in and its weight (without loudspeaker) is 34½lb. The cost of the cabinet alone is £21 15s, and that of the specially developed loudspeaker unit for use with it (Type 8/145) £7 6s 11d, including purchase tax. The address of the manufacturer is Wharfedale Wireless Works, Ltd., Idle, Bradford, Yorkshire.



Arcoelectric Type SL78 miniature neon signal lamp.

Left: Wharfedale "Column Eight" Loudspeaker

Miniature Neon Indicator Lamp

SMALL size and low cost are the two principal features of a new miniature neon signal lamp, Type SL78, introduced by Arcoelectric (Switches), Ltd., Central Avenue, West Molesey, Surrey. It has a built-in ¼-watt neon

tube with limiting resistor and is available for working voltages of from 80 to 600 a.c. or d.c. It fits into a ¼in diameter hole with connection made by means of two p.v.c.-covered fly leads emerging at the back. Normally these are 8in long but leads up to 15in can be supplied to order. The screw-on plastic lens may be red, amber or clear and the price is 5s 6d.

New Tape Recorder

A NEW Grundig tape recorder, the TK30, has a frequency response within ±3dB from 50 to 10,000 or

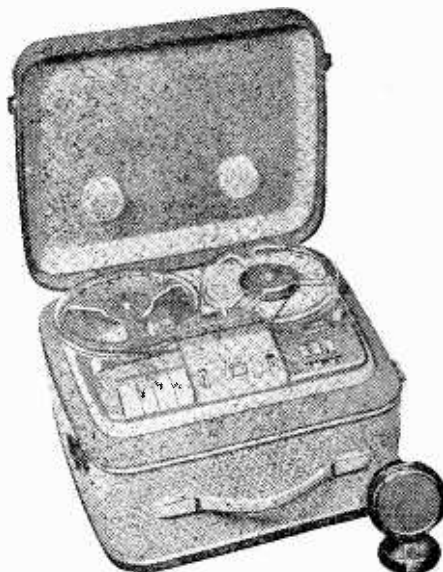

Grundig TK30 tape recorder.

15,000c/s for the two speeds of 3¼in/sec or 7½in/sec respectively; the wow and flutter at these slow and fast speeds being quoted at less than 0.25% and 0.2% respectively. A Mullard EM84 double-column type tuning indicator level control is used, overload occurring when the two luminous columns overlap. Start/stop remote control facilities are also provided. The recorder weighs 31lb and costs 72 guineas. The address of the manufacturer is Grundig (Great Britain), Ltd., 39-41, New Oxford Street, London, W.C.1.

Lightweight Oscilloscope

A WEIGHT of only 2½lb and dimensions of 6in x 5in x 4in characterize the "Uniscope," a new oscilloscope introduced by Bourne Engineering. The Y-deflection sensitivity of the "Uniscope" does not, it is claimed, fall 3dB below its mid-frequency value of 100mV/cm in the frequency range from 5c/s to 350kc/s. The timebase frequency is continuously variable from 5c/s to 50kc/s. A 1-in self-focusing ICPI cathode-ray tube is used. For building into equipment, two monitor versions without a cabinet and power pack are available. One of these, the P62, has the same specification as the "Uniscope"; while the other, the

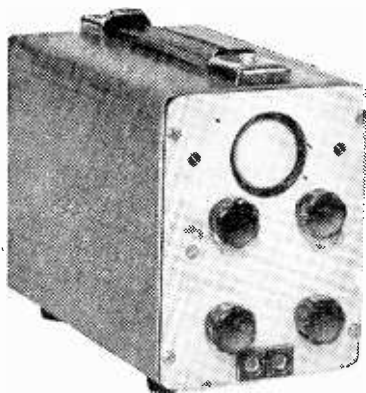

Bourne Engineering miniature oscilloscope.

P62BS, has an additional 50c/s beam-switch for the simultaneous examination of two signals. The phase of the beam switch waveform relative to the a.c. mains can be varied. The cost of the "Uniscope" is £23, that of the P62 monitor £16, and that of the P62BS monitor £18. The address of the manufacturer is Bourne Engineering Ltd., Abbey Mill, St. Albans, Herts.

Precision Potentiometers

THE illustration shows one of the new miniature wire-wound potentiometers Type 11 introduced by Ferranti, Ltd., Ferry Road, Edinburgh, 5. Single units measure 1 in in diameter and 0.78 in deep and up to three can be ganged for operation by a single spindle, the ganging adding only 0.281 in per unit to the overall depth.

Resistance values range from 1,000Ω to 50kΩ and the inclusion of twin wiping contacts ensures reliable and noise-free operation.

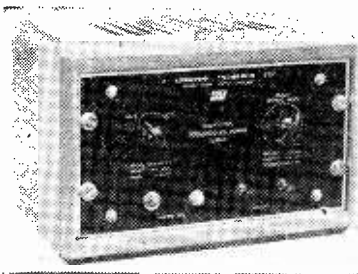

Variable-voltage transistor-stabilized d.c. power supply unit (J. Langham Thompson).

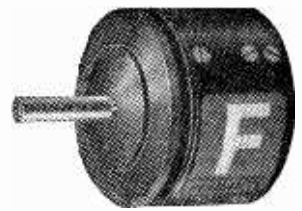

Ferranti miniature precision potentiometer Type 11.

Transistor Regulated Power Supplies

SEMICONDUCTORS are used in place of valves in a range of voltage-regulated power supply units introduced by J. Langham Thompson, Ltd., Springland Laboratories, Bushy Heath, Herts. These models are intended for low-voltage, high-current applications such as for operating certain kinds of laboratory and industrial electronic apparatus, cine sound-head lamps, low-power transducers and similar equipment.

The model illustrated provides a d.c. output which is variable between 4.5 and 14 volts and for currents up to 500mA with stabilization to $\pm 0.15\%$. Two other models are available for use where a fixed d.c. output of 12.5 volts is required. Regulation is held to within 0.1% and one model gives 750mA and the other 1.5A maximum output.

The use of semiconductors results in compact, lightweight equipment with heat dissipation reduced to a minimum. The variable-output model weighs 7½ lb and measures 10¼ in × 7½ in × 8½ in, while the two fixed-voltage models each weigh 4½ lb only and measure 8 in × 3½ in × 3¼ in.

NOVEMBER MEETINGS

LONDON

4th. I.E.E.—"Operating experience with a transistor digital computer" by R. C. M. Barnes and Dr. J. H. Stephen; and "A new high-speed digital technique for computer use" by D. Eldridge at 5.30 at Savoy Place, W.C.2.

5th. British Kinematograph Society.—"Inlay and overlay in television" by D. R. Campbell (B.B.C.) at 7.30 at the Royal Society of Arts, John Adam Street, W.C.2.

6th. I.E.E.—"The recognition of moving vehicles by electronic means" by T. S. Pick and A. Readman at 5.30 at Savoy Place, W.C.2.

14th. R.S.G.B.—"Radio conditions in Antarctica" by Major G. Watson (War Office) at 6.30 at the I.E.E., Savoy Place, W.C.2.

19th. I.E.E.—"Television recording: a survey of the problems and the methods currently in use" by J. Redmond at 5.30 at Savoy Place, W.C.2.

19th. Society of Instrument Technology.—Symposium on analytical instrumentation developed at Harwell from 2.30 to 6.30 at Manson House, Portland Place, W.1.

21st. Television Society.—"The European television network—some operational problems" by J. Treeby Dickinson (European Broadcasting Union) at 7.0 at the Cinematograph

Exhibitors' Association, 164 Shaftesbury Avenue, W.C.2.

21st. B.S.R.A.—"Design of stereophonic pickup cartridges" by S. Kelly at 7.0 at The Royal Society of Arts, John Adam Street, W.C.2.

21st. Institution of Mechanical Engineers.—"The transmission of acoustic waves through structures" by Professor L. L. Beranek at 6.0 at 1 Birdcage Walk, Westminster, S.W.1.

21st. Junior Institution of Engineers.—"Printed circuit techniques" by P. A. Trigg at 7.0 at Pepys House, 14 Rochester Row, S.W.1.

24th. I.E.E.—"The use of dispersive dielectrics in a beam-scanning prism" by Dr. J. S. Seeley and Dr. J. Brown; "The quarter-wave matching of dispersive materials" by Dr. J. S. Seeley; and "Theory of reflections from the rod-type artificial dielectric" by A. Carne and Dr. J. Brown at 5.30 at Savoy Place, W.C.2.

26th. Brit.I.R.E.—Presidential address of Professor E. E. Zepler at 7.15 at the London School of Hygiene and Tropical Medicine, Keppel Street, Gower Street, W.C.1.

BIRMINGHAM

3rd. I.E.E.—"Some impressions of technical and industrial training in the United States" by Dr. K. R. Sturley,

at 6.0 at the James Watt Memorial Institute.

14th. Society of Instrument Technology.—"Transistors" by S. S. Goldberg at 7.0 at Regent House, St. Phillips Place, Colmore Row.

24th. I.E.E.—"Development of a guided missile" by W. R. Thomas at 6.0 at the James Watt Memorial Institute.

BRISTOL

11th. Television Society.—"Television relaying" by T. Kilvington (G.P.O.) at 7.30 in the Colston Room of the Hawthornes Hotel, Clifton.

25th. Brit.I.R.E.—"Electronic transducers" by G. F. N. Knewstubb at 7.0 at the School of Management Studies, Unity Street.

27th. I.E.E.—Faraday Lecture on "Automation" by Dr. H. A. Thomas at 6.45 at Colston Hall.

CAMBRIDGE

4th. I.E.E.—"Random thoughts of a propagation engineer" by G. Millington at 8.0 at the Cavendish Laboratory.

CHELMSFORD

25th. I.E.E. Graduate and Student Section.—"A review of industrial ultrasonics" by R. D. Foskett and D. H. Hardy at 7.0 in the Public Library.

CHELTENHAM

3rd. Society of Instrument Technology. — "Instruments for guided flight" by G. G. Roberts at 7.30 at the Rotunda.

28th. Brit.I.R.E. — "Television recording" by P. J. Guy at 7.0 at North Gloucestershire Technical College.

CHESTER

24th. I.E.E.—"The recognition of moving vehicles by electronic means" by T. S. Pick and A. Readman at 6.30 at the Town Hall.

DERBY

24th. I.E.E.—"The importance of research in hearing and seeing to the future of telecommunication engineering" by Dr. E. C. Cherry at 6.30 at E.M.E.B. Service Centre.

EDINBURGH

5th. I.E.E.—"Operating experience with a transistor digital computer" by R. C. M. Barnes and Dr. J. H. Stephen; and "A basic transistor circuit for the construction of digital-computing systems" by P. L. Clood at 7.0 at the Carlton Hotel, North Bridge.

21st. Brit.I.R.E.—"An electronic engine indicator" by G. F. Norman and "An electronic pin-hole detector for tin plate inspection" by D. Goodwin at 7.0 at the Department of Natural Philosophy, The University, Drummond Street.

EXETER

6th. I.E.E.—"Domestic high-fidelity sound reproduction" by J. Moir at 3.0 at S.W.E.B. Showrooms, Bedford Street.

GLASGOW

4th. I.E.E.—"Operating experience with a transistor digital computer" by R. C. M. Barnes and Dr. J. H. Stephen; and "A basic transistor circuit for the construction of digital-computing systems" by P. L. Clood at 7.0 at the Royal College of Science and Technology, George Street.

11th. I.E.E.—"The recognition of moving vehicles by electronic means" by T. S. Pick and A. Readman at 7.0 at the Institution of Engineers and Shipbuilders, 39 Elmbank Crescent, C.2.

20th. Brit.I.R.E.—"An electronic engine indicator" by G. F. Norman and "An electronic pin-hole detector for tin plate inspection" by D. Goodwin at 7.0 at the Institution of Engineers and Shipbuilders, 39 Elmbank Crescent, C.2.

HALIFAX

5th. Institution of Production Engineers. — "Electronic control of machine tools" by R. P. Gardner (Asquith Machine Tool Corporation) at 7.30 at The Percival Whitley College of Further Education.

LEEDS

12th. Plastics Institute.—"Printed circuits on plastics panels" by F. Hicks-Arnold (Cossor) at St. Marks House, 185 Woodhouse Lane.

LIVERPOOL

17th. I.E.E.—"The importance of research in hearing and seeing to the future of telecommunication engineering" by Dr. E. C. Cherry at 6.30 at the Royal Institution, Colquitt Street.

28th. Brit.I.R.E.—"The first transatlantic telephone cable" by F. Scowen at 7.0 at the University Club.

LOUGHBOROUGH

20th. Society of Instrument Tech-

nology.—"Control of the Jodrell Bank radio-telescope" by P. J. Bhatt at 7.0 at the College of Further Education, Greenclose Lane.

LUTON

20th. I.E.E. Graduate and Student Section.—"The application of electronics to jet engine control" by H. E. Coles at the Staff Canteen, D. Napier & Son, The Airport.

MANCHESTER

6th. Brit.I.R.E.—"The determination of aspect by a shipborne radar" by E. L. Crouchman at 6.30 at the Reynolds Hall, College of Technology, Sackville Street.

12th. I.E.E.—"The relation between picture size, viewing distance and picture quality, with special reference to colour television and to spot-wobble techniques" by L. C. Jesty at 6.45 at the Engineers' Club, Albert Square.

NEWCASTLE

12th. Brit.I.R.E.—"The use of transistors in communication and control equipment" by E. Wolfendale at 6.0 at the Institution of Mining and Mechanical Engineers, Neville Hall, Westgate Road.

17th. I.E.E.—"A new cathode-ray tube for monochrome and colour television" by Dr. D. Gabor, P. R. Stuart and P. G. Kalman at 6.15 at King's College.

PORTSMOUTH

12th. I.E.E.—"A survey of harbour approach aids" by A. L. P. Milwright at 6.30 at C.E.G.B. Offices, 111 High Street.

RUGBY

11th. I.E.E.—"A new cathode-ray tube for monochrome and colour television" by Dr. D. Gabor, P. R. Stuart and P. G. Kalman at 6.30 at the College of Technology and Arts

SALISBURY

19th. I.E.E.—"Colour television" by C. J. Stubbington at 6.30 at S.E.B. Showrooms, 17 New Canal.

SOUTHAMPTON

5th. I.E.E.—"The use of transistors in radio and television" by E. Wolfendale at 7.0 at Southampton University.

SWANSEA

25th. I.E.E.—Faraday Lecture on "Automation" by Dr. H. A. Thomas at 6.0 at Brangwyn Hall

TORQUAY

7th. B.S.R.A.—"Stereo sound reproduction" by J. Moir (B.T.H.) at 7.30 at Callard's Cafe.

TREFOREST

12th. Brit.I.R.E.—"Problems of television servicing" by E. A. W. Spreadbury at 6.30 at Glamorgan College of Technology.

WEYMOUTH

28th. I.E.E.—"The design of transistors" by Dr. J. R. Tillman, at 6.30 at the South Dorset Technical College.

WOLVERHAMPTON

12th. Brit.I.R.E.—"Transistors in television receivers" by B. R. Overton at 7.15 at the Wolverhampton and Staffordshire College of Technology, Wulfruna Street.

Hong Kong to Hatfield

World record and sun beating Comet IV—pride of the British aircraft industry, ultimate in airline luxury—has built-in Trixadio Passenger Announcement System for the convenience of its transmondial travellers. Developed to meet the exacting needs of engineers who seek high quality, long service and realistic costs. Trix equipment is built with integrity—and the pioneering spirit which is constantly in search of perfection.

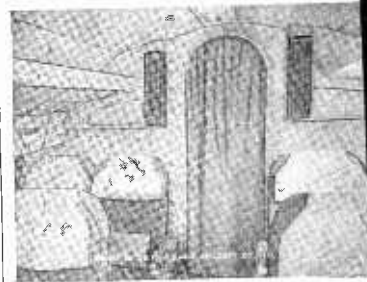

- ★ The first completely transistorised Aircraft Passenger Announcement and music system.
- ★ The first Aircraft system using high efficiency Sound Column Radiators.
- ★ Low weight—low power requirements—reduced wiring cost.

THE TRIX ELECTRICAL CO. LTD.

TRIX

1-5 MAPLE PLACE, LONDON, W.1
Tel: MUSEum 5817 (6 lines). Cables &
Grams: Trixadio, Wesdo, London

DHB/6189

RANDOM RADIATIONS

By "DIALLIST"

Saturation Point in the U.S.?

IN the September number of the French monthly, *Television*, E. Aisberg gave a very interesting account of a chat that he'd had with Dr. Zworykin on a Riviera beach. Zworykin (the inventor of the iconoscope) retired a few years ago from the R.C.A., but the firm has provided him with a laboratory for his own special use. Apparently the approaching saturation of the television market in America is one of the industry's biggest headaches. There are, it seems, now nearly 50,000,000 TV receivers in use in the U.S.A. and I was surprised to learn that the average American once he has bought a set keeps it going for seven years. Since the American manufacturers can turn out eight million sets a year they are obviously going to be confronted with a very sticky problem unless something can be done to boost sales of TV apparatus. Zworykin's idea is to extend the usefulness of the ordinary domestic receiver by enabling it to be employed without modification for closed-circuit television over short distances.

A Miniaturized Vidicon

To this end he has evolved an almost incredibly small Vidicon camera tube. It is no more than 3-inches in length and under half-an-inch in diameter. He has so perfected the focusing system that a 525-line image can be recorded on its tiny screen. The miniature camera and transmitter would be connected to the receiver by a length of coaxial cable, which would carry both the mains current to the transmitter and the vision signal from transmitter to receiver. In the home the apparatus would enable parents to keep an eye on children in the playroom or the garden and one can think of many other uses. Miniaturized closed-circuit television would also be of great value in offices, factories and so on. The snag is that unless it could be mass-produced the cost of the little tube would be prohibitive. So far only small runs have been made and the cost worked out at nearly £150 apiece; but the inventor holds that large-scale production in a well-equipped factory could

bring the price down to something not much over a fiver. It's a wonderful idea and the development of that little tube is indeed ingenious.

Views on Printed Circuits

DEALERS who have written to me about the merits and shortcomings of printed circuits in electronic apparatus hold widely differing views. A few swear by them, but I'm bound to confess that the majority of my correspondents swear at them. One says: "Printed circuits are in my view (which is shared by many service engineers) hopelessly untrustworthy and do not lend themselves to sound, reliable construction methods". That's, perhaps, going a bit far; but my correspondent ought to know what he's talking about, for he is service manager of an important north-country firm. I'd like to hear from more readers on the subject and I should be grateful if the "swear-attars" would tell me what faults they most commonly meet with. If only it can be made completely reliable—as no doubt it will be in time—the printed circuit would represent one of the biggest advances yet made in methods of manufacturing electronic apparatus. Every portion is an exact copy of the original model, which is certainly more than can be said when all the wiring is done by hand.

Make 'em Adjustable

THE most popular type of television receiver today seems to be the console— a table model fitted with screw-in legs. So far as I know, nobody has thought of making the height of these legs adjustable, though it would surely be a great improvement. As I've mentioned before, by far the most comfortable conditions for viewing are when your eyes and the middle of the screen are at the same height from the floor, or very nearly so. The mid-point of the screen of the average console set is some 30-in. above ground level and, unless you are very short in the body or emulate Miss Muffet by sitting on a tuffet, your eyes are likely to be several inches higher than that. Adjustable legs couldn't be just plain telescopic, or there would be a risk of their folding up on their own and letting the set down with a bang, or capsizing it with disastrous results. But it wouldn't be difficult or expensive to provide a device for locking them securely at the chosen length. Anyone who brings out TV legs of this kind would, I'm sure, be on to a good thing.

Stereo-sound Broadcasts

THE B.B.C. has already made successful stereo-sound broadcasts by making use of two transmitters. They will shortly be trying out an entirely



"WIRELESS WORLD" PUBLICATIONS

	Net Price	By Post
LOW-COST HIGH-QUALITY AMPLIFIER. P. J. Baxandall, B.Sc.(Eng.)	3/6	4/-
GUIDE TO BROADCASTING STATIONS 1958-59. Compiled by "Wireless World"	2/6	2/11
THE OCILSCOPE AT WORK. A. Haas and R. W. Hallows, M. A. (Cantab.), M.I.E.E.	15/-	16/-
TELEVISION RECEIVING EQUIPMENT. W. T. Cocking, M.I.E.E. 4th Edition	30/-	31/9
TRANSISTOR A.F. AMPLIFIERS. D. D. Jones, M.Sc., D.I.C., and R. A. Hilbourne, B.Sc.	21/-	21/10
LONG-WAVE AND MEDIUM-WAVE PROPAGATION. H. E. Farrow, Grad. I.E.E.	4/6	4/10
RADIO LABORATORY HANDBOOK. M. G. Scroggie, B.Sc., M.I.E.E. 6th Edition	25/-	26/9
RADIO VALVE DATA. Compiled by "Wireless World." 6th Edition	5/-	5/9
TELEVISION ENGINEERING VOLUME IV: General Circuit Techniques. S. W. Amos, B.Sc.(Hons.), A.M.I.E.E. and D. C. Birkenshaw, M.B.E., M.A., M.I.E.E.	35/-	36/2

A complete list of books is available on application

Obtainable from all leading booksellers or from

ILIFFE & SONS LTD., Dorset House Stamford Street, London, S.E.1

new system using one transmitter only. This is the E.M.I. Percival system, which needs only a single channel. Although I have not yet seen any technical details of the system I understand that one of its strong points is that it is compatible. That is, if an ordinary receiver is tuned in to the transmission, the programme is received with the same quality as with a stereo receiver, but, of course, without the stereo effect. Other points about the Percival system are that it calls for nothing more at the transmitting end than the addition of one extra unit to a standard transmitter and that it leads to no loss of range. The stereo reproduction of sound from records and tapes has achieved such rapid popularity that one needn't be a prophet to forecast a great future for stereo broadcasting.

Servicing Made Easy

A NOTEWORTHY feature of many of the new sound and television receivers is that great efforts have been made by the manufacturers to lighten the task of the serviceman when he is tracking down troubles, or replacing faulty components. Not a few of the sets of yesteryear gave one the impression that their designers had taken a fiendish joy in making things as difficult as possible for him! It is good to see how much more readily accessible the innards of today's sets have become. The use of plug-in components, such as line-output transformers, is one step in the right direction. Another is the adoption of a number of small and easily exchangeable panels with printed wiring. If any fault develops in the wiring, or in a component mounted on it, the whole panel is removed and replaced in a jiffy. In all the more kindly (from the serviceman's point of view!) designed receivers you can readily get at each of the valves and in some of them the pre-set controls are so placed that alignment can be carried out with the chassis still in the cabinet. There are still, though, too many TV sets in which dust can't be wiped off the screen end of the tube without taking out the chassis.

Sackcloth and Ashes

HOW I came to write last month that the dark side of the moon lived up to its name I just can't think, for I know as well as the next man that what we call the dark side is illuminated when the one facing us isn't. My apologies to our satellite and, of course, to my readers.

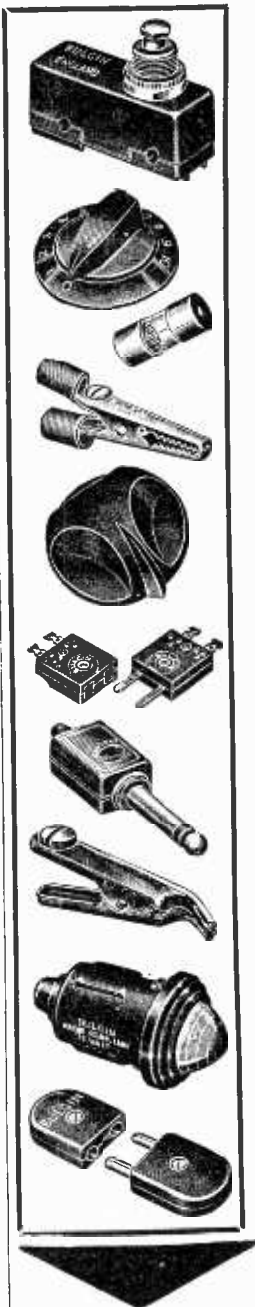

DEFENCE

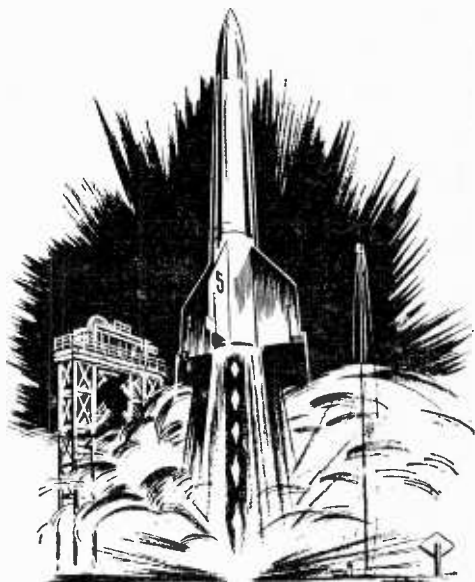

... through the unknown

Extreme of heat and cold, moist or arid. Today, modern uses depend on outstanding Components. That is why Bulgin, leading in design and manufacture, help to make possible new feats, help to achieve new ambitions.

The Bulgin research and manufacturing Division, with its unique skill and experience, is solving many problems of today and tomorrow.

OVER 10,000 COMPONENTS AVAILABLE

★ Full details will be found in fully illustrated Catalogue No 199/W.W. (Free to trade letterhead or order.)



THE HOUSE OF

BULGIN

Components



A. F. BULGIN & COMPANY LTD.
BARKING · ESSEX Tel.: RIPPleway 5588 (8 lines)

MANUFACTURERS OF RADIO AND ELECTRONIC COMPONENTS

Shylock Up to Date

OFFICIALLY the cash we pay for our broadcast receiving licences is a tax and nothing else. It is not meant as a contribution to the funds of the B.B.C. which are provided by a Treasury grant. Yet we all know the B.B.C.'s income bears a certain relationship to the fees paid for licences.* To put it bluntly, the more cash the P.M.G. gets in licence fees, the greater the B.B.C.'s rake-off. It is obviously, therefore, to the financial interest of the B.B.C. to encourage people to trade-in their "sound" £1 licence for a £4 "TV-sound" licence.

Now nobody can object to the officials of the B.B.C. trying to sell their goods by all legitimate means, but when they try, as they *are* trying, to force people to buy expensive TV licences when they want to hear only sound broadcasting it is time to protest, and this I do most strongly. I have no personal axe to grind as I already have a TV licence but there are still several million people who want to receive sound programmes only, and it is on their behalf that I take up the cudgels.

My complaint is in respect of the B.B.C.'s experimental stereo transmissions. These are obviously "sound only," as stereoscopic television is still a thing of the future. Yet any sound enthusiast who

* Now fixed at 87½% of the net licence revenue after the P.M.G. has deducted his "expenses." The Treasury receives the 12½% plus the recently added £1 excise duty on the £3 TV-sound licence.—Ed.

wishes to hear these stereo programmes is forced to buy a £4 TV licence to do so, as the B.B.C. is transmitting one of the stereo channels solely on television sound carriers. Furthermore the would-be listener will have to buy himself a TV set.

No doubt some smart Alec at Broadcasting House will point out that listeners can avoid all this expense by building or buying a five-metre sound receiver, but even that would put them to unnecessary expense. The other stereo channel is being transmitted on a medium wavelength as well as on v.h.f.; why not also a medium wavelength for the other channel as well as the Band I carriers?

Note of Interrogation

I WAS exceptionally interested in the detailed drawing in the October issue, of the B.B.C.'s impressive TV Centre, now being built at Wood Lane, as it occupies the site of the main part of the old White City with which I was very familiar. It opened just fifty years ago, in May 1908, as the Franco-British Exhibition, and in 1910 Japanese gardens were added for the Japan-British Exhibition of that year; their site is now occupied by the already completed scenery block.

The centre of the circular part of the B.B.C.'s structure coincides with the centre of the lake which was the main feature of the Court of Honour, a photograph of which I reproduce. The Franco-British Exhibition was

held to foster the *entente cordiale*, the foundations of which had been laid by King Edward VII when he paid a State visit to Paris in 1903. Is it too much to hope that the successor of the old White City will be used to further a world *entente cordiale* where nations shall do a bit more than merely *speak* peace unto nations? Maybe that is why the B.B.C. architect has designed the building in the form of a question mark.

Hi-Fi TV

I WONDER how much longer we in this country will have to put up with the crudities of the 405-line television system. I was derided by both pundits and polloi twenty-six years ago when I demanded in these pages (February 17th, 1932) something better from the B.B.C. than the 30-line system then used, and no doubt history will repeat itself.

However, although the pundits will attack me, I am on this occasion more likely to have the people on my side, owing, strangely enough, to the great popularity of the day trips to France which now run throughout each summer. On these trips the ordinary man has a chance of seeing the high-definition of the non-liney, but certainly not non-linear, 819-line French television.

From what I heard, it seemed that many people took these trips solely for the purpose of seeing French television, and so I determined to take one myself. I noticed that most of my fellow trippers on board were men as, indeed, used to be the case in pre-war and pre-TV days, but the explanation is, of course, that women are notoriously poor sailors, and as their menfolk do not like to see them suffer they naturally persuade them to stay at home.

I noticed that as soon as the steamer tied up alongside the quay my fellow men all hurried off to the town centre to see the usual sights, after which they all gravitated to the several large cafés in which TV was installed.

I can only say that the enthusiasm of everybody for French TV was unbounded and many men had to be dragged away from the screens when sailing time came round. Here and there among the audience there were a few of the non-technical type whose main interest was the subject matter which they saw on the screen—or more correctly what they expected to see—but these were not numbered among those including myself whose technical interest caused us to miss the ship; in fact we didn't know that they too had missed it until they rejoined us the following morning.

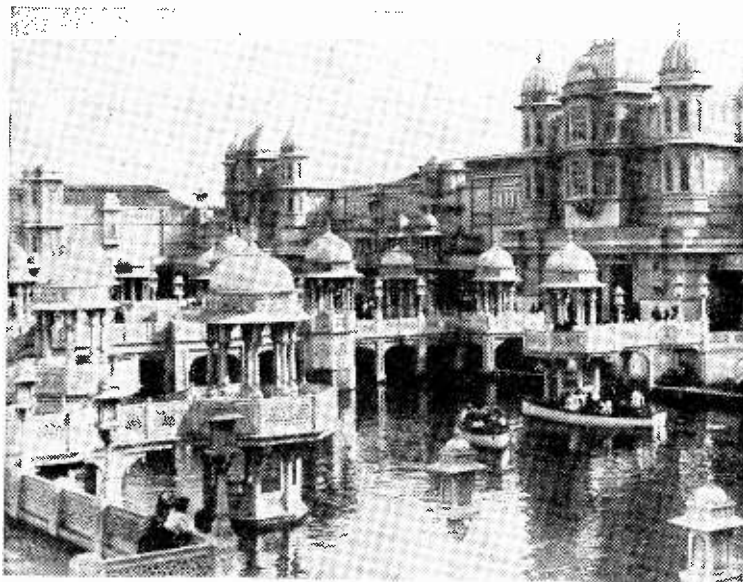

Site of the Television Centre 50 years ago.